

EVERYDAY ELECTRONICS

NOVEMBER 1987

INCORPORATING ELECTRONICS MONTHLY

£1.20

Free Inside

**GREENWELD
88 PAGE
CATALOGUE**

**ACCENTED BEAT
METRONOME**

**BBC
SIDEWAYS RAM**

ACOUSTIC PROBE



The Magazine for Electronic & Computer Projects



£1 BAKERS DOZEN PACKS

Price per pack is £1.00.* Order 12 you may choose another free. Items marked (sh) are not new but guaranteed ok.

- 1 - 5 13 amp ring main junction boxes
- 2 - 5 13 amp ring main spur boxes
- 5 - 3 flush electrical switches
- 7 - 4 in flex line switches with noons
- 8 - 2 80 watt brass cased elements
- 9 - 2 mains transformers with 6V 1A secondaries
- 10 - 2 mains transformers with 12V 1/4 A secondaries
- 11 - 1 extension speaker cabinet for 6 1/2" speaker
- 12 - 5 octal bases for relays or valves
- 13 - 12 glass reed switches
- 14 - 4 OCP 70 photo transistors
- 16 - 4 tape heads, 2 record, 2 erase
- 17 - 1 ultrasonic transmitter and 1 ditto receiver
- 18 - 2 15000 mfd computer grade electrolytics
- 19 - 2 light dependent resistors
- 20 - 5 different micro switches
- 21 - 2 mains interference suppressors
- 22 - 2 25 watt crossover units 2 way
- 23 - 1 40 watt 3 way crossover unit
- 28 - 1 6 digit counter mains voltage
- 30 - 2 Nicad battery chargers
- 31 - 1 key switch with key
- 32 - 2 humidity switches
- 34 - 96 x 1 metre lengths colour-coded connecting wires
- 36 - 2 air spaced 2 gang tuning condensers
- 37 - 2 solid dielectric 2 gang tuning condensers
- 38 - 10 compression trimmers
- 41 - 6 Rocker Switches 10 amp mains SPST
- 43 - 5 Rocker Switches 10 amp SPDT Centre Off
- 44 - 4 Rocker Switches 10 amp DPDT
- 45 - 1 24 hour time switch mains operated (s.h.)
- 46 - 1 6 hour clock timeswitch
- 48 - 2 6V operated reed switch relays
- 49 - 10 neon valves - make good night lights
- 50 - 2 x 12V DC or 24V AC, 4 CO relays
- 51 - 1 x 12V 2C O very sensitive relay
- 52 - 1 12V 4C relay
- 55 - 1 locking mechanism with 2 keys
- 56 - 1 Miniature Unselector with circuit for electric jigsaw
- 57 - 5 Dolls' House switches
- 60 - 5 ferrite rods 4" x 5/16" diameter aerials
- 61 - 4 ferrite slab aerials with L & M wave coils
- 62 - 4 200 ohm earpieces
- 63 - 1 Mullard thyristor trigger module
- 64 - 10 assorted knobs 1/4 spindles
- 65 - 5 different thermostats, mainly bi metal
- 66 - 1 Magnetic brake - stops rotation instantly
- 67 - 1 Low pressure 3 level switch
- 69 - 2 25 watt pots 8 ohm
- 70 - 2 25 watt pots 1000 ohm
- 71 - 4 wire wound pots - 18, 33, 50 and 100 ohm
- 73 - 4 3 watt wire wound pots 50 ohm
- 77 - 1 time reminder adjustable 1-60 mins
- 78 - 5 5 amp stud rectifiers 400V
- 85 - 1 mains shaded pole motor 1/4" stack - 1/4 shaft
- 86 - 2 5" ali fan blades fit 1/4" shaft
- 87 - 2 3" plastic fan blades fit 1/4" shaft
- 88 - 1 Mains motor suitable for above blades.
- 89 - 1 mains motor with gearbox 1 rev per 24 hours
- 91 - 2 mains motors with gearbox 16 rpm
- 93 - 4 11 pin moulded bases for relays
- 94 - 5 B7G valve bases
- 95 - 4 skirted B9A valve bases
- 96 - 1 thermostat for fridge
- 98 - 1 motorised stud switch (s.h.)
- 101 - 1 2 1/2 hours delay switch
- 103 - 1 6v mains power supply unit
- 104 - 1 4 1/2 V mains power supply unit
- 105 - 1 5 pin flex plug and panel socket
- 107 - 1 5" speaker size radio cabinet with handle
- 109 - 10 1/4" spindle type volume controls
- 110 - 10 slider type volume controls
- 112 - 1 heating pad 200 watts mains
- 114 - 1 1W amplifier Mullard 1172
- 115 - 1 Wall mounting thermostat 24V
- 118 - 1 Teak effect extension 5" speaker cabinet
- 120 - 2 p.c.b. with 2 amp full wave and 17 other recs
- 122 - 10 mtrs twin screened flex white p.v.c. outer
- 132 - 2 plastic boxes with windows, ideal for interrupted beam switch etc
- 155 - 3 varicap push button tuners with knobs
- 188 - 1 plastic box, sloping metal front, 16 x 95mm, average depth 45mm
- 241 - 1 car door speaker (very flat) 6 1/2" 15 ohm made for Radiomobile
- 243 - 2 speakers 6" x 4" 15 ohm 5 watt made for Radiomobile
- 266 - 2 mains transformer 9V 1/2 A secondary split primary so OK also for 115V
- 267 - 1 mains transformers 15V 1A secondary p.c.b. mounting
- 330 - 2 6V 0.6V mains transformer 3a p.c.b. mounting
- 350 - 40 double pole leaf switches
- 365 - 1 7uf 660V 50hz metal cased condenser
- 453 - 2 2 1/2 in 60 ohm loudspeakers
- 454 - 2 2 1/2 in 8 ohm loudspeakers
- 463 - 1 mains operated relay with 2 sets c/o contacts
- 464 - 2 packets resin filler/sealer with cures
- 465 - 3 5A round 3 pin plugs will fit item 193
- 466 - 4 7 segment i.e.d. displays
- 470 - 4 pc boards for stripping, lots of valuable parts
- 480 - 1 3A double pole magnetic trip, saves repairing fuses
- 498 - 4 1000uf 25V axial electrolytic capacitors
- 504 - 1 Audax PM 8" speaker 15 ohm 5 watt rating
- 515 - 100 4BA 1 1/2" cheesehead plated screws and 100 4BA nuts
- 541 - 1 pair stereo tape head as in cassette recorder/players
- 546 - 1 bridge rectifier 600V international rectifier ref 3SB100
- 548 - 2 battery operated relays (3-6v) each with 5A c/o contacts 2 pairs
- 553 - 2 lithium 3V batteries (everlasting shelf life)

TELEPHONE BITS

- Master socket (has surge arrester - ringing condenser etc) and takes B.T. plug.....£3.95
- Extension socket.....£2.95
- Dual adaptors (2 from one socket).....£3.95
- Cord terminating with B.T. plug 3 metres.....£1
- Kit for converting old entry terminal box to new B.T. master socket, complete with 4 core cable, cable clips and 2 B.T. extension sockets.....£11.50
- 100 mtrs 4 core telephone cable.....£8.50

COMPACT FLOPPY DISC DRIVE EME-101

The EME-101 drives a 3" disc of the new standard which despite its small size provides a capacity of 500k per disc, which is equivalent to the 3 1/2" and 5 1/4" discs. We supply the Operators Manual and other information showing how to use this with popular computers: BBC, Spectrum, Amstrad etc. All at a special snip price of £27.50 including post and VAT. Data available separately £2, refundable if you purchase the drive.

MULLARD UNILEX AMPLIFIERS

We are probably the only firm in the country with these new in stock. Although only four watts per channel, these give superb reproduction. We now offer the 4 Mullard modules - i.e. Mains power unit (EP9002) Pre amp module (EP9001) and two amplifier modules (EP9000) all for £6.00 plus £2 postage. For prices of modules bought separately see TWO POUNDERS.

CAR STARTER/CHARGER KIT

Flat Battery! Don't worry you will start your car in a few minutes with this unit - 250 watt transformer 20 amp rectifiers, case and all parts with data case £17.50 post £2.

THIS MONTH'S SNIP

is a 2 1/2 kW tangential heater, metal box to contain it and 3 level switch to control it. Special price £7.50 post paid.

VENNER TIME SWITCH

Mains operated with 20 amp switch, one on and one off per 24 hrs. repeats daily automatically correcting for the lengthening or shortening day. An expensive time switch but you can have it for only £2.95 without case, metal case - £2.95, adaptor kit to convert this into a normal 24hr time switch but with the added advantage of up to 12 on/off per 24hrs. This makes an ideal controller for the immersion heater. Price of adaptor kit is £2.30



Ex-Electricity Board. Guaranteed 12 months.

12 volt MOTORS BY SMITHS

Made for use in cars, etc. these are very powerful and easily reversible. Size 3 1/2" long by 3" dia. They have a good length of 1/4" spindle - 1/10 hp £3.45 1/8 hp £5.75, 1/6 hp £7.50



SOUND TO LIGHT UNIT



Complete kit of parts for a three channel sound to light unit controlling over 2000 watts of lighting. Use this at home if you wish but it is plenty rugged enough for disco work. The unit is housed in an attractive two tone metal case and has controls for each channel, and a master on/off. The audio input and output are by 1/4" sockets and three panel mounting fuse holders provide thyristor protection. A four pin plug and socket facilitate ease of connecting lamps. Special price is £14.95 in kit form.

9" MONITOR

Ideal to work with computer or video camera uses Philips black and white tube ref M24/306W. Which tube is implosion and X-Ray radiation protected. VDU is brand new and has a time base and EHT circuitry. Requires only a 16V dc supply to set it going. It's made up in a lacquered metal frame work but has open sides so should be cased. The VDU comes complete with circuit diagram and has been line tested and has our six months guarantee. Offered at a lot less than some firms are asking for the tube alone, only £16 plus £5 post.

LIGHT BOX

This when completed measures approximately 15" x 14". The light source is the Philips fluorescent "W" tube. Above the light a sheet of fibreglass and through this should be sufficient light to enable you to follow the circuit on fibreglass PCBs. Price for the complete kit, that is the box, choke, starter, tube and switch, and fibreglass is £5 plus £2 post, order ref 5P69.

TANGENTIAL HEATERS

We again have very good stocks of these quiet running instant heat units. They require only a simple case, or could easily be fitted into the bottom of a kitchen unit or book case etc. At present we have stocks of 1kw, 2kw, 2.5kw, and 3kw. Prices are £5 each for the first 3, and £6.95 for the 3k. Add post £1.50 per heater if not collecting.

CONTROL SWITCH enabling full heat, half heat or cold blow, with connection diagram, 50p for 2kw, 75p for 3kw.

FANS & BLOWERS

5" 5" £1.25 post. 6" 6" £1.50 post
4" x 4" Muffin equipment cooling fan 115V £2.00
4" x 4" Muffin equipment cooling fan 230/240V £5.00
9" Extractor or blower 115V supplied with 230 to 115V adaptor £9.50 £2 post.

All above are ex computers but guaranteed 12 months. 10" x 3" Tangential Blower. New. Very quiet - supplied with 230 to 115V adaptor on use two in series. Give quiet - low blow £2.00 + £1.50 post or £4.00 + £2.00 post for two

TELEPHONE LEAD

3 mtrs long terminating one end with new BT, flat plug and the other end with 4 correctly coloured coded wires to fit to phone or appliance. Replaces the lead on old phone making it suitable for new BT socket. Price £1 ref 5D52 or 3 for £2 ref 2P164.

POWERFUL IONISER

Generates approx. 10 times more IONS than the ETI and similar circuits. Will refresh your home, office, shop, work room etc. Makes you feel better and work harder - a complete mains operated kit, case included. £9.50 + £3 P&P.

J & N BULL ELECTRICAL

Dept. E.E., 250 PORTLAND ROAD, HOVE, BRIGHTON, SUSSEX BN3 5QT
MAIL ORDER TERMS: Cash, P.O. or cheque with order. Orders under £20 add £1 service charge. Monthly account orders accepted from schools and public companies. Access & B/card orders accepted. Brighton (0273) 734648 or 203500.

NEW ITEMS

Some of the many described in our current list which you will receive with your parcel.

£2 POUNDERS*

- 2P120 - 1 combined clockwork switch and thermostat for boiler control
- 2P122 - 1 30a rotary switch, surface mounting with pointer knob
- 2P123 - 1 25a rotary switch, surface mounting, cover engraved, high, medium low and off
- 2P124 - 1 28kv .001 mfd block condenser
- 2P127 - 1 30a bridge rectifier assembly on heat sinks
- 2P129 - 1 10rpm motor 115V 50hz with adaptor for 230V
- 2P131 - 1 Crouzet motor 230V fits the Crouzet gearbox
- 2P132 - 1 ceiling heat-stat for fire warming or protection
- 2P133 - 1 Circuit breaker 20a, Crabtree ref C50
- 2P134 - 1 9V 500mA psu, plugs into 13a socket
- 2P135 - 1 10m 10 conductor intercom cable
- 2P136 - 1 2 1/2kw element made for tangential blowers
- 2P137 - 1 Thermo couple, stainless steel tipped for measuring internal heat
- 2P138 - 1 Mains transformer 20V 0-20V 1a upright mounting
- 2P141 - 1 rechargeable battery D size (4 AH) solder tag ended
- 2P142 - 1 0m 4 pair intercom cable White PVC outer
- 2P144 - 1 mains operated relay with 4 x 8a c/o contacts
- 2P145 - 1 10,000 uf 70V d.c. smoothing capacitor
- 2P146 - 1 7,800 uf 150V d.c. smoothing capacitor
- 2P148 - 1 Technical information on 3" FDD refundable if you buy fdd
- 2P149 - 5 diff battery operated model motors
- 2P150 - 1 PSU chassis with all components for 24V 2A d.c. unwired
- 2P151 - 1 Metal box 14 1/2 x 14 x 4 with lid add £2.00 post
- 2P152 - 1 Motor start capacitor 80uF 250V
- 2P153 - 1 Two station intercom unused but fine reject
- 2P154a - 1 Nicad charger - plug into 13a socket 5.2V .7UA output
- 2P154b - 1 Nicad charger - plug into 13a socket 6V .9VA output
- 2P155 - 1 Mains transformer giving 16, 17, 18 & 20V 60W
- 2P158 - 1 Oven thermostat with temp calibrated knob
- 2P159 - 1 9V 500ma cased with mains lead and output lead
- 2P160 - 1 13a plug adaptor fused tacks 3 x 3a plugs
- 2P161 - 1 6" diagonal slide cutters
- 2P162 - 1 Stereo Matrix PCB mounting deemphasis K35
- 2P163 - 1 AC Working capacitor 12uF 660V AC or 1500V dc
- 2P164 - 3 Phone leads 3 mtrs long tongs one end B.T. plug other end

£3 POUNDERS*

- 3P7 - 1 DC voltage, doubler or halver for 12V to 24V 12 to 6V 24 to 12V
- 3P8 - 1 24hr time switch Sangamo, new condition Guaranteed 1 year
- 3P9 - 1 2V 500mA psu plugs in 13a socket regulated
- 3P10 - 1 Mains transformer 50V 2A with 6 3/4 piolt light winding, upright mounting, fully shielded plus £1 post
- 3P13 - 1 Noise filter to fit in mains lead of appliance up to 25a
- 3P15 - 1 waterproof case will take 150 watt transformer
- 3P16 - 1 signal box, 3 lamps on face plate of metal box size 5 1/2 x 3 1/2
- 3P17 - 1 choke and starter to work 8" fluorescent tube at 125W
- 3P18 - 1 22V 3a mains transformer with bridge rect fitted on top panel
- 3P20 - 1 0-5 amp meter 3/4 ac/dc ex equipment
- 3P21 - 1 power factor correction condenser 35uF 350ac
- 3P22 - 1 200va - auto transformer 230 to 115V toroidal encapsulated £1.50 post
- 3P23 - 1 36V 0-36V tapped 20V 0-20V 100va
- 3P24 - 1 3" floppy disc for Amstrad etc.
- 3P25 - 1 7" Electricians pliers

£4 POUNDERS*

- 4P12 - 50m low loss co-ax 75ohm + £1 post
- 4P13 - 3 Horstmann time and set switches 15amp
- 4P14 - 1 150w mains transformer "c" core 43V 3.5A secondary
- 4P15 - 1 powerful motor 2" stack fitted with gearbox final speed 60rpm mains operated, could operate door opener etc.
- 4P17 - 1 Uniselector 3 pole 25W, 50V coil standard size
- 4P18 - 1 Volt meter with digital display (DIGI-VISOR)
- 4P19 - 1 12V dc motor will fit to gearbox 4P20
- 4P20 - 1 Gear train giving speed reduction

£5 POUNDERS*

- 5P86 - 1 Transformer upright mounting 230/240V primary 2 x 100 1a secondary
- 5P88 - 1 Transformer in waterproof metal box 24V 5A add £2 post
- 5P89 - 1 4 bank heating element each 2kw ideal at convector heater
- 5P90 - 1 18" long tangential blower with motor at one end
- 5P91 - 1 14" blower, motor in middle
- 5P92 - 10m Audio co-ax double screened 75ohm super low loss for TV
- 5P93 - 1 6" Alarm bell 24V dc or ac
- 5P94 - 1 Current transformer 14V out with 1a dc input
- 5P95 - 1 Vintage photo cell
- 5P97 - 1 Impedance matching transformer 0.4-5-8-160 ohm 100 add £1.50 post
- 5P98a - 1 0-90a ammeter for mounting outside control panel
- 5P98b - 1 0-180a ammeter for mounting outside control panel
- 5P99 - 1 Mains operated blower centrifugal output side app. 5" x 1 1/2"
- 5P100 - 1 Mains splitter 45a switch 3 x 15a fused circuits
- 5P101 - 1 Model motor 1rpm from 8V reversible

£7 POUNDERS*

- 7P1 - 1 Instant heat solder gun - mains with renewable tip and job light

£8 POUNDERS*

- 8P1 - 1 Charger transformer 10a upright mounting 230/240 primary 16v 10a secondary
- 8P2 - 1 6" underdome alarm bell suitable for a fire alarm or burglar alarm mains operated.
- 8P3 - 1 heat sink big powerful so ideal for power transmitter
- 8P5 - 1 1/2 hp motor 900 rpm capacitor run
- 8P6 - 1 24hr time switch - 2 on off 16a c/o contacts 3" x 3" x 1 1/2"
- 8P7 - 1 Silent sentinel invisible ray kit
- 8P8 - 1 Papst fan 3 1/2 x 3 1/2 x 1 1/2 230V metal bodied

£10 POUNDERS*

- 10P13 - 1 reversible motor with gearbox 104 rpm Parvalux
- 10P14 - 1 100a time switch 1 on/off per 24hr extra triggers £1 per pair
- 10P15 - 1 Max demand meter 230 ac mains
- 10P16 - 1 powerful air mover 2 small type blowers with motor in middle
- 10P18 - 1 mains operated klaxon
- 10P19 - 1 12V alarm bell really loud, mains operated, in iron case + £5 post
- 10P22 - 1 sensitive volt meter relay
- 10P23 - 1 fruit machine heart 3 fruit wheels each stepper motor operated add £3 post
- 10P24 - 1 big panel meter face size 4 1/2 x 2 1/2 200uA movement scaled 1-10
- 10P26 - 1 "Secretary" phone auto-dialer complete untested sold as such
- 10P29 - 1 12V engine cooling fan
- 10P30 - 1 instrument psu on pcb has 4 outputs. 12V/ 5V 6A/12V 5A/5V 5A
- 10P31 - 1 7 day time switch 16a c/o contacts sep switches for each day
- 10P32 - 1 68 rpm 1/8th hp motor reversible

£15 POUNDERS*

- 15P1 - 1 kit for 115V hi fi amp
- 15P2 - 1 kit for psu to supply one or two 15P1 amps
- 15P3 - 1 time switch battery or mains operated - 16a c/o contacts, 7 day programmable has 36hr reserve

LIGHT CHASER KIT motor driven switch bank with connection diagram, used in connection with 4 sets of xmas lights makes a very eye catching display for home, shop or disco, only £5 ref 5P56.

ISSN 0262-3617

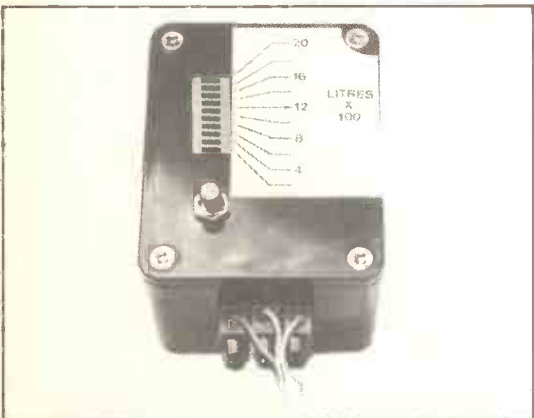
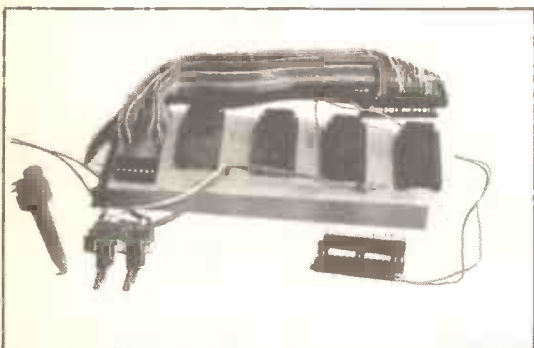
PROJECTS... THEORY... NEWS...
COMMENT... POPULAR FEATURES...

© Wimborne Publishing Ltd 1987. Copyright in all drawings, photographs and articles published in EVERYDAY ELECTRONICS is fully protected, and reproduction or imitations in whole or in part are expressly forbidden.

Our December 1987 issue will be published on Friday, 13 November 1987. See page 614 for details.

Everyday Electronics, November 1987

Projects

- ACCENTED BEAT METRONOME** by Robert Penfold 584
Electronic equivalent to the traditional pendulum "timekeeper"
- ACOUSTIC PROBE** by Andy Flind 588
Give your car a "medical" with this electronic stethoscope
- OBJECT COUNTER** 600
Simple counting circuit - An Exploring Electronics project
- BBC SIDWAYS RAM/ROM** by A.P. Guest 604
Increase the power of your Beeb with this useful add-on
- OIL TANK GAUGE** by T.R. de Vaux-Balbirnie 620
Make sure you do not run out of fuel this winter

Series

- INTRODUCING MICROPROCESSORS** by Mike Tooley BA 592
An EE exclusive C&G certificate course.
Part One: Microcomputer Systems
- EXPLORING ELECTRONICS** by Owen Bishop 600
Part Seventeen: Counting circuits
- ON SPEC** by Mike Tooley BA 610
Readers Sinclair Spectrum page
- ROBOT ROUNDUP** by Nigel Clark 612
Investigating the world of robotics
- ACTUALLY DOING IT** by R.A. Penfold 616
Producing printed circuit boards
- BBC MICRO** by R.A. & J.W. Penfold 624
Regular spot for Beeb fanatics

Features

- EDITORIAL** 583
- SPECIAL OFFER** 603
Sony Loudspeakers
- NEWS** 608
What's happening in the world of electronics
- FOR YOUR ENTERTAINMENT** by Barry Fox 613
Cordless Code; Talking Toys
- SHOPTALK** by David Barrington 617
Product news and component buying
- AMATEUR RADIO** by Tony Smith G4FA1 618
Old Timers; China Again; Question Time
- BOOK SERVICE** 626
Our own service to readers of EE
- PRINTED CIRCUIT BOARD SERVICE** 628
- ADVERTISERS INDEX** 632

FREE

Greenweld 88-page Catalogue

between pages 604 and 605

BI-PAK BARGAINS

RESISTORS

Pak No	Qty	Description	Price
VP1	300	Assorted Resistors, mixed values & types	£1.00
VP2	300	Carbon Resistors, 1/2 watt, pre-formed, mixed	£1.00
VP4	200	1/2-1 watt Resistors, mixed values and types	£1.00
VP16	50	Wirewound Resistors, mixed watt values	£1.00
VP140	50	Precision Resistors, 1% tolerance	£1.00
VP181	100	1 and 2 watt Resistors, assorted values	£1.00

CAPACITORS

VP5	200	Assorted Capacitors, all types	£1.00
VP6	200	Ceramic Capacitors, Min. mixed values	£1.00
VP9	100	Assorted Polyester/Polystyrene Capacitors	£1.00
VP10	60	C280 Capacitors, metal foil, mixed values	£1.00
VP11	50	Electrolytics, all sorts	£1.00
VP12	40	Electrolytics, 0.07mf-150mf, mixed volts	£1.00
VP13	30	Electrolytics, 150mf-1000mf, mixed volts	£1.00
VP14	50	Silver Mica Caps, mixed values	£1.00
VP15	25	01-250v Min. Layer Metal Caps	£1.00
VP180	25	Tantalum Bead Caps, assorted values	£1.00
VP182	4	1000uf 50v Electrolytics	£1.00
VP192	30	Min. Electrolytics, mixed values, 0.47mf-1000mf 6/16v	£1.00
VP193	6	Sub Min. Electrolytics, 2 x 1000/2200/3300mf 10/16v	£1.00

OPTOS

VP24	10	125° clear showing Red LEDs	£1.00
VP25	10	Mixed shape and colour LEDs	£1.00
VP26	15	Small 125° Red LEDs	£1.00
VP27	15	Large 2° Red LEDs	£1.00
VP28	10	Rectangular 2° Red LEDs	£1.00
VP29	25	Opto special pack, Assorted, Super Value	£3.00
VP130	6	RED 7 Seg. CC 14mm x 7.5mm RDP FND33 LED Display	£2.00
VP131	4	GREEN 7 Seg. CA 6° LDP XAN620 LED Display	£2.00
VP133	6	RED Overflow 6° 3x CA 3x CC 6630/LED Display	£2.00
VP134	5	GREEN Overflow 6° CA XAN630 LED Display	£2.00
VP138	20	Assorted LED Displays. Our mix, with data.	£5.00
VP147	1	Pair Opto Coupled Modules	£6.00
VP199	4	LD707R LED Displays CA	£1.00
VP203	15	Triangular shape LEDs, Mixed colours	£1.00
VP204	10	Large Green LEDs, 5mm	£1.00
VP205	10	Small Green LEDs, 3mm	£1.00
VP206	10	Large Yellow LEDs, 5mm	£1.00
VP207	10	Small Yellow LEDs, 3mm	£1.00
VP208	10	Large LEDs clear showing Red, 2°	£1.50
VP241	2	DRP12 Light Dependent Resistor	£1.50
VP242	4	Tri-colour LEDs, 5mm Dia. 5mA 2v R.G.Y.	£1.00
VP243	3	Tri-colour LEDs, Rectangular 5mm R.G.Y.	£1.00

DIODES AND SCRS.

VP29	30	Assorted volt Zeners, 50mw-2w	£1.00
VP30	10	Assorted Volt Zeners, 10w, coded	£1.00
VP31	10	5A SCRs T066, 50-400v, coded	£1.00
VP32	20	3A SCRs T066, up to 400v, uncoded	£1.00
VP33	100	Sil. Diodes like 1N4148	£1.00
VP34	200	Sil. Diodes like 0A200/0A13-16, 40v	£1.00
VP35	50	1A 1N4000 Diodes, all good, uncoded	£1.00
VP49	30	Assorted Sil. Rectifiers 1A-10A, mixed volts	£1.00
VP141	40	1N4002 Sil. Rectifiers 1A 100v, preformed pritch	£1.00
VP142	4	40A Power Rectifiers, silicon, T048 300 PIV	£1.00
VP143	5	BY187 12kv Sil. Diodes, in carriers, 2.5MA	£1.00
VP184	3	4A 400v Triacs, plastic	£1.00
VP187	10	SCRs 800MA, 200v, ZN5264, plastic, T092	£1.00
VP194	50	0A91 point contact germ. Diodes, uncoded	£1.00
VP195	50	0A47 gold bonded germ. Diodes, uncoded	£1.00
VP196	50	0A70-79 detector germ. Diodes	£1.00
VP197	50	0A90 type germ. Diode, uncoded	£1.00
VP198	40	0A248 Sil. Diodes, 30v 2A, fast recovery	£1.00
VP222	20	3A Stud Rectifiers, 50-400v Assorted	£1.00

TRANSISTORS

VP38	100	Sil. Trans. NPN plastic, coded, with data	£3.00
VP39	100	Sil. Trans. PNP plastic, coded, with data	£3.00
VP47	10	Sil. Power Trans. 5mA 12N355, uncoded	£1.00
VP48	5	Pairs PNP/PNP plastic Power Trans. 4A, data	£1.00
VP50	60	PNP Sil. Switching Trans. T0-18 and T0-32	£1.00
VP51	60	PNP Sil. Switching Trans. T0-18 and T0-32	£1.00
VP50	100	All sorts Transistors, NPN/PNP	£1.00
VP150	20	BC163B Sil. Trans. NPN 30v 200mA Hfe240 + T092	£1.00
VP151	25	BC171B Sil. Trans. NPN 45v 100mA Hfe240 + T092	£1.00
VP152	15	TIS90 Sil. Trans. NPN 40v 400mA Hfe100 + T092	£1.00
VP153	15	TIS91 Sil. Trans. PNP 40v 400mA Hfe100 + T092	£1.00
VP154	15	MPS456 Sil. Trans. PNP 20v 800mA Hfe50 + T092	£1.00
VP155	20	BF995 Sil. Trans. NPN eqvt BF184 M.F. T092	£1.00
VP156	20	BF485 Sil. Trans. NPN eqvt B0173 M.F. T092	£1.00
VP157	15	TX1500 series Sil. Trans. PNP plastic	£1.00
VP158	15	TX1107 Sil. Trans. NPN eqvt BC108 plastic	£1.00
VP159	15	TX1108 Sil. Trans. NPN eqvt BC108 plastic	£1.00
VP161	25	BC183 Sil. Trans. NPN 30v 200mA T092	£1.00
VP162	5	SJES451 Sil. Power Trans. NPN 80v 4A Hfe20	£1.00
VP163	2	NPN/PNP pairs Sil. Power Trans. like SJES451	£1.00
VP164	4	2N6293 Sil. Power Trans. NPN 40v 40v 7A Hfe30 +	£1.00
VP165	6	BT133 NPN Sil. Trans. 80v 5A Hfe50-200 T039	£1.00
VP166	5	BT134 NPN Sil. Trans. 100v 5A Hfe50-200 T039	£1.00
VP167	1	BU6C5 NPN Trans. T03 VCB 50v, 10A, 100w, Hfe60 +	£1.00
VP168	10	BC478 eqvt BCY71 PNP Sil. Trans. T018	£1.00
VP169	10	BX521 eqvt BC334 NPN Sil. Trans. 80v 50mA T018	£1.00
VP170	10	Assorted Power Trans. NPN/PNP coded and data	£1.00
VP171	10	BF355 NPN T0-39 Sil. Trans. eqvt BF258 225v 100mA	£1.00
VP172	10	SM 1502 PNP T0-39 Sil. Trans. 100v 100mA Hfe100 +	£1.00
VP200	30	OC71 type germ. AF Transistors, uncoded	£1.00
VP201	25	OC45 germ. RF Transistors	£1.00

I.C.S.

VP40	40	TTL I.C.s all new gates - Flip Flop - MSI. Data	£4.00
VP59	20	Assorted I.C.s linear, etc. all coded	£2.00
VP20	12	74LS00	£2.00
VP210	12	74LS74	£2.00
VP211	10	CD4001B	£2.00
VP212	10	CD4011B	£2.00
VP214	10	CD4098B	£2.00
VP215	10	7419 8 pin	£2.00
VP216	10	565 Timers 8 pin	£2.00

MISC.

VP17	50	Metres PVC single strand Wire, mixed colours	£1.00
VP18	30	Metres PVC multi strand Wire, mixed colours	£1.00
VP19	40	Metres PVC single/multi strand Wire, mixed colours	£1.00
VP22	200	Sq. inches total copper clad board	£1.00
VP23	10	40mm track slider pots 100K Lin	£1.00
VP42	10	Black heatsinks, fit T03 and T0220, drilled	£1.00
VP43	4	Power-fin heatsinks, 2 x T03, 2 x T056	£1.00
VP44	4	Assorted heatsinks, T01/01/5/18/220	£1.00
VP54	20	Assorted I.C. DIL Sockets, 8-40 pin	£2.50
VP56	100	Semiconductors from around the world, mixed	£4.00
VP81	1	Echam & Dill Kit PCB, inc drill, transfers, etc	£19.50
VP83	1	Electronic Buzzer, 6v, 25MA	£0.95
VP84	1	Electronic Buzzer, 9v, 25MA	£0.95
VP85	1	Electronic Buzzer, 12v, 25MA	£0.95
VP86	1	TECASBOTY Components Pack, semiconductors, caps, etc	£8.00
VP87	1	Telephone pick-up coil with 3.5mm jack plug	£1.25
VP88	1	Pillow Speaker with 3.5mm jack plug	£1.45
VP95	1	Plastic Vice, small, with suction base	£1.75
VP97	1	Logic Probe/Tester, Supply 4.5v-18v, DTL, TTL CMOS	£8.50
VP99	1	Universal Tester, with ceramic buzzer	£5.00
VP107	1	Piezo Buzzer, miniature, 12v	£1.25
VP108	1	Piezo Buzzer, miniature, 240v	£1.25
VP113	1	Coax Antenna Switch, 2 way	£4.50
VP114	1	Coax Antenna Switch, 3 way	£4.75
VP115	1	High Pass Filter/Suppressor CB/TV	£0.50
VP116	1	Low Pass Filter, VHS/TV Band	£2.00
VP122	1	Precision Morse Key, fully adjustable	£1.85
VP128	1	Miniature FM Transmitter/Babyphone	£7.50
VP144	4	100K Lin multi turn Pots, ideal vari cap tuning	£1.00
VP145	10	Assorted Pots, inc. dual and switched types	£1.00
VP146	30	Presets, horizontal and vertical, mixed values	£1.00
VP174	5	DIL Switches, 1 and 2 way slide, 5 way SPST, assorted	£1.00
VP176	30	Fuses, 20mm and 1 1/2" glass, assorted values	£1.00
VP177	1	Pack assorted Hardware, nuts, bolts, etc.	£1.00
VP178	5	Assorted Battery holders and clips PP3/9, AA/0, etc	£1.00

TOOLS

VP103	1	6 pc Stanley screwdriver set, flat and crosspoint	£3.50
VP139	1	Pick up Tool, spring loaded	£1.75
VP217	1	Helping Hand	£4.00
VP218	1	Watchmakers Screwdriver Set, 6 pieces	£1.75
VP219	1	Miniature Side Cutters	£1.95
VP220	1	Miniature Bent-nose Pliers	£1.55
VP221	1	Miniature Long nose Pliers	£1.55

BI-PAK

Send your orders to Dept EE BI-PAK PO BOX 5 WARE, HERTS
TERMS CASH WITH ORDER, SAME DAY DESPATCH, ACCESS,
BARCLAYCARD ALSO ACCEPTED, TEL 0763-48851, GIRO 388 7006
ADD 15% VAT AND £1.50 PER ORDER POSTAGE AND PACKING



Use your credit card. Ring us on 0763 48851 NOW
and get your order even faster. Goods normally
sent 2nd Class Mail.
Remember you must add VAT at 15% to your order.
Total Postage add £1.50 per Total order.

THREE ACES FROM ALCON!

MINI 20



200Ω/V d.c. and 6.6kΩ/V a.c.
26 RANGES WITH PROTECTIVE FUSE
Accuracy: 2% d.c. and resistance, 3% a.c. (of f.s.d.)
26 RANGES: d.c. V: 100mV, 1V, 10V, 30V, 100V, 300V,
1000V; d.c. I: 50μA, 1mA, 10mA, 100mA, 1A, 3A; a.c. V:
10V, 30V, 100V, 300V, 1000V; a.c. I: 3mA, 30mA, 300mA,
3A; Ohms: 0-5kΩ, 0-50kΩ, 0-500kΩ, 0-50MΩ.
Dimensions: 105 x 130 x 40mm.

ONLY £25.30

SUPER 50



50kΩ/V d.c. and a.c.
39 RANGES - INDESTRUCTIBLE
Electronically protected on all ranges but 3A
Accuracy: 2% d.c. - 3 a.c. - 1% centre scale on ohms
39 RANGES: d.c. V: 150mV, 1V, 3V, 10V, 30V, 100V,
300V, 1000V; d.c. I: 20μA, 100μA, 300μA, 1mA, 3mA,
10mA, 30mA, 100mA, 1A, 3A; a.c. V: 10V, 30V, 100V,
300V, 1000V; a.c. I: 3mA, 10mA, 30mA, 100mA, 1A, 3A;
Ohms: 0-5kΩ, 0-50kΩ, 0-500kΩ, 0-5MΩ, 0-50MΩ;
dB from -10 to +61 in 5 ranges.
Dimensions: 105 x 130 x 40mm.

ONLY £39.50

ELECTRO SUPER



20kΩ/V a.c. and d.c.
40 RANGES - electronically protected
plus 30A for the power man!
Accuracy: d.c. ranges and ohms 2.5% a.c. 3% of f.s.d.
40 RANGES: d.c. V: 100mV, 300mV, 1.0V, 3.0V, 10V,
30V, 100V, 300V, 1000V; d.c. I: 50μA, 300μA, 300μA,
1.0mA, 3mA, 10mA, 30mA, 100mA, 1.0A, 6.0A, 30A;
a.c. V: 10V, 30V, 100V, 300V, 1000V; a.c. I: 3.0mA,
10mA, 30mA, 100mA, 1.0A, 6.0A, 30A, Ohms: 10kΩ,
100kΩ, 1MΩ. dB from -10 to +61 in 5 ranges.
Dimensions: 105 x 130 x 40mm.

ONLY £38.35

3 HIGH QUALITY TEST INSTRUMENTS AT SUPERDEAL PRICES

EACH INSTRUMENT HAS A CLEAR MIRRORED SCALE AND COMES COMPLETE WITH A ROBUST CARRYING CASE, LEADS & INSTRUCTIONS.

PRICES Our prices include VAT and postage and goods are normally despatched by return.

Please write or telephone for details of these and the many other instruments in the Alcon range, including multimeters, components measuring, automotive and electronic instruments.

ALCON Instruments Ltd.

19 MULBERRY WALK - LONDON SW3 6DZ - TEL: 01-352 1897 - TELEX: 918867

JUST ARRIVED!!

A major electronic distributor's discontinued lines all being sold off at LESS THAN HALF PRICE!! - Boxes, cases, connectors, LEDs, switches, DIP boards, cable ties, etc. All goods detailed in a 16 page supplement, available now, FREE!!

Examples:

Briefcase type combination locks £4.71 per pair. Sloping front cases: 161 x 96 x 57/39mm £2p; 215 x 130 x 73/47mm £1.49. Plastic box with PCB slots 190 x 110 x 60mm £1.40. Large steel case 336 x 269 x 148mm £15.45. 'Tidyman' Kits: contain a wide variety of support pillars, stand offs, cable straps and clamps, etc (46 diff) all in attractive plastic case. Small: (201 total) £7.80; Large (708 total) £13.00. Full details in Supplement. (Post on all above £2).

NewBrain

Z494 Motherboard microprocessor panel 265 x 155mm. Complete PCB for computer. Z80, char EPROM, etc. 68 chips altogether + other associated components, plugs, skts, etc. £5.50

Z495 RAM panel. PCB 230 x 78mm with 14 x MM5290 - 2 (4116) (2 missing) giving 28k of memory. Also 8 LS chips. These panels have not been soldered, so chips can easily be removed if required. £5.00

'NEWBRAIN' PSU

BRAND NEW Stabilized Supply in heavy duty ABS case with rubber feet. Input 220/240V ac to heavy duty transformer via suppressor filter. Regulated DC outputs: 6.5V @ 1.2A; 13.5V @ 0.3A; -12V @ 0.05A. All components readily accessible for mods etc. Chunky heatsink has 2 x TIP31A. Mains lead fitted with 2 pin continental plug is 2m long. 4 core output lead 1.5m long fitted with 6 pole skt on 0.1" pitch. Overall size 165 x 75 x 72mm. £5.95 ea 10 for £40

Z679 KEYBOARD 62 keys on ally chassis 260 x 90mm. No PCB. £6.50

Z670 HANDBOOK 204pp. Useful appendix (about 1/2 the book) gives some tech info. £5.00

Z674 DATA PACK. Interfaces and connector pin-out, i/p, o/p, port map, cct diagram + data on COP420C £2.00

Z672 MOTHERBOARDS Complete but probably faulty. £3.50

VIDEO FANS!!

Here's your chance to never be without power again!! We're offering a set of 10 6V 3A sealed lead acid rechargeable batteries, together with a mains powered charger that takes all 10 batts at an unbeatable price! They can be wired up in parallel/series combination to provide 6V 30A or 12V 15A, thus giving over 20hrs recording time on most camcorders. Limited stocks, so order now! Price includes 10 charging leads and mains lead. Z802 £99 + £5car

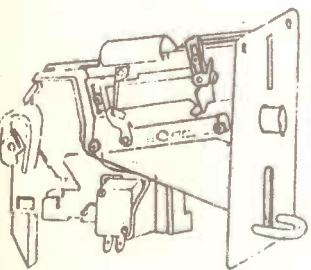

Z652 COIN ACCEPTOR MECHANISM Made by Coin Controls, this will accept various size coins by simple adjustment of 4 screws. Incorporates various security features - magnet, bent coin rejector etc. Microswitch rated 5A 240V. Front panel 115 x 64, depth 130mm. Cost £10.85. Our Price £4.00

NEW THIS MONTH

SOLAR CELLS

Giant size, 90mm dia giving 0.45V 1.1A output. £4 each; 10 + £3.50
Mega size - 300 x 300mm. These incorporate a glass screen and backing panel, with wires attached. 12V 200mA output. Ideal for charging nicads. £24.00

CREAM DISPENSER

Z801 Coin operated machine for dispensing hand cream. Cabinet 620 x 365 x 200mm, wt 10kg, contains coin mech, PCB, counter, pump mech consisting of high torque geared 6V motor driving cam that pumps cream and sensing components, all powered by internal 6V 2.6A rechargeable battery £15 + £5 carr.

Parts available separately. See list 30

SPEECH CHIP

Z733 SPO256A + index chip + ULA chip as used in Currah microspeech. Cct and info for using SPO256 with Spectrum, ZX81, BBC, VIC & C64. No info on other 2 chips. All 3 for £3.00

AUTO DIALLER

Sloping front case 240 x 145 x 90/50 contains 2 PCB's: one has 4 keypad (total 54 switches) + 14 digit LED display, 2 x ULN2004, ULN 2033 and 4067; the other has 12 chips + 4 power devices etc. Case contains speaker. 8 core cable 2m long with plug. For use with PABX £9.00

SWITCHED MODE PSU

Astec type AA7271. PCB 50 x 50mm has 6 transistor cct providing current overload protection, thermal cut-out and excellent filtering. Input 8-24V DC. Output 5V 2A. Regulation 0.2% £5.00

PANELS

Z620 68000 Panel. PCB 190 x 45 believed to be from ICL's 'One per Desk' computer containing MC68008P8 (8MHz 16/8 bit microprocessor, + 4 ROMs, all in skts; TMP5220CNC, 74HCT245, 138, LS08, 38 etc. £5.00

Z625 32k Memory Board. PCB 170 x 170 with 16 2k x 8 6116 static RAMs. Also 3.6V 100 mA memopack nicad, 13 other HC/LS devices, 96w edge plug, 8 way DIL switch, Rs, Cs etc. £4.80

SOLDER SPECIAL!!

- ★ 15W 240V ac soldering iron
- ★ High power desolder pump
- ★ Large tube solder

ALL FOR
£7.95

DIODE BARGAINS

Minimum 10 of any one type: 20 for £1; 50 for £2; 250 for £8; 1000 for £25.00. Types available: BAX12, BAX12A, BAX16, BY206, BYX55-300, BY207, CV8308, LR75C, MR817, MV1404, VSK140, 1N659, 1N4933.

sinclair

MICROVISION

CASES!!

We now have a supply of cases, complete with aerial at the special low price of £5.00.

We have a quantity of these units in varying states. From labels attached to some of the PCBs it seems after assembly on the production line they did not function correctly. No attempt has been made to repair them, though - instead the following parts were removed:

- RF Tuner
- Vol control and switch
- ZN401E chip

Z666 2 x PCB in good condition with 2 x CRT that have been removed, but may be repairable. Conductive paint (15ml bottle £3.45) will probably be needed to remake contacts. With diagram and notes. £6.95

RF Tuner £6.95; ZN401 chip £9.95; Vol control + switch with knob £1.00

All prices include VAT; just add 60p P&P

Min Access order £5. Official

orders from schools etc.

welcome - min invoice charge £10.

Our shop has enormous stock of components and is open

9.5-30 Mon-Sat. Come and see us!!

443D Millbrook Road, Southampton

SO1 0HX. Tel. (0703) 772501/783740



JOIN UP WITH LITESOLD

Professional Soldering Equipment at Special Mail-Order Prices.

EC50 Mains Electronic Iron. £33.16



Features spike-free, solid state

proportional electronic temperature control inside the handle. Adjustable 280° to 400°C. Burn-proof 3-wire mains lead. Fitted 3.2mm Long-Life bit. 1.6, 2.4 and 4.7mm available. 240v a.c.

SK18 Soldering Kit. £16.70

Build or repair any electronic project.

LC18 240v 18w iron with 3.2, 2.4, and 1.6mm bits. Pack of 18 swg flux-cored 60/40 solder. Tweezers. 3 soldering aids. Reel of De-Solder braid. In PVC presentation wallet.

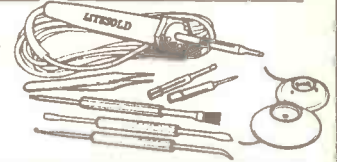

ADAMIN Miniature Iron £7.67



Possibly smallest mains iron in the world. Ideal for fine work. Slim

nylon handle with finger grip. Interchangeable bits available 1.2, 1.6, 2.4, 3.4 and 4.7mm. Fitted with 2.4mm. 240v 12w (12w available). Presentation wallet.

'L' Series Lightweight Irons. 12w £7.68

High efficiency irons for all electronic hobby work. Non-roll handles with finger guards.

Stainless steel element shafts. Screw-connected elements. Slip-on bits available from 1.8 to 4.7mm. LA12

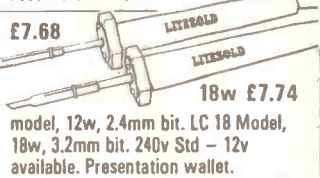

18w £7.74

model, 12w, 2.4mm bit. LC 18 Model, 18w, 3.2mm bit. 240v Std - 12w available. Presentation wallet.

Soldering Iron

Stands 3&4

£5.99

No.5

£6.22

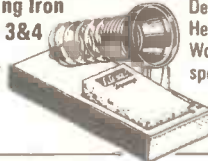

Designed specially for LITESOLD irons.

Heavy, solid-plastic base with non-slip pads. Won't tip over, holds iron safely. With wiping sponge and location for spare (hot) bits.

No 5 stand for EC50 iron No 4 stand for ADAMIN miniature iron No 3 stand for LA12 and LC18 Irons.

Replacement Bits

For all above irons. Non-stick designs, machined from special copper alloy, with Inconel retaining rings. Two types - Chromium plated with copper face (for economy and ease of use) and Iron plated with

Pre-tinned face (Long Life). State tip size, iron and type.

	Copper	L/L
EC50	-	£1.74
Adamin 12 and		
LA12	£1.00	£1.71
LC18	£1.12	£1.90

Yellow £1.33 Green £1.39



Blue £1.44 per Reel

For simple, safe and effective de-soldering of all types of joint, using a standard soldering iron. Handy colour-coded packs of 1.5 metres in 3 widths: Yellow - 1.5mm, Green - 2mm, Blue - 3mm.

De-Solder Pumps £7.28

High Quality version of increasingly popular type of tool. Precision made anodised aluminium body, plunger guard and high-seal piston. Easy

thumb operation. Automatic solder ejection. Conductive PTFE nozzle - no static problems.

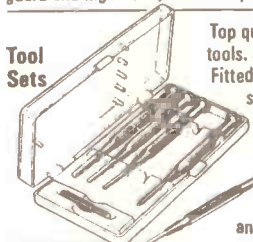

Top quality Japanese metric hardened and tempered tools. Swivel-top chrome plated brass handles.

Fitted plastic cases. 113 set - 6 miniature

screwdrivers 0.9 to 3.5mm £3.92

227 set 5 socket spanners 3 to 5mm £2.98

305 set 2 crosspoint and 3 hex wrenches

1.5 to 2.5mm £2.86

228 set 20 piece combination:

5 open, 5 skt spanners, 2 crosspoint, 3 hex and 3 plain drivers, scriber, handle/holder £6.42

Microcutters. £5.39 Light weight hardened and precision ground. Flush cutting. Screw joint, return spring, cushion-grip handles. Safety wire-retaining clip.



Soldering Aids.



Set of 3 £4.45

Scraper/Knife, Hook/Probe, Brush/Fork. 3 useful double-ended aids to soldering/desoldering/assembly. In plastic wallet.



ADAMIN Electric Stylus. £16.71

Writes like a ballpoint in Gold, Silver, Copper or 6 colours, on card, plastics, leather etc. Personalise wallets, bags, albums, books,

models... Operates at 4.5v from its own plug/transformer - totally safe. Supplied with coloured foils.



SEND FOR OUR ORDER FORM TODAY AND JOIN UP WITH THE PROFESSIONALS

Prices include VAT and P&P. Send order with Cheque. PO. Ring for Access. Visa sales - ask for order forms

LIGHT SOLDERING DEVELOPMENTS LTD., DEPT. ET
97-99 GLOUCESTER ROAD, CROYDON CR0 2DN. 01 689 0574

GREENWELD
ELECTRONIC COMPONENTS

Full Kits inc. PCBs, or veroboard, hardware, electronics, cases (unless stated). Less batteries.
If you do not have the issue of E.E. which includes the project - you will need to order the instruction reprint as an extra - 80p each.
Reprints available separately 80p each + p&p £1.00.

THIS MONTH'S KITS SAE or 'phone for prices

VIDEO CONTROLLER Oct 87	£27.75
TRANSTEST Oct 87	£9.24
AUTOMATIC PORCH LIGHT Oct 87	£16.35
CARAVAN FRIDGE ALERT Oct 87	£5.18
STATIC MONITOR Oct 87	£8.25
ELECTRONIC MULTIMETER Sept 87	£44.72
NOISE GATE Sept 87	£22.14
PERSONAL STEREO AMP Sept 87	£13.83
CAR OVERHEATING ALARM Sept 87	£8.21
BURST-FIRE MAINS CONTROLLER Sept 87	£12.91
SUPER SOUND ADAPTOR Aug 87	£36.56
IMMERSION HEATER TIMER Aug 87	£17.98
3 BAND 1.6-30MHz RADIO Aug 87	£25.27
BUCCANEER I.B. METAL DETECTOR inc. coils and case, less handle and hardware July 87	£25.19
DIGITAL COUNTER/FREQ METER (10MHz) inc. case July 87	£67.07
MONDRIX July 87	£20.00
FERMOSTAT July 87	£11.56
VIDEO GUITAR TUNER Jan 87	£21.99
MINI DISCO LIGHT Jan 87	£11.99
WINDSCREEN WASHER WARNING May 87	£4.88
FRIDGE ALARM May 87	£9.41
EQUALIZER (IDONISER) May 87	£14.79
ALARM THERMOMETER April 87	£25.98
BULB LIFE EXTENDER April 87 (less case)	£4.99
EXP. SPEECH RECOGNITION April 87	£19.98
COMPUTER BUFFER INTERFACE Mar 87	£11.96
ACTIVE I/R BURGLAR ALARM Mar 87	£33.95
VIDEO GUARD Feb 87	£7.99
MINI-AMP Feb 87	£14.99
CAR VOLTAGE MONITOR Feb 87	£11.98
SPECTRUM SPEECH SYNTH. (no case) Feb 87	£19.92
SPECTRUM I/O PORT less case, Feb 87	£8.99
STEPPING MOTOR BOOSTER (for above) Feb 87	£5.19
STEPPING MOTOR MD200 Feb 87	£16.80
HANDS-OFF INTERCOM (per station) inc. case Jan 87	£9.99
CAR ALARM Dec 86	£10.97
DUAL READING THERMOMETER (less case) Dec 86	£39.98
RANDOM NUMBER GENERATOR Dec 86	£14.97
8 CHANNEL A-D (SPECTRUM) CONVERTER Dec 86	£34.29
BBC 16K SIDEWAYS RAM Dec 86	£12.35
MODEM TONE DECODER Nov 86	£18.99
OPTICALLY ISOLATED SWITCH Nov 86	£11.89
CAR FLASHER WARNING Nov 86	£7.92
ZOOMING DIG. FREQUENCY METER Nov 86	£59.98
10 WATT AUDIO AMPLIFIER Oct 86	£34.95
LIGHT RIDER LABEL BADGE Oct 86	£9.71
LIGHT RIDER DISCO VERSION	£18.69
LIGHT RIDER 16 LED VERSION	£12.99
SCRATCH BLANKER Sept 86	£53.17
INFRA-RED BEAM ALARM Sept 86	£26.99
FREEZER FAILURE ALARM Sept 86	£14.76
CAR TIMER Sept 86	£8.30
BATTERY TESTER Aug 86	£6.85
TILT ALARM July 86	£7.45
HEADPHONE MIXER July 86	£27.69
CARAVAN BATTERY MONITOR July 86	£16.35
SQUEAKIE CONTINUITY TESTER July 86	£3.35
ELECTRONIC SCREWDRIVER July 86	£8.45
VOX BOX AMP July 86	£12.73
PERCUSSION SYNTH June 86	£28.98
LIGHT PEN (less case) June 86	£5.80
PERSONAL RADIO June 86	£10.98
WATCHDOG June 86	£7.85
MINI STROBE May 86	£13.11
PA AMPLIFIER May 86	£24.95
LOGIC SWITCH May 86	£14.93
AUTO FIRING JOYSTICK May 86	£11.86
STEREO REVERB Apr 86	£25.18
VERSATILE PSU Apr 86	£23.51
CIRCLE CHASER Apr 86	£20.98
FREELoader Apr 86	£8.08
STEPPER MOTOR DRIVER Apr 86	£26.61
BBC MIDI INTERFACE Mar 86	£17.97
INTERVAL TIMER Mar 86	£48.85
STEREO HI-FI PRE-AMP	£8.40
MAINS TESTER & FUSE FINDER Mar 86	£23.66
FUNCTION GENERATOR Feb 86	£7.62
POWER SUPPLY FOR ABOVE	£12.25
TOUCH CONTROLLER Feb 86	£23.11
pH TRANSDUCER (less Probe) Feb 86	£10.72
SPECTRUM OUTPUT PORT Feb 86	£7.14
OPORT Jan 86	£24.57
TACHOMETER Jan 86	£18.83
MAIN DELAY SWITCH less case Jan 86	£8.29
ONE CHIP ALARM Jan 86	£17.83
MUSICAL DOOR BELL Jan 86	£9.45
TTL LOGIC PROBE Dec 85	£39.57
DIGITAL CAPACITANCE METER Dec 85	£28.72
FLUX DENSITY TRANSDUCER Nov 85	£4.20
FLASHING PUMPKIN less case Nov 85	£9.49
SQUEAKING BAT less case Nov 85	£10.97
SCREAMING MASK less case Nov 85	£28.00
STRAIN GAUGE AMPLIFIER Oct 85	£5.21
SOLDERING IRON CONTROLLER Oct 85	£7.46
VOLTAGE REGULATOR Sept 85	£9.89
PERSONAL STEREO P.S.U. Sept 85	£15.94
R.I.A. PRE-AMP Sept 85	£10.30
CARAVAN ALARM Sept 85	£7.50
FRIDGE ALARM Sept 85	£20.82
SEMI-CONDUCTOR TEMP. SENSOR Sept 85	£20.82
RESISTANCE THERMOMETER Sept 85 less Probe	£20.71

TOOLS			
ANTEX MODEL C IRON	£8.98	SOLDER REEL SIZE 10	£4.67
ANTEX SOLDERING		LOW COST PLIERS	£1.98
IRON 25W	£7.25	LOW COST CUTTERS	£1.99
S74 STAND FOR IRONS	£2.85	BENT NOSE PLIERS	£1.89
HEAT SINK TWEEZERS	£1.50	MINI DRILL 12V (MD1)	£8.38
SOLDER HANDY SIZE 5	£1.29	MULTIMETER TYPE 1 1000ppmv	£6.38
SOLDER CARTON		MULTIMETER TYPE 2 2000ppmv	£7.98
		MULTIMETER TYPE 3 3000ppmv	£27.98
		MULTIMETER TYPE 4 10M	£39.98
		DIGITAL	£5.48
		DESOLDER PUMP	£2.98
		SIGNAL INJECTOR	£2.98
		CIRCUIT TESTER	78p
		HELPING HANDS JIG 6	£7.98
		MAGNIFIER	£7.98
		MINIATURE VICE (PLASTIC)	£1.85

E.E. PROJECT KITS MAGENTA

PLATINUM PROBE Extra	£24.20
LOW COST POWER SUPPLY UNIT Aug 85	£18.39
TRI-STATE THERMOMETER (Batt) Aug 85	£5.66
TREMOL/VIBRATO Aug 85	£37.92
STEPPER MOTOR INTERFACE FOR THE BBC COMPUTER less case Aug 85	£13.99
1035 STEPPER MOTOR EXTRA	£14.50
OPTIONAL POWER SUPPLY PARTS	£5.14
CONTINUITY TESTER July 85	£5.90
TRAIN SIGNAL CONTROLLER July 85	£9.66
AMSTRAD USER PORT July 85	£16.83
ACROSS THE RIVER June 85	£19.77
ELECTRONIC DOORBELL June 85	£7.20
GRAPHIC EQUALISER June 85	£25.66
AUTO PHASE May 85	£17.98
INSULATION TESTER Apr 85	£18.85
LOAD SIMPLIFIER Feb 85	£18.88
GAMES TIMER Jan 85	£8.39
SPECTRUM AMPLIFIER Jan 85	£6.58
TV AERIAL PRE-AMP Dec 84	£14.83
Optional PSU 12V £2.44	240V £11.83
MINI WORKSHOP POWER SUPPLY Dec 84	£41.98
DOOR CHIME Dec 84	£17.89
BBC MICRO AUDIO STORAGE SCOPE INTERFACE Nov 84	£34.52
PROXIMITY ALARM Nov 84	£21.58
MAINS CABLE DETECTOR Oct 84	£5.27
MICRO MEMORY SYNTHESIZER Oct 84	£7.67
DRILL SPEED CONTROLLER Oct 84	£8.27
GUITAR HEAD PHONE AMPLIFIER Sept 84	£7.66
SOUND OPERATED FLASH less lead Sept 84	£6.98
TEMPERATURE INTERFACE FOR BBC Aug 84	£23.64
CAR RADIO BOOSTER Aug 84	£16.64
CAR LIGHTS WARNING July 84	£9.58
VARICAP AM RADIO May 84	£12.52
EXPERIMENTAL POWER SUPPLY May 84	£22.46
SIMPLE LODP BURGLAR ALARM May 84	£16.34
MASTERMIND TIMER May 84	£6.52
FUSE/DIODE CHECKER Apr 84	£4.14
QUASI STEREO ADAPTOR Apr 84	£13.08
DIGITAL MULTIMETER add on for BBC Micro Mar 84	£29.98
NI-CAD BATTERY CHARGER Mar 84	£11.82
REVERSING BLEEPER Mar 84	£8.14
PIPE FINDER Mar 84	£4.32
IONISER Feb 84	£28.78
SIGNAL TRACER Feb 84	£17.88
CAR LIGHT WARNING Feb 84	£4.51
GUITAR TUNER Jan 84	£21.28
BIOLOGICAL AMPLIFIER Jan 84	£22.99
CONTINUITY TESTER Dec 83	£11.98
CHILDREN'S DISCO LIGHTS Dec 83	£8.42
NOVEL EGG TIMER Dec 83 inc. case	£12.29
SPEECH SYNTHESIZER FOR THE BBC MICRO Nov 83	£26.38
83 less cable & sockets	£20.38
MULTIMOD Nov 83	£20.38
HOME INTERCOM less link wire Oct 83	£17.26
STORAGE 'SCOPE INTERFACE FOR BBC MICRO Aug 83 less software	£18.42
HIGH POWER INTERFACE BOARD Aug 83 no case	£12.45
USER PORT I/O BOARD less cable & plug	£12.59
USER PORT CONTROL BOARD July 83 less cable & plug + case	£30.16
MW PERSONAL RADIO less case, May 83	£9.14
MOISTURE DETECTOR May 83	£6.55
NOVELTY EGG TIMER April 83 less case	£6.58
DUAL POWER SUPPLY March 83	£69.48
BUZZ OFF March 83	£5.41
PUSH BIKE ALARM Feb 83	£14.07
ZX TAPE CONTROL Nov 82	£8.55
2-WAY INTERCOM July 82 no case	£5.42
REFLEX TESTER July 82	£9.32
SEAT BELT REMINDER Jun 82	£4.92
EGG TIMER Jun 82	£6.53
CAR LED VOLT METER less case, May 82	£3.81
V.C.O. SOUND EFFECTS UNIT Apr 82	£15.75
CAMERA OR FLASH GUN TRIGGER Mar 82 less trigod bushes	£16.38
POCKET TIMER Mar 82	£4.92
SIMPLE STABILISED POWER SUPPLY Jan 82	£32.37
MINI EGG TIMER Jan 82	£5.28
SIMPLE INFRA RED REMOTE CONTROL Nov 81	£22.44
SUSTAIN UNIT Oct 81	£16.79
TAPE NOISE LIMITER Oct 81	£5.97
HEADS AND TAILS GAME Oct 81	£3.30
PHOTO FLASH SLAVE Oct 81	£4.56
FUZZ BOX Oct 81	£9.57
SOIL MOISTURE UNIT Oct 81	£7.66
0-12V POWER SUPPLY Sept 81	£23.38
COMBINATION LOCK July 81 less case	£25.93
SOIL MOISTURE INDICATOR E.E. May 81	£5.39
PHONE BELL REPEATER/BABY ALARM May 81	£7.38
MODULATED TONE DOORBELL Mar 81	£8.82
2 NOTE DOOR CHIME Dec 80	£13.62
LIVE WIRE GAME Dec 80	£15.44
GUITAR PRACTICE AMPLIFIER Nov 80 £14.10 less case, Standard case extra	£5.98
SOUND TO LIGHT Nov. 80 3 channel	£28.08
AUDIO EFFECTS UNIT FOR WEIRD SOUNDS Oct 80	£17.28
SPRING LINE REVERB UNIT Jan 80	£32.64
UNIBOARD BURGLAR ALARM Dec 79	£7.98
DARKROOM TIMER July 79	£3.84
MICROCHIME DOORBELL Feb 79	£20.98
SOUND TO LIGHT Sept 78	£10.98
R.F. SIGNAL GENERATOR Sept 78	£37.44
IN SITU TRANSISTOR TESTER Jun 78	£9.00
WEIRD SOUND EFFECTS GENERATOR Mar 78	£5.44
ELECTRONIC DICE Mar 77	£7.97

DIGITAL TROUBLESHOOTING

Top quality kits & parts for this new series. Our excellent technical back-up service helps to ensure that your projects succeed every time.
PART 1 BENCH POWER SUPPLY—Full kit £24.98.
LOGIC PROBE—£7.58 including case.
LOGIC PULSER—£7.48 including case.
VERSATILE PULSE GENERATOR—£29.98 including case.
DIGITAL I.C. TESTER—£29.21 (case different).
CURRENT TRACER—£20.56.
AUDIO LOGIC TRACER—£8.99.

EXPLORING ELECTRONICS

A full set of parts including the Verobloc breadboard to follow the series right up to Aug. 87 issue. £29.43
Follow this excellent beginners series. Full set of reprints £5.00 or 80p per issue.

INTRODUCTION TO ELECTRONICS

An introduction to the basic principles of electronics. With lots of simple experiments. Uses soldering. Lots of full colour illustrations and simple explanations. A lovely book. Ideal for all ages.
INTRODUCTION TO ELECTRONICS COMPONENT PACK £10.99
BOOK EXTRA £2.45
Book also available separately.

TEACH IN 86

MULTIMETER TYPE M10282 as specified. Guaranteed. Top quality. 20kV, with battery check, continuity tester buzzer and fuse and diode protection. 10A dc range.
Complete with leads, battery and manual. £14.98
VEROBLOC BREADBOARD, DESIGN PAD, MOUNTING PANEL AND 10 CROCODILE CLIP CONNECTING LEADS £9.98
REGULATOR UNIT AND SAFE POWER SUPPLY. All components including the specified case. Specially re-designed by Magenta. No external transformer or adaptor required. PCB design for complete safety and ease of assembly. £26.84
COMPONENTS FOR PRACTICAL ASSIGNMENTS. Full set. £16.84

TEACH IN 86 PROJECTS

UNIVERSAL LCR BRIDGE Nov 85	£25.83
DIODE/TRANSISTOR TESTER Dec 85	£18.89
USEFUL AUDIO SIGNAL TRACER Jan 86	£16.75
AUDIO SIGNAL GENERATOR Feb 86	£26.21
R.F. SIGNAL GENERATOR March 86	£24.48
FET VOLTMETER Apr 86	£21.48
DIGITAL PULSE GENERATOR May 86	£16.68

MINI MODEL MOTORS
1½-3V, 2 TYPES. MM1—59p MM2—61p

MOTOR — GEARBOX ASSEMBLIES

Miniature precision made. Complete with quality electric motor. Variable reduction ratios achieved by fitting from 1-6 gearwheels (supplied) as required. Operates from 1.5V to 4.5V. Small unit type MGS speed range 3rpm-2200rpm depending on voltage & gear ratio. Large unit type MGL (higher torque motor) 2rpm-1150rpm. Long 3mm dia output shafts. Ideal for robots and buggies.
Small Unit (MGS) £3.49. Large Unit (MGL) £3.98.

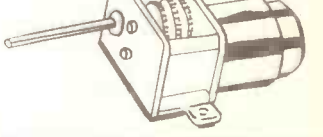

1987 CATALOGUE

Brief details of each kit, our books, & illustrations of our range of tools & components. Also stepper motor, interface kit & simple robotics. Plus circuit ideas for you to build. If you read Everyday Electronics then you need a copy of the MAGENTA catalogue.

CATALOGUE & PRICE LIST — Send £1 in stamps or add £1 to your order. Price list — 9x4 size. Catalogue FREE TO SCHOOLS/COLLEGES REQUESTED ON OFFICIAL LETTERHEAD.

ADVENTURES WITH ELECTRONICS

An easy to follow book suitable for all ages. Ideal for beginners. No soldering, uses an S-Dec Breadboard. Gives clear instructions with lots of pictures. 16 projects — including three radios, siren, metronome, organ, intercom, timer, etc. Helps you learn about electronic components and how circuits work. Component pack includes an S-Dec breadboard and all the components for the projects.
Adventures with Electronics £3.98
Component pack £20.98 less battery.

MAGENTA ELECTRONICS LTD.
E58, 135 HUNTER ST., BURTON-ON-TRENT, STAFFS, DE14 2ST.
0283 65435, Mon-Fri 9-5.
Access/Barclaycard (Visa) by phone or post.
24 hr Answerphone for credit card orders.
Our prices include VAT.

SHOP NOW OPEN—CALLERS WELCOME
ADD £1 P&P TO ALL ORDERS.
PRICES INCLUDE VAT.
SEE ALL ENQUIRIES.
OFFICIAL ORDERS WELCOME.
OVERSEAS: Payment must be sterling.
IRISH REPUBLIC and BFPO. UK PRICES.
EUROPE: UK PRICES plus 10% ELSEWHERE: write for quote.
SHOP HOURS: 9-5 MON-FRI.

PRICE LIST—FREE WITH ORDERS OR SEND SAE

TOP KITS

A SELECTION OF OUR BEST PROJECT KITS

As usual these kits come complete with printed circuit boards, cases, all components, nuts, screws, wire etc. All have been tested by our engineers (many of them are our own designs) to ensure that you get excellent results.

INSULATION TESTER

An electronic High Voltage tester for mains appliances and wiring. An inverter circuit produces 500 volts from a PP3 battery and applies it to the circuit under test. Reads insulation up to 100 Megohms. Completely safe in use.



OUR KIT REF E444 £18.65

DIGITAL CAPACITANCE METER

Simple and accurate (1%) measurements of capacitors from a few pF up to 10,000 uF. Clear 5 digit LED display indicates exact value. Three ranges – pF, nF, and uF. Just connect the capacitor, press the button and read the value.



**£39.57
OUR KIT
REF E493**

3 BAND SHORTWAVE RADIO

Covers 1.6-30 MHz in 3 bands using modern miniature coils. Audio output is via a built-in loudspeaker. Advanced design gives excellent stability, sensitivity and selectivity. Simple to build.



OUR KIT REF E718 £25.27

DIGITAL FREQUENCY METER 200 MHz

An 8 digit meter reading from A.F. up to 200 MHz in two ranges. Large 0.5" Red LED display. Ideal for AF and RF measurements, Amateur and C.B. frequencies.

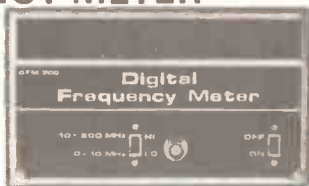

KIT REF E 563 £59.98

'EQUALISER' IONISER

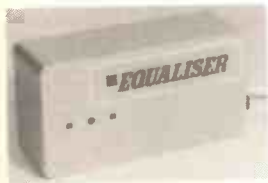

A mains powered Ioniser that produces a breeze of negative ions in the air. A compact, safe, simple unit that uses a negligible amount of electricity.

KIT REF E707 £14.79

VISUAL GUITAR TUNER



A crystal controlled tuner with a New type of 'rotating' LED display. Clockwise or Anticlockwise rotation indicates high or low frequency. Perfect tuning is obtained when the pattern is stationary. Suitable for electric guitar pick-ups or may be used with a microphone for acoustic instruments. Also has an audio 'pitch pipe' output.

KIT REF E711 £21.99

FROM MAGENTA

EVERYDAY ELECTRONICS

INCORPORATING ELECTRONICS MONTHLY

NEWSAGENT ORDER FORM

Please reserve/deliver a copy of *Everyday Electronics* for me each month.

Signed

Name & Address
(BLOCK CAPITALS PLEASE)

.....
.....
.....

Everyday Electronics is published on the third Friday of each month and distributed by Seymour.

Make sure of your copy of *EE* each month – cut out this form, fill it in and hand it to your newsagent.

SUBSCRIPTIONS

Sell-out disappointment can upset any reader! So why not take out a year's subscription and make sure of every issue, by post, straight from the Publisher? Complete the order form below and post to:
EVERYDAY ELECTRONICS, Subscription Dept., 6 Church Street, Wimborne, Dorset BH21 1JH.
Tel. 0202 881749.

Annual subscription rates:
UK £14. Overseas £17 (£ sterling only)
Overseas air mail £33 (£ sterling only)

EVERYDAY ELECTRONICS SUBSCRIPTION ORDER FORM

Annual subscription rates:
UK £14. Overseas £17 (surface mail) £33 (air mail)

To: *Everyday Electronics*,
Subscription Dept., 6 Church Street, Wimborne, Dorset
BH21 1JH.

Name

Address

I enclose payment of £..... (cheque/PO in £ sterling only payable to *Everyday Electronics*)

Subscriptions can only start with the next available issue. For back numbers see the Editorial page

For KITS & COMPONENTS - Choose the easy way - with

*refundable with first order

Send **50p* & SAE** for CATALOGUE

ORDERS: RING (01) 567 8910 - 24 HRS.

NEW ELECTRONIC GUARD DOG KIT



One of the best deterrents to a burglar is a guard dog and this new kit provides the barking without the bite! The kit when assembled can be connected to a doorbell, pressure mat or any other intruder detector and will produce a random series of threatening barks making the would be intruder think again and try his luck elsewhere. The kit is supplied complete with high quality PCB, transformer, all components and instructions. All you need is a mains supply, intruder detector and a little time. The kit even includes a horn speaker which is essential to produce the loud sound required. The "dog" can be adjusted to produce barks ranging from a Terror to an Alsatian and contains circuitry to produce a random series of barks giving a more realistic effect.

XK125 Complete kit of parts £21.95

DISCO LIGHTING KITS

DL1000K - This value-for-money 4-way chaser features bi-directional sequence and dimming. 1kW per channel. **£17.50**
DL21000K - A lower cost uni-directional version of the above. Zero switching to reduce interference. **£9.85**
DLA/1 (for DL & DL21000K) Optional opto input allowing audio 'beat' light response. **70p**
DL3000K - 3-channel sound to light kit features zero voltage switching, automatic level control and built-in microphone. 1kW per channel. **£14.25**

The **DL8000K** is an 8-way sequencer kit with built in opto-isolated sound to light input which comes complete with a pre-programmed EPROM containing EIGHTY - YES 80! different sequences including standard flashing and chase routines. The KIT includes full instructions and all components (even the PCB connectors) and requires only a box and a control knob to complete. Other features include manual sequence speed adjustment, zero voltage switching, LED mimic lamps and sound to light LED and a 300 W output per channel.

And the best thing about it is the price.

ONLY £28.50



TEN EXCITING PROJECTS FOR BEGINNERS

This Kit has been specially designed for the beginner and contains a **SOLDERLESS BREADBOARD, COMPONENTS**, and a **BOOKLET** with instructions to enable the absolute novice to build **TEN** fascinating projects including a light operated switch, intercom, burglar alarm, and electronic lock. Each project includes a circuit diagram, description of operation and an easy to follow layout diagram. A section on component identification and function is included, enabling the beginner to build the circuits with confidence.

ORDER NO XK118 £13.75

XK102-3-NOTE DOOR CHIME

Based on the **SAB0800 1C** the kit is supplied with all components, including loudspeaker, printed circuit board, a pre-drilled box (95 x 71 x 35mm) and full instructions. Requires only a **PP3 9V** battery and push-switch to complete.

AN IDEAL PROJECT FOR BEGINNERS £6.00

XK113 MW RADIO KIT

Based on **ZN414 IC**, kit includes PCB, wound aerial and crystal earpiece and all components to make a sensitive miniature radio. Size: 5.5 x 2.7 x 2cms. Requires **PP3 9V** battery. **IDEAL FOR BEGINNERS £6.00**

VERSATILE REMOTE CONTROL KIT

This kit includes all components (+ transformer) to make a sensitive IR receiver with 16 logic outputs (0-15V) which with suitable interface circuitry (relays, triacs, etc - details supplied) can be used to switch up to 16 items of equipment on or off remotely. The outputs may be latched (to the last received code) or momentary (on during transmission) by specifying the decoder IC and a 15V stabilised supply is available to power external circuits. Supply: 240V AC or 15-24V DC at 10mA. Size (excluding transformer) 9 x 4 x 2 cms. The companion transmitter is the **MK18** which operates from a 9V PP3 battery and gives a range of up to 60ft. Two keyboards are available - **MK9** (4-way) and **MK10** (16-way), depending on the number of outputs to be used.

MK12 IR Receiver (incl. transformer) £14.85
MK18 Transmitter £7.50
MK9 4-Way Keyboard £2.00
MK10 16-Way Keyboard £5.95
601 133 Box for Transmitter £2.60

HOME LIGHTING KITS

These kits contain all necessary components and full instructions and are designed to replace a standard wall switch and control up to 300W of lighting.

TDR300K Remote Control Dimmer £16.45
MK6 Transmitter for above £4.95
TD300K Touchdimmer £8.50
TS300K Touchswitch £8.50
TDE/K Extension kit for 2-way switching for TD300K £2.70
LD 300K Light Dimmer £4.35

NEW POWER STROBE KIT

Designed to produce a high intensity light pulse at a variable frequency of 1 to 15Hz this kit also includes circuitry to trigger the light from an external voltage source (eg. a loudspeaker) via an opto isolator. Instructions are also supplied on modifying the unit for manual triggering, as a slave flash in photographic applications or as a warning beacon in security applications. The kit includes a high quality pcb, components, connectors, SVS strobe tube and full assembly instructions. Supply: 240V ac. Size: 80 x 50 x 45.

XK124 STROBOSCOPE KIT £12.50

NEW HIGH SECURITY LOCK KIT

Designed for use with our lock mechanism (701 150) this kit will operate from a 9V to 15V supply drawing a standby current of only 50µA. There are over 5000 possible 4-digit combinations and the sequence can be easily changed. To make things even more difficult for an unauthorised user an alarm can be sounded after 3 to 9 incorrect entries - selectable by means of a link. The alarm can sound for a few seconds to over 3 minutes during which time the keyboard is disabled preventing further entries. A latched or momentary output is available making the unit ideal for door locks, burglar alarms, car immobilisers, etc. A membrane keyboard or pushbutton switches may be used and a beep sounds when a key is depressed. Kit includes high quality PCB, all components, connectors, high power piezo buzzer and full assembly and user instructions.

XK121 LOCK KIT £15.95
350 118 Set of Keyboard Switches £4.00
701 150 Electric Lock Mechanism 12 volt £16.50

PROPORTIONAL TEMPERATURE CONTROLLER KIT

Uses "burst fire" technique to maintain temperature to within 0.5°C. Ideal for photography, incubators, wine-making, etc. Max. load 3kw (240V ac) Temp. range up to 90°C. Size: 7x4x2.5cms. **MK4 £7.10**

PACK A
650 x .25W
Resistors 47R to 10M
£4.25

PACK B
60 x Electrolytics
1uf x 1000uf
£3.25

PACK C
35 x Polyester
Capacitors 10uf - 1uf
£4.50

PACK D
35 Horizontal Presets
1K to 1M
£3.00

PACK E
30 x IC Sockets
8, 14 & 16 pin
£2.00

PACK F
25 Red LEDs
5mm
£1.75

PACK G
25 Green LEDs
5mm
£2.00

PACK H
30 x 5mm LEDs
Red, Green, Yellow
£2.50

PACK J
50 x 1N4148
Si. Diodes
£1.00

PACK K
40 x NPN/PNP Transistors
BC182/212 General Purpose
£2.25

SPECIAL OFFER
10% OFF if you buy
ALL TEN PACKS

TOOLS ★ TOOLS ★ TOOLS



Good quality tools selected to offer outstanding value for money.

650 004 6in mini. Snipe Nose Pliers. Serrated jaws and return spring. £2.10
650 005 6in lap jointed side cutters. Insulated handles and return spring. £2.10
650 006 Light duty cutters. Cutting capacity 0.22-1.2mm copper wire. £1.60
TOOL KIT - Contains: side cutters, snipe nose pliers, wire strippers, flat blade screwdriver, philips screwdriver in black textured, reinforced and padded case which when opened out measures 240x205mm **£6.80**



650 007 Self-adjustable automatic wire stripper with built-in cable cutter. £3.95
650 012 Watchmakers Screwdriver Set. 1.0/1.4/2.0/2.4/3.0/3.8mm £1.75
650 019 Set of 4 Stainless Steel Tweezers. Straight nosed, straight nosed-reverse action, bent nosed, flat nosed. 110mm long. £3.65
650 502 Reliant 9-12V dc Drill. £6.90
650 500 Titan 12V dc Drill. £10.25
650 570 Saturn Mains Drill. £16.50
WE ALSO STOCK ANTEX IRONS AND ACCESSORIES

LOGIC PROBE



A MUST for working with **TTL & CMOS** devices. Displays logic levels and pulses down to 25ns with LEDs and sound. Comprehensive instruction booklet supplied.
 Working voltage 4-16V dc
 Input Impedance 1M
 Max. I/p frequency 20MHz
ONLY £9.50

RECHARGEABLE SOLDERING IRON

Powerful cordless iron complete with table-top/wall-mounting charging bracket. Reaches soldering temperature in 10 seconds. Includes lamp which lights when soldering. Comes with mains charging unit and 12V car battery adaptor. **£17.95**

HELPING HANDS

Magnifier and crocodile clips on ball and socket joints mounted on a heavy base. Ideal for holding and inspecting PCBs during soldering, fault finding, etc. (650 035) **£3.95**



MW RADIO

SCOOP PURCHASE ONLY £1.99!!!

Comprises ready-built AM Tuner module (superhet), separate audio amp with volume control and miniature speaker. All you have to do is connect these three items to a 9V battery. Full instructions supplied. **AVAILABLE WHILE STOCKS LAST.**

HANDY MULTIMETER

An ideal multimeter for the hobbyist featuring 20kV input impedance, 19 ranges including 10A d.c., battery checker and continuity buzzer. Supplied complete with test leads, battery and instruction manual. As recommended for the EE "Teach In" series. Dimensions: 135mm x 89mm x 40mm.
 AC Volts: 0-50-250-1kV (5%).
 DC Volts: 0-2.5-10-50-250-1k.
 DC Current: 0-5-10-500mA-10A
 Resistance: 10k-100k-10M
 dBs: -20dB to +62dB
 Part no. 405104 **£12.95**



P.C.B. ETCHING KIT

Ideal starter pack. 2 pieces Copper Laminated, Circuit Etchant, Etch Resist Pen, 7 Assorted Transfer Sheets and Tray. Full and comprehensive instructions on laying out and etching your own PCB designs. **£5.20**

SOLAR POWERED NICAD CHARGER

Takes up to 4 x AA size. Charges 2 batteries in 4-6 hrs., 4 in 10-14 hrs. depending on strength of sunlight. Ideal for boating, caravanning, modelers, etc. **£5.95**

VELLEMAN KITS

We stock the full range of Velleman Kits. Why not try one of these!!
K1771 Miniature FM TRANSMITTER (60mW). 9-12V DC. Frequency: 100-108MHz. Ideal for babyphone, etc. £6.50
K2572 STEREO PRE-AMPLIFIER £7.93
K2583 HEATING CONTROLLER. Enables four temperatures to be set and maintained for set periods in a day. Display shows time or temperature. £75.76
K2638 CAR ALARM. Easy to mount. No false alarms. Adjustable entry/exit times. Automatic reset prevents discharging of battery. £16.80
K2603 YEAR TIMER. Standard memory - 40 steps expandable to 240 steps. Non-volatile memory holds program without any power source. Auto-start after power failure. Two programmable "sleep" times. 4 relay outputs - one relay (3A/240V) supplied with kit. Extra relays (K2632). Membrane keyboard and housing included. (Transformer not included.) Size: 241x116x59mm. £132.30
K2632 Hardware extension kit £19.20
TR2603 Transformer for K2603 £8.40
 Send see 12" x 9" for full catalogue.

TK ELECTRONICS
13 BOSTON RD
LONDON W7 3SJ
Tel: 01-567 8910

SEND 9"x6" S.A.E. & 50p FOR CATALOGUE OR CALL AT SHOP MON-FRI 9-5pm SATURDAY 10-4pm

ORDERING INFORMATION: ALL PRICES EXCLUDE VAT

FREE P&P on orders over £20 (UK only), otherwise add 75p + VAT. Overseas P&P: Europe £2.75. Elsewhere £6.50. Send cheque/PO/Barclaycard/Access No. with order. Giro No. 529314002.

LOCAL AUTHORITY AND EXPORT ORDERS WELCOME GOODS BY RETURN SUBJECT TO AVAILABILITY



EVERYDAY ELECTRONICS

INCORPORATING ELECTRONICS MONTHLY

The Magazine for Electronic & Computer Projects

VOL 16 No. 11

November '87

ESOTERIC

THESE days virtually everyone needs to know about electronics and digital systems — even if it is just how to program the video or the central heating — and more and more people need to know a little about computing. However after the first flush of learning, computing can be pretty esoteric and not really much fun, unless you get high from programming!

Of course, electronics can extend the hobby of computing into the real world in two ways:

1. Computer interfaces can be built to enable any microcomputer to control virtually any electronic, electrical or mechanical system.
2. A computer (or microprocessor) can form the heart of an electronic project — to provide a dedicated control unit which can be built into other systems or equipment.

For these reasons many computer hobbyists are now turning to electronics to add a new dimension to their hobby — to put the fun back if you like. While *EE* has never given over large sections of the magazine to software we have tried to cater for the computer fanatic who wants to use his micro as a piece of test gear or to play music, etc. Our regular *On Spec* and *BBC Micro* pages look at those areas of using computers which employ electronics and which are most often overlooked by the popular computer magazines.

TRUMPET

As you may have noticed I have recently been “blowing our own trumpet” about circulation and market leadership. No doubt some of the new found circulation increases are a direct result of boredom with playing computer games and writing endless software.

Initial response to our City and Guilds series on Microprocessors has been very satisfying and we know a number of colleges will be using *EE* to back up their C & G courses. It is also interesting to see so many hobbyists taking up this course either to expand their knowledge for their own satisfaction or to enhance their job prospects. For a few years computing has distracted the electronics hobbyist, it now seems to be encouraging him.

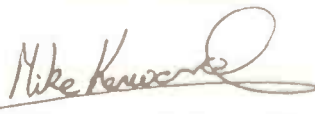

SUBSCRIPTIONS

Annual subscriptions for delivery direct to any address in the UK: £14.00. Overseas: £17.00 (£33 airmail). Cheques or bank drafts (in

£ sterling only) payable to Everyday Electronics and sent to EE Subscriptions Dept., 6 Church Street, Wimborne, Dorset BH21 1JH. **Subscriptions can only start with the next available issue.** For back numbers see below.

BACK ISSUES & BINDERS

Certain back issues of EVERYDAY ELECTRONICS are available price £1.50 (£2.00 overseas surface mail) inclusive of postage and packing per copy. Enquiries with remittance, made payable to Everyday Electronics, should be sent to Post Sales Department, Everyday Electronics, 6 Church Street, Wimborne, Dorset BH21 1JH. In the event of non-availability remittance will be returned. **Please allow 28 days for delivery. (We have sold out of Sept. Oct. & Nov. 85, April, May & Dec 86, & Jan 87.)**

Binders to hold one volume (12 issues) are available from the above address for £4.95 (£9.00 overseas surface mail) inclusive of p&tp. **Please allow 28 days for delivery.**

Payment in £ sterling only please.

Editorial Offices

EVERYDAY ELECTRONICS EDITORIAL,
6 CHURCH STREET, WIMBORNE,
DORSET BH21 1JH
Phone: Wimborne (0202) 881749

See notes on **Readers' Enquiries** below—we regret that lengthy technical enquiries cannot be answered over the telephone

Advertisement Offices

EVERYDAY ELECTRONICS ADVERTISEMENTS
4 NEASDEN AVE., CLACTON-ON-SEA, ESSEX
CO16 7HG. Clacton (0255) 436471

Editor MIKE KENWARD

Assistant Editor
DAVID BARRINGTON

Editorial Assistant
COLETTE MCKENZIE

Editorial: WIMBORNE (0202) 881749

Advertisement Manager
PETER J. MEW Clacton (0255) 436471

Classified Advertisements
Wimborne (0202) 881749

READERS' ENQUIRIES

We are unable to offer any advice on the use, purchase, repair or modification of commercial equipment or the incorporation or modification of designs published in the magazine. We regret that we cannot provide data or answer queries on articles or projects that are more than five years old. Letters requiring a personal reply **must** be accompanied by a **stamped self-addressed envelope** or a **self-addressed envelope and international reply coupons**.

All reasonable precautions are taken to ensure that the advice and data given to readers is reliable. We cannot, however, guarantee it and we cannot accept legal responsibility for it.

COMPONENT SUPPLIES

We do not supply electronic components or kits for building the projects featured, these can be supplied by advertisers.

OLD PROJECTS

We advise readers to check that all parts are still available before commencing any project in a back-dated issue.

We regret that **we cannot provide data or answer queries on projects that are more than five years old.**

ADVERTISEMENTS

Although the proprietors and staff of EVERYDAY ELECTRONICS take reasonable precautions to protect the interests of readers by ensuring as far as practicable that advertisements are *bona fide*, the magazine and its Publishers cannot give any undertakings in respect of statements or claims made by advertisers, whether these advertisements are printed as part of the magazine, or are in the form of inserts.

The Publishers regret that under no circumstances will the magazine accept liability for non-receipt of goods ordered, or for late delivery, or for faults in manufacture. Legal remedies are available in respect of some of these circumstances, and readers who have complaints should address them to the advertiser or should consult a local trading standards office, or a Citizen's Advice Bureau, or a solicitor.

TRANSMITTERS

We would like to advise readers that certain items of radio transmitting equipment which may be advertised in our pages cannot be legally used in the U.K. Readers should check the law before using any transmitting equipment as a fine, confiscation of equipment and/or imprisonment can result from illegal use.

The law relating to this subject varies from country to country; overseas readers should check local laws.



ACCENTED BEAT METRONOME

ROBERT PENFOLD

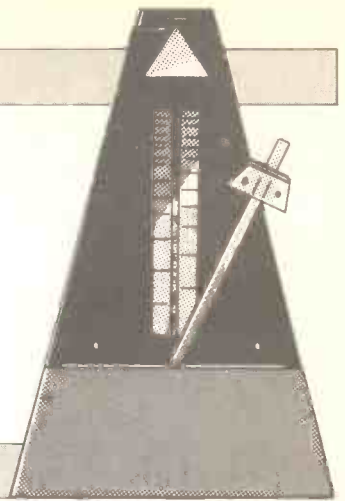

Accentuate the positive, eliminate the negative, that's how to stay in tune!

ALTHOUGH purely electronic, the Accented Metronome is a modern equivalent to the traditional pendulum style mechanical type and has even been designed to give the same sort of "click" sound to indicate each beat.

Some mechanical metronomes also have a bell which can be used to give an accented beat, and this unit has a similar facility. This is in the form of an additional circuit which enables a longer and deeper "thud" sound to be used to accent anything from every second beat to every tenth beat. The accentuation can be switched out altogether when it is not required.

The unit also has a bargraph display which gives a visual indication of the beat sequence, and is the equivalent of being able to see the pendulum of a traditional metronome. However, the ten l.e.d. bargraph shows exactly which beat is the current one in the sequence, even when (say) only every sixth or eighth beat is accentuated.

The unit is self-contained with power being provided by an internal 9V battery, and it is quite simple and inexpensive despite the fact that it provides both an accented beat facility and an l.e.d. display. It covers a wide beat range of around one every two seconds to about five per second.

SYSTEM OPERATION

A clock oscillator, two monostable multivibrators and a digital divider circuit form the basis of the metronome, as can be seen from the block diagram of Fig. 1. The clock oscillator is a low frequency type which has its output frequency made adjustable by means of a variable resistor. The frequency range covered by the unit governs the beat rate range of the metronome, and is therefore about 0.5Hz to 5Hz.

The output of the clock oscillator drives the input of a monostable multivibrator. The direct output of the oscillator is less than ideal for driving the loudspeaker as it is virtually a squarewave signal, whereas a short pulse signal is needed to produce each "click" sound.

The monostable is a non-retriggerable type which acts as a pulse shortener, and provides an output pulse of suitable duration regardless of how long the input pulse duration happens to be. The output pulses from the monostable are fed into a mixer circuit, and from here they are coupled to an output stage which provides the fairly high drive current needed to get good volume from the loudspeaker.

This gives the basic metronome function, but some extra stages are needed in order to give the accented beat facility. The main one of these is a divide by "N" counter, and this has a division rate which under switch control can be set to any integer from two to ten.

so on. A "dot" type display perhaps gives a slightly less clear indication, but it is the only type that can be easily used with the driver circuit available in this case, and it also has the great advantage of providing the unit with a much lower level of current consumption.

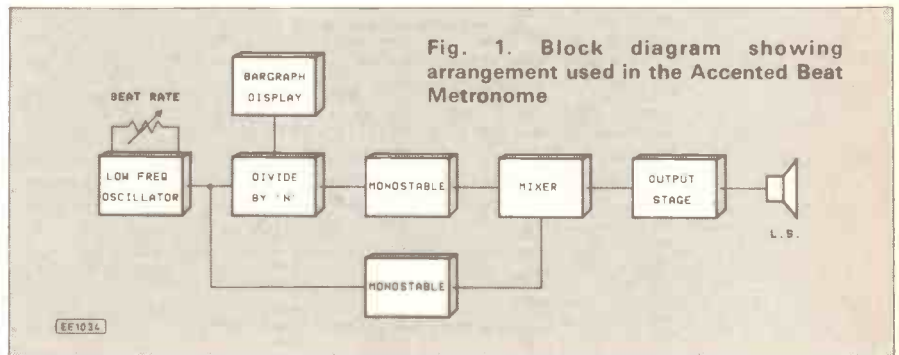

Fig. 1. Block diagram showing arrangement used in the Accented Beat Metronome

The output of the divider drives a second monostable multivibrator, but obviously this monostable will only be triggered on every second clock cycle, third clock cycle, or whatever the selected division rate dictates. The output pulses from this second monostable are mixed with the signal from the first one, but as the loudspeaker is already driven with the maximum output current that the output stage can provide, this does not in itself provide any significant accentuation of the basic "click" sounds.

The accentuation is provided by having the output pulse duration of the second monostable several times longer than the pulse length of the first one, so that the accented beats are indicated by what are really longer output pulses. These are perceived by listeners as deeper sounds which have an apparently higher volume level, and which are clearly distinguishable from the ordinary "click" sounds.

DISPLAY

The divider circuit has ten outputs which can be used to directly drive the bargraph display, and no special decoder or driver circuit is needed here. In fact the display is not a true bargraph type, which would have the first l.e.d. lit to indicate the first beat, l.e.d.s one and two switched on to indicate the second beat, and so on.

This display operates in what is generally known as the "dot" mode, where the first l.e.d. lights up to indicate the first beat, the second l.e.d. (and only the second l.e.d.) switches on to indicate the second beat, the third l.e.d. turns on to mark the third beat, and

CIRCUIT OPERATION

The complete circuit diagram of the Accented Metronome appears in Fig. 2.

A 555 astable circuit generates the clock signal, but in order to keep the current consumption of the circuit down to an acceptable level a low power version of the 555 such as the ICM7555 or L555P is recommended for IC1. Potentiometer VR1 is the frequency control, or the Beat Rate control as it should more correctly be called in this case.

The timing capacitor C2 should be a tantalum bead component. An ordinary electrolytic type capacitor is considerably less than ideal for this application where the poor tolerance rating could give a frequency range which was well away from the desired one, and the high leakage level could result in even worse frequency accuracy or even the circuit failing to oscillate at all at the low frequency end of the range.

Both monostables are based on two of the CMOS 2-input NOR gates of IC3 and use what is a standard configuration. IC3a and IC3b have capacitor C3 and resistor R4 as their timing components, and the approximate output pulse duration is 0.2 milliseconds. This gives the higher pitched "click" sound. IC3c and IC3d have C4 and R6 as their timing components, and with an output pulse duration of about 0.8 milliseconds or so this gives the lower pitched "thud" sound.

The two sets of output pulses are mixed by resistors R7 and R8 which form a simple passive mixer circuit. The pulses drive TR1 hard into conduction so that a heavy but brief current is driven through the loudspeaker LS1.

The peak power level fed to the loudspeaker is actually quite high and constitutes a considerable overload, but as the output pulses are very brief and infrequent the average power fed to LS1 is quite low, and there seems to be no danger of it being damaged. A high impedance (about 64 ohm) loudspeaker would appear to be better suited to this type of output stage, and although loudspeakers of this type will work quite well in the circuit, they provide a substantially lower volume level than low impedance types.

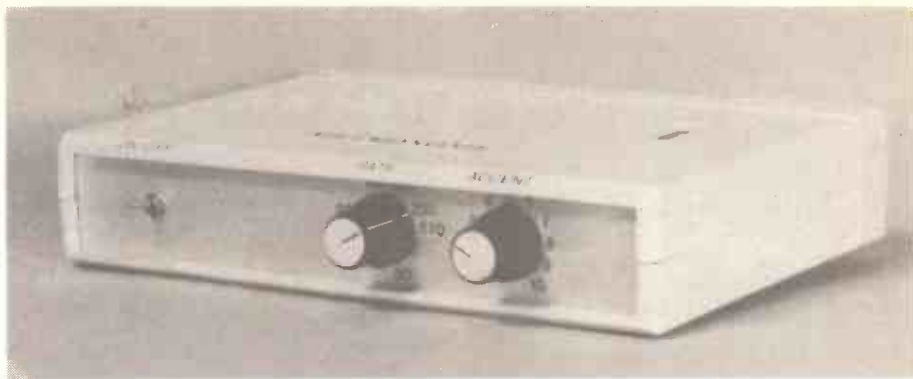

DIVIDER

The divider IC2 is a CMOS 4017BE, which is a decade counter and one of ten decoder. In this case the ordinary divide by ten ("carry out") output at pin 12 is of no interest and is ignored. It is the other ten outputs that are of use, and these are numbered from "0" to "9".

When the device is reset, output "0" goes high and all the other outputs take up the low state. On the next clock pulse output "0" goes low and output "1" assumes the high state. The next clock pulse takes output "1" low again and sets output "2" high.

This sequence of events continues until output "9" goes high. In the next clock pulse output "9" returns to the low state and output "0" goes high again. This takes things back to the beginning again, and the device cycles indefinitely in this manner.

At least, it does if it is allowed to. In this circuit the Reset input at pin 15 of IC2 is coupled by switch S1 either to one of the outputs, or in the tenth position it is simply tied to the 0 volt rail. It is therefore only in position 10 of switch S1 that IC2 provides the standard divide by ten action. In the other switch positions at some stage in the sequence the output to which the reset input is connected will

go high, and IC2 will immediately be reset to the initial state where output "0" is high.

For example, in position 2 output "0" will go high in the normal way, followed by output "1" on the next clock cycle. However, when output "2" goes high IC2 is reset and output "0" goes high again. A divide by 2 action is therefore obtained, and by selecting the appropriate switch position any division rate from two to ten can be obtained.

The "0" output of IC2 is coupled to the input of the second monostable via resistor R5, and an "accented beat" is therefore produced each time a new cycle recommences. The l.e.d.s of the bargraph display (D1 to D10) are driven from the ten outputs of IC2, and the appropriate l.e.d. for the current beat in the sequence is switched on since its output, and only its output, will be in the high state. As only one l.e.d. at a time will be switched on, a common current limiting resistor (R3) can be used for all ten l.e.d.s.

In position 0 of switch S1 the reset input is tied to output "0", and this holds the device permanently in the reset state with the clock

pulses consequently having no effect on IC2. This results in the first l.e.d. in the bargraph being switched on continuously, and with no input pulses fed to the second monostable the accentuation is disabled.

Power is obtained from a 9V battery, and the current consumption of the circuit is only about 8 milliamps. A small type such as a PP3 is therefore adequate as the power source, but a higher capacity battery such as six HP7 size cells in a plastic holder is preferable if the unit will receive a lot of use.

CONSTRUCTION

Although this is potentially a rather awkward project, the printed circuit design and component layout shown in Fig. 3 helps to make matters much more straightforward. This board is available from the EE PCB Service, code 582 (see page 628).

Construction of the board is not difficult, but bear in mind that IC2 and IC3 are both CMOS types, and that the normal anti-static handling precautions should be observed when

Fig. 2. Complete circuit diagram for the Accented Beat Metronome

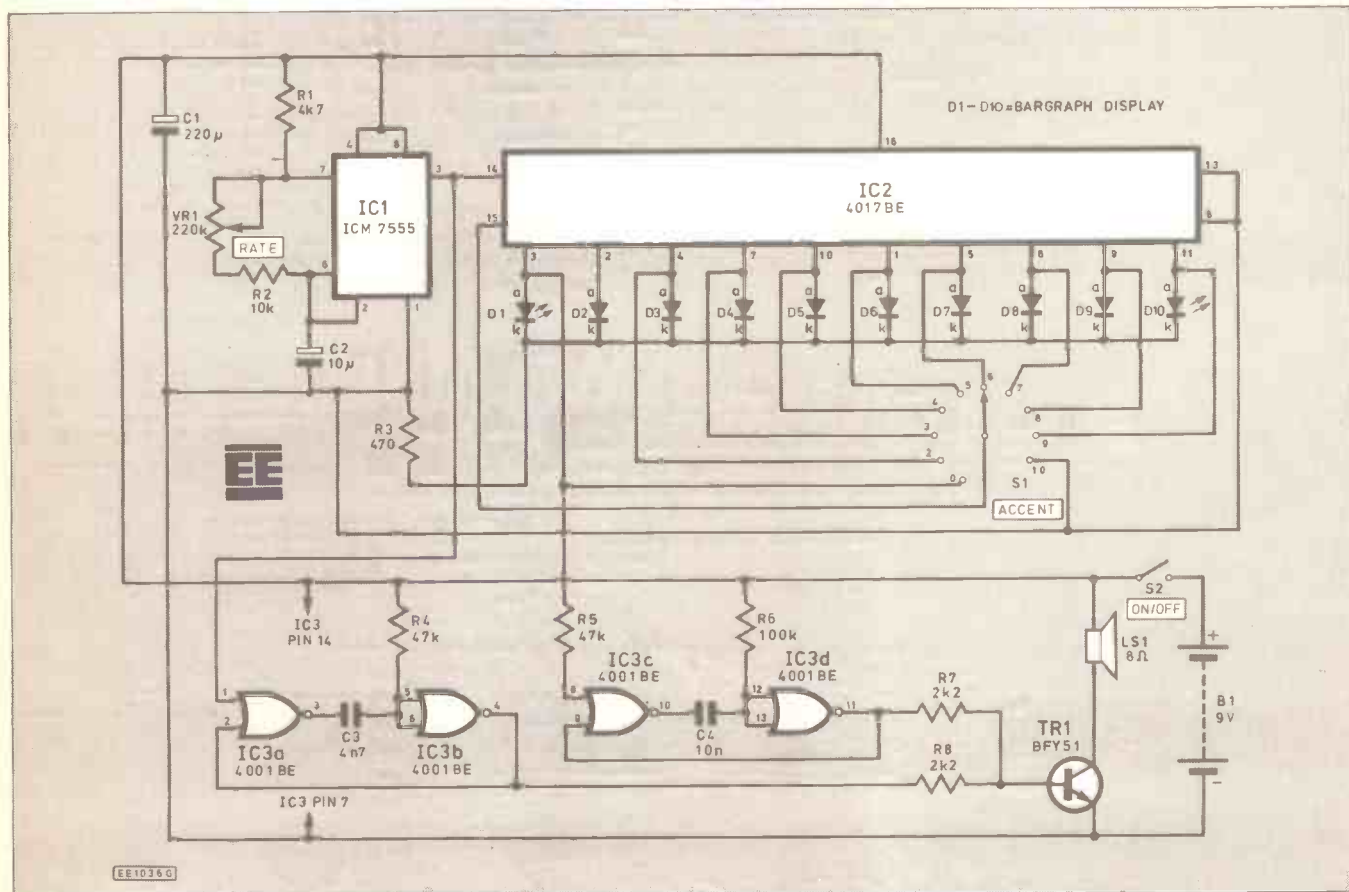

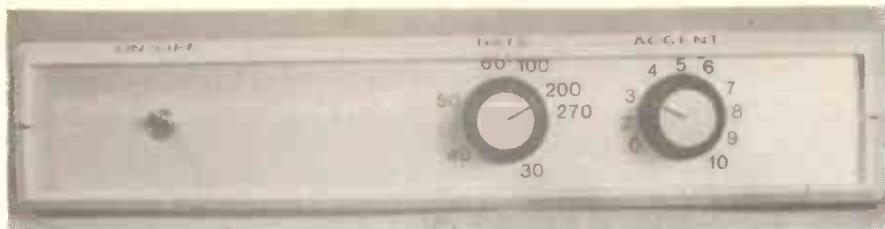

when fitting it into circuit, but is also required to physically raise the display to a more suitable height. The socket should *NOT*, therefore, be omitted.

With this type of display there usually seems to be nothing to indicate which way round it should be fitted, but if necessary the correct orientation can be found by trial and error, and the display will not sustain any damage if it is fed with power of the wrong polarity.

Of course, if preferred the bargraph display can be formed from ten ordinary panel mounting l.e.d.s fitted on the front panel of the unit, and this could actually give a much clearer display. On the other hand, it would increase

dealing with these. This basically means using integrated circuit holders for these components, and not fitting them into place until the unit has been completed in all other respects.

Until then they should be left in their anti-static packaging (plastic tubes, conductive foam, or whatever) and they should be handled as little as possible when it is time to plug them into their holders. Avoid getting them anywhere near any obvious source of strong static charges.

Although IC1 is also a CMOS device, it does not require any special handling precautions as it has very effective internal protection circuits which render them unnecessary. As neither the L555P or the ICM7555 integrated circuits are very inexpensive types I would still recommend that an integrated circuit holder is used for IC1.

It is assumed in Fig. 3 that the bargraph display is of the type which has a 20-pin DIL package, and this will plug straight into a 20-pin DIL integrated circuit holder mounted on the board. This socket is not just needed to prevent possible heat damage to the device

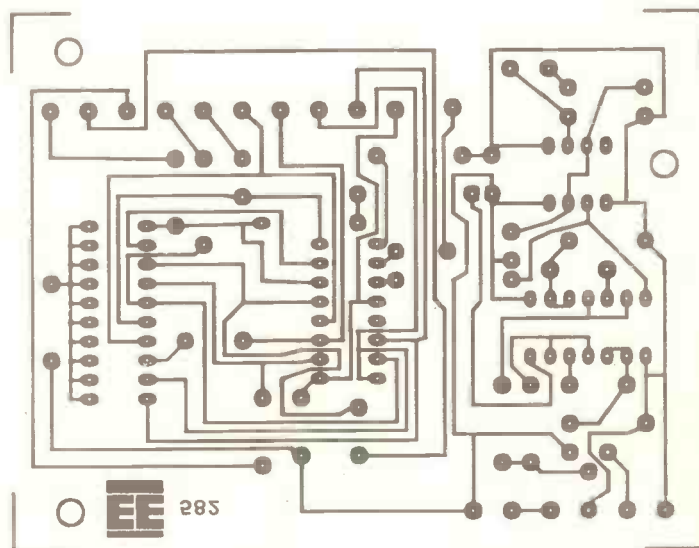

Fig. 3. Full size printed circuit board master foil pattern, component layout and interwiring for the metronome. Note that a 20-pin d.i.l. socket must be used for mounting the bargraph display.

COMPONENTS

Resistors

R1	4k7
R2	10k
R3	470
R4, R5	47k (2 off)
R6	100k
R7, R8	2k2 (2 off)

All 0.25W 5% carbon

See

**Shop
Talk**

page 617

Potentiometer

VR1	220k lin.
-----	-----------

Capacitors

C1	220 μ radial elec 10V
C2	10 μ tantalum bead 16V
C3	4n7 polyester
C4	10n polyester

Semiconductors

IC1	ICM7555 or L555P CMOS timer
IC2	4017BE decade counter
IC3	4001BE quad 2-input NOR gate
TR1	BFY51 <i>n</i> p <i>n</i> silicon transistor
D1 to D10	10 l.e.d. bargraph

Miscellaneous

S1	12-way 1-pole rotary switch, with end stop
S2	Sub-min s.p.s.t. toggle switch
LS1	8 ohm loudspeaker, 76mm diameter

Case about 205mm x 145mm x 40mm; printed circuit board, available from EE PCB Service, order code 582; 8-pin DIL i.c. holder; 14-pin DIL i.c. holder; 16-pin DIL i.c. holder; 20-pin DIL i.c. holder; 9V PP3 battery and battery clip; display window material; control knob (2 off); solder pins; wire; stand-offs etc.

Approx. cost
Guidance only

£12.50
(excluding case)

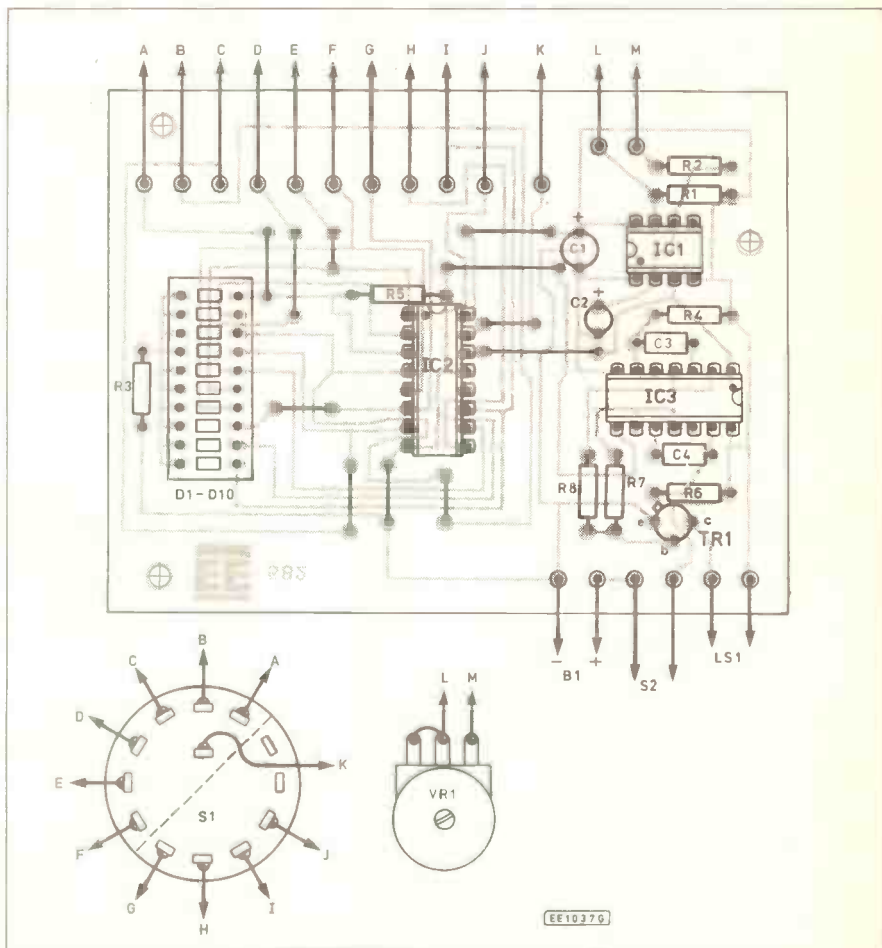

the amount of hard wiring required and would make construction of the unit much more difficult.

CASE

The case used for the prototype is a plastic type having an aluminium front panel and approximate outside dimensions of 205mm by 145mm by 40mm. The unit could actually be fitted into a much smaller case if desired, although this might necessitate the use of a smaller loudspeaker with a consequent reduction in volume, and it could prove difficult to mount the printed circuit board in a way which brings the display into a suitable position.

Assuming that the metronome is built along the same lines as the prototype, the three controls are mounted on the front panel and the loudspeaker is fitted towards the left-hand side of the top panel or case "lid".

A speaker grille of some kind is needed, and the most simple way of producing one of these is to drill a matrix of holes about 5 millimetres in diameter. Be very careful with the placement of the holes though, as it is not quite as easy to make a neat job of this as one might think.

Miniature loudspeakers rarely have any provision for screw fixing, and it is normally necessary to glue them in place. Any good

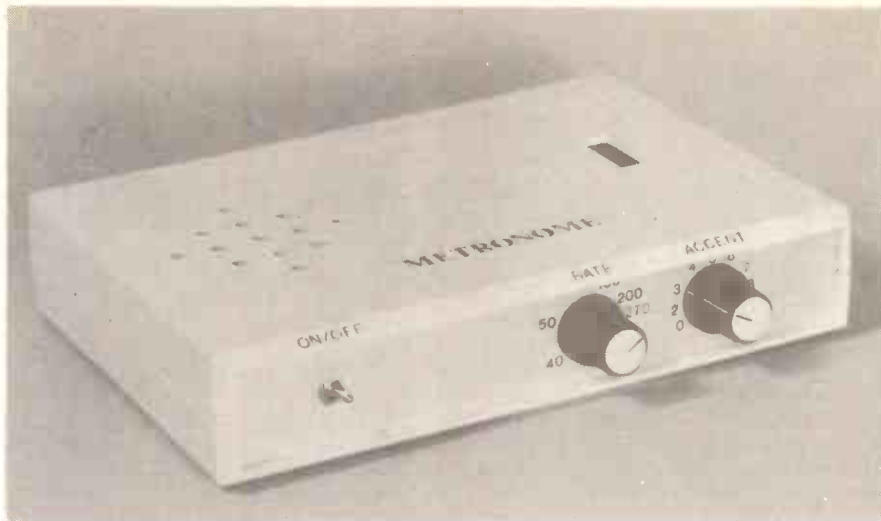

The completed metronome showing the speaker "grille" matrix and the display cutout.

general purpose adhesive will do, but try to avoid smearing any onto the diaphragm.

The printed circuit board is mounted on the base panel towards the right-hand side of the unit, and it is mounted on spacers which give a

stand-off of about 20 millimetres from the base panel. This is to bring the display to a suitable height, so that it is immediately underneath a display window cut at the appropriate position in the top panel of the case.

The rectangular cutout can be made using a coping saw or a fret saw. A piece of red display window material is glued in place behind the cutout.

To complete the metronome the hard wiring is added, and this is shown in Fig. 3. The wiring from the board to the Rate control (VR1) and the Accent switch (S1) is carried out by wiring from point "A" to point "A" and then the two point "B"'s are connected together, and so on. Ordinary multistrand connecting wire is used, and there should be no real difficulty here provided the pins, component tags, and the ends of the leads are properly tinned with solder prior to making each connection.

There is ample space for the battery, and this can be held in place with a double-sided adhesive pad. If six HP7 size batteries in a holder are used, a standard PP3 style battery clip is needed to make the connections to the holder.

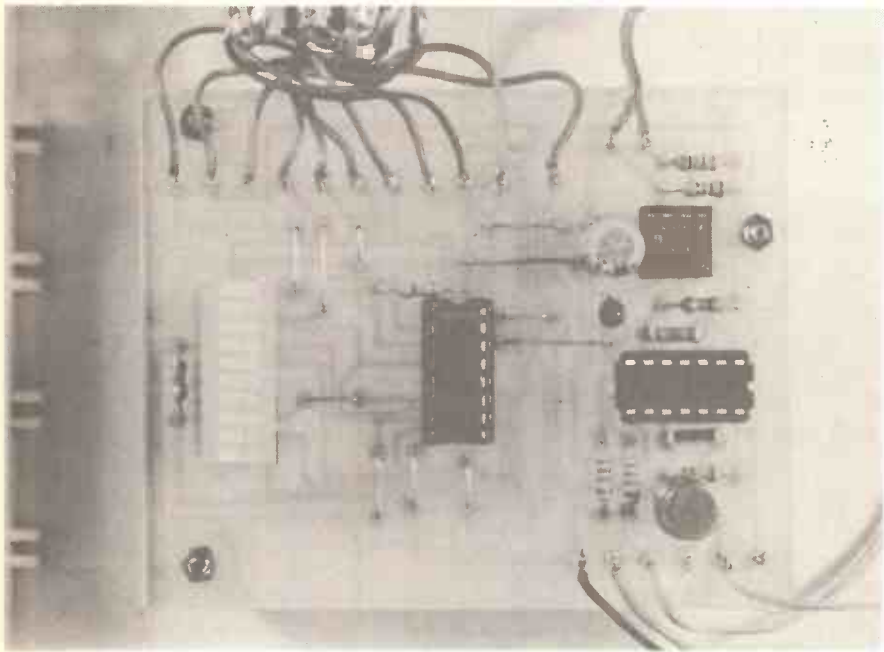

The finished circuit board showing all the semiconductor devices mounted in i.c. holders. The photograph below shows the board mounted on spacers to one side of the case to allow room for the speaker and battery.

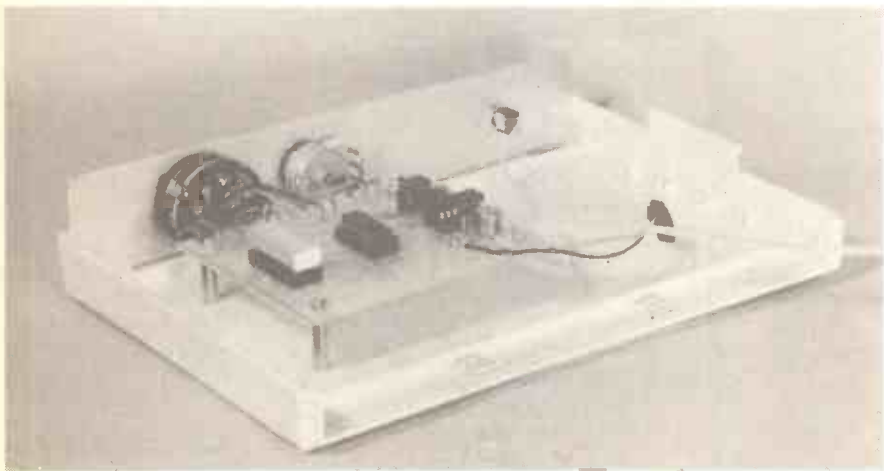

IN USE

Give the finished unit a thorough check for errors before switching it on and testing it. Once switched on it should produce a regular "clicking" sound at a rate controlled by VR1, and by setting S1 to introduce the accentuation the appropriate sounds and responses from the display should be obtained. If there is any sign of a malfunction, switch off at once and recheck all the wiring.

If the metronome is to be adjusted "by ear" there is no need to mark a scale around the control knob of VR1, but many users will require some sort of beat rate scale. There is no real difficulty in finding calibration points by counting the number of beats in a certain period of time, and using trial and error to fine tune VR1 to the correct settings. These can then be marked using rub-on transfers.

It can be difficult to mark a really accurate scale as the calibration points tend to become cramped at the high frequency end of the range. This problem can be eased by using a "logarithmic" potentiometer for VR1 and connecting it in reverse so that clockwise adjustment gives a reduction in the beat rate. This gives something approximating to a linear scale, but it is reverse reading of course.

Using a large control knob also helps to space out the calibration points and make precise adjustment easier. □

ACOUSTIC PROBE

A.J. FLIND



A relatively simple diagnostic tool which can provide excellent results on everything from watches to car engines

HOW MANY times have you raised your car's bonnet to investigate some new and worrying noise, only to be faced with a bewildering array of whirring and clattering machinery amongst which it is quite impossible to identify the offending sound? It might be tappets tapping, big ends on their way out, or simply a noisy alternator bearing.

prototype it was found that not only could the alternator of a friend's car be identified as the source, but there was no doubt whatsoever about which bearing was faulty.

Of course the instrument is not limited just to automotive applications. It can be used for almost any mechanical noise location, from clockwork to central heating systems. It is sensitive enough to pick up the tick of the author's watch, an analogue quartz model with a tiny stepping motor. Finally, for those who live in terraced accommodation and enjoy listening to the neighbours fighting, it beats a glass pressed to the wall hands down!

CIRCUIT

In principle this project is very simple. All that is required is a microphone on the end of a rod (probe), and a high-gain amplifier. The "microphone" is rather special, and will be described in detail later.

The full circuit of the Acoustic Probe appears in Fig. 1, and operates as follows. Since the microphone is a crystal device with high output impedance, it is buffered by the source follower f.e.t. TR1. The output from this goes to amplifier TR2 which, in the configuration shown, provides a voltage gain of about thirty five. The gain is actually set by the ratio of R5 to R6, less a bit for losses, and can be altered if desired by changing the value of R6. Increasing the gain here will raise the circuit noise level a little though.

The output from TR2 is buffered by emitter follower TR3, and then fed, via volume control VR1, to output amplifier IC1. The positive supply for the preamplifier stages of the circuit are decoupled from supply variations by R8 and C1.

The amplifier i.c. is the well-known TBA820M audio chip. This is available in a compact 8-pin d.i.l. package, has ample power

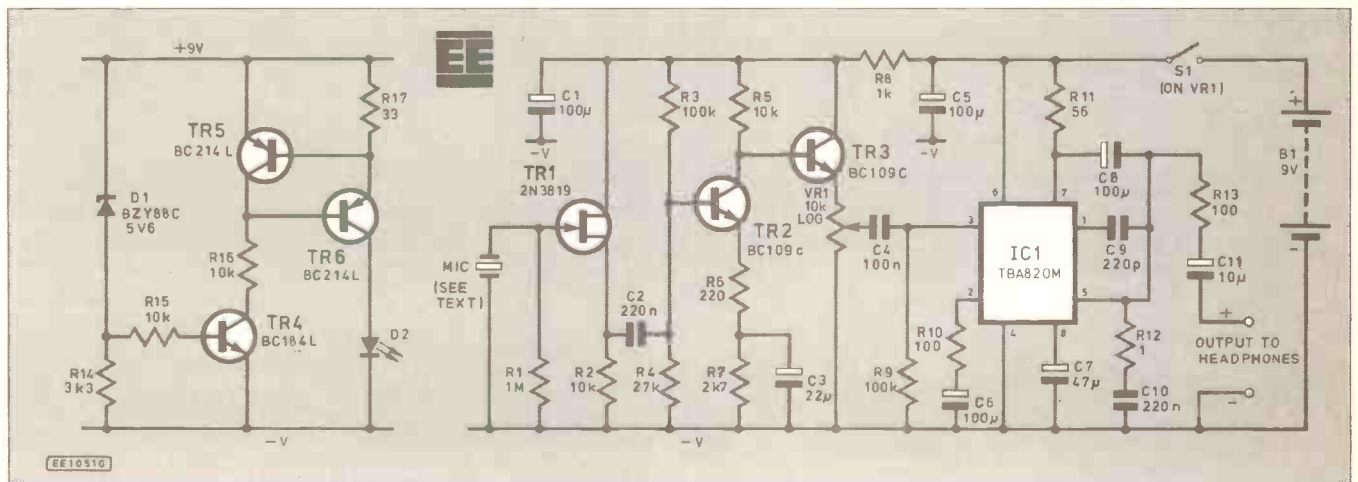

Fig. 1. Complete circuit diagram of the Acoustic Probe.

On one memorable occasion a qualified mechanic identified a noise in the author's car as "big ends" and would have stripped the engine, had a more experienced colleague not chanced to hear it and identify a faulty water pump. To pinpoint such noises, some kind of "stethoscope" is invaluable. Sometimes a skilled mechanic will use a long screwdriver for the purpose, but this is not very satisfactory, and for the amateur not entirely safe. One can get one's ears caught in the fan belt that way!

An electronic "stethoscope", easily built by any electronics enthusiast, is a far better solution. This can easily be applied to any part of the engine, the volume adjusted, and of course full-size padded headphones will help block out some of the general racket in favour of the sound being traced. The accuracy of such a tool can be surprising; in a test with the



COMPONENTS

Resistors

- R1, 1M
- R2, R5, R15, R16 10k (4 off)
- R3, R9 100k (2 off)
- R4 27k
- R6 220
- R7 2k7
- R8 1k
- R10 100
- R11 56
- R12 1
- R13 100 (see text)
- R14 3k3
- R17 33

**Shop
Talk**

See page 617

Potehtiometer

- VR1 10k log carbon with switch (S1)

Capacitors

- C1, C5, C6, C8 100 μ axial elect. 10V (4 off)
- C2, C10 220n polyester layer (2 off)
- C3 22 μ axial elect. 25V
- C4 100n polyester layer
- C7 47 μ axial elect 16V
- C9 220p ceramic plate
- C11 10 μ axial elect. 25V

Semiconductors

- D1 BZY88C5V6 400mW 5.6V Zener diode
- D2 red l.e.d. 3mm type.
- TR1 2N3819 f.e.t.
- TR2, TR3 BC109C silicon *n*p*n* (2 off)
- TR4 BC184L silicon *n*p*n*
- TR5, TR6 BC214L silicon *p*n*p* (2 off)
- IC1 TBA820M i.c. power amplifier

Miscellaneous

Printed circuit board, available from *EE PCB Service*, order code EE584; 8 pin d.i.l. i.c. holder; case, diecast alloy box, 120x65x40mm; PP3 battery and connector; knob; standard stereo jack socket; 27mm piezo transducer element; assorted hardware for transducer — see text; connecting wire, etc.

Approx. cost
Guidance only

£13

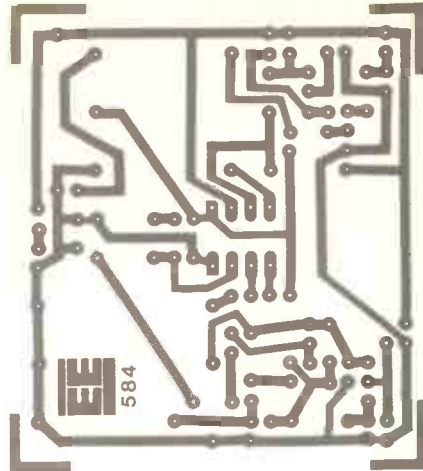
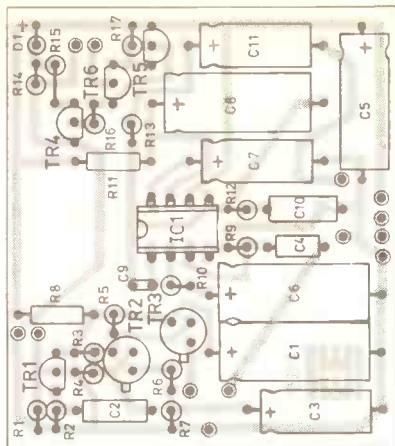

Fig. 2. Printed circuit full size master pattern and component layout

for driving ordinary stereo headphones, and can operate from as little as three volts with a typical quiescent drain of only four milliamps, making it ideal for operation from a single PP3 battery supply. About the only drawback is that its recommended circuit uses rather a lot of electrolytic capacitors, which take up most of the space on the p.c.b.

The voltage gain of this stage is about twenty but it can be adjusted slightly if required, by alteration of R10. To ensure stability the "Zobel" network, R12 and C10, has been included. The value of C11 may seem rather small to readers used to audio work, but it proved perfectly adequate in this design as headphones are the only load and the frequencies of interest are normally quite high. The resulting reduction of output current at low frequencies also helps to maintain stability.

The output is taken to a stereo socket wired so as to connect the two phones in parallel. R13 sets the maximum output, the value shown may need some adjustment to suit the headphones actually used.

An indicator l.e.d. is useful, to show that the unit is switched on and the battery is healthy. This goes a little further than usual in that l.e.d. D2 is supplied with a constant current by TR5 and TR6, which are in turn biased from TR4, which receives base current from Zener D1. So long as the supply voltage is high enough for current flow through D1 and the base-emitter junction of TR4, D2 glows with constant brightness. Once the voltage falls below this

critical point it goes out quite sharply. It will probably flicker with strong input signals when battery replacement is due.

CONSTRUCTION

The construction of this project is straightforward, provided a little care is taken to obtain neat results with the upright mounted resistors. The small printed circuit board is available from the *EE PCB Service*, code EE584 (see page 628).

The positioning of all components can be seen in the overlay drawing, Fig. 2. Take care with the orientation of the transistors, D1 and the electrolytics. C2, C4 and C10 are the small, silver coloured polyester layer type.

Capacitors C2 and C10 may present problems in that there appears to be more than one size of this value; an order recently received contained two with different pin spacings. The p.c.b. has been designed to accept either. Though omitted in the prototype, a d.i.l. socket is strongly recommended for IC1. It can be a great help if any trouble-shooting becomes necessary.

TESTING

The board should, of course, be tested before installation. The total current drain should be about 26mA, of which about 18mA will be taken by the l.e.d. If the supply voltage is gradually reduced, this will extinguish fairly rapidly at about 5 to 5.5V. If the initial current

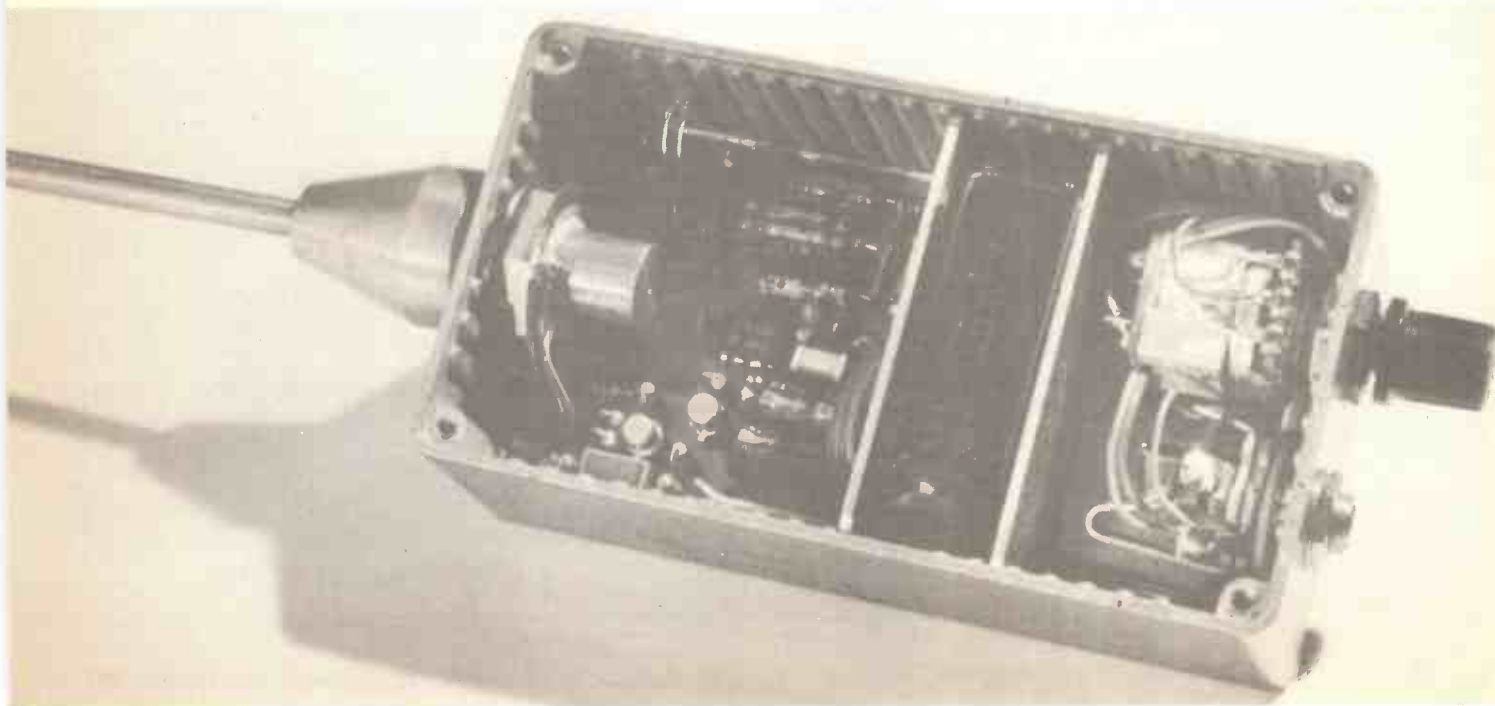

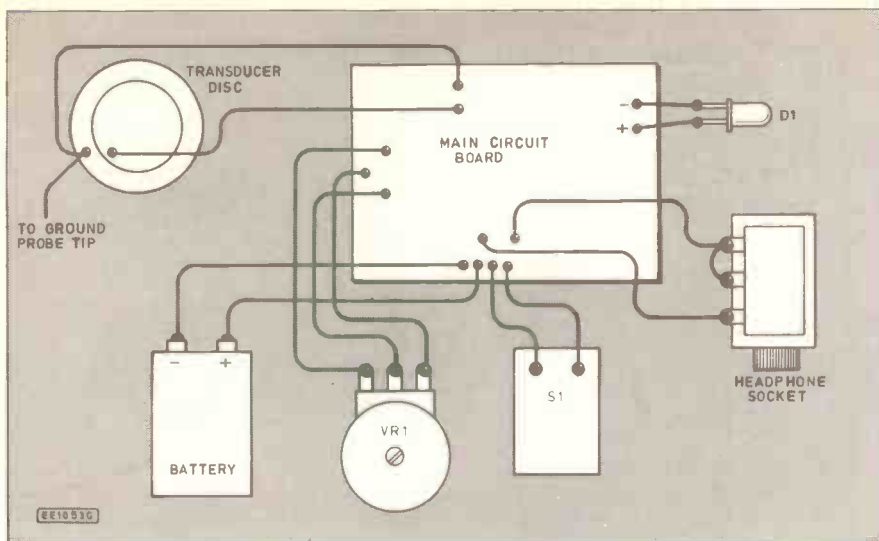

Fig. 3. Interwiring of the case mounted components and the p.c.b. VR1 is shown from the front, S1 is mounted on the back of VR1.

drain seems about right, the headphones and volume control can be temporarily connected and a quick functional check, if satisfactory, will be enough.

This is also a good time to decide whether the value of R13 needs any alteration to suit the headphones to be used. If there seems to be a problem however, some figures which may be useful are as follows; all were taken with exactly nine volts supply. TR1 source voltage will of course depend on the individual f.e.t. as these have a wide production spread, but it should be between 1 and 5 volts. Try another f.e.t. if it is outside these limits. TR2 emitter will be about 1V, this can be measured across C3, the drop across R6 being very small. TR2 collector (its metal case!) should be at about 4.4V, TR3 emitter about 3.8V. The output of IC5 (pin 5) will be about half supply, nominally 4.5V. The voltage across C1, the positive supply for the preamp stages, should be about 8V. These voltages are all intended purely as a guide for trouble-shooting.

CASE

As the circuit has a high input impedance and gain and may be used in areas where a fair amount of electrical interference may be present, a diecast metal case is specified to provide effective screening. The general layout of components in this can be seen from the photograph.

The l.e.d. is soldered directly to the p.c.b. with leads about 25mm long, allowing it to be bent over and pushed straight into a suitable hole drilled in the side of the case. A drop of "Araldite" will secure it firmly.

The board is sited at one end of the box, secured (and insulated) with double-sided sticky foam pad. The switch/volume control and the headphone socket are fitted at the other end, and between them the battery is held in a compartment formed by two small aluminium plates that fit the case slots. Plastic, such as surplus p.c.b. would do just as well. Some plastic foam prevents the battery from rattling.

The wiring passes beneath the foam and plates; ribbon cable is best as it is neat and lies flat. All the interconnections are shown in Fig. 3.

MICROPHONE

The microphone, as mentioned, is special. Any small microphone insert could be used for the job but would probably prove rather delicate. For vibration sensing something rather more robust is needed, so a vibration transducer was made with a "piezo

The head of the bolt needs to be flat and smooth; this could be achieved by rubbing it on emery paper placed on a flat surface. The weight is by no means critical and could be the head off another bolt, or a suitable nut, etc. The assembly can be so rigid in the grommet that it seems almost immobile, yet it is amazing how it will transmit sound from the tip whilst attenuating noise from the case. A "probe" can be attached by drilling a blind hole in the bolt, tapping it and fitting a threaded rod. Several rods of various lengths might prove useful.

Note how the connections are made to the element, they are soldered directly to the disc surface. The earthy (negative rail) wire should go to the side glued to the bolt, and an extra wire from here is tucked between the grommet and the bolt to ensure contact. The metal case should also be grounded; in the prototype this was achieved through the metal jack socket. In the case of an all-plastic socket separate earthing to circuit negative should be provided.

The time taken to construct this transducer is

Fig. 4. Construction details for the "microphone".

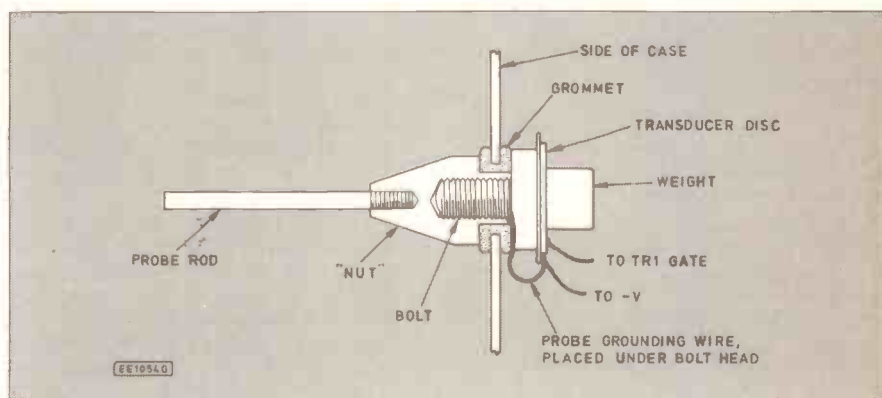

transducer" element, the sort of thing normally used to provide bleeps in calculators, watches, etc. Being essentially crystal transducers these work just as well in reverse, as microphone elements, if properly mounted. A 27mm bare transducer "disc", readily available at very low cost from most major suppliers, was mounted as shown in the drawing of Fig. 4.

Although the prototype has components that were made in a lathe, early experiments used transducers made from bits of brass bolts with methods available in any reasonably equipped home workshop, so construction should not be too difficult. In essence the bolt is screwed down fairly tightly through a grommet fitted into the end of the case, the piezo element has its larger diameter side glued to the head of the bolt with Araldite, and a small weight is glued to the other side to provide something for the vibration to work against.

well worthwhile. It is very sensitive and more robust than anything that could be achieved with a conventional microphone, and the results are excellent. The frequency response spans the complete audio spectrum; when placed against a loudspeaker surprisingly good sound can be heard. It's certainly more than adequate for the intended purpose.

A commercially produced stethoscope similar to this project is available. Constructors might be interested to know that it is priced around £300 . . . ! In fairness, there is a deluxe model with an extra feature — an output jack for tape recording! This, the makers claim, can be used to record the sounds of industrial machinery for replay through a telephone, or for comparison at some time later. Perhaps these days it might also be used for computer analysis; at any rate it would be easy to add the facility to this project □

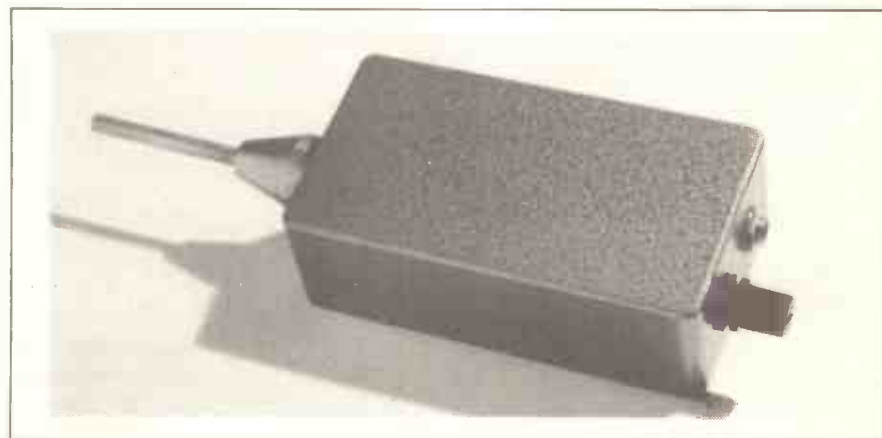

The Archer Z80 SBC

The **SDS ARCHER** – The Z80 based single board computer chosen by professionals and OEM users.

- ★ Top quality board with 4 parallel and 2 serial ports, counter-timers, power-fail interrupt, watchdog timer, EPROM & battery backed RAM.
- ★ **OPTIONS:** on board power supply, smart case, ROMable BASIC, Debug Monitor, wide range of I/O & memory extension cards.

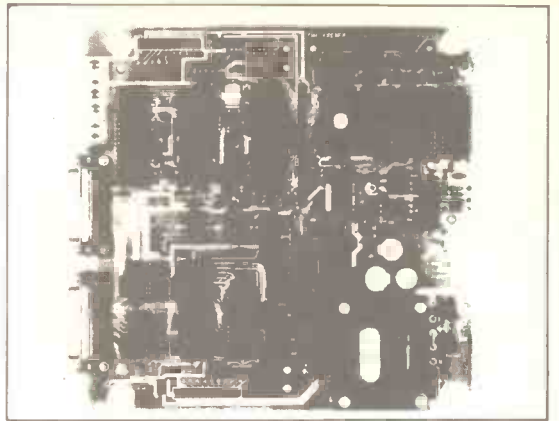

The Bowman 68000 SBC

The **SDS BOWMAN** – The 68000 based single board computer for advanced high speed applications.

- ★ Extended double Eurocard with 2 parallel & 2 serial ports, battery backed CMOS RAM, EPROM, 2 counter-timers, watchdog timer, powerfail interrupt, & an optional zero wait state half megabyte D-RAM.
- ★ Extended width versions with on board power supply and case.



Sherwood Data Systems Ltd

Sherwood House, The Avenue, Farnham Common, Slough SL2 3JX. Tel. 02814-5067

14 DAYS
FREE APPROVAL

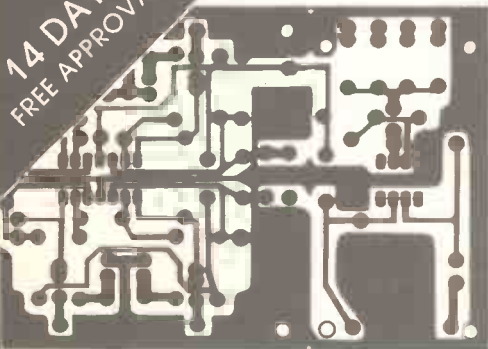

- ▼ Fully programmable with liquid crystal display
- ▼ Count-down, count-up facility with electronic alarm
- ▼ Roll-over facility – indicates time over-run
- ▼ 4 separate count-down time intervals can be stored at any time
- ▼ Pocket clip adapts to bench stand with magnet for attaching to steel cased equipment
- ▼ Battery supplied.

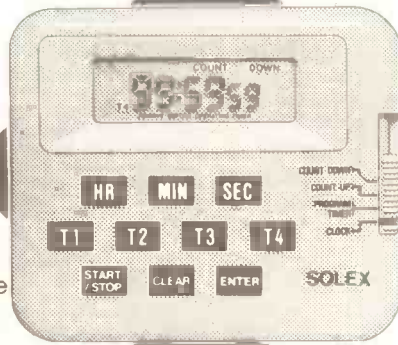

MODEL S540

SOLEX

THE TIME - PRECISELY

THE SOLEX MICROCIRCUIT LABORATORY TIMER

ONLY £14.95
inc. P & P

Special Offer!

Free five function stopwatch worth £10 (inc. VAT) with every timer ordered before 31st December 1987

Send no money – we will send your Solex timer and your free stopwatch on 14 day approval. If not completely satisfied you can return them.

SOLEX INTERNATIONAL
44 Main Street,
Broughton Astley,
Leicestershire
LE9 6RD

PHONE 0455 283486 NOW OR COMPLETE THE COUPON BELOW
Please send me the Solex S540 timer (tick) on approval (tick) payment enclosed (tick) to cover total
I enclose a cheque/PO to the value of
Cost (£14.95 each)

NAME _____
ADDRESS _____
TEL. No. _____

FOR COPIES TO BE DELIVERED ON APPROVAL YOUR TEL. No. AND BILL MUST BE APPROVED

EE1



City and Guilds

INTRODUCING MICROPROCESSORS

MIKE TOOLEY B.A.

MICROCOMPUTER SYSTEMS

Part 1

Last month we briefly outlined the City and Guilds Information Technology scheme and presented the syllabus for Introductory Microprocessors. We also attempted to deal with some of the many questions which readers might have and provided a calendar for the course. In this part we shall be starting in earnest by setting the scene for our nine part course. We begin, however, by stating the learning objectives which relate to this part:

LEARNING OBJECTIVES

The general learning objectives for part one of Introducing Microprocessors is that readers should be able to:

- (a) understand the terminology used to describe microcomputer and microprocessor based systems (1.1)
- (b) identify the major logic families and scale of integration employed within integrated circuits (1.2)
- (c) draw a diagram showing the architecture of a representative microcomputer system and state the function of the principal internal elements (1.3)
- (d) understand binary and hexadecimal number systems and convert from/to decimal (7.1)

(Note: City and Guilds module document reference numbers are shown in brackets.)

The specific objectives for this part are as follows:

1.1 TERMINOLOGY

- 1.1.1 State the meaning of any of the terms listed in the glossary (see note below).
- 1.1.2 Distinguish between the terms; computer, microprocessor, microcomputer, and single-chip microcomputer.

1.2 INTEGRATED CIRCUIT TERMINOLOGY AND LOGIC FAMILIES

- 1.2.1 Define the terms SSI, MSI, LSI and VLSI as applied to integrated circuits.
- 1.2.2 State the characteristics of CMOS

and TTL semiconductor technologies.

- 1.2.3 State the basic properties of CMOS and TTL logic families.

1.3 SYSTEM ARCHITECTURE

- 1.3.1 Draw a block diagram showing the internal architecture of a representative microcomputer system.
- 1.3.2 State the function of each of the principal internal elements of a representative microcomputer system.
- 1.3.3 Explain the bus system used to link the internal elements of a microcomputer system.
- 1.3.4 Distinguish between the following types of bus; address, data and control.

7. RELATED THEORY

- 7.1.1 Explain the binary and hexadecimal number systems.
- 7.1.2 Convert binary, hexadecimal and decimal numbers over the range 0 to 65535 (decimal).
- 7.1.3 Explain how negative numbers are represented in microprocessor systems.
- 7.1.4 Perform addition and subtraction of binary and hexadecimal numbers over the range 0 to 255 (decimal).

Note: The complete glossary appears in Appendix A of the City and Guilds module document. Rather than publish a complete glossary of terms, we shall be producing a mini-glossary for each part; introducing new terms as we progress through the series.

INTEGRATED CIRCUITS

The vast majority of today's electronic

systems rely on the use of integrated circuits in which hundreds of thousands of components are fabricated on a single chip of silicon. A relative measure of the number of individual semiconductor devices within the chip is given by referring to its "scale of integration", as shown below:

Scale of integration	Abbreviation	Logic gate equivalent
Small	SSI	1 to 10
Medium	MSI	10 to 100
Large	LSI	100 to 1000
Very large	VLSI	1000 to 10000
Super large	SLSI	10000 to 100000

The "logic gate equivalent" referred to in the table provides us with a rough measure of the complexity of the integrated circuit and simply gives the equivalent number of standard logic gates. A logic gate is a basic circuit element capable of performing a logical function (such as AND, OR, NAND or NOR). A basic logic gate (e.g. a standard TTL two-input AND) would typically employ the equivalent of six transistors, three diodes and six resistors. At this stage, readers need not worry too much about the function of a logic gate as we shall be returning to this later on. Readers need only be aware that such devices form the basis of circuits which can perform logical decisions.

Integrated circuits are encapsulated in a variety of packages but the most popular type (and that with which most readers will already be familiar) is the plastic dual-

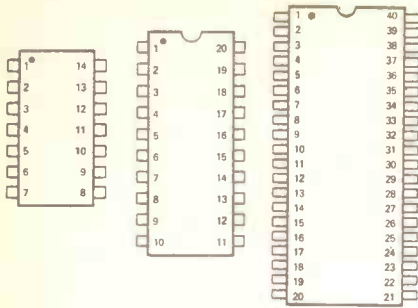

Fig. 1. Some common d.i.l. package outlines (top view).

in-line (d.i.l.) type. These are available with a differing number of pins depending upon the complexity of the integrated circuit in question and, in particular, the need to provide external connections to the device.

Conventional logic gates, for example, are often supplied in 14-pin or 16-pin d.i.l. packages whilst microprocessors (and their more complex support devices) often require 40-pins or more. Fig. 1 shows some common d.i.l. package outlines together with pin numbering. It should be noted that these are TOP views of the devices, i.e. they show how the device appears when viewed from the component side of the p.c.b., NOT from the underside.

In each case, the pins of the i.c. are numbered sequentially (starting at the indentation) moving in an anti-clockwise direction. Thus, in the case of a 14-pin d.i.l. package viewed from the top, pins one and 14 appear respectively on the left- and right-hand side of the indentation.

Problem 1.1

Fig. 2 shows the outline of an 8-pin d.i.l. device viewed from above. Identify the pin numbers for this device.

LOGIC FAMILIES

The integrated circuit devices on which modern digital circuitry depends belong to one or the other of several "logic families". Readers should note this term refers to the type of semiconductor technology employed in the fabrication of the integrated circuit. It does not imply that different families employ different logic!

The semiconductor technology employed in the fabrication of an integrated circuit is instrumental in determining its characteristics. This encompasses such important criteria as

Fig. 2. An 8 pin d.i.l. package.

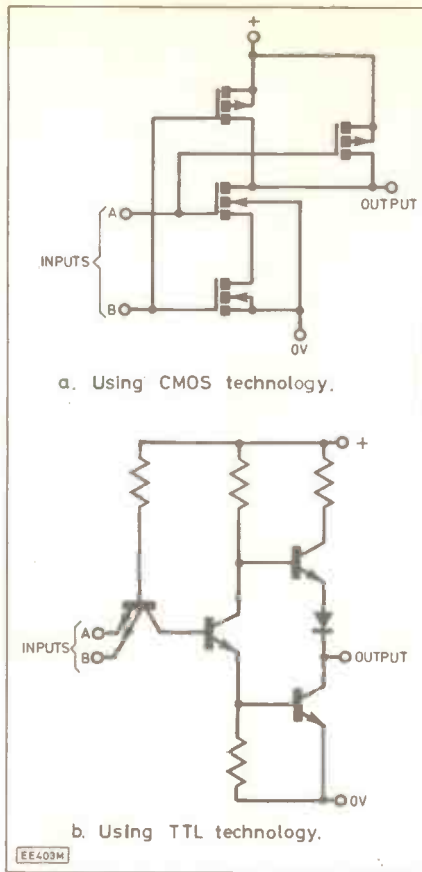
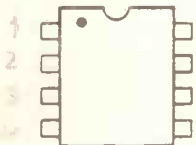

Fig. 3. Representative circuitry of two-input AND gates.

supply voltage, power dissipation, switching speed, and immunity to noise.

The most popular logic families, at least as far as the more basic general purpose devices are concerned, are Complementary Metal Oxide Semiconductor (CMOS) and Transistor Transistor Logic (TTL). TTL also has a number of sub-families including the popular Low Power Schottky (LS-TTL) variants.

For the curious we have shown the internal circuitry of representative CMOS and TTL two-input AND gates in Fig. 3. Despite the obvious dissimilarity of these two arrangements, it must be stressed that they have IDENTICAL logical functions.

TTL logic

The most common range of conventional TTL logic devices is known as the "74" series. These devices are, not surprisingly, distinguished by the prefix number 74 in their coding. Thus devices coded with the numbers 7400, 7408, 7432, and 74121 are all members of this family which is often referred to as "Standard TTL". Other versions (or "sub-families") of standard TTL exist and these are distinguished by appropriate letters placed after the "74" coding. Where "Low Power Schottky" technology is used in the manufacture of a TTL logic gate, for example, device codings include the letters "LS". Thus a 74LS00 device is a Low Power Schottky version of a standard 7400 device.

CMOS logic

The most popular CMOS family is the "4000" series and devices have an initial prefix of 4. Thus 4001, 4174, 4501 and 4574 are all CMOS devices. CMOS devices are sometimes also given a suffix letter; A to denote the "original" (now obsolete) unbuffered series, and B to denote the improved (buffered) series. A UB suffix denotes an unbuffered B-series device.

Problem 1.2

To which logic families do each of the following devices belong?

- (a) 7407
- (b) 74LS74
- (c) 4052

Power supplies

Most TTL and CMOS logic systems are designed to operate from a single supply voltage rail of nominally +5V. With TTL devices, it is important for this voltage to be very closely regulated. Typical TTL i.c. specifications call for regulation of better than $\pm 5\%$ (i.e. the supply voltage should not fall outside the range 4.75V to 5.25V).

CMOS logic devices are fortunately very much more tolerant of their supply voltage than their TTL counterparts. Most CMOS devices will operate from a supply rail of anything between +3V and +15V. This, coupled with a minimal requirement for supply current (a CMOS gate typically requires a supply current of only a few microamps in the quiescent state) makes them eminently suited to portable battery powered equipment.

TTL devices require considerably more supply current than their CMOS equivalents. A typical TTL logic gate requires a supply current of around 8mA; approximately 1000 times that of its CMOS counterpart when operating at a typical switching speed of 10kHz.

Course calendar

October 1987	Course commences in EE
January 1988	Register with your local centre
February 1988	Complete first practical assignment
March 1988	Complete first written assignment
April 1988	Complete second practical assignment
May 1988	Complete third practical assignment
June 1988	Complete fourth practical assessment
July 1988	Complete second written assessment
July 1988	Centre requests issue of certificate

CMOS versus TTL

Having spent some time in discussing the merits of CMOS and TTL devices it is now worth summarising three of the important differences between these logic families in tabular form:

	CMOS	TTL
Speed of operation	Relatively slow (power consumption increases as switching speed increases)	Fast (power consumption substantially constant)
Power consumption	Negligible (but see above)	Appreciable
Supply voltage	Operates over a wide voltage range (typically 3V to 15V)	Must be closely regulated at, or near 5V

Problem 1.3

Which logic family would be most suited for use in a piece of equipment which has to operate over long periods from dry batteries?

MICROPROCESSORS

Having dealt with the basic building blocks of digital circuits we have at last arrived at the point at which we can introduce the microprocessor.

Microprocessors are VLSI and SLSI integrated circuit devices which are capable of accepting, decoding and executing instructions presented to them in binary coded form. Microprocessors thus form the heart of all microcomputer systems in which they act as the central processing unit (CPU). Despite this, the majority of microprocessors are not capable of providing the complete range of facilities expected of a computer (i.e. input, processing, memory and output). Microprocessors require a certain amount of external hardware and other support devices, not the least important of which are those which provide a memory for the sequences of software instructions (i.e. programs) and transient information (i.e. data) used during processing.

Some specialised microprocessors incorporate their own internal memory for data and program storage as well as input/output ports for the connection of external devices such as keyboards and displays. These devices are aptly known as "single-chip microcomputers" and they are ideal for use in low-cost stand-alone control systems.

Microprocessors are often divided into categories depending upon the size of the binary number on which they fundamentally perform operations. Most modern microprocessors perform operations on groups of either eight or 16 binary digits (bits). Whilst 16-bit microprocessors tend to be more powerful than their 8-bit counterparts this is unimportant in many simple applications. Hence, for the purpose of this series and to conform with the City and Guilds programme, we shall concentrate on 8 rather than 16-bit devices.

The first generation of 8-bit microprocessors appeared a little over 14 years ago in the shape of an Intel device,

the 8008. At the time, this was something of a minor miracle – a device which could replace countless other chips and which could address a staggering 16K of memory! By modern standards, the 8008 is extremely crude but it was not long before Intel introduced another device, the 8080. This time NMOS technology was employed instead of the PMOS technology which was used in the 8008. The 8080 had 16 address lines (thus being able to address 64K of memory) and 78 software instructions for the programmer to use. The 8080 was an instant success and led the way to enhanced devices such as the 8085 and the "all-singing-all-dancing" Z80.

Other manufacturers were also developing microprocessor chips hard on the heels of Intel. These included Motorola (with the 6800) and MOS Technology (with the 6502). In subsequent years industry has not been content to stand still and much effort has been devoted into huge advances into 16 and 32-bit technology. Despite this, all of these simple 8-bit microprocessors (and their various enhancements and derivatives) are still in common use today.

Costs have fallen very significantly and it is eminently possible to put together a microprocessor system (comprising CPU and a handful of support chips) at a very moderate cost. Hence, if one had the task of designing, for example, a simple control system, one would almost certainly use a microprocessor (or single-chip microcomputer) to form the basis of the controller.

Such a system would not only be capable of fulfilling all of the functions of its conventional counterpart but it would also provide a far more sophisticated means of processing our data coupled with the ability to store it and examine it at a later date or even transmit it to a remote supervisory computer installation. The vast saving in hardware development can usefully be devoted to the software aspects of a project and future modifications can simply involve the substitution of "firmware" (ROM based software).

BITS, BYTES and BUSES

An 8-bit microprocessor fetches and outputs data in groups of 8-bits (known

as "bytes"). This data is moved around on eight separate lines (labelled D0 to D7) which collectively form a "data bus". For the curious, the word "bus" is a contraction of the Greek word "omnibus" which simply means "to all", thus aptly describing the concept of a system of wiring which links together all of the components of a microprocessor system using a common set of shared lines.

Microprocessors determine the source of data (when it is being "read") and the destination of data (when it is being "written") by outputting the location of the data in the form of a unique "address". This process involves placing a binary pattern on an "address bus". In the case of 8-bit microprocessors, the address bus invariably comprises 16 separate lines, labelled A0 to A15.

The address at which the data is to be placed or from which it is to be fetched can either constitute part of the "memory" of the system (i.e. RAM or ROM) or can be considered to be "input/output" (I/O). The allocation of the 64K memory address range of an 8-bit microprocessor can usefully be described using a "memory map". We shall discuss this in greater detail in Part Five.

A further bus is used for a variety of general housekeeping functions such as determining the direction of data movement (i.e. whether a "read" or "write" operation is being performed), and placing the machine in an orderly state on power-up. This bus is known as the "control bus" and often has between five and 13 lines depending upon the microprocessor.

SYSTEM ARCHITECTURE

We have already identified the principal elements within a microprocessor system as CPU (i.e. the microprocessor), RAM, ROM, and I/O. Before showing how they are interconnected within a typical microprocessor system, it is worth briefly restating the function of each:

Central processing unit (CPU)

The central processing unit in a microcomputer is a single VLSI device, the microprocessor. This device accepts instructions and data for processing. It also provides control and synchronising information for the rest of the system. We shall look more closely at the function of the microprocessor in Part Two.

Random access memory (RAM)

All microprocessors require access to read/write memory and, whilst single-chip microcomputers contain their own low-capacity area of read/write memory, read/write memory is invariably provided by a number of semiconductor random access memories (RAM). These will be explained in Part Five.

Read-only memory (ROM)

Microprocessors generally also require more permanent storage for their control programs and, where appropriate, operating systems and high-level language interpreters. This facility is

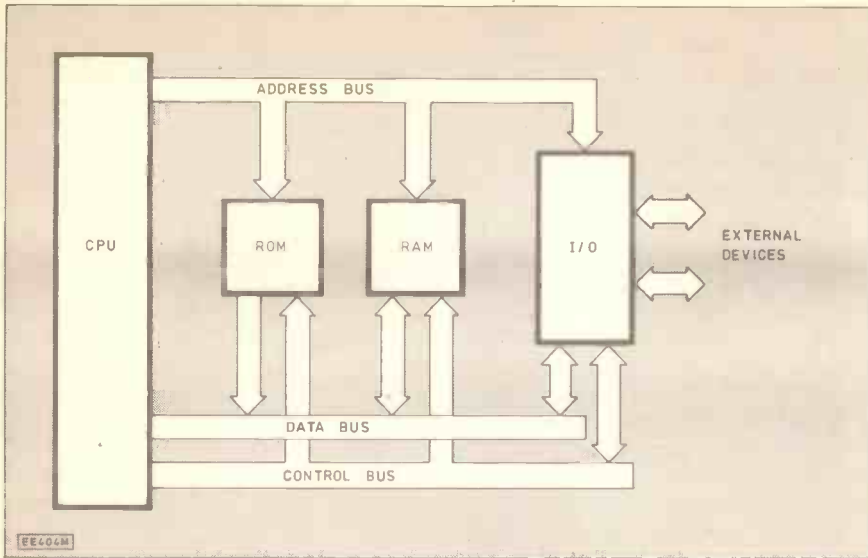

Fig. 4. Principal elements of a microprocessor system.

invariably provided by means of semiconductor read-only memories (ROM). These will also be examined in Part Five.

Input/output devices (I/O)

To fulfill any useful function, the microprocessor needs to have links with the outside world. These are usually supplied by means of one, or more, VLSI devices which may be configured under software control and are thus said to be "programmable". I/O devices fall into two general categories; "parallel" (a byte is transferred at a time) or "serial" (one byte is transferred after another along a single line). I/O devices will be dealt with in Part Six.

The basic configuration of a microprocessor system is shown in Fig. 4, the principal elements; microprocessor, ROM, RAM, and I/O have been shown. Note that the three bus systems; address, data, and control are used to link the elements and thus an essential requirement of a support device is that it should have "tri-state" outputs. It can thus be disconnected from the bus when it is not required.

Support devices (such as ROM, RAM, etc.) are fitted with select or enable inputs. These lines are usually driven by address decoding logic (not shown in Fig. 4). The inputs of the address decoding logic are derived from one, or more, of the address bus lines. The address decoder effectively divides the available memory into blocks which each correspond to a particular support device. Hence, where the processor is reading and writing to RAM, for example, the address decoding logic will ensure that only the RAM is selected and the internal buffers in the ROM and I/O chips are kept in the tri-state output condition.

Problem 1.4

The diagram shown in Fig. 5 represents a microprocessor system. Compare this diagram with that shown in Fig. 4 and hence label the diagram fully.

NUMBER SYSTEMS

Unfortunately, the decimal or denary

number system with which we are all very familiar, is not at all appropriate to microcomputers. The reason is simply that electronic logic circuits are based on devices which have only two states (variously known as "on/off", "high/low", and "true/false"). The number system most appropriate is therefore binary in which only two digits (0 and 1) are used. Powers of two are shown in Table 1.

Table 1 Powers of two

n	2 ⁿ
0	1
1	2
2	4
3	8
4	16
5	32
6	64
7	128
8	256
9	512
10	1024
11	2048
12	4096
13	8192
14	16384
15	32768

The process of converting binary to decimal and decimal to binary is quite straightforward. The binary number 101, for example, can be converted to denary as follows:

$$\begin{array}{r}
 2^2 = 4 \quad 2^1 = 2 \quad 2^0 = 1 \\
 \hline
 1 \quad 0 \quad 1 \\
 \hline
 \rightarrow 4 \\
 \rightarrow + 0 \\
 \rightarrow + 1 \\
 \hline
 5
 \end{array}$$

Now, taking a somewhat more difficult example, let's convert the binary number 11001010 to denary. We shall again write the number using column headings but this time we shall simply ignore the zeros in our addition:

$$\begin{array}{r}
 2^7 = 128 \quad 2^6 = 64 \quad 2^5 = 32 \\
 \hline
 1 \quad 1 \quad 0 \\
 \hline
 \rightarrow 128 \\
 \rightarrow + 64 \\
 \rightarrow + 8 \\
 \hline
 2^4 = 16 \quad 2^3 = 8 \quad 2^2 = 4 \\
 \hline
 \rightarrow + 2 \\
 \hline
 2^1 = 2 \quad 2^0 = 1 \\
 \hline
 202
 \end{array}$$

There are two basic methods for converting decimal to binary. One involves taking the decimal number and subtracting from it successively smaller numbers which are themselves powers of two. Where a power of two can be subtracted (to leave zero or a remainder), a 1 is placed in the appropriate column of the binary number. This all sounds very much more difficult than it really is, so here is a simple example to illustrate the process.

Suppose that we wish to convert the decimal number 21 to binary. The highest power of two which can be taken away from 21 is 2⁴ (= 16). This leaves a remainder of 21 - 16 = 5. 2³ (= 8) cannot be subtracted from the remainder but 2² can to leave a remainder of 5 - 4 = 1. 2⁰

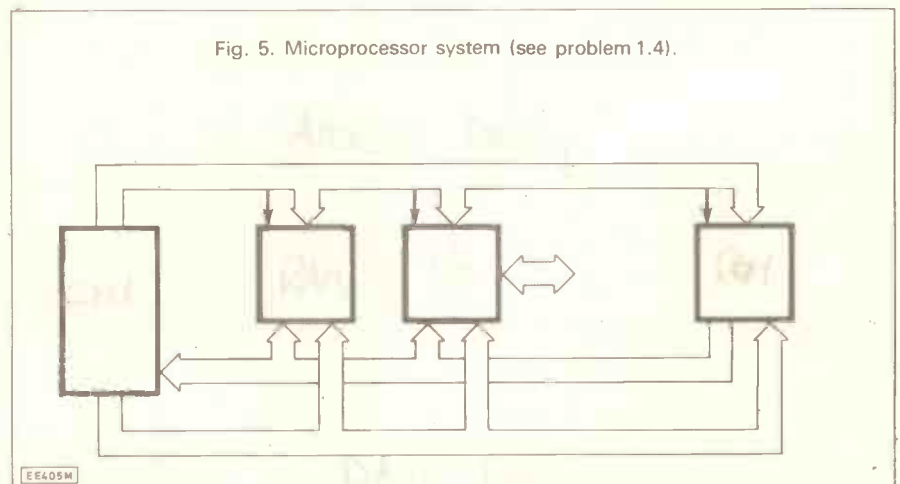

Fig. 5. Microprocessor system (see problem 1.4).

(= 1) can now be subtracted from the second remainder to leave zero. Another way of putting this is that;

$$21 = 16 + 4 + 1 = 2^4 + 2^2 + 2^0$$

We can write this as a binary number by placing 1s and 0s in columns, as follows:

$$\begin{array}{r} 2^4 \quad 2^3 \quad 2^2 \quad 2^1 \quad 2^0 \\ \hline 1 \quad 0 \quad 1 \quad 0 \quad 1 \end{array}$$

The second method involves successively dividing the decimal number by two and noting down the remainder at each stage. The binary number is then formed by reading the remainders as shown in the example below (note that the least significant remainder becomes the most significant bit of the binary number!).

Suppose we wish to convert the decimal number 50 to binary.

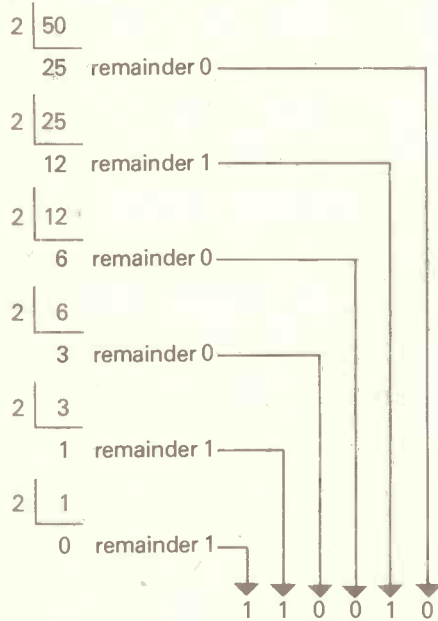

Hence 50 decimal is equal to 110010 binary

Table 2 Decimal, binary and hexadecimal numbers

Decimal	Binary	Hexadecimal
0	0000	0
1	0001	1
2	0010	2
3	0011	3
4	0100	4
5	0101	5
6	0110	6
7	0111	7
8	1000	8
9	1001	9
10	1010	A
11	1011	B
12	1100	C
13	1101	D
14	1110	E
15	1111	F

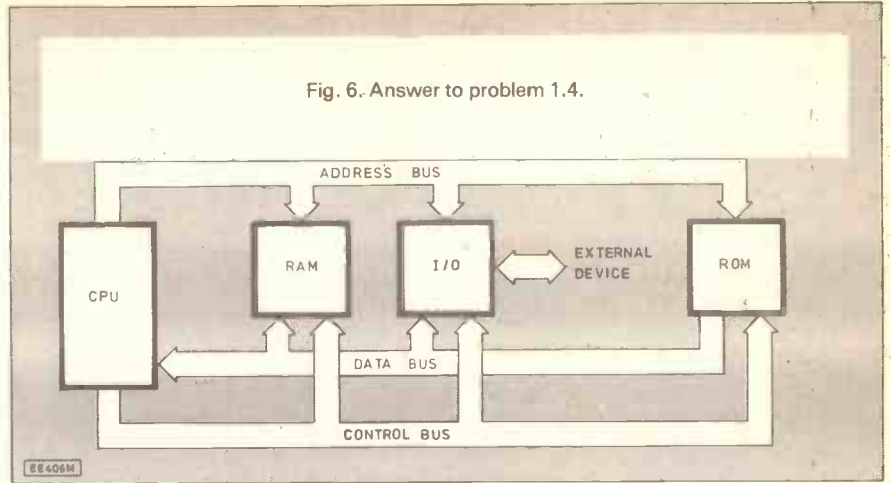

Which of the two methods you employ is entirely a matter of preference. If you can easily spot the powers of two present in a decimal number it is probably best to use the first method. If, on the other hand, you are uncertain as to which powers of two make up a number it is best to use the longer method. Remember that, in both cases, you can always convert back to denary in order to check your results!

Problem 1.5

Convert the following binary numbers to decimal:

- (a) 1011
- (b) 100110
- (c) 11100111

Problem 1.6

Convert the following denary numbers to binary:

- (a) 33
- (b) 100
- (c) 213

Hexadecimal

The binary number system is somewhat tedious for human use since numbers of any appreciable size are rather difficult to handle. For this reason we settle on the hexadecimal (base 16) number system. This has the advantage that it is relatively simple to convert from hexadecimal to binary and the hexadecimal numbers which can appear on an 8-bit data bus can be represented using just two digits (rather than the eight binary digits which would otherwise be necessary).

Since the hexadecimal numbering system employs more than 10 digits we have to make use of the first six letters of the alphabet to represent those equivalent to the denary numbers 10 to 15. Hexadecimal digits thus range from 0 to F as shown below left.

Numbers in excess of fifteen will, of course, require more than one hexadecimal digit. Suppose, for example, we wish to convert the hexadecimal number 2A to decimal. Using a similar technique to that which we employed



Address

Readers requiring their own copy of the module documentation should write to the following address, clearly stating "Everyday Electronics - Introductory Microprocessors" and enclosing a cheque or P.O. for £10 made payable to City and Guilds (do not forget to include your name and address!): Publications Department, City and Guilds, 76 Portland Place, London W1N 4AA.

Comments and queries from readers should be sent directly to the author at the following address: Department of Technology, Brooklands Technical College, Heath Road, Weybridge, Surrey KT13 8TT.

Please include a stamped addressed envelope if you require an individual reply. General queries will be dealt with in Readers' Forum which will appear in parts four and nine of the series.

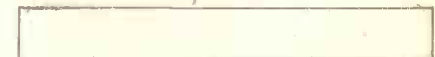

answer, it is always permissible to convert the numbers to denary in order to check the validity of a result. In the foregoing example we have the equivalent denary calculation; $13 - 6 = 7!$)

Subtraction of hexadecimal numbers again follows the same pattern. Suppose we have to find the difference of the hexadecimal numbers 2F and 1A:

$$\begin{array}{r} 2 \text{ F} \\ - 1 \text{ A} \\ \hline \text{Borrow } 0 \text{ 0} \\ 1 \text{ 5} \end{array}$$

(Note that subtracting A from F leaves 5) Hence, the result of subtracting 1A hexadecimal from 2F hexadecimal is 15 hexadecimal.

Now let's try something a little more difficult by subtracting hexadecimal 14 from hexadecimal 23:

$$\begin{array}{r} 2 \text{ 3} \\ - 1 \text{ 4} \\ \hline \text{Borrow } 1 \text{ 0} \\ 0 \text{ F} \end{array}$$

Hence, the result of subtracting the hexadecimal number 14 from the hexadecimal number 23 is 0F.

Problem 1.12

Subtract;

- (a) the binary number 01001101 from the binary number 11000101
- (b) the hexadecimal number 3C from the hexadecimal number F0

NEGATIVE NUMBERS

Thus far we have confined ourselves to positive numbers and many of you will be wondering how we go about representing negative numbers within a computer. One rather obvious method is that of using the first (most significant) bit of a number solely to indicate its sign (i.e. whether it is positive or negative). The convention used is that a 0 in the most significant bit (MSB) position indicates that the number is positive. An MSB of 1, on the other hand, indicates that the number is negative. The magnitude of the number is then given by the remaining bits. We refer to such a number as being "signed".

As an example the signed eight-bit binary number 01111111 represents the decimal number 127 (it is positive as the MSB is 0) whereas the signed binary number 11111111 represents the decimal number -127 (the MSB is 1 and therefore the number is negative).

Problem 1.13

Convert the following signed binary numbers to decimal:

- (a) 01000000
- (b) 11000000
- (c) 10001001

Problem 1.14

Convert the following decimal numbers to signed 8-bit binary:

- (a) +5
- (b) -99
- (c) +99

One's and two's complement

The one's complement of a binary number is found by simply changing all of the 0s present to 1s and changing all of the 1s present to 0s. This process is called "inversion". The one's complement of the binary number 1010 is thus 0101. Note that the result of adding a number to its one's complement will produce a succession of 1s, as shown in the following example:

$$\begin{array}{r} \text{Binary number} \quad 1 \ 0 \ 1 \ 0 \ 1 \ 1 \ 0 \ 0 \\ \text{One's complement} \ 0 \ 1 \ 0 \ 1 \ 0 \ 0 \ 1 \ 1 \\ \hline \text{Sum} \quad \quad \quad 1 \ 1 \ 1 \ 1 \ 1 \ 1 \ 1 \ 1 \end{array}$$

The two's complement of a binary number is found by simply adding 1 to its one's complement. Hence, the two's complement of 1010 is 0110 (i.e. $0101 + 0001$).

The result of adding a binary number to its two's complement is not a succession of 1s but a succession of 0s with a leading 1 in the next more significant bit position. This is demonstrated by the following example:

$$\begin{array}{r} \text{Binary number} \quad 1 \ 0 \ 0 \ 0 \ 1 \ 0 \ 1 \ 1 \\ \text{One's complement} \ 0 \ 1 \ 1 \ 1 \ 0 \ 1 \ 0 \ 0 \\ \text{Two's complement} \ 0 \ 1 \ 1 \ 1 \ 0 \ 1 \ 0 \ 1 \\ \hline \text{added } 1 \\ \hline \text{Original number} \quad 1 \ 0 \ 0 \ 0 \ 1 \ 0 \ 1 \ 1 \\ \text{Two's complement} \ + \ 0 \ 1 \ 1 \ 1 \ 0 \ 1 \ 0 \ 1 \\ \hline \text{Sum} \quad \quad \quad 1 \ 0 \ 0 \ 0 \ 0 \ 0 \ 0 \ 0 \end{array}$$

Problem 1.15

Find the one's and two's complements of each of the following:

- (a) 1001
- (b) 10110011
- (c) 10001110

Readers can be excused for wondering what all this is leading up to! It actually yields a very neat method for performing subtraction. We simply form the two's complement of the number to be subtracted (the subtrahend) and ADD it to the first number (the minuend). Any leading 1 generated is ignored. To show how this works consider the following

example which subtracts the binary number 00110110 from the binary number 10010101:

$$\begin{array}{r} \text{Subtrahend} \quad \quad 0 \ 0 \ 1 \ 1 \ 0 \ 1 \ 1 \ 0 \\ \text{One's complement} \ 1 \ 1 \ 0 \ 0 \ 1 \ 0 \ 0 \ 1 \\ \text{Two's complement} \ 1 \ 1 \ 0 \ 0 \ 1 \ 0 \ 1 \ 0 \\ \hline \text{Minuend} \quad \quad \quad 1 \ 0 \ 0 \ 1 \ 0 \ 1 \ 0 \ 1 \\ \text{Two's complement} \ + \ 1 \ 1 \ 0 \ 0 \ 1 \ 0 \ 1 \ 0 \\ \hline \text{of subtrahend} \quad \quad 1 \ 0 \ 1 \ 0 \ 1 \ 1 \ 1 \ 1 \end{array}$$

Ignoring the leading 1 gives a result of 01011111.

It is usually much easier to use two's complements to perform subtraction than to use conventional subtraction (using borrow). Readers can easily check the validity of this statement by performing the foregoing example using conventional techniques!

Problem 1.16

Use the two's complement to subtract the binary number 00011001 from the binary number 11010100.

REPRESENTING NUMBER BASES

Thus far we have been quite explicit in stating (rather longwindedly!) the number base which we have been working in. Methods commonly used to indicate the base include:

- (a) using a suffix to indicate the base e.g. 101000_2 is a number having base 2 (i.e. binary)
- 127_{10} is a number having base 10 (i.e. denary)
- 76_{16} is a number having base 16 (i.e. Hexadecimal)
- (b) adding a trailing H to indicate that a number is hexadecimal e.g. 9FH, C9H and FFH are all hexadecimal
- (c) adding a leading \$ to indicate that a number is hexadecimal e.g. \$2A is the same as 2AH which is the same as 2A

Problem 1.17

Determine the denary equivalent of each of the following:

- (a) 10_2
- (b) 10_2^{10}
- (c) $\$10$

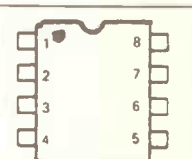

Fig. 6.

ANSWERS TO PROBLEMS

- 1.1 See Fig. 6.
- 1.2 (a) standard TTL (b) low-power Schottky (c) CMOS
- 1.3 CMOS (reasons are wide supply voltage range and very low current requirements)
- 1.4 See Fig. 7.
- 1.5 (a) 11 (b) 38 (c) 231
- 1.6 (a) 100001 (b) 1100100 (c) 11010101
- 1.7 (a) 1B (b) 1FF (c) 1004
- 1.8 (a) 190 (b) 267 (c) 49152
- 1.9 (a) B (b) AF (c) ABCD
- 1.10 (a) 111111 (b) 1000111010 (c) 1000000100101100
- 1.11 (a) 11010100 (b) CD
- 1.12 (a) 1111000 (b) B4
- 1.13 (a) +64 (b) -64 (c) -9
- 1.14 (a) 40000101 * (b) 11100011 (c) 01100011
- 1.15 (a) 0110 and 0111 (b) 01001100 and 01001101 (c) 01110001 and 01110010
- 1.16 10111011
- 1.17 (a) 2 (b) 10 (c) 16

disregard MSB -> see Jan. 88 issue.

NEXT MONTH: We shall be taking a look at the internal features and architecture of some common microprocessors.

BACKGROUND READING

The following background reading is suggested for this month:

(a) Chapter Two (The Microcomputer) of **Beginner's guide to Microprocessors** by E.A. Parr (a Newnes Technical Book published by Heinemann-Newnes) ISBN 0 408 00579 3. Available from the *EE Book Service* - see page 626.

(b) Chapter One (Numbering Systems) of **Microelectronic Systems 2 Checkbook** by R. Vears (published by William Heinemann Ltd) ISBN 0 434 92194 7. Available from the *EE Book Service* - see page 626.

CORRESPONDENCE

Comments and queries from readers should be sent directly to the author at the following address:

Department of Technology, Brooklands Technical College, Heath Road, Weybridge, Surrey KT13 8TT.

Please include a stamped addressed envelope (and be prepared to wait a little!) if you require an individual reply. General queries will be dealt with in "Readers' Forum" which will appear in Parts 4 & 9.

GLOSSARY FOR PART ONE

Address

A number which indicates the position of a word in memory. Addresses typically comprise 16 bits and therefore can range from 0 to 65535.¹⁰

Address bus

A set of lines (usually 16) used to transmit addresses, usually from the microprocessor to a memory or I/O device.

Address decoding

The process of selecting a specific address or range of addresses to enable unique support devices.

Binary

A system of numbers using base 2. Binary numbers thus use only two characters; 0 and 1.

Bit

A contraction of binary digit. A single digit in a binary number.

Bus

A path for signals having some common function. Most microprocessor systems have three buses; an address bus, data bus and control bus.

Byte

A group of eight bits.

Central Processing Unit

The part of a computer that decodes instructions and controls the other hardware elements of the system. The CPU comprises a control unit, arithmetic/logic unit and internal storage.

Chip

The term commonly used to describe an integrated circuit.

Complement

The process of changing a 1 to a 0 and vice versa.

Control Bus

The set of control signal lines in a computer system. The control bus provides the synchronisation and control information to operate the system.

CMOS

Complementary metal oxide semiconductor. A family of integrated circuit devices based on unipolar field effect devices.

The following companies specialise in the supply of electronics for educational purposes. Many of them can supply microprocessor learning systems or interfaces, etc.

UNILAB Clarendon Road, Blackburn BB19 7TA. (0254) 57643

ECONOMATICS (EDUCATION) LTD. Epic House, 9 Orgreave Road, Sheffield S13 9LQ. (0742) 690801

MICROMON Pont y Cerrig, Pentraeth, Gwynedd LL75 8RZ.

A.M. LOCK & CO. LTD. Neville Street, Oldham OL9 6LF.

(061-624) 0333

MAGENTA ELECTRONICS LTD. 135 Hunter Street, Burton on Trent, Staffs DE14 2ST. (0283) 65435

P.K.G. ELECTRONICS Orchard House, Tansley, Derbyshire DE4 5FE. (0629) 3206

RCS MICROSYSTEMS 141 Uxbridge Road, Hampton Hill, Middlesex.

L.J. Francis Way, Bowthorpe Industrial Estate, Norwich NR5 9JA.

(0603) 748001

TECHNOLOGY TEACHING SYSTEMS LTD. Penmore House, Hasland Road, Hasland, Chesterfield S41 0SJ. (0246) 78993

FLIGHT ELECTRONICS LTD. Flight House, Ascupart Street, Southampton, Hants SO1 1LU.

(0703) 227721

EDUCATIONAL ELECTRONICS LTD. 28 Lake Street, Leighton Buzzard, Beds LU7 8RX.

(0525) 373666

OMEGA ELECTRONICS 12 Oxhill road, Middle Tysoe, Warwicks CV35 0SX. (029-588) 455

PILOT ONE Campbell Road, Bedford MK40 3DD (0234) 327688

DATAMAN Lombard House, Cornwall Road, Dorchester, Dorset DT1 1RX. (0305) 68066

ELECTROMAIL PO Box 33, Corby, Northants NN17 9EL. (0536) 204555

MAPLIN ELECTRONIC SUPPLIES LTD. PO Box 3, Rayleigh, Essex SS6 8LR. (0702) 552911

FEEDBACK INSTRUMENTS LTD. Park Road, Crowborough, East Sussex. (08926) 3322

TAIT COMPONENTS LTD. 20 Cowper Street, Glasgow G4 0BL. (041-552) 5043

CLWYD TECHNICS LTD. Antelope Industrial Estate, Rhydymwyn, Mold, Clwyd CH7 5JH.

PHILIP HARRIS LTD. Lynn Lane, Shenstone, Lichfield, Staffordshire WS14 0EE.

(0543) 480077

Data

General term used to describe numbers, letters and symbols present within a computer during processing.

Data Bus

The set of electrical conductors which carries data between the different elements of a computer system.

Digital

A system which only allows discrete states. Most digital logic uses only two states (on/off, low/high or 0/1).

Firmware

A program (software) stored in read-only memory.

Hardware

The physical components of a computer system.

Hexadecimal

A number system with base 16. The first six letters of the alphabet (A to F) are used to represent the hexadecimal equivalents of the denary numbers 10 to 16.

Input/output

Lines or devices used to transfer information outside the computer system.

Input port

A circuit that connects signals from external devices as inputs to a microcomputer system.

Integrated circuit

An electronic circuit fabricated on a single wafer (chip) and packaged as a single component.

Memory

That part of a computer system into which information can be placed and held for future use. Storage and memory are interchangeable terms. Digital memories accept and hold binary numbers only. Common types of memory are magnetic disc, magnetic tape, and semiconductor (which includes RAM and ROM).

Microcomputer

A small computer based upon a microprocessor CPU. Backing storage is usually provided by magnetic disc or tape; input is provided by means of a keyboard and output by a VDU.

Microprocessor

A central processing unit fabricated on one or two chips. The processor contains an arithmetic logic unit (ALU), control block and registers.

One's complement

The inverse of a binary number which is formed by changing all 0s to 1s and vice versa.

Output port

A circuit that allows a microprocessor system to output signals to other devices.

Peripheral

Any device that is connected to a computer whose activity is under the control of the

central processing unit.

Program

A procedure for solving a problem coded into a form suitable for use by a computer and frequently described as software.

RAM (random access memory)

Usually used to mean semiconductor read/write memory. Strictly speaking, ROM devices are also random access!

Random access

An access method in which each word can be retrieved in the same amount of time (i.e. the storage locations can be accessed in any desired order).

Read

The process of transferring information from memory or I/O into a register in the central processor.

Register

A single word of memory. The CPU contains a number of registers for temporary storage of data.

ROM (read-only memory)

A permanently programmed memory. Mask-programmed ROMs are programmed by the chip manufacturer. PROMs (programmable ROM devices) can be programmed by the user. EPROMs (erasable PROM devices) can be erased under ultraviolet light before reprogramming.

TTL (transistor transistor logic)

Transistor transistor logic. A family of integrated circuit devices based on conventional bipolar transistors.

Two's complement numbers

A number system used to represent both positive and negative numbers. The positive numbers in two's complement representation are identical to the positive numbers in standard binary, however the two's complement representation of a negative number is the complement of the absolute binary value plus 1. Note that the most significant bit (usually the eighth) indicates the sign; 0 = positive, 1 = negative).

Visual display unit (VDU)

A VDU is an output device (usually based on a cathode ray tube) on which text and/or graphics can be displayed. A VDU is normally used in conjunction with an integral keyboard when it is sometimes referred to as a console.

Word

A set of characters that occupies one storage location in memory and is treated by the computer as a unit. Program instructions and program data both have the same word length (equal to 8-bits or 1-byte in the case of 8-bit microprocessors).

Write

The process of transferring information from a register within the central processor to memory or I/O.

exploring electronics

OWEN BISHOP

This series is designed to explain the workings of electronic components and circuits by involving the reader in experimenting with them. There will not be masses of theory or formulae but straightforward explanations and circuits to build and experiment with.

Part 17 Counting Circuits

This month we investigate the J-K flip-flop, another useful circuit that can be obtained ready-built as the 7473 i.c. which contains two such circuits. The J-K flip-flop consists of a number of inter-connected logic gates and has three inputs:

Clock – the flip-flop is triggered to act whenever the input to this terminal changes from high to low (but *not* when it changes from low to high).

J & K – these control what happens when the flip-flop is triggered, as you will find out below. Some J-K flip-flops, including this version, also have a "Clear" input.

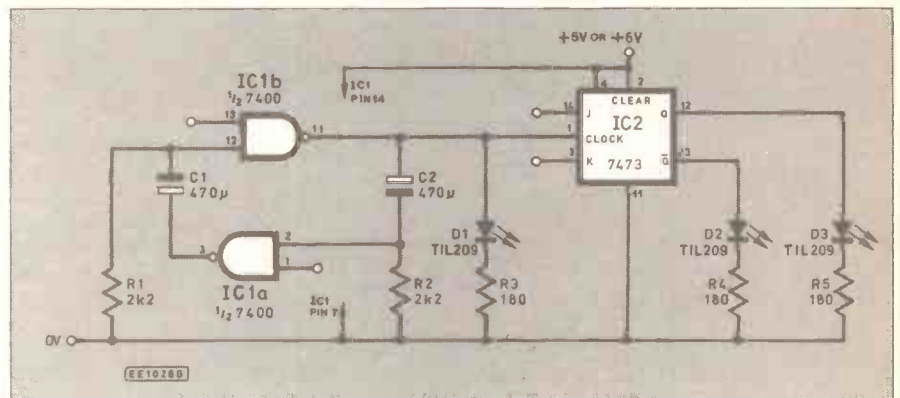

Fig. 17.1. Circuit diagram using a slow oscillator to drive a J-K Flip-Flop.

INVESTIGATION ONE

We start our investigations by using an oscillator to drive our J-K flip-flop i.c. In the circuit diagram Fig. 17.1 we have a slow oscillator made from a 7400 i.c. (see last month's instalment) to provide the input to the "Clock", pin 1.

The demonstration breadboard component layout is shown in Fig. 17.2. Be sure to connect the l.e.d.s and electrolytic capacitors the right way round.

If you prefer, the oscillator can be based on the 555 timer i.c. as described in Part 10, April '87 issue. The circuit

Fig. 17.2. Demonstration component layout for the J-K Flip-Flop.

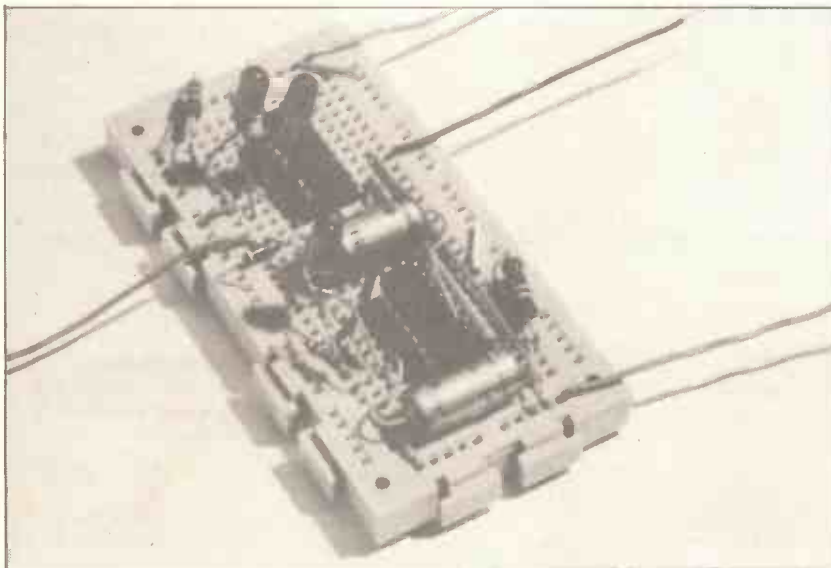
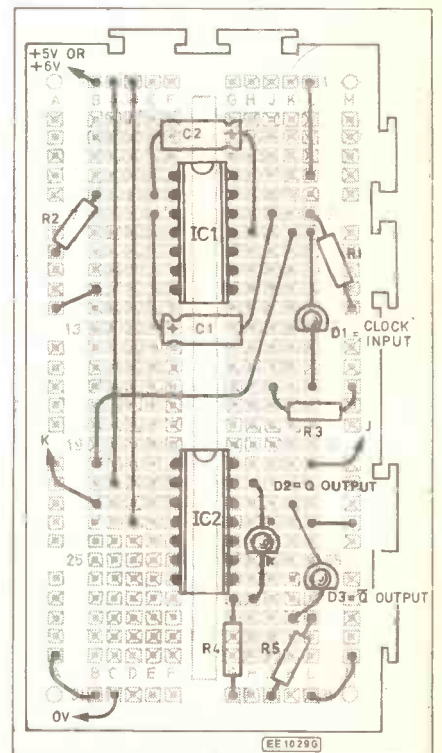

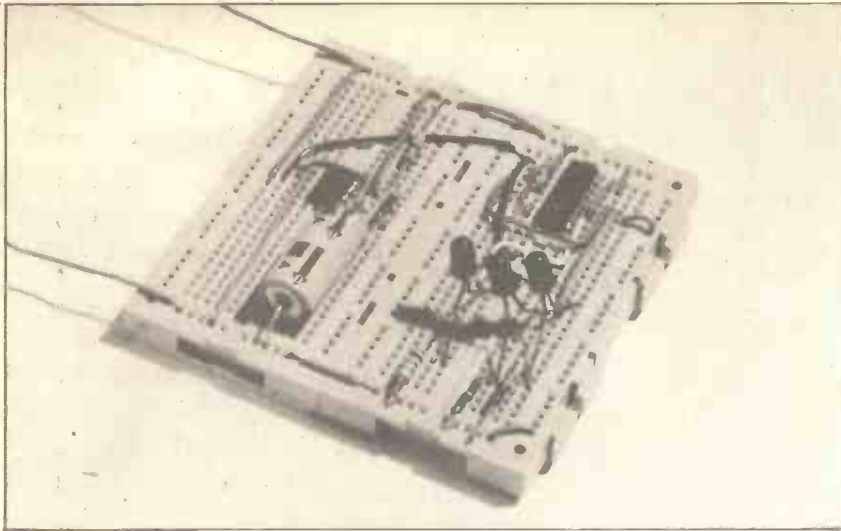

Resistors

R1, R2 2k2 (2 off)
R3-R5 180 (3 off)
All 0.25W 5% carbon

Capacitors

C1, C2 470 μ electrolytic (2 off)

Semiconductors

D1-D3 TIL 209 or similar
I.e.d. (3 off)
IC1 7400 quad 2-input
NAND gate
IC2 7473 dual J-K
flip-flop

Miscellaneous

Breadboard (e.g. Verobloc);
connecting wire and 5V to 6V supply.

OBJECT COUNTER

**Shop
Talk**
See page 617

Resistors

R1 150k
R2 180k
R3-R5 180 (3 off)

Capacitor

C1 4 μ 7 electrolytic

Semiconductors

D1-D3 TIL 209 or similar
I.e.d. (3 off)
IC1 555 timer
IC2 7473 dual J-K flip-flop

Miscellaneous

Breadboards (2 off); connecting wire
and 5V to 6V supply.

Approx. cost
Guidance only

£5 each

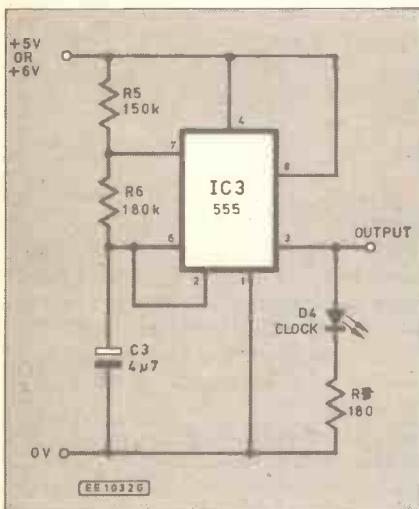

Fig. 17.3. Alternative slow oscillator circuit diagram using the 555 timer i.c.

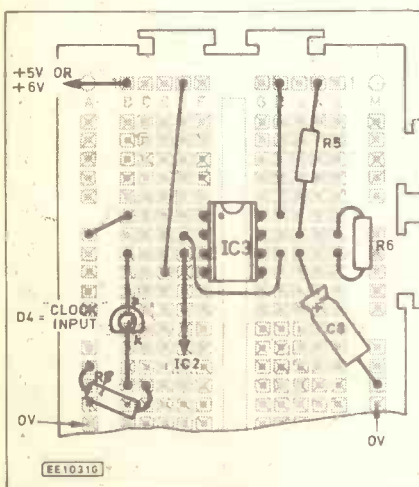

Fig. 17.4. How to connect the 555 i.c. as an oscillator driver for the "flip-flop".

The states of the outputs of the oscillator and the flip-flop are indicated by the three I.e.d.s. We need investigate only one of the two flip-flops contained in

this i.c., for the other behaves in exactly the same way.

Put both flying leads J and K into sockets on the positive 6V rail (both *high*). What happens to the outputs as the clock goes low? (Answers p. 602.)

Try changing the "clear" input from high to low when Q is high. What happens to Q? Try again when Q is low.

Make the "clear" input high again. Now repeat the above with different J and K inputs. Make J high and K low; make J low and K high; make them both low; make them both high again. Try to work out the logical rules that this flip-flop obeys.

INVESTIGATION TWO – OBJECT COUNTER

The basic counting circuit, Fig 17.5, is made by connecting two or more flip-flops together. It can be used to count all kinds of objects – people, cars (including model cars), even noises.

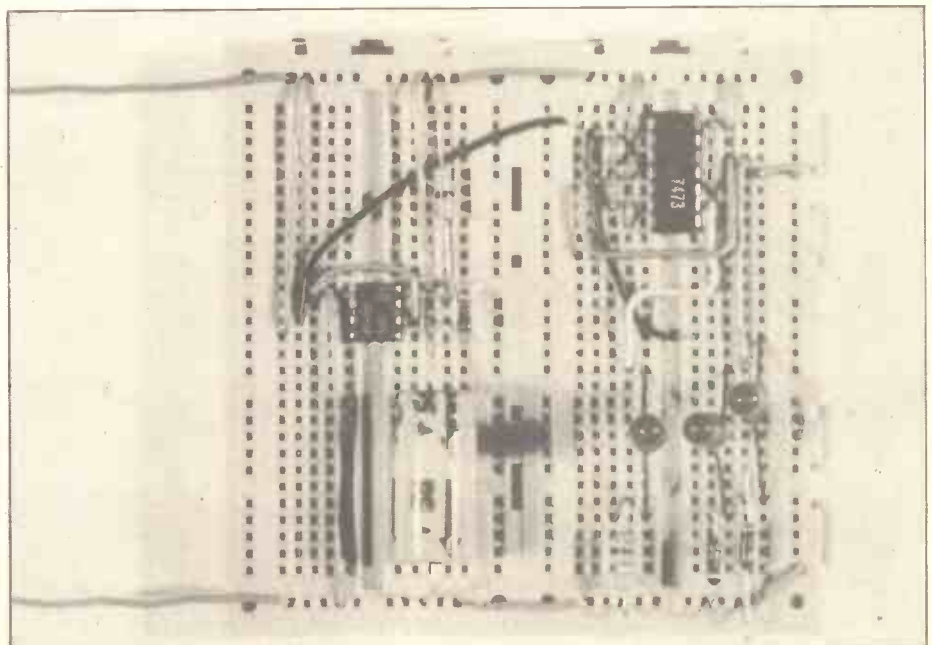

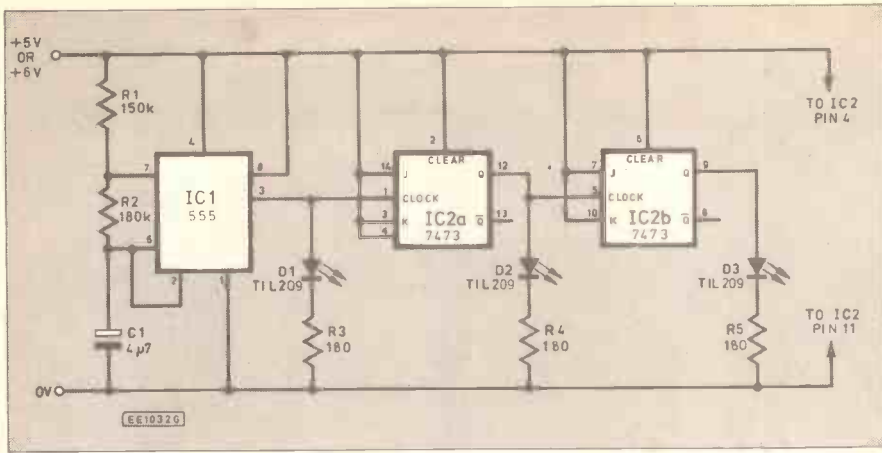

Fig. 17.5. Circuit diagram for the Object Counter.

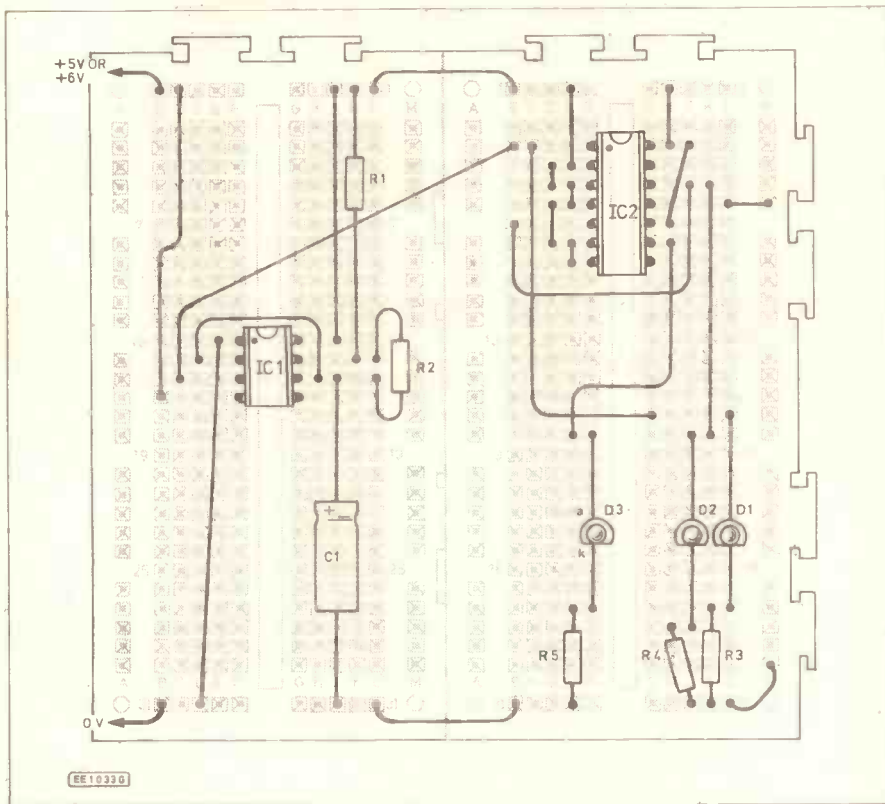
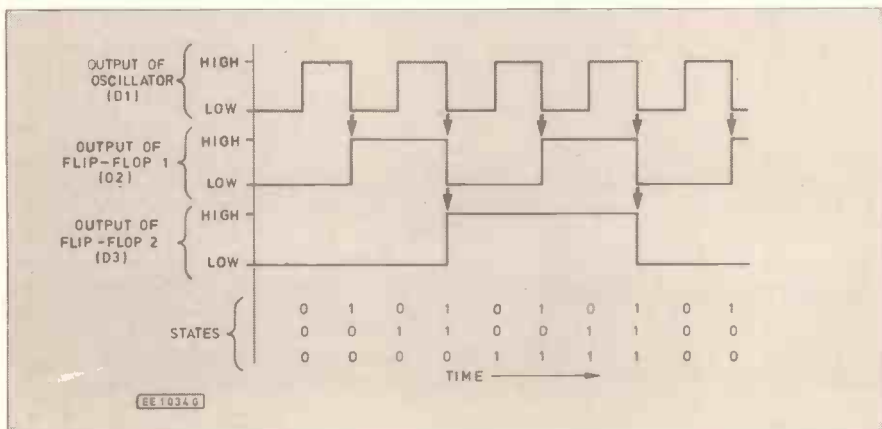

Fig. 17.6. Test-bed component layout for the Object Counter. This project is made up on two inter-linked demonstration breadboards.

Fig. 17.7. The counting sequence. The arrows indicate where an output triggers a flip-flop to change state.



ANSWERS

Output \bar{Q} is always the inverse (opposite) of output Q .

Outputs change state only when the clock input changes from high to low.

With J and K both high: both outputs change state at every clock change.

With J and K both low: outputs do not change state ever.

With J high and K low: Q goes high at next clock change.

With J low and K high: Q goes low at next clock change.

Changing clear from high to low makes Q low *immediately*.

Changing clear from low to high has no effect.

The counting sequence of l.e.d.s repeats in this order:

D3	D2	D1	Decimal equivalent
0	0	0	0
0	0	1	1
0	1	0	2
0	1	1	3
1	0	0	4
1	0	1	5
1	1	0	6
1	1	1	7

0 = l.e.d. off 1 = l.e.d. on:

Reading these as binary numbers, they are equivalent to the decimal numbers 0 to 7.

The "test-bed" demonstration component layout for the Object Counter is shown in Fig. 17.6.

HOW IT WORKS

First we feed pulses from the 555 timer or the slow oscillator, to the "clock" input pin 1 of IC2a flip-flop. Then the Q output from IC2a is fed to the clock input pin 5 of the second flip-flop IC2b.

The J and K inputs of both flip-flops are permanently high (+6V), so each flip-flop *changes state* (from high to low, or from low to high) whenever its clock input falls. The effect of this is shown in the counting sequence diagram Fig 17.7.

The output of the oscillator (or 555) changes from high to low and back to high again regularly. Whenever it goes low, flip-flop IC2a *changes state*. Whenever the output of IC2a goes low, IC2b flip-flop *changes state*. The waveform or sequence counting diagram Fig. 17.7 shows the first few steps of this process. Run the circuit to find out what happens next.

Record the complete sequence by writing "0" for low and "1" for high, as has been done below the sequence diagram Fig. 17.7. What do you notice about the sequence in which the lamps light? (Answer above.)

Counting pulses is interesting, but it is more useful to be able to count other things. More on this subject next month.

Next Month. Binary counting.

SPECIAL OFFER...

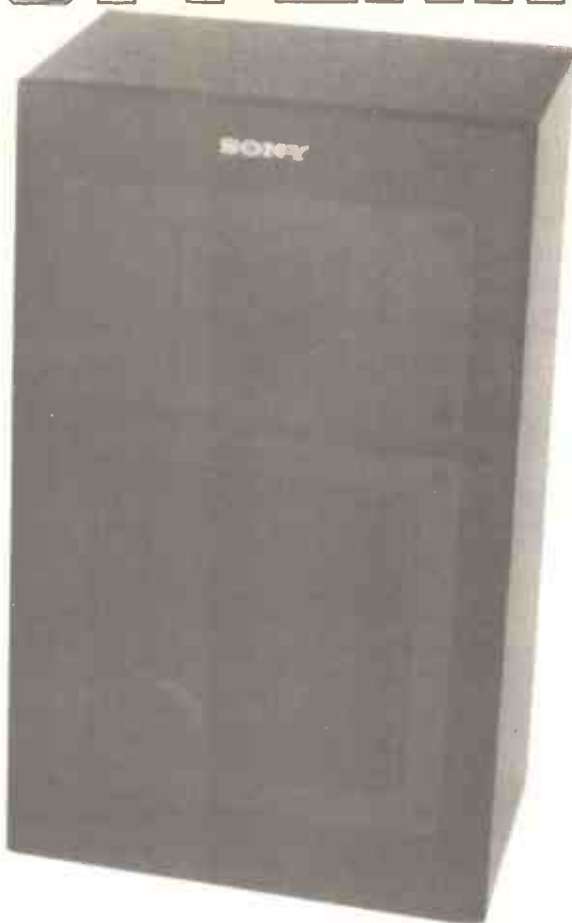
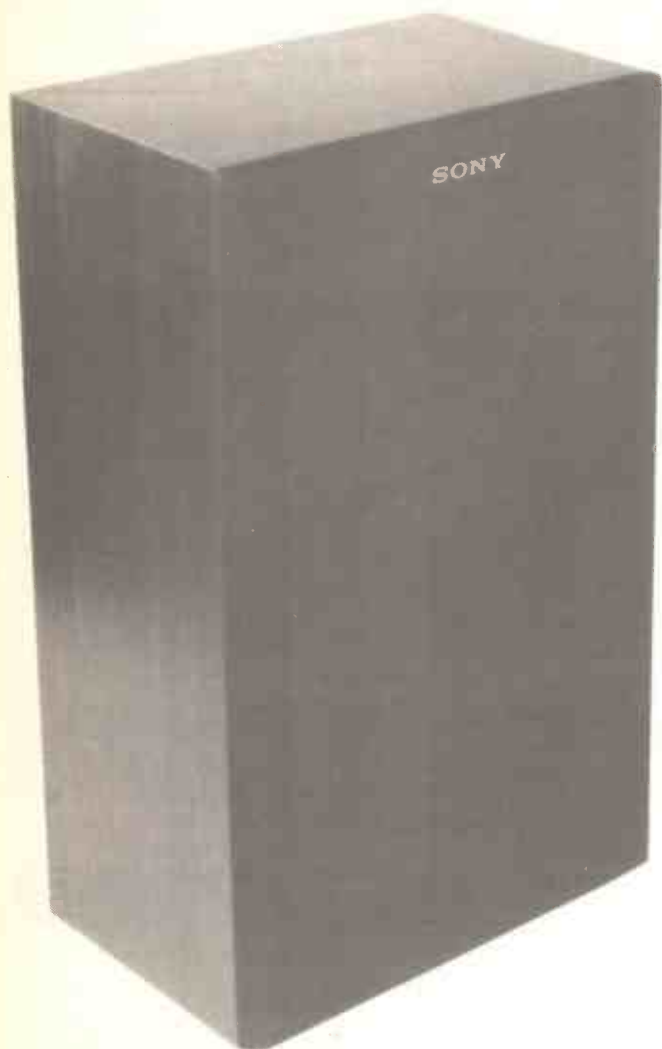

SONY SPEAKERS £20.95 per pair including VAT, plus postage

EE are pleased to be able to offer readers these modern Sony Z3000 speakers at magic prices in conjunction with R.T.V.C.

The speakers measure 41.5cm x 25cm x 17cm approx. and are 20W two way 6ohm units incorporating a 165mm bass/midrange driver plus a piezo tweeter. They are made in the UK and finished in simulated black teak with a black grille. **Quantities are limited at this special price, so first come, first served.**

Sorry but we cannot accept overseas orders due to the problem of delivery.

**Post to: EE Sony Speaker Offer, RTVC,
21 High Street, Acton, London W3 6NG.
Telephone Orders: 01-992 8430**

Please supply		Value
Quantity	Sony Speakers @ £23.95 per pair (including post)	
Only available to UK readers		<u>Total £</u>
Please make cheques payable to RTVC Ltd.		
Visa/ Access or Cheque No		
Signature		
Name		
Address		
.....		
.....		
OFFER CLOSSES Friday, November 27, 1987		
Name		
Address		
.....		
.....		
Post to: EE Sony Speaker Offer, RTVC 21 High Street, Acton, London W3 6NG Telephone Orders: 01-992 8430		

BLOCK CAPITALS PLEASE

BBC SIDEWAYS RAM/ROM



A.P. GUEST

Provides two blocks of RAM each of 16K. Can also be used as a printer buffer or data store

THIS BBC sideways RAM board will enable ROM based software to be run after being loaded from disc. Many BBC users require ROM based software such as disc, printer, and debugging utilities. Unfortunately, with the BASIC and DFS ROMs fitted there are only two spare ROM sockets left. To have more than two extra ROMs fitted would therefore involve buying a ROM expansion board. The alternative offered by this board is to save the ROMs onto disc and then load in the ones which are needed into extra RAM which can then be used as if it were a ROM.

This board also enables BBC users to write their own ROM software and test it as they go along without having to repeatedly erase and program an EPROM.

A third use for the board is that, though it cannot be used to hold programs which have not been designed for ROMs, it can be used to hold data such as a spreadsheet or a database, or it can be used as a printer buffer.

BBC MICRO

The BBC micro is based on a 6502A microprocessor and can therefore address 64K of memory (&0000 — &FFFF). The lower half of this (&0000 — &7FFF) is RAM, while the upper half (&8000 — &FFFF) is ROM. The upper half of the ROM (&C000 — &FFFF) is the operating system, and the lower half (&8000 — &BFFF) is the paged ROM area. This area of memory may be occupied by the BASIC ROM, the DFS, or any other language or service ROM which has been fitted. Though in theory the BBC can take up to 16 ROMs, only four sockets have been provided on the main circuit board.

To page in a particular ROM, the number of the ROM socket containing it (&0 — &F) should be put in location &FE30 (?&FE30 = n where n is the ROM socket number). The four ROM sockets on the circuit board are, from left to right, &C, &D, &E, &F, (see Fig. 1).

CIRCUIT

The complete circuit diagram of the BBC Sideways RAM/ROM is shown in Fig. 2. This circuit provides two blocks of RAM, each of 16K, thereby enabling two ROMs to be loaded into the BBC. Each block consists of two RAM chips, each of capacity 8K. Each RAM chip has two chip select pins, CS1 and CS2. The chip is only enabled if CS1 is high and CS2 is low.

COMPONENTS

Capacitors

C1 100n tantalum

Semiconductors

IC1, IC2, 6264LP15 8Kbyte
IC3, IC4 static RAM (4 off)
IC5 74LSO4 hex inverters

Miscellaneous

S1, S2 s.p.d.t. toggle switch (2 off)
Single sided p.c.b. 100 x 160mm, available from the EE PCB Service, order code EE585; 28 pin i.c. sockets 6 off; 14 pin i.c. socket; miniature probe clip; 14 way ribbon cable; connecting wire; insulation material (see text).

Approx. cost
Guidance only

£20

The computer selects a block by pulling the appropriate CS low. This pulls the CS2 low on both the RAM chips of that block.

Which of the two RAM chips is to be used is decided by address line A13, which is put directly onto the CS1 of one of the RAM chips, and is inverted before being put onto the CS1 of the other chip. This means that if A13 is high then the first RAM chip will be paged in, while if A13 is low then the second chip will be paged in. The second block differs from the first only in that it uses a different CS from the main circuit board.

An added facility of this unit is that by switching a switch (the Write Protect switch) a block of RAM can be turned into ROM, thereby making it impossible to accidentally write over the contents of that block. Each block has a separate Write Protect switch.

The read/write (high to read, low to write) pins on the RAM chips are switched in pairs by the write protect switches between a read/write line from the main circuit board and a +5V line. When a pair of RAM chips are switched to the read/write line from the circuit board they will act as normal RAM, but when switched to +5V they are held in the ready mode and therefore cannot be written to, so they imitate a ROM.

The OE (output enable) from the circuit board does not attempt to switch off the outputs of the ROMs when the computer wants to write to them because normally writing to them would not work anyway. When RAM is fitted though, we still take the OE from the board straight to the OE of the RAM chips, because the RAM chips switch off their outputs

Fig. 1. The main circuit board layout for the BBC Micro.

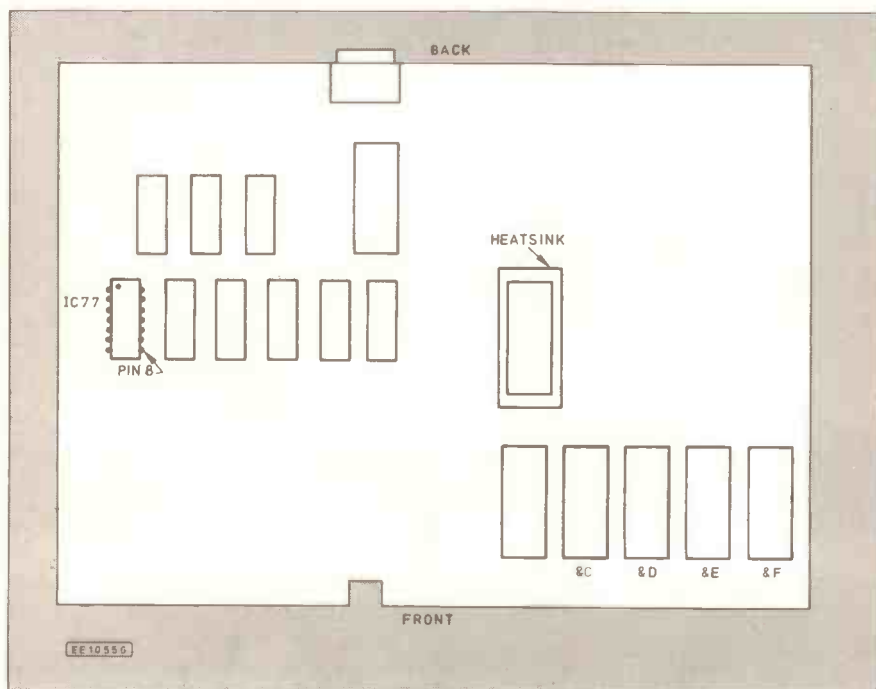

when they are in write mode, regardless of the OE line.

The circuit does not have its own power source, but takes both this, the OV line, all the data lines, address lines AO to A12, the OE line, and the first CS from one ROM socket. The other CS is taken from another ROM socket. The read/write line is taken from pin 8 of IC77 on the main circuit board using a miniature probe clip (see Fig.1). The power supply to the board is decoupled with capacitor C1.

CONSTRUCTION

The component layout and full size printed circuit board foil master pattern for the BBC Sideways RAM/ROM is shown in Fig. 3. The circuit board for this project is available from the EE PCB Service, code EE585.

If you intend to make the board yourself though, the plan is shown in Fig.3. When the board is being cut to size it must be cut close to the tracks to enable it to fit inside the BBC.

Start the assembly by putting in the one link required. Then fit i.c. sockets for IC1 to IC5 (sockets for IC1 to IC4 have 28 pins, the socket for IC5 has 14 pins). Sockets are used because the RAM chips are of the CMOS type and are therefore sensitive to static and must be handled as little as possible. Now solder in the decoupling capacitor, C1.

Next, make up the ribbon cable to connect the RAM board to the main board. The length of this cable must be measured carefully to ensure that the RAM board does not interfere with any power lines to the main board (see Fig.4). Two 14-way ribbon cables are in fact used, one for each side of the ROM socket (see Fig.3). The ribbon cables are soldered into the RAM board at one end, and at the other end

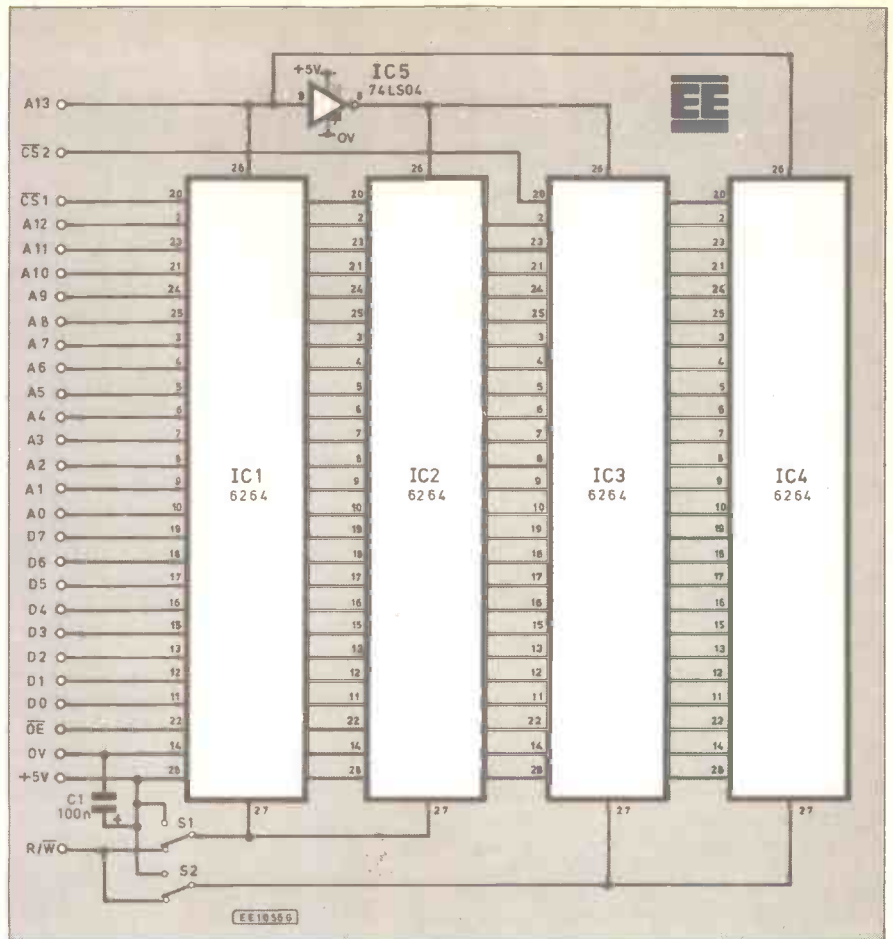

Fig. 2. Complete circuit diagram for the BBC Sideways RAM/ROM.

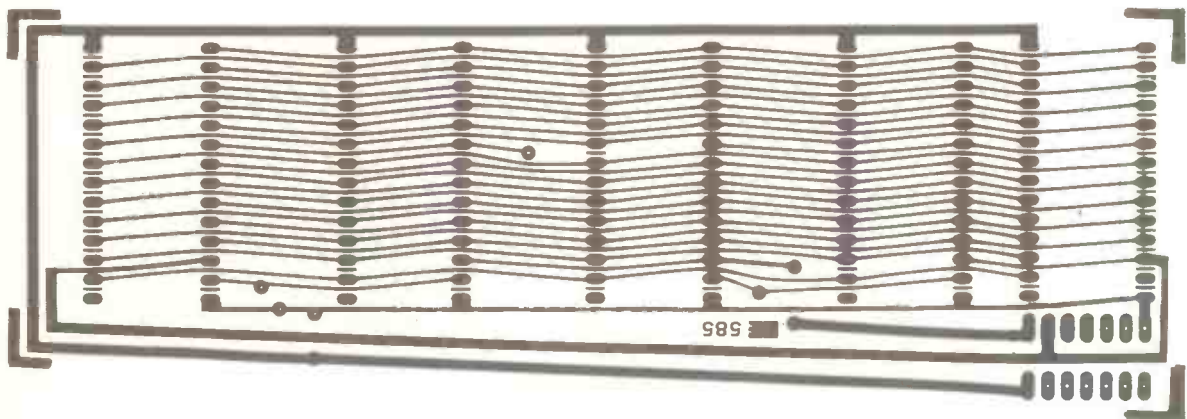
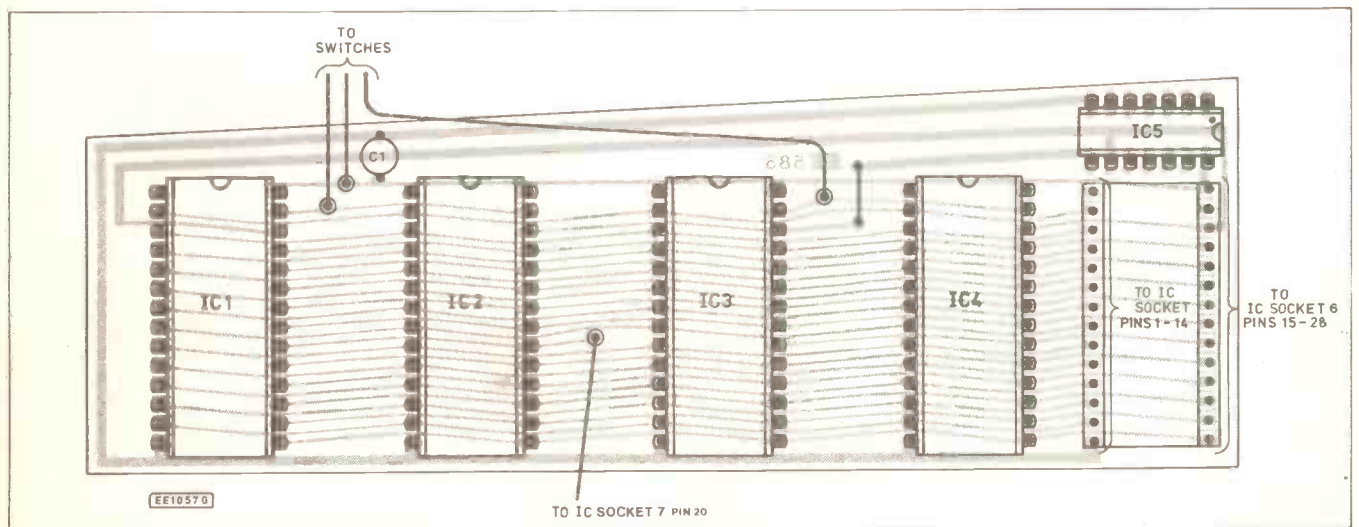

Fig. 3. Full size printed circuit foil master pattern and board component layout.



BBC SIDEWAYS RAM/ROM

SOFTWARE

```

10 REM PROGRAM 1
20 REM -----
30 REM Sideways RAM tester
40 FOR C=0 TO 1
50 READ D
70 count=0
80 F%=1100
90 (.C1 OPT 2:LDAND:STA&FE30:LDANO:|
11 STA&A0C0:LDAB&F4:STA&FE30:RTS:|
100 (.C2 OPT 2:LDAND:STA&FE30:LDANO:|
11 STA&A0C0:LDAB&F4:STA&FE30:RTS:|
120 ?(11+1)=(A MOD 256):(12+1)=(A MOD 256)
130 ?(11+2)=(A DIV 256):(12+2)=(A DIV 256)
140 FOR B=0 TO 255 STEP 255
150 ?(11+1)=B
160 CALL C1
170 CALL C2
180 IF ?B70 <>B THEN count=count+1:
PRINT"A, ?B70:" not ";~B
190 NEXT B
200 IF (A MOD 256)=0 THEN VDU7
210 NEXT A
220 PRINT
230 PRINT count
240 NEXT C
250 DATA B&
260 DATA B&

```

TEST & SAVE PROGRAMS



```

10 REM PROGRAM 2
20 REM -----
30 REM OFFLOAD source code
40 osargs=&FFDA
50 osword=&FFEE
60 osword=&FFF1
70 oscli =&FFF7
80 osbyte=&FFF4
90 inptr=&B0
100 normout=?&20E+256*?&20F
110 FOR I%=0 TO 3 STEP 3
120 P%=&900
130 (.OPT I%
140 LDX #inptr
150 LDY #0
160 LDA #1
170 JSR osargs
180 LDY #0: LDA (inptr),Y
190 SEC: SBC #&30: BCC romnumerr
200 CMP #A: BCC ahok
210 SBC #7: BCC romnumerr
220 CMP #A: BCC romnumerr
230 CMP #&10: BCC ahok
240.romnumerr BRK
250 EGB &FF
260 EBUS "Illegal ROM number"
270 EGB &0D
280. filenameerr BRK
290 EGB &FF
300 EBUS "Bad filename"
310 EGB &0D
320 BRK
330. ahok
340 STA romnum
350 LDY #1: LDA (inptr),Y: CMP #&20: BNE romnumerr:
INY: LDA (inptr),Y: CMP #&0D: BEQ filenameerr
360. loop LDA (inptr),Y: CMP #&0D: BEQ out:
STA osciname-2, Y: INY: CPY #&12: BNE loop
370. out LDX #oscliblock MOD 256:|
LDY #oscliblock DIV 256: JSR oscli
380 LDA romnum
390 STA &FE30
400. loop1
410 LDX #0
420. loop
430 LDA &3000, X
440 STA &8000, X
450 INX
460 BNE loop
470 INC loop+2
480 INC loop+5
490 LDA loop+5
500 CMP #&CO: BNE loop1
510 STA osciname-2, Y
520 INY
530 CPY #&12: BNE loop
540. out LDX #oscliblock MOD 256
550 LDY #oscliblock DIV 256
560 JMP oscli
570. oscliblock EBUS "LOAD "
580. osciname EBUS STRING$(19, " ") + "3000 7000 8000 8000"
590 EGB &0D
600 .: NEXT

```

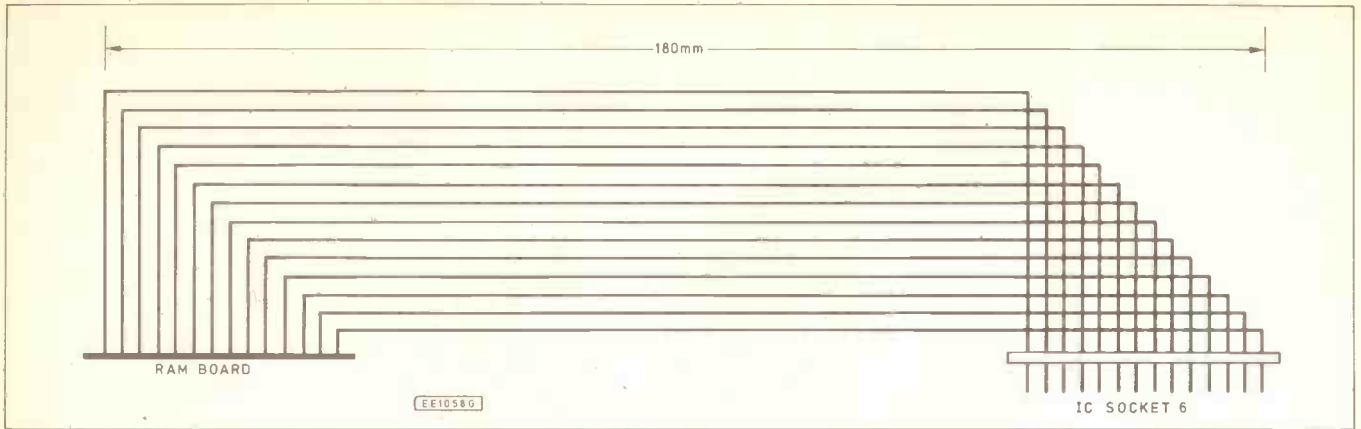



Fig. 4. Dimension and wiring details for the interconnecting ribbon cable (two required) from the RAM board to the 28-pin i.c. connecting socket 6. Note that a single lead is taken from the board to pin 20 of i.c. socket 7 (see photo below).

they are soldered into an i.c. socket (a 28 pin socket), which can then be plugged into a ROM socket on the main board.

If there is a large heatsink near to the ROM sockets then it will only fit easily into ROM socket &D, in which case if you already have a ROM in this socket take it out and put it in another socket. To take out a ROM, use a specially designed extraction tool if you have one, otherwise use a small screwdriver to carefully lever up the four corners in turn, taking care not to bend any of the corner pins.

It is easiest to solder both cables to the i.c. socket first, and then solder both to the RAM board. Now the switches can be wired up as shown in Fig.5. The read/write line comes straight from the miniature probe clip to an end terminal of one of the switches. A link goes from here to the equivalent point on the other switch. The +5V line comes from the RAM board onto the terminal at the opposite end of one of the switches and again a link takes it to the equivalent point on the other switch. One wire comes from each of the centre terminals of the switches to the RAM board.

Lastly, solder a wire from the RAM board to pin 20 of the other flying i.c. socket 7 (a 28 pin socket).

Now check the RAM board for dry joints and for any tracks which might have been shorted out. These jobs are best done with a multimeter or continuity tester.

BACKING

If the board were to be fitted now, it could well short out several points on the main circuit board. To prevent this, the back of the RAM board should be covered with some insulating material. Just covering it with sticky tape is not good enough as the ends of the wires can pierce it. The easiest thing to use is a sheet of cardboard cut to the size of the RAM board which can then be stuck onto the back with sticky pads or insulation tape.

FITTING

Since the RAM chips are sensitive to static, it is advisable to earth yourself and the RAM board before handling them. Even so, it is best only to handle them by their ends and not touch the pins. Once all five chips have been fitted, plug the RAM board into a vacant ROM socket (socket &D if you have a heatsink fitted, see Fig.1), clip on the read/write line, and plug in the other i.c. socket (with the extra CS wire on) into the last vacant ROM socket. The Write Protect switches can stick out of the slot and be stuck onto the back of the BBC. Check the fitting, reassemble the computer, and switch on. If it does not start up normally, then switch off and check everything again.

TESTING

Before using the RAM board for ROM software, it is best to test it thoroughly. Program 1 tests the board by putting first &O and then &FF into every byte and in each case reading it back and checking for any errors. If an error occurs then the program will print on the screen the location where the error occurred and what was found in the location. If it prints up every location then switch the appropriate write protect switch and try again. The program takes just under 20 minutes to run and bleeps after checking every 256 bytes to show that it has not crashed. When typing in the program, put the numbers of the two ROM sockets used by the RAM board in lines 250 and 260.

SAVING A ROM

Before a ROM can be loaded from disc, it must be saved onto disc. Program 2 does this. Type it in, save it, and run it. Then type:

***SAVE OFFLOAD A00 AB7**

To save a ROM you then just type:

***OFFLOAD n ROMNAME**

where **n** is the ROM socket number from which you want to save, and **ROMNAME** is the name of the ROM you want to save.

e.g. ***OFFLOAD F BASIC**

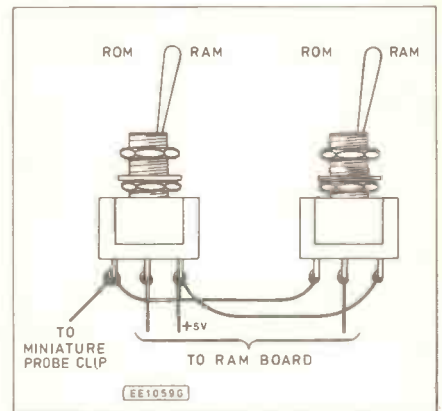

Fig. 5. Wiring details for the Write Protect switches.

SAVING A ROM

Program 3 is used to load a ROM from disc. Type it in, save it, and run it. Then type:

***SAVE ONLOAD A00 AB0**

To load a ROM from disc you then just type:

***ONLOAD n ROMNAME**

where **n** is the number of a ROM socket with RAM in it, and **ROMNAME** is the name of the ROM you want to load.

e.g. ***ONLOAD D FORTH**

The completed board showing the two connecting sockets (6, 7), toggle switches and the read/write probe clip.

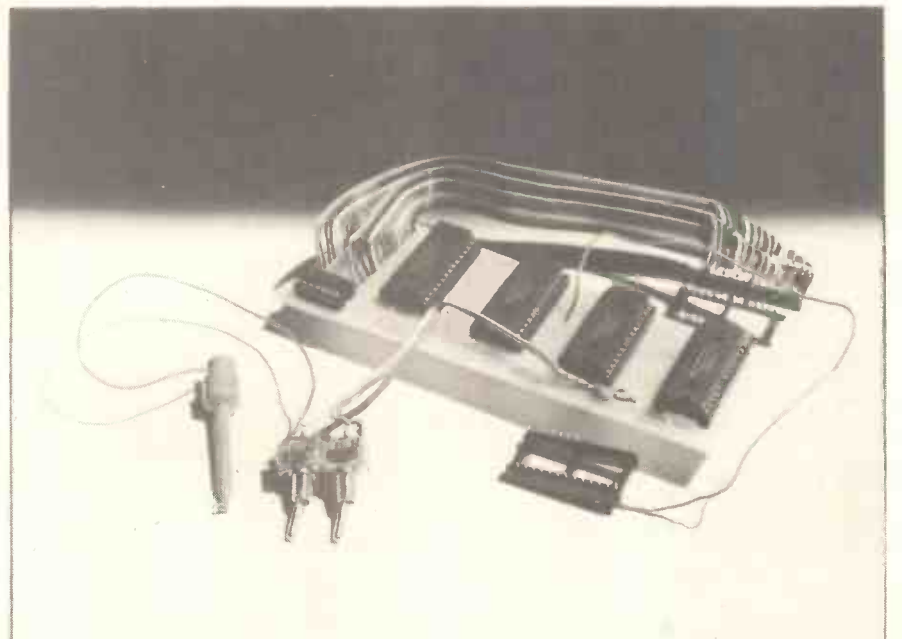

N.M.R. IMAGING

X RAY PICTURES WITHOUT X RAYS

SOME years ago the science weekly, *Nature*, sprinted a picture of a cross-section through a lemon. It wasn't a photograph, or a drawing. It had been made without cutting the lemon. It was a striking illustration of a new kind of picture-making technique with important applications in medicine.

SLICE PICTURES

Tomography, as it's called, means making an image of a slice through something — a picture of a section. One of the earlier ways of doing this without actually cutting the object under investigation used pencil-beams of X-rays (Fig. 1).

Suppose the object is a limb with a bone through the middle. The X-ray beam is moved along a circular path round the limb. On the opposite side is an array of X-ray detectors — small semiconductor "photocells".

In some positions the beam will miss the bone, passing only through the flesh. In others it will pass through the bone, to an extent which varies with the angle. If bone is a more efficient absorber of X-rays than flesh then the signal from a detector will be smallest when the beam passes straight through the diameter of the bone.

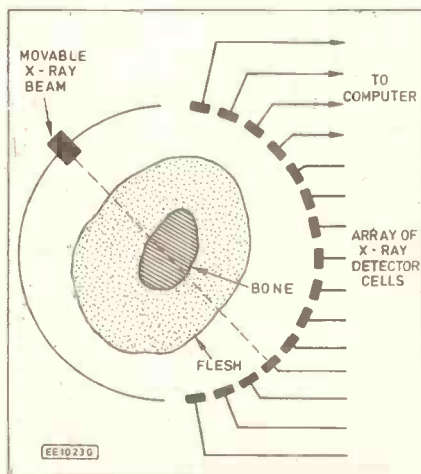

Fig.1 X-ray tomography. A beam of X-rays passing through a limb from different angles yields different detector outputs. Computation on these produces a cross-section of the limb showing the bone inside.

By correlating the detector outputs and the beam angles it is possible to compute the shape of the bone and display a sectional view on a TV screen. This is computerised X-ray tomography and it is now widely used for "scanning" patients in hospitals. In particular it is useful for taking slice-pictures of the skull to look for injuries or disease.

NO RISK SCANNING

By using highly sensitive detectors it is possible to minimise the X-ray dose to the patient. However, any dosage of ionising radiations such as X-rays involves a small risk to the patient, since radiation of this kind can cause cancer. Even though the risk is small it is better to run no risk at all.

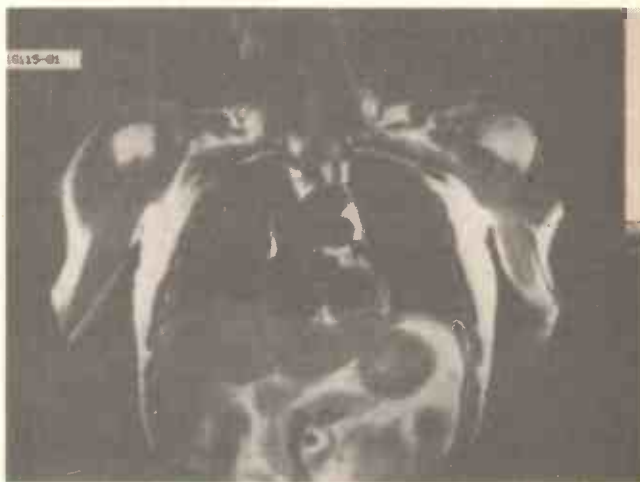

Fig.5 An NMR picture of a slice through the neck and chest. This picture was made at the National Heart and Chest Hospitals using a Picker International NMR scanner.

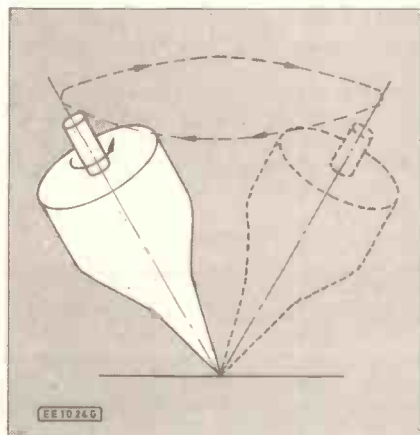

Fig.2 A spinning top given a sharp sideways push wobbles at a steady rate called the precession frequency. Spinning protons and electrons behave in a similar way.

This is one reason why medical researchers have explored ways of making pictures without using X-rays. One possibility is to use sound waves. If the frequency of the "sound" is made very high the wavelength becomes short enough to give fairly detailed images. Many hospitals now have ultrasound imagers which can show babies developing in the womb.

There is another, quite different reason for seeking an alternative to X-rays. This is that X-rays, while very good for imaging bone, are not so good for imaging soft tissues like the organs in the abdomen. It is often possible to get round this problem by giving the patient a dose of some chemical which is opaque to X-rays.

If this X-ray contrast medium can be persuaded to concentrate in the tissue of

interest then clear pictures can still be obtained. But if it can't, or if the seat of a disease is just not known, then imaging soft tissues can be a difficult problem.

NUCLEAR RESONANCE

Ideally, what is needed is an imaging technique which poses no risk to the patient and causes no discomfort, but gives clear pictures of any type of tissue.

It was realized years ago that a technique already in use for chemical analysis could in theory be adapted to imaging. This technique is based on a phenomenon called Nuclear Magnetic Resonance (NMR).

Don't be misled by the word "nuclear" into thinking that nuclear magnetic resonance involves radio-activity. It doesn't. "Nuclear" here simply refers to the fact that the technique works by exploiting the behaviour of the nucleus of an atom. Any atom: it doesn't have to be a radio-active atom. In fact, most of the NMR imaging at present being done looks at nothing more sinister than the hydrogen in the water which makes up a great part of the body.

SUB ATOMIC SPINNING TOPS

The protons, neutrons and electrons which make up atoms spin round on their axes, like the Earth. Protons carry a positive charge.

An electric current is just a collection of moving charges. Even one moving charge constitutes a tiny current. So the positive charge on a spinning proton makes a tiny circular current. The current in turn generates a magnetic field. This field is aligned along the spin axis of a proton a bit like the Earth's field.

The proton has a North pole and a South pole. This makes a proton susceptible to the influence of an external magnetic field. The proton's North pole will be attracted to the South pole of an external field, and vice versa.



The effect is to force the axes of the spinning protons to align themselves with the direction of the external field.

NMR is all about what happens when this alignment is disturbed. If the spinning proton is likened to a spinning top or gyroscope (Fig.2) you can get an idea of its behaviour. If the top is spinning strongly and you give it a sideways tap it wobbles in a particular way. Its axis moves round in a small circle. This movement is called precession, and the rate of precession is a fixed quantity: so many circular wobbles per second.

It's not possible to give a tap to a proton. But if the proton "spinning tops" in a substance are aligned with an external field (Fig.3) they can be disturbed by varying the field. This can be done by superimposing a periodic or "a.c." variation on a steady or "d.c." field.

The effect depends on the frequency of the variation. At most frequencies it's small. But if the a.c. variation is at the same frequency as the natural precession of the proton "spinning top" it is very large — perhaps millions of times larger.

TUNING THE PROTONS

The effect of subjecting the aligned protons to a variable frequency field change is rather like what happens when you loosely couple the

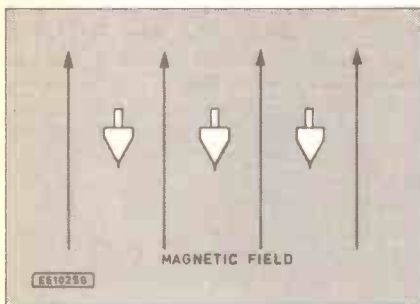

Fig.3 Spinning nuclear particles such as protons align themselves with a magnetic field. The field sets their precession frequencies to calculable values.

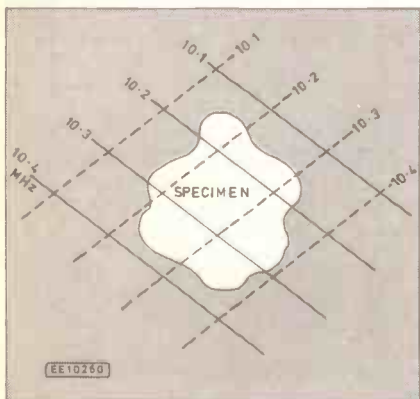

Fig.4 Contours of magnetic field strength are also contours of NMR frequency. By exploring a specimen immersed in the field with the aid of radio-frequency field-variations, the average concentration of protons along a contour can be found. Rotating the field lines gives a second set of readings (dotted). Combining many readings in a computer yields a map of the proton concentrations in the specimen.

output of a radio signal generator to a tuned LC circuit. The voltage across the circuit stays quite low until you hit the resonant frequency, when it increases sharply. The amount of increase depends on the quality factor or Q of the tuned circuit.

The tuned LC frequency depends on the values of inductance and capacitance. But what determines the frequency of the proton resonance? Answer: the strength of the magnetic field. The stronger the d.c. field used to align the spins the higher the frequency. In medical NMR imaging the fields are comparable with those in a loudspeaker magnet and the frequencies are in the short-wave radio band, say 10MHz.

The nuclear resonance frequency is affected by other protons nearby. This is very important when NMR is used for chemical analysis where the effect of nearby protons (or electrons, which also exhibit resonance) indicates the nature of a chemical compound. Potentially, it could be important in NMR imaging. It might be very useful to be able to map the presence of particular compounds or indeed particular elements in the body. But so far, hydrogen and, to a lesser extent, potassium seem to be the only elements accessible to the NMR imager, and no compounds at all.

FIELD GRADIENTS

At first sight it may seem rather pointless to map the hydrogen in a section of the body. Hydrogen — in water — is everywhere in the body, so wouldn't a hydrogen map just be totally featureless, the same all over? Fortunately not. The amount of water, the concentration, varies in different types of body tissue. If the map shows these variations, it shows the different organs, and different parts of the same organ.

But how do you obtain a map from NMR? There's no way of producing sharp pencil-

beams of magnetic field, so the X-ray tomography technique is not applicable. What can be produced, very easily, are field gradients. In NMR terms, contours of equal magnetic field strength are also contours of equal resonance frequency. Suppose the field/frequency contour map is a series of slanting lines (Fig.4), if a signal on 10.1MHz is applied, any hydrogen nuclei (protons) which happen to be threaded by the contour marked 10.1 will absorb energy. The response will indicate the average concentration of hydrogen along this contour. Signals at 10.2, 10.3 . . . etc. MHz will give the concentration of hydrogen along these contours. If the field is now rotated to give a new set of contours the specimen or body under examination can be explored in another direction.

By making measurements with field gradients running in different directions and comparing the results in a computer a map of the concentration of hydrogen can be produced. This, for practical purposes, is a map showing water concentration and so it shows the organs of the body, if this is what is being scanned. The photograph shows a vertical slice through the neck and chest, (Fig.5).

IMAGING MOVEMENT

The NMR technique can be refined to yield more information. At the National Heart and Chest Hospitals pictures of blood flow have been obtained. These are produced by exploiting some subtle effects of moving water (in the blood) on the phase of the radio frequency signals used to disturb the d.c. field. Sequences of pictures can be combined to produce "cine film" of the beating heart and reveal irregularities caused by disease.

All the patient has to do is to lie relaxed on a stretcher which is slid into the field of large electromagnet coils. The whole process is painless and doesn't take very long.

In Brief

Microprocessor Fault Test

The Distributive Industry Training Trust (DITT) has awarded a £4,000 grant to the Radio, Television & Electronics Examination Board (RTEEB) to assist in the development of a Practical Fault Location Test for microprocessor-based equipment.

The new test will be available in 1988 to all Colleges running Microprocessor Computer Systems (C&G Course 224) and Microcomputer Technology (C&G Course 223).

The Greater Manchester Exhibitions and Events Centre (G-Mex), formerly a listed railway station, is the venue for the *Northern Amstrad Computer Show*. The show will run from 23 to 25 October 1987.

In its capacity of authorised distributor, Electronic Brokers will be featuring Marconi Instruments' products at the forthcoming COMEX exhibition.

The COMEX exhibition is being held at the Sandown Exhibition Centre, Esher, Surrey from 3 to 5 November 1987.

Action Against Pirates

The destruction of 200,000 pirate music cassettes containing works by over 300 classical, jazz and pop artists was ordered by a Nigerian court recently.

This is the latest in a series of legal moves by the local music industry against importers and manufacturers of illicit tapes and follows a recent pledge by a senior government minister that measures to eradicate piracy will be introduced by the end of the year.

The EEC Commission is to undertake a full scale investigation into music piracy in Indonesia. The Commission announced its decision to open an investigation procedure concerning the unauthorised reproduction of sound recordings as a result of a formal complaint by the International Federation of Phonogram and Videogram Producers.

A new professor of information technology (IT), jointly sponsored by British Telecom and the Fellowship of Engineering, is to be appointed at Salford University.

The professor will direct research activity in the University's recently established Information Technology Institute.



a regular feature for the Spectrum Owner...

by Mike Tooley BA

THIS month, as promised, we shall be describing some software routines for use with our Z80-CTC Counter/Timer Interface. We also review the latest offering from Betasoft in the shape of BETA BASIC 4.0. We start by dealing with a problem which is becoming increasingly worrying for many Spectrum users; that of software support.

Software support

The level of support offered to the serious user of software packages is becoming an increasing cause for concern. Some time ago, I reviewed the excellent Laser Genius package produced by Ocean. Several readers have since written to say that they have had problems with the package and the suppliers have not been able to help. This, unfortunately, is becoming an all too common experience. Many of you will remember the ill-fated BLAST compiler that promised so much and delivered so little. Some of the faults in this package were put right with later versions, but who could recommend a piece of software which was originally supplied with so many faults that it proved impossible to use?

Just who should take the blame for lack of support is open to question. Some software suppliers blame narrow margins — they just can't afford to provide the sort of back-up offered to business users who will happily pay ten times more for a comparable package to run on a PC or PC clone. Others blame those users who knowingly and illegally pirate software by making copies and giving them to friends thereby reducing the income that should be realised by a piece of software. It is an unfortunate fact of life that the more successful an item of software is the more it will be pirated.

Organised software piracy on a large scale is rife in many countries and unauthorised copies of virtually any of the best selling business software can be obtained for prices starting at as little as £1! Illegally copied software is often "bundled" into "package deals" for cheap PC clones in many Far Eastern countries. All of this is doing nothing to raise the level of support we can expect from software houses.

Fortunately, end users are slowly getting wise to the need for effective software support. No longer will they pay for a package which just might perform to expectation. Somebody out there had better sit up and take notice.

Having painted a rather gloomy picture, it is fair to say that some software houses do provide consistently good back-up for their products. Typical of this is the regular Newsletter provided by Betasoft for their BETA BASIC package (more about this later). It takes effort and commitment to produce such an item and those involved should be congratulated — other software suppliers please take note!

Earlier, I made specific mention of Ocean's Laser Genius. As a user of this particular software I am obviously keen that it should stay in existence even if the original authors, Oasis, are no longer in business. If any readers have experienced problems with this package (or, even better, can offer suggestions or solutions) I would be interested to hear from them. If sufficient interest is shown I would be willing to form a "self-help group" which could extend its activities to the entire range of software development packages available for the Spectrum.

An improved SORT command will sort RAM disc string arrays as well as normal string and numeric arrays. An array of 1000 random 60 character strings will be sorted in approximately 14 seconds — no mean feat for a humble Spectrum!

A CAT\$() function returns the entire RAM disc catalogue as a string and can be used, from within a program, for checking the contents of the RAM disc. The use of BETA BASIC's CAT\$() and INSTRING functions can be illustrated by the following:

```
10 INPUT "Filename to SAVE under: ";f$
20 IF INSTRING (1,CAT$( ),f$)<>0 THEN ERASE !f$
30 SAVE !f$
```

This handy code module checks to see whether the given file exists and, if it does, the old file is erased before saving the new one. This overcomes a rather silly shortcoming in the 128K Spectrum's BASIC RAM disc handling. CAT\$() also provides information on

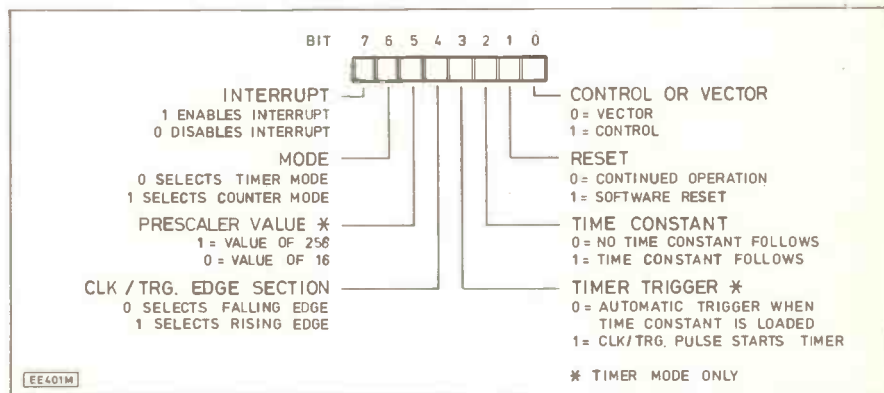

Fig. 1. Channel control word format.

Even better BETA BASIC!

Regular readers of this column will know that I am a fan of Betasoft's BETA BASIC. Some time ago I reviewed version 3.0 of this package and came to the conclusion that it had a tremendous amount to offer anyone who programs in BASIC (I guess that must be just about everybody!).

It was pleasing to note that Betasoft have further enhanced BETA BASIC with release 4.0 which is for Spectrums with 128K memory (i.e. the 128K and Plus Two machines). BETA BASIC 4.0 makes use of the additional facilities offered by the 128K versions of the Spectrum. ALL the commands and functions of BETA BASIC 3.0 are still available and existing BETA BASIC 3.0 programs should run without modification.

BETA BASIC puts the extra 64K of RAM to excellent use by allowing arrays of up to 64K. These arrays can be searched or sorted alphabetically very quickly indeed. RAM disc files can be moved to or from streams, or to the screen. BETA BASIC 4.0 also offers interrupt driven sound facilities; one now has full access to the sound chip without holding the program up every time a sound is generated! Some of the graphics commands have been enhanced, with faster or more flexible versions of CIRCLE, DRAW, PLOT and FILL.

the type of file (program, numeric array, string array or code) and its length.

Two manuals are supplied with the BETA BASIC 4.0 package. One of these is the existing BETA BASIC 3.0 manual and the other relates to the 128K extensions in BETA BASIC 4.0. Both manuals are eminently readable and contain a wealth of useful examples. The BETA BASIC 4.0 supplement also provides some useful information for (real!) disc owners and for those using various types of printer interface.

BETA BASIC can be highly recommended; it won't turn your machine into an Atari ST or Commodore Amiga but it will certainly transform your programming and inject new life into your humble Spectrum. Expect to be impressed — this is another superb offering from Betasoft!

Betasoft can be contacted at 92, Oxford Road, Moseley, Birmingham B13 9SQ.

Programming the Z80-CTC Counter/Timer

The Z80-CTC is quite simple to program and operates in two distinct modes; counter mode and timer mode. The channel selection is achieved by means of address lines A5 and A6 which result in the following assignment of the channel/control registers:

Channel No:	Address Lines								Port Address	
	A7	A6	A5	A4	A3	A2	A1	A0	Hex.	Decimal
0	0	0	0	1	1	1	1	1	1F	31
1	0	0	1	1	1	1	1	1	3F	63
2	0	1	0	1	1	1	1	1	5F	95
3	0	1	1	1	1	1	1	1	7F	127

A control word is recognised by the CTC whenever bit 0 of the data sent to the relevant channel control register is set. The remaining bits in the channel control register function according to the diagram shown in Fig. 1.

Bit 6 of the control register is particularly important as it determines whether the channel is used in timer mode or counter mode. Counter mode is enabled when bit 6 is set whereas timer mode is enabled when bit 6 is reset.

In counter mode, the CTC counts the edges of the clock/trigger input of the channel in question. In timer mode, the CTC generates timing intervals that are an integer value of the system clock period.

Timer Mode

For the moment, and for the remainder of this instalment of *On Spec*, we shall confine our use of the CTC to timer mode. Next month we shall show how the device can be employed in counter mode.

In timer mode the CTC generates timing intervals that are an integer value of the clock period. The clock is fed through the prescaler and down-counter. Depending upon bit 5 in the control register, the prescaler divides the clock by a factor of either 16 or 256. The output of the prescaler is then used to decrement the down-counter, which may be programmed with any time constant integer between 1 and 256. The time constant is automatically reloaded into the down-counter at each zero-count condition. At zero-count, the channel's time out output (ZC/TO) is pulsed resulting in a uniform pulse train of precise period given by:

$$t_{out} = t_c \times P \times TC$$

where t_c = clock period (0.285714285 μ s)

P = prescaler factor (either 16 or 256)

and TC = time constant data word (1 to 255)

Timing may be initiated automatically or with a triggering edge at the channel's timer trigger input (CLK/TRG). This is determined by programming bit 3 of the channel control word. If bit 3 is reset, the timer automatically begins operation at the start of the CPU cycle following the I/O write machine cycle that loads the time constant data word. If bit 3 is set, the timer begins operation on the second succeeding rising edge of the clock after the timing trigger edge following the loading of the time constant data word.

If no time constant is to follow, the timer begins operation on the second succeeding rising edge of the clock after the timer trigger edge and following the control word write cycle. Bit 4 of the channel control word is pre-programmed to select whether the timer trigger will be sensitive to a rising or falling edge. If bit 7 in the channel control word is set, the zero-count condition in the down-counter initiates an interrupt sequence.

The longest output period obtainable using a single channel of the CTC interface (with a prescaler divisor of 256 and time constant data word of 255) is 18.67ms (corresponding to a pulse repetition frequency of approximately 54Hz).

The shortest output period obtainable using a single channel of the CTC interface (with a prescaler divisor of 16 and time constant data word of 1) is 4.576 μ s (corresponding to a pulse repetition frequency of approximately 218.53kHz).

The desired values to be used in the prescaler and time constant data word can be easily calculated using the formula given earlier. As an example, suppose that we require a pulse repetition frequency of 1kHz (i.e. a period of 1ms of 1000 μ s). If we employ a prescaler

divisor of 16, we can arrange the formula given earlier along the following lines:

$$TC = \frac{t_{out}}{t_c \times P}$$

$$TC = \frac{1000}{0.286 \times 16}$$

(Note that t_{out} and t_c are BOTH in μ s)

Hence TC = 218.5

Since we have to use an integer value in the time constant data word a value of 219 should be employed.

Repeated calculations of time constant data words can be a little tedious and, where it is necessary to calculate a succession of values for loading into the down-counter, readers can make use of their trusty Spectrums aided by the following program:

```
5 CLS
10 INPUT "Period of output (us)"; tout
20 LET P = 16
30 LET TC = tout/(0.286*P)
40 IF TC<1 THEN BEEP 0.1,0.1: GO TO 10
45 IF TC>256 THEN GO TO 100
50 LET P = 256
60 LET TC = tout/(0.286*P)
70 IF TC>255 THEN BEEP 0.1, 0.1: GO TO 10
100 PRINT "Frequency of output = ";
    1000000/tout
110 PRINT "Prescaler = ";P
120 PRINT "Time constant = "; INT(TC)
125 PRINT: PRINT "Any key to continue,"
126 PRINT "or press Q to quit . . ."
130 LET r$ = INKEY$
132 IF r$ = "q" OR r$ = "Q" THEN STOP
135 IF r$ = "" THEN GO TO 130
140 GO TO 5
```

Testing the Z80-CTC Interface

The CTC can be tested in counter mode using the following program which generates a signal having a PRF of 218.5kHz on channel 0:

```
10 REM Load code module
20 FOR i=0 TO 12
30 READ x
40 POKE 32768+i, x
50 NEXT i
60 DATA 243,217,62,127,219,254,31
70 DATA 218,2,128,217,251,201
100 REM CTC commands
110 OUT 31, BIN 00010101
120 OUT 31,1
130 PRINT "Press SPACE to continue . . ."
140 RANDOMIZE USR 32768
150 STOP
```

The first section of code POKES a short machine code module into memory starting at 32768 decimal (8000 hex.). This code routine disables interrupts which would otherwise cause discontinuities in the output signal as an interrupt occurs every 20ms with the Spectrum in normal operation. Having disabled interrupts, the code waits for the SPACE (or BREAK) keys to be pressed. If either is pressed, interrupts are re-enabled (restoring keyboard input) and the program terminates. Note that, in this condition, the channel will still be producing an output but this will no longer be "clean" due to the presence of interrupts (which momentarily stop the system clock as it passes through the Spectrum's ULA).

Line 110 send the channel control word to the channel control register associated with channel 0 (port address 31). Note the use of the Spectrum's BIN keyword which makes it very simple to understand the structure of the control word (relate this to Fig. 1). Line 120 contains the time constant (in decimal) which is loaded into the down-counter for channel 0.

Readers having access to an oscilloscope may

like to check that the output waveform produced by the CTC Interface looks like that shown in Fig. 2. Readers not having access to an oscilloscope need not despair since the l.e.d. indicator driven by the channel 0 output should illuminate when the program is first run.

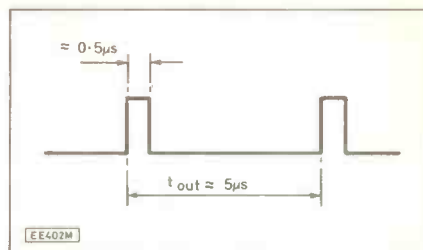

Fig. 2. Waveform produced by the test program.

Readers may wish to further experiment by entering different time constants in line 120. As an example, OUT 31,22 in line 120 will produce an output of 10kHz (actually 9.94kHz) whereas OUT 31, 219 in line 120 will produce 1kHz (actually 998Hz). Note that the l.e.d. indicator will become progressively dimmer as the duty cycle decreases. At 10kHz the l.e.d. will glow dimly, at 1kHz it will be barely illuminated.

If you would like a copy of our *On Spec Update*, please drop me a line enclosing a large (at least 250mm x 300mm!) stamped addressed envelope.

Mike Tooley, Department of Technology, Brooklands Technical College, Heath Road, Weybridge, Surrey KT13 8TT.

Next month: We shall be showing how the Z80-CTC Interface can be used as an event counter.

NATIONAL COMPONENT CLUB

All our packs are brand new, no manufacturers rejects, faulty or unmarked components. If you are anything less than delighted with your order please send it back for a full money refund within seven days of purchase.

ALL PACKS ONLY £1 EACH

- Pk1 300 ASSORTED RESISTORS Values from 1 ohm to 1M all full length leads.
- Pk2 50 WIRE WOUND RESISTORS All high wattage, lots of different values.
- Pk3 25 POTS AND PRESETS Sliders, multiturn, multigang, cermet, carbon etc.
- Pk4 70 ASSORTED CAPACITORS All different types values up to 4700uf, voltages to 250V.
- Pk5 20 LARGE ELECTROLYTICS Values like 4700uf, 2200uf at voltages up to 250V.
- Pk6 1 25,000uf Electrolytic capacitor.
- Pk7 20 ASSORTED IC's TTL, Linear etc all brand new and fully marked.
- Pk8 60 ASSORTED DIODES Zeners, signals like the IN4148, rectifiers from the IN4000 series.
- Pk9 10 18 WAY IC SOCKETS Low profile.
- Pk10 1 PROJECT BOX 153mm x 83mm x48mm complete with lid and screws.
- Pk11 1 4 DIGIT DISPLAY Seven segment, multiplexed with data sheets.
- Pk12 1 9V 105db SIREN 120mA electro mechanical.
- Pk13 10 ASSORTED SWITCHES micro-switches, highpower rockers etc.
- Pk14 5 MICRO-SWITCHES all different.
- Pk15 MYSTERY PACK Our best selling pack last month.
- Pk16 75 ASSORTED HARDWARE Rubber feet, cable ties, bolts, grommets, sleeving, PCB mounts etc.
- Pk17 5 FUSE HOLDERS 20mm new style complete with protective boots.
- Pk18 15 PP3 BATTERY CLIPS With 100mm red and black leads.

Please send your order together with cheque or postal order to:

DEPT. EE, WOODSIDE, DOWSETT LANE,
RAMSDEN HEATH, Nr BILLERICAAY, ESSEX, CM11 1JL.
Please add 75p towards P & P.
All prices include VAT at 15%.

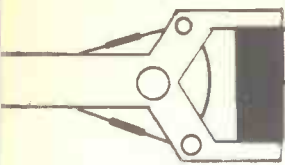

Robot Roundup



NIGEL CLARK

ROBOTS SIDE-LINED

LAST month's comprehensive list of robots was missing some well-known names, most of which had been around for a number of years, including BBC Buggy, Armdroid and the Memoco Electron. Some have been discontinued and some are in abeyance. And they have been joined by the Alfred arm.

The Buggy and Electron have been stopped but the Armdroid and Alfred are showing signs of continuing, albeit in other guises.

Economats, which designed the Buggy for the BBC series *Computers in Control* a few years ago, using Fischertechnik parts, said it was being stopped because of problems in obtaining the electronic components. The company added that the add-ons, a gripper and penholder, would still be supplied but the last of the buggies had been sent out.

Production of the Electron, a computer-controlled version of the old Armatron from Tandy, has been stopped because of pressure of work in other parts of the company. Memoco Electron Developments began research and development work some time ago while still planning to upgrade the Electron. However, the R & D work expanded and the Electron was side-lined.

"There is certainly a market for the arm," said Bob French who runs Memoco. "I stopped advertising it last November but I am still getting enquiries." However, the machine is now out of stock.

He added that he had not thought about it in detail but if anyone wanted to take over manufacture he would consider an offer. Some of the company's development plans were well advanced and there was a prototype mobile version controlled via both infra-red and radio links.

ON THE QT

The Colne Armdroid arm appears to have stopped being supplied as well.

When Colne Robotics went into liquidation last year the rights to the five-axis arm were taken over by a company called Qti which traded under the name of Qti Colne Robotics. The Armdroid name was maintained and there were plans for upgrading similar to those of the original Colne.

Nothing has been heard of the company for some time. However, plans by a group of former Colne employees to create a machine based on the Armdroid are going ahead.

Originally it was intended that the employees, as part of a group known as Richmond Logic, would design the machine with the working name of Connect 2 and it would be marketed by Shesto Tech. Richmond has now been disbanded, two of the staff have joined Shesto and the company is bringing out an arm known as Armtech 2000.

The new machine is a five-axis arm with toothed-belt drive and can be used with any computer which has a standard 8-bit parallel port. However, no specific software has been written.

The likely cost to educational establishments of the Armtech 2000 arm is expected to be around £450, plus VAT. There is also the most obligatory workcell to go with the machine.

The workcell includes a linear slide base, a rotary carousel and conveyor belt. Other accessories include pneumatic and relay kits and vacuum gripper. The arm can be controlled through its own keypad.

A larger and more robust version is being developed, but there are no further details at the moment.

FIRST SHOWING

The Armtech 2000 is getting its official launch at the *Craft, Design and Technology Show*. The event, which is aimed at the teaching of CDT subjects in schools, is being held this year over three days from Thursday October 15 to Saturday October 17. Previously it has been staged at the Wembley Conference Centre but this year it has moved to the National Exhibition Centre in Birmingham.

A service to convert existing Armdroids from the string-driven version to what Shesto calls a more efficient silent and trouble-free toothbelt version is under way. Whatever the truth of the claims, Armdroids have always suffered from a certain lack of precision because of slippage by the driving strings.

Owners who wish to take advantage of the offer should send their machines to Shesto who will carry out the conversion for £160, and £10 for carriage, plus VAT. They promise a turnaround of between two and three weeks.

The company also supplies new software for the converted machines although they will work on the old Colne software.

The story of Alfred is a little less clear at the moment. The low-cost five-axis articulated robot arm, which was featured as a project in *Everyday Electronics* a few years ago, was originally designed and manufactured by Robot City Technology.

The company closed earlier this year and for a time it appeared that production would be taken over by another Milton Keynes company.

Oxbridge Technology had shown an interest

but after about three months of talks with Robot City managers, Alan Green and Dave Dowty, and investigations, no agreement could be reached. Green and Dowty decided to go ahead on their own.

They formed a new company, Research Development Associates, and bought the rights and assets of Robot City. Since then they have been selling Alfred, at about £270 + VAT assembled and £200 + VAT in kit form, and its bigger spin-off R-200, at about £2,000.

"There is still a lot of goodwill from the days of Robot City and people remember the Alfred name," said Dowty. He added that talks were being held with two major educational distributors to take Alfred. Whoever won the deal would be launching the machine at CDT.

The deal might also include R-2000 but as this machine is aimed more at industry they may continue to sell it direct. They intend to rename it MARS, standing for Modular Automation Robot System, which is a good way to get an acronym.

In the meantime, Oxbridge is pressing ahead with plans for its own arm known as Archie. It has been announced, but the company is not releasing full details until it has sorted out its marketing plans.

Another launch planned for what it seems is going to be a busy CDT show is an addition to the range of technical kits. Joining Lego, Fischertechnik and Meccano is Plawco which, with the usual surfeit of imagination, has named its kit Plawcotech, and is being distributed by Commotion. In addition to the present kit of plastic components for making various models the "tech" package will contain gears, wheels and motors.

The full Plawcotech kit costs about £50 and the technical parts can be obtained separately for about £20. Interfaces are not available but Commotion say that the kit could be used with Beastly servos and interface which will allow the models to be controlled by a variety of small micros.

The Armdroid 1 arm

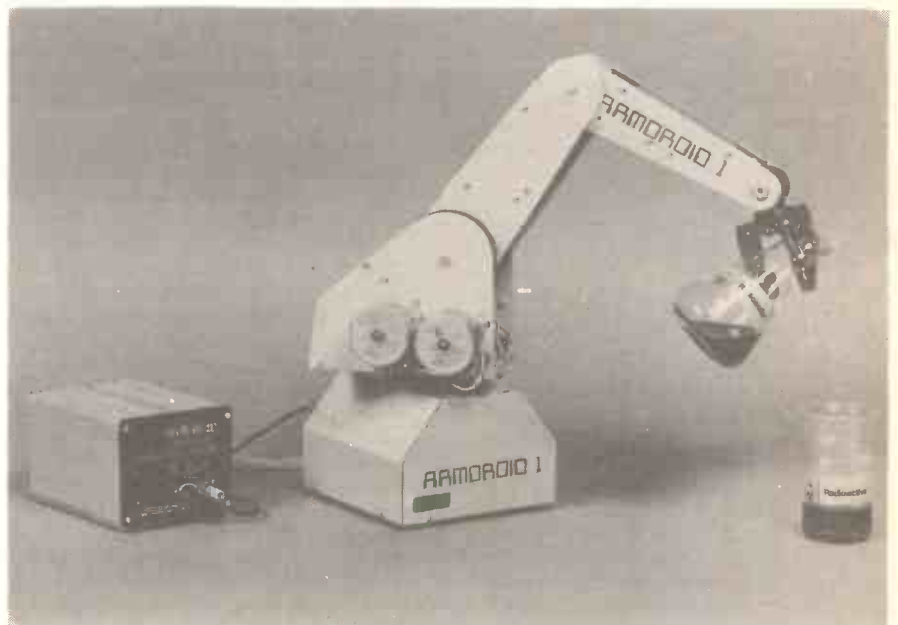

FOR YOUR ENTERTAINMENT

BY BARRY FOX

Cordless Code

At long last, it is illegal to sell unauthorised cordless telephones. It has always been illegal to use them, but a loophole in the law left shops free to sell hardware that could cost the customer a £2,000 fine and three months in jail under the "Wireless Telegraphy Act".

To set the record straight, Britain authorises cordless phones which send and return on the 1.6MHz and 47MHz bands, at a power of 10mW or below. Foreign imports often operate on different frequencies (e.g. 49MHz) and at higher power.

Look for the green approved circle, and steer clear of anything with a red warning triangle — even if it is on sale at ridiculously low prices, often out of the back of a car boot. Last year 16 people were convicted for using unauthorised cordless phones. There will be more this year.

Authorised cordless phones are getting cheaper all the time. From nearly £200 they have now fallen to around £69. But if you are buying, do watch out for the pitfalls.

Unless the handset and base station are electronically paired there is a good chance that someone else with the same make of telephone will be able to make calls on your base station, and so get them charged on your line. Fidelity of North London, the only firm actually making cordless telephones in Britain, has a security system based on around 64,000 codes. Each base station and handset is individually paired with one having the same code.

Cross Words

Once Fidelity has made 64,000 systems, the company will start re-using the same codes over again. But even then there will be very little chance of two matching handsets and base stations ending up next door or in the same block of flats. Some cheaper cordless phones use no security codes, or make do with only a few hundred so that cross dialling is much more likely.

Because there are only eight channels in the allocated frequency band, there is always a good chance that two neighbouring phones will interfere with each other to give the equivalent of a crossed line. Fidelity identifies each matched pair with a channel code A, B, C, D, E, F, G or H.

If you buy an A channel pair and find by bad luck that your next door neighbour is already operating on the A channel then — in theory at least — you can go back to the shop and ask to exchange your units for a B pair, and so on. It's not ideal, but at least it's a practical solution to an otherwise insuperable problem.

Not So Smart Imitation

The Hayes Smartmodem for electronic mail and computer communication, has a built-in loudspeaker which gives low-fi monitoring of how a call is progressing. You can hear a call being dialled, listen to the ringing tone and briefly hear the remote modem answering. Then the modem switches off.

Some Hayes-imitation modems cut cost by omitting the loudspeaker. The makers say there isn't room for one. Maybe, maybe not. But a loudspeaker can be very useful.

A friend of mine bought a speaker-less modem and couldn't get it to work with the

Telecom Gold electronic mail service. It was only when he borrowed a Hayes modem that he found out why.

Some weird fault on his line was repeatedly misrouting calls from Telecom Gold to the private home of what sounded like a little old lady. Every time the modem dialled Telecom Gold, it reached the little old lady instead. All she heard was a modem whistle at the other end of the line. And she was getting pretty fed up with it. When my friend plugged in the Hayes, he heard the low-fi sound of a frustrated voice saying, "Who is that who keeps calling and whistling?"

Thought for The Day

This Christmas, spare a thought for the Germans. They are only getting one day off this year.

The great British Christmas shut-down starts earlier every year and goes on longer. From mid-December it becomes increasingly harder to find company spokespersons who aren't shopping, partying or lurching.

The official Christmas break now stretches through New Year's Eve to early January. Japanese firms send out business letters dated December 25, but it's a non-Christian country — even though the shops are now full of Christmas cards at this time of year.

West Germany is the surprise. If Christmas falls over a weekend, that's tough luck on the workforce. They get Saturday and Sunday off and start again on Monday with nothing in lieu. It's known in Germany as a "bad year" or a "good year".

A good year for the workforce, when Christmas falls mid-week, is a bad year for the employer. A good year for the employer is a bad year for the workforce.

This year it's half and half. Boxing Day is on a Saturday. So they get Friday off and that's all.

Talking Toys

Each year the world sinks deeper into a new crust. It is made up from discarded gadgetry. There is now a world industry in electronic and mechanical "nick-nacks" which do something clever.

When that something is unashamedly pointless the gadget is labelled a toy. As the saying goes, it is only the price of their toys which now distinguishes the men from the boys.

Adults worry about buying toys. The staff at Hamleys in London, the largest toy shop in the world, soon get used to selling train sets to fathers on their way to the maternity ward to see a three-hour old son for the first time.

Last Christmas I took a trip to Hamleys' London store to find out about new trends in electronic toys. I found that solid state recording is the common factor.

Smarty Bear and Baby Talk dolls both have a microprocessor and memory inside which are triggered by the sound picked up in a hidden microphone. So they churn out stock phrases at random whenever someone talks to them.

At the same time a motor drives a gear to move the mouth and eyes in synchronism with the speech. Pressure sensitive switches trigger a giggle.

Circuit response time is deliberately slow. This way they ignore sharp impulse sounds and respond only to a few seconds of speech. The phrases are cleverly nondescript.

"Who is President of the United States", I asked Smarty Bear. "Better ask again later", he said first time. "That's a tough question" was the next answer.

"What's 2 plus 2?" produced the answer "For sure", which sounded uncannily like "Four".

The Teddy Ruxpin bear doll has a tape recorder built in. The audio signal of the tape triggers synchronised mouth and eye movements. Synchronisation is by coded pulses on a custom tape. But some music, like heavy rock, has a similar effect.

Blabber Mouth

The Talking Friends toy bear works like a spy's bug. The body contains a microphone, loudspeaker and solid state recording device. Any loud sound starts the system loading three seconds of audio into a random access memory chip. When the memory is full the stored sound is automatically replayed. So the bear immediately mimics everything that is said to it.

Blabber Mouse is a radio with a model mouse on top. The mouse has a moving mouth and a signal level sensor in the radio circuitry detects peaks in the audio signal and moves the mouth in sympathy. The effect on serious news broadcasts and political speeches is not to be missed.

This kind of gimmick does not come cheap; it costs between £20 and £60. Although marketed by British toy firms, all the technology is made in the Far East. So too is the Tomy range of robots. Each has a disarming personality all of its own.

Mini robots, like Dustbot and Dingbot walk, run or roll around until called to a halt with a sharp shout or clap. A built-in microphone senses transient peaks and temporarily disconnects the motor drive. The robot then sulks for a few seconds before busting off again.

The Tomy Omnibot 2000 is almost useful. Costing nearly £400 and larger than many children, it works either under radio control or pre-programmed timer. If you want to be woken in the morning with orange juice, Omnibot will roll across the room with a tray, grab a jug of orange juice with its claw hand, pour the drink into a glass, flash his eyes and say whatever morning greeting the proud owner has recorded on tape the night before.

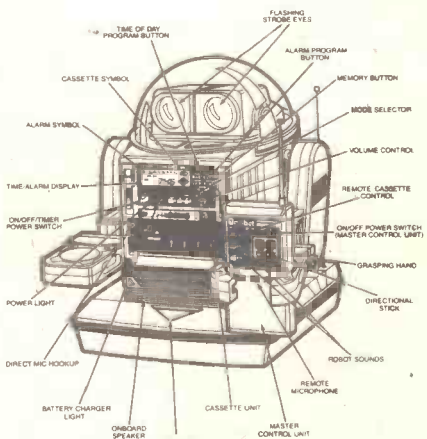

Omnibot personal robot from Tomy Toys.

DECEMBER FEATURES...

FREE!

TWO DATA CARDS

The start of a series of eight Data Cards. Cards 1 and 2 give information on the 6502 microprocessor. The reverse of each card will give more general information, e.g. binary-hex-decimal conversion tables.

16 PAGE RTVC CATALOGUE

Another free catalogue attached to the centre of every issue. 16 pages mainly featuring loudspeakers and test gear from R.T.V.C.

AUDIO SIGNAL GENERATOR

A straightforward item of test gear which will prove extremely useful to all hobbyists.

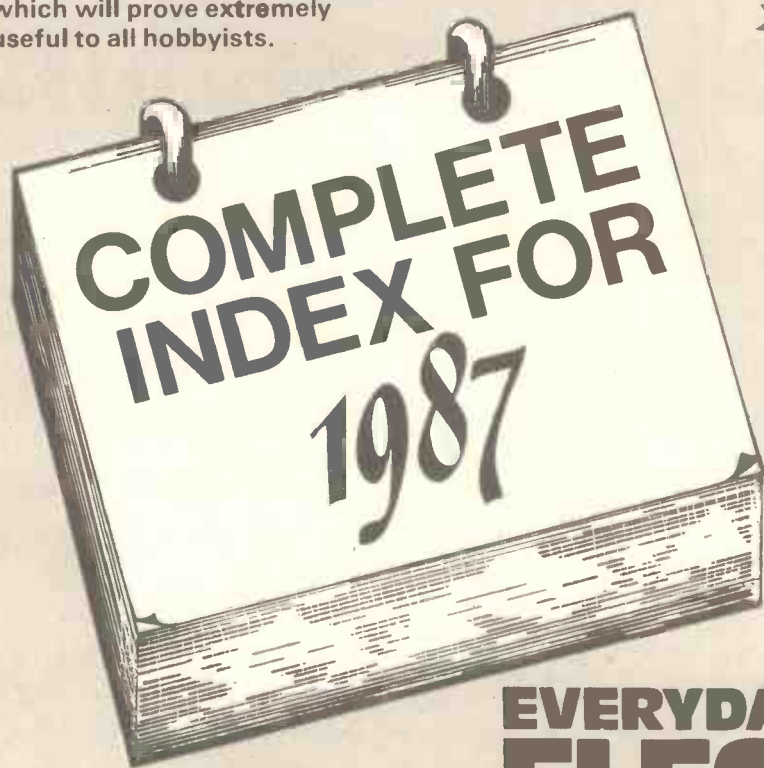

Two simple lights projects published with Christmas in mind. A control for tree lights and a Twinkling Star.

If you want to know what projects we published in '87 or if you keep your issues in a binder our comprehensive index published in the December issue is a must.

EVERYDAY ELECTRONICS

December issue on sale Friday November 13.

SECURITY

Modules
Systems
Accessories

SAVE ££££'s
BY INSTALLING YOURSELF

MINIATURE PASSIVE INFRA-RED SENSOR RP33

Size only 80x60x40mm. Detects intruders up to 12 metres away.



- 12 metre detection range.
- Size only 80x60x40mm.
- 24 Detection zones.
- Wide 85° coverage.
- Switchable LED Indicator.

This advanced new intrusion detector operates by detecting the body heat of an intruder moving within the detection field. The use of a dual element pyroelectric sensor means that changes in ambient temperatures are ignored, thus providing a stable and reliable performance. Easily installed in a room or hallway, the unit will provide effective detection of any intrusion. Operating from a 12V supply and consuming only 15mA, it is ideal for use with the CA 1382, CA 1250 or any equivalent high quality control unit. Supplied with full instructions, its performance compares with detectors costing more than twice the price.

CA 1382 ADVANCED CONTROL UNIT that's simple to install and operate.



- Fully automatic siren re-set.
- Audible entry/exit warning.
- Alarm Sounded memory.
- 2 separate loop inputs + 24hr circuits.
- Built-in electronic siren.
- Easily installed, full instructions supplied.

The latest control panel provides effective and reliable control for all types of security installations. Its advanced circuitry checks the loop circuits every time it is switched on, preventing incorrect operation. Using a simple 'on/off' key switch, it is easily operated by all members of the family. In addition it provides 24 hr. personal attack protection. Housed in a steel case, it is supplied with full operating instructions.

Only £44.95 + VAT Available in kit form with fully-built electronics, £39.95 + VAT.

CA 1250 LOW COST ALARM CONTROL MODULE



This tried and tested control unit represents the finest value for money in control systems, providing the following features:

- Built-in electronic siren drives 2 loud speakers
- Provides exit and entrance delays together with fixed alarm time
- Battery back-up with trickle charge facility
- Operates with magnetic switches, pressure pads, ultrasonic or LR units
- Anti-tamper and panic facility
- Stabilised output voltage
- 2 operating modes full alarm anti tamper and panic facility
- Screw connections for ease of installation
- Separate relay contacts for external loads
- Test loop facility.

Price £19.95 + VAT

HW 1250 - ATTRACTIVE HOUSING plus HARDWARE FOR CA 1250

An attractive steel case designed to house the Control Unit CA 1250 together with the appropriate LED indicators and key switch (available separately). Supplied with the necessary pillars, fixings and punched front panel, the unit is given a professional appearance by the adhesive silk screened label.

Size: 200x180x70mm. Only £9.50 + VAT

COMPLETE SYSTEM
FROM
£39-95
+ VAT

DP 3570 LIGHTING CONTROLLER

This versatile module provides timed switching of loads up to 3A for pre-set times between 10 secs and 5 mins, the timed period being triggered by the opening or closing of an external loop or switch. The built-in 12V 250mA power supply is available for operating external sensors. Suitable plastic enclosure £2.85 + VAT.



Only £13.95 + VAT

FL 500 QUARTZ HALOGEN FLOOD LIGHT



Whilst intended for security lighting applications, this unit is suitable for lighting patios, pathways and gardens etc. Supplied complete with 500W lamp. Protective grill, £1.95 + VAT.

Only £14.95 + VAT

IR 1470 - 50ft. INFRA-RED BEAM SYSTEM

Consists of a separate transmitter & receiver, the system provides an invisible modulated beam which when broken operates the built-in relay. For use with security systems, but also ideal for photographic purposes and industrial applications. Size: 80x50x35mm. Only £25.61 + VAT



US 5063 DIGITAL ULTRASONIC DETECTOR

- 3 levels of discrimination against false alarms
- Crystal control for greater stability
- Adjustable range up to 25ft
- Built-in delays
- 12V operation.



This advanced module uses digital signal processing to provide the highest level of sensitivity whilst discriminating against potential false alarm conditions.

Only £13.95 + VAT

ULTRASONIC MODULE ENCLOSURE

Suitable steel enclosure for housing the US 5063 supplied with the necessary mounting pillars and fixings.

Only £2.95 + VAT

RISCOMP LIMITED.
Dept EE11, 51 Poppy Road
Princes Risborough
BUCKS HP17 9DB

The Security Specialist

ORDER BY MAIL OR TELEPHONE

Tel: (084 44) 6326

CONQUERING NEW HEIGHTS

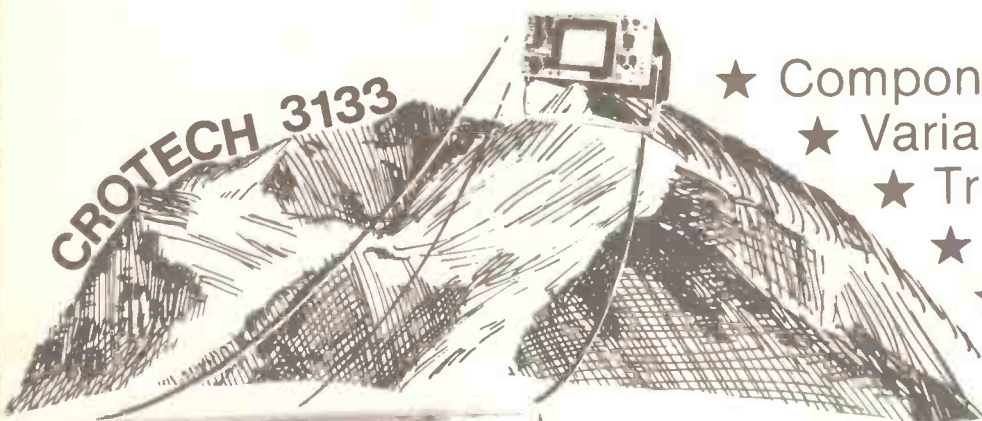

CROTECH 3133

- ★ Component Comparator
- ★ Variable Hold Off
- ★ Triple DC Source
- ★ DC - 25 MHz
- ★ 40ns/div
- ★ 2mV/div
- ★ Low Cost

Full 2 Year Warranty

£319*

To scale the heights, just call us for your FREE copy of our catalogue



*(Ex VAT & Delivery)

Yes its 25MHz for £319

Crotech Instruments Limited

2 Stephenson Road, St. Ives, Huntingdon, Cambs. PE17 4WJ
Telephone: (0480) 301818

Actually Doing it!!

IN LAST month's *Actually Doing It* we considered various ways of producing a photographic master from which a printed circuit board can be produced. Having reached that far, and by whatever means, there is then the minor matter of actually producing the board! The first stage is to prepare a suitable piece of printed circuit material.

PHOTO-RESIST

You can buy copper laminate board ready-coated with photo-resist, or resist can be added to ordinary copper laminate board. I have produced a number of boards using an ordinary board plus a do-it-yourself layer of photo-resist, and I have used both brush-on and spray-on resists. To be completely honest about it, I have always found it difficult to obtain a reasonably even coating of resist using either method, and on occasions I have struggled to get a usable end result at all. This could be due to a lack of skill on my part rather than something fundamentally wrong with the photo-resists, but initially at any rate, I would strongly recommend the use of ready coated boards. Even these often have a less than perfect coating of resist, but they are generally good enough to enable a sound finished article to be easily produced.

The basic scheme of things is to cut the board to size, expose it to ultra-violet light via the master art-work, and then develop the board. This gives a board having resist left on the areas where copper tracks and pads are needed, but devoid of resist in other places. This is then etched and drilled in the usual way.

The photo-resist boards all seem to have a protective layer of plastic or paper over the etch resist, and this enables them to be handled in normal light without any risk of fogging. It also protects the delicate coating from physical damage. Even with the protective layer, the board should be stored under dark conditions, and preferably somewhere quite cool. Although it can be obtained more cheaply if ten or more boards at a time are purchased, the board has a shelf life of only a few months. It would therefore be unwise to stock up with large amounts unless it will all be used up fairly quickly. You will be in no doubt if the board has passed its "use-by" date, as it will simply fail to develop significantly.

The protective layer provides a useful medium when marking out the cuts in the board. Ballpoint pens seem to readily mark both the plastic and paper varieties. A hacksaw is used to cut the board, and this really needs to be a full-size type rather than a junior hacksaw. Cut the board with the copper/resist side facing upwards. Cutting the board when it is the other way up can tend to damage it by ripping the copper layer away from the fibreglass board material. The cut edges can be very rough, with some quite sharp edges being produced in some cases. A small amount of gentle filing should soon render these completely harmless.

EXPOSURE

Ideally an ultra-violet lightbox should be used when exposing the board, and these are available from some of the larger electronic component retailers. Unfortunately, they are fairly expensive, and are probably not a

practical proposition unless you are likely to produce a substantial number of boards over a period of time. If you have access to a suitable lightbox the master art-work is taped to the glass top with the "copper" side facing downwards. In other words, the image you see when the art-work is on the lightbox should be a mirror image of the design copied from the magazine. Be very careful to get this right, as the finished board is unlikely to be usable if you get the art-work upside-down.

The board is taped in place over the art-work, and it is, of course, positioned copper/resist side facing downwards. The board is very insensitive by normal photographic standards, and it is little affected by visible light. Consequently it can be exposed to ordinary (indoor) light levels for periods of a few minutes without risk of fogging. Keep the board out of direct sunlight though, especially once the protective layer has been removed from the resist. Align the board accurately with the corner markings on the art-work. It is important that the lightbox has a pad of foam material in the lid to press the board firmly against the art-work, and a suitable pad must be added if it is not already present.

The optimum exposure time depends on a number of factors, such as the power of the lightbox and the amount of light passed by the clear areas of the art-work. It will range from just a couple of minutes with a powerful lightbox to as much as half an hour with a low power type and a drawing that is what might be termed a poor "conductor" of light. With my 16 watt lightbox I find an exposure time of around 18 minutes is about right. Provided the drawing is a good quality type with good opaque track and pad markings, it is better to have an exposure that errs on the long side than to use one which is too short. A little experimentation should soon reveal an exposure time that will give good results.

If access to an ultra-violet lightbox is not possible, the alternative is to improvise a simple exposure system. Something along the lines of Fig. 1 should suffice, and basically all that is needed is a sheet of glass to which the art-work is fixed, plus some means of pressing the board in place beneath this. As when using a proper lightbox, the board should be taped in place so that there is no risk of it slipping slightly out of position during the course of the exposure.

The obvious problem with an improvised

lightbox is that an ultra-violet light source is required, and could prove problematical. An ultra-violet "sunray" lamp probably represents the most practical solution, but it will need to be positioned quite close to the board in order to obtain a reasonably short exposure time. Ultra-violet light is dangerous, and can be particularly harmful to the eyes. If you use a lamp of this type, read the instruction manual and take any necessary safety precautions. It is again a matter of making a few experiments to find the best exposure time. Provided the lamp to board distance is always the same there should be no difficulty in obtaining consistent results using this method (which is one I used successfully for some time before obtaining a lightbox).

Sunlight is the other option, and although its zero cost makes it seem an attractive method, there are a couple of drawbacks with this method. The obvious one is that in Britain it is often in short supply, and on an overcast day it may well prove to be impossible to obtain a proper exposure. Even if you are prepared to wait for the sun to make an appearance, attempts to get consistent results might prove to be fruitless. The strength of sunlight varies according to the time of day, time of year, and on just how clear the atmosphere happens to be. You may find that after a few experiments you can correctly estimate the required exposure time for the prevailing conditions, or you might end up wasting a lot of expensive photo-resist copper laminate board. It is not a method I could wholeheartedly recommend, but I have managed to successfully produce a few boards using it.

DEVELOPMENT

Having exposed the board, on careful examination the track pattern will probably be visible as a faint image in the resist. The board should be developed as soon as possible after the exposure has been made. The usual developer is a solution of sodium hydroxide, which is perhaps better known as caustic soda. It should be possible to obtain sodium hydroxide crystals from large chemists, photographic suppliers, and some of the larger electronic component suppliers.

Caustic soda lives up to its name, and it should not be manipulated by hand. If the crystals should come accidentally into contact with you, or anything (or anyone) else, thoroughly wash the area of contact at once. The standard developer for spray-on resists is seven grams of caustic soda to one litre of water. For ready-coated boards a stronger solution seems to be needed, with about 15 to 20 grams per litre of water giving good results. The catalogue of the retailer who supplies you with the board or photo-resist may well give details of the recommended developer solution, and may also list suitable developer or crystals. In this case, it would obviously be advisable to follow the retailer's recommendations.

Fig. 1. With a little ingenuity a u.v. lightbox can be improvised.

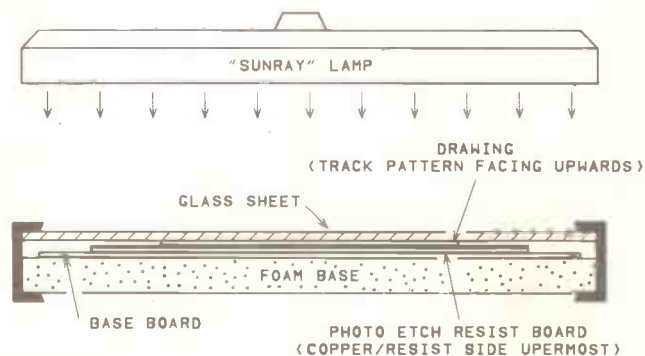

The developer is not a very strong solution, and as such it is less dangerous than the crystals. However, it still needs to be treated with respect, and contact with your skin should be avoided as far as possible. A flat bottomed dish is needed when developing the board, and proper photographic dishes are ideal. Any dish having a flattish bottom and of adequate size to accommodate the board should suffice though. Place the board in the dish (with its copper side uppermost) and then pour in enough developer to thoroughly cover it.

You may find that by gently agitating the dish for a few minutes the unwanted resist is removed, leaving the required pattern on the board. Things rarely go this smoothly though, and in order to get the board to develop reasonably quickly it is usually necessary to

swab it with a cotton bud or a piece of kitchen towel. Rapid development is important, as there is a real danger of tracks and pads being seriously eroded if development takes too long. Do not leave the board in the developer any longer than is absolutely necessary in order to remove the unwanted resist. On the other hand, do not be too eager to remove it, or you might end up with large areas of unetched copper on the finished board.

When development has been completed, remove the board from the dish using tweezers, and thoroughly rinse it in water. Sodium hydroxide developer is not reusable, and the contents of the dish should be discarded. The board should now be ready for etching. Where possible, it is advisable to etch the board immediately, as this gives the copper

no chance to oxidize in the air (which could hinder the etching process). It is a good idea to carefully examine the board, as there may be slight imperfections in the resist pattern. It is much easier to deal with these now rather than after the board has been etched. Any problems will normally be in the form of cracks in tracks, or thinning of tracks or pads. To repair any imperfections, first dry the board, and then use an etch resist pen or transfers to make the corrections.

Having reached this stage the board is next etched and drilled using the standard techniques, which will be described in next month's *Actually Doing It*.

Robert Penfold

SHOP TALK



BY DAVID BARRINGTON

On Course

The interest in our new C & G Certificate series *Introducing Microprocessors* has been very rewarding with enquiries from students, colleges and industry alike. However, for all those readers who would like the complete series now we regret that for several reasons we are unable to meet their requirements. — Why not take out a subscription or place a regular order with your newsagent now?

Good news for readers in the Manchester area, we have heard from North Trafford College that if they receive sufficient enquiries it may be possible to offer the college facilities for assessment purposes.

Interested parties should write to Mr J. Priest, Head of Engineering, North Trafford College, Talbot Road, Stretford, Manchester M32 0XH. ☎ 061-872 3731.

Digi-Lab

Still on the microprocessor front, we have received news of a comprehensive workstation for those involved in advanced digital electronics. **Flight Electronics** have recently introduced the FLT-102 Digital Training Laboratory.

Built-in features include: a multi-rail variable d.c. supply; four-range digital voltmeter; function generator; seven segment displays; logic switches; function switches; pulse switches and logic indicators. Components with 0.3mm to 0.8mm leads can be plugged into the large 1680 tie-point "test-bed" which accepts all d.i.p.s.

The FLY-102 trainer costs £250 and, for bona fide educational and industrial establishments, a 30-day evaluation

period is available. Flight have also just launched their sixth annual 44-page, full colour, catalogue which is available *Free* from: **Flight Electronics, Dept EE, Ascupart Street, Southampton SO1 1LU.** ☎ (0703) 227721.



Acoustic Probe

The 2W power amplifier i.c., type TBA820M, used in the *Acoustic Probe* is a very popular device and is listed or stocked by practically all of our advertisers.

The "heart" of the probe sensor is made from a piezoelectric buzzer element from the PB2720 range. The ceramic element is available separately from most component stockists.

The element is supplied unboxed and without connecting wires, and soldering to the silvered electrode *must* be carried out with the absolute minimum of heat. The brass rim of the transducer tends to form a heatsink and obviously more heat will be required to attach a connecting wire, but once again it is essential to keep the heat down to a minimum.

When buying the BC184L transistor it is important to purchase a device that

carries the suffix L as pin connections for this device vary. The printed circuit board for the *Acoustic Probe* is available through the *EE PCB Service*, order code EE584.

BBC Sideways RAM

The 64K CMOS Static RAM chip, type 6264, called for in the *BBC Sideways RAM* must be in scarce supply in some areas. However, it is still listed by Maplin, Cirkit and Omni Electronics.

The i.c. sockets and interconnecting ribbon cable should not prove difficult to purchase and are usually listed under "computer accessories" sections in component suppliers catalogues. The printed circuit board for this project is available from the *EE PCB Service*, code EE585 (see page 628).

Oil Tank Contents Gauge

The only source we have been able to locate for the dial cord drum, used as part of the tank sensor unit in the *Oil Tank Contents Gauge* project, is Maplin. This is listed as a "Cord Fixing Drum", code RX94C (Cord Drum Large). The 6:1 reduction ball drive appears to be available from both Maplin and Cirkit.

The linear bargraph driver i.c. and 10-segment red bar display are fairly common devices and widely stocked and should not cause buying problems. It may be a cheaper alternative to use 4-core telephone wire (using only 3-cores) in place of the 3-core light duty connecting cable. The 4-core cable is now readily available from most components shops.

Accented Metronome

The LM4017 decade counter i.c. listed in the components list for the *Accented Metronome* is another device that is now a common item and should be available "off-the-shelf" from most suppliers.

The 10-segment bargraph array is also fairly common and should not cause sourcing problems. The anodes of this device are identified by the side which carries the product code mark.

The printed circuit board is available from the *EE PCB Service*, code EE582.

We cannot foresee any component buying problems for the *Object Counter* — this month's *Exploring Electronics* project.

...REPORTING AMATEUR RADIO...

TONY SMITH G4FAI

OLD-TIMERS

There are some radio amateurs on the air today who made their earliest transmissions in the days of spark transmitters. I know one who first went on the air in 1910! Many of them belong to the Radio Amateur Old Timers' Association, membership of which is limited to those who have held an amateur transmitting licence, or have had a continuing interest in amateur radio, for not less than twenty-five years. With the experience of so many going back long before that, however, the journal of the Association, *OT News*, makes fascinating reading, preserving for posterity knowledge, memories and experiences which would otherwise be forgotten.

There's the story of the late Ken Alford, G2DX, who originally obtained an experimental licence with the call TXK in 1912, using a spark transmitter and crystal detector bought at Gamages in Holborn for £5. He took this equipment up in a friend's aeroplane over Lake Windermere, and the reception of his signals on the ground could well have been the first air-to-ground communication.

G2RW recalls how in the 1920s, while serving in the RAF in India he and a friend, using home-made equipment on the then new short wave frequencies, made contact with Gerald Marcuse, G2NM, culminating with Marcuse sending "Congratulations on the very first two-way communication between the UK and India".

REUNION

Some of today's old timers come back to the hobby after a long absence. *OT News* reports the return, after 58 years, of Marcus Samuel, G4FX, described as radio's Rip Van Winkle!

Marcus became interested in radio, listening to broadcasts from 2MT, Writtle, in the early 1920s and received the call-sign G2ACU for experiments using an artificial aerial in 1923. He obtained a full licence, G5HS, in the same year and by the mid-20s was making pioneering transatlantic contacts.

Owing to domestic circumstances he was unable to operate after 1928 and remained "dormant" for ten years. In 1939 he applied for a new licence and was allocated the call-sign G4FX. However, he never used this call as he joined the Civilian Wireless Reserve, being called up soon after.

So it was that in January 1986 at the age of 81, and now blind, he made his first modern amateur radio contact! He soon crossed the Atlantic again, and he describes his first new contact with the USA thus: "It was made in the kneeling position — this was entirely due to my large dog being fast asleep and refusing to get out of the way." A far cry from those pioneering days of the 1920s!

MEMBERS WELCOME

Short wave listeners as well as licensed amateurs can join RAOTA. It costs £6 for the first year and £4 for subsequent years. This includes copies of the *OT News* quarterly,

which can be received on tape if required. Nets are held on Thursdays at 11.00 and 19.00 clock time, on 3.765MHz, under the call G20T, when members keep in touch with each other.

Enquiries about RAOTA can be made to: *The Secretary, Mrs Sylvia Havard, 1 Merricks Lane, Bewdley DY12 2PA, enclosing an s.a.e.*

CHINA AGAIN

In the August column I described how Chinese amateur stations are getting back on the air again. I said that they were still relatively rare at present, but I didn't realise quite how rare.

According to a report in *Break-In*, journal of the New Zealand Association of Radio Transmitters, July 1987, there are just sixteen amateur stations operating in the People's Republic of China. They may be thin on the ground but they must be pretty busy. Plenty of British amateurs appear to have worked at least one of them, and the Chinese seem to be quite conscientious in sending out their QSL cards.

It's all quite exciting at present if you come across a BY station. But what is it going to be like, I wonder, when there are as many Chinese stations on the bands as there are Japanese!

of various techniques. Connecting any of these to the equipment by means of a feeder (e.g. coaxial cable) of the required impedance usually produces a suitable "match" between antenna and transmitter/receiver and an ATU is not required.

If, however, the antenna is not accurately dimensioned for the frequency to be used the impedance at the feed point may be higher or lower than that desired. A mismatch may then occur, resulting in an unsatisfactory transfer of signal, with many modern transceivers automatically reducing their power output in the face of a mismatch.

Enter the ATU. This is a device to ensure that the feeder does not present a mismatch to the equipment in use. When the impedance of the feeder does not match the impedance of the antenna the feeder line itself acts as a transformer. An ATU then placed in the line near the transmitter finds itself faced with varying impedances depending on the frequency in use. The function of the ATU is to transform that impedance to meet the transmitter's needs, at the same time discriminating against the radiation of unwanted frequencies (harmonics) by the transmitter.

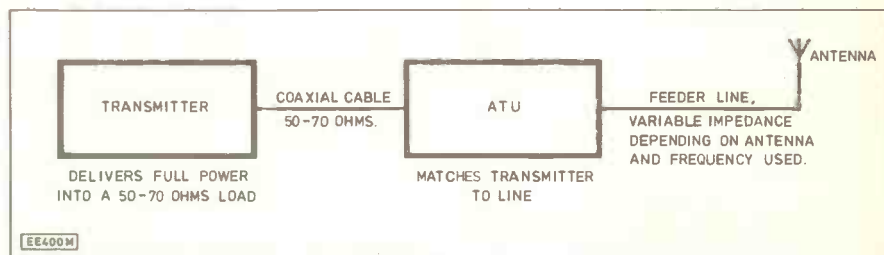

Fig. 1. Block diagram showing the function of an antenna tuning unit (ATU).

QUESTION TIME

Q. What is an ATU?

A. An antenna tuning unit is a versatile instrument found in many amateur radio stations, although the one thing it rarely does is tune an antenna! Amateurs experiment endlessly with different types of antenna, trying to find the best one for their particular location and needs, and I will describe some of these in a later column.

All antennas have a *feed point* where a feeder line from the transmitter/receiver connects into the antenna, and it is important to have a suitable impedance at this point. Most radio equipment today requires an impedance of 50-70 ohms but this is only attainable in an antenna with dimensions physically or electrically designed to represent a half-wavelength around a particular frequency.

Such antennas can be *single-band* or *multi-band*, the latter being in effect a number of single-band antennas rolled into one by the use

of receiving it ensures the maximum transfer of available signal from the antenna, and provides a high degree of selectivity, helping to reduce "image" interference from stations on other frequencies.

It does actually "tune" one type of antenna, i.e. random length end-fed wire antennas. Then, it functions as described for both transmitting and receiving as well as electrically adjusting the antenna to resonate at the desired frequency.

There are many types of ATU. They can be bought commercially, with de-luxe electric motor powered versions automatically adjusting all controls to achieve a perfect match; or they can be home-constructed from a choice of designs, some requiring only one coil and one tuning capacitor.

They are indispensable for antenna experiments and for day-to-day operation in many stations. Many designs have been published and they represent one of the most popular of all amateur radio construction projects.

TEL: 0939-32763

TELEX: 35565

TWIN 12V FLUORESCENT LIGHT £5.99

Power Lead with 4-way connector: 2.5mm Jack, 3.5mm jack, 2.1mm D.C. Lead length: 1.8 Mtr. CAR/PL - £2.98

Extension lead to project cigar lighter-type socket to 2 metres CAR/EL £2.20

Immersion heater - boils water, soup, etc. Plugs into cigar lighter socket. Lead length: 1 Mtr. CAR/IH £2.50

MARCO KITS
Ceramic 50V (125) £3.50
Electrolytics Rad. (100) £7.25
Fuse 20mm Q/B (80) £3.75
Fuse 20mm A/S (80) £7.50
Nut & Bolt (800) £3.00
Pre-set Pots. Horiz (120) £6.75
Pre-set Pots. Vert. (120) £6.75

RESISTORS
0.25W Popular (1000) £6.50
0.25W 5 off (305) £2.95
0.25W 10 off (610) £4.50
0.5W Popular (1000) £9.50
0.5W 5 off (365) £4.70
0.5W 10 off (730) £7.75
1W 5 off (365) £13.75
2W 5 off (365) £21.75
Zener diodes 5 off (55) £3.50

0.25W Resistors 1.2p 10 + 1.5p
0.5W Resistors 1.2p 10 + 1.5p

BANANA

4mm plug Red, Black, 1 + 10 +
Green, Blue, Yellow, Brown, 12p 10p
4mm socket Red, Black, Green, 1 + 10 +
Blue, Yellow Brown 14p 12p

ALL ORDERS + 85p P&P + 15% VAT UNLESS OTHERWISE STATED

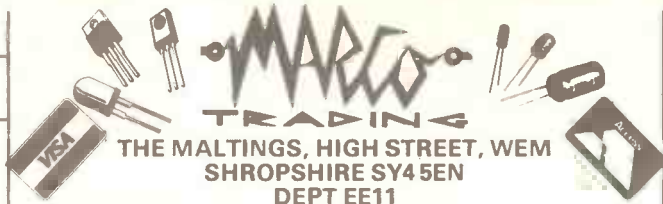

ELECTRONIC COMPONENT MAIL ORDER COMPANY - ESTABLISHED 1972
100+ PAGE CATALOGUE AVAILABLE - SEND £1 FOR YOUR COPY.

INCLUDING DISCOUNT TICKETS -
50p OFF £5 + ORDER, £1 OFF £10 + ORDER, £5 OFF £50 + ORDER



NOVEMBER SPECIAL

CAR LIGHT

ONLY £4.99

Free standing or hanging, 15ft of cable terminating in cigar lighter plug. Ideal for car, boat, caravan, van, etc. Power: 12v D.C. Dimensions: 430 x 30mm

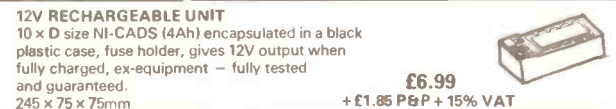

12V RECHARGEABLE UNIT
10 x D size NI-CADS (4Ah) encapsulated in a black plastic case, fuse holder, gives 12V output when fully charged, ex-equipment - fully tested and guaranteed.
245 x 75 x 75mm
£6.99
+ £1.85 P&P + 15% VAT



CHARGER FOR ABOVE 12V UNIT
Converted from 'fast charge' to 'standard charge' to prolong life of battery unit. Full charge obtained in 10-12 hours overnight. Complete with mains lead and charging lead fitted with 4-pin plug (6-pin version available on request). Ex-equipment - fully tested and guaranteed.
4-PIN £15
6-PIN £16
+ £1.85 P&P + 15% VAT

SERVISOL PRODUCTS
Supa-freeze-it £1.40
Switch cleaner £1.24
Foam Cleanser £1.22
Super 40 £1.88
Fire extinguisher £3.30
Tape head cleaner £1.10
Anti-static spray £1.20
Silicone grease £1.38
Plastic seal £1.35

BATTERY CHARGER
Suitable for AAA, AA, C, D and PP3 NI-CAD battery charging
£4.50

NI-CAD BATTERIES
AAA - £1.25 (10 + £1.20 ea.) PP3 - £4.10
AA - 90p (10 + 85p ea.) (10 + £3.90 ea.)
C - £2.10 (10 + £1.90 ea.)
D - £2.50 (10 + £2.20 ea.)

24 HR. ANSWERING MACHINE

ELECTRONIC BUZZERS
MINIATURE 6V or 12V
AUD/BUZ/6V - 75p
AUD/BUZ/12V - 75p
PIEZO ELECTRIC SUPER SLIM
AUD/BUZ/P12 - 75p
MUSICAL SEVEN AMERICAN TUNES
AUD/BUZ/MUS/LMB7 - £2.30
PIEZO ELECTRIC SIREN
AUD/SIR/SP12 - £5.95
ELECTRONIC SIREN
AUD/SIR/ELT - £7.50
ELECTRET MICROPHONE INSERT
10mm diam. 6.5mm thick
3V - 10V (9V typ.)
600 ohm
20-1200 Hz
AUD/MIC/1 - 60p

DESOLDERING PUMP £2.99

GAS SOLDERING IRON £16.00

SOLDER AT A RIDICULOUSLY LOW PRICE!!
A 500g reel of 22 SWG multi-core solder 60% tin 40% alloy non-corrosive
10 +
ONLY £4.99 £3.75

B.T. APPROVED EQUIPMENT
Master socket - £2.90
Secondary socket - £1.90
B.T. Cable - 15p per mtr.
Wiring tool - 50p
Plug - 431A - 25p
Line jack cord with plug £1.25
Extension lead 5 mtrs. £3.90

ANTEX SOLDERING
C Iron 15W £5.40 SK2 Kit £8.30
CS Iron 17W £5.60 SK5 Kit £7.99
XS Iron 25W £5.80 SK6 Kit £8.20
ST4 Stand £2.20
Elements £3.20
Spare Tips £1.20
Digital Temperature Controlled Station TCSY-D £72.50

PHONOSONICS

THROUGH ELECTRONICS UNDERSTAND ESSENTIAL TECHNOLOGY

LOW COST GEIGER COUNTERS



NUCLEAR FREE ZONES? CHECK THEM OUT - GET A GEIGER

Detectors for environmental and geological monitoring - know your background! You'd be amazed at the quantities sold since Chernobyl.

METERED GEIGER (PE MK2)

Built-in probe, speaker, meter, digital output. Detector tube options - ZP1310 for normal sensitivity. ZP1320 for extrasensitivity.
Kit-form - SET 264 - (ZP1310) £59.50, (ZP1320) £79.50
Ready-built = TZ272 - (ZP1310) £75.50, (ZP1320) £95.50

GEIGER-MITE SET 271 £39.50

Miniature geiger with ZP 1310 tube, LED displays radiation impacts. Socket for headphones or digital monitoring. Kit-form only.

THE PE GEIGER WAS SHOWN ON BBC TV "TAKE NOBODY'S WORD FOR IT" PROGRAM

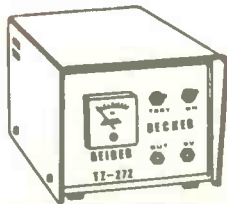

MUSIC AND EFFECTS

A-D-A INTERFACE*	SET 251	61.00
CHORUS FLANGER	SET 235	59.99
COMPANDER	SET 238	22.99
CYBERVOX	SET 228	44.76
DIGITAL DELAY	SET 234	198.50
ECHO-REVERB	SET 218	57.66
FLANGER	SET 153	28.45
GUITAR MODULO	SET 196	23.56
LINKAFEX CHORUS	SET 204	42.96
LINKAFEX DELAY	SET 206	42.09
LINKAFEX FLANGE	SET 207	34.92
MICRO TUNER*	SET 257	55.32
POLYWHATSTI	SET 252	122.69
REVERB	SET 232	27.35
RING MODULATOR	SET 231	45.58
STORM (SIMPLE)	SET 154	23.60
STORM - THUNDER	SET 250T	29.50
STORM - WIND & RAIN	SET 250W	29.50
TREMOLO	SET 136	15.62
VODALEK	SET 155	18.31

★ BE KIT CREATIVE ★ RAISE YOUR SKILLS

OTHER FINE DESIGNS

BURGLAR ALARM MULTI	SET 280	22.77
BURGLAR ALARM SIMPLE	SET 279	9.32
CHIP TESTER 16-PIN*	SET 258S	32.50
CHIP TESTER 24-PIN*	SET 258F	39.30
CHIP TESTER SIMPLE*	SET 262	28.50
DISCO LIGHT CONTROL	SET 245F	62.50
EPROM PROGRAMMER*	SET 277	25.25
EVENT COUNTER	SET 278	31.50
MICRO CHAT*	SET 276	64.50
MICRO SCOPE*	SET 247	44.50
MORSE DECODER*	SET 269	22.16

- ★ COMPUTER CONTROLLED (BBC, C64, PET)
- ★ MOST PCBs AVAILABLE SEPARATELY
- ★ LEARN BY BUILDING
- ★ ENJOY BY USING
- ★ POPULAR PROJECTS FROM A LEADING AUTHOR

KITS THAT FIT

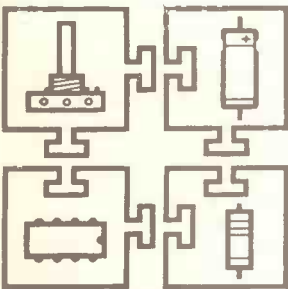

Send SAE for detailed catalogue, and with all enquiries (overseas send £1.00 or S.I.R.C.'s). Add 15% VAT. Add P&P - Sets over £50 add £2.50. Others add £1.50. Overseas P&P in catalogue. Text photocopies - Geiger & DDL Texts £1.50 each, others 50p, plus 50p post or large SAE. Insurance 50p per £50. MAIL ORDER, CWO, CHO, PO, ACCESS VISA.

PHONOSONICS, DEPT EE7N, 8 FINUCANE DRIVE, ORPINGTON, KENT BR5 4ED. MAIL ORDER
Telephone orders. Mon-Fri, 9am-6pm. 0689 37821. (Usually answering machine.)

OIL TANK GAUGE

T.R. de VAUX-BALBIRNIE

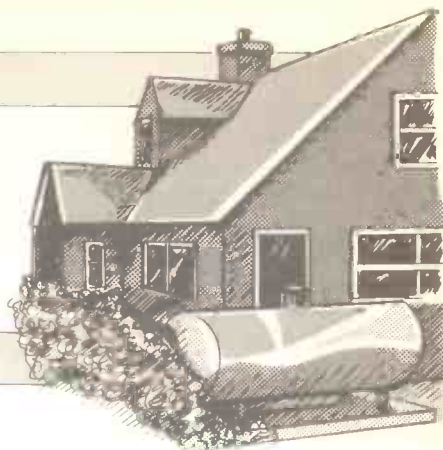

Avoid an empty tank with this in-house indicator

MANY householders use oil-fired central heating either by choice or because they are remote from a mains gas supply. They therefore rely on a storage tank which may be situated some distance from the main building.

It would be convenient to know, from a point inside the house, the quantity of oil in the tank. As well as avoiding an exhausted supply, this can help in budgeting and deciding when to buy the larger quantities which attract a discount.

Our battery-operated circuit indicates the oil level on a 10-point l.e.d. bargraph display. It is suitable for operating depths up to 1.5m (5ft. approximately). The system comprises two sections — a wall mounted unit housed in a plastic box and a tank sensor. The two sections are linked together using light duty wire.

The wall unit houses the circuit panel, l.e.d. display visible through a hole in the lid, push-to-test switch and 9V battery. The circuit draws current only while the switch is pressed so the battery will have a long life. It will be noted that negligible current flows in the tank sensor so eliminating fire risk.

Assuming a 300 gallon (1400L approximately) oil tank is used it may be that "Full" is to be indicated down to 275 gallons and "Empty" at 50 gallons. Each point on the display will then represent 25 gallons. This resolution is adequate for most household purposes.

LEVEL SENSOR

The chief problem with this type of circuit is that heating oil does not conduct electricity. Thus, any device relying on electrical conductivity, although working well with water-based liquids, will fail with oil.

In this device, a float and pulley system rotates a potentiometer to provide the electrical signal. Realising that many readers wish to concentrate on electronic aspects of construction, the mechanical side has been kept straightforward by using easily-obtained radio tuning dial components.

In use, the sensor is hooked over the filling opening of the oil storage tank. It is removed before filling and hand-wound to the start before replacing. Some readers may wish to fit a spring to return the float to the high position automatically. This was not considered worth while in the prototype since it is not done very often.

CIRCUIT DESCRIPTION

The full circuit diagram for the Oil Tank Contents Gauge is shown in Fig. 1. IC1 is a bargraph driver and IC2 an l.e.d. bar display. IC1 accepts a varying voltage at pin 5 and causes a number of IC2 "bars" to light according to the value of this voltage.

Potentiometer VR1 is part of the tank sensor and is connected through 3-core cable to the main unit. Here, Zener diode, D1, together with resistor R1, provide a reference voltage. VR1 selects a fraction of this voltage between its sliding or wiper contact and supply negative.

When the tank is empty (or at any predetermined low operating level) this voltage will be near-zero — the exact value depending on the adjustment of preset VR2 (Set Low Level). This is adjusted at the end of

construction so that the first bar of the display is just on.

Preset potentiometer, VR3, selects a fraction of the voltage at VR1 sliding contact and applies it to IC1 pin 5. This is adjusted so that all IC2 bars light up with a full tank. In this way, the full range of bars are used whatever the range of VR1 rotation — that is, whatever the size of the tank. Resistor R2 sets the l.e.d. bar operating current to the correct working level.

COMPONENTS

Resistors

- R1 10k
- R2 2k2
- All 0.25W 5% carbon

**Shop
Talk**
page 617

Potentiometers

- VR1 100k lin. rotary
- VR2 10k sub-min skeleton preset, vert.
- VR3 470k sub-min skeleton preset, vert.

Capacitors

- C1 100n polyester

Semiconductors

- D1 BZY88 4V1 Zener diode
- IC1 LM3914 linear bargraph driver
- IC2 10-segment red bar display

Miscellaneous

- S1 push-to-make switch
- TB1, TB2 3-way 3A terminal block (2 off)
- Stripboard, 0.1in matrix size 14 strips x 19 holes; plastic case, approx. 80mm x 61mm x 41mm external; 18-pin d.i.l. socket; 20-pin d.i.l. socket; 3-core light-duty connecting wire; 9V PP3 battery and connector to suit; link wire.

TANK SENSOR

- Sheet aluminium, 1mm thick; 10cm diameter dial cord drum; 6:1 reduction ball drive; brass bush; thin cord, approx. 2m; metal spacer; fixings; plastic bottle for float (see text).

Approx. cost
Guidance only

£15

Fig. 1. Complete circuit diagram for the Oil Tank Contents Gauge.

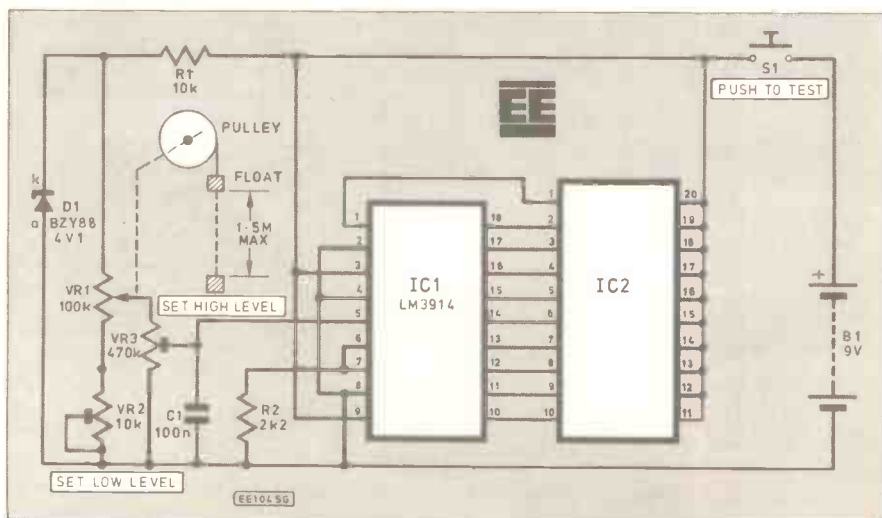

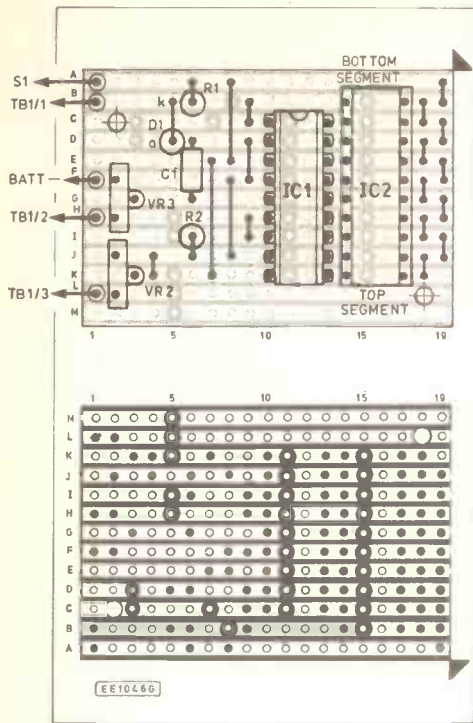

Fig. 2 (left). Circuit board component layout and details of breaks to be made in the underside copper tracks. The integrated circuits IC1 and IC2 should be mounted in i.c. holders.

(right) The completed display unit showing suggested "calibrated" scale, test switch and interconnecting terminal block.

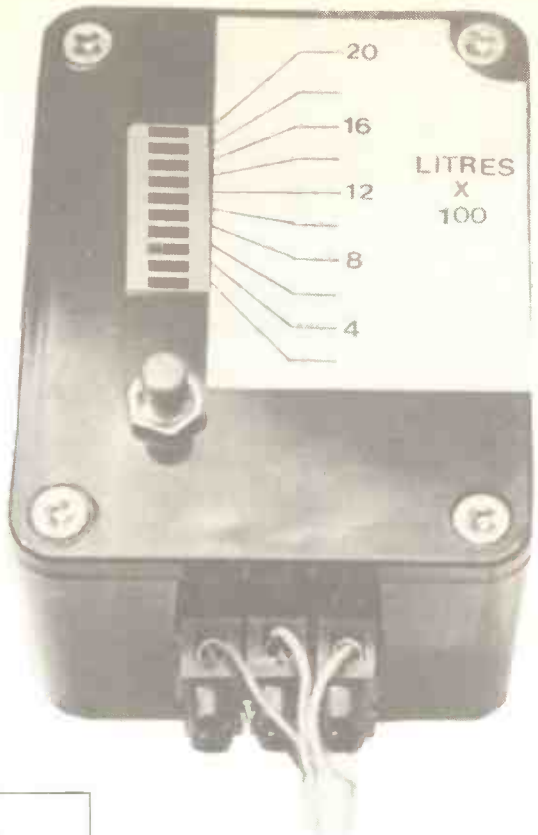
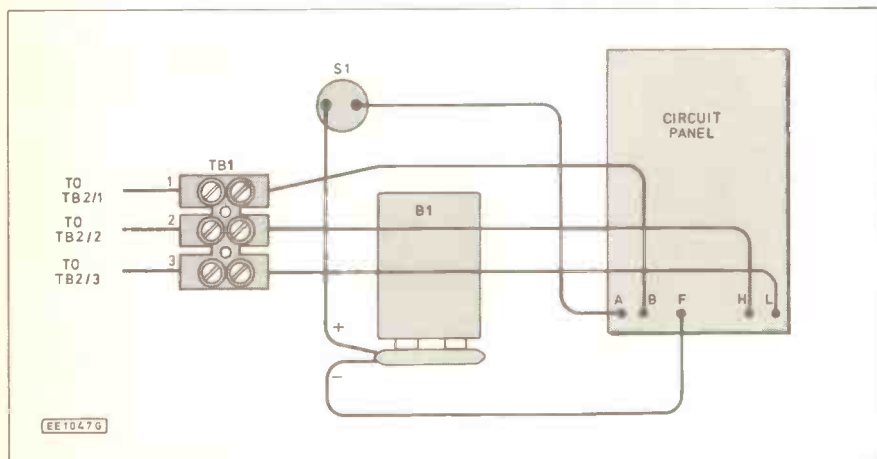

Fig. 3 (left). Interwiring from the circuit board, test switch S1, battery and interconnecting block TB1. The photograph below shows the orientation of the board in the case, i.e. presets on the right.



Measure the position of IC2 and make a hole in the lid to correspond. Mount the circuit board on tall stand-off insulators so that, with the lid on, IC2 stands level with, or slightly higher than, the front face (see photograph).

Next mount the 3-way terminal block TB1 and S1 then, referring to Fig. 3, complete all internal wiring. Connect the battery and secure it with an adhesive fixing pad.

CONSTRUCTION

The circuit panel is constructed on a piece of 0.1in matrix stripboard, size 13 strips x 19 holes. Refer to Fig 2, cut this to size and drill the fixing holes.

The component layout and underside view showing breaks in the copper strips is shown in Fig 2. Solder the inter-strip link wires and make the track breaks as indicated. Follow with the soldered on-board components then make a careful check for errors — particularly for accidental "bridging" of copper tracks.

Solder 10cm pieces of light-duty stranded connecting wire to strips A, B, H and L as indicated. Solder the negative battery connector lead to Strip F.

Adjust presets VR2 and VR3 sliding contacts to approximately mid-track position and insert the i.c.s into their sockets. Note that IC2 has printing on the anode side — this should be placed to the right of the panel. Note that as illustrated, the lower bar of IC2 is uppermost and the circuit panel will be mounted in the case upside down — that is, with the presets to the right (see photograph).

Prepare the case by making holes for circuit panel, terminal block and push-to-test switch mounting. Drill the hole for internal wires passing to the terminal block.

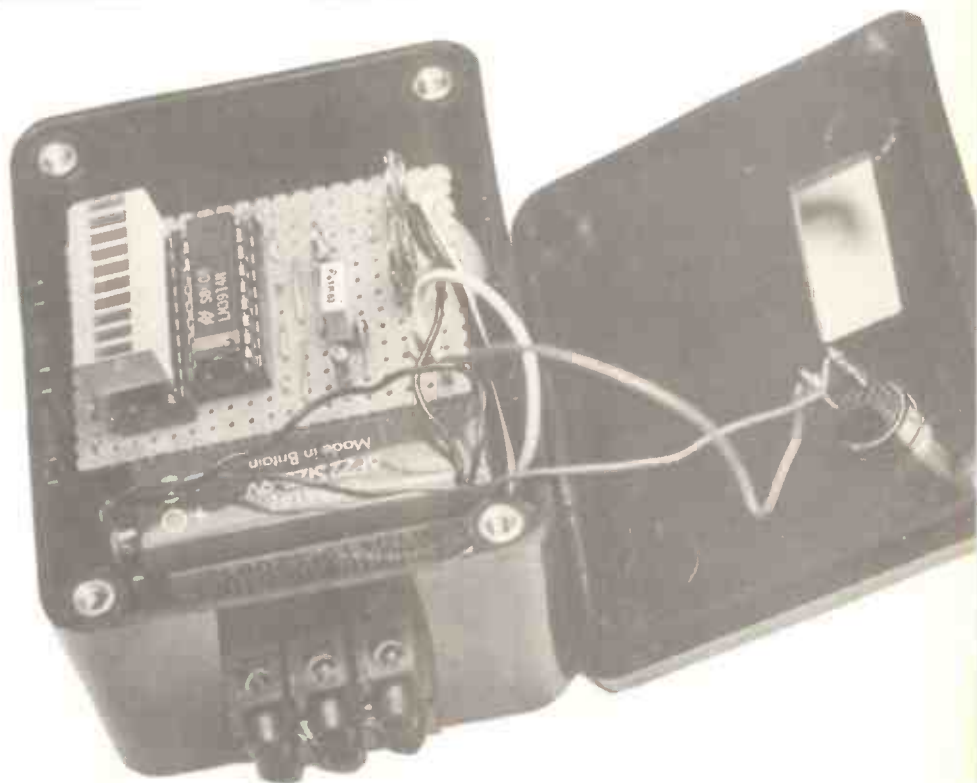

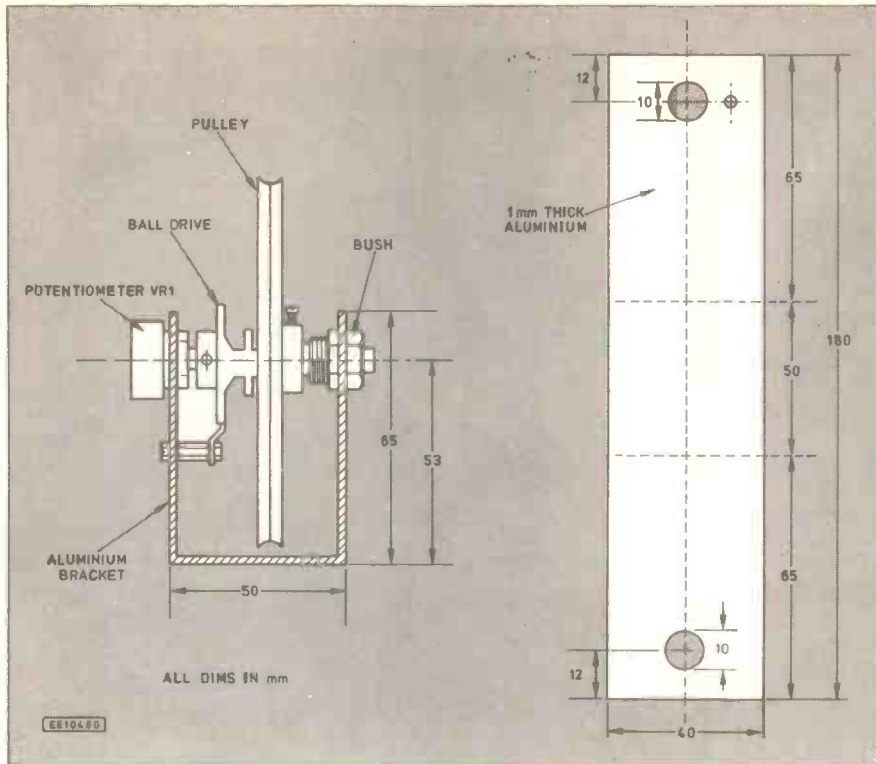

Fig. 4. Drilling details for the pulley U-bracket and mechanical arrangement for the Tank Sensor unit.

SENSOR

The mechanical arrangement, drilling details and wiring for the sensor unit is shown in Figs. 4 and 5. This uses a piece of 1mm thick sheet aluminium size 180mm x 40mm. Bend it to the form shown and drill two holes 10mm in diameter for the brass bush and VR1 potentiometer mounting.

Make the hook from a piece of the same material size 80mm x 35mm. Attach this to the

The completed Tank Sensor unit showing the slotted extension arm on the ball drive held in place by a long spacer.

rear panel using two small fixings — see photograph.

Drill a hole 3mm in diameter in the potentiometer side of the U-bracket to accommodate the lug on VR1 (if fitted) which will prevent its body from rotating. Drill a small hole to align with the slotted extension on the ball drive — see photograph. Drill two small holes for terminal block TB2 mounting.

Cut short VR1 spindle and mount the components. Use a long fixing with a metal spacer between the ball drive slotted extension and the metalwork — this prevents body rotation. Connect VR1 to the 3-way terminal block TB2 as shown in Fig. 5.

The Tank Sensor mounting hook bolted on the bottom of the pulley U-bracket.

Check that the pulley rotates smoothly. Decide on the required operating depth and cut a piece of thin, strong cord 20cm longer than this. Tie one end to a pulley fixing screw and attach the float to the other. In the prototype, a small plastic bottle loaded with a few small stones was used as a float. Check that it (a) floats in oil, (b) is heavy enough to rotate the pulley as the level falls and (c) that it is completely liquid proof.

TESTING AND ADJUSTMENT

Adjustment is carried out with the sensor unit outside the oil tank. This is easier than adjusting it under true operating conditions. Attach it temporarily to a high shelf so that the full operating height is available. Interconnect the two terminal blocks, TB2 and TB1, using light duty 3-core wire. Make sure that this is done in the correct sense — TB1/1 to TB2/1 and so on.

When the float is at maximum travel (low operating point), VR1 spindle should be turned fully clockwise. Adjust the position of the pulley on the spindle so that the cord hangs vertically through the opening on the rim.

Press switch S1 and note that some segments light. Adjust preset VR2 so that only the *first* one is on. Rotate the pulley anticlockwise (the cord passing between the pulley and hook) until the float reaches its high operating point — VR1 sliding contact should not now reach its

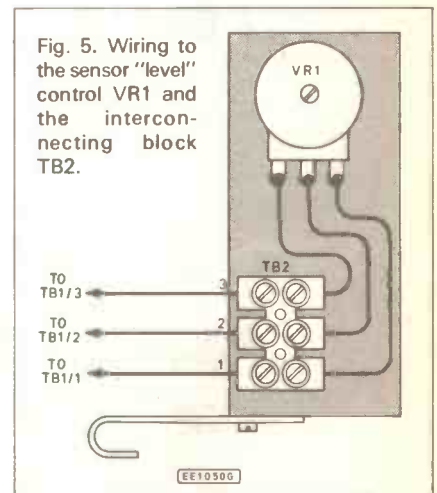

fully anticlockwise position. Adjust preset VR3 so that *all* segments are now on.

Re-check low and high operating levels re-adjusting VR2, VR3 and the cord length as necessary. Each l.e.d. segment should operate in sequence as the float is allowed to fall gently between upper and lower levels.

Connect the sensor to the main unit using light-duty wire and hook it over the oil tank filling hole. Four-core telephone wire with one conductor ignored was used to make the connections in the prototype. Allow the float to fall gently to the existing oil level and check that the l.e.d. segments indicate this correctly. Check that the cover for the filler opening may be closed and does not interfere with correct operation of the pulley.

To reset the device after the oil tank has been filled, allow the float to fall to maximum travel and check that VR1 is rotated fully clockwise. Carefully turn the pulley until the float reaches the top. Hook the unit over the filler hole and allow the float to fall gently to the oil level. The Oil Tank Contents Gauge is now ready for use.

If desired, a calibrated scale may be made and attached to the lid of the case to show the actual contents of the tank in litres or gallons. □

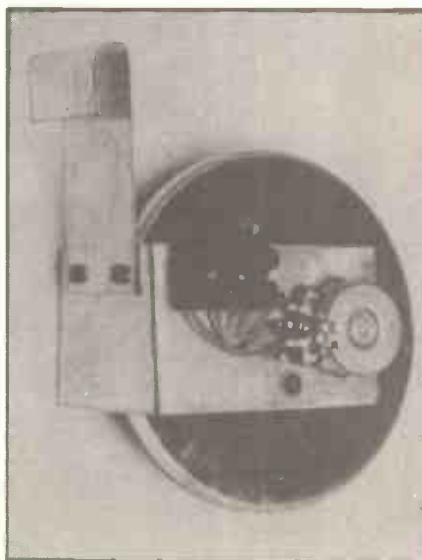

MULTIMETERS

BY
Cirkit
Affordable
Accuracy

A comprehensive range of quality Multimeters at very competitive prices

DIGITAL

All models feature full ranges, 3½ digit 0.5 in LCD, low battery indication, auto zero and auto polarity, strong ABS casing, 10 Amp range (except DM105), overload protection. Prices from £21.50 to £52.50. Battery, spare fuse, test leads and manual included with each model.

ANALOGUE

A choice of four meters with prices ranging from £5.50 to £21.00. All models include battery, test leads and manual.

Please add 15% VAT to all prices and 70p for post and packing.



DM105 £21.50

A meter to suit all pockets, including the one that holds the wallet! Full complement of ranges: 2V - 1kV DC, 200V-750V AC, 2mA-2A DC current and 2k-2M resistance range. Basic accuracy 0.5%.

Cirkit



Cirkit Distribution Ltd.

Park Lane, Broxbourne, Herts EN10 7NQ.
Telephone (0992) 444111.

252A HIGH STREET, HARLESDEN,
LONDON NW10 4TD. TEL: 01-965 5748
TELEX: 265871 MONREG
Quoting 72: MAG31197

OMEGA
OE
ELECTRONICS

4000B SERIES	4094BP	0.49	78L12	0.30	LM380N 8	1.44	TDA-1072A	2.75
CMOS	4095BP	0.75	78L15	0.30	LM380N 14	1.44	TDA-1908	1.25
4001BP	4096BP	0.65	78L18	0.40	LM381N	3.08	TDA-2002	1.95
4002BP	4097BP	0.60	78L24	0.40	LM382N	2.95	TDA-2003	3.95
4003BP	4098BP	0.47	79L05	0.40	LM384N	2.89	TDA-2004	2.48
4007BP	4502BP	0.45	79L12	0.40	LM385N	1.17	TDA-2005	2.95
4008BP	4503BP	0.40	79L15	0.40	LM387N	2.16	TDA-2006	1.95
4009BP	4504BP	0.70	79M05	1.50	LM388N	0.53	TDA-2009	3.95
4010BP	4510BP	0.30	79M12	1.50	LM741N	0.28	TDA-2010	2.95
4011BP	4511BP	0.45	79M15	1.50	LM748CH	1.58	TDA-2030	1.95
4012BP	4512BP	0.34	78T05	2.00	LM1458N	0.41	TDA-2540	2.50
4013BP	4514BP	0.61	78T12	2.00	LM2922N	0.65	TDA-2591	2.50
4014BP	4515BP	0.61	78T15	2.00	LM2977N-14	3.68	TDA-2611A	1.50
4015BP	4516BP	0.34			LM2917N	3.60	TDA-2640	3.75
4016BP	4517BP	1.05	SPECIAL		LM2917N 8	3.34	TDA-4600	3.75
4017BP	4518BP	0.34	FUNCTIONS		LM3302N	1.00	TDA-7000	2.50
4018BP	4520BP	0.34	CA3018	1.55	LM3302N	1.18	TLO71	0.33
4019BP	4522BP	0.82	CA3018A	2.38	LM3311N	2.16	TLO72	0.56
4020BP	4526BP	0.34	CA3028A	1.87	LM3914N	3.99	TLO74	1.09
4021BP	4527BP	0.47	CA3046	0.77	LM3915N	3.99	TLO81	0.39
4022BP	4528BP	0.47	CA3046	1.59	LM3916N	3.99	TLO82	0.45
4023BP	4532BP	0.47	CA3080E	1.26	MC1406L 8	3.50	TLO83	0.67
4024BP	4534BP	3.50	CA3081E	1.19	MC1408PB	2.48	TLO84	0.80
4025BP	4538BP	2.95	CA3088E	3.18	MC1340P	2.57	ULN2003	0.70
4026BP	4539BP	0.39	CA3088E	2.39	MC3329P	1.47	ULN2004	0.95
4027BP	4539BP	0.36	CA3094E	0.65	MC3420P	4.04	ULN2068	2.70
4028BP	4543BP	0.39	CA3096E	1.04	MC3423P1	1.09	ULN2803	1.85
4029BP	4556BP	0.31	CA3130E	1.20	MC3441A1P	4.36	ULN2804	1.77
4030BP	4558BP	0.75	CA3180E	0.73	MC3456N	2.86	ZNA14	2.95
4031BP	4572BP	0.20	CA3180E	1.39	MC3489N	2.86	ZNA25E-8	3.50
4035BP	4584BP	0.34	CA3181E	1.40	MC3487P	2.86	ZNA26E-8	2.00
4038BP	4585BP	0.41	CA3182E	4.50	NE531N	1.72	ZNA27E-8	6.28
4040BP			CA3182E	2.39	NE531N	1.47	ZNA28E-8	4.78
4041BP			CA3240E	1.46	NE544N	2.17	ZNA47E	8.00
4042BP			ICL7106	6.50	NE555N	0.25	ZNA49E	2.80
4043BP			ICL7107	6.50	NE566N	0.88	ZNA50E	6.72
4044BP			ICL7611	0.95	NE568N	1.89	ZNA51E	7.60
4045BP			ICM7555	0.90	NE569N	0.26	ZNA104RSD	21.00
4046BP			ICM7556	1.00	NE566N	1.00	ZNA234E	10.00
4047BP			LF347N	1.10	NE567N	0.65		
4048BP			LF351N	0.75	NE570N	2.49	RECTIFIERS &	
4049BP			LF353N	1.00	NE571N	2.17	DIODES	
4050BP			LF395	1.73	NE572N	2.86	IN514	0.04
4052BP			LM7805	1.73	NE582N14	0.87	IN4001	0.04
4053BP			LM7805 CPU	5.00	NE582N2Z	1.82	IN4002	0.04
4053BP			LM7805 CPU	5.00	NE5832AN	0.65	IN4004	0.04
4054BP			LM7809 CTC	2.50	NE5833AN	0.85	IN4006	0.04
4055BP			LM7809 CTC	4.80	RC4558P	1.62	IN4007	0.05
4056BP			LM7809 DART	6.80	SL490	3.50	IN4007	0.05
4056BP			LM7809 DMA	6.50	TAA-560	1.00	IN4148	0.02
4056BP			LM7809 P10	4.80	TAA-560M	0.70	IN5400	0.10
4056BP			LM7809 SIO	5.00	TBA-530	2.99	IN5401	0.10
4057BP					TBA-520	2.99	IN5402	0.10
4058BP					TBA-530	2.99	IN5403	0.11
4059BP					TBA-540	3.26	IN5404	0.14
4060BP					TBA-560	3.99	IN5405	0.14
4061BP					TBA-750	3.80	IN5406	0.14
4062BP					TBA-800	0.75	IN5408	0.14
4063BP					TBA-810AS	0.95	IC SOCKETS LOW	
4064BP					TBA-820M	0.70	PROFILE	
4065BP					TBA-950	2.25	8 PIN	0.06
4066BP					TBA-950	2.25	14 PIN	0.06
4067BP					TBA-950	2.66	16 PIN	0.09
4068BP					TCA-940	1.15	18 PIN	0.12
4069BP					TDA-1003	4.36	20 PIN	0.14
4069BP					TDA-1008	2.90	22 PIN	0.16
4069BP					TDA-1010A	1.95	24 PIN	0.18
4069BP					TDA-1022	5.50	28 PIN	0.20
4069BP					TDA-1024	1.12	40 PIN	0.25

Please phone us for types not listed here
as we are holding over 3 000 items and quotations are given for quantity
Please add 75p p&p and VAT at 15%. Govt. Colleges, etc. orders welcome

ILP
AMPLIFIERS FROM
JAYTEE

The UK Distributor for the complete ILP Audio Range

- * Bipolar Modules - 15 watts to 180 watts
- * Mosfet Modules - 60 watts to 180 watts
- * Power Booster - 15 watts (for 12v dc supply)
- * Power Supplies
- * Pre-amplifier and Mixer Modules
- * 100 volt Line Transformers
- * Loudspeakers - 12" 350 watt Bass and 200 watt Wideband Bass
- * Power Slave Amplifiers

Write or phone for free Data Pack

Jaytee Electronic Services

143 Reculver Road, Beltinge, Herne Bay, Kent CT6 6PL
Telephone: (0227) 375254

ILP
TRANSFORMERS FROM
JAYTEE

The UK Distributor for the Standard Toroidal Transformers

- * 106 types available from stock
- * Sizes from 15VA to 625VA

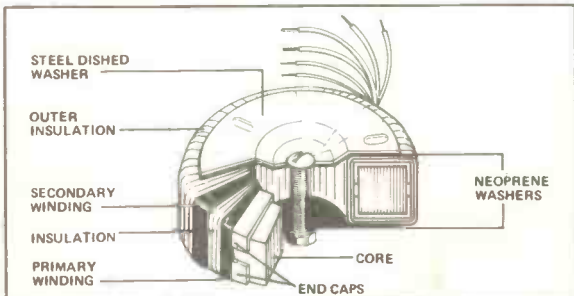

Write or phone for free Data Pack

Jaytee Electronic Services

143 Reculver Road, Beltinge, Herne Bay, Kent CT6 6PL
Telephone: (0227) 375254

...Beeb...Beeb...Beeb...Beeb...Beeb...

... Logic Tester ... Logic Tester ...

I WAS hoping to give details of a battery backed clock/calendar circuit in this month's article, but problems with the multiplexed address/data bus of the 146818 chip have resulted in a rather inefficient circuit that will need some tidying up before it is suitable for publication. However, in the mean time we will consider use of the BBC computer as a logic tester. There are actually a variety of ways in which the BBC computer can be used for logic testing, ranging from a basic logic probe function through to automatic chip testing and analysis. In earlier articles we have touched on this subject when considering the 6522 VIA in its pulse and frequency generation modes. Here we will look at ways of utilizing the machine for logic probe style checks.

State Indication

The most basic of logic probes just provide an indication of whether the test point is at logic 0 or logic 1. This is something that can easily be achieved with the BBC computer using one line of the user port as an input. For example, after first connecting one of the user port's earth lines to the earth rail of the equipment under test, PB0 could then be connected to the test points. This simple three line program is all that would then be needed to display the detected logic level on the screen.

```
10 CLS
20 PRINTTAB (10,10) ?&FE60 AND 1
30 GOTO 10
```

All this program does is to clear the screen, and then print the value returned from PB0 at approximately the middle of the screen. The logic AND function is used to mask PB1 to PB7, so that the returned value can only be 0 or 1, depending on whether the test point is low or high (respectively). Line 30 loops the program indefinitely so that the display is regularly and frequently updated. The update frequency is probably limited by the number of frames per second generated by the display driver circuit.

This method is perhaps a little risky in that there is no isolation between the test circuit and the BBC computer, and under some circumstances this could result in damage to the computer. It would certainly be unwise to use this method with anything other than a test circuit having ordinary five volt logic levels (a few CMOS logic circuits use higher supply voltages of up to 18 volts). I have only experienced difficulties when connecting other items of equipment to a computer when both pieces of equipment are mains powered, but neither of them uses a mains earth connection. This can result in a large voltage difference between the two chassis. Although this voltage is at a high impedance, it can easily result in damage to one or both items of equipment.

The BBC computers have an earthed chassis, and this seems to largely remove the possibility of problems of this sort. However, you may prefer to play safe and use opto-isolators at the inputs when using the machine for this type of testing. An alternative is to add a buffer ahead

of the input. If any damage should then occur, it will be to the buffer device costing a few pence, rather than to the 6522 VIA.

There should be no real risk if the test circuit is a five volt type which is powered from batteries. Neither should there be any risk if the five volt output of the computer is used to power the test circuit. If you use this method though, remember to keep within the output current limit of your computer.

Transitions

A logic probe which provides no more than simple high/low level indication is of limited practical value. A valid logic level will always be indicated, even if the voltage at the test point is an invalid one. In other words, a high state will be indicated if the test point is above a certain level, or a low state will be indicated if it is below this level. To be completely accurate the system should indicate a low level if the test point is below a certain voltage, a high state if it is above a different and higher voltage, and an illegal state if it is between these two voltages.

Perhaps a more major problem with a basic high/low logic indicator is that it is unlikely to handle medium or high frequency pulse signals very well, and many logic test points fall into these categories. With a low frequency pulse signal having something approximating to a 1:1 mark-space ratio the on-screen indication will fluctuate rapidly between 0 and 1, showing that the input is pulsing. In fact with high frequency signals having a mark-space ratio of about 1:1 the on-screen indication seems to vary in much the same way. Presumably it is a matter of chance as to which logic state the input line happens to be at during the instant when the line is read, and the on-screen indication is purely random.

Matters are less satisfactory with signals that have very low or very high mark-space ratios, as it is then quite likely that the brief pulses will be missed. A change in the on-screen indication will only occur if the input line happens to be read at the instant one of these pulses occurs, and the chances of each pulse being read could literally be a million to one.

The BBC computer has the facilities to overcome both these shortcomings with the aid of a little discrete circuitry. The analogue port enables the voltage at the test point to be accurately measured, and warning to be provided if it is not a valid voltage for the logic devices used in the circuit. The user port has edge sensitive inputs, and these can be used to detect whether or not the input signal is pulsing.

Fig. 1 shows the simple way in which this can all be achieved in hardware, and the software provided in Listing 1 provides this set-up with high/low, pulsing, and voltage warning indicators.

If we take the pulse detection first, this is provided by line CBI of the user port. As explained in an earlier article (see the November 1986 issue of *Everyday Electronics*),

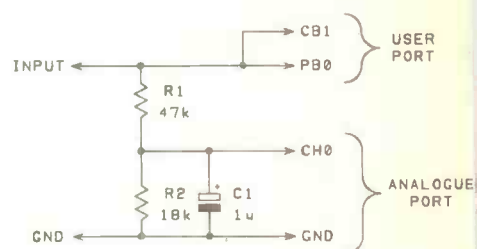

Fig. 1. A simple arrangement that enables the BBC Micro to function as a logic checker.

both CBI and CB2 can be used as edge triggered inputs. Either line could be used here, but as CBI can only be operated as an input and has no output modes, CBI is the better choice as it leaves the more versatile CB2 line free for other purposes. CBI has two operating modes, and it can set its interrupt flag bit on either a high to low transition, or a low to high type. In this case it does not matter which mode is used, since a brief pulse will provide both types of transition in rapid succession. CBI can therefore be left in whatever operating mode it happens to be set in at switch-on.

The CBI flag is bit 4 of the interrupt flag register at address &FE6D. It can be reset by writing a 1 to this bit (i.e. ?&FE6D = 16).

Voltage measurement via the analogue port has also been covered in a previous article in this series (see the June 1986 issue of *Everyday Electronics*). In this circuit channel 0 of the analogue port (read from BASIC as ADVAL1) is fed from the test point via a potential divider comprised of R1 and R2. These reduce the sensitivity from 1.8 volts full scale to about 6.3 volts full scale. The resistance through the potential divider has been kept quite high so that no significant additional loading is placed on the test circuit. C1 provides smoothing so that the signal fed to the analogue input is a reasonably stable d.c. voltage.

Some simple division is all that is needed in order to convert the values returned by the ADVAL1 function to a voltage value that can be displayed on the screen. The on screen indication could be in the form of an "illegal voltage" message when appropriate, with a

LISTING 1

```
10 CLS
20 PRINTTAB (10,10) ?&FE60 AND 1

30 FLAG = ?&FE6D AND 16
40 IF FLAG = 16 THEN PRINTTAB
(17,12)"PULSE"
50 VOLTS = ADVAL(1) DIV 1024
60 PRINTTAB (8,14) VOLTS/10; "VOLTS"
70 ?&FE6D = 16
80 FOR DELAY = 1 TO 100:NEXT
90 PRINTTAB (17,12) " "
100 GOTO 20
```

program line being used to detect whether or not the detected voltage was a valid one for the device under test. The problem with this system is that what constitutes a valid voltage depends on the device being checked, and to some extent on how heavily its output(s) are being loaded. It is probably more practical to have a voltage readout so that the user can make a subjective judgement as to what does and what does not qualify as a legitimate voltage.

An essential point to keep in mind is that with a pulsing input signal the displayed voltage is an average level. This renders it largely meaningless with this type of input signal, and it will often show an illegal voltage even though the signal is switching between two valid potentials. When the input signal is indicated as a pulsing type, the voltage reading can still provide some useful information. It provides a rough indication of the mark space ratio of the input signal.

If the indicated voltage is very low, this shows that the input signal is at the low state for most of the time, with only brief or very infrequent positive pulses. Conversely, if a high voltage is indicated, the signal is high for the majority of the time with only very short or infrequent pulses. A 1:1 mark-space ratio would produce a voltage reading half way between the logic 0 and logic 1 voltage levels.

This arrangement is quite versatile, and is much more informative than most logic probes. Its only major shortcoming is that it cannot detect very short pulses of less than about one microsecond in duration. These are too fast for the 6522 VIA to handle, and will pass totally undetected. In practice this does not render the system unusable with many circuits, as few have the entire circuit operating at high frequencies with short pulses, or even have a substantial amount of the circuitry

handling such signals. However, this is something that should obviously be kept in mind when using this equipment.

There is actually a simple solution to the problem, which is to add a monostable pulse stretcher circuit ahead of CBI. This will detect very short input pulses, but gives an output of a few milliseconds in duration that will reliably trigger CBI. A suitable circuit is shown in Fig. 2.

Software

The program in Listing 1 is very simple, and does not merit a detailed description. Note that the voltage readings are only given with a resolution of 0.1 volts. The 12 bit analogue to digital converter of the BBC machines can give much better resolution than this, but in the present application higher resolution is not really needed, and could make the display less clear. Note also that a "PULSE" indication may briefly flash on the screen when the unit is initially connected to a test point which is at a static level, or when it is disconnected from one. This can happen with any logic checker, and it occurs simply because the input is normally at logic 1, and if it is connected to logic 0 this results in transitions as it is connected to and disconnected from the test point.

The ability of the BBC computer to

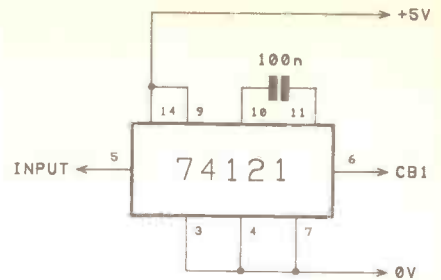

Fig. 2. Positive edge triggered pulse stretcher.

provide a number of logic outputs while simultaneously monitoring several logic and (or) analogue inputs enables it to operate as a very versatile linear/logic integrated circuit tester. In fact it can also be used for checking other devices such as transistors, and these are subjects which will be explored in future articles.

BUMPER BARGAIN BAGS

LIQUIDATION STOCK

MIXED BAGS of new computer grade components. Normal value at least £20. Limited number only, at £5 per bag. Buy two bags - GET ONE FREE!
EQUIPMENT COOLING FANS Brand new 'PAPST' 240V axial fans. Approx 119 x 119 x 39mm complete with protective grill £7.50

All prices INCLUDE VAT and postage.

TELEPHONE ACCESSORIES

MAIN SOCKET KIT Allows conversion of tel. line to new socket	£8.90	refurbished B.T. Statesman phones. Ideal for extension	£16.50
EXTENSION SOCKET KIT D.I.Y. extension kit incl. socket, cable, clips & instructions	£7.50	TELEPHONE CABLE 3 pair (6 core)	15p per m
MAIN SOCKET	£2.95	JUNCTION BOX	£0.86
EXTENSION SOCKET	£2.40	INTERNAL EXTENSION BELL	£12.50
DUAL OUTLET Allows 2 plugs to fit into 1 socket	£5.95	EXTERNAL EXTENSION BELL	£17.00
5m EXTENSION LEAD	£5.95	PHONE RINGER ADAPTOR plugs into extension socket	£6.95
10m EXTENSION LEAD	£7.95	MAINS ADAPTORS 3, 4, 5, 6, 0, 7, 5, 9, 12V, 300m.a.	£2.50 or 2 for £4.00

(SEND S.A.E. FOR FULL LISTS)

PRICES INCLUDE VAT. PLEASE ADD £1 POSTAGE PER ORDER

REGRET NO B'CARD ACCESS AT THESE PRICES!
SEND CHEQUE P.O. TO: AZTEC 19 LON CAE PORTH, RHIWBINA, CARDIFF
Tel: 0222 692913

Visit Audiokit's stand at the Festival of Sound & Vision (Edinburgh Sheraton Hotel) 6/8 November '87

The EE APEX PREAMP AND POWER AMP KITS

Build this superb preamp and power amp kit and enjoy high fidelity sound at a fraction of the cost of comparable ready built amplifiers.

Complete kits as described in March-June issues of Everyday Electronics including high current transformers and attractively styled cases with high quality components.

Preamp	£195.00
Power amp-stereo	£195.00

Or build it with the very best components available including IAR Wonder caps, Extended foil polystyrene capacitors, bulk foil resistors, Holco precision resistors, silver plated switches, gold plated phono sockets and Kimber cable for internal wiring.

Preamp	£411.00
Stereo Power amp	£310
UK Post and Packing on all kits	£6

All components including PCBs available separately

For full parts price list of the EE Apex preamp and details of **AUDIOKITS** audiophile components and kits, please send 9" x 4" SAE to:

AUDIOKITS Precision Components
6 MILL CLOSE, BORROWASH, DERBY DE7 3GU. Tel: 0332 674929

BOXING PROBLEMS?? LOOK NO FURTHER!!

Choose from our standard range below, or if you are looking for a specific size, then we can produce YOUR OWN CUSTOM BOX WITHOUT ANY TOOLING COSTS, with all holes, slots, PCB grooves, etc, already machined in, ready to assemble.

H	W	D	D10: 50 x 100 x 110*	CONSOLE BOXES
C1: 30 x 50 x 80*			D20: 35 x 145 x 170*	PRG1: 20/60 x 130 x 160*
C2: 40 x 60 x 90*			D30: 40 x 120 x 170*	PRG2: 35/70 x 230 x 160*
C3: 50 x 70 x 110*			D40: 70 x 110 x 145*	PRG3: 35/77 x 290 x 190
			D50: 60 x 160 x 170	
			D60: 100 x 180 x 210	All sizes are in millimetres, and are internal.
BA4: 20 x 85 x 120			D70: 70 x 200 x 215	
			GA1: 93 x 280 x 160	
			GA2: 140 x 400 x 205	

All made from high impact resistant plastic which is easily drilled or cut.

For other sizes and details of Custom Service contact us at the address below.
Distributor enquiries welcome.

BAFBOX LTD.

Unit A, Park End Works, Croughton,
BRACKLEY NN13 5LX
Telephone: 0869 810830

BOOK SERVICE

The books listed below have been selected as being of special interest to our readers, they are supplied from our editorial address direct to your door.

DATA AND REFERENCE

PRACTICAL ELECTRONICS CALCULATIONS AND FORMULAE

F. A. Wilson, C.G.I.A., C.Eng., F.I.E.E., F.I.E.R.E., F.B.I.M.
Bridges the gap between complicated technical theory, and "cut-and-try" methods which may bring success in design but leave the experimenter unfulfilled. A strong practical bias—tedious and higher mathematics have been avoided where possible and many tables have been included.

The book is divided into six basic sections: Units and Constants, Direct-current Circuits, Passive Components, Alternating-current Circuits, Networks and Theorems, Measurements.
256 pages **Order Code BP53 £2.95**

ESSENTIAL THEORY FOR THE ELECTRONICS HOBBYIST

G. T. Rubaroe, T.Eng (C.E.I.), Assoc.I.E.R.E.
The object of this book is to supply the hobbyist with a background knowledge tailored to meet his or her specific requirements and the author has brought together the relevant material and presented it in a readable manner with minimum recourse to mathematics.
128 pages **Order Code 228 £2.50**

MICROPROCESSING SYSTEMS AND CIRCUITS

F. A. Wilson, C.G.I.A., C.Eng., F.I.E.E., F.I.E.R.E., F.B.I.M.
A truly comprehensive guide to the elements of micro-processing systems which really starts at the beginning. Teaches the reader the essential fundamentals that are so important for a sound understanding of the subject.
256 pages **Order Code BP77 £2.95**

COMMUNICATION

F. A. Wilson, C.G.I.A., C.Eng., F.I.E.E., F.I.E.R.E., F.B.I.M.
A look at the electronic fundamentals over the whole of the communication scene. This book aims to teach the important elements of each branch of the subject in a style as interesting and practical as possible. While not getting involved in the more complicated theory and mathematics, most of the modern transmission system techniques are examined including line, microwave, submarine, satellite and digital multiplex systems, radio and telegraphy. To assist in understanding these more thoroughly, chapters on signal processing, the electromagnetic wave, networks and transmissions assessment are included, finally a short chapter on optical transmission.
256 pages **Order Code BP89 £2.95**

AUDIO

F. A. Wilson, C.G.I.A., C.Eng., F.I.E.E., F.I.E.R.E., F.B.I.M.
Analysis of the sound wave and an explanation of acoustical quantities prepare the way. These are followed by a study of the mechanism of hearing and examination of the various sounds we hear. A look at room acoustics with a subsequent chapter on microphones and loudspeakers then sets the scene for the main chapter on audio systems—amplifiers, oscillators, disc and magnetic recording and electronic music.
320 pages **Order Code BP111 £3.50**

HOW TO IDENTIFY UNMARKED ICs

K. H. Recorr
Shows the reader how, with just a test-meter, to go about recording the particular signature of an unmarked i.c. which should enable the i.c. to then be identified with reference to manufacturers' or other data. An i.c. signature is a specially plotted chart produced by measuring the resistances between all terminal pairs of an i.c.
Chart **Order Code BP101 £0.95**

RADIO AND ELECTRONIC COLOUR CODES AND DATA CHART

B. B. Babani
Although this chart was first published in 1971 it provides basic information on many colour codes in use throughout the world, for most radio and electronic components. Includes resistors, capacitors, transformers, field coils, fuses, battery leads, speakers, etc. It is particularly useful for finding the values of old components.
Chart **Order Code BP7 £0.95**

CHART OF RADIO, ELECTRONIC, SEMICONDUCTOR AND LOGIC SYMBOLS

M. N. Banani, B.Sc.(Eng.)
Illustrates the common, and many of the not-so-common, radio, electronic, semiconductor and logic symbols that are used in books, magazines and instruction manuals, etc., in most countries throughout the world.
Chart **Order Code BP27 £0.95**

INTERNATIONAL TRANSISTOR EQUIVALENTS GUIDE

A. Michaels
Helps the reader to find possible substitutes for a popular selection of European, American and Japanese transistors. Also shows material type, polarity, manufacturer and use.
320 pages **Order Code BP85 £2.95**

TRANSISTOR SELECTOR GUIDE

This unique guide offers a range of selection tables compiled so as to be of maximum use to all electronics engineers, designers and hobbyists.
Section 1: Covers component markings, codings and standards, as well as explaining the symbols used.
Section 2: Tabulates in alpha-numeric sequence the comprehensive specifications of over 1400 devices.
Section 3: Tabulates the devices by case type.
Section 4: Considers particular limits to the electrical parameters when compiling the tables.
Section 5: Illustrates package outlines and leadouts.
Section 6: Consists of a surface mounting device markings conversion list.
192 pages **Order code BP234 £4.95**

TRANSISTOR RADIO FAULT-FINDING CHART

C. E. Miller
Used properly, should enable the reader to trace most common faults reasonably quickly. Across the top of the chart will be found four rectangles containing brief description of these faults, viz—sound weak but undistorted, set dead, sound low or distorted and background noises. One then selects the most appropriate of these and following the arrows, carries out the suggested checks in sequence until the fault is cleared.
Chart **Order code BP70 £0.95**

DIGITAL IC EQUIVALENTS AND PIN CONNECTIONS

A. Michaels
Shows equivalents and pin connections of a popular selection of European, American and Japanese digital i.c.s. Also includes details of packaging, families, functions, manufacturer and country of origin.
256 pages **Order code BP140 £4.95**

LINEAR IC EQUIVALENTS AND PIN CONNECTIONS

A. Michaels
Shows equivalents and pin connections of a popular selection of European, American and Japanese linear i.c.s. Also includes details of functions, manufacturer and country of origin.
320 pages **Order code BP141 £4.95**

INTERNATIONAL DIODE EQUIVALENTS GUIDE

A. Michaels
Designed to help the user in finding possible substitutes for a large selection of the many different types of diodes that are available. Besides simple rectifier diodes, also included are Zener diodes, i.e.d.s, diacs, triacs, thyristors, OCIs, photo and display diodes.
144 pages **Order code BP108 £2.25**

NEWNES ELECTRONICS POCKET BOOK

E. A. Parr
Newnes Electronics Pocket Book has been in print for over twenty years and has covered the development of electronics from valve to semiconductor technology and from transistors to LSI integrated circuits and micro-processors. To keep up to date with the rapidly changing world of electronics, continuous revision has been necessary. This new Fifth Edition takes account of recent changes and includes material suggested by readers of previous editions. New descriptions of op.amp. applications and the design of digital circuits have been added, along with a totally new chapter on computing, plus other revisions throughout.
315 pages (hard cover) **Order Code NE02 £8.95**

CIRCUITS AND DESIGN

ELECTRONICS SIMPLIFIED—CRYSTAL SET CONSTRUCTION

F. A. Wilson, C.G.I.A., C.Eng., F.I.E.E., F.I.E.R.E., F.B.I.M.
Especially written for those who wish to participate in the intricacies of electronics more through practical construction than by theoretical study. It is designed for all ages upwards from the day one can read intelligently and handle simple tools.
80 pages **Order Code BP92 £1.75**

50 CIRCUITS USING GERMANIUM SILICON AND ZENER DIODES

R. N. Soar
Contains 50 interesting and useful circuits and applications, covering many different branches of electronics, using one of the most simple and inexpensive of components—the diode. Includes the use of germanium and silicon signal diodes, silicon rectifier diodes and Zener diodes, etc.
64 pages **Order Code BP36 £1.50**

50 SIMPLE LED CIRCUITS

R. N. Soar
Contains 50 interesting and useful circuits and applications, covering many different branches of electronics, using one of the most inexpensive and freely available components—the light-emitting diode (LED). Also includes circuits for the 707 common anode display.
64 pages **Order Code BP42 £1.95**

COIL DESIGN AND CONSTRUCTION MANUAL

B. B. Babani
A complete book for the home constructor on "how to make" RF, IF, audio and power coils, chokes and transformers. Practically every possible type is discussed and calculations necessary are given and explained in detail. Although this book is now rather old, with the exception of torroids and pulse transformers little has changed in coil design since it was written.
96 pages **Order Code 160 £2.50**

MICRO INTERFACING CIRCUITS—BOOK 1

MICRO INTERFACING CIRCUITS—BOOK 2
R. A. Penfold
Both books include practical circuits together with details of the circuit operation and useful background information. Any special constructional points are covered but p.c.b. layouts and other detailed constructional information are not included.

Book 1 is mainly concerned with getting signals in and out of the computer; Book 2 deals primarily with circuits for practical applications.
Book 1 112 pages **Order code BP130 £2.25**
Book 2 112 pages **Order code BP131 £2.25**

A MICROPROCESSOR PRIMER

E. A. Parr, B.Sc., C.Eng., M.I.E.E.
Starts by designing a small computer which, because of its simplicity and logical structure, enables the language to be easily learnt and understood. The shortcomings are then discussed and the reader is shown how these can be overcome by changes and additions to the instruction set. In this way, such ideas as relative addressing, index registers, etc., are developed.
96 pages **Order code BP72 £1.75**

A PRACTICAL INTRODUCTION TO MICROPROCESSORS

R. A. Penfold
Provides an introduction which includes a very simple microprocessor circuit which can be constructed so that the reader can experiment and gain practical experience.
96 pages **Order code BP123 £1.95**

HOW TO USE OP-AMPS

E. A. Parr
This book has been written as a designer's guide covering many operational amplifiers, serving both as a source book of circuits and a reference book for design calculations. The approach has been made as non-mathematical as possible.
160 pages **Order code BP88 £2.95**

PRACTICAL ELECTRONIC BUILDING BLOCKS—BOOK 1

PRACTICAL ELECTRONIC BUILDING BLOCKS—BOOK 2
R. A. Penfold
These books are designed to aid electronic enthusiasts who like to experiment with circuits and produce their own projects, rather than simply following published project designs.

BOOK 1 contains: Oscillators—sinewave, triangular, squarewave, sawtooth, and pulse waveform generators operating at audio frequencies. Timers—simple monostable circuits using i.c.s, the 555 and 7555 devices, etc. Miscellaneous—noise generators, rectifiers, comparators and triggers, etc.

BOOK 2 contains: Amplifiers—low level discrete and op-amp circuits, voltage and buffer amplifiers including d.c. types. Also low-noise audio and voltage controlled amplifiers. Filters—high-pass, low-pass, 6, 12, and 24dB per octave types. Miscellaneous—i.c. power amplifiers, mixers, voltage and current regulators, etc.

BOOK 1 128 pages **Order code BP117 £1.95**
BOOK 2 112 pages **Order code BP118 £1.95**

HOW TO DESIGN ELECTRONIC PROJECTS

R. A. Penfold
The aim of this book is to help the reader to put together projects from standard circuit blocks with a minimum of trial and error, but without resorting to any advanced mathematics. Hints on designing circuit blocks to meet your special requirements are also provided.
128 pages **Order code BP127 £2.25**

POPULAR ELECTRONIC CIRCUITS—BOOK 1

POPULAR ELECTRONIC CIRCUITS—BOOK 2
R. A. Penfold
Each book provides a wide range of designs for electronic enthusiasts who are capable of producing working projects from just a circuit diagram without the aid of detailed construction information. Any special setting-up procedures are described.

BOOK 1 Temporarily out of print
BOOK 2 160 pages **Order code BP98 £2.25**

GETTING THE MOST FROM YOUR PRINTER

J. W. Penfold
Details how to use all the features provided on most dot-matrix printers from programs and popular word processor packages like Wordwise, Visawrite and Quill, etc. Shows exactly what must be typed in to achieve a given effect.
96 pages **Order Code BP181 £2.95**

A Z80 WORKSHOP MANUAL

E. A. Parr, B.Sc., C.Eng., M.I.E.E.
This book is intended for people who wish to progress beyond the stage of BASIC programming to topics such as machine code and assembly language programming, or need hardware details of a Z80 based computer.
192 pages **Order Code BP112 £3.50**

AN INTRODUCTION TO 68000 ASSEMBLY LANGUAGE

R. A. & J. W. Penfold
Obtain a vast increase in running speed by writing programs for 68000 based micros such as the Commodore Amiga, Atari ST range or Apple Macintosh range etc., in assembly language. It is not as difficult as one might think and this book covers the fundamentals.
112 pages **Order Code BP184 £2.95**

THE ART OF PROGRAMMING THE ZX SPECTRUM

M. James, B.Sc., M.B.C.S.
It is one thing to have learnt how to use all the Spectrum's commands and functions, but a very different one to be able to combine them into programs that do exactly what you want them to. This is just what this book is all about—teaching you the art of effective programming with your Spectrum.
144 pages **Order code BP119 £2.50**

AN INTRODUCTION TO PROGRAMMING THE COMMODORE 16 & PLUS 4

R. A. Penfold
Helps you to learn to use and program these two Commodore machines with the minimum of difficulty by expanding and complementing the information supplied in the manufacturer's own manuals.
128 pages **Order code BP158 £2.50**

AN INTRODUCTION TO PROGRAMMING THE BBC MODEL B MICRO

R. A. & J. W. Penfold
Written for readers wanting to learn more about programming and how to make best use of the incredibly powerful model B's versatile features. Most aspects of the BBC micro are covered, the omissions being where little could usefully be added to the information provided by the manufacturer's own manual.
144 pages **Order Code BP139 £1.95**

AN INTRODUCTION TO PROGRAMMING THE ACORN ELECTRON

R. A. & J. W. Penfold
Designed to help the reader learn more about programming and to make best use of the Electron's many features. Adds considerably to the information already supplied in the manufacturer's own instruction manual.
144 pages **Order code BP142 £1.95**

AN INTRODUCTION TO PROGRAMMING THE ATARI 800/800 XL

R. A. & J. W. Penfold
Especially written to supplement the manufacturer's own handbook. The information supplied will help the reader to master BASIC programming and to make best use of the Atari's many powerful features.
128 pages **Order code BP143 £1.95**

AN INTRODUCTION TO PROGRAMMING THE AMSTRAD CPC 464 AND 664

R. A. & J. W. Penfold
The Amstrad CPC 464 or 664 running with Locomotive BASIC makes an extremely potent and versatile machine and this book is designed to help the reader get the most from this powerful combination. Written to complement rather than duplicate the information already given in the manufacturer's own manual. Also applicable to the CPC 6128.
144 pages **Order Code BP153 £2.50**

AN INTRODUCTION TO PROGRAMMING THE SINCLAIR QL

R. A. & J. W. Penfold
Helps the reader to make best use of the fantastic Sinclair QL's almost unlimited range of features. Designed to complement the manufacturer's handbook.
112 pages **Order code BP150 £1.95**

AN INTRODUCTION TO Z80 MACHINE CODE

R. A. & J. W. Penfold
Takes the reader through the basics of microprocessors and machine code programming with no previous knowledge of these being assumed. The Z80 is used in many popular home computers and simple programming examples are given for Z80-based machines including the Sinclair ZX-81 and Spectrum, Memotech and the Amstrad CPC 464. Also applicable to the Amstrad CPC 664 and 6128.
144 pages **Order code BP152 £2.75**

AN INTRODUCTION TO 6502 MACHINE CODE

R. A. & J. W. Penfold
No previous knowledge of microprocessors or machine code is assumed. Topics covered are: assembly language and assemblers, the register set and memory, binary and hexadecimal numbering systems, addressing modes and the instruction set, and also mixing machine code with BASIC. Some simple programming examples are given for 6502-based home computers like the VIC-20, ORIC-1/Atmos, Electron, BCC and also the Commodore 64.
112 pages **Order code BP147 £2.50**

THE PRE-BASIC BOOK

F. A. Wilson, C.G.I.A., C.ENG., F.I.E.E., F.I.E.R.E., F.B.I.M.
Another book on BASIC but with a difference. This one does not skip through the whole of the subject and thereby leave many would-be programmers floundering but instead concentrates on introducing the technique by looking in depth at the most frequently used and more easily understood computer instructions. For all new and potential micro users.
192 pages **Order code BP146 £2.95**

HOW TO GET YOUR COMPUTER PROGRAMS RUNNING

J. W. Penfold
Have you ever written your own programs only to find that they did not work! Help is now at hand with this book which shows you how to go about looking for your errors, and helps you to avoid the common bugs and pitfalls of program writing. Applicable to all dialects of the BASIC language.
144 pages **Order code BP169 £2.50**

AN INTRODUCTION TO COMPUTER COMMUNICATIONS

R. A. Penfold
Provides details of the various types of modem and their suitability for specific applications, plus details of connecting various computers to modems, and modems to the telephone system. Also information on common networking systems and RTTY.
96 pages **Order code BP177 £2.95**

AN INTRODUCTION TO COMPUTER PERIPHERALS

J. W. Penfold
Covers such items as monitors, printers, disc drives, cassette recorders, modems, etc., explaining what they are, how to use them and the various types and standards. Helps you to make sure that the peripherals you buy will work with your computer.
80 pages **Order code BP170 £2.50**

COMPUTER TERMINOLOGY EXPLAINED

I. D. Poole
Explains a wide range of terms that form the computer jargon used by enthusiasts. Includes a reference guide to the more commonly used BASIC commands.
96 pages **Order code BP148 £1.95**

THE PRE-COMPUTER BOOK

F. A. Wilson
Aimed at the absolute beginner with no knowledge of computing. An entirely non-technical discussion of computer bits and pieces and programming.
96 pages **Order code BP115 £1.95**

NEWNES COMPUTER ENGINEER'S POCKETBOOK

Michael Tooley
An invaluable compendium of facts, figures, circuits and data, indispensable to the designer, student, service engineer and all those interested in computer and microcomputer systems. It will appeal equally to the hardware or software specialist and to the new band of "software engineers". This first edition covers a vast range of subjects at a practical level, with the necessary explanatory text. The data is presented in a succinct and rapidly accessible form so that the book can become part of an everyday toolkit.
205 pages (hard cover) **Order code NE01 £8.95**

PROJECT CONSTRUCTION

HOW TO GET YOUR ELECTRONIC PROJECTS WORKING

R. A. Penfold
We have all built projects only to find that they did not work correctly, or at all, when first switched on. The aim of this book is to help the reader overcome just these problems by indicating how and where to start looking for many of the common faults that can occur when building up projects.
96 pages **Order code BP110 £1.95**

HOW TO DESIGN AND MAKE YOUR OWN P.C.B.s

R. A. Penfold
Deals with the simple methods of copying printed circuit

board designs from magazines and books and covers all aspects of simple p.c.b. construction including photographic methods and designing your own p.c.b.s.
80 pages **Order code BP121 £1.95**

BEGINNER'S GUIDE TO BUILDING ELECTRONIC PROJECTS

R. A. Penfold
Shows the complete beginner how to tackle the practical side of electronics, so that he or she can confidently build the electronic projects that are regularly featured in magazines and books. Also includes examples in the form of simple projects.
112 pages **Order code No. 227 £1.95**

RADIO

AN INTRODUCTION TO RADIO DXING

R. A. Penfold
Anyone can switch on a short wave receiver and play with the controls until they pick up something, but to find a particular station, country or type of broadcast and to receive it as clearly as possible requires a little more skill and knowledge. The object of this book is to help the reader to do just that, which in essence is the fascinating hobby of radio DXing.
112 pages **Order code BP91 £1.95**

INTERNATIONAL RADIO STATIONS GUIDE

Completely revised and updated, this book is an invaluable aid in helping all those who have a radio receiver to obtain the maximum entertainment value and enjoyment from their sets.
Clearly shown are the station site, country, frequency and/or wavelength, as well as the effective radiation power of the transmitter.
128 pages **Order code BP155 £2.95**

RECOMMENDED READING FOR . . . INTRODUCING MICROPROCESSORS

BEGINNERS GUIDE TO MICROPROCESSORS

E. A. Parr
An excellent grounding in microprocessors, this book is broadly relevant to the whole of our Introducing Microprocessors course. It is easy to read and well illustrated.
224 pages **Order code NE03 £4.95**

MICROELECTRONIC SYSTEMS 2 CHECKBOOK

R. Vears
The aim of this book is to provide a foundation in microcomputer hardware, software and interfacing techniques. Each topic is presented in a way that assumes only an elementary knowledge of microelectronic systems and logic functions. The book concentrates on 6502, Z80 and 6800 microprocessors and contains 60 tested programs, 160 worked problems and 250 further problems.
194 pages **Order code NE04 £4.95**

RECOMMENDED READING

EE BOOK SERVICE

TO ORDER

Please check the latest issue for price and availability.

Add 50p per order postage (overseas readers add £1, surface mail postage) and send a PO, cheque or international money order (£ sterling only) made payable to Everyday Electronics (quoting the order code and quantities required) to **EE BOOK SERVICE, 6 CHURCH STREET, WIMBORNE, DORSET. BH21 1JH.**

Although books are normally sent within seven days of receipt of your order please allow a maximum of 28 days for delivery. Overseas readers allow extra time for surface mail post.



PCB SERVICE

Printed circuit boards for certain constructional projects (up to two years old) are available from the PCB Service, see list. These are fabricated in glass-fibre, and are fully drilled and roller tinned. All prices include VAT and postage and packing. Add £1 per board for overseas airmail. Remittances should be sent to: The PCB Service, *Everyday Electronics* Editorial Offices, 6 Church Street, Wimborne, Dorset BH21 1JH. Cheques should be crossed and made payable to *Everyday Electronics*. (Payment in £ sterling only.)

Please note that when ordering it is important to give project title as well as order code. Please print name and address in Block Caps. Do not send any other correspondence with your order.

Readers are advised to check with prices appearing in the current issue before ordering.

NOTE: Please allow 28 days for delivery. We can only supply boards listed in the latest issue. Boards can only be supplied by mail order and on a payment with order basis.

PROJECT TITLE	Order Code	Cost
- DEC '85 -		
Electronic Building Blocks - 5 to 8	508	£3.85
Opto Intensity Transducer	509	£3.38
Digital Capacitance Meter	512	£6.52
- JAN '86 -		
Mains Delay	503	£2.65
Musical Doorbell	507	£3.63
Tachometer - Transducers Series	513	£3.15
- FEB '86 -		
Touch Controller	510	£3.32
Function Generator	514	£3.54
Function Generator PSU Board	515	£2.56
pH Transducer - Transducers Series	516	£3.30
- MAR '86 -		
Mains Tester & Fuse Finder	517	£2.84
BBC Midi Interface	518	£4.08
Stereo Hi Fi Preamp	519	£7.13
Interval Timer	520	£2.95
- APRIL '86 -		
Stereo Reverb	521	£3.73
- MAY '86 -		
PA Amplifier	511	£3.34
Mini Strobe	522	£2.79
Auto Firing Joystick Adaptor	523	£3.42
- JUNE '86 -		
Watchdog	524	£3.51
Percussion Synthesiser	525	£7.06
Personal Radio	526	£2.58
- JULY '86 -		
Tilt Alarm	527	£2.65
Electronic Scarecrow	528	£2.86
VOX Box Amplifier	529	£2.93
Headphone Mixer	530	£5.71
- AUG '86 -		
Solar Heating Controller	533	£4.16
- SEPT '86 -		
Car Timer	538	£2.53
Freezer Failure Alarm	534	£2.38
Infra Red Beam Alarm (Trans)	536	£4.16
Infra Red Beam Alarm (Rec)	537	£4.16
Scratch Blanker	539	£6.80
- OCT '86 -		
10W Audio Amp (Power Amp) (Pre-Amp) } £4.78 Pair	543	£3.23
	544	£3.97
Light Rider - Lapel Badge	540 & 541	£2.97
- Disco Lights	542	£5.12
- Chaser Light	546	£4.04
- NOV '86 -		
Modem Tone Decoder	547	£3.46
200MHz Digital Frequency Meter	548	£5.14
- DEC '86 -		
Dual Reading Thermometer	549	£7.34
Automatic Car Alarm	550	£2.93
BBC 16K Sideways RAM	551	£2.97
(Software Cassette)	551S	£3.88

- JAN '87 -		
Random Light Unit	552	£5.88
- FEB '87 -		
Car Voltage Monitor	553	£2.48
Mini Amp.	554 & 555	£5.68
Video Guard	556	£3.80
Spectrum I/O	557	£4.35
Spectrum Speech Synthesiser	558	£4.86
- MAR '87 -		
Computer Buffer/Interface	560	£3.32
Infra Red Alarm: Sensor head	561	£4.19
PSU/Relay Driver	562	£4.50
- APRIL '87 -		
Alarm Thermometer	559	£2.60
Experimental Speech Recognition	563	£4.75
Bulb Life Extender	564	£2.48
- MAY '87 -		
Fridge Alarm	565	£2.40
EE Equaliser - Amplifier	566	£4.10
- JUNE '87 -		
Mini Disco Light	567	£2.93
Visual Guitar/Instrument Tuner	568	£3.97
- JULY '87 -		
Fermostat	569	£3.34
EE Buccaneer Metal Detector	570	£4.10
Monomix	571	£4.75
- AUG '87 -		
Super Sound Adaptor, Main Board	572	£4.21
PSU Board	573	£3.32
Simple Shortwave Radio, Tuner	575	£3.15
Amplifier	576	£2.84
- SEPT '87 -		
Noise Gate	577	£4.41
Burst Fire Mains Controller	578	£3.31
Electronic Analogue/Digital Multimeter	579	£6.40
- OCT '87 -		
Transtest	580	£3.32
Video Controller	581	£4.83
- NOV '87 -		
Accented Metronome	582	£3.77
Acoustic Probe	584	£2.78
BBC Sideways RAM/ROM	585	£4.10

TEACH-IN-SOFTWARE

To complement each published part of the Teach-In series (Oct. '85 to June '86), we have produced an accompanying computer program. The Teach-In Software is available for both the BBC Microcomputer (Model B) and the Sinclair Spectrum (48k) or Spectrum-Plus. The programs are designed to reinforce and consolidate important concepts and principles introduced in the series. The software also allows readers to monitor their progress by means of a series of multi-choice tests, with scores at the end.

Tape 1 (Teach-In parts 1, 2 and 3), Tape 2 (parts 4, 5 and 6) and Tape 3 (parts 7, 8 and 9) are available for £4.95 each (inclusive of VAT and postage) from Everyday Electronics, 6 Church Street, Wimborne, Dorset BH21 1JH. **IMPORTANT State BBC or Spectrum; add 50 pence for overseas orders; allow 28 days for delivery.**

EE PRINTED CIRCUIT BOARD SERVICE
Please send me the following p.c.b.s.
Make cheques/PO payable to: **Everyday Electronics**
(Payment in £ sterling only)

Order Code	Quantity	Price
.....
.....

I enclose cheque/PO for £.....

Name

Address

Please allow 28 days for delivery.

BLOCK CAPITALS PLEASE

TOTAL ENERGY DISCHARGE ELECTRONIC IGNITION

IS YOUR CAR AS GOOD AS IT COULD BE ?

- ★ Is it **EASY TO START** in the cold and damp? Total Energy Discharge will give the most powerful spark and maintain full output even with a near flat battery.
- ★ Is it **ECONOMICAL** or does it "go off" between services as the ignition performance deteriorates? Total Energy Discharge gives much more output to fire lean fuel mixtures.
- ★ Has it **PEAK PERFORMANCE** or is it flat at high and low revs, where ignition output is marginal? Total Energy Discharge gives a more powerful spark from idle to the engines maximum (even with 8 cylinders).
- ★ Is the **PERFORMANCE SMOOTH?** The more powerful spark of Total Energy Discharge eliminates the near "misfires" whilst an electronic filter smoothes out the effects of contact bounce etc.
- ★ Do the **PLUGS AND POINTS** always need changing to bring the engine back to its best? Total Energy Discharge eliminates contact arcing and erosion by removing the heavy electrical load. The timing stays "spot on" and the contact condition does not affect the performance either. Larger plug gaps can be used, even wet or badly fouled plugs can be fired with this system.
- ★ **TOTAL ENERGY DISCHARGE** is a unique system and the most powerful on the market - 3.5 times the power of inductive systems - 3 times the energy and 3 times the duration of ordinary capacitive systems. Send for full technical details
- ★ **ALSO FEATURES**
EASY FITTING, STANDARD/ELECTRONIC CHANGEOVER SWITCH,
STATIC TIMING LIGHT and DESIGNED IN RELIABILITY (14 years experience and a 3 year guarantee)
- ★ In **KIT FORM** it provides a top performance system at less than half the price of a comparable ready built unit. The kit includes: pre-drilled fibreglass PCB, pre-wound and varnished ferrite transformer, high quality 2µf discharge capacitor, case, easy to follow instructions, solder and everything you need to build and fit to your car. All you need is a soldering iron and a few basic tools.

TOTAL ENERGY DISCHARGE KIT £17.95 { Prices include VAT
ASSEMBLED READY TO FIT £23.90 { Add £1.00 P&P

ALSO AVAILABLE: Other Ignition systems and electronic car alarms

Order now or send for further details:

ELECTRONIZE DESIGN tel 021 308 5877
2 Hillside Road, Four Oaks, Sutton Coldfield B74 4DQ

STAN WILLETTS

37 HIGH STREET, WEST BROMWICH,
STAFFS B70 6PB Tel: 021-553 0186

GRUNDIG INFRA-RED REMOTE CONTROL VIF-K1 (13 functions) consist of **TRANSMITTER TPV 355** and **Receiver VIF-E1**. Brand new and boxed £5.99 P&P £2.



VIF-E1 RECEIVERS box of 10 £12.99 P&P 5/50p.



GRUNDIG CBF 1900 CAMERA lead (7 metres) £1.99 P&P £1.

GRUNDIG Remote-Control 440 (cable) 7M 10 core. Brand new boxed £2.99 P&P £2.



VIDEO HEADS for 2x4 **GRUNDIG Super Stereo** complete in **Head assembly** £29 P&P £2.

2x4 **Power Pack panel** £25. 2x4 **Panels - DFT - SERVO - VIDEO - CROMA - STEREO - TON - MOTOR BOARD - MODULATOR & TUNER**, All £9.95 each P&P £1.



DATAX VIDEO Data Recorders for use with **COMMODORE COMPUTER VIC 64 & VIC 120 NEW** (manufacturer's returns all fully guaranteed £9.99 P&P £2).

INFRA-RED & ULTRASONIC Remote Controls for use with **FERGUSON, J.V.C., PHILIPS, NORMENDE, ITT, GRUNDIG & SONY** brand new boxed £22.50 P&P £1.

V2000 VIDEO TAPES brand new **VCC360** £6.99 P&P £1.



"HARRY MOSS" 8-Track Cartridge Player complete with **F/M Multiplex STEREO TUNER 12V** brand new boxed £5.99, P&P £2.

DESOLDERING PUMP All metal body **TEFLON NOZZLE** £2.99 P&P 50p

PANEL METERS 0-25 & 40 amp 72x72 m/m & 92x92 m/m brand new boxed 600 for sale **OFFERS** sample £2.

TELEVISION LEAD 12V 4 1/2 metres brands new 75p P&P 75p

CALCULATOR WATCH MULTI-FUNCTION with alarm, brand new with maker guarantee £4.99.

"SAXON" BLACK LCD Quartz watch, brand new, £1. Chrome £1.25 P&P 35p.



MICRO HEADPHONES £1 pair P&P 25p

GRUNDIG Magnetic Head Earphones, brand new 3 for £1 P&P 50p.



COMPUTER TAPES premium quality 10 minute 25p, 15 minute 30p, 15 minute 35p P&P 25p.

TRADE ENQUIRIES INVITED WANTED - ANY QUANTITY - VIDEOS, TVs RADIO & ELECTRONIC EQUIPMENT, CAMCORDERS, CAMERAS, etc., COMPONENTS, TAPES

Zenith Electronics. ©

Kits - Modules - Hardware

NEW

★ **MC-1 MAINS CONTROLLER KIT.** Control mains loads from low voltage/logic sources £7.52 inc. VAT & P&P

The following are examples of our proven product designs in kit form:

- ★ 10 Channel Variable Speed Running Light, Drives LEDs or mains lamps. It £14.97
- ★ 3 Note Electronic Door Chime unit; 9 volt operation, 3 melodious tones; variable frequency. Kit £9.83
- ★ Miniature FM Transmitter; 60-145MHz. Kit £6.95
R/Built £8.95
- ★ 3 Wall FM Transmitter, 80-108MHz. Kit £13.99
R/Built £18.99
- ★ 300 Watt Light Dimmer unit for 240 volt mains lights. Kit £6.95
- ★ 4 Code Digital Code unit plus Key Pad - select own code; 9 volt. Kit £15.95
- ★ 5-100 Watt Electronic Loudspeaker Overload Protector, adjustable. Kit £11.11
- ★ VU Meter 10 LED indicator; -5 to +12dB range. Kit £12.59
- ★ Automatic light controller; automatically turns on and off lights at pre-set times and triggered by darkness. Kit £25.08
- ★ Mains Wiring and Metal Detector. R/Built £11.00
- ★ Zenith Speech Processor P-202 R/Built £25.00
- ★ 18-Watt Car/Home Power Amp. 12-V. Kit £13.23
- ★ Amplifier Power Meter; 10 LED indicator from 0-25 - 100 Watt Input - 9 volt operation. Kit £9.52
- ★ Light sensitive relay unit; variable sensitivity trigger control; senses light or dark - selectable. Kit £8.45

ALL KITS CONTAIN FULL INSTRUCTIONS. P.C.B.s AND COMPONENTS. ALL PRICES INCLUDE VAT AND POSTAGE & PACKING. OVERSEAS ORDERS - ADD 10% TO ABOVE PRICES. PLEASE SEND CHEQUE OR POSTAL ORDERS WITH ORDER.

S.A.E. For
-FREE-
Data Pack

Zenith Electronics, 14 Cortlandt Business Centre,
Hailsham, E. Sussex, I.K. BN27 1AE.
Tel: 0323 847973 Telex: 878334

EVERYDAY ELECTRONICS

Reach effectively and economically today's enthusiasts anxious to know of your products and services through our semi-display and classified pages. The prepaid rate for semi-display spaces is £8.00 per single column centimetre (minimum 2.5cm). The prepaid rate for classified advertisements is 30 pence per word (minimum 12 words), box number 60p extra. All cheques, postal orders, etc., to be made payable to Everyday Electronics VAT must be added. Treasury notes should always be sent registered post. Advertisements, together with remittance, should be sent to the Classified Advertisement Dept., Everyday Electronics, 6 Church Street, Wimborne, Dorset BH21 1JH. Tel: 0202 881749.

Electronic Components

RESISTORS (metal film, full length leads): mixed (1, 2, 5%) 1000 off £6.50, 100 off £1.10. Mixed (1%) 70 off £1, (2%, 1/4W) 70 off £1, (1W) 35 off £1, (2W) 30 off £1. Enclosed miniature cermet trimpos (assorted): 10 off £1.50, 50 off £5. Ten turn wirewound potentiometers: 5 assorted £1.60. Low profile turned pin d.i.l. sockets: 8 off 24 pin £2.30, 40 pin 60p each. Postage and packing 70p. SAE for full list. Milner Electronics, 2 Elgarth Drive, Wokingham, Berkshire RG11 4HH.

MICRO TRANSMITTER KIT, 500m range, tunable 88-115MHz, sensitive microphone, £3.95. Cheques/PO to: Quantum Electronics (EE), 267 Rednal Road, Kings Norton, Birmingham B38 8EB.

Service Manuals

UNIQUE REPAIR DATA WITH CIRCS

Video or mono TV £10.50: CTV £12.95: Sinclair Spectrum Repair/Service £5

SERVICE SHEETS: Radios, Mono TV, Rec PP £2.50 + Isae. CTV, Mus. C., Combis £3.59 + Isae. World's largest stockist data all equipment, Isae brings quotes/price lists - or £3 for set of catalogues with £4 worth of vouchers.

Phone 0698 884585 for fast quotes.
TISEE, 76 Church St., Larkhill, Wiltshire ML9 1HE.

CIRCUIT DIAGRAMS

Any Make, Model, Type, Audio, Music Systems, Television, Video Recorders, Amateur Radio, Test Equipment, Vintage Wireless, etc.

£3.00 plus LSAE. State Make/Model/Type with order.

Full Workshop Manual prices on request with LSAE.
MAURITRON (EE), 8 CHERRY TREE ROAD, CHINNOR, OXON OX9 4QY

Special Offers

FREE MEMBERSHIP to a new national electronics club. For details and a free pack of components worth over £10 send only £1 p&p to Dept. EE, Woodside, Dowsett Lane, Ramsden Heath, Billericay, Essex CM11 1JL.

PRINTED CIRCUIT BOARDS produced to own personal requirements. Please send s.a.e. for further details to Mr. B.M. Anshro, 38 Poynings Drive, Hove, Sussex.

Services

ELECTRONIC REPAIRS

Repair and rebuild service carried out by our electronic engineers to get your project working or help you with any problems you have.
No project too small or too big.

D.G. Electronics Services Ltd.
Chelmsford (0245) 266160

TURN YOUR SURPLUS

ICS transistors etc into cash, immediate settlement. We also welcome the opportunity to quote for complete factory clearance.

Contact **COLES-HARDING & CO**, 103 South Brink, Wisbech, Cambs.
ESTABLISHED OVER 10 YEARS
Tel: 0945 584188

★ BAKER ★ GROUP P.A. DISCO AMPLIFIERS post £4

150 watt Output, 4 Input Mixer pre-amp, Illustrated £99
150 watt Output, Slave 500 mv. Input 3 Speaker Outputs £80
150 + 150 watts Stereo, 300 watt Mono Slave Mosfet £155
150 watt P.A. Vocal, 8 Inputs, High/Low Mixer Echo Socket £170
60 watt Mobile 240v AC and 12v DC, 4-8-16 ohm + 100v line £89
Compact P.A. amp 20 + 20 Stereo or 40 watts Mono £65
30 watt Guitar/P.A. Amplifier, 2 inputs £59
30 watt COMBI, 12m Speaker, Treble, Bass, etc. £95
500 watt Heavy duty Mono Slave Amplifier fan cooled £275

FAMOUS LOUDSPEAKERS		FULLY GUARANTEED			
Make	Model	Size	Watts	Ohms	Price
GOODMANS	HB WOOFER	8in.	80	8	£16
BAKER	DISCO/GROUP	10in.	50	8/16	£22
WEM	WOOFER	10in.	300	8	£49
BAKER	MID-RANGE	10in.	100	8	£30
BAKER	DISCO/GROUP	12in.	120	8/16	£35
WEM	WOOFER	12in.	300	8	£65
GOODMANS	DISCO/GROUP	12in.	120	8/15	£39
BAKER	DISCO/GROUP	15in.	100	8/16	£44
H+H	DISCO/GROUP	15in.	100	4/8/16	£59
GOODMANS	HP/BASS	15in.	250	8	£82
GOODMANS	HPD/BASS	18in.	230	8	£92

COMPACT FULL RANGE SPEAKER SYSTEMS size 24 x 17 x 12in.
120 watts £100, 200 watts £130, 400 watts £180 each. Carr. £10.
MID Hi TOP 300 watts add on system complete £140 each. Carr. £10.
DISCO CONSOLE Twin Decks, mixer pre amp £145. Carr. £10.
Ditto Powered 120 watt £195; or Complete disco £299. Carr. £30.

MAINS TRANSFORMERS VALVE TYPE 240V PRIMARY	Price	Post
250-0-250V 80mA, 6V 3A, 0.5 5V 1A	£10	£2
350-0-350V 250mA, 6.3V 6A CT	£16	£2
220V 25mA, 6V 1 Amp £3.00 220V 45mA, 6V 2 Amp	£4	£1
STEP-UP STEP-DOWN 240V-120V 150W £9.25 250W £12.50 500W	£15	£2

RECORD DECKS. P&P £2. Many others in stock. Phone for details.	Price
Make Drive Supply Cartridge	
JAP Single Belt 12V DC Magnetic	£20
BSR Single Rim 240V Magnetic	£30
BSR Single Rim 240V Ceramic	£22
BSR Auto Rim 240V Ceramic	£18
Garand Auto Rim 240V Ceramic	£24

PROJECT CASES. Black Vinyl Covered Steel Top. All Base 4 x 2 1/2 x 2 1/2 in. £3.00; 6 x 4 x 1 1/2 in. £4.00; 8 x 5 x 2 in. £4.50 p.p.p. £1; 11 x 6 x 3 in. £8.00; 11 1/2 x 6 x 5 in. £10.00; 15 x 8 x 4 in. £13.50 p.p.p. £2.
12 x 8 in. £1.80; 10 x 7 in. £1.50; 8 x 6 in. £1.00; 14 x 3 in. £1.00; 12 x 5 in. £2.40; 6 x 4 in. 85p; £2.70; 16 x 6 in. £1.80 p.p.p. 65p each.
ALUMINIUM BOXES. MANY OTHERS IN STOCK
4 x 2 1/2 x 2 in. £1.35; 3 x 2 x 1 1/2 in. £1.15; 6 x 4 x 2 in. £2.00; 8 x 6 x 3 in. £3.40; 12 x 5 x 3 in. £4.00; 6 x 4 x 3 in. £2.50; 10 x 7 x 3 in. £4.00 p.p.p. £1.
19in rack mounting equipment case 16 x 10 x 5 in. £20, p.p.p. £2.

HIGH VOLTAGE ELECTROLYTICS Many others in stock	Price
20/500V £1	22/1000V £2
32/350V 50p	8 + 8/450V £1
47/350V £1	20 + 20/350V 75p

Full range low voltage capacitors in stock

AIR SPACED TWIN GANGS, 365 + 365 + 25 + 25p/1 £2.35.
REVERSE VERNIER cord drive 90p. Spindle Extender £1.50.
VERNIER DIALS, 0:100, 36mm, £3.00, 50mm £3.50.

RADIO COMPONENT SPECIALISTS

337 WHITEHORSE ROAD, CROYDON
SURREY, U.K. Tel: 01-684 1665
Post 65p Minimum. Callers Welcome
List Large S.A.E. Delivery 7 days Closed Wednesday



ORDER FORM PLEASE WRITE IN BLOCK CAPITALS

Please insert the advertisement below in the next available issue of **Everyday Electronics** for Insertions. I enclose Cheque/P.O. for £..... (Cheques and Postal Orders should be made payable to Everyday Electronics)

HEADING REQUIRED:

NAME

ADDRESS

EVERYDAY ELECTRONICS
and **ELECTRONICS MONTHLY**
Classified Advertisement Dept.,
6 Church Street,
Wimborne,
Dorset BH21 1JH.
Telephone 0202 881749
RATE: 30p per word, minimum 12 words. Box No. 60p extra. VAT must be added.

10/87

OSCILLOSCOPES

TELEQUIPMENT D83, Dual Trace 50MHz Delay Sweep
 TELEQUIPMENT D61 Dual Trace 10MHz With Manual
 S.E. LABS SM111 Dual Trace 18MHz Solid State Portable
 AC or External DC operation 8 x 10cm display with Manual
 TELEQUIPMENT D43, Dual Trace 15MHz. With Manual
 TELEQUIPMENT 554A, Single Trace 10MHz Solid State,
 With Manual
 GOULD/ADVANCE OS255 Dual Trace 15MHz. With
 Manual
 ADVANCE OS250TV, Dual Trace 10MHz. With Manual
 HAMEG 207 Single Trace 8MHz. With Manual

MULTIMETERS

AVO 8 Complete with Batteries & Leads
 Leather cases available
 AVO 8 MkV Complete with Batteries, Leads &
 Cases
 AVO TEST SET No 1 (Military version of AVO 8) Com-
 plete with batteries, leads & Carrying Case
 TEST LEADS suitable for AVO METERS. Red & Black
 with 2 Croc Clips & 2 Prods (P&P £2)
 AVO Model 73, Pocket Multimeter (Analogue) 30 ranges
 Complete with batteries & Leads
 AVO 72 - Similar to above but no AC current range. With
 batteries & leads
 ANALOGUE POCKET MULTIMETERS; Philips/
 Taylor etc. With Batteries & Leads

COMMUNICATION RECEIVERS

RACAL RA17L, 500KHz-30MHz. With Manual.
 EDDYSTONE 73014, 480KHz-30MHz. With Manual

ISOLATING TRANSFORMER

240V Out-500VA £15 (P&P £5); 100VA £6 (P&P £2); 240V
 Out-500VA £6 (P&P £5); 200VA £4 (P&P £4)

AVO TRANSISTOR TESTER TT169

Handled, GO/NO GO for In-situ Testing. Complete with
 batteries, leads & instructions (P&P £3)
 NOW ONLY £12

STEPPING MOTORS

Type 1, 200 Steps per rev 4 Phase (5 wire) 12/24V. Torque
 25oz inch, will run on 5V with reduced torque... £15 ea.
 Type 2, 6/12 Steps per rev. 3 phase, 12/24V (will work
 on 5V) £2 ea 5 off... £7.50
 Type 3, NORTH AMERICAN PHILIPS 24 Steps per rev,
 4 wire 5V 3.3 Amps 0-250rpm 0-200 PPs... £8 ea.
 Type 4, 200 Steps per rev, 120V (3 wire) Torque 25 oz
 inch... £4 ea.
 Type 7, WARNER 24 Steps per rev, 3 Phase (6 wire), 28V,
 Holding Torque 45oz inch... £5 ea.

USED EQUIPMENT - with 30 DAYS GUARANTEE. MANUALS SUPPLIED IF POSSIBLE.
 This is a VERY SMALL SAMPLE OF STOCK. SAE or Telephone for Lists. Please check availability
 before ordering. CARRIAGE all units £16. VAT to be added to Total of Goods & Carriage.

STEWART OF READING

110 WYKEHAM ROAD, READING, BERKS RG6 1PL
 Telephone: 0734 68041
 Callers welcome 9 am-5.30 pm Mon.-Fri (until 8 pm Thurs.)

SPECIAL OFFERS

COSSOR OSCILLOSCOPE CDU159, Dual Trace 35MHz.
 Delay Sweep. Solid State, Portable 8 x 10cm Display.
 With Manual... NOW ONLY £180 each
 Optional Front Protection Cover containing 2 Probes &
 Viewing Hood... £10
 SOLARTRON OSCILLOSCOPE CD1400, Dual Beam
 15MHz. With Manual... ONLY £85 each
 AVO VALVE TESTER CT160, Suitcase style, 22 Bases.
 (P&P £7)... ONLY £25 each

MARCONI AM/FM Sig Gen TF1066B 10/47/0MHz... £250
 MARCONI AM/FM Sig Gen TF995 range from... £150
 FARNELL SINE/SQUARE type LFM2 1Hz-1MHz
 Compact... £80
 ADVANCE SC628 AM 150KHz-220MHz... £45
 Many other Generators available - Please Enquire

B+K Precision CRT Restorer/Analyser Model 467.
 Supplied with 2 Bases and Manual. (P&P £7)
 Capgear Colour Bar Generator K61 & Test Patterns. (P&P
 £4) ... ONLY £40 each

DISK DRIVE PSU, 240V 1N; 5V 1.6A & 12V 1.5A out.
 Size: W125mm, H75mm, D180mm. Cased, Un-used.
 (P&P £3)... ONLY £125 each
 Owerly keyboard las in Lynx Micro. Push to make.
 Cased. (P&P £3)... £5 each
 SWITCHED MODE PSU +/- 12V 0.25A; 5V 15A; 24V
 1.4A... £20 each P&P £3
 Other Switched Mode PSU available. Please Enquire
 DATRON 3000 PROM COPIER (copies up to 10) (P&P £7)
 £150 ea

NEW EQUIPMENT

HAMEG OSCILLOSCOPE 605, Dial Trace 60MHz. Delay
 Sweep. For Lists... £383
 HAMEG OSCILLOSCOPE 203.6 Dual Trace 20MHz,
 Component Tester & 2 Probes... £314
 All Other Models Available.

BLACK STAR FREQUENCY COUNTERS P&P £4
 Meter 100 - 100MHz... £39
 Meter 600 - 600MHz... £126
 Meter 1000 - 1GHz... £175
 BLACK STAR, JUPITOR 500 FUNCTION GENERATOR,
 Sine/Square/Triangle, 0.1Hz-500KHz. P&P £4... £110
 BLACK STAR ORION, PAL TV/VIDEO COLOUR
 PATTERN GENERATOR... £199

HUNG CHANG DMM 7030, 3 1/2 digit. Hand held 28
 ranges including 10 Amp AC/DC 0.1%. Complete with
 batteries & leads. P&P £4... £39.50
 AS ABOVE, DMM 6010, 0.25%... £33.50

OSCILLOSCOPES PROBES, Switched x1; x10,
 P&P £2... £11

£1 BARGAIN PACKS

Buy 10 packs ... get one free (your choice)

PK 1, 350 Assorted resistors. Full length leads.
 PK 2, 400 Assorted resistors. Pre-formed leads.
 PK 3, 60 Assorted resistors. Wire wound
 PK 4, 200 Assorted mixed capacitors.
 PK 5, 200 Assorted ceramic capacitors.
 PK 6, 60 Electrolytic capacitors.
 PK 7, 2 2200µF 100 volt capacitors.
 PK 8, 2 4700µF 30 volt capacitors
 PK 9, 12 Assorted rotary potentiometers. Single gang
 PK 10, 6 Assorted rotary potentiometers. Dual gang
 PK 11, 12 Assorted slider potentiometers.
 PK 12, 40 Assorted pre-set potentiometers.
 PK 13, 5 100K lin multiturn potentiometers.
 PK 14, 5 1meg lin multiturn potentiometers
 PK 15, 12 Assorted switches.
 PK 16, 1 bank 4-way push button switches c/w knobs.
 PK 17, 1 4 pole 5-way water switch.
 PK 18, 15 Assorted control knobs.
 PK 19, 20 Assorted plugs and sockets.
 PK 20, 2 Pairs D.C. plugs & sockets c/w leads & P&P clip.
 PK 21, 25 Assorted transistors. All new & coded.

PK 22, 15 Assorted I.C.'s. All new & coded.
 PK 23, 50 Assorted unmarked & untested I.C.'s
 PK 24, 100 Assorted diodes.
 PK 27, 1 Large power-fin heatsinks. T03.
 PK 28, 20 Assorted neon. Panel mounting & wire ended.
 PK 29, 1 Microphone c/w lead, switch, plugs & stand.
 PK 31, 3 Dynamic earpieces c/w lead & 3.5mm plug.
 PK 32, 2 Telescopic aerials.
 PK 35, 1 Large cassette motor.
 PK 36, 1 Wire pack. Mains cable.
 PK 38, 1 Wire pack. Connecting wire. Assorted colours.
 PK 39, 300 Assorted resistors. 1/2W or less. F.L leads
 PK 40, 200 Assorted Polyester capacitors.
 PK 41, 12 Push to make switches. pcb mounting.
 PK 43, 4 Assorted taster elements.
 PK 44, 3 Assorted record player stylus.
 PK 45, 50 Assorted I.F. and tuning coils.
 PK 46, 35 Assorted resistors 1% tolerance
 PK 47, 1 Bag of surprises
 PK 48, 25 Assorted Zener diodes

Postal order or cheque with order. Please add £1 postage & packing per order.
 Access and Barclaycard orders welcome, minimum £10.
 Electronics magazines, we have an extensive range of back issues. 50p for current lists.

MJR WHOLESALE, Mount Farm, Harford,
 Lampeter, Dyfed, Wales SA19 8DP.

MAKE YOUR INTERESTS PAY!

More than 8 million students throughout the world have found it worth their while! An
 ICS home-study course can help you get a better job, make more money and have more
 fun out of life! ICS has over 90 years experience in home-study courses and is the largest
 correspondence school in the world. You learn at your own pace, when and where you
 want under the guidance of expert 'personal' tutors. Find out how we can help YOU.
 Post or phone today for your FREE INFORMATION PACK on the course of your choice.
 (Tick one box only!)

Electronics	<input type="checkbox"/>	Radio, Audio and TV Servicing	<input type="checkbox"/>
Basic Electronic Engineering (City & Guilds)	<input type="checkbox"/>	Radio Amateur Licence Exam (City & Guilds)	<input type="checkbox"/>
Electrical Engineering	<input type="checkbox"/>	Car Mechanics	<input type="checkbox"/>
Electrical Contracting/Installation	<input type="checkbox"/>	Computer Programming	<input type="checkbox"/>
GCE over 40 'O' and 'A' level subjects <input type="checkbox"/>			

ICS Name _____ P. Code _____
 Address _____
 International Correspondence Schools, Dept ECSB7, 312/314 High St.,
 Sutton, Surrey SM1 1PR. Tel: 01-643 9568 or 041-221 2526 (24 hrs).

ELECTRONICS TECHNICIAN FULL-TIME TRAINING

(FULL TIME COURSES APPROVED BY THE BUSINESS & TECHNICIAN EDUCATION COUNCIL)

2 YEAR BTEC National Diploma (OND) ELECTRONIC & COMMUNICATIONS ENGINEERING

(Electronics, Computing, Television, Video, Testing & Fault Diagnosis)

1 YEAR BTEC National Certificate (ONC) INFORMATION TECHNOLOGY

(Electronics, Satellite TV, CD, Networks, Telecomms)

ELECTRONIC EQUIPMENT SERVICING

(Electronics, Television, Video Cassette Recorders, CCTV, Testing & Fault Diagnosis)

SOFTWARE ENGINEERING

(Electronics, Assembler, BASIC, PASCAL, CAD/CAM)

COMPUTING TECHNOLOGY

(Electronics, Computing Software/Hardware, Microelectronic Testing Methods)

10 MONTHS BTEC Higher National Certificate (HNC) COMPUTING TECHNOLOGY & ROBOTICS

(Microprocessor Based Systems, Fault Diagnosis, ATE, Robotics)

THESE COURSES INCLUDE A HIGH PERCENTAGE OF COLLEGE BASED PRACTICAL WORK TO ENHANCE FUTURE EMPLOYMENT PROSPECTS

NO ADDITIONAL FEES FOR OVERSEAS STUDENTS

SHORTENED COURSES OF FROM 3 TO 6 MONTHS CAN BE ARRANGED FOR APPLICANTS WITH PREVIOUS ELECTRONICS KNOWLEDGE

O.N.C. 11th January 1988
 FULL PROSPECTUS FROM

LONDON ELECTRONICS COLLEGE (Dept EE)
 20 PENYERN ROAD, EARLS COURT,
 LONDON SW5 9SU. Tel: 01-373 8721.

OMNI ELECTRONICS

for a comprehensive range of components aimed at the enthusiast:

10 x 1N4148 @0.35	10 x 5mm leds in black bezel
10 x 1N4001 @0.45	red 3.50 green 3.90
10 x LM741 @2.00	5 x 7 segment display - red
5 x 7805 @2.35	0.3" common cathode 2.50
10 x 5mm red leds @1.00	Data entry keypad 3.30
10 x 5mm green @1.20	Panel meters, 38mm cutout
UM1286 modulator @7.95	50µA, 100µA, 1mA, 1A, 30V 5.98
	10 bar dil led array 2.50

Velleman kits/Babani books
 The above is a sample of our range and includes VAT. P&P 60p. Send for catalogue: 20p + 18p or 13p stamp. Shop open: Monday-Friday 9a.m.-6p.m. Saturday 9a.m.-5p.m.

174 Dalkeith Road
 EDINBURGH EH16 5DX
 031-667 2611

TRANSFORMERS EX-STOCK

MAINS ISOLATORS Pk1, 120V x 2 or 220/240V or 415/440V. Sec. 440 or 240 or 110V Centre Tapped 160 to 1000VA Tapped £ each	30/15V or 15-0-25V 2 x 15V Tapped Secs 30V 15V £ P&P 0.5 1 3.86 1.41 1 2 5.24 1.70 2 4 8.47 1.92 3 6 9.82 2.10 4 A 8 11.72 2.20 5 M 10 14.49 2.31 6 P 12 16.40 2.55 8 P 16 21.56 2.60 10 20 25.32 2.64 12 24 28.07 2.85 15 20 31.86 3.51 20 40 43.22 6.95	24/12V or 12-0-12V 2 x 12V Sec. Pri. 240V 12V 24V £ P&P 0.3 0.15 2.92 1.10 0.5 0.25 3.08 1.60 1 0.5 3.70 1.60 2 1 5.15 1.70 4 A 2 5.94 1.90 6 M 3 9.31 2.05 8 P 4 10.89 2.10 12 5 6 13.20 2.25 16 8 15.73 2.60 20 10 21.17 3.04 30 15 28.31 3.10 40 20 37.56 3.75 60 30 53.92 4.90 83 41 62.09 5.65
60/30V or 30-0-30V 2 x 30V Tapped Secs. 60V 30V £ P&P 0.5 1 5.69 1.86 1 2 8.67 1.91 2 4 11.15 2.20 3 A 6 16.12 2.34 4 M 8 18.38 2.55 8 P 10 22.23 2.78 6 S 12 26.90 3.02 8 16 30.89 3.15 10 20 36.86 3.60 12 24 43.87 3.60	INVERTERS 12/24V DC to 240V AC 100W to 45W CONSTANT VOLTAGE TRANSFORMERS FOR Spike-free stable mains ALSO VALVE MAINS OUTPUT & MATCHING TRANSFORMERS WINDING SERVICE 3VA TO 18kVA Stock items by return	AUTOS 105, 115, 220, 230, 140V For step-up or down 80VA £ P&P 8.86 1.70 150 8.49 1.65 250 10.34 1.98 500 16.12 2.68 1000 25.78 3.25 1500 34.17 3.68 2000 51.09 4.62 3000 66.88 6.30 4000 112.78 0A 5000 131.33 0A 7500 202.71 0A 10kVA 239.53 0A
CASED AUTOS 240V Cable Input 115V USA Socket Outputs 20VA £ P&P 8.34 1.76 80 11.33 1.87 150 14.67 2.20 250 17.87 3.02 500 25.32 3.15 1000 41.86 4.34 2000 73.33 6.28 3000 105.26 0A	TOROIDALS Wound to Order	

PLEASE ADD 15% TO ALL ITEMS AFTER P&P

Unit 211, Stratford Workshops, Burford Road, London E15 2SP
 BARRIE ELECTRONICS LTD
 Tel: 01 555 0228 (3 lines)

OMP POWER AMPLIFIER MODULES

OMP POWER AMPLIFIER MODULES

Now enjoy a world-wide reputation for quality, reliability and performance at a realistic price. Four models available to suit the needs of the professional and hobby market i.e. Industry, Leisure, Instrumental and Hi-Fi. etc. When comparing prices, NOTE all models include Toroidal power supply, integral heat sink, Glass fibre P.C.B. and Drive circuits to power compatible Vu meter. Open and short circuit proof.

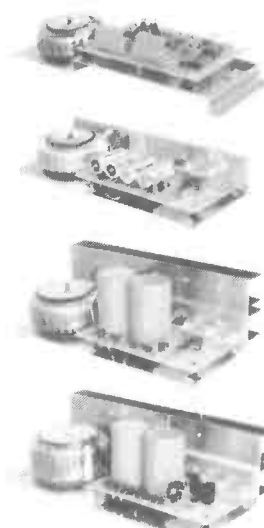

OMP 100 Mk II Bi-Polar Output power 110 watts R.M.S. into 4 ohms. Frequency Response 15Hz - 30KHz -3dB, T.H.D. 0.01%, S.N.R. -118dB, Sens. for Max output 500mV at 10K. Size 355 x 115 x 65mm. PRICE £33.99 + £3.00 P&P.

OMP/MF100 Mos-Fet Output power 110 watts R.M.S. into 4 ohms. Frequency Response 1Hz - 100KHz -3dB, Damping Factor 80, Slew Rate 45V/uS, T.H.D. Typical 0.002%, Input Sensitivity 500mV, S.N.R. -125dB, Size 300 x 123 x 60mm. PRICE £39.99 + £3.00 P&P.

OMP/MF200 Mos-Fet Output power 200 watts R.M.S. into 4 ohms. Frequency Response 1Hz - 100KHz -3dB, Damping Factor 250, Slew Rate 50V/uS, T.H.D. Typical 0.001%, Input Sensitivity 500mV, S.N.R. -130dB, Size 300 x 150 x 100mm. PRICE £62.99 + £3.50 P&P.

OMP/MF300 Mos-Fet Output power 300 watts R.M.S. into 4 ohms. Frequency Response 1Hz - 100KHz -3dB, Damping Factor 350, Slew Rate 60V/uS, T.H.D. Typical 0.0008%, Input Sensitivity 500mV, S.N.R. -130dB, Size 330 x 147 x 102mm. PRICE £79.99 + £4.50 P&P.

NOTE: Mos Fets are supplied as standard (100KHz bandwidth & Input Sensitivity 500mV) If required P.A. version (50KHz bandwidth & Input Sensitivity 775mV). Order Standard or P.A.

VU METER Compatible with our four amplifiers detailed above. A very accurate visual display employing 11 L.F.D. diodes (7 green 4 red) plus an additional on/off indicator. Sophisticated logic control circuits for very fast rise and decay times. Tough moulded plastic case, with tinted acrylic front. Size 84 x 27 x 45mm. PRICE £8.50 + 50p P&P.

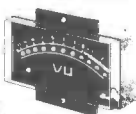

* PRICES INCLUDE V.A.T. * PROMPT DELIVERIES * FRIENDLY SERVICE * LARGE S.A.E. 28p STAMP FOR CURRENT LIST

BURGLAR ALARM

Better to be 'Alarmed' than terrified. Thandar's famous 'Minder' Burglar Alarm System. Superior microwave principle. Supplied as three units complete with interconnection cable. FULLY GUARANTEED.

Control Unit - Houses microwave radar unit, range up to 15 metres adjustable by sensitivity control. Three position key operated fascia switch - off - test - armed. 30 second exit and entry delay.

Indoor alarm - Electronic swept freq. siren 104dB output.

Outdoor Alarm - Electronic swept freq. siren 98dB output. Housed in a tamper-proof heavy duty metal case.

Both the control unit and outdoor alarm contain rechargeable batteries which provide full protection during mains failure. Power requirement 200/260 Volt AC 50/60Hz. Expandable with door sensors, panic buttons etc. Complete with instructions.

SAVE £138.00 Usual Price £228.85

BKE's PRICE £89.99 + £4.00 P&P

? Why buy a collection of self assembly boards!

IDEAL for Workshops, Factories, Offices, Home, etc. Supplied ready built.



OMP LINNET LOUDSPEAKERS

The very best in quality and value. Made specially to suit today's need for compactness with high sound output levels. Finished in hard wearing black vinyl with protective corners, grille and carry handle. All models 8 ohms Full range 45Hz - 20KHz. Size 20" x 15" x 12". Watts R.M.S. per cabinet. Sensitivity 1W 1mtr dB.

OMP 12-100 Watts 100dB. Price £149.99

OMP 12-200 Watts 102dB. Price £199.99

per pair. Delivery Securicor £8.00 per pair



OMP 19" STEREO RACK AMPS



Professional 19" cased Mos-Fet stereo amps. Used the World over in clubs, pubs, discos etc. With twin Vu meters, twin toroidal power supplies, XLR connections, MF600 Fan cooled. Three models (Ratings R.M.S. into 4ohms). Input Sensitivity 775mV.

MF200 (100 + 100)W. £171.35 Securicor

MF400 (200 + 200)W. £228.85 Delivery

MF600 (300 + 300)W. £322.00 £10.00

1 K-WATT SLIDE DIMMER

- * Control loads up to 1Kw
- * Compact Size 4 1/2" x 1 1/2" x 2 1/2"
- * Easy snap in fixing through panel/cabinet cut out
- * Insulated plastic case
- * Full wave control using 8 amp triac
- * Conforms to BS800

Suitable for both resistance and inductive loads. Innumerable applications in industry, the home, and disco's, theatres etc.

PRICE £13.99 + 75p P&P



LOUDSPEAKERS 5" to 15" up to 400 WATTS R.M.S.

Cabinet Fixing in stock. Huge selection of McKENZIE Loudspeakers available including Cabinet Plans. Large S.A.E. (28p) for free details.



POWER RANGE
8" 50 WATT R.M.S. Hi-Fi/Disco.
 20 oz magnet 1" ally voice coil. Ground ally fixing escutcheon. Res. Freq. 40Hz. Freq. Resp. to 6KHz. Sens. 92dB. PRICE £10.99 available with black grille £11.99 P&P £1.50 ea.
12" 100 WATT R.M.S. Hi-Fi/Disco.
 50 oz magnet. 2" ally voice coil. Ground ally fixing escutcheon. Die-cast chassis. White cone. Res. Freq. 25Hz. Freq. Resp. to 4KHz. Sens. 95dB. PRICE £28.60 + £3.00 P&P ea.

McKENZIE
12" 85 WATT R.M.S. C1285GP Lead Guitar/Keyboard/Disco.
 2" ally voice coil. Ally centre dome. Res. Freq. 45Hz. Freq. Resp. to 6.5KHz. Sens. 98dB. PRICE £29.99 + £3.00 P&P ea.
12" 85 WATT R.M.S. C1285TC P.A./Disco 2" ally voice coil. Twin cone.
 Res. Freq. 45Hz. Freq. Resp. to 14KHz. PRICE £31.49 + £3.00 P&P ea.
15" 150 WATT R.M.S. C15 Bass Guitar/Disco.
 3" ally voice coil. Die-cast chassis. Res. Freq. 40Hz. Freq. Resp. to 4KHz. PRICE £57.87 + £4.00 P&P ea.
10" 60 WATT R.M.S. 1060GP Gen. Purpose/Lead Guitar/Keyboard/Mid. P.A.
 2" voice coil. Res. Freq. 75Hz. Freq. Resp. to 7.5KHz. Sens. 99dB. PRICE £19.99 + £2.00 P&P.
10" 200 WATT R.M.S. C10200GP Guitar/Keyboard/Disco.
 2" voice coil. Res. Freq. 45Hz. Freq. Resp. to 7KHz. Sens. 101dB. PRICE £44.76 + £3.00 P&P.
15" 200 WATT R.M.S. C15200 High Power Bass.
 Res. Freq. 40Hz. Freq. Resp. to 5KHz. Sens. 101dB. PRICE £62.41 + £4.00 P&P.
15" 400 WATT R.M.S. C15400 High Power Bass.
 Res. Freq. 40Hz. Freq. Resp. to 4KHz. Sens. 102dB. PRICE £89.52 + £4.00 P&P.

WEM
5" 70 WATT R.M.S. Multiple Array Disco etc.
 1" voice coil. Res. Freq. 52Hz. Freq. Resp. to 5KHz. Sens. 89dB. PRICE £22.00 + £1.50 P&P ea.
8" 150 WATT R.M.S. Multiple Array Disco etc.
 1" voice coil. Res. Freq. 48Hz. Freq. Resp. to 5KHz. Sens. 92dB. PRICE £32.00 + £1.50 P&P ea.
10" 300 WATT R.M.S. Disco/Sound re-enforcement etc.
 1 1/2" voice coil. Res. Freq. 35Hz. Freq. Resp. to 4KHz. Sens. 92dB. PRICE £36.00 + £2.00 P&P ea.
12" 300 WATT R.M.S. Disco/Sound re-enforcement etc.
 1 1/2" voice coil. Res. Freq. 35Hz. Freq. Resp. to 4KHz. Sens. 94dB. PRICE £47.00 + £3.00 P&P ea.

SOUNDLAB (Full Range Twin Cone)
5" 60 WATT R.M.S. Hi-Fi/Multiple Array Disco etc.
 1" voice coil. Res. Freq. 63Hz. Freq. Resp. to 20KHz. Sens. 86dB. PRICE £9.99 + £1.00 P&P ea.
6" 100 WATT R.M.S. Hi-Fi/Multiple Array Disco etc.
 1" voice coil. Res. Freq. 56Hz. Freq. Resp. to 20KHz. Sens. 89dB. PRICE £10.99 + £1.50 P&P ea.
8" 60 WATT R.M.S. Hi-Fi/Multiple Array Disco etc.
 1 1/2" voice coil. Res. Freq. 38Hz. Freq. Resp. to 20KHz. Sens. 89dB. PRICE £12.99 + £1.50 P&P ea.
10" 60 WATT R.M.S. Hi-Fi/Disco etc.
 1 1/2" voice coil. Res. Freq. 35Hz. Freq. Resp. to 15KHz. Sens. 89dB. PRICE £16.49 + £2.00 P&P.

BSR P295 ELECTRONIC TURNTABLE

- * Electronic speed control 45 & 33 1/3 r.p.m.
- * Plus Minus variable pitch control
- * Belt driven
- * Aluminium platter with strobed rim
- * Cue lever
- * Anti-skate (bias device)
- * Adjustable counter balance
- * Manual arm
- * Standard 1" cartridge fixings
- * Supplied complete with cut out template
- * D.C. Operation 9.14V D.C. 65mA

Price £36.99 + £3.00 P&P.



ADC Q4 mag cartridge for above. Price £4.99 ea. P&P 50p

PIEZO ELECTRIC TWEETERS MOTOROLA

Join the Piezo revolution. The low dynamic mass (no voice coil) of a Piezo tweeter produces an improved transient response with a lower distortion level than ordinary dynamic tweeters. As a crossover is not required these units can be added to existing speaker systems of up to 100 watts (more if 2 put in series). FREE EXPLANATORY LEAFLETS SUPPLIED WITH EACH TWEETER.

TYPE 'A' (KSN2036A) 3" round with protective wire mesh. Ideal for bookshelf and medium sized Hi-Fi speakers. Price £4.90 each + 40p P&P

TYPE 'B' (KSN1005A) 3 1/2" super horn. For general purpose speakers, disco and P.A. systems etc. Price £5.99 each + 40p P&P

TYPE 'C' (KSN6016A) 2" - 5" wide dispersion horn. For quality Hi-Fi systems and quality discos etc. Price £6.99 each + 40p P&P

TYPE 'D' (KSN1025A) 2" - 6" wide dispersion horn. Upper frequency response retained extending down to mid range (2KHz). Suitable for high quality Hi-Fi systems and quality discos. Price £9.99 each + 40p P&P

TYPE 'E' (KSN1038A) 3 3/4" horn tweeter with attractive silver finish trim. Suitable for Hi-Fi monitor systems etc. Price £5.99 each + 40p P&P

LEVEL CONTROL Combines on a recessed mounting plate. Level control and cabinet input jack socket 85 x 85 mm. Price £3.99 + 40p P&P

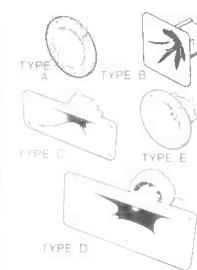

PANTEC HOBBY KITS. Proven designs including glass fibre printed circuit board and high quality components complete with instructions.

FM MICROTRANSMITTER (BUG) 90/105MHz with very sensitive microphone. Range 100/300 metres. 57 x 46 x 14mm (9 volt). Price: £8.62 + 75p P&P.

3 WATT FM TRANSMITTER 3 WATT 85/115MHz varicap controlled professional performance. Range up to 3 miles 35 x 84 x 12mm (12 volt). Price: £14.49 + 75p P&P.

SINGLE CHANNEL RADIO CONTROLLED TRANSMITTER/RECEIVER 27MHz. Range up to 500 metres. Double coded modulation. Receiver output operates relay with 2amp/240 volt contacts. Ideal for many applications. Receiver 90 x 70 x 22mm (9/12 volt). Price: £17.82 Transmitter 80 x 50 x 15mm (9/12 volt). Price: £11.29 P&P + 75p each. S.A.E. for complete list.



3 watt FM Transmitter

STEREO DISCO MIXER

STEREO DISCO MIXER with 2 - 5 band L & R graphic equalisers and twin 10 segment L E D Vu Meters. Many outstanding features. 5 inputs with individual faders providing a useful combination of the following - 3 Turntables (Mag), 3 Mics, 4 Line plus Mic with talk over switch, Headphone Monitor, Pan Pot L & R Master Output controls. Output 775mV. Size 360 x 280 x 90mm. Price £134.99 + £3.00 P&P

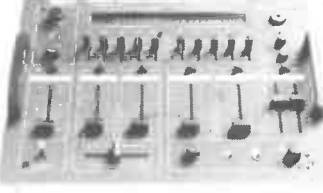

B. K. ELECTRONICS

UNIT 5, COMET WAY, SOUTHEND-ON-SEA, ESSEX. SS2 6TR TEL: 0702-527572

POSTAL CHARGES PER ORDER £1.00 minimum. OFFICIAL ORDERS WELCOME. SCHOOLS, COLLEGES, GOVERNMENT BODIES, ETC. PRICES INCLUSIVE OF V.A.T. SALES COUNTER VISA/ACCESS/C.O.D. ACCEPTED



1988 BUYER'S GUIDE TO ELECTRONIC COMPONENTS

Maplin

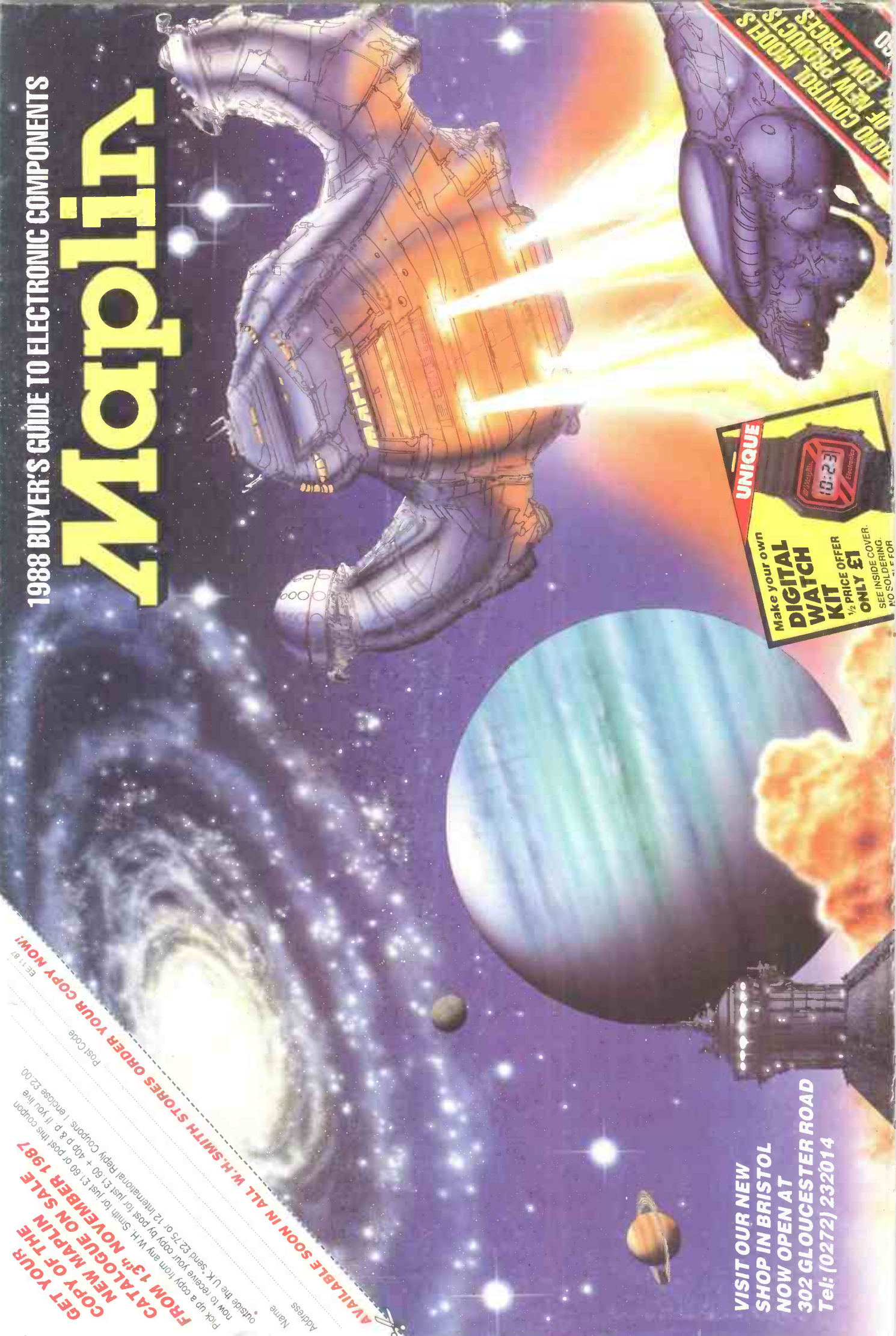

**VISIT OUR NEW
SHOP IN BRISTOL
NOW OPEN AT
302 GLOUCESTER ROAD
Tel: (0272) 232014**

UNIQUE



Make your own
**DIGITAL
WATCH
KIT**
1/2 PRICE OFFER
ONLY £1
SEE INSIDE COVER.
NO SOLD FOR

**MAJOR CONTROL MODELS
OF NEW PRODUCTS
AT LOW PRICES**

**GET YOUR
COPY OF THE
NEW MAPLIN
CATALOGUE ON SALE
FROM 13th NOVEMBER 1987**

AVAILABLE SOON IN ALL W.H. SMITH STORES ORDER YOUR COPY NOW!

Pick up a copy from any W.H. Smith or just £1.60 or post this coupon
now to receive your copy by post for just £3.60 + 40p p & p. If you live
outside the UK send £2.75 or 12 International Reply Coupons. I enclose £2.00.

Name _____
Address _____
Post Code _____