

**EVERYDAY**

JUNE 1987

# **ELECTRONICS**

INCORPORATING ELECTRONICS MONTHLY

£1.20

**VISUAL Guitar/  
Instrument TUNER**

**RS232  
BREAKOUT BOX**



**Door Chime - Mini Disco Light**

**EXPLORING ELECTRONICS...SIMPLE TOUCH SWITCH**

**The Magazine for Electronic & Computer Projects**



### £1 BAKERS DOZEN PACKS

Price per pack is £1.00. \* Order 12 you may choose another free. Items marked (sh) are not new but guaranteed ok.

1. 5 - 13 amp ring main junction boxes
2. 5 - 13 amp ring main spur boxes
4. 5 - surface mounting
5. 3 - electrical switches, white flush mounting
7. 4 - in flex line switches with neon
9. 2 - mains transformers with 6V 1A secondaries
10. 2 - mains transformers with 12V 1/2 A secondaries
11. 1 - extension speaker cabinet for 6 1/2" speaker
13. 12 - glass reed switches
17. 2 - ultrasonic transmitters receivers with circuit
19. 2 - light dependent resistors
25. 4 - water switches - 6p 2 way, 4p 3 way, 2p 6 way, 2p 5 way, 1p 12 way small one hold fixing and good length 1/4 spindle your choice
28. 1 - 6 digit counter mains voltage
30. 2 - Nicad battery chargers
31. 1 - key switch with key
32. 2 - aerosol cans of ICI Dry Lubricant
34. 96 - 1 metre lengths colour-coded connecting wire
39. 1 - long and medium wave tuner kit
41. 8 - rocker switch 10 amp mains SPST
45. 1 - 24 hour time switch mains operated (s.h.)
49. 10 - neon valves - make good night lights
50. 2 - 12V DC or 24V AC, 3 CO relays
51. 1 - 12V 2 CO miniature relay very sensitive
52. 1 - 12V 4 CO miniature relay
54. 10 - rows of 32 gold plated IC sockets (total 320 sockets)
55. 1 - locking mechanism with 2 keys
56. 1 - miniature unselector with circuit for electric jigsaw puzzle
60. 5 - ferrite rods 4" x 5/16" diameter aerials
61. 4 - ferrite slab aerials with L & M wave coils
63. 1 - Mullard thyristor trigger module
66. 1 - magnetic brake - stops rotation instantly
67. 1 - low pressure 3 level switch can be mouth operated
69. 2 - 25 watt pots 8 ohm
70. 2 - 25 watt pots 1000 ohm
71. 4 - wire wound pots - 18, 33, 50 and 100 ohm your choice
77. 1 - time reminder adjustable 1-60 mins clockwork
85. 1 - mains shaded pole motor 1/2" stack - 1/2 shaft
89. 1 - mains motor with gear box 1 rev per 24 hours
91. 2 - mains motors with gear box 16 rpm
96. 1 - thermostat for fridge
98. 1 - motorised stud switch (s.h.)
101. 1 - 2 1/2 hours delay switch
103. 1 - mains power supply unit - 6V DC
104. 1 - mains power supply unit - 4 1/2 V DC
107. 1 - 5" speaker size radio cabinet with handle
112. 1 - heating pad 200 watts mains
114. 1 - 1W amplifier Mullard 1172
115. 1 - wall mounting thermostat 24V
118. 1 - teak effect extension 5" speaker cabinet
120. 2 - p.c. boards with 2 amp full wave and 17 other rears
121. 4 - push push switches for table lamps etc.
122. 10 - mtrs twin screened flex white p.v.c. outer
124. 25 - clear plastic lenses 1 1/2 diameter
127. 4 - pilot bulb lamp metal clip on type
128. 10 - very fine drills for pcbs etc.
129. 4 - extra thin screw drivers for instruments
132. 2 - plastic boxes with windows, ideal for interrupted beam switch
134. 10 - model aircraft motor - require no on/off switch, just spin to start
137. 1 - 6 1/2" 4 ohm 10 watt speaker
142. 10 - 4 BA spanners 1 end open, other end closed
145. 2 - 4 reed relay kits 3V coil normally open or c/o if magnets added
146. 20 - pilot bulbs 6.5V 3A Philips
154. 1 - 12V drip proof relay - ideal for car jobs
155. 3 - varicap push button tuners with knobs
169. 4 - short wave air spaced trimmers 2-30F
172. 10 - 12V 6W bulbs Philips m.e.s.
178. 3 - oblong amber indicators with lilliputs 12V
180. 6 - round amber indicators with neons 240V
181. 100 - p.v.c. grommets 3/8 hole size
182. 1 - short wave tuning condenser 50 pf with 1/2" spindle
184. 1 - three gang tuning condenser each section 500 pf with trimmers and good length 1/2" spindle
188. 1 - plastic box sloping metal front, 16 x 95mm average depth 45mm
193. 6 - 5 amp 3 pin flush sockets brown
195. 5 - B.C. lampholders brown bakelite threaded entry
196. 1 - in flex simmerstat for electric blanket soldering iron etc.
197. 2 - thermostats, spindle setting - adjustable range for ovens etc.
199. 1 - mains operated solenoid with plunger 1" travel
200. 1 - 10 digit switch pad for telephones etc.
201. 8 - computer keyboard switches with knobs, pcb or vero mounting
206. 20 - mtrs 80 ohm, standard type co-ax off white
211. 1 - electric clock mains driven, always right time - not cased
216. 1 - stereo pre-amp Mullard EP3001
232. 2 - 12V solenoids, small with plunger
236. 1 - mains transformer 9V 1 amp secondary C core construction
241. 1 - car door speaker (very flat) 6 1/2" x 15 ohm made for Radiomobile
241. 2 - speakers 6" x 4" 4 ohm 5 watt made for Radiomobile
243. 2 - speakers 6" x 4" 16 ohm 5 watt made for Radiomobile
244. 1 - mains motor with gear-box very small, toothed output 1 rpm
245. 4 - standard size pots, 1/2 meg with dw switch
249. 1 - 13A switched socket on double plate with fused spur
266. 2 - mains transformers 9V 1/2 A secondary
267. 1 - mains transformers 15V 1A secondary p.c.b. mounting
291. 1 - ten turns 3 watt pot 1/2 spindle 100 ohm
296. 3 - car cigar lighter socket plugs
298. 2 - 15 amp round pin plugs brown bakelite
300. 1 - mains solenoid with plunger compact type
301. 10 - ceramic magnets Mullard 1" x 3/8 x 5/16
303. 1 - 12 pole 3 way ceramic wave charge switch
305. 1 - tubular dynamic microphone with flex rest
308. 1 - T.V. turret tuner (black & white T.V.)
310. 2 - oven thermostats
313. 5 - sub miniature micro switches
316. 1 - round pin kettle plug with moulded on lead
453. 2 - 2 1/2 in. 80ohm loudspeakers
454. 2 - 2 1/2 in. 80hm loudspeakers
463. 1 - mains operated relay with 2 sets c/o contacts
464. 2 - packets resin filler/sealer with cures
465. 3 - 5A round 3 pin plugs will fit item 193
466. 4 - 7 segment i.e.d. displays
470. 4 - pc boards for stripping, lots of valuable parts
473. 1 - 5" 4ohm speaker with built in tweeter Radio mobil
480. 1 - 3A double pole magnetic trip, saves repairing fuses
498. 4 - 1000uf 25V axial electrolytic capacitors

**POWERFUL MOTOR (2 in. stack)** fitted with gearbox with final speed 60 r.p.m. Mains operated. Suitable to operate garage doors etc. Price £4.00. Our ref. 4P15.

### CAR STARTER/CHARGER KIT

Fiat Battery! Don't worry you will start your car in a few minutes with this unit - 250 watt transformer 20 amp rectifiers, case and all parts with data £17.50 post £2.



Ex-Electricity Board. Guaranteed 12 months.

### VENNER TIME SWITCH

Mains operated with 20 amp switch, one on and one off per 24 hrs. repeats daily automatically correcting for the lengthening or shortening day. An expensive time switch but you can have it for only £2.95 without case, metal case - £2.95, adaptor kit to convert this into a normal 24hr. time switch but with the added advantage of up to 12 on/off's per 24hrs. This makes an ideal controller for the immersion heater. Price of adaptor kit is £2.30.

### SOUND TO LIGHT UNIT



Complete kit of parts of a three channel sound to light unit controlling over 2000 watts of lighting. Use this at home if you wish but it is plenty rugged enough for disco work. The unit is housed in an attractive two tone metal case and has controls for each channel, and a master on/off. The audio input and output are 1/4" sockets and the three panel mounting fuse holders provide thyristor protection. A four pin plug and socket facilitate ease of connecting lamps. Special price is £14.95 in kit form.

### 12 volt MOTOR BY SMITHS

Made for use in cars, etc. these are very powerful and easily reversible. Size 3 1/2" long by 3" dia. They have a good length of 1" spindle - 1/10 hp £3.45 1/8 hp £5.75, 1/6 hp £7.50

### 25A ELECTRICAL PROGRAMMER

Learn in your sleep. Have radio playing and kettle boiling as you wake - switch on lights to ward off intruders - have a warm house to come home to. You can do all these and more. By a famous maker with 25 amp on/off switch. A beautiful unit at £2.50

### THIS MONTH'S SNIP

3" floppy disc drive unit plug in and with all electronics. Japanese made, brand new. We are told that this is suitable for use with the BBC, Commodore, Amstrad and most other popular computers, and we supply with technical information. Special snip price £29.50 including post and VAT.

### 12V BATTERY OPERATED SIREN

(Or you can work this off a 24V transformer). Makes a shocking noise, will frighten away any intruder. Japanese made one 50p each, 2 for £1, ref. BD106. American storage solenoid but unused and guaranteed perfect, only 20p each, 5 for £1, ref. BD221.

### WONDERFUL BREAKDOWN VALUE - HAND HELD STEREO UNIT

Contains two beautiful miniature moving coil loud speakers. These could also be used as microphones, also contains many other useful parts including mini stereo amp, transistors, condensers, rocker switches etc. To use this as a personal amplifier simply add a stethoscope, only £1, ref. BD29.

### SPIT MOTOR

Powerful mains operated induction motor with gearbox attached. Shaft has square hole which gives very easy coupling and quick release if required. Shaft speed 5rpm. Price £5, ref. SP54

### NICKEL CADMIUM RECHARGEABLE BATTERY

The high capacity (4 Amp-hour) 'D' size. £2 each. Our ref. 2P141. 20V-0-20V 1A MAINS TRANSFORMER Upright mounting. Primary thermal cutout to interrupt the supply if transformer overheats. Price £2, ref. 2P138.

### 4 BOOKS FOR £1

Book 1 describes the Mullard Unilux amplifier and gives details of a suitable cabinet. Book 2 describes several useful pieces of test equipment which could be quite easily constructed. Book 3 is electronic projects. Book 4 describes short wave receivers which can be easily constructed and is intended for mainly beginners. Our ref. BD400.

### TRANSFORMER IN WATERPROOF METAL CASE

24V 5A output. Ideal for garden lighting or to operate pond pump etc. Case has cable glands for mains in and low voltage output leads. Price £5 plus £1 post, ref. SP88.

### MAINS RELAY

With transparent plastic cover. Could be box or clip mounted, has single 8-10A c/o contact. Retail bargain 2 for £1, ref. BD466.

### PANEL METERS

Engraved vul, approximately 1 1/2" square. Luminate these from behind and you will have a really super looking panel. Retail bargain 2 for £1, ref. BD366.

### TRANSMITTER TUNING CONDENSOR

180pf made for a very famous RAF transmitter, only £1 each. Unused but mounting brackets will need a bit of cleaning up due to storage. Our ref. BD424.

### MAGNETIC READ/WRITE UNIT

A read/write head mounted on a thumb operated lever is made to traverse magnetisable paper. The paper is held between top and bottom rollers which can be spun for localization of the written message - new and unused only £1 each, ref. BD381.

### IONISER KIT

Refresh your home, office, shop, work room, etc. with a negative ION generator. Makes you feel better and work harder - a complete mains operated kit which we guarantee is ten times more powerful than other popular kits. Price includes case and instructions. £9.50 plus £2.00 post.

### TELEPHONE BITS

Master socket (has surge arrester - ringing condenser etc) and takes B.T. plug £3.95  
Extension socket £2.95  
Dual adaptor sockets (2 from one socket) £3.95  
Cord terminating with B.T. plug 3 metres £2.95  
Kit for converting old entry terminal box to new B.T. master socket, complete with 4 core cable, cable clips and 2 BT extension sockets £11.50  
100 mtrs 4 core telephone cable £8.50

## J & N BULL ELECTRICAL

Dept. E.E., 250 PORTLAND ROAD, HOVE, BRIGHTON, SUSSEX BN3 5QT

MAIL ORDER TERMS: Cash, P.O. or cheque with order. Orders under £20 add £1 service charge. Monthly account orders accepted from schools and public companies. Access & B/card orders accepted. Brighton 0273 734648. Bulk orders: write for quote.

### £2 POUNDERS\*

- 2P2 - Wall mounting thermostat, high precision with mercury switch and thermometer
- 2P3 - Variable and reversible 8-12v psu for model control
- 2P4 - 24 volt psu with separate channels for stereo made for Mullard UNILUX
- 2P6 - 100W mains to 115V auto-transformer with voltage tappings
- 2P8 - Mains motor with gear box and variable speed selector. Series wound so suitable for further speed control
- 2P9 - Time and set switch. Boxed, glass fronted and with knobs. Controls up to 15 amps. Ideal to program electric heaters
- 2P10 - 12 volt 5 amp mains transformer
- 2P12 - Disk or Tape precision motor - has balanced rotor and is reversible 230v mains operated 1500 rpm
- 2P14 - Mug Stop kit - when thrown emits piercing squawk
- 2P15 - Interrupted Beam kit for burglar alarms, counters, etc.
- 2P17 - 2 rev pr minute mains driven motor, ideal to operate mirror ball
- 2P18 - Liquid/gas shut off valve mains solenoid operated
- 2P19 - Disco switch motor drives 6 or more 10 amp change over micro switches supplied ready for mains operation
- 2P20 - 20 metres extension lead, 2 core - ideal most Black and Decker garden tools etc.
- 2P21 - 10 watt amplifier, Mullard module reference 1173
- 2P22 - Motor driven switch 20 secs on or off after push
- 2P26 - Counter resettable mains operated 3 digit
- 2P27 - Goodmans Speaker 6 inch round Bohm 12 watt
- 2P28 - Drill Pump - always useful couples to any make portable drill
- 2P31 - 4 metres 98 watt interconnecting wire easy to strip
- 2P32 - Hot Wire amp meter - 4 1/2 round surface mounting 0-10A - old but working and definitely a bit of history
- 2P34 - Solenoid Air Valve mains operated
- 2P38 - 200 R.P.M. Gearing Mains Motor 1" stack quite powerful, definitely large enough to drive a rotating aerial or a tumbler for polishing stones, etc.
- 2P43 - Small type blower or extractor fan, motor inset so very compact, 230V
- 2P46 - Our famous drill control kit complete and with prepared case
- 2P49 - Fire Alarm break glass switch in heavy cast case
- 2P51 - Stereo amplifier, 3w per channel
- 2P55 - Mains motor, extra powerful has 1 1/2" stack and good length of spindle
- 2P57 - 1 pair Goodmans 15 ohm speakers for Unilux
- 2P64 - 1 fine bladed fan 6 1/2" with mains motor
- 2P66 - 1 2Kw tangential heater 115v easily convertible for 230V
- 2P67 - 1 12V-0-12V 2 amp mains transformer
- 2P68 - 1 15V-0-15V 2 amp mains transformer
- 2P69 - 1 250V-0-250V 60 mA & 86.3V 5A mains transformer + 50p post
- 2P70 - 1 E.M.I. tape motor two speed and reversible
- 2P72 - 1 115V Muffin fan 4" x 4" approx. (s.h.)
- 2P75 - 1 2 hour timer, plugs into 13A socket
- 2P82 - 9v-0-9v 2 amp mains transformer
- 2P84 - Modem board with press keys for telephone redialler
- 2P85 - 20V-0-20V 1 A Mains transformer
- 2P88 - Sangamo 24 hr time switch 20 amp (s.h.)
- 2P89 - 120 min. time switch with knob
- 2P90 - 90 min. time switch with edgepiece engraved controller
- 2P94 - Telephone handset for EE home telephone circuit
- 2P95 - 13A socket on satin chrome plate
- 2P97 - mains transformer 24V 2A upright mounting
- 2P98 - 20m 4 core telephone cable, white outer
- 2P99 - 500 hardened pin type staples for telephone cable
- 2P101 - 15V mains transformer 4A upright mounting
- 2P105 - capillary type thermostat for air temperature with c/o switch
- 2P108 - mains motor with gear box giving 110rpm
- 2P109 - 5" wide black adhesive pvc tape 33m, add £1 post if not collecting

### OVER 400 GIFTS YOU CAN CHOOSE FROM

There is a total of over 400 packs in our Baker's dozen range and you become entitled to a free gift with each dozen packs.

A classified list of these packs and our latest "News Letter" will be enclosed with your goods, and you will automatically receive our next news letter.



### £5 POUNDERS\*

- 5P1 - 12 volt submersible pump complete with a tap and switch, an ideal caravan unit.
- 5P2 - Sound to light kit complete in case suitable for up to 750 watts.
- 5P6 - 12V alarm bell with heavy 6" gong, suitable for outside if protected from direct rainfall. Ex. GPO but in perfect order.
- 5P12 - Equipment cooling fan - mini small type mains operated.
- 5P15 - Unselector 4 pole, 25 way 50 volt coil
- 5P18 - motor driven water pump as fitted to many washing machines
- 5P20 - 2 kits, matchbox size, surveillance transmitter and FM receiver
- 5P23 - miniature (appr. 2 1/2" wide) tangential blow heater, 1.2kw
- 5P24 - 4 pin motor, ex computer, 230V, mains operation 1450rpm. If not collect add £3 post
- 5P25 - special effects lighting switch. Up to 6 channels of lamps can be on or off for varying time periods
- 5P27 - cartridge player 12V. Has high quality stereo amplifier
- 5P34 - 24V 5A toroidal mains transformer
- 5P35 - modem board from telephone auto dialler, complete with keypad and all ICs
- 5P37 - 24 hour time switch, 2 on/off's and clockwork reserve, ex Elec. Board loading up to 50A. Add £1 post
- 5P41 - 5" extractor fan, very quiet runner (s.h.), gntd 12 mths
- 5P48 - telephone extension bell in black case, ex-GPO
- 5P52 - mains transformer 26V 10A upright mounting, add £2 post
- 5P54 - mains motor with gear box, final speed 5rpm
- 5P58 - Amstrad stereo tuner FM and L.M. AM
- 5P60 - DC Muffin type fan 18 to 27V, only 3W. Brushless.
- 5P61 - drill pump mounted on frame, coupled to mains motor
- 5P62 - 2 1/2 kw tangential blow heater, add £1.50 post if not collecting
- 5P73C high pressure mains operated gas or water valve with tube connection suitable soldering
- 5P74 6rpm 60W mains motor and gearbox with instant stop
- 5P79 30rpm 80 watt mains driven motor with gearbox
- 5P82 1 25rpm mains 60w motor with gearbox
- 5P84 1 delay time switch, adjust 0-20 seconds
- 5P69 1 light box size 14" x 12" for circuit tracing pcb's. Add £3 for postage and packing
- 5P72 1 turntable for vdu or disc
- 5P81 1 stepper motor bi-directional, 7.5" steps 12-14V coil
- 5P86 1 mains transformer with 2 x 100V 1A secondaries. Add £1.50 post
- 5P88 1 24V 5A mains transformer in waterproof case, ideal for garden lighting, pond pump etc.

**LIGHT CHASER KIT motor driven switch bank with connection diagram, used in connection with 4 sets of xmas lights makes a very eye catching display for home, shop or disco, only £5 ref 5P56.**

ISSN 0262-3617

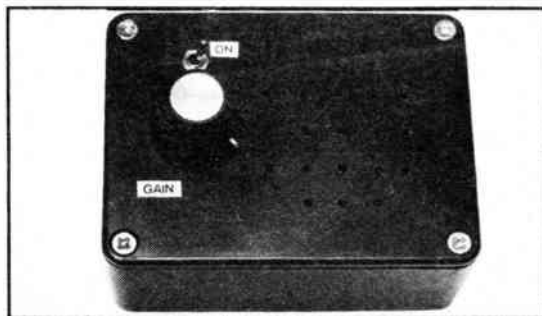
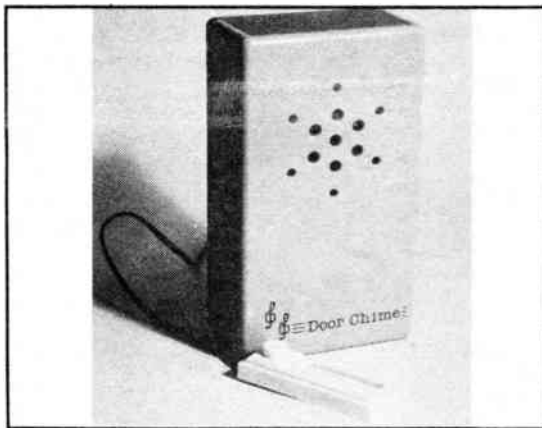
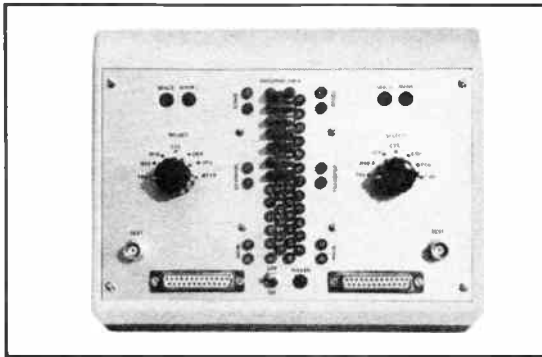
PROJECTS... THEORY... NEWS...  
COMMENT... POPULAR FEATURES...

## Projects

- VISUAL GUITAR/INSTRUMENT TUNER** by Mark Stuart 296  
Keep in tune with your group
- DOOR CHIME** by A. R. Winstanley 300  
A traditional welcome for callers
- RS232C BREAKOUT BOX** by Mike Tooley BA 316  
Improve your lines of communication
- MINI DISCO LIGHTS** by T. R. de Vaux-Balbirnie 319  
Small size, powerful, performance
- TOUCH SWITCH** 322  
Touch sensitive circuit with rewarding applications—  
An "Exploring Electronics" project
- EE APEX AMPLIFIER—4** by Graham Nalty 330  
50W per channel top quality hi fi amplifier—Power Amplifier

## Series

- ROBOT ROUNDUP** by Nigel Clark 303  
Investigating the world of robotics
- BBC MICRO** by R. A. & J. W. Penfold 308  
Regular spot for Beeb fanatics
- DIGITAL TROUBLESHOOTING** by Mike Tooley BA 310  
RS232C serial interface and the IEEE-488 General Purpose  
Instrument Bus
- EXPLORING ELECTRONICS** by Owen Bishop 322  
Part Twelve: Introducing the Op-Amp
- ACTUALLY DOING IT** by R. A. Penfold 334  
Understanding Capacitors
- AMATEUR RADIO** by Tony Smith G4FA 1 336  
Learning Morse; Novice Licence
- ON SPEC** by Mike Tooley BA 337  
Readers' Sinclair Spectrum page

## Features

- EDITORIAL** 295
- REGENERATIVE RECEIVERS—1** by Joe Pritchard 304  
Theory and practice of these low cost radio sets
- SHOPTALK** by David Barrington 306  
Product news and component buying
- PLEASE TAKE NOTE** 324  
Experimental Speech Recognition Unit
- FOR YOUR ENTERTAINMENT** by Barry Fox 326  
Computer Show; Z88 Launch
- BOOK SERVICE** 328  
Our own service for readers of EE
- READER'S DISCOUNT SCHEME** 335
- MARKET PLACE** 339  
Free readers buy and sell spot
- PRINTED CIRCUIT BOARD SERVICE** 340
- ADVERTISERS INDEX** 344

## SPECIAL OFFER

Battery Tester; Mains Socket Tester 325

© Wimborne Publishing Ltd 1987. Copyright in all drawings, photographs and articles published in EVERYDAY ELECTRONICS is fully protected, and reproduction or imitations in whole or in part are expressly forbidden.

Our July 1987 issue will be published on Friday, 19 June 1987. See page 307 for details.

Readers' Services • Editorial and Advertisement Departments

295

# BI-PAK BARGAINS

## RESISTORS

Pak No	Qty	Description	Price
VP1	300	Assorted Resistors mixed values & types	£1.00
VP2	300	Carbon Resistors 1/4-1/2 watt pre-formed, mixed	£1.00
VP3	200	1/8 watt Min. Carbon Resistors mixed values	£1.00
VP4	200	1/2-1 watt Resistors mixed values & types	£1.00
VP16	50	Wirewound Resistors mixed watt values	£1.00
VP112	1	Sub Resistance Box. 36 values 50ohms - 10kOhm	£4.76
VP140	50	Precision Resistors 1% Tol	£1.00
VP181	100	1 and 2 watt Resistors, assorted values	£1.00

## CAPACITORS

VP5	200	Assorted Capacitors, all types	£1.00
VP6	200	Ceramic Capacitors Min mixed values	£1.00
VP8	100	Mixed Ceramic Disc. 50pF-015pF	£1.00
VP9	100	Assorted Polyester/Polystyrene Capacitors	£1.00
VP10	60	C280 Capacitors. Metal foil, mixed values	£1.00
VP11	50	Electrolytics, all sorts	£1.00
VP12	40	Electrolytics 47µf-150µf mixed volts	£1.00
VP13	30	Electrolytics, 150µf-1000µf mixed volts	£1.00
VP15	25	01/250V Min. Layer Metal Caps.	£1.00
VP146	25	Solid Tantalum Caps. mixed values	£1.00
VP180	25	Tantalum Bead Caps. assorted values	£1.00
VP182	4	1000µf 50v Electrolytics.	£1.00
VP192	30	Min. Electrolytics mixed values 47µf-1000µf 6-16v	£1.00
VP193	6	Sub Min. Electrolytics. 2x1000/2200/3300µf 10-16v	£1.00

## 74 SERIES SALE "ROCK BOTTOM" PRICES

VP223	50	Asst 74 TTL IC's. "ALL GATES" new & coded our mix 7400-7453	£6.00
VP224	100	Asst 74 TTL IC's. "ALL GATES" new & coded our mix 7400-7453	£10.00
VP7413	4	7413 Dual Hand Switch Trigger. 4-input	£1.00
VP7440	4	7440 Dual 4-input. Positive Handed Buffer	£1.00
VP7470	4	7470 And-gated Schmitt-edge-triggered Flip-Flop with preset	£1.00
VP7480	4	7480 Gated full Adder	£1.00
VP7481	4	7481 16-Bit Random Access memories	£1.00
VP7490	4	7490 Decade Counter	£1.00
VP7491	4	7491 8-Bit Shift Register	£1.00
VP7492	4	7492 Divide by 12 Counter	£1.00
VP7493	4	7493 4-Bit Binary Counter	£1.00
VP7494	4	7494 4-Bit Shift Register	£1.00

VP7495	4	7495 4-Bit Shift Register	£1.00
VP74111	4	74111 Dual J-K Master Slave Flip-Flop	£1.00
VP74141	4	74141 BCD-Decimal Decoder/Driver	£1.00
VP74151	4	74151 1 of 8 Data Selectors/Multiplexers	£1.00
VP74153	4	74153 Dual 4 line to 1 line Data Selectors/Multiplexers	£1.00
VP74164	4	74164 8 Bit Parallel Output Shift Registers	£1.00
VP74167	4	74167 Synchronous Decade Rate Multipliers	£1.00
VP74174	4	74174 Hex D-Type Flip-Flops	£1.00
VP74181	4	74181 Arithmetic Logic Units/Function Generators	£1.00
VP74193	4	74193 Sync. Up/Down Dual Clock Counters Binary clear	£1.00
VP74279	4	74279 Quad S-R Latches	£1.00

VPX6 1 TTL Data Book 74 Series, including "LS". Complete with Pin out Diagrams 7400-74870. TTL Interchangeability Guide. Function Selection Guide and Explanation of Function Tables "NO VAT" £1.00

## TOOLS

VP246	1	25 watt High Quality Low Cost Soldering Iron 240v AC Long Life Element. 1.7m lead	£3.50
VP247	1	15 watt "Lightweight" High Quality Low Cost Soldering Iron 240v AC. 1.7m lead	£3.50
VP248	1	High Suction Desoldering Pump, Teflon nozzle. Auto Eject. Heavy duty return spring	£4.00
VP249	1	High Quality Soldering Iron Stand Cast iron base Top cleaning sponge	£4.00
VP250	1	Long Finger Grip, soldering aid Heavy metal base. Serrated jaws with rev. tweezers action. Ideal for holding small components. Fully adjustable	£3.00
VP251	1	Multi-tester. Pocket size. 18 ranges 10000 ohms/100C-4000 ohms/VAC. Fuses and diode protection. Mirrored scale. Leads with 2mm plugs. Batt. & instructions inc.	£8.50
VP252	1	Multi-tester & Transistor Tester. 20000 ohms/V. 19 ranges Audio output. Test term. Fuse & Diode protection. Test leads & Transistor test leads. Batt. & Instructions. Mirrored scale. Size 147 x 97 x 45 mm	£18.50
VP253	1	Digital Multi-tester. 3 1/2 digit. Slide switches for single hand operation. High quality construction. Tough ABS body. Fully guaranteed. Overload protection. Input impeded 10Mohms. 19 ranges incl. 10ADC plus diode & transistor test. Accuracy 0.8%. Complete with leads. Batt. and manual. Size 145 x 70 x 31 mm	£35.00
VP254	1	250 grams Etchant Granules (Ferric chloride) makes 3 pint.	£1.00
VP255	1	Etching Pan. Etch resistant. Spare tip. Blue.	£1.00
VP256	1	PCB Mini Drill. Operating voltage 5-14V DC + 1mm twist drill and collet for 8 to 1.2mm drills and tonny bar inc.	£5.00
VP257	1	Pack of 3 Twist Drills 1, 1.5, 2mm for PCB Mini Drill	£1.00
VP258	1	Microtore Solder. 5m total 18 and 22.5W.G.	£1.00
VP259	1	PCB Holder. Fully adjustable from 0-320mm wide and to any angle. Complete with iron stand and sponge. Strong metal construction with rubber feet. Very High Quality	£15.00

## MISC

VP223A	8	Tag Boards 36 way Paxalene	£1.00
VP225	20	DIM Plugs, plastic 2-8 pin 180/240/360 mixed	£2.50
VP226	20	DIM Chassis Sockets, metal 2-8 pin 180/240/360 mixed	£2.50
VP227	18	DIM In-line Sockets, plastic 2-8 pin 180/240/360 mixed	£2.50
VP228	10	C15 Computer Cassette Tape, leadless	£3.00
VP229	10	C60 Cassette Tape, 2 x 30 min, low noise	£6.00
VP230	10	C90 Cassette Tape, 2 x 45 min, low noise	£6.00
VP231	1	Cassette Head Cleaner Tape, non abrasive, in case	£1.00
VP232	1	Cassette Head Cleaner/Demagnetizer, in case	£2.00
VP233	1	Revolving Cassette Rack, holds 32, smoke perspex	£2.50
VP234	1	Demagnetizer Curved Probe, 240v AC	£3.00
VP235	1	VHS Video Head Cleaner Cassette. Wet type	£4.00
VP236	1	Betamax Video Head Cleaner Cassette. Wet type	£4.00
VP237	1	Universal Ni-Cad Battery Charger. AA-HP11 HP2-PP3	£6.00
VP238	4	AA Ni-Cad Batteries. 1.25v 800mAh C/R mA	£4.00
VP239	2	C-HP11 Ni-Cad Batteries. Rechargeable	£3.50
VP240	2	D-HP2 Ni-Cad Batteries. Rechargeable	£4.00
VP241	2	DHP12 Light Dependant Resistor	£1.50
VP242	4	Tri-colour LED's. 5mm Dia 5mA 2v R.G.V.	£1.00
VP243	4	Tri-colour LED's. Rectangular 5mm R.G.V.	£1.00
VP244	1	High Power Photo Electric Siren. Emits Expanding warbling sound. Ideal alarms. White plastic body with mounting bracket. Power 12v DC 150mA. Output 100db(A) at 1m typ. Freq. 2.5KHz. Size 57 x 42 x 37 mm	£6.00
VP245	1	Automatic Lighting Switch. Photo electric, weatherproof. Switches lights on equipment "ON" at dusk "OFF" at dawn. Loads up to 3A at 240v AC. Size 50 x 45 mm	£5.00

## SPEAKERS OFFER. SAVE UP TO 50%

VPL001	1	6 x 4" Elliptical 8 ohms 4W RMS Freq. Res. 135-10080 Hz General purpose Speaker. Gauss 7000	£2.50
VPL003	1	7 x 5" Elliptical 8 ohms 4W RMS Freq. Res. 90-10000 Hz Speaker. Centre HF cone. Gauss 7500	£3.00
VPL005	1	8 x 5" Elliptical 8 ohms 8W RMS Speaker. Freq. Res. 45-15000 Hz Gauss 9000. Wide range Air suspension, sponge edge. Centre HF cone.	£4.50
VPL006	1	9 x 6" Elliptical 8 ohms 10W RMS Speaker. Freq. Res. 60-10000 Hz Gauss 10000. Centre HF cone	£4.50
VPL018	1	2 1/2" Transducer Waterproof. Polyester film Diaphragm. Moisture res. 8 ohms 300mW RMS Freq. Res. 20-20000 Hz 1.00	£1.00
VPL018B	1	4" Round 8 ohms 1.2W RMS Freq. Res. 190-10K Hz General purpose speaker. 100 x 100 x 35mm	£1.00
VPL022	1	5" Round 8 ohms 3W RMS Freq. Res. 90-9500 Hz Car/General purpose Speaker. Gauss 7500. 133 x 42 mm	£3.00
VPL025	1	5 1/2" Round 8 ohms 15W RMS Wide range speaker. Freq. Res. 50-15000 Hz Air suspension. Centre HF Cone	£7.00
VPL025A	1	6" Round 8 ohms 5W RMS Freq. Res. 70-2000 Hz General purpose Speaker. Gauss 9000	£2.50
VPL029	1	8" Round 8 ohms 10W RMS Freq. Res. 45-1600 Hz Wide Range Speaker. Centre HF cone	£4.00

# BI-PAK

Send your orders to Dept EE BI-PAK PO BOX 6 WARE, HERTS  
 TERMS CASH WITH ORDER, SAME DAY DESPATCH. ACCESS.  
 BARCLAYCARD ALSO ACCEPTED. TEL 0763-48851. GIRO 388 7006  
 ADD 15% VAT AND £1.50 PER ORDER POSTAGE AND PACKING.

Use your credit card. Ring us on 0763 48851 NOW and get your order even faster. Goods normally sent 2nd Class Mail.  
 Remember you must add VAT at 15% to your order.  
 Total Postage add £1.50 per order size 57.

## INSTALL YOUR OWN SYSTEM AND SAVE

# SECURITY

## MODULES ACCESSORIES KITS

**NEW**

### "PASSIVE INFRARED INTRUDER DETECTOR RP33"



- 12 metre detection range.
- Size only 80 x 60 x 40mm.
- 24 Detection zones.
- Wide 85° coverage.
- Switchable LED indicator.

This advanced new intrusion detector operates by detecting the body heat of an intruder moving within the detection field. The use of a dual element pyroelectric sensor means that changes in ambient temperatures are ignored, thus providing a stable and reliable performance. Easily installed in a room or hallway, the unit will provide effective detection of any intrusion. Operating from a 12V supply and consuming only 15mA, it is ideal for use with the CA 1382. CA 1250 or any equivalent high quality control unit. Supplied with full instructions, its performance compares with detectors costing more than twice the price.

**ONLY £23.95 + V.A.T.**

### CA 1382 An advanced control unit with automatic loop testing.



- Fully automatic siren re-set.
- Audible entry/exit warning.
- Alarm Sounded memory.
- 2 separate loop inputs & 24hr circuits.
- Built-in electronic siren.
- Easily installed, full instructions supplied.

This latest control panel provides effective and reliable control for all types of security installations. Its advanced circuitry checks the loop circuits every time it is switched on, preventing incorrect operation. Using a simple 'on/off' key switch, it is easily operated by all members of the family. In addition it provides 24 hr. personal attack protection. Housed in a steel case, it is supplied with full operating instructions.

**Only £44.95 + VAT**  
 Available in kit form with fully-built electronics. £39.95 + V.A.T.

### Digital Ultrasonic Detector US 5063 only £13.95 + VAT



- 3 levels of discrimination against false alarms
  - Crystal control for greater stability
  - Adjustable range up to 25ft
  - Built-in delays
  - 12V operation
- This advanced module uses digital signal processing to provide the highest level of sensitivity whilst discriminating against potential false alarm conditions.

### Individual Enclosure SC 5063 only £2.95 + VAT

Suitable metal enclosure for housing the ultrasonic module type US 5063. Supplied with the necessary mounting pillars and screws etc

### Control Unit CA 1250 Price £19.95 + VAT



This tried and tested control unit represents the finest value for money in control systems, providing the following features

- Built-in electronic siren drives 2 loud speakers
- Provides exit and entrance delays together with fixed alarm time
- Battery back up with trickle charge facility
- Operates with magnetic switches, pressure pads, ultrasonic or IR units
- Anti-tamper and panic facility
- Stabilised output voltage
- 2 operating modes full alarm anti tamper and panic facility
- Screw connections for ease of installation
- Separate relay contacts for external loads
- Test loop facility

### 500W Quartz Halogen Floodlight FL 500



**only £14.95 + VAT**

Whilst intended for security lighting applications, this unit is suitable for lighting patios, pathways and gardens etc. Supplied complete with 500W lamp priced only £14.95 - VAT. Protective grill. £1.95 - VAT

### Lighting Controller DP 3570 only £13.95 + VAT



This versatile module provides timed switching of loads up to 3A for pre set times between 10 secs and 5 mins, the timed period being triggered by the opening or closing of an external loop or switch. The built-in 12V 250mA power supply is available for operating external sensors. Priced only £13.95 - VAT. Suitable plastic enclosure £2.85 - VAT

### HW 1250 - Enclosure & fixings for CA 1250 only £9.50 + VAT



This attractive case is designed to house the control unit CA 1250, together with the appropriate LED indicators and key switch. Supplied with the necessary mounting pillars and punched front panel, the unit is given a professional appearance by an adhesive silk screened label. Size 200 x 180 x 70mm

### Infra-red System IR 1470



**only £25.61 + VAT**

Consisting of separate transmitter and receiver both of which are housed in attractive moulded cases the system provides an invisible modulated beam over distances of up to 50ft operating a relay when the beam is broken. Intended for use in security systems, but also ideal for photographic and measurement applications. Size 80 x 50 x 35mm

### SAMPLE OF OUR WIDE RANGE OF ACCESSORIES

- AL 243 - Automatic Light Switch Switches 3A at 240V - £4.30
- VS 39 - Vibration Contact - £2.30
- IS 128 - Miniature 12V Siren Supplies 1000db output - £6.95
- SL 157 - Siren Module - £2.95
- MS 588 - 5 1/2" Horn Speaker for use with control unit, siren module, etc - £6.25

The above prices are plus V.A.T.

**Complete systems from only £39.95 + VAT**

For full information of systems and accessories, send or call for details.

## RISCOMP LIMITED

Dept. EE76,  
 51 Poppy Road,  
 Princes Risborough,  
 Bucks HP17 9DB.  
 Tel: (084 44) 6326



Order by phone or mail or call at our showroom and see

### UNITS ON DEMONSTRATION

Monday to Friday 9.00 - 5.00 p.m.  
 Saturday 9.00 - 1.00 p.m.  
 Please add 15% VAT and 75p P&P to all UK orders  
 Export no VAT - postage at cost

# OMNI ELECTRONICS

We stock a wide range of components: transformers, switches, pots, ICs, capacitors, resistors, diodes, boxes, triacs, LEDs, cable, connectors, PCBs—in fact, all you need for your projects.

## SEND FOR CATALOGUE NOW

— send 20p + 13p or 18p stamp or call at our shop Mon–Fri 9am–6pm, Sat 9am–5pm.

**174 Dalkeith Road  
EDINBURGH EH16 5DX  
031-667 2611**

## TRANSFORMERS EX-STOCK

Mains Isolators		30/15V or 15-0-15V		24/12V or 12-0-12V		105, 115, 220, 230, 240V	
VA	P&P	30V	15V	24V	12V	VA	P&P
20	7.06	0.5	1	0.3	0.15	80	1.88
60	11.51	1	2	0.5	0.25	150	2.84
100	13.43	2	4	0.7	0.35	250	4.19
150	15.03	3	6	1.0	0.5	500	18.12
200	19.03	4	8	1.3	0.7	1000	28.79
250	23.01	5	10	1.6	0.8	1500	36.17
300	26.96	6	12	1.9	1.0	2000	41.89
350	30.44	7	15	2.2	1.2	3000	56.88
400	33.48	8	18	2.5	1.5	4000	68.88
500	38.40	10	20	3.0	1.8	5000	81.78
600	42.82	12	24	3.5	2.1	6000	94.68
700	46.74	15	30	4.0	2.4	7500	107.58
800	50.66	18	36	4.5	2.7	10KVA	131.33
900	54.58	20	40	5.0	3.0		155.08
1000	58.50	24	48	5.5	3.3		178.83
1500	68.92	30	60	6.5	3.9		202.58
2000	79.34	36	72	7.5	4.5		226.33
3000	113.89	45	90	8.5	5.1		250.08
4000	148.44	60	120	9.5	5.7		273.83
5000	182.99	75	150	10.5	6.3		297.58
6000	217.54	90	180	11.5	6.9		321.33
		105	210	12.5	7.5		345.08
		120	240	13.5	8.1		368.83
		135	270	14.5	8.7		392.58
		150	300	15.5	9.3		416.33
		165	330	16.5	9.9		440.08
		180	360	17.5	10.5		463.83
		200	400	19.0	11.7		514.83
		220	440	20.5	12.9		565.83
		240	480	22.0	14.1		616.83
		260	520	23.5	15.3		667.83
		280	560	25.0	16.5		718.83
		300	600	26.5	17.7		769.83
		320	640	28.0	18.9		820.83
		340	680	29.5	20.1		871.83
		360	720	31.0	21.3		922.83
		380	760	32.5	22.5		973.83
		400	800	34.0	23.7		1024.83
		420	840	35.5	24.9		1075.83
		440	880	37.0	26.1		1126.83
		460	920	38.5	27.3		1177.83
		480	960	40.0	28.5		1228.83
		500	1000	41.5	29.7		1279.83
		520	1040	43.0	30.9		1330.83
		540	1080	44.5	32.1		1381.83
		560	1120	46.0	33.3		1432.83
		580	1160	47.5	34.5		1483.83
		600	1200	49.0	35.7		1534.83
		620	1240	50.5	36.9		1585.83
		640	1280	52.0	38.1		1636.83
		660	1320	53.5	39.3		1687.83
		680	1360	55.0	40.5		1738.83
		700	1400	56.5	41.7		1789.83
		720	1440	58.0	42.9		1840.83
		740	1480	59.5	44.1		1891.83
		760	1520	61.0	45.3		1942.83
		780	1560	62.5	46.5		1993.83
		800	1600	64.0	47.7		2044.83
		820	1640	65.5	48.9		2095.83
		840	1680	67.0	50.1		2146.83
		860	1720	68.5	51.3		2197.83
		880	1760	70.0	52.5		2248.83
		900	1800	71.5	53.7		2299.83
		920	1840	73.0	54.9		2350.83
		940	1880	74.5	56.1		2401.83
		960	1920	76.0	57.3		2452.83
		980	1960	77.5	58.5		2503.83
		1000	2000	79.0	59.7		2554.83

Please add 15% VAT after P&P  
Unit 211, Stratford Workshops  
Burford Road, London E15 2SP

**BARRIE ELECTRONICS LTD**  
Tel: 01-555 0228 (3 lines)

## TWO GREAT HOBBIES

ONLY £119.99 INC VAT



## ...IN ONE GREAT KIT!

The K5000 Metal Detector Kit combines the challenge of DIY Electronics assembly with the reward and excitement of discovering Britain's buried past.

THE KIT — simplified assembly techniques require little technical knowledge and no complex electronic test equipment. All stages of assembly covered in a detailed 36 page manual.

THE DETECTOR — features Analytical Discrimination & Ground Exclusion, backed by the proven pedigree of C-Scope, Europe's leading detector manufacturer.

Ask at your local Hobby/Electronics shop or contact:—

**CSCOPE** C-Scope International Ltd., Dept. EE88,  
Wotton Road, Ashford, Kent TN23 2LN.  
Telephone: 0233 29181.

## A Great Reverb Amp for £75!

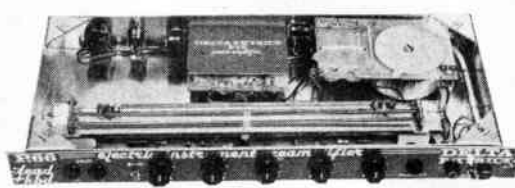

Shown — 45W Reverb Amp with Master Volume

Instrumentalists — are you looking for a great professional sound from your guitar or keyboard? Delta Physics' range of built and tested boards give you a convincingly valve-like sound at the lowest possible cost. Our custom-built chassis, control panels, and other accessories help you to produce a robust, reliable and good-looking unit for stage and studio use.

Compact units can be made with up to 100 watts of power for any electric instrument. They are simple to wire and assemble with full instructions.

- Our products include:
- P.66 Reverb Preamp (spring and controls included) **£27.50**
- P.36 Power Amp — 45W into 4 ohms — fully protected **£14.75**
- P.45 Power Supply for up to 45W **£13.45**
- P.47 Power Supply for up to 100W **£18.50**
- P.48 Power Supply for preamps only **£9.50**
- C.34 Bridge Driver — use with 2 x P.36 for 100W system **£4.50**

A full range of chassis, control-panels and accessories is also available. Details and prices are given in our brochure.

COMING SOON: P.68 Bass/Acoustic Preamp—available early August —WATCH THIS SPACE.

Please add £1.80 postage, packing & insurance and 15% VAT to each order. For FREE brochure, write to:

## DELTA PHYSICS

52 Codrington Hill, London SE23 1ND

Tel: 01-690 1512

PLEASE NOTE that from 8–28 June, only written enquiries can be answered

RUSH ME A BROCHURE, PLEASE!

Name.....

Address.....

## THREE INTO ONE WILL GO — WITH THE CROTECH 3132

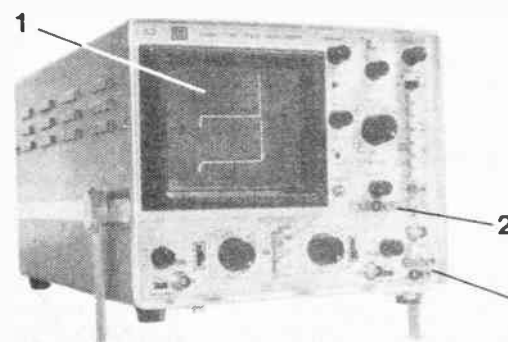

- 1 SCOPE:  
DC — 20MHz Bandwidth  
2mV/div Sensitivity  
40ns — 0.2s/div Sweep  
14 Trigger Functions  
Including active TV trigger on line & frame.
- 2 Active Component Comparator  
(for checking Transistors, diodes and I.C.'s etc)  
Test Voltage: 8.6Vrms (28mA)
- 3 Triple Output DC Source  
+5V (1A); —ve grounded  
±12V (200mA) Common Floating

All for the price of a scope at **£285\***



\* (Excluding Delivery and VAT)  
Correct at time of going to press

## Crotech Instruments Limited

2 Stephenson Road, St. Ives, Huntingdon, Cambs. PE17 4WJ  
Telephone: (0480) 301818



Also available from Audio Electronics & Henry's

# JOIN UP WITH LITESOLD

Professional Soldering Equipment at Special Mail-Order Prices.

## EC50 Mains Electronic Iron. £33.16



Features spike-free, solid state

proportional electronic temperature control inside the handle. Adjustable 280° to 400°C. Burn-proof 3-wire mains lead. Fitted 3.2mm Long-Life bit. 1.6, 2.4 and 4.7mm available. 240v a.c.

## SK18 Soldering Kit. £16.70

Build or repair any electronic project. LC18 240v 18w iron with 3.2, 2.4, and 1.6mm bits. Pack of 18 swg flux-cored 60/40 solder. Tweezers. 3 soldering aids. Reel of De-Solder braid. In PVC presentation wallet.

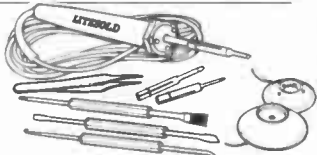

## ADAMIN Miniature Iron £7.67

Possibly smallest mains iron in the world. Ideal for fine work. Slim

nylon handle with finger grip. Interchangeable bits available 1.2, 1.6, 2.4, 3.4 and 4.7mm. Fitted with 2.4mm. 240v 12w (12v available). Presentation wallet.

## 'L' Series Lightweight Irons. 12w £7.68

High efficiency irons for all electronic hobby work. Non-roll handles with finger guards.

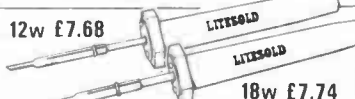

Stainless steel element shafts. Screw-connected elements. Slip-on bits available from 1.6 to 4.7mm. LA12

model, 12w, 2.4mm bit. LC 18 Model, 18w, 3.2mm bit. 240v Std - 12v available. Presentation wallet.

## Soldering Iron

### Stands 3&4

£5.99  
No.5  
£6.22



Designed specially for LITESOLD irons. Heavy, solid-plastic base with non-slip pads. Won't tip over, holds iron safely. With wiping sponge and location for spare (hot) bits.  
No 5 stand for EC50 iron No 4 stand for ADAMIN miniature iron No 3 stand for LA12 and LC18 Irons.

## Replacement Bits

For all above irons. Non-stick designs, machined from special copper alloy, with Inconel retaining rings. Two types - Chromium plated with copper face (for economy and ease of use) and iron plated with

Pre-tinned face (Long Life). State tip size, iron and type.

	Copper	L/L
EC50	-	£1.74
Adamin 12 and LA12	£1.00	£1.71
LC18	£1.12	£1.90

## Yellow £1.33

## Green £1.39



Blue £1.44 per Reel

For simple, safe and effective de-soldering of all types of joint, using a standard soldering iron. Handy colour-coded packs of 1.5 metres in 3 widths: Yellow - 1.5mm, Green - 2mm, Blue - 3mm.

## De-Solder Pumps £7.28

High Quality version of increasingly popular type of tool. Precision made anodised aluminium body, plunger guard and high-seal piston. Easy



thumb operation. Automatic solder ejection. Conductive PTFE nozzle - no static problems.

## Tool Sets



Top quality Japanese metric hardened and tempered tools. Swivel-top chrome plated brass handles. Fitted plastic cases. 113 set - 6 miniature screwdrivers 0.9 to 3.5mm £3.92  
227 set 5 socket spanners 3 to 5mm £2.98  
305 set 2 crosspoint and 3 hex wrenches 1.5 to 2.5mm £2.86  
228 set 20 piece combination:  
5 open, 5 skt spanners, 2 crosspoint, 3 hex and 3 plain drivers, scriber, handle/holder £6.42

**Microcutters. £5.39** Light weight hardened and precision ground. Flush cutting. Screw joint, return spring, cushion-grip handles. Safety wire-retaining clip.



## Soldering Aids.



**Set of 3 £4.45**  
Scraper/Knife, Hook/Probe, Brush/Fork. 3 useful double-ended aids to soldering/desoldering/assembly. In plastic wallet.



**ADAMIN Electric Stylus. £16.71**  
Writes like a ballpoint in Gold, Silver, Copper or 6 colours, on card, plastics, leather etc. Personalise wallets, bags, albums, books, models... Operates at 4.5v from its own plug/transformer - totally safe. Supplied with coloured foils.



**SEND FOR OUR ORDER FORM TODAY AND JOIN UP WITH THE PROFESSIONALS**

Prices include 0Gp and VAT. Send order with Cheque/PO. Ring for Access/Visa sales, or ask for order forms.  
**LIGHT SOLDERING DEVELOPMENTS LTD. DEPT. E M**  
97-99 GLOUCESTER ROAD, CROYDON CR0 2DN. 01 689 0574

# Universal Semiconductor Devices Ltd.

17 GRANVILLE COURT, GRANVILLE ROAD, HORNSEY, LONDON N4 4EP, ENGLAND.  
TEL. 01-348 9420/9425 \* TLX. 25157 usdco g



WE OFFER ONE OF THE LARGEST RANGES OF SEMICONDUCTORS AT HIGHLY ECONOMICAL PRICES. THE FOLLOWING SEMICONDUCTOR TYPES ARE AVAILABLE FROM STOCK. IF WE DON'T STOCK WHAT YOU NEED THEN WE CAN GET IT FAST FROM OUR FACILITIES IN WEST GERMANY AND USA UPON REQUEST.

**TRANSISTORS - BIPOLARS - GERMANIUM AND SILICON**  
SMALL SIGNAL  
POWER  
DARLINGTONS - ALL SHAPES AND SIZES  
VHF/UHF DEVICES - ALL SHAPES AND SIZES



**FETS - POWER MOSFETS**  
UNIUNCTIONS



**DIODES - GERMANIUM AND SILICON**  
RECTIFIERS AND BRIDGES  
OPTO-ELECTRONIC DEVICES  
LEDS OF ALL SHAPES AND SIZES



**THYRISTORS AND TRIACS - ALL**



SHAPES  
SIZES  
RATINGS

**INTEGRATED CIRCUITS:**  
CONSUMER - DIGITAL/ANALOGUE  
MICROPROCESSORS AND PERIPHERALS  
IC SOCKETS



**JAPANESE COMPONENTS - VAST RANGE OF DISCRETES AND CONSUMER IC's.**

MAIL ORDER CUSTOMERS: PLEASE SEND FOR OUR COMPREHENSIVE PRICE LIST, ENCLOSED £1 IN STAMPS, CHEQUE OR POSTAL ORDER.

CATALOGUE SENT FREE OF CHARGE, WHEN REQUESTED ON OFFICIAL LETTERHEAD (WITHOUT REFUND), TO OEM'S, SCHOOLS, COLLEGES, UNIVERSITIES, GOVERNMENT INSTITUTIONS, COMPUTER FIRMS, ELECTRONIC REPAIR FIRMS AND DISTRIBUTORS.

**SPECIAL DISCOUNTS AND PAYMENT TERMS ARE AVAILABLE TO ABOVE INSTITUTIONS.**

PLEASE ENQUIRE FOR QUANTITY DISCOUNTS.  
WE WELCOME TELEPHONE AND TELEX ENQUIRIES!

# Zenith Electronics

## Kits - Modules - Hardware

YOU KNOW US FOR OUR TRANSMITTER KITS—NOW  
TAKE A LOOK AT OUR GROWING RANGE OF  
QUALITY KITS AND READY-BUILT PROJECTS  
MODULES AND ELECTRONIC HARDWARE

The following are examples of our proven product designs in kit form:

- ★ Miniature FM Transmitter; 60-145MHz. Kit £6.95; R/Built £8.95.
- ★ 3 Watt FM Transmitter, 80-108MHz. Kit £13.99; R/Built £18.99.
- ★ 10 Channel Variable Speed Running Light; Drives LEDs or mains lamps. Kit £14.97.
- ★ 3 Note Electronic Door Chime unit; 9 volt operation, 3 melodious tones; variable frequency. Kit £9.83.
- ★ 300 Watt Light Dimmer unit for 240 volt mains lights. Kit £6.95.
- ★ 5 Code Digital Code unit plus Key Pad—select own code; 9 volt. Kit £14.21.
- ★ 5-100 Watt Electronic Loudspeaker Overload Protector, adjustable. Kit £11.11.
- ★ VU Meter 10 LED indicator; -5 to +12dB range. Kit £12.59.
- ★ Automatic light controller; automatically turns on and off lights at pre-set times and triggered by darkness. Kit £25.08.
- ★ Mains Wiring and Metal Detector; complete with case. £11.00
- ★ Digital Clock module; 12-24 hour timing; LED type—£17.49, or LCD type—£22.80.
- ★ Amplifier Power Meter; 10 LED indicator from 0-25-100 Watt Input—9 volt operation. Kit £9.52.
- ★ Light sensitive relay unit; variable sensitivity trigger control; senses light or dark—selectable. Kit £8.45.

ALL KITS CONTAIN FULL INSTRUCTIONS: P.C.B.s AND COMPONENTS.

ALL PRICES INCLUDE VAT AND POSTAGE & PACKING.

OVERSEAS ORDERS—ADD 10% TO ABOVE PRICES.

PLEASE SEND CHEQUE OR POSTAL ORDERS WITH ORDER.



**Zenith Electronics, 14 Cortlandt Business Centre, Hailsham, E. Sussex, U.K. BN27 1AE.**  
Tel: 0323 847973

# Super alpha electronics

Dept. EE, P.O. Box 21,  
Selsey, Chichester,  
West Sussex PO20 0TH



0243  
607108

— ALL ORDERS DESPATCHED SAME DAY BY FIRST CLASS POST —

## TRANSISTORS

BC107	0.15
BC107A	0.15
BC107B	0.15
BC108	0.15
BC108A	0.18
BC108B	0.15
BC108C	0.15
BC109	0.18
BC109B	0.18
BC109C	0.18
BC182	0.12
BC182B	0.12
BC183	0.12
BC183B	0.12
BC184	0.12
BC212	0.12
BC212B	0.12
BC213	0.12
BC213B	0.12
BC214	0.12
BC327	0.16
BC337	0.16
BC548	0.12
BCY70	0.22
BCY71	0.22
BD131	0.60
BD132	0.60
BD135	0.34
BD136	0.35
BF258	0.60
BFX85	0.40
BFX88	0.40
BFY50	0.37
BFY51	0.37
BFY52	0.39
TIP31	0.42
TIP31A	0.48
TIP31B	0.56
TIP31C	0.54
TIP32A	0.42
TIP32C	0.42
TIP33A	1.00
TIP41A	0.63
TIP42A	0.55
TIP3055	0.76
TIP2955	0.76
ZTX300	0.17
ZTX500	0.17
2N3053	0.60
2N3054	1.60
2N3707	0.12
2N3703	0.12
2N3705	0.12
2N3771	1.40
2N3904	0.15
2N3906	0.15

## DIODES

IN4001	0.05
IN4002	0.05
IN4003	0.06
IN4004	0.06
IN4448	0.06

## OPTO ISOLATORS

TIL111 transistor o/p	1.10
TIL113 Darlington o/p	1.20
3021 Triac driver	1.50

## LEDs

T1 5mm	
Red	0.18
Yellow	0.18
Green	0.18
Super bright	
T1 5mm	
Red	0.35

## TRIACS

3 Amp 400V	0.75
8 Amp 400V	0.90

## ZENER DIODES

BZY88C 500m W	
4V7	0.10
10V	0.10
12V	0.10
BZX55C 500m W	
24V	0.10
BZX85C 1.3 Watt	
4V7	0.20
10V	0.20
12V	0.20
24V	0.20

## VOLTAGE REGULATORS

LM317T	
+1.2V to 37V	1.50
LM341P	
+5V	0.60
LM7905	
-5V	0.70

## BRIDGE RECTIFIERS

W004 1.5A	0.50
6005 6A	0.90

## CAPACITORS

### Electrolytic

47uF	25V	0.10
100uF	25V	0.12
470uF	25V	0.28
1000uF	25V	0.36

### Tantalum

0.1uF	35V	0.10
0.22uF	35V	0.10
0.47uF	35V	0.10
1uF	35V	0.10
2.2uF	35V	0.15
4.7uF	35V	0.20

### Ceramic

220pF	500V	0.06
470pF	500V	0.06
1000pF	100V	0.06
2200pF	100V	0.06
4700pF	100V	0.06

## RESISTORS

Metal Film 5% 1/3 Watt

2p each

100R	680R	1K	1K2	2K2
4K7	5K6	6K8	10K	12K
15K	22K	27K	33K	39K
47K	56K	68K	82K	100K
120K	150K	180K	220K	
270K	330K	390K	470K	
560K	680K	820K	1M	

## SKELETON PRESETS

Horizontal	0.19
Vertical	0.19

## LINEAR ICs

741	0.18	NE5534	0.80
555	0.30	ZN414	0.90
556	0.65	ZN416	1.60
LM301	0.28	LM308	0.70
NE5532	1.20	TL081	0.50

## B.T. APPROVED TELEPHONES

### B.T. Statesman with last number redial

Stone	31.26
Brown	31.26
Maroon	31.26
Grey	31.26

### B.T. Viscount with last number redial

Beige	26.04
Ice Grey	26.04
Red	26.04
White	26.04

### B.T. Freeway cordless 700ft range Security coded, last number redial with base paging

Ivory	85.00
-------	-------

Carriage on telephones and telephone accessories £1.50  
Add 15% VAT to total allow ten days for delivery.

## SUPER ALPHA GUARANTEE

All components brand new and by top manufacturers to full specification.

ORDERING: Cash, Postal-Order, Access and Visa, orders despatched same day by first class post. Add 50p p&p to order then add 15% VAT. Telephone orders welcome with Access or Visa, orders accepted by answer service outside office hours. Overseas orders add £2.00 no VAT. Prices subject to alteration.

*This is just a small selection of our stock.  
Please phone for further details.*

Full Kits inc. PCBs, or veroboard, hardware, electronics, cases (unless stated). Less batteries  
If you do not have the issue of E.E. which includes the project - you will need to order the instruction reprint as an extra - 80p each. Reprints available separately 80p each + p&p £1.00

## THIS MONTH'S KITS SAE or phone for prices

VISUAL GUITAR TUNER Jun 87	£21.99
WINDSCREEN WASHER WARNING May 87	£4.88
FRIAGE ALARM May 87	£9.41
EQUALIZER (IONISER) May 87	£14.79
ALARM THERMOMETER April 87	£25.98
BULB LIFE EXTENDER April 87 (best case)	£4.99
EXP. SPEECH RECOGNITION April 87	£19.98
COMPUTER BUFFER INTERFACE Mar 87	£11.96
ACTIVE I/R BURGLAR ALARM Mar 87	£33.95
VIDEO GUARD Feb 87	£7.99
MINI-AMP Feb 87	£14.99
CAR VOLTAGE MONITOR Feb 87	£11.98
SPECTRUM SPEECH SYNTH. (no case) Feb 87	£19.92
SPECTRUM I/O PORT less case. Feb 87	£8.99
STEPPING MOTOR BOOSTER (for above) Feb 87	£5.10
STEPPING MOTOR M0200 Feb 87	£16.89
RANDOM LIGHT UNIT Jan 87	£58.00
HANOS-OFF INTERCOM (per station) inc. case Jan 87	£9.99
HAND LAMP CHARGER (mains) Jan 87	£7.70
CAR ALARM Oct 86	£17.97
QUAL READING THERMOMETER Dec 86	£39.98
RANDOM NUMBER GENERATOR Dec 86	£14.97
8 CHANNEL A-O (SPECTRUM) CONVERTER Dec 86	£34.29
BBC 16K SLOWWAYS RAM Dec 86	£12.35
MODEM TONE DECODER Nov 86	£18.99
OPTICALLY ISOLATED SWITCH Nov 86	£11.99
CAR FLASHER WARNING Nov 86	£7.92
200MHz OHZ. FREQUENCY METER Nov 86	£59.98
10 WATT AUDIO AMPLIFIER Oct 86	£34.95
LIGHT RIDER LABEL BADGE Oct 86	£18.69
LIGHT RIDER DISCO VERSION Oct 86	£18.69
LIGHT RIDER 16 LED VERSION Oct 86	£12.99
SCRATCH BLANKER Sept 86	£53.17
SIMPLE PRINTER BUFFER Sept 86 less PCB and EPROM	£47.89
INFRA-RED BEAM ALARM Sept 86	£26.99
FREZZER FAILURE ALARM Sept 86	£14.76
CAR TIMER Sept 86	£8.30
BATTERY TESTER Aug 86	£6.85
TILT ALARM July 86	£7.45
HEADPHONE MIXER July 86	£27.69
CARAVAN BATTERY MONITOR July 86	£16.25
SQUEAKIE CONTINUITY TESTER July 86	£3.35
ELECTRONIC SCARECROW July 86	£8.45
VOX BOO AMP July 86	£12.73
PERCUSSION SYNTH June 86	£28.98
LIGHT PEN (less case) June 86	£5.80
PERSONAL RADIO June 86	£10.98
WATCHDOG June 86	£7.82
MINI STROBE May 86	£13.11
PA AMPLIFIER May 86	£24.95
LOGIC SWITCH May 86	£14.93
AUTO FIRING JOYSTICK May 86	£11.86
STEREO REVERB Apr 86	£25.18
VERSATILE PSU Apr 86	£23.51
CIRCLE CHASER Apr 86	£20.98
FREZZER Apr 86	£7.82
STEPPER MOTOR DRIVER Apr 86	£4.89
BBC MIQI INTERFACE Mar 86	£26.61
INTERVAL TIMER Mar 86	£17.97
STEREO HI-FI PRE-AMP Mar 86	£46.85
MAINS TESTER & FUSE FINDER Mar 86	£8.40
FUNCTION GENERATOR Feb 86	£23.66
POWER SUPPLY FOR ABOVE Feb 86	£12.25
TOUCH CONTROLLER Feb 86	£12.25
pH TRANSDUCER (less Probe) Feb 86	£23.11
LIGHT EFFECTS/GAMES UNIT Feb 86	£10.89
SPECTRUM OUTPUT PORT Feb 86	£10.72
HEADLIGHT ONE SHOT Feb 86	£11.22
DPORT Jan 86	£7.14
TACHOMETER Jan 86	£24.57
MAIN DELAY SWITCH less case Jan 86	£18.83
ONE CHIP ALARM Jan 86	£8.29
MUSICAL OODOR BELL Jan 86	£17.83
TTL LOGIC PROBE Dec 85	£9.45
DIGITAL CAPACITANCE METER Dec 85	£39.57
FLUX DENSITY TRANSDUCER Nov 85	£28.72
FLASHING PUMPKIN less case Nov 85	£4.20
SQUAKING BATTERY ABOVE Nov 85	£9.45
SCREAMING MASK less case Nov 85	£10.97
STRAIN GAUGE AMPLIFIER Oct 85	£28.00
SIMPLE AUDIO GENERATOR Oct 85	£2.85
SOLDERING IRON CONTROLLER Oct 85	£5.21
VOLTAGE REGULATOR Sept 85	£7.46
PERSONAL STEREO P.S.U. Sept 85	£9.89
R.I.A. PRE-AMP Sept 85	£15.98
CARAVAN ALARM Sept 85	£10.30
FRIAGE ALARM Sept 85	£7.50
SEMI-CONDUCTOR TEMP. SENSOR Sept 85	£20.82
RESISTANCE THERMOMETER Sept 85 less Probe	£20.71
PLATINUM PROBE Extra	£24.20
LOW COST POWER SUPPLY UNIT Aug 85	£18.39
TRI-STATE THERMOMETER (Batt) Aug 85	£6.66
TREMOLLO/VIBRATO Aug 85	£37.92
STEPPER MOTOR INTERFACE FOR THE BBC COMPUTER less case Aug 85	£13.99
1035 STEPPER MOTOR EXTRA	£14.50
OPTIONAL POWER SUPPLY PARTS	£5.14
CONTINUITY TESTER July 85	£5.90
TRAIN SIGNAL CONTROLLER July 85	£9.65
AMSTRAO USER PORT July 85	£16.83
CROSS THE RIVER June 85	£19.77
ELECTRONIC OODORBELL June 85	£7.20
GRAPHIC EQUALISER June 85	£25.66
AUTO PHASE May 85	£17.98
INSULATION TESTER Apr 85	£18.65
LOAD SIMPLIFIER Feb 85	£18.68

SOLIO STATE REVERB Feb 85	£43.97
GAMES TIMER Jan 85	£8.39
SPECTRUM AMPLIFIER Jan 85	£6.58
TV AERIAL PRE-AMP Dec 84	£14.83
Optional PSU 12V £2.44	240V £11.83
MINI WORKSHOP POWER SUPPLY Dec 84	£41.98
OODOR CHIME Dec 84	£17.89
BBC MICRO AUDIO STORAGE SCOPE INTERFACE Nov 84	£34.52
PROXIMITY ALARM Nov 84	£21.58
MAINS CABLE DETECTOR Oct 84	£5.27
MICRO MEMORY SYNTHESIZER Oct 84	£57.57
ORILL SPEED CONTROLLER Oct 84	£8.27
GUITAR HEAD PHONE AMPLIFIER Sept 84	£7.66
SOUND OPERATED FLASH less lead Sept 84	£6.98
TEMPERATURE INTERFACE FOR BBC Aug 84	£23.64
CAR RADIO BOOSTER Aug 84	£16.64
CAR LIGHTS WARNING July 84	£9.58
VARICAP AM RADIO May 84	£12.52
EXPERIMENTAL POWER SUPPLY May 84	£22.46
SIMPLE LOOP BURGLAR ALARM May 84	£16.34
MASTERING TIMER May 84	£5.52
FUSE/DIODE CHECKER Apr 84	£4.14
QUASI STEREO ADAPTOR Apr 84	£13.08
DIGITAL MULTIMETER add on for BBC Micro Mar 84	£29.98
NI-CAO BATTERY CHARGER Mar 84	£11.82
REVERSING BLEEPER Mar 84	£8.14
PIPE UNDER Mar 84	£28.78
IONISER Feb 84	£17.38
ZXB1 EPROM PROGRAMMER Feb 84	£17.88
SIGNAL TRACER Feb 84	£4.51
CAR LIGHT WARNING Feb 84	£21.28
GUITAR TUNER Jan 84	£22.99
BIOLOGICAL AMPLIFIER Jan 84	£11.99
CONTINUITY TESTER Dec 83	£11.99
CHILDREN'S DISCO LIGHTS Dec 83	£18.42
NOVEL EGG TIMER Dec 83 inc. case	£12.29
SPEECH SYNTHESIZER FOR THE BBC MICRO Nov 83 less cable & sockets	£26.38
MULTIMOD Nov 83	£20.38
LONG RANGE CAMERA/FLASHGUN TRIGGER Nov 83	£16.20
HOME INTERCOM less link wire Oct 83	£17.26
DIGITAL TO ANALOGUE BOARD Oct 83 less cable, case & connector	£23.95
HIGH POWER DAC DRIVER BOARD Oct 83 less case	£14.99
HIGH SPEED A TO O CONVERTER Sept 83 less cable & connector	£33.57
STORAGE SCOPE INTERFACE FOR BBC MICRO Aug 83 less software	£18.42
HIGH POWER INTERFACE BOARD Aug 83 no case	£12.45
USER PORT I/O BOARD less cable & plug	£12.59
USER PORT CONTROLLER BOARD July 83 less cable & plug & case	£30.16
GUITAR HEADPHONE AMPLIFIER May 83	£9.50
PERSONAL RADIO less case, May 83	£9.14
MOISTURE DETECTOR May 83	£4.55
CAR RADIO POWER BOOSTER April 83	£14.39
FUNCTION GENERATOR April 83	£55.17
FLANGER SOUND EFFECTS April 83	£29.00
NOVELTY EGG TIMER April 83 less case	£6.58
QUAL POWER SUPPLY March 83	£69.48
BUZZ OFF March 83	£54.11
PUSH BITE ALARM Feb 83	£19.57
ZX TAPE CONTROLLER Feb 83	£8.55
CONTINUITY CHECKER Sept 82	£6.56
2-WAY INTERCOM July 82 no case	£5.42
ELECTRONIC PITCH PIPE July 82	£6.48
REFLEX TESTER July 82	£9.32
SEAT BELT REMINDER Jun 82	£4.92
EGG TIMER Jun 82	£6.53
CAR LIGHT METER less case, May 82	£3.81
C.O. SOUND EFFECTS UNIT Apr 82	£15.25
Y.A.M.E.R. OR FLASH GUN TRIGGER Mar 82 less tripod bushes	£16.38
POCKET TIMER Mar 82	£4.92
GUITAR TUNER Mar 82	£20.62
SIMPLE STABILISED POWER SUPPLY Jan 82	£37.37
MINI EGG TIMER Jan 82	£5.28
SIMPLE INFRA RED REMOTE CONTROL Nov 81	£22.44
CAPACITANCE METER Oct 81	£30.98
SUSTAIN UNIT Oct 81	£16.79
TAPE NOISE LIMITER Oct 81	£5.97
HEADING LIGHTS GAME Oct 81	£3.30
CONTINUITY TESTER Oct 81	£5.38
PHOTO FLASH SLAVE Oct 81	£4.56
FUZZ BOO Oct 81	£9.57
SOIL MOISTURE UNIT Oct 81	£7.66
0-12V POWER SUPPLY Sept 81	£23.38
COMBINATION LOCK July 81 less case	£25.89
SOIL MOISTURE INDICATOR E.E. May 81	£5.39
PHONE BELL REPEATER/BABY ALARM May 81	£7.38
INTERCOM April 81	£29.31
MODULATED TONE DOORBELL Mar 81	£8.82
2 NOTE OODOR CHIME Dec 80	£13.62
LIVE WIRE GAME Dec 80	£15.44
GUITAR PRACTICE AMPLIFIER Nov 80 £14.10 less case, Standard case extra	£28.08
SOUND TO LIGHT Nov. 80 3 channel	£28.00
TRANSISTOR TESTER Nov 80	£15.36
AUDIO EFFECTS UNIT FOR WEIRO SOUNDS Oct 80	£17.28
MICRO MUSIC BOX Feb 80	£21.43
Case extra	£4.32
SOUND LINE REVERB Unit Jan 80	£32.64
IMBROGO BURGLAR ALARM Dec 79	£7.98
OARKROOM TIMER July 79	£3.84
MICROCHIME OODORBELL Feb 79	£20.98
SOUND TO LIGHT Sept 78	£10.98
CAR BATTERY STATE INDICATOR LESS CASE Sept 78	£2.76
R.F. SIGNAL GENERATOR Sept 78	£37.44
IW SITU TRANSDUCER TESTER Jun 78	£9.00
WEIRO SOUND EFFECTS GENERATOR Mar 78	£7.44
ELECTRONIC OICE Mar 77	£5.97

## NEW SERIES As Usual we shall be providing a comprehensive top quality kits & parts service for this new series.

Our excellent technical back-up service helps to ensure that your projects succeed every time.  
PART 1 BENCH POWER SUPPLY—Full kit £24.98.  
LOGIC PROBE—£7.58 including case.  
LOGIC PULSER—£7.48 including case.  
VERSATILE PULSE GENERATOR—£29.98 including case.  
DIGITAL I.C. TESTER—£29.21 (case different).  
CURRENT TRACER—£20.56.  
AUDIO LOGIC TRACER—£8.99.

## EXPLORING ELECTRONICS

A full set of parts including the Verobloc breadboard to follow the series right up to Nov. issue. £14.87. Dec parts £4.99. Jan parts £4.99. Feb parts £4.29. March parts £6.99. April parts £4.44. May parts £3.98.

## INTRODUCTION TO ELECTRONICS

An introduction to the basic principles of electronics. With lots of simple experiments. Uses soldering. Lots of full colour illustrations and simple explanations. A lovely book. Ideal for all ages.  
INTRODUCTION TO ELECTRONICS COMPONENT PACK £10.99  
BOOK EXTRA £2.45  
Book also available separately.

### NEW BOOKS

A T.V.-Oxers Handbook BP176 £5.95  
Mini Projects. Penfold £2.95  
Getting The Most From Your Printer. Penfold £2.95  
More Advanced Electronic Music Projects. Penfold £2.95



### BOOKS

How to Get Your Electronic Projects Working. Penfold £2.15  
A practical Introduction to Microprocessors. Penfold £2.10  
Basic Electronics. Hodder & Stoughton £8.98  
Beginners Guide to Building Electronic Projects. Penfold £2.25  
DIY Robotics & Sensors Billingsley. BBC £7.95  
Commodore 64 £7.99  
Elementary Electronics Sladdin £5.98  
Science Experiments with Your Computer £2.43  
How to Design & Make Your Own PCBs. BP121 £2.15  
How to Make Computer Controlled Robots. Potter £3.20  
How to Make Computer Model Controllers. Potter £3.19  
Interfacing to Microprocessors & Microcomputers. 6.50  
Machine Code for Beginners. Usborne £2.45  
Micro Interfacing Circuits Book 1 £7.45  
Microprocessors for Hobbyists. Coles £. 3  
Practical Computer Experiments. Parr £1.45  
Practical Things to do With a Microcomputer. Usborne £2.19  
Questions & Answers — Electronics. Hickman £3.45  
Understanding the Micro. Usborne £1.95

• JUST A SMALL SELECTION. LOTS MORE IN OUR PRICE LIST •

# TEACH IN 86

MULTIMETER TYPE M102BZ as specified. Guaranteed. Top quality. 20kV, with battery check, continuity tester buzzer and fuse and diode protection. 10A dc range. Complete with leads, battery and manual. £14.98  
VEROBLOC BREADBOARD, DESIGN PAD, MOUNTING PANEL AND 10 CROCODILE CLIP CONNECTING LEADS. £6.98  
REGULATOR UNIT FOR SAFE POWER SUPPLY. All components including the specified case. Also the plugs, fuse and fuseholders to suit the EE mains adaptor. £16.78  
COMPONENTS FOR PRACTICAL ASSIGNMENTS. Parts 1 and 2 (Oct & Nov) £1.94. Part 3 (Dec) £1.37. Part 4 (Jan) £2.48. Part 5 (Feb) £2.22. Part 6 (Mar) £6.31. Parts 7, 8 & 9 (combined) £2.55.

## TEACH IN 86 PROJECTS

UNIVERSAL LCR BRIDGE Nov 85	£25.83
DIODE/TRANSISTOR TESTER Dec 85	£18.89
USEFUL AUDIO SIGNAL TRACER Jan 86	£16.75
AUDIO SIGNAL GENERATOR Feb 86	£26.21
R.F. SIGNAL GENERATOR March 86	£24.48
RET. VOLTMETER Apr 86	£21.48
DIGITAL PULSE GENERATOR May 86	£16.68

## LEGO Technic Sets

TEACHERS WE ARE STOCKISTS OF THE WHOLE RANGE. CONTACT US FOR BROCHURES. VERY COMPETITIVE PRICES AND QUICK DELIVERIES.

## STEPPING MOTORS 12 VOLT

48 STEPS	1 200 STEPS
ID35	M0200
£14.50	£16.80

## MOTOR — GEARBOX ASSEMBLIES

Miniature precision made. Complete with quality electric motor. Variable reduction ratios achieved by fitting from 1-6 gearwheels (supplied) as required. Operates from 1.5V to 4.5V. Small unit type MGS speed range 3rpm-2200rpm depending on voltage & gear ratio. Large unit type MGL (higher torque motor) 2rpm-1150rpm. Long 3mm dia output shafts. Ideal for robots and buggies.  
Small Unit (MGS) £3.49. Large Unit (MGL) £3.98.  
PULLEY WHEELS. New Range—PLASTIC WITH BRASS BUSH 1/8" dia. hole—easily drilled to 3 or 4mm. 1/8" dia. 35p. 1/2" dia. 36p. 3/4" dia. 44p. 1" dia. 44p.  
Metal collar with fixing screw, 3mm bore 24p. Flexible spring coupling 5mm. Length 31mm 68p.  
Flexible metal coupling (universal) 3mm £2.98; 2mm £3.34.



## 1987 CATALOGUE

Brief details of each kit, our books, & illustrations of our range of tools & components. Also stepper motor, interface kit & simple robotics. Plus circuit ideas for you to build. If you read Everyday Electronics then you need a copy of the MAGENTA catalogue.  
CATALOGUE & PRICE LIST — Send £1 in stamps etc. or add £1 to your order. Price list — 9x4d. s.a.s.  
Catalogue FREE TO SCHOOLS/COLLEGES REQUESTED ON OFFICIAL LETTERHEAD.

## ADVENTURES WITH ELECTRONICS

An easy to follow book suitable for all ages. Ideal for beginners. No soldering. Uses an S-0ec Breadboard. Gives clear instructions with lots of pictures. 16 projects — including three radios, siren, metronome, organ, intercom, timer, etc. Helps you learn about electronic components and how circuits work. Component pack includes an S-0ec breadboard and all the components for the projects.  
Adventures with Electronics £3.58. Component pack £20.98 less battery.

### TOOLS

ANTEX MODEL C IRON	£6.98	BENT NOSE PLIERS	£1.89
ANTEX X5 SOLDERING IRON 25W	£7.25	MINI DRILL 12V (M01)	£8.38
ST4 STAND FOR IRONS	£2.85	MULTIMETER TYPE 1 1000000p	£17.98
HEAT SINK TWEEZERS	45p	MULTIMETER TYPE 2 2000000p	£6.98
SOLDER HANDY SIZE 5	1.39	MULTIMETER TYPE 3 3000000p	£27.98
SOLDER CARTON	£4.67	MULTIMETER TYPE 4 10M DIGITAL	£39.98
SOLDER REEL SIZE 10	£1.86	DESOLDER PUMP	£5.48
LOW COST PLIERS	£1.89	SIGNAL INJECTOR	£2.98
		CIRCUIT TESTER	78p
		HELPING HANDS JIG & MAGNIFIER	£7.98
		MINIATURE VICE (PLASTIC)	£1.85



MAGENTA ELECTRONICS LTD. SHOP NOW OPEN—CALLERS WELCOME  
EES3, 135 HUNTER ST., BURTON-ON-TRENT, STAFFS, OE14 2ST. D283 65435, Mon-Fri 9-5. Access/Barclaycard (Visa) by phone or post. 24 hr Answerphone for credit card orders. Our prices include VAT.

ADD £1 P&P TO ALL ORDERS. PRICES INCLUDE VAT. SAE ALL ENQUIRIES. OFFICIAL ORDERS WELCOME. OVERSEAS: Payment must be sterling. IRISH REPUBLIC AND BFPO. UK PRICES. EUROPE: UK PRICES plus 10%. ELSEWHERE: write for quote. SHOP HOURS: 9-5 MON-FRI.



PRICE LIST—FREE WITH ORDERS OR SEND SAE



# EVERYDAY ELECTRONICS

INCORPORATING ELECTRONICS MONTHLY

The Magazine for Electronic & Computer Projects

VOL 16 NO6

JUNE '87

**Editorial Offices**  
EVERYDAY ELECTRONICS EDITORIAL,  
6 CHURCH STREET, WIMBORNE,  
DORSET BH21 1JH  
Phone: Wimborne (0202) 881749

See notes on **Readers' Enquiries** below—we regret that lengthy technical enquiries cannot be answered over the telephone

**Advertisement Offices**  
EVERYDAY ELECTRONICS ADVERTISEMENTS  
4 NEASDEN AVE., CLACTON-ON-SEA, ESSEX  
CO16 7HG. Clacton (0255) 436471

## RISEING FIGURES

IT MAY seem a little late to be talking about 1986 but at the time of writing we have just had our 1986 circulation figures confirmed by ABC (Audit Bureau of Circulations)—the figures were a little late due to the change of publisher early in 1986. We are pleased to say that for the second year running EE has had the highest certified UK circulation of any monthly hobby electronics publication sold in this country.

During 1986 our UK circulation rose and is continuing to do so in 1987. This of course is thanks to you our loyal readers. The result is a better audience for our advertisers, every month over 400 more UK readers buy EE than take our nearest competitor. As this trend continues it leads to more adverts which eventually allow us to provide more editorial pages, more articles and more interest for you. This in turn helps sell more copies and so it goes on.

For some years, up to the end of '85, UK sales of the hobby electronics magazines were falling. I'm very pleased to say there is now a continuing strong upward trend on EE's circulation.

## SUMMER

To keep up this trend we are always trying to give good value for money. The summer is coming and we start to think of suitable projects for the months when there may be some sunshine. Next month we will publish an excellent metal locator project which should help to provide some interest on the beach and on other outside sites through the summer.

We also have a couple of car and caravan projects coming up—to go with the *Fridge Alarm* we published last month. Of course there are many other projects which are equally useful in the summer and some that are perhaps not obviously so. Take for instance an Immersion Heater Timer—coming soon, at first sight it might be considered a winter project, but when the central heating is turned off a timed immersion heater may prove to be the most economical means of obtaining hot water.

We will of course continue to publish all the regular features plus our usual sample of test gear and computer items.

**Editor** MIKE KENWARD

**Personal Assistant**  
PAULINE MITCHELL

**Assistant Editor/Production**  
DAVID BARRINGTON

**Assistant Editor/Projects**  
DAVID BRUNSKILL

**Editorial:** WIMBORNE (0202) 881749

**Advertisement Manager**  
PETER J. MEW Clacton (0255) 436471

**Classified Advertisements**  
Wimborne (0202) 881749

## READERS' ENQUIRIES

We are unable to offer any advice on the use, purchase, repair or modification of commercial equipment or the incorporation or modification of designs published in the magazine. We regret that we cannot provide data or answer queries on articles or projects that are more than five years old. Letters requiring a personal reply **must** be accompanied by a **stamped self-addressed envelope** or a **self-addressed envelope and international reply coupons**.

All reasonable precautions are taken to ensure that the advice and data given to readers is reliable. We cannot, however, guarantee it and we cannot accept legal responsibility for it.

## COMPONENT SUPPLIES

**We do not supply electronic components or kits** for building the projects featured, these can be supplied by advertisers.

## OLD PROJECTS

We advise readers to check that all parts are still available before commencing any project in a back-dated issue.

We regret that **we cannot provide data or answer queries on projects that are more than five years old**.

## ADVERTISEMENTS

Although the proprietors and staff of EVERYDAY ELECTRONICS take reasonable precautions to protect the interests of readers by ensuring as far as practicable that advertisements are *bona fide*, the magazine and its Publishers cannot give any undertakings in respect of statements or claims made by advertisers, whether these advertisements are printed as part of the magazine, or are in the form of inserts.

The Publishers regret that under no circumstances will the magazine accept liability for non-receipt of goods ordered, or for late delivery, or for faults in manufacture. Legal remedies are available in respect of some of these circumstances, and readers who have complaints should address them to the advertiser or should consult a local trading standards office, or a Citizen's Advice Bureau, or a solicitor.

## SUBSCRIPTIONS

Annual subscription for delivery direct to any address in the UK: £14.00. Overseas: £17.00 (£33 airmail). Cheques or bank drafts (**in £ sterling only**) payable to Everyday Electronics and sent to EE Subscription Dept., 6 Church Street, Wimborne, Dorset BH21 1JH. **Subscriptions can only start with the next available issue.** For back numbers see the note on the left.



## BACK ISSUES & BINDERS

Certain back issues of EVERYDAY ELECTRONICS and ELECTRONICS MONTHLY are available price £1.50 (£2.00 overseas surface mail) inclusive of postage and packing per copy. Enquiries with remittance, made payable to Everyday Electronics, should be sent to Post Sales Department, Everyday Electronics, 6 Church Street, Wimborne, Dorset BH21 1JH. In the event of non-availability remittances will be returned. **Please allow 28 days for delivery. (We have sold out of Oct. and Nov. 85, April and May 86.)**

Binders to hold one volume (12 issues) are available from the above address for £4.95 (£9.00 overseas surface mail) inclusive of p&p. **Please allow 28 days for delivery.**

**Payment in £ sterling only please.**



# VISUAL GUITAR/ INSTRUMENT TUNER

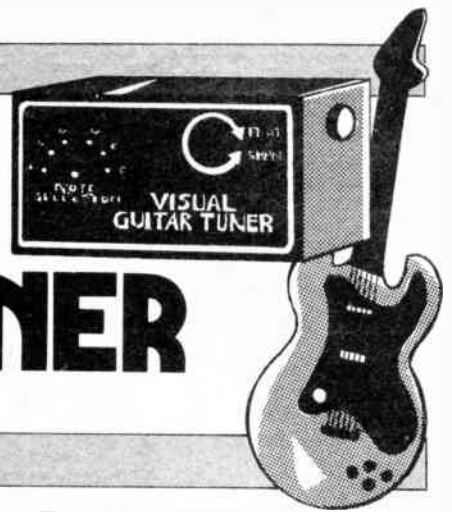

MARK STUART

## Keep in tune with this crystal controlled musical instrument tuner

THIS circuit was designed as a multi-purpose musical instrument tuner that could be pre-set to cover a wide range of crystal controlled reference frequencies. Tuning the instrument to the reference frequency is achieved by a novel and very effective display using a ring of l.e.d.s which light in a pattern that indicates relative phase and frequency.

The display also indicates whether the incoming frequency is above or below the reference frequency by the direction in which the pattern appears to rotate. As tuning becomes nearer, the apparent speed of rotation reduces, until the pattern is stationary when the tuning is exact. The display thus combines the benefits of a meter and an l.e.d.-type beat in indicator and is better than both.

The tuner is quick and easy to use, has a clear unambiguous display and is not over sensitive to input signal waveform or amplitude. Being a solid state display means that the tuner is robust and compact. The tuner requires a low level signal from either a microphone or an instrument pick-up (input impedance 47k).

A built-in acoustic resonator allows the reference frequency to be heard if required by pressing a button. This facility is useful when a suitable microphone or pick-up signal is not available as it enables simple tuning to be achieved by ear.

### CIRCUIT

The circuit diagram of the tuner is shown in Fig. 1. The switch connections shown are set to produce the standard guitar string frequencies E, A, D, G, B, E through two octaves. The production of other notes and octaves for other instruments is achieved by the use of alternative pin connections to IC2 and IC3.

The crystal reference frequency is produced by X1 which is connected in a standard i.c. oscillator circuit using a single inverting gate from IC1. Capacitors C1 and C2 provide the correct loading for the crystal and R1 provides a d.c. bias path which ensures that IC1 is operating in its "linear" range. The output from IC1 is a square wave at 4MHz. This is too high for some of the notes required so it is divided in two stages in IC2 to produce alternative

outputs of 2MHz and 1MHz. These outputs are on pins 9 and 6 of IC2 respectively. A third output from IC2 on pin 11 provides a buffered, undivided output at 4MHz.

Switch S1 is a two-pole six-way switch which is used to select the required note in two stages. For the two lower notes a 1MHz clock is required, the next three notes require a 2MHz clock and the top note uses the full 4MHz. The first section of S1 (S1c) selects the appropriate clock frequency which passes to the input of a "top octave divider" IC3.

IC3 is a chip designed to generate 13 output frequencies at the correct musical intervals over one octave from C to C. Only five of the outputs are used in this application—the difference between top and bottom E being determined by the selection of 1MHz or 4MHz for the input clock frequency. All of the other outputs are available of course and may be used if required by arranging suitable switching.

The table below shows the pins and the notes available from IC3

Available notes		
Pin	Note	
4	C sharp	
5	D	
6	D sharp	
7	E	
8	F	
9	F sharp	
10	G	
11	G sharp	
12	A	
13	A sharp	
14	B	
15	top C	
16	low C	

The frequencies at the output of IC3 are exactly eight times the frequency of the note being tuned. This factor is required to give the correct display action. The selected output of IC3 is passed on to the "clock"

Fig. 1. Complete circuit diagram for the Visual Guitar/Instrument Tuner.

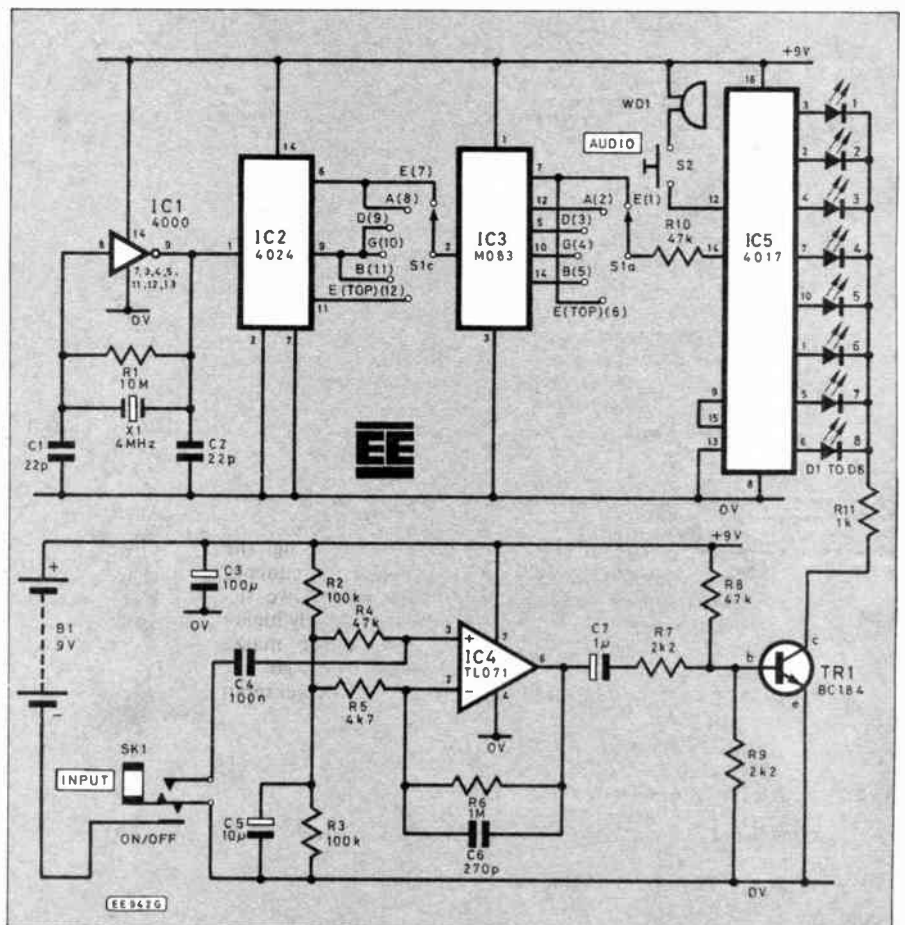

input IC5 which is a 4017 decode counter. The extensively used i.c. has ten outputs which switch from low to high and back again in turn on each clock pulse. Only one output can be high at any time so that a ripple effect is provided with a sequence of ten outputs each going high and then low again one by one in turn. For this circuit a sequence of only eight outputs is required not ten. This is achieved by connecting the ninth output to the "reset" pin on the i.c. (pins 9 and 15). This ensures that as soon as the ninth output attempts to go high the counter is automatically reset and assumes the starting state with the first output high.

The effect of this arrangement on the l.e.d.s (D1 to D8) is to scan through them one by one, taking the anode of each one in turn up to the positive supply voltage. If the cathodes of all of the l.e.d.s were held at 0V each l.e.d. would be lit when its turn came and all l.e.d.s would appear equally bright. This would be the case if transistor TR1 were to be turned on all the time. If TR1 were turned off all the time all l.e.d.s would be off.

In this circuit the state of TR1 is deter-

mined by the input signal to the tuner. The signal, from a microphone or pickup, passes via C4 to IC4 which is a standard non-inverting i.c. op-amp circuit. D.C. bias for the two inputs at half of the supply voltage is provided by potential divider resistors R2 and R3. C5 decouples this bias voltage which is then passed to the inputs via R4 and R5. Feedback around the amplifier is provided by R6 and C6, which in conjunction with R5 set the gain of the stage to 200. From IC4 the amplified signal is coupled to the base of TR1 via C7 and R7. Resistors R8 and R9 set the standing bias on TR1 so that in the absence of any input it is turned off.

signal reverses the rotation. This is an extremely useful feature as it shows which way tuning is required.

At higher difference frequencies the pattern rotates faster and when the difference is very large all that can be seen is a general flickering effect. By the time this occurs the difference is so great that it is usually obvious which way to start tuning, if not, a quick process of trial and error soon results in a rotating pattern.

So far a perfect input signal waveform has been assumed which turns on exactly four l.e.d.s. A waveform which is rich in harmonics may result in a larger or smaller number of l.e.d.s, being lit. The rotational effects are still exactly the same however, and so practically nothing is lost. As the combined gain of IC4 and TR1 is very high the input signal can decay a long way before any effect is noticed on the brightness of the l.e.d.s. Use of the special high efficiency low current l.e.d.s specified is not essential but does produce a far superior display than ordinary "cooking" l.e.d.s. As the signal dies away it eventually falls below the level necessary to turn on TR1 and the l.e.d.s all go out.

The circuit is switched on and off by means of the input jack socket which is of the make/break type. Piezo-electric transducer WD1 allows the unit to be used as a pitch-pipe for tuning instruments by ear. It allows the tuner to be used when a microphone or pick-up is not available.

## SCANNING

When a note of the correct frequency is applied to the input, TR1 will be turned on during the positive half cycle and off during the negative half cycle. During this time all eight l.e.d. anodes will have been scanned by IC5. Those l.e.d.s enabled during the positive half cycle of the input will be turned on and those during the negative half cycle turned off. This process repeats rapidly for each cycle of the incoming signal and provided the input is exactly one eighth of the scan frequency a stationary pattern of four l.e.d.s on and four l.e.d.s off will result.

In fact the four l.e.d.s that appear to be on are flickering at the input frequency as they are scanned. This is too fast for the eye to follow and so a steady pattern is perceived. When the input frequency is slightly different from the reference frequency the relative phase of the two signals changes progressively through successive scans. This has the effect of making the l.e.d. pattern appear to rotate slowly, the frequency of rotation being the difference frequency between the two signals. A slightly higher input signal makes the rotation go one way and a lower input

Positioning of components inside the case. The p.c.b. is mounted on the lid so that the ring of l.e.d.s can protrude through the top of the case.



## COMPONENTS

### Resistors

R1	10M
R2,R3	100k (2 off)
R4,R8,R10	47k (3 off)
R5	4k7
R6	1M
R7,R9	2k2 (2 off)
R11	1k
All 5% carbon film 0.25Watt	

See  
**Shop  
Talk**

page 206

### Capacitors

C1,C2	22p ceramic plate (2 off)
C3	100µ radial elect. 16V
C4	100n polyester
C5	10µ axial elect. 16V
C6	270p ceramic plate
C7	1µ axial elect. 16V

### Semiconductors

IC1	4000B CMOS
IC2	4024B CMOS
IC3	MO83 top octave generator
IC4	TL071 op-amp
IC5	4017B CMOS
TR1	BC184 (see text)
D1 to D8	KLMP1700 high efficiency low current red l.e.d.s (8 off)

### Miscellaneous

S1	2-pole 6-way rotary switch
S2	Push to make switch
SK1	¼ in. mono jack socket with 1 make contact and 1 break
X1	4MHz crystal HC18U wire-ended
WD1	PB2720 ceramic resonator
Knob; connecting wire; p.c.b. available from the <i>EE PCB Service</i> , order code EE568; case; PP3 battery clips; d.i.l. i.c. holders 8-pin, 14-pin (2 off), 16-pin (2 off).	

Approx. cost  
Guidance only **£23.50**

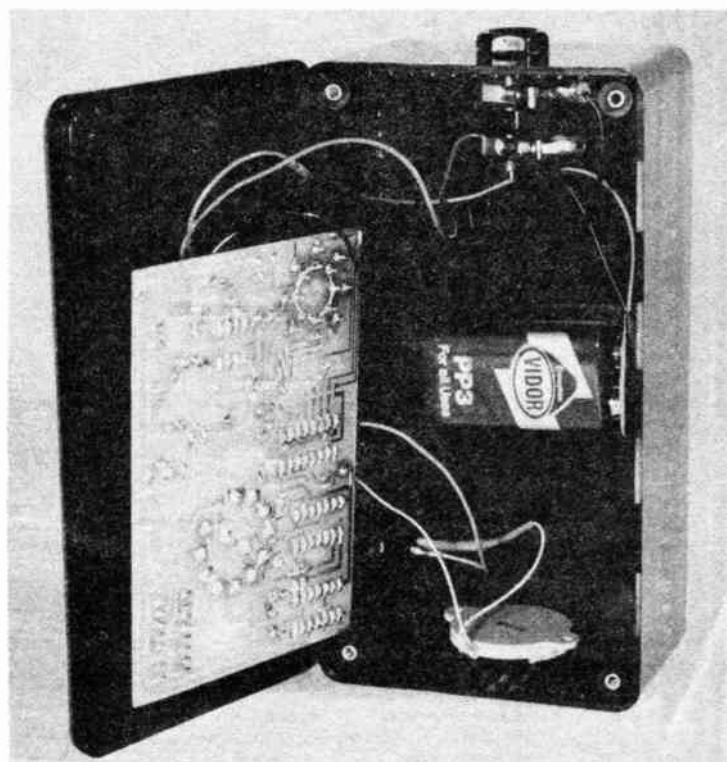

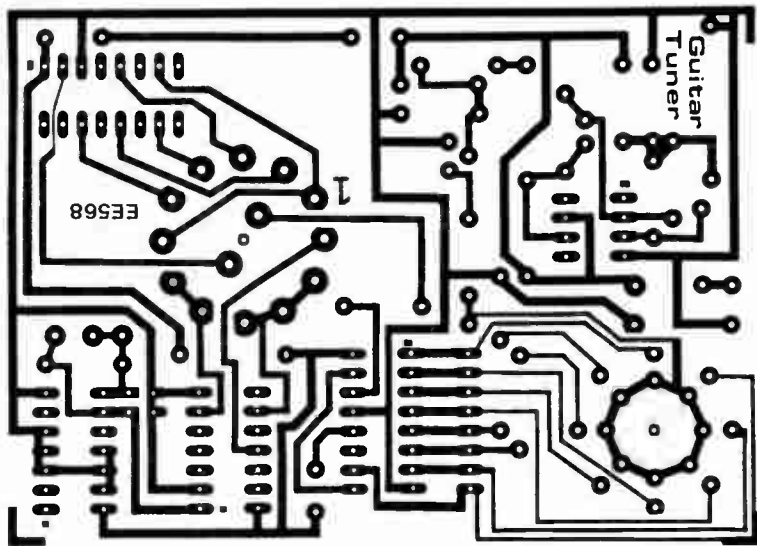

Fig. 2. Printed circuit board foil master pattern. This board is available through the EE PCB Service, order code EE 568.

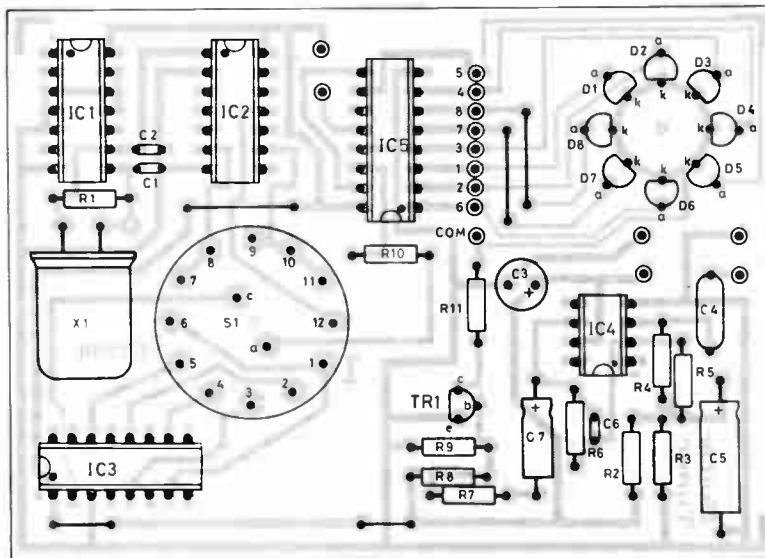
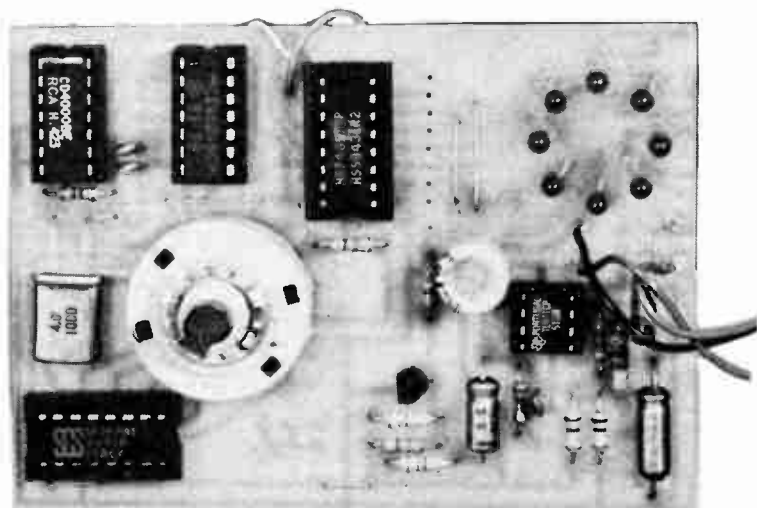

Fig. 3. Printed circuit board component layout. The numbers to the side of IC5 are the order of the outputs if the l.e.d.s are mounted off the p.c.b.



The completed board with the display l.e.d.s forming a circle.

## CONSTRUCTION

The circuit is built on a single printed circuit board. Fig. 2 shows the p.c.b. track patterns and Fig. 3 the component layout. This board is available from the *EE PCB Service*, code EE568. See page 340.

S1 and the l.e.d.s can be mounted on the board as shown or may be mounted remotely if a different style of case layout is preferred. A set of connection points are provided for remotely mounted components.

Assemble the circuit in the usual order: small components, wire links and i.c. sockets first followed by larger components and wiring. TR1 must be the standard BC184 type and **not** a BC184L (which has the collector connected to the middle lead). Capacitors C3, C5 and C7 must be fitted with the correct polarity as shown. The l.e.d.s have a small flat at the point where the leads are attached which identifies the cathode.

In the prototype the l.e.d.s were all mounted directly on the board and the case front drilled appropriately. It is easier to do this if the l.e.d.s are first pushed into close fitting holes drilled for them in the case front and the printed circuit board fitted over the leads so that they all pass through the correct holes. The leads can then all be soldered and the board removed complete with the l.e.d.s, which will be in perfect alignment.

If a standard switch is used for S1 the letters and numbers shown are moulded on the switch body. The board is designed so that the switch can be mounted directly on it. Alternatively it can be mounted elsewhere and connected by wiring. The type of switch specified will need its tag ends removed for p.c.b. mounting.

## CRYSTAL

The crystal X1 should have its leads supported whilst they are bent, so that the glass seal is not broken. A small double-sided sticky pad can be used to hold the crystal firmly down on the board. Wiring simply involves the connection of S2 and WD1, a battery clip and the input socket SK1. Use flexible connecting wire and take care to connect SK1 exactly as shown in Fig. 4 so that the switch section works correctly. Other types of switched socket can be used if they have the correct switching arrangement.

The board can be mounted by means of the fixing nut of S1 if this is fitted to the board. If S1 is mounted off the board it will be necessary to drill some fixing holes and mount the board using spacers or long screws fitted with extra nuts. The front panel of the prototype was marked as shown in Fig. 5. If the specified case and layout are used this panel layout can be photocopied, covered with plastic film, and used as a label. Details for drilling the front panel are shown in Fig. 6.

## TESTING AND USE

Insert all i.c.s. switch on and check that the l.e.d.s do not light. Press S2 and check that a rough sounding note is produced. Keep S2 pressed and rotate S1 to obtain all six of the set notes. If everything is correct so far it remains only to inject a signal and see if the lights behave as described. A signal generator can be used as the source to simplify fault finding (if any is required).

If none of the l.e.d.s light there could be a fault in the signal path or IC5. Short circuit

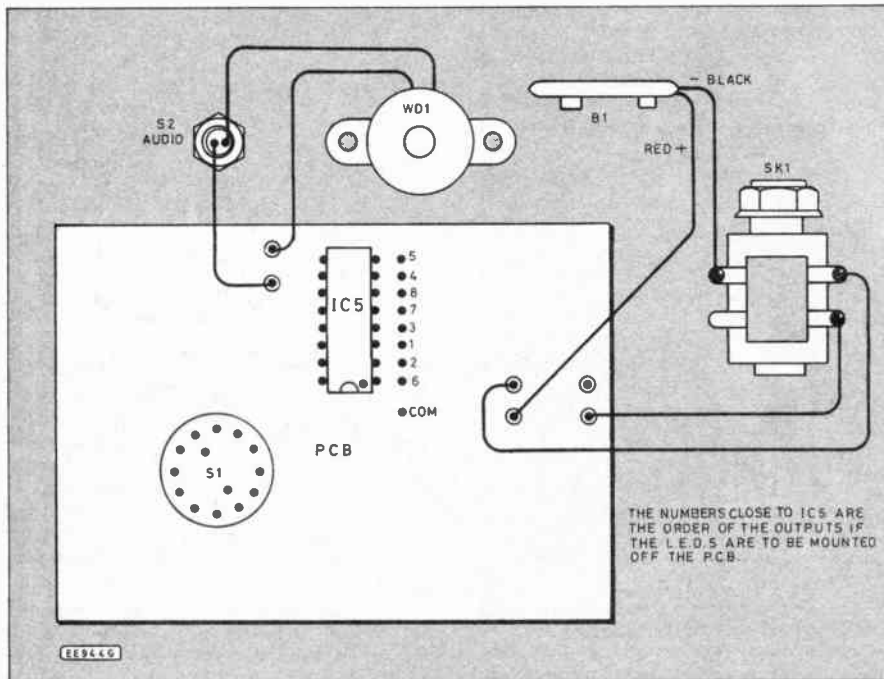
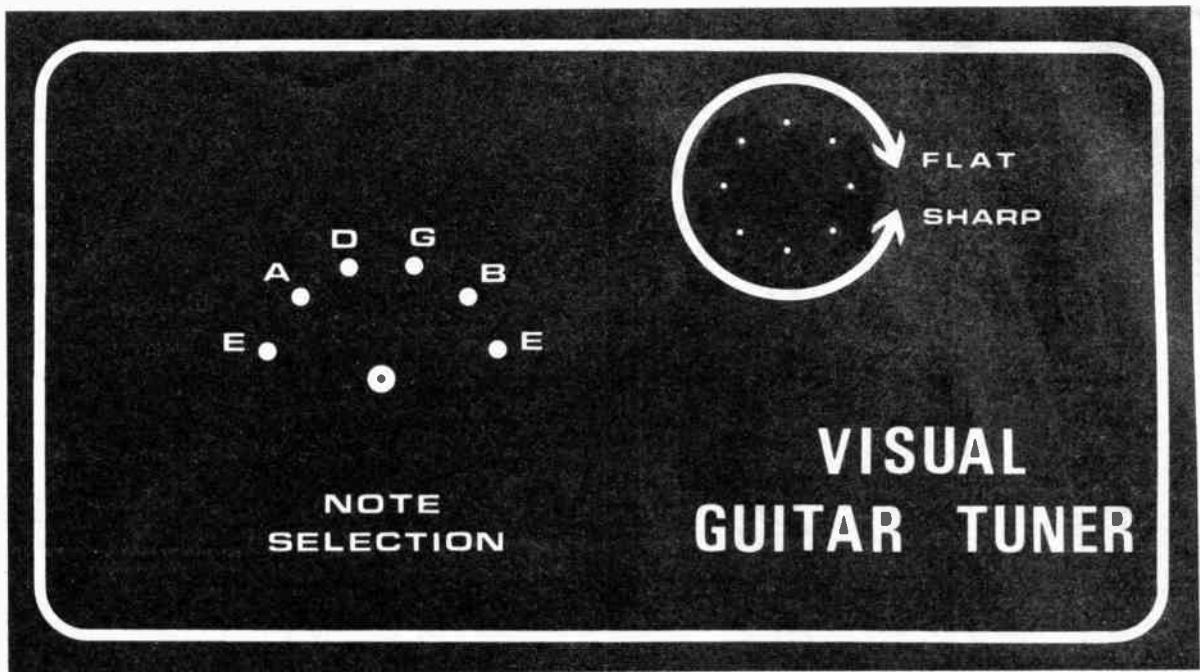
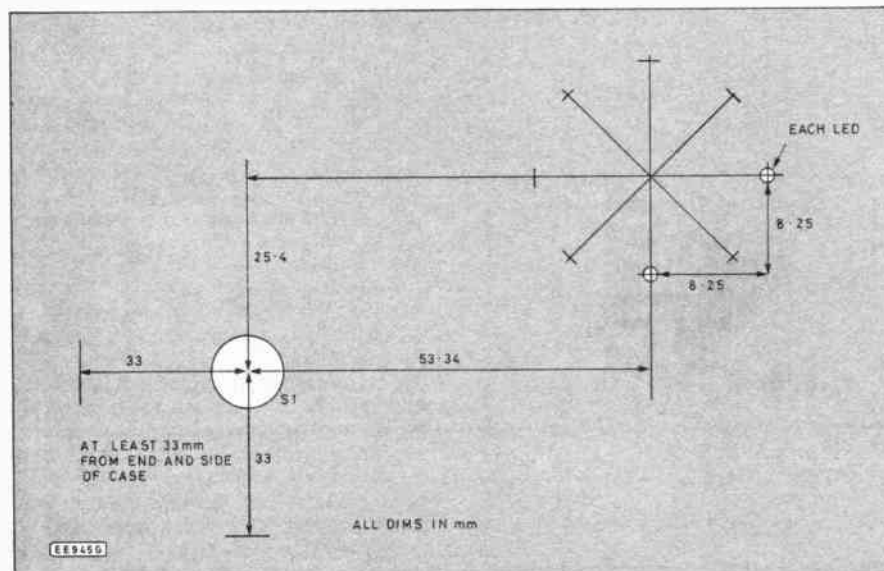

Fig. 5 (above). Full size front panel legend for the tuner. This diagram may be photocopied and fixed on the case to give a neat finish.

Fig. 4 (left). Interwiring details to the off-board components.

Fig. 6 (bottom left). Front panel drilling details for the note selection switch and the display l.e.d.s.



collector-emitter of TR1 and all l.e.d.s will light if IC5 is working and is receiving the correct signals. If only one l.e.d. lights, check that S1a is correctly wired.

If all l.e.d.s light when TR1 is shorted out but refuse to light when a signal is connected it is likely that either IC4 or TR1 is at fault. Check that both are inserted the right way round and that C7 and C5 are also the right way round. If a multimeter is available check that the output of IC4 (pin 6) is at exactly half of the supply voltage.

If these checks are correct but the circuit still refuses to work there could be a fault in the wiring of SK1 or in one of the capacitors C4, C5, C6, and C7 which would prevent the signal from getting through to TR1. As there is very little wiring it is likely that the circuit will work first time. Remember that 99 per cent of faults are due to poor soldering—dry joints, bridges, short-circuits—or incorrectly fitted components. If you cannot see anything wrong, ask a friend to look. It's surprising how easy it is not to see one's own errors!

As the circuit is crystal controlled, temperature stability and accuracy are excellent and no setting up is required at all. Battery drain is about 30mA when operating, most of this being used by IC3 and the l.e.d.s. A PP3 should have a good life provided the jack plug is removed when tuning is complete. A failing battery will be shown by the display getting dimmer but accuracy will not be affected.

The type of display used is a very effective way of comparing two frequencies and probably has a wide range of other applications where a clear simple indication of frequency difference is needed. The author would be delighted to hear of readers' suggestions which could possibly be used as the basis of other projects. □

# DOOR CHIME

A.R. WINSTANLEY



## No gimmicks, low cost "traditional" three-tone chime with decay

MANY designs have been published in the past for electronic door bells which generate a twin-tone chime, and some of them incorporate further circuitry in order to imitate more accurately the "ding dong" of a classical Friedland chime.

Other more elaborate microprocessor-based systems incorporate a custom chip which generates musical tunes, although there is always the danger that the integrated circuits utilised can become obsolete almost overnight, so that if the chip in a particular unit fails, there is no alternative but to scrap the unit altogether.

Electromechanical chimes themselves rely on the action of a solenoid-driven hammer striking a chime bar and then hitting another lower-frequency chime bar upon returning to its original position. The bars are suspended on rubber bushes to aid reverberation and clarity, and this results in a pleasant tone which decays over a period of several seconds.

## TONE GENERATION

It is possible to emulate this effect electronically and it is a simple matter to generate uncomplicated tones over a loud-speaker: the trick however is to modify this by modulating the tones to introduce the reverberation and decay characteristics of a Friedland. This can involve some fairly extensive circuitry.

The Door Chime to be described here utilises a single eight-pin integrated circuit which requires very little additional circuitry indeed to construct a complete chime. It incorporates an integral audio amplifier stage and will drive an eight ohm speaker directly.

The output is a little restricted—something to be expected in such a simple circuit as this—and is claimed to be about 160mW or so. This is obviously not quite as loud as a conventional chime but will prove quite adequate for use in smaller apartments; alternatively it could easily be employed in a larger household if the main Door Chime unit could be mounted within earshot of the occupants.

The Door Chime can actually generate a single, twin or treble chime, depending on which type of integrated circuit the user employs in his model. The author recommends the three-tone chime for its novelty value and pleasing effect.

If the twin or three-tone chime is constructed, the Door Chime will generate each tone successively, each tone overlapping the previous one which then decays away "naturally". After the last tone has died away, the Door Chime switches off automatically. The device operates from a 9V battery, and since the quiescent or "stand-by" current is tiny—less than 1µA—battery life should be exceptional.

Ease of construction is a keynote of this design, which has been kept deliberately simple, and the author recommends this project to beginners who will be able to assemble the Door Chime without any difficulty.

More experienced readers will also find this unit of value since it forms a quickly and economically assembled gift for a friend or relation.

triggering pulses of less than this duration are disregarded by the chip, and this provides some protection against false triggering caused by the switch wiring picking up interference from, for example, mains-borne glitches.

## FREQUENCY SELECTION

The basic frequency of the chimes, together with the overall period for which the chime sequence plays, is determined by an external RC network—the resistance comprises VR1 and R1, and C4 is the timing capacitor. Adjusting VR1 produces effects ranging from a high-pitch tinkle at one extreme, to an effect similar to a grandfather clock striking, at the other!

The three-chime effect itself consists of three tuned frequencies which are switched

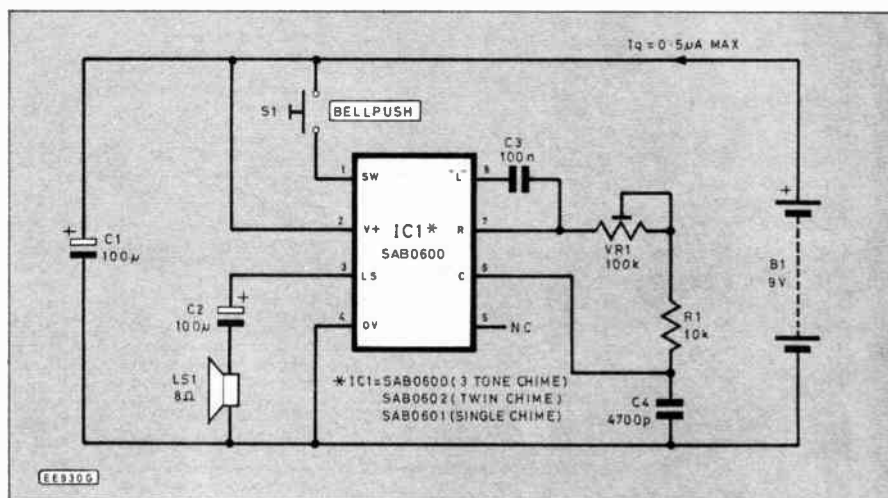

Fig. 1. Complete circuit diagram for the Door Chime. The i.c. used in this circuit is for the three-tone version.

## CIRCUIT DESCRIPTION

The circuit diagram is shown in Fig. 1. It will be seen that the Door Chime is of very simple design. IC1 does all the work and the user should select at the outset which chip he requires to produce the desired effect:

I.C. TYPE	EFFECT
SAB 0600	Three-tone Chime
SAB 0602	Twin-tone Chime
SAB 0601	Single Chime.

Any of the above chips can be employed in the circuit without any modification being necessary.

Switch S1 is the bell-push switch and this is a normally-open push to make switch which, when closed, will activate the chime sequence by connecting pin 1 to the positive rail. Pin 1 includes a 2mS time delay:

successively to a summing point. Three internal digital-to-analogue converters then generate the envelope decay waveforms which attenuate each chime individually so that each tone is heard to diminish in a manner similar to a traditional doorbell.

The single and twin-tone derivatives are all based on the three-tone chip, but with the relevant number of tones being suppressed from the end of the sequence.

The audio output is observed at pin three of IC1 and the chip will drive a speaker directly through a decoupling capacitor C2. When the last tone has decayed, the chip will automatically switch off. The quiescent current is typically less than 1µA. A PP3-type battery is used to power the circuit (B1) and should remain serviceable for at least one year. An alkaline type is preferred for its leakproof properties as well as the extended life that these batteries offer.

## TONE QUALITY

The tone quality itself, together with output volume, will depend not only on the power output of the chip, but also the following major factors:

1. The resonant frequency of the loudspeaker—the larger the speaker, the lower the resonant frequency. Maximum volume is achieved when the speaker is driven at its resonant frequency.
2. The operating frequencies of the chime circuit, as determined by VR1.
3. The resonant characteristics of the enclosure housing the loudspeaker.

A large speaker will improve the tone colour. A small 200mW speaker, for example, produces a "tinny" effect which is not particularly pleasant to listen to, nor is it particularly audible.

In practice, a compromise will have to be attained whereby volume is traded off to a certain extent for a more melodious tone, and this is achieved by setting VR1 to a fairly low resistance—generating higher frequency chimes—and reproducing the tones over a larger speaker than would theoretically be necessary to handle the power. The prototype utilised an eight ohm, one Watt loudspeaker and the resultant effect was quite acceptable.

Finally, C1 decouples the power supply rail and is essential to maintain stability when the i.c. is generating the chimes. Some pretty weird effects may be heard without it! C1 also smoothes out to a certain extent any fluctuations on the power rails which will occur during operation once the battery starts to age.

## CONSTRUCTION

With such a simple circuit as this, the author considered it unnecessary to design a printed circuit board, and so in the interests

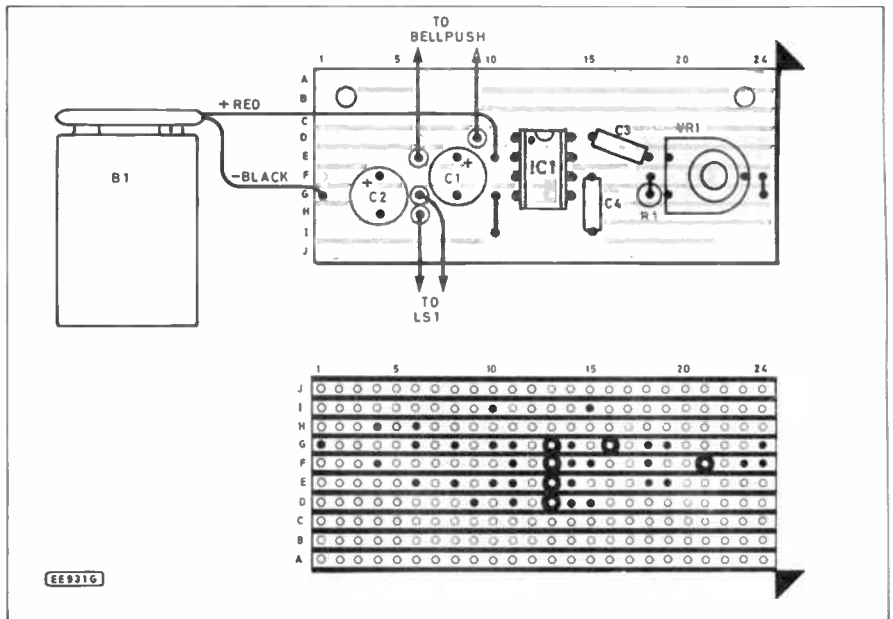

Fig. 2. Circuit board component layout, details of breaks to be made in the underside copper tracks and wiring details to the speaker LS1 and bellpush S1. An i.c. holder should be used to mount IC1 on the board.

of keeping construction simple, the circuit was assembled on a piece of 0.1 inch matrix stripboard size 24 holes x 10 strips—see Fig. 2.

Assembly of the components upon the stripboard is a straight-forward matter and should present no problems. An eight-pin d.i.l. socket is recommended to carry IC1. This will prevent any thermal damage being caused to the chip during the soldering process. It will also permit the constructor to change the chip at a later date for an alternative SAB type—so you can convert to a twin or single chime if desired.

Two holes are necessary in the stripboard at the positions indicated, to accommodate standard circuit-board mounting hardware, e.g. M3 or 6BA nuts, bolts and spacers.

## CASE

Since the completed Door Chime may well be displayed prominently in the home, it is desirable to house the circuit in a cabinet which is aesthetically pleasing. For the prototype an all-plastic Verobox type 65 40767F was employed. This measures 188 x 110 x 60 mm and is moulded in beige and

## COMPONENTS

### Resistor

R1 10k 0.25W carbon 5%

### Potentiometer

VR1 100k lin. min horizontal preset

### Capacitors

C1,2 100µ radial elect. 16V (2 off)

C3 100n polyester layer

C4 4700p polyester layer

### Semiconductors

IC1 SAB0600  
(three tone chime), or  
SAB0602  
(twin tone chime), or  
SAB0601  
(single tone chime)

### Miscellaneous

B1 PP3 alkaline 9V, with battery clip  
S1 single pole push to make bell push  
LS1 8 ohm loudspeaker—see text  
Verobox 65-40767F size 188 x 110 x 60mm;  
0.1inch matrix stripboard, 24 holes x 10 strips; twin-core interconnecting wire to suit; wire; solder; 8 pin d.i.l. socket; circuit board mounting hardware, etc.

See  
**Shop  
Talk**  
page 306

Approx. cost  
Guidance only

**£7 (Plus case)**

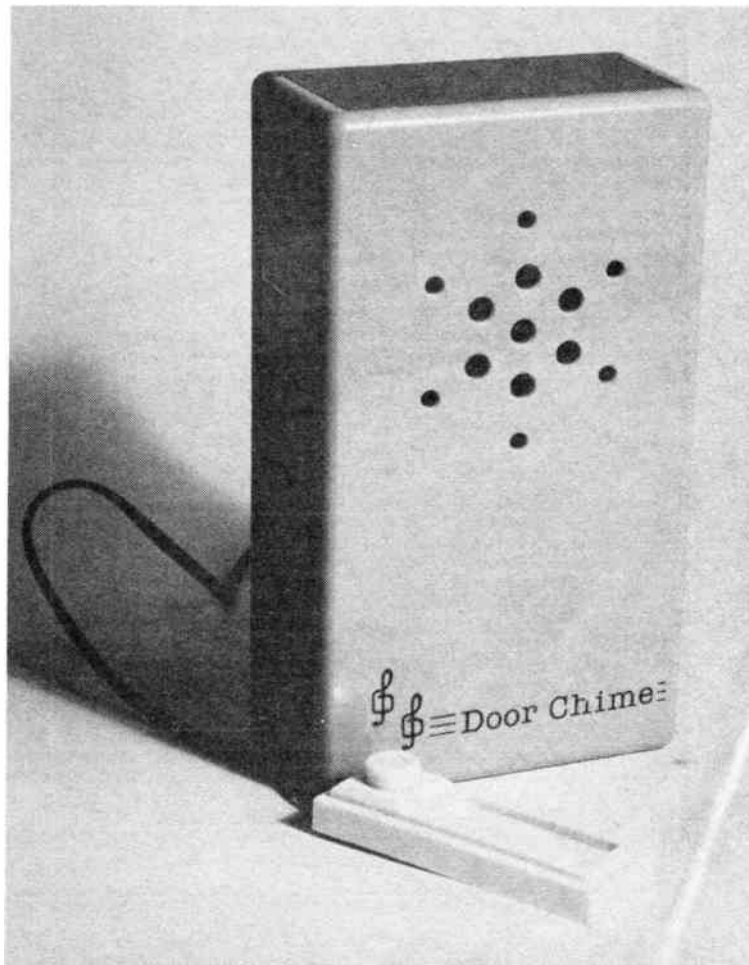

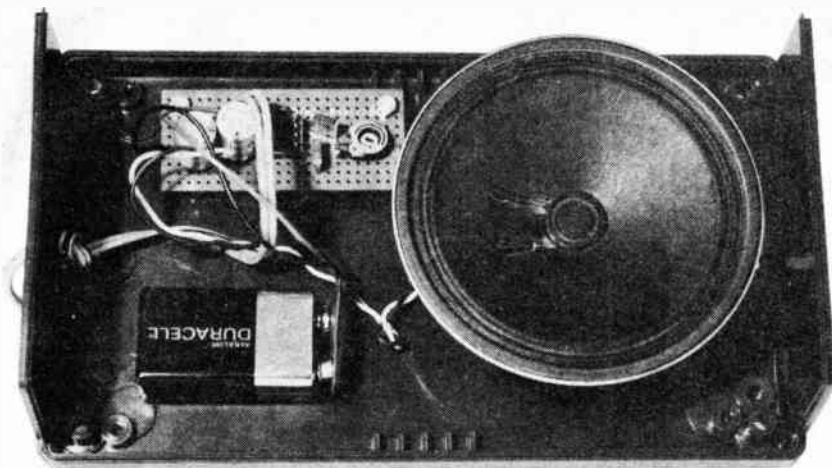

brown plastic. It proves to be the most expensive component in the design, and you could of course use a different type if you wish, or perhaps make your own out of wood. Preferably acquire the loudspeaker first and then select a cabinet of appropriate dimensions to fit it.

The recommended case is prepared in the following manner. The base of the housing has knock-out keyhole slots which can be drilled out to permit the box to be positioned on the wall. Two further countersunk holes are required for the circuit board mounting hardware. Countersinking will prevent damage arising to wallpaper or paintwork.

On the prototype, the loudspeaker was merely glued down by applying a drop of cyanoacrylate adhesive gel ("Superglue Xtra") to the rear of the speaker and then

sticking into position on the base. It should never be dislodged, and apart from simplifying construction, also means that no unsightly loudspeaker mounting screws are visible anywhere.

An alternative means of affixing the speaker is to apply cement around the "gasket" or rim of the speaker and then sticking it to the lid of the case. However experience has shown that eventually the gasket—being made of cardboard—will separate into layers and the loudspeaker will simply fall off.

Obviously a loudspeaker grille is necessary in the removable lid to permit the chimes to be heard. The holes are best effected by careful use of a hand drill. Great care should be exercised when marking out the location of each hole prior to drilling. Afterwards, chamfer each hole to "soften"

the appearance by gently applying a countersinking bit: a couple of revolutions of the hand-held drill are all that are required.

The bell-push switch can be connected by a length of twin core "zip" wire and this passes through a hole in the base of the cabinet and is soldered to the stripboard inside. The wire was approximately five metres long on the prototype and the indications are that a much greater length could be used effectively (but see "Installation").

Finally a battery is clipped onto the battery connection clip and it can then be stuck down inside the case with a small piece of double-sided adhesive foam strip.

With assembly completed, the unit can be tested by operating the bell push to generate the chimes, and VRI can be adjusted to achieve the best effect. The cabinet can then be installed in the home.

## INSTALLATION NOTES

The main unit should naturally be installed in a location where it has most chance of being heard by the occupants of the house, though like most doorbells, the Door Chime may be drowned out by a loud T.V. or hi-fi.

When routing the twin-core wire it is desirable to keep the wires away from any mains cable or apparatus. In spite of the 2mS delay built into the trigger pin of IC1, it has been found that the Door Chime will upon occasion still sound if any adjacent mains equipment is switched on or off. This is especially true if the equipment incorporates a large mains transformer.

There should be no problem if the user steers clear of such equipment when installing the bell-push wiring. □

# OMEGA ELECTRONICS

252A HIGH STREET, HARLES DEN, LONDON NW10 4TD.

TEL: 01-965 5748

MAIL ORDER & RETAIL SHOP

**QUALITY COMPONENTS FROM OMEGA.** This list contains only a FRACTION OF OUR STOCK, which is constantly being updated. Prices quoted are for "one-offs"—quantity discounts by negotiation. Official orders from Schools, Colleges, Govt. Dept etc. welcomed. WE SPECIALISE IN 24 HRS CREDIT CARD PHONE ORDERS. A quick call will check stock position and current prices. Add 75p p&P + 15% VAT to all orders. All in-stock items despatched same day unless notified.

**PRICES SUBJECT TO CHANGE**



**ASK FOR OUR NEW FREE CATALOGUE NO SAE REQUIRED**

CMOS	4055	0.86	4553	2.20	74LS78	0.33	74LS244	0.76
4000	4056	0.62	4555	0.28	74LS83	0.86	74LS245	0.80
4001	4058	0.40	4558	0.40	74LS85	0.71	74LS247	0.90
4002	4063	0.80	4589	0.55	74LS86	0.24	74LS248	0.89
4006	4066	0.22	4584	0.30	74LS90	0.48	74LS249	0.89
4007	4067	1.90	4585	0.40	74LS92	0.56	74LS251	0.70
4008	4068	0.14	40101	1.20	74LS93	0.55	74LS252	0.70
4009	4070	0.14	40102	1.90	74LS107	0.42	74LS256	0.80
4010	4071	0.14	40103	1.90	74LS109	0.42	74LS257	0.70
4011	4072	0.18	40104	1.45	74LS112	0.42	74LS258	0.80
4012	4073	0.14	40105	1.85	74LS113	0.42	74LS249	1.20
4013	4075	0.14	40106	0.60	74LS114	0.42	74LS260	0.70
4014	4076	0.39	40107	0.49	74LS122	0.85	74LS268	0.80
4015	4077	0.28	40108	2.25	74LS123	0.80	74LS273	1.20
4016	4078	0.18	40109	0.75	74LS125	0.48	74LS278	0.90
4017	4081	0.14	40110	1.85	74LS132	0.52	74LS280	1.80
4018	4082	0.14			74LS138	0.45	74LS282	0.59
4019	4085	0.25			74LS139	0.50	74LS293	0.69
4020	4089	1.00			74LS138	0.50	74LS365	0.75
4021	4093	0.18	74LS500	0.24	74LS145	0.95	74LS366	0.75
4022	4094	0.60	74LS501	0.24	74LS148	1.36	74LS367	0.50
4023	4095	0.85	74LS502	0.24	74LS151	0.85	74LS368	0.75
4024	4096	0.85	74LS503	0.24	74LS153	0.85	74LS373	0.90
4025	4098	0.58	74LS504	0.24	74LS155	1.00	74LS374	0.90
4026	4099	0.39	74LS505	0.24	74LS156	0.52		
4027	4502	0.62	74LS506	0.24	74LS157	0.52		
4028	4503	0.45	74LS508	0.24	74LS158	0.52		
4029	4508	0.68	74LS509	0.24	74LS180	0.70		
4030	4510	0.37	74LS510	0.24	74LS181	0.70		
4031	4511	0.46	74LS511	0.24	74LS182	0.70		
4032	4512	0.59	74LS512	0.24	74LS183	0.70		
4033	4514	0.58	74LS515	0.24	74LS184	0.70		
4034	4515	0.88	74LS516	0.24	74LS185	0.70		
4035	4516	0.38	74LS520	0.24	74LS186	0.75		
4036	4517	1.35	74LS521	0.24	74LS188	0.75		
4037	4518	0.38	74LS522	0.24	74LS174	0.90		
4038	4520	0.38	74LS526	0.24	74LS175	0.70		
4039	4521	0.38	74LS27	0.24	74LS181	0.70		
4040	4522	0.80	74LS30	0.24	74LS182	0.70		
4041	4523	0.38	74LS32	0.24	74LS183	0.82		
4042	4524	0.68	74LS33	0.24	74LS184	0.70		
4043	4525	0.38	74LS37	0.24	74LS185	0.70		
4044	4527	0.68	74LS42	0.48	74LS186	0.70		
4045	4528	0.38	74LS47	0.82	74LS189	0.70		
4046	4529	1.35	74LS48	0.82	74LS192	1.00		
4047	4530	0.50	74LS51	0.24	74LS196	0.70		
4048	4532	0.38	74LS54	0.24	74LS197	1.00		
4049	4533	3.48	74LS55	0.24	74LS221	0.90		
4050	4534	3.39	74LS57	0.38	74LS240	0.80		
4051	4536	0.46	74LS74	0.41	74LS241	0.80		
4052	4538	0.55	74LS75	0.44	74LS242	0.82		
4053	4543	0.46			74LS243	0.82		

CA3130E	0.76	LM741	0.20	IC27107	0.25	LM3902N	1.15	7805 +5V	0.40	BC237	0.12
CA3140E	0.40	LM747C	1.10	IC27811	0.90	LM3907N	1.74	7800 +8V	0.40	BC238	0.12
CA3141E	1.12	LM747C	1.10	ICM7555	0.70	LM3907N	3.50	7812 +12V	0.40	BC239	0.12
CA3180E	1.74	LM747C	1.10	ICM7558	1.60	LM3907N	3.50	7818 +18V	0.45	BC327	0.15
CA3181E	2.25	LM747C	1.10	LF347	1.80	LM3907N	3.50	7824 +24V	0.50	BC328	0.15
CA3182E	7.70	LM747C	1.10	LF351	1.70	LM3907N	3.50	7905 -5V	0.45	BC337	0.15
CA3189	2.60	LM747C	1.10	LF355	1.70	LM3907N	3.50	7908 -8V	0.45	BC338	0.15
CA3240E	1.39	LM747C	1.10	LF368N	5.81	LM3907N	3.50	7912 -12V	0.45	BC339	0.15
ICL7108	7.09	LM747C	1.10	LM100CH	8.88	LM3907N	3.50	7915 -15V	0.45	BC347A	0.12
ICL7107	0.25	LM747C	1.10	LM110CH	10.50	LM3907N	3.50	7924 -24V	0.45	BC347E	0.12
CA3181E	2.25	LM747C	1.10	LM35CH	7.20	LM3907N	3.50	7950 -5V	0.45	BC347E	0.12
CA3189	2.60	LM747C	1.10	LM35CH	7.20	LM3907N	3.50	7958 -8V	0.45	BC347E	0.12
CA3240E	1.39	LM747C	1.10	LM35CH	7.20	LM3907N	3.50	7958 -8V	0.45	BC347E	0.12
ICL7108	7.09	LM747C	1.10	LM35CH	7.20	LM3907N	3.50	7958 -8V	0.45	BC347E	0.12
ICL7107	0.25	LM747C	1.10	LM35CH	7.20	LM3907N	3.50	7958 -8V	0.45	BC347E	0.12
CA3181E	2.25	LM747C	1.10	LM35CH	7.20	LM3907N	3.50	7958 -8V	0.45	BC347E	0.12
CA3189	2.60	LM747C	1.10	LM35CH	7.20	LM3907N	3.50	7958 -8V	0.45	BC347E	0.12
CA3240E	1.39	LM747C	1.10	LM35CH	7.20	LM3907N	3.50	7958 -8V	0.45	BC347E	0.12
ICL7108	7.09	LM747C	1.10	LM35CH	7.20	LM3907N	3.50	7958 -8V	0.45	BC347E	0.12
ICL7107	0.25	LM747C	1.10	LM35CH	7.20	LM3907N	3.50	7958 -8V	0.45	BC347E	0.12
CA3181E	2.25	LM747C	1.10	LM35CH	7.20	LM3907N	3.50	7958 -8V	0.45	BC347E	0.12
CA3189	2.60	LM747C	1.10	LM35CH	7.20	LM3907N	3.50	7958 -8V	0.45	BC347E	0.12
CA3240E	1.39	LM747C	1.10	LM35CH	7.20	LM3907N	3.50	7958 -8V	0.45	BC347E	0.12
ICL7108	7.09	LM747C	1.10	LM35CH	7.20	LM3907N	3.50	7958 -8V	0.45	BC347E	0.12
ICL7107	0.25	LM747C	1.10	LM35CH	7.20	LM3907N	3.50	7958 -8V	0.45	BC347E	0.12
CA3181E	2.25	LM747C	1.10	LM35CH	7.20	LM3907N	3.50	7958 -8V	0.45	BC347E	0.12
CA3189	2.60	LM747C	1.10	LM35CH	7.20	LM3907N	3.50	7958 -8V	0.45	BC347E	0.12
CA3240E	1.39	LM747C	1.10	LM35CH	7.20	LM3907N	3.50	7958 -8V	0.45	BC347E	0.12
ICL7108	7.09	LM747C	1.10	LM35CH	7.20	LM3907N	3.50	7958 -8V	0.45	BC347E	0.12
ICL7107	0.25	LM747C	1.10	LM35CH	7.20	LM3907N	3.50	7958 -8V	0.45	BC347E	0.12
CA3181E	2.25	LM747C	1.10	LM35CH	7.20	LM3907N	3.50	7958 -8V	0.45	BC347E	0.12
CA3189	2.60	LM747C	1.10	LM35CH	7.20	LM3907N	3.50	7958 -8V	0.45	BC347E	0.12
CA3240E	1.39	LM747C	1.10	LM35CH	7.20	LM3907N	3.50	7958 -8V	0.45	BC347E	0.12
ICL7108	7.09	LM747C	1.10	LM35CH	7.20	LM3907N	3.50	7958 -8V	0.45	BC347E	0.12
ICL7107	0.25	LM747C	1.10	LM35CH	7.20	LM3907N	3.50	7958 -8V	0.45	BC347E	0.12
CA3181E	2.25	LM747C	1.10	LM35CH	7.20	LM3907N	3.50	7958 -8V	0.45	BC347E	0.12
CA3189	2.60	LM747C	1.10	LM35CH	7.20	LM3907N	3.50	7958 -8V	0.45	BC347E	0.12
CA3240E	1.39	LM747C	1.10	LM35CH	7.20	LM3907N	3.50	7958 -8V	0.45	BC347E	0.12
ICL7108	7.09	LM747C	1.10	LM35CH	7.20	LM3907N	3.50	7958 -8V	0.45	BC347E	0.12
ICL7107	0.25	LM747C	1.10	LM35CH	7.20	LM3907N	3.50	7958 -8V	0.45	BC347E	0.12
CA3181E	2.25	LM747C	1.10	LM35CH	7.20	LM3907N	3.50	7958 -8V	0.45	BC347E	0.12
CA3189	2.60	LM747C	1.10	LM35CH							



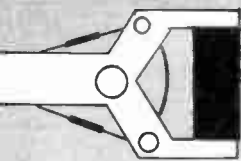

# Robot Roundup

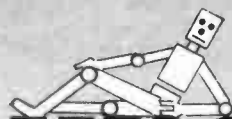

NIGEL CLARK

## ON THE QT

A few years ago when people began to realise that there was a market for small robot arms, particularly in education and training, one of the first machines to appear in Britain was the Armdroid I. It was a conventional articulated arm with five axes plus a gripper driven by stepper motors. Transmission was provided by nylon cords and it cost about £500.

With a reach of 430mm and an accuracy of  $\pm 4$ mm it could lift 300gm. It could be interfaced with most of the popular micros of the time and operated either direct from the keyboard or could be given a series of moves by moving it from point to point and then, having remembered each point in the sequence, it would retrace its steps when ordered.

It was bought by schools and colleges throughout the country and proved popular despite a tendency for the nylon cords to slip on the pulleys, making long-term repeatability difficult.

Other arms, both cheaper and more efficient entered the market but the Armdroid continued until last year when Colne Robotics, its maker, went into voluntary liquidation, hit by a variety of problems. The major factor being blamed was financial difficulties experienced by its US agent.

Now a new company has bought the assets of Colne and, trading as Qti Colne Robotics from Merthyr Tydfil, is continuing all the old Colne lines. As well as Armdroid I there will be Armdroid II, the long-awaited upgrade which was being worked on when the company closed.

The new model is said to be more robust and stronger than the original with stronger stepper motors, a toothed-belt drive and optical encoders to provide a more accurate check on movement than is possible with steppers alone. The lifting capacity is increased to 400gm and the accuracy is greatly improved and is now claimed to  $\pm 1$ mm. It is being priced at about £700.

The new owners are also trying to build on the foundations laid down by Colne. Chris Magee, managing director of Qti, said that he did not think sales of the arms would match previous levels. The section of the market which they serve had been well covered but he expected steady sales.

## LOOKING AHEAD

As well as upgrading Armdroid, on which some work was still needed when Qti took over, Magee said he was looking to change the concept of robotic software. In the past the software had been seen as subordinate to the robot and was developed to allow people to learn about the machine. The software to be provided with the Armdroids would help people learn about programming as well as find

out what the software was doing; this would enable the users to write their own control programs.

However, at the moment the company's main attention is being focussed on the Colvis Vision System. This had been sold for some time by Colne and was one of the few vision systems for which software had been developed to allow it to be used with an arm. The Armdroid, with a small camera attached, was often to be seen at exhibitions sorting different shapes on a turntable.

Although costing more than the inexpensive Snap system, developed by Microbotic Systems, Colvis has still proved popular. Magee now plans to increase the resolution from  $32 \times 32$  to  $256 \times 256$  and increase the power of the processor by switching from the original Z80 to the 68000 series. "That should make it accurate enough for industrial uses," he said.

But it will still be possible to use the Colvis system in conjunction with the Armdroid. Qti is pressing ahead with plans made by Colne to link the two in a special package with a software system called Coordinator 32. For about £1,300 the company is supplying the vision system plus software which can control two Armdroids acting in synchronisation. For an extra £400 an Armdroid will be included.

The Coordinator has 32K of control software on EPROM and another 24K on RAM allowing the storage of up to 2,255 steps for pick and place operations.

## CONNECT

Another new name has entered the robot arm market. Shesto Tech is marketing the Connect RL1 arm, developed by Richmond Logic which has taken on some former Colne Robotics employees. Based loosely on the Armdroid it has five axes plus a three-fingered gripper as standard with the option of a two-fingered gripper. Powered by stepper motors on an open loop, transmission is by a belt drive.

Interfaces are available for the BBC, IBM PC, Amstrad and Apple

*Marketing of the Armdroid I articulated arm, with five axes plus a gripper driven by stepper motors, is now being undertaken by Qti Colne Robotics of Merthyr Tydfil.*

8-bit machines. The software allows the input of sequences from the keyboard, which will then be repeated at differing speeds, or the development of a sequence off-line using cartesian coordinates to define points in the sequence.

Maximum reach is 380mm and it can lift up to 5ozs. The base can move through 360 degrees, the shoulder through 270 degrees, elbow 180 degrees, the wrist has continuous rotation with a pitch of 180 degrees. It is priced at £575 plus VAT.

Richmond is also working on a bigger version driven by d.c. motors to be ready later in the year and priced provisionally at £1,400.

## NO REPLACEMENT

One of the few Japanese companies to produce a small arm was Mitsubishi with its bottom of the range RM101. The company however has ceased production of this 5-axis stepper-motor driven machine, which has led to E & L Instruments of Wrexham leaving the arm market.

E & L had included the machine as part of an educational package with a detailed manual and control provided by the company's Fox micro. Reg Jones, UK sales and marketing manager said at the moment the company was not actively seeking a replacement. They were concentrating on their other products but might return if an upturn in demand was seen, however Jones added that there were already a lot of suppliers involved in selling arms.

It is thought that an American company had taken over the rights to make the RM101. The other Mitsubishi arm, the RM501, which is more robust and suitable for small industrial uses, is still being made.

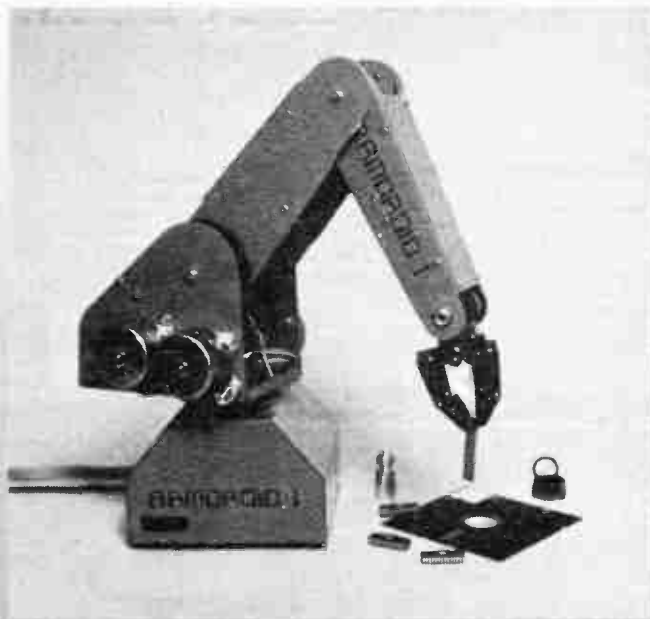

# REGENERATIVE RADIOS Part 1

JOE PRITCHARD (GIUQW)

"WHEN I were a lad . . ." (well, about 12 years ago actually), I was very interested in simple radio sets. I built a simple crystal set which tuned the 49, 41 and 31 metre broadcast bands on short wave with a decent aerial and earth. This led onto other homebrew sets, culminating in a two transistor regenerative receiver for the 80m amateur band, based on a design published in a 1973 edition *Everyday Electronics*. The original was for medium waves, but I found that excellent results on short wave could also be obtained, and I soon logged my first US amateurs.

Well, that's how I got interested in the regenerative receiver, a set that's just about the oldest of all the useful amateur designs, but which is still effective today and is cheap to build. In these two articles I'll explore the theory and practice of regenerative radio sets, their operation, some practical ideas, and the results you can expect to get.

## WHAT IS A REGENERATIVE RECEIVER?

The simplest of all radio sets is a crystal set; Fig. 1 shows a simple short wave set that you might like to try out. The crystal set allows us to take in stations and hear them with no battery or power supply. All the energy needed comes from the received radio waves. For this reason a good aerial—the larger and higher the better—and an earth—usually a metal object buried in the ground—are normally necessary. Don't use the mains earth. This won't give such good results and could be dangerous.

Fig. 1 The crystal set.

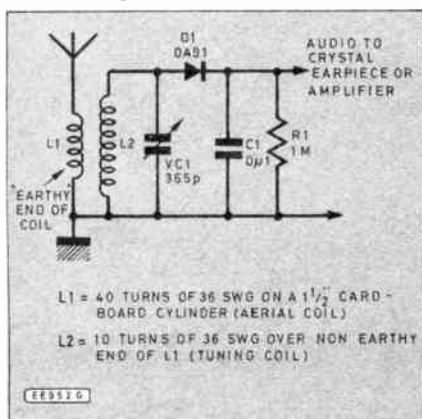

L1 is the aerial coil—this induces a voltage in L2, the tuning coil, and voltages of a single frequency, that tuned by L2 and VC1, a variable capacitor, are passed on to the diode, D1. This extracts the sound signals being carried on the radio waves tuned in by VC1 and L2, and the earphone or amplifier allows the sounds to be heard. C1 provides a bypass for any radio frequency signals that may have got this far, and R1 provides a discharge path for C1 when a crystal earphone is used. If this were omitted then it's possible that audio quality would suffer.

## PROBLEMS

After that whistle-stop tour of the crystal set, why isn't it more commonly used? Well, build one and see! Seriously though, it has a number of shortcomings:

1. Low volume sound output—no audio amplifier.
2. Needs large aerial and good earth.
3. Can only give good results with strong signals.
4. Often you hear two or more stations at once.

Problem 2 is due to the lack of amplification of the radio signals before the audio is extracted by diode D1. D1 acts as a detector and requires that a fairly strong signal be presented to it before the audio can be detected. The response of any radio set to weak signals is called its sensitivity. A set with good sensitivity will receive and make audible very faint signals. The crystal set has poor sensitivity.

Problem 4 is a more serious one;

even when we can hear the strong signals, we may be able to hear two or more at once! The set needs to be able to pick out or select one signal at a time for detection. The selectivity of a radio is a measure of this ability, and our crystal set has very poor selectivity. (Fig. 2).

So, what can we do to get around these problems? The solution is in replacing the simple diode detector with an amplifier which will also detect the audio signal. This would clearly solve our sensitivity problem by amplifying the incoming signals.

Fig. 3 shows a simple amplifier and its effect on an incoming radio wave. The signal is made bigger, but its *phase* is reversed. That is, the signal is turned "upside down" by the single stage f.e.t. amplifier. This phase reversal is a common side effect in single stage amplifiers.

## POSITIVE FEEDBACK

If we want the most efficiency from just a single stage of amplification, then we can use a technique called *positive feedback* to take a small portion of the output signal and apply it again to the input of the amplifier. The signal is thus amplified again. For this to work, though, the signal fed back to the input must be the same phase as the input; taking a fraction of the out-of-phase output at B and re-applying it at A would actually cancel out the input, thus reducing gain and sensitivity! However, if we have a circuit that will

Fig. 2 Crystal set selectivity.

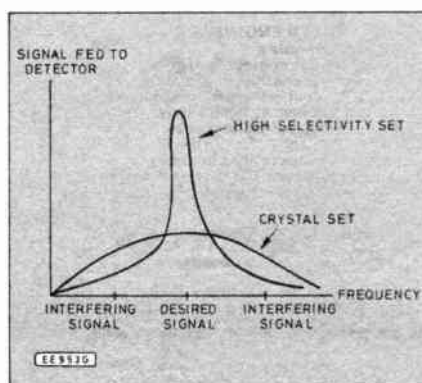
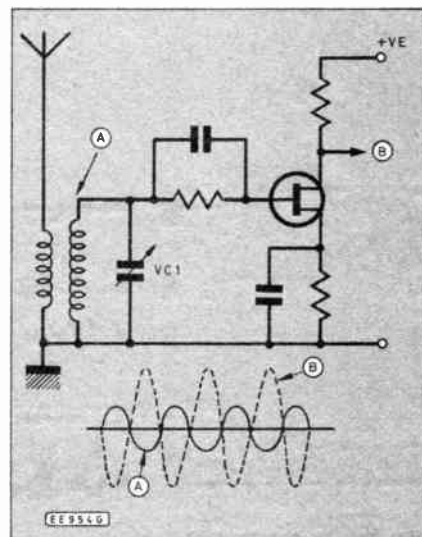

Fig. 3 An amplifier added to a simple receiver.



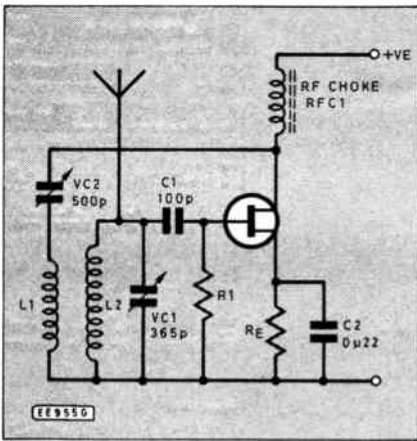

Fig. 4. Simple regenerative receiver.

make the phase of the output like that of the input, the feedback will be effective. Fig. 4 shows such a circuit, with VC2 acting as a control to limit the amount of positive feedback.

Resistor R1, RFC1 and RE set up the load and bias condition of the f.e.t. L1 does the phase change, and the currents flowing in these induce voltages in L2 which are in phase with the radio signals picked up by the aerial. Thus the gain is increased. If too much positive feedback is applied, then the circuit turns into an oscillator, creating r.f. signals at the frequency set by VC1 and L2.

In order for the signals fed back by VC2/L1 to be in phase with those in L2, coil L1 must be connected the "right way around". One way will not give positive feedback, thus dropping the gain of the amplifier. In practice, if one way of connecting up the feedback coil doesn't give positive feedback, simply try the coil the other way round.

## REGENERATIVE

This *regenerative amplifier* gives maximum gain when the positive feedback is at a point just below the level needed to sustain oscillation. This is different for each frequency selected by L2/VC1, hence the use of VC2 to adjust the amount of feedback. You'll probably have realised by now that Fig. 4 is a very simple, almost "classical" regenerative receiver. VC1 is a tuning control and VC2 is the regeneration control, setting the gain of the receiver.

Detection is carried out by virtue of the fact that one half cycle of the input is amplified more than the other half by the amplifier. This is basically distortion of the signal, but it serves the purpose of producing an audio signal.

What about the selectivity? Well, poor selectivity is often due to signal losses in L2/VC1. Positive feedback makes up these losses, and this causes the selectivity to increase. The selectivity is highest at a point just below that at which oscillation starts. If positive feedback exceeds this the selectivity will decrease.

And there we have it! The regenerative receiver shown in Fig. 4 is just about as simple as you can get. The main requirements are thus:

1. A tuned circuit.
2. An amplifier.
3. A means of achieving positive feedback.
4. An audio amplifier.
5. An aerial and earth.

For the rest of these two articles I will adopt the following design principles. Items 1, 2 and 3 are found in r.f. oscillator circuits, so I have designed a couple of regenerative receivers by selecting an r.f. oscillator circuit and then reduced its positive feedback to give a regenerative amplifier. This is the "other way around" to the description just given, but it gets the same results. In addition, it's often easier to "calm down" an r.f. oscillator than it is to "beef up" an r.f. amplifier to the point of oscillation.

Fig. 5. Various regenerative receivers.

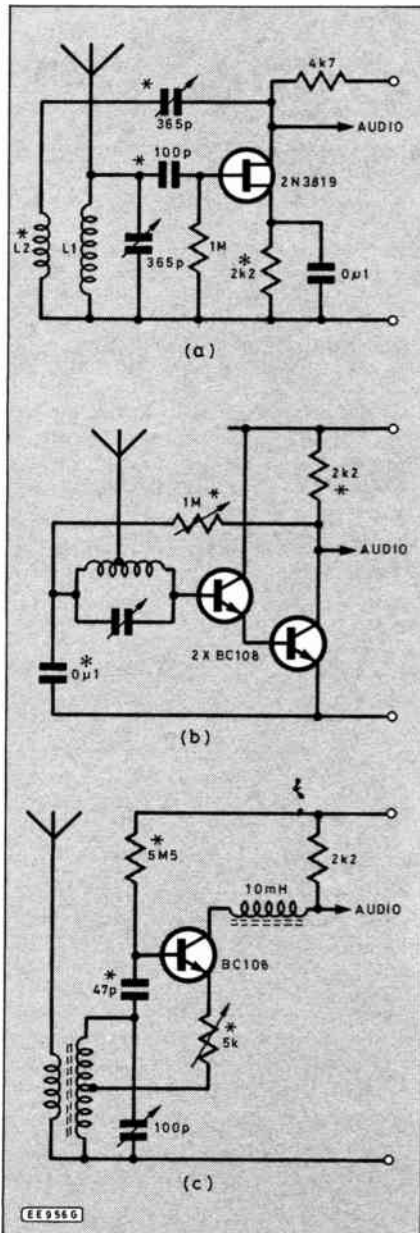

## RF CIRCUITS

The RF stage of these simple sets will be a "calmed down" r.f. oscillator. Some circuits are better than others in this respect, and you may need to experiment to get the best results. However, I've used sets based on the r.f. oscillators shown in Fig. 5. The components used to control positive feedback are shown marked with a \* In each case, selection of the "\*" parts will have an impact on the performance of the set. You may have to experiment for best results. The coil/capacitor combination is selected to tune the frequency of interest and you may find that a circuit will work well on some frequencies but not others.

Fig. 5a uses a variable capacitor to control feedback. The others use a variable resistor. The circuits with variable resistors will give as good results and are cheaper, but often need more care in use. In each case, the amount of positive feedback applied is limited, either directly or by limiting the gain of the amplifier. Alternative designs apply sufficient positive feedback to get the circuit into oscillation then apply a small amount of negative feedback to reduce the gain until oscillation no longer occurs.

## AUDIO AMPLIFICATION

The audio output provided is usually small, so some sort of amplification is desirable. However, it's also necessary to get rid of any remaining r.f. that might get to the audio amplifier. If this were to happen, the audio amplifier might easily oscillate at r.f., thus generating signals that could interfere with those being received. The cause of this is that many devices used in audio circuits will also work at radio frequencies as well. This isn't very desirable, so we usually include an r.f. filter to short any r.f. signals to earth and prevent them getting to the amplifier. A couple of simple filters are shown in Fig. 6.

The final stage of any regenerative receiver is the audio amplifier stage, usually capable of providing adequate output to headphones. Loudspeakers

Fig. 6. Two simple r.f. filters.

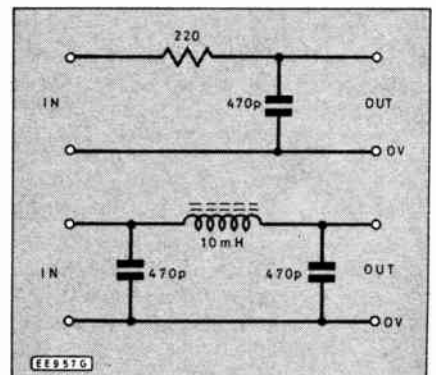

aren't a good idea; some of the squawks and whistles produced by regenerative receivers could tend to strain family relationships if audible to all! Fig. 7a shows a small audio amplifier using the popular LM380 integrated circuit. Alternatively, a simple two transistor amplifier, as shown in Figure 7b, could be used. Both provide output to an 8 ohm pair of headphones.

Well, that completes the outline of the theory of regenerative receivers and the circuit "building bricks" out of which they're made. Next month, I'll give you a couple of practical circuits to experiment with, and explore how to use these sets to get the best results.

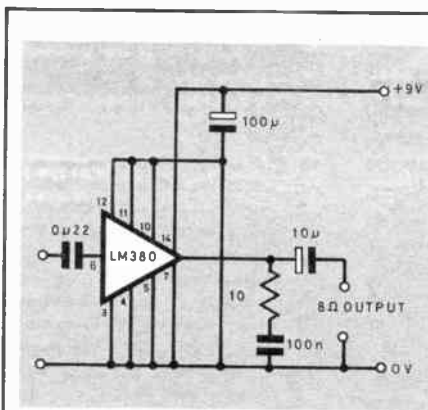

Fig. 7a. Integrated circuit amplifier.

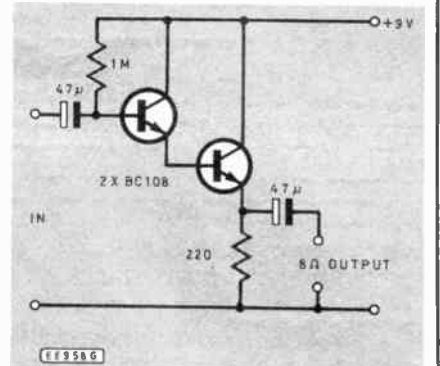

Fig. 7b. Two transistor amplifier.

# SHOP TALK



BY DAVID BARRINGTON

## Whoof Whoof!

If you do not have or are unable to take advantage of a local "neighbourhood watch" group, the problem of safe guarding your home from unwanted intruders is always an added worry when you want to take your annual holidays. If you have a pet/guard dog it usually travels with you or is boarded out during this period, leaving the home unattended.

A novel approach to this problem from **TK Electronics** would appear to offer an ideal solution to this problem. With the holiday season approaching, they have produced an "Electronic Dog" kit, whose bark is definitely worse than its bite!

The "dog" may be connected to a doorbell, pressure mat or to any other intruder device, such as an infra-red beam alarm. The only food required is an 18V d.c. or 12V a.c. supply, which it consumes at only 4mA, when not barking!

A re-entrant loudspeaker is provided, which, it is claimed, is essential to generate the loud barks required to deter the intruder. The "guard dog" can be adjusted to give a random sequence of barks and can be "tuned" to mimic a range of voices from a terrier to an alsatian.

The kit comes complete with p.c.b., mains transformer and full instructions, and costs £21.95 plus VAT. For details, contact **TK Electronics, Dept EE, 13 Boston Road, London W7 3SJ**.

Next month: We hope to offer the first "litter" of *Electronic Dogs* to readers of *EE* at a special price!

## Enterprise

Last month we advised readers of the "bargain price" offered by Greenweld Electronics for the Enterprise 64 home computer. We must report that within the first few days of publication of *EE*, the entire stock of complete Enterprises had been sold.

## CONSTRUCTIONAL PROJECTS

### Visual Guitar/Instrument Tuner

Most of the parts required for the *Visual Guitar/Instrument Tuner* appear to be standard components and should be available from most component suppliers. However, for those readers who experience difficulties, a complete kit (£21.99, including p.c.b.) is available from **Magenta Electronics, Dept EE, 135 Hunter Street, Burton on Trent, Staffs DE14 2ST**. Add £1 for p&p per order.

The printed circuit board is obtainable through the *EE PCB Service*—see page 340.

When ordering components, it is important to specify the standard BC184 for transistor TR1 and not the BC184L. The leadouts for the L are different (centre lead being collector) and can cause confusion.

### RS232C Breakout Box

The chassis mounting 25-way D-sockets called for in the *RS232C Breakout Box* "comp list" are now fairly common items and should not cause local sourcing problems. The sloping front instrument case was purchased from *Electromail*, stock code 509-276 (£11.25). However, it is not essential to use the same case as the prototype model and any case that will accommodate the circuit board and "patching" matrix will suffice.

As a total of 62 1mm chassis mounting sockets are required for this project, it might be worth while asking for a "bulk" discount. Alternatively, one of our "bargain packs" advertisers, such as **Bi-Pak** or **MJR Wholesale**, should be willing to help.

The only source we have been able to locate for the insulated 0.4in p.c.b. jumper plugs is from *Electromail*. These are available in packs of ten, with red and black mouldings, and are listed under p.c.b.

selector plugs, stock codes: red—435 428 and black—435 412.

### EE Apex Hi Fi Amplifier

If readers are to obtain the very high performance expected from the *EE Apex Hi Fi Amplifier* then we strongly advise constructors to adhere to the components specified.

A complete kit of parts, including printed circuit boards, for the "standard" or "enhanced" version may be purchased from **Audiokits Precision Components**. Also, separate individual circuit stage kits, to enable the constructor to spread the costs over several months, are available. The p.c.b.s. are also available separately.

For a complete listing and prices write to **Audiokits Precision Components, Dept EE, 6 Mill Close, Borrowash, Derby DE7 3GU**.

### Mini Disco Light

We have only been able to find two suppliers who list the specified triac opto-isolator used in the *Mini Disco Light*. The MOC3020 device is currently listed by **TK Electronics and Electromail**.

The input current to trigger the triac is a typical 15mA and a maximum 30mA. The triac output is capable of switching 240V a.c. supplies. As these characteristics appear to be fairly standard, most component suppliers should be able to supply an equivalent device.

It is most important to use 3A three-core mains wire when specified. Please remember that since mains voltages exist inside the case, extreme care must be taken whenever it becomes necessary to inspect the circuit for faults. If possible, always unplug from the mains when testing the unit.

### Door Chime

The specified instrument case for the *Door Chime* is available from **Verspeed**, code 65-40767F (£6.41). The beige/brown type made a change to the usual standard grey Verobox.

The choice of "chime" is left to the constructor and is governed by the chip used. The only sources for the three-note chime i.e., type SAB0600, we have been able to locate are **TK Electronics** and **Electrovalve**.

We cannot foresee any component buying problems for the *Simple Touch Switch*—*Exploring Electronics* project. Several of our advertisers are prepared to make up complete kits of parts.

# JULY FEATURES

## E.E. Buccaneer INDUCTION BALANCE METAL DETECTOR

An excellent but relatively simple induction balance type of metal detector, designed to give good sensitivity combined with ease of construction and the ability to reject iron.

## FERMOSTAT



A simple unit for controlling the temperature of fermenting wine. The Fermostat can also be used to control virtually any form of mains heating, holding the temperature constant.

## MONOMIX

A simple four channel monophonic mixer designed primarily with the video enthusiast in mind. One input is for a microphone and the other three are line level inputs for sources such as cassette decks, tuners, etc.

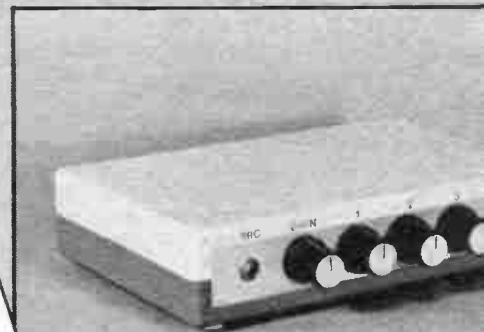

## MIDI THRU BOX

MIDI means Musical Instrument Digital Interface. MIDI THRU is a buffered duplication of the MIDI IN signal. Unfortunately, many manufacturers do not include this socket. However, at its best it cannot match a MIDI THRU box, which allows any of the devices to be used as the Master and provides several MIDI THRU outputs.

# EVERYDAY ELECTRONICS

OUR JULY ISSUE IS ON SALE ON FRIDAY JUNE 19.

# ...Beeb...Beeb...Beeb...Beeb

## ...RPM and Frequency Meter...

IN THE previous article the subjects of event timing and frequency counting using the BBC Micro were covered, but the frequency meter circuit was rather crude in that it would only operate with signals at logic levels, and it provided a maximum input frequency of 65.535kHz. Both these limitations can be overcome by adding suitable input circuits, with no modifications being required to the basic gating circuit described last month. In this article we will conclude our look at use of the timer counters with some input circuits for the digital frequency meter unit that enable it to be used as an audio frequency measurement, radio frequency measurement, or as a revolutions per minute (r.p.m.) meter.

### Audio Use

For audio frequency applications the basic 0 to 65.535kHz range of the frequency meter should be perfectly adequate, as should the 1Hz resolution. Its shortcoming in this application is that most audio sources will not reliably drive the unit. Even those signals that do provide a high enough drive level may not have sufficiently short rise and fall times to give reliable operation, and there is a danger of high level signals actually damaging at least the input device. Thus, really all that is required is some signal conditioning circuitry ahead of the main frequency meter circuit.

A suitable circuit appears in Fig. 1, and this consists basically of an input protection circuit, a high input impedance buffer stage, a voltage amplifier, and a Schmitt trigger. The input impedance is just under one megohm and an input level of only about four millivolts r.m.s. is required to drive the circuit properly.

Resistor R1, D1, and D2 provide a simple clipping action that limits the input signal to about 1.3V peak to peak and prevents high signal levels from damaging any subsequent circuitry. Of course, there is a limit to the input level that can be applied to the unit without damaging the protection circuit, but this should be over 100V peak to peak, and very much higher than the signal level from any likely audio signal source.

IC1 acts as the buffer stage, and this is a simple operational amplifier voltage follower circuit. TR1 provides the voltage amplification, and this is a common emitter stage which provides around 40dB of voltage gain. Finally, IC2 is connected as a conventional operational amplifier Schmitt trigger. VR1 is adjusted to optimise sensitivity.

The circuit is quite simple, but when constructing it bear in mind that the unit is quite sensitive and has a high input impedance. Due care must be taken to avoid problems with stray feedback and pick up of electrical noise, and the test leads should be the screened variety (the types used for oscilloscopes being equally suitable for this application).

### RPM Interface

In some cases r.p.m. measurement can be achieved by tapping off a signal from the equipment being monitored, and then using some signal conditioning to give an output at logic levels to drive the basic frequency meter unit. The circuit of Fig. 1 will often be suitable as the signal conditioner in applications where this approach is usable. It is obviously not applicable in all cases, since not all machinery is electrical in nature, and there may be no easy and safe way of tapping off a signal anyway.

There are two common approaches to monitoring shaft rotation without actually building some form of pulse generator into the machinery. One is to fix small magnets onto the shaft and then detect the passing magnetic poles using a Hall effect device or some other form of magnetic sensor. The other is to use a method of optical detection, and this is generally the type which can be most easily implemented in practice. There is more than one approach to this problem, but the method which seems to be the most simple, and which will normally give excellent results, is to use reflective optical detection.

The basic idea is to shine a light onto the shaft, with a photocell to detect the reflected light level. Alternate light and dark bands are marked around the shaft so that as it rotates it alternately reflects large and small

amounts of light onto the photocell. The signal from the photocell is amplified and used to drive the frequency meter circuit. Calibration of r.p.m. meters can often be a problem, but in this case it is just a matter of applying some simple mathematics in the software in order to get a direct reading in r.p.m., with no adjustments being needed.

The exact mathematics required depends on the number of bands marked around the shaft. In general, the more bands that are used the better as this helps to give good resolution. On the other hand, making the bands too narrow would make the system unreliable, or could even prevent it from working at all. This is really a matter of experimenting to find the best compromise. For the sake of this example we will assume that there are six dark bands and six light ones. Each pair of bands produces one pulse per revolution, giving a total of six pulses per revolution. The frequency meter has a one second gate period and normally gives readings direct in Hertz, but in this case a gate period of one minute is required in order to give a direct reading in r.p.m. Such a long gate period could be achieved by modifying the divider circuit, but it is inconveniently long for most purposes. It is normally necessary to settle for a relatively short gate period and to accept the reduced resolution that this provides.

In this case, sixty r.p.m. are needed in order to produce one pulse per gate period, but with six pulses per revolution this conveniently gives ten r.p.m. per measured pulse. In other words, simply dividing the frequency reading by ten gives an answer in r.p.m., and the resolution is ten r.p.m. This should be adequate for most applications. The frequency meter program provided in last month's article could obviously be very easily modified to suit this application. Using other than six sets of bands around the shaft might make the mathematics work out less conveniently than this, and it is probably best to only use three, six, or twelve sets of bands. These represent resolutions of twenty, ten, and five r.p.m. respectively.

### Optical RPM Interface

A suitable optical r.p.m. interface appears in Fig. 2. D1 is the light source, and it should ideally be a five millimetre, high brightness i.e.d., or better still an ultra-high brightness type. TR1 is the photocell, and this is a silicon photo-transistor having a built-in lens. Virtually any silicon n.p.n. photo-transistor will work in this circuit, but for good results it is best to use a type which has a built-in lens. The fluctuations in received light level result in small changes in TR1's collector current, which in turn give variations in the collector voltage. These are then amplified by TR2 to bring them to a suitable level to drive the Schmitt

Fig. 1. Circuit of the audio frequency signal conditioner.

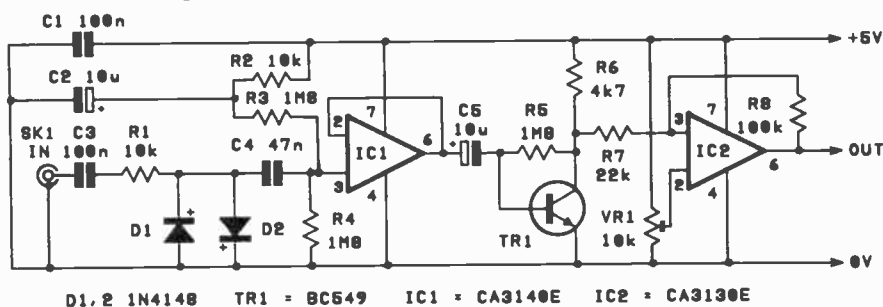

D1, 2 1N4148 TR1 = BC549 IC1 = CA3140E IC2 = CA3130E

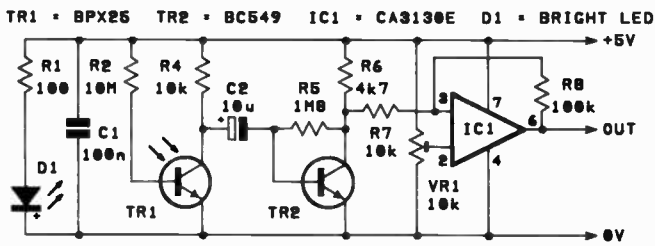

Fig. 2. The r.p.m. interface circuit.

trigger circuit based on IC1. This provides a suitable output signal for the frequency meter circuit.

### In Use

In use TR1 and D1 are mounted side by side and aimed in the same direction. I did not experience any difficulty in obtaining good results from this set up, but for optimum results it is a good idea to shield TR1 from any light it might otherwise receive direct from D1, and it seems to be necessary to have the two cells about 10 millimetres or more away from the shaft. The maximum usable distance is very much dependent on the strength of the light output from D1, and the reflectivity of the light bands around the shaft. I found that good results could be obtained by marking black bands onto a metal shaft using a marker pen. Presumably even better results would be obtained using mat black paint though. Of course, the system can only work well if the shaft is shielded from strong light sources other than D1 (especially mains lighting which carries 100Hz modulation that could prevent correct operation of the system).

### R.F. Frequency Meter

There is no difficulty in extending the maximum operating frequency of the basic frequency meter circuit, and it merely requires the addition of a prescaler. This is just a frequency divider circuit, and with a division rate of one hundred for example, the full scale reading would be increased to 6.5535MHz. There is a disadvantage in the prescaler method in that it reduces the resolution of the system, with 100Hz resolution being obtained in this case. However, there is no easy solution to this problem, and for a radio frequency d.f.m. a resolution of 100Hz or even 1kHz is sufficient for most purposes.

The circuit diagram for a simple three stage prescaler and input amplifier is shown in Fig. 3. The input amplifier consists of a source follower input stage (TR1), a common emitter voltage amplifier (TR2), and an emitter follower output stage (TR3). The input sensitivity is about 20 millivolts into one megohm, but the gain falls away somewhat at high frequencies, and the input impedance also reduces substantially at high frequencies.

The prescaler is a three stage divide by ten type, with each stage consisting of a 74LS90 decade counter in the standard divide by ten configuration. S1b selects either the divided by ten, divided by one hundred, or the divided by one thousand signal, and it therefore operates as the range switch. The three ranges are 65.535MHz, 6.5535MHz, and 655.35kHz respectively, giving resolutions of 1kHz, 100Hz, and 10Hz respectively. Note that on the highest frequency range it might not be possible to obtain operation right up to the 65.535MHz maximum frequency. The input amplifier might not operate properly right up to this frequency, and the 74LS90 is only guaranteed to operate up to 42MHz. The unit should certainly work well at frequencies up to the 30MHz upper limit of the short wave range.

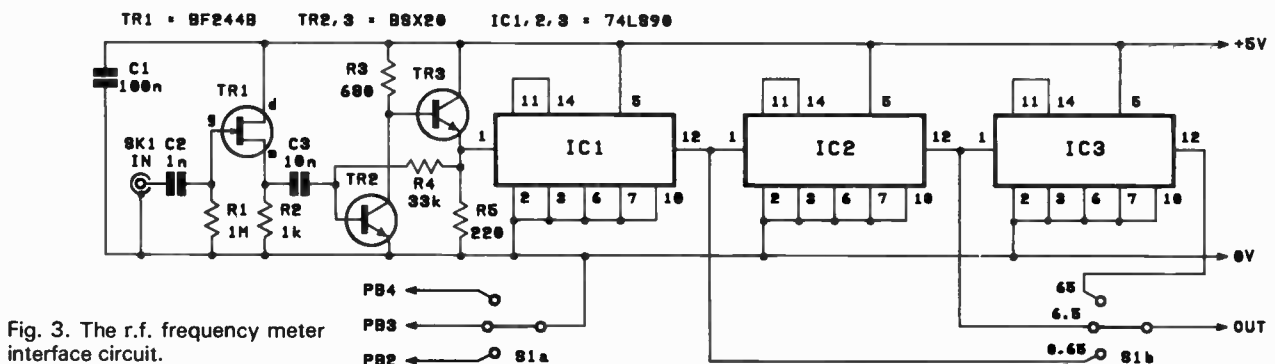

Fig. 3. The r.f. frequency meter interface circuit.

```

10 REM DFM PROGRAM
20 REM FOR BBC MICRO JWP 3/87
30 MODE 7
40 PRINTTAB(12,3)CHR$(141);"DFM READOUT"
50 PRINTTAB(12,4)CHR$(141);"DFM READOUT"
60 ?&FE6B=224
70 ?&FE64=80
80 ?&FE65=195
90
100 REPEAT
110 ?&FE68=255
120 ?&FE69=255
130 IF (?&FE60 AND 32)=0 THEN 130
140 IF (?&FE60 AND 32)=32 THEN 140
150 PRINTTAB(15,14)CHR$(141);FNread
160 PRINTTAB(15,15)CHR$(141);FNread
170 PRINTTAB(15,8)CHR$(141);R$
180 PRINTTAB(15,9)CHR$(141);R$
190 UNTIL FALSE
200 END
210
220
1000 DEF FNread
1010 R=FNrange
1020 V=FNval
1030 IF R=1 THEN V=V/100:R$=" kHz":@Z=&
2020A
1040 IF R=2 THEN V=V/10000:R$=" MHz":@Z=
&2040A
1050 IF R=3 THEN V=V/1000:R$=" MHz":@Z=
&2030A
1060 =V
1070
1080
2000 DEF FNrange
2010 N=?&FE60 AND 14
2020 IF N=12 THEN R=1
2030 IF N=10 THEN R=2
2040 IF N=6 THEN R=3
2050 =R
2060
2070
3000 DEF FNval
3010 LB=?&FE68
3020 HB=?&FE69*256
3030 val=LB+HB
3040 val=65535-val
3050 =val

```

Switch S1a is used to indicate to the computer which range is in use so that the software can adjust the display to have the decimal point in the right place, and show the units of measurement as 'kHz' or 'MHz', as appropriate. This is achieved by pulling one of lines PB2 to PB4 low, and reading these lines on each loop of the software. Suitable software for use with this unit is provided in the above listing.

An alternative which might be worth pursuing would be to use spare lines of the user port as outputs to drive a data selector which would be used to select the appropriate output of the prescaler. The required range would then be selected using the computer's keyboard and suitable software routines.

It is certainly well worth gaining an understanding of the BBC machine's timer/counters, and they can be useful in a variety of applications. They are a subject to which we will probably return at some later date.

# DIGITAL Trouble Shooting Part Eight

MIKE TOOLEY BA

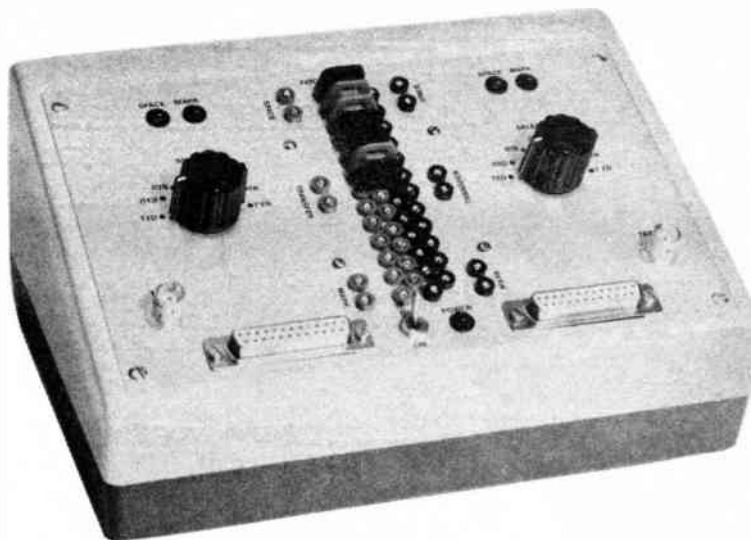

**Our nine part series on Digital Troubleshooting aims to provide readers with a practically biased introduction to the diagnosis of faults within digital equipment. The series should also be of interest to anyone wishing to update their knowledge of modern digital devices and circuitry.**

IN LAST month's instalment of *Digital Troubleshooting* we dealt with programmable I/O devices. This month we shall continue this theme by taking a look at two important methods of interconnecting microprocessor based systems and peripheral devices.

The first of these makes use of the well known (but often misunderstood!) RS-232C serial interface whilst the second, somewhat lesser known system, is the IEEE-488 General Purpose Instrument Bus (GPIB). Our companion Digital Test Gear Project is dedicated to the construction of an *RS-232C Break-out Box*.

## RS-232C

The RS-232C/CCITT V24 interface undoubtedly reigns supreme as the most widely used standard for serial communication between microcomputers and peripheral devices. The interface, defined by the Electronic Industries Association (EIA) standard, relates essentially to two types of equipment. The first of these is known as Data Terminal Equipment (DTE) whilst the second is referred to as Data Communications Equipment (DCE).

To avoid one of the most problematic pitfalls of the RS-232C system, it is important to make a clear distinction between these two forms of equipment. Data Terminal Equipment (e.g. a microcomputer) is capable of sending and/or receiving data via the serial interface. It is thus said to "terminate" a serial link.

Data Communications Equipment, on the other hand, is generally thought of as a device which can facilitate serial data communications in conjunction with a DTE. A prime example is that of a modem (modulator-demodulator). This device forms a link in the serial chain between a microcomputer and a telephone line (as shown in Fig. 8.1).

Unfortunately the distinction between DTE and DCE is somewhat blurred and this gives rise to a number of problems. Consider,

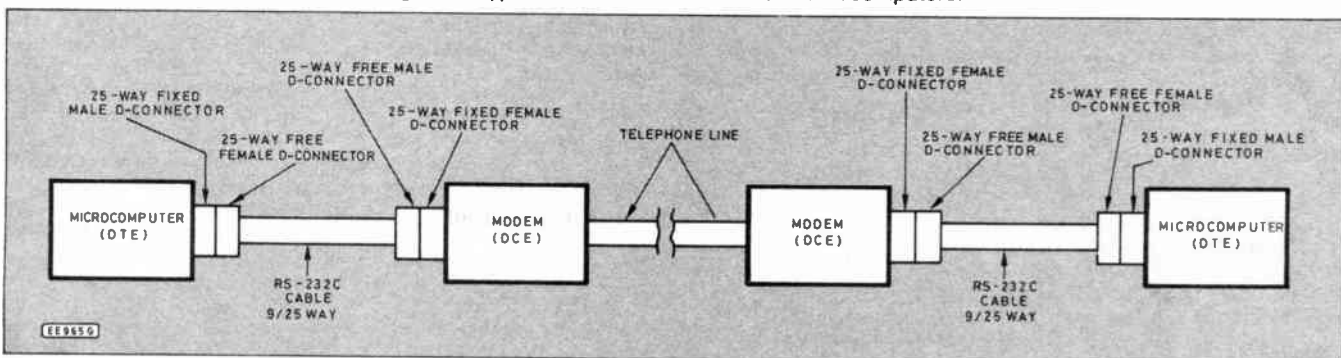

Fig. 8.1. Typical serial data link between microcomputers.

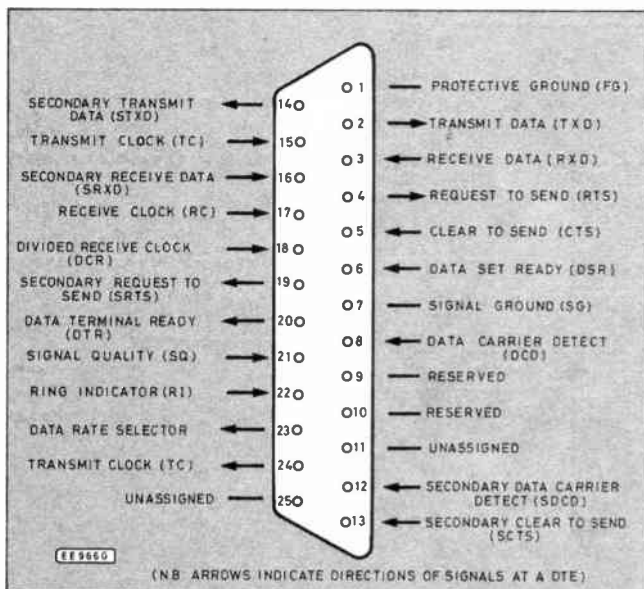

Fig. 8.2. Pin assignment of the 25-way D-connector used with RS-232C.

for example, the case of a printer. Is this a DTE or DCE? Alternatively, suppose we need to link together two microcomputers when both machines are configured as DTE. How can this be achieved?

The key to both of these problems lies in the physical interconnection of the devices. With only a few changes to the wiring of the



RS-232C system, it is quite possible to make a DCE behave as a DTE, and vice versa. To understand how this can be achieved it is necessary to have some idea of the function of each of the RS-232C signals.

### RS-232C SIGNALS

Readers will almost certainly be familiar with the appearance of a "standard" RS-232C serial port which invariably takes the shape of a 25-way D connector. DTE equipment is normally fitted with a male connector whilst DCE equipment uses a female connector (note that this is not a hard and fast rule and there are a few exceptions!).

The pin assignment for the RS-232C connector is shown in Fig. 8.2 and the function of each of the lines is listed in the table shown below:

Pin No.	Abbreviation	Direction	Full name
1	FG	—	Frame or protective ground
2	TD (TXD)	To DCE	Transmitted data
3	RD(RXD)	To DTE	Received data
4	RTS	To DCE	Request to send
5	CTS	To DTE	Clear to send
6	DSR	To DTE	Data set ready
7	SG	—	Signal ground
8	DCD	To DTE	Data carrier detect
9		To DTE	(positive test voltage)
10		To DTE	(negative test voltage)
11	QM	To DTE	Equaliser mode
12	SDCD	To DTE	Secondary data carrier detect
13	SCTS	To DTE	Secondary clear to send
14	STD	To DCE	Secondary transmitted data
15	TC	To DTE	Transmit clock
16	SRD	To DTE	Secondary received data
17	RC	To DTE	Receive clock
18	DCR	To DTE	Divided receive clock
19	SRTS	To DCE	Secondary request to send
20	DTR	To DCE	Data terminal ready
21	SQ	To DTE	Signal quality
22	RI	To DTE	Ring indicator
23		To DCE	(data rate selector)
24	TC	To DCE	External transmit clock
25		To DCE	(busy)

#### Notes:

- Lines 11, 18 and 25 are normally referred to as "unassigned". The functions given above relate to the Bell 113B and 208A specifications.
- Lines 9 and 10 are often referred to as "reserved". A typical use for these lines is testing of the positive and negative voltage levels used to represent the MARK and SPACE levels.
- To avoid any confusion which may exist between RD (Read) and RD (Received data), we shall refer to RXD and TXD (rather than RD and TD) throughout. We shall similarly refer to SRXD and STXD for the secondary channel (rather than SRD and STD).
- Some manufacturers use "spare" RS-232C lines for testing or for special functions peculiar to particular hardware (some equipment even feeds power and analogue signals along "unused" RS-232C lines—so beware!).

### Signal categories

RS-232C signals fall into one of three categories which may be briefly summarised as follows:

#### Serial data (e.g. TXD, RXD)

RS-232C provides for two independent serial data channels (described as "primary" and "secondary"). Both of these channels provide for full duplex operation (i.e. simultaneous transmission and reception).

#### Handshake control signals (e.g. RTS, CTS)

The handshake signals provide the means by which the interchange of signals is controlled allowing, for example, a DTE to open a dialogue with the DCE prior to actually transmitting or receiving data over the serial data path.

#### Timing signals (e.g. TC, RC)

For synchronous (rather than the more usual asynchronous) mode of operation, it is necessary to pass clock signals between the devices. These timing signals facilitate synchronism of the received signal for decoding purposes.

In practice, few RS-232C implementations make use of the secondary channel and, since asynchronous (non-clocked) opera-

tion is the norm, only eight or nine of the 25 are regularly used. The function of these lines are listed below:

Pin No.	Signal	Function
1	FG	Earth connection to the equipment frame or chassis.
2	TXD	Serial data transmitted from DTE to DCE.
3	RXD	Serial data received by the DTE from the DCE.
4	RTS	When active, the DTE is signalling that it wishes to send data to the DCE.
5	CTS	When active, the DCE is signalling that it is ready to accept data from the DTE.
6	DSR	When active, the DCE is signalling that a communications path has been properly established.
7	SG	Common signal return path.
8	DTR	When active, the DTE is signalling that it is operational and that the DCE may be connected to the communications channel.

### RS-232C WAVEFORMS

In most RS-232C systems, data is transmitted asynchronously. This simply means that it is transmitted as a series of "data packets". Each data packet contains sufficient information for it to be decoded without the need for a separate clock signal. Each packet contains a single ASCII character.

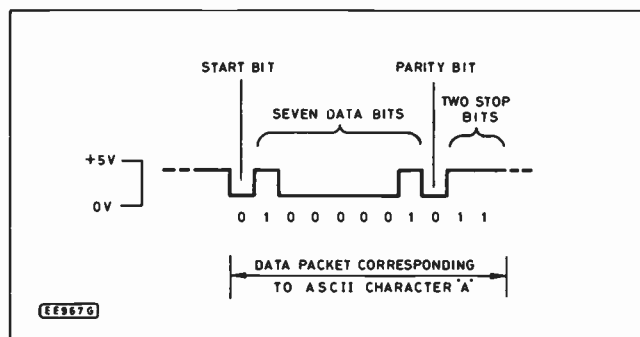

Fig. 8.3. Typical representation of the ASCII character 'A' using TTL signal levels

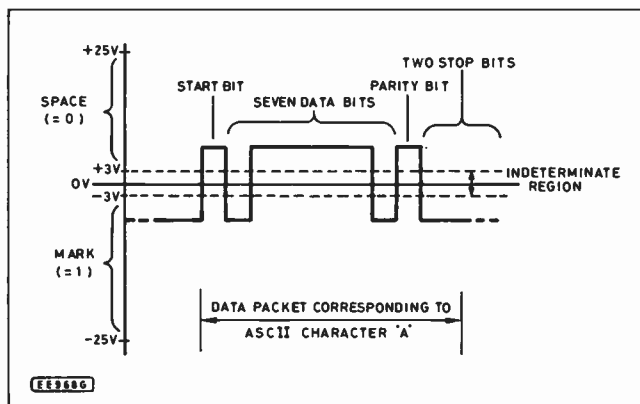

Fig. 8.4. ASCII character 'A' as it would appear on the TXD or RXD signal lines.

Readers will probably be aware that ASCII characters are represented by seven binary digits (bits). The upper case letter 'A', for example, is represented by the seven-bit binary word: 1000001. In order to send a letter 'A' via an RS-232C system, we need to add extra bits to signal the start and end of the data packet. In addition, we may wish to add an extra bit to provide a simple parity error detecting facility.

One of the most commonly used schemes involves the use of one start bit, one parity bit, and two stop bits. The equivalent TTL signal for an ASCII character 'A' has been shown in Fig. 8.3. The commencement of the data packet is signalled by the low start bit. This bit is always low irrespective of the contents of the packet.

The start bit is followed by the seven data bits representing the ASCII character concerned. A parity bit is added to make the resulting number of 1's in the group either odd ("odd parity") or even ("even parity"). Finally, two stop bits are added. These are both high.

The complete asynchronously transmitted data word thus has eleven bits (note that only seven of these actually contain data!). In

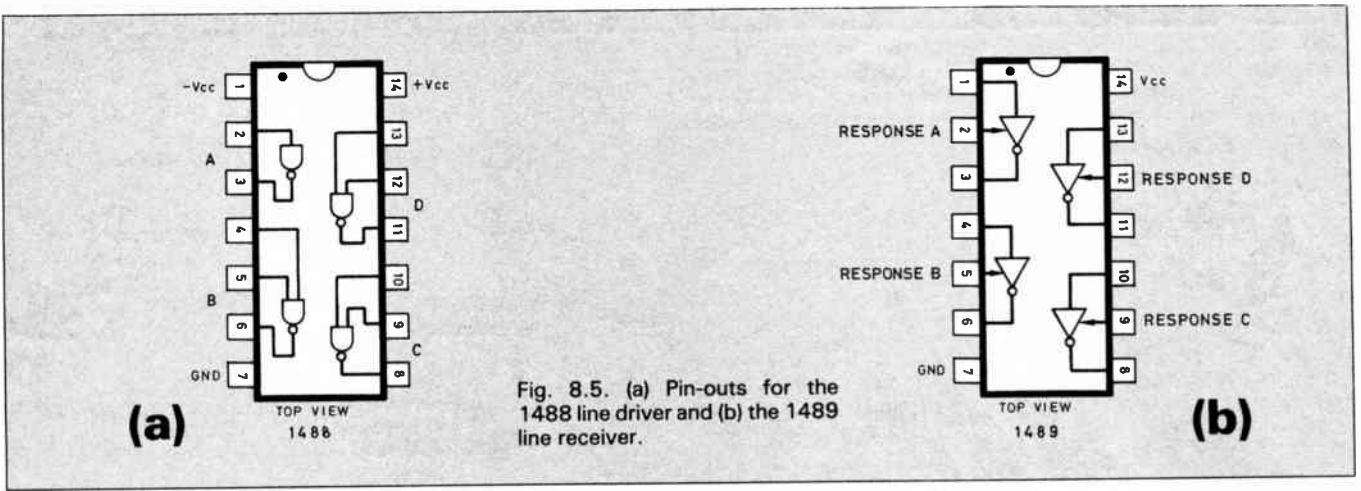

binary terms the word can be represented as: 0100001011. In this case, even parity has been used and thus the ninth (parity bit) is a 0.

Unfortunately, the voltage levels employed in an RS-232C system are quite different from those used within a microcomputer. A positive voltage (of between +3V and +25V) is used to represent a logic 0 (or *SPACE*) whilst a negative voltage (of between -3V and -25V) is used to represent a logic 1 (or *MARK*). Fig. 8.4 shows the waveform of a data packet corresponding to the ASCII character 'A' as it would appear on the RS-232C TXD or RXD lines.

The level shifting (from TTL to RS-232C signal levels and vice versa) is accomplished using special "line driver" and "line receiver" chips. The most commonly used devices are the 1488 and 1489 devices, the pinouts for which are shown in Fig. 8.5.

A typical microcomputer RS-232C interface is shown in Fig. 8.6. IC1 is a programmable serial I/O device which provides the necessary parallel-to-serial and serial-to-parallel data conversion. IC2 and IC3 provide level shifting for the three output signals (TXD, RTS and DTR) whilst IC4 provides level shifting for the three input signals (RXD, CTS and DSR). Readers should note that IC2 and IC3 both require  $\pm 12V$  supplies.

### ENHANCEMENTS

Several further standards have been introduced in order to overcome some of the shortcomings of the original RS-232C specification. These generally provide for better line matching, increased distance capability, and faster data rates.

Notable amongst these systems are the RS-422, a balanced system which caters for a line impedance as low as 50 ohm and the RS-432, an unbalanced system which will tolerate a line impedance of 450 ohm minimum. There is also the RS-449, a very fast serial data standard which uses a number of changed circuit functions and a 37-way D-connector.

### RS-232C TEST EQUIPMENT

Where one is engaged in regularly testing or commissioning systems which use an RS-232C (or equivalent) serial interface, a number of specialised accessories and test instruments will be required. The following items are commonly available:

#### Patch Boxes

Patch boxes are low-cost devices which facilitate the cross connection of RS-232C signal lines. The equipment is usually fitted with two D-type connectors (or ribbon cables fitted with a plug and socket) and all lines are brought out to a patching area into which links may be plugged. In use, these devices are connected in series with the RS-232C serial data link and various patching combinations are tested.

#### Gender Changers

Gender changers normally comprise an extended RS-232C connector which has a male connector at one end and a female connector at the other.

Fig. 8.6. Typical RS-232C interface circuitry.

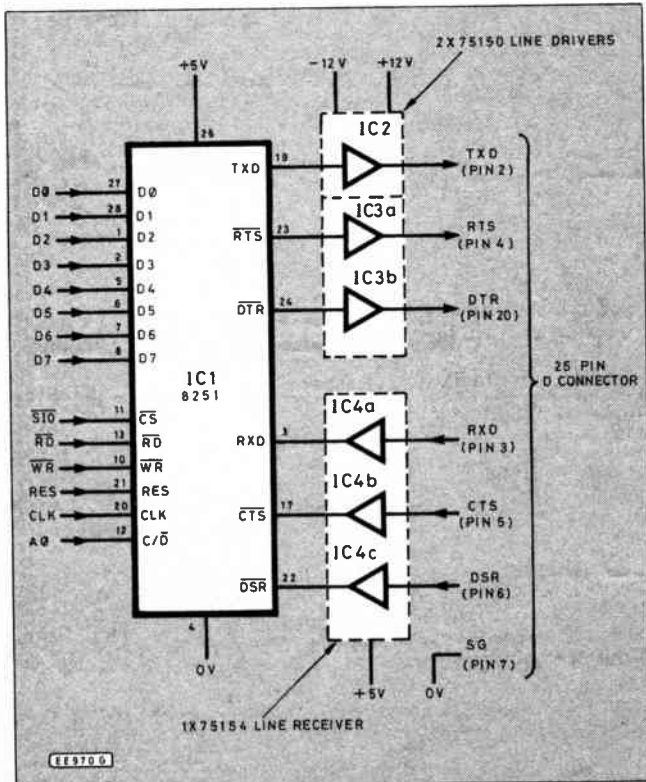
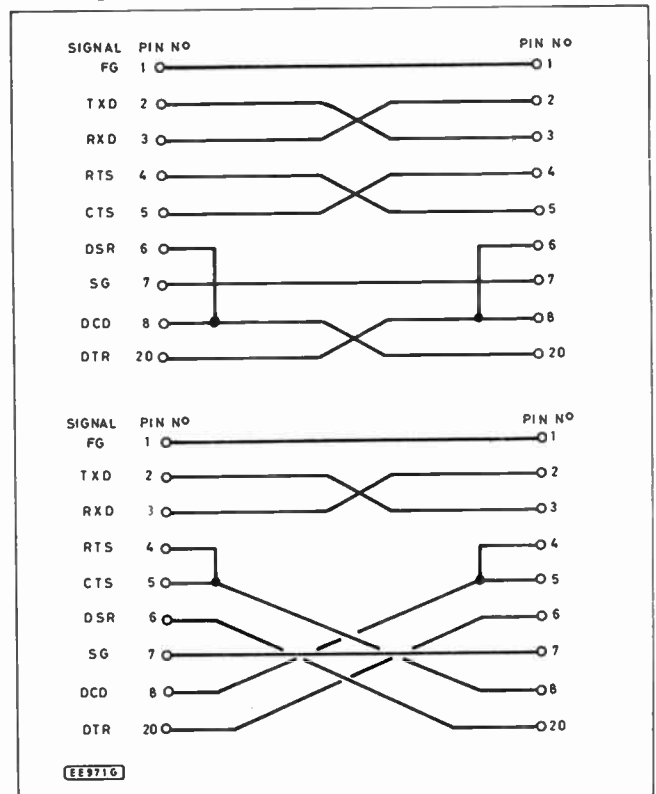

Fig. 8.7. Two possible null modem arrangements.



### Null Modems

Like gender changers, null modems are connected in series with the RS-232C serial data path. Their function is simply that of changing the signal lines so that a DTE is effectively configured as a DCE. Null modems can easily be set up using a patch box or manufactured as required. Fig. 8.7 shows two possible null modem configurations.

### Line Monitors

Line monitors display the logical state (in terms of MARK or SPACE) present on the most commonly used data and handshaking signal lines. They thus give the user a rapid indication of which signals are present and active within the system.

### Breakout Boxes

Breakout boxes provide access to the signal lines and usually combine the features of patch boxes and line monitors. In addition, switches or jumpers are usually provided for linking lines on either side of the box. Connection is almost invariably via two 25-way ribbon cables terminated with connectors.

### Interface testers

Interface testers are somewhat more complex than simple breakout boxes and may incorporate facilities for forcing lines into MARK or SPACE states, detecting "glitches", measuring baud rates, and even displaying the data word structure in use. Such instruments are, not surprisingly, rather expensive and a fully fledged interface tester will usually cost in excess of £250.

## FAULT FINDING ON RS-232C SYSTEMS

Fault finding on RS-232C systems usually involves the following basic steps:

(a) Ascertain which device is the DTE and which is the DCE. This can usually be accomplished by simply looking at the connectors (remember that DTE equipment is normally fitted with a *male* connector whilst DCE equipment invariably uses a *female* connector). Where both devices are configured as DTE (as is often the case) a null modem will have to be inserted for correct operation.

(b) Check that the correct cable has been used. Note that RS-232C cables are provided in a variety of forms; 4-way (for "dumb" terminals), 9-way (for normal asynchronous data communications), 15-way (for synchronous communications), and 25-way (for "universal" applications). Fig. 8.8 shows the various possibilities which exist. If in doubt, use a full 25-way cable.

(c) Check that the correct word format and baud rate has been selected at each end of the serial link.

(d) Activate the link and investigate the logical state of the data (TXD and RXD) and handshaking (RTS, CTS etc) signal lines using a line monitor, breakout box, or interface tester.

(e) If in any doubt, refer to the equipment manufacturer's data in order to ascertain whether any special connections are required and to ensure that the interfaces are truly compatible. Note especially that some manufacturers have implemented quasi-RS-232C interfaces which make use of TTL signals. These are clearly *NOT* electrically compatible with the normal RS-232C system even though they may use identical protocols!

## THE IEEE-488 GENERAL PURPOSE INSTRUMENT BUS

The IEEE-488 bus (also known as the Hewlett Packard Instrument Bus or General Purpose Instrument Bus) is popularly used as a means of interconnecting microcomputer controllers in automatic test equipment (ATE) configurations. Many of the more powerful items of modern electronic test equipment (including digital voltmeters and signal generators) are fitted with the necessary IEEE-488 interface to allow them to be connected to a microcomputer controller which can be used to both supervise their operation and process data which they may collect.

The IEEE-488 standard provides for the following categories of device:

### Listeners

Listeners can receive data and control signals from other devices connected to the bus but are not capable of generating data. An obvious example of a listener is a signal generator.

### Talkers

Talkers are only capable of placing data on the bus and cannot receive data. A typical example of a talker is a tape reader. Note that, whilst only one talker can be active at a given time, it is possible for a number of listeners to be active and receiving data at the same time!

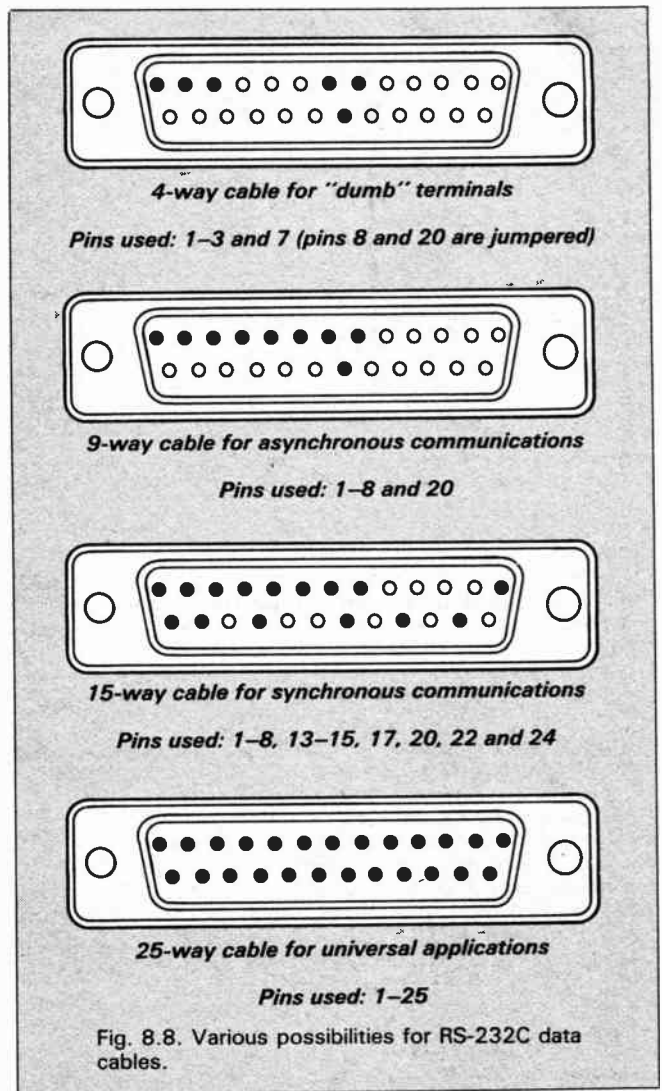

### Talkers/listeners

Talkers/listeners can both send and receive data to/from the bus. A digital multimeter is a typical example of a talker/listener. Data is sent to it in order to change ranges and returned to the bus in the form of digitised readings of voltage, current, and resistance.

### Controllers

Controllers are used to supervise the flow of data on the bus and provide processing facilities. The controller within an IEEE-488 system is invariably a microcomputer and, whilst many systems make use of the ubiquitous IBM PC, some test equipment manufacturers provide their own dedicated microprocessor based controllers.

The IEEE-488 bus uses 8 multi-purpose bi-directional data lines. These are used to transfer data, addresses, commands and status bytes. In addition, five bus management and three handshake lines are provided.

The connector used for the IEEE-488 bus is invariably a 24-pin type (as shown in Fig. 8.9) having the following pin assignment:

Pin No.	Abbreviation	Function
1	D101	Data line 1
2	D102	Data line 2
3	D103	Data line 3
4	D104	Data line 4
5	EOI	End or identify. This signal is generated by a talker to indicate that transfer of data is complete.
6	DAV	Data valid. This signal is asserted by a talker to indicate that valid data has been placed on the bus.
7	NRFD	Not ready for data. This signal is asserted by a listener to indicate that it is not yet ready to accept data.
8	NDAC	Not data accepted. This signal is asserted by a listener whilst data is being accepted.

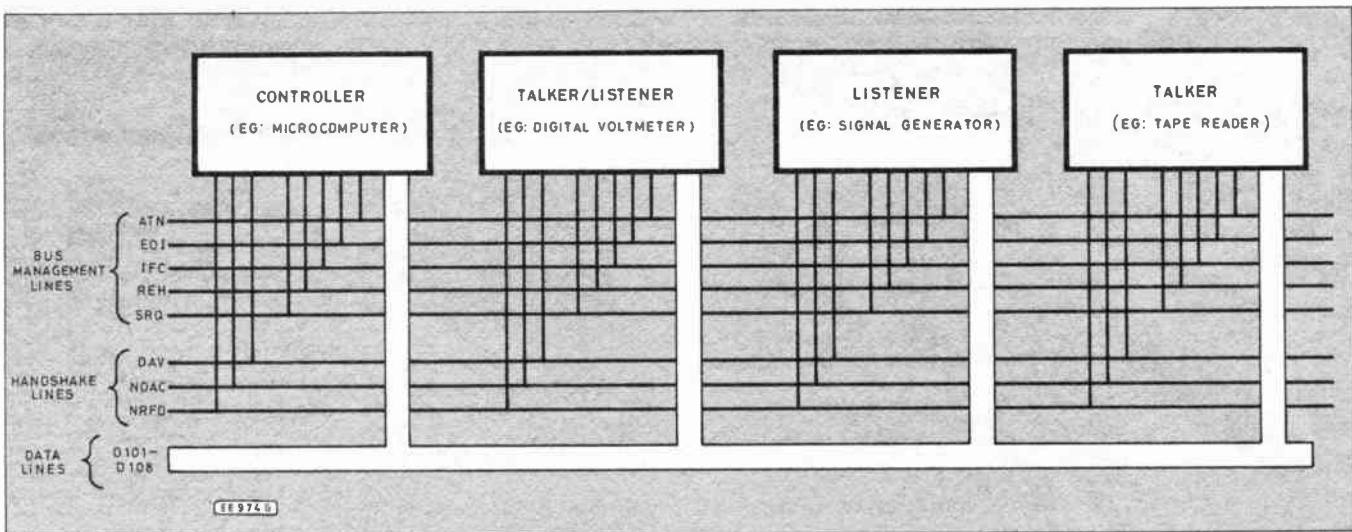

Fig. 8.10. Typical IEEE-488 bus arrangement.

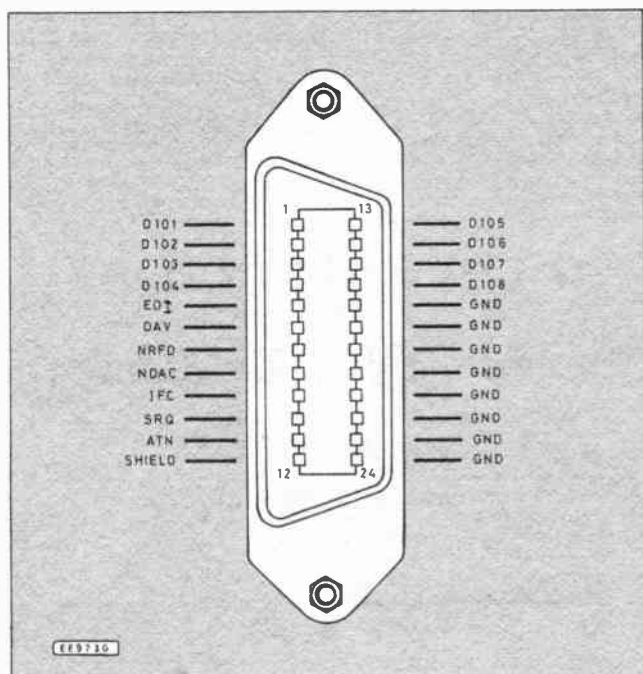

Fig. 8.9. Pin assignment for the 24-way connector used with IEEE-488.

9	IFC	Interface clear. Asserted by the controller in order to initialise the system in a known state.
10	SRQ	Service request. This signal is asserted by a device wishing to gain the attention of the controller.
11	ATN	Attention. Asserted by the controller when placing a command on to the bus.
12	SHIELD	Shield.
13	D105	Data line 5.
14	D106	Data line 6.
15	D107	Data line 7.
16	D108	Date line 8.
17	REN	Remote enable. This line is used to enable or disable bus control (thus permitting an instrument to be controlled from its own front panel rather than from the bus).
18-24	GND	Ground/common signal return.

Notes:  
 1. Handshake signals (DAV, NRFD and NDAC) employ active low open-collector outputs which may be used in a wired-OR configuration.

2. All remaining signals are fully TTL compatible and are active low.

Bus commands are signalled by taking the ATN line low. Commands are then placed on the bus by the controller and directed to individual devices by placing a unique address on the lower five data bus lines. Alternatively, universal commands may be issued to all of the participating devices.

Since the physical distance between devices is usually quite small, data rates may be relatively fast. Data rates of between 50Kbyte/second and 250Kbyte/second are typical, however, to cater for variations in speed of response, the slowest listener governs the speed at which data transfer takes place. Fig. 8.10 shows a typical IEEE-488 bus arrangement in which a microcomputer is used as the controlling device.

### FAULT FINDING ON IEEE-488 BUS SYSTEMS

Fault finding on the IEEE-488 bus is usually very much simpler than that associated with RS-232C systems. There are two main reasons for this; firstly, the IEEE-488 bus standard is open to much less variation in implementation and secondly, all signals use standard TTL voltage levels.

This latter fact permits the use of conventional digital instruments (such as logic probes and pulsers). Furthermore, the controlling software often contains its own diagnostic routines and will warn the user if, for example, an external device is not responding to commands placed on the bus.

Where troubles are encountered, it is worth checking the configuration of the software and the assignment of addresses to the various devices employed within the system. If it is necessary to check the state of the various signal lines, a common or garden logic probe can be used to check for activity (remember that lines are active low).

Next month: we shall be rounding off the series by taking a look at some complete digital systems and describing several study programmes for readers who wish to progress further. Our Digital Test Gear Project features a highly versatile Digital Counter/Frequency Meter.

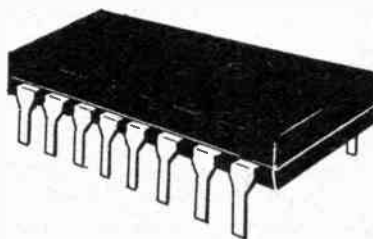

**ORDER YOUR COPY NOW!**

**For KITS & COMPONENTS -**  
**Choose the easy way - with**  
*\*refundable with first order*

**Send 50p\* & SAE for CATALOGUE**

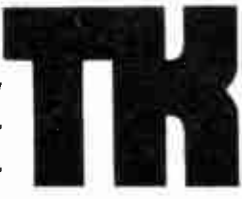

ORDERS: RING (01) 567 8910 - 24 HRS.

**NEW POWER STROBE KIT**

Designed to produce a high intensity light pulse at a variable frequency of 1 to 15Hz this kit also includes circuitry to trigger the light from an external voltage source (eg. a loudspeaker) via an opto isolator. Instructions are also supplied on modifying the unit for manual triggering, as a slave flash in photographic applications, or as a warning beacon in security applications. The kit includes a high quality pcb, components, connectors, 5W strobe tube and full assembly instructions. Supply: 240V ac. Size: 80 x 50 x 45.  
**XK124 STROBOSCOPE KIT £12.50**

**NEW HIGH SECURITY LOCK KIT**

Designed for use with our lock mechanism (701 150) this kit will operate from a 9V to 15V supply drawing a standby current of only 50µA. There are over 5000 possible 4-digit combinations and the sequence can be easily changed. To make things even more difficult for an unauthorised user an alarm can be sounded after 3 to 9 incorrect entries—selectable by means of a link. The alarm can sound for a few seconds to over 3 minutes during which time the keyboard is disabled preventing further entries. A latched or momentary output is available making the unit ideal for door locks, burglar alarms, car immobilisers, etc. A membrane keyboard or pushbutton switches may be used and a beep sounds when a key is depressed. Kit includes high quality PCB, all components, connectors, high power piezo buzzer and full assembly and user instructions.  
**XK121 LOCK KIT £15.95**  
**350 118 Set of Keyboard Switches £4.00**  
**701 150 Electric Lock Mechanism 12 volt £16.50**

**REMOTE CONTROL SWITCH KIT**

Comprises a compact 9V (PP3) powered single channel unencoded infra-red transmitter and a mains powered receiver, this kit is ideal for switching table lamps, radios, etc. on and off remotely. Range 20ft. Max load 500W (240V a.c. only). Size—Transmitter: 7 x 5 x 3cm (including box). Receiver: 7 x 3.5 x 3cm.  
**MK6 TRANSMITTER £4.95**  
**MK7 RECEIVER £11.50**

**TEN EXCITING PROJECTS FOR BEGINNERS**

This Kit has been specially designed for the beginner and contains a **SOLDERLESS BREADBOARD, COMPONENTS**, and a **BOOKLET** with instructions to enable the absolute novice to build **TEN** fascinating projects including a light operated switch, intercom, burglar alarm, and electronic lock. Each project includes a circuit diagram, description of operation and an easy to follow layout diagram. A section on component identification and function is included, enabling the beginner to build the circuits with confidence.  
**ORDER NO XK118 £13.75**

**NEW ELECTRONIC GUARD DOG KIT**

One of the best deterrents to a burglar is a guard dog and this new kit provides the barking without the bite! The kit when assembled can be connected to a doorbell, pressure mat or any other intruder detector and will produce a random series of threatening barks making the would be intruder think again and try his luck elsewhere. The kit is supplied complete with high quality PCB, transformer, all components and instructions. All you need is a mains supply, intruder detector and a little time. The kit even includes a horn speaker which is essential to produce the loud sound required. The "dog" can be adjusted to produce barks ranging from a Terrier to an Alsatian and contains circuitry to produce a random series of barks giving a more realistic effect.  
**XK125 Complete kit of parts £21.95**

**XK102-3-NOTE DOOR CHIME**

Based on the SAB0600 1C the kit is supplied with all components, including loudspeaker, printed circuit board, a pre-drilled box (95 x 71 x 35mm) and full instructions. Requires only a PP3 9V battery and push-switch to complete.  
**AN IDEAL PROJECT FOR BEGINNERS £6.00**

**ELECTRONIC SIREN KIT**

Produces an extremely loud piercing sweet frequency tone from a 9-15V supply. Enable input for easy connection to alarm circuits. Includes 5in. Horn Speaker.  
**XK116 £8.65**

Mini Siren  
 As above, but with a small speaker (instead of horn speaker) for internal use. Complete with box.  
**XK117 £4.70**

**HOME LIGHTING KITS**

These kits contain all necessary components and full instructions & are designed to replace a standard wall switch and control up to 300W of lighting.  
**TDR300K Remote Control Dimmer £16.45**  
**MK6 Transmitter for above £4.95**  
**TD300K Touchdimmer £8.50**  
**TS300K Touchswitch £8.50**  
**TDE/K Extension kit for 2-way switching for TD300K £2.70**  
**LD 300K Light Dimmer £4.35**

**PROPORTIONAL TEMPERATURE CONTROLLER KIT**

Uses "burst fire" technique to maintain temperature to within 0.5°C. Ideal for photography, incubators, wine-making, etc. Max. load 3kW (240V a.c.). Temp. range up to 90°C. Size: 7 x 4 x 2.5cms.  
**MK4 £7.10**



**ELECTRONICS 13 BOSTON RD LONDON W7 3SJ Tel: 01-567 8910**

**SEND 9"x6" S.A.E. & 50p FOR CATALOGUE OR CALL AT SHOP MON-FRI 9-5pm SATURDAY 10-4pm**

**ORDERING INFORMATION: ALL PRICES EXCLUDE VAT**

**FREE P&P** on orders over £20 (UK only), otherwise add 75p + VAT. Overseas P&P: Europe £2.75. Elsewhere £6.50. Send cheque/PO/Barclaycard/Access No. with order. Giro No. 529314002.

**LOCAL AUTHORITY AND EXPORT ORDERS WELCOME GOODS BY RETURN SUBJECT TO AVAILABILITY**

**ENTERPRISE SIXTYFOUR**

**sinclair**



**ENTERPRISE 64 COMPUTER**

We have obtained all remaining supplies of this versatile machine — and offer it at an amazingly low price! Just look at the spec. — resolution 672x512, 256 colours, built in net, printer port, monitor and TV output, cartridge ROM, stereo sound, built in word processor, 68 full travel keys, built in joystick. Supplied brand new in original packing complete with power supply, TV lead, 2 cassette leads, Basic cartridge, comprehensive handbook & Demo tape. Limited quantity — Buy now! Originally £199.95 —  
**OUR PRICE £39.95**

**Z601 Complete PCB** from above — Z80A, 64k of RAM, UHF modulator. Just needs keyboard, TV & PSU. Supplied with lots of data: Full circuit diagram, connections for expansion port, ROM bay, joysticks ports, printer port, video output, serial port. Also demo cassette + 2 booklets that were supplied with complete machine. £20.00  
 Data only £2.00

**MICROVISION**

We have a quantity of these units in varying states. From labels attached to some of the PCB's it seems after assembly on the production line they did not function correctly. No attempt has been made to repair them, though — instead the following parts were removed:

- a) RF Tuner
  - b) Vol control & switch
  - c) ZN401E chip
- Because of the varying needs of constructors and the differing states of the microvisions, we are offering the following alternatives:
- Z555 Grade A: PCB** in good condition with CRT fitted. Supplied as seen with circuit diagram and notes ..... **£6.95**
- Z556 PCB** in good condition with CRT that has been removed, but maybe repairable. Conductive paint (15ml bottle £3.45) will probably be needed to remake contacts ..... **£3.95**
- Z558 CRT** in 'as seen' condition — possibly repairable ..... **£2.00**
- Z559 PCB** in good condition without CRT ..... **£2.50**
- Z560 Circuit diagram and notes: 7 pages** detailing tech. spec., description, cct operation, fault diagnosis & repair, aid to fault-finding chart, picture set up procedure, PCB layout, info on the various possibilities. .... **£2.00**
- RF Tuner £6.95; ZN401 chip £9.95; Vol control + switch with knob £1.00**

**SOLDER SPECIAL!!!**



- ★ 15W 240Vac soldering iron
- ★ High power desolder pump
- ★ Large tube solder

**ALL FOR £7.95**

**1987 CATALOGUE**

Out now! Bigger and better than ever — 80 pages packed with components and equipment, from humble resistors to high tech scopes! Bargain List, Order Forms and £1.50 Discount Vouchers all included for just £1.00 inc. post.

**+ FREE! KIT-CAT**

24 page illustrated catalogue with over 100 kits from simple amplifiers to complex EPROM programmers — also computer interface kits enabling many popular computers to be linked with the outside world. PLUS kits utilizing breadboards for beginners.

**'NEWBRAIN' PANELS**

**Z494 Motherboard** microprocessor panel 265 x 155mm. Complete PCB for computer. Z80, char EPROM, etc. 68 chips altogether + other associated components, plugs, skts, etc. **£5.50**

**Z495 RAM panel.** PCB 230 x 78mm with 14 x MMS290-2 (4116) (2 missing) giving 28k of memory. Also 8 LS chips. These panels have not been soldered, so chips can easily be removed if required. **£5.00**

**'NEWBRAIN' PSU**

**BRAND NEW Stabilized Supply** in heavy duty ABS case with rubber feet. Input 220/240V ac to heavy duty transformer via suppressor filter. Regulated DC outputs: 6.5V @ 1-2A; 13.5V @ 0-3A; -12V @ 0-05A. All components readily accessible for mods etc. Chunky heatsink has 2 x TIP31A. Mains lead (fitted with 2 pin continental plug) is 2m long. 4 core output lead 1.5m long fitted with 6 pole skt on 0.1" pitch. Overall size 165 x 75 x 72 mm. **£5.95 ea 10 for £40**

**KEYBOARDS**

**COMPUTERS LYNX keyboard** 58 full travel keys size 334 x 112 mm. Brand new Reduced to ..... **£5.95**

**Z607 Keytronics.** High quality type 8500, 95 keys. Serial interface 405 x 173mm ..... **£16.00**



All prices include VAT; just add 60p P&P  
 Min Access order: £10. Official orders from schools etc. welcome — min invoice charge £10.  
 Our shop has enormous stock of components and is open 9-5.30 Mon-Sat. Come and see us!!!  
**443D Millbrook Road, Southampton SO1 0HX. Tel. (0703) 772501/783740**

# RS232C BREAKOUT BOX

MIKE TOOLEY B.A.

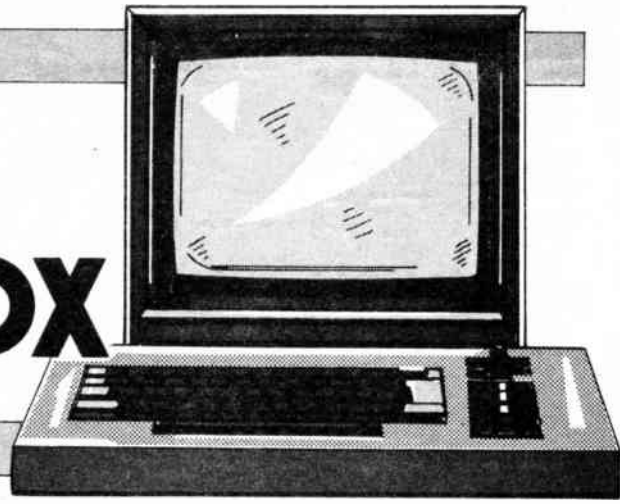

## Make all the right connections with this versatile unit

THIS MONTH'S Digital test Gear Project deals with the construction of an RS-232C Breakout Box. This indispensable device allows the user not only to alter the configuration of an RS-232C system but also provides a means of examining the various signals present and diagnosing the more common faults which can arise.

In the last few years, a wide variety of breakout boxes has appeared. Some provide only basic patching and line monitoring facilities whilst others can display baud rates and automatically detect the RS-232C system configuration (in terms of DCE and DTE).

Our own Breakout Box has been designed with home construction in mind and offers the following facilities:

*Ability to simultaneously display the logical state (i.e. MARK or SPACE) present on any two lines.*

*Ability to patch any line to any other line (on either side of the interface).*

*Ability to force any line into either a MARK or SPACE condition.*

*Ability to connect external equipment (e.g. oscilloscope, digital counter, pulse generator etc) to any line.*

*Self contained and operates from internal batteries.*

## CIRCUIT DESCRIPTION

The simplified circuit of the RS-232C Breakout Box is shown in Fig. 1. Circuitry is duplicated on either side of a "patching area" which allows any line to be patched to any other line (on either side of the interface).

Connections within the patching area may be made using PCB jumpers or using short link wires terminated with 1mm plugs. The patching area also has 1mm connecting points fed with d.c. levels to represent the MARK and SPACE states.

The six most important signal lines (TXD, RXD, RTS, CTS, DSR, and DTR) are taken to a selector switch on each side of the interface. The output of this switch is taken to the mark/space detecting circuitry and also to an input/output socket for external test equipment. A seventh position

on the switch is used for transferring the remaining signals from the patching area to the mark/space detecting circuitry as and when necessary.

The circuit of the RS-232C Breakout Box is shown in Fig. 2. Circuitry duplicated on the other side of the interface has not been included (duplicate components have numbers separated by 100).

Signals from the patching area are selected by means of Select switch S1 and S101. IC1a and IC1b operates as comparators whose outputs go "high" when the input voltage exceeds +3V or falls below -3V respectively. Diodes D1 to D4 provide protection for input voltages in excess of the positive and negative voltage rails (the maximum voltage allowed in the RS-232C system is  $\pm 25V$ ).

Zener diodes D7 and D8 establish the

comparator reference voltages (the minimum voltage for SPACE and maximum voltage for MARK respectively). D5 and D6 help to overcome a limitation of the operational amplifier employed when presented with an input voltage close to the negative supply rail. The supply for the RS-232C Breakout Box is derived from two 9V dry batteries and the red light emitting diode D11 provides an indication that the supply is switched "on".

## CONSTRUCTION

The two mark/space detecting circuits are mounted on a piece of 0.1in matrix strip-board measuring 60mm x 64mm approx and having 24 tracks each with 23 holes. This may be cut from a standard size Veroboard.

Fig. 1. Simplified circuit of the RS232C Breakout Box. Note: Frame ground(1) and signal ground (7) are connected together and linked to OV (chassis).

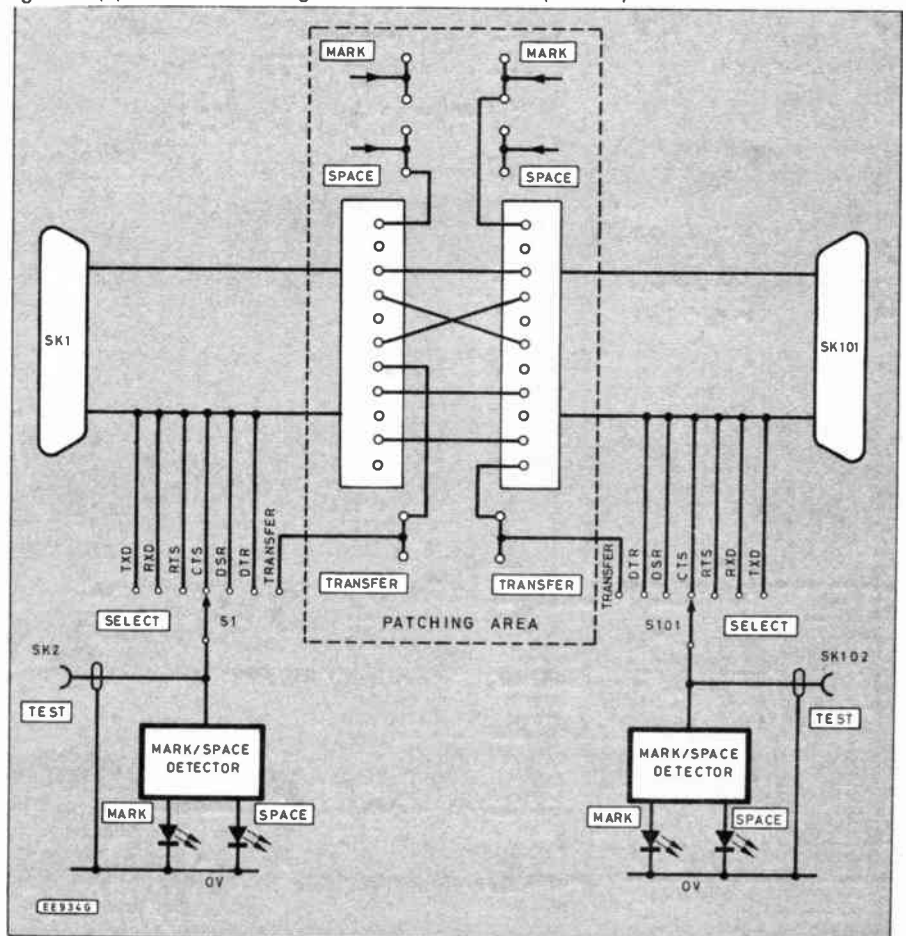

# COMPONENTS

See  
**Shop  
Talk**  
page 306

## Resistors

- R1 R101 1k
- R2 R102 1k
- R3 R103 1k
- R4 R104 1k
- R5 R105 4k7
- R6 R106 4k7
- R7 R107 1k
- R8 R108 1k
- R9 R109 270
- R10 R110 270
- R11 270

All 0.25W 5% carbon

## Capacitors

- C1 10 $\mu$  tant. 25V
- C2 10 $\mu$  tant. 25V

## Semiconductors

- IC1 IC101 TL082 Dual op-amp
- D1 D101 1N4148
- D2 D102 1N4148
- D3 D103 1N4148
- D4 D104 1N4148
- D5 D105 BZY88 C3V9 Zener
- D6 D106 1N4148
- D7 D107 BZY88 C3VO Zener
- D8 D108 BZY88 C3VO Zener
- D9 D109 Green l.e.d.
- D10 D110 Red l.e.d.
- D11 Red l.e.d.

## Miscellaneous

- S1 S101 1-pole 12-way rotary switch (with rotation stop adjusted for 1-pole 7-way operation)
- S2 miniature DPDT toggle switch

LED mounting clips (5 sets); 8-pin low profile i.c. socket (2 off); 25-way chassis mounting type D-socket (2-off); sloping front instrument case, measuring 220mm x 156mm x 100mm approx; single-sided 1mm terminal pins (15 required); 0.1in matrix stripboard measuring 60mm x 64mm approx; nuts, bolts, and mounting pillars (4 sets); BNC chassis mounting sockets (2 off); 1mm chassis mounting sockets (31 black and 31 red); insulated 0.4in. p.c.b. jumpers; knobs (2 off); PP3 snap-fit battery connectors (2 off).

Approx. cost **£20** (excluding Guidance only case)

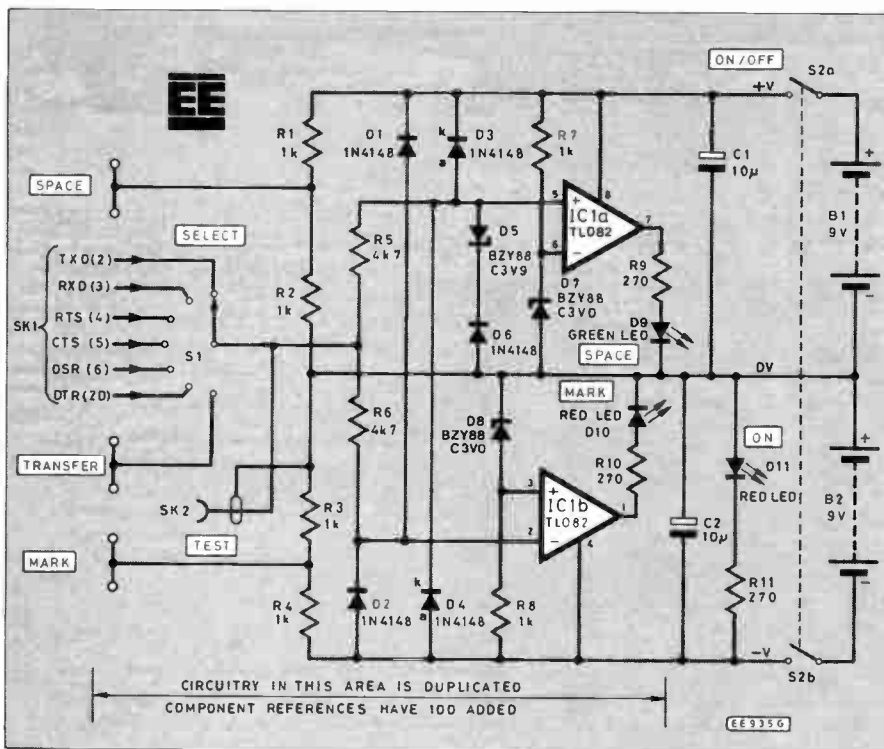

Fig. 2. Circuit diagram of the RS232C Breakout Box.

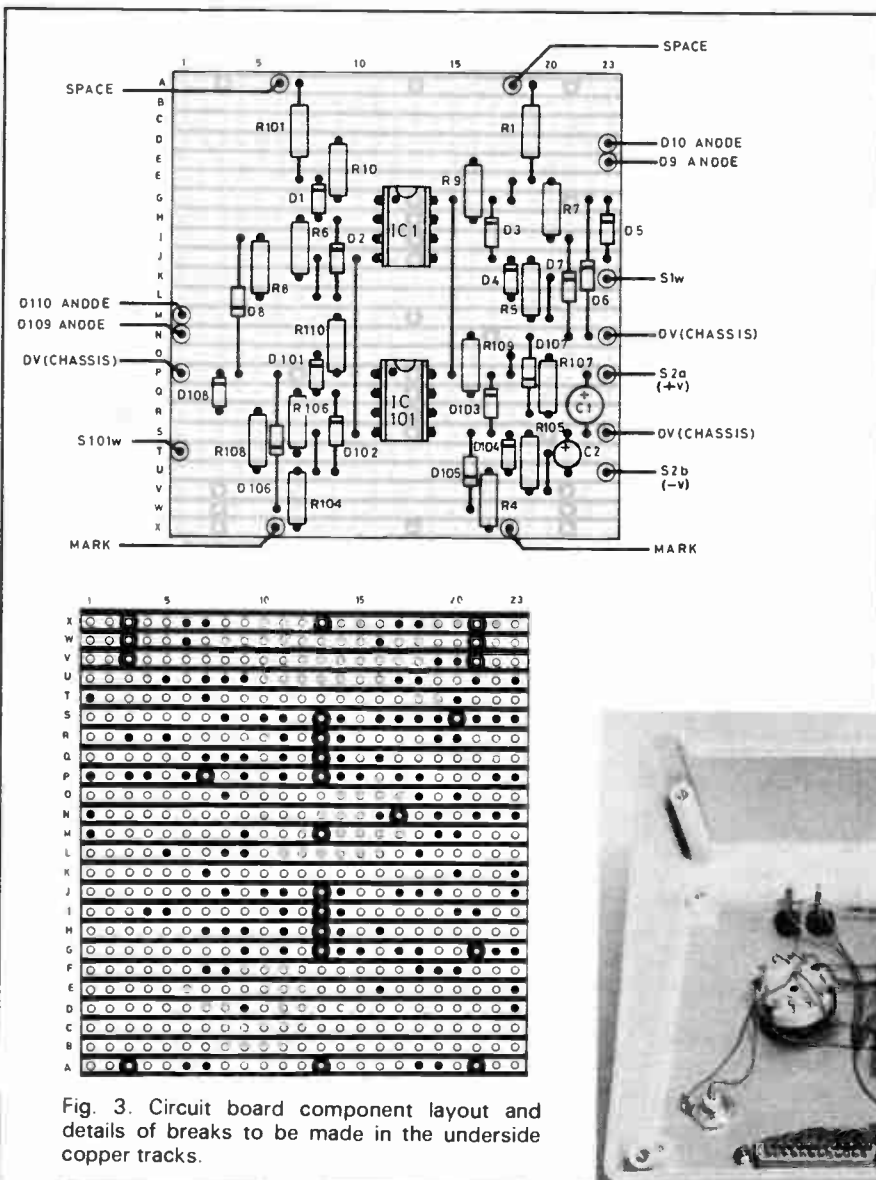
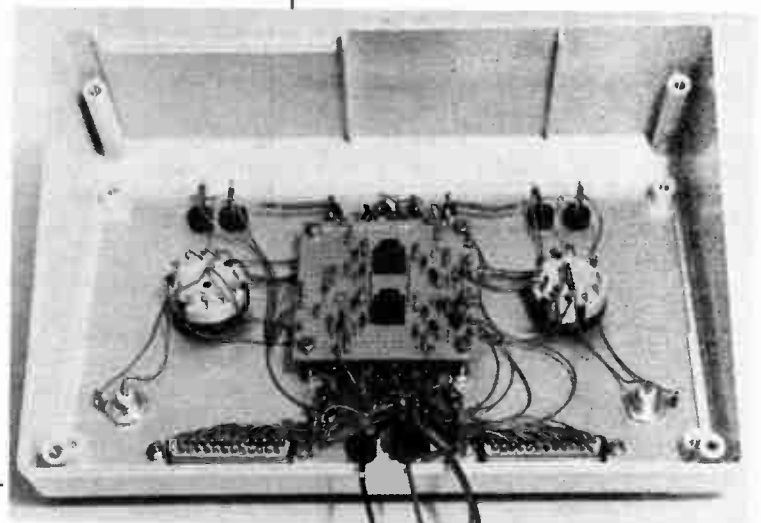

Fig. 3. Circuit board component layout and details of breaks to be made in the underside copper tracks.



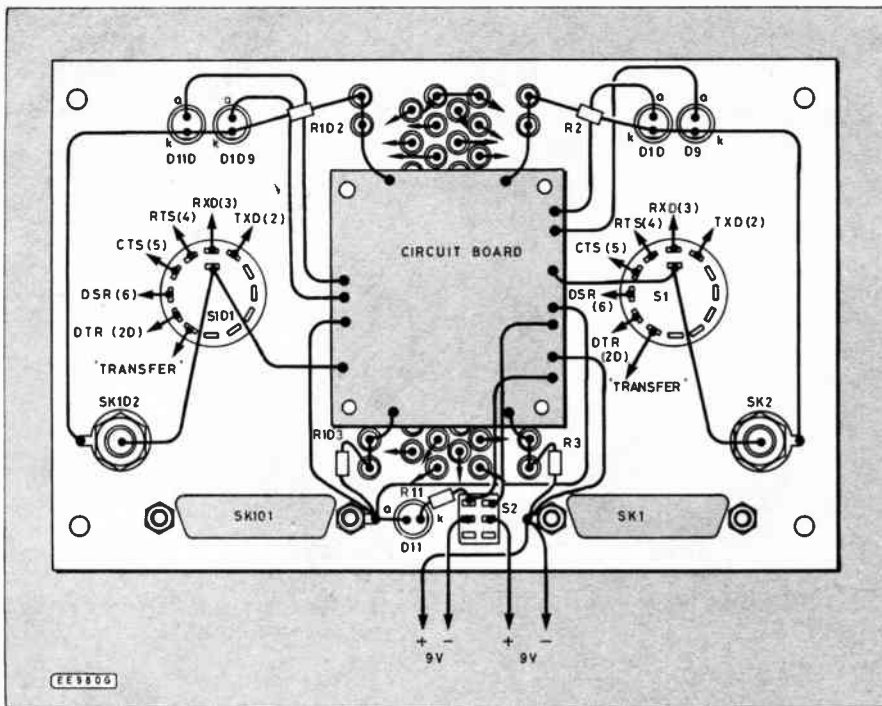
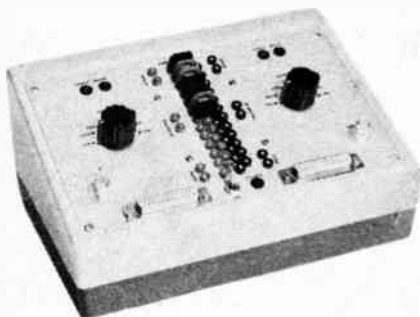

Fig. 4. Interwiring of front panel mounted components. The sockets in the patching area are linked to correspondingly numbered connections on SK1 and SK101. Patching area sockets for pins 1 and 7 (on both sides) are connected together and linked to 0V (chassis)

The stripboard component layout of the RS-232C Breakout Box is shown in Fig. 3. Readers should note that a total of 23 track breaks are required and these should be made using a spot face cutter. If such a tool is unavailable, a sharp drill bit of appropriate size may be substituted.

The following sequence of component



assembly is recommended; i.e. sockets, terminal pins, links, resistors, diodes, and capacitors. Before inserting the two integrated sockets into their holders and mounting the stripboard in its final position, constructors should very carefully check the components, links, and track breaks.

It is also worth checking that all of the polarised components (including i.e.d.s, diodes and electrolytic capacitors) have been correctly oriented. Constructors should carefully examine the underside of the board for dry joints, solder splashes, and bridges between adjacent tracks. When the board has been thoroughly checked, the two integrated circuits should be inserted into their holders (taking care to ensure correct orientation).

The interwiring to the front panel mounted components is shown in Fig. 4. The patching area consists of a matrix of 1mm

sockets (a total of 62 sockets will be required). These sockets are laid out in the same format as the two 25-pin D-connectors (SK1 and SK101) and are wired to correspondingly numbered pins. When drilling the front panel, constructors should ensure that the horizontal spacing between alternate rows is 0.4in. (to permit the use of 0.4in. p.c.b. jumpers) while the vertical spacing should be 0.3in.

The two sockets corresponding to pin-1 (protective ground) should be linked together as should the two sockets corresponding to pin-7 (signal ground). Furthermore, both ground sockets (pin-1 and pin-7) should be connected to the front panel (common 0V) at a suitable point using an earth tag.

The six links from the selector switches (S1 and S101) to the patching sockets should be connected as follows:

RS-232C signal	Switch position	Patch socket
TXD	1	2
RXD	2	3
RTS	3	4
CTS	4	5
DSR	5	6
DTR	6	20

(NB: Position 7 on each switch should be linked to its respective Transfer socket.)

Once wiring of the patching area has been completed, the stripboard should be mounted above the patching area using four pillars of suitable length. The remainder of the front panel wiring can then be completed as shown in Fig. 4.

Finally, a bracket should be made for retaining the batteries and attached to the rear base of the case. The batteries should then be connected to the front panel by means of two sets of battery connecting leads fitted with snap-fit clips.

## TESTING

Initial testing of the RS-232C Breakout Box should be carried out without connection to a microcomputer system. Connect two fresh PP3 batteries to the unit and switch "on" (Diode D11 should become illuminated indicating that power is available).

Switches S1 and S101 should both be switched to the "Transfer" position, neither MARK nor SPACE i.e.d.s should be illuminated. The Transfer sockets on each side of the patching area should then be linked in turn to the MARK and SPACE connecting points. The respective i.e.d.s should become illuminated but, if this is not the case, constructors should carefully recheck the internal wiring; including that associated with the stripboard mounted components.

The RS-232C Breakout Box should now be tested using a known operational computer system. The unit should be connected in series with the RS-232C signal path using short lengths of ribbon cable terminated with appropriate 25-way D-connectors. The Breakout Box should be configured for normal operation (it will usually only be necessary to place jumpers in positions 2, 3, 4, 5, 6 and 20).

Initially, the slowest available baud rate should be selected (e.g. 50 baud) and the system set up to send a file of reasonable length to the peripheral. The signal present on each line should be examined and the effect of breaking various lines (in particular RTS and CTS) noted.

Next month: Digital Counter/Frequency Meter.

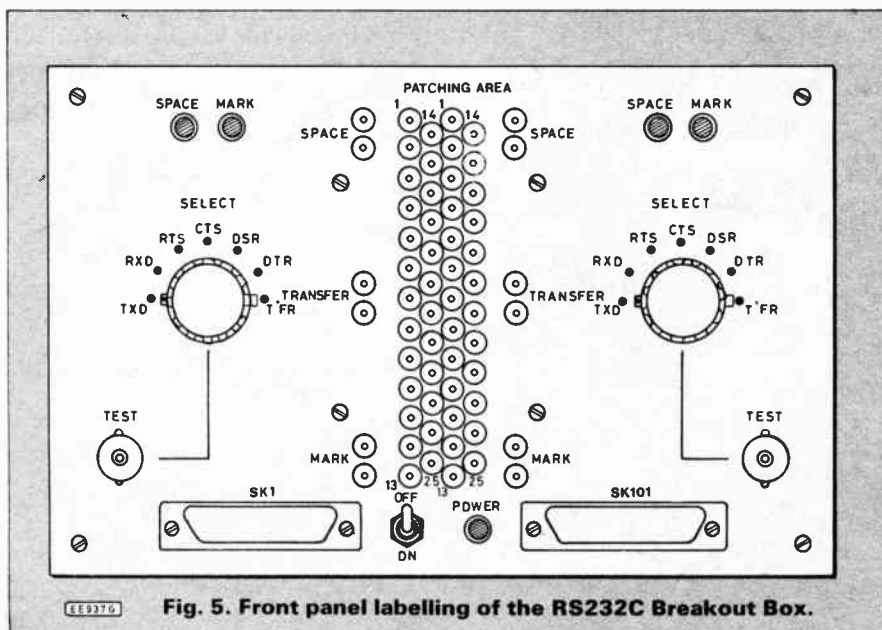

Fig. 5. Front panel labelling of the RS232C Breakout Box.



# MINI DISCO LIGHT

T.R. de VAUX-BALBIRNIE

**Simple unit to provide 240W of mains powered flashing lights without audio connections to amplifiers etc.**

OF ALL the disco effects available, lights which flash to the beat of the music continue to enjoy greatest popularity. This circuit fills the gap between simple low-voltage circuits (for example, *Children's Disco Lights*, EE, December, 1983) and high-power multi-channel systems. The low constructional cost makes this ideal for parties or for use in teenagers' bedrooms. Note that this is a *single channel* system so all bulbs connected to it will flash in unison, unlike more sophisticated circuits.

The Mini Disco Light will operate mains filament lamps to a maximum total loading of 240W on 240V a.c. mains. The prototype unit was used with four 60W coloured

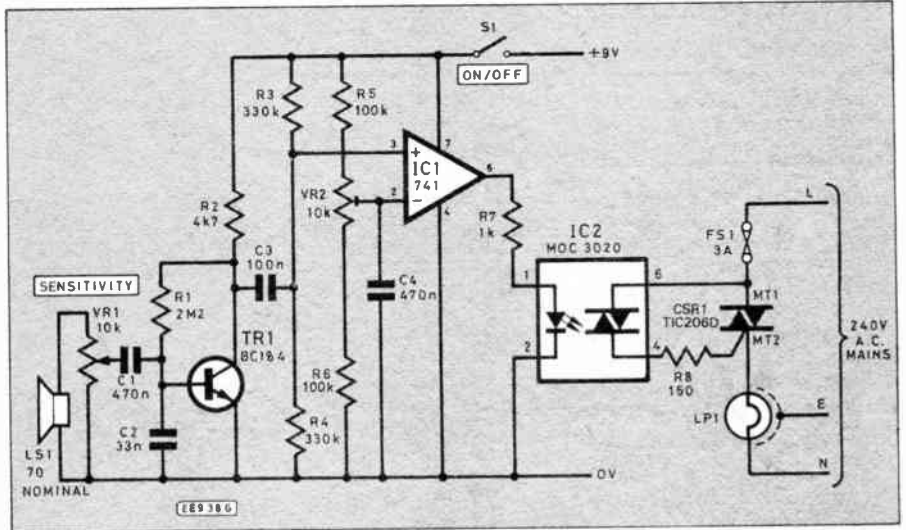

Fig. 1. Circuit diagram of the Mini Disco Light

spotlights. The circuit itself is battery operated which reduces costs and simplifies construction—the battery will provide excellent service. An inbuilt microphone picks up the music so avoiding direct connections with the amplifier. This has the benefit of causing the lights to flash with other sounds in the room. A gain control, which matches the response of the unit to the volume of

sound and a supply on-off switch are provided on the front panel.

## CIRCUIT DESCRIPTION

The circuit for the Mini Disco Light is shown in Fig. 1. LS1 is a miniature loud-speaker but in this application it is used as a microphone. When sound waves impinge on its cone, a small a.c. voltage is developed between its terminals. VR1 "taps off" a proportion of this voltage and a weak a.c. current passes via C1 to TR1 base. VR1 thus provides a means of adjusting the sensitivity of the circuit. R1 and R2 bias TR1 which amplifies the signal and delivers larger voltage changes through C3 to the operational amplifier non-inverting input, IC1 pin 3. In the absence of detected sound, the potential divider action of R3 and R4 apply a fixed voltage to pin 3 while the inverting input (pin 2) receives a voltage which depends on the adjustment of VR2. R5 and R6 narrow the range of VR2 adjustment making it easier to obtain the correct setting. With this adjustment correct, the voltage at pin 2 will just exceed that at pin 3 so IC1 is off with pin 6 (the output) low. This has no effect on the rest of the circuit.

When LS1 detects sound, the voltage variations passed to IC1 pin 3 modulate the existing voltage which rises and falls in sympathy. On rising excursions, the voltage at pin 3 exceeds that at pin 2 and the op-amp switches on with pin 6 going high (battery positive voltage). This operates the light-emitting diode contained within IC2. (Resistor R7 limits the l.e.d. operating current to the correct working value.)

IC2 is an optically-coupled triac and operating the l.e.d. in this way establishes a

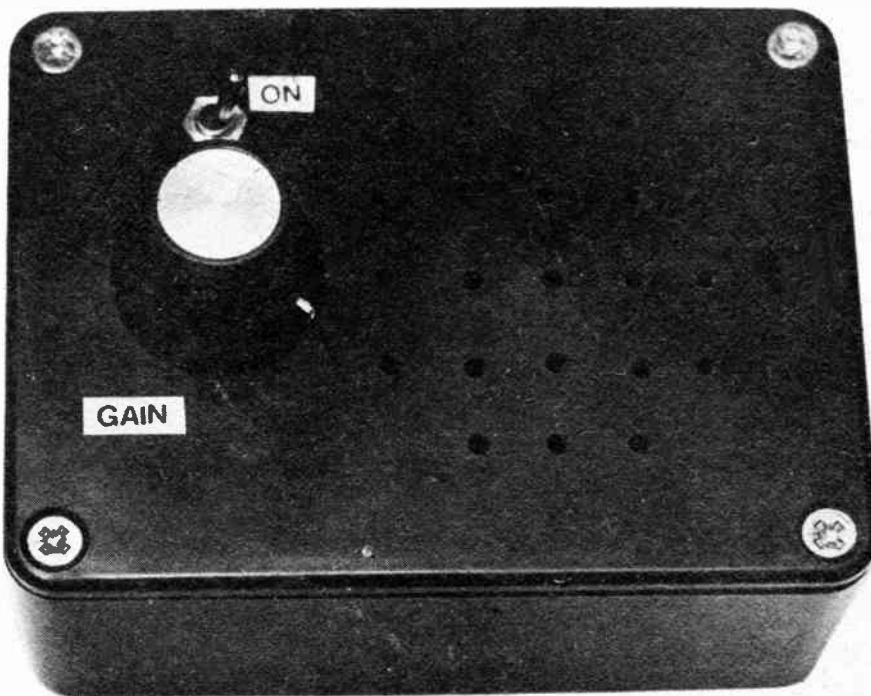



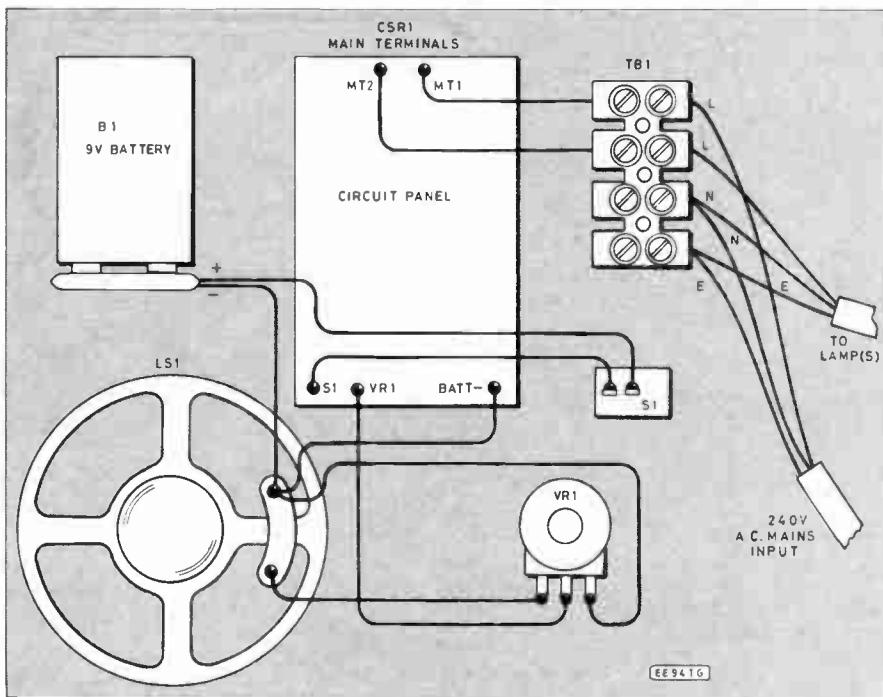

Fig. 4. Wiring of the Mini Disco Light. The mains plug must be fused at 3A.

Refer to Fig. 3 and make the triac heat sink using thin sheet aluminium—mount this as shown (see photograph). Note that a mounting kit consisting of a thin mica washer and a plastic bush must be used to isolate the heat sink from the mains. Mount the p.c.b. and T81 to the base of the case using small fixings. Prepare the lid by drilling holes for S1 and VR1. Drill a matrix of small holes for the sound to pass to LS1. Mount S1 and VR1 then secure LS1 using quick-setting adhesive sparingly around the rim, make sure the adhesive does not touch

the paper cone. When the adhesive is fully hardened, check LS1 for security.

Refer to Fig. 4 and complete the internal connections shortening any wires as necessary. Note that one LS1 terminal is used as a common anchorage for the battery negative connections. Make a mains input lead of suitable length. Use 3A three-core mains wire for this and fit a plug carrying a 3A fuse. Use similar wire for the output lead—fit a mains line socket or multi-socket. A block of four in-line sockets will be found most useful. If the output socket requires a

fuse, fit one of 3A rating. Fit suitable strain relief clamps inside the case to both mains input and output leads.

Gently bend CSR1 pins so that the heat sink rests horizontally (see photograph). Slowly offer the lid to the rest of the case and check for trapped wires. Check also that all internal components remain clear of the heat sink. Connect the battery and secure it to the side of the case using an adhesive fixing pad. Finally, fit the case with self-adhesive plastic feet. This will prevent scratched table tops when the unit is in use.

## TESTING AND OPERATION

**Safety warning:** Since mains voltage exists inside the case, the unit must be unplugged from the supply whenever the lid is removed. Adjustment to VR2 must therefore be made in a series of small steps with the lid replaced before testing.

Potentiometer VR2 sliding contact should be adjusted so that IC1 just remains off when no sound is detected. Plug a reading lamp into the output socket. Adjust VR1 fully anti-clockwise (least sensitive position), adjust VR2 sliding contact fully clockwise (as viewed from IC2). Replace the lid and plug the unit into the mains. Switch on S1. The lamp may flash briefly but should then remain off. Make small anti-clockwise adjustments to VR2 to find the position where the lamp remains on. It should then be adjusted slightly so that it stays off. If this operation is carried out 100 critically, there will be a tendency for the lamp to "lock on" and fail to respond as it should. If it is not done carefully enough, the circuit will lack sensitivity. Test for correct adjustment by increasing the gain with VR1 then speak into LS1. The lamp should flash with the sound.

If all is well, the unit may be put into use with, perhaps, further small adjustments to VR2 over a trial period for best effect. After use, do not forget to switch off at S1 or the battery will not last long! □

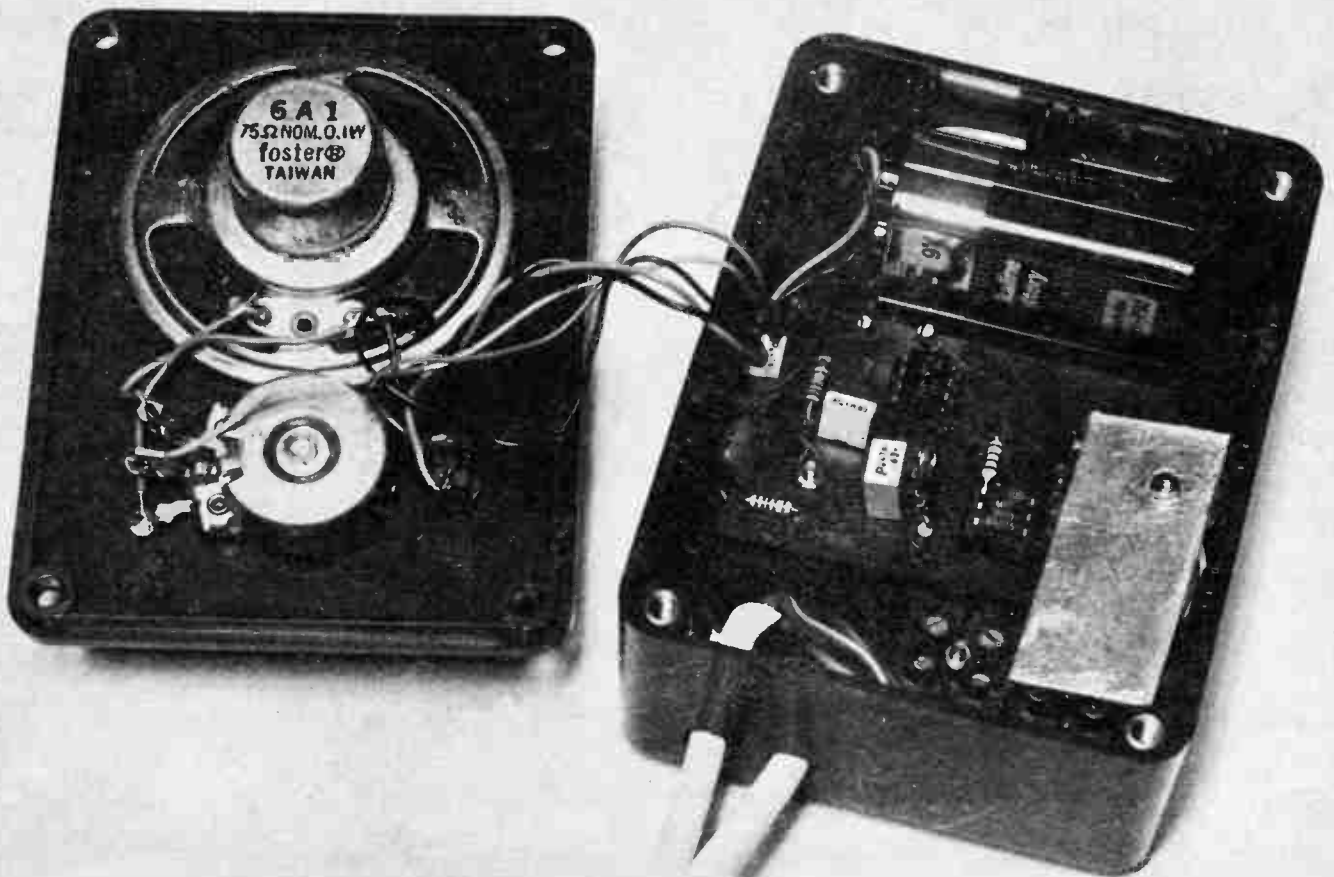

# exploring electronics

OWEN BISHOP

This series is designed to explain the workings of electronic components and circuits by involving the reader in experimenting with them. There will not be masses of theory or formulae but straightforward explanations and circuits to build and experiment with.

## Part 12 Operational amplifiers

**T**HIS MONTH we introduce another inexpensive yet extremely versatile integrated circuit (i.c.) the 741 operational amplifier. This is but one of an ever increasing family of such devices, each with their own special features, but all doing more-or-less the same thing.

There are several ways in which operational amplifiers can be connected up and used, and we shall investigate one of these. The *op-amp*, as it is often called for short, has many transistors and resistors inside, connected as an amplifier that has very high gain. The i.c. has only seven external connections, two of which we are not concerned with here.

### POWER SUPPLY

The power supply to the 741 i.c., is a little different from what we have met so far. It requires a voltage greater than zero at pin 7, and a voltage less than zero at pin 4. By splitting the battery into two sections as shown, we can arrange for +3V and -3V supplies. This is the minimum voltage on which the i.c. will work.

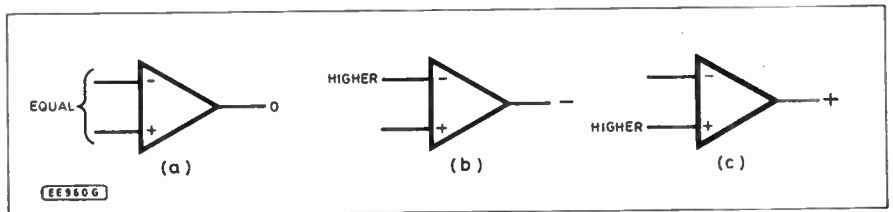

Fig. 12.2. Input and output voltage of an operational amplifier.

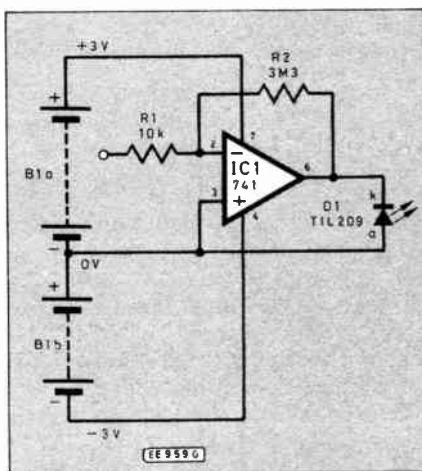

Fig. 12.1 (above). Circuit to demonstrate the action of an operational amplifier.

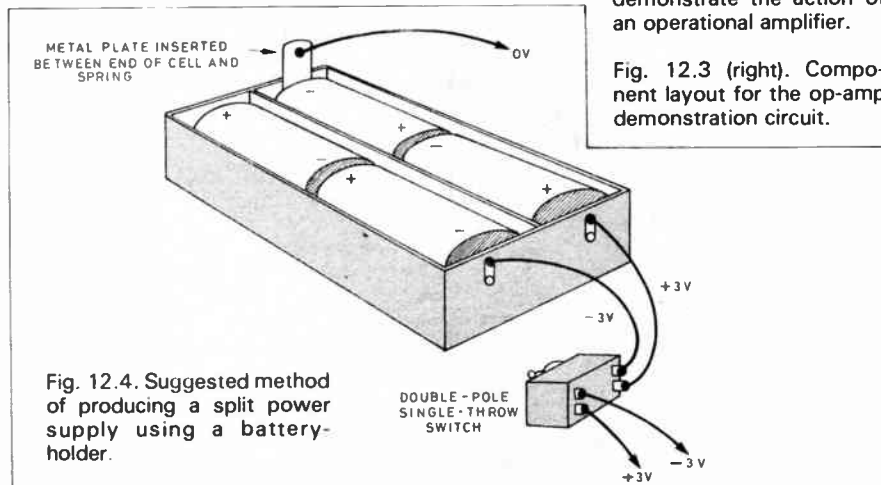

Fig. 12.4. Suggested method of producing a split power supply using a battery holder.

The recommended voltage range is 5V to 8V and the i.c. will give its best performance within that range. However, 3V is easier to obtain, as only a standard battery-holder is required, and this is adequate for the purposes of this article, see Fig. 12.4.

The amplifier is represented in the diagrams as a triangle. It has two

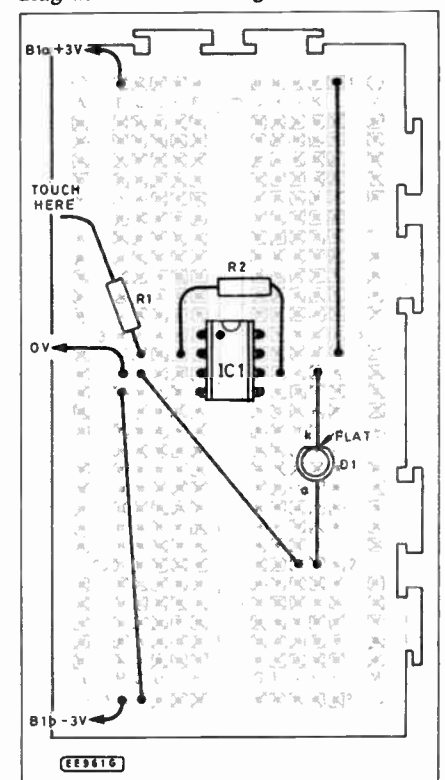
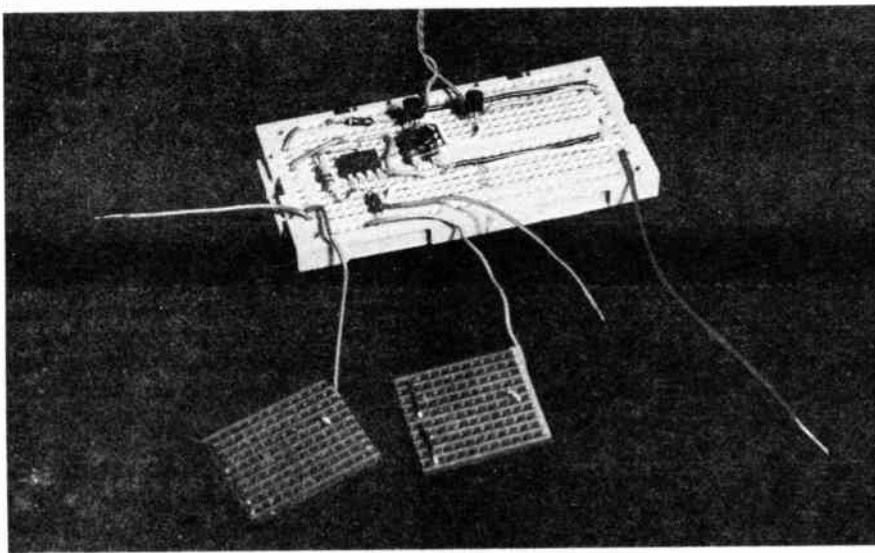

Fig. 12.3 (right). Component layout for the op-amp demonstration circuit.



## DEMO-MODEL

### Resistors

- R1 10k
- R2 3M3
- All 0.25W 5% carbon

### Semiconductors

- D1 TIL209 light emitting diode
- IC1 741 operational amplifier

### Miscellaneous

Split power supply, four 1.5V cells and battery holder (see Fig. 12.4); breadboard (e.g. Verobloc); 8-pin d.i.l. i.c. socket and connecting wire.

inputs, labelled '-' and '+', and an output (at the point of the triangle).

The amplifier is very sensitive to a difference between the voltages applied to its inputs, as Fig 12.2 shows. Gain is high so, if there is a small difference in voltage at the inputs, the output voltage is very high or low, almost reaching that of one of the supply lines.

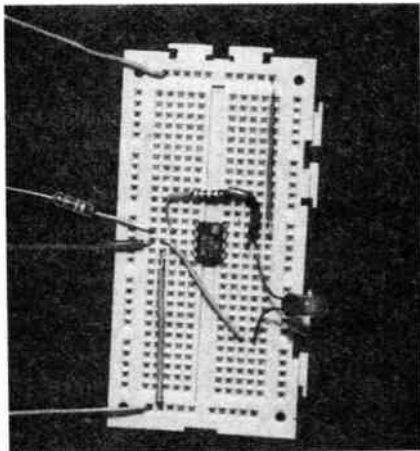

The completed op-amp "test-bed".

well under  $1\mu\text{A}$ , and the voltage at the hand touching resistor R1 is only about 7.5mV.

Yet with a difference of only 7.5mV between the inputs, the output of the op-amp swings low enough to make the l.e.d. light. Note that, with a positive voltage applied to the inverting input, the output swings negative.

In this circuit the l.e.d. has been connected so as to pass current when the output swings below 0V. We will learn more about operational amplifiers and look into their many applications next month.

## TOUCH SWITCH

The circuit diagram for a Simple Touch Switch is shown in Fig. 12.5. This "switch" makes a buzzer sound when you place your finger against two small metal contacts so as to bridge the gap between them. It can also be used for lighting lamps, triggering a timer circuit and in many other ways.

## TOUCH SWITCH

### Resistors

- R1 10k
- R2 3M3
- All 0.25W 5% carbon

### Potentiometer

- VR1 1k miniature horizontal carbon preset

### Capacitor

- C1 47 $\mu$  elec. (single touch-plate version)

### Semiconductors

- TR1, TR2 ZTX 300 npn transistor (2 off)

### Miscellaneous

- S1 DPST toggle switch.
- WD1 Solid state audible warning buzzer.
- Split power supply; four 1.5V cells and battery holder (See Fig. 12.4); breadboard; 8-pin d.i.l. i.c. socket; touch-plate—see text; connecting wire.

See  
**Shop  
Talk**  
page 306

## WHAT TO DO

The Op-Amp demonstration circuit is shown in Fig. 12.1. The non-inverting input ('+') is connected to the zero volt rail so, if the inverting input is also at zero volts (making both inputs equal), output is zero too.

The circuit shown in the diagram will be in that state because, if resistor R1 is unconnected and output is zero volts, then the inverting input must also be at zero. The amplifier is in a stable state. Now take hold of the free end of resistor R1 in one hand, then touch your finger against the other positive terminal of battery B1a. What happens?

The resistance of your body, from one hand to the other, is about  $4\text{M}\Omega$  (Megohm), so the current flowing through your body to the op-amp is

Fig. 12.5. The complete circuit diagram of the Simple Touch Switch.

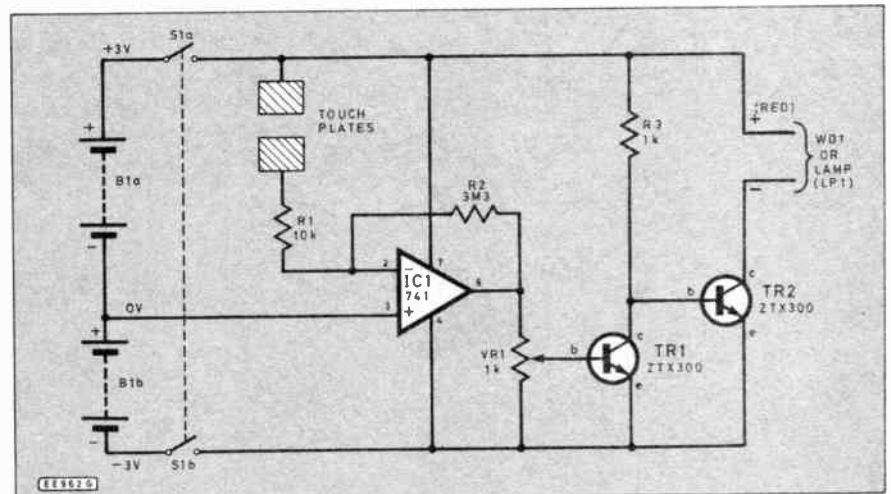

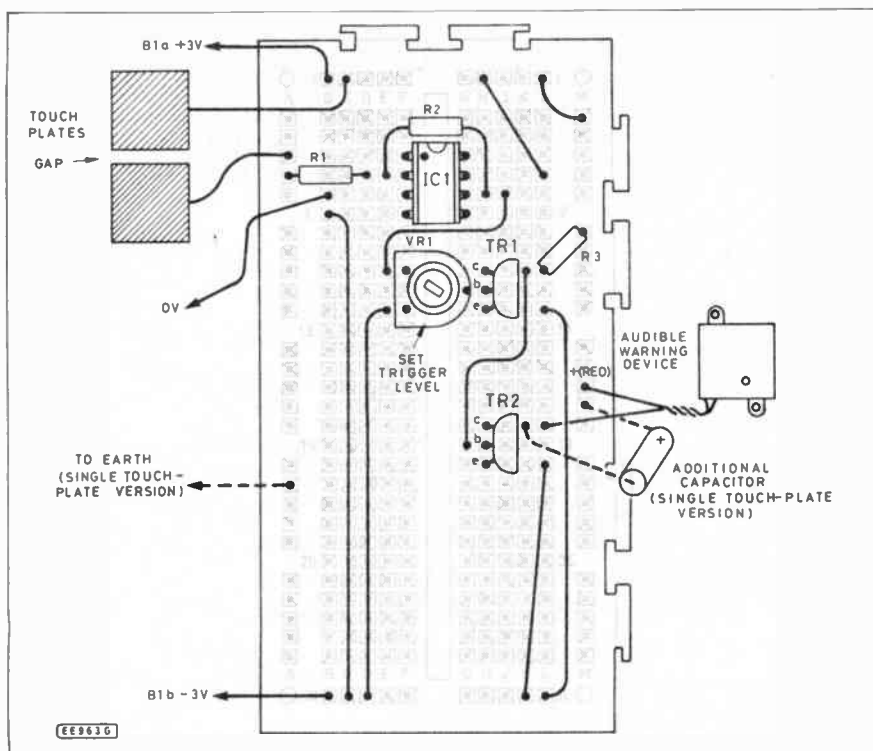

Fig. 12.6. Demonstration breadboard component layout for the Simple Touch Switch.

## HOW IT WORKS

The touch-plates have a small gap between them so resistor R1 is unconnected (compare with Fig. 12.1) and the voltage at the inverting input of the op-amp is zero. Its output is also zero.

When a finger is placed across the gap a small current flows to the inverting input. The voltage at the inverting input becomes slightly higher than that of the non-inverting input. This makes the output voltage fall below zero (Fig 12.2b), almost to  $-3V$ .

The variable resistor (potentiometer) VR1 acts as a potential divider. It is adjusted so that when the output from the op-amp IC1 is zero (or  $+3V$  relative to the emitter of TR1) transis-

tor TR1 is switched on, causing TR2 to be off and the buzzer to be silent.

When the circuit is triggered, by touching the plates, IC1 output goes low turning TR1 off, which causes TR2 to be turned on. A collector current flows through the buzzer to TR2, and the buzzer sounds.

## CONSTRUCTION

The demonstration breadboard component layout for the Simple Touch Switch is shown in Fig. 12.6.

There are lots of ways of making the touch-plates. A simple method is to push two drawing-pins into a piece of wood or plastic, so that they have a gap of about 1mm between them. This can

The finished Touch Switch. The "touch-plates" have been made from some spare stripboard, with the copper tracks soldered together using bare link wires.

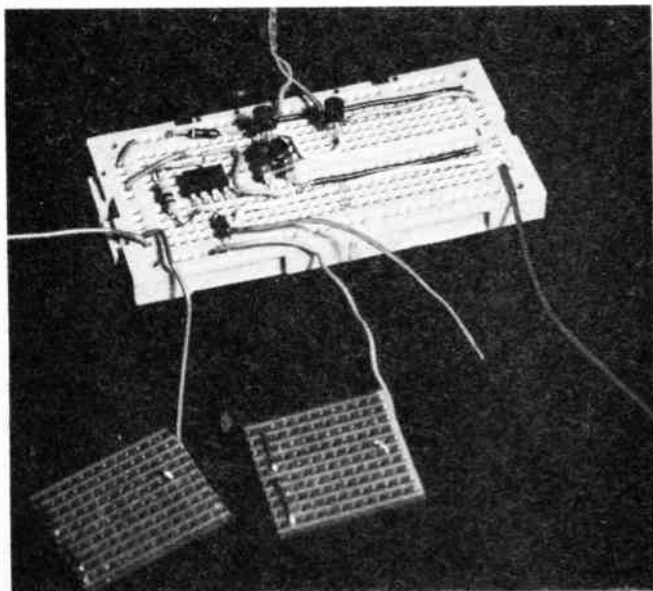

be mounted beside a doorway, or wherever else you wish the control switch to be.

Set VR1 so that the buzzer sounds then turn it back again to a position in which it *just* fails to sound.

Touching the plates should now make it sound.

## VARIATIONS

We can carry the touch switch idea still further and use only one touch-plate. This circuit must be earthed and also needs a capacitor ( $47\mu$ ) across the terminals of the buzzer to obtain steady operation.

This version of the touch switch depends on the fact that your body is in a rapidly changing magnetic field due to all the many and changing electrical currents that are flowing in the mains wires in your home. The changing fields induce changing electrical currents in your body. These are exceedingly small, but are sufficient to trigger the circuit.

Instead of the buzzer, you can use a filament lamp (LP1) or an l.e.d. The capacitor is not then required.

The touch-plate can take many forms. It can be a single drawing-pin, a square of stripboard, or disc of metal. It could be the metal number-plate on the front door, or a metal door-knob. It could be a length of bare wire tacked along the edge of a window-sill, so that the alarm sounds when someone tries to climb in.

It could be a really large metal plate so that it can be easily found in the dark, or by a blind person. Even the slightest touch on it causes the buzzer to sound.

If transistor TR2 is replaced by a BD131 transistor, you can use the Touch Switch to control a low voltage electric motor. You could build a touch switch control panel for controlling model railways or other motor-powered models.

**Next month: Telephone Alarm and Model Speed Control using an Op-Amp.**

## PLEASE TAKE NOTE

**Experimental Speech Recognition Unit (April 1987)**

Page 204, Components List. The numerical sequence of the capacitors is incorrect and should be as follows:

C8,C11,C14,C17	1 $\mu$ radial elec. 63V (4 off)
C9,C10	4n7 miniature polyester layer (2 off)
C12,C3	2n2 miniature polyester layer (2 off)
C15,C16	1n miniature polyester layer (2 off)

Capacitors C1 to C7 are correct as listed.

# SPECIAL OFFER...

## BATTERY TESTER



**£4.95**

including VAT & p.&p.

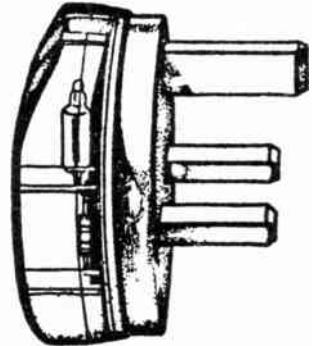

## MAINS TESTER

**£7.95** including VAT & p.&p.

# UNIVERSAL BATTERY TESTER and MAINS SOCKET TESTER

We are pleased to be able to offer readers these two really clever testers that take the guesswork out of testing batteries and 13amp sockets.

**Battery Tester.** A very compact hand held battery tester that allows you to test any domestic battery from the smallest "button" batteries, found in watches and calculators, to batteries up to 70mm high.

A spring loaded testing arm ensures good contact and the clearly marked dual scales, one for button batteries, the other for standard cells, indicate whether replacement is required—low power—or good condition. There is a separate contact point for the press-stud type PP3 battery. The tester has a built-in load to ensure a true and accurate reading. Some testers do not have this feature and, whilst they show the battery has power, no indication is given that it is insufficient to power an appliance. No internal battery is required. By testing your batteries you can now avoid the costly exercise of discarding a complete set when some may still have life in them.

**13amp "all points check" Mains Socket Tester.** Just plug this unit into a 13amp outlet and it immediately diagnoses the safety and supply to your power points. Three neon lights indicate the following conditions; (a) live, neutral and earth OK, (b) no neutral, (c) no earth, (d) live and neutral reversed, (e) live and earth reversed.

This clever unit can be used by anyone, as it is so easy to understand, and not only does it help protect you from unforeseen faults, it shows you whether the supply or appliance is at fault.

Post to: EE Offer, J.E.M. Marketing, 6 Green Dragon Lane, Winchmore Hill, London N21 2LD. Tel: 01-364 0464.

Please supply

Quantity		Value
	Universal Battery Tester @ £4.95	
	Mains Socket Tester @ £7.95	
		Total £

Visa/Access or cheque no.....

Signature.....

Name.....

Address.....

OFFER CLOSES Friday, July 3, 1987

Name.....

Address.....

Post to: EE Offer, J.E.M. Marketing, 6 Green Dragon Lane, Winchmore Hill, London N21 2LD.  
Tel: 01-364 0464

# FOR YOUR ENTERTAINMENT

BY BARRY FOX

## Computer Show

To the eighth annual Which Computer? Show at the National Exhibition Centre in Birmingham . . .

Still crowded, like hi fi and video shows used to be, before their boom times passed. First and main impression was an almost total commitment now to the IBM standard, or more accurately range of IBM standards. Only Apple stay out of the IBM PC world with the Mac.

This puts some writing on the wall. It may well have been the uncertainty, and confusion of conflicting standards, which has fuelled public interest in the computer market. Now IBM compatibility has become the norm, the only source of real future interest will be price, features and bolt-on accessories.

The computer market will then emulate the audio and video market. People who have bought computers to use will be too busy using them to prowl round a show. People who haven't yet bought one, will go to a local dealer.

Within a few years anyone trying to stage a computer show will be up against the same difficulties that face anyone now trying to stage an audio or video show. The large consumer electronic shows in America, and the Berlin Radio Show, point to the future. At these exhibitions everything is under one roof; audio, video, computers, radio, TV, satellite systems, telephones and general electronic gadgetry. That is the path exhibitions must follow in Britain, or perish.

## Accessory Market

At Birmingham the accessory market was clearly booming. I counted no less than twenty exhibitors showing equipment which is claimed to protect computers from the evil effects of mains-born interference and voltage drops and surges. All these systems doubtless work as claimed. There were some impressive demonstrations of how expensive circuitry can eliminate spikes, stabilise widely varying supply voltages and bridge gaps in the supply.

Repeatedly I asked the exhibitors what work they had done on analysing mains supply problems in Britain, and the ability of available computers to cope with the kind of problems likely to be encountered. I asked, because the British electricity supply is commendably stable and most computers made by respectable manufacturers have good smoothing and stabilisation circuits, with large enough capacitors in the power supply to bridge brief voltage dips.

I could not find one exhibitor with convincing evidence to show that respectable computers cannot cope with what they face from the mains. On the face of things, the boom in line conditioners looks like a sophisticated and expensive solution looking for a problem.

The technology is interesting, but is it necessary? It would be useful to hear

readers' views on this, based on practical experience. We can then return to the technology in a later column.

## Optical Illusion

There was still no sign of the optical storage revolution reaching the home or small business computer market. No-one was showing a CD-ROM system and no-one was showing a working optical disc recorder for a PC.

In the press room Maxell had posted a notice, inviting all present to come and see the company's new 5-25 inch optical disc. This sounded interesting, because the computer industry is currently trying to set a standard for optical discs which allow users to record their own data—either permanently or semi-permanently.

So far there has been only confusion, with different firms adopting different disc sizes (14, 12, 8, 5-25 and 3-5 inch) and different coding standards for the data. The only thing these systems have in common is that the blank disc is coated with a metal surface into which pits are burned by a laser in the recorder. Rotational speed is constant to give orderly sectoring. But there is no agreed standard for the fixed speed.

Sometimes the blank disc has a groove to guide the laser; sometimes it has a pre-formed spiral track of servo control pits. As a result it is a safe bet that data recorded on one manufacturer's optical disc system will not replay on another.

Philips and Sony have been trying to set a standard based on a 5-25 inch disc contained in a protective cassette. The disc drive would fit in a standard PC drive slot. The Maxell demonstration turned out to be a damp squib. Simply a 5-25 inch disc in a demonstrator's pocket. No working hardware and no working demonstration.

## Quickdisk

Maxell was also talking about, but not demonstrating, an interesting system called Quickdisk. The Japanese company is offering this to firms in Europe which make budget computers.

Quickdisk is a low cost magnetic floppy disc which offers an alternative to cassette tapes for data storage. It was developed by Mitsumi and Maxell and is already used in Japan for toy computers made by Nintendo. Maxell now suggests that Quickdisks would make an ideal memory store for low cost office equipment, such as electronic computers.

Quickdisk looks like a conventional floppy disc, 2-75 inch in diameter, but requires much simpler and thus much cheaper read-write electronics to store and retrieve the data.

Conventional floppy disc systems divide the magnetic surface into evenly distributed pie-shaped sectors. Each sector is digitally labelled and a magnetic pick-up moves rapidly between sectors under

servo control to record or retrieve labelled blocks of data. The head can find any sector and read its data in less than a second.

Data is recorded on Quickdisk as a spiral track, like a magnetic gramophone record, instead of sectors. The read-write head starts at one end of the spiral track and runs right through to the other end as the disc rotates at a fixed speed of 423rpm. So all the data to be stored is recorded as a serial stream.

The spiral track on one side of the disc can store 64 kilobytes, which is equivalent to around 64,000 text characters. It takes eight seconds to run through the complete track, either recording or retrieving the full data stream.

Although Quickdisk is a clumsy method of storing data when compared to conventional floppy disc, it is far cheaper because there is no need for complicated servo and search control of the head. It is also much faster to use than a tape cassette, which can take minutes rather than seconds to run through. Maxell reckons it could sell Quickdisks for around £1 each, which is as cheap as a data cassette tape.

I couldn't help thinking that Maxell would have more chance of selling the system to British manufacturers if it had staged a demonstration at the Birmingham show, rather than just putting out a pile of leaflets and leaving journalists like myself to try and find someone who knew what the leaflets meant.

## Z88 Launch

The Birmingham show saw the official launch of Sir Clive Sinclair's new computer. Because Sir Clive literally sold his name to Amstrad for use on computers, he has had to start a new company called Cambridge Computers. Although he can still call himself Sir Clive Sinclair, he has to call the new computer simply the Z88. As usual with Sir Clive, the Z88 is available only by mail order.

The "no-compromise" Z88 is a portable and much improved version of the old Spectrum. Although the 'rubbery' keyboard is better than the Spectrum keyboard, it still fits the classic description—"like shaking hands with a dead man". The i.c.d. screen is reasonably clear, but the text characters are small, and could prove pretty wearing on the eyes. Working with the larger Tandy 100 screen is bad enough.

At Birmingham, the Sinclair (sorry Cambridge Computers) stand was small—quite a comedown from Sir Clive's days of past glory. But otherwise it was *déjà vu*. Although there was a pile of cardboard boxes, there was only one working model on display.

A milling crowd were given a brochure with mail order form. The brochure promised a "special introductory price" of £199.95 but the form told potential customers to send £229.95 plus £7.50 postage. All very puzzling.

It will be interesting to see whether history repeats itself and there now follows the familiar saga of complaints from members of the public who send their money for a new Sinclair gadget, only to find that it is not yet available. It would be nice to think that Sir Clive, having lost his fortune, has finally learned his lesson. Time will tell.





# BOOK SERVICE

The books listed below have been selected as being of special interest to our readers, they are supplied from our editorial address direct to your door.

## DATA AND REFERENCE

### PRACTICAL ELECTRONICS CALCULATIONS AND FORMULAE

**F. A. Wilson, C.G.I.A., C.Eng., F.I.E.E., F.I.E.R.E., F.B.I.M.**  
Bridges the gap between complicated technical theory, and "cut-and-try" methods which may bring success in design but leave the experimenter unfulfilled. A strong practical bias—tedious and higher mathematics have been avoided where possible and many tables have been included.

The book is divided into six basic sections: Units and Constants, Direct-current Circuits, Passive Components, Alternating-current Circuits, Networks and Theorems, Measurements.  
256 pages **Order Code BP53 £2.95**

### ESSENTIAL THEORY FOR THE ELECTRONICS HOBBYIST

**G. T. Rubaro, T.Eng (C.E.I.), Assoc.I.E.R.E.**  
The object of this book is to supply the hobbyist with a background knowledge tailored to meet his or her specific requirements and the author has brought together the relevant material and presented it in a readable manner with minimum recourse to mathematics.  
128 pages **Order Code 228 £2.50**

### MICROPROCESSING SYSTEMS AND CIRCUITS

**F. A. Wilson, C.G.I.A., C.Eng., F.I.E.E., F.I.E.R.E., F.B.I.M.**  
A truly comprehensive guide to the elements of micro-processing systems which really starts at the beginning. Teaches the reader the essential fundamentals that are so important for a sound understanding of the subject.  
256 pages **Order Code BP77 £2.95**

### COMMUNICATION

**F. A. Wilson, C.G.I.A., C.Eng., F.I.E.E., F.I.E.R.E., F.B.I.M.**  
A look at the electronic fundamentals over the whole of the communication scene. This book aims to teach the important elements of each branch of the subject in a style as interesting and practical as possible. While not getting involved in the more complicated theory and mathematics, most of the modern transmission system techniques are examined including line, microwave, submarine, satellite and digital multiplex systems, radio and telegraphy. To assist in understanding these more thoroughly, chapters on signal processing, the electro-

magnetic wave, networks and transmissions assessment are included, finally a short chapter on optical transmission.  
256 pages **Order Code BP89 £2.95**

### AUDIO

**F. A. Wilson, C.G.I.A., C.Eng., F.I.E.E., F.I.E.R.E., F.B.I.M.**  
Analysis of the sound wave and an explanation of acoustical quantities prepare the way. These are followed by a study of the mechanism of hearing and examination of the various sounds we hear. A look at room acoustics with a subsequent chapter on microphones and loudspeakers then sets the scene for the main chapter on audio systems—amplifiers, oscillators, disc and magnetic recording and electronic music.  
320 pages **Order Code BP111 £3.50**

### HOW TO IDENTIFY UNMARKED ICs

**K. H. Recorr**  
Shows the reader how, with just a test-meter, to go about recording the particular signature of an unmarked i.c. which should enable the i.c. to then be identified with reference to manufacturers' or other data. An i.c. signature is a specially plotted chart produced by measuring the resistances between all terminal pairs of an i.c.  
Chart **Order code BP101 £0.95**

### RADIO AND ELECTRONIC COLOUR CODES AND DATA CHART

**B. B. Babani**  
Although this chart was first published in 1971 it provides basic information on many colour codes in use throughout the world, for most radio and electronic components. Includes resistors, capacitors, transformers, field coils, fuses, battery leads, speakers, etc. It is particularly useful for finding the values of old components.  
Chart **Order code BP7 £0.95**

### CHART OF RADIO, ELECTRONIC, SEMICONDUCTOR AND LOGIC SYMBOLS

**M. H. Banani, B.Sc.(Eng.)**  
Illustrates the common, and many of the not-so-common, radio, electronic, semiconductor and logic symbols that are used in books, magazines and instruction manuals, etc., in most countries throughout the world.  
Chart **Order Code BP27 £0.95**

### TRANSISTOR RADIO FAULT-FINDING CHART

**C. E. Miller**  
Used properly, should enable the reader to trace most common faults reasonably quickly. Across the top of the chart will be found four rectangles containing brief description of these faults, viz—sound weak but undistorted, set dead, sound low or distorted and background noises. One then selects the most appropriate of these and following the arrows, carries out the suggested checks in sequence until the fault is cleared.  
Chart **Order code BP70 £0.95**

### DIGITAL IC EQUIVALENTS AND PIN CONNECTIONS

**A. Michaels**  
Shows equivalents and pin connections of a popular selection of European, American and Japanese digital i.c.s. Also includes details of packaging, families, functions, manufacturer and country of origin.  
256 pages **Order code BP140 £4.95**

### LINEAR IC EQUIVALENTS AND PIN CONNECTIONS

**A. Michaels**  
Shows equivalents and pin connections of a popular selection of European, American and Japanese linear i.c.s. Also includes details of functions, manufacturer and country of origin.  
320 pages **Order code BP141 £4.95**

### INTERNATIONAL TRANSISTOR EQUIVALENTS GUIDE

**A. Michaels**  
Helps the reader to find possible substitutes for a popular selection of European, American and Japanese transistors. Also shows material type, polarity, manufacturer and use.  
320 pages **Order code BP85 £2.95**

### INTERNATIONAL DIODE EQUIVALENTS GUIDE

**A. Michaels**  
Designed to help the user in finding possible substitutes for a large selection of the many different types of diodes that are available. Besides simple rectifier diodes, also included are Zener diodes, i.e. d.s. diacs, triacs, thyristors, OCLs, photo and display diodes.  
144 pages **Order code BP108 £2.25**

## CIRCUITS AND DESIGN

### ELECTRONICS SIMPLIFIED —CRYSTAL SET CONSTRUCTION

**F. A. Wilson, C.G.I.A., C.Eng., F.I.E.E., F.I.E.R.E., F.B.I.M.**  
Especially written for those who wish to participate in the intricacies of electronics more through practical construction than by theoretical study. It is designed for all ages upwards from the day one can read intelligently and handle simple tools.  
80 pages **Order Code BP92 £1.75**

### 50 CIRCUITS USING GERMANIUM SILICON AND ZENER DIODES

**R. N. Soar**  
Contains 50 interesting and useful circuits and applications, covering many different branches of electronics, using one of the most simple and inexpensive of components—the diode. Includes the use of germanium and silicon signal diodes, silicon rectifier diodes and Zener diodes, etc.  
64 pages **Order Code BP36 £1.50**

### 50 SIMPLE LED CIRCUITS

**R. N. Soar**  
Contains 50 interesting and useful circuits and applications, covering many different branches of electronics, using one of the most inexpensive and freely available components—the light-emitting diode (LED). Also includes circuits for the 707 common anode display.  
64 pages **Order Code BP42 £1.95**

### COIL DESIGN AND CONSTRUCTION MANUAL

**B. B. Babani**  
A complete book for the home constructor on "how to make" RF, IF, audio and power coils, chokes and transformers. Practically every possible type is discussed and calculations necessary are given and explained in detail. Although this book is now rather old, with the exception of torroids and pulse transformers little has changed in coil design since it was written.  
96 pages **Order Code 160 £2.50**

### MICRO INTERFACING CIRCUITS—BOOK 1

**MICRO INTERFACING CIRCUITS—BOOK 2**  
**R. A. Penfold**  
Both books include practical circuits together with details of the circuit operation and useful background information. Any special constructional points are covered but p.c.b. layouts and other detailed constructional information are not included.

Book 1 is mainly concerned with getting signals in and out of the computer; Book 2 deals primarily with circuits for practical applications.

Book 1 112 pages **Order code BP130 £2.25**  
Book 2 112 pages **Order code BP131 £2.25**

### A MICROPROCESSOR PRIMER

**E. A. Parr, B.Sc., C.Eng., M.I.E.E.**  
Starts by designing a small computer which, because of its simplicity and logical structure, enables the language to be easily learnt and understood. The shortcomings are then discussed and the reader is shown how these can be overcome by changes and additions to the instruction set. In this way, such ideas as relative addressing, index registers, etc., are developed.  
96 pages **Order code BP72 £1.75**

### A PRACTICAL INTRODUCTION TO MICROPROCESSORS

**R. A. Penfold**  
Provides an introduction which includes a very simple microprocessor circuit which can be constructed so that the reader can experiment and gain practical experience.  
96 pages **Order code BP123 £1.95**

### HOW TO USE OP-AMPS

**E. A. Parr**  
This book has been written as a designer's guide covering many operational amplifiers, serving both as a source book of circuits and a reference book for design calculations. The approach has been made as non-mathematical as possible.  
160 pages **Order code BP88 £2.95**

### PRACTICAL ELECTRONIC BUILDING BLOCKS—BOOK 1

**PRACTICAL ELECTRONIC BUILDING BLOCKS—BOOK 2**  
**R. A. Penfold**  
These books are designed to aid electronic enthusiasts who like to experiment with circuits and produce their own projects, rather than simply following published project designs.

BOOK 1 contains: Oscillators—sinewave, triangular, squarewave, sawtooth, and pulse waveform generators operating at audio frequencies. Timers—simple monostable circuits using i.c.s, the 555 and 7555 devices, etc. Miscellaneous—noise generators, rectifiers, comparators and triggers, etc.

BOOK 2 contains: Amplifiers—low level discrete and op-amp circuits, voltage and buffer amplifiers including d.c. types. Also low-noise audio and voltage controlled amplifiers. Filters—high-pass, low-pass, B, T, and 24dB per octave types. Miscellaneous—i.c. power amplifiers, mixers, voltage and current regulators, etc.  
BOOK 1 128 pages **Order code BP117 £1.95**  
BOOK 2 112 pages **Order code BP118 £1.95**

### HOW TO DESIGN ELECTRONIC PROJECTS

**R. A. Penfold**  
The aim of this book is to help the reader to put together projects from standard circuit blocks with a minimum of trial and error, but without resorting to any advanced mathematics. Hints on designing circuit blocks to meet your special requirements are also provided.  
128 pages **Order code BP127 £2.25**

### POPULAR ELECTRONIC CIRCUITS

**—BOOK 1**  
**POPULAR ELECTRONIC CIRCUITS**  
**—BOOK 2**  
**R. A. Penfold**  
Each book provides a wide range of designs for electronic enthusiasts who are capable of producing working projects from just a circuit diagram without the aid of detailed construction information. Any special setting-up procedures are described.  
BOOK 1 Temporarily out of print  
BOOK 2 160 pages **Order code BP98 £2.25**

**GETTING THE MOST FROM YOUR PRINTER**

**J. W. Penfold**  
Details how to use all the features provided on most dot-matrix printers from programs and popular word processor packages like Wordwise, Visawrite and Quill, etc. Shows exactly what must be typed in to achieve a given effect.  
96 pages **Order Code BP181 £2.95**

**A Z80 WORKSHOP MANUAL**  
**E. A. Parr, B.Sc., C.Eng., M.I.E.E.**

This book is intended for people who wish to progress beyond the stage of BASIC programming to topics such as machine code and assembly language programming, or need hardware details of a Z80 based computer.  
192 pages **Order Code BP112 £3.50**

**AN INTRODUCTION TO 68000 ASSEMBLY LANGUAGE**

**R. A. & J. W. Penfold**  
Obtain a vast increase in running speed by writing programs for 68000 based micros such as the Commodore Amiga, Atari ST range or Apple Macintosh range etc., in assembly language. It is not as difficult as one might think and this book covers the fundamentals.  
112 pages **Order Code BP184 £2.95**

**THE ART OF PROGRAMMING THE ZX SPECTRUM**

**M. James, B.Sc., M.B.C.S.**  
It is one thing to have learnt how to use all the Spectrum's commands and functions, but a very different one to be able to combine them into programs that do exactly what you want them to. This is just what this book is all about—teaching you the art of effective programming with your Spectrum.  
144 pages **Order code BP119 £2.50**

**AN INTRODUCTION TO PROGRAMMING THE COMMODORE 16 & PLUS 4**

**R. A. Penfold**  
Helps you to learn to use and program these two Commodore machines with the minimum of difficulty by expanding and complementing the information supplied in the manufacturer's own manuals.  
128 pages **Order code BP155 £2.50**

**AN INTRODUCTION TO PROGRAMMING THE BBC MODEL B MICRO**

**R. A. & J. W. Penfold**  
Written for readers wanting to learn more about programming and how to make best use of the incredibly powerful model B's versatile features. Most aspects of the BBC micro are covered, the omissions being where little could usefully be added to the information provided by the manufacturer's own manual.  
144 pages **Order code BP139 £1.95**

**AN INTRODUCTION TO PROGRAMMING THE ACORN ELECTRON**

**R. A. & J. W. Penfold**  
Designed to help the reader learn more about programming and to make best use of the Electron's many features. Adds considerably to the information already supplied in the manufacturer's own instruction manual.  
144 pages **Order code BP142 £1.95**

**AN INTRODUCTION TO PROGRAMMING THE ATARI 800/800 XL**

**R. A. & J. W. Penfold**  
Especially written to supplement the manufacturer's own handbook. The information supplied will help the reader to master BASIC programming and to make best use of the Atari's many powerful features.  
128 pages **Order code BP143 £1.95**

**AN INTRODUCTION TO PROGRAMMING THE AMSTRAD CPC 464 AND 664**

**R. A. & J. W. Penfold**  
The Amstrad CPC 464 or 664 running with Locomotive BASIC makes an extremely potent and versatile machine and this book is designed to help the reader get the most from this powerful combination. Written to complement rather than duplicate the information already given in the manufacturer's own manual. Also applicable to the CPC 6128.  
144 pages **Order Code BP153 £2.50**

**AN INTRODUCTION TO PROGRAMMING THE SINCLAIR QL**

**R. A. & J. W. Penfold**  
Helps the reader to make best use of the fantastic Sinclair QL's almost unlimited range of features. Designed to complement the manufacturer's handbook.  
112 pages **Order code BP150 £1.95**

**AN INTRODUCTION TO Z80 MACHINE CODE**

**R. A. & J. W. Penfold**  
Takes the reader through the basics of microprocessors and machine code programming with no previous knowledge of these being assumed. The Z80 is used in many popular home computers and simple programming examples are given for Z80-based machines including the Sinclair ZX-81 and Spectrum, Memotech and the Amstrad CPC 464. Also applicable to the Amstrad CPC 664 and 6128.  
144 pages **Order code BP152 £2.75**

**AN INTRODUCTION TO 6502 MACHINE CODE**

**R. A. & J. W. Penfold**  
No previous knowledge of microprocessors or machine code is assumed. Topics covered are: assembly language and assemblers, the register set and memory, binary and hexadecimal numbering systems, addressing modes and the instruction set, and also mixing machine code with BASIC. Some simple programming examples are given for 6502-based home computers like the VIC-20, ORIC-1/Atmos, Electron, BCC and also the Commodore 64.  
112 pages **Order code BP147 £2.50**

**THE PRE-BASIC BOOK**  
**F. A. Wilson, C.G.I.A., C.ENG., F.I.E.E., F.I.E.R.E., F.B.I.M.**

Another book on BASIC but with a difference. This one does not skip through the whole of the subject and thereby leave many would-be programmers floundering but instead concentrates on introducing the technique by looking in depth at the most frequently used and more easily understood computer instructions. For all new and potential micro users.  
192 pages **Order code BP146 £2.95**

**HOW TO GET YOUR COMPUTER PROGRAMS RUNNING**

**J. W. Penfold**  
Have you ever written your own programs only to find that they did not work? Help is now at hand with this book which shows you how to go about looking for your errors, and helps you to avoid the common bugs and pitfalls of program writing. Applicable to all dialects of the BASIC language.  
144 pages **Order code BP169 £2.50**

**AN INTRODUCTION TO COMPUTER COMMUNICATIONS**

**R. A. Penfold**  
Provides details of the various types of modem and their suitability for specific applications, plus details of connecting various computers to modems, and modems to the telephone system. Also information on common networking systems and RTTY.  
96 pages **Order code BP177 £2.95**

**AN INTRODUCTION TO COMPUTER PERIPHERALS**

**J. W. Penfold**  
Covers such items as monitors, printers, disc drives, cassette recorders, modems, etc., explaining what they are, how to use them and the various types and standards. Helps you to make sure that the peripherals you buy will work with your computer.  
80 pages **Order code BP170 £2.50**

**COMPUTER TERMINOLOGY EXPLAINED**

**I. D. Poole**  
Explains a wide range of terms that form the computer jargon used by enthusiasts. Includes a reference guide to the more commonly used BASIC commands.  
96 pages **Order code BP148 £1.95**

**THE PRE-COMPUTER BOOK**

**F. A. Wilson**  
Aimed at the absolute beginner with no knowledge of computing. An entirely non-technical discussion of computer bits and pieces and programming.  
96 pages **Order code BP115 £1.95**

**PROJECT CONSTRUCTION**

**HOW TO GET YOUR ELECTRONIC PROJECTS WORKING**

**R. A. Penfold**  
We have all built projects only to find that they did not work correctly, or at all, when first switched on. The aim of this book is to help the reader overcome just these problems by indicating how and where to start looking for many of the common faults that can occur when building up projects.  
96 pages **Order code BP110 £1.95**

**HOW TO DESIGN AND MAKE YOUR OWN P.C.B.s**

**R. A. Penfold**  
Deals with the simple methods of copying printed circuit

board designs from magazines and books and covers all aspects of simple p.c.b. construction including photographic methods and designing your own p.c.b.s.  
80 pages **Order code BP121 £1.95**

**BEGINNER'S GUIDE TO BUILDING ELECTRONIC PROJECTS**

**R. A. Penfold**  
Shows the complete beginner how to tackle the practical side of electronics, so that he or she can confidently build the electronic projects that are regularly featured in magazines and books. Also includes examples in the form of simple projects.  
112 pages **Order code No. 227 £1.95**

**RADIO**

**AN INTRODUCTION TO RADIO DXING**

**R. A. Penfold**  
Anyone can switch on a short wave receiver and play with the controls until they pick up something, but to find a particular station, country or type of broadcast and to receive it as clearly as possible requires a little more skill and knowledge. The object of this book is to help the reader to do just that, which in essence is the fascinating hobby of radio DXing.  
112 pages **Order code BP91 £1.95**

**INTERNATIONAL RADIO STATIONS GUIDE**

Completely revised and updated, this book is an invaluable aid in helping all those who have a radio receiver to obtain the maximum entertainment value and enjoyment from their sets.  
Clearly shown are the station site, country, frequency and/or wavelength, as well as the effective radiation power of the transmitter.  
128 pages **Order code BP155 £2.95**

**NEW RELEASE**

**COMPUTER ENGINEER'S POCKETBOOK**

**Michael Tooley**  
An invaluable compendium of facts, figures, circuits and data, indispensable to the designer, student, service engineer and all those interested in computer and microcomputer systems. It will appeal equally to the hardware or software specialist and to the new band of "software engineers". This first edition covers a vast range of subjects at a practical level, with the necessary explanatory text. The data is presented in a succinct and rapidly accessible form so that the book can become part of an everyday toolkit.

205 pages (hard cover) **Order code NE01**

**PRICE £8.95**

**BOOK SERVICE**

**TO ORDER**  
Please check the latest issue for price and availability.

Add 50p per order postage (overseas readers add £1, surface mail postage) and send a PO, cheque or international money order (£ sterling only) made payable to **Everyday Electronics** (quoting the order code and quantities required) to **EE BOOK SERVICE, 6 CHURCH STREET, WIMBORNE, DORSET. BH21 1JH.**

Although books are normally sent within seven days of receipt of your order please allow a maximum of 28 days for delivery. Overseas readers allow extra time for surface mail post.



# EE APEX

# Hi Fi AMPLIFIER

## PART 4

GRAHAM NALTY

**T**HIS month we look at the construction, wiring up and final testing of the power amplifier. Thus completing the four part series on the *EE Apex Hi Fi Amplifier*.

### CONSTRUCTION

The input phono sockets are fixed to the fibreglass insulating boards. They should be tightly fixed to prevent them from working loose when the amplifier is completed. Next build the low current power supply boards. Construction is fairly straightforward apart from the i.c. regulators, but do check and double check the polarity of the diodes and electrolytic capacitors. The installation of the i.c. regulators should be undertaken with care—each regulator requires one 6 BA × 12mm bolt, nylon insulating bush (to insulate the i.c. from the bolt), a mica or silicone rubber TO220 insulator between the i.c. and bracket and a shakeproof washer and nut. Attach the board to the chassis with four sets of two 6BA × 6mm bolts, and a 6BA × 12mm spacer.

Two identical boards are used for each power amplifier.

The components should be attached to the board in order of ascending size, leaving TR8 and TR10 to TR15 to last. If Wondercaps are used for C1 and C3, they should be installed vertically. Three terminal pins should be fitted close to the end of R14. The fuseholder clips are best installed with a

fuse placed inside them. Otherwise there is a tendency for the clips to twist and make it more difficult to install the fuse. TR8 and TR10 should be installed together with about 2mm of lead below the board. For better sound quality, a small heat sink should be attached to both TR8 and TR10, and one of the two transistors, should be insulated from the heatsink. Mounting the five transistors to the main heat sink bracket needs some care. If you are using mica washers, use heat sink compound on either side for better thermal contact. Place the two TO3 transistors in position and screw down gently. Each TO3 transistor requires two 6BA × 12mm bolts, two 6BA washers, one TO3 insulator between transistor and bracket, two insulating bushes, one 6BA soldertag and washer and two 6BA nuts. The insulating bush should insert all the way into the p.c.b. and part of the way into the bracket to insulate the bolt from the bracket.

The TO-220 transistors are best installed by inserting them into the p.c.b. and bending them over so that the hole in their tab lies above the hole in the bracket and p.c.b. Place the insulating washer between the transistor and bracket, and add heat sink compound on both sides if you are using mica washers. Place an insulating bush on a 6BA × 12mm bolt and insert. Because of the proximity of p.c.b. track a 6BA insulating washer should be placed immediately below the p.c.b. followed by a 6BA plain or

shakeproof washer and 6BA nut. Before finally tightening the transistors, align the bracket so that its position is true to the p.c.b. This also can be done within the case. Attach the heatsink to the chassis via 6 × 4BA × 10mm bolts and 6 × 4BA washers. Next attach the stand off to the floor of the chassis. One 20mm or two 10m 6BA spacers are required. These are fixed using a 6BA × 12mm bolt. The boards can be fixed to the heat sink via two 4BA × 10mm bolts and washers to the chassis via two 6BA × 6mm bolts and washers. With the board firmly fixed, the seven bolts holding the power transistors can be tightened. For final tightening, remove the board, then check the insulation of the transistors with a meter. Solder the solder tags to the p.c.b. track for electrical connection to the supply. Remember that these bolts fix the power transistors to the heat sink and must be tight for good heat transmission. Check all the components and solder joints visually and screw into position.

The input socket board is attached to the rear of the chassis via two sets of 6BA × 6mm bolt, 6BA shakeproof washer and nut. The power supply capacitors are held by capacitor clips each using one 4BA × 12mm bolt, two 4BA washers and nut. These are attached to the chassis via four 4BA × 10mm bolts, 4BA washers and 4BA nuts. The mains transformer is attached using the hardware provided in the following order: bolt, chassis, neoprene pad, transformer neoprene pad, metal circular piece, washer and nut. It is important to ensure that none of the metal on the top side of the transformer touches any part of the chassis as it will create a short circuit single turn around the core of the transformer and pass a very high current. The mains switch and headphone socket are fixed to the front of the chassis and are used to hold the front panel in position. The mains switch may need to be shortened to accommodate the knob. It is best to do this before connecting any wires to it and remove it from the chassis to do so. This way you avoid scratching the front panel with a hacksaw blade.

### CONNECTING WIRE

The quality of wiring you use will have a significant effect on the overall sound quality of the amplifier, far more than most people would expect. The best cable I have used to date for internal wiring is Kimber cable. It is flexible and its insulation is easy (with experience) to cut. The secret of stripping the insulation of Kimber cable is to cut the insulation with the strippers and move the cable round about a ¼ turn and cut the insulation again. The insulation is then removed much more easily than with a

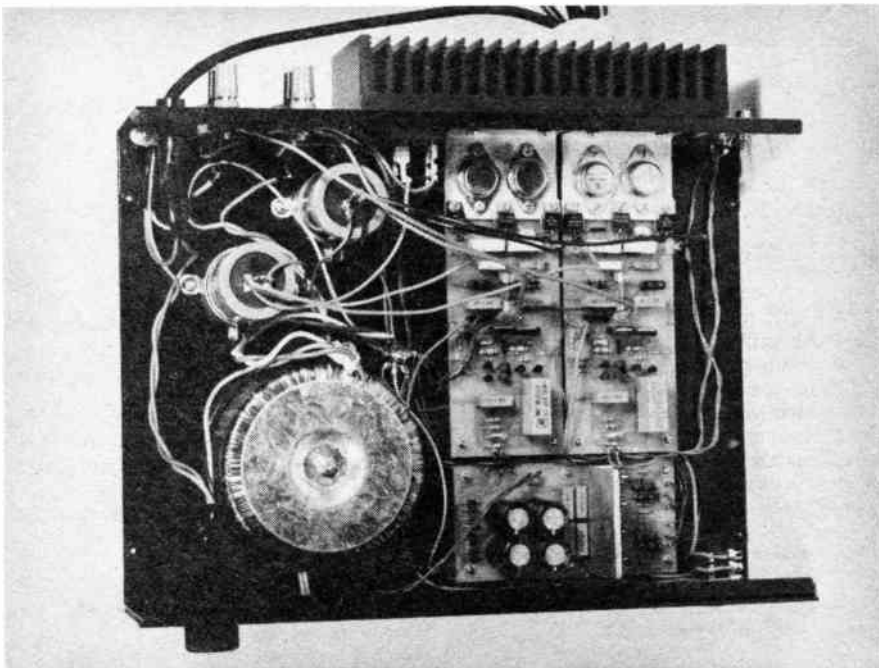

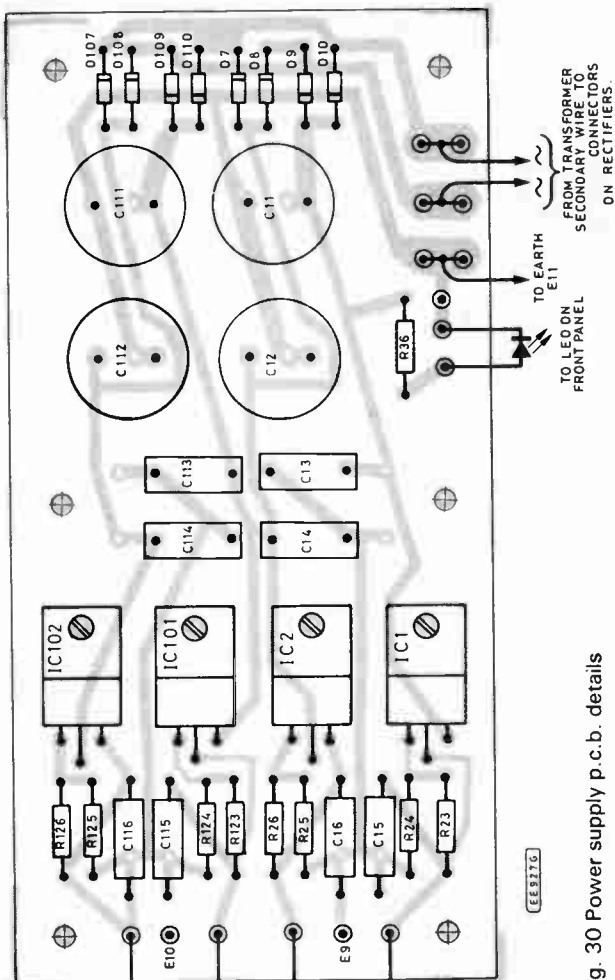

Fig. 30 Power supply p.c.b. details

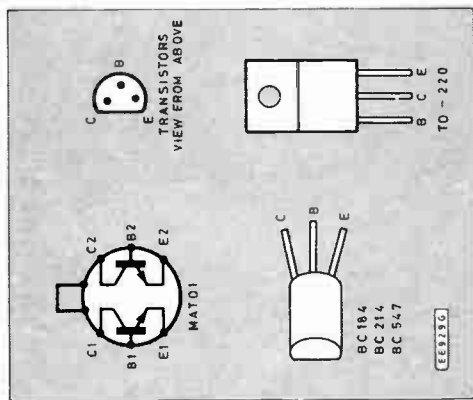

Fig. 32 (above) Transistor leadouts

single cut. Sound quality from using Kimber cable is excellent, but there is perhaps less bass subjectively than you might expect or require. The disadvantage is the high cost. Single core cables are a fraction of this cost. Large single core cables are very good for high current connections but are inflexible. They are usually covered with p.v.c. and, surprising though it is, can sound better if the p.v.c. insulation can be removed.

Small single core cables can be obtained with high quality polythene insulation. They can look very neat in a finished amplifier as they can be bent into shape, but if you have to remove a board to test it, they tend to break off. Also it is difficult to remove the insulation without nicking the wire. One answer is to wire the amplifier

with flexible cables until it has been completely tested and then change each cable to single core. Multistrand cables are easy to use, but the sound quality from using multistrand cables is generally inferior to single core cables. But for simplicity, I shall assume the use of multistrand cables for internal wiring, using cables rated four to six amps for mains and high current (output stage and speakers) and at one to three amps for low current wiring, heavier grade multistrand or single strand cable can be used to gain improved sound quality, but will be less easy to install.

## MAINS WIRING

The mains wiring can be carried out first.

Fig. 31 Power amplifier p.c.b. Two identical boards are required. All transistors are electrically isolated from the heatsink bracket.

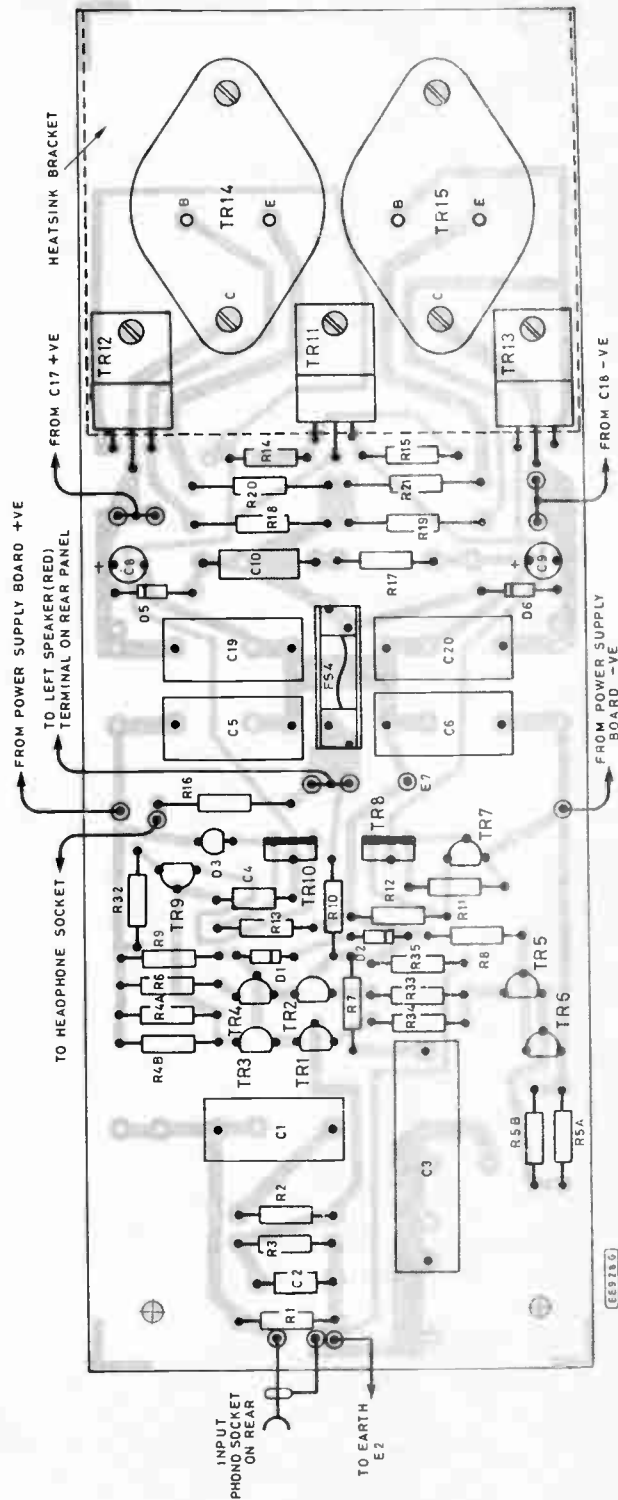

The mains lead is stripped of its outer insulation for several inches. A few inches down the cable it is held in a nylon clamp by a 4BA x 12mm bolt, two washers and a 4BA nut. This prevents the cable from being pulled out of the amplifier. The earth core is attached to a 6BA solder tag (E1). The live end is placed into the insulating boot for the mains fuseholder and soldered to the fuseholder. A similar wire is soldered to the other tag on the fuseholder via the cover, then through the rectangular mains switch cover and soldered to the mains switch.

The neutral core is twisted around the live core from the fuseholder, inserted into the switch cover and soldered onto the switch. The primary leads from the mains transformer are pushed into the fuseholder cover (this will be getting rather tight now)



## CABLES

Pin No.	From	To	Lgth.	Stdrd.	Colour	Kimber (Direction)
	Input signal	L. power amp.	32	Blue	Blue	→
	Input earth	L. power amp.	32	Green	Black	→
	Input signal	R. power amp.	25	Brown	Red	→
	Input earth	R. power amp.	25	Green	Black	→
E2	L. power amp.	Earth	12	Green	Black	→
E3	R. power amp.	Earth	18	Green	Black	→
	L. + regulator	L. power amp.+	25	Brown	Red	→
E9	L. OV regulator	Earth	24	Green	Black	→
	L. - regulator	L. power amp.-	19	Blue	Blue	→
	R. + regulator	R. power amp.+	19	Brown	Red	→
E10	R. OV regulator	Earth	27	Green	Black	→
	R - regulator	R. power amp.-	18	Blue	Blue	→
	Regulator board	l.e.d.+	18	Brown		
	Regulator board	l.e.d.-	18	Green		
E7	L. power amp.	Earth	9	Green	Black	→
E8	R. power amp.	Earth	15	Green	Black	→
	L. (h'dphone) amp.	H'dphone socket	38	Blue	Blue	→
	R. (h'dphone) amp.	H'dphone socket	24	Red	Red	→
E4	H'dphone socket	Earth	30	Green	Black	←
	L. power amp.	L. Speaker+	21	Brown	Blue	→
E5	Earth	L. Speaker-	20	Green	Black	→
	R. power amp.	R. Speaker+	24	Brown	Red	→
E6	Earth	R. Speaker-	17	Green	Black	→
	Rectifier a.c.	Regulator board	27	Brown	Red	→
	Rectifier a.c.	Regulator board	27	Brown	Red	→
	Rectifier+	C17+	12	Red	Red	→
	C17+	L. power amp.	19	Red	Red	→
	C17+	R. Power amp.	23	Red	Red	→
	Rectifier-	C18-	7	Black	Blue	→
	C18-	L. power amp.	13	Black	Blue	→
	C18-	R. power amp.	20	Black	Blue	→
	FS2	Rectifier a.c.	15	Brown	Red	→
	FS3	Rectifier a.c.	13	Brown	Red	→
	FS1	Mains switch	26	Red	Red	→
E11	Earth	Regulator board	12	Green	Black	→

Total lengths of Kimber cable: red 279; blue 168; black 241.

## EARTH WIRING

Three earth leads (E9, E10, E11) can now be taken from the low current power supply board to the earth point. One solder tag is used for E9 and E10 and a second for E11. Now connect all other earth leads, using shared solder tags for E2 + E3 and E7 + E8. The purpose of the shared tags is to reduce the number of tags to a more manageable number. The earth tags can now be attached to the chassis via a 6BA x 12mm bolt and nut in correct order, with E1 closest to the chassis and E13 farthest away. Speaker earths E5 and E6 are connected to the black speaker terminals which are fixed to the rear of the chassis. The solder tags are fixed securely to the terminals with 4BA shake-proof washers.

## TESTING

Now test the low current regulators. Connect to the mains, switch on and measure the voltage at the output of the regulators.

If there are no faults, the output voltage of the regulator should read close to + or - 30V. Now connect from the low current regulators to terminals on the amplifier boards. The output stage is not powered, but you can test the operation of the circuit as follows:

The offset voltage at FS4 should be quite a bit less than 300mV (the final output offset after completion should read lower than 100mV). The voltage across each transistor base/emitter junction or across each diode should read close to 600mV, except for D3 which should read 1.6V. If these tests are O.K. disconnect the mains,

and wire up the output stages. First attach R27 and R28 to the capacitor terminals. If you are using capacitors with screw terminals, you will need an additional set of 2BA solder tags for them and crimp tags for the cables.

You will need to attach three wires to the positive tag of C17 and three wires to the negative tag of C18. The other ends of each wire are soldered to ¼-inch blade connectors. One wire from the positive tag of C17 is connected to the +ve output of BR1. One wire from the negative tag of C18 is connected to the -ve output of BR1. (Make sure these are correct by using different colour wires). The other wires are connected to the ¼-inch blades on the amplifier boards, but you will need first to insert 4 x 47ohm 5W w/w resistors between the leads and the board to test.

**Check**—have you soldered the solder tags below TR14 and TR15, TR114 and TR115 to the p.c.b. Place one ¼-inch blade and one ¼-inch push-on connector at each end of the 47ohm 5W resistors (cut the leads so that the connectors are close to the body of the resistor). Connect one resistor to each of the four power supply leads at one end, and to the amplifier board (correctly!) at the other ends.

Connect to the mains and switch on. R30 and R31 should get warm, but you should be able to measure about 0.3V to 0.4V across R18 and R19 each. If not or you notice R30 and R31 getting red hot, switch off and examine for faults. When you are certain that both power amplifiers are functioning correctly switch off and remove the resistors (allow five minutes for C17 and C18 to discharge). Switch on; the amplifier

should run warm and the transistors TR12 and TR13 hot to touch.

Check the d.c. offset voltage. If this is greater than 100mV you can reduce it by altering the value of R3 by up to a factor of two. If this adjustment is not enough you can adjust by placing a resistor (typically about 10 times the value) across R5 (if offset is negative) or across R4 (if offset is positive). The positions on the board marked R4B and R5B are provided for this purpose.

## FINAL CONNECTIONS

The final connections are output signal connections to the speaker terminals and headphone socket. Remember to use shake-proof washers in fixing to the speaker terminals. If you have used a heatsink bracket on TR8 and TR10, TR108 and TR110, you should cover the ¼-inch push on connector for the speakers with an insulator.

The mains transformer may induce a very small amount of hum into the circuitry of the power amplifier. This can be virtually eliminated by turning the transformer around until a null point is reached (in one prototype this was about 20 degrees clockwise from the position shown in the photographs). The ideal way to do this is with the amplifier on and loudspeakers connected but you must be very careful and wear rubber gloves whilst turning the transformer as your hand is close to the mains connections—the rubber cover on the mains switch can easily be dislodged! The safe way is to switch off, disconnect the mains plug, rotate the transformer a little and try again.

Your amplifier should now be complete. To get the best performance from the amplifier mount it on a vibration free surface. Accessories such as the RATA Torlyte platform or Mission Isoplat will improve the sound quality if placed under the amplifier.

Use a new mains plug, preferably one of high quality by a recognised manufacturer (e.g. Crabtree, MK etc.). Also use a high quality interconnect between the preamp and power amp and between the power amp and loudspeakers. Such measures will ensure that you get the very best performance from your amplifier. □

## NOTE

EE Apex Additions/Corrections  
Preamp March page 148

C17, 18, 117, 118

improved version 47n 1½% LCR  
EXFS/RP

C29-32, 129-132

10µ 35V (35V capacitors can be used)

page 149

C3, 10, 25

470n polypropylene (3 off) 470n  
polypropylene

Higher current versions of the Apex power amp can be built by using alternative devices

	10A	20A	30A
TR14	2N3716	MJ15003	MJ802
TR15	2N37392	MJ15004	MJ4502

Some components used in the improved versions have very limited distribution outlets and may be subject to fairly long delivery times if suppliers' stocks become exhausted.

# Actually Doing it!!

IN LAST month's article we considered the subject of resistors, and this month we make the natural progression to the subject of capacitors. Capacitors are amongst the most simple and inexpensive of electronic components, but from the readers' letters that I receive they are obviously a continuing source of minor problems. The fact that there are a number of types available does not help, and the availability of variations on most types exacerbates the problems. Like other components, they are subject to continuing development and consequent changes which can lead to confusion.

## DIELECTRICS

The main difficulty seems to be in obtaining components having the right dielectric. A capacitor is basically just two metal electrodes with a thin insulating layer in between. Practical components generally consist of two thin strips of metal foil rolled up into a tube, with two thin strips of insulating material interleaved with them so as to provide the electrical isolation. This enables reasonably high values to be easily condensed into a small and convenient size. The dielectric is the insulating material.

There are several common dielectric materials. High quality low value types use mica, and low through to high value types sometimes use a ceramic material. The latter are generally only specified for high frequency decoupling applications. With both these types of component it is not advisable to substitute a different type of capacitor, or for that matter, to use components of these types where they are not specified.

The most common dielectric these days is probably the plastic foil type. In fact this is a generic term for a variety of materials, the most common of which are mylar, polystyrene, polycarbonate and polyester. Polystyrene is normally only used for capacitors up to a few nanofarads in value, whereas the other three are mostly used for values of about one nanofarad and above. Confusion sometimes seems to result if a component list merely specifies something like "plastic foil" rather than a specific material. If plastic foil or something similar is quoted, then mylar, polystyrene, polycarbonate and polyester (or poly anything) are all suitable from the electrical point of view. It is always unwise

to ignore the physical characteristics of components though, and it might be possible to obtain (say) a polystyrene capacitor of the required value, but it would not be a good choice if it was far too big to be easily accommodated on the printed circuit board.

Polycarbonate capacitors are often just referred to as "carbonate" types, and these seem to have largely disappeared from component catalogues with miniature polyester types now taking their place. If you come across a design which specifies polycarbonate capacitors, there will probably be no alternative but to substitute polyester capacitors. Although the polycarbonate type is generally superior in certain respects, it is unlikely that using polyester types instead would give any problems.

High value capacitors are mostly of the electrolytic type, and these should not provide any major difficulties. Remember that these are almost invariably "polarised", and must be connected the right way round. Also, components lists do not usually specify the voltage rating for non-electrolytic capacitors, since most circuits operate at potentials of a few volts, and virtually all capacitors of this type will operate at around 100V or more. The voltage rating is therefore unimportant. The same is not true of electrolytic types where the maximum voltage rating can be as low as 6V, and you therefore need to be careful to obtain components with an adequate voltage rating.

For low value types (about 470n to 4 $\mu$ F) components lists often stipulate a fairly high voltage of around 50 to 63 volts. This does not necessarily mean that a voltage rating as high as this is required, and it is often just because low value electrolytic capacitors are only widely available in these relatively high voltage ratings. It is often quite acceptable to use components which have a much lower voltage rating if your supplier stocks them, but unless you are sure you know what you are doing it is advisable to play safe and use types having the specified rating. Many of the low value low voltage electrolytic capacitors I have encountered have proved to be of mediocre quality, and I tend to avoid these anyway.

There should be no difficulty in using an electrolytic capacitor which has a maximum working voltage that is much higher

than the one specified in that such a component should work perfectly. On the other hand, a capacitor such as a 100 $\mu$  63V type could easily be double the length and diameter of a 100 $\mu$  10V type, and the small size of most modern circuit boards does not provide enough space for components that are more than marginally bigger than the ones for which they were designed to accept. Most component catalogues specify a maximum size for electrolytic capacitors, and so this is something that can usually be checked before ordering.

## AXIAL AND RADIAL

You will often encounter terms which refer to the physical characteristics of a capacitor rather than any electrical properties. The most vague of these is "printed circuit mounting", or just "PCM". This just means a component which has both lead-out wires protruding from the same end, and which is intended for vertical mounting on the circuit board. All the ceramic capacitors I have come across have been of the PCM variety, either in the form of "disc" ceramic capacitors (Fig. 1a) or the ceramic "plate" type (Fig. 1b). Some of the disc ceramic capacitors currently on sale seem to be quite large and are difficult to fit into many component layouts. I would recommend that miniature types are obtained whenever possible, even if they cost a little more.

Plastic foil capacitors are often of the PCM type, and they generally have the box type appearance depicted in Fig. 1c. Ceramic types normally have quite long and flexible leadout wires, and can be manoeuvred into most component layouts without too much difficulty. PCM plastic foil capacitors are a very different proposition, and almost invariably have short, stiff leadouts that are intended to fit mounting holes a certain distance apart. The standard pitches are 2.5, 5, 7.5 and 10 millimetres, which in imperial measure corresponds to almost exactly 0.1, 0.2, 0.3 and 0.4 inches. In previous articles I have warned about the difficulties of using a capacitor of the wrong pitch, but it is one that is well worth repeating here. It is sometimes possible to gently persuade one of these capacitors to fit into mounting holes of the incorrect pitch, but the necessary bending of the leadout wires can easily result in one of them being broken away from the body of the component.

"Axial" is a term that is applied to any component, including electrolytic and non-electrolytic capacitors, which take the general form shown in Fig. 2a. Printed circuit mounting electrolytic capacitors normally take the form shown in Fig. 2b. These are more usually referred to as "radial" rather than printed circuit types.

## COLOUR CODES

Colour codes are less common with capacitors than they are with resistors, and most capacitors have the value, volt-

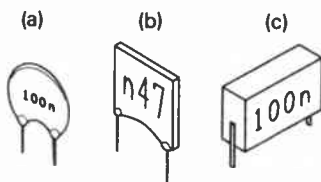

Fig. 1. Three popular types of PCM capacitor; (a) disc ceramic, (b) ceramic plate, (c) miniature polyester/carbonate.

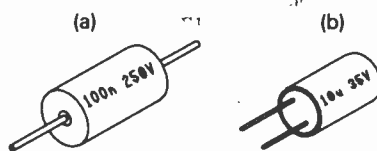

Fig. 2. Two common styles of capacitor; (a) is axial and (b) is radial. Both styles are only common in electrolytic capacitors though.

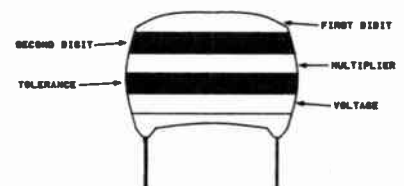

Fig. 3. The C280 capacitor style of colour coding.



age, and polarity (where appropriate) simply written on the body of the component. There are still a few tantalum bead types which use colour coding, but as this coding was covered in the "Actually Doing It" which appeared in the December 1986 issue this will not be described again here.

Polyester capacitors of the Mullard C280 variety (and some similar types) used to have colour coded value markings, but many of the capacitors of this type that I have obtained over the last few years seem to have the values etc. just written on. However, you are still likely to come across colour coded versions of these capacitors quite frequently, and will need to understand the system of coding.

Fig. 3 helps to explain this coding system which has some similarities to resistor types. It is a five band system which indicates value, maximum operating voltage and tolerance.

The first three bands indicate the value in exactly the same way as the standard four band resistor colour code which was described last month. However, in this case

the value is in picofarads instead of ohms. Divide the value by 1,000 to give an answer in nanofarads, or by 1,000,000 to give an answer in microfarads. The fourth band shows the tolerance, but not using the standard resistor colour codes this time. Instead this band will either be black to indicate 20 per cent tolerance, or white to signify 10 per cent tolerance. The fifth band indicates the maximum working voltage, and will either be red (250V) or yellow (400V).

#### MARKINGS

When capacitors have the value written on it is not always in a form that makes the value immediately obvious. In particular, with ceramic and mylar capacitors the value is often indicated by a simple three digit code. The first two numbers are the first two digits of the value, and the third number is the number of zeros to be added in order to give the full value. This has obvious similarities to the standard resistor colour coding. As an example of this system, "332" would indicate 33 as the

first two digits plus two zeros giving a total value of 3,300. This is picofarads, and dividing by 1,000 to give an answer in nanofarads produces a result of 3.3 nanofarads (or 3n3 if you prefer).

It is quite common for low value ceramic capacitors to have the value marked in nanofarads rather than picofarads, which can be a little confusing. For instance, a 100 picofarad component might be marked n10. There may well be other markings apart from the value, but these are not normally of any significance and can be ignored. Many ceramic capacitors have the top part of the body a different colour to the rest of the component, and this is not to make them look pretty. It indicates the temperature coefficient of the component, but unless you build sophisticated pieces of radio equipment you are unlikely to come across a components list that specifies a particular temperature coefficient.

*Robert Penfold*



# READERS DISCOUNT SCHEME



**Readers—you can obtain a 5% discount on goods from the advertisers listed using coupons cut from EE, provided you follow the rules below:**

**CROTECH's** complete range of single and dual trace oscilloscopes along with accessories is eligible for the discount scheme. For orders below £250.00 then one voucher is required, on orders above £250.00 only two vouchers are required. This could mean a saving of over £14.00 on our 3132 Dual Trace 20MHz scope.

#### CPL ELECTRONICS

Kits for *Everyday Electronics* and *Electronics Monthly* and *Practical Wireless* projects including kits for the "Teach In" series. Plus a wide range of competitively priced components, hardware, test equipment and tools. We can also supply, in many cases, "one off" kits for specific projects. Free price lists on request.

#### GREENWELD ELECTRONICS LTD.

A full range of components at our shop in Southampton; open 9-5.30 Mon-Sat, as well as many surplus lines, all available by mail order. Bargain List free with our Catalogue. Send for your copy today, only £1 inc. post. Now even better value with EE Discount Vouchers!

**OMNI ELECTRONICS** are willing to give a 5% discount on all orders over £10.00, excluding VAT, if a valid voucher is enclosed. We stock a wide range of components—ideal for the hobbyist. Goods listed in our catalogue are generally in stock, orders will be sent by return post. Why wait?

**EE BOOK SERVICE**, a 5% discount will be given on the total cost—including postage—of all orders that are sent with a valid voucher. Our complete list of books appears in each issue together with ordering details.

**E.S.R. ELECTRONIC COMPONENTS** supplies the full range of Velleman kits which include amplifiers, light controllers, power supplies, timers and computer interfaces. To complement these kits E.S.R. can offer connectors, switches, control knobs and project cases. A range of small handtools, soldering irons, test equipment and service aids is also available.

**BECKER-PHONOSONICS**, established 1972. Designers and suppliers of a wide range of kits for projects published in *Everyday Electronics* and other leading periodicals. Range includes musical and audio effects, computer controlled circuits and Geiger counters. EE discount scheme applies to all full kits over £30 goods value, excluding Geiger counters.

#### RADIO COMPONENT SPECIALISTS

Amplifiers—(PA, disco, music), audio leads all types, components, capacitors, potentiometers, resistors, disco lighting, sound to light units, disco decks, disco consoles, disco mixers, echo chambers, fuzz lights. Multimeters, mains transformers, microphones, stands, leads, goose necks, speakers with or without cabinets, tweeters, mid range units, 100V line matching audio transformers, etc.

**TK ELECTRONICS** stock a wide range of components including triacs, ICs & opto together with other accessories (switches, tools, multimeters, buzzers, crystals, Antex, Velleman and Vero products, etc.). We specialise in kits for timers, disco and home lighting, remote control kits for beginners. Send s.a.e. and 50p (refundable on first order) for catalogue.

#### RULES

1. Discounts are available from advertisers listed on this page.
2. Unless otherwise stated by the advertiser, discounts are only available on orders over £20 in value.
3. Unless otherwise stated by the advertiser, one voucher is required for each £50 value of the order placed (i.e. for orders between £20 and £50 send one voucher, between £50 and £100 send two vouchers, etc.)
4. Cut out vouchers (not photostats) must be sent when claiming the discount.
5. Each voucher sent must be valid on the day of posting (i.e. it cannot be used after its expiry date).
6. Discount is not available on "sale" or "special offer" items.
7. You must indicate on your order that the 5% EE Readers Discount has been deducted from the payment sent.
8. All advertisers reserve the right to refuse this discount on any item supplied. **Discounts will not be given or coupons returned if these rules are broken.**

★ ★ ★ ★ ★ ★ ★ ★ ★ ★ ★ ★ ★ ★ ★ ★

## EVERYDAY ELECTRONICS

# ONE COUPON

**VALID UNTIL END OF JUNE 1987**

Entitles EE readers to discount from listed advertisers when used according to the scheme rules as set out in EVERYDAY ELECTRONICS

★ ★ ★ ★ ★ ★ ★ ★ ★ ★ ★ ★ ★ ★ ★ ★

# ...REPORTING AMATEUR RADIO...

TONY SMITH G4FAI

## MORSE TELEGRAPHY

Samuel F. B. Morse invented his electric telegraph and associated code in America in the 1830's, and introduced an improved code, known as American Morse, about 1844. The code used today is *International Morse*, devised in Europe in 1851, retaining 16 of the symbols from American Morse. The telegraph was the wonder of the age in Victorian times. Its single wire and earth return circuits circled the globe, providing instant communication more often than not by means of the Morse code.

Marconi introduced to the world the means of sending those same Morse signals *without wires* and that was the sole purpose of wireless at that time. Since then, of course, radio technology has advanced by leaps and bounds, and Morse code communication has become increasingly redundant.

Ships at sea were the first to benefit from the new invention and eventually every ship was required by international law to carry one or more wireless operators able to signal in Morse code. With the advent of satellite communications and other advanced techniques, maritime communications from the 1990's will no longer require ships' wireless officers of any kind, and all communications will be conducted from the bridge, with no sign of Morse on the maritime airwaves anywhere. These are the proposals of the Future Global Maritime Distress and Safety System due to be finalised at a meeting of members of the International Maritime Organisation, and others, next year.

## AMATEUR MORSE

But if Morse is so old-fashioned and out-of-date, how is it that radio amateurs take it up with enthusiasm, and a good many operate only with code and nothing else?

Morse radio transmission in its basic form is known as c.w., signifying continuous wave transmission, which is simply the radiation of radio waves maintaining a constant amplitude and constant frequency. It is a somewhat confusing title since the Morse signals are obtained by interrupting the transmitted carrier wave so that it is, in fact, not continuous!

As a mode of communication c.w. offers advantages over all others. It takes up far less space on the crowded radio bands (at least ten c.w. stations could operate in the space taken up by an amateur station using speech); c.w. signals can often get through when other signals cannot; and the use of international abbreviations and code groups permits communication between operators having little or no knowledge of the other's language.

It might be thought that having to spell out words, etc, letter by letter is a tedious way of communication, but it doesn't really work out like that. C.W. operating is a combination of qualities. **Skill**, in using

transmitter, receiver, antenna, and Morse key to the best advantage. **Knowledge** of, and fluency in, the Morse code and its abbreviations. **Technique**, in knowing how to conduct a contact to ensure effective communication with the minimum of time and effort. And **patience**, because sometimes signals are blotted out by adjacent stronger stations. Sometimes they become weaker and more difficult to copy. Then, the successful completion of a contact may call for personal qualities of patience and perseverance as much as anything else.

## HOME-MADE EQUIPMENT

Another advantage of c.w. communication is that it is relatively easy to make your own transmitter and receiver. Unfortunately, modern equipment for speech operation is fairly complex to build and beginners are reluctant to attempt home-construction. With c.w. the position is entirely different. Simple circuits operate extremely well and it is possible for beginners to make equipment which can put them on the air with low cost and high satisfaction.

Morse operating is a compelling, absorbing, world, but one which is difficult to demonstrate to an outsider. It is an entirely personal thing as far as the individual operator is concerned, who is concentrating on what he is doing to the total exclusion of everything else at that moment in time. He is also enjoying himself immensely. Incidentally, for "he" always read "he or she" since there are also a good number of YL ("young lady") amateur Morse operators.

It is necessary to pass a Morse test to obtain a class A amateur licence to operate on the international h.f. (high frequency) bands. At one time amateurs had to use Morse exclusively for a year before they could transmit speech. Nowadays this is not required and, regrettably, some pick up their microphones as soon as they get their class A licence and forget about Morse code from that moment on. This is a great pity, because they are giving up a major aspect of amateur radio, capable of giving great satisfaction and pleasure, without ever having tried it.

## LEARNING MORSE

There are a number of ways to learn Morse for the amateur test. There are home-study courses available, using tapes or records. There are "how-to-do-it" books; evening classes; and there are electronic devices which send random Morse at the speed of your choice, including one which speaks and tells you what it has just sent. There are also a number of excellent Morse learning programs for home computers. Radio clubs run courses for their members, and the Radio Society of Great Britain puts out slow Morse

transmissions for learners on the amateur bands daily.

A recent concession for class B licensees (v.h.f. bands only) permits them to send and receive Morse on the bands for which they are licenced, to help prepare themselves for the amateur Morse test. In doing this, however, they must give their call-sign by telephony at the beginning and end of each over.

Morse telegraphy was the first kind of amateur radio, and among the various modes available to today's operator it is the one which relates most to "original" wireless operating, including some of the "olde-worlde" virtues such as courtesy and consideration for others. The many thousands of operators, worldwide, who remain faithful to the mode bear witness to its continuing attraction! There is even an international magazine, *Morsum Magnificat*, devoted entirely to Morse telegraphy, past, present, and future.

## NOVICE LICENCE?

C.W. operating is ideal for beginners to amateur radio, since it is so easy to get on the air at low cost. Many countries have graduated licensing systems starting at "Novice" level with simple examinations and slow Morse requirements, progressing later to more demanding examinations to qualify for full licence privileges.

There is a movement to obtain a no-age-limit Novice licence in the UK which would permit Morse-only operation on the 10 metre band with a transmitter output of 5 watts, preferably using inexpensive home-made equipment. It is suggested that an eight week study course, covering theoretical and technical matters, at an appropriate level, could be followed by a two hour examination set by the RSGB, and a Morse test at 5 wpm conducted by local amateurs.

The Secretary of the Amateur Radio Novice Licence Campaign is Ian Abel, G3ZHI, who says, "The idea has the support of the G-QRP (low power) Club, the Scouts, Sea Cadets, the RSGB, and a number of radio amateurs. The Novice Licence could find its way into schools, etc; it is learning with a purpose and a use.

"The system is proven in the States, as I have seen for myself. Morse is the 'key' to its success—it is a code to learn and then communicate with, like learning a foreign language. Youngsters will love it because to them it is like a 'secret code', and the practical emphasis on construction and Morse operating skills should make the Novice approach a more attractive proposition/challenge than the present system of entry for any age of candidate. Ian will gladly provide further information on these proposals. His address is 52 Hollytree Avenue, Maltby, Rotherham, S66 8DY, tel: 0709 814911.

# ON SPEC

*a regular feature for the Spectrum Owner...*

by Mike Tooley BA

THIS month, as promised, we shall be describing the programming of the Versatile Sound Synthesiser described last month. We shall also be taking a look at some handy routines for manipulating the Spectrum's screen.

Before we get started, there's just time to deal with one or two important points from the post...

## Free Memory Revisited

Several readers have written to say that M. Tucker's free memory routine (see March *On Spec*) fails to provide a sensible

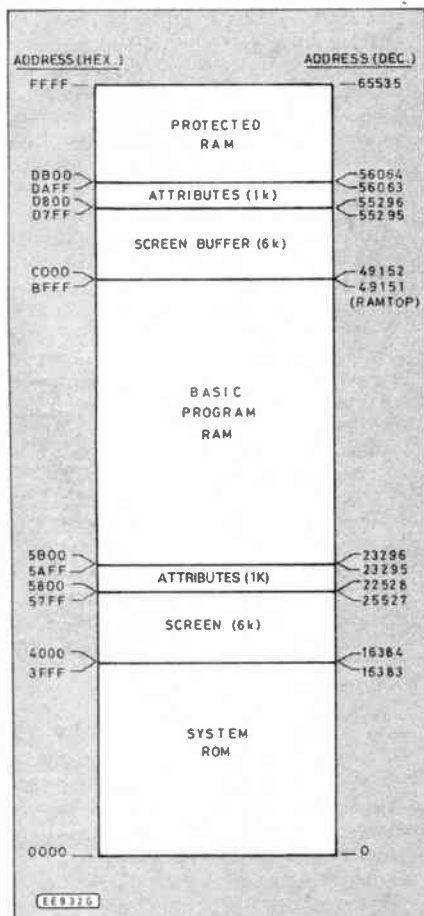

Fig. 1. Memory map for the screen swapping routines.

indication of the amount of RAM remaining. In fairness to Mr Tucker, his machine code routine is quite correct. The problem is, however, nothing more than a missing "USR" in the calling routine! To put the record straight, the line of BASIC in our mythical program which makes use of the free memory routine should read:

```
190 PRINT USR USR "t"; "bytes free"
```

On the same topic, John Wall writes from Tyne and Wear with a much more elegant solution to the problem. John points out that the Spectrum already has a routine in ROM which determines the extent of free memory.

This routine starts at a decimal address of 7962. In order to find how much free memory exists it is thus only necessary to incorporate a line of the form:

```
9999 PRINT 65536 — USR 7962
```

Whilst on the subject of ROM routines, Andrew Wilson writes from Basildon to enquire about the availability of a disassembled and commented listing of the Spectrum's ROM code. For the benefit of anyone out there needing this information, *The Complete Spectrum ROM Disassembly* by Dr Ian Logan and Dr Frank O'Hara (published by Melbourne House, ISBN 0-86161-116-0) is the definitive text which can be recommended to serious Spectrum programmers as well as those wishing to exploit the occasional ROM routine in their own programs!

## Spectrum Screen Manipulation

Anyone who has delved into the inner workings of the Spectrum will be aware that the Spectrum screen memory occupies the 6K RAM block extending from 16384 decimal (4000 hex.) to 22527 decimal (57FF hex.). A further 1K block of RAM extending from 22528 decimal (5800 hex.) to 23295 (5AFF hex.) is used to store the attributes of the 1024 screen character cells. The total memory devoted to the Spectrum's screen is thus 7K (extending from 4000 hex. to 5AFF hex.).

Let's assume that we wish to implement an "alternative" screen by setting up a screen buffer starting at C000 hex. This would extend to DAFF hex. (including the 1K attribute file).

The memory map for this arrangement is shown in Fig. 1. To ensure that any program does not attempt to use the screen buffer it would be prudent to lower RAMTOP to 49151 before attempting to run software which uses the "alternative" screen.

Fortunately, when it comes to manipulating large areas of memory, the Z80 instruction set provides the programmer with some very easy to use block move instructions. Of these, the "load increment and repeat" (LDIR) instruction is perhaps the most useful.

LDIR takes the contents of the HL and BC register pairs as the source and destination addresses for the block move. The number of bytes to be moved is taken from the BC register pair.

To take the existing screen memory (a 7K block comprising video RAM and attributes) and copy it to the block starting at

hexadecimal address C000 it is necessary to:

- load the HL register pair with the start address of video RAM (4000 hex.)
- load the DE register pair with the start address of the RAM into which the block is to be moved (C000 hex.)
- load the BC register pair with the length of the screen memory (1B00 hex.)

The routine thus becomes:

```
LD HL,4000H ; HL points to the start of the source block
LD DE,C000H ; DE points to the start of the destination block
LD BC,1B00H ; BC contains the number of bytes to be moved
LDIR ; perform the block move
```

We now have a routine which can transfer (copy) the video RAM (complete with attribute file) to another block of RAM (we shall call this the "screen buffer"). We could easily modify the routine to copy the block back (from the screen buffer into the video RAM) by simply changing the contents of HL (to C000 hex.) and DE (to 4000 hex.). In practice, both routines could be extremely useful. The only remaining question is where to put them!

Most of the machine code routines introduced in *On Spec* have been safely tucked away above RAMTOP in protected memory. Another alternative is that of making use of the "printer buffer". This small block of memory starts immediately above the screen attributes file and extends from 23296 decimal (5B00 hex.) to 23551 decimal (5BFF hex.). Provided one is not making use of the original ZX-printer, this area is quite safe to use and is quite large enough to accept the short routines used for screen manipulation.

The following code is required:

```
5B00 21 00 40 LD HL,4000H ; Where it starts
5B03 11 00 C0 LD DE,C000H ; Where we want it
5B06 01 00 1B LD BC,1B00H ; How much to move
5B09 ED B0 LDIR ; Move it!
5B0B C9 RET ; Back to BASIC
5B0C 21 00 C0 LD HL,C000H ; Where it starts
5B0F 11 00 40 LD DE,4000H ; Where we want it
5B12 01 00 1B LD BC,1B00H ; How much to move
5B15 ED B0 LDIR ; Move it!
5B17 C9 RET ; Back to BASIC
```

The following BASIC loader sets up the two screen swapping routines within the printer buffer:

```
1 RESTORE
2 FOR x=23296 TO 23319
3 READ z: POKE x,z
4 NEXT x
5 DATA 33,0,64,17,0,192,1,0
6 DATA 27,237,176,201,33,0
7 DATA 192, 17,0,64,1,0,27,237
8 DATA 176, 201
```

Thereafter the screen swapping code can be called from BASIC by a statement of the form RANDOMIZE USR nnnnn (where nnnn is the decimal start address of the required routine). Furthermore, it is possible to load and save screen images to the screen buffer in much the same way as it is to load and save the screen directly.

The following BASIC statements should thus cope with most requirements:

- (a) Copy screen to buffer: RANDOMIZE USR 23296
- (b) Copy buffer to screen: RANDOMIZE USR 23308
- (c) Load screen from tape: LOAD "pic" SCREEN\$
- (d) Load buffer from tape: LOAD "pic" 49152,6912
- (e) Save screen to tape: SAVE "pic" SCREEN\$
- (f) Save buffer to tape: SAVE "pic" 49152,6912

Finally, here is a little BASIC program which can be used to test the screen swapping routines (make sure that you have previously installed the machine code with our earlier program!):

```

10 INK 0: PAPER 7: CLS
20 PRINT AT 10,12; "SCREEN 1"
30 INPUT "Press <ENTER> to store";r$
40 RANDOMIZE USR 23296
50 INK 7: PAPER 0: CLS
60 PRINT AT 10,12; "SCREEN 2"
70 INPUT "Press <ENTER> to
restore";r$
80 RANDOMIZE USR 23308
90 GO TO 10
  
```

When the program is run and the prompts are followed, the change from "SCREEN 1" to "SCREEN 2" should be virtually instantaneous. It now remains for the reader to make good use of the screen swapping routine. The possibilities are endless—drop me a line if you come up with something that may be worthy of a wider audience!

### PROGRAMMING THE SOUND SYNTHESISER

Last month we glibly mentioned that individual bits stored in the control register array of the AY-3-8913 are responsible for determining such things as the frequency and amplitude of the outputs of the three tone generators. In addition, bits are used to determine the envelope of the waveform and the amount and period of noise mixed into the output.

The function and organisation of the AY-3-8913's internal registers can be made a whole lot clearer by studying Table 1. Registers 0 and 1 determine the frequency of the signal produced by the oscillator assigned to channel A.

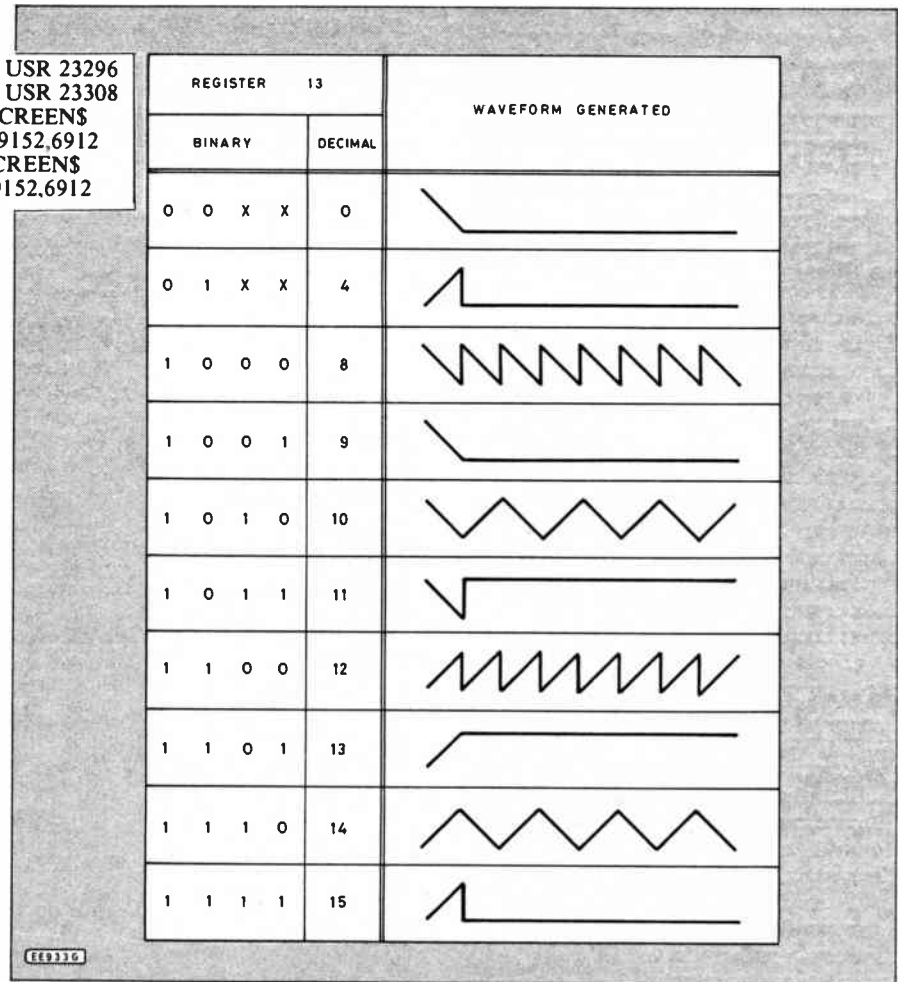

Fig. 2. Envelope waveforms produced by the AY-3-8913.

Register 0 provides "fine tuning" of the oscillator whilst register 1 provides "coarse tuning". Readers should note that, whereas all 8-bits of register 0 are used, only the four least significant bits of register 1 have any effect on the tone produced.

The same arrangement is used to tune the oscillators assigned to channels B and C. Registers 2 and 3 are respectively used for fine and coarse tuning of channel B whilst registers 4 and 5 are respectively used for fine and coarse tuning of channel C.

Table 1. AY-3-8913 register functions

Register Number	Register Function	Bit Number							
		7	6	5	4	3	2	1	0
0	Channel A	8-Bit Fine Tune							
1	Tone Period					4-Bit Coarse Tune			
2	Channel B	8-Bit Fine Tune							
3	Tone Period					4-Bit Coarse Tune			
4	Channel C	8-Bit Fine Tune							
5	Tone Period					4-Bit Coarse Tune			
6	Noise Period	5-Bit Noise Period							
7	Enable			Noise C	Noise B	Noise A	Tone C	Tone B	Tone A
8	Channel A Amplitude				Envelope Control	4-Bit Amplitude Control			
9	Channel B Amplitude				Envelope Control	4-Bit Amplitude Control			
10	Channel C Amplitude				Envelope Control	4-Bit Amplitude Control			
11	Envelope Period	8-Bit Fine Period							
12		8-Bit Coarse Period							
13	Envelope Waveform					Continue	Attack	Alternate	Hold
14	Not Used On								
15	AY-3-8913								

The five least significant bits of register 6 are used to determine the period of the noise signal whilst register 7 is used to enable the internal oscillators and noise generators. The six least significant bits are used and they act as active-low control signals.

To put this into context, suppose that we only wish to make use of the tone generator of channel A. We would have to ensure that bit-0 of register 7 was taken low whilst all other bits were high. The binary pattern required is thus:

Bit Number	Decimal Value
5 4 3 2 1 0	
1 1 1 1 1 0	62

We would thus have to output a data value of 62 to register 7. Alternatively, suppose that we wished to enable the tone generators of all three channels (A to C) and mix some noise into the signal produced by the tone generator of channel A. The following bit pattern would be required:

Bit Number	Decimal Value
5 4 3 2 1 0	
1 1 0 0 0 0	48

The four least significant bits of registers 8, 9 and 10 control the amplitude of the signals produced by channels A, B and C respectively. The output amplitude increases in fifteen logarithmic steps (corresponding to increasing data values of 1 to 15 decimal) whereas a data value of 0 results in no output at all.

### Envelope Control

Bit 4 of registers 8 to 10 is used to enable envelope control of the outputs and is active when high. When envelope control is employed, the characteristics of the output waveform (in terms of amplitude versus time) are determined by the contents of registers 11 to 13.

Registers 11 and 12 are used to determine the period of the envelope (register 11 is the least significant) whilst register 13 allows selection of a particular envelope waveform (see Fig. 2). Since it is difficult to describe the effects of the various bits in register 13

(the nomenclature used by G.I. is not particularly helpful either!) it is best to experiment a little.

Readers should make use of the simple program described last month and make the following entries in response to the prompts:

Register Number	Data Value
0	28
1	1
7	62
8	16
11	255
12	255
13	0

Having confirmed that the output is a tone of constant frequency but steadily falling amplitude (over a period of about 5 seconds), experiment by placing different data values in register 13 (values should be selected from Fig. 2). Finally, change the envelope period (by placing, say, 0 in register 12) and repeat the exercise. You should very quickly get some idea of the sort of effects that can be produced!

The following entries can be made to investigate the output of the noise generator (we shall assume that data from the previous example is still resident and, in particular, that envelope control has been selected):

Register Number	Data Value
6	31
7	247
12	255
13	8

Again it is worth experimenting by changing the contents of the various registers and keeping a note of the effects produced for future reference!

### Sound Routine

Having demonstrated some of the effects that can be produced, we shall conclude this month's *On Spec* with a few clues for those of you ready to incorporate sound routines into your own programs. Readers should recall that port address 191 decimal (BF hex.) is used for selecting particular internal

registers and that data may be written to the synthesiser chip using port address 63 decimal (3F hex.).

A BASIC statement of the form OUT 191,rn (where rn is a decimal register number in the range 0 to 15) can be used to

Register Number	Data Value	Comment
0	28	Set channel A to produce an output at approx. 440Hz
1	1	Enable channel A
7	62	Select envelope control
8	16	Set longest possible envelope period
11	255	Single falling ramp (see Fig. 2.)

select one of the AY-3-8913's internal registers. A statement of the form OUT 63,val (where val is the data to send in the range 0 to 255) can then be used to send data to the register previously selected.

A series of OUT may be used to produce the desired sound effects at particular points in a program. An arguably better solution would be that of making use of one, or more, sound generating subroutines to be called as, and when, desired.

Register Number	Data Value	Comment
6	31	Set noise period
7	247	Mix noise into channel A
12	255	Restore longest envelope period
13	8	Produce a repetitive negative going ramp waveform

If you would like a copy of our "On Spec Update", please drop me a line enclosing a large (A4 size) stamped addressed envelope.

Mike Tooley  
Department of Technology  
Brooklands Technical College  
Heath Road, Weybridge  
Surrey KT13 8TT

Next month: We shall be taking a look at one of the latest Spectrum software development systems in the form of Ocean's "Laser Genius".

# MARKET PLACE

**TBA 820** or LM380N in circuit 75p; 2in. loudspeakers 25p; post and packing 50p. D. L. Walters, 39 Lon Cadog, Swansea, W. Glam. SA2 0TN.

**WANTED** copies of timer, mains controlling projects (complete); **EE (1971-81)**, other magazines. Will pay for magazine postage. Leng Chi Meng, 74 Jalan Ampang Hilir, 55000 Kuala Lumpur, Malaysia.

**WANTED** AY-1-0212 or MO87 master tone generator i.c. to complete electronic piano project. Cash paid. Mr. J. S. Runacre, 21 Dundonald Rd., Ramsgate, Kent CT11 9PU. Tel: Thanet 586371.

**HELP!** Could someone supply me with circuit diagrams of external B.F.O.s to use with S.W. radio. D. Shipley, 3 Church Drive, Shirebrook, Mansfield, Notts. NG20 8DE.

**FREE READERS ADS.**  
**RULES** Maximum of 16 words plus address and/or phone no. Private advertisers only (trade or business ads. can be placed in our classified columns). Items related to electronics only. No computer software. EE cannot accept responsibility for the accuracy of ads. or for any transaction arising between readers as a result of a free ad. We reserve the right to refuse advertisements. Each ad. must be accompanied by a **cut-out valid** "date corner". Ads. will not appear (or be returned) if these rules are broken.

**WANTED** urgently Spectrum 48K adaptor good condition £10. R. Smith, 1 Hubbard House, Manciple Street, London SE1 4DN.

Please read the **RULES** then write your advertisement here—one word to each box. Add your name, address and/or phone no. Please publish the following small ad. **FREE** in the next available issue. I am not a dealer in electronics or associated equipment. I have read the rules. I enclose a **cut-out valid** date corner.

Signature ..... Date .....

**COUPON VALID FOR POSTING BEFORE 19 JUNE, 1987**  
(One month later for overseas readers.)

**SEND TO: EE MARKET PLACE, EVERYDAY ELECTRONICS, 6 CHURCH STREET, WIMBORNE, DORSET BH21 1JH.**

BLOCK CAPITALS PLEASE

Name & Address:			

For readers who don't want to damage the issue send a photostat or a copy of the coupon (filled in of course) with a **cut-out valid** "date corner"

# PCB SERVICE

Printed circuit boards for certain constructional projects are now available from the PCB Service, see list. These are fabricated in glass-fibre, and are fully drilled and roller tinned. All prices include VAT and postage and packing. Add £1 per board for overseas airmail. Remittances should be sent to: The PCB Service, Everyday Electronics and Electronics Monthly Editorial Offices, 6 Church Street, Wimborne, Dorset BH21 1JH. Cheques should be crossed and made payable to Everyday Electronics. (Payment in £ sterling only.)

Please note that when ordering it is important to give project title as well as order code. Please print name and address in Block Caps. Do not send any other correspondence with your order.

Readers are advised to check with prices appearing in the current issue before ordering.

**NOTE: Please allow 28 days for delivery. We can only supply boards listed in the latest issue. Boards can only be supplied by mail order on a payment with order basis.**

PROJECT TITLE	Order Code	Cost
— JULY '83 —		
User Port Input/Output <i>M.I.T. Part 1</i>	8307-01	£4.82
User Port Control <i>M.I.T. Part 1</i>	8307-02	£5.17
— AUGUST '83 —		
Storage Scope Interface, BBC Micro	8308-01	£3.20
Car Intruder Alarm	8308-02	£5.15
High Power Interface <i>M.I.T. Part 2</i>	8308-03	£5.08
Pedestrian Crossing Simulation <i>M.I.T. Pt 2</i>	8308-04	£3.56
— SEPTEMBER '83 —		
High Speed A-to-D Converter <i>M.I.T. Pt 3</i>	8309-01	£4.53
Signal Conditioning Amplifier <i>M.I.T. Pt 3</i>	8309-02	£4.48
Stylus Organ	8309-03	£6.84
— OCTOBER '83 —		
D-to-A Converter <i>M.I.T. Part 4</i>	8310-01	£5.77
High Power DAC Driver <i>M.I.T. Part 4</i>	8310-02	£5.13
— NOVEMBER '83 —		
TTL/Power Interface for Stepper Motor <i>M.I.T. Part 5</i>	8311-01	£5.46
Stepper Motor Manual Controller <i>M.I.T. Part 5</i>	8311-02	£5.70
Speech Synthesiser for BBC Micro	8311-04	£3.93
— DECEMBER '83 —		
4-Channel High Speed ADC (Analogue) <i>M.I.T. Part 6</i>	8312-01	£5.72
4-Channel High Speed ADC (Digital) <i>M.I.T. Part 6</i>	8312-02	£5.29
Environmental Data Recorder	8312-04	£7.24
Continuity Tester	8312-08	£3.41
— JANUARY '84 —		
Biological Amplifier <i>M.I.T. Part 7</i>	8401-02	£6.27
Temp. Measure & Control for ZX Comprs Analogue Thermometer Unit	8401-03	£2.35
Analogue-to-Digital Unit	8401-04	£2.56
Games Scoreboard	8401-06/07	£9.60
— FEBRUARY '84 —		
Oric Port Board <i>M.I.T. Part 8</i>	8402-02	£9.56
Negative Ion Generator	8402-03*	£8.95
Temp. Measure & Control for ZX Comprs Relay Driver	8402-04	£3.52
— MARCH '84 —		
Latched Output Port <i>M.I.T. Part 9</i>	8403-01	£5.30
Buffered Input Port <i>M.I.T. Part 9</i>	8403-02	£4.80
VIC-20 Extension Port Con. <i>M.I.T. Part 9</i>	8403-03	£4.42
CBM 64 Extension Port Con. <i>M.I.T. Part 9</i>	8403-04	£4.71
Digital Multimeter Add-On for BBC Micro	8403-05	£4.63
— APRIL '84 —		
Multipurpose Interface for Computers	8404-01	£5.72
Data Acquisition "Input" <i>M.I.T. Part 10</i>	8404-02	£5.20
Data Acquisition "Output" <i>M.I.T. Part 10</i>	8404-03	£5.20
Data Acquisition "PSU" <i>M.I.T. Part 10</i>	8404-04	£3.09
A.F. Sweep Generator	8404-06	£3.55
Quasi Stereo Adaptor	8404-07	£3.56

Simple Loop Burglar Alarm	8405-01	£3.07
Computer Controlled Buggy <i>M.I.T. Part 11</i>	8405-02	£5.17
Interface/Motor Drive	8405-03	£3.20
Collision Sensing — MAY '84 —	8405-04	£4.93
Power Supply		
— JUNE '84 —		
Infra-Red Alarm System	8406-01	£2.55
Spectrum Bench PSU	8406-02	£3.99
Speech Synthesiser <i>M.I.T. Part 12</i>	8406-03	£4.85
Train Wait	8406-04	£3.42
— JULY '84 —		
Ultrasonic Alarm System	8407-01	£4.72
Electronic Code Lock	8407-03	£2.70
Main Board	8407-04	£3.24
Keyboard		
— AUGUST '84 —		
Microwave Alarm System	8408-01	£4.36
Temperature Interface—BBC Micro	8408-02	£2.24
— SEPTEMBER '84 —		
Op-Amp Power Supply	8409-01	£3.45
— OCT '84 —		
Micro Memory Synthesiser	8410-01*	£8.20
Drill Speed Controller	8410-04	£1.60
— NOVEMBER '84 —		
BBC Audio Storage Scope Interface	8411-01	£2.90
Proximity Alarm	8411-02	£2.65
— DEC '84 —		
TV Aerial Pre-Amp	8412-01*	£1.60
Digital Multimeter	8412-02/03*	£5.20
Mini Workshop Power Supply	8412-04	£2.78
— JAN '85 —		
Power Lighting Interface	8501-01	£8.23
Games Timer	8501-02	£1.86
Spectrum Amplifier	8501-03	£1.70
— FEB '85 —		
Solid State Reverb	8502-01	£3.68
Computerised Train Controller	8502-02	£3.38
— MARCH '85 —		
Model Railway Points Controller	8503-01	£2.78
— APRIL '85 —		
Insulation Tester	8504-02	£2.53
Fibrealarm	8504-03	£3.89
— MAY '85 —		
Auto Phase	8505-01	£3.02
Amstrad CPC464 Amplifier	8505-02	£2.56
Mains Unit	8505-03	£2.56
Micro Unit	8505-04	£2.67
Voltage Probe		
— JUNE '85 —		
Graphic Equaliser	8506-01	£3.21
Computerised Shutter Timer	8506-02	£2.09
Mono-Bi-Astables (Experimenters Test Bed)	8506-03	£2.45
Across The River	8506-04	£2.63
— JULY '85 —		
Amstrad User Port	8507-01	£3.17
Nascom Printer Handshake	8507-02	£1.90
— AUGUST '85 —		
Electronic Building Blocks—1 to 4†	8508-01	£2.98
Tremolo/Vibrato	8508-02	£4.03
Stepper Motor Interface	8508-03	£2.40
Drill Control Unit	8508-04	£2.90
— SEPTEMBER '85 —		
RIAA Preamplifier Input Selector	8509-01	£2.36
Transducers Resistance Thermometer	8509-03	£2.64
Transducers Semiconductor Temp. Sensor	8509-04	£2.72
— OCT '85 —		
Transducers Strain Gauge	501	£2.87
Soldering Iron Power Controller	504	£2.09
— NOV '85 —		
Transducers—	505	£3.93
Magnetic Flux Density Amplifier	506	£2.68
Hallowe'en Projects (single board price)		
— DEC '85 —		
Electronic Building Blocks—5 to 8†	508	£3.07
Opto Intensity Transducer	509	£2.70
Digital Capacitance Meter	512	£5.22
— JAN '86 —		
Mains Delay	503	£2.13
Musical Doorbell	507	£2.91
Tachometer—Transducers	513	£2.52
— FEB '86 —		
Touch Controller	510	£2.65
Function Generator	514	£3.10
Function Generator PSU Board	515	£2.09
pH Transducer	516	£2.75

\*Complete set of boards.

*M.I.T.*—Microcomputer Interfacing Techniques, 12-Part Series.

†Four separate circuits.

PROJECT TITLE	Order Code	Cost
Mains Tester & Fuse Finder	517	£2.27
BBC Midi Interface	518	£3.26
Stereo Hi Fi Preamp	519	£5.70
Interval Timer	520	£2.36
Stereo Reverb — APRIL '86 —	521	£2.89
PA Amplifier	511	£2.67
Mini Strobe — MAY '86 —	522	£2.24
Auto Firing Joystick Adaptor	523	£2.73
Watchdog	524	£2.81
Percussion Synthesiser — JUNE '86 —	525	£5.65
Personal Radio	526	£2.07
Tilt Alarm	527	£2.13
Electronic Scarecrow	528	£2.28
VOX Box Amplifier — JULY '86 —	529	£2.35
Headphone Mixer	530	£4.56
Solar Heating Controller — AUG '86 —	533	£3.32
Car Timer — SEPT '86 —	538	£2.02
Freezer Failure Alarm	534	£1.90
Infra Red Beam Alarm (Trans)	536	£3.32
Infra Red Beam Alarm (Rec)	537	£3.32
Scratch Blanker	539	£5.43
10W Audio Amp (Power Amp)	543	£2.58
(Pre-Amp) £4.78 Pair	544	£3.18
Light Rider—Lapel Badge	540 & 541	£2.70
—Disco Lights	542	£4.55
—Chaser Light — OCT '86	546	£3.23
Modem Tone Decoder — NOV '86 —	547	£2.76
200MHz Digital Frequency Meter	548	£4.12
Dual Reading Thermometer	549	£5.87
Automatic Car Alarm	550	£2.35
BBC 16K Sideways RAM — DEC '86 —	551	£2.38
(Software Cassette)	551S	£4.95
Random Light Unit — JAN '87 —	552	£4.70
Car Voltage Monitor	553	£2.00
Mini Amp.	554 & 555	£4.55
Video Guard — FEB '87 —	556	£3.05
Spectrum I/O	557	£3.78
Spectrum Speech Synthesiser	558	£3.88
Computer Buffer/Interface — MAR '87 —	560	£2.66
Infra Red Alarm: Sensor head	561	£3.35
PSU/Relay Driver	562	£3.60
Alarm Thermometer — APRIL '87 —	559	£2.10
Experimental Speech Recognition	563	£3.80
Bulb Life Extender	564	£2.00
Fridge Alarm —MAY '87 —	565	£1.86
EE Equaliser—loniser	566	£3.28
Mini Disco Light —JUNE '87 —	567	£2.35
Visual Guitar/Instrument Tuner	568	£3.18

Prices for **ELECTRONICS MONTHLY** PCBs are shown below.

PROJECT TITLE	Order Code	Cost
Cymbal Synth	EM/8412/2	£4.86
The Thing	EM/8412/4	£3.18
Speak Board — JAN '85 —	EM/8501/2	£3.97
Headphone Amp	EM/8502/1	£2.08
Intelligent Nicad Charger	EM/8502/2	£3.50
Anti Phaser — FEB '85 —	EM/8502/3	£4.56
Logical Lock	EM/8502/4	£3.58
Touch Dimmer	EM/8502/5	£3.29
Courtesy Light Extender — MAR '85 —	EM/8503/4	£3.29
Disco Light Chaser	EM/8503/5	£8.11
Sound to Light Unit	EM/8504/1	£4.02
Car Audio Booster — APRIL '85 —	EM/8504/2	£3.12
Short Wave Converter	EM/8504/3	£4.15
Car Burglar Alarm — MAY '85 —	EM/8505/3	£2.88
Metal Detector	EM/8506/1	£4.24
Power Supply Module — JUNE '85 —	EM/8506/3	£3.20
Flanger	EM/8506/4	£4.29
EI Tom/EI Tom+	EM/8507/1	£4.10
EI Cymb — JULY '85 —	EM/8507/2	£4.10
Heartbeat Monitor	EM/8507/3	£3.98
Real Time Clock	EM/8507/4	£4.62
Intelligent Windscreen Wiper (incl. Terminal Board)	EM/8508/1/2	£4.12
HiFi Intercom (2 boards)	EM/8508/3	£2.92
Plug Power Supply — AUG '85 —	EM/8508/4	£2.28
Hot Water Alarm	EM/8508/5	£1.93
Sinewave Generator — SEPT '85 —	EM/8509/1	£2.76
Household Battery Checker	EM/8509/2	£1.97
Audio Signal Generator	EM/8509/3	£3.65
Compressor Pedal	EM/8510/1	£2.87
Computer Cont Filter — OCT '85 —	EM/8510/2	£2.94
Spectrum MIDI Interface	EM/8510/3	£3.20

**BLOCK CAPITALS PLEASE**

**EE PRINTED CIRCUIT BOARD SERVICE**  
Please send me the following p.c.b.s.  
Make cheques/PO payable to: **Everyday Electronics**  
(Payment in £ sterling only)

Order Code	Quantity	Price
.....	.....	.....
.....	.....	.....
.....	.....	.....

I enclose cheque/PO for £ .....

Name.....  
Address.....

Make cheques/PO payable to: **Everyday Electronics**

**TEACH-IN SOFTWARE**

To complement each published part of the Teach-In series (Oct. '85 to June '86), we have produced an accompanying computer program. The Teach-In Software is available for both the BBC Microcomputer (Model B) and the Sinclair Spectrum (48k) or Spectrum-Plus. The programs are designed to reinforce and consolidate important concepts and principles introduced in the series. The software also allows readers to monitor their progress by means of a series of multi-choice tests, with scores at the end.

Tape 1 (Teach-In parts 1, 2 and 3), Tape 2 (parts 3, 4 and 5) and Tape 3 (parts 6, 7, 8 and 9) are available for £4.95 each (inclusive of VAT and postage) from Everyday Electronics and Electronics Monthly, 6 Church Street, Wimborne, Dorset BH21 1JH. **IMPORTANT** State BBC or Spectrum; add 50 pence for overseas orders; allow 28 days for delivery.

**SUBSCRIPTIONS**

Sell-out disappointment can upset even the less ambitious reader! So why not take out a year's subscription and make sure of every issue, straight from the Publisher? Complete the order form below and post to: **EVERYDAY ELECTRONICS and ELECTRONICS MONTHLY**, Subscription Dept., 6 Church Street, Wimborne, Dorset BH21 1JH. Tel. 0202 881749.

**Annual subscription rates:**  
**UK £14. Overseas £17 (£ sterling only)**  
**Overseas air mail £33 (£ sterling only)**

**EVERYDAY ELECTRONICS and ELECTRONICS MONTHLY SUBSCRIPTION ORDER FORM**

Annual subscription rates:  
UK £14. Overseas £17 (surface mail) £33 (air mail)

To: Everyday Electronics and Electronics Monthly, Subscription Dept., 6 Church Street, Wimborne, Dorset BH21 1JH.

Name.....  
Address .....

I enclose payment of £.....(cheque/PO in £ sterling only payable to Everyday Electronics)

**Subscriptions can only start with the next available issue.** For back numbers see the Editorial page

# EVERYDAY ELECTRONICS

Reach effectively and economically today's enthusiasts anxious to know of your products and services through our semi-display and classified pages. The prepaid rate for semi-display spaces is £8.00 per single column centimetre (minimum 2.5cm). The prepaid rate for classified advertisements is 30 pence per word (minimum 12 words), box number 60p extra. All cheques, postal orders, etc., to be made payable to Everyday Electronics VAT must be added. Treasury notes should always be sent registered post. Advertisements, together with remittance, should be sent to the Classified Advertisement Dept., Everyday Electronics, 6 Church Street, Wimborne, Dorset BH21 1JH. Tel: 0202 881749.

## Surveillance Transmitters

QUALITY TRANSMITTERS kits/made. SSAE details: GISO, 119 Downland Drive, Crawley RH10 6HA.

## Electronic Components

DELUXE WALKIE TALKIES 49MHZ. long range. £24.99/pair (normally £31.49). Satisfaction or refund. Send £3 now, pay balance upon receipt. 48hrs delivery. Xenon (Dept EE9), 24 Wharncliffe Street, Barnsley, Yorkshire.

GOOD QUALITY electronic components. Send for free list. M. Porter, 21 Pulleys Lane, Hemel Hempstead, Herts. HP1 2PZ.

WE OFFER a complete service! Components, vintage facilities. T/equipment, valves etc. SAE catalogue A.G.S. Electronics, 49 Farringdon Road, Plymouth PL4 9ER.

**MANUFACTURERS STOCK CLEARANCE!**  
THOUSANDS OF BRAND NEW COMPONENTS AT  
ROCK BOTTOM PRICES!

Op-Amps, Regulators, TTL, CMOS,  
LED'S, Displays, Transistors,  
Capacitors, Resistors, Switches,  
etc. etc...

All brand new and guaranteed.  
No minimum order charge.

DON'T MISS THIS GREAT OPPORTUNITY. SEND  
SAE FOR DETAILS OR RING (0384) 74540.



**ELECTRONIC COMPONENTS**

MAKES DISCOUNT VOUCHERS

● Velleman Electronic Kits ● 1st Equipment & Tools ● Instrument Cases

Send for New Catalogue 60p inc. P&P  
(Mon.-Sat. 9.30-5.30. Closed Thurs.)

**13A Station Rd, Cullercoats, North Shields,  
Tyne & Wear NE30 4PQ Tel. 091 251 4363**

THE SCIENTIFIC WIRE COMPANY				
811 Forest Road, London E17. Telephone 01-531 1568				
ENAMELLED COPPER WIRE				
SWG	1 lb	8 oz	4 oz	2 oz
8 to 34	3.63	2.09	1.10	0.88
35 to 39	3.82	2.31	1.27	0.93
40 to 43	6.00	3.20	2.25	1.61
44 to 47	8.67	5.80	3.49	2.75
48	15.96	9.58	6.38	3.69
SILVER PLATED COPPER WIRE				
14 to 30	9.09	5.20	2.93	1.97
TINNED COPPER WIRE				
14 to 30	3.97	2.41	1.39	0.94
Fluxcore				
Solder	5.90	3.25	1.82	0.94
Prices include P&P. Please add VAT. Orders under £3 add 50p. SAE for list of copper and resistance wire. Dealer enquiries welcome				

## Service Manuals

SERVICE SHEETS from £2.50/1sae ctv/ music/combs £3.50/1sae. Sae Newnes & TV Technic Books in stock. Thousands Service & Repair Manuals. SAE Free Review/pricelists. TIS (EE), 76 Church St, Larkhall (0698 883334), Lanarkshire.

### WORKSHOP SERVICE MANUALS

Thousands stocked, most makes, models, types, audio, TV, video, test, amateur etc. SAE enquiries/ quotation. Bumper Catalogue £3.00 including FREE Phonograph speed disc. Details Unique Repair and Data Guides.

**MAURITRON (EE), 8 CHERRYTREE ROAD, CHINNOR, OXON OX9 4QY.**

## ORDER FORM PLEASE WRITE IN BLOCK CAPITALS

Please insert the advertisement below in the next available issue of *Everyday Electronics* for ..... insertions. I enclose Cheque/P.O. for £.....(Cheques and Postal Orders should be made payable to Everyday Electronics)

--	--	--	--

NAME .....

ADDRESS .....

**EVERYDAY ELECTRONICS,  
Classified Advertisement Dept.,  
6 Church Street,  
Wimborne, Dorset BH21 1JH.  
Telephone 0202 881749**

RATE: 30p per word, minimum 12 words.  
Box No. 60p extra. VAT must be added.

6/87

## Special Offers

**FREE MEMBERSHIP** to a new national electronics club. For details and a free pack of components worth over £10 send only £1 p&p to Dept. EE, Woodside, Dowsett Lane, Ramsden Heath, Billericay, Essex CM11 1JL.

**CASSETTE MOTORS** large and small. 2 for £1.00. Mono and stereo cassette tape heads. 2 for £1.00. Microphone small for cass, tel. etc. 2 for £1.00. Please add 75p p&p, no VAT. Access card accepted. Golden Orange Supplies, Brockhollands Road, Woodside, Bream, Lydney, Glos. Tel: 0594 563009.

## Miscellaneous

### TURN YOUR SURPLUS

ICS transistors etc into cash, immediate settlement. We also welcome the opportunity to quote for complete factory clearance. Contact **COLES-HARDING & CO**, 103 South Brink, Wisbech, Cambs. **\*ESTABLISHED OVER 10 YEARS\*** Tel: 0945 584188

## 2000 TV TUNERS

UHF TV TUNERS WITH 7-BUTTON CHANNEL SELECTOR. HOUSED IN SLIMLINE CASE, COMPOSITE VIDEO OUTPUT. BRAND NEW. CHEAP TO CLEAR.

**£26<sup>95</sup>** + VAT EACH

**SCREENS MICROCOMPUTERS & ELECTRONICS**  
MAIN AVENUE, MOOR PARK,  
NORTHWOOD, MIDDX.  
TEL: 09274 20664 TLX: 929224 SCREEN G

**SECURITY LIGHT KIT**—mains operated can control up to 600W of additional lighting. Multi-beam passive I.R. people detector triggers light. Kit complete with case, PCB, I.R. module and all components. For details send SAE to Beeches Security Systems, 64 Carrs Way, Harpole, Northampton NN7 4DA.

### EDUCATIONAL SOFTWARE

To use on Spectrum 48K and higher.  
For transistors and their circuits:  
**ANALOGUE ELECTRONICS** Groups 1-2-3,  
3 programs on cassette, £9.50.  
For computer circuitry:  
**DIGITAL ELECTRONICS** Parts 1 to 6,  
6 programs on cassette, £16.  
Post free throughout Europe.

**Lancing Technical Services Ltd,**  
Dept E2, 54 Grand Avenue, Lancing, W. Sussex BN15 9PZ



# £1 BARGAIN PACKS

Buy 10 packs... get one free (your choice)

- PK 1. 350 Assorted resistors. Full length leads.
- PK 2. 400 Assorted resistors. Pre-formed leads.
- PK 3. 60 Assorted resistors. Wire wound.
- PK 4. 200 Assorted mixed capacitors.
- PK 5. 200 Assorted ceramic capacitors.
- PK 6. 60 Electrolytic capacitors.
- PK 7. 2 2200µf 100 volt capacitors.
- PK 8. 2 4700µf 30 volt capacitors.
- PK 9. 12 Assorted rotary potentiometers. Single gang.
- PK 10. 6 Assorted rotary potentiometers. Dual gang.
- PK 11. 12 Assorted slider potentiometers.
- PK 12. 40 Assorted pre-set potentiometers.
- PK 13. 5 100k lin multitrack potentiometers.
- PK 14. 5 1 meg lin multitrack potentiometers.
- PK 15. 12 Assorted switches.
- PK 16. 1 bank 4-way push button switches c/w knobs.
- PK 17. 1 4 pole 5-way waver switch.
- PK 18. 15 Assorted control knobs.
- PK 19. 20 Assorted plugs and sockets.
- PK 20. 2 Pairs O.C. plugs & sockets c/w leads & PP3 clip.
- PK 21. 25 Assorted transistors. All new & coded.

- PK 22. 15 Assorted I.C.'s. All new & coded.
- PK 23. 50 Assorted unmarked & untested I.C.'s.
- PK 24. 100 Assorted diodes.
- PK 25. 20 E.H.T. diodes.
- PK 26. 3 Large power-fin heatsinks. T03.
- PK 27. 1 4 section 7 segment L.e.d. clock display.
- PK 28. 20 Assorted neons. Panel mounting & wire ended.
- PK 29. 1 Microphone c/w lead, switch, plugs & stand.
- PK 30. 300 Assorted Polyester capacitors.
- PK 31. 3 Dynamic earpieces c/w lead & 3.5mm plug.
- PK 32. 2 Telesonic aerials.
- PK 35. 1 Large cassette motor.
- PK 36. 1 Wire pack. Mains cable.
- PK 38. 1 Wire pack. Connecting wire. Assorted colours.
- PK 39. 300 Assorted resistors. 1/2W or less. F/I. Leads.
- PK 40. 200 Assorted Polyester capacitors.
- PK 41. 12 Push to make switches. pcb mounting.
- PK 42. 12 Push-on-Push off switches.
- PK 43. 4 Assorted toaster elements.
- PK 44. 3 Assorted record player stylus.
- PK 45. 50 Assorted I.F. and tuning coils.
- PK 46. 35 Assorted resistors 1% tolerance.

Postal order or cheque with order. Please add £1 postage & packing per order. Access and Barclaycard orders welcome, minimum £10. Please phone orders before 4pm. Electronics magazines, we have an extensive range of back issues. 50p for current lists.

**MJR WHOLESALE, Unit 3, 238 Waterside, Chesham, Bucks HP5 1PG. ☎ 0494 771033**

## MAKE YOUR INTERESTS PAY!

More than 8 million students throughout the world have found it worth their while! An ICS home-study course can help you get a better job, make more money and have more fun out of life! ICS has over 30 years experience in home-study courses and is the largest correspondence school in the world. You learn at your own pace, when and where you want under the guidance of expert 'personal' tutors. Find out how we can help YOU. Pick one phone today for your FREE INFORMATION PACK on the course of your choice. (This one box only!)

Electronics	<input type="checkbox"/>	Radio, Audio and TV Servicing	<input type="checkbox"/>
Basic Electronic Engineering (City & Guilds)	<input type="checkbox"/>	Radio Amateur Licence Exam (City & Guilds)	<input type="checkbox"/>
Electrical Engineering	<input type="checkbox"/>	Car Mechanics	<input type="checkbox"/>
Electrical Contracting/Installation	<input type="checkbox"/>	Computer Programming	<input type="checkbox"/>
GCE over 40 'O' and 'A' level subjects <input type="checkbox"/>			



Name \_\_\_\_\_ P. Code \_\_\_\_\_  
 Address \_\_\_\_\_  
 International Correspondence Schools, Dept ECS67, 312/314 High St., Sutton, Surrey SM1 1PR. Tel: 01-643 9568 or 041-221 2926 (24 hrs).

**EQUIVALENT BOOKS**

- DATA VOL. 1 £9.99
- DATA VOL. 2 £10.75
- DATA VOL. 3 £10.20
- DATA VOL. 4 £13.50
- DIODES VOL. 1 £10.25
- DIODES VOL. 2 £10.85
- BOTH FOR £20.60**
- IC—CMOS £8.95
- IC—LIN VOL. 1 £6.95
- IC—LIN VOL. 2 £6.99
- BOTH FOR £13.00**
- IC—TTL £7.99
- THYRISTORS £10.45
- TRANSISTORS A-Z £5.40
- TRANSISTORS 2N-3N £5.50
- BOTH FOR £10.00**

**TWIN 12V FLUORESCENT LIGHT**  
 SUITABLE FOR CARAVANS, BOATS, VANS ETC. £5.50

**RESOLDERING PUMP** £2.99

**STEREO HEADPHONES**  
 ULTRA-LIGHTWEIGHT £1.99

**BATTERY CHARGER**  
 SUITABLE FOR AAA, AA, C, D AND PP3 NI-CAD BATTERY CHARGING. £4.50

**PORTABLE GAS SOLDERING IRON**  
 £14.50  
 SPARE TIPS £4.50  
 SIZE 2.4, 3.2 & 4.8mm

**TEST PROD—FUSED** 50p

**VALVES**

NI-CAD BATTERIES			
AAA—£1.25 (10+ £1.20 each)			
AA—90p (10+ 85p each)			
C-£2.10 (10+ £1.90 each)			
D-£2.50 (10+ £2.20 each)			
PP3-£4.10 (10+ £3.90 each)			

**12V RECHARGEABLE UNIT**  
 10 x D SIZE NI-CADS (4 Ah) ENCAPSULATED IN A BLACK PLASTIC CASE. FUSE HOLDER. GIVES 12V OUTPUT CHARGED. EX-EQUIPMENT. FULLY GUARANTEED.  
 245 x 75 x 75mm  
**£5.99**  
 + £1.85 P&P + 15% VAT

**MARCO TRADING**  
 DEPT. EEG THE MALTINGS,  
 HIGH STREET, WENLOCK,  
 SHROPSHIRE SY4 5EN

**MARCO TRADING**

**LATEST '87 CATALOGUE SEND £1 NOW (£2.50 OVERSEAS)**  
 (INCLUDES A 50P VOUCHER PRE-PAID ENVELOPE & SPECIAL OFFERS!)

**JUNE SPECIAL HELPING HANDS WITH MAGNIFIER**  
 75P P&P + 15% VAT **ONLY £3.50**

**BT EQUIPMENT**

- FLUSH MASTER SOCKET £2.90
- SURFACE MASTER SOCKET £2.75
- SURFACE SECONDARY SOCKET £1.90
- SURFACE SECONDARY SOCKET £1.85
- ADAPTOR 10/3A £2.99
- BELL TONE RINGER £6.95
- EXTENSION LEAD—5 MTR £3.90
- WIRE INSERTION TOOL 50p

**STARTER PACK**  
 1 x MASTER SOCKET  
 1 x SECONDARY SOCKET  
 15 MTR B.T. CABLE  
 50 CABLE CLIPS  
 LINE JACK CORD WITH PLUG  
 WIRING INSTRUCTIONS  
 ORDER CODE

**BT/CONVERSION KIT ONLY—£6.99**

**TELEPHONE ANSWERING MACHINE**  
 COMPLETE WITH REMOTE CONTROL FACILITY—LISTEN TO YOUR MESSAGES ANYWHERE IN THE WORLD!  
**£99.00**

**MARCO KITS**

- CERAMIC—50V (125) £3.50
- ELECTROLYTICS—RADIAL (100) £7.25
- FUSE 20MM QUICK-BLOW (80) £3.75
- NUT & BOLT (800) £3.00
- PRE-SET POTENTIOMETERS HORIZONTAL (120) £6.75
- PRE-SET POTENTIOMETERS VERTICAL (120) £8.75

**RESISTORS**

- 0.25W POPULAR (1000) £6.50
- 0.25W 5 OFF (305) £2.95
- 0.25W 10 OFF (810) £4.50
- 0.5W 5 OFF (385) £4.70
- 0.5W 10 OFF (730) £7.75
- 1W 5 OFF (385) £13.75
- 2W 5 OFF (385) £21.75
- ZENER DIODES 5 OFF (55) £3.50

**ALL ORDERS ARE PLUS 75P P & P PLUS 15% V.A.T.**  
**TEL: (0939) 32763**  
**TELEX: 35565**

# TELEVISION/COMPUTER FULL-TIME TRAINING

(FULL TIME COURSES APPROVED BY THE BUSINESS & TECHNICIAN EDUCATION COUNCIL)

**2 YEAR**  
**BTEC National Diploma (OND)**  
**ELECTRONIC & COMMUNICATIONS ENGINEERING**  
 (Electronics, Computing, Television, Video, Testing & Fault Diagnosis)

**15 MONTHS**  
**BTEC National Certificate (ONC)**  
**ELECTRONIC EQUIPMENT SERVICING**  
 (Electronics, Television, Video Cassette Recorders, CCTV, Testing & Fault Diagnosis)

**15 MONTHS**  
**BTEC National Certificate (ONC)**  
**COMPUTING TECHNOLOGY**  
 (Electronics, Computing Software/Hardware, Microelectronic Testing Methods)

**9 MONTHS**  
**BTEC Higher National Certificate (HNC)**  
**COMPUTING TECHNOLOGY & ROBOTICS**  
 (Microprocessor Based Systems, Fault Diagnosis, ATE, Robotics)

THESE COURSES INCLUDE A HIGH PERCENTAGE OF COLLEGE BASED PRACTICAL WORK TO ENHANCE FUTURE EMPLOYMENT PROSPECTS

NO ADDITIONAL FEES FOR OVERSEAS STUDENTS

SHORTENED COURSES OF FROM 3 TO 6 MONTHS CAN BE ARRANGED FOR APPLICANTS WITH PREVIOUS ELECTRONICS KNOWLEDGE

O.N.C. 21st September 1987  
 FULL PROSPECTUS FROM

**LONDON ELECTRONICS COLLEGE (Dept EE)**  
 20 PENYVERN ROAD, EARLS COURT,  
 LONDON SW5 9SU. Tel: 01-373 8721.

# C.P.L. ELECTRONICS



**EVERYDAY ELECTRONICS KITS**

Modem Tone Decoder	Nov '88	£15.90
Car Flashing Warning	Nov '88	£6.85
Optically Isolated Switch	Nov '88	£8.00
Freezer Failure Alarm	Sept '88	£9.65
Micro Mini Tuner (Excluding PCB)	Aug '88	£17.00
Battery Tester	Aug '88	£5.00
Caravan Battery Monitor	July '88	£14.70
Vox Box Amp	July '88	£10.50
Headphone Mixer	July '88	£21.50
Watchdog	June '88	£8.65
Personal Radio	June '88	£11.40
Perussion Synthesiser (Excl. PCB)	June '88	£19.75
Versatile PSU	Apr '88	£16.95*
Stereo Reverb	Apr '88	£20.20
Mains Tester & Fuse Finder (Excl. PCB)	Mar '88	£5.30
Interval Timer	Mar '88	£13.90
Stereo Hi-Fi Preamp	Mar '88	£37.65*
Touch Controller	Feb '88	£10.70
Mains Delay Switch	Jan '88	£15.95
One Chip Alarm	Jan '88	£6.50
Oport	Jan '88	£8.65
Caravan Alarm (Excl. Horn)	Sept '85	£13.30
Fridge Alarm	Sept '85	£6.65
Tremolo/Vibrato	Aug '85	£27.50
Drill Control Unit (Excl. Case)	Aug '85	£16.35*
Low cost PSU	Aug '85	£12.45
Train Signal Controller	July '85	£9.20
Continuity Tester	July '85	£7.40
Electronic Doorbell	June '85	£5.65
Caravan PSU	June '85	£8.95
Across The River	June '85	£11.80
High Z Multimeter (Excl. Case)	June '85	£26.90
Graphic Equaliser	June '85	£22.00

**DIGITAL TROUBLE SHOOTING**

1—EE Bench Power Supply	Nov '88	£24.95*
2—Logic Probe	Dec '88	£8.90
3—Logic Pulsar	Jan '87	£9.40
4—Versatile Pulse Generator	Feb '87	£25.90
5—Digit IC Tester	Mar '87	£25.90
6—Current Tracer	Apr '87	£28.75
7—Audio Logic Tracer	May '87	Phone

**ELECTRONICS MONTHLY KITS**

Compressor/Sustain Pedal	Oct '85	£20.00
Sinewave Generator	Sept '85	£19.65
Household Battery Checker	Sept '85	£12.20
Hot Water Indicator	Aug '85	£8.20
Intelligent Windscreen Wiper	Aug '85	£20.50
Hi Fi Intercom	Aug '85	£21.45
Heartbeat Monitor	July '85	£21.45
Freezer Temperature Alarm	July '85	£6.35
Sound Effects Box	July '85	£18.30
Visual Doorbell (Less bulb)	July '85	£12.95
Footpedal Flanger	June '85	£21.00

**TRANSISTORS**

BC107	.14	CA3046	.80	4000	16
BC108	.14	CA3140E	.42	4001	18
BC109	.14	ICL7660	2.50	4001	18
BC109C	.14	ICL7660	2.50	4001	18
BC183	.11	LF353	.82	4013	24
BC184L	.11	LF441	1.28	4018	20
BC187	.11	LM324	5.00	4017	35
BC208	.23	LM358	4.2	4021	38
BC212	.11	LM390	90	4023	19
BC214	.11	LM394	1.72	4024	30
BC547	.11	LM396	92	4026	88
BC548	.11	LM586	1.28	4027	22
BC557	.11	LM741	2.0	4040	39
BD131	.45	LM747	.64	4045	48
BD132	.47	LM748	40	4060	45
BD140	.34	LM1458	40	4068	16
BF224	.38	LM1458	40	4077	29
BF241	.31	MFI0CN	3.80	4078	26
BF244	.64	NE555	.22	4093	22
BF256	.43	NE556	.62	4093	26
BF494	40	NE588	1.28	4512	48
BF961	.77	NE554	1.20	4555	36
BF950	.26	SO42P	2.30	40105	1.45
BF951	.26	SL1821	6.10		
BF990	.88	SL340	5.10		
BZ206A	1.20	SL60CDP/8	2.20	7805	42
J309	.74	SL6440	4.80	7815	42
J310	.74	SP8829	3.00	7824	42
MPP102	.62	TL071	.46	7805	29
W100M	.80	TL072	.65	7815	29
W101M	.76	TL081	.38	7812	29
TX300	.20	TL082	.52	7812	29
TX302	.14	TL084	1.00	LM317T	1.05
TX3704	.14	XR2206	4.88	DIL SOCKETS	
2N3819	40	XR2211	3.46	8 Pin	05
2N3866	1.42			9 Pin	08
2N3904	1.14	SB11	6.55	18 Pin	08
2N3906	1.14	MIXER		18 Pin	08

**DIODES**

1N914	.04	BRIDGES			
1N4001	.05	W005	.22	20	10
1N4002	.05	SKB2/DZLSA	.72	24	13
1N4005	.08	C1060	.45	40	19
1N4007	.08	BT151/500R	.96	ZENERS	
1N4148	.025	BT151/850R	.88	BZ78 Series	.67
0A30	.14	OASO	.09	BZ61 Series	1.3
0A91	.10	C2080	.66	Presets	.89

**RESISTOR KITS** 1/2W 5%, 84 Values, 5 per Value = 3.90  
 Article Reprints—50p (if required)  
 POSTAGE 70p EXCEPT WHERE INDICATED \* = £1.60  
 1 = £2. PRICES EXCLUDE VAT WHICH SHOULD BE ADDED TO THE TOTAL ORDER INCL P&P VALUE. ALL KITS COMPLETE (LESS BATTERIES), UNLESS SPECIFIED, INCLUDING ALL COMPONENTS, PCB OR VERO, CASE AND HARDWARE. COMPONENTS NEW/FULL SPEC. CHEQUE OR P.O. TO—

**C.P.L. ELECTRONICS**  
 8 Southpenn Close, Hemlington, Middlesbrough,  
 Cleveland TS8 9HE. Tel: 0642 591157  
 FREE PRICE LIST ON REQUEST

# AFFORDABLE ACCURACY

## Quality Multimeters from

# Cirkit

A  
comprehensive  
range of  
Analogue and  
(Pushbutton or  
Rotary Switched)  
Digital Models



HB-102BZ



HC-7030

### ANALOGUE

HM-102BZ — Illustrated above. 20kΩ/V  
DC. DC voltage range, 2.5-1000V; AC volts  
10-1000V; resistance, 10kΩ-1MΩ; DC  
current, 5-500mA + 10A; battery test and  
continuity buzzer. £12.50  
HM-1015 — Rugged, Pocket sized meter,  
for general purpose use. £7.50  
16 measuring ranges

Battery, Test Leads and Manual included  
with each model.

Please add 15%  
for VAT and  
70p for P&P

### DIGITAL

HC-7030  
0-1% Accuracy. Standard Model.....£39.50  
HC-6010  
0-25% Accuracy. Standard Model.....£33.50  
HC-5010T  
0-25% Accuracy. TR Test Facility.....£39.50  
DM-105  
0-5% Accuracy. Pocketable.....£21.50

All models have full functions and ranges and  
feature: 3½ digit 0.5° LCD display — low  
battery indication — auto zero & auto polarity  
— ABS plastic casing — DC AC 10amp range  
(not DM-105) — Overhead protection on all  
ranges — battery, spare fuse, test leads and  
manual.

Full details and specification from:

## Cirkit Distribution Ltd

Park Lane, Broxbourne, Herts, EN10 7NQ

Telephone (0992) 444111 Telex 22478

TRADE ENQUIRIES WELCOME



## INDEX TO ADVERTISERS

AUDIOKITS .....	327
BARRIE ELECTRONICS.....	291
BI-PAK .....	290
B.K. ELECTRONICS.....	Cover III
BULL, J. & N. ....	Cover II
CIRKIT HOLDING .....	344
C.P.L. ELECTRONICS.....	343
CROTECH INSTRUMENTS	291
C-SCOPE .....	291
DELTA PHYSICS.....	291
ESR ELECTRONIC COMPONENTS .....	342
GREENWELD ELECTRONICS .....	315
I.C.S. ....	343
LIGHT SOLDERING DEVELOPMENTS .....	292
LONDON ELECTRONICS COLLEGE .....	343
MAGENTA ELECTRONICS .....	294
MAPLIN ELECTRONICS .....	Cover IV
MARCO TRADING.....	343
M.J.R. WHOLESALE .....	343
OMEGA ELECTRONICS .....	302
OMNI ELECTRONICS .....	291
PHONOSONICS .....	344
RADIO COMPONENT SPECIALISTS .....	344
RISCOMP LTD .....	290
STEWART OF READING.	327
SUPER ALPHA ELECTRONICS .....	293
T.K. ELECTRONICS .....	315
UNIVERSAL SEMICONDUCTOR DEVICES .....	292
XEN-ELECTRONICS .....	327
ZENITH ELECTRONICS.....	292

## ★ BAKER ★ GROUP P.A. OISCO AMPLIFIERS post £4

150 watt Output. 4 Input Mixer pre-amp. Illustrated.	£95
150 watt Output. Slave 500 mv. Input 3 Speaker Outputs	£80
150 + 150 watts Stereo. 300 watt Mono Slave 500 mv. Inputs	£145
150 watt P.A. Vocal. 8 Inputs. High/Low Mixer Echo Socket	£149
50 watt Mobile 240V AC and 12V DC. 4-8-16 ohm + 100v line	£89
Compact P.A. amp 20 + 20 Stereo or 40 watts Mono	£85
30 watt Guitar/P.A. Amplifier. 2 inputs	£59
30 watt COMBI. 12n. Speaker, Treble, Base etc	£95
500 watt Heavy Duty Mono Slave Amplifier	£275

### FAMOUS LOUDSPEAKERS

Make	Model	Size	Watts	Ohms	Price	Post
GOODMANS	HIFAX	7 1/4 x 4 1/2 in.	100	8	£38	£1
GOODMANS	HE WOOFER	8 in.	60	8	£16	£1
BAKER	DISCO/GROUP	10 in.	50	8/16	£22	£2
BAKER	MID-RANGE	10 in.	100	8	£27.50	£2
BAKER	DISCO/GROUP	12 in.	120	8/16	£32	£2
WEM	WOOFER	12 in.	300	8	£85	£2
GOODMANS	DISCO/GROUP	12 in.	120	8/15	£39	£2
BAKER	DISCO/GROUP	15 in.	100	8/16	£44	£4
H+H	DISCO/GROUP	15 in.	100	4/8/16	£54	£4
H+H	DISCO/GROUP	15 in.	200	8/16	£55	£4
GOODMANS	HP/BASS	15 in.	250	8	£82	£4
GOODMANS	HPD/BASS	18 in.	230	8	£92	£4

### FULLY GUARANTEED

COMPACT FULL RANGE SPEAKER SYSTEMS size 24 x 17 x 12 in.  
120 watts £100, 200 watts £130, 400 watts £180 each. Carr. £10.  
MINI-TOP 300 watts add on system complete £130 each. Carr. £10.

DISCO CONSOLE Twin Decks, mixer pre amp £149. Carr. £10.  
Ditto Powered 120 watt £199, or Complete Disco £299. Carr. £30

### MAINS TRANSFORMERS VALVE TYPE

Make	Drive	Supply	Cartridge	Price	Post
JAP Single	Belt	12V	Magnetic	£30	£10
BSR Single	Belt	240V	Magnetic	£30	£16
BSR Single	Rim	240V	Ceramic	£22	£4
BSR Auto	Rim	240V	Ceramic	£18	£2
Garrard Auto	Rim	240V	Ceramic	£24	£1

LOW VOLTAGE MAINS TRANSFORMERS £5.50 each post paid  
STEP-UP STEP-DOWN 240V-120V 150W £9, 250W £12. 500W £15 £2

2V. 3A. 12V. 3A. 16V. 2A. 20V. 1A. 30V. 1A. 30V. 5A + 17.0-17V. 2A. 35V.  
9A. 2A. 40.60V. 1A. 12.0-12V. 2A. 20.0-20V. 1A. 0.12-27V. 2A.

### RECORD DECKS. P&P £2. Many others in stock. Phone for details

Make	Drive	Supply	Cartridge	Price	Post
JAP Single	Belt	12V	Magnetic	£30	£10
BSR Single	Belt	240V	Magnetic	£30	£16
BSR Single	Rim	240V	Ceramic	£22	£4
BSR Auto	Rim	240V	Ceramic	£18	£2
Garrard Auto	Rim	240V	Ceramic	£24	£1

PROJECT CASES. Black Vinyl Covered Steel Top. All Base  
4 x 2 1/2 x 2 1/2 in. £1.00, 6 x 4 x 1 1/2 in. £4.00, 8 x 5 x 2 in. £4.50 p.p. £1.  
11 x 6 x 3 in. £6.00, 11 1/2 x 6 x 5 in. £10.00, 15 x 8 x 4 in. £13.50 p.p. £2.  
ALUMINIUM PANELS 18 s.w.g. 12 x 12 in. £2.50, 14 x 9 in. £2.40, 6 x 4 in.  
85p; 12 x 8 in. £1.80, 10 x 7 in. £1.50, 8 x 6 in. £1.00, 14 x 3 in. £1.  
12 x 5 in. £1.15, 16 x 10 in. £2.70, 16 x 6 in. £1.80 p.p. 65p each

ALUMINIUM BOXES. MANY OTHER SIZES IN STOCK  
4 x 2 1/2 x 2 1/2 in. £1.35, 3 x 2 x 1 in. £1.15, 6 x 4 x 2 in. £2.00, 8 x 6 x 3 in. £3.40,  
12 x 5 1/2 x 3 in. £4.00, 6 x 4 x 3 in. £2.50, 10 x 7 x 3 in. £4.00 p.p. £1.

### HIGH VOLTAGE ELECTROLYTICS Many others in stock

20/500V	£1	220/400V	£2	32+32/500V	£2
32/350V	50p	8+8/450V	£1	32+32/350V	85p
47/350V	£1	20+20/350V	75p	80+40+20/350V	95p

AIR SPACED TWIN GANGS 365 + 365 + 25 + 25p £2.00.

REVERSE VERNIER cord drive 90p Spindle Extender £1.50

VERNIER DIALS. 0.100, 36mm. £3.00, 50mm £3.50

### RADIO COMPONENT SPECIALISTS

337 WHITEHORSE ROAD, CROYDON  
SURREY, U.K. Tel: 01-684 1665

Post 65p Minimum. Calls Welcome  
List, Large S.A.E. Delivery 7 days Closed Wednesday



EVERYDAY

KIT CATALOGUE

# PHONOSONICS

FASCINATING ELECTRONIC PROJECTS

MUSIC  
MODULES

DIGITAL  
INTERFACES

GEIGER  
COUNTERS

MANY MORE  
FINE DESIGNS

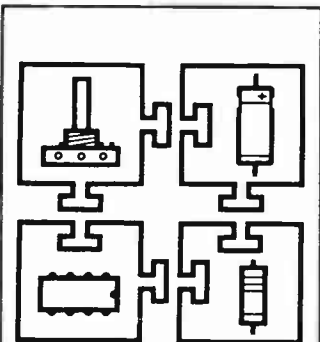

KITS THAT FIT

THROUGH  
ELECTRONICS  
UNDERSTAND  
ESSENTIAL  
TECHNOLOGY

- ★ BE KIT CREATIVE
- ★ RAISE YOUR SKILLS
- ★ LEARN BY BUILDING
- ★ ENJOY BY USING



POPULAR PROJECTS FROM A LEADING AUTHOR

A-D-Interface*	Set 251	61.00	Mixer Simple 4 Chan	Set 256	19.99
Bass Boost	Set 138B	13.62	Mock Stereo	Set 213	24.37
Blow Box	Set 214	29.33	Morse Decoder*	Set 269	22.16
Chip Test 16-Pin*	Set 258S	32.50	Noise Gate	Set 227	26.61
Chip Test 24-Pin*	Set 258F	39.30	Phaser - Enhanced	Set 226	42.36
Chorus Flanger Dual	Set 235	59.99	Polywhatsit! FX	Set 252	122.69
Compander	Set 238	22.99	Reverb Simple Dual	Set 203	36.54
Cybervox Voice FX	Set 228	44.76	Reverb Simple Mono	Set 232	27.35
Digital Delay & MCS	Set 234RK	198.50	Rhythm Gen*	Set 185	34.64
Disco Light Control	Set 245F	62.50	Rhythm Generator	Set 240	59.99
Echo-Reverb Stereo	Set 218	57.66	Ring Mod (Simple)	Set 179	23.90
Envelope Shaper	Set 174	25.20	Ring Modulator	Set 231	45.58
Equaliser 3-Chan	Set 217	25.33	Roger 2-Gong	Set 126	16.63
Fader (Voice Op)	Set 167	22.22	Signal Generator	Set 233	46.96
Flanger (Mono)	Set 153	28.45	Sirens Drum Trig	Set 199	23.75
Frequency Changer	Set 172	45.56	Sirens Wheezy Jeeby	Set 151	21.16
Fuzz (Smooth)	Set 209F	19.58	Storm Wind & Rain	Set 250W	29.50
Guitar Modulo	Set 196	23.56	Storms Simple	Set 154	23.60
Guitar to Synth	Set 173	41.41	Sustain	Set 222	25.31
Hand Clapper	Set 197	26.69	Thunder & Lightning	Set 250T	29.50
Linkafex Chorus	Set 204	42.96	Tom-Tom Synth	Set 190	19.37
Linkafex Delay	Set 206	42.09	Treble Boost	Set 138T	13.62
Linkafex Equaliser	Set 216	25.43	Tremolo	Set 136	15.62
Linkafex Flange	Set 207	34.92	Tuner - Micro*	Set 257	55.32
Linkafex Fuzz	Set 209L	23.24	Tuner - Simple*	Set 259	22.50
Linkafex Modulo	Set 211	25.41	Vodalek Voice FX	Set 155	18.31
Linkafex Overdrive	Set 215	25.13	Voice Op Switch	Set 123	20.41
Linkafex Phaser	Set 205	34.38	Wah Auto & Manual	Set 140	24.36
Linkafex Sustain	Set 223	26.47			
Metronome	Set 143	21.35			
Mic Pre-Amp	Set 144	14.93			
Micro-Scope*	Set 247	44.50			
Micro-Trace*	Set 261	19.50			
Mini-Sampler	Set 246	75.00			
Mixer 4-Ch Stereo	Set 229S	82.15			

\* Computer controlled (BBC, C64, PET)

† Ready-built Geigers

Send A4 SAE for detailed catalogue, and with all enquiries (overseas send £1.00 or 51 R.C.'s).

Add 15% VAT. Add P&P - Sets over £50 add £2.50. Others add £1.50. Overseas P&P in catalogue. Text photocopies - Geiger & DDL Texts £1.50 each, others 50p, plus 50p post or large SAE. Insurance 50p per £50. Mail order. CWO, CHQ, PO, Access, Visa.

PHONOSONICS, DEPT EE76, 8 FINUCANE DRIVE,  
ORPINGTON, KENT BR5 4ED. Tel: 0689 37821.

# OMP POWER AMPLIFIER MODULES

## OMP POWER AMPLIFIER MODULES

Now enjoy a world-wide reputation for quality, reliability and performance at a realistic price. Four models available to suit the needs of the professional and hobby market i.e. Industry, Leisure, Instrumental and Hi-Fi etc. When comparing prices, NOTE all models include Toroidal power supply, Integral heat sink, Glass fibre P.C.B. and Drive circuits, to power compatible Vu meter. Open and short circuit proof.

Supplied ready built and tested.

**OMP100 Mk II Bi-Polar Output power 110 watts R.M.S. into 4 ohms, Frequency Response 15Hz - 30KHz -3dB, T.H.D. 0.01%, S.N.R. -118dB, Sens. for Max. output 500mV at 10K, Size 355 x 115 x 65mm. PRICE £33.99 + £3.00 P&P.**

**OMP/MF100 Mos-Fet Output power 110 watts R.M.S. into 4 ohms, Frequency Response 1Hz - 100KHz -3dB, Damping Factor 80, Slew Rate 45V/uS, T.H.D. Typical 0.002%, Input Sensitivity 500mV, S.N.R. -125dB, Size 300 x 123 x 60mm. PRICE £39.99 + £3.00 P&P.**

**OMP/MF200 Mos-Fet Output power 200 watts R.M.S. into 4 ohms, Frequency Response 1Hz - 100KHz -3dB, Damping Factor 250, Slew Rate 50V/uS, T.H.D. Typical 0.001%, Input Sensitivity 500mV, S.N.R. -130dB, Size 300 x 150 x 100mm. PRICE £62.99 + £3.50 P&P.**

**OMP/MF300 Mos-Fet Output power 300 watts R.M.S. into 4 ohms, Frequency Response 1Hz - 100KHz -3dB, Damping Factor 350, Slew Rate 60V/uS, T.H.D. Typical 0.0008%, Input Sensitivity 500mV, S.N.R. -130dB, Size 330 x 147 x 102mm. PRICE £79.99 + £4.50 P&P.**

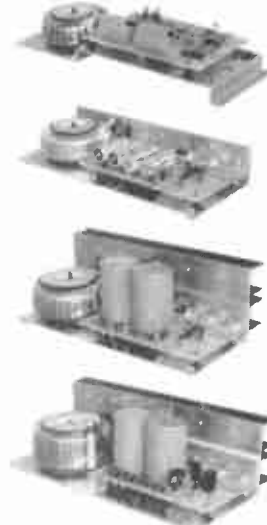

NOTE: Mos Fets are supplied as standard (100KHz bandwidth & Input Sensitivity 500mV). If required, P.A. version (50KHz bandwidth & Input Sensitivity 775mV). Order — Standard or P.A.

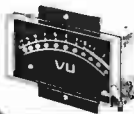

**Vu METER** Compatible with our four amplifiers detailed above. A very accurate visual display employing 11 L.F.D. diodes (7 green, 4 red) plus an additional on/off indicator. Sophisticated logic control circuits for very fast rise and decay times. Tough moulded plastic case with tinted acrylic front. Size 84 x 27 x 45mm. PRICE £8.50 + 50p P&P.

**LOUDSPEAKERS 5" to 15" up to 400 WATTS R.M.S.** Cabinet Fixing in stock. Huge selection of McKenzie Loudspeakers available including Cabinet Plans. Large S.A.E. (28p) for free details.



### POWER RANGE

8" 50 WATT R.M.S. Hi-Fi Disco.  
20 oz magnet 1" ally voice coil Ground ally fixing escutcheon Res Freq 40Hz Freq Resp to 6KHz Sens 92dB PRICE £10.99 Available with black grille £11.99 P&P £1.50 ea  
12" 100 WATT R.M.S. Hi-Fi Disco  
50 oz magnet 2" ally voice coil Ground ally fixing escutcheon Die cast chassis White cone Res Freq 25Hz Freq Resp to 4KHz Sens 95dB PRICE £28.60 + £3.00 P&P ea

### McKENZIE

12" 85 WATT R.M.S. C1285GP Lead Guitar/Keyboard/Disco.  
2" ally voice coil. Res. Freq. 52Hz. Freq. Resp. to 5KHz. Sens. 99dB. PRICE £29.99 + £3.00 P&P ea.  
12" 85 WATT R.M.S. C1285TC P.A./Disco 2" ally voice coil. Twin cone.  
Res. Freq. 45Hz. Freq. Resp. to 14KHz. PRICE £31.49 + £3.00 P&P ea.  
15" 150 WATT R.M.S. C15 Bass Guitar/Disco.  
3" ally voice coil. Die-cast chassis. Res. Freq. 40Hz. Freq. Resp. to 4KHz. PRICE £57.87 + £4.00 P&P ea.  
10" 60 WATT R.M.S. 1060GP Gen. Purpose/Lead Guitar/Keyboard/Mid. P.A.  
2" voice coil. Res. Freq. 75Hz. Freq. Resp. to 7.5KHz. Sens. 99dB. PRICE £19.99 + £2.00 P&P.  
10" 200 WATT R.M.S. C10200GP Guitar/Keyboard/Disco.  
2" voice coil. Res. Freq. 45Hz. Freq. Resp. to 7KHz. Sens. 101dB. PRICE £44.76 + £3.00 P&P.  
15" 200 WATT R.M.S. C15200 High Power Bass.  
Res. Freq. 40Hz. Freq. Resp. to 5KHz. Sens. 101dB. PRICE £62.41 + £4.00 P&P.  
15" 400 WATT R.M.S. C15400 High Power Bass.  
Res. Freq. 40Hz. Freq. Resp. to 4KHz. Sens. 102dB. PRICE £89.52 + £4.00 P&P.

### WEM

5" 70 WATT R.M.S. Multiple Array Disco etc.  
1" voice coil. Res. Freq. 52Hz. Freq. Resp. to 5KHz. Sens. 99dB. PRICE £22.00 + £1.50 P&P ea.  
8" 150 WATT R.M.S. Multiple Array Disco etc.  
1" voice coil. Res. Freq. 48Hz. Freq. Resp. to 5KHz. Sens. 92dB. PRICE £32.00 + £1.50 P&P ea.  
10" 300 WATT R.M.S. Disco/Sound re-enforcement etc.  
1" voice coil. Res. Freq. 35Hz. Freq. Resp. to 4KHz. Sens. 92dB. PRICE £36.00 + £2.00 P&P ea.  
12" 300 WATT R.M.S. Disco/Sound re-enforcement etc.  
1" voice coil. Res. Freq. 35Hz. Freq. Resp. to 4KHz. Sens. 94dB. PRICE £47.00 + £3.00 P&P ea.

### SOUNDLAB (Full Range Twin Cone)

5" 60 WATT R.M.S. Hi-Fi Multiple Array Disco etc.  
1" voice coil Res Freq 63Hz Freq Resp to 20KHz Sens 86dB PRICE £9.99 + £1.00 P&P ea  
6" 60 WATT R.M.S. Hi-Fi Multiple Array Disco etc.  
1" voice coil Res Freq 56Hz Freq Resp to 20KHz Sens 89dB PRICE £10.99 + £1.50 P&P ea  
8" 60 WATT R.M.S. Hi-Fi Multiple Array Disco etc.  
1" voice coil Res Freq 38Hz Freq Resp to 20KHz Sens 89dB PRICE £12.99 + £1.50 P&P ea  
10" 60 WATT R.M.S. Hi-Fi/Disco etc.  
1" voice coil Res Freq 35Hz Freq Resp to 15KHz Sens 89dB PRICE £16.49 + £2.00 P&P

**ANTIC HOBBY KITS.** Proven designs including glass fibre printed circuit board and high quality components complete with instructions.

**FM MICROTRANSMITTER (BUG)** 90/105MHz with very sensitive microphone. Range 100/300 metres. 57 x 46 x 14mm (9 volt) Price: £8.62 + 75p P&P.  
**3 WATT FM TRANSMITTER** 3 WATT 85/115MHz varicap controlled professional performance. Range up to 3 miles 35 x 84 x 12mm (12 volt) Price: £14.49 + 75p P&P.  
**SINGLE CHANNEL RADIO CONTROLLED TRANSMITTER/RECEIVER** 27MHz. Range up to 500 metres. Double coded modulation. Receiver output operates relay with 2amp/240 volt contacts. Ideal for many applications. Receiver 90 x 70 x 22mm (9/12 volt). Price: £17.82 Transmitter 80 x 50 x 15mm (9/12 volt). Price: £11.29 P&P + 75p each. S.A.E. for complete list.



3 watt FM Transmitter

POSTAL CHARGES PER ORDER £1.00 minimum. OFFICIAL ORDERS WELCOME. SCHOOLS, COLLEGES, GOVERNMENT BODIES, ETC. PRICES INCLUSIVE OF V.A.T. SALES COUNTER VISA/ACCESS/C.O.D. ACCEPTED



\* PRICES INCLUDE V.A.T. \* PROMPT DELIVERIES \* FRIENDLY SERVICE \* LARGE S.A.E. 28p STAMP FOR CURRENT LIST

## BURGLAR ALARM

Better to be 'Alarmed' than terrified. Thandar's famous 'Minder' Burglar Alarm System. Superior microwave principle. Supplied as three units complete with interconnection cable FULLY GUARANTEED.

**Control Unit** — Houses microwave radar unit, range up to 15 metres adjustable by sensitivity control. Three position, key operated fascia switch — off — test — armed. 30 second exit and entry delay.  
**Indoor alarm** — Electronic swept freq siren 104dB output.  
**Outdoor Alarm** — Electronic swept freq siren 98dB output. Housed in a tamper-proof heavy duty metal case.

Both the control unit and outdoor alarm contain rechargeable batteries which provide full protection during mains failure. Power requirement 200/260 Volt AC 50/60Hz. Expandable with door sensors, panic buttons etc. Complete with instructions.

SAVE £138.00 Usual Price £228.85

**BKE's PRICE £89.99 + £4.00 P&P**

Why buy a collection of self-assembly boards!

IDEAL for Workshops, Factories, Offices, Home, etc. Supplied ready built.



## OMP LINNET LOUDSPEAKERS

The very best in quality and value. Made specially to suit today's need for compactness with high sound output levels. Finished in hard wearing black vinyl with protective corners, grille and carry handle. All models 8 ohms. Full range 45Hz - 20KHz. Size 20" x 15" x 12". Watts R.M.S. per cabinet. Sensitivity 1W 1mtr dB.

**OMP 12-100 Watts 100dB. Price £149.99**

per pair.

**OMP 12-200 Watts 102dB. Price £199.99**

per pair.

Delivery Securicor £8.00 per pair



## OMP 19" STEREO RACK AMPS



Professional 19" cased Mos-Fet stereo amps. Used the World over in clubs, pubs, discos etc. With twin Vu meters, twin toroidal power supplies, XLR connections. MF600 Fan cooled. Three models (Ratings R.M.S. into 4ohms). Input Sensitivity 775mV

**MF200 (100 + 100)W. £171.35 Securicor**

**MF400 (200 + 200)W. £228.85 Delivery**

**MF600 (300 + 300)W. £322.00 £10.00**

## 1 K-WATT SLIDE DIMMER

- \* Control loads up to 1Kw
- \* Compact Size 4" x 1" x 2 1/2"
- \* Easy snap in fixing through panel cabinet cut out
- \* Insulated plastic case
- \* Full wave control using 8 amp triac
- \* Conforms to BS800
- \* Suitable for both resistance and inductive loads. Innumerable applications in industry, the home, and disco's, theatres etc.

BS800

PRICE £13.99 + 75p P&P

## BSR P295 ELECTRONIC TURNTABLE

\* Electronic speed control 45 & 33 1/3 r.p.m. \* Plus Minus variable pitch control \* Belt driven \* Aluminium platter with strobed rim \* Cue lever \* Anti-skate (bias device) \* Adjustable counter balance \* Manual arm \* Standard 1/2" cartridge fixings \* Supplied complete with cut out template \* D.C. Operation 9-14v D.C. 65mA  
Price £36.99 — £3.00 P&P



ADC Q4 mag. cartridge for above Price £4.99 ea. P&P 50p

## PIEZO ELECTRIC TWEETERS MOTOROLA

Join the Piezo revolution. The low dynamic mass (no voice coil) of a Piezo tweeter produces an improved transient response with a lower distortion level than ordinary dynamic tweeters. As a crossover is not required these units can be added to existing speaker systems of up to 100 watts (more if 2 put in series) FREE EXPLANATORY LEAFLETS SUPPLIED WITH EACH TWEETER.

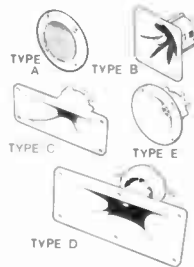

**TYPE 'A' (KSN2036A)** 3" round with protective wire mesh. Ideal for bookshelf and medium sized Hi-Fi speakers. Price £4.90 each + 40p P&P

**TYPE 'B' (KSN1005A)** 3 1/2" super horn. For general purpose speakers, disco and P.A. systems etc. Price £5.99 each + 40p P&P

**TYPE 'C' (KSN6016A)** 2" x 5" wide dispersion horn. For quality Hi-Fi systems and quality discos etc. Price £6.99 each + 40p P&P

**TYPE 'D' (KSN1025A)** 2" x 6" wide dispersion horn. Upper frequency response retained extending down to mid range (2KHz). Suitable for high quality Hi-Fi systems and quality discos. Price £9.99 each + 40p P&P

**TYPE 'E' (KSN1038A)** 3 1/2" horn tweeter with attractive silver finish trim. Suitable for Hi-Fi monitor systems etc. Price £5.99 each + 40p P&P

**LEVEL CONTROL** Combines on a recessed mounting plate, level control and cabinet input jack socket 85 x 85 mm. Price £3.99 + 40p P&P

## STEREO DISCO MIXER

**STEREO DISCO MIXER** with 2 x 5 band L & R graphic equalisers and twin 10 segment LED Vu Meters. Many outstanding features. 5 Inputs with individual faders providing a useful combination of the following:  
3 Turntables (Mag), 3 Mics, 4 Line plus Mic with talk over switch. Headphone. Monitor. Pan Pot. L & R Master Output controls. Output 775mV. Size 360 x 280 x 90mm.  
Price £134.99 — £3.00 P&P



# B. K. ELECTRONICS

UNIT 5, COMET WAY, SOUTHEND-ON-SEA, ESSEX, SS2 6TR TEL: 0702-527572

# IN METERS ... WE'RE MILES AHEAD



Just three  
Multimeters from  
our large range



### ▲ Pocket Digital Multimeter

A calculator size autoranging DMM which reads 1mV-400V DC, 1mV-400V AC, 0.1Ω-2MΩ and has a continuity buzzer. Overall size only 120 x 75 x 15mm. Order Code YN78K **Price £24.95**

### ▲ Hobby Digital Multimeter

A very high quality multimeter at a very low price! 14 selectable ranges covering AC and DC volts, DC current and resistance. Also has a diode junction test range. Order Code YM63T **Price £28.95**

### ▲ Auto Ranging Digital Multimeter with Transistor Tester

A 6 position rotary switch selects off, volts, ohms/continuity, 20MΩ, 200mA/h<sub>FE</sub> or 10A. Features include display hold, NPN and PNP transistor tester, autorange override and low battery indication. Order Code YM64U **Price £45.95**

*All prices include VAT. Please add 50p towards postage. Prices firm until 15th August 1987. Subject to availability.*



## Maplin ELECTRONIC SUPPLIES LTD.

**Mail Order:** P.O. Box 3, Rayleigh, Essex SS6 8LR. Tel: Southend (0702) Sales: 554161, Enquiries: 552911; Trade sales: 554171, Trade enquiries: 552961.

### Shops

**Birmingham:** Lynton Square, Perry Barr. Telephone: 021 356 7292.

**London:** 159-161 King Street, Hammersmith W6. Telephone: 01 748 0926.

**Manchester:** 8 Oxford Road. Telephone: 061 236 0281.

**Southampton:** 46-48 Bevois Valley Road. Telephone: 0703 225831.

**Southend-on-Sea:** 282-284 London Road, Westcliff-on-Sea, Essex. Tel: 0702 554000.

*All shops except Manchester closed all day Monday.*



Pick up a copy of our 1987 catalogue from any branch of W.H. Smith for just £1.50. Or to receive your copy by post just send £1.50 + 40p p & p to Mail Order address. If you live outside the U.K. please send £2.50 or 11 International Reply Coupons.