

# EVERYDAY ELECTRONICS and computer **PROJECTS**

MARCH 1984

90p

## DIGITAL MULTIMETER ADD-ON for COMPUTERS MEASURES VOLTAGE RESISTANCE & CAPACITANCE



**METAL PIPE FINDER**  
**Ni-Cad BATTERY CHARGER**  
**CAR REVERSING BLEEPER**

electronize **AUTO-ELECTRONIC PRODUCTS**  
KITS OR READY BUILT

**TOTAL ENERGY DISCHARGE  
ELECTRONIC IGNITION**

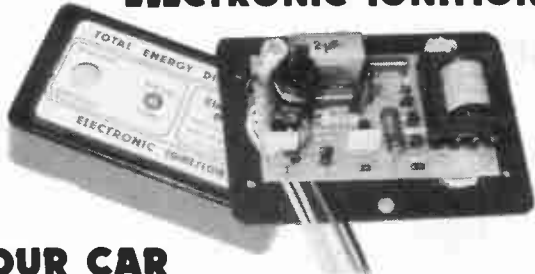

**IS  
YOUR CAR  
AS GOOD AS IT COULD BE ?**

- ★ Is it **EASY TO START** in the cold and the damp? Total Energy Discharge will give the most powerful spark and maintain full output even with a near flat battery.
  - ★ Is it **ECONOMICAL** or does it "go off" between services as the ignition performance deteriorates? Total Energy Discharge gives much more output and maintains it from service to service.
  - ★ Has it **PEAK PERFORMANCE** or is it flat at high and low revs. where the ignition output is marginal? Total Energy Discharge gives a more powerful spark than the engines maximum (even with 8 cylinders).
  - ★ Is the **PERFORMANCE SMOOTH**. The more powerful spark of Total Energy Discharge eliminates the "near misfires" whilst an electronic filter suppresses the effects of contact bounce etc.
  - ★ Do the **PLUGS SPARK**? Always need changing to bring the engine back to life? Total Energy Discharge eliminates contact arcing and so, by removing the cause, prevents the spark plugs staying "spotted" and the engine condition doesn't affect the performance either. New plug caps can be used, even wet or badly fouled plugs can be used with the system.
  - ★ **TOTAL ENERGY DISCHARGE** is a unique spark and the most powerful of any spark, 1 1/2 times the energy of inductive systems, 3 1/2 times the energy and 3 times the duration of ordinary capacitive systems. These are the facts:  
Performance at only 12V (max. 1000V 11 volts)  
SPARK POWER — 4800 JAPAK ENERGY — 36mJ  
SPARK DURATION — 600µS STORED ENERGY — 135mJ  
LOADS — 100µS OUTPUT VOLTAGE  
50pF load — 38kV, 50pF + 500k — 26kV
- We challenge any manufacturer to publish better performance figures. Before you buy any other make, ask for the facts, its probably only an inductive system. But if an inductive system is what you really want, we'll still give you a good deal.
- ★ **All ELECTRONIZE electronic ignitions feature:**  
**EASY FITTING, STANDARD/ELECTRONIC CHANGEOVER SWITCH, STATIC TIMING LIGHT and DESIGNED IN RELIABILITY (14 years experience and a 3 year guarantee).**
  - ★ **IN KIT FORM** it provides a top performance system at less than half the price of comparable ready built units. The kit includes: pre-drilled fibreglass PCB, pre-wound and varnished ferrite transformer, high quality 2uF discharge capacitor, case, easy to follow instructions, solder and everything needed to build and fit to your car. All you need is a soldering iron and a few basic tools.

Most **NEW CARS** already have electronic ignition. Update **YOUR CAR**

**ELECTRONIZE  
ELECTRONIC CAR ALARM**



**HOW SAFE IS YOUR CAR ?**

More and more cars are stolen each week and even a steering lock seems little help. But a car thief will avoid a car that will cause him trouble and attract attention. If your car has a good alarm system - well there are plenty of other cars to choose from.

**LOOK AT THE PROTECTION AN ELECTRONIZE ALARM CAN GIVE :**

- ★ **MINIATURE KEY PLUG** A miniature jamp plug attaches to your key ring and is coded to your particular alarm.
- ★ **2025 IN DIVerse COMBINATIONS** The key plug contains two 1% resistors, each must be the correct value and together give 2025 different combinations.
- ★ **ATTRACTS MAXIMUM ATTENTION** This alarm system not only intermittently sounds the horn, but also flashes the headlight and prevents the engine from starting.
- ★ **60 SECOND ALARM** Once triggered the alarm will sound for 60 seconds, unless cancelled by the key plug. Before resetting ready to be triggered again.
- ★ **30 SECOND EXIT DELAY** The system is set by depressing a small button on a dashboard mounted control panel. This starts a 30 second delay period during which the owner can open and close doors without triggering the alarm.
- ★ **10 SECOND ENTRY DELAY** When a door is opened a 10 second delay operates to allow the owner to disarm the system with the coded key plug. Latching circuits are used and once triggered the alarm can only be cancelled by the key plug.
- ★ **L.E.D. FUNCTION INDICATOR** An LED is included in the dashboard unit and indicates the systems operating state. The LED lights continuously to show the system is armed and in the exit delay condition. A flashing LED indicates that the alarm has been triggered and is in the entry delay condition.
- ★ **ACCESSORY LOOP - BONNET/BOOT SWITCH - IGNITION TRIGGER** These operate three separate circuits and will trigger the alarm immediately, regardless of entry and exit delays.
- ★ **SAFETY INTERLOCK** The system cannot be armed by accident when the engine is running and the car is in motion.
- ★ **LOW SUPPLY CURRENT** CMOS IC's and low power operational amplifiers achieve a normal operating current of only 2.5 mA.
- ★ **IN KIT FORM** It provides a high level of protection at a really low cost. The kit includes everything needed, the case, fibreglass PCB, random selection resistors to set the code and full set of components etc. In fact everything down to the last washer plus easy to follow instructions.

**THE BEST STARTER**

fill in the coupon and send to:  Please send more information

**ELECTRONIZE DESIGN** Dept C · Magnus Rd · Wilnecote · Tamworth · B77 5BY · tel 0827 281000

---

**TOTAL ENERGY DISCHARGE** (6 or 12 volt negative earth)

D.I.Y. parts kit £15.95 £12.75

Assembled ready to fit (positive earth) £24.95 £19.95

**TWIN OUTPUT** (for cars and vans with dual ignition)

Twin, Assembled ready to fit £29.95 £22.95

Twin, D.I.Y. parts kit £24.95 £19.95

**TOTAL ENERGY DISCHARGE** (12 volt only)

Assembled ready to fit £15.95 £12.75

Goods normally despatched within 7 days.

Prices include VAT £1-00 PP(UK) per Unit, C

---

**CAR ALARM** (12 volt negative earth)

Assembled ready to fit (All wires and connectors incl.) £37.95 £29.95

D.I.Y. parts kit £24.95 £19.95

I enclose cheque/postal order OR debit my Access/Visa card

VISA

Name \_\_\_\_\_

Address \_\_\_\_\_

Code \_\_\_\_\_

**LOW MAIL ORDER PRICES**

# EVERYDAY ELECTRONICS and computer PROJECTS

VOL. 13 NO. 3 MARCH 1984

PROJECTS ... THEORY ... NEWS ...  
COMMENT ... POPULAR FEATURES ...

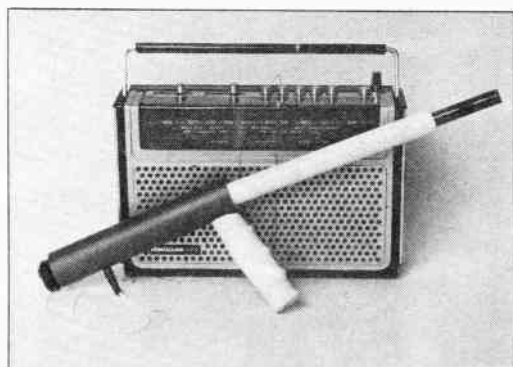

© IPC Magazines Limited 1984. Copyright in all drawings, photographs and articles published in EVERYDAY ELECTRONICS is fully protected, and reproduction or imitations in whole or in part are expressly forbidden.

## PROJECTS

- NI-CAD BATTERY CHARGER** by R. H. Marco **154**  
Enables Ni-Cad cells to be recharged from a 12V car battery charger
- DIGITAL MULTIMETER ADD-ON FOR COMPUTERS** by R. A. Penfold **157**  
Measures and displays, resistance, capacitance and voltage
- DIN LEAD TESTER** by L. A. Privett **166**  
Checks out DIN, jack and phono leads. The first in an occasional series of "Black Box" projects
- LATCHED OUTPUT PORT** by J. Adams and G. M. Feather **180**
- BUFFERED INPUT PORT** by J. Adams and G. M. Feather **183**
- LOW POWER STEREO AMPLIFIER** by D. J. Edwards **192**  
Provides 2.5 watts output per channel
- PIPE FINDER** by George Hylton **198**  
Simple metal locator. Solderless project ideal for the beginner
- REVERSING BLEEPER** by T. R. de Vaux-Balbirnie **202**  
Alerts pedestrians by giving an audible warning when the driver engages reverse gear

## SERIES

- TEACH-IN 84** by G. Hylton Part 6: Operational Amplifiers **168**
- MICROCOMPUTER INTERFACING TECHNIQUES** by J. Adams and G. M. Feather Part 9: Direct Bus Interfacing **176**
- COMPUTER AIDED EXPERIMENTS** by A. A. Chanerley Part 6: Ohmic and non-Ohmic conductors **206**

## FEATURES

- EDITORIAL** Purely Constructive **153**
- SOFTWARE SERVICE** **156**
- SHOP TALK** by Dave Barrington **164**  
Product news and component buying
- PRINTED CIRCUIT BOARD SERVICE** **165**
- SPECIAL REPORT** by R. A. Penfold **174**  
Oric 1 Microcomputer
- FOR YOUR ENTERTAINMENT** by Barry Fox **186**  
Broadcasting Research Unit Report; Kodak Video; Computer Pyramid Selling
- EVERYDAY NEWS** **188**  
What's happening in the world of electronics
- RADIO WORLD** by Pat Hawker G3VA **190**  
Not Unique, Amateur Boom; Grow Your Own Aerial
- CIRCUIT EXCHANGE** **191, 200**  
A forum for readers' ideas
- BRIGHT IDEAS** **197**  
Readers' tips
- NEW PRODUCTS** **201**  
Facts and photos of instruments, equipments and tools
- BOOK REVIEWS** **204**  
A selection of recent releases
- SQUARE ONE** **205**  
Beginners' page: Project Housings
- COUNTER INTELLIGENCE** by Paul Young **208**  
A retailer comments
- BACK NUMBERS** **209**

Our April 1984 issue will be published on Friday, March 16. See page 187 for details.

Readers' Services • Editorial and Advertisement Departments

TWO FABULOUS OFFERS FROM

# ALCON

## SUPER 20 20kΩ/V a.c. & d.c.

### A SUPER PROTECTED UNIVERSAL MULTIMETER

Undestructible, with automatic protection on all ranges but 10A.

**ONLY £33.50**

inc. VAT, P&P, complete with carrying case, leads and instructions.

This special offer is a wonderful opportunity to acquire an essential piece of test gear with a saving of nearly £20.00.

**Accuracy:** d.c. ranges and Ω 2% a.c. 3% (of f.s.d.)  
**39 ranges:** d.c. V 100mV, 1.0V, 3.0V, 10V, 30V, 100V, 300V, 1000V.  
 d.c. I 50μA, 100μA, 300μA, 1.0mA, 3mA, 10mA, 30mA, 100mA, 1A, 10A  
 a.c. V 10V, 30V, 100V, 300V, 1000V.  
 a.c. I 3mA, 10mA, 30mA, 100mA, 1.0A, 10A.  
 Ω 0-5.0kΩ, 0-50kΩ, 0-500kΩ, 5MΩ, 50MΩ.  
 dB from -10 to +61 in 5 ranges.

**Dimensions:** 105 x 130 x 40mm.

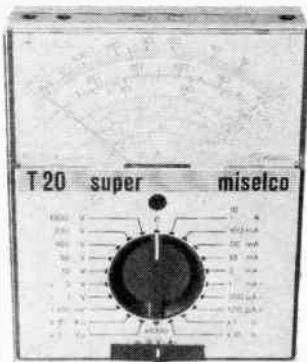

## SUPER TESTER 50 50kΩ V a.c. and d.c.

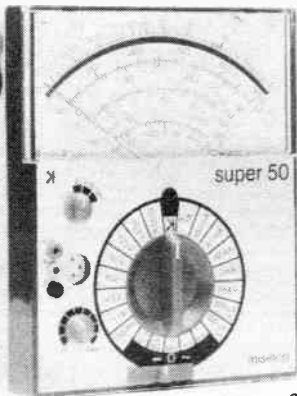

A 39 ranges fool-proof multimeter with protective diodes, quick acting 1.25A fuse and resettable cut-out.

### PROFESSIONAL SOLUTION TO GENERAL MEASUREMENT PROBLEMS

**ONLY £36.30**

incl. VAT, P&P, complete with carrying case, leads and instructions. Goods normally by return of post.

The best instrument for the workshop, school, toolbox, TV shop and anywhere accurate measurement is needed quickly and simply.

**Accuracy:** d.c. ranges and Ω 2% a.c. 3% (off.s.d.)  
**39 ranges:** d.c. V 150mV, 1V, 3V, 10V, 30V, 100V, 300V, 1000V;  
 d.c. I 20μA, 100μA, 300μA, 1.0mA, 3mA, 10mA, 30mA, 100mA, 1A, 3A.  
 a.c. V 10V, 30V, 100V, 300V, 1000V;  
 a.c. I 3mA, 10mA, 30mA, 100mA, 1A, 3A.  
 Ohms 5kΩ, 50kΩ, 500kΩ, 5MΩ, 50MΩ.  
 dB from -10 to +61 in 5 ranges.

**Dimensions:** 105 x 130 x 40mm.

For details of these and the many other instruments in the Alcon range, including multimeters, components measuring, automotive and electronic instruments, please write or telephone:

**ALCON** Instruments Ltd.

19 MULBERRY WALK LONDON SW3 6DZ TEL: 01-352 1897 TELEX: 918867

# T.V. SOUND TUNER

**SERIES II BUILT AND TESTED** Complete with case. £26.50 + £2.00 p&p.

In the cut-throat world of consumer electronics, one of the questions designers apparently ponder over is "Will anyone notice if we save money by chopping this out?" In the domestic TV set, one of the first casualties seems to be the sound quality. Small speakers and no tone controls are common and all this is really quite sad, as the TV companies do their best to transmit the highest quality sound. Given this background a compact and independent TV tuner that connects direct to your Hi-Fi is a must for quality reproduction. The unit is mains-operated.

This TV SOUND TUNER offers full UHF coverage with 5 pre-selected tuning controls. It can also be used in conjunction with your video recorder. Dimensions: 10 1/2" x 7 1/2" x 2 1/2". E.T.I. kit version of above without chassis, case and hardware. £16.20 plus £1.50 p&p.



Also available with built-in headphone amp. ONLY £32.50 + £2.00 p&p.

## PRACTICAL ELECTRONICS STEREO CASSETTE RECORDER KIT

COMPLETE WITH CASE

ONLY £34.50 plus £2.75 p&p.

• NOISE REDUCTION SYSTEM. • AUTO STOP. • TAPE COUNTER. • SWITCHABLE E.Q. • INDEPENDENT LEVEL CONTROLS. • TWIN V.U. METER. • WOW & FLUTTER 0.1%. • RECORD/PLAYBACK I.C. WITH ELECTRONIC SWITCHING. • FULLY VARIABLE RECORDING BIAS FOR ACCURATE MATCHING OF ALL TYPES.

Kit includes tape transport mechanism, ready punched and back printed quality circuit board and all electronic parts, i.e. semiconductors, resistors, capacitors, hardware, top cover, printed scale and mains transformer. You only supply solder & hook-up wire. Featured in April P.E. reprint 50p. Free with kit.

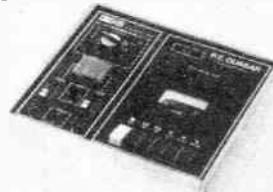

## BSR RECORD DECKS

Auto-Changer model - takes up to 6 records with manual override. Supplied with stereo ceramic cartridge.

£12.95 plus £1.75 p&p.



3 speed, auto, set-down; with auto return. Fitted with viscous damped cue, tubular aluminium counter-weighted arm, fitted with ceramic head. Ideally suited for home or disco use. £17.50 plus £1.75 p&p.

Manual single play record deck with auto return and cueing lever. Fitted with stereo ceramic cartridge 2 speeds with 45 rpm spindle adaptor ideally suited for home or disco. 13" x 11" approx. £14.95 plus £1.75 p&p.



**SPECIAL OFFER!** Replacement st. cassette tape heads. £1.80 ea. Add 50p p&p to order. Philips st. mag. cartridge. £3.95 + 60p p&p.

**PLINTH to suit BSR Record Player Deck (with cover).** Size 16 1/2" x 14 1/2" x 2 1/2" Cover size. £14 1/2" x 13 1/2" x 3 1/2". Due to fragile nature, Buyer collect only. Price: £8.95.

## STEREO TUNER KIT

**SPECIAL OFFER!**

£13.95 + £2.50 p&p.



This easy to build 3 band stereo AM/FM tuner kit is designed in conjunction with P.E. (July '81). For ease of construction and alignment it incorporates three Mullard modules and an I.C. IF System. Front scale size 10 1/2" x 2 1/2" approx. Complete with diagram and instructions.

## 125W HIGH POWER AMP MODULES

The power amp kit is a module for high power applications - disco units, guitar amplifiers, public address systems and even high power domestic systems. The unit is protected against short circuiting of the load and is safe in an open circuit condition. A large safety margin exists by use of generously rated components, result, a high powered rugged unit. The PC board is back printed, etched and ready to drill for ease of construction and the aluminium chassis is performed and ready to use. Supplied with all parts, circuit diagrams and instructions.

Accessories: Stereo mains power supply kit with trans. £10.50 + £2 p&p. Mono: £7.50 + £2 p&p.



### SPECIFICATIONS:

Max. output power (RMS): 125 W. Operating voltage (DC): 50 - 80 max. Loads: 4 - 16 ohm. Frequency response measured @ 100 watts. 25Hz - 20KHz. Sensitivity for 100w: 400mV @ 47K. Typical T.H.D. @ 50 watts, 4 ohms: 0.1%. Dimensions: 205x90 and 190x36mm.

**KIT £10.50** + £1.15 p&p.

**BUILT £14.25** + £1.15 p&p.

## HI-FI SPEAKER BARGAINS

AUDAX 8" SPEAKER £5.95 + £2.20 p&p.

High quality 40 watts RMS bass/mid. Ideal for either HiFi or Disco use this speaker features an aluminium voice coil and a heavy 70mm dia. magnet. Freq. Res.: 20Hz to 7kHz. Imp.: 8 ohms.



AUDAX 40W FERRO-FLUID HI-FI TWEETER Freq. res.: 5KHz - 22KHz. Imp.: 8 ohms. 60mm sq. £5.50 + 60p p&p.

GOODMANS TWEETERS 8 ohm soft dome radiator tweeter (3%sq) for use in systems up to 40W. £3.95 ea + £1 p&p. £6.95 pr + £1.50.

£3.95 ea + £1 p&p. £6.95 pr + £1.50.

£3.95 ea + £1 p&p. £6.95 pr + £1.50.

£3.95 ea + £1 p&p. £6.95 pr + £1.50.

£3.95 ea + £1 p&p. £6.95 pr + £1.50.

£3.95 ea + £1 p&p. £6.95 pr + £1.50.

£3.95 ea + £1 p&p. £6.95 pr + £1.50.

£3.95 ea + £1 p&p. £6.95 pr + £1.50.

£3.95 ea + £1 p&p. £6.95 pr + £1.50.

£3.95 ea + £1 p&p. £6.95 pr + £1.50.

£3.95 ea + £1 p&p. £6.95 pr + £1.50.

£3.95 ea + £1 p&p. £6.95 pr + £1.50.

£3.95 ea + £1 p&p. £6.95 pr + £1.50.

## MONO MIXER AMP

for halls and clubs.

£45.00 + £2 p&p.

50 Watt, six individually mixed inputs for 2 pickups (Cer. or mag), 2 moving coil microphones and 2 auxiliary for tape tuner, organs etc. Eight slider controls - 6 for level and 2 for master bass and treble, 4 extra treble controls for mic. and aux. inputs. Size: 13 1/2" x 6 1/2" x 3 1/2" app. Power output 50 W RMS (cont.) for use with 4 to 8 ohm speakers. Attractive black vinyl case with matching fascia and knobs. Ready to use.

All mail to: 21A HIGH ST, ACTON W3 6NG. Callers: Mon - Sat 9.30 - 5.30. Half day Wed. Access phone orders on 01-992 8430. Note: Goods despatched to U.K. postal addresses only. All items subject to availability. Prices correct at 30/1/83 and subject to change without notice. Please allow 14 working days from receipt of order for despatch. RTVC Limited reserve the right to update their products without notice. All enquiries send S.A.E. Telephone or mail orders by ACCESS welcome

CALLERS TO: 323 EDGWARE ROAD, LONDON W2. Telephone: 01-723 8432. (5 minutes walk from Edgware Road Tube Station) Now open 6 days a week 9 - 5.30. Prices include VAT.



# The Rapid Electronics

**MAIL ORDERS:**  
Unit 3, Hill Farm Industrial Estate,  
Boxted, Colchester, Essex CO4 5RD.  
**TELEPHONE ORDERS:**  
Colchester (0206) 36412.

**ACCESS AND  
BARCLAYCARD  
WELCOME**

MIN. D CONNECTORS			
Plugs solder lugs	5 way 15 way	25 way 37 way	
Right angle	60p 85p	125p 170p	
Sockets lugs	120p 180p	240p 350p	
Right angle	90p 130p	195p 290p	
Covers	160p 210p	290p 440p	
	100p 90p	100p 110p	

CONNECTORS			
DIN	Plug Skt	Jack	Plug Skt
2 pin	9p	9p	25mm 10p
3 pin	12p	10p	3.5mm 9p
5 pin	13p	11p	Standard 16p 20p
Phono 10p	12p	Stereo	24p 25p
1mm 12p	13p	4mm	18p 17p
UHF (CB) Connectors.			
PL259 Plug 40p.	Reducer 14p.		
SO239 square chassis skt 38p			
SO239S round chassis skt 40p.			
IEC 3 pin 250V/6A.			
Plug chassis mounting.			38p
Socket free hanging.			60p
Socket with 2m lead.			120p

SWITCHES			
Submit toggle.			
SPST 55p.	SPDT 60p.	DPDT 65p.	
Miniature toggle.			
SPDT 60p.	SPDT centre off 90p.		
DPDT 90p.	DPDT centre off 100p.		
Standard toggle.			
SPST 35p.	DPDT 48p		
Miniature DPDT slide 14p.			
Push to make 14p.			
Push to break 22p.			
Rotary type adjustable 55p.			
1P12W, 2P6W, 3P4W all 50p each.			
DIL switches:			
4SPST 80p 6 SPST 80p. 8SPST 100p.			

SOCKETS			
	Low profile	Wire wrap	
8 pin	8p	28p	
14 pin	6p	45p	
16 pin	9p	50p	
CA109	12p	60p	
20 pin	12p	68p	
22 pin	18p	75p	
24 pin	18p	82p	
28 pin	22p	95p	
40 pin	25p	135p	

SOLDERING IRONS			
Antex CS 17W Soldering iron	495		
2.3 and 4.7mm bits to suit.	85		
CS 17Wor XS 25W element.	210		
Antex XS 25W	525		
3.3 and 4.7mm bits to suit.	85		
2.5 x 5	75		
3.75 x 5	75		
VQ board	160		
Veropins per 100:			
Single sided	50		
Double sided	60		
Spot face cutter	130		
Pin insertion tool	162		
Wiring pen	330		
Spare spool 75p	Combs	6	

VERO			
VEROBLOC	375		
Size 01 matrix:			
2.5 x 1	75		
2.5 x 3.75	85		
2.5 x 5	75		
3.75 x 5	160		
VQ board	160		
Veropins per 100:			
Single sided	50		
Double sided	60		
Spot face cutter	130		
Pin insertion tool	162		
Wiring pen	330		
Spare spool 75p	Combs	6	

REGULATORS			
78L05	30	79L05	45
78L12	30	79L12	45
78L15	30	79L15	45
7805	35	7905	40
7812	35	7912	40
7815	35	7915	40
LM309K	130	LM723	35
LM317K	270	78H05	550
LM317T	420		

DIODES			
BY127	12	1N4001	3
OA47	10	1N4002	5
OA90	8	1N4007	7
OA91	7	1N5401	10
OA200	8	1N5404	16
OA202	8	1N5405	17
1N914	4	400mW Zen	6
1N4148	3	1.3W zeners	13

OPTO			
3mm red	7	5mm red	7
3mm green	10	5mm green	10
3mm yellow	10	5mm yellow	10
Circle suit - 3p each.			
Rectangular:			
Red	12	TIL32	40
Green	17	TIL111	60
Yellow	17	ORP2	85
ILDT74	95	IL074	185
IL078	40	TIL100	70
ZN5777	45	Dual colour	60
Seven segment displays:			
Com cathode	Com anode		
DL704 0.3"	DL707 0.3"	95	
PNF507	PNF507		
0.5"	100		
10 bar DIL LED display	red 180.		
LCD	3 1/2 digit 495p.	4 digit 520p.	

MICRO			
6116P3	320	6852	240
6502CPU	325	6875	495
6522VIA	295	6880	100
6532	570	81LS95	85
6551 ACIA	650	81LS96	85
6800CPU	220	81LS97	85
6802CPU	250	8080A	250
6809CPU	620	8085AC	340
6810RAM	115	8156	350
6821 PIA	110	8212	110
6840	360	8216	100
416P20	85	6850	110

COMPONENT KITS			
An ideal opportunity for the beginner or the experienced constructor to obtain a wide range of components at greatly reduced prices. $\times W$ 5% Resistor kit. Contains 10 of each value from 4.7 ohms to 1M (total of 650 resistors)			
50 resistors			530
Ceramic Cap. kit. 5 of each value: 22p to 0.1uF (135 caps)			
50 caps			370
Preset kit. Contains 5 of each value from 100 ohms to 1M (total of 65 presets)			
65 presets			425
Nut and Bolt kit (total 300 items). 180p			
25 6BA $\frac{1}{2}$ " bolts	50 6BA washers	50 6BA nuts	
25 6BA $\frac{3}{8}$ " bolts	25 4BA $\frac{1}{2}$ " bolts	50 6BA washers	
50 6BA nuts	25 6BA $\frac{1}{2}$ " bolts		

CAPACITORS			
Polyester, radial, 250v.	250v. C280		
100: 0.01, 0.015, 0.022, 0.033			
60: 0.047, 0.068, 0.1	7p: 0.15,		
0.22 - 9p; 0.33, 0.47 - 13p; 0.68 - 1u; - 23p.			
Electrolytic, radial or axial leads:			
0.47/63V, 1.63V, 2.2/63V, 4.7/63V,			
10/25V - 7p; 22/25V, 47/25V - 8p;			
100/25V - 8p; 220/25V - 14p;			
470/25V - 22p; 1000/25V - 30p;			
2200/25V - 50p.			
Tag end power supply electrolytics:			
2200/40V - 110p; 4700/40V - 160p			
2200/63V - 140p; 4700/63V - 230p			
Polyester, miniature Siemens PCB:			
1n, 2n2, 3n3, 4n7, 6n8, 10u; 100n; 9p;			
150n; 1.5 - 220n; 33p; 330n; 20p;			
470n; 26p; 680n; 29p; 1u; 33p; 2u; 50n.			
Tantalum bead.			
0.1, 0.22, 0.33, 0.47, 1.0 @ 35V - 12p; 2.2, 4.7, 10 @ 25V - 20p;			
15/16V - 30p; 22/16V - 27p; 33/16V - 45p; 47/20V - 27p; 47/16V - 30p;			
68/6V - 40p; 100/10V - 90p.			
Car. disc. 22p-0.01uF 50V, 3p each.			
Multilayer miniature ceramic plate: 1.8pF to 100pF 6p each.			
Polystyrene, 5% top: 10p-1000p, 6p.			
15/16V - 30p; 22/16V - 27p; 33/16V - 45p; 47/20V - 27p; 47/16V - 30p;			
68/6V - 40p; 100/10V - 90p.			
Car. disc. 22p-0.01uF 50V, 3p each.			
Multilayer miniature ceramic plate: 1.8pF to 100pF 6p each.			

LINEAR			
555CMOS 80	ICL7106	680	
555CMOS 150	ICM7611	110	
709	ICL7621	180	
741	ICL7622	180	
748	ICL8038	295	
3400C1	ICL8211A	200	
AY-31270	ICM9224	785	
AY-38910	ICM7555	55	
AY-39112	LF351	45	
CA3084	LF352	85	
CA3080	LF356	90	
CA3089	LF357	130	
CA3090A	LF301A	55	
CA3130E	LM311	50	
CA3140E	LM318	120	
CA3161E	LM324	30	
CA3189	LM334L	120	
CA3240E	LM335Z	125	

LM339	40	LM3911	120	NE566	140	TL064	96
LM348	60	LM3914	225	NE567	100	TL071	30
LM358	50	LM3915	225	NE570	70	TL072	45
LM377	170	LM13600	105	NE571	370	TL074	95
LM380	75	MC1498	68	RC4136	55	TL081	25
LM393	120	MC3340	135	RC4558	40	TL082	45
LM382	120	MF10CN	350	SL480	170	TL084	90
LM384	130	ML922	400	SL490	250	TL170	50
LM386	90	ML924	195	SL76018	150	UA2240	120
LM387	120	ML925	210	SN76477	380	ULN2003	70
LM393	40	ML929	140	SP25A12	850	ULN2004	70
LM709	25	ML927	140	TBA1205	70	XR205	290
LM711	60	ML928	140	TBA800	75	YN414	80
LM725	350	ML929	140	TBA810	96	ZN423	135
LM733	75	MM5387A	465	TBA820	70	ZN424	135
LM741	14	N229	725	TBA950	220	ZN425E	350
LM747	60	NE531	140	TDA1008	320	ZN425E	300
LM1458	40	NE544	205	TDA1022	490	ZN427E	600
LM2917	200	NE555	16	TDA1024	125	ZN428E	410
LM3900	45	NE556	45	TL061	40	ZN459	285
LM3909	75	NE565	110	TL062	60	ZN1034E	200

RESISTORS			
$\times W$ 5% Carbon film E12 series 4.7 ohm - 10M	1p each.		
$\times W$ 5% Carbon film E12 series 4.7 ohm to 4M7	2p each.		
$\times W$ 1% metal film E24 series 10 ohm - 1M	6p each.		

PCB MATERIALS			
A14c transfer sheets - please state type (e.g. DIL pads etc.)	45		
Dalco etch resistant pen	90		
Fibre glass board 3.75 x 8"	80		
Fibre glass board 8 x 12"	200		
Ferric Chloride crystals	100		

BOXES			
Aluminium	3 x 2 x 1"	65	
Plastic with lid & screws	4 x 2 x 1 1/2"	95	
	3 x 2 x 1 1/2"	55	
	4 1/2 x 3 x 1 1/2"	85	
	7 x 4 x 2"	160	
	8 x 6 x 3"	205	

TRANSISTORS			
AC126	30	BC149	9
AC127	30	BC157	8
AC129	30	BC158	10
AC128	20	BC159	8
AC176	25	BC160	45
AC187	22	BC168C	10
AC188	22	BC169C	10
AD142	120	BC170	8
AD149	80	BC171	10
AD161	40	BC172	8
AD162	40	BC177	18
AF124	60	BC178	18
AF126	50	BC179	18
AF139	40	BC182	10
AF186	70	BC182L	8
AF239	75	BC183	10
BC107	10	BC183L	10
BC107B	12	BC184	10
BC108	10	BC184L	10
BC108B	12	BC212	10
BC108C	12	BC212L	10
BC109	10	BC213	10
BC109C	12	BC213L	10
BC114	10	BC127	14
BC115	22	BC214L	8
BC117	18	BC237	8
BC119	35	BC238	14
BC137	40	BC305	12
BC139	40	BC306	12
BC140	28	BC328	14
BC142	30	BC337	14
BC143	25	BC477	30
BC147	8	BC478	30
BC148	8	BC479	30

# BI-PAK BARGAINS

## BI-PAK SOLDER - DESOLDER KIT

Kit comprises: ORDER NO. VP80  
 1 High Quality 25 watt General Purpose Lightweight Soldering Iron 240v mains incl 3/16" (4.7mm) bit  
 1 Quality Desoldering Pump High Suction with automatic ejection Knurled anti-corrosive casing and Teflon nozzle  
 1.5 metres of De-Soldering braid on plastic dispenser  
 2 yds (1.83m) Resin Cored Solder on Card  
 1 Heat Shunt tool tweezer Type  
 Total Retail Value over £12.00  
**OUR SPECIAL KIT PRICE £9.95**

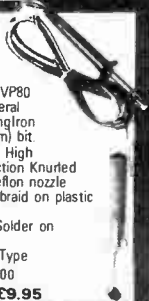

## BI-PAK PCB ETCHANT AND DRILL KIT

Complete PCB Kit comprises  
 1 Expo Mini Drill 10,000RPM 12v DC incl 3 collets & 3 x Twist Bits  
 1 Sheet PCB Transfers 210mm x 150mm  
 1 Etch Resist Pen  
 1 1/2 pack FERRIC CHLORIDE crystals  
 3 sheets copper clad board  
 2 sheets Fibreglass copper clad board  
 Full instructions for making your own PCB boards  
 Retail Value over £15.00  
**OUR BI-PAK SPECIAL KIT PRICE £9.95**  
 ORDER NO. VP81



## DIGITAL VOLT METER MODULE

3 x 7 segment displays Basic Circuit. 0-10 instructions provided to extend range & current ranges Operating voltage 9/12v. Typ. Power Consumption 50mA

D/No. VP99 Once only price **£9.95**

## SINGLE SIDED FIBREGLASS BOARD

Order No	Pieces	Size	Sq. Ins	Price
FB1	4	9" x 2 1/2"	100	£1.50
FB2	3	11" x 3"	100	£1.50
FB3	4	13" x 3"	156	£2.00

## DOUBLE SIDED FIBREGLASS BOARD

FB4	2	14" x 4"	110	£2.00
-----	---	----------	-----	-------

## SILICON BRIDGE RECTIFIERS

Comprising 4 x 1 1/2 Amp rectifiers mounted on PCB. VRM - 150 vits IFM - 1.5 Amps

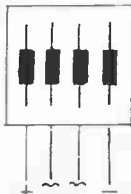

Size: 1 inch square  
 10 off £1.00  
 50 off £4.50  
 100 off £7.50

ORDER NO: 4R1 B Rect.

## INTRUSION ALARM

The DOOR BIRD DB 2000 alerts you before your door is opened. Just hang on the inside door knob - alarm is activated as soon as the outside door knob is touched. **ONLY £3.95**

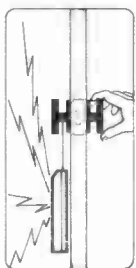

## OPTO 7-Segment Displays

Brand new 1st Quality LITRONIX DL 707R 14-pin Red 0.3" Common Anode Display 0-9 with right hand decimal point TTL compatible 5V DC Supply. Data supplied

IN	5 pieces	£3	(60p each)
PACKS	10 pieces	£5	(50p each)
OF	50 pieces	£20	(40p each)
	100 pieces	£35	(35p each)
	1,000 pieces	£300	(30p each)

**THE MORE YOU BUY - THE LESS YOU PAY**

## VALUE PACKS

Pak No.	Qty	Description	Price
VP1	300	Assorted Resistors Mixed Types	£1.00
VP2	300	Carbon Resistors 1/4 Watt Pre-Formed	£1.00
VP3	200	150 1/2 Watt Resistors 100 ohm-1M Mixed	£1.00
VP4	200	Assorted Capacitors All Types	£1.00
VP5	200	Ceramic Caps Miniature - Mixed	£1.00
VP6	100	Mixed Ceramics Disc. 1pf - 56pf	£1.00
VP7	100	Mixed Ceramic Disc. 68pf - 015pf	£1.00
VP8	100	Assorted Polyester/Polystyrene Caps	£1.00
VP9	50	C280 Type Caps Metal Foil Mixed	£1.00
VP10	100	Electrolytics - All Sorts	£1.00
VP11	60	Bead Type Polystyrene Min Caps	£1.00
VP12	50	Silver Mica Caps Ass. 56pf - 150pf	£1.00
VP13	50	Silver Mica Caps Ass. 180pf - 4700pf	£1.00
VP14	50	High Voltage Disc. Ceramic 750v - 8Kv Mixed	£1.00
VP15	50	Wirewound Res. 9W (avg) Ass 1 ohm - 12K	£1.00
VP16	50	Metres PVC Covered Single Strand Wire Mixed Colours	£1.00
VP17	30	Metres PVC Covered Multi Strand Wire Mixed Colours	£1.00
VP18	40	Metres PVC Single/Multi Strand Hook-Up Wire Mixed	£1.00
VP19	6	Rocker Switches 5 Amp 240v	£1.00
VP20	20	Pcs. 1 - 2, 4 & 4 mm Plugs & Sockets Matching Sizes	£1.00
VP21	200	Sq. Inches Total, Copper Clad Board Mixed Sizes	£1.00
VP22	20	Assorted Slider Pots. Mixed Values	£1.00
VP23	10	Slider Pots. 40 mm 22K 5 x Log. 5 x Lin	£1.00
VP24	10	Slider Pots. 40 mm 47K 5 x Log. 5 x Lin	£1.00
VP25	20	Small 125" Red LED'S	£1.00
VP26	20	Large 2" Red LED'S	£1.00
VP27	10	Rectangular 2" Green LED'S	£1.00
VP28	30	Ass. Zener Diodes 250mW - 2W Mixed Vits. Coded	£1.00
VP29	10	Ass. 10W Zener Diodes Mixed Vits. Coded	£1.00
VP30	10	5 Amp SCR'S TO 66 50-400v Coded	£1.00
VP31	20	3 Amp SCR'S TO 66 Up To 400v Uncoded	£1.00
VP32	200	Sil. Diodes Switching Like IN4148 DD-35	£1.00
VP33	200	Sil. Diodes Gen. Purpose Like DA200/BAX13/16	£1.00
VP34	50	1 Amp IN4000 Series Sil. Diodes Uncoded All Good	£1.00
VP35	8	Bridge Rets. 4 x 1 Amp 4 x 2 Amp Mixed Vits. Coded	£1.00
VP36	8	Black Instrument Type Knobs With Pointer 1/2" Std	£1.00
VP37	10	Black Heatsinks To Fit TD-3, TD-220 Ready Drilled	£1.00
VP38	4	Power-Fin Heatsinks 2 x TD-3 2 x TD-66 Size	£1.00

## SEMICONDUCTORS FROM AROUND THE WORLD

**100** A collection of Transistors, Diodes, Rectifiers & Bridges SCR's, Triacs, I.C.'s & Dpto's all of which are current every-day useable devices.

Guaranteed Value Over £10 Normal Retail Price.

Data etc in every pack. Order No. VP56

Our Price £4.00

## BI-PAK'S OPTO SPECIAL

A selection of large and small sized LED's in various shapes, sizes & colours, together with 7 Segment Displays both anode & cathode plus photo transistors emitters and detectors. Cadmium Cell ORP12 and Germ. photo transistor OCP71 included. In all a total of 25 Opto pieces valued over £12 Normal Price

Order No. VP57  
**Our Super Value Price Just £5.00**



## HYBRID LED COLOUR DISPLAYS

Red, Green, Yellow - .3/.5/.6 inch Mixed types and colours NUMERIC & OVER-FLOW Common Anode/Cathode. GaAsP/GaP. Brand New, Full Data incl.



10 pieces (our mix) . . . £4.00  
 Normal Retail Value Over £10.00  
 Order No. VP58

## TECASBOTY THE ELECTRONIC COMPONENTS AND SEMICONDUCTOR BARGAIN OF THE YEAR!

This collection of Components and Semiconductors for the hobbyist is probably the most value-packed selection ever offered, it consists of Resistors, carbon and wirewound of various values. Capacitors: All types, sorts and sizes including electrolytics. Potentiometers - single, dual, slider and preset. Switches, Fuses, Heatsinks, Wire, P.C.B. Board, Plugs, Sockets etc., PLUS a selection of Semiconductors for everyday use in popular Hobby Projects. These include: SCR's, Diodes, Rectifiers, Triacs & Bridges as well as a first class mix of Transistors and I.C.'s. In all, we estimate the value of this in current retail catalogues to be over £25! So, help yourself to a great surprise and order a Box TODAY for just £6.50 ONLY at BI-PAK. Remember, stocks are limited so hurry! You can call us on 0920-3182/3412 and order with your Barclaycard or Access Card - 24hr. Answerphone Service NOW. Order No. V.P. 85.



## TRANSISTOR CLEARANCE

All Sorts Transistors. A mixed Bag NPN-PNP Silicon & Germ. Mainly Uncoded You 100 To Sort Pack includes Instructions For Making Simple Transistor Tester. Super Value. Order No. VP60 **£1.00**



## POWER SUPPLY OUR PRICE £3.25

Power supply fits directly into 13 amp socket Fused for safety. Polarity reversing socket. Voltage switch. Lead with multi plug Input - 240V AC 50HZ, Output - 3, 4, 5, 6, 7.5, 9 & 12V DC Rating - 300 ma MW88.

## MULTITESTERS

1,000 opv including test leads & Battery  
 AC volts 0-15-150-500-1,000  
 DC volts - 0-15-150-500-1,000  
 DC currents - 0-1ma-150ma  
 Resistance - 0-25 K ohms 100 K ohms  
 Dims - 90 x 61 x 30mm

O/No. 1322. OUR PRICE £6.50 ONLY

## ELECTRONIC SIREN

12v DC

Red plastic case with adjustable fixing bracket. Emits high-pitched wailing note of varying pitch - 100 cycles per minute. Dims - 90mm (dia.) 60mm (depth). Power - 12v DC.

Our Price: **£5.50**

## OUR GREAT NEW 1984 CATALOGUE

Presented with a Professional Approach and Appeal to ALL who require Quality Electronic Components, Semiconductors and other Accessories ALL at realistic prices. There are no wasted pages of useless information so often included in Catalogues published nowadays. Just solid facts i.e. price, description and individual features of what we have available. But remember, BI-PAK's policy has always been to sell quality components at competitive prices and THAT WE STILL DO.

We hold vast stocks "in stock" for fast immediate delivery, all items in our Catalogue are available ex stock. The Catalogue is designed for use with our 24 hours "ansaphone" service and the Visa/Access credit cards, which we accept over the telephone.

To receive your NEW 1984 BI-PAK Catalogue, send 75p PLUS 25p p&p to:-

## RATCHET SCREWDRIVER KIT

Comprises 2 standard screwdriver blades 5 & 7mm size. 2 cross point size 4 & 6. 1 Ratchet handle. 5-in-1 Kit. £1.45 each. D/No 329B

## REGULATED VARIABLE POWER SUPPLY

Stabilised  
 Variable from 2.30 volts and 0.2 Amps. Kit includes -  
 1 VPS30 Module, 1 - 25 volt 2 amp transformer,  
 1 0-50v 2" Panel Meter, 1 - 0-2 amp 2" Panel Meter,  
 1 470 ohm wirewound potentiometer, 1 - 4K7 ohm wirewound potentiometer. Wiring Diagram included. Order No. VPS30 KIT **£20.**

## MINIATURE FM TRANSMITTER

Freq: 95-106MHz. Range: 1 mile  
 Size: 45 x 20mm. Add: 9v batt. **ONLY £5.50**  
 Not licenced in U.K.  
 Ideal for: 007-MIS-FBI-CIA-KGB etc.

# BI-PAK

Send your orders to Dept EE3 BI-PAK PO BOX 6 WARE, HERTS  
 SHOP AT 3 BALDCK ST. WARE, HERTS  
 TERMS CASH WITH ORDER. SAME DAY DESPATCH. ACCESS  
 BARCLAYCARD ALSO ACCEPTED. TEL (0920) 3182. GIRD 388 7006.  
 ADD 15% VAT AND 75p PER ORDER POSTAGE AND PACKING



Use your credit card. Ring us on Ware 3182 NOW and get your order even faster. Goods normally sent 2nd Class Mail. Remember you must add VAT at 15% to your order. Total Postage add 75p per Total order.

# Heathkit - IT'S A PLEASURE TO BUILD

Bring the enjoyment back into your hobby with a kit from Heathkit. The beautifully illustrated documentation and step-by-step instructions make building a Heathkit a relaxing, absorbing pleasure! Every kit includes a constructors' guide covering soldering and component identification which makes construction straightforward even for a beginner.

The Heathkit range contains many kits ideal for beginners as well as amateur radio kits, computerised weather stations, a highly sophisticated robot, a 16-bit computer kit and a range of home (or classroom) learning courses that have easy-to-understand texts and illustrations, in sections so that you can progress at your own pace, whilst the hands-on experiments ensure long-term retention of the material covered.

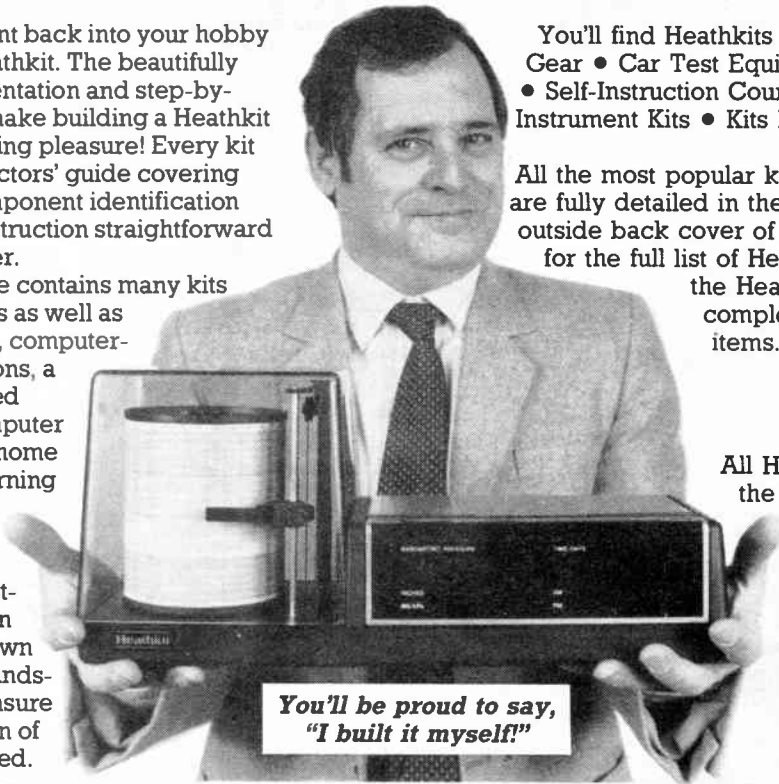

*You'll be proud to say,  
"I built it myself!"*

You'll find Heathkits available for Amateur Radio Gear • Car Test Equipment • Kits For The Home • Self-Instruction Courses • Computer Kits • Test Instrument Kits • Kits For Weather Measurements.

All the most popular kits and educational products are fully detailed in the 1984 Maplin catalogue (see outside back cover of this magazine for details) or for the full list of Heathkit products send 50p for the Heathkit International Catalogue complete with a UK price list of all items.

All Heathkit products available in the UK from:

**Maplin Electronic Supplies Ltd.**  
P.O. Box 3, Rayleigh,  
Essex, SS6 8LR.  
Tel: (0702) 552911.

(For shop addresses see back cover.)

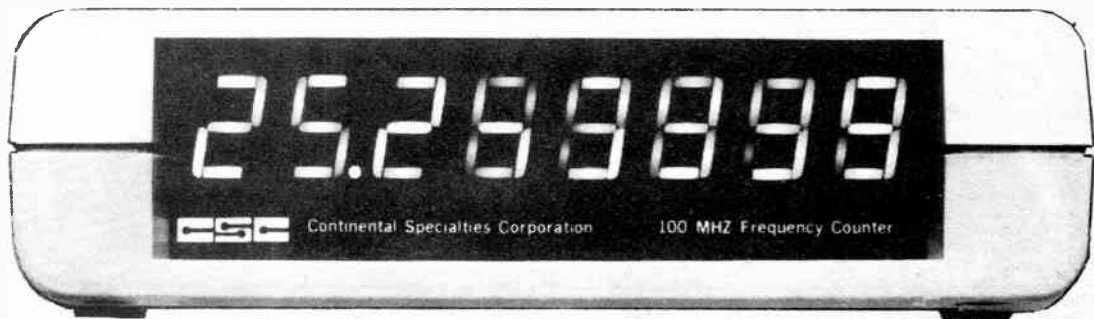

# 5 Hz TO 100 MHz

**TOMORROW'S TOOLS TODAY**

GLOBAL SPECIALTIES CORPORATION



G.S.C. (UK) Limited Dept. 4D  
Unit 1, Shire Hill Industrial Estate,  
Saffron Walden, Essex. CB11 3AQ  
Telephone: Saffron Walden (0799) 21682  
Telex: 817477

Instant frequency indication from 5 Hz to 100MHz; no range selection problems; a brilliant 8-digit LED display; mains or battery operation; an accuracy of 4 parts per million  $\pm 1$  count; and totally automatic operation - all this for only £116.00\* with GSC's new Max-100 frequency counter.

Just take a look at our spec. Where else could you find anything similar at the price?  
\*Frequency range 5Hz - 100 MHz \*Input impedance 1M shunted by 10pF \*Sensitivity 30mV from 1KHz up to 50MHz; 120mV r.m.s. over full frequency range \*Timebase accuracy  $\pm 4$  parts in  $10^6$  (from 5 to 45°C) \*Maximum aging rate 10 parts in  $10^6$  per year \*Over-frequency indication \*Low-battery-power alarm \*Operates from dry or rechargeable cells, an external 7.5 to 10VDC supply, or a car battery (via an adaptor) \*Dimensions: 45 x 187 x 143mm \*Options: 12V adaptor; battery eliminator; r.f. antenna, low-loss r.f. tap, carrying case.

Fill in the coupon for further details . . .

\*price excludes post, packing and VAT

G.S.C. (UK) Limited, Dept 4D, Unit 1, Shire Hill Industrial Estate, Saffron Walden, Essex CB11 3AQ.

MAX 100	FREQ. COUNTER	Unit price inc P&P 15% VAT £136.85	Qty. Recd.	
---------	---------------	------------------------------------	------------	--

Name \_\_\_\_\_  
Address \_\_\_\_\_

I enclose cheque/P.O. for £ \_\_\_\_\_ or debit my Barclaycard/Access/  
American Express card no. \_\_\_\_\_ exp. date \_\_\_\_\_

FOR IMMEDIATE ACTION - The G.S.C. 24 hour, 5 day a week service.

Telephone (0799) 21682 and give us your Barclaycard, Access, American Express number and your order will be in the post immediately.

For Free catalogue tick box





## GOODIES FOR THE BBC MICROCOMPUTER

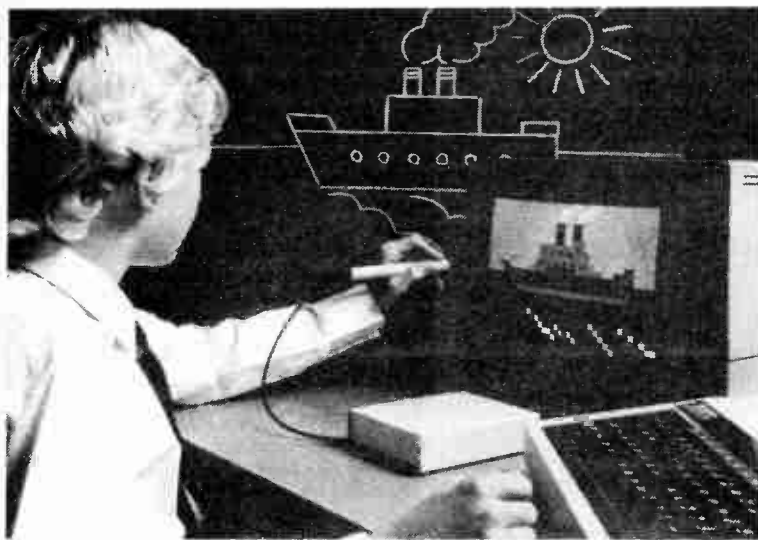

### RH Lightpen

The RH lightpen is compact, little bigger than a felt-tip. It is versatile, with a sophisticated microswitch at its point which responds to the slightest pressure, and an LED lamp at the user's end to indicate data transmission. Both microswitch and LED are fully programmable.

The RH lightpen is reliable, with a rugged metal case to provide physical and electronic protection. Its sensitivity can be adjusted to the thickness and type of your TV screen, giving the highest levels of accuracy.

With the lightpen connected to your BBC Micro you can draw lines on the screen, or give commands simply by pointing to a menu.

### Colour-Graphic software

This additional software is available so that all the colours of the BBC Micro's palette are available at the tip of your pen. Complex graphics can be created in minutes.

### Art-Fun software

This program is guaranteed to bring out the artist in you. It provides inspiration for users of the lightpen and provides full interaction between pen and screen.

Lightpen **£45.95** — 40 track disc version of lightpen software **£5.95** — Colour-graphic software (tape) **£9.95** — Art-fun software (tape) **£9.95**

### RH Software

RH Electronics has a whole series of excellent software for the BBC Microcomputer Model B. For games, business and education, they will be highly valued by any BBC Micro owner.

**Plegaron People Eaters** **£8.95**  
Stop the Plegaron's path of destruction by walling them in. A game of skill (9 levels) and cunning.

**Galactic Wipeout** **£8.95**  
Fight off alien attackers and meteor showers as you transport the survivors of the human race to a new planet.

**Ski Slalom** **£8.95**  
Guide the skier through the 40 gate course avoiding deadly ice and landsliding snowballs.

**Viper** **£8.95**  
Guide the snake around its electric cage devouring as much food as you can. Avoid touching the electrified walls, swallowing unsavoury food or causing the snake to eat its own tail.

### 3 In 1 (A)

This set of three games for the younger enthusiast includes: Task Force — a strategic battle of sea and air; Demolish — blast your way to freedom avoiding radioactive fall-out and falling masonry as you go; Cosmos — where you have to defend the earth from an invading battle fleet.

### Ed-master

This program uses the quiz format, combining the element of fun with educational teaching. 160 questions may be programmed by the teacher, divided into eight subject areas of 20 questions each. Questions and answers can be changed as often as you wish. The computer will tell the pupil whether he or she has the correct answer or not, but cheating is prevented as pupils cannot access the program to find out the correct answers. The scores of up to 40 pupils are stored in the quiz memory and easily recalled for comparison.

### Snail Trail

Help the snail escape from the maze he's fallen into before he starves to death. There are two skill levels to this cassette.

### Database

A cassette for the business of home. It enables you to file, sort and access a great number of items such as diary entries, addresses, telephone numbers, accounts or other information.

**£7.50**

**£12.95**

**£4.95**

**£12.95**

## AT LAST!! A worthwhile peripheral

*"These computers are all very well but they can't REALLY do anything can they?"*

How many times have you heard that sentence and realised that you are inclined to agree? That's all in the past with these long awaited exciting new products from DCP.

For the BBC Microcomputer:

### INTERBEEB

The self-powered INTERBEEB is a rugged new peripheral, housed in a neat thermo-plastic case the INTERBEEB contains the following hardware to allow your computer to control the outside world... and get an answer WITHOUT having to re-invent the wheel!

1) an 8 bit, 8 channel Analogue to Digital converter (ADC). 2) 4 high current relay outputs. 3) an 8 bit input port and a SEPARATE 8 bit output port. 4) 4 switch inputs. 5) DCP bus connection allows communication with other units in the DCP range.

The unit comes complete with all the necessary cables, a mains power unit and a manual giving examples for beginners, all for **£59.95** + postage and packing.

For the ZX Spectrum or ZX81:

### INTERSPEC

The INTERSPEC gives users of Sinclair computers the same facilities for control and interrogation of the outside world as the INTERBEEB and with the advantage of the DCP bus connector, which presents all the necessary bus connections and power lines to the user, upto 4 further packs may be added allowing (for instance) proportional control of analogue driven equipment.

The INTERSPEC comes complete with a comprehensive manual including examples of use and hints for ZX81 users. Control of your environment can be yours for only **£39.95** + post and packing.

### DAC PACK

The DAC PACK (Digital to Analogue Converter) will give your computer, for the first time, the capability to

communicate with the outside world in its own language. The DAC PACK features a 2.55 volt internal reference voltage for rock-steady output and a step resolution of 10mV in 255 levels and high quality connectors for reliable operation. The DAC PACK connects to the DCP bus and therefore requires that either the INTERSPEC or INTERBEEB be present.

As with all other DCP products the DAC PACK comes complete with a comprehensive manual and costs **£19.95** + post & packing.

### AD PACK

The AD PACK (Analogue to Digital Converter) is easy to both use and understand and consists of a fast A to D converter with an internal precision voltage reference source for accurate conversions. The input voltage swing is 0 to 2.55V with a tolerance allowable of  $\pm 5\%$ , therefore giving a 10mV input resolution. The AD PACK is connected using the DCP bus and will therefore require either the INTERSPEC or INTERBEEB to be connected to the host computer.

The AD PACK comes with a manual which includes examples of operation and costs **£19.95** + postage & packing.

### S-PACK

The Speech Pack is a completely self-contained add-on speech synthesiser for the ZX81 or Spectrum Computers which may be used in addition to a ZX RAM PACK, DCP PACK and/or ZX printer. The S-PACK is supplied complete with Word Pack ROM 1 which contains all the letters of the alphabet, numbers 0 to over a million and some other general words which can all be 'spoken' under computer control. Up to three more Word Pack Rom's

can be fitted to expand the vocabulary, details of which are available on request. The 2 versions of the speech pack for the ZX81 and Spectrum operate in similar manners but are NOT interchangeable, therefore the type of host computer should be specified when ordering.

The S-PACK comes complete with an operating manual and is available for **£59.95** plus postage & packing.

Word Packs 2, 3 and 4 are **£14.95** + postage & packing. Dealer and Quantity enquiries welcome. For further information regarding the above range please contact RH Electronics (Sales) Ltd.

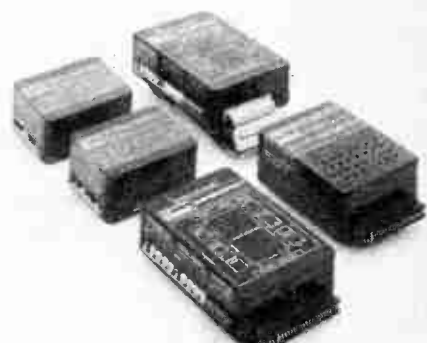

**R.H.ELECTRONICS (SALES) LTD.**  
Exclusive Distributors of DCP  
Microdevelopment products

Make cheque or PO payable to **RH Electronics (Sales) Ltd.** allowing 28 days for delivery. All prices include VAT and p&P. Send or telephone your order to: **RH Electronics (Sales) Ltd., Chesterton Mill, French's Rd, Cambridge CB4 3NP.** Tel: (0223) 311290

# ENFIELD ELECTRONICS

208 Baker Street, Enfield, Middlesex. EN1 3JY. Tel: 01-366 1873



TRANSISTORS				TTL			
AC125 30p	BC183C 12p	BF198 14p	TIP29C 45p	2N1304 80p	7417 28p	7447 75p	7486 35p
AC126 30p	BC183L 12p	BF199 14p	TIP30A 45p	2N1305 80p	7420 20p	7448 55p	7489 140p
AC127 30p	BC184 12p	BF200 35p	TIP30B 50p	2N1307 70p	7422 28p	7450 21p	7490 37p
AC132 90p	BC184B 12p	BF258 35p	TIP30C 45p	2N1308 80p	7425 28p	7451 20p	7491 45p
AC141 30p	BC184L 12p	BF259 35p	TIP31 38p	2N1613 36p	7426 28p	7452 21p	7492 40p
AC142 30p	BC186 30p	BF594 40p	TIP31A 40p	2N2222A 36p	7427 28p	7453 21p	7493 41p
AC176 30p	BC187 30p	BF595 30p	TIP31B 40p	2N2907 40p	7428 28p	7454 21p	7494 37p
AC188 30p	BC212L 12p	BF789 30p	TIP32A 45p	2N2964 68p	7430 28p	7455 21p	7495 41p
AD149 80p	BC213 12p	BF870 30p	TIP32B 40p	2N2904A/5A 30p	7405 18p	7432 26p	7472 25p
AD161 45p	BC213B 12p	BF871 30p	TIP32C 40p	2N2906A 60p	7406 32p	7433 35p	7473 30p
AD162 45p	BC213L 12p	BF872 30p	TIP32E 140p	2N2907A 30p	7407 32p	7437 30p	7474 35p
BC107 12p	BC214 12p	BF873 30p	TIP32V 140p	2N2926G 12p	7408 25p	7438 30p	7475 46p
BC107A 14p	BC214B 12p	BF874 30p	TIP41A 50p	2N2928L 12p	7409 25p	7440 23p	7476 35p
BC107B 14p	BC214L 12p	BF875 30p	TIP42A 60p	2N2926Y 12p	7410 18p	7441 51p	7480 30p
BC108 12p	BC237 18p	BF950 25p	TIP42B 65p	2N3053 30p	7411 25p	7442 40p	7481 110p
BC108A 14p	BC238B 18p	BF951 25p	TIP120 80p	2N3054 75p	7412 25p	7443 71p	7482 70p
BC108B 14p	BC307 18p	BF952 25p	TIP121 90p	2N3055E 60p	7413 26p	7444 95p	7483 81p
BC108C 14p	BC308 14p	BF953 25p	TIP142 120p	2N3442 150p	7414 37p	7445 71p	7416 70p
BC109 12p	BC327 14p	BF954 25p	TIP295 70p	2N3615 200p	7416 28p	7446 71p	7485 75p
BC109A 14p	BC328 14p	BF955 25p	TIP296 70p	2N3702 12p	7417 28p	7447 75p	7486 35p
BC109B 14p	BC329 14p	BF956 25p	TIP297 70p	2N3703 12p	7418 28p	7448 75p	7487 35p
BC109C 14p	BC337 16p	BF957 25p	TIP298 70p	2N3704 12p	7419 28p	7449 75p	7488 35p
BC140 35p	BC338 16p	BF958 25p	TIP299 70p	2N3705 12p	7420 28p	7450 75p	7489 140p
BC141 35p	BC339 16p	BF959 25p	TIP300 70p	2N3706 12p	7421 28p	7451 75p	7490 37p
BC142 35p	BC340 16p	BF960 25p	TIP301 70p	2N3707 12p	7422 28p	7452 75p	7491 45p
BC143 35p	BC341 16p	BF961 25p	TIP302 70p	2N3708 12p	7423 28p	7453 75p	7492 40p
BC144 35p	BC342 16p	BF962 25p	TIP303 70p	2N3709 12p	7424 28p	7454 75p	7493 41p
BC145 35p	BC343 16p	BF963 25p	TIP304 70p	2N3710 12p	7425 28p	7455 75p	7494 37p
BC146 35p	BC344 16p	BF964 25p	TIP305 70p	2N3711 12p	7426 28p	7456 75p	7495 41p
BC147 35p	BC345 16p	BF965 25p	TIP306 70p	2N3712 12p	7427 28p	7457 75p	7496 41p
BC148 35p	BC346 16p	BF966 25p	TIP307 70p	2N3713 12p	7428 28p	7458 75p	7497 41p
BC149 35p	BC347 16p	BF967 25p	TIP308 70p	2N3714 12p	7429 28p	7459 75p	7498 140p
BC150 35p	BC348 16p	BF968 25p	TIP309 70p	2N3715 12p	7430 28p	7460 75p	7499 37p
BC151 35p	BC349 16p	BF969 25p	TIP310 70p	2N3716 12p	7431 28p	7461 75p	7500 37p
BC152 35p	BC350 16p	BF970 25p	TIP311 70p	2N3717 12p	7432 28p	7462 75p	7501 37p
BC153 35p	BC351 16p	BF971 25p	TIP312 70p	2N3718 12p	7433 28p	7463 75p	7502 37p
BC154 35p	BC352 16p	BF972 25p	TIP313 70p	2N3719 12p	7434 28p	7464 75p	7503 37p
BC155 35p	BC353 16p	BF973 25p	TIP314 70p	2N3720 12p	7435 28p	7465 75p	7504 37p
BC156 35p	BC354 16p	BF974 25p	TIP315 70p	2N3721 12p	7436 28p	7466 75p	7505 37p
BC157 35p	BC355 16p	BF975 25p	TIP316 70p	2N3722 12p	7437 28p	7467 75p	7506 37p
BC158 35p	BC356 16p	BF976 25p	TIP317 70p	2N3723 12p	7438 28p	7468 75p	7507 37p
BC159 35p	BC357 16p	BF977 25p	TIP318 70p	2N3724 12p	7439 28p	7469 75p	7508 37p
BC160 35p	BC358 16p	BF978 25p	TIP319 70p	2N3725 12p	7440 28p	7470 75p	7509 37p
BC161 35p	BC359 16p	BF979 25p	TIP320 70p	2N3726 12p	7441 28p	7471 75p	7510 37p
BC162 35p	BC360 16p	BF980 25p	TIP321 70p	2N3727 12p	7442 28p	7472 75p	7511 37p
BC163 35p	BC361 16p	BF981 25p	TIP322 70p	2N3728 12p	7443 28p	7473 75p	7512 37p
BC164 35p	BC362 16p	BF982 25p	TIP323 70p	2N3729 12p	7444 28p	7474 75p	7513 37p
BC165 35p	BC363 16p	BF983 25p	TIP324 70p	2N3730 12p	7445 28p	7475 75p	7514 37p
BC166 35p	BC364 16p	BF984 25p	TIP325 70p	2N3731 12p	7446 28p	7476 75p	7515 37p
BC167 35p	BC365 16p	BF985 25p	TIP326 70p	2N3732 12p	7447 28p	7477 75p	7516 37p
BC168 35p	BC366 16p	BF986 25p	TIP327 70p	2N3733 12p	7448 28p	7478 75p	7517 37p
BC169 35p	BC367 16p	BF987 25p	TIP328 70p	2N3734 12p	7449 28p	7479 75p	7518 37p
BC170 35p	BC368 16p	BF988 25p	TIP329 70p	2N3735 12p	7450 28p	7480 75p	7519 37p
BC171 35p	BC369 16p	BF989 25p	TIP330 70p	2N3736 12p	7451 28p	7481 75p	7520 37p
BC172A 35p	BC370 16p	BF990 25p	TIP331 70p	2N3737 12p	7452 28p	7482 75p	7521 37p
BC173 35p	BC371 16p	BF991 25p	TIP332 70p	2N3738 12p	7453 28p	7483 75p	7522 37p
BC174 35p	BC372 16p	BF992 25p	TIP333 70p	2N3739 12p	7454 28p	7484 75p	7523 37p
BC175 35p	BC373 16p	BF993 25p	TIP334 70p	2N3740 12p	7455 28p	7485 75p	7524 37p
BC176 35p	BC374 16p	BF994 25p	TIP335 70p	2N3741 12p	7456 28p	7486 75p	7525 37p
BC177 35p	BC375 16p	BF995 25p	TIP336 70p	2N3742 12p	7457 28p	7487 75p	7526 37p
BC178 35p	BC376 16p	BF996 25p	TIP337 70p	2N3743 12p	7458 28p	7488 75p	7527 37p
BC179 35p	BC377 16p	BF997 25p	TIP338 70p	2N3744 12p	7459 28p	7489 75p	7528 37p
BC181 35p	BC378 16p	BF998 25p	TIP339 70p	2N3745 12p	7460 28p	7490 75p	7529 37p
BC182 35p	BC379 16p	BF999 25p	TIP340 70p	2N3746 12p	7461 28p	7491 75p	7530 37p
BC182B 35p	BC380 16p	BF1000 25p	TIP341 70p	2N3747 12p	7462 28p	7492 75p	7531 37p
BC182L 35p	BC381 16p	BF1001 25p	TIP342 70p	2N3748 12p	7463 28p	7493 75p	7532 37p
BC183 35p	BC382 16p	BF1002 25p	TIP343 70p	2N3749 12p	7464 28p	7494 75p	7533 37p
BC183B 35p	BC383 16p	BF1003 25p	TIP344 70p	2N3750 12p	7465 28p	7495 75p	7534 37p

### RIBBON CABLE

(Priced per ft)

WAYS	CDLOUR
10	26p
20	53p
26	76p
34	100p

### D CONNECTORS

MALE	FEMALE
9 way 75p	100p
15 way 100p	1140
15 way 140p	195p

### D-CONNECTOR COVERS

9 way	110
15 way	110
25 way	125

### RECHARGEABLE BATTERIES

HP2, 1.2V, 4.0AH	£3.95
HP2, 1.2V, 1.2AH	£2.60
HP11, 1.2V, 1.2AH	£2.40
HP7, 1.2V, 500mAh	£1.00
AAA, 1.2V, 180mAh	30p
PF3, 8.4V, 110mAh	£4.50

### POTENTIOMETERS

Carbon track, 1 watt log & linear values:

Range	Price
470R-2.2MR (single track)	40p
4.7K-2.2MR (dual gang)	100p
4.7K-2.2MR (single gang D/P switch)	90p

### DIODES

AA119 15p	DA202 9p	1N5600 18p
AA215 15p	DA203 9p	1N5602 20p
BA1X 10p	1N414 12p	1N5604 18p
BY100 30p	1N415 12p	1N5606 18p
BY127 18p	1N416 12p	1N5607 18p
BY133 20p	1N417 12p	1N5608 18p
BY206 30p	1N418 12p	1N5609 18p
BY207 30p	1N419 12p	1N5610 18p
BY239 40p	1N420 12p	1N5611 18p
BY298 40p	1N421 12p	1N5612 18p
BY310 40p	1N422 12p	1N5613 18p
BY311 40p	1N423 12p	1N5614 18p
BY312 40p	1N424 12p	1N5615 18p
BY313 40p	1N425 12p	1N5616 18p
BY314 40p	1N426 12p	1N5617 18p
BY315 40p	1N427 12p	1N5618 18p
BY316 40p	1N428 12p	1N5619 18p
BY317 40p	1N429 12p	1N5620 18p
BY318 40p	1N430 12p	1N5621 18p
BY319 40p	1N431 12p	1N5622 18p
BY320 40p	1N432 12p	1N5623 18p
BY321 40p	1N433 12p	1N5624 18p
BY322 40p	1N434 12p	1N5625 18p
BY323 40p	1N435 12p	1N5626 18p
BY324 40p	1N436 12p	1N5627 18p
BY325 40p	1N437 12p	1N5628 18p
BY326 40p	1N438 12p	1N5629 18p
BY327 40p	1N439 12p	1N5630 18p
BY328 40p	1N440 12p	1N5631 18p
BY329 40p	1N441 12p	1N5632 18p
BY330 40p	1N442 12p	1N5633 18p
BY331 40p	1N443 12p	1N5634 18p
BY332 40p	1N444 12p	1N5635 18p
BY333 40p	1N445 12p	1N5636 18p
BY334 40p	1N446 12p	1N5637 18p
BY335 40p	1N447 12p	1N5638 18p
BY336 40p	1N448 12p	1N5639 18p
BY337 40p	1N449 12p	1N5640 18p
BY338 40p	1N450 12p	1N5641 18p
BY339 40p	1N451 12p	1N5642 18p
BY340 40p	1N452 12p	1N5643 18p
BY341 40p	1N453 12p	1N5644 18p
BY342 40p	1N454 12p	1N5645 18p
BY343 40p	1N455 12p	1N5646 18p
BY344 40p	1N456 12p	1N5647 18p
BY345 40p	1N457 12p	1N5648 18p
BY346 40p	1N458 12p	1N5649 18p
BY347 40p	1N459 12p	1N5650 18p
BY348 40p	1N460 12p	1N5651 18p
BY349 40p	1N461 12p	1N5652 18p
BY350 40p	1N462 12p	1N5653 18p
BY351 40p	1N463 12p	1N5654 18p
BY352 40p	1N464 12p	1N5655 18p
BY353 40p	1N465 12p	1N5656 18p
BY354 40p	1N466 12p	1N5657 18p</

# EVERYDAY ELECTRONICS and computer PROJECTS

VOL. 13 No. 3 MARCH 1984

**Editor**

F. E. BENNETT

**Assistant Editor**

B. W. TERRELL B.Sc.

**Production and News Editor**

D. G. BARRINGTON

**Projects Editor**

G. P. HODGSON

**Technical Sub-Editor**

R. A. HOOPER

**Art Editor**

R. F. PALMER

**Assistant Art Editor**

P. A. LOATES

**Technical Illustrator**

D. J. GOODING Tech. (CEI)

**Secretary**

JACQUELINE DOIDGE

**Editorial Offices**

KING'S REACH TOWER  
STAMFORD STREET  
LONDON SE1 9LS  
Phone: 01-261 6873

**Advertisement Manager**

D. W. B. TILLEARD  
Phone: 01-261 6676

**Secretary**

CHRISTINE POCKNELL

**Sales Executive**

A. TONGE  
Phone: 01-261 6819

**Representative**

R. WILLETT  
Phone: 01-261 6865

**Classified Supervisor**

B. BLAKE  
Phone: 01-261 5897

**Make-Up and Copy Department**

Phone: 01-261 6615

**Advertisement Offices**

KING'S REACH TOWER  
STAMFORD STREET  
LONDON SE1 9LS

**Readers' Enquiries**

We cannot undertake to answer readers' letters requesting modifications, designs or information on commercial equipment or subjects not published by us. All letters requiring a personal reply should be accompanied by a stamped self-addressed envelope.

We cannot undertake to engage in discussions on the telephone.

**Component Supplies**

Readers should note that we do not supply electronic components for building the projects featured in EVERYDAY ELECTRONICS, but these requirements can be met by our advertisers.

All reasonable precautions are taken to ensure that the advice and data given to readers are reliable. We cannot, however, guarantee it and we cannot accept legal responsibility for it. Prices quoted are those current as we go to press.

## PURELY CONSTRUCTIVE

FROM temporary lash-ups to final models, there are more ways of putting electronic circuits together than might generally be supposed. Chiefly for the benefit of newcomers to the hobby we will range over these methods of construction, with some concrete examples taken from this month's contents.

In our current *Teach-In 84* series, planned to make the introduction to electronics as simple as possible, the need for soldering has been eliminated by the use of a breadboard system, the component leads being simply plugged into holes in the plastics breadboard. Breadboarding is an admirable system not only for the beginner but also for more advanced experiments and ad hoc circuit hook-ups, as in our *Computer Aided Experiments* series.

Other examples of solderless techniques have appeared in EE from time to time. This month we include a practical design for a *Metal Pipe Finder* where the circuit components are joined together by means of terminal blocks. This particular method of construction will enlarge the scope of operations for those followers of *Teach-In* who have not as yet acquired the implements nor the practical skills required for making soldered connections.

None of this of course detracts in any way from the essential requirement for soldering whenever permanency is the object. So coming now to the mainstream of our operations, there are basically two choices: stripboard or printed circuit. The first is a well-known product universally available and versatile in its application. The second is an item made expressly for one particular design and is thus "dedicated" to that purpose.

Stripboard (Veroboard) has been the foundation of the majority of projects published in EE prior to the last twelve months or so. Since then increasing use has been made of printed circuits in our designs. This has been backed up by our *PCB Service* and the response by our readers confirms the view that a substantial number prefer this method of construction. There is less chance of error when positioning components compared with stripboard and in appearance the finished assembly can be indistinguishable from a factory produced item. The p.c.b. has obvious advantages where large and complex circuits are concerned; it eases the task of the constructor and offers a good guarantee that the finished project will meet the specified performance. The use of p.c.b.s is well exemplified in the computer projects *Multimeter Add-On* and in the *Microcomputer Interfacing Techniques* series.

Stripboard on the other hand retains popularity as a general purpose medium for circuit building. One advantage is instant availability, whereas the p.c.b. has to be ordered, or made. A good introduction to the use of this versatile board is provided by our *Black Box* series of handy and useful devices, which starts this month.

Finally, there is a form of hard-wired constructive that calls for nothing other than the components and the housing, save for perhaps a tag strip. Components are soldered directly to each other or to terminals fixed to the case. This method of construction is limited to certain designs using only a few components. An example appears in the *Ni-Cad Charger*.

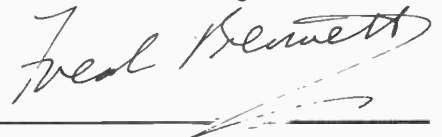

**Back Issues**

Certain back issues of EVERYDAY ELECTRONICS are available worldwide price £1.00 inclusive of postage and packing per copy. Enquiries with remittance should be sent to Post Sales Department, IPC Magazines Ltd., Lavington House, 25 Lavington Street, London SE1 0PF. In the event of non-availability remittances will be returned.

**Binders**

Binders to hold one volume (12 issues) are available from the above address for £4.60 inclusive of postage and packing worldwide. Please state which Volume.

**Subscriptions**

Annual subscription for delivery direct to any address in the UK: £12.00. Overseas: £13.00. Cheques should be made payable to IPC Magazines Ltd., and sent to Room 2613, King's Reach Tower, Stamford Street, London SE1 9LS.

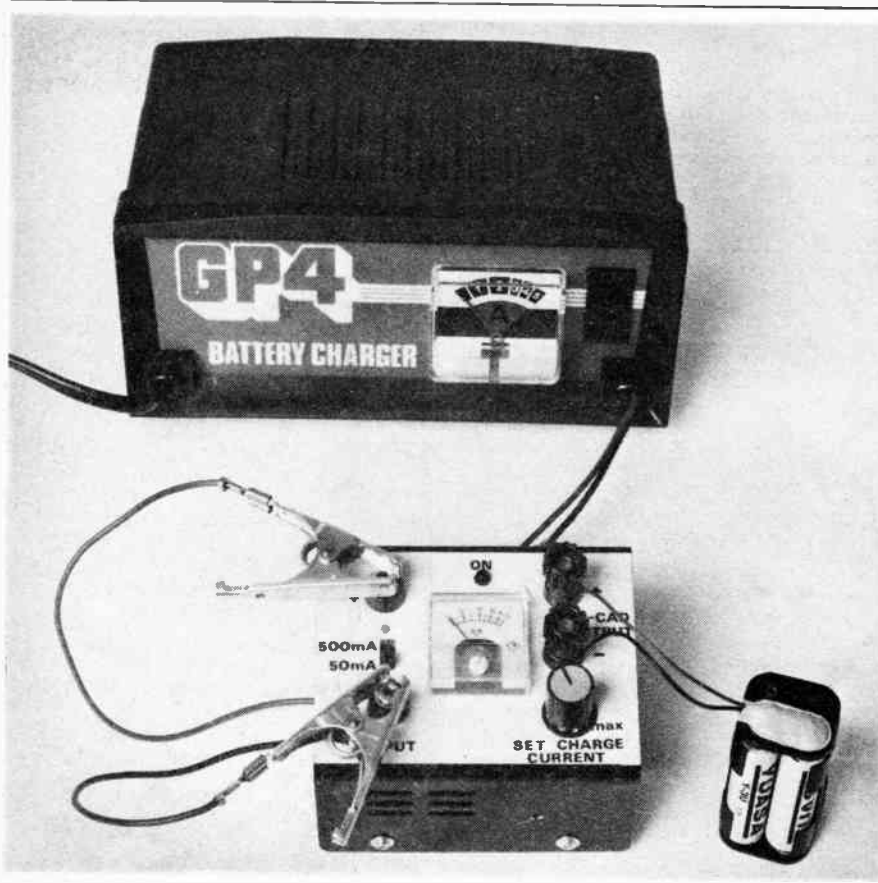

# NI-CAD BATTERY CHARGER

BY R. H. MARCO

THE unit described here is a simple add-on to convert a 12V car battery charger into a ni-cad battery charger catering for PP3, HP7, HP11 and HP2 size cells. Up to 12 cells of the same type in series (excluding the PP3) can be charged in one go.

By using the car battery charger, no expensive power supply components are required, so consequently the cost is kept low.

## CIRCUIT DESCRIPTION

The circuit diagram of the Ni-Cad Battery Charger is shown in Fig. 1. SK1 and SK2 are connected to the positive and negative output leads from the car battery charger, respectively. Diode D1 prevents damage to the unit should the leads be incorrectly connected and capacitor C1 provides smoothing.

The l.e.d. D2 indicates that the car battery unit is switched on, R1 limiting the current through D2. The network consisting of R2, Zener diode D3 and potentiometer VR1 generates a reference

voltage on the base of TR1, and this reference is variable between 10V and 0V by rotating VR1.

Transistors TR1 and TR2 form a Darlington pair and when a discharged

ni-cad cell is connected across SK3 and SK4 (that is, in the collector circuit of the Darlington), the current through it can be preset by adjusting VR1.

## METER

The meter ME1 shows the charge current and has two ranges; 50mA full-scale deflection or 500mA when shunt resistor R3 is switched in with S1. Diode D4 prevents reverse current discharge.

The ni-cad cells being charged (up to a bank of 12 in series) must all be of the same type and each must have the same capacity, usually expressed in mAh (milliampere-hours). The charge rate for any given type is the same for one cell as it is for 12 and once set by VR1, need not be re-adjusted for the rest of the charging time, usually 10 hours.

## CONSTRUCTION

As there are so few components, and most of those are case mounted, no circuit board was employed in the construction of the prototype unit. The case used on this model is a two piece aluminium box, 100 x 80 x 55mm, but any enclosure of similar dimensions will suffice.

The general layout of the components can be seen in the photos and Fig. 2 gives the interwiring information. The input and output sockets are terminal posts with insulated mounts. Note that the inputs (SK1 and SK2) have had the plastic covers removed from the top to facilitate connection of the crocodile clips usually fitted to car battery chargers.

The meter is a miniature type requiring only one mounting hole and the TO3 transistor TR2 is mounted to the side of the case using an isolating mica washer if the case is metal.

Meter shunt resistor R3 is made from a 200mm length of 32 s.w.g. enamelled copper wire, wound onto a plastic former and secured with a little glue. Its value should be about 0.2 ohms.

With the type of construction employed on the Ni-Cad Battery Charger unit, extra care must be taken with solder joints and all bare leads must be sleeved to prevent short circuits.

Fig. 1. Circuit diagram of the Ni-Cad Battery Charger unit.

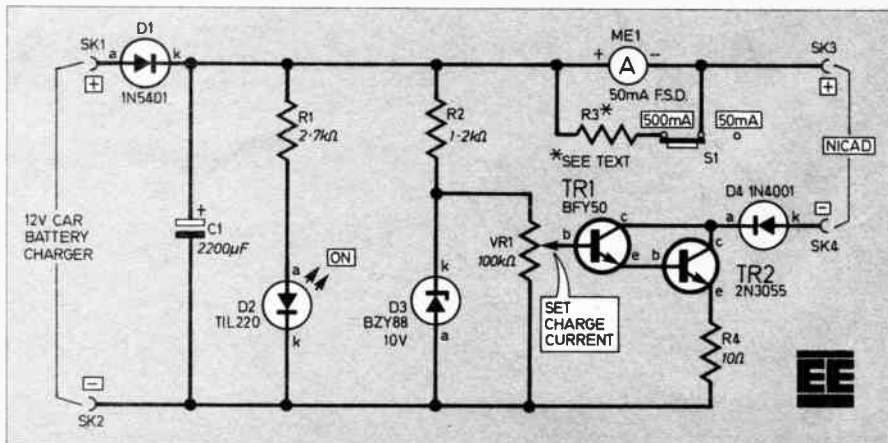

# COMPONENTS

Fig. 2. The component layout and interwiring diagram for the Ni-Cad Battery Charger. Note that, for clarity, the chassis type case (as used in the prototype) has been drawn folded flat to show the mounting of TR2 on the rear face. All wired connections are to be made with a good solid insulated wire and long component leads must be sleeved with p.v.c. sleeving.

## Resistors

- R1 2.7k $\Omega$
- R2 1.2k $\Omega$
- R3 see text
- R4 10 $\Omega$  3W wirewound
- All  $\frac{1}{2}$ W carbon  $\pm 5\%$  unless otherwise stated

## Capacitor

- C1 2200 $\mu$ F 40V elect., radial lead

## Semiconductors

- D1 1N5401 silicon
- D2 TIL220 5mm red l.e.d.
- D3 BZY88 10V Zener
- D4 1N4001 silicon
- TR1 BFY50 npn silicon
- TR2 2N3055 npn silicon

## Miscellaneous

- S1 s.p.d.t. slide switch
- VR1 100k $\Omega$  lin. control potentiometer
- SK1,3 insulated screw terminal red (2 off)
- SK2,4 insulated screw terminal black (2 off)
- ME1 quick-fit miniature panel meter, 50mA f.s.d., 1.8 $\Omega$  coil

Case to suit (approximately 100 x 80 x 60mm); control knob; 32 s.w.g. enamelled copper wire (for R3); TO3 insulated mounting kit; soldertags; wire; plastic sleeving.

**COMPONENTS**  
approximate  
cost **£8**

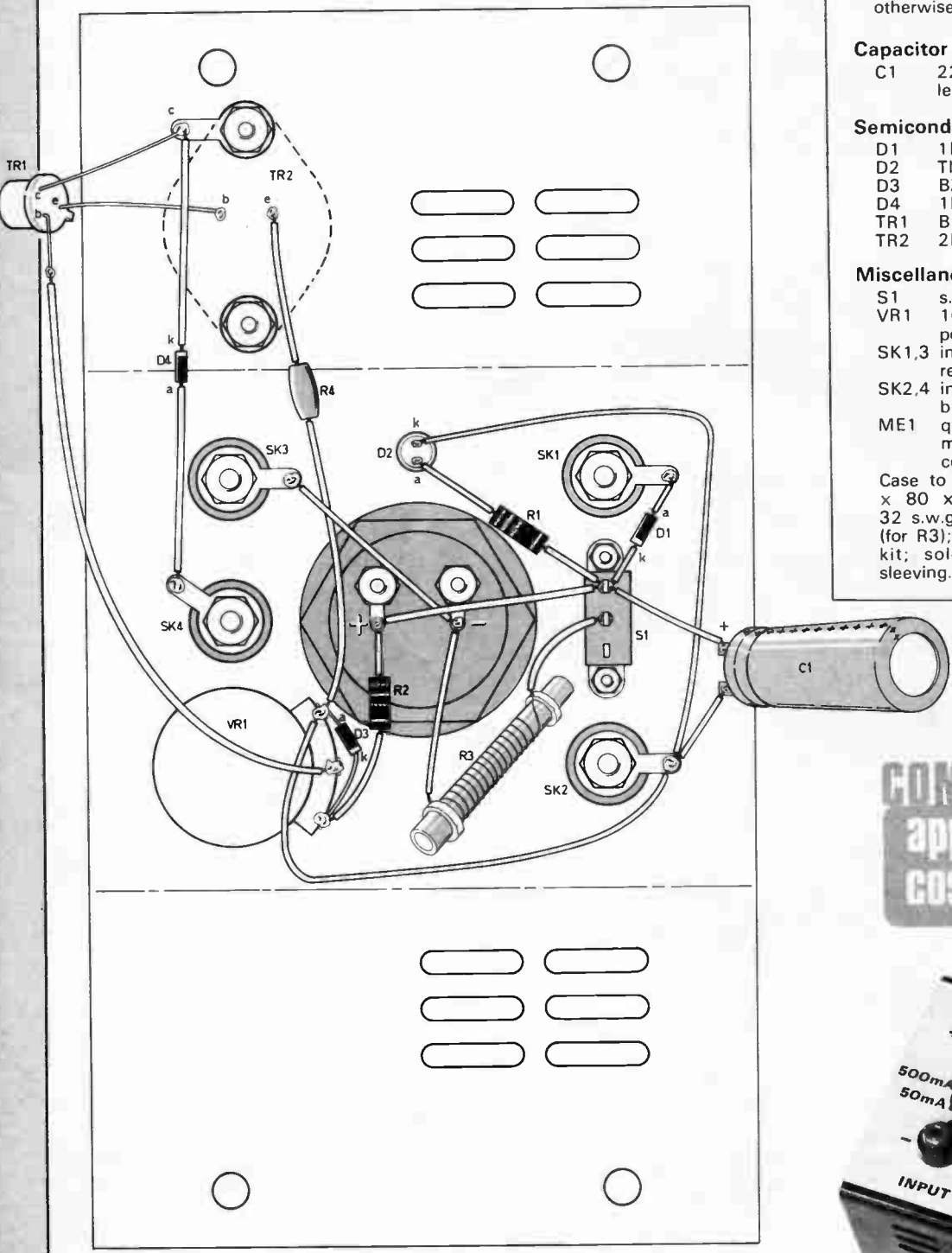

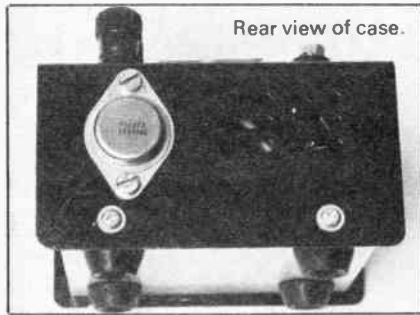

BATTERY SIZE	CAPACITY	CHARGE RATE	METER RANGE
PP3 (RX22)	100mAh	10mA	50mA
HP7 (RX6)	500mAh	50mA	50mA
HP11 (RX14)	2000mAh	200mA	500mA
HP2 (RX20)	4000mAh	400mA	500mA

Charge time in each case is ten hours.

### IN USE

To use the Charger unit, the car battery charger is clipped to the input terminals, carefully observing the correct polarity and avoiding the two clips touching each other (insulated crocodile clips are best). Before switching on, connect the ni-cad battery across the output, again carefully observing the correct polarity. It is advisable to have the SET CHARGE CURRENT control initially at the minimum position.

### CHARGE RATE

From Table 1, the correct charge rate for each type of ni-cad can be selected and the meter range switch setting is also given. Note that the charge rate in mA is one tenth of the cell capacity in mAh.

The correct charge rate is then set by slowly rotating VR1 in a clockwise direction until the meter shows the correct value. Remember that on the 500mA range, the readings on the scale of the meter must be multiplied by ten. □

# EVERYDAY ELECTRONICS SOFTWARE SERVICE

The EE Software Service provides an easy and reliable means of program entry for our computer-based projects. All programs have been tested by us and consist of two good quality copies of the working program on cassette tape. Certain program listings are also available.

All prices include VAT, postage and packing. Remittances should be sent to Everyday Electronics Software Service, Editorial Offices, King's Reach Tower, Stamford Street, London SE1 9LS. Cheques should be crossed and made payable to IPC Magazines Ltd.

PROJECT TITLE	CASSETTE CODE	CASSETTE COST	LISTING CODE	LISTING COST
ZX81 SPEED COMPUTING SYSTEM (Feb 83)	T001	£2.95	L001	£2.95
REAL-TIME CLOCK (Apple II) (May 83)	T002	£2.95	L002	£2.95
REAL-TIME CLOCK (BBC Micro) (May 83)	T003	£2.95	L003	£2.95
EPROM PROGRAMMER (TRS-80 & GENIE) (June 83)*	T004	£3.95	N/A	—
STORAGE SCOPE INTERFACE (BBC Micro) (Aug 83)	T005	£2.95	—	—
ELECTRO-CARDIOGRAPH (BBC Micro) (Jan 84)	T006	£2.95	—	—
EPROM PROGRAMMER/ROM CARD (ZX81)** (Feb 84)	T007	£3.95	—	—

\*Includes Command List with examples.  
\*\*Includes Keyboard Overlay.

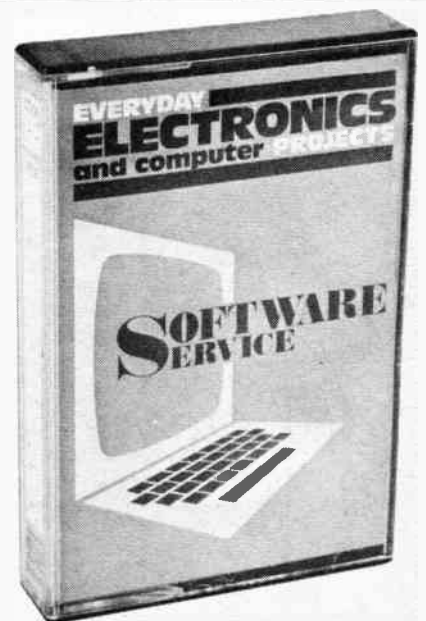

# DIGITAL MULTIMETER ADD-ON FOR COMPUTERS



BY R. A. PENFOLD

IT IS NOT difficult to adapt most home-computers to measure electrical quantities, such as resistance or voltage, and it is very simple indeed in the case of a machine such as the BBC Micro model B which has a built-in analogue-to-digital converter.

The analogue-to-digital converter in the BBC model B microcomputer is not a high speed type, having a fastest sampling rate of once every 10 milliseconds with just one of the four channels in use, but measurements in electronics are often of static quantities such as the value of a resistor or capacitor, and high speed operation is by no means essential.

## SPECIFICATION

This simple add-on unit enables the BBC model B microcomputer to measure d.c. voltage, resistance, and capacitance.

There are three voltage measurement ranges having full-scale values of 1, 10, and 100 volts, and there is a high input impedance of approximately 11 megohms on all ranges.

There are five resistance and five capacitance ranges with full-scale resistance values of 1k $\Omega$ , 10k $\Omega$ , 100k $\Omega$ , 1M $\Omega$ , and 10M $\Omega$ . The full-scale capacitance values are 1nF, 10nF, 100nF, 1 $\mu$ F, and 10 $\mu$ F.

The BBC model B computer has a 12-bit analogue-to-digital converter, and although problems with noise limit the resolution and accuracy to a certain extent, this still enables a reasonably high degree of accuracy to be obtained. Results are certainly more than adequate for normal requirements.

The system gives a warning if over-ranging occurs so that misleading results are avoided, but this facility is provided by the software rather than the hardware. The unit is powered from the computer and does not need any form of additional power supply.

## SIMPLY PLUGS INTO THE USER AND ANALOGUE PORTS

### MEASURES

#### Resistance (5 ranges):

1k $\Omega$ , 10k $\Omega$ , 100k $\Omega$   
1M $\Omega$  and 10M $\Omega$

#### Capacitance (5 ranges):

1nF, 10nF, 100nF,  
1 $\mu$ F and 10 $\mu$ F

#### Voltagess (3 ranges):

1, 10 and 100 volts.

Software available

The computer can be used simply as a digital (or quasi analogue) readout in conjunction with a TV set or monitor, or it could be used in a more sophisticated manner.

Systems of this type can be used in checking pieces of equipment or components, with the computer indicating whether or not the results from a test or set of tests are within acceptable limits, and showing which ones the equipment under test has failed where appropriate.

Another possibility is to use the system when checking for intermittent faults, since the equipment could be programmed to monitor a strategic voltage and register any change that occurs when the fault appears.

Incidentally, the circuit can be used as a simple analogue resistance, capacitance, voltage meter if its output is connected to a 100 $\mu$ A meter in series with a 16k $\Omega$  resistor, and it is not only of use to BBC micro owners. However, a stabilised supply of around 5 volts to 9 volts would be required.

## SYSTEM OPERATION

Fig. 1 shows the unit in block diagram form, and there are really three separate sections to the circuit. One to measure resistance, one to measure voltage, and the third to deal with capacitance measurements.

## RESISTANCE

If we take the resistance section first, this consists basically of just a constant current generator and a buffer amplifier having a very high input impedance. The resistor being tested is fed with the output

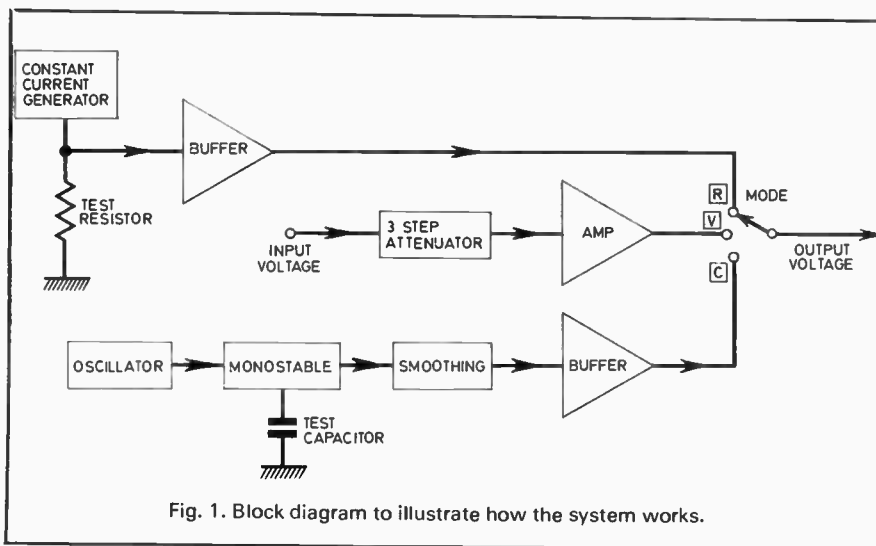

Fig. 1. Block diagram to illustrate how the system works.

from the constant current generator, and the computer monitors the voltage produced across the resistor.

The buffer amplifier ensures that no significant resistance is placed across the test resistance (which would effectively lower its value).

With the test current at a fixed value the output voltage is proportional to the test resistance, so that a linear relationship between test resistance and output voltage is produced. This is not actually essential in this application since the computer could be programmed to counteract a non-linear resistance-voltage characteristic, but this system is simple, accurate, and enables straightforward software to be employed.

## VOLTAGE

For voltage measurements an amplifier having a high input resistance is used to act as a buffer ahead of the computer. This ensures that there is minimal loading on the circuit under test so that reliable readings are obtained. As the lowest voltage range has a full-scale value of 1 volt, and around 1.3 volts is needed to fully drive the analogue inputs of the computer, the amplifier provides a small amount of voltage amplification in addition to the buffering. A three-step attenuator at the input can be used to reduce the sensitivity of the circuit by a factor of 10 or 100, so that the two higher voltage ranges are produced.

## CAPACITANCE

For capacitance measurement an oscillator is used to trigger a monostable multivibrator, and the test capacitor is the timing capacitance for the latter.

With the monostable triggered at a fixed rate, its average output potential depends on the pulse length produced by the test capacitance. The higher this capacitance the higher the average output voltage, and there is a linear relationship between capacitance and output potential.

The output from the monostable is, of course, a pulse signal, and in order to obtain accurate results this must be smoothed to a steady d.c. potential before it is applied to the analogue input of the computer.

A simple C-R smoothing circuit is used, followed by a buffer amplifier which gives a suitably low output impedance to drive the analogue-to-digital converter.

A three-way switch is used to select the desired circuit and couple it through to the computer.

## THE CIRCUIT

Fig. 2 shows the full circuit diagram of the Digital Multimeter Add-On for the BBC Micro model B.

TR1 and IC1a form the basis of the resistance measurement interface. TR1 is used as a conventional single transistor constant current source having a nominal 1.3 volt forward bias fed to its base by D1, D2, and R6. This gives a potential of about 0.65 volts across whichever of the emitter resistances is switched into circuit by S2a, and an emitter current which is set by the selected resistance plus this bias voltage.

The resistor under test is connected in the collector circuit of TR1, and this will pass a current which is almost identical to TR1 emitter current, provided the resistance is not excessively high.

Having five switched emitter resistances (and test currents) gives the unit its five resistance ranges, and in practice VR1 to VR5 are adjusted to give the required full-scale values.

IC1a is the buffer amplifier, and this is an operational amplifier used in the non-inverting mode with 100 per cent negative feedback to give unity voltage gain. The CA3120E used for IC1 (and the CA3140E single amp version used for IC4) has a PMOS input stage which gives an extremely high input impedance of over 1 million megohms. This gives negligible shunting on the resistor under test and no loss of accuracy.

Fig. 2. The complete circuit diagram of the Digital Multimeter Add-On for computers.

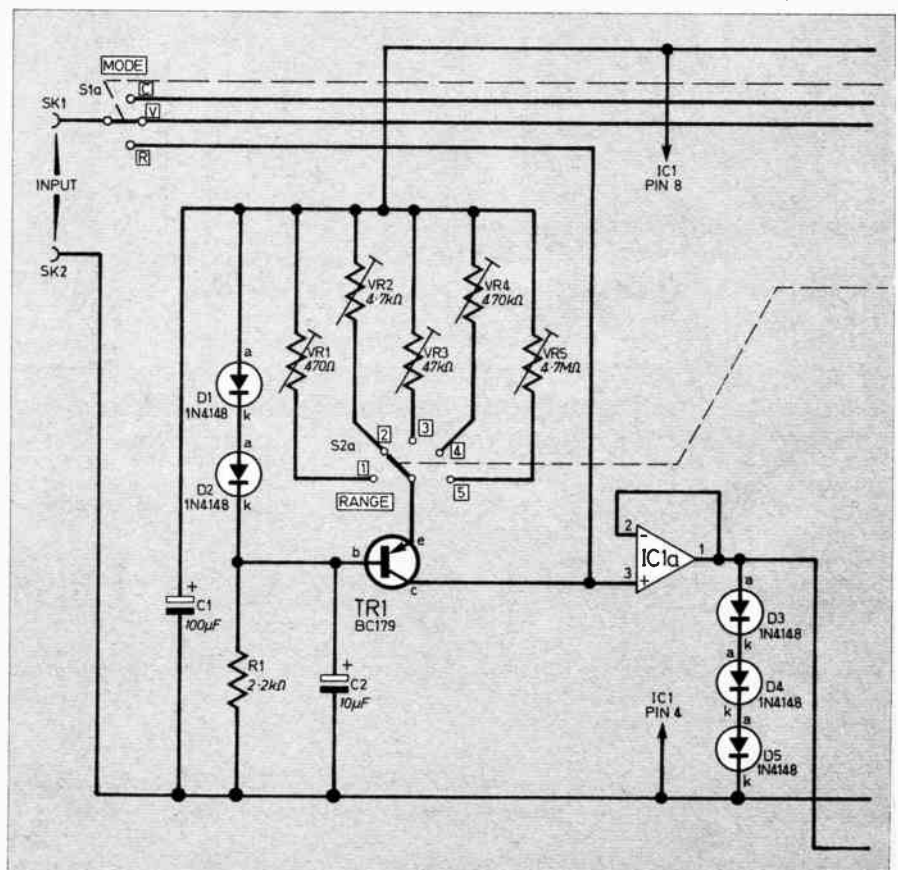





This device also has a class A output stage that enables its output to go within a few millivolts of the negative supply rail, and this obviates the need for a  $-5$  volt supply. D3 to D5 limit the output voltage of IC1a to no more than about 2 volts, so that serious overloading of the analogue input of the computer cannot occur.

### VOLTAGE

IC1b is used as the amplifier in the voltage measuring circuit. It is used in the non-inverting mode, and its voltage gain is controlled by feedback resistors. VR6 and R7. VR6 is adjusted to give the circuit the correct sensitivity. R2 to R5 are the three-step attenuator, and S3 is the range switch for the voltage circuit. R6

and D6 prevent IC1b or the input of the computer from being seriously overloaded.

In the capacitance measuring interface the clock oscillator uses 555 timer IC2 to generate the short negative trigger pulses for the monostable circuit. This is a conventional 555 astable circuit apart from the inclusion of steering diode D7 which effectively bypasses R9 when C3 is discharging. This produces a very rapid discharge, and, as the output of IC2 is low during this period it also produces the required brief negative pulses.

The monostable multivibrator is based on IC3 which is a 7555. This is the CMOS version of the 555, and in this application it has the advantage of a slightly lower self capacitance which helps to give better accuracy when measuring low values of capacitance.

The output pulse from this type of monostable cannot be any shorter than the trigger pulse, and it is for this reason that it is important to use a very brief trigger pulse. There are five switched timing resistors (R10 to R14) and these give the five measuring ranges. A single (2-pole) switch is used as the resistance and capacitance range switch.

The output of IC3 is smoothed by R15, VR7 and C4. VR7 enables the circuit to be calibrated, and R10 to R14 are close tolerance (1 per cent) components so that good accuracy is obtained on all five ranges. IC4 is the output buffer amplifier, and S1a couples the output of the desired interface circuit through to the analogue input of the computer.

S1a connects input socket SK1 to the non-earthly input of the appropriate interface circuit. No switching is needed for SK2 as this must connect to earth in all three modes of operation.

S1b connects to the user port of the computer and is used to indicate to the computer what mode of operation is in use by pulling one of the data lines (PB0 to PB2) low. It would be feasible to indicate to the computer the range in use in a similar way, but it was felt that this would over-complicate the unit, and this feature has not been included.

Power is obtained from the user port, and the 5-volt output here seems to be sufficiently well smoothed and stabilised to give good results.

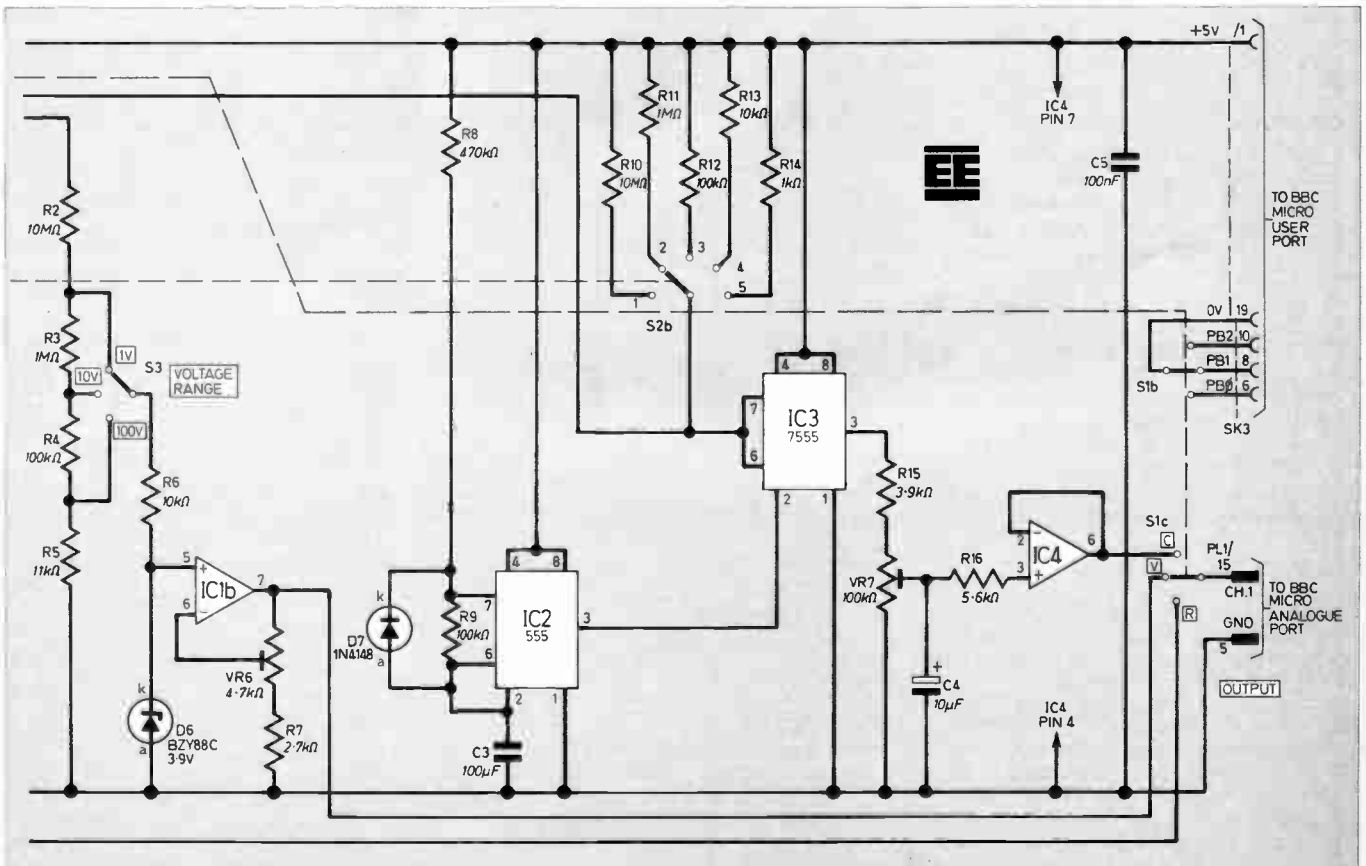

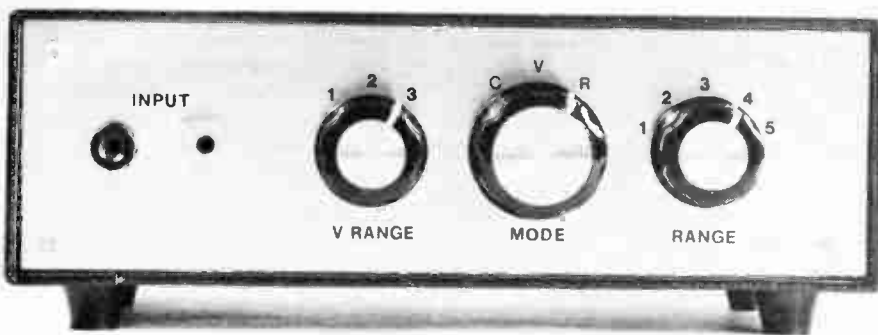

## CONSTRUCTION

Start by building the printed circuit board. The actual-size master pattern of this is shown in Fig. 3. This board is available from the *EE PCB Service*, Order code 8403-01. As IC1 and IC4 have PMOS input stages they should be fitted in (8-pin d.i.l.) i.c. sockets and the normal MOS handling precautions should be taken.

IC3 is a CMOS device, but due to its internal protection circuitry it does not require any special handling precautions. However, it is still probably advisable to use a socket for this device as it is not one of the cheapest integrated circuits.

Be careful to connect the integrated circuits the right way round, and note that IC3 has the opposite orientation to the other three. It is important to use the specified types of preset resistor if they are to fit onto the printed circuit board properly, and two different types are utilised in this design. Do not overlook the single link wire between IC2 and IC3. Veropins are fitted to the board at points where connections to off-board components will eventually be made, see Fig. 4.

## CASE DETAILS

An instrument case measuring about 203 × 114 × 64mm was used as the case for the prototype, but this is somewhat larger than is really necessary, and a slightly smaller case could probably be used without too much difficulty. The three switches and two input sockets are mounted on the front panel of the case; rear panel is drilled to take the output lead to the analogue input of the computer.

As the output impedance of the unit is quite low it is not essential to use a screened cable here. Fig. 5(a) shows the two connections to the analogue input of the computer. These connections can be made via a 15-way D-type connector or a couple of 1mm plugs.

A rectangular hole for the ribbon cable which connects to the user port must also be made in the rear panel. On the prototype a ready-wired 20-way i.d.c. header socket and ribbon cable are used to make the connections to the user port (the 15 unused wires just being ignored), and this is probably the most simple way of making the connections. However, a home-wired 20-way i.d.c. connector and 5-way ribbon cable could be used if preferred. Fig. 5(b) shows the connections to the user port.

On the prototype the exit hole for the ribbon cable is actually a rectangular cut-out which was filled in the top of the removable rear panel, but this is something that must be varied to suit the particular case and cable that are used.

The printed circuit board is mounted on the base panel or chassis of the case using 6BA fixings.

To complete the unit the point-to-point wiring is added, and this is shown in Fig. 4. This wiring will be more neat if ribbon cable is used, but ordinary hook-up wire is suitable.

## COMPONENTS

### Resistors

R1	2.2k $\Omega$
R2	10M $\Omega$ 1% metal film 0.4W
R3	1M $\Omega$ 1% metal film 0.4W
R4	100k $\Omega$ 1% metal film 0.4W
R5	11k $\Omega$ 1% metal film 0.4W
R6	10k $\Omega$
R7	2.7k $\Omega$
R8	470k $\Omega$
R9	100k $\Omega$
R10	10M $\Omega$ 1% metal film 0.4W
R11	1M $\Omega$ 1% metal film 0.4W
R12	100k $\Omega$ 1% metal film 0.4W
R13	10k $\Omega$ 1% metal film 0.4W
R14	1k $\Omega$
R15	3.9k $\Omega$
R16	5.6k $\Omega$

All  $\frac{1}{4}$ W carbon  $\pm 5\%$  except where stated otherwise

### Potentiometers

VR1	470 $\Omega$	} 0.25W carbon vertical preset
VR2	4.7k $\Omega$	
VR3	47k $\Omega$	
VR4	470k $\Omega$	
VR5	4.7M $\Omega$	
VR6	4.7k $\Omega$	0.1W horizontal carbon preset
VR7	100k $\Omega$	0.1W horizontal carbon preset

### Capacitors

C1	100 $\mu$ F 10V elect. axial leads
C2,4	10 $\mu$ F 25V elect. axial leads (2 off)
C3	100nF polycarbonate
C4	100nF ceramic

### Semiconductors

IC1	CA3240E m.o.s.f.e.t. dual op-amp
IC2	555 timer i.c.
IC3	7555 timer i.c.
IC4	CA3140E m.o.s.f.e.t. op-amp
TR1	BC179 silicon <i>pnp</i>
D1,2,3	
4,5,7	1N4148 silicon signal diode (6 off)
D6	BZY88C3V9 3.9V 400mW Zener diode

### Miscellaneous

PL1	15-way D-type plug (or two 1mm plugs—see text)
SK1	4mm socket (red)
SK2	4mm socket (black)
SK3	20-way i.d.c. socket
S1,3	4-pole 3-way rotary switch
S2	2-pole 6-way rotary switch with end stop at position 6

**Printed circuit board:** single-sided, size 150 × 38mm, *EE PCB Service*, Order code 8403-05; single-sided Veropins (24 off); control knobs with index (3 off); 20-way i.d.c. ribbon cable; screened cable; case type WB3 vinyl covered, size 203 × 127 × 51mm or similar; hook-up wire, ribbon or single; 6BA fixings; 20mm screws, nuts, shakeproof Block washers and 10mm long spacers.

COMPONENTS  
approximate  
cost £18

See  
**Shop  
Talk**  
page 164

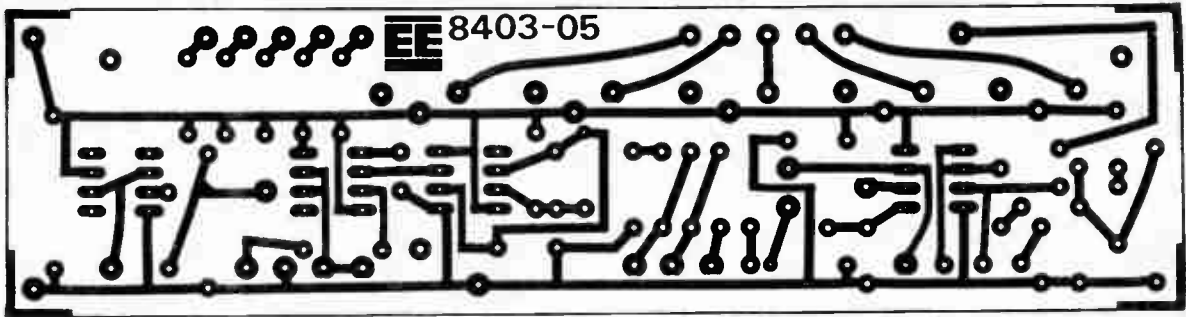

Fig. 3. The master p.c.b. pattern shown actual-size from copper track side. This board is available from the *EE PCB Service*, Order code 8403-05.

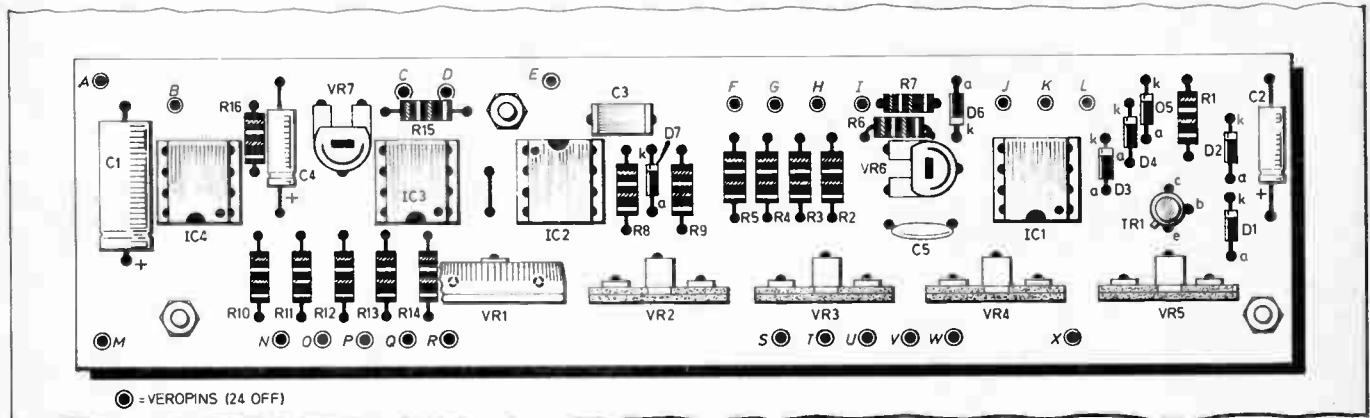
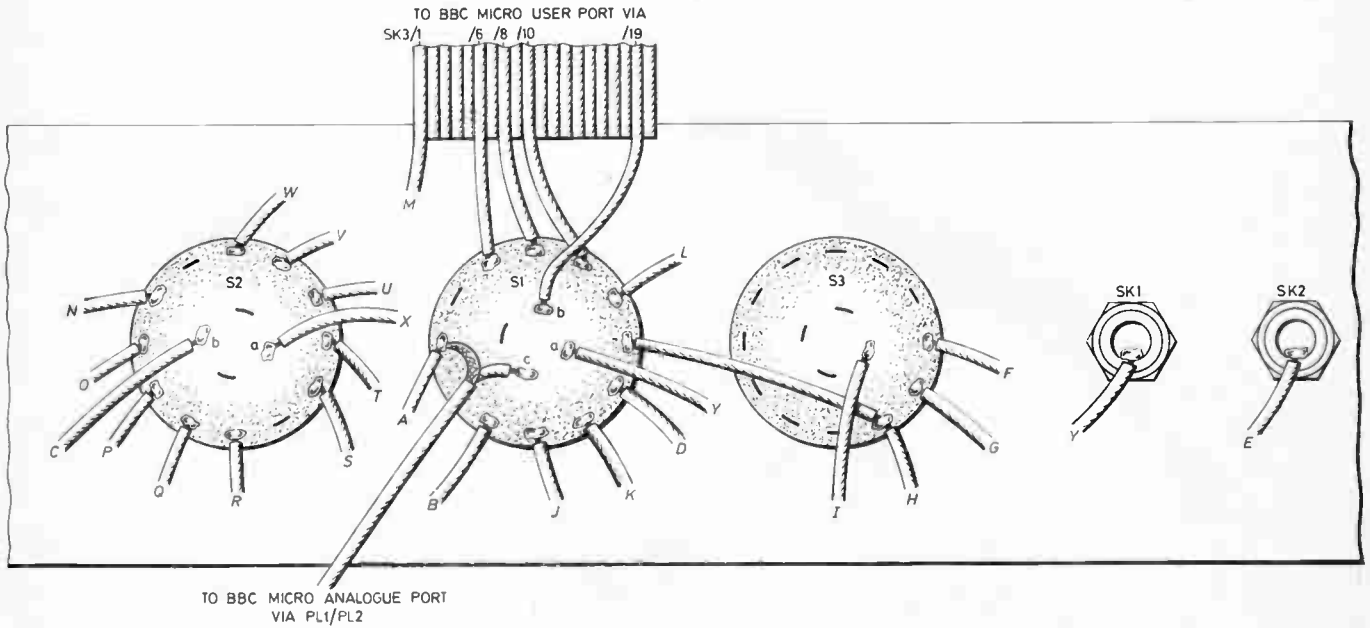
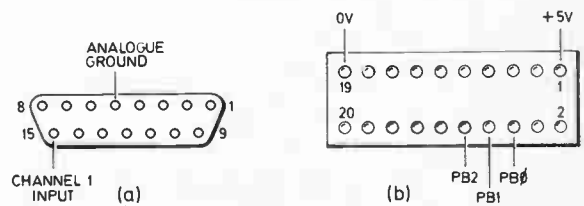

Fig. 4. Shows the layout of the components on the top-side of the printed circuit board. Note that there are 24 Veropins labelled which receive the correspondingly labelled wires from the front panel mounted components, shown above.

Fig. 5. Pin identification details for (a) the Analogue port and (b) the User port on the BBC Micro model B.



## PROGRAM : MULTIMETER

```

10 REM MULTIMETER PROGRAM
20 REM by John Penfold
30 REM EVERYDAY ELECTRONICS
40 REM
50 MODE 2:VDU 23,1,0,0,0,0;
60 OSBYTE =%FFF4: function=0: setrange=0: range=3
70 DIM P% 60
80 COPT 0
90 .SET
100 LDA #0.97
110 LDX #0.62
120 LDY #0.0
130 JSR OSBYTE
140 LDA #0.E1
150 LDX #1.60
160 LDY #0.0
170 JSR OSBYTE
180 LDA #1.6
190 LDX #1
200 JSR OSBYTE
210 .FUNCTION
220 LDA #0.96
230 LDX #0.60
240 JSR OSBYTE
250 STY 0.70
260 RTS:J
270 CALLSET
280 VDU 23,225,0,28,54,99,99,54,99,0
290 VDU 23,226,0,0,51,51,51,18,108,96
300 PROCscreen
310 PROCmeter
320 END
330 DEF PROCscreen
340 COLOUR 132:CLS
350 GCOL 0,3
360 MOVE 440,512:DRAW 0.0,512:DRAW 0.0,600:DRAW 440,600:DRAW 440,512
370 COLOUR 0
380 PRINT TAB(2,4):"RANGE"
390 CALLFUNCTION
400 PROCchange_function
410 COLOUR 1:PRINT TAB(2,24):"Change range with"
420 PRINT TAB(2,26):"function keys."
430 ENDPROC
440 DEF PROCmeter
450 REPEAT
460 CALLFUNCTION:IF ?%70<>function THEN PROCchange_function: function=?%70
470 T=TIME
480 REPEAT
490 setrange=INKEY(0):IF setrange>160 THEN PROCchange_range(setrange)
500 current_reading=(ADVAL(1)/64-4):IF current_reading<1020 PRINT TAB(8,1
4):"****" UNTIL FALSE
510 total=total+current_reading
520 readings=readings+1
530 UNTIL TIME=T+40
540 average_reading=INT(total/readings)
550 IF average_reading<0 THEN average_reading=0
560 COLOUR 1:PRINT TAB(8,14):FNdisplay(average_reading,range)
570 total=0:readings=0
580 UNTIL FALSE
590 ENDPROC
600 DEF PROCchange_function
610 COLOUR 0
620 IF ?%70=251 PRINT TAB(15,14):"F":PRINT TAB(2,2):"CAPACITANCE"
630 IF ?%70=253 PRINT TAB(15,14):"V":PRINT TAB(14,14):" ":PRINT TAB(2,2):"VOL
TAGE"
640 IF ?%70=254 PRINT TAB(15,14):CHR$(225):PRINT TAB(2,2):"RESISTANCE"
650 PRINT TAB(8,14):" "
660 IF ?%70=253 AND range>3 THEN range=3
670 IF setrange<160 THEN setrange=range+160:PROCchange_range(setrange)
680 ENDPROC
690 DEF PROCchange_range(setrange)
700 IF setrange>165 OR (setrange>168 AND ?%70=253) THEN ENDPROC
710 range=setrange-160
720 COLOUR 0
730 PRINT TAB(9,4):range
740 IF range<4 AND ?%70=251 THEN PRINT TAB(14,14):"n"
750 IF range=4 AND ?%70=251 THEN PRINT TAB(14,14):CHR$(226)
760 IF range<4 AND ?%70=254 THEN PRINT TAB(14,14):"k"
770 IF range=4 AND ?%70=254 THEN PRINT TAB(14,14):"M"
780 IF ?%70=253 THEN PRINT TAB(14,14):" "
790 ENDPROC
800 DEF FNdisplay(average_reading,place)
810 display%=STR$(average_reading)
820 IF place>3 place=place-3
830 IF LEN(display%)*4-place THEN display%=STRING$(4-place)-LEN(display%),"0
")+display%
840 IF LEN(display%)=4-place THEN display%="0"+display%
850 IF LEN(display%)*4 THEN display%=STRING$(4-LEN(display%)),"")+display%
860 display%=LEFT$(display%,place)+". "+RIGHT$(display%,4-place)
870 =display%

```

## PROGRAM NOTES

Obviously the software must be varied to suit individual requirements, but the suggested program enables the equipment to function as a straightforward multimeter, and would make a good basis for a more specialised program.

The program reads the user port and displays the appropriate mode ("RESISTANCE", "CAPACITANCE", or "VOLTAGE") at the top of the screen provided the unit is connected.

Lines 210 to 260 read the port (in assembly language) and PROCchange\_function in conjunction with PROCscreen prints the appropriate label on the screen. These also display the appropriate unit of measurement after the digital readout (with lines 280 and 290 defining two special characters for this part of the display) and draw a box around the digital readout.

PROCchange\_range is used to give the correct display reading for the range in use, and function keys f1 to f5 are used to enter the appropriate range (f1 for range 1, f2 for range 2, and so on).

## UPDATED DISPLAY

An infinite loop is used so that the display is being continuously updated. Due to problems with noise in the analogue-to-digital converter, rather than periodically taking and displaying a single reading from the analogue-to-digital converter a process of taking a number of readings and displaying the average is used.

In order to obtain the fastest possible sampling rate lines 180 to 200 enable only channel 1. The reading returned by ADVAL(1) is in the range 0 to 65535, but this is divided by 64 to give a reading of between 0 and 1023. However, line 500 includes a check for overload values and these are indicated by stars in the display box.

Of course, the readout is not a straightforward 0 to 1000 reading, and operating the correct function (range) key puts the decimal point in the appropriate position. Leading zeros are suppressed incidentally, and the display is flicker free.

Line 50 sets the mode and switches off the cursor, but note that this VDU statement will not work with one of the early BBC model B micros if it is still fitted with O.S. 0.1.

## SETTING UP

After a thorough check of the wiring, the unit is connected to the user and analogue ports of the computer, and the program "MULTIMETER" is loaded into the computer. Refer to the program

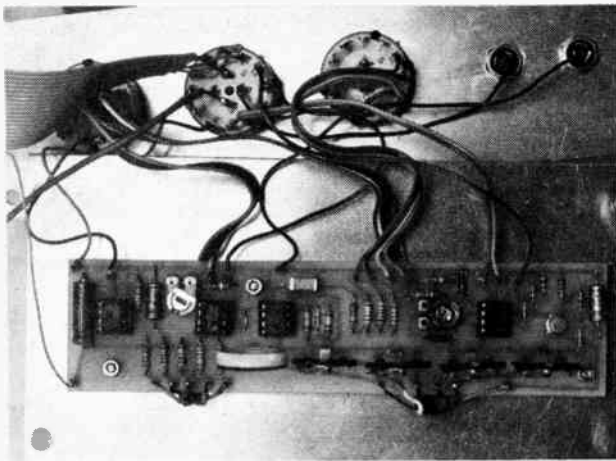

The completely assembled printed circuit board shown fitted here to the case chassis plate.

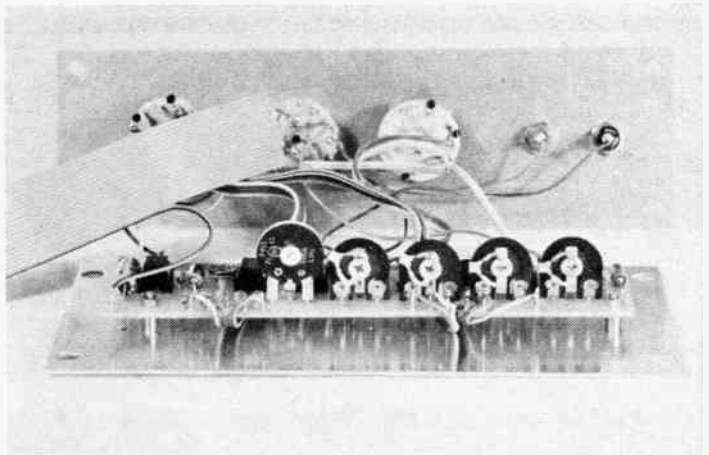

Rear view of the completed unit which has been removed from its case.

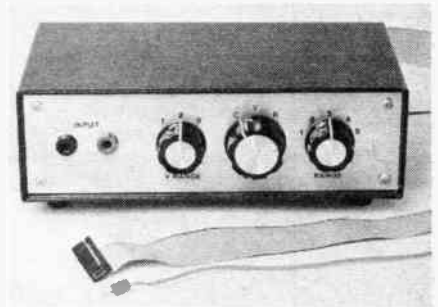
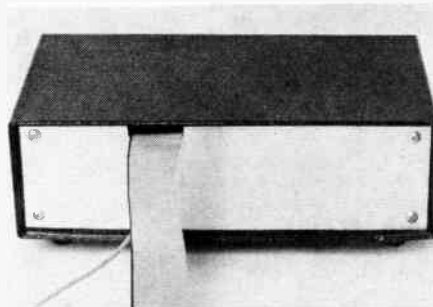
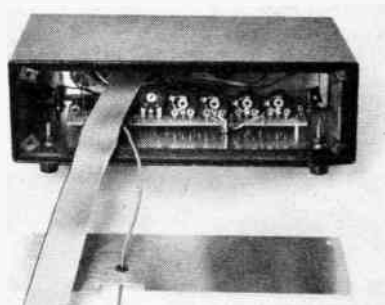

Various views of the completed prototype.

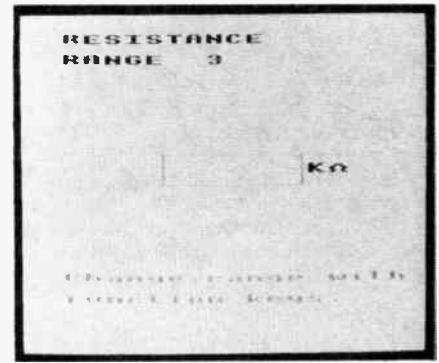
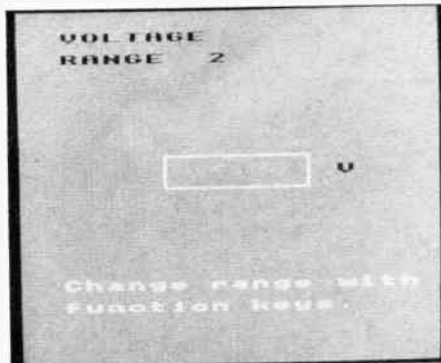
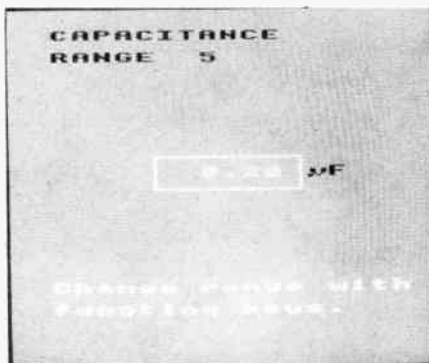

Screen displays for each of the three operational modes.

notes if you are uncertain about the way in which the program is used.

In order to calibrate the voltage ranges a known voltage is required, and this should correspond to between 50 per cent and 100 per cent of the full-scale reading of the range on which the unit is calibrated (it does not matter which range this is). For example, a 9-volt battery could have its actual output potential measured using a multimeter, and with the add-on switched to voltage range 2 (0V to 10V) VR6 would be adjusted to produce the correct reading on the display.

### CAPACITANCE RANGE

A similar procedure is used to calibrate the capacitance ranges, but the calibration reference source is a close tolerance (1 or 2 per cent) capacitor. For instance, a 10nF 1 per cent capacitor could be used to calibrate the unit on capacitance range 2, with VR7 being adjusted to give the appropriate display reading.

Note that accuracy on range 1 is limited by stray capacitance, and a high degree of accuracy will not be obtained, especially when measuring very low value capacitors. It is thus better to calibrate the unit on one of the other four ranges.

### RESISTANCE RANGE

Calibration of the resistance ranges is somewhat different in that each range is individually calibrated. This requires five 1 per cent resistors, and ideally values of 1kΩ, 10kΩ, 100kΩ, 1MΩ, and 10MΩ should be used to calibrate ranges 1 to 5 respectively. The calibration presets are VR1 and VR5 respectively.

When using the unit make sure that the mode switch is in the correct position, especially when measuring high voltages or voltages having a low impedance source. Otherwise there is a risk of the circuit being damaged. □

# SHOP TALK

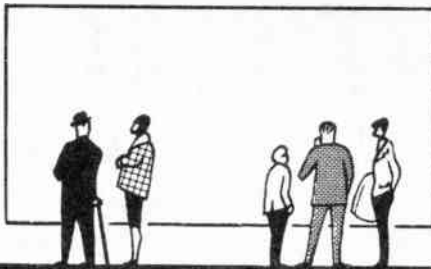

BY DAVE BARRINGTON

## Saw Bench

Spotlighting a new product that is really going to repay its outlay in time-saving and usefulness, in the workshop, is not always forthcoming. However, one of the latest items being stocked by **Toolrange** that is worth further investigation is a low power circular saw bench.

Ideal for cutting and trimming printed circuit boards and Veroboards, the circular saw bench is supplied complete with its own 12V to 20V d.c. motor and two 2in diameter cutting blades.

The table size is 5½in x 4½in, height 2¾in. It is fitted with an adjustable width stop and has graduated markings engraved in cm and mm from 0 to 60mm. Fixing lugs on the base of the unit allow for permanent mounting.

On/Off safety switch gives overall control and a microswitch under the cutting table gives Start/Stop control when passing material through the blade. Maximum depth of cut is 7mm.

The P.C.B. Circular Saw Bench, together with over 3,000 other tools are listed in the Toolrange 1983/4 catalogue. For more details and price of the saw bench, write to: **Toolrange Ltd., Dept EE, Upton Road, Reading, Berks RG3 4JA.**

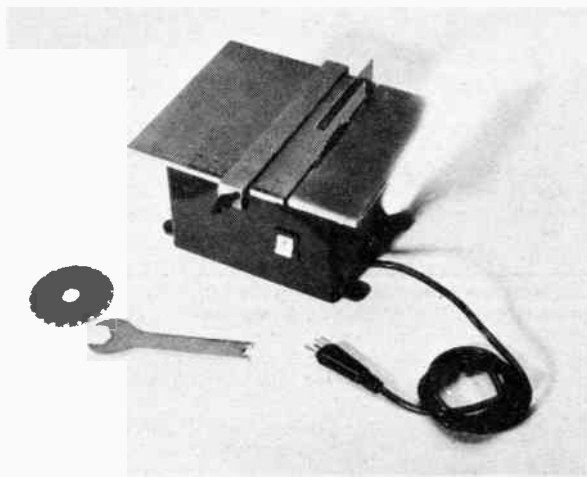

Low voltage circular saw bench from the Toolrange collection, ideal for trimming and cutting circuit boards.

## CONSTRUCTIONAL PROJECTS

### Low Power Stereo Amplifier

The mains transformer used in the *Low Power Stereo Amplifier* is listed as a 16V 500mA secondary type. The nearest we have been able to locate with similar ratings is the mains transformer range from Maplin.

This should be ordered as: WB15R (Min Tr 15V). This transformer has two secondaries and these should be wired in parallel.

The transformer used in the author's model is marked: Davenset Part No. 480425H 250V.

### Black Box Projects—DIN Lead Tester

The first project in our occasional "black box" series is a *DIN Lead Tester* and should not cause any component purchasing problems.

All the projects to be described in this series are built in the same size box. This is from the popular range of the high impact ABS plastic boxes, with brass fixing inserts. The one used in our series measures 80 x 61 x 41mm and is listed by Maplin and Greenweld Electronics.

### Ni-Cad Battery Charger

The 10 ohm 3 watt wirewound resistor called-up for the *Ni-Cad Battery Charger* is currently stocked by Electrovalue, Benningcross, Enfield and Magenta Electronics.

The rating of the resistor supplied may differ from that specified, but should not be less than 3 watts.

### Reversing Bleeper

The warning device WD1 used in the prototype *Reversing Bleeper* was obtained from RS Components. The one used in our model is the 12V version and should be ordered as: RS 248-808.

We would point out that RS Components will not supply to the general public but must be ordered through a local recognised trader. However, most of our advertisers stock suitable 12V buzzers and one of these could be used in this circuit.

### Pipe Finder

A suitable ferrite rod for the "search coil" used in the *Pipe Finder* is stocked by Ambit, Benningcross, Greenweld and Maplin.

When ordering components for this project be sure to specify a "log law" type for the tuning potentiometer VR1.

### Digital Multimeter Add-On for Computers

If the *Digital Multimeter Add-On for Computers* is to be built on the EE printed circuit board, the preset potentiometers must be of the types specified. This is to agree with the mounting lug spacings allocated on the board.

Potentiometers VR6 and VR7 are "sub-miniature", 0.2in x 0.1in spacing types and VR1 to VR5 are "standard" 0.4in x 0.2in spacing.

The semiconductors are currently stocked by Enfield, Rapid, Magenta and Maplin. The 15-way D-type plug, 20-way i.d.c. socket and ribbon cable are available from Computer Link.

### Microcomputing Interfacing Techniques

The Minicon interconnecting p.c.b. plugs and sockets used in this month's *Microcomputer Interfacing Techniques* projects are stocked by Maplin Electronic Supplies.

The only source of supply we have been able to locate for the 74LS133 13-input NAND gate, used in both the *Latched Output Port* and *Buffered Input* boards, is Greenweld Electronics. Their stocks are limited, but they have been notified and should have ample stocks by the time this article appears.

The other semi-conductor devices listed for these two boards are currently available as "off-the-shelf" items from most of our advertisers.

## SUPPLIERS OF KITS FOR TEACH-IN 84

Please refer to advertisement on page stated.

Greenweld Electronics (page 216)  
43 Millbrook Road,  
Southampton, SO1 0HX.

Magenta Electronics (page 150)  
135 Hunter Street,  
Burton-on-Trent, Staffs  
DE14 2ST.

TK Electronics (page 212)  
11 Boston Road,  
London, W7 3SJ.

# EVERYDAY ELECTRONICS PRINTED CIRCUIT BOARD SERVICE

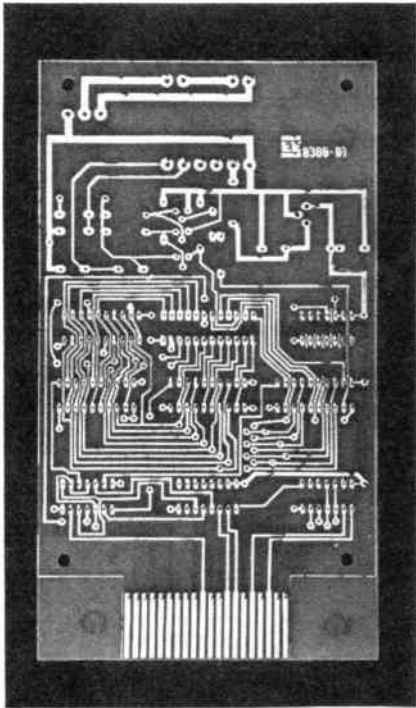

Printed circuit boards for certain EE constructional projects are now available from the EE PCB Service, see list. These are fabricated in glass-fibre, and are fully drilled and roller tinned. All prices include VAT and postage and packing. Remittances should be sent to: EE PCB Service, Everyday Electronics Editorial Offices, King's Reach Tower, Stamford Street, London SE1 9LS. Cheques should be crossed and made payable to IPC Magazines Ltd.

We regret that the ordering codes for the August projects have been incorrectly quoted in the Sept-Oct issues. Correct codes are given here.

Please note that when ordering it is important to give project title as well as order code.

**Readers are advised to check with prices appearing in current issue before ordering.**

PROJECT TITLE	Order Code	Cost
Eprom Programmer, TRS-80 (June 83)	8306-01	£9.31
Eprom Programmer, Genie (June 83)	8306-02	£9.31
Eprom Programmer, TRS-80 & Genie (June 83)	8306-03	£1.98
User Port Input/Output <i>M.I.T. Part 1</i> (July 83)	8307-01	£4.82
User Port Control <i>M.I.T. Part 1</i> (July 83)	8307-02	£5.17
Storage Scope Interface, BBC Micro (Aug 83)	8308-01	£3.20
Car Intruder Alarm (Aug 83)	8308-02	£5.15
High Power Interface <i>M.I.T. Part 2</i> (Aug 83)	8308-03	£5.08
Pedestrian Crossing Simulation <i>M.I.T. Part 2</i> (Aug 83)	8308-04	£3.56
Electronic Die (Aug 83)	8308-05	£4.56
High Speed A-to-D Converter <i>M.I.T. Part 3</i> (Sept 83)	8309-01	£4.53
Signal Conditioning Amplifier <i>M.I.T. Part 3</i> (Sept 83)	8309-02	£4.48
Stylus Organ (Sept 83)	8309-03	£6.84
Distress Beacon (Sept 83)	8309-04	£5.36
Distress Beacon Pocket Version (Sept 83)	8309-05	£3.98
D-to-A Converter <i>M.I.T. Part 4</i> (Oct 83)	8310-01	£5.77
High Power DAC Driver <i>M.I.T. Part 4</i> (Oct 83)	8310-02	£5.13
Electronic Pendulum (Oct 83)	8310-03	£5.43
TTL/Power Interface for Stepper Motor <i>M.I.T. Part 5</i> (Nov 83)	8311-01	£5.46
Stepper Motor Manual Controller <i>M.I.T. Part 5</i> (Nov 83)	8311-02	£5.70
Digital Gauss Meter (Nov 83)	8311-03	£4.45
Speech Synthesiser for BBC Micro (Nov 83)	8311-04	£3.93
Car On/Off Touch Switch (Nov 83)	8311-05	£3.11
4-Channel High Speed ADC (Analogue) <i>M.I.T. Part 6</i> (Dec 83)	8312-01	£5.72
4-Channel High Speed ADC (Digital) <i>M.I.T. Part 6</i> (Dec 83)	8312-02	£5.29
TRS-80 Twin Cassette Interface (Dec 83)	8312-03/09	£7.43
Environmental Data Recorder (Dec 83)	8312-04	£7.24
Touch Operated Die (Dot matrix) (Dec 83)	8312-05/06	£4.34
Touch Operated Die (7-segment) (Dec 83)	8312-05/07	£4.34
Continuity Tester (Dec 83)	8312-08	£3.41
Central Heating Pump Delay (Jan 84)	8401-01	£3.33
Biological Amplifier <i>M.I.T. Part 7</i> (Jan 84)	8401-02	£6.27
Temp. Measurement and Control System for ZX Computers (Jan 84)		
Analogue Thermometer Unit	8401-03	£2.35
Analogue-to-Digital Unit	8401-04	£2.56
Games Scoreboard (Jan 84)	8401-06/07	£9.60
Eprom Programmer/ROM Card for ZX81 (Feb 84)	**8402-01	£7.84
Oric Port Board <i>M.I.T. Part 8</i> (Feb 84)	8402-02	£9.56
Negative Ion Generator (Feb 84)	*8402-03	£8.95
Temp. Measurement and Control System for ZX Computers (Feb 84)		
Relay Driver Unit	8402-04	£3.52
Latched Output Port <i>M.I.T. Part 9</i> (Mar 84)	8403-01	£5.30
Buffered Input Port <i>M.I.T. Part 9</i> (Mar 84)	8403-02	£4.80
VIC-20 Extension Port Connector <i>M.I.T. Part 9</i> (Mar 84)	8403-03	£4.42
Commodore 64 Extension Port Connector <i>M.I.T. Part 9</i> (Mar 84)	8403-04	£4.71
Digital Multimeter Add-On for BBC Micro (Mar 84)	8403-05	£4.63

\*Set of four boards.      \*\*Calibrated with C1, VR1 and IC3 fitted.  
*M.I.T.*—Microcomputer Interfacing Techniques, 12-Part Series.

# DIN LEAD TESTER

**T**HIS Black Box circuit, the first in an occasional series of projects all based on the same size box and stripboard, is for testing audio leads. Catering for 5-pin DIN to 5-pin DIN, jack plug and phono leads, it will show, by means of an l.e.d. display, the condition of the lead, whether it is open circuit, working normally or a short between two or more leads or pins.

It does this by testing each line independently in a sequential mode so that the condition of each lead is shown separately. This is most useful when testing DIN leads as there are five lines to deal with.

## CIRCUIT DESCRIPTION

The circuit diagram of the DIN Tester is shown in Fig. 1. It is based around two CMOS i.c.s, IC1 contains four 2-input NAND gates, two of these used to form a bistable multivibrator with R1, R2 and C1. The output (pin 4) is taken to the next part of the circuit. The oscillator frequency is very low, of about 1Hz.

IC2 is a 4017 decade counter. It has a clock input so that when a pulse (ground to positive transition) appears at this input, the output advances one. This continues for ten counts then automatically returns to the first output. The reset and clock enable pins are not used and so are held at ground potential.

Each output (seven used altogether) is taken to the anode of an l.e.d. (D1 to D7), the cathode is then taken to one of the terminations of the various sockets (five on the DIN and two for the phono and jacks). This is one set of sockets; on the other set, the corresponding pins are connected to the anodes of seven more l.e.d.s (D8 to D14) with their cathodes all connected down to ground.

The l.e.d.s are arranged so that if a correct connection is made between two respective pins of each socket, then a pair of l.e.d.s will light up showing a complete circuit.

SK1 and SK2 are the 5-pin DIN sockets and can only be used for testing this type of lead. However, the phono sockets (SK3 and SK4) and the jack sockets (SK5 to SK10) are wired in parallel so that it is possible to test, for example, phono to jack or 0.25in jack to 3.5mm jack leads.

## CONSTRUCTION

Space is very tight in the case, but it will all go in, including the battery. It is advisable to buy the smallest type of socket available and for the jacks, this is the "open" chassis version (although the prototype used moulded types and it still all went in).

The stripboard layout is shown in Fig. 2, and this is a piece of board 22 holes by 10 strips cut from a standard 24-hole piece. C1 is fairly large and should have the leads preformed so that it lies flat to save space.

The mounting of the components in the case requires careful thought and the layout on the model proved to be ideal. The 2.5mm and 3.5mm jacks are mounted on one end and the larger jacks, phono and DIN sockets are on the sides (see photos). Note that corresponding sockets of the same type are opposite one another.

The l.e.d.s, D1 to D14, are glued into holes in the base of the case (which becomes the "top") in two rows as shown, and the miniature slide switch (S1) is mounted in a cut-out at the other end to the sockets. It is a good idea to

have a "dry run" assembly of components in the box, including battery and board, to ensure that it all fits.

The wiring is completed as shown in Fig. 3. Remember that SK3, 5, 7 and 9 are wired in parallel as are SK4, 6, 8 and 10. When wired, a piece of cardboard is placed over the leads of the l.e.d.s to protect and insulate them and the battery lies flat on top of this. The board is positioned, component side down, on the battery and the lid is secured.

## TESTING

With a battery inserted, the unit can be tested by plugging a good DIN-to-DIN lead and jack-to-jack lead and switching on. The l.e.d.s should light up in pairs, in order, and then pause a while (for the last three counts of the decade counter) and then repeat the cycle.

On testing a DIN lead, if the l.e.d.s do not light up in corresponding pairs, for example, pin 2 with pin 3, then the wires to these pins in the lead have been transposed.

If one pair of l.e.d.s fail to light, then there is an open circuit on the lead somewhere on the line between the pin number that fails to light.

When two or more l.e.d.s on the same side light up, there is a short circuit between those respective pins. These faults and their diagnoses applies to both DIN and phono/jack leads. Note that when testing phono/jack leads, the first five l.e.d.s do not light. □

Fig. 1. Circuit diagram of the DIN Lead Tester.

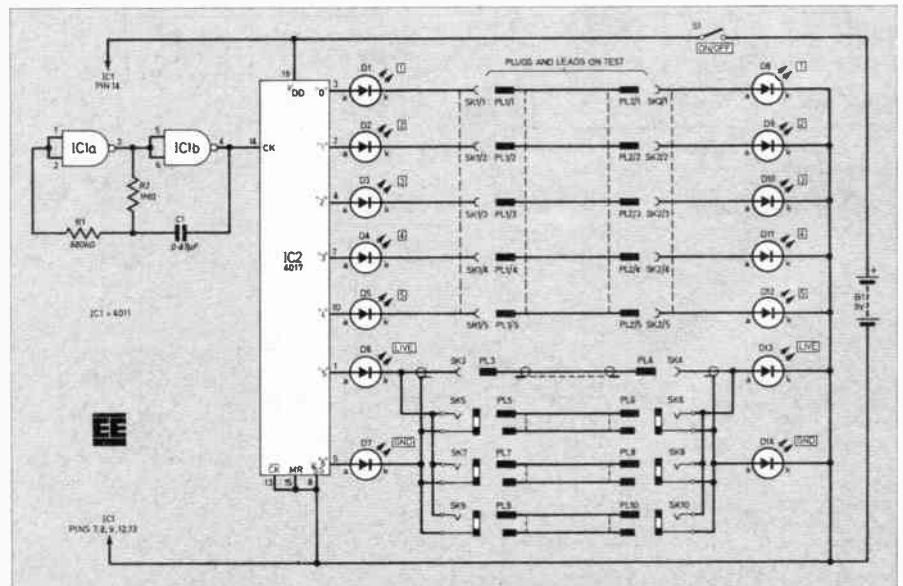



FOR CONTINUITY OR SHORT  
CIRCUIT CHECKS ON DIN,  
JACK AND PHONO LEADS

BY L. A. PRIVETT

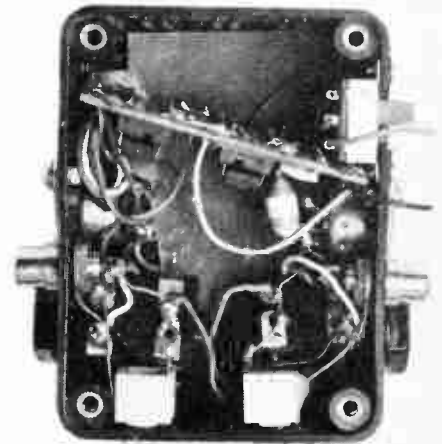

View inside case. Note board is not shown in correct position.

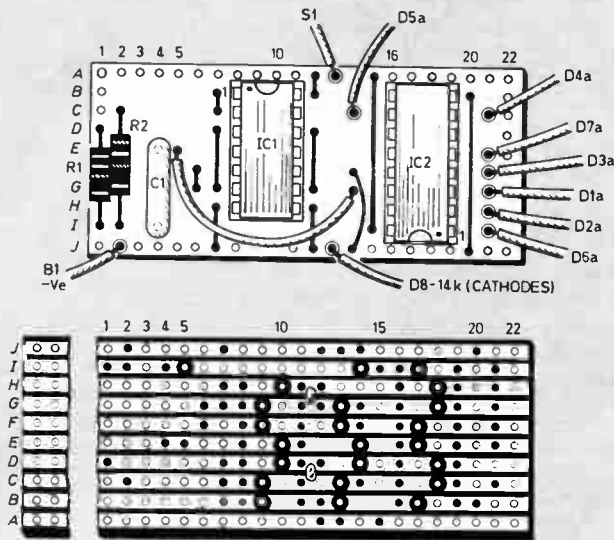

Fig. 2. DIN Lead Tester stripboard layout. Note the two links made from solder bridges on the track-side of the board.

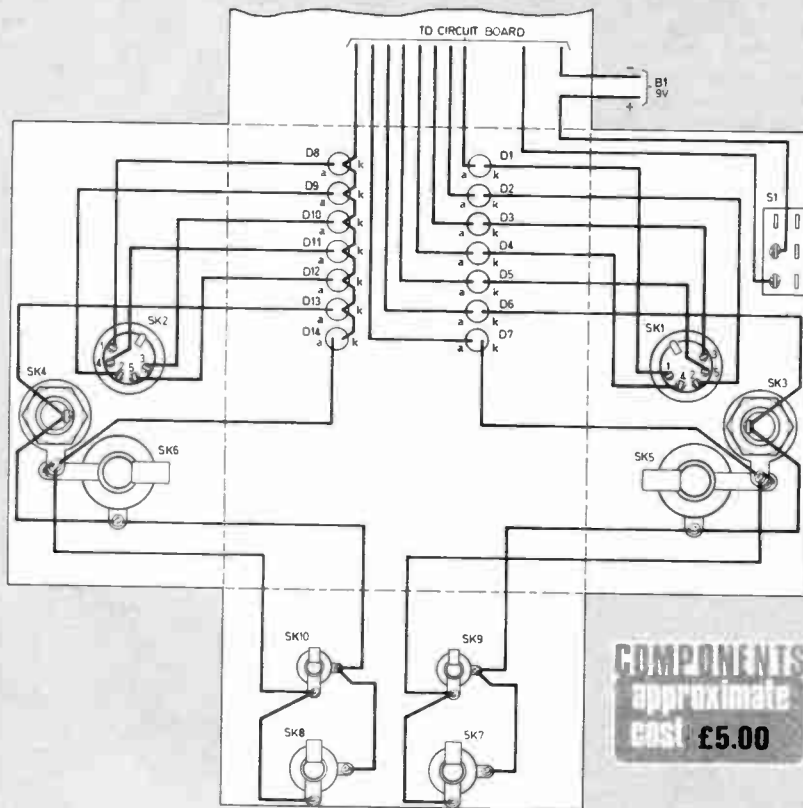
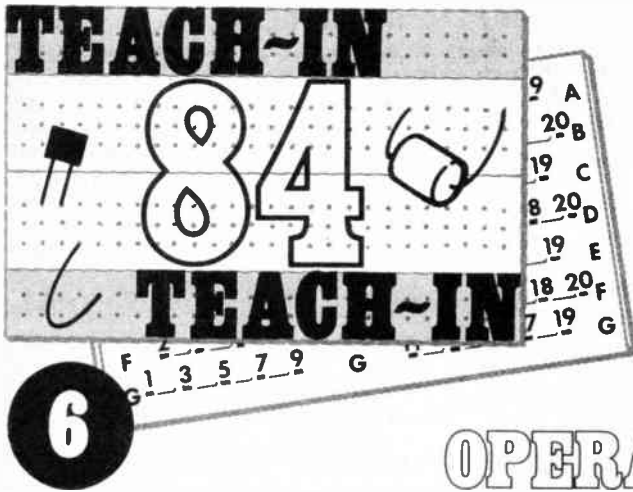

Fig. 3. Interwiring diagram showing the positions of the case mounted components. For clarity, the case sides have been drawn folded flat.

## COMPONENTS

<b>Resistors</b>		<b>See Shop Talk page 164</b>
R1	680k $\Omega$	
R2	1M $\Omega$	
All $\frac{1}{4}$ W carbon $\pm 5\%$		
<b>Capacitor</b>		
C1	0.47 $\mu$ F polyester C280	
<b>Semiconductors</b>		
D1-14	TIL209 3mm red l.e.d. (14 off)	
IC1	4011B CMOS quad 2-input NAND gate	
IC2	4017B CMOS decade counter	
<b>Miscellaneous</b>		
SK1,2	5-pin 180° DIN socket (2 off)	
SK3,4	phono socket (2 off)	
SK5,6	0.25in mono jack socket (2 off)	
SK7,8	3.5mm mono jack socket (2 off)	
SK9,10	2.5mm mono jack socket (2 off)	
S1	miniature d.p.d.t. slide switch	
B1	9V PP3 battery	
Black plastic case, 80 x 61 x 41mm; 0.1in matrix stripboard, 10 strips by 24 holes (cut to 22 holes); battery clip; 16-pin i.c. socket; 14-pin i.c. socket; wire.		



A TWELVE-PART HOME STUDY COURSE IN THE PRINCIPLES AND PRACTICE OF ELECTRONIC CIRCUITS. ESSENTIALLY PRACTICAL, EACH PART INCLUDES EXPERIMENTS TO DEMONSTRATE AND PROVE THE THEORY. USE OF A PROPRIETARY BREADBOARD ELIMINATES NEED FOR SOLDERING AND MAKES ASSEMBLY OF CIRCUITS SIMPLE. THE IDEAL INTRODUCTION TO THE SUBJECT FOR NEWCOMERS. ALSO A USEFUL REFRESHER COURSE FOR OTHERS.

By GEORGE HYLTON

# OPERATIONAL AMPLIFIERS

THIS month we use our first integrated circuit: an operational amplifier, type CA3140E. Strictly speaking, an "op-amp" need not take the form of an integrated circuit (i.c. for short), but nowadays it almost always does, because i.c.s lend themselves to the fabrication of matched transistors, one of the requirements for a good op-amp.

## D.C. AMPLIFICATION

"Operational" refers to the original use of this kind of amplifier. It was used to perform mathematical operations such as addition and integration in analogue computers. In an analogue computer, numbers are represented by the amplitudes of the input voltages. These voltages are d.c. So operational amplifiers had to be able to amplify d.c. voltages.

This need, leads straight to one of the features of "traditional" op-amp circuitry: two-battery or "split" power supplies. The reason for this is illustrated by Fig. 6.1. Here TR1 is a voltage amplifier. (No biasing circuit is shown, but assume that TR1 is biased correctly.) A d.c. input produces changes in the collector voltage, as we've seen. However, to make TR1 work, its collector must always be positive with respect to its emitter.

Suppose the collector voltage (with no input signal) stands at +3V. The collector cannot then be connected directly to another amplifier because +3V signifies a number. We can't have numbers at the output when there is no input or the calculations will be wrong.

Adding a negative voltage supply  $V_{cc2}$  makes it possible to bring down the standing output voltage to the correct

level. One end of VR1 is more negative than the zero volts (0V) line. The other is at +3V. There must be some point on the VR1 track where the voltage is 0V. If the output is taken from this point the standing collector voltage of TR1 is "balanced out".

## NPN AND PNP TRANSISTORS

Some loss of output has to be tolerated since VR1 is a voltage divider. But this can be allowed for, or better, avoided by using a combination of *npn* and *pnp* transistors.

A *pnp* is like the *npn* ones you've been using, except that all the voltages and currents are reversed. Current in a *pnp* device flows into the emitter and out of the collector. The collector must be more negative than the emitter, and so must the

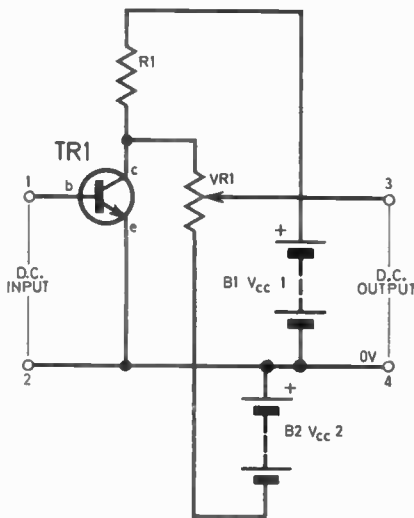

Fig. 6.1. Arrangement for equalising input and output standing voltages.

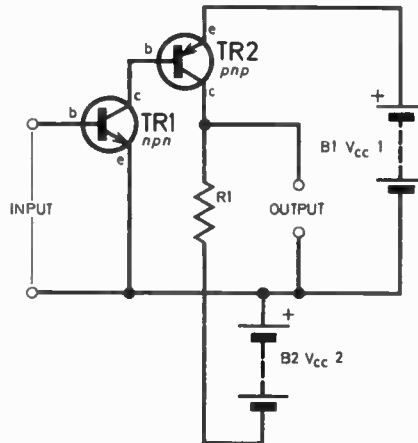

Fig. 6.2. Amplifier using "complementary" transistors.

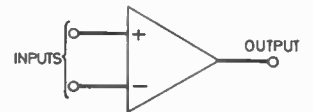
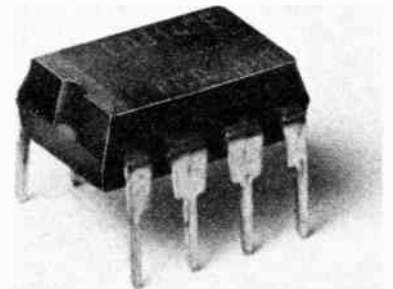

Fig. 6.3. Operational amplifier symbol.



base. In a circuit where the supply voltage  $V_{CC}$  is "positive up", *pnp* transistors appear "upside down".

In Fig. 6.2, TR1 (*nnp*) is the input stage. Its collector current becomes the base current of TR2 (*pnp*). So TR1 and TR2 form a two-stage amplifier. TR2 is operated from the total power supply ( $V_{CC1}$  plus  $V_{CC2}$ ). Its standing collector voltage is adjusted so that the voltage drop across R1 brings its collector voltage to "zero volts". The output can then be connected to another amplifier.

## PRACTICAL OP-AMPS

Figs. 6.1 and 6.2 are not practical d.c. amplifiers. They merely illustrate the need for split power supplies and the convenience of "complementary" (mixed *nnp* and *pnp*) circuitry. Real op-amps are much more complicated. Fortunately, their inner circuitry need not concern us, as users. But they have another key feature which does.

Op-amps have two input transistors and therefore two input terminals. These inputs appear on the conventional symbol (Fig. 6.3) for an op-amp. The + and - signs have a special meaning. They do not mean that a d.c. input should be applied with its positive end to the + terminal and its negative end to the - terminal.

What they do mean is this. If a positive input is applied to the + terminal the voltage at the output goes positive. But if a positive input is applied to the - terminal the output goes negative. That is, the polarity of the signal is inverted. For this reason, the - input point is called the inverting input terminal. The + input point is then the non-inverting input terminal.

You can apply signals of either polarity to either input. If you apply them to the + terminal they emerge, amplified, with their *original* polarity. If applied to the - terminal, they emerge, amplified, but with *reversed* polarity: positive in, negative out; negative in, positive out.

## BALANCED AMPLIFIER

In an ideal op-amp the amount of amplification (the voltage gain) is the same for both inputs. What happens if you apply the same input to both terminals? The two inputs cancel one another out. One tries to drive the output positive, but the other tries to drive it negative, by the same amount. Result: no output.

This sort of amplifier is called a balanced amplifier. It is also called a difference or differential amplifier, because if there is any difference between the two inputs this difference gets amplified. If, for example, the + terminal is at +2.5V and the - terminal at +2V then the amplifier behaves as if the difference, +0.5V, were applied to the + terminal and nothing to the - terminal. The output goes positive.

## OP-AMP GAIN

The ideal op-amp would have an infinitely large voltage gain. This may seem odd. Surely, infinite gain means that any noise at the input gets enormously amplified? What use is an amplifier which just pours out noise?

Not a lot. But practical op-amp circuits embody large amounts of negative feedback. This reduces gain to something usable. It also makes the performance of the amplifier very predictable.

The voltage gain of a typical op-amp without feedback is around 100,000. This is called the open-loop gain.

## IMPEDANCES

An ideal op-amp would have an infinitely high input resistance (input impedance). It would then draw no current from the signal circuit. The signal voltage would then be the same, whether connected to the op-amp or not. There would be no errors in voltage caused by the loading effect of the amplifier input resistance.

In practice, this ideal can be almost achieved. In the type CA3140E, by using field-effect transistors in the input stages, an input resistance of the order of a million million ohms is achieved. (Many op-amps use bipolar—*nnp* or *pnp*—transistors in their input stages and have much lower input resistances, usually a few megohms.)

Ideally, the output resistance of an op-amp should be zero. Current could then flow freely into any load, high-resistance or low-resistance, without change of output voltage. In practice, output resistances are usually a few tens or hundreds of ohms. They can be reduced by negative feedback.

## FREQUENCY RESPONSE

It sounds as if the op-amp is the designer's dream come true . . . stacks of gain, convenient impedances, all in one small package costing perhaps only a few tens of a penny.

The op-amp gives all this. But its performance is then marred by an appallingly bad frequency response. The l.f. response is fine—it goes right down to d.c. But the h.f. response is almost non-existent. A typical op-amp begins to "cut off" at about 10Hz, which is below the audio frequency band. And the higher you go the worse it is.

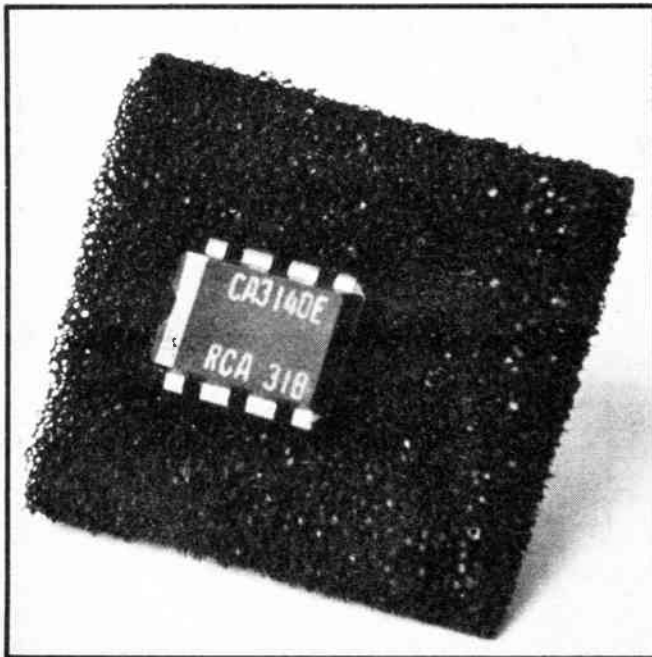

(Left). The CA3140E integrated circuit as supplied mounted on conductive foam. This protects against possible damage from static charges and the i.c. should not be removed from the foam until it is required for fitting into the EBBO module. (Below). The CA3140E mounted on the EBBO module (yellow strips).

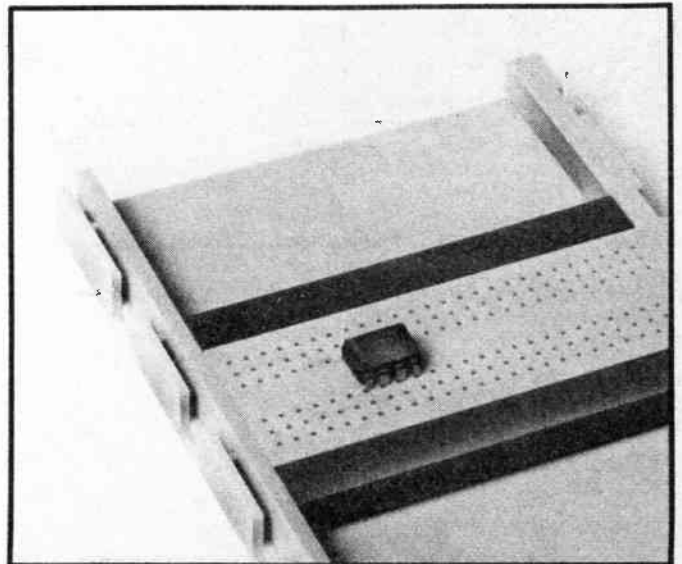

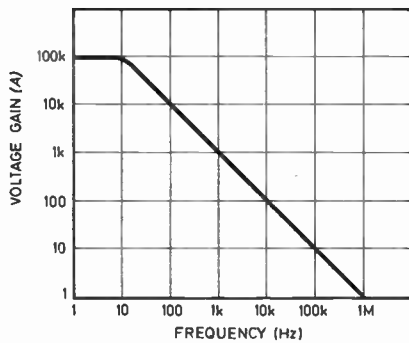

Fig. 6.4. Gain versus frequency for a typical op-amp.

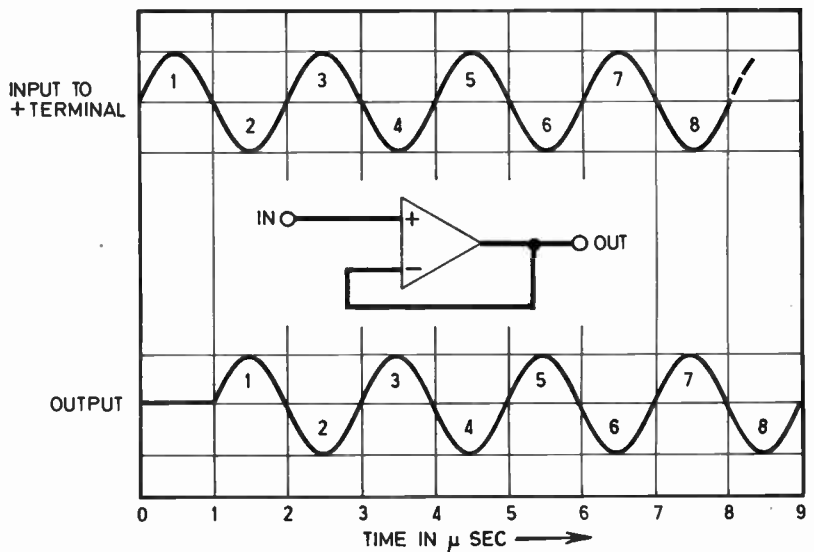

Fig. 6.5 (right). Phase relations at input and output at high frequency.

Before you get too depressed, let me say that op-amps are really quite useful for audio jobs. When their high d.c. gain is reduced to something reasonable by negative feedback, the frequency response improves.

If the op-amp described by Fig. 6.4 has its gain reduced to 1,000 (1k), its frequency response now follows the  $A = 1k$  line horizontally until it reaches the sloping curve. Then it goes down the slope to reach a "gain" of 1 at 1MHz.

If you can settle for a gain of 100, the response is flat to 10kHz. Settle for  $A = 10$  and it's flat to 100kHz. For  $A = 1$ , it's flat to 1MHz. What's the use of a gain of 1? A great deal, as we'll see later.

## COMPENSATION

First, however, an explanation of why the average op-amp has such a bad h.f. response. It's designed that way! Somewhere in the internal circuitry is a capacitor, connected so as to reduce the h.f. gain severely.

This is called compensation. If your op-amp is not compensated then you'll generally have to add a capacitor yourself, otherwise the circuit will oscillate. (The CA3140E is compensated, by the way.)

There are two causes of oscillation. One is simple, the other subtle. Let's deal with the simple one first.

If an amplifier has a voltage gain of 100, then it can be turned into an oscillator by feeding back positively 1/100 part of its output to its input. If it's a typical op-amp, with a gain of 100,000, it will oscillate if only 1/100,000th of its output is fed back to its + input.

This amount of positive feedback can easily happen by accident. If the output connections are close enough to the input connections, the stray capacitance between them may allow enough high-frequency signal (or noise) to leak back and cause oscillation. Stray capacitance happens when two conductors act as the plates of a capacitor, with the air or insulation between them acting as the dielectric.

In an uncompensated op-amp, a fraction of a picofarad between output and input can be enough to cause oscillation. The answer is to cut the h.f. gain so much that it doesn't happen.

## PHASE SHIFT

The more subtle cause of oscillation ("instability") has to do with the use of negative feedback. The trouble with negative feedback is that it isn't always negative. It turns into positive feedback at high frequencies. Result: oscillation, unless the h.f. gain is reduced.

Signals don't pass instantaneously through an amplifier. They take time. Let's suppose they take one millionth of a second (1 microsecond, 1μsec.). In passing through, all signals are time-delayed by this amount.

Now feed back the output to the non-inverting input terminal. The fed-back voltage opposes the input voltage. This negative feedback reduces the gain.

No problems here. But now we'll increase the frequency. At some frequency, it takes the signal one half-cycle's worth of time to get through the amplifier. Fig. 6.5 illustrates this. At zero time, a sine-wave signal is applied to the non-inverting input (upper curve). After 1μsec., the first

half-cycle (marked "1") appears at the output. It is then instantly fed back to the inverting terminal, as negative feedback. But what does it find when it gets there? By now, half-cycle 1 is finished, and half-cycle 2 has started. Far from opposing this changed signal, the fed-back voltage reinforces it. This is positive feedback and if the gain is high enough the circuit oscillates.

The time delay has the effect of shifting the lower curve to the right. This is called a phase shift. In any amplifier there are inevitable phase shifts which have the effect of turning what should be positive half-cycles into negative ones or inverting the signal, at particular frequencies.

If negative feedback is to be applied these danger frequencies must be attenuated so much that when the signals do arrive back at the input they are too small to provoke oscillation. Hence the drastic "top cut" built into most op-amps as "compensation".

## UNITY GAIN

Compensation is very necessary when the whole of the output is fed back negatively as in Fig. 6.5. This is the condition for unity gain (output equal in amplitude to input).

The unity-gain configuration is used a great deal and is often called a voltage follower. Voltage followers are useful as buffer amplifiers, that is, amplifiers which can transfer a signal from one circuit to another without loading the signal source.

We'll use a voltage follower to feed our voltmeter. The high input resistance of the op-amp will avoid "loading errors". The low output resistance will prevent the meter from loading the op-amp too much.

## CONNECTIONS

It may have struck you that so far our op-amps don't seem to have any power supplies! These are often left out of circuit diagrams but of course must be there in real life.

In Fig. 6.6 the op-amp is encapsulated in an 8-pin dual-in-line (d.i.l.) plastic package. The pins are numbered as shown, viewed from above. An indentation on the plastic identifies the "1 and 8" end.

Many op-amps have connections as shown in (a). The connecting link C between the two halves of the split power supply is used as the common or earthy leg of the signal circuits. The non-inverting input goes between pin 3 and C; the inverting input between 2 and C; and the output comes between 6 and C.

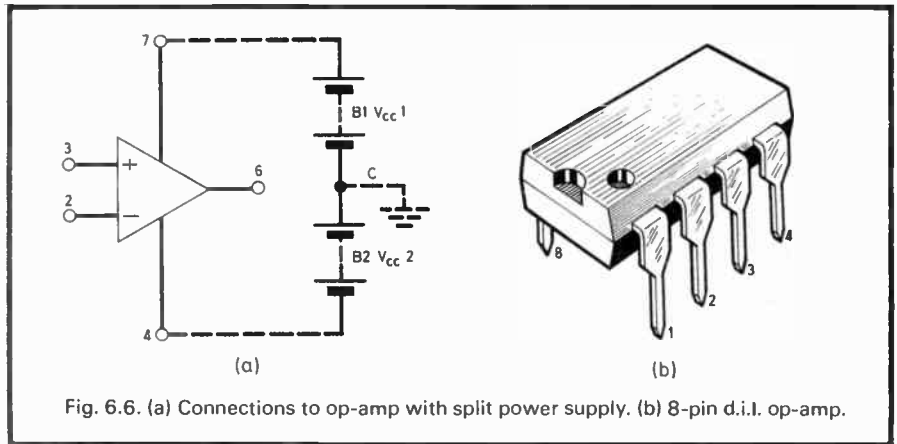

Fig. 6.6. (a) Connections to op-amp with split power supply. (b) 8-pin d.i.l. op-amp.

## SINGLE BATTERY WORKING

Although op-amps were originally designed for "two-battery" working, it is now often possible, for many purposes, to use only a single battery.

If the op-amp is to be used only for a.c. signals, for instance, blocking capacitors can be used to keep d.c. where it's wanted while allowing a.c. to pass. The op-amp can be fooled into thinking it has a split power supply when, in fact, it hasn't. With some special op-amps like the CA3140E, it is even possible to use a single supply for a d.c. voltage follower arrangement.

vulnerable to damage by static electricity. In dry weather, friction generates this on your clothes. To avoid accidentally discharging yourself through the i.c., a simple precautionary tactic is advised. Before handling the i.c., or working on a circuit incorporating it, touch the surface on which it lies (for example, the table top).

A wooden table top is good because wood is a rather poor insulator and allows charges to leak away. Plastics are more risky. Since the EBBO boards are plastic, after "earthing" yourself to the table, earth the circuit you are working on by touching the VCC-line.

Get into the habit of carrying out this simple "safety drill" every time you come to work on a circuit. It applies equally to the CMOS circuits we'll use later.

It is convenient also to have two of the thin red terminal strips, one above the i.c. modules and one below, as shown in Fig. 6.8. The red strips contain horizontal rows of connections which are handy for taking battery connections near the yellow ones.

Fig. 6.7(a) shows the voltage follower circuit. Fig. 6.8 shows this circuit assembled on the EBBO Block. Test it by using a fixed voltage-divider, Fig. 6.7(b), to apply various input voltages. Connect your meter (10V d.c.) to the output. If your battery gives exactly 9V it should register the indicated voltages, with small variations due to resistance and meter tolerances.

Circuit, Fig. 6.7(c), enables you to apply smoothly varying inputs. It reveals a limitation of the i.c., and possibly two. As the potentiometer is turned up, the meter voltage rises smoothly at first, then sticks at some value such as 6V. This means that the circuit cannot handle inputs above this limit. You may also find that when the input voltage is zero the meter still shows a small output such as 0.4V.

## EXPERIMENT 6.1

### BUILDING THE VOLTAGE FOLLOWER

Integrated circuits incorporating the kind of f.e.t. used in the CA3140E are

### EBBO MODULES

The d.i.l. op-amp fits the yellow (i.c.) EBBO modules. You need two yellow strips, without any spacer between them. Note that the connections run vertically, in columns of three, not along the rows.

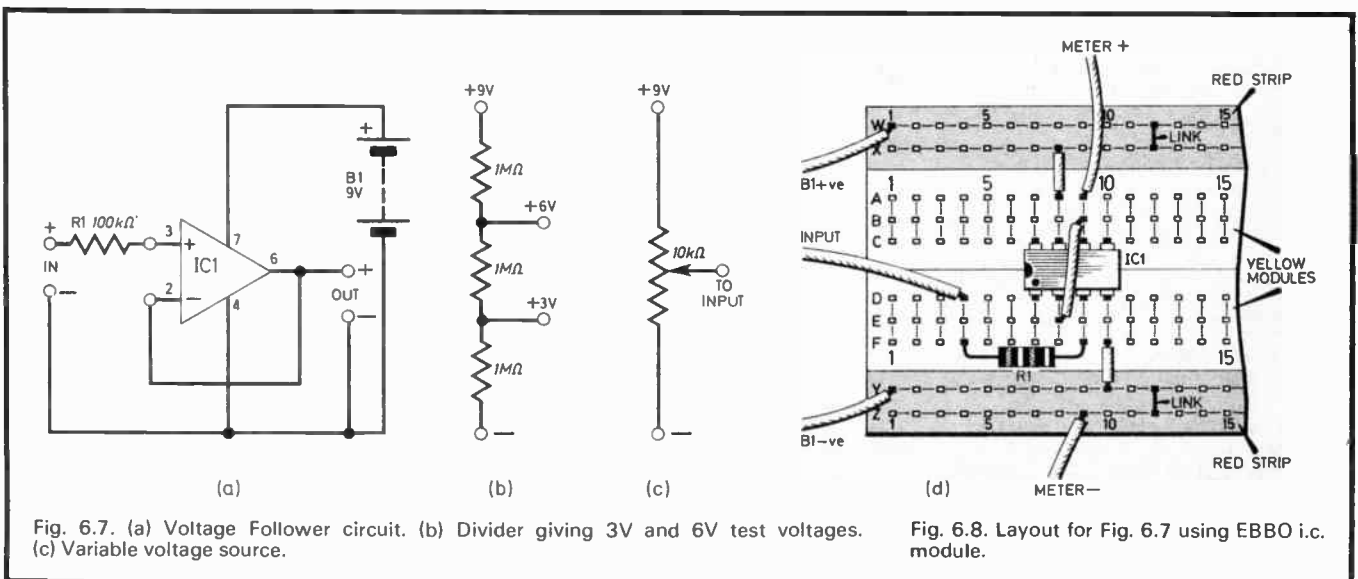
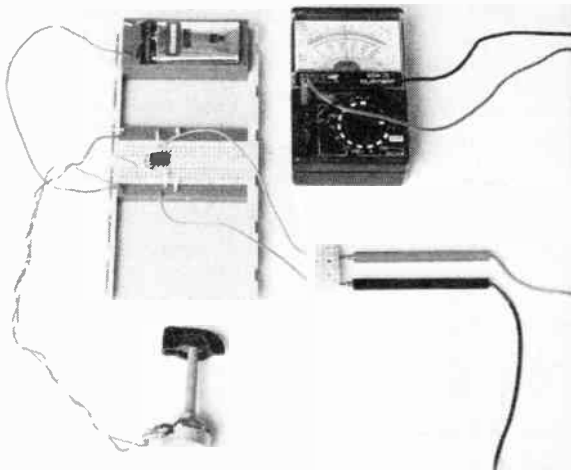
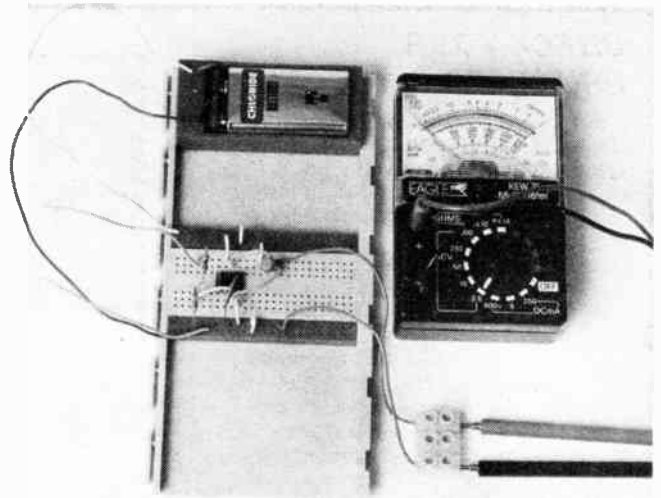

Fig. 6.7. (a) Voltage Follower circuit. (b) Divider giving 3V and 6V test voltages. (c) Variable voltage source.

Fig. 6.8. Layout for Fig. 6.7 using EBBO i.c. module.



The EBO layout for Experiment 6.1, showing the potentiometer and meter connected.



The EBO layout for Experiment 6.2, with the meter showing a reading of 2.5V d.c.

## EXPERIMENT 6.2

A voltmeter which can measure 0.4V to 6V without loading the circuit to which it is connected, is useful, but a wider range would be better. The small "zero error" (if any) is easily dealt with (Fig. 6.9) by interposing the base-emitter voltage ( $V_{BE}$ ) of a transistor between the i.c. and the meter. A small "zero voltage" then does not register. If your meter has a d.c. volts range below 10V, such as the 2.5V range of the KEW7S, then the high-voltage limit can be dealt with satisfactorily. What we do is turn 10V into 2.5V with a voltage divider, and apply this to the voltage follower. On its 2.5V range the meter then reads full-scale, because

the i.c. can handle 2.5V with no overloading.

Since the 2.5V is really 10V in terms of input signal at the divider, reading the voltage off the meter 10V scale (although it is set to 2.5V) then gives the correct reading.

The "infinite" input resistance of the CA3140E is reduced by  $R_1$  and  $R_2$  to 1.33 megohms, but this is still high. It could be made higher by using, say,  $10M\Omega$  and  $3.3M\Omega$  for  $R_1$  and  $R_2$ . Other, higher, input voltages could be measured by using voltage dividers of different ratios. For example, 100V could be turned into 2.5V with a "divide by 40" circuit, to give a 0–100V d.c. range, again using the meter on its 2.5V setting.

When a high-impedance meter is used in a building wired for a.c. mains, quite large mains voltages can get to the meter

by accidental leakage. This may produce false meter readings. To filter out these a.c. voltages, connect  $C_1$ . A value of, say,  $100nF$  will present such a low impedance compared with  $R_1$  that little mains voltage reaches the i.c.

## A.C. OP-AMPS

So far we haven't looked very closely at how the voltage follower works. It's really rather neat. Remember that an op-amp responds to the difference between the voltages at its two inputs. With no input the output is zero. Since, here, the output is tied straight to the inverting input this too is zero.

When a positive voltage is applied to the + input, an instant later the output voltage starts to rise. This positive-going output is fed back to the – input. Because

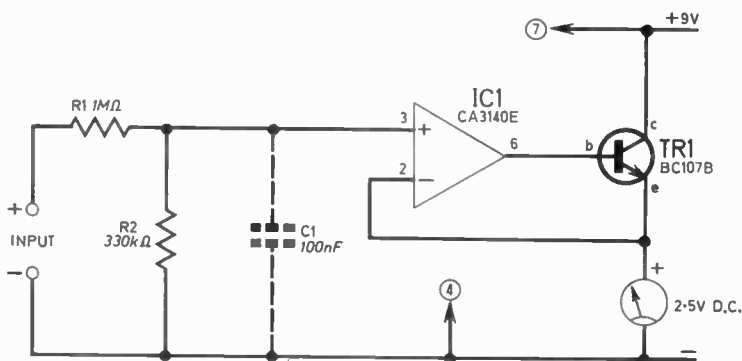

(a)

Fig. 6.9. Arrangement overcoming voltage limitations.

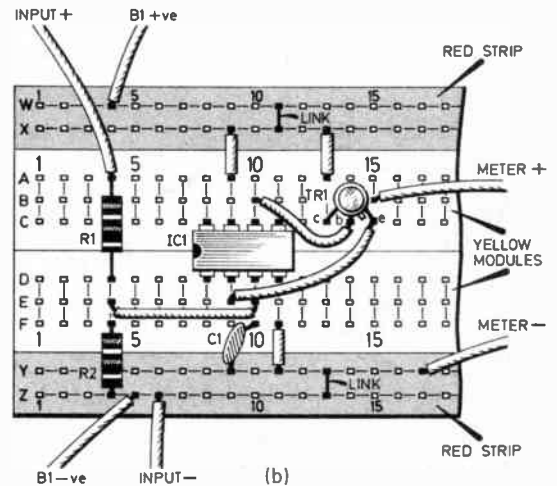

(b)

Fig. 6.10. EBO layout for Fig. 6.9.

## CHECK YOUR PROGRESS

Questions on *Teach-In 84 Part 6*  
Answers next month

- Q6.1 The circuit shown in Fig. 6.13 is designed to fix TR1 emitter current at a value set by R1, R2 and R3.
- What is the polarity of TR1?
  - How does the circuit work?
  - What is TR1 collector current?
  - Small changes in R4 have no effect on the output current, but the circuit does not work if R4 is over 1k $\Omega$ . Why?
  - If R1 and R2 are both 5% high, what is the effect on the output current?
  - If R1 is reduced to 5k $\Omega$  what is the output current?

### ANSWERS TO PART 5

Q5.1 About 0.8 $\mu$ F. The Alignment Chart shows that the time

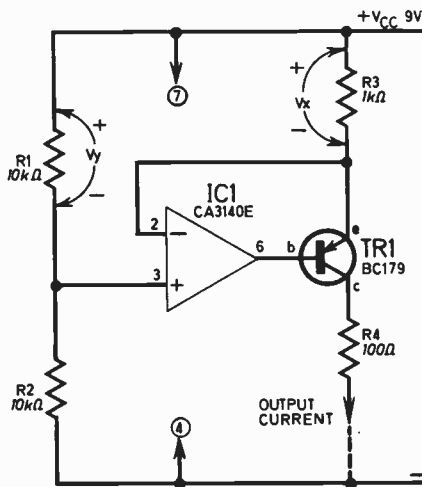

Fig. 6.13. Current source circuit.

constant required is about 8msec, and that msec are obtained by multiplying k $\Omega$  and  $\mu$ F. So with 10k $\Omega$ ,  $10 \times C = 8$ , giving  $C = 0.8$ , and this is in  $\mu$ F. In practice, a 1 $\mu$ F, 20 per cent tolerance capacitor

might be used. Note that our calculation makes no allowance for any loss of low frequencies in other couplings inside the amplifier. If such losses occur it will be necessary to increase the input-coupling capacitance.

- Q5.2 (a) 0.7V approx. C1 receives the base-emitter voltage of TR1.  
(b) A little over 0.7V ( $V_{BE}$  of TR1 plus the small voltage drop due to TR1 base current in R1).  
(c) About 2V. If R4 drops 0.7V (to provide bias for TR1) then R3 must drop ten times as much; that is, 7V. The voltage at TR2 collector is then  $V_{CC} - 7V = 9V - 7V = 2V$ . Since TR2 emitter is at 0.7V approx., this leaves only 1.3V across TR2. If the battery voltage is low this is reduced and the circuit may not work. Remedy: reduce R3.

Q5.3 10 $\mu$ V. (10mV = 10,000 $\mu$ V)

of the differential action, it counteracts the positive signal to the + input.

Of course, the fed-back voltage can never quite wipe out the input, because then there'd be nothing to feed back. But it can get very close.

Suppose the input is 1V, and the open-loop gain is 100,000. To produce an output of 1V, the differential input need only be 1/100,000th of 1V, which is 10 $\mu$ V. This means that the fed-back voltage sets itself just 10 $\mu$ V short of 1V. But the fed-back voltage is also the output voltage, which is therefore 0.99999V—so close to the input as to be indistinguishable.

If the open-loop gain were only 1,000, the output would be 0.999V. This is still very close to the input and illustrates how negative feedback irons out the effects of variations in open-loop gain.

When an op-amp has to handle a.c. signals, d.c. feedback can be used to set up the correct working conditions, rather like the d.c. bias used in amplifiers based on separate (discrete) transistors.

Fig. 6.11 is a typical a.c. amplifier. The whole of the d.c. output voltage is fed back via R4 to the - input. The + input is set to half  $V_{CC}$  by R1 and R2. The circuit acts as a d.c. voltage follower and the

output sits at  $V_{CC}2$ . A.C. input signals are applied via C1, and a.c. output signals go via C3. There is a.c. negative feedback via R4. But the full a.c. output is not fed back because R4 and R3 form an a.c. voltage divider. (C2 allows a.c. to pass freely). Only the a.c. across R3 is fed back.

With this arrangement, the a.c. gain is the same as the voltage attenuation factor of the R4, R3 divider. (With the values shown, the a.c. gain is 101.) D.C.-wise, the op-amp thinks it is connected to a split power supply, each part of which gives half the battery voltage.

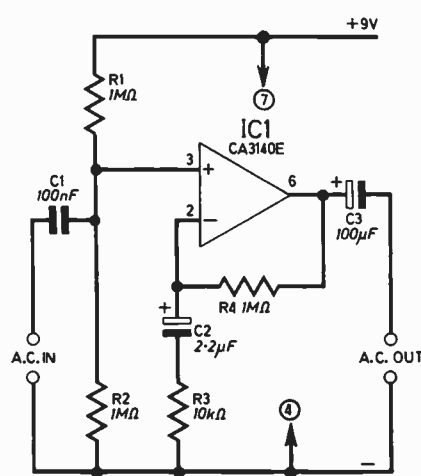

Fig. 6.11. A.C. amplifier using single supply.

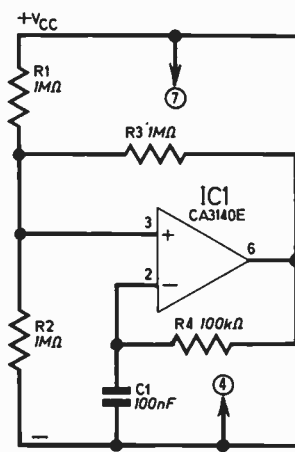

Fig. 6.12. Op-amp oscillator.

## OSCILLATORS

An op-amp can easily be turned into an oscillator. In Fig. 6.12, there is positive feedback via R3 and full d.c. negative feedback via R4. A.C. negative feedback is reduced because R4 and C1 form an a.c. voltage divider. The circuit oscillates at a frequency which is related to the time constant R4, C1.

With the values shown, my oscillator produced 86Hz. Changing R4 to 10k $\Omega$  produced 860Hz. The periods of these oscillation cycles are much less than the R4, C1 time constant. This shows that C1 is not charging or discharging to the full supply voltage.

Well, that's your introduction to op-amps. You now have enough information to do some simple designs of your own. Try the Quiz!

**Next month:**  
Waveforms and Distortion

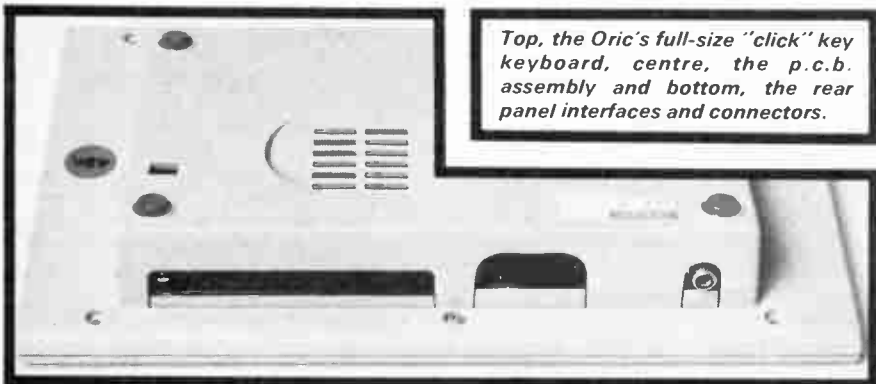
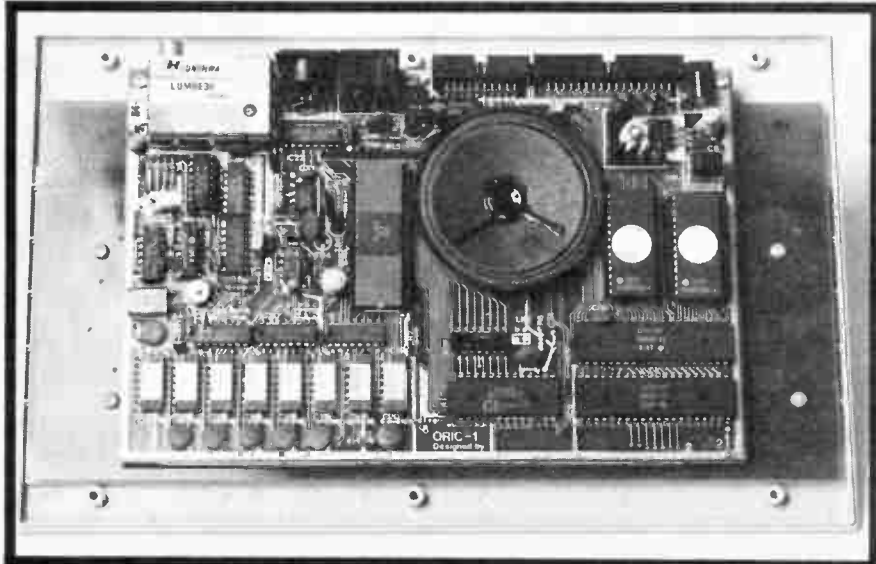

*Top, the Oric's full-size "click" key keyboard, centre, the p.c.b. assembly and bottom, the rear panel interfaces and connectors.*

THE Oric is a low cost home-computer, but it is well made, has a solid feel, a nicely moulded and styled case, proper sockets for the interfaces, and a keyboard of reasonable quality. It is not really possible to touch-type properly on the Oric keyboard, but it is possible to type quite quickly, and I find it faster than the Spectrum (despite the latter's single-keyword-entry).

### BASIC

The language is a fairly standard implementation of Microsoft BASIC, with some extensions, mostly to take account of the Oric's graphics, and serial attribute colour system.

Oric BASIC allows for floating-point and 16-bit integer variables. The latter allows a saving in memory space but are handled slower than "real" variables. Arrays can have any number of elements, and, in theory, up to 255 dimensions. However, a 255-dimension array is impossible to declare as the Oric has a maximum length line of 78 characters! An unusual feature is that, if you don't need more than 11 elements, arrays do not need to be pre-declared. In Oric BASIC element zero is valid.

String variables and elements in string arrays can have up to 255 characters. Unlike Sinclair BASIC, elements in string arrays are not of fixed length. In general, Oric handles arrays well.

Oric BASIC has a rather limited user-defined function capability. Functions are strictly numeric-only; they cannot be used for string slicing. You can, however, use the string functions which return numeric values, such as LEN() and VAL within functions. Functions have one argument—no more and no less.

REPEAT . . . UNTIL loops are included in the BASIC, the IF . . . THEN statement can include ELSE, and there is an ON . . . GOTO or GOSUB statement. Structured programming purists will be duly offended by the presence of POP and PULL. There is no BASIC TIME function, but there is a WAIT command which holds up the program for a specified number of hundredths of a second. This is a feature which could be useful if the machine is used for certain control applications, such as sequencing a synthesiser or as a sophisticated timer/controller.

Most of the problems in Oric BASIC

# SPECIAL REPORT

# ORIC-1

# MIC



concern the PRINT statement and formatting text on the screen. There is a single-dimensional TAB statement to control the horizontal print position, but this does not appear to work. The comma (used to control the PRINT fields) also appears to have a somewhat haphazard effect. There is a PLOT statement that can be used to place strings or characters at absolute positions on the screen, but you cannot carry out calculations in a PLOT statement, use it to PLOT more than one string at a time, or use it to print numeric values. There is a SPC() statement which can print a specified number of spaces on screen. There is no way of controlling the INPUT position on screen.

## SERIAL ATTRIBUTES

One of the most interesting features of the Oric is the use of teletext-style serial attributes to control the colours of the display. In the TEXT and LORES modes these allow a sixteen-colour (eight steady, eight flashing) display, whilst using only 1K of memory. Unfortunately, the manual is rather lacking in concise information on this subject.

There is also a HIRES mode, which has the usual DRAW and (somewhat saton) CIRCLE commands. There are also CURSET (move cursor to absolute position) and CURMOV (move cursor relative) statements. Unfortunately, the DRAW statement also uses relative coordinates, which makes it difficult to use, especially as any move to a position off the screen results in an error message. However, it is only fair to say that it is no different to the Spectrum in this regard.

There is a CHAR statement that allows characters to be printed at the HIRES cursor position, but only one character at a time. A PATTERN statement allows dotted or dashed lines to be plotted, following the bit pattern of the binary form of the number specified. This is great fun to play with.

Though I like serial attributes for text handling, I do not feel they are really appropriate to high-resolution graphics. Though Oric's HIRES resolution is 200 × 240, the colour resolution is only 200 × 40. This somewhat limits the usefulness of the HIRES mode.

The actual colour quality is very good—clearer and brighter than that of some other machines. A small informa-

tion sheet gives details of how to trim the Oric for optimum display quality with the particular TV set used as the monitor, and this certainly seems to be a very worthwhile idea.

## CASSETTE

The cassette interface has its good and bad points. There are two Baud rates available. The slower, 300 Baud, rate is reliable, and the volume and tone settings not critical, but it can take a very long time to load or save a long program. The faster, 2400 Baud, rate is very fast indeed, but perhaps somewhat over-ambitious for a cassette system, bearing in mind that most users will wish to use an inexpensive recorder and not a hi-fi type. On trying a number of inexpensive recorders with the fast rate, one failed to work at all, and none gave 100 per cent reliability however carefully the tone and volume controls were adjusted. The cassette socket includes motor control terminals, but this facility has not always worked, with the relay contacts occasionally sticking in the closed position.

It is possible to save blocks of memory, such as machine code routines, but there is no direct way of saving data or arrays. Variables are not saved with programs.

Some good points of the Oric are that it will accept Hex numbers, preceded with a hash (#), and has a HEXS function to convert from decimal to hex (upper limit 65535 or #FFFF). It is possible to restart a program interrupted by a break (either a STOP statement in the program or CTRL C from the keyboard) by typing CONT. However, if the program stops because of an error all variables are lost. There is built-in error trapping in the INPUT statement to prevent a string input when a number is required, and to prevent a null input (the latter a mixed blessing).

There is a POINT function which reveals whether a particular pixel in HIRES is foreground or background, and a SCRN function which returns the ASCII value of the character or attribute at a specified position in TEXT and LORES modes. Overall, the BASIC is a good implementation for a computer in this price range.

The sound is very good for a low cost machine, with three tone channels and one noise channel (the AY-3-8912

sound chip is used). There are four pre-programmed sound effects (PING, ZAP, SHOOT and EXPLODE), plus BASIC instructions PLAY, SOUND and MUSIC which enable music and sound effects to be produced without too much difficulty. A proper loudspeaker and amplifier are used, so that the sound quality and volume are all one could reasonably expect, and some impressive sounds can be generated.

## INTERFACES

At the rear of the Oric there is a power socket which takes the output from the separate power supply unit, an output for a monochrome or colour TV set, an RGB socket for a colour monitor, the cassette interface socket, a parallel printer port, and an expansion port. There is also an audio output for a hi fi amplifier on the cassette socket, but the internal loudspeaker cannot be switched off.

The parallel printer port is a useful feature, although there can be problems getting some printers to work with the machine. However, the ability to drive a printer without a costly add-on unit is obviously a plus factor for a low cost machine. The expansion port has all the address, data and control lines, and user built hardware add-ons can easily be added here (there is no user port).

## CONCLUSIONS

The Oric I appears to offer a lot for a computer in this price range, and it certainly offers good value for money and is capable of good results. Unfortunately, it does have a few bugs which should ideally be eliminated, although it is quite usable despite them. The Oric manual really seems rather inadequate when one considers the not inconsiderable capabilities of the machine, and there are a number of errors and omissions. This makes learning to use the machine more difficult than it needs to be, but obviously does not detract from its capabilities.

Having used both an Oric I and a Sinclair Spectrum, it is difficult not to compare the two. I find the Oric easier to work with, and it certainly has the higher specification with its better keyboard, RGB output, superior sound generator, and printer port. However, with the Oric now priced somewhat higher than the Spectrum this is no more than one would expect. □

# ORICOMPUTER

BY R.A. PENFOLD

# MICROCOMPUTER INTERFACING TECHNIQUES

INCLUDING MANY USEFUL CONSTRUCTIONAL PROJECTS

PART NINE: DIRECT BUS INTERFACING

BY J. ADAMS B.Sc., M.Sc. & G.M. FEATHER B.Sc.

In last month's article, the technique of direct bus interfacing was introduced and the functions of the address and data bus were described. Readers should acquaint themselves with this together with the ideas of address bus decoding, latching and data bus buffering.

## FULL AND PARTIAL DECODING

The device select pulse for the 6522 VIA, employed in the construction project for the Oric-1, was derived by means of a decoding circuit on the address bus. The

output from this decoder, which activated the VIA, necessitated that a unique code should appear on only twelve of the sixteen available address lines—the other four lines being routed directly to the VIA. Such an arrangement is called *partial decoding*.

In this article decoding circuitry will be employed which will only furnish a device select pulse when a single unique address appears on the address bus. This is called *full decoding*.

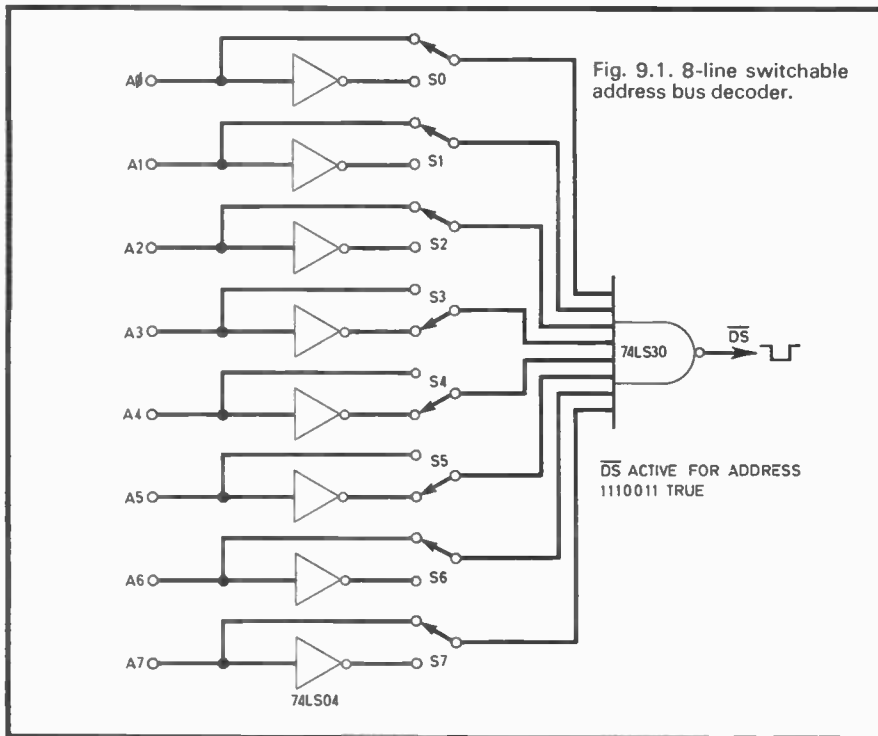

Fig. 9.1. 8-line switchable address bus decoder.

## CHANGEABLE ADDRESSES

A limitation of a full decoding circuit is that it provides a device select signal for a fixed address and this, as such, cannot be changed without an appropriate hardware modification. If it is wished to change that fixed address without including extra inverters and so on then a possible, although not particularly elegant, solution is to include switchable inverters in the decoding circuitry so that the address may be altered. Fig. 9.1 shows a possible arrangement.

Single pole, double throw switches S0-S7 (or simple wire jumpers) allow the selection of address bus lines at logic 0 to be applied to the NAND gate input via an inverter.

An altogether better approach to this problem involves the use of digital comparators. These devices compare two binary inputs and provide a logic 0 output only when the inputs are equal. The 74LS682 8-bit comparator is represented in Fig. 9.2.

A0, A1, A2, and so on, are the bit inputs for number A whilst the B pins are the corresponding bit inputs for the B number. When number A = number B, the output A = B pin goes low.

Fig. 9.3 shows how the 74LS682 device can be used in a changeable address decoding scheme for an eight line bus; clearly the arrangement can be extended to decode a sixteen-line address bus using a second comparator and OR-ing the outputs together to give a low device select pulse.

Table 9.1. Block Select Lines and Internal Decoding

Machine	$\overline{ID}$ Line	Active	Block Size	Lines Decoded	Lines Undecoded	Starting Address Hex	Starting Address Decimal
PET	SEL10	Low	4K	A15-A12	A11-A0	9000	36864
	SEL11	Low	4K	A15-A12	A11-A0	A000	40960
	SEL12	Low	4K	A15-A12	A11-A0	B000	45056
VIC-20	$\overline{I/O2}$	Low	1K	A15-A10	A9-A0	9800	38912
	$\overline{I/O3}$	Low	1K	A15-A10	A9-A0	9C00	39936
CMMDR 64	$\overline{I/O1}$	Low	1K	A15-A8	A7-A0	DE00	56832
	$\overline{I/O2}$	Low	1K	A15-A8	A7-A0	DF00	57088
BBC	NPGFC( $\overline{FRED}$ )	Low	0.25K	A15-A8	A7-A0	FC00	64512
	NPGFD(JIM)	Low	0.25K	A15-A8	A7-A0	FD00	64768

## PROVIDING MULTIPLE ADDRESSES

Many applications require a provision for adding several I/O devices to the ex-

tension bus, and decoding circuits can be devised which will provide active low device select ( $\overline{DS}$ ) for a series of consecutive addresses. A possible arrangement, which provides 16 consecutive addresses, is shown in Fig. 9.4.

The 74LS154 is a 4-to-16 line decoder and operates in much the same way as the 3-to-8 decoder mentioned in the last article. The 4-line input ABCD selects one of the 16 outputs, sending it active low. Unselected outputs remain high. Chip enable inputs G1 and G2 are active low; these signals are provided by:

- (1) an active low  $\overline{DS}$  pulse from the address decoding circuitry for A15 and A14.
- (2) an inverted  $\Phi 2$  clock high signal. The  $\Phi 2$  clock signal will be discussed later in the article.

### INTERNAL DECODING

In discussing address decoding it has been assumed that all address bus lines are brought out to the expansion port and that external decoding circuitry must be added to provide device select pulses.

In many microcomputer systems some of the address bus lines are already decoded internally. This means that a device select pulse, or internal decode signal ( $\overline{ID}$ ) will be obtained whenever the appropriate signals appear on the address bus.

As not all of the address lines are decoded such partial decoding will mean that whole blocks will be activated by the internal decode signal ( $\overline{ID}$ ). In this context a block can be thought of as an area of contiguous memory locations of predetermined length made active by the  $\overline{ID}$  signal.

### BLOCK SELECT LINES

The exact philosophy adopted varies from machine to machine but generally involves the provision of one or more expansion port lines which become active low when a particular bit pattern appears on the high order address lines. This is shown in Table 9.1.

In the PET, address lines A15 to A12 are decoded into sixteen 4K block select lines,  $\overline{SEL1}$ ,  $\overline{SEL2}$ ,  $\overline{SEL3}$ , and so on, most of which appear at the expansion port. Blocks 10 to 13 are intended to addition ROM, but there is no reason why external I/O devices should not be located here.

The VIC-20 and Commodore 64 microcomputers provide a number of internally decoded  $\overline{ID}$  signals for 1K blocks specifically intended for external I/O devices.

The BBC microcomputer provides two pages of 256 bytes each, enabled by  $\overline{ID}$  signals known as  $\overline{FRED}$  and  $\overline{JIM}$ .

Details of these internally decoded  $\overline{ID}$  lines and the blocks of memory (of variable sizes) controlled by them and their locations within the address space of the microprocessor are given in Table 9.1.

Fig. 9.2. Pin-out details for the 74LS682 8-bit digital comparator.

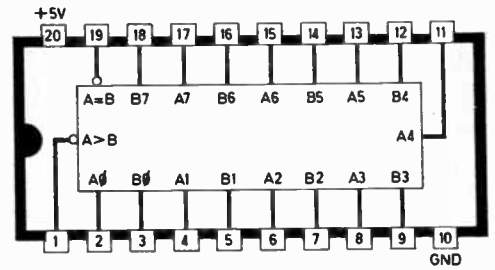

Fig. 9.3. Switchable address decoding, using an 8-bit digital comparator.

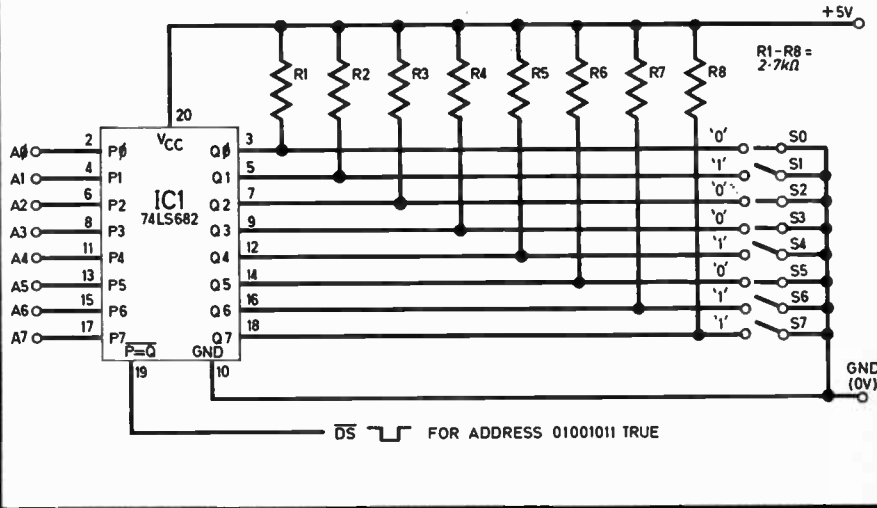
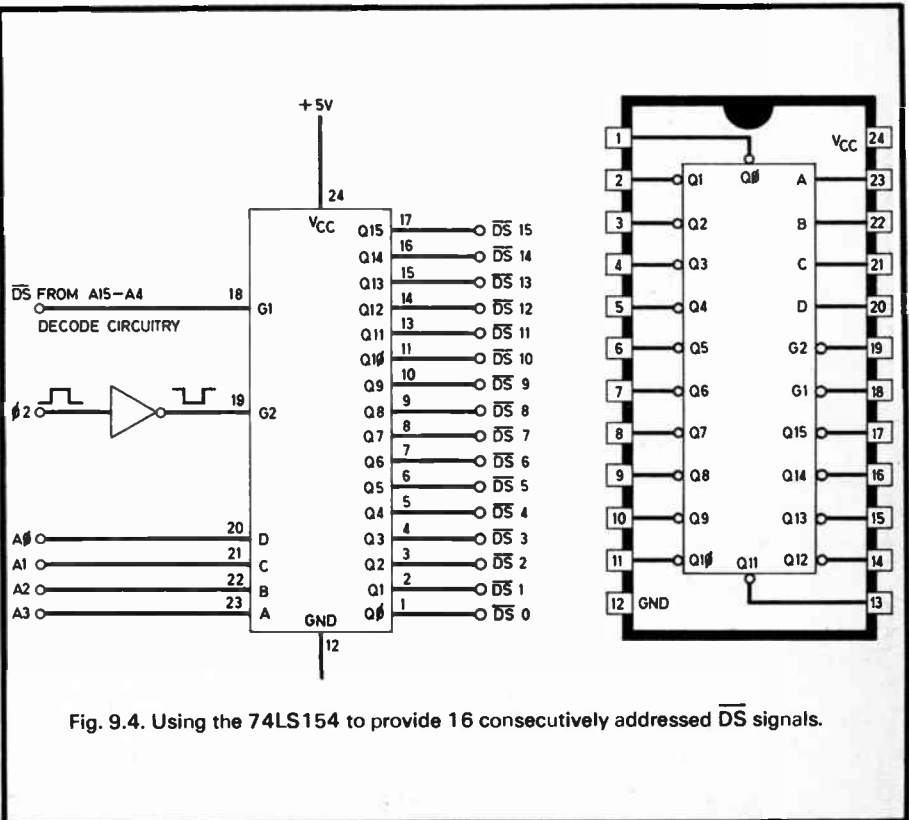

Fig. 9.4. Using the 74LS154 to provide 16 consecutively addressed  $\overline{DS}$  signals.



**Table 9.2. Extension Bus Signals and Pin Identifications**

Signal	BBC			VIC-20		Commodore 64		PET		
A0	A0	27	CA0	B	A0	Y	BA0	J9	2	
A1	A1	28	CA1	C	A1	X	BA1	J9	3	
A2	A2	29	CA2	D	A2	W	BA2	J9	4	
A3	A3	30	CA3	E	A3	V	BA3	J9	5	
A4	A4	31	CA4	F	A4	U	BA4	J9	6	
A5	A5	32	CA5	H	A5	T	BA5	J9	7	
A6	A6	33	CA6	J	A6	S	BA6	J9	8	
A7	A7	34	CA7	K	A7	R	BA7	J9	9	
A8			CA8	L	A8	P	BA8	J9	10	
A9			CA9	M	A9	N	BA9	J9	11	
A10			CA10	N	A10	M	BA10	J9	12	
A11			CA11	P	A11	L	BA11	J9	13	
A12			CA12	R	A12	K	BA12	J9	14	
A13			CA13	S	A13	J	BA13	J9	15	
A14					A14	H	BA14	J9	16	
A15					A15	F	BA15	J9	17	
D0	D0	18	CD0	2	D0	21	BD0	J4	2	
D1	D1	19	CD1	3	D1	20	BD1	J4	3	
D2	D2	20	CD2	4	D2	19	BD2	J4	4	
D3	D3	21	CD3	5	D3	18	BD3	J4	5	
D4	D4	22	CD4	6	D4	17	BD4	J4	6	
D5	D5	23	CD5	7	D5	16	BD5	J4	7	
D6	D6	24	CD6	8	D6	15	BD6	J4	8	
D7	D7	25	CD7	9	D7	14	BD7	J4	9	
R/W	R/NW	2	CR/W	18	R/W	5	BR/W	J9	22	
φ2	1MHZE	4	S/φ2	V	φ2	E	B02	J9	21	
NMI	NNMI	6	NMI	W	NMI	D	NMI	J4	24	
IRQ	NIRQ	8	IRQ	19	IRQ	4	IRQ	J9	19	
RST	NRST	14	RESET	X	RESET	C	RES	J4	22	
GND	OV	1	GND	1	GND	1	GND	J9	1	
+5V			+5V	21	+5VDC	2				
ID	NPFC	10	I/O3	U	I/O2	10				
									Various	

**THE EXTENSION BUS**

It is worthwhile to present a brief overview of some of the lines available at the expansion port. These constitute the extension bus lines that will be used in the two constructional projects described in the following pages. As each microcomputer has its own style of signal labelling these lines have been assigned with the standard nomenclature indicated in Table 9.2.

**THE ADDRESS LINES (A0-A15)**

These sixteen parallel paths are used to carry the address generated by the microprocessor. Note that the BBC and VIC-20 microcomputers do not bring out all of their address lines at the extension bus interface.

**THE DATA LINES (D0-D7)**

There are eight bi-directional data lines. During any WRITE operation these lines transfer data from the microprocessor whereas during a READ operation data is sent to the microprocessor.

**THE READ-NOT-WRITE LINE (R/W)**

The logic level on the R/W line provides the essential information as to whether the microprocessor is performing a READ operation (logic 1) or a WRITE operation (logic 0).

**THE CLOCK LINE (φ2)**

The microprocessor not only determines the direction of data transfer but also the timing of such transfer. Data is transferred during a period when this signal is high.

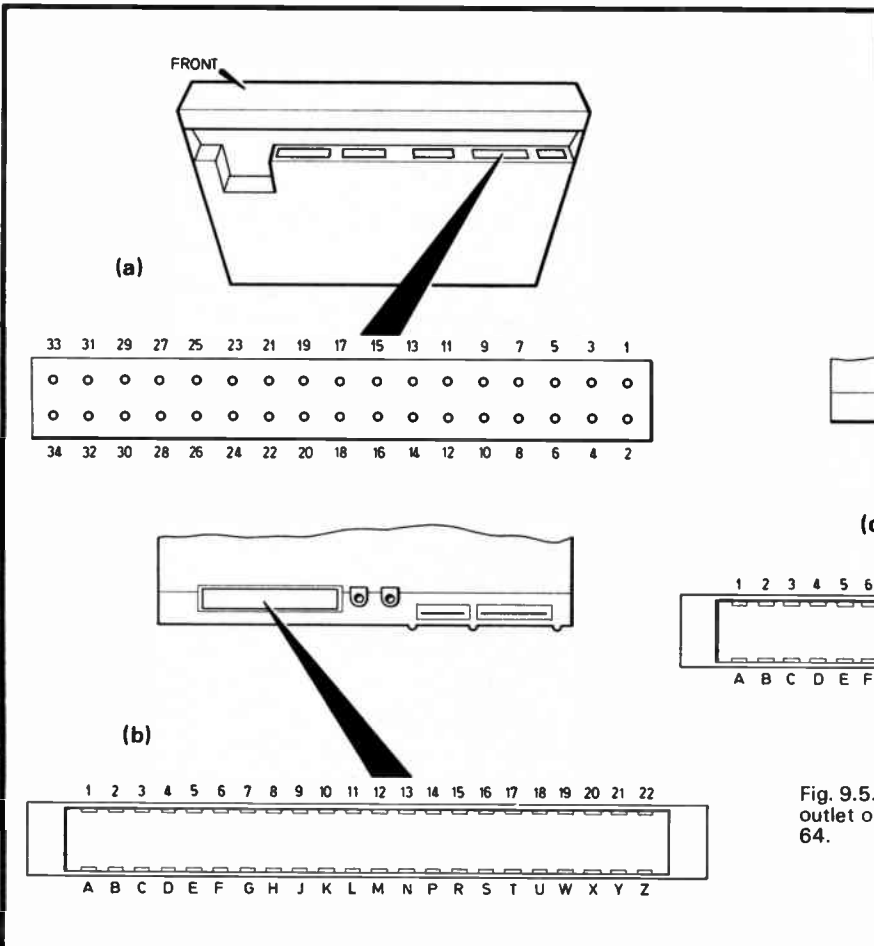

Fig. 9.5. Location and pin numbering of the extension bus outlet on (a) the BBC Micro; (b) VIC-20; (c) Commodore 64.

## THE INTERNAL DECODE SIGNAL ( $\overline{ID}$ )

The internal decode signal allows the necessity of complete external decoding as some of the address lines are decoded to give this signal. (See Table 9.1).

Other control lines, although indicated in Table 9.2, are not required in this article. These include  $\overline{NMI}$ ,  $\overline{IRQ}$  and  $\overline{RST}$ .

The locations for the various expansion ports are shown in Fig. 9.5.

## TIMING OF CONTROL SIGNALS

### READ

Fig. 9.6 shows how the microprocessor places a logic 1 on the  $R/\overline{W}$  line prior to a READ operation simultaneously placing the address of the location to be read on the address bus. After a short delay the data on the data bus is latched into the microprocessor on a trailing edge of the clock signal ( $\Phi 2$ ).

### WRITE

Fig. 9.7 illustrates how, during a WRITE operation, the microprocessor places a logic 0 on the  $R/\overline{W}$  line simultaneously placing the address of the respective location on the address bus. Again after the trailing edge of the  $\Phi 2$  signal the data is written to the external device.

Note that the decoded device select pulse ( $\overline{DS}$ ) is delayed and will not begin until slightly after the address lines have reached their stable values.

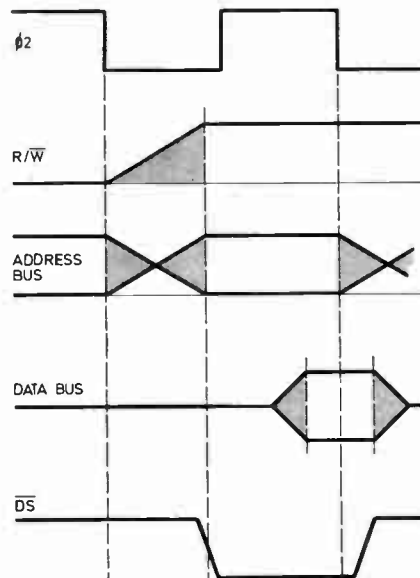

Fig. 9.6. Timing signals for a READ operation.

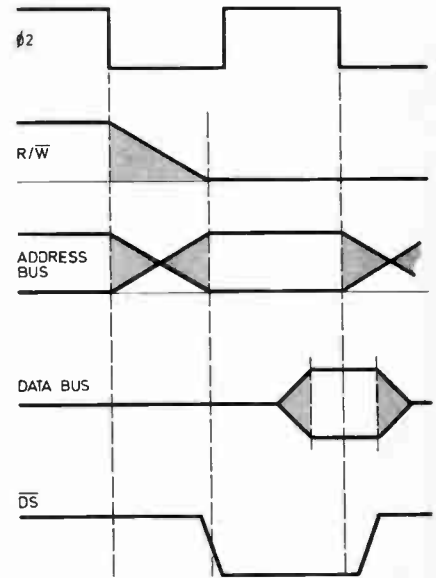

Fig. 9.7. Timing signals for a WRITE operation.

## THE BBC SYSTEM TIMING CLOCK (1MHzE)

The clock signal on the extension bus of the BBC runs at 1MHz whereas the

BBC microprocessor can run at either 1MHz or 2MHz. As most processing is carried out at the maximum clock speed the processor must slow down when accessing the 1MHz extension bus. This is

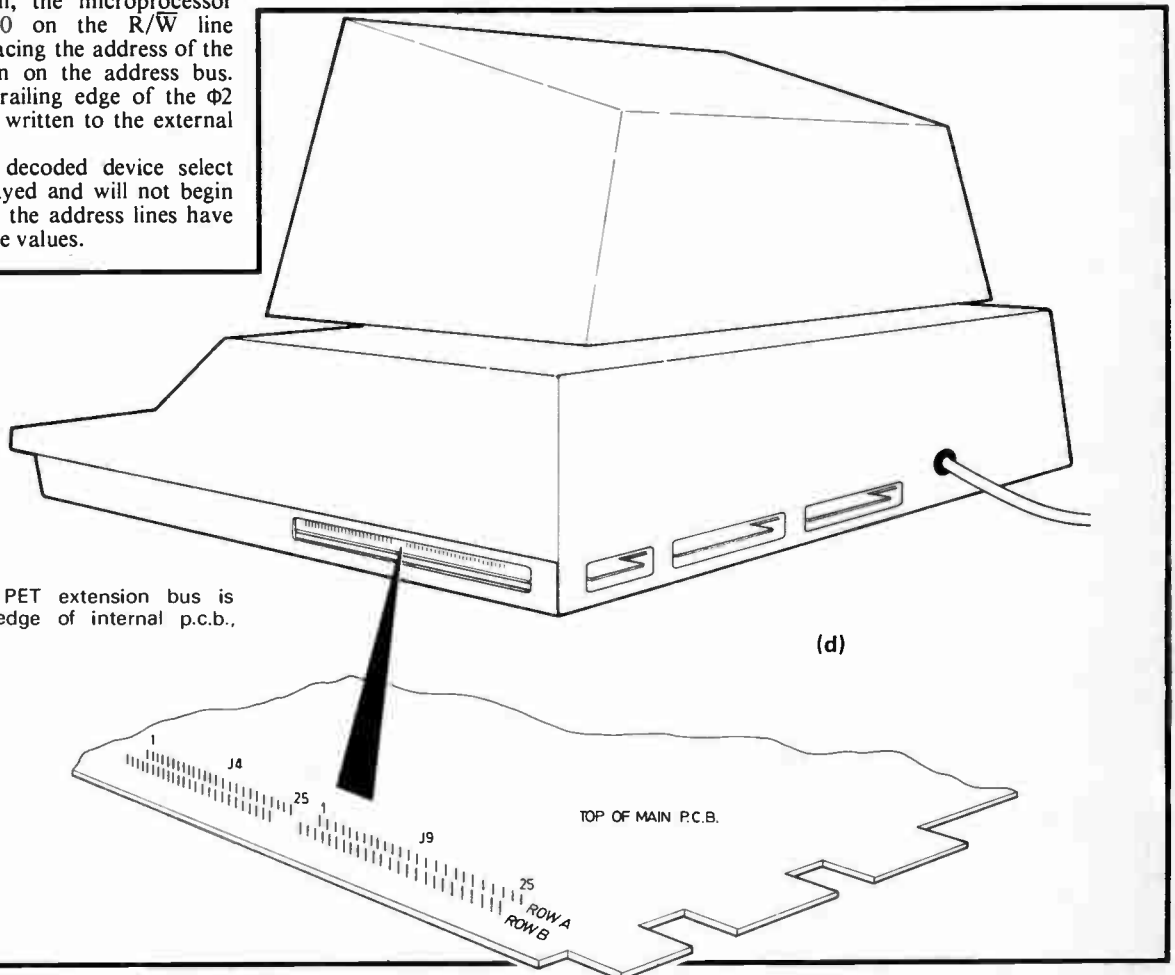

Fig. 9.5(d). The PET extension bus is located on the edge of internal p.c.b., row A.

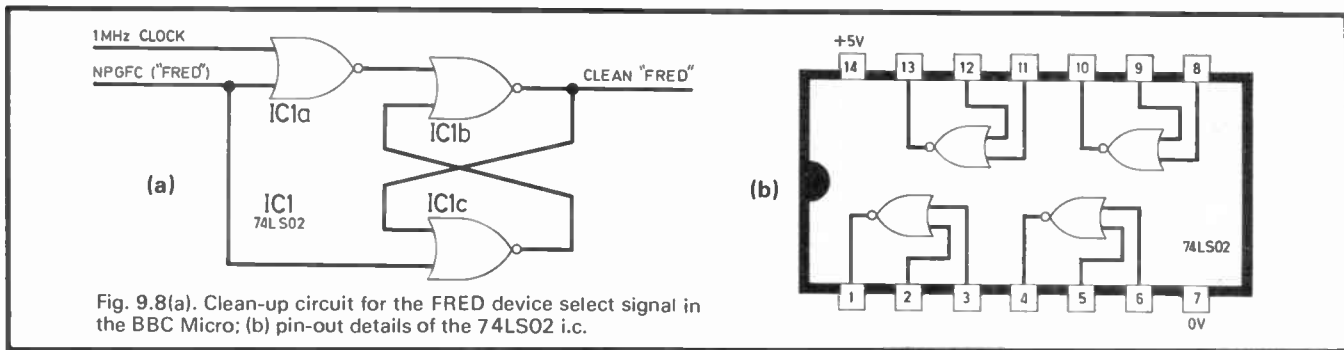

Fig. 9.8(a). Clean-up circuit for the FRED device select signal in the BBC Micro; (b) pin-out details of the 74LS02 i.c.

achieved by "cycle stretching" by a special circuit so that when an appropriate address decode signal indicates that the 1MHz extension bus has been accessed the microprocessor clock signal will coincide with the extension bus clock.

When addresses on the bus change, the 2MHz clock will be low but there is no guarantee that the 1MHz signal on the bus will also be low. This may result in rogue "glitches" (spurious pulses) on the ID pin NPGFC (FRED—pin 10). This

problem may be obviated by using a clean up circuit as shown in Fig 9.8 so that the FRED signal will only become active low after the 1MHz clock has gone low.

# LATCHED OUTPUT PORT

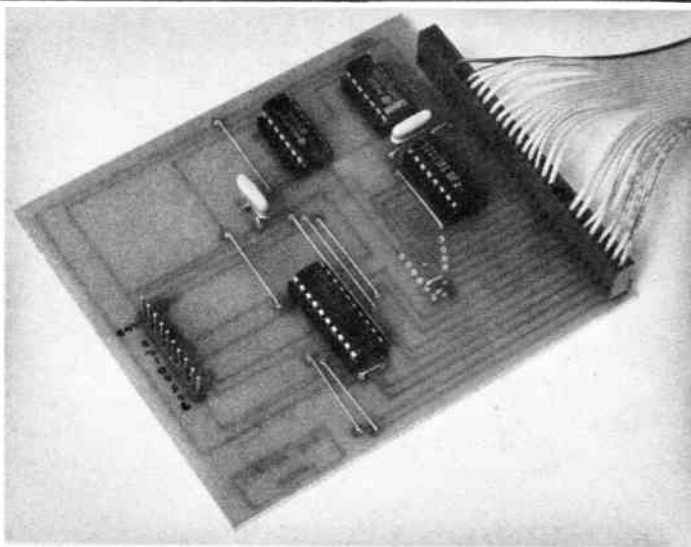

## A LATCHED OUTPUT PORT FOR COMMODORE AND BBC MICROCOMPUTERS

If it is wished to output data to some external device by placing that data on the data bus then, because of the transient nature of that data, it is necessary to provide some sort of latch which allows the very brief duration signal to be read and then held at its outputs until new data is presented.

Several integrated circuits capable of performing this function are available, most being based upon some form of bistable latch.

The output port circuit described here employs a 74LS273 octal D-type flip-flop and a schematic diagram of this is shown in Fig. 9.9.

Data from the expansion bus is applied to the D pins (which are all inputs) whilst the Q pins are the corresponding outputs.

For each input, data (logic 0 or logic 1) is transferred to and latched on to the corresponding Q output on a negative

transition of the clock input at pin 11. Any Q output pin will thus remain at that level until the data at its D input is changed to another value.

Pin 1 clears the data present at the output latches if taken to logic 0 and, since in this application this is not required, pin 1 is held at logic 1 by connecting it to the +5V supply.

Fig. 9.9. Pin-out details of the 74LS273 Octal D-type flip-flop.

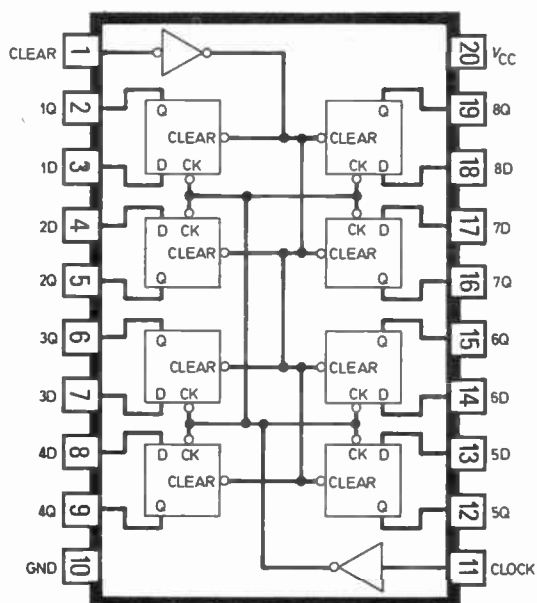

## LATCHED OUTPUT PORT

**COMPONENTS**  
approximate  
cost **£10**  
excluding PL1/SK1

### Capacitors

C1,2 4.7nF polyester type C280 (2 off)

### Semiconductors

IC1 74LS133 TTL low power Schottky 13-input NAND gate  
IC2 74LS27 TTL low power Schottky triple 3-input NOR gate  
IC3 74LS04 TTL low power Schottky hex inverting buffer  
IC4 74LS273 TTL low power Schottky 8-bit register

### Miscellaneous

PL1/SK1 Plug or socket to suit computer in use, such as:

Printed circuit board *EE PCB Service*,

Order code 8403-04 for Commodore 64

Printed circuit board *EE PCB Service*, Order code 8403-03 for VIC-20

PL2 27-way p.c.b. mounted in-line plug (made from 2 x 10-way and 1 x 7-way inter-p.c.b. straight plugs)

PL3 10-way inter-p.c.b. straight plug

SK2 27-way inter-p.c.b. socket (made from 3 x 10-way inter-p.c.b. in-line sockets)

SK3 10-way inter-p.c.b. in-line socket

**Printed circuit board:** single-sided, size 108 x 95mm, *EE PCB Service*, Order code 8403-01; ribbon cable, length and No. of ways to suit computer used; 22 s.w.g. tinned copper wire.

See  
**Shop  
Talk**  
page 164

Fig. 9.10. Circuit diagram for the microcomputer Latched Output Port. More address bus lines may be decoded by the 74LS133. Any unused inputs on this chip should be pulled up using the link wire positions provided.

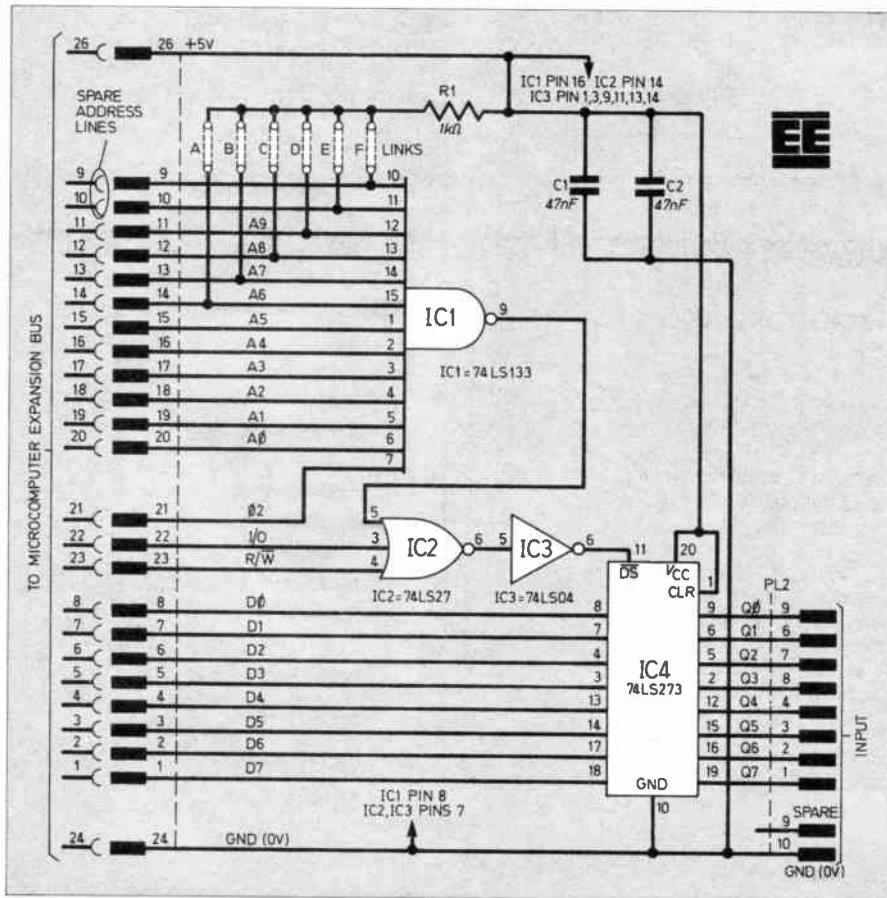

The device select signal acts as the clocking pulse for the data latch and is derived from the address bus lines by the decoding circuitry comprising IC1, IC2 and IC3.

The complete circuit of the arrangement is shown in Fig. 9.10. IC1 is a thirteen input NAND gate (it provides a logic 0 output when all of its inputs are at logic 1) and this decodes the lower ten address lines of the address bus along with the  $\Phi 2$  clock signal. It will thus provide a logic 0 output when the  $\Phi 2$  clock is high and the ten lower order address lines are all high (that is, the binary bit pattern on these lines is 111111111). The  $\Phi 2$  clock signals are included in the decoding and device circuitry in order to obviate the effect of glitches affecting the transfer of data.

The block or page select line  $\overline{ID}$  (which is active low for all machines) is taken to one input of a 3-input NOR gate (IC2) along with the active low output from the 74LS133 and the  $R/\overline{W}$  line from the expansion bus. This latter line also goes low during a WRITE operation so the NAND gate output will go to logic 1 for the conditions:

- (1) address true,
- (2)  $\Phi 2$  clock high, and
- (3) WRITE operation.

The 74LS273 output latch requires a negative transition in order to activate it, so the NOR gate output is inverted by one section of the hex inverter, IC3, a 74LS04 integrated circuit. There are unused inputs on the 74LS133; these are pulled up to logic 1 by links on the board—the number of links necessary depends on the number of address lines that need to be decoded which is, in turn, dependent upon the microcomputer being used. Table 9.2 includes details of this.

### ASSEMBLY

The components forming the circuit of Fig. 9.10 are mounted on a printed circuit board. The actual-size pattern to be etched is shown in Fig. 9.11. This board is available from the *EE PCB Service*, Order code 8403-01.

The layout of the components on the topside of the p.c.b. is shown in Fig. 9.12. Begin by inserting and soldering in the link wires, followed by the i.c. sockets, in-line plugs and decoupling capacitors C1 to C4. Next insert the i.c.s paying attention to their orientation.

With reference to Table 9.2, make the necessary links from the address bus to the inputs of the 74LS133 (IC1) according to where the latched port is to reside in memory. A cable should next be prepared to connect the board to the computer bus. Details of this with p.c.b. type connector board/plug for the VIC-20 and Commodore 64 are given later in this article, see pages 182, 184.

# LATCHED OUTPUT PORT

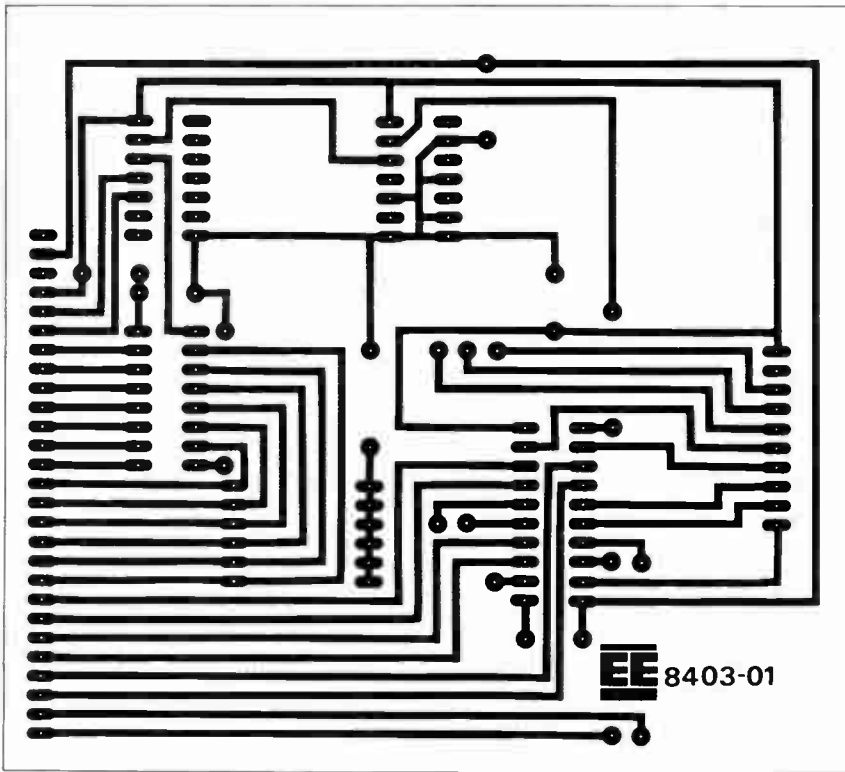

Fig. 9.11. Master printed circuit pattern (actual-size) for the Latched Output Port board. This p.c.b. is available from the *EE PCB Service*, Order code 8403-01.

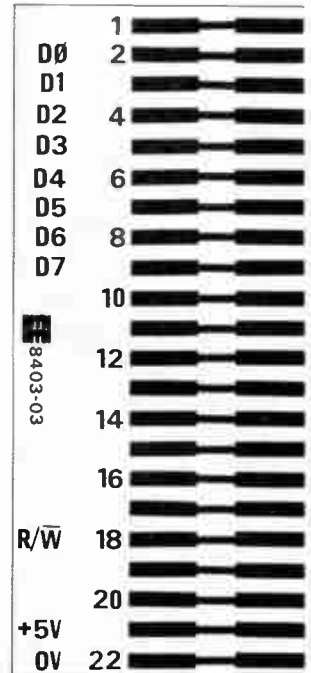

Fig. 9.17 (Above and below). Printed circuit patterns (actual size) for the two sides of the double-sided VIC-20 extension bus connector. This board is available from the *EE PCB Service*, Order code 8304-03.

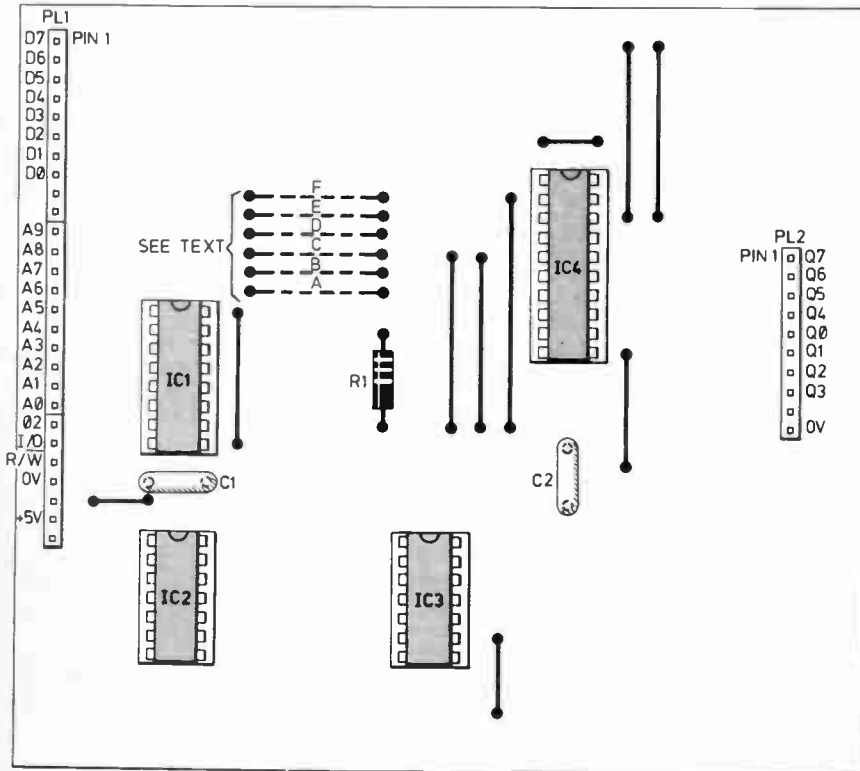
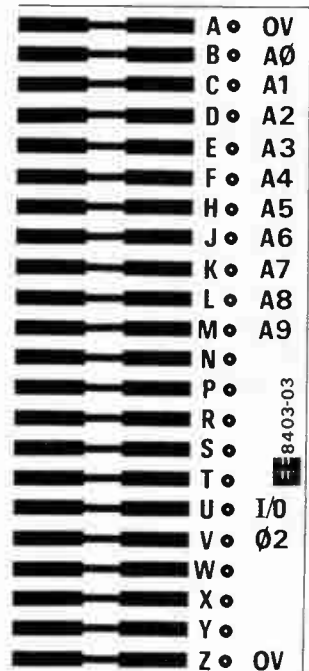

Fig. 9.12. Layout of the components on the topside of the board with labelling details for the p.c.b. mounted plugs.





# BUFFERED INPUT PORT

## A BUFFERED INPUT BOARD FOR COMMODORE AND BBC MICROCOMPUTERS

Earlier in this article the necessity for employing tri-state devices when interfacing external inputs on to the data bus lines was discussed.

A very useful device which performs this function is the 74LS245 octal bus transceiver. This 20-pin integrated circuit contains eight identical bi-directional tri-state buffers. Its pin-out diagram is shown in Fig. 9.13.

Bi-directional means that data can be transferred in two directions and the direction of such bus transfer is controlled by pin 1 which, when held at logic 0, sets the device up as an input buffer.

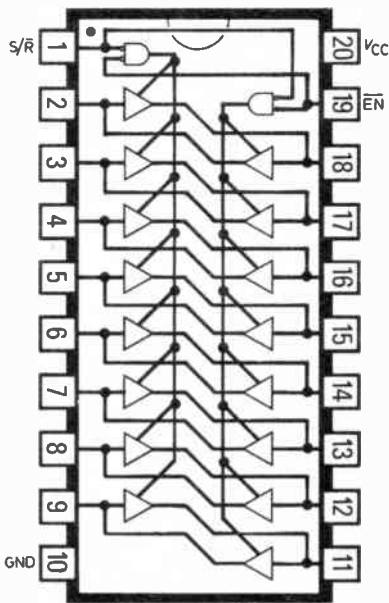
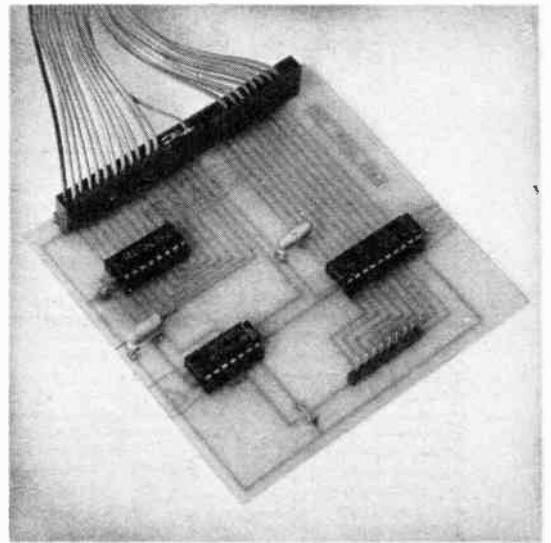

Fig. 9.13. Pin-out details for the 74LS245.



The reader may wonder why a bi-directional device has been used when simpler input only buffers are obtainable: the reason is that the pin layout of the 74LS245 is much more convenient than, for example, the 74LS244 insofar as circuit design is concerned.

Pin 19 of the input buffer i.c. is the chip enable input and is active low, that is, the device is inactive and its outputs

are in the high impedance state when this pin is at logic 1; this condition effectively disconnects the chip from the data bus lines. When taken to logic 0, the buffers are active, and the buffer outputs follow the inputs so data from external sources is transferred to the data bus.

Fig. 9.14 shows the complete circuit diagram of a buffered input board, for the data bus.

Fig. 9.14. Circuit diagram for the microcomputer Buffered Input Port. More address lines may be decoded by the 74LS133. Any unused inputs on this chip should be pulled up to +5V using the link wire positions provided.

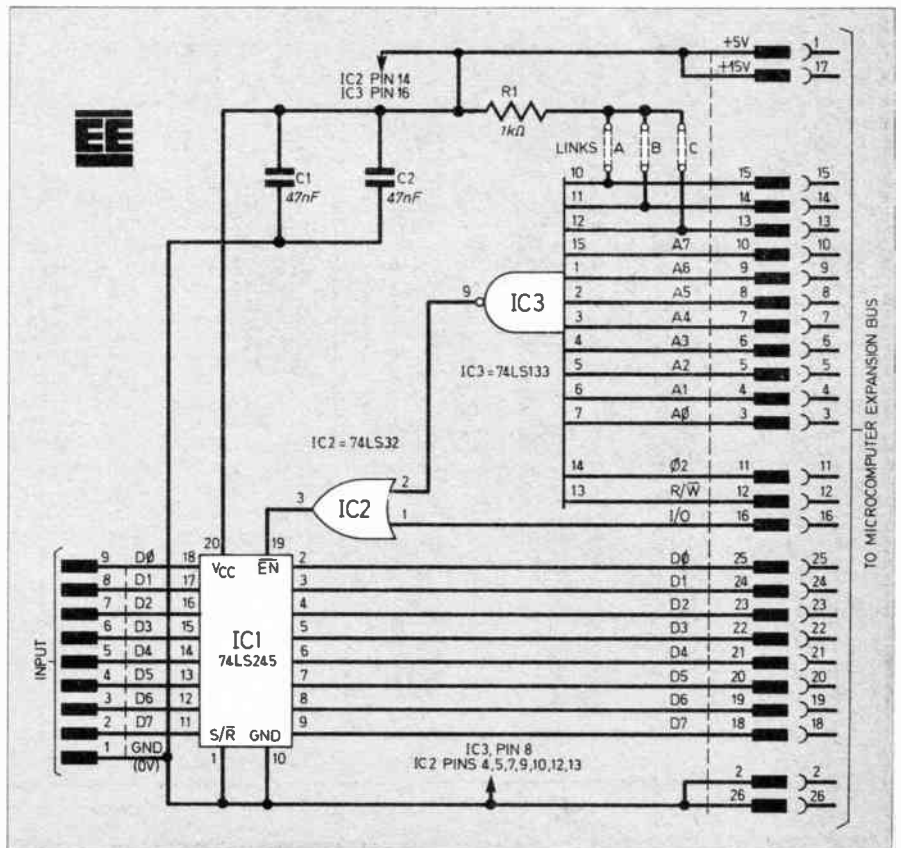

# BUFFERED INPUT PORT

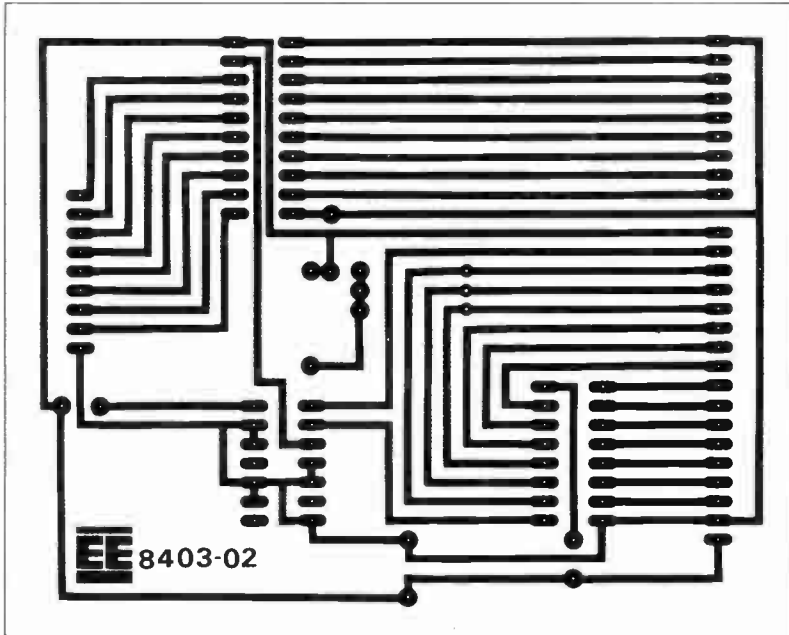
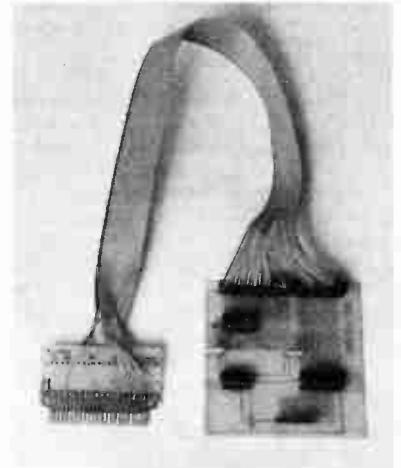

Fig. 9.15. Master printed circuit pattern (actual-size) for the Buffered Input Port. This board can be obtained from the *EE PCB Service*, Order code 8403-02.



Buffered Input Port board wired up for use with the Commodore 64.

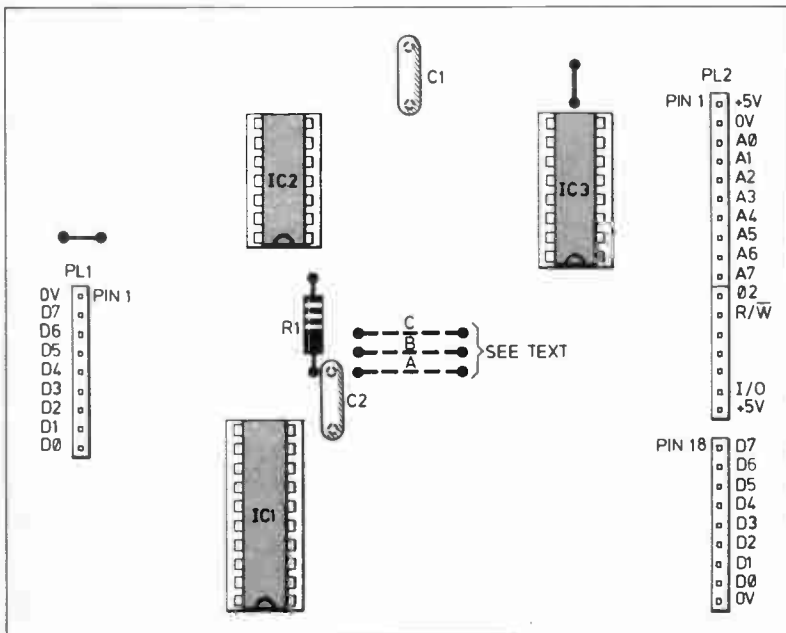
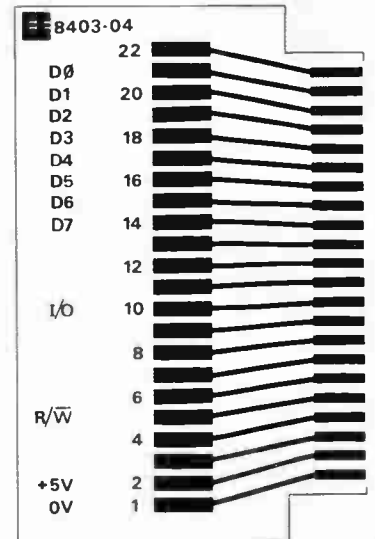

Fig. 9.16. Layout of the components on the topside of the printed circuit board with labelled board mounted plugs.

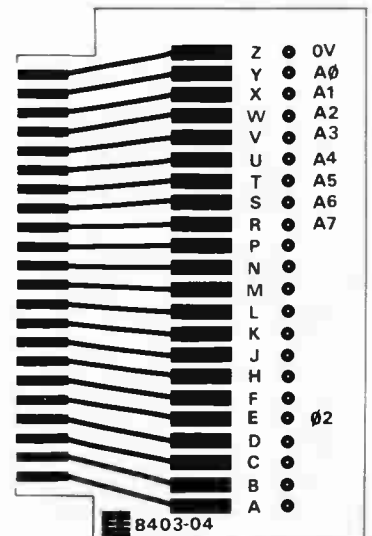

Fig. 9.18. The two printed circuit patterns (actual-size) for the double-sided Commodore 64 extension bus connector. This board is available from the *EE PCB Service*, Order code 8304-04.

The chip enable signal is obtained from the address bus decoding circuitry which consists of IC2 and IC3.

IC3 is a thirteen input NAND gate as used in the output board circuit appearing in this article. As with that circuit, the un-decoded address bus lines are applied to the inputs of the gate, along with the  $\Phi 2$  clock signal (the reader will recollect that data is transferred on the clock high period of this signal).

As the port is designed for input to the microcomputer, the 74LS245 should be enabled during a READ operation only. To achieve this, the R/W line (which goes high during a READ operation) is also applied to one of the NAND gate inputs.

This chip will thus provide an active low output when the address is true and the R/W line is high. The block or page select line goes low when made active by the microprocessor and this is OR-ed with the NAND gate output by IC2 so as to provide an active low device select signal for the buffer.

As before, any unused inputs to the thirteen input NAND gate are pulled up to logic 1.

## ASSEMBLY

The components forming the Buffered Input board are mounted on a printed circuit board, the actual size master is shown in Fig. 9.15. This board is available from the *EE PCB Service*, Order code 8403-02. The layout of the components on the p.c.b. topside is given in Fig. 9.1.

Insert and solder in place the two link wires followed by the i.c. sockets, plugs and decoupling capacitors. Prepare a length of ribbon cable to connect the board to the computer bus. Details of this for the four computers considered in this series are given below.

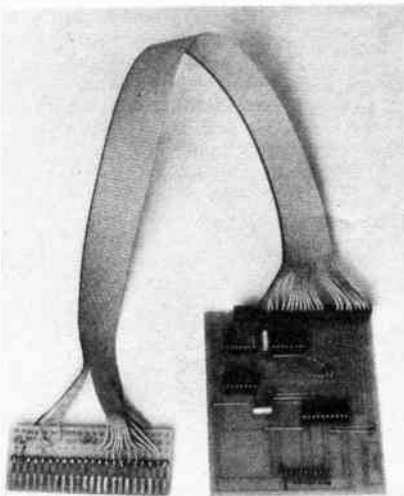

Latched Output Port board wired up for use with the VIC-20.

# COMPONENTS

## BUFFERED INPUT PORT

### Capacitors

C1,2 4.7nF polyester type C280 (2 off)

### Semiconductors

IC1 74LS133 TTL low power Schottky 13-input NAND gate  
 IC2 74LS32 TTL low power Schottky quad 2-input OR gates  
 IC3 74LS245 TTL low power Schottky octal bus transceiver tri-state outputs

### Miscellaneous

PL1 10-way inter-p.c.b. straight plug  
 PL2 26-way inter-p.c.b. straight plug (made up from 1 x 10-way, 1 x 9-way, 1 x 7-way plugs)  
 PL3/SK3 Plug or socket (as required) to suit computer in use, such as:  
 Printed circuit board *EE PCB Service*, Order code 8403-04 for Commodore 64  
 Printed circuit board *EE PCB Service*, Order code 8403-03 for VIC 20  
 SK1 10-way inter-p.c.b. in-line socket  
 SK2 26-way in line inter-p.c.b. socket (made up from 3 x 10-way in-line inter-p.c.b. sockets)

**Printed circuit board:** single-sided, size 108 x 95mm, *EE PCB Service*, Order code 8403-02; ribbon cable length and width to suit computer used; 22 s.w.g. tinned copper wire; d.i.l. i.c. sockets: 20-pin (1 off), 16-pin (1 off), 14-pin (1 off).

**COMPONENTS**  
 approximate  
 cost **£10**  
 excluding PL1/SK1

See  
**Shop  
 Talk**  
 page 164

## DETAILS OF EXPANSION PORT PLUGS FOR EXTENSION BUS

### BBC MICROCOMPUTER

A standard 34-way i.d.c. female socket is employed on the BBC Micro 1MHz expansion port and this should present no problems other than the order of ribbon cable lines. It is probably more convenient to route these lines to their appropriate destinations at the board end rather than attempt to change the order of connection to the i.d.c. plug.

### PET MICROCOMPUTER

The expansion port connectors on the new style PET are to be found inside the casing of the machine. Berg type plugs are used here and should be wired in accordance with the pin-out diagram.

### VIC-20 MICROCOMPUTER

A similar technique was adopted for the VIC-20 as on the Commodore 64 machine, the manufacture of the plug being, if anything, even easier, since the whole plug is on a rather larger scale than that used for the Commodore 64. Details for this plug are given in Fig. 9.17.

In all cases, unused ribbon cable lines should be cut back.

### COMMODORE 64 MICROCOMPUTER

Expansion port plugs are available for the Commodore 64 bus connectors, but the plug is, in fact, relatively simple (and much cheaper) to make. Double-sided epoxy p.c.b. can be used and Fig. 9.18 gives details of the track layout. Care should be taken to ensure that the lower connections are positioned exactly below those on the upper row.

## HEXADECIMAL ADDRESSES

The hexadecimal number system is widely used to represent addresses within the microcomputer memory space. In this system the sixteen characters 0,1,2,3,4,5,6,7,8,9,A,B,C,D,E and F are used to represent the address. The coding system can be readily grasped by separating the 16-bit wide address bus into artificial 4-bit packages each represented by one hexadecimal digit.

For example:

1111 1101 0000 0000  
 F D 0 0

It can be seen that one byte (8 bits) can be described by two hexadecimal digits. The address space of the microcomputer can hence be re-defined in the more useful and elegant base sixteen notation 0000-FFFF instead of the base ten 0-65,535.

## OUTPUT SOFTWARE

The appropriate address, which has been fixed by the requisite hardware circuit, can be written to use either a POKE command (in Commodore BASIC) or the BBC BASIC indirection operator, ?.

## INPUT SOFTWARE

The address can be read using either a PEEK command (Commodore BASIC) or again, the BBC BASIC byte indirection operator, ?.

It should be noted that Acorn has anticipated the interest in adding devices to the BBC 1MHz extension bus and has suggested that user applications should be confined within the address space 64 704 (&FCC0) to 64,736 (&FCE0) inclusive.

**Next month:**  
 Environmental Data Monitoring

# FOR YOUR ENTERTAINMENT

BY BARRY FOX

## Corrigenda

Journalists, especially technical writers, suffer from the perennial problem that their words can get garbled somewhere along the line to print. So it's tempting providence to criticise other people's published errors. But I would dearly love to know what happened to the text of the bulky Broadcasting Research Unit report, published recently by the British Film Institute.

The BRU is an independent body jointly funded by the BBC, the IBA, the Markle Foundation of New York and the BFI.

The BRU calls its report (£5 plus £1 postage from the BFI) a "major survey of the many issues raised by recent developments in cable, satellite and video". Without doubt there is some interesting material buried in the hundreds of pages. But it's hard to know what to trust, because even a cursory glance reveals errors which will be obvious to anyone with a knowledge of the kind of technologies which the report is supposedly surveying.

The BRU refers at least twice to "ultra high frequency (u.h.f.) 405-line signals". But, of course, the 405-line service is on very high frequency (v.h.f.).

A list of frequencies used for broadcasting says there are 2134 channels in band IV and 3568 channels in band V. What they are meaning to say, presumably, is that band IV covers channels 21-34 and band V covers channels 35-68.

References to bands I, II and III are confused. Likewise the "Independent Review of the Radio Spectrum," by Dr. James Merriman published in 1983, covers the frequency range 30MHz to 960MHz, not the frequency 30960MHz!

When discussing radio communications the BRU makes the absurd over-simplification that "with some exceptions, the two pieces of apparatus (transmitter and receiver) have to be in line of sight". What about long-wave curvature, medium-wave bounce and short-wave skip?

Then, after that over-simplification there are pages of text about power flux density, dBW<sup>2</sup>, dB/K, C/kT, and G/T values, without any explanation of what these terms mean. Worse still there are some paragraphs on satellite communication which baldly state that the carefully calculated predictions for satellite power needed to transmit direct into homes, have "proved inaccurate".

True, there are those who now say that satellites need not transmit with the full allocation of 200 watts for good DBS (Direct Broadcast Satellites) reception on the ground with a small dish. But there are plenty of people (including BBC engineers) who argue strongly that it is false economy to put low power transmitters in the sky and so force everyone on the ground to pay more for high sensitivity reception equipment.

I tried to phone the Broadcasting Research Unit at its office in the BFI with these and other technical queries. But there was no-one there who even understood the questions, let alone had any answers. How long can the BBC, IBA, Markle Foundation and BFI afford to subsidise such dangerous dabbling in new technology?

## Kodak Video

I couldn't raise these questions at the press conference called to launch the BRU Report, for the simple reason that the BRU had timed its own press conference to clash with arguably the most important new video technology announcement of the year—the long-awaited unveiling of Kodak's plans to move into video. How on earth a committee working on cable, satellite and video technology, and part sponsored by the British Film Institute, can have failed to know about the Kodak launch, I cannot imagine.

As it happened, the Kodak unveiling brought its own surprises. First and foremost, it turned out that Kodak in Britain is quite astonishingly ignorant of video!

The product line unveiled is called Kodavision. It's a combined video camera and recorder, or "camcorder", that uses a small cassette of 8mm tape. But believe it or not, Kodak did not even have a working model camcorder to demonstrate! Video tapes of happy camcorder users were screened, but when quizzed Kodak had to admit that these were running from a professional U-matic video system.

In a significant break with tradition, Kodak is not even making the equipment itself. Matsushita of Japan is making the camcorder hardware and TDK of Japan is making the tape.

Incidentally, Matsushita is also making similar 8mm camcorders for Philips as well as VHS machines for Philips. This is while the Dutch company starts its slow and painful switch from the ailing V2000 format to the ever-more-successful VHS.

How can we write about a system we haven't seen working, asked the photographic press. How can we write about a new technology on which you can give us no technical details, asked the video press. But because the popular press has blandly

## Computer Pyramid Selling

I am now convinced that computers will go the same way as hi fi and video, that is to say, be mass-marketed by people who know nothing whatsoever about what they are selling. The good news for consumers is that this will bring the price of computers down to levels that even now sound ridiculously low.

The bad news for Europe is that the Japanese, past masters in the art of mass production at low cost, will corner the computer hardware market just as they've cornered the hi fi and video hardware markets by low cost mass-production. The bad news for consumers is that the spivs who have made a killing out of selling hi fi and video in sealed cardboard boxes that might just as well contain cabbages, will move in on computers and put some knowledgeable dealers out of business.

Sharp, of Japan, explained how the company plans to make computers a mass-market product in Britain, by selling through independent electrical stores that until now have only sold radio and television sets. "Training is a huge problem," admits Sharp. So the company has started a pyramid training scheme.

reported Kodak's entry into video as if it were as straightforward as selling a new box "Brownie", here are a few hard facts to bear in mind while Kodak gears up for the Autumn launch.

## How it works

According to Kodak the video format used for Kodavision, is the 8mm format agreed by 122 companies last March. So I can report that for European television, the tape runs at 20mm a second, the video tracks across the tape are 34.4 micrometres wide and the video writing speed (which is the speed at which the heads scan the tape) is 3.1 metres a second. For the American and Japanese television standard, the tape runs at 14.3mm a second, the track width is 20.5 micrometres and the writing speed is 3.8 metres a second.

Writing speed is the key factor. Domestic systems, like VHS, Beta and V2000 write at around 5 metres a second.

So 3.1 metres per second for Europe is a tall order. That is why the 8mm tape has to be coated with a metal powder, or a metal evaporated film. This tape is very difficult to mass produce in bulk and only a few companies in the world would dream of trying.

By the way, if you read elsewhere reports that the British system will use a writing speed of 3.8 metres a second don't take any notice. This is because the Kodak press release in Britain was clumsily culled from papers prepared for America, where the writing speed is 3.8 metres a second.

Obviously we need to explain to Kodak that the difference in video writing speed between countries is a direct result of the different speed at which the drum carrying the video heads must rotate. For ease of manufacture the same size video head drum is used all round the world.

In NTSC television countries, like America and Japan, it rotates at 1800 r.p.m. to cope with the 30 pictures a second which are standard for NTSC. In Europe, for PAL and SECAM television, the drum rotates at only 1500 r.p.m., for 25 pictures a second. So inevitably the writing speed is lower in Europe. It is disturbing to see a company like Kodak apparently unaware of such basic facts of video life.

Forty wholesale managers are going on a one-day course to learn about computers. Then, so the theory goes, the forty wholesale managers will train their staff who in turn will train the staff in 5,000 electrical shops.

It's a nice idea but one, I fear, that is born in cuckoo land. I've been on a one-day beginner's computing course. It was run by Texas Instruments and it was excellent. But there's a very definite limit on what you can teach in one day, if the novice pupil is to have any hope of remembering anything.

The idea of every novice wholesaler on a one-day course passing their acquired wisdom onto more novices, who then teach more novices, brings to mind the old party whispering game, where a simple phrase passed by word of mouth down a line ends up as something completely different.

Well done to Sharp for trying to do something. But in the long run the only shops that give their customers good advice on computers will be those staffed by salesmen who have taken the time and trouble to educate themselves in the new technology.



# APRIL FEATURES

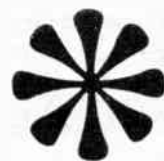

## QUIZ MASTER 11

---

### INTERFACE FOR RM380Z

AN EASY-TO-BUILD, INEXPENSIVE ADD-ON FOR ANY MICRO EQUIPPED WITH AN INTERNAL/EXTERNAL PRINTER OR USER PORT (WITH  $\pm 5V$  SUPPLY). THIS UNIT PROVIDES EIGHT INDEPENDENTLY CONTROLLABLE POWER SWITCHES UNDER SOFTWARE MANAGEMENT THE ARTICLE, WHICH CONTAINS FULL, EASY-TO-FOLLOW CONSTRUCTIONAL AND TESTING DETAILS, HAS BEEN PREPARED SPECIALLY FOR USE WITH THE RM380Z. THERE ARE SOFTWARE EXAMPLES FOR CONTROLLING MODEL TRAIN SPEED AND DIRECTION, USING THE RM380Z AND VIC-20.

### BLACK BOX PROJECT



### FUSE / DIODE CHECKER

This unit is designed for simple and quick testing of fuses and semiconductor diodes. The use of touch plates means one handed operation (no awkward probes!) and an l.e.d. display indicates continuity, and in the case of the diode, the cathode end is identified.

---

## PLUS QUASI STEREO AND AUDIO SINEWAVE SWEEP GENERATOR

EVERYDAY  
**ELECTRONICS**  
and computer PROJECTS

APRIL 1984 ISSUE ON SALE FRIDAY, MARCH 16

## SINCLAIR SKIPS SIXTEEN

*New 32-bit Computer Means Serious Business*

**H**OME COMPUTER trail blazer Sir Clive Sinclair now turns his attention up-market to the professional and business user.

Presenting his latest "baby" to a large gathering of the press in London last month, Sir Clive explained—for the benefit of those who had not already deciphered the enigma—that QL stands for "a quantum leap in personal computing". In his quest for new fields to conquer, our dashing knight of electronic innovation has in characteristic fashion adroitly leap-frogged the 16-bit stage and has gone straight for a 32-bit machine.

A demonstration on colour monitors gave evidence of the advance QL has contributed to computer design. The full-colour graphics with data inserted, at will, into different windows—these being positioned under software control—will have immediate appeal to the businessman, although one can be certain that the "more serious home user" who is also being wooed with QL will soon be applying these enhanced features in the quest for even more exciting and complex games.

Technically, the QL starts off with the great advantage of using the Motorola 68008 32-bit processor which is recognised as the most powerful chip of its kind at present available. The 68008 is currently being used in only a very few other professional computers, all of these priced well above the £2,000 mark.

*A screen from the QL Easel graphics package, one of the four programs from the Psion-written software suite which is supplied with every QL.*

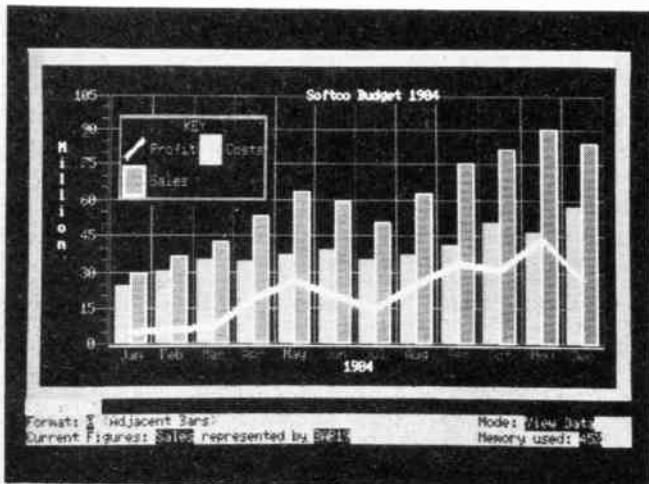

Price indeed is where the QL scores, at £399 it must represent another break-through in the computer world.

### QL features include:

- 128K RAM—expandable to 640K by means of a 0.5 Megabyte RAM pack from Sinclair;
- 32-bit processor;
- Two built-in microdrives, each offering 100K of storage for programs and data (up to six drives may be connected);
- Local area network facility (allows up to 64 QL and

- Spectrum computers to be linked);
- A full-size QWERTY keyboard;
- It drives colour and monochrome monitors and TV;
- Professional style software included on microdrive cartridges for word-Processing, Spreadsheet, Database, Management and Business Graphics.

*The QL microdrive cartridge being inserted into one of the two built-in 100K microdrives.*



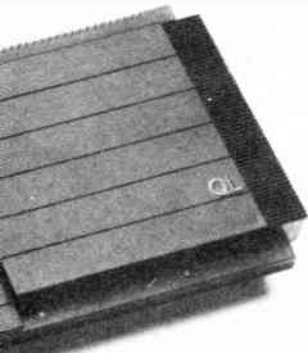

The QL's features include high resolution colour graphics, 128K RAM (expandable via a 0.5Mb RAM pack to 640K); two built-in 100K QL microdrives and a full-size 65-key professional QWERTY keyboard.

## MORE POWERFUL LANGUAGE

A new language Sinclair Superbasic has been devised for the QL. It is a more powerful version of the Sinclair Basic.

## PERIPHERAL PORTS

At the left end of the machine is an expansion slot for a 0.5Mb memory board and forthcoming peripherals. At the opposite end is a microdrive extension slot.

At the rear are no less than nine additional peripheral ports. These include two for standard communications interfaces for such as printers and modems; two for joysticks, for games or cursor control, and a ROM cartridge slot to accept a QL ROM cartridge (ZX ROM cartridges are not suitable for the use of QL). Up to 32K ROM is possible.



A prototype of the forthcoming QL 0.5Mb RAM pack, connected via the internal expansion slot.

## PERSONALITIES

Sony Broadcast have announced the appointment of Mr. Jeff Meadows as Managing Director Designate. He joins Sony from NBC Network, America.

Digital Equipment Co. have announced that Darryl Barbe, Managing Director of the Company since 1977, has left to join Sun Microsystems. With immediate effect Mr. Geoff Shingles takes over as Managing Director.

Greenwood Electronics, makers of the ORYX range of soldering equipment, have appointed Mr. John Polden as Managing Director. Mr. Polden was formerly General Manager, Microelectronics Division of Welwyn Electronics.

Casio Electronics appointment of Mr. Tony Manton to the new specialist post of Product Manager for computers is the first sign of their intended launch into the computer market during 1984.

The IBA Engineering Division announces two senior appointments: Mr. Christopher Daubney is to become Head of the IBA's Engineering Information Service following the retirement of Dr. Boris Townsend, MBE.

Mr. Brian Salkeld has been appointed to the new post of Head of Satellite Engineering to cover all engineering aspects of the IBA's use of space satellites for broadcasting purposes.

## IBA Goes Soft

The Independent Broadcasting Authority has placed an order worth around £200,000 with Software Sciences for a transmitter network information system. The system will employ 22 Digital Equipment Professional 350 microcomputers linked to the IBA's existing Ferranti Argus minicomputers.

The aim of the system is to improve the flow of information to Mobile maintenance teams relating to the operational state of the IBA's growing network of more than 1,000 unattended television and local radio transmitters. At present, four Regional Operations Centres (ROCs) gather telemetered data from the transmitters which is processed by the Ferranti Argus minicomputers. The ROC operators pass information on potential or existing faults by telephone to the maintenance teams.

The first Sinclair Education Exhibition will be held at the Central Hall, Westminster, London, from 28 to 30 March 1984. Sinclair and around 50 supporting companies will be exhibiting.

Entry to the exhibition is by invitation only, and is restricted to teachers, lecturers and other educationalists.

## SAVE IT

An order to supply the largest synchronous motor inverter drives to be installed in the UK has gone to Brush Electrical Machines.

The two 6MW Synchrosil drives, ordered for the Royal Aircraft Establishment at Pyestock, are expected to save the Ministry of Defence more than £1,000 per day in energy costs. The drives will be used in conjunction with a supervisory computer and switch panel for soft starting any one of 12 motors, one of which is rated at 27MW and will require two variable frequency inverter sets to be run in parallel, giving a total capacity of 12MW.

## Facsimile

The UF 800 range of Panafax facsimile machines announced by Panasonic recently are to be distributed by Reliance Systems Ltd., the marketing arm of GEC Information Systems Group (GECIS), and will be known as the GEC800.

GECIS have been expected to enter the facsimile market for some time, but have held back until a suitable digital machine became available and the way was clear, with general acceptance of standards, for the facsimile market to expand. They believe that this time has now arrived.

## CB NEWS

A number of changes to the existing CB radio licence are to come into effect from 5 March 1984.

Licences and licence renewals taken out from this date will only be valid if the licence holder is aged 14 or over. Children under this age will still be able to use CB, but only under the supervision of an older person. Those under 14 whose licence will expire after 5 March may continue to operate under their own licences until such time as they fall due for renewal.

Other changes include an explicit ban on the playing of music and the re-transmission of radio and television broadcast material. Also, to help counter abuse of Channel 9, the new licence will draw attention to the CB Code of Practice and point out that Channel 9 is used for emergencies and assistance only, but is not a substitute for the 999 service.

The 27MHz antenna description will be modified to allow loading coil(s) to be positioned at places other than the base of the aerial. The overall length restriction, which will now include the loading coil, remains. This restriction on length is retained to minimise the risk of harmonic interference.

# RADIO WORLD

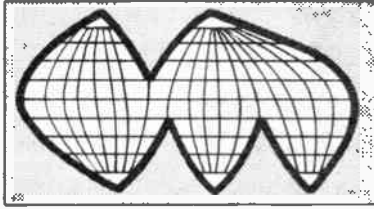

BY PAT HAWKER G3VA

## Not Unique

Many of us tend to think that the h.f. ("short wave") band is unique in making possible direct world-wide reception of radio transmissions. What we forget is the waveguide-type propagation of very low and extremely low frequencies below about 30kHz (wavelengths exceeding 10,000 metres).

High power transmitting installations with enormous aerials, such as Rugby Radio (GBR) on 16kHz, (18,750 metres), can be received in all parts of the world although the narrow bandwidth of the aerials means that transmissions have to be restricted to Morse and machine telegraphy (radio-teleprinting). The use of v.l.f. signals have one very important advantage over h.f. the signals penetrate much farther below the surface of the sea and permit the transmission of messages to submarines, although usually not when these are deeply submerged.

The electromagnetic spectrum theoretically extends down to 0Hz and the Americans have done a good deal of work on radio frequencies below 100Hz, though this requires transmitting aerials many miles in length. This has proved highly unpopular with people living near proposed operational aerials up to 100 miles long.

Signals at these extremely low frequencies penetrate deeply into the oceans but have extremely limited information capacity that makes it necessary for each "bit" of information to last many seconds, but nevertheless permitting a short "crack signal" type of coded message to be sent to a submarine many feet under the surface of the sea.

## Long Waves

In Europe, but not in most other parts of the world, frequencies between 150 and 285kHz (2000 to 1053 metres) are used for broadcasting. A single high-power transmitting station, such as Droitwich on 200kHz (1500 metres), can provide reasonably good coverage both day and night over the whole of England and Wales: coverage would be even better were not these frequencies so vulnerable to many forms of electrical interference.

The radio spectrum between 160 and 190kHz (1875 and 1580 metres) includes some of the highest power European long-wave stations: Paris Inter (Allouis), Radio Moscow, Europe 1 and Deutschlandsender (GDR).

If you take a European receiver to North America this part of the radio spectrum seems almost deserted (American radio receivers do not normally include a long-wave band). In fact the F.C.C., the American

regulatory body, permits anyone to transmit in this band provided that the power input to the transmitter does not exceed one watt and the length of the aerial is less than 50ft.

With these limitations it must have seemed to the F.C.C. that any transmissions would be of an extremely local nature. Although a short aerial is reasonably effective for receiving, the "radiation resistance" at these frequencies would be only one or two hundredth of an ohm, so that the percentage of the 1-watt of power actually radiated is unlikely to be more than a few milliwatts.

Nevertheless, despite these severe limitations, some American enthusiasts have apparently found it possible, using Morse, to transmit over several hundreds of miles, with the current record about 700 miles on 1750 metres.

## Amateur Boom

The number of licensed radio amateurs in the UK is approaching 50,000 or almost one per thousand of the total population and roughly double the number of about five years ago.

The RSGB has a record number of more than 35,000 members; of the small specialist clubs the G-QRP Club devoted to low-power operation has almost 2500 members; the British Amateur Radio Teleprinter Group roughly 1300 members. Local groups and societies throughout the UK seem to be flourishing.

## Aerial Supports

In the days when large passenger liners had tall masts to support long aerials, the marine shipping band with a calling frequency of 143kHz (2100 metres) was a popular alternative to the 500kHz (600 metres) band. Today one hears complaints that even large ships seldom have masts suitable for effective 500kHz aerials, and tend to use vertical "whip" aerials that require extremely good insulation. This is difficult to maintain in conditions of salt-laden spray. The long-wave marine band has virtually disappeared.

Aerials and aerial supports have always been a problem for listeners and viewers. Photographs taken in the 1920s and 1930s show that many radio listeners used an inverted-L aerial running down the length of the garden to cross-topped wooden poles between 15 to 35ft high.

Today, apart from a few h.f. enthusiasts and radio amateurs, such aerials have long been superseded by the convenient ferrite-rod aerials built into radio sets. Similarly, the tangle of Band I and Band III v.h.f. television aerials that cluttered roof-tops in the 1950s and 1960s have given way to a single, reasonably compact, aerial pointing to the nearest co-sited BBC/IBA u.h.f. transmitter.

Nevertheless there are still problem areas, particularly in places subject to "urban shadowing", where metal poles up to about 16ft in length have to be erected. The British Standards Institute have just published BS6330:1983 a "British Standard Code of Practice for reception of Sound and Television" to replace the now out-of-date "CP 1020:1973."

The new BSI, which took a number of years to produce, provides recommendations on good practice not only for domestic aerial installations but also for master aerial and cable distribution systems. This, perhaps unfortunately, turns the 44-page BSI into a pretty formidable document which is likely to prove beyond not only the ordinary listener and viewer but also many of the installers of domestic aerials for whom it is intended.

This seems a pity as it does contain a lot of practical advice on how to make sure that aerials last a long time and do not constitute a hazard to householders.

## Grow Your Own Aerial!

Some ten years ago the American signals research people at Fort Monmouth devised a new aerial matching device that enabled the 50-ohms output of a transmitter to be coupled into almost any conductive vertical structure, including metal poles or even trees. It was shown that in a damp and dense jungle situation a growing tree could itself form an aerial many times more efficient than the customary short whip aerials used with manpack equipment. It was even shown that by using several trees it was possible to provide a ready-made directional aerial.

At the time I was quite interested as I had once attempted, with very limited success, to use a metal drain-pipe running up the side of a tallish building in central London as a transmitting aerial. But in the decade since 1973 I have not heard of many people actually using trees except as supports for wire aerials.

However, a team of Indian scientists, led by S. P. Kosta, took the American work very seriously and in the past few years have described work on using date palm trees, cypress trees, coconut tree branches, and most recently the green vegetation canopy of a whole series of tropical plants, to form v.h.f. and u.h.f. aerials. They have proved that certain geometrically-shaped vegetation, due to its water and chlorophyll content, can propagate electromagnetic waves when suitably fed with r.f. power.

Tests at 1GHz, 3GHz and 4GHz have all proved satisfactory. In one test TV pictures from the Bangalore TV transmitter were received over distances of 12km and later 25km using live banana trees between 10ft and 15ft high.

The centre conductor of a length of coaxial cable is simply fitted with a short probe to tap the r.f. energy out of the vegetation, finding the optimum tapping point by trial and error. Presumably you trim your aerial with a pair of garden shears!



# CIRCUIT EXCHANGE

This is the spot where readers pass on to fellow enthusiasts useful and interesting circuits they have themselves devised. Payment is made for all circuits published in this feature. Contributions should be accompanied by a letter stating that the circuit idea offered is wholly or in significant part the original work of the sender and that it has not been offered for publication elsewhere.

## VERSATILE JOYSTICK CIRCUIT

SEVERAL joysticks have appeared on the market for use with many popular makes of microcomputer. They all tend to fulfill their purpose adequately apart from one aspect. That is they demand rapid and continual mechanical depression of the push-button for many games.

The circuit outlined here enables the push-button contacts to be made in one of two ways; a continuous mode of operation by a single depression of an external push-button; or by voice or sound actuation. The external push-button may be foot-operated, one hand therefore freed for mechanical operation of the joystick. Certain games may lend themselves to efficient operation using this circuit, with the resultant astronomical scores!

The first option uses half of a 556 timer, operated in the astable mode. Values of the timing resistors and capacitor were chosen to give a frequency of around 10Hz. This speed was considered sufficient for most applications, although the preset resistor (VR1) allows for increase or decrease of this value. The output from this astable is used to drive a miniature d.i.l. relay.

This mechanical method of closing the push-button contacts (A and B) may be replaced by a quad bi-lateral switch (4016) if desired, but the existing relay gives an aural indication of circuit operation in the form of relay clicks. The diodes D1, D2 and D3, are essential to prevent possible latch up of the circuit. This state could occur if a negative

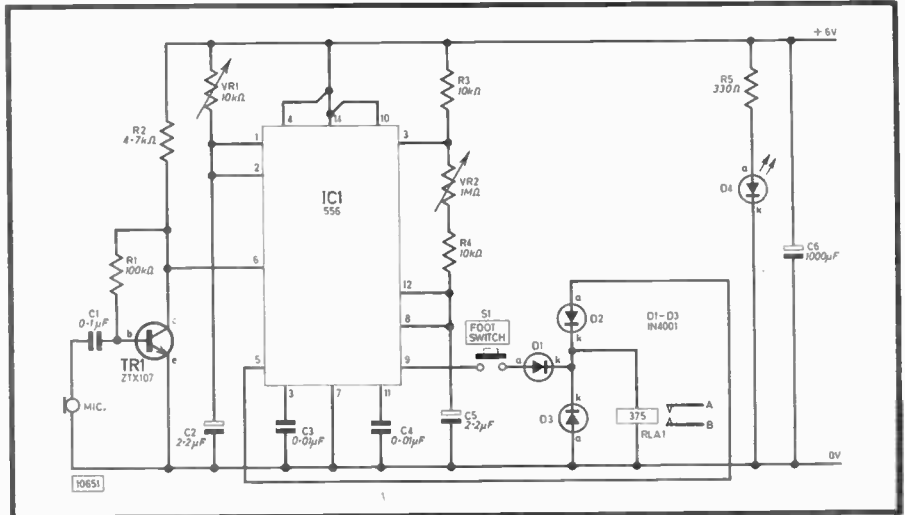

voltage reached the output pin (9, 5). The contacts A and B are wired in parallel with the existing joystick wiring, so as to permit "conventional" use of the joystick's push-button.

The voice actuated circuit uses the other half of the 556. This time the circuit is of the monostable type with a time delay of about 100ms (variable). A single stage microphone pre-amplifier is directly coupled to the trigger pin of the monostable. A negative-going pulse is produced when its sound is detected by the microphone. This pulse is sufficient to trigger the monostable.

The timing interval commences on the cessation of the sound. Thus the relay may be closed for as long as there is detectable sound. This fact may lead the

circuit to be applicable for other purposes where it may be inconvenient to keep a contact closed by manually holding down a button. The microphone used, is a non-critical device. In fact almost any crystal type will be adequate for the purpose. The circuit may be initiated by either speech or sound; or even blowing.

A calculator mains adaptor may be used for a power supply, alternatively batteries can be used. A voltage in the range of 6V to 9V at about 250mA is sufficient for operation of the circuit. The total project may be mounted in a small plastic case fitted with a footswitch (push-button) or hand operated push-button.

P. R. G. Reynolds,  
Benfleet,  
Essex.

## SOUND-TO-LIGHT

THIS sound-to-light circuit operates by a small output from a radio being applied across the secondary winding of the transformer T1, which is used in reverse, in a step-up mode. The increased output from the primary winding of the transformer is then applied across the base and emitter of the transistor TR1, which causes the transistor to turn on, and allows the bulb to flash on, according to the output of the radio.

Capacitor C1 gives the bulb a slow decrease in brightness effect. The windings on transformer T1 do not have

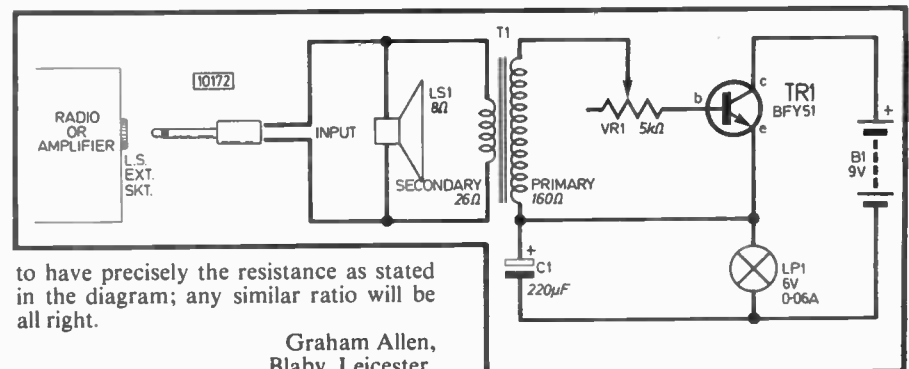

to have precisely the resistance as stated in the diagram; any similar ratio will be all right.

Graham Allen,  
Blaby, Leicester.

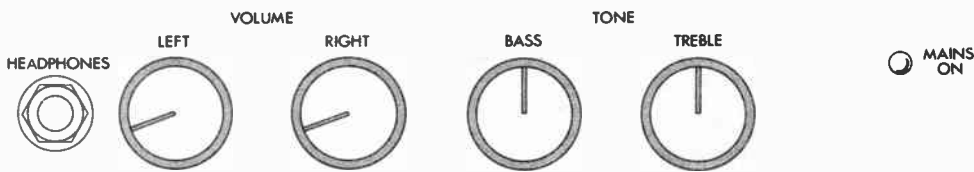

# Low Power Stereo Amplifier

BY D. J. EDWARDS

**T**HIS article describes a stereo amplifier of modest proportions that will be ideal for use in a small room or listening area where a low level of output is all that is required. The quality, while not claimed to be hi fi, is very good.

The stereo amplifier provides 2.5 watts output per channel and while this is by no means excessive, if used with efficient loudspeakers the resulting sound output will be ample for the purposes suggested above. Tone controls and input facilities similar to those found in more elaborate (and expensive!) stereo amplifiers are included in this present design.

From a practical point of view this simple and straightforward design should provide a useful introduction to the building of audio equipment and it can be undertaken with confidence by anyone who has some basic experience in project building.

## THREE INPUTS

There is provision for three inputs: ceramic cartridge, tape recorder (input and recording output) and an auxiliary. Many cheaper cassette recorders benefit hugely from being played back through a stereo system. This overcomes the poor quality of their small, in-built speakers and lack of tone controls.

Note that this amplifier cannot be driven from a magnetic cartridge. This would necessitate a high gain equalisation circuit to be incorporated in the design and it was felt that this would make the final circuit too complicated. It would also belie the high quality which can be achieved from a ceramic cartridge.

Magnetic cartridges are best appreciated when played through a hi-fi system, and this amplifier makes no claim to be able to match the sound-quality produced by a magnetic cartridge.

## MECHANICAL DESIGN

This project has four distinct sections which breaks down a large circuit into small and manageable units. These sections are: power supply, power amplifier, tone controls and pre-amplifier.

The tone control circuitry is not built on a piece of stripboard, as in the case of the other three sections, but is assembled around and on the bass and treble potentiometers.

## CIRCUIT DESCRIPTION

The complete circuit is shown in Fig. 1. The main sections are clearly identified, as well as the terminal pins which provide the connection points between the three boards and the remainder of the circuitry.

## INPUT STAGE

Considering the left-hand channel: the input signal is selected by S1 and applied to the pre-amplifier TR1. This transistor is biased by R6, R7, R8 and R9 to give unity gain, and input impedance of approximately 900 kilohms and an output impedance of 22 kilohms. The high input impedance makes for efficient matching with music sources and the low output impedance ensures good matching to the tone control circuitry and recording socket (SK2/4).

For the tape "record" function, only the pre-amplifier stage is employed, the signal (from Disc or Aux. input) passing back to SK2/4 for application to the tape recorder record input. On tape "replay" the output from the tape recorder is applied to SK2/5 and via S1, passes through the entire amplifier system.

## TOPE CONTROLS

The output from TR1 is coupled via C2 to the tone control circuit. This utilises a Baxandall network which cunningly allows for both bass and treble boost and cut, and yet has no active components.

The audio signal entering via blocking capacitor C2 splits to go down the two legs of the network incorporating VR1a and VR2a. VR2a is the treble potentiometer by virtue of the fact that C3 blocks low frequency signals, which must instead pass through VR1a, the bass potentiometer. By altering the sliders of the potentiometers, the frequency bandwidth of the two legs can be increased or reduced resulting in boost and cut.

## POWER AMPLIFIER

Output from the tone circuit is applied to the volume control VR3. The slider of VR3 feeds the input of IC1, a LM380 3-watt amplifier. It requires very few external components resulting in a simple and cheap, yet good quality, circuit.

Pins 14 and 7 are the positive and negative power supply terminals respectively for IC1 (pins 3, 4, 5, 10, 11 and 12

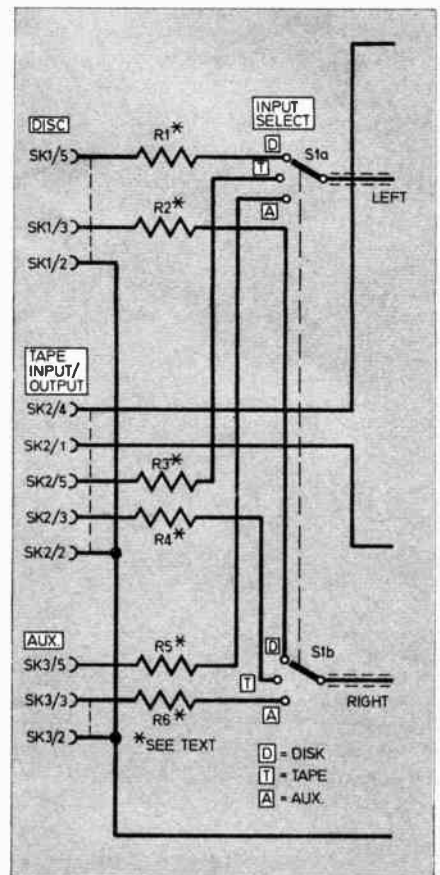

Fig. 1. Circuit diagram of the Low Power Stereo Amplifier.

are a relic from the days when the i.c. needed an external heatsink attached to them).

The input signal is coupled to pin 2 via C7, a blocking capacitor. C8 merely limits the high frequency response of the amplifier. The output to the loudspeaker socket SK4 is from pin 8 via C11, another d.c. blocking capacitor. C9 connected from pin 1 to earth results in improved hum rejection. C10 and R13 contribute to the stability of the circuit.

The headphones jack socket SK6 is connected via limiting resistor R14 to the output of IC1. The switch S2a (incorporated in SK6) automatically disconnects the loudspeaker when the jack plug is inserted.

The above described circuit is repeated in identical fashion for the right-hand channel; the components have a similar reference number to their counterparts but prefixed by "100".

## POWER SUPPLY

Power supply is derived from the mains via transformer T1. The incoming mains is switched by S3 and applied to the primary of T1, a step-down transformer producing 16V a.c. at 500mA at the secondary. This is rectified by diodes D1-D4 connected in a bridge rectifier configuration. The full-wave rectified d.c. is smoothed by reservoir capacitor C12 to give approximately 21 volts.

The l.e.d., D5, provides an indication that the unit is on and FS1 has not blown. Current through D5 is limited to a safe level by R15.

## THE CASE

The case is formed from a piece of 16 s.w.g. sheet aluminium bent to form a chassis. Wooden cheeks are fitted to enclose the ends; these are glued in with

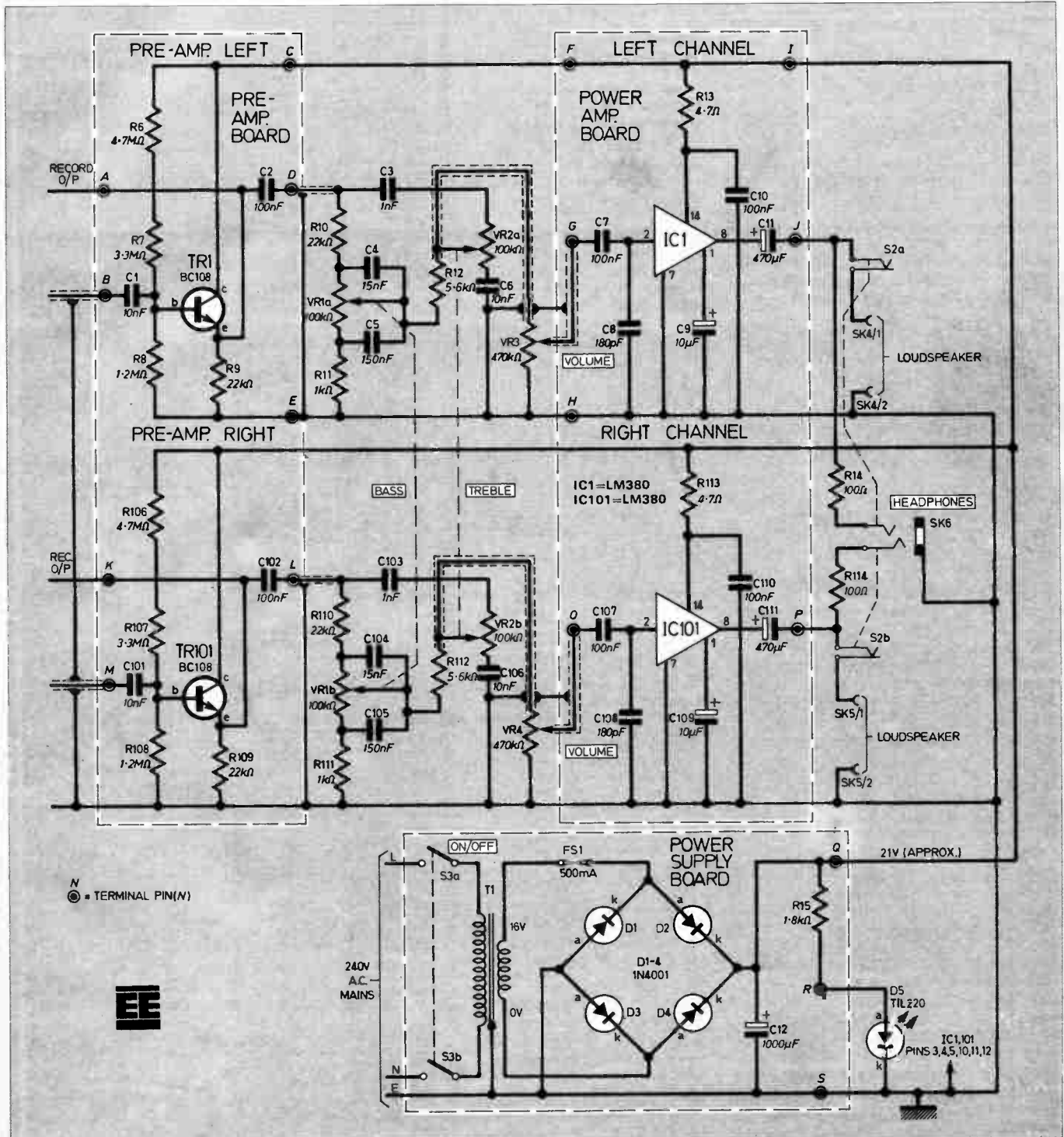

Araldite. Varnished mahogany cheeks were used in the prototype and these make an attractive finish to the completed amplifier.

Cut the aluminium to the dimensions given in Fig. 2. Score across two lines where the bends will be made. Next position the components on the back and front panel areas and, using the components as templates, work out accurately the drilling centres for each. Then drill all the holes to suit, including those for fixing screws.

NOTE. The depth of the front and rear panels may have to be increased if a larger mains transformer than that specified is used. See below.

Bend the aluminium sheet along the lines marked to produce a U-shaped chassis.

## CIRCUIT BOARDS

There are three circuit boards. These pieces of stripboard should be prepared and components mounted on their top

(plain) surface as shown in Fig. 3, Fig. 4, and Fig. 5. Note the various breaks that have to be made in the copper strips (underside); also the wire links that have to be provided (on top). Fit all terminal pins, these will greatly facilitate the interwiring of the final assembly within the case. All semiconductors should be soldered in last, and special care must be taken with the orientation and soldering of the i.c.s.

## ASSEMBLY AND WIRING

Mount and secure components on front and back panels, see Fig. 6 and Fig. 7. Fit the three completed circuit boards in position, securing each by means of BA screws and nuts to the chassis. Use spacers to keep the boards well away from the metal chassis.

Mount the resistors and capacitors onto the bass and treble tone controls as shown in Fig. 6. This work calls for care and attention since the components are mounted in close proximity to each other directly onto the potentiometer tags. Note

the earth side of C6 and C106 is soldered to the metal case of the potentiometer, likewise R11 and R111. Lower wattage irons will not be adequate for this purpose; a 25-watt iron with a larger bit fitted than for normal wiring was employed by the author.

Now proceed to the interwiring. Take care that the ends of the eight screened cables are correctly prepared and that the screening is soldered—at one end only—to the exact point on the circuit boards as indicated in the diagrams.

All other connections should be made with plastic covered tinned (stranded) copper wire 7/0.2mm. The mains wiring from S3 to T1 primary should be a twisted pair.

Resistors R1–R6 associated with the input sockets will have to be adjusted on test (see below).

Ensure that all "earthed" leads are connected to the main earth point on the chassis, indicated in Fig. 2. This consists of a 6BA screw on to which are fitted six

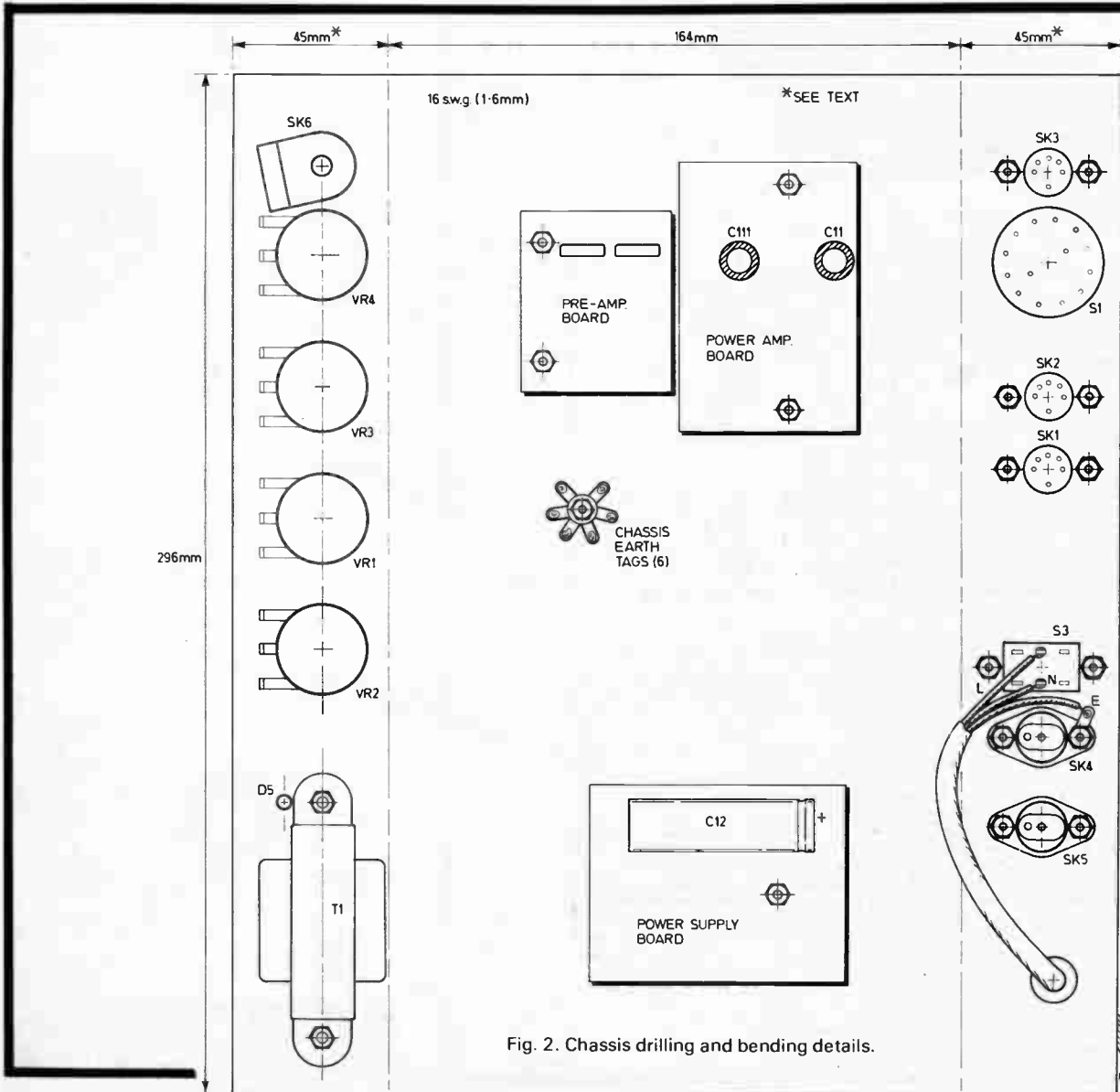

Fig. 2. Chassis drilling and bending details.

# COMPONENTS

## Resistors

R1	A.O.T. see text
R2	
R3	
R4	
R5	
R6,106	4.7M $\Omega$
R7,107	3.3M $\Omega$
R8,108	1.2M $\Omega$
R9,109	22k $\Omega$
R10,110	22k $\Omega$
R11,111	1k $\Omega$
R12,112	5.6k $\Omega$
R13,113	4.7 $\Omega$
R14,114	100 $\Omega$
R15	1.8k $\Omega$
All $\frac{1}{4}$ W 5% carbon	

See  
**Shop  
Talk**

page 164

## Potentiometers

VR1a,b	100k $\Omega$ linear dual gang
VR2a,b	100k $\Omega$ linear dual gang
VR3	470k $\Omega$ log.
VR4	470k $\Omega$ log.

## Capacitors

C1,101	10nF polyester	} (2 off)
C2,102	100nF polyester	
C3,103	1nF silver mica	
C4,104	15nF polyester	
C5,105	150nF polyester	
C6,106	10nF polyester	
C7,107	100nF polyester	
C8,108	180pF silver mica	
C9,109	10 $\mu$ F 25V elect.	
C10,110	100nF polyester	
C11,111	470 $\mu$ F 25V elect.	
C12	1,000 $\mu$ F 25V elect.	

## Semiconductors

TR1,101	BC108 <i>n</i> p <i>n</i> transistor (2 off)
IC1,101	LM380 3W amplifier (2 off)
D1-4	1N4001 silicon rectifier (4 off)
D5	TIL220 0.2in red l.e.d.

## Sockets

SK1,2,3	5-pin DIN (3 off)
SK4,5	2-pin DIN (2 off)
SK6	6.3mm stereo headphone jack, with two c.o. contacts (S2,b)

## Switches

S1	2-pole, 3-way rotary
S2a,b	part of SK6
S3	d.p.s.t. mains

## Miscellaneous

F1 500mA 20mm fuse and holder  
 T1 mains transformer, 16V 500mA secondary (see text)  
 Stripboard, 3 pieces: 21 holes x 17 strips, 32 holes x 20 strips, 30 holes x 23 strips. Knobs (5 off); screened audio cable, connecting wire, soldertags, terminal pins, mains cable and plug. Case (see text).

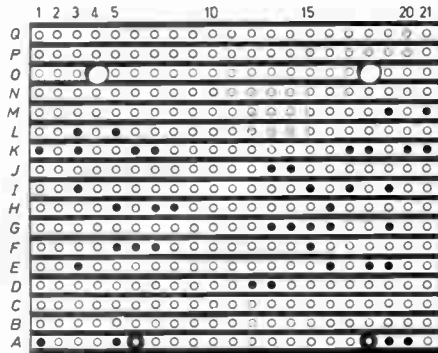
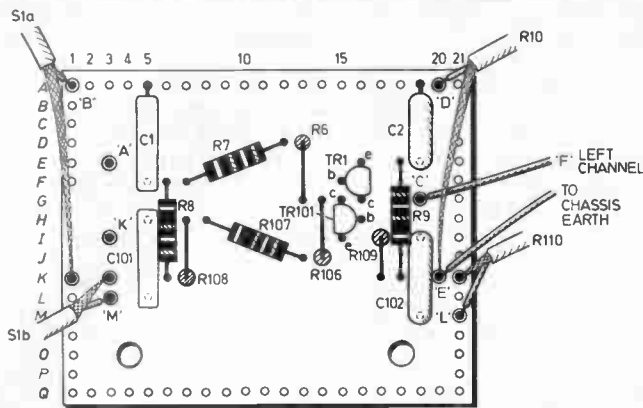

Fig. 3. Pre-amplifier circuit board; (a) topside; (b) underside.

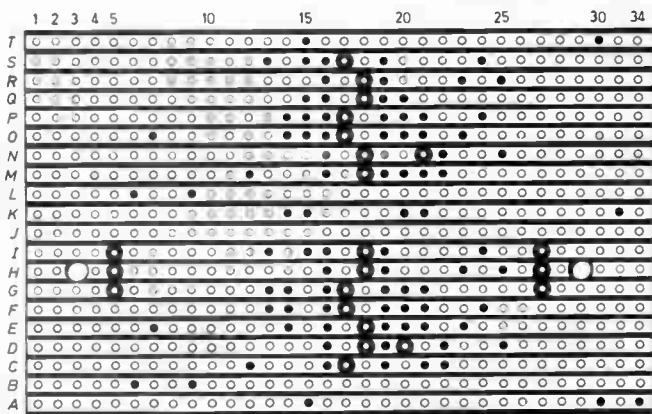
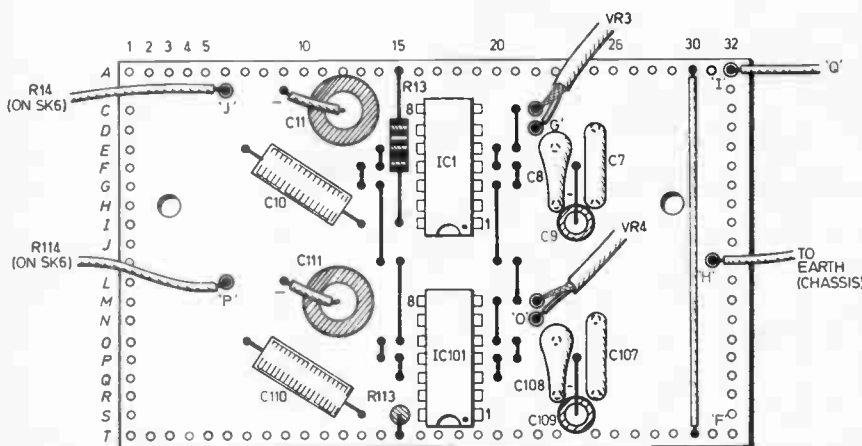

Fig. 4. Power amplifier circuit board; (a) top side; (b) underside.

Approx. cost  
Guidance only

**£25**

soldertags, these finally secured with a nut. The earth wire of the mains lead is soldered to a tag which is fixed to the case by one of the bolts securing SK4.

### MAINS TRANSFORMER

Since the mains transformer tags are only just below the top edge of the front panel, it is advised that the exposed side of the transformer be covered with a piece of plain s.r.b.p. This board can be held in position by Araldite applied to the edge making contact with the front panel.

This precaution is particularly important if the completed amplifier is to be fitted with a metal cover or top plate.

With reference to the Components List: the Maplin mains transformer type LY03D has suitable dimensions; it has two 0-15V 330mA secondaries which should be wired in parallel. The 15V output will be perfectly adequate.

### SELECT ON TEST COMPONENTS

There are six resistors which must be selected on test. These are the input attenuating resistors, R1, R2, R3, R4, R5 and R6 which are wired directly between their sockets and S1. Their values must be selected according to the input voltage applied to them (so as not to overload the amplifier) and the input impedance required.

For a ceramic cartridge on SK1, for example, R1 and R2 will be around one megohm. This reduces the cartridges output by approximately half and gives an input impedance of nearly two megohms, which is eminently suitable for such a cartridge. □

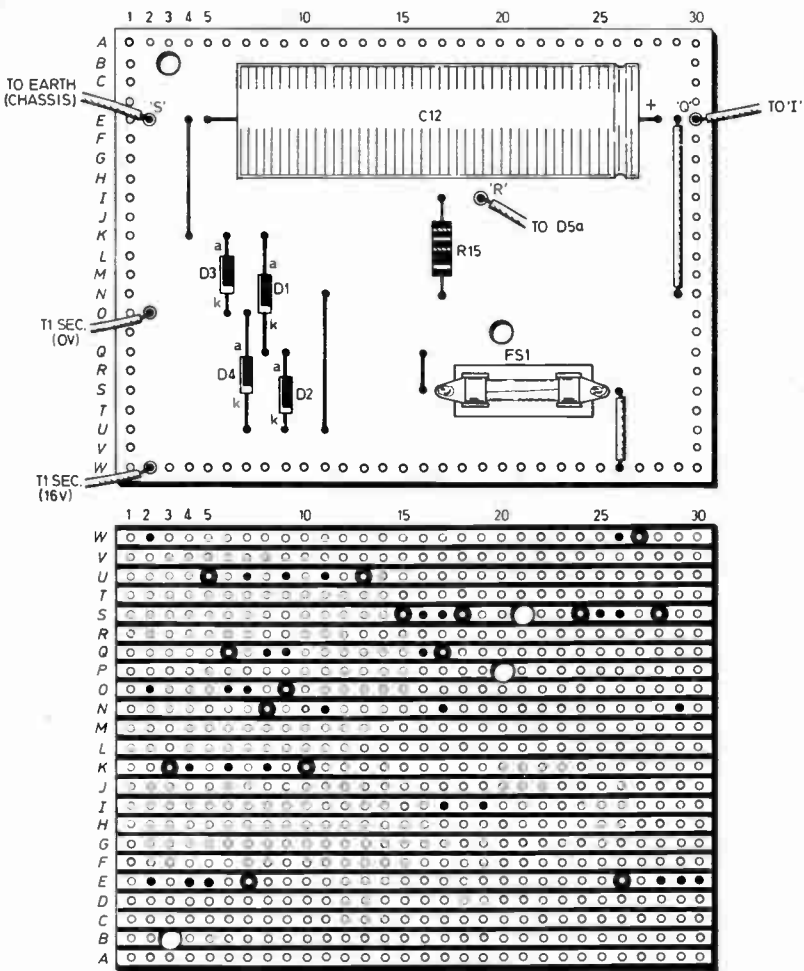

Fig. 5. Power supply circuit board; (a) top side; (b) underside.

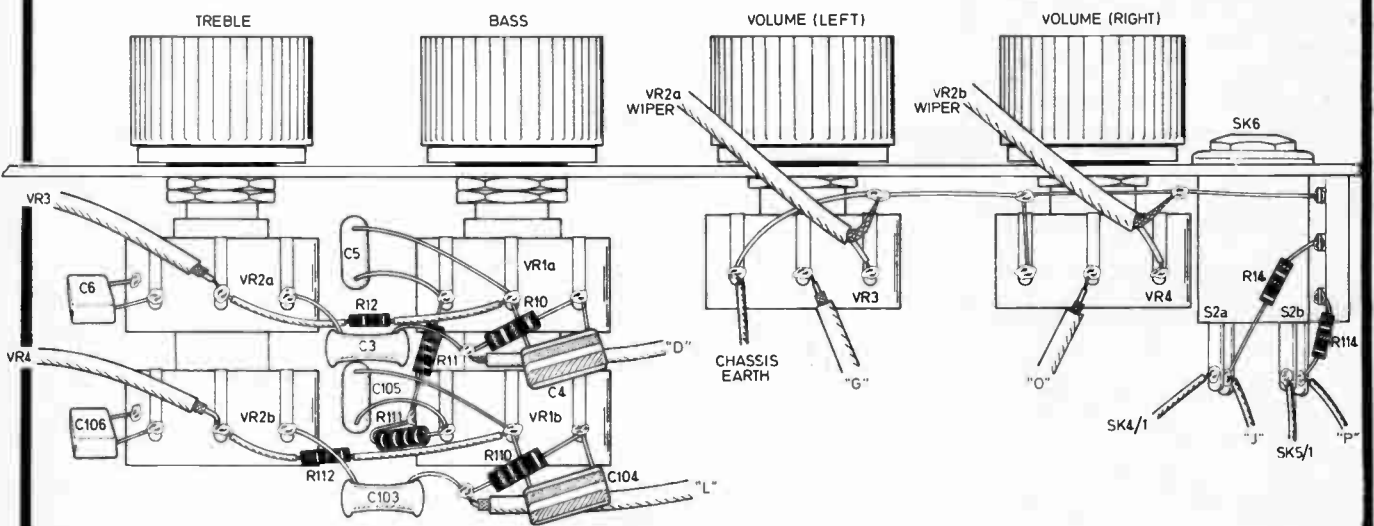

Fig. 6. Front panel components and wiring.

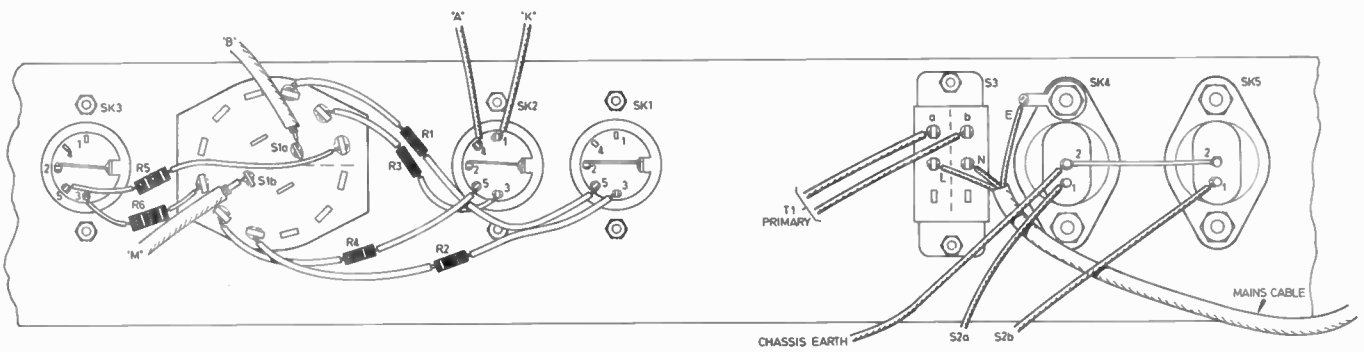

Fig. 7. Rear panel components and wiring.

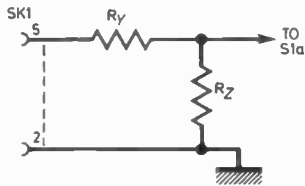

Fig. 8. A potential divider attenuator.

Other music sources such as a radio or tape recorder do not need such a high input impedance and yet their outputs may

be as great, if not greater, than that of the cartridge. In these cases a potential divider attenuator may need to be used, see Fig. 8. Bear in mind that the total input impedance will be given by:

$$R_t = R_y + \left( \frac{R_z \times 900k\Omega}{R_z + 900k\Omega} \right)$$

### TROUBLE-SHOOTING

Upon switching on with a pair of 8-ohm speakers connected to the output

sockets there will be a faint hiss and hum at full volume. If this is not the case switch off immediately.

If there is a problem with the amplifier, such as no output, distortion, or noise, the problem can be isolated to some extent by bypassing various stages and seeing if this produces an improvement.

An advantage with stereo amplifiers in trouble-shooting is that if one channel is playing up you can compare voltage measurements at strategic points with similar measurements taken from the working channel. □

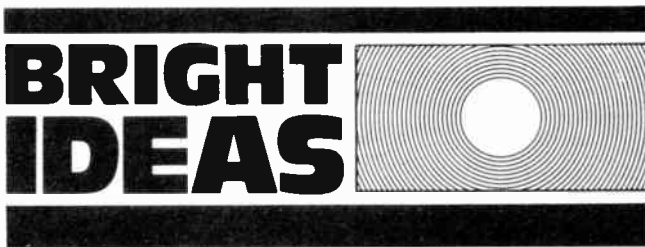
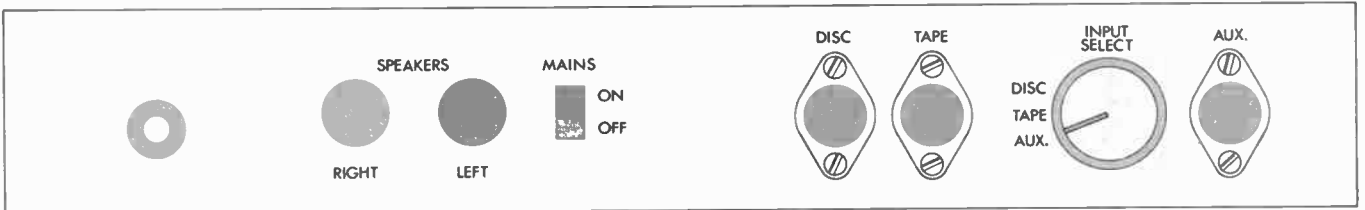

### CIRCUIT BOARD HOLDER

I AM a newcomer to the electronics hobby, but I have quickly learned that two hands are not enough when soldering components to Veroboards or p.c.b.s. I need one for the soldering iron, one for the solder and a third hand to hold the board and the components. So I knocked up the adjustable holder shown in Fig. 1. The gadget is made entirely from 1/4 inch plywood, joined with glue and panel pins.

The moveable jaw slides about the guide piece (c) with rounded ends, which is fixed with glue and panel pins to the baseboard. This guide piece should be thinned by a single passage of the plane so that the wing nut can grip the sliding jaw.

Slots are cut in the facing surfaces of the fixed and moveable jaws. The p.c.b. should not be held tightly. It can then be slid in and out as required in horizontal or vertical positions, and there is almost no risk of damage to components.

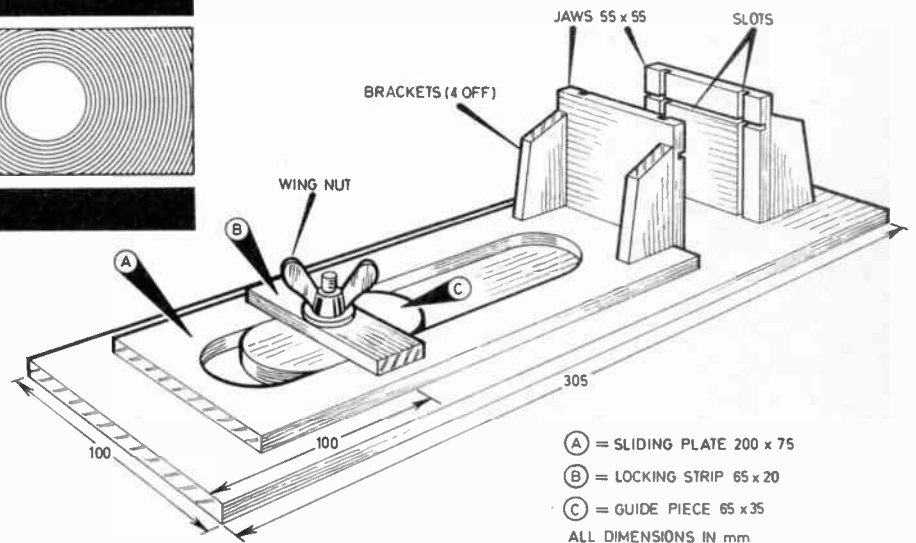

### TWO MORE TIPS

The problem of holding the component in position is readily solved by using a narrow strip of masking tape, which is cheaper and much easier to fix, and to remove, than the polythene type of adhesive tape.

Incidentally, I have found that a pair of the rather large Japanese nail-clippers, obtainable

from many shops for less than 50p are ideal for trimming off excessive leads. They clip closer, cleaner and more certainly on very fine wires than almost any side cutters costing less than about six pounds.

L. L. Nash,  
Tregony,  
Cornwall.



# PIPE FINDER

BY GEORGE HYLTON

**D**RILLING holes in walls, or knocking a nail into floorboards can result in punctured water pipes. This project is a very simple metal detector which will help you to locate metal pipes or conduits through an inch or two of wood or plaster.

It will not find plastic pipes, nor will it find electric cables unless these are very thick and very near the surface.

## ELECTRICAL CONDUCTIVITY

Metal detectors work by exploiting the fact that the metallic objects usually have a much higher electrical conductivity than their surroundings, for example, plaster, wood, or earth. When a metal object is immersed in an alternating magnetic field, currents are induced to flow in the metal.

These in turn set up their own a.c. field which react against the field that produced them. If, as in metal detectory, this original field came from the inductance of a search coil (L1), the effect of the presence of metal is to change the inductance.

By detecting this change, the metal object can be located.

## BEAT FREQUENCY OSCILLATOR

Finding hidden metal pipes is not an everyday task. Rather than describe how to make a complicated, permanently available Pipe Finder, this article gives a quick recipe for lashing one up when needed. The detector is of the b.f.o. (beat frequency oscillator) variety.

In this, the search coil forms the inductance (L) of a parallel-tuned inductive capacitive (LC) circuit. This LC circuit determines the frequency of the search oscillator. The presence of a metal object in the field of the search coil alters the tuned frequency and this change must be detected to show that the metal object is there.

## OPERATING FREQUENCY

On the face of it, the obvious way to do this would be to arrange for the search oscillator to be tuned to a musical note,

such as middle C, and listen for the note to go sharp or flat as a metal object comes within range. Unfortunately this simple method is hopelessly insensitive.

A metal pipe a few centimetres away has no audible effect: the frequency change is too small. The change may only amount to 1/100,000th of the oscillator frequency.

For this reason b.f.o. metal detectors usually operate at a frequency of around 150kHz. A change of one part in 100,000 is then 1.5Hz. To make it audible (150kHz is way beyond the human hearing limit), the 150kHz is mixed with another, nearly equal, high frequency and the difference frequency, which can be an audio frequency, is presented to the human ear as shown in Fig. 1.

If the difference is, say, 500Hz, then to most people a change of 3Hz is perceptible, and a good musician can detect as little as 1Hz. Using a higher search frequency would increase the sensitivity. However, there are practical difficulties—including the fact that really high frequencies are illegal.

The design presented here gets round the problem in a special way which makes the detector very easy to make.

## FREQUENCY MULTIPLICATION

The search frequency is in fact quite low and in the upper audio range of around 10kHz. This has several advantages. First, you can hear it (assuming that your hearing range is normal) so that you can check that the search oscillator is functioning by attaching a crystal earphone to the LC circuit and listening.

Secondly, at audio frequencies, iron pulls the frequency down while copper and other non-ferrous metals increase it.

## COMPONENTS

### Resistors

R1 330 $\Omega$   
R2,3 100k $\Omega$  (2 off)  
All  $\frac{1}{4}$ W carbon  $\pm 5\%$

### Capacitors

C1 10nF polyester  
C2 220nF polyester  
C3 3.3nF polystyrene

### Semiconductors

TR1,2 BC107 silicon *n*p*n*

### Miscellaneous

VR1 10k $\Omega$  log. control potentiometer  
L1 see text  
L2 see text  
Terminal block 2A 3-way and 9-way; 30 s.w.g. enamelled copper wire; ferrite rod, 100 x 9mm; insulating tube into which the rod fits; connecting wire.

See  
**Shop  
Talk**  
page 164

Approx. cost  
Guidance only

**£3.00**



This enables the user (with practice) to distinguish between ferrous and non-ferrous pipes, between iron screws and brass ones, and so on.

Thirdly, the capacitance of the audio LC circuit can be made so large that the effects of the stray capacitance between coil and object are swamped. This stray capacitance, in high frequency metal detectors, can produce seriously misleading effects.

To enable the frequency change to be easily detected the audio search frequency is multiplied about 50 times inside the detector. This turns it into a radio frequency. If this is now fed into a medium-wave receiver it can interact with incoming stations to produce whistles. To use the detector, the whistle is adjusted to a comfortable musical note. Metal then changes the note.

Frequency multiplication is very easy. Any waveform that is not a pure sine wave contains multiples of the fundamental frequency. By driving the transistors in the oscillator hard, they are made to distort the waveform and so generate multiples (harmonics).

### ECONOMY

The strength of the high harmonics is very low, but still can be more than enough for easy audibility in a typical pocket a.m. radio, so long as the receiver is coupled to the search oscillator as described below. This means that the only part of the circuit which you need to build is the search oscillator (Fig. 2).

The search coil consists of about 250 turns of enamel-insulated copper wire of number 30 standard wire gauge (s.w.g.).



The search coil constructed from 250 turns of 30 s.w.g. with the ferrite rod positioned in cardboard former.

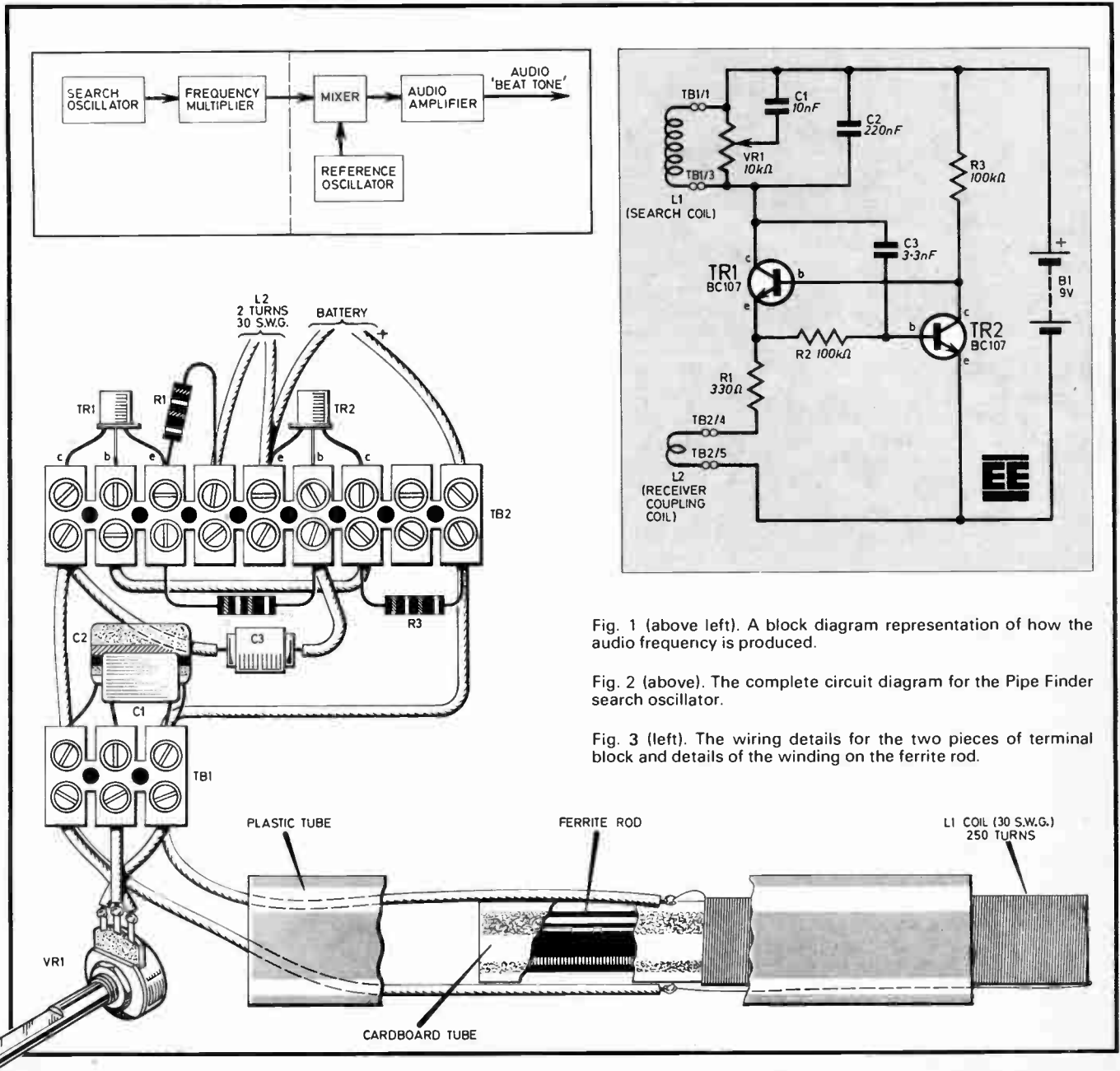
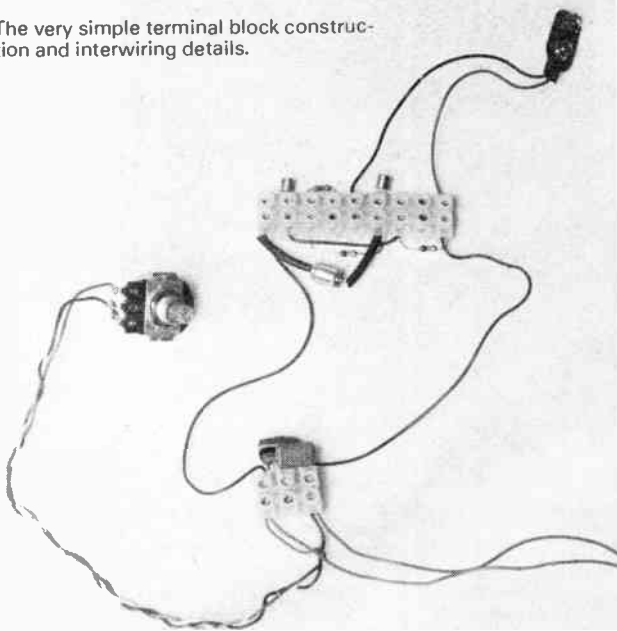

Fig. 1 (above left). A block diagram representation of how the audio frequency is produced.

Fig. 2 (above). The complete circuit diagram for the Pipe Finder search oscillator.

Fig. 3 (left). The wiring details for the two pieces of terminal block and details of the winding on the ferrite rod.

The very simple terminal block construction and interwiring details.



A ferrite aerial rod of 9mm diameter is used as a core. A 100mm rod was used for the prototype, but anything from about 51mm upwards will serve.

Obtain or make a tube of insulating material into which the rod fits. The tube should be strong, and at least a couple of inches longer than the rod. It acts both as a coil former and a socket into which a stick or length of dowelling can be inserted to act as a handle.

### COIL WINDING

To wind the coil, put marks on the tube at 12.5, 25, 38, 51 and 63.5mm from one end. You need to wind 50 turns in each of the marked-off sections. Insert the ferrite rod until it is flush with the end of the tube and start winding.

Leave an inch or two of loose wire at the start of the coil, for connections. Wind your first 50 turns in the section furthest from the end, then the next 50 in the next section, and so on. When you

have completed the turns, run the loose end back to match the first loose end.

Secure the coil by winding sticky tape round it. Insert the wooden handle firmly and tape to the tube where they meet. Rub off the enamel insulation on the last 12.5mm of each tail of the coil.

These exposed ends are used to make twisted connections to the ends of a length of flex running down the handle and then to the circuit block, with enough slack to enable the coil to be moved freely over the wall or floor to be examined.

### TERMINAL BLOCK CONSTRUCTION

For those who cannot use a soldering iron, the main part of the search oscillator circuit can be wired up, as in previous articles, with the help of a 2A electrician's terminal block as shown in Fig. 3. It is important to insist on a 2A block, which is the smallest size made, because blocks

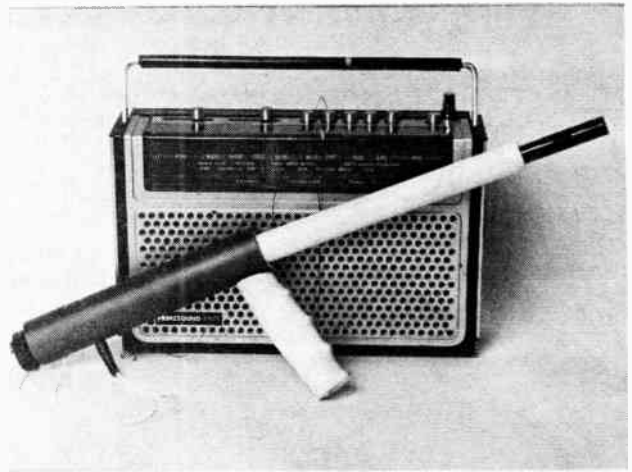

The finished Pipe Finder can be fitted into a housing of personal choice and, as shown in the picture, you can use your imagination.

for higher currents such as 5A will not accommodate TR1 and TR2.

The circuit is designed to work from 6V, but in fact it will probably work from any voltage between 3V and 9V.

### USING THE DETECTOR

The oscillator is coupled to the pocket a.m. radio by wrapping two turns of wire (L2) round the case. Tune the receiver to a station and switch on the search oscillator. A whistle will probably be heard.

Using the tuning potentiometer (VR1) adjust the pitch to a note in your own voice range. Bringing a steel nail or screwdriver near the end of the coil will cause the pitch to change. It may rise or fall. Substituting a copper coin for the steel will cause a change in the other direction.

You will find that some tuning points on both VR1 and your radio give clearer notes than others; choose one that is loud and clear. Practice detecting visible objects before you use the detector in earnest. □

# CIRCUIT EXCHANGE

## SIMPLE TIMER

THIS very simple timer uses the popular CMOS i.c., type CD4011. The circuit shows the four NAND gates and the associated discrete components. VR1 and R1 produce a minimum timing period of about seven minutes.

The timing period can also be varied with the function of the power supply which is between 9V and 12V.

How Nan Chong,  
Sainter-Croix,  
Mauritius.

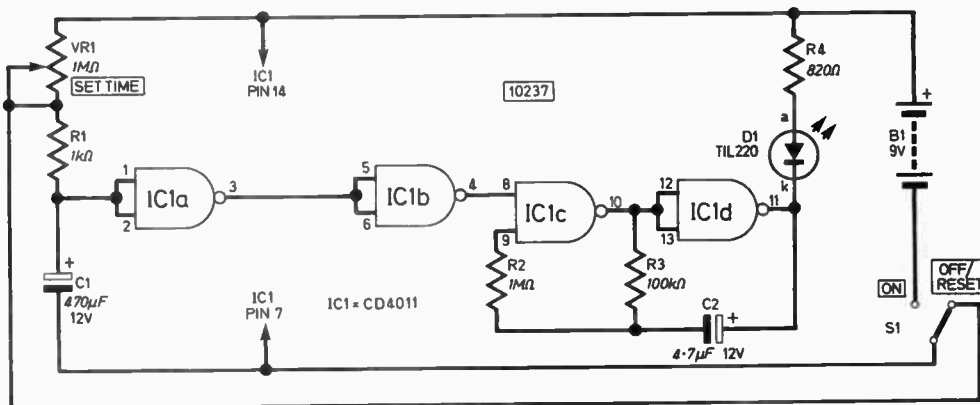

# NEW · NEW · NEW · NEW PRODUCTS NEW · NEW · NEW · NEW

## BUMPER SCOPES



A PAIR of laboratory performance, portable oscilloscopes for industrial, computer and field service applications has been introduced by **Electronic Brokers**.

The fully ruggedised and lightweight Philips PM3254 and PM3256 oscilloscopes are purpose designed for tough operating conditions. They are both dual trace instruments; the PM3254 with single timebase and the PM3256 with added delayed timebase.

Trigger and timebase circuits have been developed to over 100MHz with vertical amplifier bandwidth of 75MHz over a wide temperature range.

Full operational capabilities included are: separate variable control of main and delayed

timebases, variable hold-off, X-Y display facilities and TTL triggering as standard. The trigger-view function can also be used as a third channel.

The oscilloscopes are constructed around a strong tubular chassis. Front and rear panels are rigid plastic mouldings, the side panels are tough ABS and thick rubber bumpers offer protection to the corners. A shoulder strap is provided for easy transportation from laboratory to alternative locations.

Both oscilloscopes can be operated from either a.c. or d.c. power supplies. For details of prices contact:

**Electronic Brokers Ltd.,**  
Dept EE,  
61/65 King's Cross Road,  
London, WC1X 9LN.

## GOOD CONNECTION

THE increasing popularity of home computers, video, and hi-fi separates means that many households are suffering from a proliferation of cable "spaghetti" in their living rooms. Two new products from **Electro Replacement Ltd.**, should help eliminate the problem—and restore domestic harmony in homes where the situation has got out of hand.

The ERL Multiplug is a compact four-way mains distribution

unit. Supplied with high quality three-core cable and plugs, the complete unit can be mounted unobtrusively either on a wall or directly on to the back of the equipment.

Alternatively it could form the basis of a simple do-it-yourself housing for computer, television, video or hi-fi equipment. The unit is rated at 13 amps and can handle up to 6 amps at each outlet. The recommended retail price is £7.95 or less.



## FREQUENCY COUNTER

A NEW low-cost gigahertz frequency counter, the Model 6002, has recently been launched by **Global Specialties Corporation**. The counter will measure frequency from 5Hz to 1GHz and also offers period measurement from 1µs to 200ms. A 10MHz crystal-oven oscillator timebase ensures very high stability:

The 6002 is designed for ease of operation, with touch-button controls and a large 8½-digit i.e.d. display. Three different resolutions can be selected via front-panel buttons, and a switchable low-pass filter provides a 6dB/octave roll-off at 60kHz to facilitate audio and ultrasonic measurements.

Two front panel a.c.-coupled input connectors provide a high degree of measurement flexibility. The "A" input, which incorporates the low-pass filter, accepts signals from 5Hz to 100MHz with an input impedance of 1MΩ at 20pF, resolutions of 10Hz, 1Hz and 0.1Hz, and a ×100 multiplication mode for speeding lower-frequency measurements. The "B" input accepts signals from 80MHz to 1GHz with an input impedance of 50Ω at 10pF and resolutions of 1kHz, 100Hz and 10Hz.

For more information write to:  
**Global Specialties Corporation,**  
Dept EE, Shire Hill Industrial  
Estate, Saffron Walden,  
Essex CB11 3AQ.

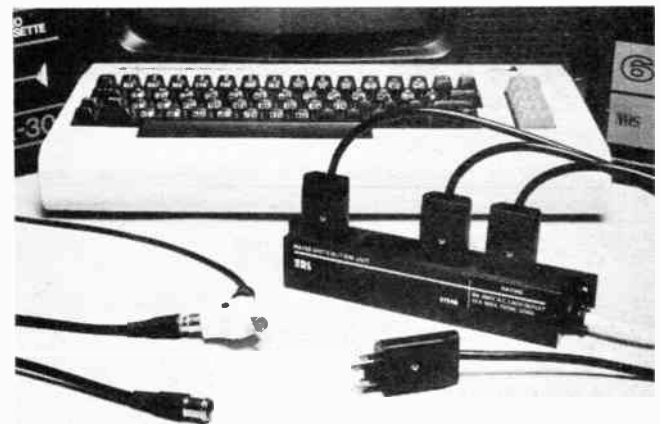

They also market an Aerial Adaptor which will be of interest to people who also use their television sets with a computer or video input. It is a switched 2-way adaptor which allows the user to select either of two coaxial inputs into the TV monitor.

It can be used with a stand alone games unit as well as a microcomputer. The recommended retail price is £1.50.

Both products are British made and available through good electrical, hi-fi and computer stores. In case of difficulties further information is available from:

**Electro Replacement Ltd.,**  
Dept EE,  
Wembley Commercial Centre,  
Unit 2, 11 East Lane,  
North Wembley,  
Middx HA9 7U'.

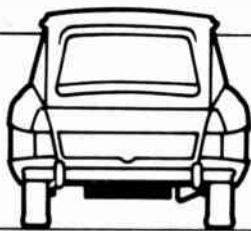

# REVERSING BLEEPER

BY T.R. de Vaux-Balbirnie

**R**EVERSING a car is always a dangerous manoeuvre. Accidents often happen when a pedestrian steps out behind the vehicle just as it is about to move.

This project warns pedestrians by giving a loud bleeping sound when the driver moves the gear lever into reverse. At night, where this sound could prove to be a nuisance, the circuit is automatically cancelled, as the reversing lights give adequate warning.

The Reversing Bleeper is in no way intended to reduce the driver's need for extreme caution when reversing, and is simply an aid to safer driving.

The system could benefit van drivers and others for whom poor visibility increases the risk of accident. It would be possible to fit it to a caravan, for instance. It is suitable for negative-earth vehicles having the usual reversing light (or lights) activated by the gear lever, and it should be noted that the rate of bleeping is about once per second and this distinguishes it from the more rapid tone of the Pelican Crossing.

The circuit draws no current from the car battery except during the act of reversing.

## OPERATION

The circuit consists of a low-frequency oscillator which operates from the existing reversing light circuit. The output from the oscillator feeds an audible warn-

ing device which emits a loud tone pulsed at the oscillator frequency. A connection to the side light circuit inhibits the system at night.

Tests show that the audible warning device (WD1) specified in the parts list will sometimes give a satisfactory signal when mounted in the boot of the car. This has the advantage of providing protection from the effects of the weather. With hatchback and estate cars it is likely that too much sound will be produced inside the car. If this is the case, the box containing the circuit can be mounted in the boot and WD1 mounted under the car.

The constructor will then have to provide satisfactory weather-proofing. Another idea would be to pipe the sound through a short piece of wide diameter plastic tubing to the underside of the car.

Before constructing the project, it would be a good idea to make some tests to find the best position for WD1. This may be done by connecting it directly to the car battery. Make certain that the connections are properly insulated to prevent short circuits and observe the polarity, or it will fail to operate.

## CIRCUIT DESCRIPTION

The circuit is based on a 555 integrated circuit (Fig. 1) and this forms the low-frequency oscillator. The output from this is not sufficient to operate WD1

directly, so TR1 is included to act as an amplifier. WD1 is placed in the emitter circuit and will bleep in sympathy with the oscillator.

The transistor, TR2, and associated components inhibit the action of the circuit at night. When the side lights are switched on, base current flows into TR2 and turns it on, and pin 4 of IC1 is then effectively at negative battery voltage. This prevents the circuit from oscillating and no sound will be produced.

When the side lights are switched off, TR2 receives no base current and remains off. Pin 4 of IC1 is now at positive battery voltage and the oscillator operates.

## CONSTRUCTION

The prototype unit was constructed on a piece of 0.1 inch matrix stripboard, 12 strips by 21 holes, as shown in Fig. 2. It is helpful to mount the i.c. holder first, after all the track-breaks have been made, these will then act as reference points for positioning the other components.

The terminal block and offboard components may now be wired together and once this has been completed a final check on the wiring may be made. The power supply for the circuit is taken from the car battery, although an electrical check may be made using a 9V battery.

## CASE

A plastic box with internal dimensions 76 × 56 × 35mm was used to house the project although any case of similar size would be suitable. WD1 may be conveniently mounted inside the case with only the front part of the device protruding through a hole in the front. The terminal block TB1 may be mounted on the side of the case and the terminal block connections are shown in Fig. 3.

The project may now be wired into the car. Locate the wires leading to the reversing lights and the rear side lights (or number plate lamp). Usually a bunch of bullet connectors may be found and disconnecting these one by one will locate the correct wires. Make a connection to each of these using light-duty auto wire. Do not use taped connections since these are likely to fail in service.

Connect TB1/1 to the reversing light wire, TB1/2 to the side light wire and TB1/3 to earth as shown in Fig. 3. If an existing earth point cannot be found, make a connection to the chassis of the car by drilling a small hole in a metal part and use an eyelet and a self-tapping screw.

Fig. 1. Complete circuit diagram for the Reversing Bleeper showing the very simple design.

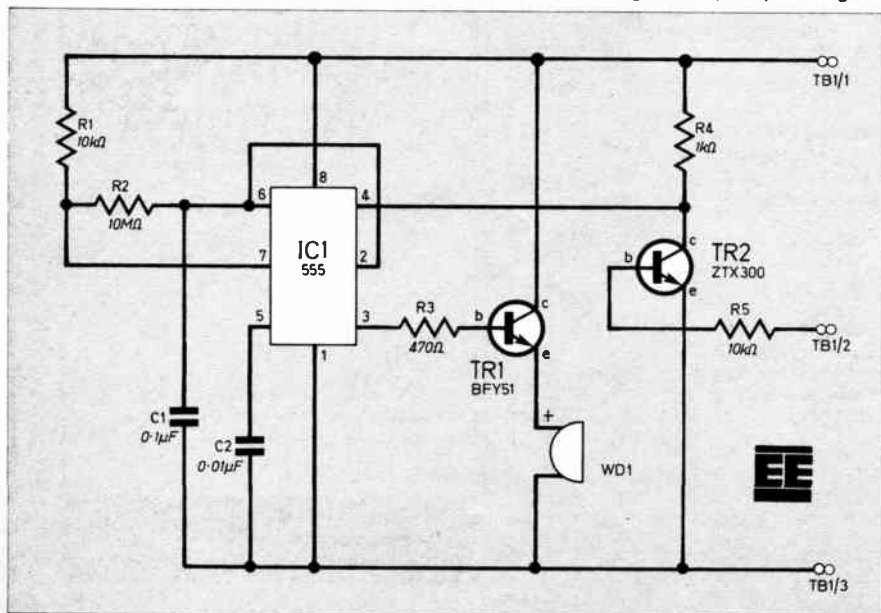

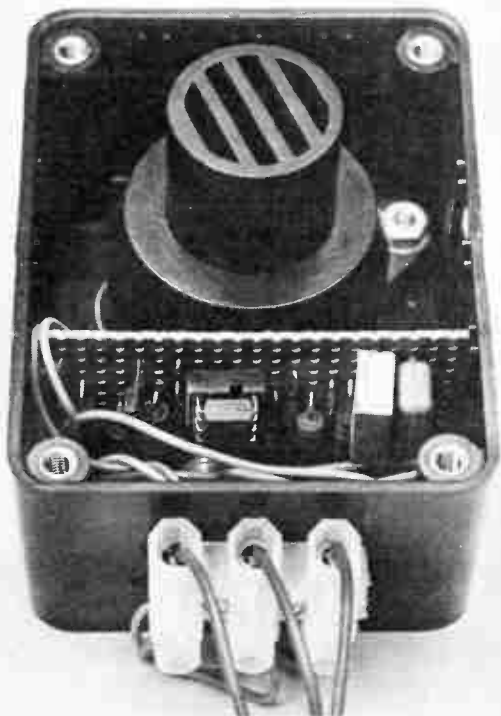

Case lid removed showing the positioning of WD1.

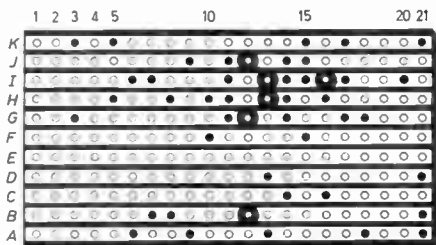
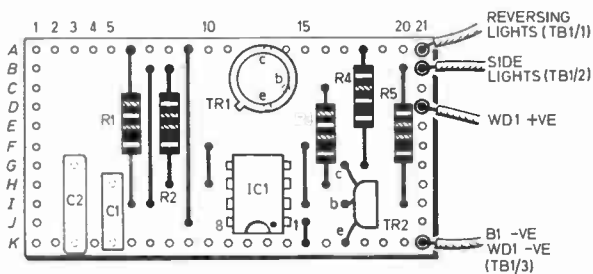
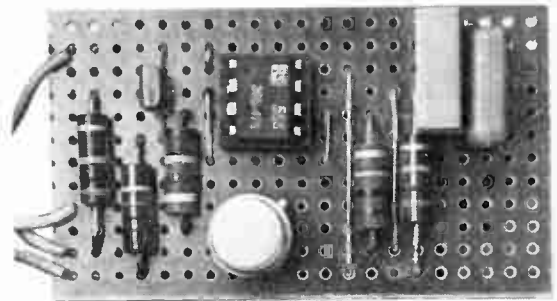
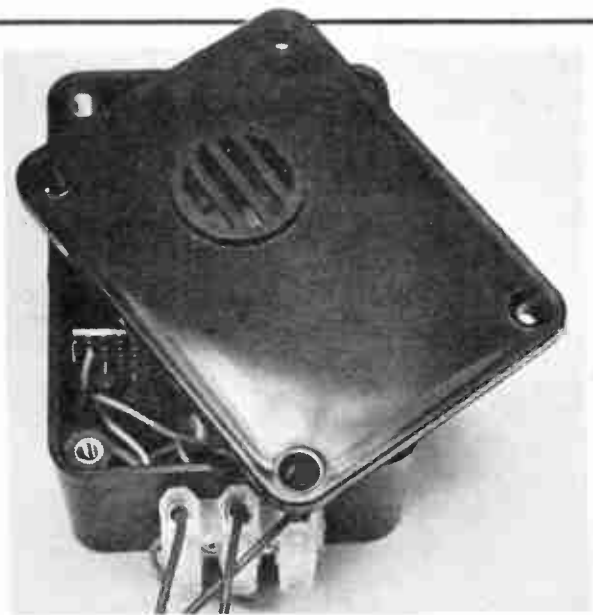
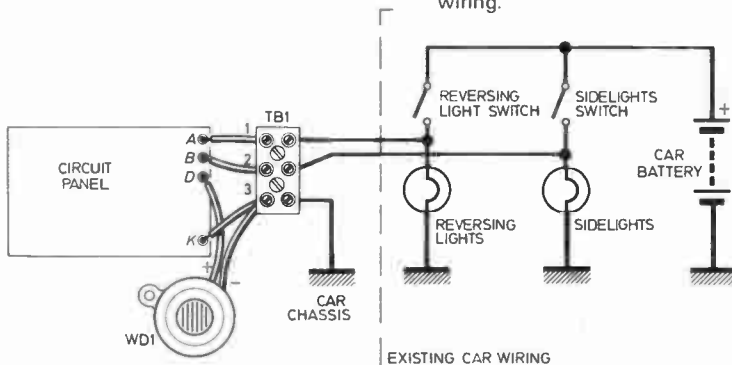

Fig. 2. Component layout, inter-wiring details and underside of the stripboard showing breaks in the copper strips.

Fig. 3 (below). Details of the terminal block connections and connections to the existing car wiring.



## COMPONENTS

### Resistors

- R1,5 10k $\Omega$  (2 off)
- R2 10M $\Omega$
- R3 470 $\Omega$
- R4 1k $\Omega$
- All  $\frac{1}{4}$ W carbon  $\pm 5\%$

### Capacitors

- C1 0.1 $\mu$ F polyester
- C2 0.01 $\mu$ F polyester

### Semiconductors

- TR1 BFY51 silicon *n*p*n*
- TR2 ZTX300 silicon *n*p*n*
- IC1 555 timer

### Miscellaneous

- WD1 12V buzzer
- Stripboard: 0.1 inch matrix size 21 holes by 12 strips; plastics case, 76 x 56 x 35mm (MB1); 8-pin d.i.l. holder; terminal block 3-way; connecting wire.

Approx. cost  
Guidance only

**£5.36**

# BOOK REVIEWS

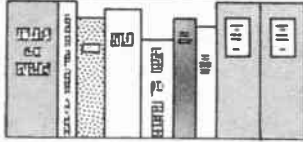

## ENJOYING ELECTRONICS

**Author** Owen Bishop  
**Price** £2.70 limp  
**Size** 243 x 190mm. 94 pages  
**Publisher** Cambridge University Press  
**ISBN** 0-521-28773-1

**T**HE cartoon style of this book helps to remove the mystery and sophistication of electronics systems for the beginner and enables straightforward teaching whilst entertaining. Each project circuit is shown accurately drawn to British Standards, only the large, clearly labelled practical diagrams are presented as informative cartoons.

Each of the forty-four projects involving re-usable components (listed with suppliers) are displayed across the double pages with the minimum of written information, a simple breadboard wiring system and a low voltage battery or power supply.

The calculations relevant to each section are introduced simply and the whole approach is similar to teaching via the blackboard without the need for note-taking. Self assessment questions provide a check on the reader's understanding of electron flow through lamps, meters, fuses, heaters, resistors, diodes, transistors, thermistors, flip-flops, capacitors and relays. Finally, the subject of alternating current is briefly introduced. Just a pity that this book's cover looks so "high-tech" . . . belying its content.

D.J.G.

## UNDERSTANDING COMPUTER GRAPHICS

**Authors** L. Howarth & J. Tatchell  
**Price** £1.99 limp  
**Size** 240 x 170mm. 48 pages  
**Publisher** Usborne Publishing Ltd.  
**ISBN** 0-86020-739-0

**A**T a time when people are beginning to look at the more serious applications for microcomputers, a vast number of micro-users are still using their machines entirely for games. These users enjoy experimenting by designing their own games and for this reason Usborne's new publication *Understanding Computer Graphics* could prove to be a priceless addition.

There are 48 pages contained within the book, starting with a basic technical description on how a computer makes pictures and what use is made of the CPU, ROM and RAM. A vital new area of games graphics is also covered, although only two brief pages are devoted to 3-D graphics.

Like all the other Usborne computer publications the book is in colour and has plenty of illustrations to help with the text. All graphics words are listed in a special section at the back of the book along with several graphics programs.

R.A.H.

## TELEVISION AND RADIO 1984

**Editor** Eric Croston  
**Price** £3.90 limp  
**Size** 230 x 195mm. 224 pages  
**Publisher** Independent Broadcasting Authority  
**ISBN** 0-900485-46-9

**O**NCE again the annual jamboree of colourful memories is upon us with the arrival of another IBA Year Book reviewing the many programmes, stars and events of 1983.

Lavishly illustrated and interesting in both style and content; many happy hours can be spent remembering the programmes of the past year and finding out more about the productions in a detailed and informative way.

In an age when the Direct Broadcasting Satellite (DBS); cable "broad" and "narrowcasting" are nearly here it is interesting to see only two pages of this "annual" and a brief mention in the letter from the Director General actually touch upon the subject.

In his forward John Whitney (IBA Director General) comments on the future plans for DBS, he says: "We are actively planning to provide new choices of programmes from the sky". Of cable he suggests that "they should not undermine the capacity of our own general services . . ." He then adds that the programmes should be of "a quality people have the right to expect".

The many aspects of broadcasting in Britain are covered together with some interesting comparisons made between Independent Broadcasting and the BBC.

D.J.G.

## PRACTICAL ELECTRONICS

### APRIL 1984

#### FREE: LOGIC DESIGN CARD No. 2

Covering logic sources, TTL supplies, supply distribution, and a typical p.s.u. design for TTL; plus more i.c. pin-outs.

#### MICROSTEPPER

"Freeze frame" your micro, instruction by instruction, to see what's going on during educational and debugging exercises.

#### TRANSPUTER

Inmos claim the Transputer array processor will set new standards, provide maximum performance, exploit new developments and be able to form fifth generation systems. We take a close look at the revolutionary new device.

#### MICROPROFESSOR 1—PLUS REVIEW

The Microprofessor system has been improved and added to by Multitech, we review this updated learning system.

All in the APRIL issue

ON SALE — 2ND MARCH

# SQUARE one FOR BEGINNERS

To finish off a project it is always good practise to fit the finished project into a custom-made case with the correct fittings and fixings. No matter how simple the project, it is always possible to finish it off with style.

The two materials most commonly used for making housings are metal and plastic. Cases made of these materials can be purchased in a number of styles and colours. So every home-built unit can have a professionally finished look.

All the projects in EE have the recommended cases listed in the components section although this advice does not have to be strictly adhered to. Where projects are designed for incorporation within other pieces of equipment, the builder must think out the installation for himself.

The greater majority of projects are, however, entirely enclosed within their own box or case. It is a must for portable or hand-held units and is necessary also for safety reasons in many instances where the electronic unit is permanently installed in position, as in a project for a motor car. The growth in custom-made cases is a great asset to the home constructor and these cases enhance the appearance of the finished project. Plastic cases are normally strong enough for the environmental conditions generally encountered.

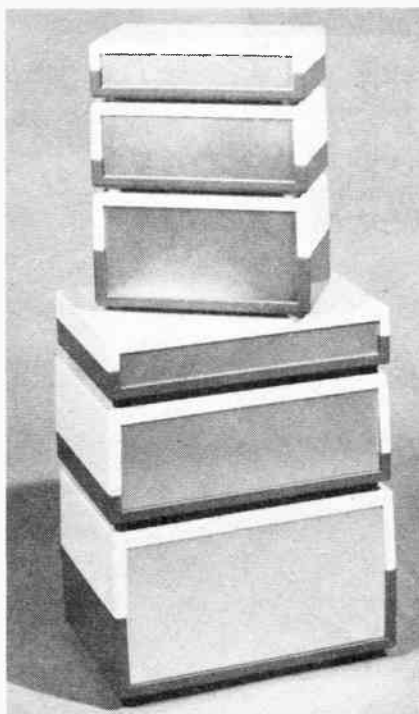

A range of high quality moulded boxes in two-tone high impact ABS. Top and bottom sections include fixing points for circuit boards and chassis plates.

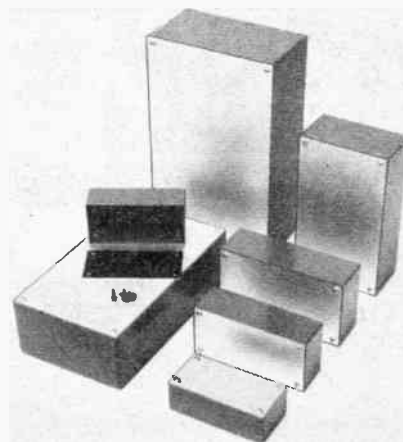

to prevent either the radiation or the pick-up of electro-magnetic signals.

## WEATHERPROOFING

Note that if a project is to be used where weather conditions are likely to effect the circuit, this must be taken into account when designing the housing. Suitable weatherproofing, such as varnish, silicone grease and waterproof casings should be used.

Once the component board has been completed it is secured in the case by a couple of small screws and nuts, for example, No. 6 BA or a similar fixing. Care has to be taken that the screws do not make contact with "live" parts of the circuit boards. Spacers can be fitted to the screws to provide clearance between the board and the box. This is important where the housing is made of metal.

The entire circuit of a project may be assembled on the one board. However, it is usual for a few larger components, including those that have some mechanical function—such as volume controls and on/off switches—to be mounted directly on the box itself. Likewise, if a loudspeaker is involved this will probably be mounted on the top panel or lid.

The casing should always be prepared before the completed components board is secured, this means drilling all the offboard component holes. Operating controls are usually potentiometers and they have a standard diameter spindle and threaded bush and are secured to the case by a locking nut.

Switches, rotary or toggle may also have threaded bushes but some types are secured by screws and may require a slot for the moving part.

Drilling and cutting out is not difficult with plastic or aluminium cases and holes for fixing offboard components can be made by enlarging a drilled pilot hole with a round "rat tail" file. Occasionally the need arises to make your own enclosure for a project and this can be a very satisfying task indeed. The best materials for this task are wood and aluminium, and once the enclosure is finished these two materials may be coated with varnish and paint, respectively. □

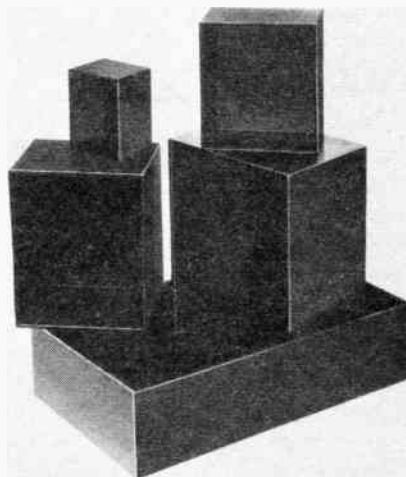

Potting boxes are for use with a resin mix (potting compound), which will set hard after several hours. This type of casing is used to encapsulate the circuit to make it damage- and moisture-proof, while at the same time providing high electrical insulation.

## METAL CASES

Burglar alarms and power controllers are examples where the greater security afforded by a sheet aluminium or a diecast box might be beneficial. The protection that a metal casing affords is not only in strength but also in its electro-magnetic screening ability.

Some electronic circuits must be enclosed within a metal container in order

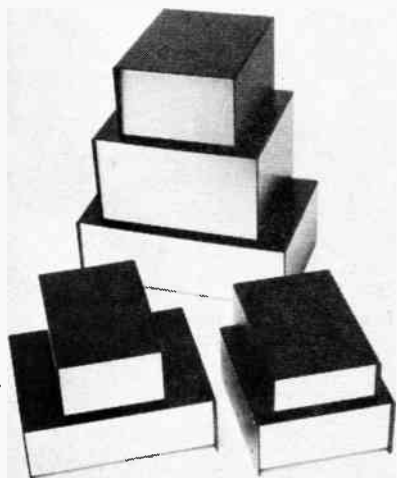

Steel covered instrument cases.

# COMPUTER AIDED EXPERIMENTS

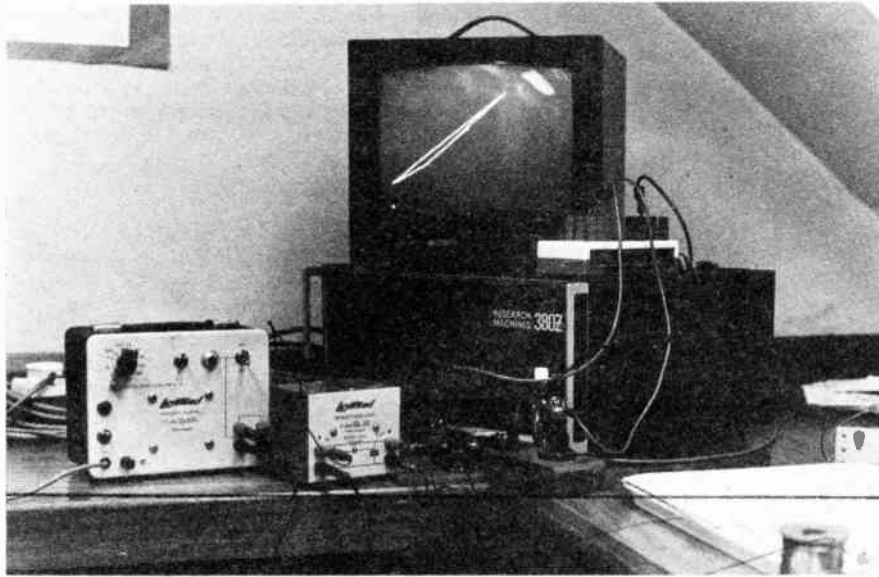

BY A. A. CHANERLEY B.Sc. M.Sc.

## 6. OHMIC AND NON-OHMIC CONDUCTORS

THIS computer aided experiment describes the essential difference between Ohmic and non-Ohmic conductors, and the limitations of Ohm's law. Until recently texts did not clearly make distinctions between Ohmic and non-Ohmic conductors, and defined resistance in terms of Ohm's law, thereby invariably confusion resulted in the teaching of these simple but vital ideas.

### RESISTANCE

If a current  $I$  is passing through a substance across which the p.d. is  $V$  volts then a property of the substance is defined as the ratio:

$$(V/I) = R \quad \dots(1)$$

This quantity is called the resistance  $R$ . It does not have any other meaning and does not make any presupposition to being a universal law. It simply names the ratio  $V/I$ .

In some cases, for example transistors and diodes, we are more concerned with changes of current resulting from changes in p.d. and therefore we define:

$$R = \left( \frac{\Delta V}{\Delta I} \right) = \frac{\text{change in p.d.}}{\text{change in current}} \quad \dots(2)$$

However, for most simple conductors,

equation (1) is quite sufficient for defining resistance.

### OHM'S LAW

Ohm's law states that, providing the temperature is constant, the current is proportional to the applied p.d.

$$V = (\text{constant}) \times I$$

This constant of proportionality is of course the resistance, since as can be seen, on rearranging the equation:

$$(V/I) = \text{constant} = R$$

as for equation (1), therefore we end up with the familiar relationship known as Ohm's law:

$$V = IR$$

This law is obeyed exactly by metals and alloys and only approximately by some non-metals, but semiconductors, for example, deviate markedly from Ohm's law.

It must be recognised that this law does not define resistance, which is defined by equation (1). The law simply states that the resistance will remain the same for metals in particular under the conditions of constant temperature, so

that  $R$  has the simple relation of  $V/I$ . However, if the voltage-current dependence was different:

For example—

$$V = kI^2$$

where  $k$  is a constant, and we now have an  $I^2$  dependence

The resistance of the material is now:

$$R = \frac{\Delta V}{\Delta I} \\ = 2kI \text{ on differentiation}$$

The resistance is now specified for certain values of current and it no longer has the simple  $V/I$  relation as when conditions for Ohm's law apply, therefore the material clearly shows non-Ohmic behaviour and has a different value of resistance specified at different currents.

Similarly, if  $V$  had an  $I^2$  dependence or some other function of current  $I$ , the resistance is still defined by the ratio,  $V/I$  or  $\Delta V/\Delta I$ , but the value of the ratio will be different for different currents and the material will be exhibiting non-Ohmic behaviour.

In the past it was usually taught that at constant temperature for any conductor Ohm's law is usually obeyed and that  $V/I$  is a constant called the resistance  $R$ . Therefore equation (1) by this argument is an expression of Ohm's law. It should be obvious that this approach leaves resistant undefinable under all conditions in which Ohm's law does not apply.

### EXPERIMENTAL STUDY

The graphs of Fig. 6.1 illustrate an Ohmic  $V-I$  characteristic at temperatures T1, T2, T3 and Fig. 6.2 illustrates a non-Ohmic  $V-I$  characteristic. It can be seen that in Fig. 6.1 the gradient and hence the

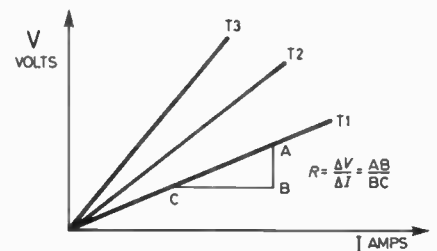

Fig. 6.1. Graph showing Ohmic  $V-I$  characteristics at three different temperatures.

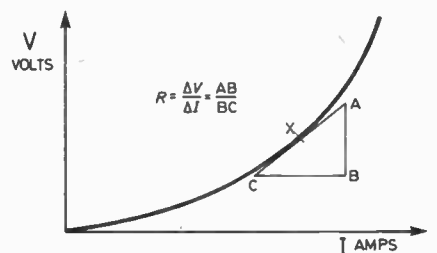

Fig. 6.2. Graphical representation of a non-Ohmic  $V-I$  characteristic.



resistance is a constant at a constant temperature.

In Fig. 6.2 however the gradient  $\Delta V/\Delta I$  is increasing with increasing current and hence the resistance is not a constant. A lamp with a metal filament would give this type of non-Ohmic characteristic if the current were to slowly increase. An increasing current, in this case, increases the temperature of the filament and the temperature radiation increases from orange/yellow to blue/white radiation, since the temperature is not constant we would expect non-Ohmic behaviour with a gradual increase in resistance.

The circuit to show this is shown in Fig. 6.3. A smoothed 10V supply is used, one which is readily available in most school labs, in this case a Linstead PSU with a separate inductive/capacitive smoother unit. This is connected directly to a 25-ohm potentiometer obtainable from the electromagnetics/science kits

obtainable in most lower schools. The wiper is connected to a 10-ohm standard resistor encapsulated in a plastic casing.

The resistor (R1) used, has a low temperature coefficient and the voltage variations across it are a measure of the current through the lamp. The resistor is connected directly to a 12V bulb and back to the PSU.

The voltage across the 10-ohm resistor is inputted directly into channel 1 of the Analogue-to-Digital Converter (ADC). The maximum input voltage per channel is 10V, therefore it should not be exceeded. The voltage across the bulb is inputted straight into channel 0.

Best results are obtained by turning the lamp on to the maximum 10V allowed, and running the software called "OHM". The 380Z microcomputer then reads the values of  $V$  and  $I$ , plots it and extrapolates back to zero so that a straight line is obtained.

This then would be Ohmic behaviour if

the resistance stayed constant at the maximum values of  $V$  and  $I$  during subsequent lowering of current. However, as the voltage is subsequently lowered by turning the wiper on the 25-ohm potentiometer, the slope is seen to change, in fact decrease, as the current is lowered and the bulb experiences cool-down.

This decrease in slope represents a decrease in resistance and the Ohmic and non-Ohmic behaviour can then be directly compared.

Fig. 6.5 shows a plot of the type of graphs expected and the photo of Fig. 6.6 shows the plots obtained on the VDU. There are no axes plotted for the sake of brevity of software.

## THE SOFTWARE

Again the software is similar to all the previous experiments in this series. Two channels are used requiring two separate POKE statements and two separate PEEK statements in order to read and

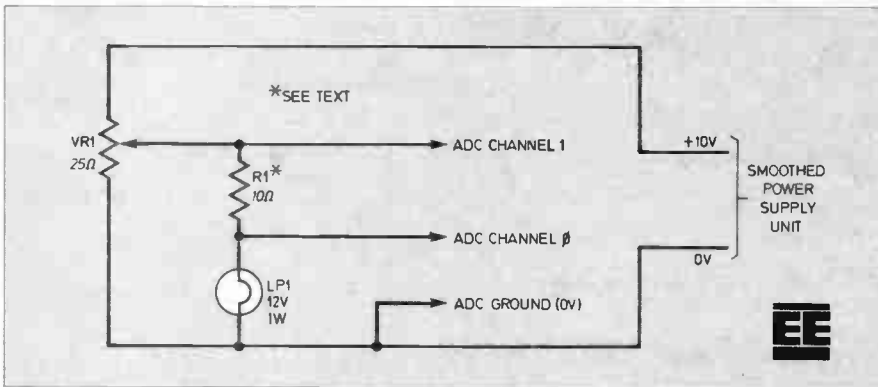

Fig. 6.3 (left). Circuit diagram of the experiment to show the non-Ohmic behaviour of a filament lamp, LP1.

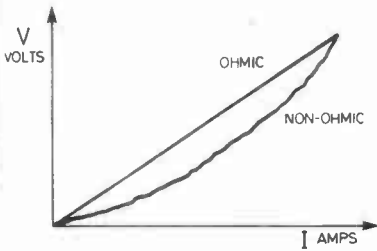

Fig. 6.5. Graph of a typical  $V-I$  plot obtained with this experiment.

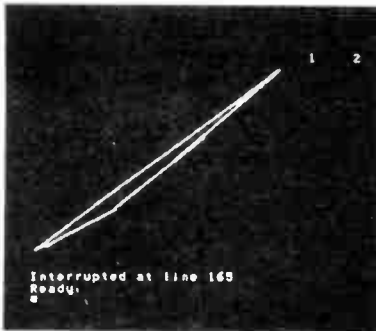

Fig. 6.6. Photograph of an actual plot displayed on the VDU.

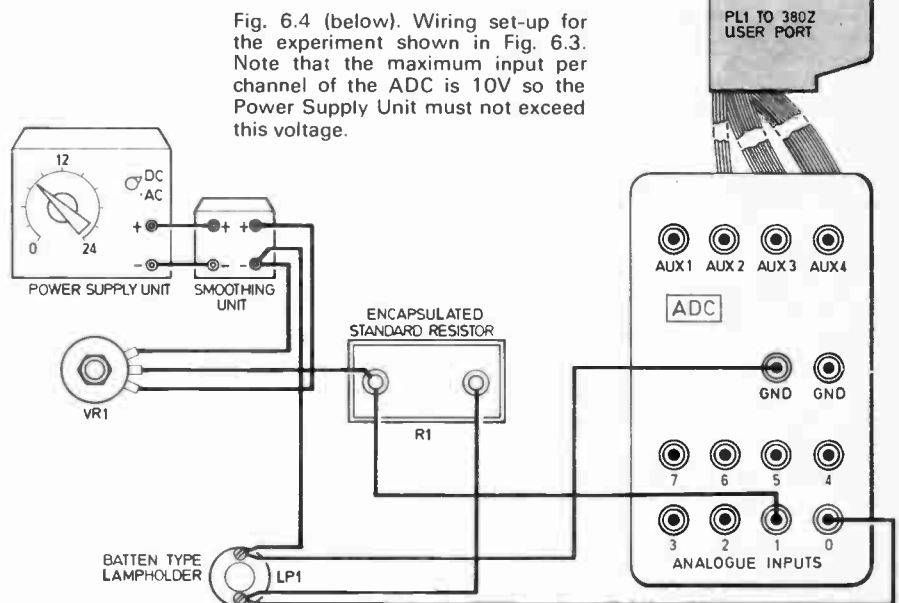

Fig. 6.4 (below). Wiring set-up for the experiment shown in Fig. 6.3. Note that the maximum input per channel of the ADC is 10V so the Power Supply Unit must not exceed this voltage.

initialise the respective channels. The values of the converted data-bytes are then read at the user port, which is memory-mapped at location 64511.

The resistance values are calculated in line 140 and stored starting at memory locations &6000, subsequently to be transferred to disk file using the STORE program.

The value of A in line 165 gives the number of readings taken which gives the number of locations used for storing R. This number of locations needs to be inputted into line 20 of the STORE program as well as line 20 of the POKER program which re-POKES the values from disk file back into memory, these resistance values can then be plotted.

To be continued

## COMPUTER AIDED EXPERIMENTS SOFTWARE: EXP. 6

### PROGRAMME OHM

```
10 GRAPH 1:GRAPH 0
20 A=0
30 CALL "RESOLUTION",0,2:REM initialize HRG
40 CALL "PLOT",0,0,3
50 POKE 64511,1:REM initialize channel 1
70 X=PEEK(64511):REM read channel 1
80 POKE 64511,0:REM initialize channel 0
90 Y=PEEK(64511):REM read channel 0
100 CALL "LINE",X*3,Y/2,3
110 PLOT 70,50,STR$(X)+" "
120 PLOT 60,50,STR$(Y)+" "
130 IF X=0 THEN 170
140 R=Y/X
150 POKE (&6000+A)
160 A=A+1
165 ?"A=";A
167 FOR Z=1 TO 500:NEXT
170 GO TO 50
```

### PROGRAMME STORE

```
10 CREATE £10,"OHM.DAT"
20 FOR I=24576 TO (24576+A)
30 R=PEEK(I)
40 PRINT £10,I;",";R:REM store to disk
50 NEXT
```

### PROGRAMME POKER

```
10 OPEN £10,"OHM.DAT"
20 FOR I=24576 TO (24576 + A)
30 INPUT £10,ADDR,R:REM read from disk-file
40 POKE ADDR,R:REM put back in memory
50 NEXT
```

# COUNTER INTELLIGENCE

BY PAUL YOUNG

## Postal Charge

There are certain questions I get asked which I call "Hardy Annuals" for obvious reasons. The one I have in mind at the moment relates to high postal charges. I recently received one such letter from a customer, who wishes to remain anonymous, and I will therefore refer to as "Mr. X."

If I may quote from part of his letter: "Like many people, I have to buy by post, as there is no suitable shop within reach. My beef is, the blatant over-charging by almost all suppliers for post and packing. Sums of 50p, 60p and 75p plus 15% VAT are quite common, and completely unjustified.

"It is surprising how many i.c.s can be sent for 12½p or 16p in a padded envelope, so that anything over 30p or 40p (to include the cost of the envelope) is unjustified. Far better, if necessary, to impose a minimum order value, with a reasonable P. & P. charge."

To the outsider, so many easy solutions suggest themselves, but most of us in the business have given much thought to this matter and have never found the perfect answer. Take, for example, Mr. X's suggestion of a minimum order value. Supposing a customer has just sent you a £20 order, and discovers later he has inadvertently forgotten two transistors?

Mr. X's claim that a large quantity of i.c.s can be sent for 16p is undoubtedly true, but what about books, tools, transformer or metal work?

We could, of course, refuse to sell them by mail, though we must remember that many customers are in the same position as our friend Mr. X and have no other source of supply. Even adding a few pence to the price of each article works unfairly against the shop customer.

Our own method, for what it's worth, is to add up the number of parcels sent out over a fortnight and divide it into the

amount spent on postage. This gives us an average figure to base our charges on. We do this every 3 or 4 months, or whenever there is a change in postal rates. It is not perfect, but it is workable, and there are very few complaints.

## Young Clairvoyant

There is something rather satisfying about making a forecast and seeing it come true, so on the very few occasions when Old Moore Young gets it right, he is duly elated. Two successes come to mind: one, I forecast that someone would bring out a toaster, using an i.c. for timing, at least two years before it appeared, not that you had to be a Nostradamus to work that one out.

My second prediction was that soon everyone would tire of video games. I read recently that this has already happened in America, with disastrous effects on all the amusement arcades, and already about 70 per cent of them have closed.

As surely as night follows day, the same pattern will be repeated here. This will eventually be followed by a return to construction, and then, the one or two magazines like "Everyday Electronics" who have kept the art alive, will reap their just reward.

## Curiosity Shop

I was very intrigued by a shop I noticed near my domicile with a large sign over it bearing the legend, "The Computer Shop". The windows were full of leaflets describing the merits of Apples, Acorns and Spectrums, but little else. Despite the obvious lack of hardware, I thought it might be a way of passing an agreeable hour or so, meeting the proprietor and chatting about Bytes, RAMs and ROMs.

It was at this point that I made my discovery—the shop wasn't open. I watched the shop day after day, week after week, but the doors remained locked. It had a backless window, and I could see not only all the interior but also into the living-room behind. During all that time nothing stirred.

By now the pamphlets were yellowing with age and curling up at the corners, so Sherlock Young filled his Meerscham and began weighing all the possibilities. Was it perhaps the first shop designed to eliminate all staff? Did customers gain entry by inserting a magnetic card, and were all served by computer? If I gained entry, should I find a half-eaten meal on the table, leaving us with another "Marie Celeste" mystery?

It made me think of the old Punch joke about two old ladies, gazing through the window of a shop, empty except for two vacant chairs. A sign above proclaims it to be an "Invisible Mender's", and oblivious of the sign on the door saying: "Gone To Lunch", one says to the other: "Look dear, you would never believe they are really there, busily working".

So, for further information on this saga, watch this space . . . In the meantime I shall be watching the shop.

## Switch Off

I expect there are many people, our readers among them, who almost go berserk at the repetition of some of the inane adverts put out by the commercial television channels. In which case I have some good news for them.

An American has bought out a device to plug into your television set. As soon as the unwanted advert appears you press a button, and the sound-track is fed into a memory chip. If the advert is repeated at any time, the memory triggers a relay which cuts out the whole sequence.

This may seem rather hard on the promoters who have spent thousands of pounds to show it, though my father was of the opinion that all advertising was unnecessary.

He used to say, if there are two kinds of soap, and one is better than the other, don't make the inferior one. Of course, he was rather an idealist, and when he said it, I was at an age where I considered that in an ideal world there would be no soap.

# COMPUTER PROJECTS

## PUBLISHED IN PREVIOUS ISSUES

*APRIL 1982*

### **2K RAM PACK FOR SINCLAIR ZX81**

*Also:* Capacitance/Frequency Meter; Magnetic Lock; V.C.O. Sound Effects Unit; In-Car P.S.U.; Light Activated Switch.

*JUNE 1982*

### **KEYBOARD SOUNDER FOR SINCLAIR ZX81**

*Also:* C.B. Power Supply; Nightlight; Seat Belt Reminder; Public Address System (pt 2); Egg Timer.

*AUG/SEPT 1982*

### **TEMPERATURE INTERFACE FOR TANDY TRS-80**

*Also:* (Aug) C.B. Roger Bleeper; Two-Tone Doorbell; Quiz Master; Instrument Pre-Amp; Public Address System (pt 4). (Sept) Sound Splitter; C.B. Battery Charger; Screen Washer Delay; Monthly Planner; Continuity Tester.

*OCTOBER 1982*

### **EXPANSION SYSTEM FOR SINCLAIR ZX81**

*Also:* Sine Wave Generator; General Purpose Pre-Amp; Optical Tachometer; Lights On Alert; Simple S.W. Radio.

*NOVEMBER 1982*

### **TAPE CONTROLLER FOR SINCLAIR ZX81 AND SPECTRUM**

*Also:* Combination Lock; Digital Metronome; Oscilloscope Companion; Photo Finish; Beat The Relay.

*DECEMBER 1982*

### **EXTRA RAM FOR SINCLAIR ZX81**

*Also:* Security Vari-Light; Car Indicator Alarm; Velocity Measurer; Electric V/I Meter; 5V Regulated Supply.

*JANUARY 1983*

### **A TO D CONVERTER FOR PET**

*Also:* Personal LS Amplifier; Coulomb Meter; Opto Repeater; Double Dice.

*FEBRUARY 1983*

### **SPEED COMPUTING SYSTEM FOR SINCLAIR ZX81**

*Also:* Pushbike/Motorbike Alarm; Beehive Temperature Meter; Short Interval Timer; Speech Processor.

*FEB/MARCH 1983*

### **EPROM PROGRAMMER FOR ACORN ATOM**

*Also:* (March) Multi-Station Intercom; Car Thermometer; Buzz Off; Dual Power Supply.

*MARCH/APRIL 1983*

### **EXPANDED ADD-ON KEYBOARD FOR SINCLAIR ZX81**

*APRIL 1983*

### **AMPLIFIER FOR SINCLAIR SPECTRUM**

*Also:* (April) Function Generator; Novelty Egg Timer; Flanger Sound Effect; Neon Nightlight; Car Radio Booster.

*MAY 1983*

### **REAL-TIME CLOCK FOR APPLE II and BBC MICRO TEMPERATURE SENSOR FOR PET and VIC 20**

*Also:* Guitar Headphone Amplifier; MW Personal Radio; Laboratory Amplifier; Model Train Controller; Moisture Detector.

All the above are fully illustrated, detailed constructional articles. Back numbers £1.00 (inclusive of p&p) per copy currently available from: Post Sales, IPC Magazines Ltd., Lavington House, 25 Lavington Street, London SE1 0PF.

*JUNE 1983*

### **EPROM PROGRAMMER FOR TRS-80 and GENIE**

*Also:* Push Button Combination Lock; Caravan Power Supply; Caravan Fridge Alarm; Transistor Tester; Envelope Shaper for Bass Guitar.

*JULY 1983*

### **USER PORT INPUT/OUTPUT BOARD(\*) USER PORT CONTROL BOARD(\*)**

*Also:* Automatic Greenhouse Watering System; Digi Alarm Wristwatch Amplifier; Tri Boost Guitar Tone Controller; Binary Bandit Game; Pulse Generator.

*AUGUST 1983*

### **STORAGE 'SCOPE INTERFACE FOR BBC MICRO—HIGH POWER INTERFACE BOARD(\*)—PEDESTRIAN CROSSING SIMULATION BOARD(\*)**

*Also:* Electronic Die; Home Systems Monitor; Car Intruder Alarm; 1kW Mains Power Controller.

*SEPTEMBER 1983*

### **A-TO-D CONVERTER FOR RM380Z COMPUTER—COMPUTER AIDED EXPERIMENTS—HIGH SPEED ANALOGUE-TO-DIGITAL CONVERTER(\*)—SIGNAL CONDITIONING AMPLIFIER**

*Also:* Stylus Organ; Distress Beacon; Traffic Light Simulator; Voltage Dualiser.

*OCTOBER 1983*

### **DIGITAL-TO-ANALOGUE BOARD(\*)—HIGH POWER DAC DRIVER BOARD—COMPUTER AIDED EXPERIMENTS—TEMPERATURE TRANSDUCER AMPLIFIER—ELECTRONIC PENDULUM**

*Also:* Home Intercom; Immersion Heater Tell-Tale; Model Car "Petrol Tank"; Short Wave Radio.

*NOVEMBER 1983*

### **SPEECH SYNTHESISER FOR THE BBC MICRO—TTL/POWER INTERFACE FOR STEPPER MOTOR(\*)—STEPPER MOTOR MANUAL CONTROLLER(\*)—COMPUTER AIDED EXPERIMENTS**

*Also:* Multimod; Long Range Camera/Flash Gun Trigger; Digital Gauss Meter; Car On/Off Touch Switch.

*DECEMBER 1983*

### **TRS-80 TWIN CASSETTE INTERFACE—ENVIRONMENTAL DATA RECORDER FOR ZX SPECTRUM—4-CHANNEL HIGH SPEED ADC(\*)**

*Also:* Children's Disco Lights; Magic Candle; Novel Egg-Timer; Continuity Tester; Touch Operated Die.

*JANUARY 1984*

### **BIOLOGICAL AMPLIFIER—TEMPERATURE MEASUREMENT AND CONTROL SYSTEM FOR ZX COMPUTERS—COMPUTER AIDED EXPERIMENTS**

*Also:* 4-Channel Gas and Smoke Sentinel; Games Scoreboard; Central Heating Pump Delay; Guitar Tuner.

*FEBRUARY 1984*

### **EPROM PROGRAMMER/ROM CARD FOR ZX81—TEMPERATURE MEASUREMENT AND CONTROL SYSTEM FOR ZX COMPUTERS—ORIC PORT BOARD—COMPUTER AIDED EXPERIMENTS**

*Also:* Negative Ion Generator, Loudspeaker Protection Unit, Car Lights Warning, Signal Tracer.

### **\* For BBC MICRO, VIC-20, PET and Commodore 64**

Stocks of back issues are limited. In the event of non-availability a photocopy of the relevant article will be supplied. Please enclose appropriate remittance and specify month of issue and title of article required.

**EVERYDAY  
ELECTRONICS  
and computer PROJECTS**

# MASTER ELECTRONICS NOW! The PRACTICAL way!

YOUR CAREER..YOUR FUTURE..YOUR OWN BUSINESS..YOUR HOBBY  
THIS IS THE AGE — OF ELECTRONICS!  
the world's fastest growth industry...

There is a world wide demand for designers/engineers and for men to service and maintain all the electronic equipment on the market today — industrial — commercial and domestic. No unemployment in this walk of life!

Also — the most exciting of all hobbies — especially if you know the basic essentials of the subject. . . .

A few hours a week for less than a year — and the knowledge will be yours. . . .

We have had over 40 years of experience in training men and women successfully in this subject.

Our new style course will enable anyone to have a real understanding of electronics by a modern, practical and visual method. No previous knowledge is required, no maths, and an absolute minimum of theory.

You learn by the practical way in easy steps, mastering all the essentials of your hobby or to start, or further, a career in electronics or as a self-employed servicing engineer.

All the training can be carried out in the comfort of your own home and at your own pace. A tutor is available to whom you can write personally at any time, for advice or help during your work. A Certificate is given at the end of every course.

You will do the following:

- Build a modern oscilloscope
- Recognise and handle current electronic components
- Read, draw and understand circuit diagrams
- Carry out 40 experiments on basic electronic circuits used in modern equipment using the oscilloscope
- Build and use digital electronic circuits and current solid state 'chips'
- Learn how to test and service every type of electronic device used in industry and commerce today. Servicing of radio, T.V., Hi-Fi, VCR and microprocessor/computer equipment.



CACC

**British National Radio & Electronics School** Reading, Berks. RG1 1BR

**FREE!**

COLOUR BROCHURE



POST NOW TO

Please send your brochure without any obligation to

NAME \_\_\_\_\_

ADDRESS \_\_\_\_\_  
\_\_\_\_\_  
\_\_\_\_\_

BLOCK CAPS PLEASE  
EE/3/841

I am interested in:

- COURSE IN ELECTRONICS as described above
- RADIO AMATEUR LICENCE
- MICROPROCESSORS
- OTHER SUBJECTS please state below

OR TELEPHONE US  
0734 51515 OR  
TELEX 22758  
(24 HR SERVICE)



**British National Radio & Electronics School** Reading, Berks. RG1 1BR

Step-by-step fully illustrated assembly and fitting instructions are included together with circuit descriptions. Highest quality components are used throughout.

# Sparkrite

SELF ASSEMBLY ELECTRONIC KITS

PRICES REDUCED  
ON SUPER SAVE  
D.I.Y. KITS

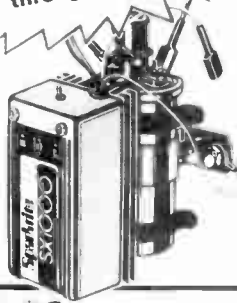

## SX 1000 Electronic Ignition

- Inductive Discharge ● Extended dwell circuit stores greater energy in coil ● Three position changeover switch ● Patented clip-to-coil fitting ● Easy to assemble, easy to fit ● Contact breaker triggered - includes bounce suppression circuit

**SUPER SAVE**

## SX 2000 Electronic Ignition

- Reactive Discharge ● Combines inductive & capacitive energy storage ● Gives highest possible spark energy ● Patented clip-to-coil fitting ● Easy assembly sequence ● Contact breaker triggered - includes bounce suppression circuit

**SUPER SAVE**

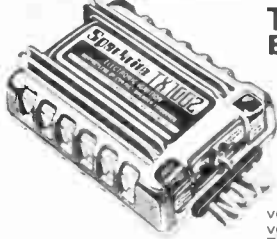
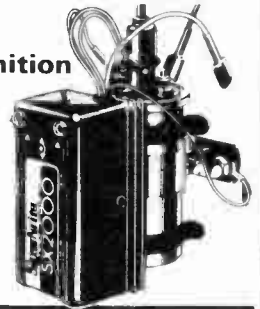

## TX 1002 Electronic Ignition

- Inductive discharge ● Extended dwell circuit stores greater energy in coil ● Three position changeover switch ● Contactless or contact breaker triggered ● Clip to coil or remote mounting ● Rugged die cast case ● Contactless adaptors included for majority of 4 & 6 cylinder vehicles ● Easy to build ● For details of vehicles fitted by contactless trigger, ring Technical Service Dept on (0922) 611338-9

## TX2002 Electronic Ignition

- Two separate systems in one unit! ● Reactive Discharge OR Inductive Discharge, with three position changeover switch ● Gives highest possible spark energy ● Clip-to-coil or remote mounting ● Rugged die-cast case ● Contactless or contact breaker triggered ● Contactless adaptors included for majority of 4 & 6 cylinder vehicles ● For details of vehicles fitted by contactless trigger, ring Technical Service Dept on (0922) 611338-9.

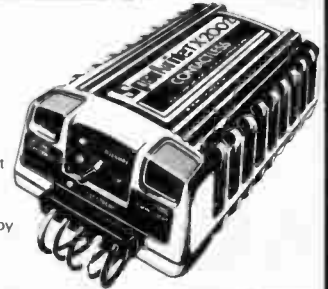

## AT-40 Electronic Car Alarm

- Guards doors, boot, bonnet from unauthorised entry ● Armed/disarmed using concealed switch ● 30 second delay-to-arm ● 7 second entry delay ● Can alternatively be wired to exterior key switch ● Flashes headlights & sounds horn intermittently for 60 seconds when activated ● Security loop protects accessories ● Low consumption C-MOS circuitry



**NEW**

## AT-80 Electronic Car Security System

- Guards doors, boot, bonnet from unauthorised entry ● Armed/disarmed from outside vehicle by magnetic key fob passed across sensor pad adhered to inside of windscreen ● Individually programmable code ● 30 second delay-to-arm ● Flashes headlights and sounds horn intermittently for 60 seconds when activated ● Security loop protects accessories ● Function lights to assist setting-up ● Low consumption C-MOS circuitry

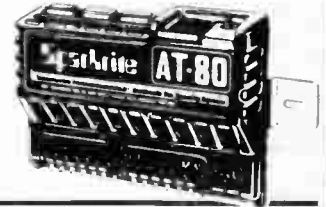

**SUPER SAVE**

## ULTRASONIC Intruder Detector

- Supplementary to AT-40 & AT-80 ● Will work in conjunction with any door switch input or voltage sensing alarm ● Detects attempted break-in and movement within passenger compartment & triggers alarm ● Includes high efficiency ultrasonic transducers ● Crystal controlled for low drift ● Ingenious sensitivity control allows freedom from false alarms ● Low current consumption



**NEW**

## VOYAGER Car Drive Computer

- 12 functions centred on Fuel, Speed, Distance and Time ● Single chip microprocessor ● Large high brightness fluorescent display with auto-dimming feature ● High accuracy distance & fuel transducers included ● Displays MPG, L/100km and miles/litre at the flick of a switch ● Visual & audible warnings of excess speed, ice, lights-left-on ● Independent LOG & TRIP functions ● Low consumption crystal controlled circuitry.



**SPECIAL OFFER**  
"FREE" MAGIDICE KIT WITH  
ALL ORDERS OVER £40.00



## MAGIDICE Electronic Dice

- Triggered by waving hand over dice ● Completely random selection ● Bleeps & flashes during 4 sec tumble ● Throw displayed for 10 seconds then flashes to conserve battery ● Low consumption C-MOS circuitry

**SUPER SAVE**

82 BATH ST., WALSALL WS1 3DE.

SPARKRITE (A Division of Stadium Ltd) 82 Bath Street, Walsall, WS1 3DE England Tel (0922) 614791

Always 2d stamps for heaven!

KIT	OLD PRICE	NEW PRICE
SX 1000	£12.95	£11.95
SX 2000	£18.95	£18.95
TX 1002	£22.95	£22.95
TX 2002	£32.95	£32.95
AT-40	—	£9.95
AT 80	£32.95	£24.95
ULTRASONIC	—	£17.95
VOYAGER	£64.95	£64.95
MAGIDICE	£9.95	£6.95

NEW  
NEW

NAME \_\_\_\_\_  
ADDRESS \_\_\_\_\_  
\_\_\_\_\_

I ENCLOSE CHEQUE(S)/POSTAL ORDERS FOR

£ \_\_\_\_\_ KIT REF. \_\_\_\_\_

CHEQUE No. \_\_\_\_\_

EE/3/84

PRICES INC VAT, POSTAGE & PACKING

PHONE YOUR ORDER WITH



**CUT OUT THE COUPON NOW!**

**BRANDLEADING BRITISH ELECTRONICS**

### XK113 MW RADIO KIT

Based on ZN414 IC, kit includes PCB wound serial and crystal capacitor and all components to make a sensitive miniature radio. Size 5.5 x 2.7 x 2cms. Requires PP3 9V battery IDEAL FOR BEGINNERS £5.50

### HOME LIGHTING KITS

These kits contain all necessary components and full instructions & are designed to replace a standard wall switch and control up to 300w of lighting.

- TOR300K Remote Control Dimmer £14.95
- MK6 Transmitter for above £4.50
- TD300K Touchdimmer £7.75
- TS300K Touchswitch £7.75
- TDE/K Extension kit for 2-way switching for TD300K £2.50
- LD300K Rotary Controlled Dimmer £3.95



### DVM/ULTRA SENSITIVE THERMOMETER KIT

This new design is based on the IC17126 (a lower power version of the IC17106 chip) and a 3 1/2 digit liquid crystal display. This kit will form the basis of a digital multimeter (only a few additional resistors and switches are required—details supplied), or a sensitive digital thermometer (-50°C to +150°C) reading to 0.1°C. The basic kit has a sensitivity of 200mV for a full scale reading, automatic polarity indication and an ultra low power requirement—giving a 2 year typical battery life from a standard 9V PP3 when used 8 hours a day, 7 days a week.



Price £15.50

**NOW OPEN**

# COMPUTER SHOWROOM

Hours: Mon - Fri 9am - 5pm  
SAT 10am - 4pm



We also stock peripherals and accessories - disc drives, printers, joy sticks etc. together with a wide range of books and the latest software for all the above computers including ZX81.

SEND S.A.E. FOR LIST TODAY!

### COMPONENT PACKS

- PACK 1 1650 Resistors 47 ohm to 10 Mohm 10 per value £4.00
- PACK 2 40 16V Electrolytic Capacitors 10µF to 1000µF - 5 per value £3.25
- PACK 3 360 Polyester Capacitors 0.01 to 1µF 250V - 5 per value £5.55
- PACK 4 45 Sub miniature Presets 100 ohm to 1 Mohm - 5 per value £2.90
- PACK 5 30 Low Profile IC Sockets 8 14 and 16 pin - 10 of each £2.40
- PACK 6 25 Red LEDs 15mm dia. £1.50

### 3-NOTE DOOR CHIME

Based on the SAB0600 IC, the kit is supplied with all components, including loudspeaker, printed circuit board, a pre-drilled box (95 x 71 x 35mm) and full instructions. Requires only a PP3 9V battery and push-switch to complete. AN IDEAL PROJECT FOR BEGINNERS. Order as XK 102

£5.50

### Have you got our FREE YELLOW CATALOGUE yet?

NO! Send S.A.E. 6" x 9" TODAY!! It's packed with details of all our KITS plus large range of SEMICONDUCTORS including CMOS, LS TTL, linear, microprocessors and memories, full range of LEDs, capacitors, resistors, hardware, relays, switches etc. We also stock VERO and Antex products as well as books from Texas Instruments, Barban and Elektor.

ALL AT VERY COMPETITIVE PRICES. ORDERING IS EVEN EASIER - JUST RING THE NUMBER YOU CAN'T FORGET FOR THE PRICES YOU CAN'T RESIST

5-6-7 8-9-10 and give us your Access or Barclaycard No. or write enclosing cheque or postal order. Official orders accepted from schools, etc. Answering service evngs and wnds

### TEACH-IN 84

Complete kit of top quality components as specified by EE including two EBBO starter packs.

£15.80



### LCD 3 1/2 DIGIT MULTIMETER

16 ranges including DC voltage (200 mv-1000 v) and AC voltage, DC current (200 mA-10 A) and resistance (0-2 M) + NPN & PNP transistor gain and diode check. Input impedance 10M. Size 155x88x31 mm. Requires PP3 9v battery. Test leads included. ONLY £29.00

### ELECTRONIC LOCK KIT XK101

This KIT contains a purpose designed lock IC, 10 way keyboard, PCBs and all components to construct a Digital Lock requiring a 4-key sequence to open and providing over 5000 different combinations. The open sequence may be easily changed by means of a pre-wired plug. Size 7 x 6 x 3 cms. Supply 5V to 15V d.c. at 40uA. Output 750mA max. Hundreds of uses for doors and garages, car anti-theft device, electronic equipment, etc. Will drive most relays direct. Full instructions supplied. ONLY £11.50

Electric lock mechanisms for use with latch locks and above kit £14.95

### DL 1000K

This value-for-money kit features a bi-directional sequence, speed of sequence and frequency of direction change, being variable by means of potentiometers and incorporates a master dimming control.



£15.95

DL2100K A lower cost version of the above, featuring unidirectional channel sequence with speed variable by means of a pre-set pot. Outputs switched only at mains zero crossing points to reduce radio interference to a minimum.

£8.95

Optional opto input DLA1 Allowing audio ("beat") -light response

60p

### DL3000K

This 3 channel sound to light kit features zero voltage switching, automatic level control & built in mic. No connections to speaker or amp required. No knobs to adjust - simply connect to mains supply & lamps (1Kw Channel)

£12.95

**FAST SERVICE · TOP QUALITY · LOW LOW PRICES**

No circuit is complete without a call to



**ELECTRONICS**

11-13 Boston Road  
London W7 3SJ

Add 6% postage & packing - 15% VAT to total Overseas Customers. Add £2.50 (Europe). EG 00 (elsewhere) for p&p. Send S.A.E. for further STOCK DETAILS. Goods by return subject to availability. 9am to 5pm (Mon to Fri) 10am to 4pm (Sat)

**OPEN**

**ALL PRICES EXCLUDE VAT**

TEL: 01-567 8910 ORDERS  
01-579 9794 ENQUIRIES  
01-579 2842 TECHNICAL AFTER 3PM

# ELECTROVALUE

## Your SPECIALIST SUPPLIERS for CONNECTORS

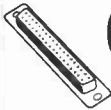

Not only will you find a wide selection of all the usual types you may require in our A-Z products list; there are also many others made necessary by today's ever-advancing electronics - just one more example of how much better Electrovalue serves you.

Please mention this journal when getting in touch with Electrovalue

### D SERIES CONNECTORS

9, 15, 25, 37 or 50 way connectors with corresponding covers and retainers. Gold-plated contacts. Max current per contact - 5A.

### ID CONNECTORS

For connecting ribbon cable to PCBs. Insulation Displacement Type: 16, 20, 26, 34 or 40 way, 1A per socket. Straight or right angle plug fitting; cable socket has strain relief.

### RPC CONNECTORS

5 way and 7 way chassis plugs and sockets. DIN style layout. Gold-plated pins. 250V/5A rating per socket.

### OTHER TYPES

Edge connectors, DIN, jack plugs and sockets, phono, QG, BNC, UHF and power.

**BRITAIN'S LEADING QUALITY COMPONENT SUPPLIERS - SEND FOR FREE 32 PAGE A-Z LIST ATTRACTIVE DISCOUNTS - FREE POSTAGE - GOOD SERVICE & DELIVERY**

**ELECTROVALUE LTD**

28 St. Jude's Road  
Englefield Grn, Egham  
Surrey TW20 0HB

**ACCESS AND BARCLAYCARD Phoned Orders Welcome**

Phone (0784) 33603. Telex 264475  
North: 680 Burnage Lane, Manchester (061) 432 4945  
EV Computing Shop: 700 Burnage Lane, Manchester (061) 431 4866



**METERS: 110 x 82 x 35mm**  
30µA, 50µA, 100µA. £6.90  
Post 50p.

**METERS: 45 x 50 x 34mm**  
50µA, 100µA, 1mA, 5mA, 10mA, 25v, 1A, 2A, 5A 25V. £3.54. Post 30p.

**METERS: 60 x 47 x 33mm**  
50µA, 100µA, 1mA, 5mA, 10mA, 100mA, 1A, 2A, 25v, 50v, 50-0-50µA, 100-0-100µA. £6.04.  
VU meters £6.04.  
Post on above meters 30p.

**Silicone grease 50g £1.32.**  
Post 16p.

### NI-CAD BATTERY CHARGER

Led indicators charge-test switch. For PP3, HP7, HP11 & HP2 size batteries. Price £5.85. Post 94p.

T.V. UHF Aerial Amplifier 300-890MHz £6.03 post 57p  
2 1/2" 8 ohm Speaker 46p post 21p  
2 1/2" 64 ohm Speaker 56p post 21p  
Desoldering Pump £4.25 post 27p  
Resistance Substitution Box £3.97 post 17p

Vernier Dial 50mm Dia. £2.31 post 17p  
Tape Head Demagnetizer £2.60 post 39p  
Min. Buzzer 6 or 12V 63p post 21p

### TRANSFORMERS

**240v Primary**

3-0-3v	100mA	82p
6-0-6v	100mA	£1.20
6-0-6v	250mA	£1.33
12-0-12v	50mA	£1.13
12-0-12v	100mA	£1.21
9-0-9v	75mA	£1.20
9-0-9v	250mA	£1.37

Post on above transformers 48p.

9-0-9v	1A	£2.05
12-0-12v	1A	£2.52
15-0-15v	1A	£3.11
6-0-6v	1 1/2A	£2.20

Post on above transformers 94p.

All above prices include V.A.T. Send £1 for a new comprehensive 1983/84 fully illustrated catalogue with a new price list. Send S.A.E. with all enquiries. Special prices for quantity on request.

All goods despatched within 3 days from receipt of the order.

**M. DZIUBAS**  
158 Bradshawgate, Bolton,  
Lancs. BL2 1BA.

## PREVIOUSLY ADVERTISED STILL AVAILABLE

Tape punch and reader	£22.50
Bench isolating transformer 250 watt	£7.75
BOAC in-flight stereo unit	£1.50
Drill assortment 4 each 25 sizes between .25mm & 2.5mm	£11.50
Battery condition tester, less box	£1.75
Nicad chargers, mains	£0.75
Flourescent inventor 13 watt from 12v	£3.50
Ten digit stich pad-bb phone etc.	£1.95
Uniselector 2 pole 25 way	£4.60
Water valve mains operated	£2.50
Counter 6 digit mains operated	£1.15
ditto 12v resettable	£3.45
Double glazing clear PVC sheet, 23 1/2" wide-per running ft.	£0.15
Locking mechanism with 2 keys	£1.15
Magnetic Clutch	£4.50
Mouth operated suck or blow switch	£2.30
Solenoid with slug 8 - 12v battery op.	£1.82
ditto 230v mains	£2.30
Timer Omron STP NH 110v AC Coil	£6.90
Key switch with 2 keys pd coils	£1.75
Air valve mains operated	£3.75
Latching relay mains operated	£3.50
Dry film lubricant aerosol can	£0.65
Coin op switch, cased with coin tray	£4.60



**8 POWERFUL MODEL MOTORS (all different)**  
for robots, meccanos, drills, remote control planes, boats, etc. £2.95.

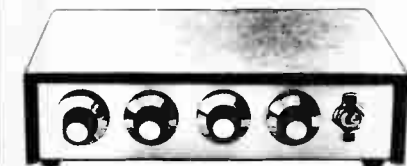

Complete kit of parts for a three channel sound to light unit controlling over 2000 watts of lighting. Use this at home if you wish but it is plenty rugged enough for disco work. The unit is housed in an attractive two tone metal case and has controls for each channel, and a master on/off. The audio input and output are by 1/2" sockets and three panel mounting fuse holders provide thyristor protection. A four pin plug and socket facilitate ease of connecting lamps. Special price is £14.95 in kit form or £25.00 assembled and tested.

### 12 volt MOTOR by SMITHS

Made for use in cars, etc. these are series wound and they become more powerful as load increases. Size 3 1/2" long by 3" dia. They have a good length of 1/2" spindle - Price £3.45. Ditto, but double ended £4.25. Ditto, but permanent magnet £3.75.



### EXTRA POWERFUL 12v MOTOR

Probably develops up to 1/2 h.p. so it could be used to power a go-kart or to drive a compressor, etc. £7.95 + £1.50 post.

### THERMOSTAT ASSORTMENT

10 different thermostats. 7 bi-metal types and 3 liquid types. There are the current stats which will open the switch to protect devices against overload, short circuits, etc., or when fitted say in front of the element of a blow heater, the heat would trip the stat if the blowers fuses: appliance stats, one for high temperatures, others adjustable over a range of temperatures which could include 0 - 100°C. There is also a thermostat pod which can be immersed, an oven stat, a calibrated boiler stat, finally an ice stat which, fitted to our waterproof heater element, up in the loft could protect your pipes from freezing. Separately, these thermostats could cost around £15.00 however, you can have the parcel for £2.50.

### MINI MONO AMP on p.c.b., size 4" x 2" (app.)

Fitted volume control and a hole for a tone control (app.) should you require it. The amplifier has three transistors and we estimate the output to be 3W rms. More technical data will be included with the amp. Brand new, perfect condition, offered at the very low price of £1.15 each, or 10 for £10.00.



### BARGAIN OF THE YEAR -

#### The AMSTRAD Stereo Tuner.

This ready assembled unit is the ideal tuner for a music centre or an amplifier, it can also be quickly made into a personal stereo radio - easy to carry about and which will give you superb reception.

Other uses are as a "get you to sleep radio", you could even take it with you to use in the lounge when the rest of the family want to view programmes in which you are not interested. You can listen to some music instead.

Some of the features are: long wave band 115 - 270 KHz, medium wave band 525 - 1650KHz, FM band 87 - 108MHz, mono, stereo & AFC switchable, tuning meter to give you spot on stereo tuning, optional LED wave band indicator, fully assembled and fully aligned. Full wiring up data showing you how to connect to amplifier or headphones and details of suitable FM aerial (note ferrite rod aerial is included for medium and long wave bands. All made up on very compact board.

Offered at a fraction of its cost: **only £6.00** + £1.50 post + insurance.

## THIS MONTH'S SNIP

**WHY PAY £10 OR MORE** - Make yourself a Jovystick - full details were given in Dec/Jan 'Sinclair Projects'. We will supply complete kit for £2.30. Although designed for the Spectrum or ZX81 it is equally suitable for any home computer.

**REVERSIBLE MOTOR with control gear** Made by the famous Franco Company this robust motor is approx 7 1/2" long, 3 1/2" dia. 3/8" shaft. Very powerful, almost impossible to stop. Ideal for operating stage curtains, doors, ventilators, etc. Even garage doors if properly balanced. Offered complete with control gear as follows: 1 Franco motor with gear box 1 push to start switch 1 manual reversing & on/off switch 2 limit stop switches 1 circuit diag. of connections **ONLY £19.50 + postage £2.50.**

### FOR SOMEONE SPECIAL

Why not make your greeting card play a tune? It could play 'Happy Birthday', 'Merry Christmas', 'Wedding March', etc. or 'Home Sweet Home', etc. Wafer thin 3 part assemblies, for making cards musical. Mini microchip speaker and battery with switch that operates as the card is opened. Please state tune when ordering. Complete, ready to work £1.25.

### REEL TO REEL TAPE DECKS

Ex-Language Teaching School. Second, but we understand these are in good order; any not so would be exchanged. The deck is standard with normal record, replay facilities and an additional feature is tape rev counter. Nicely finished in teak type box. We have 30 only of these. Price £8.50 each + £3 carriage.

### TELEPHONE ITEMS

Plug and Wall socket - 4 pin or 5 pin	£3.45
Plugs only 4 pin or 5 pin	£1.15
Modern desk telephone	£7.50
Heavy black old type	£5.50
External bell unit	£6.50
Bell ringing power unit	£4.50
Pick up coil	£1.15

### STABILISED POWER SUPPLY (Mains Input)

By LAMDA (USA) - Ideal for computer add-on d.c. output. Regulated for line volts and load current. Voltage regulation .1% with input variations up to 20% - load regulation 1% from no load to full load - or full load to no load. Complete in heavy duty case - Models available: 5v - 9A £23. 12v - 1.5A £13.25. 15v - 1.2A £13.25. 24v - 2A £23.

**PRESTEL UNIT** - brand new and complete except for 7 plug in IC's - Price: £19.75 + £2.00 p&p.

Note: British Telecom may not connect this equipment as there is no manufacturer to guarantee it, however it is well worth buying for its immense breakdown value - sold originally at over £150.



**FROZEN PIPES.** Can be avoided by winding our heating cable around them - 15 mtrs connected to mains costs only about 10p per week to run. Hundreds of other uses as it is waterproof and very flexible. Resistance 60 ohms/metre. Price 28p/metre or 15m for £3.95

**25A ELECTRICAL PROGRAMMER** Learn in your sleep. Have radio playing and kettle boiling as you wake - switch on lights to ward off intruders - have a warm house to come home to. You can do all these and more. By a famous maker with 25 amp on/off switch. Independent 60 minute memory jogger. A beautiful unit at £2.50.

**24 HOUR TIME SWITCH** Made for control of Randall Central Heating Boilers these give 2 on offs per 24 hrs. Equally suitable for control of immersion heaters of heating systems. £4.60.

## 50 THINGS YOU CAN MAKE

Things you can make include Multi range meter, Low ohms tester, A.C. amps meter, Alarm clock, Soldering iron minder, Two way telephone, Memory jogger, Live line tester, Continuity checker, etc. etc., and you will still have hundreds of parts for future projects. Our 10Kg parcel contains not less than 1,000 items - panel meters, timers, thermal trips, relays, switches, motors, drills, taps, and dies, tools, thermostats, coils, condensers, resistors, neons, earphone/microphones, nicad charger, power unit, multi-turn pots and notes on the 50 projects.

**YOURS FOR ONLY £11.50 plus £3.00 post.**

### MINI-METER TESTER

Deluxe pocket size precision moving coil instrument, Jewelled bearings - 2000 o.p.v. mirrored scale. 11 instant range measures:



DC volts 10, 50, 250, 1000.  
AC volts 10, 50, 250, 1000.  
DC amps 0 - 100 mA.  
Continuity and resistance 0 - 1 meg ohms in two ranges. Complete with test prods and instruction book showing how to measure capacity and inductance as well. Unbelievable value at only £6.75 + 60p post and insurance.

**FREE** Amps range kit to enable you to read DC current from 0 - 10 amps, directly on the 0 - 10 scale. It's free if you purchase quickly, but if you already own a Mini-Tester and would like one, send £2.50.

## J. BULL (Electrical) Ltd.

(Dept. EE), 34 - 36 AMERICA LANE, HAYWARDS HEATH, SUSSEX RH16 3QU. Established 30 YEARS

**MAIL ORDER TERMS:** Cash, P.O. or cheque with order. Orders under £12 add 60p service charge. Monthly account orders accepted from schools and public companies. Access & B/C card orders accepted day or night. Haywards Heath (0444) 454563. Bulk orders: phone for quote. Shop open 9.00 - 5.30, mon to Fri, not Saturday.

### STORE CLOSING SALE

All stocks must go from one of our big warehouses. 10,000,000 items, everything from AERIALS to ZENER will be cleared at fantastically low prices - if you are a manufacturer you can save yourself a fortune - send for our Sale List, not for small buyers as minimum order £100.

## EXTRACTOR FANS - MAINS OPERATED

Woods extractor:  
5" - £5.75, Post £1.25.  
6" - £6.95, Post £1.25.  
5" Planair extractor  
£6.50, Post £1.25.  
4" x 4" Muffin 115v.  
£4.50, Post 75p.  
4" x 4" Muffin 230v.  
£5.75, Post 75p.  
All the above ex-computer, those below are unused.  
4" x 4" £8.50, Post 75p.  
9" American made  
£11.50, post £2.00.  
Tangential Blower 10x3 air outlet, dust speed  
£4.60, Post £1.50.



### TANGENTIAL BLOW HEATER

by British Solartron, as used in heat blow heaters. 2Kw approx 9" wide £5.95, 3Kw either 9" or 12" wide (your choice) £6.95 complete with 'cold' half and 'full' heat switch, safety cut out and connection dig. Please add post £1.50 for 1 or £2.30 for two.



**2.5 Kw Kit** Still available: £4.95 + £1.50 post.



### MINIATURE WAFER SWITCHES

2 pole, 2 way - 4 pole, 2 way - 3 pole, 3 way  
4 pole, 3 way - 2 pole, 4 way - 3 pole, 4 way  
2 pole, 6 way - 1 pole, 12 way.  
All at 25p each.

**BLEEP TONE** These work off 12v and have an unusual and pleasant bleep 69p each.

**CONNECTING WIRE PACK** 48 lengths of connecting wire, each 1 metre long and differently colour coded, a must for those difficult interconnecting jobs. 85p the lot.

**RED LEDS** 10 for 69p, 100 for £5.75, 1000 for £52.

**IN LINE SIMMERSTAT** ideal heat controller for soldering iron and many other hand-held appliances. £2.30, 10 for £17.25.



### VENNER TIME SWITCH

Mains operated with 20 amp switch, one on and one off per 24 hrs. repeats daily automatically correcting for the lengthening or shortening day. An expensive time switch but you can have it for only £2.95. These are without case, but we can supply a plastic case - £1.75 or metal case - £2.95. Also available is adaptor kit to convert this into a normal 24 hr. time switch but with the added advantage of up to 12 on/off's per 24 hrs. This makes an ideal controller for the immersion heater. Price of adaptor kit is £2.30.

### IONISER KIT

Refresh your home, office, shop, work room, etc. with a negative ION generator. Makes you feel better and work harder - a complete mains operated kit, case included. £11.95 plus £2.00 post.

## OTHER POPULAR PROJECTS

Short Wave Set - covers all the short wave bands using plug-in coils. Kit complete	£14.50
R C Bridge Kit	£9.95
3 Channel Sound to Light - with fully prepared metal case	£14.95
Otto - made up	£25.00
Big Ear, listen through walls	£9.50
Robot controller - receiver/transmitter	£9.50
Ignition kit - helps starting, saves petrol, improves performance	£13.95
Silent sentinel Ultra Sonic Transmitter and receiver	£9.50
Car Light 'left on' alarm	£3.50
Secret switch - fools friends and enemies alike	£1.95
3 - 30v Variable Power Supply	£13.80
2 Short & Medium wave Crystal Radio	£3.99
3v to 16v Mains Power Supply Kit	£1.95
Light Chaser - three modes	£17.50
Mullard Unilux HiFi stereo amplifier with speakers	£16.75
Radio stethoscope - fault finding aid	£4.80
Mug stop - emits piercing squawk	£2.50
Morse Trainer - complete with key	£2.99
Drill control kit	£3.95
Drill control kit - made up	£6.95
Interrupted beam kit	£2.50
Transmitter surveillance kit	£2.30
Radio Mike	£6.90
FM receiver kit - for surveillance or normal FM	£3.50
Seat Belt reminder	£3.00
Car Starter Charger Kit	£15.50
Soil heater for plants and seeds	£16.50
Insulation Tester - electronic megger	£7.95
Battery shaver or fluorescent from 12v	£6.90
Matchbox Radio - receives Medium Wave	£2.95
Mixer Pre-amp - disco special with case	£16.00
Aerial Rotator - mains operated	£29.50
Aerial direction indicator	£5.50
40 watt amp - hifi 20Hz - 20kHz	£9.50
Microvolt multiplier - measure very low currents with ordinary multimeter	£3.95
Pure Sine Wave Generator	£5.75
Linear Power output meter	£11.50
115 Watt Amplifier 5Hz 25kHz	£13.50
Power supply for 115 watt amps	£8.50
Stereo Bass Booster, most items	£8.95

# EVERYDAY ELECTRONICS and computer PROJECTS

Reach effectively and economically to-days enthusiasts anxious to know of your products and services through our semi-display and classified pages. Semi-display spaces may be booked at £7.80 per single column centimetre (minimum 2.5cm). The prepaid rate for classified advertisements is 33 pence per word (minimum 12 words), box number 60p extra. All cheques, postal orders, etc., to be made payable to

## SECURITY Alarm Systems

- FREE COMPREHENSIVE CATALOGUE!
- LOWEST DISCOUNT PRICES
  - HIGHEST QUALITY EQUIPMENT
  - FREE DIY DESIGN GUIDE
  - FULLY ILLUSTRATED
  - MICROCHIP CIRCUITRY
  - QUICK DESPATCH SERVICE
  - FULL INSTRUCTIONS
- SEND SAE OR PHONE
- C-TEC SECURITY, Dept EE,  
60 Market St. Wigan WN1 1HX.  
Telephone (0942) 42444
- Trade Enquiries Welcome

BURGLAR ALARM EQUIPMENT. Free catalogue. C.W.A.S. Ltd., 0274-308920, showrooms open 9-5, Mon-Sat.

### Miscellaneous

#### THE SCIENTIFIC WIRE COMPANY

PO Box 30, London E.4. 01 531 1568

ENAMELLED COPPER WIRE

SWG	1 lb	8 oz	4 oz	2 oz
8 to 34	3.30	1.90	1.00	0.80
35 to 39	3.52	2.10	1.15	0.85
40 to 43	4.87	2.65	2.05	1.48
44 to 47	8.37	5.32	3.19	2.50
48 to 49	15.96	9.58	6.38	3.69

SILVER PLATED COPPER WIRE

14 to 30	6.63	3.86	2.28	1.50
----------	------	------	------	------

TINNED COPPER WIRE

14 to 30	3.97	2.41	1.39	0.94
----------	------	------	------	------

10 x 10 mtr reels 3 amp PVC cable mixed colours 5.00  
Prices include P & P vat. Orders under £2 add 20p.  
SAE for list of copper and resistance wire. Dealer enquiries welcome.

#### LEARN ELECTRONICS WITHOUT SOLDER

Build electronic circuits without solder on a Roden S-Dec. This has built-in contacts and holes into which you plug your components. Suitable for all ages. Can be used time after time. Ideal gift for students or experimenters. Full instructions and 2 circuit diagrams with each S-Dec.

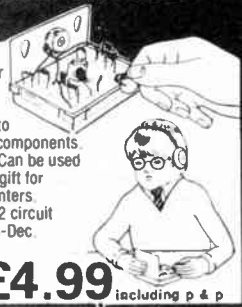

Send cheque or P.O. to:  
Roden Products, Dept EE  
High March, Daventry,  
Northants, NN11 4OE

**£4.99** including p & p

### Receivers & Components

#### AERIAL BOOSTERS

Next to the set fitting

B45H/G-UHF TV, gain about 20db. Tuneable over the complete UHF TV band. PRICE £8.70.

BH-VHF/FM RADIO, gain about 14db, when on the off position connects the aerial direct to the radio. £7.70.

All Boosters we make work off a PP3/006p/8F22 type battery or 9v to 18v DC. P&P 30p PER ORDER.

ELECTRONIC MAILORDER, 62 Bridge St, Ramsbottom, Lancs BL0 9AG. Tel (070682) 3036

Access/Visa Cards Welcome SAE Leaflets

COMPONENTS & EQUIPMENT - 1984 Catalogue 70p + 20p P&P. Callers: 18 Victoria Road, TAMWORTH. 369 Alumrock Road, BIRMINGHAM. 103 Coventry Street, KIDDERMINSTER. Express Mail Order Service. LIGHTNING ELECTRONICS, PO Box 8, Tamworth, Staffs.

ELECTRONIC COMPONENTS MERSEYSIDE, Myca Electronics, 2 Victoria Place, Seacombe Ferry, Wallasey, L44 6NR. 051-638 8647.

TURN YOUR SURPLUS capacitors, transistors etc., into cash. Contact Coles Harding & Co., 103 South Brink Wisbech, Cambs. 0945-584188. Immediate settlement.

**TO ADVERTISE ON THESE PAGES PLEASE RING PAT ON 01-261 5942**

500 SMALL COMPONENTS including TTL transistors £2.50, 7lbs or 10lbs assorted components £5.00/£6.50. Fifty 74 series 1.Cs on panel £2.20. Post Paid. J. W. BLANSHARD, 2 Barnfield Crescent, Sale Cheshire, M33 1NL.

#### BUMPER BOX OF BITS

WOW!!! We've got so many components in stock, we can't possibly list them all!!! - So buy a box, in it you'll find resistors, capacitors, displays, switches, panels with transistors, diodes, IC's etc, coils, pots . . . and so on. All modern parts - guaranteed at least 1000 items, minimum weight 10lbs. ONLY £8.50.

#### PSU PANEL

Stabilized 5v, variable  $\pm 0.5V$ . Regulation 1% Max. current 2A. Will take AC/I/P up to 15V, or DC/I/P up to 24V. Panel 140x35mm contains all components except series reg. transistor which is mounted separately. PCB stand-offs, included ONLY £3.95. Heatsink 75p; transformer £5.00.

#### RESISTOR PACK

All sorts - everything from 1/16 to 10W. Carbon, Film, W/W, Oxide, PCB, etc. 2000 resistors - yes, 2000!!! For only £4.95.

#### SWITCH PACK

Slide (up to 9 way), push button banks, push types - a total of 50 switches for only £3.95.

All prices include VAT and Post/Packing.

Send SAE for latest lists.

**ELECTRONICS WORLD**

1d Dews Road, Salisbury, Wilts, SP2 7SN

### Courses

CONQUER THE CHIP-master modern electronics the practical way by seeing and doing in your own home. Write for your free colour brochure now to BRITISH NATIONAL RADIO & ELECTRONICS SCHOOL, Dept C3, Reading, Berks RG1 1BR.

### ORDER FORM PLEASE WRITE IN BLOCK CAPITALS

Please insert the advertisement below in the next available issue of **Everyday Electronics** for . . . . . Insertions. I enclose Cheque/P.O for £ . . . . . (Cheques and Postal Orders should be crossed Lloyds Bank Ltd. and made payable to **Everyday Electronics**)

NAME . . . . .  
ADDRESS . . . . .  
. . . . .  
. . . . .

#### EVERYDAY ELECTRONICS

Classified Advertisement Dept., Room 2612, King's Reach Tower, Stamford Street, London SE1 9LS Telephone 01-261 5942

Rate: 33p per word, minimum 12 words. Box No. 60p extra.

Company registered in England. Registered No. 53626. Registered Office: King's Reach Tower, Stamford Street, London SE1 9LS.



# AT YOUR SERVICE

Everyday Electronics and Computer Projects and crossed "Lloyds Bank Ltd." Treasury notes should always be sent registered post. Advertisements, together with remittance, should be sent to the Classified Advertisement Department, Everyday Electronics and Computer Projects, Room 2612, IPC Magazines Limited, King's Reach Tower, Stamford St., London SE1 9LS. (Telephone 01-261 5942).

## For Sale

**VARIABLE VOLTAGE POWER SUPPLY 0-15V 1.5A.** 14 working order with built in voltmeter and overload protection £13.50 + £3.00 P&P. S.a.e. lists. S.H.E., 5 St Josephs Park, Ballycruttle, Downpatrick BT30 7EN.

## Service Sheets

**BELL'S TELEVISION SERVICE** for service sheets on Radio, TV etc. £1.50 plus SAE. Service Manuals on Colour TV and Video Recorders, prices on request. SAE with enquiries to: BTS, 190 King's Road, Harrogate, N. Yorkshire. Tel: 0423 55885.

**FULL SIZE SERVICE SHEETS £2 + 1sae;** CTV/MusC £3 + 1sae. Repair/circs almost any named TV/VCR £9.50. 1sae free quotations for manuals, sheets - free mag inc. service sheet. T.I.S.E.E. 76 Church Street, Larkhall, Lanarks - Phone 0698 883334.

# NO!

If you see an advertisement in the press, in print, on posters or a cinema commercial which you find unacceptable, write to us at the address below. (TV and radio commercials are dealt with by the I.B.A.)

**The Advertising Standards Authority.**

ASA Ltd., Brook House, Torrington Place, London WC1F 7HN

★ BAKER ★

GROUP P.A. DISCO AMPLIFIERS post £2

150 watt Output, 4 input Mixer pre-amp. Illustrated ..... £99  
150+150w Stereo, 300w Mono Slave 500 mv. Inputs ..... £125  
150w P.A. Vocal, 8 inputs, High/Low Mixer Echo Socket ..... £129  
100 watt Valve Model, 4 inputs, 5 Outputs. Heavy duty ..... £125  
60 watt Valve Model, 4 inputs, Low imp and 100v line output ..... £69  
60 watt Mobile 240v AC and 12v DC. 4-8-16 ohm+100v line ..... £89

BAKER LOUDSPEAKERS

Make	Model	Size	Watts	Ohms	Price
Baker Hi-Fi	Major	12in	30	4/8/16	£16.00
Baker Hi-Fi	Superb	12in	30	8/16	£26.00
Baker P.A.	Group 45	12in	45	4/8/16	£16.00
Baker Hi-Fi	Auditorium	12in	45	8/16	£24.00
Baker Hi-Fi	Auditorium	15in	60	8/16	£37.00
Baker P.A.	DG75	12in	75	4/8/16	£30.00
Baker P.A.	Group 100	12in	100	8/16	£36.00
Baker P.A.	Disco 100	12in	100	8/16	£26.00
Baker P.A.	Group 100	15in	100	8/16	£35.00
Baker P.A.	Disco 100	15in	100	8/16	£35.00

BAKER DISCO SYSTEMS

150 Watts twin turntables, twin speakers, headphones, microphone, side controls. Complete £330 or Console only £185.

RCS SOUND TO LIGHT CONTROLLER KIT

Printed circuit. Cabinet. 3 channels. 1,000 watts each. Will operate from home Hi-Fi or Disco. £19. Post £1 or Ready Built £27. Disco Bulbs 100w ES or BC £2.20 pp £1.50 for 6.

PANEL METERS

50µa, 100µa, 500µa, 1ma, 5ma, 50ma, 100ma, 500ma, 1 amp, 2 amp, 25 volt, VU 2 1/2 x 2 x 1 1/2. Stereo VU 3 1/2 x 1 1/2 x 1in. £5 pp 50p.

ALUMINIUM CHASSIS 18 s.w.g. Undrilled, 4 sides, riveted corners: 6 x 4 x 2 1/2in. £1.75; 8 x 6 x 2 1/2in. £2.20; 10 x 7 x 2 1/2in. £2.75; 14 x 9 x 2 1/2in. £3.60; 16 x 6 x 2 1/2in. £3; 12 x 3 x 2 1/2in. £1.80; 12 x 8 x 2 1/2in. £3.20; 16 x 10 x 2 1/2in. £3.80.

ALL ANGLE BRACKET 6 x 1 x 1/2in. 30p.  
ALUMINIUM PANELS 18 s.w.g. 12 x 12in. £1.80; 14 x 9in. £1.75; 6 x 4in. 55p; 12 x 8in. £1.30; 10 x 7in. 90p; 8 x 6in. 90p; 14 x 3in. 72p; 12 x 5in. 90p; 16 x 10in. £2.10; 16 x 6in. £1.30.

ALUMINIUM BOXES. MANY OTHER SIZES IN STOCK.  
4 x 2 1/2 x 2in. £1.00; 3 x 2 x 1in. 90p; 6 x 4 x 2in. £1.60; 8 x 6 x 3in. £2.50; 12 x 5 x 3in. £2.75; 6 x 4 x 3in. £1.80; 10 x 7 x 3in. £3.

HIGH VOLTAGE ELECTROLYTICS 32+32/350V ..... 50p  
20/500V ..... 75p 8+8/500V ..... £1 32+32/500V ..... £2  
32/350V ..... 45p 8+16/450V ..... 75p 125/500V ..... £2  
32/500V ..... 95p 16+16/350V ..... 75p 16+32+32/500V ..... £2

SINGLE PLAY DECKS. Post £2

Make	Model	Cartridge	Price
BSR	P170	Ceramic	£20
GARRARD	6200	Ceramic	£22
BSR	P232	Magnetic	£28
AUTOCHANGER	BSR	Ceramic	£20

RADIO COMPONENT SPECIALISTS

Dept 4, 337, WHITEHORSE ROAD, CROYDON

SURREY, U.K. TEL: 01-684 1665

ACCESS

Post 65p Minimum. Callers Welcomed. Lists 32p. Same day despatch Closed Wed

VISA

## COMPUTER LINK

DIL PLUG (Headers) IDC		DC SOCKET CONNECTORS		CARD EDGE CONNECTORS	
Pins		2 Row		IDC Female	
14	£0.80	10-way	£0.80	10-way	£1.20
16	£1.00	14-way	£0.80	16-way	£1.60
24	£1.40	16-way	£1.00	20-way	£1.90
40	£2.15	20-way	£1.20	26-way	£2.40
		26-way	£1.45	34-way	£3.10
		34-way	£1.60	40-way	£3.40
		40-way	£1.85	50-way	£3.85
		50-way	£2.00	60-way	£4.80
		60-way	£2.25		
IDC P C B PLUGS		IDC D CONNECTORS		IDC SHROUDED HEADERS WITH EJECTING LOCKING ARMS	
10-way	£0.85	9-way	£2.70	10-way	85 90
16-way	£1.20	15-way	£3.20	14-way	£1.00 £1.20
20-way	£1.35	25-way	£3.20	18-way	£1.25 £1.45
26-way	£1.60	37-way	£5.90	20-way	£1.40 £1.60
34-way	£1.95			26-way	£1.70 £1.95
40-way	£2.00			34-way	£2.00 £2.20
50-way	£2.25			40-way	£2.15 £2.45
60-way	£2.60			50-way	£2.30 £2.85
				60-way	£2.45 £2.85
IDC AMPHENOL PLUGS		EDGE CONNECTORS		D CONNECTORS	
24-way	£5.00	23-way (ZX81)	£1.85	(Solder Bucket) Male	Female
36-way	£5.20	28-way (Spectrum)	£2.10	9-way	75 1.00
				15-way	95 1.60
				25-way	£1.50 1.90
				37-way	£2.40 3.25
				DDDS 95	
RIBBON CABLE (Price per ft)		DIL PLUG HEADERS		JUMPER LEAD RIBBON CABLE ASSEMBLY	
9-way	Gray Rainbow 13 24	Length	14 Pin 18 Pin 24 Pin 40 Pin	280A CPU	£2.95
10-way	15 28			280A CTC	£2.65
14-way	18 32			280A DART	£5.45
18-way	20 36			280A RID	£2.70
19-way	22 40			ZM424E	£1.25
20-way	30 50			ZM425E	£3.40
24-way	36 60			ZM426E	£2.95
25-way	40 65			ZM427E	£5.95
26-way	45 70				
34-way	60 80				
37-way	65 85				
40-way	70 90				
50-way	95 115				
60-way	£1.10 £1.40				
64-way	£1.15 £1.50				
IDC JUMPERS 36" SINGLE ENDED		ASSORTMENTS			
Ways	2 Row Socket	Card Edge	PCB	C12 - C14 - C15 Casettes at 52p each	
10	£1.35	£1.95	£1.45	(ZX81) 23-way Plug Board	£1.25
14	£1.70			(SPECTRUM) 28-way Plug Board	£1.50
16	£1.90	£2.45	£1.75		
20	£2.20	£2.95	£1.95		
26	£2.95	£3.85	£2.95		
34	£3.40	£4.35	£3.35		
40	£4.50	£5.85	£4.20		
50	£5.25	£6.85	£5.20		
60	£6.25	£8.25	£6.20		
ANY COMBINATION OR LEAD MADE TO ORDER				COMPUTER LEADS	
				BBC Computer to Printer 2metre	£12.75
				BBC or ORIC 7-pin lead	£4.20
				DIN plug to 2 x 3.5mm Jack to 1 x 2.5mm Jack 1 metre	£2.25
				5-pin Domino Plug 50	
				6-pin DIN Plug 50	
				7-pin DIN Plug 50	
				Light Pen for SPECTRUM or BBC enables you to produce high resolution drawings on your own TV screen	ONLY £24.95
NO HIDDEN EXTRAS ALL PRICES FULLY INCLUSIVE FREE P&P C.W.O.					
COMPUTER LINK, Dept. EEZ, P.O. Box 1, Ware, Herts. Tel: 0920 5285					
Tel: 0992-466832 462371					

## FREE CAREER BOOKLET

### Train for success, for a better job, better pay

Enjoy all the advantages of an ICS Diploma Course, training you ready for a new, higher paid, more exciting career.

Learn in your own home, in your own time, at your own pace, through ICS home study, used by over 8 million already!

Look at the wide range of opportunities awaiting you. Whatever your interest or skill, there's an ICS Diploma Course there for you to use.

Send for your FREE CAREER BOOKLET today—at no cost or obligation at all.

TICK THE FREE BOOKLET YOU WANT AND POST TODAY

<input type="checkbox"/> ELECTRONICS ENGINEERING	<input type="checkbox"/> TV & AUDIO SERVICING
<input type="checkbox"/> ELECTRICAL ENGINEERING	<input type="checkbox"/> RUNNING YOUR OWN BUSINESS

Name \_\_\_\_\_  
Address \_\_\_\_\_

**ICS** ICS Dept EC134, 160 Stewart's Road, London SW8 4UJ. 01-622 9911 (all hours)

# TEACH-IN 84

Once again GREENWELD will be supplying a complete set of parts for this ever popular series — as we have done for all previous series. Our experience in this field means your kit can be supplied from stock at the best possible price, so order with confidence. Price for complete kit is only £18.95 inc post and VAT.



## MOTORIZED GEARBOX

These units are as used in a computerized tank, and offer the experimenter in robotics the opportunity to buy the electro-mechanical parts required in building remote controlled vehicles. The unit has 2 x 3V motors, linked by a magnetic clutch, thus enabling turning of the vehicle, and a gearbox contained within the black ABS housing, reducing the final drive speed to approx 50rpm. Data is supplied with the unit showing various options on driving the motors etc. £5.95. Suitable wheels also available: 3" Dia plastic with black tyre, drilled to push-fit on spindle. 2 for £1.30 (limited qty). 3" dia aluminium disc 3mm thick, drilled to push-fit on spindle. 2 for 68p.

## SEAT BELT ALARM

Originally for sale at £8.95, these well made units 70 x 50 x 25mm provide both audible and visual alarms. Uses 2 IC's, PB2720 transducer, etc. Available ready built, with circuit and instructions for just £4.95. Also available as a kit, PCB + all components, box, wire, etc, together with instructions. Only £3.95.

## RIBBON CABLE

Special purchase of multicoloured 14 way ribbon cable — 40p/metre; 50m £18; 100m £32.00; 250m £65.00.

## TTL PANELS

Panels with assorted TTL inc LS types. Big variety. 20 chips £1.00; 100 chips £4.00; 1000 chips £30.00.

## "THE SENSIBLE 64"

David Highmores new book on the Commodore 64 now available. £5.95.

## THE 1984 GREENWELD CATALOGUE NOW AVAILABLE!!

It's Bigger, Brighter, Better, more components than ever before. With each copy there's discount vouchers, Bargain List, Wholesale Discount List, Bulk Buyers List, Order Form and Reply Paid Envelope. All for just £1.00! Order now for early delivery!

## COMPUTER GAMES

Z901 Can you follow the flashing light/pulsating tone sequence of this famous game? Supplied as a fully working PCB with speaker (no case) plus full instructions. Only £4.95

Z902 Probably the most popular electronic game on the market — based on the old fashioned pencil and paper battleship game, this computerized version has brought it bang up to date! We supply a ready built PCB containing 76477 sound effect chip, TMS1000 micro-processor chip, R's, C's etc. Offered for its component value only (board may be cracked or chipped, it's only £1.95. Instructions and circuit, 30p.

## STABILIZED PSU PANEL

A199. A versatile stabilized power supply with both voltage (2-30V) and current (20mA-2A) fully variable. Many uses inc bench PSU, Nicad charger, gen. purpose testing. Panel ready built, tested and calibrated. £7.75. Suitable transformer and pots £6.00. Full data supplied.

## NICAD CHARGERS

Versatile unit for charging AA, C, D and PP3 batteries. Charge/test switch, LED indicators at each of the 5 charging points. Mains powered. 210 x 100 x 50mm £7.95. Model A124. Unit plugs directly into 13A socket, and will charge up to 4 AA cells at a time. Only £4.80.

## NICAD BATTERIES

AA size 99p each; C size 199p; D size 220p; PP3 size 395p.

## PRECISION PCB DRILL

Small size, 35mm dia x 165mm long. 12V operation. Supplied with collet + 1mm bit 6000RPM. Only £7.50.

## 5mm RED LED SCOOP!!

Full spec brand new devices at a low, low price!! 25 £1.95; 100 £6; 250 £13.50; 1000 £39.50.

## LOGIC POWER SUPPLY

This ready built mains adaptor supplies 4.5V @ 150mA DC, so can easily be modified to a stabilized 5V supply. Built in continental plug for standard mains supply. Only £1.95; 10 £16; 25 £32; 100 £110.

## PACKS! PACKS! PACKS!

K517 Transistor Pack. 50 assorted full spec marked plastic devices PNP NPN RF AF. Type numbers include BC114, 117, 172, 182, 183, 198, 239, 251, 214, 225, 320, BF198, 255, 394, 2N3904 etc etc. Retail cost £7+. Special low price **275p**

K523 Resistor Pack. 1000 — yes, 1000 ½ and ½ watt 5% hi-stab carbon film resistors with pre-formed leads for PCB mounting. Enormous range of preferred values from a few ohms to a several megohms. Only 250p. 5000 £10; 20,000 £36.

K520 Switch Pack. 20 different assorted switches — rocker, slide, push, rotary, toggle, micro etc. Amazing value at only **200p**

K522 Copper clad board. All pieces too small for our etching kits. Mostly double sided fibreglass. 250g (approx 110 sq ins) for **200p**

K541 It's back!! Our most popular pack ever — Vero offcuts. This has been restricted for some time, but we have now built up a reasonable stock and can once again offer 100 sq ins of vero copper clad offcuts, average size 4x3". Offered at around ½ the price of new board **320p**

K530 100 Assorted polyester caps — all new modern components, radial and axial leads. All values from 0.01 to 1uf at voltages from 63 to 1000!! Super value at **395p**

K503 100 assorted wirewound resistors, 1W-12W. Wide range of values **2.00**

## BIMBOXES 2000 Series, ABS. Guides for vertically mounting PCB's, bimductors for horizontal mounting.

Part No.	Size	Grey or Black	White
BIM 2002/12	100x50x25	1.10	1.21
BIM 2003/13	112x62x31	1.25	1.37
BIM 2004/14	120x65x46	1.32	1.45
BIM 2005/15	150x80x56	1.54	1.69
BIM 2006/16	190x110x60	2.70	2.97
BIM 2005/25	150x80x76	Grey Base, Clear Lid 1.91	
BIM 2006/26	190x110x80	3.20	
BIM 2007/17	112x62x31	Grey Polystyrene, No Guides 0.63	

## BIMBOXES 4000 Series, ABS Base, Aluminium recessed lid.

BIM	Size	Grey or Black	BIMTOOLS
BIM 4003	85x56x35	1.18	12v Mini Bimdrill inc collets 8.05
BIM 4004	111x71x48	1.46	Mini Bimdrill Kit inc 20 tools 14.45
BIM 4005	161x59x96	2.02	Mains Bimdrill inc collets 9.55

## BIMCASES 1000 Series, ABS base, Sloping-Front, Aluminium recessed lid.

BIM 1005	161x39/57x96	1.78	Mains Bimdrill Kit inc 20 tools 15.45
BIM 1006	215x47/72x130	2.88	Bimron 17W 6.15
			Bimron 27W 5.75
			Bimpump, Desoldering Tool 6.25



All prices inc VAT. Add 60p per order p&p. S.A.E. for full list. Mail order only.

## BIMSALES

Dept EE4, 48a Station Road, Cheadle Hulme, Cheadle, Cheshire SK8 7AB. Tel: 061-485 6667.

# INDEX TO ADVERTISERS

Alcon Instruments .....	146
Bimsales .....	216
Bi-Pak .....	148
BK Electronics .....	Cover III
B.N.R.E.S. ....	210
Bull J. ....	213
Computer Link .....	215
Dzubias M. ....	212
Electronize Design .....	Cover II
Electrovalue .....	212
Enfield Electronics .....	152
Global Specialists Corporation .....	149
Greenweld Electronics .....	216
ICS Intertext .....	215
Magenta Electronics .....	150
Maplin Electronics .....	149 Cover IV
Radio Component Specialists .....	215
R & TVC .....	146
Rapid Electronics .....	147
RH Electronics Suppliers .....	151
Sparkrite .....	211
T.K. Electronics .....	212

# GREENWELD

Goods normally despatched by return of post.

443D Millbrook Road Southampton SO1 0HX

Our shop has enormous stocks of components and is open from 9-5.30 Mon-Sat. Come & see us!!

Tel (0703) 772501  
ALL PRICES INCLUDE VAT;  
JUST ADD 80p P&P



### MULLARD SPEAKER KITS

Purposefully designed 40 watt R.M.S. and 30 watt R.M.S. 8 ohm speaker systems recently developed by MULLARD'S specialist team in Belgium. Kits comprise Mullard woofer (8" or 5") with foam surround and aluminium voice coil. Mullard 3" high power domed tweeter. B.K.E. built and tested crossover based on Mullard circuit, combining low loss components, glass fibre board and recessed loudspeaker terminals. SUPERB SOUNDS AT LOW COST. Kits supplied in polystyrene packs complete with instructions. 8" 40W system — recommended cabinet size 240 x 216 x 445mm  
 Price £14.90 each + £2.00 P & P.  
 5" 30W system — recommended cabinet size 160 x 175 x 295mm  
 Price £13.90 each + £1.50 P & P.

Designer approved flat pack cabinet kits, including grill fabric. Can be finished with iron on veneer or self adhesive vinyl etc.  
 8" system cabinet kit £8.00 each + £2.50 P & P.  
 5" system cabinet kit £7.00 each + £2.00 P & P.

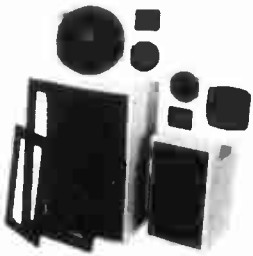

### STEREO CASSETTE TAPE DECK MODULE

Comprising of a top panel and tape mechanism coupled to a record/play back printed board assembly. Supplied as one complete unit for horizontal installation into cabinet or console of own choice. These units are brand new, ready built and tested.

Features: Three digit tape counter. Autostop. Six piano type keys, record, rewind, fast forward, play, stop and eject. Automatic record level control. Main inputs plus secondary inputs for stereo microphones. Input Sensitivity: 100mV to 2V. Input Impedance: 68K. Output level: 400mV to both left and right hand channels. Output Impedance: 10K. Signal to noise ratio: 45dB. Wow and flutter: 0.1%. Power Supply requirements: 18V DC at 300mA. Connections: The left and right hand stereo inputs and outputs are via individual screened leads, all terminated with phono plugs (phono sockets provided). Dimensions: Top panel 5 1/2" x 11 1/2". Clearance required under top panel 2 1/2". Supplied complete with circuit diagram and connecting diagram. Attractive black and silver finish.  
 Price £26.70 + £2.50 postage and packing.  
 Supplementary parts for 18V D.C. power supply (transformer, bridge rectifier and smoothing capacitor) £3.90



### LOUDSPEAKERS POWER RANGE

THREE QUALITY POWER LOUD-SPEAKERS (15", 12" and 8" See 'Photo'). Ideal for both Hi-Fi and Disco applications. All units have attractive cast aluminium (ground finish) fixing escutcheons. Specification and Prices.

15" 100 watt R.M.S. Impedance 8 ohms. 50oz. magnet. 2" aluminium voice coil. Res. Freq. 20 Hz. Freq. Resp. to 2.5KHz. Sens. 97dB. Price: £34.00 each + £3.00 P&P  
 12" 100 watt R.M.S. Impedance 8 ohms. 50oz. magnet. 2" aluminium voice coil. Res. Freq. 25Hz. Freq. Resp. to 4 KHz. Sens. 95dB. Price £26.00 each + £3.00 P&P.  
 8" 50 watt R.M.S. Impedance 8 ohms 20 oz. magnet. 1 1/2" aluminium voice coil. Res. Freq. 40Hz. Freq. Resp. to 6 KHz. Sens. 92dB. Black Cone. Price: £9.50 each. Also available with black protective grille. Price: £10.50 each. P&P £1.50.

12" 85 watt R.M.S. MCKENZIE C1285GP (LEAD GUITAR, KEYBOARD, DISCO) 2" aluminium voice coil, aluminium centre dome, 8 ohm imp., Res. Freq. 45Hz, Freq. Resp. to 6.5 KHz. Sens. 98dB. Price £24.99 + £3 carriage.  
 12" 85 watt R.M.S. MCKENZIE C1285TC (P.A., DISCO) 2" aluminium voice coil. Twin cone, 8 ohm imp., Freq. 45Hz, Freq. Resp. to 14KHz. Price £24.99 + £3 carriage.  
 15" 150 watt R.M.S. MCKENZIE C15 (BASS GUITAR, P.A.) 3" aluminium voice coil. Die cast chassis. 8 ohm imp., Res. Freq. 40Hz, Freq. Resp. to 4KHz. Price £49 + £4 carriage. Cabinets fixings in stock. S.A.E.



### PIEZO ELECTRIC TWEETERS - MOTOROLA

Join the Piezo revolution. The low dynamic mass (no voice coil) of a Piezo tweeter produces an improved transient response with a lower distortion level than ordinary dynamic tweeters. As a crossover is not required these units can be added to existing speaker systems of up to 100 watts (more if 2 put in series). FREE EXPLANATORY LEAFLETS SUPPLIED WITH EACH TWEETER.

TYPE 'A' (KSN2036A) 3" round with protective wire mesh, ideal for bookshelf and medium sized Hi-fi speakers. Price £4.29 each.

TYPE 'B' (KSN1005A) 3 1/2" super horn. For general purpose speakers, disco and P.A. systems etc. Price £4.99 each.

TYPE 'C' (KSN6016A) 2" x 5" wide dispersion horn. For quality Hi-fi systems and quality discos etc. Price £5.99 each.

TYPE 'D' (KSN1025A) 2" x 6" wide dispersion horn. Upper frequency response retained extending down to mid range (2KHz). Suitable for high quality Hi-fi systems and quality discos. Price £7.99 each.

TYPE 'E' (KSN1038A) 3 3/4" horn tweeter with attractive silver-finish trim. Suitable for Hi-fi monitor systems etc. Price £4.99 each.

TYPE 'F' (KSN1057A) Cased version of type 'E'. Free standing satellite tweeter. Perfect add on tweeter for conventional loudspeaker systems. Price £10.75 each.  
 P&P 30p ea. (or SAE for Piezo leaflets).

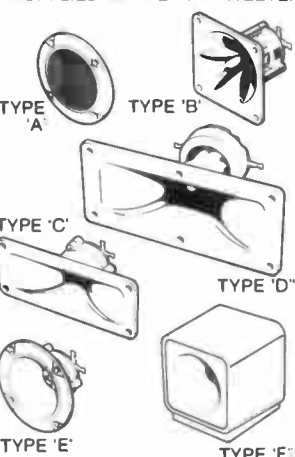

### OMP 80 LOUDSPEAKER

The very best in quality and value.  
 Ported tuned cabinet in hard-wearing black vinylite with protective corners and carry handle. Built and tested, employing 10in British driver and Piezo tweeter. Spec: 80 watts RMS; 8 ohms; 45Hz-20KHz; Size: 20in x 15in x 12in; Weight: 30 pounds.  
 Price: £49.00 each  
 £90 per pair  
 Carriage: £5 each £7 per pair

### BK ELECTRONICS

Prompt Deliveries  
 VAT inclusive  
 prices  
 Audio Equipment  
 Test Equipment  
 by  
 Thandar  
 and  
 Leader



### HOBBY KITS. Proven designs including glass fibre printed circuit board and high quality components complete with instructions.

FM MICROTRANSMITTER (BUG) 90/105MHz with very sensitive microphone. Range 100/300 metres. 57 x 46 x 14mm (9 volt)  
 Price: £7.99p

DIGITAL THERMOMETER -9.9 C to +99.9 C. LED display. Complete with sensor. 70 x 70 mm (9 volt) Price: £27.60p

3 WATT FM TRANSMITTER 3 WATT 85/115MHz varicap controlled. professional performance. Range up to 3 miles 35 x 84 x 12 mm (12 volt) Price: £12.49p

SINGLE CHANNEL RADIO CONTROLLED TRANSMITTER/RECEIVER 27MHZ Range up to 500 metres. Doubled coded modulation. Receiver output operates relay with 2amp/240 volt contacts. Ideal for many applications. Receiver 90 x 70 x 22 mm (9/12 volt) Price: £16.49 Transmitter 80 x 50 x 15 mm (9/12 volt) Price £10.29 P&P All Kits + 75p each. S.A.E. for complete list.

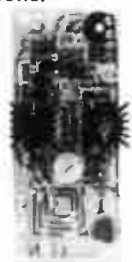

3 watt FM Transmitter

### BSR P256 TURNTABLE

P256 turntable chassis ● S shaped tone arm ● Belt driven ● Aluminium platter ● Precision calibrated counter balance ● Anti-skate (bias device) ● Damped cueing lever ● 240 volt AC operation (Hz) ● Cut out template supplied ● Completely manual arm  
 This deck has a completely manual arm and is designed primarily for disco and studio use where all the advantages of a manual arm are required.  
 Price £32.35 each. £2.50 P&P.



### OMP POWER AMPLIFIER MODULE



NEW OMP100 Mk.II POWER AMPLIFIER MODULE Power Amplifier Module complete with integral heat sink, toroidal transformer power supply and glass fibre p.c.b. assembly. Incorporates drive circuit to power a compatible LED Vu meter. New improved specification makes this amplifier ideal for P.A., Instrumental and Hi-Fi applications.

SPECIFICATION  
 Output Power: — 110 watts R.M.S.  
 Loads: — Open and short circuit proof 4/16 ohms.  
 Frequency Response: — 15Hz - 30KHz -3dB. T.H.D.: — 0.01%.  
 S.N.R. (Unweighted): — 118dB ±3.5dB  
 Sensitivity for Max Output: — 500mV @ 10K. Size: — 360 x 115 x 72 mm Price: — £31.99 + £2.50 P&P. Vu Meter Price: — £8.50 + 50p P&P

New model.  
 Improved specification

MOSFET versions available up to 300W. R.M.S.

### HOME PROTECTION SYSTEM

Better to be 'Alarmed' than terrified.  
 Thandar's famous 'Minder' Burglar Alarm System. Superior microwave principle. Supplied as three units, complete with interconnection cable. FULLY GUARANTEED.  
 Control Unit — Houses microwave radar unit, range up to 15 metres adjustable by sensitivity control. Three position, key operated fascia switch — off — test — armed. 30 second exit and entry delay.  
 Indoor alarm — Electronic swept freq. siren. 104dB output  
 Outdoor Alarm — Electronic swept freq. siren. 98dB output. Housed in a tamper-proof heavy duty metal case.  
 Both the control unit and outdoor alarm contain rechargeable batteries which provide full protection during mains failure. Power requirement 200/260 Volt AC 50/60Hz. Expandable with door sensors, panic buttons etc. Complete with instructions



READY BUILT

SAVE £128 Usual price £228 85  
 BKE's PRICE £99.p&p£4  
 SAE for colour brochure



### STEREO DISCO MIXER READY BUILT

STEREO DISCO MIXER with 7 band graphic equaliser and 10 segment L.E.D. Vu Meters. Many outstanding features.  
 5 Inputs with individual fader controls:—  
 2 Mag. turntable, 2 Aux. plus Mic. with talk-over switch. Headphone monitor. Master output control with Hi-Low outputs. Compatible with our OMP Power Amplifiers.  
 Size: 360 x 200 x 120 mm. Supply 240V 50Hz AC.

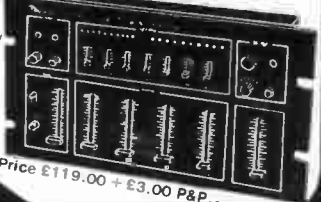

Price £119.00 + £3.00 P&P..

# B.K. ELECTRONICS

UNIT 5, COMET WAY, SOUTHEND-ON-SEA, ESSEX, SS2 6TR



★ SAE for current lists. ★ Official orders welcome. ★ All prices include VAT. ★ Sales Counter. ★ All items packed where applicable in special energy absorbing PU foam. ★ Please phone 0702 527572 ★

# Full-travel, full size KEYBOARD Simply plugs into expansion port on your SPECTRUM



**KIT ONLY**  
**£39.95**  
**READY-BUILT**  
**£44.95**

Case included in both prices

- ★ Single-key selection of all major multi-key functions.
- ★ Plugs directly into Spectrum expansion port and extends port for other peripherals.
- ★ Can accept Atari-type joysticks (optional extra).
- ★ Absolutely no soldering or dismantling of Spectrum.
- ★ Available in kit-form or ready-built.

The kit is sold in three parts — the Keyboard Main Kit which allows you to make your own arrangements for connection to the Spectrum — the Adaptor Kit which contains the extension board and socket for the expansion port and the cable between the

extension board and the keyboard — and the Case Kit which includes all the necessary mounting hardware.

Order As **LK29G (Keyboard Main Kit)** Price £28.50  
**LK30H (Adaptor Kit)** Price £6.50  
**XG35Q (Case)** Price £4.95

Full construction details in *Projects Book 9*.

Also available ready-built for direct connection and including case.

Order As **XG36P (Spectrum Keyboard)** Price £44.95

## Maplin's Fantastic Projects

Full details in our project books. Price 70p each.

In **Book 1 (XA01B)** 120W rms MOSFET Combo-Amplifier • Universal Timer with 18 program times and 4 outputs • Temperature Gauge • Six Vero Projects.

In **Book 2 (XA02C)** Home Security System • Train Controller for 14 trains on one circuit • Stopwatch with multiple modes • Miles-per-Gallon Meter.

In **Book 3 (XA03D)** ZX81 Keyboard with electronics • Stereo 25W MOSFET Amplifier • Doppler Radar Intruder Detector • Remote Control for Train Controller.

In **Book 4 (XA04E)** Telephone Exchange for 16 extensions • Frequency Counter 10Hz to 600 MHz • Ultrasonic Intruder Detector • I/O Port for ZX81 • Car Burglar Alarm • Remote Control for 25W Stereo Amp.

In **Book 5 (XA05F)** Modem to European standard • 100W 240V AC



Inverter • Sounds Generator for ZX81 • Central Heating Controller • Panic Button for Home Security System • Model Train Projects • Timer for External Sounder.

In **Book 6 (XA06G)** Speech Synthesiser for ZX81 & VIC20 • Module to Bridge two of our MOSFET amps to make a 350W Amp • ZX81 Sound on your TV • Scratch Filter • Damp Meter • Four Simple Projects

In **Book 7 (XA07H)** Modem (RS232) Interface for ZX81/VIC20 • Digital Enlarger Timer/Controller • DXers Audio Processor • Sweep Oscillator • CMOS Crystal Calibrator.

In **Book 8 (XA08J)** Modem (RS232) Interface for Dragon and Spectrum • Synchime • I/O Ports for Dragon • Electronic Lock • Minilab Power Supply • Logic Probe • Doorbell for the Deaf.

In **Book 9 (XA09K)** Keyboard with electronics for ZX Spectrum • Infra-Red Intruder Detector • Multimeter to Frequency Meter Converter • FM

Radio with no alignment • Hi-Res Graphics for ZX81 • Speech Synthesiser for Oric • VIC Extendiboard • ZX81 ExtendIRAM • Dynamic Noise Limiter for Personal Cassette Players • TTL Levels to Modem/RS232 Converter • Logic Pulser • Pseudo-Stereo AM Radio • Ni-Cad Charger Timer • Adder-Subtractor • Syndrums' Interface • Microphone Pre-Amp Limiter.

## THE MAPLIN MODEM KIT

Exchange programs with friends, leave or read messages from the various Billboard services, talk to computer bureaux, or place orders and check stock levels on Maplin's Cashtel



service. A Maplin Modem will bring a whole new world to your computer and vastly increase its potential.

Now you can exchange data with any other computer using a 300 baud European standard (CCITT) modem and because the Maplin Modem uses this standard, you could talk to any one of tens of thousands of existing users.

Some computers need an interface and we have kits for the ZX81, VIC20/Commodore 64, Dragon and Spectrum and shortly Atari, whilst the BBC needs only a short program which is listed in *Projects Book 8*.

A Maplin Modem will add a new dimension to your hobby.

Order As **LW99H (Modem Kit)** excluding case. Price £39.95.  
**YK62S (Modem Case)** Price £9.95.

Full construction details in *Projects Book 5*.

## 1984 CATALOGUE

A massive 480 big pages of description, pictures and data and now with prices on the page. The new Maplin catalogue is the one book no constructor should be without. Now includes new Heathkit section. On sale in all branches of W.H. Smith. Price £1.35 — It's incredible value for money. Or send £1.65 (including p & p) to our mail-order address.

## Great Projects From E&MM

Our book "Best of E&MM Projects Vol. 1" brings together 21 fascinating and novel projects from E&MM's first Year.

Projects include Harmony Generator, Guitar Tuner, Hexadrum, Syntom, Auto Swell, Partylite, Car Aerial Booster, MOS-FET Amp and other musical, hi-fi and car projects. Order As **XH61R**. Price £1.

Post this coupon now for your copy of the 1984 catalogue. Price £1.35 + 30p post and packaging. If you live outside the U.K. send £2.20 or 11 International Reply Coupons. I enclose £1.65

Name .....

Address .....

EE384



## MAPLIN ELECTRONIC SUPPLIES LTD

Mail Order: P.O. Box 3, Rayleigh, Essex SS6 8LR. Tel: Southend (0702) 552911 • Shops at: 159-161 King Street, Hammersmith, London W6. Tel: 01-748-0926. • 8 Oxford Road, Manchester. Tel: 061-236-0281. • Lynton Square, Perry Barr, Birmingham. Tel: 021-356-7292. • 282-284 London Road, Westcliff-on-Sea, Essex. Tel: 0702 554000. • 46-48 Bevois Valley Road, Southampton. Tel: 0703 25831. All shops closed all day Monday. All prices include VAT and carriage. Please add 50p handling charge to orders under £5 total value (except catalogue).