

198

Easy to build projects for everyone

APRIL 82
70p

Everyday ELECTRONICS

**Secret
and
Secure
with
our
MAGNETIC
LOCK**



MORE MEMORY



ADD-ON UNIT

SALE ELECTRONIC GAMES



NOW £40 OFF

ATARI T.V. GAME

THE GAME WITH 50 CARTRIDGES
R.R.P. £129.95 (inc. VAT)
OUR PRICE
£78.22 + VAT
(£89.95 inc. VAT)
The Atari is supplied with a free mains adaptor, a pair of paddles, a pair of joysticks and a combat cartridge and is the most popular television game on the market and has a range of over 40 different cartridges. In addition to the standard Atari range we also now stock the new Activision cartridges which are currently on special offer reduced from £18.95 to **£16.95 inc. VAT**

ATARI CARTRIDGES

20% OFF R.R.P.
Atari Soccer £29.95
NOW £23.95
Activision Dragster £18.95
NOW £14.95
Activision Boxing £18.95
NOW £14.95

ATARI OWNERS CLUB — Why not join our **FREE** Silica Atari Owners Club and receive our bi-monthly newsletter with special offers and details of the latest new cartridge releases. Telephone us with your name and address and we will add your name to our computer mailing list.

MATTEL INTELLIVISION



NOW £50 OFF

THE ULTIMATE T.V. GAME
R.R.P. £229.95 (inc. VAT)
OUR PRICE
£156.48 + VAT
(£179.95 inc. VAT)

6 NEW CARTRIDGES JUST RELEASED
**ASTROSMASH • SNAFU • BOWLING
SPACE ARMADA • BOXING
TRIPLE ACTION**
All 19 current cartridges - the six new ones above now retail at £19.95 — Silica special offer price **£17.95 inc. VAT**

The Mattel Intellivision is the most advanced T.V. game in the world with a range of over 25 different cartridges all at our special offer price of £17.95. This game uses a 16-bit microprocessor giving 16 colours and three-part harmony sound. The picture quality is incredible with 3D effects and realistic animation. An add on keyboard will be available in the Spring 1982 to convert the Mattel into a full home computer with 16K RAM which will be fully expandable and programmable in Microsoft Basic. Other accessories will be added later in the year. The normal price of the Intellivision + free soccer cartridge is £229.95 but our special offer price is £179.95 inc. VAT saving you £50.00

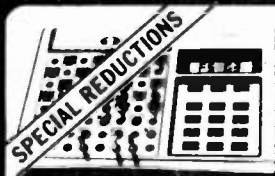
MATTEL OWNERS CLUB — Why not join our Mattel Owners Club and receive our regular newsletters containing details of all the latest cartridge releases. Telephone us with your name and addresses and we will add your name to our computer mailing list.
FREE 16 PAGE CARTRIDGE CATALOGUE — If you are interested in owning a Mattel, we now have available a 16 page catalogue describing the latest six cartridges to be released, as well as a new Mattel colour leaflet with brief descriptions of all 25 cartridges. Telephone us for further details.

T.V. GAME CARTRIDGES

We specialise in the whole range of T.V. games and sell cartridges for the following games: **ATARI • MATTEL • ACETRONIC • PHILIPS • DATABASE • ROWTRON • INTERTON • TELENG**. Let us know if you own any of these games and we will let you have details of the range of cartridges available.

Attention INTERTON & ACETRONIC owners: we have over 75 assorted used cartridges in stock all with 1 year guarantee — **SPECIAL OFFER £8.95 each**

We also have a number of secondhand games and cartridges



SPECIAL REDUCTIONS

ELECTRONIC CHESS

Liquid crystal battery chess computer with 100 200 hrs battery life and two levels of play. Comes with separate chess board and pieces.
R.R.P. £26.95
SALE PRICE
£19.95
(inc. VAT)

GRADUATE CHESS

A de luxe version of the electronic chess set with integral chess board. The ideal portable chess set — see illustration.
NOW
£29.95
INC VAT

FIDELITY MINI-SENSORY CHESS COMPUTER

The very first chess computer of its price to offer a portable computer with integral sensory board. Battery (6-8 hrs) or mains operated. This is a modular game and additional plug-in modules are planned for 1982 for advanced chess, popular openings, greatest master games, draughts and reversi.

MINI-SENSORY COMPUTER WITH STANDARD CHESS MODULE Was £54.50 **NOW £49.95** INC VAT

Silica Shop are one of the country's leading specialists in Chess Computers and now stock a range of more than 20 Chess Computers, including Challenger 7, 10, voice, Sensory 8 and Sensory Voice, Diplomat, System 3, Morphy, Great Game Machine, Voice Champion, and the new Scissors Mark V.



NOW £8 OFF

HAND-HELD GAMES EARTH INVADERS

These invaders are a breed of creature hitherto unknown to man. They cannot be killed by traditional methods — they must be buried. The battle is conducted in a maze where squads of aliens chase home troops. The only way of eliminating them is by digging holes and burying them.
R.R.P. £26.95 **NOW £18.95** inc. VAT



NOW £10 OFF

PAC MAN 2

Pac Man 2 is based on the latest pub game. It is a two colour game of strategy, tactical pursuit and destruction pitting Pac Man against the large Ghosts. The object of the game is for Pac Man to attain as high a score as possible by capturing and destroying Ghosts, Bugs and Energizers without being himself destroyed by the Ghosts. Pac Man 2 incorporates the most modern and complex status displays ever produced and is now on release for the first in the UK offering an ideal present.

R.R.P. £34.95 **NOW £24.95** inc. VAT



NOW £8 OFF

SPACE INVADERS

Based on one of the most popular arcade games, Space Invaders™ packs in lots of action with multi-shaped, brilliant LED vessels, including attack ships, bombs, defenders, missile rockets and a beam force cannon, plus exciting electronic sound effects. The attack ships attempt to bomb the ground defenders as they are moving. You manoeuvre the missile rockets — avoiding alien bombs — and destroy the invader force as quickly as you can. Progressive degree of difficulty includes automatic digital scoring. For ages 8 to adult.

R.R.P. £24.95 **NOW £16.95** inc. VAT



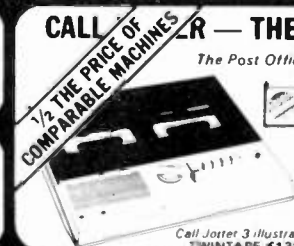
LESS THAN 1/2 PRICE

COLOUR CARTRIDGE T.V. GAME
Semi-programmable T.V. game
• 8 cartridges
• mains transformer
NOW £43.50 OFF
88 x 73
SALE PRICE £29.50 inc. VAT



SCOOP PURCHASE NOW 1/2 PRICE

BACKGAMMON COMPUTER
• 16 x 16 x 16 grid
• Backgammon computer
• 128 x 64 x 64
• Special offers, free available
• Comprehensive
• Was £99.95
NOW £48.95 inc. VAT



CALL THE PRICE OF 2/3 THE PRICE OF COMPARABLE MACHINES

CALL JOTTER 1 — THE AFFORDABLE ANSWER
The Post Office certified telephone answering machine
"Sorry darling, I will be late home — Love John"
The Call Jotter 1 brings the affordable answer at the amazing price of £69 (or £99 for the Call Jotter 2 with built-in remote recall facilities). These amazing telephone answering machines are Post Office certified and guaranteed for one year. They make a thoughtful gift for home or business use.
Call Jotter 3 illustrated TWINTAPE £129 **NOW £69.00** inc. VAT

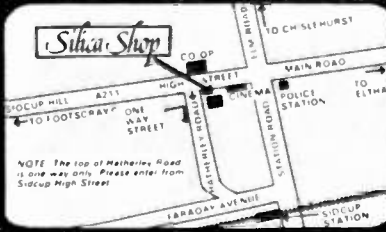


NOW £75 OFF

RADOFIN TELETEXT
Plus the addition of the new 16 character Teletext TV and receive the CLEAR and ORACLE data with teletext services.
THIS NEW MODEL INCORPORATES:
• Double channel reception
• Main menu PR, L, R, S
• Main menu 1, 2, 3, 4
• Main menu 5, 6, 7, 8
• Main menu 9, 10, 11, 12
• Main menu 13, 14, 15, 16
• Main menu 17, 18, 19, 20
• Main menu 21, 22, 23, 24
• Main menu 25, 26, 27, 28
• Main menu 29, 30, 31, 32
• Main menu 33, 34, 35, 36
• Main menu 37, 38, 39, 40
• Main menu 41, 42, 43, 44
• Main menu 45, 46, 47, 48
• Main menu 49, 50, 51, 52
• Main menu 53, 54, 55, 56
• Main menu 57, 58, 59, 60
• Main menu 61, 62, 63, 64
• Main menu 65, 66, 67, 68
• Main menu 69, 70, 71, 72
• Main menu 73, 74, 75, 76
• Main menu 77, 78, 79, 80
• Main menu 81, 82, 83, 84
• Main menu 85, 86, 87, 88
• Main menu 89, 90, 91, 92
• Main menu 93, 94, 95, 96
• Main menu 97, 98, 99, 100

ADD-ON ADAPTOR
Was £199 inc. VAT
SALE PRICE £124 inc. VAT

FOR FREE BROCHURES — TEL: 01-301 1111



For free illustrated brochures and reviews on our range of electronic games, please telephone 01 301 1111. Free delivery service available. To order by telephone please quote your name, address and ACCESS/BARCLAYCARD number, and leave the rest to us. Post and packing free of charge. Express 48 hour delivery service available.

SCHEMATA DELIVERED — Deliveries made direct to your door. Shipping charges apply from 10th April. Minimum quantities apply. Delivery times subject to change. Late deliveries 100% refund.

YEAR GUARANTEE — All goods are guaranteed by a full year's quality assurance. Returns are accepted. Money back. No questions asked. If you are not satisfied, we will refund your money.

FREE DELIVERY SERVICE — Available on all orders over £50.00. Delivery times subject to change.

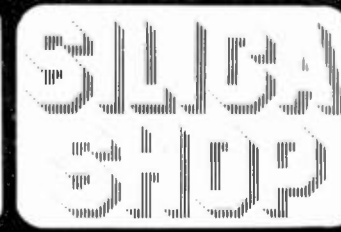
CREDIT FACILITIES — Available on all orders over £50.00. Delivery times subject to change.

CREDIT FACILITIES — Full credit facilities available on 12, 24 or 36 months at competitive rates.

PART EXCHANGE SERVICE — Available on all orders over £50.00. Delivery times subject to change.

FREE DELIVERY SERVICE — Available on all orders over £50.00. Delivery times subject to change.

SILICA SHOP LIMITED Dept. EE 4
1-4 The Mews, Hatherley Road, Sidcup, Kent OA14 4DX
Telephone: 01 301 1111 or 01 309 1111

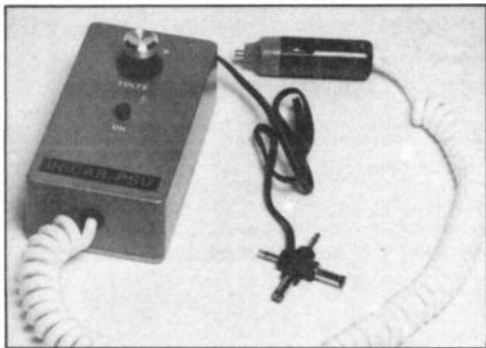


Everyday ELECTRONICS

VOL. 11 NO. 4

APRIL 1982

PROJECTS . . . THEORY . . . NEWS . . .
COMMENT . . . POPULAR FEATURES . . .



ZX81 cover photo—Sinclair Research Ltd.

SCHOOLS Electronic Design Award COMPETITION

Joint sponsors Mullard Ltd and EVERYDAY ELECTRONICS are delighted with the great response from secondary schools to their challenge. The judges have just completed their examination of entry papers and all participants will be notified directly of the results for Stage 1.

The twelve winning schools are to submit their working models for Stage 2 judging during May. An exhibition of models and presentation of prizes will take place at Mullard House, Torrington Place, London WC1, in June. Further news regarding SEDAC will appear in next month's issue.

© IPC Magazines Limited 1982. Copyright in all drawings, photographs and articles published in EVERYDAY ELECTRONICS is fully protected, and reproduction or imitations in whole or in part are expressly forbidden.

PROJECTS

- CAPACITANCE/FREQUENCY METER** by A. P. Donleavy 228
Dual purpose digital meter for the workshop
- 2K RAM PACK** by V. Terrell 234
Memory expansion for the Sinclair ZX81 Microcomputer
- MAGNETIC LOCK** by R. A. Penfold 244
The lock that doesn't betray its presence
- V.C.O. SOUND EFFECTS UNIT** by D. Butler 257
Simple experimental sound generator
- IN-CAR P.S.U.** by A. R. Winstanley 260
Provides 6V, 7.5V or 9V d.c. from a 12V car battery
- LIGHT ACTUATED SWITCH** by R. A. Penfold 264
Controls equipment by light

SERIES

- TEACH-IN 82** by O. N. Bishop 238
Part 7: Amplifiers and the Amplifier Module
- INTRODUCTION TO LOGIC** by J. Crowther 252
Part 12: Final part of this series—flip-flop circuits

FEATURES

- EDITORIAL** 227
Inconspicuous; Flag Flying
- SHOP TALK** by Dave Barrington 233
Product news and component buying
- JACK PLUG AND FAMILY** by Doug Baker 237
Cartoon
- FORMING AN ELECTRONICS CLUB** 249
by T. R. de Vaux-Balbirnie
A school teacher's advice
- EVERYDAY NEWS** 254
What's happening in the world of electronics
- RADIO WORLD** by Pat Hawker G3VA 256
Empire Broadcasting, Amateur Satellites
- READERS LETTERS** 267
Your news and views
- DOWN TO EARTH** by George Hylton 268
Designing a simple a.m. radio
- COUNTER INTELLIGENCE** by Paul Young 269
A retailer comments
- BRIGHT IDEAS** 269
Capacitor Measurement
- FOR YOUR ENTERTAINMENT** by Barry Fox 270
A visit to a Japanese semiconductor factory
- SQUARE ONE** 272
Beginners' Page: Switches
- NEW PRODUCTS** 273
Facts and photos of instruments, equipments and tools
- CIRCUIT EXCHANGE** 274
A forum for readers' ideas

Our May issue will be published on Friday,
April 16. See page 251 for details.

Readers Services ● Editorial and Advertisement Departments 277

KITS & COMPONENTS

DO YOU LONG TO HEAR YOUR DOORBELL RING?

Our latest kit gives you a pleasing three-note harmonically related tone sequence (not a microprocessor controlled buzz or the same old ding dong) at a touch of a button. This kit, based on a new integrated circuit, is supplied complete with a printed circuit board, loudspeaker and drilled box and requires only 9V battery and push button common to most households. It may also be switched by logic in such applications as car alarms, clocks, toys, P.A. systems, etc. The unit produces a 150mW output and draws less than one 1uA from a PP3 battery when the tone ceases. Supplied complete with circuit and assembly instructions.

IDEAL PROJECT FOR BEGINNERS—Only £5



HOME LIGHTING KITS

These kits contain all necessary components and full instructions & are designed to replace a standard wall switch and control up to 300w. of lighting.

TDR300K	Remote Control Dimmer	£14.30
MK6	Transmitter for above	£ 4.20
TD300K	Touchdimmer	£ 7.00
TDE/K	Extension kit for 2-way switching for TD300K	£ 2.00
LD300K	Rotary Controlled Dimmer	£ 3.50



TEACH-IN '82

EE Minilab	£13.50
Parts 1 - 6	£ 7.50
Parts 7 - 12	£ 4.90

Special price for all kits purchased together: £23.50

Woodwork not included

The above kits include all the components specified in the Teach-In '82 projects parts 1 - 12 plus sockets for ICs specified.

DISCO LIGHTING KITS

DL1000K. This value-for-money kit features a bi-directional sequence, speed of sequence and frequency of direction change, being variable by means of potentiometers and incorporates a master dimming control. **Only £14.60**

DL21000K. A lower cost version of the above, featuring unidirectional channel sequence with speed variable by means of a pre-set pot. Outputs switched only at mains zero crossing points to reduce radio interference to a minimum. **Only £8.60**

Optional opto input DLA1
Allowing audio ("beat")—light response. **60p**



REMOTE CONTROL

Published remote control systems tend to be quite complex, requiring difficult-to-get components and a well-equipped lab to get them to work. If this has put you off making your own system we have just the kits for you. Using infra-red, our KITS range from simple on/off controllers to coded transmitter/receivers with 16 on/off outputs or three analogue outputs for controlling, e.g. TV or Hi-Fi systems. The kits are easy to build and simple to set up—and they are extremely versatile, controlling anything from garage doors to room lighting just by adding the required output circuits, i.e. relays, triacs, etc. If you can design your own system we stock a wide range of remote control components at very competitive prices.

We have compiled a booklet on remote control, containing circuits, hints, data sheets and details of our remote control kits and components. So don't control yourself—SEND US 30p and a stamped addressed envelope for your copy TODAY!

24 HOUR CLOCK/APPLIANCE TIMER KIT

Switches any appliance up to 1kW on and off at present times once per day. Kit contains: AY-5-1230 IC, 0.5" LED display, mains supply, display drivers, switches, LEDs, triacs, PCBs and full instructions.



CT1000K Basic Kit	£14.90
CT1000K with white box (56/131 x 71mm). (Ready Built)	£17.40 £22.50

LEDs

3mm & 5mm Round	Red.....09p	Green.....12p
Clips 3mm & 5mm03p	Yellow.....12p

(Shaped Led's)

Rectangular (Gravelstone)	Red	Green	Yellow
Rectangular 5x2.5mm	16p	16p	16p
Square 5x5mm	17p	20p	20p
Triangular 5mm	17p	20p	20p
Arrowhead 2.5x5mm	17p	20p	-

(Flashing Led's)
5mm diameter Red.....39p Flashing/Continuous.....42p

(Tri Colour Led's)
5mm round.....30p 5mm Rectangular.....32p



DVM/ULTRA SENSITIVE THERMOMETER KIT

This new design is based on the ICL7126 (a lower power version of the ICL7106 chip) and a 3 1/2 digit liquid crystal display. This kit will form the basis of a digital multimeter (only a few additional resistors and switches are required—details supplied), or a sensitive digital thermometer (-50°C to +150°C) reading to 0.1°C. The basic kit has a sensitivity of 200mV for a full scale reading, automatic polarity indication and an ultra low power requirement—giving a 2 year typical battery life from a standard 9V PP3 when used 8 hours a day, 7 days a week.... Price £15.50



FAST SERVICE · TOP QUALITY · LOW LOW PRICES

ALL PRICES EXCLUDE VAT



No circuit is complete without a call to—
ELECTRONICS
11 Boston Road
London W7 3SJ

DEPT. E.E.

Telephone: 01 579 9794/2842

Add 55p postage & packing + 15% VAT to total
Overseas Customers:
Add £1.75 (Europe), £4.50 (elsewhere) for p & p.
Send S.A.E. for further STOCK DETAILS.
Goods by return subject to availability.

OPEN
9am to 5pm (Mon to Fri)
10am to 5pm (Sat)

CLICK TOWER
ULSBIDGE ROAD
CAR PARK
MANNELL GARAGE

So you've fancied some WHARFEDALE E90 speakers —

But the bank manager won't co-operate! Don't despair—now there are Wilmslow Audio flat-pack kits for the Wharfedale E50, E70 and E90. A few hours of easy and interesting work will complete your speakers at a very considerable saving on buying 'assembled' E systems.



The kits contain all cabinet components — accurately machined for easy assembly — all drive units, crossover networks, acoustic wadding, reflex port trim, nuts, bolts, terminals, grille fabric, etc. The cabinets can be painted or stained or finished with iron-on veneer. Easy, foolproof assembly instructions are supplied — no electronic or woodworking knowledge necessary.

Prices: E50 kit **£182** per pair including VAT, carriage and insurance £ 8
E70 kit **£220** per pair including VAT, carriage and insurance £ 8
E90 kit **£330** per pair including VAT, carriage and insurance £10

Credit terms available through leading finance house.
Written details on request.



0625 529599

35/39 Church Street, Wilmslow, Cheshire SK9 1AS

Lighting service on telephoned credit card orders!

MUSIC KITS

ALL WITH PRINTED CIRCUIT BOARDS

128-Note Sequencer	SET76	120 45	Drum-Synthesiser	SET119	50 11
16-Note Sequencer	SET86	84 63	Enlarger Timer	SET93	39 22
3-Channel Mixer	SET107	21 50	Frequency Doubler	SET98	11 75
3-Microphone Mixer	SET108	12 99	Funny Talker	SET99	16 55
6-Channel Mixer	SET90	96 67	Guitar Effects	SET42	15 92
Analogue Reverb	SET83	45 92	Guitar Multiprocessor	SET85	79 15
Audio Effects	SET105	15 12	Guitar Overdrive	SET56	21 17
Chor synth	SET100	125 04	Guitar Sustain	SET75	11 77
Compressor	SET120	25 05	Headphone Amplifier	SET104	21 15
Digital Reverb	SET78	75 50	Metronome	SET118	10 58
Disco strobe	SET57	89 78	Microphone Pre-amp	SET61	11 32

10% OFF

10% off U.K. C.W.O. orders over £20. From this advert until end of month. (5% off for credit cards). This coupon, must accompany order.

Noise Limiter	SET97	15 96	Split-Phase Tremolo	SET102	29 98
P.E. Minisonic Synth	SET38	181 56	Switched Treble Boost	SET89	12 51
Phaser	SET88	21 08	Synthesiser Interface	SET81	9 49
Phasing & Vibrato	SET70	36 25	Transient Generator	SET63	16 86
Practise Amplifier	SET106	22 15	Tremolo	SET116	13 47
Rhythm Generator	SET 103	See Lists	Tuning Fork	SET46	37 04
Signal Tracer	SET109	17 50	Voice Operated Fader	SET30	9 85
Simple Phase Unit	SET25	10 54	Voice-Scrambler	SET117	21 81
Smooth Fuzz	SET91	11 68	Wah-Wah	SET58	14 01
Speech Processor	SET110	12 18	Wind and Rain Unit	SET28	11 39

Sets include PCBs, U.K. P. & P., 15% VAT, Res., Caps., S.C.s, Pots, Knobs, SW's, Skts., Wire, Solder, Box, Photocopy of Orig. Text. Fuller details and more great kits in our Free Catalogue.

Prices correct at press, E. & O.E., subject to stock. Delivery frequently by return but please allow 14 days.

PHONOSONICS

DEPT EE24, 22 HIGH STREET, SIDCUP, KENT, DA14 6EH
01-302-6184

GREENWELD

443D MILLBROOK ROAD, SOUTHAMPTON SO1 0HX
All prices include VAT—just add 50p post. Tel (0703) 772501

Goods normally despatched by return of post

AMAZING! COMPUTER GAMES PCB'S FOR PEANUTS!

A bulk purchase of PCB's from several well known computer games including Battleships, Simon, Logic 5 and Starbird enable us to offer these at incredibly low prices:

'STARBIRD'

Gives realistic engine sounds and flashing laser blasts—accelerating engine noise when module is pointed up, decelerating noise when pointed down. Press contact to see flash and hear blast of lasers shooting. PCB tested and working complete with speaker and batt clip. (needs PPS). PCB size 130 x 60mm. Only £2.95

'SIMON'

The object of this game is to repeat correctly a longer and longer sequence of signals in 3 different games. (Instructions included) PCB contains chips, switches, lampholders and lamps, and is tested working, complete with speaker. Needs PPS and 2 x HP11. PCB size 130 x 130mm Only £3.95

'COMPUTER BATTLESHIPS'

Probably one of the most popular electronic games on the market. Unfortunately the design makes it impractical to test the PCB as a working model, although it may well function perfectly. Instead we have tested the sound chip, and sell the board for its component value only (PCB may be chipped or cracked): SN76477 sound IC; TMS1000 u-processor; batt clips, R's, C's etc. Size 180 x 140mm. Only £1.50. Instruction book and circuit 30p extra.

LOGIC 5 PANEL

Tested Logic 5 now sold out—but we have some PCB's with 10 LED's and chip on, but no keyboard. Not tested. 50p.

'MICROVISION'

Cartridges

These are a small PCB with a micro-processor chip, designed to plug in to the microvision console. Only snag is, we don't have any consoles! However, they can be used as an oscillator with 4 different freq. outputs simply by connecting a battery and speaker. Tested and working (as an osc) with pin out data. PCB size 72 x 60mm. only 25p each!

RELAY/TRIAC PANEL

Z837 PCB 100 x 78mm containing a wealth of components: 2 x 12V DPCO min relays, 2 x 47µF 16V tanis SC146E 10A 500V triac, C122D 8A 400V SCR, 555 timer, 10 x 1N4001 diodes, 2N5081 SCR, 2 x 3mm LED'S 3 x 2N5704, R's & C's—Amazing value—if bought separately, parts would cost around £811. Our price for the panel, just £2.90.

200 ELECTROLYTICS £4.00

K824 Large variety of values/voltages, mostly cropped leads for PCB mntg. 1-1000µF, 10-63V. All new full spec components, not chuck-outs!! 200 £4, 1000 £17.50

COMPONENT PACKS

K803 150 wirewound resistors from 1W to 12W, with a good range of values, £1.75.
K505 20 assorted potentiometers, all types including single, ganged, rotary and slider. £1.75.
K811 200 small value poly, mica, ceramic caps from a few pF to .02µF. Excellent variety. £1.30.
K814 100 silver mica caps from 5pF to a few thousand pF. Tolerances from 1% to 10%. £2.90.

K820 Switch pack—20 different, rocker, slide, rotary, toggle, push, micro, etc. Only £2.00.
K821 Heatshrink pack—5 diff. sizes, each 300mm. 90p.

1000 RESISTORS £2.50

We've just purchased another 5 million preformed resistors, and can make a similar offer to that made two years ago, at the same price!! K823—1000 mixed 1/2 and 1/4W 5% carbon film resistors, preformed for PCB mntg. Excellent range of preferred values. 1000 for £2.50; 5000 £16; 20k £36.

PANELS

Z821 Panel with 16236 (2N3442) on small heat sink, 2N2223 dual transistor, 2 BC108, diodes, caps, resistors, etc. 90p.

Z827 Reed relay panel—contains 2 x 6V reeds, 6 x 25030 or 25230, 6 x 400V reeds + Ra. 90p.

Z829 Pack of ex-computer panels containing 74 series ICs. Lots of different gates and complex logic. All ICs are marked with type no. or code for which an identification sheet is supplied. 20 ICs £1.90; 100 ICs £4.90.

A301 Block case 50 x 78mm with octal base. PCB inside has 24V reed relay, 200V 7A SCR, 4 x 5A 200V reeds, etc. 60p.

SWITCH BARGAIN

Push-on push-off "table lamp" type, rated 2A 250V ac. 10p each, 15 for £1, 100 for £3.

TEACH-IN 82

Full set of parts as specified by "EE". All new goods, despatched by return of post.

★ All parts for the "MINILAB" only £17.50 + £1 post.

★ All components for first 8 parts of "TEACH-IN '82" £7.50 + 80p post.

★ All components for second 6 parts of "TEACH-IN '82" £4.00 + 40p post.

BUY ALL THREE SETS FOR £29 inc post.

FREE component identification Chart!!

FREE piece of Veroboard!!

Reprints of articles: 30p per part + 30p for Tutor Deck info. (only supplied with orders for Teach-in).

CAPACITOR BARGAINS

2200µF 100V cans 77 x 35mm dia. 75p; 10/£5-90; 220µF 10V axial 5p; 100 £3-30; 1000 £16; 400+100µF 275V 102 x 44mm dia. 75p; 10 £5-90; 200µF 350V, 100 + 100 + 50µF 300V can 75 x 44mm dia 40p; 10/£3; 100/£39 100µF 25V Axial £3/100; 0-35µF 50V red. £1-50/100, £12/1000; 0-47µF 50V red. £1-50/100, £12/1000; } elec 22µF 50V red £3/100, £34/1000

1W AMP PANELS

A011 Compact audio amp intended for record player on panel 96 x 65mm including vol. control and switch, complete with knobs. Apart from amp circuitry built around LM380N or TBA820M, there is a speed control circuit using 5 transistors. 9V operation, connexion data supplied. ONLY £1.50.

TOROIDAL TRANSFORMER

110mm dia. x 40mm deep. 110/240V pri. Sec. 18V 4A, 6-3V 1A, 240V 0-4A. Ideal for scopes, monitors, VDU's, etc. Reduced to £5.95.

OP-AMP PSU KIT

A198 All parts + instructions to make a 50mA -15, 0, +15V supply from mains input. Only £1.95.

COPPER CLAD BOARD

K822 All pieces too small for our etching kits. Mostly double sided fibreless. 250gm (approx. 110 sq in) for just £1.90.

MIXED LED PACK

All new full spec by Micro, Fairchild, etc. Red, Yellow, Green, Amber, Clear, 3mm & 5mm. Pack of 50 ass'd £3.95; 250 £15.

FILAMENT DISPLAYS

Z853 7 seg display 12-5mm high. Ideal for TTL operation, taking 5V 8mA per seg. 10d 14 DIL package. Only £1 each, 4 for £3.90. Data supplied



LIE DETECTOR

Not a toy, this precision instrument was originally part of an "Open University" course, used to measure a change in emotional balance, or as a lie detector. Full details of how to use it are given, and a circuit diagram. Supplied complete with probes, leads and conductive jelly. Needs 2 x 1.5V batts. Overall size 155 x 100 x 100mm. Only £1.95—worth that for the case and meter alone!!

CHEAP CHIPS

76477 Sound IC £1.25.
2102A RAM 8 for £3.
MK4027 shift reg. 6 for £5.
uA78MG + volt reg £1.60.
uA79MG - volt reg £1.20.

ELECTRO-DIAL

Electrical combination lock—for maximum security—pick proof. 1 million combinations! Dial is turned to the right to one number, left to a second number, then right again to a third number. Only when this has been completed in the correct sequence will the electrical contacts close. These can be used to operate a relay or solenoid. Overall dia. 65mm x 60mm deep. Only £9.95.

Also available without combination—only £3.95.



METERS: 110 x 82 x 35mm
30µA, 50µA, 100µA. £5.90.
Post 50p.

METERS: 45 x 50 x 34mm
50µA, 100µA, 1mA, 5mA, 10mA,
25v, 1A, 2A, 5A
5A. 25V £2.90. Post 30p.

METERS: 60 x 47 x 33mm
50µA, 100µA, 1mA, 5mA, 10mA,
100mA, 1A, 2A, 25v, 50v,
50-0-50µA, 100-0-100µA. £4.76.
VU meters. £5.32.

Post on above meters 30p.

Silicone grease 50g £1-32 Post 14p.

MULTI-METER

7N 360TR
20,000 ohm/volt
DC Volts: 0-1,
0-5, 2-5, 10-150—
250-1,000v.
AC Volts: 10-50,
250-1,000

RESISTANCE RANGES

X1, X10, X1K,
X10K
£14.10
P.&P. 87p

TRANSFORMERS

240v Primary

3-0-3v	100mA	82p
6-0-6v	100mA	87p
6-0-6v	250mA	£1.22
12-0-12v	50mA	82p
12-0-12v	100mA	£1.15

Post on above transformers 48p.

9-0-9v	1A	£1.80
12-0-12v	1A	£2.40
15-0-15c	1A	£2.60
6-3v	1½A	£1.80
6-0-6v	1½A	£2.10

Post on above transformers 87p.

All above prices include V.A.T. Send 80p for new 1982 fully illustrated catalogue, S.A.E. with all enquiries. Special prices for quantity quoted on request.

All goods despatched within 3 days from receipt of the order.

M. DZIUBAS

158 Bradshawgate, Bolton
Lancs. BL2 1BA

TECHNICAL TRAINING IN ELECTRONICS AND TELECOMMUNICATIONS

ICS can provide the technical knowledge that is so essential to your success; knowledge that will enable you to take advantage of the many opportunities open to you. Study in your own home, in your own time and at your own pace and if you are studying for an examination ICS guarantee coaching until you are successful.

City and Guilds Certificates:
Telecommunications Technicians
Radio, TV, Electronics Technicians
Technical Communications
Radio Servicing Theory
Radio Amateurs
Electrical Installation Work
MPT Radio Communications Certificate

Diploma Courses:
Colour TV Servicing
Electronic Engineering and Maintenance
Computer Engineering and Programming
Radio, TV, Audio Engineering and Servicing
Electrical Engineering, Installation
and Contracting

POST OR PHONE TODAY FOR FREE BOOKLET

ICS To: International Correspondence Schools

Dept 268T Intertext House, London
SW8 4UJ or telephone 622 9911

Name
Address
Tel: Age:



LINEAR		LM377		LM3900		NE566		TLO71	
★709	25	★LM380	150	★LM3911	120	★NE567	100	TLO72	75
★741	14	★LM381	100	★LM3912	120	NE571	425	TLO81	30
748	35	★LM382	120	★LM3914	200	RC4136	30	TLO82	70
AY-3-1270	840	★LM386	65	★LM3915	200	SN76018	150	TLO84	90
AY-3-8910	700	★LM387	120	★LM3916	200	SN76477	250	★XR2206	300
★AY-3-8912	50	★LM390	100	★MC1310	150	TBA800	80	★ZN414	135
CA3046	60	★LM310	395	★MC3302	150	TBA810	95	★ZN423	185
★CA3080	65	★LM301A	25	★LM710	50	TBA820	80	★ZN424	135
★CA3089	215	★LM311	70	★LM725	350	TBA950	290	★ZN425E	390
★CA3090A	85	★LM318	85	★LM733	75	TCA940	170	★ZN426E	330
★CA3390	375	★LM324	40	★LM747	75	★NE531	150	★TD1004	300
★CA3410E	90	★LM339	50	★LM748	75	★NE544	185	★TD1008	480
★CA3410E	90	★LM348	90	★LM749	35	★NE555	18	★TD1010	225
★CA3160E	100	★LM358	50	★LM797	40	★NE556	45	★TD1022	560
		★LM2917	200	★NE565	120	★TDA1024	125		

CMOS		★4017		4036		285 4055		115 4082		20 4502		70 4529		150	
4000	14	4010	60	4039	295	4059	480	4085	65	4503	50	4532	85	4534	95
★4001	12	★4020	55	4041	55	4063	90	4086	140	4508	200	4538	110		
4002	14	4021	65	4042	65	4066	35	★4093	33	4510	65	4543	110		
4006	65	4022	70	4043	60	4067	395	4094	14	★4511	50	4549	300		
4007	17	4023	18	4044	65	★4068	15	4095	90	4512	70	4553	295		
4008	58	4024	40	4045	70	4069	18	4097	340	4514	180	4555	245		
4009	30	4025	18	4046	70	4070	48	4098	85	4515	190	4556	48		
4010	35	★4026	60	4048	55	4071	18	4099	95	4516	75	4559	390		
★4011	13	★4027	30	★4049	28	4072	18	4106	50	★4518	45	4560	180		
4012	17	4028	55	4050	28	4073	20	4109	100	4520	70	4564	45		
★4013	22	4029	75	4051	60	4075	20	4103	100	4521	200	4565	99		
4014	60	4030	35	4052	70	4076	60	41073	60	4522	80	4724	140		
4015	170	4031	170	4053	60	4077	60	41075	25	4523	90				
★4016	22	4034	170	4054	110	4081	18	41083	120	★4528	75				

TTL		7413		24 7442		40 7480		45 74107		30 74155		60 74177		75	
7400	11	7414	35	7444	85	7482	70	74109	32	74156	60	74179	85		
7401	11	7415	25	7445	60	7483	50	74121	28	74157	43	74180	85		
7402	12	7416	25	7447	40	7485	75	74122	45	74160	60	74181	135		
7403	14	7417	15	7448	50	7486	25	74123	48	74161	60	74182	75		
7404	14	7418	20	7449	16	7489	180	74125	40	74162	60	74183	70		
7405	14	7419	20	7451	18	7490	28	74126	40	74163	60	74184	70		
7406	26	7420	28	7453	18	7491	45	74127	40	74164	60	74185	70		
7407	26	7421	28	7454	16	7492	40	74128	40	74165	60	74186	85		
7408	15	7422	20	7455	18	7493	30	74129	40	74166	60	74187	75		
7409	15	7423	25	7456	16	7494	35	74130	40	74167	60	74188	63		
7410	14	7424	27	7457	25	7495	50	74131	40	74168	60	74189	63		
7411	20	7425	27	7458	38	7497	120	74132	45	74169	60	74190	85		
7412	20	7426	17	7459	30	74100	80	74133	45	74170	55	74191	95		

LS TTL		LS21		15 LS78		20 LS125		30 LS181		42 LS221		60 LS365		70	
LS00	13	LS26	16	LS83	20	LS132	30	LS163	42	LS241	80	LS366	38		
LS01	14	LS27	15	LS85	20	LS136	30	LS164	50	LS242	80	LS368	50		
LS02	14	LS30	16	LS86	25	LS138	35	LS165	120	LS243	85	LS370	80		
LS03	14	LS32	18	LS90	35	LS139	35	LS166	85	LS244	80	LS370	80		
LS04	15	LS37	16	LS92	38	LS145	75	LS170	170	LS245	120	LS375	50		
LS05	15	LS38	16	LS93	35	LS147	100	LS173	70	LS247	75	LS377	90		
LS08	16	LS40	16	LS95	45	LS148	95	LS174	60	LS251	40	LS378	70		
LS09	16	LS42	38	LS96	110	LS151	40	LS175	60	LS257	40	LS379	75		
LS10	16	LS47	40	LS107	45	LS153	40	LS190	55	LS258	45	LS393	75		
LS11	16	LS48	80	LS109	30	LS154	120	LS191	55	LS259	95	LS399	220		
LS12	15	LS51	16	LS112	30	LS155	45	LS192	55	LS266	25	LS441	135		
LS13	25	LS55	30	LS113	30	LS156	45	LS193	80	LS273	90	LS670	175		
LS14	40	LS57	25	LS114	30	LS157	35	LS195	50	LS279	50				
LS15	15	LS74	25	LS152	110	LS168	40	LS196	36	LS281	45				
LS20	15	LS75	25	LS123	55	LS160	42	LS197	68	LS353	100				

TRANSISTORS		BC549		BC107		BC163		BC177		BC182		BC212		BC213		BC214		BC215	
AC125	35	BC157	10	BC558	10	BC108	10	BC178	10	BC183	10	BC214	10	BC216	10	BC217	10	BC218	10
AC126	25	BC158	10	BC570	10	BC109	10	BC179	10	BC184	10	BC218	10	BC219	10	BC220	10	BC221	10
AC127	25	★BC159	8	BCY71	18	BCX85	28	TIP30A	50	ZTX109	12	2N3442	120						
★AC128	20	BC160	45	BCY72	18	BCX87	25	TIP30C	40	ZTX109	12	★2N3442	120						
AC176	25	BC168C	10	BD115	80	BCX88	25	TIP30A	45	ZTX301	16	2N3703	9						
AC187	22	BC170	10	BD131	35	BCY50	23	TIP31B	45	ZTX302	15	★2N3704	9						
AD142	120	BC171	10	BD133	50	BFY52	23	TIP31C	55	ZTX304	17	2N3705	9						
AD149	80	BC172	8	BD135	50	BFY53	32	TIP32B	55	ZTX500	15	2N3707	10						
AD161	40	BC177	18	BD136	30	BFY55	32	TIP32C	60	ZTX501	15	2N3708	10						
AD162	40	BC178	18	BD137	30	BFY56	32	TIP33A	50	ZTX502	15	2N3709	10						
AF124	60	BC179	18	BD138	30	BRV39	40	TIP33C	75	ZTX503	18	2N3772	190						
AF126	50	BC180	18	BD139	45	BSY50	20	TIP34A	60	ZTX504	15	2N3773	25						
AF138	40	★BC182L	8	BD140	35	BSX29	35	TIP34C	65	★2N697	20	★2N3819	15						
AF186	70	BC183	18	BD204	110	BSY95A	25	TIP35A	140	2N698	40	2N3820	40						
AF239	75	BC183L	10	BD206	110	BZ206	200	TIP35C	180	2N706A	20	2N3823	65						
BC107	10	BC184	10	BD222	85	BZ206	200	TIP36A	170	2N708	20	2N3866	90						
BC107B	12	★BC184L	7	BF180	35	BZ208	170	TIP36C	195	2N918	35	2N3903	10						
BC114	22	BC187	10	BF182	30	MP3A06	22	TIP412	120	2N358	25	2N4062	10						
BC115	22	BC238	14	BF198	18	MP3A05	22	TIP417	120	2N369	11	2N4062	10						
BC117	22	BC308	15	BF199	18	MPSA07	25	TIP2955	60	2N484	25	2N5457	38						
BC119	35	BC327	14	BF200	30	MPSA12	30	TIP3055	55	2N546	45	2N5458	36						
BC137	40	BC328	14	★BF244B18	10	MPSA35	30	TIS43	40	2N2904	20	2N5459	30						

Into the 80's and beyond

Learn about the op-amp

as an oscillator
as an inverting and a non-inverting amplifier
make astable, monostable and bistable circuits

Learn about the behaviour of a transistor

as an amplifier or as a switch or as an emitter follower

Learn how to use a milliammeter and make voltmeters, electronic voltmeters and electronic ohmmeters

Carry out experiments measuring the gain of the op-amp and transistor and study their characteristics

The Radionic 140 provides the perfect introduction to electronics.

A fully illustrated handbook together with 140 circuit diagrams will guide you from basic circuits onto more advanced circuitry.

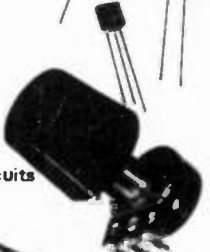
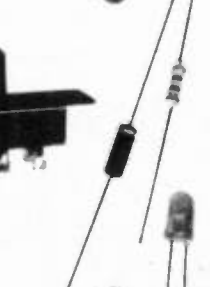
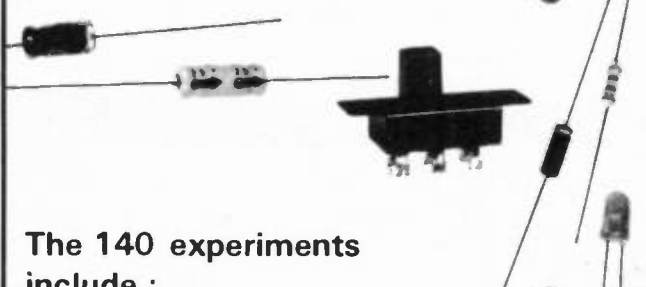
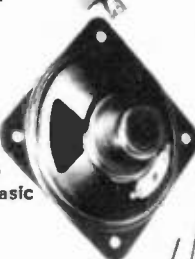
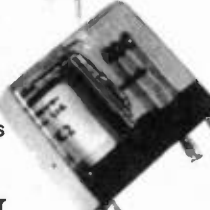
The 140 experiments include :

- Light operated switch
- Audible burglar alarm
- Radio receiver with tuning indicator
- Time delay circuit
- Police car siren
- Electronic voltmeter
- How the transistor can be used in logic circuits
- The charging of a capacitor
- Investigating a square wave generator
- Differential temperature switch

Radionic 140 £47.75 Please allow up to 14 days delivery

Price includes VAT and p. and p. order direct from

Radionic Products Ltd.,
Waverley Road, Yate, Bristol, BS17 5RB.



E.E. PROJECT KITS

Make us your No. 1 SUPPLIER OF KITS and COMPONENTS for E.E. Projects. We supply carefully selected sets of parts to enable you to construct E.E. projects. Kits include ALL THE ELECTRONICS AND HARDWARE NEEDED. Printed circuit boards (fully etched, drilled and roller tinned) or Veroboard are, of course, included as specified in the original article, we even include nuts, screws and I.C. sockets. PRICES INCLUDE CASES unless otherwise stated. BATTERIES ARE NOT INCLUDED. COMPONENT SHEET INCLUDED. If you do not have the issue of E.E. which includes the project—you will need to order the instruction reprint at an extra 45p each.

Reprints available separately 45p each + p. & p. 40p.

- CAR OVERHEATING ALARM. Feb. 82. £8-99.
- M.W. RADIO. Feb. 82. £25-92. Mono headphones extra £2-98.
- CINE INTERVAL TIMER + FRAME COUNTER. Feb. 82. less remote option £17-41.
- STEREO RECORD PLAYER. Feb. 82. less deck, cartridge, speakers & cabinets. £20-78.
- SIMPLE STABILISED POWER SUPPLY. Jan. 82. £22-98
- MINI EGG TIMER. Jan. 82. £3-69
- SIREN MODULE. Jan. 82. less speaker. £5-21.
- MODEL TRAIN CHUFFER. Jan. 82. £7-73.
- PEGBOARD GAME. Dec. 81. less nails. £6-58.
- SQUARE SIX. Dec. 81. £4-40.
- RACETRACK SPEEDO. Dec. 81. £25-40.
- GUITAR ADAPTOR. Dec. 81. £3-32.
- REACTION METER. Dec. 81. £18-41.
- HEADS OR TAILS GAME. Dec. 81. £4-82.
- ELECTRONIC IGNITION. Nov. 81. £24-33.
- SIMPLE INFRA RED REMOTE CONTROL. Nov. 81. £15-99.
- LOUDHAILER. Nov. 81. less handle. £11-93.
- HORN SPEAKER. £6-75 extra.
- PRESSURE MAT TRIGGER ALARM. Nov. 81. £5-88 less mats.
- EXPERIMENTER CRYSTAL SET. Nov. 81. Less aerial. £5-60. Headphones £2-98 extra.
- CAPACITANCE METER. Oct. 81. £21-98.
- SUSTAIN UNIT. Oct. 81. £11-83.
- 'POPULAR DESIGNS'. Oct. 81.
- SNAP INDICATOR. £3-18.
- DAMP LOCATOR. £1-51.
- TAPE NOISE LIMITER. £4-28.
- HEADS AND TAILS GAME. £2-36.
- CONTINUITY TESTER. £3-70.
- PHOTO FLASH SLAVE. £3-24.
- FUZZ BOX. £8-82.
- OPTO ALARM. £6-34.
- SOIL MOISTURE UNIT. £5-43.
- ICE ALARM. £7-38.
- MODEL RAILWAY SPEED CONTROLLER. Sept. 81. £13-46.
- 0-12V POWER SUPPLY. Sept. 81. £18-84
- CMOS CAR SECURITY ALARM. Sept. 81. £8-49.
- CMOS DIE. Sept. 81. £7-47.
- LED SANDGLASS. Aug. 81. £7-98.
- WHEEL OF FORTUNE. Aug. 81. less wire, panel and case. £39-98.
- CMOS METRONOME. Aug. 81. £7-70.
- COMBINATION LOCK. July 81. Less case. £18-30.
- BURGLAR ALARM SYSTEM. June 81 less bell, loop & Mic's. £38-30.
- TAPE AUTO START. June 81. £11-96.
- TREMELO. June 81 less case. £10-46.
- LOOP AERIAL CRYSTAL SET. June 81 £5-47.
- LIGHTS REMINDER AND IGNITION LOCATOR E.E. May 81. £5-29.
- SOIL MOISTURE INDICATOR E.E. May 81. £3-83.
- T.V. INTERFERENCE FILTERS E.E. May 81. LOW PASS less tinplate £2-88. HIGH PASS £1-58.
- GUITAR HEADPHONE AMPLIFIER E.E. May 81. £3-96.
- PHONE BELL REPEATER / BABY ALARM E.E. May 81. £5-29.
- DIGITAL RULE (ultrasonic) April 81. £30-20
- INTERCOM. April 81. £20-78.
- SIMPLE TRANSISTOR & DIODE TESTERS. Mar. 81. Ohm meter version £1-89. Led version £2-56.
- MINI SIREN. Mar. 81. £21-52.
- LED DICE. Mar. 81. £7-89.
- LED FLASHER. Mar. 81. £4-01.
- MODULATED TONE DOORBELL. Mar. 81. £6-21.
- BENCH POWER SUPPLY. Mar. 81. £49-98.
- TREBLE BOOST. Mar. 81. £8-84.
- CAR ACTUATED DRIVEWAY LIGHT. Feb. 81 less socket. £23-96.
- THREE CHANNEL STEREO MIXER. Feb. 81. £17-47.
- SIGNAL TRACER. Feb. 81. £7-84 less probe.
- FOUR BAND RADIO. Feb. 81. £39-98.
- NI-Cd BATTERY CHARGER. Feb. 81. £12-72.
- ULTRASONIC INTRUDER DETECTOR. Jan. 81 less case. £49-98.
- AUTO SLIDE CHANGER. Jan. 81. £9-28.
- LOGIC PULSE GENERATOR. Jan. 81. £7-98.
- 2 NOTE DOOR CHIME. Dec. 80. £9-65.
- LIVE WIRE GAME. Dec. 80. £10-94.
- GUITAR PRACTICE AMPLIFIER. Nov. 80. £11-99 less case. Standard case £3-88. High quality case £8-33.
- SOUND TO LIGHT. Nov. 80. 3 channel. £18-95.
- TRANSISTOR TESTER. Nov. 80. £10-87 inc. test leads.
- AUDIO EFFECTS UNIT FOR WEIRD SOUNDS. Oct. 80. £12-26.
- PHONE CALL CHARGE JOGGER. Oct. 80. £6-80.
- BICYCLE ALARM. Oct. 80. £9-68 less mounting brackets.
- IRON HEAT CONTROL. Oct. 80. £5-48.
- BEDSIDE RADIO. Sept. 80. £17-57.
- TTL LOGIC PROBE. Sept. 80. £4-85.
- COURTESY LIGHT DELAY. June 80. £9-89.
- SIGNAL TRACER. June 80. £5-98.
- ZENER DIODE TESTER. June 80. £6-23.
- 4 STATION RADIO. May 80. £15-33 less case.
- LIGHTS WARNING SYSTEM. May 80. £4-38.
- BATTERY VOLTAGE MONITOR. May 80. £4-63.
- CABLE & PIPE LOCATOR. Mar. 80. £3-85 less coil former.
- KITCHEN TIMER. Mar. 80. £13-70.
- STEREO HEADPHONE AMPLIFIER. Mar. 80. £18-97.
- MICRO MUSIC BOX. Feb. 80. £15-20. Grey Case £3-99 extra.
- SIMPLE SHORT WAVE RECEIVER. Feb. 80. £24-17. Headphones £2-98.
- SLIDE/TAPE SYNCHRONISER. Feb. 80. £11-30.
- MORSE PRACTICE OSCILLATOR. Feb. 80. £4-32.
- SPRING LINE REVERB. UNIT. Jan. 80. £24-17.
- UNIBOARD BURGLAR ALARM. Dec. 79. £3-98.
- BABY ALARM. Nov. 79. £8-98.
- ONE ARMED BANDIT. Oct. 79. £24-80.
- HIGH IMPEDANCE VOLTMETER. Oct. 79. £17-45.
- CHASER LIGHTS. Sept. 79. £21-97.
- SIMPLE TRANSISTOR TESTER. Sept. 79. £8-88.
- ELECTRONIC TUNING FORK. Aug. 79. £9-99. Suitable microphone & plug £1-79 extra.
- DARKROOM TIMER. July 79. £2-71.
- ELECTRONIC CANARY. June 79. £5-48.
- TRANSISTOR TESTER. April 79. £4-55
- TOUCH BLEEPER. April 79. £3-87.
- ONE TRANSISTOR RADIO. Mar. 79 less case £7-82.
- MICROCHIME OORBELL. Feb. 79. £14-82.
- THYRISTOR TESTER. Feb. 79. £3-54.
- ADJUSTABLE PSU. Feb. 79. £31-87.
- HEADPHONE ENHANCER. Jan. 79. £2-86.
- MIC. AMP. Dec. 78. £3-08.
- AUDIBLE FLASHER. Dec. 78. £1-33.
- VEHICLE IMMOBILISER. Inc. PCB. Dec. 78. £8-31.
- FUSE CHECKER. Oct. 78. £2-18.
- TREASURE HUNTER. Oct. 78. £19-64 less handle & coil former.
- SOUND TO LIGHT. Sept. 78. £7-87.
- CAR BATTERY STATE INDICATOR. Sept. 78. Less case. £1-98.
- R.F. SIGNAL GENERATOR. Sept. 78. £24-86.
- SLAVE FLASH. Aug. 78. £3-52 less SK1.
- IN SITU TRANSISTOR TESTER. June 78. £8-33.
- POCKET TIMER. April 78. £3-27.
- WEIRD SOUND EFFECTS GENERATOR. Mar. 78. £5-25.
- AUDIO VISUAL METRONOME. Jan. 78. £3-63.
- ELECTRONIC TOUCH SWITCH. Jan. 78. £2-56 less case.
- RAPID DIODE CHECK. Jan. 78. £2-57.
- AUTOMATIC PHASE BOX. Dec. 77. £11-50 inc. p.c.b.
- PHONE/DOORBELL REPEATER. July 77. £8-98.
- ELECTRONIC DICE. Mar. 77. £5-91.

GUITAR TUNER—SUPERB PROJECT

Featured by us in E.T.I. Jan. 82. Highly stable internal reference. Microprocessor generates fundamental frequencies. Special synchronous rectifier circuit compares input frequency from guitar pickup or microphone with internally generated pitch. Beat frequency is displayed on a large moving coil panel meter. Also operates with bass guitar, or acoustic instruments via a high impedance microphone.

Complete kit includes smart case, pcbs, panel meter etc. £28-96. Reprint extra 45p. Available separately 45p + 46p p. & p.

I.C.s
TRANSISTORS
CAPACITORS

TOOLS
RESISTORS
HARDWARE

CASES
KITS

MAGENTA ELECTRONICS LTD.

C106D 58p	2N6457 58p	BFY51 24p	LINEAR I.C.s	SN76477 £2.50
TIC46 48p	2N5484 83p	BFY32 23p	555 26p	TL064 £1.64
O A47 11p	40673 96p	BFY38 32p	556 78p	TL071 £1.71
O A90 10p	AC128 28p	BRV39 48p	741 22p	TL082 74p
O A202 16p	AC141 38p	MPS A65 38p	CA3130E 80p	TL083 £1.52
W005 33p	AC142 38p	RPY58A £1.18	CA3140E 52p	TL084 £1.54
W06 47p	AC176 37p	TIP31A 52p	HA1388 £3.20	TL430 85p
Z5J £2.92	BC182 11p	TIP32A 83p	ICL7611 88p	U237B £1.69
IN4001 51p	BC182L 11p	TIP33A 84p	ACM7555 99p	U267B £2.20
IN4005 51p	BC183 11p	TIP34A 99p	LF351N 99p	ULN2283 £1.57
IN4148 51p	BC184 11p	TIP35A 99p	LF353N 99p	ZN414 £1.96
IN5404 18p	BC184L 11p	TIP2955 69p	LF355 £1.14	ZN419CE £2.21
IN5408 19p	BC212 11p	TIP3055 69p	LF356 £1.15	7400 22p
BF244 87p	BC212L 11p	TIS43 38p	LM301A 38p	7447 £1.14
MPP102 89p	BC213 11p	TPSA13 35p	LM317K £3.20	7490 55p
TIS58A 57p	BC214 11p	SN3053 25p	LM336Z £1.18	7495 80p
VN67AF £1.21	BC214L 11p	2N3055 59p	LM3300N £1.99	CMOS 20p
2N3819 28p	BD131 48p	2N3055 59p	LM386N 92p	4001 20p
2N3820 78p	BFY50 25p	2N3704 11p	LM387N £1.10	4011 26p
			LM389N £1.10	4013 32p
			LM1830 £1.98	4017 62p
			LM3909 82p	4020 85p
			LM3914 £2.99	4024 60p
			LM3915 £3.88	4069 20p
			MC3340 £2.15	4081 20p
			NE570N £4.98	4092 38p
			NE571N £4.84	4017A £1.20
			OM335 £8.98	4522 £1.25

JW CARBON FILM RESISTORS
E12 SERIES, 1R-10M 1p each
MIN. HORIZ. PRESETS, 100R-4M7 12p each
MIDGET POTS, LINEAR, 470R-4M7 37p each
LOG, 4K7-2M3 38p each
SWITCHED POTS, 4K7-1M, LIN, 75p, LOG 76p

POLYESTER (C280) CAPACITORS, 250V
10nF; 15nF; 22nF; 33nF; 47nF 7p each, 68nF; 100nF 8p, 150nF; 220nF 12p, 330nF 15p, 470nF 20p, 680nF 28p, 1uF 33p, 1.5uF 49p, 2.2uF 69p.

SUB MINIATURE PLATE CERAMICS, 63V
Values in pF: 2.2, 3.3, 4.7, 5.6, 6.8, 8.2, 10, 15, 22, 33, 47 & 56pF 7p each, 68pF; 100pF 7p each, 150pF; 220pF; 330pF 11p each, 390pF, 470pF 1000pF 5p each, 2200pF 6p each, 3300pF, 4700pF 7p each, 10nF 13p, 100nF 22p, 47nF 14p.

ELECTROLYTIC CAPACITORS
AXIAL Leads: 1uF/16V 11p; 1uF/33V, 1uF/100V 12p; 2.2uF/33V, 3.3uF/33V, 4.7uF/33V 12p; 10uF/16V 11p; 10uF/25V, 10uF/33V 12p; 22uF/10V, 22uF/25V 12p; 22uF/33V 15p; 33uF/40V, 47uF/25V 12p; 47uF/40V 15p; 47uF/50V 18p; 100uF/10V 12p; 100uF/25V 15p; 100uF/40V 18p; 100uF/33V 29p; 220uF/10V 15p; 220uF/25V 19p; 470uF/16V 29p; 470uF/25V 36p; 470uF/40V 55p; 680uF/16V 32p; 1000uF/10V 30p; 1000uF/16V 33p; 1000uF/25V 48p; 1000uF/40V 58p; 1000uF/33V 79p; 2200uF/10V 39p; 2200uF/25V 64p; 2200uF/33V £1.10.

SWITCHES
MIN. TOGGLE spst 59p; spdt 69p; dpdt 79p.
MIN. PUSH ON, 18p. PUSH OFF, 22p.
FOOTSWITCH & ALT. ACTION spco £1.39;
dpcoc £1.88.
ROTARY SWITCHES, 1p 12 way, 2p 6w, 3p 4w, 4p 3w 69p each
12V 18SR DPCO RELAY £2.98

SPEAKERS, Miniature, 8 ohm 87p
84 ohm 88p 75 ohm 89p
CRYSTAL EARPIECE 85p
MONO HEADPHONES £2.94
TELEPHONE PICK-UP COIL 72p

MIN. BUZZERS, 6V, 50p, 9V, £1.10, 12V, 65p.
MAGNETIC EARPIECE 15p
STEREO HEADPHONES £4.35
F.M. AERIAL 49p

PP3 Clips 10p
VEROBOARD 0.1" COPPER STRIPS
10 strips 24 holes £1.20 per 5
24 strips 50 holes 89p
36 strips 50 holes 99p

ADVENTURES WITH MICROELECTRONICS by Tom Duncan
An easy to follow book suitable for all ages. Ideal for beginners. No soldering. Uses a Bimboard 1 breadboard, gives clear instructions with lots of pictures. 11 projects based on integrated circuits—includes dice, two-tone doorbell, electronic organ, MW/LW radio, reaction timer, etc. Component pack includes a Bimboard 1 breadboard and all the components for the projects.
Adventures with Microelectronics £2.55. Component pack £29.64 less battery.

ADVENTURES WITH ELECTRONICS by Tom Duncan
An easy to follow book suitable for all ages. Ideal for beginners. No soldering, uses an S-Dec breadboard. Gives clear instructions with lots of pictures. 16 projects—including three radios, siren, metronome, organ, intercom, timer, etc. Helps you learn about electronic components and how circuits work. Component pack includes an S-Dec breadboard and all the components for the projects.
Adventures with Electronics £2.40. Component pack £17.98 less battery.

MORE KITS AND COMPONENTS IN OUR LISTS
FREE PRICE LIST
Price list included with orders or send us (9 x 4) CONTAINS LOTS MORE KITS, PCBs & COMPONENTS

1982 ELECTRONICS CATALOGUE
Illustrations, product descriptions, circuits all included. Up-to-date price list enclosed. All products are stock lines for fast delivery.
Send 70p in stamps or add 70p to order.

MORE E.E. KITS PLUS H.E. and E.T.I. PROJECT KITS IN THE PRICE LIST.

TEACH IN 82

CURRENT SERIES—
ALL COMPONENTS IN STOCK NOW FOR FAST DELIVERY

All top quality components as specified by Everyday Electronics. Our kit comes complete with FREE COMPONENT IDENTIFICATION SHEET. Follow this educational series and learn about electronics—Start Today.

Send £24.98 for List 1 and List 2 together. £5.98 for List 3.

WOODEN CASE KIT also available £11.98—wood, formica, glue, screws etc. Cut to size.

12 part series, reprints available of previously published parts. 45p each.

LISTS 1, 2, AND 3 ALL AVAILABLE NOW. ALSO WOODEN CASE KIT.

SOLDERING TOOLS

ANEX X5 SOLDERING IRON 25W £5.48.
SOLDERING IRON STAND £2.40.
SPARE BITS. Small standard, large, 85p each. For X5+X25.
SOLDER. Hand, size 99p
HOW TO SOLDER LEAFLET 12p
DESOLDER BRAID 99p
HEAT SINK TWEEZERS 29p
DESOLDER PUMP £8.48
SOLDER CARTON £1.84
LOW COST CUTTERS £1.69
LOW COST LONG NOSE PLIERS £1.68
WIRE STRIPPERS & CUTTERS £2.69
VERO SPOT FACE CUTTER £1.48
PIN INSERTION TOOL £1.98
VEROPINS. (pk of 100) 0.1" 32p.
MULTIMETER TYPE 1 (1,000 opv). £8.66.
MULTIMETER TYPE 2, 20,000 opv with transistor tester. Very good. £14.75.
CROCODILE CLIP TEST LEAD SET. 10 leads with 20 clips, 99p.
RESISTOR COLOUR CODE CALCULATOR. 21p.

CONNECTING WIRE PACK. (5 x 5yd coils), 65p.
CAST IRON VICE (Small), £2.98.
SCREWDRIVER SET, £1.98.
POCKET TOOL SET, £3.98.
ILLUMINATED MAGNIFIERS. Small 2" dia (5 x mag) £1.14. Large 3" dia (4 x mag) £2.40.
DENTISTS INSPECTION MIRROR, £2.85.
JEWELLERS EYEGLASS, £1.50.
HAND MAGNIFIER 3" £2.99.
HELPING HANDS JIG, £6.30.
Heavy base. Six ball and socket joints allow infinite variation of clips through 360°. Has 2 1/2" diameter (215) magnifier attached. Used and recommended by our staff.
PCB ETCHING KIT, £4.98.
PLASTIC TWEEZERS, 69p.
LETTERS/NUMBERS TRANSFERS, £2.48.
SCREWS/NUTS/WASHERS—40p each.
M2 pack £1.80, M3 £1.78, M4 £1.84, SOLDER TAGS, M3 33p/50, M4 34p/50, STICK ON FEET 23p/4.

BOOKS

SEMICONDUCTOR DATA BOOK, Newnes £3.90
MICROPROCESSORS FOR HOBBYISTS, R. Cole £3.95
PRACTICAL ELECTRONIC PROJECT BUILDING, Ainslie & Colwell £3.35
CONSTRUCTOR'S PROJECT BOOKS
ELECTRONIC GAME PROJECTS, Rayer £3.35
ELECTRONIC PROJECTS FOR HOME SECURITY, Bishop £3.35
ELECTRONIC PROJECTS IN AUDIO, Penfold £3.35
ELECTRONIC PROJECTS IN MUSIC, Flind £3.35
ELECTRONIC PROJECTS IN PHOTOGRAPHY, Penfold £3.35
ELECTRONIC PROJECTS IN THE CAR, George £3.35
PROJECTS IN AMATEUR RADIO & SHORT WAVE LISTENING, Rayer £3.35
PROJECTS IN RADIO AND ELECTRONICS, Sinclair £3.35
ELECTRONIC PROJECTS IN HOBBIES, Rayer £3.35
ELECTRONIC PROJECTS IN THE HOME, Bishop £3.35
ELECTRONIC PROJECTS IN THE WORKSHOP, Penfold £3.35
ELECTRONIC TEST EQUIPMENT PROJECTS, Ainslie £3.35
MORE ELECTRONIC PROJECTS IN THE HOME, Flind £3.35
118 ELECTRONIC ALARM PROJECTS FOR THE HOME CONSTRUCTOR, Marston £5.35
ELECTRONIC PROJECTS—PAPERMAC
COST EFFECTIVE PROJECTS AROUND THE HOME, Watson £4.35
PROJECTS FOR THE CAR AND GARAGE, Bishop £4.35
AUDIO CIRCUITS AND PROJECTS, Bishop £5.44
TEST GEAR PROJECTS, Dixon £4.35
MODEL RAILWAY PROJECTS, Penfold £1.95
SOLID STATE SHORT WAVE RECEIVERS FOR BEGINNERS, Penfold £1.30
BEGINNERS GUIDE TO BUILDING ELECTRONIC PROJECTS, Penfold £1.50
ELECTRONIC MUSIC AND CREATIVE TAPE RECORDING, Berry £1.35
IC355 PROJECTS, Parr £1.90
BASIC ELECTRONICS. A super book covering theory and practice. Educational. Suits age 14 upwards. Lots of useful projects—circuits built on an S-Dec breadboard. Approx 525 pages £7.98

MAGENTA gives you **FAST DELIVERY OF QUALITY COMPONENTS & KITS**. All products are stock lines and are new & full specification. We give personal service & quality products to all our customers—**HAVE YOU TRIED US?**

MAGENTA ELECTRONICS LTD.

EW38, 135 HUNTER ST. BURTON-ON-TRENT, STAFFS., DE14 2ST. 0283 65435. MON.-FRI. 9-5. MAIL ORDER ONLY.
ADD 40p P. & P. TO ALL ORDERS. Normal despatch by return of post.
ALL PRICES INCLUDE 15% V.A.T. OFFICIAL ORDER WELCOME.

IRISH REPUBLIC & B.F.P.O. EUROPE: Deduct 10% from prices shown Payment must be in Sterling.
ACCESS AND BARCLAYCARD (VISA) ORDERS ACCEPTED BY PHONE OR POST.
SEE ALL ENQUIRES.

ANNOUNCEMENT ENFIELD ELECTRONICS

Listed below are some of the items stocked

We are proud to announce the opening of a much needed components shop for the north of London enthusiast.

Over 200,000 components as well as books, kits, service aids and hardware will be stocked.

We invite you to phone:

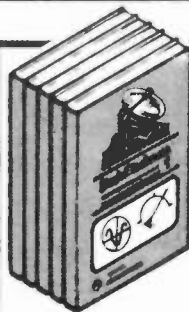
01 366 1873

Personal callers welcome.

**208 BAKER STREET,
ENFIELD, MIDDX.**

Adaptors Adhesives Aerials Alarms Aluminium boxes A.B.S. boxes Amplifiers Audio leads Audible warning devices	Batteries chargers connectors holders Bezel Books Boxes Bridge rectifiers Bulbs holders Busbars Buzzers	Cable clips ties markers sleeving wrapping stripper Capacitors air spaced trimmer suppression lead through ceramic electrolytic polyester polystyrene silver mica tantalum Cermot pre-sets Chokes Collimators Connectors Coils Continuity testers Convertors Crimp tools Crocodile clips Crystals	Dance products Demagnetisers Desolder broid Desolder pump Diacs Diodes Light emitting photo rectifier signal zener germanium infra-red Displays Drills	Earpieces Earphones Enamelled copper wire Etch resist products	Filters Ferric chloride Ferite cores Ferite rods Fixing feet Fuses Fuse holders Flourescent displays Field strength motors Frequency counter	Gas sensor Grommets Group panels Gruesu	Headphones Heat sinks	Inspection glasses I.C.s I.C. sockets infra-red source infra-red sensor Indicators Insulating tape	Jack connectors Jewellers screwdrivers	Keyboards Keystector Knobs	Lamps Lamp holders Leads Liquid crystal displays LED LED arrays LED displays	Maina adaptor Matrix board Memory I.C.s Meters Microphones inserts stands Microprocessors Morse key Multistars	Neon bulbs Ni-Cad batteries Ni-Cad chargers	Opto electronic Oscilloscopes	Panel Pick-up coils Pliers Pre-sets Potentiometers P.C.B.s P.C.B. transfore Probes Plugs Pressure mats Pre-amps Photo electric relays	Rectifiers Resistors carbon film metal film metal oxide wirewound Ring cores Regulators Relays Resistance chart	Signal injector Service aids silver paint switchlubricant solder mop silicone grease anti-static spray freezitt plastic seal Aero Hlene heat-sink compound Aero duster Spacers SWR meters Sockets Sleeving Solder Soldering Irons Sirens Speakers Switches mercury tilt micro reed rocker rotary toggle wafer slide push button	Test leads Thermistors Thyristors Traces Transformers rings audio I.F. Transistors Transistor tester Tag strips Tinned copper wire Transducers Toroids Terminals Tuning coils Tuning condensor Ultrasonic transmitter Ultrasonic receiver Vero products
---	--	--	--	---	---	--	--------------------------	--	---	----------------------------------	--	---	---	----------------------------------	--	--	--	--

We are open from 9 a.m. to 6 p.m., Monday-Saturday



ANNOUNCING A NEW SET OF BASIC ELECTRONICS

This 5 volume set contains over 500 pages.
Bound in stiff linen. Cover size 8 1/2 in x 5 in.
Price £10.00 per set (we pay the postage).

Book 1. Introducing Electronics Book 4. Meters/Voltage-dividers
Book 2. Resistors/Capacitors Book 5. Transistor Project Circuitry
Book 3. Inductors/Diodes

The manuals are unquestionably the finest and most up-to-date available and represent exceptional value.

This series has been written in a fascinating, absorbing and exciting way, providing an approach to acquiring knowledge that is a very enjoyable experience. Suitable for industrial trainees, City and Guilds students, DIY enthusiasts and readers of electronic journals.

Each part explains electronics in an easy-to-follow way, and contains numerous diagrams and half tone blocks with construction details and circuit diagrams for making the following transistor projects: Lamp Flasher, Metronome, Wailer, Photographic/Monostable Timer, Metal Locator, Geiger Counter, Radio Receiver, Intercom., Intruder Alarm, Electronic Organ, Battery Eliminator, Anemometer, Sound Switch, Light and Water-operated Switches, Pressure-operated Switches, Light meter, Radio Thermometer, Ice Alarm,

Order now:
Selray Book Company
11, Aspen Copse,
Bromley,
Kent. BR1 2NZ.

OUR 100% GUARANTEE
Should you decide to return the set after 10 days exam-
ination, your money will be refunded by return of post.

Please allow 14 DAYS Delivery

Amount enclosed: £

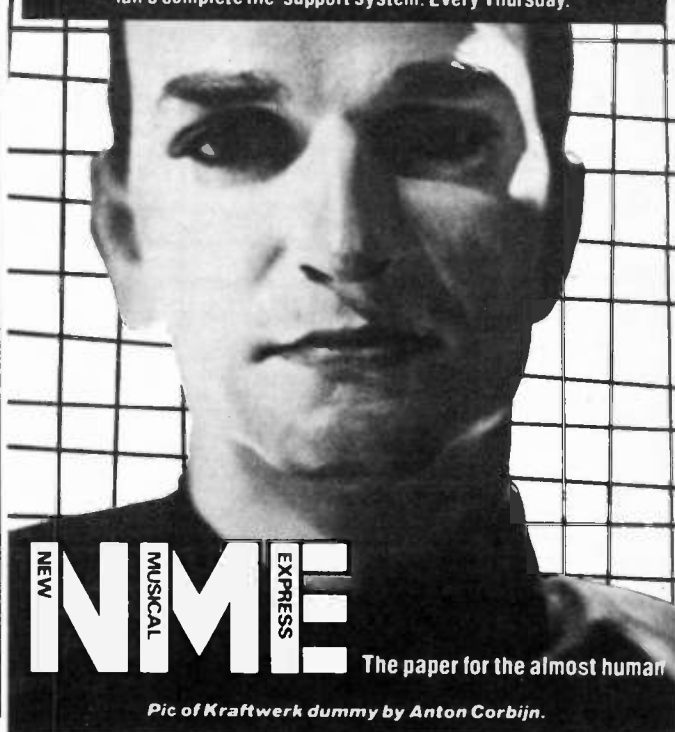
Name:

Address:

EE 4

BEFORE AND AFTER SCIENCE

HEY DUMMY! A weekly transfusion of New Musical Express is all it takes to make A REAL PERSON of you. With its scientifically-tested formula—truth and trivia, wit and gibberish—it's the modern music fan's complete life-support system. Every Thursday.



Pic of Kraftwerk dummy by Anton Corbiijn.

BI-PAK BARGAINS



5T21 SCREWDRIVER SET
6 precision screwdrivers in hinged plastic case. Sizes: — 0.8, 1.4, 2, 2.4, 2.9 and 3.8mm **£1.75**

5T31 NUT DRIVER SET
5 precision nut drivers in hinged plastic case. With turning rod. **£1.75**
Sizes: — 3, 3.5, 4, 4.5 and 5mm.

5T41 TOOL SET
5 precision instruments in hinged plastic case. Crosspoint (Phillips) screwdrivers: — H 0 and H 1 Hex key wrenches: — 1.5, 2 and 2.5mm **£1.75**

5T51 WRENCH SET
5 precision wrenches in hinged plastic case. Sizes: — 4, 4.5, 5, 5.5 and 6mm. **£1.75**
Made of hardened steel. HX71 **£1.25**



BI-PAK PCB ETCHANT AND DRILL KIT

Complete PCB Kit comprises
1 Expo Mini Drill 10,000RPM 12v DC incl 3 collets & 1 x 1mm Twist bit.
1 Sheet PCB Transfers. 210mm x 150mm.
1 Etch Resist Pen
1 1/2 lb pack FERRIC CHLORIDE crystals.
3 sheets copper clad board.
2 sheets Fibreglass copper clad board.
Full instructions for making your own PCB boards.
Retail Value over **£18.00**
OUR BI-PAK SPECIAL KIT PRICE **£9.75**
ORDER NO. SX81



BI-PAK SOLDER - DESOLDER KIT

Kit comprises ORDER NO. SX80
1 High Quality 40 watt General Purpose Lightweight Soldering Iron 240v mains incl. 3/16" (4.7mm) bit.
1 Quality Desoldering pump. High Suction with automatic ejection. Knurled, anti-corrosive casing and teflon nozzle.
1.5 metres of De-soldering braid on plastic dispenser.
2 yds (1.83m) Resin Cored Solder on Card.
1 Heat Shunt tool tweezer Type.
Total Retail Value over **£12.00**
OUR SPECIAL KIT PRICE **£8.95**



BRAND NEW LCD DISPLAY MULTITESTER.

RE 188m
LCD 10 MEGOHM INPUT IMPEDANCE
*3 1/2 digit *16 ranges plus hFE test facility for PNP and NPN transistors *Auto zero, auto polarity *Single-handed, pushbutton operation *Over range indication *12.5mm (1/2-inch) large LCD readout *Diode check *FusT circuit protection *Test leads, battery and instructions included.
Max indication 1999 or — 1999
Polarity indication Negative only
Positive readings appear without + sign.
Input impedance 10 Megohms
Zero adjust Automatic
Sampling time 250 milliseconds
Temperature range — 5°C to 50°C
Power Supply 1 x PP3 or equivalent 9V battery 20mW
Consumption Size 155 x 88 x 31mm
RANGES
DC Voltage 0-200mV
0-2-20-200-1000V. Acc: 0.8%
AC Voltage 0-200-1000V
Acc. 1.2% DC Current 0-200uA
0-2-20-200mA 0-10 A. Acc: 1.2%
Resistance 0-2-20-200K ohms.
0-2 Megohms. Acc: 1%
BI-PAK VERY LOWEST POSS PRICE **£35.00** each



SEMICONDUCTORS FROM AROUND THE WORLD

100 A Collection of Transistors, Diodes, Rectifiers, Bridges, SCR's, Triacs, IC's both Logic and Linear plus Opto's all of which are current everyday usable devices. 100

Guaranteed Value over £10 at Normal Retail Price

yours for only **£4.00** Data etc. in every pack Order No. SX56

EXPERIMENTOR BOXES - ALUMINIUM - PLASTIC ALUMINIUM BOXES

Made with Bright Aluminium folded construction with deep lid and screws

SIZE" L	W	H	Order No.	Price
5 1/4	2 1/4	1 1/2	159	83p
4	2 1/4	1 1/2	161	83p
4	2 1/2	2	163	83p
3	2	1	164	87p
8	6	3	166	£1.68
6	4	2	167	£1.12

All measurements for boxes are shown in inches. L = Length. W = Width. H = Height

Plastic Boxes

Coloured Black. Close fitting.
Flanged Lid, fixing screws into brass bushes.

SIZE" L	W	H	Order No.	Price
4	2	1	141	£1.00
4 1/2	2 1/2	1 1/2	143	£1.30
6	3 1/2	2	144	£1.60

Plastic as above but with aluminium top panel

SIZE" L	W	H	Order No.	Price
4	2 1/2	1	146	£1.40

Plastic sloping front

SIZE" L	W	H	Order No.	Price
5 1/2	4 1/4	2 1/4		Slope
				to
			148	£2.14

The Third and Fourth Hand...



... you always need but have never got until now
This helpful unit with Rod mounted horizontally on Heavy Base. Crocodile clips attached to rod ends. Six ball & socket joints give infinite variation and positions through 360° also available attached to Rod a 2 1/2" diam magnifier giving 2.5 x magnification. Helping hand unit available with or without magnifier. Our Price with magnifier as illustrated ORDER NO T402 **£5.50**
Without magnifier ORDER NO T400 **£4.75**

"IRRESISTABLE RESISTOR BARGAINS"

Pak No.	Qty	Description	Price
SX10	400	Mixed 'All Type' Resistors	£1
SX11	400	Pre-formed 1/4-watt Carbon Resistors	£1
SX12	200	1/4 watt Carbon Resistors	£1
SX13	200	1/4 watt Carbon Resistors	£1
SX14	150	1/4 watt Resistors 22 ohm-2m2 Mixed	£1
SX15	100	1 and 2 watt Resistors 22 ohm-2m2 Mixed	£1

Paks SX12-15 contain a range of Carbon Film Resistors of assorted values from 22 ohms to 2.2 meg. Save pounds on these resistor paks and have a full range to cover your projects.
*Quantities approximate, count by weight.

"CAPABLE CAPACITOR PAKS"

Pak No.	Qty	Description	Price
SX16	250	Capacitors Mixed Types	£1
SX17	750	Ceramic Capacitors Miniature	£1
SX18	100	Mixed Ceramics (pl-5 of)	£1
SX19	100	Mixed Ceramics 60pf. 0.05mf	£1
SX20	100	Assorted Polyester/Polystyrene Capacitors	£1
SX21	60	Mixed C280 type capacitors	£1
SX22	100	metal l280 Electrolytics, all sorts	£1
SX23	50	Quality Electrolytics 50 1000mf	£1
SX24	20	Tantalum Beads, mixed	£1

*Quantities approximate, count by weight.

AUDIO PLUGS, SOCKETS AND ACCESSORIES

25 pieces of Audio Plugs, Sockets and Connectors to include DIN 180°, 240° Inline 3-6 Pin, at well over £3 normal. Order No. SX25. Our Price **£1.50** per pak. Guaranteed to save you money.

SX26 3 Pks of 6 pin 240° DIN Plugs and Chassis Sockets **50p**

SX38 100 Silicon NPN Transistors—all perfect Coded mixed types with data and eqvt. sheet. No rejects. Real value. **£2.50**

SX39 100 Silicon PNP Transistors—all perfect Coded mixed types with data and eqvt. sheet. No rejects. Fantastic value. **£2.50**

Silicon NPN'L' Type Transistors

TO-92 Plastic centre collector
Like BC182L — 183L — 184L
VCE0 45 VCE0 30 IC200mA Hfe 100-400

ALL perfect devices — uncoded ORDER AS SX183L
50 off 100 off 500 off 1000 off
£1.50 £2.50 £10.00 £17.00

PNP SILICON TRANSISTORS:
Similar ZTX500 — ZTX214 — E-Line
VCE0 40 VCE0 35 Ic 300mA Hfe 50-400
Brand New — Uncoded — Select Devices
50 off 100 off 500 off 1000 off
£2.00 £3.50 £15.00 £25.00
Order as ZTXPNP

MOTOROLA PIEZO ELECTRIC TWEETER

Maximum Ratings:
25 volts rms which is equal to:
200 watts across 4 ohms
100 watts across 8 ohms
50 watts across 16 ohms
BI-PAK SPECIAL OFFER PRICE **£4.65**
ORDER NO. 1907

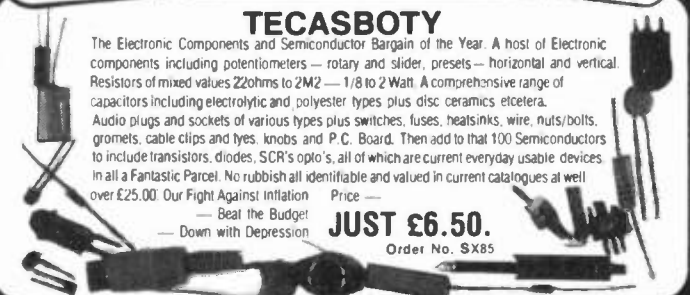


HOME TWEETER

Home tweeter for systems up to 50w.
Impedance: 8 ohms
Frequency Response: 2000-20,000Hz
Dims 98mm diam. x 31mm deep
Our Price **£2.85** OMT200

TECASBOTY

The Electronic Components and Semiconductor Bargain of the Year. A host of Electronic components including potentiometers — rotary and slider, presets — horizontal and vertical. Resistors of mixed values 22ohms to 2M2 — 1/8 to 2 Watt. A comprehensive range of capacitors including electrolytic and polyester types plus disc ceramics etcetera. Audio plugs and sockets of various types plus switches, fuses, heatsinks, wire, nuts/bolts, gromets, cable clips and ties, knobs and P.C. Board. Then add to that 100 Semiconductors to include transistors, diodes, SCR's opto's, all of which are current everyday usable devices in all a Fantastic Parcel. No rubbish all identifiable and valued in current catalogues all well over £25.00. Our Fight Against Inflation — Beat the Budget — Down with Depression
Price — **JUST £6.50.**
Order No. SX85



1 Amp SILICON RECTIFIERS

Glass Type similar IN4000 SERIES IN4001-IN4004
50 — 500v — uncoded — you select for VLT5
ALL perfect devices — NO duds Min 50v
50 for **£1.00** — worth double ORDER NO SX76

Silicon General Purpose NPN Transistors TO-18 Case
Lock fit leads — coded CV7644 Similar to BC147
— BC107 — ZT89 ALL NEW! VCE 70v IC500mA
Hfe 75-250 50 off 100 off 500 off 1000 off
PRICE **£2.00 £3.80 £17.50 £30.00**
Order as CV7644

Silicon General Purpose PNP Transistors TO-5 Case
Lock fit leads coded CV9507 similar ZN2905A to
BFX30 VC 60 IC 600mA Min Hfe 50 ALL NEW!
50 off 100 off 500 off 1000 off
PRICE **£2.50 £4.00 £19.00 £35.00**
Order as CV9507

BI-PAK

Send your orders to Dept EE4 BI-PAK PO BOX 6 WARE HERTS
SHOP AT J BALDOCK ST WARE HERTS
TERMS CASH WITH ORDER SAME DAY DESPATCH ACCESS
BARCLAYCARD ALSO ACCEPTED TEL (0920) 3182 GIRO 388 7006
ADD 15% VAT AND 50p PER ORDER POSTAGE AND PACKING



Use your credit card. Ring us on Ware 3182 NOW and get your order even faster. Goods normally sent 2nd Class Mail.
Remember you must add VAT at 15% to your order. Total. Postage add 50p per Total order.

Step-by-step fully illustrated assembly and fitting instructions are included together with circuit descriptions. Highest quality components are used throughout.

Sparkrite

BRANDLEADING ELECTRONICS

NOW AVAILABLE IN KIT FORM

SX1000 Electronic Ignition

- Inductive Discharge
- Extended coil energy storage circuit
- Contact breaker driven
- Three position changeover switch
- Over 65 components to assemble
- Patented clip-to-coil fitting
- Fits all 12v neg. earth vehicles

MAGIDICE Electronic Dice

- Not an auto item but great fun for the family
- Total random selection
- Triggered by waving of hand over dice
- Bleeps and flashes during a 4 second tumble sequence
- Throw displayed for 10 seconds
- Auto display of last throw 1 second in 5
- Muting and Off switch on base
- Hours of continuous use from PP7 battery
- Over 100 components to assemble

SX2000 Electronic Ignition

- The brandleading system on the market today
- Unique Reactive Discharge
- Combined Inductive and Capacitive Discharge
- Contact breaker driven
- Three position changeover switch
- Over 130 components to assemble
- Patented clip-to-coil fitting
- Fits all 12v neg. earth vehicles

TX2002 Electronic Ignition

- The ultimate system ● Switchable contactless. ● Three position switch with Auxiliary back-up inductive circuit.
- Reactive Discharge. Combined capacitive and inductive. ● Extended coil energy storage circuit. ● Magnetic contactless distributor triggerhead. ● Distributor triggerhead adaptors included.
- Can also be triggered by existing contact breakers.
- Die cast waterproof case with clip-to-coil fitting ● Fits majority of 4 and 6 cylinder 12v neg. earth vehicles
- Over 150 components to assemble

VOYAGER Car Drive Computer

- A most sophisticated accessory. ● Utilises a single chip mask programmed microprocessor incorporating a unique programme designed by EDA Sparkrite Ltd. ● Affords 12 functions centred on Fuel, Speed, Distance and Time. ● Visual and Audible alarms warning of Excess Speed, Frost/Ice, Lights-left-on. ● Facility to operate LOG and TRIP functions independently or synchronously.
- Large 10mm high 400ft-L fluorescent display with auto intensity. ● Unique speed and fuel transducers giving a programmed accuracy of + or - 1%. ● Large LOG & TRIP memories. 2,000 miles. 180 gallons. 100 hours. ● Full Imperial and Metric calibrations. ● Over 300 components to assemble. A real challenge for the electronics enthusiast!

AT-80 Electronic Car Security System

- Arms doors, boot, bonnet and has security loop to protect fog/spot lamps, radio/tape, CB equipment
- Programmable personal code entry system
- Armed and disarmed from outside vehicle using a special magnetic key fob against a windscreen sensor pad adhered to the inside of the screen ● Fits all 12V neg earth vehicles
- Over 250 components to assemble

All EDA-SPARKRITE products and designs are fully covered by one or more World Patents.

EDA SPARKRITE LIMITED 82 Bath Street, Walsall, West Midlands, WS1 3DE England. Tel: (0922) 614791

Please allow 28 days for delivery

NAME _____ EE, 4 82
ADDRESS _____

I ENCLOSE CHEQUE(S)/POSTAL ORDERS FOR

£ _____ KIT REF. _____

CHEQUE NO. _____
24 hr. Answerphone
PHONEYOURORDERWITHACCESS/BARCLAYCARD
SEND ONLY SAE IF BROCHURE IS REQUIRED

	SELF ASSEM. KIT	READY BUILT UNITS
SX 1000	£12.95	£25.90
SX 2000	£19.95	£39.90
TX 2002	£29.95	£59.90
AT. 80	£29.95	£59.90
VOYAGER	£59.95	£119.90
MAGIDICE	£9.95	£19.90

PRICES INC. VAT. POSTAGE & PACKING

BRANDLEADING BRITISH ELECTRONICS

CUT OUT THE COUPON NOW!

Everyday ELECTRONICS

VOL. 11 NO. 4 APRIL 1982

Editor
F. E. BENNETT

Assistant Editor
B. W. TERRELL B.Sc.

Production Editor
D. G. BARRINGTON

Technical Sub-Editor
G. P. HODGSON

Art Editor
R. F. PALMER

Assistant Art Editor
P. A. LOATES

Technical Illustrator
D. J. GOODING Tech. (CEI)

Secretary
JACQUELINE DOIDGE

Editorial Offices
KINGS REACH TOWER
STAMFORD STREET
LONDON SE1 9LS
Phone: 01-261 6873

Advertisement Manager
R. SMITH
Phone: 01-261 6671

Representative
R. WILLETT
Phone: 01-261 6865

Classified Supervisor
B. BLAKE
Phone: 01-261 5897

Make-Up and Copy Department
Phone: 01-261 6615

Advertisement Offices
KINGS REACH TOWER
STAMFORD STREET
LONDON SE1 9LS

INCONSPICUOUS

Doodling with electronic circuits is a form of innocent amusement most of us indulge in from time to time. If one single subject has inspired such abstract designing more than any other, it is likely to be the electronic combination lock. Some years ago, immediately following the introduction of digital integrated circuits, this kind of activity reached well nigh craze proportions we recall. What opportunities for creating tantalising puzzles with labyrinthine circuitry these microchips gave us. That most of these doodles on paper never finally materialised in concrete form is beside the point; more than enough did and there has been no scarcity of practical designs for electronic combination locks to satisfy general needs.

In more recent years the availability of keypads has further helped the development of electronic combination locks as serious functional devices and assured their ready acceptance in a society now well accustomed to the digital keyboard.

One advantage of the combination lock (electronic or otherwise) is that no removable key is involved. But in another respect it is like any conventional lock with a keyhole, in that its presence is advertised by the tell-tale knob or keypad. This is not a serious objection in many cases, such as external doors, for the existence of a lock of some description is a foregone conclusion anyway.

But there could be situations where it might be felt vitally important not to betray the existence of a secured area or compartment—of whatever size. In this strategy the first line of defence is based on concealment and in not attracting attention. The Magnetic Lock meets such a requirement. The particular design described in this issue does require a key—of a special kind—but there is no giveaway keyhole or keypad. Nothing at all need be visible externally to suggest the presence of a locking device. And that is not all. Should the key fall into the hands of some unauthorised person its significance will not be apparent; but even if it were, there remains the problem of just how and exactly where it is used. On that intriguing note we leave the subject, certain that readers will want to learn more from the article itself.

FLAG FLYING

Good to know of one home-brewed electronic product that is at the top of the charts. Britain's electronic entrepreneur Clive Sinclair is flying high, with over a third of a million ZX81 personal computers sold—some to Japan and the USA.

Owners of the ZX81 will find our plug-in 2K Ram Pak of special interest. This inexpensive project will increase the memory of the standard machine sufficiently for many general needs.

Anytime we can help, Clive!



Readers' Enquiries

We cannot undertake to answer readers' letters requesting modifications, designs or information on commercial equipment or subjects not published by us. All letters requiring a personal reply should be accompanied by a stamped self-addressed envelope.

We cannot undertake to engage in discussions on the telephone.

Component Supplies

Readers should note that we do not supply electronic components for building the projects featured in EVERYDAY ELECTRONICS, but these requirements can be met by our advertisers.

All reasonable precautions are taken to ensure that the advice and data given to readers are reliable. We cannot however guarantee it, and we cannot accept legal responsibility for it. Prices quoted are those current as we go to press.

Back Issues

Certain back issues of EVERYDAY ELECTRONICS are available worldwide price 80p inclusive of postage and packing per copy. Enquiries with remittance should be sent to Post Sales Department, IPC Magazines Ltd., Lavington House, 25 Lavington Street, London SE1 0PF. In the event of non-availability remittances will be returned.

Binders

Binders to hold one volume (12 issues) are available from the above address for £4.60 inclusive of postage and packing worldwide. Please state which Volume.

Subscriptions

Annual subscription for delivery direct to any address in the UK: £11.00. Overseas: £12.00. Cheques should be made payable to IPC Magazines Ltd., and sent to Room 2613, Kings Reach Tower, Stamford Street, London SE1 9LS.



by the latch/counter circuit, the frequency of oscillation of the clock being adjustable so as to calibrate the display reading. The pulses from the clock oscillator are stored in the latch of the latch/counter and only transferred to the display at the end of the monostable timing pulse. This is achieved by feeding the timing pulse into the latch monostable which is triggered by the negative going edge (also referred to as the "trailing edge"), the resulting latch pulse being very narrow, only about three microseconds long, and it is this pulse which "latches" the stored number of clock pulses into the display.

The negative going edge of the latch pulse also triggers a third monostable, the reset monostable, the purpose of which is to reset the counter and hold it at zero so that pulses from the clock oscillator are not counted during this period. The negative going edge of this reset pulse is also fed back to the timing monostable and the whole sequence restarts. The period of the reset pulse is about one second, although in theory it need only be a few microseconds, but this would give far too many readings per second of the unknown capacitance, hence causing

Capacitance/Frequency Meter

BY A.P. DONLEAVY

THIS instrument was originally designed exclusively as a capacitance meter, but the addition of a few extra components enables it to function as a frequency meter, with a degree of accuracy sufficient for the needs of most amateur constructors. The scale ranges from approximately 1,000pF to 10 μ F in the capacitance mode and from 50Hz to 1MHz as a frequency meter. The power is supplied either from a 9V PP3 battery or from a mains calculator adaptor via a 2.5mm jack socket.

CAPACITANCE METER

Fig. 1 shows the block diagram of the meter, and we shall use this to describe the operation of the circuit.

With S1 in position c as shown, the instrument measures capacitance. A monostable (single shot) multivibrator produces a pulse, the duration of which is proportional to the unknown capacitance (C_{ext}) under test, this capacitor forming part of the time constant circuit of the monostable.

During this period, clock pulses from the clock oscillator are counted

the last digit to flicker rapidly and appear as an "8".

So it is in this way that the meter counts a number of clock pulses for a period of time governed by the unknown capacitance and displays this figure as a direct capacitance value.

DIVIDE-BY-TEN

The divide-by-ten circuit is used to extend the range of the meter by dividing the clock pulse frequency by

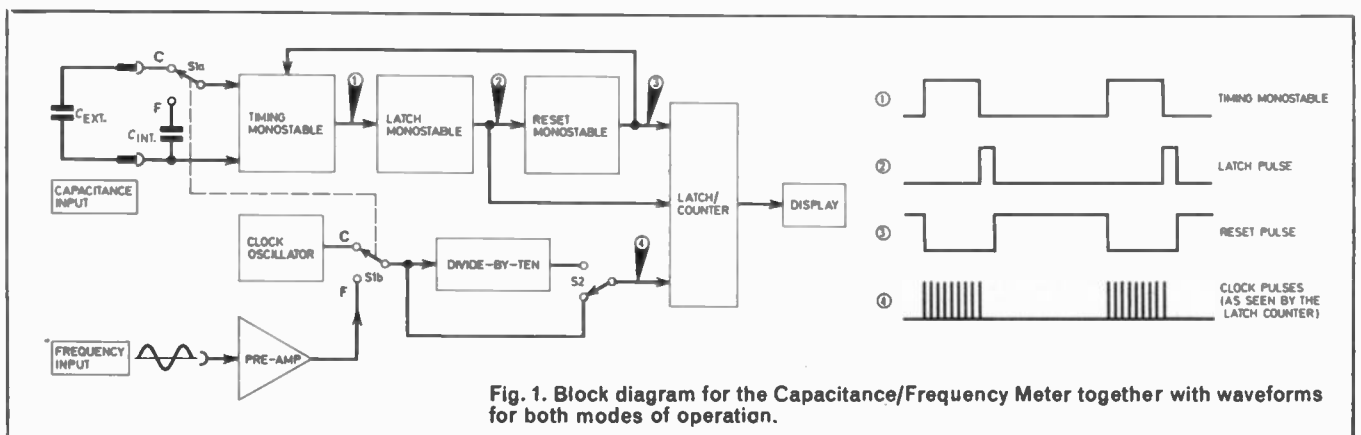


Fig. 1. Block diagram for the Capacitance/Frequency Meter together with waveforms for both modes of operation.

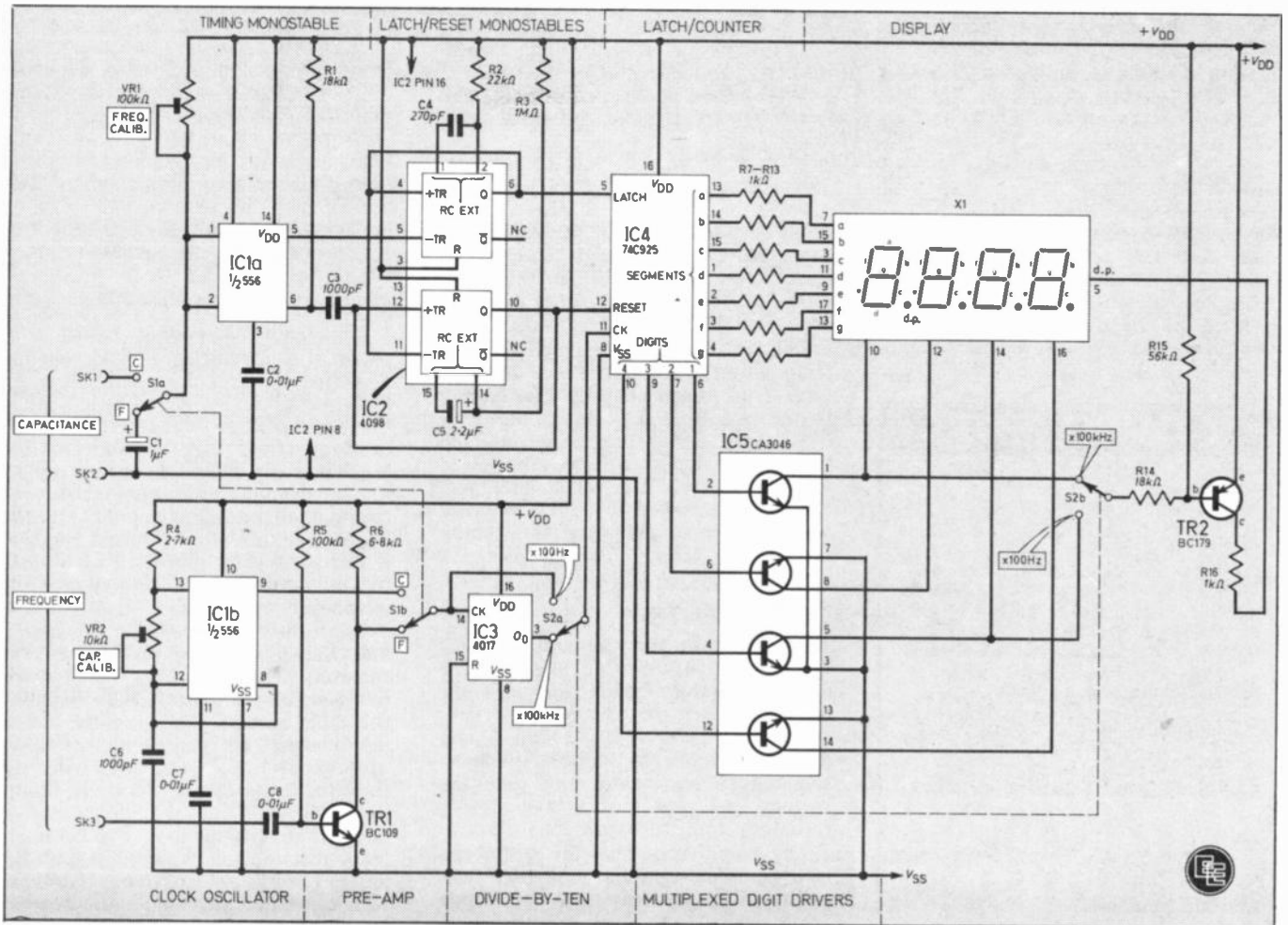


Fig. 2a. Circuit diagram for the Capacitance/Frequency Meter. Note the pin numbers on X1 are for the National Semiconductor display.

ten for evaluating the higher value capacitors. This facility is brought in with S2.

By switching S1 to position F the instrument can now be used for the measurement of frequency.

FREQUENCY MEASUREMENT

As a frequency meter, the operation is very similar to above, only a capacitor of known value (C_{int}) is used to set a fixed timing monostable pulse width. The unknown input frequency is fed into the meter via a pre-amplifier, either directly or divided by ten (again to extend the range and dependant on the position of S2), to the latch/counter. The display now gives a direct reading of frequency, calibration being achieved by varying a resistive element in the timing monostable time constant circuit.

The waveforms shown in Fig. 1 are present in both modes of operation but note that waveform 4, the clock pulses, are always present but the latch/counter only recognises them when the reset input is at logic 0. Note also that in the frequency mode, these pulses will be the unknown input signal.

CIRCUIT DESCRIPTION

The full circuit diagram is shown in Fig. 2. IC1a, half a 556 dual timer i.c., is connected as the timing monostable, with VR1 and C1 forming the time constant components in the frequency mode and VR1 and the unknown capacitor determining this in the capacitance mode.

IC1b, the other half of the 556, is connected as the internal clock oscillator, the frequency of which is adjusted by VR2, this allowing calibration in the capacitance mode. Note that the frequency calibration by means of VR1 must be carried out first, followed by capacitance calibration with VR2, as adjustment of VR1 will affect both modes of operation.

IC2, a CMOS 4098 dual monostable i.c., contains both the latch and reset monostables, the pulse width from each determined by C4/R2 and C5/R3 respectively. The negative edge of the reset pulse from pin 10 of IC2 is coupled back to IC1a via C3 and R1, the reason for these components being that the retriggering pulse must be of a shorter duration than the timing pulse and this would not be so if a direct connection was made.

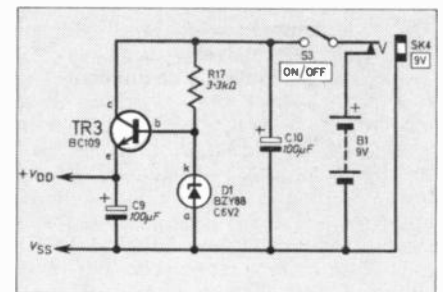


Fig. 2b. Power supply arrangement for the circuit. Insertion of a battery eliminator jack cuts out the internal battery

IC3, a CMOS 4017 decade counter/divider, i.c. is wired as a divide-by-ten and TR1 forms the preamplifier stage for the unknown input signal.

MULTIPLEXED DISPLAY

The latch/counter circuit consists of IC4, a 74C925 CMOS four digit counter with multiplexed seven-segment outputs. This i.c. counts the clock pulses at pin 1 when pin 12 (reset) is low and only when pin 5 (latch) goes high will the display give the information contained in the counter. In this circuit, the information in the counter is transferred to

update the display only during the brief period of the latch pulse.

The display is multiplexed and a CA3046 (or the equivalent LM3046, CA3086 etc) is used to drive the four digits. This i.c. contains five individual *npn* transistors, only four of which are used.

The circuitry associated with TR2 drives the decimal point on the display and this is moved accordingly with S2b, S2a being the switch to bring the divide-by-ten circuit.

With S2 in position "X 100kHz", the meter can measure up to 1 mega-

hertz and the display reading must be multiplied by 100,000. The capacitance is given directly in microfarads in the range 0.001 μ F to 10 μ F. The decimal point is after the most significant digit.

With S2 in the "X 100Hz" position, the meter measures from 50Hz to 100kHz, this time the display reading must be multiplied by 100. Again the capacitance meter reads directly in microfarads, from 0.1 μ F to the maximum of 10 μ F. The decimal point is after the third most significant digit.

The instrument is designed to work from either a 9V battery or a calculator type mains adaptor. The supply to the circuit (V_{DD}) should be about 5.5V and although this is not too critical, it should not be allowed to fall much below this value, otherwise the pulse from pin 10 of IC2 may not be sufficient to retrigger the timing monostable, IC1a.



CIRCUIT BOARD

The main component board is a piece of 0.1 inch matrix Veroboard, 32 strips by 42 holes with the plain unpunched copper strips found along the edge of the board left on. It is in these strips that the four mounting holes are drilled as shown in Fig. 4. The original prototype meter was constructed on a special d.i.l. circuit board, but this type of board requires a fairly large number of wire links so the design was transferred to stripboard.

There are 82 breaks in the tracks and the position of these must be carefully checked. The components can now be inserted, proceeding with the d.i.l. holders (this greatly assists in locating the positions of other components) followed by resistors, capacitors, semiconductors and finally links. Small, straight links of no more than 5 holes long can be made from resistor lead croppings but the longer links and particularly those which bend, must be formed from insulated wire. Ideally, the flying leads from the board to the front panel should be soldered to Veropins as this strengthens the joint considerably.

The display can be mounted directly into the board but may require to be soldered onto a row of pins inserted into the board, particularly if a slightly different display is used and any pinout changes can be accommodated at this stage (see note on alternative type of display).

INSTRUMENT CASE

To mark the board mounting holes in the bottom of the case, use the board itself as a template (prior to any components being assembled on it), placing it in position as shown in Fig. 5.

A drilling guide for the front panel is shown in Fig. 5, and the hole in the rear panel for SK4 must be large enough to clear the mounting bush and nut of the socket. The reason for this being that SK4 is to be isolated from the chassis so it is first mounted on a piece of insulating material (a piece of plain Veroboard for example) and this is then glued behind the back panel, none of the socket's metalwork touching the case.

The board is mounted into the case with long screws (M2.5 or 6BA),

COMPONENTS

Resistors

R1, 14	18k Ω (2 off)
R2	22k Ω
R3	1M Ω
R4	2.7k Ω
R5	100k Ω
R6	6.8k Ω
R7-13, 16	1k Ω (8 off)
R15	56k Ω
R17	3.3k Ω
All $\frac{1}{4}$ W carbon $\pm 5\%$	

See
**Shop
Talk**

page 233

Capacitors

C1	1 μ F 16V electrolytic
C2, 7, 8	0.01 μ F polyester (3 off)
C3, 6	1000pF polystyrene (2 off)
C4	270pF polystyrene
C5	2.2 μ F tantalum bead
C9, 10	100 μ F tantalum bead (2 off)

Semiconductors

D1	BZY88 6.2V, 400mW Zener diode
TR1, 3	BC109 silicon <i>nnp</i> (2 off)
TR2	BC179 silicon <i>nnp</i>
IC1	556 dual timer
IC2	4098 CMOS dual monostable
IC3	4017 CMOS decade counter/divider
IC4	74C925 CMOS 4 digit counter with multiplexed 7-segment output
IC5	CA3046 silicon <i>nnp</i> transistor array
X1	Calculator display National NSA 1298 (see text)

Miscellaneous

S1, 2	d.p.d.t. miniature toggle (2 off)
S3	s.p.s.t. miniature toggle
SK1, 3	4mm socket, red (2 off)
SK2	4mm socket, black
SK4	2.5mm jack socket, switched
VR1	100k Ω multiturn preset Spectrol type 43P.
VR2	10k Ω multiturn preset Spectrol type 43P.
B1	9V PP3 battery
Stripboard, 0.1 inch matrix, 32 strips by 42 holes; aluminium instrument case, 150 x 105 x 45 mm; red display filter approx 50 x 25mm (for X1); battery connector; 16 pin d.i.l. holder (3 off); 14 pin d.i.l. holder (2 off); 7/0.2 p.v.c. sleeved equipment wire; board mounting hardware M2.5 (6BA).	

COMPONENTS

All resistors and capacitors should be as small as possible and for this reason tantalum bead capacitors are used in place of electrolytic types (except for C1). TR1, 2 and 3 can be replaced by any similar specification silicon transistors and potentiometers VR1 and 2 are three-quarter inch long multiturn presets.

The display used in the prototype is a common cathode nine digit calculator display, only four of which are used. Individual displays of larger size could be used as indeed could the four digit "bubble" displays in the d.i.l. package, but larger displays will draw more current, and therefore make battery operation less feasible and the size of the box may also need to be increased.

There are several types of calculator display, some with edge connector type mounting, as in the case of the National Semiconductor display used in the prototype model (part No. NSA 1298), and it was for this type that the component board has been laid out and the pin numbers on the circuit diagram refer to. Other types may require modification to the wiring and when purchasing a display, check with the supplier that the pin connection information is available (see Fig. 3).

Generally speaking, calculator displays, often supplied as surplus stock, are cheaper than the alternatives already discussed, their only drawbacks, being the somewhat miniature digits and the need for an additional red filter.

The segment current limiting resistors R7 to 13 and R16 could be of a lower value to increase the display brightness but this would be at the expense of increased current consumption, which on the prototype was about 40mA.

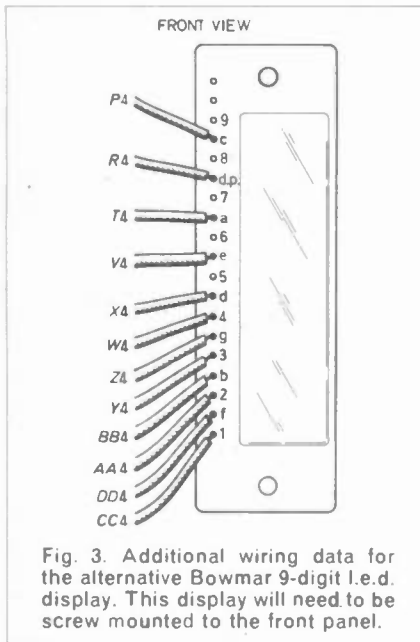


Fig. 3. Additional wiring data for the alternative Bowmar 9-digit I.e.d. display. This display will need to be screw mounted to the front panel.

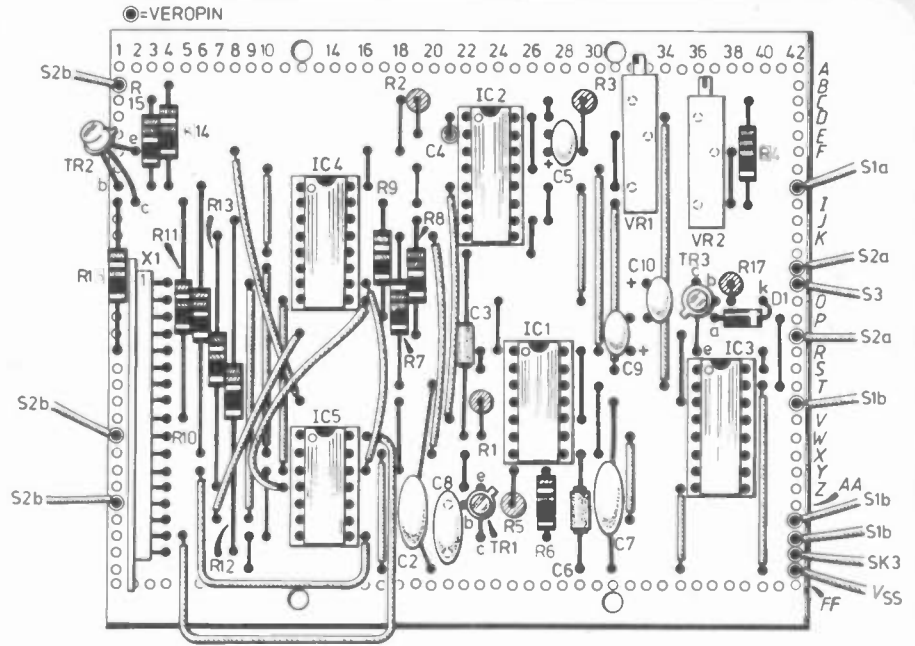


Fig. 4 (right). Component layout on the stripboard together with an underside view showing the cuts to be made in the copper tracks.

Note that there are 82 breaks to be made in the copper tracks and these should be made before inserting the topside components.

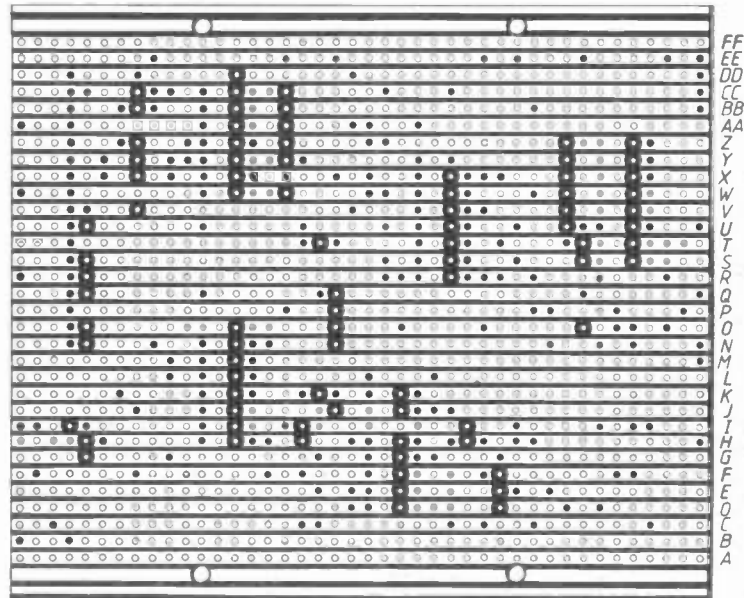
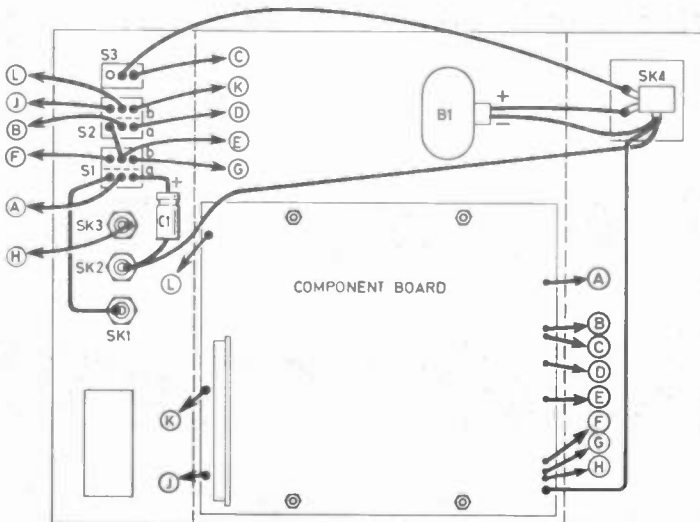
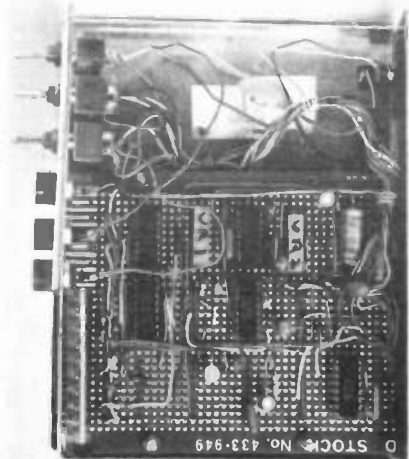


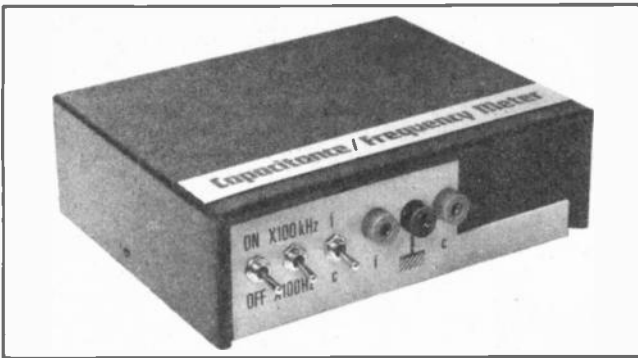
Fig. 5 (below). The case has been laid flat to show position of circuit board, switches, sockets and display cutout.

COMPONENTS
approximate
cost **£17**

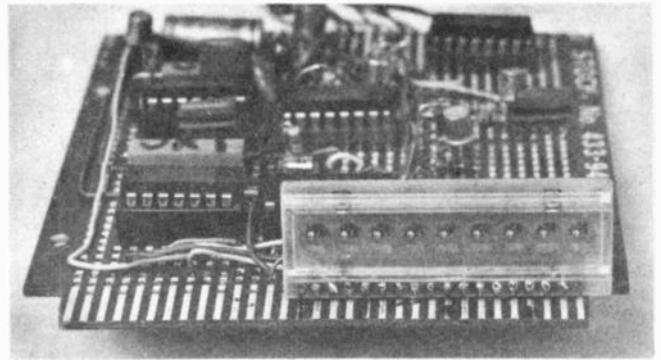


Prototype meter showing positioning of switches and the use of a d.i.l. circuit board.





Front panel arrangement showing lettering and filter over the display cutout.



Close-up of the display module used on the d.i.l. board prototype.

the reason being that this allows up and down adjustment to get the display accurately behind the window in the front panel, but the board height is typically 12mm meaning the screws must be at least 15 to 20mm long.

Having assembled the case with all switches, sockets and board, wiring can commence.

FINAL ASSEMBLY

Using Fig. 5 as a guide, all inter-connections can be made with flexible, stranded wire. Note the mounting of C1 between SK2 and S1a and that this capacitor is an electrolytic and not a tantalum bead, as the bead would not be robust enough.

Care must be taken when wiring SK4 ensuring that the V_{cc} lead is soldered to the outer sleeve terminal, the lead from S3 goes to the other contact and the battery positive wire is connected to the switched contact (only connected when no plug is in the socket).

CALIBRATION

The meter must first be calibrated as a frequency meter, and this is carried out by adjusting VR1 until the display matches a known input frequency. If a signal generator is available then this should be used to set up the instrument, but failing this, a crystal oscillator of known frequency must be built to the circuit given in Fig. 6. Any suitable crystal in the range 100 to 200kHz can be used for X1.

Another, though less satisfactory method of calibration is to take a couple of meters of wire and form it into a loose coil of about 150mm in diameter. Insert the free ends into the input terminals of the meter, and dangle the coil over the back of a turned on television set. The coil will pick up the flyback pulses from the scan coils, the frequency being 15,625Hz for a 625 line system. However, the disadvantage of this method

is the possibility of picking up other frequencies from the set.

Calibration of the capacitance range is performed using a capacitor of known value (as high a tolerance as is available) and adjusting VR2 until the display corresponds with the value. A high value component, for example, $0.47\mu\text{F}$ (not electrolytic or tantalum), is ideal.

If the frequency is recalibrated for any reason, it will also affect the capacitance readings, whereas the capacitance range can be altered without upsetting the frequency calibration.

If a frequency or capacitance is beyond the range of the meter, the display will show an inconsistent result.

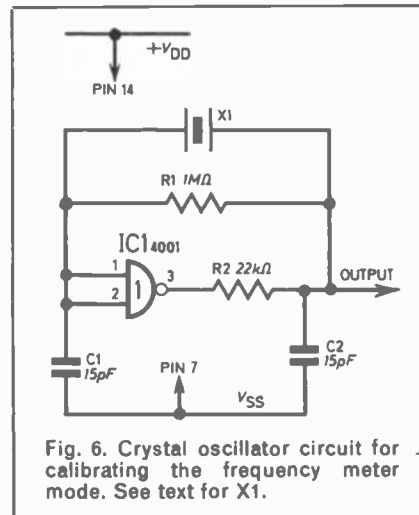


Fig. 6. Crystal oscillator circuit for calibrating the frequency meter mode. See text for X1.

TROUBLE SHOOTING

The following points may be helpful if the instrument does not work when first turned on.

The display should always show four digits and a decimal point, irrespective of faults elsewhere in the circuit and if it only reads four zeros in the capacitance mode, check that the clock oscillator is working (IC1b) by looking for a signal on pin 9 of IC1. Now check that the timing pulse is being generated by

connecting to the test terminals a high value capacitor (say $10\mu\text{F}$) and measuring the voltage across it using a high impedance voltmeter. The voltage should continually rise and then fall, recycling about once every second. If it only rises initially when first turned on, then either IC1 is at fault or more likely, there is no reset pulse coming from IC2 to retrigger the timing pulse.

Attention can then be turned to IC2, this can be easily investigated by removing IC1 from its socket (assuming it has one!) and measuring the voltage at pin 6 of IC2. This should be at 0V. Pin 10 should also be at 0V and whilst these measurements are being taken, pin 5 must be tied to $+V_{DD}$ via a resistor and this is achieved by inserting the ends of the resistor in pins 5 and 14 of the now empty IC1 socket.

Momentarily short pin 5, IC2 to 0V and pin 10, IC2 should go high (approx $+V_{DD}$) for about one second, then fall to zero volts again.

If this does not happen then either the wiring of this i.c. is incorrect or it is a defective device. If however these measurements are correct but the fault persists when IC1 is replaced, then assuming the wiring is correct, IC1 is faulty.

IN CONCLUSION

The meter will of course be only as accurate as the standard it is calibrated against and in many instances this will be, in the case of the capacitance range, an off-the-shelf component and for the frequency, a signal generator which may not have seen the calibration engineers test bench for many a year. However, it is felt that for the majority of enthusiasts, it will serve to be a very useful and indeed, accurate enough, tool to have in the workshop.

Its single board construction, dual power supply options and low cost and simplicity make it a very attractive project for the amateur constructor wishing to expand his range of test gear. □



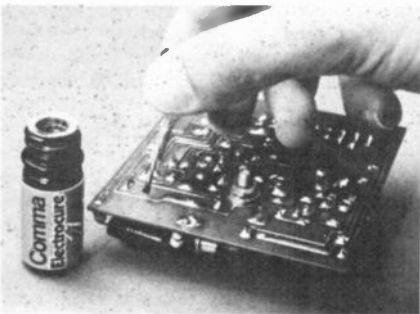
By Dave Barrington

Two aids that may help the constructor or service engineer to enhance the finished layout of a project and carry out "on-the-spot" running repairs attracted our attention this month.

Conductive Paint

A new conductive paint-on preparation from Comma Oils & Chemicals intended for the motoring fraternity is an ideal instant printed circuit board "repair kit" in a bottle.

Known as Electrocare 7, its main application is for repairing car rear window heating elements. However, this specially formulated silver based paint makes it easy to make-good broken tracks on p.c.b. boards and even stripboard.



Comma's Electrocare 7 conductive paint.

It can also be used for repairing most low voltage equipment where there is a broken connection. A feature of the product is that it has been developed for use on non-solderable surfaces, including glass, plastics, acrylics and ceramic.

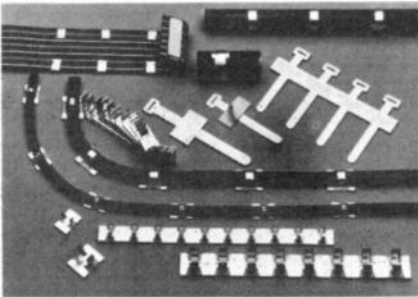
Expected to be stocked by most motoring accessory shops, more details of price and addresses of nearest stockists can be obtained from Comma Oils & Chemicals Ltd., Dept. EE, Mark Lane, Gravesend, Kent DA12 2QX.

Cable Clips

Neat wiring makes it that much easier to trace out circuits and locate faults. Apart from wiring spirals, cable retainers and the use of the usual method of tie-cord, any new addition is welcome.

A range of Brandauer self-adhesive cable clips from Stotron provide an inexpensive method of fixing round or ribbon cable to most clean surfaces. The clips can handle round cables from just a few millimetres to 19mm ($\frac{3}{4}$ in). Ribbon cables from 13mm ($\frac{1}{2}$ in) to 75mm (3in) can also be accommodated by a selection of clips with widths in stages of 6mm ($\frac{1}{4}$ in).

For more details of stockists and prices write to Stotron Ltd., Dept EE, Unit 1, Haywood Way, Ivyhouse Lane, Hastings, East Sussex.



Cable clips from Stotron

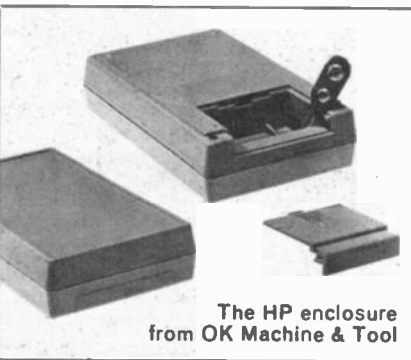
Case

A range of cases just being marketed by OK Machine & Tool feature a special battery compartment.

Called the HP-BAT-9V, the case has a removable battery "hatch" in its back panel, together with the battery clip and lead. The case is constructed of ABS material, measuring 92mm x 145mm x 28mm, and is ideal for housing all hand-held instruments.

Four standard colours are offered, grey, tan, black and blue but special custom colours are available to order.

The HP-BAT-9V case is available from OK's usual retail outlets, or direct from OK Machine & Tool (UK) Ltd., Dept EE, Dutton Lane, Eastleigh, Hants, SO5 4AA.



The HP enclosure from OK Machine & Tool

Catalogue

The latest catalogue we have received comes from Rheinbergs Science who have been appointed exclusive distributor for the complete range of astronomical and scientific equipment and kits from Edmundson Scientific Products of America.

From lasers and holograms to fibre optics and science kits the Edmundson range consists of over 4,000 items. To promote these, Rheinbergs have equipped a showroom at Tonbridge, Kent, and have issued two catalogues outlining the complete range.

The General Scientific edition consists of 48 pages, in colour, and covers optics,

holography, tools, motors, microscopes and laboratory equipment. The Science Fun kits include electronics, electricity and magnetism, solar energy and a digital electronic computer kit.

Copies of the catalogue can be obtained free from Rheinbergs Sciences Ltd., Dept EE, Sovereign Way, Tonbridge, Kent TN9 1RW.

CONSTRUCTIONAL PROJECTS

Capacitance/Frequency Meter

The display used in the prototype model of the *Capacitance/Frequency Meter* was a nine digit calculator display, only four digits being used.

We have been informed by Bart Trepak of TK Electronics that they have a Bowmar 9-digit display suitable for this project. This is available from TK for the sum of 55p plus VAT. Note, the pinning for this device is different and will have to be "hard-wired" to the board as indicated in the article.

The multitrans potentiometers are Spectrol types and stocked by Watford Electronics.

The only source of supply we have been able to locate for the four decade counter/latch i.c., type MM74C925, is Ambit International.

Magnetic Lock

The only sourcing problems likely to be encountered in the *Magnetic Lock* is the supply of the Hall Effect devices.

The magnetically-operated TL170C Hall effect i.c. contains an output transistor with open collector for use on voltages up to 30V. This device seems to be only available from Maplin Electronic Supplies, stock number WQ75S (TL170C). They are also suppliers of suitable bar magnets, stock number FX72P.

Ram Pack

The integrated circuits called up in the *2K Ram Pack* should be readily available from most advertisers, but in case of difficulty they are listed by Watford Electronics, Ambit, and Electrovalue.

Readers who are not able to make their own printed circuit for this project may be interested to learn that Proto Design are able to supply one.

The cost for this board is £2.21 including VAT and postage and packing, and can be obtained from Proto Design, Dept EE, 14 Downham Road, Ramsden Heath, Billericay, Essex, CM11 1PU.

The double-sided edge connector used in our model was cut from a 77-pin wire-wrap type to form a 23-pin version. Only a *Wirewrap* edge connector is suitable for this project and *must* be used. This is available from Redditch Electronics, Dept EE, 21 Ferney Hill Avenue, Redditch, Worcs, B97 4RU, price £2.95 + 40p p/pkg.

Light Actuated Switch

There are no unusual components in the *Light Actuated Switch* although care should be taken when choosing a suitable relay. This must have a 12V coil and mains rated contacts capable of carrying sufficient current for the load being switched. In any case they should not be rated at less than 3A. A suitable type would be the Pigmy Mains Relay available from Electrovalue.

In-Car P.S.U.

The integrated circuit type LM317T used in the *In-Car P.S.U.* is available from Tandy stores.

2K RAM PACK FOR THE SINCLAIR ZX81

BY V. TERRELL



THE "add on" Ram Pack to be described gives the ZX81 (1K) microcomputer an extra 2K of RAM. It works in conjunction with the ZX81 internal 1K of RAM therefore providing a total of 3K of usable memory. All the necessary voltages and signals are readily available from the p.c.b. dual finger-set at the rear of the ZX81 including its power supply (5V). The unit simply plugs in and is immediately ready for use.

MEMORY STORE

The 2114 memory chips used in the unit can each store 4-bit wide data at 1024 addresses. Because the ZX81 data bus is 8-bits wide, the four chips in the Ram Pack are wired in

pairs, each pair allowing data to be stored at 1024 addresses 8-bits wide.

CIRCUIT OPERATION

The complete circuit diagram for the ZX81 Ram Pack is shown in Fig. 1. The address lines A0-A9 are wired in parallel to the two pairs memory

This project has been specially designed to meet the expected memory expansion needs of the ZX81 Personal Computer user who may not immediately require or be able to afford the massive 16K byte Ram Pack from Sinclair at a cost of over £50.

chips, IC1-4. These 10 lines carry information to call up any one of the 1,024 address locations as selected by the computer.

The eight lines D0-D7 carry data which can either be written (stored) into memory when the R/W pin is low, this being controlled by the WR (write) line from the ZX81, or when this line is high, data may be read from the memory and processed by the computer.

The two 1K memory blocks IC1, IC2 and IC3, IC4 are enabled only when their CS pins are low, a high will disable them.

The ZX81 RAM starting address is 16384 and decoding is required to enable the Ram Pack to be positioned 1K beyond this address.

DECODING

Address decoding for the extra RAM is accomplished using IC5, a three-to-eight line decoder i.c. with tristate outputs. The three inputs A0, A1 and A2 on IC5 form a three-bit binary number (eight decimal numbers). The output corresponding to the binary input goes to a logic low with the remainder at logic high.

The decoding is not unique since an output will go low for the various combinations of 1s and 0s to the inputs, irrespective of the conditions of address lines A12 and A13, but does not need to be taken into account in this 2K system.

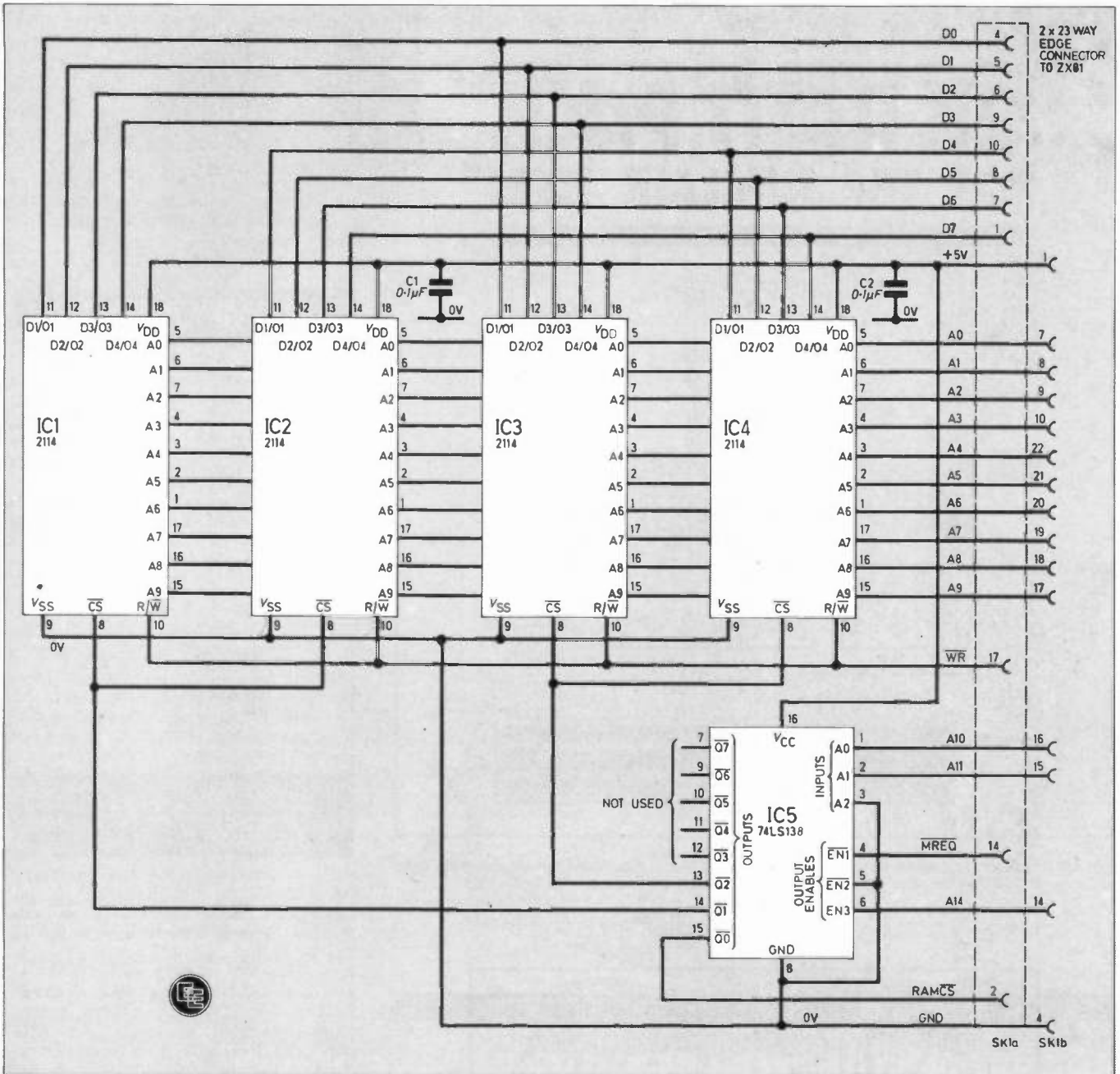
The i.c. as stated earlier is a tristate device which means that the outputs can be disabled (effectively disconnected) by suitable control signals to the three enable pins EN1, EN2, EN3 on IC5. The bar indicates that a low is required on EN1 and EN2 and a high on EN3 to "connect" the outputs to the following circuitry.

A logic high on address line A14 means that memory between 16K and 32K has been selected by the processor which is the requirement here. When addressing memory for read or write, the processor generates a low on MREQ at a time when the

Table 1: Decoder truth table.

Inputs				Outputs			Chip Enabled
A14	MREQ	A10	A11	Q0	Q1	Q2	
1	0	0	0	0	1	1	ZX81 Internal RAM
1	0	1	0	1	0	1	IC1, IC2 (First extra 1K)
1	0	0	1	1	1	0	IC3, IC4 (Second extra 1K)

If A14 is low or MREQ high, all outputs are high impedance.



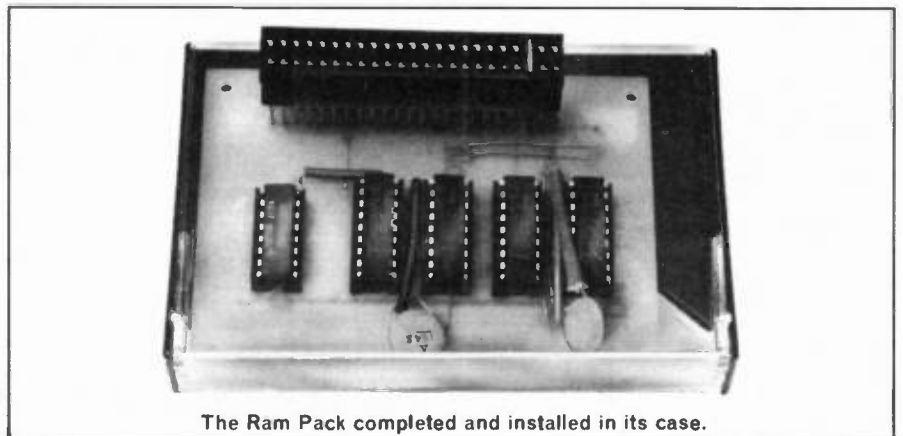
address bus is stable. Thus addressing memory above 16K causes one of the outputs Q0 to Q2 to reach the RAM i.c.s. This is summarised in Table 1. Q3 is not used.

TRUTH TABLE

The truth table for the decoder (IC5) reads as follows: When Q0 is high the internal 1K RAMCS pin is disabled. Q1 low enables the CS pins of IC1, IC2 selecting the first 1K of memory. Q2 low enables the CS pins of IC3, IC4 selecting the second 1K of memory.

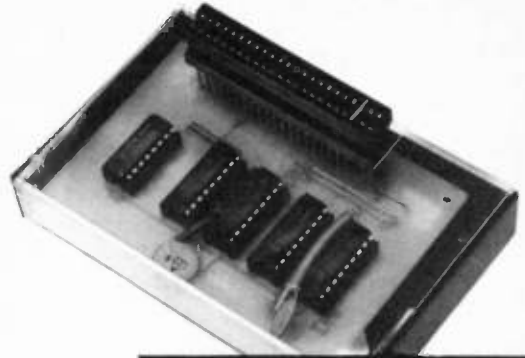
Decoupling capacitors C1 and C2 are required for each RAM pair to filter away any transients that may occur on the supply rail.

Fig. 1. The complete circuit diagram for the 2K Ram Pack for the ZX81.



The Ram Pack completed and installed in its case.

2K RAM PACK FOR THE SINCLAIR ZX81



COMPONENTS

Capacitors

C1, C2 0.1 μ F disc ceramic (2 off)

Semiconductors

IC1-4 2114-2 4096 bit MOS static RAM i.c. (1K \times 4 bit) (4 off)

IC5 74LS138 TTL tristate 3-to-8 line decoder

Miscellaneous

SK1 0.1 inch pitch 2 \times 23 way edge connector, wire wrap type with at least 3cm long pins

Printed circuit board: single sided, size 91 \times 65mm; low profile d.i.l. sockets, 18-pin (4 off), 16-pin (1 off); cassette tape case; double sided self adhesive foam pads or strip; tinned copper wire; sleeving; solder.

Approx. cost **£10**

Guidance only

See page 233

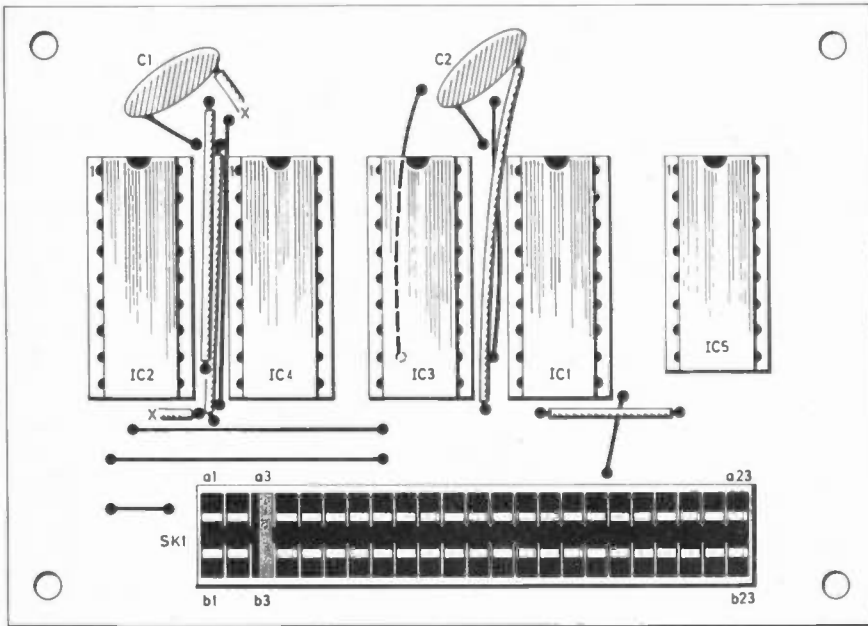


Fig. 3. Layout of the components on the topside of the p.c.b. Note that a link wire runs underneath IC3 socket. It is important to use sleeving on some of the link wires.

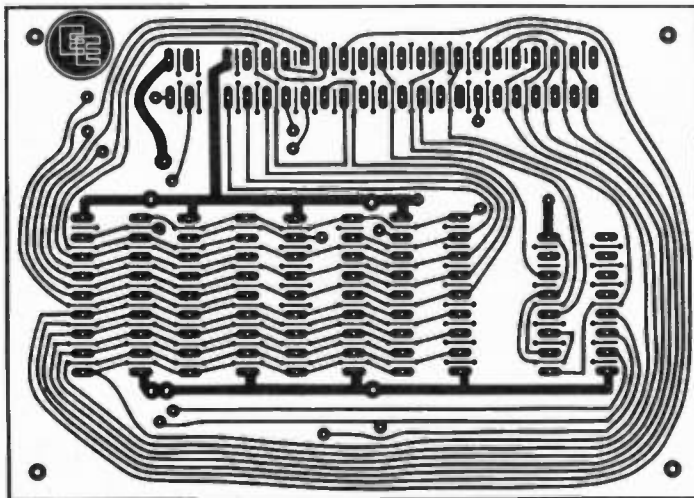
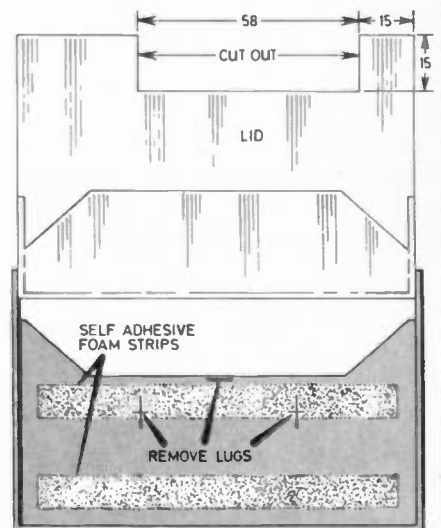


Fig. 2. Full size master of the pattern to be etched on the p.c.b. viewed from the copper side.



ALL DIMENSIONS IN mm

Fig. 4. Cut-out dimensions in the plastic cassette tape case to allow the edge connector to meet with the ZX81 p.c.b. The foam pads cushion the p.c.b. when the case lid is closed.

CONSTRUCTION starts here

EDGE CONNECTOR

The 2×23-way connector may be cut to size from a longer connector and should be of the wire wrap type with pins at least 3cm long. These pins must also be able to be removed to allow a polarising key to be located in the socket across positions 3A and 3B as shown in Fig. 3.

If a "key" is not supplied with the socket it can be cut and shaped from any suitable insulating material of the correct thickness and glued into place.

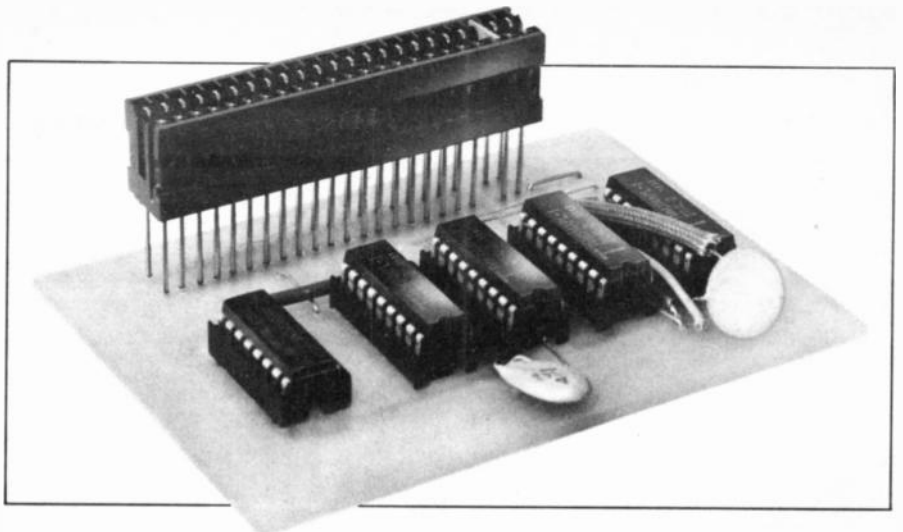
PRINTED CIRCUIT BOARD

The circuit is built on a single-sided p.c.b. size 91×65mm. The full-size master of the pattern to be etched is shown in Fig. 2.

The printed circuit board tracks are quite close together so therefore care must be taken when soldering. It is suggested that a fairly small bit be used together with 22 s.w.g. solder.

Start by fitting the ten link wires as shown in Fig. 3. Next solder the five i.c. sockets followed by the two capacitors C1, C2.

Locate and solder the edge connector so that its pins protrude through the board by no more than 2 to 3mm. Before inserting the i.c.s, thoroughly check all soldered joints making sure adjoining tracks are not bridged with solder.



The fully assembled p.c.b. It can be seen that pin 3 on both sides of SK1 has been removed and that a polarising key has been fitted. This key is important and ensures that the connector accurately aligns with the ZX81 finger set.

CASE

Details for fitting the Ram Pack into the cassette case are shown in Fig. 4. Remove the small plastic lugs in the case with a pair of sidecutters. The cut-out for the edge connector is made by cutting two slots with a junior hacksaw, then scribing between these on both sides with sufficient depth so that the plastic may be broken out.

The two strips of self adhesive foam are positioned as shown to cushion the printed circuit board, the case lid is simply secured down with Sellotape.

TESTING

The unit can easily be tested by using the ZX81 "ramtop" test. Plug the unit in, then switch the ZX81 on and type in the following:
PRINT PEEK 16388 + 256 * PEEK 16389 NEW LINE.

You should see 19456 displayed on the screen.

The result $19456 = 16384 + 3K$ of RAM. This short programme retrieves and displays the contents of locations 16388 and 16389 which contain the least and most significant bits respectively of the address plus 1 of the highest RAM location in circuit.

This information has been "poked" into these locations during the system set-up routine which is initialised at switch-on.

The following is a list of software available on the Sinclair 16K cassettes that were successfully loaded by the author using the 2K Ram Pack.

Cassette No.2 (16K)	Cassette No.4 (16K)
Crash	Substrike
Train	Codebreaker
Division	Twenty One
	Mayday

NOTE. Always make sure the ZX81 is switched off before inserting or removing the Ram Pack. □

JACK PLUG & FAMILY...

BY DOUG BAKER



EE

PART 7

BY O.N. BISHOP

TEACH-IN 82



BASIC ELECTRONIC THEORY WITH EXPERIMENTS

AMPLIFIERS AND AMPLIFIER MODULE

IN Part 5 we saw how a single bipolar transistor can be used to amplify a voltage. In those amplifiers (Figs. 5.9 and 5.11) the input was taken to the base and the output was taken from the collector. The emitter was part of both the input circuit and the output circuit. We say that the transistor is being used in the **common-emitter connection**. This is the most frequently used way of using a transistor for amplifying.

In Fig. 7.1 input goes to the emitter and output is taken from the collector. The base is common to both circuits, so this is the **common-base connection**.

The base-emitter current varies according to V_{IB} . The collector current is h_{FE} times greater than this. As I_C varies, the p.d. across R_3 varies in proportion, causing variations in the value of V_{OUT} . Thus the gain of this amplifier is the same as that of a common-emitter amplifier, but we lose the advantage of the high input impedance of the base. The main use for this amplifier is at very high frequencies.

In a common-emitter amplifier the small capacitance between the emitter and base regions has a relatively large effect (the Miller effect). Voltages cannot change rapidly enough and gain is considerably

reduced at high frequencies. The Miller effect is much smaller in the common-base connection, making this connection specially suitable for high-frequency amplifiers.

The **common-collector connection** (Fig. 7.2) might seem to have no advantages, since the base-emitter voltage must always be 0.6V (for a silicon transistor) and any increase in base voltage is matched by an equal increase in emitter voltage. Whatever the value of h_{FE} , the gain of the amplifier is always unity. Such an amplifier is called an **emitter-follower**, for the voltage at the emitter exactly follows the changes in voltage at the base.

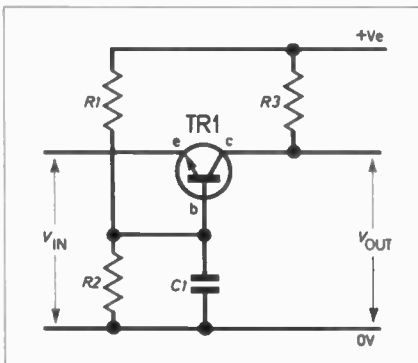


Fig. 7.1. Common base amplifier.

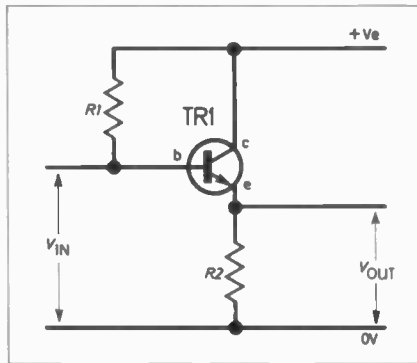


Fig. 7.2. Common collector amplifier (emitter-follower).

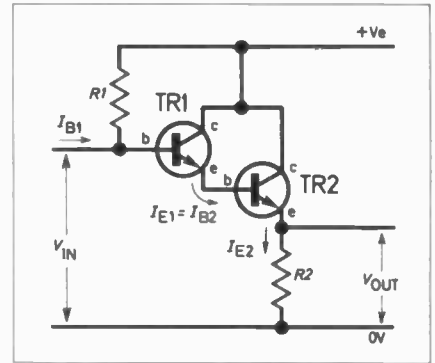


Fig. 7.3. Transistors wired in the Darlington pair configuration.

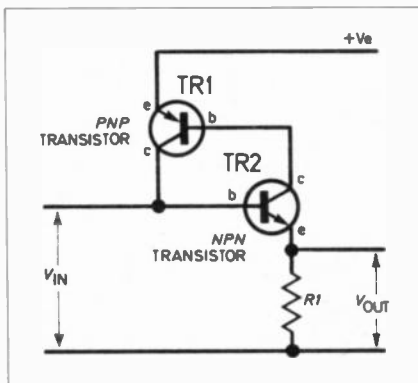


Fig. 7.4. Complementary transistor arrangement (npn and pnp) connected to obtain very high gain.

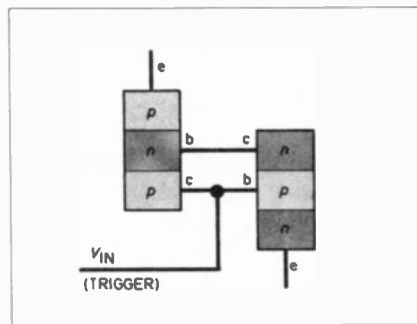


Fig. 7.5. Shows the connected regions of the two transistors of Fig. 7.4.

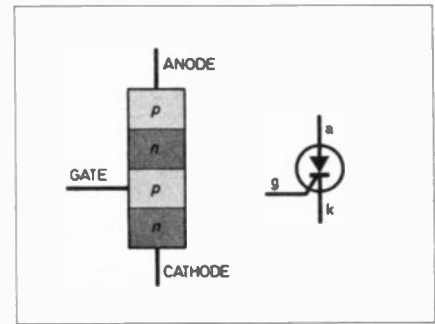


Fig. 7.6. Transistors of Fig. 7.5 combined to make a thyristor.

The advantage of this amplifier is that it has high input impedance (it draws little current on its input side), but has low output impedance (it can provide a lot of current on its output side). It is useful for connecting a high-impedance output to a low-impedance input when we do not need voltage amplification.

INCREASING GAIN

Fig. 7.3 shows two transistors connected, so that the emitter current from one becomes the base current of the other. If the gain of TR1 is h_{FE1} , then $I_{E1} = h_{FE1} \times I_{B1}$. For TR2, $I_{E2} = h_{FE2} \times I_{B2}$. But $I_{B2} = I_{E1}$. Therefore $I_{E2} = h_{FE2} \times h_{FE1} \times I_{B1}$. The gain of the Darlington pair, as this arrangement is known, is the product of the gains of the two transistors. If they each have a gain of 100, the gain of the pair is 10,000.

We can connect *nnp* and *pnnp* transistors to form a high-gain pair as in Fig. 7.4.

When power is first applied, TR2 is off, so its collector voltage is high. This makes the base of TR1 high so TR1 is off too. No current can flow to TR2 so it stays off. The transistors hold each other off and no current flows.

If we then supply a very small current to the base of TR2, it begins to turn on. Voltage at its collector falls, drawing current from the base of TR1 (current flows out of the base of a *pnp* transistor, not into the base as in an *nnp* transistor). TR2 begins to turn on, allowing current to flow to the base of TR2 and turning it further on. Its collector voltage falls further, turning TR1 further on. This process continues—even though the original source of current at the input is removed—until both transistors are fully on and a large current is flowing through them. Here we have a circuit which can be turned on by a very small, very short pulse.

Fig. 7.5 shows how the regions of TR1 and TR2 are connected and in Fig. 7.6 we see how to make a single four-layered device which has the same action as the two transistors. Such a device is called a thyristor.

A thyristor is a current-switching device. No current flows through it until a positive pulse has been applied to its *gate*. A small, brief pulse is enough. Then current flows indefinitely from *anode* to *cathode*. If the current is interrupted (for example by turning off the supply) or is reduced below a certain value, conduction stops and another pulse at the gate is required to start it again. Current cannot flow from cathode to anode, so this device has some of the properties of a diode.

EXPERIMENT 7.1

Low-noise amplifier

The circuit of Fig. 7.7 can be assembled on *Minilab* as shown in Fig. 7.8. When you have built and tested it you will find that it gives a much louder sound than the one-transistor amplifiers already investigated.

Noise in an amplifier consists of currents caused by the random motion of electrons across the junctions of the transistors. These small randomly-occurring changes in current become amplified. We hear a hissing or rushing sound at the loudspeaker.

If a large amount of noise occurs in the first stages of an amplifier, the noise currents are of the same order of size as the signal current from the microphone. Amplification acts on signal and noise equally, causing a noisy output. It is therefore particularly important to minimize noise in the first stages.

In this circuit we use BC109 transistors which are specially made to have low noise. They also have high gain. Noise is kept to a minimum by making the collector current small in the absence of any signal. Ignoring R8, I_C is approximately $12/470,000 = 25\mu A$.

The fluctuations in I_B caused by a signal from the microphone cause voltage fluctuations at the R7/TR1 collector junction, and hence at the base of TR2 which acts as a second amplifier. Now that the first stage

of amplification is complete we can allow greater collector current. Hence the low value of R11 compared with R7.

Further amplification by TR2 gives a varying voltage which is coupled by C7 to TR3. The latter is wired as an emitter-follower; no further amplification is required, but the high impedance output of the low-noise amplifier must be matched to the low impedance of the speaker.

Here we do not need a low-noise transistor but prefer instead one which can carry a larger current. Since a ZTX300 can carry up to 500mA, R15 could be reduced to 18Ω giving an increase of volume. An 80Ω loudspeaker could be wired in place of R15 and LS1 and would also give greater volume.

Try holding the microphone close in front of the loudspeaker (Fig. 7.9). You should hear a loud high-pitched whistle. Small noises in the room are picked up by the microphone, amplified, and are emitted by the loudspeaker. Now they are louder and are picked up again and amplified again.

EXPERIMENT 7.1

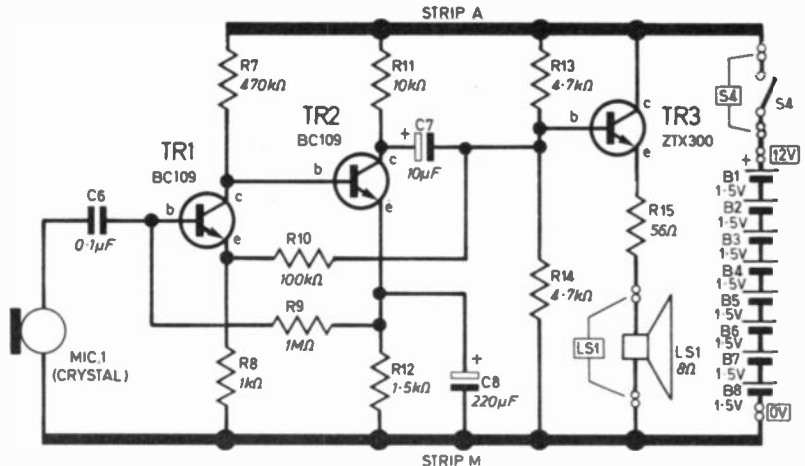


Fig. 7.7. Circuit diagram of a high gain, low noise amplifier with emitter follower amplifier (last stage).

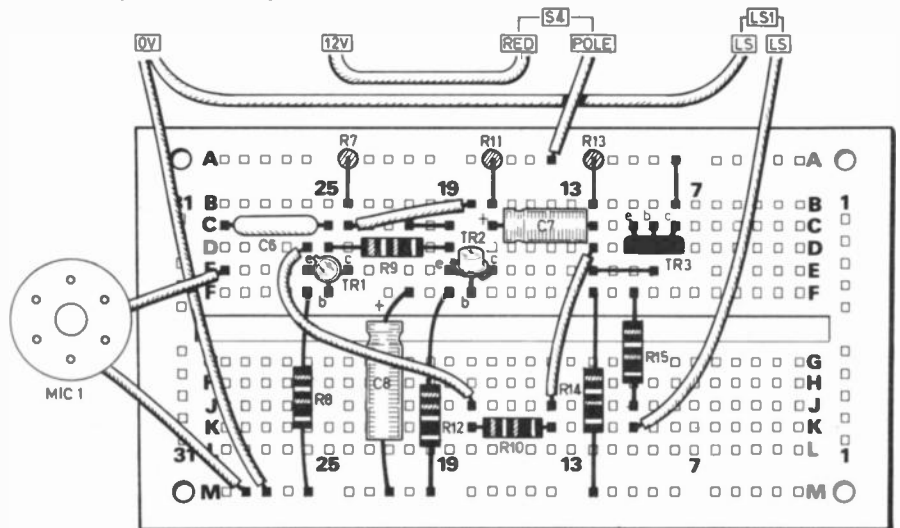


Fig. 7.8. The layout of the components on the Verobloc for the circuit in Fig. 7.7 (Expt. 7.1).

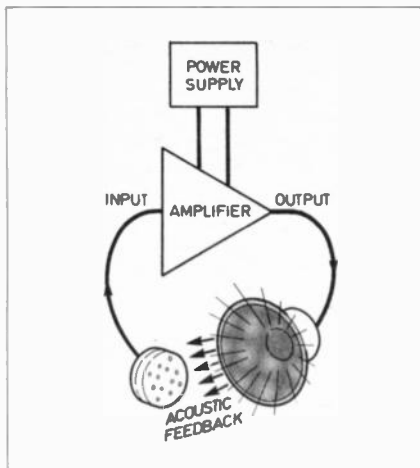


Fig. 7.9. Acoustic feedback (positive feedback).

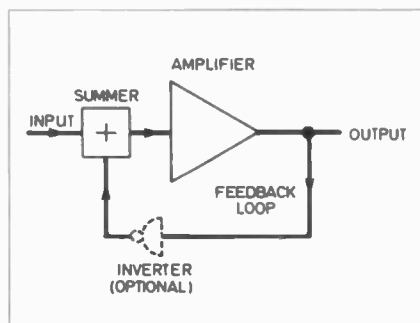


Fig. 7.10. A feedback loop.

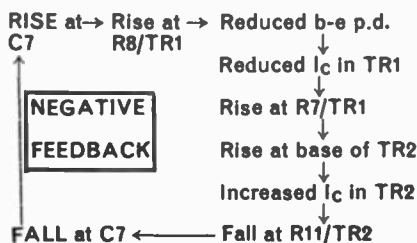
This process continues until a very loud sound is being emitted from the speaker. The signal passes round and round a loop. It is amplified each time round. Its power becomes increased, using the power obtainable from the battery.

Most of the added power spreads into the air of the room, but a small fraction is fed back to the microphone. We have **feedback**. Since the signal fed back acts to produce a further *increase* in volume, we call this **positive feedback**.

FEEDBACK LOOPS

Fig. 7.10 outlines the main stages of feedback. If we include an inverter (a NOT gate for example) in the feedback loop, we have **negative feedback**. A good example of this is found in the amplifier of Fig. 7.7. The voltage at C7 varies according to the signal. A small fraction of these voltage changes is fed back through R10 to the emitter of TR1.

How the negative feedback loop in Fig. 7.7 works is illustrated below:

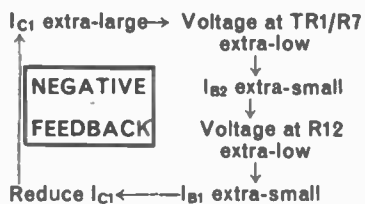


Negative feedback tends to cancel out the rise at C7. The extent to which it does this is determined by the value of R10. The greater the feedback, the greater the effect and the lower the gain of the amplifier.

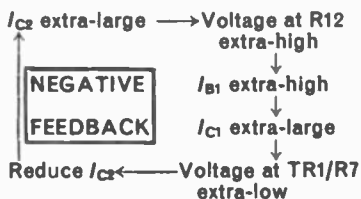
Although negative feedback reduces the gain of the amplifier, it has the advantage of stabilising its gain, irrespective of the h_{FE} of each transistor. The gain no longer depends on differences in h_{FE} due to manufacture, or to variations caused by changes in temperature.

R9 provides feedback of the potential at R12/TR2. It is unaffected by the audio signal, for this is by-passed by C8, as explained last month. The steady d.c. level at R12/TR2 is used to bias TR1. If the h_{FE} of TR1 happens to be exceptionally large, even a small signal could saturate the transistor, causing distortion. The same could happen if TR2 has extra-high h_{FE} . Feedback stabilises such conditions.

If TR1 has extra-high h_{FE} , then the following chain of events occur:



If TR2 has extra-high h_{FE} the following occurs:



The effect of the loop is to stabilise the no-signal conditions of the amplifier.

AMPLIFIER MODULE

The Amplifier Module to be installed in *Minilab* is essentially that shown in Fig. 7.7.

but has been re-drawn in Fig. 7.11 in the conventional circuit diagram format and so the component references follow on from the existing permanently wired *Minilab* components (including the Astable Module). The low-noise amplifier is a handy bench instrument which we shall use in later experiments. It is assembled on Verostrip already fitted to the *Minilab* and is to reside next to the existing module.

The layout of the components on the board and interwiring to *Minilab* are shown in Fig. 7.12. To carry out construction the Verostrip must first be removed from the rear panel. It should not be necessary to remove any wiring already connected to this board.

Before replacing the board, thoroughly check over the board, especially on the underside for solder bridges between tracks. Run the blade of a screwdriver between the tracks to dislodge any bridges which may be there.

TESTING THE MODULE

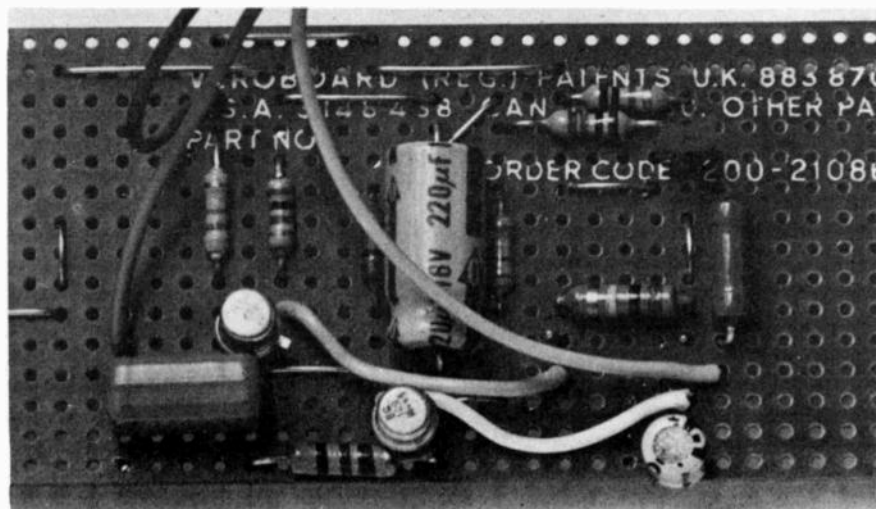
The module may be tested by wiring up as shown in Fig. 7.13. Switch on at S7. Speak into the microphone to hear your voice reproduced in the loudspeaker.

OPERATIONAL AMPLIFIERS

Operational amplifiers are very high-gain amplifiers ($\times 200,000$ for example) which usually come in the form of integrated circuits. They normally work on a dual power-supply, as in Fig. 7.14, where we split the 12V battery supply to provide +6V and -6V.

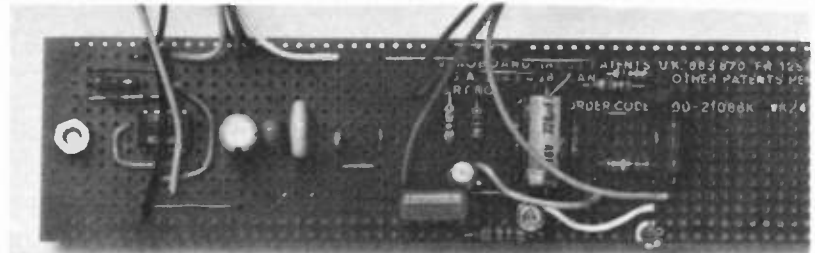
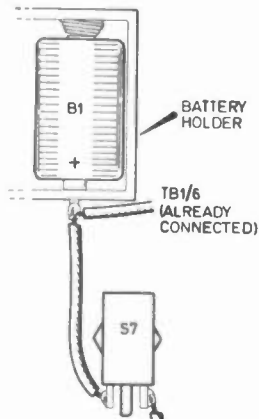
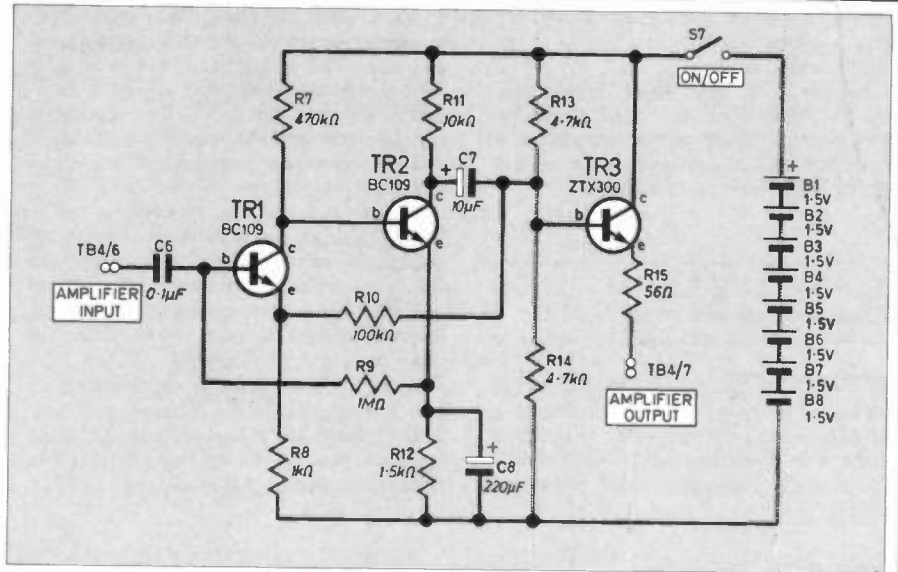
The amplifier has two inputs. If both inputs are at the same voltage, the output voltage is 0V (relative to the 0V line). If the voltage at the non-inverting (+) input, is higher than that at the inverting (-) input, a positive voltage appears at the output. If the inverting (-) input has the higher voltage, a negative voltage appears at the output. All input voltages must lie between the limits of the power supply (between -6V and +6V in this case).

Close-up of the Amplifier component layout section on the Verostrip.



AMPLIFIER MODULE

Fig. 7.11. The complete circuit diagram for the Amplifier Module to be fitted inside the Minilab. Note that the component reference numbers follow on from those already resident in the Minilab.



The amplifier components mounted on the Verostrip next to the Astable section.

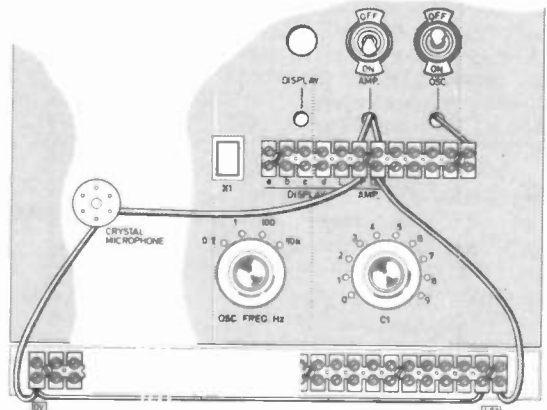
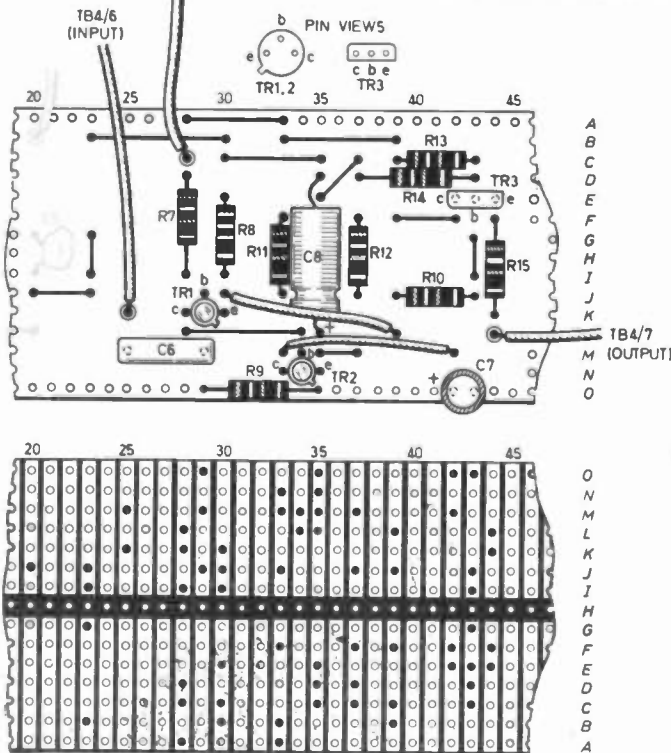


Fig. 7.13. Interwiring to test the installed Amplifier Module

Fig. 7.12. The layout of the components for the Amplifier Module on the Verostrip together with complete interwiring details. The OV line for the amplifier is obtained from the Astable Module.



Minilab from panel showing the amplifier section.

The output voltage of the 741 op-amp cannot swing to the full extent toward $-6V$ or $+6V$, though in other types, such as the CMOS op-amps, voltage can swing freely over the whole range.

Op-amps have high input impedance; $2M\Omega$ for the 741 and as high as $10^{12}\Omega$ for CMOS op-amps. Their output impedance is only a few tens of ohms. Now let us see how these amplifiers may be used.

EXPERIMENT 7.2
Op-amp voltage follower

In Fig. 7.14 the output of IC2 is fed back to the inverting input. VR2 acts as a potential divider to provide a variable voltage source of between $0V$ and $+6V$. The layout for this experiment is shown in

Fig. 7.15 (a) and 741 pinning details in Fig. 7.15b.

Turn potentiometer VR2 fully anti-clockwise to obtain $0V$ at its wiper (and at pin 3). The output reads $0V$. Now turn VR2 slowly clockwise. The voltage at pin 3 should rise from $0V$ to $6V$. You can check this by removing the wire between pin 6 and the meter and connecting it instead to pin 3 (H17). Carry out this check for a number of different settings of VR2.

As the input voltage rises, the output voltage rises too. At first it keeps pace with the input voltage but eventually it lags behind, for it cannot exceed about $5V$. For the low voltages at least, the amplifier has unity gain; output = input.

What happens is that as input voltage to pin 3 rises, the output voltage rises too. There is feedback of this voltage and, since feedback goes to the inverting input, it is negative feedback. With feedback, the out-

put changes so as to keep both inputs at equal voltages. If pin 3 is raised to $+2V$, pin 3 must be brought to $+2V$ too. The circuit can be stable only when the output is $2V$. As a result, output follows input. The amplifier behaves in a similar way to the emitter-follower circuit (Fig. 7.2). The uses of the circuit are the same too—linking a high output impedance to a low input impedance.

PART 6 ANSWERS

- 6.1. $5.7nF$, or $5700pF$.
- 6.2. Storing charge, coupling parts of circuits, passing a.c. signals, smoothing out rapid voltage changes.
- 6.3. 3.3 microcoulombs.
- 6.4. Carbon—it is a conductor.
- 6.5. $74.2Hz$

EXPERIMENT 7.2

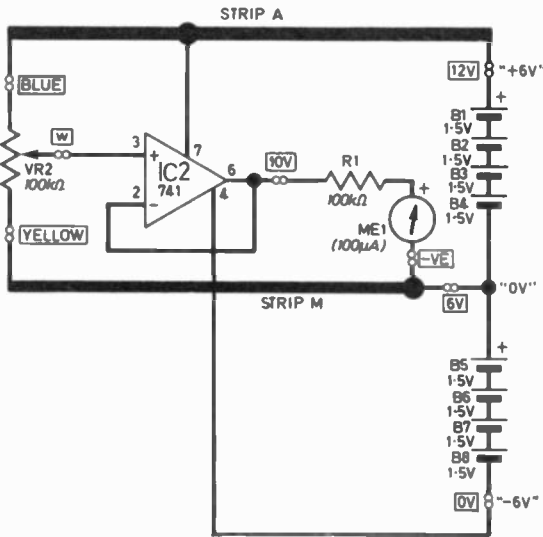


Fig. 7.14. Circuit for investigating the action of an op-amp voltage follower, Expt. 7.2.

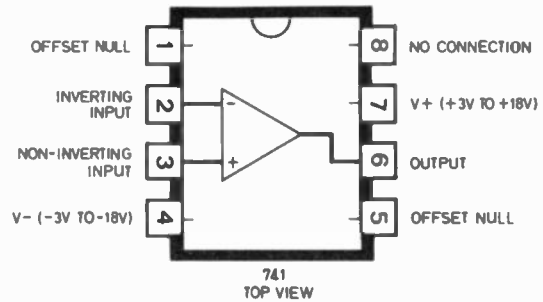


Fig. 7.15b. Pinning details for the i.c. op-amp, 741 used in Expts. 7.2 and 7.3.

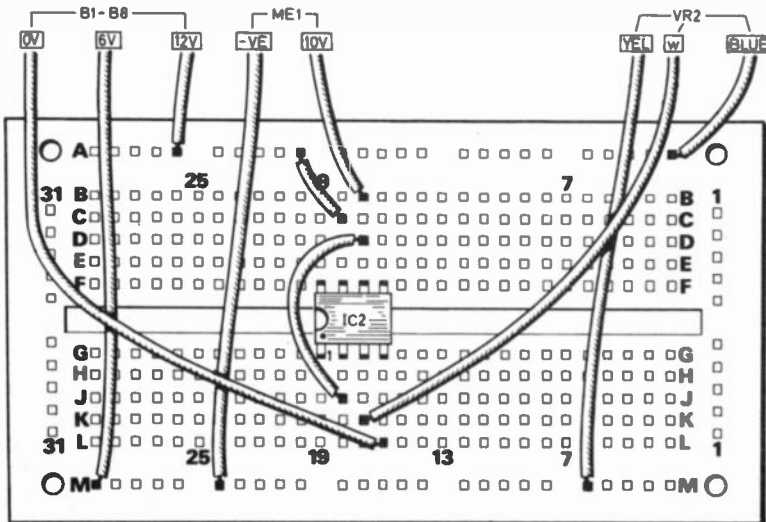


Fig. 7.15a. The layout of the components on the Verobloc for Expt. 7.2.

EXPERIMENT 7.3

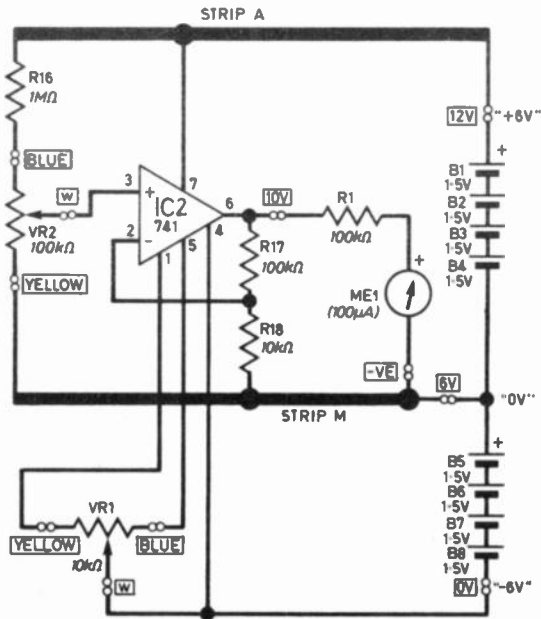


Fig. 7.16. The circuit of a non-inverting op-amp with fixed gain and offset null control.

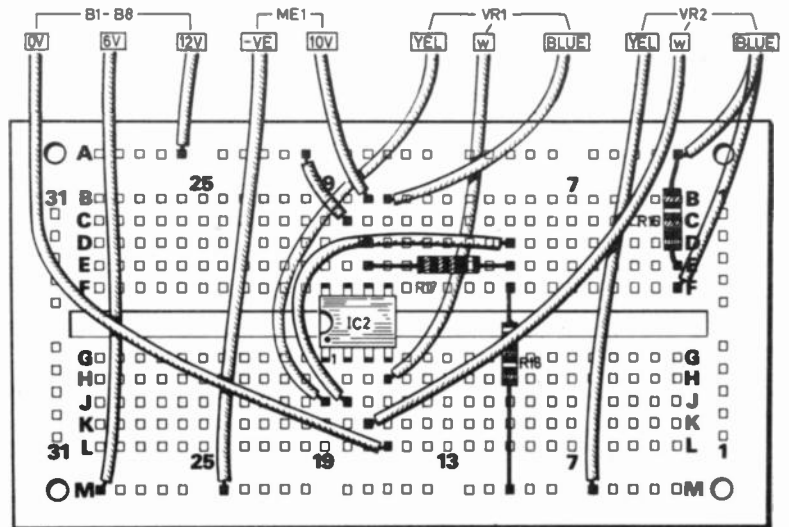


Fig. 7.17. The circuit of Fig. 7.16 wired up on the Verobloc.

EXPERIMENT 7.3 Non-inverting amplifier

Fig. 7.16 shows feedback being taken from a potential divider (R17/R18), so

QUESTION TIME

1. In the common-collector connection, which terminal of an *npn* transistor is connected directly to the positive rail?
2. Which type of connection is used to minimise the Miller Effect?
3. How is the gain of a Darlington pair calculated?
4. Which capacitors are used for a.c. coupling in Fig. 7.7?
5. Why are BC109 transistors used for the first stages of amplification in Fig. 7.7?
6. What type of feedback is used to stabilise the gain of an amplifier?
7. What is the purpose of the offset null adjustment of an operational amplifier?
8. If pin 3 (Fig. 7.14) is taken to $-3.5V$, what will be the output at pin 6?
9. If pin 3 (Fig. 7.16) is taken to $-0.1V$, what will be the output at pin 6?
10. In Fig. 7.16 if $R16=1M\Omega$, $R17=6.8k\Omega$, and the voltage at pin 3 = $0.01V$, what will be the output at pin 6?

that only a fraction of the output voltage is fed back. This circuit may be wired up on the Verobloc as shown in Fig. 7.17.

No amplifier is perfect, so the output may not be *exactly* 0V when both inputs are equal. To begin with, plug the wires from pins 2 and 3 (J18 and K17) directly into the 0V rail (strip M). Pins 1 and 5 allow for adjustment of the offset null; to carry out the nulling, you will need to connect the wire from B17 to ME1 "100μA" instead of "10V"; turn VR1 until the meter reads exactly 0V. Do not alter VR1 after this. Reconnect the wires according to Fig. 7.17.

Resistor R16 forms a potential divider with VR2, and sets the maximum possible voltage at VR2 wiper (fully clockwise) to 0.55 volts approximately.

$$\text{Max. voltage at wiper} = \frac{100k\Omega}{100k\Omega + 1M\Omega} \times 6V \approx 0.55V$$

Thus turning VR2 we obtain a range of voltages from 0V to about 0.55V. Although there may be unevenness in the track of the potentiometer, it is reasonable to assume that the subdivisions of the scale from 0 to 9 correspond to voltages 0, 0.06, 0.12, 0.18, 0.24, 0.30, 0.36, 0.42, 0.49 and 0.55V, respectively. Read the output voltage on ME1 for each setting (0 to 9) of VR1.

At each setting (except possibly the last) the output voltage is 11 times the input voltage. Gain is $\times 11$.

V_{IN} is the voltage at pin 3. Pin 2 must be brought to this voltage. When the circuit is stable the voltage at R17/R18 junction equals V_{IN} . Since R17 and R18 make a potential divider,

$$\begin{aligned} V_{OUT} &= \frac{R17 + R18}{R18} \times V_{IN} \\ &= \frac{100k\Omega + 10k\Omega}{10k\Omega} \times V_{IN} \\ &= 11 \times V_{IN} \end{aligned}$$

By choosing suitable values for R17 and R18, we can set gain to *any value* within reasonable limits. Try using different values for R17 and R18, then measure the gain obtained. Check this against the calculated value $(R17 + R18)/R18$.

Also try connecting R16/VR2 across the 0V and $-6V$ rails and reversing the connections to ME1. Then you can see that the amplifier responds equally well to negative input voltages.

Note that the gain of this circuit is determined solely by the values of R17 and R18. Variations in the performance of individual i.c.s, or variations due to temperature have no effect on gain.

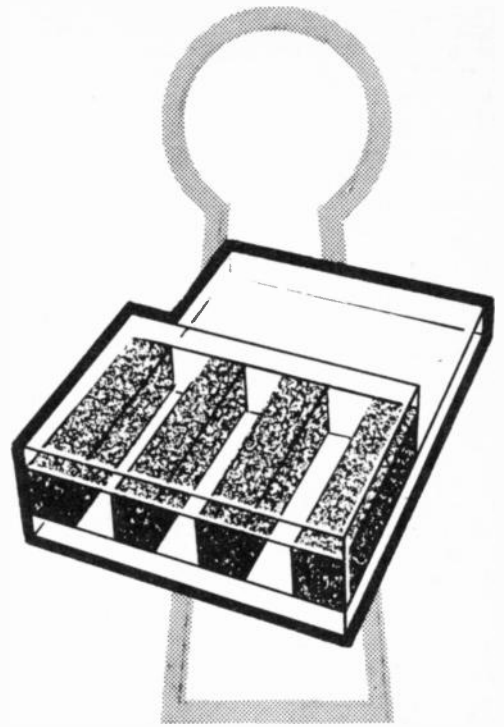
In Experiment 7.3 we joined pin 6 to pin 2 making $R17 = 0$. R18 was the value of the load (the meter) connected between pin 6 and the 0V rail. If $R17 = 0$, then gain = $R18/R18 = 1$, as found by trial.

There will be more about op-amps in Part 12.

To be continued

MAGNETIC LOCK

BY R.A. PENFOLD



The Key

to a lock that doesn't betray its presence. Virtually impossible to crack. Ideal for hidden compartments.

ELECTRONIC lock designs are by no means a rarity, and published circuits of this type are invariably for combination locks. This design is rather different in that it is opened by a key, and the key is basically just four magnets. However, in order to open the lock the magnets must be in the right position simultaneously, and they must have the correct polarity.

Without the correct key a lock of this type is practically impossible to "crack", even in the case of a very simple design such as the one described here.

The lock is mains powered, and it operates a relay which can in turn be used to operate a solenoid lock mechanism or any other item of electrical equipment. The circuit is built around four Hall Effect switches

which are semiconductor devices that respond to a magnetic field.

HALL EFFECT SWITCH

A Hall Effect sensor is basically just a thin slice of silicon fitted with two electrodes, as shown in Fig. 1(a). If a current is passed through the slice of silicon a potential gradient will be produced in the silicon. In other words there will be zero volts at the bottom of the slice, steadily rising to the full supply voltage at the top of the slice. There will be about half the supply voltage at each of the electrodes as these are both half way up the slice of silicon. This gives no voltage difference across the two electrodes, and zero output voltage.

A magnetic field has the effect of deflecting the current carriers in the silicon slice, and this is similar to a magnetic field deflecting the electron beam of a cathode ray tube. If the magnetic field is in the direction indicated in Fig. 1(b) then this deflection results in a distortion of the potential

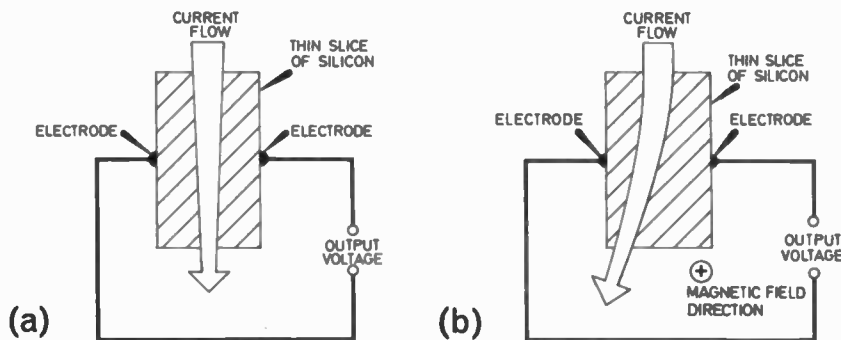


Fig. 1. Illustrates the basic principle of the Hall Effect sensor (a) in the absence of any magnetic field, output voltage is zero (b) with a magnetic field present (Into the page), the current flow is distorted providing a voltage difference between the slice electrodes and consequently a voltage level at the output.

gradient, with a consequent rise in voltage at one electrode and a voltage reduction at the other electrode.

If the magnetic field is reversed there will be an opposite distortion of the potential gradient, giving an identical change in voltage at the electrodes, but of the opposite polarity.

Thus a magnetic field gives an output voltage from the sensor, and the polarity of the output voltage is dependent on the polarity of the magnetic field. The output voltage is also proportional to the strength of the magnetic field incidentally.

A Hall Effect sensor will only respond to a magnetic field in the direction shown in Fig. 1(b), or a field in the opposite direction. A magnetic field at right angles to this direction will give no output voltage at all.

HALL EFFECT DEVICES

The Hall Effect devices used in this design are all TL170C Hall Effect switches, and the block diagram of Fig. 2 shows in simplified form the arrangement used in the TL170C (which is an integrated circuit and not just a simple Hall Effect sensor).

The output of a Hall Effect sensor is applied to a differential amplifier and provided a suitable magnetic field is applied to the sensor the output of the amplifier will go full positive (high, or logic 1) or fully negative (low, or logic 0), depending on the polarity of the magnetic field.

The output of the differential amplifier is fed to the input of a flip-flop which in turn feeds the base terminal of a common emitter switching transistor. At switch-on the output of the flip-flop goes low and the transistor is switched off.

MAGNETIC FIELD

If a magnetic field of suitable strength and polarity is applied to the device the output of the differential amplifier will go high and "set" the flip-flop so that its output goes high and switches on the output transistor.

With the magnetic field removed the output of the differential amplifier returns to its quiescent level of about half the supply voltage, and the state of the flip-flop and output transistor remain unchanged. A magnetic field of adequate strength and opposite polarity to the original one sends the output of the differential amplifier low, and this "resets" the flip-flop and switches off the output transistor. Removing the magnetic field results in the output of the differential amplifier returning to its quiescent level of half the supply voltage, and there is no change in the state of the flip-flop or output transistor.

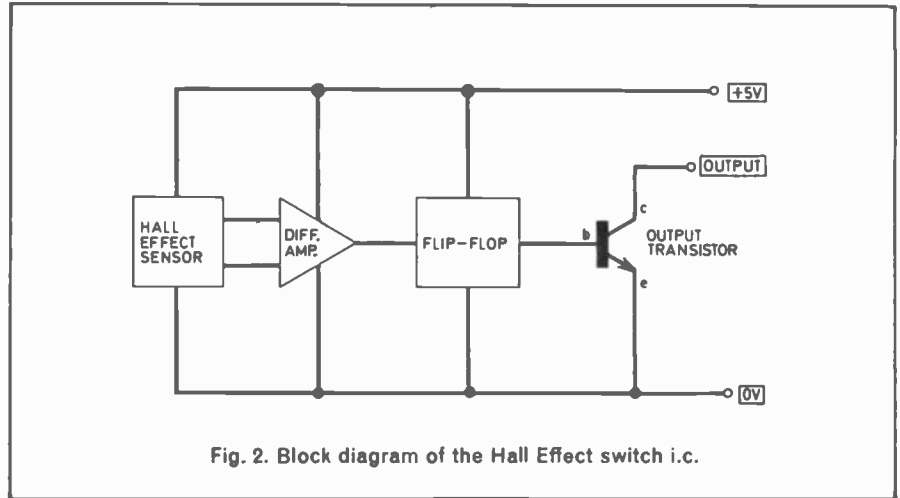


Fig. 2. Block diagram of the Hall Effect switch i.c.

SWITCHING BY MAGNETIC FIELD

The device can therefore be switched from one state to the other by applying a magnetic field of suitable strength and polarity. In practice this means that applying one pole of a reasonably powerful magnet to one side of the device causes the output transistor to be switched on and to latch in the on state. Applying the other pole of the magnet to the same face of the device causes the output transistor to switch off and latch in the off state.

The device can be switched on and off in the same way if the magnet is applied to the opposite face of the device, but the poles of the magnet will have the opposite effect if this is done. In other words, if the device was previously switched on by a south pole and off by a north pole, applying

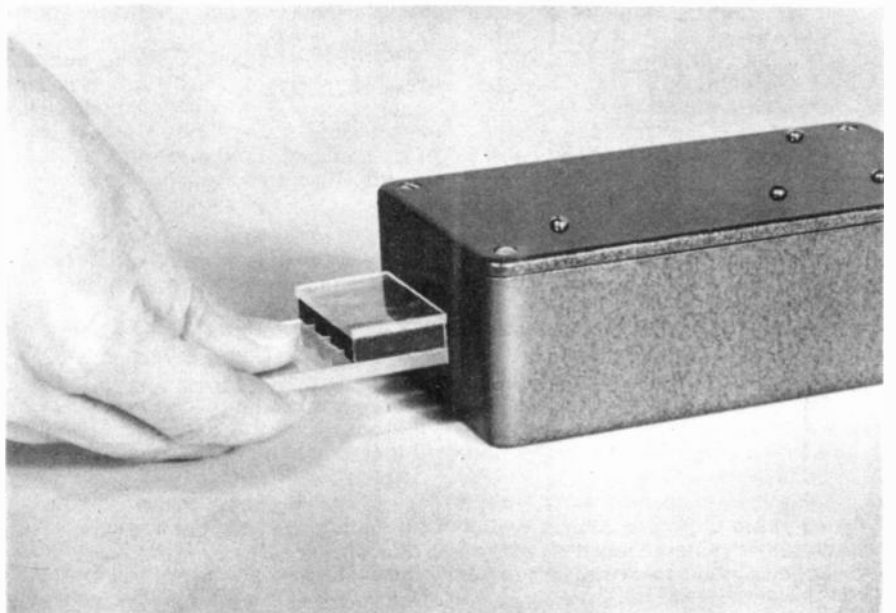
the magnet to the opposite face of the device will result in south pole switching it off and a north pole switching it on.

The TL170C is designed to operate from a 5 volt supply, and has an absolute maximum supply voltage rating of 7 volts. However, the output transistor can withstand a collector voltage of up to 30 volts and can handle collector currents of up to 20 milliamps.

THE CIRCUIT

Refer to Fig. 3 for the complete circuit diagram of the Magnetic Lock.

The four Hall Effect switches are IC1 to IC4, and these each have a discrete load resistor for the output transistor. The load resistors are R1 to R4. The output of each Hall Effect switch feeds the base of TR1, and a simple OR gate is formed in this part of the circuit by diodes D1 to D4.



The finished prototype being tested before installation and fitting of the terminal blocks.

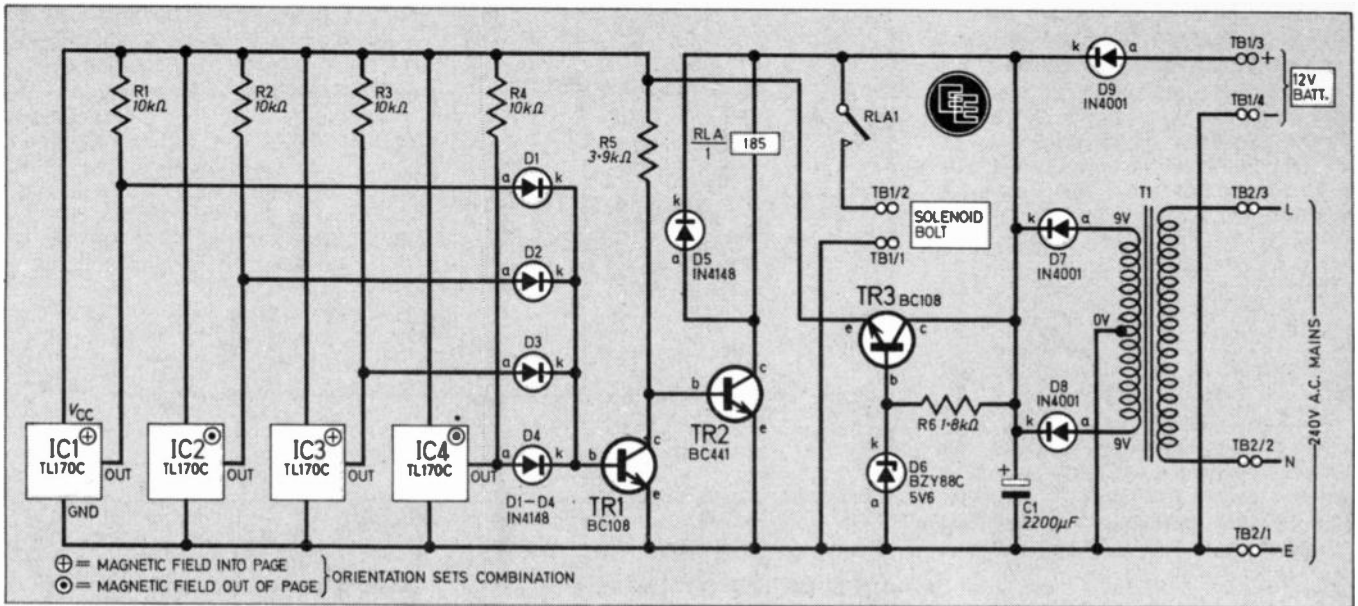


Fig. 3. The complete circuit diagram of the Magnetic Lock. The unit is mains powered but has battery back-up.

If one of the four outputs goes high it will feed a base current to TR1 via one of the gate diodes, and TR1 will be biased hard into conduction. If one of the outputs goes low it will not be able to cut off TR1 since one of the diodes will prevent it from tapping off any of the base current of TR1.

Thus, if any of the outputs are high TR1 will be switched on, and all four must be low in order to switch off TR1.

TR2 is the relay driver transistor, and with TR1 switched off TR2 is biased into conduction by R5 and the relay RLA is activated. If TR1 is switched on, TR2 becomes cut off and the relay is de-energised.

At switch-on the Hall Effect switches all assume the off state and their outputs all go high, switching TR1 on, and TR2 and the relay off. It is essential that the relay should not be activated at switch-on, as otherwise a brief power failure would be sufficient to make the lock open!

MAGNETIC KEY

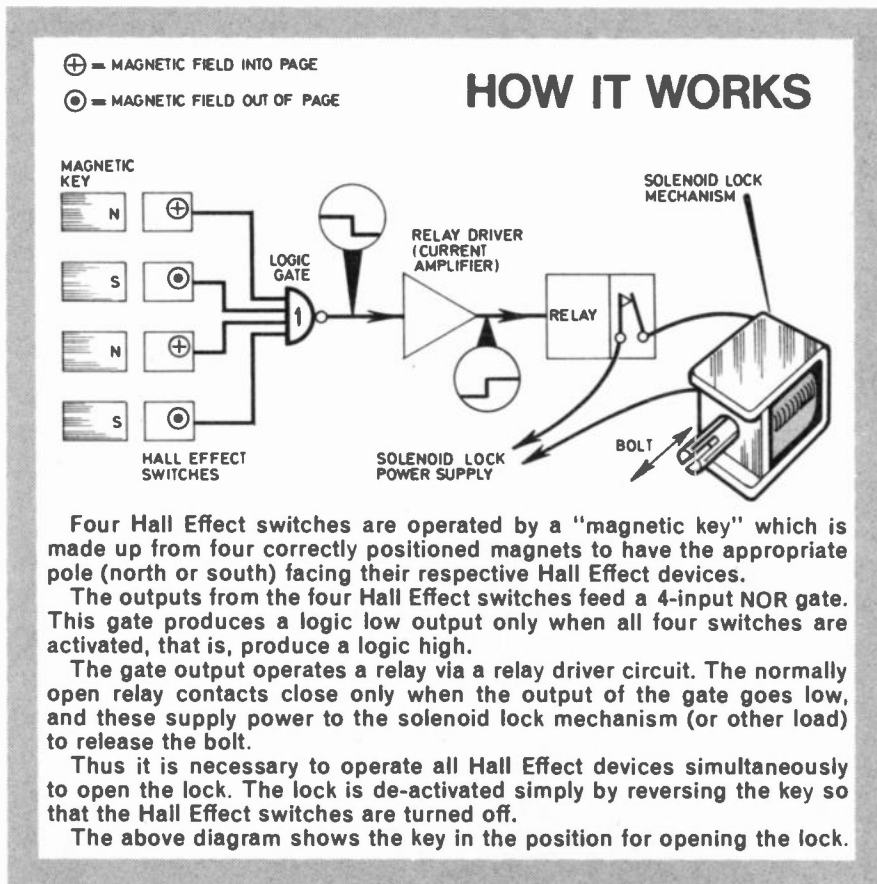
If the magnetic key is used to switch on all four Hall Effect switches the four outputs all go low. TR1 switches off, TR2 switches on, and the relay is operated. Reversing the key switches the Hall Effect devices off again, and the circuit reverts to its original state with the relay switched off.

The key can therefore be used to open and close the lock, and in order to open the lock all four Hall Effect devices must be switched on. It is only necessary to switch off one of these devices in order to close the lock, although for maximum security all four devices should be switched off.

MAINS SUPPLY

The mains power supply uses T1, D7, D8, and C1 in a straightforward fullwave circuit which gives a well smoothed but unregulated d.c. output of about 13.5 volts under zero load. The output drops to around 10 volts when the supply is subjected to maximum load.

This unregulated supply is perfectly suitable for the relay driver circuitry, but a lower and more stable supply voltage is needed for the Hall Effect devices. This is derived from a series regulator circuit, comprising TR3, R6, and Zener diode D6.



Four Hall Effect switches are operated by a "magnetic key" which is made up from four correctly positioned magnets to have the appropriate pole (north or south) facing their respective Hall Effect devices.

The outputs from the four Hall Effect switches feed a 4-input NOR gate. This gate produces a logic low output only when all four switches are activated, that is, produce a logic high.

The gate output operates a relay via a relay driver circuit. The normally open relay contacts close only when the output of the gate goes low, and these supply power to the solenoid lock mechanism (or other load) to release the bolt.

Thus it is necessary to operate all Hall Effect devices simultaneously to open the lock. The lock is de-activated simply by reversing the key so that the Hall Effect switches are turned off.

The above diagram shows the key in the position for opening the lock.

Although D6 gives a stabilised potential of nominally 5.6 volts, there is a voltage drop of approximately 0.6 volts across the base/emitter junction of TR3, so that a nominal supply potential of 5 volts is available from the output at TR3 emitter.

BATTERY BACK-UP

A failure of the mains supply would of course immobilise the magnetic lock. To guard against such an eventuality a battery back-up has been incorporated in this design.

A 12 volt battery can be connected to the unit via connector block TB1/3, 4. The diode D9 will isolate the battery so long as the mains power supply circuit is delivering a voltage of 12V or more to the h.t. line. Should this potential fall, D9 will conduct thus bringing the external battery into circuit.



CIRCUIT BOARD

With the only exception of the mains transformer T1, the components are all assembled on a 0.1in pitch stripboard. This has 21 copper strips by 36 holes. The component layout is shown in Fig. 4. Construction of the component panel is quite straightforward, and there are only three breaks in the copper strips.

RELAY

If the relay is a modern miniature type having a plastic casing it can be glued to the board, and two pieces of single strand tinned copper wire can be soldered in place so that they help to hold the relay in position. The relay coil is then wired to the board using a couple of short insulated leads.

With other types of relay it might be necessary to devise some other method of mounting, but any reasonably modern relay should be small enough to fit into the available space on the board (although the board can obviously be made larger if necessary).

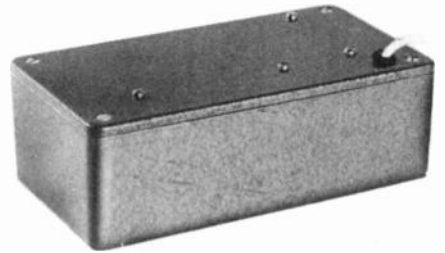
Make sure that the relay has contacts of adequate voltage and current rating for whatever load they will control, and also ensure that the relay is a six or 12 volt type having a coil resistance of no less than 185 ohms.

Plan view of the lid containing the assembly. Note that the battery back-up diode has not yet been fitted, and wiring to the terminal blocks is yet to be completed. Also, the relay flying leads are still to be attached.

HOUSING THE UNIT

Mechanically the construction of the unit must be varied to suit the exact application of the lock and the conditions under which it will operate. The case housing the electronics should obviously be a strong metal type and should be installed in such a way that there is no easy way for an unauthorised person to gain access to the circuitry. A diecast aluminium box is probably the best choice.

The key will operate the Hall Effect devices at a maximum range of about 5 or 6mm, and, like most substances, aluminium does not significantly hinder a magnetic force.



The completed unit housed in a robust metal case.

With the component panel mounted so that the Hall Effect devices are next to one side panel of the case, and the leadouts of the Hall Effect devices formed to bring these components against the side of the case if necessary, the key will operate the circuit even through a very thick case provided the key is accurately positioned.

MAKING THE KEY

The key itself consists of four 25mm x 6.4mm bar magnets glued between two pieces of plastic or plywood, as can be seen in Fig. 5 and the accompanying photograph. The Hall Effect switches are orientated on

COMPONENTS

Resistors

R1	10k Ω
R2	10k Ω
R3	10k Ω
R4	10k Ω
R5	3.9k Ω
R6	1.8k Ω
All	1/3W carbon \pm 5%

See
**Shop
Talk**

page 233

Capacitor

C1	2200 μ F 16V p.c.b. elect.
----	--------------------------------

Semiconductors

IC1-4	TL170C Hall-effect switch i.c. (4 off)
TR1	BC108 silicon <i>npn</i> transistor
TR2	BC441 silicon <i>npn</i> transistor
TR3	BC108 silicon <i>npn</i> transistor
D1-5	1N4148 diode (5 off)
D6	BZY88C5V6 5.6 volt 400mW Zener diode
D7, 8, 9	1N4001 diode (3 off)

Transformer

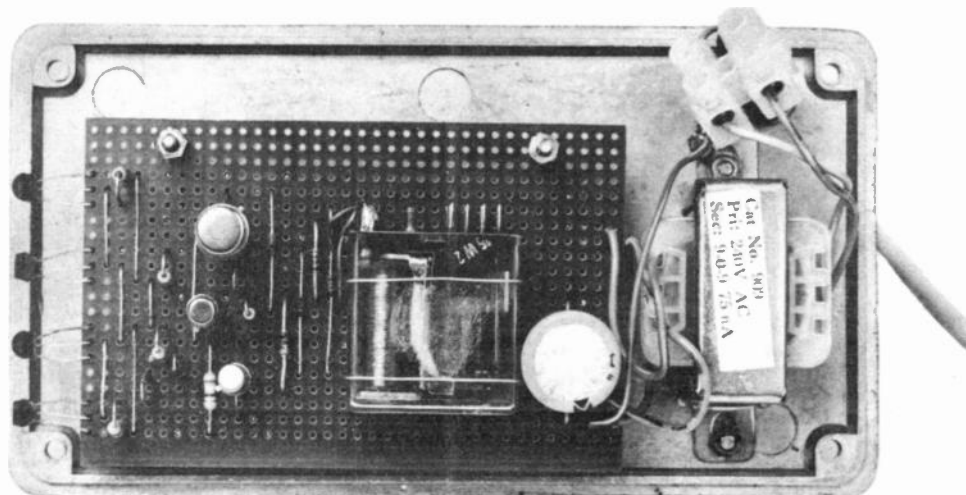
T1	Standard mains primary, 9V - 0V - 9V secondary rated at 75mA, or more
----	---

Relay

RLA	6/12 volt coil 185 ohms or more, and contacts of the required type and rating (see text).
-----	---

Miscellaneous

Case (see text). 0.1in matrix stripboard (36 holes by 21 strips). 4-way connector block (TB1). 3-way (mains) connector block (TB2). Mains lead and mains plug fitted with 3 amp fuse. Four 1in by 1/4in (25mm by 6.35mm) bar magnets (Maplin or Electrovalue) wire, solder.



MAGNETIC LOCK

COMPONENTS
approximate
cost **£14.50**

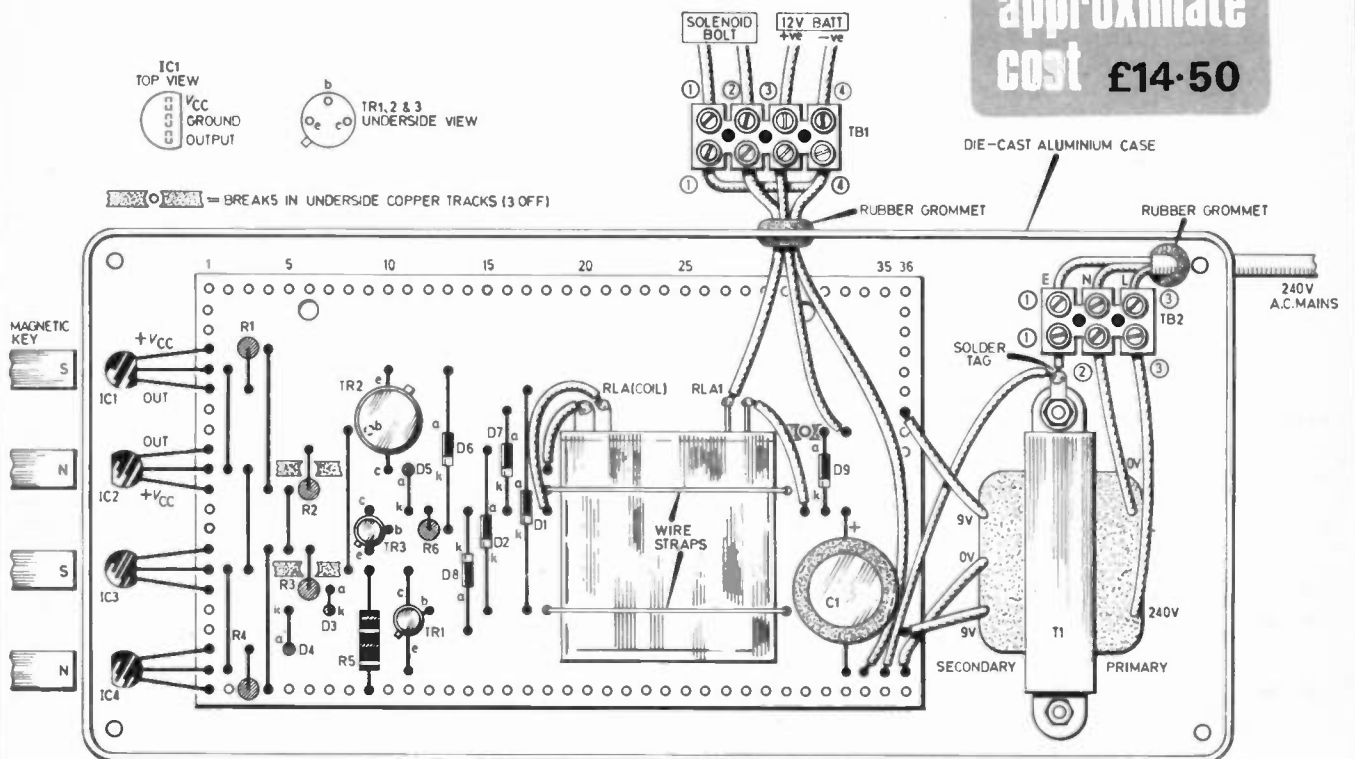
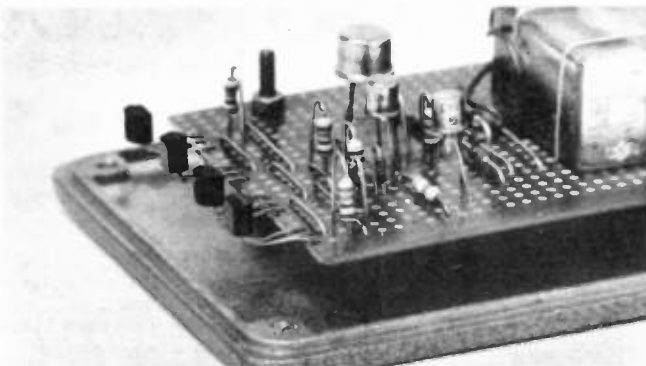
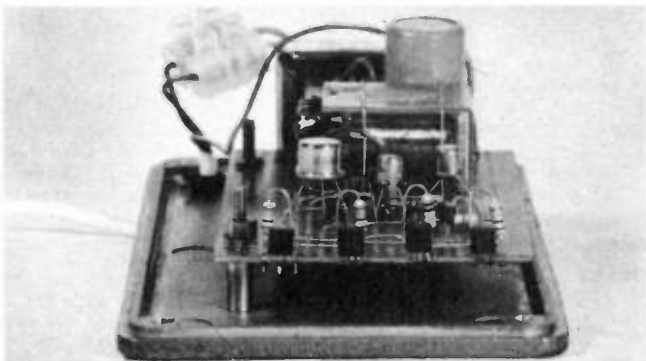


Fig. 4. The layout of the components on the topside of the stripboard and position within the diecast aluminium case. Note the orientation of the sensors to agree with the magnetic key, details below. Note that there are three breaks to be made in the strips on the underside.



Shows the orientation and position of the Hall Effect i.c.s in relation to the board and case.



Shows method of mounting the board to the case; two 10mm long plain spacers are employed.

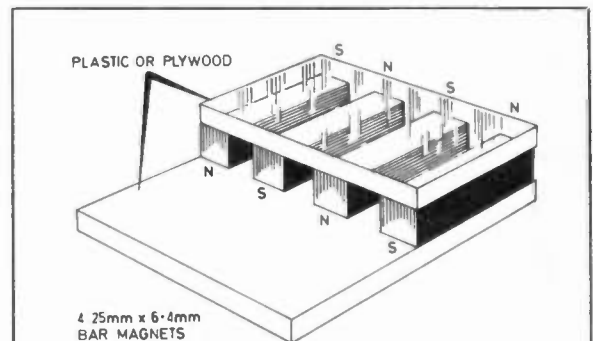
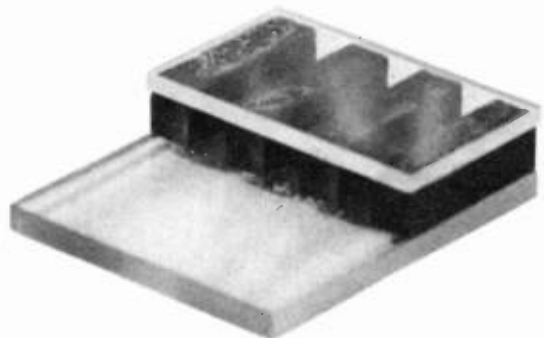


Fig. 5. Construction details for the magnetic key.



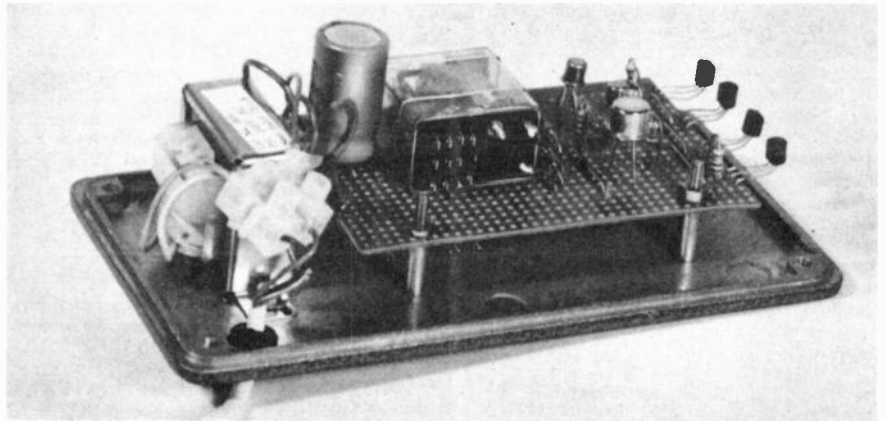
The prototype magnetic key.

the component panel in such a way that the key must present alternate north and south poles to the unit in order to operate it, and the magnets are not lined up with the same polarity.

If the magnets are lined up side by side with alternate polarities they will tend to attract one another and hold together in one lump. If two magnets next to one another have the same polarity they will not hold together and will repel one another slightly. This should eliminate any problems with getting the magnet polarities correct. Of course, the spacing of the magnets must match that of the Hall Effect switches (12.7mm between centres).

OPERATION

Applying the key to the unit at the correct point and with the correct orientation will cause the lock to open, and rotating the key through 180 degrees (end-over-end or side-ways) will close the lock. Trial and error can be used to find which orientation produces which effect.



The near completed prototype unit. Note that we have used a three-way screw terminal block in preference to the two-way block seen here.

In theory it is possible to open the lock using a single magnet if you know exactly where to apply the magnet, and what pole to apply. In practice this is practically impossible, and there is a tendency to switch off one Hall Effect device when the magnet is positioned to switch on one of the others. The only easy way of

opening and resetting the unit properly is to make up a key.

If preferred, the Hall Effect devices can be mounted off-board, and connected to the board by way of three-way insulated cables. The devices can then be positioned at any desired points on the interior of the case. □



FORMING AN ELECTRONICS CLUB

By T.R.de Vaux - Balbirnie

Some words of wisdom for any member of staff thinking of embarking upon an exciting and rewarding enterprise, which will not be without its hazards.

So you want to form an electronics club! There are things you should know because it is not going to be easy. The actual "electronics" part will probably be the least of your worries. The hardest part will almost certainly be that of finance. In these times of "tight" money, you are unlikely to obtain assistance from local authorities or school funds. Your only recourse will be self-finance and more will be said about this later.

Club aims

You will need to establish the aims of the club, even though these aims may be rather vague. Is the club to

be educational and used to supplement existing courses? Perhaps it will be organised simply to improve technical skills in circuit building. Is it to have a leaning towards audio and musical work or radio and TV? Is it going to be a "computer" club?

Most likely, it will be a club of general activities where members engage in building their own projects with you acting as adviser.

Will the club be willing to help in related fields like P.A. for sports events or stage lighting for the drama group? In return for a "home" and the use of electricity and perhaps some equipment it will probably be necessary to make yourselves useful in some such activities.

With broad aims defined, it then becomes necessary to

discuss the funding arrangements.

Funding

Although existing bodies may be unwilling to give money towards the running costs, it is possible that they will grant you a loan. Although loans have the nasty habit of having to be repaid, they can be very useful in getting the club started.

Another idea is to charge an entry fee—non-returnable in cases of "dropping out"—to be used to purchase "communal" components for the club. These jointly-owned components are invaluable for experimental work. It will be understood that where communal components are permanently built into circuits they will have to be paid for.

Even when carefully used, such components will eventually fail—wire ends break off and so on—so a steady flow of cash is needed. Whether or not to fine members who damage components through carelessness is up to you but culprits are not usually easy to find!

A repair service

Some cash may be raised by taking on basic repair work. The club (hopefully) will soon gain a reputation for speed and efficiency coupled with realistic charges. Since the public think of electronics as an extremely complicated subject, they will see any repairs as near-miracles! If you think that you would be out of your depth taking on this type of work consider the facts.

Semiconductor devices these days are extremely reliable and seldom fail. Likely causes of trouble are in mechanical components such as switches, potentiometers and plugs and sockets. An example is the earphone socket on a radio which silences the internal loudspeaker when the earphone is plugged into it. Components like this are easily and cheaply replaced. Poor quality sound from a tape recorder often indicates that the heads need thorough cleaning.

Profitable Game

It is better to avoid mains equipment for repair just in case you should become legally involved over a poor job.

A TV game was brought along a few weeks ago with a "jumpy" bat. Most dealers were unwilling to repair it and the few who would quoted high fees and a long wait. It was obvious that the potentiometer in one of the hand controls had failed. Replacement took 10 minutes and cost 40p. The customer had his game back within the week at a charge of £2.50. He was delighted to pay it. Even at today's prices £2.10 will buy quite a lot of components.

Another way to raise money is to sell finished projects—again, avoid those which are mains operated. Projects for cars are popular, as are musical circuits for special effects. You may even run a service to install them!

Component supply

You will need good suppliers of components. Unless you are lucky in having a properly geared-up dealer in your area, you will need to purchase by mail order. There are many excellent firms advertising in electronics magazines. Some supply free catalogues but often you will be asked to pay about £1. This may seem expensive at first but the possible savings will soon pay for the catalogues.

It will be necessary to shop around to some extent as prices can vary quite a lot. Remember, however, that it is foolish to save a few pence here and there on components only to be faced with extra charges for packing and postage. You must also keep an eye on V.A.T. when comparing prices and remember that V.A.T. is payable on the postage and packing charges also. It sometimes happens that a "nice

letter" from a bona-fide club will bring a free catalogue. Look for the larger advertisements in magazines—these can be almost a catalogue in themselves.

Club Buyer

It is a good idea to appoint one member of the club to be in charge of purchasing and keeping an up-to-date "shortages list". He or she can work out the best time to place an order and how to do it in the cheapest way.

Although you should always look for special offers and "bargain packs" which often give excellent value, it is not always a good idea to buy untested components. These can waste a lot of time even though the price may seem very attractive.

When members use up communal components by building them into permanent projects, they should enter the item on the shortages list if the stock is run down. They should then pay for the components. Members will be expected to pay a realistic price for components bearing in mind the convenience of the method. This price may be set in an "internal catalogue" at, perhaps, 25 per cent above cost. The profit will restock communal components and go towards the cost of basic equipment.

Storage

Good storage arrangements for electronic components are essential. Nothing is worse than boxes of assorted components. To begin with, egg boxes, margarine tubs and yoghurt containers may be used, but a more permanent system must be planned. Sets of interlocking plastic drawers are inexpensive and may be added to as the need arises. Large wooden drawers may be divided into compartments using hardboard. In this way, each value of resistor may have its own place. A "Dymo" labelling machine will be found very useful.

Salvage

Let it be known that you are collecting—sometimes junk can furnish some good components. Unfortunately, some junk is totally useless. It is impossible to specify just what is acceptable and what is not so you will need to accept graciously anything which comes along and make the occasional discreet trip to the local authority refuse dump,

Local electronics industry sometimes helps bona-fide organisations. They will give away their own throw-outs providing you do not sell them. Circuit panels replaced under guarantee can provide a wealth of useful components. It is worth enquiring at your local radio and TV repair shop. Sometimes they will provide you with junk.

Literature

Magazines are an essential source of ideas. You should subscribe to at least one of them. Enquire about the Everyday Electronics group subscription scheme. This enables educational establishments to obtain copies of the magazine at a special discount rate. As well as current issues, you should collect old magazines. These provide ideas and it often happens that old circuits are easily updated. Someone may be placed in charge of keeping a catalogue of useful articles for future reference.

Equipment and Tools

You will need some basic equipment but, perhaps, some of it can be borrowed. A few soldering irons and multimeters will certainly be required. An oscilloscope is sometimes useful but is not essential. Certain basic tools like pliers, side cutters, wire strippers, tin snips, screwdrivers and files will be needed.

Power supplies

Rather than using mains operated power supply units, batteries will be found more convenient. Many circuits use 9 volt supplies and the

physically larger batteries will be found cheaper in the long run than the smaller ones so use PP9s rather than PP3s. An alternative is to tape together two 4.5 volt "bell" batteries connected in series—these provide an excellent power supply capable of delivering fairly high currents. An excellent life may be expected in normal service.

For car circuits, access to a 12 volt battery will be needed for testing. Sometimes you can make do with three off 4.5 volt batteries in series but where high currents are required a car battery or some "Ni-Fe" cells will be needed. When using batteries like these it is essential to provide a line fuse since an accidental short circuit could allow an enormous current to flow.

Materials

Although much experimental work will be carried out on prototype boards like "S-Decks", plenty of stripboard or Veroboard will be needed for permanent work. Veroboard with a pitch of 0.1 in will be found very convenient. Materials for making printed circuits will be found useful at times.

You will need a ready supply of single core connecting wire as well as the stranded variety. A small stock of sheet aluminium will also be found useful.

Make up plenty of lengths of stranded wire with combinations of crocodile clips, plugs and bare ends. These are invaluable.

Good luck with the club, but beware! It is likely to take you over!



**Everyday
ELECTRONICS**

The MAY issue brings an Extra
8-PAGE SUPPLEMENT

A Constructors Guide to discrete and
integrated devices

COMPREHENSIVE PUBLIC ADDRESS SYSTEM 50 WATTS OF POWER

SEVEN INPUTS—Mic (4); Disc; Tape; Auxiliary—FULL MIXING OF ALL INPUTS—VU METER—8 OHM and
166 (line) OUTPUTS—OPERATES FROM EITHER MAINS OR 12V CAR BATTERY—TWO UNIT
CONSTRUCTION.



TWO-TONE TRAIN HORN

Another realistic effect for the model
railway enthusiast.
Simulates the sound made by the horn of
a diesel or electric train.



L.E.D CAR VOLTMETER

Monitors state of car electrics system
under all conditions, by indicating battery
voltage in 0.5V steps.

MAY 1982 ISSUE
ON SALE
FRIDAY, APRIL 16



BIG-NINE INDICATOR

An extended form of dice, with 0 to 9
randomly indicated on 7-segment display.

INTRODUCTION TO LOGIC

PART BY J. CROWTHER

FLIP-FLOPS

There are four main types of flip-flop (bistable multivibrator) used in practise. They are:

- (1) The R.S. or S.R. (set/reset)
- (2) The R.S.T. (set/reset/trigger)
- (3) The J.K. flip-flop (this is the true storage unit)
- (4) The D-type flip-flop (data)

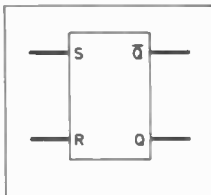


Fig. 12.1. Circuit symbol for an R.S. flip-flop.

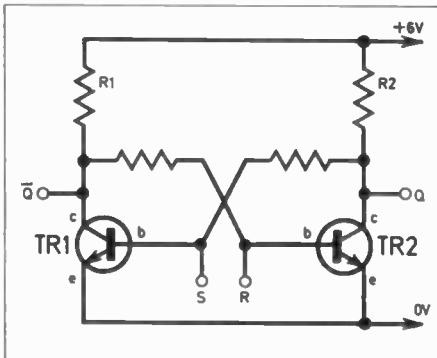


Fig. 12.2. Basic circuit of an R.S. flip-flop.

(1) The Set/Reset flip-flop

The circuit symbol and basic circuit of an R.S. flip-flop are shown in Figs. 12.1 and 12.2 respectively.

On switching on, one transistor will start to conduct fractionally before the other, and in this case suppose we assume TR2 conducts first. This will cause a voltage drop across R2 and the output at Q will start to fall making the base of TR1 more negative thus reducing the current through TR1. The effect of this is to reduce the voltage drop across R1, making the output at Q rise and consequently turning TR2 on even more giving a larger voltage drop across R2. The Q output will drop still further and this sequence continues until TR2 is conducting fully and TR1 is cut off resulting the output at Q falling to nearly zero (logic 0) and output Q rising to 6V (logic 1). This all happens almost instantaneously.

The transistors will stay in this state until a positive pulse is applied to the base of the "off" transistor, input S for TR1, switching it on. This will cause the voltage across R1 to drop so that output Q falls to zero and the base voltage of TR2 also falls switching it off. This means there will be no volts drop across R2, causing the output at Q to rise to 6V.

Once again the transistors will stay in this state until a positive pulse is applied to the base of TR2 at input R, switching the flip-flop back to the original state.

To summarise, a positive pulse at input R resets the Q output to logic zero and a positive pulse at input S sets the Q output to logic one. The first pulse will change the output state, the next pulse will change it back to its initial state, and so on.

(2) The R.S.T. flip-flop

The R.S.T. flip-flop is a development of the R.S. type, requiring only one input terminal to change the output state of the flip-flop, see Fig. 12.3.

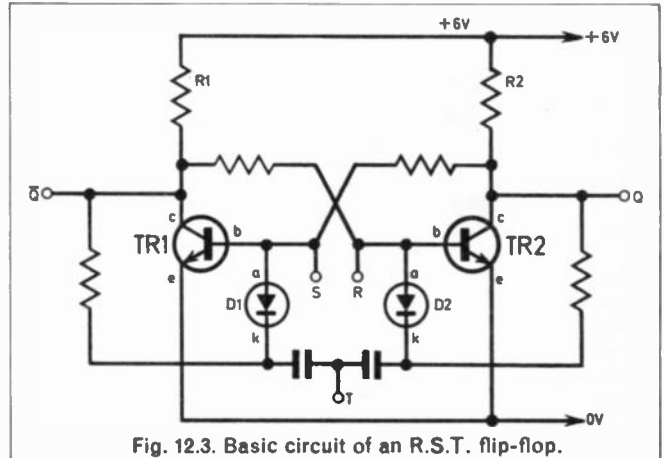


Fig. 12.3. Basic circuit of an R.S.T. flip-flop.

On switching on, suppose that TR2 is conducting and TR1 is cut off, so output Q will be at logic 0 (approximately 0.25V) and Q-bar at logic 1 (say 5V). Since TR2 is conducting its base will be 0.6V and TR1 base will be at 0V as it is turned off so the potentials on diodes D1 and D2 will be as in Fig. 12.4.

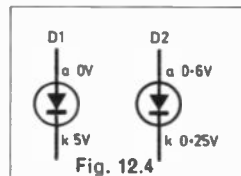


Fig. 12.4

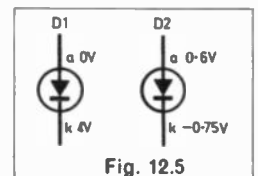


Fig. 12.5

For a diode to conduct, the anode (a) must be 0.6V positive with respect to the cathode (k), so here both diodes are reverse biased and will not be conducting and the two transistors will remain in the same state, that is TR2 on and TR1 off.

If a negative pulse of 1V is now applied to the T input, the cathode potentials of these two diodes would change, see Fig. 12.5.

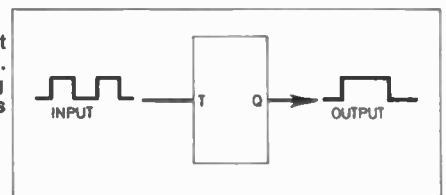
Diode D2 is now forward biased and will conduct, and so reduce the base potential of TR2 to below 0.6V, switching it off. Consequently, there will be no volts drop across R2 and output Q will rise to logic 1, TR1 will be turned fully-on causing output Q-bar to fall to logic 0.

The flip-flop will stay in this state until it receives another pulse at input T, upon which it will switch back to the original state, each pulse arriving at T being steered to the on transistor to switch it off by the diode steering circuit.

Since the pulses are fed to the diodes via capacitors, only a change in voltage level (from high to low) will trigger the flip-flop, so the R.S.T. is triggered by the falling edge of input pulse and not by a logic level as in the case of the R.S. type.

For this reason the R.S.T. flip-flop requires two input pulses to give one output pulse as shown in Fig. 12.6, and this circuit can therefore be used to divide a frequency by two. Cascading

Fig. 12.6. Circuit symbol for R.S.T. flip-flop showing operation. It acts as divider ($\div 2$).



two R.S.T. flip-flops in series so that the output of the first triggers the second would divide by four, three would divide by eight and so on.

The R and the S inputs are retained in this circuit, and a logic level on either of these will override the T input.

Differences between R.S. and R.S.T. circuits:—

- (a) Two inputs for the R.S., and only one for the R.S.T.
- (b) A voltage level triggers the R.S. but a change in voltage level triggers the R.S.T.
- (c) A stream of pulses to a single input of the R.S. (either the R or S) will give no change of state after the first pulse. but a stream of pulses to the T input of the R.S.T. causes the output to change back and forth.

(3) The J.K. flip-flop

The J.K. flip-flop is similar to the R.S.T. (see Fig. 12.7) the difference being that the cathodes of diodes D1 and D2 are connected to the J and K inputs instead of the Q and \bar{Q} outputs. The inputs applied to the J and K terminals must be complementary, that is if J is at logic 1 then K must be at logic 0, and vice-versa.

Suppose that TR2 is conducting and TR1 is cut-off at switch on, then output Q will be at logic 0. Now if a logic 1 is applied to the J input and a logic 0 to the K input, this would have no effect as the diodes are reverse biased. If a negative pulse of 1V is now applied to terminal T, D2 will be forward biased and therefore conduct and switch TR2 off, resulting in no volts drop across R2 and the Q output will be high (logic 1), TR1 turning on to give a logic 0 at \bar{Q} .

If a second pulse arrives at T with J and K still at 1 and 0 respectively, it will have no effect as it would be steered to the off transistor, therefore a trigger pulse at T will only change the

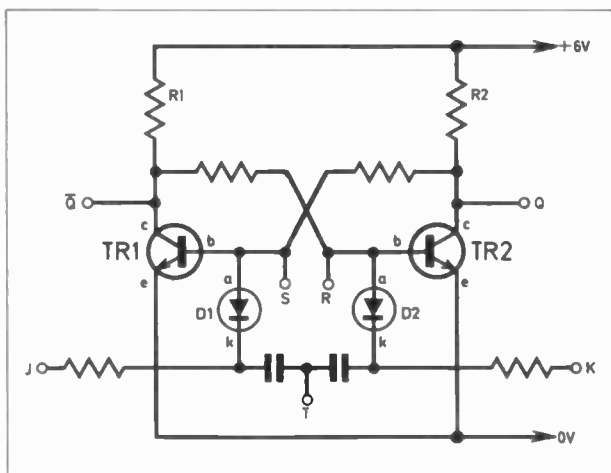


Fig. 12.7. The basic circuit diagram of a J.K. flip-flop.

state of the flip-flop if the logic levels of the J and K inputs are reversed.

A trigger pulse at T will only change the state if the logic levels at J and K are different, so a logic 1 or 0 can be stored at the J terminal until a trigger pulse arrives at T, when the stored level will be released at output Q.

(4) The D-type flip-flop

The D-type flip-flop is a modified version of the J.K. flip-flop, the J and K inputs being replaced by a single D (data) input, the complementary input to the K terminal being achieved by inverting the D input with a NOT gate whereas the D input if fed directly to the J terminal as shown in Fig. 12.8.

MAKING FLIP FLOPS WITH LOGIC GATES

(1) The R.S. flip-flop

An R.S. flip-flop can be constructed using two NAND gates, and suppose that on switching on, the Q output is at 0 and the \bar{Q} output is at 1 as shown. If both the R and the S inputs are at logic 1, there will be two 1's on the inputs of gate 2 holding its output at 0, and a 1 and 0 on the inputs of gate 1 giving a 1 on the output.

If the S input terminal is changed to a 0, there will now be a 1 and 0 on the inputs of gate 2 resulting in a 1 at the output and this consequently puts two 1's onto the inputs of gate 1 changing its output to a 0.

Changing the S input back to a 1, resulting in a 1 and 0 on the inputs of gate 2 giving a 1 at the output and with the two 1's still on gate 1 inputs, its output remains at 0, therefore the state of the flip-flop has not changed.

To change the flip-flop back to its original state, a logic 0 must be applied to the R input. Therefore a logic 0 on the S input sets the Q output to logic 1, and a logic 0 on the R input resets the Q output back to 0.

Note that the transistor R.S. flip-flop requires logic 1's on the inputs to change its state, whereas the NAND gate version requires logic 0's, so the terminals are marked \bar{R} and \bar{S} instead of R and S, the bar over the letter indicating that a logic 0 changes the state of the flip-flop.

(2) The J.K. flip-flop

If a logic 1 is applied to the J input and the K and T inputs are at logic 0, then the outputs of gates 3 and 4 will be at logic 1. Now the outputs of gates 3 and 4 are connected to the \bar{R} and S inputs of an R.S. flip-flop consisting of gates 1 and 2 with the Q output at 0 and the \bar{Q} output at 1. If the T input is pulsed with a logic 1, the output of gate 4 would go low as it now has two 1's on the inputs, and this will change the state of the outputs of the flip-flop (Q will go to 1 and \bar{Q} will go to 0). A further pulse on the T input would return the S terminal to 0 but this will have no effect on the output states of the flip-flop as a logic 0 is required on the R input to change it back to its original state. A pulse on the T input will only change the output state if the logic states of the J and K inputs are reversed.

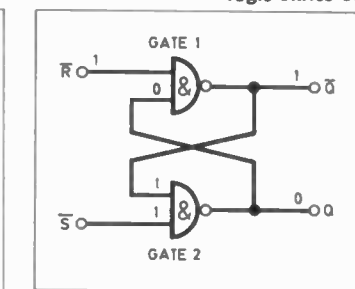
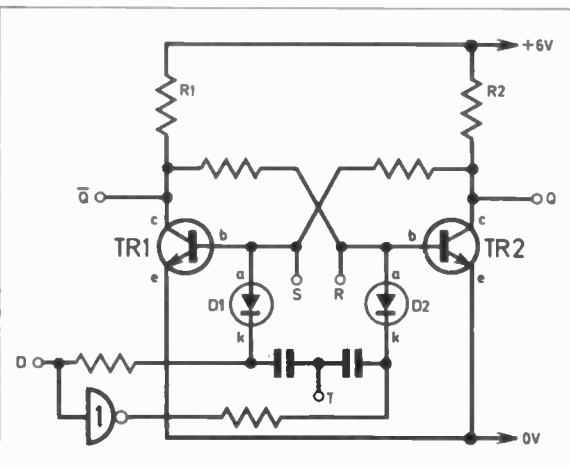


Fig. 12.9. Making an R.S. flip-flop from NAND gates.

Fig. 12.8. The basic circuit of a D-type flip-flop. Compare with Fig. 12.6.

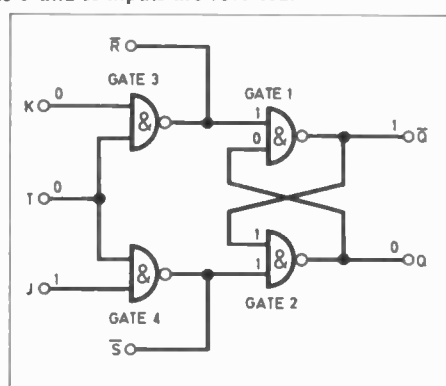


Fig. 12.10. Making a J.K. flip-flop from four NAND gates.

THE END

Everyday News

MARCHESA SPEAKS TO THE QUEEN

The Marchesa Maria Cristina Marconi and Princess Elettra Giovanelli, widow and daughter of Guglielmo Marconi, inaugurated the Inmarsat marine communications satellite system in London

WITH the inauguration of the INMARSAT marine communication satellite system in London recently, there unfolded another chapter in the fascinating story of maritime communications—a story which is really only 100 years old, for it was only in 1896 that Guglielmo Marconi managed to establish telegraphic contact between two points some 30 miles apart, so enabling ships at sea to be out of sight of, and yet to be in contact with the land as well as each other.

Elected Lord Rector of St Andrews University shortly before his death in 1937, Marconi entitled his inaugural speech, "The Path of the Inventor". In it he stressed his original intention, as the first developer of radio, to have been to "make the seas safer for seafarers by giving ships a means of communication". This too, is a declared aim of the INMARSAT organisation and it was fitting that the Marchesa Maria Cristina Marconi, his widow, was the guest of honour at the inauguration.

To inaugurate the INMARSAT system, the Marchesa Marconi spoke by satellite to the master of the liner *Queen Elizabeth 2*, Captain Peter Jackson. The ship was at that time in the South Atlantic, south east of Rio de Janeiro, headed for Cape Town on its world cruise, and the call went via the Southbury coast earth station in the USA.



To inaugurate the INMARSAT system, the Marchesa Marconi spoke by satellite to the master of the liner *Queen Elizabeth 2*, Captain Peter Jackson. The ship was at that time in the South Atlantic, south-east of Rio de Janeiro, headed for Cape Town on its world cruise, and the call went via Southbury coast earth station in the USA. Calls were also made to two other ships—one in the Indian Ocean Region and one in the Pacific Ocean Region. In the first case, INMARSAT's Director General, Mr Olof Lundberg, spoke to the general cargo vessel *Wakanami Maru*, the call going via Yamaguchi, Japan. He then called the tanker *Robert Miller* off southern Victoria, Australia, via the new Ibaraki coast earth station in Japan. (Everyday Electronics exclusive photo).

TO: All INMARSAT ship earth stations

TO: All INMARSAT ship earth stations

From: The Marchesa Maria Christina Marconi

Subject: Welcome to INMARSAT

The global maritime satellite system that your vessel is equipped to use is now being run by INMARSAT - the International Maritime Satellite Organization. It gives me great pleasure, 80 years after my late husband pioneered maritime radio communications, to be able to officially inaugurate this new era with a broadcast message to all ships by satellite.

Just as the invention of radio enabled communication for the first time between a ship at sea and land, so satellite communications permit a ship on the high seas to be connected to the worldwide automatic telecommunications networks, allowing rapid communication with virtually anyone in the world having a telephone or telex machine. This will provide the mariner closer contact with his kinfolk and friends on shore, and it will provide the master with the speedy communication necessary for the efficient management of a modern ship.

This reliable form of communication will also ensure that ships can rapidly summon assistance in the event of difficulty, and will lead to improved safety of life and property at sea.

May you find the INMARSAT service an increasingly useful one.

Maria Cristina Marconi

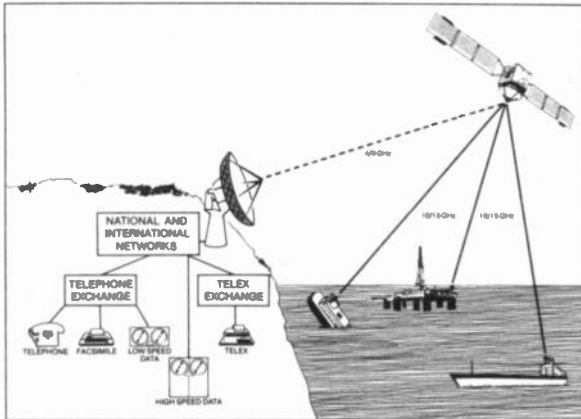
Milestones

While on the subject of maritime communications, it is perhaps appropriate to reflect on a few milestones: In 1899, the American liner *St Paul* is believed to have been the first vessel to have "a floating wireless station aboard". In November of 1899, she received a wireless message from the Marconi station on the Isle of Wight.

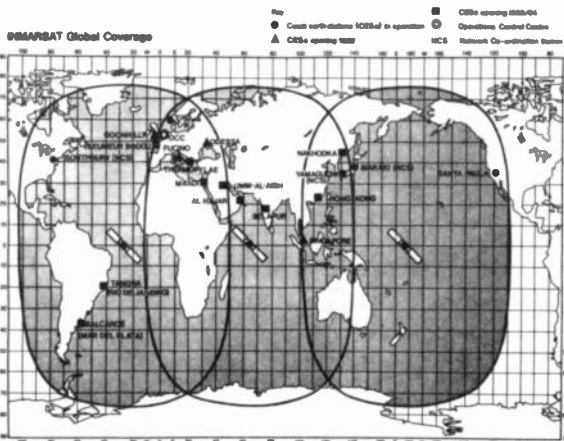
In 1906, the radio telegraph distress signal SOS, a rhythmic three dots, three dashes, three dots in Morse code, was adopted at a Berlin conference as the international call for help at sea. Some persons interpret SOS as meaning Save Our Ship or Save Our Souls but the letters actually have no intrinsic meaning.



INMARSAT System



Outline of the maritime satellite communications system.



Global coverage of the seas by the Inmarsat satellite system.

Sunday, April 14 in the year 1912 saw the tragedy of the sinking of the luxury liner *Titanic* with the loss of 1503 lives, including her wireless operator, Mr. J. G. Phillips, whose SOS was heard first by the radio officer on the ship *California* at 11.20p.m. The *Titanic* tragedy inspired regulations requiring increased transmitting power and 24-hour manning of radio rooms for passenger-carrying ships.

In 1922, the first ship-to-shore two-way voice communications took place between a station at Deal Beach, New Jersey and the *SS America*, 400 miles at sea.

The word *MAYDAY* was adopted in 1927 as the international distress call for

maritime radio telephone. "Mayday" originated in *M'aidez*, which is the French for "Help me".

In 1929, high seas radio telephone services became available to the public and technology developed fairly fast from then on. It was 1965 that saw the first commercial communications satellite, *Early Bird*.

The year 1976 saw the launch of the *Marisat* satellites over the Atlantic, Pacific and Indian Oceans. *INMARSAT* (which is where we came in) came into being on July 16 1979. February 1, 1982 saw *Inmarsat* leasing the commercial capacity on all three existing *Marisat* satellites as part of its initial space segment.

END FOR THE VALVE

The end of an era has come with the production of the last domestic receiving valve by Mullard.

The Mullard name has been synonymous with receiving valves for over 60 years. More than 1,000 million have been produced by the company's Blackburn plant during the last 40-odd years.

It is estimated that it has taken over 80,000 man-years to develop and manufacture the billion or more valves, and that in total they have consumed some two million miles of wire, 25,000 tons of glass and 20,000 million metal parts.

UK TOP SPOT

A survey of the investment intentions of 500 electronics companies in the USA revealed the UK as the favourite location for setting up overseas operations between now and 1985. West Germany came second and Ireland third.

The criteria included availability of skilled labour, transport, good communica-

tions and labour relations as well as financial incentives, the latter ranking only third in importance. But, warns the poll, the UK position only holds if the UK keeps in the EEC.

SAFT (UK) Ltd is spending £0.5 million on a new plant at Hampton, Middlesex, for making lithium oxide cells and batteries.

ANALYSIS

ENERGY UPDATE

The energy crisis of recent years has been overshadowed by more pressing anxieties of world trade recession and unemployment. There is even a glut of oil today but the long-term problems of energy supply have not gone away and possible solutions are still being vigorously pursued.

We are now reconciled to higher costs of energy although in fact all energy sources are fundamentally free. In a single week more energy falls on the earth from the sun than is contained in all our fossil fuels deposits built up through the ages. What costs money is its collection and conversion to useable form.

Direct conversion of solar energy into electricity is as yet uneconomic in favourable climates such as California, even more so in the UK where the present alternative energy favourites are harnessing of tidal power in the Severn Estuary, wave power on the Atlantic seaboard, and wind power at a number of proposed sites.

In terms of end-cost to the consumer, efficiency and continuity of supply, wave power could be the "best buy" according to laboratory tests and analysis backed up by small-scale sea trials. But the marine engineering problems are formidable and the final cost of getting electricity ashore on the most optimistic estimates is still much greater than that from land-based oil or coal-fired turbine generators.

Windmills are easier to erect and experimental systems are being built on Orkney and in Carmarthen Bay, initially with some 200kW power to be followed by 3MW units. But even a very large windmill only generates about one thousandth of the power of a conventional power station.

The immediate practical approach is conservation. Here micro-electronics plays a major role in "fine-tuning" of air conditioning systems. New levels of efficiency are being achieved in other areas such as lighting where the 16W 2D lamp from Thorn gives a light output comparable with a standard 100W incandescent bulb.

While the scientists, engineers and technologists are busy on the problem of future energy sources we can all help to conserve existing supplies. Waste not, want not, is an old saying but still a wise one.

Brian G. Peck

RADIO WORLD

By Pat Hawker, G3VA

Empire Broadcasting

Several years ago I wrote a short note under the heading "50 years of Empire broadcasting". How come? you may wonder, since it was not until this year that the BBC began holding a series of events in London to commemorate "the fiftieth anniversary of broadcasting to the world" marking the official start of the old "Empire Service" from Daventry in 1931, and inspiring *The Times* to pen a gushing piece on "A service on which the sun still never sets" in praise of Bush House's External Services.

In truth, these were services on which the sun very nearly never rose. For several years the BBC, and in particular its first renowned director-general, Sir John (later Lord) Reith, was firmly opposed to h.f. broadcasting which had been pioneered in the USA in the mid-twenties by Frank Conrad at Pittsburgh under the experimental call sign W8XK (later KDKA).

In fact it was not the BBC but a well-known British amateur radio operator, Gerald Marcuse, G2NM, who launched the first regular service aimed at listeners in all parts of the British Empire. This was in September 1927, some months before the BBC tentatively started experiments

Amateur Satellites

The Russians certainly have a sense of showmanship. Recently they launched their second series of amateur radio space satellites, satellites that pick up amateur 144MHz transmissions and send them back again to amateurs listening on 29MHz, so permitting long distances to be covered on VHF.

This time, instead of the expected one or two spacecraft they sent up no less than six: RS3 through to RS8 as company for the still working *Oscar 8* and *UoSat* (UK *Oscar 9*) Britain's first satellite for amateurs interested in scientific studies, launched in September 1981, and which has been undergoing a long period of checking out.

The Russians have asked amateur operators throughout the world not to use excessive power when working through these satellites. They feel 70 watts effective radiated power, or say a 10-watt transmitter with a reasonably high gain aerial, or under 100 watts with a dipole, is sufficient.

As for the other amateur space satellites, Wednesdays are reserved for planned experimental purposes. The British AMSAT-UK group runs a net on 3780kHz each evening Mondays to Saturdays at 7 p.m. and on Sunday mornings at 10.15 a.m. to discuss and pass on the latest news about the various amateur satellite activities.

using a Marconi transmitter, G5SW, at Chelmsford.

With Post Office permission, Marcuse broadcast daily, usually in the afternoons, on 32.5 metres from his home at Caterham, Surrey using a "studio" in the home of a friend and neighbour, Percy Valentine. He also (without permission) relayed some BBC medium-wave programmes. He rebroadcast the chimes of Big Ben, heard for the first time across the oceans, from his 100 ft-high aerials and 1.5 kW transmitter.

Occasionally, orchestras and guest soloists and singers were squeezed into the small studio. "Outside broadcasts" included bird songs from his garden and the relay of local church services.

His broadcasts were often relayed by other amateurs overseas, including one in the West Indies. As a result Gerald Marcuse was soon receiving fan mail including a letter from a lady who wrote: "I am enchanted with your voice which I hear every Sunday morning and I have three lovely daughters and a flourishing business. If you would like to come over you can have the pick of the daughters and the business."

Despite such an invitation, Gerry remained in the UK broadcasting regularly until Post Office permission was withdrawn in 1929, so leaving Empire broadcasting to G5SW until the official BBC service began in 1931.

Black Broadcasting

It was not until World War II was approaching that the foreign language services began and soon the BBC had a new rival: the "black" broadcasting operation of the Political Warfare Executive, run by Rex Leeper from Woburn Abbey and using transmitters operated by one of the wartime Special Communication Units controlled by the Secret Service.

One of the tricks of "black" broadcasting is to pretend that you are transmitting from Country A when in fact you are in Country B. A rather different situation has arisen in Switzerland and large parts of France which are now the targets of a powerful 1000kW (effective radiated power) VHF/FM "private" transmitter located 4000 metres above sea level on the Italian side of Mont Blanc.

This like vast numbers of other "private" Italian commercial stations, is operating in breach of the international Radio Regulations. Nations may not be speaking peace across the frontiers any more; instead they're flogging toothpaste!

Channel Rescue

For many years the most important radio navigational aid for ships was the simple direction-finding (d/f) loop or alternatively the Bellini Tosi twin loop and radiogoniometer. Both of these systems were developed as early as the first decade

of the 20th century. For many years ships not equipped with loops could call-up the 500kHz coast stations who would take cross-bearings and then radio the result to the ship.

The coming of radar, the Decca Navigator and Loran has diminished the importance of d/f but the system is enjoying a new lease of life with its modern extension to VHF. A note from Rascal Communications reports the use of their v.h.f. d/f equipment to effect a dramatic rescue of four people on a cabin cruiser during a violent gale in the English Channel.

The cabin cruiser en route from Cherbourg to the Isle of Wight ran into a force ten gale and coastguards found by d/f that it was some 15 miles away from the position estimated by the skipper. The d/f equipment also assisted the coastguards to guide the Poole lifeboat to the distressed craft.

The traditional d/f technique has the advantage that it can be used to locate accurately a craft carrying no other equipment than a standard marine V.H.F. two-way radio telephone. It is thus proving a valuable aid to the safety of shipping in the Channel.

Silent Room

In my library is a fascinating little wartime booklet published by Pitman at the princely sum of six old pennies: "Wireless Operating Simply Explained". It is full of good advice, rather in the manner of Victorian texts.

I like particularly a little section on "silence", including the following: "A wireless cabin should always be quiet. With faint signals or if atmospheric interference is bad, an operator needs all his hearing unimpeded to read signals."

"Imagine the feelings of the operator on watch when someone bursts into the wireless room whistling the latest popular air, bangs an attache case down, and proceeds to exchange noisy badinage with a colleague . . . The wireless cabin should resemble the consulting room of a Harley Street specialist and not a stag party."

Personally, I can recall radio stations of that era where the only time they resembled a consulting room was when half the night watch was stretched out on the floor asleep! And where the operators had to face the challenge of the station cat suddenly jumping playfully on to their keying arms. Something which I am sure Mr. Crook would have said should be "sternly discouraged". I was reminded of this by the recent High Court case in which radio intercept operators of the Composite Signals Organisation sued the Attorney-General for loss of hearing, after spending decades listening to weak signals in their headphones.

Other recommended "don'ts" included reading papers or books while on watch, working with headphones on your cheeks, placing pork pies, sandwiches etc on the operating bench. I have the impression that Mr. Crook had a good idea of what used to go on in radio stations!

ON WATCH

Readers who are wireless operators or ex-operators are likely to have some amusing "On Watch" tales to recount.

Why not share them with other readers? Pat will be delighted to hear from you.



By D. BUTLER

CIRCUIT DESCRIPTION

The circuit diagram is given in Fig. 1, IC3 being the 4046 CMOS i.c. mentioned above. An external resistor and capacitor, R7 and C4 respectively, govern the operating frequency of this v.c.o. and, with the component values given, is in the order of 1kHz.

The operation of the oscillator is dependent upon a voltage applied at pin 9 and from the circuit diagram it can be seen that there are two sources of this control voltage: (1) directly from a separate clock oscillator consisting of IC1a and IC1b, VR1 and C1; or (2) from IC2, a pseudo-random generator. Switch S2 controls which of these two options is selected.

We shall first examine the former option, whereby two NAND gates, IC1a and IC1b, from a 4011 CMOS i.c. are used as an oscillator, the timing components being potentiometer VR1 and capacitor C1. This gives a minimum operational frequency of approximately 0.5Hz with the potentiometer at its highest resistance.

So with S2 in the DIRECT position the output of this oscillator at pin 4, IC1b is coupled via D4 to the control input of IC3, thus supplying a series of pulses to the v.c.o. Therefore with a positive pulse on pin 9, IC3 will oscillate and when the input drops, it will stop.

Capacitor C3 decouples the v.c.o. input to give a decay effect to the tone generated.

All this happens when switch S1 is closed (in the VARITONE position) and

Simple Sound Box For The Experimenter

THIS project will enable the constructor to take the first tottering steps towards music synthesis with a voltage controlled oscillator (v.c.o.) sound effects unit. The varied and in-

teresting sounds it produces are generated by a circuit, the heart of which is the 4046 CMOS micropower phase locked loop i.c. used here as a v.c.o.

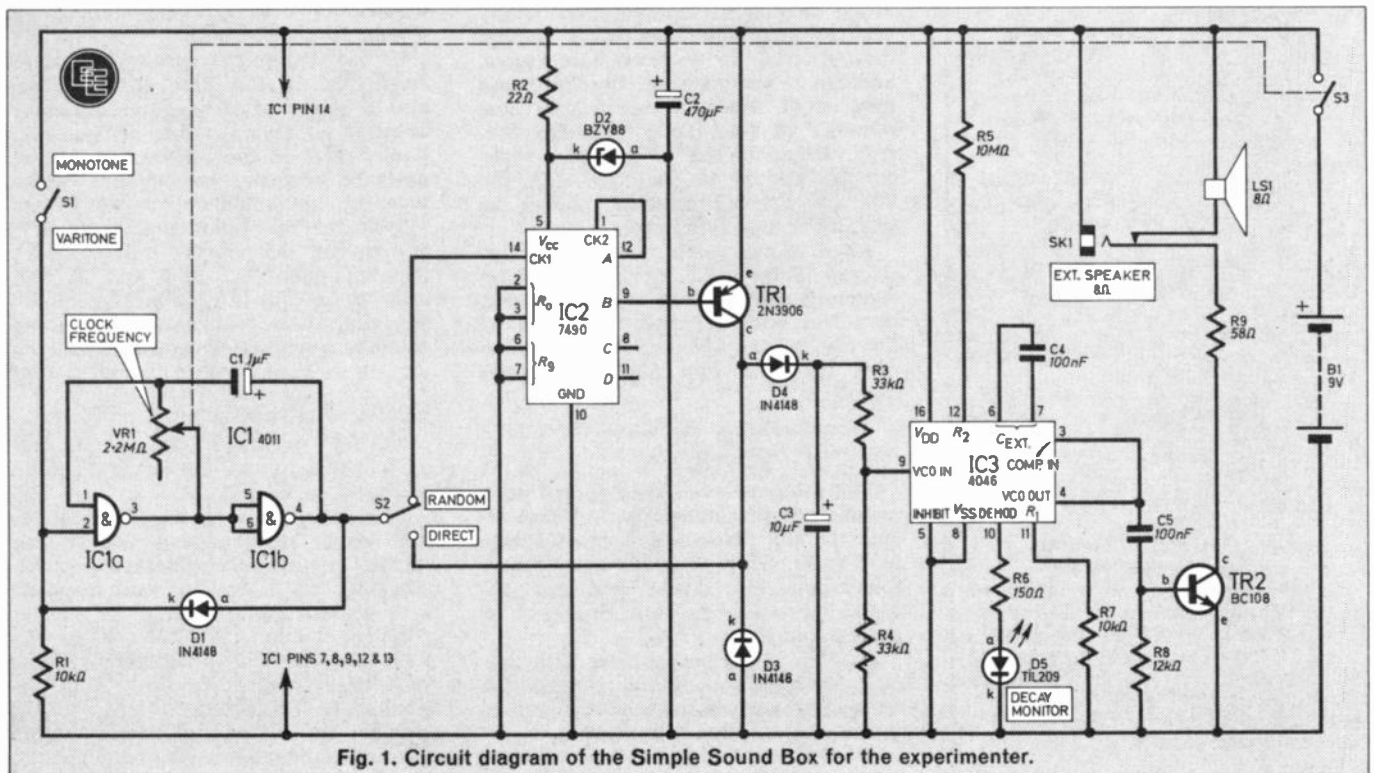


Fig. 1. Circuit diagram of the Simple Sound Box for the experimenter.

on opening S1 (MONOTONE), a constant note will be generated.

Now to discuss the second option with S2 in the RANDOM position.

RANDOM

In this case, the output from IC1b is connected to the clock input, pin 14 of IC2, a 7490 TTL decade counter wired as a randomiser.

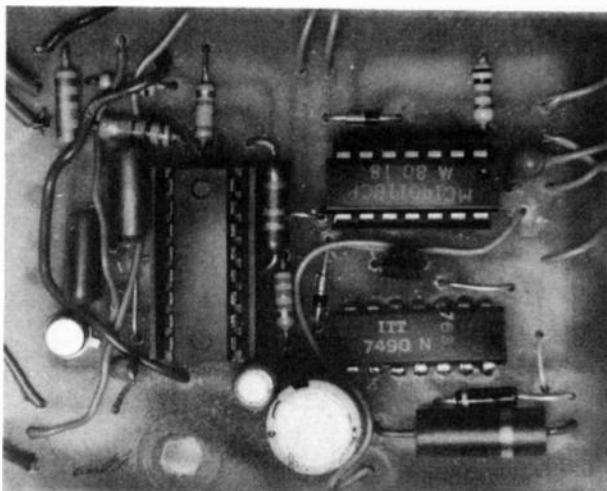
As the i.c. is a TTL device it requires a 5V power supply, so the 9V battery voltage is regulated with a 5.1V Zener diode, D2, and resistor R2. Note that R2 must be a 1W resistor as it sinks quite a lot of power. C2 is a supply decoupling capacitor.

The output of IC2 at pin 9 is a psuedo-random sequence of pulses so

COMPONENTS
approximate
cost **£8.25**

the resulting effect from the v.c.o. cannot be easily predicted.

Transistor TR1 amplifies the TTL output level to that compatible with the CMOS devices, that is swinging between the nine volt battery supply rails.



Close-up of the prototype circuit board.

COMPONENTS

Resistors

R1, 7	10k Ω (2 off)
R2	22 Ω 1W
R3, 4	33k Ω (2 off)
R5	10M Ω
R6	150 Ω
R8	12k Ω
R9	58 Ω

All $\frac{1}{2}$ W carbon $\pm 5\%$ except where stated

Capacitors

C1	1 μ F 10V tantalum bead
C2	470 μ F 10V elect. radial lead
C3	10 μ F 10V elect. radial lead
C4, 5	100nF polyester (2 off)

Semiconductors

D1, 3, 4	1N4148 silicon (3 off)
D2	BZY88 C5V1 400mW 5.1V Zener diode
D5	T1L209 red i.e.d.
TR1	2N3906 <i>pn</i> p silicon
TR2	BC108 or similar <i>np</i> n silicon
IC1	4011 CMOS quad 2-input NAND gate
IC2	7490 TTL decade counter
IC3	4046 CMOS phase locked loop

Miscellaneous

S1	s.p.s.t. miniature toggle switch
S2	s.p.c.o. miniature toggle switch
S3/VR1	2.2M Ω carbon lin. potentiometer with integral s.p.s.t. switch
LS1	8 Ω 0.3W miniature speaker
SK1	3.5mm jack socket, switched contacts

Case 120 x 100 x 45mm; single-sided p.c.b. 70 x 55mm; i.e.d. mounting clip; battery clip; 14 pin d.i.l. i.c. holder; 16 pin d.i.l. i.c. holder; epoxy resin adhesive; 7/0.2 PVC sleeved wire; knob (for VR1); board mounting hardware.

V.C.O. OUTPUT

The output of IC3 at pins 3 and 4 is coupled via C5 to TR2, a single transistor amplifier, and speaker LS1 provides the audible output, socket SK1 giving the option of an external amplifier and/or speaker.

The i.e.d., D5, is connected internally to the v.c.o. and it monitors the operation of IC3.

Power is supplied to the circuit from a nine volt PP3 battery although a battery eliminator is recommended as the power consumption is around 90mA at the highest frequency level. Switch S3, an integral part of VR1, is the main unit ON/OFF switch.

CIRCUIT OPTIONS

As the circuit stands, the sound effects available are still rather limited and to expand the range, adding a jack socket to the input (pin 9) of IC3 will enable the constructor to feed an alternative control voltage to the v.c.o. Series resistor R3 should be retained and the voltages applied must of course be of CMOS compatible levels.

Also to vary the operating frequency of the v.c.o. itself, a potentiometer of say 10 kilohm can be added in series with R7 and the value of C4 can be experimented with, however no less than 50pF is recommended.

CIRCUIT BOARD

The prototype was constructed on a printed circuit board, 70 x 55mm in size, the foil pattern of which is given in Fig. 2. This diagram also shows the component layout and no problems should be encountered in assembling it.

Just the usual precautions with getting the polarity of the electrolytic capacitors and diodes and the orientation of the transistors correct.

All three i.c.s. are shown in holders, however IC2, the TTL device can be

soldered directly to the board if desired with no danger of any damage.

CASE

Any enclosure of suitable dimensions will be suitable, bearing in mind the size of the potentiometer, switches, speaker and p.c.b. The original prototype uses a plastic box 120 x 100 x 45mm with a screw-on lid.

Four holes are to be made in the lid to accommodate the two switches S1 and S2, the potentiometer VR1 and i.e.d. D5 and these are to be made in the positions shown in the photograph of the finished unit. The potentiometer requires a 10mm diameter hole, the remainder of the lid mounting components needing a 6.4mm diameter hole.

A "grille" for the speaker needs to be drilled in the base of the case, and a series of 3 to 4mm diameter holes in a "star" pattern will suffice. It also adds to the appearance of the unit to slightly countersink these holes on the outside.

Two further holes are necessary, one in the side of the unit for SK1 (6.4mm diameter) and one in the base to accept the mounting pillar for the p.c.b. (diameter of which depends upon screw size used.)

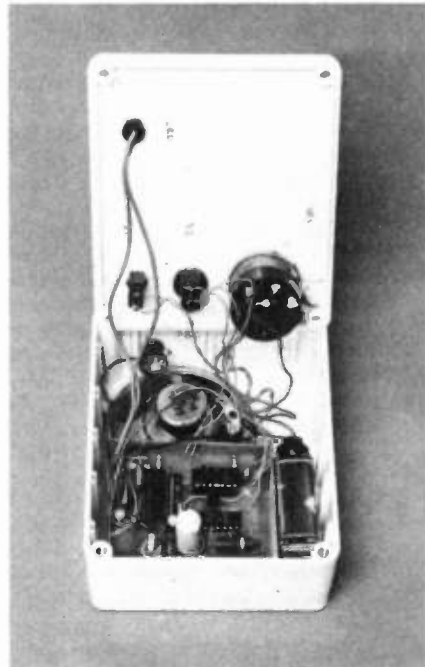
FINAL ASSEMBLY

Having prepared the case and p.c.b., the unit can be wired together as shown in Fig. 3.

The speaker is to be glued down with epoxy resin adhesive above the "grille" pattern in the base, the p.c.b. mounted on a spacer and secured with a screw and nut.

Wiring to be completed with the p.v.c. sleeved 7/0.2 equipment wire (or similar) and the controls to be labelled as illustrated.

Once completed, different sound effects can be created by manipulating S1 and S2 together with VR1. □



Prototype with lid raised showing assembly within the case.

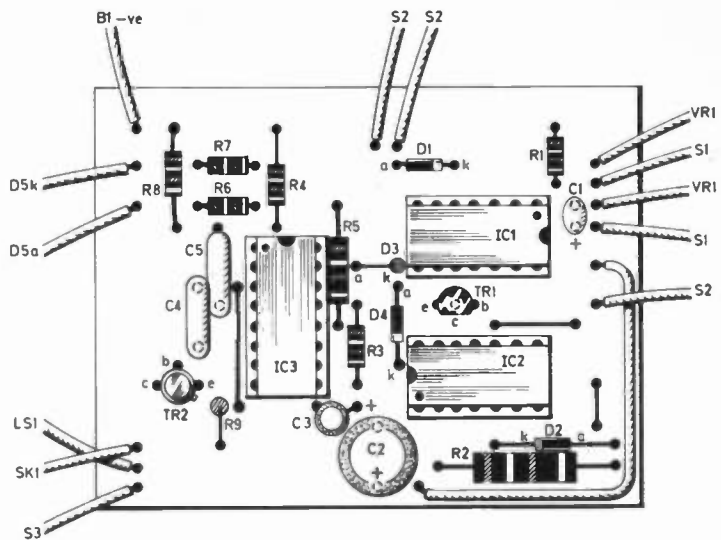


Fig. 3. Layout of the components on the topside of the p.c.b. and wiring details to other components.

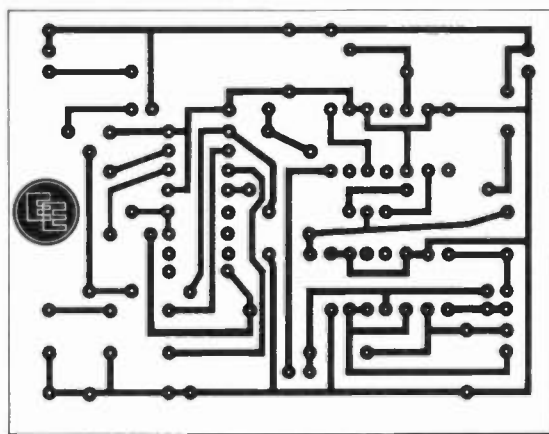


Fig. 2. Full size master for the pattern to be etched on the board. Viewed from copper side.

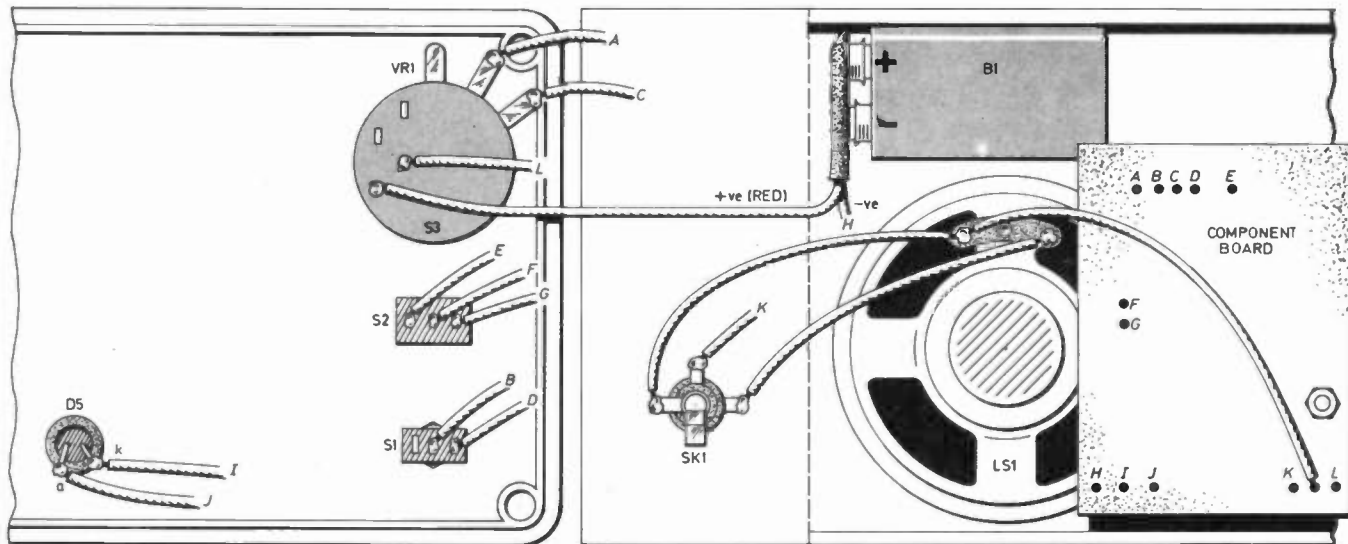
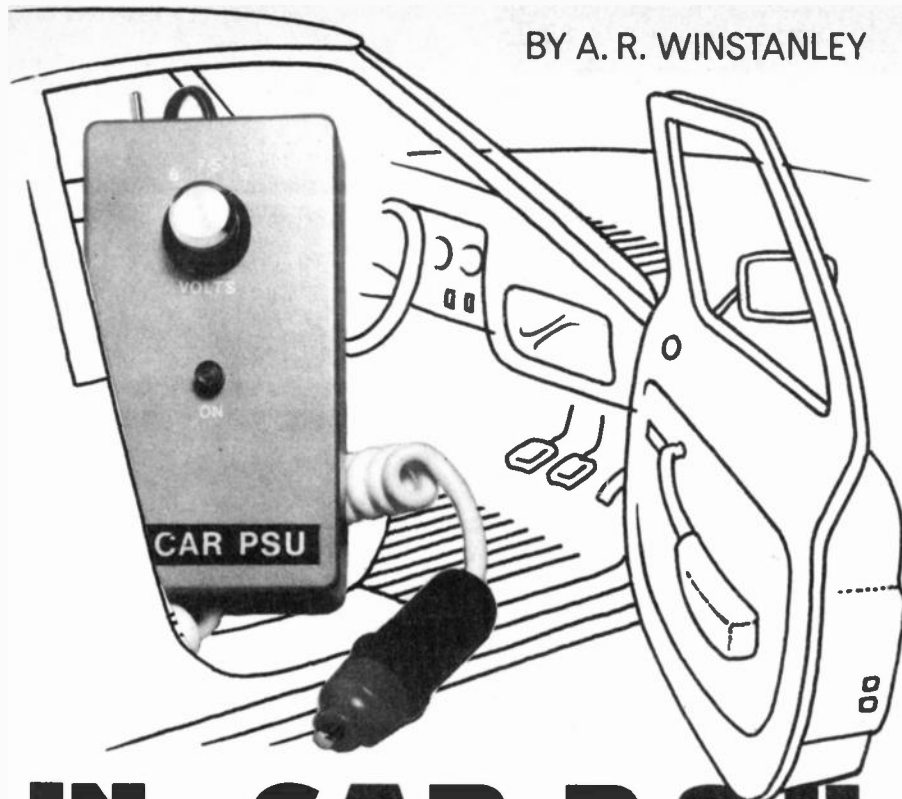


Fig. 3. Position and interwiring of the case mounted components. All flying leads from these components run to the circuit board.

BY A. R. WINSTANLEY



IN - CAR P.S.U.

ONE of the more economical methods of providing music in the car, apart from singing to oneself, is to take along a portable cassette recorder which operates from its own dry batteries. Obviously if a long journey is envisaged then it is often a good idea to carry several spare batteries for the cassette recorder as well!

The main problem of course is that cassette recorders seem to have a voracious appetite for dry cells. It would be more desirable to operate the unit from the car battery, thereby saving the recorder's own batteries for use in and around the house. However, as the car battery is normally rated at 12V, this is not immediately possible. Some sort of adaptor is required which converts the 12V of the car's electrical system to that needed by the cassette recorder. Most cassette recorders operate from either 6V or 7.5V and draw between 400 and 500mA maximum.

The In-Car P.S.U. described here is such an adaptor. Apart from providing 6 or 7.5V, it will also give 9V d.c., the three voltages being available at the touch of a switch. With a maximum current rating of 2.2A (but see later), not only will it operate cassette recorders, but other devices as well — torches, lanterns, battery shavers and radios to mention but a few.

Virtually the only requirement is that the device to be powered from

the In-Car P.S.U. must have an appropriate socket fitted to enable the d.c. supply to be connected to the apparatus. With many cassette recorders, for example, this presents no problem.

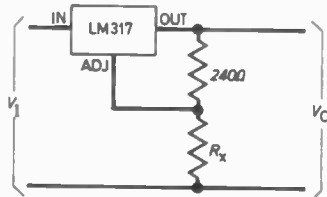


Fig. 1. The LM317T in basic voltage regulator configuration.

The circuit itself is quite simple and straightforward. This is because a modern easy-to-use integrated circuit has been used as the basis of the design. The i.c., a three-terminal variable voltage regulator type LM317T, is shown in its basic configuration in Fig. 1.

It can be seen that the three terminals are named *input*, *output* and *adjustment*. A 240 ohm reference resistor is normally placed between output and adjustment, and across this resistor exists a precision 1.2V reference voltage. By varying the value of R_x , a resistor placed between adjustment and ground, the output voltage may be altered. In fact, using a 240 ohm reference resistor, the value of R_x is given by the formula

$$R_x = (200 \times V_o) - 240 \text{ ohms}$$

where V_o is the output voltage in volts. To obtain 6, 7.5 and 9V output voltages therefore we require values of R_x to be 960, 1260 and 1560 ohms respectively.

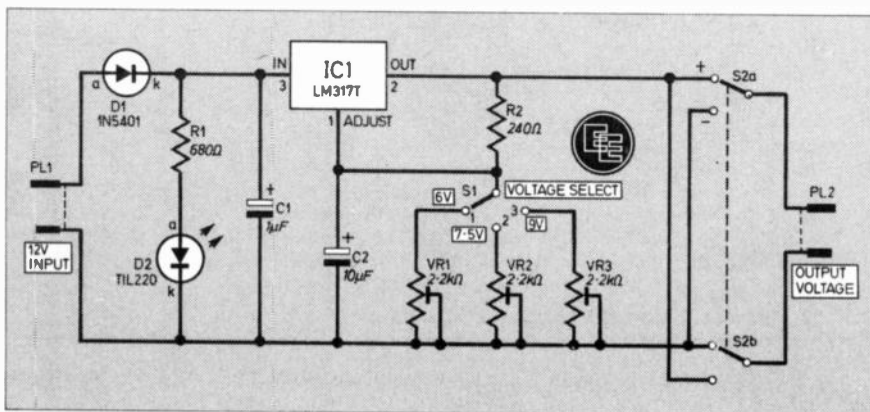
The maximum current available is 2.2A, but this will depend on the temperature and power dissipated by the i.c. The device, incorporates thermal overload shutdown and internal current limiting and is available in several packages. It is the TO-220 encapsulation (LM317T) that is employed in this design.

CIRCUIT DESCRIPTION

The complete circuit diagram is shown in Fig. 2. S1 is a one-pole three-way rotary switch which selects different values of R_x (Fig. 1) thereby enabling 6, 7.5 or 9V to be obtained. Note that three preset resistors in Fig. 2 replace R_x in Fig. 1; these are trimmed so that exact output voltages can be obtained. This does mean however that a voltmeter will be required to measure the output voltages during setting up.

D2 is a light-emitting diode which illuminates when the unit is operating. R1 is its associated series resistor which limits the forward current

Fig. 2. The complete circuit diagram of the In-Car P.S.U.



COMPONENTS



Resistors

R1 680Ω
R2 240Ω
Both $\frac{1}{4}$ W carbon $\pm 5\%$

Capacitors

C1 1μF 16V or greater tantalum bead
C2 10μF 16V tantalum bead

Semiconductors

D1 1N5401 3A rectifier
D2 T1L220 or similar red l.e.d.
IC1 LM317T adjustable voltage regulator i.c. (TO-220 case)

Miscellaneous

S1 single-pole three-way rotary
S2 miniature d.p.d.t. toggle
VR1-VR3 2.2kΩ miniature carbon preset (3 off)
PL1 two-pole plug to suit car (for example a plug to suit the car cigar/cigarette lighter socket)
PL2 two-pole plug to suit equipment (Spider or Universal—see text)
Printed circuit board, 61 × 27mm; case type BIM 5004/14, diecast aluminium, size 121 × 66 × 40 with p.c.b. guides (see text); lens clip for D2; insulating bush and mica washer for IC1 (TO-220 kit); knob; grommets (2 off); 6BA fixings for IC1.

See
**Shop
Talk**
page 233

The one remaining problem relates to the polarity of the P.S.U. output. The author's radio/cassette recorder requires a 2.1mm power plug with the tip at 0V and the "body" of the plug at +6V. It is likely however that other loads may require a reversed polarity to this, with the tip of the plug positive and the "body" negative.

S2 has been included in the output to switch over the polarity of the spider plug as necessary. This switch needs to have a heavy action on the operating lever to prevent the switch being accidentally knocked over whilst the unit is in operation. A reversed voltage polarity with some devices could have dire results!

CONSTRUCTION
starts here

through the l.e.d. to a reasonable level—about 15mA.

C1 is a tantalum bead capacitor placed across the input to eliminate transients and noise which often are present on the car 12V supply rail. C2 bypasses the adjustment terminal to ground to improve the ripple rejection of the i.c. D1 is a heavy-duty rectifier which protects the circuit from accidental reversed polarity.

CONNECTORS

The 12V input connection to the unit was made, on the prototype, with a twin-core curly lead terminated in a cigar-lighter plug; this enabled the unit to be connected quickly and easily into the car cigar-lighter socket.

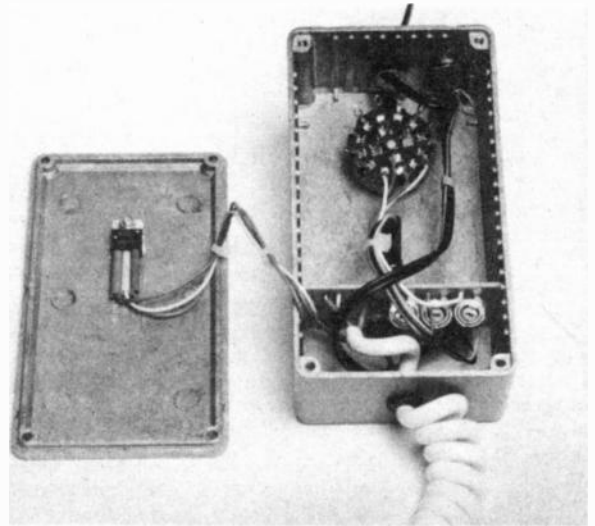
The finished unit ready for use in the car. You can see the "universal" or "spider" connector.



The form of connector can be varied to suit one's need. For example, a dashboard-mounting two-pin non-reversible connector is available from motor accessory shops and this could be used if a cigar lighter is not available.

The output connector can also be altered to meet requirements. To achieve maximum versatility however, it is recommended that a 4-way "spider" or universal connector is used. This comprises a 2.5mm and 3.5mm jack plug, together with a 2.1mm and 2.5mm power plug moulded onto the end of a twin-core lead. This means that the unit can power almost every type of apparatus which has the usual forms of external power sockets fitted.

In the final stages of assembly, the prototype with lid removed showing in particular the p.c.b. inserted in a slot and the i.c. mounted to the lid.



IN-CAR P.S.U.

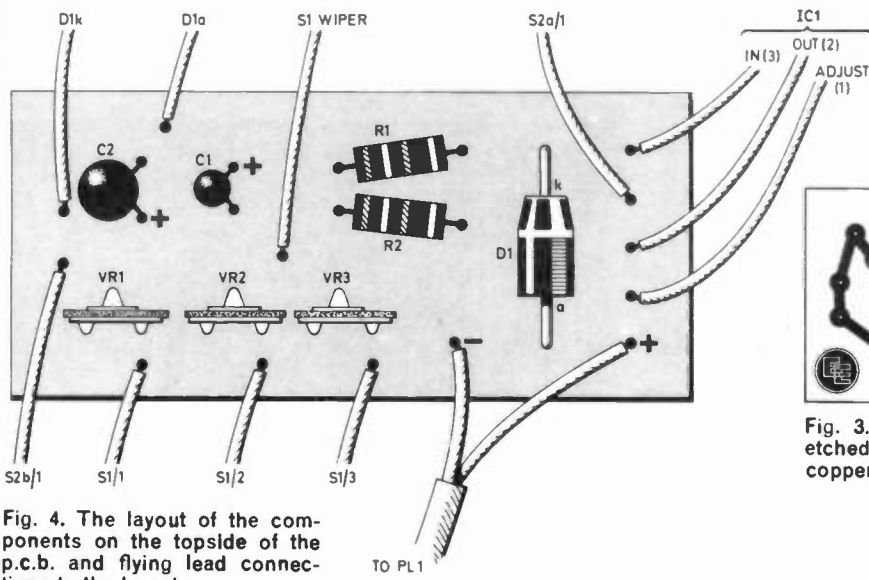


Fig. 4. The layout of the components on the topside of the p.c.b. and flying lead connections to the board.

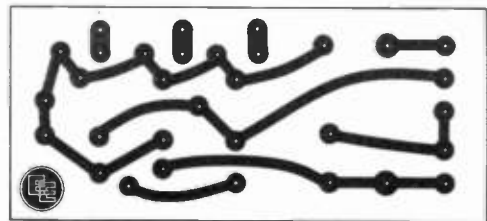


Fig. 3. Full-size master of the pattern to be etched on the board. Black regions denote the copper to remain after etching.

COMPONENTS
approximate
cost **£10.50**

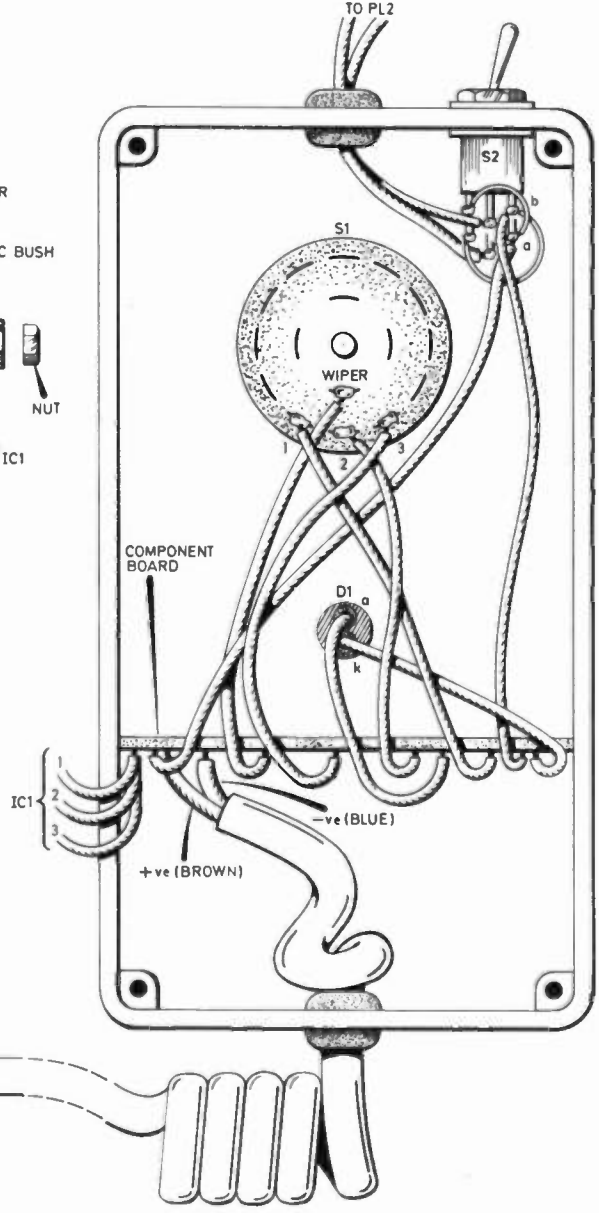
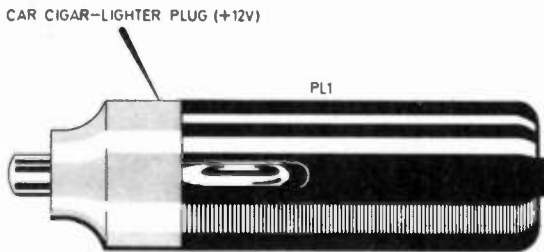
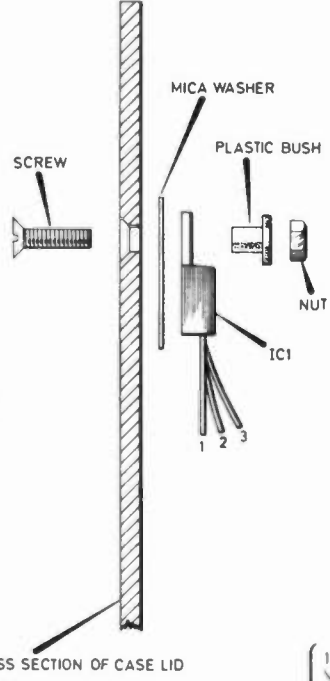
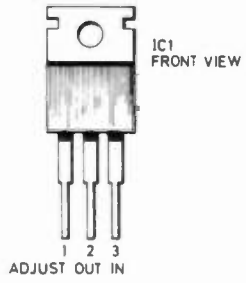
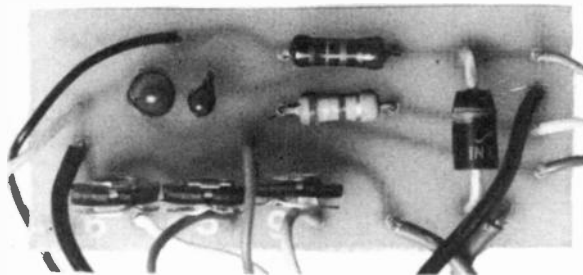


Fig. 5. Position of components and board within the specified case with complete interwiring information. Also shows mounting details for IC1 using mica washer and plastic bush.



to be etched on the board is given in Fig. 3.

Assembly details of the components on the top side of the p.c.b. are shown in Fig. 4. The polarities of the tantalum capacitors are nearly always marked on the bodies, and it is very important that these components are soldered in the right way round, as is the case with D1 and D2. The latter has a flat alongside its cathode.

The p.c.b. should be completed in accordance with Fig. 4 and then the diecast box can be prepared.

CASE

The lower section should be drilled to suit the rotary switch, the toggle switch S2, and the l.e.d. Two holes are also needed to enable the 12V input and output leads to pass through and these holes should be fitted with a grommet. It is advisable to fit cable retaining clips to both of these cables.

IC1 is mounted on the removable lid of the box, which acts as a heat-sink—hence the necessity for a metal box to be used. A diecast box has the added advantage that it is very tough and will withstand quite severe knocks.

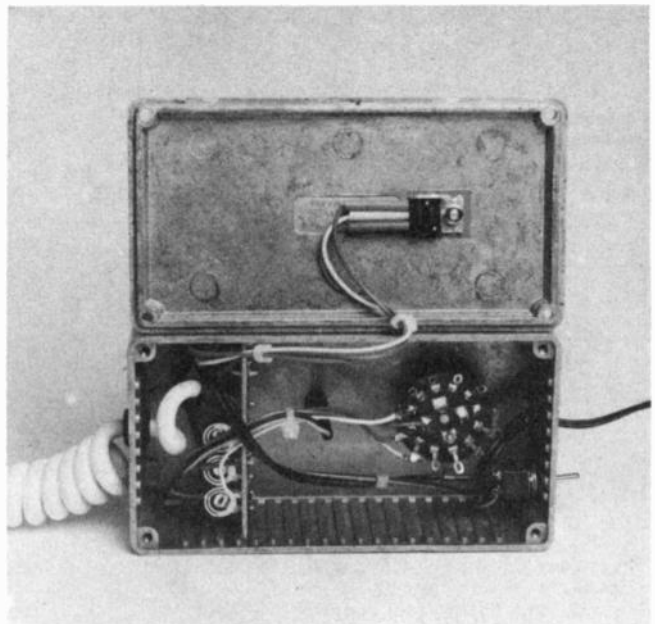
It was decided that the galvanised finish of the diecast box was somewhat less than aesthetic and so it was resprayed in an attractive shade of gold. If constructors wish to do the same it should be noted that an initial coat of primer may be required. The paint should of course be applied once all the metalworking has been completed.

After the box has been drilled and painted, the lettering can be applied to the case as required. Proprietary rub-down lettering can be used here. Note that clear protective lacquer should *not* be used over a cellulose paint finish. Experience has shown that the two tend to react unfavourably!

INTERWIRING

Once the p.c.b. and case have been completed, all interwiring can be carried out, as detailed in Fig. 5. The l.e.d. is mounted using either the usual black plastic bush/clip or alternatively a more attractive, though

Close-up view (above) of the prototype p.c.b. with all components in position.



Plan view of the completed prototype. Note the use of cable ties for the three groups of wiring.

more costly, lens-clip may be employed, as in the prototype. The integrated circuit should be mounted on the lid of the box using a TO-220 insulating kit, so that the metal tab of the device is isolated from the case.

With regard to the rotary switch, a one-pole, three-way switch is required. This is best realised using a four-pole three-way switch. Only one pole is wired up. The remainder of the switch is ignored, as Fig. 5 illustrates.

General-purpose flexible wire, preferably having a minimum rating of 1.5A can be used throughout. All flying leads, plus the input and output leads, can be soldered directly to the p.c.b.; constructors may wish to use Veropins if required.

Check all of the interwiring and set the three presets to midway before proceeding to the setting up stage. This comprises applying 12V to the input, either from the car electrics or a bench power supply unit and then adjusting the appropriate preset until 6V, 7.5V and 9V are measured at the output connected to a 10V d.c. voltmeter for the three settings of S1.

The unit once calibrated in the manner described is then complete and ready for use.

OUTPUT CURRENT

It was mentioned earlier that the i.c. has built-in current limiting which operates at 2.2A, reducing the current level as necessary if the i.c. temperature increases.

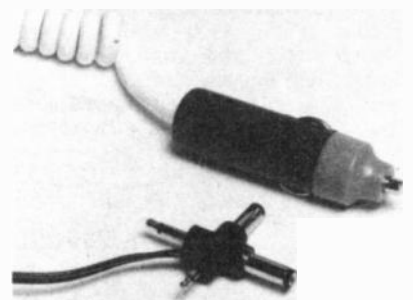
The **peak** current available from the i.c. therefore is 2.2A. To operate the unit at such current levels for a prolonged period is impracticable.

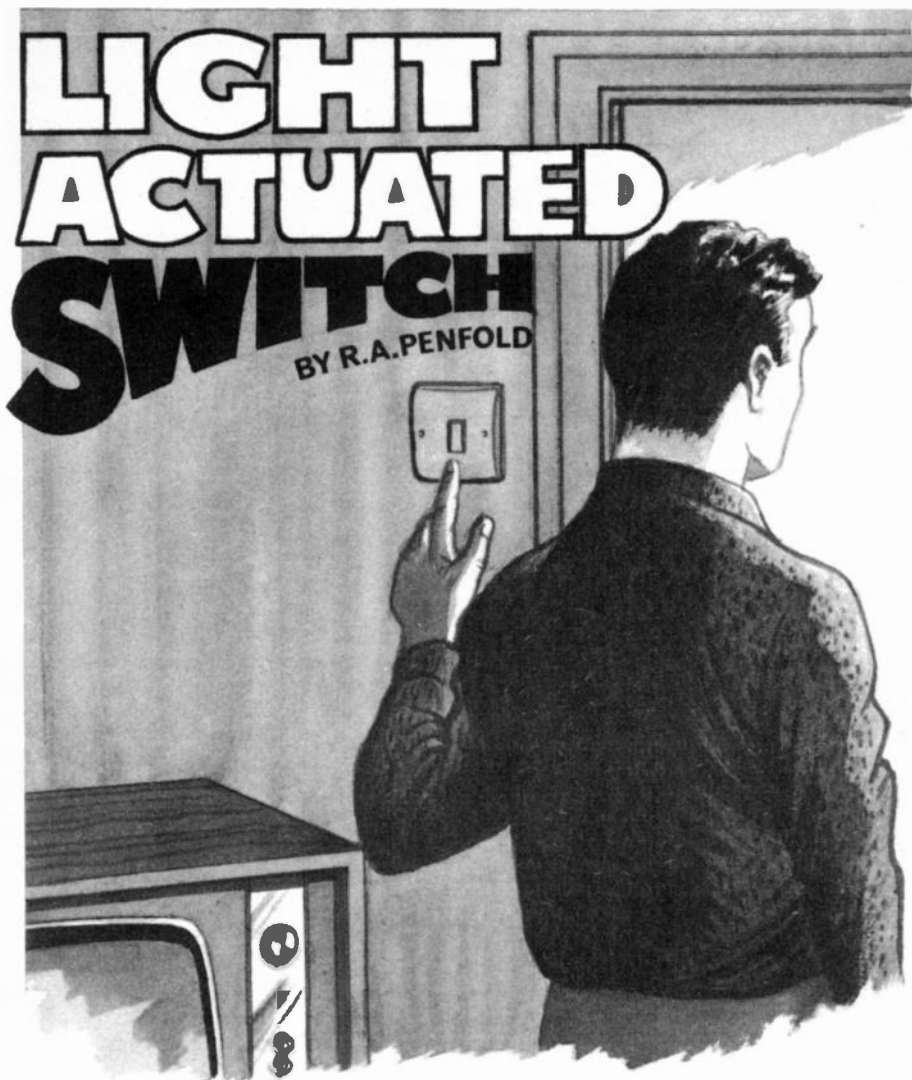
Whilst short-circuits and very heavy loads will not damage the i.c., as the device is not well heatsinked (the diecast box is not terribly efficient at this), the i.c. temperature can be expected to build up with a consequent reduction of the maximum current available.

Under worst case conditions the i.c. may shut down altogether. In such cases the device will be very hot indeed—probably too hot to touch. When powering cassette units and other devices with a current consumption of about 500mA or less, the i.c. will barely get warm. The maximum recommended current for prolonged use is about 1A. This will ensure that no thermal problems are experienced.

Finally, note that temporary short-circuits will not damage the p.s.u. unit but ensure that the circuit in the car's electrical system will carry the 2A or so which flows under such conditions.

The cigar-lighter plug and power supply connector used by the author.





ALTHOUGH a great many light actuated switch designs have been published in the past, these have virtually all been circuits which respond to the ambient light level, switching on or off at some predetermined light intensity.

This circuit is different in that it is designed to switch on some item of equipment when an electric light is switched on, and switch it off again when the light is switched off. Apart from this continuous mode of operation, the unit can be used in a single operation mode where it switches off both itself and the controlled equipment when the light is extinguished.

FLUCTUATING INTENSITY

For reliable results the unit must be designed to respond to light of rapidly fluctuating intensity, and not to any particular light level. Since mains lighting is run from a 50Hz a.c. supply, the light level increases to a peak and then dies away during the course of each mains half cycle,

producing the rapid variations to which the unit responds. Natural light does not pulsate in this way and is much more consistent in the short term, making the unit almost immune to this type of lighting.

The unit could be used by someone who watches TV in bed, or perhaps by someone who listens to a mains powered radio which cannot easily be conveniently situated.

This light activated switch can be used to automatically switch off the set when the bedroom light is extinguished, obviating the need to get out of bed and switch the set off manually. Another possible application is to ensure that a TV set, hi-fi, or other equipment is not accidentally left switched on overnight.

THE CIRCUIT

The complete circuit diagram of the Light Activated Switch is shown in Fig. 1. A simple unregulated supply of about 9 volts is obtained from the straight forward fullwave rectifier circuit which uses T1, D1,

D2, and C1. LP1 is merely the panel neon on/off indicator, and this must be a type having an integral series resistor for normal mains operation.

The heart of the unit is PCC1, a cadmium sulphide photoresistor, and this has a resistance which varies from over 10 megohms in total darkness to only a few tens of ohms in very bright conditions. Together with R2 this forms part of a potential divider, and variations in the light level received by PCC1 cause similar variations in the output from the potential divider.

When PCC1 is subjected to mains lighting, the rapid changes in intensity generate a rapidly alternating output from the potential divider. This is coupled by C3 to a single transistor amplifier. Natural light only produces very slow changes in intensity at a significant amplitude, and these will be blocked by C3, as will the d.c. level produced by the photocell circuit.

Components R1 and C2 considerably smooth and decouple the supply for the photocell circuitry. This is necessary to prevent mains hum from being coupled into the amplifier from the supply lines via R2, which would block the operation of the circuit. This decoupling also prevents instability due to positive feedback through the supply lines.

AMPLIFIER

TR1 is used as a conventional common emitter amplifier having collector load resistor R4 and base bias resistor R3. The amplified output from its collector is coupled to a rectifier and smoothing circuit using D3, D4, and C5. In the presence of a suitable input signal this produces a strong positive d.c. bias which switches on TR2, and activates the relay which is connected as its collector load.

Of course, in the absence of mains lighting being detected by PCC1, a suitable signal is not present in the circuit, and the relay is not activated. D5 is a protective diode, and this suppresses the high reverse voltage that would otherwise be generated across the relay coil as it switched off. If not suppressed, this voltage spike could damage the semiconductor devices in the circuit.

SWITCHING

For continuous operation it is necessary to close S1. Power is then continuously applied to the circuit, and the relay closes whenever PCC1 is subjected to mains light source. When the relay is energised, RLA2 closes and supplies power to the controlled equipment.

If the unit is required to switch itself off when the light is switched

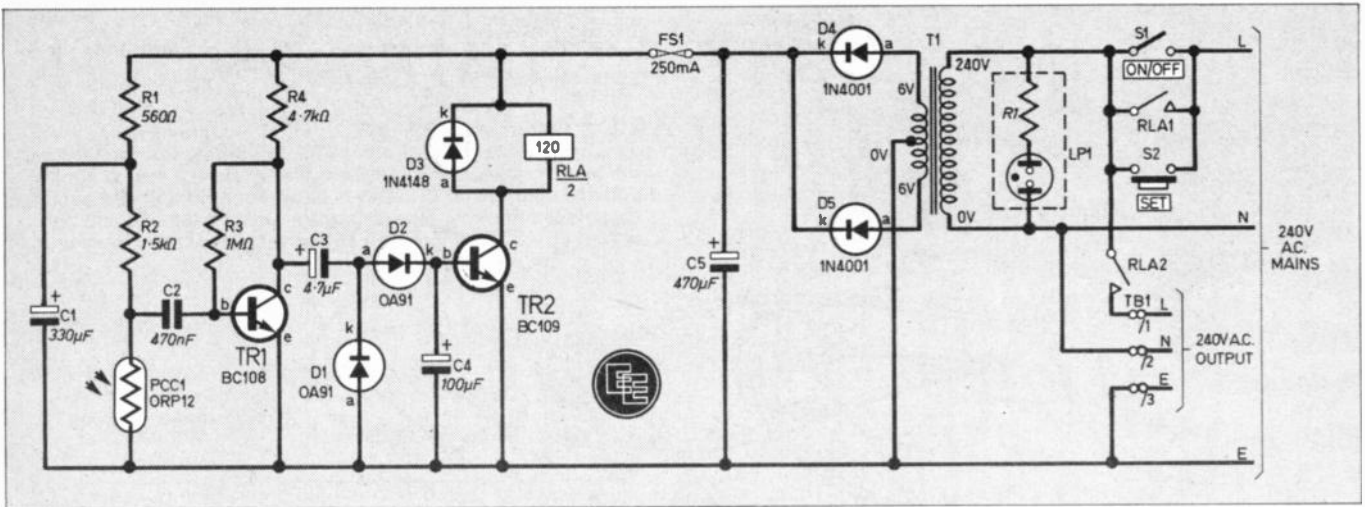


Fig. 1. Full circuit diagram of the Light Actuated Switch.

off, S1 is left in the open position, and push button switch S2 is depressed until the relay is activated (which happens almost immediately). When S2 is released, power will be applied to the unit by way of relay contact RLA1, and to the controlled equipment through both RLA1 and RLA2.

When the light is switched off and the relay contacts open, power will be disconnected from both the controlled equipment and the light switch circuitry. Switching the light on again then obviously has no effect on the unit.

CONSTRUCTION
starts here

STRIPBOARD

The main circuitry is built on a piece of 0.1 inch matrix stripboard size 18 strips by 23 holes, and the component layout is given in Fig. 2. There is one break in the copper strips, and be careful not to omit the single link wire.

Solder in the resistors and capacitors first, and leave the semiconductor devices until last. Diodes D3 and D4 are germanium devices and they are susceptible to damage by overheating. It is therefore advisable to use a heatsink on each lead of these components when they are being soldered into circuit, or at least make sure that they are quickly soldered into place so they do not overheat.

Finally, the board is completed by connecting the seven insulated flying leads, all of which are about 100mm or so long. These can be trimmed to length when it is time to connect their free ends.

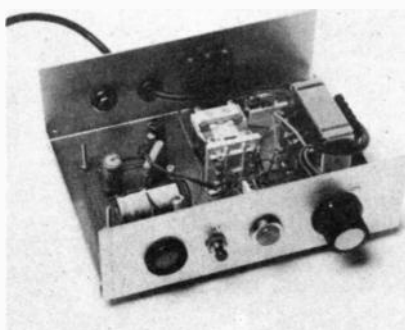
CASE

The prototype is housed in a metal instrument case which measures approximately 152 × 114 × 51mm, but any case of metallic construction and about these dimensions should also be usable. The general layout of the unit can be seen from the photographs, and is not critical, although neither T1 nor any mains wiring should be positioned close to PCC1 or its wiring.

A soldertag is fixed on one mounting screw of T1 to provide a chassis connection point to which the mains earth can be connected. For reasons of safety it is essential to ensure that the case is properly earthed.

The specified relay can be mounted using a single short 4BA screw which fits into a threaded hole in the base of the relay. It is possible to use an alternative relay if it has suitable ratings, but it may then be necessary to construct a mounting bracket of some kind.

The photocell is mounted on the front panel, and if a suitably large grommet can be obtained, this can be used as a sort of panel mounting holder for PCC1. Alternatively it is possible to drill a couple of holes in the panel to accommodate the lead. Interior view of the unit. Note the connector block TB1 on the inside rear panel for connecting up the external equipment.



COMPONENTS

Resistors

- R1 560Ω
- R2 1.5kΩ
- R3 1MΩ
- R4 4.7kΩ
- All ½W carbon ± 5%

See
**Shop
Talk**
page 233

Capacitors

- C1 330µF 10V elect.
- C2 470nF polyester type C280
- C3 4.7µF 16V elect.
- C4 100µF 10V elect.
- C5 470µF 16V elect.

Semiconductors

- TR1 BC108 npn silicon
- TR2 BC109 npn silicon
- D1,2 OA91 100V, 20mA germanium point contact diode (2 off)
- D3 1N4148 small signal silicon diode
- D4,5 1N4001 50V, 1A silicon rectifier diode (2 off)
- PCC1 ORP12 cadmium sulphide light dependent resistor

Miscellaneous

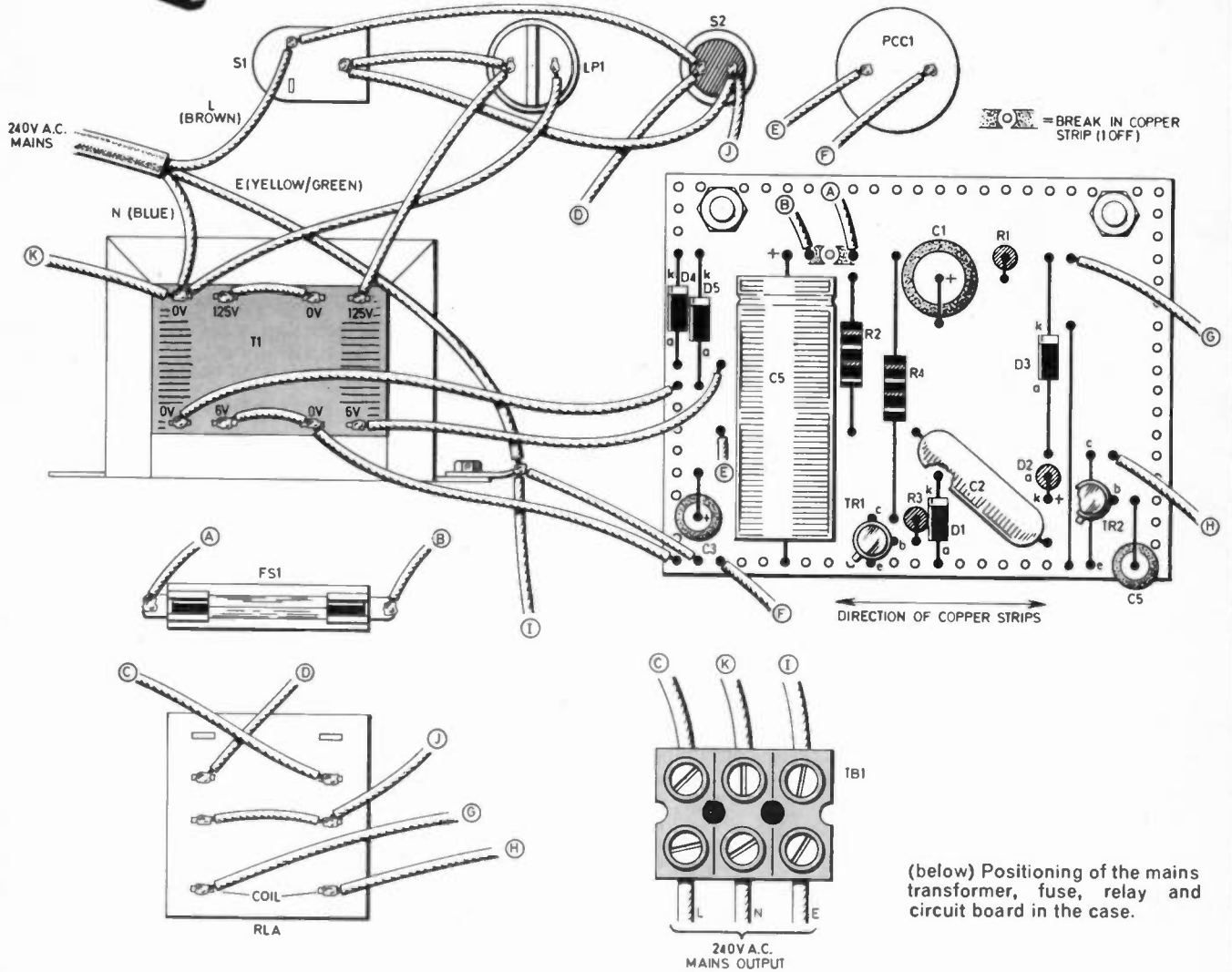
- T1 mains primary/6.0-6V 250mA secondary
 - S1 s.p.s.t. mains rotary push-to-make, release-to-break mains rated switch
 - RLA 12V 120 ohm coil with two sets mains rated n.o. contacts, MES 12V power relay or similar.
 - FS1 250mA 20mm quick-blow cartridge fuse in chassis mounting holder
 - TB1 three-way 5A screw terminal block
 - LP1 mains neon indicator with integral series resistor
- Case, 152 × 114 × 51mm, Harrison type BC1 or similar; stripboard, 0.1 inch matrix, size 18 strips by 23 holes; knob; interconnecting wire, 6BA mounting hardware for stripboard; 5A three core mains cable; interconnecting wire; grommets (3 off).

Approx. cost
Guidance only **£10**

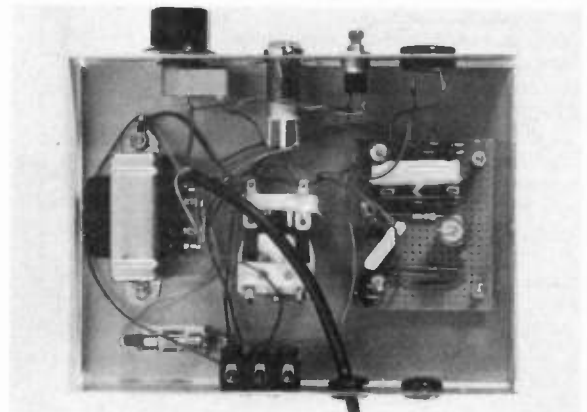
LIGHT ACTUATED SWITCH

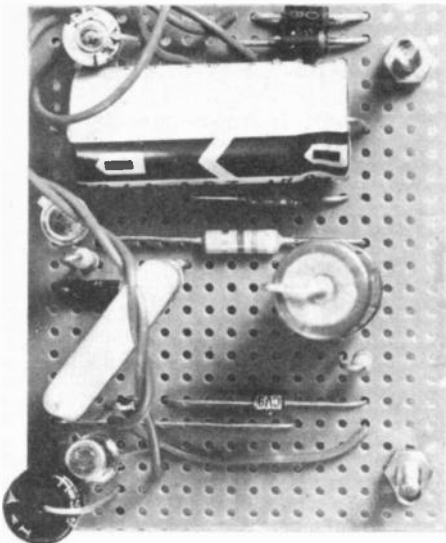


Fig. 2. Circuit board layout and full interconnection diagram. The secondary connections to T1 are below the primary shown on the left. A similar detailed diagram for the relay is shown bottom left. A similar cable is led into the case through a rubber grommet and connected up via TB1. Photo left shows exterior of completed unit.



Rear wiring to front panel components.





Close up view of the circuit board.

out wires of PCC1 (which protrude from the rear side of the component), and then glue it to the front panel, making quite sure that the leadouts do not short circuit to the metal casing.

The component panel is mounted on the base of the cabinet using two 6BA bolts and fixing nuts. Spacers are used to ensure that the connections on the underside of the board are kept well clear of the metal casing. Two holes are drilled in the rear panel to take the mains input and output leads, and these should be fitted with grommets to protect these cables.

WIRING

Once all the drilling and component mounting has been completed, the point to point wiring can be undertaken. This is all illustrated in Fig. 2. Be very careful not to make any errors here as much of the wiring is carrying the mains supply, and errors could prove to be expensive or even dangerous. Suitably rated mains cable must be used for wiring that will carry mains power.

The connections to the controlled equipment can be made via a three way terminal block which can be mounted on the rear panel of the case. These blocks are normally sold in twelve way lengths, and a block of the appropriate length is cut from

one of these using a sharp modelling knife.

If preferred, a larger case fitted with a mains outlet socket could be used, and the three output leads would then connect to this socket. However, this would be more complicated and expensive, and is probably not worthwhile unless the unit is to be used with more than one item of equipment.

TESTING

Before connecting the unit to the mains it is recommended that the wiring should be thoroughly checked over once or twice. It is then just a matter of first checking that with S1 closed, the unit switches on and off in sympathy with any mains light which throws light onto PCC1.

Then S1 should be closed and S2 should be operated so that the single operation mode can be checked. The unit should be quite sensitive, and a shaded 40W light bulb will operate the prototype reliably at a distance of 7 metres or so. However, strong natural light falling on the photocell will inevitably reduce sensitivity somewhat. □

LETTERS

Demorgan's Theorem

Readers of the *Introduction to Logic* series by J. Crowther may be interested in the following comprehensive method of converting expressions of even the most complicated kind.

Example. Demorganise: $\overline{A \cdot B \cdot (C+D)}$
Bracket terms not already so:

$(A) \cdot (B) \cdot (C+D)$

Complement each bracket:

$(\overline{A}) \cdot (\overline{B}) \cdot (\overline{C+D})$

Complement whole function:

$\overline{(\overline{A}) \cdot (\overline{B}) \cdot (\overline{C+D})}$

Change signs between brackets for opposite signs (that is, "+" to "-" and "-" to "+"):

$\overline{(\overline{A}) + (\overline{B}) + (\overline{C+D})}$

Remove extra brackets:

$\overline{\overline{A} + \overline{B} + (\overline{C+D})}$

The next exercise is slightly more difficult.

Demorganise:

$\overline{\overline{A+B+C+D+E}}$

$\overline{(\overline{A+B}) + (\overline{C}) + (\overline{D}) + (\overline{E})}$

$\overline{(\overline{A+B}) + (\overline{C}) + (\overline{D}) + (\overline{E})}$

$\overline{(\overline{A+B}) + (\overline{C}) + (\overline{D}) + (\overline{E})}$

$\overline{(\overline{A+B}) \cdot (\overline{C}) \cdot (\overline{D}) \cdot (\overline{E})}$

$\overline{(\overline{A+B}) \cdot \overline{C} \cdot \overline{D} \cdot \overline{E}}$

The following three are spot-at-a-glance conversions which can be memorised.

$\overline{\overline{A+B}} = A \cdot B$

$\overline{\overline{A} \cdot \overline{B}} = (\overline{\overline{A+B}})$

$\overline{\overline{A+B}} = \overline{\overline{A} \cdot \overline{B}}$

H. L. Taylor,
Old Trafford,
Manchester.

The Saga of 'Circuit Sam'

*Now 'Circuit Sam' was a whizz-kid bright
With a knowledge of amps and ohms
And a store of bits, and half-built kits,
And esoteric tomes.*

*His secret scheme and cherished dream
Was a plan for a robot brain
And he said, "It's true, if I carry it through,
That I'll never work again."*

*"I'll take in problems day by day
To be solved for a standard fee—
And my bank account will soon amount
To £X to the nth degree.*

*So 'Circuit Sam' took his half-built kits
To see what he could use
And from a surplus bench supply
He took the quick-rise fuse.*

*His darkroom timer came to hand
And yielded L.E.D.'s,
And his signal tracer traced no more
When he took its F.E.T.'s.*

*Thus bit by bit, through every kit,
'C. Sam' a-scrounging came,
And he acted rash in his headlong dash
To build that robot brain.*

*He ravished all his cherished gear
With a mind too fixed to change
For he'd promised himself that
future wealth
Would replace the entire range.*

*Then night and day for a month or two
He worked at his Euroboard
And the network grew with 'and', 'go-to',
Till all human knowledge was stored.*

*When the data banks, in serried ranks,
Were 'bursting at the seams'
Old 'Circuit Sam' gave heartfelt thanks,
Having realised his dreams.*

*On the final day, in a mood quite gay,
Sam pressed the action switch
And the lights came on and the
motors whirred
And the touch pads gave a twitch.*

*When the current reached its
working point
The synthesizer spoke
And it said, "Dear Sam, for my
starting plan,
You're just the very bloke."*

*"I find your feedback systems work
With an ease that sets you free
And I know the thought will not please
you, but I think
They'd just suit me."*

*"So I've searched around in my data banks
For the skill to set me free
And I've found it now, and to you
my thanks—
It is transplant surgery."*

Terrence Lee

Designing A Simple A.M. Radio

A READER enquired recently about designing the tuning circuits for a simple radio. What he had in mind was a type of A.M. radio receiver which is just one step up from a crystal set.

In the days of germanium transistors a very simple circuit (Fig. 1) was often used. Here the transistor TR1 acts as a combined detector and audio amplifier. The circuit works only with strong signals, which means that the user must live close to a transmitter and must attach a long enough aerial to the receiver.

The transistor is operated without bias and to turn it on a peak signal voltage of about 100mV is required. Signals much smaller than this have no effect.

With modern silicon transistors the circuit as it stands is virtually unusable, because the turn-on voltage for silicon is about 500mV and only very strong signals are detectable.

For this reason, when silicon transistors are used in place of germanium the circuit has to be modified to provide enough d.c. bias to turn on the transistor slightly all the time. The arrival of a signal then turns it on more (on positive half cycles

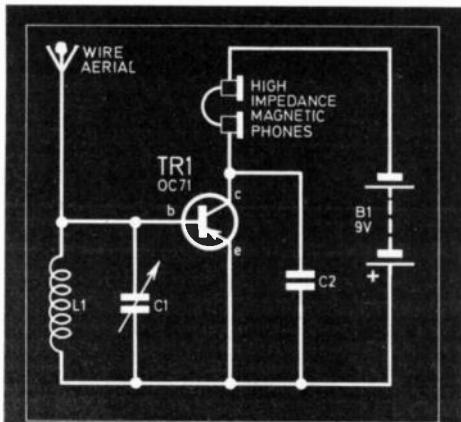


Fig. 1. A simple receiver based on a single germanium transistor.

if it is the usual *npn* silicon type) or less (on the opposite half cycles).

This detects the signal and gives an audio output to the sensitive old-fashioned magnetic earphones, which are of the high-impedance (1 kilohms up) type used with crystal sets. Reception of signals of a few tens of millivolts is then possible.

Damping

This type of circuit is neither sensitive nor selective. In view of the fact that only one transistor and one tuned circuit are used this may not be surprising. However, the performance is even worse than these limitations imply.

The reason lies in the way in which the transistor reacts upon the tuned circuit. A parallel LC circuit like this behaves as an inductance at low frequencies, a capacitance at high frequencies and a resistance at its resonant frequency.

This resistance—called the dynamic resistance to distinguish it from the static resistance of the wire in the coil—can be quite high. For a typical medium-wave

DOWN TO EARTH

BY GEORGE HYLTON

rising to a sharp peak of 100 kilohms at resonance it climbs gently to a much flattened one of less than 1 kilohm. The LC circuit is *damped* by the transistor and selectivity is much reduced. It is further reduced by the long aerial which also has a damping effect.

Matching

The textbook answer to the damping problem is matching. By using transformer techniques (Fig. 2) energy can be transferred from aerial to tuned circuit and from tuned circuit to transistor with the greatest efficiency. It is just a matter of putting the best number of turns on the coupling windings L2 and L3.

Unfortunately L3 needs a much smaller number of turns than L1, which means that much less signal voltage is applied to the base of the transistor than appears across the tuned winding L1. This step-down in voltage makes for poor detection.

So although Fig. 2 is an advance on Fig. 1 as far as selectivity goes it is not much use from the point of view of sensitivity.

circuit with an inductance (L1) of around 200 μ H the dynamic resistance at 1MHz is of the order of 100 kilohms.

Selectivity arises from the fact that the impedance changes very rapidly near resonance, falling off as the frequency moves away from the resonant frequency.

To obtain full selectivity the LC circuit must be used to couple the aerial to the transistor in such a way that as much as possible of this rapid variation of impedance is preserved. The amount of signal passed on must be made to vary in sympathy with the variation of impedance.

The Fig. 1 type of circuit does not act in this optimum way. As a result selectivity is lost. Look at it this way. The transistor has an input resistance. This is connected across the tuned circuit (L1, C1), in parallel. Now, two resistances in parallel always come to less than either resistance alone. If the input resistance of the transistor is 1 kilohm then the combination of it and the dynamic LC resistance cannot exceed 1 kilohm. So instead of the net impedance

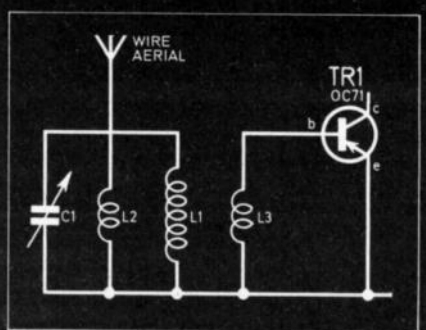
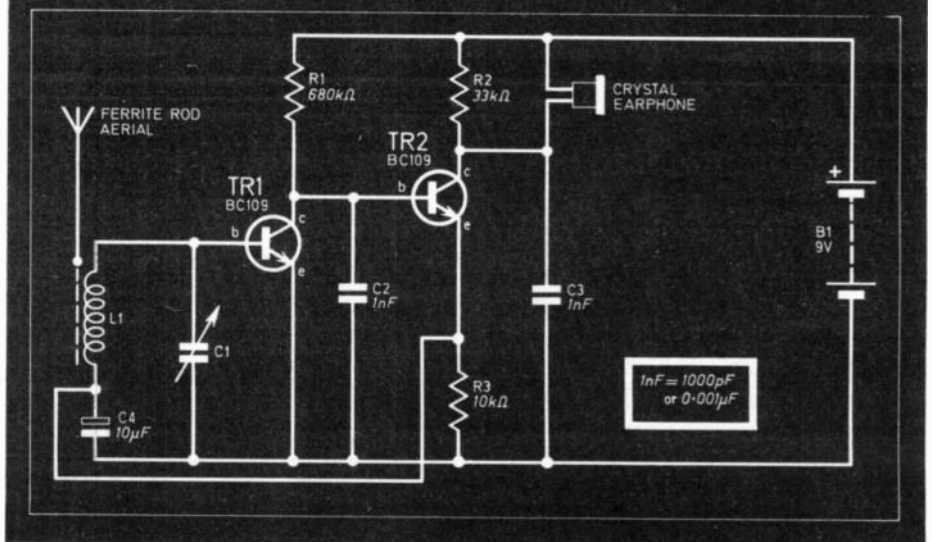


Fig. 2. Matching between aerial and tuned circuit (C1, L1) and between the latter and the transistor is delivered by transformer action. This results in efficient transference of energy.

Fig. 3. A two-stage receiver using silicon transistors. Note the ferrite rod aerial.



Transistor Input Impedance

What is needed is some means of applying the maximum possible voltage to the detector transistor (to obtain the best detection efficiency) while at the same time minimising damping.

With modern silicon transistors one option remains. By operating the detector transistor at a very low collector current its input resistance can be raised from the usual few thousand ohms to hundreds of thousands of ohms. The tuned circuit can then be connected directly to the transistor, maximising the signal voltage.

The input resistance in kilohms is roughly equal to 25 times the current amplification (hfe) divided by the emitter current in microamperes. If a transistor is operated at an emitter current of $10\mu\text{A}$ and at that current has an amplification of 100 at the relevant frequency (say 1MHz) then its input resistance is 250 kilohms, which is satisfactory.

Practical Circuit

Unfortunately, a transistor operated at $10\mu\text{A}$ can deliver very little audio output

current. So a second stage must be added. Fig. 3 is a convenient arrangement which sets the current in TR1 automatically to the correct value.

Aerial

In some locations, a ferrite rod carrying L1 will give local-station reception. An outside aerial will certainly pull in more stations but will reveal the limited selectivity of a single tuned circuit. The traditional answer to that problem is to apply positive feedback. But that's a topic for a separate Down to Earth.



Off Day

I expect, dear reader, like me, you have your off days. By ten in the morning you are saying, "This is not my Day" and by four in the afternoon, you are saying, "It's a pity I didn't stop in bed all day".

A few weeks ago, in the middle of the cold snap I had such a day. Neither my car nor my wife's car would start and I suspected the battery. I removed it and placed it by the battery charger.

My only excuse for what happened next, is that I was cold and in a hurry. Wait for it! That Electronic Wizard, Paul Young, connected positive to negative, and negative to positive. The result was spectacular!

Although I whipped the leads off in a flash, when I came to assess the damage, I found that I had burnt out the transformer, blown up the rectifier and burnt out the meter. You have to admit, that when old Paul Young blunders, he makes a thorough job of it. Anyway the steel case is still perfect!

Before I am asked why the fuse didn't blow, I will tell you. The fuse was in the battery lead. The battery leads were rather long, and in order to get a better charge I shortened them, and cut out the fuse!

Capacitor Kit

A few years ago we designed a resistor kit which has proved very popular with constructors, giving them a good selection of preferred values over the whole

range. What I have always wanted to do, is to offer a complimentary kit of fixed capacitors.

This is obviously much more difficult as there are the additional problems of size and voltage. All that is certain, is that in the small values (1 picafarad to 1000 picafarad) you have a choice of, silver mica, polystyrene, or ceramic.

In the middle range (1000 picafarad to 1 microfarad) you have paper, polyester, or mixed dielectric and in the high range you can have electrolytic or tantalum. I am determined to try and produce packs, but I would particularly welcome advice from readers, as to what they think, in their opinion, is required.

Some time ago I mentioned that my wife suffers with stomach pains during thunderstorms, and our readers, helpful as usual, made some useful suggestions. After sifting through all the information, the most likely cause seemed to be that thunderstorms produce an excess of ions in the atmosphere.

I thought the answer might be to make an ioniser to produce negative ions. I purchased a kit from Tom Powell who is a regular advertiser in *Everyday Electronics*. It was very easy to make and at £16 approximately, shows a considerable saving over the commercially built ones which are nearer £50.

As to the results of my wife, we haven't proved conclusively yet how effective it is, but she did say it made the air seem much

fresher and breathing much easier. I have since learned that Barts and other medically establishments find ionisers very beneficial in cases of asthma, although a friend or mine who is a sufferer, says they do not work in all cases.

Good Citizens

In my last article, I made a brief mention of Citizen Band Radio and said I thought the idea an excellent one especially for the sick, the old and the bedridden.

I was reminded of this today, when an old friend of mine said that CB radio had been a flop in this country. I expressed my surprise and gave my reasons. He agreed with me; not only had he bought one, but it was the finest investment he had ever made.

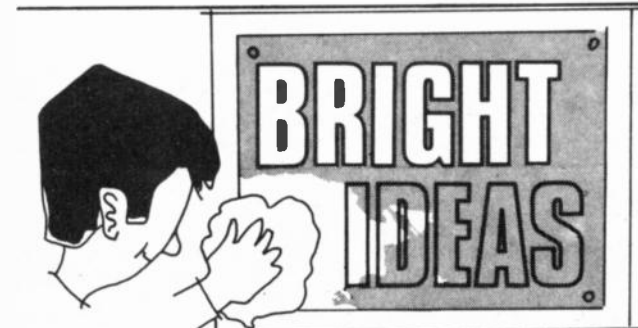
I asked him to elaborate, which he did. Jack lost his wife a few months ago and is naturally very lonely. By means of his CB radio he has gained many friends, as there is a wonderful camaraderie sprung up between CB users.

He gave me two specific examples. A few days before Christmas he was chatting to a CB'er who asked him his plans for Christmas day. Jack, with his customary humour, said he would stick a piece of mistletoe into his sausage and consume it in lonely splendour.

"We will soon see about that" said his CB friend. "Be ready at noon, you are having lunch with me and my family." They came and fetched him, gave him a splendid lunch, and later in the day ran him home.

Another time he mentioned that his eye was troubling him, and he had to get to Moorfields Hospital. Fifteen minutes later, a car drew up at his door and another CB friend ran him up to Moorfields, waited an hour while he received treatment, and then returned him safely home.

The marvellous thing was, that all these people were comparative strangers to Jack. The last time I wrote, I gave CB radio a pat on the back. I can see now I underestimated its real value and did not do it justice. This is an attempt to make amends.

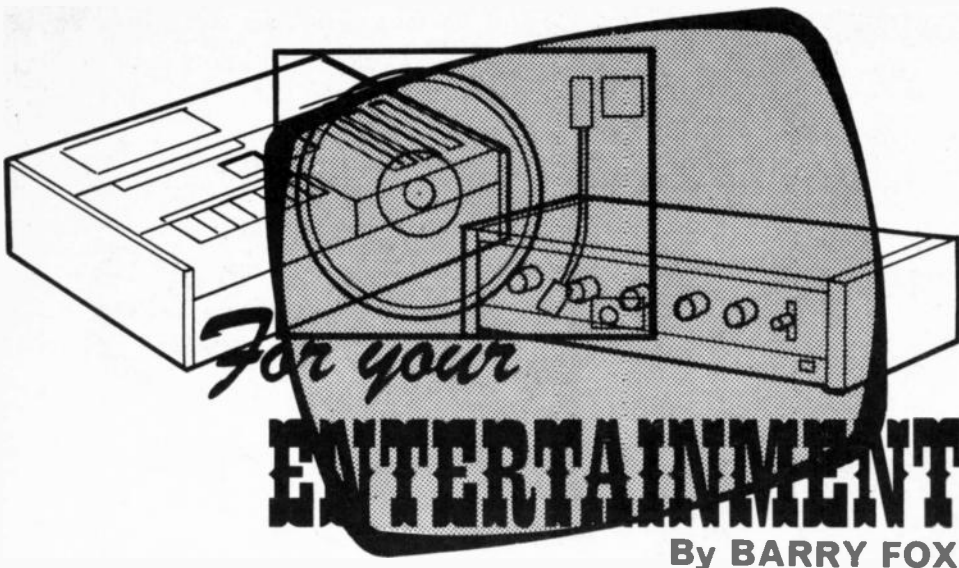


CAPACITOR MEASUREMENT

To measure the value of capacitors greater than about $1\mu\text{F}$ using a standard multimeter, select a high resistance range, apply the leads to the capacitor (for electrolytics the black terminal is positive), and note the pointer's greatest initial swing.

Calibrate with a few known capacitors and either tabulate μF against resistance, or plot a graph. This will be a straight line if "log-log" graph paper is used.

D. Marshall,
Loughborough,
Leics



Bond of Honour

Electronics firms, especially in Japan, are very secretive over their semiconductor factories. Although the basic techniques for producing chip circuits are well known, each firm has its own special know-how which is a guarded secret.

The Japanese firm Matsushita, makers of National Panasonic and Technics equipment, has a large semiconductor plant in the Japanese town of Nagaoka. Recently, and for the first time ever, they allowed a party of journalists to look round the production facilities.

Mitsushita's interest in semiconductors dates back to 1952 when the company signed a "technical" co-operation agreement with Philips of Eindhoven.

The agreement still stands firm. Philips still sell Matsushita electronic components in Europe under the Philips brand-name and still have a 35 per cent share in the Matsushita Electronics Corporation.

The commercial link between MEC and Philips has often been misinterpreted. "Philips own 35 per cent of Matsushita" was a recent headline. The truth is that although MEC is a large company, it's still just a small part of the vast Matsushita empire, which is now the largest consumer electronics conglomerate in the world.

The Matsushita-Philips link has had far reaching implications in Europe. As part of the original agreement of 30 years ago Matsushita gave an undertaking not to export any raw TV tubes to Europe. So the only way that a Matsushita tube comes to Europe is inside a completed TV set or computer terminal.

This has clearly been a serious commercial handicap to Matsushita who make 5.5 million colour TV tubes a year. It has also been a hidden shield for the European electronics industry. Perhaps most important of all it underlines how seriously the Japanese take a business undertaking; once given, it is always honoured.

Developments

Although no cameras were allowed inside the Nagaoka plant, and all the work is done in clean atmosphere rooms behind glass windows, it was possible to pick up some valuable information. VLSI products are now routinely made using a

2 or 3 micron rule scale. But two electron beam machines can draw masks to a rule below 1 micron. This is enabling Matsushita to integrate the digital/analog conversion circuitry needed for digital tape and disc recording onto a handful of chips each around 6mm square and each containing the equivalent of 15,000 circuit elements.

They have also developed a gallium-arsenide solid state laser for use in a digital disc player. This has a cost of only a few tens of dollars and a life of 50,000 hours.

Production Techniques

The Nagaoka factory introduced a new technique for chip production in 1980. The raw silicon slices are loaded by the dozen into a cartridge like a slide magazine. Normally the slices are 4inch diameter wafers, but for test purposes smaller (3 inch) wafers are used. Operators only handle the cartridges, never the wafers.

After the wafers have been coated with photo-resist material they are optically exposed to the image of the solid state circuit to be made. The coating is photographically developed and the wafer put through etching, washing, diffusion and ion-implant processes.

Apart from the manual transport of the cartridges between machines, everything is automatic. The wafers are lifted from the cartridges by robot hands at each process stage.

The completed wafers, with hundreds of individual i.c. circuits spread as a mosaic over the surface, are then 100 per cent tested. Testing is automatic by tiny probes which are pushed down onto the wafer surface to make contact.

Testing

There are two tests, first a d.c. parameter test and then a dynamic function test where the chip is electrically "inserted" into the actual circuit in which it will finally have to function.

It takes 18 seconds per chip to conduct 34 dynamic test functions. Although lengthy this, totally automated, process ensures that every single circuit is 100 per cent checked. Those circuits on the wafer which are found faulty are marked with a black dot.

The wafers are now passed to another machine which automatically scores lines between the several hundred individual devices on each wafer slice and breaks it into individual chips.

A television microscope shows what is going on at the chip surface. The wire bonder moves so fast that it is almost invisible. It takes only around 5 seconds to bond all the wires and connections to each chip.

Location of the chip with the bonding machine is automatic, using X marks for optical centring. Optical sensing also enables the machine to ignore any chip from the wafer surface which is marked with a black dot, signifying faulty.

To give some idea of the scale of the operation I counted around 200 automatic bonding machines, all in action, spaced along a corridor nearly 100 metres long.

Not surprisingly Matsushita aren't willing to discuss yield and failure rates. They say "yield is high" but add that the fault rate at the edges of each wafer is around 75 per cent whereas the success rate at the centre is around 75 per cent.

The Nagaoka plant has an astonishing output: 6.5 million LSIs a month, 25 million i.c.s, 170 million silicon transistors, 130 million diodes, 35 million i.e.d.s and 6 million silicon power transistors. Remember these are monthly figures!

Computer Designed

The most astonishing sight is the Computer Aided Design of the masks. Each individual chip circuit (of which there are several hundred on each silicon wafer) starts life as a photographic replica of the circuit which is then etched into physical reality by the photo resist technique.

Clearly it's impractical to make the mask as small as the final circuit. Instead the mask is made large and optically beamed onto the wafer in reduced size, like looking through the wrong end of a telescope.

Until recently MEC were using masks 300 times the size of the final chip circuit, but have now gone to masks 2,400 times the chip size. Up to 14 masks can be used for each chip, one exposed after the other.

This is where Computer Aided Design comes in. As MEC puts it "humans can't cope with the problem". The circuit is "drawn", stage by stage, by keying instructions into a computer terminal.

The terminal screen shows how the components will lie, and simple keyboard commands replace one component with another, alter spacing or alter connections between components and so on. The final circuit can then be automatically drawn, on a giant sheet of tracing paper (2½ metres square), by a robot head which holds four different colour pencils and moves under computer control.

It seems that Matsushita is drawing onto tracing paper only as a visual check. The photo mask is directly created by feeding digital data down a line from the CAD computer and into a mask making machine. Details were secret but presumably the data controls the movement of a laser or electron beam to "draw" the mask onto film.

Bearing in mind it was the first time MEC had allowed outsiders into the Nagaoka factory, it was a revealing experience. As I left I was bothered by a nagging thought. If this is what they are prepared to show me, what is happening in those parts of the factory which aren't on view?

The Logic Probes

Spend Less

Test More



LP-1 Logic Probe

The LP-1 has a minimum detachable pulse width of 50 nanoseconds and maximum input frequency of 10MHz. This 100 K ohm probe is an inexpensive workhorse for any shop, lab or field service tool kit. It detects high-speed pulse trains or one-shot events and stores pulse or level transistions, replacing separate level detectors, pulse stretchers and pulse memory devices.

All for less than the price of a DVM

£31.00*

© Model LP 3 illustrated



LP-2 Logic Probe

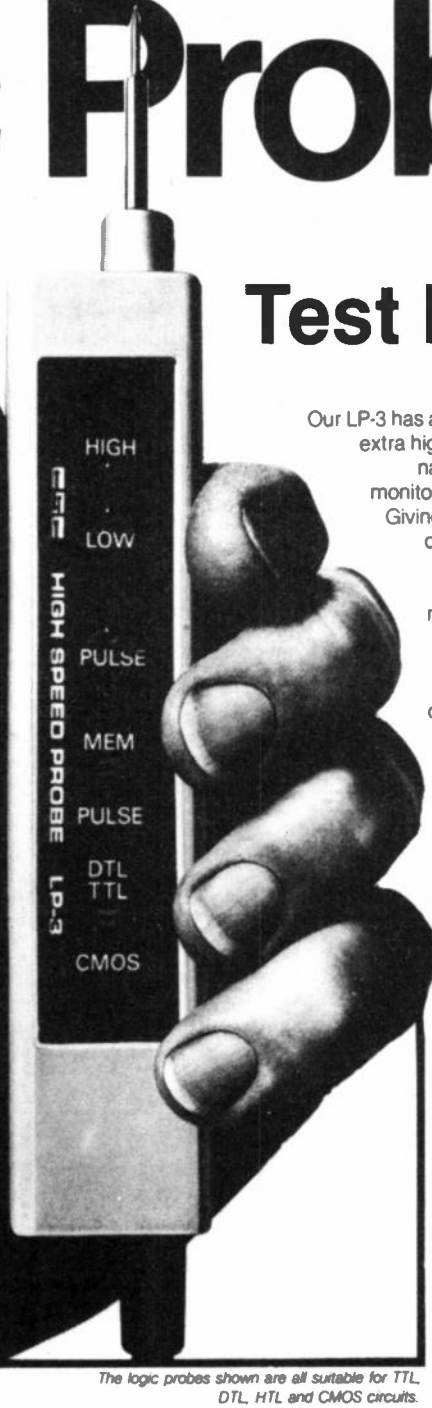
The LP-2 performs the same basic functions as the LP-1, but, for slower-speed circuits and without pulse memory capability. Handling a minimum pulse width of 300 nanoseconds, this 300 K ohm probe is the economical way to test circuits up to 1.5 MHz. It detects pulse trains or single-shot events in TTL, DTL, HTL and CMOS circuits,

replacing separate pulse detectors, pulse stretchers and mode state analysers.

(Available in kit form LPK-1 £12.50)

£18.00*

© Model LP 3 illustrated



The logic probes shown are all suitable for TTL, DTL, HTL and CMOS circuits.



LP-3 Logic Probe

Our LP-3 has all the features of the LP-1 plus extra high speed. It captures pulses as narrow as 10 nanoseconds, and monitors pulse trains to over 50 MHz. Giving you the essential capabilities of a high-quality memory scope at 1/1000th the cost.

LP-3 captures one shot or low-rep-events all-but-impossible to detect any other way.

All without the weight, bulk, inconvenience and power consumption of conventional methods.

£49.00*

© Model LP 3 illustrated



The New Pulser DP-1

The Digital Pulser: another new idea from G.S.C. The DP-1 registers the polarity of any pin, pad or component and then, when you touch the 'PULSE' button, delivers a single no-bounce pulse to swing the logic state the other way. Or if you hold the button down for more than a second, the DP-1 shoots out pulse after pulse at 1000 Hz.

The single LED blinks for each single pulse, or glows during a pulse train. If your circuit is a very fast one, you can open the clock line and take it through its function step by step, at single pulse rate or at 100 per second. Clever! And at a very reasonable price.

£51.00*

© Model LP 3 illustrated

Goods despatched within 48 hours

GLOBAL SPECIALTIES CORPORATION



G.S.C. (UK) Limited, Dept. 411
Unit 1, Shire Hill Industrial Estate,
Saffron Walden, Essex CB11 3AQ.
Telephone: Saffron Walden (0799) 21682.
Telex: 817477.

Everyday Electronics, April 1982

G.S.C. (UK) Limited, Dept 411 Unit 1, Shire Hill Industrial Estate, Saffron Walden, Essex CB11 3AQ.

Prices include P.&P. and 15% VAT

LP-1	£37.38	Only	LP-2	£22.14	Only	LP-3	£58.08	Only	DP-1	£60.38	Only	LPK-1	£15.52	Only
------	--------	------	------	--------	------	------	--------	------	------	--------	------	-------	--------	------

Name _____ Address _____

I enclose Cheque/P.O. for £ _____ or debit my Barclaycard/Access/American Express card no. _____ exp date _____

FOR IMMEDIATE ACTION — The G.S.C. 24 hour, 5 day a week service.
Telephone (0799) 21682 and give us your Barclaycard, Access, American Express number and your order will be in the post immediately.

For FREE catalogue tick box

SQUARE one FOR BEGINNERS

PERHAPS the humble switch is the most basic electronic component of all; a mechanical device for interrupting the flow of an electric current in a circuit. The most obvious example being the on/off switch fitted to almost all domestic appliances, and this simply connects or disconnects the mains to the equipment.

Modern technology has evolved a range of electronic, semiconductor and even magnetic switches but here we shall restrict discussion to the mechanical switch, to make or break the flow of electricity between the contacts.

SWITCH CONFIGURATIONS

The simplest form of switch is the *Single Pole Single Throw* (abbreviated to s.p.s.t.) and as the name suggests, this type has a single "pole" along with one other terminal, connection being made between the two when the switch is operated.

The next configuration to look at is the *Single Pole Double Throw* switch (abbreviated to s.p.d.t.), and once again this type has only one "pole" but with two other terminals and activating this type will switch the current flowing through the pole from one terminal to the other. For this reason it is also known as a *Single Pole Change-Over* switch.

DOUBLE POLE SWITCHES

The *Double Pole Single Throw* switch (d.p.s.t.) is really two on/off type switches in the same package and activated simultaneously by the same mechanism. That is, they are mechanically linked but electrically isolated from each other.

In similar fashion, the *Double Pole Double Throw* (d.p.d.t. switch is in fact two change-over switches mechanically linked and operated by the same mechanism. Once again the two halves of the d.p.d.t. switch are electrically isolated from one another. Also referred to as a *double pole change-over* switch.

LATCHING ACTION

A latched switch is one which, having been operated, will stay in that state until it is operated again.

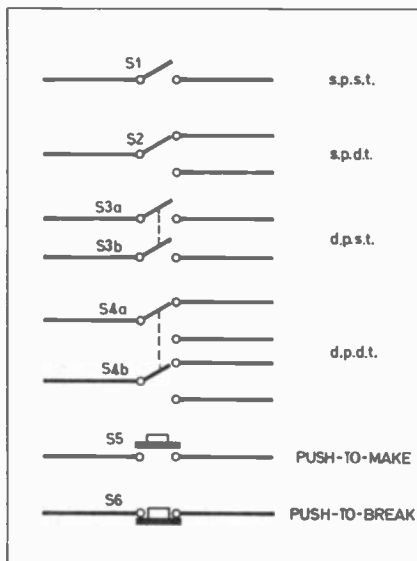
However, not all switches are latching, an alternative type being the non-latching or momentary action switch. In this case, the switch will change its state when depressed but return to its original state when the actuating force is removed.

Miniature push-button switches are examples of non-latching switches and can be broken down into a further two categories: the *push-to-make* switch, being off in the natural state and switching on when pressed (also described as having *normally open* contacts); and the *push-to-break* switch, being on in the normal state and switching off when pressed (said to have *normally closed* contacts).

LEVER SWITCHES

Probably the most familiar switch is the lever or toggle switch which uses a pear shaped metal lever (or "dolly") to activate it and the mechanism is completely enclosed in a black moulded housing with only the solder tags exposed.

Incidentally, the non-latching version of this type is often described as a *biased toggle* switch.



PUSH BUTTONS

The miniature push-button switch, mentioned previously, is usually a small cylindrical device with a sprung-loaded round button to activate it.

A more complex push-button switch is the latching, modular type that, with the aid of an interlocking bar and mounting bracket, can be made up into a bank of switches like those used for input selection on hi-fi amplifiers, operating so that actuating one switch will cancel any other switch that is actuated at that time. Each switch can have two, four or six sets of change-over contacts and are a little more expensive with the additional cost of the interlocking hardware and the clip-on buttons.

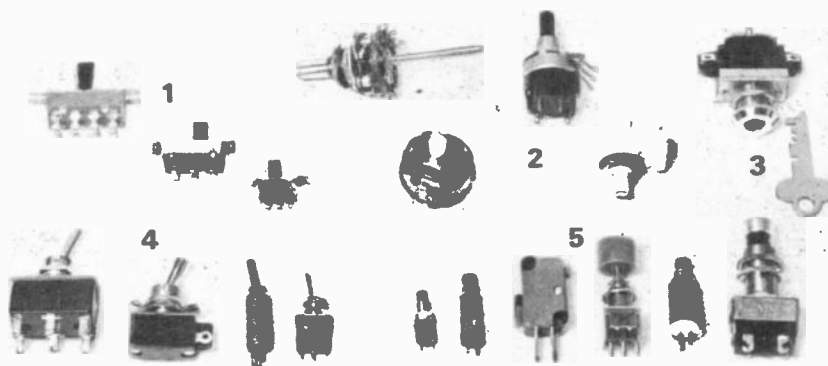
OTHER SWITCHES

Another modular switch system is the rotary wafer switch, consisting of a rotating switch mechanism onto the spindle of which is placed wafer switch elements, the maximum number of positions usually being twelve. The pole of the switch element is connected to a wiper contact which sweeps around the wafer as the switch is rotated thus making contact with the terminals of the switch. Each position is latched and an adjustable stop enables the switch to be custom designed for any number of "ways".

The microswitch is a useful device to understand, usually being a single pole change-over switch operated by a very small push-button and requiring very little actuating force.

This type of switch is frequently used to indicate the presence of something, for example, an open door operating the switch (ideal for burglar alarms).

Fig.1. (left) The circuit symbols of the four basic switch configurations plus the two types of push-button switch. Photograph (below) showing groups of various types of switch, including: (1) slide switches; (2) rotary switches, including the wafer type; (3) key operated on/off switch; (4) toggle switches ranging from a large d.p.d.t. to a miniature s.p.d.t. and (5) push-button switches, including a microswitch, third from left, and a latching type, extreme right.



On the Shelf

The latest Piccolo from Revox is not a new musical instrument, but a new loud-speaker enclosure just introduced to their range of audio equipment.

With a front panel measuring only 220mm x 140mm, the Piccolo is designed for sitting on the bookshelf. The enclosure contains a bass/mid-range driver and a dome tweeter loudspeaker.



With a claimed frequency response of 80Hz to 22kHz \pm 3dB, the Piccolo will handle up to 35W and retails at £90 plus VAT per pair.

F. W. O. Bauch Ltd, Dept EE, 49 Theobald Street, Boreham Wood, Herts WD6 4RZ.

NEW · NEW · NEW · NEW PRODUCTS NEW · NEW · NEW · NEW

DIGITAL THERMOMETER

A hand-held digital thermometer has just recently been launched onto the market by Sinclair Electronics.

Marketed under the brand name of Thandar, the TH301 features a large l.c.d. read-out display and covers a temperature range of -50 to 750°C , with a 1°C resolution. It is claimed that by using the latest technology, over 1,000 hours of battery life is obtainable.

A range of thermocouples are offered as optional extras and include mineral filled, hypodermic, right angle and surface thermocouples.

The Thandar TH301 Digital Thermometer costs £59.50 plus VAT and is supplied with battery and fast response bead thermocouple.



Sinclair Electronics Ltd, Dept EE, London Road, St Ives, Huntingdon, Cambs PE17 4HJ.

A Good Case

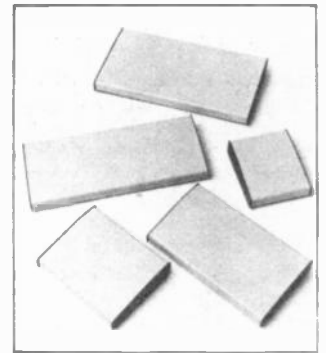
A new range of low profile consoles have recently been marketed by Boss Industrial Mouldings.

The sloping fronts on the BIM 2600 make them ideally suited for applications where meters, keyboards and switches have to be easily visible to the eye.

Ranging in size from 178mm x 261mm with an overall height of 51mm, the cases are of two piece, all aluminium, construction in which the whole unit is held together by screws running through base rubber feet into hank bushes.

The standard colour scheme for the cases is brown base and beige top panels. Alternative colours, together with special vent slots or cutouts, are available at extra cost.

Boss Industrial Mouldings Ltd, Dept EE, James Carter Road, Mildenhall, Suffolk IP28 7DE.



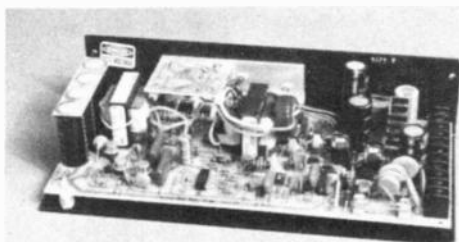
NEW POWER

As part of a new expansion programme, and to introduce a new range of power supplies, BICC-Vero Electronics have created a new division within the company which will trade under the name of BICC-Vero Distribution, Power Conversion Division.

As such, the Power Conversion Division will become sole UK distributor of the Boschert range of switched power supplies. The company will also act as master supplier to the Boschert distribution network within Europe and Scandinavia.

Based in Silicon Valley, Boschert Inc became a BICC company in 1981. They are an acknowledged leader in switched mode power supply technology, particularly in the field of open frame units. Products range from 25 watts to 400 watts, with accent on reliability.

BICC-Vero Distribution Ltd, Power Conversion Division, Dept EE, Standed Road, Boyatt Wood Industrial Estate, Eastleigh, Hants.



POCKET MICROSCOPE

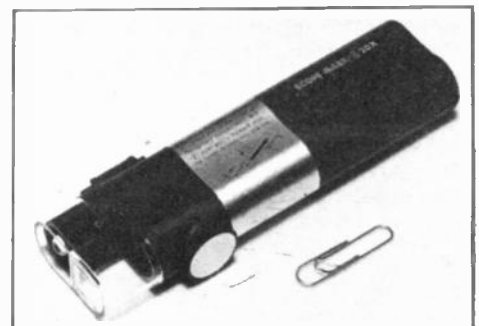
A pocket microscope, which may be useful for checking for possible "shorts" between copper tracks on p.c.b.s and stripboards, is now being marketed by Stotron.

With a 20 times magnification, the Scope Mark-III is just 125mm long and has a graticule showing linear and angular measurements. Illumination is from standard 1.5V penlight batteries.

A micro-stand, with spring clips for sample slides, is available as an option so that the device can be used like a conventional microscope.

The recommended retail price, with stand, is expected to be under £20.

Stotron Ltd, Unit 1, Dept EE, Haywood Way, Ivyhouse Lane, Hastings, East Sussex.



HOOKED

A newly formed company, I & J Products, has taken over the UK franchise for the popular EZ Hook test probes.

The range originated with a single test probe, and has advanced to DIP testers and p.c.b. probes.

I & J Products Ltd, Dept EE, Kingsbury House, 7a Christchurch Road, Ringwood, Hants

CIRCUIT EXCHANGE

This is the spot where readers pass on to fellow enthusiasts useful and interesting circuits they have themselves devised.

Payment is made for all circuits published in this feature.

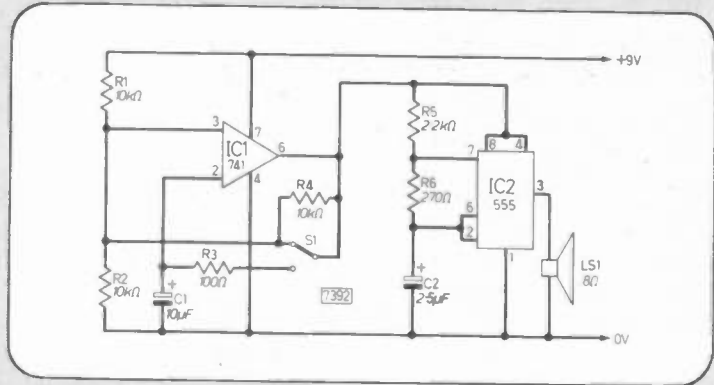
Contributions should be accompanied by a letter stating that the circuit idea offered is wholly or in significant part the original work of the sender and that it has not been offered for publication elsewhere.

AUDIBLE HEADS OR TAILS

This circuit was built as a binary decision maker, using the 741 op-amp. It is connected as an astable with an equal mark/space ratio when microswitch S1 is depressed. When S1 is released pin 6 of IC1 goes high or low depending on logic state at the moment of release.

The timer chip, IC2, is connected as an astable multivibrator and with S1 depressed generates a high frequency note in LS1. When S1 is released it will either switch to a low tone or go off altogether.

* M. Warren,
Lewes,
East Sussex.



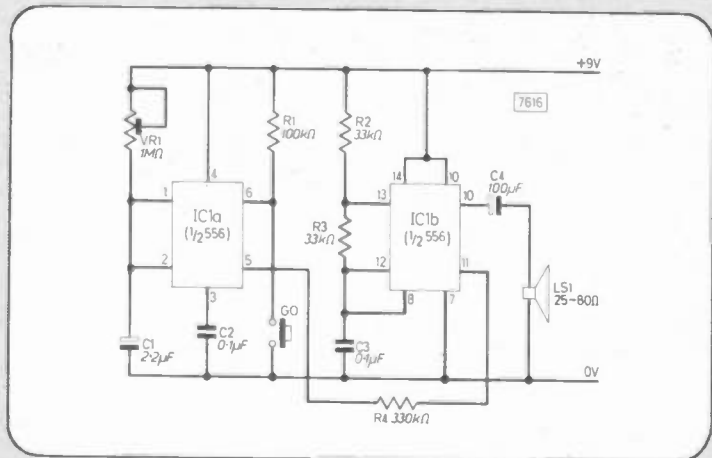
* Please let us have your full address.

"TWO-SECOND-RULE" TIMER

This simple timer was designed as a safety aid to car drivers. The prototype has been successfully used for some time. It is based on the well-known two-second-rule safety factor.

This method of use is simple, but it may well prove to be a lifesaver. A landmark is chosen, such as a bridge or a motorway signal. As soon as the bonnet of the car in front of you reaches the mark the "go" button is depressed. The tone produced immediately changes. If your car bonnet reaches the mark before the tone reverts to normal you are too close to the car in front and should drop back. When not in use the device produces a continuous tone to remind you to switch it off.

Half of a 556 dual timer is used as a monostable while the other half is used as an astable. The frequency



of the astable may be altered by applying a voltage to pin 11. When the "go" button is depressed the monostable produces an output whose

duration is dependent on the value of C1 and VR1. This output modulates the frequency of the astable.

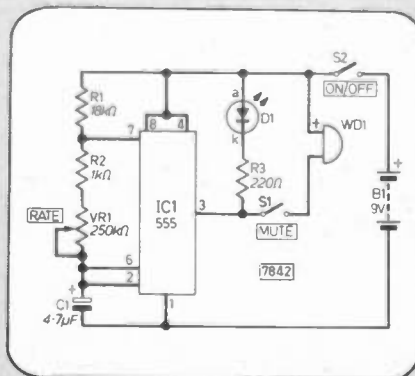
When initially setting the timer, VR1 should be adjusted to give a 2 second tone change when the "go" button is depressed.

Chris Sinclair,
Hull,
N. Humberside.

ELECTRONIC METRONOME

This circuit is for a simple electronic metronome. It is based on a 555 timer i.c. wired as an astable multivibrator. The component values have been chosen to give a set of pulse rates from about 30 to 220 beats per minute. D1 is a l.e.d. and its brightness is controlled by R3. WD1 is a 6V solid state buzzer which can be muted by opening S1. The unit is calibrated with a stopwatch by counting the pulses in one minute.

Andrew White,
Formby, Liverpool



CIRCUIT EXCHANGE

MASTER ELECTRONICS NOW!

The PRACTICAL way!

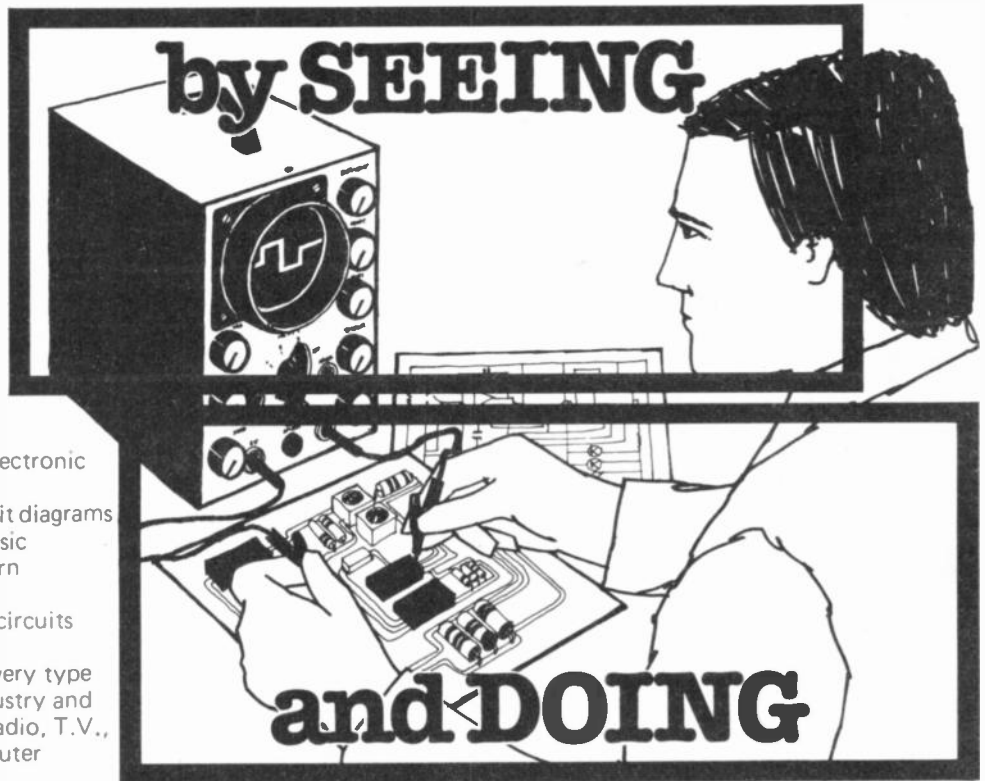
This new style course will enable anyone to have a real understanding of electronics by a modern, practical and visual method. No previous knowledge is required, no maths, and an absolute minimum of theory.

You learn the practical way in easy steps mastering all the essentials of your hobby or to start or further a career in electronics or as a self-employed servicing engineer.

All the training can be carried out in the comfort of your own home and at your own pace. A tutor is available to whom you can write personally at any time, for advice or help during your work. A Certificate is given at the end of every course.

You will do the following:

- Build a modern oscilloscope
- Recognise and handle current electronic components
- Read, draw and understand circuit diagrams
- Carry out 40 experiments on basic electronic circuits used in modern equipment
- Build and use digital electronic circuits and current solid state "chips"
- Learn how to test and service every type of electronic device used in industry and commerce today. Servicing of radio, T.V., Hi-Fi and microprocessor/computer equipment.



New Job? New Career? New Hobby? Get into **Electronics Now!**

FREE!

COLOUR BROCHURE



Please send your brochure without any obligation to

NAME _____

ADDRESS _____

I am interested in:

- COURSE IN ELECTRONICS as described above
- RADIO AMATEUR LICENCE
- MICROPROCESSORS
- LOGIC COURSE

OTHER SUBJECTS _____

POST NOW TO:

BLOCK CAPS PLEASE

EE/4/820

British National Radio & Electronics School Reading, Berks. RG1 1BR.

Sinclair ZX81 Personal Comp the heart of a system that grows with you.

1980 saw a genuine breakthrough – the Sinclair ZX80, world's first complete personal computer for under £100. Not surprisingly, over 50,000 were sold.

In March 1981, the Sinclair lead increased dramatically. For just £69.95 the Sinclair ZX81 offers even more advanced facilities at an even lower price. Initially, even we were surprised by the demand – over 50,000 in the first 3 months!

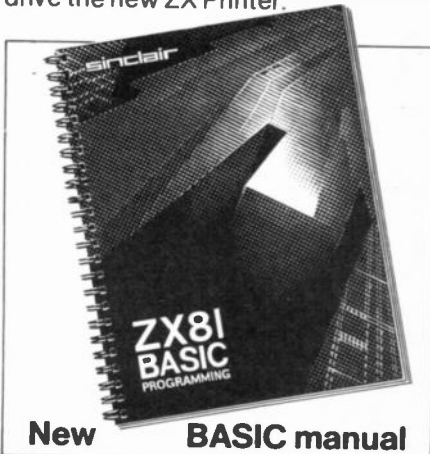
Today, the Sinclair ZX81 is the heart of a computer system. You can add 16-times more memory with the ZX RAM pack. The ZX Printer offers an unbeatable combination of performance and price. And the ZX Software library is growing every day.

Lower price: higher capability

With the ZX81, it's still very simple to teach yourself computing, but the ZX81 packs even greater working capability than the ZX80.

It uses the same micro-processor, but incorporates a new, more powerful 8K BASIC ROM – the 'trained intelligence' of the computer. This chip works in decimals, handles logs and trig, allows you to plot graphs, and builds up animated displays.

And the ZX81 incorporates other operation refinements – the facility to load and save named programs on cassette, for example, and to drive the new ZX Printer.



New BASIC manual

Every ZX81 comes with a comprehensive, specially-written manual – a complete course in BASIC programming, from first principles to complex programs.

Kit: £49.⁹⁵

Higher specification, lower price – how's it done?

Quite simply, by design. The ZX80 reduced the chips in a working computer from 40 or so, to 21. The ZX81 reduces the 21 to 4!

The secret lies in a totally new master chip. Designed by Sinclair and custom-built in Britain, this unique chip replaces 18 chips from the ZX80!

New, improved specification

- Z80A micro-processor – new faster version of the famous Z80 chip, widely recognised as the best ever made.
- Unique 'one-touch' key word entry: the ZX81 eliminates a great deal of tiresome typing. Key words (RUN, LIST, PRINT, etc.) have their own single-key entry.
- Unique syntax-check and report codes identify programming errors immediately.
- Full range of mathematical and scientific functions accurate to eight decimal places.
- Graph-drawing and animated-display facilities.
- Multi-dimensional string and numerical arrays.
- Up to 26 FOR/NEXT loops.
- Randomise function – useful for games as well as serious applications.
- Cassette LOAD and SAVE with named programs.
- 1K-byte RAM expandable to 16K bytes with Sinclair RAM pack.
- Able to drive the new Sinclair printer.
- Advanced 4-chip design: micro-processor, ROM, RAM, plus master chip – unique, custom-built chip replacing 18 ZX80 chips.



Built: £69.⁹⁵

Kit or built – it's up to you!

You'll be surprised how easy the ZX81 kit is to build: just four chips to assemble (plus, of course the other discrete components) – a few hours' work with a fine-tipped soldering iron. And you may already have a suitable mains adaptor – 600 mA at 9 V DC nominal unregulated (supplied with built version).

Kit and built versions come complete with all leads to connect to your TV (colour or black and white) and cassette recorder.



uter-



Available now - the ZX Printer for only £49.⁹⁵

Designed exclusively for use with the ZX81 (and ZX80 with 8K BASIC ROM), the printer offers full alpha-numerics and highly sophisticated graphics.

A special feature is COPY, which prints out exactly what is on the whole TV screen without the need for further instructions.

At last you can have a hard copy of your program listings - particularly

useful when writing or editing programs.

And of course you can print out your results for permanent records or sending to a friend.

Printing speed is 50 characters per second, with 32 characters per line and 9 lines per vertical inch.

The ZX Printer connects to the rear of your computer - using a stackable connector so you can plug in a RAM pack as well. A roll of paper (65 ft long x 4 in wide) is supplied, along with full instructions.

16K-byte RAM pack for massive add-on memory.

Designed as a complete module to fit your Sinclair ZX80 or ZX81, the RAM pack simply plugs into the existing expansion port at the rear of the computer to multiply your data/program storage by 16!

Use it for long and complex programs or as a personal database. Yet it costs as little as half the price of competitive additional memory.

With the RAM pack, you can also run some of the more sophisticated ZX Software - the Business & Household management systems for example.

How to order your ZX81

BY PHONE - Access, Barclaycard or Trustcard holders can call 01-200 0200 for personal attention 24 hours a day, every day.

BY FREEPOST - use the no-stamp-needed coupon below. You can pay

by cheque, postal order, Access, Barclaycard or Trustcard.

EITHER WAY - please allow up to 28 days for delivery. And there's a 14-day money-back option. We want you to be satisfied beyond doubt - and we have no doubt that you will be.

To: Sinclair Research Ltd, FREEPOST, Camberley, Surrey, GU15 3BR.

Qty	Item	Code	Item price £	Order Total £
	Sinclair ZX81 Personal Computer kit(s). Price includes ZX81 BASIC manual, excludes mains adaptor.	12	49.95	
	Ready-assembled Sinclair ZX81 Personal Computer(s). Price includes ZX81 BASIC manual and mains adaptor.	11	69.95	
	Mains Adaptor(s) (800 mA at 9 V DC nominal unregulated).	10	8.95	
	16K-BYTE RAM pack.	18	49.95	
	Sinclair ZX Printer.	27	49.95	
	8K BASIC ROM to fit ZX80.	17	19.95	
	Post and Packing.			2.95

Please tick if you require a VAT receipt TOTAL £ _____

*I enclose a cheque/postal order payable to Sinclair Research Ltd, for £ _____

*Please charge to my Access/Barclaycard/Trustcard account no. _____

*Please delete/complete as applicable. _____ Please print.

Name: Mr/Mrs/Miss _____

Address: _____

FREEPOST - no stamp needed. Offer applies to UK only.

EVE 04

sinclair ZX81

6 Kings Parade, Cambridge, Cambs., CB2 1SN.
Tel: (0276) 66104 & 21282.

ELECTROVALUE

CATALOGUE '82

A MUST FOR ANYONE USING A SCREWDRIVER OR SOLDERING IRON!



PACKED WITH INFORMATION ON MORE THAN 6000 ITEMS INCLUDING SIEMENS CAPACITORS, FERRITES AND SEMI-CONDUCTORS, ALSO SOLDER TOOLS, METERS ETC.

FOR YOUR COPY OF CATALOGUE 82 please send 70p (includes 70p voucher reclaimable against orders valued £10.00 or over).

DISCOUNTS

5% on orders over £23.00 (inc. VAT). 10% on orders over £57.50 (inc. VAT) on most catalogue items but not for payments by credit cards.

ALL ITEMS BRAND NEW AND GUARANTEED SPEEDY MAIL ORDER SERVICE

No P/P charges on U.K. C.W.O. orders over £5.75 inc. V.A.T. (add 40p handling charge if under).

PLEASE ADD 15% V.A.T. TO TOTAL VALUE OF ALL ORDERS

NEW PRICE LIST

Send S.A.E. for latest issue valid 4 months. Many reduced prices.

4000BE SERIES

4000BE	15p
4001BE	18p
4002BE	18p
4003BE	18p
4007BE	18p
4008BE	65p
4009BE	54p
4010BE	45p
4011BE	18p
4012BE	19p
4013BE	38p
4014BE	96p
4015BE	114p
4016BE	38p
4017BE	66p
4018BE	88p
4019BE	84p
4020BE	90p
4021BE	88p
4022BE	70p
4023BE	10p
4024BE	88p
4025BE	18p
4026BE	175p
4027BE	8p
4028BE	104p
4029BE	97p
4030BE	51p
4041BE	84p
4042BE	75p
4043BE	88p
4044BE	88p
4046BE	128p
4049BE	48p
4050BE	48p
4060BE	133p
4069BE	23p
4070BE	27p
4071BE	19p
4072BE	19p
4081BE	19p
4082BE	19p
4093BE	45p
4510BE	65p
4511BE	60p
4514BE	33p
4516BE	137p
4518BE	50p
4520BE	70p
4543BE	100p
4583BE	195p

74LS00 SERIES

74LS00	14p
74LS02	14p
74LS04	18p
74LS05	23p
74LS08	20p
74LS10	19p
74LS11	20p
74LS14	58p
74LS20	18p
74LS30	21p
74LS32	22p
74LS37	24p
74LS38	35p
74LS42	59p
74LS47	88p
74LS51	25p
74LS73	38p
74LS74	30p
74LS76	44p
74LS76	38p
74LS85	88p
74LS86	38p
74LS90	44p
74LS92	59p
74LS93	57p
74LS107	48p
74LS112	38p
74LS123	82p
74LS125	42p
74LS126	42p
74LS132	60p
74LS136	42p
74LS137	118p
74LS138	75p
74LS139	46p
74LS145	126p
74LS148	185p
74LS151	77p
74LS153	77p
74LS155	84p
74LS156	84p
74LS157	84p
74LS161	78p
74LS163	90p
74LS164	80p
74LS165	75p
74LS166	185p
74LS173	100p
74LS174	85p
74LS175	94p
74LS191	90p

74LS193

74LS193	90p
74LS195	87p
74LS196	14p
74LS197	90p
74LS253	90p
74LS257	75p
74LS259	160p
74LS266	31p
74LS273	130p
74LS279	78p
74LS299	295p
74LS387	58p
74LS388	55p
74LS373	150p
74LS374	150p
74LS378	84p
74LS393	85p

Computing IC's

2114	£1.50
4118	£7.90
4118 200nS	£1.50
4118 250nS	£1.38
4118 300nS	£0.90
Z80A CPU	£8.90
Z80A PIO	£6.90
Z80A CTC	£8.90
6402 UART	£4.58
Special Offer	
25 x 4118 (300nS)	£18.00 only

REGULATORS

7805/12/15/24	65p
7905/12/15/24	65p
78L05/12/15/24	32p
78L05/12/15/24	37p
723 (14 pin)	80p
78M05	£5.55
78HGKC	£7.29
79HGKC	£12.15
LM317K	£3.21

Low Profile IC Holders - BICC

pins 1 off, 25 off	
8	8p
14	12p
16	14p
18	18p
20	16p
22	21p
24	21p

NICADS AND CHARGERS

by Sanyo Cadnica	
N450AA (AA size)	99p
N1800C (C size)	£2.27
N3500D (D size)	£3.76
N175P (PP3 size)	£4.10
CHARGERS:	
NC75G (PP3)	£4.95
NC450S (4 x AA)	£4.95
NC1230 (AA, C, D)	£7.90

CAPACITOR PACK

Buy in quantity for best value
CP1: 100 ceramic capacitors from 1p8 to 1µF. Selection determined by popular demand. Pack Price £3.50

RESISTORS IN HANDY PACKS

3W, 5% tolerance, each pack 100 items from one decade. Selection determined by popularly demanded values.
RD1: 1R0-8R2; RD2: 10R-82R; RD3: 100R-820R RD4: 1K-82K; RD5: 10K-82K; RD6: 100K-820K; RD7: 1M-10M. each decade pack £1.30

ALUMINIUM BOXES WITH LIDS

Size	Price
AB7 70x133x38	85p
AB8 101x101x38	85p
AB9 101x 70x38	85p
AB10 101x133x38	85p
AB11 101x 64x51	85p
AB12 76x 51x25	67p
AB13 127x 89x64	99p

TRANSISTOR SELECTION

2N3053	23p
2N3054	73p
2N3055	70p
BC227	11p
BC337	11p
BD130	45p
BD131	77p
BD139	39p
BD140	32p
BD679	53p
BD690	55p
BFY50	28p
MJE2955	£1.20
MJE3055	87p
TIP31A	44p
TIP32A	44p
TIP41A	45p
TIP42A	45p
TIP2955	55p
TIP3055	55p

ANALOGUE IC SELECTION

741C8	18p
748C8	35p
7555	86p
CA3080E	88p
CA3130E	99p
CA3140E	40p
LM380N	99p
LM381	£1.51
LM3914N	£2.68
NE555V	23p
NE556A	78p
TD A2030	£1.45
TL071CP	45p
TL072CP	75p
TL074CN	£1.29
UA A170	£1.52
XR2206	£4.00
ZN414	£1.22
ZN425E	£3.90

COMPUTERS

Our computer business is now transferred to:
EV COMPUTING LTD,
700 BURNAGE LANE, BURNAGE,
MANCHESTER M19A 1MA.
Phone 061-432 4945.
— A MICROVALUE FOUNDER
MEMBER & DISTRIBUTOR.

Enquiries and orders may be sent to ELECTROVALUE for passing on to EV COMPUTING who will deal with you promptly and efficiently.

PANEL METERS

£2.20 each
instead of £2.69
until March 31st

TYPE MU

FSD 50µA, 100µA, 1mA, 5mA, 10mA, 50mA, 500mA, 1A.

SWITCHES AND CONNECTORS IN VERY GREAT VARIETY. VEROBEXES, I.L.P. TOROIDAL TRANSFORMERS.

SABTRONICS

FREQUENCY METER

Model 9008B: 8-digit 10Hz Frequency Meter. Professional specification: £180.00

OTHER SABTRONICS EQUIPMENT

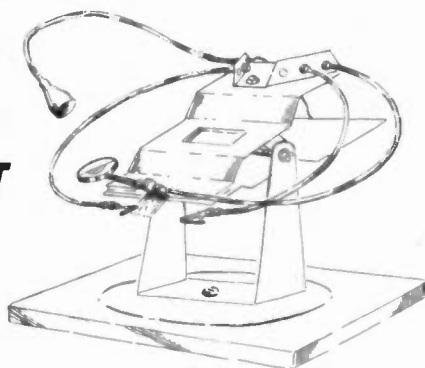
2015A Bench DMM (LCD)	£83.00
2035A Hand-Held DMM (LCD)	£42.00
8110A 8 digit 100MHz OFM	£67.00
8610A 8 digit 600MHz DFM	£82.00
5020A 1-200KHz Function Generator, Sine, Square, Triangle and separate TTL Square wave outputs	£79.00

ELECTROVALUE LTD

Dept. EE 4, 28 St Judas Rd., Englefield Green, Egham, Surrey TW20 0HB, Phone Egham 3355 (STD 0874 - London 07) Telex 264475. Northern Branch (personal shoppers only) 630 Burnage Lane, Burnage, Manchester M19A 1MA. Phone (061) 4324945.

The MINIBENCH* System

CAN YOU AFFORD TO BE WITHOUT ONE?



*Trade Mark

Pat App for

For details & price lists see March issue or write:-

ABSONGLLEN LTD

Dept. EE4

P.O. BOX 13, HERFORD, HR1 1EA

E.E. KITS

Model Train Chuffer	ZB175	Jan. 82	£7.25
Siren Module	ZB176	Jan. 82	£5.50
Mini Egg Timer	ZB177	Jan. 82	£3.25
Race Track Speedo	ZB173	Dec. 81	£22.50
Guitar Adaptor	ZB172	Dec. 81	£3.25
Re Action Meter	ZB171	Dec. 81	£14.50
Sustain Unit	ZB170	Oct. 81	£9.50
Audio Compression Mixer	ZB168	Sept. 81	£13.50
Model Railway Controller	ZB169	Sept. 81	£12.50
Led Sand Glass	ZB162	Aug. 81	£8.50
Cmos Metronome	ZB167	Aug. 81	£6.25
Morse Practise Oscillator	ZB163	Aug. 81	£10.95
Xenon Strobe Lamp	ZB161	July 81	£21.50
Electronic Multimeter	ZB159	July 81	£32.50
Oarkroom Timer	ZB155	June 81	£4.00
Phone Bell Repeater/Baby Alarm	ZB153	May 81	£5.50
Digital Rule	ZB148	April 81	£28.00
LEO Dice	ZB146	March 81	£7.50
Bench Power Supply	ZB143	March 81	£48.50
Sound to Light	ZB127	Nov. 80	£19.00
Audio Effects Unit	ZB122	Oct. 80	£12.25
Cable & Pipe Locator	ZB54	March 80	£4.00
Slide Tape Synchroniser	ZB42	Feb. 80	£11.50
Baby Alarm	ZB40	Nov. 79	£8.50
Varicap Radio	ZB1	Sept. 79	£8.50
Electronic Canary	ZB19	June 79	£5.00
Fuzz Box	ZB106	Dec. 78	£6.75
Weirs Sound Effect Generator	ZB113	March 78	£6.00

Teach-in 82! Bulk purchase of components so prices reduced List 1 and 2. Now £22.50 List 3 £6.35 list 1, 2, & 3 £27.50.

Reprints of above kits 40p + S.A.E. Teach-in Reprints 40p each from October 1981.

T. POWELL

ADVANCE WORKS,
44 WALLACE ROAD, LONDON N1
Tel: 01-226 1489
HOURS: Mon-Fri 9.5.30p.m. Sat 9-4.30p.m.



Minimum Telephone Orders £5.00
Minimum Mail Order £1.00
Callers welcome.

COMPUTER KEY SWITCHES (make your own keyboard)

These are for making up on a p.c.b. and consist of a vertical mounting computer type reed switch, which makes circuit when a magnet passes over it. The magnet is located in the plastic plunger which in turn is depressed by a push rod, to which the legged top is fixed. These are made up in banks of 6, price £2.30 per bank of 6 (including tops)

OUR CAR STARTER AND CHARGER KIT has no doubt saved many motorists from embarrassment in an emergency you can start car off mains or bring your battery up to full charge in a couple of hours. The kit comprises: 250w mains transformer, two 10 amp bridge rectifiers, start/charge switch and full instructions. You can assemble this in the evening, box it up or leave it on the shelf in the garage whichever suits you best. Price £12.50 + £3.00 post.

GPO HIGH GAIN AMP/SIGNAL TRACER. In case measuring only 5 1/2" x 3 1/2" x 1 1/2" is an extremely high gain (70dB) solid state amplifier designed for use as a signal tracer on GPO cables, etc. With a radio it functions very well as a signal tracer. By connecting a simple coil to the input socket a useful mains cable tracer can be made. Runs on standard 43v battery and has input, output sockets and on-off volume control, mounted flush on the top. Many other uses include general purpose amp, cueing amp, etc. An absolute bargain at only £1.85. Suitable 800mhz earpiece 69p.

COMPUTER PRINTER FOR ONLY £6.95

Japanese made Epson 310 — has a self-starting, brushless, transistorised d.c. motor to drive the print hammers, print drum — tape forward/reverse and paper feed. Complete in module form with electronics including Printer Synchronising Signal Amplifier & Printer Reset Signal Amplifier. Brand new and with technical data. £6.95 + £1.35 post. Data separately for £1.00.

SUPER HI-FI SPEAKER CABINETS

Made for an expensive HI-FI outfit — will suit any decor. Resonance free. Out-outs for 6 1/2" woofer and 2 1/2" tweeter. The front material is Dacron. The completed unit is most pleasing. Supplied in pairs, price £8.90 per pair (this is probably less than the original cost of one cabinet) carriage £3.00 the pair.



GOODMANS SPEAKERS

6 1/2" 8 ohm 25 watt £4.50. 2 1/2" 8 ohm tweeter. £2.50. No extra for postage if ordered with cabinets. Xover £1.50.

VU METER SNIP

Approximately 1 5/8" square, suitable for use as a recording level meter, power output indicator or many similar applications. Full vision front, cover easily removable if you wish to alter the scale. Special snip price £1.00 or 10 for £9.00.

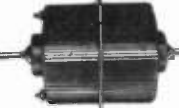


MOTORISED DISCO SWITCH

With 10 amp changerover switches. Multi-adjustable switches all rated at 10 amps, this would provide a magnificent display. For mains operated 8 switch model £6.25, 10 switch model £6.75, 12 switch model £7.25.

12v MOTOR BY SMITHS

Made for use in cars, these are series wound and they become more powerful as load increases. Size 3 1/2" long by 3" dia. These have a good length of 1/2" spindle — price £3.45. Ditto, but double ended £4.25.



EXTRA POWERFUL 12v MOTOR

Made to work battery lawnmower, this probably develops up to 1/2 h.p., so it could be used to power a go-kart or to drive a compressor, etc. etc. £6.90 + £1.50 post.

THERMOSTAT ASSORTMENT

10 different thermostats. 7 bi-metal types and 3 liquid types. There are the current stats which will open the switch to protect devices against overload, short circuits, etc., or when fitted say in front of the element of a blow heater, the heat would trip the stat if the blower fuses; appliance stats, one for high temperatures, others adjustable over a range of temperatures which could include 0 — 100°C. There is also a thermostatic pod which can be immersed, an oven stat, a calibrated boiler stat, finally an ice stat which, fitted to our waterproof heater element, up in the loft could protect your pipes from freezing. Separately, these thermostats could cost over £15.00 — however, you can have the parcel for £2.50.

UNIVAC KEYBOARD BARGAIN

50 keys, together with 5 miniature toggle switches all mounted on a p.c.b. together with 12 i.c.'s, many transistors and other parts. £13.50 + £2.00 post. This is far less than the value of the switches alone. Diagram of this keyboard is available separately for £1.



SOLENOID WITH PLUNGER

Mains operated £1.99
10 — 12 volts DC operated £1.50.

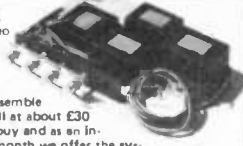
FREE OUR CURRENT BARGAIN LIST WILL BE ENCLOSED WITH ALL ORDERS.

J. BULL (Electrical) Ltd.

(Dept. EE), 34 - 36 AMERICA LANE, HAYWARDS HEATH, SUSSEX RH16 3QU. **Established 30 YEARS**

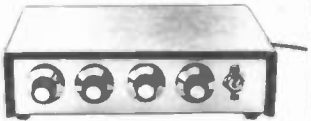
MULLARD UNILEX

A mains operated 4 + 4 stereo system. Rated one of the finest performers in the stereo field this would make a wonderful gift for almost anyone. In easy to assemble modular form this should sell at about £30 — but due to a special bulk buy and an incentive for you to buy this month we offer the system complete at only £16.75 including VAT and post. **FREE GIFT** — buy this month and you will receive a pair of Goodmans' elliptical 8" x 5" speakers to match this amplifier.



3 CHANNEL SOUND TO LIGHT KIT

Complete kit of parts for a three-channel sound to light unit controlling over 2000 watts of lighting. Use this at home if you wish but it is plenty rugged enough for disco work. The unit is housed in an attractive two-tone metal case and has controls for each channel, and a master on/off. The audio input and output are by 1/2" sockets and three panel mounting fuse holders provide thyristor protection. A four-pin plug and socket facilitate ease of connecting lamps. Special snip price is £14.95 in kit form or £25.00 assembled and tested.



FIVE UNUSUAL SWITCHES

For inventors, experimenters, service engineers, students or in fact anyone interested in making electrical gadgets. The parcel contains: — delay switch — motor driven switch — two-way and off switch — polarity changing switch — and humidity switch. Our regular price for these switches bought separately is over £10, but this month you can have the 5 for £2.50.

THIS MONTH'S SNIP

IONISER — AIR FRESHENER

Headaches, tiredness and that "Thundery Weather Feeling" — Scientist's say are caused by an excess of positive ions, they also say that heaters and other modern aids can cause this ion imbalance. The answer is a negative ion generator or ioniser — this mains operated device will fill your home, office or workshop with a refreshing breeze neg. ions, which you will find both stimulating and invigorating. Complete kit in neat sturdy plastic case. £14.95.

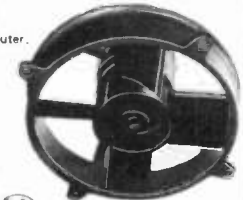
SPIT MOTORS

These are powerful mains operated induction motors with gear box attached. The final shaft is a 1/2" rod with square hole, so you have alternative coupling methods — final speed is approx. 5 revs/min, price £5.50. — Similar motors with final speeds of 80, 100, 160 & 200 r.p.m. same price.



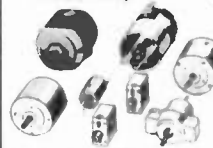
EXTRACTOR FAN

Mains operated — ex. computer.
5" Woods extractor £5.95, Post £1.50
5" Planair extractor £6.50, Post £1.25
4" x 4" Muffin 115v. £4.50, Post 75p.
4" x 4" Muffin 230v. £5.75, Post 75p.



8 POWERFUL BATTERY MOTORS

For models, maccanos, drills, remote control planes, boats, etc. £2.95.



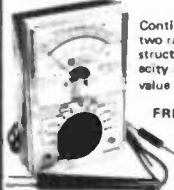
TAPE PUNCH & READER

For controlling machine tools, etc. motorised 8 bit punch with matching tape reader. Ex-computers, believed in good working order, any not so would be exchanged. £17.50 pair. Post £4.00.



MINI-MULTI TESTER

Deluxe pocket size precision moving coil instrument, Jewelled bearings - 2000 p.p.v. mirrored scale. 11 instant range measures: DC volts 10, 50, 250, 1000. AC volts 10, 50, 250, 1000. DC amps 0 — 100 mA.



Continuity and resistance 0 - 1 meg ohms in two ranges. Complete with test prods and instruction book showing how to measure capacity and inductance as well. Unbelievable value at only £8.75 + 60p post and insurance.

FREE Amps range kit to enable you to read DC current from 0 - 10 amps, directly on the 0 - 10 scale. It's free if you purchase quickly, but if you already own a Mini-Tester and would like one, send £2.50.

TRANSMITTER SURVEILLANCE

Tiny, easily hidden but which will enable conversation to be picked up with FM radio. Can be made in a matchbox — all electronic parts and circuit. £2.30. (not licenceable in the U.K.)

RADIO MIKE

Ideal for discos and garden parties, allows complete freedom of movement. Play through FM radio or tuner amp. £6.90 comp. kit. (not licenceable in the U.K.)

FM RECEIVER

Made up and working, complete with scale and pointer needs only a headphone, ideal for use with our surveillance transmitter or radio mike. £5.85.

LEVEL METER

Size approximately 1/2" square, scaled signal and power but cover easily removable for rescaling. Sensitivity 200 uA, 75p.



POCKET AUDIO COMPONENT TESTER

With it you can quickly test diodes, rectifiers, transistors, capacitors, check wiring and p.c. boards for open circuits, find the anode and cathode of a diode or rectifier and whether a transistor is PNP or NPN, which are the base collector and emitter connections. Condensers, if bad, give a continuous signal, but if good, give intermittent signals of varying length depending on their value. The test current is very low (2uA) and the voltage only 1.4V, so it is also possible to check MOS devices, as well as sensitive transistors without fear of damaging them. The unit is supplied complete with internal battery, which should last many months. Price £3.45.

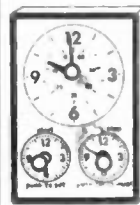


VENNER TIME SWITCH

Mains operated with 20 amp switch, one on and one off per 24 hrs. repeats daily automatically correcting for the lengthening or shortening day. An expensive time switch but you can have it for only £2.95. These are without case but we can supply a plastic base £1.75 or metal case with window £2.95. Also available is adaptor kit to convert this into a normal 24 hr. time switch but with the added advantage of up to 12 on/off per 24 hrs. This makes an ideal controller for the immersion heater. Price of adaptor kit is £2.30.

STEREO HEADPHONES

Very good quality, 8 ohm impedance, padded, terminating with standard 1/4" jack-plug £2.99 post 60p.



TIME SWITCH BARGAIN

Large clear mains frequency controlled clock, which will always show you the correct time + start and stop switches with dials. Complete with knobs. £2.50.

DELAY SWITCH

Mains operated — delay can be accurately set with pointers knob for periods of up to 2 1/2 hrs. 2 contacts suitable to switch 10 amps — second contact opens a few minutes after 1st contact. £1.95.



6 WAVEBAND SHORTWAVE RADIO KIT

Bandspread covering 13.5 to 32 metres. Based on circuit which appeared in a recent issue of Radio Constructor. Complete kit includes case materials, six transistors and diodes, condensers, resistors, inductors, switches, etc. Nothing else to buy if you have an amplifier to connect it to or a pair of high resistance headphones. Price £11.95.

MEDIUM & 2 SHORT WAVE CRYSTAL RADIO

All the parts to make up the beginner's model. Price £2.30. Crystal earpiece 65p. High resistance headphones (gives best results) £3.75. Kit includes chassis and front but not case.

RADIO STETHOSCOPE

Easy to fault find — start at the aerial and work towards the speaker — when signal stops you have found the fault. Complete kit £4.95.

INTERRUPTED BEAM

This kit enables you to make a switch that will trigger when a steady beam of infra red or ordinary light is broken. Main components — relay, photo transistor, resistors and caps, etc. Circuit diagram but no case. Price £2.30

MUGGER DETERRENT

A high-note beeper, push latching switch, plastic case and battery connector. Will scare away any villain and bring help. £2.50 complete kit.

TANGENTIAL BLOW HEATER

2.5 Kw quiet, efficient instant heating from 230/240 volt mains. Kit consists of blow-off illustrated, 2.5 Kw element, control switch and data all for £4.95, post £1.50.



12V SUBMERSIBLE PUMP

Just join it to your car battery, drop it into the liquid to be moved and up it comes, no messing about, no priming, etc. and you get a very good head. Suitable for water, paraffin and any non-explosive non-corrosive liquid. Use only if you are a camper, make yourself a shower. Price: £9.50.

MAIL ORDER TERMS: Cash, P.O. or cheque with order. Orders under £10, add 60p service charge. Monthly account orders accepted from schools and public companies. Access & Barclaycard orders phone Haywards Heath (0444) 54563. Bulk Orders: Write for quote. Normal delivery by return.

ALCON

SPECIAL OFFER

20kΩ/V d.c.
4kΩ/V a.c.

mini 20

The Mini 20 is an ideal instrument for the constructor.

This special offer is a wonderful opportunity to acquire an essential piece of test gear with a saving of nearly £10 on the normal retail price.

The 28 ranges cover all likely requirements. Operation is straight-forward, just turn the selection switch to the required range position.

RANGES

d.c. V: 100mV, 3V, 10V, 30V, 100V, 300V, 600V.

a.c. V: 15V, 50V, 150V, 500V, 1500V.

d.c. I: 50μA, 600μA, 6mA, 60mA, 600mA.

a.c. I: 30mA, 300mA, 3A.

Ohms: 2kΩ, 2MΩ.

Accuracy: 2% d.c. & resistance, 3% a.c.

Dimensions: 105 × 130 × 40mm

Movement protected by internal diode and fuse.

For details of this and the many other exciting instruments in the Alcon range, including multimeters, component measuring and electronic instruments please write or telephone:



Supplied complete
with case, leads and
instructions.

only £21.60

**INCLUSIVE OF POST
PACKAGE-V.A.T.**

Goods despatched by return of post

ALCON Instruments Ltd.

19 MULBERRY WALK · LONDON SW3 6DZ · TEL: 01-352 1897 · TELEX: 918867

Buy British—Buy Douglas Transformers
Mail Order from TITAN Transformers &
Components
Central Hall Chambers, Duncombe Street,
Grimsby, South Humberside DN32 7EG
Prices include 15% V.A.T. Send for our
Catalogue. Please allow up to 28 days delivery.



12/24V RANGE P/N 220/240V				30/60V RANGE P/N 120/220/240V				AUTOTRANSFORMERS 240V/220-115V					
SEC. CONNECTIONS				SEC. CONNECTIONS				SEC. CONNECTIONS					
0 2V 0V 12V				24V 30V 60V 120V 240V				55VA 10RVA					
VOLTS RANGE 0.2-1-10-15				VOLTS 12-20-40-60-120				240V					
TYPE	AMPS	PRICE	P/P	TYPE	AMPS	PRICE	P/P	TYPE	VA	PRICE	P/P		
	12v	24v	£	£	30v	60v	£	£		£	£		
213	1	0-50	2-85	0-94	124	1	0-5	3-30	1-57	25	65	3-90	1-20
71	2	1	2-77	1-20	126	2	1	6-36	1-57	64	80	4-82	1-20
18	4	2	3-98	1-57	127	4	2	7-86	1-90	4	150	6-21	1-57
88	3	1-5	3-46	1-57	125	6	3	11-78	2-10	69	250	7-54	1-57
85	5	2-5	6-06	1-57	123	8	4	14-72	2-40	53	350	9-73	2-10
70	6	3	6-67	1-57	40	10	5	17-10	2-40	67	500	11-70	2-40
108	8	4	8-03	1-57	120	12	6	19-44	2-55	83	750	13-51	2-55
116	12	6	9-31	2-10	121	16	8	27-70	2-90	84	1000	18-31	2-25
17	16	8	11-48	2-25	122	20	10	32-05	4-50	95	2KVA	34-36	5-50
187	30	15	19-23	2-50	189	24	12	37-92	5-50	73	3	64-74	5-50
232	40	20	27-01	5-00						57	5	97-85	7-00
										101	10	170-08	10-50

15/30V RANGE P/N 220/240V				48/96V RANGE P/N 120/220/240V				CASED AUTOTRANSFORMERS					
SEC. CONNECTIONS				SEC. CONNECTIONS				240V LEAD IN 115V 2PIN SOCKET OUT					
0 15V 0V 30V				24V 30V 60V 120V 240V				240V					
VOLTS RANGE 0.2-1-10-15				VOLTS 12-20-40-60-120				240V					
TYPE	AMPS	PRICE	P/P	TYPE	AMPS	PRICE	P/P	TYPE	VA	PRICE	P/P		
	15v	30v	£	£	48v	96v	£	£		£	£		
112	1	0-50	2-84	1-20	430	1	0-5	4-09	1-57	56W	20	6-60	0-94
79	2	1	3-29	1-20	431	2	1	7-84	1-57	64W	80	8-43	1-57
3	4	2	6-18	1-57	432	4	2	12-94	2-25	4W	150	10-88	1-90
20	6	3	7-19	1-90	433	6	3	14-82	2-40	69W	250	13-17	2-10
21	8	4	8-52	1-90	434	8	4	20-04	2-70	67W	500	20-46	2-40
51	10	5	10-57	2-10	435	10	5	28-75	2-90	84W	1000	30-24	2-50
117	12	6	11-94	2-25	436	12	6	36-16	4-50	95W	2000	54-83	5-50
88	16	8	18-14	2-40	437	16	8	39-47	5-50	73W	3000	78-67	7-00
89	20	10	18-54	2-55									
90	24	12	29-37	2-80									
91	30	15	23-63	2-90									
92	40	20	33-21	5-00									

75/150V RANGE P/N 120/220/240V				LINE ADJUSTMENT AUTOTRANSFORMERS				
SEC. CONNECTIONS				SEC. CONNECTIONS				
0 75V 0V 150V				240V/220-115V				
VOLTS RANGE 0.2-1-10-15				240V				
TYPE	AMPS	PRICE	P/P	TYPE	VA	PRICE	P/P	
	24v	50v	£	£		£	£	
102	1	0-50	3-29	1-43	415C	50	2-31	0-94
103	2	1	4-09	1-43	416C	100	3-46	0-94
104	4	2	7-65	1-73	417C	200	4-00	1-20
105	6	3	9-09	1-90	418F	350	6-26	1-57
106	8	4	12-24	1-90	419F	500	8-74	1-90
107	12	6	18-15	2-20	420E	750	8-33	2-10
118	16	8	22-46	2-55	421F	1000	11-64	2-25
119	20	10	27-05	2-55				
109	24	12	32-44	4-50				

Send Today 50p (Refundable with First Order) for Catalogue
TITAN TRANSFORMERS AND COMPONENTS
CENTRAL HALL CHAMBERS GRIMSBY DN32 7EG
MAIL ORDER ONLY - PRICES INCLUDE 15% VAT EE 4

JOIN UP WITH LITESOLD

Litesold's new 'L' Series soldering iron - now at a bargain price.
Outstanding performance. Lightweight. Easy to maintain.

Elements are enclosed in Stainless Steel shafts.
Insulated with mica and ceramic. Non-seize
interchangeable bits, choose from

'copper' or 'long life'. A very special
tool at a very special 'direct' price.
Just £5.58 for iron fitted with 3.2mm
copper bit. Just £2.40 for 3 spare
copper bits (1.6; 2.4; 4.7).

A mere £4.38 for
professional spring
stand! Or buy the
lot for £11.12!
and save 10%.



£5.58

LITESOLD
LIGHT SOLDERING
DEVELOPMENTS LTD

All prices inc. VAT P.&P.

Please allow 14 days delivery.

Write today. Send Cheque/P.O. to Litesold, 97-99 Gloucester Road, Croydon CR0 2DN
or phone 01-589 0674 for Barclaycard/Access sales.

The ONE catalogue you MUST have!

- About 2,000 items clearly listed.
- Profusely illustrated throughout.
- Large A-4 size pages.
- Bargain list, order form and 2 coupons each worth 25p if used as directed, all supplied free.

Price £1, plus 50p for post, packing and insurance.

Send cheque or P.O. for £1.50.

HOME RADIO Components Ltd
Dept. EE P.O. Box 92, 215 London Road,
Mitcham, Surrey. 91-643 5669



WE WILL BEAT BY 5% ANY LOWER PRICE ADVERTISED BY COMPETITORS★

WATER RESISTANT WATCHES

With Alarm, Hourly Time Signal, Stopwatch and Calendar
100 METRE WATER RESISTANT



W-100
Resin
case/strap
£19.95



W-150C
S/S case,
resin strap
£21.95



W-150
All
S/S
£24.95

Time and auto calendar. Alarm and hourly chimes. Countdown alarm timer with repeat memory function. Professional 1/100 second stopwatch. Time is always on display, regardless of display mode. Amazing 5 year lithium battery life. Superior to the W-250.

50 METRE WATER RESISTANT



W-20
Resin
case/strap
£12.95



W-21
Resin
S/S trim
£14.95



W-30
All
S/S
£19.95

12/24 hour time and auto calendar. Alarm and hourly chimes. Professional 1/100 second stopwatch to 12 hrs. Compact and slim cases, approx. 8mm thick. Lithium.

OTHER MODELS

AX-210. The world's most versatile watch?

- Analog Display
- LC Display of hours and minutes
- Digital display
- ★ Local time, 12 or 24 hour
- ★ Full calendar display
- ★ Dual time, 12 or 24 hour
- ★ Alarm time display
- ★ Countdown alarm timer with memory function
- ★ Professional 1/100 second stopwatch

Hourly time signal. Daily alarm electronic buzzer or 3 selectable melodies. Rapid forward/back setting. 9.4 x 35.4 x 36mm.

Usual Price £29.95

Lowest price elsewhere

★ £27.95



CA-85
Resin
Usually £19.95
Price elsewhere
★ £18.95



CA-901
Chrome
Usually £29.95
Price elsewhere
★ £27.95



J-100
Resin
£19.95

CA 85/901. Time and auto calendar. Calculator-Alarm and hourly chimes. Stopwatch. Dual time. DIGITAL SPACE INVADER game.

J-100. Similar to the CA-85 but without dual time and with a JOGGING COMPUTER instead of the game function.

GM-10. Alarm chrono with SPACE INTERCEPTOR game £19.95

CALCULATORS

£100 POCKET COMPUTER.

Casio FX-702P. NOW ONLY £99.95
FX-602P. Usual price £74.95. Price elsewhere £71.95
FP-10 Printer £44.95 (elsewhere £41.95).
FA-2 £19.95

OUR BEST SELLING SCIENTIFIC

FX-3600P
10 digits, 61 scientific functions including Integrals and Regression analysis. Up to 38 program steps, 2 programs and 7 memories, all non-volatile. Wallet size. 1,300 hour battery.
Usual Price £22.95
Price elsewhere

★ £21.95



FX-180P. Hand held version without hyperbolics £19.95



FX-8100 Scientific with Clock, Alarms and Stopwatch
8 digits, 49 scientific functions. Clock, hourly chimes, alarm. 2 countdown alarm timers. Auto calendar. 1/100 second pro stopwatch. Complete with wallet.
Usual Price £19.95
Price elsewhere £23.95 ★

FX-550
10 digits, 50 scientific functions including hyperbolics, standard deviations, etc. $\frac{1}{n} \times 2\frac{1}{2} \times 5\frac{1}{2}$ ".
Wallet. 1,300 hour lithium battery life.

Usual Price £19.95

Price elsewhere ★ £18.95



FX-5 £8.95. FX-7 £10.95. FX-82 £12.95.
FX-100 £16.95.

CALCULATING ALARM CLOCKS

FT-7 Fortune Teller and Matchmaker



Clock, alarm, hourly chimes, calendar. Predictions of individual fortunes (health, gambling/investment, business and love), or the compatibility between two persons on any given day. Usual Price £16.95.

Price elsewhere ★ £15.95

BG-15. Boxing game, alarm clock, calculator. Usual Price £16.95. Price elsewhere £15.95

ML-75. 12 melody alarms, clock, calculator. £14.95

ML-120. Wallet version of above £14.95

ML-2000 £22.95. UC-3000 £27.95. UC-300/365 £19.95.

BASIC CALCULATORS

MG-777 Compendium of Games

A game of chance, a game to test your reactions and a game to tax your intelligence. Plus a very useful clock as well and, of course, a wallet sized calculator.

ONLY £14.95

SL-801 Solar £8.95. HQ-25 Time calculations £9.95.



CATALOGUE ON REQUEST. 15p STAMP APPRECIATED

SENSATION

of the Japanese Music Fair

CASIOTONE 701 COMPUTERISED ORGAN

Fully Programmable, 5 Octave, Polyphonic Keyboard
"THE instrument of 1982... probably the best instructive keyboard I have come across. But it is also a top line musical instrument capable of satisfying even the most proficient musician" Keyboards & Music Player.



CT-701 (RRP £555) ONLY £495

Program the 345 melody steps and the 201 chord steps, (max.) with music specially scored in bar code and read by a light pen, or enter your own chords and melody via the keyboard, with full editing and repeat facilities.

3-way replay:—Automatic; One Key Play; Melody Guide. (lights above the keyboard indicate the next note to play). Split keyboard; 20 superb instrument voices; 16 rhythm accompaniments; fingered or auto chords with walking bass and arpeggio; fill-in and effect buttons. 37 $\frac{1}{2}$ x 13 $\frac{1}{2}$ x 5". Weight: 12.5kg (27.6lbs).

CT-601. As 701 but without programming functions £395

COMMON SPECIFICATIONS

All Casiotones (except VL-Tones) are 8-note polyphonic. They all have built-in amplifiers and speakers, with output jacks for headphones and external amplification and a pitch control. CT models are mains only and have volume and sustain pedal jacks.

CT-403



RRP £325.00
ONLY £275.00

25 instruments over 4 octaves. Four voice memory function with push button selection. Vibrato and sustain switches. 16 rhythm accompaniments with fill-in variation Casio Auto Chord for one finger or auto playing of major, minor and 7th chords with bass. Ten functional controls 4 $\frac{1}{2}$ x 30 $\frac{1}{2}$ x 11 $\frac{1}{2}$ ". Weight 17.6lbs.

CT-202



RRP £325
ONLY £275

"Son of success... The two harpsichords demonstrate the Casiotone's talent for sparkling, crystal clear tones... Even more impressive is the clav... (Melody Maker).

49 instruments over 4 octaves. 4 voice memory function with push button selection, 3 vibrato settings and sustain 3 $\frac{1}{2}$ x 34 $\frac{1}{2}$ x 11 $\frac{1}{2}$ ". 16.8lbs.

CT-101. Similar to 202 but has 25 voices. ONLY £195

MT-40



RRP £125
ONLY £99

37 key, 3 octave keyboard plus 15 key bass keyboard with automatic, synchronised bass function. 22 instrument voices; 6 auto rhythms with dual fill-in. Sustain and Vibrato. Battery powered, or optional mains adaptor AD-1E (£5). 23 x 7 x 2 $\frac{1}{2}$ ". Weight 4.9lb. VL-TONE. Become an Instant Musician with this amazing programmable Musical Instrument. 10 auto rhythms, five voices + ADSR. 2 extra books worth £5.90 FREE.

£35.95

★ Providing the advertiser has stocks and we do not sell at a loss. DELIVERY NORMALLY BY RETURN

Price includes VAT and P&P. Send cheques, PO, or phone your ACCESS, VISA or B*CARD number to:
LEADING CASIO SPECIALISTS
Dept. EE,
38 Burleigh Street, Cambridge CB1 1DG
Telephone: 0223 312866

CATALOGUE
ON REQUEST
15p stamp
appreciated

TEMPUS

Everyday Electronics, April 1982

LIMITED OFFER!

As an introduction to **CRICKLEWOOD ELECTRONICS LTD.**, (Marshall's Old Shop), 40 Cricklewood Broadway, London NW2 3ET tel: 01 452 0161 Whilst stocks last and only if accompanied by this Ad.

DESOLDERING TOOL



Now every one can afford one of these superb, anodised aluminium high pressure hand desoldering tools at nearly half our normal price. Normal Price £6.50 + VAT with this ad £3.85 + VAT. Spare Teflon screw-in noses 75p + VAT.

JAPANESE TRANSISTORS May not be as hard to replace as you think. Phone our equivalent service on 01 452 0161 (everyday except Wednesdays) or write. We have thousands of Transistors, ICs, LEDs in stock, as well as every conceivable type of component—Why not make **CRICKLEWOOD ELECTRONICS** your personal **ELECTRONICS HOBBY CENTRE**? We have the goods!

Now you need no longer grope in the dark. For a miniature price you can watch those volts move! See those resistors jump to life!



THE MIGHTY MINI MULTI-TESTER 2,000 ohms per volt. DC & AC Voltage ranges: 10v, 50v, 250v, 1000v. DC current ranges 100mA. Resistance ohms x 10, ohms x 100db from -10db to +22db. Mirror arc scale, overload protected, complete with battery, test leads & instructions. Usual price £8.65 + VAT; with this Ad: £4.95 + VAT.

ORDER FORM

Name
Address

..... Desoldering tools @ £3.85 = £.....
..... Spare Teflon noses @ .75 = £.....
..... Mighty Mini Testers @ £4.95 = £.....

Postage, packing and Insurance @ 60p per one device 25p for each additional device £.....

Sub total £.....
Add 15% VAT £.....

I enclose cheque no/P.O. no.
Alternatively please credit my VISA/ACCESS no.

Signature

This offer applies to UK only. Please allow 7-10 days delivery. Overseas customers please do not add VAT but allow enough to cover postage.
TRADE ENQUIRIES WELCOME.

CRICKLEWOOD ELECTRONICS LTD.

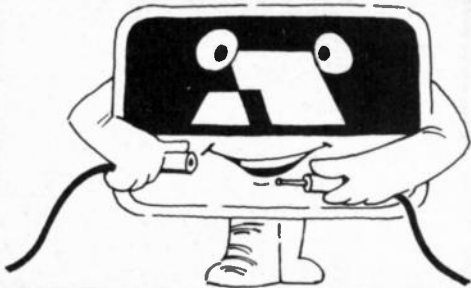
40 Cricklewood Broadway, London NW2 3ET tel 01 452 0161

THE MEKON IS BACK



IN EAGLE

Make the connection with Access



and receive a regular postal delivery of Everyday Electronics. It's easy, it's straightforward and it's quick. Just use the subscription order form to get your Access card account charged with the price of a subscription or order your subscription through Access on the phone: (01) 886 6433. If you pay by cheque or postal order, use the subscription order form in the usual way.

SUBSCRIPTION ORDER FORM

I wish to become a subscriber to **Everyday Electronics** for one year and enclose cheque/postal order value..... no..... made payable to IPC Magazines Ltd.

Complete this portion if you are using your Access card account. I authorise you to debit my Access card account with the above amount.

My Access no. is

(Block letters please)

Name.....

Address.....

Signature.....

Subscription Rates:

UK, Isle of Man, Channel Islands and Irish Republic £11

Overseas £12

Unless you are phoning your order, complete and post this order form to:

Everyday Electronics,
2613 King's Reach Tower,
Stamford Street,
London SE1 9LS.



BENNING CROSS ELECTRONICS

67 Vicarage Road, Watford, Herts
 Telephone **WATFORD (0923) 36234**
 All prices subject to VAT at 15% extra
 Export orders welcome
 All deliveries within 7 days.

All devices brand new, full spec. and fully guaranteed. Orders despatched by return of post. Terms of business. PO Cheque/Cash or Bankers Draft with order Government and educational institutions official orders accepted. Trade and export enquiries welcome. P&P add 50p to all orders under £9 nett. Overseas orders postage at cost.

Polyester capacitors radial lead type—250V
 10N, 15N, 22N, 27N 8p; 33N, 47N, 100N 7p; 150N, 220N, 10p; 330N, 470N 14p; 680N, 1uF, 20p; 1.5MF, 2.2uF, 43p.

Tantalum bead capacitors 35V;
 0.1uF, 0.22, 0.33, 15p; 0.47, 0.68, 1.0, 1.5, 16p; 2.2, 3.3, 18p; 4.7, 6.8, 22p; 10, 28p; 18V, 2.2, 3.3, 18p; 4.7, 6.8, 10, 18p; 15, 36p; 22, 30p; 33, 47, 100, 35p; 10V: 15, 22, 28p; 33, 47, 35p; 100, 55p; 5V: 10, 42p.

Polyethylene capacitors: 10PF to 1NF 8p; 1.5NF to 12NF 12p

Miniature type trimmers: 2.6PF, 2.10PF, 24p, 10.88PF 34p, 2.25 34p.

Transformers: 606, 909 12012 85p.

VEROBOARDS 0.1" Clad Plain

SPECIAL OFFER

LED

IC/S

Ceramic capacitors 50V
 range 1PF to 10NF 4p;
 15NF, 22NF, 33NF,
 47NF, 100NF, 150NF,
 220NF, 8p.

ZENERS
 Range, 2V7 to 39V
 400mW 7p each.
 Range 3V2 to 33V,
 1.3W 14p each

LEDs 125" 2"
 Red 10p 10p
 Green 12p 12p
 Yellow 12p 12p

Dalo Etch Resist Pin gs

FERRIC CHLORIDE
 1lb bag Anhydrous 19p

COPPER CLAD BOARDS
 Fibre Single- Double-
 Glass sided sided
 6" x 8" 8p 9p
 6" x 12" 14p 18p

VERO WIRING PEN and Spool
 310p Spare Wire (Spool) 75p;
 Combs 8p

IC SOCKETS

Potentiometers: carbon track
 0.25W log & linear values.
 470Ω 1K & 2.2K Lin only single

PRESET POTENTIOMETERS
 0.25W 100Ω to 4.7M horiz. larger

Low Prop. Wire Wrap

8 pin 8 24

14 pin 10 40

18 pin 15 50

20 pin 22 50

22 pin 25 60

24 pin 25 60

28 pin 28 70

30 pin 30 90

5k Ω 2M Ω single gang 28p

5k Ω 2M Ω single gang D/P switch 68p

5k Ω 2M Ω or dual gang stereo 78p

0.25W 100 Ω to 4.7M horiz. larger

0.25W 100 Ω to 4.7M vert. 7p

BD138/39 39	2N3710/11 9	NE71 418	4043 70	Diodes	LS10 15LS168 80 05	16107 97
BD140 39	2N3819 23	RC4136 69	4044 65	1N4001/2 5	LS11 15LS169 80 08	28100 25
BF115 32	2N3903/4 8	RC4151 199	4045 160	1N4003/4 6	LS12 15LS170 165 07	28111 85
BF154/8 20	2N3905/6 8	SA5560 145	4048 75	1N4005/6 6	LS13 30LS173 79 08	15118 80
BF187/73 24	2N4061/2 9	SA5570 145	4047 75	1N4007 7	LS14 40LS174 79 09	15120 75
BF194/95 10	2N4286 15	TL890 340	4051 25	1N4014 4	LS15 15LS175 85 10	13121 30
BF196/97 12	2N4289 20	SN76013 240	4049 29	1N4017 4	LS16 15LS176 80 11	20122 40
BF224B 24	2N5135/8 22	SN76023 240	4050 29	1N4048/8 17	LS21 15LS181 58 12	20123 50
BF244B 30	2N5190/1 7	SN78115 215	4051 76	1N914 4	LS22 15LS192 58 13	23125 40
BF257/8 34	40673 95	SN78225 295	4052 70	OA90/91 8	LS26 18LS193 60 14	30126 40
BF259/74 34		SN78227 95	4053 70	OA95 8	LS27 15LS195 40 16	23132 10
BF280/89 25		SN78477 175	4054 125	BY100 23	LS30 18LS196 66 17	23136 15
BFX84 25		SN78680 118	4055 125	BY126/7 13	LS32 15LS197 85 20	15141 70
BFX85/6 26		TL8909 79	4056 88		LS38 15LS240 82 22	20145 70
BFX87/8 26		TL8A820 60	4065 35		LS40 15LS241 82 25	28148 80
BFY50/51 22		TL8A820 60	4067 390		LS42 32LS242 85 26	50150 80
BFY52 22		TL8A820 60	4068 20		LS47 40LS243 85 27	23153 42
BU205/8 190		TL8A820 60	4069 20		LS48 80LS244 86 28	26154 72
MJ2955 90		TL8A820 60	4070 22		LS49 60LS245 90 30	18155 72
MJE2955 95		TL8A820 60	4071 20		LS51 13LS247 80 32	23156 72
MJE3055 85		TL8A820 60	4072 20		LS54 15LS248 80 33	23159 80
ACY17/18 69		TL8A820 60	4073 20		LS55 30LS251 40 37	28160 50
ACY19/20 69		TL8A820 60	4074 20		LS73 22LS252 40 38	48161 00
ACY21/22 69		TL8A820 60	4075 20		LS74 24LS257 46 40	16162 02
MPP102/4 35		TL8A820 60	4076 20		LS75 28LS258 46 41	50163 00
MPP103/4 35		TL8A820 60	4077 22		LS76 20LS259 82 42	34165 00
MPP105/6 35		TL8A820 60	4078 22		LS83 50LS266 20 43	38166 00
MPS A05/8 22		TL8A820 60	4079 22		LS85 70LS279 85 48	50170 18
BFSA12/55 30		TL8A820 60	4080 70		LS90 35LS283 12 50	15173 50
MPS A56/66 30		TL8A820 60	4081 35		LS93 35LS293 42 51	15174 60
OC28 125		TL8A820 60	4082 21		LS95 45LS298 130 53	15175 60
OC45 38		TL8A820 60	4083 65		LS109 30LS322 180 54	16176 50
OC71/72 38		TL8A820 60	4084 70		LS112 30LS365 35 70	23179 75
OC81/82 48		TL8A820 60	4085 14		LS113 40LS366 35 72	30180 50
TIP30/31 40		TL8A820 60	4086 70		LS114 32LS367 35 73	30181 14
TIP32A 45		TL8A820 60	4087 18		LS115 35LS368 85 74	23190 80
TIP34A 45		TL8A820 60	4088 10		LS116 30LS373 75 75	40161 60
TIP41A 48		TL8A820 60	4089 10		LS126 30LS374 75 76	30162 60
TIP42A 58		TL8A820 60	4090 12		LS132 42LS386 225 82	70164 72
TIP120 88		TL8A820 60	4091 14		LS136 28LS390 60 83	50168 72
TIP121/2 90		TL8A820 60	4092 32		LS138 35LS393 60 85	80167 82
TIP141/2 119		TL8A820 60	4093 18		LS145 75LS670 195 86	28163 62
TIP2955 58		TL8A820 60	4094 18			89169 99
LM380 72		TL8A820 60	4095 10			90169 99
LM381 100		TL8A820 60	4096 10			90169 99
LM382 120		TL8A820 60	4097 15			90169 99
LM384 135		TL8A820 60	4098 15			90169 99
LM385 118		TL8A820 60	4099 15			90169 99
LM378 199		TL8A820 60	4100 15			90169 99
LM379 399		TL8A820 60	4101 15			90169 99
LM380 72		TL8A820 60	4102 15			90169 99
LM381 100		TL8A820 60	4103 15			90169 99
LM382 120		TL8A820 60	4104 15			90169 99
LM384 135		TL8A820 60	4105 15			90169 99
LM385 118		TL8A820 60	4106 15			90169 99
LM378 199		TL8A820 60	4107 15			90169 99
LM379 399		TL8A820 60	4108 15			90169 99
LM380 72		TL8A820 60	4109 15			90169 99
LM381 100		TL8A820 60	4110 15			90169 99
LM382 120		TL8A820 60	4111 15			90169 99
LM384 135		TL8A820 60	4112 15			90169 99
LM385 118		TL8A820 60	4113 15			90169 99
LM378 199		TL8A820 60	4114 15			90169 99
LM379 399		TL8A820 60	4115 15			90169 99
LM380 72		TL8A820 60	4116 15			90169 99
LM381 100		TL8A820 60	4117 15			90169 99
LM382 120		TL8A820 60	4118 15			90169 99
LM384 135		TL8A820 60	4119 15			90169 99
LM385 118		TL8A820 60	4120 15			90169 99
LM378 199		TL8A820 60	4121 15			90169 99
LM379 399		TL8A820 60	4122 15			90169 99
LM380 72		TL8A820 60	4123 15			90169 99
LM381 100		TL8A820 60	4124 15			90169 99
LM382 120		TL8A820 60	4125 15			90169 99
LM384 135		TL8A820 60	4126 15			90169 99
LM385 118		TL8A820 60	4127 15			90169 99
LM378 199		TL8A820 60	4128 15			90169 99
LM379 399		TL8A820 60	4129 15			90169 99
LM380 72		TL8A820 60	4130 15			90169 99
LM381 100		TL8A820 60	4131 15			90169 99
LM382 120		TL8A820 60	4132 15			90169 99
LM384 135		TL8A820 60	4133 15			90169 99
LM385 118		TL8A820 60	4134 15			90169 99
LM378 199		TL8A820 60	4135 15			90169 99
LM379 399		TL8A820 60	4136 15			90169 99
LM380 72		TL8A820 60	4137 15			90169 99
LM381 100		TL8A820 60	4138 15			90169 99
LM382 120		TL8A820 60	4139 15			90169 99
LM384 135		TL8A820 60	4140 15			90169 99
LM385 118		TL8A820 60	4141 15			90169 99
LM378 199		TL8A820 60	4142 15			90169 99
LM379 399		TL8A820 60	4143 15			90169 99
LM380 72		TL8A820 60	4144 15			90169 99
LM381 100		TL8A820 60	4145 15			90169 99
LM382 120		TL8A820 60	4146 15			90169 99
LM384 135		TL8A820 60	4147 15			90169 99
LM385 118		TL8A820 60	4148 15			90169 99
LM378 199		TL8A820 60	4149 15			90169 99
LM379 399		TL8A820 60	4150 15			90169 99
LM380 72		TL8A820 60	4151 15			90169 99
LM381 100		TL8A820 60	4152 15			90169 99
LM382 120		TL8A820 60	4153 15			90169 99
LM384 135		TL8A820 60	4154 15			90169 99
LM385 118		TL8A820 60	4155 15			90169 99
LM378 199		TL8A820 60	4156 15			90169 99
LM379 399		TL8A820 60	4157 15			90169 99
LM380 72		TL8A820 60	4158 15			90169 99
LM381 100		TL8A820 60	4159 15			90169 99
LM382 120		TL8A820 60	4160 15			90169 99
LM384 135		TL8A820 60	4161 15			90169 99
LM385 118		TL8A820 60	4162 15			90169 99
LM378 199		TL8A820 60	4163 15			90169 99
LM						

ELECTRONIC IGNITION

Makes a good car better



As a
KIT
OR
READY
BUILT

TOTAL ENERGY DISCHARGE electronic ignition gives all the well known advantages of the best capacitive discharge systems.

PEAK PERFORMANCE — higher output voltage under all conditions.

IMPROVED ECONOMY — no loss of ignition performance between services.

FIRES FOULED SPARK PLUGS no other system can better the capacitive discharge system's ability to fire fouled plugs.

ACCURATE TIMING — prevents contact wear and arcing by reducing load to a few volts and a fraction of an amp.

SMOOTH PERFORMANCE — immune to contact bounce and similar effects which can cause loss of power and roughness.

PLUS

SUPER POWER SPARK — 3½ times the energy of ordinary capacitive systems — 3½ times the power of inductive systems.

OPTIMUM SPARK DURATION 3 times the duration of ordinary capacitive systems — essential for use on modern cars with weak fuel mixtures.

BETTER STARTING — full spark power even with low battery.

CORRECT SPARK POLARITY unlike most ordinary C.D. systems the correct output polarity is maintained to avoid increased stress on the H.T. system and operate all voltage triggered tachometers.

L.E.D. STATIC TIMING LIGHT for accurate setting of the engine's most important adjustment.

LOW RADIO INTERFERENCE fully suppressed supply and absence of inverter 'spikes' on the output reduces interference to a minimal level.

DESIGNED IN RELIABILITY an inherently more reliable circuit combined with top quality components — plus the 'ultimate insurance' of a changeover switch to revert instantly back to standard ignition.

IN KIT FORM

It provides a top performance electronic ignition system at less than half the price of competing ready-built systems. The kit includes everything needed, even a length of solder and a tiny tube of heatsink compound. Detailed easy-to-follow instructions, complete with circuit diagram, are provided — all you need is a small soldering iron and a few basic tools.

AS REVIEWED IN

ELECTRONICS TODAY INTERNATIONAL June '81 Issue
and EVERYDAY ELECTRONICS December '81 Issue

FITS ALL NEGATIVE EARTH VEHICLES,
6 or 12 volt, with or without ballast

OPERATES ALL VOLTAGE IMPULSE TACHOMETERS
Some older current impulse types (Smiths pre '74) require an adaptor —
PRICE £2.95

STANDARD CAR KIT £14.85
Assembled and Tested £24.95

TWIN OUTPUT KIT £22.95
For MOTDR CYCLES and CARS with twin ignition systems
Assembled and Tested £34.70

PLUS
£1.00
U.K.
P. & P.
Prices
Include
VAT.

ELECTRONIZE DESIGN

Goods normally despatched within 7 days



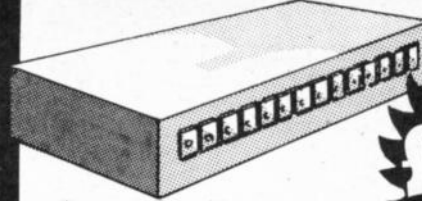
Dept. C, Magnus Road, Wilnecote

Tamworth, B77 5BY

Phone (0827) 281000



As seen on television's Tomorrows World



£98.00
Plus p & p £2.00

The Black Box

home electronics control centre

Utilizing digital circuit techniques, the Black box centralises the operation of all electrics in your home. This initial unit controls lighting and also provides an effective security alarm system to protect your home against intruders. Additions to the Black Box, offered in the next few months, will provide an infra-red remote control pack, followed by a further facility for controlling the function of switch-on appliances, together with pre-determined time selector controls. The Black Box provides absolute flexibility in command of the electrics in your home, all from the comfort of your armchair. Place your order today, or write for further details.

Black Box Specification

- Safe, low power control switching, 9v @ 1mA
- No need for dual control switching
- Zero voltage switching increases bulb life
- Two Dimmers
- Visible Bell/Intruder Alarm
- Master on/off Control
- Timer Control
- Eight on/off controls

ARA Electronics

Burrel Road, Industrial Estate, St. Ives, Cambs

Telephone: (0480) 65868

NAMAL ELECTRONICS

No. 1 Claygate Road, Cambridge CB1 4JZ

Tel: 0223 248257 Telex: 817445

MEMORY EXPANSION PACKS AT
UNBEATABLE PRICES!

3K.	FOR VIC 20	£21.30
8K.	FOR VIC 20 (expandable to 16K)	£35.00
16K.	FOR SINCLAIR ZX 81	£30.00

Please add £1.00 P & P, plus V.A.T.

**If you find an ad
unacceptable,
don't turn the page:
turn to us.**

The Advertising Standards Authority.
If an advertisement is wrong, we're here to put it right.

ASA Ltd, Brook House, Torrington Place, London WC1E 7HN

LOOK

Kit includes tape transport mechanism, ready punched and back printed quality circuit board and all electronic parts i.e. semiconductors, resistors, capacitors, hardware, top cover, printed scale and mains transformer. You only supply solder & hook-up wire.

Self-assembly simulated wood cabinet. £4.50 + £1.50 p+p.

Featured In April issue Practical Electronics, reprint 50p - Free with Kit.

INTRODUCTORY OFFER - ONLY

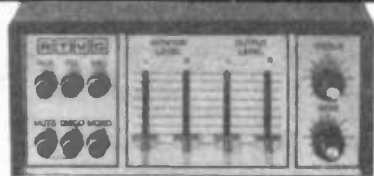
£32.95
+ £2.75 p&p.



P.E. STEREO CASSETTE RECORDER KIT

- NOISE REDUCTION SYSTEM
- AUTO STOP
- TAPE COUNTER
- SWITCHABLE E.Q.
- INDEPENDENT LEVEL CONTROLS
- TWIN V.U. METER
- WOW & FLUTTER 0.1%
- RECORD/PLAYBACK I.C. WITH ELECTRONIC SWITCHING
- FULLY VARIABLE RECORDING BIAS FOR ACCURATE MATCHING OF ALL TAPES

STEREO AMPLIFIER KIT



- Featuring latest SGS/ATES TDA 2006 10 watt output IC's with in-built thermal and short circuit protection.
- Mullard Stereo Pre-amplifier Module.
- Attractive black vinyl finish cabinet, 9" x 8 1/2" x 3 1/4" (approx).
- 10+10 Stereo converts to a 20 watt Disco amplifier.

To complete you just supply connecting wire and solder. Features include din input sockets for ceramic cartridge, microphone, tape or tuner. Outputs - tape, speakers and headphones. By the press of a button it transforms into a 20 watt mono disco amplifier with twin deck mixing. The kit incorporates a Mullard LP1183 pre-amp module, plus power amp assembly kit and mains power supply. Also features 4 slider level controls, rotary bass and treble controls and 6 push button switches. Silver finish fascia with matching knobs and contrasting cabinet. Instructions available, price 50p. Supplied FREE with kit.

£16.50

+ £2.90 p&p.

SPECIFICATIONS: Suitable for 4 to 8 ohm speakers
40Hz - 20KHz
P.U. 150mV. Aux. 200mV.
Mic. 1.5mV.
Bass ±12db @ 60Hz
Treble ±12db @ 10KHz
0.1% typically @ 8 watts
220 - 250 volts 50Hz.

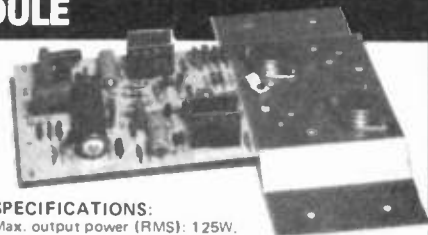
8" SPEAKER KIT Two 8" twin cone domestic speakers. £4.75 per stereo pair plus £1.70 p&p. when purchased with amplifier. Available separately £6.75 & £1.70 p&p.

125W HIGH POWER AMP MODULE

KIT: £10.50 **BUILT: £14.25**
+ £1.15 p&p + £1.15 p&p.

The power amp kit is a module for high power applications - disco units, guitar amplifiers, public address systems and even high power domestic systems. The unit is protected against short circuiting of the load and is safe in an open circuit condition. A large safety margin exists by use of generously rated components, result, a high powered rugged unit. The PC board is back printed, etched and ready to drill for ease of construction and the aluminium chassis is preformed and ready to use. Supplied with all parts, circuit diagrams and instructions.

ACCESSORIES: Suitable mains power supply kit with transformer. £7.50 plus £3.15 p&p.
Suitable LS coupling electrolytic: £1.00 plus 25p p&p.



SPECIFICATIONS:

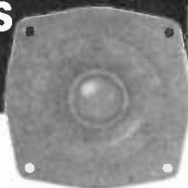
Max. output power (RMS): 125W.
Operating voltage (DC): 50 - 80 max.
Loads: 4 - 16 ohms.
Frequency response measured @ 100 watts: 25Hz - 20KHz.
Sensitivity for 100 watts: 400mV @ 47K.
Typical T.H.D. @ 50 watts, 4 ohms: 0.1%.
Dimensions: 205 x 90 and 190 x 36 mm.

HI-FI SPEAKERS AT BARGAIN PRICES

GOODMANS TWEETERS

8 ohm soft dome radiator tweeter (3 1/2" sq.) for use in up to 40W systems, with 2 element crossover.

£3.50 each (p&p £1) or £5.95 pair (p&p £2).



35 WATT MICRO 2-WAY SPEAKER SYSTEM

Unit comprises one 50w (4" app.) Audax soft dome tweeter HD100. And one 5" Audax bass/midrange 35w driver HIF11JSM. Complete with 2 element crossover. Total impedance of system 4 ohms.

£7.95

PER SET + £2.70 p&p.



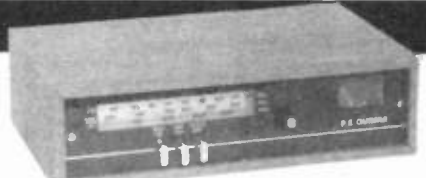
P.E. STEREO TUNER KIT

This easy to build 3 band stereo AM/FM tuner kit is designed in conjunction with Practical Electronics (July 81 issue). For ease of construction and alignment it incorporates three Mullard modules and an I.C. IF. System. **FEATURES:** VHF, MW, LW Bands, interstation muting and AFC on VHF. Tuning meter. Two back printed PCB's. Ready made chassis and scale. Aerial: AM - ferrite rod, FM - 75 or 300 ohms. Stabilised power supply with 'C' core mains transformer. All components supplied are to P.E. strict specification. Front scale size: 10 1/2" x 2 1/2" approx. Complete with diagram and instructions.

£17.95

Plus £2.50 p&p.

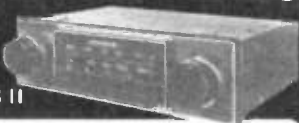
Self assembly simulated wood cabinet sleeve to suit tuner only. Finish size: 11 1/2" x 8 1/2" x 3 1/4".
£3.50 Plus £1.50 p&p.



SPECIAL OFFER! TUNER KIT PLUS:

• Matching I.C. 10 watt per channel Power amp kit. • Mullard LP1183 built pre-amp, suitable for ceramic pick-up and aux. inputs. • Matching power supply kit with transformer. • Matching set of 4 slider controls for bass, treble and volumes. **£21.95** + £3.80 P&P.

PRACTICAL ELECTRONICS CAR RADIO KIT SERIES II



2 WAVE BAND, MW - LW

• Easy to build. • 5 push button tuning. • Modern design. • 6 watt output. • Ready etched and punched PCB. • Incorporates suppression circuits. All the electronic components to build the radio, you supply only the wire and the solder, featured in Practical Electronics. Features: pre-set tuning with 5 push button options, black illuminated tuning scale. The P.E. Traveller has a 6 watt output neg. ground and incorporates an integrated circuit output stage, a Mullard IF Module LP1181 ceramic filter type re-aligned and assembled, and a Bird pre-aligned push button tuning unit.

Suitable stainless steel fully retractable aerial (locking) and speaker (6" x 4" app.) available as a complete kit. £2.50/pack + £1.50 p&p.

£12.95

+ £2.00 p&p.

BIRD AUDIO STEREO CAR RADIO BOOSTER

To boost your car radio or radio cassette to 15W r.m.s. per channel.

£9.95 + £1.50 p&p.



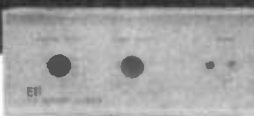
TV SOUND TUNER KIT

£11.45

+ £1.50 p&p.

As featured in E.T.I. December '81 issue. Kit of parts including PCB, UHF tuner and selector switch with all components excluding case.

• Transformer £1.50 + £1.50 p&p (p&p free on transformer if ordered with kit). • Ready built LP1183 Module for simulated stereo operation. £1.95 + 75p p&p.



MONO MIXER AMP

£39.95

+ £3.70 p&p.

50 WATT Six individually mixed inputs for two pick ups (Cer. or mag.), two moving coil microphones and two auxiliary for tape, tuner, organs, etc. Eight slider controls - six for level and two for master bass and treble, four extra treble controls for mic. and aux inputs. Size: 13 1/2" x 6 1/2" x 3 1/4" app. Power output 50 watts R.M.S. (continuous) for use with 4 to 8 ohm speakers. Attractive black vinyl case with matching fascia and knobs. Ready to use.



ALL MAIL TO:
21A HIGH STREET, ACTON, W3 6NG.

Note: Goods despatched to UK postal addresses only. For further information send for instructions 20p plus stamped addressed envelope. All items subject to availability. Prices correct at 31/1/82 and subject to change without notice. Please allow 7 working days from receipt of order for despatch.

ALL PRICES INCLUDE VAT AT 15%.

ALL CALLERS TO: 323 Edgware Rd, London W2. Telephone: 01-723 8432. Open 9.30 - 5.30pm. Closed all day Thursday. RTVC Limited reserve the right to update their products without notice.





CLASSIFIED

The prepaid rate for classified advertisements is 28 pence per word (minimum 12 words), box number 60p extra. Semi-display setting .£7.24 per single column centimetre (minimum 2.5cm). All cheques, postal orders, etc., to be made payable to Everyday Electronics and crossed "Lloyds Bank Ltd." Treasury

notes should always be sent registered post. Advertisements, together with remittance, should be sent to the Classified Advertisement Department, Everyday Electronics Room 2612, IPC Magazines Limited, King's Reach Tower, Stamford St., London SE1 9LS. (Telephone 01-261 5942).

Receivers and Components

300 SMALL COMPONENTS, transistors, diodes. £1.70 71bs assorted components £4.25 101bs £5.75. Forty assorted 74 series ICs on panel £1.70. 500 capacitors £3.20. List 20p refundable. Post 60p. Optionable insurance 20p. J. W. B. RADIO, 2 Barnfield Crescent, Sale, Cheshire M33 1NL.

MANUFACTURERS SURPLUS high quality components I.C.s, transistors, diodes, thyristors, capacitors, resistors, switches, etc. 100 assorted £1.25 post free. U.H.A. LTD, 62 Wellington Road South, Stockport, Cheshire.

NEW 1982 ACE COMPONENT CATALOGUE. Let your problems be our business. Be certain; have your components delivered quickly and efficiently and get that project working. Send 30p now for the easy to use 1982 catalogue to: ACE MAILTRONIX, Dept EE, 3A Commercial Street, Batley, West Yorkshire WF17 5HJ.

H.T. FROM LOW BATTERY VOLTAGE. Input 3V-12V DC. Output 300V-1100V DC, at 3mA continuous. Solid state circuit, low battery consumption. Applications include H.T. for Neon tubes, Geiger counters, strobos, small CRT, etc. Size 50mm x 100mm x 30mm. Price £8.50 or £14.00 for two, including postage and packaging. P. D. Crisp, 32 Churchill Crescent, Wickham Market, Suffolk.

TURN YOUR SURPLUS capacitors, transistors etc., into cash. Contact Coles Harding & Co., 103 South Brink, Wisbech, Cambs. 0945 4188. Immediate settlement.

Veteran & Vintage

"SOUNDS VINTAGE"

The only magazine for all vintage sound enthusiasts, packed with articles by top writers, covering gramophones, phonographs, 78s, wireless, news, history, reviews, etc. Bi-monthly. Annual subscription £8.75 (airmail extra). Send 75p for sample copy. 28 Chestwood Close, Billericay, Essex

Software

SEVENTY ZX81 PROGRAMS. Listings only £4.95, Barclaycard accepted. Includes many games, utility, machine code loader, home finance, maths, chequebook, etc. Includes hints 'n' tips. SUSSEX SOFTWARE, Wall-send House, Pevensey Bay, Sussex.

Service Sheets

BELL'S TELEVISION SERVICE for service sheets on Radio, TV etc. £1.25 plus SAE. Colour TV Service Manuals on request. SAE with enquiries to BTS, 190 King's Rd. Harrogate, N. Yorkshire. Tel: 0423 55885.

Any single service sheet £1/L.S.A.E. Thousands different Repair/Service Manuals/Sheets in stock. Repair data your named T.V. £6.50) with circuits £8.50). S.A.E. Newsletter, Price Lists. Quotations.

AUSEE, 76 CHURCHES, LARKHALL, LANARKSHIRE (0698 883334).

Courses

SOUND ENGINEERS

If you're following a career in Sound Engineering or interested in learning all aspects of recording studios you should attend one of our weekend studio courses. Topics covered include:

- A. The basics of studio construction, wiring and materials used.
- B. Types of microphone uses, techniques, and limitations.
- C. Use of 2" 16 track machine, lining up, remotes, etc.
- D. Use of 24 Channel Desk and all controls.
- E. Effect equipment, ADT, reverb, Echo, etc.
- F. Ancillary equipment.
- G. Mixing and Editing.

There are a maximum number of 8 students on each course and every one is tutored to their own level of knowledge with regard to their needs and interest. The cost is £98 for the weekend including hotel accommodation overnight. Details: please phone 01-580 4720 or 01-636 5308 during office hours.

ORDER FORM PLEASE WRITE IN BLOCK CAPITALS

Please insert the advertisement below in the next available issue of Everyday Electronics for..... insertions. I enclose Cheque/P.O. for £.....

(Cheques and Postal Orders should be crossed Lloyds Bank Ltd. and made payable to Everyday Electronics)

NAME

ADDRESS

Send to: Classified Advertisement Manager

EVERYDAY ELECTRONICS

Classified Advertisements Dept., Room 2612, King's Reach Tower, Stamford Street, London SE1 9LS Telephone 01-261 5942

Rate: 28p per word, minimum 12 words. Box No. 60p extra.

Company registered in England. Registered No. 53628. Registered Office: King's Reach Tower, Stamford Street, London SE1 9LS.

4/82

Personal

CHRISTIAN SINGLES. Holidays, tours, weekend houseparties. Friendship contacts —CFF Dept/N42, Edenthorpe, Doncaster.

Wanted

WANTED, Teach in kits, basic tools, equipment. **PRICE,** 15 Colbourne Road, Tipton, West Midlands DY4 8RU.

For Sale

HEATHKIT SELF INSTRUCTION PROGRAMMES plus trainer as new. £150. Reigate 47304 evenings.

NEW BACK ISSUES OF "EVERYDAY ELECTRONICS". Available 85p each Post Free, cheque or uncrossed PO returned if not in stock. **BELL'S TELEVISION SERVICES,** 190 Kings Road, Harrogate, Yorkshire. Tel: (0423) 55885.

Miscellaneous

LEARN ELECTRONICS WITHOUT SOLDER



Build electronic circuits without solder on a Roden S-Dec. This has built-in contacts and holes into which you plug your components. Suitable for all ages. Can be used time after time. Ideal gift for students or experimenters. Full instructions and 2 circuit diagrams with each S-Dec.

Send cheque or P.O. to:
Roden Products, Dep EE
High March, Deventry
Northants, NN11 4QE

£3.85

plus 40p p.&p. each

EVERYDAY ELECTRONICS P.C.B.'s
Drilled 1.5mm Glassfibre Fry's Roller Tinned

SEP 81 Model train control £1.58
CMOS die £1.13

NOV 81 Electronic ignition £1.88

APR 82 2K RAM for ZX81 £1.88

For full list and current pcb's send SAE.
CWO Please. Postage. Add 35p postage and packing.

PROTO DESIGN, 14 DOWNHAM RD., RAMSDEN
HEATH, BILLERICAY, ESSEX, CM11 1PU
Telephone 0261-710722

CENTURION BURGLAR ALARM equipment, send SAE for free list or a cheque/PO for £11.50 for our special offer of a full sized signwritten bell cover to: Centurion, Dept EE, 265 Wakefield Road, Huddersfield, W. Yorkshire. Access & Barclaycard. Telephone orders on 0484 35527.

ENAMELLED COPPER WIRE. 10 swg to 45 swg. S.A.E. for quotation by return, cheapest prices. 102 Parrswood Road, Manchester 20.

LEARN ELECTRONICS at home. Experiment kit covers audio, radio, digital, optoelectronics, timers. Instruction book with full circuits for forty projects, component layouts, and theory section. Sixty parts supplied, including transistors, LEDs, earphone, loudspeaker, ferrite-rod, reed-switches etc. No soldering, components can be re-used many times. Uses two 3-volt batteries (not supplied). Send cheque/PO for £25 (includes UK P&P and VAT) to **VYTRON (EE-04), 5 Mariners Drive, Portishead, Bristol BS20 8ET.**

PARAPHYSICS JOURNAL (Russian translations): psychotronic generators, Kirlianography, gravity lasers, telekinesis. Details: SAE 4 x 9in, Paralab, Downton, Wilts.

SPARE PARTS FOR ALL DIGITAL WATCHES. Batteries 65p; pins; display; back lights etc. Plus reports, publications charts, send SAE for full list. **PROFORDS,** Copners Drive, Holmer Green, Bucks HP15 6SG.

DIGITAL WATCH BATTERY REPLACEMENT KIT



These watches all require battery (power cell) replacement at regular intervals. This kit provides the means. We supply eyeglass, non-magnetic tweezers, watch screwdriver, case knife and screwback case opener. Also one doz. assort. push-pieces, full instructions and battery identification chart. We then supply replacement batteries —you fit them. Begin now. Send £9 for complete kit and get into a fast growing business. Prompt despatch.

BOLSTER INSTRUMENT CO. (EE36)
11 Percy Avenue, Ashford, Middx., TW15 2PB

CORDLESS TELEPHONES, make your own inexpensive units. Send £3.00 for simple easy to follow plans to **J. F. ASHLEY,** Birley Grange, Cottage Farm, Baslow Road, Cutthorpe, Derbyshire.

THE SCIENTIFIC WIRE COMPANY

PO Box 38, London E.4. 01 531 1568

ENAMELLED COPPER WIRE

SWG	1 lb	8 oz	4 oz	2 oz
8 to 34	3-30	1-90	1-00	0-80
35 to 39	3-52	2-10	1-15	0-85
40 to 43	4-87	2-65	2-05	1-46
44 to 47	8-37	5-32	3-19	2-50
48 to 49	15-96	9-58	6-38	3-69

SILVER PLATED COPPER WIRE

14 to 30	6-63	3-86	2-28	1-50
----------	------	------	------	------

TINNED COPPER WIRE

14 to 30	3-97	2-41	1-39	0-94
----------	------	------	------	------

10 x 10 mtr reels 3 amp PVC cable mixed colours 5-90
Prices include P & P vat. Orders under £2 add 20p.
SAE for list of copper and resistance wire. Dealer enquiries welcome.

INDEX TO ADVERTISERS

Absonglen	278	Global Specialist	271	Radio Component Specialists ..	288
Alcon	280	Greenweld	220	Radionic	222
ARA Electronics	284			Radio TV Components	285
		Home Radio	280	Rapid Electronics	221
Benningcross	283				
Bi-Pak	225	Intertext (ICS)	220	Science of Cambridge	276-277
BK Electronics	Cover III	Litesold	280	Selray Book	224
B.N.R.E.S.	275			Silica Shop	Cover ii
Bull, J.	279				
		Magenta Electronics	222-223	Tempus	281
Chordgate	288	Maplin Electronics Supplies Ltd.	Cover iv	Titan Transformers	280
Cricklewood Electronics	282			T.K. Electronics	218
Dziubas, M.	220	Namel Electronics	284	Vero Electronics	283
		NME	224		
E.D.A.	226			Watford Electronics	219
Electronize Design	284	Phonosonics	218	West London Direct Supplies ..	288
Electrovalue	278	Powell, T.	278	Wilmslow Audio	218
Enfield Electronics	224				

MIGHTY NINETY PACKS

**SUPER VALUE PACKS ALL AT 90p each
BUY SIX PACKS AND GET A SEVENTH FREE**

Please add 15p per pack postage
Please allow 7 days delivery.

- | | |
|---|---|
| MN2. 200 Ω & $\frac{1}{2}$ -watt Resistors. | MN37. 10 asstd audio connectors. Din phono etc. |
| MN3. 100 1 & 2-watt Resistors. | MN38. 1 PCB with triac control IC data inc. |
| MN4. 50 Wirewound Resistors. | MN39. 1 oscillator PCB loads of components (no data). |
| MN5. 100 metal oxide Resistors. 1%, 2% and 5%. | MN40. 50 Polystyrene capacitors. |
| MN6. 12 asstd potentiometers. | MN41. 12 BC548C (plastic BC109C) transistors. |
| MN7. 25 asstd skeleton pre-set Resistors. | MN42. 10 BC107 Transistors. |
| MN8. 50 asstd Electrolytic Capacitors. | MN43. 10 BC108 Transistors. |
| MN9. 100 asstd Ceramic Capacitors Pile, disc, tub and monolithic etc. | MN44. 10 Screwfix S.P.C.O. min. slide switches. |
| MN10. 100 mixed capacitors. Polyester, Polystyrene, Metallised, Radial and Axial types. | MN45. 35 asstd diodes Zener, rect, signal, switch-in. |
| MN11. 20 asstd Silver Mica Capacitors. | MN46. 15 asstd Zener diodes. |
| MN12. 8 Tantalum Bead Capacitors (useful values). | MN47. 3 \times 68 mfd 16v tantalum bead capacitors. |
| MN13. 20 asstd Transistors. BC, 2N Series + Power etc. | MN48. 200 items 4BA asstd length screws nuts & washers. |
| MN14. 40 IN4148 Diodes. | MN49. 200 items 6BA asstd length screws nuts & washers. |
| MN15. 20 min. wire-ended Neons. | MN50. 3 pieces of veroboard useful sizes, min total 35 sq inch. |
| MN17. 2 12-volt Relays. Ex newer new equip. | MN51. 10 \times 0.2" red LED. |
| MN18. 3 Encapsulated Reed Relays 9-12v coil, d-pole and 1-pole. | MN52. 10 \times 0.125" red LED. |
| MN19. 2 24-volt Relays. Ex newer new equip. | MN53. 20 \times 0.1 mfd 25v ceramic disc caps. |
| MN20. 1 240-110 to 12-volt. 100ma Transformer. | MN54. 20 \times 0.01 mfd 25v ceramic disc caps. |
| MN21. 1 240-110 to 24-volt 100ma Transformer. | MN55. 10 watt audio amp board with circuit. |
| MN22. 8 2" Led's with clips, 4 red, 2 yellow, 2 green. | MN56. 10 14 pin low profile IC skt DIL. |
| MN23. 300 asstd screws, nuts, washers, self-tappers etc. | MN57. 10 16 pin low profile IC skt DIL. |
| MN24. 100 asstd small springs. | MN58. 2 \times CA723 Voltage Regulator. |
| MN25. 50 asstd pop rivets. | MN59. 1 \times LM380 2 watt audio amp IC + 555 timer IC. |
| MN26. 50 asstd insulated crimps. | MN60. 10 asstd TTL IC's. |
| MN27. 200 items, grommets, sockets, cable markers, plastic screws, sleeving, tie wraps etc. | MN61. 3 \times TIP 32 Transistor. |
| MN28. 20 asstd fuses. 1" 20mm etc. | MN62. 3 \times TIP 31 Transistor. |
| MN29. 75mts equipment, wire, asstd colours and sizes. | MN63. 50 mixed polyester caps C280, Siemens etc. |
| MN30. 3 \times 2m length, 3 core, mains cable. | MN64. 5 Press to make min switches. |
| MN31. 12 asstd trimmer capacitors, compression film, Air-spaced etc. | MN65. 3 BF245 FETS. |
| MN32. 15 30pF Beehive trimmers. | MN66. Bank of 11 push switches 4 interlocked, 4 latch, 3 momentary. |
| MN33. 20 coil formers, ceramic, plastic, reed relay etc. | MN68. 200 asstd veropins, turret tags, PCB pins etc. |
| MN34. 25 min glass reed switch. | MN69. 4 min push to break switch. |
| MN35. 10 asstd switches, toggle, slide, micro etc. | MN70. PCB with 3 \times 250v AC 4 amp push SW with attractive chrome plastic knobs 1 \times BD241, 1 \times BC300, 2 \times BC237, 1 \times BC204, 4 \times 1N4002, 2 \times CMOS 4025, 200um fuse holder + 22 resistors, capacitors, diodes etc. |
| MN36. 10 sub-min SP. C/O slide switch. | MN71. IZM414 RADIO IC. |

CHORDGATE LIMITED

75 FARINGDON ROAD
SWINDON, WILTS. Tel. (0793) 33877
Retail shop at above address

MAINS INTERCOM



**NO BATTERIES
NO WIRES
ONLY
£29.95
PER PAIR
+ VAT £4.50
+ P & P £1.95**

The modern way of instant 2-way communications. Just plug into power socket. Ready to use. Crystal clear communications from room to room. Range 2-mile on the same mains phase. On/off switch. Volume control, with 'buzzer' call and light indicator. Useful as inter-office intercom, between office and warehouse, in surgery and in homes. Also available F.M. model.

NEW AMERICAN TYPE CRADLE TELEPHONE AMPLIFIER



**£18.95
+ VAT £2.85
+ P & P £1.65**

Latest transistorised Telephone Amplifier, with detached plug-in speaker. Placing the receiver on to the cradle activates a switch for immediate two-way conversation without holding the handset. Many people can listen at a time. Increase efficiency in office, shop, workshop. Perfect for 'conference' calls: leaves the user's hands free to make notes, consult files. No long waiting, saves time with long-distance calls. On/off switch, volume control. Conversation recording, model at £20.95 + VAT £3.15. P&P £1.65.

DOOR ENTRY SYSTEM

No house/business/surgery should be without a DOOR ENTRY SYSTEM in this day and age. The modern way to answer the door in safety to unwanted callers. Talk to the caller and admit him only if satisfied by pressing a remote control button which will open the door electronically. A boon for the invalid, the aged, and busy housewife. Supplied complete d.i.y. kit with one internal Telephone, outside Speaker panel, electric door lock release (for Yale type surface latch lock); mains power unit, cable (4 pairs) 50ft and wiring diagram. Price £29.95 + VAT £9.00 + P&P £2.58. Kit with two phones £69.95 + VAT £10.50 + P&P £2.81.

PLEASE ALLOW 8-12 DAYS FOR DELIVERY
10-day price refund guarantee on all items
Access and Barclaycard welcome.

WEST LONDON DIRECT SUPPLIES EE 4
169 KENSINGTON HIGH STREET,
LONDON, W8 Tel: 01-937 5548

**PLEASE
MENTION**

EVERYDAY ELECTRONICS

**WHEN REPLYING
TO**

ADVERTISEMENTS

BAKER 50 WATT AMPLIFIER

**£69
Post £2**



Superior quality ideal for Hi-Fi/PA systems, Discos and Groups. Two inputs with Mixer Volume Controls. Master Bass, Treble and Gain Controls. 50 watts RMS. Three loudspeaker outlets 4, 8, 16 ohm.

AC 240V (120V available). Blue wording on black cabinet.

BAKER 150 Watt AMPLIFIER 4 Inputs £89

DRILL SPEED CONTROLLER LIGHT DIMMER KIT. Easy to build kit. Controls up to 450 watts A.C. mains. £3 DELUXE MODEL Ready Built. 800 watts. £5

STEREO PRE-AMP KIT. All parts to build this pre-amp. 3 inputs for high, medium or low gain per channel, with volume control and P.C. Board. Can be ganged to make multi-way stereo mixers. £2.95

SOUND TO LIGHT CONTROL KIT MK II

Complete kit of parts, printed circuit. Mains transformer. 3 channels. Up to 1,000 watts each. Will operate from 200MV to 100 watts signal source. Suitable for home Hi-Fi £15 and all Disco Amplifiers. Cabinet extra £4.50. Post 90p 200 Watt Rear Reflecting White Light Bulbs. Ideal for Disco Lights. Edison Screw 75p each or 6 for £4 or 12 for £7.50.

MAINS TRANSFORMERS Primary 240V A.C.		POST
250-0-250V 70mA. 6-0V. 2A	£4.50
250-0-250V 90mA. 6-3V 3 2A. 6-3V 1A	£5.00
350-0-350V 250mA. 6-3V 6amp C.T.	£12.00
300-0-300V 120mA. 2 \times 6-3V 2A C.T. 5V 2A.	£13.00
230V 45mA. 6-3V 2A	£2.00

GENERAL PURPOSE LOW VOLTAGE

Tapped outputs available		
2 amp 3, 4, 5, 6, 8, 9, 10, 12, 15, 18, 25 and 30V	£6.00
2 amp 6, 8, 10, 12, 15, 18, 20, 24, 30, 36, 40, 45, 60	£6.00
2 amp 6, 8, 10, 12, 15, 18, 20, 24, 30, 36, 40, 45, 60	£12.00
3 amp 6, 8, 10, 12, 15, 18, 20, 24, 30, 36, 40, 45, 60	£12.00
5 amp 6, 8, 10, 12, 15, 18, 20, 24, 30, 36, 40, 45, 60	£16.00
5-8-10-16V ja	£2.50
6V ja	£2.00
6-0-6V 1ja	£3.00
9V 2ja	£1.50
9V 2a	£3.50
9-0-9V 50ma	£1.50
10-0-10V 2a	£3.00
10-30-40V 2a	£3.50
12V 100ma	£1.50
12V 750ma	£2.00
12V 3a	£3.50
12V 2a	£3.50
TOROIDAL 90-0-90V 4 Amp +20-0-20V 1 Amp	£10.00
CHARGER TRANSFORMERS-RECTIFIERS		
6-12V 3a	£4.00
6-12V 4a	£6.50

R.C.S. LOUDSPEAKER BARGAINS

3 ohm. 6 \times 4in. 5in. 7 \times 4in. £3.50. 8 \times 5in. £3.00.
6in. £3.00. 8in. £3.50. 10in. £4.00. 12in. £6.00.
8 ohm. 2 1/2in. £3.00. 3in. 5 \times 3in. 5in. £3.50. 5in. £3.50.
16 ohm. 6 \times 4in. 5in. £2.50. 8in. £3.50. 10 \times 6in. £4.00.
20ohm. 3 1/2in. 35 ohm. 3in. £2.50. Many others in stock.

R.C.S. LOW VOLTAGE STABILISED

POWER PACK KITS 90-100 mA Post 75p **£3.95**
All parts and instructions with Zener diode printed circuit, rectifiers and double wound mains transformer input 200-240 a.e. Output voltages available 6 or 7.5 or 9 or 12V d.c. up to 100mA. Rate voltage.

PP BATTERY ELIMINATOR. BRITISH MADE £4.50

Mains power pack 9 volt 400 ma Post 75p
stabilised, with overload cutout. Plastic case size 3 \times 5 \times 2 1/2.
Buildable Radio/Cassette.
DELUXE Switched Model 3-6-7 1/2-9V 400ma. £7.50.

THE 'INSTANT' BULK TAPE ERASER

Suitable for cassettes and all sizes of tape reels.
A.C. mains 200/240V. **£9.50** Post 90p
Leaflet 8.A.F.

HEAD DEMAGNETISER PROBE £5.00.

A.C. ELECTRIC MOTORS POST 75p.

2 Pole. 240V. 0.2 Amp. Spindle-
1-43 \times 0.212in. £1.75. 2 Pole.
240V. 0.15 Amp Double spindle-
1-75 \times 0.16in. Each £1. 2 Pole.
150V. -5 Amp Spindle. 0-75
0-2in. Two in series - 240V 50p
each. Brush Motor. Prim a Food
Mixer 240V. -3 Amp High Speed
and Powerful Spindle-0.5
0.25in. £2.95.
B.S.R. Motor £4. Garrard Motor £5.

ALUMINIUM CHASSIS 18 s.w.g. Unfilled, 4 sides, riveted
corners: 6 \times 4 \times 2 1/2in. £1.45; 8 \times 6 \times 2 1/2in. £1.90; 10 \times 7 \times 2 1/2in.
£2.30; 14 \times 9 \times 2 1/2in. £3.00; 16 \times 6 \times 2 1/2in. £2.90; 12 \times 3 \times 2 1/2in.
£1.80; 12 \times 8 \times 2 1/2in. £2.60; 16 \times 10 \times 2 1/2in. £3.20.

ALI ANGLE BRACKET 6 \times 1 \times 1in. 25p.

ALUMINIUM PANELS 18 s.w.g. 12 \times 12in. £1.50; 14 \times 9in.
£1.45; 6 \times 4in. 4sp; 12 \times 8in. £1.10; 10 \times 7in. 9sp; 8 \times 6in. 7sp.
14 \times 3in. 7sp; 12 \times 3in. 7sp; 16 \times 10in. £1.65; 16 \times 6in. £1.10;
ALUMINIUM BOXES. MANY OTHER SIZES IN STOCK.
4 \times 2 \times 2in. £1.00; 3 \times 2 \times 1in. 80p; 6 \times 4 \times 2in. £1.60; 8 \times 6 \times 2in.
£2.50; 12 \times 5 \times 3in. £2.75; 6 \times 4 \times 3in. £1.80; 10 \times 7 \times 3in. £3.

HIGH VOLTAGE ELECTROLYTICS 32 \times 32/350V £6p
8/900V £1.30 50/500V £1.30 32 \times 32/500V £1.30
32/350V 45p 230/450V 96p 32 \times 32 \times 32/352V 75p
32/500V 75p 8 \times 16/450V 75p 16 \times 32 \times 32/500V 83

DE LUXE BSR HI-FI AUTOCHANGER

Stereo Ceramic Cartridge
Plays 12in., 10in., or 7in.
records Auto or Manual. A high
quality unit 240V A.C.
Size 1 1/2 \times 1 1/2in.
Above motor board 3 1/2in.
Below motor board 2 1/2in.



£20
Post on
Decks
£2.

BSR Single Player P204 cueing device. **£20** post £2

A.C. QLM 30/5 Magnetic cartridge. **£20** post £2

Garrard Single Player 730 SP metal turntable, cueing device. Snake arm, Magnetic cartridge. **£27.50** post £2

BSR P170 Single Player. Slim arm. Ceramic cartridge. Cueing device. Auto stop. **£20** post £2

B.S.R. P232. Belt drive, ceramic cartridge, make arm, cueing device. £24 post £2.

B.S.R. Single Player. 12V D.C. motor, belt drive, magnetic cartridge. £20, post £2.

Radio Component Specialists

337, WHITEHORSE ROAD, CROYDON,

SURREY, U.K. TEL: 01-884 1065

Post 65p Minimum. Callers Welcome. Closed Wed. Same day despatch. Access-Barclay-Visa. Lists 31p.



APPROVED
thandar
STOCKIST

B.K. ELECTRONICS

A SOUND CHOICE

APPROVED
thandar
STOCKIST

★ PROMPT DELIVERY ★ PRICES INCLUDE V.A.T. ★ AMPLE STOCKS
A PERSONAL SERVICE FROM A SMALL EXPANDING COMPANY



6 piano type keys

STEREO CASSETTE TAPE DECK MODULE
Comprising of a record panel and tape mechanism coupled to a record/play back printed board assembly. Supplied as one complete unit for horizontal installation into cabinet or console of own choice. These units are brand new, ready built and tested.

Features: Three digit tape counter. Auto stop. Six piano type keys. record, rewind, fast forward, play, stop and eject. Automatic record level control. Main inputs plus secondary inputs for stereo microphones. **Input Sensitivity:** 100mV to 2V. **Input Impedance:** 68K. **Output level:** 400mV to both left and right hand channels. **Output Impedance:** 10K. **Signal to noise ratio:** 45dB. **Wow and flutter:** 0.1%. **Power Supply requirements:** 18V DC at 300mA. **Connections:** The left and right hand stereo inputs and outputs are via individual screened leads, all terminated with phono plugs (phono sockets provided). **Dimensions:** Top panel 5 1/2" x 11 1/2". Clearance required under top panel 2 1/2". Supplied complete with circuit diagram and connecting diagram. Attractive black and silver finish.

Price £26.70 + £2.50 postage and packing. Supplementary parts for 18V D.C. power supply (transformer, bridge rectifier and smoothing capacitor) £3.

NEW RANGE QUALITY POWER LOUD-SPEAKERS (15", 12" and 8"). These loudspeakers are ideal for both hi-fi and disco applications. Both the 12" and 15" units have heavy duty die-cast chassis and aluminium centre domes. All three units have white speaker cones and are fitted with attractive cast aluminium (ground finish) fixing escutcheons. Specification and Price -

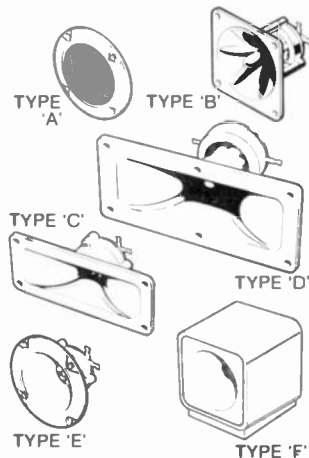
15" 100 watt R.M.S. Impedance 8ohm 59 oz. magnet, 2 aluminium voice coil. Resonant Frequency 20Hz. Frequency Response to 2.5KHz. Sensitivity 97dB. **Price £32 each.** £2.50 Packing and Carriage each

12" 100 watt R.M.S. Impedance 8 ohm, 50 oz magnet 2 aluminium voice coil. Resonant Frequency 40Hz. Frequency Response to 4KHz. Sensitivity 95dB. **Price £23.70 each.** £2.50 Packing and Carriage each

8" 50 watt R.M.S. Impedance 8 ohm, 20 oz magnet 1 aluminium voice coil. Resonant Frequency 40Hz. Frequency Response to 6KHz. Sensitivity 92dB. Also available with black cone and black protective grill. **Price £8.90 each** £1.25 Packing and Carriage each

PIEZO ELECTRIC TWEETERS - MOTOROLA

Join the Piezo revolution. The low dynamic mass (no voice coil) of a Piezo tweeter produces an improved transient response with a lower distortion level than ordinary dynamic tweeters. As a crossover is not required these units can be added to existing speaker systems of up to 100 watts (more if 2 put in series). **FREE EXPLANATORY LEAFLETS SUPPLIED WITH EACH TWEETER.**



TYPE 'A' (KSN1036A) 3" round with protective wire mesh, ideal for bookshelf and medium sized Hi-Fi speakers. Price £3.45 each.

TYPE 'B' (KSN1005A) 3 1/2" super horn. For general purpose speakers, disco and P.A. systems, etc. Price £4.35 each.

TYPE 'C' (KSN6016A) 2" - 5" wide dispersion horn. For Hi-Fi systems and quality discos, etc. Price £5.45 each.

TYPE 'D' (KSN1025A) 2" - 6" wide dispersion horn. Upper frequency response retained extending down to mid range (2,000 c/s). Suitable for Hi-Fi systems and quality discos. Price £6.90 each.

TYPE 'E' (KSN1038A) 3 1/2" horn tweeter with attractive silver finish trim. Suitable for Hi-Fi monitor systems, etc. Price £4.35 each.

TYPE 'F' (KSN1057A) Cased version of type 'E'. Free standing satellite tweeter. Perfect add on tweeter for conventional loudspeaker systems. Price £10.75 each.

U.K. post free (or SAE for Piezo leaflets).



1 K-WATT SLIDE DIMMER

- ★ Controls loads up to 1KW.
 - ★ Compact Size 4 1/4" x 1 1/4" x 2 1/4".
 - ★ Easy snap in fixing through panel/cabinet cut out.
 - ★ Insulated plastic case.
 - ★ Full wave control using 8 amp triac.
 - ★ Conforms to BS800.
 - ★ Suitable for both resistance and inductive loads. Innumerable applications in industry, the home, and disco's/theatres, etc.
- Price £11.70 each + 50p P&P. (Any quantity.)**

GENERAL PURPOSE 4 1/2" MINI SPEAKER

General purpose full range loudspeaker, ideal for mini systems, etc.

- ★ Rolled fabric surround
 - ★ Twin cone
 - ★ 8 ohm impedance
 - ★ 15 watt R.M.S.
 - ★ 1" voice coil
 - ★ 13 oz. magnet
 - ★ Frequency range 50/15,000Hz.
- Price £6.90 each + 75p P&P.**



B.S.R. P232 TURNTABLE

- P232 Turntable ★ 'S' shaped tone arm
- ★ Belt driven
 - ★ Aluminium platter
 - ★ Cueing lever
 - ★ 240 volt AC operation (50Hz)
 - ★ Cut-out template supplied
 - ★ Used as standard by Hi-Fi and Disco manufacturers
 - ★ Fitted with either a magnetic or ceramic cartridge, please state cartridge required
- Price £22.50 + £2.50 P & P.**



POWER AMPLIFIER MODULES

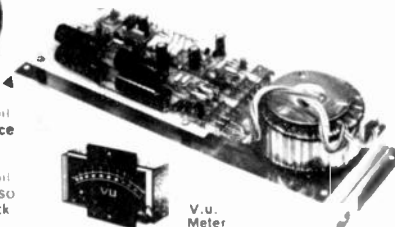
100 WATTS R.M.S.

Power Amplifier Modules with integral toroidal transformer power supply and heat sink. Supplied as one complete built and tested unit. Can be fitted in minutes. Auxiliary stabilised supply and drive circuit incorporated to power an L.E.D. V.u meter available as an optional extra.

SPECIFICATION: Max. output power 100 watts R.M.S. (OMP 100)

Loads: (Open and short circuit proof) 4-16 ohms
Frequency Response: 20Hz-25KHz ± 3dB
Sensitivity: for 100 watts 500mV at 10K

T.H.D. 00.1%
Size: 360 x 115 x 80mm
Prices: OMP 100 £29.99 P & P £2.00
V.u. Meter £6.50

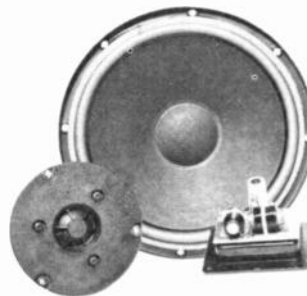


V.u. Meter

MULLARD 40 WATT R.M.S. 8 ohm SPEAKER SYSTEM.

Designed by Mullard's specialist team in Belgium. Comprising of a Mullard 8" woofer with foam surround, a Mullard 3" dome tweeter and a cleverly designed B.K. Electronics crossover combining spring loaded loudspeaker terminals and recessed mounting panel. Supplied complete with installation and cabinet details.

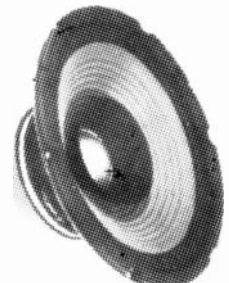
Price £13.90 + £1.50 P & P per kit.



12" 80 watt R.M.S. loudspeaker.

A superb general purpose twin cone loud speaker. 50 oz magnet 2 aluminium voice coil. Rolled surround. Resonant frequency 25Hz. Frequency response to 13KHz. Sensitivity 95dB. Impedance 8ohm. **Attractive blue cone with aluminium centre dome**

Price £17.99 ea + £2.50 P & P.



B.K. ELECTRONICS

DEPT. E.E.

37 Whitehouse Meadows, Eastwood, Leigh-on-Sea, Essex SS9 5TY

★ SAE for current lists. ★ Official orders welcome. ★ All prices include VAT. ★ Mail order only. ★ All items packed (where applicable) in special energy absorbing PU foam. Callers welcome by prior appointment, please phone 0702-527572.

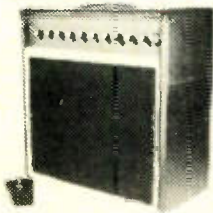


EXPRESS from MAPLIN



COMBO-AMPLIFIER

Easy to build portable 120W MOSFET amp for all stage musicians. Built-in flanger, five step equaliser, two inputs for guitars, keyboards or microphones, low noise pre amp.
Full details in our book. Price 60p.
Order As XA01B.

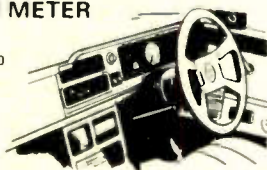


STOP-WATCH

Multi-mode 8 digit stopwatch accurate to hundredths of a second. Easy to build—complete kits available.
Full details in our projects book.
Price 60p.
Order As XA02C.

MILES PER GALLON METER

Digital display shows you how economical your driving is as you go along.
Complete kits available.
Full details in our projects book.
Price 60p.
Order As XA02C.



DIGITAL MULTI-TRAIN CONTROLLER

Control up to 14 trains individually on the same track with any four simultaneously! Low cost kits available.
Full details in our projects book. Price 60p.
Order As XA02C.

Photo by W.A. Sharman.

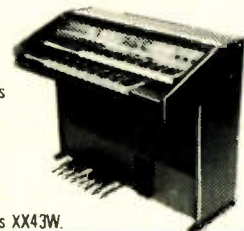


HOME SECURITY SYSTEM

Six independent channels—2 or 4 wire operation. External horn. High degree of protection and long term reliability.
Full details in our projects book.
Price 60p.
Order As XA02C.

MATINÉE ORGAN

Easy-to-build, superb specification. Comparable with organs selling for up to £1,000. Full construction details in our book. Price £2.50.
Order As XH55K.
Complete kits available:
Electronics—£299.95,
Cabinet—£99.50 (carriage extra).
Demo cassette price £1.99. Order As XX43W.



*Don't miss out—get a copy of our catalogue now!
Over 140,000 copies sold already!

*On sale now in all branches of WHSMITH price £1.

*320 big pages packed with data and pictures of over 5,500 items.



Post this coupon now!

Please send me a copy of your 320 page catalogue. I enclose £1.25 (inc. 25p p&pt). If I am not completely satisfied I may return the catalogue to you and have my money refunded.
If you live outside the U.K. send £1.68 or 12 International Reply Coupons. EE4/82

Name _____

Address _____

MAPLIN

ELECTRONIC SUPPLIES LTD.

All mail to:

P.O. Box 3, Rayleigh, Essex SS6 8LR

Tel: Sales (0702) 552911 General (0702) 554155

Shops at:

159 King St., Hammersmith, London W6. Tel: 01-748 0926

284 London Rd., Westcliff-on-Sea, Essex. Tel: (0702) 554000

Note: Shops closed Mondays