

An exciting hobby.... for everyone

everyday electronics

APRIL 76
30p

All in this issue!

Special
SUPPLEMENT
BEGINNERS GUIDE
Electronics
made easy



Keep in touch!

INTERCOM... touch to talk
MAINS POWER CONTROLLER
CAPACITANCE/RES. BRIDGE
UNIT BUILT SUPERHET



RADIO EXCHANGE LTD.

**ALL PRICES
INCLUDE VAT**

NEW EDU-KIT MAJOR

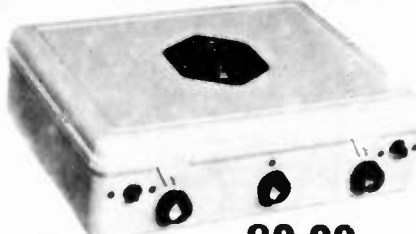

Total Building Costs

£9-99

PP+Ins. 65p. (Overseas Seamount P+P £3-50)

Completely Solderless Electronic Construction Kit. Build these projects without soldering iron or solder

- ★ 4 Transistor Earpiece Radio
 - ★ Signal Tracer
 - ★ Signal Injector
 - ★ Transistor Tester NPN-PNP
 - ★ 4 Transistor Push Pull Amplifier
 - ★ 5 Transistor Push Pull Amplifier
 - ★ 7 Transistor Loudspeaker Radio MW-LW
 - ★ 5 Transistor Short Wave Radio
 - ★ Electronic Metronome
 - ★ Electronic Noise Generator
 - ★ Batteryless Crystal Radio
 - ★ One Transistor Radio
 - ★ 2 Transistor Regenerative Radio
 - ★ 3 Transistor Regenerative Radio
 - ★ Audible Continuity Tester
 - ★ Sensitive Pre-Amplifier
 - ★ 10 Transistors
 - ★ 31in Loudspeaker
 - ★ Earpiece
 - ★ Mica Baseboard
 - ★ 2 Volume controls
 - ★ 2 Slider Switches
 - ★ 1 Tuning Condenser
 - ★ 3 Knobs
 - ★ Ready Wound MW/LW/SW Coils
 - ★ Ferrite Rod
 - ★ 6½ yards of wire
- Components include: 24 Resistors ★ 21 Capacitors
 Components include: 24 Resistors ★ 21 Capacitors
 Components include: 24 Resistors ★ 21 Capacitors

VHF AIR CONVERTER KIT

Build this Converter Kit and receive the Aircraft Band by plugging it by the side of a radio tuned to Medium Wave or the Long Wave Band and operating as shown in the instructions supplied free with all parts. Uses a retractable chrome plated telescopic aerial, Gain Control, V.H.F. Tuning Capacitor, Transistor, etc.



All Parts including Case and Plans P & P and Ins. 40p.

POCKET FIVE

NOW WITH 3" LOUDSPEAKER
 3 Tunable wavebands, M.W., L.W., and Trawler Band, 7 stages, 5 transistors and 2 diodes, supersensitive ferrite rod aerial, attractive black and gold case. Size 5½" x 11" x 3½" approx.



Total Building Costs **£3-99**

All Parts including Case and Plans. P+P+Ins. 50p.

NEW Everyday Series

Build this exciting new series of designs.



E.V.5 5 Transistors and 2 diodes. MW/LW. Powered by 4½ volt Battery. Ferrite rod aerial, tuning condenser, volume control, and now with 3" loudspeaker. Attractive case with red speaker grille. Size 9" x 5½" x 2½" approx. All parts including Case and Plans.

Total Building Costs **£4-75** P & P + Ins 50p

E.V.6 Case and looks as above. 6 Transistors and 3 diodes. Powered by 9 volt battery. Ferrite rod aerial, 3" loudspeaker, etc. MW/LW coverage. Push Pull output.

All parts including case and plans. Total Building Costs **£5-50** P & P + Ins. 55p

E.V.7 Case and looks as above. 7 Transistors and 3 diodes. Six wavebands, MW/LW, Trawler Band SW1, SW2, SW3, powered by 9 volt battery. Push Pull output. Telescopic aerial for short waves. 3" Loudspeaker.

All parts including Case and Plans. Total Building Costs **£7-05** P & P + Ins. 55p

ROAMER TEN MARK 2

WITH VHF INCLUDING AIRCRAFT

Now with free earpiece and switched socket. 10 transistors. Latest 5" x 3" loudspeaker. 9 tuneable wavebands, MW1, MW2, LW, SW1, SW2, SW3, trawler band, VHF and local stations, also aircraft band. Built in ferrite rod aerial for MW/LW. Chrome plated. 6 section telescopic aerial, can be angled and rotated for peak short wave and VHF listening. Push pull output using 600mW transistors. Car aerial socket. 10 transistors plus 3 diodes. Ganged tuning condenser with VHF section. Separate coil for aircraft band. Volume on/off. Wave change and tone controls. Attractive Case in rich chestnut shade with Gold Blocking. Size: 9" x 7" x 4". Easy to follow instructions and diagrams. Total building costs



£11-87 P & P+ Ins. 65p

EDU-KIT

Build Radios, Amplifiers, etc. from easy stage diagrams.

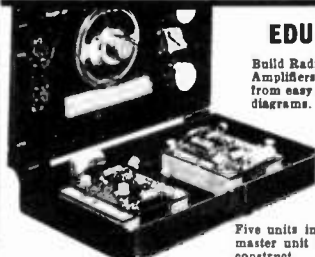

Five units including master unit to construct.

Components include: Tuning Condenser: 2 Volume Controls: 2 Slider Switches: Fine tone 3" moving coil Speaker: Terminal Strip: Ferrite Rod Aerial: Battery Clips: 4 Tag Boards: 10 Transistors: 4 Diodes: Resistors: Capacitors: Three ½" Knobs. Units once constructed are detachable from Master Unit, enabling them to be stored for future use. Ideal for Schools, Educational Authorities and all those interested in radio construction.

All Parts including Case and Plans **£6-99** P & P+ Ins. 50p

ELECTRONIC CONSTRUCTION KITS

ECK 2

Self Contained Multi-Band V.H.F. Receiver Kit. 8 Transistors and 3 Diodes. Push/Pull output. 3" Loudspeaker, Gain Control. Superb 9 section swivel ratchet, and retractable chrome plated telescopic aerial. V.H.F. Tuning Capacitor. Resistors, Capacitors, Transistors, etc. Will receive T.V. Sound, Public Service Band, Aircraft, V.H.F. Local Stations, etc. Operates from a 9 Volt PP7 Battery (not supplied with kit). Complete kit of parts including construction plans

£7-95 P & P and Ins. 55p.

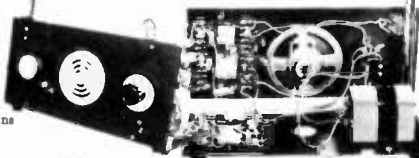

ECK 4

7 Transistors, 6 tuneable wavebands, MW, LW, Trawler Band, 3 Short Wave Bands. Receiver Kit. With 6" x 3" Loudspeaker. Push/Pull output stage, Gain Control, and Rotary Switch. 7 Transistors and 4 Diodes. 6 section chrome-plated telescopic aerial. 8" Sensitive Ready Wound Ferrite Rod Aerial. Tuning Capacitor, Resistors, Capacitors, etc. Operates from a 9 Volt PP7 Battery (not supplied with kit). Complete kit of parts including construction plans.

£7-25 P & P and Ins. 55p



EDU-KIT JUNIOR

Completely Solderless Electronic Construction Kit. Build these projects without Soldering Iron or Solder.

- ★ Crystal Radio Medium Wave Coverage — No Battery necessary.
 - ★ One Transistor Radio.
 - ★ 2 Transistor Regenerative Radio.
 - ★ 3 Transistor Earpiece Radio Medium Wave Coverage.
 - ★ 4 Transistor Medium Wave Loudspeaker Radio.
 - ★ Electronic Metronome.
 - ★ 4 Transistor Push/Pull Amplifier.
- All parts including Loudspeaker, Earpiece, MW Ferrite Rod Aerial, Capacitors, Resistors, Transistors, etc. Complete kit of parts including construction plans.

£7-25 P & P+ Ins. 55p

JIFFY TESTER

Easy to build and operate. Fits in the pocket. A quick checker for continuity of resistors, chokes, diodes, transistors, circuit wiring (not mains) and loudspeakers. Complete with earpiece, jack plug and socket resistors, capacitors, components, etc. Complete kit of parts including construction plans.



£3-15 P & P+ Ins. 50p

TO RADIO EXCHANGE LTD., 61A HIGH STREET, BEDFORD MK40 1SA. Tel: 0234 52367.

Reg. No. 788372
 ★ Callers side entrance "Lavelle" Shop.
 ★ Open 10-1, 2.30-4.30. Mon-Fri. 9-12 Sat.

I enclose £.....
 for.....
 Name.....
 Address.....
 EE476

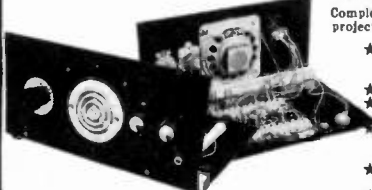

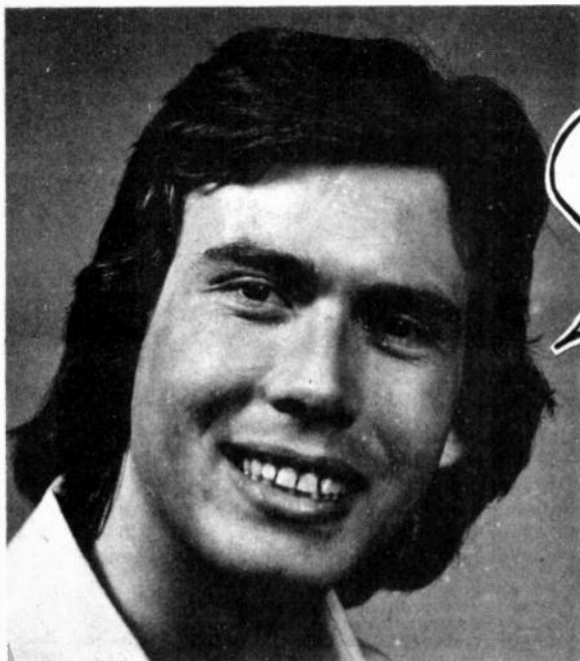

The Managing Director revealed all!



Sometimes I order my bits and pieces from Home Radio Components by post, but often I pop in to their Mitcham shop and buy over the counter. Over the years I've got quite pally with their Managing Director (nice bloke he is too) and the other day we got chatting about the mechanics of producing their catalogue. I was amazed at the amount of work that has gone into it. In fact, you could say that it has taken 20 years to produce, because the present 240-page edition de luxe has gradually evolved from the duplicated effort they turned out in 1956.

The Managing Director says that all through the years he has worked "up to a standard; not down to a price" in producing the catalogue—the illustrations, the indexing the layout, the method of listing, the quality of printing and so on. It's not surprising that today it is in use all round the world, and is recognised as the finest components catalogue money can buy. Talking of money, the catalogue costs £1.30 (85p plus 45p post and packing) but every copy contains 14 vouchers, each worth 5p against orders, so there's 70p you soon get back. So the catalogue is quite inexpensive after all! And when you consider the time, care and effort that has gone into it to make it the superb production it is,

it's almost a give-away! Talking of 'give-aways' Home Radio Components do literally give you a new updated catalogue free when you have been a credit account customer for one year. Full details about the many advantages of having a credit account are given in the catalogue. Just fill in the coupon below and send it with your cheque or postal order for £1.30. You won't regret it. I can assure you of that because the Managing Director told me that as far as he knew not one of the thousands of electronic enthusiasts who had invested in their catalogue had regretted it. Their only regret was that they didn't know about it sooner!

Today's finest Components Catalogue 85p plus 45p POST & PACKING

POST THIS COUPON
with cheque or PO for £1.30

The price of £1.30 applies only to customers in the U.K. and to BFPO Addresses.

Please write your Name and Address in block capitals

NAME

ADDRESS

.....

.....

HOME RADIO (Components) LTD., Dept. EE, 234-240 London Road, Mitcham, Surrey CR4 3HD (Regn. No London 912966)



HOME RADIO (Components) LTD, Dept EE, 234-240 London Road, Mitcham, CR4 3HD Phone 01-648 8422

Build it yourself!



Designed by
TEXAS

Featured by **PRACTICAL WIRELESS**
SOLE U.K. DISTRIBUTORS - HENRY'S

Build the Texas stereo amplifier, then you can be doubly proud! For a start, you'll own a superb home entertainment unit. And have had all the pleasure of doing it yourself, with the Henry's kit.

Look at the Texas specification

Incorporating fully integrated stereo preamp and power amp, with 6 IC's, 10 transistors, 6 rectifiers and zener diodes. Plus stabilised, protected circuitry, glass fibre pcb; Gardners low field low-line mains transformer; all facilities and controls. Slim design, chassis 14 1/2" x 6" x 2" overall, 20 watts per channel RMS, less than 0.1% distortion at 1 kHz.

- ★ Can be built Stage by stage Ask for leaflet 20.
- ★ Everything necessary supplied. Full after sales service and guarantee.

KIT PRICE
£35.00
Inc. VAT +£1 p&p

Built and tested
£45.00 inc. VAT
+ £1.00 p&p.

THE NATURAL FOLLOW-ON - THE TEXAN FM TUNER KIT!

KIT PRICE
£25.95
Inc. VAT +
50p p&p

Build the matching Texas stereo tuner! Features advanced varicap tuning, Phase lock loop decoder. Professionally designed circuit. Everything you need is in the kit. From the glass fibre pcb to the cabinet itself. Excellent spec: 2.5 uV aerial sensitivity, 500 mV output (adjustable). Tuning range 87-102 MHz. Mains powered.

Built and tested £30.95 inc. VAT +50p p&p.

VIDEO SPORT

... all the electronic excitement you could wish for!

★ OVER 10 000 ALREADY SOLD ★ IDEAL GIFT

An up-to-the-minute game. Plugs into your own TV aerial socket. Switch on. And you're away! Choose your game - football, tennis or hole-in-the-wall. Absolutely safe. For you, your children. And your TV. Mains powered.

List Price £42.50 Inc. VAT + 50p p&p.



HENRY'S PRICE-ONLY £29.50

WHATEVER YOU DO, DON'T FORGET YOUR LATEST **HENRY'S CATALOGUE!**



ONLY 50p

20p Carr/Pack

For this new edition, we have made hundreds of changes and additions. It has over 200 pages, containing virtually everything for amateurs and professionals. And you'll have no bother at all finding everything you want, because there's a complete alphabetical index as well as a section index. Together, they put you right on course for the items you need. From Sinclair projects to educational kits, Oscilloscopes to panel meters. Coils to capacitors. Transistors to valves. Loudspeakers to microphones - all at competitive prices. Over 200 pages of vital statistics - just for you! So send now for your copy.

- Over 5000 items inside!
- Every copy contains a free 50p voucher.
- Many new items.
- Over 200 pages.

FREE to Educational Establishments when ordered on official headed notepaper.

Henry's

SELF-SERVICE CENTRES 404 and 309 EDGWARE ROAD, LONDON W2
Bargains galore - Call in and see for yourself!

404/6 EDGWARE ROAD, LONDON W2 01-402 8381

LOWER SALES FLOOR, 231 TOTTENHAM CT. RD., LONDON W1 01-636 6681

NEW MIDLANDS STORE

94/96 UPPER PARLIAMENT STREET, NOTTINGHAM. 0602-40403

All mail to Henry's Radio, 303 Edgware Road, London W2

The 'MISTRAL' Digital Clock

★ A Complete Kit or fully built ★



Kit £12.50 (Incl.) Built £18.00

- Pleasant green display
- 24 Hour readout
- Silent Synchronous Accuracy
- Fully electronic
- Pulsating colon
- Push button setting
- Building time 1hr
- Attractive acrylic case
- Easy to follow instructions
- Size 10.5 x 5.7 x 8cm
- Ready drilled PCB to accept components

Also available from:

HENRY'S RADIO, 231 Tottenham Court Rd., London W1.

HENRY'S RADIO, 404 Edgware Rd., London W2.

CROFTON ELECTRONICS LTD., 124 Colne Rd., Twickenham, Middx.

IMTECH PRODUCTS LTD., Imp House, Ashford Rd., Ashford, Middx.

BYWOOD ELECTRONICS, 68 Ebbwars Rd., Hemel Hempstead, Herts.

THE RADIO SHOP, 16, Cherry Lane, Bristol.

ELECTROVALUE, 23, St. Judes Road, Egham, Surrey.

EXETRON (DEPT. E.E.)

Regal House, Penhill Road, LANCING, Sussex

Payment: CWO, Cheque, Access, Barclaycard (Quote Number)

TECHNICAL TRAINING IN ELECTRONICS AND TELECOMMUNICATIONS

IGS can provide the technical knowledge that is so essential to your success; knowledge that will enable you to take advantage of the many opportunities open to the trained man. You study in your own home, in your own time and at your own pace and if you are studying for an examination ICS guarantee coaching until you are successful.

City & Guilds Certificates:
Telecommunications Technicians
Radio, TV, Electronics Technicians
Technical Communications
Radio Servicing Theory
Radio Amateurs
Electrical Installation Work
MPT Radio Communications Certificate

Diploma Courses:
Colour TV Servicing
Electronic Engineering and Maintenance
Computer Engineering and Programming
Radio, TV, Audio Engineering and Servicing
Electrical Engineering, Installation and Contracting

POST OR PHONE TODAY FOR FREE BOOKLET.

To: International Correspondence Schools

IGS Dept. 710R Intertext House, London SW8 4UJ or telephone 622 9911

Subject of Interest

Name

Address

Tel:



Stirling Sound Products

FROM BI-PRE-PAK

BRAND NEW MODULES FROM A FOREMOST BRITISH MODULE DESIGNER AND EXCLUSIVE TO B-P-P

NEW FOR 1976

THE SS.125 HIGH-FIDELITY POWER AMPLIFIER

Not only is this Stirling Sound's best audio amplifier yet; it rightfully qualifies as one of the best of its kind yet made available to constructors. Intended above all for high-fidelity, the characteristics of the SS.125 are such that it can be used in many other applications where dependability is the prime consideration. The SS.125 integrates well with other S.S. units as well as those of other manufacturers. Incorporates new circuitry using a complimentary long-tailed pair input and full complementary output circuits to give lab standards of performance.

| | |
|---------------------------|--|
| OUTPUT | 25 watts R.M.S. into 8 Ω using 50V 22 watts R.M.S. into 4 Ω using 33V (Low imp. not less than 4 Ω) |
| DISTORTION | Less than 0.05% at all power levels (From 10Hz to 10KHz) |
| FREQUENCY RESPONSE | ± 1dB 15 Hz to 30 KHz (4 Ω) ± 1dB 10 Hz to 30 KHz (8 Ω) |
| HIGH Z INPUT | 100 Kohms (40dB gain/100x) |
| INPUT SENSITIVITY | 150mV for 25W. R.M.D. out |
| SIZE | (Inc. 40w. built on heat sink) 4½" x 3" x 7/8" high |

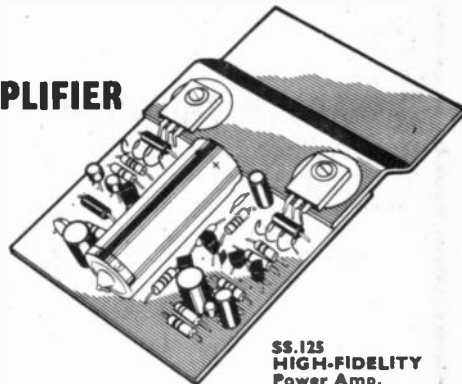

**SS.125
HIGH-FIDELITY
Power Amp.
£7.50**

More Stirling Sound Modules

With easy to follow instructions
F.M. TUNER UNITS

- SS.201 Tuner front end. Ganged, geared variable tuning, 88-108MHz. A.F.C. facility **£5.00**
- SS.202 I.F. amp. A metre and/or A.F.C. can be connected (size 3" x 2") **£2.65**
- SS.203 Stereo decoder for use with SS.201 and 202 or any good F.M. tuner. A LED beacon may be attached (3" x 2") **£3.85**
- SS.105 5 watt amplifier to run from 12V. (3½" x 2" x ½") **£2.25**
- SS.110 Similar to SS.105 but more powerful giving 10W. into 4ohms **£2.75**
- SS.120 20 watt module when used with 34 volts into 4 **£3.00**
- SS.140 Relivers 40 watts R.M.S. into 4 ohms using a 45V/2A supply such as our SS.345 the power and quality of this unit are superb—two in bridge formation will give 80 watts R.M.S. into 8ohms. size 4" x 3" x ½". **£3.75**
- SS.100 Active tone control stereo. ±15dB lift-cut bass/treble **£1.00**
- SS.102 Pre-amp for ceramic **£1.60**
- SS.103 Active pre-amp (stereo) inc. R.I.A.A. and line feed back **£2.25**

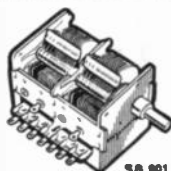

SS.201



SS.202



SS.203



SS.100

... And 5 NEW Stirling Sounds POWER SUPPLY UNITS

Robustly designed units in each of which is a stabilised take-off point to provide for tuner, pre-amp and control stages.

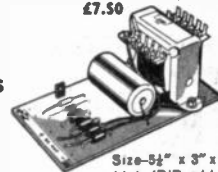

Size—5½" x 3" x 2½"
high (P/P add 50p any model)

| | | | | | |
|---------|--------|-------|------------------------------|--------|-------|
| SS. 312 | 12V/1A | £3.75 | SS. 334 | 34V/2A | £5.20 |
| SS. 316 | 18V/1A | £4.15 | SS. 345 | 45V/4A | £8.25 |
| SS. 324 | 24V/1A | £4.60 | (all above are at 8% V.A.T.) | | |

A new Stirling Sound Capacity Discharge Ignition Unit for your car.

Even better than the original B-P-P version, thousands of which are in use saving motorists appreciable time and money for petrol. Very easy to install. The Stirling Sound model incorporates switch for instant change to conventional ignition; immediate adaption to pos. or neg. earth return; anti-burglar immobilising switch, pre-set control for rev. limitation. There are no exposed parts, the unit, on p.c.b. being housed in strong enclosed metal box. With instructions and leads. Size 7½" x 4½" x 2½" ex. switches.

KIT **£7.95** BUILT & TESTED **£10.50**

A USEFUL CATALOGUE—FREE

Send us a large S.A.E. with 10p stamp and we will send you the latest Bi-Pre-Pak catalogue free by return. Packed with useful lines, its a real money saver.

TERMS OF BUSINESS:

VAT at 8% must be added to total value of order except for items marked * or (B%) when VAT is to be added at 8%. No VAT on overseas orders. POST & PACKING add 30p for UK orders unless marked otherwise. Minimum mail order acceptable—£1 Overseas orders, add £1 for postage. Any difference will be credited or charged. PRICES subject to alteration without notice. AVAILABILITY All items available at time of going to press when every effort is made to ensure correctness of information.

Order your Stirling Sound products from

BI-PRE-PAK LTD

Co Reg No 820919

222 224 WEST ROAD, WESTCLIFF-ON-SEA, ESSEX SSO 9DF.

TELEPHONE: SOUTHBEND (0702) 46344

CHEQUES/MONEY ORDERS PAYABLE TO BI-PRE-PAK LTD

Everyday Electronics, April 1976

TO STIRLING SOUND (BI-PRE-PAK LTD) 222/224 WEST ROAD, WESTCLIFF-ON-SEA, ESSEX SSO 9DF

Please send

..... for which I enclose £

Inc. V.A.T.

NAME

ADDRESS

EE 45

PATENT PENDING



Sparkrite mk2

The tried, tested, proven, reliable, complete, professional, capacitive discharge,

Electronic Ignition Kit



"Sparkrite" was voted best of 8 systems tested by Popular Motoring Magazine

Sparkrite MK2 is a high performance capacitive discharge electronic ignition system. Because of the electronic circuit it contains...

Manufacturers announcement

It is the desire of Sparkrite Design Associates that the cost of our 'Sparkrite' Mark II Ignition Kits have remained the same for the past 2 years. However, due to an increase in the cost of components, we regret that as from 1st May 1976 all prices will be increased by 8%. ALL ORDERS RECEIVED BEFORE THIS DATE WILL BE CHARGED AT THE LOWER PRICES.

Electronics Design Associates are proud to be able to say that the cost of our 'Sparkrite' Mark II Ignition Kits have remained the same for the past 2 years. However, due to an increase in the cost of components, we regret that as from 1st May 1976 all prices will be increased by 8%. ALL ORDERS RECEIVED BEFORE THIS DATE WILL BE CHARGED AT THE LOWER PRICES.

ORDER NOW

To ELECTRONICS DESIGN ASSOCIATES DEPT EE4
82 Bath Street, Walsall, WS1 3DE.
Phone 33652.

From Name

Address

Qty.

| |
|--|
| Sparkrite Mk 2 DIY Ass. kits @ £10.93 |
| Sparkrite Mk 2 Ready Built Negative earth @ £13.86 |
| Sparkrite Mk 2 Ready Built Positive earth @ £13.86 |
| Ignition changeover switches @ £2.98 |
| R.P.M. Limit systems in the above units @ £2.42 |

I enclose cheque/P.O.s for £.....

Cheque No.

(Send SAE if brochure only required)

...£13.86 Incl. V.A.T. post and packing. (Both to fit all vehicles with coil/ distributor ignition up to 8 cylinders.) Switch for instant changeover from "Sparkrite" ignition to conventional ignition £2.98 Incl. V.A.T. post and packing, R.P.M. limiting control £2.42 incl. V.A.T. post and packing. (Fitted in case on ready built unit, dashboard mounting on kit.)

CALLERS WELCOME

Constructors Guides

AVAILABLE NOW

Electronic Diagrams

M. A. Colwell

112 pages 0 408 00201 8 £1.80



Printed Circuit Assembly

M. J. Hughes, MA, AMIERE and M. A. Colwell
96 pages 0 408 00203 4 £1.80



Electronic Components

M. A. Colwell

112 pages 0 408 00202 6 £1.80



Newnes Technical Books

Newnes-Butterworths, Borough Green, Kent

ENGINEERS

FREE

YOURSELF FOR A BETTER JOB WITH MORE PAY!



This 44 page FREE book shows how!

Do you want promotion, a better job, higher pay? "New Opportunities" shows you how to get them through a low-cost home study course. There are no books to buy and you can pay-as-you-learn.

This helpful guide to success should be read by every ambitious engineer. Send for this helpful 44 page FREE book now. No obligation and nobody will call on you. It could be the best thing you ever did.

CUT OUT THIS COUPON

CHOOSE A BRAND NEW FUTURE HERE!

Tick or state subject of interest. Post to the address below.

| | | | | | |
|-------------------------------------|--------------------------|--|--------------------------|--|--------------------------|
| Electrical Engineering | <input type="checkbox"/> | Colour T.V. Servicing | <input type="checkbox"/> | CITY AND GUILDS Installations and Wiring | <input type="checkbox"/> |
| Electrical Installations and Wiring | <input type="checkbox"/> | C & G Radio, T.V. and Electronic Mechanics | <input type="checkbox"/> | CITY AND GUILDS Electrical Technicians | <input type="checkbox"/> |
| Electrical Draughtsmanship | <input type="checkbox"/> | General Radio and TV Engineering | <input type="checkbox"/> | CITY AND GUILDS Telecommunications | <input type="checkbox"/> |
| Electrical Mathematics | <input type="checkbox"/> | Radio Servicing, Maintenance and Repairs | <input type="checkbox"/> | Radio Amateurs' Exam. etc. etc. | <input type="checkbox"/> |
| Electronic Engineering | <input type="checkbox"/> | Transistor Technology | <input type="checkbox"/> | | |
| Computer Prog | <input type="checkbox"/> | | | | |

To: ALDERMASTON COLLEGE
DEPT. EEV 16 READING RG7 4PF
Also at our London Advisory Office, 4 Fore Street Avenue
Moorgate, London EC2Y 5EJ. Tel: 01-628 2721.

NAME (Block Capitals Please)

ADDRESS

POSTCODE

Other subjects Age

Accredited by C.A.C.O. Member of A.B.C.O.

HOME OF BRITISH INSTITUTE OF ENGINEERING TECHNOLOGY

MULLARD AUDIO AMPLIFIERS

All in module form, each ready built complete with heat sinks and connection tags, data supplied.

Model 1183 500mW power output £1.10 + 40p post & VAT.

Model 1173 1W power output £1.35 + 45p post & VAT.

Model EP9000 4 watt power output £2.90 + 50p post & VAT.

EP 9001 twin channel or stereo prw amp. £3.50 + 50p post & VAT.



LIGHT SWITCH

Automatically switches on lights at dusk and off at dawn. Can also be used where light and dark is a convenient way to stop and start an operation. Requires only a pair of wires to the normal switch. In bakelite box, normal switch-plate size. 1 amp model £3.75. VAT and Postage 50p.



MAINS TRANSISTOR PACK

Designed to operate transistor sets and amplifiers. Adjustable output 6V, 9V, 12 volts for up to 500mA (class B working). Takes the place of any of the following batteries: PP1, PP3, PP4, PP6, PP7, PP9 and others. Kit comprises: main transformer rectifier, smoothing and load resistor condensers and instructions. Real snip at only £1.50 VAT & Postage 90p.

SOUND TO LIGHT UNIT

Add colour or white light to your amplifier. Will operate 1, 2 or 3 lamps (maximum 450w). Unit in Box all ready to work. £7.95 plus 95p VAT and postage.



MAINS MOTOR

Precision made—as used in record decks and tapes recorders—ideal also for extractor fans, blowers, heaters, etc. New and perfect. Snip at 85p + VAT & Postage 25p. 1" stackmotor £1.50 + VAT & Postage 35p. 1 1/2" stackmotor £2 + VAT & Postage 40p.



6 DIGIT COUNTER

Made by famous American Company, operated by 24V D.C. or mains through resistor. 191/16" x 1" x 2 1/2" deep. 85p Post & VAT 20p each.



MINIATURE WAFER SWITCHES

2 pole, 2 way—4 pole, 2 way—3 pole, 3 way—4 pole, 3 way—2 pole, 4 way—3 pole, 4 way—2 pole 6 way—1 pole, 12 way. All at 90p + 15p post & VAT each.



MULTI-SPEED MOTOR

Six speeds are available 500, 850 and 1,100 r.p.m. and 8,000, 12,000 and 15,500 r.p.m. Shaft is 1/8 in. diameter and approximately 1 in. long. 230/240v. Its speed may be further controlled with the use of our Thyristor controller. Very powerful and efficient. Size approx. 3 in. dia. x 5 in. long. Price £1.40 + 45p post & VAT.



BATTERY CHARGER

Famous Atlas in metal case with meter, output leads terminated by crocodile clips. For 6 or 12V charging simply by changing plug on front panel. Ready built and priced £3.95 plus 41p Post & VAT.

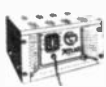

AMMETERS

Ideal for chargers etc. 2" square 0-1 amp vision 0-8 amp 85p, 1 1/2" sq. 0-3 amp 85p, 0-3 amp 85p, 0-4 amp 75p. Post & VAT 25p each.



RELAY BARGAIN

Type 600 relay, 2 changeover one open and one closed contact. 700 Ohm coils make this suitable for closing of DC 9V, DC 12V, DC 24V or AC mains using resistor and rectifier. 60p each. Resistor or rectifier 20p extra. Post & VAT 30p.

ONLY £1.50 FOR SEVEN ELECTRIC MOTORS

7 powerful bats. motors as used in racing cars & power models. Output & types vary for use in hundreds of different projects — Toys, toys, models, etc. All brand new reversible & for 11-12V. battery. Wiring diagram, inc. VAT & Post 40p. FREE plan for min. power station.

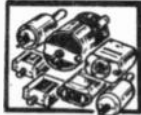

AUDIO AMPLIFIER

Part of the famous RedTone background music system, secondhand, but believed in good order. However, no guarantee; we are selling for spare value only. These are 6 valve amplifiers, the output valves are 2 x EL 84 in push/pull, complete with mains transformer, rectifier and ample smoothing equipment. The mains transformer alone, today would cost at least £4. Size is 9 1/2" x 6 1/2" x 4 1/2". Price only £3.95 + postage and VAT £1.50.



TWIN OUTPUT POWER PACKS

These have two separately R.C. smooth outputs so can operate two battery radios on a stereo amp without cross modulation (they will of course operate one radio-tape-cassette-calculator in fact any battery appliance and will save their cost in a few months). Specs.: Full wave rectification, double insulated mains transformer—total enclosed in hard P.V.C. case—three core mains lead—terminal output. When ordering please state output voltage 4V, 6V, 7 1/2V, 9V, 12V or 24V. Price £3.95, post and VAT included.



TANGENTIAL HEATER UNIT

This heater unit is most efficient, and quiet running. As fitted in Hoover and blower heaters costing £15 and more. Comprises motor, impeller, 2kW element and 1kW element allowing switching 1, 2 and 3kW with thermal safety cut-out. Can be fitted into any metal case or cabinet. Only needs control switch. £5.85 plus VAT & post £1. 2kW Model as above except 2kW 4A-25 plus VAT & post 75p. Don't miss this. Control Switch 64p. P. & P. 40p.

ISA ELECTRICAL PROGRAMMER

Learn in your sleep: Have radio playing and kettle boiling as you awake—switch on lights to ward off intruders—have a warm house to come home to. All these and many other things you can do if you invest in an electrical programmer. Clock by famous maker with 15 amp. on/off switch. Switch-on time can be set anywhere to stay on up to 6 hours. Independent 60 minute memory jogger. A beautiful unit. Price £3.95, VAT & Postage 60p, or with glass front, chrome bezel, £1.50 extra.

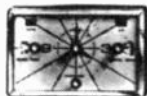

THIS MONTH'S SNIP

YOUR TIME is the most precious thing you have. Do you waste it waiting for the soldering iron to heat up? You can be soldering in a few seconds with the R.T.P. Soldering Gun which we offer at a specially keen price. It is in fact this month's snip. A well made lightweight unit with flash lamp to illuminate the work. Has 100 watt double insulated mains Transformer and is built into a shockproof Thermo-plastic case. Suitable for 240 volt, 50c.p.a. This comes complete with 5 spare tips and is offered at a special snip price £2.75 plus 65p Post & VAT.



CENTRIFUGAL FAN

Mains operated, turbo blower type. Pressed steel housing contains motor and impeller. Motor is 1/10th h.p. giving considerable air flow but virtually no noise. Approx. dimensions 10 1/2" x 4 1/2" 80-90 plus Post & VAT.



THERMOSTAT WITH THERMOMETER

Made by Honeywell for normal air temperatures 40-80 F (5-25 C). This is a precision instrument with a differential which can be adjusted to better than 1-5 F. A mercury switch breaks on temp. rise. Elegantly styled and encased in an ivory plastic case with clear plastic windows, thermometer above and switch setting scale below—size approx. 3 1/2" x 2 1/2" x 1 1/4" deep—can be mounted on conduit box or directly on wall. Price £2.25 plus 50p Post & VAT.

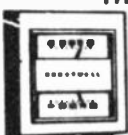

SHORTWAVE CRYSTAL SET

Although this uses no battery it gives really amazing results. You will receive an amazing assortment of stations over the 19, 20, 31, 39 metre bands—KIT contains chassis front panel and all the parts. £1.50—crystal cartridge 55p, VAT & Postage 75p.



SWITCH TRIGGER MATS

So thin is undetectable under carpet but will switch on with slightest pressure. For burglar alarms, shop doors, etc. 24in x 18in £1.95. Post & VAT 80p. 13in x 10in £1.45. Post & VAT 65p.



SMITHS CENTRAL HEATING CONTROLLER

Push button gives 10 variations as follows: (1) continuous hot water and continuous central heating (2) continuous hot water but central heating off at night (3) continuous hot water but central heating on only for 2 periods during the day (4) hot water and central heating both on but day time only (5) hot water all day but central heating only for 2 periods during the day (6) hot water and central heating on for 2 periods during the day time only—then for summer time use with central heating off (7) hot water continuous (8) hot water day time only (9) hot water twice daily (10) everything off. A handsome looking unit with 24 hour movement and the switches and other parts necessary to select the desired programme of heating. Supplied complete with wiring diagram. Originally sold, we believe, at over £15—we offer these, while stocks last, at 85.95 each, VAT & Postage 65p each.



TERMS: Where order is under £5 please add 30p surcharge to offset packing expenses. Send SAE for monthly list.

J. BULL (ELECTRICAL) LTD.
(Dept. EE), 103 TAMWORTH RD.
CROYDON CRO IXX

THIS MONTH'S SPECIAL OFFER is a very versatile transformer which can be used for many purposes. Rated at 250 watts it is very well built with frames for upright mounting and is variable in tap. It is primarily for 230/240 volts 50 cycles, it has four secondaries each 10v very high current windings. Just a few of the circuits it can power are: 10-10v at up to 12 amps; 20-20v at up to 6 amps; single 10v at 25 amps; single 20v at 12amps; single 30v at 9 amps; single 40v at 6.5 amps. The transformer can be used for power circuits (charging, etc.) or for amplifiers, there being an earth screen between primary and secondaries. A transformer like this to-day would cost at least £15 from the makers; however, we are making a special offer at £3.95 + 20p, post £1 + 5p each. (Ira some while you can, out stock may not last long.)

It is illegal for you not to provide adequate protection for any staff or persons working for or with you, your own personal comfort will be greater when you work isolated from the mains. Also, you are not likely to damage equipment if your soldering iron becomes earthed, as often happens. Isolation transformers are normally very costly, in fact we see that the average wholesaler is charging £15 plus for a 250w model. We can offer 250 watts of isolation at only £7 + 50p. Carriage £3 + 10p. Telephone handsets, ex GPO, but in good order, all you need to make an intercom between the kitchen and your office, saddle or shed down the bottom of the garden is a battery, a length of wire and two of these handsets. Price 50p + 40p, post 25p + 3p. Twin wire 84 + 32p per 100 metres, post 60p + 5p.

8pin motor with Carter gear box, probably one of the best split motors made. Originally intended for use in very high priced record players, this can be put to plenty of other uses, for instance your garden barbecue or to drive a colour disc for a dance or display or to drive a tumbler for stone polishing; in fact, there is no end to its use. Normal mains operation. Special price during January and February £3.95 + 20p, post 30p + 3p. 250wals contactor—small size approx. 4 1/2" x 1 1/2", this has 200 contacts each cross referenced above and below alphabetically and numerically so each can be easily identified. Contacts are capable of making positive connection with a strip or wire as each contact is spring loaded and has a gold "tip". Ideal if you want to make yourself a computer or direct board-based (resistors, etc. plug straight in) or for working out printed circuits, even for teaching electronics and novelties such as puzzles, combination locks, etc. Taken from unused computer panels, price only £2 + 10p each which works out to only 1p per contact, probably less than the value of the gold tip.

Post 15p + 1p. Gold plated strips for permanent contacts into slot of above panels, 15 for £1 + 8p. Vanner 1 rev per hour motor with spindle threaded and nutted ready to easily attach discs or drums. Bakelite encased motor beautifully made and finished. £3 + 10p, post 90p. Very many uses for this, for example a disc or drum attached could operate microswitches for display or mood lighting, etc.

Digital Display Unit, 'Digitron'. This is a precision instrument which consists basically of 12v lamp focused by a lens system, a numbered, numbered scale, the number appears on a ground glass front screen. The number is selected by applying a different voltage to the coil which rotates the scale e.g. 1 volt applied shows figure 1 on scale—by using ahunts or multipliers however any voltage or current could be made to indicate. For use for this, for example a disc or drum attached could operate microswitches for display or mood lighting, etc. Overall size of the unit is 2 1/2" x 1 1/2" x 4 1/2". Price £4.50 + 35p.

Fuses transformer with circuit for sound to light. It is a very simple circuit and all parts are readily obtainable from us or you may already have them in your junk box. Price of the transformer with circuit 75p, post and VAT paid.

OHP 12 light set. This device has been going for some years now but it has not been bettered and new applications keep being found for it. It has great stocks. Price 85p + 5p.

Throat mikes. These are an ex WD item as used by air crew on their intercom, but being electromagnetic they also serve as pick-ups on musical instruments, talking to passengers on motor bikes and no doubt many other uses. Price 90p a pair + 15p.

One chip radio, Ferranti EN 414 IC radio is still in stock, current price £1.40 + 35p. We can also still supply the kit to go with them, most popular one kit £1.40, comprises a permeability tuner for medium wave, and the resistors and condensers which when added to the EN 414 complete the radio for medium wave band. Price of this HQ kit No. 4 is 80p + 17p, post 20p + 5p.

15watt speaker bargain, 8" round mid-range, made for high priced hi-fi outfit, a really super speaker, £3 + 75p, post 60p + 15p. Incomparable, Honeywell ref. no. YZ RW 54-N96. This has fairly long lever and is changeover 15 amp 250v rating. Price 30p + 25p each.

Two circuit microswitch, famous American Licon, maker's ref. 16-40411, size approx. 1" long x 1" wide x 1/2" thick. Two electrically separate circuits, one makes the other breaks, when nylon push rod is depressed. Circuit rating we estimate at 5 amps 250v. A real bargain at 15p each + 1p—subject to normal quantity discounts.

Reed relay in nonseal. Resistance 1-5K, this will operate from voltages of 10v upwards on a current of 15mA upwards. The flow of the control current closes the reed switch but if you bias this with a small magnet or an opposing current, then the flow of the control current could be made to open the reed switch. Price 75p + 6p.

NO HIDDEN EXTRAS!

ALL PRICES INCLUDE V.A.T. POST FREE IN U.K.
A small selection from our comprehensive range



| Transistors | C-mos | THYRISTORS | TTL | LINEAR IC's | BUNDLES | ARROW for |
|-------------|----------------|------------------------------|-----------|-----------------|----------------------|---------------|
| AC128 22p | CD4000AE 19p | CR1/051C 1 amp 50 v 68p | 7400 11p | 741/8DIL 33p | 11 x 741/8 DIL £3 | ● OVERSEAS |
| AC176 26p | CD4001AE 19p | CR1/401C 1 amp 400 v 89p | 7402 11p | 747/14DIL £1-10 | 25 x 741/8 DIL £8-50 | ● EDUCATIONAL |
| AD161 51p | CD4002AE 19p | BTY79/400R 6 amp 400 v £2-42 | 7404 11p | 748/TOS 53p | 100 x 741/8 DIL £25 | ● GOVERNMENT |
| AD162 51p | CD4007AE 19p | BT106 1 amp 700 v 78p | 7405 11p | CA3018 94p | 8 x RED LEDS £1-08 | |
| BC107 12p | CD4009AE 52p | IRC20 1-3 amp 200 v 99p | 7408 11p | CA3018A £1-08 | 25 x RED LEDS £2-80 | |
| BC108 12p | CD4010AE 52p | 2N3228 5 amp 200 v 741p | 7410 11p | CA3028A £1-03 | 100 x RED LEDS £10 | |
| BC109 12p | CD4011AE 19p | 2N3225 5 amp 400 v £1-18 | 7413 11p | CA3035 £1-78 | 500 x IN4148 £12 | |
| BC109C 21p | CD4012AE 19p | 2N4441 5 amp 50 v 79p | 7447 11p | CA3046 91p | | |
| BC148 14p | CD4013AE 52p | 2N4444 5 amp 600 v £2-49 | 7472 11p | CA3048 £2-74 | | |
| BC149 15p | CD4014AE 84p | | 7473 11p | CA3052 £2-11 | | |
| BC158 16p | CD4015AE 84p | | 7474 11p | CA3080 £8-61 | | |
| BC169 16p | CD4018AE 52p | T2700D 6 amp 400 v £1-14 | 7475 11p | CA3088E £1-81 | | |
| BC189C 17p | CD4017AE 84p | T4700D 15 amp 200 v £1-28 | 7476 11p | CA3089E £2-52 | | |
| BC177 23p | CD4018AE 84p | T4700D 15 amp 400 v £1-48 | 7490 11p | CA3123E £1-82 | | |
| BC178 26p | CD4019AE 52p | T2800D 7 amp 400 v £1-01 | 7492 11p | MC1303L £2-87 | | |
| BC179 26p | CD4020AE £1-04 | T2800M 8 amp 600 v £1-50 | 7493 11p | MC1307P £1-78 | | |
| BD241A 57p | CD4022AE 89p | 2N5756 2-5 amp 400 v £1-02 | 7495 11p | MC1310P £2-86 | | |
| BD242A 73p | CD4023AE 19p | | 74121 11p | MC1330P £1-84 | | |
| BD243A 81p | CD4024AE 72p | RET's | 74141 11p | MFC4000B 92p | | |
| BD244A 88p | CD4025AE 19p | UJT's | 74154 11p | MFC6040 £1-48 | | |
| BF151 26p | CD4026AE £1-80 | 46p 2N2646 64p | 74184 11p | NE555V 63p | | |
| OC45 17p | CD4027AE 52p | 42p 2N4871 54p | 74196 11p | | | |
| OC71 26p | CD4028AE 83p | 64p BRY30 75p | | | | |
| OC72 26p | CD4029AE £1-06 | 32p IR2139 93p | | | | |
| OC81 36p | CD4030AE 52p | 35p TIS88A 41p | | | | |
| ZTX300 15p | CD4035AE £1-09 | 88p 2N5245 42p | | | | |
| ZTX500 15p | CD4040AE 99p | 42p S-Dec £2-24 | | | | |
| 2N706 16p | CD4042AE 78p | 64p 2N4871 £4-10 | | | | |
| 2N1711 17p | CD4043AE 94p | 42p µ-Dec "A" £4-51 | | | | |
| 2N2926 12p | CD4044AE 87p | 83p µ-Dec "B" £7-75 | | | | |
| 2N3053 21p | CD4046AE £1-24 | 10 to 5 Adaptor* £1-84 | | | | |
| 2N3055 48p | CD4049AE 52p | 31p 18 DIL Adaptor* £2-07 | | | | |
| 2N3702 19p | CD4050AE 52p | 50p 4046A £1-84 | | | | |
| 2N3704 16p | CD4051AE 87p | 40602 52p | | | | |
| 2N3707 16p | CD4058AE £1-22 | 40673 59p | | | | |
| 2N5777 51p | CD4060AE £2-50 | | | | | |

ARROW ELECTRONICS LTD.

DEPT. EE.11, 7 COPTFOLD ROAD
BRENTWOOD, ESSEX CM14 4BN
Tel. 0277 219435 Telex 99443

ARROW SERVICE
PLUS TOP QUALITY
PRODUCTS BY
RETURN. FURTHER
DETAILS →
VAT Reg.
246 0626 72

Name _____
Address _____
I enclose PO/Cheque for 10p

Arrow Electronics Limited
Dept. EE.11
7 Coptfold Road,
Brentwood,
Essex

Co. Reg. No. 1062424

ELECTROVALUE

the good components service

COMPLETE YOUR TEACH-IN WITH E.V.

To ensure success and progress, learn above all to use components you can depend on and buy from a firm that really knows the business. All electronic components for the E.E. Teach in POST PAID (UK) AND INC. VAT £14.25 NETT

CATALOGUE 8 NOW ISSUE No. 2

With our first printing sold out, Cat. 8, No. 2 is now ready, revised and brought up to date on prices, etc. 144 pages. New items. Opto-electronics, Diagrams of Components, applications, i.c. circuits, etc. Post free 40p, including voucher for 40p for spending on order over £5 list value.

DISCOUNTS

On all C.W.O. mail orders, except for some items marked NETT. 5% on orders list value 10% £15 or more

FREE POST & PACKING

On all C.W.O. mail orders in U.K. over £2 list value. If under, add 15p handling charge.

PRICE STABILIZATION POLICY

Prices are held and then reviewed over minimum periods of 3 months—Next price review end April 1st 1975.

QUALITY GUARANTEE

On everything in our Catalogue—No manufacturer's rejects, seconds or sub-standards merchandise.

ELECTROVALUE LTD

All communications to Section 4/3, 28 ST. JUDES ROAD, ENGLEFIELD GREEN, EGHAM, SURREY TW20 0HB. Telephone Egham 3603, Telex 284475. Shop hours 9-5.30 daily, 9-1 pm Sats.
NORTHERN BRANCH: 880 Burnage Lane, Burnage, Manchester M19 1NA. Telephone (061) 432 4945. Shop hours Daily 9-5.30 pm; 9-1 pm Sats.

CJL

CJL LTD. P.O. BOX 34, CANTERBURY, CT1 1YT
ALL PRICES INCLUDE P&P AND V.A.T.

| ANTEX SOLDERING IRONS | WIRE STRIPPER & CUTTER |
|------------------------------|--|
| (with slide on & off bits) | E0.85 |
| 15W 'C' miniature irons | HAND DRILLS Leytool precision, compact, 5/16" chuck |
| 3/32", 1/8", 3/16" bits—each | £3.99 |
| 'C' Elements | AERIALS Extend 15-120cm |
| 18W 'G' miniature irons | £1.50 |
| 3/32", 1/8", 3/16" bits—each | CASSETTE 'Head Demagnetisers' |
| 'G' Elements | £3.65 |
| 15W 'CCN' Low leakage irons | Shaped pole-saves time |
| 3/32", 1/8", 3/16" bits—each | £1.25 |
| 'CCN' Elements | EARPHONES Stethoscope |
| 25W 'X25' Low leakage irons | £0.65 |
| 3/32", 1/8", 3/16" bits—each | Crystal earphone, lead & plug |
| 'X25' Elements | £3.20 |
| 'SK1', 'SK2' Soldering Kits | Headphone, 2,000 Ω |
| £3.85 | INTERCOMS 2-station |
| ST3 Stands—for all models | £6.35 |
| £1.10 | MICROPHONES Dynamic |
| SOLDER in 1lb dispenser | £2.15 |
| £0.45 | PRINTED CIRCUIT KITS -All items for producing p.c.'s |
| | £3.99 |
| | SIGNAL INJECTOR -Audio through video signals, self contained |
| | £4.25 |
| | STEREO HEADPHONES 8Ω, 4Ω, 8Ω |
| | £4.85 |
| | SPEAKERS -75mm dia. 8Ω |
| | £1.00 |

DENCO (CLACTON) LTD.

Dept. E.E.
357-8-9 OLD RD., CLACTON-ON-SEA
ESSEX. CO15 3RH



Our components are chosen by technical authors and constructors throughout the world, for their performance and reliability, every coil being inspected twice plus a final test and near spot-on alignment.

General catalogue showing full product range 32p, post paid. Please enclose S.A.E. with all other enquiries.

TRADE ENQUIRIES WELCOME

VALVE BARGAINS

Any 5 64p, 10 99p, 50 £4.
Your choice from the following list: ECH84, ECC82, ECL80, EF80, EF183, EF184, PC86 PC88, PCF80, PCF802, PCL82, PCL84, PCL85, PCL805, PCL86, PFL200, PL36, PL504, PY33, PY81, PY800, PY88, EH90, 30FL1, 30FL2, 30PL14, 6F28

Colour Valves 25p each
PL508 PL509, PY500/A

Press 4 Button Transistor UHF Tuners £2.50

AERIAL BOOSTERS

We make three types of Aerial Boosters all for set top fitting, with Co-ax Plugs and Sockets.

B11—For Stereo and Standard VHF Radio
B12—For the older VHF Television, please state BBC1 and ITV Channels.

B45—For mon. or colour this covers the complete UHF band.

All Boosters are complete with Battery and take only minutes to fit.

Price £3.90 each

BARGAIN PACKS

All Components in the Bargain Packs are unused and marked.

Pack 1—Polyester (C200) Axial Leads Capacitors—250V/W & 400V/W, very good mixed selection from 0.01 UF to 2.2 UF. Price 100 £1.25, 1000 £10.00 (our choice).

Pack 2—White Plastic Boxes with flick-on tops. Ideal for most projects—inside size 3½in x 2½in x 1in deep. Price 10/£1.10, 100/£9.00.

Co-Ax Connectors 8p (70p).

Co-Ax Plug—8p (70p).

Jack Plugs—Standard 17p (£1.50), 2.5mm 10p (85p), 3.5mm 10p (85p).

Din Plugs—2 Pin 12p (£1.00), 3 Pin 14p (£1.20), 5 Pin 18p (£1.50). (Price in brackets for Ten).

Prices include V.A.T. P. & P. under £1/15p, £1 to £3/20p, above £3/25p. Overseas at cost. Money back guarantee on all orders.

ELECTRONIC MAILORDER LTD., 62 BRIDGE ST., RAMSBOTTOM, BURY, LANCS. Tel. Rams. 3036.



"I MADE IT MYSELF"

Imagine the thrill you'll feel! Imagine how impressed people will be when they're hearing a programme on a modern radio you made yourself.

Now! Learn the secrets of radio and electronics by building your own modern transistor radio!

Practical lessons teach you sooner than you would dream possible.

What a wonderful way to learn—and pave the way to a new, better-paid career! No dreary ploughing through page after page of dull facts and figures. With this fascinating Technatron Course, you learn by building!

You build a modern Transistor Radio . . . a Burglar Alarm. You learn Radio and Electronics by doing actual projects you enjoy—making things with your own hands that you'll be proud to own! No wonder it's so fast and easy to learn this way. Because learning becomes a hobby! And what a profitable hobby. Because opportunities in the field of Radio and Electronics are growing faster than they can find people to fill the jobs!

No soldering - yet you learn faster than you ever dreamed possible.

Yes! Faster than you can imagine, you pick up the technical know how you need. Specially prepared step-by-step lessons show you how to read circuits—assemble components—build things—experiment. You enjoy every minute of it! You get everything you need. Tools. Components. Even a versatile Multimeter that we teach you how to use. All included in the course. **AT NO EXTRA CHARGE!** And this is a course anyone can afford. (You can even pay for it by easy instalments).

So fast, so easy, this personalised course will teach you even if you don't know a thing today!

No matter how little you know now, no matter what your background or education, we'll teach you. Step by step, in simple easy-to-understand language, you pick up the secrets of radio and electronics. You become somebody who makes things, not just another of the millions, who don't understand. And you could pave the way to a great new career, to add to the thrill and pride you receive when you look at what you have achieved. Within weeks you could hold in your hand your own transistor radio. And after the course you can go on to acquire high-powered technical qualifications, because our famous courses go right up to City & Guilds levels.

Send now for FREE 44 page book - see how easy it is - read what others say!

Find out more now! This is the gateway to a thrilling new career, or a wonderful hobby you'll enjoy for years. Send the coupon now. There's no obligation.

QUALITY STEREO SOUND.

ALMOST **1/2 PRICE OFFER!** SOLENT AUDIO SYSTEM

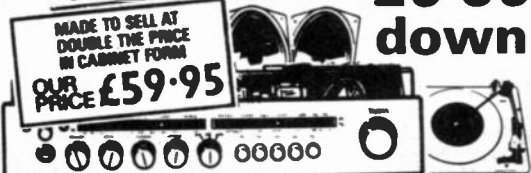

*Stereo Tuner Amplifier chassis with AM/FM radio covering long medium short and Stereo FM wavebands. Separate Base and Treble controls. 30 watts total power output (frequency response 25-20,000 Hz) AFC Switching Tape record and playback facilities. Dimensions 18½" x 9" x 3½". The very latest BSR automatic record deck with cue and pause control. Two matching elliptical speaker units.

Order early limited stocks available cash price £59.95. Credit Sale £5.95 deposit 9 monthly payments of £7.00 (Total Credit price £68.95). P. & P. £3.00. Send £8.95 today.

Chassis only available for cash at £42.00.

Full 12 months Guarantee.

CALLERS WELCOME.

Access and Barclaycard Orders Accepted by Telephone

Stereo headphones supplied with every complete order.

LEWIS radio EE/476 100 CHASE SIDE SOUTHGATE LONDON N14 5PL Telephone: 01-832-1644

POST TODAY FOR FREE BOOK

To: **ALDERMASTON COLLEGE DEPT. CEE 16 READING RG7 4PF**

Also at our London Advisory Office, 4 Fore Street Avenue, Moorpark, London EC2Y 5EJ. Tel: 01-828 2721.

Yes, I'd like to know more about your course. Please send me free details—plus your big, 44 page book that tells about all your courses.

NAME

ADDRESS

POSTCODE



HOME OF BRITISH INSTITUTE OF ENGINEERING TECHNOLOGY

The Black Watch kit

£14.95!

★ **Practical**—easily built by anyone in an evening's straightforward assembly.

★ **Complete**—right down to strap and batteries.

★ **Guaranteed.** A correctly-assembled watch is guaranteed for a year. It works as soon as you put the batteries in. On a built watch we guarantee an accuracy within a second a day—but building it yourself you may be able to adjust the trimmer to achieve an accuracy within a second a week.

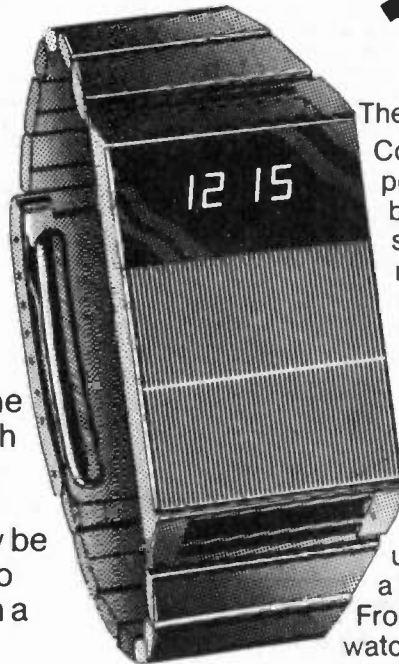

The Black Watch by Sinclair is unique. Controlled by a quartz crystal, and powered by two hearing aid batteries, it uses bright red LEDs to show hours and minutes, and minutes and seconds. And it's styled in the cool prestige Sinclair fashion: no knobs, no buttons, no flash.

The Black Watch kit is unique, too. It's rational—Sinclair have reduced the separate components to just four—and it's simple: anybody who can use a soldering iron can assemble a Black Watch without difficulty. From opening the kit to wearing the watch is a couple of hours' work.

Touch and tell

Press here for hours and minutes... here for minutes and seconds.

Batteries easily replaced at home.

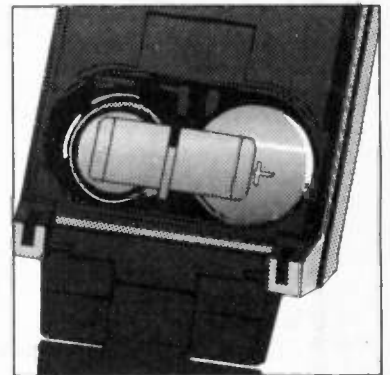
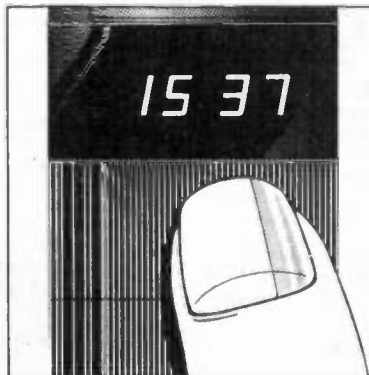
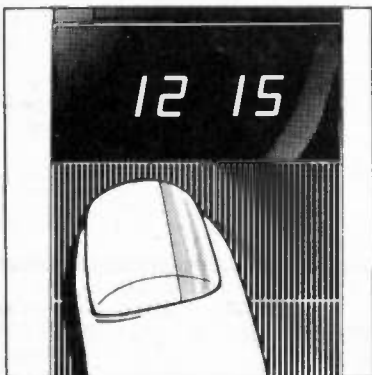

The specialist features of the Black Watch

Smooth, chunky, matt-black case, with black strap. (Black stainless-steel bracelet available as extra—see order form.)

Large, bright, red display—easily read at night. Touch-and-see case—no unprofessional buttons.

Runs on two hearing-aid batteries (supplied). Easily re-set using special button—no expensive jeweller's service.

The Black Watch—using the unique Sinclair-designed state-of-the-art IC.

The chip...

The heart of the Black Watch is a unique IC designed by Sinclair and custom-built for them using state-of-the-art technology—integrated injection logic.

This chip of silicon measures only 3 mm x 3 mm and contains over 2000 transistors. The circuit includes

- a) reference oscillator
- b) divider chain
- c) decoder circuits
- d) display inhibit circuits
- e) display driving circuits.

The chip is totally designed and manufactured in the UK, and is the first design to incorporate all circuitry for a digital watch on a single chip.

... and how it works

A crystal-controlled reference is used to drive a chain of 15 binary dividers which reduce the frequency from 32,768 Hz to 1 Hz. This accurate signal is then counted into units of seconds, minutes, and hours, and on request the stored information is processed by the decoders and display drivers to feed the four 7-segment LED displays. When the display is not in operation, special power-saving circuits on the chip reduce current consumption to only a few microamps.

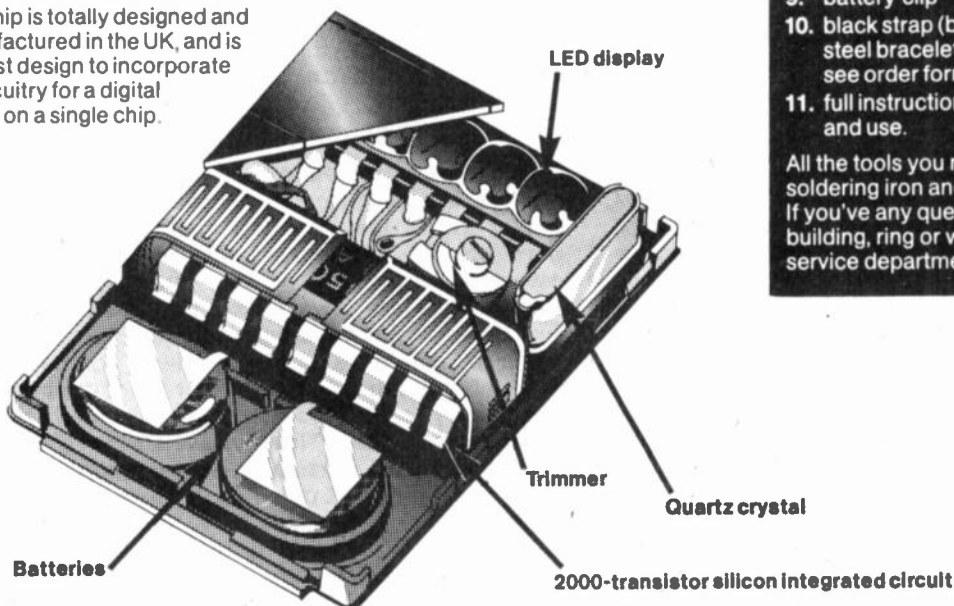

Complete kit £14.95!

The kit contains

1. printed circuit board
2. unique Sinclair-designed IC
3. encapsulated quartz crystal
4. trimmer
5. capacitor
6. LED display
7. 2-part case with window in position
8. batteries
9. battery-clip
10. black strap (black stainless-steel bracelet optional extra—see order form)
11. full instructions for building and use.

All the tools you need are a fine soldering iron and a pair of cutters. If you've any queries or problems in building, ring or write to Sinclair service department for help.

Take advantage of this no-risks, money-back offer today!

The Sinclair Black Watch is fully guaranteed. Return your kit in original condition within 10 days and we'll refund your money without question. All parts are tested and checked before despatch—and correctly-assembled watches are guaranteed for one year. Simply fill in the FREEPOST order form and post it—today!

Price in kit form: £14.95 (inc. black strap, VAT, p & p).

Price in built form: £24.95 (inc. black strap, VAT, p&p).

sinclair

Sinclair Radionics Ltd,
London Road, St Ives,
Huntingdon, Cambs., PE17 4HJ.
Tel: St Ives (0480) 64646.

Reg. no: 899483 England. VAT Reg. no: 2138170 88.

To: Sinclair Radionics Ltd, FREEPOST, St Ives, Huntingdon, Cambs., PE17 4BR.

Please send me

Total £

..... (qty) Sinclair Black Watch kit(s) at £14.95 (inc. black strap, VAT, p&p).

* I enclose cheque for £..... made out to Sinclair Radionics Ltd and crossed.

..... (qty) Sinclair Black Watch(es) built at £24.95 (inc. black strap, VAT, p&p).

* Please debit my *Barclaycard/Access/American Express account number

..... (qty) black stainless-steel bracelet(s) at £2.00 (inc. VAT, p&p).

Name (please print) _____

Address _____

Signature _____

EE/4

FREEPOST—no stamp required.

* Delete as required

everyday electronics

PROJECTS...
THEORY.....

DISCOVERY

Life is full of little surprises. Indeed some of life's pleasures are bound up with the making of new discoveries. The observant will discover something fresh everyday. Small and perhaps insignificant things in their own way, but adding usefully to the total store of personal knowledge and experience.

A particularly important kind of discovery is that which reveals the truth about something which has been "taboo" for some reason or another. It is easy for the uninitiated to be frightened-off certain subjects, often without good reason, merely in deference to some reputation. But once this taboo has been overcome it is not unusual to discover that the fears were unfounded and that the subject is easier to understand and to become closely involved in than had been anticipated.

Electronics is a case in point. The very success of electronic technology in all spheres of human affairs has of itself created an aureole of glamour and at the same time erected a kind of psychological barrier between those who are technically knowledgeable and those, the majority, who are not.

Some of those in the latter group will, we hope, very soon now make an important discovery. A discovery that will lead to further enjoyment and pleasure and be rewarding in material senses as well. For this month we offer

a golden opportunity for anyone new to electronics. What one requires to know on the practical side of circuit building is set out in words and illustrations in the special supplement included in this issue. It's rightly entitled *Electronics Made Easy*.

SHOP WINDOW

Advertisers' announcements form a valuable part of any magazine. Especially so when the reader relies mainly upon mail order for his purchases of components and other materials essential for his hobby. The ads in EVERYDAY ELECTRONICS are always worth a close perusal, for it's surprising what you might discover.

For example, a model railway enthusiast found some much sought after micro-switches in one of our advertisements. He was delighted and considered this "find" made EE worthwhile even though his particular field of interest has not, so far, received much recognition by way of projects aimed specifically at model railway enthusiasts. We are glad to report that such selfless devotion to this magazine brought at anyrate *some* reward! Our correspondent and others sharing his taste for model trains will not be overlooked in future designs, that's a promise.

Fred Bennett

Our May issue will be published on Thursday, April 15

EDITOR F. E. Bennett ● ASSISTANT EDITOR M. Kenward ● TECHNICAL EDITOR B. W. Terrell B.Sc.
ART EDITOR J. D. Pountney ● P. A. Loates ● K. A. Woodruff
ADVERTISEMENT MANAGER D. W. B. Tilleard ● P. Mew

© IPC Magazines Limited 1976. Copyright in all drawings, photographs, and articles published in EVERYDAY ELECTRONICS is fully protected, and reproduction or imitations in whole or part are expressly forbidden.

All reasonable precautions are taken by EVERYDAY ELECTRONICS to ensure that the advice and data given to readers are reliable. We cannot, however, guarantee it, and we cannot accept legal responsibility for it. Prices quoted are those current as we go to press.

Editorial Department: Everyday Electronics, Fleetway House, Farringdon Street, London EC4 4AD. Phone 01-634 4452.

Advertisement Department: Everyday Electronics Advertisements, King's Reach Tower, Stamford Street, London SE1 9LS. Phone 01-261 5148.

..EASY TO CONSTRUCT
..SIMPLY EXPLAINED



VOL. 6 NO. 4

APRIL 1976

CONSTRUCTIONAL PROJECTS

| | |
|--|-----|
| TOUCH-TO-TALK INTERCOM I.C. design, featuring unusual switching by R. A. Penfold | 196 |
| MAINS POWER CONTROLLER For electric drills and other motor driven apparatus by John S. Ryle | 202 |
| UNIT BUILT SUPERHET Part 1 Four band superhet receiver by F. G. Rayer | 218 |
| RESISTANCE/CAPACITANCE BRIDGE For checking dubious components by F. G. Rayer | 224 |

GENERAL FEATURES

| | |
|--|-----|
| EDITORIAL | 194 |
| COUNTER INTELLIGENCE A retailer comments by Paul Young | 205 |
| SHOP TALK Component buying and new products by Mike Kenward | 206 |
| TEACH-IN 76 Part 7, The Transistor by A. P. Stephenson | 208 |
| JACK PLUG AND FAMILY Cartoon | 212 |
| YOUR CAREER IN ELECTRONICS Ship's Radio Officer by Peter Verwig | 213 |
| PHYSICS IS FUN A warning made clear by Derrick Daines | 216 |
| FOR YOUR ENTERTAINMENT VAT regulations by Adrian Hope | 217 |
| READERS' LETTERS Your news | 223 |
| PROFESSOR ERNEST EVERSURE The Extraordinary Experiments of. by Anthony J. Bassett | 228 |
| EE KIT REPORT Sinclair Black Watch—more findings | 233 |
| DOWN TO EARTH Magnetic Induction by George Hylton | 234 |

SPECIAL SUPPLEMENT

BEGINNERS GUIDE—ELECTRONICS MADE EASY

Between 212—213

BACK NUMBERS, LETTERS AND BINDERS

We are unable to supply back copies of *Everyday Electronics* or reprints of articles and cannot undertake to answer readers' letters requesting designs, modifications or information on commercial equipment or subjects not published by us. An s.a.e. should be enclosed for a personal reply. Letters concerning published articles should be addressed to: The Editor, those concerning advertisements to: The Advertisement Manager, at the addresses shown opposite.

Binders for volumes 1 to 6 (state which) and indexes for volume 1 and 2 available for £1.85 and 30p respectively, including postage, from Binding Department, Carlton House, Great Queen Street, London, WC2E 9PR.

**A FREE GIFT
FOR YOU
NEXT MONTH**
See page 207 for details

HOW IT WORKS

In this unit, conventional type switches have been replaced by finger sensitive electronic contacts. The loudspeakers are used as speakers on "receive" and as a form of moving coil microphone on "send".

With neither touch switch operated, the loudspeaker at the remote unit is connected as the microphone (amplifier input) while the master unit loudspeaker is connected to the amplifier output.

Bridging of the touch contacts at the remote unit causes its electronic switch to operate and supply power to the system allowing remote-to-master conversation. When master-to-remote conversation is required, the former's touch contacts are made, and its electronic switch causes power to be supplied to the amplifier and its "direction" to be reversed.

The light emitting diode is illuminated when either contacts are made.

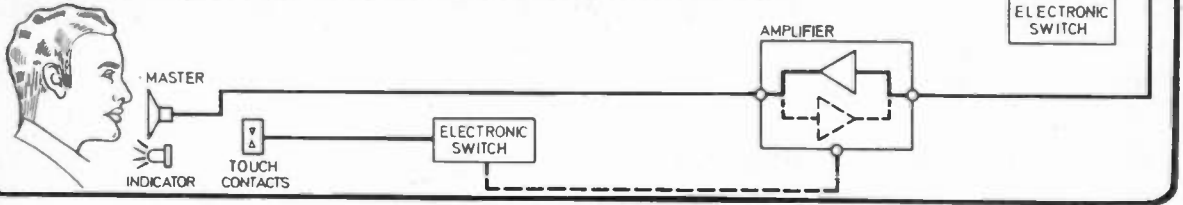

A DVANCES in modern electronics have led to vast improvements in virtually every type of electronic equipment. Types of design that would once have been considered electrically overcomplicated and expensive, even if an improvement from the consumers point of view, are now quite viable when modern components and techniques are employed.

The intercom design described here, with its novel method of switching and high quality amplifier, is a good example of this. The circuit probably uses fewer components than a conventional design of some years ago.

TOUCH CONTROL

At a first glance the most striking thing about this intercom is that it appears to have no controls. Closer inspection will show that it in fact has just two controls, one at each end of the system. Both are touch switches which are activated by touching a couple of contacts, rather than by the usual method of moving a knob or lever.

Using the system is about as simple as it could possibly be. To talk through to the opposite end of the system one simply touches the two contacts and talks. The contacts are touched for the duration that one wishes to speak, and they are released while the other person replies. Of course, during this time the touch switch at the other end of the system must be operated.

The two units are connected by a length of ordinary miniature three-core mains cable.

The prototype gave satisfactory results when tested using a connecting cable 15 metres long, and it should work perfectly well using a cable considerably longer than this.



Touch to talk

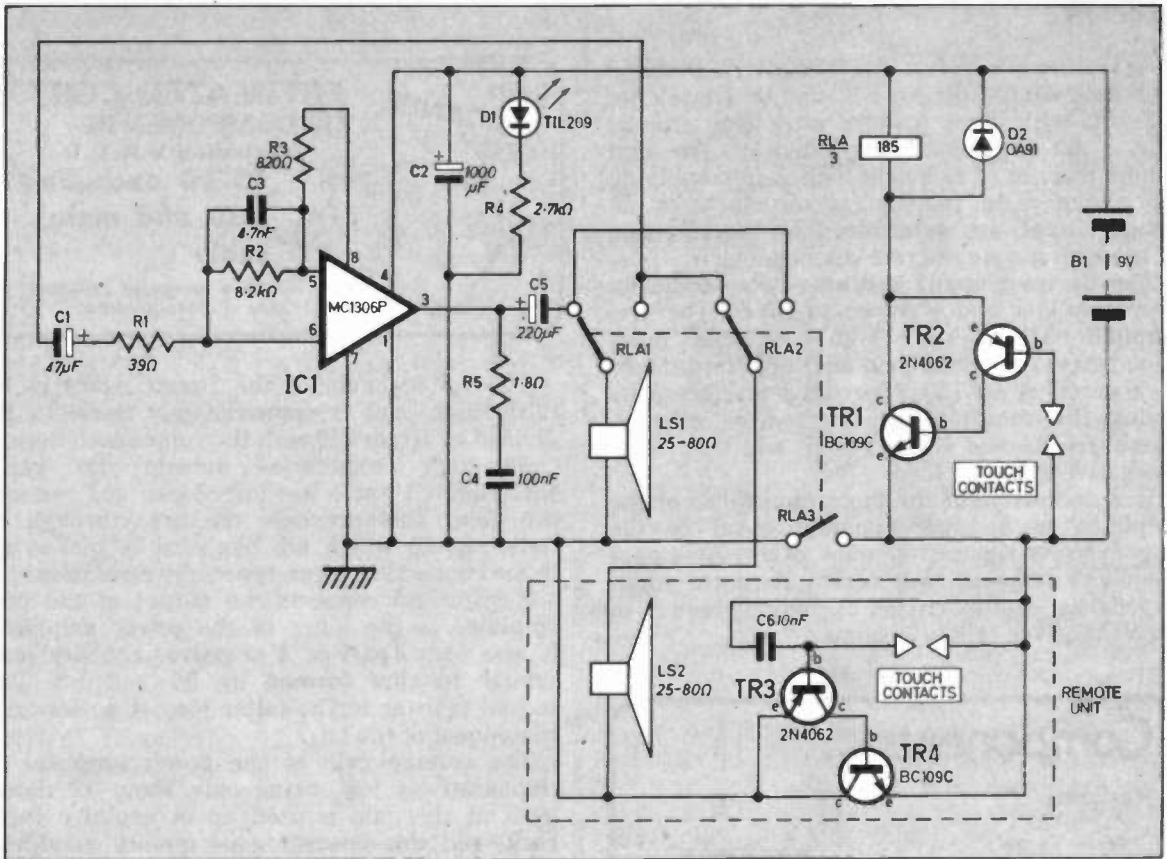

Fig. 1. The complete circuit diagram of the Touch-To-Talk Intercom.

AMPLIFIER

The complete circuit diagram of the intercom is shown in Fig. 1. The loudspeakers double as microphones in the "send" mode, and as they are rather inefficient when used as either, a high gain amplifier is used to boost the microphone signals to a level which provides good volume from the speaker.

The amplifier is based on an integrated circuit type MC1306P. This has a fairly complex internal circuit, and it uses the equivalent of



INTERCOM

By R.A. PENFOLD

14 transistors, 5 diodes, and 9 resistors. Detailed operation of the device will not be considered here. As with many modern integrated circuits this is not really necessary anyway. The unit can be thought of as a very high gain amplifying block, the main parameters of which, in an actual circuit, are determined by the selection of the appropriate discrete components.

The device actually contains two amplifiers, a preamplifier and a power amplifier. The preamplifier has a basic high gain and input impedance. The actual gain and input impedance of a practical MC1306P circuit are selected by giving the required values to two resistors. These are R1 and R2 in Fig. 1, and they form a negative feedback loop.

It is necessary for the input impedance of the amplifier to be approximately equal to the impedance of the microphones, otherwise a poor frequency response will result. Here the input impedance of the circuit is roughly equal to the value given to R1 (39 ohms).

Components

Resistors

| | |
|--------------------------------------|---------------|
| R1 | 39 Ω |
| R2 | 8.2k Ω |
| R3 | 820 Ω |
| R4 | 2.7k Ω |
| R5 | 1.8 Ω |
| All $\frac{1}{2}$ W carbon \pm 10% | |

**WAV
TALK
SHOP**
SEE

Capacitors

| | |
|----|-------------------------|
| C1 | 47 μ F 10V elect. |
| C2 | 1000 μ F 10V elect. |
| C3 | 4.7nF polystyrene |
| C4 | 0.1 μ F type C280 |
| C5 | 220 μ F 10V elect. |
| C6 | 10nF plastic foil |

Semiconductors

| | |
|-----|---------------------------|
| TR1 | BC109C silicon npn |
| TR2 | 2N4062 silicon pnp |
| TR3 | 2N4062 silicon pnp |
| TR4 | BC109C silicon npn |
| IC1 | MC1306P |
| D1 | T1L209 or similar l.e.d. |
| D2 | OA91 germanium or similar |

Miscellaneous

- LS1, 2 miniature moving coil loudspeakers, 25 to 80 ohms impedance (2 off)
- RLA 6V 185 ohm relay with two changeover contacts and one normally open contact, type PC4 or similar.
- B1 9V type HP7 (6 off)
- Veroboard: 0.1in. matrix 4-strips by 10 holes, 16-strips by 17 holes; plastic cases: 120 x 65 x 40mm (remote unit), 150 x 80 x 50mm (master unit); panel holder for D1; speaker fret; mains cable; holder for HP7's; 4BA countersunk bolts—touch contacts (4 off); 4BA solder tags (4 off); rubber grommets.

**FOR
GUIDANCE
ONLY**

**ESTIMATED COST*
OF COMPONENTS**

excluding V.A.T.

**£5.20 excluding
case and mains
cable**



*Based on prices prevailing at time of going to press

The voltage gain of the circuit needs to be fairly high, and is approximately equal to R2 divided by R1, or 210 with the values used here.

At high frequencies outside the audio spectrum, C3 has a low impedance and reduces the gain. This prevents the breakthrough of radio signals which are likely to be picked up in the connecting wires, especially after dark.

Resistor R3 connects the output of the preamplifier to the input of the power amplifier. It also forms part of a negative feedback loop similar to that formed by R1 and R2. The second resistor in the latter loop is an internal component of the i.c.

The voltage gain of the power amplifier is comparatively low, being only about 12 times. Most of the gain is used up in negative feedback, and this ensures good quality amplification.

Distortion caused by the amplifier is considerably less than 1 per cent at the power levels involved here, and the reproduction quality is only really limited by the speaker/microphones.

Components C1 and C5 are the input and output d.c. blocking capacitors respectively; C2 is the supply decoupling capacitor and R5 and C4 are required in order to prevent the amplifier from becoming unstable.

SWITCHING

A relay situated in the master unit selects which speaker is used as a microphone and which is used as a speaker. The unit is wired so that normally LS2 is the microphone and LS1 is the speaker.

If the touch contacts at the remote unit are touched, a small current will flow from the negative supply line and into the base of TR3 via the operator's finger. This causes a much larger current to flow via TR3 emitter and collector into the base of TR4.

This current turns TR4 hard on, and the negative supply line is connected through to the amplifier by way of its emitter and collector terminals; C6 filters any interference which might otherwise be picked up at the touch contacts.

Transistors TR3 and TR4 need to have a very high combined gain as only a minute current will flow through the high skin resistance of

the operator. The total current gain of this stage is about 100,000.

A similar touch switch is used in the master unit, and this utilises TR1 and TR2. It is a relay as its load, however.

When these touch contacts are bridged, the relay is turned on. The relay contacts change over to the opposite positions, and RLA1 and RLA2 connect LS1, which is now the microphone, to the amplifier's input.

Loudspeaker LS2 is connected to the output, and RLA3 connects the power to the amplifier.

A high reverse voltage can be produced across the relay coil as the operator's finger is removed from the touch contacts and the relay is de-energised. Diode D2 in effect shorts this out and prevents any possible damage to the semiconductor devices in the circuit.

Resistor R4 is the current limiting resistor for the light emitting diode i.e.d. panel indicator, D1. This lights up when power is connected to the amplifier. It is a useful feature apart from its function as a normal pilot light, as it will come on while the touch switch at the remote station is being operated. When it goes out it thus indicates that the person at the remote unit has finished speaking.

Note that no significant power is drawn from the battery until one of the pairs of touch contacts is bridged. If both switches should happen to be operated at the same time, the one fitted to the master unit will render the one at the remote unit ineffective.

REMOTE UNIT

The remote unit is contained in a small plastic case measuring about 120 × 63 × 40mm, although a slightly larger case might be required, depending upon the diameter of the speaker used. A rectangular cut-out for the speaker is made in the left hand side of the front panel using a fretsaw. A piece of speaker material or fret is glued in place behind the cut-out, and the speaker is then in turn glued to this.

The touch contacts consist of a couple of 4BA countersunk bolts. These are mounted centrally

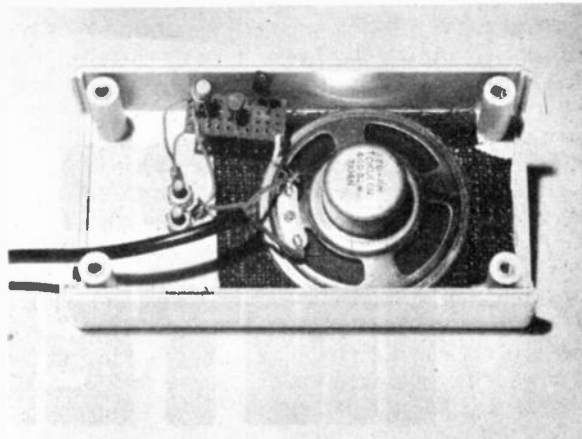

Photograph showing the inside of the prototype remote unit.

on the right hand side of the front panel, about 8mm apart. A 4BA solder tag is mounted on each screw on the inside of the case, and a couple of nuts are used to hold the screws and tags in place.

A 0.1 inch matrix Veroboard panel having four strips by ten holes is used in the wiring up of TR3, TR4, and C6 and wired up to the loudspeaker and touch contacts as shown in Fig. 2 using short lengths of insulated connecting wire. These provide the only mounting the panel requires.

A hole for the connecting cable is drilled centrally in a side panel of the case, and the cable is then threaded through this, via a rubber grommet, and wired to the rest of the unit. This completes the remote station.

MAIN STATION

Most of the small components in the master unit are wired up on a 0.1 inch matrix Veroboard having 16 strips by 17 holes, fitted to the base of the case. Details of this panel are shown in Fig. 3.

When a panel of the correct size has been cut out, the two 6BA clearance mounting holes should be drilled using a 3.2mm twist drill. The

Fig. 2. Layout of the components and wiring up details of the remote unit.

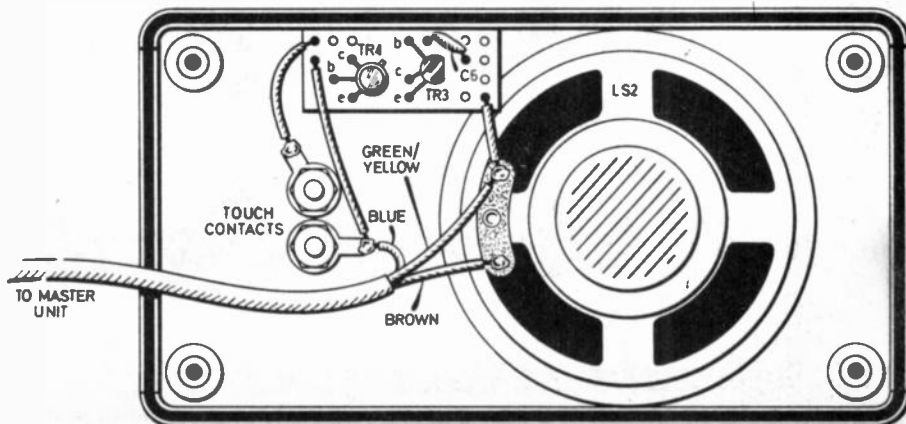

Touch to talk INTERCOM

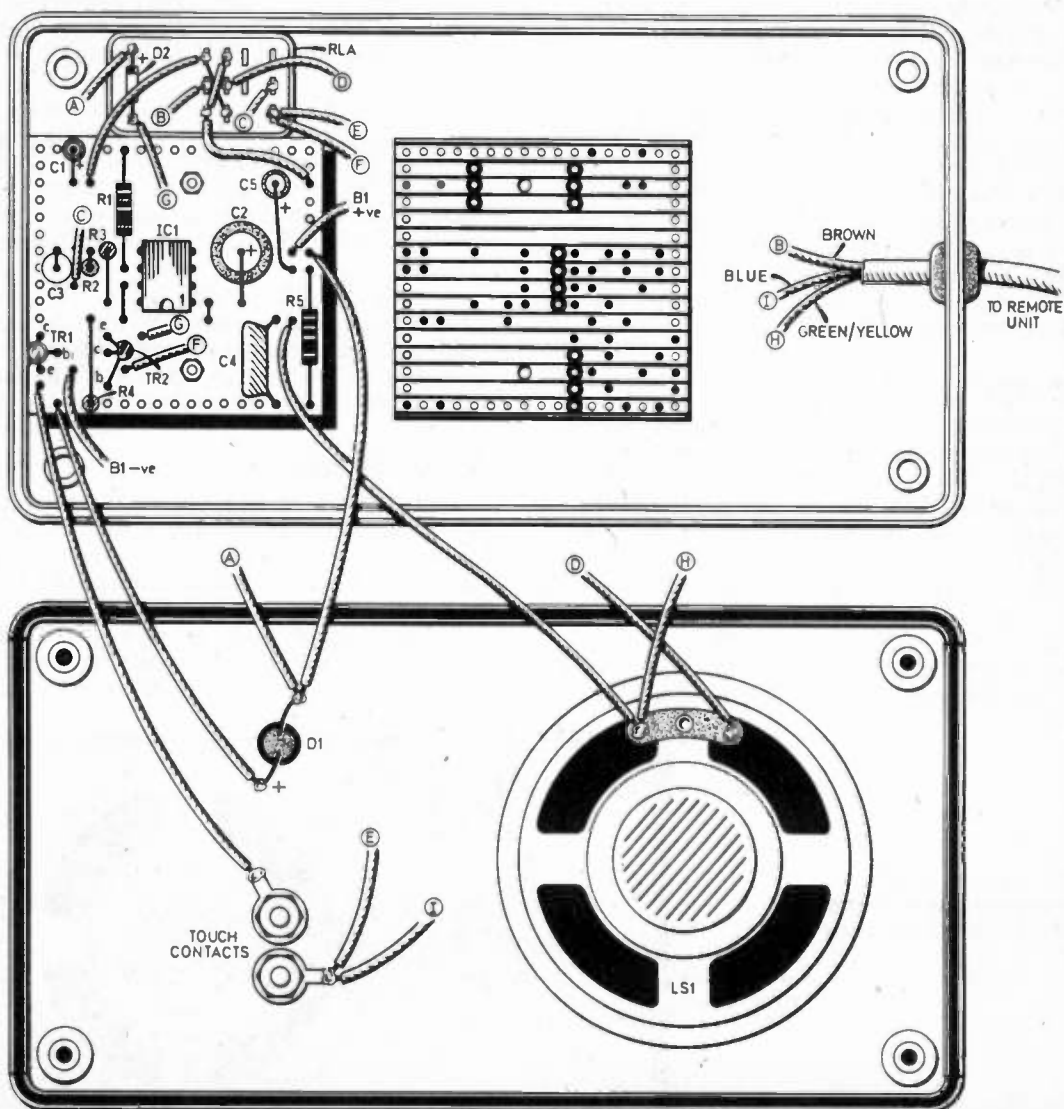
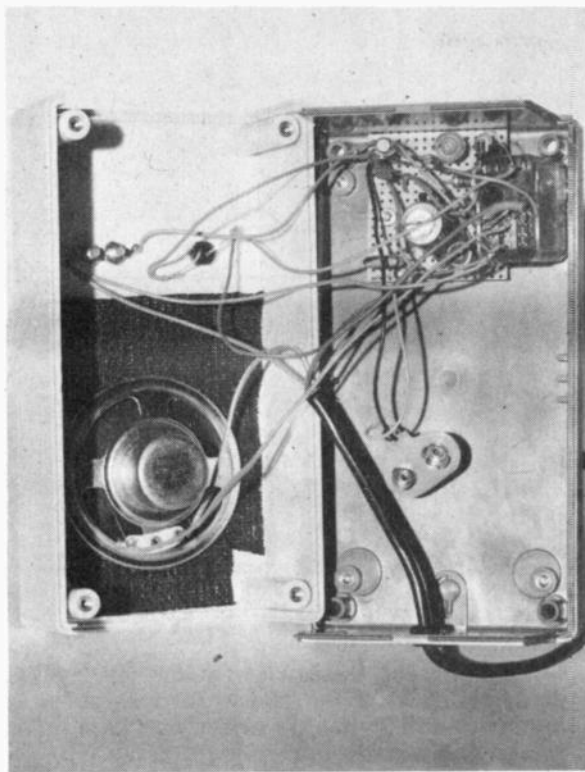

Fig. 3. Layout and wiring up details of the components in the master unit.



Photograph of completed prototype master unit with lid and battery removed.

breaks in the copper strips should then be made at the points indicated in the diagram.

If the special tool for this purpose is not available, a small twist drill (about 5mm diameter) held in the hand can be used as an alternative.

Next the components can be mounted and soldered in place, according to Fig. 3.

Make sure that the three electrolytic capacitors are connected with the correct polarity. Leave the transistors and i.c. until last and use a heatsink when soldering these in position. Ensure that no blobs of excess solder short circuit any adjacent copper strips.

The layout and wiring up of the components within the master unit are shown in Fig. 3.

A plastic case measuring about 150×80×50mm houses the unit. This is about the smallest case that can easily accommodate the components.

The work appertaining to the speaker and touch contacts is much the same as for the remote unit.

Diode D1 is mounted above the touch contacts in a small plastic holder, which is normally supplied with the l.e.d. Again, a hole is drilled in the side panel to take the connecting cable to the remote unit.

The component panel is mounted as shown onto the base of the case using a couple of 12mm long 6BA bolts with nuts. A short spacer

is used over each bolt between the case and the panel. The component panel might otherwise crack as the mounting nuts are tightened. The component board should not be finally mounted until it has been wired up to the rest of the circuit. The relay is glued to the case just below the component board.

Six HP7 batteries in a plastic holder are used to power the unit. These fit between the component panel and the speaker magnet. Make quite sure that sufficient space is left for the batteries before positioning the speaker.

When the relay, speaker, etc. have been mounted, complete the remaining wiring between components and board. This is all carried out using multistrand insulated wire.

Protection diode D2 is mounted on the relay, and must be connected with the polarity shown. It could be destroyed if connected incorrectly.

Finally connect the two units together by means of the required length of mains cable.

Once the wiring has been completed, check thoroughly for mistakes, and when satisfied that all is well, mount the component panel, connect the batteries, and screw the parts of the case together. The unit is then ready for testing.

TESTING

With the two units in the same room, touching either set of touch contacts should produce an audio tone from the other unit and cause the indicator lamp to come on. This howling sound is due to acoustic feedback.

When installing the units, try to keep both them and the connecting cable away from possible sources of electrical interference, such as mains wiring.

The units can easily be wall or table mounted. If they are to be mounted on a table it is a good idea to use a couple of wedge shaped pieces of wood or chipboard to hold each case up at an angle of about 30 degrees. These can be given an attractive finish with either paint or a self adhesive plastic material such as Fablon. They are glued to the rear of the cases. □

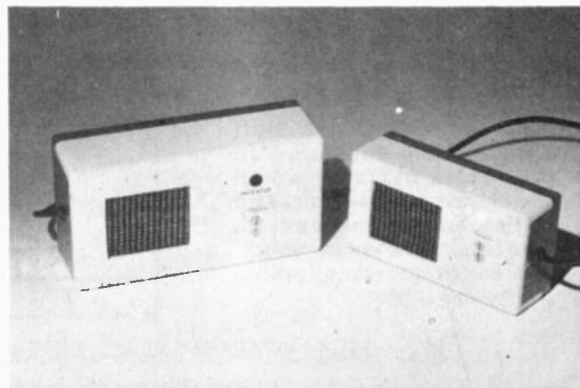

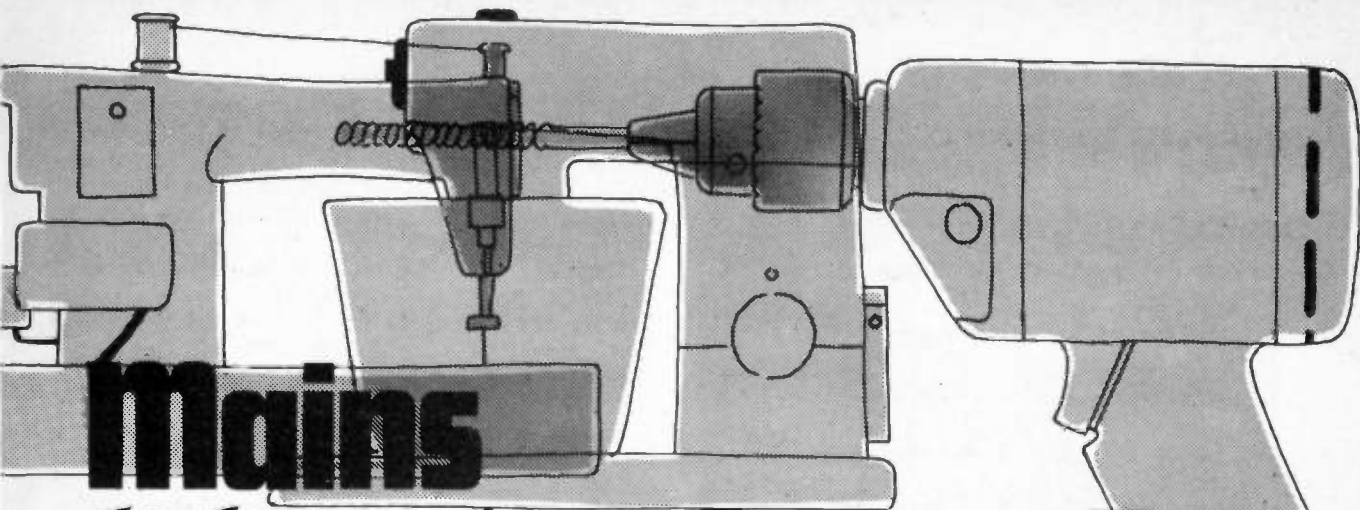

Mains POWER Controller

By JOHN S. RYLE

THERE are innumerable instances in the home, studio or workshop when it would be advantageous to have some means of regulating the power supplied to mains operated apparatus, typical examples being electric motor or drill speed control, electric heater output or lighting filament brightness variation.

Possible means of achieving this control are by use of a voltage dropping transformer, which is clumsy and unsuitable for many purposes, a rheostat, which generates a large amount of heat, or the far more elegant method of using a solid-state switching device, as employed in this unit.

PRINCIPLE OF OPERATION

The switching device that forms the central component of the regulator is the triac which functions as follows. It will conduct between mt1 and mt2 in either direction (making it ideally suited to a.c. applications) when a gate (terminal "g") voltage of either polarity is applied and will continue to conduct, even with the gating voltage removed, until the

forward current falls below a low level called the "holding current". For practical purposes the device will switch off at the end of a mains voltage half-cycle.

To regulate the power supplied by the triac, all that is necessary is to control the point in the mains cycle at which it turns on, as illustrated in Fig. 1. At the end of the half-cycle it turns off, since the mains voltage (and hence the triac current) falls to zero, and will not conduct again until re-gated. Operation in negative and positive half-cycles is identical.

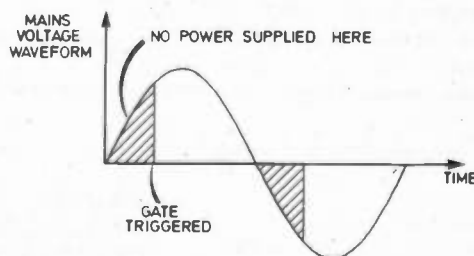
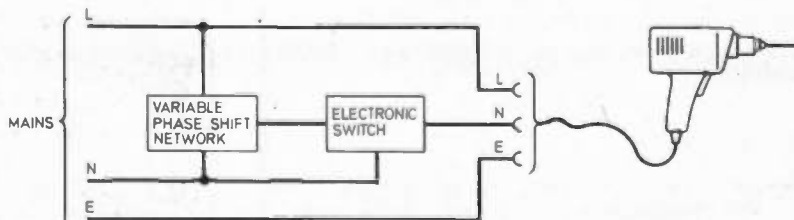

Fig. 1. Principle of operation of the controller.

HOW IT WORKS

A variable phase shift circuit alters the point in the mains cycle at which the electronic switch called a triac begins to conduct. The later the triac is "fired" the less the power supplied to the load.



PRACTICAL CIRCUIT

The full circuit diagram of the controller is shown in Fig. 2.

Control of the gate (g) of the triac CSR1 is achieved by means of the network formed by R1, VR1 and C1. The voltage on C1 will lag behind the mains waveform by a time dependent on the setting of VR1 and will be attenuated to a lower level.

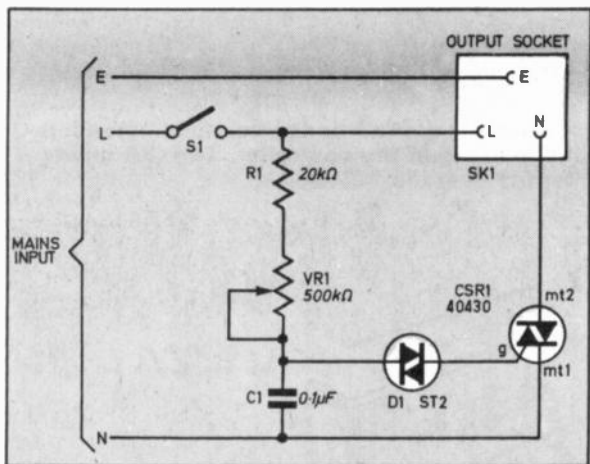

Fig. 2. The complete circuit diagram of the Mains Power Controller.

The diac D1 has the property that it will not conduct until the voltage across it reaches about 30V and will turn off again when the current drops to zero. It is used to provide a reference level, for when the voltage on C1 reaches the diac breakdown voltage, D1 will conduct, discharging C1 into the gate of CSR1, turning it on for the remainder of the half-cycle.

This operation is illustrated by the sequence of waveforms shown in Fig. 3.

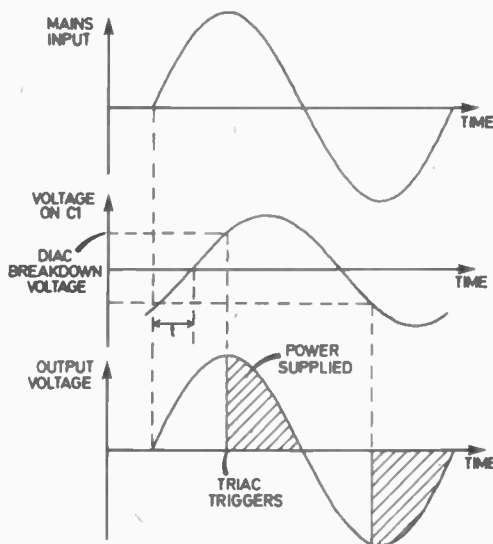

Fig. 3. Sequence of operation of the controller.

With component values as specified the switch-on point can be varied over the entire half-cycle, thus giving control from zero to full power.

CONSTRUCTIONAL DETAILS

Construction of the unit is very simple and should present no difficulty even to the beginner.

The regulator is housed in a wooden case measuring 127 x 89 x 51mm as shown in Fig. 4a with internal component layout as shown in Fig. 4b. Components C1, R1 and D1 are simply suspended in the wiring, ensuring a free flow of air round R1.

The triac requires mounting on about 18 square centimetres of aluminium to provide a heatsink, as shown in Fig. 4c.

Note that the triac case is one of its terminals and no bare wire should be allowed to touch the heatsink.

If a metal case is used the bracket *must* be electrically insulated from it using nylon bolts and fibre washers, and the case should of course be earthed.

Whatever construction method is used it is essential that no unearthed metal parts can be touched when in operation. A push on, insulated control knob and nylon fixings should be used.

Components

Resistors

R1 20kΩ 3W carbon

Capacitors

C1 0.1μF 400V paper

Semiconductors

D1 ST2 diac (or equivalent)

CSR1 SC40D 400V 6A triac (or 40430)

Switch

S1 d.p.d.t. mains toggle

Miscellaneous

VR1 500kΩ linear potentiometer

SK1 13A mains panel mounting socket
Materials for case and bracket (see text); 3-pin fused plug and 3-core correcting cable.

**RTAL
JOHS**
EES

FOR
GUIDANCE
ONLY

ESTIMATED COST*
OF COMPONENTS
excluding V.A.T.

**£2.00 excluding
case**



*Based on prices prevailing at time of going to press

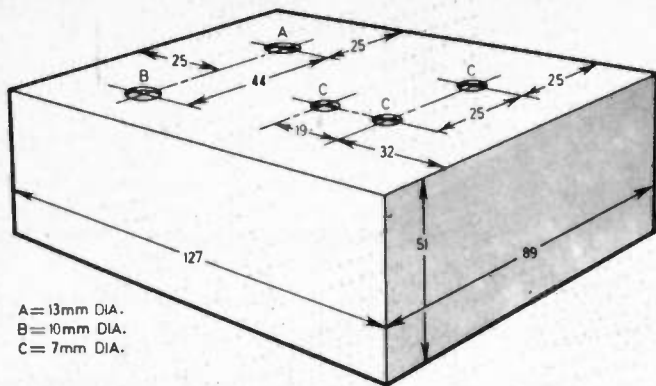

A=13mm DIA.
B=10mm DIA.
C=7mm DIA.

Mains Power Controller

Fig. 4a. Details of the wooden box recommended for the housing of the controller. The 13A mains socket fits over the "C" holes.

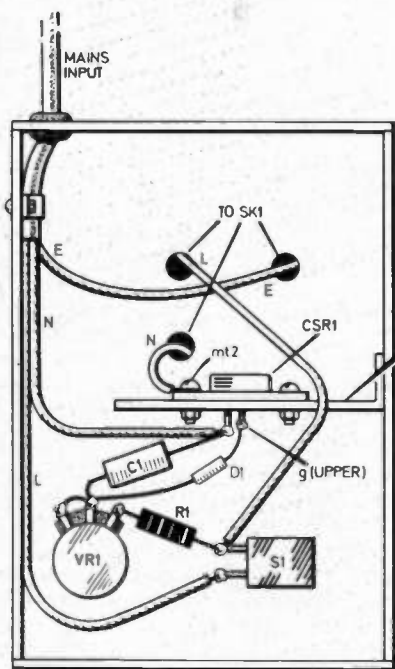

Fig. 4b. Layout and wiring up details of the components within the case.

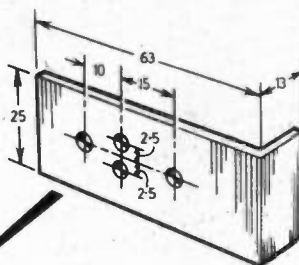

Fig. 4c. Above, shows dimensions and drilling details of the triac heat-sink.

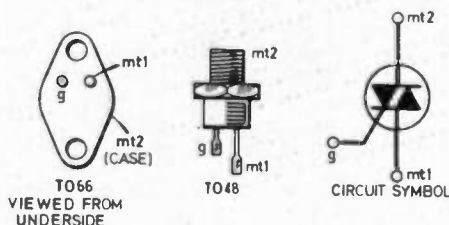
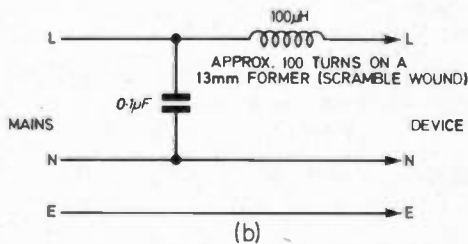
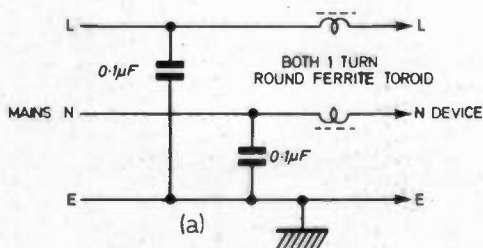

Fig. 5. Triac connection details including an alternative case style.



Figs. 6a and b. Two types of radio frequency interference suppressors. These should be fitted between the mains supply and the controller. The capacitors in Fig. 6a should be rated at 1000 volts and that in Fig. 6b at 400 volts.

APPLICATIONS

The unit may be used to control the power of electric lighting, heating, electric drills and other tools or motor driven equipment. It will not, however, work satisfactorily with discharge devices such as fluorescent lighting.

The components specified allow for a maximum load of six amps or 1400 watts, but higher rated triacs may be used if desired, to control greater loads provided that appropriate switching and wiring is used. No changes are necessary in the gating control components.

INTERFERENCE

No radio frequency interference (r.f.i.) was produced by the prototype but should this prove a problem two suggestions for r.f.i. filters are given in Fig 6 (a) and (b).

The first (Fig. 6a) uses two LC networks connected in the L and N lines and has proved extremely effective in removing noise from a refrigerator from interfering with hi-fi.

The second uses fewer components and is connected between the L and N lines. □

COUNTER INTELLIGENCE

By PAUL YOUNG

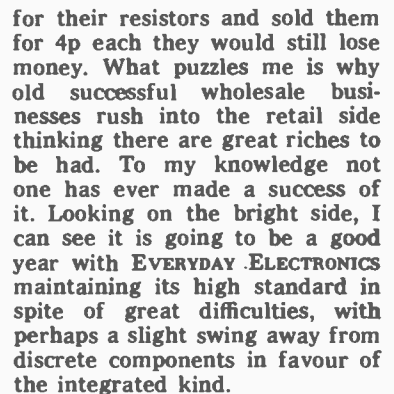

for their resistors and sold them for 4p each they would still lose money. What puzzles me is why old successful wholesale businesses rush into the retail side thinking there are great riches to be had. To my knowledge not one has ever made a success of it. Looking on the bright side, I can see it is going to be a good year with EVERYDAY ELECTRONICS maintaining its high standard in spite of great difficulties, with perhaps a slight swing away from discrete components in favour of the integrated kind.

Oh dear! The picture is fading, just wait a second until I turn up the contrast, what's this, a new Government elected, consisting entirely of computers, with Ted Heath as Prime Minister!! There's worse to follow, Ted Heath is a computer! That's ridiculous, I happen to know he is not, I have had lunch with him. At this point I seized my crystal ball and hurled it through the window (next time I will open it first). Ah well, that's made the first part of its forecast come true! Here's wishing you all a constructive 1976.

I KNOW you probably won't be reading this until late March, but looking at my calendar as I write, it informs me it is January 1 and therefore old Paul Moore intends to get out his crystal ball and see what the future portends. There, now I have dusted it, plugged it in and adjusted the line hold, and am peering earnestly into it.

The first thing it tells me is I shall start off by having a smashing time, splendid! Next I see a crowd of men being trussed up in strait-jackets and pushed into black marias. Some of them appear to be screaming, "Don't let the V.A.T. man get me!" This is ridiculous, just a moment, I will try another channel.

"Ah! that's better". I can see many electronic component shops closing down, but fortunately in most cases they are going over to mail order. This seems to tie up with a letter from a disappointed customer, I noticed recently in *Wireless World*. He stated that a few years ago he had only to stroll up Tottenham Court Road or Edgware Road to have the choice of over a dozen component shops, now there are none. This is because rent, rates, heating and telephone, to say nothing of wages, have trebled in well under a decade.

By changing to mail order, firms can move to less expensive areas and less expensive premises. Indeed I know of one colleague who ran a successful business for thirty years from two brick built garages, using a room of his council flat as an office. From the point of view of you the user, although I would not say it is an ideal situation, it might be much worse. It means more writing and less walking. Financially, although postal charges are high, so too, is public transport, so one would balance the other.

Peering into the sphere again I see several new faces joining the ranks of suppliers, but only one or two stay the course. Again this seems to bear out what I have already noticed by reading the adverts. Many new names, some weird and wonderful, spurred on perhaps by learning of a source where they can buy resistors for 50p a 100, and they know they can sell them for about 2p each. I say resistors but it could equally well be capacitors, transistors, and other small devices. I can almost hear them exclaiming "This is money for old rope". I know, I have been through it myself.

Eventually they learn the hard economic facts of life and realise that even if they paid nothing



"A pocket calculator? But who wants to calculate the number of pockets they've got?"

**New products and
component buying
for constructional
projects**

SHOP TALK

By Mike Kenward

SOME more points on the Sinclair Black Watch are made elsewhere in this issue. Although it has taken some months to cover the kit construction fully, we hope this has been of some assistance to readers. Should there be any further developments we will publish them for your information.

We have recently been buying a number of components for the construction of some projects and have dealt with various firms as mail order customers. One or two points have come out of this which some readers may be interested in.

Firstly, when ordering be careful to read the advertisement or catalogue concerning minimum order values, V.A.T. and postage, particularly when a large number of items are being purchased at once. If you send cash with order or pay within a certain period you may be able to get a small discount—we got 10 per cent off in one case.

If you want parts quickly and the

firm has them in stock it may be better to send a postal order rather than a cheque, as some firms wait for cheques to clear the bank before dispatching the goods.

Finally do not sign for anything as being received in good condition until you have had a chance to look at it carefully and test it if necessary. Much better to sign and write "not inspected" on the chit than to be unable to later claim damages. We received a fairly large package from a well known case supplier containing six cases. The package was intact and the internal packing good, but on close inspection three of the cases were found to be damaged and part of the order missing; this was not apparent from a quick look inside the box.

New Saws

From Paramo tools comes news of two new hacksaws, a junior and senior. The senior for 10 and 12 inch blades is probably not so interesting to the electronic hobbyist as the junior which is much better than the normal sprung frame type.

The new junior has a hardwood handle which screws onto a steel frame. The blade pins are fitted in slots and the blade tensioned by twisting the handle. The new junior cost 95p plus V.A.T. and should be available from Paramo Tool stockists.

Superhet

Probably the longest list of parts for any of the projects we have published. Let no one be fooled by this design, it is easily possible to buy a superhet radio for less than the cost of the *Unit Build Superhet* and no attempt has been made to compete on a cost basis. The project is presented because we are often asked for a superhet receiver and because the

construction of such a unit is instructive.

As far as component supply problems are concerned the majority of components should be readily available. Parts like the variable capacitors and case components can be obtained from Home Radio Components. Any type of metal case could of course be used to avoid the expense of the Retrokit parts.

The Denco coils are available from Denco at 357/9 Old Road, Clacton-on-Sea, Essex, CO15 3RH.

Touch-To-Talk Intercom

Quite often we get letters from readers saying that they have been unable to get relays specified for a particular project. In most cases it is not necessary to get the exact relay as long as that obtained has enough contacts and works at the required voltage. This is of course true of the relay used in the *Touch-To-Talk Intercom*.

The relay is in fact about the only component in this project that requires any mention. The cases used are the Vero or Boplast type which are now generally available.

Capacitance/Resistance Bridge

The *Capacitance/Resistance Bridge* uses the same type of case as that mentioned immediately above. Few of the other parts will cause buying problems. The close tolerance resistors and capacitors may take some looking for. Henry's Radio can supply both the ± 1 per cent resistors and capacitors but they will only sell the resistors to callers, not by mail order. Home Radio can supply both items at 1 per cent tolerance by mail order or to callers.

Mains Power Regulator

The *Mains Power Regulator* is another project that will fit into one of the cases mentioned above. However, for use in the workshop we would recommend a rather stronger type. If a diecast box or other metal container is used it must be earthed and whatever type of case is employed precautions must be taken to ensure user safety. This means the knob must be fully insulated and no un-earthed metal parts should be touchable.

There are very few electronic components employed in the design and all parts should be readily available.

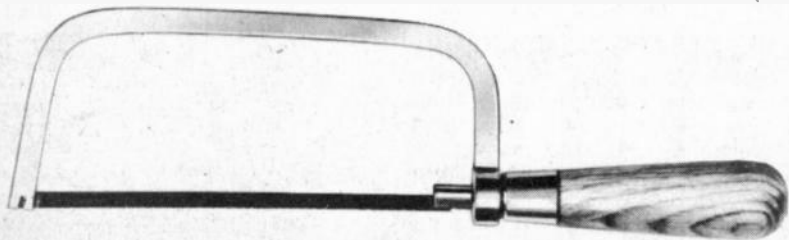

The new junior saw from Paramo.

next month...

A FREE GIFT TO ALL OUR READERS!!

WIRE BENDING GAUGE *it's new!*

it's exclusive

to
**everyday
electronics**

MAGNETONE

A miniature musical instrument of unusual design requiring no physical contact to produce the notes. Monophonic, providing a full octave including sharps and flats.

'CARSAFE' SYSTEM

Protect your car and contents with this simple but effective electronic unit.

LIGHTNING-CHESS BUZZER

If you play lightning chess this unit is for you. It provides a two second buzz to signal the selected time for a move is up.

INTEGRATED CIRCUITS EXPLAINED

Since integrated circuits are now used in almost every type of electronic equipment we feel some knowledge of their function and circuitry would be of interest to many people, this series sets out to provide that information.

IMPORTANT—make sure of your copy, place an order now.

everyday electronics

MAY ISSUE ON SALE
THURSDAY, APRIL 15

TEACH-IN '76

By A.P. STEPHENSON

Part Seven

7.1 VOLTAGE AMPLIFICATION

Although the emphasis so far has been on currents and current gains, the transistor can easily be used to provide voltage gains. To convert a current to a voltage all that is required is a resistor in the current path to produce a voltage drop. For example, the resistor marked R_c in Fig. 7.1a in the collector current path provides a voltage drop across it, and because of Khirchoff, also provides another voltage across the transistor, V_T .

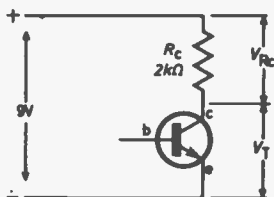

Fig. 7.1a. Current flowing through the collector resistor causes a voltage drop across it.

Suppose that base current is such that the collector current produced is 2mA. By Ohm's law, $V_{Rc} = 2 \text{ milliamps} \times 2 \text{ kilohms} = 4 \text{ volts}$, which leaves 5 volts across the transistor, V_T . Although either of these voltages could be called the "output" it is normally more convenient to use the "bottom" voltage, V_T .

The base circuit was deliberately omitted to avoid cluttering the diagram with components irrelevant to the discussion on output voltages. However we must have some forward bias voltage between base and emitter to produce the 2mA collector current. The value of this voltage, according to our previous work is 0.6 volts, but we have reached the stage where it is necessary to be a little more fussy about the accuracy of this figure. In fact it is only approximate and could be anywhere between, say 0.5 and 0.7 volts according to the base current flowing. It would be fairly true to say that 0.5 volts is the minimum voltage necessary to turn on the base current (although the figure could vary a few millivolts in different specimens and at different temperatures).

The base current will rise from a fraction of a microamp at the 0.5 volt turn on, to perhaps as much as several milliamps at 0.7 volts. Voltages much above 0.7 volts could destroy the transistor.

The following typical figures are convincing evi-



dence of the base voltage sensitivity: a rise of 0.2 volts (from 0.5 to 0.7) may change the base current from 0.1 microamps to perhaps as much as 5 milliamps.

Returning now to the idea of a voltage amplifier, see Fig. 7.1b. This simple circuit will convert a very low voltage signal (such as the output from a record player pick-up) to a much higher output voltage signal. The operation is best described under two headings:

The steady bias voltages

Base current through R_b keeps the transistor "turned on", producing a steady bias of about 0.6 volts across base and emitter. Let us presume this causes a base current of say $10 \mu\text{A}$ which if we take an h_{FE} figure of 200, gives us a collector current of $200 \times 10 \mu\text{A} = 2000 \mu\text{A} = 2 \text{ mA}$. The voltage across R_c will be 4 volts, leaving the output at 5 volts.

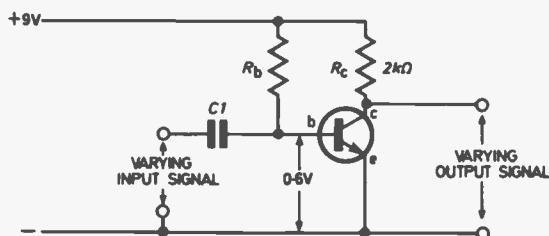

Fig. 7.1b. A simple circuit for amplifying a small varying voltage.

The signal voltages

Signals from a record player pick-up are varying voltages of a few millivolts average value. As we shall learn later in the series, a capacitor will pass varying voltages but not steady bias voltages. The signal therefore will be superimposed on the 0.6 volts,

7.2 WAVEFORMS

The superimposing of a signal on a steady voltage level is better explained by a kind of graph known as a waveform in which voltage is plotted vertically and time horizontally. The waveforms of the previous amplifier circuit are shown in Fig. 7.2a. Study these waveforms carefully in conjunction with the amplifier circuit noting particularly the following points.

(a) The signal is assumed to be a smooth ripple although the actual shape would be probably far more complex.

(b) The signal fluctuates above and below a mean level of about 0.6 volts at the base and 5 volts at the collector (relative to the emitter in both cases).

(c) The output signal is the same shape as the input, but much larger (due to the amplifying property of the transistor).

(d) The output is "upside down" relative to the input. (As the input signal rises more positively the base current increases and so does the collector current. The volts drop across R_c therefore increases

causing it to rise and fall slightly. Because of the sensitivity mentioned above, the base current and therefore the collector current varies in sympathy with the signal and a large voltage variation appears superimposed on the output terminals.

which means the collector voltage must decrease to keep old Khirchoff happy.

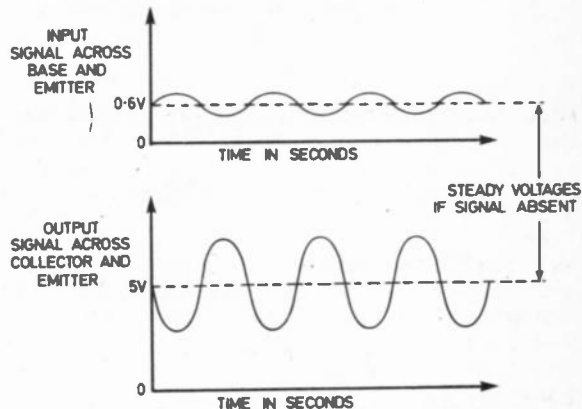

Fig. 7.2a. Input and output waveforms obtained from Fig. 7.1b. Note that the output is inverted with respect to the input.

7.3 SQUARING OR LIMITING

It is reasonable to inquire whether there are any limits on the extent to which the collector voltage can swing either side of the mean voltage. In fact there are two limits, see Fig. 7.3a.

(a) The "upper" limit is the voltage of the battery itself; the highest possible output voltage will occur when the collector current is zero (no volts drop across R_c). If the signal is too large, as shown, the positive tips are sliced or squared off (known as positive limiting)

(b) The lower limit is nearly (but not quite) zero volts, relative to the negative end of the battery (known as the "common" rail or line). This limit is called collector saturation (sometimes simply "saturation"). After all, a transistor must have some collector voltage in order to operate at all, so we may consider the term to mean the lowest voltage to which the collector can fall (typically 50 to 100 millivolts). If the signal is too large, the negative tips are sliced off (known as negative limiting).

So we must conclude that successful amplification of a signal depends on, firstly, correct biasing and secondly, the avoidance of squaring either top or bottom due to an overlarge signal input causing distorted outputs.

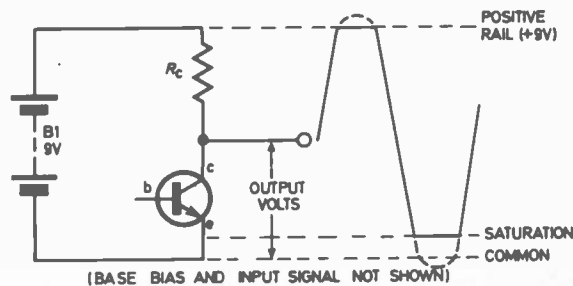

Fig. 7.3a. Too much gain or too large an input signal causes the output waveform to limit (become distorted).

7.4 THE PNP TRANSISTOR

The *pn*p transistor is similar in behaviour to the *n*pn-types except for direction of current flow. The "sandwich" construction and circuit symbol are

shown in Fig. 7.4a. Like the *n*pn-type, we may consider the device as two diodes, see Fig. 7.4b.

The base emitter diode must be forward biased

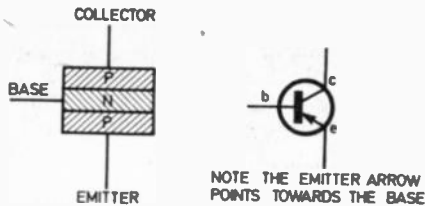

Fig. 7.4a. Schematic of the construction of a pnp transistor and its circuit symbol.



Fig. 7.4b. To explain some properties of a pnp transistor, it may be considered as two diodes connected as shown.

and base collector diode reverse biased, which means that all previous circuitry (based on *npn*) can still be used with *pnp* transistors providing we reverse the battery polarity; Fig. 7.4c shows conventional current

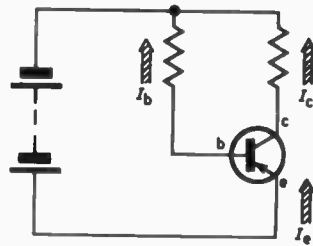

Fig. 7.4c. Shows conventional current flow in a simple pnp transistor circuit.

flow in a simple circuit using a *pnp* transistor.

Theoretically there is nothing much to choose between *pnp* and *npn*. In practice, *npn* are more common and therefore less costly so the rule is normally to use *npn* as first choice. Many circuits however employ both types, particularly power amplifiers in hi fi. The two types, *pnp* and *npn*, are said to be complementary to each other.

TEACH-IN '76 EXPERIMENTS AND EXERCISES

EXPERIMENT 7A

To show the effect of collector voltage (V_c) on collector current (I_c).

PROCEDURE

1. Assemble the components as the Circuit Deck as shown Fig. 7A.1. Leave the switch turned off, VR2 fully clockwise and VR1 anticlockwise.
2. Fix meter probes (on 10V range) across R_c .
3. Switch on and adjust VR1 until the voltage across R_c reaches 2 volts (which, by Ohm's law ensures a collector current of 2 milliamps).
4. Rotate VR2 slowly anticlockwise to reduce collector voltage and observe that the collector current

only falls slightly (volts across R_c only fall slightly). Eventually, at some position of the VR2, the collector current falls sharply to zero.

CONCLUSIONS

Collector current, I_c is not seriously affected by V_c except when V_c is very low.

Switch off but do not dismantle because this circuit is required for next experiment.

Fig. 7A.1. The circuit diagram and layout of the components on the Circuit Deck for experiment 7A.

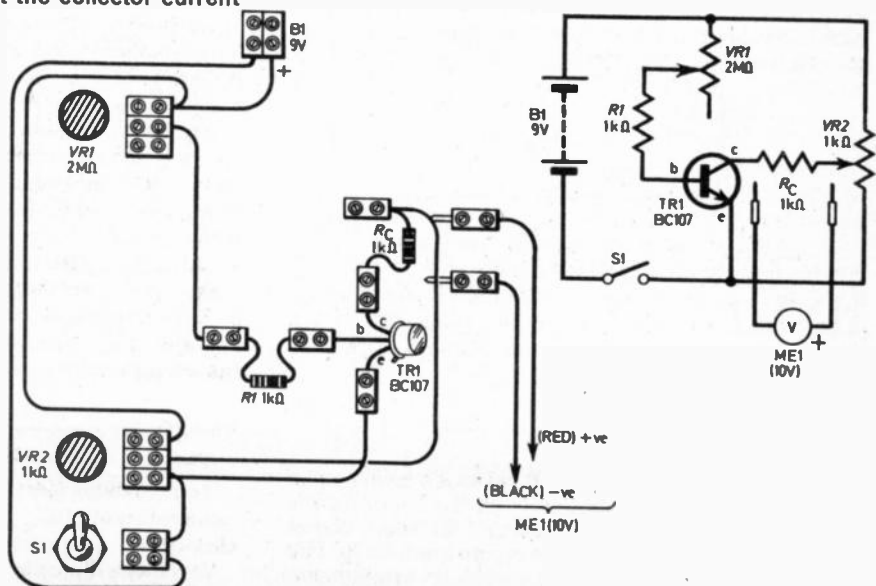

EXPERIMENT 7B

To plot the curves of I_c for different values of V_c .

This test uses the same circuit as that for *Experiment 7A*; Fig. 7B.1 below shows the circuit in skeletal form with the relevant voltage symbols and meter polarities.

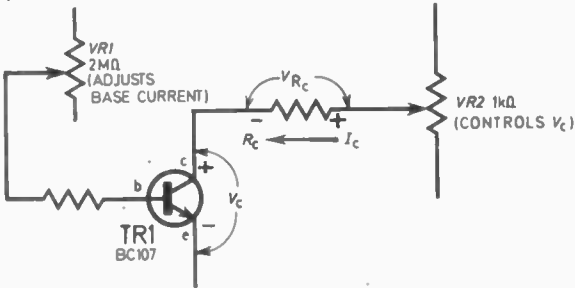

Fig. 7B.1. The skeletal circuit diagram for experiment 7B. The layout of the components on the Circuit Deck is identical to that in experiment 7A.

Plotting curves is laborious (especially when only one meter is available) but educationally rewarding. Your results should look something like the graphs Figs. 6.8a and b on page 148 last month), although the base currents will not be measured. (Base currents are always I_c/h_{FE}).

PROCEDURE

1. First set V_c to maximum by VR2 with VR1 set fully anticlockwise. Adjust VR1 until V_{RC} equals 0.5 volts (corresponding to I_c equal to 0.5 milliamps).
2. Measure V_c and record this starting value (about 9 volts).
3. Reduce V_c to 8 volts, measure V_{RC} and record I_c .
4. Repeat for progressively lower values of V_c down to 0.1 volts.
5. Plot the results of your table on a graph as shown in Fig. 7B.2.
6. Repeat the procedure again but adjust VR1 for 1 milliamp as the starting points. Plot another curve on the same graph. In fact, if you have the patience, plot several curves for different starting points up to 10 milliamps.



| V_c | $V_{RC} = I_c$ IN mA |
|-------|----------------------|
| 9 | 0.5 |
| 8 | |
| 7 | |
| 6 | |
| 5 | |
| 4 | |
| 3 | |
| 2 | |
| 1 | |
| 0.6 | |
| 0.4 | |
| 0.1 | |

Fig. 7B.2. Left shows a recommended table for recording your results for experiment 7B. Above shows axes for plotting graphs for this experiment.

EXPERIMENT 7C

To show the voltage amplification properties of a transistor.

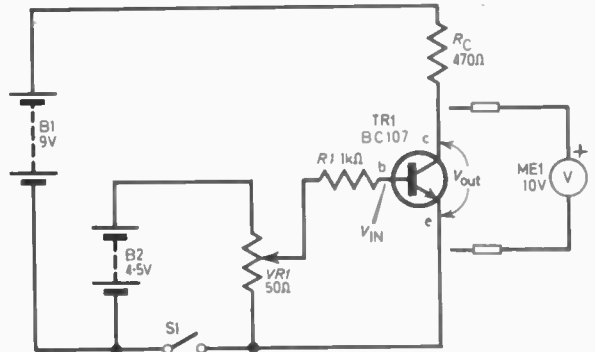
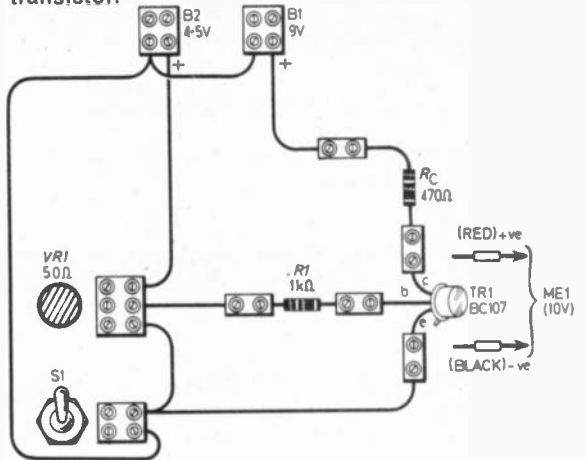

Fig. 7C.1. The layout of the components on the Circuit Deck together with circuit diagram for experiment 7C.

PROCEDURE

1. Assemble the components on the Circuit Deck as shown in Fig. 7C.1. Leave switch off, set VR1 (50 ohm) fully anticlockwise. Switch on at S1.
2. Measure V_{out} (which should read almost 9 volts because base current is zero, giving zero collector current and therefore no volts drop across R_c).
3. Very slowly advance VR1 until V_{out} equals 4.5 volts. Now measure V_{in} and record this reading. (This reading must be taken as accurately as possible).
4. Advance VR1 until V_{out} reads 3.5 volts. Again measure V_{in} accurately and record, then switch off.
5. The voltage gain of the circuit is (change in V_{out} /change in V_{in}). Since we changed V_{out} by one volt, the voltage gain is simply given by:

$$\text{Voltage gain} = \frac{1}{\text{Differences between the two } V_{in} \text{ readings}}$$

Your answer should be very large—well over one hundred to one.

Question

What was the collector current when V_{out} was 4.5V?

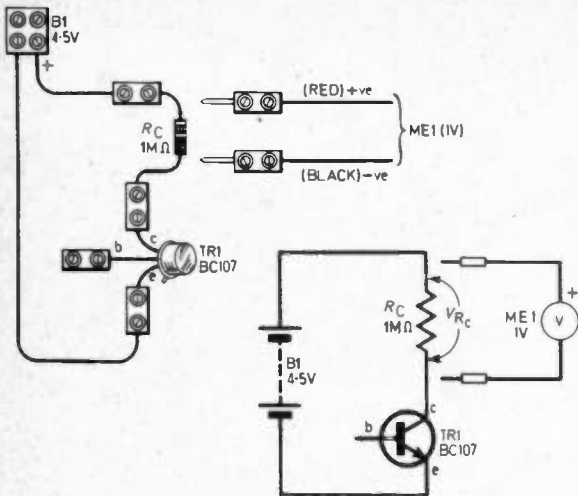

Fig. 7D.1. Positioning and wiring up details on the Circuit Deck for experiment 7D together with the theoretical circuit diagram.

EXPERIMENT 7D

To show the effect of temperature on leakage current.

Warning

Skip this test if you can't afford another BC107 because you may damage it.

PROCEDURE

1. Set up the components on the Circuit Deck according to Fig. 7D.1 and measure the voltage across the collector resistor (V_{Rc}) using the meter on the 1 volt range and fixed to the terminals.

There should be no appreciable voltage because the base is "up in the air" allowing no collector current.

2. Bring a lighted match close to the case of the transistor and notice the meter start to rise. Remove the match instantly you notice this—because it will continue to rise due to thermal inertia.

CONCLUSION

Heat causes the transistor to "leak" and procedure "leakage current". In large power transistors, this can be a problem which requires a large metal heat-sink for its solution.

Our BC107 is silicon and leakage is negligible at room temperatures. If you care to buy an old germanium transistor (such as an OC71) appreciable leakage will show up on this test even without the match. The heat from your fingers could treble the leakage current.

EXERCISES

7.1 Assume TR1 is drawing 3 milliamps collector current and has an h_{FE} of 150.

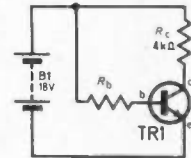

Calculate:

- Voltage across R_c
- Voltage across collector/emitter
- Approximate voltage across base and emitter
- Approximate voltage across R_b
- Voltage across base and collector
- Base current
- Value of R_b
- Approximate power consumed
- Emitter current

7.2 If TR1 was replaced by an equivalent pnp -type, what circuit modification is required?

Answers

- 7.1 (a) 12 volts (b) 6 volts (c) 0.6 volts (d) 17.4 kilohms (e) 5.4 volts (f) 20 microamps (g) 870 milliwatts (h) 54.4 milliwatts (i) 3.02 milliamperes.

7.2 Reverse the battery connections.

JACK PLUG & FAMILY...

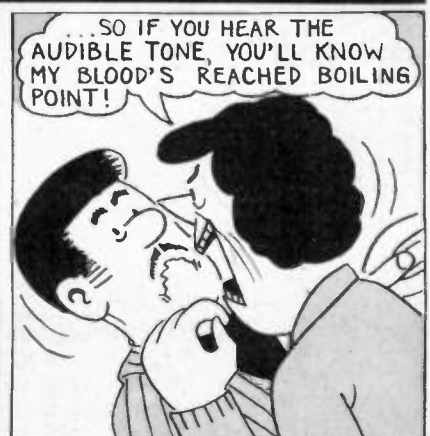

Beginners Guide—
electronics
made
easy



THE INGREDIENTS 2
Resistors 3
Colour code table 6
Capacitors 7
Semiconductors 4

PUTTING IT TOGETHER 4
Construction techniques 8

GOOD CONNECTIONS 8
Soldering

...the ingredients

RESISTORS

There are basically three different kinds of fixed resistor, each described by its composition—(a) carbon (b) metal oxide (c) wirewound.

Carbon

Carbon composition resistors are mainly used in the low power circuits, although some high power types are available.

The power handling capability of resistors is denoted by wattage ratings which for carbon resistors are 1/10, 1/8, 1/4, 1/2, 1, 2 watt and higher, the physical size of the resistor increasing with wattage. The most commonly used are the 1/4 and 1/2 watt types, ± 5 and ± 10 per cent being typical resistance value tolerances.

Carbon resistors can be subdivided into two main classes: carbon film and moulded carbon, the former being used for their low noise characteristics.

Metal Oxide

The metal oxide resistor offers high stability (usually called hi-stabs) over a very long time period, typically ± 4 per cent for 25,000 hours of operation and are virtually temperature independent over a wide range.

The resistance tolerance of these is usually ± 1 and ± 2 per cent. Generally they are not for use in high power circuitry having wattage ratings of 1/2 and 1 watt.

Metal oxide resistors have a very low noise factor typically 0.1 μ V per volt. These are more expensive than carbon types.

A selection of resistors, potentiometers and preset potentiometers.

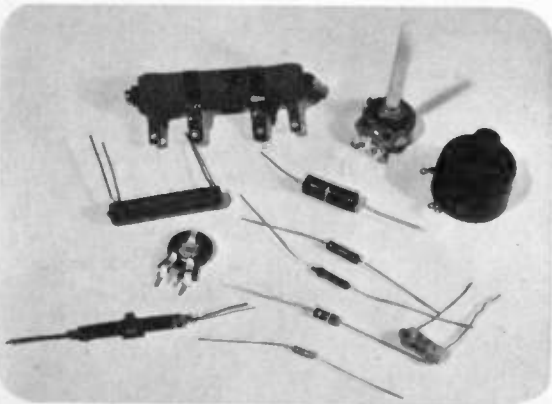

Wirewound

Wirewound resistors are used in high power circuits.

Their power ratings have an extensive range from about 1 watt up to 60 watts or more, with tolerances of ± 5 and ± 10 per cent.

Resistor Colour Code

Carbon resistors often use a coded band system to identify their ohmic values and tolerance. The colour code is given in Table 1 and is used as follows. The bands are displaced towards one end of the resistor, starting at this end, band A gives the value of the first digit, band B gives the value of the second digit while band C gives the factor for multiplying the first two digits, the fourth band gives the tolerance from nominal.

Variable Resistors, Potentiometers

Potentiometers (or pots.) are available in two types; carbon and wirewound, the latter being used where high power is being employed. Carbon types are available with a logarithmic (log.) and linear (lin.) resistance relationship with angle of rotation (see below). The angle of rotation is usually limited to about 270 degrees.

The lin. type is used where it is required to vary the resistance in direct proportion to the angle of rotation whereas the log. type is normally used for volume controls. Carbon potentiometers have a range of values from approximately 1 kilohm to about 2 megohm. Wirewound range is approximately 10 ohm to 100 kilohm.

Diagram showing change of resistance value in linear and logarithmic potentiometers with rotation of the shaft.

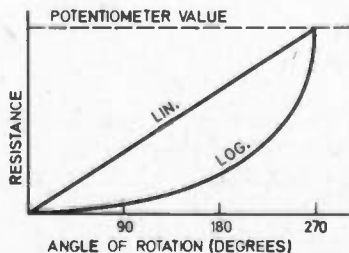

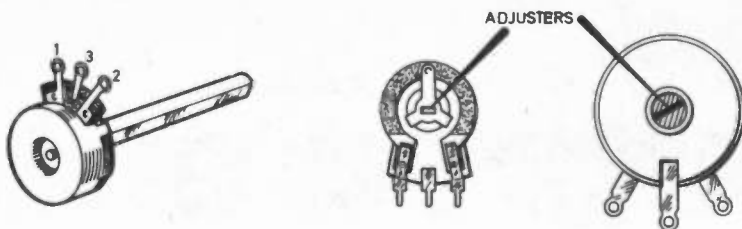

A standard potentiometer (above) and two types of preset (right).

Both types have their values printed on the body of the potentiometer and wirewound types usually have their wattage ratings also.

The pot. has three terminals and being used as a potential divider (for example) the input voltage is applied to tags 1 and 2 and taken out from tag 3 (the wiper) and one of the others. Thus any potential from zero to that across tags 1 and 2 can be obtained.

A potentiometer can be used as a variable resistor by merely using the wiper with one of the other tags. Some potentiometers have an on/off switch incorporated.

Preset Potentiometers

Another type of potentiometer or variable resistor is the preset, either carbon or wirewound. These have a specific application such as in a circuit where a fixed value resistor or potentiometer is called for, but cannot be accurately specified.

The type normally used are carbon skeleton presets which, as the name implies are provided without any case. They can be quite small physically.

Resistors and Ohm's Law

Resistors in series: $R_{total} = R_1 + R_2 + R_3 +$

Resistors in parallel: $\frac{1}{R_{total}} = \frac{1}{R_1} + \frac{1}{R_2} + \frac{1}{R_3} +$

Value of any two resistors in parallel can be calculated from the following:

$$R_{total} = \frac{R_1 \times R_2}{R_1 + R_2}$$

The two triangles shown below are an easy way of remembering Ohm's law e.g. $V = IR$ or $I = \frac{W}{V}$.

Substitution of other known values, e.g. to calculate W from V and R substitute $\frac{V}{R}$ for I .

Thus $W = \frac{V}{R} \times V$ or $\frac{V^2}{R}$

TABLE 1: COLOUR CODES

| Colour | Numerical Value | | Tolerance Resistors | Ceramic and C280 Capacitors | | Tantalum Capacitors | Capacitors Multiplier |
|----------------|-----------------|------------|---------------------|-----------------------------|-----------|---------------------|-----------------------|
| | Value | Multiplier | | Voltage | Tolerance | | |
| Black | 0 | X1 | — | — | ±20% | 10V | X1 |
| Brown | 1 | X10 | ±1% | — | ±1% | — | X10 |
| Red | 2 | X100 | ±2% | 250V | ±2% | — | X100 |
| Orange | 3 | X1,000 | — | — | ±2.5% | 35V | — |
| Yellow | 4 | X10,000 | — | 400V | — | 6.3V | — |
| Green | 5 | X100,000 | — | — | ±5% | 16V | — |
| Blue | 6 | X1,000,000 | — | — | — | 20V | — |
| Violet | 7 | — | — | — | — | — | — |
| Grey | 8 | — | — | — | — | 25V | X0.01 |
| White | 9 | — | — | — | ±10% | 3V | X0.1 |
| Silver | — | X0.01 | ±10% | — | — | — | — |
| Gold | — | X0.1 | ±5% | — | — | — | — |
| No Colour Band | — | — | ±20% | — | — | Pink 35V | — |

Resistors—values in ohms, pink band signifies high stability.
 Ceramic and C280 capacitors—values in pF.
 Tantalum capacitors—values in μF , tolerance not indicated.

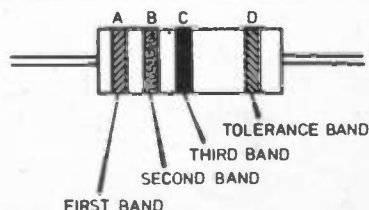

$$\frac{V}{I \mid R}$$

$$\frac{W}{I \mid V}$$

...putting it together

CONSTRUCTIONAL METHODS

There are a number of different constructional methods available to the amateur constructor. We will confine the following paragraphs to the most commonly used methods.

Perforated Board

The most widely used material is s.r.b.p. (synthetic resin bonded paper) sheet with holes drilled through it in a matrix. Veroboard is a proprietary product with copper strips on one side connecting the holes in rows.

All types of perforated board are available in three different matrix sizes 0.1inch, 0.15inch and 0.2inch. The 0.1inch and 0.15inch being the most popular for amateur construction work, the 0.2inch matrix not being in great supply. Veropins can be used with all types and matrix sizes, these pins are inserted through the holes in the board as required. A spot face cutter can be used with the standard Veroboard (with copper strips) to cut the strips where required, this can also be done using a 5mm or similar drill held in the hand.

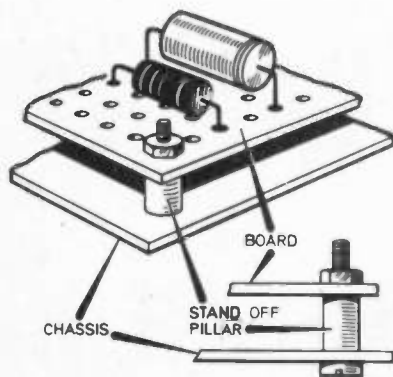

Method of mounting component board to a panel.

The main advantages of Veroboard are that the wiring is "printed" on one side in the form of the copper strips and the components are rigidly mounted by passing their leads through the holes and soldering them to the copper strips.

Plain board will hold the components in a similar manner to the board with copper strips but the components must be wired up using 18 or 22 s.w.g. tinned copper wire or single strand p.v.c. covered connecting wire. Veropins are very useful with the plain board as they form good anchorage for large components and for flying leads to other components.

In general all types of Veroboard can be mounted by cutting larger holes through the board, cutting away the copper strips around the holes where necessary to prevent any shorting, and fixing the board to the chassis or case of the unit using spacers, 4BA screws and nuts.

Printed Circuit

Printed circuit board is basically copper clad s.r.b.p. or fibreglass board. The copper is chemically

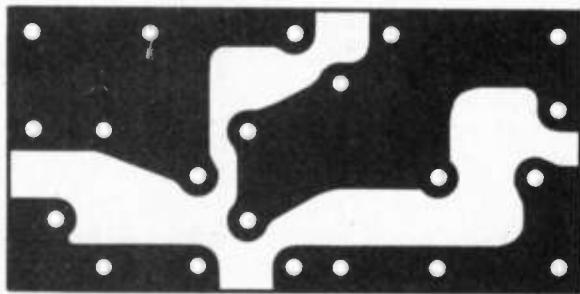

Appearance of an etched and drilled printed circuit board.

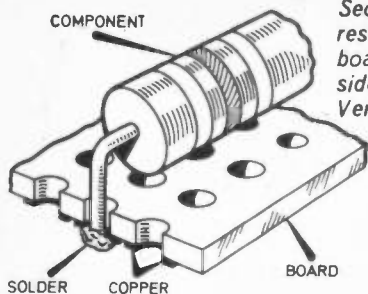

Sectioned view showing a resistor mounted on Veroboard (left) and the underside view of a unit built on Veroboard (below).

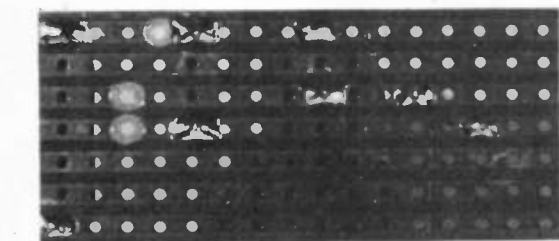

etched away to form a pattern used to inter-connect the electronic components. Once the board has been etched, holes are drilled through the board and remaining copper in the positions determined for fixing the components. The components are then mounted by passing their leads through the holes and soldering them to the copper on the other side.

Printed circuit is very versatile and perhaps the neatest and most reliable of the electronic constructional methods, although it is more suitable for production runs than for amateur constructors "one off" projects.

Printed circuit boards are sometimes available for published designs from various "kit" firms or component suppliers. Often the board is available in two types s.r.b.p. backing and fibreglass backing. Of these two fibreglass is more expensive but better as it is less affected by heat and moisture, however s.r.b.p. is quite suitable for most amateur projects.

The circuit board can be mounted to the case or chassis in a similar manner to Veroboard and pins



Soldering a transistor to Veropins using pliers as a heat shunt.

or tag post can be used for connecting flying leads to the board.

Tagboard

Tagboards are generally available in two types, double and single tags, the first being an s.r.b.p. panel approximately 2 inches wide with tags opposite each other along the sides, single tag strip is normally a thin s.r.b.p. strip on which are mounted a number of tags.

Both types are generally only used for projects with a limited number of components since neither form can neatly house large numbers of components. The "double" tag strip can be used to mount components across the opposite tags or between adjacent tags. Wiring connecting various tags can be accommodated under the tagboard. The single tagstrip is used for mounting a few components or for providing a connection point for wires in a unit.

"Double" tagstrip can be mounted in a similar way to Veroboard, using spacers to prevent shorting.

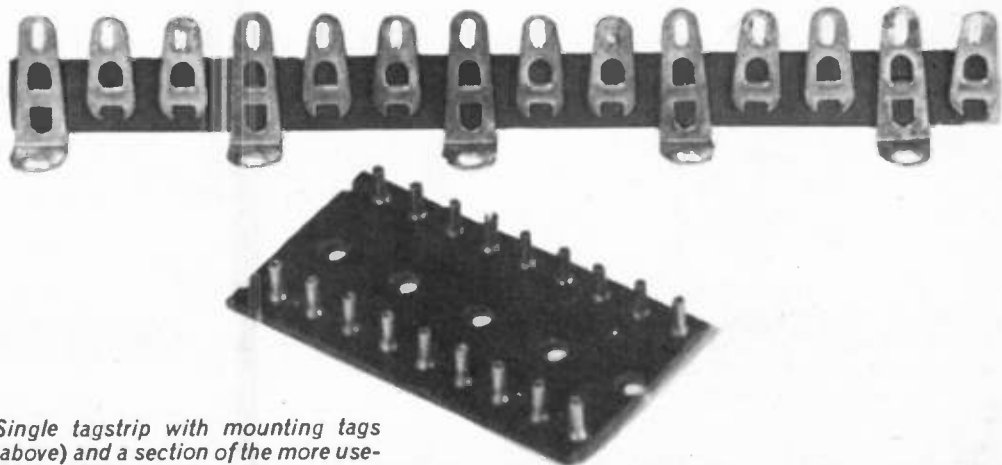

Single tagstrip with mounting tags (above) and a section of the more useful double tagboard.

...the ingredients

CAPACITORS

Capacitors are divided into three major categories:

- (a) electrolytic
- (b) non-electrolytic
- (c) variable

Normally, capacitors have their values printed on their bodies, together with the working voltage, this voltage is the maximum that should ever be applied to the capacitor.

When a particular capacitor is specified with its working voltage, it is not essential in many cases to use that exact value (since the tolerance of capacitors is quite substantial) but it is essential to use one of at least the required working voltage.

Electrolytic

Electrolytic capacitors come in a variety of shapes and sizes and are polarity conscious.

Usually the positive lead is marked on the body with a plus sign (+) red or black band or red or black face. Alternatively the negative end is marked.

Non-electrolytic

In the non-electrolytic category there are several different kinds. It is rarely critical to employ a specific type except where tolerances and leakage are important parameters such as in timing circuits or high frequency radio circuits, etc.

These various types are subdivided into classes each class being named after the dielectric.

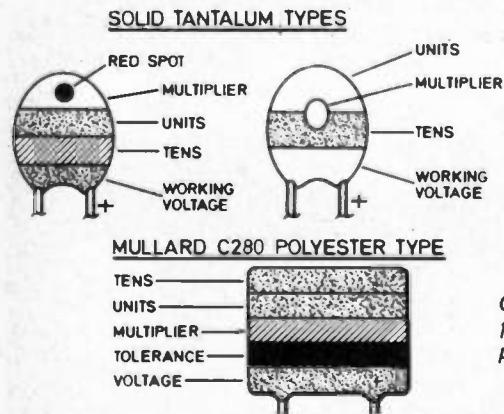

Silver mica polystyrene and ceramic capacitors have relatively low capacitance values ranging up to 0.47 μ F. The first two having low tolerance figures. Silver mica types are very stable and are mainly used for radio receiver circuitry.

Ceramic types however are very sensitive to temperature change and are sometimes employed where

this characteristic is advantageous. Some ceramic types are colour coded and their value can be determined from Table 1.

By far the most commonly used type is the polyester, probably due to its low cost and capacitance range. The Mullard C280 series of metallised polyester capacitors are colour coded.

As far as the amateur is concerned the polycarbonate type has the same adaptability as the polyester capacitors but with an extended range. They are a little more expensive than the polyester. The polystyrene, polycarbonate and polyester types are sometimes referred to generally as plastic types.

Paper capacitors cover a very wide range, have high insulation resistance at high voltages and are therefore only used where a high voltage, low leakage non-polarized type is required.

Tantalum capacitors have a very wide range of values and a very low leakage figure for their capacitance. They are usually employed in circuits where this is a vital factor—such as timing circuits. The bead type are often colour-coded and their values can be devised from Table 1.

Variable

Variable capacitors can be divided into two distinct types (1) continuously variable (2) preset.

Type (1) are designed primarily for use in radio tuning circuits and therefore have values up to 500pF.

Presets are more commonly called trimmers and are analogous in use to the preset potentiometer.

Capacitor colour coding—see table 1, page 3. For a five dot code ignore the first dot which is the temperature coefficient.

$$\text{Capacitors in series: } \frac{1}{C_{\text{total}}} = \frac{1}{C_1} + \frac{1}{C_2} + \frac{1}{C_3} +$$

Value of any two capacitors in series can be calculated from the following:

$$C_{\text{total}} = \frac{C_1 \times C_2}{C_1 + C_2}$$

$$\text{Capacitors in parallel: } C_{\text{total}} = C_1 + C_2 + C_3 +$$

TRANSISTORS

A list of some common types of transistor, field effect transistor and unijunction is shown below. The transistors are classified in three groups. Those suitable for switching, low power—and up to 1W—and high power. The base outline looking from the ends of the leads is indicated for each device.

e = emitter; b = base; c = collector; s = source; d = drain; g = gate.

TRANSISTORS

Suitable for Switching

| Device | Base |
|--------|------|
| 2N696 | 1 |
| 2N697 | 1 |
| 2N1091 | 1 |
| 2S503 | 3 |
| ACY22 | 1 |
| ACY40 | 1 |
| ACY41 | 1 |
| ASY26 | 1 |
| ASY27 | 1 |
| BSY27 | 1 |
| BSY29 | 1 |
| NKT124 | 2 |
| NKT125 | 2 |
| NKT126 | 2 |
| TIS45 | 5 |

Low Power

| | |
|---------|---|
| 2G302 | 7 |
| 2G306 | 7 |
| 2G309 | 7 |
| 2N706 | 1 |
| 2N708 | 1 |
| 2N918 | 3 |
| 2N1305 | 1 |
| 2N1307 | 1 |
| 2N1309 | 1 |
| 2N1507 | 1 |
| 2N1613 | 1 |
| 2N2926G | 4 |
| Y | 4 |
| O | 4 |
| 2N3702 | 5 |
| 2N3703 | 5 |
| 2N3706 | 5 |
| 2N3707 | 5 |
| 2N3709 | 5 |
| 2N4058 | 5 |
| 2N4060 | 5 |
| 2N4061 | 5 |
| 2S005 | 1 |
| 2S502 | 1 |
| AC107 | 6 |
| AC126 | 2 |
| AC127 | 2 |
| AC154 | 2 |
| AC187 | 2 |

| Device | Base | Device | Base |
|--------|------|--------|------|
| AC188 | 8 | BC214 | 5 |
| ACY20 | 1 | BFY50 | 1 |
| ACY44 | 1 | BFY51 | 1 |
| AF114 | 9 | C424 | 2 |
| AF115 | 9 | C425 | 1 |
| AF118 | 9 | C762 | 1 |
| AF124 | 10 | NKT212 | 2 |
| AF126 | 10 | NKT213 | 2 |
| AF139 | 3 | NKT214 | 2 |
| BC107 | 1 | NKT271 | 2 |
| BC108 | 1 | NKT274 | 2 |
| BC109 | 1 | NKT275 | 2 |
| BC147 | 11 | OC44 | 6 |
| BC169 | 5 | OC45 | 6 |
| BC177 | 1 | OC71 | 6 |
| BC182 | 1 | OC72 | 6 |
| BC183 | 1 | OC81 | 6 |
| BC184L | 5 | OC139 | 6 |
| BC212 | 5 | OC140 | 6 |

| Device | Base |
|--------|------|
| OC171 | 9 |
| OC200 | 6 |
| OC202 | 6 |
| ZTX108 | 13 |
| ZTX300 | 13 |
| ZTX301 | 13 |
| ZTX500 | 13 |
| ZTX501 | 13 |
| ZTX502 | 13 |
| ZTX503 | 13 |
| ZTX504 | 13 |
| ZTX510 | 13 |
| ZTX530 | 13 |
| ZTX550 | 13 |

High Power

| | |
|--------|----|
| 2N3055 | 12 |
| 2N3054 | 12 |
| AD161 | 12 |
| AD162 | 12 |
| BD124 | 12 |
| BD131 | 15 |
| BD132 | 15 |
| BD133 | 15 |
| BD135 | 15 |
| BD136 | 15 |
| BD137 | 15 |
| BD138 | 15 |
| BD139 | 15 |

| Device | Base |
|--------|------|
| BD140 | 15 |
| OC20 | 12 |
| OC22 | 12 |
| OC24 | 12 |
| OC26 | 12 |
| OC35 | 12 |
| OC36 | 12 |
| TIP29 | 15 |
| TIP30 | 15 |
| TIP31 | 15 |
| TIP32 | 15 |
| TIP33 | 15 |
| TIP34 | 15 |
| TIP35 | 15 |
| TIP36 | 15 |
| TIP41 | 15 |
| TIP42 | 15 |

FIELD EFFECT TRANSISTORS

| | |
|--------|--------------|
| 2N3819 | 5(1s.2g.3d.) |
| 2N3820 | 5(1s.2g.3d.) |
| MPFI02 | 5(1d.2s.3g.) |
| MPFI05 | 5(1d.2s.3g.) |

UNIUNCTION TRANSISTORS

| | |
|--------|----|
| 2N2646 | 14 |
| TIS43 | 5 |

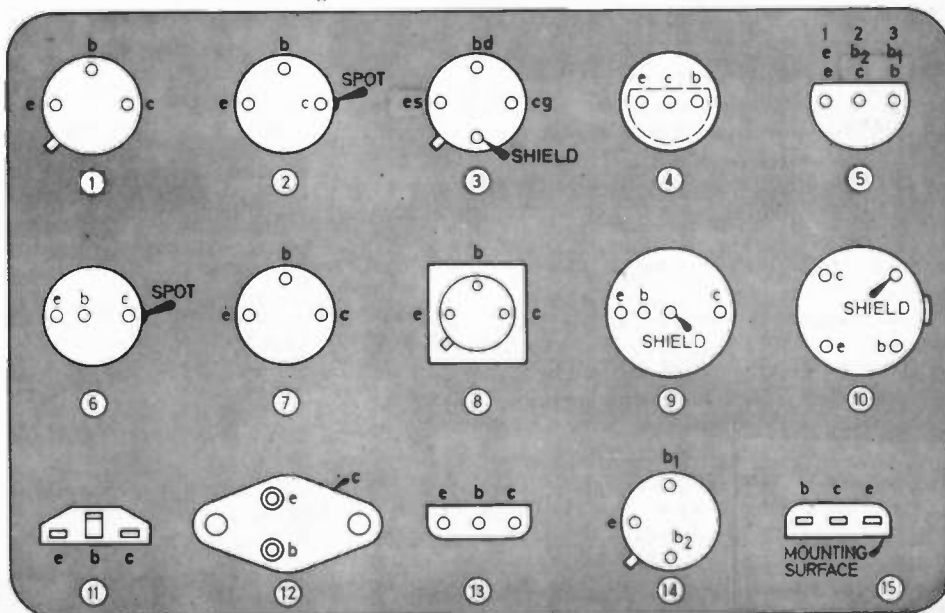
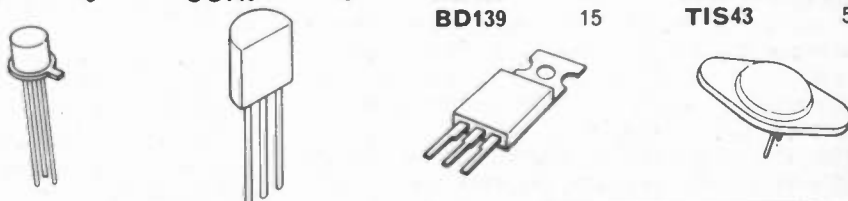

... good connections

SOLDERING

One of the main problems with soldering is that so many people think they can solder well when in fact they cannot. From time to time we see pieces of equipment which will not work, it is usually the design that is blamed by the constructor while what is really wrong is one or two bad joints.

Many people who solder poorly simply do not look closely at the finished job. If they were to compare their joints with some professional ones—say on a transistor radio circuit board—the difference would be obvious and, in nearly all cases, these joints are made in exactly the same way as any constructors.

Tools

First it is important to use the correct tools. The iron should be a small type of about 15 to 25 watts with a 3 or 5mm bit. The solder must **only be the resin cored type** sold for "electronic" or radio use and should be about 18 to 22 s.w.g. A pair of tapered nose pliers and a pair of side cutters, both about five inches long, also a pair of wire strippers, are very helpful, as is a small flat file to clean up the soldering iron bit (unless it is a long life type) when it becomes pitted.

The first basic rule is to make sure everything is clean, no grease, dirt or paint on the surfaces to be soldered. Having satisfied yourself of this point, the next step is to tin the end of the wire to be soldered.

Tinning

To do this first tin the iron bit so that a small amount of molten solder is held on the bit surface to aid heat transfer to the work—always retain a **small** amount of solder on the bit. Touch the end of the wire on the iron (either the wire or the iron can be fixed for this, we suggest using an iron stand that allows access to the bit which is pointed upwards) and melt some solder onto the wire—**not onto the iron.**

By this means the wire will be hot enough to solder correctly and will tin properly. Remove the wire from the iron, it should be thinly covered by a shiny solder. With the tinned wire make a mechanical joint to the other component. If this is a printed circuit or Veroboard pass the wire through a hole and bend about 3mm of it down flat against the copper (see page 5).

Place the bit on one side of the joint in contact with the wire and apply the solder to the other side. Apply enough solder for it to run around the wire and along the copper strip just away from the wire, as soon as the solder runs this far remove the iron, and leave the joint to cool.

Dry Joint

Do not move the joint or artificially cool it since this could produce a dry joint. The solder around the joint should be clean and shiny and it should have flowed cleanly around the joint. If the solder forms a blob on the copper then the iron has not been allowed to heat the job to the correct temperature for proper soldering, this is one type of bad joint.

The second main fault when soldering is the "dry joint", this can be caused by transferring the solder to the job on the iron—the flux burns off and the job cannot solder properly—keeping the iron on the joint too long, with similar effect, or moving the joint before it is cool.

The third bad joint is caused by trying to make a connection between two surfaces that are not in contact. Although this joint may be electrically good it will be mechanically very weak as the solder, which is soft, is forming a bridge.

Be careful not to use too much solder when tinning as the solder will tend to run back up the wire also too much heat will melt any plastic insulation.

When soldering transistors or other semiconductors it is sometimes necessary to use a heat shunt to prevent overheating of the component. For this use the pliers to grip the lead being soldered between the joint and the component (see page 5).

Most of the designs we publish utilise Veroboard of one kind or another and we would suggest that you commence construction with a simple project using standard 0.15 inch matrix Veroboard. The 0.1 inch matrix used for some projects is rather more difficult to work with.

Making a joint to a mounting pin.

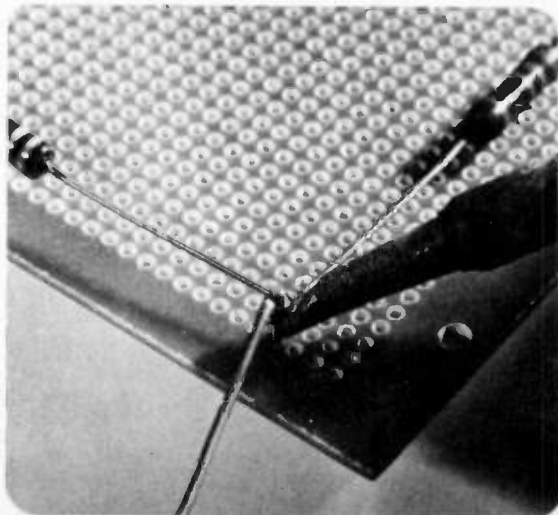

Your Career in **ELECTRONICS**

By Peter Verwig

A career in electronics is an exciting prospect! Month by month our contributor Peter Verwig explains what working in electronics is all about, how to prepare yourself for a rewarding career, and the job opportunities available in the world's fastest growing industry.

SHIP'S RADIO OFFICER

WITH the holiday season already looming ahead how does the idea of a world cruise grab you? Of course you'd like to do it in style with your own private cabin and a ship-borne status that commands respect. And have plenty of crinkly folding stuff in your wallet. As you are interested in electronics how about having, say, £75,000 worth of equipment to play around with, just to keep you out of mischief?

Sounds too good to be true, doesn't it? But it can be true and could be true for you, but not this year. The profession of ship's radio officer is not one that you can just walk into, however clever you may be. It is one of the careers in electronics in which you must be qualified before you are allowed to practice. But if you could obtain college entry at the start of the next available course you could be at sea by 1978 and be a senior officer by the early '80s.

EARLY DAYS

The profession of ship's wireless operator (as it used to be called) is the earliest recognised profession in the great industry known today as electronics. The nickname "Sparks" for this new member of the crew arose from the spark transmitters then used at sea. The first British ship to be fitted with wireless telegraphy as a permanent, rather than experimental, installation was the *Lake Champlain* of the Beaver Line (later merged with C.P.R.) in 1901.

The Cunard Line soon followed with installations first on the

Lucania, followed by the *Umbria* and *Eturia*. Belgian and French ships followed suit with the result that by the end of 1902 seventy ships had been equipped and twenty-five land stations had been built and a new age had dawned.

In the early years the installing engineers used to sail with the ship and thus automatically became the wireless operator. So right from the start the tradition was established that operators were engineers as well. Many of them only did a few voyages and came ashore again as engineers and a number of famous names in electronics had early sea-going experience.

The engineer-operator of the Cunard ship *Umbria*, for example, was a young man of the name of Charles Samuel Franklin who was to become a great inventor and innovator, perhaps his most far-reaching work being the development in the 1920s of the short-wave beam aerial system which included a concentric feeder, forerunner of today's coaxial cable.

It soon became clear that the enormous growth rate in installations at sea could not be sustained by sending engineers to sea with each new fitting and as the Marconi Wireless Telegraph Co. Ltd. had a virtual monopoly of the technology and the supply of equipment it was natural that the company, in the absence of any other training establishment, should set up its own Marconi College for the training of men as operators and this was the first such college in the world when established in 1901. Note that the accent has changed.

The new men were primarily operators and their engineering education was now more directly connected with general maintenance and running repairs rather than being engineers first and operators second.

Before our lady readers get uptight I should mention that in those days ships' crews were solely a male preserve. The profession of ship's radio operator, happily, is now equally open to qualified people of either sex and an increasing number of sea-going operators are female. In fact this branch of electronics is perhaps the most suitable of all for ladies because the basic needs are brains, not brawn.

HIRING

It was in the early days, too, that the custom was established that shipowners hired the equipment and the operator from the wireless manufacturer. For a fixed annual sum the shipowner had everything supplied. The operator was subject to ship's discipline and enjoyed equal status with the ship's officers but received his pay and allowances from the manufacturer.

There were legal reasons why the hiring of equipment was adopted rather than outright sale, mainly concerned with the Post Office monopoly of message handling. But, quite apart from the legal aspects, the system had a basic attraction for shipowners. First of all they hadn't the faintest notion of how to run a wireless station on board so hiring relieved them of a big burden. And later, when the fitting of wireless to sea-going vessels became mandatory by international law, the shipowners were delighted to leave all these extra complications to the hiring companies and get on with the thing they understood which was the marine transportation of goods and passengers.

The Marconi International Marine Co. remains today the largest supplier of equipment and operators on a hire basis but it no longer has a monopoly. Other British companies such as the International Marine Radio Company, Redifon Telecommunications Ltd., and Kelvin Hughes are also in the field and have lately been joined by United Marine Electronics, a Danish

company with a base in the UK.

But a comparatively recent development is for large fleet owners to purchase all the equipment and to employ their own operators directly. Both systems have their merits. Big shipowners such as those running huge tanker fleets argue that it is more economic to employ their own officers, while the hiring companies tend to refute this claim on the grounds that as they have a pool of officers a shipowner is saved at least the cost of standbys in the event of sickness and for normal leave.

The respective arguments need not concern us here but it is worth noting that whereas once upon a time a radio officer had only the prospect of one or two employers, today he has far more seeking his services. A crude breakdown of statistics shows that the number of ships which have directly employed officers is roughly equal to the number with hired officers.

Just because the number of employers is now greater it doesn't mean that there are more jobs available because the limit is set by the number of ships sailing the oceans. The British deep-sea Merchant Navy fleet numbers over 2,000 vessels representing about 10 per cent of the world's total tonnage and these are manned by some 4,000 radio officers. All new entrants are obliged to become members of the Radio and Electronic Officers Union which was founded in 1912.

SNAGS

Let us now look at the snags. The first is that you will have to be very lucky to get a posting on a passenger cruise ship. Far more likely that you will find yourself on a tanker engaged on a regular round-trip to and from the Persian Gulf, a monotonous existence after you've done it once or twice. Or perhaps you will end up shuttling backwards and forwards on one of the ferry routes to the Continent and by no stretch of the imagination can this be said to be "seeing the world".

In general, the hiring companies provide the best opportunity for variety because of the large number of shipping firms they serve, and an officer who has spent some time in a "grotty" posting can more easily be rotated periodically to more interesting employment. This is a real problem which the companies understand and if you work in tankers or on very prolonged voyages you will get extra allowances in compensation.

The most important thing to remember is that if you are unhappy at being away from home for long periods this is not the job for you.

PLUS POINTS

Now let's look at the plus points. Pay is excellent. As a junior officer, newly qualified and under supervision for your first six months at sea, you will receive over £220 per month. A

top radio and electronics officer can currently earn over £8,000 a year and there are not many jobs in electronics which can match this figure, especially if you add in all the "perks" which include free food and free entertainment while at sea, and duty-free smokes and drinks. It is possible on this to save quite a nest egg.

Leave is normally one day for every two days worked but depends upon the time actually spent at sea, but in the case of very arduous voyages leave can accumulate up to six months in a year. But remember that while at sea it is a 7-day a week job. Listening watches for both communications and safety at sea don't close down for the weekend. During your leaves you receive a subsistence allowance to compensate for the food not eaten on board ship.

QUALIFICATIONS

How do you become a radio officer? First of all you must be 16 years of age or over and preferably have 'O' levels in mathematics, physics or another science subject and English. You need to be a citizen of the UK or of a British Colony or of a Commonwealth country and, if the latter, one of your parents must have been or still is a British citizen. Naturalized British citizens and citizens of the Irish Republic are also eligible. You will need to be fit, and good hearing is essential. People with impaired vision are acceptable provided their eyesight is to the required standard when wearing spectacles. Colour blindness is not considered a disability.

The essential qualification is the Home Office Maritime Radio-communication General Certificate. Without it you are not allowed to operate without restriction. The college at which you will study must be licensed by the Secretary of State for the Home Department and be educationally approved. There are some 20 of these in the UK and three in the Republic of Ireland, most of them being at or near ports. Most are run by

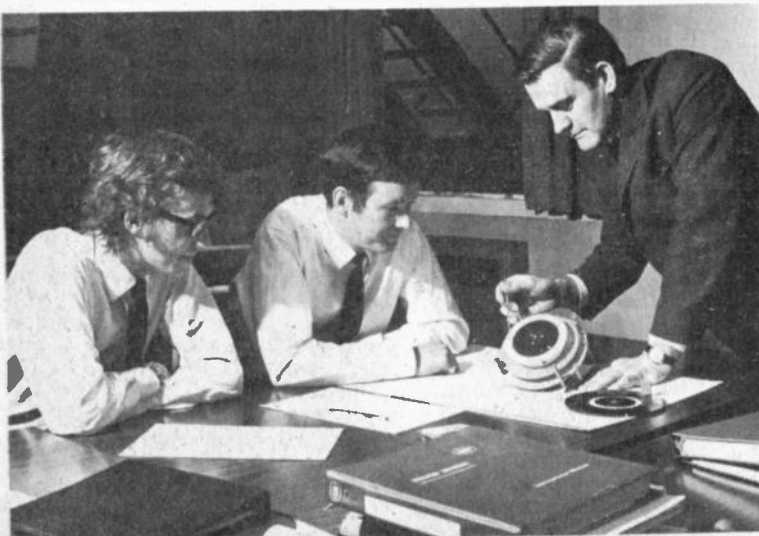

Students on a Marine Electronics course. (Photo: Kelvin Hughes)

Everyday Electronics, April 1976

local educational authorities but there are a few private colleges. You may qualify for an educational grant while studying.

The General Certificate Course demands a minimum of two years full-time study and most students stay an extra term to qualify for the Department of Trade Certificate in Radar Maintenance. Every intending student should invest now in the Post Office Handbook for Radio Operators which can be obtained from any Government Bookshop or by ordering it through a local bookseller. At a cost of 95p for over 250 pages it is a real bargain.

As well as laying down all the operating procedures for a ship's radio station which you will need to know, it also contains the complete syllabus for study, and specimen examination papers for theory and practice. They will probably frighten the life out of you but if you want to be a real professional you need to study in whatever walk of life you choose.

Once you have the precious General Certificate you are qualified but only as a junior officer and you will still be regarded as a trainee and have to work under the guidance of a senior radio officer for your first six months at sea. This is real practical training which can't be learnt at any college. Promotion is rapid and anyone who proves his worth can become a chief operator in a comparatively short time.

EQUIPMENT

A typical ocean going merchant ship's radio room will be equipped today with a powerful single-side-band main transmitter and main receiver, a reserve transmitter and receiver, VHF radiotelephone, automatic keyer and auto-alarm, and automatic direction finding equipment. Outside the radio room there will be emergency radio equipment installed in one or more lifeboats. If you have the D.O.T. Radio Maintenance Certificate you will also be responsible for maintaining but not operating the ship's radar equipment.

In recent years the amount of on-board electronic equipment has extended far beyond the radio room and its basic equipment required by law. On the bridge there can be electronic navigation aids such as Decca Navigator, the VLF Omega worldwide navigation system, or a satellite navigation system, radars and echo-sounders. In the engine room there may be automation with electronic controls and data-loggers. There will be a ship's intercom system, and on-board entertainment, both radio and television. On some ships there are electronic loading and discharge monitors for cargo.

All this extra equipment needs servicing and it is sensible that a person who has made the grade as a radio officer should extend his maintenance expertise to the whole field of ship-borne electronics and so a new category of Radio and Electronics Officer came into being a few years ago. To rise to this grade it is generally necessary to undergo further training to obtain a certificate in Marine Electronics. If you are a suitable candidate already on a company's radio staff your employer will arrange for you to take the course which

is intensive and generally of six months duration.

PROSPECTS

Although the number of sea-going officers is comparatively small the turnover rate is exceptionally high. Only five per cent stay at sea until retiring age and the average officer is at sea for only five years before coming ashore, often to well-paid and responsible jobs. The main reason, of course, is marriage and family responsibility. So there is constant demand for recruits.

The electronics training you receive before qualifying as a radio officer will serve you well if you decide to "swallow the anchor". You will not only have the technical background but also the character-building experience that comes from holding a responsible and demanding position in life. This is what employers look for and if you work as a sea-going officer for one of the hiring companies you have a good chance of obtaining a shore appointment with your company. Nearly all the managers in Marconi International Marine Co., for example, have at one time been on the sea-going staff.



A junior officer under supervision in a cargo liner's radio room. (Photo: Marconi Marine).

Physics is FUN!

By DERRICK DAINES



REGULAR readers will remember that two months ago in an almost off-the-cuff paragraph I suggested placing a pocket magnet in front of a TV screen to observe the local picture distortion caused by the deflection of the electron stream.

Now every month before writing this article, I perform the experiments suggested and following this practice I placed my magnet in front of a portable black and white set. The thought then occurred to me—perhaps some readers would try it on a colour set. So, I went into the lounge and tried it on my colour set there. Fine—no problem. I went back to my typewriter.

PLEASE—do NOT put a magnet in front of a colour TV set. It could cost you a lot of money!

Maybe I was lucky—but the fact remains that putting a magnet near a COLOUR tube can at worst necessitate complete replacement of the tube, and they don't come very cheap.

The inside of an ordinary black and white screen is coated all over with a phosphor that will momentarily glow white under the impact of an electron. In a colour set however, three phosphors are needed—one for each of red, green and blue, each glowing its appropriate colour when struck by an electron. It is tolerably obvious that no one colour may consist of a complete coating, since all electrons would cause it to glow. So what is done is to apply the phosphors as a pattern of minute dots over all the screen. This is done three times—once for each colour—each set of three dots being arranged in a triangle or triad. (See Fig. 1.)

Now it must be arranged for each colour to be excited as required. This is done by not one but three electron guns firing at the screen, but of course electrons fired from the gun under the control of the red circuit must strike only red phosphor dots, so the next step is to aim each electron stream at the appropriate phosphor dot. This is done by means of a very thin sheet of metal, called the shadowmask, pierced by a pattern of half a million incredibly small holes corresponding to the pattern of dots. (Fig. 1).

Under the influence of an external magnet such as I suggested in my paragraph, the streams of electrons are deflected after passing through the shadowmask, striking dots other than those aimed at. This results in picture distortion and colour transference, in which the defocused electron strikes a dot of a different colour. This of course was the whole point of the experiment—to show that electrons can be deflected by magnetism, but now comes the crunch. If the magnet is a powerful one it will leave behind a weak residual magnetic field that cannot be coped with by the automatic

degaussing circuit and will cause permanent misdeflection of the electrons. If you call in your TV repair man he will use a powerful degaussing coil and everything should be all right, but he certainly wouldn't do it for nothing.

A few days ago an even worse possibility was brought to my attention. It is the fact that if your magnet is really powerful, it might just cause irrevocable distortion of the shadowmask. The mask is sealed inside the glass tube by the tube manufacturer and there is nothing that can be done except to make a complete replacement of the colour tube.

My apologies to anyone who has been put to any inconvenience and to all readers since this most regrettable incident has taken up the space this month.

● Letters are beginning to trickle in with details of your favourite experiment, and the more the merrier. We will publish a selection shortly.

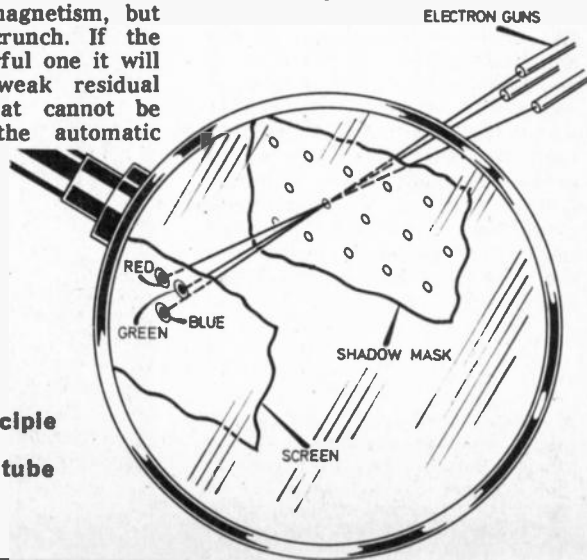
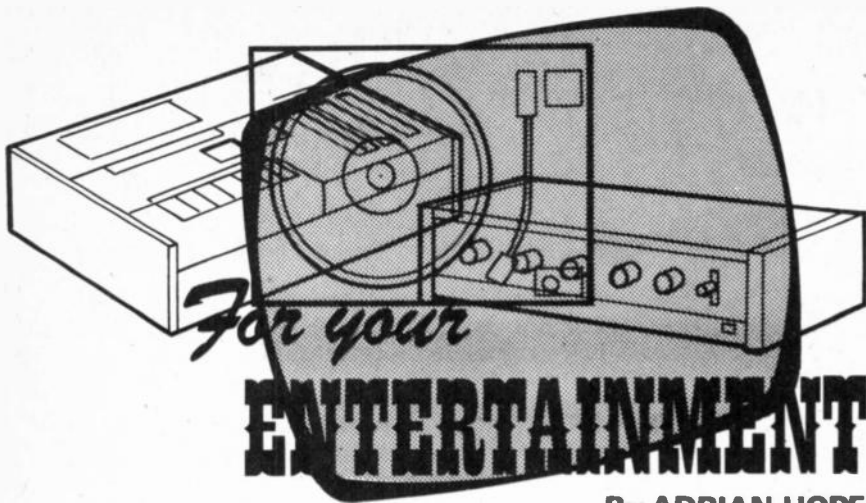

Fig. 1. Basic principle of operation of a colour television tube



By ADRIAN HOPE

WHILE of course accepting the need for legislators and civil servants, it does seem a pity that some of those handling scientific areas obviously know so little about them. Sometimes the lack of understanding doesn't really matter.

VAT on Kits

But quite often it does, as with the muddle created by the split rate of VAT. But Britain runs on muddle and it is often possible to turn it to one's own advantage.

At the 1975 Harrogate Audio Fair, I puzzled for a long while over how the electronics firm Doram, from Leeds, were arriving at the sum of £4.05 VAT for an amplifier kit costing £29.95. It seemed to be neither 8 per cent nor 25 per cent. The answer, of course, was simple: it wasn't either—it was a combination of both.

Some transistors are rated at 8 per cent as are metal chassis parts; but other transistors, for instance in the output stages, are rated at 25 per cent, as are panels.

Seeing the awful possibility of naughty enthusiasts burning the midnight oil to construct equipment normally rated at 25 per cent from kits rated at something slightly less, the VAT assessors soon ruled that any electronic component in a kit is now to carry the 25 per cent burden.

The only exceptions are parts of general use, such as nuts and bolts, and although the confused retailer is entitled to charge only 8 per cent on any such parts in a kit, many shops simply give up and blanket the kit with 25 per

cent VAT. But the parts sold separately still carry their correct rating of 8 per cent or 25 per cent, so the moral is obvious—wherever possible buy the parts separately.

[When the finished equipment is normally rated at 8 per cent, as with test gear, then the kit can be sold at 8 per cent, provided that at least two-thirds of the components (by value) would normally be rated at the lower level.—Ed.]

Video Recorders

There has been even more confusion in the area of video and the irony is that the muddle created almost killed off the European VCR system and handed the video cassette market over to the Japanese system on a plate. And this was at a time when some politicians were howling for a curb on Japanese imports!

To cut a long story short, the Philips VCR which includes a tuner and modulator to enable off-air recording and playback through a domestic TV set, has always been rated at 25 per cent, but initially the U-matic machine from Sony and the cartridge machines from National and Hitachi were rated at 8 per cent because they do not include a tuner or modulator.

Add-on tuners and modulators are available for the Japanese machines and although these were individually rated at 25 per cent the overall price gap between the Philips VCR on the one hand and the U-matic and cartridge machines on the other, was considerably narrowed. And of course it makes better sense to spend

money on engineering than VAT.

Desperately Philips knocked a hundred pounds off the price of their VCR to re-create the price differential and doubtless sold their VCR's at a loss as a result.

Luckily for Philips, however, the situation has changed again and now everything in the cassette and cartridge video field is crippled with 25 per cent.

Special Features

But there are still some escape routes in domestic video open for anyone willing to look for them. An exception to the 25 per cent rule is any machine with "special features" and these include slow motion replay and electronic edit.

Slow motion is a redundant luxury for most people but electronic edit is very desirable if you want to make up composite tapes without the usual few seconds of irritating video break-up between different recordings.

For many people, however, cassette machines with edit are just too expensive to consider for domestic use. The answer here may be that all reel-to-reel video machines are rated at 8 per cent.

Most open reel machines can be equipped with tuners and modulators which enable their use with a domestic television and because they need not incorporate elaborate automatic tape threading mechanism they can cost less than a cassette machine even without VAT considerations—especially if monochrome only. Also, open reel tape can be far cheaper to buy than tape in cassettes. It would be ironical if the much vaunted domestic video cassette revolution were finally killed off by VAT!

VAT Logic?

To revert to a lighter note the most curious piece of VAT logic is to be found in VAT News No. 8.

Item 1 lists goods which are "suitable for domestic or recreational use" and thus must be taxed at 25 per cent. This list includes walkie-talkie radios, which operate on the 27MHz band of frequencies and may not be legally used in this country.

In other words, although the Government is happy to take a 25 per cent cut on the sales of walkie-talkies, because they are intended to be used at home or for fun, that same Government will prosecute if you actually do any such thing.

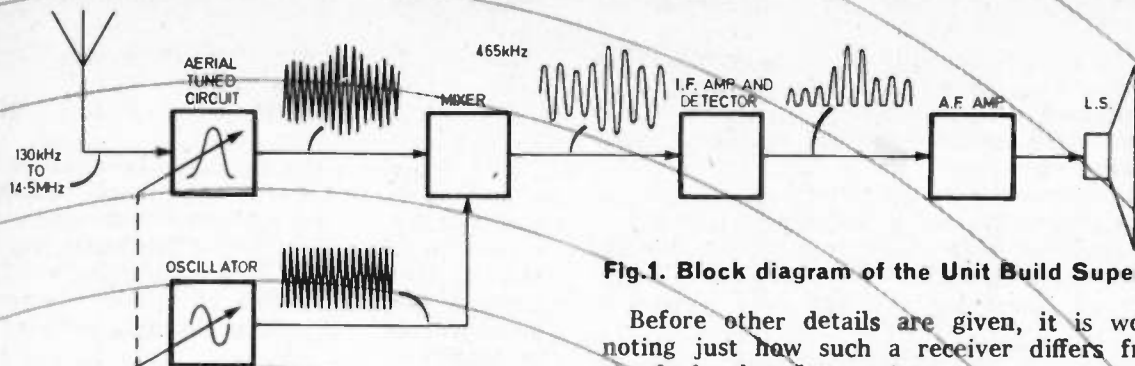

Fig.1. Block diagram of the Unit Build Superhet

Before other details are given, it is worth noting just how such a receiver differs from simple, local-station receivers.

HOW IT WORKS

An oscillator is arranged to produce a frequency exactly 465kHz away from that to which the aerial is tuned. When the received and oscillator signals are mixed they produce a signal at 465kHz which is amplitude modulated with the required audio signal. This signal is amplified by the intermediate frequency section and the audio signal recovered by rectification in the detector. It is then amplified to feed a speaker or headphones.

SUPERHET

A block diagram of the receiver is shown in Fig. 1. Incoming signals may be on frequencies from 130kHz long wave, to 14.5MHz short wave and all pass to section 1, which is the mixer/oscillator.

Here, a local oscillator circuit operates at a frequency which is 465kHz away from the frequency of the wanted signal. When the wanted signal and the oscillator frequency are combined or mixed together, the programme becomes available on a new frequency of 465kHz. In fact section 1 is sometimes termed the "frequency changer" because no matter what frequency the wanted station is using, this is changed to 465kHz by the combined action of mixer and oscillator.

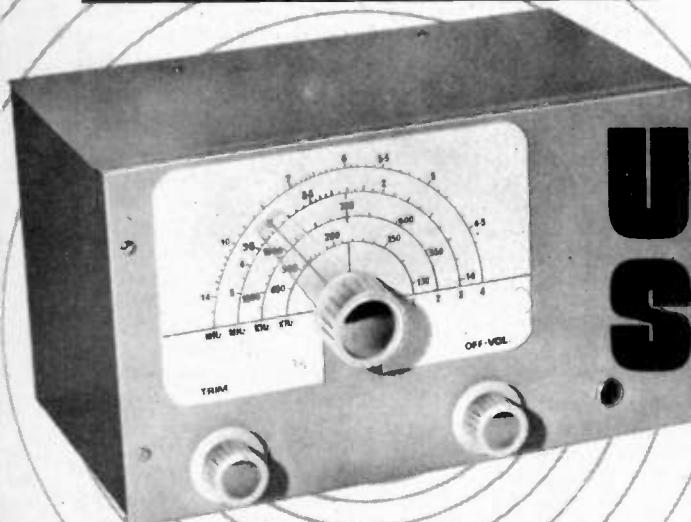

Unit built SUPERHET

By F. G. RAYER

PART 1

A SUPERHETERODYNE or "Superhet" is a type of radio which can provide high sensitivity to receive weak and distant signals, and which has high selectivity, or sharpness of tuning, to separate stations which lie near each other.

Such a receiver requires more components than does the simple, local-station type of radio. Despite this, it is not a particularly difficult project to build, and the receiver described here is simplified by avoiding any waveband switching, and by assembling the circuits on three small boards, afterwards fixed to the chassis.

The completed receiver is suitable for driving speaker or headphones, and covers long and medium waves, in addition to short waves.

The great advantage of this is that no variable tuning is needed in section 2, the intermediate frequency amplifier. Instead, the inductors (termed intermediate frequency transformers

FOR GUIDANCE ONLY

ESTIMATED COST* OF COMPONENTS excluding V.A.T.

£12.00 excluding case and headphones

*Based on prices prevailing at time of going to press



IFT's) are permanently tuned to 465kHz. The receiver has five such tuned circuits, incorporated in a two-stage amplifier. This accounts for the selectivity and sensitivity which is obtained.

A detector or demodulator in section 2 recovers the audio part of the transmitted signal. This could operate headphones, but is passed to the audio amplifier 3, which raises the signal level to give enough volume for a speaker if required.

With a simple local-station radio, there is usually only one tuned circuit. This is for the detector, which passes audio signals directly to the audio amplifier. As a result, such receivers are usually unselective and not very sensitive.

MIXER CIRCUIT

The mixer is shown in Fig. 2. L1 is the aerial coil, tuned to the wanted frequency by VC1a. The aerial is taken to its own coupling winding, pins 8 and 9 of L1. A base coupling winding (pins 5 and 7) provides signals through C1 for the base (b) of TR1; R1 and R2 bias TR1 into its active region.

To avoid waveband switching, which can be quite complicated where several wavebands are provided, small plug-in coils are used. These fit in a nine-pin holder, and any one of four aerial coils can be inserted. The ranges and frequency coverage are as follows:

Range 1. 130-400kHz, 2300-750 metres, long wave.

Range 2. 520-1600kHz, 580-190 metres, medium wave.

Range 3. 1.6-5.2MHz, 190-58 metres, short wave.

Range 4. 4.5-14.5MHz, 66-22 metres, short wave.

The oscillator coil L2 is tuned by VC1b. VC1a and VC1b are parts of a ganged capacitor operated by the tuning drive. With some receivers trimming or aligning the aerial coil L1 and oscillator coil L2 proves difficult. This problem is avoided here by having the small panel trimmer VC2, which is simply adjusted as necessary for best volume. This trimmer also allows correct alignment despite changes to the aerial.

For each waveband a pair of coils, coded blue for aerial (L1), and red for oscillator (L2), is inserted. With the oscillator coils, frequency coverage has to be adjusted so that there is a constant difference of 465kHz between L1 and L2. This is done automatically when plugging in any coil L2, by means of the padder capacitors C3, C4, C5 and C6; C3 is for long waves, C4 for medium waves, C5 for Short Wave 1 and C6 for Short Wave 2 ranges. Each Red coil has its winding to a different pin, so that the correct padder is in circuit. Thus C3 is in circuit for Range 1, C4 for Range 2, C5 for Range 3, and C6 for Range 4.

IF AMPLIFIER

The circuit of the intermediate frequency amplifier is shown in Fig. 3. Transformer IFT1 has two tuned circuits, IFT2 two, and IFT3 one tuned circuit. These IFT's are set on the correct frequency by the maker, so after construction

Fig. 2. Mixer section of the Unit Build Superhet.

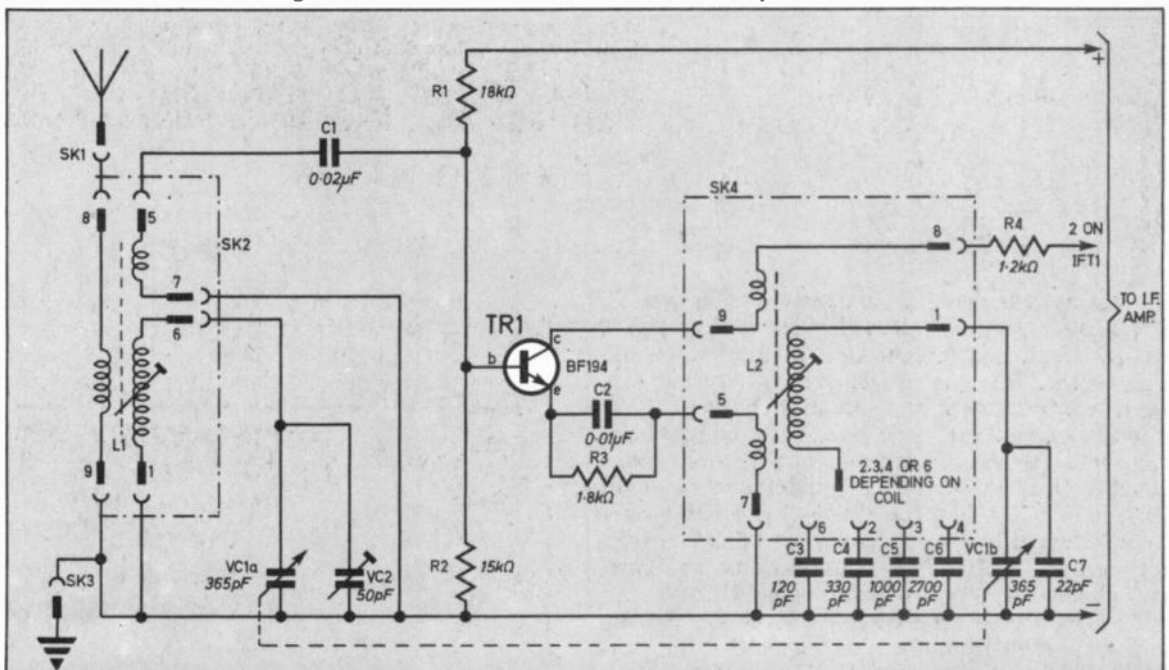

only very small movements of the cores may be needed to give maximum efficiency.

Transistor TR2 is the first amplifier and TR3 the second; D1 is the detector or demodulator. Audio signals from D1 appear across the volume control VR1, any wanted level being taken off by moving the slider.

Diode D1 also produces a steady d.c. potential, which provides bias for TR2, through R5 and R9. When signals are strong, D1 reduces the amplification of TR2, but allows amplification to rise when signals are weak. This is automatic volume control (a.v.c.), and its action results in a more uniform output from the receiver, with signals of widely varying strength.

AUDIO AMPLIFIER

The circuit of the audio amplifier section is shown in Fig. 4. Audio signals reach C13, and TR4 is the preamplifier and driver for the output transistors TR5 and TR6. Feedback is provided so that direct current working conditions are stabilised in all three transistors.

Output is suitable for a loudspeaker of 18 to 35 ohms, or for headphones of over 18 ohms. TR5 can be an AC127 and TR6 an AC128 (instead of the AC141 and AC142) without any component changes. A panel outlet (SK5) is provided for plugging in phones or speaker.

MIXER BOARD

If 0.15in matrix plain perforated board is cut with six rows of holes 10 holes long, components can be inserted exactly as in Fig. 5.

First place the board on the chassis plate in the position shown in Fig. 8 (see next month)

Components....

MIXER BOARD

Resistors

| | | |
|----|---------------|---------------------------------------|
| R1 | 18k Ω | } All \pm 5% $\frac{1}{4}$ W carbon |
| R2 | 15k Ω | |
| R3 | 1.8k Ω | |
| R4 | 1.2k Ω | |

Capacitors

| | |
|----|---------------------------|
| C1 | 0.02 μ F disc ceramic |
| C2 | 0.01 μ F disc ceramic |
| C3 | 120pF silver mica |
| C4 | 330pF silver mica |
| C5 | 1000pF silver mica |
| C6 | 2700pF silver mica |
| C7 | 22pF silver mica |

Coils

| | | |
|----|-------------------------|-----------------|
| L1 | Denco Blue type T coils | } Bands as text |
| L2 | Denco Red type T coils | |

Miscellaneous

| | |
|--|--|
| VC1a/VC1b | Jackson 365 + 365pF gang |
| VC2 | 50pF variable Jackson type C804 |
| TR1 | BF194 silicon npn |
| SK1, SK3 | 4mm sockets (2 off) |
| SK2, SK4 | B9A valve holders, non-skirted (2 off) |
| 0.15in. matrix plain perforated board 10 x 6 holes | |

**TALK
SHOP**
SEE

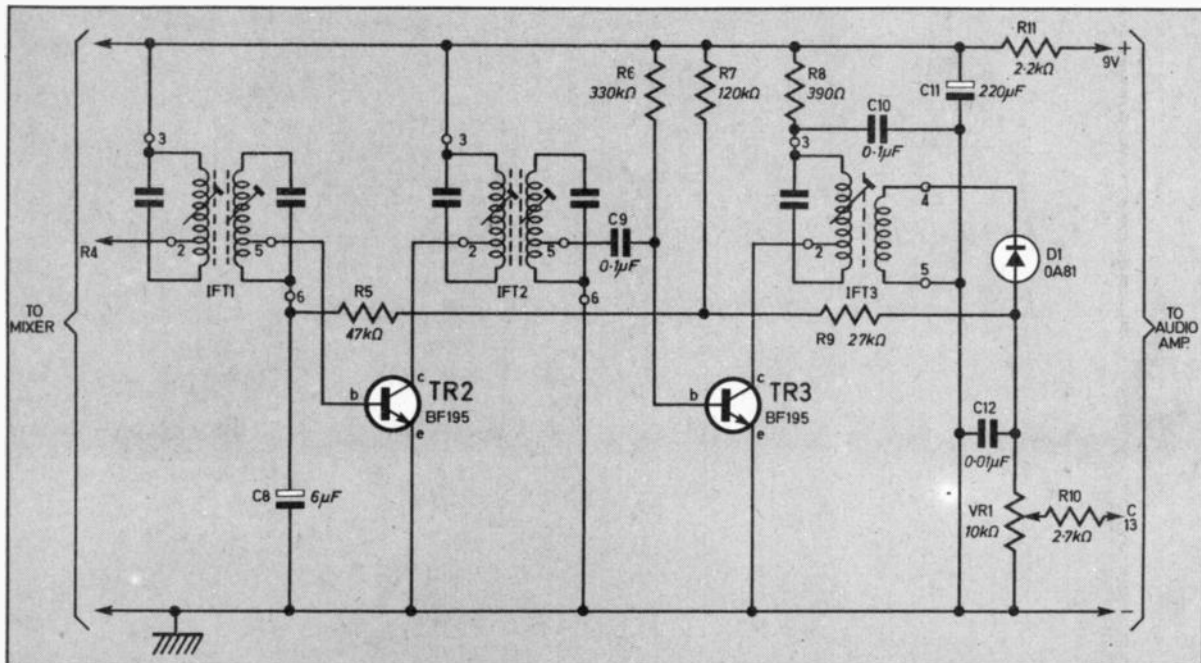

Fig.3. The i.f. amplifier and detector stages of the Superhet.

INTERMEDIATE FREQUENCY AMPLIFIER

Resistors

| | | |
|-----|---------------|---------------------------------------|
| R5 | 47k Ω | } All \pm 5% $\frac{1}{4}$ W carbon |
| R6 | 330k Ω | |
| R7 | 120k Ω | |
| R8 | 390 Ω | |
| R9 | 27k Ω | |
| R10 | 2.7k Ω | |
| R11 | 2.2k Ω | |

Capacitors

| | |
|-----|------------------------------|
| C8 | 6 μ F 6V electrolytic |
| C9 | 0.01 μ F disc ceramic |
| C10 | 0.1 μ F disc ceramic |
| C11 | 220 μ F 10V electrolytic |
| C12 | 0.01 μ F paper |

Intermediate frequency transformers

| | |
|------|-----------------|
| IFT1 | Denco IFT18/465 |
| IFT2 | Denco IFT18/465 |
| IFT3 | Denco IFT14 |

Semiconductors

| | |
|-----|-----------------------------------|
| TR2 | BF195 silicon <i>n</i> p <i>n</i> |
| TR3 | BF195 silicon <i>n</i> p <i>n</i> |
| D1 | OA81 germanium |

Miscellaneous

VR1 10k Ω logarithmic potentiometer with switch
0.15in. matrix plain perforated board 25 x 8 holes

AUDIO AMPLIFIER

Resistors

| | | | |
|-----|---------------|-----|--------------|
| R12 | 270k Ω | R15 | 47 Ω |
| R13 | 220k Ω | R16 | 2.2 Ω |
| R14 | 680 Ω | R17 | 2.2 Ω |

All \pm 5% $\frac{1}{4}$ W carbon

Capacitors

| | |
|-----|------------------------------|
| C13 | 0.1 μ F polyester |
| C14 | 220 μ F 6V electrolytic |
| C15 | 100 μ F 10V electrolytic |

Semiconductors

| | |
|-----|-------------------------------------|
| TR4 | BC107 silicon <i>n</i> p <i>n</i> |
| TR5 | AC141 germanium <i>n</i> p <i>n</i> |
| TR6 | AC142 germanium <i>p</i> n <i>p</i> |

Miscellaneous

SK5 3.5mm jack socket
B1 9V battery PP9
0.15in. matrix plain perforated board 14 x 12 holes

CASE

Letrokit parts:

Sides: LK-301 (2 off)
Panels: LK-431 Back: LK-531 Bottom: LK-531
Chassis: LK-211 chassis rails (2 off), LK-121, LK-131 Top: Aluminium plate 225 x 120mm with LK-811 hinge
Rubber feet (4 off)
Ball drive, Jackson type 4511/DRF
Knobs: 13mm (2 off) 25mm (1 off)
Nuts, bolts, etc.

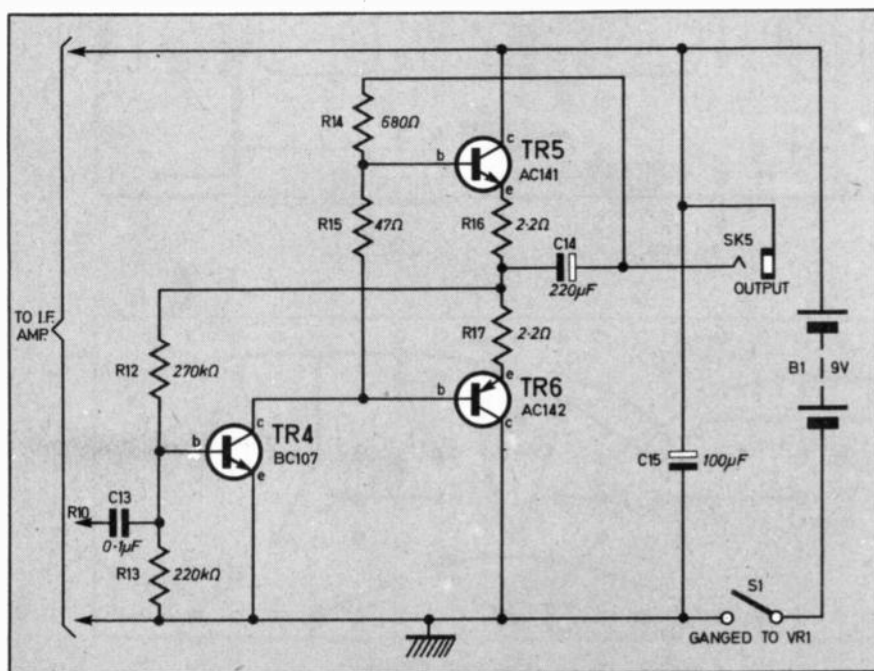

Fig.4. The audio amplifier stage of the Unit Build Superhet providing loudspeaker or ear-phone output.

UNIT BUILT SUPERHET

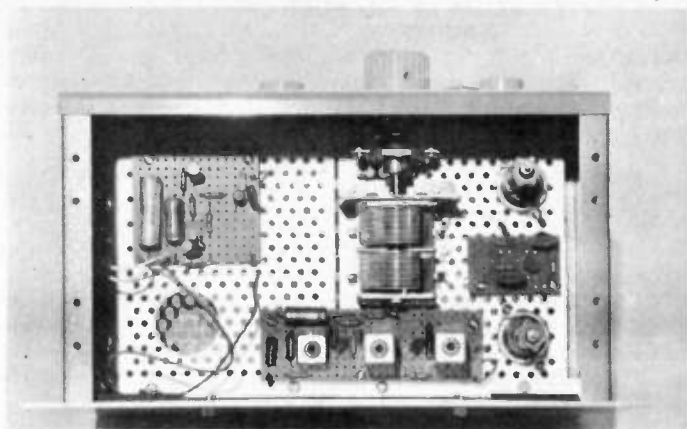

Fig. 5. The layout and wiring of the mixer board.

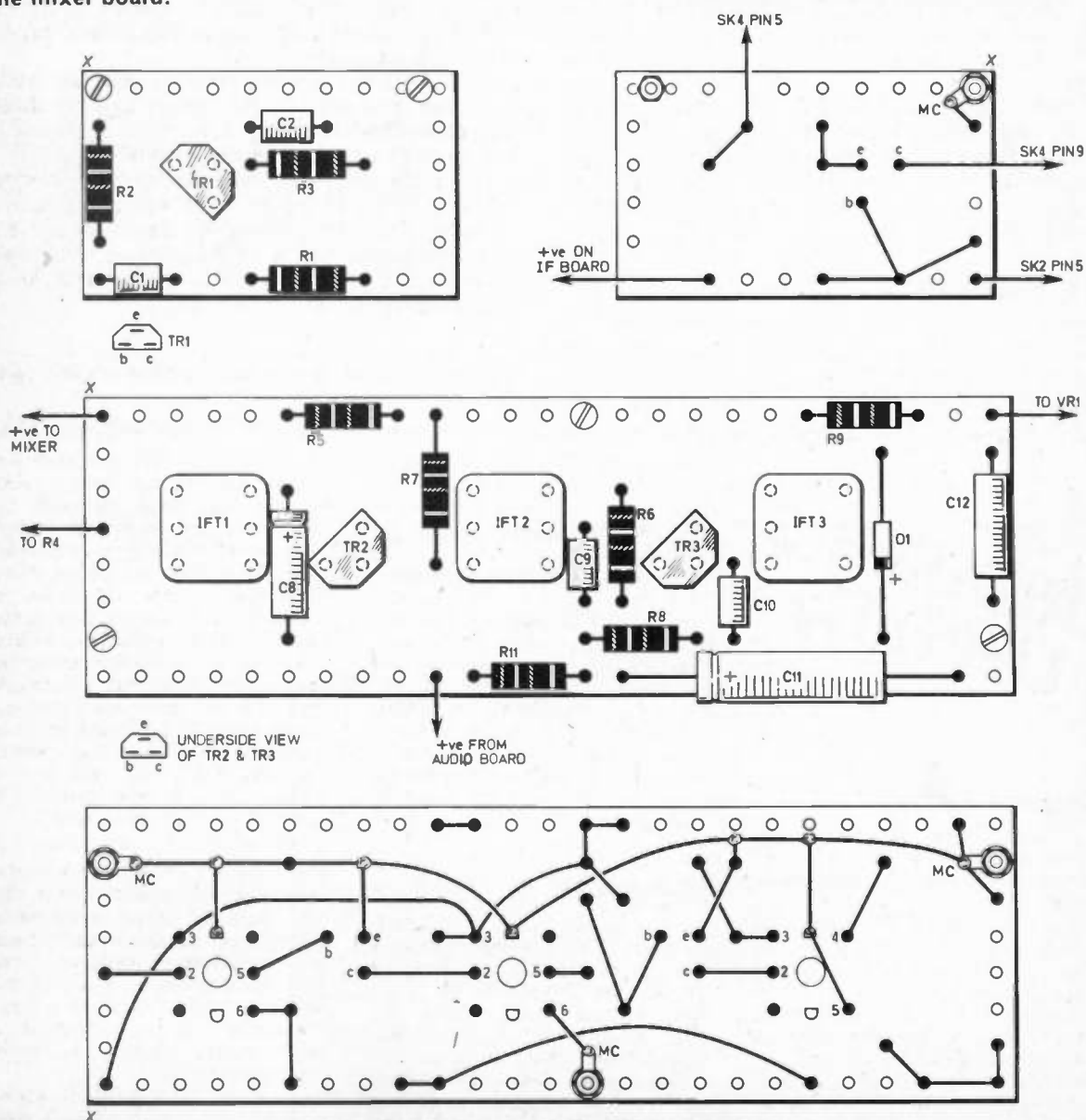

Fig. 6. Layout and wiring of the i.f. board.

and mark for two 6BA bolts. These should not be too near the board edges, or the board may break. Insert two 13mm ($\frac{1}{2}$ in) 6BA bolts, locking them with a tag under one nut for the metal chassis connection (MC), Fig. 5.

Place the resistors and capacitors as in Fig. 5. Bend and cut the leads so that they can be soldered as shown. TR1 can then be inserted and connected. The iron should be at full heat, and it is removed immediately the joint is properly made. This will be in a second or so. Unnecessarily prolonged heating may damage the transistor.

Leads have to run to the coil holders and elsewhere, and thin flex is most suitable here. The leads may be coloured as follows: Black for C1, to go to tag 5 of SK2. Purple from TR1 collector (c) to go to 9 on coil L2 holder (SK4). Yellow from C2 and R3 to go to 5 on L2 holder (SK4). Red from R1 to go to positive pin furnished on the i.f. amplifier.

Two further nuts are put on the 6BA bolts, to hold the board about 6mm from the metal chassis plate. It is then fixed with lock nuts tightened below. The tag MC, Fig. 5, and its securing bolt thus provide an earth or negative return to the chassis.

I.F. BOARD

The i.f. board is prepared, wired and fixed in the same way as the mixer board. First drill three fixing bolt holes, as in Fig. 6, matching the holes in the perforated metal chassis plates. Also

drill holes for the IFT pins and metal can tags.

Correct drilling positions can be found by pressing the pins on a piece of paper, which is then held on the Veroboard, marking through with a sharply pointed tool. Should any holes not be correct, enlarge them as necessary with a very small file, so that the IFT's fit readily.

A central hole is necessary under IFT1 and IFT2 as the lower cores may need slight adjustment later.

Bend the can tags out, and connect them to the MC line as shown. Wiring can then be completed as in Fig. 6. Where necessary, some 24s.w.g. wire can be used for connections. Put sleeving on any leads which may touch other wires etc., or which cross.

Note that C8, C11, and D1 have positive and negative ends, which must be placed as shown. Avoid unnecessary heating of transistors and D1 when soldering them.

Four Veropins are inserted for external leads, or a stiff wire may be left projecting for these. The completed board is fixed to the chassis as before, with lock nuts on the bolts MC.

Bring the red wire from R1 up near the pin marked "+ve for mixer," and cut and solder it on here. Cut both ends of R4 short. Solder one end directly to tag 8 of SK4, Fig. 9 (see next month). Run a lead from the other end of R4 to the pin marked "R4" in Fig. 6.

Continued next month with further construction details.



Speaker Testing

I have been following the Teach-In 76 series as I am particularly interested in electronics and hi fi.

I have a particular interest in loudspeakers and enclosure design and proposed to make this a topic for my 6th form research project. I should be obliged therefore for any background information or references you may be able to give me.

I had in mind to set up a signal generator feeding a loudspeaker

mounted in a variable enclosure. Output would be picked up by microphone and oscilloscope when the received signal could be studied.

A. Stewart Ogilvie,
Ruislip.

Firstly we do not consider you will get any useful results from the set up you envisage—see For Your Entertainment Feb. '76. We will be publishing an article on loudspeaker enclosures in a future issue but we would suggest that you contact some manufacturers directly for further information.

Modeller

Two things arise from the February E.E. I learnt about the effect of a permanent magnet on TV screens long ago, but was then warned never to try this with a colour screen as permanent damage could be done.

The second matter is right up my street as a railway modeller, and arises from Mr. Hughes and

circuit boards. (We use plain surfaced board in our hobby, oddly enough for track sleepers, the cross timbers under the rails!) Whenever drilling a relatively thin material or one rather brittle like this board, or prone to "flake" like it, always have a support of scrap hardboard behind the work. We modellers clamp the lot in the vice but electronics folk may not have such and will be all right if the board and support are on a good flat surface. Hardboard is best, odd bits of wood are not, as their grain might deflect and even break a drill.

This modeller much enjoys E.E. even though electronics are very sparse as yet in our hobby, but the magazine yields a lot of interest and entertainment in terms understandable; ranging from just basic common sense electrical laws to such things as a minor "bonanza" via one advertiser of microswitches—which we always find very useful!

R. C. Ormiston-Chant,
Manchester.

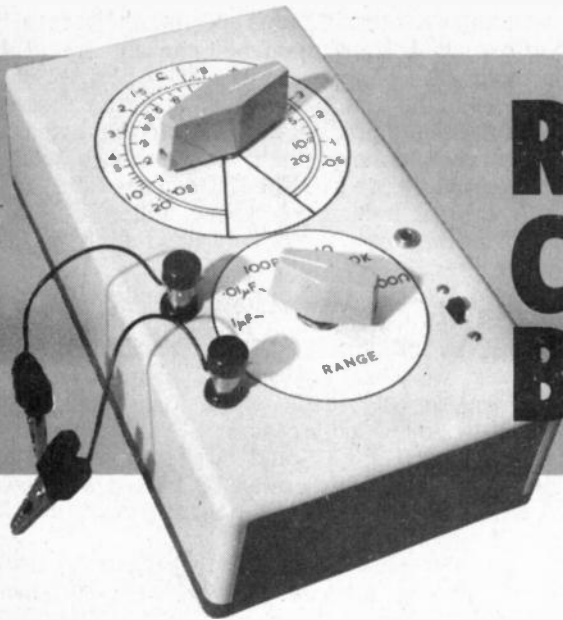

RESISTANCE CAPACITANCE BRIDGE

By F.G. RAYER

A useful unit for checking unmarked or dubious resistors and capacitors.

THIS instrument has six ranges, covering approximately 10pF to 10µF, and 70 ohms to 10 megohms. Its main use is in checking the values of components with doubtful or obliterated markings, or in testing those with some unfamiliar method of coding.

Multi-range testmeters will usually have one or more resistance measuring ranges, but no provision for measuring capacitance. Despite this, it is worthwhile including the resistance ranges on the bridge described here, as the only additional components for these is one resistor for each range, and the use of a six-way switch instead of three-way.

The whole circuit does in fact require only a small number of quite inexpensive components, so the building cost is not very great, especially if a pair of headphones or earpiece suitable for use as the balance indicator is already available.

BRIDGE OPERATION

The measuring, or "bridge" part of the circuit is shown in Fig. 1. The audio input is obtained from an oscillator. Assume that the range switch S1 connects a particular resistor R_n in circuit, and that an unknown resistor R_x is connected to the test terminals X-X.

When $R_A/R_B = R_n/R_x$ the bridge is balanced. The ratio of the potential-divider R_A/R_B is the same as that of the potential-divider R_n/R_x , so no signal voltage is present across the phones, and no audio tone is heard.

For any other values, the bridge is not balanced, and the audio tone is heard in the phones.

In the actual instrument, R_A and R_B are portions of the element of a potentiometer,

fitted with a knob and scales; R_n is one of three resistors, against which unknown resistors R_x will be checked.

To find capacitances, S1 introduces one of the three capacitors C_n , against which unknown

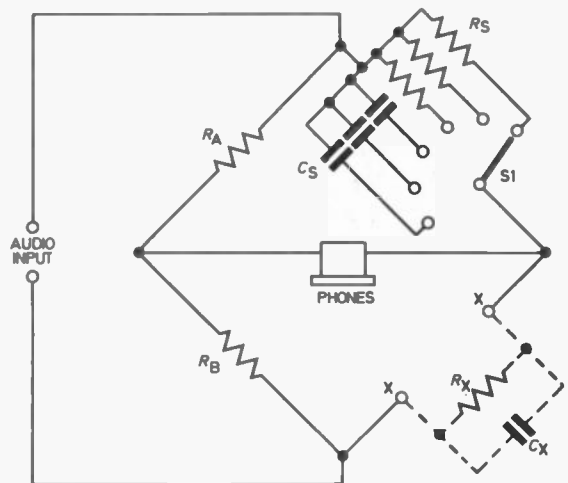

Fig. 1. Basic bridge arrangement of the unit.

FOR
GUIDANCE
ONLY



ESTIMATED COST*
OF COMPONENTS
excluding V.A.T.
£4.00

excluding case
and headphones

*Based on prices prevailing at
time of going to press

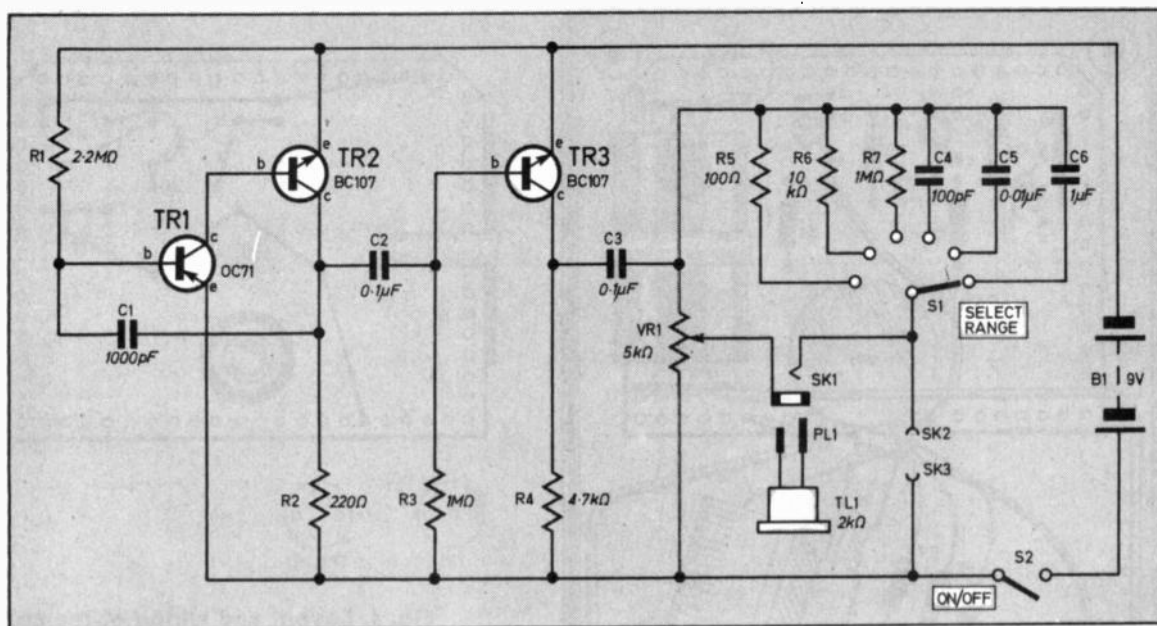

Fig. 2. Complete circuit diagram of the bridge.

capacitors C_x can be checked. Balance is arrived at in the same way as when finding resistor values.

A bridge for resistances only could employ a direct current input, as from a battery, with a sensitive d.c. meter instead of phones as indicator. However, such a d.c. bridge cannot be used with capacitances—for these, values R_A and R_B are actually balanced against the reactance of the capacitors C_x and C_x , so an alternating current input is necessary. Here, the a.c. input is an audio tone from the oscillator.

SIX-RANGE BRIDGE

The complete circuit diagram is shown in Fig. 2. The *pnp* transistor TR1 and *nnp* transistor TR2 form a directly coupled amplifier, with feedback provided by C1, and together form the audio oscillator. TR3 is an audio amplifier, to increase the level of signal heard with the phones. VR1 must be a linear potentiometer—not a log or a semi-log component.

In the interests of accuracy of measurements, R5, R6 and R7 are one per cent tolerance resistors, and C4, C5 and C6 one per cent capacitors.

The ranges used for positions of S1 are:

- R5: 10-1000 Ω
- R6: 1k Ω -100k Ω
- R7: 100k Ω -10M Ω
- C4: 10-1000pF
- C5: 0.001-0.1 μ F
- C6: 0.1-10 μ F.

With these ranges, the extreme positions of VR1, where readings become difficult, are not

too closely approached. (The 20 and 0.05 markings are for quick checks outside these ranges, as explained later.)

ACCURACY

Accuracy depends on R5, R6, and R7 for resistance; and on C4, C5, and C6 for the capacitor ranges and on the potentiometer VR1, and exactness of balance and calibration. For "middle" values the setting of VR1 is very clear and definite, but at the ends of the ranges, more care is necessary in rotating VR1 for a correct null or balance. Swing VR1 one way and the other, reducing the movement to decide on the "centre" position.

It is by no means essential to use one per cent components, R5, R6 and R7 could be two per cent, or even five per cent, with useful results; C4 and C5 are readily obtainable as silver mica one per cent capacitors. A supplier of a 1 μ F one per cent capacitor is listed, as the average "1 μ F" capacitor has a rather wide tolerance (see *Shop Talk*).

SCALES

It would be possible to fit six completely calibrated ranges—for example, one marked from 10pF to 1000pF, the next from 1000pF or 0.001 μ F to 0.1 μ F, and so on. However, as capacitor ranges are clear multiples of each other, and resistor ranges similarly clear multiples of each other, only two scales are provided—one for resistances, and the other for capacitances. As with some commercial equipment, the range switch VR1 shows the "middle value" of the swing of VR1.

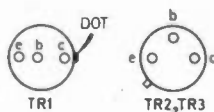
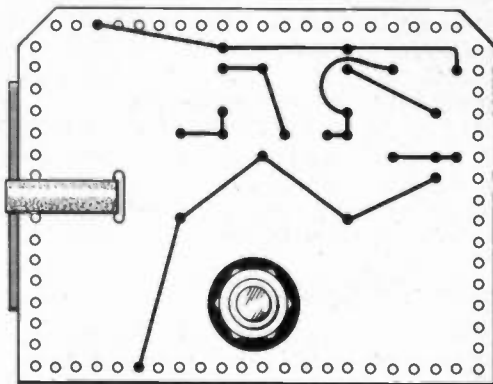
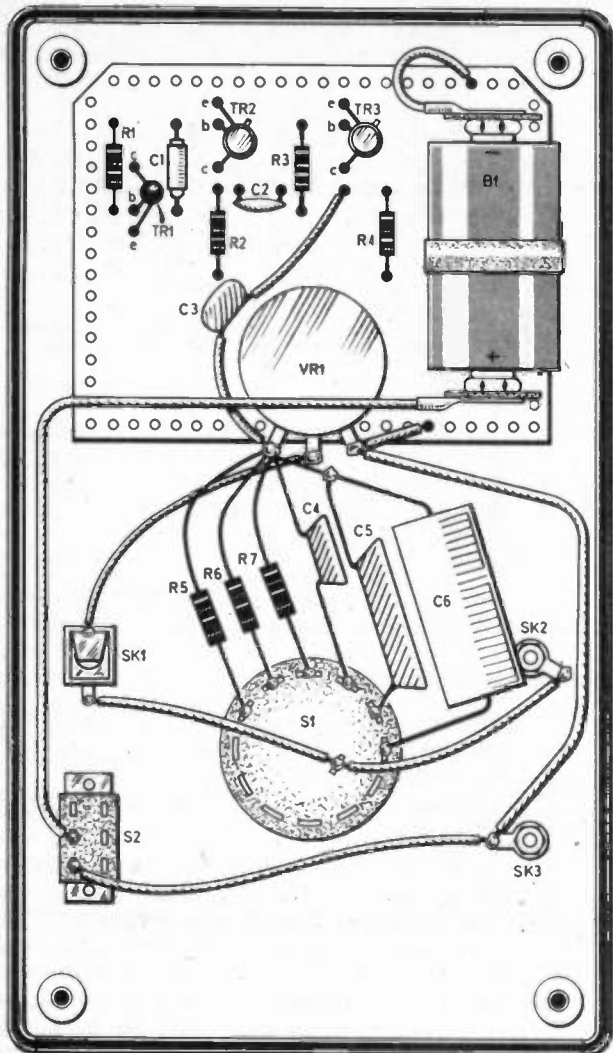

Fig. 4. Layout and wiring of the complete bridge.

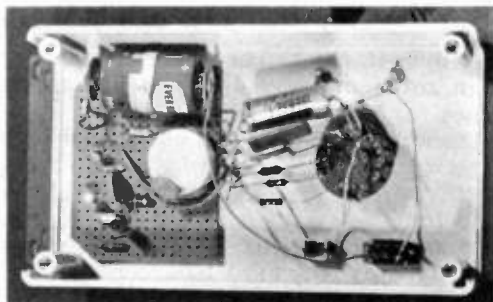
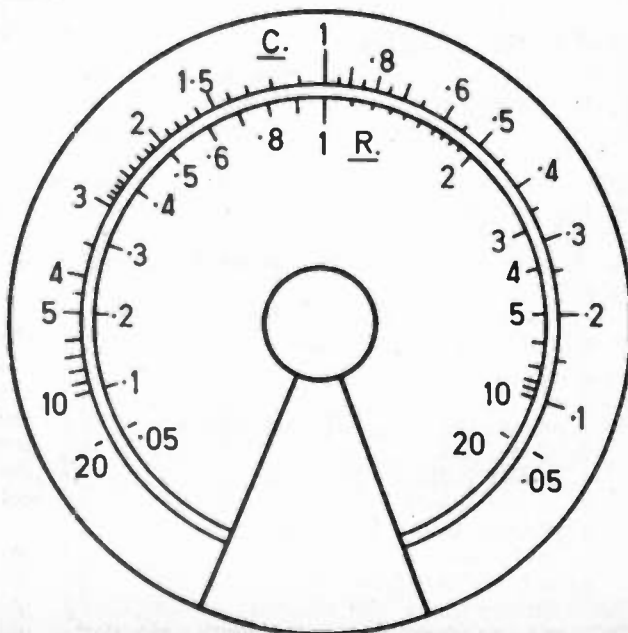
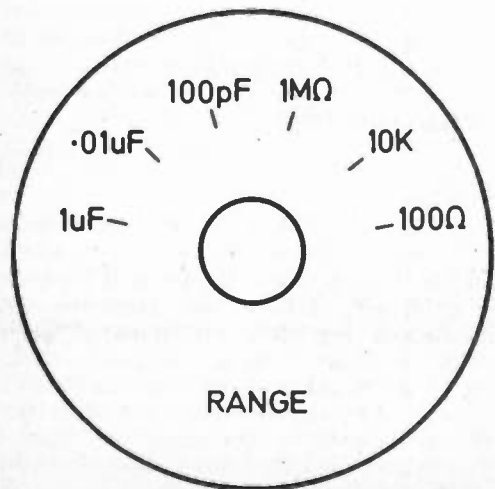

Fig. 3 (below) scales for VR1 and S1 shown full size.



It will be found that the actual reading of values from the scales will be easy. Fig. 3 shows the ready-calibrated scales, to be fitted to the case under the knob of VR1. The knob is located so that the full positions of VR1 correspond with the extreme scale markings.

The scales in Fig. 3 are shown full size and may be traced out in ink on thin paper and this cut out and glued to the front panel of the unit using the centre holes to align each scale over the potentiometer spindle.

CIRCUIT BOARD

Most items are mounted on the circuit board, Fig. 4. First drill the board for VR1. Keep connections and joints closely against the board, so that one or two washers between the board and case will give enough clearance, while leaving enough thread for the nut on the case front.

A loop of elastic is provided to hold the

battery. Fit the negative lead of the board with a negative battery clip, and take the positive board lead to VR1, from where a connection will run to one terminal SK3, and to S2.

The circuit board fits in the case as in Fig. 4. Drill this in advance for S1, S2, terminals SK2, SK3, and the phone outlet, as well as for VR1.

Connections can then be completed as in Fig. 4. The switch S1 can be a six-way two-pole component, with one pole unused. Or a single pole switch is of course suitable, though it may be found that this is manufactured with more "ways" than necessary. If so, ignore the unwanted tags.

Spring-loaded terminals are convenient for taking the capacitor or resistor to be tested or measured. One or two short flexible leads with small croc clips are also extremely handy here for easy connecting of components.

BRIDGE USE

With the component whose value is to be found connected to the test terminals, set S1 to the range anticipated, and rotate VR1 for balance, reading the value from the resistor or capacitor scale as described. If VR1 is almost at one extreme position, or balance is not achieved, switch to a different range, until balance is found with VR1.

A few tests with resistors or capacitors to hand will show how VR1 operates. With components around the extreme limits, that is around 10 ohms or 10 megohms, or 10pF or 10 μ F, signal level grows low, even with the amplifier TR3. It will be found that a good pair of headphones, preferably of about 2k Ω to 4k Ω impedance, will be most convenient.

In the case of electrolytic capacitors, a complete null will not be expected, due to leakage, so with these VR1 is turned for minimum volume, which should be quite low.

In the event of the user wanting other ranges, either to employ components to hand, or to obtain a range of particular interest, it will be seen that this can be one-tenth of the reference component to ten times this value. As an example, a 1k Ω resistor would provide a range of 100 Ω to 10k Ω . Similarly, a 1000pF capacitor would give a range of 100-10,000pF.

With the scale for VR1 shown in Fig. 3, readings are normally taken as far as the 10 and 0.1 multipliers, on either C or R range, as appropriate for capacitors or resistors. The 20 and 0.05 multipliers are useful for a quick check when values fall outside the range selected with the switch, but they are not intended for general use as readings become very cramped.

In the event of greater accuracy than that provided by the ready-made scales being required, this could be obtained by using a selection of resistors and capacitors, so that individual scales could be drawn up. □

Components

Resistors

| | |
|--|---------------------------------------|
| R1 | 2.2M Ω |
| R2 | 220 Ω |
| R3 | 1M Ω |
| R4 | 4.7k Ω |
| R5 | 100 Ω \pm 1% $\frac{1}{4}$ W |
| R6 | 10k Ω \pm 1% $\frac{1}{4}$ W |
| R7 | 1M Ω \pm 1% $\frac{1}{4}$ W |
| All \pm 5% $\frac{1}{4}$ W unless otherwise stated | |

MIL
TALK
SHOP
SEE

Capacitors

| | |
|----|-----------------------------------|
| C1 | 1000pF polystyrene |
| C2 | 0.1 μ F disc ceramic |
| C3 | 0.1 μ F disc ceramic |
| C4 | 100pF \pm 1% silver mica |
| C5 | 0.01 μ F \pm 1% silver mica |
| C6 | 1 μ F \pm 1% |

Transistors

| | |
|-----|---------------------------|
| TR1 | OC71 germanium <i>pnp</i> |
| TR2 | BC107 silicon <i>nnp</i> |
| TR3 | BC107 silicon <i>nnp</i> |

Switches

| | |
|----|--------------------------|
| S1 | 6-way single pole rotary |
| S2 | Miniature slide switch |

Miscellaneous

| | |
|--|--|
| VR1 | 5k Ω linear potentiometer |
| SK1, PL1 | 3.5mm jack plug and socket |
| SK2, SK3 | Spring loaded terminals (2 off) |
| TL1 | Earphones 2K Ω to 4K Ω impedance |
| B1 | 9V PP4 battery with battery clips |
| 0.15in matrix plain perforated board 22 x 17 holes | |
| Case (Vero type 90-40-087) | |
| Knobs, nuts and bolts, etc. | |

The Extraordinary Experiments of Professor Ernest Eversure

by Anthony John Bassett



SEATED on one of the Prof's radio controlled motorised armchairs in his computer regulated lounge, Sir Rockwell Orbiter began to describe, to the eagerly listening Prof. and his young friend Bob, the results of his journey to the International Electronic Games Symposium.

"There are some remarkable developments in games—playing computers and robots—and many of the participants presented chess playing devices. There were so many of these that rather than have each computer play a human opponent, the organisers decided to hold chess tournaments between various different computers. With one particular pair of computers, this resulted in bouts of chess at the rate of 300 different games of chess per second."

Bob's mind boggled at the thought "Isn't that rather pointless though?" he asked.

"No, not at all Bob," explained the Prof "The computers are programmed in such a way that none of the games is repeated exactly. So these computers carry on for considerable periods of time producing completely new games at the rate of 300 a second! The games are printed out so that the most interesting ones can be selected and studied! Also, by finding out which of the computers has the greater number of

winning games, and why, the construction, programming and operation of the computers themselves can be better understood, and improvements incorporated. Such improvements are in some cases beneficial for purposes other than the game of chess and may be beneficial to all of us in some way."

BACKWARDS

"At the International Games Symposium," explained Sir Rockwell "computers are now programmed to analyse the games which have been played by other computers as they do this so much more rapidly than do the human experts. The most interesting results and improvements can be produced very rapidly by this means. "What will they do?" enquired Bob, "when all possible combinations of chess and draughts have been analysed by these super computers."

"Oh!" said Sir Rockwell, the possibilities appear to be endless! Already they have programmed some of the computers to play games in reverse, by starting at the end position of a game and working back towards the positioning of pieces normally used for the beginning of the game."

Bob decided that he would mention this at the school chess

society, as this seems to be quite a challenging variation on the game. "Now there are all sorts of other electronic games, some are completely new and some are electronic versions of traditional games," continued Sir Rockwell. "But the most interesting and puzzling it seems to me comes from the principality of the I-Chingdom of Mogadoria! This is the reason for my visit here today."

"The principality of the I-Chingdom of Mogadoria!" exclaimed Bob incredulously. "But I thought that Mogadoria was a kingdom. Does this new name mean that it's gone communist or something?"

"No," explained the Prof, "something quite different has happened. For some years now that entire country has been increasingly dominated by a craze for electronic games."

"During the course of the last few years, this craze has grown to such an extent that it has affected the entire government and running of the country. It's not just simply a craze for electronic games, but a whole series of crazes for a whole series of different games! Bingo, football, chess, crossword puzzles, draughts, and many more were all computerised and electronically fed across the entire

country. Each game became a craze amongst great masses of the population. Now the latest favourite is the electronic wish-fulfilment game of I-Chingo, which is based on the ancient Eastern mystical book of divination known as the I-Ching, and this combination seems to have got everybody. This game, it appears, is so attractive that anyone who plays it even once becomes permanently addicted. One reason for this is that the prizes are not merely cash, or goods, but wish fulfilment by way of psycho-computer analysis."

"What is a psycho-computer Prof?"

"This is the nearest translation we can get to the Mogadorian name for the device. As far as I can gather from the information I have received, it analyses the wishes and desires of the I-Chingo player, and those which are impossible become modified to the most satisfying practical alternative—then, as prizes, the players obtain practical fulfilment, which is arranged by the psycho computer to come at such a time and in such a manner as to provide maximum gratification."

"What if two of the players want to fight each other, Prof?"

"Apparently the psycho-computers are programmed in such a way that they would quickly persuade each player that the wish to fight is not their true desire—then it would analyse their wishes and find the most practical rewards. This way conflict and crime have been virtually eliminated from Mogadoria by means of an electronic game and it is also this game which is responsible for the damage in the name of the country. Now I am delighted that Sir Rockwell is here to give us some up to date information on the latest developments!"

MOGGI

"Certainly I shall Prof, but first I'll mention, mainly for Bob's benefit, that Mogadoria was indeed a kingdom until recently. Then their Boss-Cat, King Moggi found that all the trendy kittens had gone for the latest electronic game of I-Chingo, so he went along to find out about it, and became hooked himself." "Ah yes," the Prof added, "He abdicated the throne, and handed all his kingly powers together with

Everyday Electronics, April 1976

his wishes and desire, over to the psycho-computers of the electronic I-Chingo. Now he is engaged upon the furtherance of the I-Chingo electronic programming and because he is convinced that the psycho-computers can govern Mogadoria better than he can, he decreed that the kingdom be re-styled the I-Chingdom of Mogadoria."

"What happens when the psycho-computers have satisfied all of a person's wishes?" Bob wanted to know.

"Not a great deal is known about that," replied the Prof, "but it does seem that such players form a tremendous psychological and emotional attachment to further the cause of I-Chingo and some people have described them as fanatics, whose every action is dedicated to service or development of the psycho-computer programmes. Robots and incredible electronically controlled machines are built to gratify the wishes of the players, and in the vicinity of Mogadoria bunches of different robots and futuristic vehicles can be seen moving around and working. Some are performing the work necessary to support the new style Mogadoria civilisation but they are all different, each from the others, because each is a product of the rationalised wishes of an individual player of the game of I-Chingo."

"Wow, Prof.!" exclaimed Bob, "this I-Chingo sounds really great! I can just imagine myself controlling all sorts of robots and gadgets which have been built specially, using all the latest electronic developments to do just what ever I want. I would have my own submarine, jet plane, helicopter, all rolled into one together with a bunch of robotic servants. One would be an enormously strong giant and another would be small and delicate for fine electronic assembly work so small I couldn't see it under a microscope. I can hardly stop thinking about all the things I could do!"

"Now, hold your horses, Bob, don't go rushing off to play I-Chingo without very carefully considering the consequences. You see many folks are becoming very suspicious about it, because when people go to play they are instantly hooked and don't come back. It may be some sinister kind of a people trap!" warned the Prof.

Sir Rockwell agreed. "The authorities in some countries are becoming very worried about this I-Chingo craze as reports from the symposium indicate it is having an effect on the populations of nearby countries. Large number of individuals and whole groups of people are crossing into Mogadoria. They do not return and the large areas of land left empty in this way are promptly grabbed by the Mogadoria robots with virtually no opposition.

SCIENTISTS

Also there are a lot of top scientists enthusiastically playing I-Chingo, apparently one of them has found a new way to utilise and recycle their energy resource and this has solved their energy crisis. Another has devised a mining machine which utilises the almost unlimited source of power to instantly split minerals into their separate constituent elements or simple compounds. It separates them by means of an electronically controlled device resembling a huge mass spectrometer and routes the resulting highly refined substances to storage for direct use in building their devices.

An example of this is that ordinary clay, which contains huge quantities of aluminium and silicon, both of which are enormously useful in electronics, is normally not much use as a source of either substance. This is because it is difficult to extract aluminium or silicon from clay and more expensive, less readily available ores must be used. However aluminium is so useful in electronics, being used in great quantities of capacitors of many types, in transistors and integrated circuits, and as a lightweight construction material that anyone who could find a cheap way to extract it from ordinary clay would stand to make a fortune, and be of great service to mankind. Likewise silicon is extremely useful as a basic material for transistors and integrated circuits and a cheap source of highly pure silicon would be much prized by the manufacturers?

So with their mysterious electronic method for extracting and refining these and all the other minerals almost instantly from low grade ones, the Mogadorians have a tremendous set of advantages.

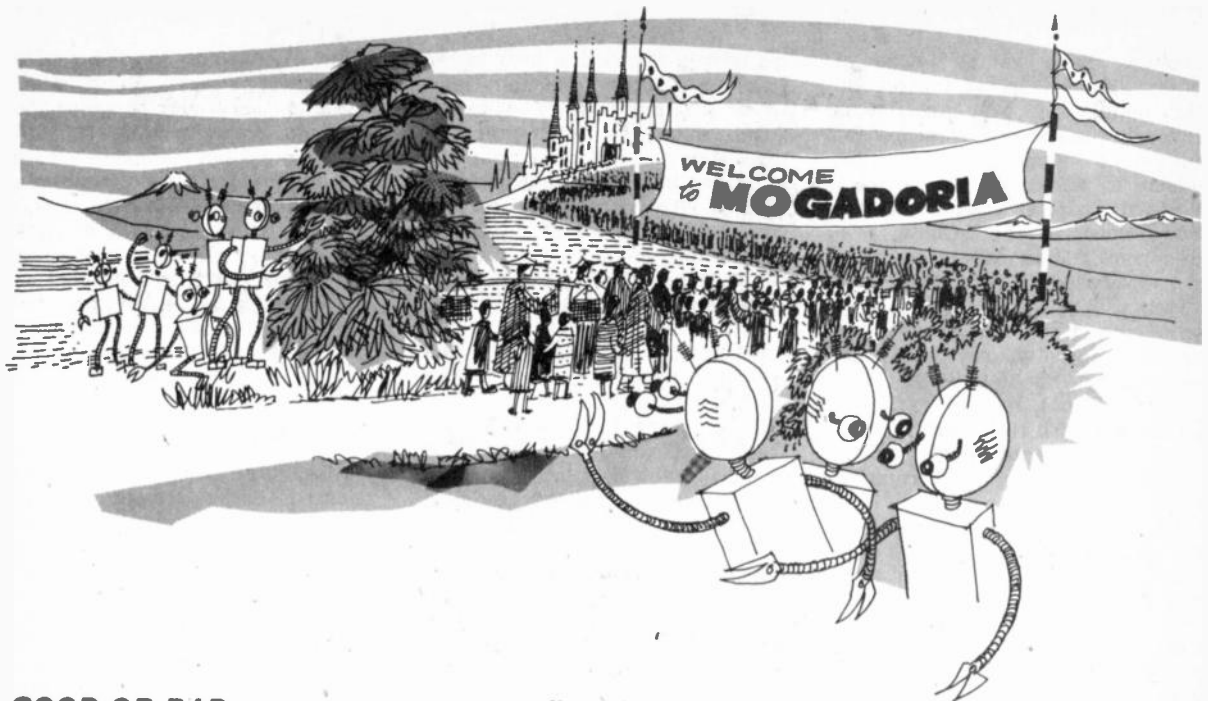

GOOD OR BAD

"They sound almost invincible, Sir Rockwell," the Prof. commented with a look of concern. "No wonder the authorities are getting worried! But this is a most fascinating situation please do carry on."

"Now it has become obvious," Sir Rockwell continued, "that the tremendous power of electronics as a force of change in the world has been very much underrated and this tremendous power can be put to either good or bad uses. It appears that the powerful capabilities of electronic technology have blown out what started as a simple innocent electronic game into something of world shaking importance and concern. Now the authorities want to know more about this I-Chingo. They want to know whether it is good or bad, because it is so powerful that if it's good, it is very good, and if it's bad it is very bad.

The trouble is, that every time they send anyone to investigate that person does not come back; and all they get is a series of messages to say that the investigator is o.k. why not come along too, and a few pictures of him or her blissfully playing I-Chingo! It's absolutely infuriating to think of all these people getting their wishes electronically analysed by computers and fulfilled, not knowing whether its a good thing or a bad thing!"

"I think," Bob said, "that patience is the answer, everyone

seems to tell me that I need more patience to restrain my curiosity but I never seem to have enough patience to completely restrain myself."

"Ah!" observed Sir Rockwell, "it can be quite difficult to control the curiosity of a healthy, active and observant mind! However the latest developments mean that patience is not entirely the answer and that urgent investigations are being called for. This is because the keen proponents of I-Chingo are getting their best brains into action to try to persuade everyone within range to go and play and they are extending their range continually by means of all sorts of electronic communications gadgets.

"First they tried ordinary TV programmes about I-Chingo, which were beamed to nearby countries. These were quite successful, and lots of people even got up part way through the programmes and rushed out straight away to go and play. But others were so worried by this that they switched off the programmes and refused to watch, and eventually they set up electronic jamsistor stations to detect and jam the transmissions."

"What is an electronic jamsistor station?" Bob wanted to know. "How does it work?"

The Prof. explained. "It is a special type of radio transmitter designed to interfere with radio and TV programmes and make reception impossible. It transmits

on the same wavelengths as the programmes to be jammed, and causes all sorts of strange sounds, whistles, buzzes hisses or white noise to be heard instead of the sound of the radio or TV channel. It puts patterns of lines, dots, flashes and flickers over the TV screen so that a proper picture cannot be seen."

"What a rotten invention!" exclaimed Bob in disgust, "it sounds to me like a form of electronic pollution of the environment! It not only completely blots out the Mogadorians' programmes, but I'm sure that it must interfere with other programmes too!

Some of my friends at school really have a difficult job to tune their favourite radio and TV programmes because of interference like this. I'll have to tell them about how to soup up a superhet and improve reception! But what else are the Mogadorians doing now that their radio and TV programmes are jammed? I would think that they could easily send out crowds of fanatics to persuade other people to play, and hold exciting fairs, exhibitions, processions and festivals, all sorts of amazing things to substitute for the jammed TV shows!"

"You're partly right, Bob," Sir Rockwell continued, "except that they do not send anyone at all—they're mostly too busy playing! Although they do have a robot circus and other electronic enter-

Complete the coupon and we'll send you our complete, new catalogue.



The new Heathkit catalogue is now out. Full as ever with exciting, new models. To make building a Heathkit even more interesting and satisfying.

And, naturally, being Heathkit, every kit is absolutely complete. Right down to the last nut and bolt. So you won't find yourself embarrassingly short of a vital component on a Saturday evening—when the shops are shut.

You'll also get a very easy to understand instruction manual that takes you step by step through the assembly.

Clip the coupon now (enclosing a 10p stamp for postage) and we'll send you your copy to browse through.

With the world's largest range of electronic kits to choose from, there really is something for everyone.

Including our full range of test equipment, amateur radio gear, hi-fi equipment and many general interest kits.

So, when you receive your catalogue you should have hours of pleasant reading.

And, if you happen to be in London or Gloucester, call in and see us. The London Heathkit Centre is at 233 Tottenham Court Road. The Gloucester showroom is next to our factory in Bristol Road.

At either one you'll be able to see for yourself the one thing the catalogue can't show you.

Namely, how well a completed Heathkit performs. Heath (Gloucester) Limited, Dept. EE-46, Bristol Road, Gloucester, GL2 6EE. Tel: Gloucester (0452) 29451.

Digital IC tester.

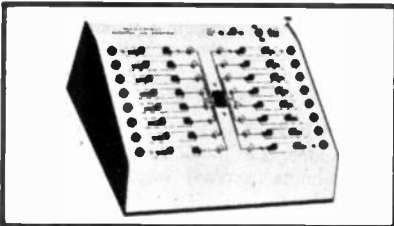

Digital electronic stop watch.



Heathkit Modulus. A new era in Hi-Fi.

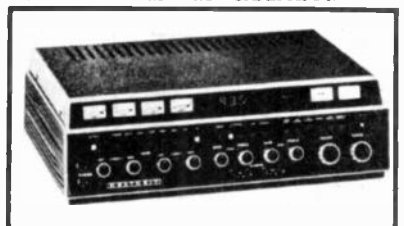

FREE
SOLDERING IRON
WORTH
£3.50
with all orders over £30

The new Heathkit catalogue. Out now. FREE.

To: Heath (Gloucester) Limited, Dept. EE-46, Gloucester, GL2 6EE.
Please send me my Heathkit catalogue. I enclose a 10p stamp for postage.

Name _____ Address _____

Postcode _____

Full details in the catalogue. Offer available for limited period only.

HEATH
Schlumberger

EASY TERMS AVAILABLE
WITH HEATHKIT MONTHLY
BUDGET PLAN

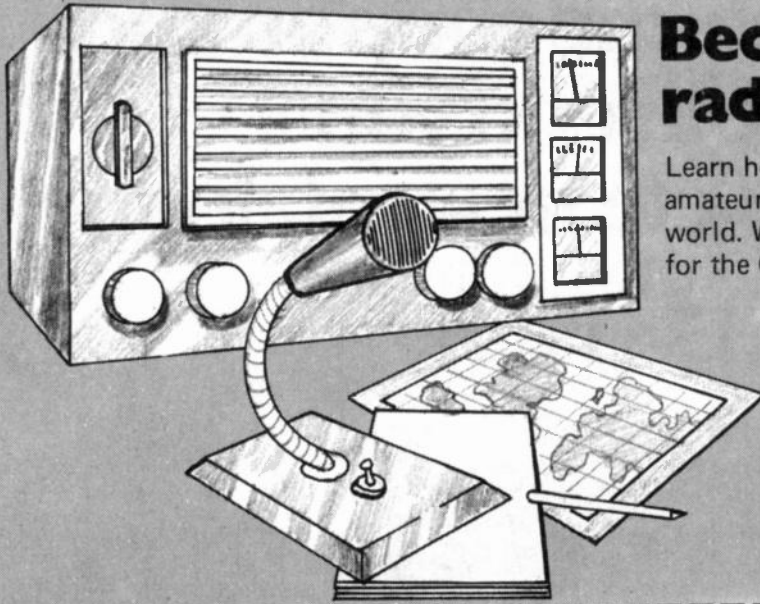

Become a radio amateur.

Learn how to become a radio-amateur in contact with the whole world. We give skilled preparation for the G.P.O. licence.

Free!

Brochure, without obligation to:

To: BRITISH NATIONAL RADIO & ELECTRONICS SCHOOL, Dept. EEB 46
P.O. Box 156, Jersey, Channel Islands.

NAME _____

ADDRESS _____

Block caps please

CRESCENT RADIO Ltd.

11-15 & 17 MAYES ROAD, LONDON N22 6TL
(also) 13 SOUTH MALL, Edmonton, N.9
MAIL ORDER DEPT. 1 St Michaels Terrace Wood Green
London N22 4SJ Phone 888 3206 & MAIL ORDER 888-4474

POWER PACKS

FP1 Switched 3, 4, 6, 7, 9 and 12 volt @ 500 m/a, with on/off switch and pilot light.
Size = 130 mm x 45 mm x 75 mm
ONLY - 84-00
FP2 Car converter. From 12v Pos. or Neg to = 6-7.5-9 volt. Easy to fit and transistor regulated.
88-00 each.
Plus 3% VAT

P.C. ETCHING KIT

This kit contains all that the constructor will need to etch the circuits of his own design.
Contents—Plastic etching disk. Sample copper clad board. Laminated Overlay. 1 lb Ferric Chloride. Large Plastic Spoon. Etch Resist Pen. Full Etching Instructions.
Complete and Big Kit Value at **88-75p** + 8% VAT.

FERRIC CHLORIDE

Anhydrous ferric chloride in double sealed one pound pld packs.
OUR PRICE - 60p + PP + 8% per lb.

2in. PANEL METERS

Size 50mm x 40mm
0-50µA —ME6
0-100µA —ME7
0-500µA —ME8
0-1mA —ME9
0-5mA —ME10
0-10mA —ME11
0-50mA —ME12
88 each. +8%.

0-100mA—ME13
0-500mA—ME14
0-1A —ME15
0-50V —ME16
0-300V a.c.—ME18
8 meter —ME19
V.U. meter—ME19

SCOOP PURCHASE AM—FM STEREO TUNER

We supply an AM, FM, Stereo tuner fully wired and aligned on a 6" x 4" x 1 1/2" Printed board, plus the ferrite aerial and a switch which you connect following our complete instructions. Now you only need a 9/13 Volt DC supply and you can feed this tuner into any stereo amplifier.
Fantastic Value at 87-00 + 8% VAT.

ALUMINIUM BOXES

Metal Project Boxes give your work a professional finish.

| | L | W | H | Price |
|------|-------|-------|-------|-------|
| AB7 | 2 1/2 | 5 1/2 | 1 1/2 | 84p |
| AB8 | 4 | 4 | 1 1/2 | 88p |
| AB9 | 4 | 2 1/2 | 1 1/2 | 84p |
| AB10 | 4 | 2 1/2 | 1 1/2 | 88p |
| AB11 | 4 | 2 1/2 | 3 | 84p |
| AB12 | 3 | 2 | 1 | 48p |
| AB13 | 6 | 4 | 2 | 88p |
| AB14 | 7 | 5 | 2 1/2 | 84p |
| AB15 | 8 | 6 | 3 | 88p |
| AB16 | 10 | 7 | 3 | 81-25 |
| AB17 | 10 | 4 1/2 | 3 | 81-00 |
| AB18 | 12 | 5 | 3 | 81-00 |
| AB19 | 12 | 8 | 3 | 81-50 |

All sizes are approx and in inches.
Plus 8% VAT

MINI LOUDSPEAKERS

2 1/2" 80 ohm 60p
2 1/2" 40 ohm 60p
2 1/2" 8 ohm 60p
+ 25%

I.C. SOCKETS +8%

D.I.L.
8 pin—18p 24 pin—84p
14 pin—18p 28 pin—88p
16 pin—14p 36 pin—88p

U.K. CARR. 50p unless otherwise stated

All prices are excluding VAT. Please add to each item the VAT rate indicated to all orders

EVERYDAY ELECTRONICS Easybuild DIGITAL CLOCK

We are offering kits for this attractive clock, featured in January E.E., at special prices. Anyone with a little experience of soldering should be able to build a fully working clock.

No moving parts—4 digit 0.5" green display—flashing or fixed colon—12 or 24 hour display—slim attractive white case—full instructions included.

COMPLETE EE CLOCK KIT £15.70

All components necessary except mains lead and plug to complete fully working clock: AY51202 clock IC, 5LTO1, display, PCB, miniature transformer, resistors, capacitors, diodes, switches, verocase, green perspex panel, nuts, screws, washers, wire, grommet.

Complete kit as above, but with lead and plug **£16.20**

EE CLOCK MODULE KIT £12.04

This kit comprises all components as in the clock kit except verocase, perspex panel, nuts, screws, washers, wire, grommet, mains lead and plug.

AVAILABLE SEPERATELY AY51202 **£4.76**

5LTO1 Transformer **£1.80** 5LTO1 **£5.80**

Verocase J and green perspex **£2.94** PCB **£1.40**

P & P FREE—ADD VAT (now 8%)
to ALL PRICES ABOVE

SINTEL

53E Aston Street, Oxford. Tel. 0865 49791

tainments for potential I-Chingo players, their scientists have come up with a far more worrying alternative to the TV programmes. It is a cheap mass-produced electronic substitute for the street corner propagandist."

BUGS.

"The human fanatics whom Bob thought might be sent, have been substituted by a kind of converted insect. So that instead of some odd fanatic who sticks a piece of paper in one's hand and asks for a contribution—we have a kind of electronic bug who hovers in

front of one and erects an electronically boosted series of telepathic images.

Whereas, although the human fanatic can be quite persistent, one can always throw away the paper, with these mysterious 'propaganda bugs' things are quite different. Whichever way the victim turns, the illusion persists! People took to swatting at the 'propaganda bug' which worked fine with the Mk I. Then along came the Mk II which is concealed behind its own projected image, and it needs a lot of determined practice with the aid of a mirror to swat one of

these accurately so naturally a lot of people give up and go!"

Now Bob secretly determined to keep an empty matchbox in his pocket so that, should propaganda bugs reach this country, he might capture one. But he also had another idea. "Maybe we could invent an alternative to I-Chingo maybe not one big game, but a whole lot of little electronic games instead!" he suggested.

Sir Rockwell observed that the Prof. appeared deep in thought, and it seemed likely that he too had something up his sleeve.

Next month: back to the lab?

EE Kit Report

sinclair

BLACK WATCH

AFTER passing last month's issue we discovered that the Black Watch kit we constructed had an odd fault. As we mentioned last month we found that wearing the watch in bed was not on because one tended to turn on the display by lying on the watch, thus quickly flattening the batteries. Because of this the watch was left on the dressing table overnight and it was found that in three consecutive nights it had gained up to 1½ hours overnight—it kept perfect time for about 16 hours during the day.

Naturally we contacted Sinclair and found that they had experienced this fault before. Their explanation is as follows:

"The i.c. has a working temperature, specified by the manufacturer, of minus 10 degrees C to +60 degrees C. We initially checked low temperature performance with a correlated room temperature functional test but, as you have found, a few devices would pass this test and still miscount in some way, at low temperature. As a result we now 100 per cent functionally test at low temperature on incoming inspection, eliminating the problem you have suffered."

This obviously means that no new watches should suffer the same fault. Sinclair sent us a replacement i.c. which we tried to fit to the watch. We say tried because it was found to be difficult to remove the old i.c. without a special tool. Also, having replaced the i.c., we found that the flexible p.c.b. would not stand up to resoldering and could not be stuck to the i.c.

without the use of some double sided Sellotape.

One of the most important things learnt from this exercise is not to try to repair the watch or change any of the components once it is finally constructed. If it does not function correctly send it back to Sinclair. If it is the construction at fault you will have to pay the £3.50 fee, if it is due to faulty components Sinclair will repair it free of charge.

Having come unstuck with the repair we returned the watch and were provided with another for our final evaluation. This does not suffer from the fault on the other watch and has now been functioning correctly for about three weeks.

The replacement watch has spent two nights in the 'fridge without any alteration of time-keeping, which is within ½ second a day. The new watch carries the copper screen mentioned last month and this has been painted black where it comes under the viewing area. This makes it virtually invisible when the watch is completed.

It is interesting to note that in our last issue the price of the Black Watch kit was dropped to £14.95 making a big saving over the complete watch. One wonders how much more the price of the kit and the complete watch will drop before the end of the year—perhaps as low as £5! If this does happen we feel the kit will be short lived, since it would not be worth constructing one's own.

DOWN TO EARTH

By GEORGE HYLTON

A READER in Scotland, Simon Little of Newport-on-Tay, has been having trouble with a "telephone amplifier"—a gadget for amplifying the sound from a telephone so that you can listen to it through a loudspeaker.

The Post Office has strict rules about connecting things to its telephones. To get round them, many of these telephone amplifiers pick up the audio signals indirectly.

A coil of some sort is placed on or near the telephone. It responds to the magnetic field of a coil or transformer which is inside the instrument. Speech signals produce audio-frequency variations in field strength and these induce a small voltage in the pickup coil.

In the present case the pickup coil is a ferrite rod aerial. It picks up, not the telephone conversation, but a radio station! Why?

Well, as regular readers of *Down To Earth* will realise, there's nothing very surprising about this behaviour. A ferrite rod with a winding on it will respond to any changing magnetic field, whether audio-frequency or radio-frequency.

SUPPRESSION

What can be done to suppress this radio interference? Several possible tactics suggest themselves.

First, it might be possible to make use of the directional characteristic of the ferrite rod. If the rod is either pointed at the transmitter or placed vertically, pickup of signals is minimised.

Secondly, it might be possible to reduce the effect of the r.f. pickup by tuning the aerial to a different frequency. My guess is that the rod is at present tuned by the stray capacitance (C_s) in the circuit (i.e. capacitance between wires, etc) to something near the frequency of a local medium wave station. Adding to C_s a relatively large capacitance (1nF to 10nF), see Fig. 1, should

greatly reduce the tuned frequency and shift it out of the m.w. band. (I'm assuming that the inductance of the winding is at least a few millihenries. One fault, a short-circuit between different turns, could reduce the inductance considerably.)

Thirdly, use can be made of the fact that the amount of pickup obtained from the telephone increases sharply as the coil is brought closer. It also increases if the pickup coil is correctly orientated with respect to the coil inside the instrument. (Since you can't see inside you have to try different orientations to find the best one.)

ELECTROMAGNETIC INDUCTION

This question draws attention to the effect known as electromagnetic induction. This is one of the basic properties of electric circuits, and therefore one which is used a lot in electronics, so let's take a look at it.

The pioneering discovery, made by the Dane, Oersted, in the early years of the 19th century, was that a conductor passing current creates a magnetic field round itself. Oersted showed this by lining up a wire beneath a small compass, so that the wire ran north to south, parallel with the compass needle. When the current was switched on, the needle was deflected.

The direction in which the needle was deflected (i.e. eastwards or westwards) depended on the direction of the current, and also on whether the needle

was above or below the wire.

This led to the development of the current-measuring instrument shown in Fig. 2. The compass needle is placed in the centre of a coil of wire, which can have many turns. The magnetic fields round all the different turns reinforce one another and the needle is deflected more strongly.

Fig. 2. Instrument for current measurement

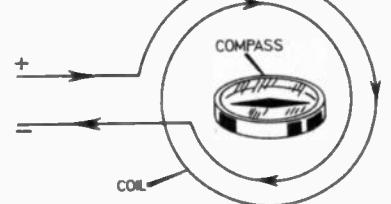

This gadget, called a tangent galvanometer, was used in school physics laboratories when I was a lad, and for all I know it still is. Compared with modern instruments it is insensitive, clumsy, and has a non-linear scale. But it works.

PARALLEL COILS

If a second galvanometer is placed close to the first one, with their coils parallel, the magnetic field of the first one reaches the coil of the second. Does current flow in the second coil? Not at the moment, because there's no circuit for it—the second coil is "open"—its terminals aren't connected to anything. But if you connect them together, so that current can flow round and round the coil, something does happen.

When the current in the first coil is switched on, the compass needle in the second one gives a slight kick. When it's switched off, it gives another kick. Between times, when the current is steady, the second compass needle is just moved slightly, as you would expect because it's near enough to the energised coil to feel some influence from the magnetic field.

Why the kicks on switching the current? Faraday showed that they are caused because a voltage is induced in the second coil, and drives a current round it. This happens only when the magnetic field is changing, not when it's steady.

From these discoveries stem the art of making electrical generators, transformers, and gadgets like the telephone pickup coil.

Fig. 1. Stray capacitance in the circuit.

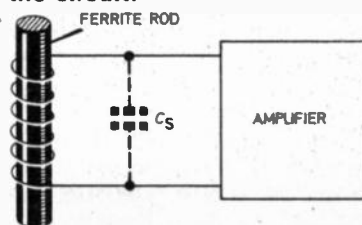

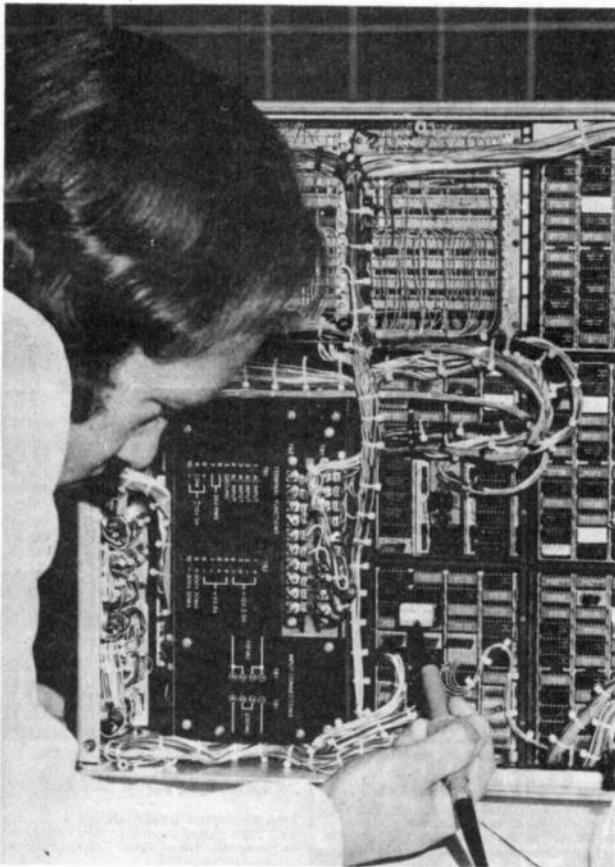

This hobby brings big rewards.

A soldering iron and a screwdriver. If you know how to use them, or at least know one end from the other, you know enough to enrol in our unique home electronics course.

This new style course will enable anyone to have a real understanding of electronics by a modern, practical and visual method. No previous knowledge is required, no maths, and an absolute minimum of theory.

You build, see and learn as, step by step, we take you through all the fundamentals of electronics and show you how easily the subject can be mastered and add a new dimension not only to your hobby but also to your earning capacity.

All the training can be carried out in the comfort of your own home and at your own pace. A tutor is available to whom you can write, at any time, for advice or help during your work. A Certificate is given at the end of every course.

1

Build an oscilloscope.

As the first stage of your training, you actually build your own Cathode ray oscilloscope! This is no toy, but a test instrument that you will need not only for the course's practical experiments, but also later if you decide to develop your knowledge and enter the profession. It remains your property and represents a very large saving over buying a similar piece of essential equipment

2

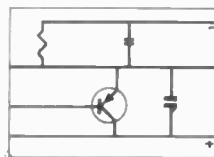

Read, draw and understand circuit diagrams.

In a short time you will be able to read and draw circuit diagrams, understand the very fundamentals of television, radio, computers and countless other electronic devices and their servicing procedures.

3



Carry out over 40 experiments on basic circuits.

We show you how to conduct experiments on a wide variety of different circuits and turn the information gained into a working knowledge of testing, servicing and maintaining all types of electronic equipment, radio, t.v. etc

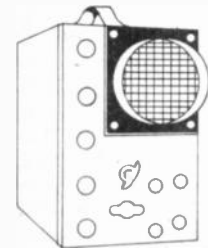

PLUS FREE GIFT!

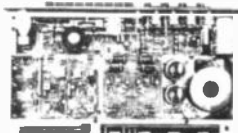

ALL STUDENTS ENROLLING IN OUR COURSES RECEIVE A FREE CIRCUIT BOARD ORIGINATING FROM A COMPUTER AND CONTAINING MANY DIFFERENT COMPONENTS THAT CAN BE USED IN EXPERIMENTS AND PROVIDE AN EXCELLENT EXAMPLE OF CURRENT ELECTRONIC PRACTICE

To find out more about how to learn electronics in a new, exciting and absorbing way, just clip the coupon for a free colour brochure and full details of enrolment.

Brochure without obligation to:
BRITISH NATIONAL RADIO EEL 46
& ELECTRONICS SCHOOL, Dept
P.O. Box 156, Jersey, Channel Islands.

NAME _____

ADDRESS _____

(Block caps please)

SEMICONDUCTORS

TRANSISTORS

BRAND NEW FULLY GUARANTEED

| Type | Price | Type | Price | Type | Price | Type | Price | Type | Price | Type | Price | Type | Price | Type | Price | Type | Price | Type | Price |
|------------|-------|--------|-------|--------|-------|-------|-------|-------|-------|---------|-------|--------|-------|---------|-------|---------|-------|--------|-------|
| AC107 | *0.20 | AD1140 | *0.51 | BC148 | *0.10 | BC225 | *0.26 | BD199 | *0.98 | BSY28 | *0.10 | OC82 | *0.10 | 2N1303 | *0.15 | 2N2906A | | 2N3705 | *0.12 |
| AC113 | *0.10 | AF114 | *0.25 | BC149 | *0.12 | BC226 | *0.38 | BD200 | *0.98 | BSY29 | *0.10 | OC82D | *0.10 | 2N1304 | *0.18 | | *0.10 | 2N3706 | *0.12 |
| AC115 | *0.20 | AF115 | *0.25 | BC150 | *0.10 | BC301 | *0.26 | BD205 | *0.81 | BSY38 | *0.10 | OC83 | *0.20 | 2N1305 | *0.18 | 2N2907 | *0.20 | 2N3707 | *0.13 |
| AC117K | *0.36 | AF116 | *0.25 | BC151 | *0.20 | BC302 | *0.25 | BD206 | *0.81 | BSY39 | *0.10 | OC139 | *0.20 | 2N1306 | *0.21 | 2N2907A | | 2N3708 | *0.06 |
| AC122 | *0.12 | AF117 | *0.25 | BC152 | *0.18 | BC303 | *0.25 | BD207 | *0.80 | BSY40 | *0.20 | OC140 | *0.20 | 2N1307 | *0.21 | | *0.22 | 2N3709 | *0.09 |
| AC125 | *0.10 | AF118 | *0.36 | BC153 | *0.20 | BC304 | *0.37 | BD208 | *0.98 | BSY41 | *0.20 | OC169 | *0.20 | 2N1308 | *0.24 | 2N2923 | *0.15 | 2N3710 | *0.09 |
| AC126 | *0.30 | AF124 | *0.31 | BC154 | *0.21 | BC440 | *0.31 | BDY20 | *1.82 | BSY95 | *0.13 | OC170 | *0.26 | 2N1309 | *0.24 | 2N2924 | *0.15 | 2N3711 | *0.09 |
| AC127 | *0.10 | AF125 | *0.31 | BC157 | *0.10 | BC400 | *0.37 | BF115 | *0.25 | BSY95A | *0.13 | OC171 | *0.20 | 2N1613 | *0.20 | 2N2925 | *0.15 | 2N3819 | *0.29 |
| AC128 | *0.10 | AF126 | *0.20 | BC158 | *0.12 | BD115 | *0.63 | BF117 | *0.46 | BU105 | *2.04 | OC200 | *0.26 | 2N1711 | *0.20 | 2N2926 | *0.13 | 2N3820 | *0.51 |
| AC132 | *0.15 | AF127 | *0.20 | BC159 | *0.12 | BD116 | *0.81 | BF118 | *0.71 | MJE521 | *0.56 | OC201 | *0.20 | 2N1712 | *0.20 | 2N2927 | *0.11 | 2N3823 | *0.29 |
| AC134 | *0.15 | AF139 | *0.31 | BC160 | *0.46 | BD121 | *0.61 | BF119 | *0.71 | MJE2955 | *0.88 | OC202 | *0.20 | 2N2218 | *0.20 | 2N2928 | *0.10 | 2N3903 | *0.20 |
| AC137 | *0.15 | AF178 | *0.51 | BC161 | *0.51 | BD123 | *0.67 | BF121 | *0.46 | MJE3055 | *0.57 | OC203 | *0.26 | 2N2219 | *0.20 | 2N2929 | *0.10 | 2N3904 | *0.31 |
| AC141 | *0.19 | AF179 | *0.51 | BC167 | *0.12 | BD124 | *0.70 | BF123 | *0.51 | MJE3440 | *0.51 | OC204 | *0.20 | 2N2220 | *0.22 | 2N3053 | *0.18 | 2N3905 | *0.20 |
| AC141K | *0.30 | AF180 | *0.51 | BC168 | *0.12 | BD131 | *0.51 | BF125 | *0.51 | MPP102 | *0.43 | OC205 | *0.36 | 2N2221 | *0.20 | 2N3054 | *0.47 | 2N3906 | *0.28 |
| AC142 | *0.10 | AF181 | *0.51 | BC169 | *0.12 | BD132 | *0.51 | BF127 | *0.46 | MPP104 | *0.38 | OC206 | *0.31 | 2N2222 | *0.20 | 2N3055 | *0.47 | 2N4287 | *0.18 |
| AC142K | *0.26 | AF186 | *0.51 | BC170 | *0.10 | BD133 | *0.67 | BF152 | *0.56 | MPP105 | *0.38 | OC207 | *0.44 | 2N2223 | *0.20 | 2N3056 | *0.42 | 2N4288 | *0.18 |
| AC176 | *0.20 | AF239 | *0.38 | BC171 | *0.10 | BD135 | *0.41 | BF153 | *0.46 | OC19 | *0.38 | ORP12 | *0.60 | 2N2224 | *0.20 | 2N3402 | *0.20 | 2N4289 | *0.18 |
| AC180 | *0.26 | AL102 | *0.60 | BC172 | *0.10 | BD136 | *0.41 | BF154 | *0.46 | OC20 | *0.85 | ORP60 | *0.60 | 2N2225 | *0.20 | 2N3403 | *0.29 | 2N4290 | *0.18 |
| AC180K | *0.30 | AL103 | *0.60 | BC173 | *0.15 | BD137 | *0.46 | BF155 | *0.71 | OC21 | *0.49 | ORP71 | *0.60 | 2N2226 | *0.20 | 2N3404 | *0.29 | 2N4291 | *0.18 |
| AC181 | *0.20 | BC107 | *0.60 | BC174 | *0.15 | BD138 | *0.46 | BF156 | *0.71 | OC22 | *0.47 | TIP20 | *0.44 | 2N2227 | *0.20 | 2N3405 | *0.43 | 2N4292 | *0.18 |
| AC181K | *0.30 | BC108 | *0.60 | BC175 | *0.35 | BD139 | *0.58 | BF157 | *0.56 | OC23 | *0.49 | TIP30 | *0.52 | 2N2228 | *0.20 | 2N3525 | *0.77 | 2N4293 | *0.18 |
| AC187 | *0.22 | BC109 | *0.60 | BC177 | *0.10 | BD140 | *0.46 | BF158 | *0.56 | OC25 | *0.57 | TIP31A | *0.58 | 2N2904 | *0.10 | 2N3614 | *0.69 | 2N4293 | *0.18 |
| AC187K | *0.23 | BC113 | *0.10 | BC178 | *0.10 | BD155 | *0.81 | BF159 | *0.51 | OC26 | *0.30 | TIP32A | *0.60 | 2N2904A | | 2N3615 | *0.76 | 2N5172 | *0.12 |
| AC188 | *0.22 | BC114 | *0.10 | BC179 | *0.10 | BD175 | *0.61 | BF173 | *0.22 | OC28 | *0.51 | TIP41A | *0.60 | | *0.21 | 2N3616 | *0.76 | 2N5172 | *0.32 |
| AC188K | *0.23 | BC115 | *0.10 | BC180 | *0.25 | BD176 | *0.61 | BF176 | *0.36 | OC29 | *0.51 | TIP42A | *0.31 | 2N2905 | *0.21 | 2N3646 | *0.69 | 2N5458 | *0.32 |
| AC197 | *0.26 | BC116 | *0.10 | BC181 | *0.25 | BD177 | *0.67 | BF179 | *0.31 | OC35 | *0.43 | TIS43 | *0.31 | 2N2905A | | 2N3702 | *0.12 | 2N5459 | *0.41 |
| AC198 | *0.24 | BC117 | *0.10 | BC182 | *0.15 | BD178 | *0.67 | BF180 | *0.31 | OC36 | *0.51 | UT46 | *0.20 | | *0.21 | 2N3703 | *0.12 | 40381 | *0.41 |
| AC199 | *0.24 | BC118 | *0.10 | BC182L | *0.15 | BD179 | *0.71 | BF181 | *0.31 | OC41 | *0.20 | ZN414 | *1.11 | 2N2906 | *0.18 | 2N3704 | *0.13 | 40382 | *0.51 |
| AC200 | *0.24 | BC119 | *0.10 | BC183 | *0.15 | BD180 | *0.71 | BF184 | *0.12 | OC42 | *0.25 | 2N696 | *0.13 | | | | | | |
| AC201 | *0.24 | BC120 | *0.31 | BC183L | *0.15 | BD185 | *0.87 | BF195 | *0.12 | OC44 | *0.18 | 2N697 | *0.14 | | | | | | |
| AC222 | *0.24 | BC129 | *0.81 | BC184 | *0.20 | BD186 | *0.87 | BF196 | *0.15 | OC45 | *0.13 | 2N698 | *0.25 | | | | | | |
| AD140 | *0.40 | BC137 | *0.16 | BC184L | *0.20 | BD187 | *0.71 | BF197 | *0.15 | OC70 | *0.15 | 2N699 | *0.38 | | | | | | |
| AD142 | *0.40 | BC139 | *0.41 | BC187 | *0.20 | BD188 | *0.71 | BF257 | *0.40 | OC71 | *0.15 | 2N706 | *0.11 | | | | | | |
| AD143 | *0.30 | BC140 | *0.31 | BC207 | *0.11 | BD189 | *0.77 | BF258 | *0.61 | OC72 | *0.15 | 2N706A | *0.12 | | | | | | |
| AD149 | *0.51 | BC141 | *0.31 | BC208 | *0.11 | BD190 | *0.77 | BF259 | *0.18 | OC74 | *0.15 | 2N708 | *0.14 | | | | | | |
| AD161 | *0.36 | BC142 | *0.31 | BC209 | *0.12 | BD195 | *0.87 | BSX19 | *0.18 | OC75 | *0.18 | 2N914 | *0.15 | | | | | | |
| AD162 | *0.36 | BC143 | *0.31 | BC212L | *0.13 | BD196 | *0.87 | BSX20 | *0.10 | OC76 | *0.18 | 2N918 | *0.31 | | | | | | |
| AD161A | | BC145 | *0.46 | BC213L | *0.13 | BD197 | *0.92 | BSY25 | *0.10 | OC77 | *0.26 | 2N1131 | *0.20 | | | | | | |
| AD162 (MP) | *0.69 | BC147 | *0.10 | BC214L | *0.17 | BD198 | *0.92 | BSY26 | *0.18 | OC81 | *0.18 | 2N1132 | *0.22 | | | | | | |
| | | | | | | | | BSY27 | *0.10 | OC81D | *0.18 | 2N1302 | *0.15 | | | | | | |

VAT CHAT

Please add 8% to prices marked *. Remainder add 25%. Do not add VAT to prices marked +.

SUPER UNTESTED PAKS

| Pak No. | Description | Price |
|---------|--|--------|
| U 1 | 120 Glass Sub-min. General purpose Germ. diodes | *0.60 |
| U 4 | 30 Germanium transistors like OC81, AC128 | *0.60 |
| U 5 | 60 200mA Sub-min. silicon diodes | *0.60 |
| U11 | 20 PNP Sil. planar trans. TO-5 like 2N1132, 2N2904 | *0.60 |
| U15 | 20 NPN Sil. planar trans. TO-5 like 2N696, 2N697 | *0.60 |
| U19 | 20 Silicon NPN transistors like BC108 | *0.60 |
| U26 | 30 Fast switching silicon diodes like 1N914 Micro-Min. | *0.50 |
| U29 | 10 1 Amp SCR's TO-5 can. up to 600 CRS/25-600 | *£1.20 |
| U32 | 25 Zener diodes 400mW DO-7 case 3-33 volts mixed | *0.60 |
| U36 | 20 Silicon planar NPN transistors TO-5 BFY50/51/52 | *£1.20 |
| U45 | 7 3A SCR. TO56 up to 800 PIV | *0.60 |
| U46 | 20 Unijunction transistors similar to TIS43 | *0.60 |
| U48 | 9 NPN Sil. power transistors like 2N3055 | *£1.20 |

Code No's mentioned above are given as a guide to the type of device in the Pak. The devices themselves are normally unmarked.

DIODES

| Type | Price | Type | Price | Type | Price | Type | Price |
|-------|-------|---------|-------|------|-------|--------|-------|
| BA100 | *0.10 | BB104 | *0.15 | OA10 | *0.14 | OA91 | *0.87 |
| BA118 | *0.21 | BY100 | *0.10 | OA47 | *0.07 | OA93 | *0.87 |
| BA126 | *0.22 | BY125 | *0.15 | OA70 | *0.07 | OA200 | *0.07 |
| BA148 | *0.15 | BY127 | *0.10 | OA79 | *0.07 | OA202 | *0.07 |
| BA154 | *0.12 | BY128 | *0.16 | OA81 | *0.07 | 1N914 | *0.06 |
| BA156 | *0.14 | BY164 | *0.51 | OA85 | *0.09 | 1N916 | *0.06 |
| BA173 | *0.15 | BYX3830 | *0.43 | OA90 | *0.07 | 1N4148 | *0.06 |

THYRISTORS

| PIV | 0-8A | 0-8A | 1A | 3A | 5A | 5A | 7A | 10A | 16A | 30A |
|-----|-------|-------|-------|-------|-------|-------|-------|-------|-------|-------|
| 10 | TO18 | TO92 | TO5 | TO66 | TO66 | TO64 | TO48 | TO48 | TO48 | TO48 |
| 20 | *0.13 | *0.15 | — | — | — | — | — | — | — | — |
| 30 | *0.15 | *0.18 | — | — | — | — | — | — | — | — |
| 50 | *0.19 | *0.22 | *0.20 | *0.25 | *0.34 | *0.34 | *0.48 | *0.51 | *0.54 | *1.18 |
| 100 | *0.25 | *0.28 | *0.25 | *0.25 | *0.48 | *0.48 | *0.51 | *0.57 | *0.58 | *1.43 |
| 150 | *0.31 | *0.38 | — | — | — | — | — | — | — | — |
| 200 | *0.38 | *0.44 | *0.25 | *0.30 | *0.50 | *0.50 | *0.57 | *0.62 | *0.62 | *1.63 |
| 400 | — | — | *0.30 | *0.39 | *0.55 | *0.57 | *0.62 | *0.71 | *0.77 | *1.79 |
| 600 | — | — | *0.39 | *0.48 | *0.69 | *0.69 | *0.70 | *0.99 | *0.90 | — |
| 800 | — | — | *0.58 | *0.65 | *0.81 | *0.81 | *0.92 | *1.22 | *1.39 | *4.87 |

SILICON RECTIFIERS

| PIV | 300mA (DO 7) | 750mA (SO 16) | 1 Amp Plastic (SO 10) | 1.5 Amp Plastic (SO 10) | 3 Amp (SO 10) | 10 Amp (SO 10) | 30 Amp (TO 18) |
|------|--------------|---------------|-----------------------|-------------------------|---------------|----------------|----------------|
| 50 | *0.05 | *0.06 | IN4001 | *0.05 | *0.07 | *0.14 | *0.19 |
| 100 | *0.05 | *0.07 | IN4002 | *0.06 | *0.09 | *0.18 | *0.21 |
| 200 | *0.06 | *0.08 | IN4003 | *0.07 | *0.12 | *0.20 | *0.23 |
| 400 | *0.07 | *0.14 | IN4004 | *0.08 | *0.14 | *0.28 | *0.35 |
| 600 | *0.08 | *0.10 | IN4005 | *0.09 | *0.16 | *0.33 | *0.42 |
| 800 | *0.11 | *0.18 | IN4006 | *0.10 | *0.18 | *0.35 | *0.51 |
| 1000 | *0.13 | *0.28 | IN4007 | *0.11 | *0.23 | *0.44 | *0.60 |
| 1200 | — | *0.32 | — | — | *0.28 | *0.54 | *0.88 |

SIL. G.P. DIODES

300mW 400 PIV (min) SUB-MIN FULLY TESTED
Ideal for Organ builders
30 for *50p, 100 for *£1.50, 500 for *£5, 1,000 for *£9.

TRIACS

| Case | 100V | 200V | 400V | |
|--------|------|-------|-------|-------|
| 2 Amp | TO5 | *0.31 | *0.51 | *0.71 |
| 6 Amp | TO66 | *0.51 | *0.81 | *0.77 |
| 10 Amp | TO48 | *0.77 | *0.92 | *1.12 |

GP300

115 WATT SILICON TO3 METAL CASE
Vcco 100V. Vcco 60V, IC 15A, Hfe, 20-100 suitable replacement for 2N3055, B0Y11 or BDY20
1-24 *50p 25-99 *80p 100+ *48p

GP Switching Trans

TO18 SIM. TO 2N706/8 BSY27/28/95A
All usable devices. No open and shorts. ALSO AVAILABLE IN PNP similar to 2N2906, BCY70. 20 for *50p, 50 for *£1, 100 for *£1.80, 500 for *£8, 1,000 for *£14.
When ordering please state NPN or PNP

WORLD SCOOP!!

JUMBO SEMICONDUCTOR PAK
Transistors-Germ. and Silicon.
Rectifiers-Diodes Triacs-Thyristors-I.C.'s and Zeners. ALL NEW AND CODED
Approx. 100 pieces only *1.85p

ZENER DIODES

FULL RANGE IN STOCK, 2-33 Volts
400mW 8p 1-5W 17p 10W *30p

HANDBOOKS

TRANSISTOR DATA BOOK
DTE 1 227 Pages packed with information on European Transistors. Full specification including outlines. Price £2.95 each

TRANSISTOR EQUIVALENT BOOK
BPE 75 256 Pages of cross references and equivalents for European, American and Japanese Transistors. This is the most comprehensive equivalents book on the market today and has an introduction in 13 languages. Price £2.88 each

DIODE EQUIVALENT BOOK
DE 74 144 Pages of cross references and equivalents for European, American and Japanese diodes, Zeners, Thyristors, Triacs, Diacs and L.E.D.'s. Price £1.98 each

THE WORLD'S BROADCASTING STATIONS
WBS 75 An up to the minute guide for those interested in DX-ing. Contains all the world's broadcasters on SW, MW and LW, as well as European FM/TV stations. Price £3

SEMI-CONDUCTORS

Linear IC's

| Type | Quantities | Type | Quantities | Type | Quantities |
|--------|----------------|---------|-------------------|--------|-------------------|
| | 1 25 100+ | | 1 25 100+ | | 1 25 100+ |
| 72702 | 0-46 0-44 0-42 | SL701C | 0-46 0-42 0-37 | 76003 | £1-39 £1-34 £1-30 |
| 72709 | 0-23 0-21 0-19 | SL702C | 0-46 0-42 0-37 | 76023 | £1-39 £1-34 £1-30 |
| 72709P | 0-19 0-18 0-17 | TA A263 | 0-74 0-65 0-56 | 76660 | 0-88 0-88 0-83 |
| 72710 | 0-32 0-31 0-28 | TA A293 | 0-83 0-88 0-83 | LM380 | 0-93 0-90 0-88 |
| 72741 | 0-28 0-27 0-26 | TA A350 | £1-71 £1-67 £1-57 | *NE555 | 0-45 0-43 0-40 |
| 72741C | 0-26 0-25 0-24 | µA703C | 0-26 0-24 0-22 | *NE556 | 0-88 0-86 0-83 |
| 72741P | 0-28 0-27 0-26 | µA709C | 0-19 0-18 0-17 | TBA800 | £1-39 £1-34 £1-30 |
| 72747 | 0-79 0-74 0-61 | µA711C | 0-32 0-31 0-28 | ZN414 | £1-11 - - |
| 72748P | 0-35 0-33 0-31 | µA712C | 0-32 0-31 0-28 | | |
| SL201C | 0-46 0-42 0-37 | µA723C | 0-45 0-43 0-40 | | |

★ 74 Series TTL IC's

BI-PAK STILL LOWEST IN PRICE. FULL SPECIFICATION GUARANTEED. ALL FAMOUS MANUFACTURERS

| Type | Quantities | Type | Quantities | Type | Quantities |
|------|-------------------|-------|-------------------|-------|-------------------|
| | 1 25 100+ | | 1 25 100+ | | 1 25 100+ |
| 7400 | 0-10 0-09 0-08 | 7448 | 0-87 0-86 0-85 | 74122 | 0-52 0-51 0-50 |
| 7401 | 0-13 0-12 0-11 | 7450 | 0-13 0-12 0-11 | 74141 | 0-78 0-77 0-75 |
| 7402 | 0-17 0-16 0-15 | 7451 | 0-13 0-12 0-11 | 74145 | 0-88 0-84 0-81 |
| 7403 | 0-13 0-12 0-11 | 7453 | 0-13 0-12 0-11 | 74150 | £1-37 £1-30 £1-20 |
| 7404 | 0-12 0-12 0-11 | 7454 | 0-13 0-12 0-11 | 74151 | 0-82 0-78 0-75 |
| 7405 | 0-12 0-12 0-11 | 7460 | 0-13 0-12 0-11 | 74153 | 0-82 0-78 0-75 |
| 7406 | 0-31 0-29 0-27 | 7470 | 0-30 0-27 0-25 | 74154 | £1-57 £1-43 £1-48 |
| 7407 | 0-31 0-29 0-27 | 7472 | 0-30 0-27 0-25 | 74155 | 0-82 0-78 0-75 |
| 7408 | 0-17 0-15 0-13 | 7473 | 0-32 0-30 0-28 | 74156 | 0-82 0-78 0-75 |
| 7409 | 0-17 0-16 0-15 | 7474 | 0-34 0-31 0-29 | 74157 | 0-93 0-88 0-83 |
| 7410 | 0-10 0-09 0-08 | 7475 | 0-52 0-50 0-48 | 74160 | £1-19 £1-12 £1-06 |
| 7411 | 0-23 0-22 0-21 | 7476 | 0-35 0-33 0-31 | 74161 | £1-19 £1-12 £1-06 |
| 7412 | 0-25 0-24 0-23 | 7480 | 0-50 0-47 0-44 | 74162 | £1-19 £1-12 £1-06 |
| 7413 | 0-30 0-29 0-28 | 7481 | £1-02 0-97 0-93 | 74163 | £1-19 £1-12 £1-06 |
| 7416 | 0-28 0-27 0-26 | 7482 | 0-83 0-79 0-74 | 74164 | £1-37 £1-25 £1-19 |
| 7417 | 0-28 0-27 0-26 | 7483 | £1-00 0-92 0-85 | 74165 | £1-37 £1-25 £1-19 |
| 7420 | 0-12 0-12 0-11 | 7484 | 0-83 0-80 0-88 | 74166 | £1-48 £1-37 £1-25 |
| 7422 | 0-28 0-27 0-26 | 7485 | £1-25 £1-19 £1-12 | 74174 | £1-25 £1-19 £1-12 |
| 7423 | 0-32 0-31 0-30 | 7486 | 0-32 0-31 0-30 | 74175 | £1-02 0-97 0-93 |
| 7425 | 0-32 0-31 0-30 | 7489 | £3-12 £2-81 £2-56 | 74176 | £1-16 £1-11 £1-06 |
| 7426 | 0-32 0-31 0-30 | 7490 | 0-48 0-44 0-48 | 74177 | £1-16 £1-11 £1-06 |
| 7427 | 0-32 0-31 0-30 | 7491 | 0-75 0-69 0-62 | 74180 | £1-16 £1-11 £1-06 |
| 7428 | 0-42 0-39 0-37 | 7492 | 0-54 0-49 0-44 | 74181 | £2-50 £2-38 £2-25 |
| 7430 | 0-13 0-12 0-11 | 7493 | 0-48 0-44 0-48 | 74190 | £1-09 0-99 0-93 |
| 7432 | 0-31 0-30 0-29 | 7494 | 0-56 0-53 0-50 | 74184 | £1-67 £1-62 £1-55 |
| 7433 | 0-39 0-37 0-35 | 7495 | 0-72 0-67 0-62 | 74190 | £1-75 £1-63 £1-50 |
| 7437 | 0-31 0-30 0-29 | 7496 | 0-85 0-81 0-78 | 74191 | £1-37 £1-31 £1-25 |
| 7438 | 0-31 0-30 0-29 | 74100 | £1-25 £1-19 £1-13 | 74192 | £1-37 £1-31 £1-25 |
| 7440 | 0-13 0-12 0-11 | 74104 | 0-38 0-34 0-31 | 74193 | £1-37 £1-31 £1-25 |
| 7441 | 0-69 0-66 0-59 | 74105 | 0-38 0-34 0-31 | 74194 | £1-20 £1-16 £1-11 |
| 7442 | 0-69 0-66 0-59 | 74107 | 0-38 0-34 0-31 | 74195 | 0-94 0-91 0-88 |
| 7443 | £1-11 £1-06 £1-02 | 74100 | 0-56 0-51 0-46 | 74196 | £1-11 £1-06 £1-02 |
| 7444 | £1-11 £1-06 £1-02 | 74111 | 0-83 0-81 0-78 | 74197 | £1-11 £1-06 £1-02 |
| 7445 | 0-94 0-89 0-69 | 74118 | 0-93 0-88 0-83 | 74198 | £2-37 £2-31 £2-25 |
| 7446 | £1-06 £1-03 £1-00 | 74119 | £1-38 £1-30 £1-20 | 74199 | £2-25 £2-16 £2-11 |
| 7447 | 0-85 0-84 0-82 | 74121 | 0-34 0-33 0-31 | 74123 | 0-69 0-68 0-65 |

Devices may be mixed to qualify for quantity price. (TTL 74 series only). Data is available for the above series of I.C.'s in booklet form. PRICE 35p.

★ DTL 930 Series

| Type | Quantities | Type | Quantities | Type | Quantities |
|-------|----------------|-------|----------------|--------|----------------|
| | 1 25 100+ | | 1 25 100+ | | 1 25 100+ |
| BP930 | 0-14 0-13 0-13 | BP944 | 0-15 0-14 0-13 | BP962 | 0-14 0-13 0-12 |
| BP932 | 0-15 0-14 0-13 | BP945 | 0-28 0-26 0-23 | BP9083 | 0-42 0-40 0-38 |
| BP933 | 0-15 0-14 0-13 | BP946 | 0-14 0-13 0-12 | BP9094 | 0-42 0-40 0-38 |
| BP935 | 0-15 0-14 0-13 | BP948 | 0-28 0-26 0-23 | BP9097 | 0-42 0-40 0-38 |
| BP936 | 0-15 0-14 0-13 | BP951 | 0-65 0-60 0-56 | BP9099 | 0-42 0-40 0-38 |

★ DIL Sockets

| Type | Quantities |
|------------------------------|----------------|
| | 1 25 100+ |
| TSO14 14 pin type | 0-31 0-28 0-25 |
| TSO16 16 pin type | 0-35 0-32 0-30 |
| TSO24 24 pin type | 0-69 0-64 0-62 |
| BPS8 8 pin type (low cost) | 0-14 0-12 0-11 |
| BPS14 14 pin type (low cost) | 0-14 0-13 0-11 |
| BPS16 16 pin type (low cost) | 0-18 0-14 0-12 |

VAT
PLEASE ADD 8%
TO ITEMS
MARKED ★
REMAINDER
ADD 25%

★ Voltage Regulators

TO.3 Plastic Encapsulation
 µA.7805/L129 5V
 (equiv. to MVR5V) £1-25
 µA.7812/L130 12V
 (equiv. to MVR12V) £1-25
 µA.7815/L131 15V
 (equiv. to MVR15V) £1-25
 µA.7818 18V
 (equiv. to MVR18V) £1-25

Untested LIN Paks

Manufacturers "Fall Outs" which include Functional and part Functional Units. These are classified as "Out-of-spec" from the makers' very rigid specifications, but are ideal for learning about I.C.'s and experimental work.

| Pak No. | Contents | Price |
|---------|----------|-------|
| ULIC709 | 10 x 709 | 0-60 |
| ULIC710 | 7 x 710 | 0-60 |
| ULIC741 | 7 x 741 | 0-60 |
| ULIC747 | 5 x 747 | 0-60 |
| ULIC748 | 7 x 748 | 0-60 |

Mammoth IC Pak

APPROX. 200 PIECES
 Assorted fall-out integrated circuits, including: Logic, 74 series, Linear, Audio and D.T.L. Many coded devices but some unmarked—you to identify.

OUR SPECIAL PRICE £1-20*

P&P

Postage and Packing add 25p unless otherwise shown. Add extra for airmail. Minimum order £1.

★ Indicators

3015F Minltron 7 Segment Indicator £1-11

★ Untested TTL Paks

| Pak No. | Contents | Price | Pak No. | Contents | Price |
|---------|-----------|-------|--------------------|-----------|-------|
| UIC00 | 12 x 7400 | 0-60 | UIC70 | 8 x 7470 | 0-60 |
| UIC01 | 12 x 7401 | 0-60 | UIC72 | 8 x 7472 | 0-60 |
| UIC02 | 12 x 7402 | 0-60 | UIC73 | 8 x 7473 | 0-60 |
| UIC03 | 12 x 7403 | 0-60 | UIC74 | 8 x 7474 | 0-60 |
| UIC04 | 12 x 7404 | 0-60 | UIC75 | 8 x 7475 | 0-60 |
| UIC05 | 12 x 7405 | 0-60 | UIC76 | 8 x 7476 | 0-60 |
| UIC06 | 8 x 7406 | 0-60 | UIC80 | 5 x 7480 | 0-60 |
| UIC07 | 8 x 7407 | 0-60 | UIC81 | 5 x 7481 | 0-60 |
| UIC10 | 12 x 7410 | 0-60 | UIC82 | 5 x 7482 | 0-60 |
| UIC13 | 8 x 7413 | 0-60 | UIC83 | 5 x 7483 | 0-60 |
| UIC20 | 12 x 7420 | 0-60 | UIC86 | 5 x 7486 | 0-60 |
| UIC30 | 12 x 7430 | 0-60 | UIC90 | 5 x 7490 | 0-60 |
| UIC40 | 12 x 7440 | 0-60 | UIC91 | 5 x 7491 | 0-60 |
| UIC41 | 5 x 7441 | 0-60 | UIC92 | 5 x 7492 | 0-60 |
| UIC42 | 5 x 7442 | 0-60 | UIC93 | 5 x 7493 | 0-60 |
| UIC43 | 5 x 7443 | 0-60 | UIC94 | 5 x 7494 | 0-60 |
| UIC44 | 5 x 7444 | 0-60 | UIC95 | 5 x 7495 | 0-60 |
| UIC45 | 5 x 7445 | 0-60 | UIC96 | 5 x 7496 | 0-60 |
| UIC46 | 5 x 7446 | 0-60 | UIC100 | 5 x 74100 | 0-60 |
| UIC47 | 5 x 7447 | 0-60 | UIC121 | 5 x 74121 | 0-60 |
| UIC48 | 5 x 7448 | 0-60 | UIC141 | 5 x 74141 | 0-60 |
| UIC50 | 12 x 7450 | 0-60 | UIC151 | 5 x 74151 | 0-60 |
| UIC51 | 12 x 7451 | 0-60 | UIC154 | 5 x 74154 | 0-60 |
| UIC53 | 12 x 7453 | 0-60 | UIC193 | 5 x 74193 | 0-60 |
| UIC54 | 12 x 7454 | 0-60 | UIC199 | 5 x 74199 | 0-60 |
| UIC80 | 12 x 7460 | 0-60 | UIC XI 25 Assorted | | £1-50 |

BI-PAK

P.O. BOX 6, WARE · HERTS

Everyday Electronics Classified Advertisements

RATES: 12p per word (minimum 12 words). Box No. 35p. extra. Semi-display—£8.00 per single column inch. Advertisements must be prepaid and addressed to GMG Classified Advertisement Department, "EVERYDAY ELECTRONICS," I.P.C. Magazines Ltd., Room 2337, King's Reach Tower, Stamford Street, London. SE1 9LS. (01-261 5042)

RECEIVERS and COMPONENTS

POLYESTER CAPS C200-1 250V 4 for 5p
BURGALAR ALARM, BUZZER TYPE 1 1/2V 50p
ASSTD. CAPACITORS OR RESISTORS 250 p.p.t.
CRYSTAL MIKES & PLUG 50p, INSERTS 32p
MAINS TRANSFORMERS 6-0-6V 100 mA 50p
GPO TYPE SPEAKERS 20 OHM 1 1/2" DIA. 30p
LOUD 8V D.C. MOTOR DRIVEN SIRENS £1.25
REED SWITCHES LARGE/SMALL 10p
BAR MAGNETS 7p
8 OHM EARPHONES AND PLUG 10p
 Prices include VAT. Add 12p post. List send 5p

GRIMSBY ELECTRONICS
 64 Tennyson Road, Cleethorpes, Humberside
 100's of Bargains for Callers at our Lambert
 Road Component's Shop. (Open Saturdays).

COMPONENTS GALORE, pack of 500
 assorted radio, TV and electronic
 components a real bargain at a
 realistic price, send only £1.50 C.W.O.
 This applies only to United King-
 dom and Ireland. Overseas prices by
 arrangement. Caledonian Components,
 P. O. Box 3, Glenrothes, Fife, Scotland.

STEREO MAIN AMP. PANEL 2XBD605.
 2XBD605 or RCA equiv. 6 other trans. requires
 27V £2.25 (15p) circuit 20p. Not guaranteed.
BANK OF 25 NEONS 75p (15p) 3 Ass. M.C.
Motor. 3-41-50 (50p). T.V. CONVERGENCE
PANELS 2XAC128. 3 slugged coils, 3 slide
switches, 11 W.W. pots, 3 carbon presets, 2
ferrite chokes etc. £1.30p.p. TALKING PAGE
PANEL 2 pots, 12 silicon trans. and SCR. 8 nice
electrolytics 50p (15p). THREE TRANSISTOR
AUDIO AMP Trans. equiv. to AC128, OCT7
40p (10p) 3-41-50 (50p). COPPER CLAD PAX
PANELS 5 1/2 x 5 1/2 6-75p. 12 x 12" 75p. 12 1/2 x 9"
65p. 8 1/2 x 8 1/2 3-41-50. All C.P. 74 SERIES IC's
ON PANEL(S) 10-35p (10p). STABILISED
POWER SUPPLY PANEL 2 x 2N3702, 2 x AC153
Bridge rectifier 2 x 1050V and 1000, 250 MFD 35V
electrolytics 45p (10p). VALVAPAKS 10 Silicon
diodes 650V 1 1/2A on tagboard 50p (10p). 100 3/
MICA caps 55p (10p) 100 C250 polyester caps
£1 (15p) Lists 15p. Refund on purchase.
 400 Small Comps. Inc. Trans. £2.80 p.p.
 7lbs Assorted Components £2.80 p.p.

J. W. B. Radio, 2 Barnfield Crescent Sale
Cheeshire M33 1NL. Mail order only
 Postage in brackets

500 COMPONENTS. Resistors, Capacitors,
 Diodes, Transistors, Pots, Coils,
 etc. Identified, formed leads, fall-out,
 & surplus. Good value at £1.60. All
 inclusive. (UK postal rates only). CWO
 please to L. PENSENEY, E. Bankhead
 Farm, South Queensferry, West
 Lothian.

AERIAL WIRE, Hardware, Vero
 products. Resistors, 1/3W, 1/2W 5%,
 2-20-2.2M, 1p. Capacitors, all types,
 from 3p. Denco D.P. coils, 1-5 Green,
 74p; 1-55 B, Y, R, W, 69p; 6-7 B, Y,
 R, 60p. IFTs 13/14/15/16/17, 68p. Vat
 excluded. P&P, 20p. S.a.e. for full
 lists.—Cleveland Supplies (EE), PO
 Box 20, Redcar, Cleveland.

SERVICE SHEETS

SERVICE SHEETS for Radio, TV,
 Tape Recorders, Stereo, etc., with free
 fault-finding guide. 50p and SAE.
 Hamilton Radio, 47 Bohemia Road, St.
 Leonards, Sussex.

BELL'S TELEVISION SERVICES for
 service sheets, manuals & books on
 radio/TV etc. Service sheets 50p plus
 SAE. Service sheet catalogue 25p.
 Back issues of magazines from April
 74 onwards cover price plus 12p post.
 Free booklists on request. SAE with
 enquiries please to—B. T. S. 190,
 Kings Road, Harrogate, Yorkshire.
 Telephone Harrogate (Code 0425)
 55885.

EDUCATIONAL

TAPETALK

The NATURAL way to learn.
 New releases:—Two C80 cassettes entitled—
 'The Science of Soldering'
 £3.44 plus 55p VAT/P. & P.

TAPETALK, P.O. Box 96 (IE)
 Milton Keynes, MK3 8BR
 Tel: Milton Keynes (0906) 77710

Study for success with ICS. An
 ICS home study course will
 ensure that you pass your C. & G.
 exams. Special courses for Tele-
 coms. Technicians, Electrical
 Installations, Radio, TV and
 Electronics Technicians, Radio
 Amateurs.

Radio Amateurs
 Covers C. & G. Radio Amateurs
 Exam. Also Practical Radio
 courses with FREE construction
 kit.

Colour TV Servicing
 Learn the techniques of servicing
 Colour TV sets through new
 home study course approved by
 leading manufacturer. Covers
 principles, practice and alignment
 with numerous illustrations and
 diagrams. Other courses for
 Radio and Audio servicing.

Technical Training
 Courses include Electronic Techni-
 cians, Computer Technicians,
 Radio and Television Technicians
 and many more.

Write for full details TODAY stating subject
 of interest.

ICS School of Electronics
 Dept. 711R, Intertex
 House, London SW5 4UJ
 or phone 622 9911 (all
 hours).

TAPETALKS are the CLEVER way to LEARN.

THIS MONTH'S SPECIAL OFFER:—
 TWO C80 Cassettes entitled
 'INTRODUCING ELECTRONICS'
 will be sent to you by return of post for only £3.42
 plus 55p. VAT/P. Pkg.
TAPETALK, P.O. BOX 96 (IE)
 MILTON KEYNES MK3 8BR.
 Tel: Milton Keynes (0906) 77710.

FOR SALE

MICROPHONES: AKG D202E1, £45.00;
 AKG D190C or 'E' £20.00; AKG D224,
 £60.00; Sennheiser MD211N, £45.00. All
 brand new and boxed. Please add 25%
 for VAT. All other AKG and Senn-
 heiser mikes. SAE for quote to J. J.
 Francis (Wood Green), Ltd., Manwood
 House, Matching Green, Harlow, Essex.
 Tel: Matching 476.

VOLUMES one to four, Everyday Elec-
 tronics. Complete in binders. Offers.
 PHONE 051-653 7796.

EVERYDAY ELECTRONICS first issue
 November 1971 to June 1974, August
 1973 missing. Offers: MR. GARCIA, 11
 High Road, Halton, Lancaster, Lancs.

WANTED

ALL BACK NUMBERS of "Everyday
 Electronics". Mr. Hughes, Woodham
 Comprehensive School, Washington
 Crescent, Newton Aycliffe, County
 Durham.

MISCELLANEOUS

HOME SCIENTISTS

Get the key to a FANTASTIC WORLD of
 previously UNHEARD-OF-PROJECTS.
 The NEW Boffin catalogue lists LOTS
 of HIGHLY UNUSUAL, LOW-COST
 BARGAINS, READY-BUILT MODULES.
 Here are just a few examples, there are
 stocks more!

Dazzling MINI-STROBE (pocket size) £3.50
 PEOPLE DETECTOR £4.20
 Big-Ear SOUND-CATCHER £4.20
 Mini DREAM LABORATORY £4.20
 Don't take our word for it though!
 GET A COPY & SEE!
 SEND ONLY 20p, and we'll RUSH YOU
 A COPY (YOU'LL GET THE GOODIES!
 JUST AS QUICKLY TOO!)
BOFFIN PROJECTS
 4 Cunliffe Road, Stoneleigh,
 Ewell, Surrey
 (Mail Order U.K. Only)

NICKEL CADMIUM, fully sealed, re-
 chargeable batteries. Equivalent dry
 cell sizes. Discount. S.a.e. brings full
 details by return.—Sandwell Plant
 Ltd., 1 Denholm Road, Sutton Cold-
 field, West Midlands B73 6PP. 021-354
 9764.

LOUDSPEAKERS



Speakers, kits and
 cabinets for D.I.Y.,
 HiFi, P.A., Disco,
 etc. by EMI, Fane,
 Goodman's,
 Baker, Kef, Elic,
 Richard Allen,
 Wharfedale, etc.
 Send stamp for
 free booklet "Choosing
 a speaker"

WILMSLOW AUDIO

Dept. EE, Swan Works, Bank Square,
 Wilmslow, Cheshire, SK9 1HF
 Tel. Wilmslow 29599

LOWEST COST IC SOCKETS. Use
 Soldercon IC socket pins for 8 to 40
 pin DIL's. 50p for strip of 100 pins,
 £1.50 for 3 strips of 100, £4 for 1000.
 10p p&p for orders under £2. Add
 8% VAT. Instructions supplied—send
 for sample. SINTEL, 53e Aston
 Street, Oxford. Tel: 0865 43203.

DIGITAL CLOCK COMPONENTS

For beginners: easy printed circuit board
 and components for digital clock, 4 x 0-3" digits (less
 case, switches, transformer): £3.25. Extra for
 4 x 0-6" 'Jumbo' displays: £3.25.
 Success guaranteed! See our free information
 etc. for details. (Can be converted to 4 range
 timer/'stopwatch' for use in e.g. darkrooms.)
 Economy type displays DL-704E & DL-747E
 available separately, 70p & £1.00 each. AY-51224
 clock chip £3.50, MK 50253 alarm clock chip £5.00.
 Circuit diagrams available free on request (an
 S.A.E. would be a help to us). Add 10p per order
 and VAT @ 5%.

GREENBANK ELECTRONICS (Dept. ECD)
 94 New Chester Road, New Ferry, Wirral,
 Merseyside, L21 5AG.

TREASURE TRACER MK III Metal Locator



- Varicap tuning
- Britain's best selling metal locator kit; 4,000 sold
- Weighs only 22oz. Fitted with Faraday shield
- Speaker and earphone operation
- Knock down to only 17in
- Prebuilt search coil assembly
- Thoroughly professional finish
- As seen on BBC1 and BBC2 TV
- You only need soldering iron, screwdriver, pliers and snips
- Five transistor circuit
- Send stamped addressed envelope for leaflet

Complete Kit **£12.50** Built & tested **£17.50**
 Post 85p-£1.00 VAT (8%) Post 85p-£1.90 VAT (8%)

MINIKITS ELECTRONICS
 1b CLEVELAND ROAD,
 LONDON, E19 2AN (Mail order only)

SUPERB INSTRUMENT CASES by Bazelli, manufactured from heavy duty PVC faced steel. Hundreds of people and industrial users are choosing the cases they require from our vast range, competitive prices start at a low 75p. Over 400 Models to choose from, Prompt despatch, Free literature, (stamp would be appreciated). Bazelli, Department No. 24, St. Wilfreds, Foundry Lane, Halton, Lancaster LA2 6LT.

MICROJET WELDER
 A TINY FLAME UP TO 5,000°F!
 WELDS-BRAZES
 SOLDERS



£15.95, INC. FLAME TIPS

Precision tool using combination of butane and compressed oxygen or microgas. A pencil lead thin flame size. Adjustable to 5,000°F. Cuts metals welds, brazes and solders gold, silver. Ideal electricians, opticians, dentists, silversmiths, modelling, jewellery, clockmakers, electronic and computer servicing. Up to 40 minutes' use on fuel supplied. Replacement set of 2 micronoz, 1 butane cylinder. £1.80 extra including post. Our Price £15.95 + 40p P. & P. Sent £16.60.

BINOCULAR MAGNIFIER
 FOR PRECISION CLOSE-UP WORK - LEAVES BOTH HANDS FREE



See close-up work with less eye strain and fatigue. Lightweight adjustable headband. Powerful optically ground lenses from Continental glassworks. Can be worn over normal glasses. An essential aid in industry. Home Workshop, Collecting, Modelling, Jewellery, Watchmakers.

£10.00

Any fine work. De-luxe models with superior quality lenses PLUS hinged lens mount. 2 1/2 x mag £10.00 + 40p P. & P. 3 x mag. £11.00 + 40p P. & P. Access accepted.

JOHN DUDLEY & CO. LTD., Dept. EE9, 301 Cricklewood Lane, Finchley Road, London, NW2. Tel. 01-458 5917. (Callers welcome).

STYLI & CARTRIDGES. For the best at keenest prices send SAE for free illus. list to **FELSTEAD ELECTRONICS (EE)**, Longley Lane, Gately, Ches. SK8 4EE.

THE SCIENTIFIC WIRE CO
 Copper - Nickel Chrome - Eureka - Manganin Wires.
 Enamelled - Silk - Cotton - Tinned Coverings.
 No minimum charges or quantities.
 Trade and Export enquiries welcome.
 S.A.E. Brings List.
 P.O. BOX 30, LONDON, E 4 9BW

CF

GIRO NO. 331 7056. Access and Barclaycard accepted. C.W.O. only. Terms of business as in our catalogue. Export Order enquiries welcome (£5 min.)

Official Orders accepted from Educational & Government Departments
ALL PRICES INCLUDE VAT AND P & P

E. & O.E.
 SHOP HOURS—9-12.30, 1.30-5 pm 6 DAYS

66 Pages—3000 Items Fully illustrated
 ★20p Credit Vouchers★All New Stock

★Satisfaction Guarantee
 ★Discounts
 ★New Price List No. 1—S.A.E.

RESISTORS - CAPACITORS - SEMICONDUCTORS - BOXES - CASES - KITS - PC MATERIALS - TOOLS - TEST METERS - BOOKS - POTS - COLLS - HARDWARE - AUDIO ACCESSORIES - CONNECTORS - VEROBORD TRANSFORMERS - SCREWS - KNOBS - CALCULATORS - AUDIO - MODULES - AUDIO LEADS - BATTERIES - HEATSINKS - S DEC STORAGE UNITS etc.

RESISTOR KITS (CARBON FILM 5%) (Prices include post & packing)
 10E12 1/2W or 1/4W KIT: 10 of each E12 value, 22 ohms—1M, a total of 570 £5-29 net
 25E12 1/2W or 1/4W KIT: 25 of each E12 value, 22 ohms—1M, a total of 1425 £12-64 net

SPECIAL CAPACITOR KITS
 C280 Kit—PC Mounting polymer 250V 5 or each value: 0-01, 0-022, 0-047, 0-1, 0-22µF, 2 of 0-47, 1µF £1-98
 C296 Kit—Tubular polyester, 400V 5 of each value: 0-01, 0-022, 0-047, 0-1, 0-22µF, 2 of 0-47µF £2-87
 Ceramic Kit—square plaque 50V 5 of each value: 22, 33, 47, 100, 220, 330, 470, 1000pF, 2200, 4700pF, 0-1µF £1-86
 250V Paper Kit—Tubular metal case 3 of each value: 0-05, 0-1, 0-25, 0-5, 1µF £1-41 net
 600V Paper Kit—Tubular metal case 3 of each value: 0-025, 0-05, 0-1, 0-25, 0-5µF £1-41 net
 1000V Paper Kit—Tubular metal case 3 of each value: 0-01, 0-025, 0-05, 0-1µF £1-63 net

B. H. COMPONENT FACTORS LTD.

MULTIMETER U4323
 22 Ranges plus AF/IF Oscillator 20,000Ω/Volt.
 Vdc—0-5-1000V in 7 ranges.
 Vac—2-2-1000V in 5 ranges.
 Idc—0-05-500mA in 5 ranges.
 Resistance—5Ω-1M Ω in 4 ranges.
 Accuracy—5% of F.S.D.
 OSCILLATOR—1 KHz and 405KHz (A, M.) at approx. 1 Volt
 Size—160 x 97 x 40mm.
 Supplied complete with carrying case, test leads and battery.
 PRICE £8-64 net P. & P. 75p U4323

MULTIMETER U4324
 34 Ranges. High Sensitivity. 20,000Ω/Volt.
 Vdc—0-5-1200V in 9 ranges.
 Vac—3-300V in 8 ranges.
 Idc—0-05-3A in 8 ranges.
 Iac—0-3-3A in 5 ranges.
 Resistance—25Ω-5M Ω in 5 ranges.
 Accuracy—dc and R—2 1/2% of F.S.D.
 ac and db—4% of F.S.D.
 Size—167 x 98 x 63mm.
 Supplied complete with storage case, test leads, spare diode and battery.
 PRICE £10-64 net P. & P. 75p U4324

TEACH-IN SERIES COMPONENT KIT
 KIT No. T12
 ALL COMPONENTS AS SPECIFIED BY E.E. FULLY GUARANTEED AND NEW STOCK (INCLUDES BATTERY) £18-59 NET + 60p p&p

WOOD KIT
 Includes: all wood as specified by E.E., cut to size, ready to assemble and includes adhesive and screws. (Not drilled) £3 NET + 75p p. & p.
FULL LIST AVAILABLE. S.A.E. PLEASE OR FREE WITH CATALOGUE

(E. E.) LEIGHTON ELECTRONICS CENTR E, 59 NORTH STREET, LEIGHTON BUZZARD, LU7 7EG. Tel: Leighton Buzzard 2316 (Std. Code 05293).

JC12 AMPLIFIER
 6W IC audio amp with free data and printed circuit £2-95.
 Special offer—only £2-45 if bought with deluxe kit.

DELUXE KIT FOR THE JC12
 Includes all parts for the printed circuit and volume, bass and treble controls needed to complete the mono version £2-29. Stereo model with balance control £4-95.

JC12 POWER KIT
 Supplies 25V 0-5 Amps £2-95.

PREAMP KITS FOR THE JC12
 Type 1 for magnetic pickups, mics and tuners. Mono model £1-75. Stereo model £3-25. Type 2 for ceramic or crystal pickups. Mono 95p. Stereo £1-90.

LOUDSPEAKERS FOR JC12
 8" x 5" 8 ohms 5W £2-50.

SEND SAE FOR FREE LEAFLET ON KITS

SINCLAIR IC20 AMPLIFIER
 JC20 10+10W stereo amp. kit with free booklet and printed circuit £6-95
 PS20 power supply kit for above £4-95.
 VP20 volume, tone control and preamp kit with printed circuits £7-95.
 SP20 10W 4 Ohm loudspeaker for IC20 £2-95

SEND SAE FOR FREE DATA LEAFLET

BATTERY ELIMINATOR BARGAINS

4-WAY SPECIAL
 Switched output of 3/4(87 1/2)/9/12V at 500mA with unique 4-way multi-jack connector and free matching socket £5-80

3-WAY MODEL
 Switched output of 6/7 1/2/9V at 250mA with unique 4 way multi-jack connector and free matching socket £2-95.

RADIO MODELS
 With press-stud battery connectors for transistor radios etc. 50mA:- 6V £2-95. 9V £2-95. Double 0+0V £4-45. 4+4+4V £4-45. 9+9V £4-45

TAPE RECORDER MAINS UNITS
 7 1/2V output complete with 5 pin DIN plug to run cassette tape recorders from the AC mains £3-45

CAR CONVERTERS
 INPUT 12V DC. Output 6/7 1/2/9V DC 1A regulated £4-25.

SINCLAIR CALCULATORS
 Cambridge £7-95
 Scientific £8-95
 Oxford 100 £8-95
 Oxford 300 £18-95
 Programmable £25-95

MAINS UNITS
 For Oxford Series £3-10
 For Cambridge, Cam. Mem. and Scientific £3-15

CBM CALCULATORS
 *776MD 7 digit %/memory £5-95.
 *796MD 7 digit %/memory £8-45.
 *SR7919D 8 digit/memory/scientific notation // /trig/log/powers/roots £13-20.
 SR4148R with mains unit £34-95.
 Mains units for * machines £2-95.

CASIO PERSONAL MINI CALCULATOR
 6 x 6 digits/square/power/reciprocal £5-95

SINCLAIR BLACK WATCH
 Fully assembled only £20-95.

FERRANTI ZN414
 IC radio chip with data £1-89. Printed circuit and extra parts for radio £3-60. Case £1 extra. Send sae for free leaflet.

SINCLAIR PROJECT 60
 AFU £7-55, FM tuner £13-25. Decoder £8-55. Z40 £5-75. Q16 £10-95. PZ8 £8-20. Trans for PZ8 £5-40. PZ6 £8-70. Stereo 80 £10-95. PZ5 £3-95. Project 805 £20-95. Project 805Q £18-95.

S-DECS AND T-DECS
 S-DeC £2-24
 T-DeC £4-05
 µ-DeC A £4-45
 µ-DeC B £7-85
 IC carriers:-
 16 dll: plain £1-18.
 With socket £2-21.
 10 TOS: plain £1-09. With socket £2-08.
 SST1 3 for £2. SSU1 3 for £2. SSN1 3 for £2-40. 25p off any order accompanied by PB Electronics coupon.

SWANLEY ELECTRONICS
 Dept E.E. PO BOX 68,
 SWANLEY, KENT BR88TQ.

Prices include post and VAT.
 Official orders from schools etc welcome.
 Overseas customers please deduct VAT (7% on calculators and S-DeC and T-DeC range, otherwise 20%).

Marshall's

A. Marshall (London) Ltd Dept: EE
 42 Cricklewood Broadway London NW2 3ET Tel: 01-452 0161/2
 Telex: 21492
 & 85 West Regent St Glasgow G2 2OD Tel: 041-332 4133
 & 1 Straits Parade Fishponds Bristol BS16 2LX
 Tel: 0272 654201/2
 & 27 Rue Danton Issy Les Moulineaux Paris 92 Tel: 644 2356
 Catalogue price 25p Trade and export enquiries welcome

Our range covers over 7,000 items. The largest selection in Britain
Top 200 IC's TTL, CMOS & Linears

| | | | | | | | | | |
|---------|-------|---------|--------|---------|--------|---------|------------|------------|-------|
| CA3020A | £1 80 | CD4049 | 45p | NE556 | £1 30 | SN7446 | 84p | SN74153 | 68p |
| CA3028A | 79p | CD4050 | 45p | NE560 | £4 48 | SN7447 | 80p | SN74154 | £1 20 |
| CA3035 | £1 37 | CD4510 | £1 25 | NE565 | £4 48 | SN7448 | 90p | SN74157 | 76p |
| CA3046 | 70p | CD4511 | £1 94 | SL414 | £2 35 | SN7450 | 16p | SN74160 | 88p |
| CA3048 | £2 11 | CD4516 | £1 25 | SL610C | £2 35 | SN7451 | 16p | SN74161 | 88p |
| CA3052 | £1 62 | CD4518 | £1 87 | SL611C | £2 35 | SN7453 | 16p | SN74162 | 88p |
| CA3089E | £1 96 | CD4520 | £1 87 | SL612C | £2 35 | SN7454 | 16p | SN74163 | 88p |
| CA3090Q | £4 23 | LM301A | 48p | SL620C | £3 50 | SN7460 | 16p | SN74164 | £1 60 |
| CA3130 | 88p | LM308 | £1 17 | SL621C | £3 50 | SN7470 | 29p | SN74165 | £1 60 |
| CD4000 | 18p | LM309K | £1 88 | SL623C | £5 24 | SN7472 | 21p | SN74167 | £3 30 |
| CD4001 | 18p | LM380 | 98p | SL640C | £4 00 | SN7473 | 31p | SN74174 | 99p |
| CD4002 | 18p | LM381 | £2 07 | SN7400 | 16p | SN7474 | 31p | SN74175 | 70p |
| CD4006 | 99p | LM702C | 75p | SN7401 | 16p | SN7475 | 45p | SN74176 | £1 14 |
| CD4007 | 18p | LM709 | £1 57 | SN7401A | 29p | SN7476 | 30p | SN74180 | £1 50 |
| CD4008 | 82p | T099 | 38p | SN7402 | 16p | SN7480 | 42p | SN74181 | £1 95 |
| CD4009 | 52p | 8DIL | 45p | SN7403 | 16p | SN7481 | £1 00 | SN74190 | £1 86 |
| CD4010 | 52p | 14DIL | 38p | SN7404 | 19p | SN7482 | 65p | SN74191 | £1 86 |
| CD4011 | 18p | LM710 | 47p | SN7405 | 19p | SN7483 | 82p | SN74192 | £1 15 |
| CD4012 | 18p | LM723C | 66p | SN7406 | 36p | SN7484 | 95p | SN74193 | £1 15 |
| CD4013 | 45p | LM741C | 40p | SN7407 | 28p | SN7485 | £1 00 | SN74196 | £1 60 |
| CD4014 | 89p | LM705 | £1 88 | SN7437 | 19p | SN7486 | 29p | SN74197 | £1 50 |
| CD4015 | 89p | 14DIL | 38p | SN7409 | 16p | SN7490 | 42p | SN74198 | £1 80 |
| CD4016 | 45p | LM747 | £1 05 | SN7410 | 16p | SN7491 | 75p | SN74199 | £1 80 |
| CD4017 | 88p | LM748 | SN7411 | 20p | SN7492 | 45p | SN76003NE2 | 92 | |
| CD4018 | 88p | 8DIL | 44p | SN7412 | 22p | SN7493 | 45p | SN76013NE1 | 95 |
| CD4019 | 52p | 14DIL | 41p | SN7413 | 28p | SN7494 | 75p | SN76023NE1 | 90 |
| CD4020 | 98p | LM3900 | 61p | SN7416 | 28p | SN7495 | 68p | SN76033NE2 | 92 |
| CD4021 | 88p | LM7805 | £1 88 | SN7417 | 28p | SN7496 | 68p | TAA26 | £1 20 |
| CD4022 | 85p | LM7812 | £1 99 | SN7420 | 16p | SN74100 | £1 10 | TAA300 | £1 84 |
| CD4023 | 18p | LM7815 | £1 99 | SN7423 | 23p | SN74107 | 30p | TAA350A | £1 96 |
| CD4024 | 72p | LM7824 | £1 99 | SN7425 | 23p | SN74118 | 85p | TAA550 | 32p |
| CD4025 | 19p | MCI303L | £1 50 | SN7427 | 23p | SN74119 | £1 75 | TAA611C | £2 18 |
| CD4027 | 43p | MCI310P | £2 50 | SN7430 | 15p | SN74121 | 32p | TAA621 | £2 03 |
| CD4028 | 88p | MC6330P | 90p | SN7432 | 22p | SN74122 | 42p | TAA661B | £1 03 |
| CD4029 | £1 06 | MCI351P | 80p | SN7437 | 28p | SN74123 | 65p | TBA611B | £2 25 |
| CD4030 | 52p | MCI4553 | £4 07 | SN7438 | 28p | SN74141 | 75p | TBA651 | £1 69 |
| CD4031 | 98p | MCI466L | £3 50 | SN7440 | 16p | SN74145 | 72p | TBA800 | 99p |
| CD4037 | 88p | MCI469R | £2 75 | SN7441A | 65p | SN74150 | £1 20 | TBA810 | 98p |
| CD4041 | 70p | NE555V | 70p | SN7442 | 65p | SN74151 | 68p | TBA820 | 80p |

LONDON GLASGOW PARIS AND NOW

BRISTOL

IT'S OUR SERVICE THAT MAKES US GROW

POPULAR SEMICONDUCTORS

| | | | | | | | | | |
|---------|-------|--------|-------|---------|-------|---------|-------|---------|-------|
| 2N696 | 22p | 2N3906 | 19p | AF139 | 65p | BD139 | 71p | MPSA56 | 31p |
| 2N697 | 16p | 2N4037 | 42p | AF239 | 65p | BD140 | 87p | OC28 | £1 48 |
| 2N698 | 82p | 2N4036 | 67p | AF240 | 90p | BF115 | 29p | OC35 | £1 16 |
| 2N699 | 59p | 2N4058 | 18p | AF279 | 70p | BF117 | 55p | OC42 | 50p |
| 2N706 | 14p | 2N4062 | 15p | AF280 | 79p | BF154 | 20p | OC45 | 32p |
| 2N708 | 17p | 2N4289 | 34p | AL102 | £1 00 | BF159 | 27p | TIP29A | 49p |
| 2N916 | 28p | 2N4920 | £1 19 | BC107 | 14p | BF180 | 35p | TIP29C | 80p |
| 2N918 | 32p | 2N4921 | 83p | BC108 | 14p | BF181 | 36p | TIP31A | 62p |
| 2N1302 | 18p | 2N4923 | £1 00 | BC109 | 14p | BF184 | 30p | TIP32A | 74p |
| 2N1304 | 26p | 2N5245 | 29p | BC147B | 10p | BF194 | 12p | TIP33A | £1 01 |
| 2N1306 | 31p | 2N5294 | 48p | BC148B | 09p | BF195 | 12p | TIP34A | £1 51 |
| 2N1308 | 47p | 2N5296 | 48p | BC149B | 11p | BF196 | 13p | TIP35A | £2 00 |
| 2N1711 | 27p | 2N5457 | 29p | BC157 | 16p | BF197 | 15p | TIP36A | £3 70 |
| 2N2102 | 60p | 2N5458 | 26p | BC158A | 16p | BF198 | 18p | TIP41A | 79p |
| 2N2147 | 78p | 2N5459 | 29p | BC167B | 15p | BF244 | 21p | TIP42A | £0 90 |
| 2N2148 | 94p | 2N6027 | 45p | BC168B | 15p | BF257 | 47p | TIP295S | 98p |
| 2N218A | 47p | 3N128 | 73p | BC169B | 15p | BF258 | 53p | TIP305S | 30p |
| 2N2219A | 52p | 3N140 | £1 00 | BC182 | 12p | BF259 | 55p | TIS43 | 28p |
| 2N2220 | 25p | 3N141 | 81p | BC182L | 12p | BF561 | 27p | ZTX300 | 13p |
| 2N2221 | 18p | 3N200 | £2 49 | BC183 | 12p | BF598 | 25p | ZTX301 | 13p |
| 2N2222 | 20p | 40361 | 40p | BC183L | 12p | BFR39 | 24p | ZTX500 | 13p |
| 2N2369 | 20p | 40362 | 45p | BC184 | 13p | BFR79 | 24p | ZTX501 | 13p |
| 2N2646 | 35p | 40406 | 44p | BC184L | 13p | BFX29 | 32p | ZTX502 | 18p |
| 2N2904 | 40p | 40407 | 35p | BC212A | 16p | BFX30 | 34p | IN914 | 33p |
| 2N2905 | 47p | 40408 | 30p | BC212LA | 16p | BFX44 | 30p | IN375A | 15p |
| 2N2906 | 39p | 40409 | 53p | BC213A | 15p | BFX85 | 35p | IN4007 | 19p |
| 2N2907 | 32p | 40410 | 52p | BC214LB | 16p | BFX88 | 30p | IN4148 | 4p |
| 2N2924 | 20p | 40411 | £2 00 | BC237B | 16p | BFY50 | 30p | IN5404 | 22p |
| 2N2926G | 12p | 40594 | 74p | BC238C | 15p | BFY51 | 28p | IN5408 | 30p |
| 2N3053 | 25p | 40595 | 84p | BC239C | 15p | BFY52 | 20p | AA119 | 8p |
| 2N3054 | 60p | 40636 | £1 10 | BC257A | 16p | BRY39 | 48p | BA102 | 23p |
| 2N3055 | 65p | 40676 | 41p | BC258B | 16p | ME0402 | 20p | BA107 | 8p |
| 2N3391 | 28p | AC162 | 20p | BC259B | 17p | ME0412 | 18p | BA154 | 12p |
| 2N3392 | 15p | AC127 | 40p | BC301 | 34p | ME4102 | 11p | BA155 | 12p |
| 2N3393 | 15p | AC128 | 35p | BC307B | 17p | MJ480 | 95p | BB103B | 23p |
| 2N3440 | 59p | AC151 | 27p | BC308A | 15p | MJ481 | £1 20 | BB104B | 25p |
| 2N3442 | £1 40 | AC152 | 49p | BC309C | 20p | MJ490 | £1 05 | BY126 | 12p |
| 2N3638 | 15p | AC153 | 35p | BC327 | 23p | MJ491 | £1 20 | BY127 | 15p |
| 2N3702 | 12p | AC176 | 41p | BC328 | 22p | MJ295S | £1 00 | BYZ11 | 51p |
| 2N3703 | 13p | AC187K | 35p | BCY70 | 17p | MJE340 | 48p | BYZ12 | 51p |
| 2N3704 | 15p | AC188K | 40p | BCY71 | 22p | MJE370 | 65p | OA47 | 6p |
| 2N3706 | 15p | AD143 | 68p | BCY72 | 18p | MJE371 | 75p | OA81 | 18p |
| 2N3708 | 14p | AD161 | 69p | BD121 | £1 00 | MJES20 | 60p | OA90 | 6p |
| 2N3714 | £1 38 | AD162 | 69p | BD123 | 82p | MJES21 | 70p | OA91 | 6p |
| 2N3716 | £1 80 | AF106 | 40p | BD124 | 67p | MJE395 | £1 20 | OA200 | 8p |
| 2N3771 | £2 20 | AF109 | 40p | BD131 | 40p | MJE305S | 75p | BY164 | 57p |
| 2N3773 | £2 65 | AF115 | 35p | BD132 | 50p | MPB113 | 47p | ST2diac | 20p |
| 2N3789 | £2 00 | AF116 | 35p | BD135 | 21p | MPF102 | 39p | 40669 | 61p |
| 2N3819 | 37p | AF117 | 35p | BD136 | 22p | MPSA05 | 23p | TIC44 | 29p |
| 2N3820 | 29p | AF118 | 35p | BD137 | 24p | MPSA06 | 31p | C106D | 65p |
| 2N3904 | 19p | AF124 | 30p | BD138 | 26p | MPSA55 | 21p | ORP12 | 60p |

Prices correct at March 1976, but all inclusive of VAT. P. & P. 25p

ENGINEERS

FREE



This 44 page
FREE book
 shows how!

YOURSELF FOR A

BETTER JOB WITH MORE PAY!

Do you want promotion, a better job, higher pay? "New opportunities" shows you how to get them through a low-cost, Home Study Course. There are no books to buy and you can pay as you learn.

This easy to follow GUIDE TO SUCCESS should be read by every ambitious engineer. Send for this helpful 44 page free book NOW! No obligation, nobody will call on you. It could be the best thing you ever did.

CHOOSE A BRAND NEW FUTURE HERE

CUT OUT THIS COUPON

- | | | |
|--|--|---|
| <input type="checkbox"/> ELECTRICAL and ELECTRONICS | <input type="checkbox"/> AUTO and AERO Motor Mechanics | <input type="checkbox"/> MECHANICAL A.M.S.F. (Mech.) |
| <input type="checkbox"/> Practical Radio & Electronics (with KIT) | <input type="checkbox"/> C. & G. Motor V. Mechanics | <input type="checkbox"/> General Mech. Eng. |
| <input type="checkbox"/> Electronic Engineering Certificate | <input type="checkbox"/> General Auto Engineering | <input type="checkbox"/> Inst. Engineers & Technicians |
| <input type="checkbox"/> General Elect. Eng. Certificate | <input type="checkbox"/> A.M.I.M.I. | <input type="checkbox"/> Maintenance Engineering |
| <input type="checkbox"/> C. & G. Elect. Installations | <input type="checkbox"/> Air Registration Board Certs. | <input type="checkbox"/> Welding |
| <input type="checkbox"/> Elect. Install. & Work | <input type="checkbox"/> M.A.A./I.M.I. Dip. | <input type="checkbox"/> MANAGEMENT and PRODUCTION |
| <input type="checkbox"/> C. & G. Elect. Technicians | <input type="checkbox"/> CONSTRUCTIONAL | <input type="checkbox"/> Computer Programming |
| <input type="checkbox"/> RADIO and TELECOMMUNICATIONS | <input type="checkbox"/> Heating, Ventilating & Air Conditioning | <input type="checkbox"/> Inst. of Cost & Managements Accts. |
| <input type="checkbox"/> Colour TV Servicing | <input type="checkbox"/> Architectural Draughtsmanship & Design | <input type="checkbox"/> DRAUGHTSMANSHIP and DESIGN |
| <input type="checkbox"/> C. & G. Telecom. Technician's Cert. | <input type="checkbox"/> L.I.O.B. | <input type="checkbox"/> Carpentry & Joinery |
| <input type="checkbox"/> C. & G. Radio, TV & Electronics Mech. Cert. | <input type="checkbox"/> Radio & TV Engineering Course | <input type="checkbox"/> Plumbing Technology |
| <input type="checkbox"/> Radio, Servicing & Repairs | <input type="checkbox"/> Radio Amateur's Exam. | <input type="checkbox"/> General Building |
| <input type="checkbox"/> Painting & Decorating | | <input type="checkbox"/> A.M.I.E.D. |
| | | <input type="checkbox"/> Electrical Draughtsmanship |

POST NOW

G.C.E.
 —58 'O' & 'A' Level Subjects
 —over 10,000 Group Passes!

Aldermaston College

Dept. TEE15 Reading RG7 4PF.
 also at our London Advisory Office, 4 Fore Street Avenue, Moorgate, London EC2Y 5EJ. Tel. 01-628 2721.

NAME (Block Capitals)

ADDRESS

Postcode

Other subjects of interest..... Age

Accredited by C.A.C.C. Member of A.B.C.C.

HOME OF BRITISH INSTITUTE OF ENGINEERING TECHNOLOGY

M. D. D. D. D.

FANTASTIC VALUE! ONLY 40P

132 PAGES INCLUDING PROJECTS FOR YOU TO BUILD. PLUS HUNDREDS OF ILLUSTRATIONS OF COMPONENTS.

PRICES GUARANTEED FOR TWO MONTH PERIODS

FULL DETAILS AND PICTURES OF A WIDE RANGE OF COMPONENTS

SAME-DAY MAILING SERVICE!

PAGES OF TRANSISTOR AND I.C. DATA

THOUSANDS OF COMPONENTS

A BEAUTIFULLY PRODUCED BOOK!

VALUABLE DISCOUNT VOUCHERS

MAPLIN ELECTRONIC SUPPLIES

GET THIS! BOOK NOW AND TAKE OFF TODAY WITH MAPLIN SUPERSERVICE

EASY TO ORDER LAYOUT

Clear pictures and full description of every component makes ordering simple—you'll know exactly what you're buying.

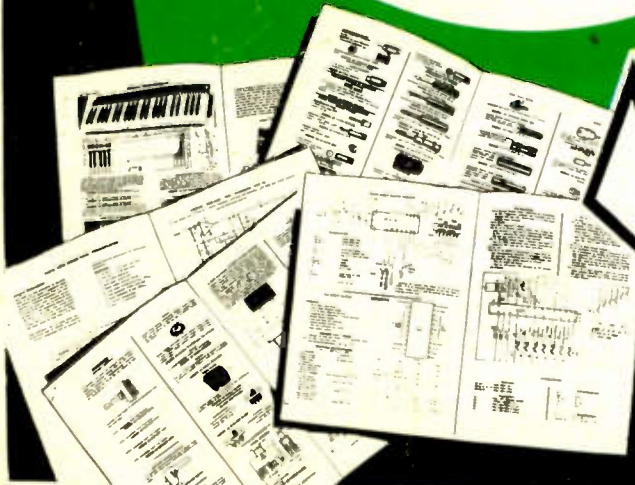

I enclose Cheque/P.O. value (EE)
For copy/copies of your Catalogue
NAME
ADDRESS

MAPLIN ELECTRONIC SUPPLIES P.O. Box 3, Rayleigh Essex SS6 8LR.