

ETI
ELECTRONICS
TODAY INTERNATIONAL

ELECTRONICS, COMPUTERS, TECHNOLOGY

JUNE 1993 £1.95

SUPER SPOOKER
5 BAND GRAPHIC EQUALISER
SUPER STEREO

Increase the width of your sound



**Beep
Beep
Beep**

**SPEED
CONTROLLER**
More for your
RC models

**THE HISTORY
of BATTERIES**

**NO
PCB?
ASK
YOUR
NEWSAGENT**

**The Chaperon
Personal
Attack
Alarm**

BEST VALUE
SPECIALIST PUBLICATION

9 770142 722023

06



OMP MOS-FET POWER AMPLIFIERS HIGH POWER. TWO CHANNEL 19 INCH RACK

THOUSANDS PURCHASED BY PROFESSIONAL USERS



THE RENOWNED MXF SERIES OF POWER AMPLIFIERS FOUR MODELS:- MXF200 (100W + 100W) MXF400 (200W + 200W) MXF600 (300W + 300W) MXF900 (450W + 450W)

ALL POWER RATINGS R.M.S. INTO 4 OHMS, BOTH CHANNELS DRIVEN

FEATURES: ★Independent power supplies with two toroidal transformers ★ Twin L.E.D. Vu meters ★ Level controls ★ Illuminated on/off switch ★ XLR connectors ★ Standard 775mV inputs ★ Open and short circuit proof ★ Latest Mos-Fets for stress free power delivery into virtually any load ★ High slew rate ★ Very low distortion ★ Aluminium cases ★ MXF600 & MXF900 fan cooled with D.C. loudspeaker and thermal protection.

USED THE WORLD OVER IN CLUBS, PUBS, CINEMAS, DISCOS ETC.

SIZES:- MXF200 W19" xH3 1/2" (2U)xO11"
MXF400 W19" xH5 1/4" (3U)xO12"
MXF600 W19" xH5 1/4" (3U)xO13"
MXF900 W19" xH5 1/4" (3U)xO14 1/2"

PRICES:- MXF200 £175.00 MXF400 £233.85
MXF600 £329.00 MXF900 £449.15
SPECIALIST CARRIER DEL. £12.50 EACH

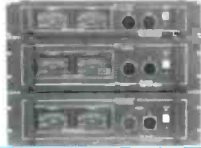

OMP VARISPEED TURNABLE CHASSIS



★ Manual arm ★ Steel chassis ★ Electronic speed control 33 & 45 R.P.M. ★ Vari pitch control ★ High torque servo driven DC motor ★ Transit screws ★ 12" die cast platter ★ Neon strobe ★ Calibrated balance weight ★ Removable head shell ★ 1/2" cartridge fixings ★ Cue lever★ 220/240V 50/60Hz ★ 390x305mm ★ Supplied with mounting cut-out template.

PRICE £61.30 + £3.70 P&P

OPTIONAL MAGNETIC CARTRIDGES

STANTON AL500mkII
PRICE £16.95 + 50P P&P

STEREO DISCO MIXER DJ6500

★ WITH ECHO ★

STEREO DISCO MIXER with 2 x 7 band L & R graphic equalisers with bar graph LED Vu meters. **MANY OUTSTANDING FEATURES:-** including Echo with repeat & speed control, DJ Mic with tone control & talk-over switch, 7 Channels with individual faders plus cross fade, Cue Headphone Monitor. Useful combination of the following inputs:- 3 turntables (mag), 3 mics, 5 Line for CD, Tape, Video etc.

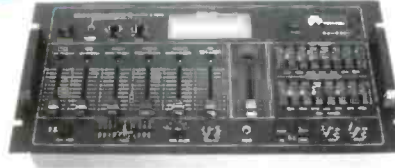

Price £134.99 + £5.00 P&P

SIZE: 482 x 240 x 120mm

PIEZO ELECTRIC TWEETERS - MOTOROLA

Join the Piezo revolution! The low dynamic mass (no voice coil) of a Piezo tweeter produces an improved transient response with a lower distortion level than ordinary dynamic tweeters. As a crossover is not required these units can be added to existing speaker systems of up to 100 watts (more if two are put in series). **FREE EXPLANATORY LEAFLETS ARE SUPPLIED WITH EACH TWEETER.**

TYPE 'A' (KSN1036A) 3" round with protective wire mesh. Ideal for bookshelf and medium sized Hi-Fi speakers. Price £4.90 + 50p P&P.
TYPE 'B' (KSN1005A) 3 1/4" super horn for general purpose speakers, disco and P.A. systems etc. Price £5.99 + 50p P&P.
TYPE 'C' (KSN1016A) 2" x5" wide dispersion horn for quality Hi-Fi systems and quality discos etc. Price £6.99 + 50p P&P.
TYPE 'D' (KSN1025A) 2" x6" wide dispersion horn. Upper frequency response retained extending down to mid-range (2KHz). Suitable for high quality Hi-Fi systems and quality discos. Price £9.99 + 50p P&P.
TYPE 'E' (KSN1038A) 3 1/2" horn tweeter with attractive silver finish trim. Suitable for Hi-Fi monitor systems etc. Price £5.99 + 50p P&P.
LEVEL CONTROL Combines, on a recessed mounting plate, level control and cabinet input jack socket. 85x85mm. Price £4.10 + 50p P&P.

TYPE A
TYPE B
TYPE C
TYPE D
TYPE E

ibi FLIGHT CASED LOUDSPEAKERS

A new range of quality loudspeakers, designed to take advantage of the latest speaker technology and enclosure designs. Both models utilize studio quality 12" cast aluminium loudspeakers with factory fitted grilles, wide dispersion constant directivity horns, extruded aluminium corner protection and steel ball corners, complimented with heavy duty black covering. The enclosures are fitted as standard with top hats for optional loudspeaker stands.



POWER RATINGS QUOTED IN WATTS RMS FOR EACH CABINET FREQUENCY RESPONSE FULL RANGE 45Hz - 20KHz

ibi FC 12-100WATTS (100dB) PRICE £159.00 PER PAIR
ibi FC 12-200WATTS (100dB) PRICE £175.00 PER PAIR
SPECIALIST CARRIER DEL. £12.50 PER PAIR

OPTIONAL STANDS PRICE PER PAIR £49.00
Delivery £6.00 per pair

IN-CAR STEREO BOOSTER AMPS



PRICES: 150W £49.99 250W £99.99
400W £109.95 P&P £2.00 EACH

THREE SUPERB HIGH POWER CAR STEREO BOOSTER AMPLIFIERS

150 WATTS (75 + 75) Stereo, 150W Bridged Mono
250 WATTS (125 + 125) Stereo, 250W Bridged Mono
400 WATTS (200 + 200) Stereo, 400W Bridged Mono
ALL POWERS INTO 4 OHMS
Features:
★ Stereo, bridgable mono ★ Choice of high & low level inputs ★ L & R level controls ★ Remote on-off ★ Speaker & thermal protection.

OMP MOS-FET POWER AMPLIFIER MODULES SUPPLIED READY BUILT AND TESTED.

These modules now enjoy a world-wide reputation for quality, reliability and performance at a realistic price. Four models are available to suit the needs of the professional and hobby market i.e. Industry, Leisure, Instrumental and Hi-Fi etc. When comparing prices, NOTE that all models include toroidal power supply, integral heat sink, glass fibre P.C.B. and drive circuits to power a compatible Vu meter. All models are open end short circuit proof.

THOUSANDS OF MODULES PURCHASED BY PROFESSIONAL USERS



OMP/MF 100 Mos-Fet Output power 110 watts
R.M.S. into 4 ohms, frequency response 1Hz - 100KHz -3dB, Damping Factor >300, Slew Rate 45V/uS, T.H.D. typical 0.002%, Input Sensitivity 500mV, S.N.R. -110 dB. Size 300 x 123 x 60mm.
PRICE £40.85 + £3.50 P&P



OMP/MF 200 Mos-Fet Output power 200 watts
R.M.S. into 4 ohms, frequency response 1Hz - 100KHz -3dB, Damping Factor >300, Slew Rate 50V/uS, T.H.D. typical 0.001%, Input Sensitivity 500mV, S.N.R. -110 dB. Size 300 x 155 x 100mm.
PRICE £64.35 + £4.00 P&P



OMP/MF 300 Mos-Fet Output power 300 watts
R.M.S. into 4 ohms, frequency response 1Hz - 100KHz -3dB, Damping Factor >300, Slew Rate 60V/uS, T.H.D. typical 0.001%, Input Sensitivity 500mV, S.N.R. -110 dB. Size 330 x 175 x 100mm.
PRICE £81.75 + £5.00 P&P



OMP/MF 450 Mos-Fet Output power 450 watts
R.M.S. into 4 ohms, frequency response 1Hz - 100KHz -3dB, Damping Factor >300, Slew Rate 75V/uS, T.H.D. typical 0.001%, Input Sensitivity 500mV, S.N.R. -110 dB, Fan Cooled, D.C. Loudspeaker Protection, 2 Second Anti-Thump Delay. Size 385 x 210 x 105mm.
PRICE £132.85 + £5.00 P&P

NOTE: MOS-FET MODULES ARE AVAILABLE IN TWO VERSIONS: STANDARD - INPUT SENS 500mV, BAND WIDTH 100KHz. PEC (PROFESSIONAL EQUIPMENT COMPATIBLE) - INPUT SENS 775mV, BAND WIDTH 50KHz. ORDER STANDARD OR PEC.



Vu METER Compatible with our four amplifiers detailed above. A very accurate visual display employing 11 L.E.D.s (7 green, 4 red) plus an additional on/off indicator. Sophisticated logic control for very fast rise and decay times. Tough moulded plastic case, with acrylic tinted front. Size 84 x 27 x 45mm.
PRICE £8.70 + 50p P&P

LOUDSPEAKERS

LARGE SELECTION OF SPECIALIST LOUDSPEAKERS AVAILABLE, INCLUDING CABINET FITTINGS, SPEAKER GRILLES, CROSS-OVERS AND HIGH POWER, HIGH FREQUENCY BULLETS AND HORNS, LARGE (A4) S.A.E. (50p STAMPED) FOR COMPLETE LIST.

P - From McKenzie Professional Series
S - From McKenzie Studio Series

McKENZIE:- INSTRUMENTS, P.A., DISCO, ETC

ALL MCKENZIE UNITS 8 OHMS IMPEDANCE
8" 100WATT C8-100GP GEN. PURPOSE, LEAD GUITAR, EXCELLENT MID, DISCO. RES. FREQ. 80Hz, FREQ. RESP. TO 7KHz, SENS 96dB. **PRICE £31.45 + £2.00 P&P**
10" 100WATT C10-100GP GUITAR, VOICE, KEYBOARD, DISCO, EXCELLENT MID. RES. FREQ. 72Hz, FREQ. RESP. TO 6KHz, SENS 97dB. **PRICE £38.89 + £2.50 P&P**
10" 200WATT C10-200GP GUITAR, KEYB'D, DISCO, EXCELLENT HIGH POWER MID. RES. FREQ. 69Hz, FREQ. RESP. TO 5KHz, SENS 97dB. **PRICE £53.21 + £2.50 P&P**
12" 100WATT C12-100GP HIGH POWER GEN. PURPOSE, LEAD GUITAR, DISCO. RES. FREQ. 49Hz, FREQ. RESP. TO 7KHz, SENS 98dB. **PRICE £40.35 + £3.50 P&P**
12" 100WATT C12-100TC (TWIN CONE) HIGH POWER, WIDE RESPONSE, P.A., VOICE, DISCO. RES. FREQ. 45Hz, FREQ. RESP. TO 12KHz, SENS 97dB. **PRICE £41.39 + £3.50 P&P**
12" 200WATT C12-200B HIGH POWER BASS, KEYBOARDS, DISCO, P.A. RES. FREQ. 45Hz, FREQ. RESP. TO 5KHz, SENS 99dB. **PRICE £71.91 + £3.50 P&P**
12" 300WATT C12-300GP HIGH POWER BASS, LEAD GUITAR, KEYBOARDS, DISCO ETC. RES. FREQ. 49Hz, FREQ. RESP. TO 7KHz, SENS 100dB. **PRICE £95.66 + £3.50 P&P**
15" 100WATT C15-100BS BASS GUITAR, LOW FREQUENCY, P.A., DISCO. RES. FREQ. 40Hz, FREQ. RESP. TO 5KHz, SENS 98dB. **PRICE £59.05 + £4.00 P&P**
15" 200WATT C15-200BS VERY HIGH POWER BASS. RES. FREQ. 40Hz, FREQ. RESP. TO 3KHz, SENS 98dB. **PRICE £80.57 + £4.00 P&P**
15" 250WATT C15-250BS VERY HIGH POWER BASS. RES. FREQ. 39Hz, FREQ. RESP. TO 4KHz, SENS 99dB. **PRICE £90.23 + £4.50 P&P**
15" 400WATT C15-400BS VERY HIGH POWER, LOW FREQUENCY BASS. RES. FREQ. 40Hz, FREQ. RESP. TO 4KHz, SENS 100dB. **PRICE £105.46 + £4.50 P&P**
18" 500WATT C18-500BS EXTREMELY HIGH POWER, LOW FREQUENCY BASS. RES. FREQ. 27Hz, FREQ. RESP. TO 2KHz, SENS. 98dB. **PRICE £174.97 + £5.00 P&P**

EARBENDERS:- HI-FI, STUDIO, IN-CAR, ETC

ALL EARBENDER UNITS 8 OHMS (Except EB8-50 & EB10-50 which are dual impedance tapped @ 4 & 8 ohm)
BASS, SINGLE CONE, HIGH COMPLIANCE, ROLLED SURROUND
8" 50WATT EB8-50 DUAL IMPEDANCE, TAPPED 4/8 OHM BASS, HI-FI, IN-CAR. RES. FREQ. 40Hz, FREQ. RESP. TO 7KHz SENS 97dB. **PRICE £8.90 + £2.00 P&P**
10" 50WATT EB10-50 DUAL IMPEDANCE, TAPPED 4/8 OHM BASS, HI-FI, IN-CAR. RES. FREQ. 40Hz, FREQ. RESP. TO 5KHz, SENS. 99dB. **PRICE £13.65 + £2.50 P&P**
10" 100WATT EB10-100 BASS, HI-FI, STUDIO. RES. FREQ. 35Hz, FREQ. RESP. TO 3KHz, SENS 96dB. **PRICE £30.39 + £3.50 P&P**
12" 100WATT EB12-100 BASS, STUDIO, HI-FI, EXCELLENT DISCO. RES. FREQ. 26Hz, FREQ. RESP. TO 3KHz, SENS 93dB. **PRICE £42.12 + £3.50 P&P**
FULL RANGE TWIN CONE, HIGH COMPLIANCE, ROLLED SURROUND
5 1/2" 60WATT EB5-60TC (TWIN CONE) HI-FI, MULTI-ARRAY DISCO ETC. RES. FREQ. 63Hz, FREQ. RESP. TO 20KHz, SENS 92dB. **PRICE £9.99 + £1.50 P&P**
6 1/2" 60WATT EB6-60TC (TWIN CONE) HI-FI, MULTI-ARRAY DISCO ETC. RES. FREQ. 38Hz, FREQ. RESP. TO 20KHz, SENS 94dB. **PRICE £10.99 + 1.50 P&P**
6" 60WATT EB8-60TC (TWIN CONE) HI-FI, MULTI-ARRAY DISCO ETC. RES. FREQ. 40Hz, FREQ. RESP. TO 18KHz, SENS 89dB. **PRICE £12.99 + £1.50 P&P**
10" 60WATT EB10-60TC (TWIN CONE) HI-FI, MULTI ARRAY DISCO ETC. RES. FREQ. 35Hz, FREQ. RESP. TO 12KHz, SENS 98dB. **PRICE £16.49 + £2.00 P&P**

TRANSMITTER HOBBY KITS

PROVEN TRANSMITTER DESIGNS INCLUDING GLASS FIBRE PRINTED CIRCUIT BOARD AND HIGH QUALITY COMPONENTS COMPLETE WITH CIRCUIT AND INSTRUCTIONS
3W TRANSMITTER 80-108MHz, VARICAP CONTROLLED PROFESSIONAL PERFORMANCE, RANGE UP TO 3 MILES, SIZE 38 x 123mm, SUPPLY 12V @ 0.5AMP. PRICE £14.85 - £1.00 P&P
FM MICRO TRANSMITTER 100-108MHz, VARICAP TUNED, COMPLETE WITH VERY SENS FET MIC, RANGE 100-300m, SIZE 56 x 46mm, SUPPLY 9V BATTERY. PRICE £8.80 - £1.00 P&P



PHOTO: 3W FM TRANSMITTER

B.K. ELECTRONICS

UNITS 1 & 5 COMET WAY, SOUTHERN-ON-SEA, ESSEX, SS2 6TR.
Tel.: 0702 - 527572 Fax.: 0702 - 420243

POSTAL CHARGES PER ORDER £1.00 MINIMUM. OFFICIAL ORDERS FROM SCHOOLS, COLLEGES, GOVT. BODIES, PLCs ETC. PRICES INCLUSIVE OF V.A.T. SALES COUNTER, VISA AND ACCESS ACCEPTED BY POST, PHONE OR FAX.



**Volume 22 No.6
June 1993**

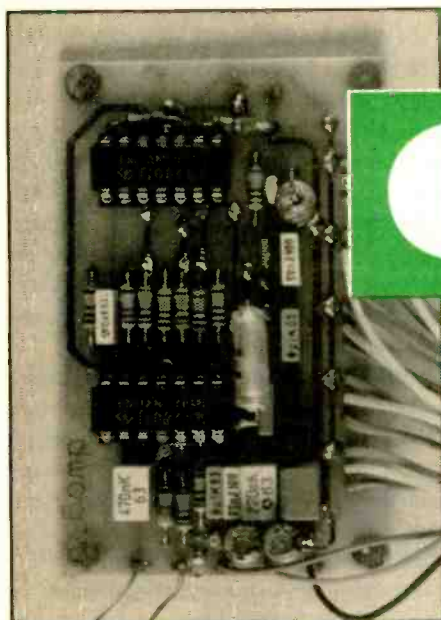

Page 12

Features & Projects

5 Band Graphic Equaliser	12
A design from Andrew Armstrong.	
The Chaperon	16
A personal attack alarm can be an invaluable aid to deter a would-be attacker. Bob Noyes provides a cheap and very loud solution to the problem.	
Super Spooker	21
A spooky sound effects generator for the party by Alan Jones.	
Moving Coil Meters	26
More from that celebrated man of circuits, Ray Marston.	
RC Low Power Speed Controller	32
A Craig Talbot produces the second in our series on radio-controlled projects.	
Crossing The Great Divide	36
A project to increase your hi-fi stereo width by Colin MacLiesh.	
AutoMate Mixing Desk	39
Mike Meechan continues his long running series with a look at console switching mechanisms.	
The History of Batteries	49
From the Leclanche and Voltaic pile to the Nickel hydride and Lithium ion cells, Jim Slater takes a look at electricity storage.	

Contents

Regulars

Open Channel	4
News	5
News Stateside	9
Read/Write	10
PCB Service	60
PCB Foils	61

Editorial

by Paul Freeman

**SUBSCRIPTION
& BACK ISSUES
HOTLINE
0737 768611**

There have not been many occasions when one could praise government bodies for giving encouragement to science and technology. As many of us know, most departments are run by scientifically illiterate and therefore unsympathetic individuals. However, the DTI is putting on a very public face this year in many areas, to encourage industry to be innovative, to reward inventiveness and, among other things, put academics in touch with the real world. This last initiative, called the Senior Academics in Industry Scheme, should not only continue but should be extended to all interested parties at Universities, colleges and schools. Bridging this part of our great

divide can only bring benefit to both sides. The problem, typified by the now well known British phrase or syndrome of 'Another lost invention to a foreign country', applies to both academics and creative hobbyists, who also encounter a third party to this problem - the unscientific, uninterested financial institutions who do not appreciate a good invention when they see one. The shift from a dwindling manufacturing base to service industry in the UK has been caused by a variety of things, but a continued, co-ordinated relationship between government, industry and academia could well provide the necessary impetus for a reversal of that trend.

OPEN CHANNEL



To HDTV or not to HDTV

In a not-altogether surprising move, Société Européenne des Satellites (SES) - better known as the organisation which runs the Astra group of satellites - has said it won't yet be supporting high definition television channels for transmission from its existing and foreseeable satellites.

While it has always been an option to be able to transmit high definition signals from its satellites (some tests have already been carried out which prove its viability) and it has often been that assumed later satellites in the series (Astra 1D, due to be launched late next year, as well as others) will be used for the purpose, SES has decided it will not be so.

Instead of transmitting high definition television signals, SES plans to use a new digital compression technique which will allow a single digital video channel to be compressed down to 8Mbit s⁻¹. From each digital transponder channel on the satellite, 6 to 10 channels can therefore be transmitted,

depending on required picture quality.

This isn't pie-in-the-sky. Decoder integrated circuits have already been designed by three manufacturers and these are due to be available for commercial use before the satellite launches. SES' decision to eschew high definition television calls into question the whole prospect of European attempts to develop a decent high definition television system. Simply because no-one has been able to get the European broadcasters, manufacturers and users to decide on a suitable system it all looks like going the way of the Cheshire cat. Soon, there'll be nothing left of European high definition television except its own grin.

SES has taken this step simply as a logical consequence of the high definition television debacle. As a spokesperson for SES says - any transmission service has to be driven by broadcasters' requirements. There are simply no high definition television receivers to broadcast to, and there won't be for many years yet.

Low-Earth What?

In a previous Open Channel, I've already covered Motorola's project to produce a series of low-earth orbit (LEO) satellites for a worldwide mobile 'phone system. Motorola's project gained the nickname Iridium, as it was originally designed with the same number of satellites (77) as the element Iridium's atomic number. I've also reported

the later plans to use fewer satellites - which calls into doubt the project's name, I guess. Now, another satellite mobile 'phone system has been announced by Inmarsat (the International Maritime Satellite Organisation) which could well cut right across Motorola's plans to use low-earth orbit satellites. The project is known as Inmarsat-P.

Inmarsat is an international partnership of some 67 countries which to date has existed primarily to provide maritime and aviation communications systems (from ship-to-satellite, 'plane-to-satellite and so on). Inmarsat-P is intended as a consumer communications system, which greatly changes the organisation's main role. Users will have a tiny, handheld 'phone which will work over all parts of the globe. If it goes ahead with the Inmarsat-P, the organisation intends to launch the service by the end of the century.

Actually, Inmarsat hasn't fixed upon a low-earth orbit system yet, but it's a fair bet that it will. Other alternatives currently being considered depend upon where the satellites are pitched in orbit around earth. While low-earth orbit satellites are quite close to the earth's surface, an intermediate circular orbit (ICO) system needs fewer satellites (12 to 15) higher up, while a geostationary orbit (GSO) system needs even fewer satellites - theoretically, just three. However, the higher the orbit, the more expensive the satellites and the more powerful a transmission system they need to have, so overall costs tend to even out and it becomes just a technical decision which system is used.

Inmarsat has recently awarded contracts to various companies worldwide to study the options of the three satellite system methods. Marconi and British Aerospace both have contracts. Work on the contracts has already started and interim results are expected by the end of May - I'll be reporting when these are published.

There's no doubt, whether users (that is, you and me) want portable communications or not is simply a conjecture on the behalf of all the telecommunications providers. The (almost) runaway success of cellular 'phone systems has made all manufacturers rather bullish about future systems. The fact that everyone who might ever need mobile communications has probably already got an acceptable system, and that further systems will simply be underused (if not merely not used at all) seems to have escaped their attention.

The New Man

Ofel has a new boss. As Sir Bryan Carsberg leaves the post, new man Don Cruickshank slips quietly into the hot-seat. Mr Cruickshank, although not that well-known in the field of telecommunications and electronics, is famous for the revisions he undertook in his last job as chief executive of the National Health Service in Scotland. He had a reputation for hard-negotiating, so it looks like British Telecom (Sir Bryan's long-term adversary) will find it no easier to get along with Ofel's new chief than it did the last.

Keith Brindley

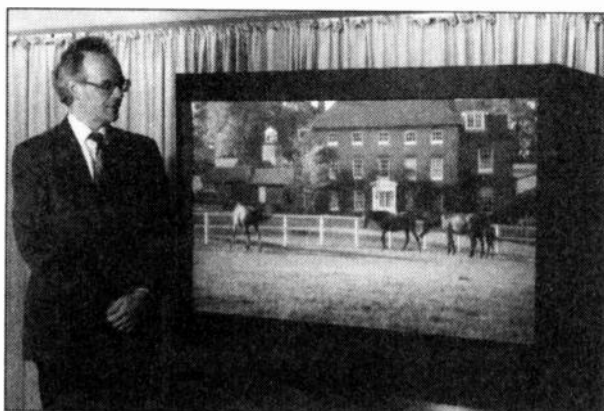

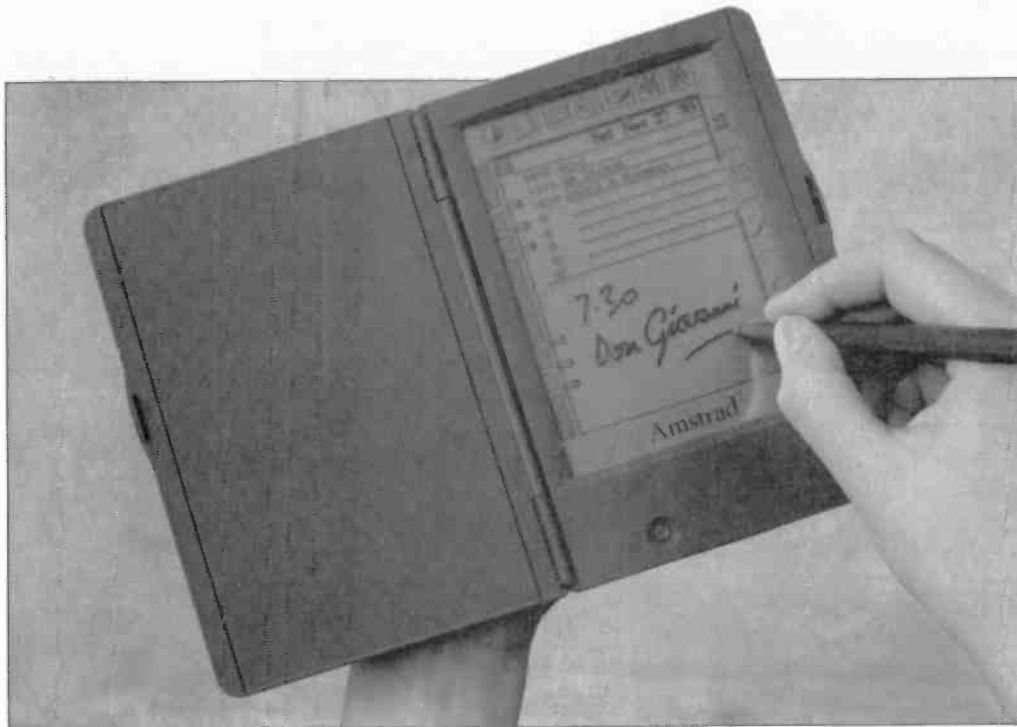

Amstrad plc has recently launched Pen Pad, a slim, pocket sized personal organiser, at a press conference held at London's Science Museum.

The Amstrad Pen Pad recognises handwriting and turns it into text for storage, transfer, fax transmission or printout. Designed for international markets, the unit is fully multi-lingual, with the owner selecting the desired language when first switching on.

Directed squarely at the traditional 'loose-leaf and more recent electronic organiser markets, the Pen Pad PDA600 uses a simple 'pen' for all input, doing away with the need for a keyboard. It will reach the shops with a £299.99 (inc. VAT) price tag.

PEN-PAD COMPUTER FROM AMSTRAD

Announcing the Pen Pad, Amstrad chairman Alan Sugar said: "Never has a new product category been so hyped by major world computer suppliers, without any evidence that their equipment is actually nearing production. I keep reading about PDA machines that are due from the States, but we have yet to see one working. Their deadlines come and go, but I am pleased to say that Amstrad, without any advance publicity, will start to ship the Pen Pad in May, at a price that will embarrass the competition

when their products eventually arrive."

Weighing 400gm, the Amstrad Pen Pad is lighter and less bulky than a traditional loose-leaf organiser, but it is its ability to recognise your handwriting, no matter how illegible, that is its main selling point.

When you open the cover of the A6 sized Pen Pad, you find a LCD screen, along the top and side of which are ranged a number of symbols, each depicting a function. The 'pen', a slim stylus, is then used to touch the desired

function symbol. The pen can then be used in a normal way to update or add to the diary, address/telephone listings, meetings lists and the other functions available, or to create pages for storing handwritten notes, sketches and diagrams.

Among the features built into the Pen Pad are a full function calculator, calendar, automatic phone dialling, a search facility by word or number, alarm calls and world time clock. Running for up to 40 hours on 3 AA batteries, the Pen Pad can additionally be connected to any printer with a serial port for data printout and will link up to any PC for data back-up and transfer of information.

You can also connect a pocket fax modem and, with a software applications card, transmit handwritten notes, diagrams and text by fax.

A standard PCMCIA slot has been incorporated for memory expansion cards to give up to an additional 5000 pages of recognised text, or to load in other ROM card based applications such as travel guides, spread sheets and so on.

1.6GHz SPECTRUM ANALYSER IN A PC

Chase Electronics has launched the model 9052, a fully featured spectrum analyser that slots directly into a PC, manufactured by Morrow Technologies Corp.

Frequency coverage is from 100kHz to 1.6GHz with a ± 1.5 dB level accuracy, a resolution bandwidth of 300Hz to 3MHz and up to 5×10^{-8} frequency stability as a result of direct synthesis.

The product is for remote monitoring applications and simple connection to a modem is all that is needed. Other facilities include the ability to display up to four traces in user-definable colour. Traces and set up data are

stored on disk, readily accessible for reuse. Automation of test sequences is also an option.

Captured sweeps can be zoomed in, to view the narrow detail of a signal, without the need to resweep and overlays can be drawn, providing user definable windows for go no-go measurements. In addition, full marker functions include peak-find, tracking, delta and zoom.

A burst mode also allows detection of sporadic, short duration signals. Here, frequency cells are scanned for a user definable dwell time and the peak signal held.

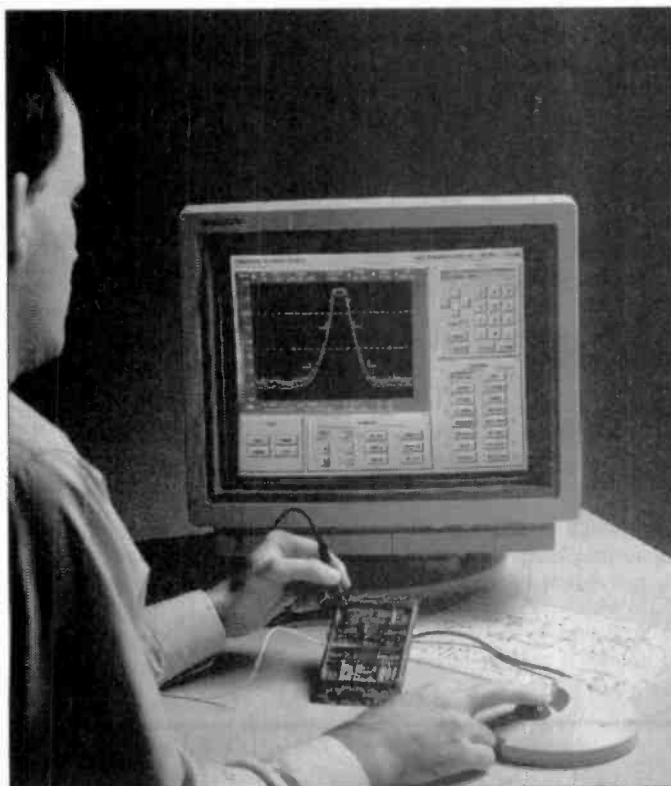

NOTEBOOK- PEN COMPUTER

Tandy GRiD Europe has started shipment of its Convertible, the Windows notebook PC that is also pen based. It functions equally as a notebook and a pen-tablet PC and provides the capability to use PC software.

With the screen raised, the Convertible is a standard notebook PC with a 79-key industry

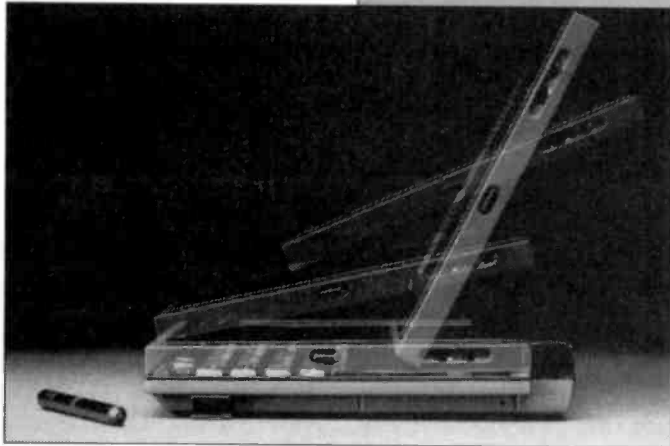

standard keyboard. In that mode, this computer can use a standard mouse pointing device, but many users find it more natural to use

the Convertible's pen for that purpose. With the screen folded down, the Convertible becomes a pen-input tablet computer.

The GRiD Convertible is based on a 25MHz, Intel 386SL processor. It comes with 2MB RAM, expandable to 8MB, and a 125MB hard disk drive. The Convertible is packaged in a slim, magnesium case and comes bundled with the latest version of the MS-DOS operating system and Microsoft Windows for Pen Computing software. It also supports PenRight, GRiD's DOS-based graphical applications package.

The Convertible comes with an attached 3.5", 1.44MB floppy disk drive. It also contains a PCMCIA version 2.0 compatible

expansion slot which can be used for removable storage media such as the new Sundisk SDP flash memory card.

The system features a backlit, 9.5" (diagonally) VGA screen with 640 x 480 resolution. Simultaneous colour VGA output is available for a monitor or video projection system. The GRiD Convertible measures 295 x 239 x 41mm. It weighs 2.5kg, including standard battery. The unit is now available in 25 countries through GRiD's local offices and their direct and indirect sales channels.

NEW READER/WRITER

Mitsubishi is announcing the introduction of a PCMCIA and JEIDA memory card reader and writer system and development kit, following cooperation with Elan. The unit is said to be high speed, flexible and reliable, as well as providing low cost development, emulation and copying capabilities.

The reader/writer should enable Mitsubishi memory cards to be programmed at speeds up to 100 times faster than alternatives. Two versions are available, for either internally mounting in a standard IBM PC or compatible 3.5" disk drive frame or alternatively a stand alone peripheral which is connected to a PC via a ribbon cable. Read and write support is provided for RAM memory

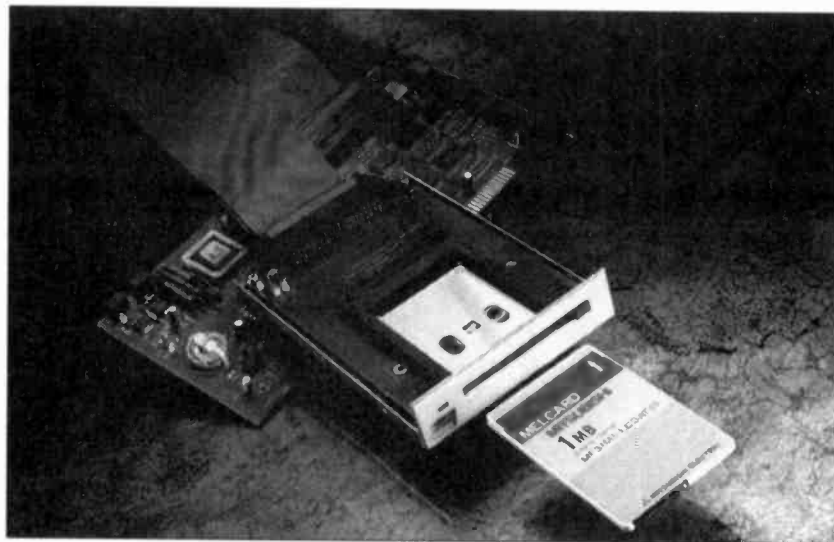

cards featuring PCMCIA and JEIDA standard connectors and optional software is available for Flash, OTP, EPROM and EEPROM versions. The units come with an 8/16bit interface

card which is plugged into an expansion slot on the host PC and an appropriate interface, according to whether you have the internal or external version. An range of low level card drivers is also

provided, together with a Mitsubishi 1Mb SRAM card and transparent software for programming and editing.

The optional software enables memory cards of up to 64Mb to be programmed on the system. All card lines are fully buffered to provide protection to the card and host systems. The software options available include a socket service driver, to allow users to interface their own application programs to the reader/writer and to address the low level drivers.

DOS line commands can also be supplied to allow for card addressing using standard DOS commands and the FFS2 DOS FAT allows floppy disk emulation.

AMUSEMENT ARCADE WORKERS HIT TRAINING JACKPOT

A Dulwich-based company hit the jackpot the day it came up with the idea for a fruit machine called Seven Heaven. The model has sold over 10,000 machines in the past three years and it has become the biggest-selling gaming machine in the UK ever.

Project Coin Machines Ltd, of Parkhall Industrial Estate, became aware that the workers who assembled Seven Heaven and other machines actually had very limited knowledge of the whys and wherefores of fruit machine technology, so they approached nearby Lambeth College's commercial arm, called Enterprise, who were able to come up with a

training scheme to introduce 11 staff to the concepts of electronics.

The company are just one of the many businesses to take advantage of the Services to Business offered by the region's colleges and universities.

Any businesses with a problem that requires training, consultancy or research can consult the free Services to Business Guide issued by the Department for Education.

Dympna Hardy, Project Coin office and personnel manager, said: "We felt it would be better if all the staff, both on the assembly and servicing sides, knew more

about basic electronics, and we were very pleased when the college was able to come up with just the course we wanted, for what was, after all, a very particular product."

Lambeth College has now gained special accreditation to run a City and Guilds Amusement Arcade Technicians Course and hopes to run other, higher level courses for the company in the future.

Dick Palmer, college director, said: "Fruit machines are very complicated things, full of micro electronic circuitry. It used to be that the company's factory staff just slotted the components

together, with little understanding of what the parts were, or how they worked. We believe that the course has allowed the company to make good progress on the quality side of its operations."

As well as illustrating the breadth of specialist areas on offer, the Guide includes a list of contact names, phone numbers and addresses. It is available by phoning 081 533 2000, quoting INF 060.

For more details of the schemes, you can contact Dympna Hardy, Project Coin Machines Ltd, on 081 671 5114, or Dick Palmer at Lambeth College on 081 670 4488.

ALARM CONTROL UNITS

Autona Ltd has released two new alarm control units to add to their range of security products known as the 2000 Series. The microprocessor based panels have been designed to provide all of the necessary functions required for controlling security systems, from the most basic up to the advanced multi-sensor installations found in commercial applications.

The models differ only in the method of switching, offering a choice of keyswitch or keypad operation; the keypad version allows the user to enter pass codes between 2-12 digits.

Simplicity of operation and ease of installation were two of the major design objectives which contributed to the decision to use an 8 bit microcontroller to monitor a variety of sensing loops, control switching and timing functions.



Loop response time is accurately defined which provides a high degree of immunity to any radiated or mainsborne interference.

The particular controller used, a PIC 16C54, provides the required I/O lines in an 18 pin package and is so code efficient that the complete operational software together with the installation test

routines is contained in only 512 bytes of ROM. With the resulting reduction in size of the circuit board it was possible to reduce the overall size of the steel enclosure by more than 40%, over the previous model, even after making provision for a full size 1.2A stand by battery and an internal siren. The temptation to include a number of gimmicky

features was stoutly resisted so the units could be operated by all members of the family without the need for extensive familiarisation.

The 2150 is priced at £49.95 +VAT and the 2250 is available at £54.95 + VAT

For further information contact Autona Ltd. on 08444 5740

INDUSTRY DOORS OPEN FOR SENIOR ACADEMICS

Some of the country's top academics could soon be helping innovative British firms under the terms of a new government-backed initiative.

Senior British academics are to be invited to participate in a new Department of Trade and Industry scheme, working in industry on four to six-month projects. The initiative is called the Senior Academics in Industry Scheme (SAIS). Leading researchers from science and engineering departments in higher education will be eligible to take part in strategic new technology

projects - particularly those involving small and medium-sized companies in manufacturing and engineering.

Participating academics will require a minimum of 10 years senior academic experience and high-level expertise in the field of the proposed project. However, lack of previous direct contact with industry will not be a disadvantage - one of the main objectives is to help senior academics and their faculties to increase their sensitivity to industry's needs and practices and reflect these in their teaching and research.

Although any size of company can benefit from a placement, small ones (with fewer than 250 employees) will be given preference. Projects should be of strategic importance to the company's research, development, design or manufacturing activities. Companies will oversee the projects, provide the necessary support staff and resources and may need to make a contribution towards academic costs. The DTI provides funding to assist the higher education institution to release the academic for the duration of the project.

The Teaching Company Directorate (part of The Cranfield Institute of Technology) has been chosen by the DTI to run SAIS because of its long experience in managing the Teaching Company Scheme.

Over the past 17 years, the Directorate has set up and run well in excess of a thousand Teaching Company Programmes, which are intended to help companies grow through tapping academic expertise and developing young graduates for industrial careers.

TALKING DIGITAL MULTIMETER.

Maplin's latest Talking Digital Multimeter is designed to provide additional safety and convenience when working on mains or high voltage equipment, or in conditions where positioning of the test probes makes reading a meter difficult or impossi-

ble. Housed in a slim case, the probes are not detachable, but when not in use, are wrapped round the outside of the case and held in a recess.

The probe tips are held in two receptacles on the side of the case for safety. A 3-position voice

switch selects either off, single or auto. While in single mode, an announcement is made only when a talk button on the positive probe is pressed, or whenever there is a change in range in manual mode or a change of function. When in auto mode, an announcement is

made whenever there is a new reading captured.

A further handy feature, is the 'memory' switch, which is used to record the measured data and recall the most recently made memory entry.

DON'T MISS OUT!

SUBSCRIBE!

Guarantee your home delivery of
ELECTRONICS TODAY INTERNATIONAL
at no extra cost to you,
SUBSCRIBE NOW
- make SURE of your post-free* copy.

Get inside every issue!

*U.K. only.

GET IT DELIVERED!

Please commence my subscription to *ELCTRONICS TODAY INTERNATIONAL* with theissue. (If renewal please quote subscription number).....

I enclose my cheque/MO for £.....made payable to ASP or please debit my Access/Visa

Card No.....Expiry Date.....

Signature.....Name.....

Address.....

.....Post Code.....

SUBSCRIPTION RATES: UK £23.40, Europe £29.50, Sterling Overseas £31.00, US Dollars \$56
Please return coupon to: Argus Subscription Services, QUEENSWAY HOUSE, 2 QUEENSWAY, REDHILL, SURREY RH11 0QS.

Please note you may receive further information about offers and services which may be of particular interest to you.

**CREDIT CARD
HOTLINE
0737 768611**

DMO

Simulating electrical cooling

Models simulating the way electronic products cool are usually in the form of finite-element analysis or computational fluid dynamic software. Both approaches require hefty investments in software and hardware.

Sauna is a package that calculates classical equations or closed-form solutions and models components such as enclosures, heat sinks and sources, and cooling modes.

To examine the software features, Thermal Solutions constructed a rectangular heat sink, added fins to it, positioned and identified a heat source on it, and calculated the heat flow throughout the assembly to an ambient.

In the modelling process, the programme draws a rectangular

outline (the plate) and fills it with nodes, each connected to adjacent nodes with thermal resistors. A few simple menu selections added fins to one side of the plate.

An off-plate node was then chosen to represent ambient temperatures on the fin side and another isolated node on the opposite side was chosen to represent air that would be inside an enclosure with plate-mounted components. The software automatically connects each plate node with two additional thermal resistors, one to the ambient node and one to the enclosure node.

Assigning nodes is analogous to meshing in finite-element analysis.

After assigning values to the heat source and ambient and component-side temperatures, the programme calculates plate and source temperatures. Modifications and additions are easily made.

The evaluation copy lets users model only the problems in the manual, but it provides a good feel of the software's flexibility and potential problem complexity. For example, models can also include enclosures, multiple PCBs and heat sources and sinks.

A standard version lists for \$995 and the advanced \$2,995 version tackles more complex enclosures and modules.

Thermal Solutions, 3135 S. State St., Suite 108, Ann Arbor, Michigan

World's first semantic network

A group of former radar engineers has created an infor-

mation-retrieval system that purports to conquer vague and ambiguous English. Conquest Software Inc.'s ConQuest is said to be the world's first semantic network for pulling desired texts out of vast databases.

Conquest engineers applied a statistical approach to recognize

Charging electric vehicles

Filling stations equipped with hookups for recharging batteries on electric vehicles look like being the thing of the future in the US. Carmakers and utility companies are now looking at several systems and will choose a standard based on cost, safety, and convenience.

Perhaps the safest system proposed so far is Hughes Aircraft Co.'s inductive charger. Working with parent company General Motors, Hughes designed a family of charging stations that transfer energy magnetically rather than electrically. An inductive coupler, basically an electromagnet, fits in the vehicle and a pickup coil automatically clamps around it. Power

flows from the coupler to the pickup through magnetic induction.

Covered in plastic, the paddle-shaped coupler is easy to handle and presents no shock hazard. This contrasts with conventional 220V plugs and cords which are cumbersome.

Hughes originally developed inductive couplers for powering valves on oil-well heads at the bottom of the North Sea. To shrink the components enough to fit into cars, Hughes used technology from its high-frequency radar systems. Fast switching circuits based on IGBTs (insulated-gate bipolar transistors) boost line frequency to around 80kHz, letting designers use smaller coils and capacitors than normal. Little energy is wasted as heat because of the low-loss switches. The designers also used special RF shielding techniques to stem electromagnetic interference.

concepts in text. A textual database is first indexed by the concepts in it. Plain English queries are subjected to morphological, syntactical and semantical analysis and reduced to a statistical amalgamation of the concepts contained in them. Obvious matches with a database of documents are displayed immediately, while the system finds and ranks less obvious matches. The user can type English queries or merely give examples of documents in the style of those desired.

ConQuest's technology depends upon its semantic network of 250,000 common English concepts - a superset of a dictionary, thesaurus and the WordNet database from Princeton University. WordNet goes beyond ordinary dictionaries by weighting the

relations among words. For example, 'platypus' has a 50% link in the semantic network to 'mammal' and 50% to 'fish'. WordNet also reveals many other relations in non-traditional approaches, such as part-of relations (a 'wing' is part of a 'plane' and a 'bird'), kind-of relations ('vodka' is a kind of 'alcohol') and other weighted links.

Specialised concepts can be added by the user, or attached with specialised dictionaries available for engineering, scientific, medical, pharmaceutical, legal, financial and others.

ConQuest's approach does not attempt to truly understand words, but rather to quantify the subtlety of distinctions among the concepts they denote.

Conquest Software Inc., Columbus, Maryland.

Call us now! We have the widest range of components available - At competitive prices

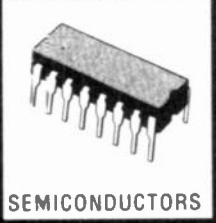
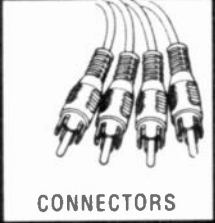
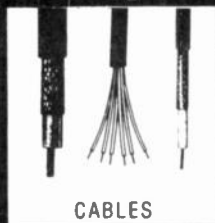

CRICKLEWOOD
ELECTRONICS

Cricklewood Electronics Ltd. 40 Cricklewood Broadway, London NW2 3ET.
Telephone: 081 452 0161 Faxsimile: 081 208 1441

All Major Credit Cards Accepted



READ/WRITE **ETI** Letters

45Watt Hybrid Valve Amp

Much interest has surrounded this design of amplifier featured in our September issue last year. We feature a few comments and suggestions made about the amplifier here in order to help constructors. -Ed

The September 1992 issue of ETI described amongst other things a 45W Hybrid Power Amp. I found this project quite interesting and consequently I wrote to Hobtek, the company mentioned in the article.

After the reply from a Mr Henderson I decided to buy a kit. I sent £192.00 to Hobtek on 14th October last year. Some weeks later I received a letter from Mr Henderson confirming the arrival of my money. In November I received another letter from Mr Henderson. In this he explained the delay for the delivery. Furthermore he gave a firm despatch date for my kit.

Since then I have not heard anything from Mr Henderson and I have not received any kit. In December I wrote to him asking him to explain his failure to deliver. Mr Henderson has not cared to answer my letter. I have lost interest in the whole project and would prefer to have my money back.

Leif Urdén
Taberg
Sweden

We have had similar complaints to this letter. The matter is under investigation - Ed.

Having read the article in your September Edition of ETI I am concerned that the 45W Hybrid Power amplifier has some serious flaws in its design.

The biasing arrangement in valve power amplifiers is crucial if you want to achieve both performance and good life from your output tubes.

To quote the article "Valves require a negative bias voltage on their grids to operate correctly. Normally this is achieved by con-

45W Hybrid Amp Modifications

N Brooks
London

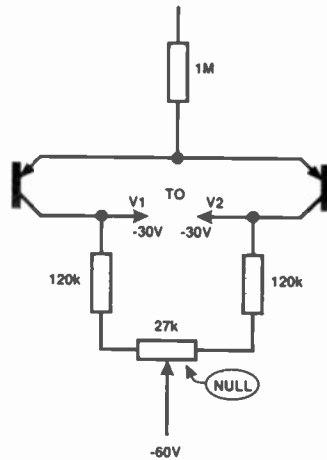

TOTAL RESISTANCE = 267k

MIN. HUM CANNOT BE ACHIEVED WITHIN RANGE OF 27k PRESET

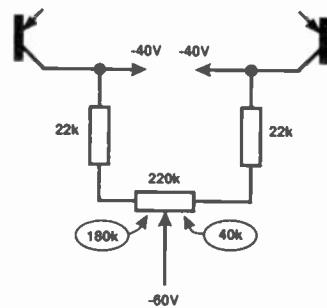

THEREFORE 220k PRESET +22k +22k USED

TOTAL RESISTANCE = 264k

g1

VOLTAGE = -40V
-40V

ZERO HUM ACHIEVED WITH PRESET OFF-CENTRE

AUDIO RESULT= FULL RANGE, BUT MID AND UPPER RANGE DISTORTED

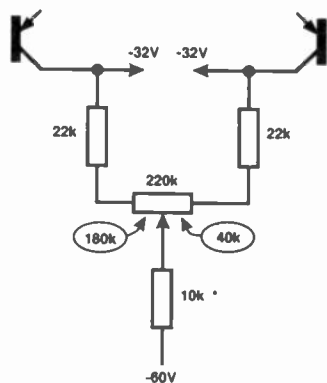

THEREFORE ADDITIONAL RESISTOR PLACED IN -60V SUPPLY 10k*

TOTAL RESISTANCE = 264k

g1

VOLTAGE = -32V
-32V

ZERO HUM ACHIEVED

BUT SIMILAR MID AND UPPER RANGE DISTORTION

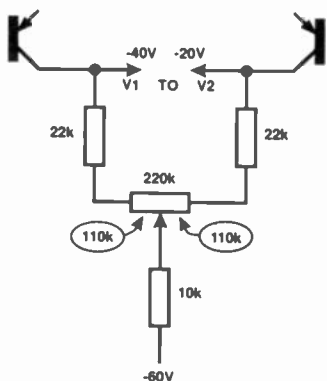

IF PRESET WIPER SET CENTRAL DISTORTION DECREASED

HUM LEVEL IS HIGH

g1 VOLTAGES -40V ON V1
-20V ON V2

V2 GRID IS RED HOT

necting a small resistor between cathode and ground.....A better method is to use fixed bias....

What this paragraph does not explain is:-

A. The resistor used in cathode biasing provides a degree of -ve feedback around the output tube keeping the DC current in the tube constant with respect to tube age and temperature.

B. Fixed bias may be fixed but it is usually adjustable. There is no way in the current circuit to adjust the bias current. Usually you include a 10R resistor or so in series with the cathodes in order to measure the tube currents and you adjust the bias to achieve the desired quiescent current. A simple but crude modification to this circuit could be achieved by replacing R3 with a 1M trimpot in series with a 500k resistor.

With the circuit as stands the bias current is totally dependent on the make and condition of the output tubes. It is quite possible that with one set of tubes you get horrific crossover distortion and with another you would get scorching class A and the tubes only last 50 hours. With a good set of tubes costing 50 pounds or so

and Mullard ones costing hundreds of pounds, building a circuit which gives output tubes good life is vitally important. With few people left who understand valves it is a shame to show such poor quality circuits to the new generation of hobbyists. If I had built this circuit when I was younger it would have put me off tubes for life.

Marco Corsi
Design Engineer
Texas Instruments

In November last year I bought the kit and although I had a few problems at first I have successfully constructed it and have had a couple of months to assess the performance.

I had a few problems setting up the amp as instructed and wondered whether any others had experienced the same difficulties.

I was unable to balance the output valve bias voltages with the original MPSA92s. Their h_{FE} values varied between 85 + 150! Fitting selected with similar h_{FE} values (approx 96) seems to cure the problem.

After sitting up the voltages to balance and then removing the

short circuit from the inputs the balance was unstable - moving out of balance quickly with one of each pair of EL34s getting overheated. Changing the value of R1 (R1a) to 100R seemed to cure the problem.

The amplifier was very sensitive to any DC component coming in with the input signal but this was cured by fitting a couple of good quality (audio) capacitors in series with R1 & R1a at the input.

The toroidal transformer incorporates all mains/heater/bias windings on the one unit, but I found that the winding that produced -40V was a little too low and the unit gets far too warm! It's

best to fit separate 20-0-20 6VA type separately as in the schematic.

The feedback connections shown in Figure 6 overlay should be transposed (as schematic).

I don't have access to the manufacturers data for teh EL34, but presume -30V is correct although my 20-0-20 transformer gives a little more than the calculations given and seems to work OK. The whole amp runs much cooler than with the much lower bias voltage than the transformer provided, being around -23V.

E Bentley
Buntingford
Herts

An Omission On Infra-guide

Last month we failed to mention where you could get the main printed circuit board for the Infra-guide project. The board, a double sided one with plated through holes, has been professionally made and is available from the author at the following address:

PC Designs,
38A High St,
Ealing,
London
Tel: 081 579 1881

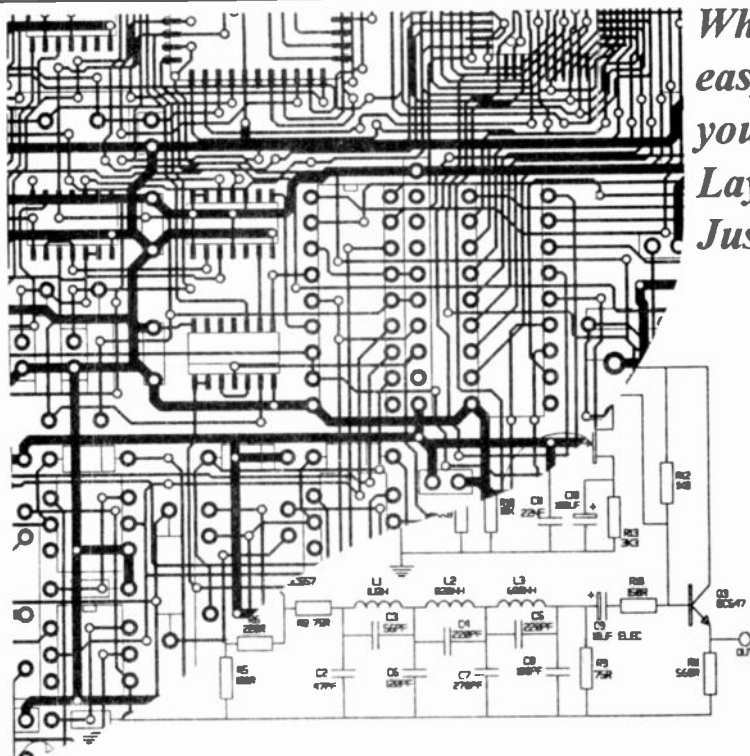

Layo1 is priced at £99 up to £999 (ex. carriage & VAT) which includes: Layo1 Schematics, 90 days FREE updates and technical support.

What more do you need than a practical, easy to use and fast program to design your electronics in your own way? Layo1 is the ideal solution to do just that. Just ask the thousands of satisfied users!

Layo1

- > Netlist import via Project Manager from Layo1 Schematics
- > Also for OrCAD/SDT, Schema III, Tango etc.
- > Forward Annotation
- > Graphics netlist entry
- > Manual-, Interactive and Auto Routing
- > Design Rule Checking
- > SMD Support
- > Extensive component library
- > User definable Macro's

Powerfull output drivers for:

- > Gerber photoplotters
- > Excellon, Sieb&Meyer and HPGL drillingmachines
- > HPGL, DMPL compatible penplotters (with open pads)
- > Adobe 2.0 Postscript (with open pads and 10 greyscales)
- > HP-Laserjet, Deskjet and Epson compatible printers

UK Distributor

Pentagram Electronic Designs
6, Pasture Close, Clayton, Bradford BD14 6 LY
Phone: (0274) 882609 Fax: (0274) 882295

LAYO1

International headquarters

Baas Electronics bv Rijksweg 42
3281 LW Numansdorp The Netherlands
Phone: (+31) 1865 4211 Fax: (+31) 1865 3480

5-Band Graphic Equaliser

Designed by our
Electronics
consultant, Andrew
Armstrong.

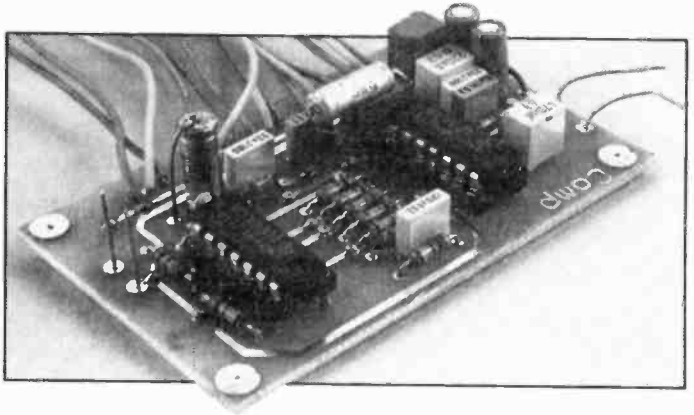

For today's sophisticated musical reproduction systems, a conventional tone control circuit is perhaps too coarse in its control. No longer is the tone control necessary to compensate for glaring defects in the equipment and modern listeners want to be able to make fine adjustments to the sounds they hear.

More often than not, the response of the hi-fi equipment is reasonable, the recording engineers have balanced the sound recorded onto the CD for their intended audience, so that the main reason for adjusting the frequency response of a sound system is to compensate for room resonances. To do a really good job, one might choose an octave - or even half-octave - graphic equaliser, but very good results can be obtained even with a five-band unit in many cases. Here is a project to build a five-band equaliser with hi-fi performance.

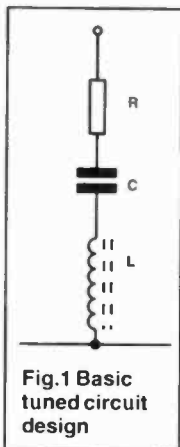

Fig.1 Basic tuned circuit design

Tuned circuits

The unit tailors the frequency response by applying tuned circuits set at various frequencies to the feedback loop of an op-amp. The tuned circuits are of the series-resonant type, as shown in Figure 1, so that at resonance, the circuit presents an impedance which is completely resistive and has the value R . Far above the resonant frequency, the impedance of the inductor is very high, so that the circuit presents a negligible load, while at frequencies below resonance, the impedance of the capacitor is high. This gives rise to the standard form of resonance curve shown in Figure 2. Referring to the circuit diagram, shown in Figure 3, no actual inductors are present. Instead, op-amps have been used to simulate inductors, in order to obtain the required value of inductance as a function of easily-obtainable resistor and capacitor values. This type of circuit is called a gyrator.

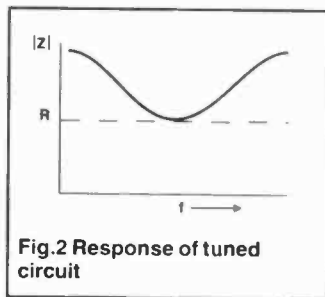
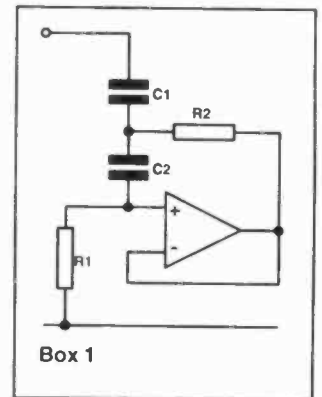

Fig.2 Response of tuned circuit

abrupt change of voltage at the junction of $C2$ and $R2$ will cause the non-inverting input of the op-amp to track the voltage change. This causes the output to track the change, so that the current in $R2$ does not change instantaneously. During the period following a step-change of voltage at the junction of $C2$ and $R2$, $C2$ gradually charges through $R1$, meaning that the voltage on the op-amp's input and therefore on its output, gradually returns towards zero with an exponential time-constant. This causes the current in $R2$ to change, tending exponentially towards a new value. This is exactly the behaviour expected from a series combination of a resistor and an inductor.



Box 1

R1	R2	C1	C2	Frequency Hz	Q
68k	680R	122n	1220	61	1.00
68k	680R	39n	330n	206	0.92
62k	620R	10n	100n	812	1.00
68k	680R	2n7	22n	3037	0.90
62k	680R	0n68	8n2	10380	1.05

Table 1 Active tuned circuit calculation

Table 1 shows the component values, centre frequencies and Q values for the five tuned circuits. In order to minimise the frequency-response ripple at maximum boost or cut, the resonances should be chosen to overlap at approximately their 3dB points. With the frequencies chosen here, a Q value of approximately 1 is suitable. Anyone who wishes to can, by making use of the mathematics given, devise an equaliser of a greater number of bands, in which case high Q values appropriate to the spacing of the bands would be required.

HOW IT WORKS

Referring to the circuit diagram shown in Figure 3, the input signal is capacitively coupled to the non-inverting input of IC1a, which is used to buffer the signal because a low-impedance is required at this point, to minimise noise pickup on the potentiometer wires. Ignoring the potentiometers for a moment, the signal is fed via R2 to IC2c, which serves as a unity-gain buffer DC-coupled to the output.

If all potentiometers are set at their centre point, then any loading on the sliders will pot down the input signal to the non-inverting input of IC2c, while similarly potting down the negative feedback and providing a gain which compensates the potting-down of the input signal. In this state, therefore, we still have unity gain at all frequencies.

If the 206Hz slider, RV2, is moved to the inverting input end of its travel, the action of potting down the negative feedback is, at resonance, much greater than the potting-down of the input signal, so that the system exhibits a net gain at this frequency. Similarly, if the slider is moved to the non-inverting input end of its travel, the input signal is potted down while the negative feedback is not, so that there is a dip in the response at 206Hz. The same reasoning applies to all of the potentiometers.

Local decoupling is provided on the board to minimise the effects of crosstalk through the power supply.

Construction

The unit may be assembled on the PCB designed for it. Note that a single pcb accommodates a mono equaliser, so two PCBs are required for stereo. The board is double-sided, but it has been laid out so that top-soldering of components is not required. All links from top to bottom of the board may be carried out using track-pins or pieces of tinned copper wire, such as clipped-off component legs. Top-to-bottom links should be installed first. Any constructors who wish to make their own PCBs should be able to make the unit work with a single-sided board, using a combination of tinned copper wire and insulated copper wire links on the top to make the necessary top-connections.

Note that, although it is not shown on the circuit diagram, the unused quarter op-amp has its non-inverting input connected to 0V and its inverting input connected to its output. This avoids the possibility of noise pickup or oscillation which may crosstalk to other channels.

Two quad op-amps are used in this unit and the type of op-amp may be chosen according to the quality required from the completed item. The lowest-cost op-amp suitable for the job is the LM324. The slew-rate and noise performance of this device is such that constructors may prefer to substitute the LM837, which is designed for audio use.

The extremely-picky may instead prefer the OP-470GP, but the only characteristic on which my data-book shows it as being markedly superior is on channel separation. As it costs nearly three times as much as the LM837 I would not be inclined to choose it myself.

When all the components on the board have been fitted, the potentiometers should be connected. None of the connections to the pots is a ground connection - all are sensitive signal points. For this reason, wiring to the pots should be kept as short as practical and the power-supply should be positioned as far as possible away from the potentiometers.

The graphic equaliser may be added to an existing piece of equipment which already contains a power supply. If this is the case, then it may be possible to power the unit directly from the main power supply of the equipment, or a pair of extra voltage regulators may be needed. A 7812 and 7912 would do, so long as the equipment power-supply does not

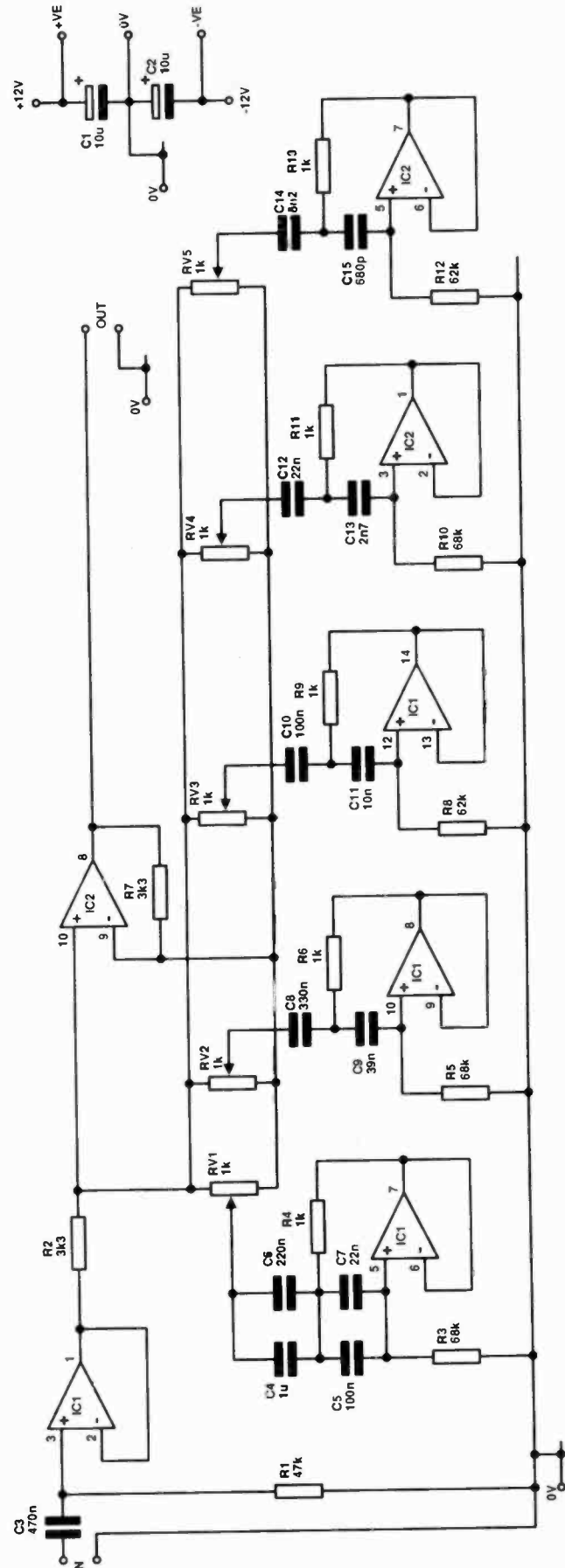

Fig.3 Circuit diagram of Graphic Equaliser

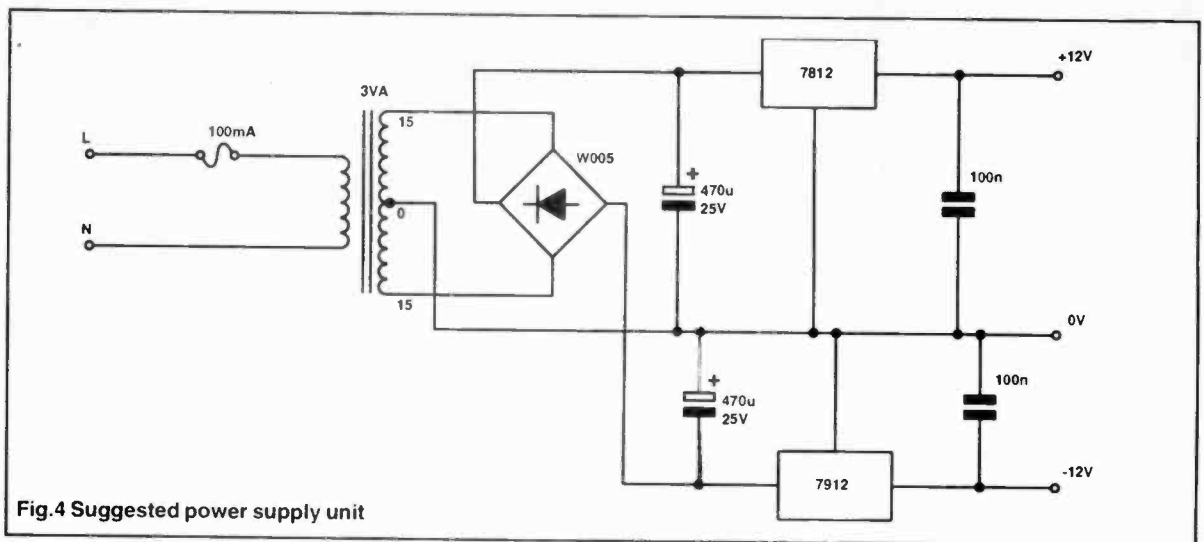

Fig. 4 Suggested power supply unit

exceed 40 volts under any conditions, otherwise LM317 and LM337 would be necessary. In cases where even the voltage rating of the LM317 and LM337 is inadequate, a separate power supply is recommended. Figure 4 shows a power unit for use when no suitable power supply already exists.

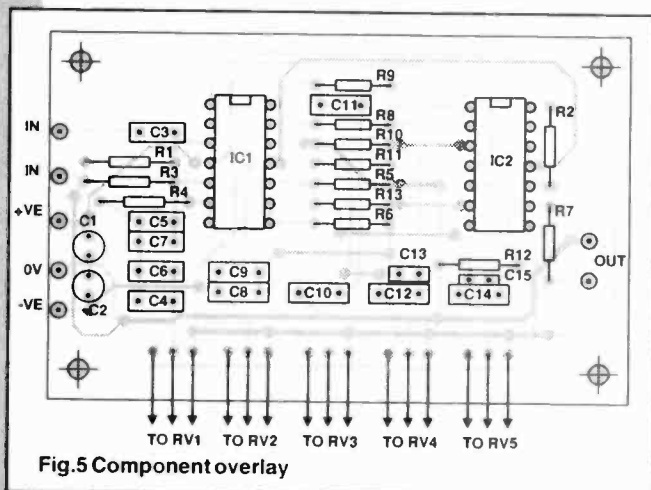

Fig. 5 Component overlay

Testing

Testing of the unit should be straightforward. First of all, power it up and measure the output voltages of all the op-amps. Check that no output is more than a few mV from zero. If any output shows a significant offset, then look for solder blobs, badly soldered joints and so forth, around that IC.

When all the offsets are close to zero, you can either feed in an audio signal, for example from a CD player, and feed the output to an audio amplifier, then listen to the results of adjusting the slider controls. Alternatively, if you have an oscilloscope and a sweep-generator, you can check the response to various settings by connecting the oscilloscope to the output and synchronising its horizontal sweep to the frequency sweep of the sweep generator. Most oscilloscopes can be switched to XY mode, to permit the frequency control ramp of the sweep generator to perform the horizontal scan.

All should be well, but if it is not, remember to check that the output of the sweep generator is constant across the audio range before searching for faults in the graphic equaliser.

Test results

The model tested, shown in the photograph, has an extra capacitor fitted to it to make up the value 39n. As I have

discovered, 39n capacitors are not easily available, though Maplin do stock one. To make the prototype work I used 33n in parallel with 5n6, also a difficult value to obtain. Probably the nearest most bits boxes will have is 4n7 and 33n, which works well enough.

On test, the graphic equaliser frequencies were correct to within component accuracy, but when I checked the frequency response a minor snag appeared. With two adjacent controls at maximum, and the rest at normal, there was a dip in the response between the two centre frequencies.

Clearly the Q values chosen were too high, so an increase in the value of the damping resistors to 1k was necessary to make the response smoother. The original calculated values for R4,6,9,11, and 13 were 680 or 620R. Changing to 1k made the response acceptable.

I have left the original calculations unchanged as a demonstration of how easy it is to have minor problems even with carefully throughout analogue designs, and to show the need for careful testing to find any snags.

PARTS LIST

RESISTORS (0.25W 5% metal-film unless otherwise stated.)

R1	47k
R2,7	3k3
R3,5,10	68k
R4,6,11,13	1k
R8,12	62k
R9	620
RV1-RV5	1k slider pots

CAPACITORS

C1,2	10µ, 16V radial electro
C3	470n, 0.2" pin spacing polyester
C4	1µ 0.2" pin spacing polyester
C5,10	100n 0.2" pin spacing polyester
C6	220n 0.2" pin spacing polyester
C7,12	22n 0.2" pin spacing polyester
C8	330n 0.2" pin spacing polyester
C9	39n 0.2" pin spacing polyester
C11	10n 0.2" pin spacing polyester
C13	2n7, 0.1" pin spacing ceramic or polyester
C14	8n2, 0.2" pin spacing polyester
C15	680p 0.1" pin spacing ceramic

SEMICONDUCTORS

IC1,2	See text
-------	----------



AUTONA LTD

UK's leading module manufacturer since 1972

SECURITY EQUIPMENT DIRECT FROM THE MANUFACTURER

NEW 2000 SERIES MICROPROCESSOR CONTROL UNITS NEW ★ EASY TO INSTALL ★ SIMPLE TO USE



2250

£54.95
+VAT

- Auto alarm reset and reduction
- Alarm sounded memory
- Intelligent exit delay.
- Built in loop checks.

These brand new control panels use state of the art electronics to provide highly effective protection of the home, with all sizes of security systems. Attractively styled in a steel case and supplied with full instructions. Detailed colour brochure available.

2150

£49.95
+VAT

MINIATURE PASSIVE INFRA-RED SENSOR-RP33



Quantity discounts start at 3 units.

£16.95
VAT

Switchable Dual range, detects intruders up to 6 or 12 metres. This advanced sensor operates by detecting the body heat of an intruder moving within the detection field. Slow ambient changes such as radiators etc. are ignored. Easily installed in a room or hallway. Providing reliable operation from a 12V supply, it is ideal for use with the CA 1382 or equivalent high quality control unit. Supplied with full instructions.

Size 80x60x40mm

50FT INFA-RED BEAM-IR 1470

Advanced 12v system using modulated beam for security and industrial application



£25.61
+VAT

DIGITAL ULTRASONIC DETECTOR-US 5063

Variable sensitivity and adjustable noise threshold built in timing ideal for vehicle alarms.



£14.93
+VAT

FULL RANGE OF CONTACTS, CABLE, SIRENS ETC FOR COMPLETE SECURITY INSTALLATIONS

★ AUDIO MODULES ★

AL 12580-125W AMPLIFIER

A rugged high powered module that is ideal for use in discos & P.A. Systems where powers of up to 125W, 4 ohms are required. The heavy duty output transistors ensure stable and reliable performance. Its is currently supplied to a large number of manufacturers where reliability and performance are the main considerations, whilst for others its low price is the major factor. Operating from a supply voltage of 40-80V into loads from 4-16 ohms.

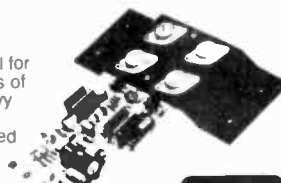

£18.95
+VAT

AL 2550-COMPACT LOW-COST 25W AMPLIFIER

High fidelity at a low price. This popular module with tens of thousands installed. Ideal for domestic applications. Supply rail 20-50v with load of 8 - 16 ohms.



£6.55
+VAT

MM 100-BUDGET 3-INPUT MIXER

With a host of features including 3 individual level controls, a master volume and separate bass and treble control, it provides for inputs for microphone, magnetic pick-up and tape, or second pick-up (selectable), and yet costs considerably less than competitive units. This module is ideal for discos and public address units and operates from 45V-70V.



£17.49
+VAT

MM 100G GUITAR MIXER

As MM100 with two guitar + 1 microphone input intended for guitar amplifier applications.

£17.49
+VAT

COMPLETE AUDIO RANGE FROM 10W-125W SEND FOR DETAILS TODAY

DEPT ETI-6
51 POPPY ROAD
PRINCES RISBOROUGH
BUCKS HP17 9DB
TEL: (084 44) 6326
FAX: (084 44) 7102

Order by Credit Card for immediate despatch

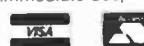

Add VAT Carriage only £2.00
Export 10% minimum £2.00

Low cost data acquisition for IBM PCs & compatibles

All our products are easy to install - they connect directly to either the printer or serial port and require no power supply. They are supplied with easy to use software which collects data for aether display or print-out.

ADC-10

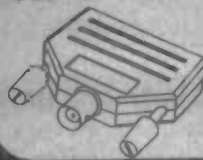

- 8-bit resolution
- one channel
- 10-25K samples per second
- Oscilloscope/Voltmeter software
- 0-5V input range
- Connects to printer port

£49

ADC-11



- 10-bit resolution
- 11 channel
- 5-10K samples per second
- Data logger software
- 0-2.5V input range
- Connects to printer port

£75

ADC-16

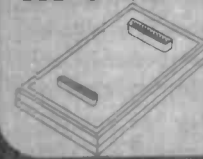

- 8, 12, 16-bit resolution + sign
- 8 or 4 differential inputs
- 216 or 300 8-bit samples per second
- ± 2.5V input range
- Data logger software
- Connects to serial port

£99

All prices exclusive of V.A.T.

PICO TECHNOLOGY LTD

Brookway House, 149 - 151 St Neots Road, Hardwick, Cambridge CB3 7QJ

WISA TEL: 0954-211716 FAX: 0954-211880

TEKTRONIX 7000 SERIES OSCILLOSCOPES

Dual Trace Plug-in with TB from £200
Many Plug-in options available. 4 Traces.
Differential etc. PLUG-INS SOLD SEPARATELY

TEKTRONIX 2336 Dual Trace 100MHz Delay Sweep Ruggedised	£1000
PHILIPS 3070 Dual Trace 100MHz Delay Sweep Trig View	£350
HITACHI V1050F Dual Trace 200MHz Dual TB with 4 Channel Mode	£450
SCHLUMBERGER 5218 Dual Trace 200MHz Delay Sweep with Trig View	£375
TEKTRONIX 475 Dual Trace 200MHz Delay Sweep	£350
KIKUSUI COSS100M 3 Channel - Ch4 Ch5 Trig view 100MHz Delay Sweep With probes Un-used	£200
H.P. 7715A Dual Trace 200MHz Delay Sweep	£500
TEKTRONIX 465M Dual Trace 100MHz Delay Sweep with 2 x P6134 Tektronix probes. Un-used	£600
TEKTRONIX 465 Dual Trace 100 MHz Delay Sweep	£450
H.P. 1746A Dual Trace 100MHz Delay Sweep	£400
TEKTRONIX 2225 Dual Trace 50MHz alternate TB	£400
Magnification	£450
PHILIPS PM3217 Dual Trace 50MHz Delay Sweep	£400
HITACHI 1660F Dual Trace 60MHz Delay Sweep	£400
TELEQUIPMENT D83 Dual Trace 50MHz Delay Sweep	£200
KIKUSUI 5530 Dual Trace 30MHz	£160
GOULD CS1100 Dual Trace 30MHz	£200
GOULD CS300 Dual Trace 20MHz	£125
GOULD CS250B Dual Trace 15MHz	£125
THIS IS JUST A SAMPLE - MANY OTHERS AVAILABLE	

PHILIPS PMS193 PROGRAMMABLE SYNTHESIZER/FUNCTION GENERATOR

0.1HzHz IEEE-488 As new

£1500

MARCONI 2019 Synthesized AM/FM Sig Gen 80KHz-1040MHz	£2000
MARCONI 2018 Synthesized AM/FM Sig Gen 80KHz-520MHz	£950
MARCONI 2017 Stable Low noise AM/FM Sig Gen 10KHz-1024MHz GPIB	£2000
EIP 545 Microwave Frequency Counter 10Hz-18GHz	£1400
EIP Autolite 3510 Microwave Frequency Counter 20Hz-18GHz	£350
HP 339A Distortion Measuring Set 10Hz-110KHz	£1300
RACAL/DANA 1991 Nanosecond Universal Counter	£800
RACAL 3902 RF Millivoltmeter True RMS 10KHz-1.5 GHz	£450
RACAL 3301A RF Millivoltmeter True RMS 10KHz-1.5GHz	£300
RACAL 9009 Automatic Mod. Meter 10MHz-1.5GHz Wide Deviation	£250
H.P. PULSE GENERATOR type 214B	£750
LYONS 973N Pulse Gen. PRF 1Hz-20MHz	£150
MARCONI 2610 True RMS Voltmeter	£800
GOULD BIOMATION K5000 Logic Analyser	£500
KEITHLEY 224 Programmable Current Source	£1000
KEITHLEY 197 51/2 Digit Autoranging Microvolt DMM with IEEE	£250

SPECTRUM ANALYSERS

HP 1411 with 855A & IF plug-in 10MHz - 180GHz	£2,000
HP 140T with 855A & 8552A 500KHz - 250MHz	£1,300
HP 141T with 8556A & 8552B 20Hz - 300KHz	£1,000
HP 140T with 8553L & 8552A 1KHz - 110MHz	£800
MARCONI TF 2370 30Hz - 110MHz	£1,500
HP 182c with 855B 100KHz - 1500MHz	£1,500

DATRON 1071 - 7 1/2 digit Autocal DC Multimeter with True RMS AC Resistance/Current	£1750
DATRON 1051A - 6 1/2 digit Autocal Multimeter with True RMS AC/Current	£1250
DATRON 1065 - 5 1/2 digit Autocal Multimeter AC/DC/Ohms with IEEE	£800
HEWLETT PACKARD 3490A Bench Multimeter	£200
PHILIPS PM2534 Multifunction DMM 3 1/2 - 6 1/2 digit GPIB - IEEE	ONLY £450
MARCONI Digital Frequency Meter 2430A 10Hz-80MHz	£125
MARCONI Digital Frequency Meter 243LA 10Hz-200MHz	£150
MARCONI Universal Counter Timer 2437 DC-100MHz	£175
MARCONI Universal Counter Timer 2438 DC-520MHz	£225
HP 3311A Function Generator 0.1Hz-1MHz Sine/Sa Tri	£125
MULTIMETER Handheld. M2353-32 ranges AC/DC 10 Amps Diode/Transistor Tester. Free counter	£32.50

FARNELL ELECTRONIC LOAD RL 1030-35

1kW 30 Amp 35 Volt

£800

RACAL/DANA RF Power Meter 9140	£800
RACAL/DANA 8341 Databridge Automatic Measurements LCR R.O.	£350
WAYNE KERR 3424 RCL Meter LCD Display	£125
WAYNE KERR 4210 LCR Meter LCD Display	£800
AYO AC/DC Breakdown Leakage & Ionization Tester	£300
RM1215LAYO Valve Characteristic Meter VCM143	£300
TELEQUIPMENT CT71 Curve Tracer	£250
MARCONI TF2700 Universal LCR Bridge. Battery from £150	£250
FARNELL PSU TV570 5A/30V 10A type TV5 70mA2 Metered	£300
FARNELL PSU 60V 25A Metered	£400
FARNELL PSU 30V 5A Metered type L30E	£80

FARNELL SSG520 Synthesized Sig Gen 10-520MHz	£400
FARNELL TTS520 Transmitter Test Set Consisting of F/AF Counter RF Mod Meter RF Power Meter AF Voltmeter AF Distortion Meter AF Synthesiser	£400
SOLD AS A PAIR	£750

NEW EQUIPMENT

HAMEG OSCILLOSCOPE HM1005 Triple Trace 100MHz Delay Timebase	£847
HAMEG OSCILLOSCOPE HM604 Dual Trace 60 MHz Delay Sweep	£853
HAMEG OSCILLOSCOPE HM203 7 Dual Trace 20MHz Component Tester	£362
HAMEG OSCILLOSCOPE HM205 3 Dual Trace 20MHz Digital Storage	£653
All other models available	
- all oscilloscopes supplied with 2 probes	
BLACK STAR EQUIPMENT (P&P all units £5)	
APOLLO 10-100MHz Counter Timer Ratio/Period/Time interval etc	£222
APOLLO 100 - 100MHz (As above with more functions)	£325
METEOR 100 FREQUENCY COUNTER 100MHz	£109
METEOR 600 FREQUENCY COUNTER 600MHz	£135
METEOR 1000 FREQUENCY COUNTER 1000Hz	£178
JUPITOR 500 FUNCTION GEN 0.1Hz-500Hz Sine/Sa Tri	£110
ORION COLOUR BAR GENERATOR PAL/TV/Video	£229
All other Black Star Equipment available	

OSCILLOSCOPE PROBES Switchable x 1 x 10 (P&P £) £11

Used Equipment - Guaranteed. Manuals supplied if possible. This is a VERY SMALL SAMPLE OF STOCK. SAE or Telephone for lists. Please check availability before ordering. CARRIAGE all units £16. VAT to be added to total of Goods and Carriage.



STEWART of READING

110 WYKEHAM ROAD, READING, BERKS RG6 1PL

Tel: (0734) 268041 Fax: (0734) 351696. Callers welcome 9am-5.30pm Mon-Fri (until 8pm Thurs).

The Chaperon

An invaluable personal attack alarm, described by Bob Noyes.

It's 11 pm in a cold, badly lit car park which backs on to a patch of woodland. The secretary of a local Scout group is leaving a committee meeting at the Scout hall. She makes sure that she's not the only one leaving the building at that time, but at the front door the two people with her decide to go and check on something elsewhere in the hall and say goodnight. The secretary leaves the hall with a heavy shoulder bag of files and her car keys in her hand. She doesn't like the dark and runs across the car park to her car, which is parked in a bay directly backing on to the woodland (there were no empty bays closer to the hall when she arrived). She knows she has her keys ready and she knows that her car

has an alarm with a siren loud enough to wake the dead, but she still has to open the door. It's pitch black in the car park and panic sets in as she fumbles to find the lock. She starts to imagine all sorts of things and is petrified to turn around for fear of seeing someone behind her. At last the car door is open, she leaps in and locks her door. The car starts first time. She's safe.

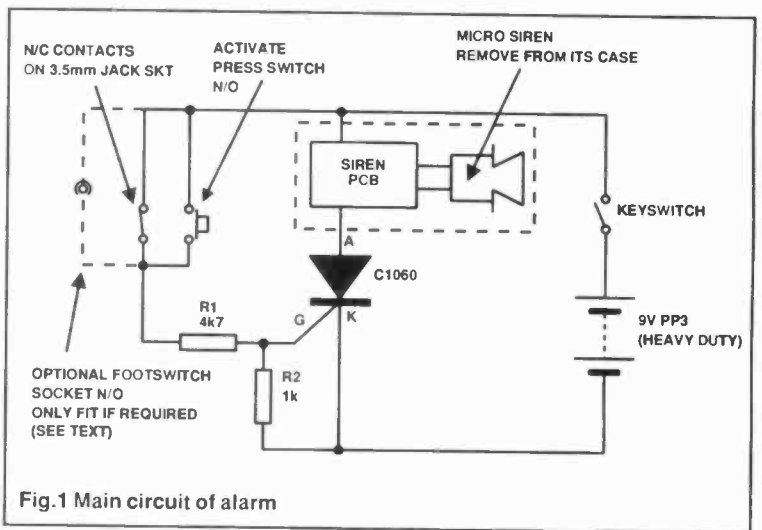

Fig.1 Main circuit of alarm

That secretary is my wife and she told me of her fears when she arrived home from that meeting. Unfortunately, long gone are the days when anyone, male or female, young or old could walk out anywhere in complete safety. Anyone, it seems, these days is open to assault, mugging or rape. Many people won't go out at night for fear that their shouts may not be heard.

This project, Chaperon, although one of the most simple yet featured as a free PCB project, is hopefully one of the most useful and topical. Nothing yet invented can prevent the possibility of attack (we're still working on that one), but a small hand held device that can easily be triggered to give a very loud shrieking sound and can't be switched off in the same way as it was activated does give a measure of reassurance.

Chaperon was designed to be carried in the hand, secured with a wrist strap. It is activated via a key switch, which switches the battery power on, but the electronics have been designed to draw no current in the standby mode. The reason for the key switch is that when Chaperon is not required it can be carried in a pocket, handbag, dashboard or wherever. On some other hand held attack alarms the activate button may accidentally be pressed causing the alarm to go off, leading to great embarrassment. My wife had one of these and it went off (in her pocket) in a crowded hospital waiting room. She refuses to use it now.

Before the key switch is turned on, the wrist strap plug should be checked to ensure that it is fully pressed in and that the activate button is out. When you're happy with this, the

ETI
Cover PCB
Project



DEVICE	VOLTS	GATE V	GATE I	NOTES
C106D [#]	400	1.0V	0.2mA	CHEAPEST
C106M	600	1.0V	0.2mA	
TIC106D	400	1.2V	0.2mA	
TIC106M	600	1.2V	0.2mA	
CF106D	400	1.0V	0.2mA	ISOLATED TAB
CF106M	600	1.0V	0.2mA	ISOLATED TAB

SUITABLE THYRISTORS # CHEAPEST

key switch is turned to 'On' (the key is vertical) and Chaperon is now 'armed'. The wrist strap should be carefully slipped over the wrist - great care being taken not to pull out the plug. When this is done, the key should be removed and put somewhere you can easily find it again, such as in a pocket or on a chain out of sight (not around your neck). Remember that if Chaperon is set off accidentally or in anger, the key is needed to turn the alarm off. The alarm is now in standby mode and either pressing the button or removing the wrist strap plug will set the alarm off. The idea of the wrist strap and its plug is that if you are grabbed from behind, it may not be possible to press the activate button, but by dropping Chaperon the weight of it will cause the wrist strap plug to come out - instantly activating the alarm.

This method of activation is absent in several of the very expensive attack alarms currently on the market. The corners of the alarm casing have been internally strengthened so Chaperon won't disintegrate on hitting the deck - although we don't recommend trying this too often when testing the alarm. Surface damage could result, spoiling the look of it, admittedly something not foremost in your mind during an actual attack.

When you've reached your destination and are out of danger, the key switch should be turned off before the wrist strap is removed from your wrist. The wrist band plug can be removed for convenience, but must be plugged back in before the alarm is armed again.

The Circuit

The circuit could not really be more simple; it relies on the thyristor's property that once turned on by a positive pulse to its Gate, it stays turned on until the current through it is reduced to almost zero - or in our case, until the key switch turns off the power completely. Switching back on again will arm the alarm but silences the siren so long as the wrist strap plug is in and the button is not depressed.

The thyristor chosen, C106D, is a cheap, very sensitive device and readily available. A list of other suitable devices is included in case of an availability problem. R1 and R2 form a

potential divider as well as limiting the gate current when either of the two methods of activation occurs, either the wrist strap plug is removed completing the normally closed contacts on the socket, or the activate button is pressed. The top end of R1 is switched to +9 volts which in turn produces a positive on the gate in respect of the cathode. The maximum required is 1 volt at 0.2mA for the C106D and 1.2 volts at 0.2mA for the TIC106D, so the values of R1 and R2 chosen will support either suggested thyristor (or any of the others in the list).

The thyristor, when turned on, applies power to the siren. Several sirens were tried - most were not loud enough to be a deterrent and a couple that were loud enough were too big, physically, to fit into a hand held box. The one chosen was the Micro Siren which is sold in several outlets including

Maplin. This, when cased, is too large but when stripped down into the piezo element housing and electronic PCB, can be easily mounted in the hand held box recommended.

To remove the piezo element from its case, the indented circles shown in the siren diagram are drilled out. This is done by marking the centre of the circles with a sharp object to ensure that drilling is accurate, using a small, 1mm drill. Great care

must be taken not to over drill and cause damage either to the siren or the drill. A simple drill sleeve could be used, as shown in the diagram. This can be made out of a cut length of a biro tube and should leave 10mm of drill showing; prevent the drill entering too far. When all four holes have been drilled, they can be opened up to 2mm, then 3mm. The 3mm drill should completely remove the plastic rivets which

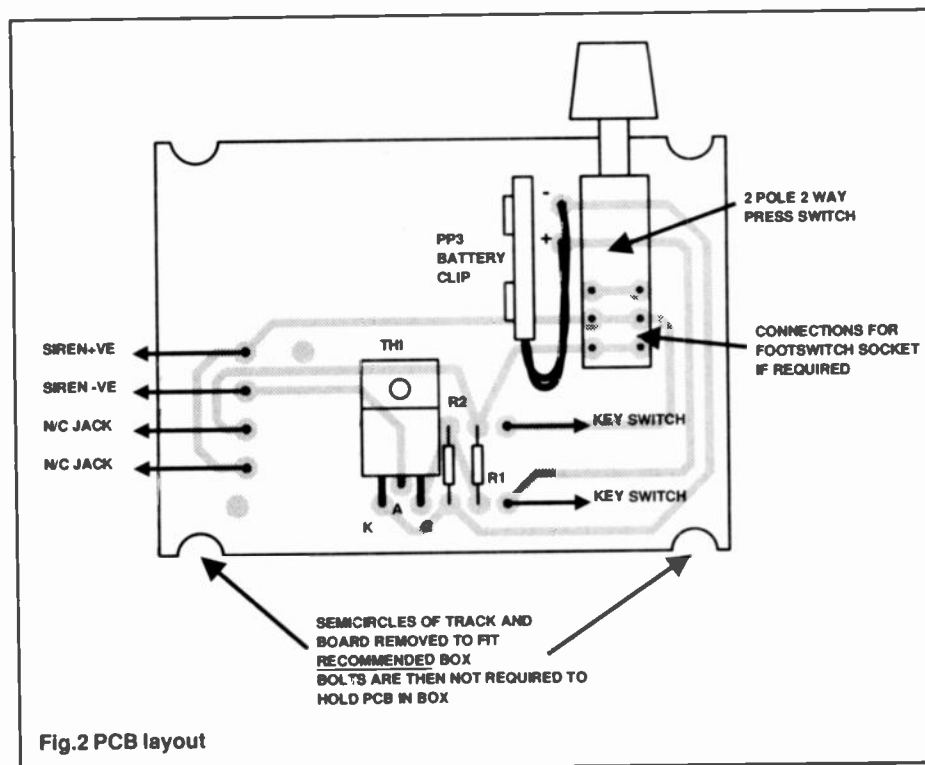
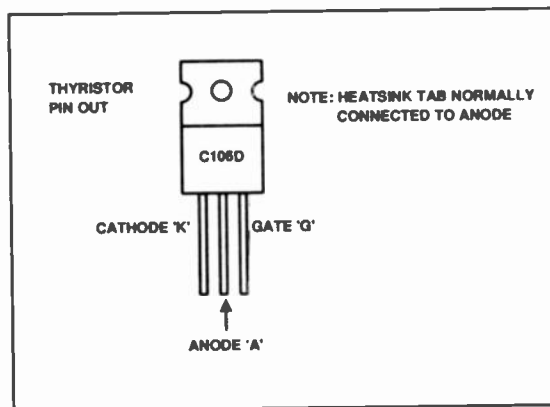

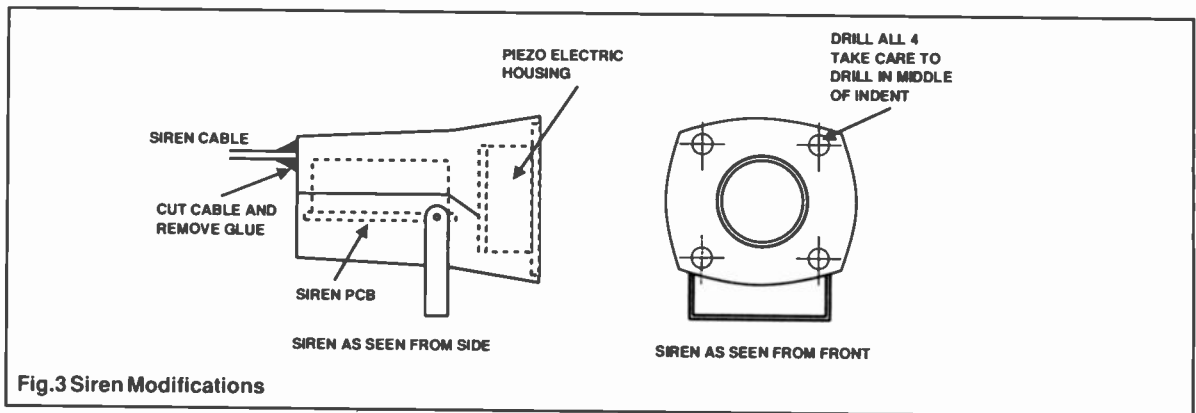

Fig.3 Siren Modifications

holds the siren together.

The front of the siren can now be removed -this is the piezo housing. It only comes out a few centimetres because it is connected to the small PCB by short thin wires. The lead at the back of the siren can now be cut completely as it will be replaced when connected inside Chaperon. Some sirens have a small amount of glue from a glue gun to keep out moisture and this should also be removed. The PCB can then be removed from the siren casing, care being taken not to damage the thin wires connecting the PCB to the piezo.

The wires from the piezo to the PCB should be noted as to where they go on the PCB and the power connections noted as to which way they go because the PCB is polarity conscious. There is a protective diode thoughtfully included on the PCB, stopping any damage caused by the power being applied the wrong way round. Great care should be taken when handling this PCB when power is applied to it, such as during testing. Its output stage consists of a step up transformer, which is the secret of its high volume. As the impedance of a piezo is extremely high, virtually no current flows at 9 volts or so, but low volts and extremely low current equals very low power, so the output stage increases the voltage to a couple of hundred volts peak to peak via the step up transformer: This still produces low current because of the high impedance of the Piezo but increases the volume considerably, so don't hold the PCB when under power.

Safety Note: The high voltage does not have the power to be fatal because as soon as any current is drawn, the voltage reduces accordingly, but it still gives a nasty nip - so treat it with respect.

Optional Foot Switch

While trying out Chaperon, I was asked if the device could be used by people serving in shops who often feel vulnerable, especially those in small shops who work alone.

Obviously, in these situations it's not feasible to carry Chaperon around in your hand all day, although it could possibly be worn on a belt. I felt it was better to place the alarm in a high position, out of general reach, so when sounding, the noise could travel, but activated by a hidden foot switch behind a counter. Several switches could be incorporated, all in parallel - pressing any one of these would activate the alarm. The wrist band socket could be used but

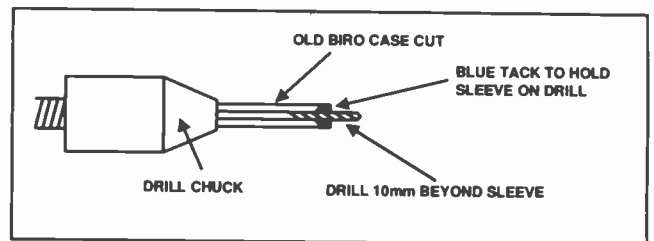

this would mean switching off the alarm while the plugs were exchanged because removing the plug would activate the alarm.

On models that require this facility, another socket is fitted, which brings out the two connections required to be connected together to activate the alarm. These go to a mini jack socket and a mini jack plug is then connected to the foot switch or switches as required, via a suitable length of cable. This plug can then be plugged in or removed without

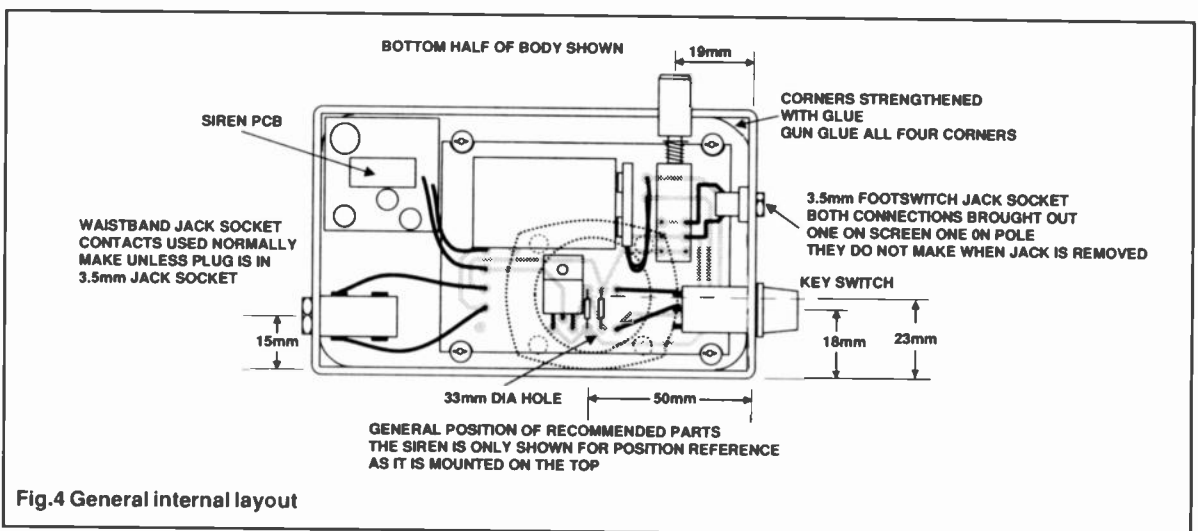

Fig.4 General internal layout

switching the alarm off. The socket need only be fitted if the footswitch facility is required. The connections on top of the activate switch are used in the alarm as shown in the diagram.

Construction

These construction details apply to the recommended box, but may prove useful with other types of enclosure.

The semi-circles of board must be removed so that it will fit between the box's mounting pillars. A round file should be used and care taken not to over-file these semi-circles or

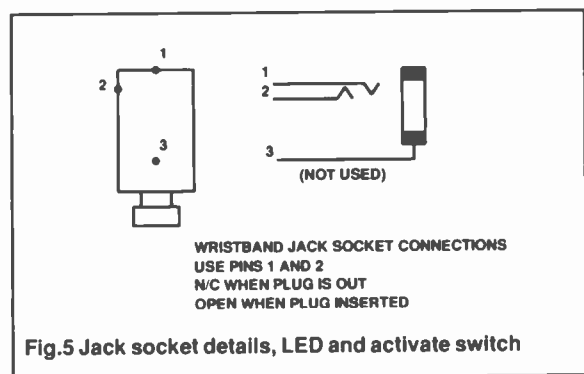
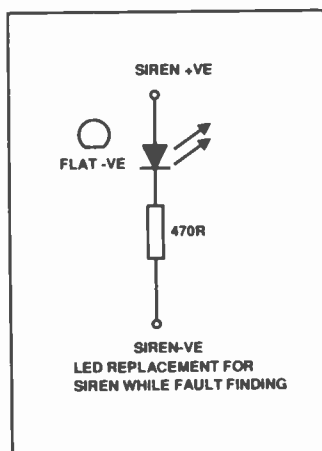

Fig.5 Jack socket details, LED and activate switch

the board will float around in the box. The large raised indent in the bottom of the box should be removed as per the drawing -do not remove the small one as this is used to help support the front panel.

All four components are fitted and soldered to the PCB. Flying leads are fitted for the siren and wrist strap jack socket; the battery connector is fitted with shortened leads i.e. 35mm. If the footswitch option is required, then two more leads are fitted on top of the activate switch-N/O contacts, as shown in the diagram.

The soldered joints are cut as short as possible for a good joint, but flat enough to allow the board to fit as close to the bottom of the box as possible (every micron helps when closing the box). A hole for the activate button needs to be drilled in the box; the size of which should be 1mm larger than the diameter of the button to allow it to be pressed freely. The board is positioned in the box and the centre of the button marked to indicate where to drill. Remove the board and bolt the box together. A small



pilot hole is drilled in the join of the two halves of the box at the marked positions. The hole is then opened out to the correct size with increasing sized drills. If the correct size of drill is unavailable, then the hole can be filed to size, care being taken to keep it round.

The board is now positioned and fitted in the bottom of the box, the bottom being the half with the fixing holes going right the way through. The key switch fits between the fixing mount (bottom right of the box) and the activate switch. The front of the box is then marked out; masking tape can be stuck

over the front so as not to damage the plastic while marking, drilling and filing. The key switch recommended requires a square hole. This should be marked out on the front of the panel and a series of small holes drilled inside the marked hole. These are filed to the shape of a square. The switch should be a good tight fit and care should be taken when drilling and filing as there's not a lot of plastic left around the sides of the hole. The front should also be drilled to accommodate the foot switch jack if this option is required. This is done as per the diagram and the jack used should be checked to see that it doesn't foul the activate switch once fitted. A hole is drilled in roughly the position shown, although its exact position is not critical.

Any printing, such as 'On' or 'Footswitch', should be done before the key switch or jack socket are fitted. Any dry print system will do and sheets of letters are available in all big stationery shops. A spray of varnish on the top should prevent the lettering from peeling off in use, but make sure the varnish is completely dry before fitting the switch and jack socket. Check the switch orientation conforms with the lettering. The key switch anchor ring must be pressed fully home to ensure that the metal tabs locate into the indents on both sides of the switch.

The front panel can then be slotted into place and the key switch can be connected. Check that the correct pins are used. The siren PCB is then connected, care being taken to connect

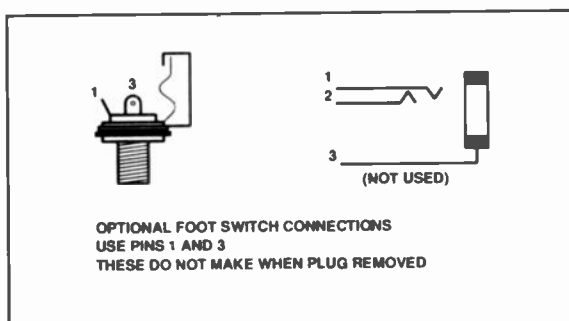

it the right way round. The wrist strap jack socket can then be fitted as per the diagram and a hole drilled in the bottom half of the box to suit. Its wires can then be connected either way round (it is not polarity conscious). They are connected in such a way as to make contact with each other when the jack plug is not inserted.

The piezo element is disconnected from its PCB, care being taken to note the positions of the two connections. The top of the box is drilled to accept the piezo element housing. When fitted, it is pushed through the hole drilled in the top of the box and bolted down. The position of the piezo element is quite critical because it must clear the battery and activate switch (dimensions are given in the diagram). The hole is 33mm in diameter and can be marked out on masking tape on top of the box. Small holes are drilled inside the 33mm ring and filed out to size. After a trial fitting, the piezo element is squared up, mounted neatly and the small bolt holes drilled using the front of the housing as a template. This can then be bolted down using instrument headed 3mm bolts for neatness. The jack plug is inserted into the wristband jack socket and the activate switch checked to see that it is not jammed in. A general check of the circuit should be made before the battery is connected. The key should be inserted into the key switch and turned off. Connect the battery and turn the key switch on. Be prepared for an almighty din when the activate

button is pressed, so quickly turn the key switch off. If for some reason the alarm sounds when it shouldn't, switch off and disconnect the siren. Connect a LED and 470R resistor in series in place of the siren, taking care not to get the LED the wrong way round (the flat should be to thyristor end), until the problem is resolved, because ear damage could result from prolonged exposure to the noise while fault finding. Once the problem has been solved, the siren can then replace the LED and resistor.

Once Chaperon is working in all modes, pressing the activate button, pulling out the wrist band jack plug or pressing the footswitch, the corners of the box can be strengthened with a glue gun. Be careful not to glue in the battery (which must be removable) or obstruct any of the parts when the box is assembled. Make sure that the halves of the box dry and cool down completely before assembly. If you don't, the halves will glue themselves together. The battery should last well in excess of a year as no current is

drawn when in standby: only when the siren is sounding. Always use a good quality alkaline battery such as Duracell or an equivalent.

It's not often you design a project and hope that it is never activated, except in testing, but I sincerely hope Chaperon need never be activated in anger!

PARTS LIST

RESISTORS

R1 4k7
R2 1k

SEMICONDUCTORS

TH1 C106D1

MISCELLANEOUS

Siren Micro siren 12V 150mA (Maplin or Greenweld source)
Box Dimensions 146 x 95.1 x 28.5mm recommended
Key Switch one pole on/off, key must be removable in on and off positions Switch used was Electromail cat no. 332-515 or 332-521 Activate switch 2pole, 2way wave change switch. This is a latching switch with the pin removed
Knob
Wristband 3.5mm jack socket-must have normally closed contacts when plug is out (Electromail cat no. 476-328 or Maplin FKO2C)
Wristband jack plug (remove contacts inside. No connection to pins)
Optional Foot switch (one that can be rewired is Maplin KWO2C, the lead is short and has the wrong plug but can be easily rewired).
Nuts, bolts, washers
PP3 battery and connector
Wrist strap (an old pocket camera strap)

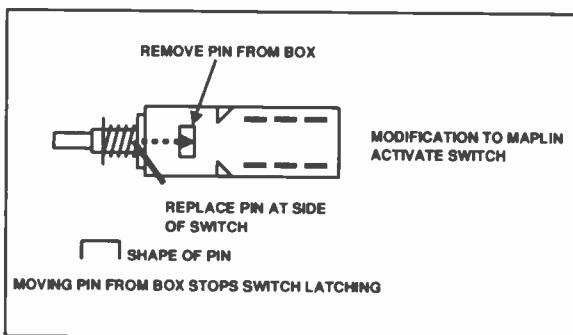

SHAREWARE is the TRY-BEFORE-YOU-BUY APPROACH TO SOFTWARE. You pay a nominal charge for program distribution to cover disks, copying, carriage, etc. ONLY IF YOU FIND A PACKAGE USEFUL ARE YOU THEN REQUIRED TO PAY A REGISTRATION FEE (to the software author), which allows you to continue using it. THIS CAN WORK OUT CONSIDERABLY LESS EXPENSIVE THAN BUYING SIMILAR SOFTWARE IN THE CONVENTIONAL WAY.

ENGINEERING - GRAPHICS - BUSINESS - PC-TUTORIALS - CALCULATIONS - SCIENCE - EDUCATION

Electronics CAD/CAM

- Now simple & AFFORDABLE !

CAD/CAM - PCB DESIGN - CIRCUIT EMULATION & TEST - PC-ENGINEERING - RADIO - COMMS

Choosing from the many 1000's of excellent Shareware & Public Domain programs on offer can be a daunting task for anyone outside the "initiated" fraternity of computer programmers, bulletin board users, etc. To simplify evaluation we have grouped together sets of distribution disks according to function, e.g. Electronics Design & Simulation, Wordprocessing, Printing Utilities, etc. In this way we are also able to keep costs down, allowing us to offer HIGH QUALITY DISKS AT THE LOWEST DISTRIBUTION PRICES AROUND.

Ask for our free IBM-PC Shareware/PD guide TODAY - AND SAVE £££!!!

Profile Electronics (ETI)

"Your APPROACHABLE supplier."

100-102 Woodhouse Road, Leytonstone, London, E11 3NA. Telephone: 081-470 2038

MAIL ELECTRONICS KITS, SPEAKERS, COMPONENTS. TEL/FAX 0282 426670

KITS

ELECTRONIC DOOR BUZZER very loud (excludes speaker) 5.95
ENTRY/EXIT LATCHING BURGLAR ALARM 12vdc ent/ext time 35sec's 7.95
9 VOLT DC FM MICRO TRANSMITTER varicap tuned, long range 6.95
DARK/LIGHT ACTIVATED RELAY SWITCH switches on or off with darkness falls no need to switch on, will also act as normal flasher 5.95
1.5 VOLT DC FM MINI MICRO TRANSMITTER 15mmx20mm good range 6.95
ELECTRONIC SIREN mimics exact sound of a large siren (speaker not included) 5.95

SPEAKERS 8 OHMS (all speakers made by MONACOR) (prices on each)

SP80X	8"	FULL RANGE, DUAL CONE,	70 WATTS	18.49 + 2.50 p+p
SP90	8"	BASS,	70 WATTS	21.49 + 2.50 p+p
SP250GI	10"	FULL RANGE,	70 WATTS	25.49 + 2.50 p+p
SP300GI	12"	FULL RANGE,	150 WATTS	36.49 + 4.00 p+p
SP300P	12"	BASS,	200 WATTS	57.49 + 4.00 p+p
SP385G	15"	FULL RANGE,	350 WATTS	76.49 + 4.50 p+p

METAL SPEAKER GRILLS

8" = 3.99, 10" = 4.99, 12" = 5.99, 15" = 9.00 add 2.00 FOR p+p

All speaker GRILLS come with CLAMPING KITS. (above prices on each)

POPULAR COMPONENTS AT SURPLUS PRICES

2N3055	0.45	2N3819pref*	0.25	2N2222	0.15	2N5401	0.12
2N3703	0.08	2SC2060	0.25	BC107	0.10	BC108	0.09
BC212	0.07	BC184	0.07	BC237	0.07	BC337	0.08
BC548B	0.07	BD236	0.18	BF177	0.20	BFX29	0.20
BSW6B	0.15	BUS12A	1.00	TIP31	0.20	TIP30B	0.20
TIP32A	0.25	TIP35	0.60	TIP42C	0.35	TIP50	0.50
TIP111	0.25	TIP112	0.25	TIP136	0.65	TIP140	0.80
7805	0.20	7915	0.25	79L05	0.22	79L15	0.22
LM3337T	0.35	LM317K	1.25	LM2931T	0.50	LM309K	1.00
555	0.15	741	0.15	LM723	0.30	LM386-1	0.35
LF351	0.30	LF353	0.30	LM733	0.40	MCX1458	0.30
555 CMOS	0.40	CA3140E	0.45	CA3240E	0.85	ULN2003	0.30
ULN2004	0.38	TL062	0.35	TL064	0.35	TL064	0.38
TL084	0.40	NE5532	0.65	NE5533	0.45	NE5534	0.70
NE5539	0.45	RCA3055	0.40	TBA820M	0.30	TBA231	0.35
1Mhz xtal	0.90	10Mhz OSC*	1.00	48Mhz OSC*	1.00	4116	0.40
4164-15	0.85	41256-12	1.20	THIS IS JUST A SMALL RANGE OF COMPONENTS THAT WE STOCK. PLEASE GIVE US A CALL FOR YOUR REQUIRED PART.			

UK Customers only. Please send cheques PO's or reg' cash. Please add 89p for P+P (all speakers are extra for P+P). All above items are inc' of V.A.T. Please make cheques PAYABLE TO: "MAIL ELECTRONICS", UNIT 6, FORBES COURT, BILLINGTON RD, BURNLEY, LANCASHIRE, BB11 5UB TEL/FAX 0282 426670 or evenings 061 797 3515

NOTE: ALL PRICES ARE SUBJECT TO AVA' AND CHANGE WITHOUT NOTICE

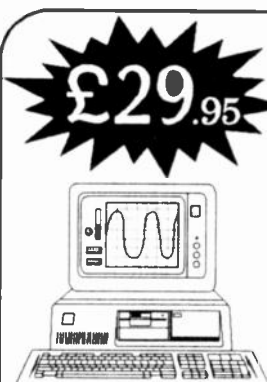

8-bit A to D

For PC's & 100% Compatibles

- * Plugs into printer port.
- * Up to 25 KHz sampling.
- * 0 to 5V input range.
- * Software drivers in C and BASIC
- * Voltmeter/Oscilloscope software including source code.
- * 3.5" or 5.25" disk (Please specify)
- * Price includes Post & Packing

MAIL ORDER TO
Cheques & Postal
Orders only please

C. P. Technology
Red Lion Yard Market Place
Blandford, DORSET DT11 7EB

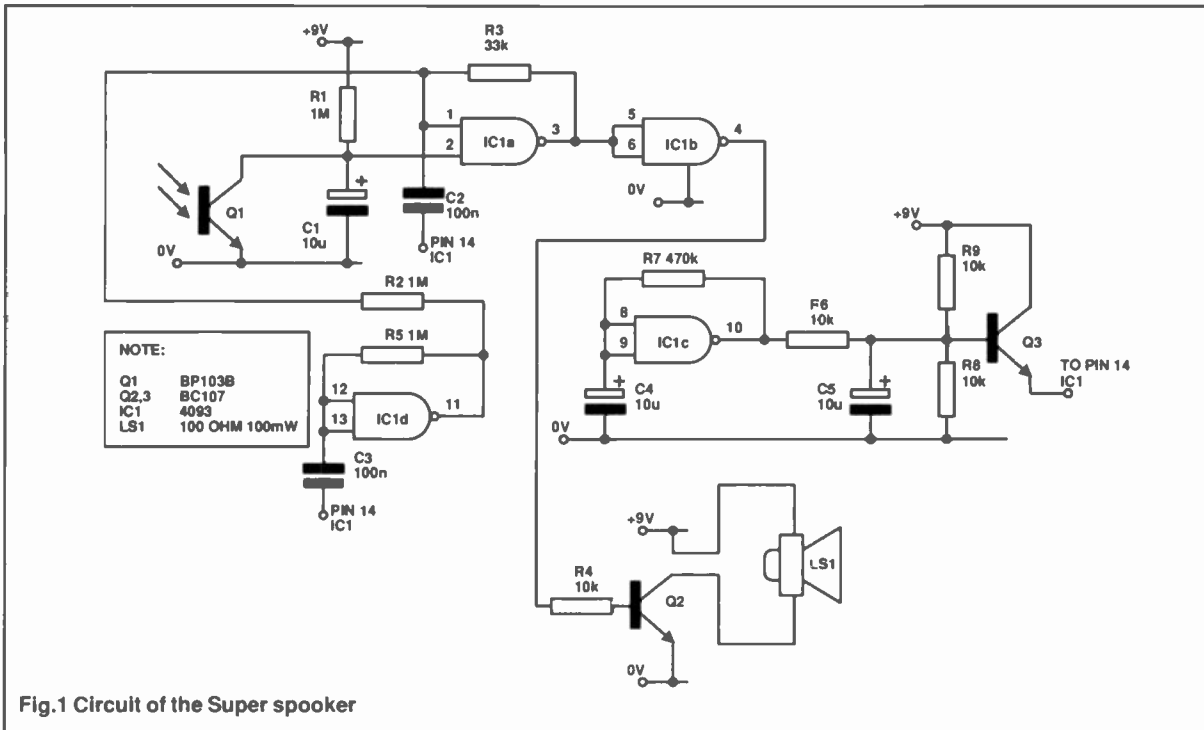

Fig.1 Circuit of the Super spooker

HOW IT WORKS

The sound is generated by a number of interacting free running oscillators. IC1a generates the basic tone of the sounder, Q1; R1 and C1 prevent the circuit from operating if the light is above a certain level. When the lights go out, Q1 releases its hold and C1 will charge via R1. When the threshold of the CMOS gate is reached and IC1a begins to oscillate, IC1b inverts the drive from the primary oscillator to ensure Q2 is 'off' when the lights are on and hence there is a low quiescent current.

IC1d is a second oscillator with a frequency of oscillation of a few Hz and causes the frequency of IC1a to be modulated with a warble tone. R2 injects a voltage to the junction of R3 and C2 and causes a rapid change. The frequency of all the oscillators is a function of the supply voltage to the IC, which is controlled and defined by Q3, R8 and R9. IC1c is a low frequency oscillator with a frequency of 1Hz. The output from this oscillator is used, via R6, to control the voltage at the base of Q3 and hence the supply to the IC. Each oscillation of IC1d will cause a change in pitch of the oscillators, while C5 ensures a slow change of the voltage and hence a gradual change in pitch.



Alan Jones provides a sound scarer for the party.

when the light is turned back on again. The original circuit was sensitive enough to respond to the light of a candle - all in all a very frightening experience!

Construction

The circuit is based upon a single CMOS IC and a handful of discrete components. To achieve the simplicity a number of novel techniques had to be used. No adjustment is necessary and layout is not critical. A PCB layout is illustrated but the circuit can easily be built on Vero-board.

If the unit is built in to a box then the photo-transistor must be arranged to see the light of the room. The sound is generated by a small 100R speaker.

Power is provided by a 9 volt battery and the quiescent current is only 0.5mA, hence a long spooky life.

PARTS LIST

RESISTORS

R1 1M
R2 1M
R3 33k
R4 10k
R5 1M
R6,8,9 10k
R7 470k

SEMICONDUCTORS

IC1 4093
Q1 BP103B
Q2,3 BC107

MISCELLANEOUS

Speaker 100 ohm 100 mW

CAPACITORS

C1,4,5 10u/16V tant
C2,3 100n

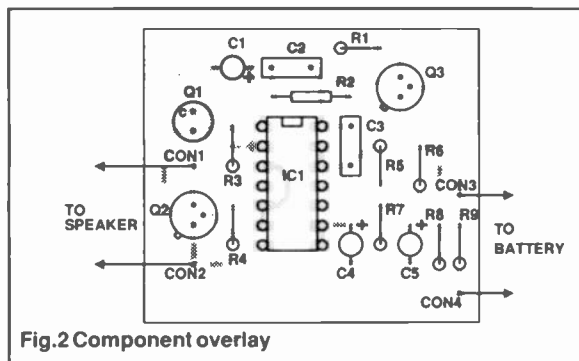

Fig.2 Component overlay

This circuit was designed to add atmosphere to a Halloween party. Its purpose is to produce a ghostly 'spook-like' sound that resembles a wailing spectre. While the device is in the light, nothing will happen but 30 seconds after the lights are turned out a strange sound will be emitted that will immediately stop



18th Sandown Park Model Exhibition & Display



SANDOWN EXHIBITION CENTRE,
Esher, Surrey
on 15th & 16th May 1993

Calling all model enthusiasts and families –

Enjoy a day out at Sandown Park.

Watch * Continuous Flying Displays * Novelties on the Boat Pool
* Model Car Racing * Railway Display

Admission: Adults £5 Senior Citizens £3.50 Children £2
Family Tickets £12 (2 Adults & up to 4 children)
Advance & Group tickets available on request: Adults £4.50
Senior Citizens £3.00 Children £2

Further details available from:

Argus Specialist Exhibitions
Argus House,
Boundary Way,
Hemel Hempstead,
Herts.
Tel: 0442 66551

**WANDER ROUND THE
NUMEROUS TRADE STANDS
YOU WILL FIND EVERYTHING AT SANDOWN**

Radio control equipment • Aircraft • Car and marine engines • Helicopters • IC and electric cars • Boats and yachts • Railway layouts and engineering products.

Please look out for new parking arrangements, traffic control and directional signs

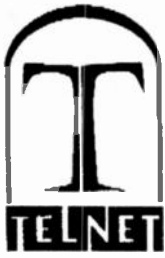

8 CAVANS WAY, BINLEY INDUSTRIAL ESTATE,
COVENTRY CV3 2SF, ENGLAND.
TELEPHONE (0203) 650702. FAX (0203) 650773

KEITH MORRIS
Tel: 0203 650702
Fax: 0203 650773

LIST OF TEST EQUIPMENT AVAILABLE

OSCILLOSCOPES

HEWLETT PACKARD	1741A-100 MHz Dual Trace Analogue Storage Scope	£325
HEWLETT PACKARD	1744A-100 MHz Dual Trace Analogue Storage Scope	£325
HEWLETT PACKARD	182C-100 MHz 4 Channel fitted with 1809A 4 channel Vertical amplifier and 1825A time base & delay generator -	£300
PHILIPS	3211 - 15 MHz Dual Trace	£150
PHILIPS	3217 - 50 MHz Dual Trace	£250
PHILIPS	3226 - 15 MHz Dual Trace	£150
PHILIPS	3240 - 50 MHz Dual Trace	£250
PHILIPS	3261 - 120 MHz Dual Trace	£325
GOULD	OS4200 - 50 MHz Digital Storage Scope Dual Trace	£250
TEKTRONIX	7803 - 100 MHz 4 Channel	£300
TEKTRONIX	7313 - 100 MHz 4 Channel Analogue Storage Scope	£325
HEWLETT PACKARD	182T with 8755B Sweep Amplitude Analyser	£250
HEWLETT PACKARD	180TR with 8755B Sweep Amplitude Analyser	£250
PHILIPS	PM 8226 Six Line Pen Recorders	£399
HEWLETT PACKARD	RMS Voltmeter - Models 400E/400FL/400F	From £125
HEWLETT PACKARD	Test Oscillator 651B 10 Hz to 10 MHz	£150
LYONS	Pulse Generators Type PG2B 0-10 MHz	£250
MARCONI	Electronic Voltmeter TF 2604	£50
TECHTEST	Model 260 1.5 GHz Linear Up Converter Input 240 MHz 350 MHz Output 1440 - 1550 MHz	£399
HEWLETT PACKARD	3730A Down Converter with 3738A Oscillator - 6.3 GHz - 8.5 GHz Down to 70 MHz	£1K
WANDEL & GOLTERMANN	Display Unit SG3 200 Hz - 20 MHz	£300
HEWLETT PACKARD	8745A "S" Parameter Test Set (0.1 GHz - 2 GHz)	£499
ADRET	Codasyn 301 Synthesiser 0 - 1 MHz	£150
WANDEL & GOLTERMANN	PS 6 Level Generator 6 KHz - 18.6 MHz	£400
WANDEL & GOLTERMANN	PS 60 Level Generator 6 KHz - 18.6 MHz	£500
WANDEL & GOLTERMANN	SPM 60 Level Meter 6 KHz - 18.6 MHz	£500
WANDEL & GOLTERMANN	PS 12 Level Generator 200 Hz - 4.5 MHz and 20 Hz - 6 MHz	£500
WANDEL & GOLTERMANN	SPM 12 Level Meter 200 Hz - 4.5 MHz and 20 Hz - 6 MHz	£500
HEWLETT PACKARD	8620C Sweep Oscillator Mainframes	£499
HEWLETT PACKARD	RMS Voltmeters - 3406A - Broadband Sampling Voltmeters	£150
HEWLETT PACKARD	Logic Analysers with Podis - 1615A	£200
AVO	CZ457/6 Component Comparators	£50
MARCONI	Type 6057B/1 Signal Source 4-8 GHz	£499
HATFIELD	Type 1000 Psophometer	£100
HATFIELD	Type 1015 Level Measuring Set	£150
RADIO SPARES	Mains Filters (Isolating Transformers) EPMS - 207481	From £30
POWER SUPPLIES	By Solartron/Wayne Kerr/Weir/Countant and Farnell - such as L301, LT301, L3905, E350, L30F, L1210C etc	From £25 to £120
DIGITAL MULTIMETERS	Fluke 8010A/8050A/8800A/8600A	£100/£125/£80/£75
	Solartron 704SLM14202	£50
	Gould Alpha III and Alpha IV	£15
AVO'S	Model B and Selectests	£10 to £40
FREQUENCY COUNTERS	Racal 9520/9903/9805	£15/£100/£125
	Advance TC17A	£75
CAPACITANCE/INDUCTANCE/RESISTANCE DECADE BOXES - MANY TYPES		£5 TO £15
MARCONI	TF 2356 - 20MHz Oscillator	£300
OFF AIR FEQU.STD	Celebris	£75
RACAL DANA 202	Logic Analyser + 8800 Disassembler	£325
MARCONI	2306 Programmable Interface	£125
HEWLETT PACKARD	16409 - Serial Data Analyser	£600
RACAL DANA	9084 Synthesised Sig Generator (0.01-104MHz)	£320
TEKTRONIX	TM5003 - AFG 5101 - Programmable Arbitrary Functional Gen. Counter	£1500
MARCONI	2435 - Dig Freq Counter (2GHz)	£550
TEKTRONIX	603 Storage Monitors x 2	£50
KIKUSUI	5081 Alignment Scope	£150
AIM LIMITS COMPARATOR 402 WITH LCR DATA BRIDGE 401		£250
ADRET	2230A Frequency Synthesiser - Up to 1MHz	£200
FISCHERSCOPE BETA 2060	(Non destructive coating thickness measuring instruments - based on the Beta Backscatter principle)	
FISCHER	Printer F3050	
FISCHER	Proprint SD	£3K
FISCHER	Proprint S (Electrophotographic Porosity Tester)	
FISCHER	Through-Hole Plating Measurement Device	
FISCHERSCOPE BETA 2040 COATING THICKNESS COMPUTER		
FISCHER	WP240H - Hand Press	
FISCHER F1-12	Press	
ALL ABOVE CAN BE PURCHASED AS JOB LOT		
METROHM	Polarcord (Polarograph) - 626	
METROHM	VA-Timer 621	£1K
METROHM	VA Stand (For Polarographic and Voltametric Analysis)	
METROHM	R40 Scales	£100
OERTLING	O40 Scales	£100
OERTLING	Non Destructive Thickness Tester	£250
DEMITRON	CH9435 Photomicroscope (Swiss Made)	£1K
PROJECTINA	Series 4000 Ultra Violet Oscillograph	£350
BRYANS SOUTHERN	Pat's Testers	£125
METROHM	Long Scale Galvanometer	£50
WPA	Scaling Fluxmeter	£50
PYE	Uralgivo	£50
CORNING EEL	Electrolytic Water Analyser	£150
MIECO INSTRUMENTS	MULTICORE SOLDERABILITY TEST MACHINE MK III	£300
BENTHAM	223 and 217 Lock In Amplifier and Current Amplifier	£200

HEWLETT PACKARD	MP 9GHZ to 13GHZ - O/P 18GHZ to 26GHZ	
HEWLETT PACKARD	3702B I.F. Baseband Receiver	} Microwave Link Analysers
HEWLETT PACKARD	3705A Differential Phase Detector	
HEWLETT PACKARD	3710A I.F. Baseband Transmitter	
HEWLETT PACKARD	3716A Baseband Transmitter	
HEWLETT PACKARD	3200B VHF Oscillator 10MHz - 500MHz	
HEWLETT PACKARD	8750A Storage Normalisers	
HEWLETT PACKARD	4204A Oscillator (10Hz to 1MHz)	
HEWLETT PACKARD	196A Oscilloscope Cameras	
PHOTODYNE	1800 Fibre Optic Attenuators	
TEKTRONIX	7904 500MHz Oscilloscopes	
TEKTRONIX	4041 Disc Drives	
TEKTRONIX	4926 Disc Drives	
TEKTRONIX	1103 Tek Probe Power Supply	
TEKTRONIX	7623A Oscilloscopes (100MHz) with storage	
KINGSHILL	150 Power Supply (300V-10A)	
MARCONI	TF 1073A R/F Attenuators 0-100db.	
MARCONI	TF 2801/4 Error Detectors	
MARCONI	TF 23701:1 Spectrum Analysers (110MHz)	
MARCONI	TF 2909 Grey Scale Generators	
MARCONI	TF 2905/6M Sine/Square Pulse & Bar Generators	
MARCONI	TF 2802/2 Pattern Generator & SLMS	
MARCONI	TF 2806 Differential Voltmeters	
MARCONI	TF 2600 Sensitive V/V/M	
MARCONI	TF 1313A Universal Bridges	
MARCONI	TF 2213A/1 X-Y Display	
MARCONI	TF 1245 20-300MHz Oscillator with TF 1247 - Q meter	
MARCONI	TF 144H/4 STD. SIG. GEN 10K - 72MHz	
MARCONI	6057B/1 Signal Source	
MARCONI	Insertion Loss Test Set	
MARCONI	Power Supply Double 30V-3A	
NARDA	5073 Reflector Coupler (1.7-4.2GHz)	
NARDA	5074 Reflector Coupler (3.7-8.7GHz)	
NARDA	5075 Reflector Coupler (7-12.4GHz)	
NARDA	757 Attenuators - various	
NARDA	5KV Voltmeter	
ELECTROSTATIC	2475R Photomultiplier Power Supply (2KV)	
BRANDEBURG	Prom Eraser	
ANDERSON	J3B 10KHZ - 100KHZ Oscillator	
GOULD	DM12 True RMS Voltmeter	
GOULD	74216A Audio Noise Generator	
S.T.C.	GT A9A Milliwatt Test Sets (Power Meter)	
S.T.C.	156A Milliwatt Test Sets (Power Meter)	
S.T.C.	P.A.T.S. Testers	
S.T.C.	G35 Tuned Detectors	
EDGEcombe	J2 A.F. Signal Generators (15-50KHZ)	
J.J. LLOYDS	ADVANCE	
GAYMILANO	F.T.M. Fast Transient Monitors	
FLUKE	8922A True RMS Voltmeters	
ROBAND	500 Voltmeters (1KV)	
550	Fibre Optic Power Meters	
SYSTRON DONNER	101D Pulse Generators	
TELETRON	J5008 Composite Transmission Test Set	
RACAL	1200 Universal Switch Controllers	
RACAL	9303 True RMS R/F Level Meters with	
RACAL	11-1476 Sensing Heads	
HATFIELD	1015 Level Measuring Sets (30Hz-120KHZ)	
HATFIELD	1016 Level Oscillator Sets (30Hz-120KHZ)	
SIEMENS	W2008 Level Oscillators (200Hz-18.6MHz)	
SIEMENS	D2008 Level Meters (200Hz-18.6MHz)	
SIEMENS	Low Pass Filters 2.4GHz, 3.3GHz & 4.3GHz	
SIEMENS	REL 3R 114E Inductance Bridges (0.1µH-1000H)	
TREND	1-9-1 Data Transmission Test Sets	
TREND	1-4 Data Transmission Test Sets	
PHILIPS	3211 Oscilloscopes (15MHz)	
PHILIPS	3217 Oscilloscopes (50MHz)	
PHILIPS	3226 Oscilloscopes (15MHz)	
PHILIPS	3261 Oscilloscopes (120MHz)	
PHILIPS	3240 Oscilloscopes (50MHz)	
LYONS	PG75A Pulse Generators	
WANDEL & GOLTERMANN	RG1 Noise Generators (0-100KHZ)	
WANDEL & GOLTERMANN	PRT1 Test Signal Generators (4.433618MHz)	
WANDEL & GOLTERMANN	ORT1 Regenerator Test Sets	
WANDEL & GOLTERMANN	TFPM43 Level Meter (10KHZ 14MHz)	
BRADLEY	192 Oscilloscope Calibrators	
LEVELL	TG200M RC Oscillators	
LEVELL	Transistor Decade Oscillator	
RHODE & SCHWARZ	UHF Resonance Frequency Meters	
RHODE & SCHWARZ	BN4150 Noise Generators	
WAYNE KERR	B642 Universal Bridges	
WAYNE KERR	TE200 Transducers	
DELTEST	Family Module General Purpose	} Component Test Sets
DELTEST	Family Module Linear Devices	
DELTEST	Family Module Digital Devices	
DELTEST	Family Module Remote Test Hea	
DELTEST	Family Module Power Supply Un	
G.E.C.	Audio Noise Generators	
G.E.C.	Variable Low Pass Filters	
G.E.C.	Flash Testers	
G.E.C.	Insulation Testers	
ENGLISH ELECTRIC	64 Kbit Test Sets	
D.T.L.S.	Universal Prom Programmers	
INTEL (NTELLEC MDS)	Network Measurement Sets	
FILTRONIC	AZD-1 Display Expanders	
WANDEL & GOLTERMANN	Capacitance Deviation Bridges CDBI	
DANBRIDGE	TT Line Attenuators	
ARRA	Isolated Line Conditioners.	
AZTECH		

**ALL EQUIPMENT IS USED, WITH 30 DAYS GUARANTEE.
PLEASE CHECK AVAILABILITY BEFORE ORDERING.
CARRIAGE CAN BE ARRANGED - VAT TO BE ADDED TO TOTAL PRICE OF ALL GOODS AND CARRIAGE.**

Devantech

Industrial Electronic Controls

80C552 Expandable Single Board Processor

- 80C552 at 14.7456Mhz
- 128k EPROM
- 128k Battery Backed RAM
- Ideal for use with Compilers
- RS232 Serial Port
- DIN41612 for Bus & I/O
- 10 Bit 8 channel A/D Converter
- User Presetable Reference
- 2 X 16 bit timers
- 4 Capture, 3 Compare Registers
- 2 X 8 bit PWMs
- 1²C Serial Port
- Watchdog timer
- 2 Relays
- Small size - 80 X 100mm
- Quality Multilayer PCB
- Hardware & Software Options

Comprehensive Data available on Request:

Tel: 0379 640450 Fax: 0379 650482

NEW

THE DEFINITIVE 'OFF-AIR' FREQUENCY STANDARD



Only
£195 + VAT
carriage extra

- ★ Provides 10MHz, 5MHz & 1MHz
- ★ Use it for calibrating equipment that relies on quartz crystals. TCXOs VCXOs, oven crystals.
- ★ Phase locks to DROITWICH (rubidium controlled and traceable to NPL)
- ★ For ADDED VALUE also phase locks to ALLOUIS (cesium controlled and traceable to OP - French eq to NPL)
- ★ British designed and British manufactured

Output frequencies -
10MHz, 5MHz, 1MHz
Short term stability -
better than 1×10^{-9} (1 sec)
Typical - 2×10^{-9} (1 sec)
Long term - tends to
 2×10^{-11} (1000sec)

PHILIPS PM6456 FM STEREO GENERATOR	£149	MARCONI 365B MORSE KEY BRAND NEW	£75
MARCONI TF23333 M/F OSC/LEVEL METER	£95	MCKENZIE 7 DAY TEMP/HUMIDITY RCDR	£95
H.P. 8405A VECTOR V/METER 1GHZ	£595	19" RACK CASE 20U x 31" DEEP	£99
PHILIPS PM3226 15MHz DUAL TRACE	£195	FEEDBACK SS0603 1MHz SINE/SQ OSC.	£125
LEADER LB6522 20MHz DUAL TRACE	£225	AVERY 9.1 & 99.1 SCALES	£125
TELEQUIPMENT D61A 10MHz DUAL TRACE	£149	KAYE DEE. PNEUMO UV EXP UNIT 390x260mm	£175
SE LABS SM111 18MHz DUAL TRACE	£129	BARCO CDCT5451 20" M/SYNC RGB I/PS	£495
TEK 465B 100MHz DUAL TRACE DEL T/B	£475	CONRAC 20" RGB HI-RES LONG PERS. M/SYNC	£495
HP 1740A 100MHz DUAL TRACE DEL T/B	£450	HITACHI 20" CM2073A/301 RGB CAD/DTP ETC	£395
HAMEG HZ65 COMPONENT TESTER	£29	BOONTON 928D R.F. MILLIVOLTMETER	£295
TEKTRONIX 520 521A PAL V/SCOPES	From £475	FARNELL E350 0-350v 100mA 2 x 6.3V	£49 to £69
TELEQUIPMENT D67A 25MHz, 2T, DEL T/B	£215	FARNELL FG1 FUNC. GEN. 2-2.2MHz	£129
H.P. 1700A 35MHz DUAL TRACE	£249	COMMUNICATIONS RECEIVERS, VARIOUS	POA
SCOPEX 4025 25MHz DUAL TRACE	£169	PERISCOPES MILITARY No. 43 Mk.3	£19
BECKMAN 9020 20MHz DUAL TRACE	£249	LCR MARCONI TF1313 0.25%	£95
HITACHI VC 6015 10MHz DIGITAL STORAGE	£345	LCR MARCONI TF1313A 0.1%	£149
H.P. 1340A X-Y DISPLAYS	£99	LCR MARCONI TF2701 IN SITU BRIDGE	£125
TEK 545-585 SERIES PLUG-INS	From £10	LCR MARCONI TF368A BRIDGE	£59
WANDEL/GOLTERMANN SPM-2 LEVEL METER	£169	LCR COMPONENT COMPARATOR AVO CZ457/S	£75
WANDEL/GOLTERMANN SPM-3 LEVEL METER	£189	WAYNE KERR B321 LOW IND. BRIDGE	£39
WANDEL/GOLTERMANN PS-3 SIGNAL GEN	£169	LEVELL TM68 MICRO V-METER 450MHz	£95
MARCONI TF2304 AM/FM MOD METER PRIBLE	£249	LEVELL TM38 MICRO V-METER 3MHz	£85
XFORMERS SEC 30-0-30V 20A. UNIV PRI'S, C-Core	£20	OERTLING V20 SINGLE PAN BALANCES 200GM	£95
CONSTANT VOLTAGE TRANSFS 150VA-2KVA	POA	ANALYTICAL BALANCES WITH WEIGHTS 250GM	£69
MARCONI TF2331 DISTN FACTOR METER	£175	VACUUM PUMPS TYP 100 MBAR (28L/MIN)	£95
MARCONI TF2300 FM/AM MODULATION METER	£195	CALIBRATION STANDARDS CAV/LR	POA
NASCOM GEMINI CARDS, VARIOUS	POA	TOPAZ 91007-117.5KVA 120/240-120/240 ISOL	£175
DECADE R/C/V BOXES	FROM £15	KINGSHILL NS1540 15V 40A PSU CASED, AS NEW	£195

SURVEILLANCE

A SMALL SAMPLE OF OUR RANGE

	KIT	MODULE	PROF FINISHED
ROOM TRANSMITTER RT1 An extremely sensitive miniature transmitter with long battery life. Dimensions: 20 x 20mm	9.95	13.75	19.00
MAINS TRANSMITTER MT4 Can be connected inside any equipment that is mains powered. Dimensions 35 x 20mm	19.75	31.50	45.00
TELEPHONE TRANSMITTER TTS Small enough to conceal within a telephone. Will transmit both sides of a conversation (series connection) Dimensions: 10 x 20mm	12.75	17.50	25.00
TELEPHONE SOCKET TRANSMITTER TSTS Replace your telephone socket with this one within which a transmitter has been concealed.	14.74	—	29.00
ROOM AND TELEPHONE TRANSMITTER RTT Operates as a room transmitter, then switches to telephone transmitter mode during telephone calls. Dimensions: 30 x 25mm	31.50	45.50	65.00
AUTOMATIC TELEPHONE RECORDER SWITCH TRS2 Record telephone conversations with this interface unit and your own tape recorder. Dimensions: 36 x 50mm	16.80	25.90	39.00
AUTOMATIC TELEPHONE RECORDER ATR1 Adapt the tape recorder included to record telephone calls automatically.	34.95	—	59.00
TELEPHONE TAP ALERT TTA1 Visual warning of any invasions of privacy on your telephone line. Dimensions: 38 x 52mm	21.95	31.50	45.00
RF DETECTOR RFD1 Highly sensitive hand-held detector. Range between 10MHz and 600MHz. Silent operation. Dimensions: 70 x 50mm	42.75	69.00	95.00
CAMERA DETECTOR CDB Detects hidden video cameras (even miniature CCD models). Dimensions: 63 x 38mm	69.00	89.00	125.00
RECORDING BRIEFCASE RBC1 Completely discreet recordings at a value for money price.	—	—	145.00
SHOTGUN MICROPHONE AMPLIFIER SMA Ideal for surveillance. The amplifier will pick up sounds from a long distance.	24.95	36.00	45.00
SIGNALLING TRANSMITTER SIGT Sends a continual audio pulse. Can be integrated into alarm, tracking or warning systems. Dimensions: 20 x 50mm	21.95	34.89	45.00
TELEPHONE AMPLIFIER TA5 Connected directly to the telephone, this unit will amplify both sides of a telephone call. Dimensions: 25 x 52mm	10.95	16.95	19.95
PROFESSIONAL SOUND TO LIGHT UNIT SK72 Custom built for disco or home use. Audio signal divided into bass, mid and treble bands, with internal microphone and spotlight option. Dimensions 210 x 45mm	21.95	32.49	44.95
MICRO METAL DETECTOR MMD Detect the presence of ferrous and various non-ferrous metals. Useful for all those DIY jobs. Dimensions: 40 x 25mm	9.95	16.95	—

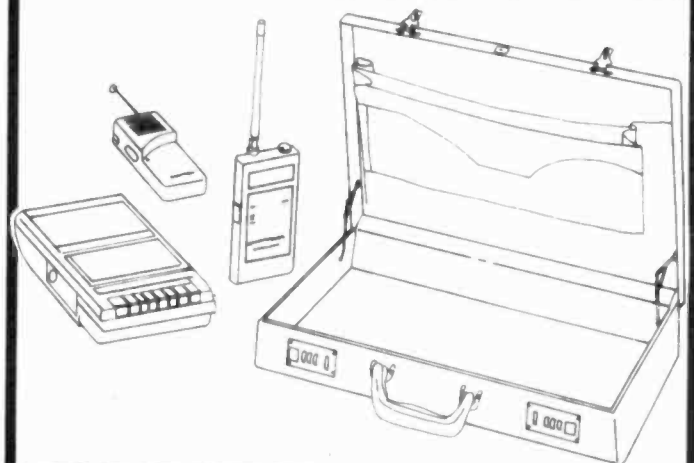

Please add £2.00 P & P to all orders and 17.5% VAT on all U.K. orders.

For full catalogue please send two 1st class stamps or 2 IRC'S

172 Caledonian Road
Dept ET

London N1 0SG

CANAL

BRIDGE AUDIO

071-837 4423



Surplus always wanted for cash!

THE ORIGINAL SURPLUS WONDERLAND!

Surplus always wanted for cash!

LOW COST PC SPECIALISTS - ALL EXPANDABLE - ALL PC COMPATIBLE

8088 XT - PC99



- 256k RAM - expandable to 640k
- 4.7 Mhz speed
- 360k 5-1/4" floppy
- 2 serial & 1 parallel ports
- MS-DOS 4.01
- Factory burnt-in
- Standard 84 key keyboard
- 12" green screen included
- In good used condition

Optional FITTED extras: 640K RAM £39. 12" CGA colour monitor with card £39. 2nd 5-1/4" 360k floppy £29.95. 20 mbyte MFM hard drive £99.

Only £99.00 (F)

FLOPPY DISK DRIVES

5 1/4" from £22.95 - 3 1/2" from £21.95!

Massive purchases of standard 5 1/4" and 3 1/2" drives enables us to present prime product at industry beating low prices! All units (unless stated) are removed from often brand new equipment and are fully tested, aligned and shipped to you with a 90 day guarantee and operate from standard voltages and are of standard size. All are IBM-PC compatible (if 3 1/2" supported).

- 3.5" Panasonic JU363/4 720K or equivalent £29.95(B)
- 3.5" Mitsubishi MF355C-L 1.4 Meg. Laptops only £29.95(B)
- 3.5" Mitsubishi MF355C-D 1.4 Meg. Non laptop £29.95(B)
- 5.25" EXTRA SPECIAL BRAND NEW Mitsubishi MF501B 360K. Absolutely standard fits most computers £22.95(B)

- * Data cable included in price.
- Shugart 800/801 SS refurbished & tested £175.00(E)
- Shugart 851 double sided refurbished & tested £275.00(E)
- Mitsubishi M2894-63 double sided switchable hard or soft sectors - BRAND NEW £250.00(E)

Dual 8" drives with 2 mbyte capacity housed in a smart case with built in power supply! Ideal as exterior drives! £499.00(F)
End of line purchase scoop! Brand new NEC D2246 8" 85 megabyte of hard disk storage! Full CPU control and industry standard SMD interface. Ultra hi speed transfer and access time leaves the good old ST506 interface standing. In mint condition and comes complete with manual. Only £299(E)

THE AMAZING TELEBOX!

Converts your colour monitor into a QUALITY COLOUR TV!!



TV SOUND & VIDEO TUNER!

The TELEBOX consists of an attractive fully cased mains powered unit, containing all electronics ready to plug into a host of video monitors made by manufacturers such as MICROVITEC, ATARI, SANYO, SONY, COMMODORE, PHILIPS, TATUNG, AMSTRAD and many more. The composite video output will also plug directly into most video recorders, allowing reception of TV channels not normally receivable on most television receivers (TELEBOX MB). Push button controls on the front panel allow reception of 8 fully tuneable "off air" UHF colour television or video channels. TELEBOX MB covers virtually all television frequencies VHF and UHF including the HYPERBAND as used by most cable TV operators. Composite and RGB video outputs are located on the rear panel for direct connection to most makes of monitor. For complete compatibility - even for monitors without sound - an integral 4 watt audio amplifier and low level Hi Fi audio output are provided as standard.

- Telexbox ST for composite video input monitors £32.95
 - Telexbox STL as ST but with integral speaker £36.50
 - Telexbox MB as ST with Multiband tuner VHF-UHF-Cable. & hyperband For overseas PAL versions state 5.5 or 6mhz sound specification. £69.95
 - Telexbox RGB for analogue RGB monitors (15khz) £69.95
- Shipping code on all Teleboxes is (B)
RGB Telexbox also suitable for IBM multisync monitors with RGB analog and composite sync. Overseas versions VHF & UHF call. SECAM / NTSC not available.

No Break Uninterruptable PSU's

Brand new and boxed 230 volts uninterruptable power supplies from Densel. Model MUK 0565-AUAF is 0.5 kva and MUD 1085-AHBH is 1 kva. Both have sealed lead acid batteries. MUK are internal, MUD has them in a matching case. Times from interrupt are 5 and 15 minutes respectively. Complete with full operation manuals.....MUK.....£249 (F) MUD.....£525 (G)

286 AT - PC286



- 640k RAM expandable with standard SIMMS
- 12 Mhz Landmark speed
- 20 meg hard disk
- 1.2 meg 5-1/4" floppy
- 1.4 meg 3-1/2" floppy
- EGA driver on board
- 2 serial & 1 parallel ports
- MS-DOS 4.01
- Co-processor socket
- Enhanced 102 key keyboard
- Clock & calendar with battery back up

BRAND NEW AND BOXED!

Only £249.00 (F)

The Philips 9CM073 is suggested for the PC286 and the CM8873 for the PC386. Either may use the SVGA MTS-9600 if a suitable card is installed. We can fit this at a cost of £49.00 for the PC286 and £39.00 for the PC386.

POWER SUPPLIES

- Power One SPL200-5200P 200 watt (250 w peak). Semi open frame giving +5v 35a, -5v 1.5a, +12v 4a (8a peak), -12v 1.5a, +24v 4a (6a peak). All outputs fully regulated with over voltage protection on the +5v output. AC input selectable for 110/240 vac. Dims 13" x 5" x 2.5". Fully guaranteed RFE. £85.00 (B)
- Power One SPL130. 130 watts. Selectable for 12v (4A) or 24v (2A). 5v @ 20A. ±12v @ 1.5A. Switch mode. New. £59.95(B)
- Astec AC-8151 40 watts. Switch mode. +5v @ 2.5a. +12v @ 2a. -12v @ 0.1a. 6-1/4" x 4" x 1-3/4". New £22.95(B)
- Greendale 19AB0E 60 watts switch mode +5v @ 6a, ±12v @ 1a, +15v @ 1a. RFE and fully tested. 11 x 20 x 5cm. £24.95(C)
- Conver AC130. 130 watt hi-grade VDE spec. Switch mode. +5v @ 15a, -5v @ 1a, ±12v @ 6a. 27 x 12.5 x 6.5cm. New. £49.95(C)
- Boshert 13090. Switch mode. Ideal for drives & system. +5v @ 6a, +12v @ 2.5a, -12v @ 0.5a, -5v @ 0.5a. £29.95(B)
- Farnell G6/40A. Switch mode. 5v @ 40a. Encased £95.00(C)
- Farnell G24/5S. As above but 24v @ 5a. £65.00(C)

BBC Model B APM Board

WIN £100 CASH!
£100 CASH FOR THE MOST NOVEL DEMONSTRABLE APPLICATION!

BBC Model B type computer on a board. A major purchase allows us to offer you the PROFESSIONAL version of the BBC computer at a parts only price. Used as a front end graphics system on large networked systems the architecture of the BBC board has so many similarities to the regular BBC model B that we are sure that with a bit of experimentation and ingenuity many useful applications will be found for this board!! It is supplied complete with a connector panel which brings all the I/O to 'D' and BNC type connectors - all you have to do is provide +5 and ±12 v DC. The APM consists of a single PCB with most major ic's socketed. The ic's are too numerous to list but include a 6502, RAM and an SAA5050 teletext chip. Three 27128 EPROMs contain the custom operating system on which we have no data. On application of DC power the system boots and provides diagnostic information on the video output. On board DIP switches and jumpers select the ECONET address and enable the four extra EPROM sockets for user software. Appx. dms: main board 13" x 10". I/O board 14" x 3". Supplied tested with circuit diagram, data and competition entry form.

Only £29.95 or 2 for £53 (B)

SPECIAL INTEREST

- Trio 0-18 vdc bench PSU, 30 amps. New £ 470
- Fujitsu M3041 600 LPM band printer £2950
- DEC LS/02 CPU board £ 150
- Rhode & Schwarz SBUF TV test transmitter 25-1000mhz. Complete with SBTF2 Modulator £6500
- Calcomp 1036 large drum 3 pen plotter £ 650
- Thurby LA 160B logic analyser £ 375
- 1.5kw 115v 60hz power source £ 950
- Anton Pillar 400 Hz 3 phase frequency converter 75Kw POA
- Newton Derby 400 Hz 70 Kw converter POA
- Nikon PL-2 Projection lens meter/scope £750
- Sekonic SD 150H 18 channel Hybrid recorder £2000
- HP 7580A A1 8 pen high speed drum plotter £1850
- Kenwood DA-3501 CD tester, laser pickup simulator £ 350

BRAND NEW PRINTERS

- Microline 183. NLQ 17x17 dot matrix. Full width. £139 (D)
- Hyundai HDP-920. NLQ 24x18 dot matrix full width. £149 (D)
- Qume LetterPro 20 daisy. Qume QS-3 interface. £39.95 (D)
- Centronics 152-2.9 x 7 dot matrix. Full width. £143 (D)
- Centronics 159-4.9 x 7 dot matrix. Serial. 9-1/2" width £ 99 (D)

386 AT - PC386



- 2 meg RAM expanded by slots
- 20 Mhz with 32k cache. Expandable to 64k
- 40 meg hard disk
- 1.2 meg 5-1/4" floppy
- VGA card installed
- 2 serial & 1 parallel ports
- MS-DOS 4.01
- Co-processor socket
- Enhanced 102 keyboard
- Kwik Disk Accelerator Software - FREE

BRAND NEW AND BOXED!

Only £425.00 (F)

MONITORS

- 14" Forefront Model MTS-9600 SVGA multisync with resolution of 1024 x 768. 0.28 pitch. *Text* switch for word processing. Overscan switch included. Ideal for the PC-386 or PC-286 with SVGA card added. Also compatible with BBC, Amiga, Atari (including the monochrome high resolution mode), Archimedes etc. In good used condition (possible minor screen burns). 90 day guarantee. 15" x 14" x 12". Only £159(E)
- 14" Philips Model CM8873 VGA multisync with 640 x 480 resolution. CGA, EGA or VGA, digital/analog, switch selectable. Sound with volume control. There is also a special *Text* switch for word processing, spreadsheets and the like. Compatible with IBM PCs, Amiga, Atari (excluding the monochrome high resolution mode), BBC, Archimedes etc. Good used condition (possible minor screen burns) 90 day guarantee. 15" x 14" x 12". Only £139(E)
- Philips 9CM073 similar (not identical) to above for EGA/CGA and compats. 640 x 350 resolution. With Text switch with amber or green screen selection. 14" x 12" x 13-1/2". £99(E)
- KME 10" high definition colour monitors. Nice tight 0.28" dot pitch for superb clarity and modern styling. Operates from any 15.625 khz sync RGB video source, with RGB analog and composite sync such as Atan, Commodore Amiga, Acom Archimedes & BBC. Measures only 13.5" x 12" x 11". Also works as quality TV with our HUB Telebox. Good used condition. 90 day guarantee. Only £125 (E)
- KME as above for PC EGA standard. £145 (E)
- Brand new Centronic 14" monitor for IBM PC and compatibles at a lower than ever price! Completely CGA equivalent. Hi-res Mitsubishi 0.42 dot pitch giving 669 x 507 pixels. Big 28 Mhz bandwidth. A super monitor in attractive style moulded case. Full 90 day guarantee. Only £129 (E)
- NEC CGA 12" IBM-PC compatible. High quality ex-equipment fully tested with a 90 day guarantee. In an attractive two tone ribbed grey plastic case measuring 15" L x 13" W x 12" H. The front cosmetic bezel has been removed for contractual reasons. Only £69 (E)

Superbly made UK manufacture. PIL all solid state colour monitors, complete with composite video & sound inputs. Attractive teak style case. Perfect for Schools, Shops, Disco, Clubs. In EXCELLENT little used condition with full 90 day guarantee. 20"£135 22"£155 26"£185 (F)
CALL FOR PRICING ON NTSC VERSIONS!
Superb Quality 6 foot 40u
19" Rack Cabinets
Massive Reductions
Virtually New, Ultra Smart!
Less Than Half Price!
Top quality 19" rack cabinets made in UK by Optima Enclosures Ltd. Units feature designer, smoked acrylic lockable front door, full height lockable half louvered back door and removable side panels. Fully adjustable internal fixing struts, ready punched for any configuration of equipment mounting plus ready mounted integral 12 way 13 amp socket switched mains distribution strip make these racks some of the most versatile we have ever sold. Racks may be stacked side by side and therefore require only two side panels or stand singly. Overall dimensions are 77-1/2"H x 32-1/2"D x 22"W. Order as:
Rack 1 Complete with removable side panels.....£275.00 (G)
Rack 2 Less side panels£145.00 (G)

1992 Winter Issue of Display News now available - send large SAE - PACKED with bargains!

DISPLAY

MAIL ORDER & OFFICES
Open Mon-Fri 9.00-5.30
Dept ET.32 Biggin Way,
Upper Norwood,
London SE19 3XF.

LONDON SHOP
Open Mon-Sat 9.5-3.30
Thursday till 9.00pm
215 Whitehorse Lane,
South Norwood,
London, SE25.

DISTEL © The Original
Free dial-up database!
1000's of items+info on line
V21, V22 & V22 bis
081-679-1888

ALL ENQUIRIES
081-679-4414
Fax-081-679-1927



-ELECTRONICS-

All prices for UK Mainland. UK customers add 17.5% VAT to TOTAL order amount. Minimum order £10. PO orders from Government, Universities, Schools & Local Authorities welcome-minimum account order £30. Carriage charges (A)=£2.00. (B)=£3.75. (C)=£5.50. (D)=£11.50. (E)=£14.00. (F)=£18.00. (G)=Call. Scotland surcharge: call. All goods supplied subject to our standard Conditions of Sale and unless otherwise stated guaranteed for 90 days. All guarantees on a return to base basis. Rights reserved to change prices & specifications without prior notice. Orders subject to stock. Quotations willingly given for higher quantities than those stated. Bulk surplus always wanted for cash.

Moving Coil Meters

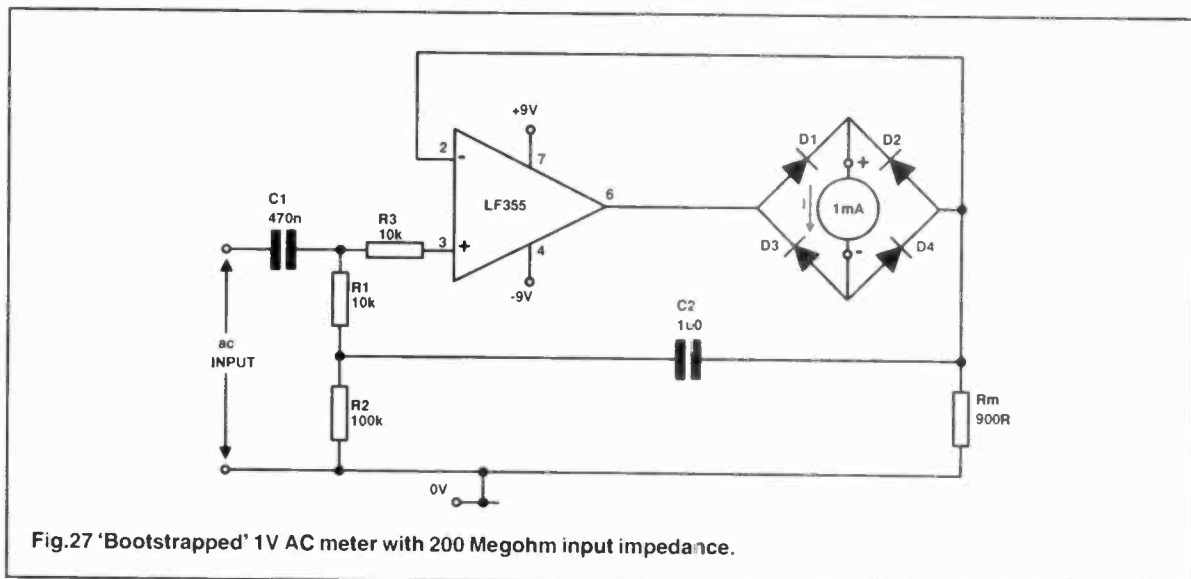

Fig.27 'Bootstrapped' 1V AC meter with 200 Megohm input impedance.

Circuit Variations

Ray Marston continues his in-depth look at modern electronic analogue V, I, and R meter circuitry.

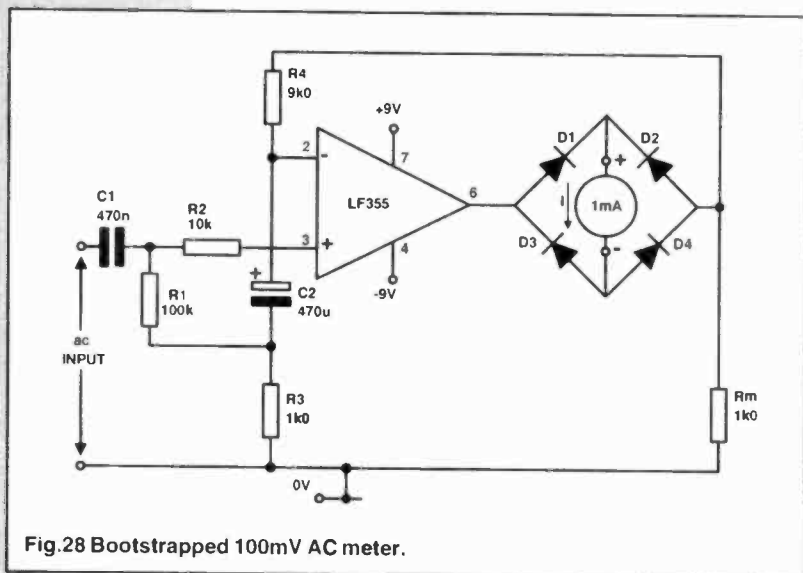

Fig.28 Bootstrapped 100mV AC meter.

The Figure 25 circuit shown last month is, allowing for the limitations mentioned, really an excellent one and can, by using suitably 'fast' op-amps, give a good performance to well above 100kHz. The basic circuit can be subjected to a number of useful modifications (and a few of these are shown in Figures 27 to 29) which are all shown using a medium-speed LF355 JFET op-amp.

Figure 27 shows how the input impedance of the basic circuit can be raised to about 200 Megohms by using R1 and R2 as input-grounding resistors and bootstrapping their junction via C2, so that identical signal voltages appear at each end of R1, which thus passes near-zero signal current and appears as a near-infinite impedance.

Figure 28 shows the basic circuit modified to drive an FSD sensitivity of 100mV by subjecting the inverting terminal's AC feedback signal to 20dB of attenuation via the R4-C2-R3 'divider' network, so that the op-amp acts as a 'x10' amplifier feeding a linearised 1 volt meter. The meter's basic '1 volt' sensitivity is set via Rm, but this is shunted by the impedance of the R4-C2-R3 feedback network and is thus given an actual value of 1k Ω , to set its shunted impedance close to the ideal '900 ohm' value (a variable resistor can be used to precisely set the FSD sensitivity, if preferred). Note in the diagram that input resistor R1 is bootstrapped via R3, thus giving the circuit a 100 Megohm input impedance.

Figure 29 shows the above circuit modified for use with a 100uA movingcoil meter, which needs an Rm value of 9k Ω to give an FSD sensitivity of 1V. In this case Rm serves a dual purpose and forms part of the Rm-C2-R3 feedback network that sets the op-amp's closed-loop gain at x10, to give 100mV overall FSD sensitivity. -1 is again bootstrapped, to give a 100 Megohm input impedance.

Three design points are worth noting about these circuits. The first concerns the 'frequency' performance of the Figure 28 and 29 '100mV' designs and is that when used with Schottky diodes and a 3140 op-amp they maintain 1% linearity down to 10% of FSD up to 70kHz, and down to 25% of FSD to well above 100kHz. The second point concerns C2 in these two circuits - this component affects low-frequency response, which starts to fall off when the C2 impedance

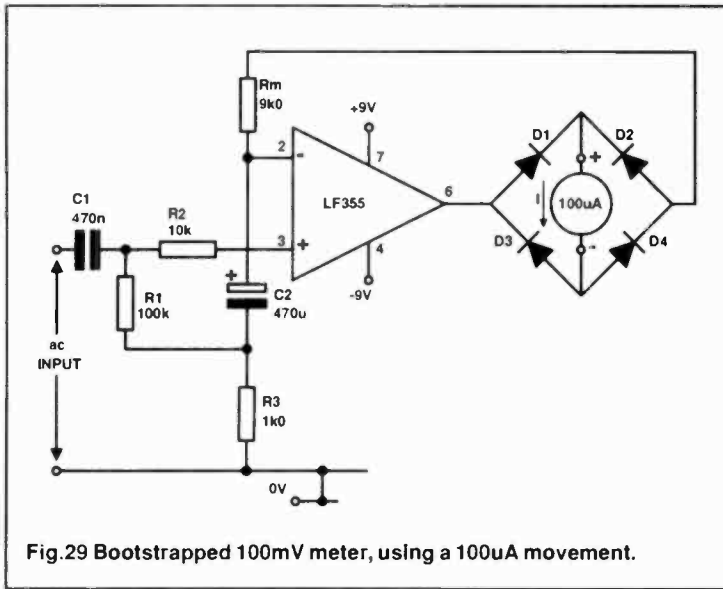

Fig.29 Bootstrapped 100mV meter, using a 100uA movement.

becomes significant relative to R3. C2 thus needs a large value and, since it operates with zero bias, can be an electrolytic type of capacitor.

The final design point concern all three circuits and is that each of them operates with such heavy DC negative feedback between the output and the inverting input terminal that a 'Set Zero' balance control is not needed (on the LF355, such a control takes the form of a 25k pot wired between pins 1 and 5, with the pot slider taken to the positive supply rail).

Multi-range AC Meters

The bootstrapped 100mV AC voltmeter circuits of Figures 28 or 29 can easily be converted into a multi-range voltage or current meter. Figure 30 shows a basic circuit that gives conversion into a five-range AC voltmeter. Input signals are fed to the multi-decade attenuator via DC-blocking capacitor C1, and the attenuator is frequency compensated by C2, C3, and C4. Range switch SW1 feeds the attenuator output to the AC-coupled input of the 100mV AC voltmeter.

Figure 31 shows a switched shunt circuit that gives conversion into a five-range AC current meter. In this case it is not feasible to block DC currents from the shunts, but DC components are automatically blocked from the meter circuit's input via its AC-coupler, so the meter reads AC currents only.

AC/DC Converter Circuits

All the 'AC voltmeter' circuits shown so far use their electronic circuitry to drive the meter via a direct AC input. Figure 32 shows an alternative type of metering system, in which the AC input is fed directly to a precision AC/DC converter which then drives a high quality DC voltmeter, thus giving an accurate but indirect reading of the AC input voltage. This system has considerable merit, since it enables DC circuitry to handle tasks such as meter overload protection and interdecade ranging, etc., and leaves the ac circuitry to take care of the relatively simple problem of AC/DC conversion. This basic system is used in all modern digital multimeter circuits. Figures 33 to 38 show examples

of some well known types of op-amp based AC/DC converter circuit. All of these designs are shown using a 741 op-amp and 1N4148 silicon diodes, but for the very best high-frequency and linearity performance a high-frequency op-amp and Schottky diodes should be used.

Figure 33 shows a simple precision half-wave rectifier circuit, based on a unity-gain voltage follower and having a high input impedance; the circuit gives a positively-rectified output, but can be made to give a negatively-rectified one by reversing D1. The circuit can be used to accept direct-coupled or AC-coupled input signals by using the connections shown in (a) or (b) respectively.

Figure 34 shows how the basic circuit can be modified to act as a peak-voltage detector with a buffered output. Figure 35 shows an alternative version of the precision half-wave rectifier, which gives improved linearity and frequency response, but at the expense of a reduced input impedance (equal to R1). In this case the op-amp is wired as an inverting

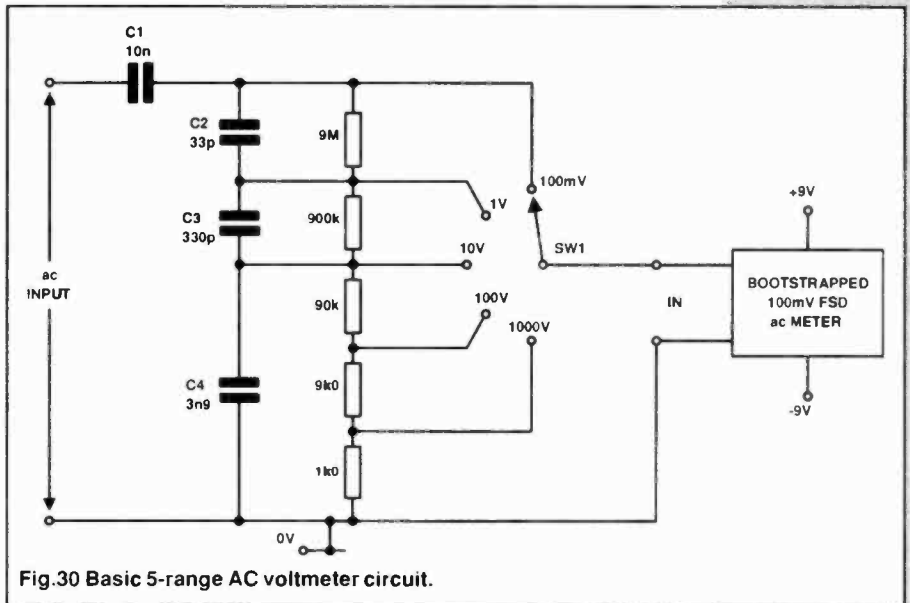

Fig.30 Basic 5-range AC voltmeter circuit.

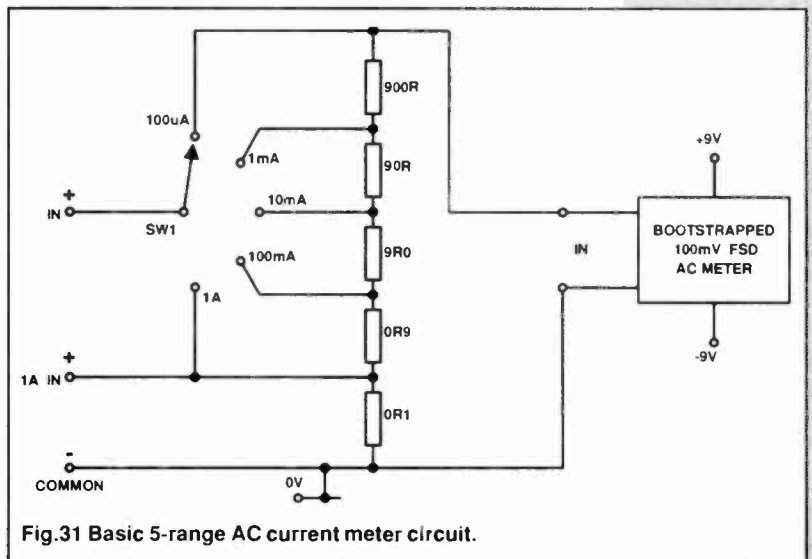

Fig.31 Basic 5-range AC current meter circuit.

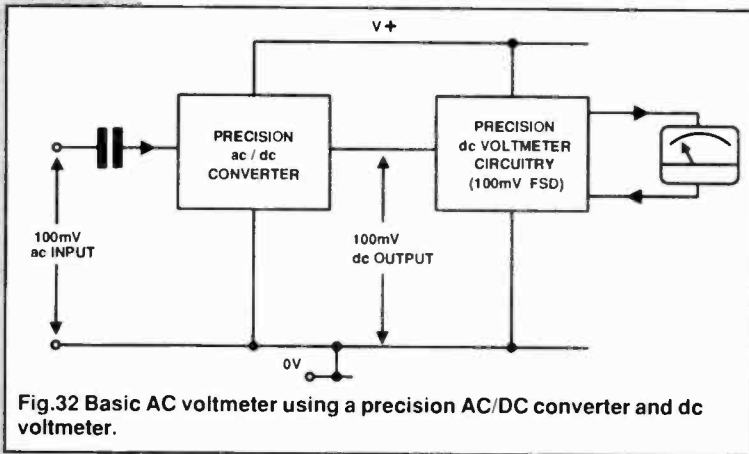

Fig.32 Basic AC voltmeter using a precision AC/DC converter and dc voltmeter.

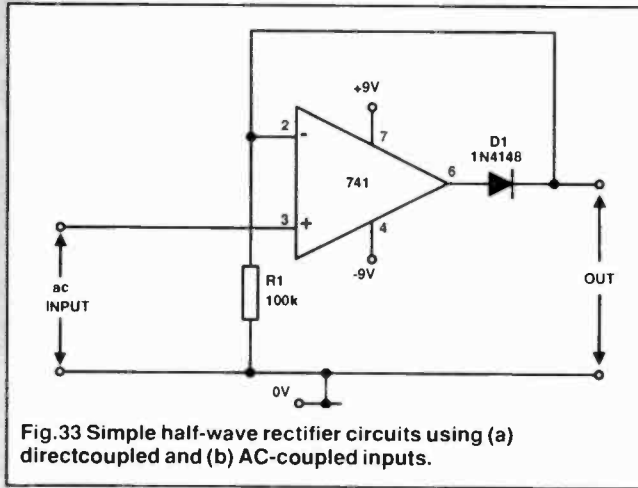

Fig.33 Simple half-wave rectifier circuits using (a) directcoupled and (b) AC-coupled inputs.

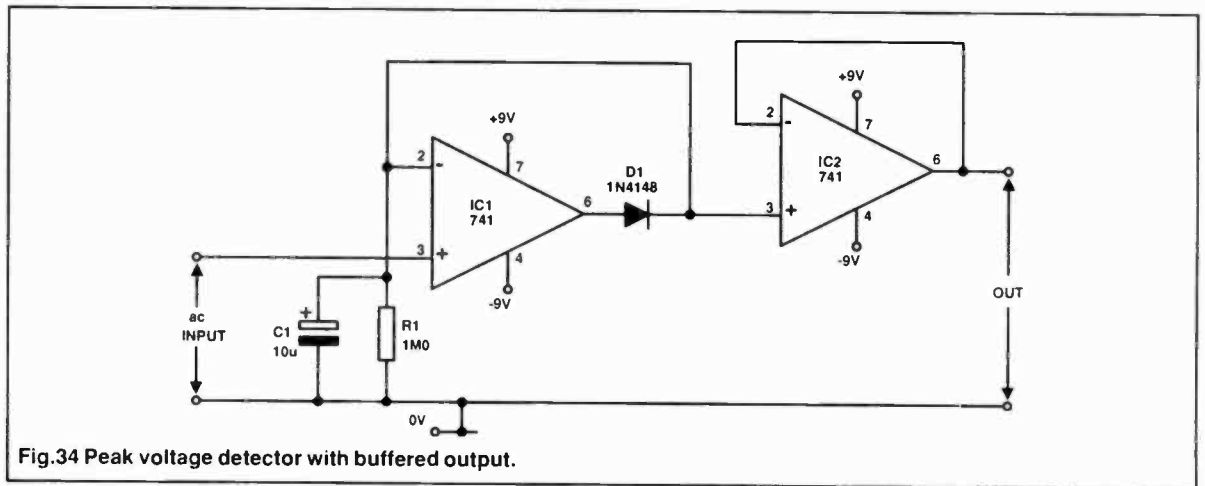

Fig.34 Peak voltage detector with buffered output.

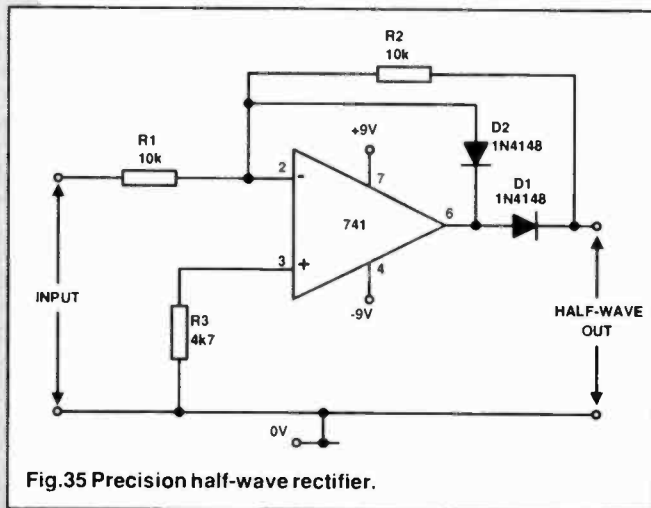

Fig.35 Precision half-wave rectifier.

amplifier. When the input signal goes positive, the op-amp output tries to go negative, but is effectively prevented from doing so by D2; when the input goes negative the op-amp output goes positive and forward biases D1, which then sets the circuit's voltage gain at unity via R1-R2. The circuit's output thus consists of positive half-cycles only. Figure 36 shows how this circuit can be used as a true AC/DC voltage converter by increasing the value of R2 to 22k Ω , giving form-factor correction and by using C1 (in conjunction with R2) to integrate the output waveform and convert it to DC. Note that this circuit has a high output impedance and must be buffered if fed to a low-impedance load.

Figure 37 shows how a negative-output version of the Figure 35 circuit can be combined with an inverting adder to make a precision full-wave rectifier. Here, IC2 inverts and gives x2 gain (via R3-R5) to the half-wave rectified signal of IC1 and inverts and gives unity gain (via R4-R5) to the original input signal (E_{in}). Thus, when a negative input is applied the output of IC1 is zero, so IC2's output equals $+E_{in}$. When positive inputs are applied, IC1 gives a negative output, so IC2 generates an output of $+2E_{in}$ via IC1 and $-E_{in}$ via the original input signal, thus giving an actual output of $+E_{in}$.

The final output is thus a full-wave rectified, unity-gain, version of the input signal. Figure 38 shows how this circuit can be used as a precision AC/DC voltage converter by giving R5 a value of 11k Ω to give form-factor correction and by using C1-R5 to give waveform integration. Note that this circuit has a low output impedance.

Special AC/DC Converters

The precision rectifier and converter circuits of Figures 35 to 38 offer good linearity but have relatively low values of input impedance. In recent years, mainly as a result of developments in the digital multimeter field (see chapter 7), a demand has grown for a really good and inexpensive AC/DC voltage converter with excellent linearity and a very high input impedance. This demand has largely been met by the 'standard' circuit of Figure 39.

In this design, the op-amp is used as a non-inverting amplifier with DC biasing applied by R1 and R2, with D1-D2-R3-R4 and R5-RV1 acting as a 'ghosted' half-wave rectifier that is AC to the circuit's negative feedback path. The op-amp's basic action is such that pin-2's AC signal intrinsically 'follows' the input voltage (e) of pin-3, and (since R5-RV1 are AC-coupled between pin-2 and ground) this causes a current (I) of $e/(R5+RV1)$ to flow in R5-RV1.

This current is derived from the op-amp's output and flows via D1-R4 on positive half-cycles and via D2-R3 on negative ones and generates near-perfect half-wave rectified-positive waveforms across R4, and near-perfect negative ones across

R3. The output signal generated between the ground is thus a near-perfect positively rectified half wave superimposed on a duplicate of the AC input signal. When this signal is integrated via R6-C4, the AC element is eliminated and the rectified portion of the signal is converted into DC; RV1 enables the R4 to R5-RV1 ratio to be set to give perfect sinewave form-factor correction, enabling the circuit to give precision AC/DC voltage conversion.

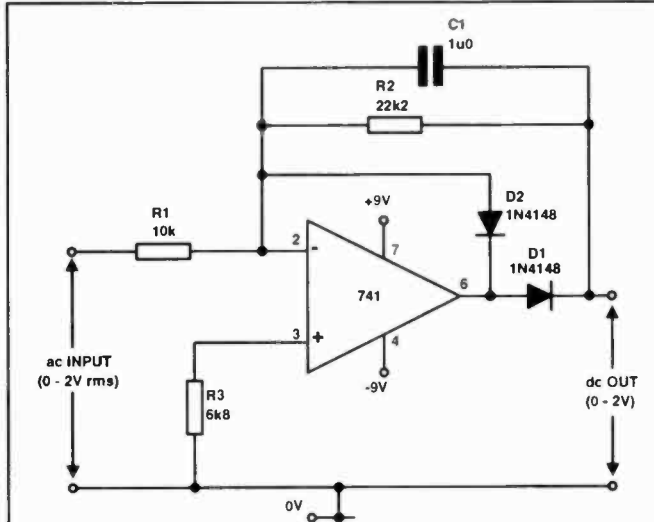

Fig.36 Precision half-wave AC/DC converter.

All The Range

The circuit in Figure 39 has a useful AC/DC conversion range (with excellent linearity) from above 1 volt to less than 10mV. Precision falls off at low values of input and the output is typically 1mV down with a 10mV input, i.e. linearity is typically 1% of a 100mV FSD value, or 0.1% of a 1 volt FSD value. The circuit's input impedance is slightly less than the R1 value of 10 Megohms.

Figure 40 shows a high-performance version of the AC/DC converter. Its input impedance is raised to about 100 Megohms by bootstrapping R1 via R7-RV1 and the op-amp is given input overload protection via R2. The circuit's linearity is enhanced by trebling the forward operating currents of D1 and D2 (to peak

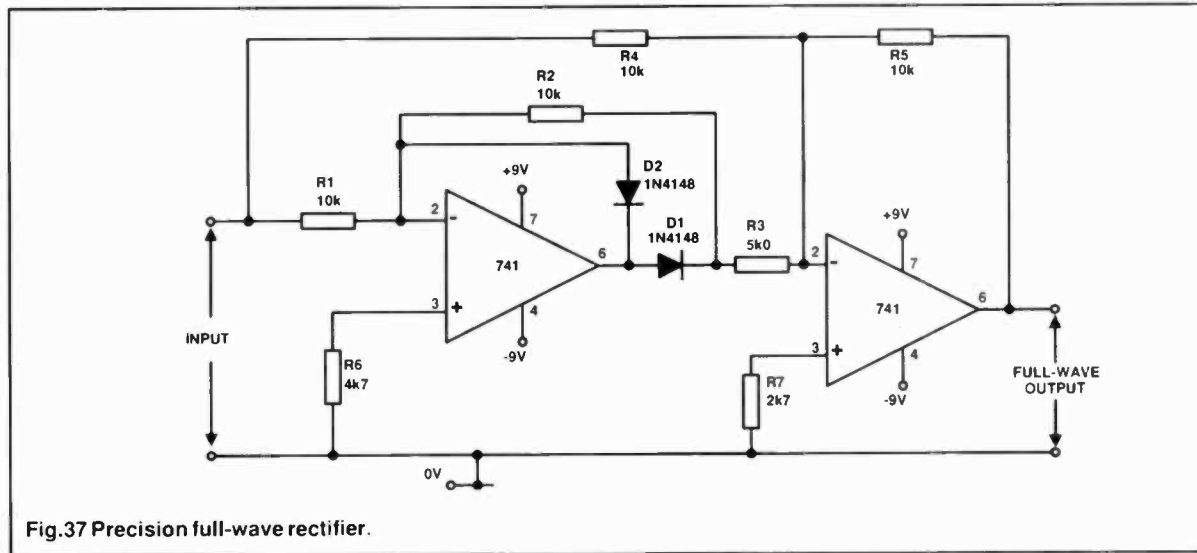

Fig.37 Precision full-wave rectifier.

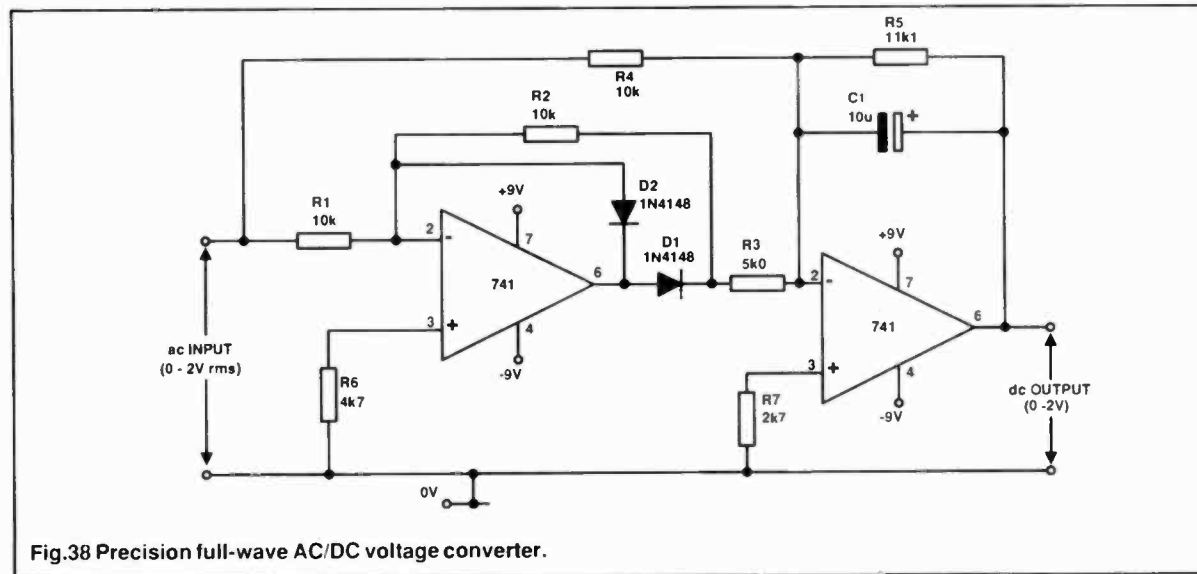
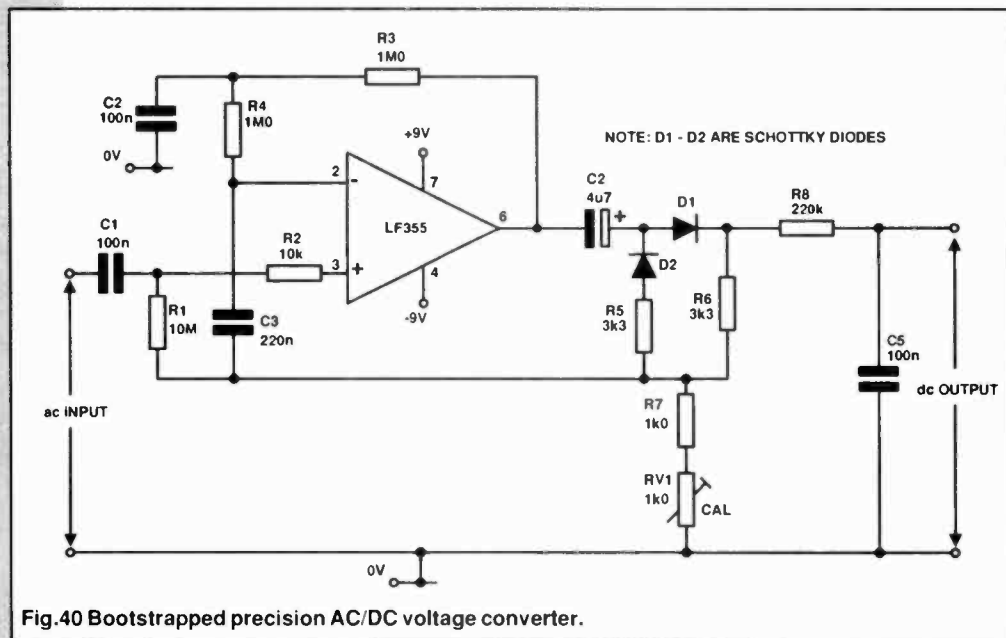
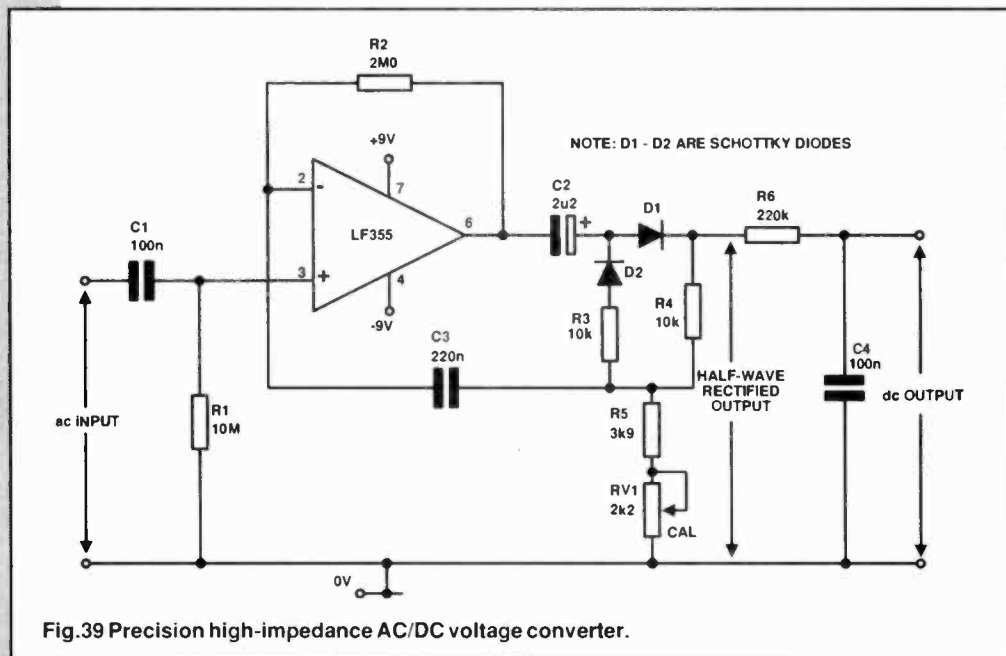
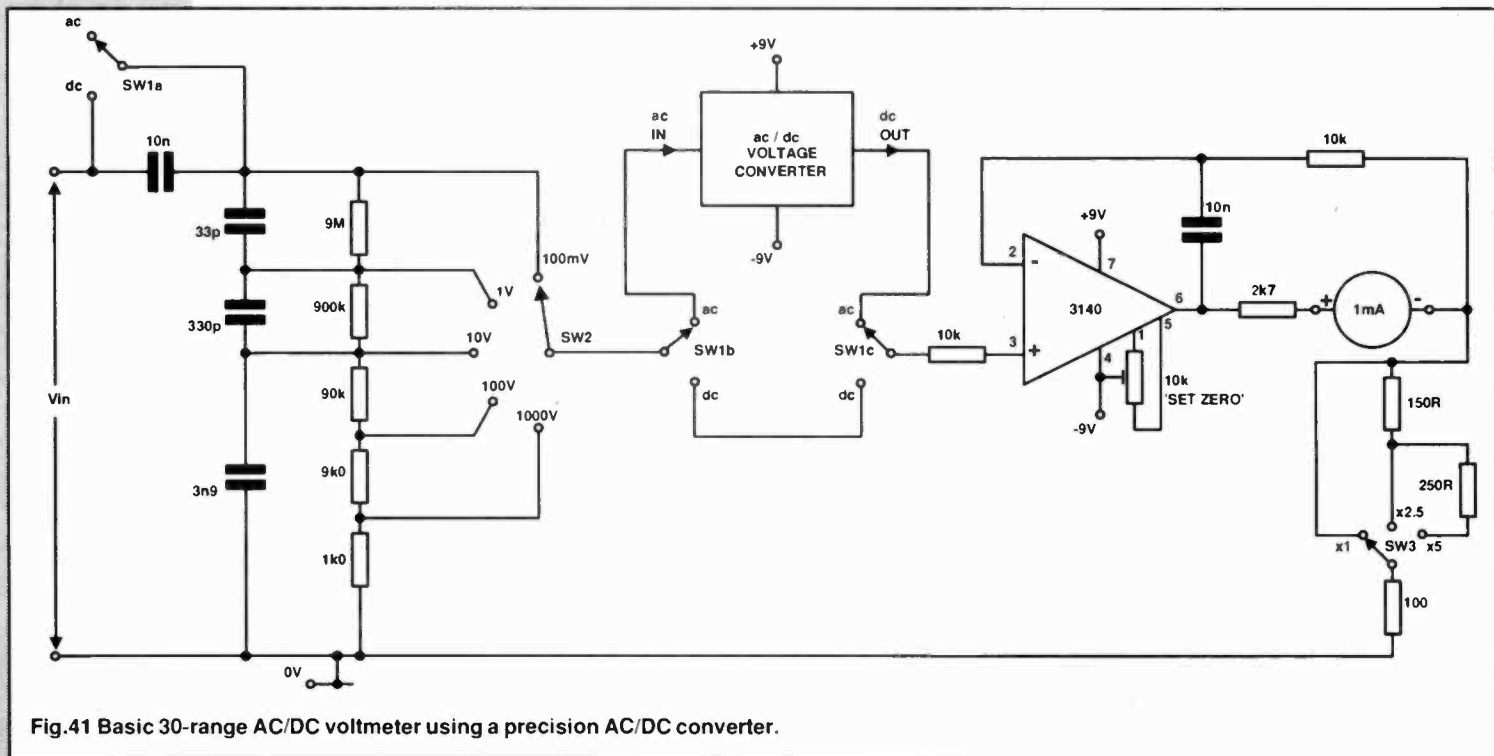

Fig.38 Precision full-wave AC/DC voltage converter.



values of about 100uA at 100mV, giving improved forward/reverse current ratios, and by AC-decoupling the R3-R4 DC-biasing network so that it does not significantly shunt the D1-D2-R5-R6 feedback network.

These simple measures improve linearity by some 300%, to give DC errors of only 0.3mV at 10mV input, and a linearity factor of 0.3% of a 100mV FSD input value. D1 and D2 should be BAT85 Schottky diodes, in which case (when using an LF355 op-amp) the circuit maintains its linearity to within 1% of a 500mV FSD value to above 150kHz, or to within 1% of a 100mV FSD value to about 40kHz. Figure 41 shows, in basic form, how an AC/DC converter of the above type can be used in conjunction with a compensated input attenuator (see Figure 30) and a simple DC voltmeter (see Figure 7 in March) to make a precision 30-range AC/DC voltmeter; in a practical instrument the converter should be disabled by breaking its supply connections when not in use.





Chelmer Valve Company for Audio Valves

Audio valves with famous Brand Names of yesteryear such as MULLARD, MOV, GEC, RCA etc., are in very limited supply and their scarcity also makes them very expensive.

We at Chelmer Valve Company however provide high quality alternatives to these old makes. We have over 30 years experience in the supply of electronic valves of all types and during this time have established close ties with factories and sources worldwide.

For high fidelity use we further process valves from these sources using our specially developed facilities. After rigorous testing – including noise, hum, microphony, post burn-in selection and matching as needed – we offer this product as CVC PREMIUM valves.

A selection of the more popular types is listed here.

Price list & Order Form for CVC PREMIUM Audio Valves

	UNIT PRICE	QTY.	TOTAL PRICE	UNIT PRICE	QTY.	TOTAL PRICE
PRE-AMP VALVES				CARRIED FORWARD		
ECC81/12AT7	5.00			RECTIFIERS		
ECC82/12AU7	4.00			GZ33	4.50	
ECC83/12AX7	5.00			GZ34/5AR4	4.50	
ECC85	4.00			5U4G	5.00	
ECC88	5.00			5Y3GT	3.20	
EF86	4.00			5Z4GT	3.50	
E81CC (GOLD PIN)	6.00			SOCKETS		
E82CC " "	6.00			B9A (PCB)	1.60	
E83CC " "	6.00			B9A (CHASSIS)	1.60	
E88CC " "	7.00			OCTAL (CHASSIS)	1.75	
E80F	12.00			4 PIN (UX4)	3.00	
E83F	5.50			MATCHING CHARGES*		
6SL7GT	4.00			POST & PACKING		
6SN7GT	4.20			TOTAL EXC. VAT		
POWER VALVES				VAT @ 17½%		
2A3 (4 PIN)	14.00			TOTAL TO PAY £		
2A3 (OCTAL)	14.00			* MATCHING, if required; state valve types & if PAIRS, QUADS or OCTETS – Allow £1.00 per valve for this service.		
211	22.00			Make CHEQUES payable to 'CHELMER VALVE COMPANY' or pay by ACCESS/MASTERCARD/VISA, give details:-		
300B	50.50			<input type="checkbox"/> <input type="checkbox"/> <input type="checkbox"/> <input type="checkbox"/> <input type="checkbox"/> <input type="checkbox"/> <input type="checkbox"/> <input type="checkbox"/> <input type="checkbox"/> <input type="checkbox"/> <input type="checkbox"/> <input type="checkbox"/> <input type="checkbox"/> <input type="checkbox"/> <input type="checkbox"/>		
811A	9.50			Signature Expiry		
845	29.90			Name		
EL34/6CA7	7.50			Address		
EL84/6BQ5	4.00				
E84L/7189A	5.10				
KT66	9.20				
KT88	12.50				
KT88 (GOLD Q)	18.50				
6L6GC	6.50				
6L6WGC/5881	8.00				
6V6GT	5.00				
6146B	10.20				
6336A	30.00				
6550A	11.00				
7581A	10.00				
TOTAL CARRIED FORWARD Post Code		

Valve amplifiers sound better still with CVC PREMIUM valves!

130 New London Road. Chelmsford. Essex CM2 0RG, England. Telephone: (0245) 355296/265865 Fax: (0245) 490064

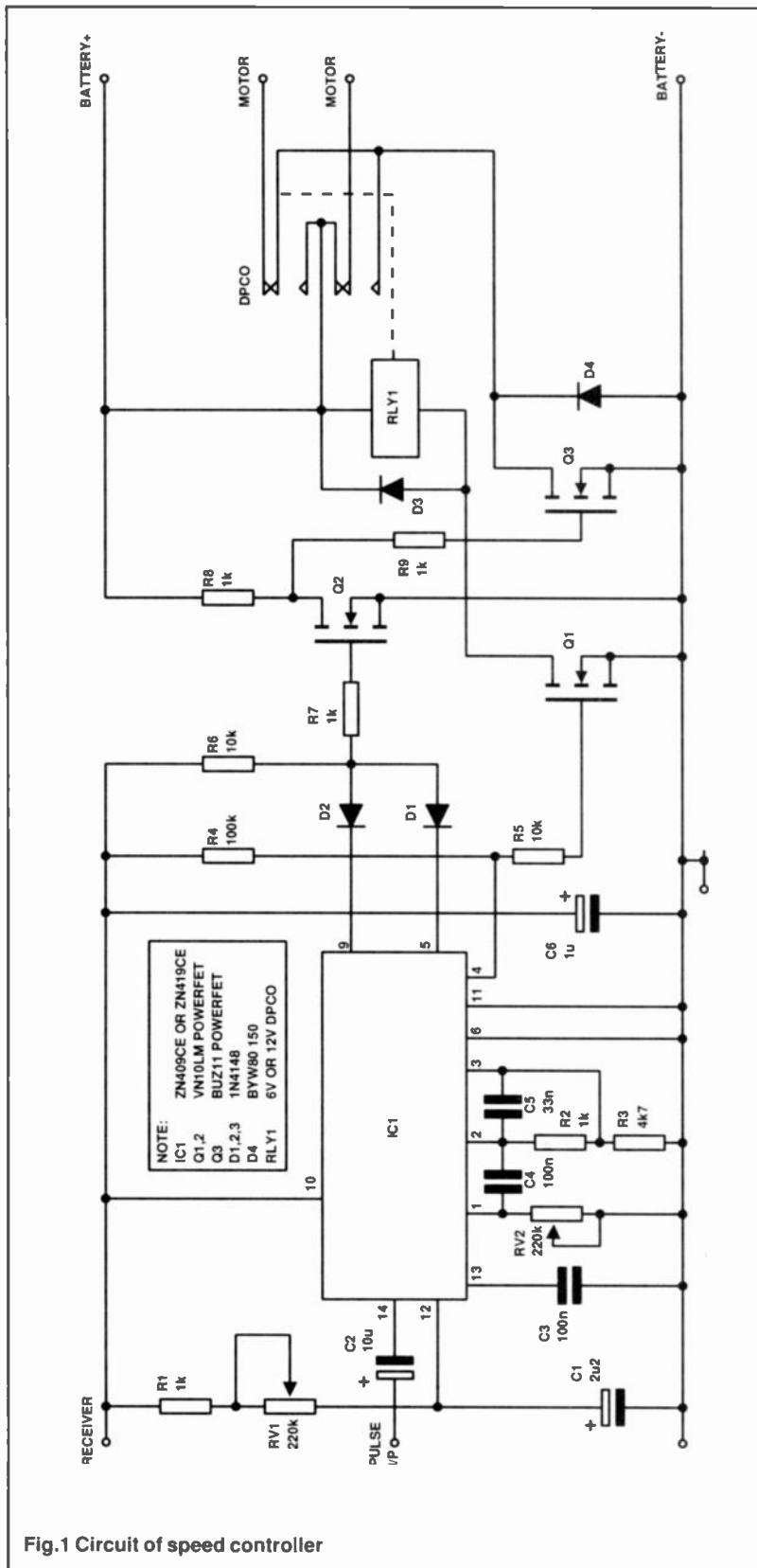
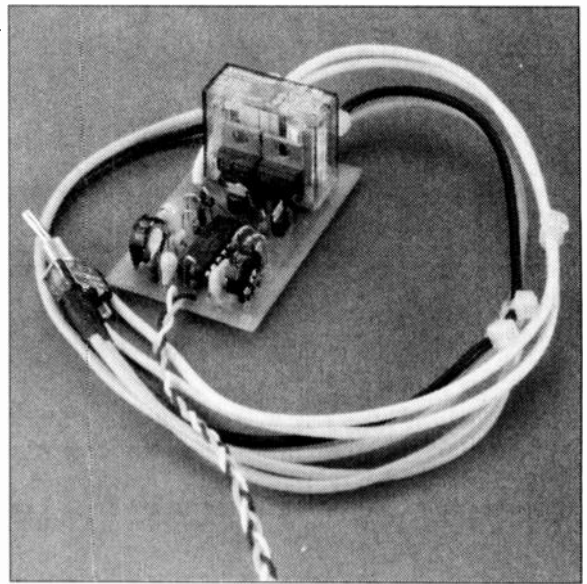

Fig.1 Circuit of speed controller

Most of the speed controllers available commercially for models are high power units and 50 to well over 150A is not uncommon. It makes little sense using a speed control that is designed for 100A on a model that is a few inches long, requires 1A or so and needs smooth, gentle acceleration rather than the powerful wheel spinning speed control that you would need on rough ground racers.



RC Spe

Craig Talbot produces the second of our radio-controlled projects.

The cost of high power commercial units is naturally high, whereas the circuits I have designed are both simple and inexpensive, so this little offering may help. It would be ideal for robots using normal R/C servos etc.. I have used this controller in a small boat and it was a joy to use, and the speed controller has also driven my model of an articulated Volvo F12 truck, with a large 12V motor driving a gearbox and twin differential axles, for over a year with no problems of any kind. The model pulls away smoothly at very low speed and copes with very slow reversing (it's difficult to back up with a juggernaut) and this is where the controller works the hardest. I have to admit that this particular truck has a very good five pole motor, which helps with the smoothness at low speed. A cheap three pole unit wouldn't be half as good. The model is about 1 metre long, is of metal construction and it's very heavy. I initially built about three different printed circuit boards for this unit, all using the same circuit, in different layouts. The one presented here is the better layout and as you can see, it is not too big for small cars, boats, tanks or robots.

The Circuit

The unit was designed for the standard 1-2ms positive pulse width, 20ms frame speed, in keeping with the other projects I have designed. It can be built for 6 or 12V operation with only a change of relay.

The controller had to be small and electrically efficient in order to fit in small models, so it should not waste power through costly voltage drops with all its attendant heat problems. The batteries in small models don't leave you with any power to waste. With this in mind, a relay was used for

the reverse function as this wastes little power in one direction and no power in the other. Next, the output device must have a low saturation voltage drop (a 1V drop at, say, 5A will waste 5W of power), which led me to look at Power Field Effect Transistors (PowerFets). They are now available with very low saturation voltage drops at high currents and at reasonable prices. The PowerFet I have used has a resistance of only 0.03R when fully switched on, which will result in a 0.75W loss at 5A. With this device, no heat sink would be required as long as the current requirement was kept below 5A.

So there I had it, a small 5A controller output stage. A smaller PowerFet was used to drive the relay and a further one to OR and invert the outputs of the servo driver chip. The ZN409 IC is the perfect device to use for this application as it has a reverse/forward drive output. All that was now required was a few more components to make the unit adjustable for a variety of uses.

full on. This is not as great a problem as one may think as the controller is low power (5A) and a small switch can be fitted to the power lead or a double pole switch may be used to switch off the power and radio batteries - the choice is yours. I found it to be very useful on one occasion, when a receiver battery failed and the boat in which the controller was fitted ran to the edge of the lake, instead of being stranded in the middle.

The output at pin 4 of the IC together with FET 1 and the relay give the reverse function, effectively reversing the connections to the motor while in the stop condition. Because of this, the relay will never switch while on load, which should ensure long life for the contacts. The relay is the only item that is different on the 6 and 12V versions.

The result is a small forward and reverse speed controller capable of driving motors with stall currents of around 5A. The total number of components is low and they are widely stocked and well advertised in the Electronics press.

ed Controller

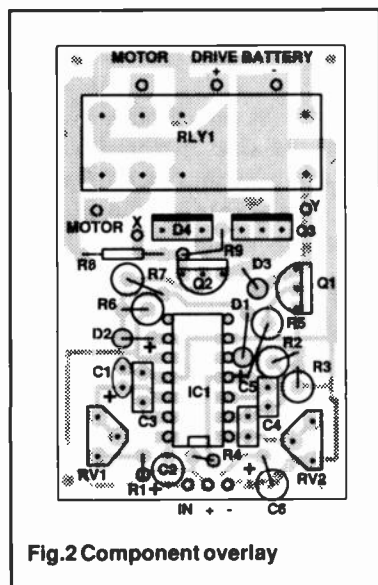

Fig. 2 Component overlay

The presets adjust the stop motor, at stick centre (RV2) and the slope of speed increase, gentle to sharp, (RV1). Diodes D1 and D2 form an OR gate which FET2 inverts to supply the correct drive for FET3. FET1 drives the relay, diode D3 protects the FET from the back EMF (voltage) of the relay coil. The only other component

of note is C5 which gives the dead band at the centre of the control so that a tiny movement of the drive pulse width will not cause the motor to drive either way but stay at rest. This ensures that very small drifts of transmitter encoder, due to temperature coefficients, low battery etc., have little effect on the control of the model.

The next thing on the agenda was construction and of course a PCB was the obvious way to do it. It can also be constructed by any other method you wish, but a PCB is the most compact form. The only disadvantage with this simple design is that the motor will run at full speed if the Radio Control receiver supply is switched off. The reason is that the drive for the output FET (FET3), is via R8 and R9 from the drive supply. When FET 2 is not conducting, for instance when the Receiver battery is switched off, FET 3 is biased

Construction

The PowerFETs are static sensitive and care should be taken when handling them. Observe the recommended precautions with these devices.

It's not a difficult board to build but the components may be a little closer than you are used to. The experienced will find it very easy. As the IC is in the middle of the board and will be difficult to fit at a later stage, it should be fitted first, making sure that the notch is at the correct end as per the layout diagram. Next, fit the presets, which are both the same value. The capacitors should then be fitted, taking careful note of the polarity of C1, C2, and C6. Diodes can then be fitted and reference to Figure 2 will ensure that these are fitted correctly. Keep the printed circuit tidy - by that I mean leads cleanly soldered and cropped close to the board.

The resistors can now be fitted, the only thing to note being that they are bent as per Figure 2 and that none of the exposed upright leads are allowed to short out with any other. You will find R9 needs an extra bend to go around D4, but a bit of insulation sleeve from a scrap of wire can be used to insulate the wire lead to avoid shorting out to the legs on the power diode D4. The PowerFets should now be fitted, along with D4, remembering not to touch the leads - after all we want our speed control to die of old age, not an early life failure.

A point to mention is that two of the three pads of the diode D4 appear to be shorted together on the PCB. This is not a mistake as I used the extra copper area of the middle pad to give more conducting surface. The Diode, of course, only has the normal two leads. You will no doubt have noticed a couple of extra holes which are marked on the layout as 'X' and 'Y'. These are outputs for future applications and are not required at this time. Finally, the relay. Do not be mean with the solder as these joints will be carrying quite a bit of current. They say it's good to have the right connections, so

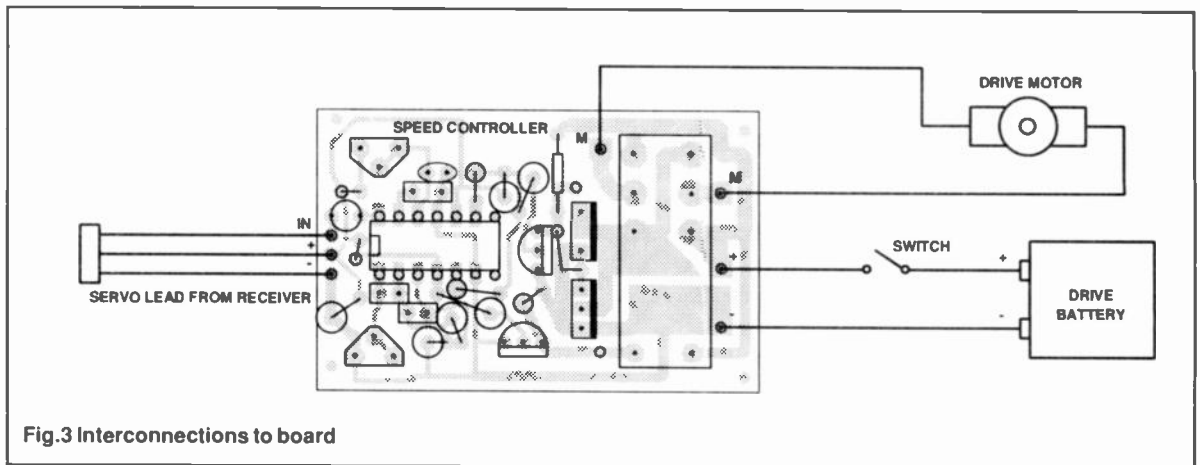

Fig.3 Interconnections to board

let's make sure we get them right. With reference to Figure 3, the motor and power leads are the first ones to connect. These will have to be a heavier gauge than the normal hook up wire and something like 6A wire should be used. They should have the insulation removed at the PCB end only, at this stage. When all four wires are fitted, the positive drive battery lead should have a switch fitted, at a position along its length that is convenient to you. Make sure that the power switch is off at this point in the proceedings (so that the motor will not run when connected to the battery).

The three square boxes shown on the left of Figure 2 and on Figure 3 are where the unit is fed from the radio control receiver and a lead will have to be purchased from your local

should give forward and reverse. With the stick at centre and the stick trimmer at centre, make the final adjustment to RV2 to set it at the stop position. The previous adjustment will make sure that you are close to the point.

As I have said before, RV1 will adjust the sharpness of the speed increase so this will have to be left to your own taste - a Scale model has very different requirements to a performance model. Presets RV1 and RV2 can now be sealed with a small blob of paint or nail varnish.

That is all there is to testing and calibration. If things have gone as they should, you now have a cost effective speed controller which can be fitted in a suitable plastic box or, if like me, you prefer to enclose it in heat shrink tubing, you will need to obtain some with an open diameter to clear the relay and PCB.

The disadvantage of heatshrink tube on this unit is that it can move components as it shrinks and a preset is difficult to adjust at a later date. The first problem is helped if you can obtain clear shrink, which will also make it easy to cut around the presets, thus solving the second problem. You will no

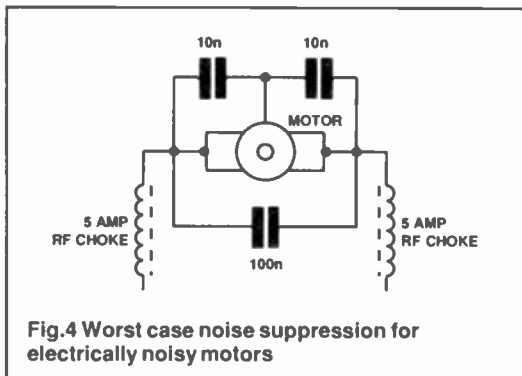

Fig.4 Worst case noise suppression for electrically noisy motors

Radio Control supplier for whatever radio outfit you use. Just ask for a replacement servo lead. Take care when fitting the input lead as it is not in the same configuration as the previous project. The input lead is fitted red to positive, black to negative and the third lead (probably white) goes to the square marked IN, for Input. This completes the main construction, but the motor and battery wires have got to be terminated. Now its time to clear the decks for testing.

Testing

I will presume that you have sensibly checked the solder side of the board to check for no solder bridges and dry joints. If you haven't got round to it yet, now is your last chance!

The first thing is to adjust both RV1 and RV2 to centre. Get out the radio outfit and connect the input lead to the receiver. Connect the drive battery next, as this will provide the drive to the relay. Make sure that you have the battery and relay in agreement about your chosen voltage. The battery lead will have a switch fitted at this point, so switch it on.

Switch on the transmitter, then the receiver and, with the selected channel at centre stick position, adjust RV2 until the relay clicks - any final trimming can be done when the unit is complete. Switch off the transmitter, receiver and power switch before proceeding. The motor should now be connected and the Radio gear and power switched on again. Now, movement up and down of the stick on your selected channel

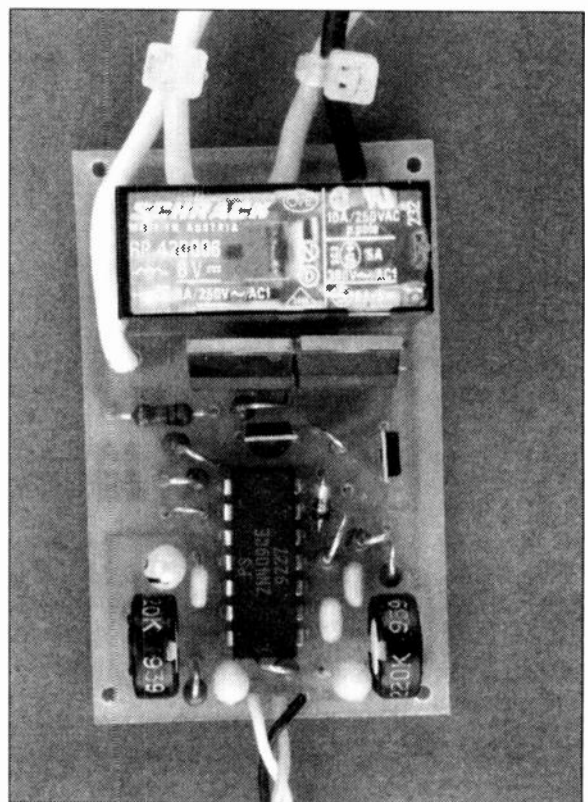

doubt have noticed that four mounting holes have also been provided, just in case you want to screw it to a panel or into an oversize box.

Conclusion

A couple of points are worth mentioning. The first is that electrically noisy motors can play havoc with R/C equipment. Always use the best motor that you can afford, one that has more than three poles if possible. Note the stall current of the motor, as this is what the controller will have to handle and take 5A as the maximum. (this leaves a margin of error already taken into account). A good general practice is to fit a couple of 10n ceramic capacitors from each brush connection to the case of the motor and a 100n ceramic across the two brushes. In very bad cases a couple of 5A RF Chokes in the feed leads may be required. Bear in mind that the chokes will carry the motor current. If neither of these measures work, you probably need a new, or better quality motor. I have found that very cheap or worn out motors and radio control do not mix, so bear it in mind.

The additional components that may be required for the suppression of electrically noisy motors are listed in the parts list and Figure 4 illustrates their fitting.

The second point is to watch out for trouble if you have metal to metal contacts as these can be, as it were, seen by the receiver aerial, presumably as an aerial reflector with a bad connection. Rotating bearings don't normally give problems but keep them greased to prolong their life anyway.

That's just about it and I hope that you get as much pleasure and satisfaction out of your unit as I have from mine.

PARTS LIST

RESISTORS (all 5% 1/4 Watt)

R1,2,7,8,9	1k
R3	4k7
R4	100k
R5,6	10k
RV1,2	220k Min enclosed verica

CAPACITORS

C1	2.2µ10V tant
C2	10µ10V tant
C3,4	100n ceramic 0.1" pitch
C5	33n ceramic 0.1" pitch
C6	1µ10V tant

SEMICONDUCTORS

IC1	ZN409CE or ZN419CE IC
FET1,2	VN10LM powerFET
FET3	BUZ11 power FET
D1,2,3	1N4148
D4	BYW80-150 Part No. UK3T (See Buylines)

MISCELLANEOUS

RLY1	6V or 12V 6A DPCO Relay (See Buylines)
	6V DPDT Part No. FJ42V (Use for 5-9V)
	12V DPDT Part Nr FJ43W (Use for 9-15V)
Wire	6A Wire (for motor and battery leads)
Switch	5A DPDT sub-min Part No. FH04E (See Buylines)
Servo lead	suitable for your receiver. (See Buylines)

ADDITIONAL SUPPRESSION COMPONENTS

For electrically noisy motors (see Figure 4)
 0.01u low voltage Ceramic Disc Capacitors 2 off
 0.1u low voltage Ceramic Disc Capacitors 1 off
 5 Amp RF Axial Chokes 2 off

BUYLINES

The diode (D4), relay and switch are all available from MAPLIN Electronics
 A servo lead of the type used on your servos should be readily obtainable from any good Model shop that stocks Radio Control equipment.

The PCBs for this project and last months traficator board are available from the author, A Craig Talbot at:

Action,
 140 Holme Court Ave,
 Biggleswade,
 Beds SG18 8PB.

Prices are: Traficator £1-52
 Speed Controller £1-96
 Postage & packing 50p

LEDs 3mm or 5mm red or green 6p each, yellow 11p each, High intensity red, green or yellow 5mm 30p each
 Cable ties 1p each, £5.95 per 1000, £49.50 per 10,000
 Stepping motor 4 phase 12V 7.5' step 50 ohms £8.95
 SAA1027 stepping motor driver chip £3.95
 FM Transmitter kit, good quality sound £8.00
 High quality photo resist copper clad epoxy
 Dimensions glass boards double sided
 3x4 inches £0.95 £1.07
 4x8 inches £2.40 £2.68
 6x12 inches £5.37
 12x12 inches £10.00

Rechargeable Batteries
 AA (HP7) 500mAh £0.99
 AA 700mAh £1.95
 C 2AH with solder tags £3.60
 D 4AH with solder tags £4.95
 1/2AA with solder tags £1.55
 AAA (HP16) 180mAh £1.75
 AA 500mAh with solder tags £1.55
 C (HP11) 1.8AH £2.20
 D (HP2) 1.2AH £2.60
 PP3 6 4V 110mAh £4.95
 Sub C with solder tags £2.50
 1/3 AA with tags (Philips CTV) £1.95
 Standard charger, charges 4 AA cells in 5 hours or 4Cs or 4Ds in 12-14 hours + 1x PP3 (1, 2, 3 or 4 cells may be charged at a time) £5.95
 High power charger, as above but charges the Cs and Ds in 5 hours. AAs, Cs and Ds must be charged in 2s or 4s £10.95

Special offers - please check for availability
 F cells 32da x 87mm £3.95
 F cell with solder tags, 1.2V £4.30
 42mm x 16mm dia 1.2V £1.45
 8 stick of 4 171mm x 16mm dia., with red & black leads 4 5V £6.95
 4 cell battery 94mm x 25mm dia., (1/2C cells) £3.50
 Computer grade capacitors with screw terminals
 3800µf 20V £2.95; 8700µf 10V £1.95;
 6800µf 15V £2.95; 1000µf 16V £1.50
 7 segment common anode led display, 12mm £0.45
 LM2831 AT 5.0 low drop out 5V regulator TO220 package £0.85
 7812 and 7812 1.2V 1A regulators £20.00 per 100
 LM337K TO3 case variable regulator £1.60
 100 + £1.10
 88250 P channel mosfet 45p, BC559 transistor per 100 £3.95
 Used 8748 Microcontroller £3.50
 8LS62 UHF Limiting amplifier LC 16 surface mounting package with data sheet £1.96
 AM27802 £1.25 each, 90p 100 +
 CD4007UB 10p 100 +, 6p 1000 +
 TV Mains switch, 4A double pole with momentary contacts for remote control, pack of 10 £3.95
 box of 60 £19.95

DC-DC converter, Reliability model, V12P5, 1.2V in 5V 200mA out, 300V input to output, isolation with data, £4.95 each or pack of 10 - £39.50
 Hour counter used 7 digit 240V ac 50Hz £1.45
 Resistor pack 2500 resistors 1/8-2W 50 different values £8.95

Resistor jumbo pack 25000, 1/4 and 1/2W resistors our choice of values and size will be mainly in boxes or rolls of 1000, 2000 and 5000 of one type £26.00
 Qwerty keyboard, 58 key good quality sw tches, new £6.00
 Qwerty keyboard with serial output, no data (used) £6.00
 Polyester capacitors, box type, 22 5mm lead pitch
 1µf 250V dc 20p each, 16p 100 +, 10p 1000 +
 2.2µf 250V dc 30p each, 20p 100 +, 15p 1000 +
 3.3µf 100V dc 30p each, 20p 100 +, 15p 1000 +
 1µf 50V bipolar electrolytic axial leads, 15p each, 7.5p 1000 +
 0.22µf 250v polyester axial leads, 15p each 100 + 7.5p each

Philips 123 series solid aluminium axial leads
 33p 10V & 2.2µf 40V 40p each, 25p 100 +
 Multilayer AVX ceramic capacitors, all 5mm pitch, 100V 100pf 150pf, 220pf, 10 000pf (10n) 10p each 5p 100 +, 3.5p 1000 +
 Welwyn W23 9W 120 ohm 35p each, 20p 100 + 680 ohm 2W metal film resistor, 4p 100 + 2p 1000 +
 Solid carbon resistors, very low inductance, ideal for RF circuit, 27ohm 2W 68ohm 2W 25p each, 15p each 100 +, we have a range of 0.25W 0.5w, 1w and 2w solid carbon resistors please send SAE for list
 Intelligent 4 digit alphanumeric (5x7 dot 0 145") red LED display, 12 pin 0.6 inch wide package
 Siemens type DL1414 £2.50 each, £2.00 30 + data sheets £1.00
 AMD 27256 3 Proms £2.00 each, £1.25 100 +
 DIP switch 3PCO 12 pin (ERG SDC 3 023) 80p each 40p 100 +

Disk Drive Boxes for 5.25 disk drive with room for a power supply light grey plastic 67x268x247mm £7.95 or £49.50 for 10
 Hand Held Ultrasonic remote control £3.95
 Computer grade 5800uf 60v capacitors with screw terminals £4.95
 CV 2486 gas relay 30mm x 10mm dia with 3 wire terminals will also work as a neon light 20p each £7.50 per 100
 A23 12v car alarm remote control and lighter battery 75p each £50.00 100 +
 40 uf 370vac motor start capacitor (dielectric type containing no PCBs) £5.95 each £49.50 for 10

All products advertised are new and unused unless otherwise stated
 Wide range of CMOS TTL 74HC 74F Linear Transistors kits, rechargeable batteries, capacitors, tools etc. always in stock
 Please add 95p towards P&P
 VAT included in all prices

JPG ELECTRONICS
 276-278 Chatsworth Road
 Chesterfield S40 2BH
 Access Visa Orders:
 (0246) 211202
 Callers welcome

Hesing Technology

Cromwell Chambers, 8 St. Johns Street,
 Huntingdon, Cambs. PE18 6DD

Tel: (0480) 433156
 Fax: (0480) 413357

TEST EQUIPMENT

Supply
 Maintenance
 Commissioning

SYSTEM CONSULTANCY

Replacement Parts
 Supply of Service &
 Operators Manuals
 Components

Distributors for:
 WALGH INSTRUMENTS, RAMTEST LTD, KRENZ ELECTRONICS, PANTHER

OMNIELECTRONICS

174 Dalkeith Road, Edinburgh EH16 5DX · 031 667 2611

The supplier to use if you're looking for —
 ★ A WIDE RANGE OF COMPONENTS AIMED AT THE HOBBYIST ★
 ★ COMPETITIVE VAT INCLUSIVE PRICES ★
 ★ MAIL ORDER - generally by RETURN OF POST ★
 ★ FRIENDLY SERVICE ★

Open: Monday-Thursday 9.15-6.00
 Friday 9.15-5.00 Saturday 9.30-5.00



Colin MacLeish has produced another method for widening your stereo image.

Encoding a stereo signal in Middle and Side format can have mind (or rather ear) stretching results. For most, the term Stereophonic Sound makes us think of two channels, one left, the other right and we all know that a pair of loudspeakers are the minimum requirement to plug into our Hi-Fi tower if we wish to hear our latest CD compilation in it's full glory. It is less well known that the stereo signal can be encoded in a form other than Left and Right, namely Middle and Side, or more commonly M and S. The most obvious example of this use is in stereo radio transmissions - a simple mono receiver sees only the Middle signal, while a more sophisticated stereo receiver also detects the Side information and decodes this to form the usual left and right outputs.

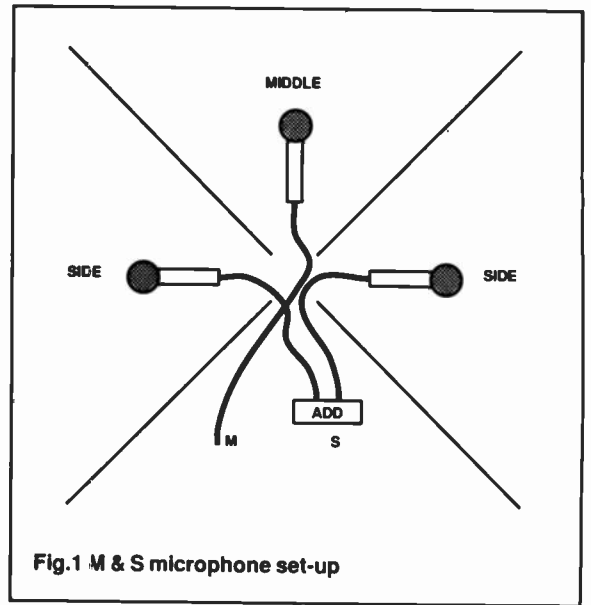

Fig.1 M & S microphone set-up

Crossing the Great Divide

The encoding process is surprisingly simple and may be performed at the recording stage, where one microphone is directed towards the sound source and the others are directed to the sides (Figure 1). This results in a firm mono signal with the option of adding stereo width later, as required. These features probably account for the recent increase in use of M and S techniques amongst location sound recordists, with the advent of stereo TV sound.

Alternatively, all standard L and R signals may be encoded at any stage, e.g. CD and tape outputs or mixer outputs and inserts (Figure 2).

The equations that describe the transformation are:

$$M = (L + R) \times 0.707$$

$$L = \text{left } R = \text{right}$$

$$S = (L - R) \times 0.707$$

$$M = \text{middle } S = \text{sides}$$

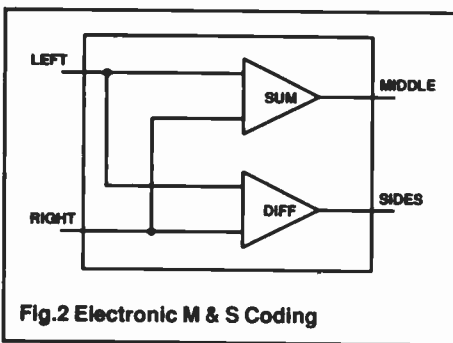

Fig.2 Electronic M & S Coding

The scaling factor of 0.707 serves only to reduce the outputs by 3dB and maintain unity gain.

Interestingly, the process of decoding M and S signals back to L and R is identical

$$L = (M + S) \times 0.707$$

$$R = (M - S) \times 0.707$$

This means that the same circuit can be used for either encoding or decoding, a typical version being shown in Figure 3. The upper signal path is the sum and the lower being the difference, so an alternative name for this process is Sum and Difference. We now know how to change from one format to the other, but is it that useful?

Well, one advantage of M and S stereo over Left and Right occurs when a mono signal is to be formed after a less than perfect signal passage has been encountered by the stereo source. With Left and Right, mono is a straight addition of the two and any phase discrepancies will result in a less than satisfactory result, whereas with M and S, you simply use the M channel (phase funnies with the decoded L and R not being so noticeable).

A very popular use, as the title suggests, is the variation of stereo width. If we put a pot across the S input of the circuit then with no attenuation the output is will be standard width stereo. However, as the S signal is attenuated the stereo width decreases, until it is mono - all M and no S. This is quite handy, but it is even better, if instead of making S smaller we make it bigger (say a gain of two). We then get an increase in stereo width, wider than the speakers themselves (Figure 4). Unfortunately, extra wide stereo doesn't mono very well, due to the exaggerated phase relationships.

This should now give you an idea of some of the tricks you can get up to with this system.

When cutting vinyl discs (large black things with music on them), it is important to keep the low frequencies towards the middle of the stereo picture and away from the sides. With L and R you can't do this without affecting the whole stereo image, but with M and S, you can put the S signal

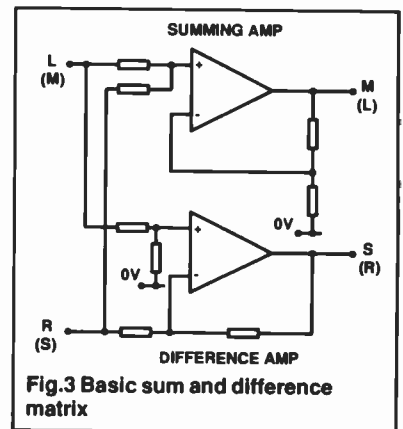

Fig.3 Basic sum and difference matrix

HOW IT WORKS

Left and right input signals are added by R3 and R4 with a resulting attenuation of 0.5. IC1a supplies a gain of 1.414, resulting in an M output of $(L + R) \times 0.707$. The difference amplifier IC1b subtracts the R input from the L input with a gain of 0.707, so forming the S output of $(L - R) \times 0.707$. The second half of the circuit is identical to the first except that the S input receives a gain of two from IC2 which may then be attenuated by P1 over a range of zero (mono), through x1 (standard width stereo) to x2 (extra-wide stereo).

The input and output caps provide ac decoupling and the feedback caps roll-off the high frequencies above 50kHz to aid stability.

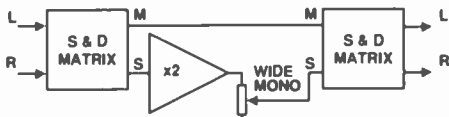

Fig.4 Stereo width control

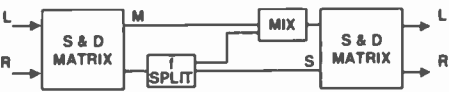

Fig.5 Elliptical equaliser



Fig.6 Side dynamics control



Fig.7 Centre sibilance control

through a frequency splitter, similar to the action of a loudspeaker cross-over and feed the offending low frequencies into the M signal (Figure 5). This is the basis of an elliptical equaliser.

Similarly, if you need to reduce the dynamic range of the side information of a stereo recording without affecting the main central component, then put a compressor or limiter across the S channel (Figure 6) and hey presto.

S...Sibilance

A common problem with vocals is sibilance, where the 's' sounds of certain singers or speakers are aggravated by the recording process and become noticeably unpleasant. With a multitrack tape you can put the offending voice through a frequency selective limiter (or de-esser) and probably be OK, but if the voice in question is in the centre of stereo recording then the action of an overall de-esser across the whole image would usually be too detrimental to the remaining sounds. Again, the solution is to apply the correction only to the M signal, leaving the sides in their original state (Figure 7).

So, if you add the M and S jiggery pokery to the standard L and R jiggery pokery, it is really quite surprising what you can get up to. Figures 8, 9 and 10 show a practical circuit and PCB that provide both encoding and decoding with stereo width control from zero to x2. Assorted and various signal

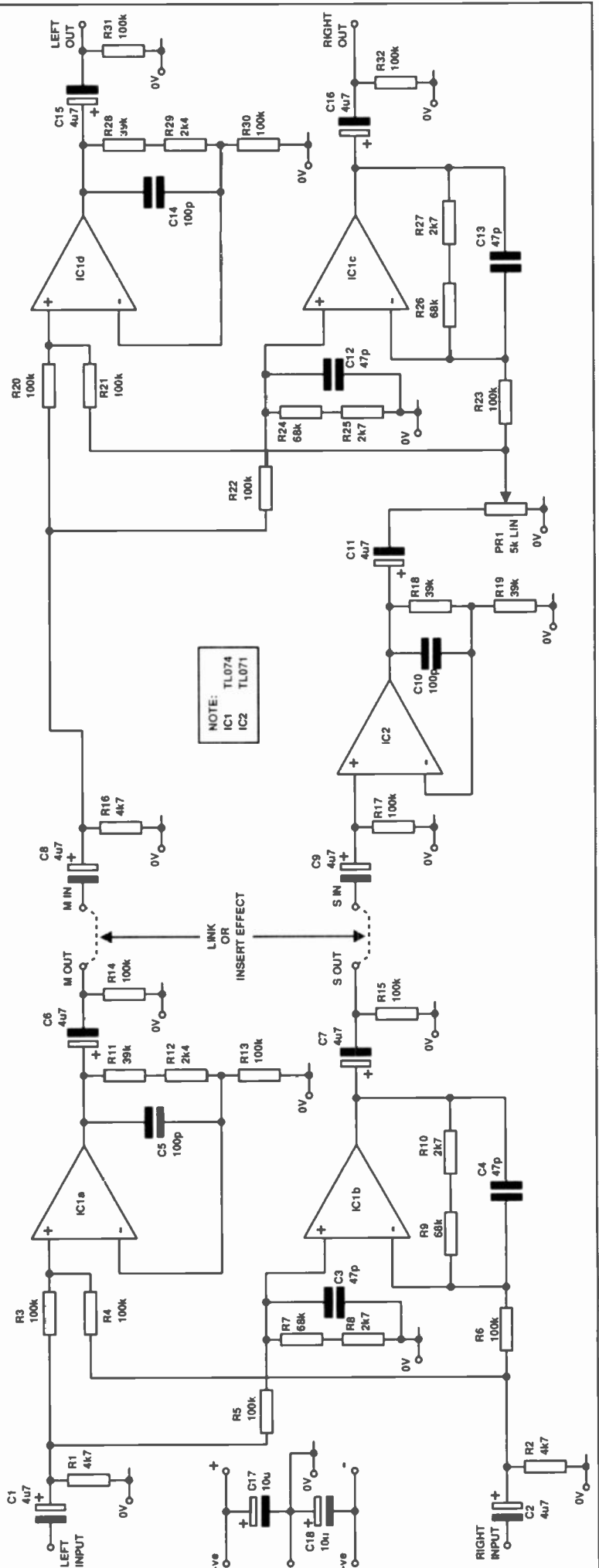
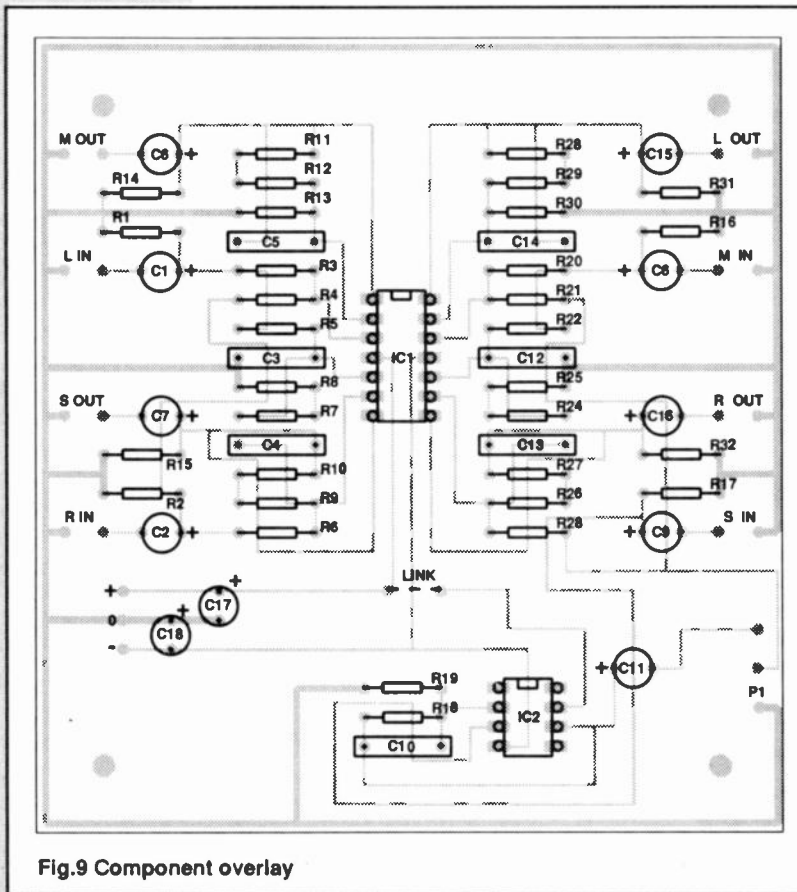

Fig.8 M & S Codec circuit diagram



processors may be inserted along the way to provide endless hours of fun.

Construction

±5 to 15 volts at less than 10mA is all that is required to power the circuit, so battery operation is possible with a couple of PP3s. By keeping the sum and difference resistors to a 1% tolerance, no alignment is required, with the exception of PR1. To calibrate this to its electrical mid point and hence standard stereo decoding position, simply connect the M output to the M input and the S output to the S input so that the encoded signal is being immediately decoded back again. Send a signal to the left input and adjust P1 about its centre until a full signal is output on the left, with zero output on the right. Similarly an input on the right should appear only at the output on the right.

PARTS LIST

RESISTORS

R1,2,16	4k7 0.25W 1%
R3,4,5,6	100k
R7,9,24,26	68k
R8,10,25,27	2k7
R11,28,18,19	39k
R12,29	2k4
R13,14,15,17	100k
R20,21,22,23	100k
R30,31,32	100k
PR1	5k linear

CAPACITORS

C1,2,6,7	4µ7/35V Elect
C3,4,12,13	47p polystyrene
C5,10,14	100p **
C8,9,11,15,16	4µ7/35V elect
C17,18	10µ35V tant

SEMICONDUCTORS

IC1	074
IC2	071

JUST LOOK AT WHAT'S AVAILABLE FROM BONEX

Balance Mixers

Batteries

Button Cells, Ni-cads, Battery Holders, Battery Eliminators, Ni-cad Chargers,

Boxes

ABS Plastic, Die-cast, Hand-Held Enclosures, Bridge Rectifiers

Bulbs

Cables

Audio, BBC, Camcorder, Cassette/Calculator, Mains, Computer, IBM PC/AT, Serial, Monitor Extension, Parallel, Patch/Video Leads, Scart Cables, Serial Printer, Video/Audio Dubbing Kit,

Cable Ties

Capacitors

Ceramic Discs, Ceramic Feedthroughs, Chip, Electrolytics, Monolithic, Mylars, Polycarbonates, Polystyrenes, Polyesters, Tantalum Beads,

Capacitors Variable

Film Dielectric Trimmers, Ceramic Trimmers,

CMOS Devices

Computer Accessories

Adaptors 9W to 25W, Data Switch Boxes, Gender Changers, RS232 - Patch Boxes, Null Modems, Plug in Testers, Surge Protectors, Surge Protector Plugs,

Connectors

Audio Adaptor/Plugs, Banana Connectors, Binding Posts BNCs, Centronics, D, D High Density, DC Power, DIL IC, DINs, IDCs, Edge, F, Jack 2.5mm, 3.5mm, 6.3mm, Mains, Microphones, Molex, N-Type, Phono, PL259, RF Adaptors, Scart, TNC, Terminal Strips, TV, XLR,

Crocodile Clips

Crystals

Desolder Pumps, Diodes, Plastic IN4000 / IN5400, Toko Varicaps, Signal Diodes, Zener, BZYs and BZXs,

Drills

Bits and Burrs, Expo, Fin Chucks, Power Supplies, Saws and Slitting Discs,

Fans

Feet, Rubber

Ferrites

Filters

FM Ceramics, Mechanical IFs, Ceramic Resonators, Crystal, Helicals, NTSC / PAL, Pilot Tone, Quadrature Detector, Satellite TV, Video,

Fuses

Grommets

Howes Kits

Heatsinks

Inductors Fixed

Inductors Moulded

Inductors Surface Mount

Inductors Variable

Infra-red Source Sensor

Insulating Tape

Integrated Circuits

CMOS,

Epmos,

Linears,

Memory,

TTL,

Kits and Modules

L.E.D.s, 3mm and 5mm

Light Dep Resistors

Loudspeakers

Microphone Inserts

Multimeters

Neon Indicators

Nuts and Bolts

Opro Switches

Optoisolators

P.C.B.s

Copper Clad, Etch Resist

Transfers, Photo Resist,

Pins, Proto-type,

Polishing Mops

Potentiometers

Control Pots, 16mm, 24mm,

Pre-sets, Horizontal/Vertical

Trimmer Pots,

Power Supplies

Relays

Resistors

Carbon Film, Metal Oxide,

Wirewound,

Screening Cans

Semi's Mount Kits

Solder

Soldering Irons

Switches

DIL, Key, Microswitches,

Push, Rotary, Slide, Toggles,

Test Leads

Test Probes

Tools

Crimping, Cutters,

Files, Insertion,

Reamers,

Screwdrivers,

Strip Board, Trimtools,

Toroid Cores

Thyristors

Transformers, Mains

Transistors

Audio Power,

Darlingtons, F.E.T.s

GaAsFETs,

Low Power RF,

Microwave,

MosFETs,

Power RF,

Small Signal,

V MOS,

Triacs

TTL

Video Modulators

Voltage Regulators

Wire

Enamelled Copper,

Tin Plated,

Silver Plated,

Zero Insert Force

Sockets



12 Elder way
Langley Business Park
Slough

Berkshire SL3 6EP. Telephone : 0753 549502 Fax : 0753 543812

CATALOGUE AVAILABLE

SPECIAL OFFER
SBL-1 BALANCE MIXERS £3.75

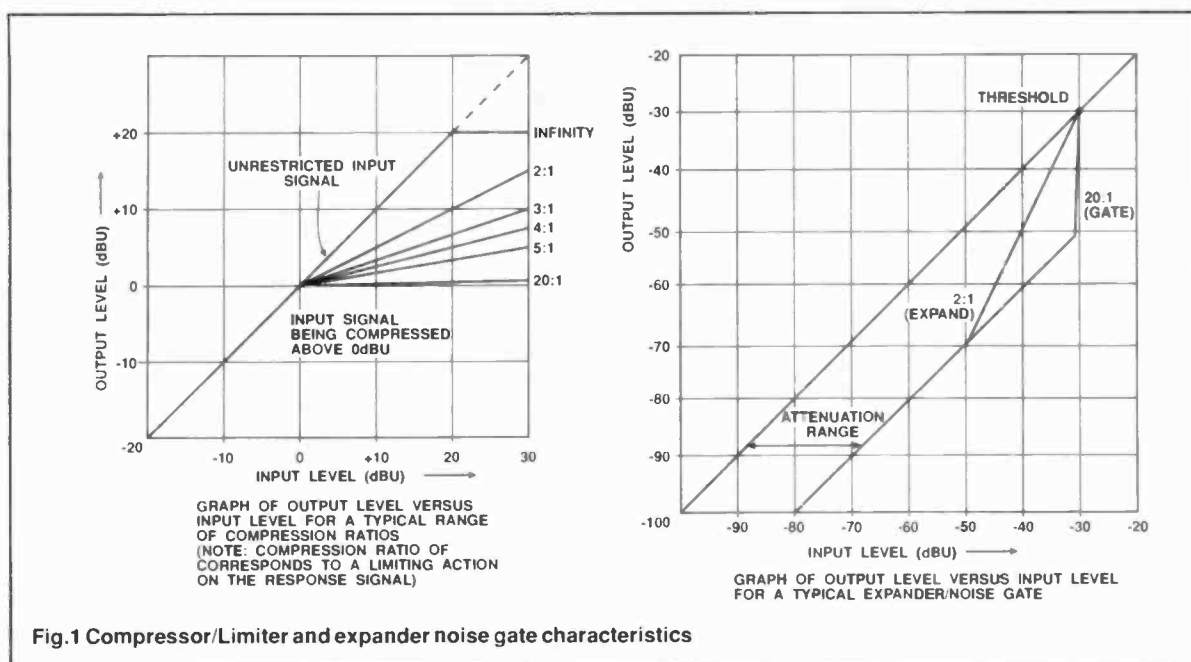

Anniversary AutoMate Mixer

This month, Mike Meechan looks at that other, less famous but just as incongruous Dynamic Duo, gain control and switching

We're now about three quarters of the way through the facilities on input channel, which is fairly representative of both the attributes and the techniques used elsewhere on the desk. Brief mention was made in January of dynamics and will be left to a later date in the explanation of the master module. After this, the next logical step in the progression as we traverse the mono mic/line channel strip is to introduce and examine the concept of switching, monitoring and routing. This is when it all gets quite exciting. If the input amplifier and mix bus design determine the overall noise/crosstalk/distortion performance of the console and equalisation the creative flexibility (as far as the tailoring of individual sounds goes), then the provision of switching and routing fixes the overall flexibility - or lack of it - of the whole desk. Later in this chapter, we'll be looking at the reasons why this should be so.

Stop Press

As a slight aside, it might be of interest to readers to learn that one has not been idle these past ten months, with much behind-the-scenes post-prototype design work going on. This has been to the extent that there is now a Mark 2, which improves on the original in a number of areas. The notable ones are as follows:

Improved ergonomic design with a smaller, lighter channel strip and more compact, logical and better thought-out control layout.

Better signal routing with larger number of and more

flexible Aux Mix facilities.

PCB now designed on a CAD system.

It will also doubtless please our readership to learn that a company has intimated an interest in producing a kit of parts for the whole kitten caboodle, thus alleviating some of the grief associated with trying to source the more difficult-to-find components.

Where to Insert Insert Points?

Last month I mentioned about insert points and the importance of choosing correctly the points in the programme chain where we can control dynamics, or, for that matter, add any sort of processing.

To understand my reasoning behind this philosophy of including, somewhat unusually, two such points, we need to look at the reason for including any insert point in the channel strip and also discuss the connection of TX units to the channel at these points.

Pump Up the Volume

Presently, we'll concern ourselves solely with dynamics. The dynamic range of a recording or playback system is defined as the ratio between the noise level at one end of the range and the onset of distortion at the other. Most will be aware that all recording and transmission media have very definite limits placed on the dynamic range available for use. Much to the audio engineer's dismay, several musical instruments and other sound sources encountered in everyday

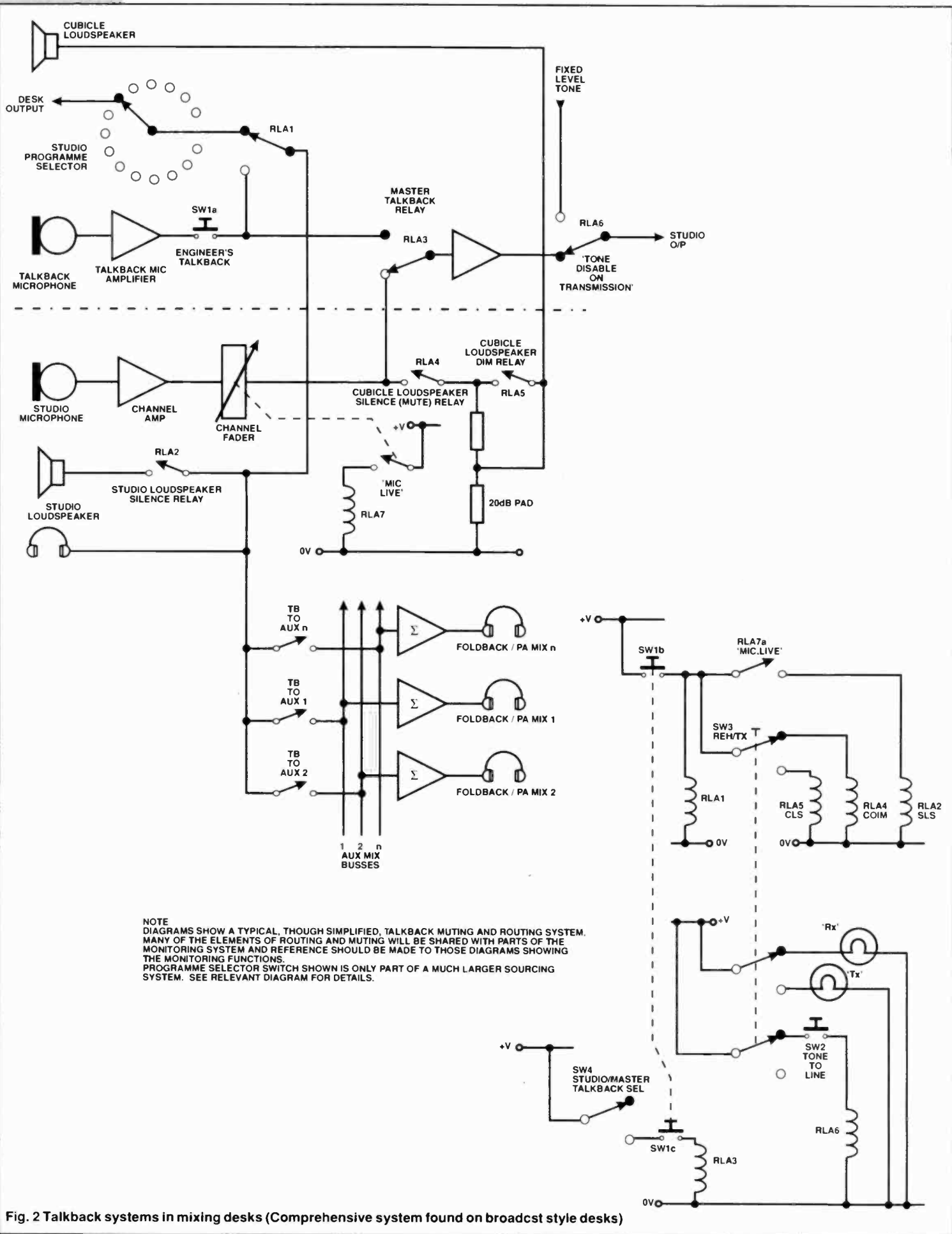

Fig. 2 Talkback systems in mixing desks (Comprehensive system found on broadcast style desks)

studio life are more than capable of dynamics which exceed these limits.

Fitting Quarts into Pint Pots

Many of the media by which the listener will hear the finished recording have dynamic range expectations less than the programme material being recorded. Figure 1 shows a typical plot of the input/output characteristics of both compressor/limiter and expander/noise gate type devices.

Dynamic range control usually refers to the control of the signal dynamic range by automatic or semi-automatic methods, such as compressors, expanders and limiters, although sitting on a fader, pushing it up during quiet passages and pulling it down during loud ones - gain riding - is still one of the simplest but most effective means of gain control. Dynamic range control in a studio environment is a vitally important part of the recording process and the three main instances where good dynamic range control is required are as follows:

Where difficult material must be recorded or must survive the final medium

Where there is a need to control the dynamics to create a specific, special effect

Where the recording medium is poor and the greatest dynamic range must be squeezed from it.

The channel strip of the AutoMate contains no gain controlling elements other than manual ones - the channel fader and assorted gain range controls. Some of the more upmarket desks do incorporate compressors and limiters into the individual channel architecture - SSL use a full-blown type whose quality is comparable to the very best rack-mounting types while Soundcraft incorporate a noise gate into each channel- so I should qualify my reasons for not including any on the AutoMate. I did toy with the idea of some sort of automatic gain-controlling option but abandoned it because of cost considerations. We are, after all, trying to create an economically viable project. Gain controlling elements would either have to be cheap and nasty or expensive and available to only the few so I thought it better to abandon the notion and put to better use the money saved. In any case there are stand-alone, dedicated signal processors which could do a much better job than any which might have been incorporated as part of this mixer channel architecture. Aside from this, the likelihood of needing more than a small number of channel signals simultaneously compressed or limited by high quality means is somewhat remote - the quality factor has to go up if available money is spread over only a few processors.

Gain Control - Why Bother?

On the face of it, gain control devices are pretty straightforward. A compressor reduces gain in the audio path as the level rises above a certain preset threshold; for expanders, the converse is true with gain increased below a certain level. Limiters do what their name suggests, limiting the maximum signal magnitude to a certain pre-defined level, while noise gates switch the incoming audio off below a certain preset threshold level.

However, practical design of devices so that they sound right is another kettle of fish and even the experts, specialising in the manufacture of such items, occasionally get it wrong.

Any automated system is only as good as the thought

that's gone into the design of the automation process. If the system is well thought out but completely automatic, with little or no manual intervention possible, there's a good chance that it will perform adequately well under most operating conditions. However, situations must exist where the automation processes are fooled and the system crashes.

The more fully automated a system is, the more the user is at the mercy of what the designer deems to be normal operation - system performance at the extremes of operation must always be compromised and nowhere is this more so than in audio. Introducing user-variable control of the various parameters - threshold, gain reduction, attack and decay or recovery times - can alleviate some of the problems, allowing the unit to be more flexible over a wider range of operating conditions than would ever be possible with a fully automatic system. Adopting this approach, can create or exacerbate other problems. Providing controls to change the internal parameters of the unit operating conditions presupposes some degree of skill and competency on the part of the person doing the tweaking. One has to be very aware of the effect to be achieved and the limitations of the equipment being used as all forms of processor have their own particular nuances and idiosyncracies. Commercial manufacturers have spent many years developing ways in which wide dynamic range material can be fitted, as an experienced balance engineer might be able to, into a narrower range 'window'. The key to success is to anticipate changes in overall signal level and then adjust the gain slightly so as to preserve the contrast between events.

For the moment, all of the above should be considered as good reasons for not including them as an integral part of the channel electronics. Later part we'll look at the reasons why it can be desirable to include integral dynamics control at other parts in the mixer although it's worthwhile looking at points in the signal progression where we can divert the audio through an external processor. Refer to Figure 2. This is fairly representative of the inserts available to the consumer in a typical commercial example. It is not definitive, since broadcast-style desks score more highly than average in this respect with most of the wished for insert points of Figure 2b also included. Very simply, I've included two insert points in the channel because there was room on the rear panel, the cost per channel was minimal and the greatly increased degree of flexibility which this approach offered far outweighed any difficulty in including it.

We are now at a point where it is logical to introduce the concept of switching within an audio system such as a mixing console. Although superficially a simple and trivial task, switching of audio is one of the most difficult tasks to implement, successfully or economically.

Audio Switching - Hard or Soft?

Switching (or more specifically within this application, routing and monitoring), aside from other purely technical considerations such as noise or crosstalk performance, ultimately determines the overall flexibility of the desk. From a commercial point of view, this can mean the acceptance or rejection of the desk by the recording industry and the success or otherwise of the product in question.

To understand just why the switch is such an important part of any desk, it is necessary to look back into the murky studios of the past. In the early days of multitrack recording, mixing desks as a complete entity did not exist at all. Rather,

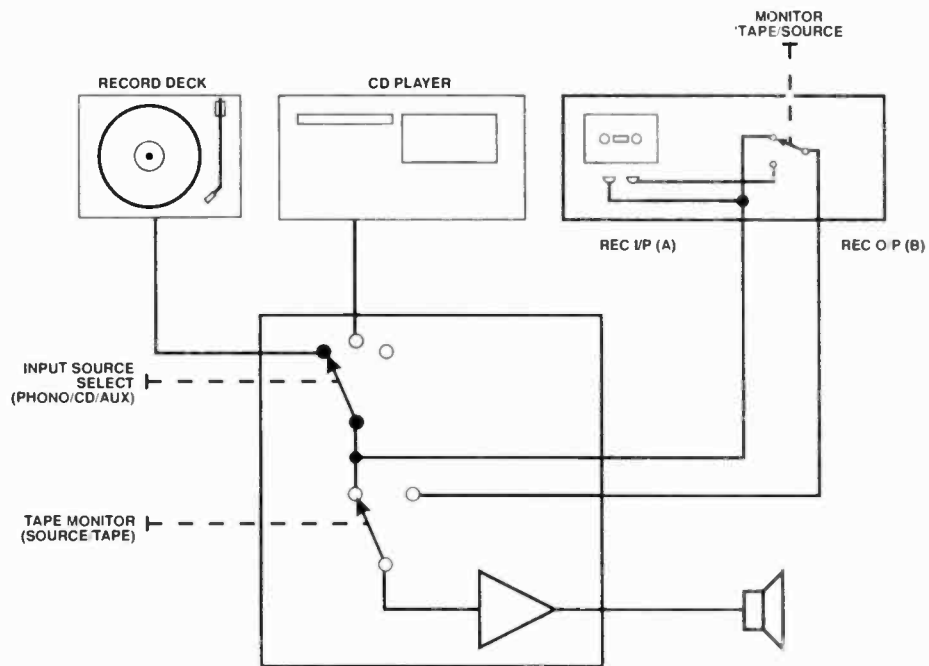

TYPICAL STEREO HI-FI REPRO/RECORDING SET-UP SHOWING OFF-TAPE MONITORING SYSTEM (1 TRACK OMITTED FOR CLARITY)

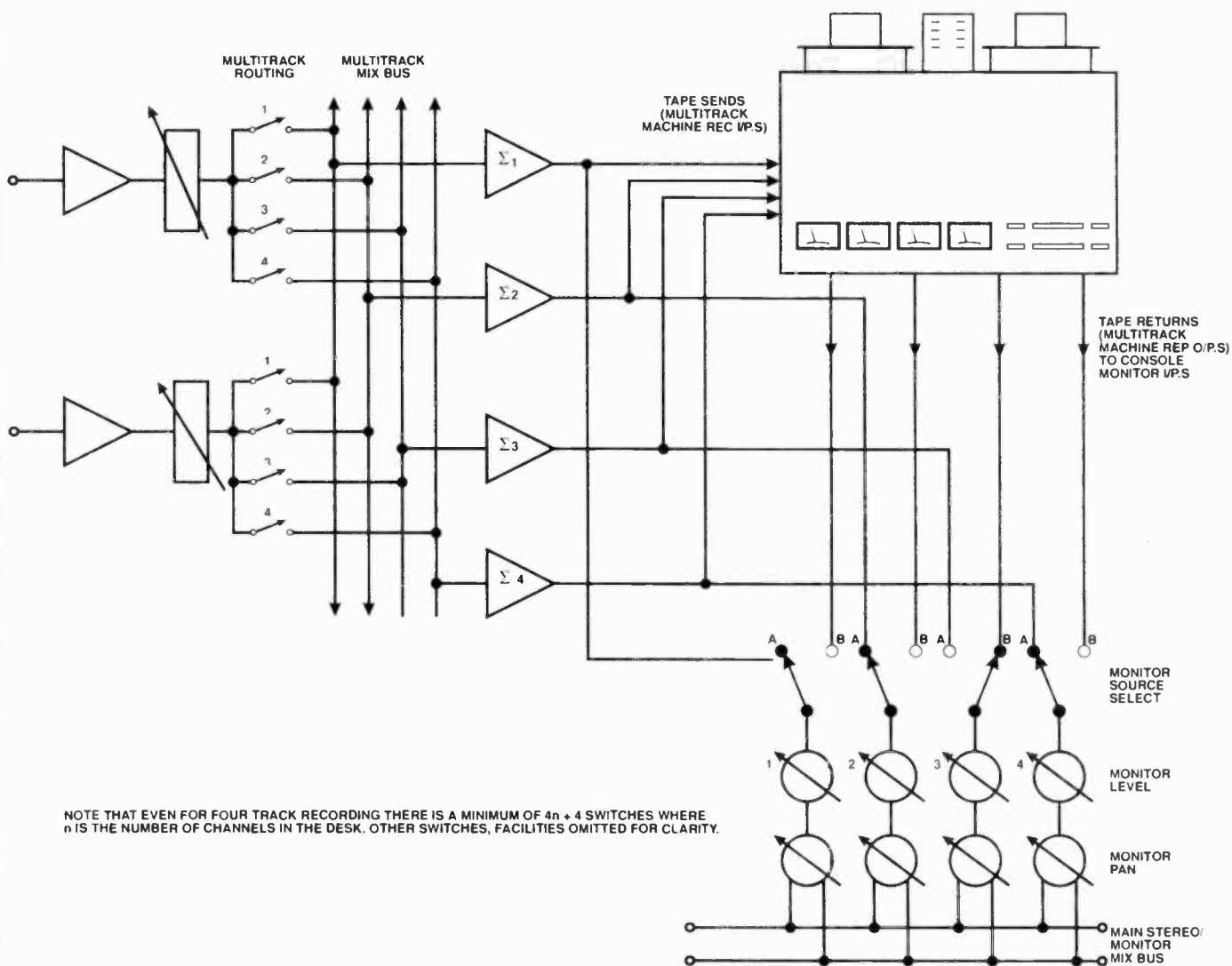

NOTE THAT EVEN FOR FOUR TRACK RECORDING THERE IS A MINIMUM OF $4n + 4$ SWITCHES WHERE n IS THE NUMBER OF CHANNELS IN THE DESK. OTHER SWITCHES, FACILITIES OMITTED FOR CLARITY.

Fig. 3 How multitrack recording creates an increase in the number of switches used

the apparatus used in its place consisted of a set of separate modules which were plugged or wired together in the desired manner to create the working system required to do the job.

So it was with early mixers. What would now be termed mic input amplifiers, line input amplifiers, equalisers, line output amplifiers and the like were, in fact, all separate and discrete modules with all connections accessible. Valve technology ruled supreme during this era and the employment of such devices meant that mixing audio sources together could be achieved simply by paralleling outputs together. That this should have been so was as a direct result of the way that valve equipment was always arranged to work into a specific impedance. There was universal use of the balanced termination, typically in the order of 600R and arranging for all amplifiers on the input side of the chain to work into this same impedance was a trivial matter. Gain lost as a consequence of this paralleling arrangement could then be made up in succeeding stages.

Virtual Mixing

Microphone amplifiers and line amplifiers didn't really exist at all. Rather, each was configured from what might be termed a universal amplifier with balanced source and terminating impedance operation. Enhancements of this very basic architecture might have been the inclusion of a secondary, high impedance (10k bridging) input and perhaps facilities for selectable gain. In this way, the amplifier could be made to behave in any one of a number of desired ways within its range - from mic. amp through line or mix amp to headphone or output amp. Variable gain control was achieved with the then ubiquitous balanced stud rotary fader. Although crude from an engineering standpoint, it worked, and rather better than anyone might first have envisaged.

Flexibility was the byword. Within a defined framework, everything could be plugged to everything else with just about all possible permutations of configurations able to be catered for. One day, an amplifier might be a mic. amp, the next, a mix amp. and so on and so forth.

Paradise Lost

The large number of sub-modules (the universal amplifier block) became unwieldy and cumbersome so these early sub-modules evolved into larger modules with many of the dedicated elements of the old, hardwired to each other. As a tentative system was created, so flexibility was ultimately lost since the smaller number of larger modules could be interconnected only in a more restricted number of different configurations. Signals could no longer be accessed where and when desired because the system was now boxed or housed in a cabinet and the internal connections were then lost to any prospective engineer or operator.

Flexibility had been compromised at the expense of convenience. Further evolution of the recording process - in the shape of proper multitrack recording - brought about the need to be able to route signals in a much more flexible manner than the first rudimentary mixing systems allowed and the switch was inexorably introduced to the mixer (see figure 3). From humble beginnings, switches multiplied from every conceivable part of mixer, to the extent that modern desks are a veritable nightmare of complex and massive, inter-linked multibank switching systems. Flexibility had been regained although the early paradise of the first non-system was gone forever.

It is nevertheless fascinating to note that the very latest assignable analogue desks do emulate many of the universal properties of the valve desks of yore, with everything able to be routed to everything else, albeit in a virtual sense.

Are Switches a Turn-off for Audio?

For the moment, we'll concern ourselves only with the concept of switching. It is another of the many necessary evils which the designer of any audio system must encounter and overcome if performance of the equipment is not to be compromised for the sake of convenience. Switching and routing is an area of much discontent and has been so for a great many years. In one form or another switching has figured in all types of audio apparatus since the birth of the recording/reproducing process. If we run the whole gamut of audio equipment, from the simplest hi-fi amplifier to the most involved multitrack desk, some sort of audio switch is in there somewhere. This is therefore the next step in our detailed analysis of all of the elements which comprise any large mixing desk (and specifically the AutoMate console).

Complex switching and routing matrices are especially prevalent in consoles with remote or assignable facilities or with in-line input and output monitoring architecture. Despite the many attractions of such an architecture - and there are indeed many - the extra switching required was one of my major misgivings and the reason why I did not adopt this design philosophy in the original. Figures 4a and 4b show the in-line versus split console routing arrangements. Both are shown without the various signal paths which exist during each of the parts of the typical recording process, although one could easily re-draw it in each of the different configurations. Aside from operational considerations (the desk can be re-configured from Recording to Remix. etc., at the push of a button in some desk examples), the in-line design actually makes better and more economical use of the console electronics. With the Mark II design, an in-line module will soon be available, although adopting an overall in-line arrangement means that re-configuring the desk (from broadcast to multitrack, for example) is a much more difficult task. It really depends whether the user is willing to sacrifice operational ease of use in one mode for difficulty in changing from one operating mode to another (and more expense at the onset).

Before looking at the physics and other intricacies behind the fact that audio and switches do not happily wed, it is probably worthwhile looking at the various places in a console where there is need of such beasts. As a finale, we'll look at the in-line console architecture and show that there are indeed far more switching elements in this kind, especially if any sort of console automation is in evidence.

Why Have Switches at all?

Audio switching is required in a console because of three needs which must always be fulfilled. These are the need to communicate, to monitor and to route. I have ignored other requirements which force the need for switches since these are common to other types of electronic equipment and in any case, don't provoke the same sort of problems as the switching of live, high fidelity audio. We shall look at each of the three needs in turn.

Communication

In any console, it is vital that the operator, engineer or

Fig 4. 'In line' versus split topology

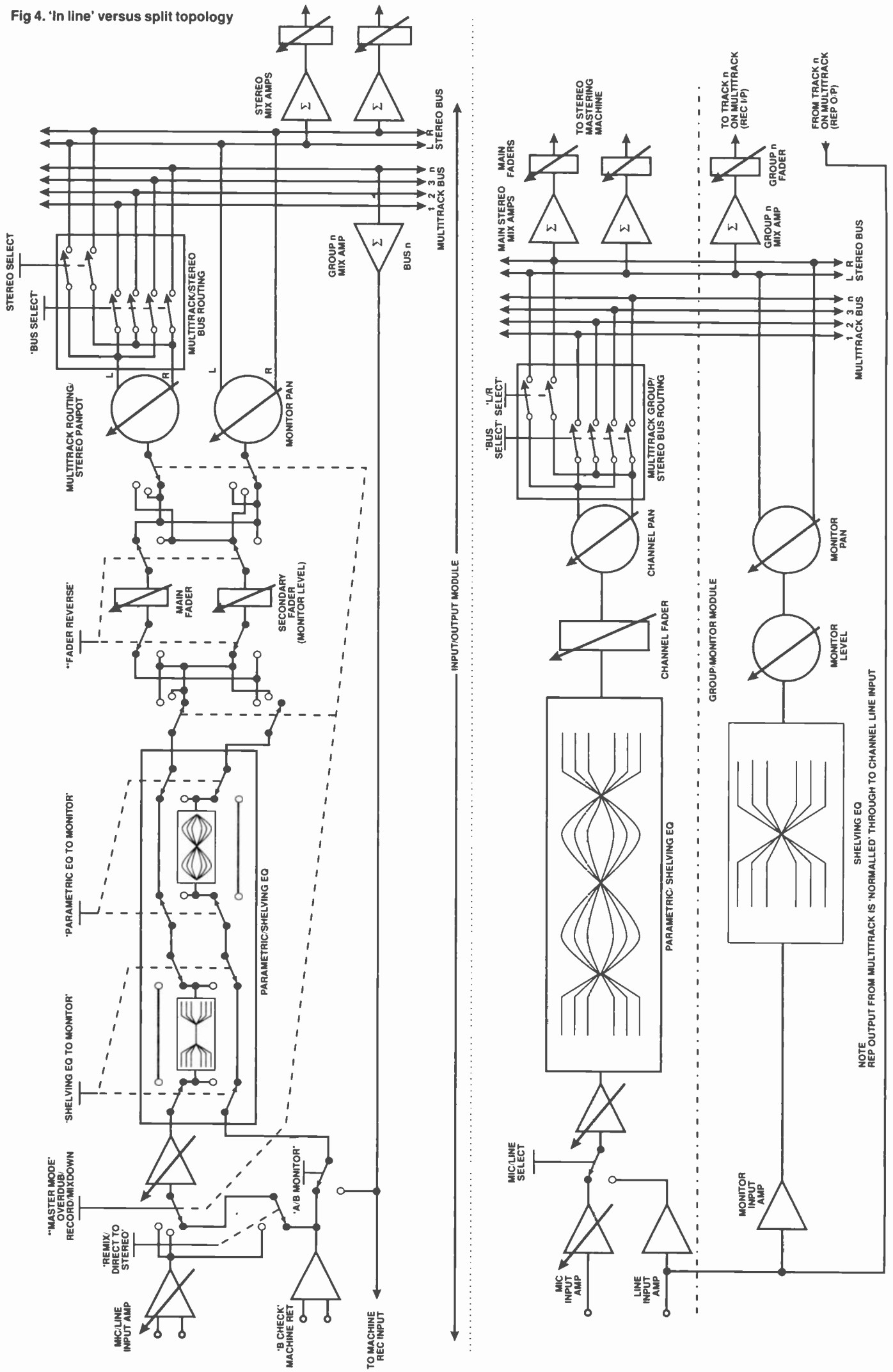

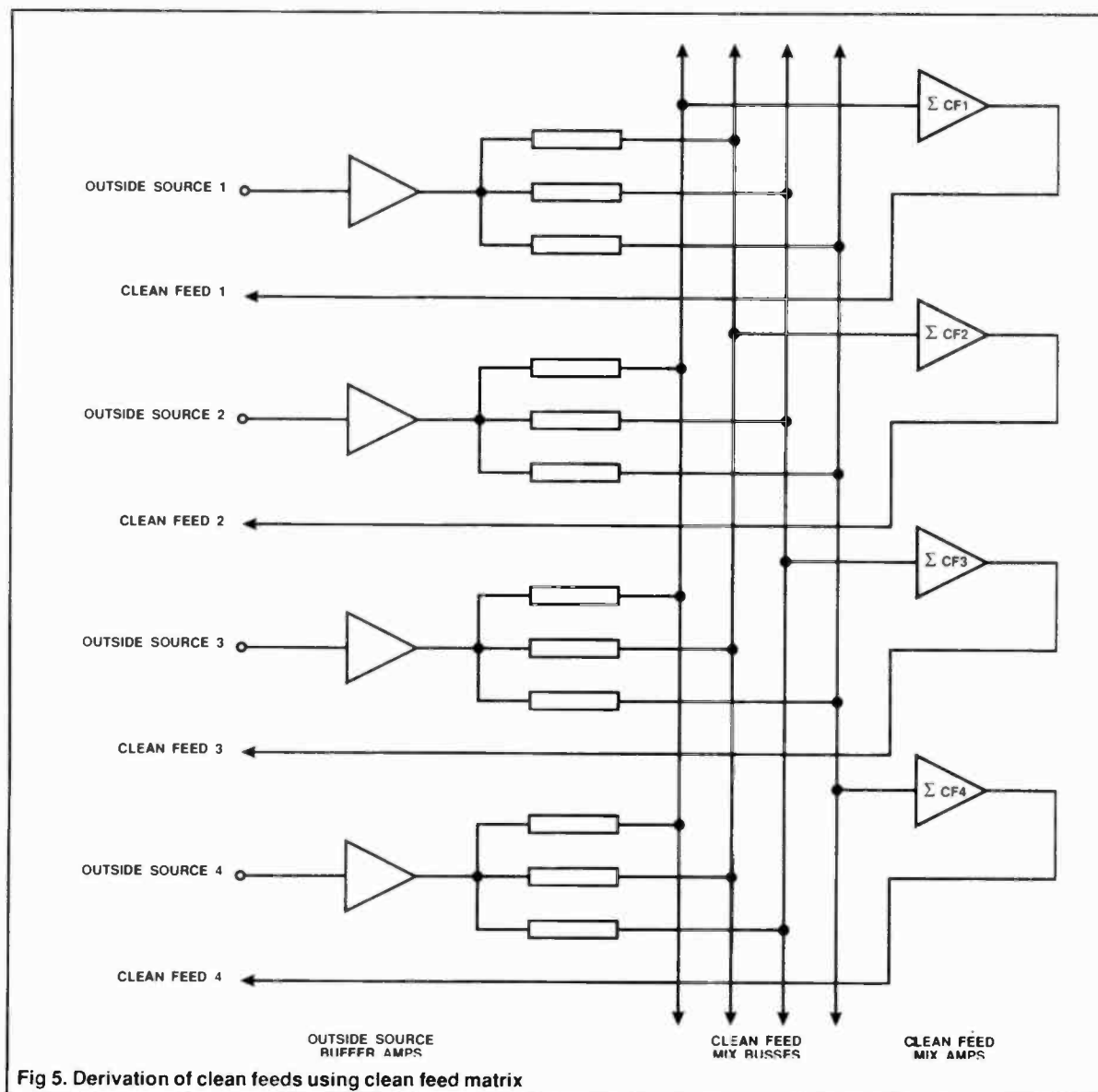

producer is able to converse and communicate with those at the other end of the microphone cables. A broadcast-style desk is probably the one where the ability to communicate is of the most importance - the essentially live aspect of most broadcasting means that it is essential to be able to speak to the person at the other end. Many radio programmes and these may include studio presenters or remote contributors.

Contributors remote from the studio are known as outside sources and may be from an outside broadcast - OB, in the vernacular - or in another studio in a different part of the country. It may be from a news studio within the complex or from a telephone contributor in the outside world. The studio itself may form part of a larger system known as a network.

All of the above dictates the need for a comprehensive communication network. Presenters or outside source contributors will require some means of knowing both what is happening in the studio and when to speak. Both of these needs can be served by sending them what is known as Cue Programme (QP), probably better known in the recording industry as Foldback (FB). Conventionally, any Foldback or Q Programme Mix is generated using one of the Post Fade Aux Mix Busses. It is usual, however, for cue programme to be purely and simply a take-off of the desk output with,

perhaps, some form of talkback added. Telephone contributors or those a long distance away - communicating via satellite, for example - pose special problems of their own.

Hearing one's own voice coming back through the ear-piece is a thoroughly off-putting experience. Adding delay to this scenario just worsens an already bad state of affairs, to the extent that the contributor may find it impossible to speak. What is done in this instance is to generate what is known as a Clean Feed Mix (CF) (or Mix Minus in the States), that is, a mix of the whole desk output (or a given selection of channel inputs) minus that particular OS contribution. In this way, the OS is sent everything except his/her own contribution. Large sports, current affairs or news studios, where Outside Sources may be contributing from a large number of far-flung places (both within and without the studio complex), require a corresponding large number of Clean Feeds. This is to such an extent that a completely separate Clean Feed Matrix is sometimes required - see Figure 5

Where remote sources are within the same building, and also with some outside sources, a circuit known as the Control Line is established when the OS (source) is routed to the desk (destination). This takes the form of a simple

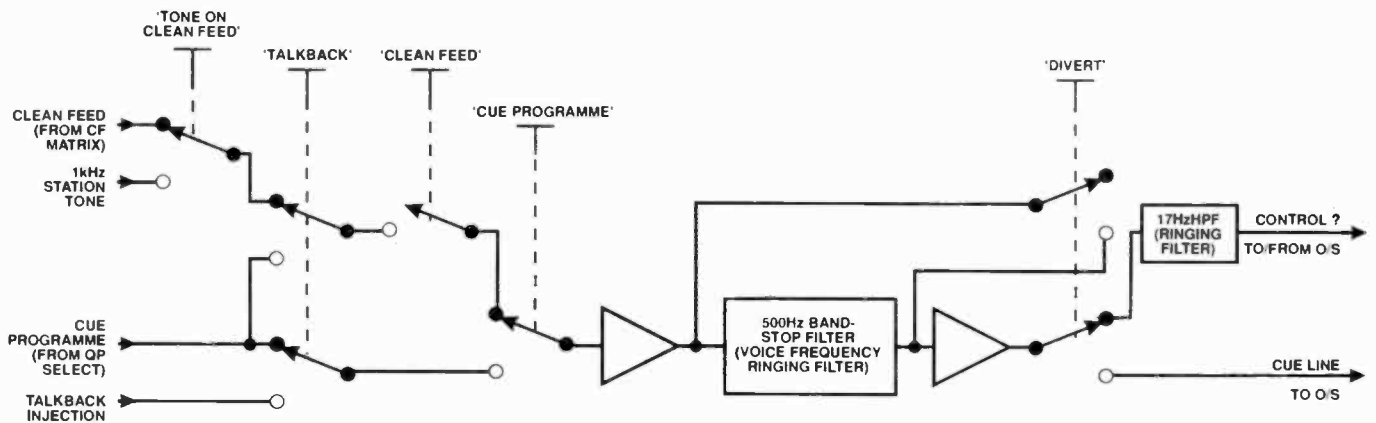

Fig 6. Outside source Q programme/control line routing

telephone circuit which allows bi-directional communication in addition to that possible with the contributor's microphone/headphones.

Also ever-present is the very real danger of howlround or feedback. Monitoring the desk output on loudspeakers, or even with headphones turned up loud, while the mic is live can cause the sound so loathed by engineers everywhere. Clean Feed can cure many problems in this area, as it can when a particular programme is networked around the country (but individual stations wish to add their own announcements, news, jingles or advertisements to the local network output). Nevertheless, cue programme is used wherever possible since remote OB's can use a receiver to monitor off-air, thus saving on valuable telephone circuits (known in the trade as land-lines or music lines depending upon their bandwidth). It can also provide much-needed confidence to the contributor if he or she can actually hear the programme with their own contribution included - we all know the panic and embarrassment evident in so many 'going live to our reporter in Chipping Sodbury' type programme when the sound link fails - see Figure 6.

We mentioned talkback. Rudimentary talkback systems exist in all desks, regardless of type, although they are probably more complicated on broadcast-type desks where the producer as well as the engineer/operator may have his/her own talkback system. Talkback allows us to communicate - usually via a console-mounted microphone - to the artists in the studio or to the outside sources on a loudspeaker and so is usually part of the post-fader foldback mix. We may also wish to use talkback to speak to each headphone foldback circuit separately or simultaneously, or perhaps to communicate with another control room (cubicle in broadcast terminology). The final possibility is the wish of the operator to speak onto tape - Slate - for the purposes of identification and so forth. As well as the voice identification - ident - on the tape, Slate usually also places low frequency tone in the same places. This is then audible when the tape is being spooled at speed past the heads. Normal convention for talkback systems is for there be a tandem tone injection circuit, with all places where talkback can be routed also switchable to the desk tone source(s). Tone is used to verify whether a circuit has been established or as an aid to line-up - see Figure 7.

LS Cut may be implemented by fader-backstop/Mic select switch operated muting system (as in the AutoMate)

or via a system known as SLS (Studio Loudspeaker Silence) where the insertion of a jack into any mic input on the patchbay and a desk input arms the muting system. Similar systems also operate in conjunction with the cubicle monitoring speakers whenever the desk talkback mic is live. The SLS system is normally employed on broadcast desks where all console inputs, inserts, break jacks, listen jacks and outputs are balanced and available on comprehensive rack-mounted patchbays - see Figure 8.

Again, broadcast desks use a comprehensive (and complicated) interlock system so that it is never possible for the talkback to be routed to the studio loudspeaker when a microphone is live and the desk is in Transmission mode. (In broadcast terminology, the "studio" is the place where the artists or presenters are situated, the control room (where the desk and ancillary equipment, and the producer and operator are situated) becomes the cubicle and the central technical area (CTA) becomes known as the control room).

A broadcast environment is such a demanding one, with its own peculiar requirements and needs, that it is of some interest to look briefly at some of the unique switching arrangements which exist at various points in the programme chain. In any case, the AutoMate may very well be used as part of a hospital or university campus radio set-up and I'm quite sure that those involved in such activities would term themselves broadcasters, albeit on a smaller scale!

An area of great importance is the Control Room. From this hub originates what is known as the building Ringmain. This is similar to its mains counterpart - with which, I'm sure, you're all familiar - but it circulates audio feeds rather than power. Conventionally, all network outputs (both radio and TV) and perhaps the speaking clock - TIM - are catered for, with all available for selection and monitoring via a rotary switch. There may be as little as 2 or as many as 24. The ringmain outputs are also available as an integral part of the desk's main monitoring system, being plumbed in during studio installation. The three points of special significance (as far as an overview of facilities which should be included) are as follows:

A point on the ringmain which is fed from the Studio Output (not to be confused with the desk output) after it has been routed to the Control Room source mult.

A feed of the Network output. This is a confidence restorer since it allows the studio to hear itself on the ringmain (and therefore ensure that that studio is on-air). In

Fig 7. Insert points in a mixing desk

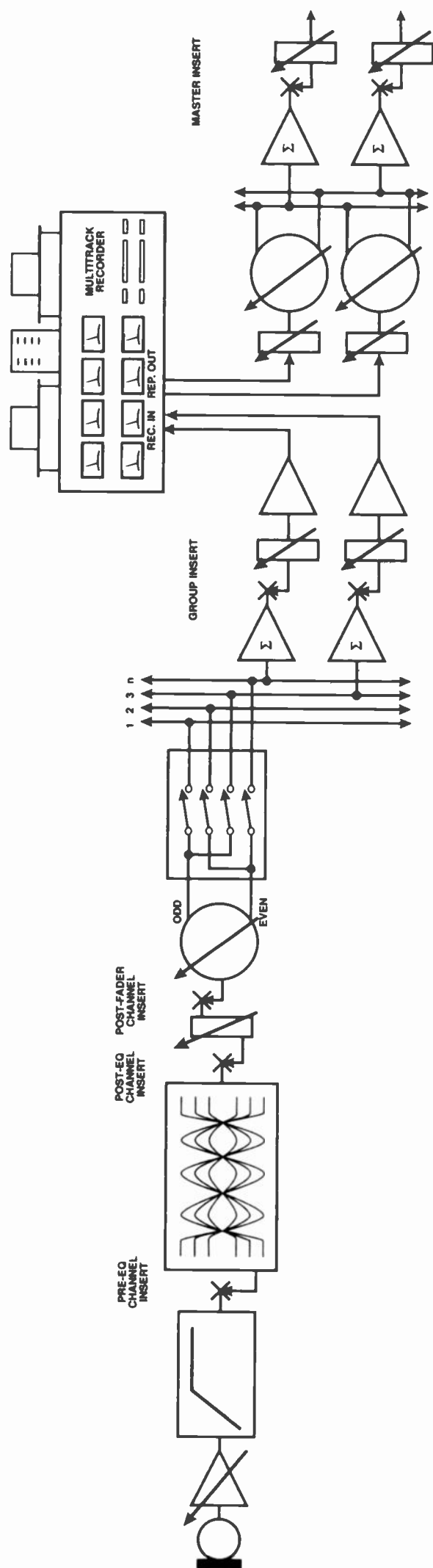
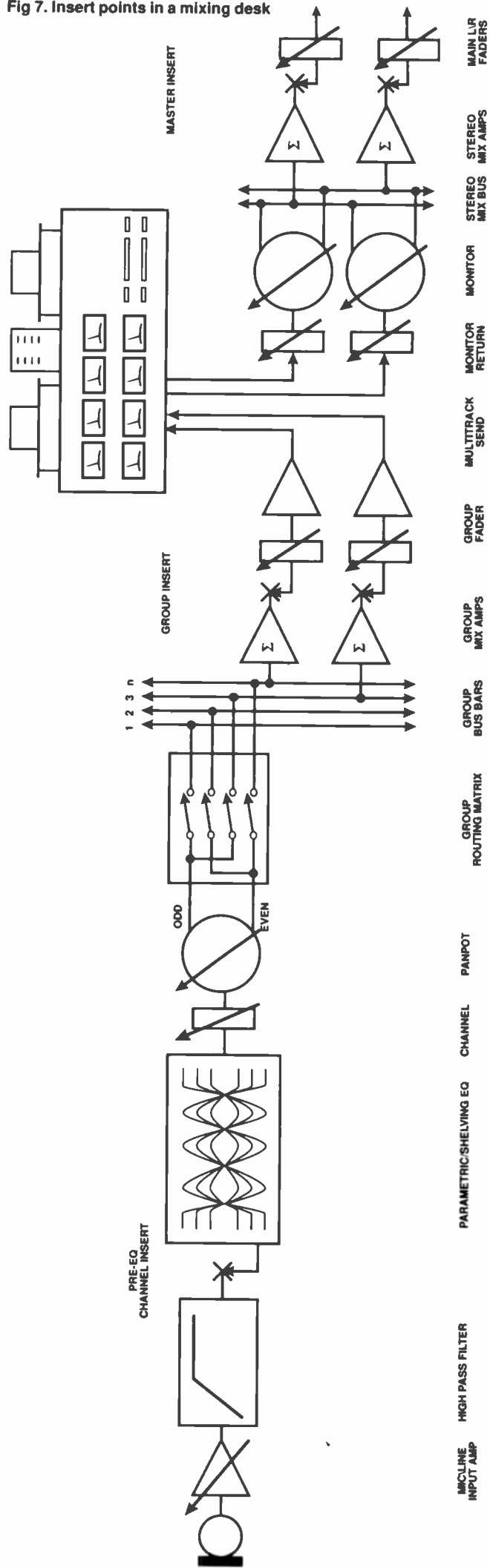

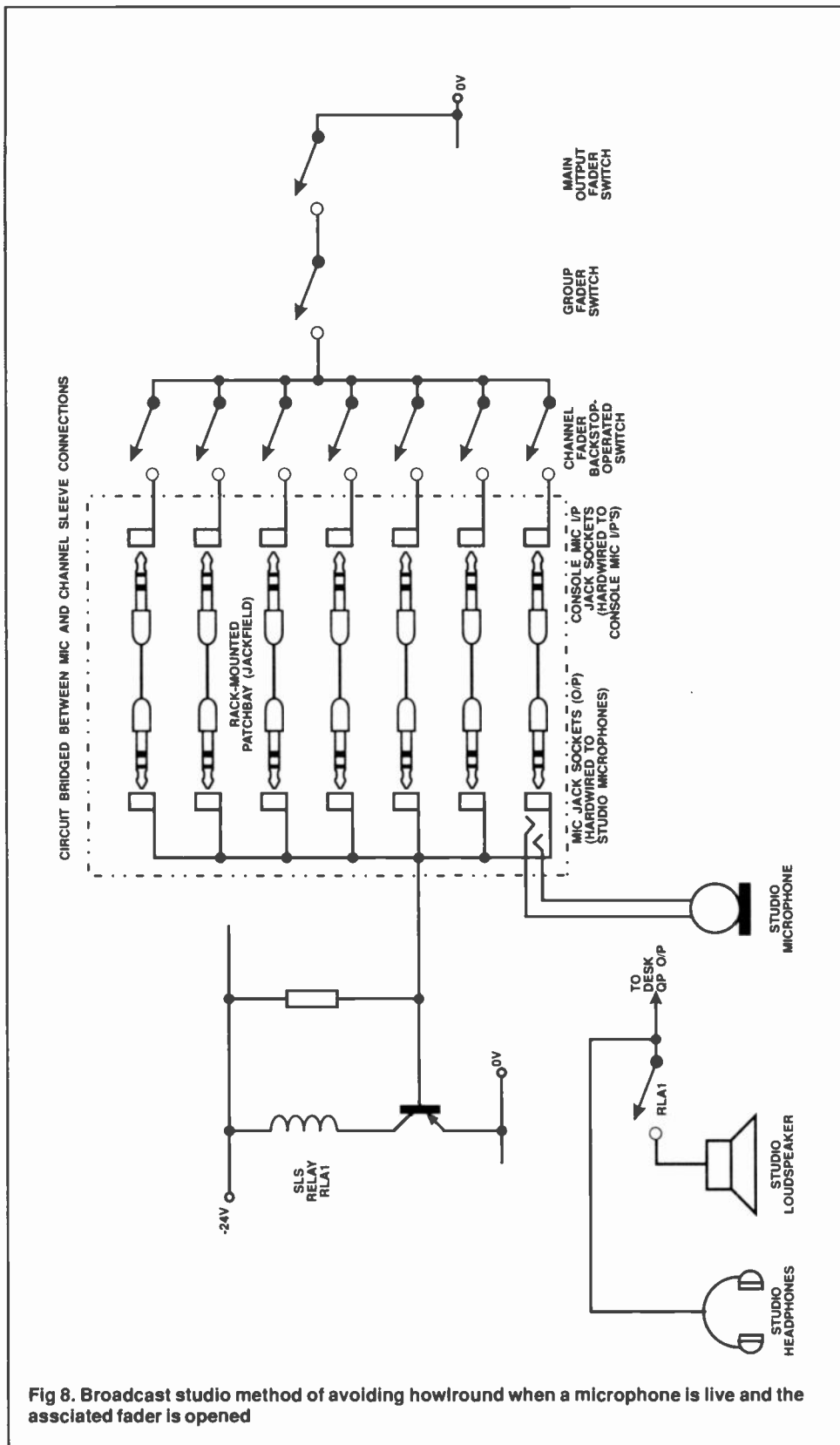

Fig 8. Broadcast studio method of avoiding howlround when a microphone is live and the associated fader is opened

other words, it is Network Feedback.

Point 11 (studio output) is not necessarily the same as network output since tone could be selected during rehearsal or the studio could be de-selected from the network.

When monitoring on point 12 the Desk Output can be heard although studio output is tone. This is because the monitoring point is taken prior to the tone injection stage - see Figure 9.

Broadcast desks have, in essence, two different modes of operation - Rehearsal and Transmission - and these affect talkback muting and routing arrangements. Talkback will replace the desk main output and studio loudspeakers will be dimmed when in Transmission, but both facilities will be disabled when the desk is in Rehearsal. Once one starts to think about it more closely, the multitude of different permutations which are possible and must be provided for escalates with frightening ease - again, see Figure 7.

Those consoles intended for use as PA or FOH (Front Of House) mixers will have talkback arrangements of similar complexity to the broadcast type (with the engineer able to speak to a wide variety of sources collectively or individually) but a much reduced monitoring system since the public address rig itself provides the main monitoring. Recording-style desks, on the other hand, normally (but not always) comprise of much simpler talkback arrangements but include more complicated monitoring systems. It should be said that the comms. side, as far as switching within a sound desk environment is concerned, does not pose as many problems as the other two areas (monitoring and routing). This is because absolute quality and fidelity is of a lesser consideration with talkback, where intelligibility of speech is of far greater importance. Clicks and the like are also less of a nuisance since all switching is done off-air and isolated from the programme path.

Next month, we'll move on to the second of the switch-related topics, that of Monitoring, finishing the section with a look at the actual physics involved in achieving noiseless, inexpensive audio switching.

References

Sound Recording Practise (edited by John Borwick), Mixing Consoles, Analogue (Richard Sweetenham) - sound Processing (Richard Elen) - Radio Broadcasting (Dave Fisher) Oxford University Press

The New Audio Cyclopedia (edited by Glen M. Ballou) - Consoles and Systems (Steve Dove) - Howard W Sams

The History of Batteries

Jim Slater gives us a guided tour of the wide range of batteries

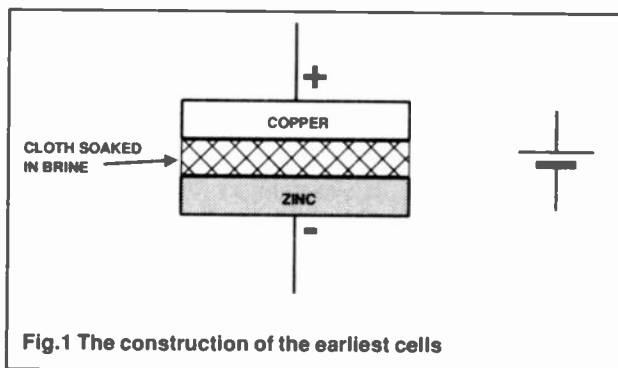

Fig.1 The construction of the earliest cells

Batteries are the unseen and generally unthought about component of all portable equipment and they are the ultimate example of a 'distress purchase', in that we only buy them when we absolutely have to. Indeed, we only really think about them when something has gone wrong and we need to replace or recharge them. Most people learned about simple cells in their school science lessons, but battery technology has moved on in leaps and bounds over the last ten years, with new types being introduced to the market almost as often as new pieces of Japanese electronic wizardry appear in the shops. These have not been made just for the sake of introducing a new technology, but to satisfy the particular requirements of various pieces of equipment, from the high current capacity required to drive the film winder on a compact still camera to the extra long life required of the battery preserving the clock and CMOS memory functions of the latest personal computers.

The earliest batteries were very primitive affairs, but batteries made up of series connected electrolytic cells of the Voltaic type or the Leclanche type, named after their respective inventors, formed the basic power supplies of virtually all the earliest radio receivers. An electrolytic cell is a device in which chemical energy is converted to electricity and sometimes vice versa, if such a cell is rechargeable. Cells of this type consist of pairs of conductive electrodes in a chemical solution known as an electrolyte, and the Italian experimenter Volta is generally credited as being the first to

invent such a cell. He placed a piece of cloth soaked in brine between a plate of copper and a plate of zinc and the copper plate formed the positive connection or pole of what was to become known as a Voltaic cell. Several such cells in series formed a 'pile', or battery, from which greater voltages could be obtained. Cells that merely convert chemical energy into electrical energy and cannot be recharged, are known as 'primary cells', whereas rechargeable cells, where the electrochemical process is reversible, are called 'secondary cells'.

Development of the Voltaic cell led to sulphuric acid being used as the electrolyte, but the current would flow for only a few minutes before a layer of hydrogen gas built up on the copper electrode, stopping the current flow. Effectively, the hydrogen layer then acts as the second electrode instead of the copper, setting up an electromotive force which opposes that of the original cell. This effect is known as polarisation of the cell. Various other cell designs were tried and one that was found to be very usable was the Leclanche cell, which was manufactured first in liquid form, then in the far more practical dry cell form. This type of dry cell survives to the present day as the standard 'zinc-carbon' cell which is used to power our torches.

The negative electrode of the Leclanche cell is a zinc rod in a solution of ammonium chloride. The positive electrode is a carbon rod in a porous pot packed with manganese

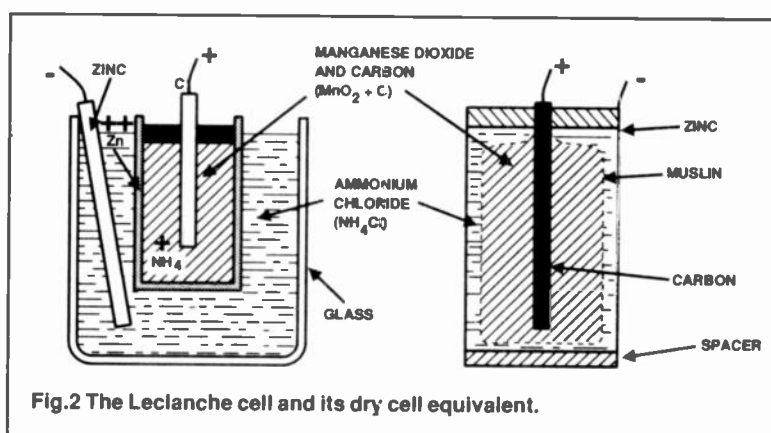

Fig.2 The Leclanche cell and its dry cell equivalent.

dioxide, which acts as a depolariser. since manganese dioxide is a poor conductor of electricity, it is necessary to mix it with powdered carbon. In operation, the zinc goes into solution, in the form of ions and the ammonium ions pass through the porous pot towards the carbon rod. When a load is put across the electrodes and a current is drawn, electrons flow from the zinc to the carbon and discharge the ammonium ions. Hydrogen is still produced in this type of cell, but it is

gradually oxidised by the manganese dioxide. In the dry cell, which has the enormous advantage of portability, the ammonium chloride is made into a paste with water and zinc chloride and the porous pot becomes a muslin bag. The outer case of the cell is made of zinc and forms the negative electrode.

The lead acid battery

Another type is the lead-acid battery, which we rely upon every day to start our motor cars, but which our forebears in radio knew as the 'accumulator'. This type of battery, made up from what are called 'secondary cells', has the tremendous advantage of being rechargeable, since the chemical changes that take place as the battery is discharged can be reversed by driving a current of the opposite polarity through the cells.

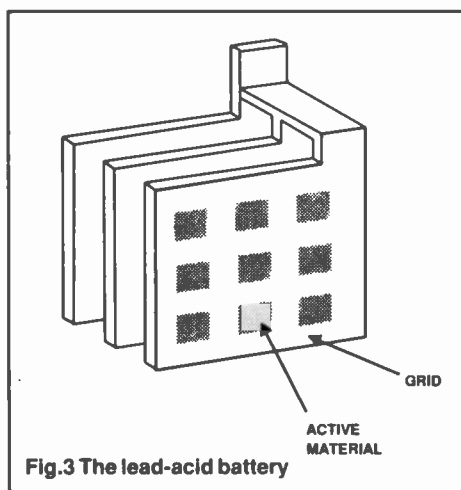

The two plates are made from lead (the negative plate) and lead dioxide (positive), the electrolyte being sulphuric acid. When the cell is being used to produce a current, hydrogen ions move to the positive plate and sulphate ions move to the negative plate. Eventually both plates become lead sulphate. Recharging the cell by forcing a current through it in opposition to its natural electromotive force, converts the materials of the plates back to

lead and lead dioxide, giving off hydrogen and forming sulphuric acid. The lead acid battery can be used to deliver currents of hundreds of amperes, as required for starting a car on a frosty morning and have the advantage that the state of charge can be monitored by measuring the specific gravity of the electrolyte with a hydrometer, since the s.g. varies from about 1.28 when fully charged to about 1.12 when completely 'flat'.

Battery Developments

These two types of battery, the lead acid and the zinc-carbon, became the mainstay of the electronics industry for the past forty years and, as the advantages and disadvantages of each became well known, equipment and circuitry was designed around the appropriate power source. Lead-acid batteries hold a massive world market share as batteries for cars, tractors, and standby power supplies. The basic materials from which they are constructed, lead and sulphuric acid, are cheap and readily available and there is now a great deal of experience with using them. Originally, the 'gassing' that took place during charging and the necessity of replacing lost water meant that it was impracticable to seal the cells and they could only be used in locations where they could be kept upright. Recent developments in construction techniques have made sealed lead acid batteries practicable and they are now in use in many electrical and electronic appliances. Such batteries are, however, necessarily fairly heavy and the fact that they are sealed generally means that the volume of the battery needs to be significantly greater, perhaps as much as

50% more than that of a non-sealed design, to allow for expansion of the gases and for the necessary safety valve seals. In spite of this, the use of modern plastics and clever plate designs means that a good modern battery of this type can be made with a total thickness of as little as 6mm, enabling it to fit readily underneath a piece of electronic equipment and can produce around 80 Watt-hours per litre of battery volume, over a one hour discharge period. This type of compact, sealed lead-acid battery is currently in use in cordless telephones, portable audio equipment, barcode readers and uninterruptable power supplies for computer based equipment.

Manganese batteries

These dry cells, based on the simple zinc-carbon design, were the earliest types to go into mass production for the domestic market and still represent a good balance between low price and reliable and safe operation for many uncritical uses. They have undergone many design changes in the last few years in order to improve their various characteristics, with some manufacturers going as far as changing the electrolyte from ammonium chloride to zinc chloride, which has been found to extend the continuous discharge capacity of the battery under heavy loads and to extend the shelf-life.

When this type of battery operates for long periods,

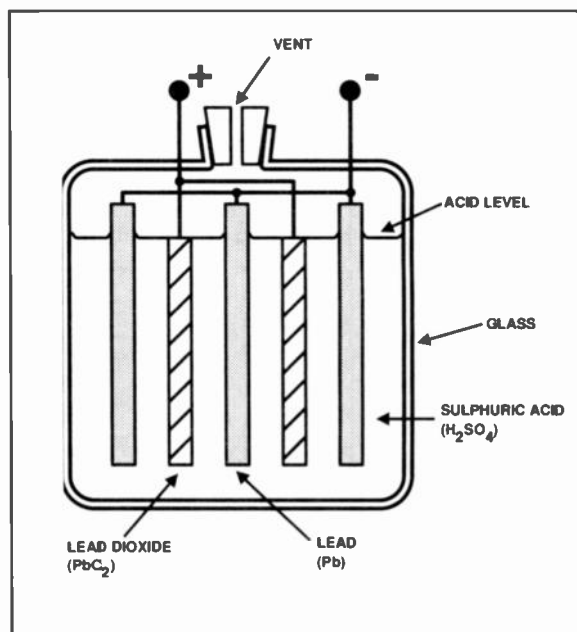

various problems can arise. Rapid over discharging can cause the internal pressure to rise, so some companies have designed special gaskets which act as a pressure release mechanism to prevent rupturing of the container. Long-term over discharging can cause the zinc casing of the battery to corrode and holes may form in the container allowing the cells internal paste/fluid to leak out. This process is made much worse if air reaches the innards of the battery. Various internal barriers have been designed to prevent this and a lining of special paper is often found to be successful.

The Ecological Cost

The performance of many types of battery have been improved by adding modest amounts of chemicals such as cadmium and mercury, but the growing realisation of the

environmental hazards that the disposal of significant quantities of such chemicals can produce has led to steps being taken to eliminate such chemicals, with more environmentally friendly substitutes being employed.

For most of the time that manganese batteries have been available, manufacturers have added mercury, which was found to help to protect the zinc container against corrosion and to improve the shelf-life, but as the toxic effects of mercury became more and more apparent, manufacturers tried to find ways of eliminating it from this type of battery. Since 1990 manganese batteries no longer use mercury. Using extremely pure materials for the main battery construction and improving the sealing techniques has made it possible to manufacture this type of battery economically and safely. Another chemical that these batteries traditionally contained was cadmium, which was added to the zinc container to improve its mechanical properties, but as the effects of cadmium on the environment became more and more appreciated, steps have been taken to eliminate this substance and these batteries now form a reasonably environmentally friendly package at an economical price.

Alkaline manganese batteries

The alkaline manganese battery has represented one of the most successful battery developments of the last twenty years, typified by the 'Duracell' name and providing a range of batteries which have an extended life to provide large currents for a long time. Like the zinc-carbon batteries, Alkaline manganese types use manganese dioxide as the anode and zinc for the cathode, but they use potassium hydroxide as the electrolyte. This type of battery has a low internal resistance and provides optimum performance from equipment that takes large currents, such as shavers and portable tape recorders. The addition of tiny amounts of indium to the zinc canister forming the negative pole has all but eliminated corrosion and reduced the amount of mercury that was previously needed. It is interesting to see that developments to this type of battery during the last ten years have in fact increased its capacity by something like 50%.

Most batteries of this type were built as high performance replacements for standard dry cells, but driven by the needs of the market for small but economical and relatively high power sources for cameras, electronic watches and electronic toys, smaller versions were developed, known as alkaline button batteries. These use pure caustic potash mixed into a paste with water as the electrolyte and offer good capacity and reliability, a long shelf-life and the ability to work over a wide range of temperatures. They are significantly cheaper than the silver oxide button batteries that can also be used where small size is important.

Manufacturers had again improved the performance of the alkaline battery by adding various chemicals and mercury used to account for perhaps 1.5 % of an alkaline battery's total weight, 400 times the mercury content of a standard zinc-carbon design. The mercury content in alkaline batteries is now down to as little as 0.025% and special anti-corrosion zinc alloys have been developed for the negative electrodes.

The family of small alkaline batteries grown from the alkaline manganese battery to include silver oxide types, zinc-air batteries and mercury 'button' cells, which use mercury oxide as the active constituent of the positive

electrode. They all have zinc as the negative electrode and use alkaline electrolytes such as potassium hydroxide. Comparative discharge characteristics of some of these types are shown in figure 4.

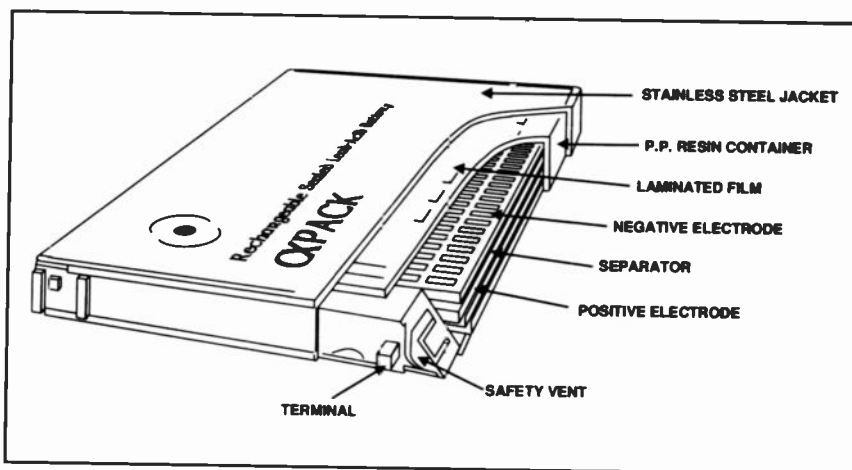

Silver Oxide Batteries

These use silver oxide as the positive pole, zinc as the negative pole, and caustic potash solution as the electrolyte, so still come under the classification of alkaline batteries. A major characteristic of this type of cell is that it has an excellent energy density, so that relatively high power cells can be produced from a small physical size. Silver oxide cells are expensive compared with many other designs, but they have found a market in equipment such as electronic calculators, toys, and electronic thermometers.

Zinc-Air Batteries

Yet another type of alkaline battery is the zinc-air design, where zinc forms the negative electrode and potassium hydroxide acts as the electrolyte, but the positive electrode is effectively formed from the oxygen contained in the air, a technique that requires a very special film that allows air to permeate through it in a carefully controlled manner. This type of cell has very long term discharge capabilities and it is interesting to compare these with those of other types of alkaline based cells.

The Nickel/Cadmium Battery

Probably the best known type of battery amongst domestic users, after the ordinary zinc-carbon types and the much promoted 'Duracell' manganese alkaline heavy duty batteries, is the Nickel-Cadmium, or Ni-Cad type, which has the big advantage over ordinary dry cells that it can be recharged over and over again. As in all forms of engineering, however, you never get something for nothing and the price that the Ni-Cad user pays is that the voltage from one of these cells is no more than 1.25 volts, as against the 1.5 volts that a standard dry cell provides. Even so, the bonus of rechargeability makes this type of cell very popular as the Ni-Cad battery is very suitable for applications that require short-term bursts of fairly heavy current, such as portable electric drills.

The Ni-Cad, which first came into use about 30 years ago, uses foamed metal nickel for the anode and cadmium for the cathode. They come in two main constructions - cylinder and button. The cylinder models provide power for camcorders and mobile phones, whereas the button designs are good for computer memory backup.

Recharging problems with Ni-Cads - the 'memory' effect.

As Ni-Cad batteries came into greater use, some people found that their batteries, which had been expected to be capable of being recharged at least 500 times, started to behave peculiarly after only a few dozen charges, after which the batteries appeared to quickly lose their charge. If the

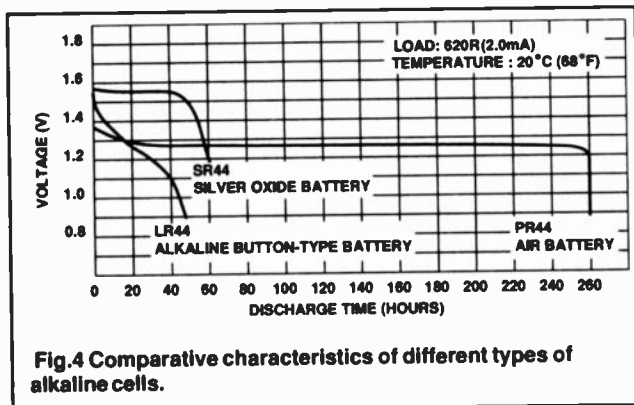

battery is fully discharged before re-charging is attempted, the problem does not occur, but if the nervous user attempts to keep giving the battery a top-up charge just to make sure that the battery will always be 'full', the so-called 'memory effect' comes into play and the battery will only allow you to take out the amount of charge that has been most recently put in, after which it appears flat. There is no sensible way of monitoring the state of charge of this type of battery, which makes life even more difficult. Modern chargers often incorporate an automatic discharging circuit which initially puts a load across the cell until it has been completely discharged and only then does the actual recharging process begin.

Another disadvantage of the Ni-Cad is that during charging and discharging crystalline needles of cadmium grow from the cathode and these can sometimes penetrate the separator and cause internal dendrite short-circuiting.

Fast recharging

All types of rechargeable batteries need to be carefully controlled during the recharging process if effective use is to be made of their full capacity and if the maximum possible lifetime and number of charge/discharge cycles is to be accomplished. Most rechargeable batteries have usually been recharged from the mains via a fairly simple battery charger consisting of a simple transformer and rectifier circuit. With Ni-Cads, this has generally meant at least a 16 hour trickle charging period. If the batteries are recharged faster, the battery can be damaged. Portable computers are just one example of a piece of equipment where the user will want to recharge the batteries as quickly as possible and manufacturers have now developed integrated circuits to carry out the necessary control and monitoring functions, so that small batteries can be re-charged in as little as half an hour. Battery charging management involves measuring the state of charge of the battery and maintaining it in good condition. A typical battery management IC monitors the

amount of energy left in a battery by calculating the charge and discharge currents and whenever the battery-full condition is detected, the charger is switched from fast-charge to trickle. Philips have developed a range of ICs to look after all aspects of the re-charging of small batteries and a typical system configuration suggested by the manufacturer is shown.

The power module, which is the source of the charging current, can be anything from the most basic transformer/rectifier circuit to a sophisticated switched mode power supply. In mains isolated equipment the control module can send signals to the switched mode power supply via an opto-coupler, but in cases where mains isolation is not necessary, a direct connection can be made. The control module monitors the state of the battery and the instantaneous load current, then issues commands to the circuitry which controls the charging, from a very fast charge down to a trickle.

Now Obsolete - The Nickel-Iron Ni-Fe Cell

A rechargeable battery that was popular for many years, powering such things as miners' helmet lamps, is the nickel-iron design, which proved rugged and long-lasting, but has now virtually been replaced by the much lighter and maintenance-free Ni-Cad. The Ni-Fe cell, sometimes called the Edison Cell, used positive plates of steel packed with nickel hydroxide and negative plates containing iron oxide and mercurous oxide, with a liquid electrolyte of potassium hydroxide.

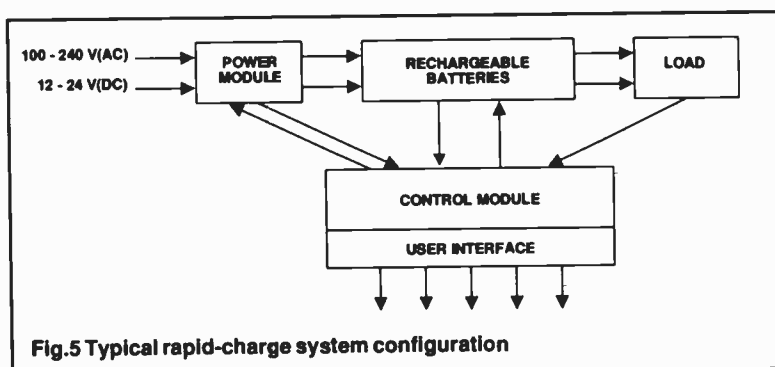

Nickel-Hydrogen Cells

These secondary (rechargeable) cells use nickel oxide for the anode and a hydrogen absorbing metal alloy for the cathode, rather than the cadmium of the Ni-Cads. The task of the alloy cathode is to extract hydrogen (H) from the battery water and to absorb it. The cathode can absorb up to 100 times its own volume of hydrogen. The chief factor to consider in the design of such cells is the hydrogen storage capability of the alloy. The cells charge and discharge using an alkaline electrolyte and the basic chemical reaction principles are shown in the diagram. They are more properly called nickel metal hydride cells.

Ni/MH cells have a greater energy density than Ni-Cads, generally offering about 75% more electrical capacity than a Ni-Cad of equivalent physical size. One cell of this type, using nickel and a metal hydride as the hydrogen storage element, claims to provide an energy density of 180 Watt-hours per litre. The figure shows the comparative discharge characteristics of a standard Ni-Cad penlight cell and its Ni/MH equivalent.

Ni/MH cells can provide currents of several amps and

have a voltage of 1.2V. They have the same self-discharge properties as the Ni-Cad, can be recharged in about an hour, have a low internal resistance and can typically withstand over 500 charge/discharge cycles. The major drawback with Ni/MH batteries is their price - they currently cost around twice the price of Ni-Cads.

Lithium Batteries

A good example of a battery technology coming along in response to a definite need, the lithium battery has made its mark as the power supply of choice for computer memory chips. These require only a very low current, but demand a battery that will not easily self-discharge and which has a

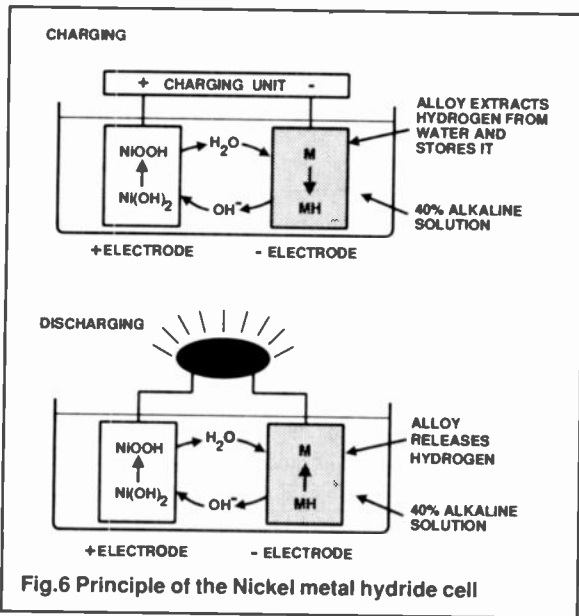

Fig.6 Principle of the Nickel metal hydride cell

shelf lifetime of several years. Some types of standard lithium cell also have the advantage of providing about 3 volts, more than double that of most other cells, and this is sufficient to keep a semiconductor memory chip operational. Such cells thus ensure that the CMOS memory of a personal computer can retain its set-up data as well as the time and date, even when the main power supply is switched off. Cell types providing three volts are graphite fluoride lithium, thionyl lithium chloride, and manganese dioxide lithium (3.6 volts) types, the name of the battery indicating the material from which the positive electrode is made. The positive electrode determines the specific properties of the battery and, as an example, the use of copper oxide for the positive electrode gives a cell with an electromotive force of 1.5 volts. This type of cell is tending to replace the more expensive silver oxide type in many applications.

Lithium batteries have many advantages over manganese and manganese alkali dry cells: in addition to their greater energy storage capacity they can deliver higher voltages, are less prone to self-discharge and also operate over a wider range of temperatures, which can be very important for equipment that has to work reliably in a wide range of outdoor conditions.

There are actually two major types of lithium battery construction, suitable for very different purposes. The type for computer memory backup uses the so-called 'inside out' design and is suitable for only very light current discharge operations. In complete contrast, the spiral versions allow for heavy load use from a very small physical size and have

become the standard for many types of compact camera where high currents are needed to drive the film winding mechanism, but small size is essential. Manganese dioxide lithium designs have been found to be ideal for this purpose and the construction of this type of cell is shown below. The separator material is kept exceptionally thin in order to minimise the cell's internal resistance, allowing it to deliver heavy currents. The lithium negative electrode and the organic electrolyte could prove inflammable if the cell were to over-heat, so the construction has to be arranged to ensure that the cell will not catch fire if a sustained short circuit should take place. The special separator material is designed so that in the event of overheating occurring, it forms a film to ensure that the positive and negative electrodes cannot touch. A safety valve is placed at the top sealing plate of the cell, which can vent any gases produced to the air, so preventing any possible explosive effect and this is usually backed up by a third line of safety - the inclusion of a positive temperature coefficient device whose resistance rises with temperature, so reducing the current that can be taken from the cell.

Rechargeables Too - Lithium Secondary Cells

One of the latest developments in battery technology has been the rechargeable lithium battery, which has only been on the market for a couple of years. As with lithium based primary cells, the performance characteristics of lithium secondary cells varies according to the actual materials used in the cell. Lithium aluminium alloys are often used for the cathodes and the electrolytes vary from manufacturer to manufacturer, but most lithium secondary batteries can deliver some two to three times the capacity of the nickel

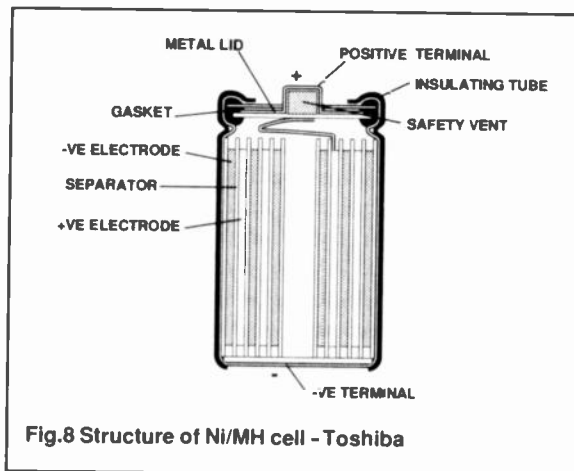

Fig.8 Structure of Ni/MH cell - Toshiba

metal hydride batteries with which they are often compared. Another major bonus of the lithium secondary battery is that long service lives can be achieved, with up to 5000 charge/discharge cycles being possible, perhaps ten times the number possible with Ni-Cads. They are light in weight, compared with their competitors and research is currently going into the development of optimised rechargeable cells of this type.

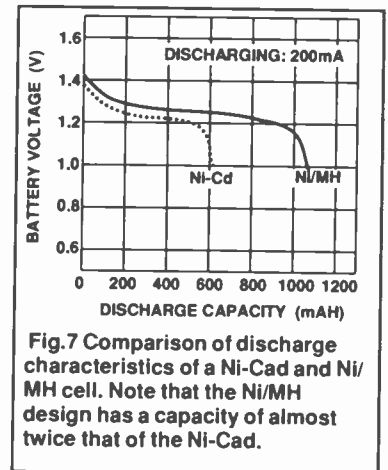

Fig.7 Comparison of discharge characteristics of a Ni-Cad and Ni/MH cell. Note that the Ni/MH design has a capacity of almost twice that of the Ni-Cad.

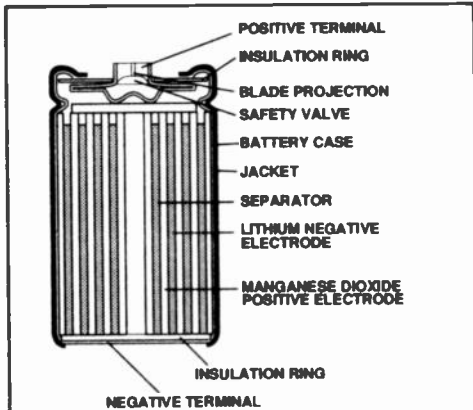

Fig.9 Cylindrical manganese dioxide Lithium cell

Vanadium Lithium

These designs provide from 3 to 3.5 volts with good charge and discharge capacities. The anode is made from vanadium pentoxide, the cathode is an alloy of lithium and aluminium and the organic electrolyte is made up from a solvent, often propylene carbonate and dimethoxy-ethane, into which is dissolved a compound of lithium, boron and fluoride LiBF₄. Such cells are ideal for memory backup applications and the construction of a typical 3V button or coin shaped

cell, some 20mm in diameter and 2mm high, is shown in the figure.

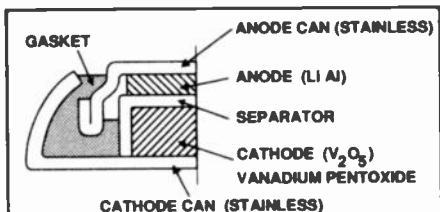

Fig.10 The construction of a rechargeable vanadium lithium cell.

Vanadium Niobium Lithium

The Matsushita company manufacture another popular type of secondary lithium cell, this time providing 1.5 volts with sufficient power to drive relatively heavy loads such as LED clock displays from only a coin-sized cell. Vanadium pentoxide is again used in the

anode, but the cathode material uses a niobium compound especially developed to provide improved charge/discharge characteristics of up to 1000 cycles. The electrolyte is a fairly exotic solution of lithium-chloride-oxide, LiClO₄, dissolved in a mixture of propylene carbonate and 1.2 dimethoxy-ethane.

Lithium Ion

It seems that by carefully adjusting the precise cocktail of the chemicals which are used in lithium batteries, manufacturers can 'tune' their designs to give just the performance characteristics they are seeking. Sony recently gave details of a so-called 'Lithium Ion' battery, which it is using to power its latest range of camcorders. The anode is made of carbon and lithium and the cathode is a complex chemical compound of lithium, cobalt, manganese, and nickel. The electrolyte is a similar organic compound to that described for the vanadium lithium design of cell. As with other lithium batteries, these should provide improved performance over the Ni-Cad design, with lower self-discharge rates, more charge/discharge cycles and improved storage life, but they are likely to be more expensive to manufacture than conventional Ni-Cads.

Successful Progress, But One Huge Failure.

The energy density of storage batteries continues to grow, but there is some feeling amongst manufacturers that the limits of the existing technologies are close to being reached. Although enormous progress has been made in battery technology, giving improved performance together with enhanced suitability for particular applications, and although enormous strides have been made towards achieving greener,

environmentally sound batteries that do not pollute our environment, the battery industry has one huge failure to own up to. The search for the electric motor car has gone on for as long as the car has existed and yet none of the existing battery technologies, nor even those that are currently being developed from all sorts of materials currently shows any sign of producing enough power for a long enough period at a reasonable enough price to displace the internal combustion engine.

The failure to develop batteries suitable for electric transport has had enormously detrimental effects on our environment, far greater than the effects of throwing cadmium on our waste tips from a few million penlight cells. The continued existence of the internal combustion engine as the prime power source for our vehicles must do far more harm all round. Let us hope that the long hoped-for miracle, a battery for the electric car which will enable the car to perform as well as a petrol-engined model is not too far away.

It is better by boat!

It was interesting to see that at this years boat show, a fair few boats powered by electric motors were on sale, especially for use on inland waterways and areas like the Norfolk broads where the pollution from petrol and diesel engined boats has started to make itself apparent. Because the electric motor on a boat is expected merely to drive a screw (apart from the myriad electric gadgets that the modern boat owner finds indispensable) and because the expected 'performance' of boats in terms of acceleration and speed is much less than that of motor cars, the modern lead-acid battery is proving very satisfactory as a power source. The almost silent running of an electric motor compared with a petrol engine brings yet another bonus.

The Norfolk Broad's now have charging points along the banks of the waterways, which can be used as the boats tie up and an overnight charge can provide sufficient battery power for the whole of the next day's leisurely cruising, at a price for electricity which compares favourably with that of petrol or diesel. Who knows, in sunnier climes it might be possible to use solar panels to charge up the boat's batteries, providing complete freedom of the waterways, but you know that you wouldn't ever be able to rely on the English weather and, anyway, solar panels must wait for another article!

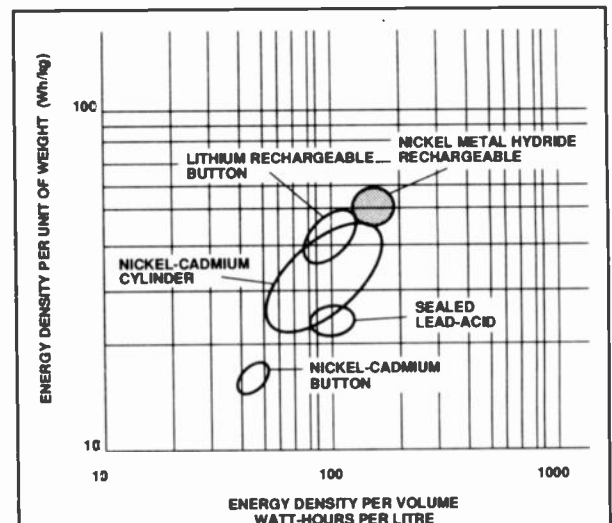
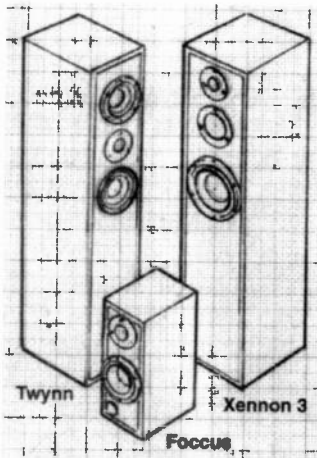

Fig.11 Energy densities of various types of cell by weight and volume

Dynaudio is considered one of the most distinguished manufacturers in audio. By means of untiring and successful research and exceptional solutions to questions of concept, design and construction Dynaudio has acquired this excellent reputation, yet success has not altered their independence and single minded concentration on creating products of the highest quality. Dynaudio continues to search for solutions to the basic problems of loudspeaker engineering and then puts these solutions to the test in loudspeakers of their own design. This is especially true for chassis technology. They have set the standards that others must follow.

There are three new speaker kits available from Wilmslow Audio, each kit contains all necessary components to build a superb pair of speakers. 18mm M.D.F. flat pack cabinets are also available.



	Plus Kit	Carr/Ins	Total Kit	Carr/Ins
Gemini	£590.00	£10.00	£645.00	£15.00
Foccus	£360.00	£10.00	£395.00	£15.00
Twynn	£425.00	£10.00	£510.00	£18.00
Xenon 3	£675.00	£10.00	£750.00	£20.00
Finale	£1200.00	£15.00	£1600.00	£25.00

Wilmslow
Audio

DIY Speaker catalogue £2.00
post free (export £3.50)

Open Tuesday to Saturday, 4 demonstration rooms available

Dept. ET1
Wellington Close,
Parkgate Trading Estate
Knutsford, Cheshire
WA16 8DX
Tel: (0565) 650605
Fax: (0565) 650080
Telephone credit card
orders welcome



SUMMER 1993 CATALOGUE

THE NEW ENLARGED CIRKIT CATALOGUE WILL BE OUT SOON!

- 32 more pages
- New range of Kenwood 'scopes
- The latest scanning receivers and accessories
- New section of low cost security products
- Extended range of Velleman kits including: 250W 12Vdc to 220Vac inverter, in-car amplifier power supply, 200 and 400W amplifiers, melody generator, synthesized FM tuner, suppressed lamp dimmer, halogen lamp dimmer, day/night thermostat and telephone remote control unit
- New test equipment, includes: 2.3GHz bench frequency counter, EPROM emulator/programmer, portable 'scopes and bench function generators
- Host of new components, including: trimmer and variable capacitors, connectors, RF filters, fuses and fuse holders, potentiometers, IC's, soldering irons and lead free solder
- Published 27th May 1993
- Available from most large newsagents or directly from Cirkit

£1.90
plus 30p p&p

EQT LTD STEVENAGE

Professional Sub-Contract Manufacturing & Suppliers to the Electronics Industry

Do you have a requirement for any of the following services:
PCB Assembly (Conventional and Surface Mount)
Wave & Hand Soldering
Complete Equipment Manufacture
Device Programming from hand written sheets or PC 3 1/2" disc
Cable Harness Assembly /loom Manufacture
Card Cage and Module Wiring
Full Inspection
Product Design/Consultation
Full Procurement Service
PCB Test & "Burn in" Facilities
Enclosure Design & Manufacture
PCB Artwork Manufacture
Circuits Drawn Professionally
Kit Procurement & Supply
Component Sales
Refurbishment a speciality
Top Quality Work at Reasonable Rates

Phone Tracey on (0438) 310066 or Fax details of your requirements to us on (0438) 315829
EQT LTD, BTC, Beasmer Drive, STEVENAGE, HERTS, SG1 2DX

BADGER BOARDS

Printed Circuit Boards

Prototype-Singles-Multiple runs. Minimum charge £15.00. Artwork, Plotting from Schematic to final board layout. Send S.A.E. now for Catalogue of Kits-Boards-Projects available. Many magazine boards produced for individual customers.

Dept: HRT 87, Blackberry Lane, Four Oaks, Sutton Coldfield, B74 4JF *** 021-353 9326

PROFESSIONAL SERVICES

We offer a full R.F. DESIGN SERVICE from design and development to prototype. Our extensively equipped laboratory with screened room is available for EMC PRE-TESTING to ensure products comply with the EC Directive on emissions and susceptibility.

R. N. Electronics EMC
1 ARNOLDS COURT, ARNOLDS FARM LANE, MOUNTNESSING
ESSEX CM13 1UT. Tel: 0277 352219 Fax: 0277 352968

Cirkit



CIRKIT DISTRIBUTION LTD
Park Lane · Broxbourne · Hertfordshire · EN10 7NQ
Telephone (0992) 444111 · Fax (0992) 464457

HITACHI

ELECTRONIC COMPONENTS

MAINS TRANSFORMER Pri. 120V-0V, 120V-0V.
Sec. 0V-12V, 0V-12V, at 3VA

£2.62 each

PROJECT BOXES A range of high quality boxes moulded in black high impact ABS, easily drilled or punched to produce a professional looking end product

TYPE	W	L	H	PRICE
T2	75	56	25	£0.77
T4	111	57	22	£0.92
MB1	79	61	40	£1.35
MB2	100	76	41	£1.47
MB3	118	98	45	£1.71
MB4	216	130	85	£5.19
MB5	150	100	60	£2.35
MB6	220	150	64	£3.95
MB7	177	120	83	£3.42
MB8	150	80	50	£2.22

All sizes are in millimetres

SPECIAL OFFER - PROJECT BOX

As above boxes
50 x 70 x 25mm
60p each 10 for £5.00

KEY SWITCH

3 Position keyswitch £2.35

CRYSTAL OSCILLATORS

4.0 mhz	ALL
7.5 mhz	£1.50 each
12.0 mhz	OR
18.432 mhz	4 FOR
33.33 mhz	£5.00

MICRO SWITCH roller arm operation spdt 40p each
MINIATURE TOGGLE SWITCHES

spdt	60p each	spdt 3 position c/off	70p each
dpdt	70p each	dpdt 3 position c/off	80p each
spdt biased	60p each	spdt 3 position c/off biased both ways	70p each
		dpdt 3 position c/off biased one way	80p each

MINIATURE TOGGLE SWITCH pcb mounting 3pdt 50p each 10 for £4.00

MINIATURE PUSH TO MAKE SWITCH 50p each

DIL RELAYS 5 volt dp/changeover 60p 10 for £5.00

12 volt dp/changeover 80p 10 for £6.00

RELAY 10 amp contacts sp/changeover 12 volt coil £1.20 each

CAR HORN RELAY in metal can with fixing lug, s/pole on

10 amp contacts £1.00 each 6 for £5.00

20 AMP RELAY dp on 12 volt coil £1.50 each 4 for £5.00

REED RELAY 12 volt 50p each 10 for £4.00

240 VOLT AC RELAY. 3-pole c/o 10 amp contacts £1.50 each 4 for £5.00

DIL SKTS		'D' CONNECTORS	
8 pin	10 for £0.60	plug	socket cover
14 pin	10 for £0.90	9 pin	30p 30p 35p
16 pin	10 for £1.00	15 pin	40p 40p 35p
18 pin	10 for £1.00	25 pin	50p 50p 40p
20 pin	8 for £1.00		
24 pin	8 for £1.00		
28 pin	6 for £1.00		
40 pin	5 for £1.00		

ALL COMPONENTS FULL SPECIFICATION DEVICES

SEMICONDUCTORS - TRANSISTORS - ICS - DIODES - REGULATORS - ETC

TIP31B	30p each	VOLTAGE REGS	7812/7805/7912/7905
TIP 3055	90p each		all 35p each, any 4 for £1.20
2N3055H	60p each	AD592An	Temperature Sensor i.c.
2N3771	£1.20 each		mounted on 1.5m screened
741 op-amp	25p each		lead complete with data and
555 timer ic	30p each		application notes £1.50 each
LM324 quad op-amp	30p each	LM3914/LM3915	Bargraph ics £2.95 each

MICRO IC'S - Z80A CPU £1.20; Z80A PIO £1.50; Z80B SIO-1 £4.00

OPTO DEVICES - LEDS - ETC

5mm rnd red/yellow/green/amber	10p each 12 for £1.00 any mix
5mm rnd high brightness red/green	20p each 6 for £1.00 any mix
5mm rnd flashing	red 60p each, yellow/green 70p each
5mm rnd bi-colour	35p each, tri-colour 45p each
LED mounted in chrome bezel red, yellow or green	30p each, 4 for £1
LED mounted in a black bezel red only	25p each, 5 for £1.00
PLASTIC BEZEL for 5mm rnd leds	10 for 40p
High brightness bi-colour i.e.d., rectangular, red/green, two leads	40p each

LCD DOT MATRIX GRAPHICS DISPLAY
made by Hitachi
part No. LM225
module size
270w x 150h x 13t (mm)
display area
239w x 104h
640 x 200 dots
data sheet supplied
ONLY £23.50

COOLING FANS - BRAND NEW!

230V a.c. 50/60Hz impedance protected	80mm x 80mm x 25mm	£6.96 each
115V a.c. 50/60Hz impedance protected	92mm x 92mm x 25mm	£5.25 each
24V d.c. brushless fan motor	2.9 watt 80mm x 80mm x 25mm	£5.25 each
12V d.c. brushless fan motor	0.15 amp 60mm x 60mm x 25mm	£6.96 each

PS68K/CPU-2B 68000 HIGH PERFORMANCE VMEBUS BASED MICROCOMPUTER BOARD

6800 CPU (8MHz), 246K Dual ported RAM expandable to 1 mega byte, Up to 32 kbyte eprom space, 8 bit status register, Fast multi-protocol comms Interface link, (RS232 compatible), VMEBUS INTERFACE, On-board single chip floppy disk controller, Real time clock, 24-bit parallel/0, Over 200 pages of data supplied **£88.50** each.

RESET TIMER PCB

Gives a timed relay closure following a momentary input. Requires 12V d.c. supply SP c/o relay output LED indication, 19 different time intervals from 25sec to 35min 20sec. £5.98 each.

ALARM CONTROL UNIT

Single zone alarm control unit built into a domestic light switch box. Ideal for home, caravan, boat, garage, shed etc.
Facilities:- Normally closed loop for pir sensors, door/window contact etc. Normally open loop for pressure mats.
SIREN
24-hour loop for personal attack button 12 volt dc for external use
Visual indication that the system is 115db £8.95 operational.
BELL BOX
Automatic ebrty/exit delay. A plastic box cover supplied with backplate. Red/yellow/white £8.99 each
Automatic system reset.
Alarm output cmos logic level.

PRICE COMPLETE WITH FULL INSTRUCTIONS £8.95
BELL/SIREN INTERFACE BOARD COMPLETE £3.95

ALARM CONTROL PANEL

★ Wire free alarm control panel, detectors communicate with the panel by means of radio transmitters ★ Speech synthesis for programming and general operating guidance ★ Built in user programmable telephone dialler ★ Up to 32 transmitters can be used ★ Programmable exit/entry and bell timers ★ Programmable user codes ★ Full installation data supplied, the only thing that has to be hardwired is the output to the siren/bell unit (not supplied). Please note we do not supply the transmitters but some information as to source of these will be included. ★ These control panels originally cost over £300.00 each. Yours for only **£49.92**

EX INSTALLATION SENSORS tested working.

Type 1. Measures 180 x 112 x 70mm with walk test led, relay output and tamper protection. 12 volt dc supply required **£8.50** each
Type 2. As above but a smaller unit 123 x 62 x 50mm **£11.75** each
Type 3. Ceiling mounting passive, infra red sensor 360° detection, 12V d.c. supply relay output, tamper circuit and pulse count option. Data supplied. **£15.70** each

DOOR/WINDOW CONTACTS

Surface or flush mounting, white £1.10 each
JUNCTION BOX
white 6 way 60p

Please note: There may be variations in the size of the above passive infra red sensors depending on stock at the time of ordering. But the unit will certainly be within the stated sizes.

DUAL TECH SENSOR Microwave and passive infra-red combined. Separate led indication for each function. Measures 120 x 75 x 50mm. 12 volt d.c. supply. Relay output. Tamper protection. **£29.95** each

BREADBOARDS - CAPACITORS - SOLAR CELLS - HEATSHRINK - ETC

SOLAR CELL 2 volt 150mA max, size 60 x 100mm £1.35 each 5 for £6
BNC SOCKETS 50 ohm single hole fixing 50p each 10 for £4.00
MIN BNC PLUG AND SOCKET 2 pairs for £1.50

MERCURY TILT SWITCH
Standard on/off £1.00 each
4 Contact (Directional) £1.50 each

PIEZO VIBRATION SENSOR
with data sheet £1.00 each

BREADBOARD
173 X 65mm 840TP £5.25 each
TEXT TOOL ZIF SOCKET
28 pin zero insertion socket £5.95 each
SOLID STATE RELAY
Switch mains up to 7 amp 12 volt control voltage. Data supplied. £2.95 each

6 VOLT NI-CAD PACK 5AA NI-CADS, fast charge type **£3.95**
CAPACITOR 10,000 mfd 25 volt with fixing clip 60p each
CAPACITOR 470 mfd 400 volt **£1.50** each 4 for £5.00
EPROMS 27C256 - 30 27C512 - 25. Once programmed but never used eprom. Mounted on a plastic carrier, can easily be removed from the carrier or used with a low insertion force socket.
27C256 £1.00 each 6 for £5.00 27C512 £1.20 each 5 for £5.00
Suitable low insertion force socket 28 pin 40p each 3 for £1.00
MULTITURN PRESETS 20mm RECT, 500R, 1K, 5K, 10K, 20K, 50K, 100K 1MO. 40p each, 3 for £1.00

CAR CIGAR LIGHTER ADAPTER (DUAL SIZE)
mounted on two metres of cable **£2.00** each

100db PIEZO SOUNDER

2KHZ note, 3-12V d.c. 40Ma, 45mm dia. x 26mm **£1.76** each

VIBRATION SENSITIVE ALARM BOARD WITH PIEZO SOUNDER

Originally a bike alarm. There is a short delay after activation then the piezo sounnder operates for a preset period. **£3.76** each

or the above alarm board with custom designed case, fixing clip and keyswitch **£9.95**

ENCAPSULATED TOROIDAL TRANSFORMER

prim. 0-120, 0-120 V; sec. 0-15, 0-15 V 50VA **£7.85**

INFRA-RED BREAK BEAM Transmitter and receiver p.c.b. with 2 lens assemblies. 12V d.c. supply. These are ex-installation units and are not guaranteed to be working. **£4.96** pair

ALUMINIUM DIE-CAST BOX 220mm x 145mm x 105mm deep **£7.64** each

RECHARGEABLE BATTERIES

AA (HP7) 600 mA AH £1.02 each C (HP11) 1200 mA AH £2.29 each

D (HP2) 1200 mA AH £2.40 each PP3 8.4V 100 mA AH £4.77 each

£1.00 BARGAIN PACKS

SUB-MINIATURE TOGGLE SWITCHES P.C.B. Mounting

- BO1 S.P. on 4 for £1.00
 BO2 D.P. on 3 for £1.00
 BO3 3 x D.P. 3 pos. centre off
 BO04 DIL SWITCHES 4-way S.P. on 3 for £1.00
 BO05 DIL SWITCHES 8-way S.P. on 2 for £1.00
 BO06 DIL SWITCHES 12-way 90° sp on 2 for £1.00
 BO07 12 x PP3 BATTERY SNAPS
 BO08 1 x CAPACITOR 1 FARAD 5.5 VOLT 20mm dia. x 7mm high
 BO09 INSTRUMENT KNOBS (0.25" SHAFT) High quality grey plastic knob, collet fixing 15mm dia, 5 for £1.00
 BO10 as above but 29mm dia, 3 for £1.00
 BO11 4 x MAGNETIC EARPIECE 8 ohm with 3.5mm plug
 BO12 4 x 28-WAY TURNED PIN DIL SOCKET
 BO13 15 x 12 VOLT WIRE-ENDED LAMPS
 BO14 8 x 2 PIN DIN PLUGS screw terminal connection
 BO15 2 x LIGHT DEPENDENT RESISTOR Less than 200 ohms in daylight, greater than 10 megohms in darkness
 BO16 1 x KEYPAD 20-key in 5 x 4 matrix bubble type switch contacts
 BO17 2 x PIEZO BUZZERS approx 3 to 20 volt d.c.
 BO18 5 x 78M12 VOLTAGE REGULATORS positive 12V 500mA
 BO19 4 x TL082CP bi-fet op-amps
 BO20 20 x ASSORTED LEDS full spec. varlous shapes and sizes
 BO21 3 x INFRA-RED DIODE TX/RX PAIRS made by Honeywell (no info)
 BO22 4 x CONSTANT CURRENT LED 5mm round, red 2-18V d.c. or a.c. nominal 14mA
 BO23 50 x IN4148 diode
 BO24 2 x INFRA-RED TRANSISTOR FPT5133
 BO25 5 x DIACS
 BO26 3 BDX33C 10 amp 100V npn transistor
 BO27 12 x 2N3702 Transistor
 BO28 12 x 2N3904 Transistor
 BO29 12 x BC337 Transistor
 BO30 4 x LM317T Variable regulator mounted on a small heatsink
 BO31 2 x MAN6610 2 digit 0.6" 7 segment display Com anode, amber
 BO32 3 x PHONO TO PHONO LEAD 63cm long
 BO33 15 x RECTANGULAR RED LEDs 6 x 6 x 2mm stackable
 BO34 1 x PHOTO SENSITIVE SCR mounted on a PCB, data sheet supplied
 BO35 4 x IEC Panel Mounting Mains Plug Snap fix
 BO36 5 x ASSORTED PIEZO TRANSDUCERS
 BO37 5 LENGTHS OF HEATSHRINK SLEEVING 8mm dia. 400mm long
 BO38 25 x CERAMIC DISC CAPACITORS 0.1 mfd 63V
 BO39 15 x MONOLITHIC CERAMIC CAPACITORS 0.1 mfd 63V, in a dil package
 BO40 25 x ASSORTED ELECTROLYTIC CAPACITORS PCB mounting useful values
 BO41 25 ASSORTED PRE-SET RESISTORS
 BO42 8 x 3-5mm LINE JACK SOCKETS (mono)
 BO43 8 x 3-5mm JACK PLUG (mono)
 BO44 8 x 3-5mm CHASSIS SOCKET (mono)
 BO45 2 x TRIACS 800 volt 8 amp
 BO46 12 x BC213L Transistor
 BO47 12 x MIN SLIDE SWITCH dpdt
 BO48 15 x MIN CERMET TRIMMER POTS (good range of values)
 BO49 1 x PCB WITH TWO LARGE LEDES 15mm square, one red and one green
 BO50 1 x 12V DC RELAY 4-pole c/o with plug in base
 BO51 4 x LM324 quad op-amps
 BO52 4 x 555 Timer
 BO53 5 x 741 op-amp
 BO54 25 x IN4001 diode
 BO55 20 x IN4007 diode
 BO56 1 x SLOTTED OPTO
 BO57 1 x DAC08 Digital to analogue convertor with data
 BO58 4 x OPTO ISOLATOR
 BO59 20 ASSORTED 74LS IC'S

Please use order code when ordering the bargain packs.
 Please make cheques and postal orders payable to Mailtech.

All prices include VAT.
 Please add 75p postage to all orders

At the moment it is not possible to have a full telephone answering service. But we will have the phone definitely manned on Tuesdays, Wednesdays and Thursdays between 10am and 5pm.

**Dept EE, Mailtech
 PO Box 16 Ludlow
 Shropshire SY8 4NA
 Tel: 058 474475**



UK DISTRIBUTOR AND STOCKIST FOR THE COMPLETE ILP RANGE

- ★ AMPLIFIER MODULES
- ★ PRE-AMPLIFIERS
- ★ 100V LINE TRANSFORMERS
- ★ TOROIDAL TRANSFORMERS
- ★ LIGHTING TRANSFORMERS

*Write, phone or fax
for data and prices*

Jaytee Electronic Services

143 Reclver Road, Beltinge, Herne Bay, Kent CT6 6PL
 Telephone: (0227) 375254. Fax: (0227) 365104

PLASTIC BOXES



A RANGE OF SMALL PLASTIC BOXES,
 CASES AND POTTING BOXES AVAILABLE
 IN ANY QUANTITY.

SEND FOR FREE CATALOGUE

**SLM (MODEL) ENGINEERS
 CHILTERN ROAD, PRESTBURY,
 CHELTENHAM, GLOS GL52 5JQ
 FAX: 0242 226288**

TELEPHONE
ORDERS
may be made on
(0442)
66551
ACCESS or VISA



PCB Service June

Price code	Price (inc. VAT)
C	£1.80
D	£2.50
E	£3.25
F	£4.00
G	£4.75
H	£5.50
J	£6.62
K	£7.20
L	£8.80
M	£10.60
N	£13.10
O	£15.80
P	£17.90
Q	£21.80
R	£23.90
S	£25.90
T	£29.00
U	£32.20
V	£35.80
W	£37.90
X	£40.70

E9306-1	Graphic Equaliser (Double Sided)	F
E9306-2	Super Spooker	H
E9306-3	Middle and Side Stereo Coding (Crossing the Great Divide)	D
E9306-FC	The Chaperon	F

PCBs for the remaining projects are available from the companies listed in Buylines.
Use the form or a photocopy for your order. Please fill out all parts of the form. Make sure you use the board reference numbers. This not only identifies the board but also tells you when the project was published. The first two numbers are the year, the next two are the month.
Terms are strictly payment with order. We cannot accept official orders but we can supply a proforma invoice if required.
Such orders will not be processed until payment is received.

E9112-7	Power On and Overload Regulator	P	E9207-1	Improved Rear Bike Lamp	D
E9201-1	Laboratory Power Supply	F	E9207-2	Mini Baby Bug Monitor	C
E9201-2	Test Card Generator Board	M	E9207-3	Ultrasonic Audio Sender (2 boards)	H
E9201-3	LED Star (2 sided)	L	E9207-4	Camera Add-on unit (4 boards)	O
E9201-4	Enlarger Timer Main PCB (2 sided)	N	E9207-5	AutoMate 5V/48V Mixer power supply	J
E9201-5	Enlarger Timer Selector Board (2 sided)	K	E9207-6	AutoMate Precision 17V power supply	J
E9201-6	Enlarger Timer Switch PCB	E	E9207-FC	Surround Sound Decoder	F
E9203-1	MIDI Switcher- Main Board	L	E9208-1	Dynamic Noise Limiter	F
E9203-2	MIDI Switcher- PowerSupply	E	E9208-2	Touch Controlled Intercom (2 boards)	H
E9203-3	Sine Wave Generator (surface mount)	F	E9208-3	MIDI Keyboard	K
E9204-1	Auto Car Lights	F	E9208-FC	Battery charger	F
E9205-1	Bat Detector	E	E9209-1	Intercom for light aircraft	H
E9205-2	Pond Controller	F	E9209-2	Alarm protector	C
E9206-FC	Stereo amplifier	G	E9209-3	Temperature controller	M
E9206-2	Xenon flash trigger Main Board	J	E9209-FC	45W Hybrid power amp	F
E9206-3	Xenon flash trigger Flash Board	F	E9210-1	Universal I/O Interface for PC (2 Sided)	N
E9206-4	Scanner for audio generator	D	E2910-2	Rapid Fuse Checker	E
			E9210-3	Heartbeat/Audio Listener	E
			E9210-FC	Wizards Hat	E
			E9211-1	Electronic Die	E
			E9211-FC	Car Alarm	F
			E9212-1	Digital Circuit Tester	F
			E9212-2	Communications Link by RS232	L
			E9212-FC	Mains Inverter	E
			E9301-2	Fading Festoonery	G
			E9301-FC	Infra Red Receiver	F
			E9302-1	EPROM Programmer (2 Sided)	N
			E9302-2	Sound to MIDI Board	L
			E9302-3	Puddle Tec	E
			E9302-4	DiscoAmiga Light Selector	H
			E9302-FC	Infra Red Transmitter	F
			E9303-1	Ni-Cd Battery Charger	E
			E9303-2	IC Tester	E
			E9303-3	Disco Amiga (motor driver board)	H
			E9303-4	Direct Conversion Receiver (2 Sided)	N
			E9303-FC	LFD Stoboscope	F
			E9304-1	Solo Mic Pre-Amplifier	F
			E9304-2	Multimate Tester	C
			E9304-3	The Keepsafe Alarm	F
			E9304-4	Proving Unit	E
			E9304-5	Infra Guide Receiver Module	C
			E9304-6	Infra Guide Transmitter	F
			E9304-FC	(AutoMate) Peak Program Meter	F
			E9305-1	Pentacode Main Board	F
			E9305-2	Pentacode Relay Board	F
			E9305-3	Radio Control Trafficators	D
			E9305-4	Vibration Detector	D
			E9305-FC	The Fuzztone	E

**ETI PCB Service, Reader's Services, Argus House,
Boundary Way, Hemel Hempstead HP2 7ST**

Please Supply:

Quantity	Ref No.	Price Code	Price	Total Price
	E		£	£
	E		£	£
	E		£	£
Post & Packing				£ 0.75
Total Enclosed				£

Please send my PCBs to:

Name

Address

.....

.....

..... Postcode

CHEQUES SHOULD BE MADE PAYABLE TO ASP Ltd.



PCB Foils

The PCB foil patterns presented here are intended as a guide only. They can be used as a template when using tape and transfer for the creation of a foil.

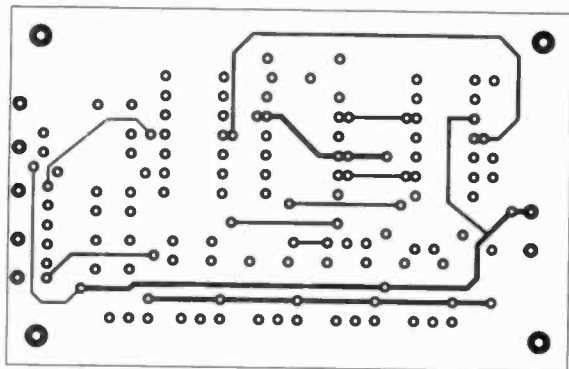

Graphic Equaliser (Component Side)

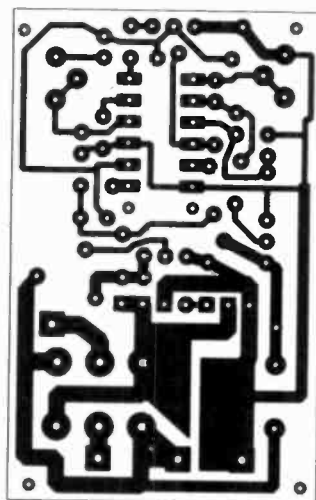

RC Speed Controller

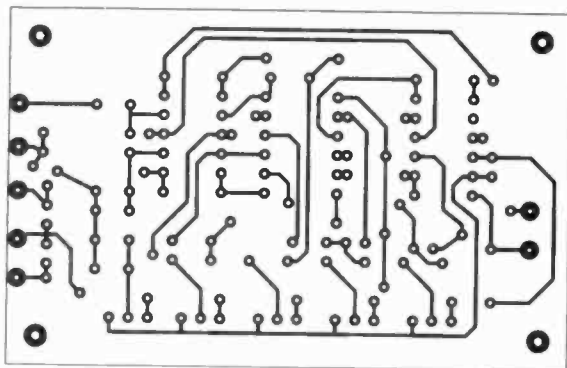

Graphic Equaliser (Solder Side)

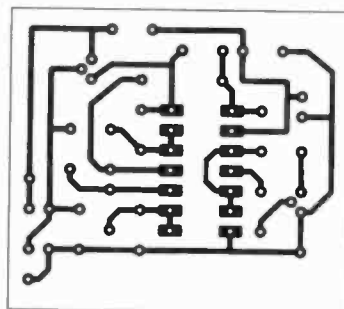

Super Spooker

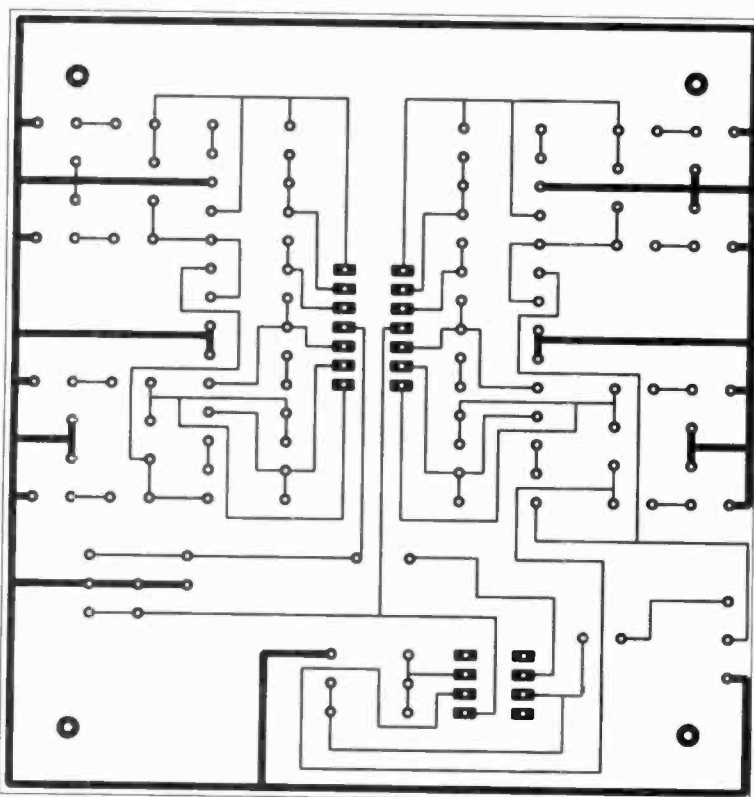

Middle & Side Stereo Coder



Infra Guide Part 2 May '93

Vcc should be added to pin of IC5 and junction of R17 and R20 in Fig.2. Q10 should be shown as a PNP device. Page 51 second column and page 53, all references to ...greater than 4V should read greater than 1V and last but one line, page 51 should read ...voltage at pin K

Page 52 column 2 line 10. Replace ...If this is OK.. with ..If no frequency is present, .. Fig.5 should read . 3276800Hz by 66842.

Fuzztone May '93

Fig.2 circuit diagram should show the bottom of R6 connected to the junction of R9/C6 and not R8. The component overlay is correct.

LOW COST RANGER 1 PCB DESIGN FROM SEETRAX

- **Circuit Schematic**
- **Circuit Capture**
- **PCB Design**
- **Host Of Outputs**



WHAT THE PRESS SAID ABOUT RANGER 1

For most small users, Seetrax Ranger 1 provides a sophisticated system at an affordable price. It is better than Easy PC or Tsien's Boardmaker since it provides a lot more automation and takes the design all the way from schematic to PCB - other packages separate designs for both, that is, no schematic capture. It is more expensive but the ability to draw in the circuit diagram and quickly turn it into board design easily makes up for this.

Source JUNE 1991
Practical Electronics

ALL-IN-ONE DESIGN SYSTEM.....£100

FULLY INTEGRATED AUTO ROUTER.....£50

Ask about trade-in Deals! Call Now For Demo Disk on 0705 591037



Seetrax CAE, Hilton Daubnay House, Broadway Lane, Lovedean, Hants. PO8 0SG. TEL. 0705 591037. FAX. 0705 599036

READER OFFER

Set of four tweezers Only £6 inc p&p

The answer to the common question of 'how do you do such fiddly work with big fingers?' is generally that you don't. If a hobbyist has to be the master of his knife, he must also be a virtuoso with his tweezers. A selection of good quality tweezers is an absolute must!

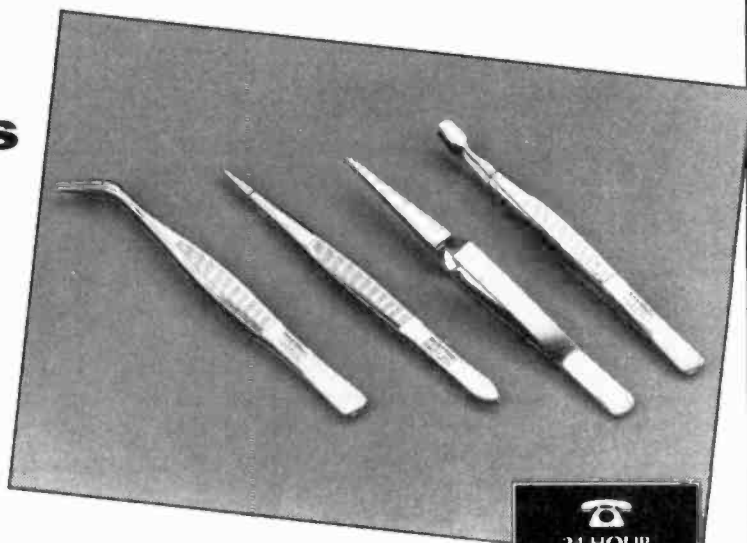

24 HOUR
CREDIT CARD
HOTLINE
0442 66551

COUPON

Please supplyROSM/9 Set of four tweezers @ £6 inc p&p. I enclose my cheque/P.O. for £ made payable to ASP or please debit my Access/Visa

SIGNATURE EXPIRY DATE

Name Address

Post Code

Send coupon to :

ASP Readers Offers, Argus House, Boundary Way, Hemel Hempstead, Herts, HP2 7ST. Please allow 28 days for delivery U.K. only - Overseas upon request. Please the above information may be used for marketing purposes.

ETI Classified



James Gale
0442 66551

Send your requirements to:
ETI Classified Department, ASP, Argus House,
Boundary Way, Hemel Hempstead, HP2 7ST
Lineage: 60p per word (+VAT) (minimum 15 words)
Semi display: (minimum 2.5cms)
£15.00 per single column centimetre (+VAT) } Per
Electromart £24.00 (+VAT) } Insertion



Ring for information on series bookings/discounts.
All advertisements in this section must be prepaid.
Advertisements are accepted subject to the terms and conditions
printed on the advertisement rate card (available on request).

FOR SALE

COOKE INTERNATIONAL
SUPPLIER OF QUALITY USED TEST INSTRUMENTS
ANALYSERS, BRIDGES, CALIBRATORS, VOLTMETERS,
GENERATORS, OSCILLOSCOPES, POWER METERS, ETC
ALWAYS AVAILABLE

ORIGINAL SERVICE MANUALS FOR SALE
COPY SERVICE ALSO AVAILABLE

EXPORT, TRADE AND U.K. ENQUIRIES WELCOME
SEND S.A.E. FOR LISTS OF EQUIPMENT AND MANUALS ALL
PRICES EXCLUDE VAT AND CARRIAGE
DISCOUNT FOR BULK ORDERS SHIPPING ARRANGED

OPEN MONDAY TO FRIDAY 9AM - 5PM
ELECTRONIC TEST & MEASURING INSTRUMENTS
Unit Four, Fordingbridge Site, Main Road, Barnham, Bognor Regis,
West Sussex, PO22 0EB
Tel (+44) 0243 545111/2 Fax +44) 0243 542457

N.R. BARDWELL LTD (ETI)

200 Signal diodes 1N4148	£1.00	20 24-way turned pin IC sockets	£1.00
75 Rectifier Diodes 1N4001	£1.00	16 40 pin d.i.l. wire wrap IC sockets	£1.00
50 Rectifier Diodes 1N4007	£1.00	2 ORP12 light dependent resistors	£1.00
56 Rectifier Diodes 1N5401	£1.00	200 Printed circuit board 20mm fuse clips	£1.00
100 Asstd Zeners	£1.00	200 Asstd. disc ceramic capacitors	£1.00
10 NE555 Timer ICs	£1.00	80 Asstd. capacitors 1nf to 1uf	£1.00
8 C108D 400V 6 amp thyristors	£1.00	80 Asstd. electrolytic capacitors	£1.00
8 BY51 Transistors	£1.00	80 4.7UF 18V Radial electrolytics	£1.00
30 BC478 Transistors	£1.00	75 4.7UF 63V Radial electrolytics	£1.00
30 MPSA42 Transistors	£1.00	80 10UF 16V Radial electrolytics	£1.00
30 SMM Red LEDs	£1.00	80 10UF 50V Radial electrolytics	£1.00
25 Asstd. high brightness LEDs	£1.00	80 22UF 25V Radial electrolytics	£1.00
24 Miniature red LEDs 3mm dia	£1.00	80 33UF 16V Radial electrolytics	£1.00
50 Axial LEDs (Diode package) wide angle	£1.00	80 100UF 10V Radial electrolytics	£1.00
12 Asstd. seven segment displays	£1.00	50 47UF 50V Radial electrolytics	£1.00
30 Asstd. I.F. transformers	£1.00	50 220UF 16V Radial electrolytics	£1.00
48 Asstd. coil formers	£1.00	60 470UF 10V Radial electrolytics	£1.00
100 Asstd. RF chokes (inductors)	£1.00	12 1000UF 10V Radial electrolytics	£1.00
30 Asstd. connectors edge-dill-sil etc	£1.00	1 1 Farad 5.5V memory back up capacitor	£1.00
10 4P 3W 4WB min rotary switches	£1.00	1 Pellet effect heat pump	£1.95
20 1 inch Glass reed switches	£1.00	1 10 watt Stereo amplifier, 4 controls plus data	£2.95
20 Magnetic reed pipe plus lead & plug	£1.00		
20 Min SP/CO slide switches	£1.00		
30 Asstd. I sockets up to 40 pin	£1.00		

Prices include VAT, postage £1.25. Stamp for Lists
288 Abbeydale Road, Sheffield S7 1FL
Phone (0742) 552886. Fax (0742) 500689

VARIABLE VOLTAGE TRANSFORMERS

INPUT 220/240V AC 50/60
OUTPUT 0-280V

Output	Price	P&P
0.5KVA 2.5 amp max	£29.00	£4.66
1KVA 5 amp max	£37.40	£6.26
2KVA 10 amp max	£54.00	£7.80
3KVA 15 amp max	£71.50	£7.80
5KVA 25 amp max	£126.50	

(Plus Carriage)
Buy direct from the Importers. Keenest prices in the country

COMPREHENSIVE RANGE OF TRANSFORMERS-LT-ISOLATION & AUTO
(110-240V Auto transfer either cased with American socket and mains lead or open frame type. Available for immediate delivery)

ULTRA VIOLET BLACK LIGHT FLOURESCENT TUBES

4ft 4 watt £12.00 (callers only)	(£14.10 inc VAT)
2ft 20 watt £7.44 + £1.26 p&p	(£10.21 inc VAT)
13in 10 watt £5.80 + 75p p&p	(£6.82 inc VAT)
12in 8 watt £4.80 + 75p p&p	(£5.24 inc VAT)
9in 6 watt £3.96 + 50p p&p	(£4.24 inc VAT)
6in 4 watt £3.96 + 50p p&p	(£4.24 inc VAT)

230V AC BALLAST KIT
For either 6in, 9in or 12in tubes £5.50 + £1.15 p&p (£7.81 inc VAT)
For 13in tubes £6.00 + £1.35 p&p (£8.64 inc VAT)

400 WATT UV LAMP
Only £34.00 + £2.50 p&p (£42.89 inc VAT)

180 WATT SELF BALLASTED BLACK LIGHT MERCURY BULB
Available with BC or ES fitting price inc VAT & p&p and VAT £28.86

12V D.C. BILGE PUMPS
500 GPH 1 1/2" head 3 amp £18.21
1750 GPH 1 1/2" head 3 amp £31.73
Also now available 24V D.C. 1750 GPH 1 1/2" head 5 amp £32.90. All designed to be used submerged. PRICES INCLUDE P&P & VAT

EPROM ERASURE KIT
Build your own EPROM ERASURE for a fraction of the price of a made-up unit kit of parts less case includes 12in 8 watt 2537 Argus Tube Ballast unit pair of bi-pin leads, neon indicator, on/off switch, safety microswitch and circuit £14.00 + £2.00 p&p (£16.80 inc VAT)

SUPER MY-LIGHT STROBE KIT
Designed for Disco, Theatrical use etc.
Approx. 16 joules. Adjustable speed £80.00 + £3.00 p&p (£83.28 inc VAT)
Case and reflector £24.00 + £3.00 p&p (£31.73 inc VAT)
S.A.E. for further details including My-Light and industrial Strobe Kits

"BOFFINS SPECIAL" -- UNIQUE OFFER

Surplus Precision Medical Unit, internally in excellent condition. Designed primarily to eject a precise controllable amount of fluid from a medical syringe (letter not supplied). Contains the following removable components: Dual Micro Processor Boards and EPROMS Escap Precision 12V DC Motor with 300:1 Gear Box and optical encoder coupled to a precision threaded drive mechanism. Mains supply with 6 x 1.5V Ni-Cad AA cells back-up L.C.D. Digital read-out 17mm high with legends. Audible warning.

These are sold for the dismantling of the exceptional quality components. Regret no Circuits available. Reluctantly low price. £18.00 + £4.00 p&p (£23.50 incl VAT)

WIDE RANGE OF XENON FLASH TUBES
Write/Phone your enquiries

12V O.C. GEARED MOTOR
12V D.C. Reversible precision-built Motor Output speeds no load approx. 12V-28 rpm. 9V-20 rpm. 6V-12 rpm. Will work at lower voltages and still retain a reasonable torque. Ideal for robotics etc. Size: L. 40mm W. 29mm H. 38mm. Shaft: 3mm dia x 10mm long Price: £8.00 + 50p p&p (£10.00 inc. VAT)

TORIN CENTRIFUGAL BLOWER
230V AC, 2.800 RPM, 0.9 amp, 130mm diameter, impeller outlet 83 x 37mm, overall size 196 x 180 x 180mm long Price: £17.60 + £2.60 p&p (£23.80 inc. VAT)

SOLID STATE RELAY
7 amp x 240V A.C. when mounted on suitable Heat-sink. Can be driven from T.T.L. or Computer output between 3-10V D.C. Size: 24mm x 17mm x 15mm high. Fixing centres 30mm (TO-3) Price: £3.00 + 40p p&p (£4.00 inc VAT)

GEARED MOTORS
71 RPM 20lb inch torque reversible 115V AC input including capacitor and transformer for 240V AC operation. Price inc VAT & p&p £23.80.

SOLID STATE HYUNT
Input 230/240V AC Output approx 15KV Producing 100mm spark. Built-in 10 sec timer. Easily modified for 20 sec, 30 sec to continuous. Designed for boiler ignition. Dozens of uses in the field of physics and electronics, eg supplying neon or argon tubes etc. Price less case £8.80 + £2.40 p&p (£12.81 inc VAT) NIMS

SAVE POUNDS!!!
Build your own forged bank note detector. Can detect counterfeit amongst a quantity of notes. Complete kit of parts less case 240V a - including 5" uv black light tube, starter and holder, a pair b1 pin tube holders. Total price including p&p & VAT only £13.06

RHEOSTAT
50W 2 ohm 5 amp ceramic power rheostat price inc VAT & p&p £10.61

MICROSWITCH
Pye 15 amp changeover lever microswitch, type S171 Brand new price 5 for £7.05 inc VAT & p&p

TECHNICAL & SCIENTIFIC SUPPLIES

- Professional second user equipment.
- Components
- Special spares
- Transducers
- Instrumentation
- Professional Consultancy

Please write, phone or fax anytime
PO Box 19, Hythe, Southampton, Hampshire SO4 6XQ.
Tel. 0703 848666 Fax. 0703 897079

CATALOGUE £1.00 + 25p P&P

LEDs 3mm or 5mm - red or green 6p each yellow 11p each
High intensity red, green or yellow 5mm 30p each
Cable leads 1p each £5.95 per 1000 £49.50 per 10 000
Stepping motor 4 phase 12v 7.5 step 50 ohms £8.95
SA11027 stepping motor driver chip £3.95
FM Transmitter kit good quality sound £8.80
High quality photo resist copper clad epoxy glass boards

Dimensions	single sided	double sided
3x4 inches	10.95	£1.07
4x6 inches	£2.40	£2.68
6x12 inches	£5.37	-
12x12 inches	£10.66	-

Special Offers
Computer grade capacitors with screw terminals 38000uf/20v £2.50
87000uf 10v £1.95 58000uf 15v £2.95 10000uf 16v £1.50
7 segment common anode led display 12mm £2.45
LM331A 15.0 low drop out 5v regulator 10220 package £2.95
BS250 P channel mosfet £0.45 BC559 transistor £3.95 per 100
74LS05 hex inverter £10.00 per 100 used 8748 Microcontroller £3.50
TV Mains switch 4A double pole with momentary contacts for remote control pack of 10 £3.95 box of 60 £19.95
D.C. DC converter R184bly model V12PS 12v in 5v 200ma out 300v input to output isolation with data £4.95 each or pack of 10 £39.50
Hour counter used 7 digit 240v ac 50Hz £1.45
Resistor pack 2500 resistors 1/8W 50 different values £2.95
QWERTY keyboard 58 key good quality switches new £5.00
QWERTY keyboard with serial output no data (used) £5.00
Wide range of CMOS TTL 74HC 74F Linear Transistors kits
rechargeable batteries capacitors tools etc always in stock. Please add 95p towards P&P vat included

JPG ELECTRONICS
276-278 Chateaufort Road Chateaufort S40 2BH
Access/Visa Orders (0246) 211202 callers welcome

AUDIOAMPS!! 50w MOSFET - MODULE £4 + REGULATED PSU/240V £10 - Rack £14. Ideal for P.A. -Disco!! K.I.A. 1 Regent Rd, Ilkley. Stereoamps / £10 - Catalogue £1 + Free PSU

SECOND HAND MEGURO MAK/651 AUDIO ANALYSER £400 ono. SECOND HAND PHILLIPS PM 6307 wow and flutter meter £60 ono Telephone 06487 48669

EX-EQMT PCB includes dual 4 1/2 Digit LCD (backlit) with 2X1CL7224 counter chips, incl P&P Tel: 0394 670320

FOR SALE

HOME AUTOMATION

LAMP MODULE Plugs in to wall socket to control incandescent lamps up to 300W Responds to ON/OFF/DIM/BRIGHT commands from controllers. LM565 £22.45

MINI TIMER Timed control of up to 4 modules twice a day. Also features direct ON/OFF/DIM/BRIGHT control plus clock functions MT522 £29.95

ENERLOGIC 1400e Controller

The first intelligent home automation system. A remarkable hardware + software package that adds brains to the range of X-10 modules and controllers. £349.95

UNDERSTANDING & INSTALLING HOME SYSTEMS, How to Automate Your Home

The best practical guide to date for the home automation enthusiast. Packed full of advice and ideas on installing home systems and equipment. 140 pages and 120 illustrations of the most up to date data on home automation. £22.95

Part of a remarkable range of home automation components from
SMART HOUSE SYSTEMS LTD
3 Buchanan Street, Largs, Ayrshire KA30 8PP
Tel: 0475 672589

SYSTEM 200 DEVICE PROGRAMMER

SYSTEM Programs 24, 26, 32 pin EPROMS, EE-PROMS, FLASH and Emulators as standard, quickly, reliably and at low cost.

Expandable to cover virtually any programmable part including serial E², PALS, GALS, EPLD's and microcontrollers from all manufacturers.

DESIGN Not a plug in card but connects to the PC serial or parallel port; it comes complete with powerful yet easy to control software, cable and manual.

SUPPORT UK design, manufacture and support. Same day dispatch, 12 month warranty. 10 day money back guarantee.



ASK FOR FREE INFORMATION PACK



MQP ELECTRONICS Ltd.
Unit 2, Park Road Centre,
Malmesbury, Wiltshire, SN16 0BX UK

TEL. 0666 825146 FAX. 0666 825141



GERMANY 089/4602071
NORWAY 071-17890
ITALY 02 92 10 3554
FRANCE (1) 69.41.28.01
Also from VEROSPEED UK

A & L SYSTEMS LTD.

If your looking for a supplier with the following -

A Massive Range of Electrical and Electronic Components, Systems, All Aimed at the Professional and Hobbyist Markets along with Very Competitive Prices, First Class Service and Response then -

LOOK NO FURTHER

For Batteries and Accessories, Boxes and Equipment Housings, Cables, Capacitors, Connectors, Electrical and Security Products, Filters and Suppressors, Fuses and Circuit Breakers, Hardware, Optoelectronics, Power Supplies, Relays, Resistors, Semiconductors and Hardware, Switches, Telecomms, Tools, Transformers, etc.

For Detailed Listings Send /1.25 to -

7 West Street, West Butterwick, Scunthorpe, Sth Humberside. DN17 3JZ

KITS

HEATHKIT. U.K. spares and service centre/Educational Products Distributor. Cedar Electronics, 12, Isbourn Way, Winchcombe, Cheltenham GL54 5NS Tel. (0242) 602402.

NEW VHF MICROTRANSMITTER KIT tuneable 70-115MHz, 500 metre range, sensitive electret microphone, high quality PCB, SPECIAL OFFER complete kit ONLY £5.95 assembled and ready to use £9.95 inclusive P&P. 3 Watt FM transmitter kit £15.95 Credit card orders telephone 021 486 3092 Cheques/PO's to: Quantek Electronics, (DEPT ETI) 3 Houldey Rd, Birmingham, B31 3HL. Send 2 x 1st Class stamps for details of these and other kits.

ADVERTISE YOUR KITS TELEPHONE 0442 66551

TO ADVERTISE TELEPHONE JAMES GALE ON 0442 66551

WANTED

WANTED RE-USABLE AND ALL TYPES OF ELECTRIC SCRAP

P.C.B's, PLUGS AND SOCKETS, EDGE CONNECTIONS, TEST EQUIPMENT, VALVES, ETC. PAID ON CLEARANCE.

A.R.S.
2 NORMANS LANE, RABLEY HEATH, WELWYN, HERTS AL6 9TO
TEL: 0438 812193 FAX: 0438 812387 MOBILE: 0860 214302

TURN YOUR SURPLUS TRANSISTORS, IC'S ETC INTO CASH immediate settlement. We also welcome the opportunity to quote for complete factory clearance.

Contact:
COLES-HARDING & CO.
Sandall Road, Wisbech, Cambs PE13 2PS
BUYERS OF SURPLUS INVENTORY ESTABLISHED OVER 15 YEARS
Tel: 0945 584188
Fax: 0945 475216

COURSES

Start training now for the following courses. Send for our brochure — without obligation or Telephone us on **0626 779398** ETI/693

- | | |
|------------|---|
| Name _____ | <input type="checkbox"/> Telecomms Tech C&G 271 |
| _____ | <input type="checkbox"/> Radio Amateur Licence C&G |
| _____ | <input type="checkbox"/> Micro-processor |
| _____ | <input type="checkbox"/> Introduction to Television |

Radio & Telecommunications Correspondence School
12 Moor View Drive, Teignmouth, Devon TQ14 9UN

SURPLUS STOCK

ASTEC LOW VOLTAGE POWER SUPPLIES:

- 36 to 100 watt from £15.00
- STORAGE DEVICES:**
- 3.5 Internal 720k Floppy Drives
- 5.25 External 360k Floppy Drives
- Internal tape Streamers, half-height

ADAPTERS:

- 8/16 Bit SCSI Cards
- Graphics Adapters 1MB on board
- FANS, SWITCHES, PLUGS, etc...**

Stock constantly changing, phone/fax for latest and/or full stock list
Call: 081 441 4189
or Fax: 081 364 9495

AD TECHNOLOGY LIMITED



46 Salisbury Road,
Barnet, EN5 4JN

Falcon DIY SPEAKERS

Send for our FREE price list PL21 All we ask for is a large S.A.E (34p stamp) or \$2 bill (Air) overseas (Europe - 3 International reply coupons) SYSTEM DESIGNS (Total Kits) Focal, KEF Constructor, Seas, etc DRIVE UNITS FOCAL, KEF, Audax, Coles, Peerless, Seas, Siare, Elac Metal Dome, Scanpeak, etc

Also Group/Disco Units CROSSOVER NETWORKS - Active & Passive Components, Accessories, Polypropylene Caps AUDIO AMATEUR PUBLICATIONS BACK ISSUES Speaker Builder, Audio Amateur & Glass Audio, L/S Cookbook - books

Full details from **FALCON ELECTRONICS** (Dept E.T.I.) Tabor House, Mulbarton, Norfolk NR14 8JT (0508) 78272 (Proprietors: Falcon Acoustics Ltd.)



EDITORIAL

Editor *Paul Freeman*
Sub Editor *Jim Bluck*

CREATIVE

Art Editor *Peter Kirby*
Designer *Iain Houston*
Technical Illustration *John Puczynski*
Photography *Manny Cefai*

ADVERTISEMENT SALES

Advertisement Manager
Mark Linacre
Advertisement Sales
Tony Hill
Advertisement Copy Control
Marie Quilter
Key Accounts Manager
Donna Wells

MANAGEMENT

Managing Director
Terry Pattison
Circulation & Promotions Manager
Debra Stupple
Production Manager
Tony Dowdeswell
Group Editor
Stuart Cooke
Group Advertisement Manager
Claire Jenkinson



ISSN
0142-7229

ETI is normally published on the first Friday in the month preceding the cover date. The contents of this publication including all articles, plans, drawings and programs and all copyright and all other intellectual property rights therein belong to Argus Specialist Publications. All rights conferred by the Law of Copyright and other intellectual property rights and by virtue of international copyright conventions are specifically reserved to Argus Specialist Publications and reproduction requires the prior written consent of the company ©1990 Argus Specialist Publications. All reasonable care is taken in the preparation of the magazine contents, but the publishers cannot be held legally responsible for errors. Where mistakes do occur, a correction will normally be published as soon as possible afterwards. All prices and data contained in advertisements are accepted by us in good faith as correct at the time of going to press. Neither the advertisers nor the publishers can be held responsible, however, for any variations affecting price or availability which may occur after the publication has closed for press.

● Subscription rates...UK £23.40 Europe £29.50 Sterling Overseas £31.00 US Dollars Overseas \$59.00

Published by Argus Specialist Publications, Argus House, Boundary Way, Hemel Hempstead HP2 7ST. Telephone (0442) 66551. UK newstrade distribution by SM Distribution Ltd, 6 Leigham Court Road, London SW16 2PG. Telephone 081-667 8111. Overseas and non-newstrade sales by Magazine Sales Department, Argus House, Boundary Way, Hemel Hempstead, HP2 7ST. Telephone (0442) 66551. Subscriptions by Argus Subscription Services, ETI, Queensway House, 2 Queensway, Redhill, Surrey RH1 1QS. US subscriptions by Wise Owl Worldwide Publications, 4314 West 238th Street, Torrance, CA90505 USA. Telephone (310) 375 6258. Typesetting and origination by Ebony, Liskeard, Cornwall. Printed by Wiltshire Ltd, Bristol.



Argus House, Boundary Way,
Hemel Hempstead HP2 7ST
Telephone (0442) 66551 Fax (0442) 66998

Next Month

With ETI rapidly moving into summer, we have many projects and feature articles lined up for you. Microwave ovens can be very safe and economical to use, but it's often assumed that they will go on working safely and efficiently for ever. As a safety precaution, it would be wise to check every so often, the front door is not leaking harmful radiation. Our cover PCB project next month, a microwave monitor, could help to provide this service.

We present a feature article and design project on how a hands-free telephone works, channel switching for radio-controlled models, more on that ever popular topic surrounding biofeedback with a project called a 'Mind Trainer' and finally a car battery tester. This last project also emphasizes the need to keep a check on another piece of often neglected technology.

Find out more in the July edition of ETI, out in your newsagents on June 4th.

The above articles are in preparation but circumstances may prevent publication

Last Month

Our May issue featured:

- The Fuzztone
- Pentacode Lock
- Moving Coil Meters Part 2
- Radio Control Trafficators
- AutoMate Mixer PPM
- Low Voltage Circuits
- Infra-red Remote Controlled Telescope
- Vibration Detector

Back issues can be obtained from Argus Subscription Services. Address in column to left.

ADVERTISERS' INDEX

AUTONA	15	J&N BULL	58,59
BK ELECTRONICS	IFC	JAY TEE ELECTRONICS	57
BAAS ELECTRONICS	11	JPG	35
BADGER BOARDS	23	MAIL ELECTRONICS	20
BONEX	38	MAILTECH	56,57
CANAL BRIDGE AUDIO	24	MAPLIN ELECTRONICS	0BC
CHELMER VALVE Co.	31	NUMBER ONE SYSTEMS	IBC
CIRKIT	55	OMNI ELECTRONICS	35
CP TECHNOLOG*	20	PICO TECHNOLOGY	15
CRICKLEWOOD ELECTRONICS	9	RN ELECTRONICS	55
DEVAN TECH	24	SEETRAX	62
DISPLAY ELECTRONICS	25	STEWARTS OF READING	15
EQT	55	TELNET	23
HALCYON ELECTRONICS	24	WILMSLOW AUDIO	55
HESING TECHNOLOGY	35		

Electronic Designs Right First Time?

From Schematic Capture -

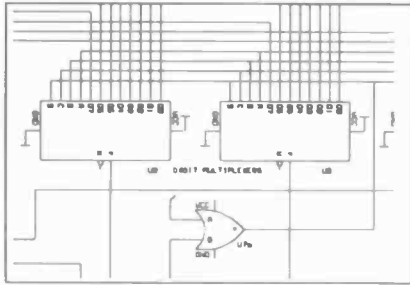

EASY-PC Professional

Create your schematics quickly and efficiently on your PC using EASY-PC Professional. Areas of the circuit can be highlighted on screen and simulated automatically using our PULSAR, ANALYSER III and Z-MATCH II simulation programs.

through Analogue and Digital Simulation -

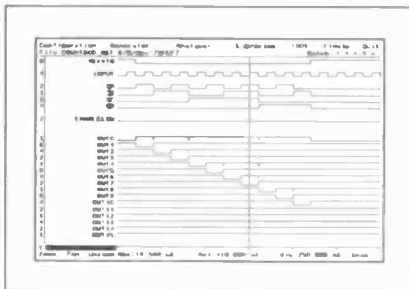

PULSAR

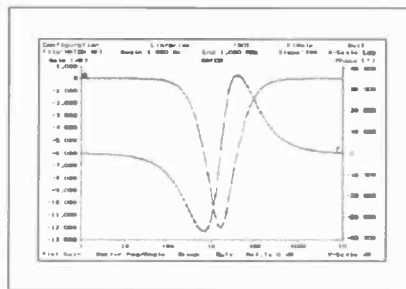

ANALYSER III

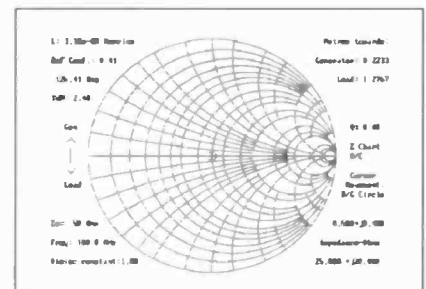

Z-MATCH II

If the results of the simulations are not as expected, the configuration and component values of the circuit can be modified until the required performance is achieved.

to Printed Circuit Board Design!

The design, complete with connectivity, can then be translated into the PCB. The connectivity and design rules can be checked automatically to ensure that the PCB matches the schematic.

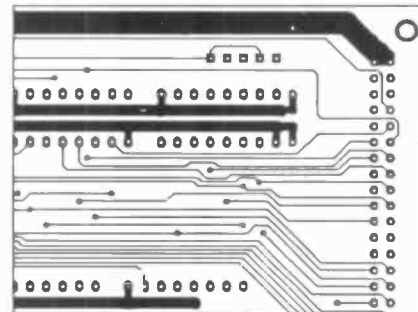

EASY-PC Professional

Affordable Electronics CAD

EASY-PC: Low cost, entry level PCB and Schematic CAD.	\$195.00	£98.00
EASY-PC Professional: Schematic Capture and PCB CAD. Links directly to ANALYSER III and PULSAR.	\$375.00	£195.00
PULSAR: Low cost Digital Circuit Simulator ~ 1500 gate capacity.	\$195.00	£98.00
PULSAR Professional: Digital Circuit Simulator ~ 50,000 gate capacity.	\$375.00	£195.00
ANALYSER III: Low cost Linear Analogue Circuit Simulator ~ 130 nodes.	\$195.00	£98.00
ANALYSER III Professional: Linear Analogue Circuit Simulator ~ 750 nodes.	\$375.00	£195.00
Z-MATCH II: Smith Chart program for RF Engineers - direct import from ANALYSER III.	\$375.00	£195.00

We operate a no penalty upgrade policy. You can upgrade at any time to the professional version of a program for the difference in price.

US\$ prices include Post and Packing
Sterling Prices exclude P&P and VAT.

Number One Systems Ltd.

Harding Way, St. Ives, Huntingdon, Cambs. PE17 4WR, UK.

For Full Information: Please Write, Phone or Fax.

Tel: 0480 461778

Fax: 0480 494042

USA tel: 011- 44 - 480 461778 fax 011- 44 - 480 494042

VISA, MasterCard, AMERICAN EXPRESS

SERIOUS SOUND SERIOUS SAVING

HIGH QUALITY PROFESSIONAL 100W POWER AMPLIFIER KIT – SAVE £30

★ Ideal for Instrument Amplification ★ Stage Foldback ★ Small Venue P.A. ★ Studio Monitor Amplifier



This superb amplifier kit brings together five of the best and most popular 'Audio Building Blocks', to produce an amplifier of unrivalled sound quality at the price. The Power Output Stage is an excellent 150W MOSFET design which is currently Maplin's Best Selling Audio Kit. It is complemented by the excellent performance of the SSM2016 Differential Pre-amplifier which has also featured in Maplin's 'Top 20' kits. The superb audio stages are supported by a High Quality Power Supply Unit, sophisticated Monitoring Circuitry and a Thermal Protection System. Housed in a rugged 19in. rack mounting case, this outstanding amplifier is designed for longevity, purity of sound reproduction and ease of integration with other professional equipment.

The kit contains everything you need to build this superb amplifier and is supplied complete with comprehensive constructional information.

Features:

- ★ Standard 19in. 2U Rack Mounting Case
- ★ 100W RMS Power Output
- ★ Balanced Line Input
- ★ Loudspeaker Protection
- ★ Switch-on Mute
- ★ Thermal Protection

Typical Specification:

Rated Load Impedance: 4 to 8Ω

Maximum Power Output:

4Ω 105W RMS

8Ω 90W RMS

THD @ 75W (1kHz): 0.02%

Frequency Response: 10Hz to 40kHz, -1dB

Maplin
ELECTRONICS

CREDIT CARD HOTLINE
0702 554161

Mail Order to: P.O. Box 3, Rayleigh, Essex SS6 8LR

For a friendly welcome and the best of service, visit your local Maplin store: **BIRMINGHAM**: Sutton New Road, Erdington. **BRIGHTON**: 65 London Road. **BRISTOL**: 302 Gloucester Road. **CARDIFF**: 29-31 City Road. **CHATHAM**: 2 Luton Road. **COVENTRY**: 12 Bishop Street. **EDINBURGH**: 126 Dairy Road. **GLASGOW**: 264-266 Great Western Road. **ILFORD**: 302-304 Green Lane. **LEEDS**: Carpet World Building, 3 Regent Street. **LEICESTER**: Office World Building, Burton Street. **LONDON**: 146-148 Burnt Oak Broadway, Edgware. 107-113 Stanstead Road, Forest Hill. 120-122 King Street, Hammersmith. **MANCHESTER**: 8 Oxford Road. **NEWCASTLE-UPON-TYNE**: Unit 4, Allison Court, The Metro Centre, Gateshead. **NOTTINGHAM**: 86-88 Lower Parliament Street. **PORTSMOUTH**: 98-100 Kingston Road. **READING**: 129-131 Oxford Road. **SHEFFIELD**: 413 Langsett Road, Hillsborough. **SOUTHAMPTON**: 46-48 Bevois Valley Road. **SOUTHEND-ON-SEA**: 282-284 London Road, Westcliff. Plus a NEW STORE opening soon in **MIDDLESBROUGH**. Phone 0702 552911 for further details. Subject to availability. Price subject to change. Price inclusive of VAT. H Indicates a carriage charge of £5.50.