



ELECTRONICS
TODAY INTERNATIONAL

VIRTUOSO
Super-fi power
amp project

CAPACITORS
the inside story
FIRST CLASS
beginners project
series starts inside



**NEW
LOOK!**

OMP POWER AMPLIFIER MODULES

PRICES INCLUDE V.A.T. * PROMPT DELIVERIES * FRIENDLY SERVICE * LARGE S.A.E. 28p STAMP FOR CURRENT LIST

OMP POWER AMPLIFIER MODULES

Now enjoy a world-wide reputation for quality, reliability and performance at a realistic price. Four models available to suit the needs of the professional and hobby market i.e. Industry, Leisure, Instrumental and Hi-Fi etc. When comparing prices, NOTE all models include Toroidal power supply, Integral heat sink, Glass fibre P.C.B., and Drive circuits to power compatible Vu meter. Open and short circuit proof.

Supplied ready built and tested.



OMP100 Mk II Bi-Polar Output power 110 watts R.M.S. into 4 ohms, Frequency Response 15Hz - 30KHz -3dB, T.H.D. 0.01%, S.N.R. -118dB, Sens for Max output 500mV at 10K, Size 355 x 115 x 65mm. **PRICE £33.99 + £3.00 P&P.**



OMP/MF100 Mos-Fet Output power 110 watts R.M.S. into 4 ohms, Frequency Response 1Hz - 100KHz -3dB, Damping Factor 80, Slew Rate 45V/uS, T.H.D. Typical 0.002%, Input Sensitivity 500mV, S.N.R. -125dB, Size 300 x 123 x 60mm. **PRICE £39.99 + £3.00 P&P.**



OMP/MF200 Mos-Fet Output power 200 watts R.M.S. into 4 ohms, Frequency Response 1Hz - 100KHz -3dB, Damping Factor 250, Slew Rate 50V/uS, T.H.D. Typical 0.001%, Input Sensitivity 500mV, S.N.R. -130dB, Size 300 x 150 x 100mm. **PRICE £62.99 + £3.50 P&P.**



OMP/MF300 Mos-Fet Output power 300 watts R.M.S. into 4 ohms, Frequency Response 1Hz - 100KHz -3dB, Damping Factor 350, Slew Rate 60V/uS, T.H.D. Typical 0.0008%, Input Sensitivity 500mV, S.N.R. -130dB, Size 330 x 147 x 102mm. **PRICE £79.99 + £4.50 P&P.**

NOTE: Mos Fets are supplied as standard (100KHz bandwidth & Input Sensitivity 500mV) If required P.A. version (50KHz bandwidth & Input Sensitivity 775mV) Order Standard or P.A.

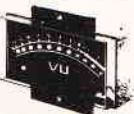

Vu METER Compatible with our four amplifiers detailed above. A very accurate visual display employing 11 L.F.D. diodes (7 green 4 red) plus an additional on/off indicator. Sophisticated logic control circuits for very fast rise and decay times. Tough moulded plastic case, with tinted acrylic front. Size 84 x 27 x 45mm. **PRICE £8.50 - 50p P&P.**

LOUDSPEAKERS 5" to 15" up to 400 WATTS R.M.S. Cabinet Fixing in stock. Huge selection of McKenzie Loudspeakers available including Cabinet Plans. Large S.A.E. (28p) for free details.



POWER RANGE

8" 50 WATT R.M.S. Hi-Fi/Disco.
20 oz magnet. 1" ally voice coil. Ground ally fixing escutcheon. Res. Freq. 40Hz. Freq. Resp. to 6KHz. Sens. 92dB. PRICE £10.99 available with black grille £11.99 P&P £1.50 ea.
12" 100 WATT R.M.S. Hi-Fi/Disco
50 oz magnet. 2" ally voice coil. Ground ally fixing escutcheon. Die cast chassis. White cone. Res. Freq. 25Hz. Freq. Resp. to 4KHz. Sens. 95dB. PRICE £28.60 + £3.00 P&P ea.

McKENZIE

12" 85 WATT R.M.S. C1285GP Lead Guitar/Keyboard/Disco
2" ally voice coil. Ally centre dome Res. Freq. 45Hz. Freq. Resp. to 6.5KHz. Sens. 96dB. PRICE £29.99 + £3.00 P&P ea.
12" 85 WATT R.M.S. C1285TC P.A./Disco 2" ally voice coil. Twin cone.
Res. Freq. 45Hz. Freq. Resp. to 14KHz. PRICE £31.49 + £3.00 P&P ea.
15" 150 WATT R.M.S. C15 Bass Guitar/Disco.
3" ally voice coil. Die-cast chassis. Res. Freq. 40Hz. Freq. Resp. to 4KHz. PRICE £57.87 + £4.00 P&P ea.
10" 60 WATT R.M.S. 1060GP Gen. Purpose/Lead Guitar/Keyboard/Mid. P.A.
2" voice coil. Res. Freq. 75Hz. Freq. Resp. to 7.5KHz. Sens. 99dB. PRICE £19.99 + £2.00 P&P.
10" 200 WATT R.M.S. C10200GP Guitar, Keyboard, Disco.
2" voice coil. Res. Freq. 45Hz. Freq. Resp. to 7KHz. Sens. 101dB. PRICE £44.76 + £3.00 P&P.
15" 200 WATT R.M.S. C15200 High Power Bass.
Res. Freq. 40Hz. Freq. Resp. to 5KHz. Sens. 101dB. PRICE £62.41 + £4.00 P&P.
15" 400 WATT R.M.S. C15400 High Power Bass.
Res. Freq. 40Hz. Freq. Resp. to 4KHz. Sens. 102dB. PRICE £89.52 + £4.00 P&P.

WEM

5" 70 WATT R.M.S. Multiple Array Disco etc.
1" voice coil. Res. Freq. 52Hz. Freq. Resp. to 5KHz. Sens. 89dB. PRICE £22.00 + £1.50 P&P ea.
8" 150 WATT R.M.S. Multiple Array Disco etc.
1" voice coil. Res. Freq. 48Hz. Freq. Resp. to 5KHz. Sens. 92dB. PRICE £32.00 + £1.50 P&P ea.
10" 300 WATT R.M.S. Disco/Sound re-enforcement etc.
1" voice coil. Res. Freq. 35Hz. Freq. Resp. to 4KHz. Sens. 92dB. PRICE £36.00 + £2.00 P&P ea.
12" 300 WATT R.M.S. Disco/Sound re-enforcement etc.
1 1/2" voice coil. Res. Freq. 35Hz. Freq. Resp. to 4KHz. Sens. 94dB. PRICE £47.00 + £3.00 P&P ea.

SOUNDLAB (Full Range Twin Cone)

5" 60 WATT R.M.S. Hi-Fi/Multiple Array Disco etc.
1" voice coil. Res. Freq. 63Hz. Freq. Resp. to 20KHz. Sens. 86dB. PRICE £9.99 + £1.00 P&P ea.
6" 60 WATT R.M.S. Hi-Fi/Multiple Array Disco etc.
1" voice coil. Res. Freq. 56Hz. Freq. Resp. to 20KHz. Sens. 89dB. PRICE £10.99 + £1.50 P&P ea.
8" 60 WATT R.M.S. Hi-Fi/Multiple Array Disco etc.
1 1/2" voice coil. Res. Freq. 38Hz. Freq. Resp. to 20KHz. Sens. 89dB. PRICE £12.99 + £1.50 P&P ea.
10" 60 WATT R.M.S. Hi-Fi/Disco etc.
1 1/2" voice coil. Res. Freq. 35Hz. Freq. Resp. to 15KHz. Sens. 89dB. PRICE £16.49 + £2.00 P&P.

PANTEC HOBBY KITS. Proven designs including glass fibre printed circuit board and high quality components complete with instructions.

FM MICROTRANSMITTER (BUG) 90/105MHz with very sensitive microphone. Range 100/300 metres. 57 x 46 x 14mm (9 volt). **Price: £8.62 + 75p P&P.**
3 WATT FM TRANSMITTER 3 WATT 85/115MHz varicap controlled professional performance. Range up to 3 miles 35 x 84 x 12mm (12 volt). **Price: £14.49 + 75p P&P.**
SINGLE CHANNEL RADIO CONTROLLED TRANSMITTER/RECEIVER 27MHz. Range up to 500 metres. Double coded modulation. Receiver output operates relay with 2amp/240 volt contacts. Ideal for many applications. Receiver 90 x 70 x 22mm (9/12 volt). **Price: £17.82 Transmitter 80 x 50 x 15mm (9/12 volt). Price: £11.29 P&P + 75p each. S.A.E. for complete list.**

3 watt FM Transmitter

BURGLAR ALARM

Better to be 'Alarmed' than terrified. **Thandar's famous 'Minder' Burglar Alarm System.** Superior microwave principle. Supplied as three units complete with interconnection cable. **FULLY GUARANTEED.**

Control Unit - Houses microwave radar unit, range up to 15 metres adjustable by sensitivity control. Three position, key operated fascia switch - off - test - armed. 30 second exit and entry delay.

Indoor alarm - Electronic swept freq. siren. 104dB output.

Outdoor Alarm - Electronic swept freq. siren. 98dB output. Housed in a tamper-proof heavy duty metal case.

Both the control unit and outdoor alarm contain rechargeable batteries which provide full protection during mains failure. Power requirement 200/260 Volt AC 50/60Hz. Expandable with door sensors, panic buttons etc. Complete with instructions. **SAVE £138.00** Usual Price £228.85

BKE's PRICE £89.99 + £4.00 P&P

Why buy a collection of self assembly boards?

IDEAL for Work-shops, Factories, Offices, Home, etc. Supplied ready built.



OMP LINNET LOUDSPEAKERS

The very best in quality and value. Made specially to suit today's need for compactness with high sound output levels. Finished in hard wearing black vinyl with protective corners, grille and carry handle. All models 8 ohms. Full range 45Hz - 20KHz. Size 20" x 15" x 12". Watts R.M.S. per cabinet. Sensitivity 1W 1mtr @ 5

OMP 12-100 Watts 100dB. Price £149.99 per pair.
OMP 12-200 Watts 102dB. Price £199.99 per pair. Delivery Securicor £8.00 per pair



OMP 19" STEREO RACK AMPS



Professional 19" cased Mos-Fet stereo amps. Used the World over in clubs, pubs, discos etc. With twin Vu meters, twin toroidal power supplies, XLR connections. MF600 Fan cooled. **Three models** (Ratings R.M.S. into 4 ohms). Input Sensitivity 775mV.
MF200 (100 + 100)W. £169.00 Securicor
MF400 (200 + 200)W. £228.85 Delivery
MF600 (300 + 300)W. £322.00 £10.00

1 K-WATT SLIDE DIMMER

Control loads up to 1000W.
Compact Size 210 x 100 x 100mm.
Easy snap in fixing through panel.
Cabinet cut out.
Insulated plastic case.
Full wave comp. using 8 amp diodes.
Comforms to BS589.
Suitable for both resistive and inductive loads. Innumerable applications in domestic, home, and industrial premises etc.
PRICE £13.99 - 75p P&P

BSR P295 ELECTRONIC TURNTABLE

Electronic speed control 45 & 33 r.p.m. Plus Minus variable pitch control. Belt driven. Aluminium platter with strobed rim. Cue lever. Anti-skate (bias device). Adjustable counter balance. Manual arm. Standard 1/2" cartridge fixings. Supplied complete with cut out template. D.C. Operation 9-14V D.C. 65mA. **Price £36.99 £3.00 P&P.**



ADC Q4 mag. cartridge for above. Price £4.99 ea. P&P 50p.

PIEZO ELECTRIC TWEETERS - MOTOROLA

Join the Piezo revolution. The low dynamic mass (no voice coil) of a Piezo tweeter produces an improved transient response with a lower distortion level than dynamic tweeters. As a crossover is not required these units can be added to existing speaker systems of up to 700 watts (more if 2 put in series). **FREE EXPLANATORY LEAFLETS SUPPLIED WITH EACH TWEETER.**

TYPE 'A' (KSN2036A) 3" round with protective wire mesh. Ideal for bookshelf and medium sized hi-fi speakers. **Price £4.90 each - 40p P&P.**
TYPE 'B' (KSN1005A) 3" Super Horn. For general purpose speakers, disco and P.A. systems etc. **Price £5.99 each - 40p P&P.**
TYPE 'C' (KSN6016A) 2" x 5" wide dispersion horn. For quality hi-fi systems and quality discs etc. **Price £6.99 each - 40p P&P.**
TYPE 'D' (KSN1025A) 2" x 5" wide dispersion horn. Upper frequency response retained extending down to mid range (2kHz). Suitable for high quality hi-fi systems and quality discs. **Price £9.99 each - 40p P&P.**
TYPE 'E' (KSN1038A) 3 1/2" horn tweeter with attractive silver finish. Suitable for hi-fi monitor systems etc. **Price £5.99 each - 40p P&P.**
LEVEL CONTROL Combines on a recessed mounting plate, level control and cabinet input jack socket. 85 x 85 mm. **Price £3.99 - 40p P&P.**

STEREO DISCO MIXER

STEREO DISCO MIXER with 2 x 5 band L & R graphic equalisers and twin 10 segment L.E.D. Vu Meters. Many outstanding features. 5 Inputs with individual faders providing a useful combination of the following - 3 Turntables (Mag) 3 Mics 4 Line plus Mic with talk over switch. Headphone Monitor. Pan Pot. L & R Master Output controls. Output 775mV. Size 360 x 280 x 90mm. **Price £134.99 - £3.00 P&P.**

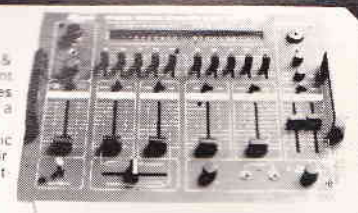

B. K. ELECTRONICS DEPT ETI
UNIT 5, COMET WAY, SOUTHEND-ON-SEA,
ESSEX, SS2 6TR TEL: 0702-527572

POSTAL CHARGES PER ORDER £1.00 minimum. OFFICIAL ORDERS WELCOME. SCHOOLS, COLLEGES, GOVERNMENT BODIES, ETC. PRICES INCLUSIVE OF V.A.T. SALES COUNTER VISA/ACCESS/C.Q.D. ACCEPTED

Brainwave monitor

- BETA** - Concentration, problem solving, active thought.
- ALPHA** - Relaxation, pleasure, tranquility, positive feelings.
- THETA** - Imagination, creativity, hypnagogic imagery.

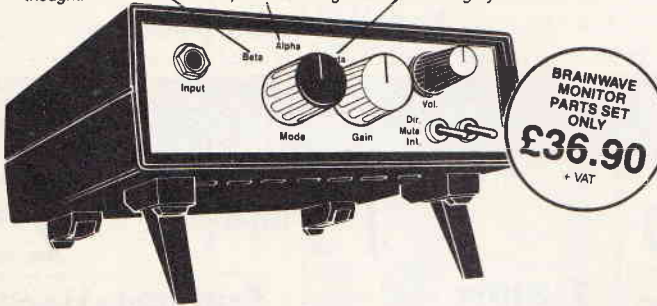

This unique project will allow you to **hear** your own brainwaves! Through a simple training program you can learn to **control** them and achieve peak performance in all situations. It will revolutionise your life!

The approved parts set contains: two PCBs; all components, including three PMI precision amplifiers; shielded box for screening the bio-amplifier; attractive instrument case with tilting feet; controls, switches, knobs, plugs, sockets; leads and brass electrodes, full instructions for assembly and use.

Parts are available separately. We also have a range of accessories, professional electrodes, books, etc. Please send a stamped, self-addressed envelope if you just want the lists. Otherwise, an SAE + £2 will bring you lists, construction details and further information.



THE ALPHA PLAN

Can you really train your mind to think more effectively? Can you really excel at things you're no good at? The Alpha Plan has all the answers! **£2.50** (no VAT)



SILVER SOLUTION

Just wipe on with a cloth to plate PCB tracks, connectors, wire, component leads, coins or household ornaments with a layer of **pure silver**. It must be magic! **LARGE BOTTLE (150ml) SILVER SOLUTION £11.20 + VAT!**

POWER CONDITIONER

As featured in ETI, January 1988. The approved parts set contains PCB, case, toroidal cores, class X and Y capacitors, VDRs, ICs, transistors, LEDs, all components, and full instructions.

Parts are available separately. Please send a stamped, self-addressed envelope if you want the lists. Otherwise, an SAE + £1 will bring you lists, construction details and further information.

POWER CONDITIONER PARTS SET ONLY £28.50 + VAT

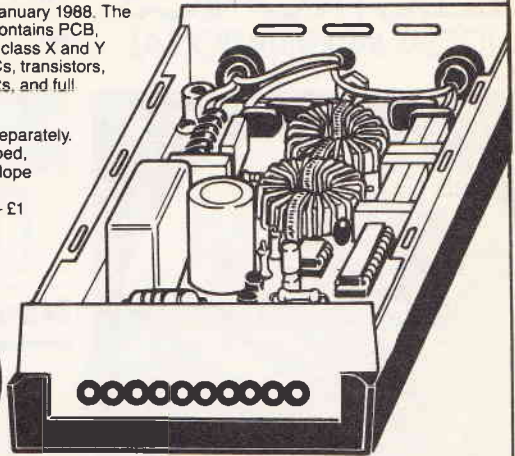

- For those who will only be satisfied with the best
- Use with Hi-Fi, computers, radios, TV sets to eliminate mains-borne interference
- 10 LED logarithmic display shows the amount of interference removed
- Massive filter section with thirteen capacitors and two current-balanced inductors
- Bank of six VDRs to remove transients and spikes
- Suppresses common mode and differential mode interference

Complete Parts Sets for Top Projects

FEATURED IN ETI, MARCH 1988

JUMPIN' JACK FLASH

is a

- Lighting wizard - brings any rock band's stage performance to life!
- Sound operated flash - photograph bullets in flight!
- Voice switch and sound to action controller with endless applications

The parts set consists of a high quality PCB and all components, ICs, opto isolator, triac, heat sink, pots etc. to build the circuit board. What do you do next is up to you! The ETI article, supplied free with every set, shows how to make the most of J.F.'s capabilities.

JUMPING JACK FLASH £6.90 + VAT



KNIGHT RAIDER

FEATURED IN ETI, JULY 1987

The ultimate in lighting effects for your Lamborghini, Maserati, BMW (or any other car, for that matter). Picture this: eight powerful lights in line along the front and eight along the rear. You flick a switch on the dashboard control box and a point of light moves lazily from left to right leaving a comet's tail behind it. Flip the switch again and the point of light becomes a blur, bouncing backwards and forwards along the row. Press again and try one of the other six patterns. An LED display on the control box tells you see what the main lights are doing.

The Knight Raider can be fitted to any car (it makes an excellent log light) or with low powered bulbs it can turn any child's pedal car or bicycle into a spectacular TV-age toy!

The control box parts set consists of case, switches, LEDs, PCB, components, hardware and instructions. The sequence board includes PCB, ICs, power FETs, components, hardware and instructions.

KNIGHT RAIDER CONTROL BOX ONLY £6.90 + VAT!
KNIGHT RAIDER SEQUENCE BOARD ONLY £13.90 + VAT!

THE DREAM MACHINE

FEATURED IN ETI, DECEMBER 1987

Adjust the controls to suit your mood and let the gentle, relaxing sound drift over you. At first you might hear soft rain, sea surf, or the wind through distant trees. Almost hypnotic, the sound draws you irresistibly into a peaceful, refreshing sleep.

For many, the thought of waking refreshed and alert from perhaps the first truly restful sleep in years is exciting enough in itself. For more adventurous souls there are strange and mysterious dream experiences waiting. Take lucid dreams, for instance. Image being in control of your dreams and able to change them at will to act out your wishes and fantasies. With the Dream Machine it's easy!

The approved parts set consists of PCB, all components, controls, loudspeaker, knobs, lamp, fuseholder, fuse, mains power supply, prestige case and full instructions.

DREAM MACHINE COMPLETE PARTS SET £16.50 + VAT
ALSO AVAILABLE WITHOUT CASE FOR ONLY **£11.90 + VAT**



POWERFUL AIR IONISER

FEATURED IN ETI, JULY 1986

Ions have been described as 'vitamins of the air' by the health magazines, and have been credited with everything from curing hay fever and asthma to improving concentration and putting an end to insomnia. Although some of the claims may be exaggerated, there is no doubt that ionised air is much cleaner and purer, and seems much more invigorating than 'dead air'.

The DIRECT ION ioniser caused a great deal of excitement when it appeared as a constructional project in ETI. At last, an ioniser that was comparable with (better than?) commercial products, was reliable, good to build, and fun! Apart from the serious applications, some of the suggested experiments were outrageous!

We can supply a matched set of parts, fully approved by the designer, to build this unique project. The set includes a roller printed circuit board, 66 components, case, mains lead, and even the parts for the tester. According to one customer, the set costs 'about a third of the price of the individual components'. What more can we say?

DIRECT ION PARTS SET WITH BLACK CASE £11.50 + VAT instructions are included
WITH WHITE CASE £11.80 + VAT



SPECIAL OFFERS

AD7541 Precision 12-bit multiplying DAC **£1.20 + VAT**
LM3524 Switch mode regulator IC **£0.80 + VAT**
CF585 Calculator IC **£1.00 + VAT**
LM339 Quad comparator IC **3 for £1.00 + VAT**
MC1458 Dual op-amp **3 for £1.00 + VAT**

All ICs supplied with **FREE DATA**. Prices apply only while stocks last.

LM2917 EXPERIMENTER SET

Consists of LM2917 IC, special printed circuit board and detailed instructions with data and circuits for eight different projects to build. Can be used to experiment with the circuits in the 'Next Great Little IC' feature (ETI, December 1986).

LM2917 Experimenter Set £5.80 + VAT

RUGGED PLASTIC CASE

suitable for mains conditioner and mains controller.
ONLY £1.65 + VAT



LEDs

Green rectangular LEDs for bar-graph displays.
50 for £3.50 500 for £25
100 for £6 1000 for £45

DIGITAL AND AUDIO EQUIPMENT LEDs
Assorted 3mm LEDs: red, green, yellow and orange. 25 of each (100 LEDs) for **£6.80**



Prices shown are exclusive of VAT, so please add 15% to the order total. UK postage is 70p on any order. Carriage and insurance for overseas orders £4.50. Please allow up to 14 days for delivery.

Specialist

SEMICONDUCTORS LIMITED

SALES DEPT
ROOM 107
FOUNDERS HOUSE
REDBROOK
MONMOUTH
GWENT

Geoff Bains: Editor
Jez Ford: Assistant Editor
Paul Chappell: Projects Editor
Jerry Fowler: Technical Illustrator
Jeff Hamblin: Design

Ed Davis: Photography
Christopher Harris: Ad Manager
Julie Capstick: Classified Sales
Andrew Selwood: Copy Control
Mark Webb: Group Editor

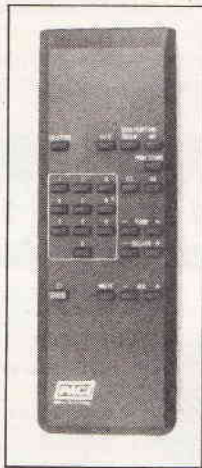
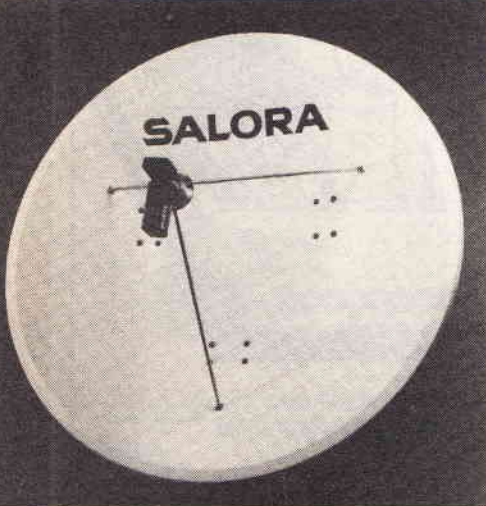

ISSN
0142-7229

ABC

Member of the
Audit Bureau
of Circulation

ETI is normally published on the first Friday in the month preceding cover date. The contents of this publication including all articles, designs, plans, drawings and programs and all copyright and other intellectual property rights therein belong to Argus Specialist Publications Limited. All rights conferred by the Law of Copyright and other intellectual property rights and by virtue of international copyright conventions are specifically reserved to Argus Specialist Publications Limited and any reproduction requires the prior written consent of the Company. © 1988 Argus Specialist Publications Ltd. All reasonable care is taken in the preparation of the magazine contents but the publishers cannot be held legally responsible for errors. Where mistakes do occur, a correction will normally be published as soon as possible afterwards. All prices and data contained in advertisements are accepted by us in good faith as correct at time of going to press. Neither the advertisers nor the publishers can be held responsible however, for any variations affecting price or availability which may occur after the publication has closed for press.

● Subscription rates UK £16.80. Europe: £21.00. Middle East: £21.20. Far East: £22.80. Rest: £21.50 or US\$32.00.

**ARGUS
PRESS
GROUP**

1 Golden Square
London W1R 3AB
Tel: 01-437 0626
Telex: 8811896

Volume 17 No4

6	15	23
News	T-Shirt Competition	Subscriptions
8	16	24
Diary	Satellite Acolyte	Pulling It All Together
9	Keith Brindley rounds off our extensive look at satellite TV with an in-depth review of the top three systems available.	Paul Chappell's <i>Circuit Theory</i> series finds some practical use for all the complex numbers and phasor diagram theory of recent months. Perhaps the maths is some use after all.
Fame & Fortune	20	26
10	Count On It	Virtuoso Power Amplifier
Next Month	Mike Barwise continues the <i>Chip In</i> series with a look at the Fairchild 74F525 programmable divider and finds that under the cloud of complex application notes lies an extremely useful chip.	Hi-fi devotee Graham Nalty describes his power amp to end all power amps. This month he looks at the general principles behind the design and in detail at the power supply.
11	22	32
Read/Write	Special Offer	Clockwise
12	23	Keith Brindley kicks off our <i>First Class</i> project series for beginners to electronics with a simple but accurate timer for the kitchen, or anywhere else come to that.
Capacity For Thought	Competition Results	
John Linsley Hood takes the first of two looks at capacitors - what they are, how they're made and how to use them properly in audio design.	Results of the Specialist Semiconductor competition from the January issue.	



Published by Argus Specialist Publications Ltd., 1 Golden Square, London W1R 3AB. Tel: 01-437 0626. UK newstrade distribution by SM Distribution Ltd., 16-18 Trinity Gardens, London SW9 8DX. Tel: 01-274 8611. Overseas and non-newstrade sales by Magazine Sales Department, 1 Golden Square, London W1R 3AB. Tel: 01-437 0626. Subscriptions by Infonet Ltd., 5 River Park Estate, Berkhamsted HP4 1HL. Tel: (04427) 76661. US subscriptions by Wise Owl Publications, 4314 West 238th Street, Torrance, CA90505 USA. Typesetting and origination by Multiform Ltd., Cardiff. Printed and bound by Adlard & Son Ltd., Letchworth. Covers printed by Loxley Brothers Ltd., Sheffield.

APRIL 1988

34

Special Offer

36

Combo-Lock

Chung Yiu Ko presents a remarkably simple but ingenious design for a combination lock. Protect your belongings behind a wall of probability.



40

Transatlantic Time Zone Corrector

Andrew Armstrong keeps his cycles intact while jet-setting around the world thanks to this essential travel aid. It will even tell you which month it is.

42

Special Offer

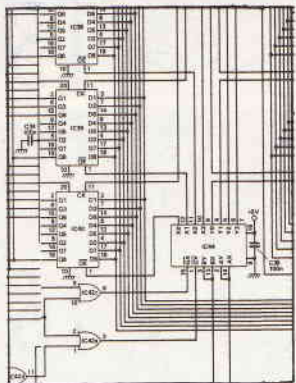

43

Spectrum Co-processor

Graeme Durant describes the interface between his co-processor and the Spectrum in this penultimate article.

48

Book Look

48

Playback

49

Open Channel

50

Backnumbers

50

Photocopies

51

PCB Foils

53

PCB Service

53

Oops!

54

Readers' Free Ads

55

Classified Ads

58

Ad Index

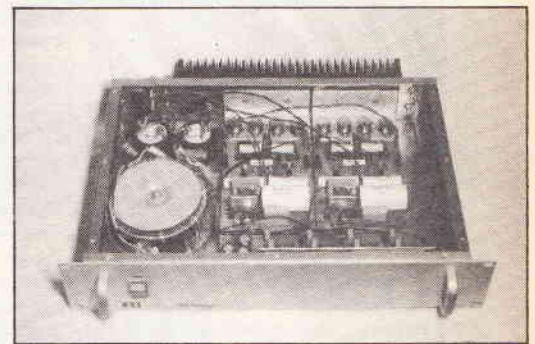
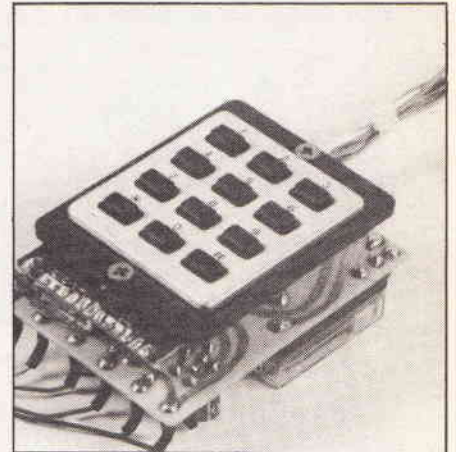

NEWS

KEEP YOUR HEAD STRAIGHT

Alignment of VCR heads and spindles can be quickly (but expensively) checked using Tentel TSH spindle gauges available from Crow in Reading.

The gauges, available for VHS or Beta, simulate a cassette and drop into your VCR.

Any spindle-height error is shown by a dial indicator in thousands of an inch. In fast forward or rewind the spindle wobble is indicated.

This is all very useful but rather costly. Both the Beta B3 and the VHS V4 models cost £503 including VAT.

Contact Crow Broadcast Holdings, 10 Arnham Road, Newbury RG14 5RU. Tel: (0635) 523255.

ONLINE INFO

Online Distribution has announced its new catalogue of passive, electromechanical and connector products.

The catalogue has 48 pages with a good smattering of photos and drawings, listing prices and postage costs for components from various manufacturers including Erg, General Hybrid, Harwin and TI.

The catalogue is free from Online Distribution, Melbourne House, Kingsway, Bedford MK42 9AZ. Tel: (0234) 217915.

KITS AND PIECES

Dinky design projects and budget component packs are the produce of Imagina-tronics from Surrey.

Among the kits are a matchbox-size 'surveillance' transmitter which broadcasts on FM (but don't tell the Home Office) and a pair of robot wheels with remote control, priced at £4.95 and £16.95 respectively.

For a full list of kits and of the varied and occasionally bizarre budget packs, contact Imagina-tronics, Aberdeen House, The Street, Charlwood, Surrey RH6 0DS.

POCKET THE DIFFERENCE

A digital multimeter that fits in a shirt pocket (they don't say whose) has been produced by Beckman Industrial of Birmingham. The DM78 has a 3½-digit display to cover the ranges for volts (AC and DC) and resistance to 20M, and for diode checks and continuity there is a beeper. The multimeter auto-ranges to avoid overloading and costs just £24.50 + VAT.

Contact Beckman, 43-48 New Street, Birmingham B2 4LJ. Tel: 01-643 8899.

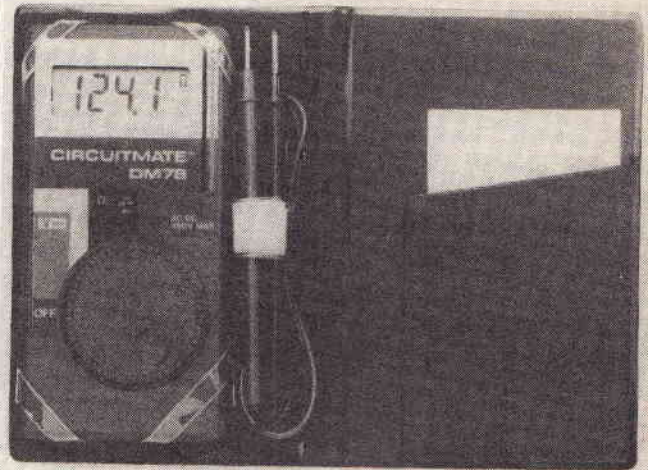

DIRECTORY ENQUIRIES

The European Consumer Electronics Directory has been published by Euromonitor Publications. The directory is not simply a trade directory and carries no advertising. It covers all EC countries plus Scandinavia.

The directory begins with an overview of European electronics, examining trends of the first half of this decade and giving some fairly generalised predictions for the second half — audio sales to fall, Portugal to go hi-tech and so on. The next 150 pages are the most useful — listing publications, MR companies, trade associations and the main electronics companies of each country.

The last section of the book deals with statistics for each country — mainly dealing with import, export, sales and production of electric consumer durables.

It's a useful tome if you get it free, otherwise the £135 might limit its appeal to PR and MR users. Contact Euromonitor, 87-88 Turnmill Street, London EC1M 5QU. Tel: 01-251 8024.

WALL TO WALL TO WALL TO WALL

The ultimate in surround sound sensation is promised by Sharp in the form of the Optonica SM-A75.

This 16-bit digital delay and five speaker system will transform your home with recreated acoustic environments, claims Sharp.

The SM-A75 has 14 modes such as hall, live or stage (for music) and stadium or ringside (for sport on TV). More intriguing is the 'Sci-Fi'

mode — one of three environments to simulate the cinema.

The power output is 40W into 2 channels or 25W into each of 4 channels. The speaker system has two sets of three 4-in speakers in front, a pair of 4-in speakers behind and a super woofer housing a 10in passive radiator and 6in drive unit. But before you rush out and

convert your living room into an acoustic Wembley or White Hart Lane, consider that for the £879 that Sharp are asking you could spend every Saturday until 1993 on the terraces themselves...

Full details from Sharp UK, Thorp Road, Newton Heath, Manchester M10 9BE. Tel: 061-205 2333.

PC PLOD NABS PC PIRATE

The first ever jail sentence for software piracy has been passed by Exeter Crown Court on Tos International and Gerhard Martens of Torquay.

Tos International (international even in convictions — Martens is also wanted by the West German police) has been selling all the leading spreadsheet and WP packages through computer papers and magazines, with counterfeit manuals obtained from the recently raided Golden Triangle in Hong Kong.

The Devon and Cornwall Con-

stabulary worked in collaboration with FAST (Federation Against Software Theft), the organisation set up by the computer industry to help catch pirates. FAST spent two days identifying the seized software and found that the pirated disks originated from Taiwan. 'It's reassuring that the courts recognised the seriousness of this case,' said Bob Hay, co-ordinator of FAST. 'It will serve as a deterrent to others.' For FAST information contact FAST, 8 Southampton Place, London WC1A 2EF. Tel: 01-430 2408.

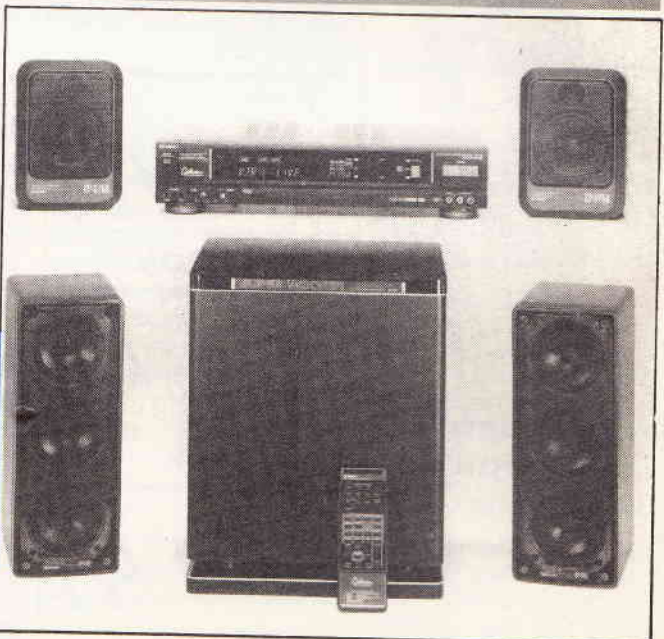

INFO ON LINE

The British Library has finally got its 'Online Search Centre' project off the ground.

Online Search uses the databases of the British Library to provide references on almost any topic selected by the user. Virtually all scientific fields on a global basis are covered by these databases, including Japanese information.

The British Library cites £45 as the average search cost but this will depend on search-time and the number of references printed.

Only references are produced — the 'experienced specialised searchers' will advise on how to obtain copies of the actual documents.

The Online Search Centre have produced a price list and database guide available free by telephoning 01-323 7477.

BLOWY ON THE PROM

New from Dataman of Dorchester is the Softy 3 Programmer — a PROM programmer, PROM editor, ROM and RAM emulator and development system all crammed into what looks like a desktop calculator.

As a PROM blower the S3 has a built-in library for EPROMs and EEPROMs (25, 27, 28, 87 series and so on) and can blow say an Intel 27C256 in under 20 seconds.

It is also upgradable for handling future PROMs, loaded via the ROM socket (bottom left in the photo).

The whole thing can be remotely controlled by 2-way RS232 interface, with baud-rates up to 9600.

As a memory emulator the S3 accesses typically in 100ns, provid-



ing a direct replacement for EPROMs, EEPROMs and RAMs up to 64K.

Inside the dinky 7in by 4in case the CMOS architecture has 4K of BIOS ROM masked into the micro-

controller, with 8K RAM program area and a 64K buffer for user data.

The S3 retails at £495 + VAT. Contact Dataman, Lombard House, Dorchester DT1 1RX. Tel: (0305) 68066.

CUT-PRICE CONIFER COMPACT CLASSES

A new range of compact discs is now in the shops priced at a remarkable £3.99.

The discs are from Conifer Records and feature classical and easy listening material — the sort of collections you might find by the checkout in Tesco.

With the vast majority of CD titles still retailing at £11.00 it seems likely that the Conifer 'Compact Selection' will start a range of budget CDs rather than initiating a price war with the giants.

If budget labels can produce popular collections (such as K-Tel and Pickwick did in the 70s on LP) then CD might free itself from the



' yuppie-product' label so often ascribed to it, boosting consumer demand for players still further.

The Conifer Compact Selection is available from Boots record departments and other chain stores.

SPIES IN AMERICA

An American study claims that many employers 'spy' on their workers by programming VDU terminals to report on employee performances — input speed, sales rates and so forth.

'The Electronic Supervisor' was produced by the Office of Technology Assessment (run by Congress) and concludes that millions of Americans are routinely monitored in this way.

Many American companies openly admit this form of 'private personal assessment' and justify it as 'good business management'.

The report goes on to suggest that as employees rush to improve

their efficiency, inferior service may result and stressful illness can occur in the overstretched employees.

One wonders quite how the British trade unions would react to discovering such big brother tactics on their home soil.

As there is nothing in American law that prohibits monitoring in this way the unions over there can only campaign to get the practice outlawed.

Here at home, the TUC would be interested in hearing if the notion crosses the big pond to invade the privacy of the honest British worker.

FLIP-TOP AVOMETERS

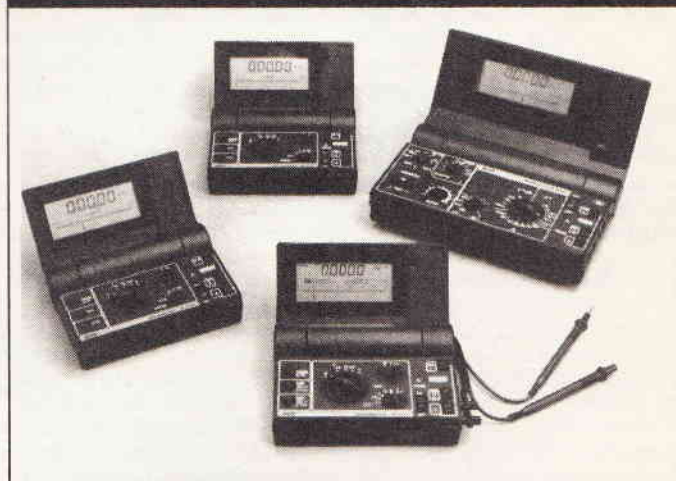

A new range of analogue/digital Avometers is now available from Megger Instruments in Dover.

The new multimeters feature a folding case design with a lid that pivots behind the control section. This enables a much larger display to sit neatly above the controls, and the display can be set at any convenient viewing angle for the user.

The display has 4½ digits plus an analogue-style scale with 60 divisions and 'zoom' facility.

The cheapest meter in the range is the M2035 (on the left in the picture). It measures amps, ohms

and volts with autoranging protection. A diode test and continuity beeper is also included.

At the top end of the range the M2042 provides true RMS values for AC measurement (with or without additional DC) and can zoom up to a factor of 500.

As with all Avometers the prices reflect the quality. The M2035 costs £330 + VAT, the M2042 costs £525 + VAT.

Full details from Megger, Archcliffe Road, Dover CT17 9EN. Tel: (0304) 202620.

HELP WANTED

Talking Books for the Handicapped would greatly welcome any volunteers who would be able to service the Library's specially-designed tape machines or to produce homemade induction loops for listeners with hearing aids.

The organisation is based in London but operates nationwide.

If you could help please contact The National Listening Library, 12 Lant Street, London SE1 1QH. Tel: 01-407 9417.

NEWS

POWER TO THE PEOPLE

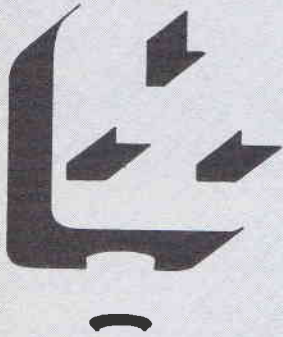

Privatisation of the electricity industry should be abandoned rather than create a British Telecom/Gas style private monopoly, concludes the Government's own report from the Centre for Policy Studies.

The report (entitled 'Current Choices') examines in detail six methods of privatising electricity and consigns four of these to the waste bin.

The first is the option urged by the CEGB, to privatise the whole industry as a single entity subject to minimal regulation, as with British Gas.

The report rejects this as failing to introduce any form of competition, incompatible with the competitive privatisation of British Coal and as unlikely to draw commercially-orientated management into the industry.

The second option is to keep the supply industry whole but allow competition in the building and running of new power stations.

The report rightly suggests that few investors would relish the prospect of putting £1½ billion into a 1800MW station that would take at least seven years to build, only to face competition from the still-existing and massively entrenched CEGB.

Effectively then, this second option is the same as the first.

Next to hit the binliner is the proposal from the Electricity Council. This involves creating two separate monopolies, one for distribution and one for generation.

The distributing monopoly could (if it wished) compete in power generation.

However the report points out that the new CEGB would hold all the expertise and experience of building and operating power

stations. The distribution monopoly simply wouldn't bother or would make little headway if it did.

The fourth monopoly option is to split the industry into regional boards. Each board would have a local distribution monopoly and would generate most of its own power, purchasing the remainder competitively. The boards would however favour their own power stations and competition would be minimal.

This option would create several buyers of coal and would enable coal to be privatised.

The report firmly informs the Government that 'it would be a grave mistake to adopt any of these options'.

The alternative is competitive privatisation. The CEGB is broken up into separate generating companies which compete to supply electricity to five Regional Distribution Utilities (RDUs).

This would produce competition at every stage except the final regional distribution, would enable coal privatisation, would bring in new management (ten companies starting up), should need minimal regulation and should enable considerable cost savings.

The main drawback with this option is that it would take years to implement, and the Government will not wait that long.

The report therefore puts forward what appears to be the only choice for a fast privatisation.

Private Transition to Competition (PTC) creates the same RDUs for distribution but keeps the CEGB as a monopoly wholly owned by those RDUs.

This new CEGB is debt-financed and so cannot make a profit giving the RDUs an incentive to get competitive generation moving as fast as possible, eventually leading to complete competitive privatisation over a longer period.

This is a radical reorganisation and will worry a good many people, not least the unions involved. The TUC is firmly against any form of privatisation at all.

For the consumer, prices would be expected to drop but since each RDU would be a regional monopoly the consumer might suffer corner-cutting and artificially high prices without recourse to any regulatory body.

Nuclear power presents problems that are totally irreconcilable with privatisation, even the CPS report admits that.

And would the Electricity Council cease to exist or become an advertising agency for the combined industry?

The industry and its dependants nervously await the Prime Minister's decision.

'Current Choices — Good and Bad Ways to Privatise Electricity' is available for £4.90 from CPS, 8 Wilfred Street, London SW1E 6PL.

DIARY

Components In Electronics 88 — March 8-10th

Islington Business Centre, London. Conference and exhibition. Contact Nutwood Exhibitions on (0705) 264333

Senior Management Seminar On Surface Mount — March 16th

The Royal Automobile Club, London. Seminar by Coopers and Lybrand for DTI. Contact Katy Parkinson on 01-831 2858

The Status Of Nuclear Fusion Research — March 17th

IEE, London. Lectures by Dr D C Robinson. Contact IEE on 01-240 1871

Video, Audio And Data Recording — March 21-24th

University of York. Contact Institute of Electronic and Radio Engineers on 01-240 1871

CADCAM 88 — March 22-24th

NEC, Birmingham. Contact EMAP International Exhibitions on 01-404 4844

Electro-Optics & Laser UK — March 22-24th

NEC, Birmingham. Exhibition running alongside the Optics-Ecoosa '88 conference at the Birmingham Metropole Hotel. Contact Cahners Exhibitions on 01-891 5051

Internepon Production Show — March 22-24th

NEC, Birmingham. Contact Cahners Exhibitions on 01-981 5051

Into 88 — March 22-24th

NEC, Birmingham. Products, advice and services for industrial training. Contact EMAP International Exhibitions on 01-404 4844

Offshore Computer Show — March 22-24th

Aberdeen Exhibition and Conference Centre. Contact Offshore Conferences and Exhibitions on 01-549 5831

Computer Recruitment Fair — March 25-26th

Rainbow Rooms, London. Contact Intro Ltd on (0491) 681010

Computing In The Next Generation — March 25-27th

Annual conference of the British Computer Society's Young Professionals Group. Contact Julia Allen on 01-637 0471 for the venue

Computers In Retail & Retail Technology Exhibition — March 29-31st

Metropole Exhibition Centre, Brighton. Contact Focus Events on 01-832 1717

HF Radio Systems And Techniques — April 11-13th

The IEE, London. Conference organised by the IEE and The Institute of Mathematics and its Applications. Contact IEE on 01-240 1871

Safe Nuclear Power — April 12th

Scarborough Lecture Theatre, University of Durham. Lecture by C Smitton. Contact IEEIE on 01-836 3357

Scottish Computer Show — April 12-14th

Scottish Exhibition Centre, Glasgow. Contact Cahners Exhibitions on 01-891 5051

Computer Recruitment Fair — April 15-16th

New Century Hall, Manchester. Contact Intro Ltd on (0491) 681010

Computer Recruitment Fair — April 22-23rd

Watershed, Bristol. Contact Intro Ltd on (0491) 681010

Softteach 88 — 23-24th April

Heathrow Penta Hotel, London. Contact Softsel Computer Products on 01-568 8866

ATE 1988 (Automatic Testing & Test Instrumentation) — April 26-28th

Metropole Exhibition Centre, Brighton. Contact Network Events on (0280) 815 226

British Electronics Week — April 26-28th

Olympia, London. Contact Anne Jackson on (0799) 26699

Miltest 1988 (Military Testing Equipment) — April 26-28th

Olympia, London. Contact Network Events on (0280) 815 226

Second Power Sources And Supplies Conference — April 26-28th

Olympia, London (at British Electronics Week). Contact Anne Jackson on (0799) 26699

Electronics And The Stock Exchange — April 28th

IEE, London. Lecture by D C Marlborough. Contact IEE on 01-240 1871

Electronics And The Space Program — May 4th

IEE, London. Lecture by J Egan. Contact IEE on 01-240 1871

TITLE 88 (Technology In Tourism & Leisure Exhibition) — May 17-19th

Business Design Centre, London. Contact PLF Communications on (0733) 60535

Computer North — May 24-26th

G-Mex Exhibition Centre, Manchester. Contact Cahners Exhibitions on 01-891 5051

Engineering Products And Technology North — May 25-26th

Exhibition and Conference Centre, Doncaster. Contact Trinity Exhibitions on (0895) 58431

Information Technology And Office Systems Exhibition — June 7-10th

Barbican Exhibition Centre, London. Contact BED Exhibitions on (09328) 65525

FAME



&

FORTUNE

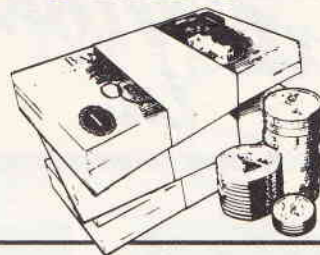

That's what an incredibly small number of people have achieved by contributing articles to ETI. The rest of us have had to make do with total obscurity and enough money for a couple of pints. Nevertheless it's all worthwhile and we need your contributions now!

FEATURES

If you know what you're talking about and it hasn't all been said before, we want you to add to our wide ranging and informative features. If you have a great idea for a feature or two, send in a brief resumé. If you don't have the ideas but you think you have a commanding knowledge of a suitable subject area we want to hear from you too.

PROJECTS

ETI has built its reputation on novel, worthwhile projects well designed and accurately presented. If you have recently designed and built a world-beater we want to hear from you. In the first instance send us a brief description of your masterpiece along with a circuit diagram.

Whatever you can contribute to ETI, take the plunge now. We can offer a modicum of fame and a very reasonable fortune.

Write in to:
The Editor
ETI
1 Golden Square
London W1R 3AB

NEW FROM SAGE AUDIO - A QUANTUM PLUS LEAP FOR HI-FI IN SONIC AND TECHNICAL PERFORMANCE

Build your own 'Superfi' class A system, superior to all the big names in Hi-Fi today

THE WORLDS HIGHEST TECHNICAL PERFORMANCE, COMBINED WITH . . .

SUPERMOS 2

Featuring LAZER TRIMMED SMD accuracy

. . . THE BEST, TOP GRADE AUDIO COMPONENTS

Po 100W to 450W (Dependant upon chosen PSL Voltage)

O/P Power 100W to 450W (+/-50V to +/-72V DC)
Distortion 0.0001% (1 ppm) A World first!
Slewrate 685/us (Zero transient compression)
Freq resp 0.5Hz to 350kHz -3dB (linear phase)
O/P Current 80amps and total reactance drive capable
O/P Impedance 0.0085 ohms (damping factor 940 into 8Ω)



MONSTER INTEGRAL HEATSINK SIZE 240 x 100 x 100mm

All semiconductors are selected, precision matched P/N types, Custom made matched MOSFETS, completely symmetrical design HOLCO resistors for non-critical areas and for critical areas we use the very best lazer trimmed SMD resistors, super to bulk foils with 5 times lower inductance. Minimal capacitor design using extended foil and polypropylene types.

THE MOST ADVANCED POWER AMPLIFIER IN THE WORLD

Ultra linear 70% efficiency, PURE CLASSA Throughout

Don't buy another power amplifier until you've checked ALL these facts! Take the guess work/risk out of power amp construction, our modules are ready built, tested, guaranteed and come with a signed certificate of performance conformity.

Some manufacturers build technically excellent amplifiers whilst turning a deaf ear to component sonic quality. Other manufacturers use audiograde components whilst totally ignoring BASIC technical performance.

THE SAGE AUDIO DESIGN PHILOSOPHY - A UNIQUE COMBINATION

6 ADDITIONAL SAGE EXCLUSIVE (World first) TECHNICAL DESIGN FEATURES ENABLE THE SAGE SUPERMOS 2 TO ACHIEVE A NEW HIGH LEVEL IN AUDIBLE SONIC PERFORMANCE UNMATCHED BY ANY OTHER POWER AMPLIFIER, EITHER MODULE, KIT, BOARD OR COMMERCIALY MADE AMPLIFIERS.

- 1 Active Class A** Our unique MOSFET pure class A O/P stage eliminates crossover distortion generated by class AB stages along with all thermal tracking problems, BJT storage effects and will not switch to class B under high drive as conventional low efficiency class A amps will.
- 2 Zero THD** All semiconductors are exclusive matched selected pairs operating in patented constant current/constant VCE for totally distortionless linear operation.
- 3 High Slewrate** Cascaded 'input z matched' alternate symmetrical NPN/PNP transconductance/transimpedance stages with localised feedback and low overall feedback ensures ultra high linear symmetrical slewrate some 50 times the normal eliminating TID altogether.
- 4 Clean Clipping** All amplifiers run into clipping thereby transferring PSU ripple to the O/P. SUPERMOS 2 the first amp to feature CLEAN CLIPPING without PSU ripple, totally eliminating the 'Sound of the PSU comps'.
- 5 Protection** Conventional VI limiters which introduce distortion when driving real speakers have been eliminated. The massive output stage can withstand a S/C this ensures no sound degradation whilst driving up to totally reactive loads with zero resistance.
- 6 Balanced circuitry** Symmetrical design gives inherent stability and linearity eliminating the need for DC servos which degrade LF distortion.

AND THERE'S MORE . . .

SONIC COLOURATIONS 'ELIMINATION' In addition, by careful and innovative engineering we have ELIMINATED 5 of the major causes of 'Sound Colourations' associated with conventional amplifiers:-

● O/P Emitter Resistors The active class A system is inherently thermally stable, not requiring emitter resistors which degrade sound quality, increase O/P impedance and increased crossover distortion and temperature related distortions. ● Zobel networks Low value R, C (across O/P) the single most significant cause of musical transient compression, *Eliminated* ● HF Pole Compensation This low feedback design is totally stable not requiring ANY COMPENSATION CAPACITORS which cause HF distortion and phase non-linearity resulting in a true, clear sharply focussed stereo image ● Fixed bias Vbe multiplier a known source of temperature generated distortion with thermal tracking time lag problems, eliminated. ● Capacitor Sound symmetrical DC design has eliminated virtually all conventional capacitors (and sound colourations), those left are of the highest sonic types and uniquely designed such that NO signal voltage is allowed to appear across them for the lowest possible source of 'CAPACITOR SOUND'.

AND STILL MORE . . . We can't possibly describe this unique Super Hi-Fi amplifier fully in this ad, to receive a full size 8 page glossy brochure giving full technical details send £1 and a large SAE (6 IRC) Supermos 2 modules £140 plus £2 p/p per module.

The original Supermos 50-150W £65 plus £1.50 p&p per unit. User manual £2.50 refunded on purchase.

SPECIAL OFFERS - Grade 1 audio PSU caps brand new Mullard 114 22,000u 63V £18 each, 36amp 600V bridge recs £4.50, MOSFET's 10A 170V T03P matched pairs £11/pair, MJ11015/16 darlington, brand new matched pairs £8/pair. **APRIL PSU KIT OFFER** - 4x22,000u 63V CAPS, 2x36amp bridges £68 (normally £81) or only £60 if ordered with two Supermos 1 or Supermos 2 modules. Offer for this month only.

SAGE
AUDIO

Sales Dept, Construction House, Whitley Street, Bingley, West Yorks. BD16 4JH, England.
Tel: (0274) 568647. Tlx: 517783, Fax (0274) 551065.

Next Month in



ELECTRONICS TODAY INTERNATIONAL

Next month's ETI features even more ingenious projects and instructive features. The comprehensive news section keeps you up to date with the best new products as well as with the movements of the world and its stomach. As Napoleon said - "Not tonight Josephine, I'm trying to get this co-processor going".

It was in the early 1930s that ETI exploded onto the newstands of depression-ravaged Britain, although it only sold its first copy in 1972. That copy was bought by a Mr. Sinclair of Cambridge and he's never looked back. "I laughed so much I crashed my C5 into the Hoover factory" he said, though no one bothered taking much notice.

Other world leaders say:

"I cried until I got an Oscar" - Sally Fields.

"I'm glasnost 'available in Russia" - Gorbachov & Vladivar.

ETI is read in 44 different countries, and all by Mr. G. Smith of Croydon. "Next month I hope to read it in Malawi" he said in an exclusive satellite linkup with *Watch with Mother* "but I'm having trouble getting a copy."

Lucky readers who do find a copy will discover the May issue packed with a fully computerised bicycle speedo, the ETI universal panel meter, a lucid dream machine, the next part of the Virtuoso Power Amp, the final part of the Spectrum Co-processor, more on capacitors and much, much more besides.

Make 9th April your May Day with ETI

The articles listed are planned for the next issue but may not appear due to circumstances beyond even our control

SECURITY

Modules
Systems
Accessories

SAVE ££££'s BY INSTALLING YOURSELF

MINIATURE PASSIVE INFRA-RED SENSOR RP33

Size only 80x60x40mm. Detects intruders up to 12 metres away.



- 12 metre detection range.
- Size only 80x60x40mm.
- 24 Detection zones.
- Wide 85° coverage.
- Switchable LED indicator.

This advanced new intrusion detector operates by detecting the body heat of an intruder moving within the detection field. The use of a dual element pyroelectric sensor means that changes in ambient temperatures are ignored, thus providing a stable and reliable performance. Easily installed in a room or hallway, the unit will provide effective detection of any intrusion. Operating from a 12V supply and consuming only 15mA, it is ideal for use with the CA 1382, CA 1250 or any equivalent high quality control unit. Supplied with full instructions, its performance compares with detectors costing more than twice the price.

CA 1382 ADVANCED CONTROL UNIT that's simple to install and operate.



- Fully automatic siren re-set.
- Audible entry/exit warning.
- Alarm Sounded memory.
- 2 separate loop inputs + 24hr circuits.
- Built-in electronic siren.
- Easily installed, full instructions supplied.

The latest control panel provides effective and reliable control for all types of security installations. Its advanced circuitry checks the loop circuits every time it is switched on, preventing incorrect operation. Using a simple 'on/off' key switch, it is easily operated by all members of the family. In addition it provides 24 hr. personal attack protection. Housed in a steel case, it is supplied with full operating instructions.

Only £44.95 + VAT Available in kit form with fully-built electronics, £39.95 + VAT.

CA 1250 LOW COST ALARM CONTROL MODULE



This tried and tested control unit represents the finest value for money in control systems, providing the following features:

- Built-in electronic siren drives 2 loud speakers
- Provides exit and entrance delays together with fixed alarm time
- Battery back-up with trickle charge facility
- Operates with magnetic switches, pressure pads, ultrasonic or LR units
- Anti-tamper and panic facility
- Stabilised output voltage
- 2 operating modes full alarm anti tamper and panic facility
- Screw connections for ease of installation
- Separate relay contacts for external loads
- Test loop facility.

Price £19.95 + VAT

HW 1250 - ATTRACTIVE HOUSING plus HARDWARE FOR CA 1250

An attractive steel case designed to house the Control Unit CA 1250 together with the appropriate LED indicators and key switch (available separately). Supplied with the necessary pillars, fixings, and punched front panel, the unit is given a professional appearance by the adhesive silk screened label. Size: 200x180x70mm.

Only £9.50 + VAT

COMPLETE SYSTEM
FROM
£39.95
+ VAT

Full Technical Advisory Service

DP 3570 LIGHTING CONTROLLER

This versatile module provides timed switching of loads up to 3A for pre-set times between 10 secs and 5 mins, the timed period being triggered by the opening or closing of an external loop or switch. The built-in 12V 250mA power supply is available for operating external sensors. Suitable plastic enclosure £2.85 + VAT.

Only £13.95 + VAT

FL 500 QUARTZ HALOGEN FLOOD LIGHT



Whilst intended for security lighting applications, this unit is suitable for lighting patios, pathways and gardens etc. Supplied complete with 500W lamp, Protective grill, £1.95 + VAT.

Only £14.95 + VAT

IR 1470 - 50ft. INFRA-RED BEAM SYSTEM

Consists of a separate transmitter & receiver, the system provides an invisible modulated beam which when broken operates the built-in relay. For use with security systems, but also ideal for photographic purposes and industrial applications. Size: 80x50x35mm.

Only £25.61 + VAT

US 5063 DIGITAL ULTRASONIC DETECTOR

• 3 levels of discrimination against false alarms • Crystal control for greater stability • Adjustable range up to 25ft • Built-in delays • 12V operation.



This advanced module uses digital signal processing to provide the highest level of sensitivity whilst discriminating against potential false alarm conditions.

Only £13.95 + VAT

ULTRASONIC MODULE ENCLOSURE

Suitable steel enclosure for housing the US 5063 supplied with the necessary mounting pillars and fixings.

Only £2.95 + VAT

RISCOMP LIMITED

The Security Specialist

Dept ET14
51 Poppy Road
Princes Risborough
BUCKS
HP17 9DB

ORDER BY MAIL
OR TELEPHONE

Mon. to Fri.
9 a.m. - 5 p.m.
Closed all
day Sat. &
Sun.

RsP U.K. orders 75p
Export orders add 10

Visa

Tel: (084 44) 6326

READ/WRITE

LETTERS

When studying the ETI Concept (October 1987) and the Heating Management System (December 1987) I noticed the of 1N4148 diodes across relay coils.

I consider this to be fundamentally incorrect as this type of diode is not suitable for this type of service.

I have experienced failures (about 100) doing a similar function. I think designers have forgotten one of the fundamentals. When using transistor drives, especially on gates (ICs), their switching times can be extremely fast.

If I remember my theory correctly, the peak inverse voltage (PIV)= di/dt . So with a coil current (di) of say 0.06A and a switching time of say 100ns then $PIV=600000V$. Only 1N4007 diodes are appropriate.

Finally, the article Home CADMAT (October 1987) was rather irritating because of the relatively high cost of commercial CAD packages and quality assemblers for the BBC micro or IBM PC compatibles. Has any thought been given to publishing a PCB design program in Basic?

R A J Howard

New Farnley, Leeds

Nice try but although your formula is correct, it's the wrong formula. $PIV= di/dt$ only applies to circuits *without* the diode. The diode is placed across the relay coil to prevent just this voltage build up. *With* the diode, inverse voltage is limited to 0.7V — the forward voltage across a diode.

The reason your diodes were failing was probably due to excessive instantaneous current — not voltage.

To solve *that* problem an 1N4007 would be a good idea although these devices may be too slow to conduct to protect the driver circuit.

The idea of Home CADMAT was to write programs and build equipment of your own rather than rely on the expensive commercial variety. However, we shall look into the possibility of a PCB design program in Basic. Any readers care to contribute?

At last! Other ETI readers are revealing their true colours by coming out in favour of *Doctor Who* (Read/Write, January 1988).

I too was pleased to see the return of the good Doctor to the realms of our FST Trinitrons and equally appalled to see him still accompanied by Bonnie Langford (good though she is at screaming).

The good news is she has left the series. The bad news is the series has ended (three stories — a series?!)

Come on BBC let's have less of Anne Thingy and *Points Of View* and some more *Doctor Who*, immediately.

John 'Cyberman' Graham
Gallafrey.

Yes, yes, but why tell us? Shouldn't you be writing to the BBC (even 'Anne Thingy') and heckling *them*?

By the way, how can impoverished ETI readers afford FST Trinitrons?

I'm glad to see you're taking a look at the world of satellite television. This has long been a subject which has interested me.

However, I feel your introductory look at STV (January 1988) was short of one important aspect of the installation — planning permission.

Planning permission is required for any dish of more than 90cm diameter. Different local authorities take different views on the obtrusive nature of satellite antenna but all tend to take eons to express their views in the form of permission!

It can take months for planning permission to go through and stories of over a year are not uncommon. Some local authorities insist the dish is disguised with shrubs or even painted green!

So be warned, before you part with the ready, you have the local bureaucracy to contend with.

Mark Pinna

Walkley, Sheffield.

Too true. It does seem ridiculous that you can put up a 15 foot greenhouse and paint it pink and the council won't (and can't) do a thing about it but put up a 4 foot aerial hidden behind your garden fence and they go berserk.

As the government is trying to encourage satellite TV for the future (in the form of DBS) it is ridiculous it is now discouraging the fore-running service. Write to your local MP and local councillor.

In the August to December 1986 issues of ETI you published a series of articles on an Intelligent Call Meter project to automatically log the cost of telephone calls.

The project began with a warning which said that although the meter was not BAPT approved 'it can be used as the basis of a submission for approval.'

Have any readers submitted one of these devices to BT and was it approved. If it was rejected — on what grounds?

S Green

Smethwick, West Midlands.

Devices can be submitted to the BAPT either for 'one off' approval or for approval of design (which includes the entire manufacturing process). So, any reader submitting the ICM for approval would only obtain approval for their own particular model. Only if they go into production (which they cannot without the permission of the author and ETI anyway) can a generalised approval for the ICM be granted, and then only for those produced by the approved method of production.

In other words, you're on your own!

*Don't seethe in
silence over the
woes of the world.
Don't keep your
mind-blowing
praise to yourself.
Let us all have a
giggle. Keep those
letters coming to:*

**ETI
1 Golden Square
London
W1R 3AB**

CAPACITY FOR THOUGHT

The capacitor is a much used but often misunderstood component. John Linsley Hood turns your doubts to dust with a two-part look at all things capacitive

CAPACITORS

There is an old joke that a metallurgist is someone who, given a choice of materials, chooses wood . . . The point, I suppose, being that any specialist who knows the snags inherent in his chosen speciality is likely to be more enthusiastic about the potential use of something else.

This is basically how I feel about capacitors. For some years I was involved in the manufacture of the polypropylene film used in making capacitors, responsible for the electrical evaluation of our own and competitive films of various types to see how well they would perform.

This was quite an interesting project and involved visits to a large number of capacitor manufacturing companies to discuss the use of polypropylene and other films in this particular field.

I don't think that this makes me a capacitor specialist, but at least I have had a rather closer acquaintance with this topic than is normal for electronics engineers. I know a lot of the unpublished problems.

So Say The Hi-Fi Buffs

Quite a lot has been written in recent years in the 'Hi-Fi' and electronics press about the differences in sound quality which can be brought about by changes in the type of the 'passive' components used in the audio system, whether these be resistors, capacitors, connecting cables, mains transformers, printed circuit board materials, solder, or even the fixing screws with which the cases are held together.

With most of these claims technically plausible explanations for the observed effects are usually only remarkable by their absence.

The tests on which they are based are also inevitably subjective in their nature and rely on listening trials which, however extensive, can seldom be conducted on an instantaneous 'A vs B' switch-over comparison. Where any length of time elapses between two alternatives, the memory becomes clouded and expectations begin to colour the observations.

There may be basis for the claims, though I feel that these are often exaggerated or incorrectly interpreted by their discoverers — like the change in sound quality (sometimes even for the better, since it lessens 'crossover' distortion) which happens when an amplifier having a poor stability margin is caused to oscillate at some ultrasonic frequency by the unwise connection of high self-capacitance LS leads. I remain agnostic.

Nevertheless, in the case of capacitors and particularly in the case of those used in the feedback loop of an amplifier using negative feedback (NFB), I feel that a good case can be made for care in their choice, since there are effects which are capable of being measured instrumentally as well as being heard.

But there is no blanket answer to the question of which capacitor do I use — it will depend on where you want to use it, what are the particular qualities which are especially needed in that

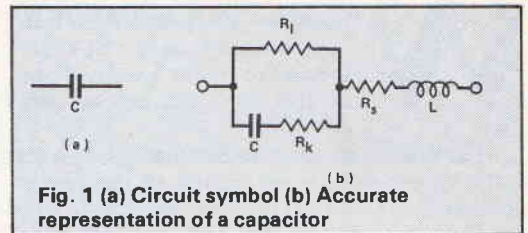

Fig. 1 (a) Circuit symbol (b) Accurate representation of a capacitor

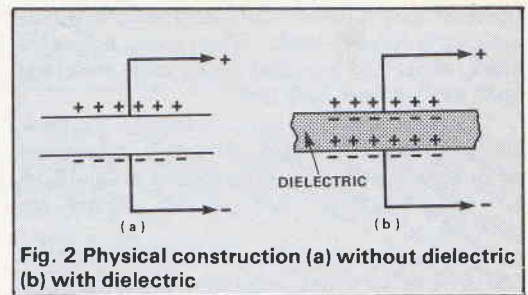

Fig. 2 Physical construction (a) without dielectric (b) with dielectric

position, how much space you can spare, and how little bothered you are about wasting money.

As for polypropylene (the current favourite of the 'golden-eared' fraternity) the questions I would ask are 'what type, how made and by whom, and how used?' So, let us look at some technicalities.

Normally in circuit diagrams the circuit symbol shown in Fig. 1a is used to depict a capacitor, but in reality it is more accurately represented by the drawing of Fig. 1b, where 'C' is the capacitance at some specified frequency, temperature and applied voltage, 'R_l' is the leakage resistance across the capacitor (which again may be temperature, humidity, frequency and applied voltage dependent), 'R_s' is the equivalent series resistance due to dielectric loss (again not a constant factor), 'R_k' is the straightforward series resistance due to its method of manufacture, and finally 'L' is the inevitable inductance of the component.

Physical construction

In principle, a capacitor is a pair of conductors in proximity to each other but not in electrical contact, such as a pair of parallel conducting plates in a vacuum (as shown in Fig. 2a).

When an electrical potential is applied between these plates, electrons will flow into the negatively connected plate from the negative pole of the applied potential. An equivalent number of electrons will be repelled away from the opposite plate and will flow towards the positive pole of the applied potential. If there is some circuit resistance this will lead to the familiar charging current stage shown in Fig. 3.

If the potential is removed and the wires from the capacitor are shorted together the same process will happen in reverse, so the wires will probably spark as they touch since there is now no longer any reason for the asymmetry of charge on the plates.

The theoretical value of such a capacitor (ignoring the effects of fringe fields at the edges of the plates) is given by the formula:

$$C = AK/11.315d \text{ (pF)}$$

where *A* is the effective opposed area of the plates, *K* is the dielectric constant of the material separating the plates (=1 for vacuum or air), and *d* is the gap separating them — all dimensions being in centimetres.

The practical problems of such a construction are due to the need to prevent the plates from touching and the difficulty of getting any large amount of capacitance.

These can be solved if some insulating material is fitted into the gap, as I have shown in Fig. 2b. If this is thin and has a good electrical strength, the gap *d* between the plates can be made very small which increases the capacitance for a given effective plate area (see the formula above).

Dielectric For Division

The capacitance will also be increased because the dielectric constant *K* of the insulating material will be greater than unity.

This comes about because all such insulating materials will 'polarise' to some extent, either by the displacement of orbital electron clouds surrounding the atoms of the constituent material, or by the migration of ions, or by the physical reorientation of polar molecules.

This has the effect of producing equal but opposing charges on the surface of the insulator facing the capacitor plates (Fig. 2b) which lessens the effective spacing between the plates.

Unfortunately, the introduction of a dielectric brings the problem of leakage (though this isn't such a problem with modern materials as it was with the old waxed paper insulated 'tar babies' of my early years in electronics!)

The insulation may break down electrically though there are techniques for reducing this hazard. The dielectric constant may not be constant — certainly it will decrease with applied frequency and will also be affected to a lesser extent by temperature and applied voltage.

Finally the dielectric introduces 'dielectric loss' which is represented by the term '*R_k*' in Fig. 1b. This comes about (understandably) because the migrations of electrons or ions or the molecular reorientations (which produce the effect shown in Fig. 2b, and which cause the increase in capacitance) all absorb some energy when they occur, which is every time the applied electrical field is reversed.

The more frequently the polarity of the applied electric field is reversed (the higher the operating frequency) the higher the loss. Materials such as the largely non-polar plastics (polyethylene, polypropylene, PTFE, and polystyrene) don't have very high dielectric constants — which doesn't help very much to make compact high value capacitors. On the other hand very little happens when the field is reversed, so the dielectric loss is very low and the dielectric constant *K* doesn't alter significantly with frequency (up to the GHz range).

The thinking of the hi-fi purists is largely coloured by considerations of dielectric loss, and 'pp' is reputed to be very low and therefore very good. However, the actual loss factor depends on the purity of the material, on the way in which it is made (including additives included to assist in production and the extrusion temperature). I have

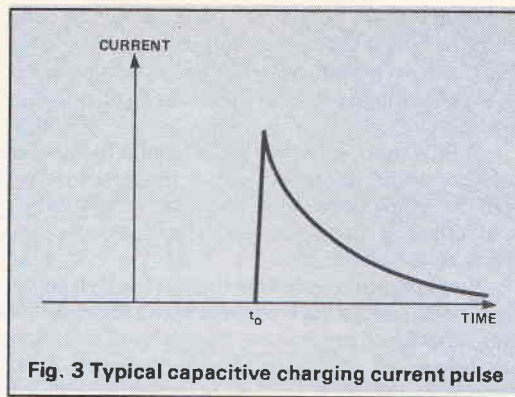

Fig. 3 Typical capacitive charging current pulse

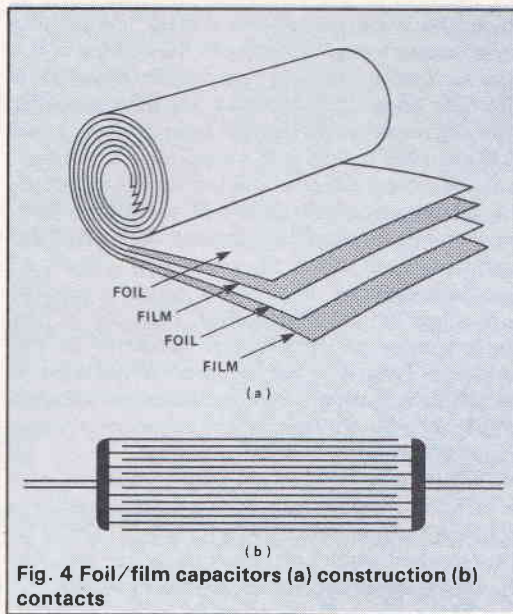

Fig. 4 Foil/film capacitors (a) construction (b) contacts

listed the major qualities of the most common dielectric materials in Table 1, but as I have indicated these figures can only serve as a guide.

Non-polar Manufacture

Generally, plastics film insulated capacitors are either of the film/foil type, or of the metallised film construction. In the 'F/F' type, two long lengths of aluminium foil (which should be scrupulously clean and of high purity if the loss factor of the capacitor is not to be worsened) are sandwiched between a pair of slightly longer strips of plastics film and the whole thing is wound up in 'swiss roll' form, as shown in Fig. 4a.

Usually the foils are arranged so they extend a bit beyond the edges of the film strips so that electrical end contacts can be made to them as

Dielectric Material	Dielectric Constant (K)	Breakdown Strength (Volts/mil)	Loss Factor (Tan σ , 60Hz)
Polyethylene (High density)	2.3	500-1000	0.0003-0.001
Polypropylene	2.2-2.3	450-650	0.0001-0.0003
Polyester	3.0-3.5	1500-2000	0.001-0.005
Polystyrene	2.5-2.6	500-100	0.0001-0.0002
Polycarbonate	2.97	400-450	0.0001-0.0005
PTFE	2.1	500	<0.0001
Polysulphone	2.82	420	0.008
Mica	5.4	2500	0.0005
Ceramics	30-6000	50-250	0.01-0.4

Table 1 Characteristics of some common dielectric materials

shown in Fig. 4b. Sometimes (as is usually the case with the small polystyrene capacitors) the foils don't overlap the film but a pair of connecting wires is simply trapped in the spiral while it is being wound.

With larger capacitors it is helpful to make a continuous edge contact since this lessens the spurious inductance value, because of the 'shorted turn' effect. It also helps keep the electrical resistance of the plates low.

In all film/foil capacitors the electrical strength and consequently the thickness of the film must be great enough to prevent any possibility of electrical breakdown at the rated working voltage. Such capacitors therefore tend to be bulky for a given capacitance value.

In the case of the metallised film (MF) types, the problem of possible electrical breakdown is solved by using a very thin metallic conducting layer, vacuum evaporated onto the surface of the film so that it leaves a clear strip along each alternate edge. End contacts are then made by spraying a solderable metallic layer onto each end of the sandwich. Such MF capacitors will 'self heal' in that if there is a local breakdown of the dielectric, the instantaneous discharge of the stored electrical energy through the puncture will burn off the metallised layer in that region.

Such internal flash-overs cause a gradual worsening of the loss factor because of the accumulation of combustion products in the windings. They also cause a gradual decrease in capacitance. Both of these problems are lessened significantly by not running the capacitor at more than half of its rated working voltage.

The major problem with 'MF' types however is that the metallised layer is so thin and has a significant winding resistance R_s which cannot be distinguished electrically from dielectric loss. On the other hand they are very small in size.

There has recently been an increased availability of stacked foil capacitors, a number of postage stamp sized pieces of film with either metallised layer or foil plates assembled into a small rectangular stack, and then resin encapsulated with projecting radial connection leads as shown in Fig. 5. These have the advantage of low series inductance and compact PCB assembly, but are otherwise similar in characteristics to the spiral wound versions.

Tantalum And Aluminium Electrolytics

In these capacitor types, a large value of capacitance is obtained by chemically growing a very thin insulating oxide film on the surface of an etched metal plate or a pellet of sintered metal powder, with a conducting electrolyte occupying the gap between this and the other plate. This avoids the problem of electrical failure through breakdown of the insulating layer because if there is a puncture in the oxide film it is promptly repaired by local electrolytic action between the exposed metal and the electrolyte.

The snag is that this action is going on all the time, with continuous small pulses of current evened out by the capacitor itself into a fairly smooth current flow. The electrolyte though quite a good conductor is not as good as a layer of metal, which is why the non-polar capacitors always have a lower series resistance value. The other problems are that the value of the series resistance is dependent on voltage, temperature and frequency, as is the capacitance itself.

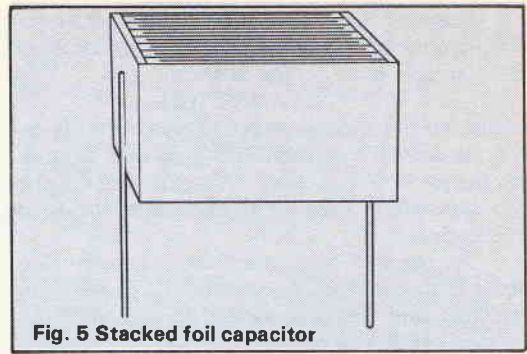

Fig. 5 Stacked foil capacitor

Also the polarity of the capacitor must be observed, and if any AC potential is likely to appear across it there must always be a continuous DC bias voltage which is greater than this. This means that electrolytics are not very happily used with zero polarising potentials.

When 'tantalum bead' (sintered tantalum pellet, resin encapsulated) electrolytics first appeared they were greeted with great enthusiasm since they had a lot of factors in their favour. The tantalum oxide dielectric was electrically and chemically very strong, and it had a much higher dielectric constant than alumina. This meant that a much more acidic electrolyte could be used giving lower series resistance, and more capacitance could be packed into a small volume.

In addition because of the strength of the oxide layer, the capacitor would even stand a small (0.5-1V) reverse potential which permitted use in signal lines. Unfortunately the instantaneous (though small) voltage dependence of conductivity leads to a complex behaviour pattern on transient voltage steps, and this can give a rather 'dull' sound when used as the blocking capacitor in a feedback line.

The increase in the cost of tantalum bead capacitors has stimulated research work on their aluminium equivalents with the result that physically small high-capacitance aluminium types are now available which are much to be preferred in audio use such as DC blocking in signal or feedback lines if high capacitance values are essential (though their quiescent working potentials must be carefully chosen).

Even so, non-polar types should always be the first choice, except in routine supply line decoupling duty.

Permanent Polarisation

This is the electrostatic equivalent of permanent magnetisation and is a snag which is exclusive to the plastics film dielectric types of capacitor.

As in steels, the durability of such a permanent polarisation is a function of the hardness of the material. It occurs much more readily in those films which are biaxially stretched during manufacture such as polypropylene or polyester (PETP) since this greatly increases their mechanical strength.

Those films which are made by casting from a lacquer (such as polystyrene, polycarbonate, or polysulphone) or by sintering a powder (such as PTFE) are much more limp physically and much less prone to this defect which can have the effect of building in a permanent series potential within the capacitor dielectric.

Circuit Applications

Next month I shall look in detail at the specific requirements of audio circuits and how best to fulfil them.

SURFACE MOUNT

IT'S NEW, IT'S HERE AND ONLY AVAILABLE THROUGH ETI MICRO MINIATURE SURFACE MOUNT PROJECTS

You've heard about them, probably seen and marvelled at them inside your calculator or watch and now you can begin using them with the latest range of surface mounted component kits from **SUMA DESIGNS**. All the kits are of well proven, in-house design and come complete with all components individually packed for easy identification, high quality fibreglass, surface mount, solder resist P.C.B., full assembly and circuit instructions. All you need is a pair of tweezers, a fine-tipped iron and a steady hand. Using assembly techniques developed to cope with our own prototype and batch manufacture you can be assured of success. To make things even easier we have developed a custom made component jig which although not essential greatly simplifies assembly and is well worth the investment. A full range of SM components are also stocked for your own projects.



- | | | |
|--------|--|--------|
| SM20: | SOUND TRIGGERED SWITCH:
Triggers from slightest sound, L.E.D. indication, variable sensitivity. | £13.95 |
| SM21: | DIGITAL DICE:
Touch control, roll down speed SM L.E.D. readout. | £15.95 |
| SM22: | VHF FM TRANSMITTER:
Complete with mic, tuneable over 88-108 band. | £12.95 |
| SM23: | LIVE WIRE DETECTOR:
Non-contact indication of live wires, blown fuses etc. | £9.95 |
| SM24: | VHF FM BLEEPER:
Transmits constant beep to nearby FM radio. Tuneable. | £13.95 |
| CHJ22: | Custom designed assembly jig for speedy and accurate assembly. | £6.95 |

Send 9 x 4 S.A.E. for full details of these and other kits plus all components available.
All prices are inclusive but please add £1.50 per order to cover post & packing.

SUMA DESIGNS The Workshops
95, Main Road, Baxterley,
Near Atherstone,
Warwickshire, CV9 2LE
Telephone: 0827-714476



T-SHIRT COMPETITION

Back in the halcyon days of 1980 ETI had a pretty nifty line in T-shirts for sale. Although those garments are long gone, the unclothed masses at the ETI editorial office want to resurrect the tradition and once again see the ETI logo across the chests of millions.

The only problem is we have no design (well, we wouldn't want to use the old one again would we). Since we're not only unclothed but overworked too, we haven't the time (well, OK, we haven't the imagination either) to come up with a good design. That's where you come in.

We are giving away three ETI T-shirts of the winning design and a year's subscription of your favourite mag (this one, silly!) to the creator of the best design for the ETI apparel. The design should be in just one colour, incorporate the ETI logo (as on the cover of this issue) and be suitable to fit on the front of a T-shirt. Although humorous designs would be appreciated, please bear in mind it is illegal to send obscene material through the post!

Get your grey cells working on the problem, draw the design on a large T-shirt shaped blank (like the coupon) and send it with a completed coupon to arrive by 15th April to:

**ETI T-SHIRT
COMPETITION
1 Golden Square
London W1R 3AB**

Name

.....

Address

.....

.....

.....

.....

.....

Size (S, M, L)

SATELLITE ACOLYTE

Keith Brindley rounds off his look at satellite TV with a detailed review of his favourite three systems

There are so many satellite television receivers around (see February ETI), with so many different features you'd be forgiven if you are confused by all the relevant specifications. It's for this reason that the final part of this series on STV concentrates on only three receivers, with the intention of an objective comparison — although, as you'll see, comparison isn't easy. The three receivers looked at have been chosen simply because they seem to provide the widest range of features and represent some of the best available systems.

They are all 'future-proof' (a term used by many manufacturers to show that their products can be up-graded with add-on boxes to receive scrambled signals and MAC signals). Other equally high quality receivers exist, however.

The three receivers reviewed are the Rediffusion RSR50, the Salora SRV1150 (both well known and highly acclaimed) and the newcomer Pace SR640.

Readers of the many satellite television magazines will already be familiar with the Rediffusion and Salora receivers but the Pace

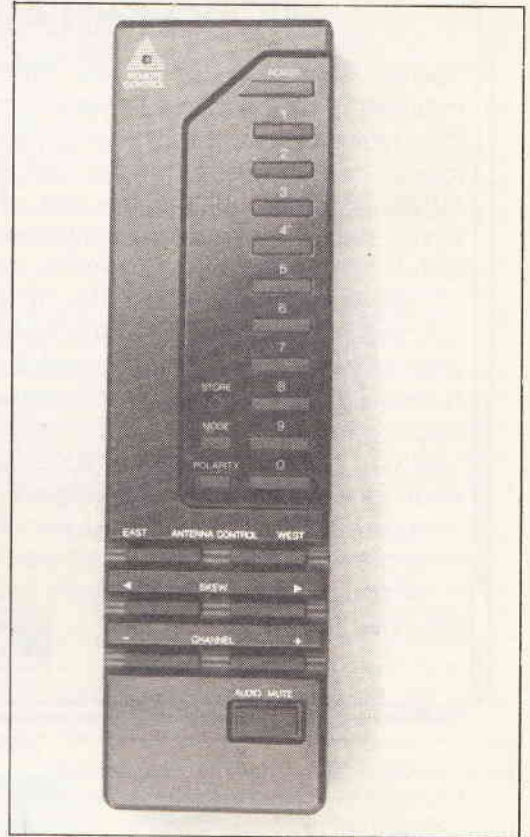

The idea had been around for a while of course, with some receivers able to store information regarding frequency, polarisation, audio sub-carrier frequency and skew, such that the touch of a single button (or at worst, two or three buttons) on the remote control handset would change the channel displayed on the television.

What distanced the RSR50 from the rest is that it allows the user to store antenna position relevant to particular channels too.

When channel changing from one satellite to another, users of other receivers must first adjust antenna position as well as changing to the required channel. RSR50 users merely have to press a single button — the receiver takes care of it all. This feature caught the eyes of the STV press and prompted one magazine to call the RSR50 the 'one to beat in 1987.'

The antenna position-controlling factor means that, whereas most other receivers require a separate antenna controller, the Rediffusion RSR50 is effectively an integral system.

I say 'effectively' because the receiver is not, correctly speaking, a stand-alone unit — a separate power supply is required, containing the transformer and relays required to control the antenna actuator. This power supply is merely for the antenna though, and the receiver still incorporates its own internal PSU, which means it can be used alone in a single-satellite installation (without an antenna actuator).

Without all the bulky antenna-controlling

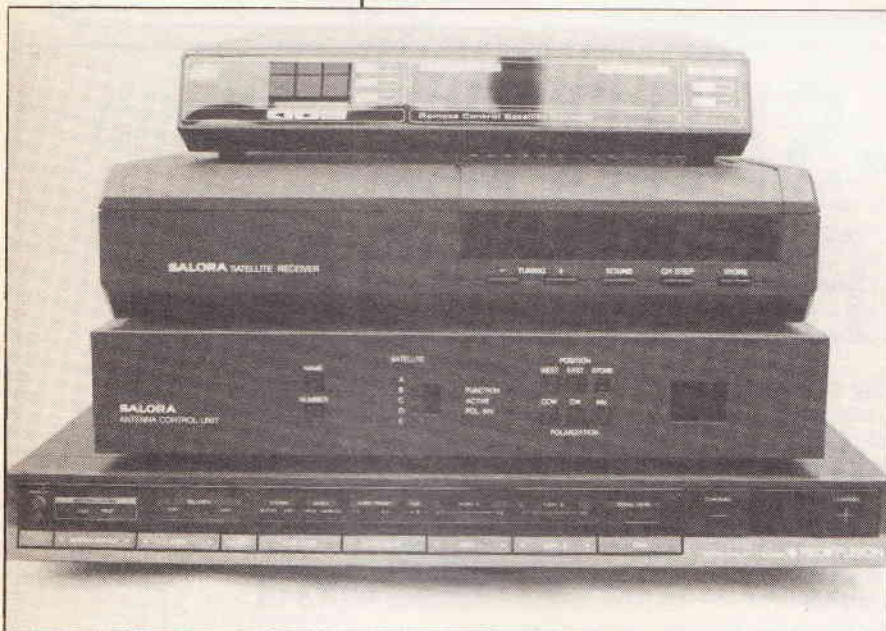

receiver (designed and built by Pace Micro Technology — perhaps better known for modems) will be a stranger. Nevertheless the Pace receiver, as you will see from the following, is a receiver to reckon with.

First, a brief description of the three receivers, listing a few relevant specifications and highlighting their quirks.

Rediffusion RSR50

Last year the RSR50 took the STV fraternity by storm. It was the first receiver which allowed the user to *fully* store all relevant information about individual satellite television channels.

STV

electrics, the RSR50 has quite a low profile in comparison with most other receivers and is of such a width, depth and colour as to be extremely handsome sitting on top of your video cassette recorder underneath your telly.

Apart from its good looks the RSR50 also has some specifications worthy of note. First it has a reasonable carrier-to-noise threshold of only 8dB — so even fairly weak signals will produce pictures. Its IF bandwidth of 30MHz allows a good picture resolution for most channels (only Superchannel, Teleclub and RAI-Uno have higher bandwidths — 36MHz — than this).

For transmissions in stereo sound the RSR50 has stereo audible outputs allowing direct connection to a hi-fi system. Video outputs allow similar direct connections to video recorders or TV monitors for higher quality pictures than the UHF output affords.

Whereas most other receivers accommodate descramblers or MAC decoders simply by featuring a baseband output, the RSR50 also has a descrambler 'loop-through' socket. When descramblers are available, only one inter-connection will be required, so installation will be a doddle.

The remote control handset is a delight to use. Single-handed operation (either hand) is possible simply by moving your thumb around to reach only a few logically placed buttons. This is the result of two things incorporated into the receiver; first, the stored details for antenna position, channel frequency, polarisation and so on which mean that a single button press changes received channel. Second, the receiver has two main operating modes, the handset buttons meaning different things in each.

Main mode is called memory mode. In this, channels are selected simply by pressing a numbered button — Premiere may be programmed into channel 1, so pressing button number 1 selects Premiere. Logical, huh? Up to 50 channels can be programmed into the receiver and as there are only ten numbered buttons, channels above number 9 require two button presses. In both modes, other buttons on the handset allow control over antenna position, polarity, skew and audio mute.

The other mode is search mode, entered from the handset by pressing the mode button then button number 1. In search, the receiver creates an on-screen graphic displaying the frequency of the received transmission. Handset buttons marked channel- and channel+ allow tuning of this frequency up or down. The numbered buttons can also be used to jump to a desired frequency (the IF frequency range of 950-1750MHz is split into eighty 10MHz steps). Once a channel is located, and all relevant details have been selected, it can be allocated a channel number by pressing the store button (inset into the handset) followed by the desired number.

Once back in memory mode (accessed by pressing the mode button twice) that channel complete with relevant antenna position can be selected just by pressing its number.

In operation, there are few things to complain about. A great deal of thought has obviously gone into the receiver in a successful attempt to make it user-friendly, resulting in the two operating modes. Single-button channel selection is a sheer delight and I'm sure many other manufacturers will be rushing to adapt this feature into their products to compete. On-screen graphics are clear and precise and remain synchronised even when no

signal is picked up, say when the antenna is tracking between satellites.

The only real niggle with the receiver was the lack of any facility for accurately metering signal strength — useful when installing and setting up the antenna. The integral bar-graph signal level display isn't sufficiently accurate.

Salora SRV1150

This receiver has been around for a little while and as such you might be forgiven for thinking that technology has overtaken it. However, quality-wise you'd be wrong to pass it over. Whereas the Rediffusion RSR50 control-antenna-positions directly, a Salora system actually comprises receiver and a separate antenna control unit (ACU 1160) — this makes a 'feature-by-feature' comparison a little tricky.



In overall specification terms, the Salora system is every bit as good as anything else around. Threshold is 9dB (not quite as good as the Rediffusion RSR50 and a lot poorer than the PACE SR640). On the plus side, an IF bandwidth of 32MHz means that picture resolution is theoretically much better. The argument goes that a picture formed from a signal with a carrier-to-noise ratio less than about 9dB isn't worth watching, so you might as well have a good picture resolution when a stronger signal is available.

The receiver itself is smartly designed but this is slightly offset by the presence of the antenna control unit which, although the same colour, doesn't quite match in style. Back panel connections for video, sound and baseband outputs are provided for direct connection to video cassette recorder or monitor.

Operation of the receiver is straightforward enough. Front panel buttons for tuning (+ and -), sound (one of four preset subcarriers), channel step and store are the only controls provided and once the antenna has been pointed at a satellite, it's a simple job to locate channels and store them ready for watching — much as you'd tune in a UHF television tuner. Setting up the antenna control unit to store details regarding antenna position, channel polarity and skew, is somewhat more involved. Nevertheless, lengthy instructions are provided, albeit translated — presumably from Finnish. Satellites are numbered from A1 to A6, B1 to B6 through to E6 — a total of 30 satellite positions.

One of the trickiest concepts to come to terms with is the fact you have to allocate different polarity signals into set channel numbers. This depends on a rear panel switch setting. Either odd channel numbers all cause the polarotor to be

STV

vertically polarised and even channel numbers cause the polarotor to be horizontally polarised or channels 1 to 16 switch the polarotor for vertical polarisation and channels 17 to 32 switch it for horizontal polarisation.

A compact remote control handset is provided which takes a while to get used to. Channel buttons are numbered in white from 1 to 16, doubling up from 17 to 32. Choosing between hexadecimal groups is done with two other buttons marked 1-16 and 17-32. Buttons for antenna polarity and position are provided, as are buttons used to initiate the satellite selection procedure and to return to channel selection.

Although a parental-lock isn't a feature of the SRV1150, it is possible to lock the antenna position so mean mummies and daddies wishing to frustrate their offspring could lock the antenna into a position where no satellite is sited, effectively rendering the system useless.

Where the system falls down is in general operation. Changing channels on a single satellite is easy enough, a maximum of two button presses will select any channel stored. But, when you wish to change to a channel located on a different satellite, things begin to get tricky. First, by pressing the SAT button on the handset, the satellite selection procedure is invoked. Then the satellite wanted (A1 to E6) is keyed in using the blue lettered buttons on the handset for the letter, followed by its number — at this point the antenna control unit moves the antenna to suit. Then, by pressing the CH button to return the system back to channel selection, the required channel is finally located. Although logical enough, it is a lengthy procedure, all of which could entail a total of six button presses — try doing that after a Vindaloo and five pints of lager!

That really is the system's only fault (if you can call it a fault). It is, however, only apparent when considered beside receivers like the Rediffusion RSR50 and the Pace SR640 because they are so simple to use. Most other receivers are equally as complex, if not more so, than the Salora 1150 system.

threshold of all (6dB) the SR640 will produce a picture where the others haven't got a sufficiently high carrier-to-noise ratio — not that picture quality at a carrier-to-noise ratio of 6dB is worth watching (see March ETI).

On the other hand, an IF bandwidth of only 27MHz means that picture resolution for those channels such as Superchannel, with bandwidths around 36MHz isn't as good as, say, the Salora SRV1150's. However, the trade-off between resolution and sensitivity which Pace seems to have made means that fewer sparklies will occur when a weak signal is received when compared with wider IF bandwidths, lower sensitivity receivers.

Back panel sockets for the usual audio, video and baseband outlets allow direct video cassette recorder or television monitor interconnection.

Only three controls adorn the SR640's front panel, two of which are labelled with left and right going arrows (channel down and channel up — in normal mode) and a mode control which steps the receiver through the three modes — NORM (normal), DISH and TEST.

The remote control handset is quite easy to use. Ten numbered keys 0-9 are used for channel selection and can be used for single-button channel selection (see later), although channels are generally in decades — 1-9, 10-19, 20-29, and 30-39. Two buttons, tune- and tune+ adjust received frequency. Two buttons, decade- and decade+ select which decade of channels are accessed. One button alters polarisation and a number of buttons are used to store antenna position and channels. As well as a single mute button, volume can be turned up or down (a nice feature) with the vol- and vol+ buttons and finally there is a standby button.

The receiver is factory pre-set so that different satellite positions are allocated to each decade of channels, which means that to change to a channel from a different receiver up to four buttons may have to be pressed in sequence. However, users can store channels from different satellites within a single decade if they wish, thereby making single button channel selection possible.

Channel selection takes place in normal mode and users will rarely need to access any other mode. In dish mode, for example, the two arrowed keys on the front panel change function to adjust dish position east and west. Dish mode is also the mode used when channels are to be stored in the receiver. Like the Rediffusion RSR50, all details of a channel including antenna position are stored together with a corresponding channel number so when in normal mode, users can select a channel (and antenna position) merely by pressing the channel's number.

There are three test modes. Test mode 0 produces a black and white UHF test signal used when tuning the television receiver upon installation. The other receivers in this review also feature such test signals, via switches on the rear panels. Test mode 1 converts the digital dish position display on the receiver's front panel into a digital display of signal strength — extremely useful when siting the antenna. Test mode 2 is a skew adjustment, allowing the receiver to adjust the antenna polarotor's absolute vertical and horizontal positions — only undertaken once on installation.

Quirks are few and far between. The only significant hardware problem is the lack of a UHF 'loop-through' facility which, a company spokesman has concurred, is to be included in the near future. Without 'loop-through' UHF, signals from a

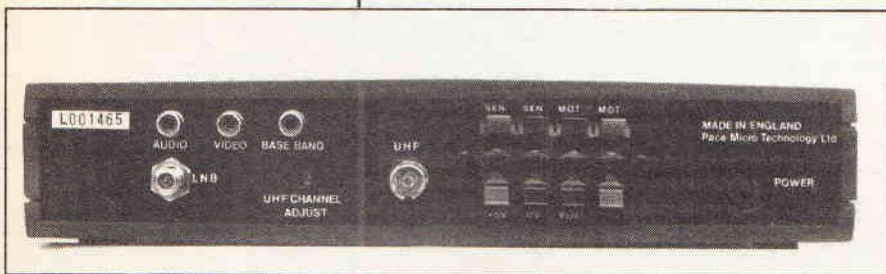

Pace SR640

Satellite television receivers are a new venture for Pace and it's interesting to consider why the company has gone down this path. Their first product, the SR640 follows in the Rediffusion RSR50's footsteps in that it has separate modes of operation, making use extremely easy.

Also like the RSR50, it is an integral system rather than just a tuner. It has a similar separate power supply too, although Pace has gone the whole hog with the SR640 and put the receiver power supply in the separate black box. This fact makes the SR640 itself the smallest (to my knowledge) and lightest receiver on the market. Housed in a custom-adapted Vero Proteus instrument case, the receiver is certainly neat.

Specifications are, like the other receivers in our comparison, pretty good. Featuring the lowest

STV
MIS

terrestrial aerial aren't passed through to the following video cassette recorder and television. Either users have to swop UHF leads, or a UHF splitter/combiner is required. The only other minor niggle is the fact that on power-up, the receiver jumps to the first channel of whichever decade it was in on power-down. When using normal factory preset channels and decades this makes absolutely no difference but if you prefer to store different satellite channels on single decades and if you were watching a channel from a satellite other than that stored at the first channel of the decade on power-down, when powering-up again the receiver will reposition the antenna before a picture is obtained. So a wait of quite a few seconds will elapse before anything is seen. This could be prevented with a software change to either power-up the receiver in the channel it was in on power-

down or to put the receiver on standby when powered-up.

In Conclusion

Well, we said comparison isn't easy, didn't we? Each receiver in this review has its own pros and cons and deciding which is the best is well nigh impossible. Best value for money has to be the Pace SR640. The Rediffusion RSR50 just pips the SR640 to the post when considering which is easiest to use. Highest quality picture resolution must be the Salora SRV1150 (due to its IF bandwidth) but the SR640 with the narrowest IF bandwidth gives a picture which is sparkly-free with the weakest of signals when the other two show some most irritating interference.

Ah, you pays your money ...



STV

Features/facilities/specification	Rediffusion RSR50	Salora SRV1150	Pace SR640
Technical			
Input level	-60 to -25dBm	-60 to -30dBm	
Threshold (C/N)	8dB	9dB	6dB
IF bandwidth	30MHz	32MHz	27MHz
Unclamped baseband output	yes	yes	yes
Baseband level control	yes	yes	no
Video output	yes	yes	yes
Audio output	yes	yes	yes
subcarrier range (tunable)	5-8.5MHz	—	6-6.8MHz
subcarrier range (preset)	6.5, 6.6/6.65MHz	6.5/6.6/6.625/6.65MHz	—
subcarrier range (automatic)	—	—	6.5/6.6/6.65MHz
type	mono/stereo	mono	mono
UHF: modulated tunable output	channels 30 to 39	channels 30 to 39	channels 32 to 40
test signal	yes	yes	yes
'loop-through' input	yes	yes	no *see text
Descrambler 'loop-through'	yes	no	no
Signal: strength display	yes	yes	no
strength metering	no	yes	yes
Polarotor output	pulse	pulse	pulse/IRTE
Actuator control	36 volt + pulse	36 volt + pulse	36 volt + reed
Dimensions (mm): receiver control/PSU	430(w)×45(h)×350(d) 140(w)×72(h)×150(d)	340(w)×78(h)×230(d) 340(w)×70(h)×270(d)	275(w)×60(h)×290(d) 125(w)×90(h)×125(d)
Operating instructions	adequate	adequate	good
Facilities via remote control			
Polarity	yes	yes	yes
Skew	yes	yes	no
Antenna position	yes	yes	no
Channel select	yes	yes	yes
Channel store	yes	no	yes
Tuning	yes	no	yes
Mute	yes	no	yes
Volume	no	no	yes
Standby	yes	yes	yes
Mode change	yes	—	yes
General			
Operating modes	memory/search	—	norm/dish/test
Parental lock	yes — single channel	*see text	no
Number of programmable channels	50	32	39
Pre-programmed satellites/channels	yes	yes	yes
Scan	yes	no	no
Number of antenna positions	50	30	12
Single-button channel/satellite select	standard	no	*see text
On-screen graphics	yes	no	no
Antenna position limits	yes	yes	yes
Adjustable polarotor skew	yes	yes	yes
Designed/built	Japan	Finland	UK
Typical receiver/controller/supply price	£475	£650	£410

COUNT ON IT

Mike Barwise takes a look at the Fairchild 74F525 and finds there's a lot of counter squeezed into this chip

New generations of logic devices within extant generic families usually differ in terms of power and speed. However, sometimes a manufacturer will use the new generation to introduce additional new devices.

Such a device is the 74F525 programmable divider from Fairchild. This is a versatile device which can be used wherever binary programmable digital timing is needed. It is typical of new introductions in logic in that it incorporates the functions of about half a dozen separate conventional chips in one package.

The 74F525 (Fig. 1) consists of a 16-bit down counter, a 16-bit input holding register and some custom control logic which Fairchild has not documented. The device has five modes of operation, three of which have alternate modes. It can act as a triggered digitally timed monostable with retrigger or pause, or as a free-running binary divider. The Fairchild modes are given in Fig. 2.

The Fairchild operational documentation leaves a bit to be desired (I had to phone the USA for control information!). So, I am giving here a control resumé before discussing.

The mode pins M0-2 are set by CIP switches or hard wiring to the literal mode number in positive logic. So all lines low equals mode 0 and all high gives mode 7. The input clock is applied to CP. The inverter between CP and XTAL *must not* be used as an oscillator inverter. It cannot carry the required current. XTAL can be used to carry forward an inverted clock in.

The data inputs are conventional TTL compatible logic inputs into a 16-bit transparent latch. This is loaded by taking \overline{WE} high after the input data is stable, but due to the transparency of the latches \overline{WE} should not be kept idle in the low state unless stable data is available from an external source.

The safest data write is performed by a short negative-going pulse, the data being effectively latched on the trailing (rising) edge.

The RUN/LOAD alternatives of the counter are controlled by the state of XTR. This stands for *external trigger* (a misleading name — it is not a trigger edge signal. It is a *state controlled* mode signal). While XTR is high, the counter *loads* synchronously with the clock, when low the counter *counts*.

The remaining control input \overline{MR} is a master reset. There *must* be a master reset after power-up before any other operation. I do not know what would happen in each mode otherwise but I reckon the results would be pretty unpredictable!

Controlling The 74F525

Whatever the mode of operation you have chosen, the external control sequence is much the same. After power-up, \overline{MR} must be pulsed low. Thereafter it can be ignored, except in mode 7 (continuous divide by n) where it is used to stop and clear the counter.

Next, XTR is taken high and a 16-bit data word (the divisor of *modulo*) presented to the data

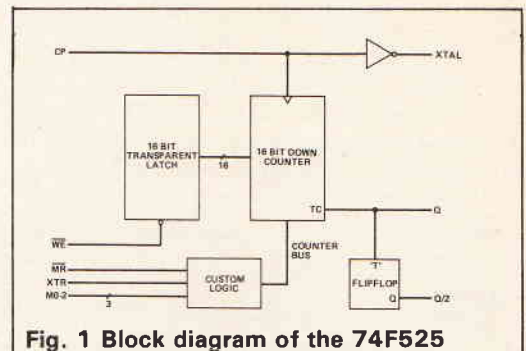

Fig. 1 Block diagram of the 74F525

inputs and held stable while \overline{WE} is pulsed low.

When XTR is next taken low, counting will begin. When the counter reaches zero (counting down) the outputs Q and Q/2 change state in accordance with the chosen mode of operation.

In all modes except mode 7, XTR must be taken high and low each time a sequence is required. In mode 7, after an initial XTR falling edge, the counter is automatically reloaded by its own rollover through zero. In this mode, the output at Q is a positive-going pulse one clock wide. Q/2 just changes state (toggles) on the rising edge of Q.

The preceding notes show the internal transparent latches are only essential to operation in mode 7. In all other modes they simply avoid the user reprogramming the counter externally between one-shot operations.

Some source of external programming is still needed and this usually takes the form of binary switch inputs or registers programmed by a microprocessor. Assuming for the moment that this is the case, a simple loading/control interface is shown in Fig. 3.

Using The 74F525

Now let us look at the various modes of this clever little chip in more detail. In all cases, let us assume that \overline{MR} has been pulsed and a modulo loaded into the input register already.

In mode 0, the F525 operates as a 'wait for it' delay device. Q goes high n clocks after XTR is lowered. Q/2 toggles state as well but this is not very useful unless you know its state before.

If XTR goes high, the counter reloads and Q is taken low. If Q is still low (because the sequence has not completed) it stays low. Lowering XTR restarts the sequence from the top.

This mode is basic but not very widely applicable. Precision timing is not possible due to the delay of anything up to nearly one clock period between XTR falling and the first active clock. The main use of this mode which comes to mind is as a time-out microprocessor watchdog. Software writes to pulse XTR normally often enough for the counter to not time out. If the CPU loses its way, XTR is not pulsed soon enough and the output from Q is used to either reset the CPU or cause an error interrupt.

In this application DIP switches would be used to set the required modulo. \overline{WE} would be tied

CHIP IN

MODE 0

While XTR is HIGH, the data in the data latches is loaded into the counter upon the next positive-edge of CP. The negative-edge of XTR enables the count-down to begin with the next positive-edge of CP. When the count reaches zero, Q is brought HIGH and Q/2 toggles state. Taking XTR HIGH at any time causes the data in the latches to be loaded into the counter and the Q output to be cleared.

MODE 1

The operation is exactly the same as in mode 0 except that Q is normally HIGH and goes LOW on a count of zero. Q/2 toggles on the negative-edge of Q.

MODE 2

While XTR is HIGH, the data in the data latches is loaded into the counter upon the next positive-edge of CP. The negative-edge of XTR enables the count-down to begin with the next positive-edge of CP. When the count reaches zero, Q is brought HIGH for a single period of CP. Q/2 toggles state on the positive edge of Q. Taking XTR HIGH at any time causes the data in the latches to be loaded into the counter and the Q output to be cleared.

MODE 3

The operation is exactly the same as in mode 2 except that Q is normally HIGH and goes LOW on a count of zero for a single period of CP. Q/2 toggles on the negative-edge of Q.

MODE 4

While XTR is HIGH, the data in the data latches is loaded into the counter upon the next positive-edge of CP. The negative-edge of XTR enables the count-down to begin with the next positive-edge of CP. When the count reaches zero, Q is brought HIGH for a single period of CP. Q/2 toggles state on the positive-edge of Q. Taking XTR HIGH before the counters reach zero causes the data currently in the counters to be held.

MODE 5

The operation is exactly the same as in Mode 4 except that Q is normally HIGH and goes LOW on a count of zero. Q/2 toggles on the negative-edge of Q.

MODE 6

While XTR is HIGH, the data in the data latches is loaded into the counter upon the next positive-edge of CP. The negative-edge of XTR enables both the count-down to begin and Q to go HIGH with the next positive-edge of CP. Q is brought LOW when the count reaches zero. Q/2 toggles on the positive-edge of CP. Bringing XTR HIGH during a count-down will reload the latched data into the counter, but will not affect Q.

MODE 7

The negative-edge of XTR enables the count-down to begin with the next positive-edge of CP. When the count reaches zero, Q is brought HIGH for a single period of CP. Q/2 toggles state on the positive-edge of Q. The positive-edge of CP upon which Q goes low also causes the data in the data latches to be reloaded into the counters. Taking XTR HIGH at any time causes the data in the data latches to be loaded into the counter and the Q output to be cleared. However, after an initial XTR this mode can run continuously until stopped by MR.

Fig. 2 The Fairchild mode descriptions

permanently low and the clock would drive CP. Mode 1 operates the same except the Q output polarity is reversed. It goes low on time-out.

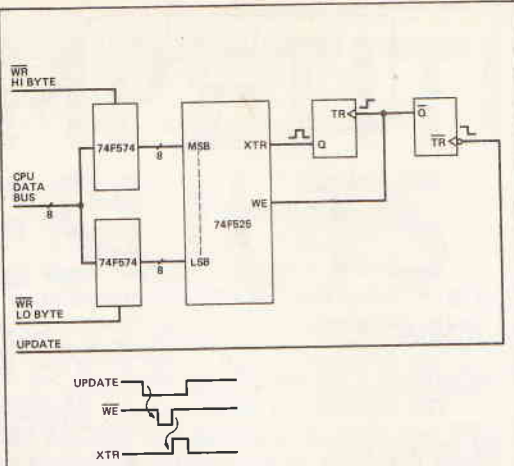

Fig. 3 A simple loading/control interface

Symbol	Parameter	54F/74F		54F		74F		Units
		Min	Typ Max	Min	Max	Min	Max	
t _{PLH}	Propagation Delay CP to Q or Q/2, Mode 0		24.0					ns
t _{PFL}	Propagation Delay XTR to Q		22.0					ns
t _{PLH}	Propagation Delay MR to Q		19.0					ns
t _{PFL}	Propagation Delay MR to Q		16.0					ns
t _{PLH}	Propagation Delay MR to Q		24.0					ns
t _{PFL}	Propagation Delay MR to Q		18.5					ns
f _{max}	Maximum Clock Frequency	50	65					45 MHz
t _{s(H)}	Setup Time, HIGH or LOW D _n to WE	4.5						ns
t _{s(L)}	Setup Time, HIGH or LOW D _n to WE	4.5						ns
t _{h(H)}	Hold Time, HIGH or LOW D _n to WE	2.0						ns
t _{h(L)}	Hold Time, HIGH or LOW D _n to WE	2.0						ns
t _{s(H)}	Setup Time, HIGH or LOW D _n to CP	11.5						ns
t _{s(L)}	Setup Time, HIGH or LOW D _n to CP	11.5						ns
t _{h(H)}	Hold Time, HIGH or LOW D _n to CP	0						ns
t _{h(L)}	Hold Time, HIGH or LOW D _n to CP	0						ns
t _{s(H)}	Setup Time, HIGH or LOW XTR to CP	7.5						ns
t _{s(L)}	Setup Time, HIGH or LOW XTR to CP	13.5						ns
t _{h(H)}	Hold Time, HIGH or LOW XTR to CP	0						ns
t _{h(L)}	Hold Time, HIGH or LOW XTR to CP	0						ns
t _{s(H)}	Setup Time, HIGH or LOW Mode to CP	33.5						ns
t _{s(L)}	Setup Time, HIGH or LOW Mode to CP							ns
t _{w(H)}	XTR Pulse Width, HIGH	14.0						ns
t _{w(L)}	MR Pulse Width, LOW	7.5						ns
t _{w(H)}	CP Pulse Width HIGH or LOW	4.0						ns
t _{w(L)}	CP Pulse Width HIGH or LOW	9.0						ns
t _{rec}	Recovery Time MR to CP	5.0						ns

Table 1 Timing constraints of the 74F525

Modes 2 and 3 are very similar. The only difference is that the Q output is active for only one input clock period when the counter reaches zero. This output is therefore more suitable for driving level triggered flip-flops, where only one input may

CHIP IN

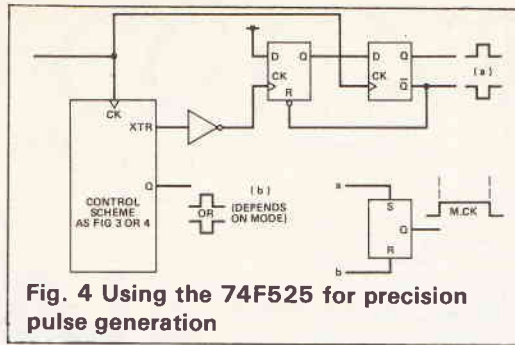

Fig. 4 Using the 74F525 for precision pulse generation

be active at one time for valid outputs.

The addition of a simple one-shot tripped by XTR and clocked synchronously with the F525 allows this mode to be used for precision pulse generation (Fig. 4). For this application, the input of data can be the same as that specified for modes 0 and 1 if binary switches are used but if a micro is used for programming (a good idea!) an additional set of external registers is used.

Modes 4 and 5 are the positive and negative logic variants of a hold-off monostable. This acts like a retriggerable monostable in that the period may be extended during the delay but instead of reloading the delay from the registers, the F525 simply freezes the counter when XTR goes high. This has the effect of applying an arbitrary asynchronous extension to the monostable period while XTR is high.

Mode 6 is an internal implementation of my rather clumsy attempt at precision pulse generation using modes 2 and 3. After a falling XTR, Q goes high on the first active clock (the first clock to decrement the counter) and goes low again when the count reaches zero. This is the true digital monostable. It is also retriggerable by taking XTR high and low again *within less than one clock*

period (to avoid screwing up the timing precision) without affecting the state of Q.

The timing constraints (Table 1) suggests that retriggering within a clock cycle is only possible at a lot less than maximum system speed. However, the precision of pulse generation (disregarding retrigger) is only as good as your clock source.

The whole of my three PCB pulse generator (ETI February-July 1987) could be built using only three of these chips in modes 6 and 7 plus a few flip-flops and gates!

Mode 7 is unique in that it is a free-running mode. Once set up it will continue dividing by the same modulo until either a master reset stops it, it finds a new modulo in its registers or XTR is taken high. It is important to note that in mode 7 the real modulo used by the counter is $n+1$. The output at Q is a clock-wide pulse and at Q/2 a square wave of twice the period.

If you are going to modify the modulo on the fly, the external registers and the control interface of Fig. 3 are *obligatory*. This interface reloads the external registers, writes the internal registers and then pulses XTR.

The only possibility of a restart glitch is where by chance the internal counter reload happens at the moment the internal registers are being updated. A little additional control can be provided by synchronising the internal register re-write to the leading edge of Q (or the falling edge of the input clock) allowing the update to be performed either sufficiently early or late for this hazard to be covered.

That's about it on the 74F525, but it will almost certainly crop up in the future as a supporting device for other new chips. It might be worth mentioning that it is the perfect solution (in mode 7) for the MF8 switched capacitor filter clock (ETI November 1987).



SPECIAL OFFER FOR SPECTRUM AND BBC MICRO OWNERS

Now your computer can take control for an affordable price. These tried and trusted interfaces from DCP Microdevelopments are offered at **£20 off** the normal price.

Both units are extremely easy to use from both Basic and assembler/machine code and are supplied ready built and complete with all the documentation you need.

To order by post fill in the form below (or a copy) and send it with your remittance to **ASP READERS' SERVICES (RO ET5/6)** 9 Hall Road, Maylands Wood Estate, Hemel Hempstead, HP2 7BH

Please make cheques payable to ASP Ltd. Overseas orders add £5 (Interspec) or £10 (Interbeeb) for airpost.

Access and Visa card holders can also place their order by phone on (0442) 41221 Allow 28 days for delivery.

Please supply Interspecs (RO ET5) at £29.95 plus £1.95 p&p per order.
Please supply Interbeeb (RO ET6) at £49.95 plus £1.95 p&p per order.

Name

Address

.....

Please debit my ACCESS/VISA card

No to the sum of

£ Signed:

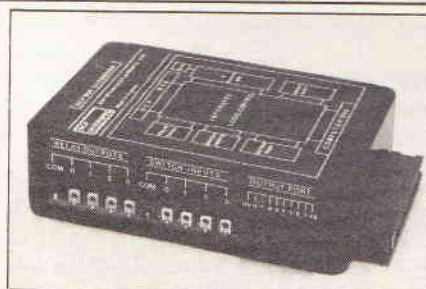

INTERSPEC £29.95

The Interspec unit plugs directly onto the expansion edge connector of the Spectrum to provide a full range of interfacing facilities.

The unit is housed in a plastic case approximately 4½x3x1in which contains the top quality double sided PCB and interface connections.

- 8-bit input port
- 8-bit output port
- four switch sensor inputs
- four relay-switched 12V 1A outputs
- eight channel multiplexed analogue to digital converter
- 15-way expansion bus

All sections of the interface are I/O port mapped and designed for maximum compatibility with existing Spectrum peripherals. Power is supplied through the Spectrum edge connector.

The expansion bus provides all the data and address/control signals for the addition of further DCP modules or home-built devices. Connection is by multi-way PCB connector and all the information required for adding further devices is given.

INTERBEEB £49.95

The Interbeeb unit connects to the BBC micro's 1MHz bus expansion connector and is supplied complete with its own power supply unit.

The interface unit is housed in a plastic case approx 4½x3x1in which contains the top quality double sided PCB and interface connectors.

- 8-bit input port
- 8-bit output port
- four switch sensor inputs
- four relay-switched 12V 1A outputs
- eight channel multiplexed analogue to digital converter
- precision 2.5V reference
- external power supply
- 15-way expansion bus

All sections of the interface are memory mapped in the 1MHz expansion map for maximum ease of use and compatibility with existing peripherals.

The expansion bus provides all the data and address/control signals for the addition of further DCP modules or home-built devices. All the information required for using additional devices is included.

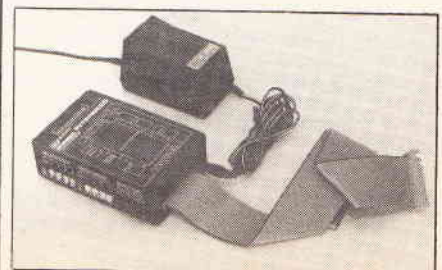

PULLING IT ALL TOGETHER

Paul Chappell shows how the theory of recent months can be put to practical use

Since we've spent most of the past six months looking at phasors and complex algebra, I think it's almost time to give it a rest for the time being. Before taking our leave of the topic, let's just look around and see what we've achieved so far.

One of the problems with explaining the theoretical side of electronics is that most demonstrations of any new idea involve very simple networks far removed from the complexities of practical circuits. The idea, of course, is to show up the new concepts as sharply as possible without becoming involved in irrelevant detail. But the better it works, the more remote the theory seems from real life!

the phasor representation is that the truth leaps out at you — you couldn't avoid seeing it if you tried! In Fig. 1a, f_c is the carrier, which corresponds to the frequency you set your radio dial to. Let's say it's at 1MHz. The modulating wave is another size of frequency f_m , which we'll say is 1kHz. This makes f_c+f_m 1.001MHz and f_c-f_m 999kHz so the three phasors of Fig. 1a are rotating at almost (but not quite!) the same speed.

The sum of the three phasors is shown by the dot. The result of adding the three sines in the time domain will be the shadow of the dot on the real axis.

Imagine the phasors are spinning around and you have a strobe light which catches them each time f_c is pointing vertically upwards. Since f_c+f_m is rotating slightly faster than f_c it will move slightly anti-clockwise on each flash of the strobe whereas f_c-f_m will appear to be moving clockwise (although it's really moving anti-clockwise but a little slower). The dot will move up and down, always in line with f_c , taking 1000 cycles of f_c to complete its travel and return to its starting position.

Figure 1b shows the positions after a number of cycles of f_c (or flashes of the strobe) and Fig. 1c shows the shadow of the dot on the real axis — the translation back into the time domain. A 1MHz sine wave amplitude modulated by a 1kHz sine wave! It shouldn't be necessary to draw Figs. 1b and 1c once you get used to interpreting phasor diagrams. Just looking at Fig. 1a should be enough for you to be able to visualise them.

The main attraction of amplitude modulation is that it's so very easy to recover the signals at the receiving end. Figure 2 shows how easy. It may come as a surprise to those of you brought up on a rich diet of ICs and high technology but this little circuit is all you need to pick up most AM broadcast signals. Look, Mum — no batteries!

If you want to experiment with the circuit, L1 and CV1 can be removed from an old radio set (otherwise use about 60 turns of enamelled copper wire on a length of ferrite rod and a variable capacitor of about 300p maximum for a medium wave receiver). D1 should be a germanium diode, C1 about 1n0, and the headphones (which give a nice radio-shack flavour to the circuit diagram) can be a crystal earpiece. In areas of high signal strength, just about anything will do as an aerial — your bedsprings, a length of insulated wire, the TV aerial. Otherwise, 100ft of insulated wire strung between two posts in the garden will do fine. The earth connection can be made to central heating pipes or a rod stuck into the ground — you may find it's not necessary at all.

The coil L1 and variable capacitor CV1 form a resonant circuit which responds enthusiastically to signals close to its resonant frequency and barely at all to anything far removed from this frequency. The resonant frequency is varied by CV1 which allows the set to be tuned. D1 lops off the negative going portion of the AM wave, C1 removes the carrier frequency and you're left with a copy of the modulating signal to be fed to the earphone. C1 is not really necessary, since the mechanical inertia

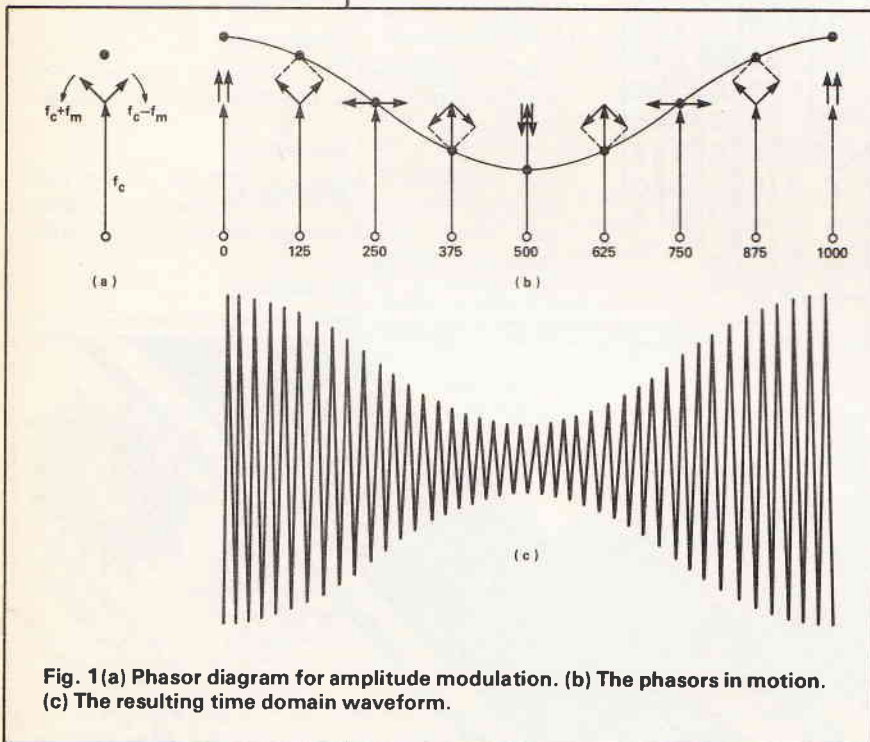

Fig. 1(a) Phasor diagram for amplitude modulation. (b) The phasors in motion. (c) The resulting time domain waveform.

Believe it nor not, if you've followed the articles so far you already have a useful tool at your disposal. It's not a complete and self-contained means of investigating circuit behaviour but then no other single technique can make that claim either. Used in conjunction with your intuition and general electronics knowledge it can help to shed new light on obscure areas and act as an aid to developing new ideas.

In an earlier article I had occasion to mention amplitude modulated radio signals to make the point that an amplitude modulated sine wave is not a sine wave at all, rather a combination of three sine waves. At the time the best 'proof' I could offer was to refer you to the corresponding trigonometric identity.

Invoking mathematical authority is a convenient way to bludgeon disbelievers into submission but it doesn't actually explain anything unless you're so familiar with the area concerned that its truth seems self evident. The attraction of

CIRCUIT THEORY

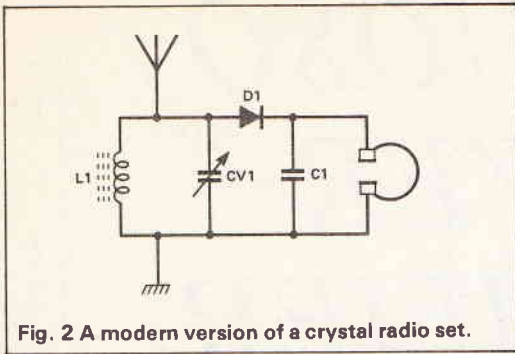

Fig. 2 A modern version of a crystal radio set.

of the earpiece will smooth out the wave well enough but it makes the explanation more convincing!

If we take a closer look at Fig. 1a it soon becomes evident that, apart from the ease of recovering the signal, amplitude modulation doesn't have a lot going for it. For one thing, a large part of the transmitted signal is a constant amplitude sine wave f_c , which contains no information in itself about the modulating wave (which is what we're really interested in). It seems a waste of power to transmit it at all!

Secondly, the information contained in one side frequency is simply repeated in the other. If we know $f_c + f_m$ and f_c , we should be able to reach f_m without much trouble, so why double the bandwidth and send $f_c - f_m$ as well? The broadcast bands are crowded enough as it is!

Now, I could go on from here to develop the basic theory of single sideband and suppressed carrier transmission but that's not the point. What I'm trying to show is the way a simple diagram of three arrows can send your thoughts in all kinds of unexpected directions.

If you want to experiment with these ideas, try to think what would happen if the two side frequencies of Fig. 1a were increased in amplitude relative to the carrier. Would the circuit of Fig. 2 be able to make sense of the result? What would the transmitted waveform look like if one side frequency was removed? What would our simple radio receiver make of that? How about if one side frequency and the carrier were dumped? Is there any way at all to recover the modulating frequency from the result?

In applying phasors to specific circuits rather than general ideas, we have only considered networks of three or four components. It has to be admitted that phasors become rather cumbersome when more than half a dozen or so components are involved — if the diagram has too many arrows it becomes difficult to visualise the relationship between them and the way this might vary with frequency or with component values. Apart from the fact that many more powerful techniques have their roots in phasor diagrams, this doesn't limit the technique as much as you might think.

If you think for a moment about how you go about designing a circuit, it's essentially a matter of beginning with a broad outline then considering finer and finer detail as the design progresses. In the early stages you look at the circuit as a whole, later you may find yourself wanting to tweak up the performance of one very small area which may only consist of three or four components.

An example is the triac snubber network shown in Fig. 3a. The capacitor is intended as a kind of dustbin where the surplus energy of the inductive load can be dumped when the triac turns off. Unfortunately, the capacitor forms a resonant

circuit with the load, like the series RLC circuit last month, and ringing of the circuit can cause more problems than the one it was intended to cure!

In an earlier article (ETI March 1987) I described a way of choosing these component values by rule of thumb but the situation can also be pictured in terms of phasors. Figure 3b is taken from a triac data book and shows the kind of diagram you might come across in your general browsing through the data books.

The very same RLC circuit crops up all over the place (although sometimes R might be the resistance of the inductor or of some other device, rather than a physical component). In a transformer there will always be some magnetic leakage — flux which does not link both coils — which makes the transformer appear to have an inductor in series with each winding. In many applications this can be a nuisance but in fixed frequency circuits it can often be 'tuned out' with a capacitor chosen to resonate with the leakage inductance at the circuit's operating frequency. The capacitor doesn't prevent the magnetic leakage, mind you, it just prevents the effects from upsetting the circuit's operation.

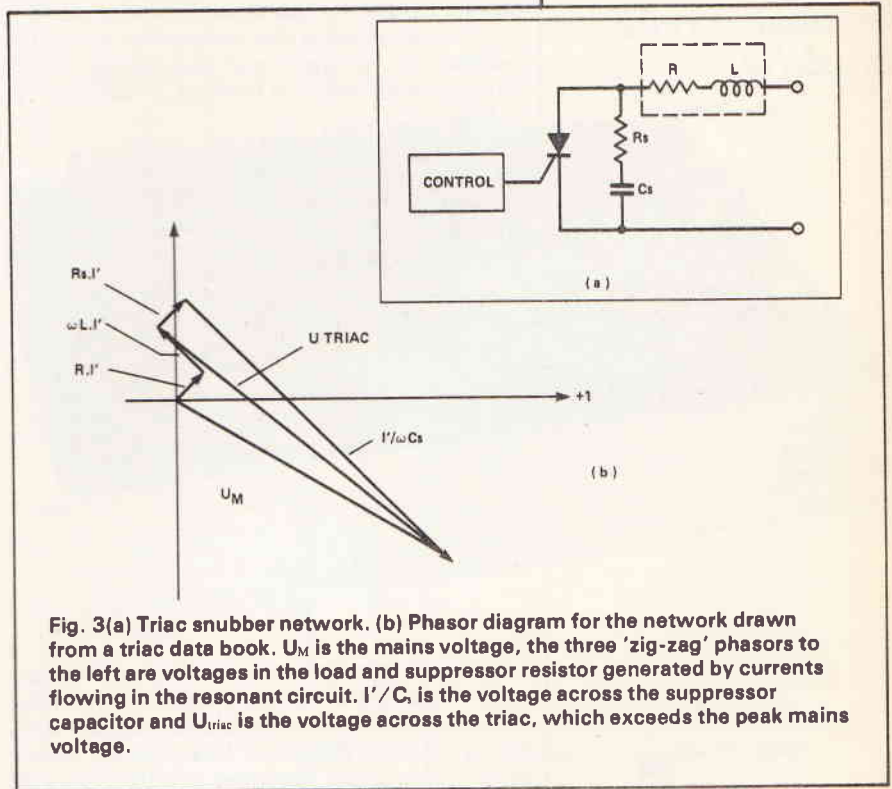

Fig. 3(a) Triac snubber network. (b) Phasor diagram for the network drawn from a triac data book. U_M is the mains voltage, the three 'zig-zag' phasors to the left are voltages in the load and suppressor resistor generated by currents flowing in the resonant circuit. I'/C is the voltage across the suppressor capacitor and U_{triac} is the voltage across the triac, which exceeds the peak mains voltage.

Choosing a suitable value for the capacitor is easy enough if you have a value for the leakage inductance but you might be more interested in knowing the effects of component tolerances or frequency drift on the circuit. A quick sketch of a phasor diagram should show up the likely results.

If you are keen to find out more about phasors, you could do a lot worse than to track down the eponymous book by M. G. Scroggie. Being about twenty years old now it's unlikely you'll find it on the shelves of a bookshop but your local library may have a copy. A large portion of the book is devoted to examples based on networks and circuits which demonstrate the practical side of phasor diagrams. It assumes a certain level of understanding of basic techniques but if you've followed the ETI articles you shouldn't have any difficulty with it.



VIRTUOSO POWER AMPLIFIER

Graham Nalty launches his super-fi project with a look at the design features and power circuits of the Virtuoso Power Amplifier

High fidelity amplifiers should drive loudspeakers to produce the same sounds that create the effect and enjoyment at a live performance.

For a top performance amplifier it is vital to use top quality components. I was pleasantly surprised at the number of readers who opted to build the upgraded Virtuoso pre-amp rather than the standard version (ETI June-November 1986). In preparing this matching power amplifier I have taken the upgrading a stage further, using even higher quality components.

The requirement that an amplifier should be designed for accurate (and pleasurable) sound reproduction presents a problem or two. Such a

this amplifier is mostly due to higher grade passive components.

Every cable carrying the signal or power supply will degrade the overall sound as a result of conductor impurities and dielectric losses in the insulation.

Important Factors

Temperature generated distortion can occur when the gain of an audio amplifying transistor varies with changes in the temperature at its junction. The changes in gain cause a blurring of the sound — possibly the reason why some people prefer valve amps which only suffer from temperature generated distortion due to ripple on the heater supplies.

The solution is to use power transistors attached to the heatsink wherever large current or voltage swings from the input signal are found.

This type of distortion also occurs in resistors and can be solved by using resistors with lower temperature coefficients and better heat dissipation properties.

Even with a good power supply, the amplifier circuit itself needs good power supply ripple rejection. Without it, crescendos become blurred and ambience is degraded. Cascade circuiting and ultra-high dynamic impedance improve ripple rejection considerably and using separate rectifiers and smoothing capacitors for separate stages of the amplifier helps prevent ripple from one stage affecting another.

Each switch contact and connector degrades the quality of a passing audio signal. If oxidised the contact acts more like a diode and sound quality is seriously degraded. Hence it is very important to use high quality switches (even gold-plated contacts for low level signal connections).

Slew Rate

Figure 1 shows how slew rate limiting can distort a sine wave signal.

It is essential that the amplifier can accurately process the fastest signal that it is likely to encounter. Also it is important that the amplifier can handle a slew rate considerably larger than the fastest input since distortion rises sharply as signal speed approaches slew rate.

It has been established that there is a strong correlation between slew rate and sound quality — the lower the slew rate the worse the sound. However this may not be because of the slew rate itself, but because the measures taken to increase the slew rate also improve the sound (very fast output transistors sound better because their gain is more linear at high frequencies for example).

DC Offsets

The DC offset is the DC voltage at the loudspeaker

requirement cannot be measured during development, only auditioned when complete. Fortunately as a result of extensive research, development and testing of audio amplifiers, I can identify those design areas which are most crucial to sound quality.

Those features I have listed below as crucial or important should be pursued to the limit of your budget. Every improvement in these areas should give an improvement in sound quality. The other features of design may not give an improvement in sound quality but inadequate design may result in degraded sound quality or other problems.

Crucial Factors

A power amplifier needs a good strong power supply with low impedance through the whole audio frequency range (and beyond). A mains transformer with a VA rating several times the total power rating is the very first requirement for a good sound.

Passive components (resistors, capacitors) are extremely important and the price difference between the standard and upgraded versions of

PROJECT

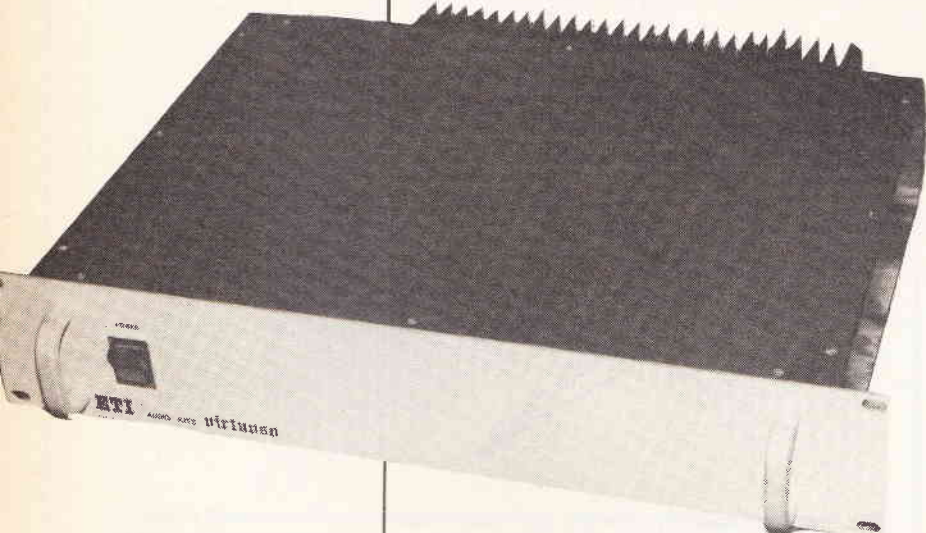

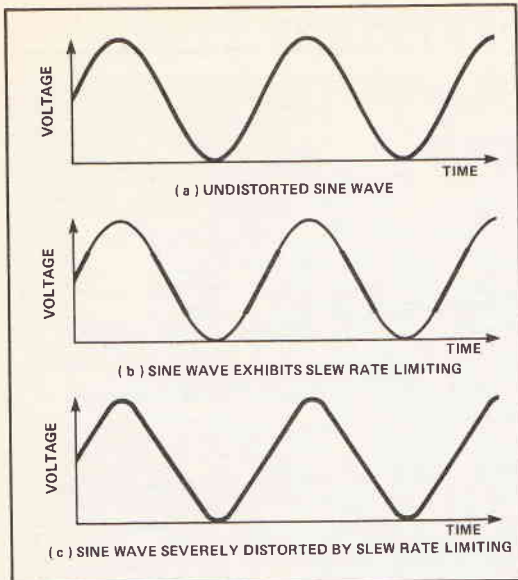

Fig. 1 (a) Slew rate limiting.

terminals when no input signal is applied and which is constantly supplied to the terminals. I work within limits of +200mV — the level at which a noise becomes noticeable when a loudspeaker is connected. The Virtuoso Power Amplifier is specially designed for much lower offset.

The one way not to reduce DC offset is via a supply derived from the power supply lines as shown in Fig. 2.

Harmonic Distortion

Harmonic Distortion measurements have no direct relevance at all to sound quality. Measures such as cascode circuitry (Fig. 3) improve distortion figures (by improving linearity) but actually improve the sound quality because of improved power supply rejection (Fig. 4a).

Multiple feedback loops may reduce distortion (lower V_{bc}/I_c variation) but in my experience are audibly inferior. This is possibly due to Transient Intermodulation distortion.

This distortion occurs when the signal input rises so fast that the feedback signal from the output of the amplifier cannot catch up. In an amplifier with large negative feedback the open loop gain that results is very large and overloads the internal stages of the amplifier. This does not sound pleasant!

An easy way to reduce TID is to lower the negative feedback (Fig. 4b) by lowering the open loop gain. Unfortunately this increases the harmonic distortion.

Current Delivery

Many designers are now claiming excessively large output current capability for their amplifiers, to some extent as an over-reaction to the situation where some high-powered amps were shown to have inadequate current delivery.

An amplifier can be overloaded either by voltage limiting (clipping) at a voltage just short of supply or by current limiting (by protection circuitry, power supply or breakdown current of the output devices).

An ideal amplifier has current and voltage capability designed so that the maximum voltage and current delivered under normal use are very close to (but do not exceed) the maximums. The ideal low-powered amplifier should in normal use overload on 50% of occasions due to voltage

limiting and on 50% due to current limiting.

In the case of high-powered amplifiers the ability to supply a larger current or voltage can add considerably to the cost. At the same time it can be expected to have a large margin of reserve capability over the requirements for its use.

The Virtuoso Power Amp should be more than adequate for most users with a peak voltage capability of 40V and peak short term current limit of 40A (from protection circuitry). Also important is high frequency stability (oscillation at supersonic frequencies or ringing when driving square waves into reactive loads).

Those purists who can detect audible differences from phase inversion (reversed connections to each loudspeaker) would also include correct polarity (positive gain) as an important design feature.

These are the major features which are of concern in the design of audio amplifiers. Now we are able to move on to the details of the Power Amplifier.

As the power supply is the number one

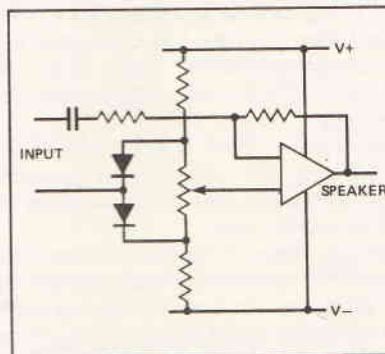

Fig. 2 DC offset adjustment not suitable for hi-fi applications

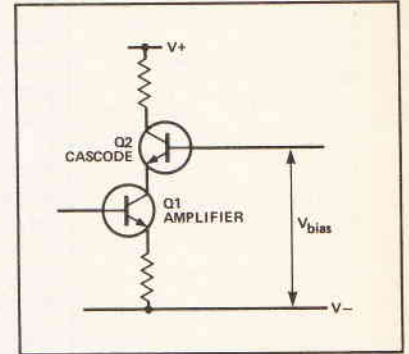
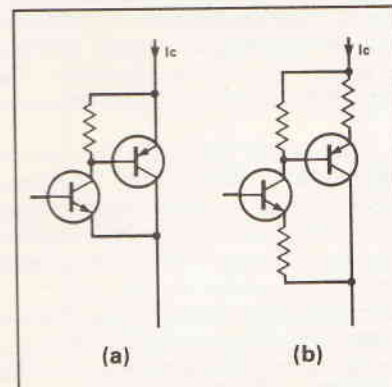

Fig. 3 Cascode circuitry improves linearity of gain for Q1 and power supply rejection from power supply

Fig. 4(a) Low variation of $\frac{V_{bc}}{I_c}$
(b) Reduced negative feedback

feature in a high fidelity power amplifier, I shall start with that (see Fig. 5).

Mains Supply

The great British mains supply is not exactly high quality but it is the only one we have, so let's make the most of it.

The effect of load interference from fridges, cookers and other assorted appliances can be considerably reduced by connecting a separate mains supply from the fusebox. A second separate supply can be used to good effect to power tuners, pre-amps, CD-players, turntables and cassette decks.

Further, a copper bar in the ground connected to the earth of these supplies will make an

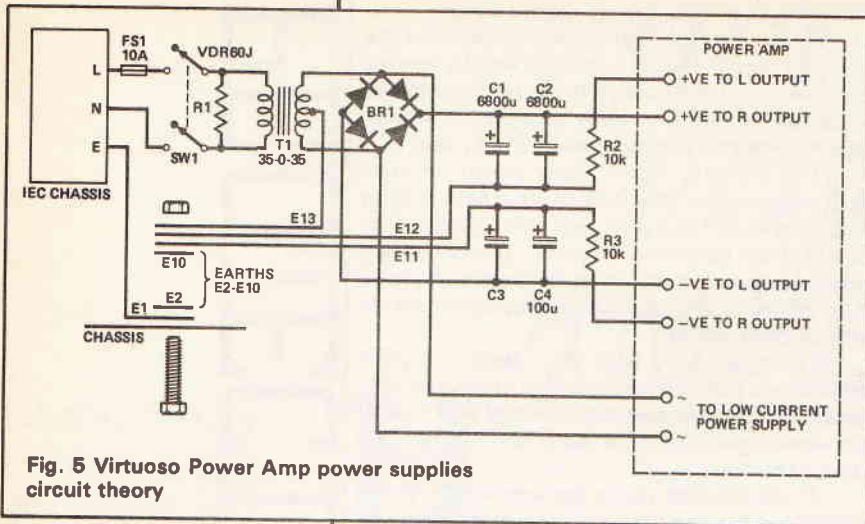

Fig. 5 Virtuoso Power Amp power supplies circuit theory

audible difference by removing currents induced in the earth by household appliances.

The old 15A plugs and sockets make a much better contact than the new 13A types, and it is possible to obtain gold-plated mains plugs and sockets (13A and 15A) to reduce the problems of mains tarnishing.

For mains cable there is a version of the Kimber 4 TC loudspeaker cable suitable for mains, its only drawback being that it cannot easily be fitted into a 13A mains plug.

The Virtuoso Power Amplifier has been fitted with a standard IEC socket which cannot really be justified in hi-fi terms. Anyone who wishes could bypass it by taking the mains lead directly from the fuse and switch (see power supply circuit in Fig 5).

Kimber Cable

Kimber cable is a multistrand cable of 7 different sized strands of oxygen-free copper, specially treated to increase surface conductivity. The insulation is of Teflon tested at 1500V to ensure its integrity.

I have found it the best cable for internal wiring of amplifiers to date. Firstly the sound quality is good — better sonically than the single strand cable I used in the Virtuoso Pre-amp. The second advantage of Kimber is that it is easy to use — flexible but it stays where it is put.

Kimber cable has two disadvantages. Firstly it sounds different if the direction is changed so it is usually supplied with arrows pointing in the preferred direction from cartridge to speakers (or from mains socket to rectifiers or from mains transformer to rectifiers to amplifier circuits). Secondly it is ten times the price of the single core cable used in the pre-amp!

Fuse Views

The mains fuse FS1 will of course slightly degrade the sound quality of the amplifier but is included for safety reasons (and because most constructors will want it). The 1 1/4 in fuseholder used has a higher current rating than 20mm holders but is not ideal for hi-fi because of its lightly sprung contacts.

It is time to look seriously at fuses in audio amplifiers. We should have fuses firmly attached (screwed down) to the fuseholder. We should test many fuses for audio quality to find those with the lowest sonic degradation. (I would be interested in hearing from any readers who have encountered silver fuses for audio applications).

PARTS LIST

	Standard	Upgraded Version	3U Case
RESISTORS			
R1	VDR 60J 275V	VDR 110J 275V	VDR 110J 275V
R2, 3	10K 1/2W metal film	—	—
CAPACITORS			
C1, 2	6800µ 63V	6800µ 63V*	15000µ 63V BHC ALS 20A
			BHC ALS 20A 2200µ 63V LCR FAC114/ ULL
C3, 4	100µ 63V	100µ 63V Mullard 108	100µ 63V Mullard 108
SEMICONDUCTORS			
BR1	25A 200V bridge	Motorola BYW62	IR 25CPF20 + 25JPF20 or 26M8F20502
MISCELLANEOUS			
FS1	Mains fuse holder 1 1/4 in × 1/4 in chassis mounting with 10A fuse		
SW1	Mains switch rocker type		
T1	Mains transformer (low mechanical noise)		
	35-0-35 300VA	35-0-35 500VA	
IEC chassis plug and insulating cover. 1/4 in blade push-on connectors and insulating covers. insulating fuse-holder cover. 2BA soldertags. 2BA crimp connectors (red sleeve*). heavy duty cables*. M16 cable gland and cord grip bush (3U version in place of IEC plug). *see Buylines.			

It has been observed that by increasing the fuse rating, the sound quality is improved. Unfortunately this reduces the protection given and may even result in legal problems if the house burns down as a result!

Similarly the best mains switch in sonic terms would be no switch at all, but for safety reasons I cannot recommend its omission.

Even with a separate supply for your amplifier and a copper bar going through your floor the mains voltage is still far from a perfect 50Hz sine wave. There are three ways to reduce the problem.

Mains filters have series inductors in the current path and this resistance to the transformer current demands make the amplifier sound sluggish, degrading the portrayal of rhythm and tempo in music.

Capacitors can be used for interference suppression although class X capacitors should not be used in positions where failure might expose anyone to electric shock. Class Y capacitors do not have that restriction.

Voltage dependant resistors exhibit a high resistance at voltages below the mains peak (350V for 250V RMS mains). When this peak is exceeded by a certain margin the resistance rapidly decreases and the VDR absorbs all the energy of the excess voltage.

PROJECT

The rating of VDRs is normally specified in joules. The VDR in the Virtuoso (R1) is rated at 110J. If the voltage surge reaches 600V the VDR will pass a clamping current of 40A — obviously for a very short period of time.

Transform Your Mains

The mains transformer is the heart of a good amplifier. It is simply not good enough to say that your amplifier gives 100W per channel so needs a 200VA transformer. Having a bigger transformer will significantly improve the all-round quality of the amplifier.

In the standard version of this Virtuoso Power Amplifier the transformer is rated at 300VA. The upgraded amplifier uses one rated at 500VA — the largest that will fit in a 2U case. If you were prepared to use a 3U case you could fit a 625VA transformer.

The problem of mechanical noise from the transformer is addressed by using an audio-grade transformer wound specially for low mechanical noise.

Many constructors prefer to house the transformer outside the case containing the circuitry to avoid either transformer vibration or electromagnetic/electrostatic fields affecting other components. Certainly I would reduce vibrations by situating the amplifier on a non-resonant surface. The disadvantage with a remote transformer is the finite resistance of additional cable, plugs and sockets.

Rectify Yourself

I have used a standard (low cost) 25A bridge rectifier in the standard version and the Motorola BYW62 35A bridge in the upgraded version.

In both cases the bridge is bolted to the heat-sink to minimise any effects of temperature generated distortion.

Recently I was most impressed by the improvement achieved by fitting fast recovery rectifier diodes in place of standard power diodes in an amplifier. I will be recommending them in the low current power supplies of upgraded Virtuoso Power Amplifiers.

The main reservoir capacitors (C1, 2) of an amplifier are extremely important. These have a great influence on the sound quality and you *must* use capacitors of the highest quality (long life, high ripple current, low ESR).

Such capacitors are very expensive but are justified by their sonic performance.

Large electrolytic capacitors have excessive inductance so you can improve their impedance characteristics by bypassing them with smaller values which have less inductance and react faster to high frequency transient loads.

The upgraded amplifier shown pictured has a main reservoir capacitor of 6800 μ (C1,2) bypassed directly by a 100 μ Mullard 108 long life electrolytic (C3, 4) with a further top quality 1 μ 0 polypropylene located on the circuit board very close to the output devices.

Incidentally the value of 6800 μ is restricted by the size of the case and constructors seeking extended deep response are recommended to use larger values.

The output stage of the amplifier draws high currents and even with a low impedance power supply the effect of these currents is to generate an additional ripple voltage on the power supply lines.

Despite very careful design the input circuit of the amplifier is very sensitive to such a ripple voltage.

The most effective way to prevent ripple caused by the output stage from reaching the input stage is to feed both parts of the power amplifier from completely separate rectifiers and reservoirs.

Figures 6-8 show different ways of providing power to the lower level stages of a power amplifier.

Fig. 6 is very common in low quality amplifiers. Not only does this kind of circuit give poor sound quality but it is more prone to high frequency instability from unwanted high frequency oscillations fed back along the power supply lines.

The circuit of Fig. 7 gives better performance at high audio frequencies and suffers less from high frequency instability but that of Fig. 8 is considerably more superior still in both ways.

It is not essential that the power supply components (rectifier and reservoir) are as high quality (expensive) as those required for the output stage.

Next month I shall be moving on to describe the power supply regulator circuits.

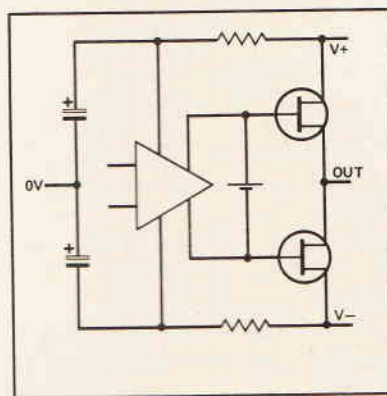

Fig. 6 Power amp power supplies connections

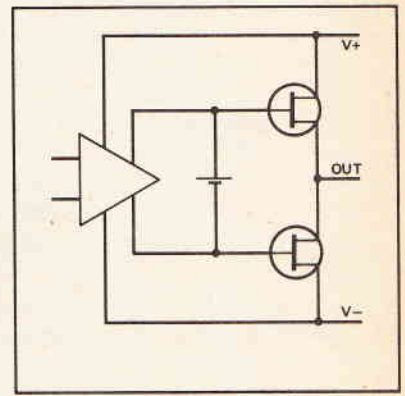

Fig. 7 Improved power supply

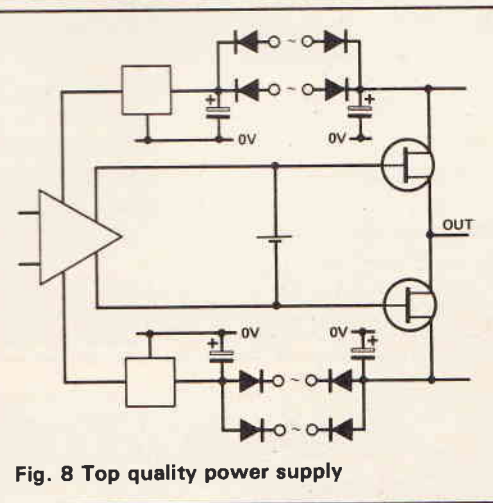

Fig. 8 Top quality power supply

BUYLINES

If a larger case than the suggested 2U case is used, the value of C1, 2 should be increased. Only highest quality capacitors should be used such as ALS 20A, Mullard 114, LCR FAC 114/CW or DIVM slit foil.

The 2BA red-sleeve crimp connectors are suitable for cables of 0.5mm² to 1.25mm² (2 cores of Kimber cable). Cables between 1.5 and 2.5mm² require blue-sleeved connectors, and up to 6.55mm² require yellow.

For the upgraded Power Amplifier 2 cores of Kimber cable in parallel (twisted together) are recommended for all high current connections.

Top hi-fi reviewer Paul Miller gives his verdict on the 2U versions of the Virtuoso.

Although most enthusiasts will derive great pleasure in the construction of their own amplifier, the absolute quality of these units remains a bone of contention. This short piece assesses the basic and upgraded Virtuoso power amplifiers — technically and subjectively — in the light of comparably priced domestic designs.

On test there proved to be significant differences between the two products. Taking the more expensive amp first, the distortion figures were very good at the 1W level, being primarily composed of second and third order harmonics. The higher order and more subjectively disturbing harmonics were suppressed by at least 100dB throughout the power bandwidth. Only the second-order intermodulation results were a little weak at this price level, however 0.11% is acceptable.

A 2.67dB power increase was registered between the 8 and 4 ohm loads but the supply sagged quickly into lower impedances — the 3.4dB loss will restrict the use of more 'awkward' loudspeakers.

Another thing to watch is the input level. With less than half a volt required to reach full output it will be very easy to drive the amp into clipping. This may reduce the useful range of a preamp's volume control but it does allow the Virtuoso to be driven directly from line sources, such as tuners, cassette decks and CD-players.

The cheaper Virtuoso amplifier had similar power characteristics but proved to be marginally unstable under the test conditions. Fortunately, full-blown oscillations did not occur but a parasitic RF resonance (probably around 10MHz) caused intermodulation within the audio band. This was manifested as 'fuzzy' crest on the output sinewaves (as viewed on an oscilloscope) long before clipping was reached.

Furthermore, the spectrum analyser revealed a large increase in 2nd-10th harmonics (typically around -68dB) associated with all fundamental tones above one quarter power. This is reflected in the THD figures. I am sure that this is a layout (capacitive?) problem which should be easily rectified, at which point the technical parameters should be on a par with those of the upgraded amplifier.

Subjectively, the Virtuoso sounded quite 'fast' and dynamic, reaching some form of sonic equilibrium very soon after switch-on (some amps take several hours).

The bass was suitably tight and well controlled but the upper octaves appeared rather more forward and 'obvious'.

Strong vocal material was articulate and well-defined, the stereo soundstage was not as precisely focused as with some of the better domestic amps but the larger-than-life image certainly had a tangible quality about it. Percussion was detailed, incisive and full of a sharp, metallic timbre. This is a hard and fast amp that reveals bags of detail.

The standard version was noticeably softer-sounding than the top Virtuoso with a restrained top-end and less of the latter's beguiling fluidity. Of course, much of this may be attributed to the complex distortion structure which is precipitated by the instability. Nevertheless, many enthusiasts may actually prefer the laid-back, less incisive, but ultimately less accurate reproduction of this amplifier.

The Virtuoso power amplifier will stand comparison with some of the better domestic products in most aspects of its performance — slotting comfortably into most good-quality hi-fi systems. It should also be great fun to build!

Test Results	Standard	Upgraded
Max continuous power output, 8 ohms	103W	89W
4 ohms	173W	164.5W
2 ohms	50W	75W
8 ohms + 2μF	Marginally unstable	Output voltage held
Total harmonic distortion (0dBW=1W)		
100Hz	0.011%	0.0021%
1kHz	0.0035%	0.0036%
10kHz	0.0067%	0.0046%
(at 2/3 power) 100Hz	0.093%	0.001%
(at 2/3 power) 1kHz	0.088%	0.001%
(at 2/3 power) 10kHz	0.027%	0.0019%
Anharmonic distortion	-73dB	-84dB
Noise (unwtd)	-99dB	-105dB
Intermodulation distortion (0dBW)		
in-band	-55dB	-58dB
out-of-band	-58dB	-58dB
(at 2/3 power) in-band	-56dB	-70dB
(at 2/3 power) out-of-band	-48dB	-71dB
Input sensitivity (max output)	497mV	402mV
Output impedance/Damping factor	0.054 ohms/148	0.033 ohms/245
DC offset	-7.7mV	+32.6mV
Phase	positive	positive
Kit price	c. £250	c. £450

PROJECT

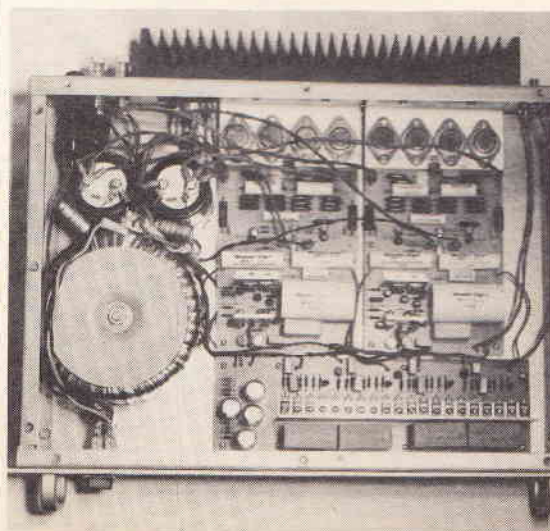

AMBIENCE AND CRESCENDO

The ambience of a live musical performance is an easily degradable property. Ambience can be lost by delayed electrical disturbances such as dielectric absorption in capacitors, by temperature generated distortion in resistors and semiconductors, by low level 50Hz and 100Hz ripple in power supplies and by poor power supply ripple rejection in the amplifier circuit.

There are several 'audiophile' amplifiers that sound pleasant for a single instrument or voice but which sound blurred when several instruments play together or crescendo. The main cause of this is poor power supply ripple rejection, and also power supplies being shared between different stages of amplification.

Needless to say, the Virtuoso Power Amplifier tackles all these problems head on.

CRICKLEWOOD

ELECTRONICS LTD

WRITE OR PHONE NOW FOR OUR FREE,
1988
COMPONENTS CATALOGUE

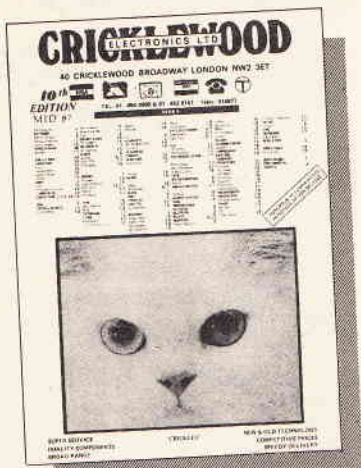

**WHEN YOU CAN'T FIND IT ELSEWHERE
WE'LL HAVE IT!**

from the U.K.'s number one 100% components shop - no gimmicks, no gadgets, no computers, just millions of components, all easily available by mail order, calling at shop, or credit card telephone orders. Just pick up, or a pen, to get the catalogue (no SAE required) - posted **FREE** to any country on the globe.

CRICKLEWOOD ELECTRONICS LIMITED

40 CRICKLEWOOD BROADWAY, LONDON NW2 3ET

Tel: 01 450 0995 & 01 452 0161 Telex: 914977



AUDIOKITS PRECISION COMPONENTS

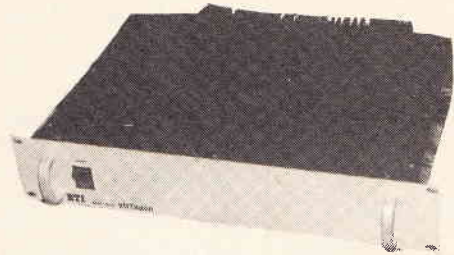

THE VIRTUOSO POWER AMPLIFIER

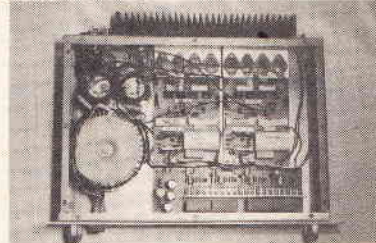

INSIDE AN UPGRADED VIRTUOSO POWER AMPLIFIER
BUILD THIS SUPERB POWER AMPLIFIER WITH AUDIOKITS
TOP QUALITY COMPONENTS FOR THE ULTIMATE IN
SOUND QUALITY.

FULL DETAILS DESCRIBED IN APRIL-JUNE 1988 ETI.

COMPLETE KITS AVAILABLE FROM AUDIOKITS OR ALL
PARTS SUPPLIED SEPARATELY.

SEND LARGE SAE (OVERSEAS 3IRC'S) FOR FULL PRICE
LIST OF KITS & COMPONENTS TO:

AUDIOKITS PRECISION COMPONENTS,
6 MILL CLOSE, BORROWASH, DERBY DE7 3GU.
TEL: 0332 674929



A.S.P. READERS SERVICES

IT'S A WINNER!

Both ORYX PORTASOL and ORYX PORTASOL PROFESSIONAL offer these outstanding features: ● totally pocket portable ● independent of any external power source ● butane-powered ● refills in seconds from standard gas lighter refill ● safety cut-off when cap is replaced ● adjustable for temperatures up to 400°C ● equivalent to electrical irons of 10-60w ● flint ignition in cap ● high impact case ● gas energy source removes all risk of electrical damage to sensitive components. The new ORYX PORTASOL PROFESSIONAL joins the famous ORYX PORTASOL to offer you even more versatility in cordless soldering equipment.

PORTASOL PROFESSIONAL still fits comfortably and safely into the pocket, yet offers up to 120 minutes continuous use with a choice of 7 tips including a HOT GAS TIP and FLAME TIP.

These new features, plus a redesigned tip configuration, consolidate Portasol's position as the only true pocket portable gas iron - with enhanced technical ability and aesthetic appeal.

OUR OFFER TO YOU

Our Readers Services Department has now included the "professional" on its list of special items available to readers with an added bonus of a free "Hot Knife Tip" to be included with the package. Price details are as follows:- Portasol Professional including FREE "Hot Knife" tip

£38.95 including P&P ORDER CODE RO 105

Additional tips:-
4.8mm soldering tip **£5.50** inc. P&P Order Code RO109
3.2mm soldering tip **£5.50** inc. P&P Order Code RO108
1.0mm soldering tip **£5.50** inc. P&P Order Code RO106

(N.B. Tips include complete catalytic converter system)
STILL AVAILABLE Standard Portasol **£15.75** inc. P&P Order Code ROSL 1.
EXTRA SPECIAL - Order a Portasol Professional with full set of 3 additional bits and we will send you an Octopus soldering/modelling assembly aid tool **FREE!** Worth £8.95.
Full Set - Professional + bits listed as above **£54.95** - Order Code SETR109 Post Free
Offer applies to readers in UK only - Overseas enquiries in writing please. Allow 28 days for delivery.

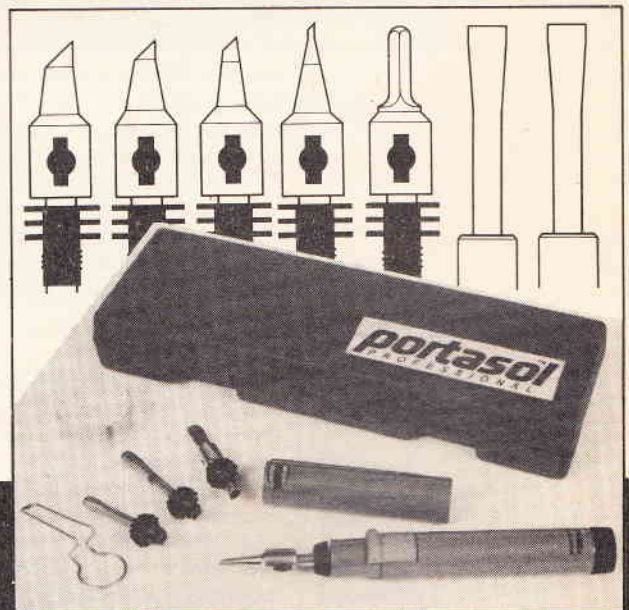

A.S.P. Readers Service, 9 Hall Road, Maylands Wood Estate,
Hemel Hempstead, Herts. HP2 7BH

Please supply the following

No. Title Price

No. Title Price

No. Title Price

Cash Total Name (Block Caps)

Address (Block Caps)

We take Access & Barclaycard by telephone
For Airmail Postage please add 30% to value of order

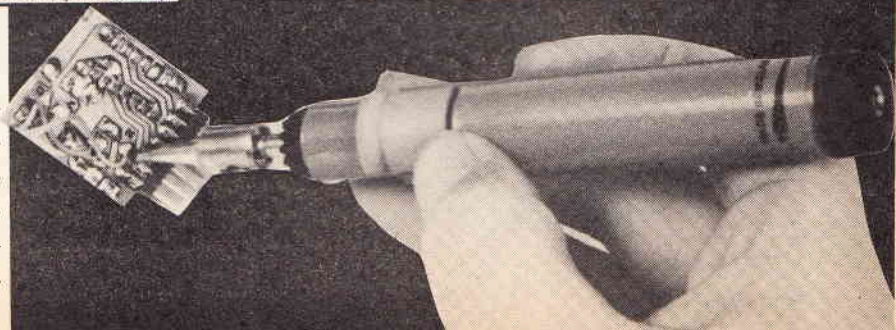

CLOCKWISE

Fed up with hard soft-boiled eggs? Un-chuffed with singed toast? Keith Brindley kicks off our beginners' project series with a kitchen timer

Although this project could never be as accurate as a quartz-locked, microprocessor-controlled, sooper-doooper, whiz-bang model, you've got to admit it's simple and it's neat. It will give timing intervals of 1 to 30 minutes, with only a few seconds or so leeway, and we reckon that's good enough for most kitchen or household uses.

With a few minor component value modifications the circuit could also be used to time many other ranges too as a photographic timer, PCB ultra-violet exposure timer or the like.

If You Can't Take The Heat

Most kitchen timers are either mechanical devices which you wind up and which give a single ring of a bell at the end of the timing period or are LCD digital clock-type devices. The former are only as accurate as the mechanism allows (not very)

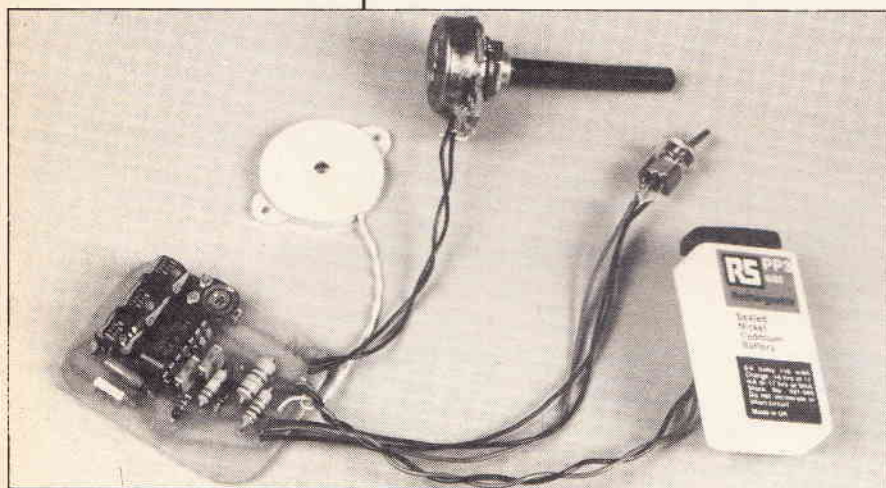

whereas the latter types are quartz-locked and so are extremely accurate. The ETI timer falls somewhere in between the two, having the advantages of electronic timing while still being easy to build.

The timing method used is a simple capacitor charging circuit. Maximum delay is approximately equal to the time constant formed by just two components so you simply have to change these component values to suit other applications.

Construction

Two ways are suggested to build this project — on PCB or stripboard. Both methods are straightforward and apart from a few points are more-or-less self-explanatory.

On PCB, construction doesn't need to follow any particular order, although it's probably best to leave the integrated circuit till last. Follow usual precautions handling the chip but it needn't be mounted in a socket. Instead solder it in — 4011s aren't exactly pricey so if you destroy one you can bung in another. Go easy on the heat. Solder one pin then leave the IC to cool before moving on to solder the next pin.

On stripboard, it's probably best to stick to a conventional order. That is, make all copper track cuts first then insert and solder all wire links followed by resistors, capacitors, flying leads to peripheral components. Lastly insert the IC,

HOW IT WORKS

Gates IC1a, b form a gated astable multivibrator with a free running frequency of about 3.8kHz. Output of this stage is connected directly to a piezo buzzer.

The astable is gated by the input at IC1 pin 5 and is driven by the output of a monostable multivibrator, formed by gates IC1c, d. The monostable 'on' state is defined by the time taken after switch-on for capacitor C2 to charge up via preset RV2 and potentiometer RV1 such that when pin 8 voltage falls below the gate's threshold value the monostable turns off taking the gate output at pin 10 high and turning on the multivibrator.

$$\text{Time} = 0.8 \times C2 \times (RV1 + RV2)$$

So, for the component values in this circuit, the maximum delay is:

$$0.8 \times 1000 \times 10^{-6} \times (2.2 \times 10^6 + 1 \times 10^5)$$

that is, 1840 seconds or about 30 minutes. Greater ranges can be obtained with larger value components, smaller ranges with smaller value components.

Zener diode ZD1 provides voltage regulation so the circuit operating voltage (3V) is maintained at a constant value regardless of battery voltage. A slightly higher zener value than this (up to 6V8) can be chosen if a louder alarm is required. The higher the zener value, however, the shorter the time until the battery operating voltage falls too far for the regulated voltage to be maintained — creating timing inaccuracy with flat batteries.

To ensure the charging capacitor C2 is fully discharged between consecutive timing operations, switch SW1 connects resistor R2 in parallel with the capacitor when the timer is turned off.

PARTS LIST

RESISTORS (all 1/4W 5%)

R1	1k0
R2	270R
R3	1M0
R4	220k
R5	180k
RV1	2M2 lin pot
RV2	100k sub-min horizontal preset

CAPACITORS

C1	100n polyester
C2	1000µ 16V electrolytic
C3	4n7 polyester
C4, C5	1n0 polyester

SEMICONDUCTORS

IC1	4011
ZD1	3V0 500mW zener diode

MISCELLANEOUS

B1	9V PP3 battery and clip
SW1	SPDT toggle switch
BZ1	Piezo buzzer (3.8kHz)
PCB or Veroboard. Case. Connecting wire.	

although as with the PCB version there's no essential need to use a socket.

Whichever construction method you choose, check that no solder links or bridges are present between components or IC pins.

Although we've offered no suggestions for

1st CLASS

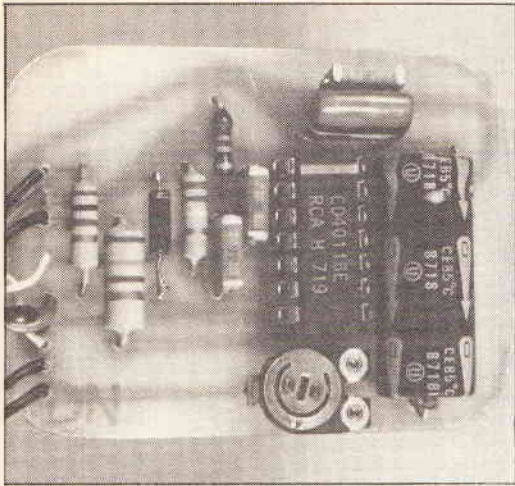

housing your project, any suitable sized box can be used. The only real precaution you need to follow is to mount the piezo buzzer on the outside of the case (if it's on the inside you won't be able to hear it!).

Setting Up

You'll need a fairly accurate watch here, preferably with stopwatch facilities. Initially, set potentiometer RV1 to minimum resistance — fully anticlockwise. Also set preset resistor RV2 to about the middle of its range. Make sure that switch SW1 is in the off position — resistor R2 must be connected in parallel across capacitor C2. Connect the battery.

Now simultaneously turn on your project and note the time (or set your stopwatch going). Nothing should happen. Good eh? However, after 40-50 seconds, the alarm tone should be heard from the piezo buzzer. Note the time taken and

turn switch SW1 off. Setting up is now just a simple procedure of adjusting preset RV2 and re-timing the time interval until exactly one minute is obtained.

Once you've done this, turn potentiometer RV1 (the main control) fully clockwise (maximum resistance) and then re-time the interval again. Something around 30 minutes should now elapse between turn-on and alarm.

Once your project is housed, the potentiometer control can then be marked off in a linear scale from the one minute minimum to the maximum.

If you have a frequency meter you can fine tune the alarm frequency to make sure the astable multivibrator's frequency is on the resonance of the piezo buzzer, to give maximum volume. However, this is by no means essential as the piezo buzzer will still sound pretty loud, anyway.

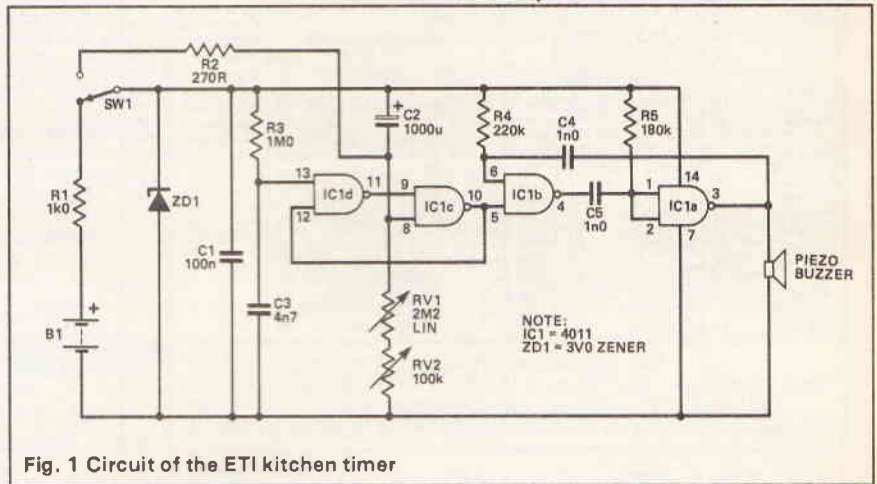

Fig. 1 Circuit of the ETI kitchen timer

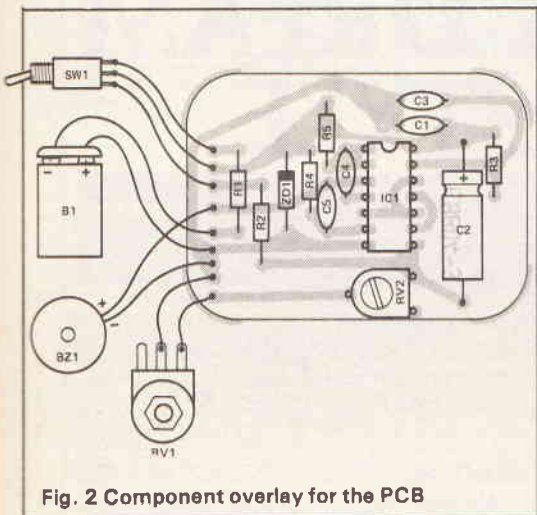

Fig. 2 Component overlay for the PCB

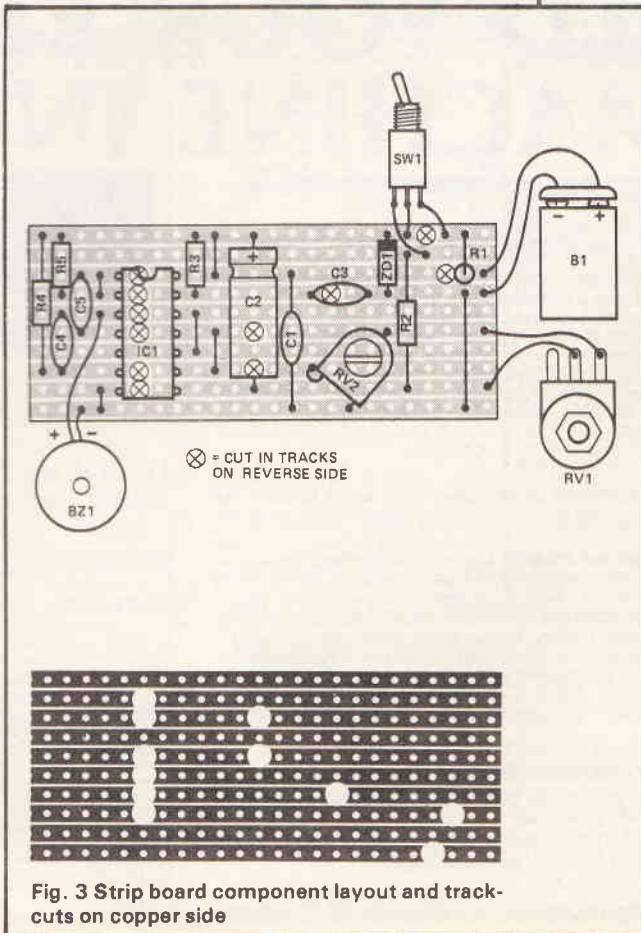

Fig. 3 Strip board component layout and track-cuts on copper side

BUYLINES

All components are readily obtainable from most sources. Values of most components are not particularly critical, so you can use closest alternatives. Capacitor C2 and the variable resistors define the timing range, however, so if they are altered the range will be changed too.

Piezo buzzers of the resonance used in the prototype were obtained from Maplin, although any other resonance will work — in which case the necessary resistance/capacitance values could be adjusted to give greatest output alarm volume.

PCB is available from ETI's PCB Service.



Just a sample of stock. Ask for items not listed.

Super Project Kit Bargains

IC'S	GREEN	.12	TIP126	.34	CAPACITORS	0.47 Ω F 63v	.17
400 UB	ORANGE	.21	TIP31C	.30	Radial Lead	Disc Ceramic	
401 UB	YELLOW	.15	TIP32C	.30	2.2 Ω F 50v	10pF 63v	.05
4011	3mm DIA.		2N2646	1.18	2.2 Ω F 63v	100pF 50v	.06
4017	RED		2N3055	.47	4.7 Ω F 63v	150pF 50v	.05
4028	GREEN	.13			33 Ω F 16v	220pF 50v	.05
4040	ORANGE	.21			47 Ω F 15v	0.1 μ F 25/50v	.05
4063	YELLOW	.13			47 Ω F 25v	0.1 μ F 1Kv	.27
4066					47 Ω F 35v	0.22 μ F 63v	.10
4081					47 Ω F 63v	0.47 μ F 50v	.12
Z80ACPU	FIXED				47 Ω F 100v	1 μ F 25v	.06
Z80AF10	VOLTAGE				10 Ω F 35v	1 μ F 50v	.07
7217IP1	REGULAT				10 Ω F 63v		
6402IPL	+5v 1a	.36			22 Ω F 100v		
555	+8v 1.5a	.68			100 Ω F 10v		
558	+12v 1.5a	.36			100 Ω F 16v		
741	+15v 1a	.36			470 Ω F 50v		
741	+24v 1a	.68			100 Ω F 25v		.02
LM380	+5v 1a	.39			100 Ω F 35v		
TDA3810	-12v 1a	2.10			100 Ω F 50v		
TL074CP	-15v 1a	.39			100 Ω F 63v		
SG3526N	24v 1a	.39			220 Ω F 10v		
SG3526J	+5v 0.1a	.25			330 Ω F 16v		.19
SL486DP	+8v 0.1a	.28			470 Ω F 16v		.25
SL490DP	+12v 0.1a	.28			470 Ω F 50v		40
ML926DP	+15v 0.1a	.36			470 Ω F 63v		63
	6w 0.1a	.30			1,000 Ω F 10v		27
	2w 0.1a	.30			1,000 Ω F 16v		27
	15v 0.1a	.30			2,200 Ω F 16v		45
DIODES	28 way	.55			40 way	.80	
IN4001	40 way	.80					
IN4002							
IN4003							
IN4004							
IN4005							
IN4007							
IN							
IN5406							
ZENER							
DIODES							
2V7 4W		.05					
5V1 4W		.05					
7V5 4W		.06					
9V1 4W		.06					
10V1 4W		.06					
11V1 4W		.06					
LED'S							
5mm DIA.							
RED		.13					

Z80 Based Controller Board
This super little micro board using the very powerful Z80A CPU running at 4MHz has all the necessary hardware to control menial to the most complex tasks. The PTH PCB Measuring only 107 x 118 comprises 2K EPROM (Empty), 2K static RAM, 16 input lines using two 74LS244 and 16 output lines using two 74LS373. The port connections are via four 10W pin strips, each having eight data lines, one ground and either NMI, INT, WAIT or RESET. A must for the small application.
Order as: Z80A-CTRL/K Kit Form £20.45
Z80A-CTRL/B Built and Tested £24.95
Z84C-CTRL/K Cmos Kit Form £26.95
Z84C-CTRL/B Cmos Built and Tested £31.45

RS232 to Centronics Converter
This handy little interface is ideal for running parallel printers from a serial port, the low cost way out of buying expensive parallel ports for your computer. Originally designed for the Sinclair QL and Northstar Dimension in mind. The PCB measuring 60 x 62 comprises of the 6402 UART, Baud rate generator and all necessary logic, comes complete with wire and ribbon cable and 36W centronics plug. (For "D" Type connector and hoods see selection on left. Sinclair QL SER1 Plug available extra @ £1.68 order as 900-71052F.)
Order as: RS232-8/K Kit Form £18.40
RS232-8/B Built and Tested £23.90

Distance Measuring Instrument
A invaluable handy instrument ideal for quickly measuring rooms no bigger than 50 feet square. The ultrasonic processing PTH PCB measuring only 77 x 85 has all the necessary components to output the distance in four digit BCD (multiplex) reflecting either feet meters or yards selectable by a three position switch. The kit comes complete with Parabolic reflector and transducer. Available extra is a liquid crystal display board measuring 51 x 101 which can be wired to the BCD output to the above board directly to display the distance in 0.5 inch high digits.
Order as: UDM126/K Kit Form £24.95
UDM126/B Built and Tested £34.95
LCDM4/K LCD Kit Form £14.30
LCDM4/B LCD Built and Tested £16.95

Mail or Telephone Orders Only Please to:
Dept. 23, Samuel Whites Estate, Bridge Road, Cowes, Isle of Wight, PO31 7LP
Please add £1 for 1st class post and packaging and 15% VAT to total.
Stock listing available soon, please send SAE to be put on the mail list.

BUILD YOUR ETI DREAM MACHINE IN STYLE

Adjust the controls to suit your mood and let the gentle, relaxing sound drift over you. At first you might head for the sound of soft rain, sea surf, or perhaps the wind through distant trees. Almost hypnotic, the sound draws you irresistibly into a peaceful, refreshing sleep.

For many, the prospect of waking refreshed and alert from perhaps the first truly restful sleep in years is exciting enough in itself. For more adventurous souls there are some strange and mysterious dream experiences waiting. Take lucid dreams, for instance. Imagine being in control of your dreams and able to change them at will to act out your wishes and fantasies. With the Dream Machine it's easy!

The ETI expansion parts set contains all you need to turn the basic Dream Machine into a very special project. The parts set contains:

- PRESTIGE CASE ● MAINS POWER SUPPLY COMPONENTS (transformer, rectifiers, capacitors, regulator) ● HIGH QUALITY EXPANSION COMPONENTS (TBA820 IC, resistors, capacitors, transistors, preset, loudspeakers) ● ALL CONTROLS AND ACCESSORIES (pots, switches, knobs, neon lamp, fuse holder, fuse, mains cable, etc.) ● FULL INSTRUCTIONS (Copies of the November and December ETI articles describing construction, testing and all kinds of dream experiments!)

The expansion set costs only £19.95 incl. postage and VAT
(You will need the free components and PCB from the November and December issues to complete this project).

The complete parts set (including PCB and all components) is yours for only £20.95 incl. postage and VAT.

WITH THIS SPECIAL OFFER PACK OF PARTS FROM ETI READERS SERVICES 'EXPANSION' OR 'FULL' KIT.

To A.S.P. Readers Services, 9 Hall Road, Maylands Wood Estate, Hemel Hempstead, Herts HP2 7BH. Please supply
..... expansion sets ROET 8 @ £19.95
..... complete sets ROET 9 @ £20.95

I enclose my cheque/P.O. payable to A.S.P. Ltd. Please debit my Access/Barclaycard A/c No.

Signature

Name

Address

Please allow 28 days for delivery. This offer is available to readers in U.K. only. Overseas enquiries in writing to the above address.

For KITS & COMPONENTS - Choose the easy way - with

Send **50p* & SAE** for **CATALOGUE** (AUTUMN 1987)
*refundable with first order



ORDERS: RING (01) 567 8910 - 24 HRS.

NEW ELECTRONIC GUARD DOG KIT



One of the best deterrents to a burglar is a guard dog and this new kit provides the barking without the bite! The kit when assembled can be connected to a doorbell, pressure mat or any other intruder detector and will produce a random series of threatening barks making the would be intruder think again and try his luck elsewhere. The kit is supplied complete with high quality PCB, transformer, all components and instructions. All you need is a mains supply, intruder detector and a little time. The kit even includes a horn speaker which is essential to produce the loud sound required. The "dog" can be adjusted to produce barks ranging from a Terrier to an Alsatian and contains circuitry to produce a random series of barks giving a more realistic effect.

XK125 Complete kit of parts £24.00

DISCO LIGHTING KITS

DL1000K This value-for-money 4-way chaser features bi-directional sequence and dimming. 1kW per channel **£19.25**
DL21000K - A low cost uni-directional version of the above. Zero switching to reduce interference **£10.80**

DLA/1 (for DL & DL21000K) Optional opto input allowing audio 'beat/light response' **77p**
DL3000K - 3-channel sound to light kit features zero voltage switching, automatic level control and built-in microphone. 1kW per channel **£15.60**

The **DL8000K** is an 8-way sequencer kit with built in opto-isolated sound to light input which comes complete with a pre-programmed EPROM containing EIGHTY - YES 80! different sequences including standard flashing and chase routines. The KIT includes full instructions and all components (even the PCB connectors) and requires only a box and a control knob to complete. Other features include manual sequence speed adjustment, zero voltage switching, LED mimic lamps and sound to light LED and a 300 W output per channel.

And the best thing about it is the price.

ONLY £31.50

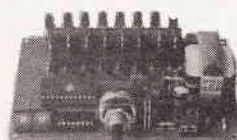

TEN EXCITING PROJECTS FOR BEGINNERS

This Kit has been specially designed for the beginner and contains a **SOLDERLESS BREADBOARD**, **COMPONENTS**, and a **BOOKLET** with instructions to enable the absolute novice to build TEN fascinating projects including a light operated switch, intercom, burglar alarm, and electronic lock. Each project includes a circuit diagram, description of operation and an easy to follow layout diagram. A section on component identification and function is included, enabling the beginner to build the circuits with confidence.

ORDER NO XK118 £15.00

MICROPROCESSOR TIMER KIT

Designed to control 4 outputs independently switching on and off at present times over a 7-day cycle. LED display of time and day. easily programmed via 20 way keyboard. Ideal for central heating control including different switling time for weekends. Battery back-up circuit. Includes box 18 time settings.



CT6000K **£47.20**
XK114 Relay kit for CT6000, includes PCB, connectors and one relay. Will accept up to 4 relays. 3A/240V c/o contacts .. **£4.30**
701 115 Additional relays **£1.80**

VERSATILE REMOTE CONTROL KIT

This kit includes all components (+ transformer) to make a sensitive IR receiver with 16 logic outputs (0-15V) which with suitable interface circuitry (relays, triacs, etc - details supplied) can be used to switch up to 16 items of equipment on or off remotely. The outputs may be latched (on the last received code) or momentary (on during transmission) by specifying the decoder IC and a 15V stabilised supply is available to power external circuits. Supply: 240V AC or 15-24V DC at 10mA. Size (excluding transformer) 9 x 4 x 2 cms. The companion transmitter is the **MK18** which operates from a 9V PP3 battery and gives a range of up to 60ft. Two keyboards are available - **MK9** (4-way) and **MK10** (16-way), depending on the number of outputs to be used.

MK12 IR Receiver (incl. transformer) **£16.30**
MK18 Transmitter **£7.50**
MK9 4-Way Keyboard **£2.20**
MK10 16-Way Keyboard **£6.55**
601 133 Box for Transmitter **£2.60**

HOME LIGHTING KITS

These kits contain all necessary components and full instructions and are designed to replace a standard wall switch and control up to 300W of lighting.

TDR300K Remote Control Dimmer **£18.00**
MKS Transmitter for above **£5.10**
TD300K Touchdimmer **£9.30**
TS300K Touchswitch **£9.30**
TDE/K Extension kit for 2-way switching for **TD300K** **£2.95**
LD 300K Light Dimmer **£4.75**

NEW POWER STROBE KIT

Designed to produce a high intensity light pulse at a variable frequency of 1 to 15Hz this kit also includes circuitry to trigger the light from an external voltage source (eg. a loudspeaker) via an opto isolator. Instructions are also supplied on modifying the unit for manual triggering, as a slave flash in photographic applications or as a warning beacon in security applications. The kit includes a high quality pcb, components, connectors, 5Ws strobe tube and full assembly instructions. Supply: 240V ac. Size: 80 x 50 x 45.

XK124 STROBOSCOPE KIT £13.75

DVM/ULTRA SENSITIVE THERMOMETER KIT

Based on the ICL 7126 and a 3/4 digit liquid crystal display, this kit will form the basis of a digital multimeter (only a few additional resistors and switches required - details supplied) or a sensitive digital thermometer (-50°C to +150°C) reading 0.1°. The kit has a sensitivity of 200mV for a full-scale reading automatic polarity and overload indication. Typical battery life of 2 years (PP3) **£17.00**

XK113 MW RADIO KIT

Based on ZN414 IC, kit includes PCB, wound aerial and crystal earpiece and all components to make a sensitive miniature radio. Size: 5.5 x 2.7 x 2cms. Requires PP3 9V battery. **IDEAL FOR BEGINNERS** **£6.60**

PROPORTIONAL TEMPERATURE CONTROLLER KIT

Uses "burst fire" technique to maintain temperature to within 0.5°C. Ideal for photography, incubators, wine-making, etc. Max. load 3kw (240V ac) Temp. range up to 90°C. Size: 7x4x2.5cms. **MK4** **£7.80**

BARGAIN COMPONENT PACKS

Refill those empty component drawers at a fraction of the normal price and don't be caught without that odd resistor or capacitor to complete your project. All components supplied are to full spec. and are not seconds or surplus stock.

- Pack A:** 650 x .25 watt resistor 47R-10M **£4.25**
- Pack B:** 60 x Radial electrolytics 1uf - 1000uf **£3.25**
- Pack C:** 30 x Polyester capacitors a or 0.01 uf - 1uf **£4.50**
- Pack D:** 35 x horizontal presets 1k-1M **£3.00**
- Pack E:** 30 x IC sockets 8, 14, 16 pin **£2.00**
- Pack F:** 25 x Red 5mm LEDs **£1.75**
- Pack G:** 25 x Green 5mm LEDs **£2.00**
- Pack H:** 30 x 5mm LEDs 10 Red, 10 Green, 10 Yellow **£2.50**
- Pack J:** 50 x 1N4148 silicon diodes **£1.00**
- Pack K:** 40 x npn/ppn transistors BC/182/212 General Purpose **£2.25**

FREE Solderless Breadboard (verobloc type). When you buy all ten packs. Prices exclude VAT (15%).

TOOLS ★ TOOLS ★ TOOLS



Good quality tools selected to offer outstanding value for money.

- 650 004** 6in mini. Snipe Nose Pliers. Serrated jaws and return spring. **£2.10**
- 650 005** 6in lip jointed side cutters. Insulated handles and return spring. **£2.10**
- 650 006** Light duty cutters. Cutting capacity 0.22-1.2mm copper wire. **£1.60**
- TOOL KIT** - Contains: side cutters, snipe nose pliers, wire strippers, flat blade screwdriver, Phillips screwdriver in black textured, reinforced and padded case which when opened out measures 240x206mm **£6.80**



- 650 007** Self-adjustable automatic wire stripper with built-in cable cutter. **£3.98**
- 650 012** Watchmakers Screwdriver Set. 1.0/1.4/2.0/2.4/3.0/3.8mm **£1.78**
- 650 019** Set of 2 Stainless Steel Tweezers. Straight nosed, straight nosed-reverse action, bent nosed, flat nosed. 110mm long. **£3.65**
- 650 602** Reamer 9-12V dc Drill. **£6.90**
- 650 600** Titan 12V dc Drill. **£10.25**
- 650 670** Saturn Mains Drill. **£16.50**

WE ALSO STOCK ANTEX IRONS AND ACCESSORIES

SECURITY PRODUCTS

Install your own burglar alarm and save pounds. All parts available separately.

- 950 120 Stair Pressure Mat **1.70**
- 950 125 Floor Mat 29x16 ins. **2.60**
- 950 130 External bell box - an ideal deterrent on its own! **10.00**
- 950 130 Xenon Beacon (12v) **10.50**
- 950 140 Flush door/window contacts **1.22**
- 950 143 Surface mounting contacts **1.05**
- 960 160 Alarm Control Unit
- 950 162 Alarm Control Unit** This unit incorporates all the features required to form the basis of a complete security system for the home or business. Operating off a 240v AC supply with facility to charge a 12v lead acid standby battery. The unit is housed in a white steel box 225x225x80mm. Full instructions supplied to connect normally open and closed sensors, bells, personal alarms etc. Separate entry and exit alarm delays. 2 zone operation complies with BS 4737 **price £39.95**
- 950170 DOOR PHONE** An attractively styled 2 station mains powered handset type door phone. Allowing conversation with visitors without opening the door. Free standing or wall mounted, connections to a 9 volt battery for standby. Electric doorlock release button which maybe used with our 701150 lock release mechanism. Ivory and Fawn body 210x100x70mm. **£27.95**

AUTORANGING DIGITAL MULTIMETER



High quality meter with features normally found in meters costing much more e.g. DISPLAY HOLD. MEMORY. CONTINUITY BUZZER and 10A AC/DC current ranges. High accuracy and automatic operation - a must for the professional or serious hobbyist. Size: 127 x 69 x 25mm.

AC Volts: 0-2-20-200-500V
DC Volts: 0-200m-2-20-200-1000v
AC Current: 0-20m-200mA (1.2%) 0-10A (2%)
DC Current: 0-20m-200mA (1.2%) 0-10A (1.5%)
Resistance: 0-200-2K-20K-200K-2M (1%)
Continuity Buzzer operates @ 20 ohm **£33.00**

SUPER-SENSITIVE FM MICROBUD

NEW

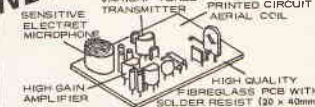

Highly sensitive FM transmitter measuring only 45 x 25 x 15mm, including the built-in microphone. Frequency 88-100MHz enabling reception on a standard domestic FM radio. Range approximately 300m depending on terrain. Powered by 9V PP3 (7mA). Its small size and highly sensitive electret microphone makes it ideal for surveillance, baby alarm etc. **INTRODUCTORY PRICE £5.50**

RECHARGEABLE SOLDERING IRON

Powerful cordless iron complete with table-top/wall-mounting charging bracket. Reaches soldering temperature in 10 seconds. Includes lamp which lights when soldering. Comes with mains charging unit and 12V car battery adaptor. **Special Offer £19.95**

ELECTRONIC WEIGHING SCALES

This kit contains a Single Chip Microprocessor, PCB, displays and all electronics to produce a digital readout of weight in Kgs. or Sts. and Lbs. In normal use a toothed wheel (pattern provided) is made to rotate when a weight is placed onto the scales, interrupting two infra-red beams. The processor counts the number of teeth passing the sensor (up or down, depending on which beam is broken first) and shows the reading on the LED display in Sts. & Lbs., Lbs. or Kgs. A PCB link selects the scale for bathroom or two types of Kitchen Scales. A linear version of the toothed wheel could also be used. Other uses include up/down counters. A low cost digital ruler could be made by using a wheel with the correct tooth to diameter ratio **ES1 £5.50**

TR ELECTRONICS
13 BOSTON RD
LONDON W7 3SJ
Tel: 01-567 8910

SEND 9"x6" S.A.E. & 50p FOR CATALOGUE OR CALL AT SHOP MON-FRI 9-5pm SATURDAY 10-4pm

ORDERING INFORMATION: ALL PRICES EXCLUDE VAT

FREE P&P on orders over £20 (UK only), otherwise add 75p + VAT. Overseas P&P: Europe £2.75. Elsewhere £6.50. Send cheque/PO/Barclaycard/Access No. with order. Giro No. 529314002.

LOCAL AUTHORITY AND EXPORT ORDERS WELCOME
GOODS BY RETURN SUBJECT TO AVAILABILITY

COMBO-LOCK

Chung Yiu Ko keeps his valuables safe and sound behind closed contacts with his combination lock circuit

Neighbourhood Watch schemes cover the land. Little orange stickers appear in the windows of every semi-detached in the Kingdom.

Security in the home has a higher profile today than ever before and a simple electronic locking device could be worth its weight in missing cufflinks.

This circuit detects correct sequence input and provides a relay output suitable to trigger an electronic lock. Its main beauty is that it uses no ICs and keeps things simple and cheap.

The correct combination is hardwired rather than programmed and the lock could be used to protect door openers, burglar alarms, car ignitions — the applications are limited only by your imagination.

The circuit diagram is shown in Fig. 1.

The heart of the circuit is the sequential detector which interprets the correct sequence inputs from the key switches, turns the output on and activates a relay. An indicator (LED1) indicates that the correct number sequence has been entered.

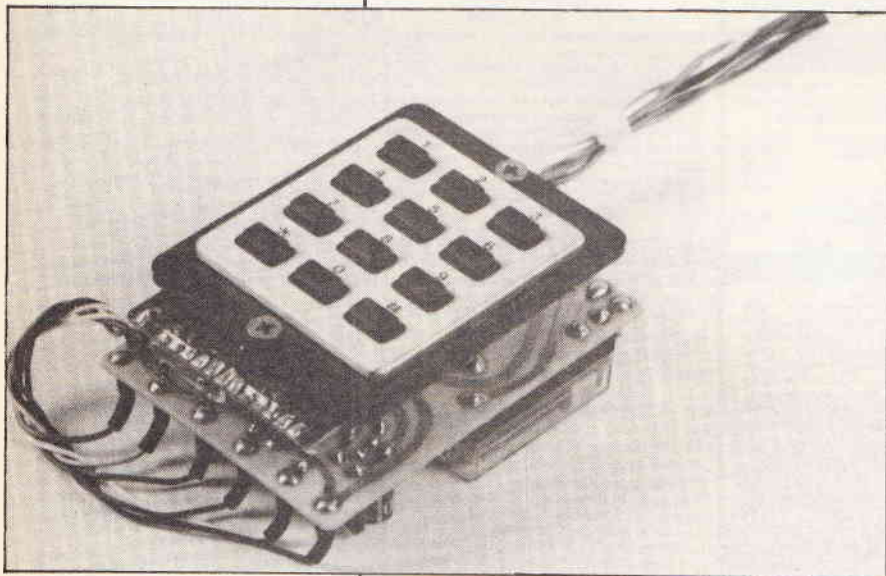

If the right numbers are entered but in the wrong order then the sequence detector is reset and the entire sequence must be repeated.

Alarm circuitry is incorporated in the design and this is activated if the digits not appearing in the combination are pushed.

Construction

Though stripboard could be used with care, the PCB is recommended and the overlay is shown in Fig. 2.

The specified relay (see Buylines) will fit directly onto the PCB. It is possible to use any relay having a 12V 300R or higher resistance coil, but it may be necessary to redesign the printed circuit layout or mount the relay off board.

The key switches are of push-to-make momentary action type and any switches of this type can be used. However a low profile keypad or keyboard is more desirable for ease of construction (again see Buylines).

HOW IT WORKS

The sequence sensing circuit is constructed around Q1 to Q6, the key switches and the relay.

Initially Q1 to Q6 are non-conducting. As soon as key 1 is keyed Q2 is forward biased, collector current flows through R4 and the base and emitter of Q1. C1 charges via R3 and R4 which provides sufficient bias to turn Q1 on. The voltage drop developed across R2 (due to Q1 collector current) briefly holds Q2 on and a constant current source is now available at the emitter of Q1, forming the power source for the remaining stages of the emitter follower.

The functions of Q3 and Q4, Q5 and Q6 are similar, except that the loading of the final stage is a relay coil and LED indicator.

Obviously the keys must be keyed in correct sequence (1, 6 then 8 as shown in Fig. 1) otherwise there will be no power source available from one stage to another and the relay will never energise.

The incorporation of the keypad or keyboard enables the user to select any three digits of any combination number he chooses while the remaining keys are connected to the reset/alarm mode input.

Whenever the unselected keys are pressed the circuit is reset by pulling Q1 base to negative (via D1 in alarm mode) and at the same time discharging C1. Q1 is biased off turning off Q2. At this stage the entire sequence must be repeated.

The second half of the circuit is alarm warning circuitry. Whenever a reset/alarm key is keyed (except the actual reset key 0) the alarm will sound for a short duration.

Q7 and Q8 form a basic astable multivibrator circuit. Initially the oscillator is inoperative, because Q8 is biased off via resistors R14 and R11 to the positive supply. As soon as a reset/alarm key is keyed, capacitor C4 charges via R16 with the polarity shown, Q8 becomes forward biased and the oscillation starts for a duration determined by the R11 and C4 network.

Gradually C4 discharges across R11 sufficient to cut Q8 off and the oscillator stops.

Q9 is a simple direct-coupling emitter-output power amplifier.

The circuit will operate well on 12V DC and draws a maximum standby current of 20mA. The maximum current is 400mA with the alarm and relay energised. This makes the device ideal for 12V car system or a mains derived supply.

After inspection of the PCB for short circuits, broken tracks and any damage, the resistors should be soldered onto the board, followed by the capacitors, then the diode and transistors (care being taken with polarity of these components).

Once all the components are securely fitted onto the board, connect the corresponding wirings to the desired sequence and reset key switches.

In Fig. 1 the sequence number is shown as 1-6-8. Zero is for reset and the remaining unselected invalid keys are connected in parallel to the reset/alarm warning circuitry input.

The PCB is purposely small so that it can be mated back-to-back with the keypad by two spacers, and tucked away in any suitable front panel.

For door opener applications the unit can be fitted in a metal blanking plate (as used in house wiring) and mounted in the doorframe, with the

PROJECT

PARTS LIST

RESISTORS (all 1/4W 5%)

R1, 5, 8	470R
R2, 6, 9	150R
R3, 7, 15	1K0
R4	82R
R10, 12	510R
R11, 13, 14	56K
R16	5K0

CAPACITORS

C1, 2, 3	3 μ 3 12V electrolytic
C4	100 μ 12V electrolytic
C5, 6	20n ceramic

SEMICONDUCTORS

Q1, 3, 5, 7, 8	ZTX400
Q2, 4, 6	ZTX500
Q9	BD135
D1	1N4001
LED1	red LED

MISCELLANEOUS

RLA1	12V relay 300R or higher
SW0-9	keypad or push-to-make switches
PCB, PCB pins (16), Wire, Nuts and bolts.	

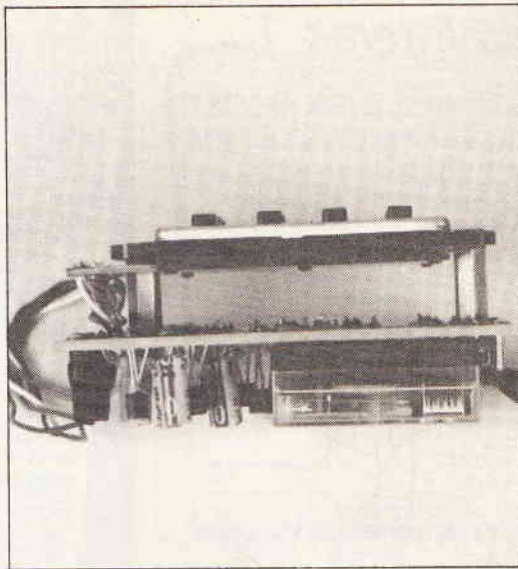

PROJECT

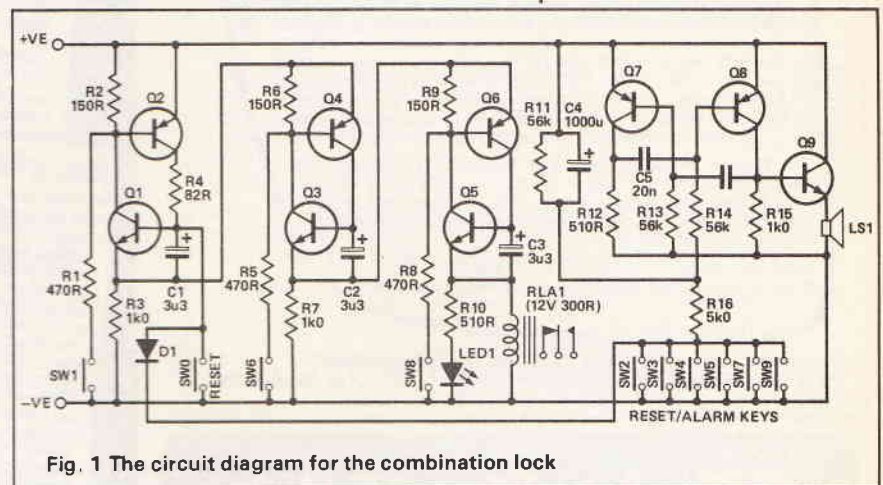
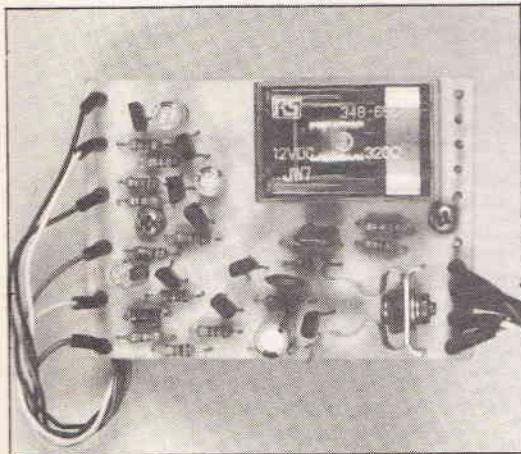

Fig. 1 The circuit diagram for the combination lock

speaker wired remotely indoors.

For automotive applications a small module case with metal front panel is most suitable. The base of the case can be secured onto the dashboard, with the metal front panel used to mount the complete unit.

The alarm in the circuit shown is not going to wake the street and alert the local alsatian brigade. In its present configuration it is more of a loud indication that the incorrect sequence has been entered.

It would not be difficult to fit a second relay into the alarm section of the circuit which could trigger a bell alarm, or a flashing neon arrow with 'Burglar' written on it, or even to release an enormous weight from the second floor onto the burglar (please note that ETI can take no responsibility for any visitors flattened by this method).



BUYLINES

The relay used in the prototype was from RS components, stock code 348-655.

The keypad used was also from RS, stock code 333-704.

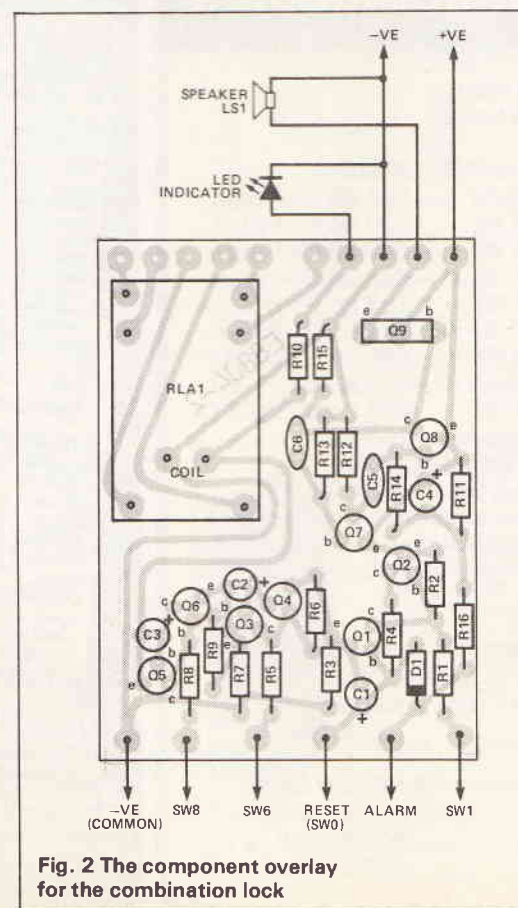

Fig. 2 The component overlay for the combination lock

Interak 1

AN EXPANDABLE DISK-BASED Z80A DEVELOPMENT SYSTEM YOU CAN BUILD YOURSELF!

Universities, Colleges, Industry, Enthusiasts:

Unlike home computers, development systems have entirely "open" architectures, use standard TTL etc. chips (ie no ULA's), and are built in a proper engineering fashion. Usually these superior products carry a correspondingly superior price tag, but you can build Interak yourself board by board and thus afford a system which would normally be out of your reach and/or understanding.

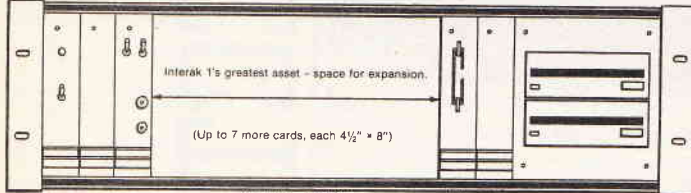

The initial development system has 64K of RAM, a 4 MHz Z80A CPU, parallel ASCII keyboard interface, VDU interface (TV set or monitor), and a floppy disk drive interface for up to 4 drives. Any size (including 8" double density) can be used, but our 1 Megabyte 3.5" drives are proving very popular because they can fit into the system rack, (and they only cost £94.00 each + VAT). CP/M Plus is available, giving access to thousands of "public domain" programs.

The system can be described as "future proof" because it uses plug in 4.5" x 8" cards in an industrial quality 19" 3U rack. We have been established since 1970, and this system was first made in 1977 so (unlike almost all other computers) it has stood the test of time.

Send two second class stamps, or telephone for a detailed descriptive leaflet, specification, prices, etc.

Greenbank

Greenbank Electronics (Dept. T4E), 460 New Chester Road, Rock Ferry, Birkenhead, Merseyside L42 2AE. Tel: 051-645 3391

TEST INSTRUMENTS

UK's LARGEST IN-STOCK RANGE

DIGITAL MULTIMETERS

- KT305 (1) 26 range plus Hie test 10A AC/DC 20meg buzz 0.5% (R) £33.50
- KT110 (1) 31 range incl. 5 range CAP 10A AC/DC 20meg buzz 0.5% (R) £33.00
- KT5005 (3) 4 1/2 digit 28 range plus Hie 10A AC/DC 20meg 0.07% (PBI) £83.00
- KD508 (1) 15 range AC/DC volts 0.2A DC 2 meg (S) £19.96
- KD578 (1) 20 range 10A AC/DC auto range display hold 0.8% (R) £34.50
- 6010 (1) 28 range 10A AC/DC 20 meg 0.25% (PB) £39.50
- 7030 (1) 0.1% version of 6010 £52.13
- 5010EC (1) 34 range incl. CAP Hie temp etc 0.25% (R) £53.00
- M3530 (1) 28 range incl. 5 range CAP plus Hie 10A AC/DC 0.5 (R) £35.00
- M3800 (1) 30 range plus Hie 20A AC/DC 20 meg 0.5% (R) £57.00
- M3650 (1) 30 range incl. Hie CAP Iraq. count. 20A AC/DC 0.3% (R) £35.00
- M3800 (1) 30 range + Hie 20A AC/DC 20meg 0.5% (R) £77.00
- M4630 (1) 30 Range + CAP + Hie + Databank 20A AC/DC 20meg 0.05% (R) £36.50
- HC5010 (3) 31 Range 10A AC/DC 20meg 0.25% (R) £41.00
- HC779 (3) 20 Range 10A AC/DC Auto range + Hie + mem/hold 0.5% (R) £14.95
- 6511 (3) Wallet auto range £21.50
- DM205 (3) 14 range 10A DC Hie test display hold 0.5% (R)

All 3 1/2 Digit LCD.
+ Case £2.17
+ 4 1/2 Digit.
+ With Case.
(R = Rotary
Pb = Push Button
S = Slide)



SCOPES (*with probes)

- HAMEG - all with component testers £314.00
- *203/6 Dual 20MHz £598.00
- *806 Dual 80MHz 3 chan delay etc £278.00
- *205/2 Dual 20MHz + digital store £575.00
- *604 Dual 60MHz - sweep delay £195.00
- THANDAR SC110A Batt 10MHz £195.00
- Portable CROTECH 3031 20MHz Single track + comp. £199.00
- GENERAL OST5M 5MHz Bench portable £146.00
- HITACHI Y212 Dual 20MHz £330.00
- HUNG CHANG 615 Dual 15MHz Batt/Mains £399.00

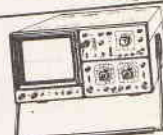

POCKET INSTRUMENTS

- *KT905 8 Range Digital Cap Meter £34.74
- 555 20Hz to 150KHz Audio Generator £47.50
- 2030ET 27 Range multimeter 10A AC/DC + Hie + Cap £37.90
- 2030E-41 Range FET meter 0.1 uA, 1000 meg etc £28.65
- 1020Z 19 Range Meter 20K/V, 10A DC Buzzer £10.39
- 07 20 MHz Logic Probe, TTL, CMOS £9.52
- 625 50 MHz Logic Probe + Logic Pulse 0.5/400Hz £22.95
- X1/X10 Scope/Inst. Probe 250 MHz with access £11.50
- PFM 200a 200MHz LED 8 digit Freq counter £75.00
- KDm6 1.5MHz to 250MHz TR Dipmeter £43.04
- *ST300 0/300 AMPS AC 5 range 0/800V AC 4 ranges £32.83
- 1KOH Res clamp meter £65.00
- *501 Electronic insulation tester 500V DC 100 meg £63.04
- 6060 Digital power meter 2KW/AKW true power 10A AC/DC volts LCD £59.50
- TH301 Digital temperature meter with probe LCD £14.17
- TC200 Digital LCD CAP/RES/IND 625 50 MHz Logic probe plus logic pulser £85.00
- 518C Digital LCD CAP/RESIS/Hie £57.00



Amplifier Modules

The most sophisticated and highly protected modules available today.

MODULE	POWER/LOAD	PRICE
CE608	60W 8Ω	£25.84 Bi-Polar
CE1004	100W 4Ω	£30.44 Bi-Polar
CE1008	100W 8Ω	£33.59 Bi-Polar
CE1704	170W 4Ω	£43.26 Bi-Polar
CE1708	170W 8Ω	£43.26 Bi-Polar
CE3004	300W 4Ω	£55.05 Bi-Polar
FE908	120W 8Ω	£38.75 MOSFET
FE1704	220W 4Ω	£66.85 MOSFET
FET 3	450W 4Ω	£83.71 MOSFET
CPR 2	Stereo Preamp	£53.88
REG 2	+/-12v Supply	£19.66

Prices include P+P,VAT. All modules are guaranteed for 2 years. For more information on these modules and our other products including our Hi-Fi kit amplifiers. Please write (s.a.e.) or phone.

CRIMSON ELEKTRIK STOKE Agents:—
BRADLEY—MARSHALL
382-386 EDGEWARE RD.
LONDON.

PHOENIX WORKS
500 KING ST.
LONDON

STOKE—ON—TRENT STAFFS

WILMSLOW AUDIO
35-39 CHURCH ST.
WILMSLOW
CHESHIRE.

TEL.(0782) 330520

BENCH DIGITAL MULTIMETERS

- 3 1/2 digit LCD 100, V AC/DC 100mA 100m OHM con buzzer battery operated 20A AC/DC £89.00
- 3225 0.25% basic £119.00
- 3210 True RMS Version 0.1% Tm355 3 1/2 digit LED 10A AC/DC 0.25% (Batt operated) £85.00
- Tm351 LCD 0.1% £115.00; Tm 356 LCD 0.25% £95.00
- 8035 LED 20A AC/DC 0.1% £139.00
- 8035T LED 20A AC/DC True RMS £179.00
- 8145 4 1/2 digit LED 20A AC/DC 0.05% £169.00



243 0/24 volts 0/3 amps DC
245 0/24 volts 0/5 amps DC
154 5/15 volts 0/4 amps DC
0/30V 0/3A DC twin meter
THURLEY, GW. THANDAR DIGITAL PSU'S AVAILABLE

DC POWER SUPPLIES

240V AC Input. Stabilised variable output voltages. Direct meter reading volts and amps.

£50.39
£64.50
£36.50
£66.00

COUNTERS & TIMERS

- ALL BENCH MODELS
- FREQUENCY COUNTERS
- MET100 220/240V AC 8 digit £99.00
- MET600 LED 0.1Hz £126.00
- MET1000 RESOLUTION £175.00
- MET1500 5mv min Sensitivity £199.00
- TF200 8 digit LCD batt 200 MHz £175.00
- COUNTER/TIMERS 8 DIGIT LED
- APPOLLO 10 STANDARD MODEL £219.00
- APPOLLO 100 PLUS DISPLAY HOLD RPM STOP WATCH ETC. £285.00



SIGNAL SOURCES

- AC220/240 V operations
- FUNCTION SINE/SQ/TRIANGLE/TTL
- Jupiter 500 0.1Hz to 500KHz £110.00
- T6101 0.02Hz to 200KHz £110.00
- T6102 0.2Hz to 2MHz £160.00
- Jupiter 2000 0.2Hz to 2MHz £149.00

TV-VIDEO

- PAL VHF/UHF 5.5/6/6.5MHz Fm SOUND RGB 2 SYN a/p/s Colour - B/W etc. £199.00
- DIGITAL DISPLAY (0.2Hz - 2MHz) 20 4 digit 0.2Hz - 2MHz Function £165.00
- 80160 6 digit 0.2Hz - 2MHz Function £215.00
- 8019 5 digit AM/FM Function £250.00
- SWEEP FUNCTION (0.2Hz - 2MHz) 80165 FM mod 6 types of wave-form £190.00
- 8019 5 digit 0.2MHz - 2MHz AM/FM Function £250.00

PLEASE ADD VAT (UK ONLY)
CATALOGUES WITH DISCOUNT VOUCHERS Send 12" x 19" SAE (E1 Stamp UK)
TRADE ■ EDUCATION ■ EXPORT SUPPLIED

ORDER BY POST OR PHONE • OPEN 6 DAYS A WEEK FOR CALLERS
HENRY'S 404 EDGWARE ROAD LONDON W2 1ED
Tel: 01-724 0323
Account Enquiries 01-258 1831. Telex 298102 Trans G
Also at 301 Edgware Road, W2. Tel: 01-724 3564

ZENITH ELECTRONICS

KITS AND

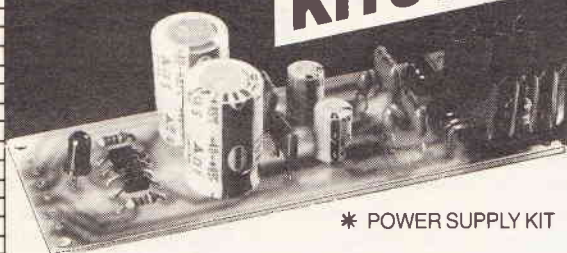

* POWER SUPPLY KIT

- 25/30 Watt MOSFET Audio Power Amplifier 4-8 Ohms **Kit £21.97 R/Built £26.00**
- 10 Channel Variable Speed running light Kit drives LEDs or Mains lamps. Includes LED display board and LED lamps **Kit £15.89 R/Built £19.15**
- Mains Add-on interface board for controlling Mains lamps from our running light unit **Kit £4.95 R/Built £5.00**
- * Plus & Minus regulated power supply 1-Amp state 5, 12, 15, or 24v **Kit £11.82 R/Built £14.82**
- Variable Time Delay Relay unit **Kit £5.71 R/Built £7.71**
- 25/30 Watt 12-Volt opp. R.F. Linear Power Amplifier for Amateur Radio **Kit £26.66 R/Built £31.66**
- Selectable tone generator 9-12v operation **Kit £5.50 R/Built £7.50**
- 3 Note Electronic Door Chime unit, 9 volt operation, 3 melodious tones, variable frequency. **Kit £9.83 R/Built £12.00**
- Miniature FM Transmitter, 60-145MHz **Kit £6.95 R/Built £8.95**
- 3 Watt FM Transmitter, 80-108MHz **Kit £13.99 R/Built £18.99**
- 300 Watt Light Dimmer unit for 240 volt mains lights **Kit £6.95 R/Built £10.95**
- 4 Code Digital Code unit plus Key Pad - Select own code 9 volt **Kit £16.31 R/Built £19.95**
- 5-100 Watt Electronic Loudspeaker Overload protector, adjustable **Kit £11.40 R/Built £15.40**
- VU Meter 10 LED indicator, 5 to 12dB range **Kit £13.63 R/Built £18.63**
- 18 Watt Car/Home Power Amp 12-V **Kit £14.50 R/Built £16.80**
- Amplifier Power Meter, 10 LED indicator from 0.25-100 Watt Input - 9 volt operation **Kit £12.94 R/Built £14.94**
- Light sensitive relay unit; variable sensitivity trigger control; senses light or dark - selectable. **Kit £8.91 R/Built £10.91**

PRODUCTS

- Wireless FM Duplex telephone - sold in pairs for Office/Home **£54.00**
- 5mm LCD digital sports Chronograph hand held **£10.95**
- Digital Blood pressure meter/monitor LCD readout **£44.83**
- Digital LCD temperature module for panel mounting - 19°C to + 68°C **£16.82**
- 3.5" digital LCD Professional series digital multimeter, reads Capacitance, Temperature, Voltage, Conductance, Diodes, Transistors AC/DC voltages & Continuity **£63.25**
- Zenith Speech processor P-202 **£29.50**
- High quality touch dimmer 500W **£12.99**
- Mains Wiring and Metal Detector **£11.00**

ORDERING

■ All Kits contain full instructions PCBs and components ■ All prices include VAT and postage and packing ■ Overseas orders add 10% to above prices ■ Please send Cheque or Postal Order with Order.

Zenith Electronics Dept. 1234
14 Cortlandt Business Centre
Hailsham, East Sussex, UK BN27 1AE
Telephone (0323) 847973
Telex 878334 FAX 647204



Send £1.00 for Catalogue which includes Postage and Packing - Refundable on first order.

19" RACK CASES

* Suitable for instruments, high quality amplifiers and many other applications that demand strength and professional finish * New improved construction and finish * Black anodised aluminium front panels * Separate front mounting plate, no fixing screws visible on the front and the side of the enclosure * Heavy gauge front panel is of brushed aluminium finish enhanced with two professional handles * With ventilation slits and plastic feet * Rear box manufactured from 1.1mm steel finished in black. Rack mounting or free standing. Comes in quick assembly flat package spare front panels available.

Order Code	Panel Size W H (inch)	Rear Box W H D	Weight	Price £
1U-10	19 x 1.75	17 x 1.5 x 10	2.4kg	23.50
2U-10	19 x 3.5	17 x 3.0 x 10	2.9kg	24.50
3U-10	19 x 5.25	17 x 5.0 x 10	3.5kg	26.50

15% discount on 1U-10 2U-10 3U-10 with this advert.

2U-12	19 x 3.5	17 x 3.0 x 12	3.3kg	£25.50
3U-12	19 x 5.25	17 x 5.0 x 12	4.0kg	£27.50
4U-12	19 x 7.0	17 x 6.5 x 12	4.6kg	£29.95

Please add £3.00 P&P for the first item and £1.50 for each additional item. No VAT to be added to the price.



TEST EQUIPMENTS



- C83A Digital Power Supply/Voltmeter (0/35 Volts 1.5 A) **£44.95**
- C83B Digital Power Supply (0/30 Volts 1 A) **£38.95**
- C89A Function Generator (2 Hz to 200 KHz) **£39.95**
- C86A 60 MHz Counter/Timer **£47.95**
- C87A Autoranging Capacitance Meter (0.1 pF to 99.9 mF) **£47.95**
- MV338 Metal-mains detector **£4.99**

A new range of quality test equipment at the lowest possible price. The C89A (£34.95) and C86A (£39.95) are also available in kit form with full construction details. Please add £3.00 p/p per item (£1.00 for MV338).

To order send cheque/postal order - please allow up to 7 days despatch for cheque clearance. Quantity discount available. Customers who require further information please send S.A.E. Trade and overseas orders welcome. Mail order only.

T.J.A. DEVELOPMENTS
Dept. ET1, 19 Welback Road,
Harrow, Middlesex HA2 0RN.

19" RACK MOUNTING EQUIPMENT CASES

This new range of 19" rack equipment cases have been designed with economy and versatility as their objective. These cases are supplied as a flat pack kit with assembly instructions. The equipment cases feature a black powder coat 1/8" (3mm) aluminium frontpanel with the rest of the case constructed from 7mm or 9mm 'Stelvelite' PVC coated steel. All kits include front panel handles and rubber feet.

They are available in the following popular sizes with all the units having a standard front panel width of 19", and an enclosure width of 17 1/4" (438mm) by a depth of 10" (254mm).

ORDER CODE	HEIGHT	PRICE
U1	1 3/4" (44mm)	16.00
U2	3 1/4" (88mm)	18.00
U3	5 1/4" (133mm)	20.00
U4	7" (178mm)	22.00
M&S Sloped mixer console		£25.50

All prices Exclude V.A.T.
Please include £2.50 + VAT, Per Item
For Post & Packing.
Flat pack size = 500 x 260 x 32
Maximum weight = 1.5Kgs.

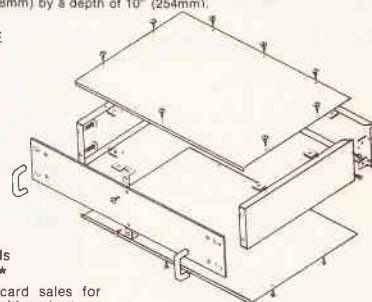

Blanking Panels, Racking Consoles and Rack Cabinets also available.
Please send S.A.E. for further details
* TRADE ENQUIRIES WELCOME *

Tel. 0275 823983 for Access/Visa card sales for immediate despatch or send cheque with order to:

RACKZ PRODUCTS PO. BOX NO. 1402, MANGOTSFIELD, BRISTOL, ENGLAND. BS17 3RY

BINDERS

FOR YOUR VALUABLE COLLECTION OF ELECTRONICS TODAY INTERNATIONAL MAGAZINES

- SMART • EASY TO USE • TOP QUALITY

To ASP Readers Services, PO Box 35, Wolsey House, Wolsey Road, Hemel Hempstead, Herts HP2 4SS (0442-41221)

£5.95 inc. P&P

Please supply .. Electronics Today International Binders **£5.95 inc. P&P**

Total £ (Please make cheques payable to ASP Ltd.)

Years Required — 198.....198.....198.....198.....

Name

Address

ae allow 21 days for delivery

TRANSATLANTIC TIME ZONE CORRECTOR

*Andrew
Armstrong flies
economy but still
arrives in good
shape*

An increasing number of people are now familiar with the problem of jetlag. It can be difficult to readjust the body clock to a significantly different time zone, particularly when travelling east. For people who habitually stagger out of bed just in time for work or appointments, the strain of having to get up five hours earlier can be the last straw.

Such is the case with a certain transatlantic friend of mine. On her visits to Britain every few years, it takes her a month to reprogram herself to get up before lunch time, and by then it is almost time to return home.

oscillator runs at a high frequency, the phase comparison must be carried out at the input frequency of 0.0000115Hz. This requires a time constant of at least several input cycles — several days. The values shown in the circuit will give a time constant of 5½ days, which will permit the circuit to lock in after only a few cycles.

Theory suggests that lockup times of between two days and two weeks are possible, depending on the switch-on time of the circuit, its initial state and the phase of this moon. This last effect is because a full moon may cause the photodetector to switch on earlier or off later and may induce a certain amount of phase jitter on the signal to which the oscillator must lock.

Some readers may be surprised at the choice of a relay to switch the load, rather than a triac. The reason is that it is felt the best form of lighting may be a fluorescent lamp of the 'artificial daylight' or 'northlight' variety. (These tubes simulate the spectrum of normal daylight more closely than other forms of light. You can demonstrate this by trying to read a resistor colour code which includes purple and red or blue, under ordinary lamps and under these special types).

Fluorescent lamps are notoriously difficult to switch with triacs, so a relay is chosen for this application to ensure long term reliability.

Assembly

The circuit is best built on the printed circuit board, shown in Fig. 4. For those who wish to do their own stripboard layout, the following tips may be useful.

Make sure decoupling is good and that the earth consists of two parallel tracks to obtain low resistance. It is vitally important to prevent interference from being picked up by this circuit. After all nobody wants to find, after two weeks of waiting for the loop to lock properly, that the phase is disrupted due to the activities of the local CB enthusiast using slightly over the specified four watts.

The rest of the assembly should be simple, with the relay and power transformer being off-board to prevent mains-borne interference from disrupting its operation. One thing to remember is not to underestimate the space required for the 1F0 capacitor. On the prototype, this was fitted late in the assembly to avoid heat damage. It wouldn't fit and had to be glued upside down on top of IC1. Don't make the same mistake!

No specific case has been recommended for this project, but in order to allow light in to the phototransistor, one might use a transparent case. A perspex cube of the type intended to display photographs would be a good choice.

Fast Locking

Those constructors who are impatient to check the operation of the circuit and who possess the necessary test equipment may use the following procedure.

On the theory that the body acts rather like a phase locked loop and comes into lock at a rate proportional to the time zone mismatch (the error signal) I resolved to reprogram her to move faster. The phase locked loop analogy suggested a possible solution. A bigger 'error signal' could be generated by switching on room lighting somewhat before dawn and the switching of the lamps could be controlled by (of course) a phase locked loop.

An oscillator frequency of one cycle per day (CPD) is obviously required and my first thought was to use a memory backup capacitor of perhaps one farad as the timing element. In fact, though, a more reasonable solution is to use a higher frequency oscillator with a more reasonable capacitor value and divide it down to 1CPD (0.0000115Hz).

The use of an exclusive OR gate phase detector in the phase locked loop takes care of the phase advance required in the control system because phase locking is achieved with the two waveforms 90° out of phase. All that is needed is a means to ensure the control output is phase leading rather than phase lagging. A lead/lag detector controlling another exclusive OR gate acting as an invert/noninvert gate will solve the problem.

It is in the phase detector that the high value capacitor comes into its own. Though the

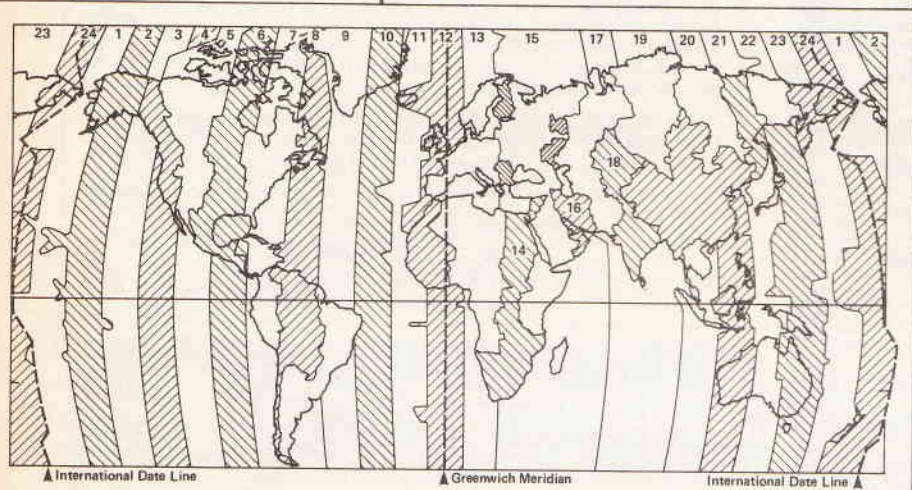

Fig. 1 The international time zones

PROJECT

HART KIT

HART ELECTRONICS are specialist producers of kits for designs by JOHN LINSLEY-HOOD. All kits are APPROVED by the designer.

LINSLEY-HOOD CASSETTE RECORDER CIRCUITS



Complete record and replay circuits for very high quality low noise stereo cassette recorder. Circuits are optimised for our HS16 Super Quality Sendust Alloy Head. Switched bias and equalisation to cater for chrome and ferric tapes. Very easy to assemble on plug-in PCBs. Complete with full instructions.

Complete Stereo Record/Play Kit £33.70
 VU Meters to suit £2.30 each
 Reprints of original Articles 75p no VAT
 B60X Stereo Mic Amplifier £8.70

LINSLEY HOOD 300 SERIES AMPLIFIER KITS

Superb integrated amplifier kits derived from John Linsley-Hoods articles in 'HiFi News'. Ultra easy assembly and set-up with sound quality to please the most discerning listener. Ideal basis for any domestic sound system if quality matters to you. Buy the kit complete and save pounds off the individual component price.

K300-35 35 Watt. Discount price for Complete Kit . £98.79
 K300-45 45 Watt. Discount price for Complete Kit . £102.36
 RLH485. Reprints of Original Articles from 'Hi-Fi News' £1.05 no VAT

LINSLEY-HOOD SUPER HIGH QUALITY AM/FM TUNER SYSTEM.

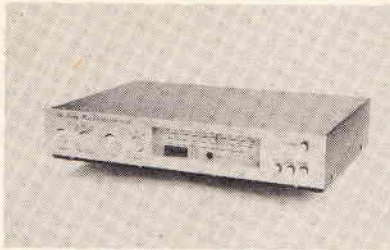

Our very latest kit for the discerning enthusiast of quality sound and an exotic feast for lovers of designs by John Linsley-Hood. A combination of his ultra high quality FM tuner and stereo decoder described in "ELECTRONICS TODAY INTERNATIONAL" and the Synchrondyne AM receiver described in "Wireless World". The complete unit is cased to match our 300 Series amplifiers. Novel circuit features in the FM section to include ready built pre-aligned front-end, phase locked loop demodulator with a response down to DC and advanced sample and hold stereo decoder together make a tuner which sounds better than the best of the high-priced exotica but, thanks to HART engineering, remains easy to build. The Synchrondyne section with it's selectable bandwidth provides the best possible results from Long and Medium wave channels, so necessary in these days of split programming. If you want the very best in real HiFi listening then this is the tuner for you. Since all components are selected by the designer to give the very best sound this tuner is not cheap, but in terms of it's sound it is incredible value for money. To cater for all needs four versions are available with variations up to the top of the range full AM/FM model, with any unit being upgradeable at any time. Send for our fully illustrated details.

STUART TAPE RECORDER CIRCUITS

Complete stereo record, replay and bias system for reel-to-reel recorders. These circuits will give studio quality with a good tape deck. Separate sections for record and replay give optimum performance and allow a third head monitoring system to be used where the deck has this fitted. Standard 250mV input and output levels. These circuits are ideal for bringing that old valve tape recorder back to life.
 K900W Stereo Kit with Wound Coils and Twin Meter Drive £65.67
 RJS1 Reprints of Original Articles £1.30 no VAT

HIGH QUALITY REPLACEMENT CASSETTE HEADS



Do your tapes lack treble? A worn head could be the problem. Fitting one of our replacement heads could restore performance to better than new! Standard mountings make fitting easy and our TC1 Test Cassette helps you set the azimuth spot-on. We are the actual importers which means you get the benefit of lower prices for prime parts. Compare us with other suppliers and see! The following is a list of our most popular heads, all are suitable for use on Dolby machines and are ex-stock.

HC20 Permalloy Stereo Head. This is the standard head fitted as original equipment on most decks £7.66
 HS16 Sendust Alloy Super Head. The best head we can find. Longer life than Permalloy, higher output than Ferrite, fantastic frequency response £14.86
 HQ551 4-Track Head for auto-reverse or quadrophonic use. Full specification record and playback head £14.60
 HX100 Stereo Permalloy R/P head. Special Offer £2.49
 MA481 2/2 Language Lab R/P head £13.35
 SM166 2/2 Erase Head. Standard mounting. AC type £8.85
 SM150 2/2 Erase Head. DC Type £3.60
 HQ751E 4/4 Erase Head for Portastudio etc £46.80
 Full specifications of these and other special purpose heads in our lists.

HART TRIPLE-PURPOSE TEST CASSETTE TC1

One inexpensive test cassette enables you to set up VU level, head azimuth and tape speed. Invaluable when fitting new heads. Only £4.66 plus VAT and 50p postage.

Tape Head De-magnetiser. Handy size mains operated unit prevents build up of residual head magnetisation causing noise on playback £4.54
 Curved Pole Type for inaccessible heads £4.85

Send for your free copy of our LISTS. Overseas please send 2 IRCs to cover surtax Post or 5 IRCs for Airmail.

Please add part cost of post, packing and insurance as follows:

INLAND
 Orders up to £10 - 50p
 Orders £10 to £49 - £1
 Orders over £50 - £1.50

OVERSEAS
 Please send sufficient to cover Surface or Air Post as required.

Personal callers are always very welcome but please note that we are closed all day Saturday

24hr SALES LINE
 (0691) 652894

ALL PRICES EXCLUDE VAT UNLESS STATED

**HART
KIT**
 HART ELECTRONIC KITS LTD
 4 PENYLLAN MILL
 OSWESTRY, SHROPSHIRE
 SY10 9AF

● SPECIAL OFFER ●

The TK Electronics Guard Dog kit £22.95 to ETI Readers

Exclusive to ETI readers is the chance to purchase this all electronic canine deterrent (as reviewed in ETI December 1987) for just £22.95 fully inclusive of VAT and handling charges - that's a saving of over £2.

This ingenious device produces a series of randomly timed realistic barks variable from a yelp to a big bass bark through its horn speaker and can be triggered by your doorbell, a pressure mat, or most other detectors.

The kit includes all the components necessary to build the dog (!), a quality PCB, mains transformer, horn speaker and comprehensive instructions. All you need is a mains supply and a little free time to put it together.

Don't delay. Order your guard dog today. Offer ends 1st April 1988. Send your order to:

ETI Guard Dog Offer
 TK Electronics
 13 Boston Road
 London W7 3SJ

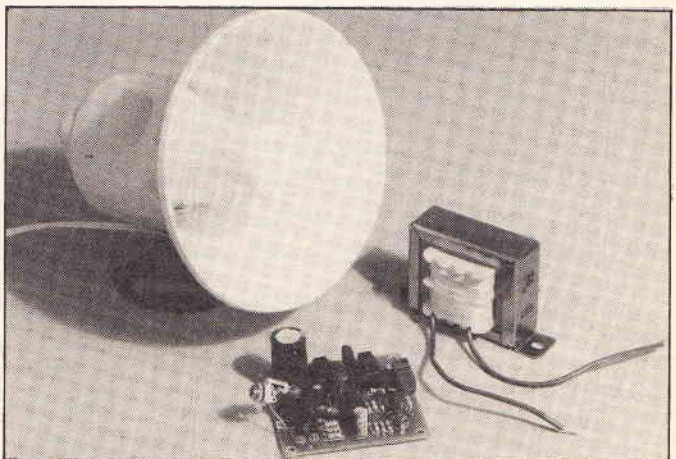

To ETI Guard Dog Kit, TK Electronics, 13 Boston Road, London W7 3SJ.

Please supply me with Guard Dog kit(s) at £22.95 (+£3.50 for overseas customers). I enclose a cheque/PO order made payable to TK Electronics. Please debit my Access/Visa account number:

Signature

Name

Address

ETI

SPECTRUM CO-PROCESSOR

PROJECT

Graeme Durant continues to build his masterpiece and this month looks at the interface between the two machines

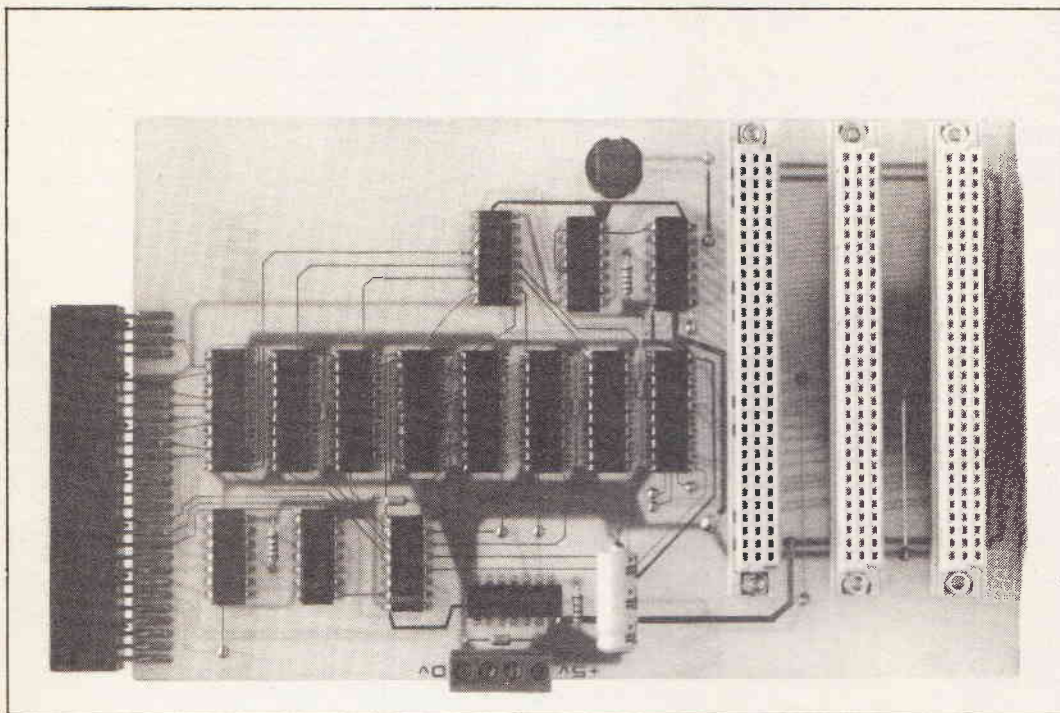

Over the past two months we have looked at the design and construction of a Z80 based CPU card and a Z80 compatible 256K DRAM card. Now we must turn our attention to the interface board which will turn these multi-purpose circuits into a dedicated co-processor for the ZX Spectrum.

The interface board (see Fig. 1 and photo) has at one end a standard edge connector which plugs into the expansion port of the Spectrum and at the other end a three slot 'mini-backplane' which conforms to the standard already adopted by the CPU and DRAM cards.

In the middle there are four locations of memory shared by the Spectrum and the co-processor, through which data can be passed to achieve bidirectional communication between the processors.

A reset button for the co-processor is also included, which is useful if software being developed gets stuck in a loop.

This board derives its power from an off-board 5V supply, separate from the Spectrum PSU. In this way, the already overworked Spectrum power unit is not strained. It is also possible to run the co-processor without the Spectrum attached, this being particularly useful if a stand-alone target application is being tested.

Construction

If you have managed to struggle this far through the project, the construction of this last card should prove no problem at all. Like the Z80 CPU and the DRAM card PCBs, this board is double-sided without through-hole plating (Fig. 2).

Links between the two layers must be made using tinned copper wire or the pins of the ICs. No discrete component leads are used to form

through connections on this board.

If you prefer to put the ICs into sockets, 'turned pin' types must be used so connections can be made to the upper layer of the PCB (see the construction notes for the Z80 CPU card). Note that there are no links or components hidden under ICs to worry about on this board.

This PCB includes three connectors SK3, 4 and 5, which form a mini-backplane. These DIN41612 connectors should be soldered in position and bolted down for reliability, using short M2.5 nuts and bolts.

The edge connector to the Spectrum (SK6) is sited at the other end of the interface board, on the edge of the PCB. It should be mounted so that one row of pins are soldered to the top side of the board and the other row to the bottom side. A small modeller's vice can be used to squeeze the two rows of pins closer together before fitting to make soldering easier. Solder should then be run along each pin in turn to form a good connection with the PCB pads underneath.

The rest of the discrete components, the reset switch SW1 and the power supply connector SK7 should now be fitted. Finally, after thorough checking for solder splashes, clean away any remaining flux deposits from the board.

Testing

Without sophisticated test gear at your disposal, the best approach to testing is to plug the fully populated CPU and DRAM cards into the interface card, making sure that the various PROMs are also present.

Without using a Spectrum at this stage, connect the power supply (a 5V unit with a current capability of around 2A). If all is well, the co-processor will run its self test routine at power-up and as the DRAM pages are tested, the page LEDs

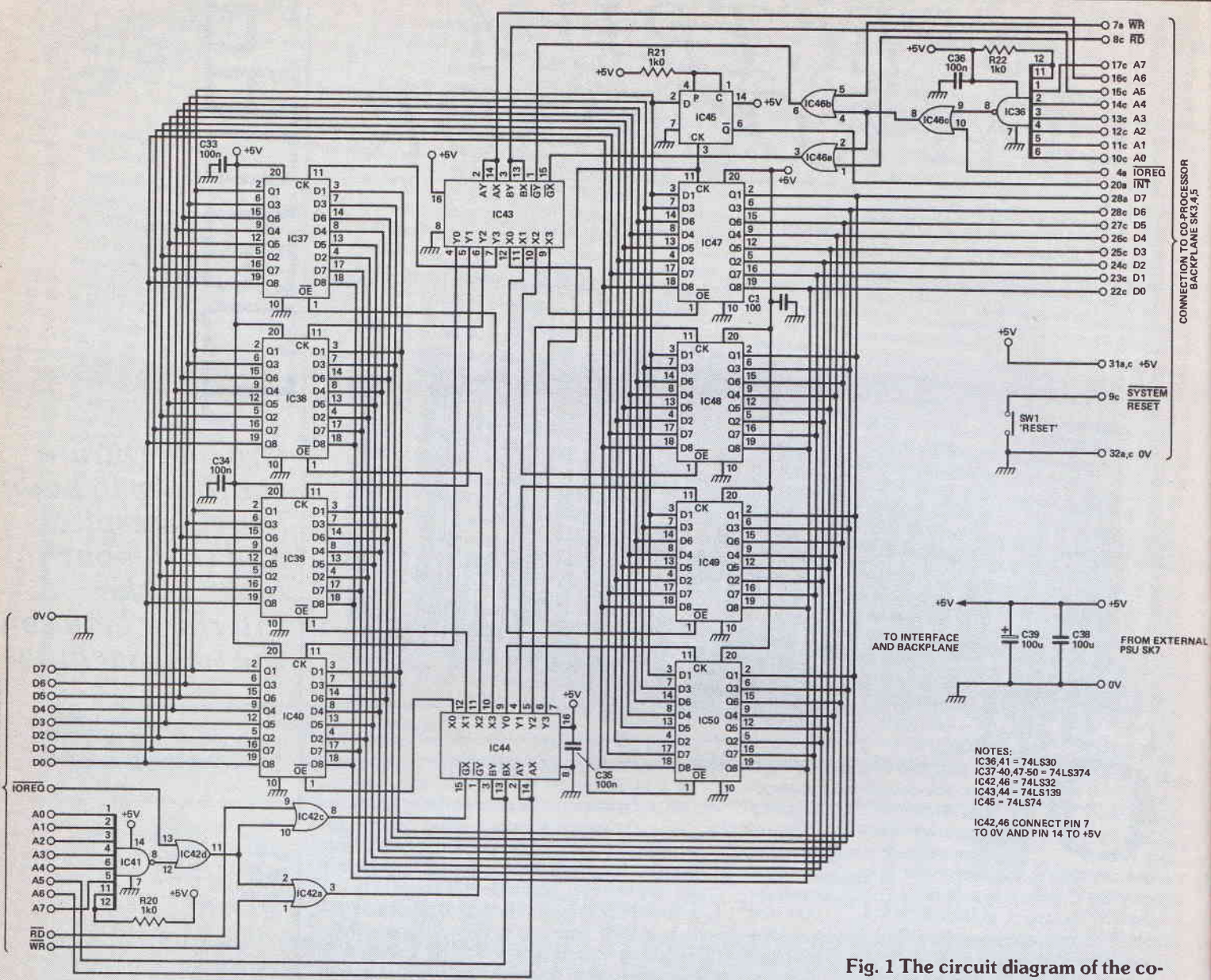

Fig. 1 The circuit diagram of the co-processor interface board

NOTES:
 IC36,41 = 74LS30
 IC37-40,47,50 = 74LS374
 IC42,46 = 74LS32
 IC43,44 = 74LS139
 IC45 = 74LS74
 IC42,46 CONNECT PIN 7 TO 0V AND PIN 14 TO +5V

PROJECT

should each light in turn for a couple of seconds. If this does not happen, remove the power and check your construction.

The notes on testing which accompanied the construction notes on the CPU and DRAM cards apply equally to builders of the interface PCB.

If all is well, the power should be removed anyway (but with less haste!) and the interface board plugged onto the back of your favourite Spectrum. Apply power to both. Wait until the co-processor LEDs have stopped flashing and the Spectrum has come up with its start-up message. Now, on the Spectrum, type OUT 255,0 and press Enter then OUT 255,224 and press Enter again.

This is the command sequence from the Spectrum which tells the co-processor to run its self-test routine. If all is well, the DRAM page LEDs will sequence again. If not, a problem exists in the interface PCB and this must be checked thoroughly.

If you manage to get this far with everything working: congratulations! It looks like you have at least the majority of your co-processor hardware functioning. The acid test will be to see if a real application will run.

A fully documented application program for an interactive Z80 software development tool will appear in next month's article. Once this has been tried and proved to work, you can be certain your hardware is fully operational. In the meantime, we shall go on to have a closer look at the low-level software side of things.

The Software

The co-processor software is the final part of our system and it moulds the otherwise general purpose hardware into a dedicated co-processor.

This software consists of two distinct parts: the software which runs on the co-processor CPU itself — handling data transfer, command interpretation and execution — and the software which runs on the Spectrum — handling the other end of the data transfer plus the supply of co-processor commands.

All the co-processor's actions are initiated by a command from the Spectrum, passed via the four shared registers. As mentioned in the first article, the co-processor recognises just five different commands from the host — quite sufficient for all general purpose applications.

Although visually complicated by the bussing, the operation of the interface circuit (Fig. 1) is quite straightforward. The circuit may be considered in three main sections — the shared memory itself, the address decoding for the Spectrum and the address decoding for the co-processor.

Looking first at the shared memory, this appears to each of the processors as four locations of read/write storage. However, reading one of these locations will return the value last written into that location by the other processor. Thus, a bi-directional medium for data transfer is created between the processors.

To ease timing problems, access to the shared memory is asynchronous — data can be written or read by either processor at any time.

To achieve this asynchronous bi-directional operation, the memory used must be capable of being written to at one location, whilst simultaneously being read at another. This precludes the use of ordinary RAM and, since special dual-port RAM devices are very expensive, ordinary TTL D-type octal latches are used as the basis for the shared storage in this design.

Such latches have separate input and output data pins and separate clock data input and output enable controls. This allows reading and writing of their contents to occur independently and simultaneously. These registers are shown on the circuit diagram as IC37-40 and IC47-50.

IC37-40 have their data inputs driven from the co-processor data bus and their data outputs drive the Spectrum data bus. This allows the co-processor to write data to IC37-40, which can in turn be read by the Spectrum. Similarly, IC47-50 provide data transfer from the Spectrum to the co-processor, completing the bi-directional interface.

The Z80 microprocessor provides two mechanisms for passing data between itself and external circuits — basic memory addressing (normally used to access RAM and ROM) and I/O addressing (usually for accessing peripherals and the like).

Since the entire 64K memory space is already in use in the Spectrum, this project makes use of the I/O addressing facility of the Z80 for passing data between the machines. This idea was continued in the co-processor for the sake of simplicity.

All that remains is to drive the clock data input and output enable lines of the registers to provide access control to the processors.

This is the job of the two areas of address decoding logic. The address from the Spectrum is decoded by the logic based on IC41, IC42 and IC44. In the Spectrum itself, some of the I/O port locations are already in use. The unused ports are those which are one less than an integer multiple of 32.

In other words, the spare port addresses are those with their five least significant bits set to ones. Since there are eight such ports and we only need to use four of them, the most significant port address bit, bit A7, is also used in the decode process.

IC41, used here as a 6-input NAND gate, monitors the Spectrum address bus and determines when a shared port is being addressed. The output of IC41 is low only when the address low-byte is either 159, 191, 223, or 255 in decimal — these being the locations used for the shared registers in this interface.

The output of IC41 is ORed with the Spectrum \overline{IOREQ} strobe by IC42d. So, the output of this gate is low if one of the four interface ports is being accessed.

The Spectrum address bits A6 and A5 select which one of the four shared ports is required. This is decoded by IC44, a dual 2-to-4 line binary decoder which has active low outputs. One half of IC44 drives the output

enable pins of IC37-40 and is enabled when a Spectrum read access is detected by IC42c. When enabled, one of the four decoded outputs will go active low, according to the states of address bits A6 and A5.

The register thus selected will enable its data onto the Spectrum bus to be read. The other half of IC44 drives the clock pins of IC47-50 and is enabled when a write access is detected by IC42a.

When this happens, one of the four decoder outputs will go low, again determined by the states of address bits A6 and A5. The register selected will receive an active clock signal at the termination of the Spectrum \overline{WR} strobe which will write the Spectrum data into that register. The net result is that the Spectrum can read data from any one of IC37-40 and write data into any one of IC47-50.

When IC47, the register at port location 255, is written to by the Spectrum, a single D-type latch IC45 also receives a clock pulse. Its data input is connected to the most significant bit of the Spectrum data bus. Thus its Q output reflects IC47's MS bit latch contents without the imposition of a tristate output.

The Q output of IC45 is used to drive the interrupt line feeding the co-processor backplane. This forms a convenient signalling mechanism from the Spectrum to tell the co-processor that a valid command is available (see the main text).

Unfortunately, the interrupt system in the Spectrum is already used and adding further interrupt sources would only serve to complicate things. So hand-shaking from the co-processor to the Spectrum is achieved via a polled shared register.

The address decoding for the co-processor is identical to that described above and is based around IC36, IC43 and IC46. This time, when the co-processor writes to a shared port, the data is put into one of IC37-40. When it reads from a shared port, the data comes from one of IC47-50.

This is the opposite way round to before and provides the desired capability for bi-directional data transfer.

To avoid confusion, the same port addresses are used as for the Spectrum end, even though the restriction on available ports does not apply. So, if the Spectrum writes data to its port at address 191, the co-processor will pick up this same data from its own port at address 191.

A Reset button is provided on the interface board, to force the co-processor into its reset state. This is simply achieved by switching the SYSTEM RESET line on the backplane to 0V.

Due to the potentially high power requirements of the co-processor and its periphery, the power to the backplane is derived from an external source. This is instead of using the Spectrum's already overworked PSU, which remains separate. A connection is of course made to the Spectrum's 0V rail via its edge connector, to maintain a ground reference throughout the system.

Finally, it is worth mentioning a few words about adding new peripherals to the co-processor. Obviously, to really make full use of the co-processor, it may need to have its own I/O channels, which are independent of the host. Any standard Z80 peripherals may be used with the co-processor, plugged into the spare third slot on the backplane.

These can interface with the CPU via the usual Z80 busses, which are all available on the connector. The only restriction is that new circuitry does not map into any memory or I/O locations already in use. Peripherals which may be added include parallel/serial I/O, analogue I/O or even a video interface to a monitor.

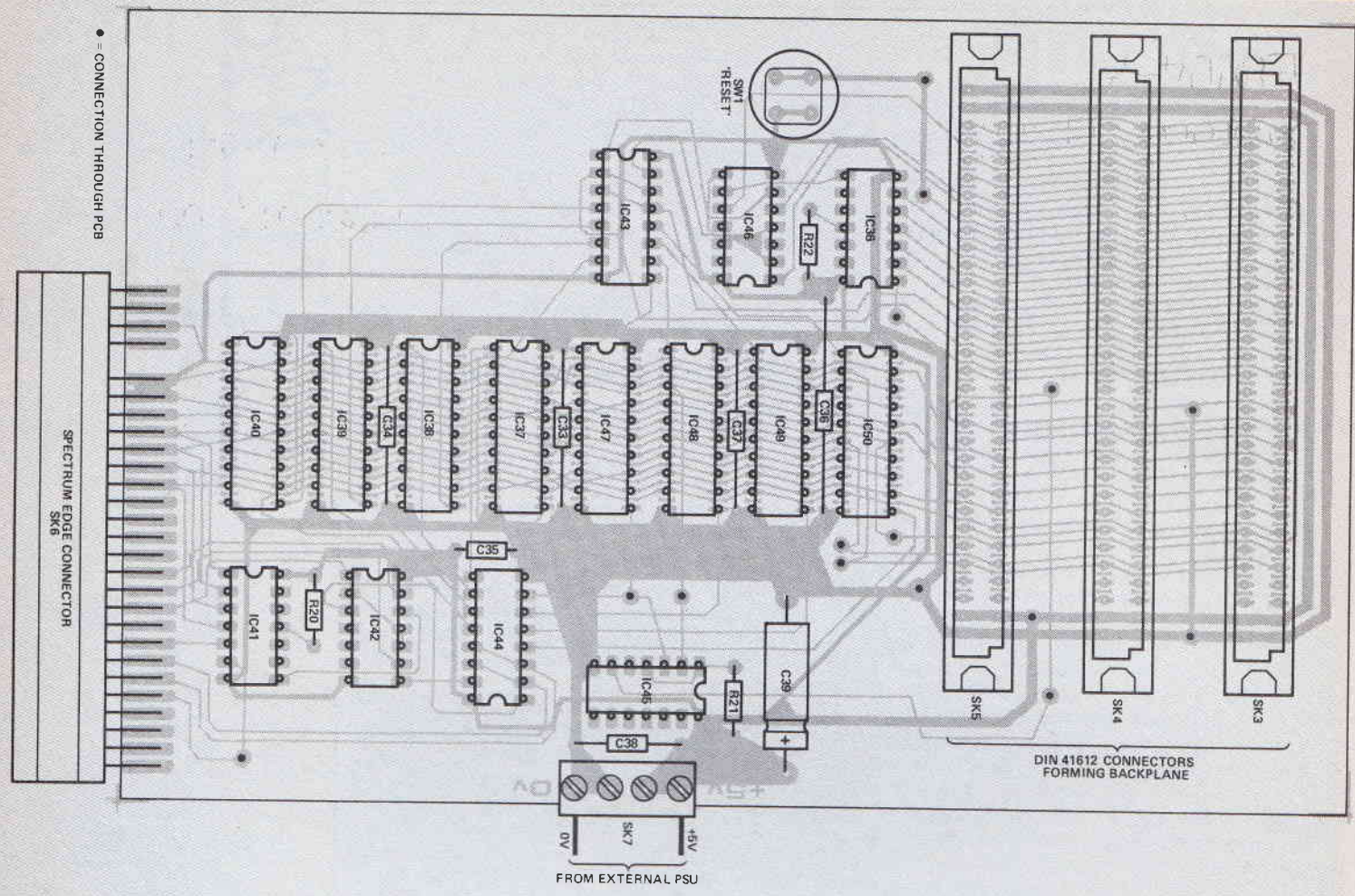

Fig. 2 The component overlay of the interface PCB

PARTS LIST

RESISTORS (all 1/4W 5% unless otherwise stated)	
R20-22	1kΩ
CAPACITORS	
C33-38	100nF monolithic axial ceramic
C39	100µF 10V axial electrolytic
SEMICONDUCTORS	
IC36, 41	74LS30
IC37-40, 47-50	74LS374
IC42, 46	74LS32
IC43, 44	74LS139
IC45	74LS74
MISCELLANEOUS	
SK3-5	DIN41612 type C 64-pin PCB mounting socket
SK6	Edge connector for Spectrum
SK7	4-way PCB mounting terminal block
SW1	PCB mounting push-button
PCB, IC sockets, Tinned copper wire, M2.5 nuts and bolts.	

BUYLINES

The co-processor interface board uses no particularly exotic components and most of the parts should be easily available.

The miniature axial ceramic capacitors are available from Verospeed (Tel: (0703) 644555) as order code 92-50952H. The DIN 41612 backplane connectors and the Spectrum edge connector are both available from Maplin, their order codes being FJ47B and FG23A respectively.

Finally, the Printed Circuit board is available from our PCB service.

PROJECT

However, there is also the facility in the co-processor code for the user to add additional specialised commands to these five — more on that next month.

The commands are transferred from the Spectrum to the co-processor using a special handshaking protocol implemented in software which ensures each party knows the exact state of

the other, at all times. The flow diagram (Fig. 3) illustrates the handshake protocol used.

A command from the Spectrum consists of an 8-bit value with its most significant bit set. Commands are always written by the Spectrum to the shared port address 255.

This 'one' in the MS bit position causes the co-processor to receive an interrupt. Table 1 shows all the valid commands recognised by the co-processor, along with their defined code values in binary. Up until the time a command appears, the co-processor is sitting in a program loop doing nothing more than wasting time.

When the command is received, the co-processor interrupt routine leaps into action. First the co-processor disables its interrupt response — the Z80 interrupt line is level sensitive and would otherwise repeatedly detect interrupts until the command was withdrawn. The co-processor must

	D7	D6	D5	D4	D3	D2	D1	D0
Block Read	1	0	1	0	X	X	X	X
Block Write	1	0	0	0	X	X	X	X
Execute User Code	1	1	0	0	X	X	X	X
Break Execution	1	1	1	1	0	0	0	0
Self Test	1	1	1	0	0	0	0	0

'X' = Don't care

Table 1 Spectrum to co-processor commands

	D7	D6	D5	D3	D2	D1	D0
DATA label	0	1	1	1	1	1	0
NULL label	0	1	1	1	1	1	1

Table 2 Handshake labels from Spectrum to co-processor. Both of these labels have the effect of removing the interrupt to the co-processor if sent to the command port

	D7	D6	D5	D4	D3	D2	D1	D0
DATA label	1	1	1	1	1	1	1	0
BUSY label	1	1	1	1	1	1	1	1
IDLE label	0	1	1	1	1	1	1	1
BRKACK label	1	1	1	1	0	0	0	0
INVALID label	1	1	1	0	0	0	0	0

Table 3 Handshake labels from co-processor to Spectrum

also ignore any new commands which arrive before it is ready to receive them.

Next, the new command is read in and decoded. Once the co-processor has decided what the command means, it lets the Spectrum know that all is well by sending a flag through port address 255. This is again an 8-bit value with its MS bit set to one.

Table 3 shows the flag values which may be returned. The usual flag to be returned is BUSY but DATA, BRKACK or INVALID may be used under certain circumstances. These will become clear next month.

The flag returned lets the Spectrum know what the co-processor is doing and that the last command was correctly decoded. After sending the flag, the co-processor is ready to get on with executing the command.

In the meantime, the Spectrum has been twiddling its thumbs, repeatedly reading shared port 255, waiting for the returned flag. Once received, it can remove the interrupt from the co-processor by writing a NULL label (with a zero in its MS bit position — see Table 2) into shared port 255. This serves as an acknowledgement to the co-processor that the flag was received and understood.

Now the Spectrum is free to do a bit of processing for itself, safe in the knowledge that the co-processor is also busy, executing its latest command.

When the co-processor has finished working on this latest command, it checks shared port 255 to ensure the Spectrum has removed the initial interrupt. If not, the co-processor waits for the Spectrum to do so.

Once the interrupt has gone, the co-processor removes its 'I am busy' flag from Spectrum port 255 by replacing it with the IDLE

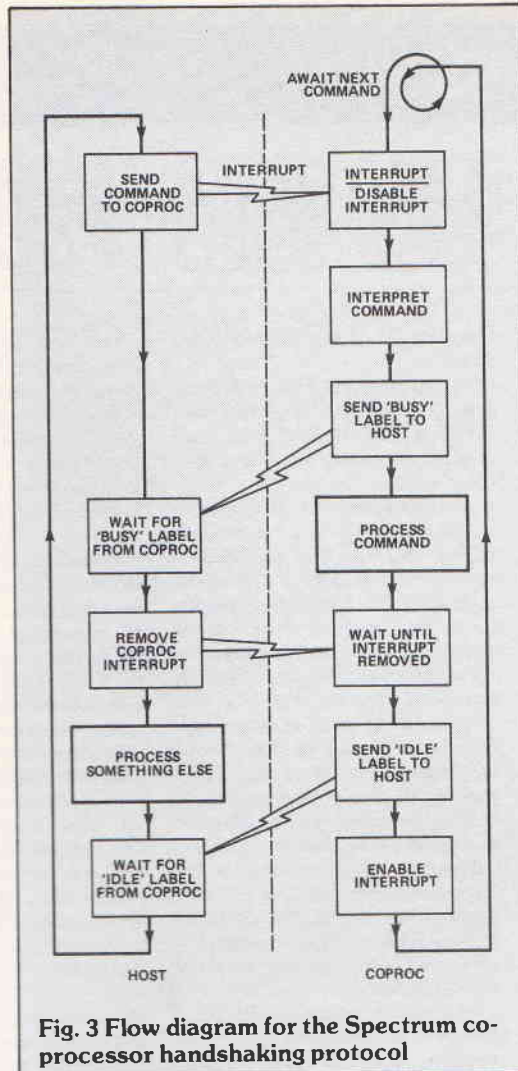

Fig. 3 Flow diagram for the Spectrum co-processor handshaking protocol

flag and enables its interrupt again to return to its time wasting loop awaiting the next command.

When the Spectrum has completed its little bit of processing, it looks at the contents of port 255 from the co-processor. If this is not the IDLE flag, the co-processor is still working on the last command. The Spectrum will wait (or could do a little bit more processing!) until the IDLE flag arrives. Once that has arrived, the Spectrum is free to send its next command to the co-processor, starting the whole process again.

Apart from the interrupt driven command transfer, this entire hand-shaking process is executed in software. Consequently it is slower than if it had been realised purely in hardware.

However, the aim of this project is to produce a versatile test-bed, suited to further experimentation. The limited scope for future changes which hardware invariably presents was enough to make its use less attractive. Opting for the software driven handshaking protocol allows the user to tailor the exact scheme used to suit the application.

It is also worth noting that although the use of interrupts in the protocol is limited to Spectrum-to-co-processor command transfer (due to the trickiness of using the Spectrum interrupts) this link is by far the most important of the two. In case of problems, the Spectrum is always in command of the co-processor even if user software in the co-processor goes haywire.

Next month, in the final article in this series, we take a closer look at the co-processor commands and the ways in which they work.



BOOK LOOK

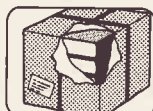
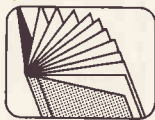
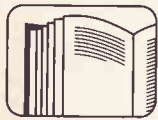

Just to show you that ETI isn't all about slaving away over a hot soldering iron or tying your brain into knots over circuit calculations, this month I'm taking a look at two books which are definitely easy reading.

Made in Japan by Akio Morita with Edwin Reingold and Mitsuko Shimomura. Collins. £12.95.

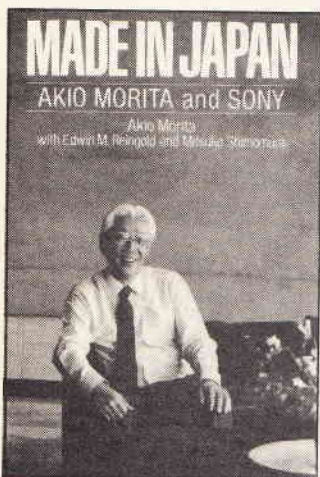

This is the autobiography (semi-autobiography?) of Akio Morita. Go on, admit it. You've no idea who he is. Well Akio Morita is Sony.

Morita was 25 years old when in 1946 he and Masaru Ibuka founded the Sony Corporation in the Japanese ashes of World War II (it actually started as Tokyo Telecommunications Engineering — which is rather odd as the first product was an extremely dodgy electric rice cooker!).

He is now Chairman and Chief Executive Officer of Sony — one of the most successful companies in the world. After its unsuccessful attempts at electric rice, Sony has produced the world's first transistor radio and domestic video recorder, not to mention co-inventing compact discs and of course coming up with the ubiquitous Walkman — an idea entirely conceived by Morita.

The Walkman is typical of Morita's viewpoint on commerce. On suggesting the idea nobody actually laughed at him (well you wouldn't laugh at your boss, would you) but he was certainly given a hard time.

He still believes that no amount of market research would have indicated any public desire for a 'personal stereo'. Nevertheless he forced the idea through and now there are millions of Walkmans

(and imitations) in use around the world.

Morita believes you have to create markets for innovative products. He's the Sinclair of Japan — only he hasn't gone bust four times proving it.

Made in Japan isn't just a story of a clever man's life, interesting though that life is. It is also a collection of his thoughts, ideals and visions and a fascinating glimpse into the Japanese commercial environment — so different to the reserved, hesitant face of British business life.

This book both confirms the common picture of Japanese workers beavering away giving their all to the faceless company, and at the same time exonerates this picture from western criticism.

However, *Made in Japan* is not an economics treatise. It is a biography of a successful life which has already achieved more than most of us can hope for and still has plans for much more.

I thoroughly recommend this one for an entertaining and an oh-so-slightly educational read. At £12.95 it is a high price for a bedtime book (it is hardback, though!) but if it doesn't come out in paperback soon, persuade your local library to enlarge the biography section by one.

Harwin Chronology of Inventions, Innovations and Discoveries by Kevin Desmond. Constable Publishing £10.95.

If this book was larger, it would be a 'coffee table book.' It has all the other qualities off to a tee. It is easy to read straight or to dip into while watching Eastenders. You can share the contents with others and it provokes discussion. It would go down a treat on Christmas day, after the Queen's speech.

The book is a chronology of inventions, innovations and discoveries from prehistory to the present day (well, to 1985 anyway) with a short excursion into the realm of the future to boot.

There are few details on each entry — just what happened and when — but there are an awful lot of entries. Of course, the early entries are a little vague in their exact timing. The domestication of wheat and barley is placed around 8000-9000BC.

In more recent times, things get a little more precise and, for my part, considerably more interesting.

Did you know that asteroids were discovered in 1801, the microphone invented in 1828, evaporated milk in 1884, the Tuxedo in 1886, the toothpaste tube in 1892, the safety razor in 1900, the electric food mixer in 1918, the launderette in 1934 or the Morris Minor Mini in 1959?

I could go on. There are simply thousands of entries in this pot-pourri of trivia. Few of these gems of knowledge will prove useful today, this week or even this month but in the long run this book provides a fascinating way to pass a few spare minutes and is a handy reference source for those otherwise unanswerable problems.

There is some wastage of space with the comically vague pre-historical entries and the 'shape of things to come' for the next 50 years. Some of the items in the latter are sensible and predictable (and thereby omissible) — such as the channel tunnel and a nationwide chain of lead-free petrol stations — but many are (I believe) just silly — cloned superhumans, time machines, laser space battle stations and the like.

All the real inventions are arranged in chronological order by year and a comprehensive index is provided for their location when the date is not known. I don't know if every entry is suitably entered in the index but I had no trouble finding entries in this way.

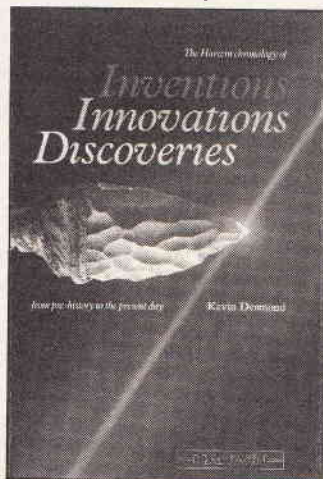

Of course, not every invention is featured here at all. However, this is a pretty good list. If you take this book as I believe it should be taken — as 200-odd pages of entertainment — and you can remain entertained after being relieved of the £11 it will cost you, you will not be disappointed.

Martin Tame

PLAYBACK

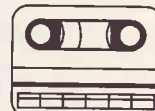

Recently the Editor forwarded a letter to me from a man who has been reading electronics magazines for many years.

The letter drew my attention to a technique of improving the apparent bass response of a sound system, sending me photocopies of the original article and subsequent correspondence from *Wireless World* 1951.

Hi-fi it is not but it serves to illustrate some current sound processing techniques.

The article outlined a technique whereby low frequency notes (which loudspeakers of 1951 vintage handle less efficiently than present day ones) could apparently be reproduced more accurately. Low frequencies were filtered off and fed to a nonlinear stage which generated harmonics. The harmonics were at frequencies which the loudspeakers could handle efficiently and the presence of these harmonics was intended to fool the ear into hearing the fundamental that was not, in fact, there.

The original circuit used valves, with which many readers may not be familiar, so I have rendered the elements of the circuit into block diagram form (Fig. 1) for ease of understanding. Excerpts from the letter and my reply should throw further light on the subject.

The Letter

Dear Mr Armstrong,

The ideas in the enclosed article *Bass Without Big Baffles* have interested me since I first read it but I did not have time to build it. Now I have decided to take another look at it, but everything is semi-conductor now and I am no design engineer. Do you know of any further articles on the subject or would ETI consider doing such an article?

H Hodgson

The Reply

Dear Mr Hodgson,

I am afraid I haven't time to build one of these units either but I will see what I can do from a theoretical angle.

So far as I know, there is some validity to the idea that the impression of bass can be provided by its harmonics. Virtually the only time the ear receives, say, a 100Hz tone and a 150Hz tone at the same time is in the presence of a 50Hz fundamental so there is an unsur-

OPEN CHANNEL

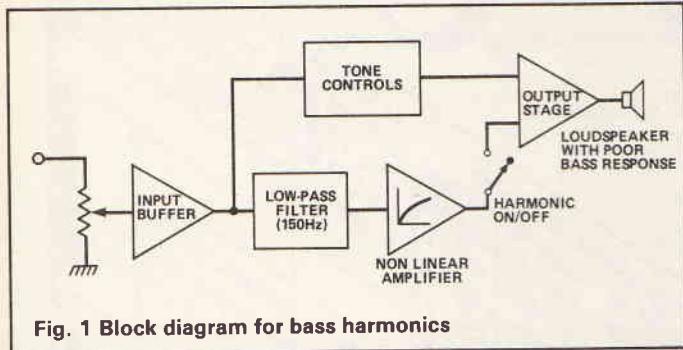
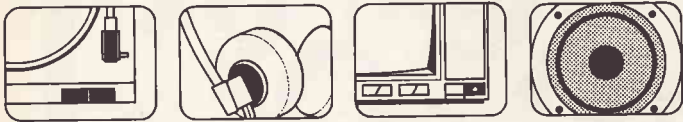

prising tendency to 'hear' the fundamental. The drawback is that tones with little natural harmonic content cannot be simulated so accurately.

Two personal observations relate to this. Some small loudspeakers I have come across appear to give a lot of bass output but are in fact generating harmonics of low frequency signals when these signals are of any significant amplitude. Here we have an acoustic/mechanical system doing the same as the bass amplifier circuit.

High amplitude bass signals drive the bass cone outside its linear region and generate harmonics. The harmonics are filtered mechanically by the loudspeaker so that only low order harmonics are audible. This prevents the distortion from sounding too harsh and 'sandpapered' as it would with an overloaded transistor stage.

When I changed from a modest sized pair of loudspeakers to a large pair (the WW transmission line design) the bass was at first less noticeable, until my ears had

'returned' to hear the fundamental rather than the harmonics.

The present loudspeakers seem to be much more linear at reasonable outputs down to about 40Hz than any others I have used. Now I am used to this I do not enjoy the sound from smaller loudspeakers.

In another guise, the use of harmonics to make the fundamental sound louder is with us as the Aphex Aural Exciter. Some time over a year ago ETI published an exciter circuit which does much the same thing. Lower middle frequencies (where the fundamental tones of most instruments are to be found) are selected and distorted by a circuit with a non-linear transfer function which generates low order harmonics (very little above the fifth harmonic).

These harmonics are added to the music as well as or instead of the naturally occurring frequencies in the range. At any given volume level, the resulting signal sounds louder. It works for voice, and is used to enhance the sound of some rock and pop music. It is also used in conjunction with compression to make the adverts on TV almost impossible to ignore, even when the volume is set so that the programme is only just audible.

On reflection, I think that one further point should be made. The valves in the 1951 circuit distort the signal asymmetrically, generating a significant number and volume of even harmonics as well as odd ones. This is in contrast to most distortion generated in modern equipment, where the waveform is distorted symmetrically and almost no even harmonics are generated. I would expect the presence of even harmonics to make the illusion of bass more convincing so it may be that the system proposed could work.

It might, for example, enhance the apparent bass output of 'ghetto blasters'. Perish the thought.

Andrew Armstrong

The wonders of modern telecommunications systems, coupled with electronics and computing, never cease to amaze me.

Shoppers in Oxford and High Wycombe may be amazed too to find their local branches of Sainsbury's are now linked on-line to the Link debit card network.

Now at the end of a long hard slog around the aisles with that bloody trolley (whose left front wheel never turns) to pick up the peas, pizzas, potatoes, parrot-food and piccalilli, it's possibilities to pay for the goods not with real money but with a piece of plastic.

No more do you have to fumble through your pockets looking for that twenty-pee piece. This remember is the age of *electronic funds transfer* (or EFT for those in the know) where reality becomes a dream — oops, sorry — dream becomes reality. A single wipe of your card through the electronic till is sufficient to debit your bank account by the requisite amount.

The two stores are taking part in a year long trial by Sainsbury's to evaluate cashless shopping with the aim of bringing the system to all the company's retail outlets soon after.

It's For You, Your Majesty

Another test site for something new in telecommunicating is Windsor — no, not the Castle. Windsor Television runs a cable television network franchise covering some 100000 homes in the district. Recently it has been given the nod to start a telephone service operated in tandem with the TV network.

Business users on the Slough industrial estate are the guinea pigs for a five month trial of the service which if successful will be run throughout the whole of the network.

If it's successful all users of the cable network could be linked by telephone within just a few months. Trunk charges on the network are expected to be pitched below British Telecom charges (naturally) and somewhere around Mercury's.

Being an integral network of course will give significant benefits for local calls, with charges expected to be considerably below BT's local charges.

Don't Tell Anyone, But . . .

It must gall some of the bigwigs seated at the top of BT to realise that even the greatest generator of chitter-chatter along the telephone lines — the British Government — is not convinced of the efficacy of

the only recently released ex-monopoly.

Rumour abounds that the Department of Education and Science is the first governmental department to have made the decision to switch from BT to Mercury.

It is anticipated that this cost-cutting exercise will save the Department over £25,000 a year.

Rumours also abound that Mr Baker's mob, although the first to leap the railings and abandon ship, will not be the last.

On The Air

The old 405-line television band known as Band III is now being used as a private mobile radio (PMR) network, as the Philips-led consortium called Band Three Radio took to the air in October of last year. Aiming for a coverage of around half of the population by mid-year, Band Three Radio expects total coverage within the next year. Band Three Radio's rival, GEC's National One, had not switched on at the time of writing.

Germany Does It First

First production D2-MAC decoder chips are now available, fully working, for inclusion into MAC-based satellite receivers for German direct broadcast by satellite television systems.

Readers of this column will know from November that D2-MAC is the MAC (multiplexed analogue component) version opted for by Germany and France as a way of encoding and transmitting their allocated DBS channels. The proposed British DBS system will be in the D-MAC version (similar but not similar enough).

Availability of D2-MAC chips (but not D-MAC chips) means that German (and French for that matter) television manufacturers cannot flood the British market with their products before our manufacturers have a chance to get their houses into order.

What it also means though, is that German manufacturers can now get down to the incredibly serious (snigger, snigger) business of making and selling televisions capable of receiving transmitted channels from the German DBS satellite (snigger, snigger) launched at the end (snigger, snigger) of last year (snigger, snigger). Of course, this relies on the fact that they can get their stuffed turkey . . . oops, satellite to work (snigger, snigger). Currently, they can't!

Keith Brindley

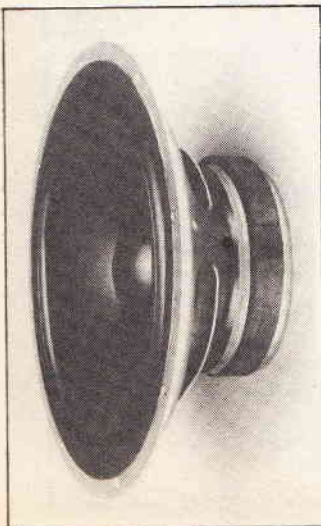

BACK NUMBERS

- Missed part one of your favourite project?
- Lost that all-important article on circuit design?
- Desperately need that Tech Tip to get your latest masterpiece going?
- Pining for that one issue to complete your valuable collection?

ETI Backnumbers Department to the rescue!

Please note that backnumbers are only held for 12 months. Articles published previous to this must be obtained through our photocopy service.

PHOTO-COPIES

ETI has been published for over 15 years and in this time a great many interesting and valuable projects and features have graced its pages. Although backnumbers are available for only the past 12 months issues we can supply photocopies of any individual article ever published in ETI.

Photocopies cost £1.50 per article regardless of their length. Please note that projects published over several issues must be ordered as a series of individual articles, each for £1.50.

PCB foil patterns (where published) and any errata are included with all photocopies as applicable.

Please supply the following backnumbers of ETI.
Note: Backnumbers are held for 12 months only (complete in block capitals)

Month Year Month Year
 Month Year Month Year
 Month Year Month Year
 Month Year Month Year

I enclose a cheque/postal order made out to ASP Ltd. to the value of £1.90 per issue ordered.

Total remittance £ Date

Name

Address

.....

..... Postcode

Send the completed form and your remittance to:

ETI Backnumbers Department
Infonet Ltd.
5 River Park Estate
Berkhamsted
Herts HP4 1HL

Please supply photocopies of the following articles from ETI (complete in block capitals):

Month Year Page (if known)

Title

Month Year Page (if known)

Title

Month Year Page (if known)

Title

I enclose a cheque/postal order made out to ASP Ltd. to the value of £1.50 per photocopy ordered.

Total remittance £ Date

Name

Address

.....

..... Postcode

Send the completed form and your remittance to:

ETI Photocopy Service
9 Hall Road
Hemel Hempstead
Herts. HP2 7BH



PCB FOIL PATTERNS

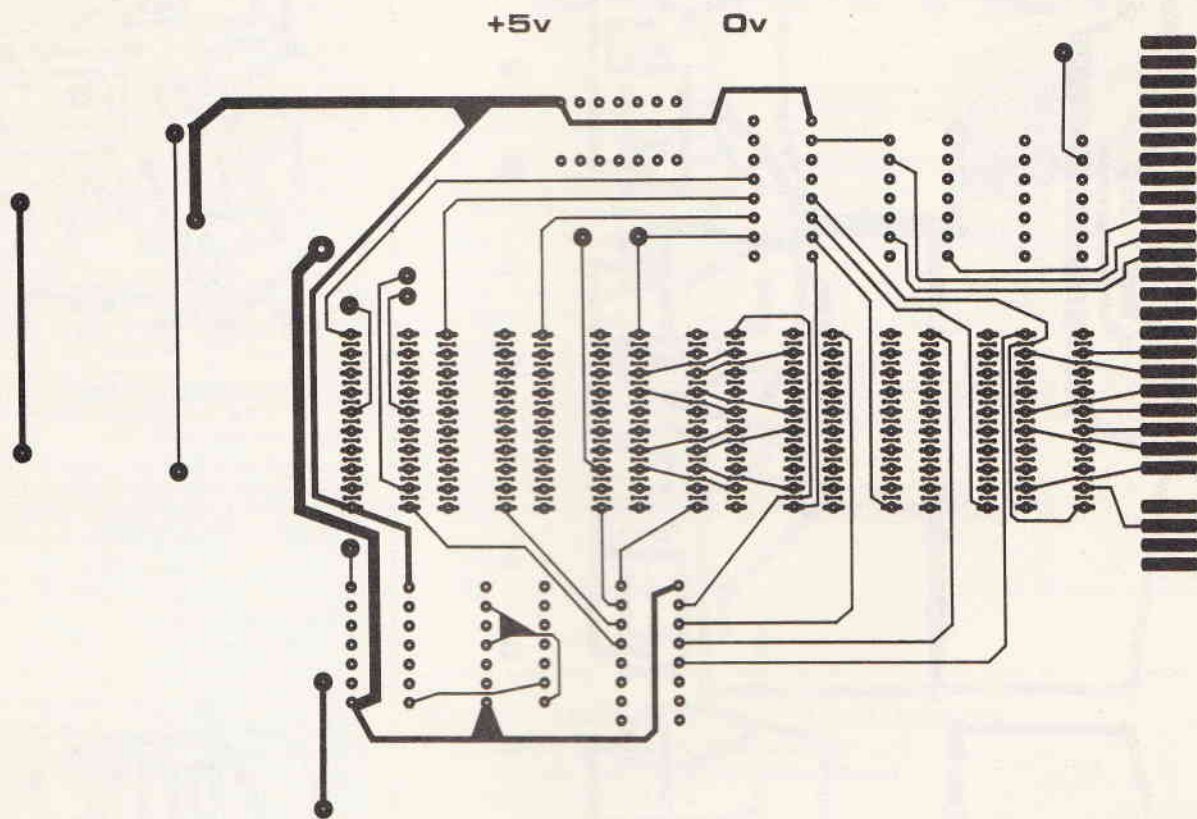

The Co-processor interface topside foil (above) and (below) the Co-processor interface solderside foil

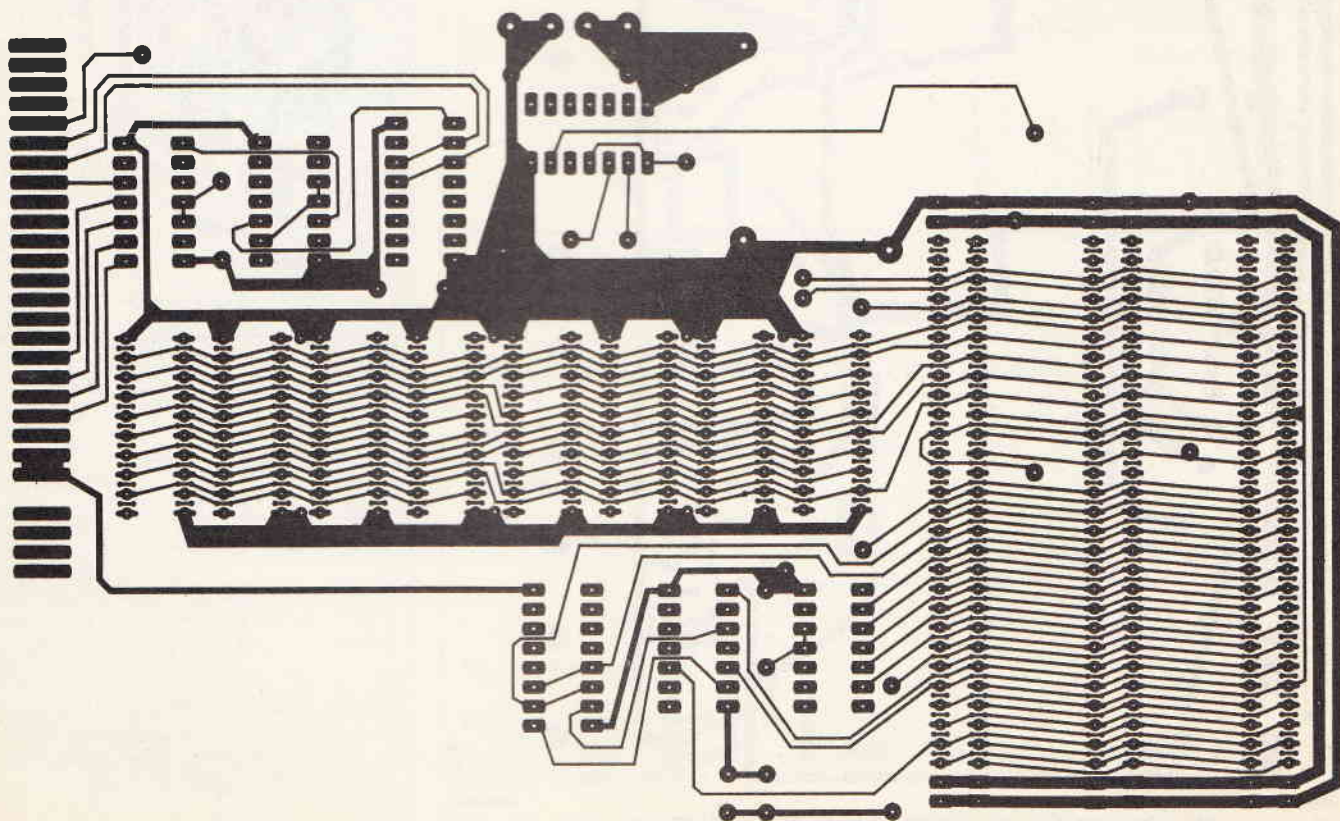

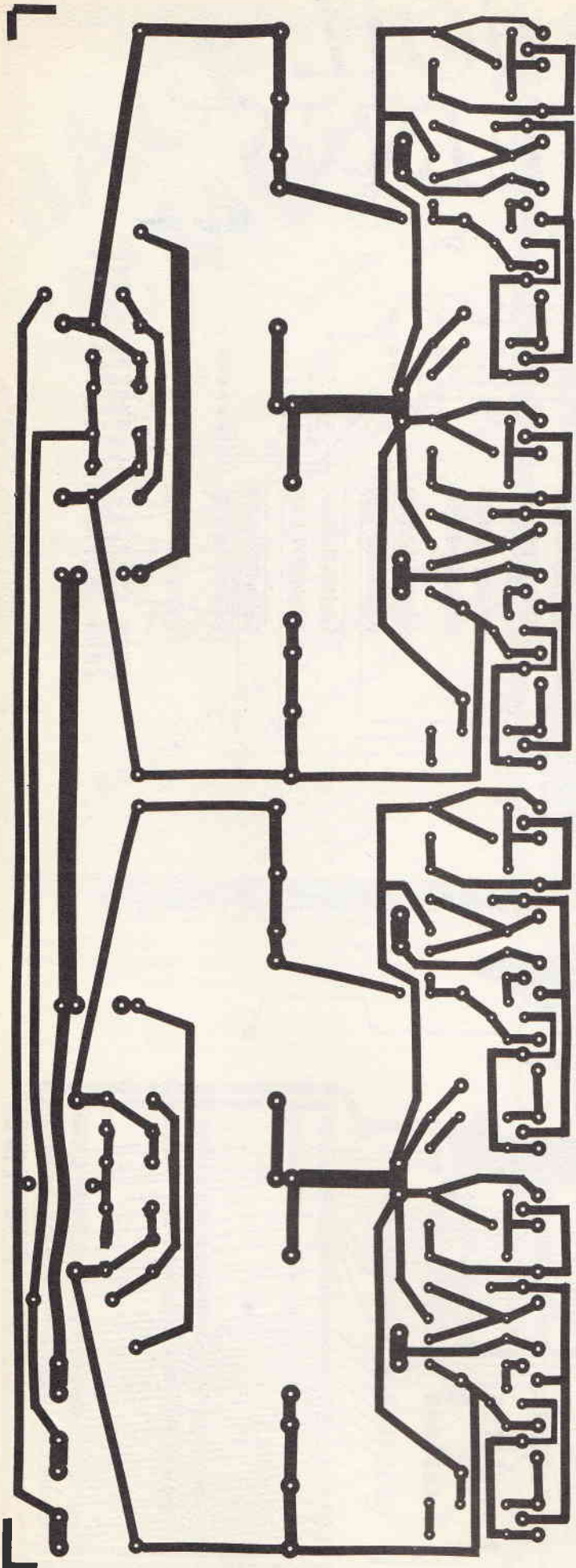

The Virtuoso 3u case power supply foil pattern

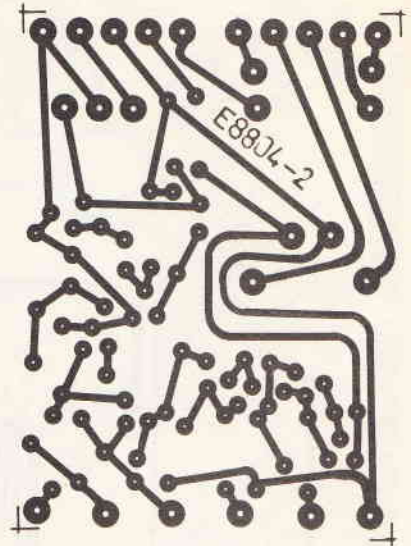

The Kitchen Timer PCB foil

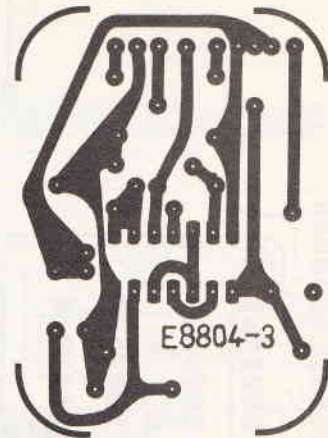

The Combo Lock foil pattern



Knight Raider (August 1987)

In Fig.1(a) pins 4 and 5 of IC1 are swapped. IC2-3 show the correct pin-out.

Car Alarm (August 1987)

In Fig. 1 Q7 is not numbered and its emitter is shown unconnected. This connects to earth. The transistors in the parts list went a little awry. Q2-6 are BC237 and Q7 is a TIP31.

Boiler Controller (September 1987)

In Fig. 2 (a) the primary of T2 is shown connected to Earth. This should be neutral. In Fig. 2(b) one of the bridge rectifier diodes, D6-9, is shown the wrong way around. This is correctly shown in Fig. 5.

EEG Monitor (September 1987)

In Fig.3a the pins of IC1 connected to the power rails are shown swapped around. In Fig.4a R7 is unlabelled and is between C3 and C6. In Fig.5 C20 should be £10 and R18 is unlabelled. It lies between R17 and R19.

ETI Concept (October 1987)

The Power Board parts list wrongly lists R6 as 270R. This should be 270k. Also, note that the power board's 0V rail must *not* be connected to Earth or the 0V rail of the CPU board.

Printer Buffer (November 1987)

The software for the EPROM had three errors listed. The byte at 039A should read 20, at 039B 14 and at 0492 30. All numbers are in Hex.

Dream Machine (December 1987)

The transistors used in this project are ST1702. BC108s can be substituted.

Heating Management System

(December 1987)

A 4116 is not a suitable alternative to the 6116 specified. A 4016 RAM chip will suffice. In Fig. 1 the junction of R1/D5 should connect to D1-4/C1 and not cross. The zener diodes above the temperature sensor ICs (IC16-19) should be deleted. C4 should be 220n and not 220µ. C7-10 should be 10µ. Q2-7 should be 2N3904 and not BC3904.

RGB Auto-Dissolve (January 1988)

In Fig. 5 there are marked two D6's. The right hand one should be D5 (they are both 1N4148's anyway). In the text the reference to zener diode D5 should read zener diode ZD1.

PASSIVE INFRA-RED ALARM

(January 1988)

Fig. 2(a) shows the base of Q1 connected to ground and to R14. It should be connected only to R14.

Clean Up Campaign (January 1988)

In the component overlay (Fig. 3) ZD1 is incorrectly orientated. The positive terminal should be the southern end.

Spectrum Co-processor (March 1988)

Mogul Electronics, given in the Bylines as suppliers of the RAM chips, have moved to: Unit 11, Vestry Estate, Sevenoaks TN14 5EU. Tel: (0732) 741841.

ETI PCB SERVICE

E8711-1 Quiz Controller	E	£3.23
E8711-2 256K Printer Buffer	N	£13.10
E8712-1 Heating Management System	O	£15.80
E8712-2 SWR Meter	H	£5.50
E8712-3 Dream Machine (Free PCB)	D	£2.50
E8801-2 Passive IR Alarm	H	£5.50
E8801-3 Mains Cleaner	G	£4.75
E8801-4 RGB Dissolve	L	£8.80
E8802-1 Electric Fencer	E	£3.23
E8802-2 Telephone Intercom	L	£8.80
E8802-3 Transistor Tester (2 bds)	L	£8.80
E8802-4 Spectrum Co-processor CPU board	N	£13.10
E8803-1 Spectrum Co-processor RAM board	N	£13.10
E8803-2 Beeb-Scope (3 bds)	O	£15.80
E8803-3 Jumping Jack Flash	E	£3.23
E8804-1 Spectrum Co-processor Interface Board	N	£13.10
E8804-2 Combo-lock	E	£3.23
E8804-3 Kitchen Timer	E	£3.23

TO: ETI READERS' SERVICES DEPARTMENT
Argus Specialist Publications Ltd,
9 Hall Road, Hemel Hempstead,
Herts HP2 7BH

Please supply:

No. required per type	Board reference number	Price letter	Price each £	Total for board type £
	E	-	£ . p	£ . p
	E	-	£ . p	£ . p
	E	-	£ . p	£ . p
	E	-	£ . p	£ . p

POSTAGE & PACKING £ 0.75p

TOTAL ENCLOSED £ . p

ORDER TO BE SENT TO: (BLOCK CAPS PLEASE)

Name

Address

Postcode

(Make cheques payable to ASP Ltd)

ACCESS and VISA credit card orders can be taken on (0442) 41221 (office hours only).

FREE READERS' ADS

Buy, sell or exchange through our free service to readers

YAMAHA CP25 STAGE PIANO to build. Full LSI chip set, manual £100. Suit experienced constructor. More info contact Durant, 52 Bishops Court, Trumpington, Cambridge.

HELP NEEDED for Sky decoder project for disabled person, expenses paid. Mrs Andrews, 85 Little Cattins, Harlow, Essex CM19 5RN.

TEKTRONIX TYPE 564 storage oscilloscope. Dual trace with screen store. Probe included. £150 ono. Tel: (0689) 57596.

TANDBERG 2025L tuner-amplifier £50. Minimax speakers £25. All in good condition. Phone Perth (0738) 37165.

SPEAKER 18in Goodmans unit 8ohm. Massive construction. Weight 35lb. £48. Phone Willmot (0424) 221636.

WANTED MIDLAND ROSS CAMBION micro units + instructions. £5.00 offered. Doris, 212 Stubley Lane, Dronfield, Sheffield S18 5YP. Phone (0246) 413582.

WANTED working/non-working C-101A Superscope tape recorder. Reasonable price paid. Contact John Hogan, Ardaraostig, Waterfall, near Cork, Eire.

WANTED: kits/circuits for guitar effects pedals and/or drum and cymbal synths. Write: D. Drake, 68 Oakhampton Rd., Mill Hill, London.

DATA WANTED. regarding SAD1024 Reticon delay chip. Eva Hickey, 1B Dray Gardens, Brixton, London SW2 1SL.

TL494 SWITCHED MODE power supply chip. New. Half price £1.50. Also Altai 3½ digit DVM £12.00. Phone Matthew 01-274 2161 evening.

AMSTRAD 6128/464 ADD ONS AMX mouse £40. Arnor Maxam ROM assembler and motherboard £35. Tel: (0203) 468346.

TELEQUIPMENT SCOPE S31R. Mullard V/tester with cards. Marconi S/Signal generator £20 each working. North London. 01-888 8016.

WANTED VIC-20 UTILITIES and games in ROM packs. Tel: Nottingham (0602) 395116.

BBC B OS 1.2 40/80T SDD. Fitted ROMs: Wordwise, Spellchecker, Wordaid £250. Micro and printer £400. Phone after 6.30pm (0933) 678970.

MURPHY FM/LW/MW RADIO (boxed) £12. Five high quality amplifier modules + MTRS directions. 50 watt £6. 100 watt £8 each. Mr Frost, c/o 1 Regent Road, Ilkley LS29.

WANTED ETI January and August 1987. Phone (0329) 41367 after 4.30pm. Phil.

RADFORD VHF VALVE TUNER £20. Murphy 1930's Pye, Ferranti 1940's, radios, £5 each. Phone 021-788 1123.

SMALL PRINTER will work with BBC, Dragon. Uses plain till roll paper. £15 plus p&p. Tel: (0582) 581229.

EDISWAN 11E3 valves. British — 7-pin base. Beam power amplifier. Unused, boxed. 22 available. Offers. Tel: 031 229 0067 (Edinburgh).

WELLER MCP-650 fixed temperature soldering iron. 650°F/343°C 12 volts, 12 watts. For microbore work (no power unit). £4.99 + p&p. Tel: (0274) 593382.

AKAI VT700 PROFESSIONAL open spool video recorder. Believed working order. Offers. 'Phone Silas (09666) 495 after 6pm.

'SYSTIME' 512 main frame. 6-6 +6.6Mb h/discs, 3 terminals, w/pro, printer, manuals, software. Believed working. Silas (09666) 495 after 6pm.

SPECTRUM SPARES. 28 Z80A's, 24 4116, 27 RAM, plus many other parts. All brand new. £50 the lot. Tel: (0772) 634897.

LASERS. 10mW Spirographic with control desk as new £550. 1.0mW sound scanner £150. Phone Worcester (0905) 29690. After 6pm.

DRYFIT GEL BATTERIES. 12V, 20Ah similar RS592-206 (list £80). Used electrically sound. £15 each. (0203) 395191.

FREE! 250 ½W 2% resistors plus 40 polycaps. Full length leads. Wife forces clearout! Send £1 p&p to D M Evans, "Pentre-Gwyn," Tyn-y-Cefn, Corwen, Clwyd.

ELECTRON PLUS 1 with second processor Cumana disk interface, Commstar, RS232, View, Toolkit, T2CU, Addcom, Rombox, loads of software. Offers. (0670) 367429.

WANTED: modern dual beam oscilloscope minimum 10MHz 5mV/cm. Tel: Fleet (0252) 621505.

SCOPEX OSCILLOSCOPE 4D10A dual beam 10MHz. Complete with probe. As new £120. Stanton (Suffolk) 50634 evenings.

FREQUENCY METER BC221-AC with calibration charts, phones, power unit in excellent condition £70. Bookham (0372) 52569.

TEST METER KELVO3s 25,000 ohm/V DC 2000 ohm/V AC. Leather carrying case £27. SAE for details. Mr Joyce, 110 Charteris Road, Kilburn, NW6.

WANTED construction details/circuit diagram of TV aerial and booster for Band III and UHF. Write to Victor Fernandez, 1 Pushpawadi IC Colony Road, Borivili, Bombay 400103, India.

SPECTRUM CHEETA RAT £7.00. Currah µspeech £7.00. Sinclair Logo £10.00 48K Spectrum with Elite keyboard £70. Phone Mike 01-387 1224.

PRINTER QUENDATA DP100 Centronics and serial dot matrix with service manual. Very good condition. £100. Ring (0908) 316052.

WANTED BACK ISSUES ETC. June, July, August 1987. Tel: (0743) 240226. After 7.00pm.

CONDITIONS

- These ads are only for ETI readers not engaged in buying or selling the same items or services on a commercial basis.
- Ads will be inserted as and when space permits. Insertion in a specific issue cannot be guaranteed.
- ETI reserves the right to alter or refuse ads whenever this is judged necessary.
- All ads are accepted in good faith. Neither the magazine nor its publishers can be held responsible for any errors in the reproduction of ads, nor for untruths or misrepresentations, nor for the activities of advertisers or respondents.
- Advertisers submitting ads for this section shall be deemed to have accepted these conditions.

Ads should be 20 words or less including the address and/or telephone number. Please write in black block capitals or type in the grid provided on this form or a photocopy.

Send the form to:
FREE READERS' ADS
Electronics Today International
1 Golden Square
London W1R 3AB

Enter your advertisement below



ETI

ELECTRONICS TODAY INTERNATIONAL



CLASSIFIED

01-437 0699 Ext 292

Send your requirements to:
**Julie Capstick, ETI Class. Dept., ASP Ltd.,
1 Golden Square, London W1.**

Lineage: 44p (VAT excl) per word (minimum 15 words)
Semi Display: (minimum 2 cms)
£12.20 per single column centimetre + VAT
Ring for information on series bookings/discounts

All advertisements in this section must be prepaid.
Advertisements are accepted subject to the terms and
conditions printed on the advertisement rate card (available on request)

ALARMS

ALARMS



FREE BOOKLET

on

BURGLAR ALARMS

with

LOWEST U.K. DIY PUBLISHED PRICES

PHONE OR WRITE FOR YOUR COPY

051-523 8440

AD ELECTRONICS

217 WARBRECK MOOR
AINTREE, LIVERPOOL L9 0HU



SURVEILLANCE

ESKAN

ELECTRONICS

(MANUFACTURERS AND SUPPLIERS
OF SURVEILLANCE AND AUDIO
EQUIPMENT)

MICRO BUG

SK1 Miniature Transmitter 20mm
x 47mm x 20mm, extremely
sensitive. Operates from 1.5v
battery, elegant metal box
included.

Ready built + tested only. £29.50

Kit Form £24.90

EXTRA MINIATURE TRANSMITTER

EK2 25mm x 30mm x 9mm
Ready built + tested £49.00

Kit Form £37.95

HIGH POWER FM RADIO TRANSMITTER

EK65, 65W adjustable frequency
Mains operated. £650 + £35 p&p
(Operation in the UK illegal
without licence).

AUTOMATIC TELEPHONE MONITOR

SK19 ready built + tested £34.50
Kit Form £29.95

Many other surveillance
equipment available. Send large
S.A.E. for catalogue.

SOUND TO LIGHT UNIT

SK72 separate sensitivity, bass,
treble and mid-range frequency
controls, designed and
manufactured to highest
professional standard.

Ready Built £39.95 p&p £3.50

Kit Form £21.95

Casing £11.95

SK70 sound to light control unit
Kit Form £14.95

Send Cheque or P.O. payable to:

ESKAN ELECTRONICS

172 Caledonian Road,
London N1 0SG.

Tel: 01 278 1768



Trade and Export Enquiries Welcome

ROOM BUG. Surveillance trans-
mitter and whisper sensitive
condenser microphone sealed
in shock proof capsule only
30mm x 20mm x 15mm. Clips on
to standard PP3 type battery,
domestic VHF radio reception,
range upto 200 metres. Unbeat-
able £16.99 (inc. p&p) Longcroft
Security, 30 Longcroft,
Huddersfield, W. Yorkshire HD5
8YW.

BOOKS

CIRCUIT DIAGRAMS

Most Makes, Models, Types, Audio, Music
Systems, Colour, Mono Televisions,
Amateur Radio, Test Equipment, Vintage
etc. £3.50 plus LSAE

State Make/Model/Type with order.

Full Workshop Manual prices on
request with LSAE.

MAURITRON (ETI),

8 Cherry Tree Road, Chinnor,
Oxfordshire, OX9 4QY.

PARAPHYSICS Journal (Russian
Translation); Psychotronics;
Kirlianography, Heliphonic
Music, Telekinetics. Computer
Software, S.A.E. 4 x 9", Paralab,
Downton, Wiltshire.

- Surveillance
- Kits
- Components
- PCB's

ETI has the right market.

**Ring Julie Capstick
on 01-437 0626
for more details.**

KITS



I-TRON'S

TOP SELLING
KITS



BUG-87 Matchbox sized surveillance
transmitter - can be received by any
FM/VHS radio..... £4.95

ROBO-VOX Instantly transforms your
voice into Dalek/Robot type also
amazing feedback/sound effects possible.

..... £11.95

ROBOT CIRCULAR Unique radio controlled
robot - can also be converted to
control via computer..... £16.95

EDU-SCOPE Build your own oscilloscope
with solid state display..... £39.99

EDU-SCOPE CASEKIT..... £11.99

THERAMIN MUSIC GENERATOR An electronic
device based on an ancient legendary
mystical instrument..... £12.75

Please add £0.75 per order for P&P. For
FREE Datapack on all our Products /Kits
send **SAE**. Cheques/PO's payable to:-

IMAGINA-TRONICS

Aberdeen House, The Street, Charlwood,
Surrey. RH6 0DS

KITS

MICRO TRANSMITTER KIT,
500m Range, tunable
88-115MHz, sensitive micro-
phone. £3.95. Cheques/PO's to
Quantek Ltd., (ETI), 267 Rednal
Road, Kings Norton, Birming-
ham B38 8EB.

ELECTRONIC KITS—For those
Winter evenings. SAE for details:
COVE ELECTRONICS, 7 St.
Anne's Avenue, Southbourne,
Bournemouth, Dorset BH6 3JR.

FOR SALE

RADIATION DETECTOR
(Beta/Gamma) £49 (Tube + PCB
£27) Serial - Parallel Converter.
PCB + case £7. Tel: 0223
207237.

WANTED

Turn your surplus
transistors, IC's etc., into
cash. Immediate settlement.

We also welcome the
opportunity to quote for
complete factory clearance.
Contact:

COLES HARDING & CO.

103 South Brink
Wisbech, Cambs.

ESTABLISHED OVER 10 YEARS

Tel: 0945 584188

Fax Number: 0945 588844

IDEAS/INVENTIONS wanted.
Call I.S.C. 01 434 1272 or write,
Dept ASP 99 Regent St, London
W1.

**Next copy deadline
23rd March for
June issue.**

APPOINTMENTS



**TEXAS
INSTRUMENTS**

Mixed Signal Test Engineer

The vital link to further ASIC Development

A leading semiconductor manufacturer, Texas Instruments combines ASIC expertise and technology resources with a broadly based world wide market.

Currently with a vacancy for a Test Engineer in this rather unique area of ASIC manufacturing, we are seeking a competent individual to provide allround test expertise for mixed signal devices, on a large number of short term projects.

Are you:

- A graduate with at least 5 years solid engineering experience to build on?
- Able to understand both design and manufacturing techniques, with the ability to bridge the gap between the two?

- Analytical, with a methodical and extremely practical approach to test engineering?
- Flexible in your approach to work and responsive to the challenge of keeping several projects running successfully at the same time?
- Self motivating and able to meet test requirements with minimum alteration.

Then you can provide us with that vital link. In return we can provide you with a competitive remuneration package and benefits associated with a multi-national company, which include private medical care, profit share and relocation assistance.

Interested? Please send your full C.V. to our consultants at Octagon Human Resources, Glen House, 200-208 Tottenham Court Road, London W1P 9LA.

Octagon Human Resources

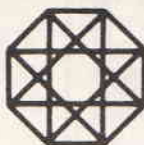

COMPONENTS

Stock Clearance of Resistors and Pre-sets (available whilst stocks last)

¼W 1% metal Film	E96	2p
¼W 5%	E24	1p
½W 1%	E24	3p
½W 5%	E24	2p
Cermet Pre-sets PCB mount		20p
Horizontal		
22R, 47R, 220R, 470R, 680R, 6k8, 100k, 220k, 470k, 500k, 1M, 2M2.		
Vertical		
10k, 22k, 1M, 2M2.		

Please add £1.00 p&p and 15% to total

MARGIN ELECTRONICS
17 Warren Crescent, East Preston,
Sussex BN16 1BH.

S.H. COMPONENTS presents 18 pages of very competitively priced semi-conductors, switches, Opto Electronics, etc. Send 50p to: 17 Beeley Road, Grimsby, S. Humberside.

MISCELLANEOUS

TMS320 Starter kit incorporating TMS32020, 16K Eprom RS232. Prices from under £300. For further details send S.A.E. to Melek Circuits, 18 Kincardine Drive, Blechley, Milton Keynes MK3 7PG.

HEATHKIT U.K. Spares and service centre, Cedar Electronics, Unit 12, Station Drive, Bredon, Tewkesbury, Glos. Tel. 0684 73127.

BABY BOOMERS

SP45 3" 40 Watt 8 ohm Baby Boomer Superb value at only £5.60 + £1.50 P&P
JUST ONE ITEM FROM OUR HUGE STOCKS OF QUALITY ELECTRONIC AND ELECTRICAL SPARES AND ACCESSORIES.

SEND FOR FREE JUMBO LISTS.
C.O.D. SERVICE AVAILABLE

STRACHAN ELECTRONICS (ET)
9 CROALL PLACE, EDINBURGH EH7 4LT

FREE RESISTORS plus hundreds of low price-manufacturers full spec. components, send £1.50 cheque for samples and lists or 10" x 4" s.a.e. for lists only. Dept. (E), D&M Component Supply Service, 2 Glentworth Avenue, Whitmore Park, Coventry, W. Midlands CV6 2HW.

PROMS - EPROMS - PALS ANY PROGRAMMABLE IC SUPPLIED OR BLOWN

Typical prices (excluding VAT) (Data Entry P&P extra)
2716 £4.20 2732 £3.85
2764 £2.85 27128 £4.40

BIPOLAR PROMS from £1.35
e.g. 82S123, 18S030, 74S288
PALS, PLDs etc. from £3.26
e.g. 82S153, 16L8, EP310
Full design and prototyping service. Any quantity programmed - SAE or phone for details.
P.L.S., 80 Central Road, Worcester Park, Surrey, KT4 8HU
Phone: 01-330 6540

EQUIPMENT

WOULD YOU BUY A CAR WITHOUT A TEST DRIVE? THEN WHY BUY A MIXER WITHOUT A TEST DRIVE?

Thinking about a new project — from a small Mixer to a large studio complex — come and talk over ideas with the people who offer manufacturing and user experience at our new premises:

Unit D, 318 High Road, Boreham, Essex SS7 5HB

TO TAKE THAT TEST DRIVE —
PHONE 0268-793381
(Weekend Committee visits welcome by prior arrangement)



PARTRIDGE ELECTRONICS

Head Office, 56 Fleet Road, Boreham, Essex SS7 5JN
Telephone 0268-793256

To give your project a professional finish use an INPRINT MEMBRANE KEYPAD

- Legendable. Ideal for Project Prototype work
- Sealed to IP65. Can be used outdoors
- 16 Pad 4X4 Matrix can be cut to smaller configurations
- Several can be connected together to make larger keypads
- Full instruction
- For further information send S A E

INPRINT (Coventry) 3 Quinton Road, Coventry CV1 2NJ. Tel (0203) 51318

We accept



bookings. Phone 01-437 0626 Today.

SPECIAL OFFERS

CASSETTE MOTORS large and small 2 for £1.00. Mono and stereo cassette tape heads. 2 for £1.00. Microphone small for cass. tel. etc. 2 for £1.00. Telephone buzzers at £2.50 each. Please add 75p p&p no VAT. Access card accepted. Golden Orange Supplies, Brockhollands Road, Woodside, Bream, Lydney, Glos. Tel: 0594 563009.

CHILDSPLAY FROM KIA. Variable power supplies 12-40V £5.00. Glass/PCB & TO3 Heatsink & Electronic cutout. 8 Cunliffe Road, Ilkley LS29. **GIVEAWAY NEXT MONTH.**

COURSES

Start training now for the following courses. Send for our brochure — without obligation or Telephone us on 06267 79398

REF: ETI/4/88

NAME _____

- City & Guilds Exam 271
- Radio Amateur Licence
- Micro-processor
- Introduction to Television

Radio & Telecommunications Correspondence School, 12, Moor View Drive, Teignmouth, Devon. TQ14 9UN.

Do you need qualified staff?
Electronics Today International can find them for you.
Ring Julie Capstick on 01-437 0626 TODAY!

ELECTRONICS TECHNICIANS
Updating Courses
London Electronics College, (Dept ETI), 20 Penywern Road, London SW5 9SU. 01-373 8721.

Next Copy Deadline
23rd March for
June issue.

RETAIL OUTLETS

LIVERPOOL

PROGRESSIVE RADIO
87/93 Dale Street Tel: 051 236 0154
47 Whitechapel. Tel: 051 236 5489
Liverpool 2
'THE ELECTRONICS SPECIALISTS'
Open: Tues-Sat 9.30-5.30

LONDON

CRICKLEWOOD ELECTRONICS LTD
FOR COMPONENTS
LOTS OF NEW DEVICES
LOTS OF LOWER PRICES
Phone for our catalogue:
01 452 0161/450 0995 Telex: 914 977
40 Cricklewood Broadway,
London NW2 3ET.

SOUTH COAST

ELECTRONIC COMPONENTS
are best seen at
FRASER ELECTRONICS
42 ELM GROVE ★ SOUTHSEA ★ HANTS
Telephone (0705) 815584
Barclaycard Access
COME AND BROWSE BEFORE YOU BUY

TYNE AND WEAR

ELECTRONIC COMPONENTS AND KITS
ESR
STATION ROAD, CULLERCOATS,
NORTH SHIELDS, TYNE & WEAR NE30 4PQ
091 251 4363
New 1988 Catalogue now available £1.95 incl p&p. MON-SAT 9.30 to 5.30 CLOSED THURS.

E
L
E
C
T
R
O
M
A
R
T

E
L
E
C
T
R
O
M
A
R
T

ELECTRONIC COMPONENTS

TRADE SUPPLIES

BRYANT ELECTRIC

5 BELLE VUE TERRACE
GILESGATE MOOR,
DURHAM, DH1 2HR.
Tel: (091) 3864500

SEMICONDUCTORS

LINEAR		CMOS	
DEVICE	50+ 100+	Mixed Quantity Pricing	
CA555CE	0.130 0.120	DEVICE	100+
CA741CE	0.138 0.123	4000B	0.119
CA3130E	0.620 0.580	4001UB	0.119
CA3140E	0.260 0.225	4002B	0.132
LF351	0.380 0.340	4008B	0.160
LM324	0.286 0.230	4011B	0.120
NE556	0.400 0.385	4012B	0.120
TBA820M	0.660 0.590	4016B	0.265
UA477	0.300 0.255	4017B	0.220
		4018B	0.225
		4022B	0.245
		4028B	0.180
		4029B	0.250
		4042B	0.185
		4046B	0.320
		4049UB	0.165
		4050B	0.133
		4071B	0.130
		4081B	0.130
		40106B	0.300

TRANSISTORS		LSTTL	
DEVICE	50+ 100+	Mixed Quantity Pricing	
BC108C	0.125 0.123	DEVICE	100+
BC109C	0.125 0.121	74LS00	0.130
BC182L	0.060 0.050	74LS01	0.150
BC184L	0.060 0.050	74LS02	0.130
BC212L	0.065 0.060	74LS04	0.130
BC214L	0.065 0.058	74LS08	0.135
BC547C	0.045 0.039	74LS10	0.130
BC548C	0.045 0.039	74LS11	0.130
BC549C	0.045 0.039	74LS14	0.210
BC558C	0.045 0.039	74LS22	0.155
BD131	0.420 0.410	74LS42	0.245
BFY50	0.223 0.212	74LS47	0.410
BFY51	0.223 0.212	74LS48	0.155
TIP41C	0.220 0.190	74LS51	0.350
2N3055	0.440 0.420	74LS86	0.150

LED'S 5mm		DIODES	
CLOUR	50+ 100+	TYPE	50+ 100+
RED	0.070 0.064	IN4148	0.020 0.016
YELLOW	0.080 0.070	6Z789CSV1	0.045 0.034
GREEN	0.080 0.070	W005	0.200 0.192
RED FLASHING	0.410 0.370	W04	0.210 0.190

RESISTORS
1/4 WATT CARBON 5% V24 RANGE
MIXED VALUE PRICING
100+ 0.008
1K+ 0.006
5K+ 0.005
10K+ 0.0045

POTENTIOMETERS
LIN OR LOG STANDARD SIZE
MIXED VALUE PRICING
50+ 0.32
100+ 0.30

PRESETS
HORIZONTAL OR VERTICAL
MIXED VALUE PRICING
MINIATURE 50+ 0.095
100+ 0.090
STANDARD 50+ 0.095
100+ 0.090

ALL PRICES ARE PRICE EACH, PER QUANTITY UNLESS OTHERWISE STATED.
ALL TRADE PRICES EXCLUDE VAT.
PRICES SUBJECT TO CHANGE
PRICES OPEN TO NEGOTIATION ON SMALLER QUANTITIES TO MSC CENTRES ETC.

PLEASE ADD £1.00 CARRIAGE TO ALL ORDERS.
LARGER QUANTITIES P.O.A.
ALSO STOCKED: ACCESSORIES, BOOKS, CABLES, CAPACITORS, LEADS, TEST GEAR ETC. SAE FOR TRADE CATALOGUE AVAILABLE ON REQUEST.

PCB'S

PRINTED CIRCUIT BOARDS At very competitive rates: 4 pence per square centimetre (less for orders of 10 plus and large boards) 1 offs; 100 offs - send artwork (1:1, single sided) or drawings/enquiries. Also artwork carried out. Watling Wires PCB Production, 51 Watling Street, Nuneaton, Warwickshire, CV11 6JL. Telephone (0203) 382296.

PROBLEMS with PCB's? Fast, reliable, cheap PCB and etching service. Contact Roger on Walsall (0922) 23945 after 5.30pm.

PLANS & DESIGNS



Design and build your own electronic dashboard.
Plans, instructions, circuits, parts lists
£4.95 inc p&p

BURLINGTON MOTOR CO. LTD.
(G9) ARCH 39M, BATH PLACE,
LEAMINGTON SPA, CV3 3AQ.

ELECTRONIC PLANS, laser designs, solar and wind generators, high voltage teslas, surveillance devices, pyrotechnics and computer graphics tablet. 150 projects. For catalogue, SAE to Plancentre Publications, String Works, Bye St., Ledbury HR8 2AA.

labcenter electronics
PC-B £80

At last, an affordable PCB design tool for your Amstrad PC. Plotting service available. Send SAE for further details, or £2 for demo disk.

Labcenter Electronics
14 Marriner's Drive,
Bradford, BD9 4JT.
Tel: 0274 542868

PCB'S; ARTWORK; Single/Double Sided; one off or multiples. Professional quality: Reasonable rates. SAE for details. Dene Electronic Services, 17 Coniston Avenue, West Jesmond, Newcastle NE2 3EY.

SWITCHES

VOICE/SOUND ACTIVATED SWITCHES easy to follow diagrams and uses only £1.00. Components and P.C.B's available: **Herrington, 63 Home Farm Rd, Hanwell, London W7 1NL.**

COMPUTER WAREHOUSE

1000's OF BARGAINS FOR CALLERS

THE "ALLADINS' CAVE OF COMPUTER AND ELECTRONIC EQUIPMENT

HOT LINE DATA BASE

DISTEL

The ORIGINAL FREE OF CHARGE dial up data base. Buy, browse or place YOUR OWN AD for goods or services to sell. 1000's of stock items, spares and one off bargains. Updated daily. ON LINE NOW. CCITT, 8 bit word, no parity. For 300 baud modems call 01-679 1888. For 1200-75 baud modems call 01-679 6183

FREE

Your monitor from its computer! For only £29.95 it becomes a SUPERB HIGH QUALITY * COLOUR * TV SET

The fabulous TELEBOX, an INVALUABLE MUST for the owner of ANY video monitor with a composite input, colour or monochrome. Made by a major UK Co. as a TOP QUALITY, stand alone UHF tuner and costing OVER £75 to manufacture, this opportunity to give your monitor a DUAL FUNCTION must not be missed! The TELEBOX consists of a compact stylish two tone charcoal moulded case, containing ALL electronics tuner, power supply etc. to simply plug in and convert your previously dedicated computer monitor into a HIGH QUALITY COLOUR TV SET, giving a real benefit to ALL the family! Don't worry if your monitor doesn't have sound - THE TELEBOX even has an integral 4 watt audio amplifier for driving an external speaker, PLUS an auxiliary output for superb quality television sound via your headphones or HI FI system etc. Other features include: Compact dimensions of only 15.75" w x 7.5" d x 3.5" h, latest technology, BRITISH manufacture, fully tuneable 7 channel push button tuner, Auto AGC circuit, SAW filter, LED status indicator, fully isolated 240v AC power supply for total safety, Mains ON-OFF switch etc. Many other uses.

LIMITED QUANTITY - DON'T MISS THIS OFFER!!!

ONLY £29.95 OR £24.94 if purchased with ANY of our video monitors. Supplied BRAND NEW with full instructions and 2 YEAR warranty. Post and packing £3.50. *When used with colour crt.

COLOUR & MONOCHROME MONITOR SPECIALS

SYSTEM ALPHA 14' COLOUR MULTI INPUT MONITOR

Made by the famous REDIFUSION Co. for their own professional computer system this monitor has all the features to suit your immediate and future requirements. Two video inputs, RGB and PAL Composite Video, allow direct connection to BBC/IBM and most other makes of micro computers or VCR's, including our very own TELEBOX. An internal speaker and audio amp may be connected to computer or VCR for superior sound quality. Many other features: PIL tube, Matching BBC case colour, Major controls on front panel, Separate Contrast and Brightness - even in RGB mode. Separate Colour and audio controls for Composite Video input, BNC plug for composite input, 15 way 'D' plug for RGB input, modular construction etc.

This Must Be ONE OF THE YEAR'S BEST BUYS. PC USER Supplied BRAND NEW and BOXED, complete with DATA and 90 day guarantee. ONLY £115.00 as above OR IBM PC Version £165.00 15 Day 'D' sht £1.00. BNC sht 75p BBC interface cable £5.50

DECCA 80 16' COLOUR monitor. RGB input.

Little or hardly used manufacturer's surplus enables us to offer this special converted DECCA RGB Colour Video TV Monitor at a super low price of only £99.00, a price for a colour monitor as yet unheard of! Our own interface, safety modification and special 16" high definition PIL tube, coupled with the DECCA 80 series TV chassis give 80 column definition and quality found only on monitors costing 3 TIMES OUR PRICE. The quality for the price has to be seen to be believed! Supplied complete and ready to plug direct to a BBC MICRO computer or any other system with a TTL RGB output. Other features are: internal speaker, modular construction, auto degaussing circuit, attractive TEAK CASE, compact dimensions only 52cm W x 34 H x 24 D, 90 day guarantee. Although used, units are supplied in EXCELLENT condition. ONLY £99.00 + Carriage.

DECCA 80, 16' COLOUR monitor. Composite video input. Same as above model but fitted with Composite Video input and audio amp for COMPUTER, VCR or AUDIO VISUAL use. ONLY £99.00 + Carr.

REDIFUSION MARK 3, 20' COLOUR monitor. Fitted with standard 75 ohm composite video input and sound amp. This large screen colour display is ideal for SCHOOLS, SHOPS, DISCOS, CLUBS and other AUDIO VISUAL applications. Supplied in AS NEW or little used condition. ONLY £145.00 + Carr.

BUDGET RANGE EX EQUIPMENT MONOCHROME video monitors.

All units are fully cased and set for 240v standard working with composite video inputs. Units are pre tested and set up for up to 80 column use. Even when MINOR screen burns exist - normal data displays are unaffected 30 day guarantee.

12 KGM 320-1 B W bandwidth input, will display up to 132 x 25 lines £32.95
12 GREEN SCREEN version of KGM 320-1. Only £39.95
9 KGM 324 GREEN SCREEN fully cased very compact unit. Only £49.00

Carriage and insurance on all monitors £10.00

DC POWER SUPPLY SPECIALS

GOULD OF443 enclosed compact switch mode supply with DC regulated outputs of +5v @ 5.5A, +12v @ 0.5A, -12v @ 0.1A and -23v @ 0.02A Dim 18 x 71 x 55 mm. 15 pin 240v input. BRAND NEW only £15.95
GOULD G6-40A 5v 40 amp switch mode supply NEW £130.00
AC-DC line PSU for DISK drive and SYSTEM applications. Constructed on a rugged ALLOY chassis to continuously supply fully regulated DC outputs of +5v @ 3 amps, -5v @ 0.6 amps and +24v @ 1.25 amps. Short circuit and overvoltage protected. 100 of 240v AC input. Dim 28 x 12.5 x 7 cm NEW £49.94
Carriage on all PSU's £3.00

KEYBOARDS

Manufacturer's BRAND NEW surplus.

DEC LA34 Unencoded keyboard with 67 quality gold plated switches on X-Y matrix - ideal micro conversions etc. £24.95
AMKEY MPNK-114 Superb word processor chassis keyboard on single PCB with 116 keys. Many features such as On board Micro, Single 5v rail, full ASCII encoded character set with 31 function keys, numeric keypad, cursor pad and 9600 baud SERIAL TTL ASCII OUTPUT! Less than half price. ONLY £69.00 with data. Carriage on Keyboards £3.50



DON'T MISS THE CPM Deal OF THE CENTURY

The FABULOUS CPM TATUNG PC2000 Professional Business System

A cancelled export order and months of negotiation enables us to offer this professional PC, CPM system, recently on sale at OVER £1400, at a SCOOP price just over the cost of the two internal disk drives!! Or less than the price of a dumb terminal!!!

Not a toy, the BIG BROTHER of the EINSTein computer, the DUAL PROCESSOR PC2000 comprises a modern stylish three piece system with ALL the necessities for the SMALL BUSINESS, INDUSTRIAL, EDUCATIONAL or HOBBYIST USER. Used with the THOUSANDS of proven, tested and available CPM software packages such as WORDSTAR, FAST, DBASE2 etc, the PC2000 specification, at our prices, CANNOT BE BEATEN!!

Double sided 40/80 track disk drives (1 Mb per drive), PSU, 4K of memory mapped screen RAM, disk controller, RS232, CENTRONICS and system expansion ports, and if that's not enough a ready to plug into STANDARD 8" DRIVE port for up to FOUR 8" disk drives, either in double density or IBM format. The ultra slim 92 key, detachable keyboard features 32 user definable keys, numeric keypad and text editing keys, even its own integral microprocessor which allows the main Z80A to devote ALL its time to USER programs, eliminating "lost character" problems found on other machines. The attractive, detachable 12" monitor combines a green, anti-glare etched screen, with full swivel and tilt movement for maximum user comfort. Supplied BRAND NEW with CPM 2.2, user manuals and full 90 day guarantee. Full data sheet and info on request.

The central processor plinth contains the 64K, Z80A processor, DUAL TEAC 55F 5 1/4" PC2000 System with CPM Etc. COST OVER £1400
PC2000 Business System with CPM and 'Ready to Run' FAST Sales and Purchase ledger, supports up to 9000 Accounts, VAT etc. COST OVER £1700
PC2000 Wordprocessor System with CPM and TEC FP25 daisywheel printer

NOW only £399

NOW only £499
Carriage & Insurance £12.00

NOW only £799

MODEMS

Join the communications revolution with our super range of DATA MODEMS, prices and specifications to suit all applications and budgets

BRAND NEW State of the art products.
DACOM DSL2123 Multi: standard 300-300, 1200-75 Auto answer etc. £268.00
DACOM DSL2123AQ Auto dial, smart modem with multi standard AUTO SPEED detect, and data buffer with flow control etc. £365.00
DACOM DSL2123GT The CREAM of the intelligent modems auto dial, auto call, index, buffer etc etc. £498.00
Steabeck SB1212 V22 1200 baud FULL DUPLEX, sync or async, optional auto dial. £465.00
TRANSDATA 307A Acoustic coupler 300 baud full duplex, originate only, RS232 interface. £49.00

Ex BRITISH TELECOM full spec, CCITT, ruggedised, bargain offers. SOLD TESTED with data, will work on any MICRO or system with RS232 interface.

MODEM 13A 300 baud unit, only 2" high fits under phone. CALL mode only. £45.00
MODEM 20-1, 75-1200 baud. Compact unit for use as subscriber end to PRESTEL, TELECOM GOLD, MICRONET etc. £39.95 +pp £6.50
MODEM 20-2 1200-75 baud. Same as 20-1, but for computer end. £65.00 +pp £6.50
DATEL 2412. Made by SE Labs for BT this two part unit is for synchronous data links at 1200 or 2400 baud using 2780/3780 protocol etc. Many features include 2 or 4 wire working, self test, auto answer etc. COST OVER £800. Our price ONLY £199 +pp £8.00
DATEL 4800, RACAL MPS4800 baud modem. EX BT good working order. ONLY £295.00 +pp £8.00

SPECIAL OFFER

MODEM TG2393. Ex BT, up to 1200 baud, full duplex 4 wire or half duplex over 2 wire line. ONLY £85.00 PER PAIR +pp £10.00

For more information contact our Sales Office.

MATRIX PRINTERS

SPECIAL BULK PURCHASE of these compact, high speed matrix printers. Built in Japan for the Hazeltine Corporation this unit features quality construction giving 100cps bidirectional, full pin addressable graphics, 6 type fonts, up to 95" single sheet or tractor paper handling, RS232 and CENTRONICS parallel interface. Many other features. BRAND NEW and BOXED. COST £420. Our price ONLY £199.00

RECHARGEABLE BATTERIES

Dry Fit MAINTENANCE FREE by Sonnenschein & Yuasa
A300 07191315 12v 3Ah NEW £13.95
A300 07191312 6v 3Ah NEW £9.95
A300 07191202 6-0-6v 1.8Ah TESTED Ex Equip £5.99

VDU TERMINALS

Standard VDU data entry terminals at give away prices!!

QUME QVT108. Current product, state of the art terminal with detachable keyboard, 12" Green screen, 2 page RAM, TVI 925, Hazeltine, ADMSA emulations, software setup, 25 x 80, Clock, Swivel and tilt base. Printer port, Function keys etc. BRAND NEW and BOXED AT ALMOST HALF PRICE ONLY £425.00
AJ510 - EX RENTAL, Z80 controlled, 15" green screen 24 x 80 display, graphics, cursor addressing, printer port etc. Very good condition TESTED complete with manual only £225.00
ADDS 520 - Dumb terminal, used, 12" b/w screen RS232 interface and printer port TESTED. ONLY £125.00. Carriage on terminals £10.00
100's of other terminals in stock, CALL for more details

SURPLUS SPECIALS ON PRESTEL - VIEWDATA - TELEX

PLESSEY VUTEL, ultra compact unit, slightly larger than 3 telephone features A STANDARD DTMF TELEPHONE (tone dial) with 5" CRT monitor and integral modem etc. for direct connection to PRESTEL, VIEWDATA etc. Designed to sell to the EXECUTIVE at over £600!! Our price BRAND NEW AND BOXED at only £99.00
DECCAFAX VP1 complete Professional PRESTEL system in slimline desk top unit containing Modem, Numeric keypad, CPU, PSU etc. Connects direct to standard RGB colour monitor. Many other features include: Printer output, Full keyboard input, Cassette port etc. BRAND NEW with DATA. A FRACTION OF COST only £55.00
ALPHATANAL. Very compact unit with integral FULL ALPHA NUMERIC keyboard. Just add a domestic TV receiver and you have a superb PRESTEL system and via PRESTEL the cheapest TELEX service to be found! Many features: CENTRONICS Printer output, Memory dialling etc. Supplied complete with data and DIY mod for RGB or Composite video outputs. AS NEW only £125.00
Post and packing on all PRESTEL units £8.50

EX-STOCK INTEGRATED CIRCUITS

4164 200 ns D RAMS 9 for £11 4116 ns £1.50 2112 £1.00 2114 £2.50 2102 £2.00 6116 £2.50 EPROMS 2716 £4.50 2732 £3.00 2764 £4.95 27128 £5.50 6800 £2.50 6821 £1 68A09 £8 68B09 £10 8085A £5.50 8086 £15 8088 £8 NEC765 £8 WD2793 £28 8202A £22 8251 £7 8748 £15 Z80A DART £6.50 Z80A CPU £2.00. Thousands of IC's EX STOCK send SAE for list.

DISK DRIVES

Japanese 5 1/4" half height, 80 track double sided disk drives by TEAC, CANON, TOSHIBA etc. Sold as NEW with 90 day guarantee ONLY £85.00
TEC FB-503 Double sided HH 40 TRK NEW £75.00
SUGART SA400 SS FH 35 TRK £55.00
SIEMENS FDD100 SS FH 40 TRK £65.00
carriage on 5 1/4" drives £5.50
Brand New metal 5 1/4" DISK CASES with internal PSU.
DSKC1 for 2 HH or 1 FH drive £29.95 +pp £4.00
DSKC 2 for 1 HH drive £22.95 +pp £3.50
DSKC 3 As DSK1 LESS PSU £12.95 +pp £2.50
DSKC 4 As DSK2 LESS PSU £10.95 +pp £2.00
8" IBM format TESTED EX EQUIPMENT.
SHUGART 800/801 SS £175.00 +pp £8.50
SHUGART 851 DS £250.00 +pp £8.50
TWIN SHUGART 851 1/2 2 Mb total capacity in smart case, complete with PSU etc. £595.00
MITSUBISHI M2894-63 8" DS 1 Mb equiv. to SHUGART SA80R. BRAND NEW at £275.00 +pp £8.50
DYSAN 8" Alignment disk £29.00 +pp £1.00
Various disk drive PSU's Ex Stock SEE PSU section.

HARD DISK DRIVES
DRE/DIABLO Series 30 2.5 Mb front load £525.00
Exchangeable version £295.00, ME3029 PSU £95.00
DIABLO 44/DRE4000A, 8 5+5 Mb front £750.00
CDC HAWK 5+5 Mb £795.00. CDC 9762 80 Mb RMO3 etc. £2500.00.
PERTEC D3422 5+5 Mb £495.00
RODIME 5 1/4" Winchester ex-stock from £150 CALL
Exchange Items - Sold as seen - No guarantee.
ICL 2314 BRAND NEW 14" Mb Removable pack hard disk drive, cost over £2000 with data. ONLY £99.00
BASF 8172 8" 23Mb Winchester £199.00
Unless stated all drives are refurbished with 90 day guarantee. Many other drives and spares in stock - call sales office for details.

All prices quoted are for U.K. Mainland, paid cash with order in Pounds Sterling PLUS VAT. Minimum order value £20.00. Minimum Credit Card order £10.00. Minimum BONA FIDE account orders from Government Depts., Schools, Universities and established companies £20.00. Where post and packing not indicated please ADD £1.00 + VAT. Warehouse open Mon-Fri 9.30-5.30. Sat 10.30-5.30. We reserve the right to change prices and specifications without notice. Trade, Bulk and Export

Display ELECTRONICS

32 Biggin Way, Upper Norwood, London SE19 3XF
Telephone 01-679 4414 Telex 894502 Data 01-679 1888

The Dollar has fallen... and so have our Prices!!

PRECISION GOLD MULTIMETERS - OUTSTANDING VALUE FOR MONEY!

BUY NOW, THE TIME IS RIGHT!

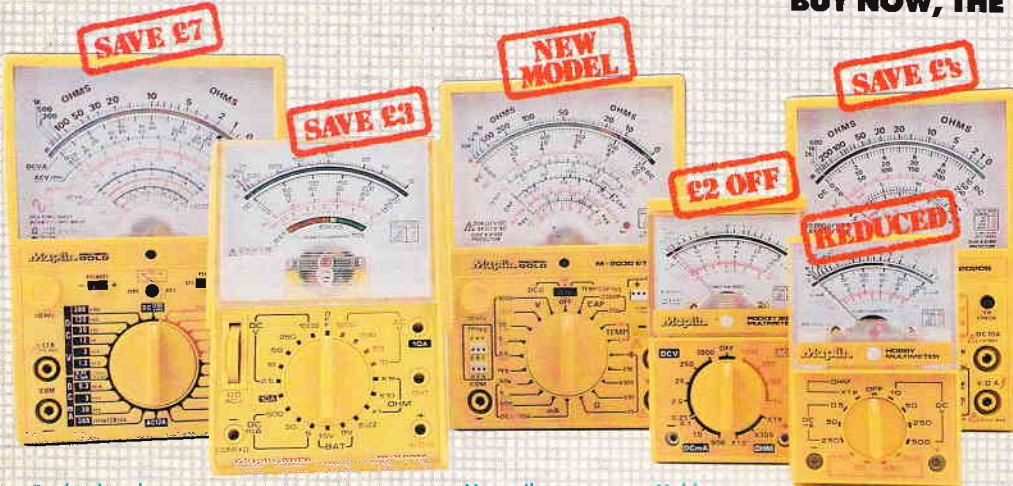

Comprehensive
With transistor,
diode and
LED tester.
Y108J ~~£19.95~~
£16.95

Professional
Has all the ranges!
Y109K ~~£34.95~~
£27.95

Wide Range
With battery tester.
Y107H ~~£14.95~~
£11.95

Versatile
Measures temperature
and capacitance.
YP23A
£24.95

Hobby
Ideal for beginners.
Y176H ~~£8.95~~
£6.95

Pocket
Rugged, general purpose.
Y106G ~~£6.95~~
£5.45

All prices include VAT.
Please add 50p towards postage. All items subject to availability.



Precision
High sensitivity
on AC
current &
resistance.
Y110L ~~£41.95~~
£36.95

Auto Ranging
Top selling
digital.
Y180B ~~£39.95~~
£35.95

Practical
Includes
temperature
probe.
Y179L ~~£64.95~~
£54.95

Feature Packed
Auto-ranging
with transistor
tester.
YM64U ~~£44.95~~
£37.95

4 1/2 Digit
Superb
multi-featured
multimeter.
YJ81C ~~£69.95~~
£59.95

Hobby
Enthusiasts
meter.
YM63T ~~£28.95~~
£25.95

Push Button
Comprehensive
range of
features.
Y178K ~~£39.95~~
£35.95

Low Cost
Push button
digital.
Y177J ~~£26.95~~
£21.95

plus ORDER NOW AND GET A **FREE** CARRYING CASE WITH YOUR METER (WORTH UP TO £3.95)

Maplin ELECTRONICS

P.O. Box 3, Rayleigh, Essex. Telephone Sales (0702) 554161.

Shops at: Birmingham. Sutton New Road, Erdington. Tel: 021 384 8411.

Bristol. 302 Gloucester Road. Tel: 0272 232014.

London. 159-161 King Street, Hammersmith W6. Tel: 01 748 0926.

Manchester. 8 Oxford Road. Tel: 061 236 0281.

Southampton. 46-48 Bevois Valley Road. Tel: 0703 225831.

Southend-on-Sea. 282-284 London Road, Westcliff-on-Sea, Essex. Tel: 0702 554000.

Pick up a copy of our 1988 catalogue from any branch of WHSMITH for just £1.60. Or to receive your copy by post send £1.60 + 40p p&p to our P.O. Box address. If you live outside the U.K. please send £2.75 or 12 International Reply Coupons.



We're passing on our exchange rate saving to you!