

electronics today

INTERNATIONAL

NOVEMBER 1986 £1.30

BIOFEEDBACK THEORY AND PRACTICE

POWER MOSFETS

PLUS

DIGITAL AUDIO SWITCHER

BUSINESS:

WHAT KIND OF
COMPANY TO KEEP

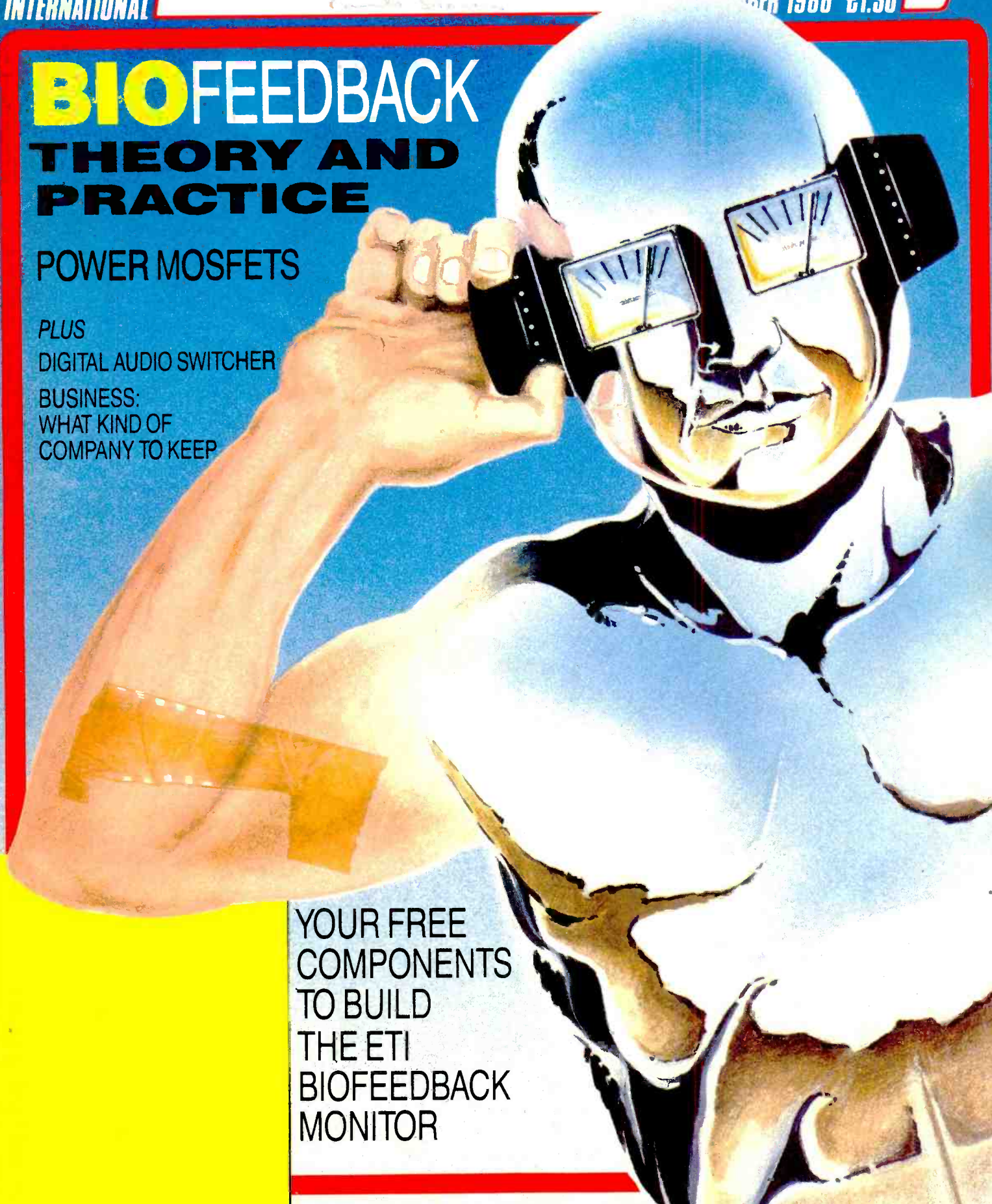

YOUR FREE
COMPONENTS
TO BUILD
THE ETI
BIOFEEDBACK
MONITOR

RTING...MUSIC...RA

OMP POWER AMPLIFIER MODULES

OMP POWER AMPLIFIER MODULES

Now enjoy a world wide reputation for quality, reliability and performance at a realistic price. Four models available to suit the needs of the professional and hobby market, i.e. Industry, Leisure, Instrumental and Hi-Fi etc. When comparing prices, NOTE all models include Toroidal power supply, Integral heat sink, Glass fibre P.C.B. and Drive circuits to power compatible Vu meter. Open and short circuit proof.

Supplied ready built and tested.



OMP100 Mk II Bi-Polar Output power 110 watts R.M.S. into 4 ohms. Frequency Response 15Hz - 30KHz -3dB. T.H.D. 0.01%. S.N.R. -118dB. Sens for Max output 500mV at 10K. Size 355 x 115 x 65mm. PRICE £33.99 + £3.00 P&P.



OMP MF100 Mos-Fet Output power 110 watts R.M.S. into 4 ohms. Frequency Response 1Hz - 100KHz -3dB. Damping Factor 80. Slew Rate 45V uS. T.H.D. Typical 0.002%. Input Sensitivity 500mV. S.N.R. -125dB. Size 300 x 123 x 60mm. PRICE £39.99 + £3.00 P&P.



OMP/MF200 Mos-Fet Output power 200 watts R.M.S. into 4 ohms. Frequency Response 1Hz - 100KHz -3dB. Damping Factor 250. Slew Rate 50V uS. T.H.D. Typical 0.001%. Input Sensitivity 500mV. S.N.R. -130dB. Size 300 x 150 x 100mm. PRICE £62.99 + £3.50 P&P.



OMP/MF300 Mos-Fet Output power 300 watts R.M.S. into 4 ohms. Frequency Response 1Hz - 100KHz -3dB. Damping Factor 350. Slew Rate 60V uS. T.H.D. Typical 0.0008%. Input Sensitivity 500mV. S.N.R. -130dB. Size 330 x 147 x 102mm. PRICE £79.99 + £4.50 P&P.

NOTE: Mos Fets are supplied as standard (100KHz bandwidth & Input Sensitivity 500mV). If required P.A. version (50KHz bandwidth & Input Sensitivity 775mV). Order: Standard or P.A.

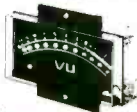

VU METER Compatible with our four amplifiers detailed above. A very accurate visual display employing 11 L.F.D. diodes (7 green, 4 red) plus an additional on/off indicator. Sophisticated logic control circuits for very fast rise and decay times. Tough moulded plastic case with tinted acrylic front. Size 84 x 27 x 45mm. PRICE £8.50 + 50p P&P.

LOUDSPEAKERS 5" to 15" up to 400 WATTS R.M.S. Cabinet Fixing in stock. Huge selection of McKenzie Loudspeakers available including Cabinet Plans. Large S.A.E. (28p) for free details.



POWER RANGE

8" 50 WATT R.M.S. Hi-Fi Disco
20 oz magnet, 1" ally voice coil. Ground ally fixing escutcheon. Res. Freq. 40Hz. Freq. Resp. to 6KHz. Sens. 92dB. PRICE £110.99. Available with black grille £119.99 P&P £1.50 ea.
12" 100 WATT R.M.S. Hi-Fi Disco
50 oz magnet, 2" ally voice coil. Ground ally fixing escutcheon. Die cast chassis. White cone. Res. Freq. 25Hz. Freq. Resp. to 4KHz. Sens. 95dB. PRICE £28.60 + £3.00 P&P ea.

MCKENZIE

12" 85 WATT R.M.S. C1285GP Lead guitar/keyboards/Disco
2" ally voice coil. Ally centre dome. Res. Freq. 45Hz. Freq. Resp. to 6.5KHz. Sens. 98dB. PRICE £29.99 + £3.00 P&P ea.
12" 85 WATT R.M.S. C1285TC P.A./Disco 2" ally voice coil. Twin cone.
Res. Freq. 45Hz. Freq. Resp. to 14KHz. PRICE £31.49 + £3.00 P&P ea.
15" 150 WATT R.M.S. C15 Bass Guitar/Disco.
3" ally voice coil. Die-cast chassis. Res. Freq. 40Hz. Freq. Resp. to 4KHz. PRICE £57.87 + £4.00 P&P ea.
8" 50 WATT R.M.S. 1060GP Gen. Purpose/Lead Guitar/Keyboard/Mid. P.A.
2" voice coil. Res. Freq. 75Hz. Freq. Resp. to 7.5KHz. Sens. 99dB. PRICE £19.99 + £2.00 P&P.
10" 200 WATT R.M.S. C10200GP Guitar, Keyboard, Disco.
2" voice coil. Res. Freq. 45Hz. Freq. Resp. to 7KHz. Sens. 101dB. PRICE £44.76 + £3.00 P&P.
15" 200 WATT R.M.S. C15200 High Power Bass.
Res. Freq. 40Hz. Freq. Resp. to 5KHz. Sens. 101dB. PRICE £62.41 + £4.00 P&P.
15" 400 WATT R.M.S. C15400 High Power Bass.
Res. Freq. 40Hz. Freq. Resp. to 4KHz. Sens. 102dB. PRICE £89.52 + £4.00 P&P.

WEM

5" 70 WATT R.M.S. Multiple Array Disco etc.
1" voice coil. Res. Freq. 52Hz. Freq. Resp. to 5KHz. Sens. 89dB. PRICE £22.00 + £1.50 P&P ea.
8" 150 WATT R.M.S. Multiple Array Disco etc.
1" voice coil. Res. Freq. 48Hz. Freq. Resp. to 5KHz. Sens. 92dB. PRICE £32.00 + £1.50 P&P ea.
10" 300 WATT R.M.S. Disco/Sound re-enforcement etc.
1" voice coil. Res. Freq. 35Hz. Freq. Resp. to 4KHz. Sens. 92dB. PRICE £36.00 + £2.00 P&P ea.
12" 300 WATT R.M.S. Disco/Sound re-enforcement etc.
1 1/2" voice coil. Res. Freq. 35Hz. Freq. Resp. to 4KHz. Sens. 94dB. PRICE £47.00 + £3.00 P&P ea.

SOUNDLAB (Full Range Twin Cone)

5" 60 WATT R.M.S. Hi-Fi. Multiple Array Disco etc.
1" voice coil. Res. Freq. 63Hz. Freq. Resp. to 20KHz. Sens. 86dB. PRICE £9.99 + £1.00 P&P ea.
6" 60 WATT R.M.S. Hi-Fi/Multiple Array Disco etc.
1" voice coil. Res. Freq. 56Hz. Freq. Resp. to 20KHz. Sens. 89dB. PRICE £10.99 + £1.50 P&P ea.
8" 60 WATT R.M.S. Hi-Fi/Multiple Array Disco etc.
1 1/2" voice coil. Res. Freq. 38Hz. Freq. Resp. to 20KHz. Sens. 89dB. PRICE £12.99 + £1.50 P&P ea.
10" 60 WATT R.M.S. Hi-Fi/Disco etc.
1 1/2" voice coil. Res. Freq. 35Hz. Freq. Resp. to 15KHz. Sens. 89dB. PRICE £16.49 + £2.00 P&P.

PANTEC HOBBY KITS. Proven designs including glass fibre printed circuit board and high quality components complete with instructions.

FM MICROTRANSMITTER (BUG) 90/105MHz with very sensitive microphone. Range 100/300 metres. 57 x 46 x 14mm (9 volt). Price: £8.52 + 75p P&P.
3 WATT FM TRANSMITTER 3 WATT 85/115MHz varicap controlled professional performance. Range up to 3 miles 35 x 84 x 12mm (12 volt). Price: £14.49 + 75p P&P.
SINGLE CHANNEL RADIO CONTROLLED TRANSMITTER/RECEIVER 27MHz. Range up to 500 metres. Double coded modulation. Receiver output operates relay with 2amp/240 volt contacts. Ideal for many applications. Receiver 90 x 70 x 22mm (9/12 volt). Price: £17.82. Transmitter 80 x 50 x 15mm (9/12 volt). Price: £11.29 P&P + 75p each. S.A.E. for complete list.



3 watt FM Transmitter



POSTAL CHARGES PER ORDER £1.00 minimum. OFFICIAL ORDERS WELCOME. SCHOOLS, COLLEGES, GOVERNMENT BODIES, ETC. PRICES INCLUSIVE OF V.A.T. SALES COUNTER VISA/ACCESS/C.O.D. ACCEPTED



* PRICES INCLUDE V.A.T. * PROMPT DELIVERIES * FRIENDLY SERVICE * LARGE S.A.E. 28p STAMP FOR CURRENT LIST

BURGLAR ALARM

Better to be 'Alarmed' than terrified. Thandar's famous 'Minder' Burglar Alarm System. Superior microwave principle. Supplied as three units complete with interconnection cable. FULLY GUARANTEED.

Control Unit - Houses microwave radar unit, range up to 15 metres adjustable by sensitivity control. Three position, key operated fascia switch - off - test - armed. 30 second exit and entry delay.

Indoor alarm - Electronic swept freq siren 104dB output.

Outdoor Alarm - Electronic swept freq siren 98dB output. Housed in a tamper-proof heavy duty metal case.

Both the control unit and outdoor alarm contain rechargeable batteries which provide full protection during mains failure. Power requirement 200, 260 Volt AC 50/60Hz. Expandable with door sensors, panic buttons etc. Complete with instructions.

SAVE £138.00. Usual Price £228.85

BKE's PRICE £89.99 + £4.00 P&P

Why buy a collection of self assembly boards!

IDEAL for Workshops, Factories, Offices, Home, etc. Supplied ready built.



OMP LINNET LOUDSPEAKERS

The very best in quality and value. Made specially to suit today's need for compactness with high sound output levels. Finished in hard wearing black vinyl with protective corners, grille and carry handle. All models 8 ohms. Full range 45Hz - 20KHz. Size 20" 15" - 12" Watts R.M.S. per cabinet. Sensitivity 1W 1mtr dB.

OMP 12-100 Watts 100dB. Price £149.99

per pair.

OMP 12-200 Watts 102dB. Price £199.99

per pair.

Delivery Securicor £8.00 per pair



OMP 19" STEREO RACK AMPS



Professional 19" cased Mos-Fet stereo amps. Used the World over in clubs, pubs, discos etc. With twin Vu meters, twin toroidal power supplies, XLR connections, 10000 Fan cooled. Three models (Ratings R.M.S. into 4ohms). Input Sensitivity 775mV.

MF200 (100 + 100)W £169.00 Securicor

MF400 (200 + 200)W £228.85 Delivery

MF600 (300 + 300)W £299.99 £10.00

1 K-WATT SLIDE DIMMER

- Control loads up to 1Kw
- Compact Size 4 1/2" x 1" x 2 1/2"
- Easy snap in fixing through panel cabinet cut out
- Insulated plastic case
- Full wave control using 8 amp triac
- Conforms to BS800

BS800

Suitable for both resistive and inductive loads. Innumerable applications in industry, the home and disco's, theatres etc.

PRICE £13.99 + 75p P&P

BSR P295 ELECTRONIC TURNTABLE

Electronic speed control 45 & 33 r.p.m. Plus Minus variable pitch control. Belt driven. Aluminium platter with strobed rim. Cue lever. Anti-skate (bias device). Adjustable counter balance. Manual arm. Standard cartridge fixings. Supplied complete with cut out template. D.C. Operation 9-14V D.C. 65mA. Price £36.99 + £3.00 P&P.



ADC Q4 mag. cartridge for above. Price £4.99 ea. P&P 50p

PIEZO ELECTRIC TWEETERS - MOTOROLA

Join the Piezo revolution. The low dynamic mass in voice coil of a Piezo tweeter produces an improved transient response with a lower distortion level than ordinary dynamic tweeters. As a crossover is not required these units can be added to existing speaker systems of up to 100 watts (more if 2 put in series). FREE EXPLANATORY LEAFLETS SUPPLIED WITH EACH TWEETER.

TYPE 'A' (KSN2036A) 3" round with protective wire mesh. Ideal for bookshelf and medium sized Hi-Fi speakers. Price £4.90 each - 40p P&P.

TYPE 'B' (KSN1005A) 3" super horn. For general purpose speakers, disco and P.A. systems etc. Price £5.99 each - 40p P&P.

TYPE 'C' (KSN6016A) 2" - 5" wide dispersion horn. For quality Hi-Fi systems and quality discos etc. Price £6.99 each - 40p P&P.

TYPE 'D' (KSN1025A) 2" - 6" wide dispersion horn. Upper frequency response retained extending down to mid range (2KHz). Suitable for high quality Hi-Fi systems and quality discos. Price £9.99 each - 40p P&P.

TYPE 'E' (KSN1038A) 3" horn tweeter with attractive silver finish trim. Suitable for Hi-Fi monitor systems etc. Price £5.99 each - 40p P&P.

LEVEL CONTROL Combines on a recessed mounting plate, level control and cabinet input jack socket. 85 x 85 mm. Price £3.99 + 40p P&P.

Price £134.99 - £3.00 P&P

STEREO DISCO MIXER

STEREO DISCO MIXER with 2 x 5 band L & R graphic equalisers and twin 10 segment LED Vu Meters. Many outstanding features. 5 inputs with individual faders providing a useful combination of the following - 3 Turntables (Mag), 3 Mics, 4 Line plus Mic with talk over switch. Headphone Monitor. Pan Pot L & R. Master Output controls. Output 775mV. Size 360 x 280 x 90mm. Price £134.99 - £3.00 P&P.

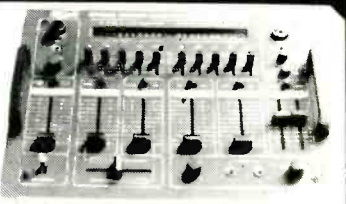

B. K. ELECTRONICS DEPT ETI

UNIT 5, COMET WAY, SOUTHEND-ON-SEA, ESSEX, SS2 6TR. TEL: 0702-527572

electronics today

INTERNATIONAL

NOVEMBER 1986 VOL 15 NO 11

EDITORIAL AND ADVERTISEMENT OFFICE

1 Golden Square, London W1R 3AB. Telephone 01-437 0626.
Telex 8811896.

FEATURES

POWER MOSFETS 16
Geoff Phillips investigates how being upright makes you powerful.

HARDWARE DESIGN CONCEPTS 20
Mike Barwise is busy implementing a coprocessor-host interface.

SPECIAL PULL-OUT SUPPLEMENT (No. 2)
TAKING CARE OF BUSINESS (INTRODUCTION) 35
MUSIC TO YOUR EARS 36
ORGANISING THE ORGANISATION 38
USEFUL ADDRESSES 40

Due to shortage of space, we regret that the article on the LM2917 scheduled for publication this month has been held over.

PROJECTS

BIOFEEDBACK MONITOR 23
Take a deep breath while Paul Chappell begins his explanation of bio-feedback and introduces our neat little GSR device.

DIGITAL AUDIO SWITCHER .. 26
Andy Amrstrong's hi-fi couldn't cope with all his signal sources. This was his answer. It turns any old amp into a digital marvel and brings your system painlessly into the present.

PLL FREQUENCY COUNTER ... 29
Graeme Durant with the construction, setting-up and use.

LOW-COST FRAMESTORE 43
Dan Ogilvie gives some insights into the sights in store.

UPGRADEABLE AMP 46
Graham Nalty links up his boards and turns on the power.

INTELLIGENT CALL METER 53
Chris Ranklin says you don't need to be as intelligent as his meter to get it going.

REGULARS

DIGEST 7
Watts going on.

READ/WRITE 15
Amplifying on some projects.

TECH TIPS 57
A bicolour LED driver which offers logic control and infinite gradations of colour, and a pulse adder for totalising transducer outputs.

ETCETERA 67
Helen Armstrong takes Playback to the British Music Fair while Keith Brindley's Open Channel investigates GEC, System X, ISDN, IDA and Beryl. Beryl? Well, Beryl A and B to keep things initially consistent.

CROSSWORD 70
No sooner has she returned than Auntie Static has been called away on urgent business. She's had to take Alf with her, but they'll be back. Alf said something about XOR and XNOR gates as he left.

INFORMATION

SPECIAL OFFER 34
PCB FOIL PATTERNS 58
PCB SERVICE 62
FREE READERS' ADS 64

FREE ADS (COUPON) 65
NEXT MONTH'S ETI 66
CLASSIFIED ADS 68

electronics today

INTERNATIONAL NOVEMBER 1986 VOL 15 NO 11

EDITORIAL AND ADVERTISEMENT OFFICE
1 Golden Square, London W1R 3AB. Telephone 01-437 0626.
Telex 8811896.

FEATURES

POWER MOSFETS 16
Geoff Phillips investigates how being upright makes you powerful.

HARDWARE DESIGN CONCEPTS 20
Mike Barwise is busy implementing a coprocessor-host interface.

PROJECTS

BIOFEEDBACK MONITOR 23
Take a deep breath while Paul Chappell begins his explanation of bio-feedback and introduces our neat little GSR device.

DIGITAL AUDIO SWITCHER .. 26
Andy Amrstrong's hi-fi couldn't cope with all his signal sources. This was his answer. It turns any old amp into a digital marvel and brings your system painlessly into the present.

PLL FREQUENCY COUNTER ... 29
Graeme Durant with the construction, setting-up and use.

REGULARS

DIGEST 7
Watts going on.

READ/WRITE 15
Amplifying on some projects.

TECH TIPS 57
A bicolour LED driver which offers logic control and infinite gradations of colour, and a pulse adder for totalising transducer outputs.

INFORMATION

SPECIAL OFFER 34
PCB FOIL PATTERNS 58
PCB SERVICE 62
FREE READERS' ADS 64

Gary Herman: Editor
Ian Pitt: Deputy Editor
Paul Chappell: Project Editor
Jerry Fowler: Technical Illustrator
Paul Stanyer: Ad. Manager
Duncan Neilson
Classified Sales Executive
Andrew Selwood: Copy Control
Dave Bradshaw: Group Editor
- Electronics

PUBLISHED BY:
Argus Specialist Publications Ltd.,
1 Golden Square, London W1R 3AB.
DISTRIBUTED BY:
Argus Press Sales & Distribution Ltd.,
12-18 Paul Street, London EC2A 4JS
(British Isles)

TYPESET AND ORIENTATION BY:
Design International.

PRINTED BY:
The Garden City Press Ltd.

COVERS DESIGNED BY:
Argus Design.

COVERS PRINTED BY:
Loxley Brothers Ltd.

ISSN
0142-7229



Member of the
Audit Bureau
of Circulation

Electronics Today is normally published on the first Friday in the month preceding cover date. The contents of this publication including all articles, designs, plans, drawings and programs and all copyright and other intellectual property rights therein belong to Argus Specialist Publications Limited. All rights conferred by the Law of Copyright and other intellectual property rights and by virtue of international copyright conventions are specifically reserved to Argus Specialist Publications Limited and any reproduction requires the prior written consent of the Company. © 1986 Argus Specialist Publications Ltd. All reasonable care is taken in the preparation of the magazine contents, but the publishers cannot be held legally responsible for errors. Where mistakes do occur, a correction will normally be published as soon as possible afterwards. All prices and data contained in advertisements are accepted by us in good faith as correct at time of going to press. Neither the advertisers nor the publishers can be held responsible, however, for any variations affecting price or availability which may occur after the publication has closed for press.

Subscription Rates. UK: £18.10. Overseas: £22.50. USA: \$29.50. Airmail: £49.50.

BBC Micro Computer System

BBC Master Series

AMB15 BBC MASTER Foundation computer 128K	£395 (a)
AMB12 BBC MASTER Econet computer 128K (only ANFS)	£319 (a)
AMC06 Turbo (65C102) Expansion Module	£105 (b)
ADF13 Rom Cartridge	£13 (d)
ADF10 Econet Module	£43 (c)
ADJ22 Ref. Manual Part I	£14.95 (c)
ADJ23 Ref. Manual Part II	£14.95 (c)
ADJ24 Advanced Ref. Manual	£19.50 (c)

ACORN ADD-ON PRODUCTS

Z80 2nd Processor	£329 (a)
6502 2nd Processor	£160 (b)
Multiform Z80 2nd Processor	£299 (b)
Acorn Teletext Adaptor	£125 (b)
Acorn IEEE Interface	£269 (a)

incl. 1770 controller	£35 (a)
1.2 OS ROM	£15 (d)
DNFS ROM	£17.50 (d)
ADFS Rom (for B with 1770 DFS & B Plus)	£26 (d)
64K Upgrade Kit for B Plus	£35 (d)

ECONET ACCESSORIES

Econet Starter kit	£85 (d)
Econet Socket Set	£29 (c)
Econet Bridge	£174 (b)
File Server Level II	£179 (d)
Printer Server Rom	£41 (d)
10 Stallion Lead set	£26 (c)
Adv. Econet User Guide	£10 (d)

COMMUNICATIONS ROMS

Terminator	£25 (d)
Communicator	£49 (d)
Commstar	£28 (d)
DATABEEB	£24 (d)

BBC FIRMWARE & SOFTWARE
Database Management Systems, Word Processors, Languages, Spreadsheets, Utilities
For full details on the wide range of above packages please write to us.

UPGRADE KITS
1770 DFS Upgrade for Model B £43.50 (d)
Dual Disc Controller Board for Model B

DISC DRIVES

These are fully cased and wired drives with slim line high quality mechanisms. Drives supplied with cables manuals and formatting disc suitable for the BBC computer. All 80 track drives are supplied with 40/80 track switching as standard. All drives can operate in single or dual density format.

PD800P (2 x 400K/2 x 640K 40/80T DS) with built in monitor stand	£249 (a)	PS400 with psu 1 x 400K/1 x 640K 40/80T DS	£114 (b)
PD800 (2 x 400K/2 x 640K 40/80T DS)	£229 (a)	3.5" DRIVES	
TD800 (as PD800 but without psu)	£205 (a)	1 x 400K/1 x 640K 80T DS TS35	£89 (b)
TS400 1 x 400K/1 x 640K 40/80T DS	£103 (b)	PS35 1 with psu	£99 (b)
		2 x 400K/1 x 640K 80T DS TD35	£155 (b)
		2	£169 (b)
		PD35 2 with psu	£169 (b)

3M FLOPPY DISCS

High quality discs that offer a reliable error free performance for life. Each disc is individually tested and guaranteed for life. Ten discs are supplied in a sturdy cardboard box.

5 1/4" DISCS		3 1/2" DISCS	
40T SS DD	£10.50 (d)	40T DS DD	£12.75 (d)
80T SS DD	£16.50 (d)	80T SS DD	£20.00 (d)
		80T DS DD	£16.50 (d)
		80T DS DD	£27.00 (d)

DISC ACCESSORIES

FLOPPICLENE Disc Head Cleaning Kit with 20 disposable cleaning discs ensures continued optimum performance of the drives... 3 1/2" £16 (d), 5 1/4" £14.50 (d)

Single Disc Cable	£8 (d)	Dual Disc Cable	£8.50 (d)
10 Disc Library Case	£1.80 (c)	30 Disc Case	£8 (c)
40 Disc Lockable Box	£8.50 (c)	100 Disc Lockable Box	£13 (c)

MONITORS

All 14" monitors now available in plastic or metal cases, please specify your requirement.

MICROVITEC: 14" RGB		14" RGB with PAL & Audio	
1431 Std Res	£179 (a)	1431 AP Std Res	£195 (a)
1451 med Res	£225 (a)	1451 AP Med Res	£260 (a)
1441 Hi Res	£365 (a)		
Swivel Base for Plastic 14" Microvitecs	£20 (c)		

20" RGB with PAL & Audio	
2030CS Std Res	£380 (a)
2040CS Hi Res	£685 (a)

TAXAN SUPERVISION III with amber/green option, BBC & IBM... £325 (a)
MITSUBISHI XC1404 14" RGB Med Res IBM & BBC Compatible... £229 (a)

MONOCHROME MONITORS:

TAXAN KX1201G Hi Res 12" Etched Green Screen	£87 (a)
TAXAN KX1202G Hi Res 12" Long Persistence (P39)	£98 (a)
TAXAN KX1203A Hi Res 12" Etched Amber Screen	£96 (a)
PHILIPS BM7502 12" Hi Res Green Screen	£75 (a)
PHILIPS BM7522 12" Hi Res Amber Screen	£79 (a)
HANTAREX HX12	£69 (a)
Swivel Base for Taxan Monochrome fitted with Digital Clock	£21 (c)

SPECIAL OFFER

2764-25	£2.00
27128-25	£2.50
6264LP-15	£3.40

ATTENTION

All prices in this double page advertisement are subject to change without notice.

ALL PRICES EXCLUDE VAT
Please add carriage 50p unless indicated as follows:
(a) £8 (b) £2.50 (c) £1.50 (d) £1.00

Serial Mini Patch Box
Allows an easy method to reconfigure pin functions without rewiring the cable assembly.
Jumpers can be used and reused. £22 (d)

Serial Mini Test
Monitors RS232C and CCITT V24 Transmissions, Indicating status with dual colour LEDs on 7 most significant lines. £22.50 (d)

PRINTERS

EPSON

LX86NLQ (80 col)	£229 (a)
FX85 (80col) NLQ 8K RAM	£315 (a)
FX105 (136col)	£449 (a)
LQ800 (80col)	£459 (a)
LQ1000 (136col)	£659 (a)
JX80 4 colour	£420 (a)

TAXAN KP810 (80col) NLQ	£229 (a)
TAXAN KP910 (156col)	£369 (a)
NATIONAL PANASONIC KXP1080 (80col)	£159 (a)
STAR NL10 (80col)	£209 (a)
JUKI 6100 Daisy Wheel	£249 (a)
BROTHER HR15 Daisy Wheel	£325 (a)
CANNON PJ1080A (Colour)	£409 (a)
INTEGREX Inkjet Colour	£549 (a)
EPSON H180 A4 Plotter	£325 (a)
HITACHI 672 A3 Plotter	£459 (a)

Paper:

2000 Sheets Fanfold:	
9.5" x 11"	£13 (b)
14.5" x 11"	£18.50 (b)
Labels: (per 1000)	
3.5" x 17/16" Single row	£5.25 (d)
27/16" x 17/16" Triple row	£5.00 (d)

ACCESSORIES

EPSON

FX plus sheet feeder	£129.00 (b)
LX80 Sheet feeder	£49.00 (b)
Paper Roll Holder	£17.00 (d)
FX80 Tractor attachment	£37.00 (c)
Interfaces: 8143 RS232	£20.00 (c)
8148 RS232 + 2K	£57.00 (c)
8132 Apple II	£80.00 (c)
8165 IEEE + cable	£85.00 (c)
Serial & Parallel Interfaces with larger buffers available.	
Ribbons: RX/FX/MX80	£5.00 (d)
RX/FX/MX100	£10.00 (d)
LX80	£6.00 (d)
Spare pens for H180	£7.50/set (d)
FX80 Tractor Attachment	£37 (c)

KAGA TAXAN

RS232 Interface + 2K Buffer	£85 (c)
Ribbon KP810/910	£8.00 (d)

JUKI:

RS232 Interface	£85 (c)
Spare Daisy Wheel	£14.00 (d)
Ribbon	£2.50 (d)
Sheet Feeder	£182 (a)
Tractor Feed Attachment	£129 (a)

BROTHER HR15:

Sheet Feeder	£189 (a)
Tractor Feeder	£99 (a)
Ribbons Carbon or Nylon	£4.50 (d)
Red Correction Ribbon	£2.00 (d)

BBC Printer Lead:

Parallel (42")	£7.00 (d)
Serial	£7.00 (d)

Printer Leads can be supplied to any length.

MODEMS

— All modems listed below are BT approved

MIRACLE 3000:

MIRACLE WS2000 V21/23 Manual	£99 (b)
MIRACLE WS4000 V21/23. (Hayes Compatible, Intelligent, Auto Dial/Auto Answer)	£149 (b)
MIRACLE WS3000 V21/V23 As WS4000 and with BELL standards and battery pack up for memory	£275 (b)
MIRACLE WS3000 V22 As WS3000 V21/V23 but with 1200 baud full duplex	£475 (a)
MIRACLE WS3000 V22 bis As V22 and 2400 baud full duplex	£629 (a)
MIRACLE WS3022 As WS3000 but with only 1200/1200	£395 (a)
MIRACLE WS3024 As WS3000 but with only 2400/2400	£570 (b)
DATA Cable for WS series/PC or XT	£10 (d)

DATATALK Comms Package *If purchased with any of the above modems*

PACER Nightingale Modem V21/V23 Manual	£70 (c)
	£95 (b)

Serial Test Cable
Serial Cable switchable at both ends allowing pin options to be re-routed or linked at either end using a 10 way switch making it possible to produce almost any cable configuration on site.
Available as M/M or M/F £24.75 (d)

GANG OF EIGHT INTELLIGENT FAST EPROM COPIER

Copies up to eight eproms at a time and accepts all single rail eproms up to 27256. Can reduce programming time by 80% by using manufacturer's suggested algorithms. Fixed Vpp of 21 & 25 volts and variable Vpp factory set at 12.5 volts. LCD display with alpha moving message. £395 (b).

SOFTY II

This low cost intelligent eprom programmer can program 2716, 2516, 2532, 2732, and with an adaptor, 2564 and 2764. Displays 512 byte page on TV — has a serial and parallel I/O routines. Can be used as an emulator, cassette interface. Softy II... £195 (b)
Adaptor for 2764/2564. £25.00 (c)

UV ERASERS

All erasers with built in safety switch and mains indicator.
UV1 B erases up to 6 eproms at a time... £47 (c)
UV1 T as above but with a timer... £59 (c)
UV140 erases up to 14 eproms at a time... £88 (b)
UV141 as above but with a timer... £88 (b)

I.D. CONNECTORS

(Speedlock Type)			
No of ways	Header	Recep	Edge Conn.
10	90p	85p	120p
20	145p	125p	195p
26	175p	150p	240p
34	200p	160p	320p
40	220p	190p	340p
50	235p	200p	390p

D CONNECTORS

No of Ways			
9 15 25 37			
MALE:			
Ang Pins	120	180	230 350
Solder	60	85	125 170
IDC	175	275	325 -
FEMALE:			
St Pin	100	140	210 380
Ang pins	160	210	275 440
Solder	90	130	195 290
IDC	195	325	375 -
St Hood	90	95	100 120
Screw Lock	130	150	175 -

TEXT TOOL ZIF

SOCKETS	24-pin	£7.50
	28-pin	£9.00
	40-pin	£12

EDGE CONNECTORS

		0.1"	0.156"
		—	300p
2 x 6-way (commodore)	150p	—	—
2 x 10-way	—	—	350p
2 x 12-way (vic 20)	—	—	140p
2 x 18-way	—	—	220p
2 x 23-way (ZX81)	175p	—	220p
2 x 25-way	225p	—	—
2 x 28-way (Spectrum)	200p	—	—
2 x 36-way	250p	—	—
1 x 43-way	280p	—	—
2 x 22-way	190p	—	—
2 x 43-way	395p	—	—
1 x 77-way	400p	—	500p
2 x 50-way (S100conn)	600p	—	—

EURO CONNECTORS

Plug Socket		
DIN 41612	230p	275p
2 x 32 way St Pin	230p	275p
2 x 32 way Ang Pin	275p	320p
3 x 32 way St Pin	260p	300p
3 x 32 way Ang Pin	375p	400p
IDC Skt A + B	400p	—
IDC Skt A + C	400p	—
For 2 x 32 way please specify spacing (A + B, A + C).		

MISC CONNS

21 pin Scart Connector	200p
8 pin Video Connector	200p

AMPHENOL CONNECTORS

Solder ZDC	
36 way plug	500p 475p
36 way skt	550p 500p
24 way plug	—
24 way skt	475p 475p
IEEE	—
24 way skt	500p 500p
IEEE	—
PCB Mtg Skt Ang Pin	—
24 way 700p	36way 750p

GENDER CHANGERS

25 way D type	
Male to Male	£10
Male to Female	£10
Female to Female	£10

RS 232 JUMPERS

(25 way D)	
24" Single end Male	£5.00
24" Single end Female	£5.25
24" Female Female	£10.00
24" Male Male	£9.50
24" Male Female	£9.50

4-way 90p	6-way 105p
8-way 120p	10-way 140p

RIBBON

(grey/metre)		
10-way	40p	34-way 160p
16-way	60p	40-way 180p
20-way	85p	50-way 200p
26-way	120p	64-way 280p

DIL HEADERS

Solder IDC	
14 pin	40p 100p
16 pin	50p 110p
18 pin	60p -
20 pin	75p -
24 pin	100p 150p
28 pin	180p 200p
40 pin	200p 225p

TECHNOLINE VIEWDATA SYSTEM

Using 'Prestel' type protocols for information and orders phone 01-450 9764. 24 hour service, 7 days a week.

74 SERIES		74181	340p	74LS162A	75p	74S08	50p	4063	85p
7400	30p	74182	140p	74LS163A	75p	74S10	50p	4066	40p
7401	30p	74183	180p	74LS164	75p	74S11	75p	4067	230p
7402	30p	74184	180p	74LS165A	110p	74S12	50p	4068	25p
7403	30p	74185A	180p	74LS166A	150p	74S22	50p	4069	24p
7404	30p	74190	130p	74LS168	130p	74S30	50p	4070	24p
7405	30p	74191	130p	74LS169	100p	74S32	60p	4071	24p
7406	30p	74192	110p	74LS170	140p	74S37	60p	4072	24p
7407	30p	74193	110p	74LS173A	100p	74S38	60p	4073	24p
7408	30p	74194	110p	74LS174	75p	74S40	50p	4075	24p
7409	30p	74195	80p	74LS175	75p	74S41	45p	4076	25p
7410	30p	74196	130p	74LS181	200p	74S64	45p	4077	25p
7411	30p	74197	220p	74LS182	100p	74S74	70p	4078	25p
7412	30p	74198	220p	74LS190	75p	74S 85	55p	4081	24p
7413	30p	74221	110p	74LS191	75p	74S86	100p	4082	25p
7414	30p	74251	110p	74LS192	80p	74S112	150p	4085	60p
7415	30p	74259	150p	74LS193	80p	74S113	120p	4086	75p
7416	30p	74265	30p	74LS194A	75p	74S114	120p	4089	120p
7417	40p	74273	200p	74LS195A	75p	74S124	300p	4093	35p
7420	30p	74276	140p	74LS196	80p	74S132	100p	4094	90p
7421	60p	74278	170p	74LS197	80p	74S133	60p	4095	90p
7422	36p	74279	100p	74LS221	90p	74S138	180p	4096	90p
7423	36p	74283	100p	74LS240	80p	74S139	180p	4097	270p
7424	36p	74285	100p	74LS241	80p	74S139	180p	4098	75p
7425	40p	74290	90p	74LS242	90p	74S140	100p	4099	90p
7426	40p	74293	90p	74LS243	90p	74S151	150p	4501	36p
7427	40p	74298	180p	74LS 244	70p	74S152	150p	4502	36p
7428	43p	74351	200p	74LS 245	90p	74S157	200p	4503	36p
7429	30p	74355A	80p	74LS247	110p	74S158	200p	4504	36p
7430	30p	74366A	80p	74LS248	110p	74S163	300p	4505	36p
7431	30p	7436A	80p	74LS249	110p	74S163	300p	4506	36p
7432	30p	74367A	80p	74LS251	75p	74S174	300p	4507/4030	90p
7433	30p	74368A	70p	74LS253	75p	74S175	320p	4509	90p
7434	30p	74376	160p	74LS256	90p	74S188	450p	4508	120p
7435	30p	74390	110p	74LS257A	70p	74S189	180p	4510	55p
7436	30p	74393	112p	74LS258A	70p	74S194	300p	4511	55p
7437A	100p	74490	140p	74LS259	120p	74S195	300p	4512	55p
7438	100p	74490	140p	74LS260	75p	74S196	350p	4513	110p
7439	100p	74490	140p	74LS261	120p	74S200	450p	4514	110p
7440	100p	74490	140p	74LS262	60p	74S201	320p	4515	110p
7441	100p	74490	140p	74LS263	125p	74S225	520p	4516	55p
7442	120p	74501	24p	74LS279	70p	74S240	400p	4517	220p
7443	36p	74502	24p	74LS280	100p	74S241	400p	4518	440p
7444	36p	74503	24p	74LS283	80p	74S 244	400p	4519	32p
7445	36p	74504	24p	74LS290	80p	74S251	250p	4520	80p
7446	36p	74505	24p	74LS292	£14	74S257	250p	4521	115p
7447	36p	74506	24p	74LS293	80p	74S258	250p	4522	80p
7448	36p	74507	24p	74LS295	140p	74S260	100p	4526	70p
7449	36p	74510	24p	74LS 297	£14	74S261	300p	4527	80p
7450	36p	74511	24p	74LS298	100p	74S283	70p	4528	85p
7451	36p	74512	24p	74LS299	220p	74S287	225p	4529	100p
7452	36p	74513	30p	74LS321	370p	74S288	200p	4531	75p
7453	36p	74514	30p	74LS323	300p	74S289	225p	4532	85p
7454	36p	74515	24p	74LS324	320p	74S 299	450p	4534	380p
7455	36p	74516	24p	74LS328	200p	74S373	400p	4536	250p
7456	36p	74521	24p	74LS352	120p	74S374	400p	4538	75p
7457	36p	74522	24p	74LS353	120p	74S377	225p	4539	75p
7458	36p	74524	50p	74LS356	210p	74S381	450p	4541	90p
7459	36p	74526	24p	74LS363	180p	74S383	450p	4541	90p
7460	36p	74527	24p	74LS364	180p	74S384	450p	4541	90p
7461	36p	74528	24p	74LS365	50p	4000	20p	4553	240p
7462	36p	74530	24p	74LS366	50p	4001	20p	4555	36p
7463	36p	74532	24p	74LS367	50p	4002	20p	4557	240p
7464	36p	74533	24p	74LS368A	50p	4003	20p	4557	240p
7465	36p	74537	24p	74LS 373	70p	4006	70p	4560	140p
7466	36p	74538	24p	74LS 374	70p	4007	25p	4566	140p
7467	36p	74540	24p	74LS375	75p	4008	60p	4568	240p
7468	36p	74542	24p	74LS377	130p	4009	45p	4569	170p
7469	36p	74543	150p	74LS378	85p	4010	60p	4572	45p
7470	36p	74547	80p	74LS379	130p	4011	24p	4583	90p
7471	36p	74548	80p	74LS381	450p	4012	25p	4584	48p
7472	36p	74549	100p	74LS385	325p	4013	36p	4585	60p
7473	36p	74551	24p	74LS390	60p	4014	60p	4724	150p
7474	36p	74554	24p	74LS393	100p	4015	70p	14411	750p
7475	36p	74555	24p	74LS395A	100p	4016	36p	14412	750p
7476	36p	74573A	30p	74LS399	140p	4017	55p	14416	300p
7477	36p	74574A	35p	74LS445	100p	4018	60p	14419	260p
7478	36p	74575	45p	74LS465	120p	4019	60p	14490	420p
7479	36p	74576A	30p	74LS467	120p	4020	80p	14495	450p
7480	36p	74583A	36p	74LS490	150p	4021	70p	14500	850p
7481	36p	74585	75p	74LS540	100p	4022	70p	14599	300p
7482	36p	74586	75p	74LS541	100p	4023	30p	22100	250p
7483	36p	74590	48p	74LS508	70p	4024	48p	22101	700p
7484	36p	74591	80p	74LS 610	£25	4025	24p	22102	700p
7485	36p	74592	55p	74LS 612	£25	4026	90p	40014/4584	40p
7486	36p	74593	54p	74LS624	350p	4027	40p	40106	40p
7487	36p	74595B	75p	74LS626	225p	4028	60p	40106	48p
7488	36p	74596	80p	74LS628	225p	4029	75p	40085	120p
7489	36p	745107	40p	74LS629	125p	4030	35p	40097	36p
7490	36p	745109	40p	74LS640	200p	4031	120p	40098	40p
7491	36p	745112	45p	74LS640-1	40p	4032	100p	40100	150p
7492	36p	745113	45p	74LS641	300p	4033	125p	40101	125p
7493	36p	745114	45p	74LS641	150p	4034	250p	40102	150p
7494	36p	745115	45p	74LS642-1	40p	4035	70p	40103	140p
7495	36p	745123	80p	74LS643	300p	4036	70p	40104	120p
7496	36p	745124	140p	74LS643	200p	4037	110p	40105	150p
7497	36p	745125	80p	74LS643-1	50p	4038	100p	40106	48p
7498	36p	745126	50p	74LS644	300p	4039	250p	40107	55p
7499	36p	745126	50p	74LS644	350p	4040	300p	40108	320p
7500	36p	745132	65p	74LS645	200p	4041	55p	40109	20p
7501	36p	745133	50p	74LS645-1	100p	4042	50p	40110	225p
7502	36p	745136	45p	74LS646	400p	4043	60p	40114	225p
7503	36p	745138	55p	74LS668	90p	4044	60p	40117	250p
7504	36p	745139	55p	74LS669	90p	4045	100p	40163	100p
7505	36p	745145	95p	74LS670	170p	4046	60p	40173	120p
7506	36p	745147	175p	74LS682	250p	4047	60p	40174	100p
7507	36p	745148	140p	74LS684	350p	4048	55p	40175	100p
7508	36p	745151	65p	74LS687	350p	4049	36p	40192	100p
7509	36p	745152	200p	74LS688	350p	4050	36p	40192	100p
7510	36p	745153	65p	74LS 783	£16	4051	85p	40244	150p
7511	36p	745154	160p			4052	60p	40245	150p
7512	36p	745155	85p	74S SERIES		4053	60p	40257	180p
7513	36p	745156	85p			4054	80p	40373	180p
7514	36p	745157	50p	74S00	50p	4055	80p	40374	180p
7515	36p	745158	85p	74S02	50p	4056	85p	80C95	75p
7516	36p	745159	150p	74S04	50p	4059	40p	80C97	75p
7517	36p	745161A	75p	74S05	50p	4060	70p	80C98	75p

LINEAR ICs

AD7581	£18	LM710	48p	TBA820M	78p
AD0900C	110p	LM711	100p	TBA920	200p
AM79100C	£28	LM723	100p	TBA960	220p
AN103	200p	LM725CN	400p	TC9108	400p
AY-1-8000	100p	LM733	80p	TC9484	175p
AY-3-1350	450p	LM741	23p	TD41010	230p
AY-3-8910	450p	LM747	70p	TD41022	400p
AY-3-9812	500p	LM748	20p	TD41024	110p
CA3019A	100p	LM1011	380p	TD41170S	300p
CA3028A	110p	LM1014	180p	TD42002	325p
CA3046	110p	LM1018	180p	TD42003	180p
CA3080	350p	LM1801	400p	TD42004	240p
CA3090E	70p	LM1810	300p	TD42005	230p
CA3090E	70p	LM1817	300p	TD42006	230p
CA3090E	70p	LM1888	580p	TD42020	320p
CA3090E					

DIGEST

IC Testing On The BBC Micro

The Datapen Chiptester is an add-on for the BBC micro-computer which allows the user to test and evaluate most CMOS and TTL logic ICs.

It can be used to identify unknown ICs as well as to test known types and the programme can be modified by the user to cope with more complex logic devices.

The Chiptester will work with any disc-based version of the BBC microcomputer, including Master series machines, and it plugs into the user and 1MHz bus ports. A zero insertion force socket on the front panel accepts ICs with up to 28 pins in widths from 0.3 to 0.6" and a disc supplied

with the system contains a library of device data.

In use, the type number of the IC under test is entered into the computer and the display then indicates where in the ZIF socket the IC must be placed. In batch test mode, a simple indication of pass or fail is given, allowing a large number of identical devices to be tested in a short time. Where more information is required, the waveform on each pin can be displayed, and it is also possible to carry out continuous loop testing so that intermittent and warm-up-related faults are revealed.

Where the type number of an IC is not known, the Chiptester can be instructed to identify the logic function and then search the disc file in an attempt to identify the device. The system can handle derivatives such as ALS

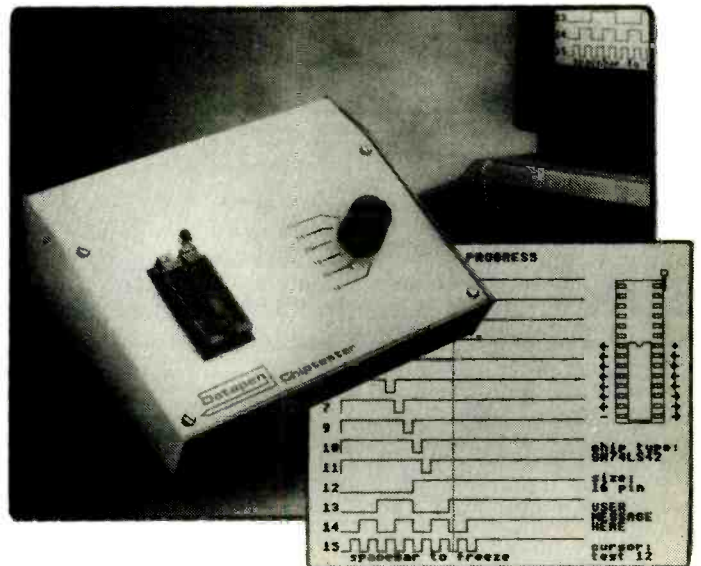

and HCT as well as the basic CMOS and TTL logic families, and all test parameters and logic function tests can be modified by the user.

The Chiptester is housed in a grey aluminium and ABS case and comes complete with disc, manuals and all necessary con-

necting leads. Datapen intend the Chiptester to be supported by a user group so that software and data on new ICs can be circulated to keep the system up to date. Datapen Microtechnology Ltd, Kingsclere Road, Overton, Hampshire RG25 3JB, tel 0256-770 448.

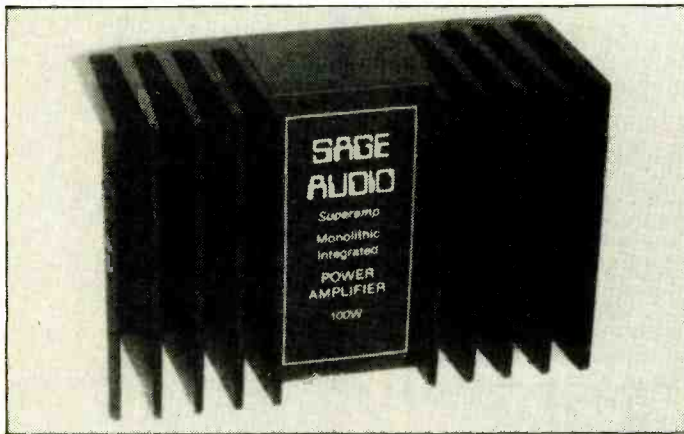

High Performance Amplifier Modules

New from Sage Audio are two power amplifier modules, one bipolar and one with a MOSFET output stage, which offer high performance and high efficiency at outputs of up to 150W.

The modules have been designed by Les Sage, author of the

series "Designing Transistor Stages" which was published in ETI earlier this year. He claims they will out-perform all other modules on the market and that the MOSFET design offers at least a ten-fold improvement over its competitors.

The bipolar Superamp and the MOSFET-output SuperMOS are fully-monolithic devices with integral heatsinks. Input and output connections are made directly to the package and the only external circuitry required is a dual-rail power supply.

The fully-complementary output stages use four transistors and operate in what Sage calls dynamic class A. In this mode, he claims, current flows continuously as in a conventional class A stage but the efficiency is around 70% and the transient handling speed is increased. The Superamp has a slew rate of 125V/us while the SuperMOS

achieves a very high 250V/us. Both types have a transient current capability of around 45A peak-to-peak.

Other design features include nested feedback loops coupled with a low level of overall negative feedback and the use of very high transition frequency output transistors. The results include distortion levels for the Superamp and SuperMOS of 0.0009% and 0.0002% respectively and frequency responses which are 3dB down at 5Hz and 125kHz in the Superamp and at 5Hz and 200kHz in the SuperMOS.

The amplifier modules are available by post and the fully-inclusive prices are £47.50 for the Superamp and £59.95 for the SuperMOS. Discounts are available on quantities.

Sage Audio, Construction House, Whitley Street, Bingley, West Yorkshire BD16 4JH, tel 0274-568 647.

• The secrets of digital signal processing can be yours for just £320.00. Online distribution can supply an evaluation kit which includes Texas Instruments TMS 32010NL and TMS 32020 GBL ICs, four pre-programmed PROMs, a TCM 2916J codec and data sheet, a software library, a comprehensive literature including a 735-page manual and worked examples of speech and FFT system design. The devices are said to be very fast and capable of implementing complex algorithms in real time. Contact Online Distribution Ltd, Melbourne House, Kingsway, Bedford, tel 0234-217 981.

• The valve pre-amp designed by Jeff Macaulay produced a considerable ripple of interest. We're happy to announce, therefore, that Bewbush Audio are offering kits at a special price of £39.95 plus £3 p&p for a limited period. The kit contains low noise 1% resistors and close tolerance capacitors 'where appropriate', say Bewbush. Orders should be sent to arrive no later than Saturday November 1st, to Bewbush Audio, 47b Elmer Road, Middleton-on-Sea, Bognor Regis, Sussex PO22 6DZ. Bewbush also say that they will supply the mains transformer used in the kit for £8.95 inclusive.

Science Awards

Philips Electronics and the British Association for the Advancement of Science are looking for young people to compete in two major science events.

Apart from the chance of winning valuable prizes, the competitions also offer winners the chance to compete with students from overseas in a European contest to be held in Paris and an International contest to be held in Puerto Rico next year.

The competitions are open to

individuals or teams of young people between the ages of 12 and 21 and require the completion of an innovative project in some field of science. Projects already completed as well as those currently underway can be submitted and possible subject areas include technology, mathematics, computing, environmental and physical sciences, biology, etc.

The winning entries will be selected at a special event in London Zoo on March 28th 1987. Application forms can be obtained from Dr. Peter Briggs, BAAS, Fortress House, 23 Saville Row, London W1X 1AB, tel 01-734 6010.

COMPUTER WAREHOUSE

1000's OF BARGAINS FOR CALLERS

THE "ALLADINS' CAVE OF COMPUTER AND ELECTRONIC EQUIPMENT"

HOT LINE DATA BASE

DISTEL

The ORIGINAL FREE OF CHARGE dial up data base. Buy, browse or place YOUR OWN AD for goods or services to sell. 1000's of stock items, spares and one off bargains. Updated daily. ON LINE NOW. CCIIT, 8 bit word, no parity. For 300 baud modems call 01-679 1888 For 1200-75 baud modems call 01-679 6183

FREE

Your monitor from its computer!! For only £29.95 it becomes a SUPERB HIGH QUALITY * COLOUR * TV SET

The fabulous TELEBOX an INVALUABLE MUST for the owner of ANY video monitor with a composite input, colour or monochrome. Made by a major UK Co. as a TOP QUALITY, stand alone UHF tuner and costing OVER £75 to manufacture, this opportunity to give your monitor a REAL FUNCTION must not be missed! The TELEBOX consists of a compact, stylish but, tone charcoal moulded case, containing ALL electronics tuner, power supply etc to simply plug in and convert your previously dedicated computer monitor into a HIGH QUALITY COLOUR* TV SET, giving a real benefit to ALL the family! Don't worry if your monitor doesn't have sound - THE TELEBOX even has an integral 4 watt audio amplifier for driving an external speaker, PLUS an auxiliary output for superb quality television sound via your headphones or HI FI system etc. Other features include: Compact dimensions of only 15.75" w x 7.5" d x 3.5" h, latest technology, BRITISH manufacture, fully tuneable 7 channel push button tuner, Auto AGC circuit, SAW filter, LED status indicator, fully isolated 240v AC power supply for total safety, Mains ON/OFF switch etc. Many other uses.

LIMITED QUANTITY - DON'T MISS THIS OFFER!!!

ONLY £29.95 OR £24.95 if purchased with ANY of our video monitors. Supplied BRAND NEW with full instructions and 2 YEAR warranty. Post and packing £3.50 *When used with colour crt.

COLOUR & MONOCHROME MONITOR SPECIALS

'SYSTEM ALPHA' 14" COLOUR MULTI INPUT MONITOR

Made by the famous REDIFFUSION Co. for their own professional computer system this monitor has all the features to suit your immediate and future requirements. Two video inputs: RGB and PAL Composite Video, allow direct connection to BBC/IBM and most other makes of micro computers or VCR's. Including our very own TELEBOX. An internal speaker and audio amp may be connected to computer or VCR for superior sound quality. Many other features: PIL tube, Matching BBC case colour, Major controls on front panel, Separate Contrast and Brightness - even in RGB mode. Separate Colour and audio controls for Composite Video input, BNC plug for composite input, 15 way 'D' plug for RGB input, modular construction etc.

This Must Be ONE OF THE YEARS BEST BUYS. PC USER Supplied BRAND NEW and BOXED complete with DATA and 90 day guarantee. ONLY £149.00 as above OR IBM PC Version £165.00 15 Day 'D' sct £1.00, BNC sct 75p BBC interface cable £5.50

DECCA 80 16" COLOUR monitor. RGB input. Little, or hardly used, manufacturer's surplus enables us to offer this special converted DECCA RGB Colour Video TV Monitor at a super low price of only £99.00, a price for a colour monitor as yet unheard of! Our own interface, safety modification and special 16" high definition PIL tube coupled with the DECCA 80 series TV chassis give 80 column definition and quality found only on monitors costing 3 TIMES OUR PRICE. The quality for the price has to be seen to be believed!! Supplied complete and ready to plug direct to a BBC MICRO computer or any other system with a TTL RGB output. Other features are: internal speaker, modular construction, auto degaussing circuit, attractive TEAK CASE, compact dimensions only 52cm W x 34 H x 24 D, 90 day guarantee. Although used, units are supplied in EXCELLENT condition. ONLY £99.00 + Carriage.

DECCA 80, 16" COLOUR monitor. Composite video Input. Same as above model but fitted with Composite Video input and audio amp for COMPUTER, VCR or AUDIO VISUAL use. ONLY £99.00 + Carr.

REDIFFUSION MARK 3, 20" COLOUR monitor. Fitted with standard 75 ohm composite video input and sound amp. This large screen colour display is ideal for SCHOOLS, SHOPDS, DISCOS, CLUBS and other AUDIO VISUAL applications. Supplied in AS NEW or little used condition ONLY £145.00 + Carr.

BUDGET RANGE EX EQUIPMENT MONOCHROME video monitors. All units are fully cased and set for 240v standard working with composite video inputs. Units are pre tested and set up for up to 80 column use. Even when MINOR screen burns exist - normal data displays are unaffected 30 day guarantee.

12" KGM 320-1 B/W bandwidth monitor, will display up to 132 x 25 lines £32.95
12" GREEN SCREEN version of KGM 320-1. Only £39.95
9" KGM 324 GREEN SCREEN fully cased very compact unit. Only £49.00

Carriage and insurance on all monitors £10.00

DC POWER SUPPLY SPECIALS

GOULD OF443 enclosed, compact switch mode supply with DC regulated outputs of +5v @ 5.5a, +12v @ 0.5a, -12v @ 0.1a and -23v @ 0.02a. Dim 18 x 11 x 6 cm, 110 or 240v input. BRAND NEW call sales office for details.
GOULD G6-40A 5v 40 amp switch mode supply NEW £130.00
AC-DC Linear PSU for DISK drive and SYSTEM applications. Constructed on a rugged ALLOY chassis to continuously supply fully regulated DC outputs of +5v @ 3 amps, -5v @ 0.6 amps and +24v @ 5 amps. Short circuit and overvoltage protected 100 or 240v AC input. Dim 28 x 12.5 x 7 cm NEW £49.94

Carriage on all PSUs £3.00

KEYBOARDS

Manufacturer's BRAND NEW surplus. DEC L434 Uncoded keyboard with 67 quality gold plated switches on X-Y matrix - ideal micro conversions etc £24.95

AMKEY MPNK-114 Superb word processor chassis keyboard on single PCB with 116 keys. Many features such as On board Micro, Single 5v rail, full ASCII coded character set with 31 function keys, numeric keypad, cursor pad and 9600 baud SERIAL, TTL ASCII OUTPUT!! Less than half price. Only £69.00 with data. Carriage on Keyboards £3.50



DON'T MISS THE CPM Deal OF THE CENTURY

The FABULOUS CPM TATUNG PC2000 Professional Business System

A cancelled export order and months of negotiation enables us to offer this professional PC, CPM system, recently on sale at OVER £1400, at a SCOOP price just over the cost of the two internal disk drives!! Or less than the price of a dumb terminal!!

Not a toy, the BIG BROTHER of the EINSTEIN computer, the DUAL PROCESSOR PC2000 comprises a modern stylish three piece system with ALL the necessities for the SMALL BUSINESS, INDUSTRIAL, EDUCATIONAL or HOBBYIST USER. Used with the THOUSANDS of proven, tested and available CPM software packages such as WORDSTAR, FAST, DBASE2 etc, the PC2000 specification, at our prices, CANNOT BE BEATEN!!

The central processor plinth contains the 64K, Z80A processor, DUAL TEAC 55F 5 1/4" Double sided 40/80 track disk drives (1 Mb per drive), PSU, 4K of memory mapped screen RAM, disk controller, RS232, CENTRONICS and system expansion ports, and if that's not enough a ready to plug into STANDARD B' DRIVE port for up to FOUR B' disk drives, either in double density or IBM format. The ultra slim 92 key, detachable keyboard features 32 user definable keys, numeric keypad and text editing keys, even its own integral microprocessor which allows the main Z80A to devote ALL its time to USER programs, eliminating "lost character" problems found on other machines. The attractive, detachable 12" monitor combines a green, anti-glare etched screen, with full swivel and tilt movement for maximum user comfort. Supplied BRAND NEW with CPM 2.2, user manuals and full 90 day guarantee. Full data sheet and info on request.

PC2000 System with CPM Etc. COST OVER £1400

PC2000 Business System with CPM and 'Ready to Run' FAST Sales and Purchase ledger, supports up to 9000 Accounts, VAT etc. COST OVER £1700

PC2000 Wordprocessor System with CPM and TEAC FP25 daisywheel printer

NOW only £399

NOW only £499
Carriage & Insurance £12.00

NOW only £799

MODEMS

Join the communications revolution with our super range of DATA MODEMS, prices and specifications to suit all applications and budgets....

BRAND NEW State of the art products.
DACOM DSL2123 Multi standard 300-300, 1200-75 Auto answer etc. £288.00
DACOM DSL2123AQ Auto dial, smart modem with multi standard AUTO SPEED detect, and data buffer with flow control etc. £385.00
DACOM DSL2123GT THE CREAM of the Intelligent modems, auto dial, auto call, index, buffer etc. £498.00
Steekbe SB1212 V22 1200 baud FULL DUPLEX, sync or async, optional auto dial. £465.00
TRANSDATA 307A Acoustic coupler 300 baud full duplex, originate only, RS232 interface. £49.00

Ex BRITISH TELECOM full spec, CCIIT, ruggedised, bargain offers. Sold TESTED with data. Will work on any MICRO or system with RS232 interface.
MODEM 13A 300 baud unit, only 2" high fits under phone. CALL mode only. £45.00
MODEM 20-1, 75-1200 baud. Compact unit for use as subscriber end to PRESTEL, TELECOM GOLD, MICRONET etc. £39.95 +pp £6.50
MODEM 20-2 1200-75 baud. Same as 20-1 but for computer end. £85.00 +pp £6.50
DATEL 2412. Made by SE Labs for BT this two part unit is for synchronous data links at 1200 or 2400 baud using 2780/3780 protocol etc. Many features include 2 or 4 wire working, self test, auto answer etc. COST OVER £800. Our price ONLY £199 +pp £8.00
DATEL 4600, RACAL MPS4800 baud modem, EX BT good working order. ONLY £295.00 +pp £8.00

SPECIAL OFFER

MODEM TG2393. Ex BT, up to 1200 baud full duplex 4 wire or half duplex over 2 wire line. ONLY £85.00 PER PAIR +pp £10.00

For more information contact our Sales Office.

SURPLUS SPECIALS ON PRESTEL - VIEWDATA - TELEX

PLESSEY VUTEL, ultra compact unit, slightly larger than a telephone, features A STANDARD DTMF TELEPHONE (tone dial) with 5" CRT monitor and integral modem etc for direct connection to PRESTEL, VIEWDATA etc. Designed to sell to the EXECUTIVE at over £600!! Our price BRAND NEW AND BOXED at only £99.00
DECCAFAX VP1 complete Professional PRESTEL system in slimline desk top unit containing Modem, Numeric keypad, CPU, PSU etc. Connects direct to standard RGB colour monitor. Many other features include: Printer output, Full keyboard input, Cassette port etc. BRAND NEW with DATA. A FRACTION OF COST only £55.00

ALPHATANTEL. Very compact unit with integral FULL ALPHA NUMERIC keyboard. Just add a domestic TV receiver and you have a superb PRESTEL system and via PRESTEL the cheapest TELEX service to be found!! Many features: CENTRONICS Printer output, Memory dialling etc. Supplied complete with data and DIY mod for RGB or Composite video outputs. AS NEW only £125.00

Post and packing on all PRESTEL units £8.50

EX-STOCK INTEGRATED CIRCUITS

4164 200 ns D RAMS 9 for £11 4116 ns £1.50 2112 £10.00 2114 £2.50 2102 £2.00 6116 £2.50 EPROMS 2716 £4.50 2732 £3.00 2764 £4.95 27128 £5.50 6800 £2.50 6821 £1 68A09 £8 68B09 £10 8085A £5.50 8086 £15 8088 £8 NEC765 £18 WD2793 £28 8202A £22 8251 £7 8748 £15 Z80A DART £6.50 Z80A CPU £2.00. Thousands of IC's EX STOCK send SAE for list.

DISK DRIVES

Japanese 5 1/4" half height, 80 track double sided disk drives by TEAC, CANON, TOSHIBA etc Sold as NEW with 90 day guarantee ONLY £85.00
TEC FB-503 Double sided HH 40 TRK NEW £75.00
SUGART SA400 SS FH 35 TRK £55.00
SIEMENS FDD0100 SS FH 40 TRK £65.00
Carriage on 5 1/4" drives £5.50

Brand NEW metal 5 1/4" DISK CASES with Internal PSU.
DSKC1 for 2 HH or 1 FH drive £29.95 +pp £4.00
DSKC 2 for 1 HH drive £22.95 +pp £3.50
DKSC 3 AS DSK1 LESS PSU £12.95 +pp £2.50
DSKC 4 AS DSK2 LESS PSU £10.95 +pp £2.00
8" IBM format TESTED EX EQUIPMENT.
SHUGART 800/801 SS £175.00 +pp £8.50
SHUGART 851 DS £250.00 +pp £8.50
TWIN SHUGART 851 2 Mb total capacity in smart case, complete with PSU etc. £595.00
MITSUBISHI M2894-83 8" DS1 1 Mb equiv. to SHUGART SA850R. BRAND NEW at £275.00 +pp £8.50
DYSAN 8" Alignment disk £29.00 +pp £1.00
Various disk drive PSUs in Ex Stock SEE PSU section.

HARD DISK DRIVES
DRE/DIABLO Series 30 2.5 Mb front load £525.00
Exchangeable version £295.00. ME3029 PSU £95.00
DIOBLO 44/DRE4000A, B 5-1/2 Mb for £750.00
CDC HAWK 5-1/2 Mb £795.00. CDC 9782 80 MbrmC3 etc. £2500.00
PERTEC D3422 5-1/2 Mb £495.00
RODIME 5 1/4" Winchester ex-stock from £150 CALL Clearance Items - Sold as seen - No guarantee.
ICL 2314 BRAND NEW 14" Mb Removable pack hard disk drive, cost over £2000 with data. ONLY £99.00
BSF 6172 8" 23Mb Winchester £199.00

Unless stated all drives are refurbished with 90 day guarantee. Many other drives and spares in stock - call sales office for details

MATRIX PRINTERS

SPECIAL BULK PURCHASE of these compact, high speed matrix printers. Built in Japan for the Hazeltine Corporation this unit features quality construction giving 100cps bidirectional, full pin addressable graphics, 6 type fonts, up to 9.5" single sheet or tractor paper handling, RS232 and CENTRONICS parallel interface. Many other features. BRAND NEW and BOXED. COST £420. Our price ONLY £199.00

RECHARGEABLE BATTERIES

Dry Fit MAINTENANCE FREE by Sonnenschein & Yuasa.
A300 07191315 12v 3Ah NEW £13.95
A300 07191312 6v 3Ah NEW £9.95
A300 07191202 6-0-6v 1.8Ah TESTED Ex Equip £5.99

VDU TERMINALS

Standard VDU data entry terminals

at give away price!!
QUME QVT108. Current product, state of the art terminal with detachable keyboard, 12" Green screen, 2 page RAM, TVI 925, Hazeltine, ADMSA emulations, software setup, 25 x 80, Clock, Swivel and tilt base, Printer port, Function keys etc. BRAND NEW and BOXED AT ALMOST HALF PRICE ONLY £425.00
AJ510 - EX RENTAL, Z80 controlled, 15" green screen 24 x 80 display, graphics, cursor addressing, printer port etc. Very good condition TESTED complete with manual only £225.00
ADD524 Dumb terminal, used, 12" b/w screen RS232 interface and printer port. TESTED. ONLY £125.00. Carriage on terminals £10.00
100's of other terminals in stock. CALL for more details.

All prices quoted are for U.K. Mainland, paid cash with order in Pounds Sterling PLUS VAT. Minimum order value £1.00. Minimum Credit Card order £10.00. Minimum BONA FIDE account orders from Government Dep'ts., Schools, Universities and established companies £20.00. Where post and packing not indicated please ADD £1.00 + VAT. Warehouse open Mon-Fri 9.30-5.30, Sat 10.30-5.30. We reserve the right to change prices and specifications without notice. Trade, Bulk and Export

32 Biggin Way, Upper Norwood, London SE19 3XF
Telephone 01-679 4414 Telex 894502 Data 01-679 1888



The Show Goes On

The undoubted star of September's Personal Computer World show was Alan Sugar's IBM PC clone — the Amstrad PC1512. The machine had only been launched to the press the day before the show began amid, it must be said, enormous quantities of ballyhoo. Actually, the 1512 came as no surprise, since at least one trade paper had leaked all the details of the new range (including prices) weeks ago — much to the apparent chagrin of Alan Sugar who seems to have a liking for the theatrical.

The range runs from a basic model at £399 plus VAT to a 20Mb hard disc version with colour monitor which will weigh in (VAT included) at over £1000. All versions are powered by an 8MHz 8086, 512K of RAM and come with at least one 5 1/2" disk drive and a monitor. The machines don't claim to be 100% compatible IBM clones, but they will run much of the software intended for IBMs.

If people want an IBM-alike in the sort of quantities Sugar must have pre-ordered to get the price down, then Amstrad may well be on the way to knocking IBM into a cocked hat. Perhaps it's more than a coincidence that both Sugar and IBM's real founder, John Watson, started out as salesmen. Sugar's recipe, like IBM's, has little to do with leading-edge technology and a lot to do with targetting the right market with reliable, if comparatively staid, technology. The difference is that Sugar competes on the basis of price while IBM exploits a near-monopoly and, latterly, the power of its name and reputation.

Of course, Sugar may come a cropper if he discovers the market isn't there. A number of commentators have observed that the word-processor was a hit largely because non-computer users could understand the virtues of a super-duper typewriter. The attraction of a general purpose computer is a different matter.

Going by the crowds at the show, no-one can be in any doubt. Certainly the Amstrad stall seemed to be permanently six or

seven deep and Alan Sugar himself presided over it all like a veritable Phineas T. Barnum. It should have been enough to worry Acorn, Tatung and Commodore — all of whom were there with 'new machines' that were mostly old machines in new packages. Even Amstrad was not averse to a bit of repackaging with the Sinclair 128 Mk.II.

There was, in fact, little new to look at. What did impress, however, was the variety and quantity of peripherals, software and accessories. Videk Ltd. had a stall featuring a wide range of specialised cables and connectors, including almost every conceivable variety of monitor cable, disk drive cable, printer cable, modem and joystick cable. Electromusic Research had a complete MIDI-TRACK system on show and unveiled a MIDI system for use with Amstrad 464/664 and 612Bs. Robin Bradbeer's Digital Delicatessen was one among many stalls selling low priced disks, listing paper and disk boxes. Bradbeer was also showing a low-cost colour printer/plotter and a cheap IBM compatible, along with an ingenious carrier for transporting your disks safely and easily and — everybody's favourite, this — the Mouse House, a furry cover for your mouse. Author and publisher, Rae West, was selling reduced price copies of the very useful Commodore 128 Programmers' Reference Guide, which he is importing from the USA. Metacomco's stall offering Cambridge LISP for the Amiga, ST and CP/M-68K machines caught my attention as did MicroProcessor Engineering's FORTH based products and their development and evaluation systems.

Then there were the user groups (machines like the Enterprise and the Lynx were in evidence), and the cheap software dealers (including a stall run by the Public Domain Software Interest Group), and the stalls selling hard-disk cards, comms cards and graphics packages for every conceivable machine. The show had the busy atmosphere of a genuine fair and the fact that there was nothing very new in the way of hardware or software didn't really matter.

● Microsoft Corporation, the software company who developed MS-DOS and the familiar Microsoft BASIC, have become the first high technology company to our knowledge to declare their intention to withdraw from any trade links with South Africa. Incidentally, one arm of the company — Microsoft Press — have recently published a collection of writings focusing on the applications of

CD-ROM. The book is called 'CD ROM: The New Papyrus' and takes off from where our article (ETI, October 1986) left off. In his foreword to the book, Microsoft's founder, the former boy genius William H. Gates, announces that his company's is so committed to CD ROM that we have formed a special division... just to focus on this new opportunity.'

PINEAPPLE SOFTWARE

Programs for the BBC model 'B' with disc drive with FREE updating service on all software

ARE YOU GETTING THE MOST FROM YOUR DOT MATRIX PRINTER AND DISC DRIVE?

DIAGRAM is a new program which really exploits the full potential of the BBC micro and will enable you to obtain printouts of a size and quality previously unobtainable from your system.



FEATURES

- Draw diagrams, schematics, plans etc. in any aspect ratio, e.g. 10*3, 2*12 screens.
- Access any part of the diagram rapidly by entering an index name, e.g. TR6, R5 etc., to display a specific section of the diagram, and then scroll around to any other part of the diagram using the cursor keys.
- Up to 128 icons may be predefined for each diagram, e.g. Transistors, resistors etc., in full mode 0 definition, up to 32 pixels horizontally by 24 vertically.
- Hard copy printouts in varying print sizes up to 18 mode 0 screens on an A4 size sheet, compatible with most dot matrix printers.
- Many other features including, selectable display colours, comprehensive line drawing facilities, TAB settings, etc.
- The latest version of DIAGRAM is now fully compatible with the Marconi Tracker Ball, which allows 'scrolling' of the screen and many of the editing features to be carried out using the tracker ball.
- DIAGRAM is supplied in an attractive hard backed disc wallet with keystick and comprehensive instruction manual.

DIAGRAM SOFTWARE **£25**
PLUS VAT AND P&P FREE
(Supplied only on disc. Please specify printer type and 40/80T disc when ordering)

MARCONI TRACKER BALL **£60**
PLUS VAT AND P&P £1.75
includes icon Artmaster software

MARCONI TRACKER BALL AND ICON ARTMASTER PLUS DIAGRAM SOFTWARE
£79.00
PLUS VAT P&P £1.75

ALL ORDERS SENT BY RETURN OF POST

39 Brownlea Gardens, Seven Kings, Ilford, Essex IG3 9NL

☎ Tel: 01-599 1476.

Hi-Fi AMPLIFIER KITS

Still the reference kit amplifier!
For less than £250 you can own an esoteric pre-power combination with the added pleasure of building it for yourself.

CK1010	Stereo Preamplifier	£99
	2 Disc/CD/Tape/Tuner/Tape Monitor.	
P.P.S.	Preamp Power Supply	£27.50
	Only necessary if not using Crimson Power Amp.	
CK1040	40+40 Stereo Power Amp	£133
CK1080	80+80 Stereo Amp	£148
CK1100	100+100 Stereo Power Amp	£165

Free moving coil module with every CK1010 sold - while stocks last!

Prices include P+P VAT. All kits are guaranteed for 2 years. For further information on these kits and our other products please write (s.a.e.).

CRIMSON ELEKTRIK STOKE
PHOENIX WORKS
500 KING ST.
LONGTON
STOKE-ON-TRENT
STAFFS.
TEL. (0782) 330520

Agents:-
Bradley-Marshall
382-386 Edgeware Rd,
London
Wilmslow Audio
35-39 Church St.
Wilmslow
Cheshire



The CMC Components

42 Clifton Industrial Estate, Cherry Hinton Rd, Cambridge CB1 4ZZ
Telephone: (0223) 213374

Ordering: All components are brand new and to full specification. Please add 65p postage/packing (unless otherwise specified) to all orders and then add 15% VAT to the total. Minimum order £5.00. Either send cheque/cash/postal order or send/telephone your credit card number. Official orders from schools, universities, colleges etc most welcome.



Credit Cards welcome

Trade counter open: Mon to Sat 9.00 - 5.00

TTL74

7400	20	7432	28
7401	20	7437	28
7402	20	7440	24
7403	24	7451	30
7404	24	7470	45
7405	24	7473	40
7406	37	7474	35
7407	24	7483	80
7408	24	7485	95
7410	24	7486	34
7412	24	74121	44
7416	34	74123	72
7417	34	74147	125
7420	24	74164	100
7423	30	74176	75
7428	30	74192	100
7430	22	74198	185

VOLTAGE REGULATOR

7805	35	7912	40
7812	35	7915	40
7815	35	7918	40
7818	35	7924	40
7824	35	LM323K	400
7905	40		

COMPUTER IC's

ET41116-3	75
UPD41256-15	400
HM4864-15	200
HM6116-3	150
R6532	500
R6551	525
F6800	200
MC6802	250
MC6809	550
F6821	150
MC6840	350
MC6845	600
DP8216	150
Z80A SIO	650
Z80A CTC	250
Z80 PIO	250
Z80A DART	660
Z80 CPU	180
2764-25	200
27128-25	240

TOROIDAL TRANSFORMERS

VA	1-9	These prices are for single primary with two secondary taps, with 8" colour coded fly leads. Each transformer is supplied with a mounting kit, consisting of one steel washer, two neoprene pads, and a nut and bolt.
15	5.47	
30	5.56	
50	6.31	
80	6.82	
120	7.40	
160	8.72	
225	9.70	
300	10.84	
500	14.47	
1000	29.76	
1.2KVA	34.32	P&P £2.50 for above items.

DIL SOCKETS

low profile

8 pin	5
14 pin	8
16 pin	9
18 pin	10
20 pin	12
22 pin	14
24 pin	16
28 pin	18
40 pin	20

74LS

LS00	15	LS154	90
LS01	15	LS155	41
LS02	15	LS156	48
LS03	18	LS157	30
LS04	15	LS158	32
LS05	15	LS160	48
LS08	15	LS161	50
LS09	18	LS163	46
LS10	15	LS164	44
LS11	15	LS165	65
LS12	18	LS166	74
LS13	22	LS168	90
LS14	28	LS169	65
LS15	15	LS170	80
LS20	15	LS173	80
LS21	15	LS174	40
LS22	18	LS175	40
LS26	15	LS190	55
LS27	15	LS191	52
LS28	15	LS192	52
LS30	15	LS193	50
LS32	17	LS195	52
LS33	18	LS196	62
LS37	16	LS197	55
LS38	17	LS221	55
LS40	16	LS240	55
LS42	32	LS241	55
LS48	55	LS242	55
LS54	16	LS243	60
LS73	30	LS244	50
LS74	24	LS245	50
LS75	28	LS247	50
LS76	28	LS249	90
LS78	28	LS251	30
LS83	42	LS253	50
LS85	45	LS257	42
LS86	30	LS260	40
LS90	32	LS266	30
LS92	38	LS273	52
LS93	30	LS279	40
LS95	48	LS280	140
LS96	60	LS283	70
LS107	32	LS290	30
LS109	34	LS293	30
LS112	36	LS295	125
LS114	35	LS298	100
LS123	42	LS299	200
LS124	84	LS348	135
LS125	36	LS353	84
LS126	36	LS363	135
LS132	40	LS366	36
LS133	34	LS367	36
LS136	36	LS373	55
LS138	36	LS374	55
LS139	36	LS375	60
LS145	82	LS378	84
LS151	82	LS393	50
LS153	40	LS395	98

SWITCHES

DIL 4 way	65
6 way	75
8 way	80
10 way	95
Sub-min Toggle	
240v 2A	
SPST (2 tag)	55
SPDT (3 tag)	60
DPDT (6 tag)	55
240V 1A	
SPST (2 tag)	55
SPDT (3 tag)	60
SPDT (3 tag centre off)	65
DPDT (6 tag)	65
DPDT (6 tag centre off)	80
Rockers	
10A/250v SPST	25
10A/250v SPDT	35
10A/250v SPST (neon)	80

LINEAR

LM 301	25	LM388	100
LM310	60	LM389	160
LM311	35	LM556	90
LM318	130	LM557	90
LM319	160	LM709	35
LM324	35	LM723	40
LM339	40	LM747	60
LM348	60	MC1488	70
LM387	100	MC1489	70

CMOS

4000	13	4050	20
4002	13	4051	38
4006	35	4052	37
4007	37	4053	37
4009	20	4060	40
4011	13	4066	20
4012	13	4068	15
4013	20	4069	15
4015	34	4070	15
4016	18	4071	15
4017	32	4072	15
4018	33	4073	15
4019	28	4075	15
4020	35	4076	45
4021	36	4077	15
4022	36	4078	15
4023	15	4081	15
4024	25	4082	13
4025	13	4085	40
4027	18	4089	80
4028	30	4093	20
4029	35	4099	45
4031	90	40106	40
4034	80	40107	55
4035	45	4501	30
4038	50	4510	38
4040	35	4511	40
4042	30	4516	40
4043	36	4517	120
4044	38	4518	38
4046	45	4519	30
4047	45	4520	36
4049	20		

CRYSTALS

100kHz	360
200kHz	350
1.0MHz	260
1.008MHz	260
1.8432MHz	175
2.0MHz	180
2.4576MHz	85
3.278MHz	100
4.0MHz	90
5.0MHz	120
6.0MHz	80
6.114MHz	105
8.0MHz	80
10.0MHz	80
12.0MHz	80
16.0MHz	80
18.0MHz	90
20.0MHz	120

RIBBON CABLES

price/			
foot			
10way	14	100ft	
16way	24	1100	
20way	28	1400	
24way	36	1700	
26way	38	1800	
28way	50	2000	
34way	58	2100	
40way	67	2700	
50way	84	3400	

DISC DRIVES (uncased)

400k 5.25 TEAC Slimline	£99
400k 5.25 TEAC Slimline, complete with a 40/80 switch	£104
400K 5.25 Namal Drive	£75
400K 3.5 NEC Drive	£ 70
(p&p £5.00 for above items)	

SERIAL CABLES

APPLE iie to NIGHTINGALE MODEM/JUKI 6100
APPLE iie to NEC Printer
APPLE iii to BROTHER HR/25/EPSON DX 100
MACINTOSH to IBM pc/DIABLO 630/EPSON PX8/
MACINTOSH/BBC MICRO

We can supply serial cables for all other popular computers. Please contact us for details.
Introductory Price £12 each

DRIVE ACCESSORIES

Single disk cable	£5.50
Dual disk cable	£7.50
Single disk drive case	£8.00
Dual disk drive case	£16.00
Single disk drive case with own power supply complete with signal and power cable	£17.00
Twin disk drive case with own power supply complete with signal and power cable	£25.00
p&p £2.50 for above items.	

TRANSISTORS

AC128	28	BC183A	12	BC449	20
AC187	24	BC183L	10	BC477	30
AC187K	40	BC184	10	BC546A	10
AC1Y18	130	BC184L	11	BC547C	12
ACY20	125	BC205	10	BC548C	12
ACY22	110	BC208	10	BC549	10
ACY40	120	BC212B	10	BC556	10
ACY41	120	BC212L	11	BC557B	10
ACY44	120	BC213A	10	BC558C	10
BC107	11	BC214	9	BC559	10
BC108	10	BC214L	10	BC560	10
BC109	11	BC232A	14	BCY42	30
BC109C	12	BC237B	9	BCY58	35
BC110	12	BC238B	9	BCY65	24
BC113	10	BC238C	10	BCY70	20
BC114	10	BC239	10	BCY71	18
BC125	10	BC258A	9	BCY72	18
BC126	10	BC258B	10	BCY78	18
BC143	25	BC259B	10	BCY79	18
BC147A	12	BC259C	12	BCY91	90
BC148	10	BC268	15	BD116	50
BC149	10	BC307	10	BD131	40
BC149C	12	BC309	8	BD132	40
BC159	10	BC318	10	BD135	30
BC160	30	BC319	8	BD136	30
BC168B	10	BC327	8	BD137	30
BC172B	10	BC328	8	BD138	25
BC173C	12	BC337	10	BD139	25
BC177B	15	BC378	18	BD144	90
BC179C	15	BC394	20	BD233	30
BC182	10	BC407	10	BD234	30
BC182L	12	BC409	10	BD236	35

'D' CONNECTORS (miniature)

male	9	15	25	37
solder angled	50	80	120	145
110	170	220	290	
female				
solder	85	120	175	270
angled	150	200	250	380
cover	70	70	70	80

The Cash Nexus

Nexus Technical Services of Reading have produced a complete EPROM development system for the Atari ST computers. The system can be used as a simulator or programmer. A single board, measuring about 9½ins. by 7ins., plugs into the ST's cartridge port and contains 64K of static

RAM. The GEM compatible system software — supplied on a single 3.5in. desk — allows intelligent programming of common EPROMs of 8K or more (specifically, the 2764 up to 27256 and 27256A). It will deal with them in 8-bit or 16-bit form, handling two EPROMs at a time. It can also provide internal ST, or target system EPROM simulation and Nexus claim it is 'the first ever true 16-bit

simulator/programmer'. The price is a very reasonable £175 exclusive, £201.25 including VAT and p&p. Nexus will also supply a socketed board to carry up to four 256Kbit EPROMs for £14.75 inclusive. (A review of the system will be featured in a forthcoming issue).

Contact: Nexus Technical Services Ltd., 38, Melrose Avenue, Reading RG6 2BN (0734 664559).

● Yugoslavian component manufacturer, Iskra, have produced a new guide to their range of potentiometers. Included in the guide are full technical data and applications notes on Iskra's presets, miniature PCB mounting presets, rotational carbon track pots, multi-turn pots and sliders.

Contact: Iskra Ltd., Redlands, Coulsdon, Surrey CR3 2HT (01-688 7141).

Call For Papers

The Institution of Electrical Engineers has issued a call for papers to be presented at the 6th International Conference on Automotive Electronics which will be held at the IEE in Savoy Place, London from 12 to 15 October, 1987.

The first conference was held in 1976 and as the importance of electronics in the motor industry has grown so has the scope and influence of the conference. Today, the motor industry worldwide is the single biggest consumer of electronic components and products. The conference aims to study 'the current status

of and future trends in design, development and operation of electronic components and systems as applied to motor vehicles'. Major sessions are planned to include power train controls; displays, information and entertainment systems; multiplex and system communication; truck, bus and off-highway electronic systems; navigational and vehicle location systems; suspension, steering and braking systems; sensors, actuators and components; ergonomics, comfort, safety, security and convenience; electronics quality, reliability and serviceability.

To enter a paper, first send a synopsis of around 1000 words to Conference Services, IEE, Savoy Place, London WC2R 0BL, England (tel: 01-240 1871 ext 222) by 6th January 1987.

Plugging A Gap . . .

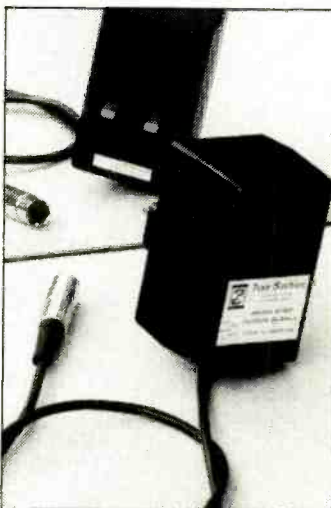

The split-rail power supply in a plug is such a simple and useful idea that we're surprised that nobody seems to have done it before. Time Machine Sound Engineering have to be on to a winner.

They supply units providing 5-0-5V, 12-0-12V or 15-0-15V as well as a 48V for phantom powering of condenser microphones. The illustration shows three-pin DIN connectors attached, but Time Machine say you can have any connector you wish. Whatever version you order, the price is the same — just £24 inclusive of everything.

Contact: Time Machine Sound Engineering, Abbotsford, Deer Park Avenue, Teignmouth, Devon TQ14 9LJ (06267 2353).



UNIVERSAL COUNTER / TIMERS

The TF1000 and TF1100 are high performance Universal Counter/Timers with frequency, period, period average, time interval, time interval average, frequency ratio and totalise measurement modes.

The Counters also feature a bright 14mm LED display and many additional facilities which make them truly precision measurement instruments.

- Direct frequency measurement to 100MHz
- Frequency range extended to 1GHz on TF1100
- Period measurement from 50ns to 100s
- Time interval measurement from 1ns to 10⁶s
- Totalise and frequency ratio modes
- Matched high sensitivity 100MHz inputs
- AC/DC coupling, attenuator and HF filter
- Slope and trigger level controls, with monitor output
- Standard timebase or high stability option

TF1000 £495 + VAT TF1100 £595 + VAT
High stability timebase option £75 + VAT

For further information contact:

Thandar Electronics Ltd., London Road, St. Ives, Huntingdon, Cambridgeshire PE17 4HJ.
Telephone: 0480-64646. Telex: 32250.



thandar
ELECTRONICS LIMITED

WHATEVER YOUR HOBBY...

PHOTOGRAPHY

OCTOBER 1986

PHOTOGRAPHY

OCTOBER 1986

PHOTOGRAPHY

OCTOBER 1986

PHOTOGRAPHY

OCTOBER 1986

PHOTOGRAPHY

OCTOBER 1986



FREE: FOUR SUPERB
PRINTS BY O'NEILL
DOWNING: THE FACE OF WAR

£1.0



Don't
miss it!

... YOU'LL CLICK WITH PHOTOGRAPHY

Britain's newest, brightest and most exciting
photographic magazine is on sale at your
newsagent now.

DIARY

Sound Comm '86 — October 1/2nd

New Century Hall, Manchester. See September '86 ETI or contact Brenda White on 06286 - 67633.

Wideband Communications — October 1/2nd

Tara Hotel, London. Contact Online at the address below.

Amstrad Computer Show — October 4-5th

Novotel, London. Contact Database Exhibitions at the address below.

Internecon — October 7-9th

Brighton. Conference and exhibition devoted to electronic component packaging and connections with particular emphasis on surface-mounting devices. Contact Cahners Exhibitions Ltd on 01-891 5051.

Design For Testability — October 9th

The IEE, London, 2.00pm. Colloquium, sub-titled "What should be taught, and why?". Contact the IEE at the address below.

Stereophonic Sound in Television Broadcasting — October 16th

The IEE, London, 6.00pm. Lecture by G. Baker of the BBC. Contact the IEE at the address below.

Lighting Workshop — October 17-19th

BBC Engineering Training Centre, Woodnorton, Near Evesham. See October '86 ETI or contact the Royal Television Society on 01-387-1970.

Open Systems Interconnection (OSI) Seminar — October 20/21st

Rembrandt Hotel, London. Contact Online at the address below.

Systems Network Architecture (SNA) Seminar — October 20-24th

Tara Hotel, London. Contact Online at the address below.

3D Television — A Solid Future? — November 4th

The IEE, London, 6.00pm. Lecture by Dr. R. Borner of the Heinrich Hertz Institute, Berlin. Contact the IEE at the address below.

Electron & BBC Micro User Show — November 7-9th

Royal Horticultural Halls, London. Contact Database Exhibitions at the address below.

Compec '86 — November 11-14th

Olympia, London. Exhibition of computers, peripherals and systems for professional and business users. For details contact Reed Exhibitions on 01-643 8040.

High Definition Television: The Technical Challenge — November 12th

The IEE, London, 6.00pm. Lecture by T.S. Robinson of the IBA. Contact the IEE at the address below.

Audio Fair — November 12-16th

Olympia 2, London. Major industry audio exhibition organised by the Federation of British Audio. Contact them on 01-930 3206.

The History Of Television — November 13-15th

The IEE, London. International conference commemorating the inauguration of the world's first high-definition TV service in 1936. Contact the IEE at the address below.

Commodore Horizons Show — November 15/16th

Novotel, London. Contact Database Exhibitions at the address below.

Addresses

Database Exhibitions, Europa House, 68 Chester Road, Hazel Grove, Stockport SK7 5NY, tel 061-456 8835.

Institution of Electrical Engineers, Savoy Place, London WC2 0BL, tel 01-240 1871.

Online International, Pinner Green House, Ash Hill Drive, Pinner, Middlesex HA5 2AE, tel 01-868 4466.

ETI

Forthright

mpe



SUMMER COURSES — 3 day introductory and advanced Forth courses with notes and working software **£375.00**



Cross Compilers to produce ROM code
Core (buy only once) **£250**
Targets (each) **£175**
6502, 6511Q, 6800, 6801/3, 6809, 68000, 280, 8080, 8086, 1802, 28, 99xxx, LSI 11.



FORTH 83 HS/FORTH
1 megabyte programs, graphics, floating point, assembler, strings **£230**



MPE-FORTH/09 for FLEX or OSS
Editor, assembler, full system integration, cross compilers available. **£175**

Work-FORTH

New

Complete with:
SCREEN EDITOR
MACRO-ASSEMBLER
APPLICATION GENERATOR
COMPREHENSIVE MANUAL

Out now for:
IBM PC, APRICOT, MSDOS
CPM 85, CPM 80 Price £48
AMSTRAD Price £35

Extensions:
Floating point **£35**
VIEW-TRACE
debugger **£35**
Cross-compilers

MicroProcessor Engineering Ltd

21 Hanley Road, Shirley
Southampton SO1 5AP
Tel: 0703 780084



OSCILLOSCOPES	COMMUNICATION RECEIVERS
TELEQUIPMENT D75 Dual Trace 50MHz Delay Sweep £200 COSSOR CDU150. Dual Trace 35MHz Solid State. Portable 8x10cm display. With Manual £350 GOULD DS255. Dual Trace 15MHz £200 TELEQUIPMENT D61 Dual Trace 10MHz. With Manual £150 S.E. LABS SM111. Dual Trace 18MHz Solid State. Portable AC or External DC operation 8x10cm display. With Manual £100 TELEQUIPMENT D43. Dual Trace 15MHz. With Manual £110 TELEQUIPMENT S54A. Single Trace 10MHz. Solid State. With Manual £110 Philips PM3230 Dual Beam 10MHz. Solid State £100	Racal RA17L 500kHz-30MHz ... ONLY £140 each with manual Eddystone 730/4 480KHz-30MHz only £110 each with manual TELE-VERT converts VHF signals to UHF (P&P £3) #10 CROSSHATCH GENERATOR TVTSM Crosshatch/Dots/White RF & Video Outputs. Tuner Control (P&P £4) #10 Degaussing Coils (P&P £4) £20 ADVANCE AM SIGNAL GENERATOR S662B 150 KHz-220MHz £45 ADVANCE AM SIGNAL GENERATOR Type 62 150KHz-220MHz £30 METRIX WOBBLATOR Type 210 5-220MHz £20 PHILIPS WOBBLATOR GM2877S 5-220MHz & 440-880MHz £100 LABGEAR COLOUR BAR GENERATOR CM6037 (P&P £4) £60 RACAL 32MHz UNIVERSAL COUNTER TIMER Type 836 £50 MARCONI TF2604 (Later version of TF 1041 VTVM) 20Hz-1500MHz. AC/DC/Ohms AC 300mV-300V FSD £60 MARCONI VALVE VOLTMETER TF2600 10Hz-100MHz; 1mV-300V FSD £40 PHILIPS COLOURBAR GENERATOR type 5501 (P&P £5) £100 PHILIPS COLOURBAR GENERATOR type 5508 Video out. Many Functions £125
MULTIMETERS AVO 9 Mk 4 (Identical to AVO 8 Mk 4 but scaled differently) Complete with Batteries & Leads. ... £55 AVO 8 Mk 2 Complete with Batteries & Leads £45 Above items in GOOD WORKING ORDER - appearance not A1 hence the price AVO TEST SET No 1 (Military version of AVO 8) Complete with batteries, leads & Carrying Case £65 AVO Model 7x. Complete with batteries, leads & carrying case £40 AVO Model 73. Pocket Multimeter (Analogue) 30 ranges. Complete with batteries & leads. £18 AVO 72 - Similar to above but no AC current range. With batteries & leads £10	ISOLATING TRANSFORMERS 240V INPUT - 240V OUTPUT 500 VA £15ea P&P £5 100 VA £6ea P&P £2
ADVANCE/GOULD DVMS Auto ranging. max reading 20,000 AC/DC volts - resistance only £50 p&p £5	NEW EQUIPMENT HAMEG OSCILLOSCOPE 605 Dual Trace 60MHz. Delay Sweep Component Tester £515 HAMEG OSCILLOSCOPE 203.5 Dual Trace 20MHz. Component Tester £270 All Other Models Available
AVO TRANSISTOR TESTER TT169 Handled. GO/NO GO for In-situ Testing. Complete with batteries, leads & instructions. (p&p £3) NOW ONLY £12	BLACK STAR FREQUENCY COUNTERS P&P £4 Meteor 100 - 100MHz £99 Meteor 600 - 600MHz £126 Meteor 100 - 1GHz £175 BLACK STAR JUPITOR 500 FUNCTION GENERATOR Sine/Square/Triangle 0.1Hz - 500KHz P&P £4 £110
PROFESSIONAL 9" GREEN SCREEN MONITORS made by KGM for REUTERS Gives quality 80 column x 24 line display. Composite video in. Cased. Good condition ONLY £32 each DISK DRIVE PSU-240V 1A: 5V 1.6A & 12V 1.5A out. Size: W125mm, H75mm, D180mm. Cased. Un-used. Only £10.00 each (P&P £2) Qwerty keyboard (as in Lynx Micro). Push to make Cased £5 each (P&P £2)	HUNG CHUNG OMM 6010. 3 1/2 digit. Hand held 28 ranges including 10 Amp AC/DC. Complete with batteries & leads. P&P £4 £33.50
Various 5 1/4" Floppy Disk Drives and Stepping Motors Available	OSCILLOSCOPES PROBES. Switched x1; x10 P&P £2
Used equipment - with 30 days guarantee. Manuals supplied if possible. This is a VERY SMALL SAMPLE OF STOCK. SAE or Telephone for Lists. Please check availability before ordering. CARRIAGE all units £12. VAT to be added to Total of Goods & Carriage	
STEWART OF READING 110 WYKEHAM ROAD, READING, BERKS RG6 1PL Telephone: 0734 68041 Callers welcome 9 am - 5.30 pm Mon.-Fri. (until 8 pm Thurs.)	

Master Electronics - Microprocessors - Now! The Practical Way!

- Electronics - Microprocessors - Computer Technology is the career and hobby of the future. We can train you at home in a simple, practical and interesting way.
- Recognise and handle all current electronic components and 'chips'.
- Carry out full programme of experimental work on electronic computer circuits including modern digital technology.
- Build an oscilloscope and master circuit diagram.
- Testing and servicing radio - T.V. - hi-fi and all types of electronic/computer/industrial equipment.



New Job? New Career? New Hobby?

SEND THIS COUPON NOW.

FREE! COLOUR BROCHURE OR TELEPHONE US 062 67 6114
Please send your brochure without any obligation to OR TELEX 22758 (24 HR SERVICE)

NAME _____ I am interested in

ADDRESS _____ ELECTRONICS

MICROPROCESSORS

RADIO AMATEUR LICENCE

CITY & GUILDS EXAMS

Other Subjects _____

British National Radio & Electronics School P.O. Box 7, Teignmouth, Devon, TQ14 0HS

Universal Semiconductor Devices Ltd.

17 Granville Court, Granville Road,
Hornsey, London N4 4EP, England.
Tel: 348 9420/9425* Tlx: 25157 usdco g



We offer one of the largest ranges of semiconductors at highly economical prices. The following semiconductor types are available from stock. If we don't stock what you need then we can get it fast from our facilities in West Germany and USA upon request.

TRANSISTORS - Bipolars - Germanium and Silicon
Small signal
Power
Darlingtons - all shapes and sizes
VHF/UHF devices - all shapes and sizes



FETS - Power Mosfets
Unijunctions



DIODES - Germanium and Silicon
Rectifiers and Bridges
Opto-Electronic devices
LEDs of all shapes and sizes

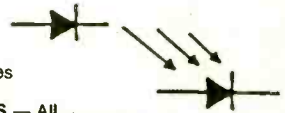

THYRISTORS and TRIACS - All shapes sizes ratings



INTEGRATED CIRCUITS: Consumer - Digital/Analogue
Microprocessors and Peripherals
IC Sockets

JAPANESE COMPONENTS - Vast range of discrete's and consumer IC's
System A - All semiconductors available from USD. Amp - £75.00 incl. VAT & p&p. Pre-amp - £90.00 incl. VAT & p&p.

Mall order customers: Please send for our comprehensive price list, enclosing £1.00 in stamps. Cheque or postal order.

SYSTEM A AMP
All semi-conductors available.
Amp plus pre-amp £90, amp
only £75

Catalogue sent free of charge, when requested on official letterhead (without refund), to OEM's, Schools, Colleges, Universities, Government Institutions, Computer Films, Electronic Repair Firms and Distributors. Special discounts and payment terms are available to above institutions.

Please enquire for quantity discounts.

WE WELCOME TELEPHONE AND TELEX ENQUIRIES!

CROFTON PM101

THE VIDEO SPECIALISTS

(05448) 557

SUMMER OFFER £40

Inclusive VAT and carriage £49.45 total

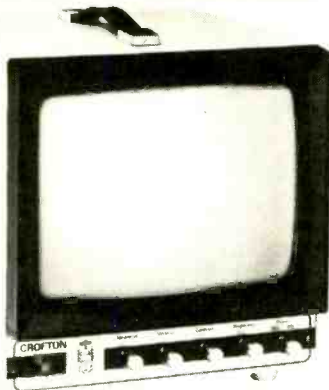

This 9 inch metal cased, monochrome monitor offers you the chance to obtain a high quality product at a budget price!

SPECIAL OFFERS

BRAND NEW professional board and green tube to make 12" T.T.L./comp open home monitor. **ONLY £30 + VAT** and carriage. ZX81 Full sized keyboard in metal case £13.80. COMPUTER DESKS £20.

Be sure to ask for our various catalogues. We have a full range of products including:

- 1—Discrete listening devices
- 2—Plugs/sockets/connectors/leads
- 3—Television accessories
- 4—Security products
- 5—Computer products
- 6—NEC cased and uncased monitors

If you would like all our catalogues - Please send a 38p 9 x 12 S.A.E.

THERE'S ALWAYS A SPECIAL DEAL FOR YOU AT CROFTON

If we haven't listed what you are looking for, please ask, we probably have it in stock.

Just starting to refurbish CCTV Cameras, and Monitors, Ask For Details. First Come First Serve, these are very popular items and won't last long.

CCTV camera at attractive prices

ALL OUR PRICES INCLUDE VAT, CARRIAGE & INSURANCE AND CAN ONLY BE HELD AS LONG AS STOCKS LAST!

PHONE YOUR ORDER NOW!

MOST MAJOR CREDIT CARDS ACCEPTED. OFFICIAL ORDERS FROM APPROVED INDUSTRIAL OR EDUCATIONAL ESTABLISHMENTS WELCOME.

Delivery within 28 days.

PHILIPS BM7502
Also in stock: PHILIPS BM7522
PHILIPS CT2007

Phone for today's best price

CROFTON ELECTRONICS

KINGSHILL, NEXTEND, LYONSHALL,
Nr KINGTON, HEREFORDSHIRE HR5 3HZ.

LYONSHALL
(05448) 557

READ/WRITE

Thermionic Omissions

Dear Sir,

I was intrigued by Jeff Macaulay's article on the experimental transistor preamplifier in ETI September 1986.

I can't help feeling that there must be a catch somewhere. It would be interesting for potential constructors such as myself to have one or two additional bits of information. As a minimum, I should like to know the signal-to-noise ratio at the disc input. But it would also be interesting to have some distortion and overload figures at the frequency extremes, rated voltage output, disc input sensitivity and output impedance.

I should also like to know whether the three coupling capacitors must be as high as 10u in value, and what the ideal RIAA network component values are to give exact equalisation.

Yours faithfully,
B. Wadsworth,
London SW1.

Jeff Macaulay replies: The sensitivity of the disc input is 5mV and the signal-to-noise ratio measured on the prototype was -60dB unweighted.

Overload ratios are a subject of some debate in hi-fi circles at present. Basically, if the input overloads before the volume control it is impossible to correct for the resulting distortion. However, this is not the whole story. In a simple stage of the type used in the experimental preamplifier the transistors operate in class A, and class A amplifiers have a distortion level which decreases with decreasing output. In order to produce a low distortion level it is necessary to

operate the stage as far away from overload as possible. The front end of this design has an overload margin of 40dB, which means that it normally operates at a level 100 times below its maximum output. The overload threshold remains constant across the audio band.

10u coupling capacitors may seem a little large but their use helps ensure a good low frequency response.

The RIAA equalisation is achieved passively in this design. As with all engineering, anything exact is impossible and it is necessary to work to a realistic tolerance. The best that can be done is to determine what level of error is permissible and then design the equipment so that the actual error is smaller than the permissible maximum. In this case, the use of 5% tolerance components in the equalisation network will result in a response which is accurate to within ± 1 dB of the theoretical curve. That is close enough!

For the sake of interest, I include below a table comparing the performance of an ECC83 valve and two MPSA42s arranged as a Darlington pair.

Making The Grade

Dear Sir,

I have been reading Graham Nalty's Upgradeable Amplifier series with some interest, but I would like to question the concept of replacing critical components at a future date to improve performance.

First, it has been pointed out earlier in ETI that the cost of the electronic components in a finished unit is seldom as much as half the total cost, so this is surely an argument for starting with the most appropriate ones.

Second, the time and effort in dismantling, de-soldering and re-assembling is not going to be much less than initial assembly, never mind the wear and tear on PCB track pads.

May I ask for clarification of another point that Graham Nalty has raised? I am at present building an amplifier, which will include a CD input. In 'Playback' in the July issue he says the output level from a CD player is of the order of 2V. The service department at my local hi-fi dealer says 400mV. Help!

I remain,
Chris Cosgrove,
Bathgate,
West Lothian.

We have indeed suggested in the past that the cost of the components is seldom more than half of the total cost of a project, but the Upgradeable Amplifier is an exception. Even in its standard form, the cost of the components for the preamplifier is likely to be twice the cost of the case and other hardware.

Of course, it is true to say that you would save yourself time and effort (and, in the long run, money) by building the amplifier in its fully-upgraded form in the first place, and we know that many readers have done this. However, it seemed a good idea to present a design which could be built at a certain cost and later, when more money is available, upgraded to provide a higher performance rather than being thrown out entirely and replaced. And yes, upgrading it will involve some soldering and other work, but presumably electronics hobbyists enjoy that sort of thing or they wouldn't have chosen electronics as a hobby in the first place!

Secondly, regarding the output of compact disc players: every unit we have seen has an output of around the 2V level and the literature put out by various manufacturers suggests that this is the norm. Although 400mV is the normal output level for other powered signal sources such as tuners, tape-decks, etc, we have not encountered any compact disc players with this output level.

	supply voltage	maximum output voltage (V RMS)	signal-to-noise ratio	THD at full output	Z _{in}	I _a /I _c
ECC83	250V	35V	-60dB	1.8%	1M0	1mA
MPSA42	250V	60V	-60dB	<0.1%	>10M	1mA

POWER MOSFETS

Geoff Phillips takes power MOSFETs apart and finds some useful little devices.

MOSFET is an acronym of Metal Oxide Semiconductor Field Effect Transistor. A field effect transistor (or FET) consists of a channel of silicon whose resistance can be varied by the application of an electric field. The two ends of the channel are called the source and the drain and the terminal which controls the electric field is called the gate. The field is varied by changing the voltage between the gate and the source.

There are many kinds of FET. The MOSFET uses a particular kind of construction in which the gate is insulated from the channel by a very thin layer of metal oxide (actually silicon dioxide grown on the surface of the channel). Hence its alternative name, the Insulated Gate FET or IGFET. The gate to source resistance is very high indeed, which means that MOSFETs present very little loading of gate drive circuits.

Power MOSFETs are devices capable of handling tens of amps in drain current (I_D). They are invariably produced by the same sort of processes used to make ICs, and many power MOSFETs are, in fact, formed from a number of individual FETs all feeding a common drain.

Non-Lateral Thinking

Power MOSFETs utilise a 'vertical' construction with gates and sources at the top and drain at the bottom, rather than the more familiar planar (or 'lateral') construction with source, gate and drain all in a line. Manufacturers' versions of the 'vertical' MOS include VMOS (in which the gate is formed in a V-shaped groove etched into layers of semiconductor and the source runs parallel to the top of the groove) and DMOS, TMOS and HEXFET (in which several source 'cells' cluster around a gate). In both cases, the effect is to increase the surface area for source and drain and, at the same time, shorten the current path between them. VMOS typically tolerates a lower maximum drain-source voltage than the source-cell type of MOSFET, but since that voltage is usually around 60V and can be much higher, for most applications the limitation is irrelevant.

Vertical structures date from the mid-sixties when a device known as the MUCH-FET was the first to be fabricated vertically. Early research was undertaken with junction FET technology because the technical problems were too great to allow the construction of useful high power MOSFETs. But the JFET requires two power supplies of opposite polarities. Similar objections can be levelled at the depletion mode MOSFET, in which a current path exists between source and drain when the gate voltage is zero.

When it became possible to construct high power FETs using MOS techniques, manufacturers and designers naturally opted for enhancement mode devices which are turned on by the application of a voltage of the same polarity as the drain-source voltage. Because the mobility of the charge carriers in P-type silicon is considerably less than the mobility of the charge carriers in N-type silicon, it was inevitable that the dominant type of power MOSFET would be the N-channel enhancement mode device.

P-channel devices are available and operate in the same way as the N-channel devices we refer to here, assuming you change all the voltages round. However,

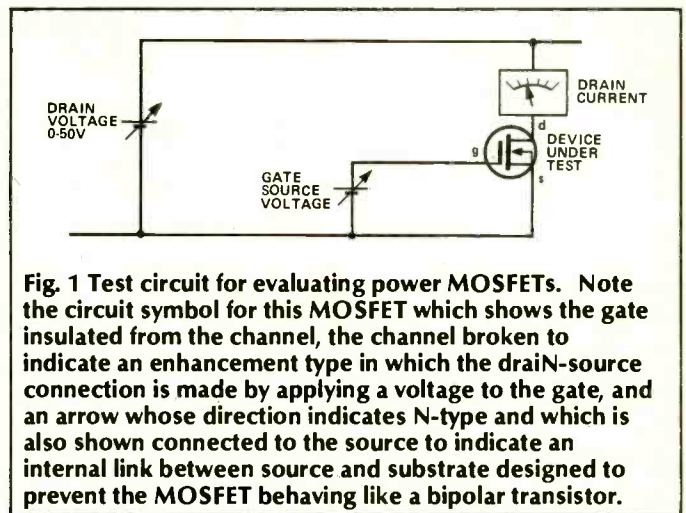

Fig. 1 Test circuit for evaluating power MOSFETs. Note the circuit symbol for this MOSFET which shows the gate insulated from the channel, the channel broken to indicate an enhancement type in which the drain-source connection is made by applying a voltage to the gate, and an arrow whose direction indicates N-type and which is also shown connected to the source to indicate an internal link between source and substrate designed to prevent the MOSFET behaving like a bipolar transistor.

it's worth bearing in mind that exactly complementary P and N-channel power MOSFETs can't be made. Matching is usually on the basis of on-resistance and transconductance, leaving capacitance unmatched. Usually, a P-channel device demands a heavier drive than its N-channel 'equivalent'.

Despite the claims made by manufacturers and the proliferation of superficially different varieties of power MOSFETs, for most applications VMOS, DMOS, HEXFET, TMOS and the like will all behave indistinguishably. Designers and experimenters should base their choice on actual performance rather than manufacturers' claims.

Figure 1 shows a test circuit for evaluating MOSFETs and Fig. 2 shows a typical graph of drain current against gate to source voltage. No drain (channel) current flows at all until the gate voltage reaches about 3V. This figure is the 'gate threshold voltage' and might be between

about 0.5V and 5V depending on the device under test. A high threshold is useful for switching applications, where it reduces noise.

In the case of the MOSFET described by Fig. 2, drain current increases linearly with gate voltage after the gate voltage reaches about 4.5V. Increasing the drain source voltage while holding the gate voltage constant demonstrates that after a certain point the relationship between drain-source voltage and drain current also becomes linear. These linearities are due to the short drain-source channel, which ensures that electron velocity saturates. In fact, with the gate voltage held fairly low, the power MOSFET is almost a perfect constant current source (Fig. 3).

If a resistor is placed between the drain and its supply, the drain voltage can be made to change in response to gate voltage changes. A very simple ampli-

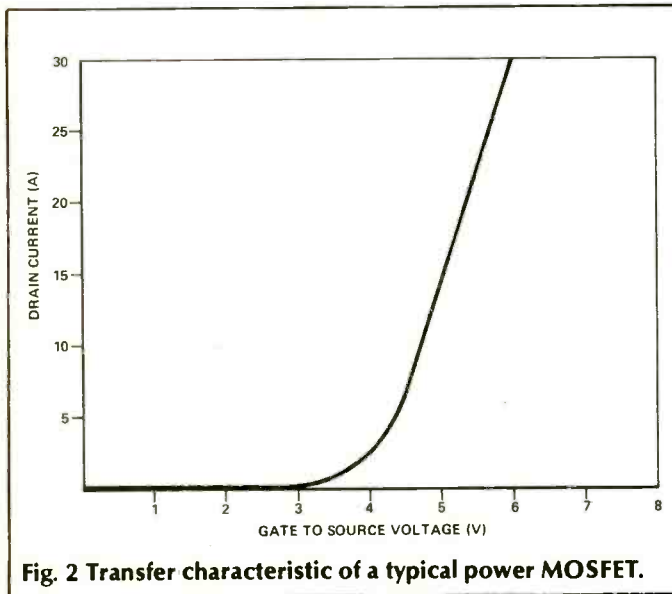

Fig. 2 Transfer characteristic of a typical power MOSFET.

fier is produced which has a fair voltage gain and theoretically infinite current gain. If the drain resistor is increased in value until the drain voltage ceases to decrease any more, the MOSFET is said to have saturated.

Unlike a bipolar transistor whose saturation voltage remains fairly constant with current changes, a power MOSFET exhibits a linear resistance-like saturation region where voltage is proportional to drain current. The ratio between the two is called $R_{DS(on)}$. Manufacturers try to reduce this as it dictates the power dissipated by a device when it is hard on and drawing load current. At present, the figure ranges from around one twentieth of an ohm to 3 or 4 ohms.

If a MOSFET is used to switch DC at infrequent intervals, the gate drive circuit can be very simple. A 30A bipolar power transistor may require 3A base current to turn it on. A power MOSFET only requires nanoamps. The output of a CMOS logic gate can quite happily turn a 30A MOSFET on and off and control 3kW of DC. Being a voltage controlled device and having such an extraordinarily high input impedance (more than 10^{12} ohms) means that a MOSFET requires barely any power to keep it in a stable state. Only when the drain-source current is changing does the gate-source circuit begin to dissipate more than negligible amounts of power.

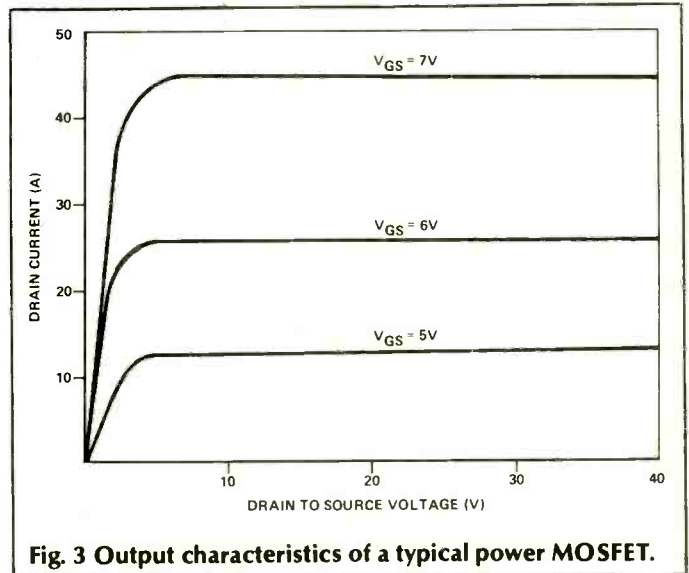

Fig. 3 Output characteristics of a typical power MOSFET.

Although the gate draws very little current when a DC voltage is applied, the MOSFET does have an input capacitance which may be hundreds of picofarads in a high power device. This capacitance has to be charged up when a gate voltage is applied. The situation is complicated by the fact that the capacitance increases due to the Miller effect while the MOSFET is turning on by a factor of, perhaps, five.

MOSFETs are advertised as being very fast devices for use in switching power supplies and regulators thanks to the short drain-source current path and the absence of minority charge carriers. But their theoretical speed can only be realised if the gate voltage rises and falls fast enough. The rise time of a MOSFET may be quoted — conservatively — as being 200ns, but to charge an effective capacitance of, say, 2n0 to 5V in 200ns would take a constant 50mA. Granted the gate drive circuit would only have to supply this briefly, but a CMOS logic gate, for example, couldn't even do that. A practical dynamic drive circuit is shown in Fig. 4. For fast turn-off, the gate capacitance has to be discharged just as quickly as it is charged — hence the push-pull arrangement.

Fast And Efficient

What is the appeal of the speed of power MOSFETs? In switch-mode power supplies (SMPS), the dissipation of the switching devices is not just governed by the power expended during the 'on' state. This would be given by $I_{D(ON)}$ and might, typically, be equal to a maximum of eight or ten watts. But when devices are actually

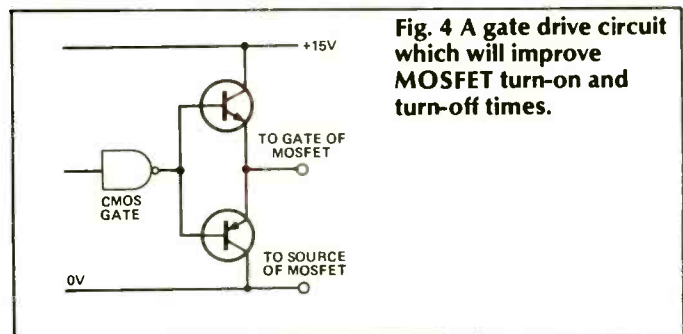

Fig. 4 A gate drive circuit which will improve MOSFET turn-on and turn-off times.

turning on and off, they pass through high dissipation regions in which there may be a significant voltage across them combined with a substantial current flow. The shorter the time a device is in a high dissipation region, the better. This is a major reason for the high speed. Devices need smaller heat sinks and can be operated at much higher frequencies — making the filter components of an SMPS much smaller and cheaper.

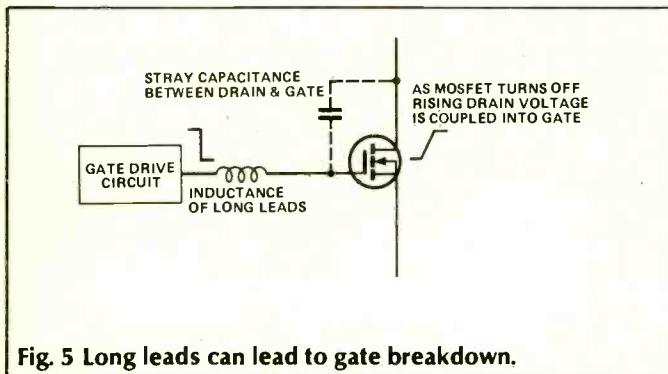

Fig. 5 Long leads can lead to gate breakdown.

But there are problems which may be encountered when driving power MOSFETs at very fast speeds. Because of the capacitance between the drain and the gate, the faster the drain voltage changes the more energy is coupled into the gate. The maximum gate-source voltage — which is usually considerably less than the drain-gate or drain-source voltages — may well be exceeded. If long leads are used from the gate drive circuit, their inductance may be enough to decouple the gate from the drive circuit (Fig. 5). This can lead to gate oxide breakdown. It is important to keep gate leads short and, as an extra precaution, wire a suitable zener (say, 16V) between the gate and source close to the MOSFET. Zener's used to be built-in to all power MOSFETs, but with modern power devices it is no longer considered necessary. It may, however, be better to be safe than sorry. (Some types still incorporate zeners — for example, the VN10KM. The VN10LM has no zener but is otherwise identical).

Gate lead inductance can also cause problems if it results in resonance with the gate capacitance. In extreme cases, the MOSFET may break into oscillation. A 10R resistor is often fitted in series with the gate lead to damp any interchange of energy between lead inductance and gate capacitance. Another problem encountered when high currents are switched very fast is the generation of radio frequency interference (RFI). Circuits should be well screened.

Audio Use

There has been a lot of mystery generated about the appearance of MOSFETs in high power audio applications. I challenge anyone to tell the difference between the sound of a bipolar amp and that of a MOSFET amp of comparable quality. Enthusiasts juggle with distortion figures and slew rates which could only be detected using precision test equipment.

One characteristic of MOSFETs which is relevant is the absence of secondary breakdown which makes a MOSFET power amp a lot more tolerant of abuse at the speaker end. Consider a bipolar power transistor to be made up of numerous current paths in parallel. If a

region of the transistor breaks down so that it heats up excessively then thermal runaway follows. The negative coefficient of resistance of the transistor material means that the hotter the region gets, the lower its resistance will be. It will take more current and get even hotter, eventually causing the destruction of the whole transistor.

The power MOSFET has a positive temperature coefficient of resistance along the drain-to-source channel, which means that current falls if temperature rises, thus avoiding thermal runaway. Thermal effects are, in fact, the predominant cause of device failure.

One disadvantage of the use of power MOSFETs in an audio output stage is the fact that the gate has to be taken quite a few volts above the source to supply appreciable

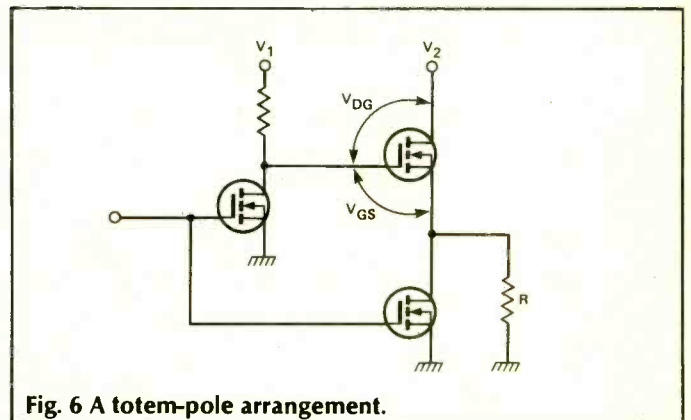

Fig. 6 A totem-pole arrangement.

drain current. This can limit how close to the positive supply the top device in a push-pull output stage can go, which will limit the maximum output power available for a given set of power supply rails.

How To Handle A MOSFET

I must admit, I've yet to 'blow' one during handling, but if you are silly enough to approach one wearing rubber-soled shoes and a nylon coat, and then walk across a nylon rug whilst wiping your hands on the coat before picking the thing up by its gate, the static will probably punch through the oxide layer. If someone offers you one, touch the person's hand first (or just say 'no'). Touch the conducting foam packing before you take a MOSFET out of its box so that you establish yourself at the same potential as the device.

How To Test A MOSFET

They can easily be tested with a multimeter set to ohms. First ascertain whether the positive of the internal battery of your multimeter is connected to the negative probe (as on a traditional analogue AVO) or the positive probe (as on most digital meters). Also check that the internal batteries do not exceed 20V.

The generally accepted limits on gate to source voltage are $\pm 30V$, and $\pm 20V$ will exceed the gate threshold of all MOSFETs while remaining within safe limits.

Maximum allowable gate-source voltage is always less than the maximum allowable drain-gate voltage, although there are some MOSFETs whose gate-source

FEATURE: MOSFETs

voltage may equal or exceed the drain-gate voltage (the 2N6659/VN35AB, the 2N6656/VN35AA, the VN0300 and VP0300 types, and the VN40 and VN46 types, for example).

There is sometimes a problem if a MOSFET is configured in such a way that its source voltage rises. This will happen with the top device in totem pole and push-pull arrangements, as mentioned earlier. It is also a feature of a number of common-drain or source-follower circuits. In Fig. 6, for example, as the voltage across the load R increases, the gate-source voltage on the upper MOSFET decreases and the MOSFET may turn off before the voltage on R reaches V_2 . This can, of course, be avoided if V_1 is allowed to be suitably greater than V_2 , which can be achieved by use of reactive components in, for example, a capacitive 'bootstrap' or an inductive

nect the positive of the meter's internal battery to the drain and the negative to the source. Short the gate to the source. The meter should read high resistance. Momentarily touch the gate lead with the positive probe and then reconnect the probe to the drain. A very low 'on' resistance should be seen. The gate capacitance actually stores the positive charge long enough to test drain-source resistance in an 'on' condition. If the probes are

There has been a lot of mystery generated about the appearance of MOSFETs in high power audio applications ...

'kickback' arrangement. It can also be achieved, of course, by using a second power supply, but in all cases it is important to observe the operating characteristics of the device. Where gate-source voltage will exceed drain-gate voltage, it should still remain within safe limits.

To return to testing. With an n-channel device, con-

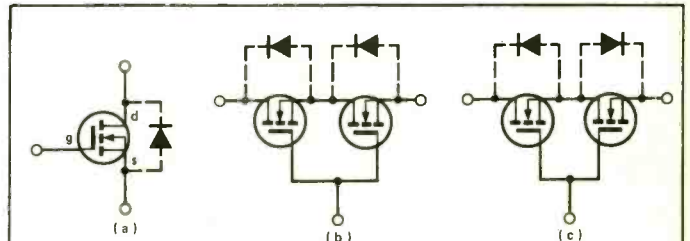

Fig. 7 (a) The parasitic body-drain diode and (b) and (c) the wrong and right way of connecting two MOSFETs in an analogue switch arrangement.

now reversed, you will observe the effect of the inherent, parasitic diode in the drain-source channel.

This 'body drain' diode (Fig. 7) is reverse polarised in normal use and can therefore be useful in, for example, motor control applications. The polarity of the diode should be remembered when MOSFETs are used in analogue switch arrangements with two or more devices connected in series or parallel.

ETI

HART

LED DISPLAY DIGITAL ELECTRONIC CLOCK MODULE
Electronic clock module with MOS LSI circuit, 4-digit 0.5" LED display, power supply and other components on a single PCB. Only needs a transformer and switches to construct a complete, pretested digital clock/timer for many applications. Suitable for 50 or 60 Hz mains supplies. Direct (non-multiplexed) LED drive eliminates RF interference. Supplied complete with 240v mains transformer and wiring diagram/data. Order as SOL 144 Alarm Clock Module £6.85

LIQUID CRYSTAL DISPLAY WATCH MODULE
With LCD display, 2 pieces of Polarising material, backlight diffuser, micro lamp, precision crystal, trimmer, battery contacts and open microcircuit. Untested 5 for £1

PLESSEY MAINS INTERFERENCE SUPPRESSORS
Filter unit for mains borne interference. Max current 1.5A. Our Price, brand new only £2.27
Same item, store soiled only £1.61
Similar Unit but 10A Brand new £3.49

10W POWER AMPLIFIER MODULE
Mullard LP1173 Amplifier module. Needs 24v DC Supply to give 10 watts into 4 ohm speaker. Size 112x70x29mm. Complete with heat sink Only £2.40 complete with Data

ALPS FF317U FM FRONT END
Beautiful precision made High Quality variable capacitor tuned FM Front End with Dual-gate MosFet. Covers full FM range of 87 to 109MHz. 12v supply ONLY £8.90
Circuit if required 35p

CAR RADIO FM IF AND STEREO DECODER



Miniature PCB with 10.7MHz ceramic filters, 2-transformer ratio detector, AX010 noise suppression IC and TCA4500A advanced stereo decoder IC. Only needs front end to make FM tuner or car radio. Complete with circuit. Incredible value at Only £1.99

HART ELECTRONICS are specialist producers of kits for designs by JOHN LINSLEY-HOOD. All kits are APPROVED by the designer.

LINSLEY-HOOD CASSETTE RECORDER CIRCUITS



Complete record and replay circuits for very high quality low noise stereo cassette recorder. Circuits are optimised for our HS16 Super Quality Sendust Alloy Head. Switched bias and equalisation to cater for chrome and ferric tapes. Very easy to assemble on plug-in PCBs. Complete with full instructions.

Complete Stereo Record/Play Kit £33.70
VU Meters to suit £2.30 each
Reprints of original Articles 75p no VAT
86X8 Stereo Mic Amplifier £8.70

LINSLEY-HOOD 300 SERIES AMPLIFIER KITS
Superb integrated amplifier kits derived from John Linsley-Hoods articles in 'HiFi News'. Ultra easy assembly and set-up with sound quality to please the most discerning listener. Ideal basis for any domestic sound system if quality matters to you. Buy the kit complete and save pounds off the individual component price.

K300-35. 35 Watt. Discount price for Complete Kit £98.79
K300-45. 45 Watt. Discount price for Complete Kit £102.36
RLH4&5. Reprints of Original Articles from 'Hi-Fi News' £1.05 no VAT

LINSLEY-HOOD SYNCHRODYNE AM RECEIVER
Very high quality kit for this recent design featured in 'Wireless World'. This unit represents the first attempt to make a much needed HIGH QUALITY AM Tuner since pre-FM days. This will give you Radio 4, or even 1 in better quality than your Eastern 'Tranny'. Advanced construction system, approved by the Author, uses 3 double sided PCBs in a stacked layout for total stability, ease of construction and minimal wiring. This module will form the AM section of an ultra high quality AM/FM switched bandwidth tuner to match our 300 series amplifiers. Power supply and tuning gang will be included with the FM section.
K450 JLH Synchrodyne Kit Special Price £59.95

HIGH QUALITY REPLACEMENT CASSETTE HEADS



Do your tapes lack treble? A worn head could be the problem. Fitting one of our replacement heads could restore performance to better than new! Standard mountings make fitting easy and our TC1 Test Cassette helps you set the azimuth spot-on. We are the actual importers which means you get the benefit of lower prices for prime parts. Compare us with other suppliers and see! The following is a list of our most popular heads, all are suitable for use on Dolby machines and are ex-stock.

HC20 Permalloy Stereo Head. This is the standard head fitted as original equipment on most decks £7.66
HS16 Sendust Alloy Super Head. The best head we can find. Longer life than Permalloy, higher output than Ferrite, fantastic frequency response £14.86
HQ551 4-Track Head for auto-reverse or quadrophonic use. Full specification record and playback head £14.60
Please consult our list for technical data on these and other Special Purpose Heads. MA481 Latest version Double Mono (2/2) Record/Play head £13.35
Replaces R484 £13.35
SM166 Standard Mounting 2/2 Erase head. Compatible with above or HQ551 4-Track Head £8.85
H524 Standard Erase Head. Semi double gap, high efficiency £2.25
H561 Metal Tape Erase Head. Full double gap £7.35

HART TRIPLE-PURPOSE TEST CASSETTE TC1
One inexpensive test cassette enables you to set up VU level, head azimuth and tape speed. Invaluable when fitting new heads. Only £4.66 plus VAT and 50p postage.

Tape Head De-magnetiser. Handy size mains operated unit prevents build up of residual head magnetisation causing noise on playback £4.54
Curved Pole Type for inaccessible heads £4.85

Send for your free copy of our LISTS. Overseas please send 2 IRCs to cover surface Post or 5 IRCs for Airmail.

Please add part cost of post, packing and Insurance as follows:

INLAND
Orders up to £10 - 50p
Orders £10 to £49 - £1
Orders over £50 - £1.50

OVERSEAS
Please send sufficient to cover Surface or Air Post as required.

Personal callers are always very welcome but please note that we are closed all day Saturday

24hr SALES LINE
(0691) 652894

ALL PRICES EXCLUDE VAT UNLESS STATED

HART
HART ELECTRONIC KITS LTD
1 PENYLAN MILL
OSWESTRY, SHROPSHIRE
SY10 9AF

HARDWARE DESIGN CONCEPTS

To complete his introduction to the arithmetic co-processor, Mike Barwise looks into its ports and sees stars ...

The input and output boards of the co-processor differ from those of the through (printer-type) buffer in several respects, which can be summed up as:

- the ports both open onto the same host micro bus (this is a closed loop);
- as the loop is closed, both processors may use interrupts for communication;
- they do not require the \overline{STB} , \overline{ACK} Protocol of the Centronics interface.

However, each of the two ports is still unidirectional. Each port consists of a write register with tri-state outputs controlled by the port's target (the processor it is writing to), and interrupt generation logic. A status register in each direction is optional.

Contention Blocking

Figure 1 is a general schematic of the interface pair. The use of interrupts to read the port loaded by the other processor in each case guarantees that there is no data transfer contention.

Contention is the situation where one processor is trying to read data from a port WHILE the other processor is actually writing data to the same port, and would almost certainly result in a corrupt transfer. The reason for this will be discussed in the near future. Suffice it is to say for the moment that the interrupt response time of most 8-bit processors (see ETI April 1986, pp.29-31) normally avoids the necessity for elaborate contention blocker logic, as might well be needed in a polled transfer interface.

Choosing The Chips

When it comes to a real implementation, there are potentially a couple of alternatives. The traditional answer would be to use an octal register like the 74LS374 for each port of the interface. However, just coming on to the market is another Texas device, the 74LS652 (also available from Monolithic Memories), which is a bi-

directional register transceiver with a separate clock and output enable for each side. The LS652 also has a superfluous select for stored or real-time data (it converts in to the equivalent of a 74LS245) which should be hard wired to stored data. A similar device from Monolithic Memories is the 74LS546, which has a Clock Enable for each

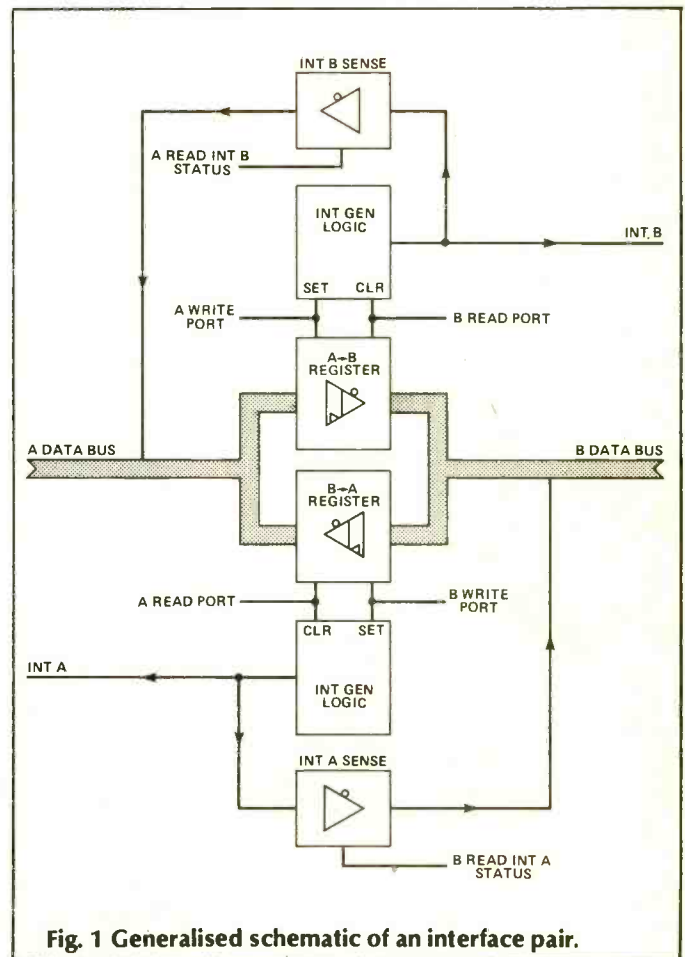

Fig. 1 Generalised schematic of an interface pair.

direction instead of the select function. This can simplify decoding the device on the bus.

Whichever approach you use for your registers, the interrupt control logic is the same (Fig. 2).

Note once again the inverse use of the 74LS74 to eliminate the need for an extra gate to allow hardware initialisation. There is an additional benefit of this configuration, in that the trailing edge of the target processor READ signal clears the interrupt, allowing the use of edge triggered interrupts. Even when the source processor is running very much faster than the target — for example, a 2MHz 6502 target (host)/16MHz co-processor source (slave) — a new edge-triggered interrupt cannot be recognised until after the completion of the read operation.

Status Register

The optional status register can come in useful. If the state of the interrupt line on the target side of the port is read back to the source processor in a buffer (Fig. 3), the source processor can poll out (or at least test) the interrupt it has generated.

Supposing there is some delay in servicing this interrupt, as when the target processor is saving to disk or some similar operation which disallows interrupt recognition the byte at the port will remain unread until after the target has re-enabled its interrupt service. Unless the source processor monitors the interrupt status, it would be possible to overwrite the port register contents and corrupt the data sequence.

This function is very similar to the BUSY status line in the Centronics interface.

*Whichever approach you use ...
the interrupt control logic is the
same ...*

Note that only the one status bit is required on each port (see later notes), so the remaining seven can be:

- used for other status functions;
- left unconnected. The status byte is then software masked when read;
- tied high or low to minimise software overhead.

The most suitable alternative when using only one slave processor is the last, as we are going to transfer large volumes of data across our interface. The bit masking operation and the read operation take about the same time, and each takes about twice the time of the branch on result.

Thus the third option takes about three-fifths of the time to perform, compared with a 'read, bit mask, branch' operation. This is admittedly reduced to about half the difference once the full transfer operation is included in the calculation, but the result can still be as high as a 30 per cent time saving.

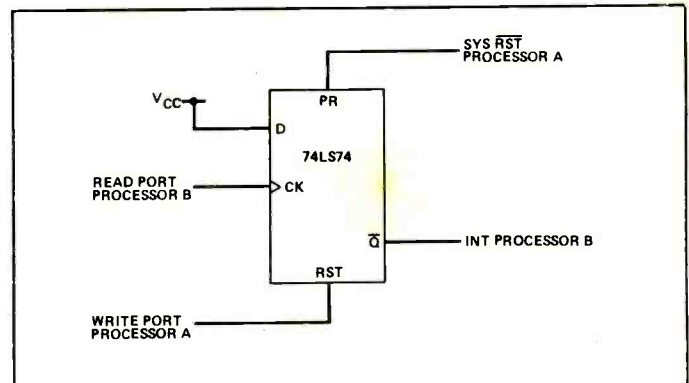

Fig. 2 Processor B interrupt generator (processor A is similar).

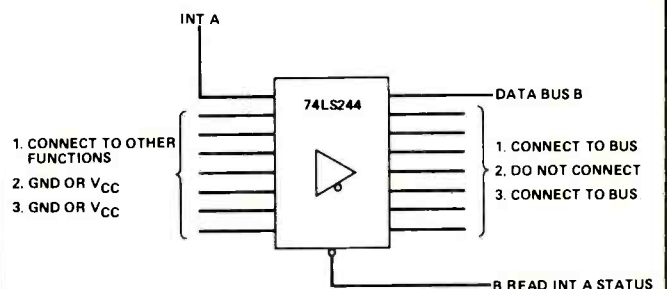

Fig. 3 Reading the status register options.

Transfer Mechanism

The software sequence to perform a byte transfer is identical, regardless of the data direction. An identical routine is installed on each processor for each of the two operations: READ byte; WRITE byte.

The WRITE BYTE sequence is:

- (a) TEST BUSY flag
- (b) if BUSY then to (a), else
- (c) STORE byte in REGISTER
- (d) RETURN

The READ BYTE sequence relies on an interrupt vector already pointing to it:

- (a) ON interrupt
- (b) READ byte from REGISTER
- (c) RETURN

As you can see, nothing could be simpler. This pair of routines is sufficient to allow real-time bi-directional communication between any two processors, for practical purposes running at any two different rates, and requires no inter-processor cycle synchronisation.

Build A Network!

Note that each processor only uses one interrupt for the bi-directional transfer. By provision of interrupt prioritization (watch this space) it is a simple matter to build a star configuration multi-processor system (see ETI March, 1986, pp.20-21).

A central communications processor provides a loop-through to allow any two processors at the points of the star to talk to each other, rather like a simple telephone exchange. The choice of target (the answering party) is determined by an identification token transmitted to

FEATURE: Hardware Design

the communication processor (the exchange). This token (the phone number) can either be stripped off by the exchange, or, for greater reliability, passed on to the answering party, which knows its own number. A mismatch results in a 'sorry — wrong number' message to the exchange, which tries again using another port.

In this way, although each target has a unique phone number, these do not have to be permanently cross-referenced to a literal, mapped address on the exchange. This means that targets can be added or removed at will from the system.

The only provisos for dynamic addition and removal of targets (or STATIONS — now we have a network) are that

- address tokens (phone numbers) are settable, for example by DIP switches, rather than coded, so they can be changed;
- an additional status bit at each interface reflects the presence or absence of a station.

Using The Network

The two alternative implementations are:

- a multi-processor for a single user with multiple autonomous tasks (see ETI March, 1986, p.21);
- a network of identical processors, which need not be function dedicated, but can work independently and also inter-communicate.

In the single communication processor star configuration only the communication processor needs to be equipped with prioritized interrupts.

There is no reason why you could not build a composite network using several primary processor networks of either configuration star-coupled about a

It is a simple matter to build a star configuration multi-processor system ...

central processor. In this case, the hub processor of each star must also have prioritized interrupts, in order to identify the secondary processors coupled to it.

Where To Now?

These multi-processor networks form a fascinating and challenging subject, and will be touched on again in the future, but for the time being, it's back to fundamentals. Over the next couple of months I will be guiding you through the interpretation of microchip data sheets, as an aid to 'designing for reliability'.

ETI

AUDIO KITS

PRECISION AUDIO COMPONENTS



BUILD THE ETI VIRTUOSO PREAMP

	Standard version Tone controls	Standard version No tone controls	Upgraded version Tone controls	Upgraded version No tone controls
COMPLETE KIT	£177	£138	£372	£256
MC stage component pack	£12.50		£25	
MM (RIAA) stage pack	£23		£58	
Tone control board pack	£29.60	Not needed	£89.40	Not needed
Switches & Connectors pack	£24.95	£16.25	£77.30	£49.50
Output stage pack	£11.60	£11.60	£28.25	£29.25
Power supply excl. transformer	£15.50		£29.50	

VIRTUOSO preamp case - state whether tone control option. £49
All parts including pcb's available separately. SAE for price list

IAR WONDER CAPS

uF	V	L x	Dia	Price
0.01	630	21	9	£2.25
0.1	425	30	8	£2.50
0.22	630	50	14	£4
0.33	425	40	10	£2.50
0.47	425	50	14	£3
0.68	425	50	16	£3
1	425	57	17	£5
2	425	57	20	£6
3	425	57	25	£8
4	425	57	27	£9
5	310	57	20	£7.50
6	310	57	23	£8.50
8	310	57	26	£10
10	310	57	29	£11

The improvement in sound quality when you replace your caps with Wonder caps or bypass your electrolytics with WONDERFUL

Holco 0.5% 50ppm/°C resistors 1/4W any E96 value 20R-442K
1-9 35p each
10+ per value 30p each

Top Quality Transistors by Motorola

BC184C	12p
BC214C	12p
BC547C	12p
BC307C	12p
MPSA06	25p
MPSA56	25p
BD139	50p
BD140	60p
MJ11015	£6
MJ11016	£5.50

BUILD THESE SUPERB ETI PROJECTS WITH AUDIOKITS COMPONENTS

SYSTEM A preamp	SYSTEM A power amp	AUDIO DESIGN preamp	AUDIO DESIGN VALVE PREAMP power amp
			Aug 86

Please ask for our parts price list which includes all electronic parts to build the projects and top quality components which enable owners of these amps to substantially upgrade the sound. Resistor and Capacitor pack for ETI Valve preamp £220.10
Includes Holco resistors, Wonder caps and the best computer grade electrolytics

All prices include VAT. SAE or IRCs with all enquiries.
EXPORT orders. Deduct VAT (multiply by 0.87) and add £2 extra for postage.
Please add 50p P&P for orders under £10.

AUDIOKITS

6, Mill Close, Borrowash, Derby DE7 3GU
Tel: 0332-674929

CRICKLEWOOD

ELECTRONICS LTD



FREE!

catalogue

It's no secret...

... that there is a real difference at Cricklewood Electronics.

That's why you should never be without the FREE CRICKLEWOOD ELECTRONICS COMPONENTS CATALOGUE, for sheer variety, competitive prices and service from the U.K.'s number one 100% component shop. No gimmicks, no gadgets or computers, just components, millions of them, all easily available by mail order, calling or credit card telephone orders. Just pick up the phone (or a pen) to get your FREE copy now (no SAE required). You have nothing to lose.

CRICKLEWOOD ELECTRONICS LIMITED

40 Cricklewood Broadway, London NW2 3ET

Tel: 01-450 0995/01-452 0161
Telex: 91 4977





ETI

BIOFEEDBACK MONITOR

You can build a GSR monitor with your free components and learn to play with your internal organs. Paul Chappell explains the background to the project.

In the early Seventies, a wave of sensational advertising swept across the USA. 'Cure cancer with biofeedback', 'New miracle cure puts an end to migraine', 'Feel wonderful without the urge to drink alcohol', proclaimed the ads. Backed up by ill informed articles in the popular press, the biofeedback boom had begun.

The principle of biofeedback is essentially this: by becoming aware of some bodily event, and by being able to measure the intensity or frequency of that event, one can gain control over the event. What this boils down to in practice is that you first choose some attribute of your body — the temperature of your hand, let's say. By taping a thermistor to your hand and connecting the thermistor to a resistance meter, you can quantify hand temperature, or at least see whether the general trend is to remain steady, to rise or to fall. Being aware of the temperature of your hand, the theory is that you will now be able to learn to make it rise or fall at will.

Does It Work?

Biofeedback, as a newcomer to the therapeutic scene, has had a tough time gaining respectability within the medical establishment. At the time when many doctors did their training, the official doctrine was that biofeedback was impossible in principle. It *couldn't* work.

According to the medical textbooks, the nervous system is split into two parts: the *central*, or voluntary, nervous system which controls the skeletal muscles, and the *autonomic*, or involuntary, nervous system which takes care

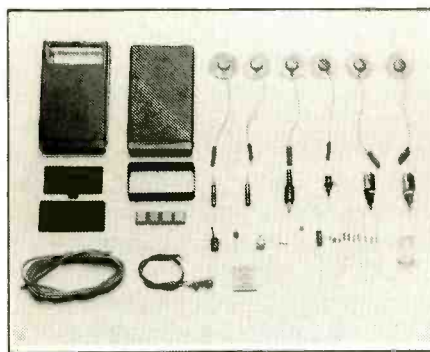

of bodily 'housekeeping' duties such as beating the heart or maintaining a steady temperature. You would have no problems if I asked you to scratch your nose since this action is under the control of your central nervous system, and you can choose whether or not to do it. On the other hand, 'Please digest your lunch a little faster' would seem to be a totally unreasonable request — the province of the autonomic system, and therefore beyond your conscious control.

By the mid-Sixties, there was a considerable body of evidence pointing to the fact that the distinction between the two branches of the nervous system was not as clear cut as had previously been supposed. Much of the early research was centred on yogis, who appeared to have abilities that were theoretically impossible. One well documented case involved the Swami Rama who claimed, in common with many other yogis, to be able to stop his heart.

As it turned out, far from stopping his heart the Swami actually had the ability to induce at will a condition known as *atrial flutter* in which the heart beats at very high speed — about 300

beats a minute in this case — without either the chambers filling correctly or the valves operating effectively. The heart beat under these conditions could not be detected without instruments — hence the yogis' belief that they could stop their hearts.

Since this would be a very dangerous condition under normal circumstances, an ability to bring it on voluntarily was hardly likely to be regarded as a great therapeutic breakthrough. There still remained the question of whether the Swami was indeed controlling his heart, or whether some muscle under voluntary control was in some way interfering with the correct operation of the heart as a secondary effect.

Progress speeded up immensely when it was discovered that, with the aid of simple measuring apparatus, similar physical control could be taught to just about anybody within a very short space of time. By means of biofeedback, as the technique came to be called, subjects in numerous studies were able to control skin temperature and heart rate, to produce galvanic skin responses at will, and to alter their brain wave frequencies. Simultaneously, it was discovered that control of this sort was not merely a laboratory curiosity — it could have useful results.

A Suitable Case For Treatment

A particular example of the clinical use of biofeedback is the treatment of migraine headaches. In studies at the Menninger clinic, it was found that patients' hands

became flushed on recovery from a migraine attack, with a temperature rise of about 6°C. This suggested that training in controlling hand temperature might have some effect on the migraine. A number of subjects were taught to raise their hand temperature at the first sign of an attack developing, with a certain degree of success at preventing the migraine.

Later experiments took a more direct approach. One characteristic of migraine is that the blood vessels of the head become abnormally enlarged. Conventional treatment usually involves medication designed to constrict the blood vessels and relieve the painful pressure. Patients have been taught to relieve the pressure for themselves by controlling blood flow through the temporal artery, with very encouraging results.

Other areas where extensive studies into biofeedback techniques have been carried out include cardiac arrhythmia (heart rate disorders), reduction of high blood pressure, cure of stuttering, control of pain, and even such bizarre disorders as bruxism (excessive grinding of the teeth). The results of some studies have been very impressive; others have been less successful, often due to the difficulty of weaning patients away from the equipment. The aim of biofeedback is that patients should develop sufficient sensitivity to their own bodies that they can dispense with the measuring apparatus. This last step often seems to be the stumbling block.

Actually Doing it

One question that may be puzzling you is: once you are sitting with a meter connected to you, measuring some aspect of your physical processes, what do you actually do to control it?

Some say it's a bit like learning to ride a bike: you just keep trying, and you know you've got it right when you don't fall off. I won't try to fob you off with that unsatisfactory answer.

An early experiment in teaching people to control brain wave frequencies used a second

person to complete the feedback loop. The person to be trained was connected to an EEG machine (a brain wave monitor) but could not see the display. He was told that there were two states of mind of interest: state A and state B. The assistant would keep an eye on the EEG display, and every now and again would ask the subject whether he thought he was in state A or state B (without specifying what these states might be).

At first, the subject had no choice but to make a wild guess, but after a while began to develop a 'feel' for the difference in the two states. The difference in the two states in technical terms was the presence or absence of alpha activity in the brain (which is associated with visualising). To the subject it was a difference between two states of mind.

After successfully discriminating between the two states, the subject was asked to attempt to remain in one particular state. The equipment was changed slightly so that a tone

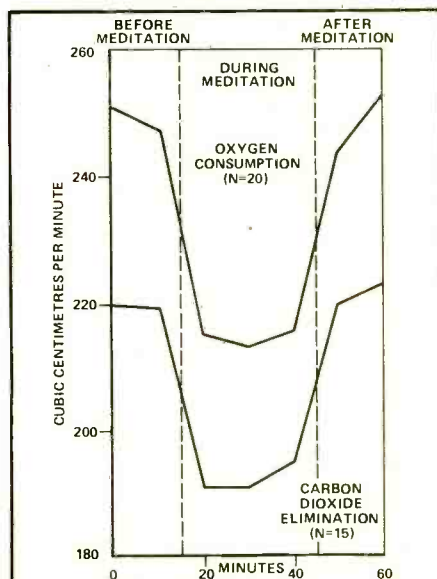

Fig. 1 This graph shows the reduced oxygen consumption which can be attained during meditation, without harming the body.

would sound when alpha activity was present, and the subject was to try to keep the tone on continuously. Many people were able to do so within a very short space of time.

In the migraine headache study in which subjects were trained to raise their hand temperature, a

start was made by repeating phrases such as 'my hands feel heavy' and 'my hands feel warm'. Often, the first steps are made in a biofeedback situation simply by imagining that the desired result has already been achieved. You want your heart to beat faster, so you imagine that your heart is beating faster, and as often as not your heart rate will increase slightly. Carry on, and it may increase more.

The GSR meter that you can build with your free components is essentially an aid to relaxation and controlling stress. Next month there will be some aids to progress related specifically to this. For the moment you may be interested to know what benefits you can get from achieving this kind of control.

Stress And Disease

Smoking causes cancer, we are told, yet there are many heavy smokers who will live to a ripe old age without ever developing lung cancer. Certain types of diet lead to heart disease, yet there is no diet which is certain to lead to heart disease, nor one which is guaranteed to make you safe from it. Some people will suffer only mildly if they contract a disease; others may die from exactly the same illness. Why?

During the past century there has been a steady decline in communicable diseases like flu or polio, only to be matched by a huge increase in stress-related disorders — high blood pressure, ulcers, heart disease, and the like. According to who you approach for your figures, stress is a major factor, if not the root cause, of anything from 50% to 80% of ailments. Some would claim that it is always at least a contributory factor.

Imagine that you have been transported back in time. You are a hunter, living on your wits and your physical skills. Absorbed in stalking your prey, your attention is suddenly caught by a sound behind you: a pack of wolves bearing down on you at high speed. Instantly, your body responds. Your heart beats faster and your blood pressure rises. The cortisone level in your blood is increased to speed clotting in case

you are wounded. Fatty acids are injected into your blood stream as a readily available source of energy. Your digestive system shuts down, and blood is diverted from your internal organs to your muscles. In short, you are fully prepared to meet immediate physical danger, to fight or to run as necessary.

Back in the present, you are sitting in your office when the phone rings. Your boss would like a word with you. Now, he doesn't sound too pleased, but then he never does. There have been rumours of a redundancy... surely they wouldn't, not after so many years... do they hold that Smith and Hackett affair against you? Instantly your body responds. Your heart races, your blood pressure rises... but wait a minute. What is going on? You are not about to face any physical danger, and yet your body is reacting as if you were.

Your autonomic nervous system generally aims to keep your body in a state of equilibrium. But part of the autonomic system, known as the sympathetic nervous system, causes changes in the usual balance when danger is present. The parasympathetic system is the part which attempts to clean up the mess and return everything to normal afterwards.

A complete return to normal is not always possible. If not used for their intended purpose in violent physical activity, fatty acids released into the blood are not easily re-absorbed and end up deposited on the artery walls. Eventually the arteries can end up so constricted that the heart becomes overworked trying to maintain sufficient blood flow, resulting in heart disease.

Some researchers believe that the body does not quite return to normal after stress so that certain organs eventually become over- or under-productive. The cumulative effects can be serious — ulcers, for instance, from incorrect acid secretions in the stomach which eat their way through the lining.

Despite the very different environment we have made for ourselves to live in, our bodies still appear to operate on the caveman level, and our natural survival mechanisms have been turned

against us. Control of stress, by whatever means, aims to eliminate the inappropriate activation of the 'fight or flight' response, while allowing it to take place if we should ever have to face a real life or death situation.

The GSR Meter

There is a strong correlation between skin resistance and arousal or relaxation, with a higher

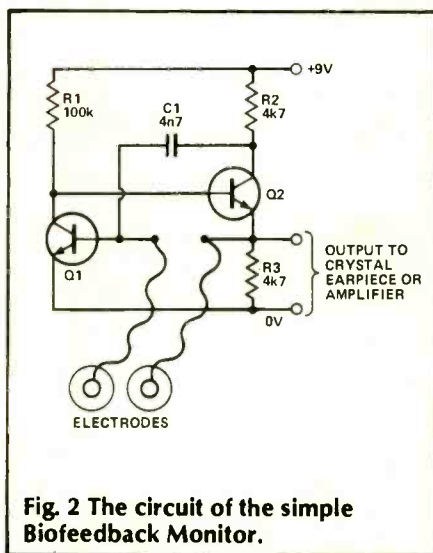

Fig. 2 The circuit of the simple Biofeedback Monitor.

resistance indicating a more relaxed state and a lower resistance indicating tension. The GSR (Galvanic Skin Resistance) meter measures skin resistance and gives feedback either by means of a tone which varies in pitch, or the movement of a meter needle. The variations in resistance arise from differences in electrolyte concentration in the interstitial fluid of the deeper skin tissues (dermis). Contrary to popular belief, perspiration has very little effect on the reading — a damp palm can have a high or a low resistance just as a dry one can.

The circuit of the basic GSR monitor you can build with your free components is shown in Fig. 2. The circuit is simply an oscillator whose output frequency depends on the resistance between the two electrodes, which should be attached to the palms of your hands — one in each palm. It is possible to get a good GSR response from the fingertips, but as movement of the fingers will vary blood flow across the knuckles, the fingers must be kept absolutely still, which can be

a distraction if you are trying to relax.

Best results will be obtained if you use the proper electrodes and conductive gel (as these items are not commonly available, we will be arranging supplies via our Readers' Service department), but it is possible to make measurements with nothing more than the bared ends of a pair of wires taped to your palms.

Once the electrodes are connected, you should hear a tone which will probably vary in pitch if you move your hands. Push the tape on firmly and rest your hands, palms upwards, by your side. Now, take a deep breath. Don't hold on to it; just breathe in deeply, and then out again. A second or two after breathing out, you should hear a distinct rise in pitch. A series of deep breaths should make the pitch rise higher still. We tried it in the office, and it works well.

Free PCB

There is no reason why you should not breadboard the circuit and have a go at altering the pitch by trying to relax (the pitch will get lower if you are successful). If you can wait until next month, there will be a free PCB to build the circuit on, which will also accommodate the more sophisticated high-sensitivity biofeedback monitor.

We will also be presenting some relaxation techniques, biofeedback experiments, and looking into the lighter side of biofeedback: lie detection (for fun), how to beat the lie detector, guessing the chosen card — all done by biofeedback!

Although the circuit of the free biofeedback monitor is simple, it should be adequate to get a response from most of the experiments to appear next month. If you would prefer to have a more sensitive instrument at your disposal, a set of all the extra parts you will need (including the electrodes and conductive gel) is available from our Readers' Services department. You will find the special offer advertised in this issue.

DIGITAL AUDIO SELECTOR

Tired of trying to listen to Simply Red while you're recording the Archers? Want to hear video through your hi-fi and tape-to-tape at the same time? Then try this project from Andy Armstrong. To start with, here's the electronic latch module.

As audio signal sources proliferate and profuse, the number of inputs on the average hi-fi preamp looks decreasingly adequate. The old 'Phono-Radio-Aux' switch, with a 'Tape/Source' button for the fortunate, just will not do. A stereo system these days might like to accept inputs from two cassette machines, a turntable, a CD player, a stereo tuner, and a VCR.

It is very tedious to have to plug and unplug leads repeatedly, but the final incentive to improve the situation was that the pre-amp switches were becoming crackly. An electronic switching system seemed like the best solution.

This design is for a six-way electronically latched and switched signal selector and is intended as a building block enabling the construction of custom equipment. The complete system is designed to support comprehensive tape recording facilities, with a separate signal

switch. Thus there will be two electronic latches, two signal switches with output buffering, but only one set of input buffering amplifiers.

Those hi-fi purists who believe that tone controls are no longer necessary may find this signal switcher suitable for use as a pre-amp, with the addition of just a volume control. Others may prefer to add filters or other tone shaping circuitry.

The Design Parameters

There are many ways to design an electronically latched signal switch. The difficulty was to determine which one was the most suitable. Eventually the following requirements were evolved:

- the switches must contain a LED indicator to show which channel has been selected;
- for ease of assembly, the switches should be separate from the signal switching

board;

- for ease of assembly, the wiring between the switches and the signal switch board should be minimized. This implies that the latching is carried out on the switch board, and the control signals are transferred in binary form;
- there should be a reasonable compromise between number of channels switched and circuit complexity.

Putting all these requirements together, the obvious first idea was to use a binary latch to switch eight channels, making optimum use of three data lines. Closer consideration of the circuit design showed that two complete CMOS ICs (4068s) would be needed for each latch, though three of the inputs to each would be unused.

Cutting down to six inputs, still enough for normal use, reduced the IC count in the latch circuit to four.

This type of latch stores the

Fig. 1
Audio selector
block diagram.

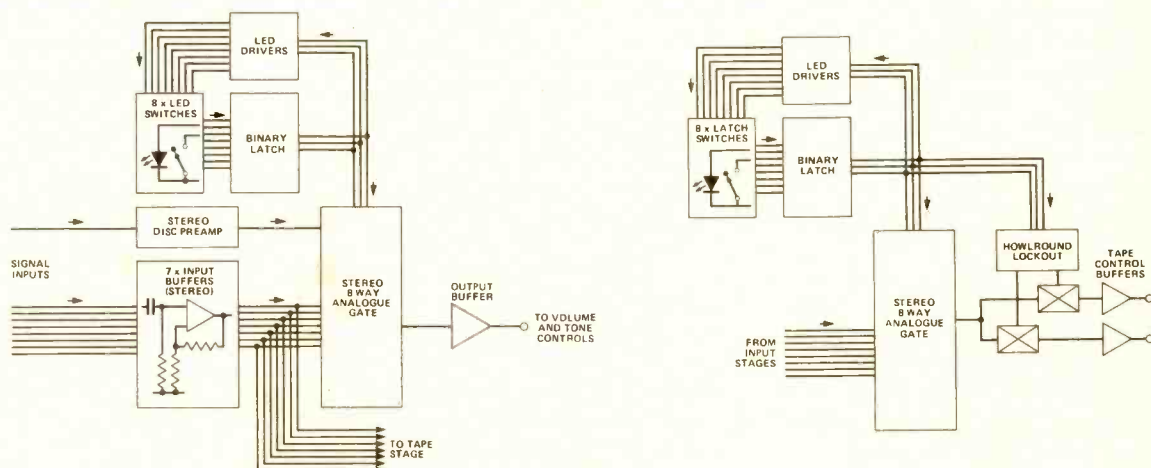

state of the switches in binary, which is what is needed to connect to the signal switch board. To illuminate the LEDs therefore requires a decoder. If an ordinary CMOS IC were used as a decoder it would still be necessary to add drive transistors because the current output from an ordinary CMOS IC is insufficient for the task. An analogue switch IC, however, can switch enough current for the job without being overloaded.

The scheme is illustrated by the block diagram, Fig. 1.

Boardspace

Even with a total of five ICs on it, the switch board occupies enough area to interfere with a compact front panel layout, so it was decided that some of the ICs should be on a separate board mounted on the switch board. To minimise the number of connections between the two, the LED driver IC is on the same board as the switches.

With some careful thought it was possible to design a pair of equal sized boards which will mount back to back. All connections between them are via pads which are in similar positions on each board, so that they may be interconnected and held together by straight pieces of tinned copper wire or by hermaphrodite blade connectors.

The result is a neat assembly which does not occupy too much more panel space than the switches alone. The switches themselves are stacked side by side, so that only a single rectangular cut-out is required in the front panel.

Assembly

One of the first things to notice in assembling the boards is that both of them are double sided, and that the switch board has components mounted on both sides (Fig. 2). For this reason, components should be assembled in the specified order or they may be difficult to fit.

The first thing to do is to fit track pins or pieces of tinned copper wire to the through holes connecting from top tracks to

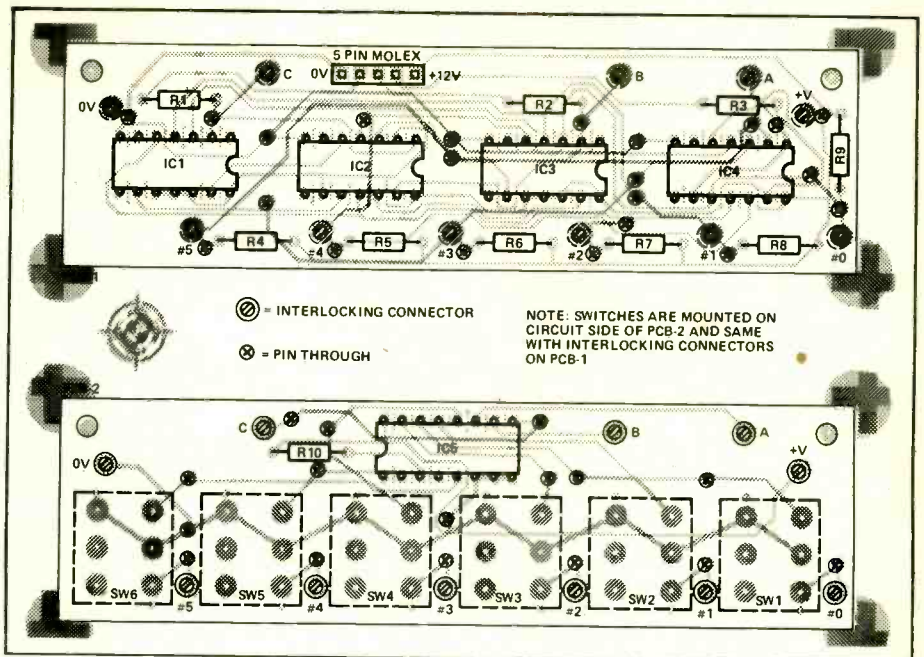
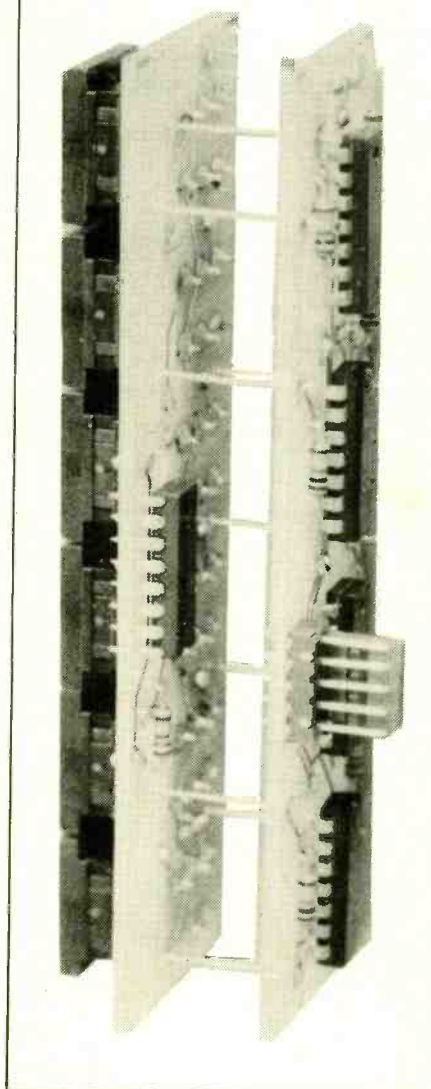

Fig. 2 Component overlay of the latch module boards which are both double-sided.

The two boards are joined by stiff wire: switches on the left.



bottom tracks on both boards.

The resistors can be fitted next, followed by the ICs and the five way Molex connector on the latch board. Don't forget to observe static precautions when handling the CMOS ICs. Because of the way this unit is assembled, it would be more than usually difficult to change a damaged IC.

If you decide the boards are to be joined by means of hermaphrodite connectors then the connector blades should be joined together and then fitted between the two boards (Fig. 3). When the boards and connector blades are in place they should be soldered in. Now the switches can be fitted, on the opposite side from the connectors. It is not easy to solder the connectors after the switches are fitted.

If the boards are to be joined by means of tinned copper wire, a slightly different procedure is required. Pieces of wire about an inch long should be soldered on to the switch board, with their ends folded over to improve the mechanical strength of the joint. Then fit the switches.

Now the rear board should be fitted over the wires, and the wires should be joined to the pads by a small dab of solder, to make a sound but temporary joint. The unit should now be tested, and any fault can be traced and remedied without the need to unsolder the tinned copper wire.

PROJECT: Audio Selector

When the unit is in working order, the solder should be sucked off the temporary joints and the latch board should be pushed closer to the switch board, for the sake of neatness and mechanical strength. When the boards are only far enough apart to avoid the danger of a short circuit, the tinned copper wire should be clipped to length and soldered to the pads on the latch board permanently. A brief retest should confirm that the unit still works.

Testing

The boards cannot be tested separately, so it is important to be able to take them apart to correct any faults. Once they are fitted together temporarily, as described above, they can be tested.

Connect a source of 12V DC to the molex connector and try pressing each switch in turn. The LED in the switch most recently pressed should illuminate and stay on until another switch is operated. If this does not happen, then it is necessary to trace

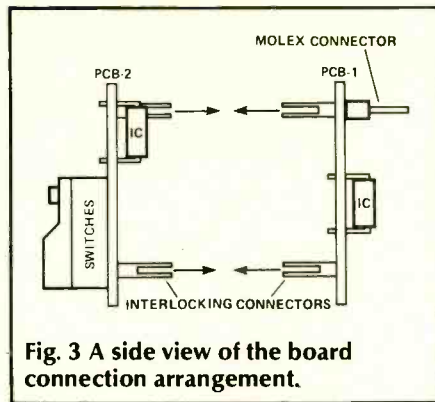

Fig. 3 A side view of the board connection arrangement.

through the logic and find the gates which are not in the correct state.

From the circuit diagram it is simple to trace which latches should be in which state when a

given switch is pressed. If all three latches are in the expected state, but the appropriate LED still does not light up, then check the connections to the 4051, IC5.

If not all the latches were in the right state, you should check that the relevant gate inputs switch to logic 0 when the switch is operated. If they do, then the next thing to check is whether the output of each gate follows the correct logic function in relation to its inputs. If it does not, then the IC either has a short circuited output, or is dead.

Coming next, the signal switch incorporating RIAA equalization and input/output buffering.

PARTS LIST

RESISTORS

R1 to 9 10k

R10 2k2

SEMICONDUCTORS

IC1, 3 4068

IC2, 4 4012

IC5 4051

MISCELLANEOUS

6 x LED keyswitches; 1 x 5 way Molex connector; 22 x hermaphrodite blade connectors; track pins' PCBs.

HOW IT WORKS

The principle on which this circuit works is straightforward (Fig. 4). Each switch sets or resets each of the latches, so that the state of the latches is a binary code giving the number of the switch last operated. Each latch half must have enough inputs to correspond with the number of times it appears in the truth table for the circuit. This is shown in Table 1.

If the circuit were designed for the eight states possible with three bits, then each half of each latch would need four inputs from switches, as well as one to sustain the latch action. Because only six states are actually used, some parts need less inputs, as is evident from an inspection of the truth table.

The binary output of the latch is short circuit protected by 10k series resistors, though the connections to the LED driver on the switch board are direct. The LED current itself is determined by R10 and by the on resistance of the 4051. This latter is sufficiently low that there will be no significant difference between different samples of the unit. The value of R10 is chosen to keep the current through the 4051 within its specification.

TABLE 1

Switch No.	Q _c	Q _b	Q _a
1	0	0	0
2	0	0	1
3	0	1*	0
4	0	1*	1
5	1*	0	0
6	1*	0	1

* gates requiring only 3 inputs.

BUYLINES

No problems here. The keyswitches are RS type 337-374 (red), 337-380 (green) available from Electromail. They will also supply the hermaphrodite connectors, which should be vertical types, part number 434-188.

ETI

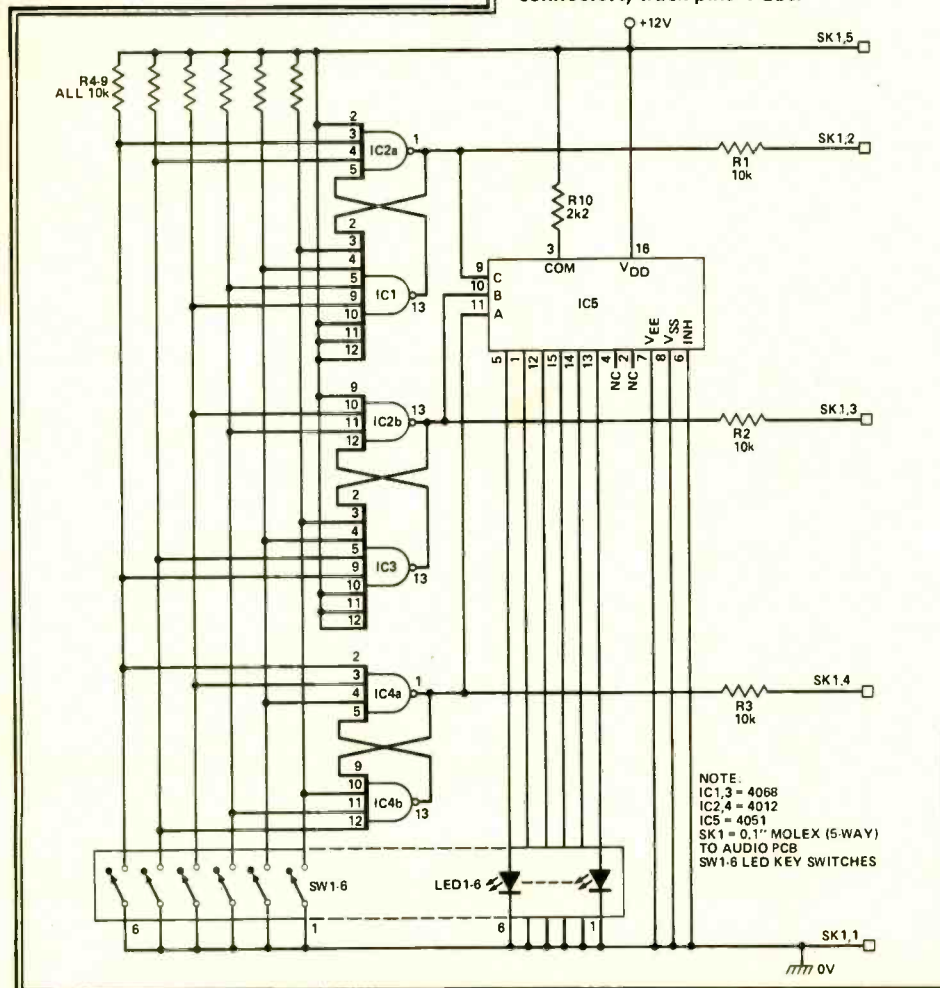

PLL FREQUENCY COUNTER

With the construction, testing and setting-up notes, Graeme Durant's frequency counter is complete.

The complete unit is built up on four PCBs. These are designed to fit the mounting hardware in the enclosure used in the prototype. The display PCB is single-sided and requires a small number of wire-links to be inserted. The main PCB and the ranging PCB are double-sided and require connections to be made between the two layers. Where a component lead is used to make this through connection, it must be soldered on both sides of the boards: Otherwise use a short length of tinned copper wire to connect opposite tracks.

Apart from these links, the PCBs should be assembled as normal — start with the resistors and capacitors, then move on to the diodes and transistors. Finally the ICs should be added — note that those ICs on the two double-sided boards require soldering on both sides of the boards, so conventional IC sockets cannot be used. The answer is either to grit your teeth and solder them all in place, or get special IC sockets which can be soldered on both sides of a PC board (these are available from Verospeed).

The CMOS devices require the usual careful handling. The small display for the range on the display PCB is soldered in as normal, but the main four digit display, LED5, is a little different. This has a series of PCB pads along one edge for making the connections, and so short lengths of tinned copper wire should be used to make these connections to the display board.

The four indicating LEDs on the front panel should be soldered in place with enough lead length



outstanding to make them push-fit into the front panel. The push switch should be fitted at a similar height, to protrude slightly from the front panel. There is about 20mm between the display PCB and the front panel and I used veropins to lift the push switch off the board to the required height.

The three PCBs are interconnected by flexible 0.1" spaced multiway jumpers. The connections to the display PCB are soldered to the copper track side of the board, whilst the connections to all the other PCBs

are to the component sides. These flexible interconnections allow the display PCB and the ranging board to be mounted vertically in PCB guide slots. The main PCB is fixed horizontally between them using self-tapping screws into the mounting pillars provided in the base.

Care should be taken with the main connections to the power supply PCB. These should be made via a suitable 500mA fuse for safety, and all live connections should be insulated using sleeving. Once tested, the output of the power supply unit must be individually connected to the main PCB and the ranging PCB.

Apart from the four indicating LEDs and the push-switch for range hold mentioned previously, the front panel should be fitted with a display bezel through which

OOPS!

In the circuit diagram on page 30 of last month's ETI, the two input pins of IC14a (pins 1 and 2) should be shown connected together. The unidentified component between C13 and CV1 in the same diagram is XTAL1.

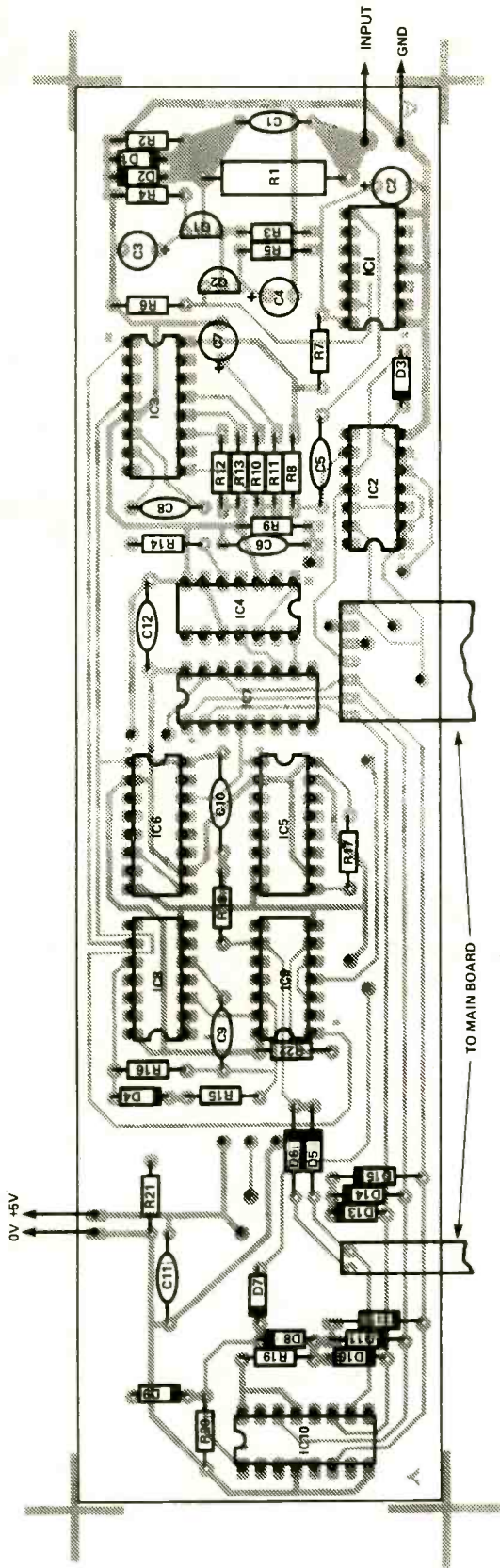

Fig. 1 Component overlay for the ranging PCB.

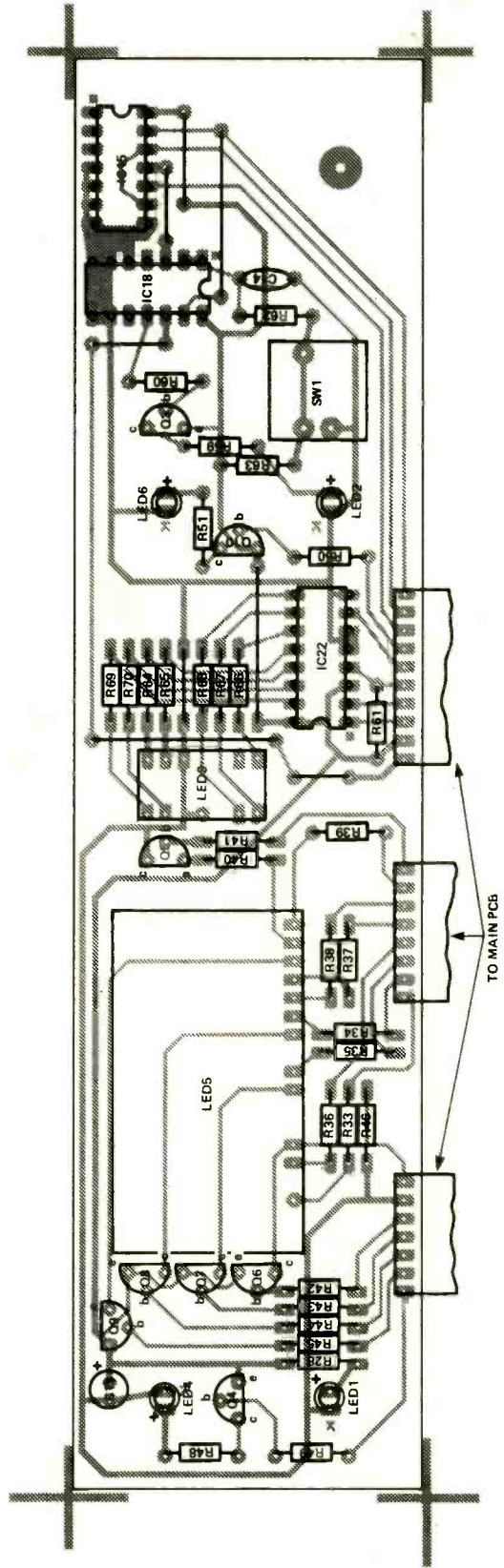

Fig. 2 Component overlay for the display PCB.

PROJECT: Frequency Counter

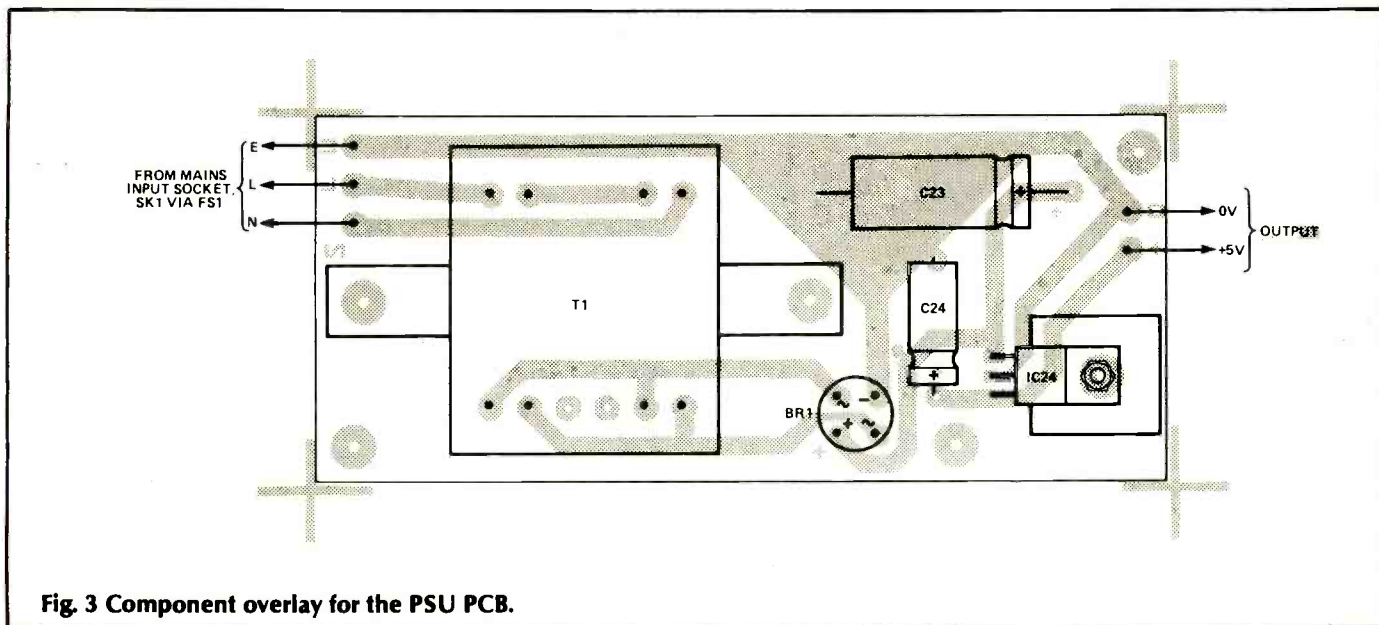

Fig. 3 Component overlay for the PSU PCB.

PARTS LIST — RANGING BOARD

RESISTORS

R1	10k 1W
R2	1M0
R3	1k5
R4	1k0
R5	470R
R6	330R
R7	10R
R8, 9	1M5
R10	150k
R11, 12, 15, 18, 19	10k
R13	270k
R14, 17, 22	4k7
R16, 20, 21	100k

CAPACITORS

C1, 8	560p
C2,3	10u 16V radial electrolytic
C4	100u 16V radial electrolytic
C5, 6, 10, 11, 12	100n polyester
C7	2u2 16V radial electrolytic
C9	220n

SEMICONDUCTORS

IC1	74LS13
IC2,9	4011
IC3	4046
IC4	74LS90
IC5, 6	4518
IC7	74LS253
IC8	4001
IC10	4510
Q1	2N3819
Q2	BC557
D1, 2	1N914
D3-15	1N4148

MISCELLANEOUS

PCB; ribbon cable for connections to main board.

PARTS LIST — DISPLAY BOARD

RESISTORS

R28, 33-40, 48, 51, 59	120R
R41, 49, 50, 60	10k
R42-45	270R
R46, 61, 62	100k
R63	4k7
R64-70	470R

CAPACITORS

C14	100n
C19	100u 16V radial electrolytic

SEMICONDUCTORS

IC15	4013
IC18	4093
IC22	4511
Q3-10	BC557
LED1, 2, 4, 6	rectangular red LED
LED3	0.3" digit 7-segment LED display
LED5	4 x 0.5" digit 7-segment LED display

MISCELLANEOUS

SW1 non-latching, push-to-make keyboard switch

PCB; ribbon cable for connections to main board.

PARTS LIST — PSU AND CASE

CAPACITORS

C23	1000u 25V axial electrolytic
C24	10u 16V axial electrolytic

SEMICONDUCTORS

IC24	7805
BR1	W005 or other bridge rectifier rated at 50V, 1A or more

MISCELLANEOUS

FS1	1A fuse and panel-mounting holder
SK1	BNC socket, panel mounting
SK2	Chassis-mounting IEC mains plug
SW2	DPDT mains switch, rocker or toggle
T1	9-0-9V, 6VA PCB-mounting mains transformer

PCB; heatsink for IC24; case (see buylines); display bezel for front panel plus colour filter if required; nuts, bolts, etc.

BUYLINES

Virtually everything in this design is readily available from any number of suppliers. The case is made by O.K. Industries and can be obtained direct from them or from RS Components.

Note that RS parts can now be ordered through Electromail (see last month's News Digest). The PCBs will be available from our PCB Service — see page 62.

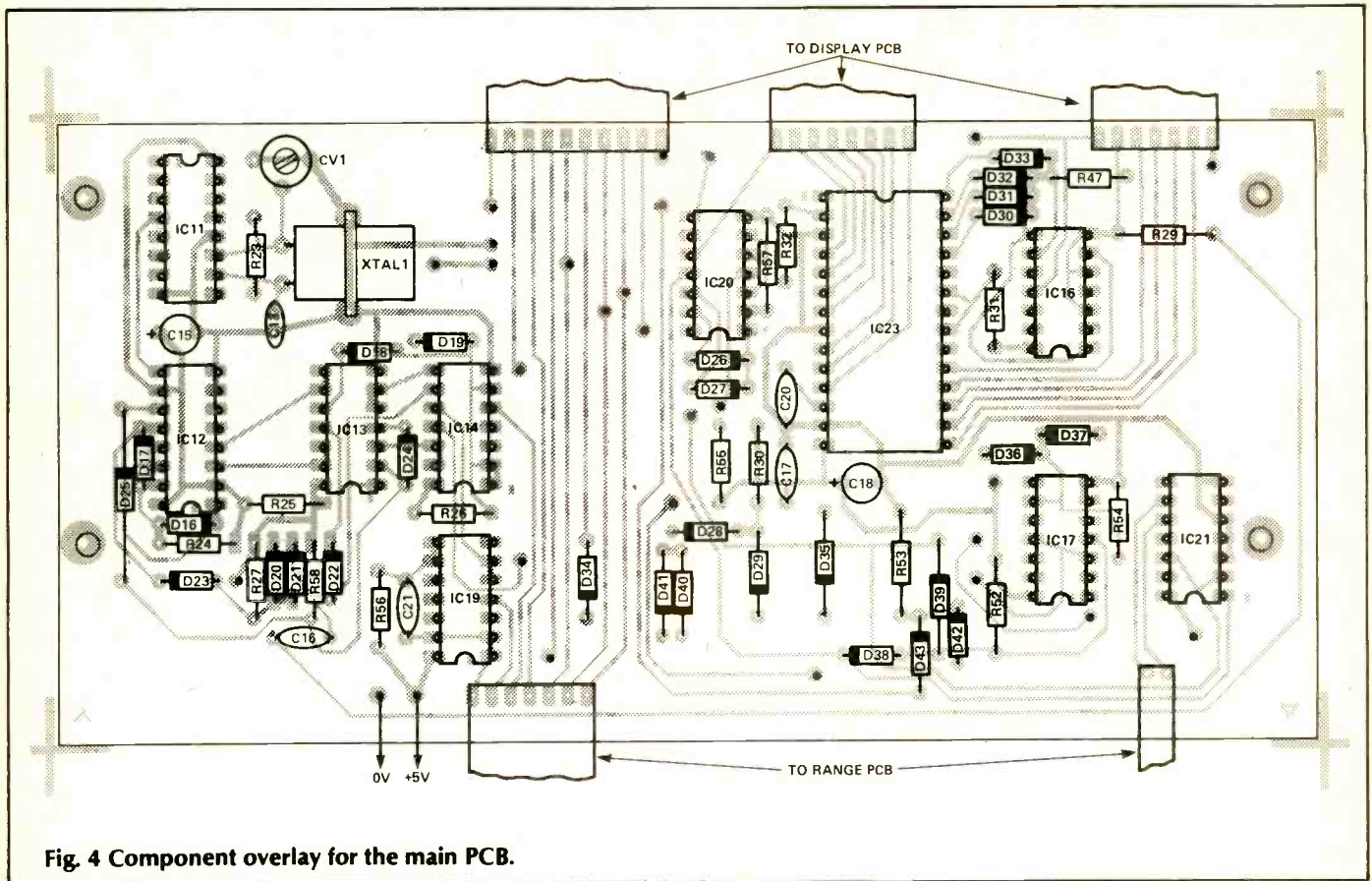

Fig. 4 Component overlay for the main PCB.

PARTS LIST — MAIN BOARD

RESISTORS

R23	10M
R24, 26, 27, 29, 30,	
47, 52-58	100k
R25	100R
R31, 32	1k0

CAPACITORS

C13	22p
C15	10u 16V radial electrolytic
C16, 21	1n0
C17	100n
C18	100u 16V radial electrolytic
C20	10n
CV1	2-22p trimmer

SEMICONDUCTORS

IC11	4060
IC12	4520
IC13, 14, 20	4011
IC16, 17	4013
IC19	4093
IC21	4073
IC23	ZV1040E
D16-43	1N4148

MISCELLANEOUS

XTAL1	3.2768MHz crystal
-------	-------------------

PCB; ribbon cable for connections to other boards.

to view the readout, and an input socket. This socket needs to be wired up to the ranging PCB. Ordinary miniature co-axial cable is suitable and this passes through a hole provided in the display boards to the input connections on the range PCB.

Testing

Before the power supply board is connected, test that its output voltage is $5V \pm 0.2V$. If it isn't, check the circuit thoroughly; we do not want all your expensive counter circuitry to perish at this early stage! When all is well, connect up the power supply to the main PCBs and switch on.

Hopefully, the power LED should light, the count LED should flash regularly and the main display digits should read all zeros, flashing on and off to indicate that no input signal is present. If any of these things fail to work correctly, switch off the power immediately and check the circuitry once again, taking care to observe the orientation of polarised components and semiconductors and your soldering. If all is working

as described, connect an input signal of some sort. The display should blank briefly, then show a readout and range indication.

The only setting up required inside the unit is the twiddling of CV1, a trimmer which allows fine adjustments to be made to the timebase crystal frequency. If another frequency counter is available, adjust CV1 until the signal frequency at pin 7 of IC11 is exactly 204,80Hz. If no counter is obtainable, setting CV1 about half-way will give acceptable results, with readings accurate to one or two digits. This completes the extensive calibration procedure!

Use

The counter is very simple to use. You only have to connect an input signal greater than about 35mV RMS, and wait for the correct range to be selected. Input frequencies above 10MHz will light the over-range LED. This LED can also be used to provide a limited increase in the available measurement resolution at range extremes. This is achieved in

PROJECT: Frequency Counter

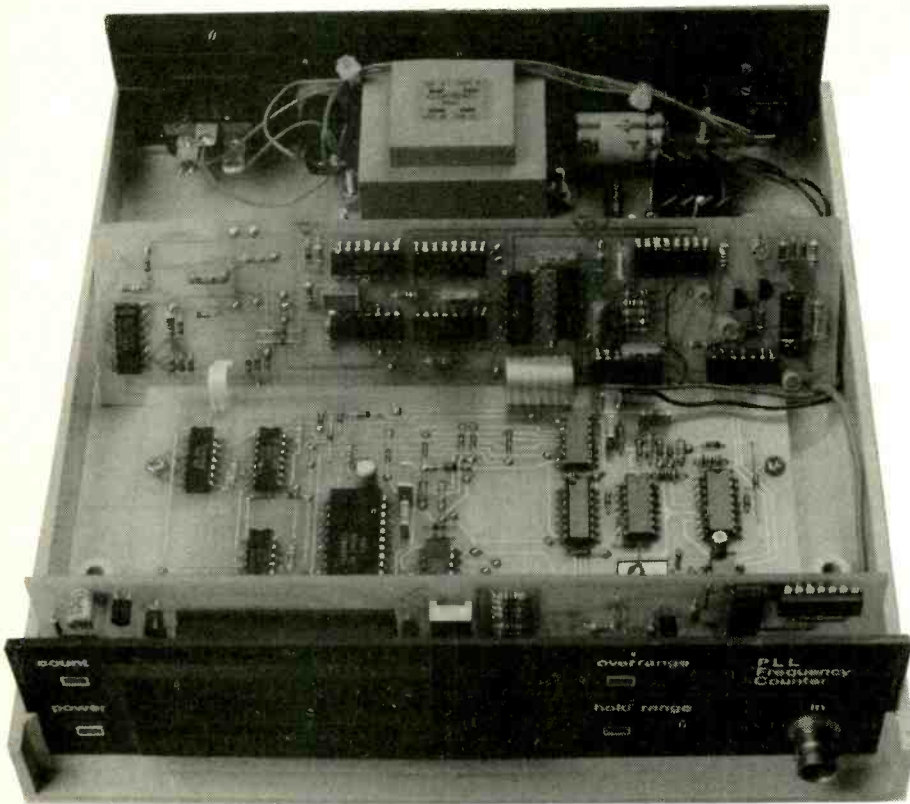

Inside the frequency counter — note the four PCBs.

conjunction with the hold range function.

Pressing this button when a stable reading is obtained should hold the current range and flash the panel LED. If the held range's top end is exceeded, the over-range LED will light to indicate the position, but the display will remain valid unless the PLL loses lock. In this case, the overrange condition can be interpreted as an extra most significant one digit, the four following digits being shown on the display.

Naturally, the range hold function can be used at the lower end of a range, but if the input signal frequency becomes less than the lower extreme, one digit's accuracy is lost — it would be better to have held the next range down.

If at any time the PLL loses lock, due to too big a change in input frequency or the loss of the input signal, the hold range function will automatically cancel, and auto-ranging will take over.

ETI

NEW FROM **Cirkit**

HM 203-6 Oscilloscope

Y: 2ch, DC-20MHz, sens 2mV/cm
x: 0.2s - 20ns/cm incl. x10 magnification

Triggering up to 40MHz

Component tester

Supplied with 2 x1/x10 switchable probes.

Already widely used and recommended in schools, colleges and universities the Hameg HM203-6 is Western Europe's best selling oscilloscope. Cirkit are pleased to offer the HM203-6 to the hobbyist.

Both vertical amplifiers incorporate variable gain controls and max input sensitivity is 2mV/cm over the full bandwidth, the sum and difference of the two signals may be displayed. In addition to line and TV triggering, HF and DC triggering are possible. The HM203-6 will trigger stably with a 5mm display height up to at least 40MHz. Using the manual level control even relatively complex signals can be stably triggered. The time resolution in horizontal direction including x 10 magnification is 20ns/cm (max).

An 8 x 10cm internal graticule permits parallax free viewing over a wide angle. Also featured is a built-in component tester, which, among other applications, enable rapid in-circuit testing of semiconductors.

Supplied complete with instruction manuals, 2 x1/x10 probes and a full 2 year warranty.



Price £328.45 inc. VAT and carriage.

The HM203-6 is just one of many new products featured in the new Winter edition of the Cirkit catalogue — on sale at your newsagent for October 16th.

Full details of this and other models from:-



Cirkit Distribution Ltd

Park Lane, Broxbourne, Herts EN10 7NQ Telephone: (0992) 444111 Telex: 22478



BEST PRICE COMPONENTS

FOR HOBBYISTS, BUSINESS USERS, EDUCATIONAL ESTABLISHMENTS, ETC.

PRICES HELD

Unlike other suppliers whose prices are subject to change without notice, we guarantee not to increase our prices during the cover months of ETI. You may order in confidence from our large stocks ready for despatch by return of post.

DISCOUNTS

You do not have to buy 25+ or 100+ of a single device from MICROKIT LTD to benefit from a discount. Our discounts are based on the total value of your order, regardless of mix.

10% DISCOUNT ON ORDERS OVER £25, ADD 15% V.A.T., SENT P&P FREE U.K. 15% DISCOUNT ON ORDERS OVER £100, ADD 15% V.A.T., SENT P&P FREE U.K. ORDERS UNDER £25 ADD 15% V.A.T. PLUS 50p P&P FOR U.K. OVERSEAS ORDERS WELCOME. ADD £2 P&P, NO V.A.T. (PAYMENT IN STERLING PLEASE).

MEMORIES

We only stock memories manufactured by established manufacturers whose products have been subjected to long-term U.K. testing like: NEC, MITSUBISHI, HITACHI, TOSHIBA, INTEL. Beware of cheap Far Eastern devices sold elsewhere.

DRAM 5v NMOS 150nS

(not Samsung or Texas)	
4164 64K x 1	£0.99
41256 256K x 1	£2.20
4416 16K x 4	£2.80
41464 64K x 4	£5.90
MSM37564 128K x (IBM AT upgrade)	£5.90

SRAM 5v CMOS 150nS

2114 1K x 4	£1.50
6116 LP 2K x 8	£1.30
6264 LP 8K x 8	£2.40
62256 LP 32K x 8	£39.50

EPROM 5v NMOS 250nS

2716 2K x 8 350 nS	£2.25
2732 4K x 8 250 nS	£2.75
2764 8K x 8 250 nS	£1.95
27128 16K x 8 250 nS	£2.45
27256 32K x 8 250 nS	£3.95

EPROM 5v CMOS 250nS

27C64 8K x 8	£8.50
27C256 32K x 8	£15.00

EEPROM

2816A 2K x 8 250nS	£13.50
2864A 8K x 8	£45.00

4000 SERIES CMOS

4000	17p	4011	20p	4024	30p	4512	35p
4001	20p	4012	20p	4025	20p	4516	35p
4002	20p	4013	25p	4040	35p	4518	25p
4006	40p	4014	35p	4051	35p	4528	35p
4007	20p	4015	45p	4052	35p	4532	35p
4008	35p	4016	25p	4069	20p	4538	45p
4009	35p	4018	35p	4070	20p	4539	40p
4009UBP	45p	4019	35p	4093	25p	4540	40p
4010	35p	4020	45p	4511	35p	4555	25p

OUR EXTREMELY POPULAR EX-EQUIP MEMORIES

GUARANTEED UV ERASED, CLEANED & TESTED.

1000's sold to delighted customers

4116 16K x 1 DRAM

ONLY 60p EACH

2716 2K x 8 EPROM

ONLY £1.50 EACH

2732 4K x 8 EPROM

ONLY £1.50 EACH

FLOPPY DISK CONTROLLERS

WD 2797	£20.00
FDC 765A	£12.00
FDC 9218B	£12.00
FDC 9229 BTP	£25.00
FDC 1793	£19.00
FD 1691	£12.00

REGULATORS

ALL TO220 PACKAGE

7812	35p	10 FOR	£3.00
78M12	35p	10 FOR	£3.00
LM337	£1.00	10 FOR	£9.00

LINEAR BARGAINS

TL072CP	50p	TLC27L4CN	£1.99	SN75154N	95p
TL074CN	80p	LM311P	40p	OP07CP	£1.20
TL082CP	40p	LM324	40p	ULN2003AN	70p
TL084CP	85p	LM348N	45p	ULN2004AN	70p
NE555	20p	LM358	45p	AM26LS32ACN	£1.00
TLC555CP	70p	LM3900N	65p	ADC0808N	£8.75

74HC CMOS LOGIC

74HC00	25p	74HC42	53p	74HC157	58p	74HC242	88p
74HC02	25p	74HC51	25p	74HC158	58p	74HC244	88p
74HC04	38p	74HC74	58p	74HC161	78p	74HC245	98p
74HC04	38p	74HC86	48p	74HC164	63p	74HC257	98p
74HC08	25p	74HC107	36p	74HC165	73p	74HC259	78p
74HC10	25p	74HC109	43p	74HC166	63p	74HC273	98p
74HC11	25p	74HC123	53p	74HC173	63p	74HC373	98p
74HC14	53p	74HC132	78p	74HC174	63p	74HC374	88p
74HC20	25p	74HC138	58p	74HC175	93p	74HC393	98p
74HC27	25p	74HC139	58p	74HC240	£1.08	74HC4040	£1.18
74HC32	38p	74HC153	48p	74HC241	88p	74HC640	£1.18

TELEPHONE 0327 860130 (24 HOUR SERVICE)

LARGE QUANTITY TRADE DISCOUNTS, TECHNICAL ADVICE, ETC.

MICROKIT LIMITED

BLAKESLEY, NORTHANTS NN12 8RB

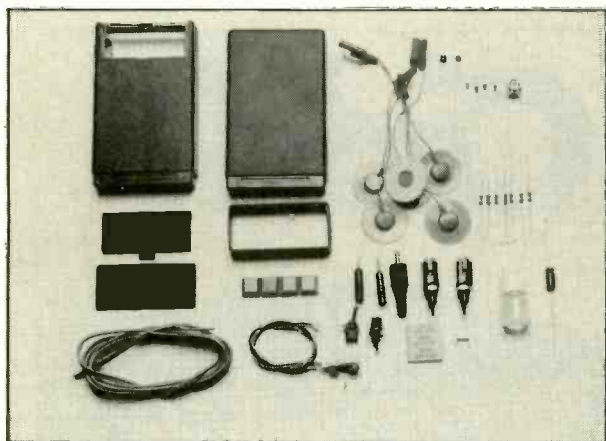

YOUR EXPANSION PARTS SET:

CASE WITH BUILT-IN BATTERY COMPARTMENT — BATTERY CONNECTOR — PLASTIC FEET FOR CASE — MINIATURE TOGGLE SWITCH — PHONO PLUG AND SOCKET — TERMINALS FOR METER CONNECTION — SIX PROFESSIONAL ELECTRODE PADS — SACHET OF CONDUCTIVE GEL — PADS FOR FIXING PCB TO CASE — LEAD AND — PLUGS FOR ELECTRODES — SIXTEEN COMPONENTS

All the parts you need to turn your free bio-feedback circuit into a highly responsive GSR monitor. The resulting instrument is sensitive enough to respond to the slightest change of mood.

Note: Parts supplied may not correspond exactly to the photograph. Offer while stocks last — order early!

ONLY £12.95 + 60p p&p

SPECIAL OFFER!!

BIO-FEEDBACK EXPANSION SET

Three sets of professional electrodes are included, together with the special conductive gel that allows precise measurements to be made. By special arrangement we can offer the complete expansion parts set for **ONLY £12.95 + 60p postage (UK only) inclusive of VAT.**

To order by post, please send the order form (or copy) with your remittance to: ASP Readers Services (RO ET4), 9 Hall Road, Maylands Wood Estate, Hemel Hempstead, Herts.

Phone ACCESS or VISA only: 0442 211882

ORDER CODE: RO ET4. Please supply.....

.....EXPANSION SETS at £13.55 inclusive

NAME

ADDRESS

REMITTANCE ENCLOSED: £.....

CREDIT CARD ORDERS: I authorise you to debit my

ACCESS/BARCLAYCARD No.

to the sum of £ Signed

Please allow up to 28 days for delivery. Thank you.

SPECIAL PULL-OUT

DIGITAL ELECTRONICS

**MADE
EASY**



SUPERKIT £22.00
SUPERKIT II £16.00
(£35.00 if bought together)

The **SUPERKIT** series introduces beginners to practical digital electronics. **SUPERKIT (SUP I)** is the first kit, which contains an instruction manual, a solderless breadboard, and components (7 integrated circuits, switch, resistors, capacitors, LEDs and wire). It teaches boolean logic, gating, flipflops, shift registers, ripple counters and half adders. **SUPERKIT II (SUP II)** extends **SUPERKIT**. It contains an instruction manual and components (10 integrated circuits, 7-segment display, resistors, capacitors and wire), and explains how to design and use adders, subtractors, counters, registers, pattern recognisers and 7-segment displays.

DIGITAL COMPUTER LOGIC £7.00
DIGITAL COMPUTER DESIGN £9.50
MICROPROCESSORS & MICROELECTRONICS £6.50

The **SUPERKIT** series is backed by our theory courses. **DIGITAL COMPUTER LOGIC (DCL)**, the beginners' course, covers the use and design of logical circuits, flipflops and registers. **DIGITAL COMPUTER DESIGN (DCD)**, a more advanced course, covers the design of digital computers both from their individual logic elements and from integrated circuits. **MICROPROCESSORS and MICROELECTRONICS (MIC)** teaches what a microprocessor is, how it evolved, how it is made and what it can do.

GUARANTEE. If you are not completely satisfied, return the item to us in good condition within 28 days for a full refund. All prices include worldwide surface postage (ask for prepayment invoice for airmail). Orders despatched within 48 hours. Overseas payment by international credit card or by bank draft drawn on a London bank.

CAMBRIDGE LEARNING LTD, Unit 13,
 FREEPOST, St. Ives, Huntingdon, Cambs. PE17 4BR, England.
 Telephone: 0480 67446.

VAT No. 313026022 Transcash No. 2789159 Reg. No. 1328762

Please send me (initial letters used):

.....	SUP I	@ £22.00	DCL	@ £7.00
.....	SUP II	@ £16.00	DCD	@ £9.50
.....	SUP I + II	@ £35.00	MIC	@ £6.50

Full details of all your courses (please tick)

I enclose a cheque/PO payable to Cambridge Learning Ltd.

for £.....

Please charge my credit card.

No. Expiry date

Telephone orders from credit card holders accepted on 0480 67446 (24 hrs).

Name

Address

..... Signature.....

CAMBRIDGE LEARNING LTD

Unit 13, Rivermill Site, FREEPOST,
 St. Ives, Huntingdon, Cambs PE17 4BR
 England.



TAKING CARE OF BUSINESS

In this month's pull-out business supplement, we'll be looking at the different forms in which you can constitute yourself as a business — a sole trader (with or without employees), a partnership, a limited company or a co-operative.

The basic structure and requirements of each are examined, so that you can make this important decision with at least some information. Of course, you'll be able to get further details by following the addresses in last month's issue. Many of the organisations represented there have as their express purpose the giving of such advice.

Which brings me to this month's address list. Before moving on to the addresses of organisations necessary or useful to your research and product development, important government and industry bodies and a key list for that bright scientific or technical idea, we're listing the addresses of some higher profile sources of finance and several institutions to help with those niggling little problems like sorting out your tax and insurance. Ho hum.

Somebody who seems to have no problem with tax and insurance is Jim Marshall, the man with his name on a million watts of rock n' roll amplification. The ebullient Marshall is profiled this month and, as they say, if he can make it selling amps with built-in distortion, there must still be golden opportunities in electronics.

The Editor

Helen Armstrong gets the low-down on Jim Marshall, the name behind (and on the front of) a million guitar amps.

"I'm a pain in the neck to people to who try to sell me advertising," chortled Jim Marshall around a healthy-sized cigar. "I couldn't pay for all the TV advertising we've had. We have a self-advertising product."

The combination of cognac, cigar and black company sweatshirt marks him out as a man who has done well in his business. The chuckle says that he's still enjoying himself. Jim Marshall (Products) Ltd. is in its 24th year as purveyor of amplifiers to rock groups who invoke the cry "turn that **** thing down..." from the next street.

Marshall combines standard electronics and meticulous production engineering to meet the preposterous demand for amplifiers deliberately designed to overdrive and give a distorted output. He identified his product by listening — first to musicians who visited his music store in Hanwell, West London, and secondly to the prototype built by engineer Ken Bran. They tweaked the design for several weeks, until they heard the right sound.

Self Taught

Childhood illness curtailed Jim Marshall's education but not his will to learn. In his teens, he started work as a self-taught toolmaker, and took up singing. He picked up drum technique doing interval slots. In 1946 he got some tuition, and three years after that he was teaching.

MUSIC TO YOUR EARS

It was as a drum teacher that he made the money and contacts which fuelled his business.

Drumming is not a conventional entry into manufacturing, but Marshall had the knack of taking good advice. He bought so many kits for pupils that a supplier suggested he start selling. One regular visitor was Peter Townshend of the Who, who advised Marshall to stock guitars and amplifiers as well as drums.

Marshall's first manufacturing venture was inspired by bass players who were being outgunned by the guitarists. In the shop, he started making specialised bass cabinets, with one 18" speaker in a sawdust-packed case. Later a 25W Leak amplifier was added and they were sold as a package.

Nineteen-sixty-two saw the arrival of Ken Bran, ex-pro musician and engineer. Bran suggested that they should produce amplifiers, as well as speaker cabinets. Marshall's priorities quickly switched from bass to lead guitar.

Creative Distortion

Creative distortion arose in the 1960s when guitarists started squeezing too much signal through low-powered valve amps. They needed a more powerful unit which would distort reliably. Marshall and Bran presented rock with an amplifier which would produce distortion under (more or less) controlled conditions.

Scouting around military surplus stores, Bran chose two 5880s for the output stage, ECC83s for the preamp, and a GZ32 rectifier. The prototype was built; as soon as the sound was there, the JMT45 Mk2 went on sale, Bran manufacturing one per day to meet demand.

The power and distortion of the original design, known as the Standard, crept up gradually to 50W with a switch first to KT66 valves and later to EL34s. The GZ32 was replaced with a semiconductor.

Pete Townshend was again asking for a more powerful amp. Ken Bran designed around four 6V6 valves, a GZ34 and a 50W transformer, the largest that Radio

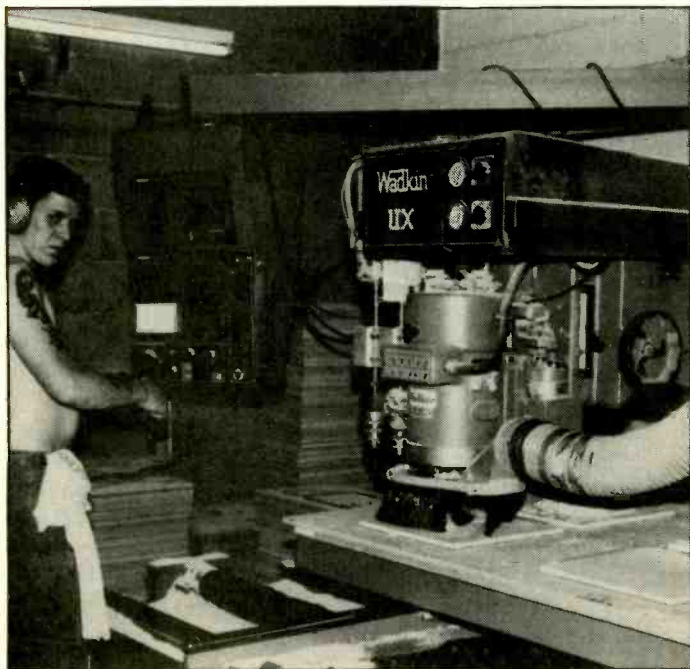

A CNC machine cuts four identical wooden cabinet panels.

Spares could supply. When this could not handle the power, Brans switched to two 30W. This worked well, and laid the way for two 50W transformers giving over 100W.

By the time this design was ready in 1965, changes included KT66 valves, a single 100W transformer, and semiconductor rectifiers. Again Jim Marshall's information paid off: the Who were part of a new generation who wanted enormous amplifier power.

Big Break

Marshall's biggest break was meeting Jimi Hendrix, whose English drummer, Mitch Mitchell, was a former pupil. 'Hendrix said "I'm going to be the best in the world". I thought, "another one who wants free equipment", but straight away, he says "I pay the full price for everything, but I want 100 per cent service back up. The first time you let me down, that's the end." And we backed him up, right round the world. He was a nice chap.' Marshall's policy 'Whoever Plays A Marshall, Pays for It', has no exceptions.

Rows of Marshalls behind Jimi Hendrix, The Who, Cream and other premier bands established the name. The showmanship was not, however, solely with the bands.

'When I started drumming, I was playing in variety. All the comedians had their backdrops, which set the stage for them. The musicians didn't have anything.

'Eventually Pete Townshend asked us for some 8 x 12 cabinets. Instead, we built two 4 x 12 cabinets, and stood them one on top of the other.' Says Marshall: 'I was thinking of image when I designed the stack. I've been thinking of ways to improve the Marshall image for the last 24 years, and I can't think of how!'

'Hendrix said "I'm going to be the best in the world". I thought "Another one who wants free equipment"...

So the Marshall stack was born, man-high, super-powerful, as essential to the guitar hero as a white stallion to the Lone Ranger.

In 1975, a version of the Standard was given volume control to allow high gain effects at low volume. The 100W Master Volume amp head has become Marshall's most popular model.

Distorted Creation

As the photograph shows, a Marshall valve amp at full output gives a large percentage of distortion, but no abrupt transitions. Consequently, the harmonics are of a low order: lots of third, a little fifth, a dash of seventh. The distortion is symmetrical, with few even order harmonics. The distortion produced by a transistor amp (whether crossover or clipping) has sharper corners with many high order harmonics, even ultrasonics, which are much harsher on the ear.

In any master volume design, distortion is produced in a single ended preamp: this is non-symmetrical, with even-order harmonics, but smooth clipping transition, smoother than transistor but not so smooth as output stage distortion.

Valve amplifiers remain big business in rock, despite potential problems of greater weight, cost, fragility and valve supply.

Says Marshall: "We do about the same value of business in valve and solid states; we sell a larger number of transistor amps at lower prices."

The first combo amps in 1965 were a match-up of the JTM 45 amplifier and early Celestion G12 speakers, sufficiently under-rated to add their own distortion! Various designs came and went. The mainstay of today's valve range is the Master Volume with models from 15 to 100 watts, alongside an equally extensive transistor range, and several bass and keyboard models.

Art Of Noise

Celestion make speakers to Marshall specifications, mostly variations on the G12, with power handling well above the amplifier rating. Mike Hill — director in charge of engineering production — explains, 'We choose speakers which saturate in the right way at the limits of the amp's performance. Speakers saturate in different ways before overloading, and they must roll off where you want them to.'

Marshall comments, 'Myself, Mike and Ken get together over a breadboard model with Steve Grindrod, the development engineer, and we try different speakers for the right sound. It used to be down just to me and Ken.'

All the cases are made from 15mm grade A birch plywood, with edges comb jointed for maximum gluing area, and then RF-curved in a press. Heavy-duty cloth-backed vinyl covering, made to Marshall's specification, is applied by hand.

I expressed surprise, bordering a little on shock, at a pile of bright scarlet cabs. 'We make all colours — it's up to the distributors what they take,' explains Hill.

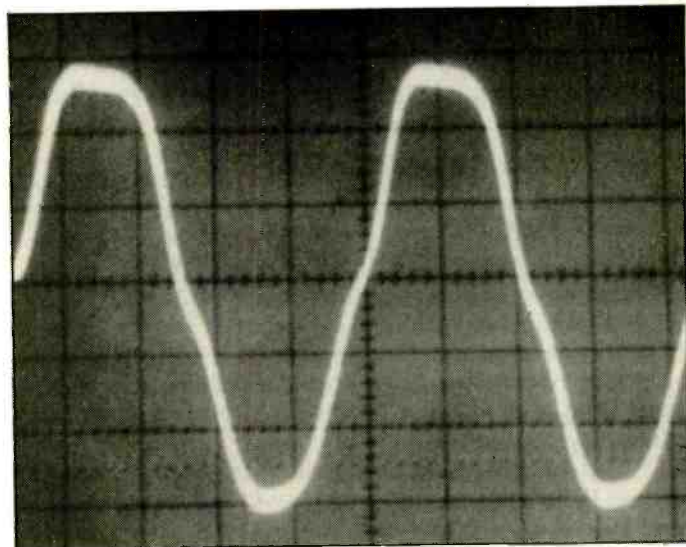

The Marshall sound — the output of a valve amp fed with a sine wave input. Note the gentle crossover distortion.

The all-steel amplifier chassis are cut, punched, folded and welded in the factory. The only process which is sent out is cadmium passivating to prevent rust. A small injection-moulder turns out half a million knobs a year.

PCBs are assembled by hand, and leads are cut and bent inwards, clamping the components firmly before soldering to reduce dry joints to an absolute minimum. The boards are then flow-soldered. All wires are machine cut and stripped, and each chassis is wired by one operator. Mike Hill reckons that 15 per cent of the workforce are involved in quality control.

'Production is increasing all the time. We used to do batches of 75 or so; now we often do batches of 200.' More than nine-tenths of Marshall's production goes for export. They won the Queen's Award to Industry in

1984, second place in the Milton Keynes Export Award in 1985, and first place in 1986.

'Export has never been a problem,' says Marshall. 'We deal with one distributor in each country. We give them a free hand. When we started exporting, we dropped the prices by 25 per cent and said to them. "Go out and make money, but we need your backing as far as payment is concerned." There's no credit, it's payment on sight.

'The equipment is built to travel. For instance, AC/DC send all their gear back for service after a world tour. We might change three output tubes and three input tubes. They would let us change them all, but we won't! That's why we have this reputation.

'We put the same parts into all the lines, and we design well over the top, like putting a 150W Motorola device into a 12W amp. It makes no profit, but it means a youngster can buy a Marshall that won't break down.

'I don't believe in empires. We have no secretaries, one typist and a sales executive doing phone sales. I do all the figures, the exterior design, I pack t-shirts, count the tea machine money. There are eight girls in the office and we have a £7 million turnover, low overheads and good salaries. You couldn't do it any cheaper.'

Secrets Of His Success

Marshall's history has a fairy-tale ring to it: the right place at the right time, testimonials from top people, a legendary name. Is it all a gilded coach, or was there a pumpkin? Astute readers will have spotted a time lapse between the first amplifier in 1962 and the Queen's Award in 1984.

'I signed a 15-year contract because that was what I thought you did. Within a year I knew I was wrong...'

'Up to 1980 when my distribution contract finished, I never made any money,' says Marshall. 'Since then, we've had 600 per cent growth. I signed a 15 year contract because I thought that was what you did. Within a year I knew I was wrong. We couldn't make money and stay competitive, especially in export. I knew I had to do a better selling job. I gained a lot of experience.

'Now we sell through approved dealers in the UK, and a network abroad. You need distributors, you can't do everything yourself.

'The business has been like a hobby to me, I love it so much that I do any hours and never feel tired. I used to come in at 6.30. Now I come in at eight. I tried nine for a while, but I couldn't stand it!

'My wife is the company secretary, and we're both involved with the Federation of Boys Clubs and the Variety Club. This is my third marriage. I can get to neglecting people outside the business — I shouldn't be married at all! But she's very involved, and I feel confident this time.

'I don't give away secrets, but I will help with business advice. I like to see young people coming along. We train our own; I'd rather have someone fresh and keen than highly qualified with no interest. Steve Grindrod started on the test bench, and went on to design. He's recently started using CAD for the circuit boards.

'I gave up doing PA, although there was money in it, because I was interested in lead amplifiers. Now we're looking at PA again, and mixers. Eventually we'll get into digital control, but there's no time scale. It's no good creating a demand we can't meet.'

Perish the thought.

ORGANISING TH

It's essential to figure out just how you are intending to constitute your business. Much depends on your level of investment and on the relationship you wish to have to the business and any partners.

You could completely merge your personal responsibility and financial liability, or the business could be constituted as a separate entity, whereby your liability, but also your identity, would be clearly differentiated. Whether it's 'artificial bodies' or 'sleeping partners' you're looking out for, there are four basic alternative constitutions to select from.

Choosing one does not rule out moving on to another, and many sole traders expand in to limited companies within a year or so.

Sole Trader

Often the simplest way to begin, particularly if you fit into one or more of the following categories:

- you are trading from home,
- the bulk of your trade is in cash,
- you do not employ many staff (although it is perfectly legal to take on employees as a sole trader),
- you are 'flying a kite' — testing the market to see if there's room for further expansion.

The main thing to guard against is losing the roof from over your head (admittedly this can only happen to home-owners, but then you would not be allowed to start trading from most privately rented or any council-owned flats or houses). Even if you trade under a name other than your own, as sole trader you have unlimited liability on your account, making you personally responsible for making good any losses and repaying creditors.

It is also a situation in which it can be hard to raise substantial sums of investment capital. Investors do not like the dirty business of stripping individuals of their assets to obtain repayment, and they may not believe you have sufficient assets to cover them in the first place.

A sole trader is a self-employed individual who is the only owner of a business. Partners are also self-employed people, but they are the joint owners of a business.

Partnerships

As in marriage, so in business? 'A partnership exists as soon as two (or more) persons carry on a common business with a view to mutual profit' (Sect. 1 (1), Partnership Act 1890).

In fact up to 20 people can describe themselves as a working partnership, so long as none is the employee of any other. Even if they don't choose to so call themselves, they are regarded in law as constituting a partnership.

Like sole trading, no registration procedure is involved and there is unlimited liability — which in this case means that, unless stipulated by a partnership deed, one partner can be made responsible for any of the others' losses. It is also perfectly possible for partners to invest different amounts of starting capital without an assumed equality of voting rights and profit shares being affected.

Amanda Hopkinson

E ORGANISATION

These are two of the reasons why it's worthwhile ensuring that you have a 'cross insurance' guaranteeing that the death or disappearance of one partner doesn't automatically dissolve the partnership and that those remaining can inherit. You might also wish a solicitor to draw up a binding Partnership Agreement, incorporating the following:

- a record of each partner's capital contribution,
- the details of profit distribution and withdrawal procedures,
- the agreed process of decision-making,
- the method of arbitration in the event of any dispute arising between members,
- the provisions for dissolving the partnership,
- the provisions for releasing and admitting partners,
- a statement of the duties of each partner with regard to accountability.

The basic expectations of each partner — without which no Partnership Agreement should be entered into — are that all other partners must be willing to account for each of their business transactions; that all profits from business transactions must be handed over unless other partners specifically waive their rights to receive; and that partners must not compete with the firm or must hand over the 'competing moneys' gained if they do.

Public and Private Limited Companies

This is where you get to put 'PLC' or 'LTD' after your name. In the former case, you will launch with a minimum nominal capital of at least £50,000 and offer shares to the public. In the latter case you will start with a lesser amount and need only involve the minimum of a mere couple of initial shareholders.

To form a limited company it is always necessary to notify the Registrar of Companies and to deposit the following with them:

- the registration fee (usually £40),
- a Memorandum of Association, signed by at least two people — usually the company secretary and any directors — which stipulates the division of the company's nominal capital into shares and lists at least two subscribers, with the number of shares each is willing to take,
- the Articles of Association, which are the rules agreed by the company's founders for its internal administration,
- the PUEI form (detailing the paid-up capital),
- a list of names of those involved in the company.

Normally the Registrar makes no objection. Where it does, the reason is often the choice of a name. Names that mislead are always out — for example, calling yourself 'International' or 'Federation' when you're not — and so are those which the Home Office can object to — for example, claiming any kind of a royal connotation. The Registrar also has a list of company names already in circulation, which cannot be re-appropriated.

It is also possible to buy an 'off-the-shelf' company from specialist agencies for about £100. These are companies which are still registered but which have ceased trading. It is always worthwhile getting a solicitor to tailor the Memorandum and Articles of an off-the-shelf company to your needs before you register its change of ownership.

examines the different ways you can organise your business.

Annual accounts have to be returned to the Inland Revenue and audited ones filed with the Registrar of Companies, although many smaller companies seem to ignore these rules with impunity.

The main advantages of a limited company are:

- those involved have a limited liability (in practice this means that if the company fails, all that anybody stands to lose is their original share capital);
- it's easier to raise investments and loans of a significant size;
- it complies with a format widely accepted by bank managers, potential investors and the like.

The main drawbacks are:

- as a director you will be regarded as an employee, and so liable for personal income tax and national insurance;
- all staff wages, including the directors', will be subject to PAYE, which in turn involves more book-keeping and helps make the compilation and filing of annual accounts more expensive;
- public accountability is maintained through the compulsory disclosure of key financial data.

Co-operatives

In common with limited companies, co-ops also need registering at some expense (usually around £150) and have to submit annual accounts to the Registrar (in this case of Friendly Societies) where they will be available for public inspection. All this increases the bill for record-keeping and accounting.

The easiest way to become constituted as a co-op is to obtain a copy of the Model Rules drawn up by either the Industrial Common Ownership Movement or the National Co-operative Development Agency, and by trying hard not to alter them fundamentally — despite their old-fashioned style. Rewriting the rules can become time-consuming and expensive.

Like a registered public company, a co-op is an 'artificial person' in law, an independent entity that (who?) continues irrespective of who joins or leaves. (An unregistered co-op is treated in law as a partnership, and dissolved whenever the membership changes). Registration means that there is no individual liability for any debts beyond that of an initial £1 share or guarantee up to a fixed sum.

There are two basic types of co-op: common and co-ownerships. In the former, assets are owned in common and cannot be distributed among individual members. Under co-ownership, members can become substantial shareholders, making it necessary for new ones to buy in, and allowing former ones to take a personal stake with them when they go.

What's unique about a co-op is that it is controlled and owned by its employees, and is therefore assumed to be more democratic than the inherently hierarchical structure of a company. While it is true that every member has a say in running the business, whatever their job, it is all too often true that those who shout loudest and longest in regular meetings do tend to dominate.

What's mystical about co-ops is that their optimum number of members, apparently tried and tested and marketed over and over again, is seven.

USEFUL ADDRESSES

SELF EMPLOYMENT... ORGANISING YOURSELF

Insurance

To find out about National Insurance and the self employed contact your local Department of Health and Social Security. Leaflets are available:-

N 127A: Small Earnings from Self Employment.

N 141: National Insurance for the Self Employed.

Department of Health and Social Security.

Alexandra Fleming House
London SE1 6BY
(01 407 5522)

Tax

Contact your local tax office for leaflet, IR28: Starting in Business.

Also get advice from an accountant or make sure that you have a reasonable understanding of keeping books.

Board of Inland Revenue
Somerset House
The Strand
London WC2R 1LB
(01 438 6622)

VAT

Contact Customs and Excise who publish a whole range of leaflets and general guide, 'Should I Be Registered For VAT?'

Health And Safety

Details of Health and Safety requirements are found in Health and Safety Executive publications. Obtainable from

HMSO Bookshop
49, High Holborn
London WC1.

The three bodies below will be able to provide advice on financial and legal matters.

The Association Of Authorised Public Accountants

10, Cornfield Rd.
Eastborne
East Sussex
(0323 641514/5)

MORE ADDRESSES NEXT MONTH (Compiled by: C.M. Herman)

The Association Of Certified Accountants

29, Lincolns Inn Fields
London WC2A 3EE
(01 242 6855)

The Law Society

The Law Society Hall
113, Chancery Lane
London WC2A 1PL
(01 242 1222)

FUNDING

The Royal Jubilee And Prince's Trust

The trust offers grants of not more than £1,000 to young people who wish to set up a business venture. You must be under 25 and you have to produce a realistic business plan and agree to accept advice and support from a local nominee of the trust and two tutors. Grants are given for tools and equipment, transport, fees, insurance and training.

8, Buckingham St.
London WC2 6BU

Youth Enterprise Scheme

Set up by the Practical Action of the National Association of Youth Clubs. Loans are given at preferential rates to young people under 25 who wish to set up in business.

Victoria Chambers
16-20 Strutton Ground
London SW1
(01 222 3341)

Young Enterprise
Robert Hyde House
48, Bryanston Square
London W1H 6LN
(01 730 4070)

British Technology Group

Finance may be available for technical innovation to individuals or companies. They have a special interest in electronics-related businesses and have provisions for small-company funding and support for regional enterprises. There are a number of regional offices.

101, Newington Causeway
London SE1 6BU
(01 730 8600)

The Small Company Innovation Fund (SCIF)

May provide finance in the case of a business which is innovative. Enquiries to the address for BTC.

Clydebank Enterprise Fund

Low interest loans available for business within Clydebank and the Enterprise zone.

Clyde House,
170 Kilbowie Road
Clydebank
(041 952 0084/5)

Innovation Linked Investment Scheme

Assistance for innovative products in the high tech area. Details available from the local Department of Trade and Industry Office.

Enterprise Allowance Scheme

Contact your Local Job Centre. Under this scheme you can be paid £40 weekly for up to a year while you are setting up and establishing a business. The business must be new and you must have £1000 to invest (this could be in the form of an overdraft facility). You must also have been unemployed and in receipt of benefit for three months before applying for the scheme.

Co-operative Research Grants Scheme

Run by the Science Research Council, who may in any case be able to advise you on the availability of grants for technical R&D. They are concerned to fund commercial co-operation with academic institutions.

Science Research Council
PO Box 18
Swindon SN2 1ET
(0793 26222 ext 2154/2279)

Technical Development Capital

Set up in 1962 to be a major source of long-term finance for small and medium-sized British companies, TDC has made over 200 investments in areas covering electronics, computing, plastics, instrumentation, machine tools and genetic engineering. TDC can also provide advice and assistance from a team drawn from the technology industries.

91, Waterloo Rd.
London SE1 8XP
(01 928 7822)

Prutec

Was established in 1980 as a wholly owned subsidiary of Prudential Assurance with the specific purpose of making investments in technology innovation in the United Kingdom.

17, Buckingham Gate
London SW1 6LN
(01 828 2082)

ETI

EXCHANGE RESOURCES

RECRUITMENT AGENCY & BUSINESS CONSULTANCY

ELECTRONICS FOR PEOPLE
For businesses and people who want a say in how their technology is used.
0225 69671/2 - EfP Ltd, Freeport,
Chippenham, Wilts SN14 8BR

RACK MOUNTING CABINET

* Suitable for instruments, high quality amplifiers and many other purposes * Black anodised aluminium front panel enhanced with two handles * Aluminium version, wholly made of black anodised aluminium sheets * Metal version, rear box is manufactured from steel painted in black with aluminium front panel. Customer who requires further details, please send SAE.

Panel Size W H (Inch)	Rear Box W H D	Price Steel	AL
19x2.5	17x2x10	22.50	27.50
19x3.5	17x3x10	24.50	29.50
19x5.25	17x5x10	26.50	—
19x3.5	17x3x12	25.50	30.50
19x5.25	17x5x12	27.50	32.50
19x5.75	17x5.5x12	28.50	33.50
* 17x2.5	15.5x2x9	16.50	—
* 17x3.5	15.5x3x9	17.00	—
* 19x3.0	17x2.5x10	—	20.50
* 19x4.0	17x3.5x10	—	19.50
* 19x4.0	17x3.5x12	—	22.50

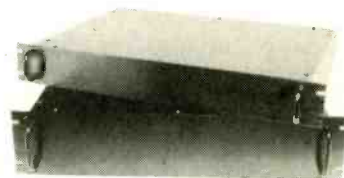

* Discontinued sizes, special price valid while stock last. Please add £3.00 P/P for the first item and £1.50 for each additional item. Quantity discount available. A limited quantity of electronic kits at give away prices. SAE for details.

* Mail order only. To order send cheque/postal order, 7 days for cheque clearance.

T J A DEVELOPMENTS

53 Hartington Road, London E17 8AS.

INSTALL YOUR OWN SYSTEM AND SAVE

SECURITY

MODULES ACCESSORIES KITS

NEW

Control Unit CA 1382

with automatic circuit testing and simple on/off operation.

- Fully automatic siren re-set.
- Audible entry/exit warning.
- Alarm Sounded memory.
- 2 separate loop inputs + 24hr circuits.
- Built-in electronic siren.
- Easily installed, full instructions supplied.



This brand new control panel provides effective and reliable control of all types of security installations. Using advanced electronics, the unit automatically checks the loop circuits every time that it is switched on, thereby reducing the possibility of false alarms and incorrect operation. Using a simple on/off key switch, it is easily operated by all members of the family. Additionally, 24hr personal attack and anti-tamper protection is provided irrespective of whether or not the unit is switched on. Housed in a strong, attractive steel case, the unit is supplied with full operating instructions and 2 keys. Supplied fully built and tested ready for installation.

Also available in kit form with built-in electronics
£39.95 + VAT

ONLY £44.95 + VAT

RISCOMP LIMITED

Dept. 51 Poppy Road, Princes Risborough, BUCKS. HP17 9DB
Tel: (084 44) 6326



Order by 'phone or mail or call at our showroom and see

UNITS ON DEMONSTRATION

Monday to Friday 9.00 - 5.00 p.m.
Saturday 9.00 - 1.00 p.m.
Please add 15% VAT and 75p P&P to all UK orders
Export no VAT - postage at cost

ETI 61

Lighting Controller DP 3570

only **£13.95 + VAT**



This versatile module provides timed switching of loads up to 3A for pre-set times between 10 secs and 5 mins, the timed period being triggered by the opening or closing of an external loop or switch. The built-in 12V 250mA power supply is available for operating external sensors. Priced only £13.95 + VAT. Suitable plastic enclosure, £2.85 - VAT

500W Quartz Halogen Floodlight FL 500



only **£14.95 + VAT**

Whilst intended for security lighting applications, this unit is suitable for lighting patios, pathways and gardens etc. Supplied complete with 500W lamp, priced only £14.95 + VAT. Protective grill, £1.95 - VAT

Infra-red System IR 1470



only **£25.61 + VAT**

Consisting of separate transmitter and receiver both of which are housed in attractive moulded cases, the system provides an invisible modulated beam over distances of up to 50ft operating a relay when the beam is broken. Intended for use in security systems, but also ideal for photographic and measurement applications. Size 80 x 50 x 35mm

HW 1250 - Enclosure & fixings for CA 1250



only **£9.50 + VAT**

This attractive case is designed to house the control unit CA 1250, together with the appropriate LED indicators and key switch. Supplied with the necessary mounting pillars and punched front panel, the unit is given a professional appearance by an adhesive silk screened label. Size 200 x 180 x 70mm.

Control Unit CA 1250



Price **£19.95 + VAT**

This tried and tested control unit represents the finest value for money in control systems, providing the following features:

- Built-in electronic siren drives 2 loud speakers
- Provides exit and entrance delays together with fixed alarm time
- Battery back-up with trickle charge facility
- Operates with magnetic switches, pressure pads, ultrasonic or I.R. units
- Anti-tamper and panic facility
- Stabilised output voltage
- 2 operating modes full alarm anti-tamper and panic facility
- Screw connections for ease of installation
- Separate relay contacts for external loads
- Test loop facility

Individual Enclosure SC 5063



only **£2.95 + VAT**

Suitable metal enclosure for housing the ultrasonic module type US 5063. Supplied with the necessary mounting pillars and screws etc.

Digital Ultrasonic Detector US 5063



only **£13.95 + VAT**

- 3 levels of discrimination against false alarms
 - Crystal control for greater stability
 - Adjustable range up to 25ft
 - Built-in delays
 - 12V operation
- This advanced module uses digital signal processing to provide the highest level of sensitivity whilst discriminating against potential false alarm conditions.

Complete systems from only £39.95 + VAT

For full information of systems and accessories, send or call for details

Unit 38, St. James Industrial Estate, Westhampnett Road, Chichester, West Sussex PO19 4JU
Telephone: National 0243 771748 International +44 243 771748 Telex: 869362 ATEC G

COMPARE OUR PRICES!! THEN DECIDE

BRIDGE RECTIFIERS

3A/50V	28p	3A/200V	33p
3A/400V	38p	3A/600V	44p
6A/100V	70p	6A/400V	78p
10A/200V	1.85	10A/600V	2.65
25A/200V	2.00	25A/600V	2.95

DIP SWITCHES

1 way	30p	2 way	50p
4 way	65p	6 way	70p
8 way	80p	10 way	1.30

DIL SOCKETS

	Double Face Wipe	Turned Pin
8 way	4p	16p
14 way	7p	28p
16 way	8p	32p
18 way	9p	36p
20 way	10p	40p
22 way	12p	44p
24 way	13p	48p
28 way	14p	56p
40 way	19p	80p

ZIF DIL SOCKETS with detachable lever

24 pin	4.65	28 pin	6.10
--------	------	--------	------

BUZZERS

12 volt 70 dB	1.10	6 volt 80 dB	50p
1-28 volt 60/90 dB	2.00	2-3 volt 85 dB	70p

Also available High Output Types - up to 110 dB

ENCLOSURES

Beige ABS Cases 100 x 120 x 40 mm - Four part snap together assembly 3.99

CONNECTORS

Turned Pin .1 Sockets			
S.I.L. 36 way	90p	D.I.L. 72 way	1.80
Pin Headers - Tin	63p	D.I.L. 72 way	1.26

CABLE ASSYS & WIRE

Centronics to 34 way IDC	5.00
Phono to Phono with 2 mtrs cable	1.00
Phono to Co-Ax 75 ohm with 2 mtrs cable	1.20
7/0.2 and 16/0.2 - Various Colours - Reeled or cut to length	

Please add £1 to all cash orders to cover P & P.
All prices are exclusive of VAT. Please add 15% to cash total inc. P & P.
**THIS IS A SMALL SELECTION OF OUR ENORMOUS RANGE OF ACCESSORIES
SEND SAE FOR OUR COMPREHENSIVE CATALOGUE**



CONSTRUCTOR SERIES SPEAKER KITS

Based on the famous Kef Reference Series, these three DIY designs give the home constructor the opportunity to own an upmarket pair of loudspeakers at a very down-to-earth price!

With a Wilmslow Audio Total Kit it's so easy — no electronic or woodworking skill is necessary. Each kit contains all the cabinet components (accurately machined from smooth MDF for easy assembly), speaker drive units, crossover networks, waoding, grill fabric, terminals, nuts, bolts etc

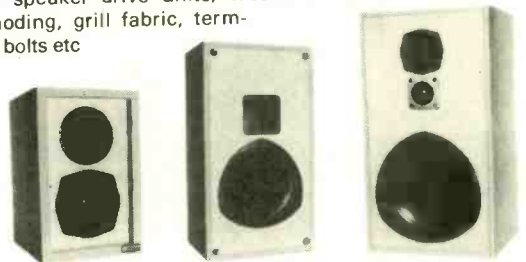

Model CS1 is based on the Reference 101, CS3 is equivalent to the Ref. 103.2 and CS9 is based on the Reference 105.2 (but in a conventionally styled encl.).

CS1 £116 pair inc. VAT plus carr/ins £6

CS3 £138 pair inc. VAT plus carr/ins £10

CS9 £383 pair inc. VAT plus carr/ins £18

We also offer a kit (less cabinet) for Elector PL301

DIY Speaker catalogue £1.50 post free (export \$6)

WILMSLOW AUDIO LTD.

35/39 Church Street, Wilmslow, Cheshire SK9 1AS

Tel: 0625 529599

Call and see us for a great deal on HiFi. (Closed all day Mondays.)

Lightning service on telephoned credit card orders!

Interak 1

AN EXPANDABLE DISK-BASED Z80A DEVELOPMENT SYSTEM YOU CAN BUILD YOURSELF!

Universities, Colleges, Industry, Enthusiasts:

Unlike home computers, development systems have entirely "open" architectures, use standard TTL etc. chips (ie no ULA's!), and are built in a proper engineering fashion. Usually these superior products carry a correspondingly superior price tag, but you can build Interak yourself board by board and thus afford a system which would normally be out of your reach and/or understanding.

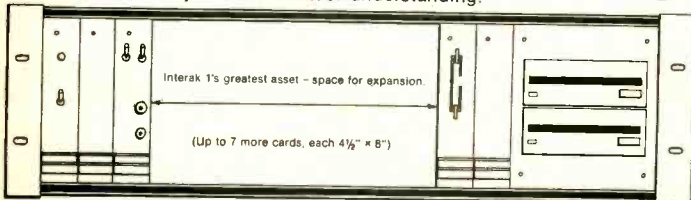

YOUR OWN EXPANSION (EG SPEECH, SOUND, EPROM, PRINTER, MODEM, TAPE RELAY, CONTROL, INTERFACING, ETC. ETC.)

ASCII KEY BOARD | DISK INTER FACE | 2 x 1 MEGYTE 3 1/2" DISKS (EXAMPLE)

The initial development system has 64K of RAM, a 4 MHz Z80A CPU, parallel ASCII keyboard interface, VDU interface (TV set or monitor), and a floppy disk drive interface for up to 4 drives. Any size (including 8" double density) can be used, but our 1 Megabyte 3.5" drives are proving very popular because they can fit into the system rack, (and they only cost £87.00 each + VAT). CP/M 2.2 is available, giving access to thousands of "public domain" programs.

The system can be described as "future proof" because it uses plug in 4.5" x 8" cards in an industrial quality 19" 3U rack. We have been established since 1970, and this system was first made in 1977 so (unlike almost all other computers) it has stood the test of time.

Send two second class stamps, or telephone for a detailed descriptive leaflet, specification, prices, etc.

Greenbank

Greenbank Electronics (Dept T7E), 92 New Chester Road, New Ferry, Wirral, Merseyside L62 5AG. Tel: 051-645 3391

FIELD ELECTRIC LTD

Plastic Boxes 76x100x40 m/m 4 for £5.50 inc c/p or £1.00 each inc c/p 6 for £5.50
 Die Cast Ali - Boxes 114x64x30 m/m £2.50 inc c/p
 Stepper Motors 4.5v 1-4A 2° Deg - Steps - Sanyo Step Syn £8.60 inc c/p
 P.C.B. 9x2532JL45 Eproms 4Kx8Bits. New £12.95 inc c/p
 12V.D.C. Audible warning device. Single tone solid state £1.75 works from 6UDC
 Cherry ASCII code Qwerty keyboards. New £12.50 c/p 1.50
 230V.A.C. 3P c/o 5amp contacts relays. c/w base £2.50 inc c/p
 Copper clad boards, epoxy glass, single & double side new.
 Single sided 508x380x3 m/m No 1 £7.95 inc c/p
 457x305x3 m/m No 2 £7.95 inc c/p Euro card size
 380x254x3 m/m No 3 £6.75 inc c/p
 254x177x1.5 m/m No 4 £2.70 inc c/p
 178x126x1.5 m/m No 5 £1.70 inc c/p
 Double sided 508x380x3 m/m No 6 £8.55 inc c/p
 457x305x3 m/m No 7 £8.45 inc c/p
 380x254x1 m/m No 8 £6.25 inc c/p
 Sonnenschein A200 Dryfit Batts - New & boxed 12V.D.C. 5.7Ah
 Charging volts 13.8v mas A.B.S. case £16.95 inc c/p
 Bardic/Chloride safety handlamp c/w sealed Alkaline battery charger pack
 24V.D.C. input. New & boxed £38.25 inc c/p
 Power supplies all 240V.A.C. input, unless stated
 P.C. card PSU, 5v 1A regulated 107x100 m/m new £6.50 c/p 1.00
 Gould switch mode 5v 20A 603x87x105 m/m £14.95 c/p 2.75
 Gould Linear PMA 4712v 3A P.S.U. £15.00 c/p 2.75
 Coutant linear P.S.U. new & boxed data G.P. series 15-18v 10A £46.00 inc c/p
 AC. DC. 24v 4.8A linear P.S.U. new & boxed 227x123x70 £19.95 c/p 3.50
 Farnell fan cooled, switch mode & 5v 10A - 5v 1A & 12v 3A - 12v 1A £28.00 c/p 2.75
 Gould 24V 15A switch mode new & boxed data 215x72x89 £57.50 c/p 2.75
 Voltex Co 12V 1.5A & 5V 30A - 12V 10A linear 17x14x4 1/2" new £38.00 c/p 5.50
 Lambda Linear 20V 5.2A 225x120x65 m/m £25.00 c/p 2.75
 Lambda metered PSU 0.40V 0.3A £125.00 c/p 6.00
 Transformers all 230VAC PRIM 12-0-12v 2Ax2 £3.50 inc c/p
 6-0-6V 20A £23.00 inc c/p - 9-0-9V 1A £2.50 inc c/p - Woden 11V 80A £40.00 inc c/p
 Woden 27V 30A c/p Please ring - 12-5-0-12-5V 750 M/A 7-0-7V/A £3.75 inc c/p
 Test equipment, Philips type PM 3212 dual Trace O'scope 25MHz £350.00
 Venner digital counter/timer 7737A 1000 MHz £150.00 c/p 4.50
 Advance Inst TC9A 32MHz Timer Counter £85.00 c/p 4.50
 Tektronix Type 7B80 Time Base £400.00 c/p 6.00
 7A12 Dual Trace amp £275.00 c/p 6.00
 DM502 Digital Multimeter £60.00 c/p 6.00
 DC504 Counter Timer £85.00 c/p 6.00
 454 O'scope 150MHz dual trace delay sweep £529.00
 New Manufactures surplus electronic fuel protection systems runs from 9V.D.C. with sensors. Control Box - cables ideal for boats - central heating, detects water in fuel. 1 Tank systems £20.00 4 Tank systems £35.00. Supplied with sensors & installation data.

FIELD ELECTRIC LTD

3 SHENLEY ROAD, BOREHAMWOOD, HERTS,

01-953-6009.

Official orders, overseas enquiries welcome, telephone orders accepted. Please ring for c/p details, not shown. Test equipment carries warranty. All prices inc 15% VAT unless stated.

Open Mon-Sat. 9am-5pm Thurs. 9am-1pm

FROM JAYTEE

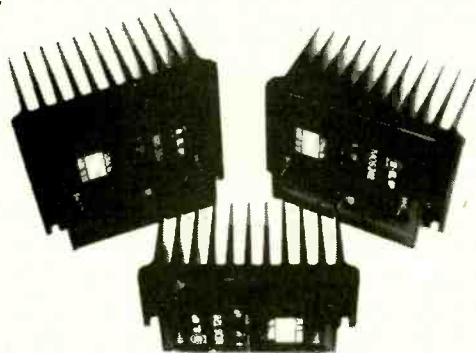

THE SPECIAL DISTRIBUTOR FOR SPECIAL AMPLIFIERS

ILP have long been recognised as manufacturers of top quality amplifiers.

All ILP products are built to extremely high specification for the ultimate in hi-fi performance. They're unique in being completely encapsulated with integral heatsinks, and can bolt straight onto the chassis. They're also extremely robust, ensuring high levels of reliability as well as performance.

ILP Amplifiers are now available through Jaytee. The UK Distributor with the availability and service to match the quality of the amplifiers.

POWER BOOSTER AMPLIFIERS

The C15 and C1515 are power booster amplifiers designed to increase the output of your existing car radio or cassette player to 15 watt rms.
 C15 15 watts £10.65
 C1515 15 + 15 watts £19.78

ILP LOUDSPEAKER

power 350 watt rms
 size 12 inches
 impedance 8 ohms
 range 20 Hz to 5 KHz

NEW £78.61

FOR FREE DATA PACK PLEASE WRITE TO OUR SALES DEPT.

PREAMPLIFIER MODULES

All modules are supplied with in line connectors but require potentiometers, switches, etc. If used with our power amps they are powered from the appropriate Power Supply.

Type	Application	Functions	Price
HY66	Mono Pre-Amp	Full Hi-Fi facilities	£8-45
HY66	Stereo Pre-Amp	Full Hi-Fi facilities	£13-95
HY73	Guitar Pre-Amp	Two Guitars plus Microphone	£14-45
HY78	Stereo Pre-Amp	As HY66 less tone controls	£13-45

NEW! HY83 Guitar and Special Effects Pre-Amp as HY 73 Plus Overdrive and Reverb £18-95

MOUNTING BOARDS: For ease of construction we recommend the B6 for HY6 £0-95. B66 for HY66-83 £1-45.

MOSFET MODULES

Ideal for Disco's, public address and applications with complex loads (line transformers etc.). Integral Heatsink
 slew rate 20V/µs distortion less than 0.01%

Type	Output Power Watts (rms)	Load Impedance (Ω)	Price
MOS128	60	4-8	£34-45
MOS248	120	4-8	£39-45
MOS364	180	4	£64-45

BIPOLAR MODULES

Ideal for Hi Fi, Full load protection
 integral Heatsink, slew rate 15v/µs

Type	Output Power Watts (rms)	Load Impedance (Ω)	Price
HY30	15	4-8	£10-45
HY60	30	4-8	£10-45
HY6060	30 + 30	4-8	£21-95
HY124	60	4	£17-45
HY128	60	8	£17-45
HY244	120	4	£22-45
HY248	120	8	£22-45
HY364	180	4	£33-45
HY368	180	8	£34-95

Distortion less than 0.01%

POWER SUPPLY UNIT

Type	For Use With	Price
PSU30	PRE AMP	£6-45
PSU121	1 or 2 HY30	£16-45
PSU412	1 or 2 HY60, 1 HY6060, 1 HY124	£18-45
PSU422	1 HY128	£20-45
PSU432	1 MOS128	£21-45
PSU512	2 HY128, 1 HY244	£22-45
PSU522	2 HY124	£22-45
PSU532	2 MOS128	£22-95
PSU542	1 HY248	£22-95
PSU552	1 MOS248	£24-95
PSU712	2 HY244	£26-45
PSU722	2 HY248	£27-45
PSU732	1 HY364	£29-45
PSU742	1 HY368	£29-45
PSU752	2 MOS248, MOS364	£29-45

All the above are for 240v operation



Jaytee Electronic Services, 143 Reculver Road, Beltinge, Herne Bay, Kent CT6 6PL Telephone: (0227) 375254
 All Prices include VAT, Post & Packing

LOW COST FRAMESTORE

Get those frames stored and fields frozen with the final part of Dan Ogilivies's project.

In the two previous episodes of this saga we have described the design and construction of a real time storage video field store. This month, we shall look at the operation of the store and describe how to get the best from it. You'll also find the overlay diagram and parts list.

OOPS!

Firstly, one or two errors have arisen in the previous two articles which I shall correct now:

- R36 should be changed from 10k to 3k3, as in parts list. This ensures no break through of line sync pulses into the field detection circuit.
 - An error in the logic circuit diagram (Fig. 2, ETI September 1986, p.38) has appeared in the write circuitry (in fact, it is far from writel). IC15e does not actually exist at all and should simply be removed, leaving IC21 pin 8 connected directly to IC25 pin 5.
 - Pins 2 and 3 of the IC23 are shown reversed on the logic circuit diagram.
 - The output video transistor (Q3 on the video circuit diagram, Fig. 6, ETI October, 1986, p.49) is now removed and the video output is taken directly from IC39, pin 2, via R86 (changed to 56R), R84 (still 75R) and C18. The two resistors ensure that the 2V output of IC39 is attenuated to 0.7V into a 75 ohm load. R85 should be omitted.
- These changes have been made, where applicable, to the parts list and the PCB supplied by Oggitronics (who now have a new address — see Buylines). If you're intent on making your own PCB from our foil pattern, link Q3 base and emitter and omit Q3 and R85.

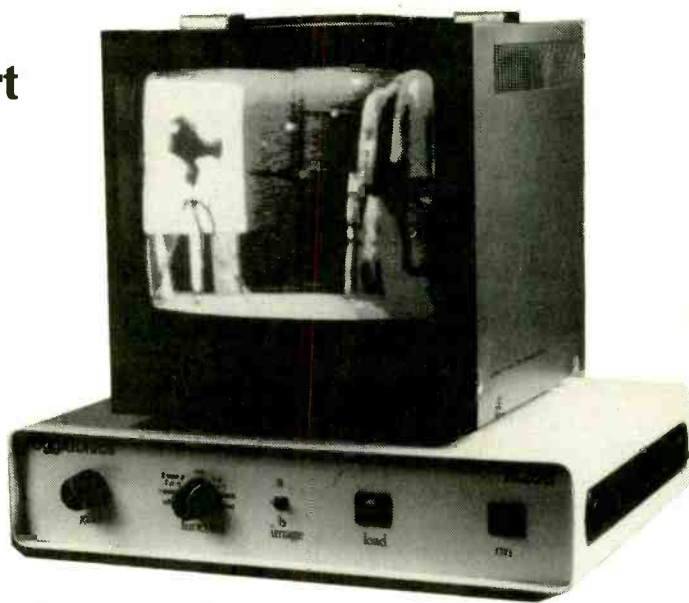

In The Frame

The field store provides a 1V composite video output into 75 ohms which is compatible with most TV monitors. Should you wish to show the output on a television set, sufficient unterminated output is provided to drive the SCART connector.

The field store accepts a 1V composite video input which it terminates in 75 ohms. To lock the framestore from an external source, the sync signals must be present on the incoming signal.

A 2V composite sync output is provided which is intended to lock up video cameras that will operate in this genlock mode. This is the preferred mode of operation in that it will provide a more stable image in the majority of cases. The INT/EXT switch (pin 4 of SK2) can be left to select this mode.

If you wish to store images from sources that do not accept a genlock input, such as VTRs or television tuners then SK2/4 must be grounded to select the external sync mode. Otherwise, the framestore and its source will just free run and attempts to load an

image will produce effects similar to the loss of lock on a TV when the vertical and horizontal hold controls are rotated too far.

The switching between internal and external sync is manual. If the video should fail (for example, at the end of a broadcast or a film on a VTR), no synchronizing signals will be generated in the framestore and, therefore, there will be no refresh to the dynamic RAM and this will corrupt the image. Once the image has been captured reverting to internal sync will prevent this happening.

Frame After Frame

Having connected up the framestore to a TV or monitor, and to a source of video, and having sorted out the sync, you are ready to load an image.

Switch on the framestore, ensuring that the FUNCTION switch is set to NORM and the A/B select image is set to A. A random pattern should appear on the monitor screen. If necessary, adjust the hold controls on the monitor to achieve a stable picture. If nothing happens or you get an unstable picture, check the

RESISTORS (all 1/4W, 5% unless otherwise stated)

R1, 30, 43-46	2k2
55-57	
R13, 14, 15, 38	33R
39, 40	
R24-27, 66, 69	4k7
79, 80	
R28, 29, 35,	10k
62, 63, 71, 73	
75, 77, 78	
R31	22R
R32, 58-61, 68	470R
R34, 74	18k
R37, 41, 42, 67,	1k0
70, 72, 76, 88	
R64	8k2
R65, 85	75R
R36, 81, 82	3k3
R83	20k
R86	56R
R87	10R
R5-12, 16-23	8-way DIL 33R packs (separate)
R47-54	8-way DIL 2k2 packs (common pin)
RV1	10k
RV2	5k0
CAPACITORS	
C1, 3	10n
C2, 10, 13, 14	1n0
C4	470p
C5, 11	470n
C6	10p
C7	100n
C8	27p
C9	100µ 6 V elect.
C12	3n3
C15, 18, 22	47µ 10V elect

C16, 17, 29, 20 10µ 10V elect
C21 33p
100n decoupling capacitors for every IC. All electrolytics are PCB mounting radial.

SEMICONDUCTORS

IC1, 11	74LS393
IC2, 12, 19, 20	74LS257A
IC3-10	TMS4164-15
IC13, 28, 31	74LS74A
IC14, 21	74LS00
IC15, 42	74LS04
IC16	74LS164
IC17, 33	74LS374
IC18, 41	74LS157
IC22	ZNA234E
IC23, 36	LM393
IC24	74LS279
IC25	74LS125
IC26, 27	74F382
IC29	74LS163A
IC30	74LS138
IC32	74LS348
IC34	LM318
IC35	LF347
IC37, 38	74LS221
IC39	UVC3101-8
IC40	74S124
IC43	74LS367
IC44	74LS245
Q1, Q2, Q4	2N3904
D1-D7	1N4148

MISCELLANEOUS

XTAL1 10MHz; SK1, SK2, 0.1" SIL crimp connectors; PCB F5256/4 available from Oggitronics; power supply and case to suit.
(NOTE: R85 and Q3 are missing — see text for these and other changes).

setting of the INT/EXT sync select.

Press the load button. The random pattern should have been replaced with the next complete field of video. Ground SK2/16 to view the other image. This should still contain a random pattern which can be loaded to in the same way as the first image. The two images may be switched between at field rate if required enabling storing of a 256x512 resolution image.

Don't alter the setting of the switch during loading of an image unless you want to corrupt the images for some reason. If there is little or no difference between two images it may not appear that a load has occurred at all. This is because the read-modify-write (RMW) operation on the DRAM always reads old information before writing new. The viewed image, therefore, does not appear to flash when a new image is loaded in. By holding the external load input low a continuous digitised live image can be viewed.

One And One Is ...

The RMW memory cycle allows us to modify the incoming data in some way before writing it in to memory. Setting the function switch to NORM by-passes the arithmetic unit. Selecting black or white overrides the data in the memory by setting it to all zeroes or ones. When the load button is pressed the data in memory is replaced with a black or white image.

Two subtraction functions are provided. They either subtract live from the store or store from the live image. The results are seen when the load button is pressed. The arithmetic unit — ICs 26 and 27 — operates all the time and it is possible, for example, to count the number of different pixels between two images by accessing the carry outputs of the arithmetic units. Further details of the operation of the ICs — 74F382 types — can be found in the Fairchild FAST data book.

The live and stored image can also be added together by setting the function switch to L+S. Remember that unless the images are low contrast the field store will quickly overload creating some unusual if useless results. An additional bit of memory to store the carry is necessary to prevent this happening.

The three logical operations provided work on each of the four individual bits of the image individually. That is to say there is no interaction between the results of each bit and care must be taken if you wish to interpret the results correctly.

Consider the LAND S function. Only if both bits are a '1' will the answer be a '1'. If the live data is white (value, 15 or 1111H) and the stored data is a mid-grey (value, 8 or 1000H), ANDING the two will result in the lower (darker) of the two values.

The exclusive OR function reveals differences between the two images. By counting the number of pixels that are different between the live and stored image and establishing a suitable threshold the framestore makes a useful intruder detector. The count might be achieved by taking the MSB, bit 3, from the arithmetic units to a hardware counter during an XOR.

The above information should help you to understand the field store a little more and to get the best from it. In a future episode, we plan to introduce an RS232 interface to the store, enabling most home computers to access and control the framestore.

BUYLINES

A complete kit of parts for the framestore is available from Oggitronics, who have recently moved in to new premises at Poole House, 37 High Street, Maldon, Essex (telephone 0621-50378). This is by far the easiest way of building it yourself, and will cost you £170 plus VAT but inclusive of postage (as with the other prices). Oggitronics will also supply you with a PTH, silk-screened PCB for £25, or a complete unit, built and cased with its own power supply for £395. If you build your own using an Oggitronics PCB, the author offers to stop you pulling your hair out if you fail to get it up and running. He will fix any kits built on the Oggitronics board for £25 plus parts. Naturally, he can be reached at the Oggitronics address.

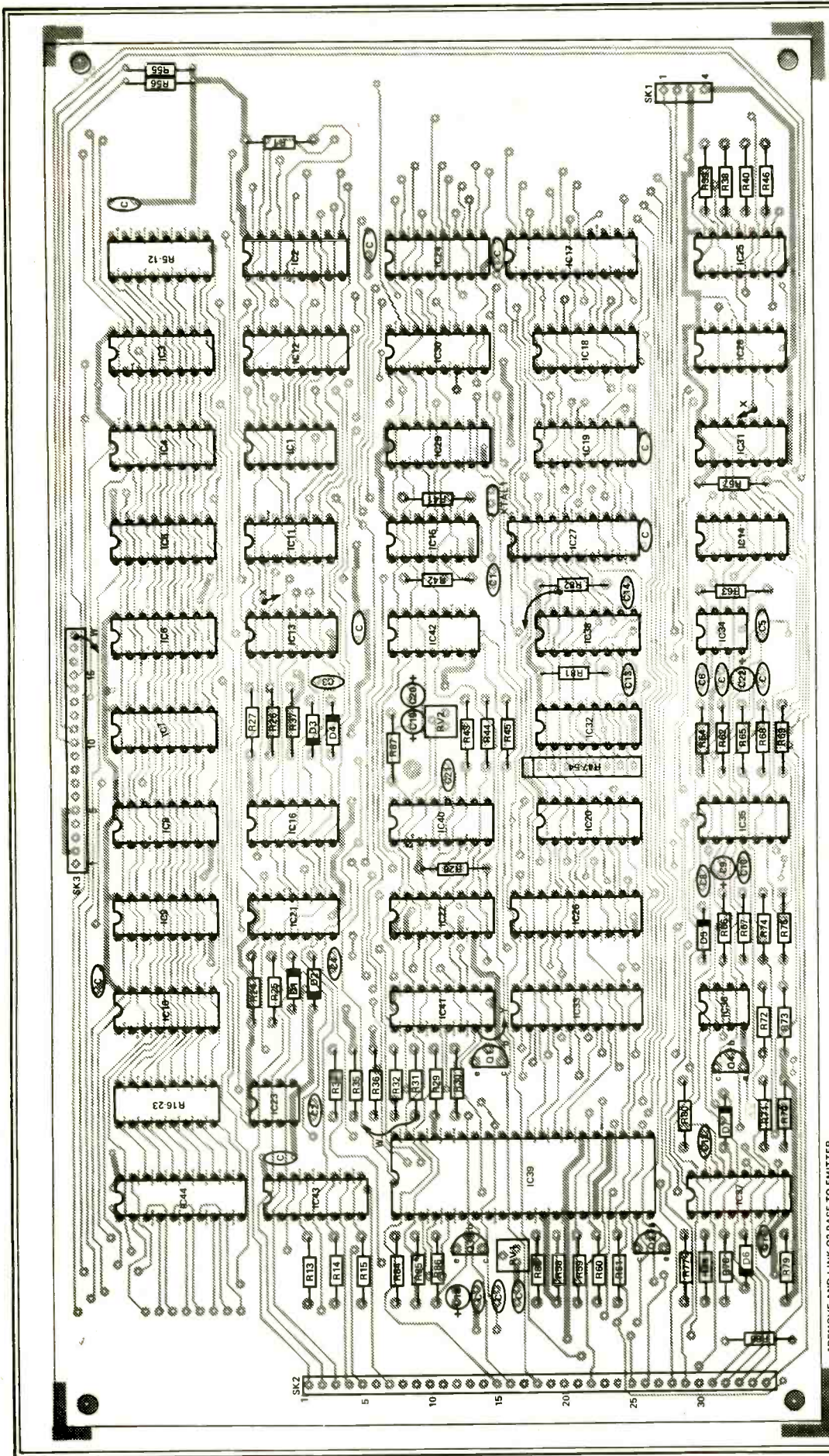

Fig. 7 Component overlay for the framestore (note: the board is double-sided through-hole plated and only one side is shown here. The complete artwork is reproduced on our foil patterns page. If you make your own board, use wire links to connect both sides of the board wherever necessary.)

*REMOVE AND LINK Q3 BASE TO EMITTER
UNMARKED CAPACITORS SEE PARTS LIST

UPGRADEABLE AMPLIFIER

Graham Nalty concludes this series on the Virtuoso preamplifier by describing the power supply board and the interwiring of the major components.

In this final article on the Virtuoso preamp, I shall cover the power supplies, earthing circuits and internal wiring. These aspects of design are as important as the amplification circuits, but the power supply is perhaps the most important of all, and has great influence on the final sound quality.

Generally speaking, the bigger the transformer the better the sound quality, but a larger transformer will produce more mechanical noise and vibration and is more likely to induce hum into the disc circuits. The Virtuoso preamp consumes just over a watt of power, but I have specified a 15VA toroidal transformer for the standard version and a 120VA transformer for the upgraded version.

Most preamps use a single regulator to feed all the circuits in both channels. The standard version of the Virtuoso uses separate rectifiers, reservoir capacitors and regulators ($\pm 15V$) for left and right channels with a second set of $\pm 12V$ regulators for the MC and MM amplifiers and another set for the tone/output stages.

These measures reduce the effect current changes in one part of the circuit have on the performance of other parts of the circuit. The extra power supplies used in the upgraded version give a further audible improvement in this area.

The size of the power supply reservoir capacitors will affect the tonal balance of the amplifier. Use too small a value and the bass will sound clean, tight and tuneful but deep bass will lack power. Use too large a value and the bass will sound heavy and lack definition. I have chosen a capacitance of 1000 μ as a compromise, but



A Virtuoso preamplifier without tone controls. The case and labelled front panel are of the type available to readers from Audio Kits.

readers may feel free to experiment with the value.

The circuit diagram for the power supply is shown in Fig 1. A voltage dependant resistor (VDR) protects the supply from high voltage spikes in the mains. Protection against RF mains interference can be achieved by using a filter. There are many commercial filters available, but Deltec Audio make one which is specifically designed for audio use. Research carried out by Deltec has shown that RFI up to 1000MHz can degrade the sound quality of an amplifier, so their filters operate over a wider range.

A great deal of care must be taken with the earth return circuits. Bad earthing techniques result in unwanted oscillations and instability, hum, noise, and poor sound quality. The important point to remember is that every earth return lead has its own resistance (and inductance and capacitance). Every length of earth wire will have

a small voltage at its non-earthed end due to the earth return current it carries.

Ideally every earth connection should be made via a separate wire to a central earth point, but this is rarely practical. In this design, separate earth returns are used for each of the major stages and the various power supply earths are separate too, as can be seen in the diagram.

Most of the power supply circuitry is self explanatory. Diodes D31 to D38 are included to raise the output voltages to $\pm 15.6V$. This ensures that there is adequate voltage drop across the 12V regulators to allow proper operation given the tolerance variations in regulator output voltages. They can probably be omitted if you are prepared to check the output voltages of the regulator with an accurate voltmeter. The power supply board contains a mute control for the FETs on the output boards.

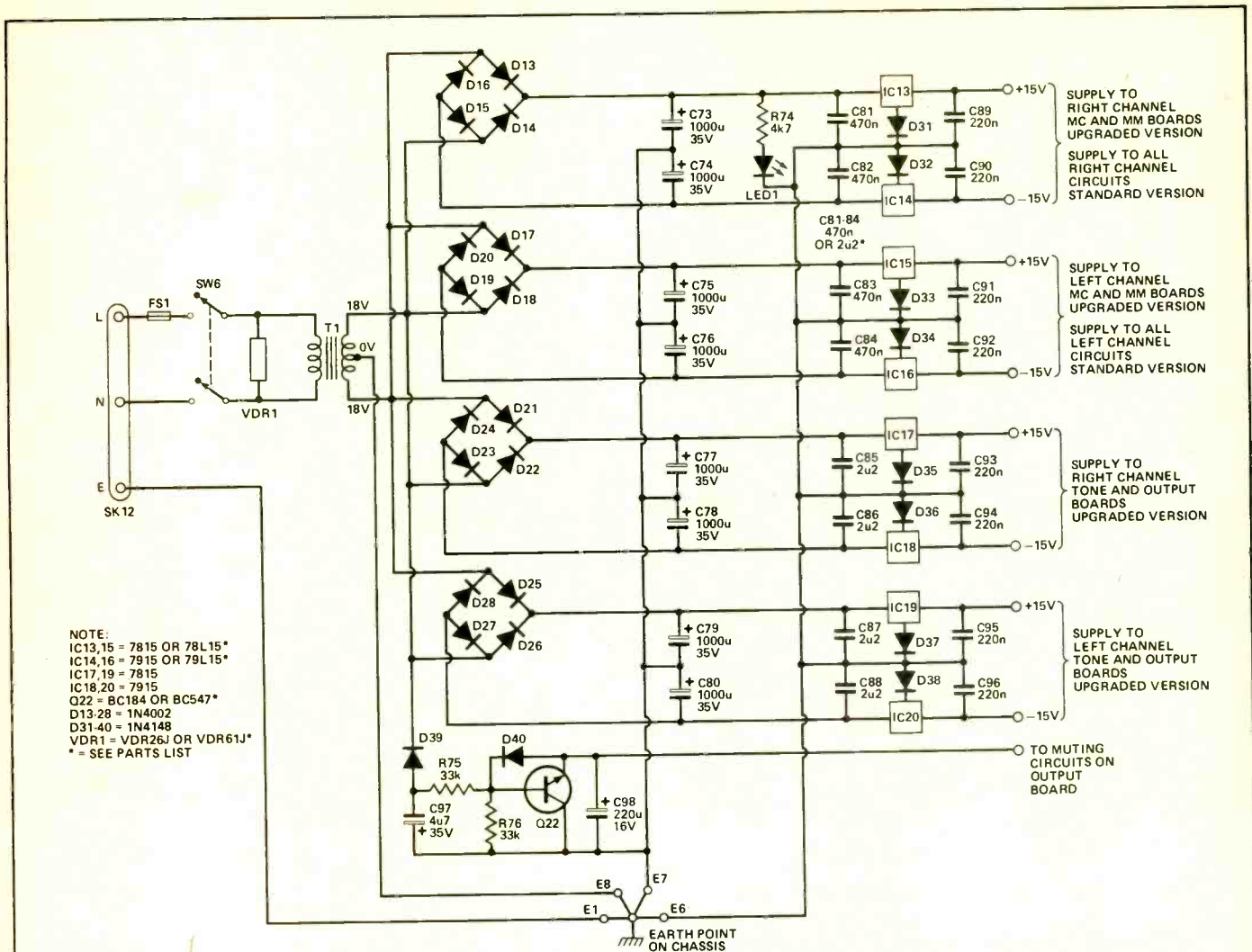

Fig. 1 Circuit diagram of the power supply. Note that all the ground connections are returned to a single earthing point and also that only two of the supplies shown are used in the standard version of the preamplifier.

BUYLINES

THE POWER SUPPLY: A complete kit of parts including PCB is available from the author at 6 Mill Close, Borrowwash, Derby DE7 3GU. The standard version costs £15.50 and the fully-upgraded version costs £29.50, both prices inclusive of VAT and postage. If you prefer to find the parts for yourself you should have few difficulties, although the voltage dependent resistors may prove a little hard to find. The ones specified for the two versions of the preamplifier are both mains voltage types and the numbers represent the amount of energy each can absorb during a mains 'spike' (26 joules or 61 joules). Obviously, mains-voltage VDRs which can absorb larger amounts of energy will be perfectly acceptable if you can't find types with the recommended ratings. A possibility is the Z250F from Cricklewood Electronics (tel 01-450 0995) which is rated at 75 joules, or you could try Marco Trading (tel 0939-32763) who stock a

large range of VDRs. The PCB for the power supply will be available from our PCB Service.

CASE, CONTROLS, ETC: Complete kits of parts for the Virtuoso preamplifier including case, transformer and PCBs are available from the author at the address above. The prices are £138.00 for the standard version without tone controls, £177.00 for the standard version with tone controls, £256.00 for the fully-upgraded version without tone controls and £372.00 for the fully-upgraded version with tone controls. All parts are also available separately including the case, the transformer, the PCBs and components for the various modules and all the sockets, switches and potentiometers, etc. Contact the author for a price list. Those who prefer to find all or most of their own parts should have no real problems although one or two components deserve a little

comment. Alps potentiometers, including the MN law type specified for the balance control, are available from Circkit (tel 0992-444 111 - catalogue available from high street newsagents), and Barrie Electronics (tel 01-555 0228) stock Bourns potentiometers. RS Components stock some of the switches required (see parts list) and also the insulating boots recommended for the mains socket, switch and fuse. Purpose-designed boots are not available for the switch so the type of boot sold for use on mains sockets (RS order code 544-112) should be used for the switch as well. Insulating boots for the fuse come in two sizes, 13.5mm internal diameter (order code 544-106) and 15.5mm internal diameter (order code 544-099). RS themselves will only accept orders from trade and professional customers but all RS parts are also available from Electromail. See the item on Electromail in last month's News Digest.

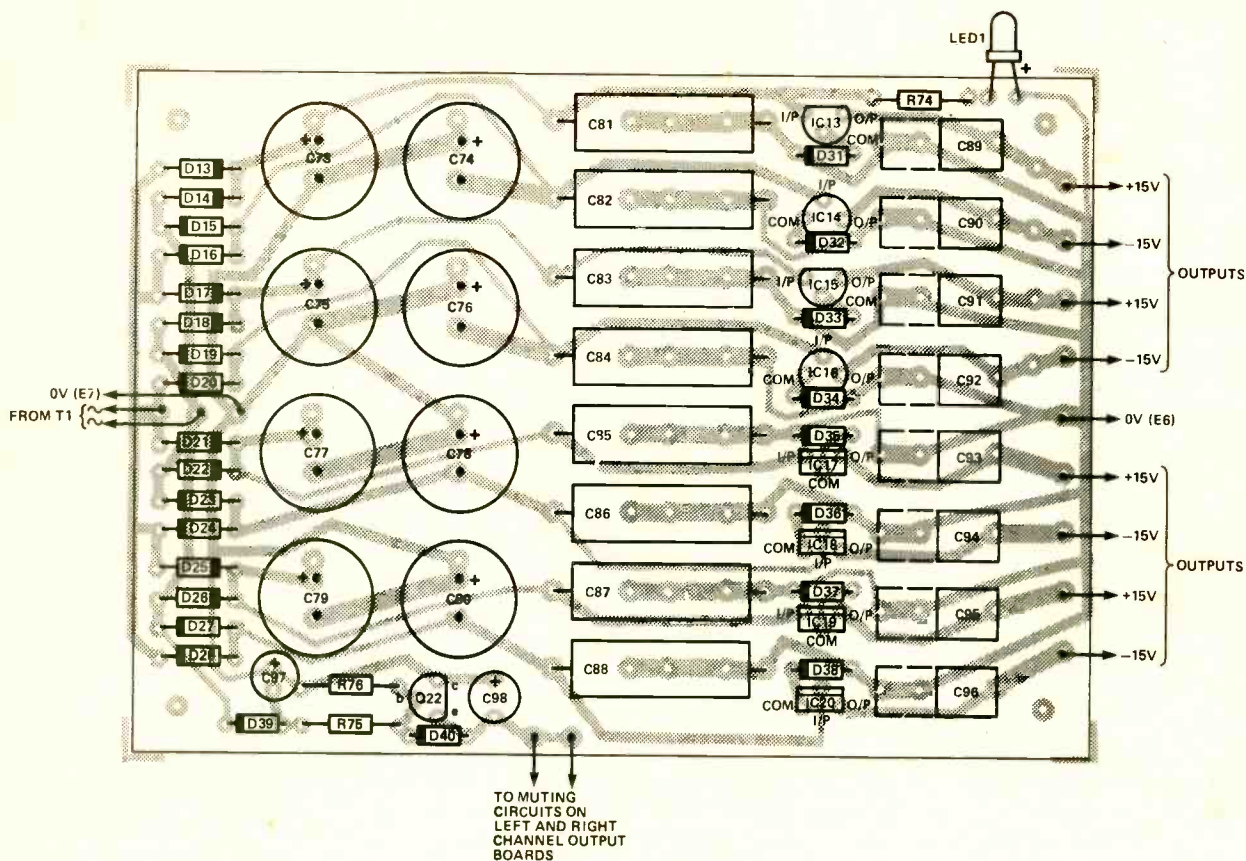

Fig. 2 Component overlay for the power supply PCB. 100mA regulators of the type used on the standard version are shown in the IC13-16 positions while the remaining four regulators, IC17-20, have been shown as the 1A type specified for the upgraded version of the preamplifier.

When the preamp is switched on C98 charges slowly to about -8V, but when it is switched off it discharges quickly via Q22.

Construction

The power supply board is quite straightforward and should present no problems provided the overlay diagram and the parts list are followed carefully. Not that only four of the eight supply rails are used in the standard version of the preamplifier, these being the two positive and two negative supplies based around ICs 13, 14, 15 and 16. 100mA regulators of the type specified for the standard version are shown in these positions on the overlay. If you are building the fully-upgraded version you will need all eight supplies on the board and should use 1A regulators of the type specified in the parts list. These should be installed as shown in the IC17, 18, 19 and 20 positions on the overlay.

Testing the power supply board

RESISTORS	STANDARD VERSION	UPGRADED VERSION
R62, 64	not used	not used
R63	220k	221k
R65	5k6	5k62
R69	47k	47k5
CAPACITORS		
C63	470n polyester	470n polycarbonate
C64		3n9 or 4n7 polystyrene

Table 1. Component changes required on the output boards when no tone controls are included.

is simply a matter of connecting it to the transformer and checking that the correct voltages appear on the outputs. Note that two separate ground connections are provided on the board and make sure you connect both to 0V during testing.

With the power supply and the other modules described over the last few months now complete and working, the final stage is to assemble the boards into the case and make the necessary interconnections. The following notes and diagrams are intended for those using the ready-drilled case supplied by

Audio Kits. Similar 2U-height, 19" racking cases would also be suitable, but you will have to work out the hole positions for yourself. Other cases with a similar internal volume could also be used, but unless you are very sure of what you are doing it is not a good idea to use a case which demands a radically different internal layout.

Gather together the case (with a front panel punched to accept tone controls or not as required), the assembled and tested circuit boards and the necessary sockets, switches, potentiometers, etc. A complete list of the parts needed for final assembly of each version

PROJECT: Upgradeable Amplifier

PARTS LIST — POWER SUPPLY BOARD

RESISTORS	STANDARD VERSION	UPGRADED VERSION
R74	4k7	4k7
R75, 76	33k	33k
CAPACITORS		
C73-76	1000u 35V radial electrolytic	1000u 35V radial electrolytic
C77-80	1000u 35V radial electrolytic	
C81-84	470n polyester	2u2 polycarbonate
C85-88		2u2 polycarbonate
C89-92	220n polyester	220n polycarbonate
C93-96		220n polycarbonate
C97	4u7 35V radial electrolytic	4u7 35V radial electrolytic
C98	220u 16V radial electrolytic	220u 16V radial electrolytic
SEMICONDUCTORS		
IC13	78L15	7815
IC14, 16	79L15	7915
IC17, 19		7815
IC18, 20		7915
Q22	BC184 or BC547	BC184
D13-20	IN4002	IN4002
D21-28		IN4002
D31-34, 39, 40	IN4148	IN4148
D35-38		IN4148
LED1	0.2" red LED	0.2" red LED
MISCELLANEOUS		
FS1	20mm panel-mounting fuseholder and 1.6A fuse	20mm panel-mounting fuseholder and 2.5A fuse
SK12	IEC mains chassis plug	IEC mains chassis plug
SW6	DPST mains rotary switch, 4A rating	DPST mains rotary switch, 4A rating
T1	18-0-18V (15-0-15 to 22-0-22V) mains transformer, 30VA or larger	18-0-18V (15-0-15 to 22-0-22V) mains transformer, 120VA
VDR1	VDR26J	VDR61J
PCB; double-sided 1.0mm PCB pins, 15 off for standard version, 19 off for upgraded version.		

of the preamplifier is given in the controls and hardware parts list.

If you are building a version of the preamplifier with tone controls, the boards can be used exactly as they have been described in the preceding articles. If, however, you are building either a standard or upgraded version without tone controls, certain minor changes need to be made to the output boards to adjust the gain for minimum noise. These changes are detailed in Table 1. Note that the two capacitors listed are not shown on the output board overlay published last month. They fit between the two sets of pads currently spanned by R62.

Begin by assembling the boards into the case using Fig. 3 or Fig. 4 as a guide. It should not be necessary to make any connections to them before installation because the PCB pins allow wiring to be carried out easily with the boards in place. Install the mains transformer, the mains switch, fuse and input socket and the earth terminal

(SK11). This last item provides a convenient external earthing point for other equipment used with the Virtuoso preamplifier. It mounts at the extreme left-hand end of the rear panel and is simply screwed and tightened into place.

Insert the switches and potentiometers loosely into their holes in the front panel. Versions of the preamplifier with tone controls include stereo/mono switching which can take the form either of a simple switch or a continuously-variable stereo width control (see last month's article). Both controls occupy the same position on the front panel, the switch (SW5) being a rotary type so that it can fit in place of the potentiometer.

The rear-panel phono sockets are mounted in groups of four on insulating panels which are then secured to the case by two screws. One way of doing this is to use PCB material on which a pattern of four squares is etched. The boards are mounted with the copper side facing inwards and the earth connections can then be made by

soldering to the copper. One of the advantages of this arrangement is that each socket is earthed to the appropriate point in the circuit rather than directly to the case. If you prefer not to use etched circuit board, simply mount the connectors on plain paxolin or SRBP board using the pattern on the foils page as a drilling guide.

Wiring

With all the hardware in place, we now come to the wiring-up. As anyone who follows the debate in the hi-fi world will know, the choice of cable used in a sound system is considered by many experts to have a significant effect on equipment performance. This is widely accepted to be the case with loudspeaker leads, but it is also true of point-to-point wiring within an amplifier. There is not enough space here to go into all the arguments for and against each type of cable, so the best I can do is to recommend types which seem to me to offer a reasonable compromise between such factors as sound quality, ease of use, price and availability.

For the standard version, I suggest a stranded cable of medium size such as 16/0.2 (16 strands of 0.2mm diameter wire). This is small enough to be manageable when making connections and will not break easily should you have to remove and re-solder connections during testing.

For the upgraded version I suggest a single-strand, high quality, data transmission cable such as that sold by RS Components (see Buylines). This is more fragile than the multi-strand types but offers a better performance. If you are not too experienced at electronics construction, you may find it easiest to use the 16/0.2 cable at the outset and upgrade to the single-strand cable later when testing is complete and further disruption of the wiring is unlikely.

The cables used for the mains wiring are not subject to the same set of selection criteria but they are important nonetheless. The best approach here is to use the thickest cables you can find, although for obvious safety reasons you should stick to types which are coloured in accordance with the recognised mains coding

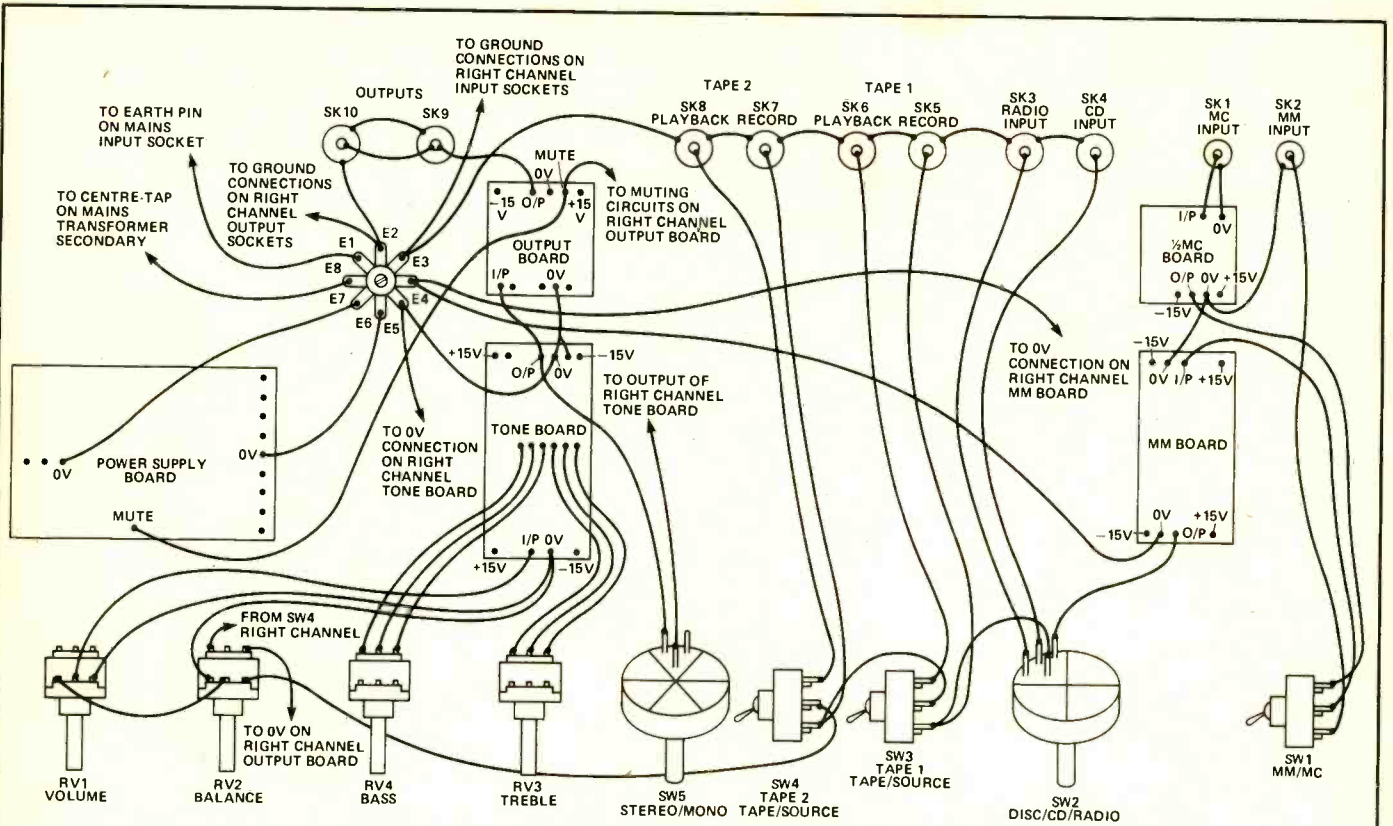

Fig. 3 Wiring diagram for versions of the preamplifier with tone controls. The stereo/mono switch shown here (SW5) is intended for use on upgraded versions of the preamplifier only.

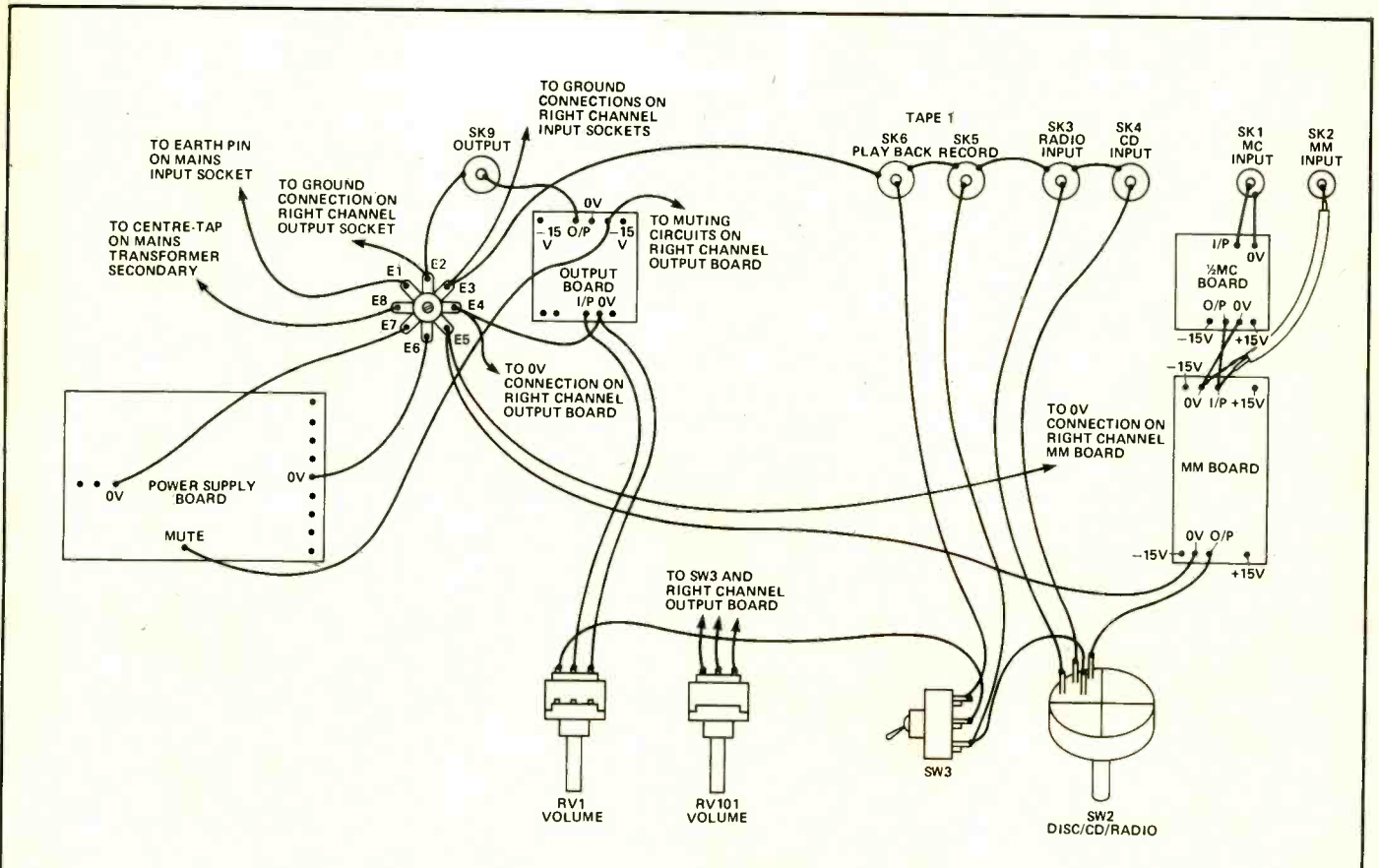

Fig. 4 Wiring diagram for versions of the preamplifier without tone controls.

PROJECT: Upgradeable Amplifier

PARTS LIST — CONTROLS, HARDWARE, ETC

	STANDARD VERSION		UPGRADED VERSION	
	with tone controls	without tone controls	with tone controls	without tone controls
POTENTIOMETERS				
RV1 (volume)	47k dual-gang logarithmic	47k single-gang logarithmic	50k dual-gang logarithmic, Bourns 91A	50k single-gang logarithmic, Bourns 91A
RV101 (volume)		47k single-gang logarithmic		50k single-gang logarithmic, Bourns 91A
RV2 (balance)	100k dual-gang, MN law		25k dual-gang, MN law, Alps	
RV3,4 (tone controls)	See parts list, Upgradeable Amplifier, ETI September '86		See parts list, Upgradeable Amplifier, ETI September '86	
RV5 (stereo width)	10k dual-gang linear			
SOCKETS				
SK1-6, 9, 101-106, 109	panel-mounting phono sockets	panel-mounting phono sockets	panel-mounting phono sockets, gold-plated	panel-mounting phono sockets, gold-plated
SK7, 8, 10, 107, 108, 110	panel-mounting phono sockets		panel-mounting phono sockets, gold-plated	
SK11	binding-post terminal, nickel-plated brass	binding-post terminal, nickel-plated brass	binding-post terminal, nickel-plated brass	binding-post terminal, nickel-plated brass
SWITCHES				
SW1, 4	miniature toggle switch, DPDT		miniature toggle switch, DPDT, gold-plated contacts	
SW2	4-pole, 3-way rotary switch, Lorlin CK	4-pole, 3-way rotary switch, Lorlin CK	4-pole, 3-way rotary switch, silver-plated contacts, RS 327-311 + 327-388 or equivalent	4-pole, 3-way rotary switch, silver-plated contacts, RS 327-311 + 327-388 or equivalent
SW3	miniature toggle switch, DPDT	miniature toggle switch, DPDT	miniature toggle switch, DPDT, gold-plated contacts	miniature toggle switch, DPDT, gold-plated contacts
SW5			SPST Rotary Switch silver-plated contacts	

MISCELLANEOUS

Case (with front panel punched and marked as appropriate according to whether tone controls are required or not); large knobs (28mm), 3 off for version with tone control, 4 off for version without tone controls; small knobs (22mm), 4 off on version with tone controls only; PCB spacers, 6BA, 1/2" high, 32 off for version with tone controls, 24 off for version without tone controls; PCB or paxolin/SRBP panels to hold phono sockets (see text), 5 off on version with tone controls, 4 off on version without tone controls; insulating boots to fit FS1, SK12 and SW6 (see Buylines); 6BA solder tags for earth connections; 6BA nuts, bolts and washers to secure PCBs, phono socket panels and for earth connection; nuts and bolts to suit SK12; insulated connecting wire, sleeving, cable clips, etc.

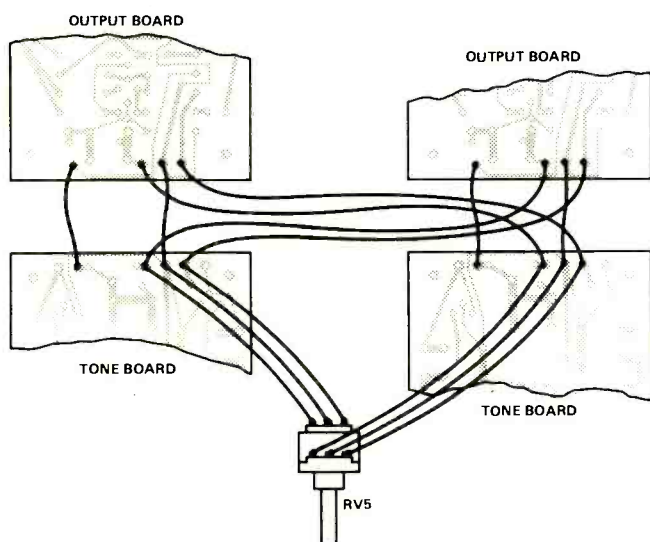

Fig. 5 A stereo width control arrangement which can be used in place of SW5 on standard versions of the preamplifier with tone controls.

(brown, blue and green/yellow).

Figure 3 shows the signal wiring and earthing arrangements in the versions of the preamplifier which include tone controls, while Fig. 4 shows the interwiring of versions without tone controls. The two diagrams apply both to the standard and upgraded versions of the preamplifier since the differences are principally in the power supply arrangements used (and in the components on the boards) rather than in the signal wiring. The only difference here is in the stereo width control which is shown separately in Fig. 5.

It is best to begin wiring at one corner of the preamplifier and then work methodically across. If the front panel controls have been installed loosely as recommended, they can be withdrawn for soldering once the wiring has been cut to length and then re-inserted and tightened into place. Use

PROJECT: Upgradeable Amplifier

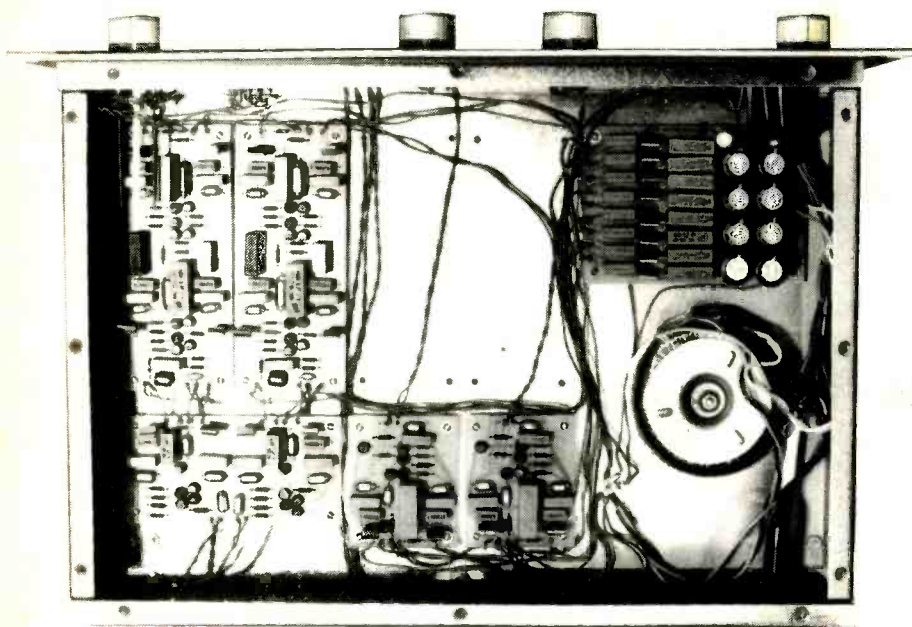

Internal view of a fully-upgraded preamplifier without tone controls.

different coloured wires for each channel if possible to avoid confusion and save red and black for use in the power supply connections and green for the earth/0V leads. Note that the MC/MM switch is shown in Fig. 3 wired with separate, insulated cables. This should prove adequate in standard versions of the preamplifier but may pick-up hum if a large mains transformer is used in an upgraded version. In this case, simply wire the disc inputs and switching with screened lead.

The power supply wiring can be deduced from the circuit diagram (Fig. 1). Take the usual care with the mains wiring and use sleeving on all exposed connections. The mains input socket, the fuseholder and the on/off switch should all be covered with moulded insulating boots of the type recommended in *Buylines*.

In standard versions of the preamplifier, one set of positive and negative supply rails is used for each channel. This means that two wires must be connected to each supply rail pin on the power supply board. One set of positive and negative leads is then connected to the MM board in each channel and the other is connected to the accompanying tone board. The power supply for the MC board is obtained by jumping short wire links across from the lower end of the MM board (see the photograph on

page 40 of the July issue) while the output boards obtain their supply via insulated wire links from the tone board in the same channel (see Fig. 10 on page 53 of the September issue). If a standard version of the preamplifier is built without tone boards, the second set of connections can go straight to the output boards.

In the upgraded version of the preamplifier, two separate sets of supply rails are used for each channel. One set powers the MM and MC boards and the other goes to the tone and output boards. It should also be noted that the MM board and the tone board in this version are equipped with two sets of regulators, one at each end. Both require a separate feed from the power supply. This means that three wires should be attached to each supply rail pin on the power supply board, two for the MM board and one for the MC board from the first set of regulators and two for the tone board plus one for the output board from the second set of regulators. If an upgraded version of the preamplifier is being built without tone controls, the second set of regulators will supply the output board only and should be fitted with just one set of wiring.

The earthing connections from the power supply and the signal circuitry all go to the same point, a 6BA bolt through the bottom of the case near the output boards. For best results, the earth

connections should be made in the correct order, with the inputs next to the incoming mains earth, followed in succession by the other stages of the preamplifier and finally the power supply earths. All the earth connections are therefore numbered and the solder tags should be placed over the bolt in sequence, starting with E1 and finishing with E8. Use a shakeproof washer to ensure a good connection and tighten the whole arrangement carefully.

Testing and Use

Check that all the components have been correctly installed on the boards and that you have carried out all the interwiring exactly as shown. Pay particular attention to the polarities of electrolytic capacitors and the regulators and also make sure that all the supply rail connectors are of the correct polarity. If all seems well, insert current-limiting resistors of 25-100 ohms in series with the transformer secondaries and then switch on.

With any luck, all will be well and the preamplifier will work correctly. Check that the correct supply voltages are arriving at each part of the circuit and then try applying a signal to each of the inputs in turn while monitoring the outputs. If all is not well, the resistors should prevent too much damage resulting from excess currents and give you an opportunity to figure out where the fault is before anything is destroyed. When everything is as it should be, remove the resistors from the transformer leads and the preamplifier is complete.

In order to get the best from the *Virtuoso*, you should mount it on a vibration-free surface such as a turntable shelf or an anti-vibration platform of the type available from specialist hi-fi shops. You should also make sure that the mains lead is of good quality and is as heavily rated as possible, and that all the connecting leads used between the *Virtuoso* and the rest of your system are of the highest quality.

I have not included any measurements of distortion for the prototype preamplifiers. In my experience, such figures do not tell you how well an amplifier will sound. The final measure of the quality of the *Virtuoso* will be the amount of pleasure you obtain from listening to music through it.

INTELLIGENT CALL METER

Chris Ranklin moves on to describe the construction of his fully-automatic telephone call charge meter.

In the first two articles in this series we looked at the facilities offered by the intelligent call meter and the operation of the hardware and software. In this article we will consider the assembly of the PCBs and the construction of the complete unit.

The component overlays for the two boards are shown in Figs. 1 and 2 and it does not matter in which order you assemble them. Take the usual care with ICs, diodes and electrolytic capacitors, all of which must be inserted in the board the right way around if everything is to work correctly, and note also that some of the ICs are CMOS and may be damaged by careless or excessive handling. IC sockets were not used on the prototype but there is no reason why they shouldn't be used if you prefer not to solder the semiconductors.

Note the position of the four LEDs and the two switches on the interface and power supply board. These are used only when setting-up or changing the data held in RAM and need not be accessible

OOPS!

Switch SW3 is missing from the circuit diagram of the call meter main board on page 38 of August 1986 ETI. It should be shown between pin 10 of IC8 (data line D5) and ground. A pull-up resistor, R40, should also be shown between that line and the +5V supply. Both components are included on the component overlay in this article.

Two resistor values were missed from the same diagram, both in the lower right-hand corner. R38 should be shown as a 10k resistor and R39 as 270R.

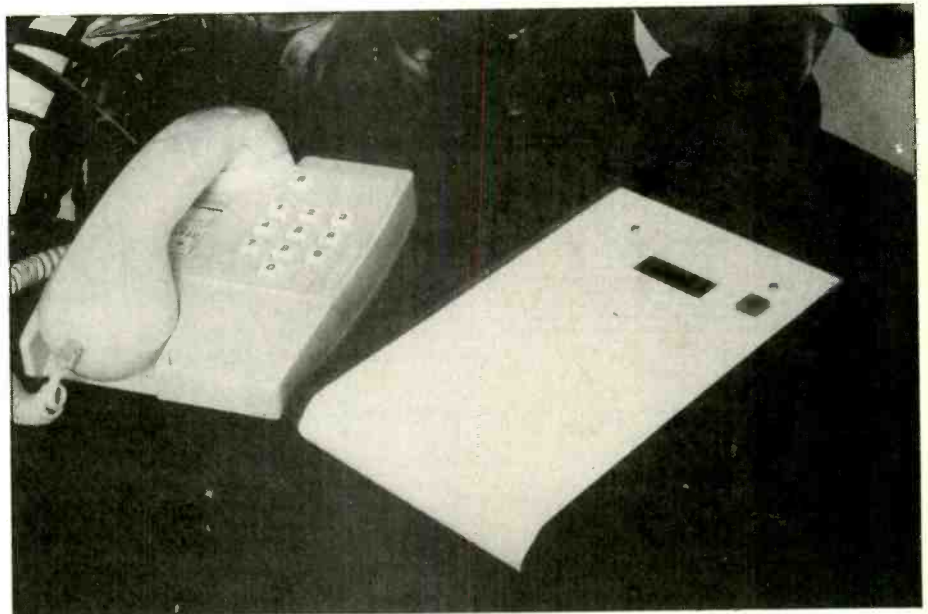

during normal use. Depending on the style of case you use and the orientation of the two boards within it, the LEDs may need to be mounted either vertically or at right-angles to the board. If in doubt, solder them into place with the leads at full length for the time being. They can then be cropped and re-soldered when you come to fit the boards into the case.

Make sure that you mount the LCD on the main board the right way around, and use snap-on edge connectors to support it a little way above the surface of the board. It is important that the LCD stands higher than any of the adjacent components so that it can be mounted flush against the front panel. Some of the components at the lower end of the board may stand a little higher than the display, but this doesn't matter because the board is angled slightly away from the front panel when mounted in the case. The battery should not be installed

at this stage but should be put aside until the boards have been tested and the power supply is known to be working correctly. You may wish to charge the battery in the meantime since most are supplied with only a residual charge in them.

Case Notes

The case used for the prototype was built from scratch using a sheet of folded plastic attached to two wooden end-cheeks. The plastic material used is known as Foamex and can be obtained with either a white or grey matt finish in thicknesses from three to six millimetres. It cuts easily and can be shaped by heating it in front of a fire whilst applying pressure. If a particularly sharp curve is required such as the one at the front end of the call meter case, it is best to score the underside of the material first with a sharp knife. It is also a good idea

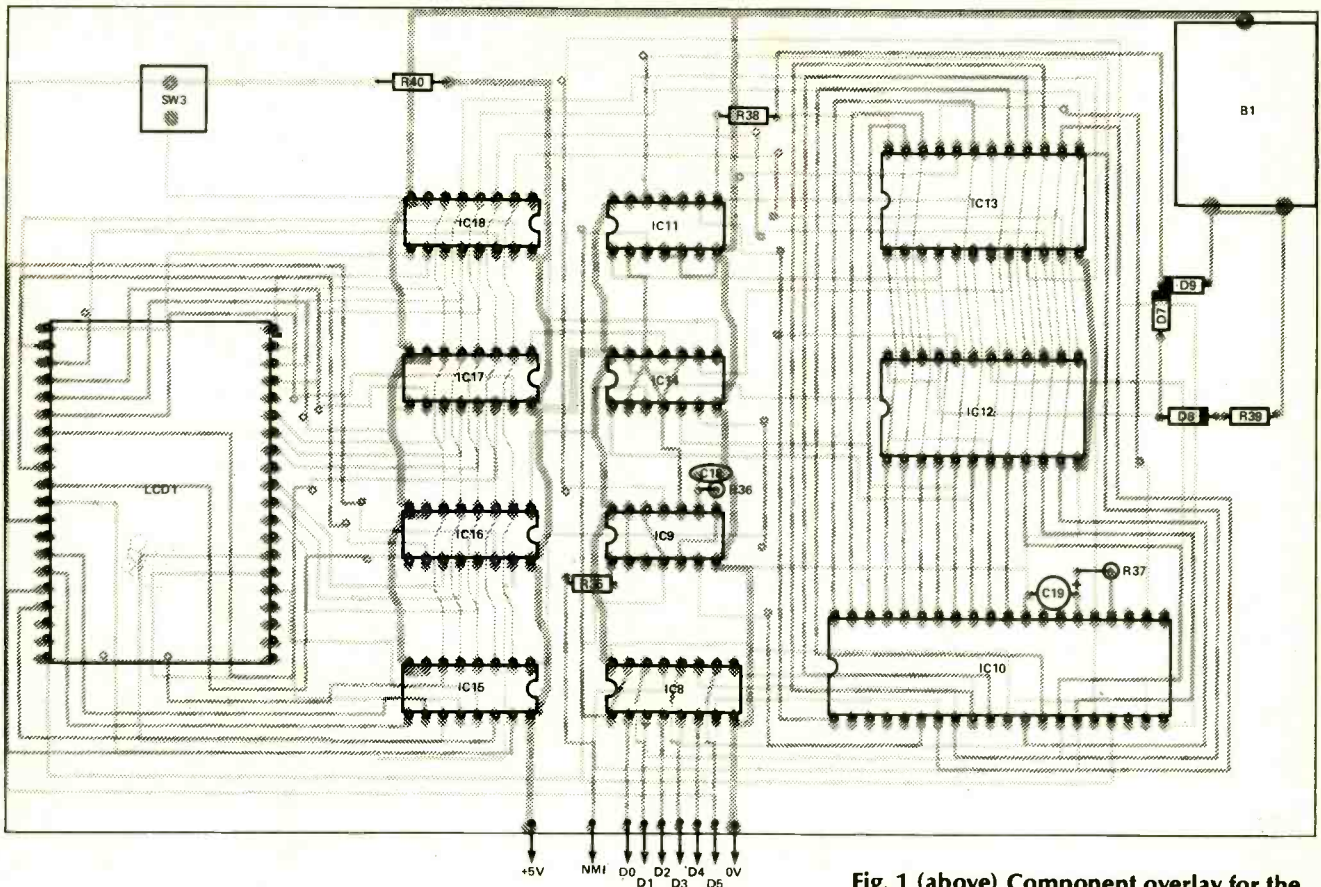
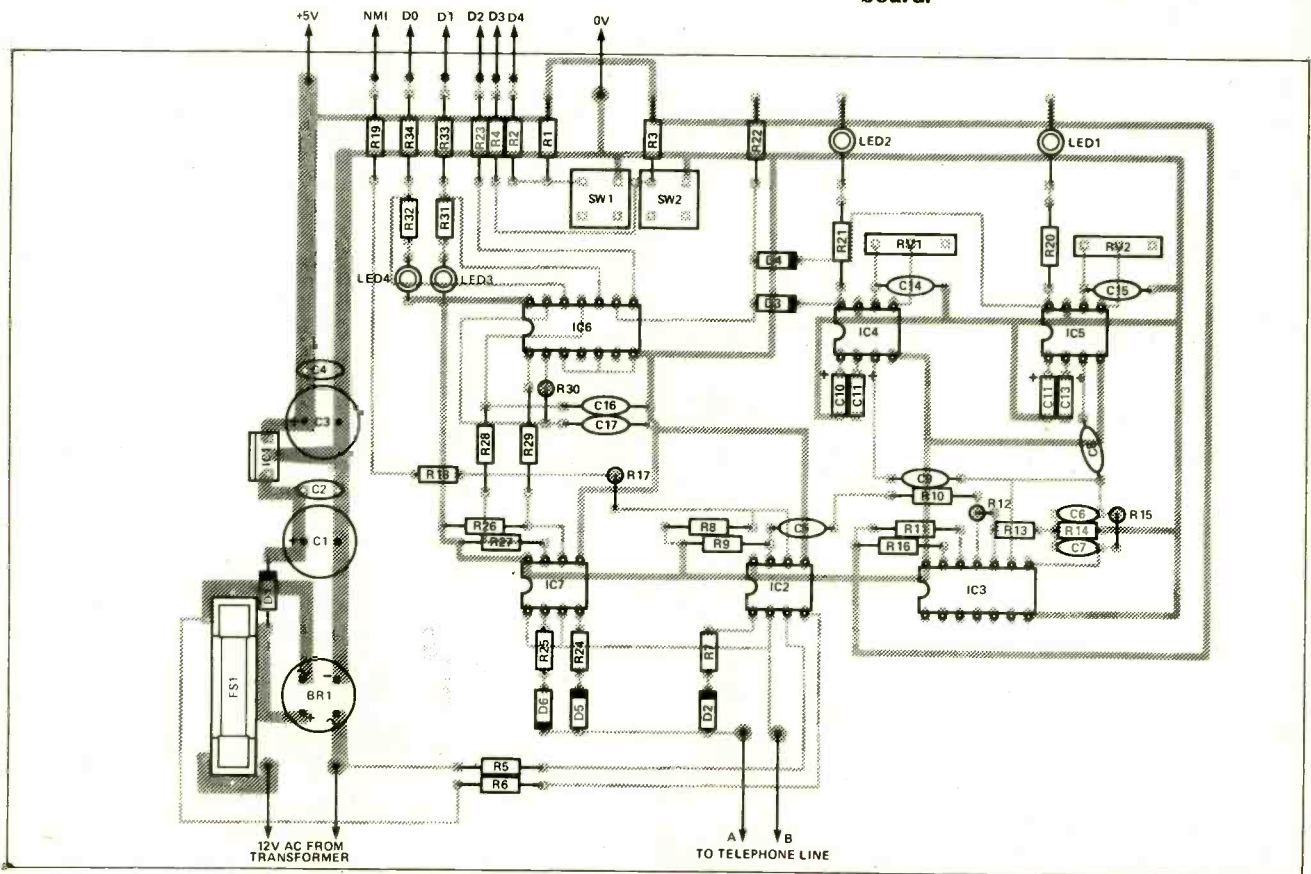

Fig. 1 (above) Component overlay for the main PCB and Fig. 2 (below), component overlay for the power supply and interface board.



PARTS LIST — MAIN BOARD

RESISTORS	
R35, 36	1k0
R37	4k7
R38, 40	10k
R39	270R
CAPACITORS	
C18	68p polystyrene
C19	10u 10V radial electrolytic
SEMICONDUCTORS	
IC8	4503
IC9	40106
IC10	Z80
IC11	74C00
IC12	2716
IC13	6116
IC14	74C08
IC15-18	4543
D7-9	1N4001
LCD1	4-digit liquid crystal display
MISCELLANEOUS	
B1	4.8V nickel-cadmium battery pack, PCB mounting
SW3	push-to-make, non-latching keyboard switch
PCB	

to wear gloves whilst working since the heated material picks up fingerprints very easily.

The wooden end-cheeks were made from balsa wood and then treated with woodstain to produce the final dark wood effect. Balsa has the advantage that it is very easy to work, but it is also very soft and tends to get damaged and dented easily in use. If your carpentry skills are up to it, you may prefer to use a harder wood.

The end-cheeks should be cut so that they are about 3mm ($\frac{1}{8}$ ") larger all round than the outside measurements of the folded plastic sheet. Measure 3mm in from each edge of the cheek and cut a groove which is 3mm deep and wide enough to accept the edge of the plastic sheet. The end-cheeks slip over the plastic sleeve at either side and are held in place by lengths of studding passed through the interior of the case. If the nuts securing the studding are recessed into the wood, they can then be hidden in some way. The small clip-on caps supplied for use with collet knobs are ideal for this purpose.

The prototype shown in the photograph did not include all of

the facilities offered in the final design and was therefore slightly smaller. For this reason, there is no point in giving the dimensions of the original case. Those who wish to produce a similar case should not find it too difficult to work out their own dimensions based on the size of the board and the transformer.

There are a number of sloping-front cases on the market for those who prefer not to make their own case. Some suggestions are given in Buylines. It would also be possible to use a completely different shape and style of case, but this may involve mounting the display off the board in order to achieve a reasonable viewing angle.

Installation

The two boards were mounted in the prototype using stand-off pillars, mostly secured through the underside of the case. The interface and power supply board was mounted component-side down in the bottom of the case, towards the forward edge. The transformer was also bolted through the bottom of the case and occupied the space behind the interface board. The display board was attached at its lower end to the interface board using flexible plastic PCB pillars and at its upper end was held against the front panel by means of two nuts and bolts (visible in the photograph).

Mounting the interface and power supply board upside down makes it easy to adjust the RAM data without opening the case. Holes are drilled through the underside of the case directly opposite the switches and LEDs, and data can then be entered or changed by operating the switches with a matchstick or screwdriver poked through the appropriate hole. You may prefer to arrange the LEDs on the interface board at right angles so that they are visible from the side. Since the two switches are close to the same side of the board as the LEDs, data can then be entered by first removing the appropriate side panel.

With the boards and the transformer installed in the case,

PARTS LIST — INTERFACE BOARD

RESISTORS		SEMICONDUCTORS	
R1, 3, 5, 6, 22, 25,	10k	IC1	7805
28-30		IC2, 7	HCPL2730
R2, 4, 17-21, 23,	1k0	IC3	LM3900
27, 31-34		IC4, 5	NE567
R7	47k	IC%	40106
R8, 9, 26	4k7	D1	1N4001
R10, 13	470k	D2-6	1N418
R11	2M2	LED1-4	red LEDs
R12	1M0	BR1	1A 50V bridge rectifier
R14	18k		
R15	1M8		
R16	4M7		
R24	100k		
RV1, 2	10k		
CAPACITORS		MISCELLANEOUS	
C1	220u 25V radial electrolytic	FS1	1A fuse and PCB-mounting holder
C2, 4, 8, 9, 16, 17	100n polyester	SW1, 2	push-to-make, non-latching keyboard switches
C3	220u 10V radial electrolytic	T1	9V or 12V, 12VA chassis-mounting mains transformer
C5, 14, 15	470n polyester		
C6, 7	2n2 polystyrene		
C10, 11	10u 10V axial electrolytic		
C12, 13	4u7 10V axial electrolytic		
			PCB; case (see text); mains cable; telephone line cable and plug if required; nuts, bolts, PCB pillars, etc.

BUYLINES

The only components likely to present any problems are the HCPL 2730 opto-isolator and the 4.8V battery pack. The opto-isolator is available from RS Components, and can be obtained either directly from them or through Electromail (see last month's News Digest). PCB-mounting rechargeable batteries for memory back-up are now widely available, but most suppliers only stock 3.6V versions. Among those who can supply 4.8V batteries are MS Components (Zephyr House, Waring Street, West Norwood, London SE27 9LH, tel 01-670 4466) and Verospeed (Stansted Road, Boyatt Wood, Eastleigh, Hampshire SO5 4ZY, tel 0703-644 555). If you buy from anyone else, make sure you get the right voltage.

Four-digit liquid crystal displays are not too hard to come by. The one used in the prototype came from Farnell (order code H1333CC), who will only supply directly to trade and professional customers. Farnell parts can be ordered through Trilogic, 29 Holm Lane, Bradford BD4 0QA, tel 0274 - 684 289. Other 4-digit LCDs should also be suitable.

The switches used in the SW1 and 2

positions on the prototype came from RS (order code 334 - 921). Similar keyboard switches with four mounting pins are widely available. A different type of keyboard switch with two mounting pins is used in the SW3 position. You may have to choose with some care here in order to find something of the correct height to project through the front panel. It should not be difficult to modify the PCB tracking to accept other types of switch should this be necessary.

Sloping-front cases are available from a number of suppliers including Mpalin, Cirkit, MS (see above), Electrovalue, etc. We haven't checked the dimensions so we can't recommend any particular type. Those who wish to build their own cases along the lines of the prototype should contact Chas Freeman Display Products Ltd, who are the sole distributors of Foamex sheet in this country. Their number is 01-568 6451.

The PCBs will be available from our PCB Service. For details see page 00. Please note that the address of Argus Readers' Service has recently changed and that the address given on previous PCB Service coupons no longer applies.

the final stage of construction is to wire everything up. The mains and telephone line cables are brought in through holes in the back of the case and secured using cable glands or clips. If you have used sockets for the ICs on the two boards, you may like to wire up the mains circuitry first and then test the power supply before installing the chips. Don't forget to put a fuse in the mains fuseholder on the power supply board. If the supply rail is operating correctly at 5V, the ICs can be installed and the positive, negative and D0-D5 connections made between the two boards. If you have soldered the ICs directly into place, connect up the mains to the power supply and interface board first and check that the supply is working correctly before making the connections to the second board.

The final article in this series will describe the setting-up and use of the call meter and will include a software listing.

ETI

ELECTROVALUE

NEWEST CATALOGUE FREE TO E.T.I. READERS

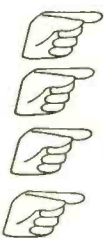

56 PAGES (A.5)
SEMI-CONDUCTORS, I.Cs.
OPTO-DEVICES
CONNECTORS, SWITCHES
ELECTRONICS COMPONENTS
GALORE
COMPUTER SECTION

FREE POSTAGE • HELPFUL DISCOUNTS • PROMPT
DESPATCH • VERY LARGE STOCKS • FAMOUS BRAND
NAME ITEMS • ACCESS/BARCLAYCARD ORDERS
WELCOMED

Write, phone or call for your free EV catalogue today!

ELECTROVALUE LTD 28 St. Jude's Road, Englefield Green, Egham,
Surrey TW20 0HB Phone Egham (0784) 33603. Telex 264475
North Branch, 680 Burnage Lane, Manchester M19 1NA
Phone 061 432 4945
Please mention this publication when replying

'Scotlands newest components shop' OMNI ELECTRONICS

We stock a wide range of components:

transformers, switches, pots, ICs, capacitors, resistors, diodes, boxes, triacs, LEDs, cable, connectors, PCBs-

in fact, all you need for your projects.

Send for our 21 page catalogue - 20p + 12p postage or call at our shop Mon-Fri 9am - 6pm, Sat 9am - 5pm.

174 Dalkeith Road
EDINBURGH EH16 5DX
031-667-2611

KESTREL ELECTRONIC COMPONENTS LTD.

* All items guaranteed to manufacturers spec.
* Many other items available.
'Exclusive of V.A.T. and Post and Package'

74LS00	1* .13	50+ .12	74LS273	46	50+ .42	2716	2.70	50+ 2.50
74LS04	.13	.12	74LS373	43	.45	27C64	3.50	3.00
74LS08	.15	.13	74LS374	48	.45	2764-250	2.30	2.20
6502	3.30	2.80	74LS393	.65	.45	27128-250	2.40	2.20
6522	3.30	2.80	74LS541	.65	.50	27256-250	3.70	3.50
74LS138	.30	.25	8155	1.50	1.30	6116LP-3	1.30	1.15
74LS139	.30	.25	8251	1.50	1.30	6264LP-15	2.30	2.10
74LS157	.27	.24	8253	1.50	1.30	4164-15	0.90	0.75
74LS16	.35	.30	8255	1.50	1.30	41256-15	2.20	2.00
LM324	.23	.20	6809	3.80	3.50	Z80ACPU	1.40	1.00
74LS240	.50	.42	6821	1.40	1.25	Z80ACTC	1.50	1.10
74LS244	.48	.45	6850	1.50	1.25	65256AP	11.00	11.00
74LS245	.50	.43	4 meg Xtels	.70	.55	62256AP-15	23.00	23.00
			6 meg Xtels	.70	.55	27512-250	15.00	15.00

All memory prices are fluctuating daily, please phone to confirm prices.

178 Brighton Road,
Purley, Surrey CR2 4HA
Tel: 01-668 7522

TECH TIPS

Pulse Adding Circuit

Des Keppel,
Eire

A circuit was required which could totalise the pulse outputs from four turbine flow meters and provide a single output for connection to a counter circuit.

The circuit consists of four D-type flip-flops (3014) which are sequentially clocked from a continuously running Johnson Counter (4017). The Q output from each flip-flop is differentiated by the RC network, converted and shaped by a schmitt trigger inverter (4584) and connected to one input of a four input NAND circuit (4012).

If any D input goes high, this is clocked through the latch and appears on the output as a positive going pulse of short duration. The differentiating networks only respond to a positive-going signal from the latch outputs and the sequential clocking of the latches ensures correct operation for all possible variations on the inputs.

A few simple precautions are necessary for correct operation.

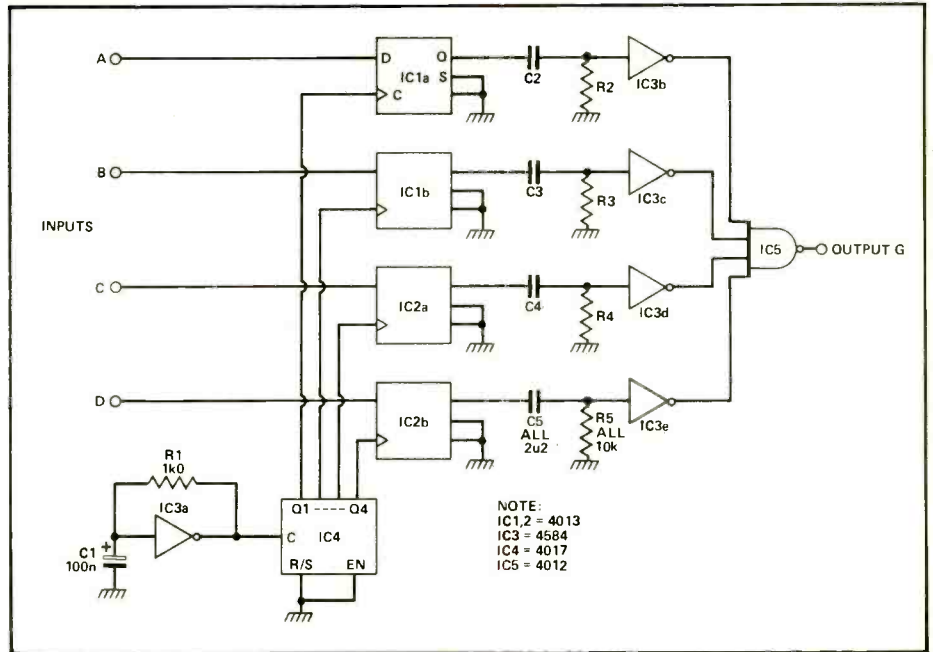

- 1) The clocking pulse duration at each flip-flop must be less than 10% of the minimum D input high time.
 - 2) The time constant of the RC differentiating network must be less than the clocking frequency of the flip-flops to prevent signal overlap.
- While this circuit was originally

designed for four inputs, up to ten inputs could be easily implemented. The circuit could be used to totalise the inputs from any pulse generating sources.

For the values specified, the maximum input frequency is 500 Hz on all inputs.

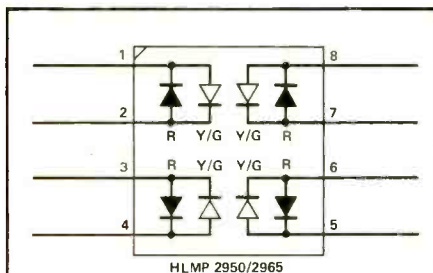
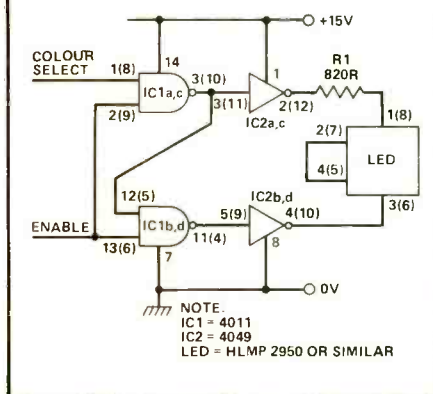

Fig. 1 The HP HLMP2950 and 2965 pin outs.

Fig. 2 The drive circuit.



Dual Colour LED Driver

Neil Muir
Shrewsbury

A convenient driver for dual colour LEDs such as the HP HLM2950 or 2965, where colour is controlled by the direction of current flow, can be realised using two gates of a 4011 and two gates of a 4049 (or 4050) as buffers.

The lamps used actually contain four sets of back-to-back LEDs. If sufficient supply voltage is available all four could be connected in series, in which case two of the 4011's four gates will suffice to drive them.

Alternatively, the LEDs can be connected in two parallel paths, each containing two of the back-to-back sets in series (as shown). Unless the current through each path is

kept below about 10mA, this will require each half of the lamp to be driven by two 4011 gates, so that the entire lamp uses all four gates in the 4011.

The drive circuit incorporates two control inputs, Colour Selection and Display Enable. By applying a variable mark/space ratio pulse wave to the Enable input, brightness can be controlled. A similar wave at the Colour Select input can vary the colour steplessly from red to yellow or green. With a suitable supply voltage and resistor value, the circuit can be adapted to any similar bi-colour LED. The 4049 (inverting) or 4050 (non-inverting) buffers allow practically any LED to be driven by the circuit, but it may be possible, in certain cases, to dispense with them and drive LEDs directly from the 4011.

PCB FOIL PATTERNS

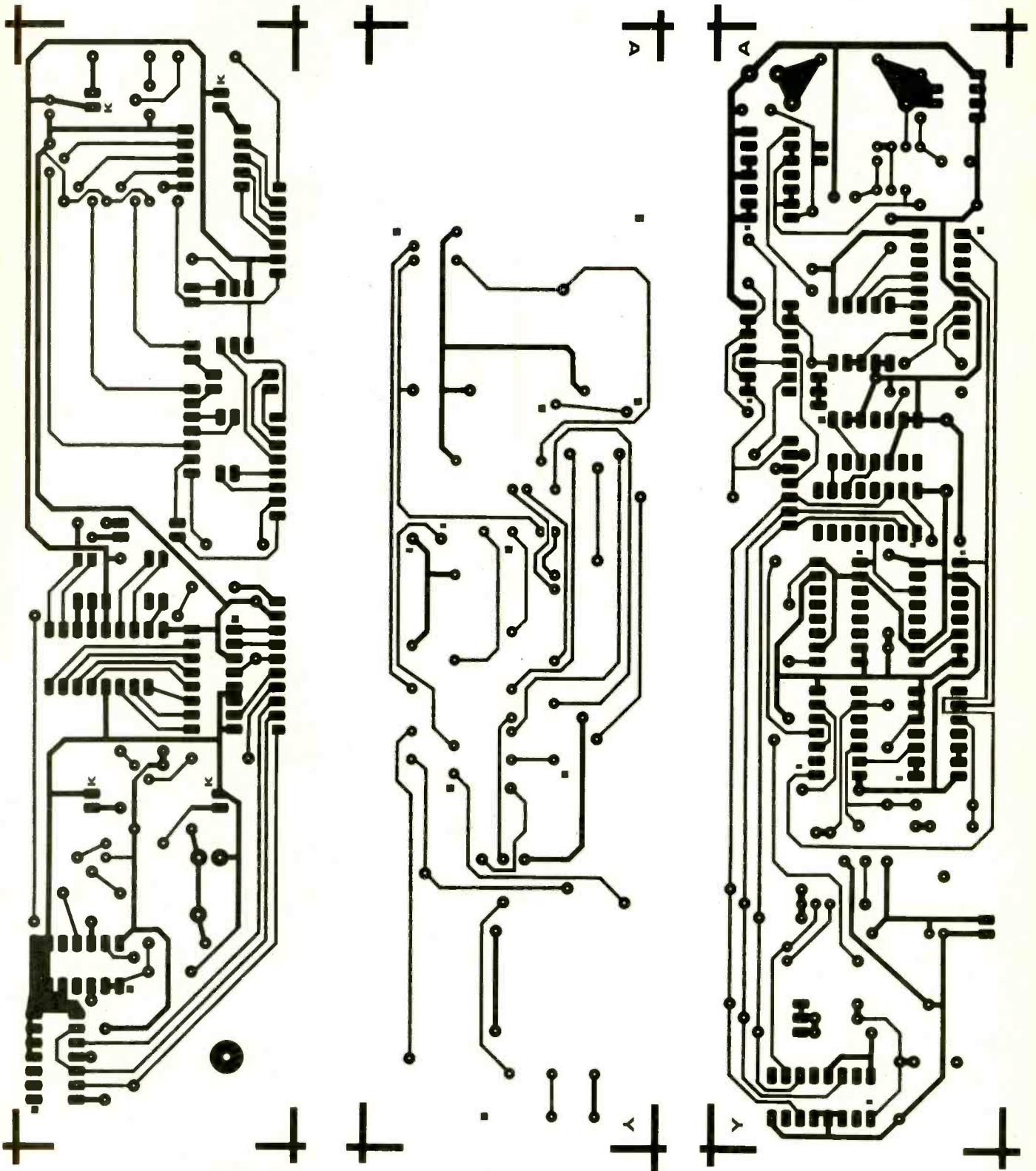

The PLL frequency counter display board.

The top and bottom foils for the frequency counter ranging board.

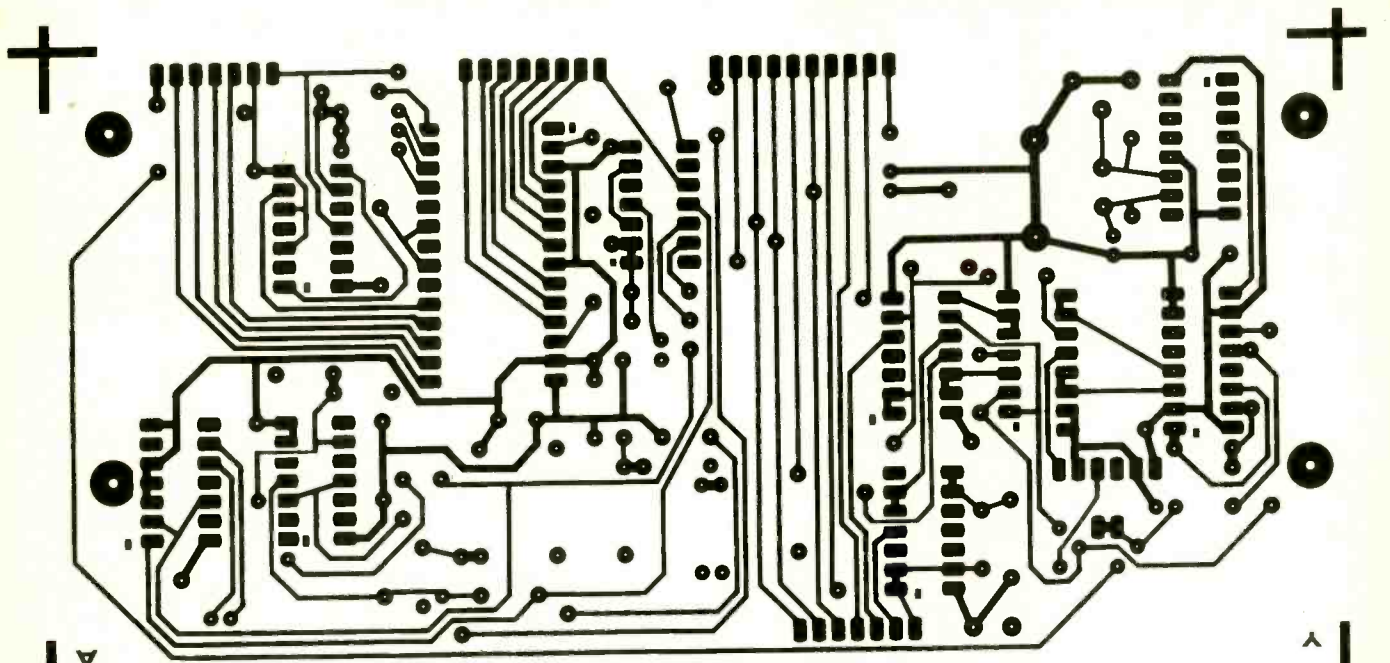

The top and bottom foils for the main board of the PLL frequency counter.

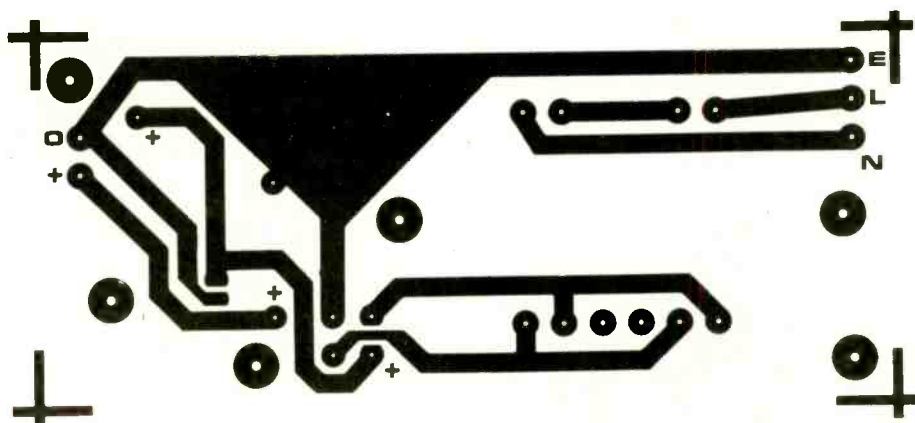
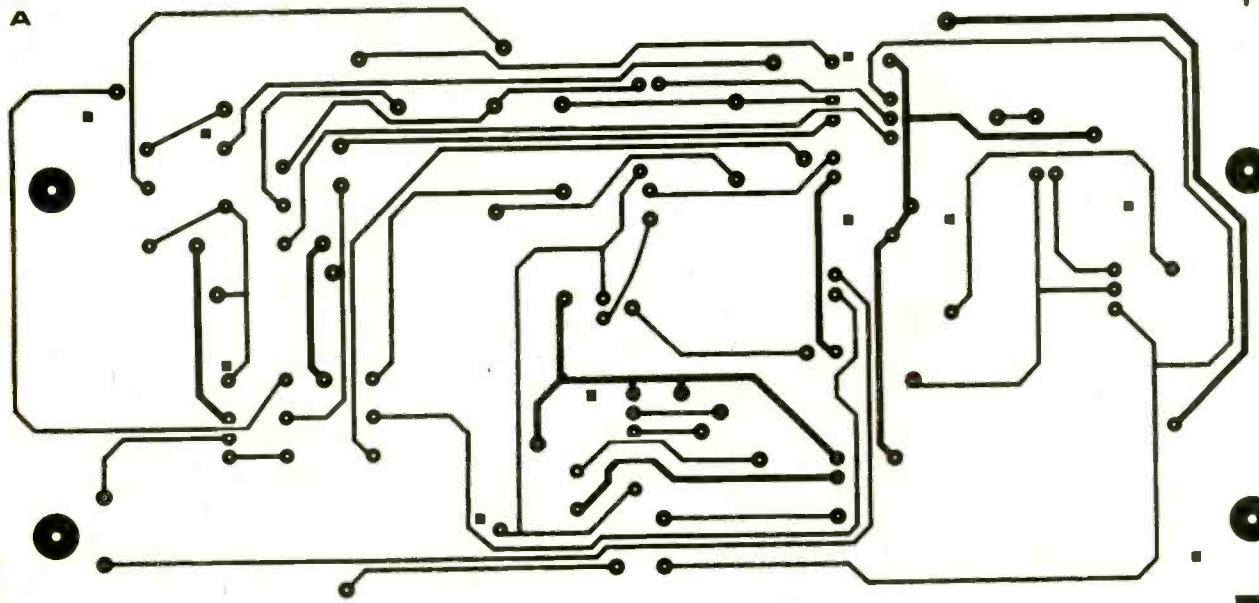

The PLL frequency counter PSU board.

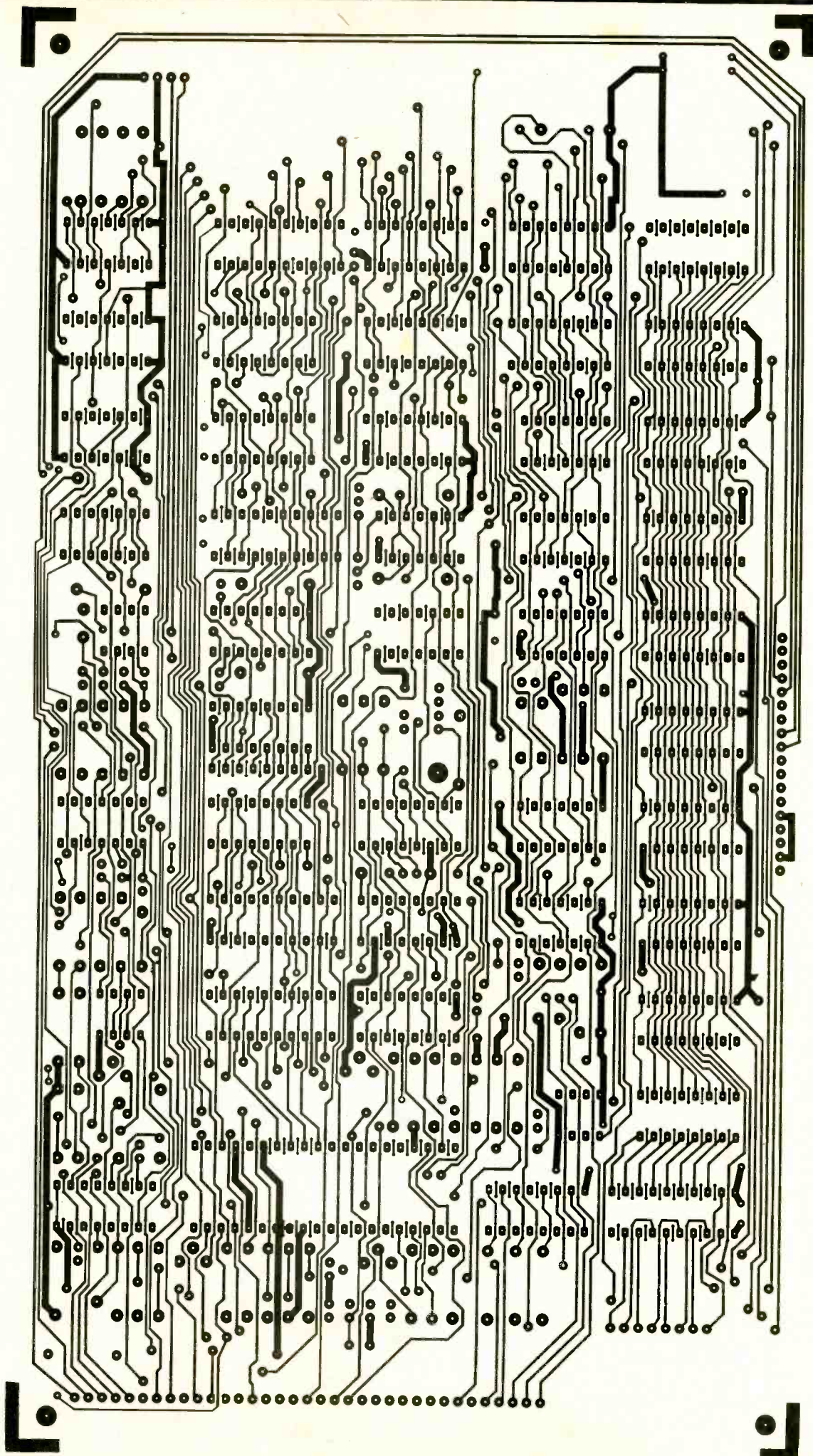

The top and bottom foils for the Framesfore PCB.

PCB FOIL PATTERNS

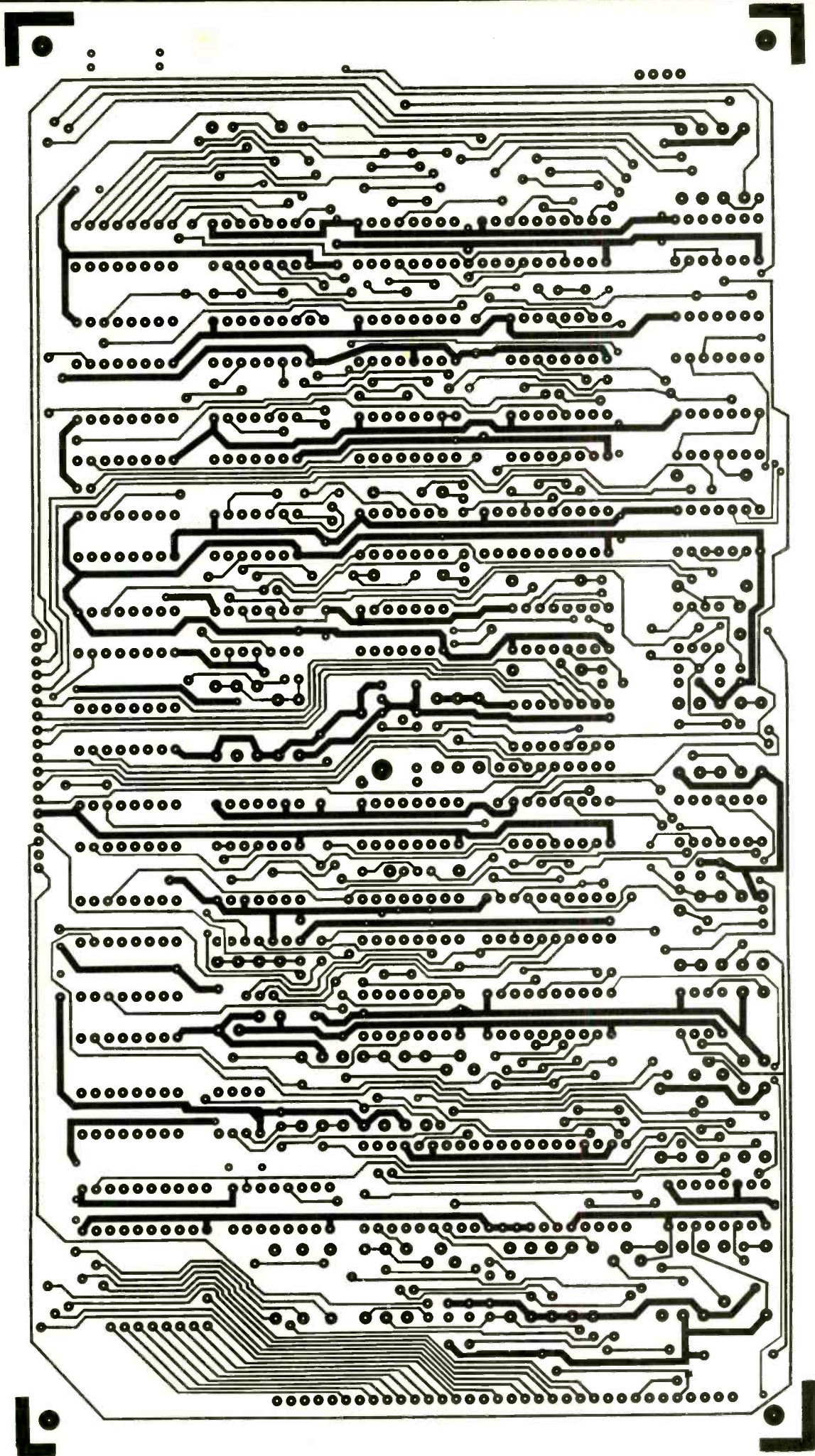

Due to lack of space, the foils for the Intelligent Call Meter, the Audio Switcher and the Upgradeable Amplifier PSU have had to be held over.

ETI PCB SERVICE

Make your project in style -
and avoid bird's nesting
- with a properly designed PCB!

E8107-1 System A Disc Input bd MC-MM. F	E8405-4 Centronics Interface F	E8511-2 Millifaradometer H
E8107-2 System A Preamplifier Main ... K	E8405-6 Drum Synth F	E8511-3 Cymbal Synth J
E8108-1 System A Power Amp L	E8406-1 Oric EPROM Board O	E8511-5 Chorus Effect H
E8109-2 System A PSU F	E8406-2 Spectrum Joystick E	E8511-7 Enlarger Exposure Meter F
E8201-2 Infant Guard C	E8406-3 Audio Design RIAA Stage ... G	E8511-8 Switching Regulator E
E8202-5 MM Stage Disc Preamp (Tilsbrook) G	E8406-4 AD Buffer/Filter/Tone H	E8511-9 Second Line of Defence M
E8206-5 Logic Lock F	E8406-5 AD Headphone Amp F	E8512-1 Specdrum connector F
E8208-1 Playmate Practice Amp 3bds SA1 K	E8406-6 AD Preamp PSU K	E8512-2 MTE Pulse Generator H
E8212-1 ELCB F	E8406-7 AD Power Amp H	E8511-3 Specdrum L
E8301-2 Analogue to digital conv (ZX81/ Spectrum) E	E8406-8 AD Power Amp PSU J	E8601-2 Walkmate L
E8305-3 Dual Audio Power Supply, Linsley Hood G	E8406-9 AD Stereo Power Meter F	E8601-3 MTE Counter-timer M
E8305-5 Balanced Input Preamplifier F	E8406-10 AD Input Clamp C	E8602-1 Digibaro O
E8307-2 Flash Trigger-sound or FR F	E8407-1 Warlock Alarm M	E8603-2 Programmable Logic Evaluation Board H
E8308-1 Graphic Equaliser 1/3 Oct/Chnl M	E8408-2 EPROM Emulator N	E8603-3 Sound Sampler Analogue Board R
E8308-2 Servo Fail-safe C	E8408-3 Infrared Alarm Transmitter ... E	E8604-1 JLLH PA PSU H
E8309-1 NICAD Charger/Regenerator F	E8408-4 Infrared Alarm Receiver F	E8604-2 Matchbox Amplifier C
E8310-3 Typewriter Interface - EX42 ... F	E8409-1 EX42 Keyboard Interface F	E8604-3 Matchbox Amp Bridging Version C
E8311-1 Mini Drum Synth F	E8409-2 Banshee Siren Unit F	E8604-4 MTE Analogue/Digital Probe M
E8311-8 Moving Coil Pre-Preamp F	E8410-1 Echo Unit F	E8605-1 Microlight Intercom E
E8312-3 Light Chaser EPROM Controlled (2 Boards) K	E8410-2 Digital Cassette Deck N	E8605-2 Baud Rate Converter M
E8402-1 Speech Board M	E8410-3 Disco Party Strobe H	E8605-3 Baud Rate Converter PSU Board G
E8402-2 Modular Pre-amp Disc Input Mono F	E8411-5 Video Vandal (3boards) ... N	E8605-4 Portable PA H
E8402-3 Modular Pre-amp Stereo Output F	E8411-6 Temperature Controller D	E8606-1 Midi-CV Converter Board H
E8402-4 Modular Pre-amp Relay, PSU F	E8411-7 Mains Failure Alarm D	E8606-2 Midi-CV Converter PSU D
E8402-5 Modular Pre-amp Tone Main Mono F	E8411-8 Knite Light D	E8606-3 Trolograph F
E8402-6 Modular Pre-amp Tone Filter, Stereo F	E8411-9 Stage Lighting Interface F	E8606-4 80m Receiver H
E8402-7 Modular Pre-amp Balanced Output F	E8411-10 Perpetual Pendulum E	E8606-5 Sound Sampler R
E8402-8 Modular Pre-amp Headphone Amp F	E8412-1 Spectrum Centronics Interface F	E8607-1 Directlon E
E8404-2 Mains Remote control Receiver F	E8412-4 Active - 8 Protection Unit F	E8607-2 Upgradeable Amp, MC stage (Stereo) G
E8405-1 Auto Light Switch F	E8412-5 Active - 8 Crossover F	E8607-3 BBC Motor Controller F
E8405-2 ZX81 EPROM Programmer ... N	E8412-6 Active - 8 LF EQ F	E8608-1 Digital Panel Meter G
E8405-3 Mains Remote Control Transmitter H	E8412-7 Active - 8 Equaliser F	E8608-2 Upgradeable Amp, MM stage (mono) H
	E8501-3 Digital Delay (2 boards) T	E8609-1 Mains Conditioner E
	E8502-1 Digital Delay Expander N	E8609-2 Experimental preamp F
	E8502-2 Data Logger J	E8609-3 Upgradeable amp, Tone board (mono) H
	E8503-1 Combo Preamplifier F	E8609-4 Upgradeable amp, Output board (mono) F
	E8503-2 THD Meter mV & oscillator bds (2 boards) K	E8610-1 Audio Analyser Filter Board L
	E8503-3 THD Meter Mains PSU F	E8610-2 Audio Analyser Display Driver K
	E8504-1 Framestore Memory M	E8610-3 Audio Analyser Display H
	E8504-3 Framestore Control N	E8610-4 Audio Analyser Power Supply F
	E8504-4 Buzby Meter E	E8611-1 Audio Switcher (2 bds) H
	E8504-5 CCD Delay F	E8611-2 PLL Frequency meter (4 bds)...Q
	E8505-5 Stereo Simulator F	E8611-3 Upgradeable Amp PSU J
	E8506-1 Audio Mixer Main J	E8611-4 Call meter, main bd. O
	E8506-2 Audio Mixer PSU F	E8611-5 Call meter, interface bd N
	E8506-3 Audio Mixer RIAA D	
	E8506-4 Audio Mixer Tone Control ... D	
	E8506-5 EPROM Prog MKII O	
	E8508-1 RCL Bridge N	
	E8508-2 EX42/BBC Interface E	
	E8508-3 EPROM Emulator L	
	E8509-1 Spectrum F	
	E8509-2 Direct Injection Box E	
	E8510-9 Sunrise Light Brightener K	
	E8511-1 MTE Waveform Generator ... H	

BOARDS AVAILABLE

Please use the form below (or a photocopy of it) to make your order. Be sure to quote the board reference number and price code correctly - mistakes will delay your order.

The board reference number tells you when a particular project was published: the first two numbers are the year and the third and fourth numbers tell you the month; the number after the hyphen indicates the particular project. Re-prints of all articles are available for a small charge from our photocopy service - see the separate page (not printed in every issue of ETI). Please note

that complex projects are usually published in several parts.

Our terms are strictly cash with order. Unfortunately, we cannot accept official orders, but we can supply a pro-forma invoice for you to raise a cheque against. We must stress, however, that your order will not be worked on until payment is received.

The boards listed below are all that are available at the moment. We hope to make more types available in the future, but no details will be available for some while (so please don't phone us to ask!).

Please allow 28 days for delivery

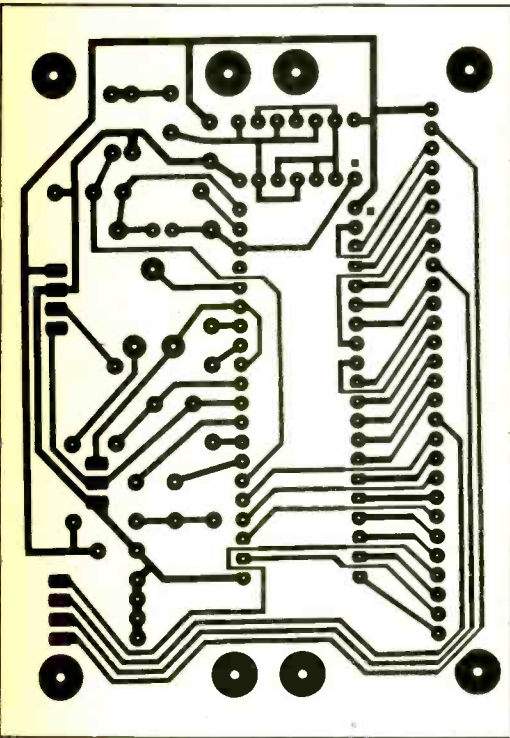

ORDER FORM

TO: ETI READERS' SERVICES DEPARTMENT
Argus Specialist Publications Ltd
PO Box 35, Wolsey House, Wolsey Road,
Hemel Hempstead, Herts HP2 4SS, UK

Please supply:

No. required per type	Board reference number	Price letter	Price each £	Total for board type £
	E	-	£ . p	£ . p
	E	-	£ . p	£ . p
	E	-	£ . p	£ . p
	E	-	£ . p	£ . p

POSTAGE & PACKING £ 0.75p

TOTAL ENCLOSED £ . p

ORDER TO BE SENT TO: (BLOCK CAPS PLEASE)

Name

Address

Postcode

(Make cheques payable to ASP Ltd)

ACCESS and VISA credit card orders can be taken on 0442 41221 (office hours only).

Price Code	Price (inc VAT) £
C	1.80
D	2.50
E	3.23
F	4.00
G	4.75
H	5.50
J	6.62
K	7.20
L	8.80
M	10.60
N	13.10
O	15.80
P	17.90
Q	21.80
R	23.90
S	25.90
T	29.00
U	32.20
V	35.80
W	37.90
X	40.70

For KITS & COMPONENTS
Choose the easy way - with
TR
 Send **50p & SAE**
for CATALOGUE
 (refundable with first order)
ORDERS: RING (01) 567 8910 - 24 HRS

MICROPROCESSOR TIMER KIT
 Designed to control 4 outputs independently switching on and off at preset times over a 7-day cycle. LED display of time and day, easily programmed via 20 way keyboard. Ideal for central heating control including different switching times for week-ends. Battery back-up circuit. Includes box. 18 time settings.
CT600K £42.90
XK114 Relay Kit for CT6000 includes PCB, connectors and one relay. Will accept up to 4 relays.
 3A/240V c/o contacts £4.30
701 115 Additional Relays £1.80



DISCO LIGHTING KITS
DL1000K This value-for-money 4-way chaser features by-directional sequence and dimming. 1kW per channel. £17.50
DLZ1000K - A lower cost uni-directional version of the above. Zero switching to reduce interference. £9.85
 Optional opto input allowing audio 'beat' light response (DLA/1) 70p
DL3000K - 3-channel sound to light kit features zero voltage switching, automatic level control and built-in microphone. 1kW per channel. £14.25
DL8000



HOME CONTROL CENTRE
 This kit enables you to control up to 16 different appliances by means of coded pulses in the mains wiring which may be decoded by special receivers anywhere in the house. The transmitter may be controlled manually or by the computer interface enabling your favourite micro to make your coffee in the morning, switch lights anywhere in the house, or your electric blanket in your bedroom. Just think of the possibilities - and no wiring!
 This kit comprises a transmitter with pre-drilled box and two receivers.
XK112 £46.20
XK111 Additional receivers £11.00

The DL8000K is an 8-way sequencer kit with built in opto-isolated sound to light input which comes complete with a pre-programmed EPROM containing EIGHTY - YES 80! different sequences including standard flashing and chase routines. The KIT includes full instructions and all components (even the PCB connectors) and requires only a box and a control knob to complete. Other features include manual sequence speed adjustment, zero voltage switching, LED mimic lamps and sound to light LED and a 300W output per channel. And the best thing about it is the price: **ONLY £28.50**

VERSATILE REMOTE CONTROL KIT

This kit includes all components (+ transformer) to make a sensitive IR receiver with 16 logic outputs (0-15V) which with suitable interface circuitry (relays, triacs, etc - details supplied) can be used to switch up to 16 items of equipment on or off remotely. The outputs may be latched (to the last received code) or momentary (on during transmission) by specifying the decoder IC and a 15V stabilised supply is available to power external circuits.
 Supply: 240V AC or 15-24V DC at 10mA.
 Size (excluding transformer) 9 x 4 x 2 cms.
 The companion transmitter is the MK18 which operates from a 9V PP3 battery and gives a range of up to 60ft. Two keyboards are available MK9 (4-way) and MK10 (16-way), depending on the number of outputs to be used.
MK12 IR Receiver (incl. transformer) £14.85
MK18 Transmitter £7.50
MK9 4-Way Keyboard £2.00
MK10 16-Way Keyboard £5.95
601 133 Box for Transmitter £2.60



DVM/ULTRA SENSITIVE THERMOMETER KIT

Based on the ICL 7126 and a 3 1/2 digit liquid crystal display, this kit will form the basis of a digital multimeter (only a few additional resistors and switches are required - details supplied), or a sensitive digital thermometer (-50°C to +150°C) reading 0.1°. The kit has a sensitivity of 200mV for a full-scale reading, automatic polarity and overload indication. Typical battery life of 2 years (PP3). £17.00



HOME LIGHTING KITS
 These kits contain all necessary components and full instructions and are designed to replace a standard wall switch and control up to 300w of lighting.
TDR300K Remote Control Dimmer £16.45
MK6 Transmitter £4.95
 for above £4.95
TD300K Touchdimmer £8.50
TS300K Touchswitch £8.50
TDE/K Extension kit for 2-way switching for TD300K £2.70



ELECTRONIC LOCK KIT
 With hundreds of uses in doors, garages, car anti-theft devices, electronic equipment, etc. Only the correct easily changed four-digit code will open it! Requires a 5V to 15V DC supply. Output 750mA. Fits into standard electrical wall box. Complete kit (excl. front panel) **XK101** £12.50
701 150 Electronic lock mechanism for use with the above kit £16.50



TR
13 BOSTON RD LONDON W7 2SJ
 Tel: 01;567 8910
 SEND 9x6" S.A.E. AND 50p FOR CATALOGUE OR CALL AT SHOP MON-FRI 9-5 pm SATURDAY 10-4 pm
ORDERING INFORMATION: ALL PRICES EXCLUDE VAT
 FREE P&P on orders over £20 (UK only), otherwise add 75p + VAT. Overseas P&P: Europe £2.75. Elsewhere £6.50. Send cheque/PO/Barclaycard/Access No. with order. Giro No. 5293 14002.
LOCAL AUTHORITY AND EXPORT ORDERS WELCOME GOODS BY RETURN SUBJECT TO AVAILABILITY

Readers' Ads Below

DIABLO 1345A Printer, Hazeltine 1500 terminal offers. Wanted Atari 800 48K. Phone Terry Southend (0702) 231950

WANTED EHT Transformer for Tektronix 541 Scope. Pref. including diodes. Tel: 061-724 6048 (Pete) Evening.

6502 Processor for B.B.C. Micro. Includes Hi-BASIC and D.N.F.S. Roms. Boxed, as new. £120 o.n.o. 061-442-4218.

27C64-15 CMOS EPROM £4 each inclusive. 20 only. Write - 43, Rushmere Walk, Havant, Hants PO9 4LY. Sent by return.

TWIN 8' Shugart Drives with PSU in very smart cabinet. £100 o.n.o. 021-705-8459 (Solihull) evenings.

YAESU FT480R 2-meter transceiver F.M. U.S.B. L.S.B. C.W. scanning etc. £250 Durham (0325) 316843.

SINGLE beam CRO. (1981). Hitachichi 538A £50. A. Wallwork, Sutton Coldfield. 021-355 3055.

NEWBURY green screen VDU plus keyboard. RS232 input. Many features. £50. ETI 78-81 Offers? Cardiff 491340.

SPECTRUM (48K) pro-keyboard, ZX-printer, 100 « software titles: £130. Phone Niall evenings 01-341 3355.

TUBED Power Amp Project to complement Valve Pre-Amplifier. August ETI. Any Designs? Bush (0947 810949).

MAKE YOUR INTERESTS PAY!
 More than 8 million students throughout the world have found it worth their while! An ICS home-study course can help you get a better job, make more money and have more fun out of life! ICS has over 90 years experience in home-study courses and is the largest correspondence school in the world. You learn at your own pace, when and where you want under the guidance of expert 'personal' tutors. Find out how we can help YOU. Post or phone today for your **FREE INFORMATION PACK** on the course of your choice. (Tick one box only!)

Electronics	<input type="checkbox"/>	Radio, Audio and TV Servicing	<input type="checkbox"/>
Basic Electronic Engineering (City & Guilds)	<input type="checkbox"/>	Radio Amateur Licence Exam (City & Guilds)	<input type="checkbox"/>
Electrical Engineering	<input type="checkbox"/>	Car Mechanics	<input type="checkbox"/>
Electrical Contracting/Installation	<input type="checkbox"/>	Computer Programming	<input type="checkbox"/>
GCE over 40 'O' and 'A' level subjects		<input type="checkbox"/>	<input type="checkbox"/>

ICS Name _____ P. Code _____
 Address _____
 International Correspondence Schools, 312/314 High St., Sutton, Surrey SM1 1PR. Tel: 01-643 9568 or 041-221 2926 (24 hrs) Dept EBS/A/6

Free Readers' ADS!

Buy, sell or exchange through our free service to readers

CONDITIONS

1. These advertisements are offered as a free service to readers who are not engaged in buying or selling the same equipment or services on a commercial basis. Readers who are should contact our advertising department who will be pleased to help.

2. Advertisements will be inserted as and when space becomes available.

3. The insertion of advertisements will be on a first-come, first-served basis, subject to condition (2). As a result, it will not be possible to guarantee the inclusion of a particular advertisement in any particular issue of the magazine.

4. Readers should either write out their advertisements in BLOCK CAPITALS or type it, underlining any words that are to appear in **bold**.

The magazine cannot accept any responsibility for printers' errors in the advertisements; however, we will do our best to ensure that legibly written advertisements are reproduced correctly. In the event of a gross error, at the Editor's discretion, a corrected version of the advertisement will be printed (at the advertiser's request) in the earliest issue in which space is available.

6. The magazine or its publishers will not accept responsibility for the contents of the advertisements, and by acceptance of these conditions, the advertiser undertakes to

indemnify the publisher against any legal action arising out of the contents of the advertisement.

7. The magazine reserves the right to refuse to accept or to delete sections of advertisements where this is judged necessary, for whatever reason.

8. Advertisements are accepted in good faith; however, the publisher cannot be held responsible for any untruths or misrepresentations in the advertisements, nor for the activities of advertisers or respondents.

9. Advertisers must fill in their names, addresses and (if available) telephone number in the space provided, and sign the form to indicate acceptance of these conditions (forms returned without a signature will not be used).

10. All that is to be reproduced in the advertisement should be entered in the space provided on the form printed in the magazine — note that **a photocopy is not acceptable**. All advertisements must give either a telephone number and/or address for respondents to contact, and this must be included in the wording of the advertisement.

11. Advertisements must be 15 words or less in length (telephone numbers and names normally count as one word, addresses as two).

Name

Address

.....

..... (tel:))

ENTER YOUR ADVERTISEMENT HERE:

I accept the conditions above.

Signature

Send this form to: Free Readers Ads,
Electronics Today International,
1 Golden Square, London W1R 3AB.

NEXT MONTH

AN ARGUS SPECIALIST PUBLICATION

electronics today

INTERNATIONAL

ARE THIS MONTH'S PAGES AUTUMN LEAVES...?

Music, Music, Music...

We're not sure what the answer is, but we are planning several major features and projects on a musical theme. We'll have the low-down on MIDI and we'll take a long look at instrument amplifiers. We have some surprise projects in store, too, as we approach the festive season. (If you've got a Commodore, we'll have something for you).

Free PCB...

Did we forget to mention the free PCB? This month, we feature more on biofeedback and the magazine will include a free printed circuit board with which you can build a basic GSR monitor, a fairly sophisticated version and... well, who knows?

More, More, More

John Linsley Hood kicks off a series on FM from the beginning which will culminate in the first new FM tuner design we've had for ages. Find out about marketing and more on where to get money in our business supplement, and see if you can get past our intruder alarm.

PLUS:

All our regular features, circuit ideas, Tech Tips, projects, letters, news and views. Also free readers' ads... and more.

THE DECEMBER ISSUE OF ETI — ON SALE 7th NOVEMBER

INSTRUMENTS • COMPONENTS EQUIPMENT • ACCESSORIES

DIGITAL MULTIMETERS

3 1/2 digit LCD displays

- +508 15 range, 200mA DC, 2 MEG £19.96
- *S3010 10mm thick pocket autorange and buzzer £24.00
- *528T 13 range, plus Hfe test £26.04
- +909 19 range, plus Hfe test, 20 MEG 10A DC £31.26
- +6010 28 range, 10A AC/DC, 20 MEG £33.50
- +578 20 range, auto+memory+hold 10A AC/DC £34.50
- *55C 28 range 10A AC/DC £35.65
- *3100 PEN type, Auto+buzz+hold £39.00
- +5010 31 range 10A AC/DC+buzz 20uA AC/DC £36.50
- +TM357 30 range 10A AC/DC+buzz £39.00
- +5010 EC As 5010+cap+Hfe+cond. £52.13

[+with case] [+case £3.91]

ANALOGUE MULTIMETERS

- 1015 15 range pocket 10K/V £7.50
- +1035 19 Range 20K/V 10A DC £10.39
- +102BZ 19 range 10A DC+Hfe 20K/V £12.61
- +2020 20 range 10A DC+Hfe 20K/V £19.09
- +3010BZ 24 range 10A DC+ buzzer 30K/V £20.83
- *155m 21 range 10A AC/DC 20K/V £22.57
- *BANANA 15 range+buzz shockproof 20K/V £23.60
- *M20K 45 range AC/DC amps. etc £39.00
- *CHALL 48 range AC/DC amps. etc £49.00
- *3000 58 range AC/DC amps. etc £56.00

[+with case] [+case £3.91]

SWITCH MODE PSU'S

Open frame models. I/P 100/240V AC

- 240Watt +5v 25A -12v 7A
- 12v 1.5A -12v 1.5A £34.74
- OF406 +5v 5A -23v £8.65
- 25mA -12v 100mA -12v 500mA £7.78
- SX510 2 to 5v (adjustable) 10amp

DIGITAL CAPACITANCE METER

8 range LCD 200pF to 2000MFD

Push-button selection (6013) £59.00

PROBE/PULSER

TP1 Logic probe 80MHz max. TTL, CMOS, Memory £23.00

TP2 Logic pulser 0.5Hz/500Hz £23.00

OSCILLOSCOPES

Hameg, Crotech, Hitachi Stockists. (UK TNT delivery £7.00 plus VAT)

HAMEG Dual trace with component testers. 8 x 10cm green screen.

- 203/6 Dual 20 MHz (with probes) £285.00
- 204 With sweep delay £365.00
- 205 Digital storage dual 20MHz £448.00
- 605 Dual 60 MHz plus sweep delay £515.00

CROTECH with component tester

- 3031 Single 20 MHz, 9.5cm CRT £195.00

HITACHI V212 Dual trace 20 MHz 8 x 10cm P.O.A.

GENERAL 05T5m single trace 5 MHz 3" CRT £139.09

THANOAR SC110A Portable 10 MHz 32 x 26mm display £175.00

OPTIONAL PROBES X1/X10 £10.00

CONNECTORS AND LEADS

Prices each - large discounts. For quantities - see below.

D' PLUGS AND SOCKETS

Goldplated contacts (P-pins M=male F=female)

- 9PM £0.52 15PM £0.85 25PM £0.77
- 34P £1.30 40P £1.57
- 9PF £0.57 15PF £0.70 25PF £0.87

COVERS 9P £0.39 15P £0.43 25P £0.52

25P with screws £0.74

25P with jack screws and cable-clip £0.87

D' ADAPTORS

25 pin available male-male, female-female, male-female (state which) £4.78 each

IDC PLUGS AND SOCKETS

Female cable connectors

- 20P £0.78 26P £0.96
- 34P £1.30 40P £1.57

Male PCB mounting header

- 20P £0.78 26P £1.04
- 34P £1.35 40P £1.43

PRINTER LEADS RIBBON CABLE

1 metre lengths.

- 26 Pin IDC to 36 pin Centronics (BBC) £7.95
- 36 Way Centronics both ends £9.95
- 34 Way card edge to 36 way Centronics (Amstrad) £7.95
- 25 Way 'D' plug to 36 way Centronics (IBM) £12.95
- 25 Way 'D' plug to 631 W/B4A (I.L.) £6.95
- 14 Way Centronics to 36 way Centronics (MSX) £11.95

DISCOUNTS
Small and large quantity prices on request.

CATALOGUE

Send S.A.E. (Min 12" x9" with 46p stamp UK) Export send £1 with address Free on written request to all education and training establishments. Price £1 to callers.

COUNTERS AND TIMERS

220/240V AC mains. 8 digit LED

Counters 0.1Hz resolution, 5mV sensitivity

- 100MHZ 2 ranges £99.00
- 600MHZ 3 ranges £126.00
- 1000MHZ 3 ranges £175.00
- 1500MHZ 3 ranges £199.00

Timers 0.001Hz Resolution, 100MHz 5mV sensitivity

- OP10 Standard model £219.00
- OP100 Incl. display hold, etc. stopwatch/RPM, etc £285.00

GENERATORS

220/240V AC operation

FUNCTION - sine, sq. triangle, TTL D/P

- J500 0.1Hz to 500KHz £110.00
- TG101 0.02Hz to 200KHz £110.00
- TG102 0.2Hz to 2MHz £160.00

PULSE Square, Complement, TTL D/P

- TG105 5Hz to 5MHz £105.00

TV-VIDEO PAL VHF/UHF, 5.5/6/6.5MHz sound carriers RGB and SYNC D/P's. AM/FM sound mod. Colour, etc £199.00

THURLBY

- CM200 Digital capacitance meter £89.00
- LA160A 10MHz logic analyser £395.00
- LA160B 20MHz version £495.00
- [Accessories in stock for LA160 series]
- OM358 Convert scopes to 8 Channels £179.00

DIGITAL PSU'S

- 0/30V 0/1A £125.00
- 0/30V 0/2A £155.00

Dual and triple versions in stock

1503/1503HA/1504/1905 0MM's in stock

DISCOUNTS AVAILABLE FOR ALL EDUCATION/ TRAINING TRADE, OEM AND EXPORT SUPPLIED

DC POWER SUPPLIES

240V AC Input, Stabilised variable output voltages.

Direct meter reading volts and amps.

- 243 0/24 volts 0/3 amps DC £43.26
- 245 0/24 volts 0/5 amps DC £56.26
- 154 5/15 volts 0/4 amps DC £33.26

Also 13.8V DC, 3 amps max. Fixed (no meter) £13.00

NEW LOW PRICES

ELECTRONIC INSULATION TESTERS

Battery operated with case

- 501 500 volt £69.00
- 830 500/1000 volt £89.00

AC CLAMP METERS

With cases and leads

- 300 300amps (5 ranges) £30.87
- 600V (4 ranges) 1K OHM £30.87
- 4300 Autorange Digital 300A
- 500V - cont. test £75.00

COMPUTER DISKS

- 5 1/4" 40 track DS.00, 48TPI
- 3M Per 10 £12.75
- Storage Master (CDC) per 10 £11.15
- (UK C/P £1 per order)

PLEASE ADD 15% V.A.T. (UK ORDERS)

ORDER BY POST OR PHONE. OPEN 6 DAYS A WEEK FOR CALLERS.

HENRY'S AUDIO ELECTRONICS

301 Edgware Road, London W2 1BN. 01-724 3564

404 Edgware Road, London W2 1ED. 01-723 1008

Sales and Account enquiries: 01-258 1831

OFFICIAL ORDERS WELCOME

OPEN CHANNEL

The GEC/Plessey takeover debacle has proved the Monopolies and Mergers Commission to be worthwhile — it decided that the takeover should not be allowed (just as I have said all along!). Now it appears the companies will meet each other in different, more businesslike, fashions.

For instance, Plessey is looking to European markets to sell its version of the System X exchanges (yes, that's right, the very same as used by BT). Many European customers are waiting for System 12 exchanges from ITT, and Plessey thinks it can get the business. I suppose BT's announcement a few months ago about now using System Y exchanges (*X, Y 12? Whatever happened to Strowger! Ed.*) means that Plessey has a deal of spare production capability to use up. On the other hand, Plessey has pulled out its drive to sell System X in the American market; experiencing

great difficulty in selling there when American designed and built exchanges are already available from its own subsidiary, Stromberg-Carlson.

GEC, however, is only now looking to America to sell its version of System X exchanges. With Plessey out of the way, perhaps it feels its salesmen can beat back the Yankee Doodle Dandy exchange single-handed. I wonder what the Plessey-owned Yanks think.

Ironically almost, the only area in which the Monopolies and Mergers Commission decided the two companies should be allowed to merge is the System X field.

Any IDAs?

British Telecom is making moves towards its integrated services digital network (ISDN) in which we can all have integrated digital access (IDA) to a digital voice and data comms network, nationwide. Currently, only a few large business users have IDA services such as fast fax, slow scan, vellygood videotex, and of

course, super-speech! based on the Baynard House System X exchange (there it is again) in the City of London, and a couple of others in Manchester and Birmingham.

To date, these IDA exchanges only give limited services to a limited number of customers on a limited trial basis, as only a single data channel along with a signalling channel is provided. Eventually, two data channels will become the norm, giving access to the full services available.

Fuelling Communications

Mobil, the oil company, says that advanced communications within its organisation has paid for itself within a year of commission. Apparently, an Autonet message switching system, installed only a year ago has been calculated by the company as being in profit already.

For example, messages from Mobil's Beryl A and Beryl B North Sea oil platforms and exploration rigs are radioed to an Aberdeen-based office then forwarded to London over the Autonet system.

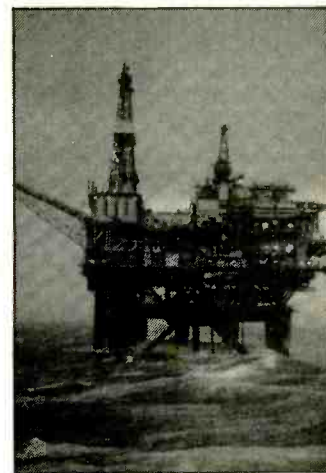

The system is also linked to Mobil's world-wide communications network, so a message from any rig, anywhere in the world, can be forwarded to any other.

No doubt advanced communications systems (which pay for themselves) used by oil companies will mean that the price of a gallon of petrol will go down. Mmmmmh. I wonder.

Keith Brindley

PLAYBACK

Nineteen-eighty-six is The British Music Fair's second year open to the public. The show was altogether on a bigger scale this year, including most of the piano trade and more and larger stands in other sectors.

The special feature was a hands on demonstration of computer music packages. This was by no means exhaustive, but it did provide an interesting cross section, including an ear-training package from Roland.

At the professional end of the market I saw the Musical System MPS Music Processing System also from Roland. This runs on the IBM PC and full compatibles and uses a minimum of 256K Ram to store, edit and print out musical scores originated from the PC keyboard or from any MIDI instrument.

The Song mode is a standard eight-track MIDI sequencer which can hold up to 65,000 notes, handle punch-in, punch-out recording, multiple time signatures, phrases coherent auto-correction which allows timing error corrections without affecting the phrasing, and full editing control of all 128 MIDI channels. The package needs the Roland MPU-401 Intelligent Interface and MIF-IPC interface card, which generates its own clock signal; or processes SMPTE code, an FSK signal or another MIDI clock.

Unwanted MIDI information can be deleted from recordings.

Music can be generated and edited in Score mode, and formatted for Print mode. The four-staff score I saw generated on a high quality laser printer was almost up to camera copy standard. The price quoted was £399 plus VAT for the software, £149 inclusive for the 401 interface and £75 inc. for the card.

Low Cost

At the other end of the scale, EMR were showing simple but versatile composing, editing and recording software for the BBC B, Commodore 64, Amstrad CPC, MSX and Spectrum at around £30 a package. Each package is fairly restricted in what it can do, but provides a good starter pack for anyone who has a micro and is moving into composing. EMR also do hardware MIDI interfaces plus a Performer recording package at around £130. More information from EMR on 0702 335747.

Also from Roland is a synthesiser driver for guitars, which allows most electric guitars to be adapted as controller for their GR-700 synthesizer with 'no holes in the guitar body'. The new GM-70 GR/MIDI Converter is a bigger step, using a new LSI signal processor to track the guitar's signals, including note bends, accurately, and convert the signal to drive any MIDI instrument on four channels. The GK-1 will be selling at around £190, and the GM-70 at

£695, so guitar MIDI is not down to bedroom prices just yet.

Effects

Sound Technology were showing two studio sound effects units, Midiverb reverb and Midifex multi reverb, delay, echo and stereo effects, using RISC (reduced instruction set computer) architecture for very fast and simple operation. There were also a series of Bokse synch devices, including a Timecode Multi-Events Controller, Universal Synchroniser, MIDI Patch Selector, Multiway Active Timebase and MIDI Humaniser (sic), which employs various touchpad and transducers so that the operator can tap in a new timecoding depending entirely on his or her sense of rhythm. This is what happens when you complain that synthesizers sound too mechanical!

Most of these units are in the £300-£400 price range, inc VAT.

Loud, Not Proud

Getting an amplifier demonstration is always a problem at shows, if not personally, then for the folk on the next stand. Session were happy to give a restrained but impressive demo of their new Rockette 20 practice amp, with versatile sounds, 20W through a 10" speaker, and a headphone socket. This will go for about £135. They also have a new combo version of their stereo amp head

delivering 150W for £460.

I am not good with keyboards, so I won't attempt a selection: but the price of multi-role synthesizers is coming down while facilities gradually increase. If I were buying today, I would start by working out which machine would turn my limited technique into the largest number of sounds (including memory space and touch sensitivity) and control operations (MIDI mandatory) for my money. Casio's new CZ1 looks like very good value at just under four figures.

Hit Me

My favourite trial of the day, if only for the amusement was the Dynacord Rhythm Stick, in MIDI and non-MIDI versions. This eerily hollow, plastic, guitar shaped instrument is a rhythm machine trigger with eight trigger selectors on the 'neck' and a tap sensitive body which can be played with both hands and anything else you can smack it with!

The BMF is always well worth a visit but, unless you know exactly what you're looking for (and you may not find it there), it's hard work. It's nearly impossible to get a meaningful demo of drums, or guitar amplification, but there were more pro demos, more sound booths and many more headphones rigged this year. Many more people, as well, as word got round.

Helen Armstrong

ELECTRONICS TODAY INTERNATIONAL CLASSIFIED

Lineage:

42p(+ V.A.T.) per word (minimum 15 words)

Semi Display: (minimum 2 cms)

£11.60 per single column centimetre

Ring for information on series bookings/discounts

All advertisements in this section must be prepaid.

Advertisements are accepted subject to the terms and conditions printed on the advertisement rate card (available on request)



01-437 0699 Ext 291

Send your requirements to:
Duncan Neilson,
ETI Class. Dept.,
ASP Ltd.,
1 Golden Square,
London W1.

ALARMS

ALARMS

FREE BOOKLET
on
BURGLAR ALARMS
with
LOWEST U.K. DIY PUBLISHED PRICES
PHONE OR WRITE FOR YOUR COPY
051-523 8440
AD ELECTRONICS
217 WARBRECK MOOR
AINTREE, LIVERPOOL L9 0HU

LOWEST PRICED TOP QUALITY fire and Intruders alarm equipment, etc. SAE for catalogue Security Services, 62 High St, Hythe, Kent CT21 5JR.

BOOKS

PARAPHYSICS Journal (Russian Translation); Psychotronics; Kirlianography, Heliphonic Music, Telekinetics. Computer Software. S.A.E. 4 x 9", Paralab, Downton, Wiltshire.

COMPUTER ADD-ONS

AMSTRAD OUTPUT PORT. Plugs into printer port and provides seven open-collector outputs. Easy to use from Basic or M/C. £14.95 inc. S.A.E. for details. NCJ Electronics, 13 Binfield Square, Ella Street, Hull HU5 3AP.

CLUBS

VIDEO INFORMATION!

Join the Video Information Club and receive information about all aspects of your video hobby - Free technical advice, video exchange service, discounts on video hardware, blanks etc. Regular club newsletter, international clearing house facility, membership unit, advertising gifts (car stickers etc) full membership card - ALL FREE. JUST RING
0898-100-430
AND JUST LISTEN TO THE TAPE (40p per minute peak 20p off peak) (family services)

MISCELLANEOUS

HEATHKIT U.K. Spares and service centre. Cedar Electronics, Unit 12, Station Drive, Bredon, Tewkesbury, Glos. Tel. 0684 73127.

WELDEC ALARMS
FOR YOUR FREE SIZING GUIDE
ON EASY TO INSTALL
BURGLAR/FIRE ALARMS
WRITE TO OR PHONE:
WELDEC ELECTRONICS
P.O. BOX 1
MARPLE
CHESHIRE
061 449 0395
(24 HOURS)

COMPUTER ADD-ONS

16K FOR £16!!! Sideways ram unit for BBC micro. Includes software. No soldering required. Viking Micro's, 5 Kirby Hill, Braddan, Isle of Man.

COILS & CHOKES

MAXI-Q

COILS AND CHOKES
PREVIOUSLY MADE BY DENCO
S.A.E. PRICE LIST
8 BRUNEL UNITS, BRUNEL RD,
GORSE LANE IND. ESTATE,
CLACTON, ESSEX CO15 4LU.
TEL: (0255) 424152

COMPONENTS

PANEL METERS, transformers, test equipment, sirens, tools, microphones, service aids. Send £1 for new fully illustrated 170 page catalogue. M. Dziubas, 158 Bradshawgate, Bolton, Lancs.

COMPONENTS

ESR ELECTRONIC COMPONENTS

- Full range of Components
 - Motors & Servos
 - Robot Arms & Interfaces
 - Velleman Electronic Kits
- Send for new catalogue. 60p inc. P&P.

13A Station Road, Cullercoats,
North Shields, Tyne & Wear NE30 4PO.
091 251 4363

PROMs - EPROMs - PALS

ANY PROGRAMMABLE IC
SUPPLIED OR BLOWN

PRICES (Including Programming)

2716	£2.85	2732	£3.10
2764	£2.60	27128	£3.85 etc.

BIPOLAR PROMs from £1.50

e.g. 82S123, 18S030, 74S288

PALS, PLDs etc. from £4.05

e.g. 82S153, 16L8, EP300

Full design and prototyping service
Any quantity programmed - SAE or
phone for details

P.L.S., 16 Wordsworth Drive,
Cheam, Surrey, SM3 8HF
Phone 01-644 8095

RESISTORS, CAPACITORS, PRESETS, NUTS & BOLTS, SELF TAPPING SCREWS, SOLDER TAGS, STAND OFFS, CABLE TIES. All available in money saving packs. All values or sizes individually packed for ease of use, no sorting or grading necessary. All components guaranteed brand new, full specification. Always have the components you want at hand send for my free lists today. I.G.S. Components, Dept ETI, 18 Queensway, Shelley, Ongar, Essex CM5 0BN.

EQUIPMENT

GEIGER COUNTER, Inexpensive gen-purpose portable radiation monitor (Audiovisual). Kitform (full assembly data) £79.92. Built £89.32. Post. incl. Others, send S.A.E. Becker-Et, 9 Finucane Drive, Orpington. 0689 37821.

FOR SALE

2000!
... Ex-Pub amusement PCB's for sale. Containing many caps, resistors, i.c.'s, Diodes, Eproms, Z80's, crystals etc. £10.00 each or offers for the lot.
RING (0532) 455685

FOR SALE

EX-EQUIPMENT HEATSINKS, various shapes and sizes. Some with components. Also ex-equipment computer grade electrolytic capacitors. All have screw terminals. Ideal for powersupplies or amplifiers. S.A.E. for list or telephone (0544) 230853 (evenings). Portable Power, 37 Church St, Kington, Herefordshire HR5 3BE.

AUTOMATIC GARAGE DOOR OPERATORS. £65.00. S.A.E. for details to Mulberry Ltd, 116 Grosvenor Road, Aldershot, Hants.

KITS

ECOLIGHT

DETERS BURGLARS FROM EVEN ATTEMPTING A BREAK-IN.

As features in ETI July 1984 and Electronic Digest Spring 1986.
Full kit of parts £23.00
PCB only £4.75
Reprint of article 75p
G.P. **ELECTRONIC SERVICES,**
87, Willow Tree Avenue,
Durham DH1 1DZ.

ETI KITS assembled and tested* by electronic trainees under supervision within a purpose built electronic workshop for as little as £10* (* depending on type of kit and complexity). Contact:- A.J. Smith, Dept K.A. Electronics Workshop, Lincoln I.T.E.C. Dean Road, Lincoln LN2 4JZ. Tel. 0522 43532.

68008 SINGLE board computer, contains 80 T/D/S disc interface, colour display, 8K monitor etc. Bare P.C.B. or built. Also 6809 micro-set system and tangerine conversions. S.A.E. for details. (state which) Ralph Allen Eng Forncett-End Norwich.

LINSLEY HOOD Designs. Send S.A.E. for details to Teleradio Electronics. 325 Fore Street, London N9 OPE.

ORGAN KEYBOARDS

ELECTRONIC ORGAN KEYBOARDS and other parts being cleared out. Special Offer: Elvins Electronic Musical Instruments, 40A Dalston Lane, London E8.

KITS AND READY BUILT

FM TRANSMITTERS Same day despatch **MINIATURE MODEL** frequency 60-145 Mhz, range 1 mile. Glass fibre P.C.B. All components. Full instructions 9-12V operation, broadcast reception. Super sensitive microphone. Pick up on **FM/VHF** radio. £6.95 inc or ready built £8.95. Size 57 x 19 x 12mm. **HIGH POWER MODEL**. 3 watts 80-108 MHz. Professional broadcast performance. Low drift varicap controlled. Range up to 7 miles. 12V operation. Any input audio/microphone. All components P.C.B. diagrams and instructions. Size 103 x 39 x 29mm. Kit 13.99 inc or ready built £18.99 inc. **TONE GENERATOR** 3-selectable functions; PIP, Warble and pulse tone: All components, instructions & P.C.B., feed into any audio input or transmitter; variable frequency and gating controls. 6-12V operation 53 x 38 x 14mm. £5.50 incl. **TONE GENERATOR POWER AMPLIFIER**. All components, instructions and P.C.B. turnstone generator into a high power siren for alarms; 18 watts max. at 12-15V. 62 x 38 x 14mm £7.00 inclusive **DIGITAL CLOCK/TIMER MODULE**. 12/24 hour & seconds (0.7inch LED) display, 8-functions. Applications: uncommitted output transistor for switching on Tape-recorders; Lighting, Security, etc. External Loudspeaker Output. 84 x 38 x 16.25mm. Full instructions & Modular PCB £17.49 inclusive. **MAINS TRANSFORMER** for above if required: £5.24 incl. **DIGITAL CODE LOCK MODULE: 4 18V.DC** operation; 10,00 combination quality key pad; programmable code; low-power 3-outputs (0.2A); **3-LED** status indicators; All components, instructions & PCB. Applications; Alarms; garage doors; cars, etc. 39 x 62 x 9mm. Kit: £15.95 incl. Ready built; £19.95 incl. **ZENITH ELECTRONICS**, 14 Cortland Business Centre, Hailsham, East Sussex BN27 1AE.

PLANS & DESIGNS

ELECTRONIC PLANS, laser designs, solar and wind generators, high voltage teslas, surveillance devices, pyrotechnics and computer graphics tablet. 150 projects. For catalogue, SAE to Plancentre Publications, String Works, Bye St., Ledbury HR8 2AA.

POWER SUPPLIES

240v AC ELECTRICITY from two 12v batteries!! Encapsulated ready built electronic module with **screw terminals!!** Comprehensive instructions supplied. Just add transformer and other easily obtained accessories. 250W output. Limited number available. £25 (inclusive). **Chataigne Products**, Green Lane, Great Horkesley, Colchester, Essex, CO6 4HD. (Proprietor J.A. Richmond.)

POWER SUPPLIES

PAXX POWER MODULES. 5-18v 1A £9.95 inc p&p. SAE info, JCE, P.O. Box 31, Bridgwater, Somerset TA5 2LO.

REPAIRS

INSTRUMENT REPAIRS oscilloscopes, generators, multimeters and more. Viking Electronics, Potkins Lane, Orford, Suffolk IP12 2SS (0394) 450006.

SCOPES

MENDASCOPE LTD.

REPAIR & RECALIBRATE OSCILLOSCOPES.
ALL MAKES ALL MODELS.
NATIONWIDE COLLECTION & DELIVERY
FREE ESTIMATES
Phone 069-172-597

TEKTRONIX OSCILLOSCOPES. Good condition, dual trace, delay sweep. 585 A 85 MHz £245, 547 50 MHz £195, 545 B 24 MHz £135, 551 8-Trace 19 MHz £185, 556 4-Trace 50 MHz £345. Telequipment D 83 50 MHz £365. Manuals, spares, other test equipment. Tel: (01) 868-4221.

SERVICES

ELECTRONIC Design Services, EPROM programming (2708-27512), PAL programming from Masters or Fuse Plots. Also PAL Design Services from Text, Boolean Expressions, etc. U.E.D. Ltd., Castlebellingham, Co. Louth, Ireland. Tel: 042-72127.

DESIGN SERVICES, microprocessor, special interfaces, analogue, digital, signalling, alarm systems, PCB design and artwork. Prototype and small batch production. **ALAB ELECTRONICS**. Grantham (0476) 860089.

FREE PROTOTYPE of the finest quality with every P.C.B. artwork designed by us. Competitive hourly rates, and high standard of work. Halstead Designs Limited, Finsbury House, 31 Head St, Halstead, Essex CO9 2BX. Tel: 0787 477408.

ELECTRONIC PROROTYPING and BBC/AMSTRAD machine code programming and hardware interfacing, work undertaken to your specifications. Ring Dynamic Data Technology Ltd on Aberystwyth (0970) 615952.

SWITCHES

VOICE/SOUND ACTIVATED SWITCHES easy to follow diagrams and uses only £1.00. Components and P.C.B's available: **Herrington, 63 Home Farm Rd, Hanwell, London W7 1NL.**

SUPPLIES

BENCH POWER SUPPLY Stabilised output. 5-9-12 & 15v at 1 amp. Overload protected £22.95
DUAL POWER SUPPLY Fully regulated and current limited. Metered voltage and current. 0-25v. 1 amp. £59.50
LOGIC PROBE Switched for TTL or CMOS. £17.95
INFRA-RED REMOTE CONTROL High security. Numerous applications, switching house and car alarms, garage doors, car locks, etc. £26. Prices include p&p. All products carry a 12 mth guarantee. Trade enquiries welcome.

Phasor Circuits,
12 Kendal Road, Leicester,
LE4 7GP. Tel: (0533) 830953.

SPECIAL OFFERS

FREE MEMBERSHIP to a new **NATIONAL ELECTRONICS CLUB**.

For details and a free gift of components worth over £10 send only £1.00 p&p to **Woodside, Dowsett Lane, Ramsden Heath, Essex CM11 1JL.**

DREAMING OF A KIA CHRISTMAS!! . . . • Power Supplies 40V Stabilised/£5 • Mixers/£12 • Stereopreamps/£5 • 60/60W Stereocamps/£10 • 100W Poweramps/£8 . . . • **Kia-8, Cunliffe Road, Ilkley . . . WHY WAIT FOR SANTA!!** . . .

TRAINING COURSE

PROFESSIONAL ELECTRONICS TECHNICIANS

Short re-training courses (1-3 weeks)
VCR SERVICING
MICROCOMPUTER SERVICING
(ONC/OND/HNC also available in modules)

* MSC GRANT AID to EMPLOYERS/TRAINEEES *

Television/Video/CCTV/
MICROELECTRONICS
Information Technology/
CAD/CAM/ATE
MICROPROCESSORS/
Computers/CONTROL
LONDON ELECTRONICS COLLEGE
Dept (ETI)
20 Penywern Road
LONDON SW5 9SU. 01-373 8721
Next course starts 6th October and 27th October.

WANTED

Turn your surplus transistors, IC's etc., into cash. Immediate settlement. We also welcome the opportunity to quote for complete factory clearance. Contact:

Coles Harding & Co.
103 South Brink
Wisbech, Cambs.

ESTABLISHED OVER 10 YRS
Tel: 0945 584188

LANCASHIRE

ETESON ELECTRONICS

15B Lower Green,
Poulton-le-Fylde, Blackpool
Tel: (0263) 885107

Open: 9.30am-12.30 1.30-5.30. Closed Wed & Sun.
Electronic Component Specialists.



ELECTRO SUPPLIES

NORTHERN COMPONENT SPECIALISTS
Test Equipment, Computers, Peripherals
SEND FOR CATALOGUE Trade Enquiries Welcome

45 LOWER HILLGATE,
STOCKPORT, CHESHIRE.
061 477 9272

also at SHAWCLOUGH ROAD,
WATERFOOT
ROSSDALE BB4 9JZ.
0706 - 215556

LIVERPOOL

PROGRESSIVE RADIO

87/93 Dale Street. Tel 051 236 0154
47 Whitechapel. Tel 051 236 5489

Liverpool 2
'THE ELECTRONICS SPECIALISTS'
Open: Tues-Sat 9.30-5.30

SCOTLAND

FOR YOUR PRE-CHRISTMAS ADVERTISING
PHONE 01-437 0626

E
L
E
C
T
R
O
M
A
R
T

E
L
E
C
T
R
O
M
A
R
T

LIGHTING

THEATRE — BAND — DISCO — CLUB

At MJL we supply a range of stage lighting equipment within everyone's budget. With world wide sales we have the backing and expertise to deliver just the system you need to 'Light Up' that Play, Gig or Dance Floor, from Basic 6 channel dimming to 30 channel rock mixing desks. So if you are a lighting engineer, stage manager or rig technician, or simply an amateur Drama group, we're the Professionals.

FOR FREE COLOUR BROCHURES
Write to:

MJL (International) LTD.
45 Wortley Rd., W. Croydon,
Surrey, U.K. CR0 3EB

or Phone:

01-689 4138

Complete Parts Sets for ETI Projects

MAINS CONDITIONER

FEATURED IN ETI,
SEPTEMBER 1986

It is astonishing how many people buy or build top-flight hi-fi equipment, and then connect it to a noisy, spiky mains supply. Rather than like buying a Ferrari and trying to run it on paraffin, you might think. Expecting crystal clear sound, the poor music enthusiast ends up with a muddy, confused mush, and feels that he has somehow been cheated. 'Is this hi-fi? My music centre sounded just as good!'

The domestic mains supply is riddled with RF interference, noise, transient spikes, and goodness knows what else. Computers crash, radios pop and crackle, tape recordings are spoiled and hi-fi sounds 'not quite right'. Why put up with it when the solution is so simple? The ETI mains conditioner is the lowest cost upgrade you will ever buy, and probably the most effective!

Our approved parts set consists of PCB, all components, toroid, enamelled wire, fixing ties, fast response VDR, and full instructions.

ETI MAINS CONDITIONER PARTS SET ONLY £4.60!

*Note: the toroid and VDR supplied are superior to the types specified in the article.

**SPECIAL
OFFER**

FREE MATCHBOX AMPLIFIER PCB

L165V IC £3.90 FREE Bridge amp. PCB with every 2 IC'S purchased.

COMPLETE SINGLE IC
AMPLIFIER PARTS SET ... £6.50

COMPLETE BRIDGE
AMPLIFIER PARTS SET ... £8.90

Orders should be sent to Specialist Semiconductors at the address below including 60p towards postage and packing. Please allow up to 14 days for delivery. There is no telephone service at the moment, but all letters or requests for lists will be answered (at top speed if you send SAE!)

POWERFUL AIR IONISER

FEATURED IN ETI,
JULY 1986

Ions have been described as 'vitamins of the air' by the health magazines, and have been credited with everything from curing hay fever and asthma to improving concentration and putting an end to insomnia. Although some of the claims may be exaggerated, there is no doubt that ionised air is much cleaner and purer, and seems much more invigorating than 'dead' air.

The DIRECT ION ioniser caused a great deal of excitement when it appeared as a constructional project in ETI. At last, an ioniser that was comparable with (better than?) commercial products, was reliable, good to build ... and fun! Apart from the serious applications, some of the suggested experiments were outrageous!

We can supply a matched set of parts, fully approved by the designer, to build this unique project. The set includes a roller tinned printed circuit board, 66 components, case, mains lead, and even the parts for the tester. According to one customer, 'the set costs about a third of the price of the individual components'. What more can we say?

**DIRECT ION
PARTS SET £9.50**

Specialist
SEMICONDUCTORS
FOUNDERS HOUSE REDBROOK MONMOUTH GWENT

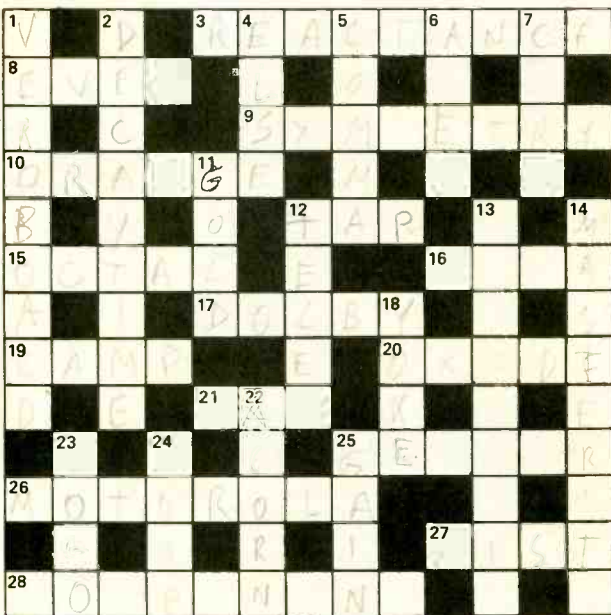

Solution to Crossword No. 9

ACROSS

- 1) Black
- 7) Chromium
- 8) Field
- 10) Low profile
- 12) Read only
- 14) File
- 16) Path
- 17) Engineer
- 20) De-emphasiss

DOWN

- 1) Buffer
- 2) Call
- 3) Whip
- 4) Colon
- 5) Digitizer

DOWN

- 6) Impede
- 9) Donor
- 11) Wattmeter
- 13) Lin
- 15) Limit
- 16) Padder
- 18) Ripple
- 19) Spots
- 21) Atom
- 22) Sine

CROSSWORD

No. 10

ACROSS

- 3) The inductive or capacitive component of an impedance, having the symbol X (7).
- 4) One of the two types of parity for data streams (4).
- 9) The property of an object or waveform having two identical, but mirror image, halves (8).
- 10) The colour which represents three (6).
- 12) A take-off point on a coil (3).
- 15) Mathematically, to the base of eight (5).
- 16) Auto Feedback (4)
- 17) Electronics laboratory which designed and developed the most common of cassette tape noise reduction formats (5).
- 19) A voltage which increases linearly with time (4).
- 20) Describes a switch contact which drops a voltage proportional to the current passing through it (5).
- 21) Abbreviation for facsimile (3).
- 25) A compound, usually barium, left in vacuum tubes to remove residual gases (6).
- 26) US electronic components manufacturer (8).

- 27) BASIC command which prints the program, line by line, on screen (4).
- 28) A discrete part such as a resistor, capacitor, diode, etc (9).

DOWN

- 1) Proprietary copper strip matrix board (9).
- 2) How long it takes for a voltage to decrease to a specified percentage of its starting value (5, 4).
- 4) An addition to the IF-THEN construct of BASIC (4).
- 5) PRINT CHR\$ (44) and this will appear on the screen (5).
- 6) Peak (4).
- 7) Lead (4).
- 11) Precious metal used for high quality switch contacts (4).
- 12) Teleprinter system for use on telephone lines (5).
- 14) The speed at which the controlling oscillator runs (5-4).
- 18) It carries the deflection coils found on the neck of a CRT (5).
- 22) Computer manufacturer, responsible for the BBC machine (5).
- 23) Graphics-orientated computer language (4).
- 24) Reiteration within a computer program (4).
- 25) Amplification factor (4).

Essential reading

The new Rapid Electronics electronic components catalogue is an absolute must for all serious electronics constructors.

Over 4000 product lines sourced from over 150 manufacturers worldwide, from self tapping screws to microprocessors, from EPROMs to sophisticated PCB production equipment all component needs are covered.

Over 100 fully illustrated pages detail all your expected requirements, all for just **£1.25 including postage.**

By placing large orders with manufacturers we can offer the **most competitive prices in the market.** Indeed we now sell more components than all the other mail order companies put together!

All orders are despatched upon day of receipt by First Class Mail or Securicor. You can even telephone your order up to 5 pm for same day despatch. **No other company can offer such a comprehensive service.**

Send for your catalogue today by simply completing the details below and enclosing £1.25.

Rapid Electronics Ltd, Unit C, Hill Farm Industrial Estate, Boxted, Colchester, Essex CO4 5RD.
Telephone 0206 272730.

Please rush me a copy of the new Rapid Electronics catalogue. I enclose £1.25.

Name

Address

.....

.....

Postcode Telephone Unit C

