

The Journal of
THE BRITISH INSTITUTION OF RADIO ENGINEERS

FOUNDED 1925

INCORPORATED 1932

VOLUME 20

JANUARY 1960

NUMBER 1

Patron

HER MOST GRACIOUS MAJESTY QUEEN ELIZABETH II

Vice-Patron

Admiral of the Fleet The EARL MOUNTBATTEN of BURMA,
K.G., P.C., G.C.B., G.C.S.I., G.C.I.E., G.C.V.O., D.S.O., LL.D., D.C.L., D.SC.

THE COUNCIL 1960

President

Professor E. E. ZEPLER, PH.D.

Immediate Past-Presidents

W. F. MILLER, M.A.

Rear-Admiral SIR PHILIP CLARKE,
K.B.E., C.B., D.S.O.

G. A. MARRIOTT, B.A.

Vice-Presidents

Air Vice-Marshal C. P. BROWN, C.B., C.B.E., D.F.C.

J. L. THOMPSON

Colonel G. W. RABY, C.B.E.

Professor EMRYS WILLIAMS, PH.D.

Ordinary Members of Council

Honorary Member :

E. K. COLE, C.B.E.

Members :

A. D. BOOTH, D.SC., PH.D.

F. G. DIVER, M.B.E.

A. A. DYSON, O.B.E.

R. H. GARNER, B.SC.(ENG.)

I. MADDOCK, O.B.E., B.SC.

H. F. SCHWARZ, B.SC.

Professor D. G. TUCKER, D.SC., PH.D.

Associate Members :

D. L. LEETE, B.SC.(ENG.)

Squadron Leader W. L. PRICE, O.B.E., M.SC.

T. B. TOMLINSON, PH.D.

Companion :

A. H. WHITELEY, M.B.E.

Honorary Treasurer

G. A. TAYLOR

Chairmen of Local Sections in Great Britain

and ex-officio Members of Council :

J. BILBROUGH (*Associate Member*) North Eastern

J. COTTERELL (*Associate Member*) South Wales

R. O. R. CHISHOLM (*Associate Member*)

J. W. HARROP, B.SC. (*Associate Member*)

South Western

North Western

P. HUGGINS (*Associate Member*) West Midlands

F. C. POTTS, M.SC. (*Associate Member*) Merseyside

J. B. RIMMER (*Associate Member*) Scottish

H. V. SIMS (*Member*) South Midlands

General Secretary

GRAHAM D. CLIFFORD

INSTITUTION NOTICES

New Year Honours

The Council of the Institution has congratulated the following members whose names appeared in the New Year Honours List. Their appointments are to the Most Excellent Order of the British Empire.

William Stubbs, M.C. (Member) as Ordinary Commander of the Civil Division of the Order. (Mr. Stubbs is Director General of Telecommunications of the Federation of Malaya and Singapore.)

Frederick Butler, B.Sc. (Member) as Ordinary Officer of the Civil Division of the Order. (Mr. Butler, a former member of the South Midlands Section Committee, is a principal scientific officer in the Royal Naval Scientific Service, attached to the Foreign Office.)

Commander Henry William Young, R.N. (Retd.) as Ordinary Officer of the Military Division of the Order. (At the time of his retirement last year Commander Young was with the Directorate of Radio Engineering, Admiralty; he is now with Associated-Rediffusion Ltd.)

Indian Advisory Committee

A meeting of the Institution's Indian Advisory Committee, under the chairmanship of Major General B. D. Kapur, B.Sc. (Member) will shortly be held in Delhi.

The Delhi Section is arranging a meeting for the same day, at which Major General Kapur will present, on behalf of the President, the Sir J. C. Bose Premium for 1958 to Professor B. R. Rao, D.Sc. and Mr. C. A. Reddy, M.Sc.

Details of the Delhi Section meeting will be circulated to members in the area, and further information may be obtained from the Honorary Secretary of the Advisory Committee, Colonel B. M. Chakravarti, M.Brit.I.R.E., P.O. Box 109, Bangalore.

Membership of Committees

It is customary in the January issue of the *Journal* to give details of the personnel of Standing and Local Section Committees. However, since this information will be contained in the 1960 List of Members, which will be published shortly, it has been omitted this year.

New Chairman of the R.T.E.B.

At the 15th Annual General Meeting of the Radio Trades Examination Board on 30th December last, Mr. E. A. W. Spreadbury (Member) was elected Chairman of the Board. Mr. Spreadbury, who represents the Institution on the Council of Management of the Board, succeeds Mr. E. M. Lee, B.Sc. (Member), a Radio Industry Council representative.

Mr. Spreadbury has been associated with the R.T.E.B. since 1943 when he was appointed an examiner and a member of the Examinations Committee. He was elected to the Council of Management of the Board in 1947 and has continued his membership of the Examinations Committee. Mr. Spreadbury is Associate Editor (Technical) of *The Wireless and Electrical Trader*, and the author of a number of books on receiver servicing. First elected an Associate in 1934 he was transferred to Associate Member in 1937 and to full Membership of the Brit.I.R.E. in 1947. A fuller note on his career was given in the December 1950 *Journal*.

Union of South Africa Section

The Council has authorized the appointment of a professional secretary to assist the honorary secretary of the South African Section in dealing with general matters in connection with the handling of membership enquiries and applications for examination entry and membership. All correspondence on such matters should therefore be addressed to Mr. A. Aitken at the Section's postal address: P.O. Box 133, Johannesburg.

The business of the Section Committee, including the arrangement of meetings, will continue to be dealt with by the honorary secretary, Mr. G. V. Meij, whose address for Institution correspondence is also Box 133, Johannesburg.

1960 List of Members

The effect of the printing dispute last summer has set back the publication date of the 1960 List of Members announced for distribution at the end of December. It is now expected that copies will be sent to all members (excepting Students) at the beginning of March.

THE ENGINEER AND THE COMMUNITY †

An Address by The President

Professor E. E. ZEPLER, PH.D.

Delivered at the Annual General Meeting in London on 2nd December 1959.

IN last year's Presidential Address‡ I devoted most of my time to discussing the education and subsequent training of an engineer. I have since asked myself whether the community at large benefits as much as it might expect to from the time, cost and facilities which are given to training qualified engineers. I have also asked myself whether the engineer takes as great a part as he might do in the life of our nation: whether his training and subsequent position in the community is such as to enable him to take a responsible part in the general affairs of management and even in more directly assisting in Government.

In his recent statements the new Minister for Science has, in fact, stated that he expects scientists and engineers to take a more active part in making known their views. The scientist has already achieved a considerable measure of recognition; this state of affairs is, however, of comparatively recent origin, for the place of the scientist in the life of the nation was certainly not recognized as being of first-class importance, say, 100 years ago. Indeed, it is probably true that the social significance of the contribution which science has made to civilization has not been recognized for more than about 50 years.

Those who apply science, and who are usually called engineers, are still not sufficiently appreciated as belonging to a profession requiring just as much study, ethical behaviour and responsibility as, for example, the medical, legal or accountancy professions. Whilst in many instances the work of the engineer follows the fundamental work of the scientist, I do not intend to differentiate between the value of the scientist and the value of the engineer.

It is normally not difficult to state whether a man is an engineer or not, but it is not so easy to say whether he is a scientist. The former is largely a matter of activity and position, the latter perhaps is more a state of mind. At the same time, it is also true that the good engineer is always something of a scientist and that very often a good scientist is also an engineer. Thus if I speak simply of the engineer I use the word in the collective sense to describe those people who work in the fields of pure and applied science.

Such work requires not only intensive training and a sense of vocation coupled with ability, but also a considerable degree of intelligence. One is therefore entitled to ask—is it more difficult to become an engineer, to obtain the required qualifications and later on pass the test of ability than, say, to secure an arts, medical, law or commerce degree?

It would be most imprudent of me to give a direct answer to that question. One thing, however, that can be said without causing offence to any other profession is that to be a successful engineer requires a special gift. A thoroughly intelligent person could probably become a good doctor or a good solicitor, but he might find it quite impossible to become a good engineer. It is a well-known fact that there are plenty of highly intelligent people who cannot pass mathematics at the Ordinary level.

It would be quite wrong to assume that because of this special gift engineers are more intelligent than other people. I suggest, however, that his intense training in logic and objective thinking should enable the engineer to apply these characteristics to many other aspects of daily life.

In striving to apply our sense of logic and

† Address No. 19.

‡ *J. Brit.I.R.E.*, 19, pp. 5-13, January 1959.

U.D.C. No. 62.007:321

objective thinking to other spheres of human activity, it is most important that we should not, as engineers, underestimate the many other qualifications required in management, in political life, in administration. In short, whilst I do maintain that the engineer is very well qualified to take a more active part in human affairs, I urge caution and the need to exert influence only in those fields where our training best enables us to give a qualified opinion.

I have mentioned that one sphere in which the engineer should be able to take a more prominent part is Management. Since my predecessor, Mr. George Marriott, dealt with this subject in his Presidential Address† the Council of the Institution has given very much thought to the question of training for Management.

We recognize, of course, that there are many avenues which may lead to management appointments. Similarly, it will be accepted that in engineering matters an intimate knowledge of the technology should, other things being equal, tip the scales in favour of the qualified engineer when top appointments are made.

Due to the fact that there are obviously fewer positions at the top than at lower levels, the engineer is first of all concerned to ensure that, if he stays an engineer all his life, his position should provide him with what he considers an adequate standard of living. This is a quite understandable attitude: we are all concerned with our own standards of living. Governments the world over are anxious to give their people better standards of living, and this desire starts with the individual.

We must, however, be realistic in our approach to this problem; most of us have heard advice being given to the effect that the young man who is concerned with his financial future should not enter engineering. This is senseless thinking and a disservice to the country as a whole. In Great Britain our prosperity is tied to our ability to export; since this ability depends, to a large extent, on the standard of our technical products, it is clear that the engineer is a vital factor in the economy of the country.

We must also not forget that in Great Britain we are in the van of progress, and it is not surprising that many other countries offer attractive terms to our engineers. This is not a bad thing because obviously the more opportunity there is for the people of the world to mix with each other, the better will be the prospects of our learning to live together in peace.

Moreover, the comparative ease by which our engineers may transfer their services to other countries, testifies to the fact that we live in a free community; nevertheless, we are faced with that additional demand and because of that factor and our own needs, we continue to be anxious to train as many engineers as possible. Before we can train them, however, we must be able to offer to these young people the same degree of recognition as they would enjoy if they turned their abilities in other directions.

The engineering Institutions of Great Britain have done a great deal to raise the prestige of engineering professions. Could they do still more?

If we compare the engineering institutions with the medical profession, we see a fundamental difference. If a doctor is to be allowed to practise, he must be on the Register of the General Medical Council. The power of this body over the members of the profession is very great, but at the same time it speaks for its profession. The very high esteem in which the medical profession is held is proof of the great work that it has done. Could a similar state of affairs exist in the engineering profession and would it be desirable?

In the Commonwealth there is one country—Canada—which does in fact exercise a measure of control over the right to describe one's self as a professional engineer. In order to secure that right, it is necessary to hold recognized engineering qualifications, and I have little doubt that the motive behind this policy is the very commendable one of inducing greater recognition of the status of the professional engineer.

There may be many who do not approve of such measures and who see in them an infringement of the freedom of the individual. What other alternatives are there, however, if an engineer is to have a means whereby he is to secure greater recognition of his status in the

† *J. Brit.I.R.E.*, 17, pp. 5-13, January 1957.

life of the community? We may have an aversion to any form of compulsory registration, but as I have pointed out, it has worked to public advantage for the lawyer, the medical man, the accountant, etc.

Should we not, therefore, examine two questions: Firstly, do we seriously pretend that the total membership of our engineering institutions represents anything like the total number of qualified engineers? Secondly, and I say this without offence to any of our sister Institutions, do we who are members of engineering Institutions do enough to educate the public and indeed, the Government, on the proper use of the word "Engineer"?

On the first question, examination of the total membership of all the engineering Institutions clearly indicates that there is nothing like 100 per cent. membership of all those qualified to become members. In some cases, and we may cite our own Institution, membership could be very much greater if there were not differences of opinion which could be settled by reasonable negotiation.

Again I quote the medical profession as an example; there we have seen over the years development of new branches of the science, and although there has obviously been a conservative approach to new ideas, in the event new developments have been encouraged by the older branches of the profession and have led to the establishment of separate associations. This postulates the question as to whether it is not one of the functions of all engineering Institutions to do all in their power to encourage the development of new applications of science.

On the second question, we in the Brit.I.R.E. have done a great deal toward education of the public in understanding that essential though he is in the community, the mechanic or technician is not an engineer and should not be described as such. It must be a criticism of all engineering Institutions that today there continues to be public misconception that a man who handles a drill or a screwdriver may describe himself as an engineer. While the properly qualified engineer is confused with the mechanic and technician, it will become increasingly difficult to establish a case for recognizing the professional status of the qualified man.

What are the reasons which prevent professional engineering bodies containing 100 per cent. membership of the profession, in much the same way as there is 100 per cent compulsory registration for architects, lawyers, doctors, etc?

One obvious reason is the apparent unwillingness of many well qualified engineers to join their professional body. They may have excellent reasons, but I am inclined to think that many engineers have the same human failing as most other people—the simple one of confusing themselves on the issue of material benefit. Too often the answer to the question of membership is that of "What do I gain" and not "Is this a good thing for all of us?"

To some extent the question of membership, especially for senior people, involves the issue of public duty and a willingness to assist others, particularly the younger man. By our working together to secure a better appreciation and recognition of the value of the engineer, we shall automatically do much to encourage young men to enter our profession and I have no need to give further emphasis to the necessity of our securing more young scientists and engineers.

Some people have a fear that this demand can be exaggerated and over-estimated. This must surely, however, be an economic and political matter; the appointment of a Minister for Science to stimulate scientific achievement is surely part of the plan for not only increasing the standard of living in the United Kingdom and the Commonwealth, but in order to enable us to play our part in assisting the under-developed countries. The engineer can play a great part in this work by his production of goods, amenities, and services, which will improve the lot of common man—all of which is called improving the standard of living.

Such ideas need far reaching thought and a willingness on the part of the engineer to accept responsibility, in the sense that responsibility can start with supporting and helping to make more useful the work of professional bodies through which it is possible to stimulate new ideas as well as disseminating knowledge; to appreciate that there are heavy responsibilities in management, and that in turn we all have responsibilities to management.

We electronics engineers have done much to assist in securing an economic flow of production, but whatever his job every engineer can often suggest new ideas which will bring down the cost of the end product. This is but one way in which we can all help in improving the standard of living.

I would criticize our own Institution—although the comment may well fit many others—in saying that there is a tendency to be content with the usual lines of procedure; to concentrate, as indeed we must, on our education work and educational policy; to ensure that the standard of the profession is maintained by having adequate safeguards in admissions to membership; by producing papers, holding meetings.

But is all this enough? In our meetings and in our *Journal*, and in our Committee work, should we not give much more time to initiating new ideas; to be a great sounding board for industry, and not to be afraid to give a platform for the discussion of fresh thought and original theories? If only one idea in ten develops into something that is useful for the common man, the other nine meetings or discussions will not be wasted.

Let us be aware that even in technical matters the human element is the major factor. Just two days ago Sir Cyril Hinshelwood gave a Presidential Address to the Royal Society. I would like to quote his comment on the relation of man to machine:

“The answer that machines like the so-called electronic brains work only to a ‘program’ brings the rejoinder that a set of machines could itself be programmed by another machine. But the master machine would itself need a program. This would have to be provided by another machine, and so on in an infinite regress, there being no way in which the sequence could be closed to a self-contained cycle.”

These words appear within a context where it is made clear that in his opinion a machine can never work like a human being. Here the scientist touches upon a problem that lies on the fringe of both physics and philosophy.

In our meetings we try to provide this stimulation of new ideas and provide a forum for logical and analytical examination. It is to encourage all these ideas that we exist as an engineering Institution, and I hope that these few remarks will help to stimulate not only good relations between all the engineering Institutions, but encourage our own members to play their individual part in securing greater recognition of the status of the engineer.

May I envisage that, at one of our future meetings (to quote Sir Cyril Hinshelwood again, this time freely) “Some quite ordinary phenomena will reveal to the eye of genius, like the fall of Newton’s apple, an undreamt of but thenceforth obvious significance.”

News from the Sections . . .

North Western Section

The North Western Section of the Institution held its first social evening on 27th November, when 66 members, their ladies and friends, met at the Palace Restaurant, Manchester, for dinner. After dinner, the Chairman, Mr. J. W. Harrop, B.Sc. (Associate Member) addressed the gathering and expressed the hope that there would be other similar social occasions in the future. The party then proceeded to the Palace Theatre. Everyone present appeared to enjoy themselves and this first social evening was considered to be very successful. F. J. G. P.

South Western Section

The annual general meeting of the South-Western Section was held in the School of Management Studies on 7th October. It was attended by the President of the Institution, Professor E. E. Zepler who, earlier in the day, had taken the chair at the Section's very successful symposium on "Apprentice Training" held at the R.A.F. Station at Locking.

After the business of the annual general meeting, Captain L. Hix presented his chairman's address, taking as his theme, "The Drift of Electronics." (The text of the paper was published in the December *Journal*.)

The discussion on the Address opened with a sharp attack on component reliability! It was suggested that we have progressed far since the early days of "Wireless" but have not gone far enough; component failure today can spell disaster in aircraft, or prove extremely costly in the automatic factory. Other speakers asked why anyone should want to produce the "robot" of fiction when man is quite easily reproduced—surely it was far better to concentrate on automatic factories, computers, etc. which could do part of man's work, reduce the toil and improve the standard of living. The contribution of the mathematician to the progress of electronics was then raised. It would appear, however, that the boot is on the other foot—progress in solid-state physics is held up by the slow mathematical methods employed, and machines were needed to speed up this work. The general conclusion reached at the end of the evening was that whatever the drift, progress will continue.

At the second meeting of the session on 18th November, a paper entitled "Data Recording and Data Presentation" was presented by Mr. D. W. Thomasson (Associate Member).

After a brief survey of the various ways by which information may be recorded, the author examined the various methods in detail. Analogue recording might be expected to give a long-term accuracy of 1 per cent. though this could be improved by careful and regular calibrating; however the main advantage of analogue recording lay in the ease with which the important parts of the record could be picked out for more detailed inspection. The work of interpreting the record is very tedious but Mr. Thomasson pointed out that the trained reader can discriminate between signal and "noise." The delays due to photographic development have been largely overcome by the use of ultra-violet and Xerographic techniques.

Digital recording offers a very high degree of accuracy and high-speed machine computation but it also presents many problems. Pure binary code fails when the parameter is changing; this may be offset to some extent by the use of codes, but Mr. Thomasson considered that there are too many codes involving too many complicated circuits. He felt it was time for some form of standardization to cope with the problem of complete automation of data processing. The author concluded with some remarks on the various recording media, and the recording density and speed of the various methods.

The paper was followed by a very lively discussion, starting with the dangers of serial digital recording and humorous references to "speaking voltmeters" in conditions of rapidly changing voltages. The problems of automatic graph plotting in two and three dimensions, and graph plotting and extracting "the law" kept the mathematicians in the audience occupied.

This was followed by a long discussion on the possible methods of presentation and examination of the large quantities of information amassed during long researches into human behaviour, etc. Could we not have machines capable of such examinations to observe the trends and other information which can only be so tediously obtained at present? E. G. D.

West Midlands Section

The paper "New Developments in Semiconductor Rectifiers," which was read by Mr. J. Bulman before the Section in Wolverhampton on 11th November, began by reviewing the history of rectifiers, from the early mechanical commutation systems to present day semiconductors. Of the barrier-type rectifiers, the earliest form was the copper-oxide, followed as an early war-time development by the selenium rectifier. Mr. Bulman made it clear that although silicon and germanium have found wide application, the vast majority of metal rectifiers at present in use for power applications are one or other of the earlier types. Brief details of manufacturing problems of the various types were considered, emphasis being placed on the high degree of material purity which is necessary for silicon and germanium junctions.

The characteristics of the various types were then compared in terms of limiting values for a single junction. The points of comparison were: forward voltage drop, safe inverse voltage, operating temperature, ability to withstand overloads, stability of characteristics with time. This analysis clearly showed the important differences which a designer should consider when choosing a rectifier for a particular purpose. One outstanding point was that certain types had less ability to withstand large overloads than others. Mr. Bulman pointed out that this was often offset to a large degree for many applications by a very favourable ratio of current rating to physical size. This enabled a designer to choose a unit having an adequate overload margin whilst keeping reasonable dimensions.

The paper continued with numerous applications of the metal rectifier, these ranging from circuits handling microamperes and kilovolts, to plating and other chemical processes where thousands of amperes at a few volts are required. In conclusion, Mr. Bulman mentioned new developments in controlled switching junctions, these having a very wide application indeed. Though only recently introduced in this country, their potentialities are such that they may well radically alter the techniques of future control circuitry.

F. D.

South Wales Section

The Section held its Annual General Meeting at the Glamorgan Technical College, Treforest, on 2nd December. This was followed by an Address, "Wastage in Technical Education" by the Chairman, Mr. J. Cotterell, Principal of Llandaff Technical College.

Mr. Cotterell demonstrated very convincingly with the aid of graphical statistics how the numbers of students had risen many times since the 1920's, and particularly since the last war. However it was a rather surprising fact that the percentage of passes each year could be taken as unchanged.

While, if taken at its face value this situation might seem satisfactory, in fact in the National Certificate case many thousands of students were actually failing. In City and Guilds examinations, taking 1958 as an example, of 128,000 students roughly 60,000 failed. Furthermore, taking National Certificate courses as an example, for every 100 students commencing the first year of the three-year course, the average number who eventually obtain an Ordinary National Certificate is 12. Much of this wastage could be avoided, Mr. Cotterell thought, by more careful selection in the first place, by providing lower grade courses within students' capabilities and a scheme for progression each session to more advanced courses as required.

Mr. Cotterell also suggested that the block release of part-time day students for one month each term provided a longer period for students to be in an academic atmosphere. This was proving to be a better arrangement for industrial managers who were often embarrassed by absences of one day every week. It had already been proved that block release produced a higher percentage of passes than the normal part-time day scheme. For more advanced courses the sandwich scheme had the same advantages and gave better results.

In the ensuing discussion, details were given of various other schemes which had been introduced, or were proposed, for improving the existing results. There were also comments on the present National Certificate scheme and it was suggested that a more basic approach with appropriate specialization would suit industry better.

C. T. L.

Factors Influencing the Applications of Magnetic Tape Recording to Digital Computers †

by

D. P. FRANKLIN‡

A paper read on 7th April 1959 at a Symposium on "Large Capacity Storage Systems" arranged by the Institution's Computer Group.

In the Chair : Dr. A. D. Booth (Member).

Summary : The merit of magnetic tape for storage of digital information and the benefits of abandoning linear in favour of two-state operation are briefly discussed. Limitations on the density of recorded information are reviewed to show the extreme precision called for in the manufacture of magnetic heads and tape guidance mechanisms. Design features made necessary by high speed and acceleration requirements are considered with reference to a recently developed high performance tape handler.

1. Introduction

As a means of computer storage, magnetic recording is very convenient in that a stale entry may readily be erased and replaced by a fresh one an unlimited number of times; also, since a binary digit may be distinguishably written on a 0.15 sq. mm or less, it compares very favourably with punched cards and perforated tape.

Of the various methods of magnetic recording, oxide-coated plastic tape on reels shows the greatest volume economy, its total thickness being about 40 microns only. Furthermore, the practicability of dealing with a large number of reels on one piece of reading-writing equipment minimizes its proportional volumetric (and economic) contribution to the complete store.

Magnetic recording has hitherto developed in the linear mode (i.e. exploiting fine gradation in the magnetic intensity recorded) in applications where an occasional imperfection can be ignored as being of no significance. For digital applications the standard of perfection is several orders higher, and these imperfections become intolerable. Information theory shows that the redundancy on reducing the number of distinguishable amplitude levels to a small value

will enable us to recognize positively the "weight" (or value) of a given recorded element. This reduction in the number of possible states is in keeping with computer practice, and therefore allows the ready assimilation of tape techniques into the overall system.

The useful number of states can be either three or two, chosen from:—

- (a) Saturation polarization in an arbitrary (positive) sense.
- (b) Zero polarization.
- (c) Saturation polarization in the opposite (negative) sense.

To obtain the sharpest possible definition on the tape, the writing current must make its transitions as rapidly as possible.

A number of methods of coding a digital event have been described^{1,2} and of these

Return to zero (R.Z.)§	uses states (a) and (b).
Polarized return to zero (Polarized R.Z.)	uses states (a), (b) and (c).
Return to bias (R.B.)	uses states (a) and (c).
Non-return to zero (N.R.Z.)	uses states (a) and (c).
"Phase" Modulation (P.M.) ³	uses states (a) and (c).

Allowance must be made on the tape for two distinguishable transitions for each binary digit,

§ When the m.m.f. in the write head has fallen to zero, a length of tape equal to the effective gap length is left magnetized. Thus the length of the flux pulse is equal in R.Z. cases to the effective gap length in addition to the product of tape speed and pulse duration.

† Manuscript first received 1st May 1959 and in final form on 5th September 1959. (Paper No. 532.)

‡ E.M.I. Electronics Ltd., Wells Division, Penleigh Works, Wells, Somerset.

U.D.C. No. 621.395.625.3:681.142

with the exception of N.R.Z systems, where the one transition identifies the digit completely.

With all these systems it is advisable, but not always necessary, to carry an unmodulated, or clock, track in parallel on the tape to provide a phase reference.

2. Factors Limiting the Density of Recorded Information

Magnetic recording differs from normal computer circuits in that the bandwidth is restricted for practical tape speeds, and that the medium is inherently noisy. The restricted bandwidth presents a systematic limitation of the possible digit packing density, whilst noise is essentially random. Additionally, multi-track systems bring with them limitations due to mechanical tolerances.

2.1. Bandwidth

When information is replayed by means of a conventional head, the signal, being proportional to the rate of change of flux, is not of the same waveform as the original impressed signal. It is approximately the result of differentiating a square flux wave as averaged over a "window" of somewhat greater length than that of the gap (i.e. effective gap length) in the reading head. A typical read waveform is shown in Fig. 1(a). If this feeds an integrating amplifier, as in audio practice, a "rounded off" version of the flux wave Fig. 1(b) will result, wherein the rate of rise relative to full amplitude will be lower than for the direct waveform. Since precision of timing is paramount, it is almost universal to work with the direct replayed waveform.

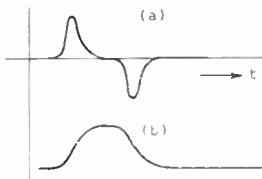

Fig. 1. Playback waveform of a rectangular pulse, (a) at head terminals (b) after equalization (integration).

The spreading of flux from the pole-tips of a write head may be expressed as an increase of effective gap length accompanying increasing separation from the head, and a similar increase of effective gap applies to a read head. If therefore, tape (or for that matter, coated drums

or discs) are held separated from write and read heads, the fine magnetic detail is lost, i.e. the bandwidth of the system for a given tape speed is reduced. In addition there is an overall loss of sensitivity; write currents must be increased to ensure oxide saturation and an extra reluctance is included in the read head magnetic circuit.

It has been found⁴ that this "separation loss" may be expressed, for sinusoidal signals, by the formula:—

$$\text{Separation loss} = \frac{55d}{\lambda} \text{ db}$$

where d = separation between head and medium
 λ = wavelength of recorded signal

For packings of up to 200 flux transitions to the inch, operation at speeds above 60 in./sec (even, with care, 200 in./sec) is practicable at a separation of 0.001 in., and is typical of storage drum practice and quite common in British tape practice. Obviously for tighter packing (corresponding to small values of λ) the importance of minimizing d , and random variations of d , becomes of great importance. Variations of d can be considered as a spurious noise and will be dealt with under that heading.

For successful writing over existing information, the degree of saturation must be high enough for the residual, imperfectly erased signal to be negligibly small; but the write current must not be increased beyond an optimum value otherwise pole tip saturation may set in, leading to an increase in effective gap length. With well-designed heads, tip saturation may be avoided and the reduction of a signal after erasure yet be 10:1 for non-contact operation and can be considerably greater for full contact.

In order that a recorded digit may be identified, the read waveform must be unequivocally recognizable. This will cease to be so if the interval between successive pulses is reduced sufficiently to cause the pulse shapes to merge. This limit may be detected as a drop in the pulse height as the pulse rate is increased as shown in Fig. 2.

At a given tape speed, the interval between sharp pulses can be made much smaller than for broad ones, and hence more digits may be

accommodated per unit length of tape. However, the broadness of a read pulse is closely dependent upon the effective gap length of the read and write head, which is influenced in turn by separation and over-saturation. The influence of the write head gap is small in comparison with that of the read head² and may be



Fig. 2. Playback waveform of a short rectangular pulse. The positive - and - negative - going components are shown dotted.

neglected to a first approximation except where the write head gap is long. With non-contact operation this effect is blurred completely by the spreading of the flux.

2.2. Noise

So far, the waveforms from the read heads have been considered somewhat ideally. In practice, some degradation is present and this can be classified broadly as noise, which can then be sub-divided into a number of independent effects:—

- (1) Background noise due to the inhomogeneity of the medium. With magnetic states of saturation value, the read pulse voltages are so great that this noise can be entirely neglected.
- (2) Long term sensitivity variations along the tape. During the manufacture and subsequent testing of the tape these variations are controlled to within 6 per cent., and this is within the amplitude tolerance of normal computer circuits.
- (3) Cross-talk arising from large currents in nearby circuits (e.g. writing currents). This can almost be considered a "man-made" interference rather than a fundamental limitation. Scrupulous attention to magnetic and electrostatic screening will usually reduce the unwanted fields to innocuous levels.
- (4) Cross-talk arising from magnetic patterns on adjacent tracks. In multi-track systems, a read head may respond to the flux crossing the inter-track guard lane, the amount being a decreasing function of the width of this lane. The wanted signal is roughly proportional to the width of the main track whose minimum value is determined largely from

considerations (5) and (7) below. Therefore, given the track width, the tolerable relative cross-talk determines the lateral density, i.e. the number of tracks to the inch. With N.R.Z. systems, the distance between successive reversals of polarization is determined by the sequence of digits, and therefore, it is possible for elementary magnets of some considerable length to arise. In consequence, flux will spread across the guard lane more strongly, albeit fairly diffusely, giving an increase in low frequency cross-talk.

- (5) Cross-talk arising from imperfect erasure. This has already been referred to in the previous section in respect of the correct value for writing current, but when tapes are to be used indiscriminately on a number of handlers, another form is introduced if the corresponding heads are not identically placed laterally. This effect will be referred to in connection with dimensional tolerances of heads.
- (6) Drop-outs, or local sensitivity variations due to temporary loss of contact between head and tape. These may be caused by protuberances in the tape surface, by flutter in the tape as it passes over the heads or by loose particles of foreign matter being dragged between them. The effect of the first cause repeats at the same location, whilst those of the other two are random.

In all cases the effect of separation increases rapidly as the digits are packed more tightly together, as will be seen from the separation loss formula already quoted. By careful attention to tension and arrangement of tape supports, a tape handler can be so constructed as to eliminate the flutter effect just mentioned. In addition, ingress of dirt must be prevented by completely enclosing the mechanism and by lightly pressurizing it with filtered air. Other defects are minimized by the use of instrumentation grades of tape in which the manufacturer pays great attention to smoothness, uniformity and hardness of

the oxide surface. Debris from the tape is therefore unlikely to accumulate between routine cleanings in sufficient amounts to cause trouble.

- (7) Drop-outs caused by local absence of oxide. These arise mainly because of holes in the base film, and tape manufacturing technology is continually directed towards reducing their incidence and size.

Size has a direct bearing on the extent to which track widths can be reduced, since it will be seen that a drop-out of half the width of the track will locally reduce the gain to approximately one half. As drop-outs are distributed in size, it is possible to choose a track width such that the selection of tapes in which no drop-out greater than, say, 50 per cent. occurs, is economically justifiable.

Instrumentation grades of tape are subjected to such selection tests for a specified track width and packing density.

Typical figures are:

Track width = 0.045 in.
 Number of reversals to the inch = 200
 With heads in contact
 no drop-out exceeds 50% amplitude

Using polyester-based tapes, greater densities become practical from the magnetic resolution point of view, and this factor is of decreasing importance as a limitation on digit packing.

- (8) Gain variation due to long-term changes in head to tape separation. This particular effect arises mainly in non-contact systems in which the tape is located from its back surface, the separation being influenced by changes in the overall thickness of the tape. A typical tolerance is ± 0.0001 in. and if this is not to give rise to excessive amplitude changes, the separation must not be set below about 0.0008 in. We saw earlier that separations of this order dictate a packing of not more than about 200 reversals to the inch.

2.3. Mechanical Tolerances

The limitations so far enumerated apply to a single channel, but when information is written in parallel on a number of tracks, questions of timing exert further constraint. Digits written simultaneously in time will, in general, not be read simultaneously, and the permissible error will provide the basic limitation.

Any difference in the skew in the tape between when it passed under the write and read heads will cause delays in proportion to the angular error and the lateral distance between a given track and the datum (usually the common clock track). Skew may arise from deficiencies of guidance in the tape transport mechanism, and the angular deviation is an important criterion in the specification of a complete machine. The slitting accuracy of the tape is also important in respect of both the width tolerance and the straightness of the edge. Although it is, in principle, possible to render the former innocuous if the tape is always guided, and hence located, at a specified edge, it is extremely difficult in practice to exclude all possibility of that edge occasionally riding up its guides, particularly if the tape is not perfectly straight.

Assuming that a small variability in skew is inevitable, the clock track is best placed along the centre line of the tape. For even greater precision, more than one clock track may be provided appropriate only to its near neighbouring digit tracks.

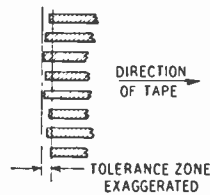

Fig. 3. Multi-track head; departures of gaps from ideal alignment (shown exaggerated).

If a tape is read by the same heads that performed the writing, no additional timing error will be introduced; but if different heads are involved, any departure from alignment of the head gaps longitudinally to the tape will introduce timing error, specific to the head blocks, but random from one block to another. Alignment error in multi-track heads is conventionally expressed in terms of whether the gaps

lie inside the tolerance zone between two parallel lines perpendicular to the direction of motion of the tape. (Fig. 3.)

If, in order to permit more tracks to be accommodated across the tape, heads are in two longitudinally displaced blocks with tracks interleaving, (Fig. 4), the timing error may also

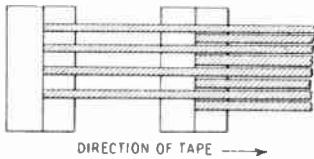

Fig. 4. Diagram showing longitudinally displaced blocks to permit track pitching smaller than minimum head pitching by interleaving.

include the tolerance of this displacement combined with the effect of tape stretch or dimensional instability. It is better, in this case, for each group of channels to include its own clock track.

2.4. Redundancy in Information

In view of the number of effects all contributing to some degradation of the recorded information, it hardly becomes economic (even if it is possible) to design with large enough safety factors to make the error incidence negligible. Accordingly it is a universal practice to introduce redundancy into the information handled and to rely on the statistical improbability of combinations of errors cancelling one another and thereby escaping detection. This redundancy usually takes the form of one or more digits per binary word, with cross checks at the end of blocks of words⁵.

3. Magnetic Heads

3.1. Contact System

Heads for multi-track digital work follow audio practice fairly closely, with the addition of generous magnetic and electrostatic screening between track units because of the low replay levels. The effect of interfering fields is also much reduced by arranging the windings to have equal numbers of turns, and placing them on parallel limbs of the magnetic circuit, one each side of the gap, i.e. the heads are physically and electrically symmetrical (balanced).

The cross-sectional area, and hence reluctance, of the gap has considerable influence on the inductance of a head, so it is clear that it will decrease as the depth of the gap is decreased by wear. At the same time the efficiency of the head increases. It is therefore advisable to couple magnetic heads onto circuits which are comparatively insensitive to changes in these quantities.

Nevertheless, changes in both amplitude and inductance will result in a small residual phase change, and it is prudent to minimize the differential change by arranging that the quantities will vary together approximately equally as the pole tips wear away. To ensure this demands extremely careful control of the physical dimensions of the pole tips and gap at all stages of manufacture.

Because of the readiness with which organic resins pick up tape debris, etc., it is highly advantageous if the construction is such that only metal surfaces are in contact with the tape.

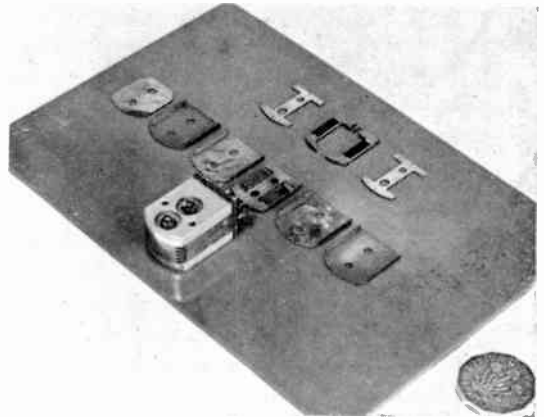

Fig. 5. Construction of typical multi-track head block for contact digital or analogue working, showing individual head unit, screens and spacer.

A typical method of construction is shown in Fig. 5 in which each head is made as a separate unit, a number of these being stacked to produce the complete multi-track block.

An alternative procedure is to assemble each half (including screens) of a multi-track block separately, true up the pole-tips and magnetic abutments into a single plane by careful machining, and then to complete the assembly. Of

course, for full interchangeability of head blocks, it is necessary that the mutual relationship between the gaps and the mounting location faces is maintained in respect both of direction and distance to high precision.

The signals which digital heads will deal with result from the differentiation of nearly rectangular flux waves, with the result that the energy is substantially at the upper end of the frequency band available for recording.

Accordingly, the effect of iron losses is likely to make itself felt as the digit rate is pushed higher, and the lamination material and thickness must be chosen judiciously. Although the highest frequencies are at present encountered in magnetic drum stores where very high medium speeds are normal, these are almost exclusively non-contact systems; development of tape handling mechanisms promises that higher packing densities and speeds will be achieved which correspond to the greater operating frequency of the drums.

The properties of ferrites extend the horizon of possibility for high frequency applications but their use has not yet become widespread for contact working owing to the pole tips crumbling and giving poor magnetic definition. This defect may be overcome, at some expense, by fastening a thin metallic pole shoe to the ferrite by means of an adhesive, and ensuring that the front gap is entirely defined by the shoes⁶. Since these must be thin to minimize the iron losses, the life is poor unless a physically hard material (e.g. Alfenol-16) can be used.

The effect of gap size has been treated from the point of view of theory⁷, and audio practice⁸ and a very brief discussion for rectangular waves was given with reference to bandwidth in Section 2.1, but as gaps become narrower a further point demands attention. It is often very convenient to make the same heads perform read or write duty as desired, but if there is sufficient remanence after writing, the read sensitivity may be objectionably reduced and some asymmetry of the read waveform will appear. This can be minimized by the careful choice of materials and losses in the light of the specific operating conditions.

3.2. Non-contact Systems

When there is no longer contact, and therefore no longer wear, between head and tape, the need for a reasonably long pole face can be questioned. Short poles would have suffered high local pressures and the wear rate would have been excessive, but in the absence of this restriction the pole size can be determined to suit other criteria.

Since in digital work all magnetic transitions are sudden, the useful external flux is concentrated in a small region around each transition and there is therefore no objection on the score of loss of coupling to reducing the lengths of the poles. Furthermore, we know that the coupled flux is insufficient to saturate the pole tips and therefore a very small cross-sectional area throughout the magnetic circuit (apart from air gaps) will suffice. Cores for the heads may thus be made from narrow strips formed to shape and, in the extreme, provided the extra losses are tolerable, from a single solid core.

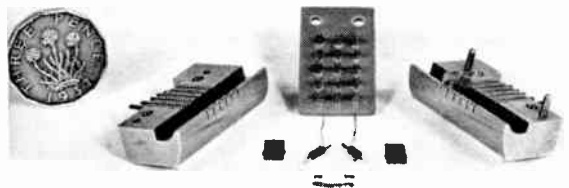

Fig. 6. Construction of an experimental multi-track head block for non-contact digital working, showing the reduction in core material and head dimensions.

Following upon the reduction of cross-section the possibility of reducing overall dimensions becomes obvious, being limited only by the necessity of providing the winding with a sufficient number of turns of a practical gauge of wire. Figure 6 shows the construction of a multi-track unit for 0.030 in. tracks made in two halves for non-contact working and using solid cores. The size of the magnetic circuit is approximately $\frac{1}{4}$ in. by $\frac{1}{8}$ in. and the cross-section 0.030 in. \times 0.015 in. The gap, suitable for 200 transitions per inch, will be 0.001 in.

As with contact systems, a "secondary gap" effect⁸ can occur if the pole tips are completely

flat, but this may be cured by providing them with a radius of 1/64 in.

This miniaturization process results in two very useful improvements in performance: (a) the reduction in the length of flux path and the closeness of windings to the main gap lead to an increase in sensitivity over a conventional laminated head carrying the same number of turns; and (b) the general reduction of the size makes for less pick-up or production of stray magnetic fields.

3.3. Tolerances.

If tapes written by one block of heads are to be accurately replayed by another, and replacement blocks are to be fully interchangeable, the tolerance problem becomes one of great importance.

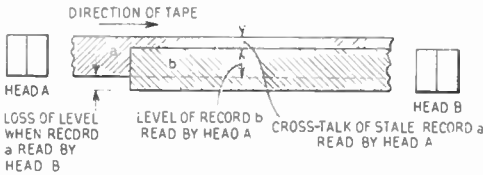

Fig. 7. Diagram illustrating the effect of errors in track positioning for different tape transports.

The need for close tolerances is exemplified in the case of tape, written on one machine, over-written on another and returned to the original for reading. In Fig. 7 there is a lateral displacement of the second head from the track laid down by the first (e.g. they lie in different parts of the tolerance range). A certain amount of the original magnetization pattern remains after the over-writing operation. This would cause small cross-talk if the track were read by the second head but, should the tape be returned to the original head (or another in the equivalent lateral position) it would induce greatly increased interference.

When one block of heads is reserved for writing and another for reading, it is possible to eliminate the above difficulty by making the read head narrow enough to cover only the lateral distance common to write heads at the extreme of tolerance. Although this causes some loss of read signal, the reduction of cross-talk due to imperfect erasure is very much greater. With dual purpose write/read heads,

this solution is not available and lateral tolerances must accordingly be tighter. Fortunately, fringing effects cause the intensity of magnetization to fall away gradually in the lateral direction, and therefore the magnitude of the cross-talk is not so great as it would be with ideally sharp boundaries.

As was discussed earlier, timing errors due to departures from perfect alignment of all the head gaps are introduced if write and read are performed by different head blocks. Here we must distinguish between write heads, where usually the trailing pole face substantially determines the point of writing, and read heads, where the flux density being read is approximately that appropriate to half way between the pole faces. It follows that the trailing poles of write heads should be in accurate alignment, whereas this should apply to the centre line of the gaps of read heads. If the gap length is always constant, these two requirements will be simultaneously met, and the head block will be suitable for both duties.

A difficulty is encountered here in that the effective gap length is not necessarily equal to the physical gap length because of loss of permeability at the pole tips. To reduce this error to manageable proportions it is imperative that the necessary removal of material from the pole faces, etc. should be carried out with the utmost care so as not to cause cold-work.

Typical track configurations are:

Track width: 0.030 in. \pm 0.001

Track pitch: 0.040 in.

Track positional tolerance: \pm 0.001 in. from block datum

Gap length: 0.0003 in. (in contact)

0.002 in. \pm 0.0002 in. (non-contact)

Gap scatter zone:

0.00015 in. (in contact) } Normal to datum face
0.0005 in. (non-contact) }

4. Tape Handlers

For some purposes it may be possible to arrange the operation of a computer to scan continually a complete reel of tape, accepting the consequent long access time. In such a case the means for moving, guiding and spooling the tape may follow conventional lines except that the machine should be reversible and the tape

speed should be as high as possible in order to minimize the access time.

When, however, for input and output or auxiliary storage duty, intermittent motion is required combined with high digit rate and large capacity, a new design problem arises. Fortunately, two-state operation and the presence on the tape of a clock track permit a larger tolerance for the working speed of the tape than would be permissible for analogue signals.

4.1. Intermittent Drive

The most direct method of providing sudden acceleration of tape is to adapt and extend the standard capstan and pinch roller technique, and this is a very popular procedure, especially in the United States. For operation in either direction, two continuously rotating capstans are required, one pinch roller or the other being engaged as required⁹.

To achieve fast operation, the total movement of the pinch roller is reduced to the practical minimum, and low density materials are used to minimize the translational inertia. In addition, the pinch rollers are kept rotating as well as the capstans so that only the tape is subjected to the high accelerations. By such means start times from command to 95 per cent. speed of 1.5 millisecc may be reliably achieved, made up by some 1 millisecc to overcome the inertia of the moving parts and less than 0.5 millisecc to accelerate the tape. Deceleration forces are provided by friction from the guiding system, often without reinforcement from a

separate static brake. For successful operation in service, cleanliness is essential if hard foreign matter is not to be embedded in the drive system, and tapes with tough binders for the oxide medium are advantageous.

Another approach starts from the premise that it is better, if possible, to relieve the active surfaces of the tape of any skidding contact, thus reducing any risk of damaging the record. The vacuum capstan is a very eligible candidate in this respect in that contact with solid matter takes place only with the backing, normal pressure being provided by air. In a typical embodiment the rotating part consists of a fairly thin perforated cylindrical shell inside which fits with minimum clearance a system of ports. The suction port subtends a smaller angle than the angle of wrap of the tape, thus minimizing air loss. Ports open to the atmosphere relieve the normal pressure as the tape is peeled off.

Two modes of operation are possible:

- (a) Constant vacuum and reversible drive. Here all intermittent contact takes place away from the tape but at the expense of increased inertia to be overcome at each operation.
- (b) Switched vacuum, contra-rotating capstans. An example of this type was developed for the Cambridge EDSAC by Wilkes and Willis¹⁰.

Figure 8 shows the construction of an improved fast-acting capstan system, for 1 in. tape¹¹. In it the volume of air between the

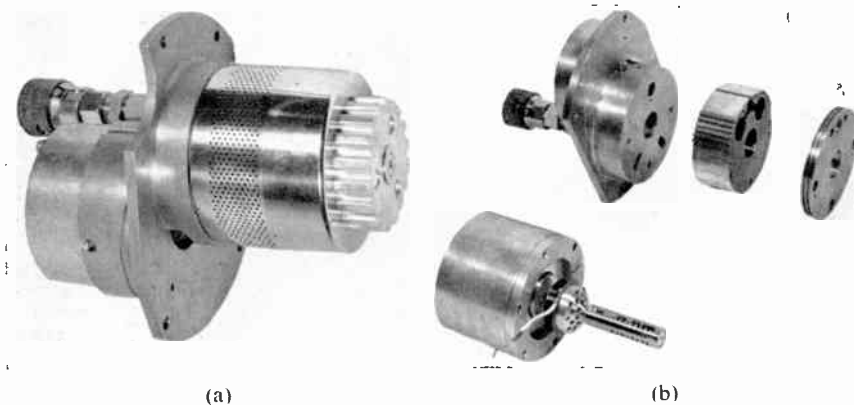

Fig. 8. Construction of high speed vacuum capstan unit. (a) complete (b) exploded view without rotating parts.

switching valve and the tape has been minimized by siting the valve inside the capstan, thus making the propagation time of a pressure step as low as possible. Reservoir chambers immediately precede the valve on the supply side to provide a low pneumatic impedance.

The shuttle valve provides eight parallel ports in order to reduce the travel to 1/16 in. and is made of light alloy to minimize its inertia. Actuation is by a moving coil suspended in the field of a permanent magnet of loudspeaker pattern, receiving a high instantaneous current pulse from a capacitor, falling to a comparatively low maintaining current.

Because the force available from a moving-coil system is not limited by saturation effects, the high instantaneous current (which would cause serious overheating if maintained) results in rapid acceleration of the valve.

A simplified circuit is shown in Fig. 9.

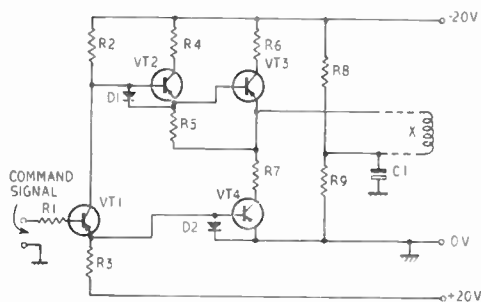

Fig. 9. Simplified drive circuit for vacuum valve.

The circuit is direct coupled, power transistors VT3 and VT4 acting as a single pole changeover switch, connecting the moving coil X either to -20V or 0V according as the input to R1 is switched from a positive to a negative voltage. At each instant of switching, capacitor C1 undergoes a potential change of nearly 20 volts, its charge (discharge) current being limited by R6 (R7). Equal resistors R8, R9, some twenty times larger in value than R6, R7, provide a low constant current to hold the vacuum valve against its stop.

From the commencement of the command pulse to the first movement of the shuttle valve stroke, takes under 2 millisecc, and to commencement of tape motion, 2 millisecc. The tape

reaches 97 per cent. of its full speed of 200 in./sec by the time the valve stroke is complete, giving a total start time of under 4 millisecc and an acceleration distance of approximately 0.1 in.

Force for deceleration is provided mainly by the friction set up over the guide bridge, the tape being held stable by light suction. Once again, the time from the commencement of the command pulse to valve movement in the return direction is under 2 millisecc, and to commencement of braking is 2 millisecc. Deceleration is complete by the completion of valve stroke giving a stop time of under 4 millisecc. The stop distance is much greater than the start distance because the tape is travelling at 200 in./sec during the "lost time" before braking commences and is approximately 0.7 in. This lost time can be offset to some extent, provided it is consistent, by arranging for the command pulse to anticipate by a certain amount, and if this is done, the stopping distance may be reduced to 0.3 in. The time for a complete reversal of motion is rather less than the sum of the start and stop times and is under 6 millisecc. It is practical with this drive system to oscillate tape under the head at an amplitude of about 2 in. at 50 c/s.

The high speeds and acceleration induced in the tape demand that extraordinary care be exercised in the design of the guidance system to prevent the formation of ripples or jumps between the capstans, and also to reduce lateral wander and tape skew to tolerable amounts. In this respect, of course, the straightness in the slitting of the tape is of prime importance and, as previously mentioned, particular care is taken over this in the manufacture of instrumentation grades of tape. Lateral wander is not more than ± 0.002 in., and skew, not more than ± 0.0005 in. in $\frac{1}{2}$ in., these being primarily determined by the width tolerance of the tape.

High speed pneumatic systems are high precision instruments and demand the utmost cleanliness of air supply because of the fine clearances involved. However, since the pressure is always below atmospheric, no difficulties are encountered with moisture condensation, and therefore no desiccation is necessary. This is fortunate, since the presence of some moisture helps in preventing the building up of troublesome electro-static charges.

5. Spooling Systems and Buffer Reservoirs

Clearly the accelerations of tape to 500 g under the heads cannot be matched by any spooling system, but spools must nevertheless be provided if it is to be possible to increase the store capacity by changing tapes. It is therefore necessary to provide some form of reservoir between the high-speed tape transport and each spool which must add negligible extra inertia to the moving tape. Control of the motion of the spools will be from the state of the reservoir to ensure that the average speeds of translation throughout the system are the same.

An elegant and widely used realization of this requirement is the vacuum box, in which a long single loop of tape is held by light suction (thus incidentally setting the working tape tension¹⁰); the length of the loop is sensed pneumatically, photoelectrically or, in one example, by means of the distortion of a flexible backing plate to the box.

The acceleration time of the driven tape is so small compared with that of the spools that instantaneous starting may be assumed when assessing the capacity of reservoir required. Let us start with a reservoir of capacity S ft. half filled with tape, and the spool stationary (the direction of motion thus becomes immaterial because the amount of buffer is equal each way). If, immediately the reservoir started to fill at V ft./sec, the change of content was detected and initiated full torque on the spool, the spool must have reached a withdrawing speed of V ft./sec after T sec, but before the reservoir became full.

Now, filling speed = $V - V \cdot \frac{t}{T}$

Increase of content =

$$\int_0^T \left(V - V \frac{t}{T} \right) dt = V \left[t - \frac{t^2}{2T} \right]_0^T = \frac{VT}{2}$$

Thus $\frac{S}{2} > \frac{VT}{2}$

or $T < \frac{S}{V}$

For a spool of a given size, the rotational energy will be proportional to the square of angular velocity, which in turn will be proportional to V . This has to be provided in less

than S/V seconds, giving

$$\text{Power } P \propto V^3 \cdot S^{-1}$$

It will be seen that any increase in tape speed to reduce access time carries with it a heavy penalty in spooling power which can be compensated with much less effect by increasing the buffer. There is an upper limit to the power that a given size of spool can accommodate, this being set by the onset of slip between the centre and outside turns. As tape speeds go up, reservoir capacity must go up too.

The length of a simple vacuum box is limited to about 3 ft. in any convenient design, and to increase its capacity involves some folding or dividing. If sensing the total content is not to become over-complicated, the tape should be shared out approximately equally between the sections and this may be achieved by using tapered boxes. Thus in Fig. 10 are shown two embodiments of this principle; any lack of equality of loop lengths sets up a preponderance of pneumatic thrust on the shorter loop, causing it to lengthen, and at the same time to reduce the projected unsupported area. This tends to equalize the loop length.

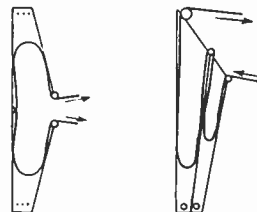

Fig. 10. Diagrams illustrating the use of tapered vacuum boxes to permit the use of more than one loop in reservoir.

A different approach is to replace the vacuum box by a bin into which tape is thrown loosely under its own momentum as shown in Fig. 11. With tape widths of 1 in. and bins only just wider, the tape forms itself into folds and can easily be extracted without tangling. Perforations in one wall serve to prevent the trapping of air between folds of tape. Although the radii of the loops so formed are small enough for some semi-permanent waviness to occur after long static periods, it produces no detectable degradation of signals and is "ironed out" after

a pass or two over the capstan system. Because of the much tighter packing, a bin of approximately 30 in.² can accommodate a length of several hundred feet of tape without jamming, although normally the contents would average about 30 feet.

It is appropriate to discuss here the effect on the tape of sliding speeds of 200 in./sec when held against metal under light normal pressure. Tests have shown that, with highly polished capstans and polyester based tape, the wear rate is minute. In practice, any wear will be spread

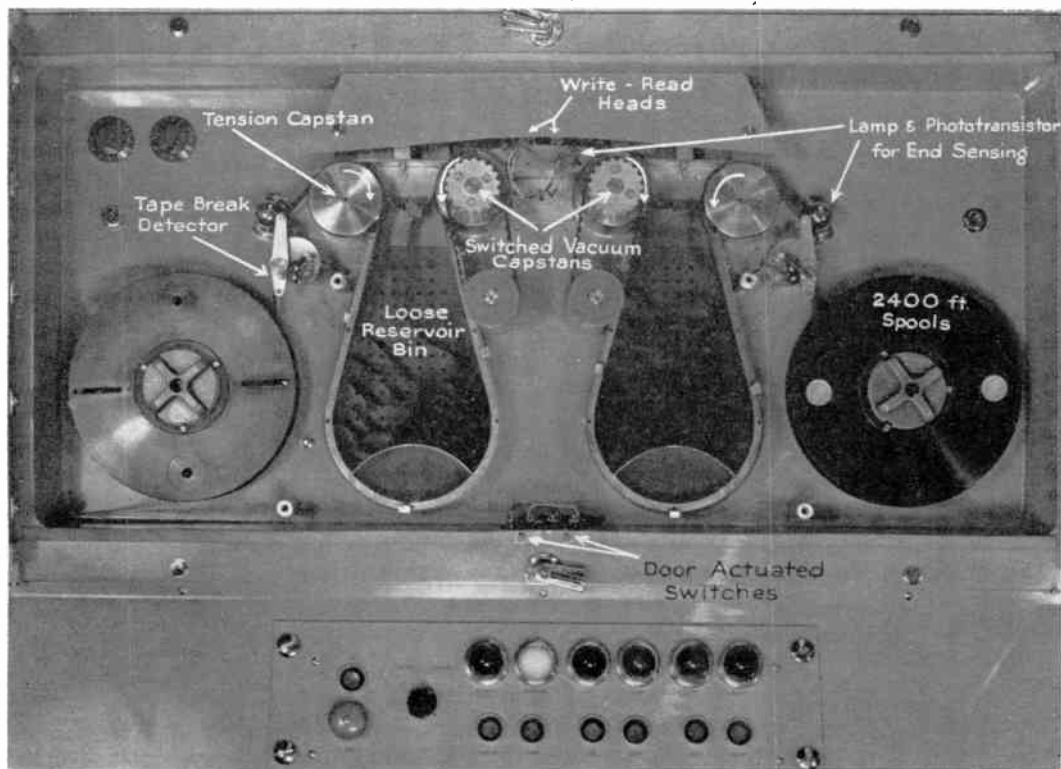

Fig. 11. High performance 200 inch/second intermittent motion 1-in. tape handler with doors open and cover removed.

Whereas, with a vacuum reservoir, tension is present to peel tape off an unwinding spool, it is necessary with a loose bin to use some auxiliary device to do this. A further vacuum capstan¹², continuously rotating and under continuous, but light, suction, readily performs this function and also helps to throw tape into the bin in a standard direction. Of course, it serves no purpose when the tape is being extracted onto the spool, but the torque exerted against rotation is small compared with the torque to produce the required acceleration, and therefore does not increase the size of the spooling motor.

over the length of the tape, so, although constant sliding under frictional forces sufficient to produce efficient braking may superficially appear a dubious proceeding, in fact, the life of a tape will be ample for its normal use.

5.1. Control of Spooling Motors

If the average speed of tape on to a spool is to equal its average speed past the heads, the contents of the reservoir must stay nominally constant, say length l , with a permissible "ripple" of amplitude not greater than l . To ensure this, it is necessary to control the rotation of the spools in accordance with the

departure of bin content from nominal, and some sensing of the content is necessitated.

The randomness of the tape folds in a bin makes simple position systems for the content sensing (e.g. interrupting a beam of light) inappropriate, and a number of methods have been proposed including weighing and obscuration of obliquely directed light.

A method which has proved satisfactory in practice is to make use of the dielectric constant of the tape to change the capacitance between the front and back plates of the bin¹³. In Fig. 10 it will be seen that the front plate has been made from electrically conductive glass to permit observation. Although the absolute change of capacitance is small, a bridge circuit will operate reliably for long periods without re-adjustment. A block diagram of a suitable arrangement is shown in Fig. 12. Excitation of

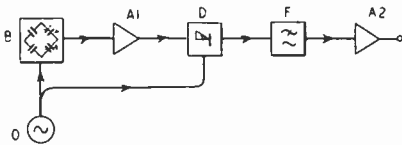

Fig. 12. Block diagram of circuit for sensing reservoir content capacitively.

some tens of kc/s is supplied to a capacitance bridge, B, in which the reference arms may be capacitive as well as the measurement arms, the unbalance voltage being amplified in a narrow band a.c. amplifier, A1, to bring it to a suitable power level. Detection is performed in a synchronous demodulator of one of the conventional diode types, followed by a low-pass filter F. As is well known, the combination of synchronous detection and low-pass filter is equivalent to a band-pass filter of twice the bandwidth of F before detection, and the system is therefore insensitive to stray pick-up voltages, noise spikes, etc. Amplifier A2 amplifies and limits the output of F to give a standard output for working the control circuits.

With such a circuit, a useful output is obtained for a change in content of 1 ft., and it is therefore possible to keep the average content within the wide tolerance permissible by the use of simple forward-brake-reverse switching of spooling motors of $\frac{1}{4}$ h.p. rating. The motors

connect to the spools via gearing to provide a measure of inertia match whilst still providing over 200 in./sec linear speed with the spool almost empty.

5.2. Tape End Sensing

The approach of the end of the tape on a spool is readily detected photo-electrically by locally removing the oxide layer, leaving the clear base material. When vacuum capstans are used, the use of perforations for photo-electric sensing is not advisable, and besides, there is a risk of permanent creases forming at the holes when the tape is thrown into small folds in a loose bin type of reservoir.

However, there is a wide difference between the effective dielectric constants of oxide-coated tape and the base only which could be enough to upset the bin content sensing. The minimum area consistent with reliable operation is therefore cleared, i.e. 6 in. long \times $\frac{1}{4}$ in. wide.

6. Controls and Interlocks

It will be gathered from the description of the principles of operation that there are many inter-dependent functions in the operation of a complete digital tape system, and it is essential that the failure of any one must never be permitted to damage the tape or record in any way. Consequently, the control circuits, which may be for local or remote operation, incorporate a large number of interlocks with detectors of departure from normal operating conditions (i.e. doors open, tape break, low vacuum, etc.). Because the interplay of the operating conditions follows the laws of switching networks, it is a simple step to design these using computer logical techniques. In the example described all the control circuits use semiconductor "logic" mounted on standard plug-in printed wiring boards, and operate from $\pm 3V$ and $\pm 20V$ supplies and 3V command signals. Relay switching is completely replaced, contacts occurring only at the fault detectors, or on auxiliary functions.

7. Reliability

As with the weakest link in a chain, a complete tape system is only as reliable as its component parts. For use with business computers it is essential that operation be trouble-free and

that maintenance routines should be simple enough for inexpert hands.

Capstan shuttle valves have been life-tested through 12×10^6 complete cycles without significant deterioration, and the complete machine has been run with the tape oscillating under the heads at 50 c/s for 28 hour periods without fault. On a more realistic information input routine, the tape has been started, stopped, etc. from one reel to the other and back for periods of 32 hours non-stop without fault.

8. Acknowledgments

Permission and encouragement to prepare this paper have been given by the Directors of E.M.I. Electronics Limited, and thanks are due to Mr. C. Dain and many others of the staff for assistance given. Acknowledgment is also due to Mr. H. Harrison and his staff who, through their persistence, have succeeded in mutually reconciling theory and practice.

9. References

1. M. V. Wilkes, "Automatic Digital Computers" pp. 168-176 (Methuen, London, 1956).
2. C. D. Mee, "Magnetic tape for data recording," *Proc. Instn Elect. Engrs*, **105**, B, pp. 373-382, July 1958.
3. British Patent No. 707,634.
4. R. L. Wallace Jnr., "The Reproduction of Magnetically recorded signals," *Bell System Tech. J.*, **30**, pp. 1145-1173, October 1951.
5. R. W. Hamming, "Error-detecting and error-correcting codes," *Bell Syst. Tech. J.*, **29**, pp. 147-160, April 1950.
6. O. Kornei, "Recording head has megacycle range," *Electronics*, **29**, November 1956, pp. 172-174.
7. W. Westmijze, "Studies in magnetic recording," *Philips Research Reports*, **7** and **8**, April to October 1953.
8. E. O. Daniel, P. E. Axon and W. T. Frost, "A survey of factors limiting the performance of magnetic recording systems," *Proc. Instn Elect. Engrs*, **104**, pp. 158-168, March 1957.
9. A. A. Robinson, F. McAulay, A. H. Banks and D. Hogg, "A magnetic-tape digital-recording equipment," *Proc. Instn Elect. Engrs*, **103**, Suppl. No. 2, pp. 346-353, 1956.
10. M. V. Wilkes and D. W. Willis, "A magnetic-tape auxiliary storage system for the EDSAC," *Proc. Instn Elect. Engrs*, **103**, B, Suppl. No. 2, pp. 337-345.
11. British Patent Application No. 13021/58.
12. British Patent Application No. 38030/58.
13. British Patent Application No. 29842/58.

A complementary paper on this equipment by H. M. Harrison, entitled "The Development of a High-Performance Tape Handler" was presented in the Symposium on Magnetic Recording Techniques in London on 15th December 1959.

A Magnetic Disk, Random Access Memory †

by

A. C. GLOVER‡

A paper read on 7th April 1959 at a Symposium on "Large Capacity Storage Systems" arranged by the Institution's Computer Group.

In the Chair: Dr. A. D. Booth (Member).

Summary: A large capacity, random access storage device is described which uses 50 rotating magnetic disks. Total storage capacity is 5×10^5 alphanumeric characters with access time between 0.15 and 0.8 sec.

1. Introduction

A large capacity, random access storage is described in this paper. The device uses magnetic disks as a storage medium and has a mechanical servo controlled access system. The device is at present in quantity production.

A typical application of this store is in a relatively cheap "in line" commercial data processing system. An "in-line" system is designed to process commercial transactions immediately they occur rather than, as in "batch" data processing systems, on a weekly or monthly basis. One of the main advantages of "in line" processing is that up-to-date data is always available for management decision. One of the major necessities for an "in line" system is a large capacity random access memory device.

The disk storage file to be described has a capacity of 5,000,000 alphanumeric characters, organized into 50,000, 100 character records. The access time to any 100 character record is 0.8 sec maximum, 0.15 sec minimum and 0.5 sec average. The data processing system to which it is attached has a serial printer capable of about 1,800 lines per hour (2 sec per line) and normally the access time to the file is not the limiting factor in operating speed. The system is capable of more than 10,000 line items per day, i.e. activity in up to 20 per cent. of the file each day. Recently it has been found that the radial accuracy of the access control system is sufficient to permit doubling of the

tracks to 200. This doubles the file capacity up to 10,000,000 characters (8×10^7 bits).

2. General Construction

The file is constructed of 50 rotating disks, both sides of each disk being used for storage. Each side has 100 concentric tracks with 500 8-bit alphanumeric characters in each track, organized into 5 100-character records. Access is by two magnetic heads which can be positioned vertically to straddle any disk and radially to any track position. One of the heads is associated with the undersides and the other head with the uppersides of the disks.

The disks are made of aluminium with an iron oxide coating and revolve at 1,200 rev./min. The overall diameter of the disks is 24 in., they are 0.1 in. thick and spaced 0.3 in. apart. The disk surfaces have to be flat to a specification of no more than 0.0015 in. out-of-flatness in any 2 in. distance on the disk face. Up to 0.030 in. axial run-out can be tolerated. The whole disk assembly runs on taper roller bearings mounted on a heavy, stationary, vertical shaft.

3. Recording System

The recording is of the non-return-to-zero type with a bit density of 100 bits to the inch on the inside track and 55 bits to the inch on the outside track. Each magnetic head consists of two distinct magnetic circuits. One circuit and its gap is used for erase, the other for read and write. The erase gap is made wider than the read/write gap to reduce tolerances on the radial positioning of the head, particularly when multiple access arms are being used. The read/write amplifier circuitry is quite conventional,

† Manuscript received 2nd June 1959. (Paper No. 533.)

‡ I.B.M. British Laboratories, Hursley, near Winchester, Hants.

U.D.C. No. 621.395.625.3:681.142

except for automatic gain control in the read amplifiers which is necessary to compensate for the varying bit density and for speed variations. The head to disk spacing is maintained by an air bearing obtained from minute jets in an annular manifold surrounding the magnetic elements (Fig. 1, inset). The 0.001 in. spacing is held despite axial runout of up to 0.030 in.

vertical and radial positions accurately. Since vertical and radial motions must be mutually exclusive, a mechanical interlock is provided so that the carriage can only move when the arm is fully retracted, and the arm can only move when the carriage is aligned with one of the disks. The driving force for the access mechanism is by two magnetic powered, motor

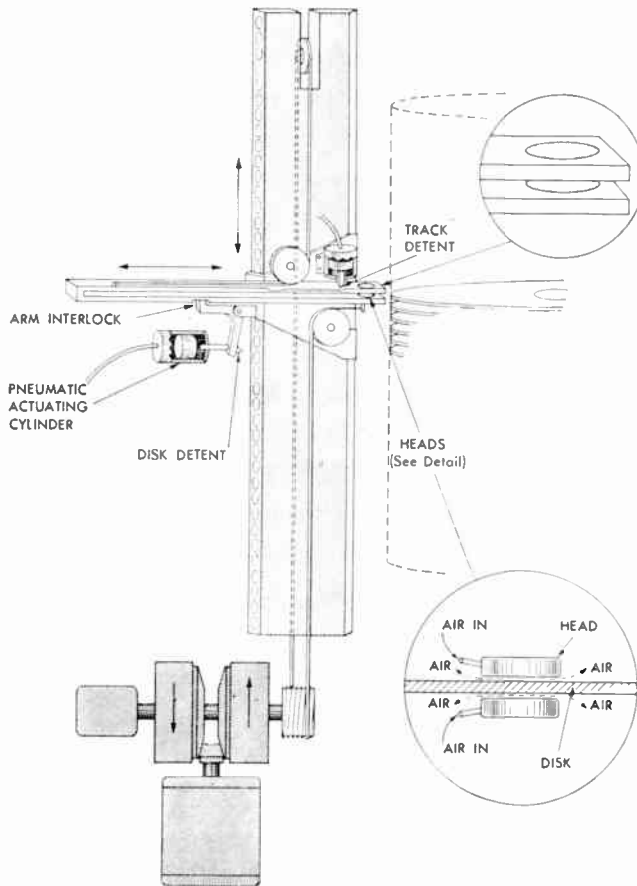

Fig. 1. Functional diagram of Access Mechanism showing general scheme of vertical and horizontal positioning, interlock and actuator group.

4. Access Mechanism (Fig. 1)

The magnetic heads are mounted in gimbal sockets so as to face one another on the end of the access arm. The access arm can move radially into the disk file. It is mounted on bearings in a carriage which can move vertically. Pneumatic detents are provided to locate the

driven, counter-rotating clutches. These clutches are connected to a common output capstan. A small wire cable is connected via pulleys from this capstan to the access arm. Each clutch can control vertical or radial motion of the access arm depending on the position of the interlock mentioned above.

A closed loop servo system controls the clutches (Fig. 2). The error signal is derived from potentiometers coupled to the carriage and arm. A tachogenerator coupled to the capstan

tors which are controlled so that while one is on the other is off. During writing one oscillator runs continuously to provide the timing. During reading operations each bit as it is read switches off the running oscillator and switches on the other. The outputs of the two oscillators are mixed to provide timing pulses for the read operation. Thus, the timing is re-synchronized as each bit is read from the track. In the coding system used on the file described here one oscillator never runs for more than 7 bit periods at a time. With this system of clocking, a tolerance of up to one per cent. is permissible between disk speed and oscillator frequency. This tolerance is easily met due to the large inertia of the disk assembly, the motor characteristics and the oscillator stability.

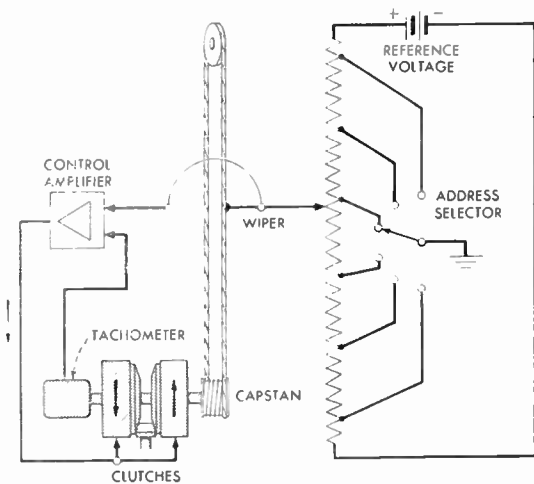

Fig. 2. Functional schematic for either horizontal or vertical positioning by Access Mechanism.

shaft provides velocity feedback to stabilize the system. Final positioning is accurately obtained by mechanical detents operated by null detectors coupled to the servo error amplifiers.

5. Self-clocking System

To reduce the accuracy required in the axial positioning of the head along the track a self-clocking system is used instead of a timing track. The system is consisted of two oscilla-

6. Multiple Access Arms

It is theoretically possible to mount up to 20 access mechanisms on one disk file, although up to the present no more than four have been used. Multiple access arms allow the reduction of effective access time, since whilst one arm is reading or writing another arm can be seeking the next location. Another application of multiple access arms is to allow more than one computer to process data from a common central file.

7. Reference

1. T. Noyes and W. E. Dickinson, "The random access memory accounting machine: 2. The magnetic-disk, random access memory," *I.B.M. Journal of Research and Development*, 1, No. 1, pp. 72-5, January 1957.

Magnetic Film File for Computer Storage †

by

A. ST. JOHNSTON, B.Sc.‡

A paper read on 7th April 1959 at a Symposium on "Large Capacity Storage Systems" arranged by the Institution's Computer Group.

In the Chair: Dr. A. D. Booth (Member).

Summary: A 35-mm oxide-coated film store is described in which the pick-up head is out of contact with the oxide. The high quality backing medium provided by the film has resulted in complete freedom from drop outs. Interchangeability between all mechanisms has been achieved with available production heads, by using special auto-strobing circuits.

1. Introduction

Before the stored programme digital computer could be applied to fully integrated data processing for business usage a file medium of suitable flexibility and speed was necessary. Development was started in 1953 to provide such a file medium. Current technique in the U.S.A. used multichannel magnetic tape, but considerable trouble, however, was experienced due to drop outs. The precise causes of these were not known then, but the faults in the backing medium were an obvious and considerable factor. Investigation of media available in this country showed that 35-mm oxide coated film already widely used for high quality professional sound recording in the motion picture industry would provide the greatest working width. As this was essentially standard optical quality film it would give also the highest quality backing medium.

2. Design Considerations

Experiments were carried out to determine the perfection of the oxide coating by running a number of random lengths of unselected film in contact with a recording reading head using two tracks and checking every cycle of the recorded waveforms against each other. Only one apparent "drop out" was detected and this continued to be present on repeated re-readings.

Examination however, of the oxide surface showed no imperfection even under the microscope, and on re-writing the "drop out" vanished. It was thus presumed that the "drop out" was caused by a particle of dust momentarily displacing the head on recording. It was decided, therefore, to run the pick-up head out of contact with the oxide; this had a second benefit in that the film, being considerably thicker and stiffer than plastic tape, had previously required a rather high contact pressure and this caused the head to wear very rapidly. By running out of contact, wear of the head would be eliminated. It was hoped at first to use a drum of several inches diameter and run the film around this, thus changing its direction by 180 deg. This would enable the clock and other timing heads to be spaced at a considerable distance from the signal head, and thus have a permanently recorded track as in normal drum practice. However, measurements of total change over a length of about six inches showed that the effects of moisture in the atmosphere could alter the length of film between heads by several times the intended packing density. The packing density intended was 166 to the inch, as this had been used satisfactorily for the 401 computer drum store, and the basic geometry was the same. In-line head gaps were therefore decided on. The initial experiments were carried out using a modified optical film recording mechanism which was available and a speed of 15 in. per second was used, this being a standard sound recording speed. Standard tape deck type heads were also used. this

† Manuscript received 10th April 1959. (Paper No. 534.)

‡ Elliott Bros. (London) Ltd., Research Laboratory, Borehamwood, Hertfordshire.

U.D.C. No. 621.395.625.6:681.142

implying $\frac{1}{8}$ in. tracks and no attempt was made initially to squeeze track packing density.

It was always intended to use the film store with a computer as a true store, i.e. to be able to change a unit of information in a file without re-writing the entire file. Fixed block lengths were therefore chosen. To divide up the blocks with a maximum packing density, i.e. the minimum gap between blocks, a permanent block marker is necessary. It was thought undesirable to use optical block markers, as in some tape usage, and it was hoped that as there was oxide on the part of the film passing over the sprockets, a head could read off single pulses from a track that ran over the sprocket holes: in practice, it was found that on bending the film round a small drum from which the head clearance is fixed, the "links-in-a-chain" effect caused the sprocket edges to touch the head and cause wear. A genuine track had therefore to be set aside for block marking and these pulses are amplitude detected.

It was considered that for the signals phase modulation was more reliable, particularly where considerable amplitude modulation might be caused by variations in head clearance and film thickness. A timing or clock track is required for decoding this type of modulation. 35-mm oxide-coated film stock (Kodak/Pathé) has almost 1 in. of working width thus allowing eight tracks at $\frac{1}{8}$ in. spacing, these could, for example, be used as one block, one clock and six information tracks. A study was carried out of the amount of hardware equipment necessary to couple this device to the working store of the 405, but the large amount necessary for various numbers of signal tracks resulted in a decision to use only three signal tracks at a time. This has the second great advantage that wasted rewind time can be largely eliminated by what is sometimes called circular usage of the file, i.e. bidirectional recording. Thus the film may be used in either direction, a set of signal tracks being assigned to each. In a file system the film is in position for re-usage after a processing cycle without a specific rewind operation. In a computing system this means either a saving in time or in the total number of mechanisms for a given job. Track packing was increased to nine to accommodate a separate clock track for each direction, the

block marker channel being common and having rather increased clearance between adjacent tracks. Figure 1 gives the dimensions finally chosen.

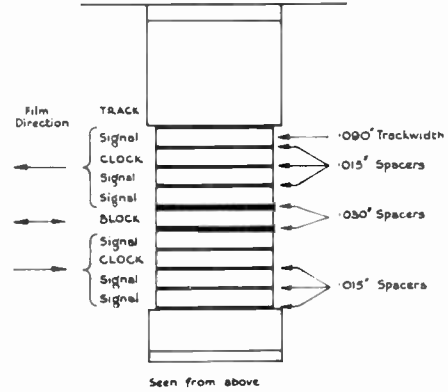

Fig. 1. Diagram of film read/write head.

The design of the 405 system¹ was advancing in sympathy at this time and a transfer unit of 64 words each of 32 digits was required. Using 3 signal channels in parallel gives a very convenient film word of 33 digits allowing a parity digit for every word (see Fig. 2). Transfers are made autonomously into the working store, one transfer system (Controller) being capable of operating any one of up to four mechanisms. Up to four Controllers were potentially possible, though no more than two have ever been supplied.

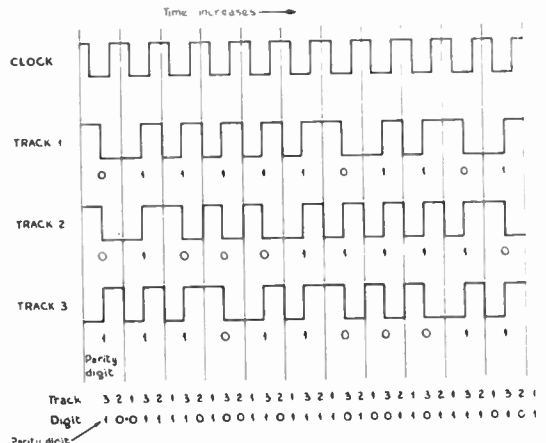

Fig. 2. Three-track recording.

3. Mechanical Design

The mechanism design was also progressing in parallel and called for the following basic features:

1. Be bidirectional.
2. Have the head operating out of contact with the film.
3. Be mechanically simple.
4. Have a film speed of 30 inches per second.

Fast start/stop was considered to be secondary to reliability which it was hoped could be obtained by simplicity. A solenoid-operated friction clutch system was adopted

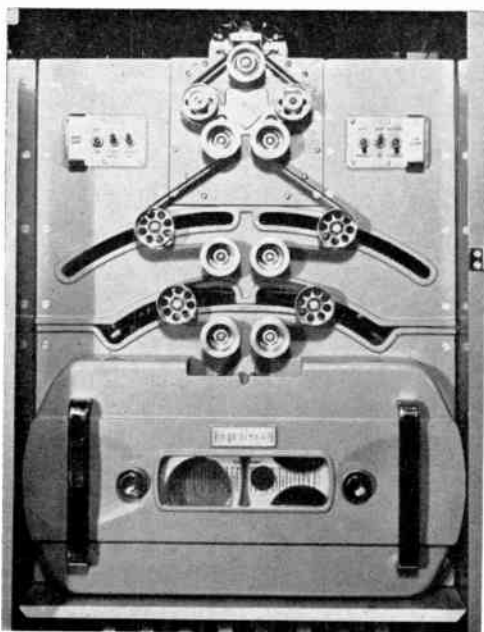

Fig. 3. Magnetic film unit.

with mechanical linkages so that one solenoid controlled forward, another reverse, and a spring controlled the brake. This is a fail-safe arrangement. A patented form of cone clutch was used for all three operations, the three members being a brake and two continuously contra-rotating drives driven by a synchronous motor with a flywheel. Useful reversal times of the order of 60 millisecc were intended and achieved. Figure 3 shows a photograph of the complete transport mechanism. The assembly

described above is separately removable and can therefore be changed for a spare mechanism, one spare only being necessary for any number of mechanisms. The servo arms are optically sensed with a conventional form of split-field servo motor drive to the reels through reduction gearing.

4. Operation

The 10-in. diameter reels store 1,000 ft. of film which represents roughly 10^7 bits or 280,000 words of 405 information. Blocks are approximately $5\frac{1}{4}$ in. long, the marks being written "permanently" by counting sprocket holes before the film is issued. This means that synchronism of information transfer between mechanisms can be achieved in a two-controller set-up as the mechanical clutches have no slip when fully engaged. Stopping is adjusted to take longer both in time and distance than starting, so that the film is always up to speed when passing a block marker. Block packing is such that only a safety gap to allow for relay track-switching times and any main frequency variations is provided; hence unless the computer is capable of absorbing information faster than the transfer rate a stop is necessary and this will occur in the middle of the subsequent block. If the next read order is not given soon enough, so that a stop is initiated, an automatic block backing-up cycle is started so that the film eventually comes to rest in the middle of the block just read. The computer orders used in conjunction with this store are as follows:

- 0 Test Busy
- 1 Run the film back n blocks
- 2 Examine parity check (checks errors in stored information)
- 3 Change direction of the film
- 4 Spare
- 5 Read the next block
- 6 Find block (the address a being given by the second half of the order word)
- 7 Write the next block

The bit rate while reading is 5 kc/s on three channels, i.e. 15 kc/s effective, but with gaps works out to 365 words per second when reading "continuously." This speed is adequate for the 405 computer, especially as the next block can be transferred while the machine is comput-

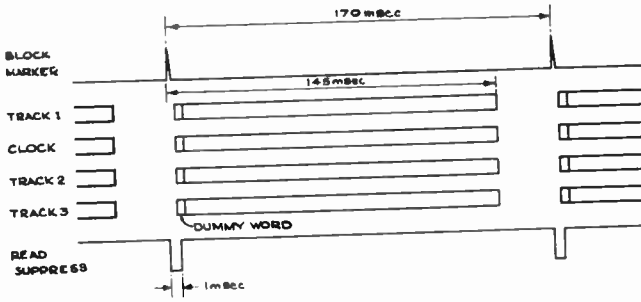

Fig. 4. Arrangement of tracks.

ing or "outputting." A block transfer takes 140 millisecond or about 200 millisecond from standstill. Processing time on a unit of information is usually considerably longer than this and thus the speed is only a limitation in low-activity file applications. A typical payroll operation takes about 1½ second per employee, for example, while a block may hold data on more than one employee.

5. Synchronizing Techniques

Phase modulation implies a continuous signal and this is violated when the film is stationary, thus a method was devised to ensure that steady state is reached before starting to decode. Also, as writing is the form of erasure used, it is essential that all transients, due to previous information, have settled down. A dummy word is used for this purpose, the timing being best understood from Fig. 4. This dummy word

serves a second and originally unsuspected requirement.

The packing density and frequency of recording are such (out of contact head) that by a simple RC network the reading waveforms are turned into the form shown. Note the timing of the clock transitions, which serve as the strobe to indicate the precise moment of reading. This moment is asynchronous to the computer timing and means have to be provided to re-establish synchronism. It is essential in this process to ensure that whichever computer digit pulse is chosen as the next following the strobe is chosen unambiguously, and that half-size pulses do not give rise to spurious transfers. Figure 5 gives the block diagram of the system and the high gain synchronized amplifier shown in this diagram performs this function. The first mechanism ran in a 405 under programme control in January 1956.

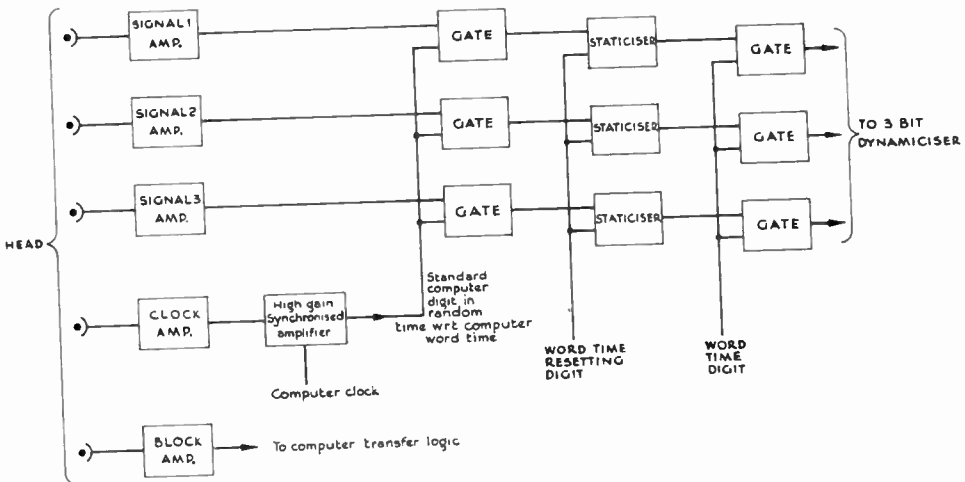

Fig. 5. Block diagram of film reading system.

6. Interchangeability

Running out of contact aggravates one multi-channel head characteristic: that of timing variations between channels. A square wave recorded simultaneously on all channels will play back with the transitions varying by as much as ± 40 microsec in a 200 microsec cycle.

results in some rejects, but for complete interchangeability a ridiculously high rejection rate would result, and unreasonable setting tolerances would be required. Hence an electronic solution was sought.

The system of auto-strobe used measures the timing error of each track at the beginning of

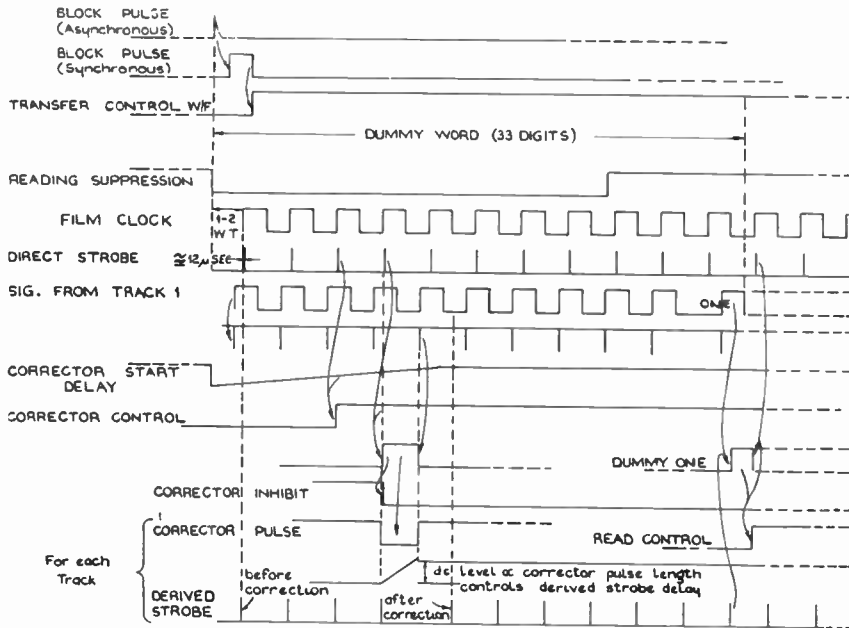

Fig. 6. Auto-strobe waveforms.

Even reading back on the same head with variations greater than ± 30 microsec has been found to cause reading errors with marginally improperly adjusted heads, and a tolerance of ± 20 microsec is therefore called for from the manufacturers. In an integrated data processing system it is essential to be able to read a film on any mechanism regardless of that which it is written on, and also on any other computer of the same type and an off-line printing equipment. The timing variations may be doubled in effect when writing on one mechanism and reading on another. To these have to be added any errors due to the lining-up of the gaps in the head unit and also any errors due to lack of rectangularity of the mounting of the head of the mechanism. Head selection for timing alone

each block, stores this information in analogue form and applies it, as a correction, over the remainder of the block. The dummy word of zeros mentioned above is used for this purpose. The waveform diagram of Fig. 6 illustrates the system. Note that the only fundamental change from the previous reading technique has been to alter the phase of the clock track so that variable time delays, determined by flip-flops individually set and controlled, can result in separately timed strobes accurate for each track.

7. Conclusions

Such a system is now in use on over twenty installations—some installations with as many as six mechanisms per computer—and has resulted in complete interchangeability of file

media and allowed a workable head selection procedure to be adopted. Figure 7 shows a controller with three mechanisms forming part of a typical computer.

Drop-outs are not experienced with this system, but the film is, however, rigorously tested for thickness before issue and block markers are written on satisfactory stock. After this, no check is necessary for oxide goodness and no case of drop-outs has been reported in hundreds of films except as a result of subsequent mishandling. In normal usage a film can be used thousands of times, and over 50,000 check reversals have been achieved with test portions of film. The payroll of the Borehamwood establishment has been carried out regularly every week for nearly three years using a film file and probably the greatest difficulty with the system has been in obtaining the auditors' approval.

8. Acknowledgments

The author has acted purely as writer of this paper—the electronic circuitry was developed by C. P. Gerrard and the mechanism by C. F. Phillips. Many more people have, of course, been instrumental in producing the complete system.

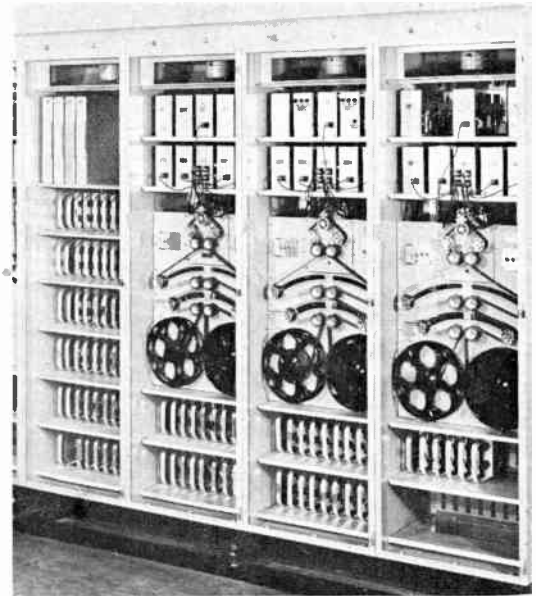

Fig. 7. Controller with three mechanisms.

9. Reference

1. A. St. Johnston and S. L. H. Clarke, "The development of a business computer system," *J. Brit.I.R.E.*, 17, p. 351, July 1957.

High-speed Digital Storage Using Cylindrical Magnetic Films †

by

G. R. HOFFMAN, B.Sc., PH.D.‡, J. A. TURNER, B.Sc.‡, and
T. KILBURN, M.A., PH.D., D.Sc.‡

*A paper read on 7th April 1959 at a Symposium on "Large Capacity Storage Systems"
arranged by the Institution's Computer Group.*

In the Chair : Dr. A. D. Booth (Member)

Summary : Digital stores consisting of closed magnetic circuits deposited on long glass tubes are described. These promise considerably increased operating speeds compared with present stores, together with the possibility of producing multi-element systems. A system designed to produce 30 tubes with 16 elements per tube in a single evaporation is now operating. Different selection modes which are more suitable for an array of this type have been tested, which permit greater tolerances than conventional selection systems.

1. Introduction

The development of thin evaporated magnetic film devices for use as storage elements in a digital computer has been under active investigation for some considerable time.^{1, 2, 3} The attraction is the promise of increased operating speed and the inherent suitability of the evaporation technique for the production of multi-element storage systems. Currently available literature has been concerned with magnetic films deposited on plane glass surfaces but the work now to be described is concerned with cylindrical structures deposited on long glass tubes. A new technique is introduced, whereby the hysteresis loops of such films may be obtained using pulsed switching fields. This method provides information concerning coercivity as a function of pulse duration. Two methods of operating a practical storage system are described. These systems permit a greater variation in coercivity from film to film to be tolerated, an advantage in view of the variability of present evaporated magnetic films.

2. Theoretical Considerations

Plane and cylindrical magnetic films are produced by vacuum evaporation of a nickel-iron

alloy, the vapour condensing onto a heated glass substrate. If the evaporation is carried out in the presence of a magnetic field, the resulting films exhibit considerable anisotropy and the coercive force is generally less. A so-called "easy direction" of magnetization is established in the film parallel to the applied magnetic field. Specimens fabricated in this manner have rectangular loops in the "easy direction" and a linear $B-H$ characteristic in the "hard direction," the latter being a direction perpendicular to the "easy direction" and in the plane of the film. Typical $B-H$ characteristics are shown superimposed in Fig. 1. A sinusoidal current was used to vary the applied magnetic field at 400 c/s and provided horizontal deflection for an oscilloscope; the output voltage due to flux changes from the film was integrated, amplified and displayed vertically.

If it is assumed that a magnetic film exhibiting uniaxial anisotropy has a single domain structure and satisfies the equation $E = K \sin^2 \theta$ where K is the anisotropy energy constant, θ is the angle between the magnetization vector M and the applied magnetic field, it may be shown that the coercive force of the rectangular loop and the saturation field of the linear characteristic are both equal to $2K/M$. The anisotropy field is defined as the saturation field of the linear characteristic and, in practice, the coercive force of the rectangular loop is generally less than the anisotropy field. Extra-

† Manuscript received 5th May 1959. (Paper No. 535.)

‡ The Electrical Engineering Laboratories, The University, Manchester, 13.

U.D.C. No. 621.395.625.3:681.142

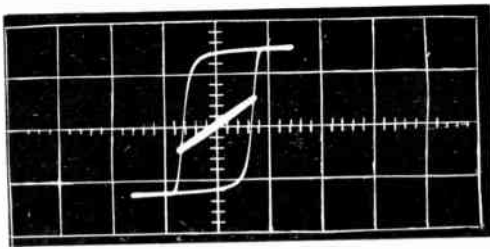

Fig. 1. Hysteresis loops in the "hard" and "easy" directions. Horizontal sensitivity 1 oersted/division.

polation of the linear characteristic to the saturation level in Fig. 1 demonstrates this feature. An increase in magnetic field drive in the "hard direction" causes the linear characteristic to open out into a sheared loop (Fig. 2). This indicates that the single domain character has been lost and that domain walls now exist in the specimen.

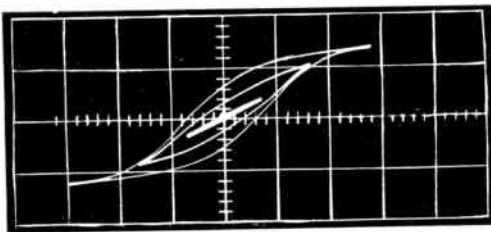

Fig. 2. Opening of the linear characteristic with increase in driving field. Horizontal sensitivity 1 oersted/division.

The cylindrical magnetic films are produced with the "easy direction" circumferential, i.e. the closed magnetic circuit is arranged to enhance the rectangularity of the $B-H$ loop. The "hard direction" is along the length of the cylinder parallel to its axis. The transverse loop in this "hard direction" can of course be observed in the conventional low frequency $B-H$ loop tester. To test the hysteresis loops of the cylindrical films in the "easy direction" a different method of attack was necessary, and proved a much more potent method for the determination of the magnetic properties of a specimen subjected to pulsed magnetic fields and will now be described.

3. Pulsed Field Hysteresis

Initially the cylindrical magnetic film is set into one of its saturation remanent states by a

large amplitude, long duration current pulse in a wire threading the cylinder. A "write" pulse of specified amplitude and duration is then pulsed along the wire in the opposite sense, and will, if large enough reverse the state of magnetization. For smaller amplitudes the "core" is left in some intermediate state. To determine this state, a large amplitude "read" current pulse is sent into a solenoid positioned coaxially with the cylindrical magnetic film. This current pulse produces a magnetic field in a direction parallel to the axis of the cylinder and is of sufficient amplitude to saturate the film in this transverse direction thus destroying the previous magnetic state. An e.m.f. is induced in the signal wire threading the cylinder when the magnetic state in the "easy direction" is reduced to zero. This e.m.f. when integrated is a direct measure of the previous remanent state of the core.

Various write pulse durations may be tested and the integrated e.m.f. plotted as a function of write pulse amplitude (Fig. 3). As the amplitude of a write pulse is increased from zero, the integrated output e.m.f. first remains at a fixed negative amplitude due to the set pulse, then when the write pulse reaches the knee of the hysteresis loop, the signal reduces in amplitude until it is zero at the "pulse coercive force." Further increase in amplitude changes the sign of the output signal and the amplitude increases up to the reverse saturation level.

It must be emphasized that the curves produced in this manner are curves of remanent magnetic states in the "easy direction," and as such are of more value than the usual low frequency or d.c. hysteresis loops. Figure 3 shows

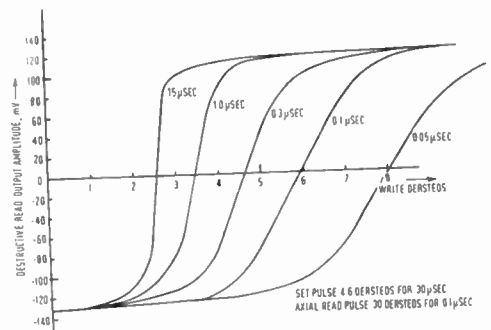

Fig. 3. Pulsed field hysteresis.

that the pulse coercive force increases as the pulse duration is reduced, and in addition the loop loses its rectangularity. Curves of this type allow an assessment of the performance of a store to be determined for various write amplitudes and durations.

4. Operation of Parallel Storage Systems Using Cylindrical Magnetic Films

It is impossible to use the conventional coincident current method of selection if the facility of having many elements along a single tube is to be retained. In the methods to be described, selection is achieved by a co-ordinate wire threading a tube, the other co-ordinate consisting of a multi-turn coil which is coaxial and external to each magnetic film.

4.1. Coincident Circumferential and Transverse Field Selection

A schematic diagram of the parallel store is shown in Fig. 4. In order to write a "word" into the store a current pulse is sent along a selected Y co-ordinate. This establishes a mag-

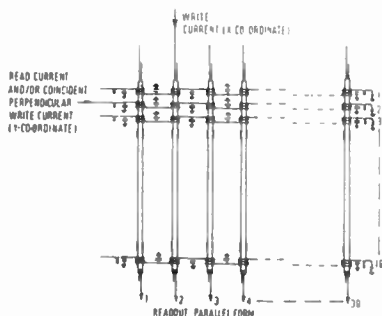

Fig. 4. Schematic diagram of a parallel store using tubular magnetic films.

netic field along the length of each element in that particular row. Simultaneously a slightly wider pulse of specified duration (say 0.1 micro-sec) is sent along all the X co-ordinates, the polarity of the X pulse determining whether a "1" or "0" is written in the circumferential or "easy direction" of the element. Previously written information on other elements threaded by the X co-ordinate wires is unaffected as the amplitude and duration of the X co-ordinate pulse is less than the pulse coercive force.

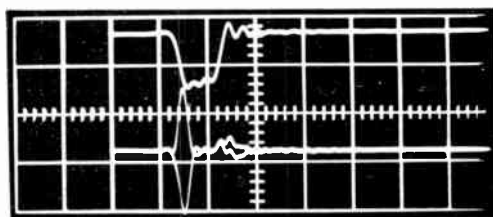

Fig. 5. Output pulses due to 0.1 microsec read pulse. Horizontal sensitivity 0.1 microsec/division.

The output signals appear as positive or negative pulses along the readout wires when the required Y co-ordinate is selected. Superimposed "1" and "0" output pulses are shown in Fig. 5, together with a 0.1 microsec read pulse. It will be seen that the output signal occurs in less than 40 millimicroseconds and is in fact limited by the front edge of the Y co-ordinate read pulse and the frequency response of the amplifier. Absence of an output on the back edge of the read pulse indicates that it was destructive. Smaller amplitude read pulses give rise to an inverted output pulse on the back edge and it can be arranged that the reading process is sensibly non-destructive.

An attractive and worthwhile feature of reading in this manner is that there is no magnetic coupling between the Y co-ordinate drive coil and the associated X co-ordinate output wires as they are mutually perpendicular. Split copper tubes between the magnetic films and the coaxial solenoids provide an earth return for the readout wires and act as electrostatic shields, thus reducing coupling of this type to a tolerable level.

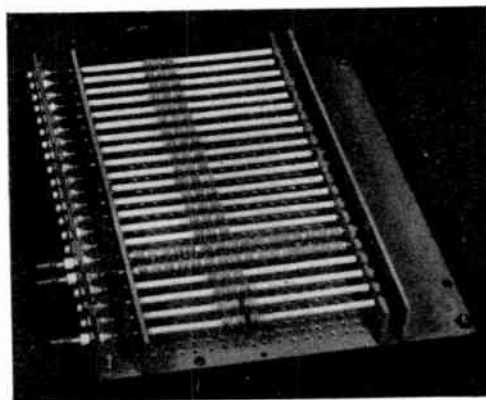

Fig. 6. Prototype array.

Part of a complete array was assembled for testing purposes and is shown in Fig. 6. The Y co-ordinate solenoids have appreciable capacitance to the copper electrostatic screens and form a transmission line of characteristic impedance 600 ohms with a delay of 3 millimicroseconds per element. There was negligible deterioration in pulse shape on arrival at the end of the terminated delay line even when all 21 magnetic films were switching.

For the purpose of experiment, the magnetic films were separated into separate cylinders; however, some work on plane films indicates that this may not be necessary⁴.

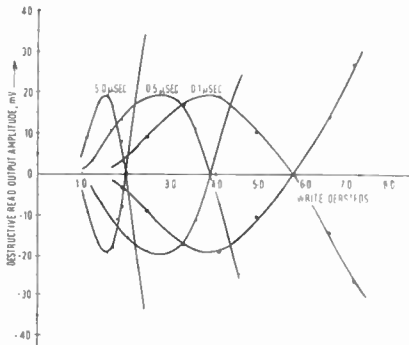

Fig. 7. Graph showing the performance of a non-coincident circumferential and transverse field selection system.

4.2. Non-Coincident Circumferential and Transverse Field Selection

It will be remembered that the tubular magnetic film possesses circumferential anisotropy, and since it has a closed magnetic circuit in this direction it is probable that thick films (10,000 Å) will exhibit a single domain structure when magnetized in this direction⁵. (Kerr magneto-optic apparatus is at present being constructed to investigate this property in more detail.) To change the direction of magnetization by applying a reverse field in the “easy direction,” this field must provide enough energy to nucleate domains of reverse magnetization, and further, it must be of sufficient amplitude and duration to enable the viscous domain walls to traverse domains of the previous magnetic state. A pulse of current in a wire threading the tube providing this field can, of course, be made of such amplitude and dura-

tion that the magnetic state of the element is virtually unaffected. If the magnetic film is first subjected to a magnetic field along its length which is sufficient to saturate it in this direction, reduction of this field to zero leaves the film in a multi-domain state. Probably there are equal numbers of domains magnetized in the “easy” anisotropic direction². Certainly there is no remanence in the “easy direction” as a further read current pulse produces no output signal. Calculation suggests that the order of 50 domain walls exist in the element in this condition. Subsequent application of a pulse with small amplitude and duration along a wire threading the tube is able to switch the film into a desired remanent state, since this pulse does not have to provide nucleation energy for the domain walls and the distance the viscous walls have to move because of their multiplicity is considerably reduced. In this way a small amplitude and short duration current pulse of the desired polarity is able to write a “1” or “0” into the store providing it is preceded by a destructive read current pulse.

The performance of such a system may be gauged by reference to Fig. 7. Here a destructive read pulse is followed by a positive then negative write current pulse, equal in amplitude and duration. The effect of the write pulses on the magnetic state of the element is observed by a following destructive read pulse. If we consider a 0.1 microsec pulse width and increase the amplitudes of the write pulses, the output on destructive read first increases to a maximum and then reduces to zero, changes sign, and increases to a negative saturation level. The positive output indicates that the pulse following the destructive read is able to write on the element and the following negative pulse is unable to reverse the magnetic state. As the amplitudes are increased, there comes a time when the negative pulse is of sufficient amplitude to reverse the direction of magnetization independent of any previous magnetic state; the read output signal is then negative. It will be seen that in the case of a 0.1 microsec write pulse the effective pulse coercive force for a preset element is 1.5 oersted, but is 5.75 oersteds for an unset element. A typical working range may be taken between the half output voltage points, the latter giving a range of write current pulse amplitudes

between 2.5 and 5 oersteds. Between these limits, two million interfering write pulses on unselected elements did not degrade the stored information. These considerable operating limits allow a much wider variation between elements to be tolerated than is permissible in conventional selection systems.

5. Grouped Transmission Line Technique

To exploit the highest operating speed of any storage scheme, it seems necessary to upgrade the geometry into transmission line circuitry; otherwise the inductance and capacitance effects will limit the rate of magnetic field build-up in the system.

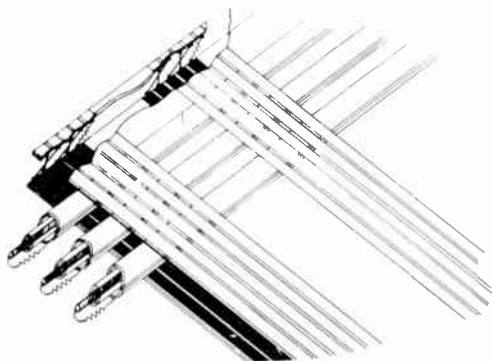

Fig. 8. Schematic diagram of a grouped transmission line system.

A simple transmission line consisting of two parallel strips of width a and spacing b may be replaced by a multiple transmission line of n elements of width a/n , cross coupled in such a way that the magnetic field is additive across the multiple group. A line of this form has been fabricated from wires where $b = 1.6$ mm, $a = 2$ mm and $n = 9$, giving a magnetic field of 32 oersteds/ampere. The line was terminated in 200 ohms and responded well to the 0.1 microsec current drive pulse used.

Figure 8 shows diagrammatically the practical application of this technique. The grouped transmission lines provide perpendicular magnetic fields, each group being separated to reduce coupling between them. During the initial transient of the current drive, the behaviour of the line is complex, but as the

total delay of the line is only a few millimicroseconds the "steady state" magnetic field will be sensibly constant during the pulse periods at present visualised. The storage tubes have a centre conductor and are surrounded by a split copper tube. The electric field produced across the transmission line is at right angles to the split in the copper tube, hence very little electrostatic pick-up will occur on the inner conductor. The split copper tube and inner conductor form a co-axial line of 40 ohms impedance, the read output appearing on this line and the write current being fed into it. Precision machining of the component parts of this system ensures that the direct pick-up between transmission lines and coaxial tubes is small.

6. Fabrication of Tubular Magnetic Films

The ease of fabrication of cylindrical magnetic films has been a prime consideration as it was deemed essential to produce a large number of elements during a single evaporation. In

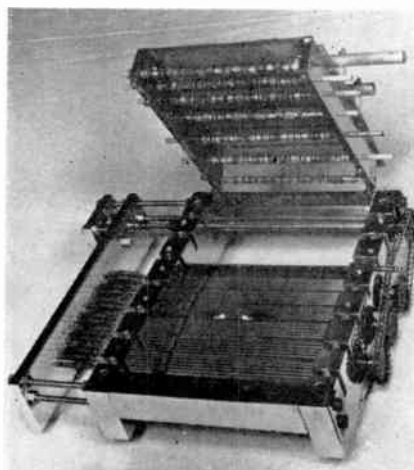

Fig. 9. Tubular substrate holder showing heating element and driving mechanism.

the apparatus constructed (Figs. 9 and 10), 30 tubes which can be divided into at least 16 elements (i.e. 480 bits) can be manufactured simultaneously, the complete apparatus being mounted inside a conventional vacuum system. A heater which encloses the mechanism maintains the substrate temperature at 325°C during

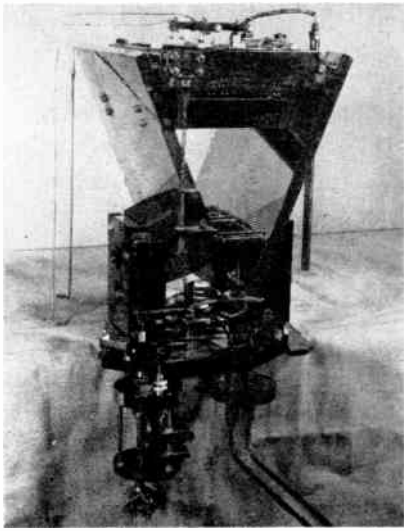

Fig. 10. Complete assembly of apparatus used to produce tubular magnetic films.

evaporation, the required circumferential anisotropy being induced by current flowing through wires which thread the tubes.

7. Conclusions

The design of the storage system has been dictated by a number of engineering requirements, these being as follows:—

- (a) A large signal from the magnetic film is desirable, hence the use of films 5,000-10,000 Å thick.
- (b) Interference due to direct coupling between the driving and sensing elements must be appreciably less than signals from the film.
- (c) The store must be compact.
- (d) Fabrication of the films and subsequent assembly of the store must be simple.
- (e) A switching speed of 0.1 microsec is near to present high speed computer requirements.

Using cylindrical magnetic films in conjunction with the particular geometrical layout and operating methods described, the above requirements are shown to advantage. The cylindrical magnetic film is a closed magnetic circuit and has much wider tolerances on dimensions such as thickness and length than a plane magnetic film. The signal output is independent of the diameter of the tubular film and depends only on the cross sectional area and length of the film, thus the diameter may in theory be reduced to dimensions comparable with the thickness of the film itself. This reduction in diameter has the advantage of allowing the current drive along the axis to be proportionately reduced. In this way, the volume of such a system can be reduced, a factor which will become of increasing importance as the operating speeds of magnetic films are used at their ultimate limit.

8. Acknowledgments

The authors are indebted to Professor F. C. Williams for his advice and encouragement. They also wish to thank Mr. R. M. Pickard for his assistance in preparing the magnetic films.

9. References

1. M. S. Blois, "Preparation of thin magnetic films and their properties," *J. Appl. Phys.*, **26**, pp. 975-80, 1955.
2. C. D. Olson and A. V. Pohm, "Flux reversal in thin films of 32% Ni; 18% Fe," *J. Appl. Phys.*, **29**, pp. 274-282, 1958.
3. D. O. Smith, "Magnetization reversal and thin films," *J. Appl. Phys.*, **29**, pp. 264-273, 1958.
4. Private communication from the Royal Radar Establishment.
5. C. Kittel, "Theory of the structure of ferromagnetic domains in films and small particles," *Phys. Rev.*, **70**, pp. 965-971, 1946.

Low Temperature Storage Elements †

by

E. H. RHODERICK, PH.D.‡

A paper read on 7th April 1959 at a Symposium on "Large Capacity Storage Systems" arranged by the Institution's Computer Group.

In the Chair : Dr. A. D. Booth (Member)

Summary : The philosophy underlying the use of low temperature computer elements is discussed and the cryogenic aspect of the problem briefly reviewed. The most advanced low temperature storage element at the moment is the Crowe cell, in which a persistent current is set up around an aperture in a thin superconducting film, the direction of the current determining whether a 0 or 1 is stored. The switching time of these elements can be as short as 10 μ sec, and the size is such that between 10^6 and 10^7 can be packed into a cubic foot. The main problem involved in the fabrication of a large memory is that of reproducibility. To exploit the high speed of the Crowe cell it may be necessary to perform the selection and logical operations in the low temperature cryostat. Modifications of Buck's original "Cryotron" or avalanche breakdown in a semi conductor could conceivably be used for this purpose.

1. Introduction

During the last few years much interest has been shown in computer elements which operate at liquid helium temperatures. The present day cost of a helium liquefier is about £15,000, and there are models under development which should cost less. This is small compared with the cost of a large computer, and the philosophy underlying the development of low temperature devices is that it may well be expedient to tolerate the added cost and complexity of a helium liquefier if, in return, significant improvements in the speed, size and cheapness of the components may be realized. Sufficient progress has been made to date to suggest that this may well be the case.

Most of the work on low temperature devices has so far been concerned with superconducting elements. Some semi-conductors show interesting avalanche effects at low temperatures which may be useful for switching applications, but these will not be discussed here. The best known property of a superconducting metal is that below a critical temperature T_c (usually less

than 10°K), the resistance disappears completely. This has two interesting consequences: (i) if a superconductor is connected in parallel with a normal conductor, then all the current goes through the superconductor, a property which can be used for "current steering," and (ii) a ring of superconducting metal has an infinite L/R ratio and a current induced in it persists indefinitely. Another important property of superconductors is that superconductivity may be destroyed by applying a magnetic field above a critical value H_c , or by passing a current greater than a critical value I_c . This property enables superconductors to be used to perform switching functions. Both H_c and I_c decrease with increasing temperature, approaching zero as the temperature approaches T_c .

2. The Crowe Cell

The persistence of a current in a superconducting ring may be used as the basis for a binary memory device, since the two possible directions of the current represent two stable states. The simplest form of such an element would be a ring of superconducting wire coupled inductively to a driving circuit. To obtain maximum speed of operation, it is necessary to make the cross-section of the wire very small, and this is most easily achieved by

† Manuscript received 5th May 1959. (Paper No. 536.)

‡ Services Electronics Research Laboratory, Baldock, Herts.

U.D.C. No. 537.312.62:681.142

replacing it by a flat ring made from a thin evaporated metallic film of, say, lead or tin. The next stage is to replace the flat ring by a hole in a sheet of film. The great step forward which was made by Crowe¹ consisted in introducing a narrow crossbar running diametrically across the hole. (Fig. 1). The persistent current flows in a figure-of-eight shaped path, so that a "0" or "1" is stored depending on the direction of the current along the crossbar. The crossbar plays an essential part in switching the device from one state to the other; the geometry also has the attractive feature that the magnetic field is much more localized than it would be for a simple ring because the magnetic field lines are closed loops linking the crossbar. To energize the cell a drive wire is provided which runs parallel to the crossbar and is separated from it by a thin layer of insulation: the pickup signal is derived from a sense wire which is similar to the drive wire but on the opposite side of the crossbar.

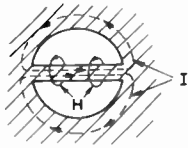

Fig. 1. Crowe cell.

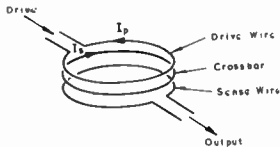

Fig. 2. Crowe cell: equivalent circuit.

To understand the operation of the cell, consider Fig. 2, which represents its equivalent circuit. A current in the drive wire sets up a magnetic field, the field lines of which are circles concentric with the drive wire. If the separation between drive wire and crossbar is small enough, practically all the field lines link the crossbar, so that the coupling between them is perfect. The cell is therefore equivalent to a transformer, the primary of which is the drive wire, while the crossbar together with the return paths around the two D-shaped apertures constitute the secondary. The sense wire is equivalent to a third winding which is tightly coupled to both drive wire and crossbar.

Suppose that there is initially a persistent current in the crossbar, and that we apply to the drive wire a trapezoidal current pulse of polarity such that the rising edge of the pulse induces an e.m.f. in the crossbar which tends to increase the crossbar current (Fig. 3).

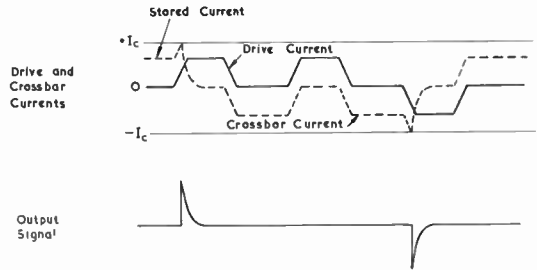

Fig. 3. Crowe cell waveforms: schematic.

Suppose, further, that the magnitudes of the initial persistent current and of the drive pulse are such that the crossbar current just reaches the critical current I_c at which the superconductivity of the crossbar is destroyed. (Superconductivity will be destroyed in the crossbar rather than the rest of the film because of the greater current density there; the film stays superconducting throughout). Then a resistance R will be introduced into the crossbar and the current will begin to decrease exponentially with a time constant L/R . Suppose, further, that the crossbar remains in the normal state long enough for the current to decay practically to zero, but recovers its superconductivity before the trailing edge of the pulse arrives. Then the trailing edge of the pulse induces in the crossbar a current of opposite sign, which is less than the critical current because there is no persistent current to begin with. The crossbar therefore does not go normal, and the cell is left with a persistent current which will last indefinitely unless it is disturbed by another drive pulse. The cell is therefore switched. A second drive pulse of the same polarity as the first merely reduces the crossbar current to zero and subsequently restores it to its former value, so does not change the state of the cell. A drive pulse of opposite polarity switches the cell in the same way as the first pulse.

The way in which an output voltage is induced in the sense wire can be understood

from Fig. 2. The equation which determines the crossbar current is $d\varphi/dt = RI$, where R is the crossbar resistance. Our assumption of perfect coupling means that the same flux φ links all three windings; the e.m.f. induced in the sense wire is therefore $d\varphi/dt$, which is equal to RI , so that the output voltage is equal to the ohmic drop in the crossbar. If the crossbar is superconducting so that $R=0$, then φ is constant and the output voltage is zero. The crossbar therefore acts as a "gate" which either screens the sense wire from the drive wire or not according to whether it is superconducting or normal. A signal is induced in the sense wire only when the crossbar is normal, i.e. when the state of the cell is changed.

We now consider the important assumption that the crossbar remains in the normal state from the time that the crossbar current first reaches I_c until it has decayed almost to zero. The way in which this comes about is that, because the transition to the normal state is not instantaneous, the crossbar current overshoots I_c slightly, and there is a brief instant during which a current flows in the crossbar while its resistance is not zero. The crossbar therefore heats up due to Joule heating, and simultaneously I begins to decay exponentially. I_c is a decreasing function of temperature, so that I must decay below the original value of I_c before the crossbar can become normal. This in turn causes additional heating, and the process is a divergent one, so that I falls almost to zero. The crossbar must be able to get rid of most of this heat before the trailing edge of the drive pulse comes along; more specifically, it must cool sufficiently for the critical current I_c corresponding to its temperature at the end of the drive pulse to be greater than the current induced by the trailing edge. The switching speed is therefore determined by the fact that the minimum pulse length, τ_{min} , which can switch the cell must be greater than the time taken for the crossbar to cool the required amount. Experimentally it is found that this "thermal relaxation time" depends very much on the nature of the crossbar and the substrate. Measurements by Broom² of the temperature of a lead crossbar show that the relaxation time when evaporated onto a mica substrate is very much less than that on a glass substrate. In

correlation with this it is found that switching speeds are substantially faster on mica than on glass, τ_{min} being about 100 μsec and 400 μsec respectively. It is also found that cells made of tin have a shorter recovery time than those made of lead³, partly because, for the same dimensions, tin has a lower critical current than lead and therefore generates less heat when driven normal. Tin cells³ can be made to switch in less than 10 μsec ; typical waveforms for such a cell are shown in Fig. 4, which shows the complete absence of any output voltage if the state of the cell remains unchanged. The drive

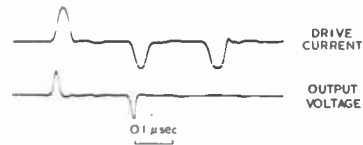

Fig. 4. Crowe cell waveforms: actual.
 Drive current = 50mA.
 Drive pulse duration = 30 μsec .
 Output voltage = 5mV.

current for this cell was about 50 mA and the output signal 5 mV. The use of tin, for which $T_c = 3.7^\circ\text{K}$, means that the helium pressure must be reduced below atmospheric, since the boiling point of helium at atmospheric pressure is 4.2°K . This has the advantage that the drive current may be made as small as one likes by working near to the critical temperature. Reduction of drive current reduces the output signal since $V_{out} = I_c R$, where R is the normal resistance of the crossbar. In practice $R \cong 0.1\Omega$, and one has to compromise between large drive current and small signal.

3. General Considerations

The Crowe cell is certainly the most promising superconducting element in existence at the moment. Its advantages include high speed, small size, relatively low drive current and complete absence of "delta noise." The tin cell referred to in Fig. 4 had a diameter of 2 mm, and this could easily be reduced to 1 mm if necessary, so that a packing density of 50 to the square inch is attainable. If one adopts the device of using a superconducting screen between layers, it should be possible to use about 10 layers per inch, thus achieving 10^6 cells per

cu. ft., which is a reasonable size for a helium cryostat. There is still considerable development work to be done before a superconducting memory with a capacity of 10^6 bits can be made. The chief problem to be overcome is that of reproducibility, and the solution of this problem will depend on a considerable advance in the technology of thin evaporated films. The problem of long term stability is also an unknown factor, though there should be no difficulty if the films can be maintained at 4°K continuously.

From a cryogenic standpoint, it is quite feasible to operate a memory containing 10^6 Crowe cells with the selection and logical circuits at room temperature, which would entail leads of length about 2 ft. running down into the cryostat. The major source of heat production in the cryostat would come from conduction down the leads and Joule heating of the leads by the drive currents; the energy dissipated in switching a cell is about 10^{-10} joules, and would be unimportant compared with that due to the leads. Even if one makes the cautious assumption that coaxial cables are used, as will probably be necessary for extremely short pulses, about 800 leads can be run down into the cryostat for a heat input equivalent to the evaporation of 2 litres/hour of helium, which is well within the capacity of a modern liquefier. A memory of 10^6 bits consisting of 20,000 50-bit words would require about 400 leads if arranged in a conventional way, so that it would be quite practicable to use a memory in this way as far as helium consumption is concerned. On the other hand, this method of operation involves the use of such long leads in the matrix itself that the high speed of the cells could not be utilized. Whether a megabit memory with a switching speed in the tens-of-millimicroseconds region would still be useful in spite of this limitation is a question which has yet to receive a clear answer.

To utilize the high speed of persistent current memory cells, it may be necessary to perform

all the selection and logical operations at low temperature, so that active elements may be required. There is some work in progress in the U.S.A. on transistors and avalanche diodes which operate at helium temperatures, some of which show considerable promise. There is also a lot of interest in active superconducting devices of the cryotron type. Buck's original cryotron⁴, in which a tantalum wire is driven normal by a current in a solenoid, is much too slow in operation, and has given way to a simpler device consisting of a narrow strip of superconducting film crossing another at right angles⁵; the principle is simply that the magnetic field of one of these can drive a portion of the other normal, so that the device acts like a relay. Although a lot of effort is being devoted to this, there is little concrete information available on how the current gain depends on switching speed, etc. The future of low temperature storage may well depend on how successfully these active elements can be developed.

4. Acknowledgment

Acknowledgment is made to the Admiralty for permission to publish this paper.

5. References

1. J. W. Crowe, "Trapped-flux superconducting memory," *I.B.M. Journal of Research and Development*, **1**, pp. 294-303, October 1957.
2. R. F. Broom and O. Simpson. (To be published.) See also: O. Simpson. Proceedings of specialist discussion meetings on "New digital-computer techniques," *Proc. Instn Elect. Engrs*, **106B**, p. 460, September 1959.
3. J. M. Lock. Proceedings of specialist discussion meetings on "New digital-computer techniques," *Proc. Instn Elect. Engrs*, **106B**, p. 460, September 1959.
4. D. A. Buck, "The cryotron—a superconductive computer component," *Proc. Inst. Radio Engrs*, **44**, pp. 482-493, April 1956.
5. E. H. Rhoderick, "Superconducting computer elements," *British Journal of Applied Physics*, **10**, pp. 193-198, May 1959.

A High-Density File Drum as a Computer Store †

by

LORIN KNIGHT‡ and MARTIN P. CIRCUIT, B.Sc.‡

A paper read on 7th April 1959 at a Symposium on "Large Capacity Storage Systems" arranged by the Institution's Computer Group.

In the Chair: Dr. A. D. Booth (Member).

Summary: The paper describes a large-capacity magnetic drum store having a capacity of $\sim 15,000,000$ bits and an average random access time of ~ 200 millisecon. A packing density of just over 1,000 bits per in. has been obtained by floating specially designed heads on a film of oil which automatically maintains a spacing of 0.002 in. between the head and the drum surface. Special considerations led to the use of a copper-nickel-iron alloy for the drum surface. A self-clocked reading system is used to obviate the need for high mechanical stability. The reading circuit also has special features which keep it operating under optimum conditions over a range of signal amplitudes.

1. Introduction

One answer to the problem of building a large-capacity store is to improve upon the conventional magnetic drum store and the file drum described here is an example of what can be achieved in this direction. The drum has a storage capacity of around 15,000,000 bits, which is of the same order of magnitude as a reel of magnetic tape and much larger than is economic with magnetic core storage.

The average random access time is 200 milliseconds which is much faster than obtainable with tape files but slower than obtainable with a core store. Nevertheless when the file drum is used in conjunction with a modestly-sized quick-access core store the access time of the drum need not be unduly restrictive. If necessary it should be possible to reduce access time by speeding up the drum.

A larger file can be built by using more than one drum. This does not give any increase in the access time.

2. Packing Density

There is a limit to the physical size which is practicable for a magnetic drum and it was obvious that if there was to be any major increase in storage capacity some way must be found of increasing the quantity of information which could be stored on a drum surface. The most promising way of doing this seemed to be to increase the number of bits per linear inch of track.

One important requirement for a high packing density is that the head should be very close to the drum surface. Due to various reasons, the most serious of which is the differential thermal expansion of the head mounts and the drum, it is not normally practicable to have a head-to-track separation of less than about 0.001 inch. The approach in the file drum was consequently to ride the head on a thin film of oil. By this means it is possible to obtain an automatically regulated spacing of 0.0002 inch, and a packing density of just over 1,000 bits per inch.

The way in which the oil produces the head separation can be understood from Figs. 1(a) and (b). The first diagram shows the drum stationary. The pivot pin is fixed to a spring which applies a force radially to the drum. The

† Manuscript first received 1st May 1959, and in final form on 2nd November 1959. (Paper No. 537.)

‡ International Computers and Tabulators Ltd., Research and Design Division, Gunnels Wood Road, Stevenage, Hertfordshire.

U.D.C. No. 621.395.625.3:681.142

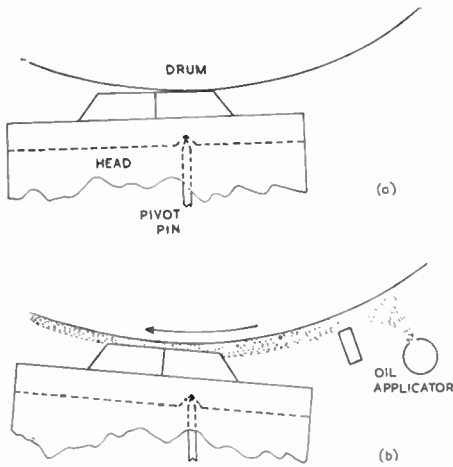

Fig. 1. (a) The drum in the stationary condition. (b) The drum when rotating showing the distribution of the oil film.

pin rests in a jewelled bearing in the head assembly and holds the head in contact with the drum.

Figure 1 (b) shows what happens when the drum is rotated. Oil is continually sprayed onto the surface of the drum and forms a film of the order of 0.01 inch thick which rotates with the drum. Near to the oil applicator is a wiper which smooths out some of the initial oil turbulence and helps to give a fairly uniform oil film.

The effect of the oil film is to lift the leading edge of the head away from the surface of the drum. At a certain tilt angle a state of equilibrium is reached with the oil holding the head slightly above the drum surface. The tilt angle and the separation are dependent on the geometry of the head, the position of the pivot, the force applied to the pivot, the viscosity of the oil and the relative velocities of the drum and the head surfaces. All of these factors can be closely controlled and thus the separation between the head and the drum can be accurately controlled.

Calculations have been done^{1,2} which describe the hydro-dynamic lubrication of narrow plane slider bearings and of wide convex slider bearings. The head-floating arrangement used in the file drum, however represents a narrow convex slider bearing. No mathematical analysis was available for this case and thus the precise values for the parameters concerned were determined experimentally.

3. Choice of Magnetic Materials

An interlock is incorporated to ensure that the drum cannot rotate unless there is oil being applied. However there is always a short initial starting period during which there may be no oil between the head and the drum. A conventional iron-oxide drum coating would not withstand this contact and it was necessary to find a

Table 1
Properties of some Permanent Magnet Materials

Material	Typical coercivity (H_c) oersteds	Typical residual induction (B_r) gauss	Remarks
Alnicos	400—700	5,000—12,000	Hard, generally brittle, not machinable.
Cunico	710	3,400	Ductile before heat treatment.
Cunife I	550	5,000	Ductile, machinable.
Cunife II	260	7,400	Ductile, machinable.
Iron Oxide	280	1,000	Easily damaged.
Magnet Steels	40—240	7,000—10,000	Hard, difficult to machine.
Vectolite	900	1,600	Brittle, weak.
Vicalloy	300	9,000	Ductile, machinable.

more durable magnetic material. The answer seemed to be Cunife I, an alloy of copper, nickel and iron³ which, beside having a tough machinable surface has the high coercivity essential for short wavelength recording, i.e. for close bit spacing.

The high coercivity of Cunife I is obtained by successive cold working and heat treating. Thus the only practical way of using this metal seemed to be to wind rectangular-section Cunife wire onto the drum. The wire is cemented in place with an epoxy resin and the surface then ground and lapped to give a surface roughness of the order of one microinch r.m.s.

The important properties of Cunife I compared with some other magnetic materials are listed in Table 1.

The pole pieces of the heads are ferrite mouldings. The choice of ferrite was largely influenced by the bit frequency of 150 kc/s at which laminated metal pole pieces would have given greater losses and, due to end effects, would have given a larger effective head-to-drum separation. The surfaces of the pole pieces adjacent to the drum are lapped to a high degree of smoothness. A beryllium copper spacer is used to give an effective gap length of about 0.0003 inch.

After a large number of stops and starts the ferrite suffers some wear. Referring back to Fig. 1 (a) however it will be seen that the region of the ferrite which actually makes contact with the Cunife is towards the leading edge. The critical region around the gap thus escapes damage during starting and the electrical performance is not impaired.

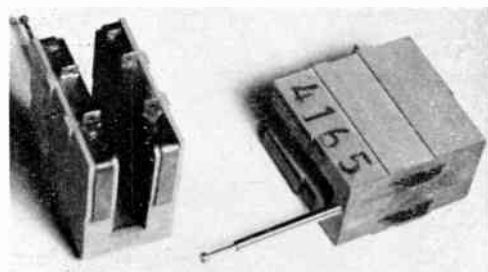

Fig. 2. Head assemblies.

4. General Construction

Figure 2 shows a view of two head assemblies. Each assembly contains two heads which are moulded in epoxy resin within a common magnesium frame. Between the two sets of pole pieces, on the inside of the head assembly and not visible in the photograph, is the jewelled cup which mates with the steel pivot pin. The complete assembly is held by the one pivot pin and when the drum is rotating equilibrium is reached with each of the two heads equally separated from the drum surface.

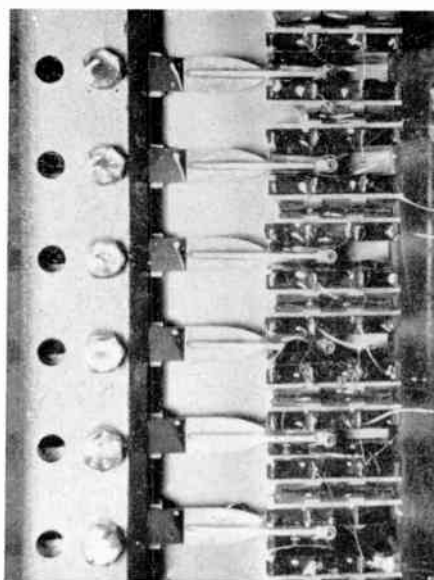

Fig. 3. Heads mounted in position.

The metal tail pins which can be seen protruding from each head assembly locate in slots in the head mounting bar and prevent the head from rotating about the pivot.

A close-up view of several heads mounted in position is given in Fig. 3.

Figure 4 shows a general view of a file drum. Along the right-hand side can be seen the pipe which applies the oil to the drum surface. Oil is withdrawn from a sump at the bottom of the drum housing, filtered and pumped back to the oil applicator at a constant pressure. The drum itself is 15 inches in diameter and 14 inches tall. It rotates at 180 rev/min and is

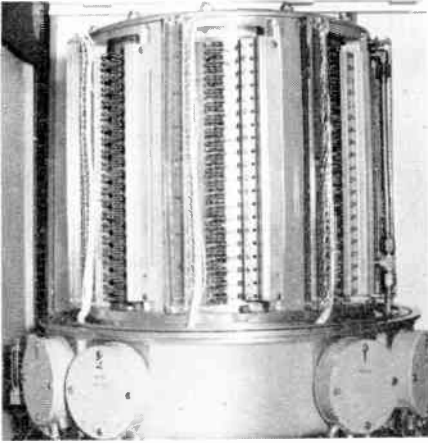

Fig. 4. General view of file drum.

driven from a synchronous hysteresis-damped motor through a toothed belt.

There is a total of 320 tracks of which 300 are available to the user and 20 are kept as spares.

5. Electronic Circuits

The attainment of a high packing density is not achieved entirely by mechanical engineering and some mention should be made of the contributory electronic circuits. It should be realized however that these may be varied depending on the particular application.

Recording is done by a phase-modulated non-return-to-zero system, a typical writing current waveform being as in Fig. 5 (a). A sequence of alternate ones and zeros corresponds to a 75 kc/s square wave and a sequence of consecutive ones or consecutive zeros corresponds to a 150 kc/s square wave. Due to the high packing density the 150 kc/s resolution is poor and the voltage waveform on playback is as in Fig. 5 (b). This signal is amplified and used to fire an Eccles-Jordan trigger circuit. The trigger is switched on whenever the signal voltage crosses the threshold T_1 in a positive-going direction and switched off whenever it crosses threshold T_2 in a negative-going direction. The resulting trigger waveform is therefore as in Fig. 5 (c) with a high potential indicating "one" and a low potential indicating "zero."

Since the end product of the reading circuits is the waveform in Fig. 5 (c) it might be thought

more logical to use this simpler waveform for writing on the drum. However there would be two disadvantages with such a system.

Firstly, unless a balanced information code were used, the writing current would have a d.c. component and transformer coupling would not be practicable.

Secondly, the erasability would be impaired. Because the Cunife is about 0.03 in. thick it never becomes saturated to its full depth. The fact that the writing current reverses at least once every bit time ensures that the saturation only extends to a very shallow depth. Consequently any new information written on the drum can always obliterate the previous recording. On the other hand, if there was no current reversal during a sequence of say six consecutive ones, the saturation might penetrate to an appreciable depth and a subsequent recording might not adequately erase the old information.

To obtain the maximum safety margin, the threshold voltages must be at about plus and minus one half of the peak signal voltage. They are then low enough reliably to intercept every significant polarity change but high enough to be immune to noise or any non-significant polarity change. Such non-significant polarity changes can occasionally occur during a sequence of consecutive ones or zeros (see Fig. 5 (b)). In order to maintain the threshold voltages near their optimum they are derived directly from the peak voltage of the signal. They are consequently self-compensating for any variation in signal amplitude due to differences in heads or inconsistencies in the characteristics of the Cunife.

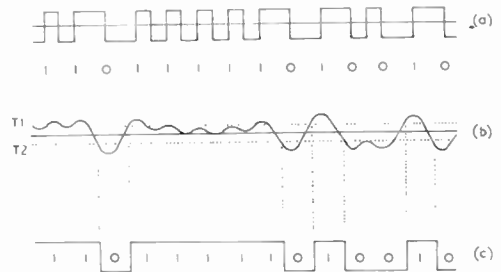

Fig. 5. (a) Typical writing current waveform. (b) Voltage waveform corresponding to (a) on playback. (c) The waveform obtained from the Eccles-Jordan trigger circuit.

In order to obviate the need for a high order of mechanical stability the read waveforms are not referred to a master clock track but are self-clocked. Each polarity change in the waveform of Fig. 5 (c) initiates a clock pulse. In a sequence of consecutive ones or zeros where there are no polarity changes, artificial clock pulses are injected, each of which has a nominal one-bit delay from the previous clock pulse. The information code is arranged so that there cannot be more than six adjacent ones or zeros and this ensures that the artificial clock pulses can never drift very far out of synchronism with the signal which is being read off the drum.

Each information block is given a special code to mark the start and the finish. A block may be identified either by its position on the track (by reference to a marker track) or alternatively may have an identity number recorded with it.

On those drums built so far, track switching has been accomplished by a tree of relays having mercury-wetted contacts.

• These relays give positive low-resistance connections at the small signal levels involved (1–2mV r.m.s.) and operate in less than 5 milliseconds.

6. Conclusion

A file drum has been described which it is felt gives a large storage capacity and a relatively quick access time for a cost of less than a tenth of a penny per bit.

The average random access time is approximately 200 milliseconds, consisting of 167 milliseconds for half a revolution of the drum and 30 milliseconds for track-switching. The maximum access time is about 365 milliseconds.

At the time of writing no file drum of this type was yet in actual service in the field but a number had been, and were being, built for incorporation in various data-processing systems in both Great Britain and the U.S.A. and for continued research into the potentialities of this type of file.

7. Acknowledgments

In conclusion the authors wish to acknowledge the work of Robert C. Kelner, Harrison W. Fuller and their team of engineers at Laboratory for Electronics, Inc., who pioneered the file drum and were responsible for all the original design and development work. Acknowledgments are also due to Brian Steptoe, Leslie J. Payne, Herbert Schotten and John H. Boorman of I.C.T. who have contributed to some of the subsequent development work.

The authors also wish to express their thanks to International Computers and Tabulators Ltd. for permission to publish this paper.

8. References and Bibliography

1. M. Muskat, F. Morgan and M. W. Meres, "The lubrication of plane sliders of finite width," *Journal of Applied Physics*, **11**, p. 208, 1940.
2. S. Abramovitz, "Theory for a slider bearing with a convex pad surface; side flow neglected," *Journal of the Franklin Institute*, **259**, p. 221, 1955.
3. R. M. Bozorth, "Ferromagnetism," p. 396 (Van Nostrand, New York, 1951).
4. H. W. Fuller, S. P. Woodsum and R. R. Evans, "The design and systems aspects of the HD file drum," *Proceedings of the Western Joint Computer Conference, Los Angeles, 1958*, p. 197 (American Institute of Electrical Engineers, New York, 1958).
5. "Computer memory" *Electromechanical Design*, Nov./Dec. 1957, p. 50.

APPLICANTS FOR ELECTION AND TRANSFER

As a result of its December meeting the Membership Committee recommended to the Council the following elections and transfers.

In accordance with a resolution of Council, and in the absence of any objections, the election and transfer of the candidates to the class indicated will be confirmed fourteen days after the date of circulation of this list. Any objections or communications concerning these elections should be addressed to the General Secretary for submission to the Council.

Transfer from Associate Member to Member

FELLOWS, Horace. *Wolverhampton, Staffs.*

Direct Election to Associate Member

CLARKE, Samuel Laurence Harrison, B.A.(Cantab.). *Boreham Wood, Herts.*
 CROSBY, Robert George, B.Sc. *Dovercourt, Essex.*
 GRANTHAM-WRIGHT, Major Kenneth, *Faringdon, Berkshire.*
 HUGHES, Nathaniel, B.Sc. *Cardiff.*
 KHAN, Lieut.-Com. Rafiq Ahmad, B.A., B.T., P.N. *Karachi, Pakistan.*
 LAMPING, Charles Thomas. *Cardiff.*
 RICHARDS, Donald Stanley. *Great Bookham, Surrey.*
 SAHNI, Major Dharam N., B.A.(Hons.), Indian Sigs. *London, W.1.*
 WILLIAMS, George Amphlett. *London, W.2.*

Transfer from Associate to Associate Member

HALL, Ephraim. *Southampton.*
 HEIGHTMAN, Anthony Norman. *Chelmsford, Essex.*
 READ, Geoffrey Leonard. *Hayes, Middlesex.*

Transfer from Graduate to Associate Member

JACOB, Abraham Hyam. *London, N.W.6.*
 RAHMAN, Flt. Lt. Syed Azizur, B.Sc., P.A.F. *Sargodha, West Pakistan.*
 IKKARE, Narayan Dattatraya, M.Sc. *Bangalore, India.*
 WEBB, Flt. Lt. Paul Rhodes William, R.C.A.F. *Ottawa, Ontario.*

Transfer from Student to Associate Member

AHMAD, Jalal-Ud-Din. *Rawalpindi, Pakistan.*

Direct Election to Associate

*CADOGAN, Alexander Joseph. *London, S.W.12.*
 HILDERSLEY, Ronald Stanley. *Portsmouth, Hants.*
 MESTON, John Frederick. *Eastleigh, Hants.*
 MORTIN, William Frank. *Wolverhampton.*
 WHITING, Roland Arthur. *Limassol, Cyprus.*

Transfer from Student to Associate

LEUNG CHEUK SING. *Hong Kong.*
 STRIDE, Regent. *Morden, Surrey.*

Direct Election to Graduate

ALSTEAD, Geoffrey Carl. *Bolton, Lancs.*
 ASGHAR, Lieut. Syed Birjees, B.Sc., P.N. *Karachi, Pakistan.*
 BROWN, John Millard. *Leigh-on-Sea, Essex.*
 COCKLE, Anthony Laurence. *Higher Bebbington, Cheshire.*
 *CROSDALE, Frank. *Stockport, Cheshire.*
 CURREY, Flt. Lt. Kenneth Frank, R.A.F. *King's Lynn, Norfolk*
 DEVINE, Trevor James. *Sevenoaks, Kent.*
 DUFFEY, Eric. *Liverpool 23.*
 FORSIER, Frederick Ronald. *London, W.5.*
 GIDDINGS, Graham John Taylor. *Tewkesbury, Glos*
 HARWOOD, William Richard. *Hillingdon, Middlesex*
 HENDERSON, George Crawford, M.A. *Bristol.*
 KITCHEN, David Charl s. *Southsea, Hants.*
 LLOYD, Gwilm Bevers, B.Sc. *Bath, Somerset.*
 NUTT, Peter Charles. *Welwyn Garden City, Hertfordshire*
 PALMER, Reginald Charles. *Cardiff.*
 *POWER, Ronald Alexander. *Woodford Green, Essex.*
 ROBERTSON, Robin Keith. *Enfield, Middlesex.*
 RYLE, Dermot, B.E.(Elec.). *London, N.W.9.*
 TEO, Chye Poh, B.Sc.(Hons.). *Coventry.*
 THOMAS, David John. *Gosport, Hants.*
 THURBON, Michael Thomas. *Cambridge.*
 WATSON, Flg. Off. Wilfred, R.N.Z.A.F. *Wellington, New Zealand.*
 WRIGHT, Peter Law. *Beckenham, Kent.*

Transfer from Student to Graduate

CHANDRASEKHARAN, Chempath. *Madras, India.*
 GLAZIER, Richard Eric George. *Bracknell, Berkshire*
 HIGGINS, Geoffrey Alfred. *Southampton, Hants.*
 HOPE, Adam William. *Edinburgh.*
 KERWOOD, Dilys Joyce. *Birmingham.*
 LAWRENCE, Peter John. *Chelmsford, Essex.*
 LOUCH, Terence George Henry. *Beaconsfield, Bucks*
 McCREADY, Kennedy Lemur. *Crayford, Kent.*
 MARIOW, Jeffrey. *London, E.10.*
 PRATTEN, Peter E. J. *London, N.3.*
 SCHINDLER, Andrew. *Newton Abbot, Devon.*
 THOMPSON, Alan Coulthurst. *Bury, Lancs.*
 WILKINS, Bryan Percy. *Bracknell, Berks.*

STUDENTSHIP REGISTRATIONS

The following 68 students were registered at the October and November meetings of the Committee. The names of a further 91 students registered at the November and December meetings will be published later.

HARLING, Norman. <i>Cheltenham, Glos.</i>	Van SWIETEN, Joseph, J. <i>The Hague.</i>	CHILDE, Percy. <i>Hong Kong.</i>
HAWORTH, John Derek. <i>Paisley.</i>	VICKERS, Alired Thomas. <i>Swansea, Glam.</i>	CHOY, Low Kum. <i>Singapore.</i>
HIBBERD, John William. <i>Wembley.</i>	WILKS, Michael Edwin. <i>Ilford, Essex.</i>	COULSON, James. <i>Newcastle-on-Tyne</i>
HILL, Ronald A. <i>Uxbridge, Middlesex.</i>	WOOD, Norman. <i>Hitchin, Herts.</i>	CRAIG, Brian. <i>Chelmsford, Essex.</i>
HOBBS, Francis John. <i>London, W.9.</i>	WYATT, Kenneth. <i>Edgware, Middlesex.</i>	DAVIES, William Peter. <i>Luton, Beds.</i>
HODGE, Alan Robert. <i>Bushy, Herts.</i>		DIXON, Cyril Ernest. <i>Luton, Bedfordshire</i>
*KEEBLE, Derek Leslie. <i>Harlow.</i>	AKNAL, Peter. <i>London, N.7.</i>	DOWSE, Peter James. <i>Chelmsford, Essex.</i>
KELLEHER, John. <i>Uxbridge, Middlesex.</i>	ALLINSON, Peter Michael. <i>Chelmsford.</i>	DRAYTON, Victor Leonard. <i>Crawley.</i>
MALIK, Farid. <i>Berg n. Norway.</i>	AMERASINGHE, Upali. <i>Mount Lavinia, Ceylon.</i>	FIRTH, Peter Thomas. <i>Sheffield, Yorks.</i>
MANTOVANI, Kenneth. <i>London, N.W.8.</i>	AMIRTHALINGAM, Saravanamuthu. <i>Trincomalee, Ceylon.</i>	FOLLAND, Flt. Lt. Edward Phillip, B.Sc., R.A.F. <i>Teheran, Iran.</i>
MITCHELL, Robert. <i>Stevenage, Herts.</i>	AVGHOUSTI, Charalambos. <i>Limassol, Cyprus.</i>	FULLICK, Peter Ernest. <i>London, E.6.</i>
MOSS, Kenneth Arthur George. <i>Hounslow.</i>	AVIAR SINGH, Captain. <i>Indian Signals, Mhow, India.</i>	GARVIN, Michael John. <i>Cambridge.</i>
NORTHEAST, J. G. <i>London, N.8.</i>	BARNETT, Christopher Frank. <i>Aylesbury.</i>	GERRARD, George Alan. <i>Stammore, Middlesex.</i>
PAGE, James William. <i>London, W.6.</i>	BENNETT, Wilfred. <i>Stoke-on-Trent, Staffs.</i>	GIBBARD, Michael John. <i>East Molesey, Surrey.</i>
PEARSON, Flg. O.T. Michael George. <i>R.A.F., Lincoln.</i>	BEN-YOSEF, Michael. <i>Givataim, Israel.</i>	GILBERT, Victor Stanford. <i>Selsdon, Surrey.</i>
PLAHAY, Manmohan Singh. <i>London, W.2.</i>	BERNARD-SMITH, Peter David. <i>St. Albans, Herts.</i>	GITTINS, Donald Gerald. <i>Rayleigh, Essex.</i>
RAE, Alexander Watson. <i>Glasgow.</i>	BHAVSAR, Chandulal, M.Sc., Mulchand-das. <i>Sabaskantha, India.</i>	GIVON, Moshe. <i>Haifa, Israel.</i>
RATTANSI, Abdulaziz Haiderali. <i>Norwich.</i>	BLANCHEITE, Eugene Aubrey, B.Sc. <i>Stevenage, Herts.</i>	GOUGH, Kenneth Ernest. <i>Epping, Essex.</i>
ROWLANDS, Tudor, B.Sc. <i>Cheltenham.</i>	CHAN, Ping Cheung. <i>Hong Kong.</i>	GULHANE, Keshao. <i>London, N.W.11.</i>
SAXENA, Man Mohan Swaroop, B.Sc. <i>Tehgarh U.P., India.</i>	CHARALABIDES, Eraclis S. <i>Nicosia.</i>	HUTCHINS, Maurice David. <i>Crowthorne, Berks.</i>
SCHIERVE, Olav. <i>Stavern, Norway.</i>	CHAUDHARY, Krishan Gopal. <i>New Delhi.</i>	KAMAT, Shamkant Dattaram, B.Sc. <i>Poona, India.</i>
SMITH, Ernest Arthur. <i>Farnborough, Hants.</i>		KANIOU, Michalis Christofi. <i>London, N.4.</i>
SON HING, Cecil Bickford. <i>London, W.8.</i>		KENDALL, Haydn George. <i>Pontypool.</i>
TAYLOR, Thomas George. <i>Newport, Mon.</i>		
TOBIN, Patrick Francis. <i>Killarny.</i>		

* Reinstatements.

A Television Master Switcher[†]

by

B. MARSDEN, MEMBER[‡]

A paper read on 3rd July 1959 during the Institution's Convention in Cambridge.

Summary: A survey is made of the standard methods at present in use for switching video signals: the simple mechanical switch, electromechanical relays, and switching systems using thermionic relays. A method of video selection is then described in which the switch elements are made up of semi-conductor diodes. Both master control room and studio type switchers are discussed. Reference is made to current development work in which transistorized pulse generators are being used to achieve vision switching between successive frames of the television waveform.

1. Introduction

In television installations it is necessary to provide switching equipment for routing various signals to different destinations. For example, in a Master Control Room it is necessary to provide means for connecting the outgoing transmission line to any one of the various signals arriving in the Master Control Room. In a studio, selection of the various camera signals for mixing and preview monitoring has to be achieved.

Television signals are usually distributed by means of co-axial cable having a characteristic impedance of 75-ohms. It is therefore usual to arrange for inter-connected equipment to have input and output impedances of 75-ohms, to avoid a mismatch in the transmission line. When several signals are to be selected in turn by one piece of apparatus, it is necessary to ensure that each line is at all times correctly terminated. If terminations are removed, spurious reflections can occur on the transmission lines, causing discontinuities in associated equipment, and preventing accurate monitoring at the sending end.

2. Review of Switching Methods

2.1. Direct switching

The simplest form of selection system consists of a mechanically inter-locked push-

button switch of the type illustrated in Fig. 1. The example shown is a five-position selector switch, although of course, the number of selector positions required is dependent upon the number of video signals to be selected. It is seen that each of the incoming video signals is terminated by a 75-ohms resistor when the corresponding selector button is out. If a button is pressed, the mechanical inter-lock

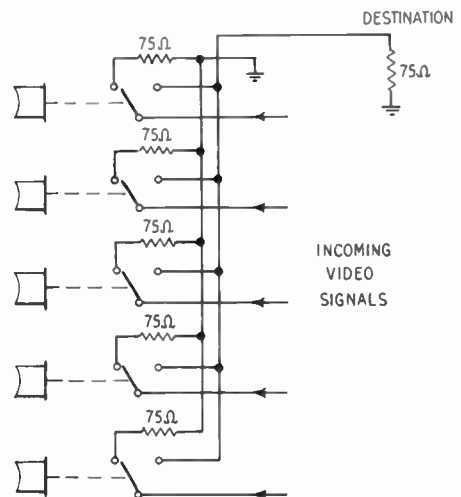

Fig. 1. Direct video switching system.

releases any other button that may be pressed, the incoming signal is removed from the 75-ohms termination and connected to the outgoing transmission line and correctly terminated at the destination.

This system is simple and effective, but suffers from the drawback that each button on

[†] Manuscript first received 3rd March 1959 and in final form on 13th May 1959. (Paper No. 538.)

[‡] Associated Television Ltd., ATV House, Great Cumberland Place, London, W.1.

U.D.C. No. 621.397.66: 621.382.2

the selector switch has to be fed from an amplifier having an output impedance of 75-ohms. In most television installations each video signal generated is required many times for feeding monitors, transmission lines, etc. To satisfy the use of selector switches similar to the one described, it is therefore necessary to use distribution amplifiers to provide isolated duplicates of the original signal. Such amplifiers usually have an output impedance of 75-ohms a gain of unity and an extremely high input impedance. Several of these distribution amplifiers can have their inputs bridged together, and an incoming signal terminated in 75-ohms connected to the common input terminal. A typical arrangement is illustrated

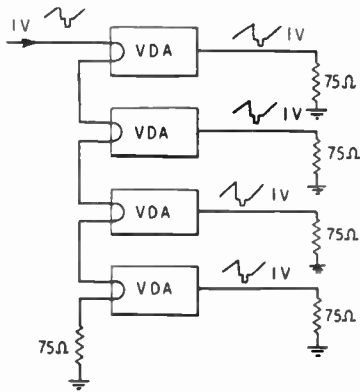

Fig. 2. Video distributing amplifiers.

in Fig. 2. Since the output impedance of each amplifier is 75-ohms, we now have the original signal repeated four times in the example shown, and available for use on switches of the type described.

2.2. Relay switching

It may be found that a television installation is of such a complex nature that the use of low impedance video selection of the type described demands an excessive number of distribution amplifiers. In such cases economies are effected by using relays. Figure 3 shows a typical example in which selection is remotely controlled by switches S1-S5. Each of the five video signals arriving at the switch unit is terminated in 75-ohms, and relay contacts A1-E1 connect any one of the incoming signals to a video distribution amplifier having

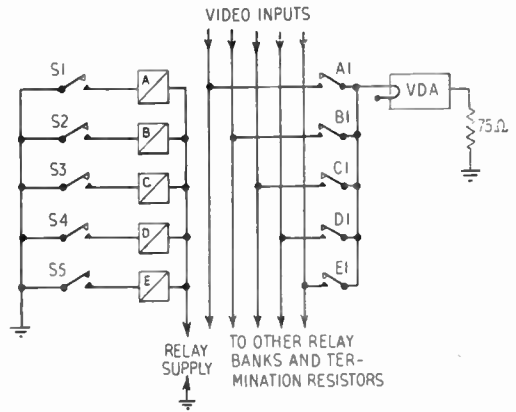

Fig. 3. Relay switching system.

a high input impedance. The selector switches S1-S5 are mechanically, or electrically, interlocked, in such a way as to permit only one relay to be active at any one time. Since the activation of any one of the relays shunts an incoming line by an extremely high impedance, it is permissible to connect several similar switch devices across the incoming video signals without degrading them. When using this method of switching the number of distribution amplifiers required is determined by the number of destinations requiring selective switching, and not, as in the first method, by the number of selector buttons in the installation.

2.3. Valve switching

A third method of video selection uses thermionic valves as on/off switches instead of mechanical relays. A typical example is illustrated in Fig. 4, where it is seen that several valves have their cathodes connected to a common load resistor. As in Fig. 3, the video signals arriving at the switch unit are terminated in 75-ohms resistors, and the grids of switching valves V1 - V4 bridge across the incoming signals. The bias potentials impressed on the grids of valves V1 - V4 are selected by a mechanically-interlocked push-button unit S1 - S4, and so arranged that at any one time only one valve is conducting. A negative bias supply is provided having sufficient magnitude to cut off the switching valves when required. The signal present across R_L when any one switching valve is active is fed into a video distribution amplifier

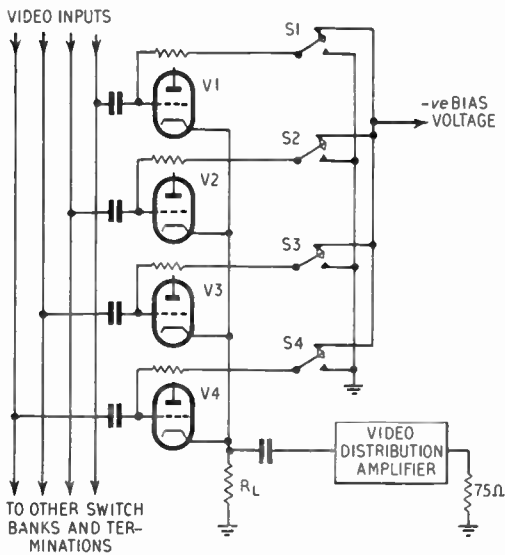

Fig. 4. Valve type switcher

having a high input impedance and a gain greater than unity to make up for the loss present in the cathode followers V1 - V4. As is the case of the relay switcher, each video input is available for feeding several switch banks due to the negligible shunting effect of the switching valves.

2.4. Appraisal of switching methods

Let us now consider the three methods of video selection described. The mechanical switch operating at an impedance of 75-ohms is the simplest and cheapest form of video switching, but its use is strictly limited to modest installations. Furthermore, it suffers from the disadvantage of producing picture flashing due to the random operation of the mechanical switches. The mechanical relay selection device permits greater flexibility and remote control, but again suffers from the disadvantages inherent in mechanical switches and their attendant maintenance problems. The switcher using thermionic relays has considerable advantages over the mechanical relay system. For example, smooth transition from one picture selection to another can be achieved by appropriate selection of the components in the bias circuits, and furthermore the switching action can be arranged to take place in frame suppression time by the addi-

tion of appropriate gating valves driven by frame pulses. It suffers, however, from a disadvantage not present in the mechanical relay system in that heat is generated by the use of many switching valves, the greater majority of which are in the non-conducting state. In designing a television installation, the question of heat generation is of paramount importance. When one considers the number of kilowatts consumed in any television installation, in order to be able to transmit a one-volt video signal into a 75-ohms load, it is obvious that the conversion efficiency is extremely low, and any means of economizing on electricity consumption and the ultimate heat dissipation should be considered.

In designing video selection devices for use in a Master Control Room and a studio, the known methods of video selection were considered in order that a method of video selection might be devised which would satisfy the particular requirements. They were as follows:—

- (a) Up to sixteen incoming signals were to be selected for routing to a maximum of eight different destinations.
- (b) Electricity consumption and resulting heat generation were to be kept as low as possible.
- (c) The switching system and associated distribution amplifiers were to be as compact as possible.
- (d) The switching unit was to be capable of modification to permit inter-frame cutting if this was found to be necessary.
- (e) The switching unit was to be capable of modification for integration with a pre-set memory system of the type used in automatically-controlled television installations.
- (f) The switching unit should not cause flashing due to erratic switch operation.

Of the three basic methods discussed, the thermionic relay system appeared to be the most favourable. Table 1 shows how the three methods of switching meet the requirements listed above. The direct switching system is completely unacceptable, mainly because of the large number of distribution amplifiers

required. The relay switching method satisfies three of the requirements, while the thermionic relay method satisfies four. Requirements (b) and (c), though not of paramount importance, were not met with the valve type: even assuming that double triodes are used in which two switches could be accommodated in one glass envelope, we would have had a minimum of sixty-four valves consuming approximately one hundred and twenty watts for the heater supply alone. To this should be added fifteen to twenty watts of h.t. consumption, assuming eight valves to be operative at any one instant. Despite these disadvantages, development was concentrated on the valve type of switcher, but during investigations into the various methods it was suggested that requirements (b) and (c) could be more readily achieved if semi-conductor diodes were used for the switches instead of valves.

2.5. The diode switch

Recent development in semi-conductor techniques has produced diodes having very low forward resistance, very high back resistance and extremely low shunt capacitances. A simple diode switch was therefore developed, and is illustrated in Fig. 5. The input signal is applied to the anode of diode D1, and the output signal taken from the anode of D2. The anode of D3 is connected to the junction of diodes D1 and D2, and its cathode is taken to a positive biasing potential. A

selector switch "S" is arranged to feed either positive or negative bias potential to the junction of the three diodes via an isolating resistor R2. When the biasing potential is positive, D1 and D2 are non-conductive and diode three conducts heavily. A path of extremely

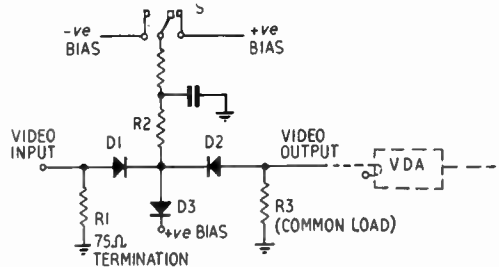

Fig. 5. Video diode switch.

high attenuation therefore exists between the input and output terminals and vice versa, due to the high impedance series path presented by D1 and D2 and the low impedance shunt path created by D3. When switch S is moved to apply a negative bias to the diode network, D1 and D2 are made to conduct, and D3 is cut off. Under these conditions a low impedance series path is presented between the input and output terminals. If now several of these units have their input terminals connected to different video signals, and their output terminals connected to a common load resistor feeding a distribution amplifier, a form of video selection is

Table 1

Comparison between Three Conventional Switching Systems

	(a) No. of Inputs	(b) Power Consumption	(c) Size	(d) Inter-frame Cutting	(e) Automation	(f) Absence of Flashing
DIRECT SWITCHING	...	U	U	U	U	U
RELAY SWITCHING	...	S	S	U	U	S
VALVE SWITCHING	...	S	U	U	S	S

S = Satisfactory.

U = Unsatisfactory.

obtained. By appropriate choice of time constants the change from one video signal to another is rendered flash free—in practice a fast mix is achieved.

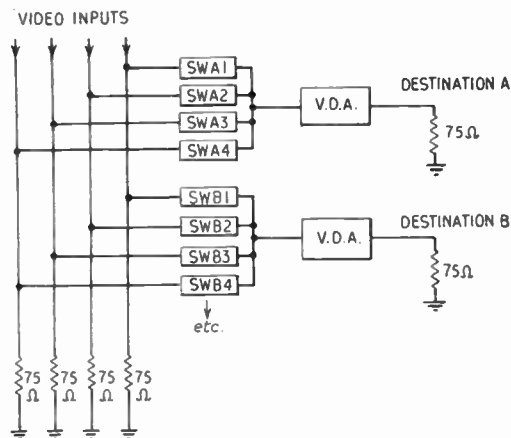

Fig. 6. Part of diode switching matrix.

A mechanically-interlocked switch can be used which arranges that at any one time only one of the diode switching units is conductive. Since the input impedance of any one diode switching unit is high, several of these units may be connected across a 75-ohms transmission line, and Fig. 6 shows how four video signals can be selected for feeding up to four destinations.

3. Master Control Switcher

A diode switching system of the type described, using simple mechanical switches to control the bias potentials on the switch units, will satisfy the requirements laid down in the early part of this paper except for (d) and (e)—inter-frame cutting and automation. At the time that this development work was being undertaken a switcher was required for a Master Control Room in which these two requirements were of no consequence. Since the Master Control Room was capable of accepting synchronous and non-synchronous signals, the ability to change a video signal during the frame blanking period was of no advantage to the operation. Furthermore, since automation was not being used this requirement could be ignored. A switching unit was therefore constructed, a photograph of which is shown

in Fig. 7. The unit was capable of accepting sixteen video inputs for routing to eight different destinations, and therefore required one hundred and twenty-eight switch units. The diode switches are mounted in small plug-in units which permits rapid replacement under fault conditions. On the same chassis are shown the distribution amplifier valves, which are used to restore the losses introduced by the switching elements, and provide 75-ohms source impedances to the outgoing transmission lines. The unit illustrated has self-testing facilities, in that a socket is provided into which a suspect unit can be inserted and, by rotation of a switch, each circuit component tested under working conditions. This same test meter is also used for checking the supply voltages required for operation of the switch

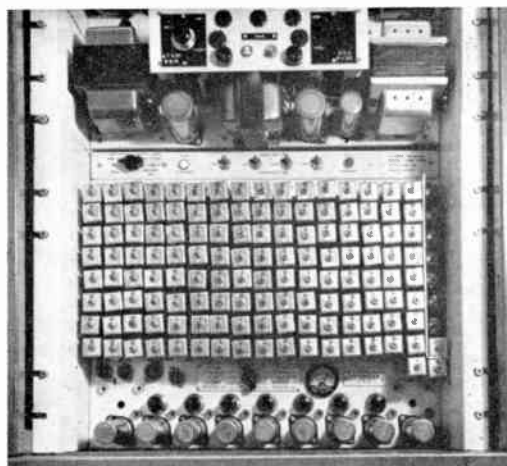

Fig. 7. Master control type diode switching system capable of handling 16 inputs and 8 outputs.

unit. Reliability of this system has been shown to be far greater than in comparable devices; the unit has been in use for a period of nearly two years under operational conditions, and during that time maintenance has been required on only one occasion. This was found to be due to a wiring fault which occurred during manufacture of the equipment.

4. Studio Type Switcher

Further development has proceeded since the manufacture of this Master Control unit, to adapt the basic diode switching unit for use in

a studio control room. A design was required for a video selection system for use in a large studio, in which it was necessary to provide inter-frame cutting of video signals. It was also felt desirable that the current consumption of the switching matrix be reduced even further below the already low value achieved in the Master Control type. Figure 8 shows the

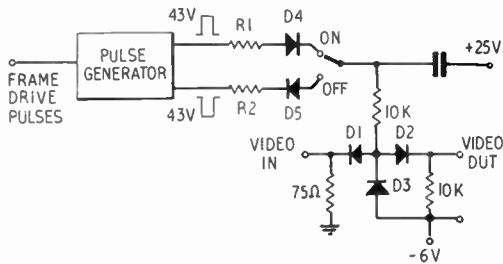

Fig. 8. Pulsed diode switch.

modification to the basic switch unit to provide video selection in frame blanking period. The pulse generator is a transistorized type driven by the frame trigger pulses of the studio. These pulses are fed via a mechanically-interlocked selector switch to a diode switch element similar to that illustrated in Fig. 5. Rectifiers D4 and D5 rectify the large amplitude frame pulses produced by generator to produce the necessary bias potentials for the switch network. Appropriate choice of time constants ensures that the necessary bias potentials are maintained between successive frame pulses, yet changeover of the polarity of keying pulse initiates the action of the switch in the next frame blanking period.

5. Performance

As in the case of all new fields of investigation, improvements are continually made within a short space of time. The latest form of diode switcher being developed has a performance greatly in excess of the one already manufactured, but it is not yet possible to quote exact figures. However, figures for the Master Control unit, which has been in use for some time, are as follows. The frequency response under the best conditions, i.e. when one signal is being selected by one destination, is substantially flat to 6 Mc/s with a 3db point at 9 Mc/s. As more switch sections are added, either in the form of available video inputs or destination banks, the frequency response falls, and in the worst condition, when the eight destinations are being fed from one of the sixteen sources, the frequency response is -0.6db. at 4 Mc/s, and -3db at 8 Mc/s. Crosstalk between any two channels is dependent upon the number of channels being used, and varies from the worst condition of -40db at 7 Mc/s to -50db at 7 Mc/s when only two input signals are present on the input switching frame. It is thus seen that this first equipment, manufactured on a prototype basis, has achieved a performance which is more than adequate for British standards. Further development work to meet the more stringent requirements of a higher definition system, and colour, is proceeding.

6. Power Consumption

As will be expected, the use of semi-conductors does produce economies in a switching system of the complexity required in

Table 2

Comparison of Power Consumption of Different Types of Switch (128 Switches).

Type of Switch	Direct	Relay	Valves	D.C. Diodes	Pulsed Diodes
Power Consumption of Switches ..				0	8	135	20	6
Consumption expressed as a percentage of Power taken by Valves				0	6	100	15	4.5

television control rooms. Table 2 shows approximate power consumptions for the following types of switches (sixteen inputs and eight outputs).

- (i) Direct vision switching.
- (ii) Switching by means of relays.
- (iii) Switching by means of valves.
- (iv) The diode switcher using steady state d.c.
- (v) The diode switcher pulsed in frame blanking.

Although the direct switcher uses no power it must be remembered that one hundred and twenty eight distribution amplifiers are needed against the eight for the remaining types of switch.

7. Conclusion

The diode switcher finally described meets the requirements for a master control or studio type switcher in the following respects.

- (a) Models have been constructed embodying up to one hundred and twenty-eight switch units on one matrix. Development work has shown that more switch elements can be accommodated, and better results achieved, by operating each switch element with lower input and output impedances than those already used.

- (b) Power consumption is very low—the unit produces negligible heat.
- (c) The unit is compact—a typical 128-way switch matrix occupies less than 15 in. of rack space.
- (d) Inter-frame cutting is achieved by using keying pulses initiated by frame drive.
- (e) Automation is readily achieved since the switcher can be remotely operated by relays.
- (f) Picture flashing is obviated by using inter-frame cutting, but in any case the change from one picture to another can be achieved by a fast mix.

Experience over many months of operation without failure has shown that the use of semi-conductors in switching devices is a notable development in television broadcasting techniques. Transistorized distribution amplifiers have been produced for use with the diode switcher, and it is likely that future development will combine the function of switching and distribution by using transistors instead of diodes for the switch elements, thus effecting even greater economies in power consumption.

8. Acknowledgment

In conclusion the author wishes to make acknowledgment to the Managing Director of Associated Television Ltd. for permission to present this paper.

DISCUSSION

A. J. Henk: We have heard a description of a most fascinating automatic Master Control system, and I would like to ask Mr. Marsden, with his experience of operations in this field, what he considers are the obstacles to be overcome in installing this type of equipment, and how long he considers it would be necessary to wait before automation in Master Control Rooms becomes fully realized.

B. Marsden (in reply): I believe that fully to automate a Master Control operation will degrade the presentation. The flow of commercials and programmes has, because of the system, to be continuous, and an automatic method of presentation cannot be as smooth as one in which manual control is used. I would

prefer to see automation applied to Master Control techniques in a limited sense, retaining a manual control to effect the smoothness of change-over from one programme to another, especially in those cases when delaying or accelerating a fade from one programme to another can improve the artistic presentation. As I have said before, automation devices can have intelligence built into them, but not a soul, and it is the artistic appreciation of the operation which does add enormously to the smoothness of Commercial Television presentation.

R. Barras: Would Mr. Marsden tell us what are the cross-talk figures on the crystal switching system.

B. Marsden (in reply): The Master Control switching system described is not as good as we would like it to be. We are fully aware of this and a later version of the device is very much better, but figures are not yet available. The first Master Control switcher made eighteen months ago has a frequency response which is given in section 5. Variation in performance as one presses more or less buttons can be compensated by the action of the compensating diode, which becomes operative when the switch is in the off condition, and throws across the incoming video signal a load equivalent to that of the diode switch which is now off. One can then achieve in the combined load, or after the combined load in the vision distribution amplifier feeding the outgoing line, overall compensation to allow for the loss in gain and frequency response, etc. of the switching matrix.

G. R. F. Metcalfe (Associate): Would Mr. Marsden tell us what facilities there are with his system of automatic diode switching for sound.

B. Marsden (in reply): Sound selection in parallel with video selection can obviously be done with germanium diodes in just the same way as for vision. The problem is easier because of the reduced bandwidth, but it has not been done in our particular case because it is not part of our normal operation to carry sound and vision together. It can be shown by subjective observation that the best impression is obtained if sound and vision are faded out at different times. There is a discrete rate at which this should be done.

D. G. Preston: Whatever type of switching one uses starts with a press-button. I wonder if Mr. Marsden has overcome the problem of finding a really reliable button. We have had, in our organization, enormous trouble with press-button switches.

B. Marsden (in reply): The switches used in our Master Control Room had to be made in

our organization. Eighteen-way press-button switches were not readily available, so we obtained the basic components from the manufacturers and made the units ourselves. To date they have given no trouble whatsoever, although considerable care had to be taken in their assembly to accommodate all the manufacturing tolerances. They are not expensive switches—they are the type used in cheap pre-war radio sets.

H. G. C. Gower: Firstly, what is the insertion loss of the switches in your switch unit; and secondly, could we be told the type of diode used. Thirdly, the cross-talk figures struck me as being rather low, I think -40 db was referred to; that of course is perfectly satisfactory for a synchronized source, but for a non-synchronous source I would suggest that it would not be so good.

B. Marsden (in reply): Insertion loss of the switch is about 0.3 db, which has to be subsequently corrected. The cross-talk figures are, as Mr. Gower says, good enough for synchronous sources, and in our method of operation, since we "slave" to all incoming signals prior to transmission, the signals presented to the Master Control panel are in effect synchronous. Those signals to which we are not slaved can be kept off the panel, but in practice no trouble has been experienced.

I would again remind you that what has been described is a prototype equipment of a new system of video selection. Contrary to normal practice, however, the prototype was put into operation to give it rather more than a bench test. A subsequent version of the switcher has considerably improved performance due to improved layout, etc. With reference to the diodes used, the first equipment used a very cheap and simple diode, such as the CG4E; since development of the equipment better diodes are available, having much lower forward resistance, and these will be used in future equipment.

CONVERSAZIONE AT THE ROYAL SOCIETY

ON 9th December last the Parliamentary and Scientific Committee* held a *Conversazione* in the Rooms of the Royal Society, London. Sir Cyril Hinshelwood, President of the Royal Society, received the Lord Privy Seal and Minister for Science, the Right Hon. Viscount Hailsham, a number of other Ministers, members of both Houses of Parliament, and representatives of scientific institutions and overseas bodies. This was the first occasion on which parliamentarians have been able to see under one roof such a comprehensive range of exhibits and demonstrations dealing with British scientific and technological developments.

The organization of the *Conversazione* was in the hands of a small working party, on which the General Secretary of the Institution served, and some 40 scientific institutions provided or sponsored exhibits. The themes for these ranged from "Animal Health and Food," "Textile Development," "Lighting and Colour," "Optics and Vision," "Water Supply Research" to exhibits dealing with aircraft navigational systems, a nuclear submarine freighter, an automatic warning system for rail transport, colour television and stereophony.

The exhibits sponsored by the Brit.I.R.E. comprised demonstrations of colour television, a panoramic radio receiver, a demonstration of stereophonic sound reproduction, and navigation systems. Several other exhibits involved electronic techniques, and the Institution also collaborated with the sponsors of some of these items.

Great interest was shown in the large screen television demonstration given by the medical colour television unit of the Smith, Kline and French Laboratories, built by Marconi's Wireless Telegraph Company Ltd. Members of the

Institution will, of course, recall that this equipment was described and demonstrated at the 1959 Television Engineering Convention in Cambridge. The programmes included special displays by some of the organizations participating in the *Conversazione*, and interviews with the Minister for Science, the President of the Royal Society and others were transmitted over the sound and vision system.

The panoramic receiver, which was provided by Racal Engineering Ltd., is basically a triple superheterodyne circuit with a crystal-controlled local oscillator; it tunes continuously over the band from 1 to 30 Mc/s without the use of waveband switches.† This receiver operates in conjunction with a panoramic display unit, on the cathode ray tube of which portions of the r.f. spectrum up to 1 Mc/s in width can be selected and shown. The received signals are visible as vertical 'pips' along the horizontal time-base sweep, together with calibration 'pips.' The combination provides a very versatile instrument with many communications applications.

Throughout the evening programmes of stereophonic sound were reproduced from discs on a high quality reproducer provided by the Decca Record Company Ltd. These demonstrations were given in the Royal Society's Meeting Room, which was also used for the projection of scientific films. The film sponsored by the Institution was entitled "Flight to Frankfurt" and showed the operation of the Decca Navigator Flight Log in air traffic control areas as well as along the route. This provided a most useful adjunct to a display of the Automatic Landing System‡ by the R.A.E. Blind Landing Experimental Unit, and sponsored by the Institution of Mechanical Engineers.

The success of this *Conversazione* indicated the usefulness of such meetings. It will undoubtedly be followed by others.

* The Parliamentary and Scientific Committee, which is an unofficial non-party group of members of both Houses of Parliament and representatives of scientific and technical institutions, was the first of such bodies to be established; it has the object of providing a permanent liaison between scientific bodies and Parliament, and its pattern has since been followed in several commonwealth and overseas countries. The Brit.I.R.E. was among the first professional institutions to obtain membership of the Committee.

† A brief note on this receiver, originally designed by T. L. Wadley in South Africa, was given in the paper "Some recent developments in communication receiver design" by A. E. Pope, *J. Brit.I.R.E.*, 15, p. 370, July 1955.

‡ A paper describing this system will be read at a London meeting of the Institution on 11th May.

REPORT OF THE ANNUAL GENERAL MEETING OF SUBSCRIBERS TO THE Brit.I.R.E. BENEVOLENT FUND

The Meeting was held on 2nd December 1959, under the Presidency of Professor E. E. Zepler.

1. To confirm the Minutes of the Annual General Meeting of Subscribers held on 26th November 1958.

The Notice convening the Annual General Meeting of Subscribers, which had been published in the November 1959 *Journal*, was read. Mr. Clifford, Honorary Secretary of the Fund, then stated that the Minutes of the last Annual General Meeting had been published in the January 1959 *Journal* and the proposal that those Minutes be signed as a correct record of the proceedings was approved unanimously.

2. To receive the Annual Report of the Trustees and

3. To receive the Income and Expenditure Account and Balance Sheet for the year ended 31st March 1959.

The President asked Mr. Clifford to deal with the Annual Report of the Trustees and the Accounts of the Benevolent Fund.

Mr. Clifford stated that the report published in the December 1959 *Journal* expressed the regret of the Trustees that only a small proportion of members supported the Benevolent Fund. The Trustees had therefore asked him to see if something could be done to secure more than 18 per cent. support from the membership, and to express their appreciation to those members who co-operated by completing deeds of covenant.

Members should also obtain encouragement from the support given to their own Benevolent Fund by the Radio Industries Clubs of London and Manchester, and by some industrial organizations. In this latter connection, the Trustees had particularly appreciated the initiative taken by Electric and Musical Industries Ltd.

Subscribers would not wish for further elaboration on the details given in the Report of the ways in which the Fund had given assistance during the year. As there had not been any fresh claims, however, the Trustees had taken the opportunity to increase the Fund's investments and thereby build up capital.

Members concurred most warmly in the congratulations expressed on their behalf to the President, Professor Zepler, who recently had the honour of being presented to Her Majesty

The Queen Mother, and thanked for the work done by the Institution for Reed's School. The occasion was the opening of a new wing at Reed's School, Cobham, and Professor Zepler was present as the Institution's representative and as a Trustee of the Benevolent Fund.

Mr. Clifford felt that the Accounts and Balance Sheet of the Fund did not require any detailed explanation and his proposal that the Annual Report and Accounts for the year ended 31st March 1959 be adopted was approved unanimously.

4. To elect Trustees for the year 1959-60.

The Agenda detailed the Trustees who had been responsible for the administration of the Benevolent Fund during the year, Mr. Clifford stated that it would appear to be the wish of subscribers that those Trustees should continue in office. Formal and unanimous approval was therefore given to the proposal that the following be elected Trustees for 1960:—

Professor E. E. Zepler—President.

Mr. G. A. Marriott—Immediate Past President.

Rear Admiral Sir Philip Clarke—Past President.

Mr. A. A. Dyson (Member).

Mr. A. H. Whiteley (Companion).

and that Mr. G. A. Taylor and Mr. G. D. Clifford should continue to act as Honorary Treasurer and Honorary Secretary respectively.

5 and 6. To appoint the Honorary Solicitor and the Honorary Accountant.

Mr. Clifford referred to the very great help which the Trustees received from Mr. Charles Hill and Mr. R. H. Jenkins who for many years had acted as the Fund's Solicitor and Accountant respectively. Both these gentlemen gave their time and services in an honorary capacity and were always willing to give every possible help in the administration of the Fund.

Mr. Clifford therefore moved that Mr. Charles Hill and Mr. R. H. Jenkins be re-appointed and the proposal was carried unanimously.

7. Any other business.

Notice of other business had not been received and after thanking all subscribers for their support during the year the Secretary declared the annual general meeting of subscribers to the Benevolent Fund at an end.

Time-base Synchronization and Associated Problems †

by

P. L. MOTHERSOLE, ASSOCIATE MEMBER ‡

A paper read on 2nd July 1959 during the Institution's Convention in Cambridge.

Summary: The definition and quality of a television picture is determined by the effectiveness of the time-base synchronization when the receiver is used in a noisy situation. The requirements of the synchronizing and time-base oscillator circuits for use with both positive and negative modulation systems are described. Circuit techniques are surveyed to show the difference in approach due to the sense of the video modulation.

1. Introduction

In this paper the problems of time-base synchronization are discussed with particular emphasis on the effects of noise pulses. Various circuit techniques are surveyed to show the difference of approach necessary due to the sense of the video modulation used in different television systems.

The quality of a television picture is determined to a very great extent by the effectiveness of the time-base synchronization. Incorrect frame synchronization will result in poor interlace which will reduce the effective horizontal definition due to the superimposition of the two frame signals and at the same time the vertical definition is reduced by a factor two. The horizontal definition may also be reduced by ragged synchronization of the line time-base by h.f. noise. As cathode-ray tube sizes increase these effects become significantly more important.

Effective interlace not only depends on the design of the frame pulse separator circuit but also on the frame and line time-base circuits layout and possible interaction. An integrating network for frame pulse separation has the advantage of a high degree of noise immunity but when equalizing pulses are not used a timing error is produced between the odd and even synchronizing pulses. The magnitude of this error is calculated for a wide range of integrating time constants and it is shown that this error is not in itself responsible for poor interlace.

† Manuscript received 28th February, 1959. (Paper No. 539.)

‡ Mullard Research Laboratories, Salfords, near Redhill, Surrey.

U.D.C. No. 621.397.335

The problems encountered in line synchronizing circuits are discussed and the conflicting requirements of an a.f.c. system analysed. Auxiliary direct synchronization in conjunction with an a.f.c. circuit is discussed as a possible method of extending the catching range of a narrow band system.

2. Synchronizing-pulse Separator

2.1. Conventional Limiting Circuit

The function of the synchronizing-pulse separator is to remove the video information from the composite video signal and to present to the following stages synchronizing-pulses as free as possible from the effects of random noise and interference pulses. The video information is transmitted by amplitude modulation of the r.f. carrier and interference pulses produce random variations of the instantaneous carrier amplitude. An interference pulse can therefore produce an increase or decrease in the instantaneous video modulation but overcancellation of the carrier produces an interference pulse in the video detector circuit.

The sense of r.f. modulation used in the system has a considerable effect on the problems associated with the design of the synchronizing-pulse separator stage. With positive modulation (e.g. as used in the 405 and 819 line systems) impulsive noise of large amplitude mainly produces pulses in the direction of, and often extending above, the picture information, leaving the synchronizing pulses relatively undisturbed. Negative modulation (e.g. as used in the 525 and 625 line systems) results in the interference pulses going in the direction of the synchronizing

pulses and often extending above them. These effects are shown in Fig. 1.

The conventional separator circuit used with the negative-going video signal from the c.r.t. cathode is shown in Fig. 2. It consists of a valve having a narrow grid base (e.g. a high slope triode or a pentode with a low value of screen-grid potential) to which the video signal is a.c. coupled with a long time-constant network (C1, R2), a typical value being 0.05 sec. The

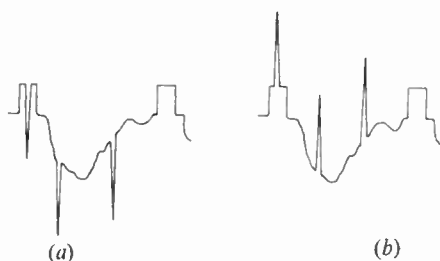

Fig. 1. Noise pulses on a video signal.

(a) Positive modulation. (b) Negative modulation.

signal is negatively d.c.-restored at the grid by grid current and since the signal amplitude is much larger than the grid base, the valve is only able to conduct during the synchronizing pulses. Thus negative-going separated pulses are produced at the anode.

To prevent the valve amplifying the tip of the pulse and the h.f. noise present the pulse tip is removed by the clipping action of grid current in the source impedance of the video amplifier and the series grid resistor (R1, Fig. 2).

This separator circuit is very satisfactory with a positive modulation system since most impulsive noise occurs when the valve is cut-off, and can only influence the output pulses if it occurs at the same time as the synchronizing pulses (Fig. 1(a)).

With a negative modulation system, however, noise pulses extending above the amplitude of the synchronizing pulses (Fig. 1(b)) will tend to produce excessive grid current, charging the coupling capacitor. The resulting negative potential at the grid holds the separator valve cut-off until the charge has leaked away through the grid resistor R2. The synchronizing pulses following a noise pulse are therefore not produced in the anode circuit. This effect is called "blocking". To minimize blocking a parallel

C-R network, C2 R3 (shown dotted, Fig. 2), having a short time constant of about 40 micro sec, is connected in series with the grid circuit. Any sudden increase in grid current charges C2, this capacitance being much smaller than C1. The capacitor C2 can rapidly discharge through R3 and thus the charge on C1 is not seriously disturbed by an interference pulse of short duration.

2.2. Multiple Clipping

Further stages of clipping following the separator are often employed to improve the shape of the pulses and to remove any residual amplitude variations. Further clipping however does not improve the synchronization on noisy signals, and often when direct line synchronization is employed it tends to exaggerate the effects of h.f. noise. Any interference signal that is within the grid base of the separator is amplified and further clipping stages amplify and shape the interference signal still further. In the same way, if the separator is "blocked" by impulsive noise on a negative modulation system any following clipping stages will also be blocked.

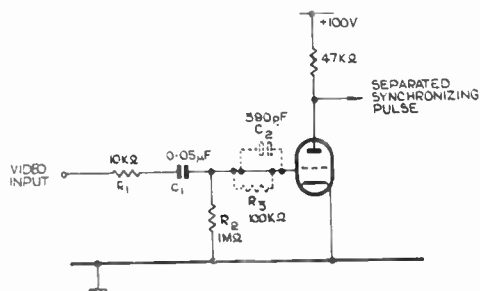

Fig. 2. Conventional separator circuit.

It is apparent therefore that the problem of synchronizing-pulse separation in the presence of impulsive interference is much more difficult with a negative modulation system. Furthermore to obtain reliable synchronization in adverse conditions the amplitude of any interference pulses must be limited before the grid of the separator valve to prevent blocking.

2.3. Noise-cancelling Circuits

These circuits can be classified into two types.

- (a) Noise-gated separators in which noise pulses are used to hold the separator non-conducting;

(b) Noise inverters which operate on the video signal applied to a conventional separator circuit.

2.3.1. Noise-gated circuit

A dual control valve may be used as a separator with the video signal applied to the second control grid in the conventional manner, and negative-going noise pulses obtained from the video detector applied to the first control grid.¹ A typical circuit is shown in Fig. 3. The first

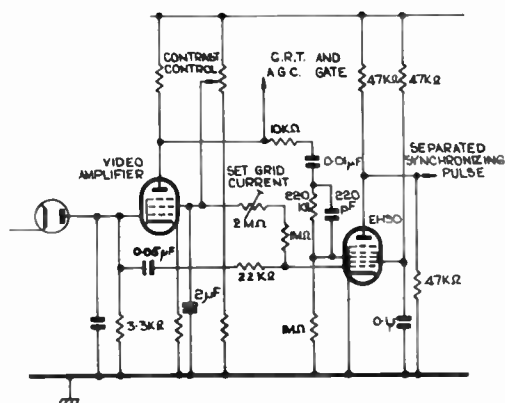

Fig. 3. Noise-gated separator circuit.

control grid is held in grid current and the valve operates as a conventional separator with the signal applied to the second control grid. The grid current is adjusted so that normal amplitude video signals at the video detector are unable to effect the operation of the valve but any noise pulses exceeding the amplitude of the video signal hold the valve cut-off on the first grid for the duration of the pulse. Thus large amplitude noise pulses are unable to "block" the separator and the resulting noise output pulse at the anode is reduced in amplitude.

The adjustment of the first control grid current is very critical and is dependent on the detector signal level and video amplifier gain. If the current is set too high the noise pulses will be unable to cut the separator valve off and if it is set too low the separated pulses at the anode will be limited in amplitude by the synchronizing pulses themselves applied to the first grid.

A further difficulty that can occur with the heptode circuit when it is used in conjunction with a line-gated a.g.c. circuit is "lock out". With a normal line-gated circuit the a.g.c.

potential falls when the line time-base is unsynchronized, increasing the video signal amplitude. The increased signal amplitude at the video detector may hold the separator cut-off and so prevent synchronization of the time-base.

The synchronizing pulses are contained in a relatively narrow frequency band about 1Mc/s wide centred on the vision carrier. Sharp noise pulses, however, have a reasonably distributed spectrum extending over the full frequency band. Thus it is possible to separate the synchronizing and noise pulses on a frequency selective basis.² A second video detector driven by a bandpass circuit, having a bandwidth of about 3 Mc/s and spaced some 3 Mc/s from the vision carrier, will only respond to sharp noise pulses and h.f. video signals. This output may therefore be applied to a noise gated separator circuit. Lock-out is not possible and the circuit is not critical of signal level since no synchronizing information is produced by the noise detector. A limitation of this circuit, however, is that it may not respond to low frequency interference.

2.3.2. Noise inverter circuit

Inverted noise pulses can be added to the video signal at the grid of a conventional separator to reduce the effects of impulsive noise and prevent blocking. A typical circuit is shown in Fig. 4. The noise inverter triode V2 is held cut-off by the negative d.c. potential applied to the control grid from the grid circuit of the synchronizing pulse separator V3, in addition to the positive cathode potential. Noise pulses exceeding the amplitude of the video signal cause

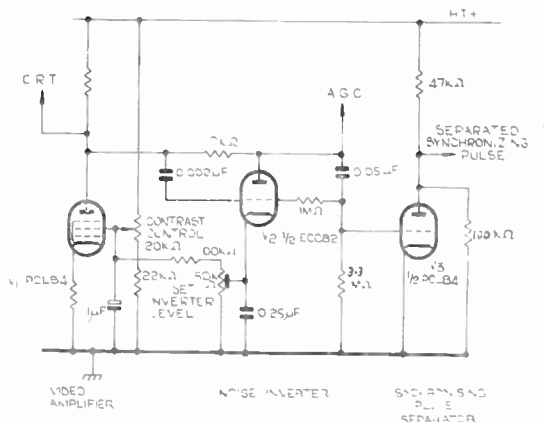

Fig. 4. Noise inverter circuit.

the valve to conduct producing amplified negative-going pulses at its anode. The normal series resistor to the separator valve is used as the anode load resistor and the noise pulse is therefore effectively cancelled at the control grid of the separator valve. The advantages of this type of noise inverter circuit are that the noise-cancelled video signal at the anode of the inverter may be used for the a.g.c. circuit and the adjustment of the bias for the inverter valve is less critical than for the heptode circuit described above, since the signal level is much higher.

2.3.3. Signal amplitude variations

A noise-cancelled circuit only remains effective if the circuit can follow changes in video signal amplitude. In most cases the circuit is pre-set to operate at a given signal amplitude and therefore the a.g.c. system must be effective in holding the signal amplitude constant at this value. By utilizing the a.g.c. delay potential and video signal itself to set the operating level of the cancelling circuit, however, compensation can be made for different contrast control settings. In the inverter circuit shown in Fig. 4 for example, part of the bias for the inverter circuit is obtained from the grid circuit of the separator valve V3 (proportional to the video signal amplitude) and part from the contrast control.

To minimize the danger of "lock-out", on a negative modulation system, due to the video signal amplitude increasing when the line time-base is not in synchronism, the a.g.c. potential must be independent of the time-base synchronization. A simple method of achieving independence with a line-gated circuit is to precede the

conventional pulsed amplifier with a peak detector.³ Such a circuit may be operated with advantage from the anode of the noise inverter (Fig. 4).

It is important to note that noise-cancelled circuits in which noise pulses are separated by amplitude selection are only effective against noise pulses that exceed the video signal amplitude. In general, these circuits are less critical to adjust when operated from the output signal of the video amplifier. The effect of noise pulses that penetrate the synchronizing separator may be minimized by a flywheel synchronizing circuit. By this means individual pulses are unable to affect the picture synchronization until they have reached a level sufficient to render the picture unusable due to modulation of the video signal.

3. Frame Synchronization

The frame pulse separator circuit forms a buffer between the synchronizing-pulse separator and the frame time-base. It is to a large extent responsible for the noise immunity of the frame time-base and also the final interlace. Poor interlace will reduce the effective horizontal definition due to the superimposition of the two frame signals and at the same time the vertical definition is reduced by a factor two. These effects can be seen in Fig. 5; (a) is part of a correctly interlaced picture, (b) shows the effect of severe pairing and (c) the effect of complete absence of interlace.

The problem of obtaining an interlaced raster can be divided into two parts: (a) the frame synchronizing-pulse separator and (b) the complete time-base design.

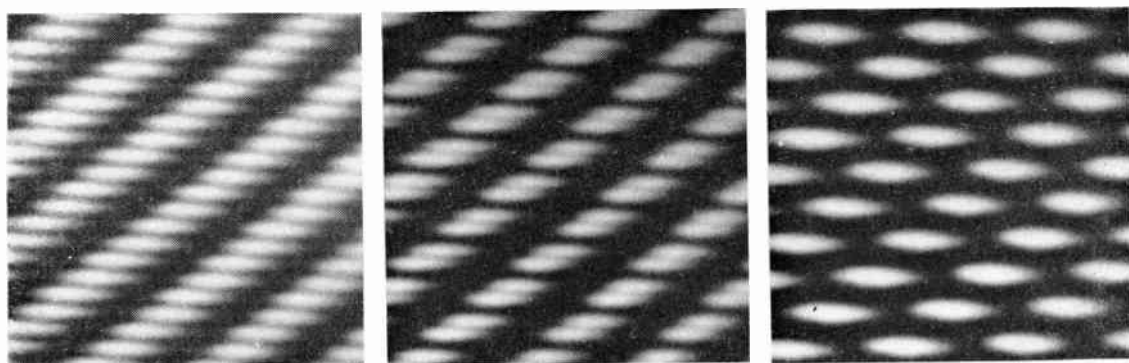

Fig. 5. (a) Correct interlace

(b) Pairing.

(c) Complete loss of interlace.

3.1. Frame Pulse Separator

The frame pulse separator circuit has been the subject of many papers, notably by Patchett.⁴ The requirement of the separator circuit is that it should produce a synchronizing pulse with a sharp leading edge and a constant time delay relative to the start of the frame synchronizing signal. The time delay should be the same on both odd and even frames. It is also very important that the circuit should be insensitive to interference pulses and h.f. noise.

The simplest method of separating the frame pulse from a composite synchronizing signal and at the same time providing a high degree of noise immunity is by integration. To obtain a sharp synchronizing pulse and to remove the residual line pulses the integrating circuit should be followed by a limiting circuit.

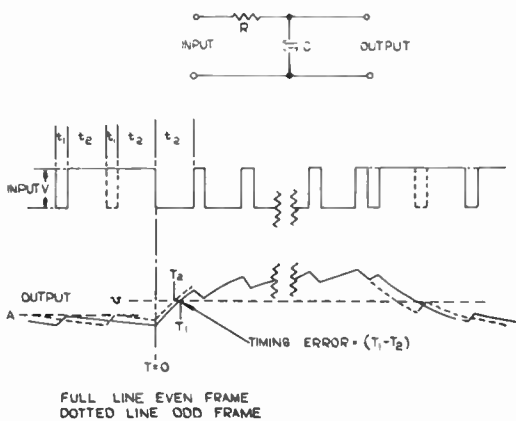

Fig. 6. R.C integrating circuit.

When equalizing pulses are not used, as in the British 405-line system, the integrated frame pulse will have a different width on odd and even frames. This results in a small timing error between the leading edges of the pulses and a much larger error between the trailing edges. These different pulse widths and the resulting timing errors are due to the different charge and discharge times for the integrating capacitor. (See Fig. 6.) It has been suggested that correct interlace cannot be obtained with an integrating circuit without the use of equalizing pulses since if the leading edge of the integrated pulse is used to trigger the time-base the inherent timing error will prevent accurate interlace. In theory this is so, but providing the timing error is small the

degree of non-interlace will be hardly discernable. If it is considered that a 10 per cent interlace error is allowable (this is just discernable on a 21-inch picture tube) the frame time-base must be triggered within 1/10th of 1/2 a line which corresponds to 5 microsec for the 405-line system and 3.2 microsec for the 625-line system. The integrating time-constant must therefore be of such a value that the inherent error is less than this value.

3.1.1. Integrating network time constant

The difference in the waveform between odd and even frames at the start of the integrated frame pulse is shown in Fig. 6. The amplitude of the integrated waveform at the end of a line pulse, ignoring the mean value, is given by

$$V_0 = V\{1 - \exp[-t_1/CR]\} \dots\dots\dots(1)$$

where t_1 = time duration of a line pulse

CR = integration time-constant

V = input signal amplitude

This corresponds to level 'A' in Fig. 6.

The potential at the start of the frame pulse, ($T=0$, Fig. 6), is given by

$$V_{0(\text{even})} = V\{1 - \exp[-t_1/CR]\} \exp[-(t_1+2t_2)/CR] \dots\dots\dots(2)$$

for the even frame and

$$V_{0(\text{odd})} = V\{1 - \exp[-t_1/CR]\} \exp[-t_2/CR] \dots\dots\dots(3)$$

for the odd frame,

where t_2 = time duration of a frame pulse.

The difference in potential

$$V_{0(\text{odd})} - V_{0(\text{even})} = \Delta V.$$

From (2) and (3)

$$\Delta V = V\{1 - \exp[-t_1/CR]\} \times \left\{ \exp[-t_2/CR] - \exp[-(t_1+2t_2)/CR] \right\} \dots\dots\dots(4)$$

During the period of the first frame pulse the output potential is given by

$$V_{0(\text{even})} = V\{1 - \exp[-t/CR]\} \dots\dots\dots(5)$$

for the even frame and

$$V_{0(\text{odd})} = (V - \Delta V)\{1 - \exp[-t/CR]\} + \Delta V \dots\dots\dots(6)$$

for the odd frame.

If a limiting circuit operates such that the time-base triggers at a potential corresponding to v (Fig. 6), the timing error is $T_2 - T_1$. Writing these values into eqns. (5) and (6) and equating

$$V\{1 - \exp[-T_2/CR]\} = (V - \Delta V) \times \{1 - \exp[-T_1/CR]\}$$

Rewriting

$$T_1 - T_2 = C.R. \log_e \left(\frac{V}{V - \Delta V} \right) = C.R. \log_e \left(\frac{1}{1 - \Delta V/V} \right) \dots\dots\dots(7)$$

Since ΔV is much less than V , eqn. (7) simplifies to

$$T_1 - T_2 \cong C.R. \frac{\Delta V}{V}$$

Using (4)

$$T_1 - T_2 = C.R. \{1 - \exp[-t_1/CR]\} \times \{ \exp[-t_2/CR] - \exp[-(t_1 + 2t_2)/CR] \} \dots(8)$$

The curve in Fig. 7 shows the relationship between the time constant $C.R$ and the timing error ($T_2 - T_1$). It can be seen from Fig. 7 that the maximum error is less than 2.5 microsec and occurs with a time constant of about 70 microsec. Thus the inherent interlace error due to the integrating network itself is less than the suggested limit of 5 microsec.

The use of multiple integration has been investigated.⁵ The use of more than one stage of integration in the separation of the frame pulse reduces the amount of noise reaching the frame time-base without any deterioration in either the height or rise-time of the frame synchronizing

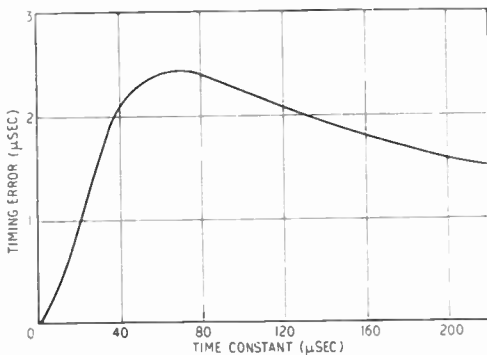

Fig. 7. Variation of timing error with time constant.

pulse. Unfortunately, however, in a system without equalizing pulses such circuits cannot be used without introducing a larger degree of non-interlace.

3.1.2. Pulse shape and optimum time constant

The interlace accuracy is not appreciably impaired by a separator circuit employing an integrating network providing the time-base oscillator is triggered at the same point on the leading edge of the pulse on both odd and even frames. The certainty of synchronization on a given part of an integrated waveform is best ensured by a clipping circuit following the integrating network. The optimum time-constant for the integrating network is to some extent dependent on the following clipping or limiting circuit.⁶

For single level clipping (i.e. a simple amplitude limiter), the time constant should be such that the amplitude difference between line pulses and the first frame pulse is a maximum. From Fig. 6 this potential difference V_d is given by

$$V_d = V\{1 - \exp[-t_2/CR]\} - V\{1 - \exp[-t_1/CR]\} \text{ approximately,}$$

Rewriting

$$V_d = V\{\exp[-t_1/CR] - \exp[-t_2/CR]\} \dots\dots(9)$$

Differentiating

$$\frac{dV_d}{dCR} = \frac{V}{C^2R^2} \{ t_1 \exp[-t_1/CR] - t_2 \exp[-t_2/CR] \} \dots\dots\dots(10)$$

Equating to zero for a maximum and rewriting

$$CR = \frac{t_2 - t_1}{\log_e(t_2/t_1)} \dots\dots\dots(11)$$

For the British 405-line system $t_1 = 9\mu\text{sec}$ and $t_2 = 40\mu\text{sec}$.

$$CR = 20 \mu\text{sec.}$$

For double level clipping (i.e. a slicing circuit), the time constant should be such that the amplitude difference between the line pulses and the start of the second frame pulse should be a maximum. From Fig. 6 this potential difference V_d is given by

$$V_d = V\{1 - \exp[-t_2/CR]\} \exp[-t_1/CR] - V\{1 - \exp[-t_1/CR]\} \text{ approx.}$$

Rewriting

$$V_a = V \left\{ 2 \exp[-t_1/CR] - \exp[-(t_2 - t_1)/CR] - 1 \right\} \dots\dots\dots(12)$$

Differentiating

$$\frac{dV_a}{dCR} = \frac{V}{C^2 R^2} \left\{ 2t_1 \cdot \exp[-t_1/CR] - (t_1 + t_2) \times \exp[-(t_2 + t_1) CR] \right\} \dots\dots\dots(13)$$

Equating to 0 for a maximum and rewriting

$$CR = \frac{t_2}{\log_e \left(\frac{t_1 + t_2}{2t_1} \right)}$$

With $t_1 = 9\mu\text{sec}$ and $t_2 = 40\mu\text{sec}$.
 $CR = 40\mu\text{sec}$.

The method by which the triggering pulse is applied to the oscillator in a system without equalizing pulses must be such that the oscillator is insensitive to the trailing edge of the pulse. The design of the limiting circuit is therefore dictated by the trigger sensitivity and the input impedance of the oscillator. A further aspect that must be considered with some oscillator circuits is the large pulse that is produced when the oscillator triggers which can effect the limiter circuit and even feed into the line time-base via the synchronizing circuits. Typical examples of such circuits are the blocking oscillator and the anode-coupled multivibrator. The cathode-coupled multivibrator is an example of an oscillator circuit that does not produce any feedback and at the same time it is very sensitive to synchronizing signals.

Some separator circuits produce a series of trigger pulses corresponding to the series of frame pulses. With such circuits it is important that the time-base triggers on the same pulse on both odd and even frames or interlace will be lost.

3.1.3. Oscillator conduction time

If the frame synchronizing-pulse used to trigger the oscillator has a non-interlaced trailing edge the valve to which it is applied must be cut-off before the edge arrives. Thus when the synchronizing pulse triggers the oscillator valve "on", (i.e. as in a blocking oscillator), the conduction time of the valve must be less than the

pulse duration. A typical value is about 200 microsec.

When the synchronizing pulse triggers the valve "off", (i.e. as in a cathode-coupled multivibrator), the valve must be held non-conducting for a time greater than the pulse duration. A typical value is about 600 microsec.

3.2. Typical Circuits

The following circuits show different approaches to the design of frame pulse separator stages. These circuits combine good noise immunity for the oscillator and at the same time produce sharp synchronizing pulse without the use of special valves or components.

3.2.1. Integrator and triode limiter

A circuit employing an integrating network followed by a triode limiter is shown in Fig. 8. The separated synchronizing pulse waveform is integrated by R1, C1 and d.c. coupled to the

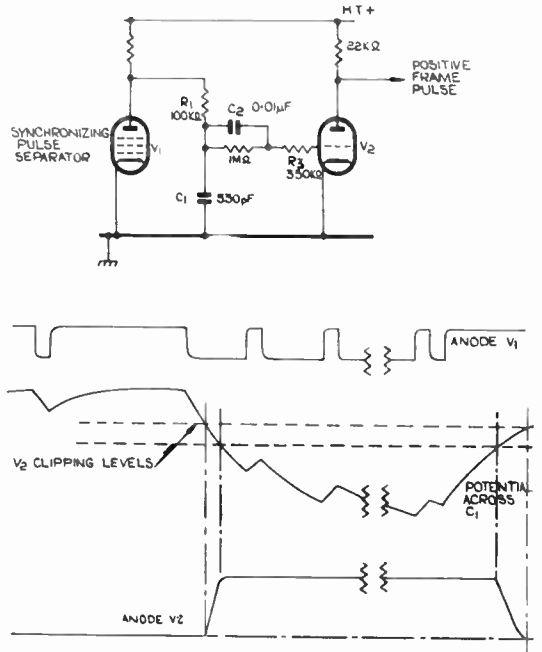

Fig. 8. Integrator and triode limiter.

grid of the triode valve. The valve is held in conduction due to the d.c. coupling to the anode of the separator valve but cut-off by the negative integrated pulse applied via C2. The clipping level is determined by the d.c. grid current and the value of the grid stopper resistor R3.

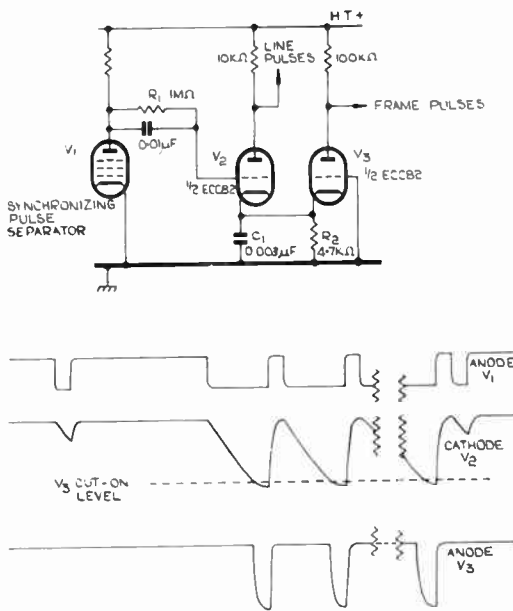

Fig. 9. Integrator with different time constants.

The large-amplitude positive pulse produced at the anode has a sharp leading edge. When used on a television system without equalizing pulses a small error of about 2 microsec occurs on the leading edge of the pulse, and a large error of about 20 microsec occurs on the trailing edge, as discussed above.

3.2.2. Integrator with different time constants

If different time constants are used for the charge and discharge of the integrating capacitor the trailing edge of the 40 microsec pulses may be made much sharper than the leading edges. The use of the first trailing edge for synchronization will then result in more consistent interlace. A practical circuit,⁷ which uses this principle and at the same time may provide a double clipped waveform for the line time-base synchronization, is shown in Fig. 9.

The first triode V2 is held conducting by the d.c. connection to its grid. The resulting positive cathode potential developed across R2 holds V3 out off. The negative-going input pulse cuts V2 off and the cathode potential falls as C1 discharges through R2. The integrating capacitor C1 is unable to discharge sufficiently during a line pulse (9 microsec) to enable V3 to conduct

and therefore no output is produced at its anode. At the end of the pulse C1 is recharged on a short time-constant by V2 which acts as a cathode follower. When V2 is cut off by a frame pulse (40 microsec) the cathode potential falls further and V3 is able to conduct, producing a negative amplified pulse at its anode. At the end of the pulse the capacitor C1 is again completely recharged by V2. Thus at the anode of V3 eight pulses are produced, corresponding to the eight frame pulses. These pulses are differentiated before applying to the time-base, which is normally arranged to trigger on the first positive-going edge.

3.2.3. Integrator and diode limiter

This separator is designed to operate in conjunction with a cathode-coupled multivibrator circuit. The high trigger sensitivity of the multivibrator is exploited in simplifying the separator circuit, the output being about 0.5 volt. The separator circuit is designed to operate with a positive-going input and is shown in Fig. 10.

The positive-going separated synchronizing pulses are integrated by R1,C1 and a.c. coupled to a diode clipper. The diode is only able to conduct on the positive tip of the waveform,

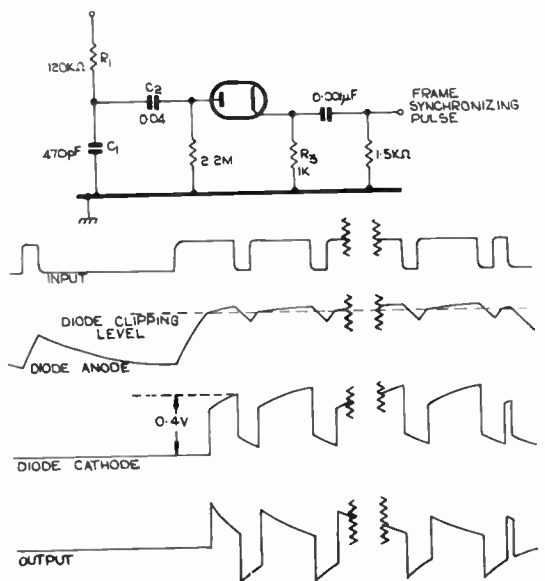

Fig. 10. Integrator and diode limiter.

which is the frame synchronizing pulse, due to the charge on the coupling capacitor C2 produced by the diode current when it conducts. Thus the clipping level of the diode follows any variation of signal amplitude automatically. The separated waveform, consisting of a series of eight pulses, is developed across the low value resistor R3, in series with the diode. These pulses are differentiated before applying to the oscillator to remove low frequency components.

3.2.4. Integration of a composite video signal

If a composite video signal is integrated the frame synchronizing pulse will be the most positive component of the integrated waveform and may be separated by a triode clipping circuit.⁸ The advantage of this method of frame pulse separation is that interference pulses of short duration and h.f. noise are prevented from reaching the synchronizing-pulse separator circuit and receiving amplification. This technique can only be used when equalizing pulses are employed, however, since the three-line interval between the video information and the frame pulses is necessary to prevent the frame pulses being influenced by the video information. This consideration also limits the integration time-constant to about 30 microsec.

It is important with this circuit technique that the amplitude of any interference pulses should be limited to that of the synchronizing pulses. The video signal must therefore be taken from the output of a noise inverter circuit (Section 2.3.2).

A complete circuit is shown in Fig. 11. The first valve V1 operates as a noise inverter supplying a noise-cancelled signal to the a.g.c. circuit (not shown) and to the synchronizing pulse separators. The line pulses are separated in a conventional circuit using a high-slope triode V2. The video signal is taken from the grid circuit of this valve via the integrating network R5,C4 to the frame pulse separator V3. The line-pulse separator V2 is driven hard into grid current on each line pulse and the resulting negative potential produced in its grid circuit is used to set the clipping level for the frame pulse separator. The frame separator just goes into grid current on the tip of the frame pulse and the resulting separated frame pulse at its anode is used to trigger the frame oscillator.

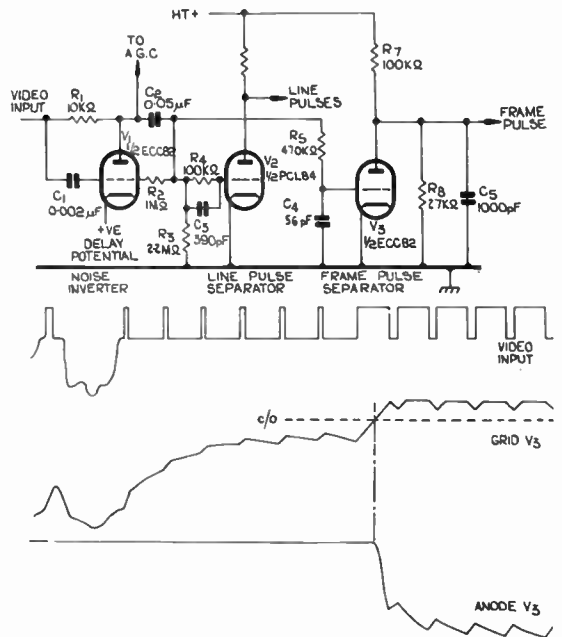

Fig. 11. Noise inverter and separator circuits.

3.3. Complete Time-base Design

In the above discussion the emphasis has been on obtaining a sharp trigger pulse for the time-base with an accurate leading edge on both odd and even frames. Unfortunately the problem of obtaining an interlaced raster does not end with the generation of such a pulse. The synchronizing pulse only initiates the oscillator flyback and an interlaced oscillator flyback does not ensure an interlaced raster.

A non-interlaced raster is obtained, for example, when the oscillator flyback duration is slightly different on odd and even frames. The amplitude of sawtooth drive waveform at the grid of the frame output valve is about 20 volts. The rate of rise is therefore 20/20000 = 1 mV/μsec. A 5 microsec timing error will produce a 10 per cent loss of interlace and therefore a 5 mV amplitude difference between odd and even frame sawteeth will produce a similar interlace error.

To observe this waveform difference on an oscilloscope the Y amplifier must have an input sensitivity of about 10 mV/cm and be capable of handling an input signal of at least 20 volts at this sensitivity. To expand the time scale a jitter-free delayed trigger pulse must be used to trigger the oscilloscope time-base.⁹

The most common cause of the oscillator fly-back differing slightly on odd and even frames is due to line pulses being injected into the oscillator circuit. This can occur through cross-talk in the deflector coils feeding line pulses via the linearity correction network into the oscillator circuit or to cross-coupling due to wiring associated with double valves common to the line and frame time-bases. These factors are

The reduction in definition due to h.f. noise disturbing the time-base synchronization on weak signal is shown in Figs. 12(a) and (b). In both of these photographs the video signal used to modulate the cathode ray tube is the same, and supplied from a separate receiver operating with a strong signal input. In Fig. 12(a) direct synchronization is used and in Fig. 12(b) flywheel synchronization.

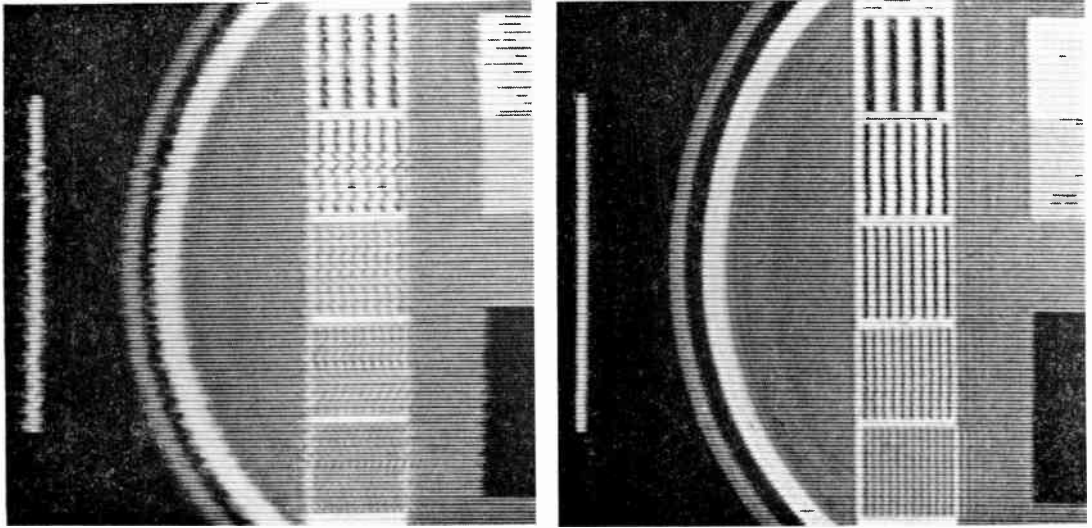

Fig. 12.

(a) Effect of h.f. noise on directly-synchronized line time-base. (b) Effect of flywheel synchronization.

related to a particular receiver layout and help to explain how a circuit that is satisfactory in one receiver can give quite different results in another with quite unrelated component changes.

4. Line Synchronization

In television receivers two systems of line synchronization are used, (a) "direct" synchronization and (b) "flywheel" synchronization.

With a directly-synchronized time-base the leading edge of the synchronizing pulse is injected into the oscillator to trigger the flyback. A noise pulse occurring just before the pulse edge is thus able to initiate the flyback prematurely, displacing the following scanning line. The only h.f. noise able to penetrate a well-designed separator stage is that occurring on the edges of the synchronizing pulses. This causes a small random variation in the triggering of the line time-base and results in a reduction of the horizontal definition.

In a flywheel-controlled line time-base, the frequency of the oscillator is controlled by the output derived from a phase detector to which the synchronizing pulses and a reference waveform from the time-base are applied. The integrating network, or filter, between the phase detector and the oscillator prevents the oscillator responding to sudden variations in the phase of the synchronizing pulses. Thus noise pulses are unable to effect individual scanning lines and h.f. noise is unable to pass through the filter.

4.1. Direct Synchronization

The synchronizing pulses from the anode of the separator valve, or following clipping stage, are applied to the line oscillator to initiate the flyback. The most attractive feature of direct synchronization is the economy in components, the circuit consisting simply of a small capacitor. The effect of the frame synchronizing pulses on

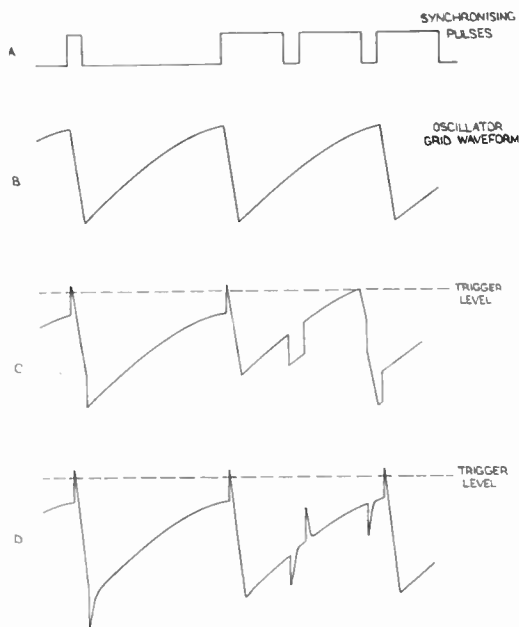

Fig. 13. Effects of frame pulses on a directly-synchronized oscillator.

the line oscillator is shown in Fig. 13. If the synchronizing waveform is not differentiated (Fig. 13(c)) the oscillator is triggered early at the start of the frame synchronization period which results in a disturbance at the top of the picture. The amplitude of the synchronizing pulses must be chosen to ensure that the twice line frequency pulses are not able to affect the oscillator (Fig. 13(d)). It is also apparent from Fig. 13(d) that the oscillator grid waveform to which the synchronizing pulses are applied should be as steep as possible to obtain the maximum noise immunity for the oscillator. The oscillator is only sensitive to synchronizing signals as the grid approaches the trigger level and therefore only interference pulses occurring towards the end of a scanning line are able to influence the synchronization.

To initiate the flyback the line output valve must be cut-off and therefore the oscillator valve must be driven hard into conduction. Since the leading edge of the synchronizing pulse at the anode of the separator valve is negative-going the oscillator circuit must be capable of accepting a negative-going trigger pulse. A blocking oscillator or multivibrator circuit may therefore be synchronized directly.

An alternative technique is to apply the negative-going synchronizing pulse to the grid of the output valve itself and to use the positive-going flyback pulse at its anode to drive the discharge valve into conduction. Thus the output valve and discharge valve form a multivibrator circuit.

4.2. Interaction of the Line and Frame Time-bases

When the line oscillator triggers, a large amplitude pulse is produced in the oscillator circuit. When the oscillator is directly synchronized this pulse is applied to the anode of the separator valve by the capacitor used for differentiating the synchronizing pulse. Thus superimposed on the separated synchronizing pulse waveform is a differentiated line oscillator pulse. Since this pulse only occurs when the line time-base triggers the effect on odd and even frames is different. At the end of the odd frame the line and frame oscillators trigger together, but at the end of the even frame the frame oscillator triggers half way along the line. Thus the pulse from the line time-base causes a difference in the frame synchronizing waveform which can effect the interlace. A similar effect is produced by line pulses picked up from the line transformer by the grid circuit of the separator valve.

To minimize such interaction the impedance at the anode of the separator valve should be as low as possible and the grid circuit isolated as far as is practical from the line time-base, in particular wiring associated with the transformer and deflector coils.

4.3. Flywheel Synchronization

4.3.1. Static characteristic of an a.f.c. loop

The basis components of an a.f.c. system are shown in Fig. 14. These consist of a phase detector D, a filter network F, and an oscillator O. The frequency of the oscillator depends on the control potential V_c derived from the phase detector after passing through the filter F.

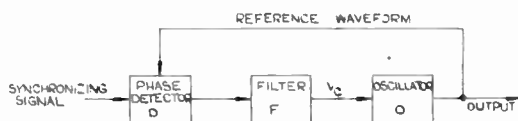

Fig. 14. Block diagram of an a.f.c. system.

The inertia of the filter network provides the "flywheel" action for the system.

The actual frequency of the oscillator is therefore given by

$$f_2 = f_0 + S \cdot F\left(\frac{d}{dt}\right) \cdot D(\varphi) \dots \dots \dots (14)$$

where f_0 = free-running oscillator frequency
 S = control sensitivity cycles/sec/volt

$F\left(\frac{d}{dt}\right)$ = filter transfer characteristic
 $D(\varphi)$ = phase detector output

This may be written

$$\frac{d}{dt} \varphi_2 = \frac{d}{dt} \varphi_0 + 2\pi \cdot S \cdot F\left(\frac{d}{dt}\right) \cdot D(\varphi) \dots (15)$$

The phase difference φ between the input signal f_1 and the output f_2 is given by

$$\varphi = \varphi_1 - \varphi_2$$

$$\text{or } \frac{d}{dt} \varphi = \frac{d}{dt} \varphi_1 - \frac{d}{dt} \varphi_2 \dots \dots \dots (16)$$

Inserting (16) into (15) and rewriting

$$\Delta\omega = \frac{d}{dt} \varphi + 2\pi \cdot S \cdot F\left(\frac{d}{dt}\right) \cdot D(\varphi) \dots (17)$$

$$\text{where } \Delta\omega = 2\pi (f_1 - f_0).$$

This is the general differential equation describing the operation of the complete network. A steady state solution to this equation may be obtained which defines the maximum difference frequency ($\Delta\omega$) between the input signal (f_1) and the free-running oscillator frequency (f_0) over which synchronism can be held. This frequency range is called the "holding range". When the system is in synchronism the phase detector produces a steady d.c. correcting potential such that $d\varphi/dt = 0$ and $\Delta\omega = \text{constant}$. If the filter network has zero attenuation at d.c. eqn. (17) may be written

$$(f_1 - f_0)_{\text{holding}} = S \cdot D(\varphi) = \text{constant} \dots \dots \dots (18)$$

The function $D(\varphi)$ defines the phase detector characteristic. If a sawtooth reference waveform s used the phase detector output will be linearly

related to φ such that $D(\varphi) = D \cdot \Delta\varphi$. Furthermore, if the characteristic is symmetrical the maximum output will be $\pm D \cdot \Delta\varphi$. Thus the total holding range is given by

$$(f_1 - f_0)_{\text{holding}} \leq 2 \cdot S \cdot D \cdot \Delta\varphi \dots \dots \dots (19)$$

This is the maximum range of frequencies over which the oscillator can be held in synchronism by the a.f.c. loop when it is once synchronized.

4.3.2. Dynamic characteristic

The dynamic performance of an a.f.c. system is determined by the transfer characteristic of the filter. The above solution to eqn. (17) is only valid when the oscillator is in synchronism with the synchronizing signal or when the change in frequency is very slow so that the transfer characteristic of the filter is still unity. Mathematically the pull-in or catching range[†] of the system can be obtained from eqn. (17) by inserting the transfer function for the filter and determining the maximum values of $\Delta\omega$ for which the system can reach a steady state solution. Unfortunately however, with practical filter circuits (i.e. proportional-plus-integral networks) and phase detector characteristics no analytical method is available to solve the equation.¹⁰ The dynamic performance of an a.f.c. system has to be determined therefore by empirical methods.

When the oscillator is unsynchronized the output from the phase detector is mainly at the beat frequency between the oscillator and the synchronizing pulses. If the beat frequency is passed by the filter, frequency modulation of the oscillator occurs and this produces a small d.c. output from the phase detector which pulls the oscillator into synchronism.

This mechanism is illustrated by means of Fig. 15. The dotted line represents the characteristic of a symmetrical phase detector in the holding zone. If the oscillator is unsynchronized the phase difference between the oscillator and the synchronizing signal is continuously changing and, therefore, the position of successive

[†] The catching range is defined by the free-running oscillator frequencies from which the oscillator will be pulled into synchronism when the synchronizing pulses are applied to the phase detector.

pulses on the characteristic is also changing. Thus the pulse appears to move across the characteristic. Suppose that the oscillator is running fast, that the reference pulses appear to move from right to left, and that a negative control potential is required to reduce the oscillator frequency towards synchronism. When the reference pulse first enters the holding zone the detector produces its maximum positive output potential ($+V$). This potential after passing through the filter tends to increase the oscillator frequency and therefore the rate at which the pulse appears to move over the characteristic is also increased. As the reference pulse moves over the characteristic the output falls to zero and then goes negative, tending to reduce the oscillator frequency. This tends to reduce the rate at which the reference pulse appears to move. The pulse, therefore, moves rapidly through the first part of the characteristic and much slower through the second half. Thus, due to the variation in the oscillator frequency (frequency modulation), the phase difference for successive pulses is a non-linear function of time and the output is therefore also a non-linear function of time. The resulting output of the detector due to the frequency modulation as a function of time is shown in the full line in Fig. 15. This has a small d.c. component (shown dotted) which is in the correct sense to pull the oscillator into synchronism.

It is apparent that the beat frequency and the filter time-constant will influence the shape of the non-linear output as shown in Fig. 15.

4.3.3. Practical requirements

The inertia of the filter network provides the flywheel action for the system and therefore determines the noise performance. If the cut-off frequency of the filter is lowered the catching range becomes smaller but the noise immunity better. Thus the time constant of the filter is a compromise between a wide catching range and good noise immunity for the oscillator.

The frame synchronizing-pulses give rise to an error signal in the detector output that tends to shift the oscillator phase each frame and causes vertical features at the top of the picture to bend. To minimize such disturbances a double time-constant proportional-plus-integral filter network is used.¹¹

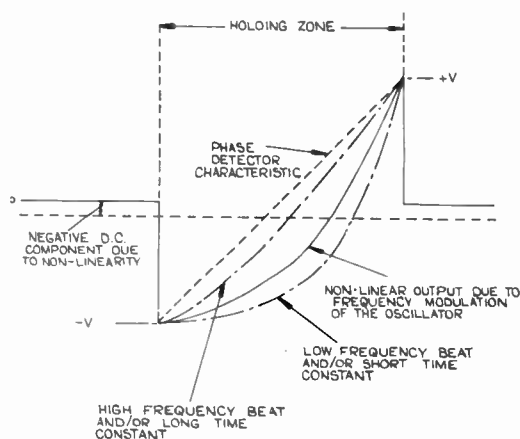

Fig. 15. Effect of f.m. on phase detector characteristic.

To obtain the most useful catching range with a given filter time constant the phase detector must be capable of pulling the oscillator into synchronism from either side of the synchronizing frequency. With such a system if the free-running oscillator frequency is approximately correct then the a.f.c. loop can correct for a drift in oscillator frequency in either direction. It is also very desirable that the phase detector characteristic should be symmetrical about its "no signal" output potential so that $D(\varphi)=0$ when $\varphi=0$ and therefore $f_1 \cong f_0$. When this condition is fulfilled, disturbances in the output control potential, due to interference pulses, are a minimum. It is also apparent that the noise protection of a flywheel circuit is a function of the error signal and therefore the free-running oscillator frequency should be maintained as close as possible to the frequency of the synchronizing pulses. A simple method of ensuring that this condition is fulfilled when the manual frequency control (line hold) is adjusted is to open-circuit the a.f.c. loop by removing either the synchronizing pulses or the reference waveform. This can be done by means of a switch incorporated in a "push-and-turn" type of line hold control.

It can also be seen from eqns. (17) and (19) that the a.f.c. loop performance is proportional to the product of the oscillator control sensitivity (S) and the phase detector output ($D \cdot \Delta \varphi$). It is apparent therefore that similar results can be achieved with either a small phase detector output controlling a sensitive oscillator or a large

detector output controlling an insensitive oscillator. In practice the latter is to be preferred since the frequency stability is better and disturbances due to hum and microphony are much less with an insensitive oscillator. A d.c. amplifier preceding the oscillator to increase its sensitivity suffers from the same defects and is therefore no improvement. The phase detector is a switch and if it is used in conjunction with a large amplitude reference waveform it is not in general sensitive to hum and microphony, and it can then provide the required control potential for an insensitive oscillator. A practical limit for the oscillator sensitivity is not greater than about 100 cycles/sec/volt.

Complete a.f.c. circuits used with positive or negative modulation systems are similar, except that the line oscillator frequencies are in general different and for negative modulation the filter time constant is often longer. These differences are due to:

- (a) The line frequency of the British 405-line system is locked to the supply mains frequency which is liable to vary, and a wide catching range is therefore required. At the same time the use of positive modulation gives a high degree of noise immunity to the synchronizing pulses so that the noise protection of a flywheel system having a wide catching range (short time constant) is satisfactory. The catching range of typical receiver circuits is about 500 to 700 c/s.
- (b) In the 525 and 625-line systems the line frequency is crystal controlled so that the catching range of the receiver is dictated primarily by the stability of the line oscillator. The use of negative modulation increases the synchronizing difficulties due to impulsive noise so that a long time-constant filter is used. The catching range of typical receiver circuits is about 100 to 300 c/s. The use of noise inverters and noise-gated separator circuits, however, reduces the effects of impulsive noise and therefore shorter time-constant filter circuits can be used.

Many different circuits have been used in a.f.c. systems but the most popular are:

- (a) A diode bridge phase detector controlling a cathode coupled multivibrator,¹¹ or a sine wave oscillator and reactance valve circuit,¹² or
- (b) A triode coincidence detector controlling a blocking oscillator. This latter circuit is gener-

ally referred to as the "Synchroguide".¹³ In most of these circuits the valves are used with signals applied to the cathode and the circuit is therefore sensitive to hum. In an a.c./d.c. receiver this is a serious problem since it is not always possible or convenient to operate the flywheel circuit at the cold end of the heater chain. To overcome this difficulty the valves must operate with their cathodes at earth potential or be insensitive to hum applied to the cathode circuit.¹⁴

4.3.4. Automatic synchronization

The catching range of an a.f.c. system is determined by the sensitivity of the complete loop ($S.D.\Delta\phi$) and the filter time constant. To extend the catching range therefore these parameters must be varied during pull-in time or an auxiliary circuit used. The various methods may be classified as follows:

- (a) Variation of the filter time constant or the loop sensitivity during the pull-in time. This type of circuit is called a d.c. quadricorrelator.¹⁵
- (b) Causing the frequency of the line oscillator to be varied by a low frequency sweep until it is within the normal catching range.¹⁶
- (c) Using auxiliary direct synchronization to lock the oscillator when normal synchronization is lost.¹⁷

The d.c. quadricorrelator circuit has so far only found application in some colour sub-carrier synchronization circuits. The low-frequency sweep method was used in an experimental receiver and demonstrated at the National Radio Exhibition in 1954 but it does not seem a practical method for a normal receiver. The auxiliary direct synchronization system is being used in some Continental receivers. A typical circuit is shown in Fig. 16, the operation is as follows.

Positive-going separated synchronizing pulses are applied to both the coincidence detector V1 and the gate valve V2. Applied to the anode of V1 are positive pulses of about 250 volts amplitude derived from the line output transformer. Providing the time-base is correctly synchronized the coincidence detector acts as a d.c. restoring diode to the anode pulses and the resulting negative d.c. bias is used, after filtering, as a control bias for the gate valve V2.

Thus when the time-base is correctly synchronized the gate valve is held non-conducting. When synchronism is lost for any reason this negative bias is not produced and V2 operates as a normal pulse amplifier. The pulses developed at its anode are applied directly to the line oscillator to trigger it into synchronism. As soon as synchronism is reached the gate valve is biased off and the normal flywheel system takes control.

chronization difficulties and noise gated or noise inverting circuits are necessary to obtain reliable synchronization in these circumstances.

Effective interlace not only depends on the design of the frame pulse separator but also on the complete line and frame circuits layout and interaction. The separation of the frame pulses by an integrating network has the advantage of good noise rejection and the optimum time constants have been calculated for different circuit requirements. Several practical circuits have been described to illustrate different separation techniques.

The problems encountered in line synchronizing circuits are discussed and the conflicting requirements of a.f.c. systems analysed. It has been shown that to obtain the maximum catching range with a given filter time constant a phase detector producing a balanced output is required and, furthermore, for the maximum noise protection the "no signal" output should equal the "phase centre" output. Automatic synchronization circuits, in conjunction with an a.f.c. system, have been discussed as a possible method of extending the catching range of a narrow band system.

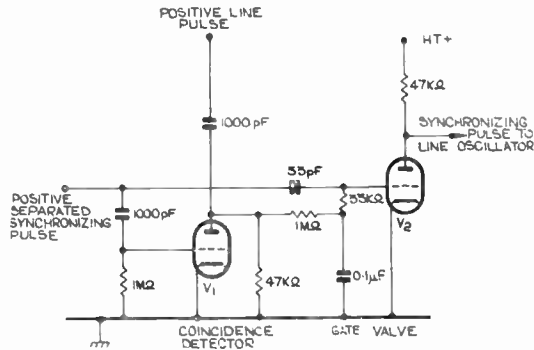

Fig. 16. Automatic pull-in circuit.

With this system, however, as in the case of a d.c. quadricorrelator circuit, the catching range is extended but the oscillator does not then operate at phase centre (i.e. free-running frequency \cong synchronizing frequency). The noise protection of a flywheel circuit is a function of the error signal and the maximum protection occurs when the error signal is close to zero. In addition to this shortcoming the additional cost of the circuits required must be considered, together with the relatively small improvement in the receiver performances it produces. Experience indicates, however, that when a very long flywheel time-constant is used, the circuit is worthwhile. In other circumstances a "push-and-turn" type of line-hold control incorporating a switch in the a.f.c. loop is the most satisfactory solution.

5. Conclusions

In this paper the problems of time-base synchronization have been discussed with particular reference to the effects of impulsive noise and interaction with other receiver circuits. The use of negative modulation increases the syn-

6. Acknowledgments

The author would like to acknowledge the assistance given by his colleagues in the preparation of this paper. He also wishes to thank the Director of the Mullard Research Laboratories and the Directors of Mullard Limited for permission to publish this paper.

7. References

1. M. Marks, "Noise immune sync. separator", *Electronics*, 25, April, 1952, pp. 124-127.
2. British Patent No. 799,132. Inventors: P. H. J. Janssen and W. Smeulers.
3. P. L. Mothersole, "Automatic gain control circuits in television receivers for negative modulation systems", *J. Brit. I.R.E.*, 18, No. 5, pp. 307-316, May, 1958.
4. G. N. Patchett, "A critical review of synchronizing separators with particular reference to correct interlacing", *J. Brit. I.R.E.*, 14, No. 5, pp. 191-214, May, 1954.
5. W. L. Stephenson, "The Use of Multiple Integration in the Separation of Television Frame Synchronizing Pulses", Mullard Research Laboratory Report No. 173, January, 1953.

6. W. L. Stephenson, "The Separation of Frame Synchronizing Pulses from the Transmitted Mixed-signal Waveform", Mullard Research Laboratory Report No. 157, June, 1952.
7. J. E. Attew, "A frame synchronizing separator", *Electronic Engineering*, **27**, pp. 70-71, February, 1955.
8. British Patent No. 791,494. Inventor: W. Smeulders.
9. P. L. Mothersole, "A television line selector unit", *Electronic Engineering*, **28**, pp. 520-523, December, 1956.
10. W. J. Gruen, "Theory of a.f.c. synchronization", *Proc. Inst. Radio Engrs*, **41**, pp. 1043-1048, August, 1953.
11. E. G. Clark, "Television Engineering Handbook", ed. D. G. Fink, Chapter 16, pp. 136-142, (McGraw-Hill New York, 1957).
12. S. Deutsch, "Theory and Design of Television Receivers", Chapter 13, pp. 439-447, (McGraw-Hill, New York, 1951).
13. J. A. Cornell, "A single tube a.f.c. circuit for television deflection systems", *Radio & Television News*, **43**, January, 1950, pp. 58-60.
14. M. C. Gander and P. L. Mothersole, "Multi-triode flywheel synchronizing circuit", *Mullard Technical Communications*, **4**, No. 39, pp. 266-72, May 1959.
15. D. Rickman, "The d.c. quadricorrelator: a two mode synchronizing system", *Proc. Inst. Radio Engrs*, **42**, pp. 288-299, January, 1954.
16. P. L. Mothersole, British Patent No. 789,315, August, 1954.
17. B. G. Dammers, A. G. W. Uitjens, A. Boekhorst, and H. Heyligers, "Improvements in television receivers, part 4: line synchronization and automatic phase control", *Electronic Applications Bulletin*, **17**, No. 4, pp. 129-149, 1956/57,

A REPORT ON THE RADIO TRADES EXAMINATION BOARD

The Pass Lists for the 1959 Servicing Examinations held by the Radio Trades Examination Board and the City and Guilds of London Institute, have now been published and reveal disappointing results, particularly in Radio Servicing. Details are as follows:—

Radio Servicing Examination :

Number of entries	1,896
Number of candidates sitting	1,847
Number of passes	689
(includes 142 referred from 1958 examination)	
Number of candidates referred ..	291

Television Servicing Examination :

Number of entries	485
Number of candidates sitting	463
Number of passes	209
(includes 22 referred from 1958 examination)	
Number of candidates referred ..	94

The Radio Servicing Practical Examination was held at 94 centres throughout the United Kingdom, and the Television Examination at 29 centres; all but three of the latter had to be used twice.

The results of the Radio Servicing Examination were very disappointing, particularly in the second of the written papers, which is of a practical nature. Performance in the Practical Test was also much poorer than on previous occasions, and generally reflected the lower performance all round in the examination. This was the first time that the Practical Test had been based on the "trainer-tester"* instead of an actual radio chassis; in addition, there was a comprehensive soldering test to enable a candidate's ability in assembling components and using tools to be assessed.

The practical test for the Television Servicing Certificate involved an actual television chassis as before. The results in this examination showed a slight increase in the percentage of successes compared with previous years.

The extension of the Board's activities in holding examinations for candidates in Electronic Servicing and the development of the

scheme and syllabus in Radio and Television Servicing, have been referred to in the Journal,† and final proposals are now being considered by the Joint Committee of the City and Guilds of London Institute and the Board. The examinations in 1960 will be held on the same syllabus as in previous years but with effect from 1961 the scheme of the Board's examinations will be as follows:

Entry requirement : Full-time education up to 16 years or completion of the appropriate preliminary course.

1st and 2nd years

RADIO, TELEVISION AND ELECTRONIC SERVICING	
<i>3rd year</i>	<i>3rd year</i>
ELECTRONIC SERVICING	RADIO AND TELEVISION SERVICING

Intermediate Examinations

(1 paper common)

<i>4th and 5th years</i>	<i>4th and 5th years</i>
ELECTRONIC SERVICING	RADIO AND TELEVISION SERVICING

Final Examinations

Thus the introduction of Electronic Servicing provides an opportunity for study in the developing field of electronics, whereas previously persons engaged on the maintenance of this equipment were only able to take a course in Radio and Television Servicing. The proposals for the Electronic Servicing Final Year include specialist subjects appropriate to the industrial requirement of the college location, and by this means the Board hopes that it will make a considerable contribution to solving the technician problem in industry.

In October 1957 the Board set up its own Appointments Service, which is only available to holders of the Radio or Television Servicing Certificates. The operation of the Service over the past two years has underlined the shortage of qualified radio and television service mechanics. The majority of Servicing Certificate holders seem to be well satisfied with their present appointments since relatively few come forward for assistance, and the Appointments Service cannot possibly fill the number of vacancies available. The majority of introductions are made to industrial appointments either in service or development departments.

† *J. Brit.I.R.E.*, 19, page 272, May 1959.

* "Practical examinations for the technician and mechanic," *J. Brit.I.R.E.*, 19, page 189, March 1959.

SCIENTIFIC MANPOWER AND POLICY

Two important reports have recently been published in London by, respectively, the Advisory Council on Scientific Policy* and its Sub-committee on Scientific Manpower†.

The Advisory Council welcomes the increasing proportion of qualified scientists and engineers in our working population and in particular the considerable increases in the last three years in certain industries which have previously employed a low proportion of scientists and engineers.

The rate of qualification of scientists and engineers is also increasing and output has reached 14,600 per year—the figure for 1958. The increase is likely to continue and the Committee cannot see any likelihood of colleges of technology training in total more qualified scientists than will be needed.

A large part of the report is concerned with space research, and here the Committee recommends that the United Kingdom should collaborate with other countries in space research before embarking on a programme of lunar, planetary or solar probes, the cost of which would be too great for our resources. It suggests that the British contribution should emphasize the design and construction of instruments to be carried in earth satellites.

The Committee also reported during the year on the financial support for research in this country from United States Government agencies and charitable foundations which amounts to £1½M per year. Most of this money has been in the form of contracts for specific research projects, but the report comments that universities are usually happier when they can work under a system of general grants.

Under overseas scientific relations it refers to the work of the N.A.T.O. Science Committee, the Organization for European Economic Co-operation and its Committee for Scientific and Technical Personnel and Applied Research, and the Overseas Research Council. This latter body, recently set up under a Committee of the Privy Council, advises on United Kingdom policy for scientific research undertaken in, or for, overseas territories.

The second survey on scientific and engineering manpower had the principal objects of comparing the scientific manpower situation in 1959 with that in 1956, and estimating the position as it will develop by 1962. As far as the Institution and the radio and electronics industry is concerned, the value of this report is lessened by the fact that the survey does not include radio and electronic engineering as a branch of engineering.

It is apparent that the Committee is aware that certain groups of specialist technologists have been omitted, and the report states "A few institutions have asked that the scope of future surveys should be extended to include specialized technologists. It is hoped that a satisfactory method of doing this can be found." Electronics is mentioned very frequently in the report, and is included as an industry group in the appendix. This was not done in the 1956 survey. There is now recognition by the Committee that this is an important branch of industry and research.

The fields of employment covered by the inquiry were: private industry; nationalized industries and public corporations; central and local government; and education. In the period 1956 to 1959 there was an increase of 19·3 per cent., or 28,000, in the number of qualified engineers and scientists employed. This represents an increase from 6 to 7 in the number of qualified engineers and scientists per thousand of the working population.

In manufacturing industry there was an actual increase in the number of scientists and engineers employed of 30·2 per cent., but rates of increase have varied considerably between industry groups. It is pertinent to note that in the electrical engineering industry the actual increase was only 9·7 per cent. although an increase of 43·2 per cent. was prophesied, but there was at January 1959 the largest number of vacancies for any manufacturing group. In private manufacturing industry as a whole, the total number of persons employed fell in the three-year period by 252,000, but the number of scientists and engineers rose by 14,750 which makes the proportion of qualified engineers to total employees rise from 8 to 11 per cent.

The report mentions the difficulty of finding

* Cmnd. 893 "The Annual Report of the Advisory Council on Scientific Policy 1958/9."
† Cmnd. 902 "Scientific and Engineering Manpower in Great Britain 1959."

reasons for the variations in the percentage increases in different industry groups. However, varying economic experience of different industries during this period, difficulties in recruiting the highly specialized scientists and engineers and the varying attractiveness of industries competing for an inadequate supply of scientists and engineers, are put forward as possible causes.

In analysing the type of work done by engineers and scientists in manufacturing industries, it is stated that 41·2 per cent. of them are engaged on research and development, which is a slight drop on the number for 1956. Some industry groups employ many more on this work, and the report particularly mentions electronics, where 66 per cent. of the scientists and engineers are on research and development. As might be expected, there is a marked tendency for the larger establishments to employ a higher proportion of scientists and engineers than the smaller establishments, and as an example of this they quote the fact that establishments with 500 or more total staff employ 69 per cent. of the scientists and engineers, whereas they only employ 46 per cent. of the total number of people engaged in manufacturing industry.

In discussing the requirements for the three years ending in 1962 it points out that employers' forecasts of requirements indicate a total percentage increase which is less than that achieved in the last three years, i.e. 27·1 per cent. as compared with 30·2 per cent. However, of those industries employing substantial numbers of scientists and engineers, the one in which the employers hope for the greatest increase is electronics—47 per cent. in the next three years.

The nationalized industries and public corporations were dealt with separately, and there the increase in employment of scientists and engineers was rather less than the manufacturing sector. However the Atomic Energy Authority increased its scientists and engineers by 71 per cent. and the proportion of scientists and engineers to total employees in the Authority has now risen to 123 per thousand.

The education field has been dealt with in some detail, and that the report shows that the staff numbers in universities increased by 28 per cent., which is almost that forecast; tech-

nical and teacher training colleges rose by 23 per cent. which is rather below the forecast, whereas in schools the number of science teachers only increased by 10 per cent.

In considering defence claims on scientific manpower, the Committee has found that the proportion of qualified engineers and scientists engaged on defence work in 1959 was smaller than in 1956. In manufacturing industry, work on defence contracts was *heavily concentrated* in the aircraft and electronics industries.

The report then analyses the distribution of scientists and engineers by subject of qualification. Discussing electrical and electronics engineers, it points out that the number employed in 1956, 17,800, rose only to 20,000 in 1959, an increase of 12·4 per cent. as compared with the forecast of 28·7 per cent. The Committee comments that the industry's forecast seems to have been overstated.

An important part of the Committee's work has been concerned with the supply of scientists and engineers. The number of scientists and engineers qualifying for the first time will increase from 14,600 in 1958 to 18,500 in 1961, and it is estimated that 47,000 newly qualified people will become available for employment during the next three years. This compares with 41,000 during the period 1956 to 1959. Allowing for replacement of wastage, the total number coming forward over the next three years is still likely to fall short of the employers' own estimates of their needs. The Committee again recommends that the minimum goal should be an annual output of 20,000 graduations in pure and applied science, and they expect this will come about in the mid-1960s.

The appendices state that in the electronics industry there are 4,541 scientists and engineers employed out of a total number of employees in the industry of 216,000. This is shown to comprise 2,483 engineers, 1,079 physicists and the remainder chemists, mathematicians, etc.

Because of the method of drawing up these figures, it is not possible to say how many electronics engineers are employed in other fields of industry. The figures quoted for the electronics industry appear to be grossly understated, presumably because the definitions exclude many engineers in the industry.

of current interest . . .

The Future of the Radio Research Station

The Council for Scientific and Industrial Research has authorized changes in the terms of reference of the Radio Research Station, D.S.I.R., and has appointed Mr. J. A. Ratcliffe, C.B.E., F.R.S., to be the new Director from October 1, 1960 when the present Director, Dr. R. L. Smith-Rose, C.B.E., retires.

The Radio Research Station has earned for itself an international reputation for its detailed studies of the propagation of radio waves. Recently the programme has been reviewed and its scope has been extended so as to take advantage of the new techniques provided by rockets and artificial earth satellites. Under its new terms of reference the Station will undertake investigations of the upper atmosphere and outer space by both radio and non-radio methods. Half the total staff effort of the Station (amounting to about 80 scientists and assistants) will be made available for this purpose, and additional staff is being recruited. The construction of a radio telescope and further extension of space research are also being planned.

Mr. J. A. Ratcliffe is at present head of the Radio Section at the Cavendish Laboratory at Cambridge. During the war he was employed on various aspects of research and development of radio and radar, latterly at the Telecommunications Research Establishment; he was elected a Fellow of the Royal Society in 1951.

A Continental View of the British Computer Industry

A computer users' mission from Western Germany, consisting of 22 representatives of German industry, trade, science, banking, insurance and transport was recently invited to the United Kingdom by the British computer industry with the support of the Board of Trade and the British Embassy in Bonn in order to see what British industry had to offer in the way of computers. Organizations visited included Ferranti, English Electric, E.M.I. Electronics, Standard Telephones & Cables, International Computers & Tabulators, Associated Electrical Industries, Elliotts, and the National Cash Register Company.

The Mission was considerably impressed by the extent of the development of computers in the United Kingdom and is of the opinion that the British electronics industry has made advances in this field which are far from widely known in Western Germany. It noted with interest that British firms have mostly concentrated on the main items of equipment they can produce most efficiently and, in contrast to continental practice, buy ancillary equipment from whatever source seems best.

The extent to which British firms understand the need for servicing on the spot and the training facilities offered by British firms in computer utilization also caused appreciative comment. Of particular interest too, in view of the often-alleged insularity of British industry were the Mission's remarks on the extent to which German was used in technical discussions by the executives of the firms visited. The Mission reached the conclusion that British computers are competitive on the German market both as regards quality and price and believes that over the next few years a substantial volume of sales in Western Germany will result.

Expansion of Indian Radio Industry

The current production of radio sets within India is 200,000 per year, a considerable increase over the figure of 30,000 a year in 1939. An increasing proportion of components are now made within the country, but a recent article in *Radio Times of India* pointed out that negotiations with overseas manufacturers for licensing agreements are made unduly protracted by the time taken by the Government to grant permission to a particular scheme. A period of 1½ to 2 years is in fact quoted.

The trend of the Industry is towards a higher proportion of indigenous components within sets, but the article states that the problem of cost is a serious one. Many of the indigenous items now available cost anything from 15 per cent. to 150 per cent. more than the imported cost of components from overseas.

The writer suggested, however, that this current phase of "growing pains" would pass if the Government were to discourage monopolies and permit lively competition.

A High-grade Industrial Television Channel with reference to Infra-red Operation †

by

J. H. TAYLOR ‡

A paper read on 4th July 1959 during the Institution's Convention in Cambridge.

Summary: The range and scope of the uses of television for industrial purposes are indicated to give some of the design requirements and to show broadly how they have been met with reference to a particular television channel employing a vidicon camera tube. In addition, two special applications are described, namely the use of this channel with infra-red and ultra-violet light.

1. Introduction

The uses of television are so many, ranging for instance from an installation in a cathedral to core cameras in atomic reactors, that it would not be possible to describe installations in detail here. Nor is the list given in the Appendix by any means exhaustive, but is intended to show the variety of uses to which television can be put.

It will be noted that the uses and requirements are very varied and this is responsible for considerable variation both in the standard of picture formation and also in the number of different facilities required. It is clearly uneconomic to provide a number of different types of camera and it was therefore decided to design a basic standard camera channel which could produce picture quality for the most exacting requirements in all respects. Extra facilities could then be added with the minimum of difficulty in the form of modification kits. These kits may be supplied with the channel, or fitted separately by semi-skilled personnel.

From all considerations, the camera head must be small and reasonably light and robust. Above all, it must be reliable in use. The camera control unit and picture monitor are designed to facilitate housing either in a separate cabinet or rack mounting. The camera channel is designed for medium quantity production.

2. Choice of Camera Tube

Size considerations govern the choice of camera tube: the vidicon is far more compact than the image orthicon (see Fig. 8) and hence the only possible choice for this reason. It has only one major shortcoming, namely its lag. This results in "ghosts" on the picture which appear if the subject is moving, or the camera is panned.

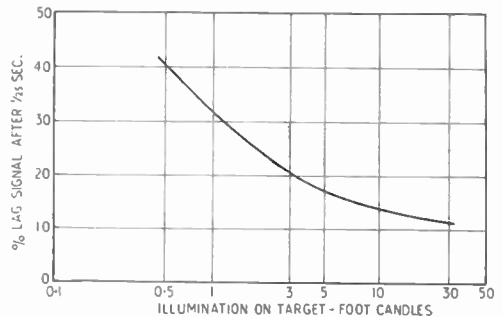

Fig. 1. Percentage lag 1/25th-sec after removing the illumination plotted against illumination. For constant signal current of 0.2μA.

Fortunately, this does not preclude its use in most industrial processes and indeed, at high light levels, the lag is small. The curve shown in Fig. 1 shows the amount of lag at various light levels which is characteristic of vidicon tubes. For certain purposes, of course, this characteristic is of value as it enables picture information to be stored over long periods.

† Manuscript received 14th May, 1959. (Paper No. 540.)

‡ E.M.I. Electronics Ltd., Hayes, Middlesex.
U.D.C. No. 621.397:535—1/3

The 1-inch version of the vidicon tube is capable of high sensitivity and definition, and moreover, special vidicons are available which are sensitive to different parts of the spectrum, two of which will be referred to later in this paper. Fixed focus lenses are available, some of which have been specially computed to take into account the thickness of the front plate of the vidicon. These are used when particularly high quality pictures are required. However, standard C type lenses which are convenient to use are adequate for many purposes. Other qualities of the vidicon which enhance its use for industrial television are, among others (a) true black level reference, (b) good gamma characteristic, (c) ease of adjustment, (d) good stability, (e) low scanning power, (f) low initial and maintenance cost, (g) robust construction, (h) ready availability.

3. Vidicon Operation

Before describing the camera equipment further a brief description will be given of the action of the vidicon camera tube.† The 1-inch diameter glass tube houses an electron gun at one end, and a photo-conductive target at the other, upon which the image is focused. It operates as follows:—

In Fig. 2, the target is a layer of photo-conductive material deposited on a transparent conducting surface. Consider a small area of target having the equivalent circuit shown, C_t is the capacitance between target faces. R_d has a constant value which does not vary with the light level. R_t varies with the incident light. One face of C_t is held to the potential of the conduc-

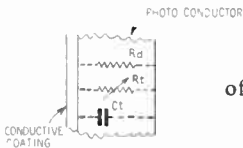

Fig. 2. Equivalent circuit of a photoconductive target.

tive signal plate. The other face is charged each time the scanning beam coincides with this particular small area of target. The value of R_t varies inversely with the amount of light focused on it during the preceding field period and C_t is discharged through R_t and R_d . The current required to recharge C_t constitutes the output

† For a fuller account of vidicon operation see reference 1.

signal. It should be noted that some of this current replaces energy lost due to R_d and this current is always added to the useful signal current. This current, known as dark current, remains even when there is no light focused on the target. Where using special vidicons, for example, the infra-red sensitive type, and also where vidicons are used at high temperature, this dark current signal is rather high, and provision is made to deal with it.

4. System Standards

Because there are many cases where high quality pictures are not required, some standard must be chosen for which the cheaper mass-produced domestic receivers will apply. At the same time, the best possible definition is desirable, consequently the channel is normally operated at 625 lines, and 50 fields per second.

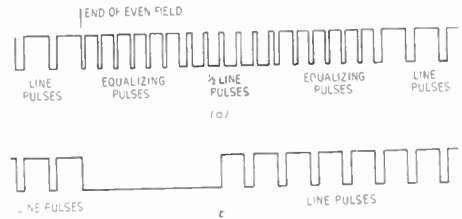

Fig. 3. (a) The waveform of standard C.C.I.R. transmissions. (b) The waveform employed in the industrial channel described in the paper.

With small modifications, however, 405 lines and 50 fields per second, and 525 lines and 60 fields per second may be used. Normally, a wave form system similar to the C.C.I.R. waveform (see Fig. 3(a)) is employed with the following exceptions (see Fig. 3(b)):

- (1) Equalizing pulses are not included.
- (2) Half-line pulses although continuously generated by the master oscillator (a necessary condition for interlace) do not appear in the output waveform.

These omissions are made from considerations of space and economy, and do not detract from the performance of the channel. As is well known, the normal British domestic television standard waveform does not include equalizing pulses, and tests have indicated that little or no advantage obtains from including them. There would be some loss, however, if some alternative

to the use of half-line pulses were not adopted, particularly on flywheel receivers. The purpose of these pulses is, of course, to maintain the receiver line oscillator frequency during the field blanking period. Without them, this frequency is liable to change, and it requires a series of line synchronizing pulses, and therefore lines, to elapse before this frequency is re-established. This results in some "hooking" at the top of the picture. This is prevented by the provision of one short field synchronizing pulse interrupting the continuous train of line pulses for only a brief period at the start of the field blanking period, so that the oscillator has little time to drift far from its operating frequency and any drift has been corrected well before the beginning of a new field. This system is similar to the one used in France, and gives satisfactory results on all television receivers tested so far. When flywheel scanning circuits are used it is particularly satisfactory.

5. Performance

Although for reasons of economy a more rudimentary waveform system than the C.C.I.R. standard has been employed, this in no way detracts from the performance of the equipment. The standard of performance has in general been limited by physical rather than economic considerations.

The bandwidth is also large, the whole system being flat to 8 Mc/s, so that by careful adjustment of optics, beam alignment, focus, etc., more than 800 lines may be resolved.

6. The Video Signal Amplifiers

6.1. Sensitivity, Noise and Bandwidth

In order to obtain the sensitivity and bandwidth, great care has been necessary in the design of the camera head amplifier and of the video amplifier and aperture-correcting circuits. For this reason also, and in spite of the layout problems associated with the greater heat dissipation, a three valve head amplifier was chosen in preference to a one- or two-valve type.

High signal/noise ratio is of paramount importance and this implies a high target signal resistor. This is because the noise voltage in this resistor varies as the square root of its value while the signal is directly proportional to it. It is also necessary to have a high gain so that a favourable target voltage giving an optimum gamma (about 0.4) can be obtained.

The voltage applied to the input of the head amplifier (Fig. 4) is derived by passing the vidicon signal current through a comparatively large resistance, and the output is maintained substantially constant at all video frequencies

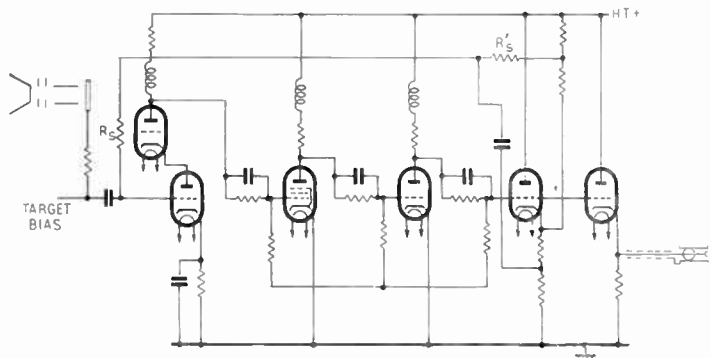

Fig. 7. Circuit of the camera head amplifier.

For instance the picture geometry is governed by the physical space available for focus and scanning coils in a necessarily small camera. The sensitivity is limited by noise and is very high. Pictures with enough information content for many purposes may be obtained with less than 1 ft.-candle illumination.

by applying feedback from the output to the end of the signal resistance remote from the vidicon target. The value of resistance used is about 0.5 megohm but, in order to minimize the effect of stray capacitance which will be present between the ends of the resistance, it is divided into two parts, R_s and R'_s . For frequencies in the lower

part of the video band the effective resistance is the sum of R_s and R'_s , but at higher frequencies R_s only is effective and a suitably reduced proportion of the feedback is applied by means of a capacitor to the junction of R_s and R'_s . Because of stray capacitance great care must be taken in the choice of the type of resistor used for R_s and in positioning it in the chassis. In addition R_s must be screened to prevent it from picking up spurious voltages from, for example, the scanning coils.

The vidicon is essentially a low-noise device and the signal/noise ratio becomes dependent on the head amplifier noise performance. It is therefore necessary to keep the signal/noise ratio of the head amplifier as high as possible and an E88CC cascode circuit has been chosen for the front end for this reason.

The amplifier has been d.c.-coupled to stabilize its performance against variations in valve characteristics and to reduce unwanted phase shift. This type of amplifier is inherently flat provided that the gain of the amplifier itself is flat and that the gain is large compared with ωCR where C is the total input capacitance and R the load resistance. In order to maintain a flat response three boost chokes have been introduced. Of these one only is variable to compensate for variations in stray capacitances, etc. As can be seen, the feedback is taken from a separate cathode follower from the output in order that the camera video cable should not effect the feedback loop.

The video output from the head amplifier is transmitted by one coaxial portion of the camera cable to the video amplifier section of the camera control unit, where it is further amplified, clamped, mixed with line and field sync pulses and fed out to the monitor. The C.C.U. video amplifier has also been designed to be flat to 8 Mc/s and in addition there is an aperture correction stage.

6.2. Aperture Correction

Optical losses, the finite size of the scanning beam, etc. reduce the modulation (Fig. 5). It is therefore necessary to apply a correction to the video amplifier frequency characteristics to correct for this^{2,3}. In the design, this correction is carried out in the video amplifier unit, part of the control unit. High peaking circuits are

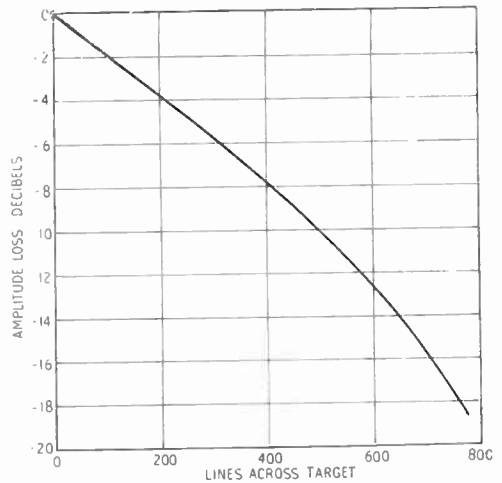

Fig. 5. Amplitude response curve for Emitron 10667 at 0.2μA signal current.

commonly used for this purpose, but this type of circuit is somewhat inconvenient, owing to the difficulty and necessity of correcting for the phase errors thus produced. An open-circuit delay line type of aperture corrector (Fig. 6) has been adopted. This arrangement is designed to correct the whole system amplitude response up to 8 Mc/s with negligible phase error. The delay line consists of three sections, the design of which is determined by the stray capacitance at each end. The characteristic impedance of the line has been kept as high as possible (620 ohms), in order to improve the gain of the stage, since this becomes the value of V1 anode resistance. The line is designed to give maximum boost, and is a quarter wavelength long at 10 Mc/s. V2 is a long-tailed pair, the cathode resistance (R_c) of which determines the amount of boost.

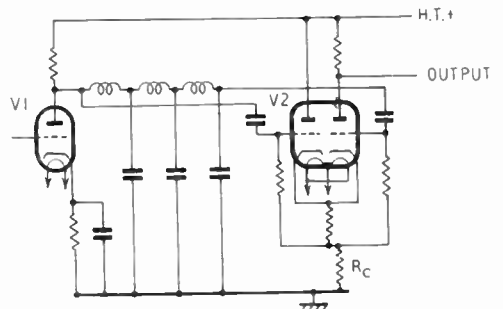

Fig. 6. Open-circuit delay line aperture corrector.

The necessity for accurate reproduction cannot be over-emphasized. It is perhaps not too unreasonable to produce a small high frequency overshoot in a domestic television video circuit, as it can be argued that it will add crispness to the picture and please the viewer. Unlike the domestic viewer, however, the industrial user is not interested in the apparent aesthetic value of his picture. He requires accurate reproduction. This is particularly essential in the photographic industry where it is only too easy for the television camera to hide or produce similar distortions in pictures taken by the film camera.

After aperture correction, the video signal is further amplified and clamped to a potential which may be varied in order to provide a variable lift for any type of vidicon, particularly those having a high dark current, e.g., the infra red tube.

7. The Camera

The camera consists of a robust light alloy casting with a detachable front plate. This arrangement allows for the attachment of different plates for special facilities, for example, a three-lens turret or microscope adaptor; these are accurately located on two dowels on the camera. The scanning and focus coils and vidicon camera tube may together be moved by means of a screwed thread in relation to the lens for focusing the camera. A demountable plate at the rear of the camera carries a manual control adjustment of focus. Alternatively this plate is easily removed and focus and/or iris motors are fitted in its place, these being electrically connected by means of plugs and sockets inside the camera. The optical focus and the lens aperture may then be adjusted by means of a small switch unit which may be conveniently mounted on the space provided on the monitor front panel or elsewhere.

Current for the focus and iris motors is supplied by conductors in the 25-way cable connecting the camera to the camera control unit.

For convenience in production the camera is divided into three sections which are separately wired. The scanning current generators are located in the C.C.U. and current for the scanning coil assembly is fed from this unit via the 25-way camera cable.

8. The Camera Control Unit

This consists of a main frame carrying four sub-units: (a) the sync. generator, (b) the scanning unit, (c) the video amplifier and (d) the power unit. Each unit is self-contained and has separate functions and all units are connected to each other via the cable form in the main frame by means of plugs and sockets. Each unit may easily be removed for maintenance purposes. The main control panel folds down and thus provides a support for these units so that they may be operated in an accessible position to facilitate fault diagnosis. The front panel itself carries the only three controls required for normal operation, these being "Focus", "Target" and "Beam". In construction Camera Control Unit sub-sections, the sync. generator and scanning unit consist of "thru-con" printed circuits on a 0.3-in. x 0.3-in. matrix. The video amplifier and power supply units however are wired by normal wiring methods. It is, in the author's experience, difficult to design and manufacture satisfactory high gain video amplifiers using printed circuit techniques without departing from a reasonable matrix system. The economics of medium quantity production do not permit spending much time organizing layout details unless this will, with some certainty, save more than the subsequent cost in the whole production run. Disadvantages include lack of flexibility, and the cost of tooling. In this last respect, the synchronizing generator and scanning unit are particularly economical, each consisting of three standard size 0.3-in. matrix boards. "Thru-con" is used mainly because this type of board allows the removal and replacement of components without damage and without resorting to the use of inconvenient temperature controlled soldering irons. The power supply unit circuits are not sufficiently complex to merit the use of printed circuits, and have therefore been wired in the usual way. Provision is also made in the camera control unit for the addition of a modulator which then forms part of the video amplifier chassis. Each sub-unit front panel carries all the necessary pre-set controls and associated test points for that unit. One aim in this design has been to make the equipment as reliable as possible, but as it has to be admitted that electronic equipment is never fully reliable, particularly when it is some-

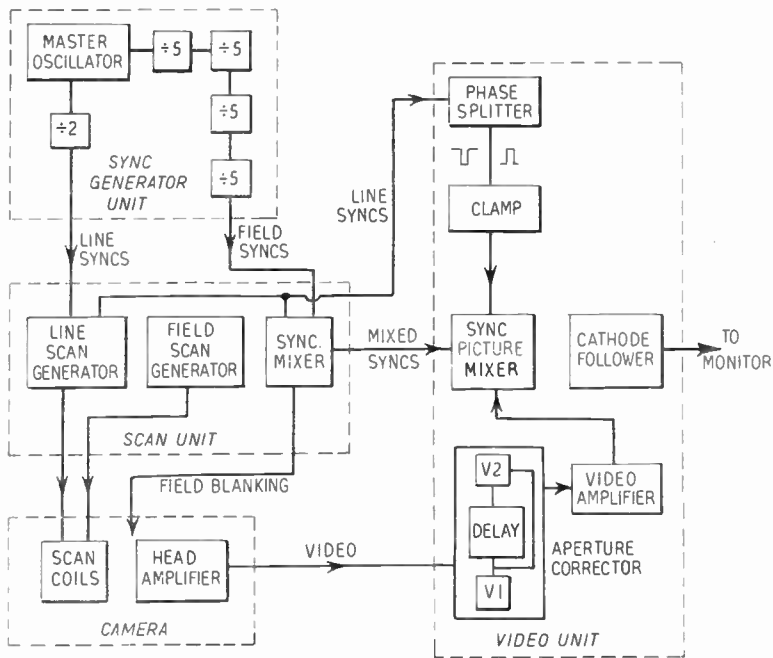

Fig. 7. Block diagram of the camera control unit.

(Note.—A connection should be inserted between the sync. picture mixer and the cathode-follower).

what complicated, it is important that it is easy to repair and diagnose so that the equipment may be kept near continuous operation. It is felt that this requirement has been fully met.

8.1. Synchronizing and Scanning

As will be evident from Fig. 7, the master oscillator situated in the synchronizing generator provides the basic tuning for all the pulses required in the channel. This master oscillator consists of a blocking oscillator generating pulses at twice line frequency. These pulses are divided by 2 to produce line pulses and also in a separate chain of four dividers (divide by 5, divide by 5, divide by 5, divide by 5 for 625 lines), 3 phantastrons and 1 multi-vibrator, to produce field pulses. These field pulses are fed to a discriminator, together with a small portion of the supply mains, the resultant voltage is used to control the master oscillator frequency and lock this to the supply mains. Line and field synchronizing pulses are fed to the scanning unit. Here they are mixed in a conventional mixer circuit and the mixed signals are fed to the video amplifier.

These pulses are also used to initiate camera line and field scans and produce blanking

pulses. In both line and field scan circuits, a saw-tooth generator valve is coupled to a "bootstrap" linearizing circuit, and stability and consistency of linearity and amplitude is achieved by the application of negative feedback. The scanning waveforms are fed to the camera via coaxial leads in the camera cable.

8.2. Blanking and Porch Pulses

Field blanking pulses are obtained from the scanning unit and are 1.6 milliseconds long, their leading edge being coincident with that of the field synchronizing pulses. Line blanking is obtained by deriving a pulse from the camera line scan flyback, thus avoiding the need for a further coaxial lead in the camera cable for this purpose. The line blanking pulses are fed to the vidicon camera tube, cathode, and the field blanking pulses to its modulator electrode. Back and front porches are not provided electrically, but optically. Thus in order to provide a black level reference period before and after the line sync. pulses a rectangular mask cut-out is provided which prevents light from falling on the vidicon target at the beginning and end of the scan period, provided that the camera tube

is scanned slightly beyond the mask. This method is simple and effective and very helpful in setting up the camera shifts so that the central area of the vidicon is used.

8.3. Shifts

Horizontal and vertical shifts are produced by passing some direct current through the line and field coils, the preset potentiometers which control these currents are located at the scanning unit.

8.4. Electric Focus

The vidicon gun system consists of a cathode, modulator, accelerator, and wall anode. The cathode/modulator potential determines the beam current for recharging target elements and this current is focused at the target surface by the combined action of the electrostatic field provided by the wall anode potential, and the magnetic field of the external focus coil. The conducting mesh in front of the target provides a uniform retarding field between itself and the target and this ensures that the beam impinges normally on the target surface. The focus anode potential can be controlled at the camera control unit, and the current in the focus coil is stabilized by a constant current pentode valve situated in the scanning unit. This current may be pre-set by a potentiometer on the front sub-panel of this unit.

8.5. Beam Alignment

Though great care is taken mechanically to align the vidicon gun target axis with that of the focus and scanning coil assembly, the gun itself is not always perfectly aligned, hence it is necessary to provide a small adjustment field to align the beam. This is provided by means of two pairs of coils at right angles to each other, mounted round the vidicon toward the gun end. A pre-set direct current is passed through each of these pairs of coils, the field of which serves to deflect the electron stream in such a way as to make it more nearly coincide with the gun axis. In order that the resulting deflection is horizontal and vertical it is necessary to assemble these coils at an angle of 45 deg. with the horizontal axis of the camera. Current is provided for these coils by using a portion of the main camera control unit h.t. current.

9. The Monitor

The circuits of the monitor are split into three parts: (a) the line scan unit, (b) the frame scan unit, and (c) the video amplifier and synchronizing separator. These again are also constructed on "thru-con" printed boards on a standard matrix. The chassis is of simple frame construction involving the minimum of tooling. It is vertically disposed about the picture tube. The perspex implosion guard may easily be removed to clean the tube face. The author has found that unless the implosion guard mask and tube form a pressure-tight seal, frequent tube cleaning is necessary in certain industrial atmospheres. The front panel of the monitor, in addition to carrying the main controls of "Contrast" and "Brightness," also carries occasional controls underneath a small flap, for example, the focus control, and height and width. The camera equipment is often operated from the monitor and so the front panel has three small false panels which may be removed to fit many of the accessories, e.g. remote C.C.U. controls, remote turret switch unit, etc. A high quality precision cathode-ray tube is used which easily resolves the 8 Mc/s detail which this channel provides. Facilities are provided at the rear of the monitor to feed out signals to further monitors, and a mains socket is provided for service purposes. The monitor is normally used at video frequencies only, but there is provision for a de-modulator. At the monitor unit, the complete video signal is applied to two separate channels, one for video amplification, and one for synchronizing pulse shaping and separation. In this case two stages of amplification are employed for video. The picture tube is grid modulated. The amplifier is a.c. coupled and d.c. restored. Provision is made to prevent the tube from going into the positive grid region. The bandwidth is again 8 Mc/s but since the requirements are not so complex this amplifier circuit has been printed.

The monitor video sensitivity is such that a signal of 0.2V d.a.p. will fully modulate the picture tube.

10. Special Requirements for Vidicon Camera Tubes

The characteristics of two special vidicons will be considered.

10.1 *The Infra-Red Tube*

This tube has an added sensitivity in the red and infra-red, and possesses an overall spectral response of 4000 to 10000 angstrom units. Many photographic materials are sensitive to visible wavelengths but are not very sensitive above 8000 angstroms. A camera using a tube sensitive to wavelengths above 8000 angstroms is useful, not only for the initial inspection of film in manufacture without "fogging" it, but also in that experimental processes can be observed and supervised by its use. An infra-red camera could also be usefully employed in research in the semi-conductor field as many semi-conductors are transparent to infra-red radiation. Unfortunately, however, up to the present, such cameras are in very limited use mainly because the camera tube spectral response is not yet sufficiently wide. Signals having signal/noise ratio of some 20:1, have however, been obtained from light transmitted through a silicon crystal of a millimetre thickness.

The infra-red camera also has a number of medical and biological uses. For example, with this tube it is possible to examine the inside of the eye, because the pupil does not close in infra-red light. A number of observers may then make a rapid detailed examination. Owing to the transparency of the skin to infra-red radiation, the superficial venous system may be studied, as also may certain diseases of the skin. Certain biological processes occur in the dark which can only be observed without disturbance by viewing with an infra-red camera. In this connection, the study of the behaviour of certain animals and insects and plants may be very usefully observed.

This infra-red camera tube is identical in size and shape to the standard vidicon tube. The photoconductive target in this case, however, consists of a mixture of antimony trisulphide and antimony triselenide. It has a resistivity in the dark of about 10^{12} ohm-cm as compared with 10^{13} ohm-cm for the standard tube, and in normal operation the dark current is of the order of 0.05 microamperes, compared with 0.01 microamperes for the standard vidicon. This dark current signal may be subtracted in the video amplifier by clamping the video signals to the appropriate potential.

The optimum target voltage for operation of the tube is governed by three factors.

- (1) Sensitivity: This will increase with target volts.
- (2) Dark current: At the higher target voltages the dark current becomes comparable with the video signal and any variations in dark current become important. This type of variation gives rise to a flare, usually seen at the corners of the pictures.
- (3) Beam limitations:
 - (a) The voltage change on a picture element between successive scans is proportional to the total signal, i.e. useful signal current and dark current. This total may amount to 0.5 microamperes and at this current the voltage change is about 6 volts. This causes the beam focus to vary enough to affect the resolution.
 - (b) At high total currents large beam currents are required, and this causes a broadening of the velocity distribution in the electron beam also affecting the resolution.

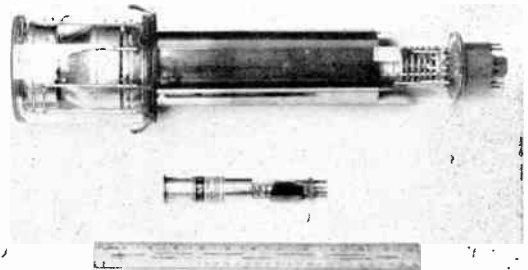

Fig. 8. Comparison of the 1-in. vidicon with the 3-in. image orthicon.

Because the dark current of the infra-red vidicon is relatively high it is even more necessary that a careful compromise be reached in the setting of the target volts depending on the type of information the camera is intended to supply. The lag of this tube tends to be slightly higher than that of the standard vidicon.

10.2. The Ultra-Violet Tube

This tube has an added sensitivity in the ultra-violet and will operate to at least 2350 angstroms. Good pictures can be produced in mercury vapour light (2550 angstroms). Its greatest value is in microscopy where the use of light of this wavelength is of great value in improving resolution and contrast. It thus helps to bridge the gap between the optical and the electron microscope.

This tube is again similar in size and shape to the standard vidicon tube but is provided with a quartz window to pass the ultra-violet light.

11. Acknowledgments

The author thanks the Directors of E.M.I. Electronics Ltd. for permission to present this paper.

12. References

1. H. G. Lubszynski, J. Wardley and S. Taylor, "Some aspects of vidicon performance." A paper read at the 1959 Brit.I.R.E. Convention and to be published in the *Journal* in the near future.
2. E. D. Goodale and R. C. Kennedy, "Phase and amplitude equalizer for television use," *R.C.A. Review*, 10, pp. 35-42, March 1949.
3. R. C. Dennison, "Aperture compensation for television cameras," *R.C.A. Review*, 14, pp. 569-585, December 1953.

13. Appendix

Typical Industrial Television Operations

Industrial Tool

Factory Intercommunications

Production schedules — Sales and inventory charts—Tables and graphs—Engineering change notes — Blueprint comparison — Production line flow — Time and motion study — Optical rigging of large jigs.

Warehousing

Traffic control — Load and unload conditions — Intercommunication — Prevention of theft.

Microscopy

Many persons able to view specimen — Safe viewing of irradiated material — Ultra-violet microscopy without lengthy photographic processing.

Power Stations and Furnaces

Furnace flame watching — Flame-out warning — Water gauge watching — Continuous internal examination.

Railways

Marshalling yard control — Quantity and position of wagons — Conditions of load and unload — Wagon reference number checking — Early warning and identification of approaching traffic/trains — Bulk fluid loading.

Road Traffic

Control of junctions.

Supervisory Control

Electrical and chemical — Process systems — Meters — Circular or roll charts.

Steel Mills

Furnace load — Rolling mill load — Stack plume watching.

Mining

Supervision of conveyor belts.

Inaccessible Locations

Extreme heat or cold — Irradiated materials — Nuclear reactors — Explosive materials — High or low pressure — High noise level — Underwater.

General Surveillance

Staff passes — Anti-pilfering — Traffic conditions.

Educational Tool

Scientific demonstrations — Job training — Microscopy — Machine control.

Broadcast

Art and theatre training — Aid to physics and engineering lectures.

Medical Tool

Remote watching — Positioning X-rays — Fluoroscopes — Radioactive treatments — Student training — Supervision in lecture and operating theatres — Physical examinations using infra-red light.

Business Tool

Intercommunications

Signatures — Accounts — Tellers' desks — Accounts Department — Between branches — Credit reference — Stock control — Sales slips — Factory tours — Shopping information — Anti-theft.

Radio Engineering Overseas . . .

The following abstracts are taken from European and Commonwealth journals received in the Library of the Institution. Members who wish to borrow any of these journals should apply to the Librarian, stating full bibliographical details, i.e. title, author, journal and date, of the paper required. All papers are in the language of the country of origin of the journal unless otherwise stated. The Institution regrets that translations cannot be supplied.

ELECTRO-CARDIOGRAPHY

The electrical action of a contracting muscle fibre is equivalent to that of a dipole and can be represented by a vector. The same applies to an entire muscle, such as the heart, insofar as the electrical phenomena are observed at a large distance from the source. During the heart beat the heart vector changes in magnitude and direction. Since the human body is a conductor, potential differences varying with time appear between various points on the human body during each heart beat. By applying electrodes to four or more parts of the body and combining the independent potential differences in an appropriate manner, the various projections of the vector-electrocardiogram can be recorded (i.e. the variation of the heart vector as a function of time). An article in a Dutch journal describes a vector-electrocardiograph for making such recordings, which is particularly insensitive to external interference such as hum.

"Vector-electrocardiography," G. C. E. Burger and G. Klein. *Philips Technical Review*, 21, No. 1, pp. 24-37, 1959/60. (In English.)

PROPAGATION FORECASTING

An empirical propagation equation (derived in a paper noted last year—see *J. Brit.I.R.E.*, January 1959, page 76) in connection with the radio path between U.S.A. and Europe has now been investigated to assess its validity. It is shown that a radio-weather forecast for a maximum of five hours is a possibility. The application of this characteristic also permits the drawing of conclusions with respect to the statistical distribution of field-strength values which can be expected and facilitates the location of exceptional interferences on the transmission path. Interferences which have been recognized and discussed include: (a) the effect of a sporadic E-layer as an attenuation component along the radio path; (b) a zone denoted as "aurora-like" and situated at the northern edge of the propagation path can contribute to increases in the field strength; (c) an eruption interference noted only in the v.h.f. bands has been found as a source for signal attenuations.

"Long distance transmission in the frequency range 40-52 Mc/s by means of the F2-layer." H. Wisbar. *Nachrichtentechnische Zeitschrift*, 12, pp. 547-553, November 1959.

INFRA-RED APPLICATIONS

Two recent papers by French engineers discuss the techniques and applications of infra-red rays. In the first paper the author recapitulates the physical bases of infra-red rays, and the laws which determine their thermal emission from solids and gases are discussed as well as the problems of their transmission and detection. Civil and military applications are then described although these fields sometimes overlap. In the civilian field, infra-red technology is used for measuring and checking temperatures remotely. Solar batteries use thermocouples and photo-voltaic cells as infra-red detectors. Infra-red rays are also used as barriers and for telecommunications for both military and civilian purposes. The major military applications are directed towards detecting and localizing objects by their heat radiations. Several recent developments in self-guided missiles with infra-red searching heads are described.

In the second paper, after recalling the main characteristics of interference type filters, the authors demonstrate the analogy which exists between these and electric filters, and experimental results are given. The calculation of multiple layer filters is discussed and the application of various types of filters to infra-red techniques described.

"Infra-red rays and their practical applications." O. Deutschbein. *L'Onde Electrique*, 39, pp. 835-844, November 1959.

"Multi-layer filter systems used in infra-red techniques." M. Barchewitz and M. Gautier. *Ibid.*, pp. 845-853.

TRANSISTOR CHARACTERISTICS

After a brief survey on the various mechanisms of voltage breakdown in junction transistors the dependence of the avalanche breakdown voltage on the bias circuit is discussed by a Swiss engineer in a recent German paper. A formula for the maximum d.c. collector voltage of an ideal junction transistor is developed which holds for all bias circuits. Deviations from the ideal model as well as the influence of a.c. impedances in the circuit are mentioned. The different kind of specifications used by the manufacturers for the maximum junction voltage of transistors are compared.

"Avalanche voltage breakdown of junction transistors in typical circuits." W. Guggenbuhl. *Archiv der Elektrischen Übertragung*, 13, pp. 451-461, November 1959.

DISTRIBUTED AMPLIFIER TUBE

A Japanese engineer has recently described a distributed amplifier tube which makes possible amplification over a very wide band. The distributed circuit is contained in the envelope of the tube, and its theory of operation is studied and applied to the case of the complete amplifier. Fundamental problems arising in manufacture are then dealt with and the author describes a prototype wide-band amplifier working from the low frequencies up to 70 Mc/s. The article concludes with a comparison of the theoretical calculations and the experimental result.

"A new wide band electronic tube." T. Kojima. *L'Onde Electrique*, 39, pp. 876-883, November 1959.

TRANSISTOR AMPLIFIERS

A distinction should be made between resistive matching and reactive matching in the tuned circuit coupling between transistor amplifier stages having finite complex impedances which depend on the operating point. According to a German paper, resistive matching results in an optimum power transfer for a given bandwidth, while reactive matching gives an optimum power transfer for a predetermined maximum detuning. The relevant formulae are discussed and are graphically shown in a normalized form in order to facilitate the design of an optimum circuit for each case.

"Narrow band amplification with transistors." H. Beneking. *Nachrichtentechnische Zeitschrift*, 12, pp. 543-546, November 1959.

BLOCKING OSCILLATORS

A Czech paper suggests that, when the method of operation of the blocking oscillator has been treated in the literature, only the negative influence of the coupling transformer stray inductivity on the front edge curvature of the relaxation oscillation has been taken into account. The paper shows that the stray inductivity of the transformer influences not only the slope of the leading edge but that it determines the duration of the relaxation oscillation in the short pulse range as well. The results of experiments agree closely with the calculated values.

"The influence of stray inductivity on the relaxation oscillation time in a blocking oscillator." V. Spanyol. *Slaboproudny Obzor*, Prague, 20, pp. 760-762, December 1959.

LOGARITHMIC INTEGRATOR

A recent French paper describes a computer which gives an output signal proportional to the logarithm to the base 10 of the input signal. Operation is based on diode pumps, which can receive signals of two polarities, positive and negative. The complete apparatus includes circuits for

correcting errors due to time of resolution, time constants and for the diodes themselves. The error curves show that a precision of about 1 per cent. can be obtained.

"Theoretical study and method of operation of a logarithmic integration." R. G. Nicolo. *L'Onde Electrique*, 39, pp. 816-822, October 1959.

MAGNETIC RING MODULATOR

Measurements show that the iron cores at present available for use in magnetic ring modulators do not conform to idealized $B-H$ characteristics and the theory can therefore not be directly verified by measurements. It is demonstrated in a German paper, however, that the equivalent circuit can be used for basic considerations and for proportioning a ring modulator circuit. A particular advantage of this modulator over a diode modulator turns out to be the gain encountered between signal input and sideband output. It is further shown that the resistive impedance transferred for tuning of the output circuit to the lower sideband takes negative values in the signal circuit, so that the arrangement acts as a parametric amplifier.

"Theory of magnetic ring modulators." R. Elsner. *Archiv der Elektrischen Übertragung*, 13, pp. 486-494, November 1959.

MODULATION SYSTEMS

It has been generally assumed that frequency modulation and phase modulation are unsuitable for long distance circuits where selective fading is likely to occur. An Australian paper indicates that this is not necessarily true for phase modulation. Early experiments appear to have been carried out with pure f.m. using relatively high modulation indices. Narrow band p.m., however, employing a modulation index of up to three has a spectrum so closely related to a.m. and so very different from wide band f.m. that, when subjected to fading, one would expect a result very similar to that obtained with a.m. Such a phase modulation system will have a 10 db signal/noise ratio advantage over an amplitude modulation system using the same carrier power. It would, furthermore, appear that independent sideband modulation is by no means the only method of providing a twin communication channel. For certain applications, such as stereo broadcasting, better results can be obtained with less complicated and less critical circuitry, such as employing a.m. for the sum of two channels and p.m. for the difference.

"Inter-relation and combination of various types of modulation." W. D. Meewezen. *Proceedings of the Institution of Radio Engineers, Australia*, 20, pp. 582-590, October 1959.

HARBOUR RADAR

Shipping on the Nieuwe Waterweg, which connects the Hook of Holland and the port of Rotterdam, is assisted in conditions of bad visibility by a chain of seven radar stations working on wavelengths in the 3 cm band. Ships proceeding along the Waterweg or inside the harbour area can be supplied with accurate information about their positions in a matter of seconds. Use is made for this purpose of a "cursor line" and other reference lines generated electronically and displayed on the c.r.t. screens. Each station is equipped with two radar transceivers and two p.p.i. screens. Normally, both screens are in use, each displaying a part of the area that the post has to cover. The pilot on board keeps in touch with the nearest radar station by radiotelephony, each radar having its own r/t channel.

"The port of Rotterdam radar system." B. H. G. Prins and J. M. G. Seppen. *Philips Technical Review*, 20, No. 12, pp. 349-353, 1958/59. (In English.)

AERONAUTICAL TELECOMMUNICATIONS

A description is given in the *Journal* of the Institution of Engineers (India) of the new transmitting station recently commissioned to serve the Aeronautical Communication Centre, Calcutta. Sixty-three transmitters to provide 19 air-ground channels, 17 fixed communication channels, two meteorological broadcast channels, and one navigational aid (an m.f. beacon) have been installed. Fifty-two aerials including four sets of rhombics and one self-radiating tower and associated feeder lines have been erected.

"A new transmitting station for the aeronautical telecommunications centre at Calcutta airport." K. N. Gopalakrishnan and S. Balaram Rao. *Journal of the Institution of Engineers (India)*, 40, pp. 27-41, September 1959.

SPACE COMMUNICATIONS

Since the power of transmitters is limited by the permissible weight and the amplification of the receiver by basic noise, the aerials used in space radio communication therefore play an important role. These aerials must satisfy very severe demands in respect of very wide bandwidth, to cope with the Doppler effect, and variable polarization. The angular theory applied to aerials, and more particularly the development of aerials in the form of spherical equi-angular spirals appears to be capable of fulfilling these conditions. The continual increase in the velocities obtained will call for new solutions, the fundamentals of which are briefly explained.

"Aerials in space." G. Chatelain. *L'Onde Electrique*, 39, pp. 785-788, October 1959.

RADIO NAVIGATIONAL AIDS

A paper has recently been published describing the radio navigational aids services operated by the Australian Department of Civil Aviation, and the organization required to deal with the problem of maintaining a large network of stations, many of which are remotely located. The aim of the maintenance organization is to meet reliability standards, which have been determined on the basis of Civil Aviation operational requirements tempered by physical practicability. In this environment, the design and construction of electronic equipment are major factors affecting reliability, and the salient features are discussed. As in other fields, the conclusion is that the foundations of efficient maintenance are laid in the design and production stages of new equipment.

"The design and construction of ground-based navigational aids and their effect on maintenance." M. Cassidy. *Proceedings of the Institution of Radio Engineers, Australia*, 20, pp. 612-621, October 1959.

TELEVISION NETWORKS

Modern knowledge and recent investigations have resulted in new methods for planning the utilization of Bands IV and V; a German paper compares these with the methods for Bands I and III. The question of height-gain characteristics, the radiation power required at transmitters and frequency converters as well as the transmitter spacing for the Bands IV and V are discussed in detail. The selection of sites suitable for a simultaneous operation of several television and sound broadcast transmitters is also discussed and a proposal for a 60-channel plan is put forward.

"Planning principles for television networks in Bands IV and V." H. Fleischer and W. Berndts. *Nachrichtentechnische Zeitschrift*, 12, pp. 554-560, November 1959.

TELEVISION WIRE-BROADCASTING

A survey has been published of the experiments made at the Dr. Neher Laboratories of the Netherlands Postal and Telecommunications Services on the application of wire television using the existing wire-broadcasting network. The subjects dealt with are the following: the cable characteristics at high frequencies; the necessary alterations of the network configuration; the choice of the frequency band. A description is given of the experiments made in a simulated and in an existing wire-broadcasting network. Finally the author discusses the possibility of simplified receivers.

"Some problems concerning the experimental wire television service as realized in the Netherlands." A. P. Bolle. *Het PTT-bedrijf*, 9, pp. 75-81, November 1959. (In English.)