

# JOURNAL OF The British Institution of Radio Engineers

(FOUNDED IN 1925—INCORPORATED IN 1932)

*“To promote the advancement of radio, electronics and kindred subjects  
by the exchange of information in these branches of engineering.”*

Vol. XIV No. 10

OCTOBER, 1954

## 28th ANNUAL REPORT OF THE COUNCIL OF THE INSTITUTION

*This report covers the Institution's activities for the twelve months ended March 31st, 1954. As already announced on page 333 of the August Journal, the Annual General Meeting will be held on October 27th, 1954, at the London School of Hygiene and Tropical Medicine, Keppel Street, Gower Street, London, W.C.1, commencing at 6 p.m.*

### INTRODUCTION

One of the problems facing industry in many countries to-day is the shortage of scientific and technical manpower, and contributions to its solution are expected of any body which is associated with the training and subsequent work of the professional engineer. The Institution is especially concerned with the shortage of radio and electronics engineers—a problem which is by no means confined to Great Britain. The report of the Membership Committee shows that there has been some movement of the membership in change of employment, particularly overseas, but there has been no easing of the overall demand for engineers such as are to be found in the Institution's membership, and the need is likely to grow.

The fundamental problem remains, therefore, as one of recruitment. Current emphasis on the shortage of engineers has caused some confusion of opinion on the value and purpose of education and training. Progress in scientific and technological fields is so rapid that all engineers tend toward specialization at an increasingly early period in their career—a tendency not wholly approved by some educationalists and others working outside the field of the specialist. To reconcile those views requires integration of education, in its broadest sense, with training for the field of application or work. Education is not an end in itself, but a means whereby the student is able to utilize fully the benefits of subsequent training for useful employment.

The first requirement for membership is to fulfil the conditions of examination and training. The report of the Education Committee shows that, in spite of an increased entry, the 1953 Graduate-ship Examination results were disappointing, and emphasize the Committee's comments on the fundamental weakness of candidates attempting the essential radio subjects of the examination. Since the war there has been much discussion on the need for a greater expansion of technical education, and backed by the experience of examining several thousand candidates in the post-war years, the Committee's comments on training are of great interest.

Future development in training will be of tremendous importance to the growth of the Institution. For the present, the report shows that there is a notable increase in the strength of the Institution; the Council is most conscious of its responsibilities and welcomes every opportunity to make a tangible contribution towards solving a problem which will become increasingly urgent.

The work of the Council is largely based on the work of the various Committees, the membership of which is drawn from Institution members whose particular interests lie in the fields of education and training, research, development, and production. During the year there were 68 meetings of the Council and its Committees, and to all those members who have assisted in this work the President and Officers of the Institution express warm thanks.

## PROFESSIONAL PURPOSES COMMITTEE

Last year's report surveyed the possibility of starting groups or sections within the Institution with the object of bringing together members interested in specialized branches of radio and electronics. Industrial electronics was mentioned as one of the first specialized groups, and it was in the nature of an experiment to devote the whole of the 1954 Convention to that theme.

The attendance and success of that Convention will already be known to members, and although it did not actually take place until after the period covered by this report, the Council wishes to pay tribute to the planning and organizing which was undertaken during the year by a specially appointed Convention Committee.

To assess the possibility of forming specialized sections, a census of the membership has taken place through a special enquiry form circulated to all corporate members. This information, together with the experience of the 1954 Convention, will enable the Professional Purposes Committee to make proposals to the Council on the establishment of specialized groups. The enquiry form has also given valuable information on the types of employing organizations and the employment status of members which will be most useful in arranging appropriate representation of the membership on the various Committees of the Institution.

**Relationship with other bodies.**—For very many years now the Institution has been represented on various Advisory Committees of the City and Guilds of London Institute, the British Standards Institution, the Parliamentary and Scientific Committee, and on Regional Education Committees. The Council much appreciates the time given by members who are nominated to represent the Institution on these outside bodies.

Although not represented on the Engineering Joint Examinations Board, which is now supported by seven engineering bodies, the Institution continues to sponsor entries for the Common Preliminary Examination conducted by the Board.

Successive annual reports have mentioned the desire of the Council to co-operate with all kindred organizations which directly or indirectly impinge on the work of the Institution and the

status of the professional engineer. Outstanding in the service which Mr. W. E. Miller has given to the Institution during his two years as President has been his personal efforts to promote friendly working relationships with other professional bodies.

**Official negotiations.**—The special Committee set up last year, under the Chairmanship of Professor Emrys Williams, continued negotiations with the Ministry of Labour and National Service regarding the operation and function of the Technical and Scientific Register.

In pursuing this matter the Council is mainly anxious to make a tangible contribution toward solving the very urgent problem of the shortage of manpower in radio and electronic engineering. The Committee regrets to report, however, that so far the Institution has not received the co-operation from the Ministry which such an urgent matter would appear to deserve.

The 1953 Annual Report of the Ministry\* states that "Progress was made toward meeting an acute need in the electronics industry for specialists in electronic valve engineering. The University Grants Committee and the industry co-operated to enable a post-graduate course in the subject to be started at the Imperial College of Science and Technology in the autumn of 1953."

The Memorandum on Higher Technological Education,† prepared by a sub-committee consisting of Members of both Houses of Parliament emphasizes, however, that such a scheme as the expansion of the Imperial College of Science and Technology must be a long-term project. It is of major importance to note that a great change is required in the general attitude toward careers in science and technology. It is certain that the growth and development of electronics, in the widest sense, is wholly governed by the provision of appropriate technical training and any tendency to resist specialization may have serious repercussions in arresting development of this branch of science. More detailed comment on this subject is given in that section of this report concerned with the Institution's education and examinations work.

The radio industry is not specifically examined in the Ministry of Labour report, other than

\* Command Paper 9207. H.M.S.O., July 1954.

† Obtainable from the Parliamentary and Scientific Committee, 31 Palace Street, London, S.W.1.

mention of the fact that "Employment in the manufacture of wireless apparatus and other electrical goods rose appreciably," although the report gives some detail of the numbers employed in other specific industries. It seems astonishing that a major industry such as radio and electronics should be submerged in such an important report under the heading "Engineering, Electrical Goods and Vehicles (including Aircraft)," which only makes reference to the fact that "those employed in the manufacture of wireless apparatus and gramophones rose by 16,000."

Emphasis on the importance of the radio industry would seem desirable in a report of this character, as well as more detailed information on total employment, such as is given by the Institution and the Radio Industry Council.\*

Fundamentally, therefore, the question of recruitment is wholly associated with encouraging students to undertake courses to fit themselves for a career in radio and electronic engineering. There was surprise, therefore, that the Ministry of Labour should have first refused deferment from National Service to a *bona fide* student of radio and electronic engineering. Consequent upon the Institution's representations to the Ministry, deferment was eventually granted on the grounds that the candidate was following an approved course of study in preparation for the Institution's Graduateship Examination.

It may well be that the Institution's efforts to assist in these problems depend in large measure on securing the professional unity which has so marked the work of the retiring President.

**Safeguarding membership.**—During the year, the Committee's attention was drawn to the fact that two unauthorized persons were describing themselves as members of the Institution and Council instituted legal action to restrain such persons from so describing themselves. In the interests of the Institution and the membership as a whole, it is the Council's intention to take similar action on any further cases brought to their notice.

**The Institution overseas.**—The Council has appreciated the need to secure for its members

\* Presidential Address of W. E. Miller. *J.Brit.I.R.E.*, 13, January 1953, p. 6.

Address of Lord Burghley to R.I.C. Annual Dinner, November, 1953.

overseas the same advantages as are enjoyed by members who belong to local sections in Great Britain. There is, in particular, a need for greater co-ordination between the five sections in India and the Committee has spent a great deal of time in formulating proposals for the formation of an Indian Advisory Committee. This Committee would be representative of the five Indian Sections and it is hoped that such an arrangement will give those sections the advantage of working as one body.

**Social activities.**—Many members have advocated that the Institution should undertake as a regular social function the holding of an annual dinner or ball. It is appreciated that such an occasion would provide greater opportunity for social intercourse between members, and would be an additional function to the annual dinner of Council and Committees.

The Committee has under consideration various proposals, including the possibility of a ball in aid of the Benevolent Fund. A recommendation is now before the General Council.

### MEMBERSHIP COMMITTEE

Since 1951, the Committee's recommendations on new applicants for membership have been published in the *Journal* before the final approval of Council is given to the elections. The desirability of this procedure is obvious and the lists have also served as a very useful reminder to local sections of possible additions to their ranks.

The Committee felt, however, that this was not an adequate method of welcoming new members and introducing them to the Institution's activities. During the 12 months under review, therefore, the procedure has been adopted in London, and at some other sections, of inviting new members to attend section meetings in order to receive their certificates of membership and generally to be welcomed to the Institution meetings by the Chairman of the section.

There has been a slight increase in the number of applications for direct election to the various grades of membership, but slightly fewer applications for transfer to higher grades. The Committee has previously reported that a review of the membership still shows that a large number of members would appear not to

be in their appropriate grades; this may particularly apply to the non-corporate members, some of whom certainly seem eligible for election as Associate Members, and to some Students who have succeeded in the examination or its equivalent but have not applied for transfer to the grade of Graduate.

Losses to the membership in the Graduate and higher grades are the same as for last year, but there is an increase in the number of removals from the Register of Students—232, compared with 188. This is wholly due to the stricter application of the rule requiring Students to complete their entry for the Graduateship Examination within five years of the date of their registration. The percentage of Students of the Institution succeeding in the Graduateship Examination is higher than those entering who have not previously been Students. Nevertheless, the report of the Education Committee on the comparatively small percentage of successes in the examination indicates the reasons why there is such a large number of Students who, each year, are removed from the Registers for the reasons stated.

During the year, the Institution received 1,711 enquiries regarding membership (*excluding those enquiries handled by the overseas sections*), and this figure compares with 1,964 and 1,703 for the years 1953 and 1952 respectively. The net increase in membership is the same as for last year, as shown in Table 1.

**Table 1**  
Membership Growth over the Last Five Years

<i>As at March 31st</i>	<i>Total Membership</i>	<i>Annual Increase</i>
1950 ..	3,349 ..	296
1951 ..	3,634 ..	285
1952 ..	4,018 ..	384
1953 ..	4,383 ..	365
1954 ..	4,750 ..	367

(Representing the active membership and therefore excluding those members who, for various reasons, have been temporarily suspended.)

There is a slight change in the presentation of the information showing elections and transfers to the various grades of membership. It is hoped that members will find Table 2 more informative in indicating the exact rate of membership accession.

**Table 2**  
Statement of Elections and Transfers for the Year Ended March 31st, 1954

	<i>Total considered</i>	Elections and transfers approved						
		Member	Associate Member	Com- panion	Associate	Graduate	Student	Total
Direct applications	732	11	60	—	44	63	513	691
Proposals for transfer	181	3	59	—	6	75	—	143
Proposals for reinstatement	3	1	1	—	—	—	1	3
<b>Totals</b>	<b>916</b>	<b>15</b>	<b>120</b>	<b>—</b>	<b>50</b>	<b>138</b>	<b>514</b>	<b>837</b>

**Losses During the Year**

Loss by resignation, removal and death	—	9	19	1	50	16	232	327
Loss by transfer to other grades	—	—	3	—	30	22	88	143
<i>Totals</i>	—	9	22	1	80	38	320	470
<b>Net gain in membership</b>		<b>6</b>	<b>98</b>	<b>—1</b>	<b>—30</b>	<b>100</b>	<b>194</b>	<b>367</b>

**List of members.**—A complete record of the membership is contained in the 1954 issue of the Year Book. The detail required for this publication involves a great deal of time, and concentration on Convention arrangements has prevented the Year Book being printed earlier. It is hoped, however, that all members, other than students, will be in possession of their copy by the end of October. As already indicated, this edition of the Year Book will not include details of registered students of the Institution.

**Honours conferred on members.**—The June and July 1953 and January 1954 *Journals* contained details of several members who were included in Her Majesty's Birthday and New Year's Honours Lists, and they have been congratulated by the Council on the distinctions conferred on them.

**Membership overseas.**—The Committee expresses appreciation for the co-operation received from the committees of overseas sections in assessing the suitability of new applicants for membership.

Members from Australia, New Zealand, South Africa, India, and Pakistan, were welcomed at Institution headquarters during the year, and in many cases valuable suggestions were made for improving the services of the Institution in overseas sections. Among the problems discussed has been the standard of degrees and diplomas awarded by overseas universities and technical institutes, and their relation to the requirements of the Institution's Graduateship examination.

As more technical institutes and colleges overseas extend their work to training in radio and electronic engineering and other branches of applied science, it is obvious that there is increasing enquiry for membership of the appropriate professional institutions, and there is constant consultation with the Education Committee in determining whether degrees, etc., obtained overseas justify exemption from the Institution's Graduateship examination.

**New Sections.**—A further section was established in Great Britain—the South Wales Section—which will have its first full programme of monthly meetings during the 1954/5 session. The first Honorary Secretary, Mr. C. C. Evans (Associate Member), of the Glamorgan Technical College, has rendered great service in ensuring the satisfactory establishment of this section.

Members from other countries visiting Great Britain have also had discussions at 9 Bedford Square on the possibility of the Institution forming further sections overseas. The regulations governing the formation of sections are detailed in the Year Book; whilst it is not intended at present to make any alteration to those rules, the growth of membership in all areas is carefully recorded so that, when the membership is sufficiently strong in any area, full consideration can be given to the establishment of further sections.

Immediate consideration is being given to the suggestion that an official Section of the Institution should be started in Canada; in this connection the Council is looking forward to forthcoming discussions with Mr. L. H. Paddle, a Vice-President of the Institution, who is now permanently settled in Canada, but who will be visiting the Institution at the time of the Annual General Meeting.

**Appointments Register.**—Considerable time has been devoted to reviewing the operation of the Institution's Appointments Service which, of course, continues to be free of charge both to employers and to members.

The questionnaire sent to corporate members, to which reference has already been made, has been of great assistance in advising firms on the type of appointments in which members may be interested, and discussions have taken place at 9 Bedford Square, and elsewhere, with personnel officers and others responsible for the engagement of engineers.

Excluding enquiries from overseas organizations, the Institution received requests from 58 employing organizations in Great Britain for assistance in engaging engineering staff. Only 54 members actually requested help in obtaining alternative employment, but the requirements of the employing organizations were met by the Institution affording no less than 151 introductions.

Help has also been given to a number of members who have taken up appointments overseas, particularly in affording introductions to members abroad. An example of this work is the Institution's discussions with the Association of Professional Engineers of Ontario—one of the bodies responsible for the registration of engineers in Canada.

In general, both employers and employees are making increasing use of the Appointments Service and no difficulty has been experienced in placing the younger engineers, particularly those who have recently graduated either from a university or by passing the Institution's Graduateship Examination. For the first time since the war, however, some difficulty has been experienced in placing senior engineers who are in the salary range of £1,500 upwards per annum.

### EDUCATION AND EXAMINATIONS COMMITTEE

There have been changes in the personnel of the Committee and in the panel of examiners, as indicated in the *Journal*. The Council wishes to make particular mention of the services of Professor E. E. Zepler, now senior Vice-President, who has continued as Chairman of this most important Committee, in addition to discharging other Institution responsibilities.

The Committee's work influences to a very large extent the growth of the membership, since for Graduate and corporate membership election is contingent upon passing or having qualifications exempting from the Graduateship Examination.

Relatively few of the elections to Graduateship or higher grade membership of this or any other professional body are admitted by exemption as a result of a university degree. The initial education of research workers and engineers must, therefore, still depend very largely on the function of technical institutes and their ability to meet the responsibility of providing the technical training best suited to the requirements of any single industry or profession.

**Examination entries.**—The most onerous part of the Committee's work is the setting of the Graduateship Examination which, in 1953, attracted 1,149 candidates—an increase of 10 per cent. over the 1952 figure. The constantly increasing number of candidates presenting themselves at the Institution's examination is an experience common to almost every other professional institution and is evidence of the desire of the younger engineer to prepare himself for responsible employment.

It is to be regretted that the effort of these students continues to be so poorly rewarded. The Committee has to report that notwith-

standing the increased number of entries in 1953, only 72 candidates succeeded in the entire Graduateship examination. It is evident that this figure will not be improved when the raising of the standard of Physics and the alteration in the structure of the syllabus come into force.

The Committee has, therefore, recommended to Council that a regulation be introduced, requiring candidates entering for the Graduateship Examination to provide evidence of supervised practical work. It is appreciated that not all candidates will have access to a technical college where facilities are available; in such cases the alternative of suitable practical training in the radio industry will probably be accepted. The exact requirements in this connection are at present being formulated.

**Training.**—In framing the examination syllabus, the Committee takes into consideration the training which is available to students without, however, restricting the scope of the questions to those courses which do not permit of specialization in radio/electronic engineering. Over the years this policy has proved that many students enter without adequate preparation, resulting in a large percentage of candidates obtaining less than a 20 per cent. mark in many subjects of the examination. It is submitted that these results show some of the reasons for the shortage of technical manpower.

Compared with pre-war conditions, industry generally gives a very large measure of assistance to the young employee by arranging part-time day release, sandwich courses, and other incentives to study. That the results are comparatively poor must reflect in some measure on the suitability and content of the courses offered to the radio engineering student.

It may be argued that a great deal of fault lies with the ability of students, but as already stated, the increasing number of entries for professional and other examinations indicates their keenness. The most popular method of preparation is, of course, evening study, but the enthusiasm needed to keep up study of this kind is seldom maintained. There is first of all, the matter of "overtime" education after a full day's work, and maintaining interest in the course after the first few months—so many students appear to be discouraged by having to pursue subjects not directly bearing upon their examination objective.

Even with the alternative schemes of part-time day release, etc., a very small percentage of students complete the advanced courses necessary for Higher National Certificate or professional examinations. Integration of the needs of industry, coupled with the proper provision of courses, is the only means of securing better results.

An essential contribution to improvement is to be found in the reorganization and upgrading of technical colleges. The Committee has, therefore, been pleased to note in the last few years an increase in the number of colleges offering training in radio engineering as a main subject and *not* as a subsequent six months' course to a general engineering training.

To this end, the Council has been anxious to promote close contact and co-operation with the principals of technical colleges. Applications for approval of courses have been a particularly welcome feature during the year and of the further applications received mention is made of the South East London Technical College whose Higher National Certificate Course with radio and telecommunications engineering subjects now secures complete exemption from the Institution's Graduateship Examination, provided that the candidates obtain credits in all subjects. Similarly, the Loughborough College of Technology Diploma with telecommunications and electronics has also been recognized for full exemption from the Graduateship examination. Other courses based on the Higher National Certificate scheme have also been submitted with a view to securing exemption from the Institution's examination. In some cases, negotiations are still proceeding, but in general the Institution requires a higher standard in radio and electronics than is achieved in many of the colleges.

In all this work it is appreciated that the technical colleges have a special problem in making the maximum use of classes teaching subjects common to a number of engineering courses. There is, in addition, the urgent problem of the supply and training of technical teachers. Much of the natural ability in search of training is wasted because of the lack of teachers—a point stressed in the Annual Report of the Advisory Committee on Scientific Policy\* and similar official reports.

The University Grants Committee has shown

\* Command Paper 9260, H.M.S.O., September, 1954.

under the heading "Electrical Engineering and Electronics" that 172 degrees and diplomas were obtained in Great Britain (excluding the degrees of London University). The total figures for degrees and diplomas in technology have dropped in the last two years and present indications are that the university population in pure and applied science has not increased over the peak figures of the post-war years.

The universities and their research departments are, of course, the key to ensuring adequate supplies of trained research workers and teachers. Obviously an improvement in the extension of university work in the field of radio and electronics will automatically be reflected in schools and technical colleges, for nearly all teachers are university trained. Thus, the whole process of encouraging, selecting, and training engineers of the future needs to begin in the universities.

All these points need consideration in determining the future work of the Institution. It is, however, heartening to note that the number of candidates wishing to take the Institution's examination continues to increase. Already entries for the 1954 examinations give a further indication that for the sixteenth successive year there will be an increase in the total number of candidates examined by the Institution.

**Careers Guidance.**—Apart from the enquiries regarding membership of the Institution, which are referred to in the report of the Membership Committee, the Institution is constantly receiving enquiries from headmasters, parents, and boys and girls, regarding careers in radio engineering. Over 200 such enquiries were dealt with during the year, including many personal interviews.

Wide interest in careers and subsequent training in radio engineering led the Committee to recommend to the Council that meetings on education and training might well be a regular feature of the Institution's programme of meetings. Such a meeting was held by the Merseyside Section of the Institution and the discussion received wide comment outside the Institution.\* Arrangements were also made for a group discussion on this subject during the Institution's 1954 Convention.

**Exemptions.**—The Committee considered 205 applications for exemption from the Graduateship examination, of which 64 were granted full

\* *J. Brit. I.R.E.*, 14, January 1954, pp. 43-48.

exemption, 82 exemption from part of the examination, and 59 were refused.

All applications considered by the Committee are based on qualifications which are not specifically quoted in the regulations, those submitted in accordance with the regulations being dealt with directly by the Secretariat.

Members of the Committee visited the R.E.M.E. training centre at Arborfield to examine the courses and training facilities for the Officers Long Electronic Engineering Course, and the Committee recommended that exemption from Parts I, II and IIIa of the Graduateship examination be granted to officers who obtain a minimum of 65 per cent. The Committee is, however, prepared to consider exemption from the entire examination in the case of officers who hold *in addition* a university degree, Higher National Certificate, or equivalent qualification.

The Committee is at present reviewing the courses of the Royal Air Force and Royal Navy, which have previously been recognized for exemption, with a view to submitting new proposals to Council.

**Theses.**—The Committee received a total of four theses, of which one was approved and three rejected. In addition, seven synopses were considered, of which two were judged suitable to proceed to a thesis stage.

The Committee has noted that some prospective applicants for membership consider the submission of a thesis an easy way to secure exemption from the Graduateship examination. This is entirely false and the Committee would like to stress that the standard required is extremely high and only those candidates who have undertaken original work or who are otherwise qualified to write a scientific criticism should undertake the submission of a thesis.

**Examination Prizes.**—The Council has approved the award of prizes for 1953 as follows:—

President's Prize: Meir Weger (*Graduate*), Tel-Aviv.

S. R. Walker Prize: S. Janakiraman (*Graduate*), Madura, India.

Audio-Frequency Engineering Prize: Peter G. Lovell (*Graduate*), London.

Electronic Measurements Prize: Srinivasa Ramabhadran (*Associate Member*), Poona.

Overseas Sections will join in congratulating

these prize winners, particularly those who obtained the President's Prize and S. R. Walker Prize through their success in the entire examination at one sitting.

**Future Examination Syllabus.**—The Committee's recommendations on alterations to part of the examination syllabus, in particular mathematics, were given in the last Annual Report.

In addition, the Council has now accepted further recommendations on alterations in the structure of the examination which will come into force as from 1956. The syllabus of Part I will be altered so that candidates will be required to write two three-hour examination papers in the subject of Physics. The syllabi of Parts II and III will remain as at present, but Part IV will provide opportunity for candidates to choose between questions with a strict radio engineering application and those in electronic engineering.

Part V (optional subject) will include two new subjects—Applied Electronics, and Radar Engineering and Microwave Techniques. The syllabi of these new subjects will be published shortly and specimen questions will be prepared.

These changes in the syllabus will, of course, affect the list of exempting qualifications, particularly in the subject of Physics. A new list of exempting qualifications is at present in the course of preparation.

**Examiners.**—The Committee takes this opportunity of expressing appreciation to the following examiners who assisted in the setting and marking of the 1953 examination papers:—

F. Butler, B.Sc.(Hons.) ( <i>Member</i> ).	J. R. Miller ( <i>Associate Member</i> ).
Sqn. Ldr. M. E. Claxton, M.Ed., B.Sc. ( <i>Member</i> ).	M. Morgan, M.Sc.
D. A. Crowther, B.Sc. ( <i>Associate Member</i> ).	E. T. A. Rapson, M.Sc. (Eng.) ( <i>Member</i> ).
T. D. Humphreys ( <i>Member</i> ).	W. P. Rowley, M.B.E. ( <i>Member</i> ).
J. A. Hutton, B.Sc. ( <i>Associate Member</i> ).	H. Stibbe ( <i>Associate Member</i> ).
S. Kelly ( <i>Member</i> ).	S. R. Wilkins ( <i>Member</i> ).
K. G. Lockyer, B.Sc. ( <i>Associate Member</i> ).	P. O. Wymer, B.Sc. ( <i>Associate Member</i> ).

**Examination Centres.**—For the two examinations held during the year 74 centres were used in Great Britain and overseas. The Council wishes to thank the universities and technical colleges concerned for their co-operation in affording the



necessary facilities for the conduct of the examinations.

**Representation on other Committees.**—The Institution is represented on the Advisory Committee of the City and Guilds of London Institute on telecommunications engineering, radio service work, and the radio amateurs examination. The Council expresses thanks to the Institution's representatives, Professor E. E. Zepler, Mr. G. A. Taylor, and Mr. R. G. D. Holmes, respectively.

**Radio Trades Examination Board.**—In industry particularly the work of the engineer must be supported by an adequate staff of technicians and mechanics, and the present shortage of technicians and skilled workers throws a further burden upon senior engineers.

The work of the Radio Trades Examination Board is, therefore, important in stimulating recruitment and in creating a demand for courses of instruction.

Members will be aware that the Board was formed in 1942 by the Institution, the Radio Industry Council, the Radio and Television Retailers' Association and the Scottish Radio Retailers' Association. Financial responsibility for the Board's work is shared by the Brit.I.R.E. and the R.I.C. equally, and the third share by the Retail Associations jointly.

It is necessary for candidates to have succeeded in the Radio Servicing Certificate Examination before proceeding to the Television Servicing Examination. Both examinations comprise written papers (conducted jointly with the City and Guilds of London Institute) and a practical examination.

Since 1944, 1734 candidates have entered for the Radio Servicing Certificate Examination and of these, 496 have subsequently sat for the Television Servicing Certificate Examination.

Courses in preparation for the Board's examinations are now provided by 69 technical colleges throughout Great Britain which, of course, accounts for the increase in the number of candidates. Hitherto one of the difficulties has been the lack of training facilities, particularly in television. Now that so many technical colleges have commenced courses in both radio and television service work, examination entries should show a further increase, especially as many of the apprenticeship schemes in industry

and trade now in operation require attendance at an approved course.

Some technical colleges are also arranging special courses to cover the introduction of frequency modulation and band-III television. Only those technicians who have had a thorough training in radio and television servicing will be in a position to take advantage of these courses, and it is hoped, therefore, that the technical schools who have now started the radio engineering and service classes will be supported by adequate enrolments.

**Radio Servicing Certificate Examination.**—In 1953 entries were received from 323 candidates, of whom 126 passed the examination and 87 were referred in the Practical Test. These figures compared with 314 entries received in 1952, of which 152 were successful, and 69 were referred in the Practical Test.

**Television Servicing Certificate Examination.**—Entries were received from 140 candidates and 64 of these were successful in the entire examination. Thirty-six candidates succeeded in the written papers but were referred in the practical test. In 1952 the entries were 135, of which 66 passed the examination and 43 were referred in the practical test.

The Board has operated since 1942 through the goodwill and co-operation of the sponsoring bodies. It is now felt that the Board should secure Incorporation under the Companies Act and during the year the necessary steps have been taken to this end.

The Institution's nominated representatives on the Board are Messrs. E. J. Lewis, E. A. Spreadbury and G. A. Taylor (*Members*), and the present Chairman is Mr. E. J. Emery (*Member*).

## PROGRAMME AND PAPERS COMMITTEE

Every issue of the *Journal* is a reminder to members that the Institution's main object is the advancement of radio science. To this end the Institution affords every facility for the communication and discussion of all new advances in the radio field, as well as technical appraisals of current progress.

Both the *Journal* and the meetings which are arranged for members provide an opportunity for the senior engineer to keep abreast of developments—particularly those outside his immediate sphere—and to the younger member

these proceedings are in the nature of a post-graduate course.

The availability of papers suitable for publication is largely determined by the time which can be given to their preparation by qualified authors. There is little doubt that a great deal of suitable material does not become available because of the working demands upon the authors due, of course, to the manpower shortage.

Nevertheless, there is great willingness to provide the Institution with papers as shown by the fact that during the year the Committee considered 67 papers from authors representing 30 manufacturing organizations and 25 Government and other research establishments. In addition to assessing these papers, the Committee had an additional responsibility during the year in assisting with the arrangements for the 1954 Convention.

**Consideration of papers.**—Of the 67 papers submitted, 56 per cent. were judged to be suitable for publication without serious revision by the authors. This is a great improvement on the previous year. Of the remainder, one in three were rejected as being wholly unsuitable for publication and the rest became suitable after detailed revision.

The Committee and the referees who assist in assessing papers once more express willingness always to help the inexperienced author in the proper presentation of a paper. It is felt that lack of experience might well be one of the greatest difficulties to overcome in encouraging the submission of more papers from members.

It is customary in these reports, and repetition does not lessen the necessity, to urge members to endeavour to make contributions. Members who are unable to submit papers can still assist in the Committee's work by making suggestions as to suitable topics for papers and in other ways indicating their interest in special subjects. Senior members can be of particular assistance in this way by suggesting names of potential authors.

The Council has been considering whether the work of the Committee would be aided by separating its functions and setting up a sub-committee whose work would be wholly concerned with the procurement of papers. To a certain extent the formation of specialized groups within the Institution, already referred to at the

beginning of this report, will help in securing papers.

This subject is constantly before the Council but meanwhile it is hoped that every member will consider in what way he can help the Committee, either directly or through his local section.

**Section meetings.**—The activity of the local sections is increasing. During the year a total of 95 meetings took place, 53 by sections in the British Isles, and 42 overseas. This is an increase of 20 over last session and is a very encouraging sign of the widening scope of the Institution's services to members.

Full programmes of meetings were held in the five Indian Sections, the New Zealand Section held meetings at the centres in Wellington and Auckland, and the South African Section has continued to consolidate its work. The new section in the South Wales area, centred on Treforest, Glamorgan, made a promising start by holding five meetings, and the two sections which have been established in Pakistan, held a number of meetings at the centres in Karachi and Lahore.

In general, attendance increased at all the meetings, with the exception of two sections; every member can give impetus to the work of his section and, therefore, the Institution, by participating in meetings and encouraging the attendance of others.

Details of local section meetings are published at regular intervals in the *Journal* and it can be seen that a very wide range of subjects has been covered. The majority of speakers were obtained from the body of the membership and to all the authors who drew generously on their time and experience in order to address meetings of the Institution, the Committee expresses thanks.

Appreciation is also recorded for the help given by the Chairmen, Secretaries, and all members of local Section Committees. Without the aid of the honorary services of these members it would not be possible to develop the Institution's work. Members have been well served by their local Committees and the Council hopes that other members who are able to assist in this work will do so.

**The Journal.**—Volume 13 of the *Journal* comprised 628 pages,\* excluding the advertising material, and has thus maintained the annual record of being larger in volume than its pre-

decessors. The Committee gratefully acknowledges the co-operation afforded by all the authors in making suitable for publication their contributions to the Institution meetings.

The range of subjects covered has again been extremely wide, covering virtually the whole field of radio and electronic engineering from television and audio-frequency engineering, to electronic methods of pH measurement and printed circuits. Particular attention was given to the general subject of microwaves which the Committee felt had not previously received sufficient attention.

The value of many of the papers published is evidenced by the number of reprints supplied to authors and/or their companies and the increasing subscriptions for the *Journal* received from universities, manufacturers, etc.

The circulation of the *Journal* has risen steadily during the year and now stands at a figure of over 5,500 as certified by the Audit Bureau of Circulations. This does not take account of circulation subsequent to the publication date and consequently the effective figure is considerably higher. The sale of back numbers is indicative of the value of the *Journal* for reference, and examination of the abstracts shows that many comparatively recent papers are already out of print.

Publication of the abstracts in the December, 1953, *Journal* received wide commendation. These abstracts were compiled according to the Universal Decimal Classification instead of alphabetically as in previous editions, a feature which adds considerably to the convenience for reference. The work of revision is now in progress with the intention of making the publication complete up to the end of 1954 and including all papers presented at the 1954 Convention. The abstracts will then be published as a separate booklet.

Printing costs have continued at their high level over the year and do not show any signs of decreasing. These costs have to some extent determined the size of the *Journal* and this in turn has led to a certain delay in publication of papers after their acceptance. Papers are, however, published in the *Journal* with more promptitude than the majority of other technical periodicals in the same field.

**Premiums.**—The Council is pleased to announce the list of recipients of Institution

premiums for 1953 and congratulations are offered to the authors concerned. Of the nine premiums offered for papers published in the *Journal*, it has been possible to make awards of six, including the first award of the Sir J. C. Bose Premium for the most outstanding paper by an Indian scientist or engineer.

The Clerk Maxwell Premium: W. Saraga, Dr. Phil., D. T. Hadley and F. Moss, B.Sc.  
*An Aerial Analogue Computer* (April, 1953).

The Heinrich Hertz Premium: B. E. Kingdon (Graduate).

*A Circular Waveguide Magic-tee and its Application to High-power Microwave Transmission* (May, 1953).

The Louis Sterling Premium: D. A. Bell, M.A., B.Sc., Ph.D.

*Economy of Bandwidth in Television* (September, 1953).

The Sir J. C. Bose Premium: S. K. Chatterjee, M.Sc.

*Microwave Cavity Resonators* (October, 1953).

The Marconi Premium: Paul Eisler, Dr. Ing. (Member).

*Printed Circuits: Some general principles and applications of the Foil Technique* (November, 1953).

The Norman Partridge Memorial Award: J. A. Youngmark, M.A.

*Loudspeaker Baffles and Cabinets* (February, 1953).

Awards were withheld for 1953 in respect of the Brabazon, A.F. Bulgin, and Leslie McMichael Premiums, as papers of sufficiently high standard were not published. As reported last year, the terms of the award of the Students' Premium are at present under review.

**Acknowledgments.**—Thanks are due to the authorities of the universities, colleges, etc., who provided facilities for the meetings of the sections. Council is also grateful to the editors of technical and scientific journals who have published notices of Institution meetings and reported on the proceedings.

During the year Mr. G. Wooldridge was appointed Chairman of the Committee, and Council wishes to place on record its appreciation of the services of Dr. G. L. Hamburger who had served as Chairman of the Committee for the previous five years.

**TECHNICAL COMMITTEE**

As indicated in various issues of the *Journal*, there have been changes in the constitution of the Committee. The Committee wish particularly to make reference to their great loss in the death of Group Captain G. N. Hancock, C.B.E. (Member), who had given extremely valuable service to the Committee.

**Special reports.**—For the last two years the Committee has been concentrating on preparing a review of basic materials used in the radio industry. The objective has been publication of an easy reference guide to supplement the specialized textbooks and papers which have been published on primary materials.

The work has involved the preparation of a series of comprehensive papers, but sufficient progress has now been made to justify the publication in the *Journal* of the first few sections. The first two of these will deal with "Aluminium" and "Piezo-electric Crystals," and will be available for publication within a few months after this report.

**Co-operation with other Committees.**—During 1953 the Committee was, of course, called upon to assist the specially appointed Convention Committee in examining papers and generally helping in the programme of the Convention.

It will be the Committee's responsibility to sponsor the specialized sections when they are formed, and during 1954 it is hoped to complete draft proposals which, subject to Council's approval, will lead to the formation of the first specialized section—Industrial Electronics.

Co-operation has also been effected with the Papers Committee on such matters as Abstracts, the use of the M.K.S. System of Units, and especially on the preparation of new notes for the guidance of authors.

Arising out of these matters and also out of other planning, the Technical Committee were able to make a number of suggestions of papers for publication and reading, and it is the special responsibility of the Committee to organize the forthcoming London Section discussion on "Maintainability of Service Equipment."

**The British Standards Institution.**—The Committee is pleased to record the continuing association with the work of the British Standards Institution. The Institution is repre-

sented on the various technical committees of the B.S.I. by the following members:—

- TLE/1 Terminology and Symbols for Telecommunications—F. G. Diver, M.B.E. (*Member*).
- TLE/2 Radio (including Television) Receivers—F. T. Lett (*Associate Member*).
- TLE/3 Radio (including Television) Transmitters—J. R. Brinkley (*Member*).
- TLE/4 Components for Telecommunications Equipment—M. H. Evans (*Associate Member*).
- TLE/5 Electronic Tubes—G. R. Jessop (*Associate Member*).
- TLE/8 Measuring Instruments and Test Equipment—E. D. Hart (*Associate Member*).
- TLE/9 Aircraft Radio Equipment — C. B. Bovill (*Member*).
- TLE/11 Piezo-electric Crystals — S. Kelly (*Member*).
- ELE/32 Radio Interference—J. H. Evans (*Associate Member*).
- ELE/66 R.F. Heating Equipment—R. E. Bazin (*Member*).

These representatives have also attended meetings of the Institution's Technical Committee to discuss matters arising out of their representation.

In addition the Committee has considered other provisional standards prepared by the B.S.I. and by industrial committees. Where necessary the Committee has submitted comments on behalf of the Institution.

**Future work.**—In the early stages of their formation, the proposed special sections of the Institution will probably work on "study circle" lines. Subsequently full meetings of the Institution would be held and thus serve the diverse interests of all members. That diversity of interests must inevitably increase in the future, and to cater for all of them is one of the prime objects of the Institution.

In addition the Committee is most anxious not only to ensure that these special sections will be capable of supporting the *Journal* by specialist contributions, but also to afford them representation on the main Technical Committee. This latter arrangement would assist publication of data and reports on, for example, reviews of progress on television and broad-

casting systems, semi-conductor devices, as well as examples of the application of electronics to specific industries.

In these ways it is hoped that a larger number of members will be encouraged to contribute papers on their own special subjects.

### LIBRARY COMMITTEE

The Committee again reports a very satisfactory year in which the Library's capacity for service to the members developed. The number of books despatched on loan totalled 692, excluding those volumes which were obtained for members from other sources.

The allocation of more spacious accommodation for the Library has enabled further volumes to be added to the existing stock and, in general, the Library is able to meet most of the requests received.

The Library now houses nearly 800 books which comprise the lending section and over 500 journals and bound volumes which comprise the reference section. The reference library now contains an extensive range of technical and scientific periodicals and its value is evidenced by the fact that over 400 visitors made use of this facility.

Whilst both the lending and reference sections of the Library are now fairly comprehensive, the Committee is always pleased to receive suggestions for improving Library services.

Work has now commenced on equipping the Library with shelving units for the more compact housing of the books. This is, of course, a costly item, but it is hoped to have most of the equipment installed within the next 12 months.

The Library is now, therefore, a most valuable asset of the Institution and, as stated elsewhere in this report, it is considered necessary to obtain a revaluation. The valuer's findings will be given in the next annual report.

The Institution continues its membership of ASLIB (The Association of Special Libraries and Information Bureaux).

**Library Catalogue.**—The task of compiling the data necessary for this publication is quite considerable, but a new catalogue is in the course of preparation. Members will be advised when this publication is available.

**Gifts.**—The Committee is most appreciative of the generosity of those members who have donated books and periodicals to the Library. Such gifts are always welcomed and thanks are particularly due to the following: F. Crosdale, A. G. Egginton, C. S. Fowler, H. Manley, L. W. Meyer, D. W. Sayer, and G. Wooldridge.

In addition, copies of new books forwarded by publishers in Great Britain and overseas for review in the *Journal* have subsequently been placed in the Library.

The *Journal* of the Institution has also been requested in exchange for a number of new technical and professional journals.

### FINANCE COMMITTEE

The accounts for the year ended 31st March, 1954, are appended to this report. The form in which the accounts are presented follows the practice first adopted last year and therefore shows easy comparison with the 1953 figures.

**Income and Expenditure Account.**—All normal items of income continue to show an appreciable increase which is the surest indication of the general growth of the Institution. Only sundry donations and building appeal contributions show a decline in comparison with previous years and particular attention is drawn to the Committee's comments on the Building Appeal. Otherwise the total increase in income for the year was nearly £4,500, which is a most satisfactory feature of the accounts.

In an endeavour to improve still further the income from subscriptions many members have enquired whether they might be allowed to sign a deed of covenant for the annual payment of their subscriptions. A test deed of this kind has already been submitted to the Inland Revenue authorities, but the matter, which is one affecting many societies, is still under review.

There is an increase of nearly 25 per cent. this year in the amount expended on Institution publications. This is largely because the *Journal* has increased in size and circulation, which is only offset to a limited extent by advertising revenue. This source of income has received the close attention of the Committee during the past 12 months.

Bearing in mind the increased services to members, coupled with rising costs, the accounts show that the affairs of the Institution continue

to be administered with all reasonable economy. Increasing membership necessarily incurs higher expenditure and it is of interest to note that within the short space of six years the expenditure of the Institution has been more than doubled. Nevertheless, had it not been for the heavy cost of repairs to the building, which were much higher than the Committee had anticipated, the excess of expenditure over income would have been avoided.

**Building Appeal.**—For some time the Committee has drawn attention to the increasing costs of maintenance and repairs to 9 Bedford Square, and in the 1949 Annual Report reference was made to the desirability of concentrating moneys received in response to the Building Appeal towards the acquisition of new freehold premises. The Committee now considers that every effort should be made to acquire more suitable accommodation.

In the 24th Annual Report the Committee stated that the Building Appeal should not be fully launched if the project of obtaining freehold premises for the Institution would “. . . impose too great a burden on the general funds of the Institution. The first step is to be sure of support from the membership.” For this purpose it was agreed that when the Appeal reached £10,000, *every member* should be asked to contribute in order to strengthen an appeal to industry for support.

It is estimated that permanent headquarters for the Institution will cost at least £50,000, and the co-operation of all members is most necessary if the Institution is to secure substantial outside help.

**General.**—The balance sheet shows that there has been an increase of £900 in respect of investments held on behalf of the Building Appeal and

it is to be hoped that these moneys will soon be shown as a fixed asset in terms of the Institution's own freehold premises.

Additions to the Library have always been capitalized at cost and depreciation written off each year. The Committee feels, however, that it is now desirable to obtain a revaluation of this asset which is probably worth more than the written-down figure of £550 shown in the balance sheet. A report on this valuation will be given next year.

Finally, the Committee reports that the item “1954 Convention” represents the receipts on account of the Convention, less expenditure, up to the 31st March. It will be appreciated, of course, that the final cost of the Convention will appear in the accounts of the Institution for the year to 31st March, 1955, as a charge to the Income and Expenditure Account.

## CONCLUSION

Any account of the year's work would not be complete without an expression of the Council's thanks for the loyal co-operation of the staff of the Institution. On them falls the responsibility of implementing in detail the plans and policy laid down by the Council and its committees. In a growing organization it is inevitable that the burden of work will fall upon too few, and whilst during the year there have been increases in the staff, the Council is much appreciative of the effort and enthusiasm which is given to the day-to-day work of the Institution.

Reference has been made in this and other reports to the importance of the active participation of each member in the work of the Institution. This cannot be stressed too often and the Council is pleased to pay tribute to the many officers and members who have been ready to give assistance to the Institution.

INCOME AND EXPENDITURE ACCOUNT FOR THE YEAR ENDED 31ST MARCH, 1954

		£	s.	d.	£	s.	d.
1953							
	<b>Administration Expenses:</b>						
6,207	<i>Salaries and State Insurance</i> ..	7,736	16	0			
378	<i>Pension Scheme</i> .. .. .	378	2	0			
619	<i>Postage and Telephone</i> .. .. .	802	17	11			
741	<i>Printing and Stationery</i> .. .. .	961	17	6			
712	<i>Travelling and Entertaining Expenses</i>	475	14	6			
284	<i>Delegates' Expenses</i> .. .. .	218	2	2			
437	<i>Council and Committee Expenses</i> ..	540	3	6			
68	<i>Audit Fee</i> .. .. .	84	0	0			
475	<i>Bank Charges and Cheque Books</i>	451	13	9			
313	<i>Sundry Expenses</i> .. .. .	229	18	7			
158	<i>Legal Expenses</i> .. .. .	95	8	9			
					11,974	14	8
	<b>Institution Premises:</b>						
1,479	<i>Rent, Rates and Insurance (Net)</i> ..	1,519	3	6			
194	<i>Lighting and Heating</i> .. .. .	325	7	9			
233	<i>Office Expenses and Cleaning</i> .. ..	397	10	2			
587	<i>Repairs</i> .. .. .	901	4	9			
					3,143	6	2
	<b>Institution's Journal and Reports:</b>						
3,339	<i>Printing and Publishing less Advertising Receipts</i> .. .. .	4,328	18	0			
486	<i>Postage</i> .. .. .	544	13	9			
209	<i>Envelopes and Wrappers</i> .. .. .	235	10	4			
					5,109	2	1
	<b>Examination Expenses:</b>						
254	<i>Printing of Papers and Regulations Examiners' and Invigilators' Fees and Expenses</i> .. .. .	270	15	3			
455	<i>Expenses</i> .. .. .	459	10	7			
75	<i>Hire of Accommodation</i> .. .. .	91	9	3			
					821	15	1
	<b>Section Expenses:</b>						
340	<i>Printing, Stationery and Postage</i> ..	457	7	7			
268	<i>Hire of Accommodation, etc.</i> .. ..	363	7	1			
443	<i>Travelling Expenses and Subsistence</i>	528	6	0			
					1,349	0	8
173	<i>Grants to Other Institutions</i> .. .. .		203	0	0		
	<i>Donation to King George VI Memorial Fund</i> .. .. .				—	—	—
53	<i>Memorial Fund</i> .. .. .						
97	<i>Premiums and Awards</i> .. .. .		92	16	8		
	<b>Depreciation:</b>						
243	<i>Office Furniture and Fittings</i> .. ..	251	11	1			
55	<i>Library</i> .. .. .	69	18	3			
					321	9	4
2,422	<i>Excess of Income over Expenditure</i>				—	—	—
					£23,015	4	8

		£	s.	d.
1953				
10,706	<i>Subscriptions, including Arrears</i> .. ..	13,060	12	4
300	<i>Sundry Donations</i> .. .. .	165	0	0
4,649	<i>Building Appeal Donations</i> .. .. .	635	13	8
1,835	<i>Examination and Exemption Fees</i> .. ..	2,386	19	11
470	<i>Entrance and Transfer Fees</i> .. .. .	1,408	17	10
	<i>Sale of Examination Papers, Reprints and Journals</i> .. .. .	3,594	6	11
49	<i>Interest on Investments (Gross)</i> .. ..	134	14	2
	<i>Radio Trades Examination Board</i> —			
558	<i>Secretarial Charges</i> .. .. .	716	13	4
—	<i>Excess of Expenditure over Income</i> .. ..	912	6	6
		£21,797	4	8

THE BRITISH INSTITUTION  
GENERAL

BALANCE SHEET

1953	<i>RESERVES</i>								
£							£	s.	d.
500	Library Reserve Account	..	..	..	..	..			500 0 0
<i>CURRENT LIABILITIES</i>									
2,286	Sundry Creditors	..	..	..	..	..	2,643	1	1
1,632	Subscriptions and Examination Fees in Advance	..	..	..	..	..	1,840	3	10
12,269	Bank Overdraft	..	..	..	..	..	14,428	11	4
							18,911	16	3
<i>1954 CONVENTION</i>									
—	Receipts, less Expenditure to date	..	..	..	..	..			123 0 9

*Signed* {
   
G. A. MARRIOTT (*Chairman, Finance Committee*).
   
S. R. CHAPMAN (*Member of Finance Committee*).
   
G. A. TAYLOR (*Honorary Treasurer*).
   
G. D. CLIFFORD (*General Secretary*).

£16,687

£19,534 17 0

REPORT OF THE AUDITORS TO THE MEMBERS OF

We have obtained all the information and explanations which to the best of our knowledge and belief were necessary for the purposes of our audit. In our opinion proper books of account have been kept by the Institution so far as appears from our examination of those books and proper Returns adequate for the purposes of our audit have been received from the Sections Overseas.

We have examined the above Balance Sheet and annexed Income and Expenditure Account which are in agreement.

18th August, 1954.

42 Bedford Avenue, London, W.C.1.



**OF RADIO ENGINEERS  
ACCOUNT**

AS AT 31st MARCH, 1954

1953		£	s.	d.	£	s.	d.
	<i>FIXED ASSETS</i>						
	Office Furniture and Fittings at Cost .. .. .				4,124	7	5
	Less Depreciation to date .. .. .				1,860	7	5
2,187							2,264 0 0
	The Louis Sterling Library at Cost .. .. .				1,050	6	6
	Less Depreciation to date .. .. .				500	6	6
500							550 0 0
	<i>INVESTMENTS AT COST</i>						
	£200 3% Savings Bonds 1960/70 .. .. .				200	0	0
	£733 10s. 9d. 4% Consolidated Stock .. .. .				650	0	0
	£306 4s. 4d. British Transport 4% Guaranteed Stock 1972/77 .. .. .				300	0	0
1,150							1,150 0 0
	<i>(Market Value 31st March, 1954, £1,199)</i>						
	<i>Building Appeal</i>						
	£1,000 4% Consolidated Stock .. .. .				877	1	6
	£1,346 10s. 8d. 3½% War Loan .. .. .				1,000	0	0
	£293 15s. 8d. British Transport 4% Guaranteed Stock 1972/77 .. .. .				301	11	11
	Halifax Building Society .. .. .				600	0	0
1,877							2,778 13 5
	<i>(Market Value 31st March, 1954, £3,028)</i>						
5,714							6,742 13 5
	<i>CURRENT ASSETS</i>						
	<i>General Fund</i>						
2,590	Stock of Stationery, Journals and Examination Papers at Valuation				2,928	17	1
	Sundry Debtors and Payments in Advance, including Subscriptions						
	in Arrears .. .. .				2,160	9	11
1,391	Sections—Cash in Hand .. .. .				83	8	2
100	Cash in Hand .. .. .				21	19	6
10							
							5,194 14 8
	<i>Building Appeal</i>						
5,339	Cash at Bank .. .. .				5,142	8	9
							10,337 3 5
15,144							17,079 16 10
	<i>RESERVE ACCOUNT</i>						
	Balance as at 1st April, 1953 .. .. .				1,542	13	8
1,543	Plus Excess of Expenditure over Income for the year .. .. .				912	6	6
							2,455 0 2
	<i>NOTES:</i>						
	(1) The Balance on Reserve Account, viz., £2,455 0s. 2d., is after credit has been taken for Building Appeal Donations and Interest on Investments.						
£16,687							£19,534 17 0
	(2) The Rupee is taken at the Exchange Rate of 1s. 6d.						

**THE BRITISH INSTITUTION OF RADIO ENGINEERS**

ment with the books of account. In our opinion and to the best of our information and according to the explanations given to us, the said accounts give the information required by the Companies Act, 1948, in the manner so required. The Balance Sheet gives a true and fair view of the state of the Institution's affairs as at 31st March, 1954, and the Income and Expenditure Account gives a true and fair view of the Excess of Expenditure over Income for the year ended on that date.

GLADSTONE, JENKINS & CO.,  
Chartered Accountants, Auditors.

## NOMINATED FOR ELECTION TO COUNCIL

**Captain (L) Arthur John Brabant Naish** was born in London in 1911 and was educated at Lee-on-Solent and in Oxford.



In 1928 he entered University College, Southampton, and in 1930 went up to Sidney Sussex College, Cambridge, taking an honours degree in 1933 in Natural Science, specializing in physics.

Before joining the R.N.V.R. in 1940 he taught physics at Cranleigh School, Surrey. During the war he

served in H.M.S. *Aberdeen* escorting North Atlantic convoys, and after a radar course and various radar appointments became Staff R.D.F. (later "Radar") Officer to the C-in-C. Western Approaches in 1942.

After the war Captain Naish served with the Director of Navigation at the Admiralty. He transferred to a permanent commission in the Electrical Branch, with the rank of Commander (L), in 1946 and was appointed to H.M.S. *Collingwood* where he was in charge of training. In 1949 he was appointed Electrical Officer of H.M.S. *Vengeance* and in 1951 joined the staff of the Commander-in-Chief, Mediterranean, at Malta as Fleet Electrical Officer. Since December, 1953, he has been attached to a special Admiralty working party investigating problems of electronic reliability.

Captain Naish was elected as an Associate Member of the Institution in 1946 and was transferred to full membership earlier this year. He served on the General Council as an Associate Member in 1949 and has now been nominated for re-election as a Member.

**Edgar William Pulsford**, who was born in 1907 in Manchester, was educated in Bath and Birmingham. He obtained an Honours Degree in Physics from the University of Birmingham in 1927, and after a year's study in the Education Department received a Diploma in Education.



He then received an appointment at Urmston Grammar School, Manchester, as assistant master for physics, etc., where he remained until the early years of the war.

From 1941 to 1946 he was at the Telecommunications Research Establishment, being concerned first with the development of synthetic trainers, and latterly with ultrasonics research. In 1946 he transferred to the Electronics Division of the Atomic Energy Research Establishment, where he has been engaged in the development of nucleonic instruments of many kinds. Mr. Pulsford has recently been concerned with special instruments for the physical, chemical, medical and industrial fields of radio-isotope applications, and he has described these in a number of papers including one entitled "The Analysis of Binary Gas Mixtures by a Sonic Method," which he read at the 1954 Convention.

Mr. Pulsford, who has held the rank of Principal Scientific Officer since 1947, was elected an Associate Member of the Institution in 1952, and earlier this year he was appointed to the Education and Examinations Committee, where he has been particularly concerned with drafting the syllabus of the new subject "Applied Electronics." He is now nominated to serve on the General Council.

The following have also been nominated:

**Mr. D. R. Chick**, M.Sc., B.Sc. (Member), joined the Programme and Papers Committee in February after several years' service on the Education and Examinations Committee. (For a biography see *Journal* for August 1952.)

**Mr. F. G. Diver**, M.B.E. (Member), has served for several years on the Technical Committee and is a representative of the Brit.I.R.E. on the British Standards Institution. (See May 1952 *Journal*.)

**Mr. F. T. Lett** (Associate Member), has been a member of the Programme and Papers Committee since 1952 and is a Brit.I.R.E. representative on B.S.I. (See July 1953 *Journal*.)

**Lt.-Col. J. P. A. Martindale**, B.A., B.Sc. (Associate Member), joined the Programme and Papers Committee in 1953. (See September 1953 *Journal*.)

## APPLICANTS FOR MEMBERSHIP

New proposals were considered by the Membership Committee at a meeting held on August 24th, 1954, as follows: 33 proposals for direct election to Graduateship or higher grade of membership and 39 proposals for transfer to Graduateship or higher grade of membership. In addition, 87 applications for Studentship registration were considered. This list also contains the names of three applicants who have subsequently agreed to accept lower grades than those for which they originally applied.

The following are the names of those who have been properly proposed and appear qualified. In accordance with a resolution of Council and in the absence of any objections being lodged, these elections will be confirmed 14 days from the date of the circulation of this list. Any objections received will be submitted to the next meeting of the Council with whom the final decision rests.

### Direct Election to Member

FLEMING-WILLIAMS, Brian Clifford, B.Sc. *London, N.W.5.*  
 KELLY, Stanley. *Enfield, Middlesex.*

### Direct Election to Associate Member

BAINES, Major Fredrick Vernon, R.A.C. Sigs. *London, W.C.1.*  
 FANZERES, Apollon. *Rio de Janeiro.*  
 GREEN, Com. (L) Philip Percival Mancha, R.N. *London, S.W.3.*  
 JONES, Cyril, B.Sc. *Wigan.*  
 LYSONS, Horace, B.Sc. *Abingdon, Berkshire.*  
 MCGLASHAN, Flt.-Lt. Donald Charles, R.N.Z.A.F. *London, W.C.2.*  
 ROSS, Raymond Elmslie. *Chilwell, Nottinghamshire.*  
 VAN OYERBEEK, Adrianus Johannes Wilhelmus Marie. *Eindhoven, Holland.*

### Transfer from Associate to Associate Member

ALVEY, Donald, B.Sc. *Iford, Essex.*  
 BUMSTEAD, Maurice Charles. *Hythe, Kent.*  
 CUNNINGHAM-SANDS, James. *Wednesfield, Staffordshire.*  
 DE SYLLAS, Pan Lawrence. *Welwyn Garden City.*  
 NOBLES, Geoffrey William. *Worcester.*  
 PARCHMENT, Ernest David. *London, S.W.9.*

### Transfer from Graduate to Associate Member

BRYANT, Allan Victor. *Wallington, Surrey.*  
 GILMOUR, Hugh Morton. *Malta, G.C.*  
 HIGHAM, Edward Hall. *Bebington, Wirral, Cheshire.*  
 IMBIEROWICZ, Marian. *Iford, Essex.*  
 MILLS, Douglas Hazelton, B.Sc. *Johannesburg.*  
 O'HAGAN, Flt.-Lt. Michael, R.A.F. *Newcastle upon Tyne.*  
 WAISTELL, Fred. *Sidcup, Kent.*

### Transfer from Student to Associate Member

BALARAM, Capt. Krishnaswami, B.Sc., Indian Sigs. *Mhow, India.*

### Direct Election to Associate

ATTWOOD, Bertie William. *Southampton.*  
 CHAMBERLAIN, Austen Charles. *Hartwell, Northamptonshire.*  
 DAVIDSON, Douglas Gordon. *Khartoum.*  
 JONES, Eric Edward. *Richmond, Surrey.*  
 KING, Capt. Edward Francis, R. Sigs. *St. Annes-on-Sea, Lancs.*  
 MANTLE, William Evan. *Watchfield, Wiltshire.*  
 MATEER, William. *Birstall, Leicestershire.*  
 UNDERHILL, Walter Thomas. *Great Baddow, Essex.*  
 WILLIAMSON, Lieut. (L) John Graham, R.N.Z.N. *H.M.S. Agincourt, c/o G.P.O., London.*

### Transfer from Student to Associate

MARSDEN, Ernest Wilson. *Westcliff-on-Sea, Essex.*

### Direct Election to Graduate

BLACK, Jan, B.Sc.(Eng). *Davyhulme, Lancashire.*  
 BOTTOMLEY, Frederick Walter. *Liverpool.*  
 FEY, Leonard James, B.Sc. *Aberdare.*  
 MEU, Gerrit Verster, B.Sc.(Eng). *Johannesburg.*  
 OCKERSE, Theo Rudolf, B.Sc.(Eng). *Johannesburg.*  
 OLISA, Peter Enebeli. *Oshodi, Nigeria.*  
 SANDERS, Robert George. *London, N.W.10.*  
 SAYAL, Bhaddar Sain, M.Sc. *London, N.W.9.*  
 TAW CHENG HOCK. *London, N.A.*  
 WADDELL, Gavin. *Feltham, Middlesex.*

### Transfer from Student to Graduate

BARTLETT, Haroun Bey. *Malvern Wells, Worcestershire.*  
 BLIGHT, Ronald Ernest. *Bedford.*  
 CHRISTMAS, Bernard Harrison. *London, E.11.*  
 COOPER, Ernest, B.Sc. *Cambridge.*  
 DICKINSON, Philip. *Manchester.*  
 GANAPATI, Koovelimadhom Subramania, B.A. *Madras.*  
 GOEL, Suraj Mall. *New Delhi.*  
 GRIFFIN, David John. *Leighton Buzzard.*  
 LONGMAN, Charles Robert. *Ickenham, Middlesex.*  
 NARAYANAN, Nambiath, B.A.(Hons). *Calcutta.*  
 RAGHAVAN NAIR, Chalaya K., B.A. *New Delhi.*  
 RAMACHANDRA RAO, A. V. *Bangalore.*  
 RAMAKRISHNAN, Narayana. *Bombay.*  
 SATYA PAUL SURI, B.Sc. *Delhi.*  
 STUBBS, John. *Liverpool.*

### Studentship Registrations

AHMAD, Hameed, B.Sc. *Southampton.*  
 ALI, Syed Zahid. *Southampton.*  
 ANNINOS, George. *Athens.*  
 ARAPAKIS, George. *Athens.*  
 ASHTON, Derek Berry Thomas. *London, W.A.*  
 BHATNAGAR, Madho Swarup, B.Sc.(Hons.). *Bulandshahr, India.*  
 BHATTACHERJEE, Amal Kumar, B.Sc. *Bangalore.*  
 BHATTASALI, Reba (Miss). *Calcutta.*  
 BRIGGS, Kenneth John. *Launceston, Tasmania.*  
 CARVOUNIS, Seraphim. *Athens.*  
 CHIU TZE KONG. *Hongkong.*  
 CHOUDHURY, Gouri Shankar. *Calcutta.*  
 CHRISTODOULOU, Christos. *Athens.*  
 CLARKE, Roy Wellesley. *Bournemouth.*  
 COLETTIS, Nicolas. *Athens.*  
 CRANFIELD, Ronald Frederick. *Bristol.*  
 CRAPPER, David Hugh. *Liverpool.*  
 DAWSON, George Gladders. *Goulburn, New South Wales.*  
 DHARAM SINGH, Hada, B.A. *Simla, India.*  
 DIDDINGS, Hylton James. *Waltham Cross, Hertfordshire.*  
 DODEJA, Vishwamber Kanayalal, B.Sc. *Rajawadi, India.*  
 DOUGLAS BROERS, Louis Engelbrecht. *Nallsworth, S. Australia.*  
 FATSEAS, Andreas. *Athens.*  
 FATSIS, Nicolas. *Piraeus, Greece.*  
 FITCH, Lawrence William. *Shepparton, Victoria.*  
 GARDINER, Alan. *Hounslow West, Middlesex.*  
 GEORGAKOPOULOS, Theodore. *Athens.*  
 GEORGIU, Gregory. *Athens.*  
 HATZOPOULOS, Georges. *Piraeus, Greece.*  
 HAWKES, John William. *Johannesburg.*  
 HELSZAFN, Josef. *London, N.16.*  
 HINGSTON, William Frederick. *Birkenhead.*  
 HOLDEN, Dennis George. *Wyton, Huntingdonshire.*  
 HOLLAND, Lieut. Peter John, Royal Sigs. *Worcester.*  
 HUGHES, John Aledwyn. *London, S.W.11.*  
 JAYACHANDRAN, Potayil, B.Sc. *Ernakulam, South India.*  
 KANAL, Nihal. *Bombay.*  
 KHOSLA, Anand Prakash. *Poona.*  
 KING, Noel Henry, B.Sc. *Sydney, New South Wales.*  
 KNIGHT, John Arnold. *Wolviston, Co. Durham.*  
 KOURAKOS, Michael. *Athens.*  
 Kvi, Maung Aung. *London, W.2.*  
 LWIN, Maung Maung. *London, W.2.*  
 MCGEARTY, Desmond Vincent. *Chesterton, Cambridgeshire.*  
 MARCAR, Douglas. *Northbridge, New South Wales.*  
 MARKANTONATOS, Nicholas. *Athens.*  
 MARSELLLOS, Nicholas. *Athens.*  
 MUNRO, Kenneth Neil. *Giffnock, Renfrewshire.*  
 NEGREPONTIS, Eleutherios. *Athens.*

Note.—The names of the remaining 38 Students registered at this meeting will be included with the next List.

# PROBLEMS OF TELEVISION CAMERAS AND CAMERA TUBES\*

by

L. H. Bedford, O.B.E., M.A., B.Sc., F.C.G.I. (*Member*)†

## SUMMARY

Questions of sensitivity and signal-to-noise ratio are discussed. While the results are of general application, the subject is developed with particular reference to the image orthicon type of camera tube. The latter, in its standard form (the 3-in image orthicon), has a considerable sensitivity advantage compared with other types of tube. For some purposes, particularly studio use, it is desirable to exchange some of this sensitivity for other properties, such as signal/noise ratio. In this case the balance of properties can be improved by increase in target area, which leads to the large (4½-in) image orthicon. A description is given of a new camera designed around the large image orthicon with maximum exploitation of the properties of the latter. Three approaches to the colour television camera problem are described, and the repercussion of colour on sensitivity and signal/noise ratio is discussed.

### 1. Fundamental Considerations

In this category the principal items to be considered are those of sensitivity and signal/noise ratio, quantities which may or may not be related.

#### 1.1. Sensitivity

In a previous paper,<sup>1</sup> the author has emphasized the fact that camera tube sensitivity is fully expressed by one quantity, namely the total photo-cathode light flux corresponding to a peak white picture.

Figure 1 shows the transfer characteristics for a number of important camera tubes, and to make the data absolute the light input has been expressed on a scale of light flux (millilumens—ml) on the photo-cathode. On these transfer characteristics the preferred operating point corresponding to peak white is marked by an arrow. For expressing sensitivity only the abscissae of these arrows are of interest. We note a sensitivity ratio of approximately 1,000 : 1 in light value between the 1936 Emitron (1) and the 1952 Image Orthicon (4), a truly remarkable achievement over a period of 16 years, bearing in mind that (1) already expresses the tremendous step to the storage-type camera tube pioneered by Zworykin.

Curve (8) of Fig. 1 shows the transfer characteristic for the overall 35-mm film process.<sup>2</sup>

\*Manuscript received May 18th, 1954. Based on a paper read before the Symposium on Electronics and Television, Milan, April 1954. (Paper No. 283.)

†Marconi's Wireless Telegraph Co., Ltd., Chelmsford.

U.D.C. No. 621.397.331.2 : 621.383.

In this case the ordinates must be read as pure numbers rather than current values, and the absolute location in the ordinate direction has no meaning. The important point which emerges is that the television camera sensitivity has now surpassed that of the film camera by a considerable factor. Indeed, in the case of the small (3-in) image orthicon, the factor of 20 times in light value is already so great that sensitivity ceases to be the leading consideration. One seeks in fact to convert some of this excess sensitivity into other more desirable properties of which the most dominant is perhaps the signal/noise ratio. Complementarily to the author's previous paper,<sup>1</sup> emphasis is now directed to this question.

#### 1.2. Signal-to-Noise Ratio

To reduce this to its most fundamental terms, while retaining a fairly usual engineering approach, we regard the picture as made of  $n$  discrete picture elements.

Let  $C_e$  be the target capacitance per picture element,

$V_e$  the picture element voltage excursion between scans,

$V_{e,w}$  be the above for a "peak white" picture element,

$T$  be the picture repetition period (time between scans),

$T'$  be the nett picture scanning time after allowing for blanking.

The elementary charge stored between scans is  $C_e V_e$ . This has to be discharged in time  $T'/n$ .

Fig. 1.—Transfer characteristics and operating points.

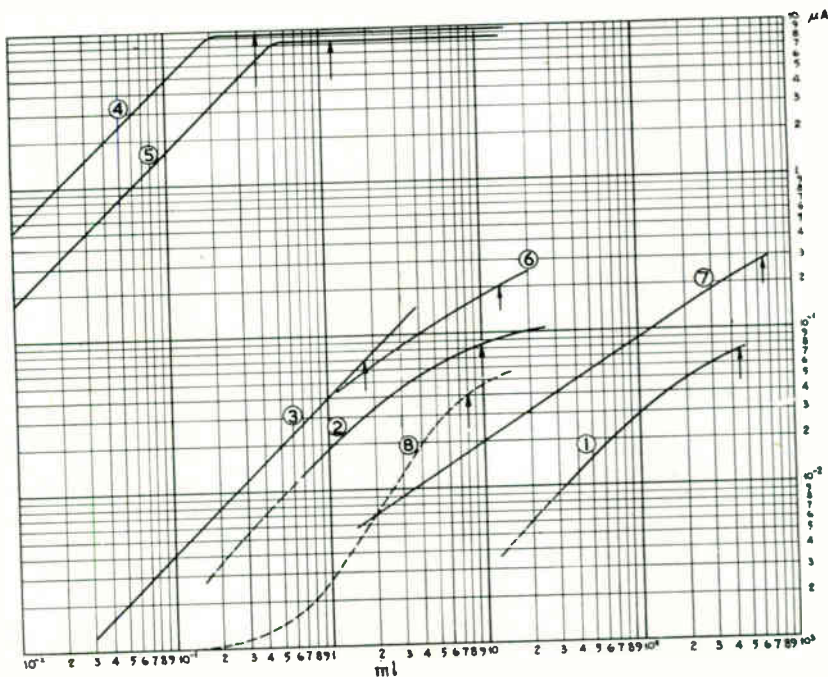

- (1) Emitron (iconoscope).
- (2) Photicon (image iconoscope).
- (3) C.P.S. emitron (orthicon).
- (4) Standard (3-in) image orthicon.
- (5) Large (4½-in) image orthicon.
- (6) Vidicon, 6198, camera conditions.
- (7) Vidicon, 6198, film-scanning conditions.
- (8) Overall transfer characteristic of 35-mm. film (arrow refers to plus-X negative stock).

If we idealize the scanning process by the temporary assumption that the whole of the scanning beam current  $I_b$  can be landed on the target, in other words assuming unity beam efficiency, we have

$$I_b = C_e V_e \frac{n}{T'}$$

and this is also the signal current. The mean square fluctuation current  $\bar{I}_n^2 = 2eFI_b$  where  $e$  is the electronic charge and  $F$  is the bandwidth of the system, which may be taken as  $\frac{1}{2} \frac{n}{T'}$  with  $k$  a factor in the vicinity of 1.

Hence the signal/noise ratio

$$= I_b^{\frac{1}{2}} (2eF)^{-\frac{1}{2}} = \left( C_e V_e \frac{n}{T'} \right)^{\frac{1}{2}} (2e)^{-\frac{1}{2}} \left( \frac{1}{2} \frac{n}{T'} k \right)^{-\frac{1}{2}}$$

$$= \left( \frac{C_e V_e}{e} \right)^{\frac{1}{2}} k^{-\frac{1}{2}}$$

But  $\frac{C_e V_e}{e}$  is just the number of electrons stored per picture element, which we may call  $N_e$ ; the only other factor appearing is  $k$ , the factor expressing the ratio between the bandwidth and half the picture element scan rate. We shall

take  $k$  as unity, thereby defining what is here meant by the picture element; namely the element having the width of one scanning line and a length equal to the product of the scanning velocity and the period of one half-cycle of the frequency  $F$  expressing the band-width.

We appear to have established the fundamental result that the signal/noise ratio of a storage-type camera tube is simply the square root of the number of electrons  $N_e$  stored per picture element per picture time (cf. Rose<sup>3</sup>).

In fact, however, for a scanned storage device this is not the complete result. To develop this we must now make an important distinction between camera tubes of two classes:—

- (a) those in which the signal current is directly the landed beam current, taken off by way of a "signal plate" capacitively coupled to the target, and
- (b) those in which the signal is primarily the unlanded beam current; or rather that the landed beam current is expressed as a deficit in the return beam current, as in the image orthicon.

For class (a) tubes an analysis of basic

signal/noise ratio is somewhat academic, since in the absence of electron multiplication this basic signal/noise ratio is never realized, the subsequent amplifier noise being overriding. However, for completeness we shall pursue this. We may note first of all that if unlanded beam contributes no noise (which is by no means certain) the actual value of the scanning beam current is irrelevant, and, in particular, there will be no noise in the blacks. If the target electron image is that arising from direct photo-emission at the target, the above result for signal/noise ratio,  $N_e^{\frac{1}{2}}$ , would appear applicable. The noise arises however, not from the scanning beam but from statistical fluctuations in the stored charge pattern, the scanning beam merely supplying such fluctuations "on demand." It may be of assistance in appreciating how this target noise pattern arises to remark that the primary photo-current contains a fluctuation in time which appears on the target as a fluctuation in space; the scanning process then reconverts this to a fluctuation time.

If the tube includes an electron image stage before the target this has some bearing on the target pattern noise.

Let the primary photo-current be  $I_1$  and the gain of the image stage  $\eta_2$ , then it is clear that the fluctuation in the target charge pattern is  $\eta_2$  times that appropriate to current  $\frac{I_1}{\eta_2}$ , which leads to the result  $\left(\frac{1}{\eta_2} N_e\right)^{\frac{1}{2}}$  for the signal/noise ratio.

Note that this result is true for any fraction of the peak white illumination. In usual television parlance, however, in the term signal/noise ratio, we refer to the signal as the peak black-to-white signal. In these terms we would write the signal/noise ratio as  $\left(\frac{1}{\eta_2} N_e, w\right)^{\frac{1}{2}}$ .

Now for the case (b), we may immediately proceed to the practical situation where the beam is not fully landed. Denoting the beam current by  $I_b$  and the landed current by  $I_l$ , the latter is  $C_e V_e \frac{n}{T}$  and the return beam current is  $I_b - I_l$ . This contributes  $2eF(I_b - I_l)$  to the mean square fluctuation current, while the target pattern noise will contribute  $2eF \frac{I_l}{\eta_2} \cdot \eta_2^2$ . The

total mean square fluctuation is

$$2eF [I_b - I_l + \eta_2 I_l] \\ = 2eF [I_b + (\eta_2 - 1) I_l]$$

The ratio of black-to-white signal to r.m.s. noise is

$$I_{l, w} \{2eF [I_b + (\eta_2 - 1) I_l]\}^{-\frac{1}{2}} \\ = I_{l, w}^{\frac{1}{2}} \left\{2eF \left[\frac{I_b}{I_{l, w}} + (\eta_2 - 1) \frac{I_l}{I_{l, w}}\right]\right\}^{-\frac{1}{2}} \\ = N_{e, w}^{\frac{1}{2}} \left\{\frac{I_b}{I_{l, w}} + (\eta_2 - 1) \frac{I_l}{I_{l, w}}\right\}^{-\frac{1}{2}} \\ = N_{e, w}^{\frac{1}{2}} \left\{S_1 + (\eta_2 - 1) \frac{I_l}{I_{l, w}}\right\}^{-\frac{1}{2}}$$

(Note.—Notation  $S_1$ —ratio of beam current to landed peak white current—is derived from previous paper.<sup>1</sup>)

In summary then, the expression  $(N_{e, w})^{\frac{1}{2}} (S_1 + \eta_2 - 1)^{-\frac{1}{2}}$  expresses the basic signal/noise ratio for both classes of tube if it is understood that in class (a) tubes—the signal-plate class—we artificially write  $S_1 - 1 = 0$ .

Before proceeding to note the positive implications of this simple formula, it is of interest to note the significance of the absence of certain quantities from it.

The first of these is the picture repetition period. This means that, contrary to one's natural premonition, one may scan the picture as fast as one pleases without detriment to signal/noise ratio, provided one can follow up with illumination and scanning beam current. Secondly, we see that the photo-cathode efficiency is absent from the signal/noise expression; this quantity affects only the sensitivity.

Reverting now to the expression

$$\text{signal/noise ratio} = (N_{e, w})^{\frac{1}{2}} (S_1 + \eta_2 - 1)^{-\frac{1}{2}} \\ = \left(\frac{C_e V_e, w}{e}\right)^{\frac{1}{2}} (S_1 + \eta_2 - 1)^{-\frac{1}{2}}$$

we see immediately that the principal tube design parameters by which we can attack the signal/noise ratio are the target capacitance, the target voltage swing, and beam landing efficiency. Of these the first admits the greater range of adjustment.

A numerical example is now appropriate. Consider the case of the standard 3-in image

orthicon having a target picture area of 6.1 cm<sup>2</sup>, a target-mesh spacing of 50 microns and hence a target capacitance of 108 pF.

The number of picture elements for the 625-line 25-frame system with 5 Mc/s video bandwidth and standard blanking factor of 0.77 is  $2 \times 5 \times 10^6 \times 0.77 \times 40 \times 10^{-3} = 3.1 \times 10^5$ .

The target capacitance per picture element is thus  $3.5 \times 10^{-4}$  pF. With a 2-V target swing the charge per element is  $7 \times 10^{-16}$ C and

$$N_e = \frac{7 \times 10^{-16}}{1.6 \times 10^{-19}} = 0.44 \times 10^4.$$

For the artificial case of  $S_1 = 1$  and  $\eta_2 = 1$ , signal/noise ratio =  $N_e^{\frac{1}{2}} = 0.66 \times 10^2 = 36.4$  db.

Now we have to correct this figure for real values of  $S_1$  and  $\eta_2$ , say 3 and 2, giving a correction of just 6 db. The practical signal/noise ratio for the small image orthicon thus becomes 30.4 db, a figure which is in good agreement with measurements.

Now considering what steps can be taken to improve the signal/noise ratio, we may note that factors such as beam bending limit the target excursion  $V_e$  to a fairly definite value in the vicinity of 2V. The only scope for improvement in the signal/noise ratio therefore resides in increasing target capacitance. This has been done, in tubes such as the 5826, by reducing the target-mesh spacing, this process giving us a 3-db signal/noise improvement for every halving of the spacing. Practical considerations rapidly impose a limit here.

There remains only one other possibility, namely to increase the target area. In the large image orthicon (4½-in) this has been increased to an area of 18.6 cm<sup>2</sup> so that for the same spacing we obtain a signal/noise improvement to 4.8 db. The signal/noise ratio for the large image orthicon with 50 microns target-mesh spacing becomes 35.2 db (for 625-line standards).

### 1.2.1. Factors determining the beam landing efficiency

It is rather easy to see that in a low velocity landing device, such as the image orthicon, the beam efficiency cannot approach 1. Fig. 2 expresses some beam landing phenomena as evaluated experimentally by Frank. It shows the proportion of beam current landed on a target for varying target voltage; this voltage

is relative to the cathode originating the beam, but the absolute location of the voltage scale is insignificant owing to contact potentials, etc.

The part of the curve AB is the normal quasi-exponential curve expected from a Maxwellian distribution of thermal energies among the beam electrons. Over this portion the landed beam current is approximately halved for every 0.2V step of target voltage. As the target voltage is raised, the curve departs from the exponential shape and according to target surface condition may continue as curve CD or as EFGH. The former represents a good

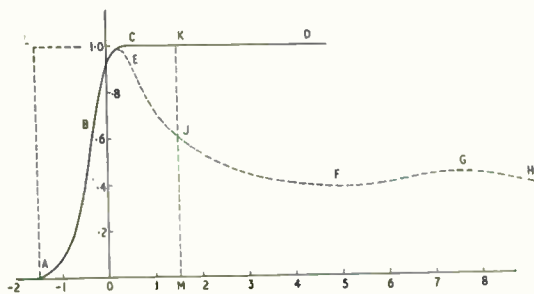

Fig. 2.—Landing conditions.

landing surface such as platinum sputtered on glass. The latter represents a bad landing surface such as aluminium evaporated on to glass and air exposed. The loss of landing in the portion EF is taken to be due to elastically reflected electrons. The portion GH denotes the commencement of secondary electron emission.

Consider the case of a target swing from -1.5V to +1.5V. The beam landing efficiency is the ratio of the area under curve ABEJ to that of the rectangle ALKM. In the particular case given this ratio is 0.56. The corresponding ratio for the good landing condition is 0.65. These figures indicate rather higher landing efficiencies than are actually encountered in the image orthicon where a good figure for landing efficiency is 0.33.

### 1.2.2. Practical measurements of signal/noise ratio of image orthicon

A series of measurements was carried out by G. Cooper, for which the results may be summarized as follows:—

The noise produced by image orthicons checks with the above theory to within 1 db. Discounting the exceptional cases of spurious noise due to incipient insulation breakdown, there are no unaccounted sources of noise in the tube. The variation in noise performance from one tube to another of the same type is attributable to variation in the target landing condition or beam landing efficiency.

Figure 3 shows the circuit used by Cooper for noise measurement. The substitution of the image orthicon anode current by that of a temperature-limited tungsten diode allows the noise to be expressed in absolute terms without involving any accurate knowledge of the amplifier characteristics. The measurement of beam current before multiplication proves to be a process of much greater experimental difficulty.

An important fact emerging from this series of measurements is that in the vicinity of 30 db signal/noise, the eye is surprisingly sensitive to variations in this quantity. There appears in fact to be a psychological wall extending from about 28 db to 32 db; on the lower side tubes are classed as objectionably noisy, on the upper side as quiet.

### 1.2.3. Note on the perversity of Nature

It is difficult to conclude this discussion on signal/noise ratio without being led to this reflection. Nature is reputed to abhor both a vacuum and the vacuum physicist, who in this case finds himself between the Scylla of class (a) and the Charybdis of class (b). Class (b) tubes are the only ones for which the basic signal/noise ratio can be realized since electron multiplication allows the subsequent amplifier noise to be overridden. Class (a) tubes show a

much more satisfactory basic signal/noise ratio but the possibility of realizing this in practice does not exist.

## 2. The Large Image Orthicon Tube and Camera

In Table 1 the principal parameters of the large image orthicon are exhibited together with corresponding figures for the standard (3-in) tube.

Table 1

Target area .. ..	18.6 cm <sup>2</sup>	6.1 cm <sup>2</sup>
Target capacitance (for 50 micron spacing) ..	330 pF	108 pF
Photocathode area ..	7.9 cm <sup>2</sup>	7.9 cm <sup>2</sup>
Target meshes per picture height (500 mesh/in) ..	445	296
Horizontal scanning V.A (625 lines, 50 f/s.) ..	160	19
Theoretical signal/noise ratio* .. .. .	35.2 db	30.4 db
Sensitivity:* Total light flux for peak white picture .. ..	1.0 ml	0.33 ml

\*Reckoned for 50 micron target-mesh spacing, 33 per cent. beam modulation, and 625/50 standards.

Having made the fundamental decision to go forward with the large image orthicon, it was next necessary to design a camera which would fully exploit the improved properties of the tube. At the same time, it was desirable to introduce all possible optical, mechanical and operational refinements which would ensure a substantial lease of life for the design, a necessary commercial consideration in view of the high cost of both camera and tube development. In the following paragraphs the principal features of the camera are outlined, and a view of the complete camera is shown in Fig. 4a.

### 2.1. General

The general approach is conditioned by the rather large size and weight of the deflection and focusing yoke. Despite the increased scanning volt-amperes as compared with the 3-in camera, it was found that the increased surface area of the yoke admitted

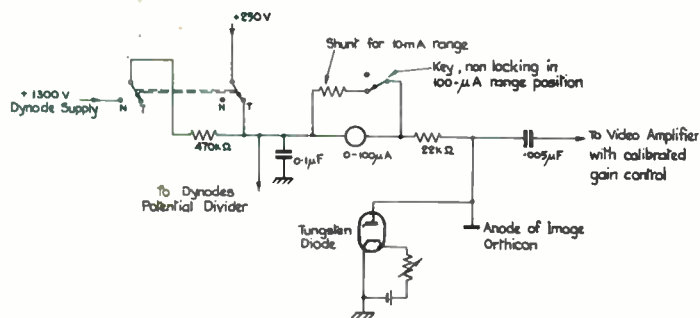
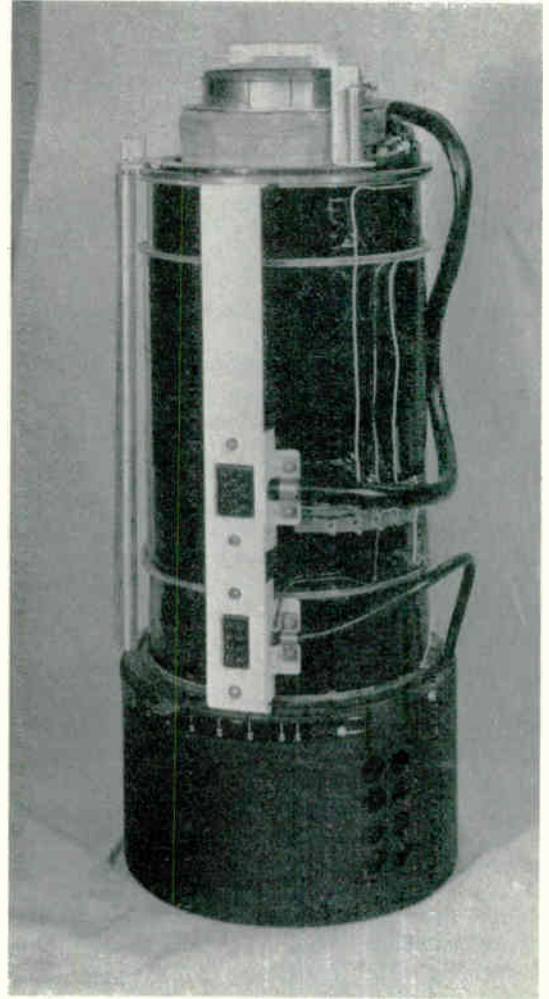

Fig. 3.—Noise measurement circuit for image orthicons.





Fig. 4.—Large Image Orthicon Camera.  
 (a) Top left: General view.  
 (b) Top right: Deflection and focusing unit.  
 (c) Bottom right: Electronic unit.



the possibility of cooling by natural convection. Because of the immense practical advantage of doing away with the blower, this feature was quickly made fundamental to the design.

Cooling conditions suggested that the tube should be placed at the bottom of the camera and, in order to isolate it from the inevitable valve heat, to one side. This geometry is also consistent with the best angle of look as determined by adjacent lenses on the turret.

## 2.2. Optical and Electron-optical Considerations

The problem here is to use to the best advantage the facility provided by the electron image stage of having geometrical magnification between the optical (photo-cathode) and the electron (target) image.

From a practical point of view, one would like to exploit this magnification indefinitely so that by having a very small optical image one would obtain the advantage of reduction in size and cost of lenses. However, one rapidly reaches a practical limitation in this respect in view of the difficulty of designing high electron magnification with sufficient freedom from aberration. A practical decision was made to

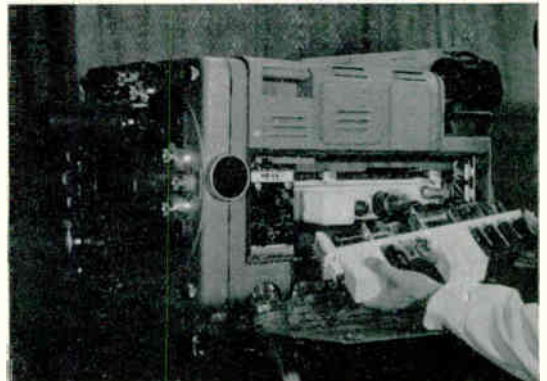

make the photo-cathode image size on the large tube the same as for the small tube, so that the highly developed and complete range of lenses for the latter would be directly applicable.

### 2.3. Deflection and Focusing Unit

Figure 4b is a photograph of this unit and Fig. 5 shows a schematic of the distribution of focusing ampere-turns and a plot of the corresponding longitudinal field.

The horizontal deflection volt-amperes for the 625-line standard is 160, which demands a reasonably efficient deflection circuit. This has been achieved, and, moreover, without the necessity for linearity controls of any kind. The h.t. input to the horizontal deflection system is 33W, showing a coefficient in performance of 4.8.

The scanning yoke also incorporates a heater coil around the target area which is under control of a thermistor-operated valve bridge circuit.

The yoke assembly with tube weighs 27 lb. and slides on a kinematically-correct system of rails and ball bearings under control of the focusing handle.

### 2.4. Video Head Amplifier

Owing to adequate electron multiplication in the tube, there is no severe signal-to-noise problem here. However, to allow ultimate exploitation of the tube, a 10-Mc/s video bandwidth is provided which imposes certain layout problems. The head amplifier is for this reason mounted immediately around the base of the image orthicon.

### 2.5. Electronic Unit

This unit, Fig. 4c, breaks down into three plug-in sub-chassis as follows:

1. Horizontal scanning unit.
2. E.H.T. generator (+ 1,200V, - 600V), scan protection circuits, vertical scanning unit.
3. Target blanking, focus modulation, video amplifier, target temperature control (thermistor bridge).

The whole unit swings out for inspection and servicing and is removable as a unit. In addition each of the sub-units is individually removable

with the intention that servicing would normally be by replacement of these sub-units.

### 2.6. Communication Facilities

Full communication and talk-back facilities are provided. The talk-back chassis forms the rear panel of the camera and the talk-back controls are located behind the hinged door.

### 2.7. Mechanical Construction and Features

In the past, television cameras have shown evidence of being designed by electronic specialists with mechanical engineering

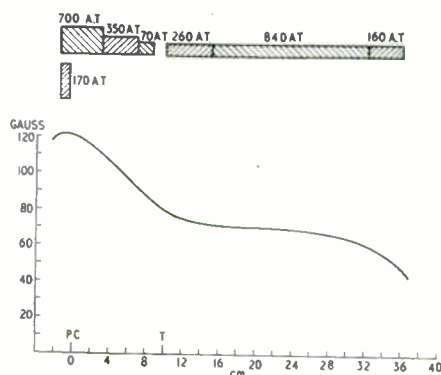

Fig. 5.—Large image orthicon camera, focus coil ampere turns and flux distribution.

considerations taking second place. In the present camera, mechanical aspects have been given full consideration from the outset, and a very much more solid and mechanically sound construction has resulted. This however, imposes a second mechanical problem of some magnitude, namely how to do this without objectionable increase of weight. The solution has been found in the extensive use of magnesium and other light alloy materials throughout.

#### 2.7.1. Turret

This is arranged to accommodate four lenses of any focal length from 5 cm to 100 cm. The lenses are fixed in position with rapid locking devices. When heavy lenses are used, counter-balance weights may be fixed to the opposite lens positions to minimize turret unbalance torques.

In addition, the rear turret drive is of a non-linear character which assists acceleration and

deceleration of the turret; one complete turn of the turret handle shifts the turret through 90 deg. The turret gearbox, which is a relatively complicated mechanism, provides also for the addition of motorized turret drive remotely operated from camera control.

### 2.7.2. Light control

Hitherto light control on a television camera has usually been by means of iris control. Some camera designs have provided for the remote control of iris. This not only imposes a somewhat untidy mechanical problem but is also not the best solution in conjunction with a tube of high sensitivity. A preferable solution would allow the iris to be set on considerations of a desired depth of focus, any excess light being then dealt with by means of a neutral attenuating filter.

In the present camera, iris setting is manual and light attenuation is remotely controlled by a motorized neutral filter having a continuous density range of approximately 0-1. In addition, a further manually-operated filter wheel, having eight discrete positions, provides for the use of individual filters for colour correction or further light attenuation.

### 2.7.3. Focus control

This is normally manual, the handle being interchangeable for right or left hand, and incorporates a non-linear mechanism which increases the gear ratio (handle movement/tube movement) as the infinity focus position is approached. Again provision is made for the addition of motorized focus movement remotely operated from Camera Control.

### 2.7.4. Viewfinder

The electronic viewfinder is a self-contained unit which is plugged into the camera and mounted on a swivel device, which allows the camera to elevate or depress through wide angles while leaving the viewfinder conveniently disposed for the cameraman. A bright picture 8.8 cm × 6.6 cm is viewed through a corrected magnifying lens, giving an equivalent view finder picture of 11.5 × 8.6 cm at 30 cm.

## 3. Colour Camera Problems

At the picture generating end of a colour television system the fundamental process, to

which there seems no alternative, is to express the picture as a super-position of three separate monochrome pictures one in each of the analysing primaries. In photographic parlance the camera has to produce "separation positives."

In one case only, that of the field sequential system, this process is reduced to rather simple terms, namely the sequential production of the three separation positives by exposing a single camera tube through a set of primary filters in time sequence. This case, however, is of limited interest as the present trend of events demands simultaneous production of the three primary pictures. This is the problem now contemplated and three possible solutions will be indicated.

### 3.1. *The R.C.A. Triple-Image Orthicon Camera*<sup>4</sup>

This solution is the most direct approach to the problem, being simply a literal interpretation of the basic process, namely, the formation of actual separation positives and the provision of individual image orthicon tubes for each.

At first sight, one would be inclined to suppose that the 14-dimensional registration process involved would rule out such a system as a practical device, but R.C.A. have demonstrated otherwise by producing in fact what are probably the best direct-colour pictures that have been seen to date.

One may pause to examine the nature of the registration problem here involved. First, then, as regards purely geometrical registration, taking one primary picture as reference, each of the other pictures must be registered for horizontal and vertical position, horizontal and vertical size and for angular rotation; this is five degrees of freedom for each tube, and further, the assumption is implied that the horizontal and vertical linearities and rectangularity of scanning axes are sufficiently good to allow these five degrees of freedom to suffice. Then, in addition, we have to consider "registration" in the brightness co-ordinate, which involves a black level setting and an amplitude control; again it is assumed that the transfer characteristics are either linear or sufficiently similar in shape to admit "brightness registration" over the necessary range.

The R.C.A. colour camera, despite the rather alarming size and weight, and the potential registration nightmare, shows a considerable degree of practicality; in particular, the retaining

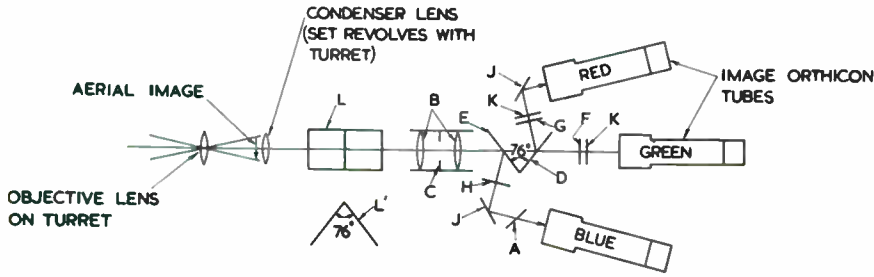

- A Horizontal astigmatism corrector.
- B Relay lenses both 9.5 in.  $f/4$ .
- C Remotely controlled iris.
- D Red reflecting dichroic.
- E Blue reflecting dichroic.
- F Green trimming filter.
- G Red trimming filter.
- H Blue trimming filter.
- J Front-surface mirrors.
- K Neutral-density filters.
- L Vertical astigmatism corrector.
- L' Ditto, side view.

Fig. 6.—Optical system of the R.C.A. three-tube colour camera.

of the lens turret feature is highly advantageous.

Figure 6 is a schematic of the optical system. To allow a sufficient (and constant) length of light path for the light splitting operation a relay lens system is employed. The main objective forms a real aerial image in a fixed plane, focusing being carried out by longitudinal movement of the objective with the entire lens turret. Immediately after the aerial image is a condenser lens, and as this must be individually suited to the focal length of the objective a set of four condenser lenses are arranged to rotate with the turret. The relay lens transfers the aerial image at unity magnification to the photocathode of the green tube. Dichroic mirrors split off the red and blue primary components. The remaining items are for the purpose of subsidiary corrections which will be evident from the diagram.

### 3.1.1. Signal/noise and sensitivity considerations for the triple-tube camera

As might be anticipated, when using image orthicon tubes in a multi-tube colour camera, it is not possible to exploit the normally useful part of the characteristic above the knee (Fig. 1). Instead, one is compelled to use the linear part of the characteristic and to apply gamma correction to each tube. The resulting loss of signal/noise ratio is, however, to some extent offset by the fact that we have three tubes in which the signals add linearly while their noises add r.m.s.-wise.

Suppose that the tubes produce signal voltages  $E_r, E_g, E_b$  and each an r.m.s. noise voltage  $E_n$ .

The resulting luminance signal is

$$k(lE_r + mE_g + nE_b)$$

and the resulting luminance noise is

$$k\sqrt{l^2 + m^2 + n^2} \cdot E_n$$

The signal/noise ratio is

$$\frac{lE_r + mE_g + nE_b}{\sqrt{l^2 + m^2 + n^2} \cdot E_n}$$

leading to the following cases:—

For saturated primary colours:—

$$\frac{l, m, n}{\sqrt{l^2 + m^2 + n^2}} \frac{E_s}{E_n} = (0.45, 0.88, 0.16) \frac{E_s}{E_n}$$

For saturated negative primaries:—

$$\frac{m+n, n+l, l+m}{\sqrt{l^2 + m^2 + n^2}} \frac{E_s}{E_n} = (1.04, 0.61, 1.68) \frac{E_s}{E_n}$$

For white:—

$$\frac{1}{\sqrt{l^2 + m^2 + n^2}} \cdot \frac{E_s}{E_n} = 1.5 \frac{E_s}{E_n}$$

The inserted numbers refer to the standard values for luminance factors ( $l, m, n$ ) = (0.30, 0.59, 0.11).

As regards sensitivity, we have a basic loss compared with the monochrome system that a given amount of light has to be distributed between three tubes instead of one. Further, colorimetric considerations prevent complete light utilization.

Consider the reproduction of a "white" corresponding to a source at 2850°K, Curve E of Fig. 7, a photo-cathode sensitivity, Curve B of Fig. 7, and analysing filter characteristics  $A_r, A_g, A_b$  of Fig. 7. These last are roughly the ideal colour filters quoted by Epstein.<sup>5</sup> The relative total photo-cathode currents corresponding to the primaries are

$$\int d\lambda \cdot A(\lambda) \cdot B(\lambda) \cdot W(\lambda)$$

A rough calculation shows that the red, green and blue photo-currents are respectively 0.15, 0.15, 0.10 of the corresponding current for the monochrome case, which means that the sensitivity is reduced ten times and that light attenuation of 1.5 times approx. must be introduced into the red and green channels.

In addition to this major loss, there are incidental light losses at the many glass-to-air surfaces in the system and there is the restriction that the maximum aperture is reduced to  $f/4$ .

### 3.2. Colour cameras with less than three tubes

Most engineers will agree that a colour-television camera will achieve ultimate practicality only when it requires a single tube. Various approaches have been made towards this ideal, of which the writer will mention two of which he has experience.

In both of these the approach is to endow the tube with chrominance discrimination at the expense of certain of its other properties, in particular, resolution. Given a tube of unlimited resolution, one very direct method of causing a primary separation positive to reveal itself is to place adjacent to the photo-cathode a strip filter having density only in the one primary. This primary component is then space-modulated by the strip filter and if the direction of the strips is normal to the scanning line the video signal acquires a sub-carrier (of strip frequency) expressing the primary component. For example, for extracting the blue primary component the filter would have a density to blue light only, i.e., it would use a yellow dye.

That such a system should work without objectionable beat pattern between the scene detail and the strip filter, the pitch of the latter requires to be less than half the finest detail which it is desired to transmit. Thus a tube of at least twice the standard (horizontal) resolution is required.

#### 3.2.1. Single-tube camera with double-frequency-selective strip filter

The above indicates a method for extracting one primary effectively as a sub-carrier (N.B.—this term should not be confused with a sub-carrier introduced for transmission). But how are we to extract two primaries? Further consideration shows that it is possible to superpose a pair of strip filters of different pitch so

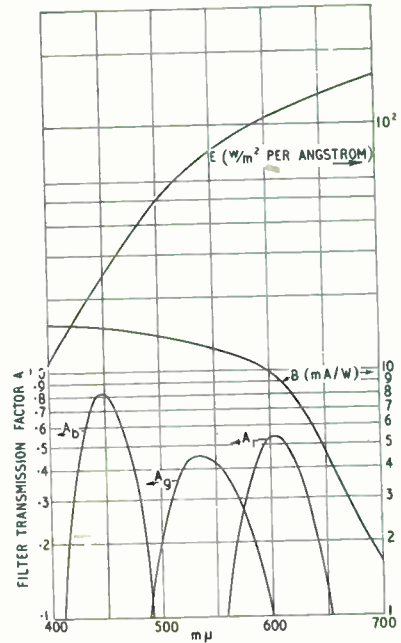

Fig. 7.—Spectral characteristics.

that the two primaries emerge on different sub-carrier frequencies; and that beat pattern between the two will not arise if the filters subscribe to the condition that there is no wavelength of light which is modulated by both filters.

In practice, it is inconvenient, if not impossible, to form these filters directly on the photo-cathode and the result is achieved by recourse to relay lens system. The strip filters are placed in the plane of the aerial image of the objective, the whole being transferred to the photo-cathode by means of the relay lens.

The successful realization of this principle has not been achieved to date owing to the excessive resolution requirements placed on the camera tube. While this does not exceed the *limiting* resolution of the large image orthicon, the latter does not meet the demand that the modulation at strip frequency should be both constant and sufficiently above noise level.

#### 3.2.2. Two-tube camera with single-frequency-selective strip filter

The above impasse was foreseen by Jesty, who

proposed an alternative scheme which, though sacrificing the advantage of single-tube operation exploits adroitly the differing requirements of the luminance and chrominance channels. There results a two-tube camera in which the first tube produces a luminance signal at full resolution and the second produces all of the chrominance information at appropriately reduced resolution.

This camera is in an experimentally working state and it is hoped that a full description will be forthcoming in a separate paper.

### 3.3. *The Sequential—Simultaneous Transducer*

An interesting camera procedure, formerly proposed by Kell and independently reduced to practice by Goldmark, is as follows:—

The cameras proper are of field-sequential type with rotating colour filters, and may operate on standards which are substantially unrelated to the final transmission standards. All cameras, through the usual mixer, feed a high-quality field sequential display of the projection kinescope category. Three storage-type cameras observe the individual red, green and blue colour fields (which, of course, are not coloured on the display); these cameras use *transmission* standards and by virtue of an assumed perfect storage, effect the necessary standards conversion.

At first sight, one would expect this process, involving two stages of the camera process in cascade, to produce a somewhat degraded quality of picture; but consideration shows that this is not necessarily the case if

- (a) the field sequential standards are higher than the transmission standards, and
- (b) the transducing kinescope display is of adequately high quality.

The assumption is further implicit that the final camera tubes are of high quality, notwithstanding some considerable restriction on the type of camera tube which can be used.

In the first place, tubes of the signal-plate variety are at a disadvantage since accurate compensation for the direct photo-current would be involved. Image orthicons have been used with some success though the experience of the writer in the related field of "Telecine with non-synchronous flash-up" indicates that the storage might be inadequate. On general

considerations, the Vidicon would appear to be the most promising tube for this application, since it should be possible to give it an amount of light comparable with that used in Vidicon Telecine, under which conditions (see Fig. 1, curve 7) the tube is known to be an outstanding performer.

While it is thought to be premature to predict the future of this type of camera system as against the other methods described, it must be pointed out that it does offer material economies by reason of concentrating the registration problem in a single place.

### 4. Acknowledgments

The author wishes to express his thanks to Marconi's Wireless Telegraph Co. for permission to publish this paper and to the following of his colleagues: Messrs. S. M. Aisenstein, G. Banks, E. D. Hendry and K. Frank, of the English Electric Valve Co., who were responsible for the development of the large image orthicon to its present form; to B. M. Poole for the development of the large image orthicon camera; to G. Cooper for the series of measurements on image orthicon noise.

### 5. References

1. L. H. Bedford. "Television camera tubes—sensitivity and other properties." Presented at Milan International Television Congress, 1949. Published in *Wireless Engineer*, 28, January 1951, pp. 4-16.
2. L. C. Jesty and N. R. Phelp. "The evaluation of picture quality with special reference to television systems." *J. Brit. I.R.E.*, 12, April 1952, pp. 211-253.
3. A. Rose. "A unified approach to the performance of photographic film, television pick-up tubes, and the human eye." *J. Soc. Motion Picture Engrs*, 47, October 1947, pp. 273-294.
4. Petition of Radio Corporation of America and National Broadcasting Company Inc. for approval of colour standards for the R.C.A. Colour Television System, June 1953.
5. D. W. Epstein. "Colorimetric analysis of R.C.A. color television system." *R.C.A. Review*, 14, June 1953, pp. 227-258, Fig. 9, etc.

## GRADUATESHIP EXAMINATION—MAY 1954

### SECOND PASS LIST

This list contains the results of the remaining overseas candidates not included in the list published on page 387 of the August Journal. A total of 645 candidates entered for the Examination.

#### Eligible for Transfer or Election to Graduateship or Higher Grade of Membership

(These candidates have passed the entire examination, or, having previously been exempt from part of the examination, have now passed the remaining subjects)

ARUNACHALAM, M. P. *Madras.*

BHARADWAJ, Shiv Kumar, B.Sc. (S) *Bombay.*  
BHARADWAJ, Vidyadhar Laxman. (S) *Bombay.*

DANIEL, Michael, B.Sc. (S) *Trichinopoly.*

GOROWARA, Satypal. (S) *Mhow.*

JAIN, Raj Kumar, B.Sc. (S) *Delhi.*  
JAYARAMAN, M. Rajagopala. *Khaspur.*

KHANNAN, Shyam Mohan. (S) *Lucknow.*

MELHOTRA, Ascharaya Lal, B.Sc. (S) *Agra.*  
MENON, Vijai Kumar. (S) *Bombay.*

NARGAS, Balbir Singh. (S) *Allahabad.*

SEKHRI, Surrinder Kumar. (S) *Bombay.*  
SEN, Kalyan Kumar. (S) *Patina.*  
SUBRAHMANYA SASTRY, Pispipati Venkata. (S) *Madras.*  
SUBRAMANIAN, D. Venkata, B.Sc. (S) *Madras.*  
SUBRAMANIAN, Vaidyalingom. (S) *New Delhi.*

#### The Following Candidates Passed the Part or Parts Indicated Against Their Names

ADUR, Mohanrao Narayanrao. (S) *Bombay.* (IV).  
AGGARWAL, Vishwa. *Jullundur City.* (IIIa).  
ANAND, Tejinder Singh. (S) *Poona.* (IIIa).  
APTE, Arvind Raghunath. (S) *Poona.* (IIIa).

BALASUBRAMANIAN, Venkatram. *New Delhi.* (IIIa).  
BALCHANDANI, Gobind. (S) *New Delhi.* (IIIa).  
BATRA, Krishan Lal. (S) *Agra Cantt.* (IIIa).  
BHANAGE, Prabhakar Gangadhai. (S) *Poona.* (IIIa).  
BHARDWAJ, Jagdish. (S) *Mhow.* (II, IIIa).  
BHATIA, Madan Mohan Sugnomal. (S) *Gurgaon, East Punjab.* (IIIa).  
BHIDE, Keshav Nilkanth. (S) *Bombay.* (II).  
BUTA SINGH. (S) *New Delhi.* (I, II).

CHAMAN, Lal Gadoo. *Delhi.* (IIIa).  
CHARANJIT SINGH, Chhabra. *Delhi.* (IIIa).  
CHAUDRY, Mool Raj. (S) *Delhi.* (IIIa).  
CHHABRA, Inder Mohan. (S) *Poona.* (II, IIIa).

DESIKAN, T. N. (S) *Madras.* (II, IIIa).

ELAMWADI, Gurcharn Singh. (S) *Patiala.* (IIIa).

GANESAN, Ramachandran, B.Sc. (S) *Anantapur.* (IV).  
GERRITSEN, J. T. A. (S) *Hilversum, Netherlands.* (IIIa).  
GURBAX SINGH. (S) *Jullundur City.* (IIIb).

HALBE, Madhusudan Narayan. (S) *New Delhi.* (IV).  
HARJAI, Bishamber Lal. (S) *Rupar, Punjab.* (IIIa).

IZZARD, Malcombe Ian. (S) *Pietermaritzburg, South Africa.* (I, IIIa).

JAIN, Naim Chand, B.A. *New Delhi.* (IIIa).  
JATHAR, Neelkant Balkrishna. (S) *East Punjab.* (II).  
JAWA, Bal Raj, B.A. (S) *New Delhi.* (IIIb).  
JONES, K. P. (S) *Amla, India.* (IIIa).

KACHARE, Madhukar Ramchandra. (S) *Poona.* (IIIa).  
KANDASAMY, Manicavasagam. (S) *Madras.* (II, IIIa, IV).  
KAPUR, Harkishan Lal. (S) *New Delhi.* (IIIa).  
KAR, Saroj Kumar. *Agra.* (I, II).  
KELKAR, Vinayak Yeshwant. (S) *Poona.* (IV).  
KHADKIKAR, Ganesh Dinkarrao. (S) *Jabalpur.* (IIIa).  
KRISHNA REDDY, Palicherla Venkata. (S) *Madras.* (II, IIIa).

LAKSHMINARAYANAN, A. K. (S) *Tirunelveli Junction.* (IIIa).  
LAL, Brij Behari. (S) *New Delhi.* (II).

MAGO, Hari Krishan Parshad. (S) *New Delhi.* (IIIa).  
MALHOTRA, Raj Kumal. (S) *Dehra Dun.* (IIIa).  
MALHOTRA, R. N. (S) *Poona.* (IIIa).  
MALIK, Baikunth Nath. (S) *Jullundur.* (IV).  
MEHAR SINGH, B.Sc. (S) *Hoshiarpore, Punjab.* (IV).  
MEHTA, Gunvant J. (S) *Saurashtra.* (II, IIIa).  
MUNIR, Mohammad. (S) *Kachi.* (IIIa).  
MUTHANNA, Mururanda Pannappa. (S) *Mysore.* (I).  
MUTHURAGHABAN, Navaneetham. (S) *Tiruchirappalli.* (II).

NARASIMHAMURTHY, Wudali. (S) *Madras.* (IIIa).  
NARAYANA RAO, Nannapaneni. (S) *Madras.* (IV).

PANDE, Chandra Bali. (S) *Gonda, India.* (IIIa).  
PARIKH, Kanaiyalal Jivantal. (S) *Bombay.* (IIIa).  
PERKINS, Geoffrey Jas. (S) *Townsville, Queensland.* (I).  
PINTO, Cyprian. *Kanpur.* (IIIa).  
PRASADRAO, G. S. (S) *Jaini, India.* (IV).

RAJA, Manakkalam Krishna. (S) *Meerut.* (IIIa, IV).  
RAJEN, Chittoor Thyaga. (S) *Madras.* (I).  
RAMACHANDRA IYER, T. (S) *Jabalpur.* (IIIa).  
RAMACHANDRAN, Gopalaswamy. (S) *Secunderabad Dn.* (IIIa).  
RAMALINGAM, V. Kuttiappa. (S) *Madras.* (II).  
ROY, Prabir Chandra. (S) *Bombay.* (IIIa).  
ROY, Susil Kumar, B.Sc. *West Bengal.* (IIIa).

SAMPAT KUMAR, G., B.Sc. (S) *Madras.* (IV).  
SARBJEET SINGH. *New Delhi.* (IIIa).  
SAXENA, Mahinder Sahai. (S) *Ferozepore Cantt.* (IV).  
SEETHARAMAN, M. R. *Calcutta.* (II, IV).  
SESHADRI, M. N. (S) *Bombay.* (II).  
SHARMA, Jagat Narain. (S) *Lucknow.* (IV).  
SHARP, Gregor Hugh. (S) *Sydney, New South Wales.* (IIIa).  
SINGH, Charanjit. (S) *Agra.* (I, II).  
SINGLA, Ratanpal. (S) *Ferozepore.* (IIIa).  
SIVARAMAKRISHNAN, P. N. I. (S) *Madras.* (II, IIIb).  
SOOD, Ramesh Chander. (S) *Bombay.* (IV).  
SUBBARAMU, Kattapur Ramaswamy. (S) *Bombay.* (IV).  
SUBRAMANIAN, Harihara. (S) *Poona.* (II).  
SUBRAMONYAN, S. Harihara. (S) *Delhi.* (IV).

TIWARI, Madhukar Eknath. (S) *Nasik City.* (IIIa).

UPASANI, Bhaskar Purushottam. (S) *Poona.* (I, II, IIIa).

VARUGHIS, Vadakedathu Samuel. (S) *Kuwait.* (IIIa).  
VENKATESWARLU, Uppala. (S) *Divi Taluq.* (IV).  
VIRENDARSINGH, Sandhu. (S) *Bombay.* (II, IIIa).

WYNN, George Douglas. *Goderich, Ontario.* (II).

(S) denotes a Registered Student

# SOME COMPARISONS BETWEEN ANALOGUE AND DIGITAL COMPUTERS\*

by

W. E. Scott, M.Sc., and A. C. D. Haley, M.A.†

*A paper presented during the Industrial Electronics Convention held in Oxford in July 1954*

## SUMMARY

The paper discusses the reasons for using computers in industry and the considerations which should apply to the choice of machine for different types of work. Examples are given of both analogue and digital machines and the uses to which they can be put. The advantages and disadvantages of each type are mentioned, with the aim of encouraging a rational approach to the specification and design of computing devices. A representative large-scale machine of each class is described briefly.

### 1. Introduction

Electronics is playing a vital part in establishing the more efficient use of man's physical and mental resources, and it was during the second world war that this need for conserving human effort reached a pronounced peak. The work begun at that time has been improved and consolidated during the last decade, so that we are now in a position to take stock of some of the techniques which this branch of science has produced for our use. The computer field is one in which electronics is playing an important part, and it is the intention of this paper to consider the two major forms of computer which have emerged and discuss their relative merits and applications. This is not intended to be a final assessment in view of the rapid progress which is still being made, but it is believed that the discussion of this paper will be of value to those interested in using such devices in addition to those engaged in designing them. In fact, such deliberations are essential if we are not to be accused of wasting our resources by designing and using equipment unsatisfactory for its purpose.

### 2. Requirements of Electronic Computers

Recent developments in the application of electronic equipment to the solution of complex mathematical problems have aroused great interest in industrial organizations. This interest is due, in part, to the fact that problems now occurring in research and design cannot be

solved in an economic time by any other means, but electronic computing devices have also been recognized as providing the possibility of solving other problems of long standing, which, owing to the enormous amounts of computation involved if other methods are adopted, have been treated empirically or by more or less crude approximations.

In general, it is advantageous to consider the use of electronic aids when the requirements to be met fall into one or more of the following categories:—

- (a) Problems involving very large amounts of calculation. These may arise, for example, in stress calculation for a complicated structure, where the requirement for accurate calculation arises from the need to minimize weight or quantity of material.
- (b) Problems requiring frequent repetition of a given calculation. This is a frequently recurring requirement, for example, where the behaviour of a system is to be studied over a range of values of one or more parameters.
- (c) Problems in which speed of solution is important. It is often desirable to link computing equipment directly to experimental apparatus, the speed of calculation being then determined by the system under investigation. Even when direct linkage is not desired or is not practicable, rapid computation often leads to greater utilization of expensive apparatus in a progressive sequence of tests.

It is perhaps necessary to examine what is meant by a "solution" to a problem and to

\*Manuscript received June 9th, 1954. (Paper No. 284.)

†Nelson Research Laboratories, English Electric Co., Ltd., Stafford.

U.D.C. No. 518.5:621.37/8.



point out that its meaning varies very much with the context of the problem. The two inseparable quantities which become involved at this stage are time and accuracy. Occasions arise in which the required accuracy is clearly defined, as appears at first sight in the case of a payroll calculation. Here the man expects, and should get, his weekly wage accurate to the nearest penny, but anyone who is familiar with the methods of assessment of income tax knows that any tax formula or set of tax tables uses assumptions in addition to the explicit rules in the Finance Act, and the assumptions used in practice make slight differences even in the long run over a tax-year. In scientific and engineering calculations we are familiar with the extreme cases in which answers are given which are allegedly more accurate than the data or the approximations used would justify. At the same time there are problems which require careful handling of rounding-off errors so that the final answer can have the same order of accuracy as the original data. Cases also arise frequently, in industry particularly, where all that is needed to answer a question is an indication of the order of the true solution, although it may require a great deal of effort to get it.

The crux of the whole question of accuracy in industrial work usually lies in the economic consequences of inaccuracy, and this is as true of a calculation as it is of a machining operation or the pH value of a chemical effluent. It is generally true that the more accurate an answer has to be the longer it takes to get it, not always because the arithmetic takes longer, although it usually does, but because the experience and knowledge of the physical situation need to be correspondingly thorough. A better understanding of the physical problem, and a grasp of which hypotheses are sound, can be helped, nevertheless, by making many trials and comparing the results with measurements and observations. This usually involves considerable routine work in any but the simplest problems, and is neglected because the time involved becomes intolerable and the interest of the investigator flags. Allied to this is the fact that many answers need to be compromises involving a large number of variables, and the effect of these variables separately, and in combinations, must be sought before the situation can be understood.

In discussing the accuracy of any machine two points must be borne in mind. Firstly, the

accuracy of the machine cannot be determined by comparing the answers obtained with the behaviour of the physical system, since it may be that the mathematical representation of the system is incorrect, or incomplete. Secondly, the data used on the machine may have been wrongly derived, either from calculation or measurement. The only fair way to measure the accuracy of a machine is to compare the results it produces with those produced, using precisely the same data and set of equations solved by long-hand calculation using a method whose accuracy can be established. In general, it is found that this figure of accuracy is not a constant quantity but depends on the problem. For example, it is possible to set up, on an analogue machine of the type described below, a set of equations whose solutions are so sensitive to small variations of the coefficients that a 1 per cent. change in a particular coefficient will change the result by 100 per cent. This is no reflection on the usefulness of the machine; on the contrary it emphasizes it, because by noting the effect of change of coefficient settings, the sensitivity of the whole physical system in reality is brought out. A well-designed physical system would be expected to have a reasonable safety margin in respect of all parts of its structure.

An important requirement of all computing machines is reliability, an elusive property to define quantitatively. Intuitively one feels that a machine is 100 per cent. reliable if on each occasion it is called upon to work it does so correctly (to the accuracy expected of it). If there are occasions on which this is not so, then there does not seem to be an accepted basis on which to calculate a figure of reliability. A record can be kept of the length of time the machine operates correctly, and a histogram produced of these "correct operating times." The information contained in these statistics would be of value in determining the suitability of machines for their applications, particularly in the case of machines intended for problems in the category (c), where the mean "correct operating time," or some figure for the chance that the machine will operate correctly for a given time, is of direct importance. In cases where problems fall into categories (a) and (b), however, it is of major importance that this figure of mean "correct operating time" should be associated with a factor depending on the speed with which the machine can carry out the

calculations. The greater this speed for a given mean "correct operating time" the greater the usefulness of the machine.

A further point which is relevant to this general subject is that of fault finding and correction. It is obvious that a low mean "fault-correcting time" is desirable in any type of machine. The incorporation of features designed to ease the location and correction of faults, and the adoption of methods of maintenance aimed at fault prevention, will all help to reduce the time required to get the machine back into correct operation. Unfortunately, any stated "fault-correcting time" is necessarily dependent on the skill and ability of the operation and maintenance staff, and is not entirely a function of the machine itself.

### 3. Types of Computer

Electronic computers have developed along two main lines using digital and analogue techniques.

The digital machine, in which all operations are carried out in terms of discrete quantities representing numbers, is the more recent and spectacular development. The basic principles of these machines are old;<sup>1</sup> they may, for the purposes of this discussion, be regarded as a means of mechanizing the normal manual methods of calculation, but an average gain of 1,000 times in speed may be achieved over a competent operator of a modern desk calculating machine. These high speeds are realized by supplying the machine with detailed instructions concerning the operations to be carried out on input data, so that there is no necessity for the machine to be stopped after each addition or multiplication while the operator sets it up for the next operation. The preparation of the "programme" is a skilled job requiring a detailed examination of the arithmetic of the problem when it has been formulated, and more will be said on this subject later.

These machines all contain the same basic elements: an input mechanism for accepting data and instructions; storage units in which the numbers and instructions can be held for future operations; a control unit to interpret the instructions and arrange for the correct operations to be carried out on the numbers in the correct sequence and without the intervention of an operator; and an output mechanism for con-

verting the results into a form for use outside the machine.

A number of machines have already been built, and described elsewhere,<sup>2</sup> in which a variety of methods have been adopted to fulfil these basic requirements.

Analogue machines, however, are not of a single basic type, but have in common only the fact that their behaviour can be made to obey mathematical relations identical with, or closely related to, those of the system whose characteristics or performance are required. Such machines may in effect be models of the system to be studied, or may bear no physical relation whatever to that system, their value lying in their capacity to solve a given set of mathematical relations under prescribed conditions.

Representative of the first type of analogue computer is the A.C. Network Analyser, used for study of loading and stability of power transmission networks.<sup>3</sup> This consists of numbers of generators, resistive and reactive loads and interconnecting links, on which a model of a power system may be set up. Each element of the power system has its counterpart in the small-scale simulation, and measurements of voltages, currents and phase-relations can readily be made for any combination of generator outputs and loads by means of a suitable metering system. It is evident that in such a computer explicit knowledge of the equations defining the behaviour of the system is not necessary, although it is, of course, necessary to ensure that the model system is a true analogue of the full-scale network.

The electronic Differential Analyser is typical of the second class of analogue machine.<sup>4</sup> In this, integrating, differentiating and adding elements are used, these being based as a general rule on the properties of fed-back amplifiers, and are interconnected in such a way that, when the specified initial conditions are applied, the voltages at certain points in the system satisfy the equation to be solved. It will be realized that integrations and differentiations can only be made with respect to time, which must, therefore, correspond to the independent variable, the various output voltages corresponding to the dependent variables.

In the differential analyser the link with the system under investigation is purely mathematical, this being true also of analogue machines

for the solution of algebraic equations of various types, but an extension of these principles leads to a further class of machine falling between those already discussed. The Servo Simulator may be taken as representative of this class.<sup>5</sup> Here a number of electronic units are provided, each obeying the relations which define the performance of part of a servo-system; that is, each unit has the same "transfer function" as its corresponding element in the servo-system, although bearing no physical resemblance to it. These units are then interconnected (as in the differential analyser) in the same manner as the units of the servo-system, so that the behaviours of the real and simulated systems are linearly related. Here again, the techniques generally adopted are based on the properties of fed-back amplifiers.

Typical digital and analogue machines are discussed in greater detail below.

#### 4. Comparisons of the Characteristics of Analogue and Digital Machines

A characteristic of all digital computing machines is that they give a set of specific answers to a set of specific questions put to them. The programming of such machines, therefore, requires not only a very detailed knowledge of the arithmetic of the problem, but also a thorough grasp of the formulation in mathematical terms.

In the case of analogue machines this programming corresponds to the selection and interconnection of the various units representing the required mathematical and physical relationships, and the choice of scales for the required operating ranges. This involves an appreciation of the analogue formulation of the problem, but does not involve a detailed step-by-step analysis of the arithmetic of the problem. Once a problem has been set up on an analogue machine, an examination of the response at various stages of the analogue representation is possible in order to establish satisfactory operation of the whole analogue. This helps not only to ensure correct representation but also to give the investigator a closer understanding in cases where he is unable, at the outset, to specify his enquiries very accurately. This latter difficulty is common to many technical problems. In engineering, for example, the fundamental problem is one of synthesis and it is almost inevitable that compromises must be made. An analogue machine

has the advantage that it enables the engineer to appreciate the part played by the different components of a system and its several alternatives, and to study its behaviour under variations of particular parameters which can be chosen in the light of results as they are obtained.

This depth of discrimination, based on the experience and knowledge of the investigator, can only be passed to a digital machine in the programme, by conversion into combinations of the "negative or positive" form of discrimination of this type of machine.

It is possible to arrange the digital machine to produce an analogue form of output (e.g., a graph on a cathode-ray tube) and make comparisons for variations of input data. By so doing, the digital machine's speed of operation is being sacrificed and it spends most of its time waiting for the investigator to make up his mind what to do next.

The outstanding merit of digital computers of the type that has been described is their wide range of applicability. Problems have been solved in such different fields as preparation of tables of ballistics, critical speeds of whirling of flexible shafts, electron optics, and the calculation of income tax. It is very difficult to conceive an analogue machine of reasonable proportions which is capable of accommodating a great range of different problems; in general, an analogue machine must be designed for a special purpose, such as power system analysis, investigation of linear and non-linear servo mechanisms, or solution of algebraic simultaneous equations (up to, say, 10 in number).<sup>6</sup> In addition the accuracy of an analogue machine depends on the accuracy of components (and the skill of the designer), whereas the accuracy of a digital machine is independent of this within broad limits and depends on the numerical method used in the programme.

A difficulty common in some degree to the effective use of all computing machines is that of assimilating the results they produce, understanding these results and making use of them. In cases where a digital machine, for example, is producing a set of tables for long and intermittent reference, there is no problem, as also in those cases where the solution required is equivalent to an answer "yes" or "no." In many industrial applications, however, the problems cannot always be formulated so that a simple

decision remains. It is hoped, however, that as the use of computing machines grows, so also will our ability to carry out the problems of synthesis, so that the final answer produced by the machine constitutes the optimum set from a complicated compromise situation.

### 5. Selection of a Suitable Computer

For many applications the most suitable type of machine is immediately apparent. Problems in engineering design, for example, frequently present themselves in the form of large sets of simultaneous algebraic equations, which can be solved with great rapidity and accuracy on a digital computer using standard numerical methods. For other applications, however, the best approach must be determined from a study of the requirements; some of the relevant factors are listed below:—

- (a) In what form is the input data available?
- (b) What use is to be made of the results produced by the machine?
- (c) What degree of accuracy is required?
- (d) What speed of solution is necessary?
- (e) Is the problem of sufficient importance or sufficiently frequent occurrence to justify a special computer? If not, can a suitable machine be designed to handle a wider range of problems?

A study of these questions will frequently resolve the issue immediately, but in some instances other considerations, such as availability of suitable operators or previous experience with certain techniques, may determine the best choice.

It will be realized that electronic digital computers are extremely fast in operation, and can deal with a wide range of problems. No analogue machine can compete on grounds of versatility, and for this reason a high-speed digital machine is a desirable tool in any organization requiring design or performance calculations covering a variety of applications.

For example, in aircraft design, a single machine can solve such diverse problems as reduction and analysis of wind-tunnel test data, stress calculation in structural design, calculation of aerodynamic loading of wings and drag on wings and fuselage, determination of critical speeds ("flutter" speeds), and a variety of per-

formance calculations such as the determination of economic flight plans under prescribed conditions. Similar examples could be quoted for any other branch of engineering science, but the aircraft industry, with its intensely competitive development and rapid progress is a particularly appropriate field of application for the high-speed digital computer.

In spite of the flexibility of the digital machine, analogue computers offer such advantages on particular problems that their installation is frequently justifiable when a digital machine is also available. Thus, although the latter type has been used in the solution of aircraft flutter problems, a special-purpose analogue machine offers great advantages in many respects. Mathematically, the final stages of the calculation require the solution of a set of simultaneous differential equations of the second order, the variables representing structural displacements in various degrees of freedom, and some coefficients being dependent on the aircraft velocity  $V$ . Primarily, it is required to find the value of  $V$  at which two or more displacements execute undamped oscillations in response to any disturbance. To solve the problem on a digital machine it is necessary to calculate frequency and damping of the oscillation at a number of discrete values of  $V$  and to interpret these results to give the actual critical airspeed and the general behaviour of the system at other speeds.

A suitable analogue machine, on the other hand, includes a number of calibrated dials on which the system parameters are set, similar means for varying all appropriate coefficients simultaneously to correspond with the airspeed  $V$ , and means of observing the response at any point in the simulated system, for example on meters or a cathode-ray tube. Not only is the critical speed easily determined (being the airspeed control setting at which steady oscillations occur), but a very rapid assessment can be made of the general behaviour of the system at other speeds and of the variation in these properties as coefficients are altered. A separate complete solution for each combination of coefficients is required if a digital machine is used for this work.

Extensions of the facilities provided are also relatively straightforward if an analogue machine is used. For example, if the aircraft under consideration uses power controls on ailerons, etc., the motional impedance of the hydraulic jacks

may be an important factor in setting up the coefficients of the flutter equation. The relations involved are invariably non-linear, and accurate representation in mathematical terms is frequently impossible. In an analogue machine, voltages representing the input and output of the jack appear at some part of the simulation, and it is, therefore, possible to link the actual power control into the system. To solve the same problem on a digital machine, it is necessary to measure the characteristics of the jack and to express these mathematically before a numerical solution can be sought.

In a further extension, described below, a similar machine may be used in conjunction with a human operator to determine some of the flight characteristics of an aircraft. Although study of these problems by means of a digital computer is a practical possibility<sup>7</sup> it is an un-economic process, for the following reasons:—

- (i) The speed of solution required is determined by the time-scale of the problem under consideration, since the components of the simulated system must be operated in the same time-scale as in the original system. This is immediately apparent when human operators form part of the system, but the restriction is general. The speed of operation of the digital machine may not be fully used.
- (ii) Analogue-digital conversion equipment is required to feed information into the computer. This involves substantial amounts of equipment, and will also in general impose limitations on the computer with which it is linked, which may limit its flexibility in other applications.
- (iii) The available accuracy of an orthodox digital computer will rarely be fully utilized. The use of a special machine of limited capacity is seldom justifiable.
- (iv) Unless special precautions are taken, increasing the complexity of computation, small random fluctuations may give rise to wildly inaccurate results.

In the problems considered above, the computing equipment is necessarily an integral part of the apparatus required for the investigation. Other experimental analyses, however, may not be suitable for solution by means of a computer intimately associated with the measuring equipment. Predominant among these are

instances where occasional random errors of measurement must be detected by the exercise of human judgment. These arise, for example, in current systems of telemetry. Here regular measurements of a number of variables must be interpreted in the light of experience before being subjected to mathematical analysis, and it is convenient to convert them manually during the process of interpretation into a suitable form for use in a digital computer. Multichannel photographic records, for example, may be read rapidly and the measured quantities punched on cards or tape in digital form for direct treatment in the computer.

The digital computer also has the advantage in many experimental processes where reduction of large quantities of data is required quickly, but where the frequency of operation of the test equipment does not justify the use of an analogue machine specifically designed for the purpose, or where complexity of processing or accuracy requirements rule out the latter type. Such situations arise in combination in the analysis of wind-tunnel tests. Readings occur in large quantities, the required calculations are complex in terms of analogue techniques and the accuracy requirements are quite stringent. Moreover, although rapid computation is necessary to determine the course of future tests, the load of work is rarely continuous. In such an application the digital machine shows to advantage: an analogue computer is likely to be insufficiently accurate and less economical.

The frequency of occurrence of any given problem may influence the type of machine to be used. It is well known that the basis of operation of a digital machine is the preparation of a detailed set of elementary operations (the "programme of instructions"), which is fed into the store or "memory" of the machine before computation commences. The preparation and testing of this programme may be a lengthy operation often justified only if several solutions for differing data are required. Data processing operations, as exemplified above with reference to wind-tunnel tests, and the solution of many types of matrix problems are examples of a recurrent requirement for a fixed type of calculation. It is obvious, however, that such a recurrent requirement may in itself constitute a powerful argument for the use of an analogue machine, particularly if the mathematical formulation of the problem is not truly constant. The

analysis of the performance of a servo system, for example, shows wide variations on a basic problem as the constitution of the system is varied. Evaluation of the transient response of such a system is practicable on a digital machine, but unless a generalized programme can be made to cover a number of variants the effective time of solution (i.e., calculating time plus an appropriate proportion of programming time) becomes long. Such generalized programmes, except for solution of fundamental problems in mathematics, are usually unwieldy, cumbersome in use and slow in operation. An analogue machine, however, for servo analysis may consist of a number of electronic "transfer function" units, as previously described, which may be interconnected in an extremely flexible manner to represent any servo-mechanism. The further advantages arise that a physical picture

development of systems of this type is greatly facilitated.

## 6. Representative Analogue and Digital Computers

It is obvious that a complete description of the many different types of analogue and digital computers cannot be given in this paper, but a general description of two representative machines, each of high performance in its own field, may be of interest.

### 6.1. A High-speed Universal Digital Computer

The basic principles of operation of electronic digital computers are now well known, and for this reason no attempt will be made to describe in detail the operation of the machine shown in Fig. 1. This machine, the DEUCE (Digital

Electronic Universal Computing Engine) is the most powerful machine in this country, and some details of its performance are given below. It has been developed in conjunction with the National Physical Laboratory, and follows closely the logical design of the very successful ACE Pilot Model, of which a number of accounts have already been published.<sup>8</sup>

In machines of this type ("serial" digital computers) numbers are represented in the binary scale of arithmetic as trains of pulses. The arithmetic and logical circuits provided are capable only of elementary operations such as addition, subtraction, multiplication, division, discrimination between positive and negative numbers, etc., so that, before the machine can be of use, any extended computation must be broken down into a sequence of such elementary processes. This is achieved by the preparation of the programme of instructions, which are then coded in numerical form and fed into the machine together with the data on which calculation is required. Within the machine this information is retained in a common store. The principal store is a system of acoustic delay lines<sup>9</sup> in which

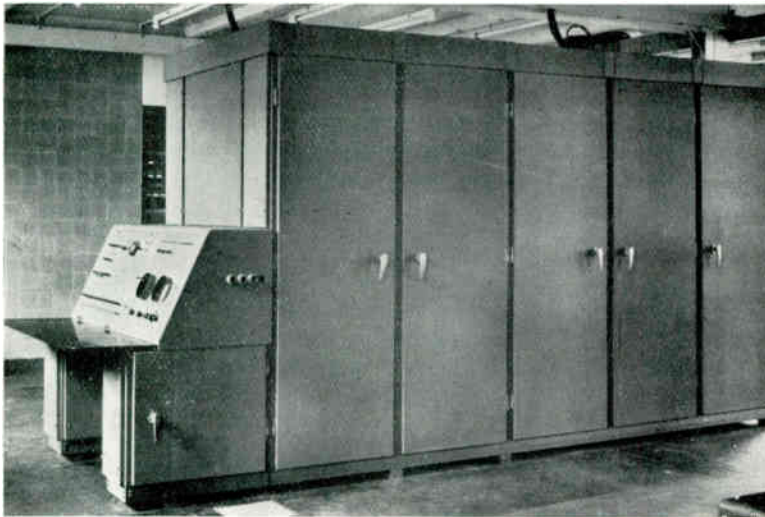

Fig. 1.—The DEUCE (Digital Electronic Universal Computing Engine).

(graph or oscilloscope trace) of the desired response is produced directly, and that the effect on response of any variation in a coefficient of the system may be directly observed. This facility leads directly to the use of machines of this type for synthesis. A servo designer is able to observe the effect of coefficient variations, and to infer and test immediately the characteristics of a derived system approaching more closely to his requirements. By thus combining the rapid solution of successive stages of the problem with the insight and experience of the designer,

each serial train of 32 digits (representing a number or an instruction) is converted into a modulated 16-Mc/s sound wave which travels through a mercury column, is reconverted to its original electrical form on arrival at the end of the column and is then reshaped and applied again to the transmitting end of the delay cell. This circulation process can be continued indefinitely, each train of pulses being available for use elsewhere as it emerges from the mercury line.

Programmes are so arranged that, although a number of separate "words" (numbers or instructions) are stored in sequence in many of the lines, each emerges at the instant at which it is required by the arithmetic and control equipment: e.g., the instructions go in turn to the logical control circuits, where they are decoded and used to control some arithmetic process. Their arrival at the control circuits is so timed that the numbers on which operations are to be carried out are available from their respective storage locations just as they are required.

The interval between successive pulses (i.e., binary digits) of a word is 1  $\mu$ sec, so that the word time is 32  $\mu$ sec, this being the time occupied by each elementary operation. Interpretation of the instruction also requires 32  $\mu$ sec, so that most operations are carried out in 64  $\mu$ sec. Multiplication and division, however, require 2 milliseconds, the circuits controlling automatically a long multiplication or long division process, consisting of 32 additions (or subtractions) and 32 shifts.

Where large quantities of data are to be used, the acoustic delay line, although eminently suitable for high-speed operation, is uneconomical in equipment, and a further store for 8,000 numbers (20 times the capacity of the acoustic line store) is provided by magnetic recording on the surface of an oxide-coated rotating drum. Information may be transferred in blocks between this and the high-speed store as it is required during the computation.

Information is fed to and from the computer by punched-card machines of the commercial accounting type, these being under the automatic control of the computer. By suitable programming arrangements it is, of course, possible to take in and feed out information in decimal, sterling or any other notation, although the computer itself works in binary arithmetic.

The electronic circuits are not intrinsically complex, but the size of the machine (it uses a total of 1,250 valves, mainly h.f. pentodes and double triodes) not only makes perfect reliability impossible but also presents difficulties in fault location unless special precautions are taken. (It should be noted that all programmes include the numerical checks necessary to ensure that faulty results are not accepted as correct.) Specially designed test programmes are used to give immediate indication of the approximate location of a fault, and final detection and correction is normally easy for failures of a definite nature: i.e., complete valve failure, non-operating relay, etc. Intermittent faults, caused by slow deterioration of valve emission, can result in a circuit failing to operate correctly on certain pulse patterns. Location of such faults can present great difficulties to the service engineer. Extensive marginal checking facilities are, therefore, provided, whereby circuit conditions displaced from the normal are applied. This enables a marginal fault to be converted to one which is permanent, and therefore more readily identifiable, and also permits some warning to be obtained of the imminence of marginal conditions. This variation may be applied at will to the whole machine or to smaller groups of circuits and single valves.

A detailed description of the machine cannot be given in the present paper, but its operation is broadly based on the transfer of numbers from one location to another, certain available transfers being associated with arithmetic or logical operations. For example, a transfer from any storage location ("Source") to one particular "Destination" results in the addition of the number held in the "Source" location into a special storage position (the "Accumulator") to which other numbers may already have been transferred. The method of achieving this object will be apparent from consideration of a system of coincidence circuits connected to obey the simple laws of binary arithmetic.

Some idea of the immense power of this machine may be obtained from a typical example of its speed of operation. A set of 60 simultaneous algebraic equations can be solved in less than half an hour, of which 20 minutes is required for the purely mechanical process of feeding in the coefficients on punched cards. Solution of such a problem by any manual method would require many weeks.

6.2. *An Analogue Machine for Aircraft Design Problems*

The principles of operation of this machine were briefly outlined above. An airframe consists of a number of structural elements, each having mechanical and aerodynamic loading, stiffness and inertia. Cross-couplings between these elements also exist. Under certain conditions a system of such interconnected elements may become unstable, so that oscillations of increasing amplitude occur, resulting in destruction of the aircraft if appropriate action is not taken immediately. This phenomenon is referred to as flutter,<sup>10</sup> and in general the damping of an oscillation occurring due to a random disturbance will be positive at low airspeeds, decreasing to zero and becoming negative as the airspeed increases. It is the objective of the aircraft designer to ensure that the critical speed (at which damping is zero) is outside the intended speed range of the aircraft, and that the damping at normal speeds is adequate.

Mathematically, the problem may be stated in the form of a set of simultaneous second-order differential equations of the form

$$\sum_{j=1}^n \left\{ A_{ij} \ddot{\theta}_j + (B_{ij} + VC_{ij}) \dot{\theta}_j + (D_{ij} + V^2 E_{ij}) \theta_j \right\} = 0; \quad i = 1, 2, \dots, n$$

where  $A, B, C, D, E$  are coefficients dependent on the mechanical and aerodynamic properties of the system,  $V$  is the airspeed and  $\theta_1, \theta_2 \dots \theta_n$  are displacements in the various degrees of freedom. The degrees of freedom used in setting up the equations are selected on the basis of past experience and it is found in practice that consideration of 6 degrees of freedom, leading to a set of six equations, usually gives adequate representation of each possible mode of vibration, although it may, of course, be necessary to examine many such sets in determining the properties of an entirely new design.

Some coefficients are immediately under the control of the aircraft designer, and others can only be varied by radical alteration of the structure. It is, therefore, desirable that any aid to solving the equations should not only enable the rapid determination of  $V_f$ , the speed at which undamped oscillations occur in response to any disturbance, but also that the general behaviour of the system at other speeds should be easily determined, and that the variations in these properties as one or more coefficients are varied

should also be displayed with a minimum of additional effort.

By the use of conventional analogue techniques, a machine having the external characteristics specified above can be constructed. Consideration of the interconnected system of fed-back d.c. amplifiers in Fig. 2 shows that, if the amplifier gain is very large, the behaviour of the system is determined by the equation

$$aE + \frac{b + vc}{T} \dot{E} + \frac{d + v^2e}{T^2} E = 0,$$

where  $T = CR$ .

This is similar to the equation of a single degree of freedom, the voltage  $E$  representing displacement  $\theta$  in the actual structure, and  $v$  being proportional to the airspeed  $V$ . If  $a, b, \dots$  are made equal to the coefficients  $A, B, \dots$  and  $T = 1$ , then there will be a one-to-one correspondence between the voltage  $E$  and the displacement  $\theta$  in response to forced excitation of the system by injection of a disturbance.

Similarly, if  $n$  single degree of freedom systems are interconnected, each of the summing amplifiers  $A$  being fed from all the amplifier outputs, a simulation of an  $n$ -degree of freedom system results. Variation of the parameter  $T$ , in conjunction with linear scaling of the coefficients, permits setting the equations into the machine on dials covering a limited range, and also permits the operation to be speeded or slowed to allow the results to be observed and recorded conveniently.

In the machine shown in Fig. 3, the six cubicles each house the setting dials relating to the coefficients of one equation and contain also the five amplifiers associated with that degree of freedom. The variable resistors and potentiometers required to perform multiplication by  $v$  and  $v^2$  are also contained in these cubicles, and are motor-driven to take up positions corresponding with the airspeed set on three decade dials at the control position. All interconnections are permanent so that this is a special-purpose machine for the solution of a set of equations for 6 degrees of freedom, but keys at the control position permit any selected cubicles to be switched out; problems in a smaller number of degrees of freedom may, therefore, be solved.

The equations are normally scaled so that the fundamental frequency of the resulting oscillations is around 1 c/s, as the potentials at various



points may then be observed directly on a set of meters on the control desk and the response at selected points in the system may also be recorded by a two-channel pen recorder.

As stated previously, however, the incorporation of aircraft components within the simulator loops permits the study of systems involving power controls, but under these circumstances the simulation must proceed on the natural time-scale. All parts of the machine are, therefore, capable of operating at frequencies from zero to 100 c/s and a six-channel magnetic oscillograph may be used in place of the pen recorder whose frequency limit is about 15 c/s.

The equations of flutter, with the addition of terms dependent on control column displacement on the right-hand side, are of the same mathematical form as the equations of motion of a complete aircraft in response to the pilot's movement of the control column. This machine, with the addition of further coefficient setting equipment and a suitable display of the artificial-

horizon type, may, therefore, also be used in conjunction with a cock-pit "mock-up" to investigate the flying characteristics of an aircraft from theoretical design data. In applications of this type an analogue computer is essential, and the present example illustrates also the way in which a single machine may frequently be adapted to solve two or more apparently unrelated problems.

7. Conclusions

No attempt has been made in this paper to cover the application of digital machines to accounting and similar processes, as an adequate treatment of the subject cannot conveniently be given in conjunction with a survey of the use of electronic aids in science and engineering. It is apparent, however, that such a flexible computing device can play a useful part in these applications where large quantities of data must be handled quickly.<sup>11</sup>

In the industrial field the digital machine will

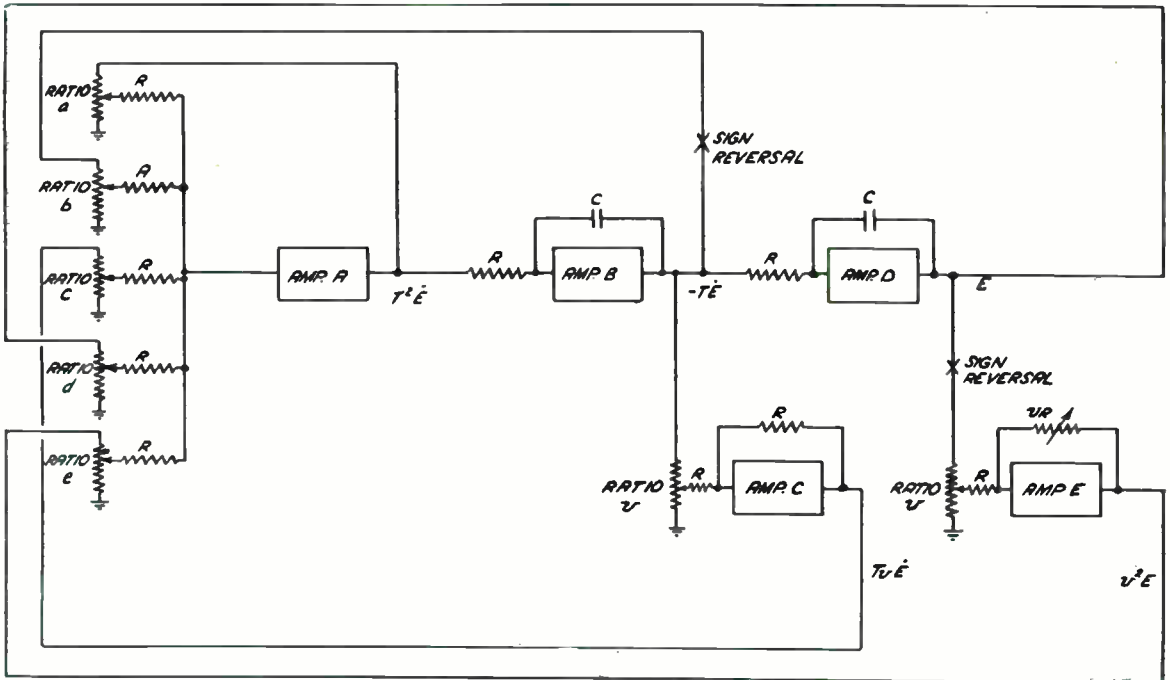

A, B, C, D, E ARE HIGH GAIN D.C. AMPLIFIERS

Fig. 2.—Analogue computer for single degree of freedom.



Fig. 3.—Analogue computer for the investigation of aircraft flutter.

obviously play an increasing part, not only because it is directly applicable to current problems, but also because experience of using such machines will stimulate new methods of approach. It has also been shown that an analogue machine can offer striking advantages on specific problems, although it has not the wide range of application of the digital computer.

At present the primary function of computers is to reduce the time required to produce answers to the many questions which arise from day to day, whether routine repetitions of similar problems or the solution of problems which would otherwise not be undertaken. They will cause shift of emphasis of human effort from routine calculation and clerical work to the more intelligent application of the vast amount of information which can be obtained in a relatively short time. It may be anticipated with confidence that by their use the necessity for expensive or hazardous experiments will be substantially reduced, and a firmer basis provided for many problems at present handled by empirical methods.

### 8. Acknowledgments

The authors wish to express their thanks to the Director of Research of the English Electric Co., Ltd., for permission to publish this paper.

### 9. References

1. H. P. Babbage. (Ed.) "Babbage's Calculating Engines." (E. & F. Spon Ltd., London, 1888.)
2. M. V. Wilkes and W. Renwick. "EDSAC—an electronic calculating machine." *J. Sci. Instrum.*, **26**, 1949, pp. 385-391.
3. A. A. Auerbach and others. "The Binac." *Proc. Inst. Radio Engrs*, **40**, 1952, pp. 12-29.
4. T. Kilburn and others. "Digital computers at Manchester University." *Proc. Instn Elect. Engrs*, **100**, Part II, 1953, pp. 487-500.
5. R. R. Everett. "Whirlwind I computer." *Electrical Engineering*, **71**, 1952, pp. 681-686.
6. M. Woodger. "The automatic computing engine at the N.P.L." *Nature*, **167**, 1951, pp. 270-271.
7. "Network analyser for electric power systems." *Engineering*, **169**, 1950, pp. 38-40.
8. G. A. Korn and T. M. Korn. "Electronic Analogue Computers." (McGraw-Hill, New York, 1952.)
9. F. C. Williams and F. J. U. Ritson. "Electronic servo simulators." *J. Instn Elect. Engrs*, **94**, Part IIA, 1947, pp. 112-124.
10. E. A. Goldberg. "A simultaneous equation solver." *R.C.A. Review*, **9**, 1948, pp. 394-405.
11. A. E. Cutler. "Analogue computers in air-crew training apparatus." *J. Brit.I.R.E.*, **14**, August, 1954, pp. 351-360.
12. "Automatic computing equipment at the N.P.L." *Engineering*, **171**, 1951, pp. 6-8.
13. E. A. Newman and others. "The mercury delay line storage system of the ACE pilot model." *Proc. Instn Elect. Engrs*, **100**, Part II, 1953, pp. 445-452.
14. W. J. Duncan and R. A. Fraser. "The Flutter of Aeroplane Wings." (Aeronautical Research Committee, R & M No. 1155, August, 1928.)
15. T. R. Thompson. "Application of electronic computers to clerical work." *J. Brit. I.R.E.*, **14**, September, 1954, pp. 400-411.

# ELECTRONIC COMPUTERS AND INDUSTRIAL MATHEMATICS\*

by

B. D. Dagnall, B.Sc., M.S., and R. L. Michaelson, F.I.A.†

*A paper presented during the Industrial Electronics Convention held in Oxford in July 1954*

## SUMMARY

The basic theory and mode of operation of a high speed digital computer is described in functional terms, without reference to details of electronic circuitry. A typical set of instructions (programme) is given and finally the programming of engineering calculations is discussed briefly.

### 1. Introduction

This paper is an attempt to describe digital electronic computers so that they may be correctly assessed as candidates for mathematical work.

The technical aspect of computers is no doubt of interest to radio engineers since they are already familiar with the components of which computers are constructed. However this paper is addressed to radio engineers in their capacity of scientists who may need to use a computer. The explanations and diagrams are therefore at a functional level; that miscellaneous electronic hardware can be assembled to realize the various functions is accepted by the authors, who know no electronics, as an act of faith. The radio engineer who wishes concrete and technical evidence before making a similar acceptance is referred to Ref. 1 which itself contains a large bibliography.

It is neither desirable nor possible in a paper of this kind to cover all the variations in design in existing computers, nor to mention the devices under development in various laboratories. The information should be regarded as a general outline of principles as they are appreciated today in this rapidly developing field and not as an accurate specification of any computer or device.

### 2. Arithmetic Inside a Computer

The arithmetic of mechanical adding machines is a direct simulation of that which we use in everyday life. There is no difficulty in mechanically counting in the scale of ten (or in the scale of twelve for pence) by means

of a wheel with ten (or twelve) notched positions; this wheel is the fundamental device in most mechanical or electro-mechanical calculators. In electronic calculators the fundamental device is a bi-stable one such as a valve or a magnetizable spot on a surface and it is more convenient to use a bi-stable arithmetic. This bi-stable arithmetic, called binary arithmetic, is used in most computers at the present day. In others a group of bi-stable devices is used to denote one decimal digit; such a method is more convenient to the user but more costly in hardware. Computer designers, may, as their techniques improve, eventually abandon binary but in the meantime a potential user must understand its principles.

In binary the digits 0 and 1 only are permitted. In decimal we can use one digit position to count all integers from 0 to 9. When we add one to nine we bring in a second position and restart the first position at zero. Binary operates in a similar manner, but a new position is brought in when the previous has reached 1. Thus the first fourteen binary integers and the decimal equivalents are:—

Decimal	Binary	Decimal	Binary
0	0	7	111
1	1	8	1000
2	10	9	1001
3	11	10	1010
4	100	11	1011
5	101	12	1100
6	110	13	1101

The radix of the decimal system is 10, and the decimal number 1901 is a shorthand way of writing

$$1 \times 10^3 + 9 \times 10^2 + 0 \times 10 + 1$$

The radix of the binary system is 2, the binary number 11101101101 is a shorthand way of writing

\* Manuscript first received April 7th, 1954, and in revised form on May 24th, 1954. (Paper No.285.)

† British Tabulating Machine Co. Ltd., London.

U.D.C. No. 518.5:621.37/8.

$$1 \times 2^{10} + 1 \times 2^9 + 1 \times 2^8 + 0 \times 2^7 + 1 \times 2^6 + 1 \times 2^5 + 0 \times 2^4 + 1 \times 2^3 + 1 \times 2^2 + 0 \times 2 + 1$$

$$\text{or } 1024 + 512 + 256 + 64 + 32 + 8 + 4 + 1 = 1901$$

Binary numbers may be added, subtracted, multiplied, divided, raised to integral or fractional powers or subjected to any of the other processes which generations of mathematicians have conceived. For example the rules for the addition of two binary numbers are simply :—

- 0 and 0 = 0
- 0 and 1 = 1
- 1 and 1 = 0 and a carry of 1
- 1 and 1 and 1 = 1 and a carry of 1

It is hoped that sufficient has been said to demonstrate that computers working in binary are capable of carrying out any calculation possible in the scale of ten. Further details can be found in references 1 and 2.

A knowledge of binary is necessary to understand only what goes on inside a computer. Decimal and indeed numbers in other scales of notation such as sterling or avoirdupois may be fed directly to a computer which will automatically convert them to binary before dealing with them. Conversely a computer will convert binary results to decimal before returning them to the outside world.

**3. Numbers and Pulses**

Pulses in a wire may represent numbers in the binary scale by the direct relationship of the presence of a pulse denoting the digit 1 and the absence of a pulse denoting the digit 0. (In practice the distinction between the two digits may not be as clear cut as the distinction between presence and absence of pulses; it may be a voltage drop, but this is a technicality we can ignore here).

A master pulse frequency generator supplies reference points to which the pulses in a number may be related. The digital position or power of two is defined on this time scale, thus the presence of a pulse in the nth time interval represents  $2^{n-1}$ . The first pulse therefore represents the least significant digit. A maximum value, say 32 to fix ideas, is selected for n so that after every 32 pulses a new number is started. It is convenient to call the time for our standard length number, in this case 32 pulses to pass through a wire a "minor cycle" and to denote the pulses, which differ only in the time of their occurrence, by  $P_1, P_2, \dots, P_{32}$ .

For example the decimal number  $39 = \text{binary}$

100111 would be represented by the presence of  $P_1, P_2, P_3, P_6$  and the absence of all other pulses. Hereafter the word "number" may refer either to the number or its pulse representation, an ambiguity not expected to confuse.

Electronic computers achieve their results by processing these pulses in an ordered manner which simulates an arithmetical operation. The function of most of the devices inside a computer can be defined in terms of the conditions necessary on its input lines to cause any pulse,  $P_i$ , to occur on its output lines. For example let us consider devices with the properties shown in Fig. 1.

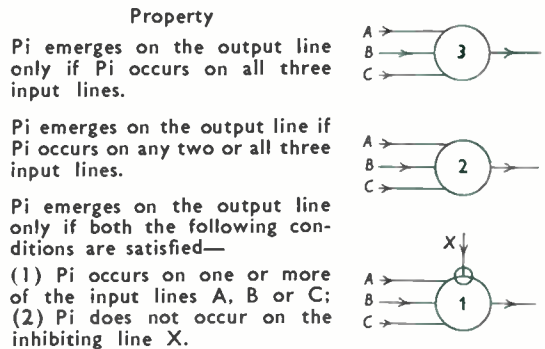

Fig. 1.—Computer symbols and their significance.

A typical computer circuit is shown in Fig. 2 where the above devices are connected together in such a way that if two numbers enter on lines A and B in the same minor cycle then their sum will emerge on line S.

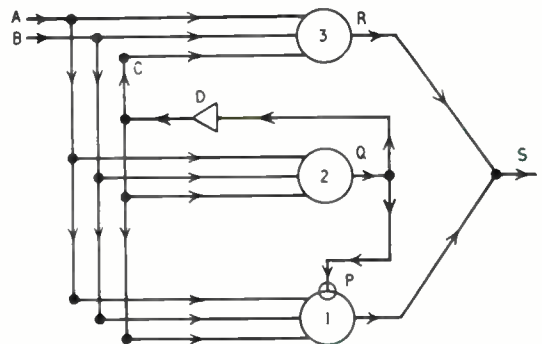

Fig. 2.—An adding circuit.

After  $P_i$  there are 8 possible pulse conditions on the two input lines A and B and the delay carry digit line C. For example if, in the time interval i, A, B, C = 1, 1, 0, then :

R receives  $P_i$  on 2 lines and does not emit a  $P_i$ ,  
 Q receives  $P_i$  on 2 lines and emits  $P_i$  to D and P,  
 P receives  $P_i$  from Q on the inhibiting line and does not emit a  $P_i$ .

Therefore S does not carry a  $P_i$  and at time  $i+1$ , D will emit a  $P_{i+1}$ , together representing  $1+1+0=10$ .

To prevent a carry spilling over to another number, the pulse delay unit D does not operate in the 32nd time interval.

Since the passage of both numbers through the circuit is simultaneous, an addition or subtraction takes place in a minor cycle.

Multiplication and division can be carried out by similar methods, the simplest of which is, perhaps, repeated addition or subtraction. The time taken for these operations is usually longer than one minor cycle; multiplication, for example, is completed in many computers in a time of the order of one minor cycle for each binary digit in the multiplier.

**4. Storage**

It is of course not sufficient to be able to perform the four basic arithmetical operations on numbers which are merely ephemeral pulse trains. Some means must be found to retain the numbers and bring them into circulation when required.

The standard length number of 32 bits may be stored on valves but this is a comparatively expensive method and is now used almost exclusively where, in addition to retaining the number, it is required that the value of the number should cause other devices to be switched to different states for an appreciable length of time. This requirement is the basic property of the important Control Unit which gives computers their high degree of automaticity; it is more fully considered later.

The following methods are examples of storage devices in current use in this country :—

(a) Delay Lines filled with mercury in which a number is continuously recirculated.

(b) Magnetic Drums, on the rotating surface of which a number is represented by the magnetization or non-magnetization of adjacent areas. Two advantages of this form of storage are that its contents do not disappear when the power supply is switched off and that it is relatively cheap. It suffers from slow access time because the period for the drum to rotate

to the position at which a required number may be read is long compared with the operating times of the other devices.

(c) Cathode-Ray Tubes, on the surface of which a number is represented by the presence or absence of dot images. This is a form of storage to which numbers may be sent or from which numbers may be read with much greater speed than is the case with the other two forms.

The capacities of these storages are high. A delay line computer at Cambridge (EDSAC) will store 16,800 bits. The Manchester University Computer is equipped with a magnetic drum with a capacity of 600,000 bits and 8 cathode ray tubes each with a capacity of 1,280 bits; the general theory of operation is to transfer number from the large capacity but slow drum to the tubes immediately before they are required.

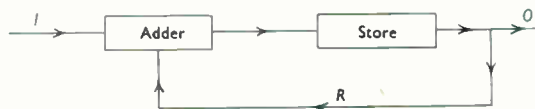

Fig. 3.—Accumulator.

We can now consider an Accumulator which is an assembly of the adding circuit in Fig. 2 and a Storage Unit. Linked in the way shown in Fig. 3 they produce a device with the same functions as the adding register in a desk calculating machine. In Fig. 3 the store is assumed to be capable of storing only one number of 32 binary digits; the box labelled "Adder" stands for all the circuitry of Fig. 2. Hence the implied function of this box is to add a new number entering on line I to the previous contents of the store which are assumed to be capable of being pulsed along line R. Dependent on the method of storage the contents of the storage may have to be passed through such devices as amplifiers or pulse reshapers not shown in this simplified conception of Fig. 3. A sum standing in the store may be read out of the accumulator to some other component by pulsing line O.

**5. Inter-relation of the Devices**

To reduce the complexity of access to a particular number held in store, we will consider each storage unit to have a capacity of one number only. (In practice many numbers are

held in one storage unit; in the case of circulating devices such as magnetic drums and delay lines, it is therefore necessary to specify the interval of time when the desired number is in the accessible position of the cycle.)

Selection of the devices to be brought into play at any operation is achieved by means of Gates for which the symbol is shown in Fig. 4. An input on line I causes an output on line 0 only if a pulse occurs simultaneously on the control line C.

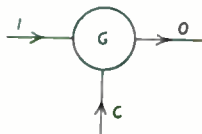

Fig. 4.—Gate.

To illustrate subtraction we introduce the charmingly named “Notter,” a device which emits a pulse if no pulse is received on its input line and does not emit a pulse when it receives one. The output of a notter is therefore the 1’s complement of the input and is used to realize subtraction in a manner similar to the use of 9’s complements in punched card machines. (For example in a six position mechanized decimal counter the 9’s complement of 682 is 999317 and 682 may be subtracted from 1894 by adding 999317 to 1894 to obtain 1211, to this result must be added 1 to give 1212. This so called “elusive 1” or end around carry requires additional equipment not shown in the following diagrams.)

An illustration of the way in which the above devices may be assembled is given in Fig. 5 when a number entering on I is directed to an Accumulator (positively or in complement through the Notter, N), or to one of three storage positions.

We assume that during a minor cycle we have the ability to pulse any one of the Gates 0 to 3 along its C line with all Pi from 1 to 32; the Gate so pulsed is then said to be open. The number entering on I will fail to pass the shut Gates because only the single opened Gate supplies a Pi on its C line to match any Pi in the number. Similarly the opening of one of the Gates, G+ or G-, defines whether a number allowed into the Accumulator by G.0 is added to or subtracted from the previous contents; if G- is opened, the number is complemented by passing through the Notter.

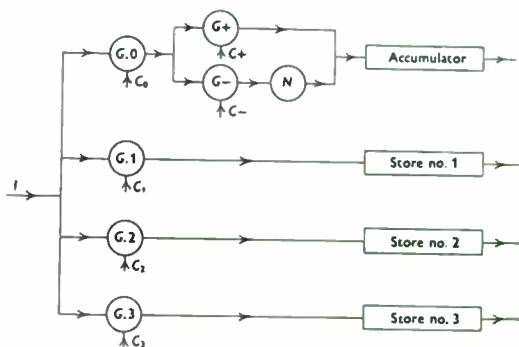

Fig. 5.—Gate circuit.

Input and output mechanisms to communicate with the outside world are necessary. Punched cards and punched paper tape are in use; output in printed form typed by a teleprinter or electric typewriter is also popular. All these mechanisms operate at slower basic speeds than the electronic internal devices and much current research effort is devoted to finding faster input and output means.

The inter-relation of the equipment so far described is shown in the somewhat idealized diagram of Fig. 5; the Accumulator and some arithmetical devices which have received scant mention are included in the block “Arithmetic Unit.”

Any calculation expressible as a sequence of arithmetical operations performed on operands stored in the machine, or available at the input, may be carried out in a series of minor cycles by such an assembly.

## 6. Control Unit.

It is necessary to arrange that the appropriate Gates should be open during each minor cycle. This important function is carried out by the Control Unit.

The simplest form of Control Unit would be a panel of manually operated switches, one for each Gate, to be set between each minor cycle, and a push button to call in the execution of a minor cycle. Such a method would be absurdly out of balance, since the time to set the switches would be measured in seconds against 1/10,000ths of a second to carry out a step.

A feasible alternative is to define the whole sequence of operations and operands by plug-

ging on a control panel similar to those in use on some punched-card machines. This method is efficiently used on smaller computers but is laborious if large-capacity stores are involved and unpractical if long sequences of operations are carried out.

For larger computers there has been developed a novel technique with tremendous power. Based on the properties of the ubiquitous valve, the method enables the switches for the Gates to be set within a space of time no longer than a minor cycle; the means used to discriminate between the different possible Gate combinations are different pulse trains. Previously we have shown that numbers may be represented by pulse trains, we now change our standpoint and assert that pulse trains to set the Gates may be represented by numbers. Numbers so used will be called instructions.

Fig. 7 is a block diagram of a section of a Control Unit which selects one of the four basic arithmetical operations.

After the completion of a minor cycle the Control Unit automatically seeks the next instruction which we will suppose to be a multiplication. This enters in the form of the absence of  $P_1$  and the presence of  $P_2$  and causes  $V_2$  to be set in the conducting stage. The states of the valves are held during the ensuing minor cycle, and cause all  $P_i$  to be directed on line 2 to open the Gates required for multiplication.

Other numbers forming part of the instruction would be read by other sections of the Control Unit to cause the opening of Gates to define the other variables such as Storage Position number.

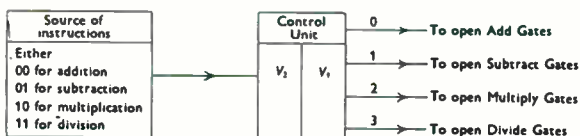

Fig. 7.—Section of control unit.

### 7. Programme Instructions

For any given calculation the Control Unit must read a sequence of instructions in their correct order. Such a set of instructions is called a "Programme." The strength of the method is apparent when it is realized that the instructions are expressed numerically and so may be stored in the Storage Unit. They are transferred to the Control Unit at an electronic speed of the same order as that at which they are executed.

Methods vary in the way in which the Control Unit automatically seeks a new instruction. One of the simplest is an arrangement which causes the Control Unit, after completing the instruction in Storage Position  $x$ , automatically to read Storage Position  $x+1$  for the next instruction. The rigidity of the sequence may, however, be broken by a sign-testing instruction. Such an instruction would cause the sign of the number in the Accumulator to determine whether the next instruction should be read from Storage Position  $x+1$  or from another Storage Position specified in the sign-testing instruction. Sign-testing instructions give computers a high degree of automaticity. For example, a set of instructions which calculates convergent approximations may be iterated until a specified degree of accuracy has been reached, when the sign-testing instruction would direct the computer to the next set of instructions. The sign-testing instructions enable a computer to make any decision expressible as a series of such tests.

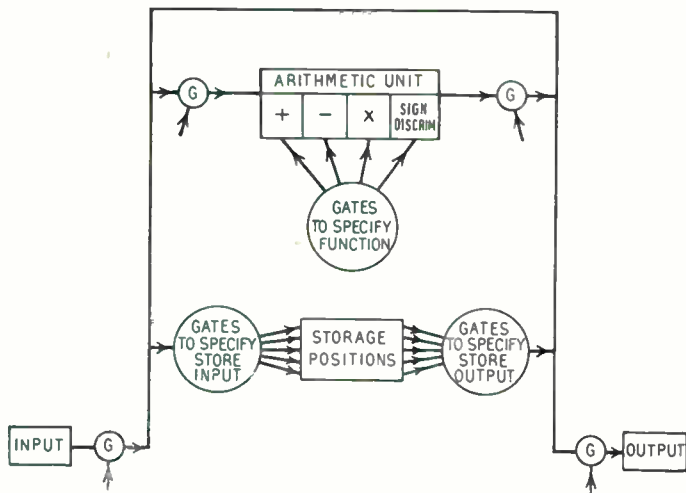

Fig. 6.—Basic computer assembly.

The writer is most familiar with the series of computers known as Hec's (Hollerith Electronic Computers); in these each instruction contains the address (i.e., storage location) of the next instruction. A magnetic drum is used for the storage of both numbers and instructions; the ability to specify the address of the next instruction permits a programme to be "optimized" in the sense that "words" (i.e., numbers or instructions) can be placed on the drum in the order in which they will pass under the reading/writing head.

Since the instructions are numbers, the computer may perform any of the arithmetical operations on them. This ability permits an economy in the storage positions absorbed by instructions. For example if it is desired to add into the Accumulator the 300 numbers in Storage Positions 200 to 499, then instead of 300 instructions each specifying a Storage Position, one "add" instruction could be used and about three more to cause 1 to be added to the Storage Position number between each reading. This economy of storage space is obtained at the cost of the extra operating time spent in modifying the instructions.

Originally the instructions are fed to the Storage Unit through the input. Once they are in, the computer functions in a fully automatic manner. It will operate on numbers which went in with the instructions, call as required for more numbers waiting at the input modifying its instructions and print results, all without further human intervention.

A block diagram summarizing the design of a computer is shown in Fig. 8. The dotted lines indicate that the transfer of information along the solid lines and the function of the Arithmetic Unit are regulated by the Control Unit causing the appropriate Gates, not now shown, to open. Though computers may depart in detail from the design shown, it is representative of principles.

The operating sequence is as follows :

(a) Insert the programme of instructions and numbers to be operated on in the Storage Positions via the input.

(b) Place in the input, in sequence, any further numbers or instructions that may be required during the course of the calculation.

(c) Press the start button. In successive intervals of about 0.003 seconds the computer proceeds to

- (i) Read the first instruction from a Storage Position to the Control Unit,
- (ii) Execute the first instruction,
- (iii) Read the second instruction from Storage.
- (iv) Execute the second instruction, and so on.

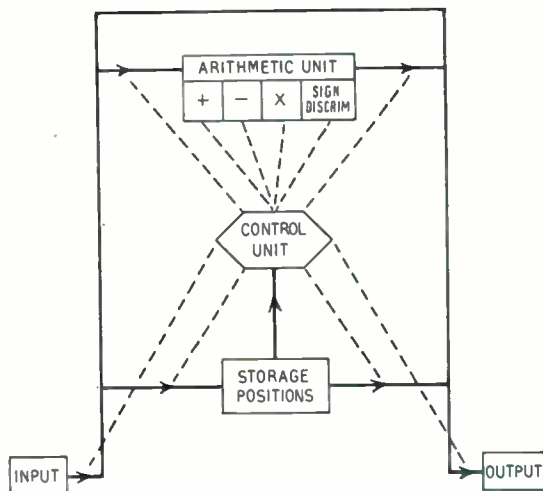

Fig. 8.—Block design of a complete computer.

### 8. Illustration of a Programme

Before using a computer to solve a specific problem it is necessary first to decide on an appropriate mathematical basis or procedure and then to write this procedure in the form of a programme of instructions which the computer can follow.

The capabilities of computers are perhaps best understood by considering the basic set of instructions available and their use in programming a specific example.

Each instruction has three forms—the pulse train stored in the computer, the input-medium form, such as holes in card or tape, and the written form from which the input-medium is created. We are now concerned only with this written form in which the programme is originally constructed.

A typical, but much simplified, set of instructions is shown in Table 1. In order to



emphasize essentials and fix ideas the computer is assumed to be designed on the lines of Hec as follows:—

*Input* : Punched Cards.

*Storage Unit* : A magnetic drum position which are identified by quoting a track number and word position number. Thus 18/6 refers to word 6 on track 18. Tracks are numbered 0 to 63 and words 0 to 15 giving a capacity of 1,024 words. The symbol (T/W) is used for the contents of storage position T/W.

*Arithmetic Unit* : Two sub-units to which numbers may be sent from any Storage Position. First the Accumulator (abbreviated to “Acc”) and secondly the Multiplier Register (abbreviated “M”). The symbols “(Acc)” and “(M)” are used for the contents of Acc and M.

*Output* : A mechanism printing digits and letters on continuous stationery.

*Instruction Word* : A three part number defining an operation which the computer can

carry out. The three parts are Operand, Function, Address of Next Instruction.

*Control Unit* : A unit which reads a word from the drum, sets the gates appropriate to the function and operand, causes the execution of the instruction, then reads the next instruction in the specified next address and so on.

Space is not available here in which to include a complete programme for a practical problem. The interested reader will find many examples in reference 3. By way of illustration let us consider a simple calculation which is formally stated thus:—

*Given at the Input*

Cards each of which is punched with values of the variables  $x$  and  $y$ . The passage of a card places  $x$  and  $y$  in 1/1 and 1/3 respectively.

*Required to Print at the Output*

$xy$  if  $xy$  is greater than or equal to 500  
500 if  $xy$  is less than 500

The following flow chart shows the programme in summary form. The construction

**Table 1**  
**A typical set of instructions**

(Specific operands and Addresses of Next Instructions are shown in order to illustrate instructions in their full written form.)

Written Form Operand	Function	Address of Next Instruction	Operation Performed by Computer
	F	8/6	Feed Card at Input and store values on it in Storage Positions punched on it. (No Operand is necessary.)
17/2	CA	17/3	Clear Acc and transfer (17/2) to it.
17/2	A	17/3	Add (17/2) to (Acc).
22/0	CS	28/1	Clear Acc and transfer the complement of (28/0) to it.
28/0	S	28/1	Subtract (28/0) from (Acc).
61/9	V	61/10	Transfer (Acc) to 61/9.
63/15	M	19/2	Transfer (63/15) to M.
46/3	H	46/6	Multiply (46/3) by (M), place product in Acc.
21/6	J	10/1	If (Acc) positive take next instruction as (19/1); if (Acc) negative take next instruction as (21/6).
	P	18/4	Print (Acc). (No operand is necessary.)

NOTES:  
(i) After performing one of the above operations the Control Unit is automatically directed to the Address of the Next Instruction, except that in the case of the J instruction, the sign of the number in Acc may direct the Control Unit to the Operand Address.

(ii) Each arithmetical instruction includes a source and a destination. Only Acc is additive, consequently the effect of all transfer instructions is to replace the contents of the destination with the source contents which are not cleared. The content of Acc are unchanged after the application of the sign test instruction, J.

of more complex programmes is facilitated by the prior drafting of a flow chart.

The above programme is optimized by placing the J instruction in 1/8 thus freeing 1/6 and 1/7 for the P and F instruction. Further time could be saved by placing the constant 500 in another location so that the second access to it does not involve a complete drum revolution. (To avoid binary to decimal conversion complexities we have assumed that the computer works directly in the scale of notation in which the data and results are expressed.)

Unfortunately so small a programme as the

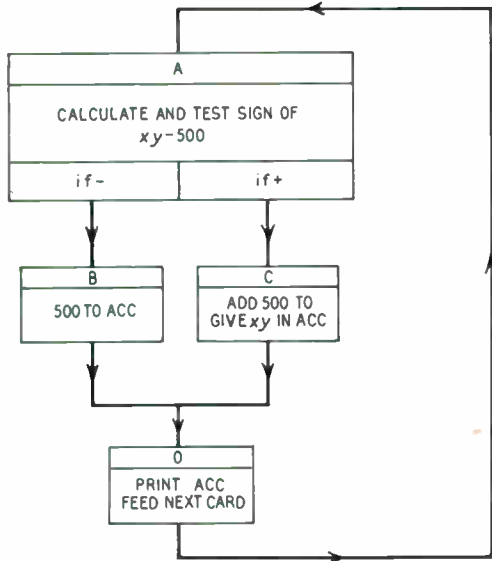

Fig. 9.—Flow chart of typical programme.

The detailed instructions for each box of the flow chart are:—

Box A				Remarks	
1/1	M	1/2	in Position	1/0	$x$ to M
1/3	H	1/4	"	1/2	$xy$ to Acc
1/5	S	1/8	"	1/4	$xy - 500$
1/10	J	1/9	"	1/8	Control to 1/9 if + To 1/10 if -
(Constant of 500 in Position 1/5)					
Box B					
1/5	CA	1/6	in Position	1/10	500 to Acc. Control to 1/6
Box C					
1/5	A	1/6	in Position	1/9	$(xy - 500) + 500 = xy$ in Acc Control to 1/6
Box D					
P	1/7	in Position	1/6	Prints $xy$ or 500	
F	1/0	"	1/7	Feeds Next Card. Control to 1/0.	

above does not illustrate the great automaticity obtained by causing the computer to modify its own instructions.

### 9. Typical Applications

In spite of its detailed appearance the explanation so far given is no more than an outline of the operation of electronic computers as seen by the programmer. Nevertheless we must leave programming, as such, to consider the performance of computers on some practical applications in the following examples.

#### 9.1. Determination of Frequencies of Vibration

A knowledge of the natural frequencies of vibration of a system of several degrees of freedom is essential in the design of many items of equipment, of which the best example is aircraft. The calculation can usually be reduced to the extraction of the  $n$  latent (or characteristic) roots of a matrix  $A$  of order  $n$ , together with the associated latent (or characteristic) vectors  $x_r$  which satisfy the equation

$$Ax = \lambda x$$

Each  $\lambda$  is the square of the frequency of the normal mode of vibration, and Rayleigh's Principle shows that comparatively accurate estimates of the frequency can be obtained from rough estimates of the mode. If only the few highest frequencies are needed, which is a typical requirement, each root is calculated by the well-known iterative process of vector post-multiplication and its effect is then removed from the matrix. The process may be repeated to obtain the next highest root.

As a particular example the extraction of the highest root of a matrix of order 16 on

Hec will be considered. The elements are punched in decimal in the ordinary way on Hollerith cards and fed to the computer in order to store them on the magnetic drum. This operation takes three and a half minutes. The programme consisting of about 200 instructions is next stored on the drum; for this some three minutes are required.

A special designation on the last card of the programme will start the computation in which the following sequence of calculations will take place:—

(i) A unit vector will be generated for use as the initial approximation to  $x$ .

(ii) The matrix  $A$  will be postmultiplied by  $x$  to obtain a new column vector  $x_1 = Ax$ . Its largest element will be taken as the first approximation  $\lambda_1$  to the highest root  $\lambda$ , and all the elements divided by this value, so that the vector will now have its largest element equal to unity. This division will be accomplished by a standard sub-routine; i.e., a set of instructions for a standard algorithm which is held on file for incorporation in programmes as required.

(iii)  $\lambda_1$  will be printed using a sub-routine for binary-decimal conversion.

(iv) The vector  $x$  will be replaced by  $x_1$ .

(v) Steps (ii)-(iv) will be repeated to obtain  $\lambda_2$  and  $x_2$ .

(vi)  $\lambda_2$  will be compared with  $\lambda_1$ . If the absolute difference is greater than an arbitrary value, say  $2^{-26}$ , the process will be repeated. If it is less, the elements of  $x_2$  will be printed and the process repeated. When the difference becomes less than, say  $2^{-30}$ , it is known that the solution has been obtained to the accuracy required and the machine will stop.

Each iteration will take about three minutes. It is difficult to generalize about the number of iterations required as the convergence depends upon the separation of the two numerically largest roots.

Despite the variation in the speed of convergence from one problem to another it is reasonable to say that in the best case the root will have been determined in half an hour or so, and in an extreme case after half a day. If the calculation were done by manual methods, using a desk calculator, the corresponding times are estimated to be one day and one week.

The same programme will, of course apply to smaller matrices merely by an alteration to one parameter, the order of the matrix. Another programme could be constructed to find the latent roots of matrices up to order 26 without exceeding the storage capacity of the machine.

## 9.2. Application to Mass Spectrometry

The use of the Mass Spectrometer for quality control has been limited by the time needed to convert the readings to quantitative analyses. Now that digital computers are available it can be considered as an instrument useful for routine plant control.

In a typical case it is desired to analyse mixtures of twelve organic constituents. This requires the solution of twelve simultaneous equations in which the coefficients depend entirely on the instrument calibration which changes only every month or so; the right-hand side consists of the peak height observations. Moreover, if, as is usual, several mixtures are analysed in a batch, there will result several sets of these twelve equations with different right-hand sides but with the same matrix of coefficients. These can be solved easily by a computer, but as the coefficients do not change for several weeks it is better, on completion of an instrument calibration, to solve the equations for the general case with unit right-hand sides, i.e., to invert the matrix of coefficients, and then, after a series of tests to obtain the particular solutions by multiplication of the inverse matrix and the matrix represented by the right-hand sides.

Thus the solution has now been divided into two parts:

- (i) The occasional inversion of a matrix of order 12.
- (ii) The routine postmultiplication of the inverse matrix of order 12 by a matrix of 12 rows and a number of columns equal to the number of tests in the series, nine is a typical number.

To invert the matrix the coefficients are punched in decimal on Hollerith cards and fed to the computer which stores them on a drum. The whole pack of instruction cards is placed in the feed, but after feeding the instructions needed for one part of the calculation the machine will automatically suspend card feeding and initiate calculation, card feeding being

resumed without attention from the operator when the calculation is complete. The method of inversion is well known, and the various steps which the computer does are outlined below :—

- (i) Generates a unit matrix of order 12.
- (ii) Obtains row sums for checking purposes.
- (iii) Searches the first column for the biggest element and re-orders the rows so that the largest element is in row 1. This is used as the pivot.
- (iv) By successive linear operations on each row in turn and the row containing the pivot reduces all elements in the first column, except the first, to zero.
- (v) Repeats operations similar to (iii) and (iv) on the other eleven rows and columns.
- (vi) Divides each row by the appropriate diagonal element, so that the inverse matrix is produced in the storage locations previously occupied by the unit matrix.
- (vii) Prints out the required inverse in decimal.

This whole operation, including card feeding, takes about half an hour. The results may be checked by reinversion or by multiplication of the inverse and original matrices, which takes about another fifteen minutes. The elements are then punched and used in the subsequent routine tests.

Briefly the method of matrix multiplication is as follows. On completion of a series of, say, nine tests, the nine sets of twelve observations are punched on cards and fed, with the inverse matrix and pack of instruction cards to the computer, which in about ten minutes obtains the nine sets of twelve solutions, divides them by the appropriate sensitivity coefficients to obtain partial pressures, and then converts them to percentage compositions before printing. Thus an analysis can be known within a few minutes of the readings being taken.

### 9.3. Some Other Applications

These two illustrations have been given as examples of typical uses of an electronic digital computer in industry. A computer such as Hec should not be regarded as limited to specific applications or valuable only in matrix operations. Some applications which have

been demonstrated on Hec indicate the type of calculations arising in industry where a digital computer may be of considerable value :—

- (i) Solution of simultaneous linear differential equations.
- (ii) Numerical solution of the equation of motion of a train, projectile or bomb with propulsive and resistance forces represented by non-analytic functions.
- (iii) The calculation of structure factors in X-ray crystallography.
- (iv) The calculation of serial correlations.
- (v) The reduction of market research data to the tabular form required by the client.

### 10. Employment of a Computer

No quick answer can be given to the question whether an industrial organization could justify the purchase of a computer. An investigation must be made to assess at least the following :—

- (i) The value of the results.
- (ii) The value of obtaining the results quickly.
- (iii) The value of any saving in existing staffs.
- (iv) Cost of the computer including operating and maintenance costs.
- (v) Performance of the computer on the regular work concerned and the ease with which it can be programmed for special work.

As an alternative to purchase, consideration must be given to taking the data to a computer which may be hired as and when problems arise.

### 11. Acknowledgments

Figs. 1, 3, 4, 5 and 7 are reproduced from a paper by one of the authors (R. L. M.) in the *Journal of the Institute of Actuaries*, by permission of the Secretary.

### 12. References

1. Engineering Research Association, Inc., "High-Speed Computing Devices." (McGraw-Hill, New York, 1950.)
2. R. L. Michaelson, "Binary arithmetic." *Journal of the Association of Incorporated Statisticians*, 3, No. 1, February 1952.
3. M. V. Wilkes, D. J. Wheeler, S. Gill "The Preparation of Programmes For An Electronic Digital Computer." (Addison-Wesley Press, Inc. Cambridge, Mass.)

# THE APPLICATION OF ELECTRONIC DIGITAL CALCULATING METHODS TO PUNCHED CARD MACHINES\*

by

J. H. Lucas, B.Sc.†

*A paper presented during the Industrial Electronics Convention held in Oxford in July 1954.*

## SUMMARY

Electronic calculating methods used to replace mechanical methods in punched card machines are described with reference to a type of machine now coming into production, known as the Electronic Multiplying Punch. An outline of the calculating systems used in sterling and decimal machines is given. The general design principles and some features of interest in the circuit design are described.

### 1. Introduction

The utility of punched card calculating machines has been considerably increased by the introduction of electronic calculating methods to replace the mechanical methods formerly used.

The circuit techniques used may appear "pedestrian" in comparison with the advanced techniques of present-day scientific computers, but they nevertheless offer a striking increase in speed compared with mechanical methods, without any sacrifice in reliability.

The need for adapting the electronic calculating system to established punched card practice has been the guiding consideration in the design of the Electronic Multiplying Punch, and a brief description of punched card methods may not be out of place.

The use of punched cards for commercial accounting applications has been developed to provide an orderly and standardized method of recording data. Punched cards form discrete storage units which enable data to be rapidly handled by mechanical means for the purposes of sorting, calculating and printing. In card handling machines designed for calculating, the time required to perform the calculation by mechanical means is generally large compared with the time required for the operations of sensing and punching the cards. This applies particularly to machines designed for multiplication, in which the rate of card feed is limited almost entirely by the time required for the calculation.

The use of electronic calculating methods offers the possibility of performing a multiplication, and more extended calculations, in a small fraction of the time required by the mechanical method. A greatly increased rate of card feed is thereby made possible, and the limiting factor becomes the rate at which the cards can be punched. The electronic multiplying systems, some features of which are described in this paper, are adapted to work with mechanical sensing and punching units of a type in established use for punched card work. These mechanical units include storage devices for holding the data sensed from the card and for holding the results of the calculation prior to punching. By adapting these mechanical storage devices to the requirements of the electronic calculator, the requirements for electronic storage have been kept down to an amount which can be provided, without undue cost, by valve circuits alone.

No attempt has been made to present a full engineering description of the Electronic Multiplying Punches as these machines are termed. The intention has been to give a general picture of the principles of operation, and the design principles used. Some features of the circuit design are described, which it is hoped will prove of general interest.

### 2. The Sterling Multiplier

The fundamental operation, on which the system of multiplication used in sterling machines is based, is that of counting, and corresponds to the mechanical counting wheels used in mechanical calculators. The electronic counters used consist of four binary counting

\* Manuscript first received April 20th, 1954, and in revised form May 25th, 1954. (Paper No. 286.)

† Vickers-Armstrong Ltd., Crayford, Kent.  
U.D.C. No. 518.5: 621.374.32 : 657.4.

stages in cascade. The natural counting sequence in the scale of sixteen is modified by a means described later to the scale of ten, or, for use with pence, to the scale of twelve. With the addition of a single scale of two counter to deal with ten shillings, a suitable bank of counting units can be assembled to work directly in pounds, shillings and pence.

Multiplication is performed by the system of repeated additions and the general principle of operation is shown in Fig. 1. The sterling amount is always the multiplicand which is sensed from card and held in a mechanical storage device. The control unit and pulse generator shown on the left, control the sequence of the calculation and provide the basic pulse trains required. Under control of this unit, the multiplicand is entered into the multiplicand accumulator twice in succession, and twice the multiplicand is then held in the register. This amount is then entered into the multiplicand accumulator four times so that at the end of this first cycle, ten times the multiplicand is held in the multiplicand accumulator. During this cycle, the multiplicand is also entered into the product accumulator a number of times corresponding to the units digit of the multiplier. In the next cycle, ten times the multiplicand is held in the register to start with and the same process is repeated to obtain a one hundred times multiplicand. During this second cycle

the amount entered in the product accumulator is under the control of the tens digit of the multiplier. These cycles are continued until all the multiplier digits have been brought in. The final product then stands in the product accumulator, and is transferred to the punching store. A check calculation is next performed with complementary values of the multiplicand and if no error has occurred, the product accumulator will become restored to zero. Only if this condition is reached is the punching allowed to proceed. The standard pulse repetition frequency used is 10 kc/s and each addition period occupies 1.6 milliseconds. Five addition periods are required for each multiplier digit so that with a five digit multiplier the complete multiplication will take 40 milliseconds. A similar time is required for the check calculation.

### 3. The Decimal Multiplier

Similar principles of operation have been used to build a Decimal Multiplier, but in this case a simplification is possible because the ten times values of the multiplicand can be obtained by simple shifting. This enables the multiplication to be performed using only a single accumulator and no register. The basic system is shown in Fig. 2, and the mode of operation is similar to the Sterling Multiplier, except that the ten times values are not accumulated, but are obtained by shifting in a special

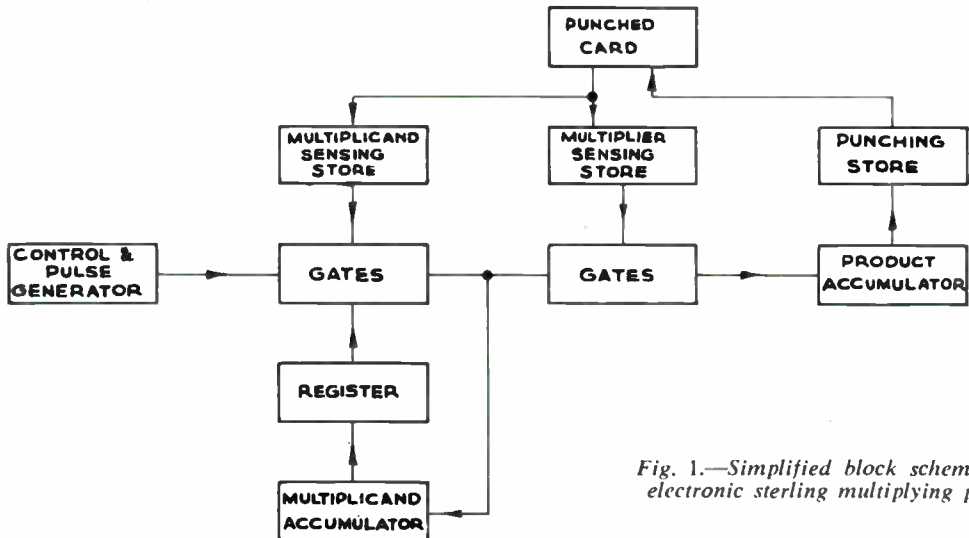
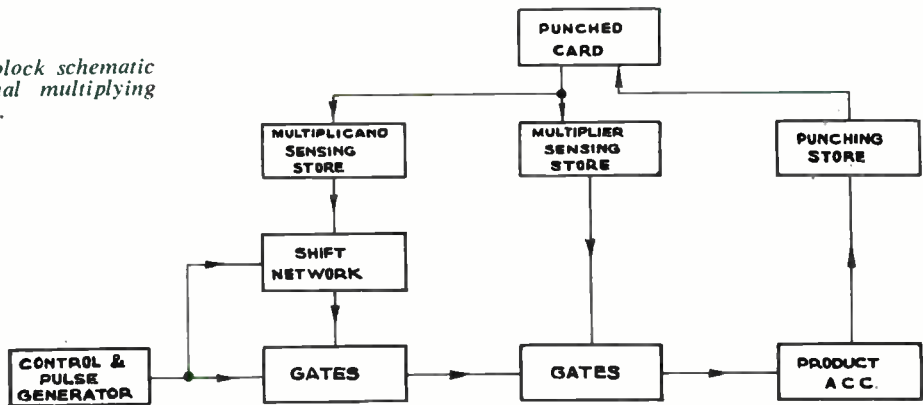

Fig. 1.—Simplified block schematic of electronic sterling multiplying punch.

Fig. 2.—Simplified block schematic of electronic decimal multiplying punch.



shifting network at the end of each multiplication cycle. Naturally, it is possible to extend this machine to perform a simple programme of multiplications and additions without undue complication.

#### 4. General Engineering Design

A reliable performance is a first essential in office machines where a prolonged breakdown may disrupt the whole office routine. Faults, when they do occur must be quickly located and put right. Overall reliability of the machine is dependent upon the mechanical sensing and punching arrangements as well as on the electronic circuits and it was a design aim that the electronic section of the machine should not be less reliable than the mechanical section.

A satisfactory standard of reliability has been achieved by careful attention to good engineering principles, e.g., marginal operation of circuits and the need for close rating of valves, resistors, capacitors, etc., has been avoided, and adequate cooling has been provided by forced ventilation with filtered air intakes. Switching on and off, and starting and stopping of the card punch mechanism are both under the control of push buttons. The correct starting and stopping sequences follow automatically from the operation of the push buttons, and full interlocking is provided to prevent any possibility of incorrect operation. The switching-on sequence includes automatic limitation of the valve heater current until about half the normal heater voltage drop has been reached.

The electronic circuits are built up in the form of eight valve plug-in units which consist

of eight single valve sub-assemblies and a diode panel. The number of types of eight valve units, and of the sub-assemblies is restricted as far as possible for greater ease of manufacture, and to keep down the number of spare units required for maintenance purposes.

In the circuit design the need for close tolerance components has been avoided and the normal resistor tolerance is  $\pm 10$  per cent. with a few in the  $\pm 5$  per cent. grade. Only two h.t. supply voltages are used, namely 200V and 150V, which are fed to all units. The heaters of the 350 valves used are supplied from a single 12.6V supply and distributed by bus-bars of suitable cross-section. All types of circuits are designed to be insensitive to mains voltage variations and the use of stabilized power supplies has been avoided entirely.

All leads carrying pulses are spaced about  $\frac{1}{8}$ -in. from adjoining leads, and low impedance terminations at the sending end are used, to keep down cross-talk between pulse-carrying circuits. Provision is made for an anti-interference filter adjacent to the mains connection, and all operating solenoids are provided with suppressors. To assist in checking the operation of the machine, a special synchronizing selector switch is fitted which selects pulses at suitable points in the operating cycle which can be used for triggering a cathode ray oscilloscope.

The calculating system is based on diode gating circuits mainly of the coincidence type, diode mixing circuits, and counters of the cascaded binary type. Only one type of valve, the 12AU7 double triode, is used throughout for trigger circuits, cathode followers, and amplifiers.

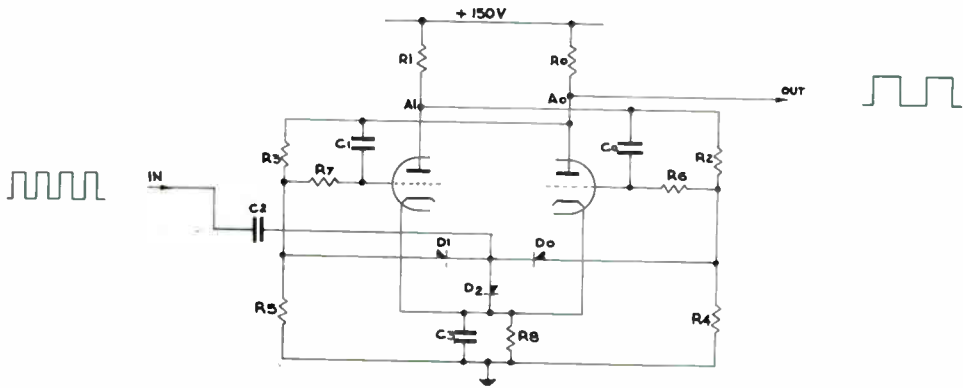

Fig. 3.—Basic binary counting circuit.

### 5. Gating Circuits

The diodes used for all gating circuits are miniature selenium rectifiers in capsule form. These selenium diodes are obtainable in several different current ratings. For most purposes a current rating of 1 milliamp has proved to be suitable. At the pulse repetition frequency of 10 kc/s used, these selenium diodes operate quite satisfactorily. Some 4,000 are used in the sterling multiplier and more than this in the decimal machine. Because of their price advantage over germanium and thermionic diodes, a considerable economy in the total cost of the machines is achieved.

No special precautions have been taken in the conditions of use of these diodes, beyond conforming to the manufacturers' ratings. Experience in operation has so far proved extremely satisfactory.

An essential condition in the use of diode coincidence and mixing circuits is that the load resistance into which the circuit is connected is large compared with the input resistances. In deriving the required control waveforms for sequencing the calculations, chains of coincidence and mixing circuits are created. To restore the circuit resistances to practical values, cathode followers are inserted at suitable points.

In the output pulse trains finally derived, the base potential level is higher than the input base levels, and steps appear in it. Several causes contribute to this effect, namely (a) the finite output/input resistance ratio of the diode coincidence circuits which is the main cause of the steps, (b) the forward voltage drop in the diodes and (c) the rise in voltage level due to

the use of direct-coupled cathode followers. Furthermore the pulse fronts deteriorate due to the capacitance of the selenium diodes and inter-wiring capacitances. These base level variations are removed, and the pulse fronts restored by a suitable clipping and amplifying circuit at the input of each counter.

### 6. Counting Circuits

The basic scale of two counting circuit is designed for a normal maximum counting rate of 10 kc/s. A triple diode arrangement is used to provide gating and d.c. restoration at the input, as shown in Fig. 3. At the above frequency, it is possible to use selenium diodes for this purpose. The buffer resistors R6 and R7 have been introduced to prevent any possible ill effects due to coupling between the grids of the two triodes through the diode self-capacity. These resistors also serve as buffers between the input pulse and the internal feedback round the circuit, thereby making the triggering time largely independent of the rise-time of the input pulse. The scale of ten counting circuit of Fig. 4 is made up of three of these circuits, and a fourth circuit, which is similar but arranged for twin triggering. The natural counting sequence of the binary chain is modified by means of a diode gating circuit as shown. The operation of the counter is clearly indicated by the waveforms given in Fig. 4. These waveforms are based on the convention that the counter registers nothing when the  $A_0$  anode conducts and a digit when the  $A_1$  anode conducts. The values assigned to the successive stages  $S_1$ ,  $S_2$ ,  $S_3$  and  $S_4$  are 1, 2, 4 and 8 respectively.



$S_1$  simply counts down the incoming pulse train in the normal manner. The input to  $S_2$  is gated by the coincidence gate and counts normally up to the count of nine. At the tenth pulse the input from  $S_1$  is blocked by the coincidence gate so that  $S_2$  is not triggered at this point.  $S_3$  counts normally on the output of  $S_2$ , and  $S_4$  is triggered from  $S_3$  on the eighth pulse, and re-set on the tenth pulse by a feed forward from  $S_1$ . The waveform out of the coincidence gate is derived from  $S_1A_0$  and  $S_4A_1$ , and is as shown in Fig. 4. The operation of  $S_2$  follows from this waveform. It will be observed that there is no forced re-set in this circuit and, therefore, no critical conditions which may affect its reliability.

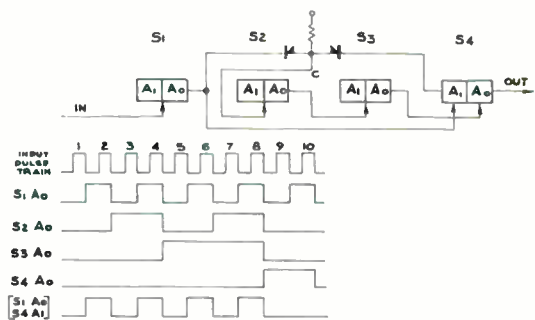

Fig. 4.—Four stage binary counter modified to count in a scale of ten, with associated waveforms.

In a similar manner the four stage binary counter may be modified to count in a scale of twelve by connecting the coincidence between  $S_2A_0$  and  $S_4A_1$  and driving  $S_3$  from it. In this case the feed forward is taken from  $S_2$ . Counting in any scale of notation can, in fact, be achieved by the introduction of one coincidence gate and one feed forward at suitable points.

A further feature of interest is the method of dealing with carries which occur between the counters forming the accumulator. Since in the machine all counters receive pulses at the same time, it is necessary to store any carries which may arise and to clear the carries in the intervening periods between counting. The carry system shown diagrammatically in Fig. 5, consists of a carry store and a diode coincidence gate. The carry, if present in the store, is fed forward to the next counter stage at an instant determined by the leading edge

of a gating waveform applied to the other side of the coincidence gate. This is arranged to be of suitable length to enable any further carries generated to clear. This condition will occur when a carry is received by a counter registering 9 (or 11 in the case of pence). If

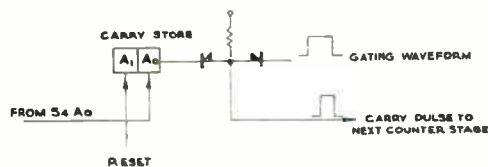

Fig. 5.—Carry system.

all counters are registering 9 (or 11) and a single further digit is entered into the counter of the lowest denomination, a succession of carries will be generated through the entire counter chain.

With the system described, the passage of a carry is delayed only by the accumulated delay due to the triggering times of the chain of trigger circuits through which it passes. In the worst condition mentioned above, this may be the entire counter chain. The carry gating waveform must be of sufficient length to allow for this condition, and in practice it has been found that two pulse periods, i.e., 200 microseconds, is adequate.

### 7. Control and Pulse Generator

The control of the calculation and the basic pulse trains required are provided by means of a system of counters and gates. The system used for the sterling multiplier is shown diagrammatically in Fig 6. A continuous pulse train at 10 kc/s is generated by the master oscillator and is applied to the scale of sixteen counter controlling the pulse gates. These gates select groups of 1, 2, 4 and 8 pulses for use during each addition period, which occupies a total of 16 pulse periods. Since the 4 and 8 groups are never selected simultaneously to represent decimal or duo-decimal digits, they may be overlapped and the total spread of these four pulse groups can be kept to eleven pulse periods. The remaining five pulse periods are used for the carry coincidence gating waveform, and for such functions as resetting, complementing, etc.

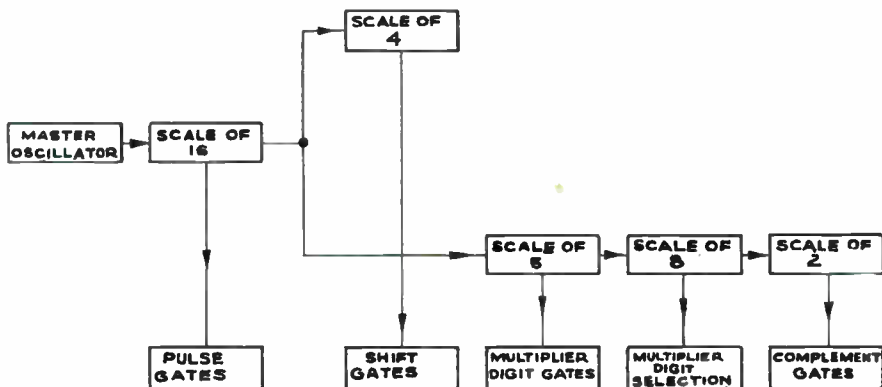

Fig. 6.—Control and pulse generator.

The output of the scale of 16 counter is taken either to the scale of four counter controlling the shift gates, or to the scale of five counter controlling the multiplier digit gates.

The shift gates are used in obtaining fractional values of the multiplicand and enable this operation to be separated into four parts, if required. The multiplier digit gates are used in selecting the number of additions into the result accumulator corresponding to the multiplier digit.

The output of the scale of five counter is transmitted to a scale of eight counter controlling the multiplier digit selection, up to eight digits. Finally a scale of two counter controls the complementing facility for checking purposes.

### 8. The De-Coding System

The result obtained on the result accumulator is in binary coded form and since cards are normally punched on a single hole system, it is necessary to provide a means for de-coding the result before setting the punches. It would be possible to do this either electrically or mechanically, and in this case a mechanical method has been chosen as the most practical economic solution. The principle of the mechanical de-coding unit is shown in Fig. 7. It is extremely simple and straightforward. Four solenoids corresponding to the four stages of a counter operate four horizontal code bars in which notches are cut in certain positions. Vertical members, whose positions are indicated by the vertical dotted lines have pins

fitted which can drop into notches which are positioned on these lines. If the code bar corresponding to the "1" solenoid is moved over to the left, notches on the code bars will be lined up on the vertical line marked "1" and will, therefore, allow this punch to be set. Setting the other punches is prevented in this case by at least one notch being out of line.

It is not necessary in this system for the solenoid to be powerful enough to pull the code bar across. It only needs to be sufficiently strong to hold the code bar, which may be pushed across by mechanical means and allowed to return if not held by the solenoid. This enables the solenoid to be operated quite safely by one half of an ordinary double triode valve.

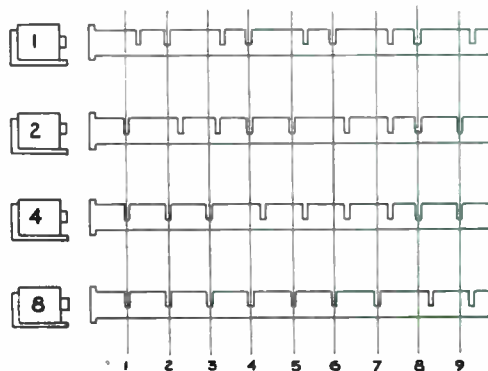

Fig. 7.—Decoding Unit.

### 9. Future Possibilities

In conclusion it may be of interest to mention that Electronic Multiplying Punches (Emps) based on the principles described in this paper are now in production and some are already in use. They fulfil an urgent need in the field of commercial and industrial accounting, but are far from exploiting the full possibilities of electronics. The introduction of more advanced electronic computing techniques for commercial applications must be considered in relation to the work involved in preparing the input data, and also in relation to the rates of input

to, and output from the computer. Future developments may be expected to improve and extend still further the usefulness of punched card accounting systems.

### 10. Acknowledgment

The development work on the machines, some features of which have been described in this paper, was carried out in the Computer Laboratory of Messrs. Vickers-Armstrongs Ltd., Crayford, under the direction of Major E. J. Guttridge, on behalf of Messrs. Powers-Samas Accounting Machines Ltd.

## DISCUSSION ON

### “Industrial Applications of Electronic Computers”†

*Chairman:* L. H. Bedford, O.B.E., M.A., B.Sc. (*Member*)

**Dr. F. M. Verzuh:** We have seen one point clearly emphasized; namely, that computers are definitely a new *tool* to be used in Research, Industry, and Manufacturing. Several questions therefore come to my mind:

1. How can we best teach people the capabilities of such computers?
2. Should we stress the professional or the non-professional aspects of programming when we consider applications in the business field?
3. How important is the knowledge of numerical analysis in the effective application of such computers?
4. At what level in the educational training programme should the teaching of computers be introduced—High school, college, or the graduate school?

Certainly some of the teaching must be done in the universities whereas part of it must be done “on the job.” I feel that non-professional programming should be taught in the undergraduate curricula.

In the proposed application of computers to the business field there appears to be some confusion in regard to the qualifications of the computer personnel. Some people feel that they must hire engineers and teach them the necessary

accounting. Others believe that they should hire accountants, and teach them all the details about the computer. Perhaps the best solution is to emphasize the need for teamwork: select men from each field and use them as a team to get the most work done in the least amount of time.

In regard to the appropriate level at which to teach students the principles of computers—I believe we should do more teaching at the undergraduate level so that graduates will be familiar with computers and will be able to use them as a *tool* when they enter industry. Perhaps we should even be doing some teaching of the principles of computers in the secondary schools!

I would like to call your attention to the fact that a recent conference entitled “Training Personnel for the Computing Machine Field,” was held at Wayne University in Detroit, Michigan, on June 21st-23rd, 1954, and that proceedings of this conference will be available shortly.

**Dr. H. A. Thomas:** In no electronic field during the past decade has progress been more rapid than in the development, design, and construction of electronic computers. The pioneering contributions of British scientists are praiseworthy—the work of mathematicians such as Hartree, Turing, Wilkes and Wilkinson coupled with that of engineers such as F. C. Williams, Robinson, Kilburn, Newman and many others has resulted in prototype machines being built such as the EDSAC

\* Discussion Meeting No. 6. Report of proceedings during Session 1 of the Industrial Electronics Convention at Oxford, July 8th, 1954.  
U.D.C. No. 518.5 : 621.37/8.

at Cambridge, the ACE at the N.P.L., and the Universal Electronic Computer at Manchester. During this pioneering period of 1946-49, these three teams represented the major effort in this country. I was privileged to direct the initial engineering development of the ACE, and know from personal experience the high technical achievements of the electronic engineers and the mathematical skill of the programme architects.

Following the basic research of these three groups, came the essential engineering development. Two electrical engineering organizations featured in this phase—Ferranti and the English Electric Company. Ferranti's built the Manchester machine and several others of similar design, while the English Electric Company engineered the pilot model of the ACE now in operation at the N.P.L., and have nearly completed the DEUCE. Other organizations such as Elliotts and British Tabulating Machines are developing smaller computers.

In America, a vastly greater effort has been put into developing both large and small computers; 20 large machines are already in use and at least 25 more are under construction. Further development, notably in the direction of transistors to replace valves, improved means of storage, and improved means of inserting and removing data is now taking place; reliability is being increased and cost reduced.

Nearly all these machines have so far been utilized for solving specific scientific problems in aircraft design, nuclear physics, ionospheric research, hydrodynamics, meteorology, population analysis, and statistics; they have enabled solutions to be obtained in many problems of so complex a nature that without them no solution could ever have been obtained. In this field alone they have more than justified the large sums of money spent on their development.

The utilization of such computers is not, however, confined to solving scientific problems. A far wider field lies in their utilization in business organization. Just as the machine has relieved man of tedious manual labour, so can equipment of this type relieve man of tedious mental labour. A revolution in business methods is imminent if only business executives can appreciate the vast potentialities. It must be emphasized that computing is only one of numerous applications of electronics to business. The major problem in most large offices is processing data, not computing it; the most time-consuming operations are

matching, selecting, arranging, writing, reading, duplicating, and filing. Computer technique coupled with other electronic techniques will ultimately enable many of these operations to be performed automatically.

In this country, with one notable exception—LEO, or the Lyons Electronic Office, developed from the Cambridge EDSAC—business executives have not yet appreciated the economics and improvements in accounting techniques which can be effected by these machines. Such appreciation will involve a lengthy process of education and a radical change in outlook. It is significant that the D.S.I.R. is giving a much needed lead in this direction by setting up a new Division at the N.P.L. to study these business applications.

Like all revolutionary developments, progress will be slow and opposition from traditional techniques considerable; ultimately, however, there can be no doubt at all that such electronic techniques will replace many of the traditional procedures in business methods.

**E. H. Cooke-Yarborough:** Mr. Lucas stated that his aim was that his electronic equipment should not be less reliable than his punch-card apparatus. I would be interested to hear whether this aim has been achieved.

I am surprised that nobody has made use of dekatrons in conjunction with punched cards; their relatively low speed of operation would not here be a disadvantage, and their simplicity and reliability make them very well suited for this use.

Several speakers have quoted the accuracy of analogue computers. I do not quite understand how accuracy is defined in such cases. Is it the percentage by which the result is expected to differ from the true result? If so, surely this depends considerably on the nature of the result. For instance, the accuracy will be poor if the voltage or current which constitutes the result is only a small fraction of the maximum the machine can handle. Also accuracy will be worse if the result is very critically dependent on one or more of the parameters. Is there a criterion of accuracy which depends less upon the nature of the computation?

One speaker mentioned an analogue computer using an analogue multiplier consisting of a servo motor driving a potentiometer, and suggested that a digital multiplier would be too slow in this application. I would have thought that a digital multiplier would be faster than the partly mechanical device he described.

I would like to make a short mention of terminology. Several speakers have referred to electronic counting circuits as counters. At Harwell, we originally did the same but got into difficulties because we found, in a typical set-up, we might have a Geiger-Müller counter, followed by a counter using valves followed by a mechanical counter. We have therefore tended to restrict the word counter to such devices as Geiger-Müller counters or scintillation counters; to call the valve device a scaler and the electromechanical device a register.

**J. H. Lucas** (*in reply*): On the question of reliability, experience so far extends over about a year, which is hardly long enough to obtain reliable figures. Without attempting to define reliability, it may be said that the general standard achieved by electronic calculating machines is about as good as that of mechanical machines, the design of which has been established over many years. It may be confidently expected that this already adequate standard of reliability will be surpassed in the future.

The use of dekatrons has been carefully considered, and there are two main reasons for preferring the four-stage binary counter using ordinary hard valves. Firstly, four double-triodes cost less than one dekatron, and the cost of the auxiliary equipment required is certainly no more. Secondly, at the time of the original development, no scale-of-twelve tubes were available for use in sterling calculations. Other scales of notation sometimes required, such as 14 and 16, can be covered without difficulty by the four-stage binary counter, but would require special tubes of the dekatron type. A further reason is the greater rate attainable by the hard valve counter, giving greater scope for future developments.

The question of terminology is a difficult one, and arises from the use of the same device in different fields of application. The term "counter" is fairly generally applied to mechanical counting devices and it naturally follows that this term should be applied to electronic devices performing a similar function. The use of the term "counter" in connection with Geiger tubes appears of doubtful validity, since these devices are detectors rather than counters. The term "scaler" applied to dekatrons or hard valve decade counters does not express the ability of these devices to register a whole number, or to accumulate the sum of two or more whole numbers precisely. It is, therefore, suggested that the term "counter" is more correctly

applied to these devices than to Geiger tubes.

**B. C. Fleming-Williams** (*Member*): At the 1954 Institute of Radio Engineers Convention, in New York, a film was shown of a Weidmann press in use, for punching holes in sheet metal. This press was entirely controlled by punched-card information. With this the information was punched on to a card directly from a drawing. It is interesting to note that great dimensional accuracy is not required either on the drawing or the card, since the press supplies this accuracy by counting along a scale marked in divisions of 1/2,000th in.

A proposed machine for the automatic assembly of electronic components was also described. With this machine the components were picked up one at a time and inserted into a chassis on which the wiring was already printed. The whole was then dip-soldered. Once again the whole operation was controlled by a punched card.

The philosophy behind both these machines seemed to be that of complete flexibility rather than high speed, with tooling time and cost reduced almost to zero. The application of automatic means to short production runs thus becomes economic.

**Dr. F. M. Verzuh**: A three-dimensional, numerically-controlled milling machine has been developed by the Servomechanisms Laboratory at the Massachusetts Institute of Technology. Admittedly, this is only the prototype model which is currently in the stage of application evaluation. At the present time, further research is being devoted to the development of a more versatile and elaborate device. Some of the things we are discussing in the field of automation are very realistic, and the day of completely automatically-controlled plants is rapidly drawing near.

**J. A. Sargrove** (*Member*): There are not enough technologists able to design apparatus well enough to supply the requirements of our modern technical revolution, and therefore, we ought to endeavour to co-ordinate our activities instead of working in separate isolated groups, and in many cases different directions to solve the same problems. In the automobile industry this sort of co-operation has progressed further than in the electronic field: you have the body made in one place, the engine in another, the tyres in another, the lighting system in yet another, and so on.

I think one organization should make the central part of the computer and another organization

the input and output mechanism; and we could collectively, therefore, solve many more of the industrial, commercial and office problems than by diverse competitive free-for-all wasteful efforts, as are taking place now.

**E. A. Newman:** The late Mr. F. M. Colebrook, working in conjunction with the British Standards Institution, spent considerable effort on the need for a good computer terminology. He compiled a list of terms, with definitions, which had been agreed by various interested parties, and will, in due course, be published.

Several people have stressed the need for fast outputs for electronic computers. I should like to take up a remark of Dr. Livesley. One of the most important stages in putting a problem on to an automatic computer, lies in deciding precisely what problem one wishes the computer to solve. Often it is known only to a research man working on an actual job, and can be difficult to explain to a mathematician.

**C. W. Miller (Associate Member):** Many problems in engineering are such that great accuracy in the final answer is not required but are concerned rather with the determination of a set of conditions which will optimize the performance of some equipment. There is therefore a case for a small analogue computer or simulator in which input parameters are set by means of adjustable potentiometers or the like and the output is provided in the form of a plotted curve possibly by cathode-ray tube presentation. One can then vary the input parameters to give the required optimum output and it is the settings of these parameters which provide the required information. Should greater accuracy then be required, the problem could be computed for this set of parameters as a single problem on a digital machine.

Another point which I feel is of importance in analogue or simulator type of equipment is that they not only solve the problem but may also considerably influence the thinking of the engineer. In certain computers of this type the relationship between the physics of the problem and the action of the computer is very clearly evident. To quote a particular case, a computer designed by one of my colleagues\* solves a particular problem in connection with particle accelerators. The computer follows exactly the physics of the problem and indeed this was how it was designed. Not only has this machine provided much numerical information but it has stimulated thought on the

physical action involved in the problem which it solves.

**Prof. E. E. Zepler (Member):** We started building an analogue computer about six months ago for investigation of aircraft problems and the question of accuracy occurred to us very early. We have consulted literature and also various firms building such computers, but so far we have not got any satisfactory answer. They build the computers and do not bother about this question. Usually it does not matter because the accuracy required is not very large.

What do we understand by accuracy of, say, 1 per cent.? To take a simple case, if your computer is to show undamped oscillation, the frequency should be correct within  $\pm 1$  per cent.

Another question is that of damping factor; you may find that the analogue computer exhibits instead of an undamped oscillation a damped one; then the amplitude should drop within the computing time by not more than 1 per cent.

Apart from the accuracy of components which is generally recognized there are other important factors. One in particular is the grid current of the input valve to the integrator. As far as I remember a grid current causing an input resistance of 0.1 megohm produces an error of 1 per cent.

**A. C. D. Haley (in reply):** Regarding the accuracy of analogue machines, I agree that there is no single satisfactory definition and all that one can do in general is to quote an accuracy for a given type of problem. Another way is to say that, in general, an analogue computer is solving mathematical relations whose coefficients are set on potentiometers, and the primary source of inaccuracy is the inaccuracy of components. You can therefore say with some degree of confidence that the solution which the computer is going to give is the solution to a similar set of equations whose coefficients are all within  $x$  per cent. of the coefficients of the original equation. That is sometimes not very useful from the point of view of the man who is going to use the machine, but he usually has a pretty good idea of the problem he is going to solve, and this accuracy can form the basis on which he can assess the actual usefulness of the machine. We mention in our paper one of the standard applications of electronic analogue machines—the solution of aircraft flutter problems; the requirements are determination of an aircraft speed at which an undamped oscillation occurs and determination of the frequency of the oscillation.

\* M. C. Crowley-Milling, *J. Sci. Instrum.*, 31, March, 1954.

A small variation of a coefficient will sometimes cause the critical airspeed to vary greatly, or change an unstable system to a stable one. This behaviour can be tied in perfectly well with the analogue machine accuracy as I have defined it.

**H. McGregor Ross:** We have found that the business or commercial applications of these digital computers have been much more difficult than the mathematical or scientific applications. The main difficulties arise when attempting to take into account the exceptional cases, or the variants from the main course of the problem; these are the points which are disposed of almost automatically by a trained or skilled person.

It has been our experience that, in general, electronic devices are rather more reliable than the electromechanical devices used in the computers. Of course, it is a little difficult to make the comparison directly because within these computers the electronic devices operate so much more frequently than the electromechanical devices, and they also carry out different operations. We have found in general that valves are less reliable than most other electronic components. Our experience is based on using thousands of valves over a period of several years, with the most stringent record-keeping. Under our conditions of use the EF 50 valve, for example, requires a replacement rate of about 2 per cent. of all the valves of this type per thousand hours of operation of the machine, and for the EF 55 the corresponding figure is about 1 per cent. These excellent results are no doubt influenced by the choice of the operating conditions.

It is often found to be rather difficult to obtain and train and hold electronic maintenance engineers. Perhaps an explanation is that in this rapidly expanding industry there is a great temptation to go into research work with its forward-moving atmosphere; maintenance work, however, is to a certain extent essentially static, and there may be in some way a disparity between the rapidity of the movement in this industry and the static nature of maintenance work.

**N. Kitz:** It has been suggested that electronic computers are not suitable for commercial calculations. The explanation for this may be that the words "general purpose" have been applied too readily to the electronic computers of to-day. At this present early stage of development, we cannot yet design computers equally suited to all types of numerical calculation, and we must therefore be satisfied with machines which only cover certain ranges of application.

The electronic computers now in operation have been designed and constructed either for, or indeed by, mathematicians who wanted them for a specialized application, namely, numerical analysis. It is not surprising that such machines become awkward to use for work of a type for which they were not intended.

The logical organization of a machine designed to perform commercial calculations and data processing must be different from that of present-day computers, and it may happen that when such machines are designed and constructed, their range of application will only partially overlap the range of mathematical computers. It is then possible that programmers using them may find commercial calculations easier than mathematical computation.

**F. L. Steghart:** The problem of maintenance of industrial equipment is becoming very difficult. Even in the case of large steelworks, it is difficult to find the necessary maintenance staff and smaller firms might find it to be insuperable before very long. One user interested in the saving of fuel find they cannot introduce automatic control for their boilers because of lack of qualified staff. Training qualified engineers for installation and maintenance appears therefore to be a greater bottleneck than problems of production.

**H. M. Scott-Smith:** Reference has been made to punch-press operation by means of punch-cards. I have seen Weidmann presses punching out chassis, and got the impression that a good operator had a time-constant not greater than the machine. It seems that all one is doing is substituting one computer for one man. The time taken to produce the automatic control equipment for the machine, averaged out over its useful life, may well be equivalent to two men operating the machine instead of one, as with non-automatic techniques.

Still thinking of U.S. practice, mention was made of the use of automatic methods. There was one application there of computing and card-work which I found most impressive. In a factory which was producing house-service meters at the rate of about six a minute, they have information concerning the running of the factory available to the factory manager in about the number of hours that it would take in days for the average British manager to obtain the same information—this meaning that the man in charge is ahead of his British counterpart in knowledge of the state of his production line. That would seem to be a very good application of control by computers.

**Major E. J. Guttridge:** I would like to refer to Mr. Sargrove's remarks concerning the pre-fabrication of components. Maybe his analogy of motor-car manufacture is closer than he thought, since at the present moment anyone connected with computer design and manufacture has to buy the bulk of his component parts from specialist manufacturers. All that we have left to do is to devise ways and means of holding them together or, perhaps better still, keeping them apart.

I think he is a little previous in his very praiseworthy suggestion that some form of collaboration on standardization should take place. We are dealing with an art that is extremely new and virile and one that, whether we like it or not, will bear the stamp of individual endeavour for some time to come.

I would, however, make one plea as a computing engineer I find that the main difficulty often consists of attempting to use components standard at the present time, and that there is a continual longing for just those special items which will make your machine so much smaller, so much cheaper, and so much more reliable. It is difficult to persuade manufacturers to give you what you want because your demand is not sufficient to justify the capital expenditure of laying down plant. If thought could be given to this aspect of the problem, which would lead to a practical realization of the need, I think one might see the beginning of Mr. Sargrove's dream.

**Kermit Lang:** The experience in the United States is generally that there is a place for both analogue and digital computers. For example, in Douglas Aircraft in Santa Monica, Cal., they now have one very large-scale digital computer, a very fast machine which is used largely for production control and scheduling work and also for mathematical researches and investigations where they need a very high order of accuracy, perhaps 8-10 significant digits. They have approximately 20 analogue computers for testing various engineering ideas as to design of wings and fins and also the fuselage for guided missiles and other types of equipment they are designing and going to build.

As one of the previous speakers has mentioned, there are approximately 2,000 electronic calculators in use in the United States. They are fast but small, being restricted to a total of 50 decimal digits of combined reading and punching. Nevertheless, they have found wide application in payroll work, public utilities billing, and other fields involving a large volume of relatively simple calculation. One of the largest American life

insurance companies has more than 25 electronic calculators in use and is faced now with the problem of whether it is better to have a large number of small-scale calculators or one or two very large computers.

**Dr. A. D. Booth (Communicated):** Dr. Livesley's conclusions regarding the type of people for programming and the length of time for training are by no means universally accepted; we have found, for instance, that an honours graduate can learn sufficient technique in about one week to make efficient use of a digital calculator. Furthermore, several people with no academic qualifications whatever have become very competent programmers in the technical sense.

Dr. Verzuh's point regarding the stage in the educational syllabus at which people should be introduced to the ideas of coding and of automatic calculators, is an interesting one. At London University we have, this year, introduced these subjects into the final Hons.B.Sc. special mathematics course, and questions on the detailed coding of a selected problem were set in this year's examinations. My personal opinion is that this subject should be introduced to all mathematics and science students in their first year at University; it does not seem to be a possible subject at sixth-form school level for two reasons, firstly, that suitable teaching staff does not exist; and secondly, that without access to actual machines the subject loses most of its interest and point.

Finally, it may be worth mentioning our valve-failure statistics at Birkbeck College. These extend over more than  $10^6$  valve hours and are:

6J6 20,000 hours; 6AL5 over 50,000 hours.

These figures exclude an initial period of 100 hours.

**Dr. R. K. Livesley (in reply):** The time taken to learn to programme must depend on the type of machine and the particular problem—the Manchester computer is one of the more difficult machines to use and has been mainly employed on “large” problems. Constructing the flow-diagram of a complicated calculation requires ability to visualize the complete programme as a unified whole, which demands more than a mere factual knowledge of the machine's instruction code.

Academic qualifications are certainly not necessary to a programmer if his job is merely to code a particular piece of numerical analysis. We have found, however, that the best programmers are often people with proven ability in some other branch of mathematics.