

THE JOURNAL OF
The British Institution of Radio Engineers

(FOUNDED IN 1925—INCORPORATED IN 1932)

*“ To promote the General advancement of and to facilitate
the exchange of information and ideas on Radio Science.”*

Vol. VII (New Series) No. 6

OCTOBER 1947

ULTRA HIGH FREQUENCY MODULATION ON WAVE-GUIDES*

by

H. Gutton (D.Sc.) and J. A. Ortusi (D.Sc.)†

A Paper read before the Institution's Radio Convention held at Bournemouth in May, 1947.

Introduction

The development of applications for the short electromagnetic waves is essentially due to the great speed of the oscillations. In fact, the very short period of micro-waves provides the possibility to transmit signals of very high frequency. Thus, a ten centimetre wave (3,000 Mc/s) allows a modulation of which the frequency can reach up to 50 Mc/s. By using an ultra high frequency carrier wave, television signals of high definition can be transmitted.

Transmission of 1,000 lines necessitates, in fact, a modulation bandwidth of 30 Mc/s reduced to 15 Mc/s for the transmission of the carrier and one side frequency only.

Another very important application is multi-channel multiplex. For a hundred channels a bandwidth of several Mc/s is necessary.

For other applications using very short pulses a very large bandwidth has to be used.

In order to produce the ultra high frequencies, velocity modulated tubes and magnetrons are normally used. The first has the advantage of allowing an amplification from a master oscillator and therefore of obtaining a very high stability of the carrier

frequency. On the other hand, the modulation of these tubes presents many difficulties.

Tubes of the klystron type have a grid controlling the electron emission so that the electronic beam can be modulated in density, but a linear variation of the electronic flow induces a non-linear variation of the field magnitude. In principle this defect necessitates the use of modulation either by pulses or by variable length rectangular signals.

A second difficulty arises when very high frequency modulation has to be used. In the velocity modulated tube a first cavity resonator of very high Q acts on the electronic beam in such a way that the electrons are grouped or “bunched” after crossing a field-free space. These bunches of electrons pass through a second cavity resonator (catcher) at the carrier frequency and deliver energy to this resonator. In order to obtain a high tube efficiency it is necessary for both resonators to have a very high loaded Q, but this condition prevents the possibility of having a large bandwidth of modulation at high frequency.

A velocity modulated tube working at a frequency of 1,000 Mc/s has an efficiency of roughly 30%. In order to transmit a modulation frequency of 15 Mc/s it would be necessary to construct a tube with an efficiency smaller than 5%.

It has been our endeavour to maintain stability of amplifiers employing velocity modulation without decreasing the efficiency of the transmitter when high frequency signals have to be transmitted.

* U.D.C. No. 621.392:621.396.619.11:621.385.16.
Manuscript Received March 1947.

† Compagnie Générale de Télégraphie sans Fil.

The principle of the method of modulation employed is based upon the possibility of varying the impedance between electrodes of a magnetron. This magnetron is cut off by a magnetic field, and the value of this magnetic field is close to that which induces resonance of the electronic charge present between anode and cathode. By modifying

impedance into a value between a short circuit on the guide and an infinite resistance. In the case of the short circuit the incident wave is totally reflected towards the transmitter; in the case of the infinite resistance the system functions as if the magnetron did not exist, i.e. uninterrupted transmission. For an intermediate case the transmission coefficient varies between zero and one. The percentage of modulation for the radiated wave is equal to 100 when the anode voltage of the magnetron varies between the values corresponding to these extremes.

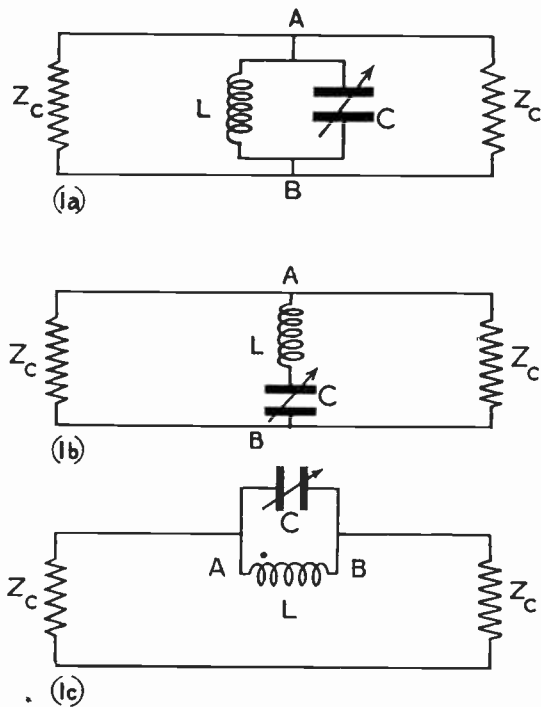

Fig. 1—Illustrating different devices for matching the magnetron impedance to the guide.

the anode voltage the quantity of the charge is either increased or decreased and the magnetron impedance varies.

1. The Functioning of the Modulation Device

The transmitter is an amplifier employing a velocity modulated tube, and its frequency remains constant whatever the variations of the load of the last stage of the amplifier. The energy produced is fed through a rectangular wave-guide inside which an H_{01} wave is transmitted towards a radiator. The variable impedance of the magnetron is connected in parallel with the guide through a matching transformer. This transformer is designed to permit transformation of the variable magnetron

impedance into a value between a short circuit on the guide and an infinite resistance. In the case of the short circuit the incident wave is totally reflected towards the transmitter; in the case of the infinite resistance the system functions as if the magnetron did not exist, i.e. uninterrupted transmission. For an intermediate case the transmission coefficient varies between zero and one. The percentage of modulation for the radiated wave is equal to 100 when the anode voltage of the magnetron varies between the values corresponding to these extremes.

Figures 1a, 1b, 1c represent different devices for matching the magnetron impedance to the guide. In these figures the magnetron is represented by a variable capacity C. The reflected part of the wave is fed back to the transmitter, and it is essential that it should be totally absorbed. This result can be obtained when the internal resistance of the source, viewed from the guide, has a value equal to the characteristic impedance of the guide. In other words, it is necessary that the transmitter should have a resistive load equal to its internal resistance. This can be obtained by coupling the klystron to the guide through an adjustable matching transformer. The setting up of this transformer can be obtained by displacing inside the guide a reflecting piston carrying a detector. If the detector current is independent of the position of the piston the radiator is perfectly adjusted to the guide, and without the magnetron modulator the transmitter then gives its maximum power.

The wave reflected by the modulator is absorbed by the transmitter and it penetrates inside the klystron catcher, and reacts on the electron beam. This reaction decreases the efficiency of the amplifier tube and the energy reflected is lost as heat inside the klystron catcher.

When the matching of the transmitter is properly adjusted the position of the modulator along the guide is of no importance if the radiator is also properly adjusted, and the modulator acts in regard to the incident wave as if the guide had an infinite length on each side.

2. Modulator Resonator.

The matching of the magnetron with the guide can be adjusted by a resonator which must fulfil the following conditions :

1. To have, looking from the guide section, an impedance varying from zero to infinity for

the range of variation of the magnetron impedance.

2. To have a Q allowing the passage of the highest modulation frequency.

The resonator (Fig. 2) is composed of two lines L_1 and L_2 (coaxial or two wires) having a characteristic impedance Z_0 . The line L_1 is terminated on the magnetron side by the variable impedance Z ; and on the other side is connected at B to the wall of the guide and at D to one end of a wire DC which crosses the guide parallel to the electric field.

The line L_2 is adjustable in length and it terminates on one side in a short circuit and on the other at A on the wall of the guide and at C at the other end of the wire CD.

The impedance Z_1 between B and D has a value :

$$Z_1 = Z_0 \frac{Z + jZ_0 \tan \frac{2\pi l_1}{\lambda}}{Z_0 + jZ \tan \frac{2\pi l_1}{\lambda}}$$

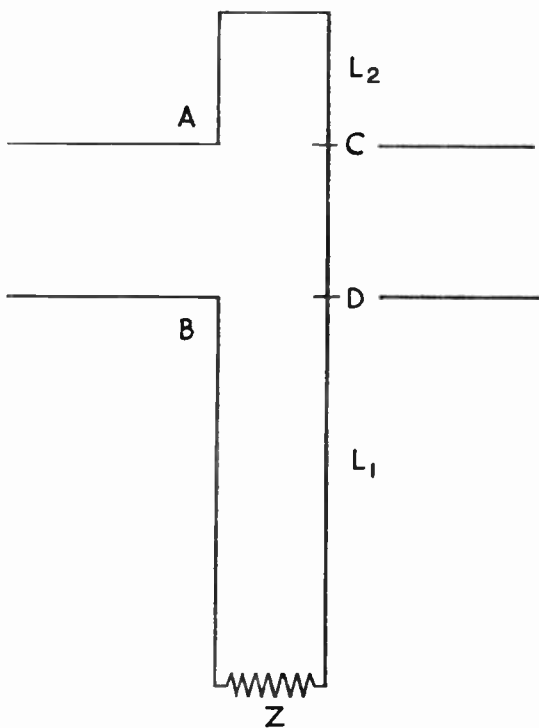

Fig. 2.—Resonator for adjusting the matching of magnetron with guide.

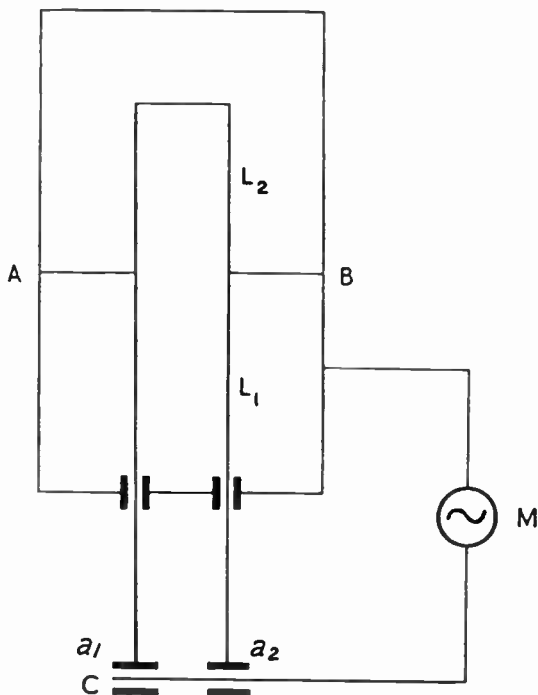

Fig. 3.—System incorporating magnetron with two full anodes.

The input impedance of the line L_2 is equal to :

$$Z_2 = jZ_0 \tan \frac{2\pi l_2}{\lambda}$$

l_1 and l_2 being the lengths of the lines L_1 and L_2 .

The wire CD is equivalent to an inductance whose value can be calculated. This inductance increases when the diameter of the wire is reduced. The corresponding impedance Z_3 varies between 50 and 100 ohms. The line L_2 is used partly to compensate the excessive value of this impedance.

For $Z = \frac{jZ_0}{\tan \frac{2\pi l_1}{\lambda}}$ the impedance Z_1 becomes

infinite, the modulator influence is reduced to nothing, and the incident wave is not reflected.

For the value of Z which makes the sum $Z_1 + Z_2 + Z_3$ equal to zero the incident wave is totally reflected. To get total reflection it is necessary that the losses should be reduced to the minimum. Most of these losses are due to the resistive part of the magnetron impedance. They are reduced to a

minimum when the anode voltage is equal to that of the cathode. The lengths of the lines L_1 and L_2 are set to obtain total reflection of the incident wave

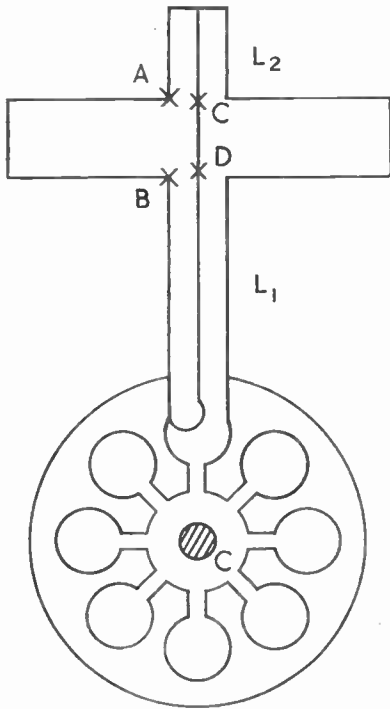

Fig. 4.—System embodying a cavity magnetron.

when the anode voltage is equal to zero. It is possible to obtain in practice a coefficient of transmission for the electric field smaller than 1%.

In the case of theoretical total transmission the losses in the magnetron reduce the transmission coefficient to a value below 100%, but it can reach 90%; this corresponds to a power loss of 19%. The greater part of this reflected power is absorbed by the klystron and a very small part (less than 1%) is lost as heat either on the cathode or on the anode of the magnetron. The best results have been obtained either with a magnetron with two full anodes surrounding the cathode or with a magnetron of the cavity type. In the first case (Fig. 3) a two-wire transmission line L_1 joins the two anodes a_1 and a_2 to the two sides of the wave guide at A and B. The line L_1 is lengthened by an element of line L_2 which permits a proper matching of the impedance of the wire AB.

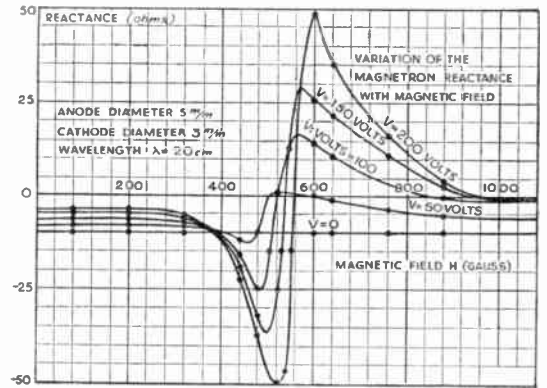

Fig. 5—Experimental characteristics for magnetron having two full anodes joined to the guide by a two-wire transmission line.

The modulation voltage M is applied between the wall of the wave-guide and the cathode C of the magnetron; M must have a value of a few hundred volts.

In the other case (Fig. 4), a coaxial line L_1 transmits the energy of the incident wave to one of the cavities of the magnetron by a coupling loop. The impedance of the wire CD placed in the guide is matched by another coaxial line L_2 . The modulation is applied between the cathode and the wall of the guide.

3. Variation of the Magnetron Impedance with the Anode Voltage.

Our experiments show that the incident wave can be modulated either with a full-anode magnetron or

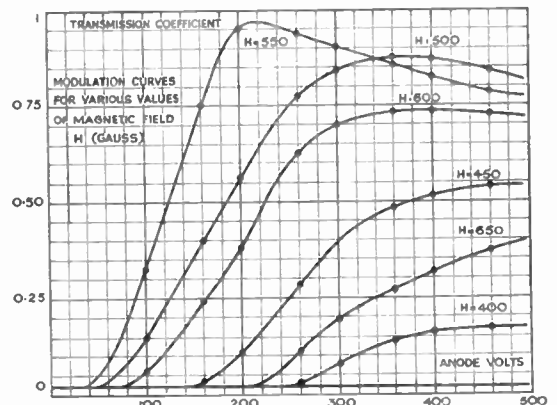

Fig. 6—Modulation characteristics at a 20 cm. wavelength with a two-anode magnetron.

a split anode magnetron. In both cases the magnetic field must have a value close to $H = \frac{m\omega}{e}$, ω being the angular frequency, $\frac{e}{m}$ the ratio of charge to mass for the electron. A theoretical study shows that the

space charge between the cathode and the anode has a resonant frequency corresponding to the same ω for this same value of the magnetic field. Experimental characteristics are plotted in Fig. 5 for a magnetron having two full anodes joined to the guide by a two-wire transmission line. Each of the curves corresponds to a given value of the anode voltage. On the horizontal axis are the different values of the magnetic field. On the vertical axis are plotted the corresponding impedances of the magnetron. The cathode has a diameter of 3 mm. and the two anodes each have a diameter of 5 mm. and a length of 5 mm. The curves have the same shape as the characteristics of absorption spectra in optics. The wave length used is 20 cm.

For a magnetic field smaller than the resonance field the magnetron is equivalent to an increasing capacity. Beyond the resonance value the magnetron is equivalent to a decreasing inductance. For the resonance value the magnetron is equivalent to a resistance. For different values of the anode voltage, the magnetic field to give resonance varies very slightly. However this field remains very close to the value :

$$H = \frac{m}{e} \omega = 525 \text{ gauss}$$

The experiment shows that the higher the anode voltage, the greater the impedance variation. This result is due to the increase of the space charge determined by the increase of the anode voltage.

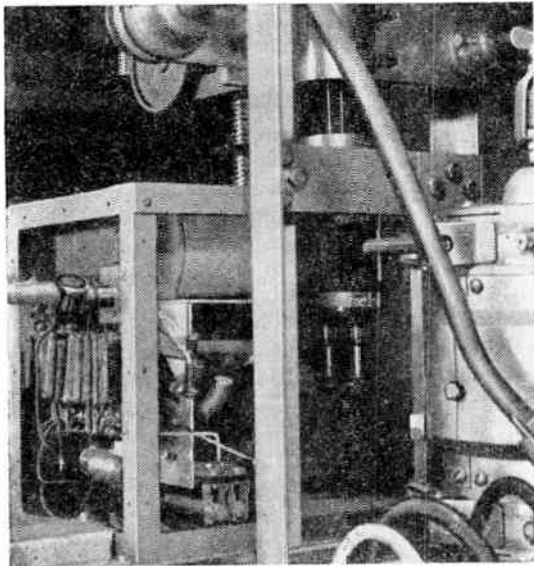

Fig. 7—View of magnetron modulator with matching unit.

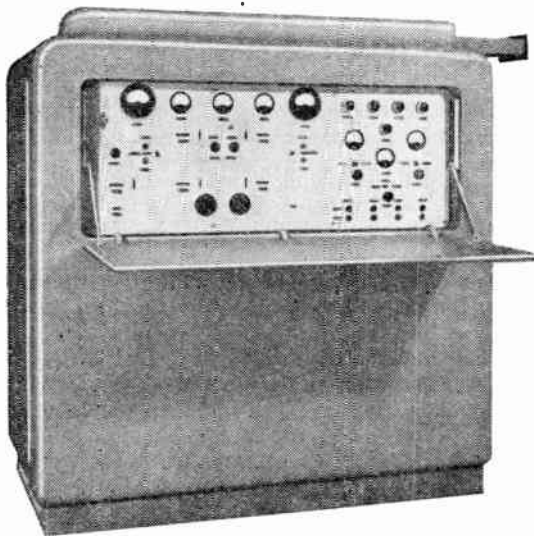

Fig. 7a—Television transmitter—wavelength 20 cm.

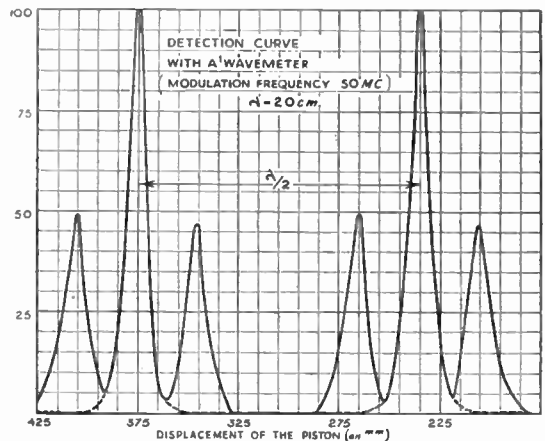

Fig. 8—Characteristics, derived with an accurate wave-meter, of magnetron modulator.

The same tests have been made with a cavity magnetron and the same results were obtained.

The modulation of the incident wave is obtained by varying the anode voltage for a constant magnetic field. There is an advantage in employing a magnetic field smaller than the resonant field; thus, the magnetron is equivalent to a capacity whose value increases with the anode voltage. When the anode volts increase, a resistance of decreasing value shunts the capacity. To obtain the best results for each frequency there are optimum sizes for the cathode and the anode.

The space which separates the cathode from the anode should decrease with increase of frequency.

Figure 6 shows some modulation characteristics at a wavelength of 20 cm. with a two-anode magnetron. Some of these characteristics allow a modulation of 90% for a variation of the anode voltage from zero to 200 volts.

The illustrations (Figs. 7 and 7a) show a television transmitter with master klystron and an amplifier for a wavelength of 20 cm. A two-anode magnetron modulates a carrier of 100 watts at 80% and the high frequency power loss in the magnetron is approximately 1 watt. The modulation voltage varies from zero to 250 volts. The average current of the magnetron anodes is approximately 10 milliamps. A check showed that a 10 Mc/s modulation band was unchanged after detection of the modulated wave as compared to the one of the modula-

ting amplifier. Neither the highest nor the lowest frequencies of the 10 Mc/s spectrum were disturbed. A test made with an accurate wavemeter for the case of a 20 cm. carrier to detect the side bands and carrier, after modulation at a frequency of 50 Mc/s, gave the curves shown in Fig. 8. The two side bands have an electric field magnitude nearly equal to half that of the carrier. For these very high frequencies the modulation is close to 100%. It is very noticeable that a tube able to dissipate a few watts only can be used to modulate a power of several hundred watts at a high modulation factor.

This modulation device which has already been used in a television transmitter allows many other developments. It should, for example, be possible to design a multiplex system with which each channel, or group of channels, is applied to a different magnetron, with a view to preventing distortion by mixing of the channels at the lowest frequency. It also allows problems to be solved concerning aerials, e.g. use of an aerial for both transmission and reception, or very fast rotation of the beam.

It is hoped that this new modulation device, which must not be mistaken for absorption modulation, will help the ultra high frequency wave specialists to solve some of the problems which become more and more numerous, and thus assist the development of the practical application of these frequencies.

CONVENTION DISCUSSION

Mr. L. G. Dobbie : Have the authors made any experiments to determine the order of magnitude of the frequency shift of the klystron transmitter between the two extreme conditions of zero and full modulation?

Professor H. M. Barlow (Member) : Since the modulation system consists of a variable impedance causing changes in the power reflected back to the source, what provision is made to prevent corresponding fluctuations of frequency?

Mr. L. W. Meyer (Member) : Would it be correct to say that the system actually provides absorption modulation when using the klystron arranged as explained and that the distinction drawn in the paper is really intended to convey that, although absorption occurs it is not the magnetron that dissipates energy?

Mr. M. M. Levy (Member) : I have been much impressed by this paper and I consider its contribution to the short wave art as of fundamental importance.

During the last ten years we have experienced a very rapid and impressive progress in very short wave technique. First came the propagation of very short waves in wave-guides developed in the Bell Laboratories, followed by brilliant studies such as those by Professor Leon Brillouin. Professor Barlow pointed out in his paper, read during the Convention, the importance of wave guides in multi-channel communication. It is expected that many thousands of telephone communications could be made through a single wave-guide. However, although we know a lot about propagation through wave guides, the technique of production and the modulation of

very short waves was still in its infancy about ten years ago, when the first studies on wave guide propagation were published. But very quickly two new methods of generation and modulation were found. The first is the klystron which appears to be the earliest very short wave generator of reasonable power and efficiency. It was soon found that frequency modulation of the wave generated by a reflex klystron is very simple and can be effected by applying the modulating voltage to the reflector electrode. This method is now applied in many wide-band radio link systems. The second is the cavity magnetron, giving considerable power at centimetre wave lengths. The cavity magnetron was found to be particularly efficient in pulsed conditions and was one of the major advances in radar during the war. Thus, frequency and pulse modulation were possible on very short waves. There was, however, a serious gap remaining in the technique; amplitude modulation. Gutton and Ortusi have just filled the gap.

The importance of their work was appreciated by the French Académie des Sciences who awarded the "Prix Pierre Laffite" for 1946 to Ortusi for this work on the propagation of very short waves.

I had the pleasure recently of visiting the research laboratories where Gutton and Ortusi are working.

This concern has first-class research laboratories directed by a very eminent man, M. Ponte. I was told how during the war, under German control, these laboratories still carried on secretly, obtaining results which surprised us when we learned about them after the French liberation. Amongst these developments, I would like to mention, apart from the studies of Gutton and Ortusi, the results obtained by Warnecke and his group. They developed new types of klystron, some of them giving an amazing amount of power. I was told that one model gave 50 kW. in the centimetre range! I would like also to mention the works of M. Chireix, world famous scientist, whom I had the pleasure of meeting during his recent visit to London.

In conclusion, I would like to express my pleasure in reading these French contributions. I believe close collaboration and an interchange of scientific and technical experience with our French colleagues will be mutually appreciated. The Société des Radioélectriciens, of which I have the honour to be a member, and very active French personalities such as M. Rigal and M. Moreau, have been very helpful in collaborating with us. I see in this excellent paper an example of what we can get from this mutual interchange.

REPLY TO THE DISCUSSION

Replying to Mr. L. G. Dobbie the Authors said: Our first tests were made with an auto-oscillator klystron with two cavities which were linked together; frequency variations were very marked and reached six parts per 1,000. In order to avoid this drawback, we have used an amplifier system comprising a pilot loosely coupled to an amplifier klystron and with this we have not found any frequency variations.

In answer to Professor H. M. Barlow's question the transmitter is regulated so that the total reflected power will be reabsorbed. The magnetron control causes variation of the impedance in

parallel with the wave-guide, and modulation is actually achieved by variation of the output of the transmitter. But the magnetron absorbs only a very small part of the power. Frequency fluctuations caused by the modulation depend on the coupling between the pilot and the amplifier and in practice are negligible.

Mr. Meyer is right in suggesting that the modulation produces absorption but that the magnetron does not itself absorb power. Our researches have shown that the system can modulate a very high power using a valve which has a very small size.

TRANSFERS AND ELECTIONS TO MEMBERSHIP

Since April 1st of this year the Membership Committee have held six meetings, namely, on April 24th, June 3rd, July 1st, July 29th, August 19th and August 26th.

At these meetings a total of 108 proposals for direct election, and 80 proposals for transfer were considered. The Council have now confirmed the election or transfer of the following (in addition to the list published on page 98 of the May/June Journal).

Transferred from Associate Member to Full Member
 GRAINGER, Ralph Eric Wellington, N.Z.

Transferred from Associate to Associate Member
 ANNS, John Joseph Salisbury, Wilts
 AHMAD, Riaz, M.Sc., B.Sc. New Delhi
 ELLORY, Frederick Ronald Hillingdon, Mddx.
 KITCHENN, Ronald Graley, Stone, Staffs
 B.Sc.
 MAKIN, Edwin St. Helier, C.I.
 MIDDLETON, Frank Martin Crewe
 TYE, Ronald William Stone, Staffs.
 WALKER, Thomas Barron West Hartlepool
 B.Sc., Major

Transferred from Student to Associate Member
 HART, Eric David, M.A. St. Albans.
 SKINNER, Arthur James Barking
 WALTER, Norman Edward Nairobi

Transferred from Student to Associate
 BOND, Donald Cubitt, P/O Hastings
 BEAUCHAMP, Kenneth George Stoke, Staffs
 CASTLE, John Lucas Heston, Mddx.
 DICKMAN, Matthew Colin Johannesburg
 GREGORY, Henry Rickmansworth
 HUMPHREYS, Edward Torpoint, Cornwall
 Kenneth
 HOLDEN, Stanley Westcliff-on-Sea
 JOHNSON, David Robert Leiston, Suffolk
 Gordon, Lieut., R.N.
 JUBBLE, Pal Singh London, N.22
 LAMBERT, John Robert Hereford
 MANNIX, Timothy Patrick Lancaster
 MANGRU, Soney James Colwyn Bay
 MASEYK, Norman Leslie, New Zealand
 B.Sc.
 McLENNAN, Douglas Crieff, Perthshire
 George, B.Sc.
 O'CONNOR, John Watchet, Som.
 NORMAN, John London, S.W.12

RUSSELL, Eric Victor Morecambe, Lancs.
 RINDNER, Wilhelm Palestine
 ROGERS, James Albert Brighton
 PLANT, Arthur Frederick Kings Lynn
 ROWE, Harry Shaw Edinburgh
 THOMPSON, Robert Frederick Natal, S. Africa
 WARD, Douglas Arthur London, N.13
 WATT-BRIGHT, John Robert New South Wales

Transferred from Graduate to Associate
 DOREY, Peter Francis Tunbridge Wells
 EPSTEIN, Jan Leo Palestine
 FIELD, Richard William East Barnet

Transferred from Student to Graduate
 BROADBERRY, Noel Edward Dublin
 HEISLER, George Henry, B.Sc. London, N.W.6
 O'RORKE, Arthur Breffne Dublin
 TAAFFE, Peter Albert London, N.10
 THOMAS, William Derrick Burnham-on-Sea
 VALENSIN, Fernand Cairo

Elected to Associate Member
 BASFORD, Albert Edward Abingdon, Berks.
 CHANG, Sing, B.Sc. London, W.1
 COOPER, Arthur McDonald Wellington, N.Z.
 ELTRINGHAM, Geoffrey London, N.W.11
 Currie
 GILLETT, William Francis Wembley, Mddx.
 Herbert
 LI, Chi-Huo, B.Sc. London, W.1
 MARATHE, Dattatray Hari, Bombay
 B.Sc.
 PHILIPPART, Henry Oxford
 Alexandre Strang
 RITSON, Basil Edgar Percival Manchester
 SHARMA, Satya Parkash, London, W.1
 B.A., B.Sc.

TRANSFERS AND ELECTION TO MEMBERSHIP

Elected to Associate

AMOR, Mervyn	Bombay	LELLOW, Raymond	Leigh-on-Sea
BOOTH, James Robert	Wrexham	LONG, George Ivor Royce	Portsmouth,
BUNNER, Alfred John	Guard Bridge,		Hants.
	Fife	MUDGWAY, Douglas James,	Trentham, N.Z.
BROOMFIELD, Bertie,	Sutton, Surrey	B.Sc.	
Lt.-Commander, R.N.		MOORE, Thomas Edward Ray	Hove, Sussex
BURTON, William Schoolcraft	Chislehurst,	MacKELVIE, John Stewart,	Bournemouth
	Kent	B.A.(Hons)Cantab.	
BEILBY, Harry	Scarborough	ODELL, Alexander Douglas	Welling, Kent
CAUVIN, Gerald Andre	Paris	PRICE, John Rhys, B.Sc.	Hereford
CRITCHLOW, Philip Sydney	Tipton, Staffs	RHODES, Arthur John	Grimsby, Lincs.
CARRINGTON, Thomas	Radcliffe, Lancs.	RAWLINGS, Reginald Jonathan	London,
DEAN, Reginald Edmund	Knott-End-on-		N.W.10
	Sea, Lancs.	SOANES, Sidney Vincent, M.A.	Ontario, Canada
DEW, Boon Seng, B.Sc.	Hong Kong	TELANG, Vishwanath	Bangalore, India
DALE, Frank Henry	Manchester	Shambrao, M.Sc.	
GUEST, Norman Edward, B.Sc.	Blackburn,	WILKINS, Peter Granville	Burghead,
	Lancs.		Morayshire
GRANGER, Herbert James	Calne, Wilts.	WHITE, Wilfrid St. John	Bristol
HIBBERT, James Ronald	Wallasey,	WILSON, Edward	Bromley, Kent
Booth, B.Eng.	Cheshire		
HANDS, David William	Eastbourne	<i>Elected to Companion</i>	
Stanhope		HANDBY, John Edmund,	India
HACK, Sydney Robert	Cosham, Hants.	M.B.E., Major	
HOWATT, George Donald	Southsea, Hants.	DEUCHARS, George	Cairo
JOHN, Angilivelil George,	Chelmsford	Dalginross, O.B.E.	
B.A., M.Sc.			
JABLONSKI, Jan	Bolton, Lancs.	<i>Elected to Graduate</i>	
LEWIS, Reginald George	London, E.27	WILKINSON, Leslie	Sheffield
		BAKER, Henry Louis	London, N.W.6

STUDENTSHIP REGISTRATIONS

Since April 1st of this year the Membership Committee have held six meetings, namely, on April 24th, June 3rd, July 1st, July 29th, August 19th and August 26th. The Membership Committee also considered at the above meetings 127 proposals of which 109 were accepted.

Student Registrations

ATKINSON, James Gibson	Newcastle-on-Tyne	COOPER, Ernest, B.Sc.	Cardiff
ANANTHARAMIAH, A. V.	Bangalore	CARMAN, Richard	Stoke-on-Trent
BANFIELD, George Eric	Knutsford	CLAY, Richard Swift	Hove, Sussex
BAXTER, John Campbell	Kettering	COLLINSON, John Dunn	Brighton
BOLTON, Guy William	Petts Wood,	CROSS, Edward Robert	London, N.5
	Kent	DANCY, Harold Collingwood	Leigh-on-Sea
BOUDOURIS, George	Athens	DUNNE, Michael Joseph	Tipperary
BOYES, Frederick	Blackpool	DURAISWAMY, A	Bangalore, India
BLACKHURST, Derek	Brooklands,	DOOLEY, Russell John	Kenton, Mddx.
	Cheshire	de SILVA, Godage Suthasena	Ceylon
BLANC, Victor Hippolyte	London, W.4	ENGLISH, William Caxton	Newcastle-on-Tyne
BOAST, John Edward	Sudbury, Suffolk		
CONROY, John Francis	Dublin	FRANKLIN, Derek	Rhos-on-Sea,
			Wales

FRYDAS, Panos	Athens	POWELL, David Keene	Hereford
FREEMAN, Anthony D	Folkestone	PRINGLE, John	Wembley,
FREEMAN, Philip Stanley	Ayr, Scotland		Mddx.
GHOSH, Birendra Mohan, B.Sc.	East Croydon	PUGH, Trevor William	Cardiff
GRIFFITHS, Reginald Clive	Newcastle- under-Lyme	PATIL, Mohun Moreshwar	Bombay
	Tipperary	ROSE, John Albert	Bedford
HARRINGTON, Philip	Liverpool	RUTHERFORD, Edward	Lyme Regis,
HALSALL, James Richard	London, E.13	Andrew Douglas	Dorset
HICKS, Charles Ernest	Liss, Hants	ROTHSCHILD, Peter Henry	Wellington, N.Z.
HALAHAN, Henry Crosby	Liverpool	ROBERTS, Robert Louis	London, N.11
HAMPSON, Ian Joseph	Hounslow,	RAMACHANDRAN, V	Coimbatore,
HILL, Richard Edgar	Mddx.		India
	Glasgow	SMITH, Derek Leslie Anthony	London, W.1
HUTCHINSON, Fred	Palestine	SCRUSE, Stanley Warren	London, N.13
HALAMISH, Itshaq	Whitley Bay	SHUTER, Joseph Stanley	Hove, Sussex
KERR, Alexander	Singapore	SINGH, Kirpal	Malaya
LIM, Keng Lin	Singapore	SINGH MOM, S. Gurbachan	India
LEE, Tshun Syn	Kings Lynn	STOODLEY, Raymond	Morden, Surrey
LINDSEY, Peter William	Sidcup	SANGSTER, Gordon Alfred	Auckland, N.Z.
LOWTHER, William Henry		SOOD, Parkash Chaud	Punjab, India
Edward		SAM, James Ah	Suva, Fiji
MAIRAL, Manohar Malharrao	Baroda, India	SUBRAMANIAN, Rangaiyar	Bombay
MANI, Krishnaswami Subra	Salem, India	Trivandrum, B.Sc.	
MELINN, Michael Gerard	Tralee, Co. Kerry	SARGUNARAJ, Samuel	India
	London, S.E.13	William, B.Sc.	
MURRAY, James George	Fetcham, Surrey	SHEPHERD, John Leo	Blackburn
MANNING, Russell Paul	Eire	TARAPHDAR, Syamananda	Calcutta
MURPHY, Matthew	Bombay	THIOPOULOS, Christos	Athens
MANI, Subramaniam		THOMAS, William Arthur	Colwyn Bay
Ramachandran		TINSON, Leonard	London, S.W.12
MARKS, Charles Quin	Palestine	TJODAS, John	Athens
MORGAN, Stephen Lascelles	Johannesburg	JAMES-TREVOR, Alexander	London, W.2
MALDEN, Desmond Anthony	London, S.W.6	Pryddors	
Drinkwater		TSEREPAS, Emmanuel	Athens
MacMAHON, Patrick Joseph	Dublin	TABART, Francis Ernest	London, N.W.1
McDONAGH, Francis James	Sligo, Eire	Vivares	
McNAMARA, Francis D	Cork, Eire	THORPE, Aubrey Clement	Leeds
NEYLAN, James Patrick	Billingham,	THOMPSON, John Howard	Swindon, Wilts
	Co. Durham	VENKATESAN, Sundara	Madras, India
O'BRIEN, Terence Joseph	Dublin	VIPOND, Ronald	Upminster,
O'CONNELL, Terence Francis	London, W.9		Essex
Kevin		VISSER, Nicolaas	London, S.W.17
OGILVY, Harry H	Leicester	WEISS, Hans Georg	London, N.W.8
O'CONNOR, Bartholomew John	Killarney	WILLIS, Aphraim James	London, S.W.7
OON, Khor Hong	Malaya	WITCHELL, Alfred Reginald	Loughborough
	Glasgow	Thomas	
PERKINS, James Arthur	London, S.W.16	WADHWA, Balwant Singh, B.A.	New Delhi
PARSONS, Kenneth Cyril	Indore	WHITEHEAD, Geoffrey	Blackpool
PANDY, Ravindra Nalt	Athens	WORKMAN, Dennis Ralph,	London, N.2
PANAGOPOULOS, Sotiris	Harrow, Mddx.	B.A.	
PARTRIDGE, John William	Transvaal, S.	WILSON, John Henry	London, N.22
PERKIN, Geoffrey Francis	Africa	WIDDISON, Geoffrey Canham	East Molesey,
Robert			Surrey
PLOWMAN, John Antony	Luton, Beds.		

RADIO NAVIGATIONAL AIDS*

by

W. J. O'BRIEN†

A Paper read before the Institution's Radio Convention held at Bournemouth in May, 1947.

1. Radio Navigational Aids

Many means of obtaining navigational information by radio exist, but all can be resolved to a common pattern, and all produce the information in the form of a line of position.

All systems involve three signal points. Those with two fixed receiving points and a mobile transmitting point are classed as direction-finding systems. Those with two fixed transmission points and one mobile reception point are navigational systems. A further group is composed of systems which measure range, and in these one signal point consists of a responder or combined receiver-transmitter.

In addition, all the signal points have signals involving a common repetition rate; this may take either the form of modulation or of carrier frequency. The phase of the signals of one pair of signal points must be known as must also the base line between them. Finally, a method of indicating the phase difference between two received signals is necessary.

In D.F. work the two receiving points are arranged in phase opposition to give a common output, as for instance, a balanced loop or a balanced "Adcock." The output from the antennae is proportional to the sine of a small angle off the null and the distance separating the two verticals. If the spacing of the verticals is large compared with the wavelength received, there will be a multiple of null, i.e. four nulls per wavelength separation. As there is zero sensitivity versus angular rotation when the base line of the antennae is phased in line with the transmitter, the null can easily be identified and such an arrangement can give a marked increase in bearing accuracy. For almost all usable D.F. frequencies

these dimensions are physically impossible for portable use. Widespread antennae can, however, be set up as permanent arrangements on land. The intelligence in this case is transferred to the land base. To maintain the intelligence at the mobile point the land antennae are used as transmission points, and such a change transfers it out of the D.C. classification.

When the intelligence is received from a single receiving point, the result is that it becomes necessary to determine the phase difference of the received signals at the receiver. The first arrangements used to meet this problem took the form of devices for changing the phase of the transmissions so as to shift the phase pattern. The arrangements provided a course line of equal signal from the two alternate transmissions and by a system of coding such that one pattern was on for a longer time than the other, an off-course in one direction would effect a Morse A (• —) and in the other an N (— •). There are many variations of equi-signal range beacons used on both long and short waves. Little use was made of the long base line on equi-signal systems until the introduction of Sonne by the Germans. The Sonne system used a base line six wavelengths long; in the centre of this a constant amplitude signal was transmitted, which acted as a carrier to the two outer signals comprising the two sidebands whose frequencies differ from the carrier by 1/120 c.p.s. The amplitude and phase of the two outer signals were arranged to give time amplitude modulation at a distant point. The phase of the two second per-cycle modulation signal was obtained by keying the outer transmitters as dots or dashes. The keying was started at a predetermined phase time and dots or dashes would be heard in changing intensity until the level of the modulation signal fell to zero. At this equi-signal level the phase of the modulation was zero. The keying time was 60 sec. at a one sec. rate, the phase shift in this time was 180°, the pattern gave three cycles per

* U.D.C. No. 621.396.933.
MS. Received April, 1947.

† Decca Navigator Co. Ltd.

quadrant, thus each quadrant was divided into 360 units, with an ambiguity every 120 units. The position lines are those of a series of confocal hyperbolae with the two outer transmitters as the foci.

Two objections to Sonne are the time required to obtain a reading and the loss of count under conditions of heavy interference. One solution to the delay time is to speed up the pattern time, i.e. the central station remains as the carrier frequency, the one outer antenna radiates that $f + 50$ cycles and the other $f - 50$ cycles. This would produce a 50-cycle note whose time phase would be dependent on the orientation of the receiver in the same way as the slow $1/120$ cycle signal of Sonne. A central antenna of some other carrier frequency could be modulated in synchronism with the outer antennae and this second 50-cycle note, which is independent of orientation, could be used as the phase reference. Similar systems, some which eliminate the central antenna and others which use single side-band modulation offer possibilities.

An ingenious arrangement known as P.O.P.I. has been put forward by the Post Office, in which a side band frequency is transmitted from one point and the carrier frequency is alternately transmitted from two or more separate points. At the receiving point the phase of the low frequency beat note resulting from the phase difference between the side band signal and carrier signal A is compared with that resulting from the alternate carrier signal band and thus provides a reading of the phase difference between the A and B carriers. By calling the side band signal S the explanation can be given as a first phase difference $A-S$, a second $B-S$ and a final phase difference as $(A-S) - (B-S)$ which equals $A-B$. As the phase of S cancels out and plays no part in the final reading, it is merely a converter signal and may be incorporated in the receiver. As the transmitted beat note signal is not a requirement this is to be classed as a direct carrier phase comparison system. The direct comparison is made possible by receiving the A and B signals separately at alternate synchronized periods of time. The conversion to a low frequency permits a long signal decay time in filter circuits and thus continuous signals can be provided for phase comparison of the separately received signals.

A direct phase comparison system allowing continuous transmissions is provided by the

transmission of different frequencies which are harmonically related to a common fundamental frequency. This is the system used in the Decca Navigator. A brief explanation is given by the following example. A 60 kc/s signal is transmitted from one point and an 80 kc/s signal from a second. These signals may be considered to be phase locked to the 6th and 8th harmonics of an imaginary short pulse having a repetition rate of 10 kc/s. The receiver comprises a first channel having a 60 kc/s amplifier followed by a frequency quadrupler, a second channel having an 80 kc/s amplifier followed by a frequency tripler. The 240 kc/s signal outputs of the two channels are equivalent to separate reception of both transmissions at the 24th harmonic of the imaginary pulse transmitter. A phase difference indicator operated by the two output signals will therefore give a direct phase indication of separately received 240 kc/s signals.

Many variations of the above system are possible. For instance, a harmonic generator could be supplied in the receiver which would give an 80 and a 60 kc/s signal which differed from the received signals by a fixed small percentage, and by hetrodyning these provide a converted low frequency signal in each channel which could be multiplied in the $3/4$ ratio to provide a common low frequency signal for phase comparison. These hetrodyne signals could also be provided by ground transmission. In the event that the $60 \text{ kc/s} \pm 6 X$ were transmitted from the 80 kc/s location and the $80 \text{ kc/s} \pm 8 X$ were transmitted from the 60 kc/s location, the indicated total phase shift in a complete travel from one base line extension to the other would be doubled.

A 1938 U.S. patent granted to Shanklin describes a low-frequency system in which the synchronized low frequency transmissions are applied as modulation to unsynchronized high frequency carriers of different frequency. The result of this is to provide for direct phase comparison two low-frequency signals which are separately received from the spaced transmission points.

During the war an ultra high frequency pulse system, known as GEE or Q.H., was developed by the Air Ministry and a similar medium wave pulse system known as Loran was developed in the United States. In all of these systems, arrangements are made to identify the individual transmissions from the spaced points and the difference

in transit time is read on a cathode ray tube with the aid of accurately timed sweep circuits.

2. (i) *The Geometry of Plotting*

The object of navigational systems is to provide means for fixing a position along a charted line of position. It is required, therefore, that the geometry of plotting the chart be known. In general, it is assumed or known that the lines of position form a series of confocal hyperbolae, using the end points of the base line as foci. A hyperbola is defined as a locus of points whose difference in distance to the foci is constant. To plot them on a chart, having a fixed unit of measurement, a series of concentric circles are drawn about both the spaced points. Lines drawn towards the base line across the diagonals of the distorted rectangles so formed produce the desired hyperbola, providing of course that increase in circle radius corresponds to the propagation distance of the time units measured. Such a chart is shown in Fig. 1. This chart is to enclose 20-unit spaced hyperbolae. The following facts

are apparent from an examination of this chart.

A line drawn across the opposite diagonal is an ellipse, and the tangent to this ellipse is always at right angles to the hyperbola. The base line may be considered as an ellipse whose minor axis is zero. Lines drawn perpendicularly to the base line which divide the major axis of an ellipse into as many equal parts as there are desired hyperbolae, will intersect that ellipse at points which are points of hyperbolae corresponding in number to the division of the major axis. Put in another way, the X value of any hyperbola at the intersection of a given ellipse is proportional to the dimension of the major axis of that ellipse.

The minor axis of an ellipse may be obtained graphically by describing an arc through the perpendicular bisector. The radius of the arc is to be equal to half the major axis and its centre located at one of the foci.

The spreading of the hyperbolae adjacent to the perpendicular bisector is proportional to the ratio of the major axis of the ellipse and the foci spacing.

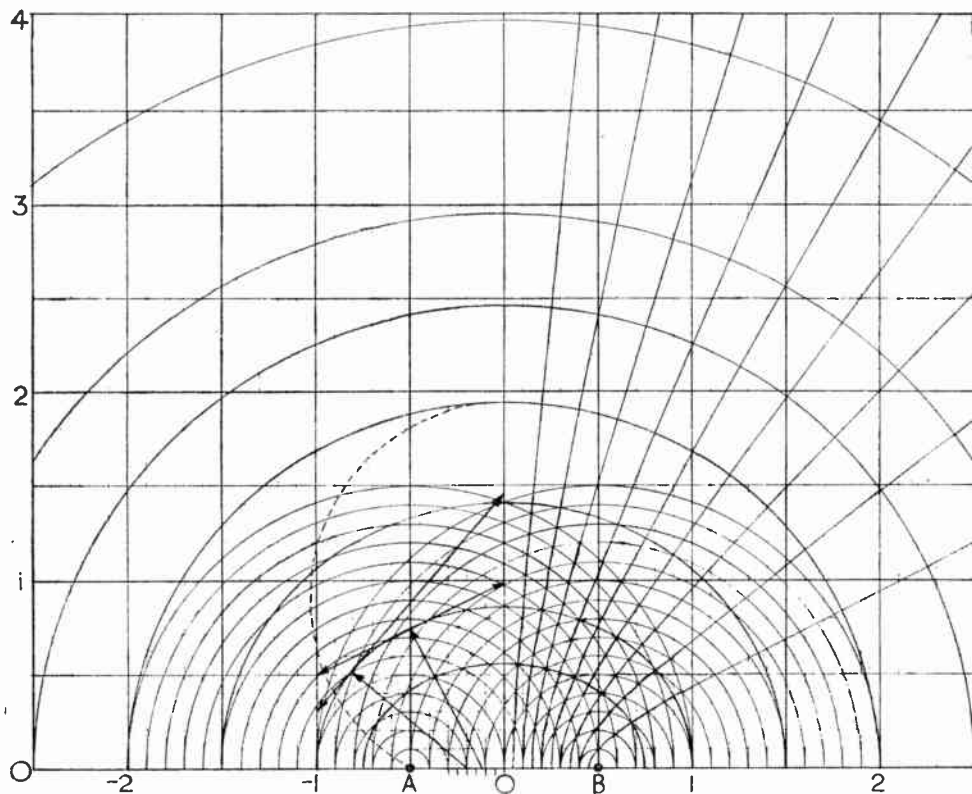

Fig. 1.—
Graphical
construction
of hyperbolic
and pattern
sensitivity.

This is an important ratio to consider, as it gives the loss in accuracy with distance away from the transmissions.

There is a marked loss of accuracy as the points swing around near the base line extension. At distances out, which are great compared with the base line distance, this loss is proportional to the cosine of the angle made from the perpendicular bisector. A line of uniform error would in such case be represented by a circle drawn tangently to the base line at its mid-point. A good approximation of this loss at close quarters is had by circles passing through both foci. Such a circle of uniform error is shown in Fig. 1.

The correct distance per small unit of indication is given by a straight line drawn between the perpendicular bisector and a perpendicular to the major axis of the ellipse on which the point lies at the point at which it cut the ellipse, the line being drawn tangently to the ellipse at that point. The ratio of this length to one half the length of the base line represents the factor of increase in distance per unit indication over that obtained along the base line.

To obtain a tangent to a hyperbola a linear scale representing the hyperbola numbers is centrally placed on the base line. The length of the scale is made smaller than the base line by an amount equal to the ratio of base line to the major axis of the ellipse, a line drawn between corresponding hyperbolae points as indicated by points on the ellipse and points on the base line scale is a line that is tangent to the hyperbola at the point on the ellipse. This arrangement is also illustrated in Fig. 1.

In plotting three patterns for station arrangements with one central antenna, such as Sonne,

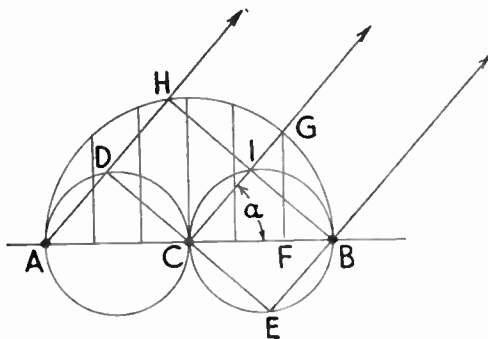

Figs. 2, 3 and 4.—Phase relations of signals from three spaced radiators.

the space pattern is calculated on the basis that the ratio of receiver distance to station separation is very large. The figure on which most of these calculations are made is shown in Fig. 2. In this figure the three stations are shown as A, B and C. The three lines extending to infinity are the signal paths to the receiver. The distance AD is the increased path length of signal A over that of C, and BE is the reduced signal path of signal B. The path length difference between signals A and B is AH, which is equal to $AB \cos a$. AD and BE are likewise equal to $AC \cos a$.

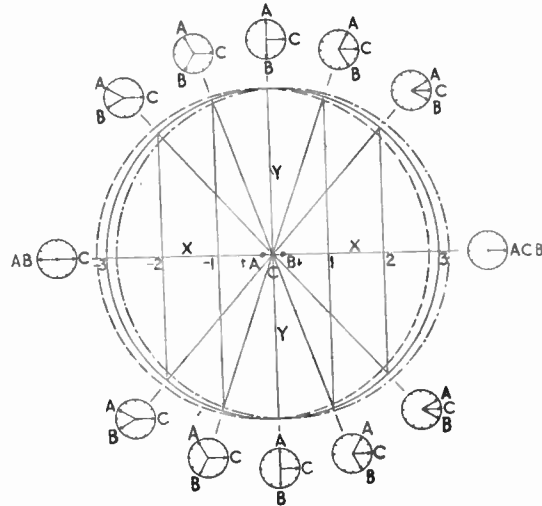

Fig. 3

A graphical representation of the pattern derived from the assumption of a receiver at infinity with a three-station transmission is shown in Fig. 3. The phase of the three transmissions A, B and C are illustrated by the corresponding vector. The phase of the corresponding received signals at points on a circle drawn about C are shown by the vector within the small calibrated circles. The large solid circle shows a line of constant phase of the C signal; similarly, the dash line is drawn for A and the dash dot for B. The transit time phase difference between C and A is represented by the distance from the A circle to the C circle along a radial line from A. The transit time phase difference between C and B is done in a like fashion. The AB stations are shown spaced by 180° .

To construct the polar diagram of the space pattern, the desired amplitude is assigned to each

of the vectors and a summation gives the signal strength along the corresponding radial.

It will be noticed in Fig. 3 that the vectors A and B, shown at points of position off either side of the bisector, show a symmetrical displacement relative to the C vector. Inspection of the radial distances from the dash line to the solid line and the dash dot line to the solid line will show that they are not symmetrical. This error of phase indication is due to the fact that the vectors shown are for infinite distances, such that an ellipse drawn about the foci A and B is equal to a circle drawn about C. If the solid line was drawn as an ellipse drawn about A and B with the major axis equal to the circle diameter shown, the phase as shown for infinity would check with the phase dimensions of the figure.

Figure 4 shows the receiving points close to the points of transmissions and oriented about an ellipse with A and B as foci. The vectors shown correspond to those given in Fig. 3. If the phase of the C station propagation were distorted so as to provide a constant phase line as shown by the ellipse instead of the upper dotted circle, then the vector as shown in Fig. 3 would check with the vector in Fig. 4. For one half of the pattern this effect can be approximated by off-setting the C transmission to position C'. It should be mentioned that the relative phase relation variations between Figs. 3 and 4 increase as the square of increase of wavelengths per unit of measurement.

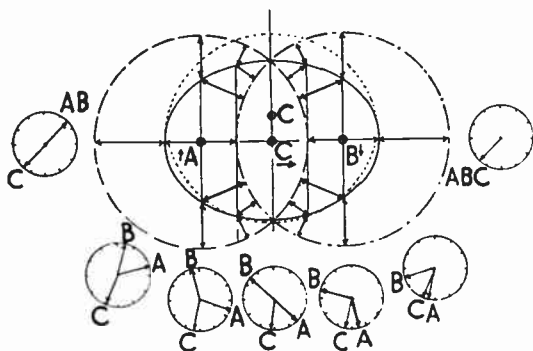

Fig. 4

One point taken from Fig. 4 that should be remarked upon and which may be applied to plotting hyperbolae, is that if all radiated signals are of the same frequency and the relative phase of their transmissions are fixed, the sum of the equal amplitude vectors from A and B at points on an

ellipse with A and B as foci are in phase or in phase opposition to a fixed vector.

It is usual to plot space patterns of field strength on polar co-ordinates. The object of these chart plots is to present the desired information in a form that is most readily understood. Polar diagrams do not, however, always present the problem in the most understandable form and it is believed that time is well spent in the study of the rectilinear charting of patterns.

The polar diagram of Fig. 5 gives the field strength angular displacement when two equal-strength signals of opposing phase are radiated from points A and B. Three curves are shown, the solid curve is for a spacing of $\lambda/10$, dot dash curve for $\lambda/2$ and the dash curve for a spacing of one wavelength. The scale of the chart is chosen so that the actual positions of points A and B cannot be distinguished as separate points. The outside diameter is divided by some even number of units which, in this example, is 12. Twelve radial lines corresponding to a family of twelve hyperbolae are constructed and numbered as illustrated. Hyperbola No. 6 is the perpendicular bisector of the A B base line, and as the radiated signals are in phase opposition the received signals on any point on that line will also be in phase opposition, giving a resultant vector sum of zero signal. The resultant sum of the two vectors is proportional to the cosine of half the phase difference of the two signals. The phase change of each signal in stepping from one hyperbola to the next is an equal and opposite value, which value is equal to the angular station separation divided by the number of hyperbolae drawn. An illustration of the phase relation of the A and B signals, for a station separation of one wavelength of 360° of phase, is shown for each of the hyperbolae at the right hand edge of Fig. 5. The dash line curve is a line drawn through the summation points plotted on each hyperbola and is the polar presentation of the field pattern. A similar plot has been shown for the other two station spacings and all three of these have been transferred to rectilinear co-ordinates as shown in Fig. 6. In Fig. 6 the amplitude of the signal as plotted against the Y axis and the angular orientation relative to the base line is given as the X axis.

2. (ii) Projections

If the plot as given in Fig. 6 is bent so as to form a half cylinder it would appear as shown in Fig. 7. This is equivalent to a projection from a

cylinder on to a tangent plane. For a full 360° coverage the single showing of Fig. 7 would hold for both sides as in the case of a transparent label and bottle. It can be seen from this that a systematic change in the patterns such as is found in Sonne should be referred to as a sliding pattern and not as a rotating pattern.

The most important point to notice in Fig. 7 is that all the curves shown are sections of a sine wave. In the case of the two equal signal transmissions this is always a condition of the pattern. The rectilinear projection, in which the hyperbolae are used as intervals along the X axis, is therefore the easiest projection to plot. A further illustration of this projection is shown in Fig. 8 and its transfer to a polar projection is shown in Fig. 9.

It is desirable that the three types of projection be named and hereafter they will be referred to as the polar, the linear, and the cylindrical projections.

Having shown that a two-station transmission

having equal signals always produces a cylindrical projection comprising sections of sine wave forms, any required projection can be made very simple as shown in Fig. 10. Along a line is drawn the equivalent of a fully rectified sine wave. At a given radius from the centre of the base line all signals enclosed by an enclosure marked + are of a given phase and those enclosed by the alternate - enclosures are of the opposite phase. The phase difference of the transmissions is determined by the phase sign and relative amplitude at the centre of the pattern. Each lobe corresponds to a quarter wavelength separation of the stations. The section from one end to the other is always represented as 180° of the pattern from one base line extension to the other.

In Fig. 11 there is added a third signal, designated as C, which has a transmitted phase difference relative to either A or B, and which is one half the phase difference between A and B. With

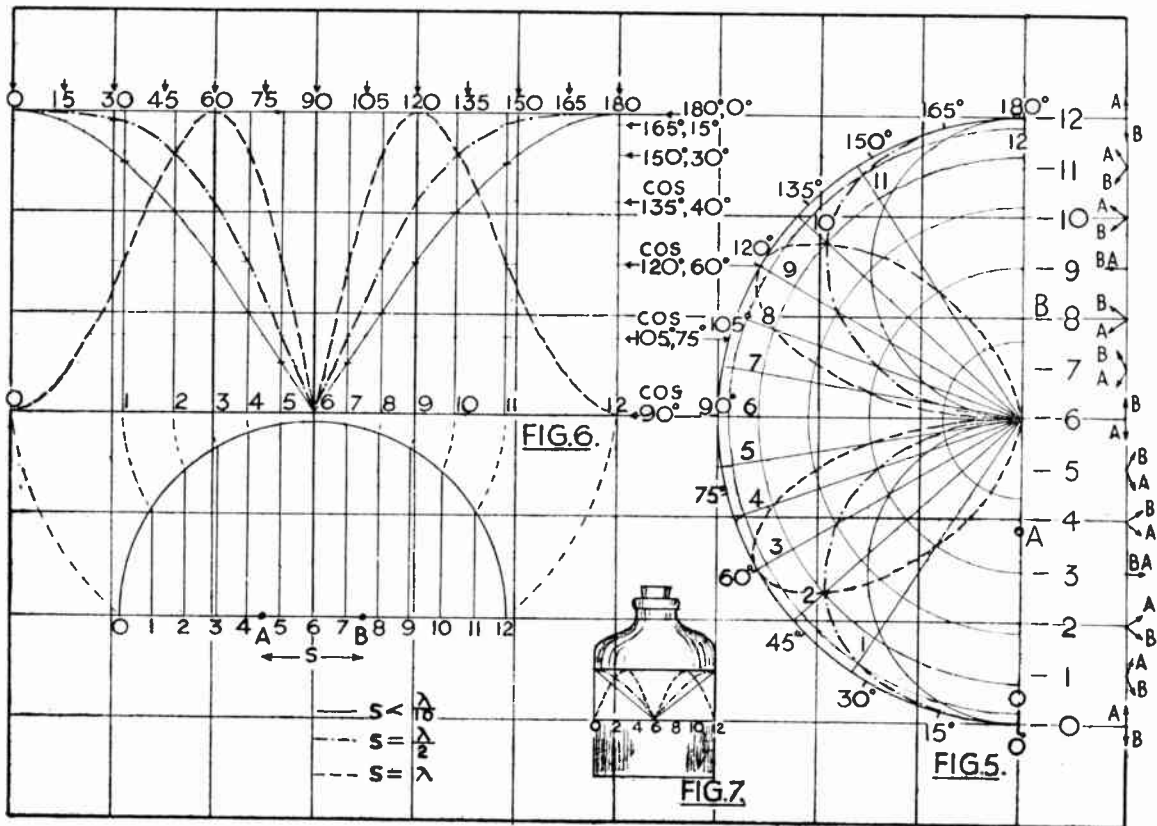

Figs. 5, 6 and 7.—Comparison of polar, linear, and cylindrical projections of field strength.

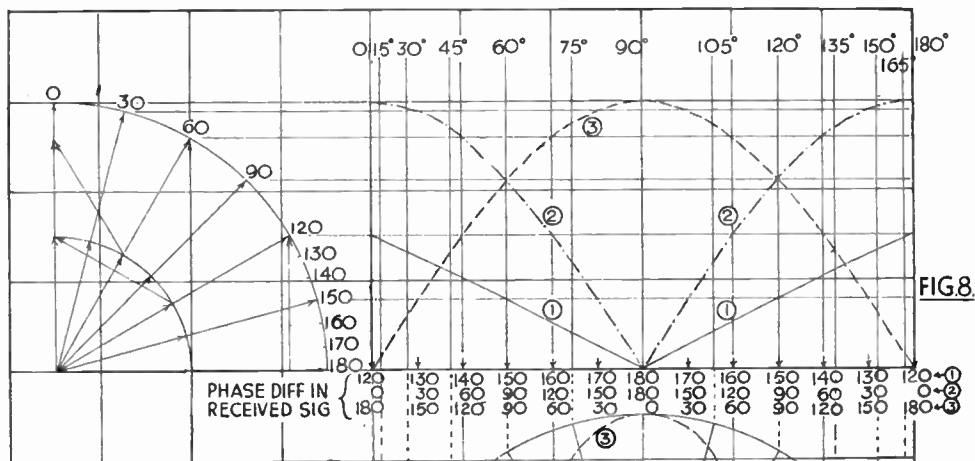

FIG. 8.

Figs. 8 and 9.—Construction of cylindrical projection and transformation to polar projection.

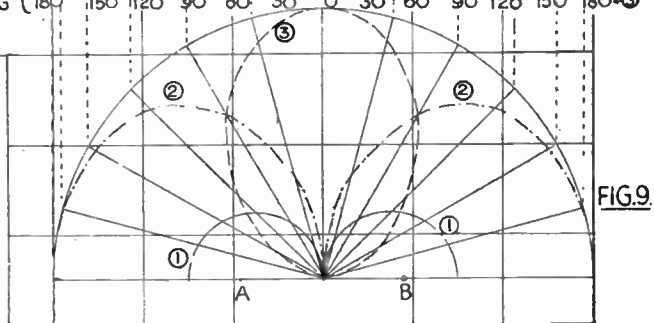

FIG. 9.

he transmitters phased in this manner the added signal from C is always of such phase as to add directly to, or subtract from, the signal level. The transmitted phase relations and signal levels for the various cylindrical projections are illustrated directly above each projection. The effect of reversing C is equivalent to reversing the phase of both A and B; this effect in the pattern is shown in Fig. 12. Figures 13 and 14 show the effects of an increased radiation from C.

Figure 15 shows the effect of unequal transmissions in a two-station system. The solid line traces are for equal signals from A and B. The dash line traced is the result of adding one-third signal strength to A or B, and the dash dot trace is the result of subtracting one-third signal strength. The construction diagram used to obtain the resultant sum of the vectors is shown in Fig. 16. The one set of curves having a maximum signal on the bisector (hyperbola No. 6) corresponds to transmissions which are in phase with each other, the second set is for transmissions which are in phase opposition. In the upper right-hand side of Fig. 15 is shown the vector sums of the equal A

and B signals for the in-phase transmission. The amplitude of the vectors for the hyperbolae numbered zero and 12 is obviously zero, that for hyperbolae 6 is maximum, and for 3 and 9 hyperbolae is .707 of the maximum. By adding signal strength to one station, the vector summation is changed as shown in the figure below. It should be noted that in this case the various summations change both in amplitude and phase.

The most important object in presenting Fig. 15 is to show the effect of an unbalance in signal strength on the equi-signal position as laid down by the alternate phasing of the transmitters. It is shown that if the signal strengths of both transmitters remain unaltered by the change over to the alternate phasing no change is effected in the location of the equi-signal by a difference in signal level of the two transmitters. If the signal level of one or both of the transmitters is changed on switching to the alternate pattern, the location of the equi-signal position will be altered. The condition when there is an equal change of level of both transmitters in changing to the alternate pattern is shown in the polar projection of Fig. 17.

Figure 18 will be used to give a similar analysis for a three-station system. The two solid line curves are for equal transmission from A and B, and a radiation from C equal to two and two-thirds that of either A or B. The alternate phasing of the transmissions to produce curves 1 and 2 are shown by the small vector diagrams marked 1 and 2 just below Fig. 18. Each of these curves forms one-half of a true sine wave. The equi-signal point lies on the perpendicular bisector of hyper-

A signal to cause the unbalance in the A and B transmissions, and an added signal ΔC applied to the normal C transmission in phase quadrature. The change in the C transmission is thus equal to an amplitude increase of about 15 per cent and a phase change of 26.5 degrees.

These curves may be obtained by the graphical summation of the vectors, as shown in Fig. 19 or by first plotting the true sine wave curves of the normal alternate transmissions and then

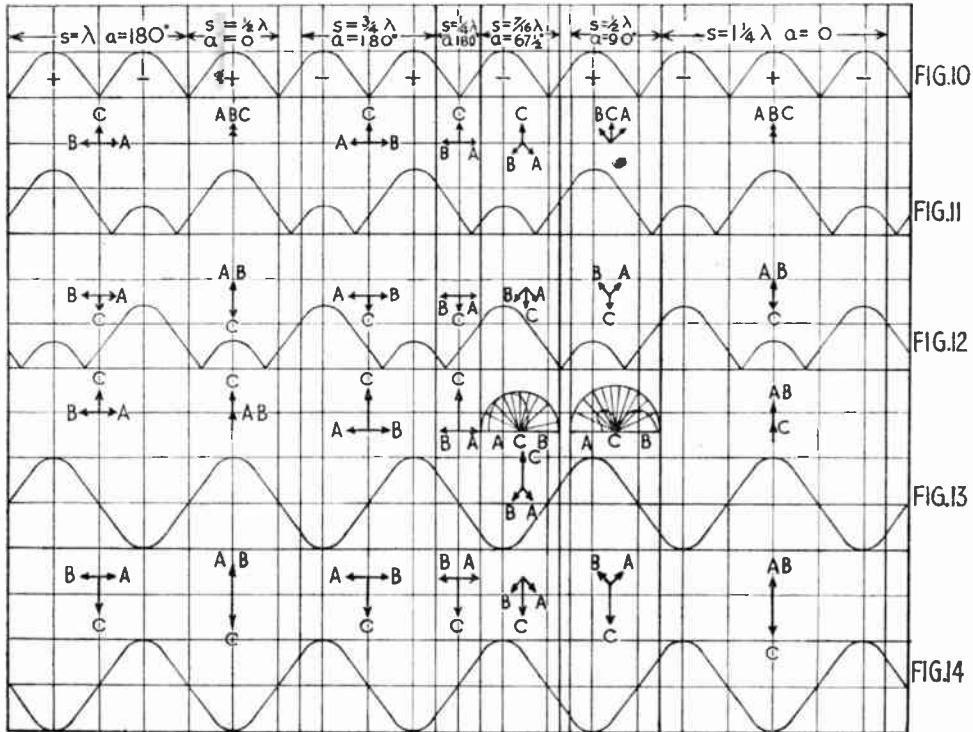

Figs. 10, 11, 12, 13 and 14.— Relationship of sine wave to cylindrical field pattern projections.

bola number 6. By adding signal level from A or B the pair of alternate curves are altered as shown by the dash-dot line. A reduction of signal level produces the dash line curves. A change of the phase transmitted by C of about 30° would effect a pair of curves very similarly to those shown by the dash line. The interesting thing to note is that in none of these cases has the point of equi-signal deviated from the number 6 hyperbola. If we combine the effects of unequal transmission from A and B and a phase shift of 26.5° in the C transmission the equi-signal point will be shifted to hyperbola number 5.7, as shown by the dotted curves. To obtain the dotted curve there is an added signal ΔA applied to the normal

applying a changed condition to these normal curves as is shown in Fig. 18.

A more clear picture of the four sets of curves may be had by the four sets of vectors shown as "a," "b," "c" and "d." In each of these figures the total vector summation for the hyperbolae 0, 3, 6, 9 and 12 are indicated for each of the alternate conditions. The numbers on one side of each figure apply to one transmission and those on the other side to the alternate transmission. Figure "a" presents the normal condition, Fig. "b" the amplitude unbalance in A and B transmissions, Fig. "c" normal A and B transmissions but a shift in the phase of the C transmission, and Fig. "d" the combined condition of

coupling. Several of the possible arrangements of P.O.P.I. using close-spaced antennae would also suffer on this score.

patterns is thereby lost beyond that of physically reversing the positions of the two antennae. On short waves the base line dimensions are so short

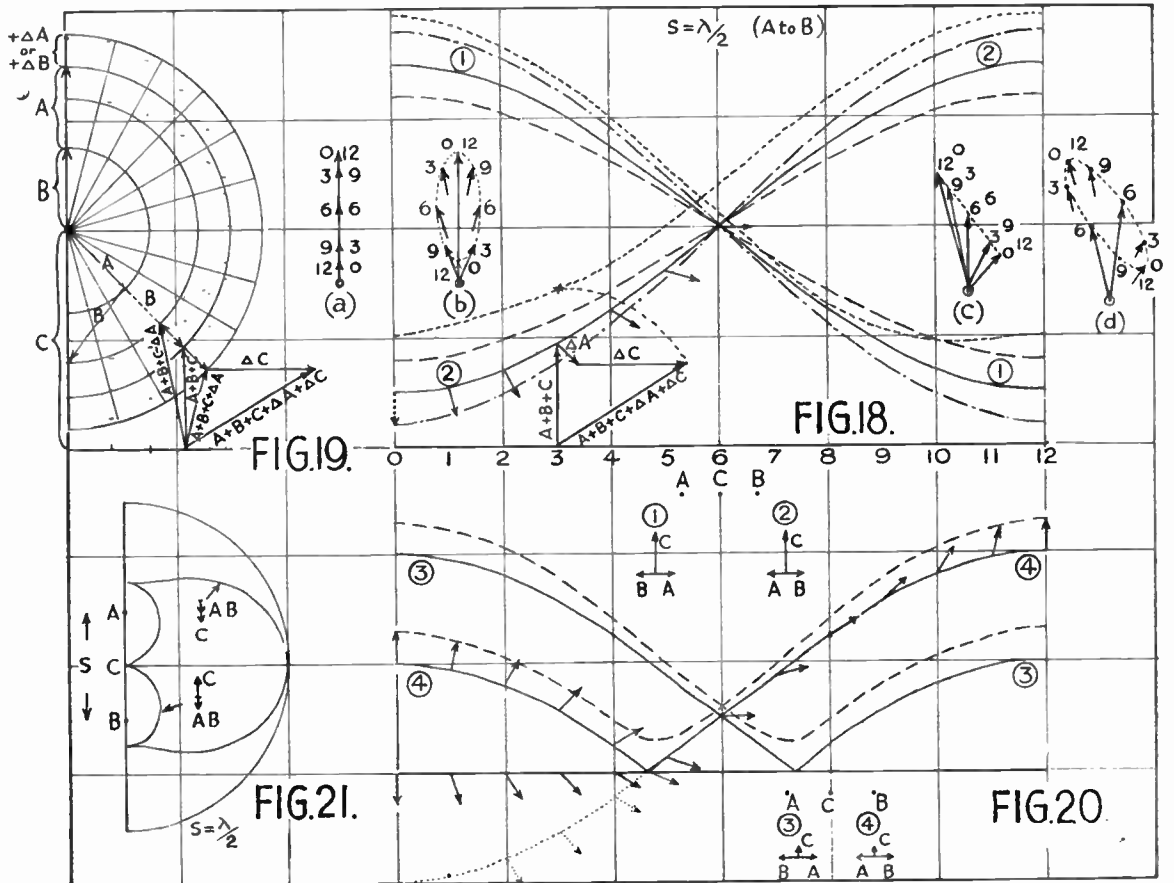

Figs. 18, 19, 20 and 21.—Effects of amplitude and phase variations on bearing error.

3. The Generation of Field Patterns

(i) Coupled Aerial Directional Patterns

Advantage is taken of the mutual coupling between antennae in order to provide directional patterns in equi-signal systems such as the short wave Lorenz variations. The simplest version is basically a two-transmission system, one antenna being excited directly and the second through mutual coupling. The phasing is controlled by the spacing of the antennae and by resonance of the parasitic antenna. In general, the parasitic antenna or reflector is adjusted to exact resonance and the phasing control applied wholly by the spacing. Control of the phasing for producing alternate

that a shift of the base line by an amount equal to its length is nil. For practical reasons, therefore, two parasitic antennae are used and displaced to either side of the excited antennae. Keying means are then applied to alternately and completely de-resonate one of the outer antennae and thereby eliminate its effect on the patterns. In effect, with proper antenna spacing, this is made the equivalent of reversing the phase of one antenna of a two-antenna system.

3. (ii) The Adcock Type Radio Range

A balanced crossed Adcock antenna system provides a dual system of antennae in which the mutual coupling between the pairs may be com-

pletely balanced out. A system of the construction is used to a large extent in the United States of America for setting down four fixed equi-signal tracks. One pair of these antennae produces a figure eight pattern which is at right angles to the figure of eight of the second pair. By alternately keying the two pairs, four tracks of equi-signal are obtained.

In direction finding crossed Adcock antennae are used in conjunction with a goniometer to effect the equivalent of a physically rotated single pair. In accordance with the reciprocity theorem the antenna system will have similar characteristics both for transmission and reception. Figures 22, 23 and 24 will be used to give a brief explanation of the Adcock antenna used in conjunction with a goniometer.

In Fig. 22, A and A' is one pair of antennae and B and B' the second pair. A goniometer consists of two crossed coils 1 and 2, and a rotatable coupling coil or primary 3. The coupling (or induced voltage) from coil 3 to coil 1 against rotation of coil 3 is shown in Fig. 23. The coupling between coil 3 and coil 2 is also shown. It is to be noted that the coupling between 2 and 3 follows as the sine of the rotation of coil 3 and that between 1 and 3 as the cosine.

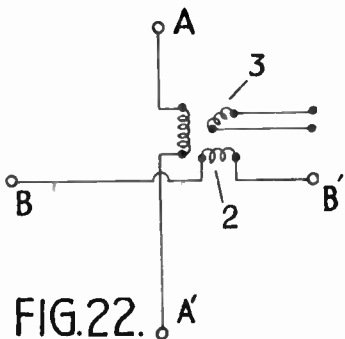

FIG.22.

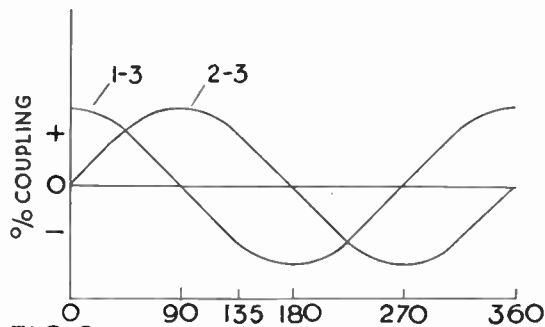

FIG.23.

Figs. 22, 23, and 24.—
Rotation of figure eight pattern by means of goniometer.

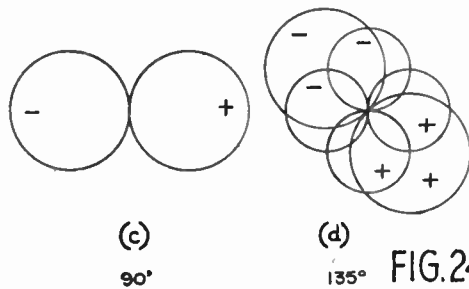
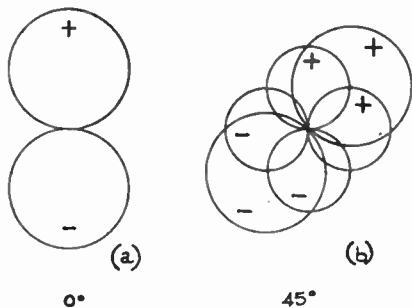

FIG.24.

In Fig. 24 four rotated patterns at four difference settings of the goniometer are shown. Figure "a" shows full coupling to the A pair and no coupling to the other. The vector relation of the signals is given as plus and minus. Figure "b" shows 70.7 per cent of full coupling to each pair. The summation of these two figure eight patterns is equal to that of Fig. "a" rotated 45°. Figure "c" shows full coupling to the B pair and zero to the other producing the effect of another 45° rotation. Figure "d" shows a reduced coupling to 70.7 per cent. for the B pair and a coupling of 70.7 per cent to the A pair. The coupling to the A pair in this is the reverse of that illustrated in Fig. "b." Again, the summation causes a further 45° rotation. As this process is carried on, the effect is a true rotation of the figure eight pattern. A required limitation to this is that each lobe of the figure eight produced by the individual pair be a true circle. This means that the wavelength spacing of the antennae must be small. A reasonable approximation is had up to spacing equal to one-sixth of a wavelength.

With crossed Adcocks and a central station, a full and uniform coverage version of Sonne may be obtained. To illustrate this Fig. 25 shows the rotatable figure of eight patterns resulting from

the four outer antennae. The phase of this pattern is to be alternately keyed to a phase reversal as it is rotated, this being the method used with the Sonne system. The central antenna provides the

directions, a useful analogy is the single-phase A.C. motor.

Having obtained a spiral field, it is necessary to provide a comparison signal. One means of

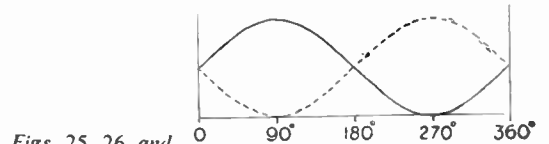
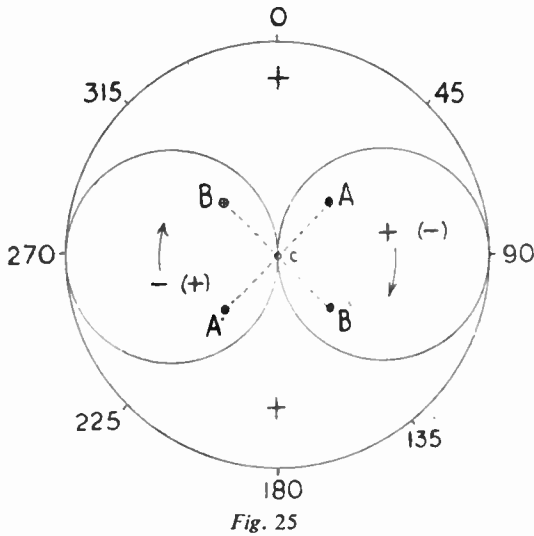

Figs. 25, 26 and 27. — A five radiator equi-signal system.

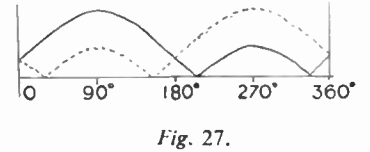

fixed circular pattern. The complete 360° label projection of the summation of the two alternate patterns as shown in Fig. 25 is shown in Fig. 26. Figure 27 is the change produced in Fig. 26 by a reduction in the strength of the central station. As the figure eight pattern is rotated, the curves of Figs. 26 and 27 are all to the right. In this system there exists only a 180° ambiguity.

doing this is to provide another signal harmonically related to a sub-multiple of the spiral field frequency. Phase comparison is then carried out on the common frequency produced by multiplication. The compass bearing is obtained by dividing the phase difference by the factor by which the spiral field frequency has been multiplied.

3. (iii) *Spiral Field Patterns*

Another arrangement utilizing the combination of a spiral radiation and a circular radiation for compass indication is to radiate a spiral pattern at a frequency f , transmitting from the central antenna a signal of $f \pm \Delta f$ and a signal f_2 which is sufficiently removed from the frequency f so as to be separately received, and modulating this signal at Δf . The separately received beat note signal of Δf is compared in phase with that of the modulated note Δf to give the compass bearing.

If it were possible to rotate the goniometer at a sufficiently high speed, the phase radiation would be in the form of a spiral rather than the normal circular radiation. This is better understood if it is assumed that a signal of frequency f is applied to the rotor of the goniometer revolving at a frequency F . The induced voltage in one of the stationary coils is composed of two signals of equal amplitude, the one having a frequency of f plus F and the other a frequency of f minus F .

There are several possible variations in the means for utilizing a combination including at least one spiral pattern. The present object is, however, to present a means for producing a spiral pattern and a possible use of such a pattern for radio navigation.

When the frequency of rotation of the goniometer is the same as the signal, then only one spiral field is radiated of frequency $2f$. A single rotating or spiral pattern can also be set up by exciting one pair of aerials in quadrature to the other pair. The normal or figure eight pattern can also be considered as two spiral fields rotating in opposite

3. (iv) *Skew Field Patterns*

When spaced stations radiate unlike signal frequencies there exists in space a series of ever-shifting hyperbolae or lines of equi-phase, this is a condition on which Sonne is based and when the movement is in such a slow motion it is quite easy to visualise. In slow motion and for close-spaced stations, it is sometimes described as a series of straight lines or asymptotes which revolve about the centre of transmission, the one half

being a mirror image of the other. For slow rotating fields, that is where the difference in frequency of the outer transmissions is less than one cycle per second, this picture is perfectly justified. As the frequency difference is increased and consequently the rate of shift of the hyperbolae it is obvious that there must be a lag in the rotation of the outermost portions of the hyperbolae. In practical form this effect manifests itself as a whip or skew to the hyperbolic lines.

Figure 28 illustrates such a skew for transmitted frequencies differing in the ratio of 4 to 5. The pattern of skewed hyperbolae drawn as dashed lines is obtained by connecting the diagonals of the diamonds produced by a series of circles drawn about A and B. The circles drawn about A have a difference of five units in radius, and those about B have a difference of four units. If the circles are taken as having a spacing of one wavelength and the skewed hyperbolae are taken to indicate the crest value of the beat note, then Fig. 28 has a base line distance of 4 wavelengths of A frequency and 5 of B frequency. This gives a total wavelength difference of 9 in going from A to B, which will

result in 9 skewed hyperbolae included between A and B.

A better understanding of the nature of the skew is obtained by reference to the confocal ellipses. In Fig. 29 ten skewed hyperbolae drawn between A and B are shown. The frequency ratio of 2 to 3 has been chosen in this case. With a 2 to 3 ratio, a unit unit distance on the base line containing 2 wavelengths of the lower frequency and 3 of the higher frequency is a repetition distance and contains 2 plus 3 or 5 skewed hyperbolae. Units of this distance are marked off along one of the base line extensions and ellipses from these points are drawn. Each ellipse is divided equally along the X axis in ten parts. These are numbered 1 to 10, starting from the lower frequency. The skewed hyperbola is then obtained by joining up the points starting from A to point 1 of the first ellipse to 2 of the 2nd, 3 on the 3rd set. The skew over of one point as the line progresses outward is continued to complete the set. If all like points are joined up, the result would be a true hyperbola or the condition where the f of A equals the f of B. With a skew of two numbers, the result would be

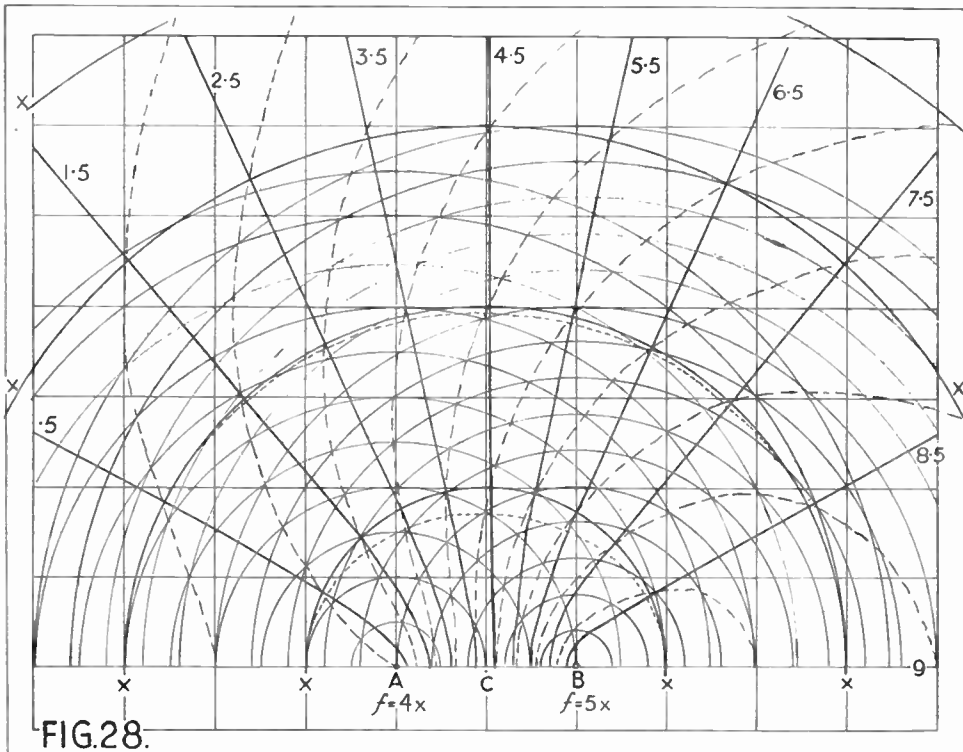

Fig. 28.—
Spaced radiators of unlike frequencies.

that of a 3 to 7 ratio. A skew of one half a number would give a 9 to 11 ratio.

In motion, these skewed hyperbolae can be imagined as starting out as an elliptical bubble at the high frequency station, expanding first to a circular shape, then in the form of a kidney bean and later reverting back to a circular shape after expanding beyond the second station.

Reverting to Fig. 28 there is, in addition to the skewed hyperbolae representing equi-phase of the beat note obtained from signals A and B, a series

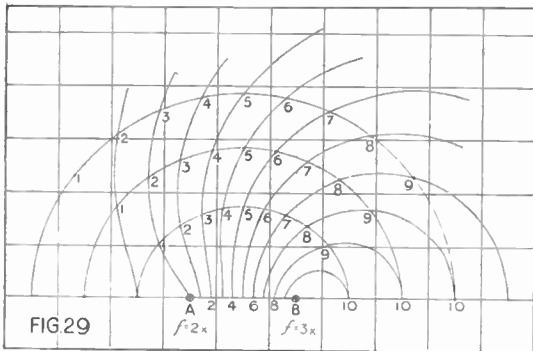

Fig. 29.—Construction of a skewed pattern.

of dark circular lines drawn about C and marked by "X"s. The distance between circles is equal to one wavelength of the beat note frequency. A signal of this frequency is sent out from C either as a C.W. signal or as a modulation of some carrier signal which may be received separately from that of A and B. The beat note and the C transmission are synchronized and a receiver is used which compares the phase of the signal received from C with that of the beat note received. The position lines of equi-phase would be those as shown by the dark solid lines which closely represent a set of true hyperbolae. These lines of position have been drawn in by joining the progressive intersections of the dark circular lines "x" drawn about C and the dotted skewed hyperbolae.

In practice this system would be used with very little difference in the A and B frequency, that is the beat note frequency used would be of the order of 50 c/s.

At all distances remote from the transmitters the lines of position would be calculated on the bases of equal wavelength from both outer stations

at a frequency equal to the average of the two actual frequencies. Along the base line from A to C the A frequency would be used and from C to B the B frequency.

If the C transmission were radiated from location A, the position line patterns would be true hyperbolae on the figured basis of a signal frequency of B being radiated from both A and B. If the C transmission were changed to the B location, the A frequency would be the true frequency for the calculations. A proof of this is given graphically in Fig. 30.

Figure 30 has been drawn up on the basis of a signal radiated from A, having a frequency four-fifths that of B, thus producing the skewed hyperbola series. Also at B a signal which is three halves of that of A frequency is radiated thus forming a second beat note frequency, radiated in circular waves from B, which is of the same frequency as the beat note the phase of which is represented by the skewed hyperbolae. A line of constant phase difference between these two beat notes is a true hyperbola and a series of these equi-phase lines is shown as the dash line hyperbolae. As is seen on Fig. 30, these position lines are traces through the intersections of the circular phase lines from B and the skewed hyperbolae. These position line hyperbolae are identical to those obtained by equal frequency transmission from A and B at the A frequency.

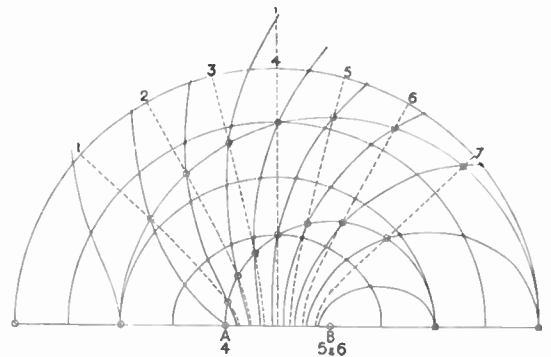

Fig. 30.—Hyperbolae formed by combining a skewed and circular radiation.

If in the receiver the beat note between the A frequency and the higher B frequency were compared in phase to the beat note of the A frequency and the lower B frequency after doubling the frequency of this second beat note, the resulting position pattern would be the same as given above. Figure 31 is shown with dotted lines as the skewed

hyperbolae of the four-fifths ratio which are identical to those shown in Fig. 30, but with twice the number shown. This is the effect of doubling the frequency of the beat note. A second set of skewed hyperbolae of a two-thirds ratio represent the equi-phase lines of the beat note of the 4 to 6 signal frequencies of Fig. 30. The dash dot lines [joining the intersections of the two skewed hyperbolae at points of equi-phase change form true hyperbolae which correspond to those of Fig. 30.

Designating the A and B signals of Fig. 30 as 4, 5 and 6 as shown, an alternate means of indicating the same position pattern may be had by

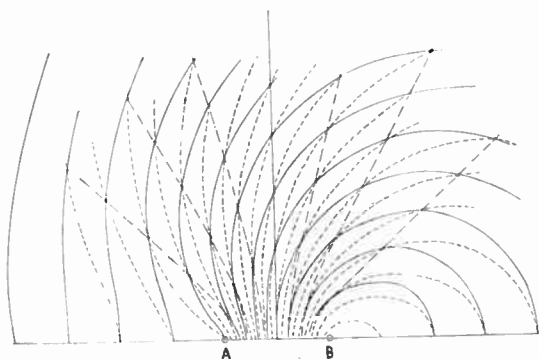

Fig. 31.—Hyperbolae formed by two skewed radiations.

producing a beat note from 4 and 6 which is compared in phase with the beat note from 5 and 6 after doubling the frequency of that beat note. The result of this is to double the skew of the beat note hyperbolae of Fig. 30 and to reduce the radius of the circular lines about B by one half.

In order to produce a pattern with the minimum of required signals one of the signals of the B station of Fig. 30 could be eliminated. As an example, the signal frequency of A is taken as 40 kc/s, and that of B as 50 kc/s. A phase comparison is to be made at the receiver between the 50 kc/s signal and the 10 kc/s beat note after frequency multiplication to 50 kc/s. The alterations required in Fig. 30 are that the circular lines about B are to be increased in number by five times, as it is now the phase of the fundamental frequency of 50 kc/s and not the lower frequency beat note of the original two-frequency transmission from B. A similar increase in the number of skewed hyperbolae is required to account for the frequency multiplication. The position pattern is now a

series of confocal hyperbolae having five times the number shown in Fig. 30. The final result of this is identical to that of a system which radiates 200 kc/s from each station with the assumption that each signal could be received independently.

3. (v) *The Hyperbolic Pattern Generated by Phase Multiplication*

Identically the same results may be had by a receiver which compares the phase of the 50 kc/s signal after multiplying to 200 kc/s with that of the 40 kc/s after multiplying to a 200 kc/s signal. With a receiver fitted with a continuous phase indicator this system is known as the Decca or Admiralty "Q.M." System.

3. (vi) *Field Patterns Generated by Two Hyperbolic Patterns*

Figure 32 shows two oppositely skewed hyperbolae families having a common focus and a skew ratio of two-thirds. It can be seen from this figure that connecting lines drawn across one set of diagonals of the diamonds formed, produce a hyperbolic line and that those across the other form ellipses. If the signals are designated 2, 3, 4 and 6 as shown and correspond in frequency, this is a type of pattern producing the hyperbolic lines of position given by a receiver which compares the phase of the beat note of signals 6 and 4 with that of the beat note of signals 3 and 2 after frequency doubling the beat note. The lines of position are those which would be produced by circular phase radiation by an identical single-frequency transmission from A and B at a frequency corresponding to 10.

Figure 33 shows two series of hyperbolae, having a common spacing at their base lines, which base lines have a common focus and are at an angle to one another. Irrespective of the angle these base lines take, the lines drawn through the diagonals of the diamonds towards the base line between the outer focus will form a third series of hyperbolae whose foci are A and C.

If, as in Fig. 34, two oppositely skewed hyperbolae, having a common skew ratio and equal spacing on the base lines are placed at an angle as in Fig. 33, the diagonals drawn across the diamonds form a series of hyperbolae between the outer stations. This diagram is one way of visualizing the operation of P.O.P.I. when the beat note is provided by the ground station, which in Fig. 34 would be C.

4. Methods of Determining Accuracy

If a system is to provide a "fix," it is obvious that two sets of hyperbolae or lines of position must be provided, and that these must be located so as to provide reasonably good diamonds of position over as great an area as possible. In fact, it is necessary or at least desirable to provide a full 360° coverage in many cases. The goodness of a line of position on the base line extension of

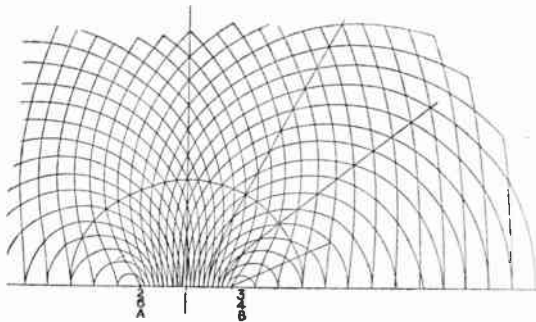

Fig. 32.—Hyperbolae formed by oppositely skewed hyperbolae.

a series of confocal hyperbolae is nil and, for great distances, it increases as the cosine of the angle made from the base line. As has been already explained, this goodness of position may be represented on a polar presentation as a figure-of-eight pattern with both circles being tangential to the base line at the mid point.

In Fig. 35 a four station arrangement in which the central station A is common to the three pairs formed by B, C and D is shown. For clarification

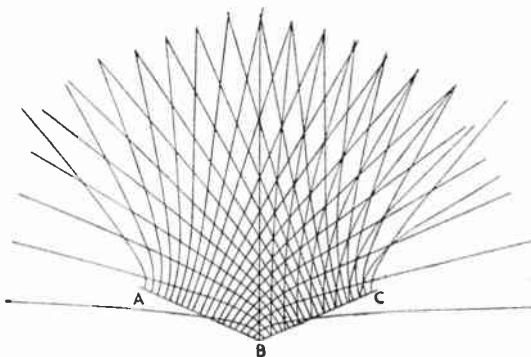

Fig. 33.—The combination of two hyperbolic patterns having a common focus.

only the two pairs formed by A B and A C will be considered, and the problem illustrated will be confined to receiving positions at very great distances. This allows the goodness of position lines of the A B pair to be represented in polar form as the two circles A B. Similarly, that for the A C pair is shown as the two circles A.C. These two curves are shown in rectilinear form in Fig. 36. It is more correct to call these goodness of bearing relative to the centre of transmission, curves. The goodness of a fix is defined as a figure which is inversely proportional to the area included in the diamond of expected maximum error. The area of the diamond is equal to the product of the two widths of error times the cos of the angle

of the diamond. The goodness is therefore $\frac{\sin \phi}{b c}$ where b and c are the widths of error from the A B and A C links. To obtain a curve which represents the magnitude of $\frac{1}{a b}$ the curves A B and A C of Fig. 36 are multiplied. This resultant curve is shown as W in Fig. 37. For small angles of the type under consideration, the factor $\sin \phi$ may be taken as the effective separation of the base line centre points of A B and A C. These are marked by "x" on Fig. 35 and are shown con-

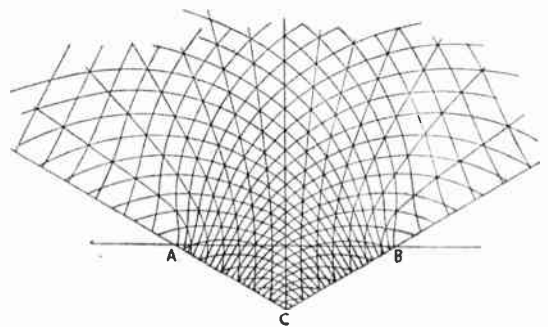
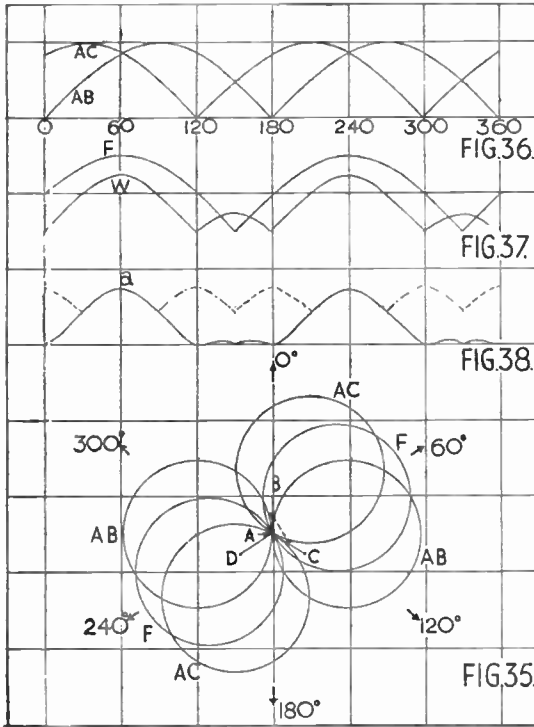

Fig. 34.—The combination of two skewed patterns having a common focus.

nected by a dotted base line. If the receiver is in line with these points the effective separation is zero. As the receiver is orbited, the effective separation increases as the cosine of the angle and can therefore be shown by a third figure of eight pattern. This pattern of circles is shown as F in Fig. 35. The equivalent is shown on the rectilinear graph of Fig. 37. To obtain the goodness of fix, the values F and W of Fig. 37 are



Figs. 35, 36, 37 and 38.—Determining accuracy of a star system.

multiplied. The result of this is shown as curve "a" in Fig. 38, and is the goodness of fix versus orientation for the AB and AC links only. If we add the links AC and AD and those of AD and AB the three resulting curves will provide a minimum goodness as indicated by the dotted line of Fig. 38.

Figures 39, 40, 41 and 42 provide a similar analysis to a three-station link arranged in delta. With this arrangement the bearings have a good full coverage as shown by Fig. 40, but the goodness of fix is poor even in the best position and nil at six positions. This arises from the fact that with this arrangement a receiving point which is in line with the BC base line or on the BC base line extension is also in line with the two centre points of the base line AB and AC. This fault can be clarified by pointing out that under such conditions the hyperbolae of AB and AC are parallel and the CB pair is of no assistance, as the point lies on its base line extension. Around the full arc there are six such positions, as is indicated in Fig. 42.

The goodness of bearing curves for the delta and star arrangements as shown by Figs. 36 and 40 indicate equal goodness for equal spacing. If only the reading of the best pair of stations was taken to obtain a bearing this would be true. If, however, all three readings were used to give an average bearing the expected error of the average would be better for the star arrangement by a ratio of 1 to $\sqrt{3}$. The reason for this is that the error produced by the central transmission signal on the reading for one pair would always be equal and opposite that of the others, thus effectively cancelling the A transmission and producing a reading such as would be had from the hyperbolae formed by BC, CD and DB.

It must be remembered that the analysis just given has assumed receiving points at infinity. With wide station separation this can lead to faulty conclusions being drawn up for more practical distances. By merely looking at the star arrangement of Fig. 35, it can be seen that for close range the pattern formed by the BA and AC links would give far better diamonds in the 60°

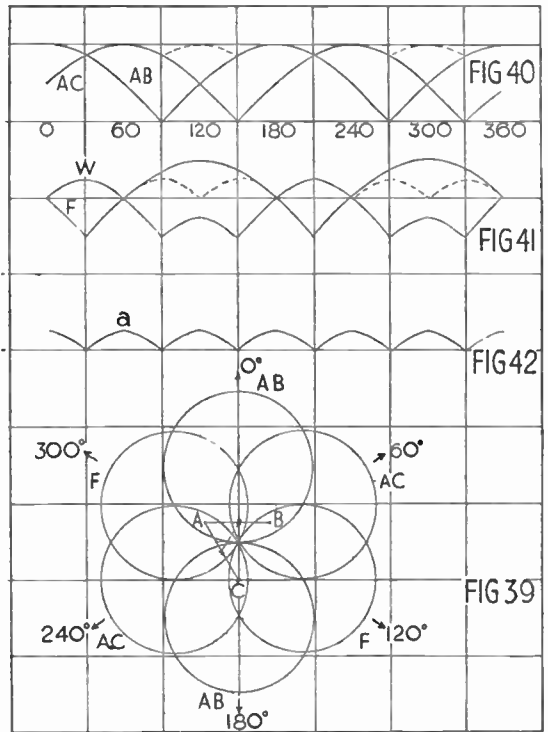

Figs. 39, 40, 41 and 42.—Determining accuracy of a delta system.

direction than in the 240° direction. Thus for close range, the 60° maximum of Fig. 38 would be increased and that of the 240° maximum would be decreased. Superimposing the curves for all three combinations would then alternately produce a high and low series of maximums rather than the uniform series shown by the dotted line.

An exact analysis of the goodness plots for the star arrangement have been made by the R.A.F. for GEE, and there is, therefore, no need to repeat this very complicated work.

5. Some Factors Determining the Choice of a Navigational Aid System

The possible accuracy afforded by a hyperbolic pattern is always increased as the base line is increased. The three limiting factors which must be considered are : the ability to maintain lock or synchronization of the signals, the useful range of the transmission, and the difficulty encountered with ambiguity.

The limitations due to range are most serious when high frequencies are used. Figure 43 shows the effect on coverage if the transmitters are spaced by a distance equal to the limit of the useful range. The cover given is then only that area in the diagram which is shaded. Figure 44 shows the effect of reducing this spacing by half. The different shading distinguishes the area for a given pair of hyperbolae and it can be seen that the front coverage of a pair constitutes almost the whole of the area covered by that pair ; the small circle in the centre represents an area of excessive error which might be caused by too great a signal from the one station relative to the other. Figure 45 shows the effect of again reducing the spacing by one half. Here the coverage is greater, but the increase in coverage may not be worth the sacrifice in accuracy.

The patterns and charting described throughout have assumed a flat earth. The problem of applying the patterns to the real earth is a very difficult task. If it were a true sphere it would be fairly complicated ; as an ellipsoid it is made still more complicated. As a matter of fact, the earth is a very complex shape and perfect charting is impossible or, at least, impracticable over very large areas. The surface of a best chosen ellipsoid for the desired area to be covered provides the best practical approximation, and charts are calculated to fit such a surface. These complications, added to the complications introduced by

the distortion of flat maps, especially that of the Mercators Projection, makes a difficult problem even more complicated.

A number of the basic arrangements for producing a chartable space pattern have been shown. The major factors involved in choosing an arrangement lie in the practical solutions of the problems involving means to radiate and maintain the pattern and means to produce intelligence at the receiver under actual conditions of interference caused by undesirable reflections, static and other forms of transmission within the receiving band.

To list all of the factors involving a choice would require a very complete knowledge of the entire radio and navigational field. A limited but perhaps helpful list may be given as follows :

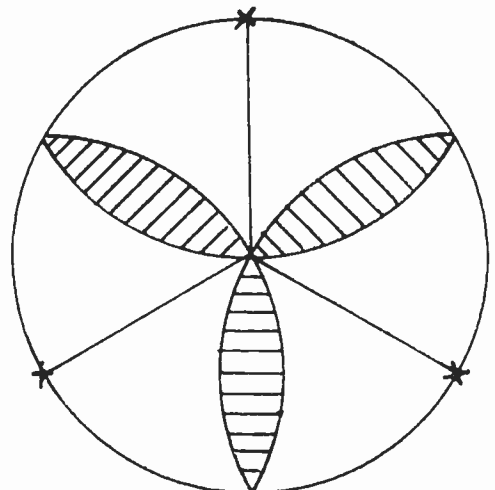

Figs. 43, 44 and 45.—Coverage pattern.

Practical ability to phase lock the transmissions, maximum range and useful coverage, propagation reliability, installation and maintenance cost of the ground equipment in relation to the area and importance of area covered. For the receiver the factors are : accuracy of position indication, freedom from ambiguity, speed and ease of indication, attention time required, freedom from interference, freedom from reflection errors, provision for choice of course, homing or left-right course indication, possible provision for remote indication, for automatic pilot control, for automatic charting, cost, weight, bulk, maintenance, power requirement, etc.

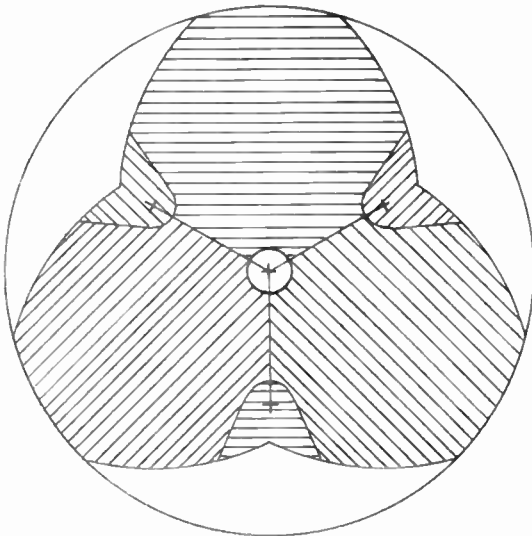

Fig. 44.

6. The Decca Navigational System

(i) The Principle of Operation of the Decca Navigational System

These problems have been tackled from many angles by different groups and, as a result, several navigational aids have been developed which are well known by name. Technical descriptions and circuit arrangements are now becoming available. The following is a description of the Decca Navigator.

This system provides a fix by the inter-section of two lines of position as given by three charted hyperbolic grids, using a base line of 70 miles for forming each of these grids. Each grid or hyperbolic series of lines is numbered in lettered groups. The numbering along the base line starts from the master station which is a common focus to both series of hyperbolae. The master station is a crystal controlled 85 kc/s transmitter. The outer stations are fitted with slave drive units which lock the one transmission to four-thirds of the master signal frequency f_m , the second to $5/6 f_m$ and the other to $3/2 f_m$. The receiver converts each pair of separately received signals to a pair of common frequency signals, which signals are applied to a continuous phase indicating meter. The indicator makes one revolution per 360° of phase difference change and is calibrated 0 to 1 with one hundred subdivisions. Gearing is used to give whole numbers of groups

and group numbers. A separate meter is used for each of the two pairs of stations. At the start of a journey (or at the time of installation if the receiver is always switched on whenever the craft is moved) the indicators are set to the nearest whole number corresponding to the start position as given on the chart. After switching on the receiver the fractional dials will take up their own correct indication. From this moment onwards the position of the receiver will be given by the readings of the indicators with reference to the chart. The charted lines of position representing whole numbers are called lanes and the indicators are called Decometers.

The major control incorporated in the slave drive equipment is obtained from a unit which is

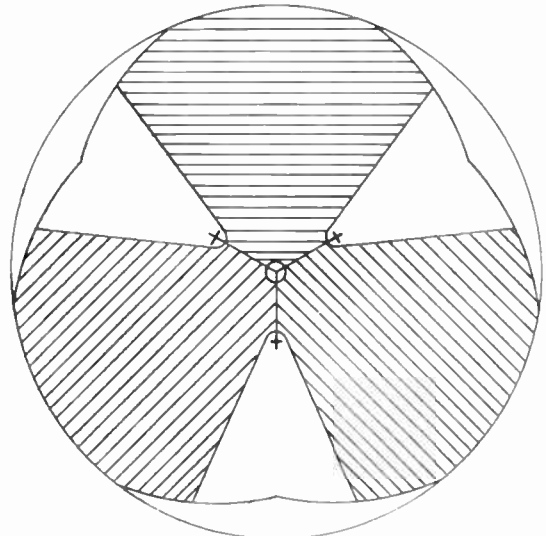

Fig. 45.

the equivalent of the receiver. It is desirable, therefore, to first assume locked transmission and describe the receiver and explain the transmission lock later. Also, in order to deal with whole numbers the master frequency will be taken as 60 kc/s, the one slave 80 kc/s, and the other 90 kc/s. To eliminate unnecessary repetition the third slave will not be considered.

6. (ii) The Decca Navigator Receiver

A block diagram of the receiver is shown in Fig. 46. The antenna is fed into three separate channels, the centre one being tuned to 60 kc/s, and the outer channels to 80 and 90 kc/s respec-

tively. At the output end of each channel, frequency multiplication is obtained by a distorting stage from which a 240 and 180 kc/s signal is taken from the 60 kc/s channel, a 240 kc/s signal from the 80 kc/s channel, and a 180 kc/s signal from the 90 kc/s channel. The two 240 kc/s signals are used to operate one meter and the 180 kc/s signals operate the other.

The receiver input may be switched from the antenna on to a reference signal generator. This generator sends out a series of short pips having a repetition rate of 10 kc/s. The signal pips are so short that the 6th, 8th and 9th harmonics are substantially equal in amplitude and have a fixed phase relationship. This generator provides a phase standard by which possible phase drifts within the receiver may be detected and corrected. A phase adjustment is provided on the 80 and 90 kc/s channels by which this zero correction is made if necessary.

Figure 47 shows a complete circuit of the receiver. The layout of the components is similar to that of the block diagram for Fig. 46.

The antenna input network is designed to balance out the effect of phase changes on each channel due to changes in input of antenna capacity. For explanation, let us assume that a change of antenna capacity from 60 to 400 micro-microfarads effects phase change of 40 degrees in the resultant 240 kc/s signal from the centre channel, and 30 degrees on its 180 kc/s signal. If the phase change in the outer channels produces an equal phase change in their respective 180 and 240 kc/s signals, the phase difference recorded by the final signals will be zero. This balance may be held very well, and in the standard Decca receiver no phase error is detectable for changes of antenna capacity from 50 micro-microfarads to infinity. Heavy leakage resistance cannot, however, be tolerated. Since any practical antenna will be only a small fraction of a wave-length in length, and the inductive components may be neglected, the only requirement of the antenna installation in regard to phase error is, therefore, that it be well insulated. An aircraft trailing antenna or any other form of upside down antenna will have signals 180° in phase difference to the normal antenna. This causes a 180° shift in the phase reading of both of the Decometers. The explanation of this lies in the fact that a 180° phase change in the centre channel is multiplied to 540° change in conversion to 180 kc/s, and in the 90 kc/s channel it is multiplied to 360° in conversion

to 180 kc/s, thus leaving a difference of 180°. The same 180° difference occurs in the other Decometer reading due to the unlike multiplication in the two signals providing the 240 kc/s phase comparison signals.

Changes in temperature will produce changes in the inductance and capacity values of the R.F. transformers. As a change of tuning is accompanied by a phase shift, an error will result unless the phase shift of the comparison signals from the two channels is equal, thereby producing no change in phase difference indication. This compensation is obtained by making the slope (represented by degrees of phase-change per unit-change of capacity) proportional to the signal frequencies. This slope of an R.F. transformer is controlled by the Q of the coils, the coupling and the value of the capacitor. The desired compensating slope is had for all three channels when all tuning capacities are equal, the Q of the coils proportional to frequency and the coupling a fixed percentage of optimum. With this slope considerable tolerance is permissible in the frequency of the reference generator. In practice, with the high stability components used in the reference oscillator, the maximum frequency drift observed in receivers that have been in service two years has been 0.02 per cent. The frequency tolerance of a standard receiver is 0.3 per cent. Units fitted with crystal filters have only a one-cycle tolerance and the reference signal frequency is obtained from a crystal or one of the received signals.

The choice of values given is also a choice which results in an equal gain per stage for all three

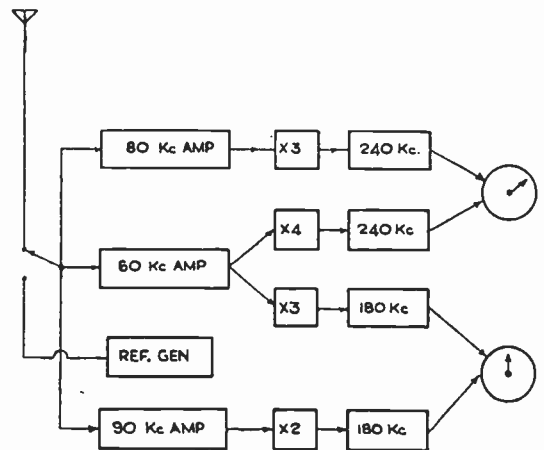

Fig. 46.—Decca receiver in block form.

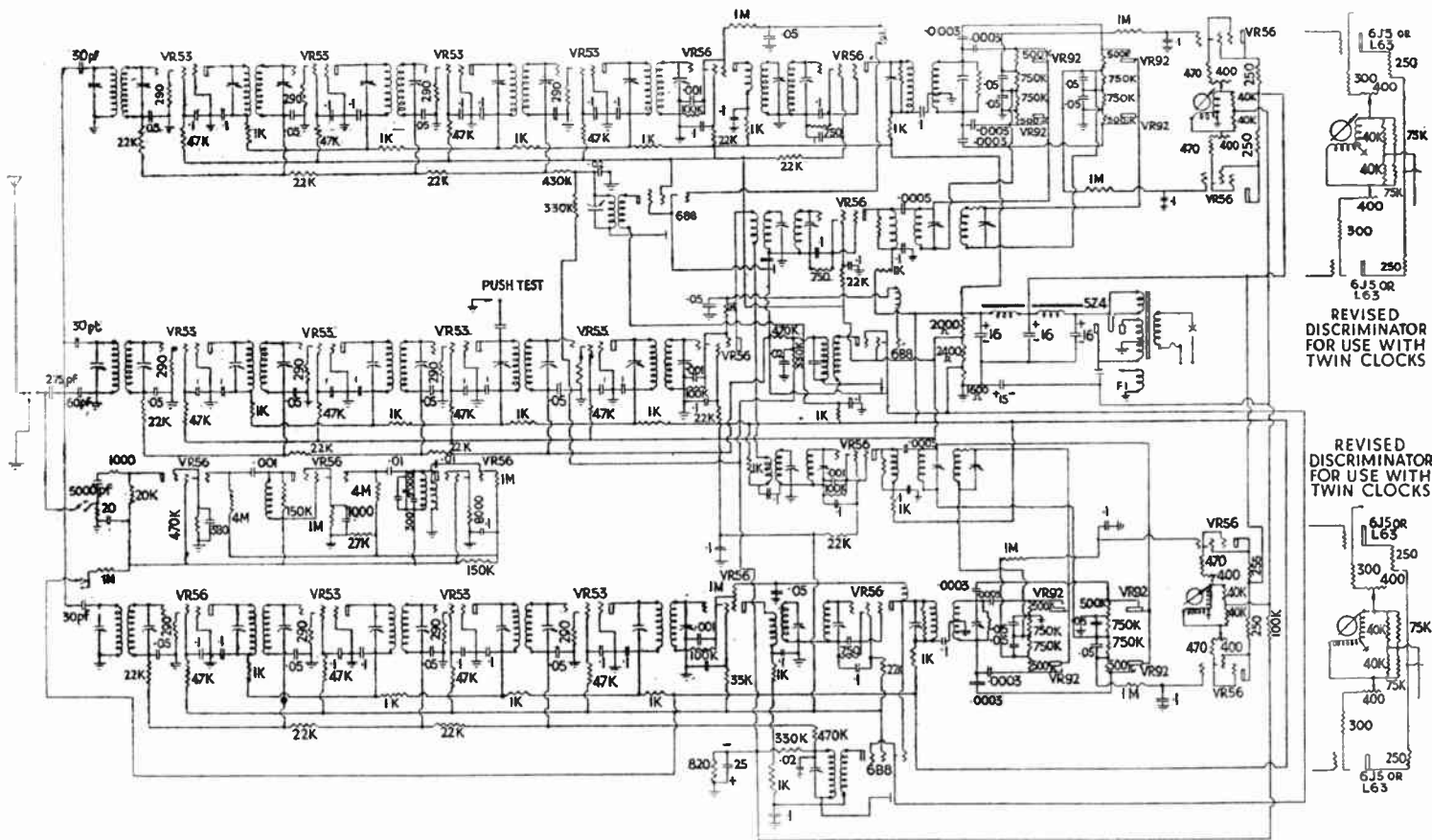

Fig. 47—Decca Navigator outfit Q.M.I. receiver B.37.

frequencies. The antenna stage gain is an exception to this, and the gain with the proper phase slope in this case is a gain proportional to frequency.

The uneven distribution of heating of the chassis is overcome by introducing small heater resistances under a selected number of coils. Compensation by negative coefficient capacitors would ruin the ambient temperature compensations obtained by the phase slope choice mentioned. Negative coefficient capacitor compensation is used only in the reference generator for frequency stability compensation.

A tuned circuit must be considerably off resonance for the resistance temperature coefficient of the coils to produce a measurable change in phase. The effect in changing the phase slope is compensating and no trouble has been experienced on this score.

Changes in input capacity of valves with changes in bias must be considered. Very effective compensation is obtained by inserting the right value of resistor in series with the cathode of the valve. Valves having anode shields or suppressor grids internally connected to the cathode cannot be used, as full compensation with these types is practically impossible.

High inductance coils, such as are needed for the lower frequencies, proved to be very unstable in inductance in temperature cycling tests over long periods, when wound with silk covered wire. On heating and cooling the inductance will increase several parts in a million. After many cycles the inductance value will have changed an intolerable amount for a phase measuring device. Coils wound with plain enamel wire impregnated with shellac and baked show no cycling or ageing drifts. The temperature coefficient is rather high (being about 15 parts in a million per degree C), but it is consistent. It has been found possible to obtain a zero temperature coefficient with controlled doping with certain varnishes, but the control is difficult and large variations occur in production even when the most elaborate precautions are taken. Since a variation in temperature coefficient cannot be tolerated, whereas there is compensation for the actual value of the coefficient, the shellac process was standardized. Difficulties with capacitors in respect of cycling instability and coefficient variation had to be overcome. Unprotected silver mica leaves were found to be more consistent in regard to temperature coefficient, and with a good grade of mica and good silvering

the cycling errors were substantially eliminated. A good deal of the cycling errors came from the edge effect of the mounting or assembly arrangement. A special mounting was designed to hold the silvered leaves from the centres, leaving the edges with considerable free space. This arrangement eliminates the capacity changes due to dielectric changes at the edges of the silvering.

Signal coupling from stage to stage will give rise to phase shifts with changes in gain, and must be substantially reduced beyond that which is satisfactory in a normal communication receiver. Common filter resistors and capacitors can probably be used for stages differing in frequency but this economy is being left for a later date. In the standard Decca mains receiver the overall gain per channel at signal frequency is over 3,000,000. A change in antenna voltage from 20 microvolts to 1 volt produces no noticeable change in phase indication.

The frequency multiplier consists of a self-biased detector of a conventional type. Diode multipliers and grid leak triodes have also been used with no difficulty. The current practice is to drive them hard and to what extent this is necessary is not known for lack of data.

The A.G.C. is obtained by rectifying a signal impressed on a separate circuit. The input signal is derived from the phase comparison transformer, and is applied to a valve having a rather high cut-off bias. This bias is reduced by the rise in cathode potential of the multiplier valve with increases in input signal. This cathode potential increases directly with signal input until the A.G.C. valve is operative. The signal from the separate circuit is not rectified until its level overcomes the delay bias of the diode. At this level of input signal, the gain of the receiver is retarded, and an increase of some 10 or 15 per cent in the multiplier valve input would effect a bias which would reduce the gain to zero. This condition is impossible and the overall effect is an almost constant signal output for input variations of 30 microvolts to one volt. Fast A.G.C. circuits along similar lines have been developed.

A double discriminator is used to provide signals to effect a rotating magnetic field, the rotation of which is proportional to the phase difference of the two radio frequency comparison signals. The circuit arrangement of Fig. 47 complicates the explanation of the basic principle to some extent, and for this explanation the simplified circuit of Fig. 48 will be used.

voltage of the smaller of the two signals applied to a diode. By making the centre-tap signal the smaller of the two the maximum voltages of V_1 and V_2 are both equal to twice the signal voltage and the desired equality is assured.

Large errors would arise in a circuit as shown in Fig. 48 due to coupling between the various

high frequency circuits. This coupling is caused by the centre of the star connection being above earth potential. Careful balancing could be carried out to neutralize the intercoupling, but it is easier to avoid coupling than to neutralize it. The alterations of the basic circuit of Fig. 48 as shown in the actual receiver diagram have been

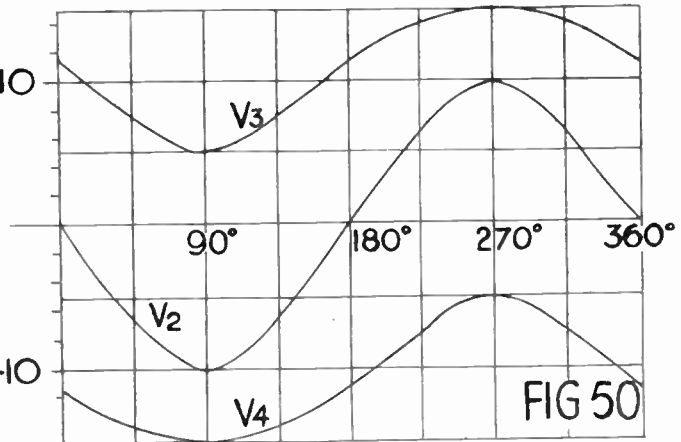
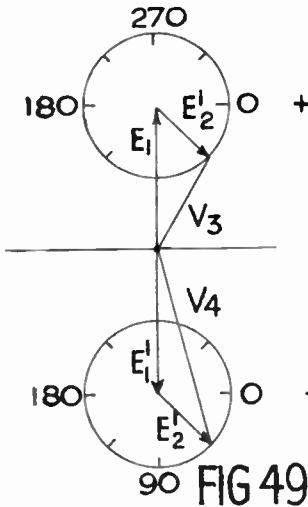
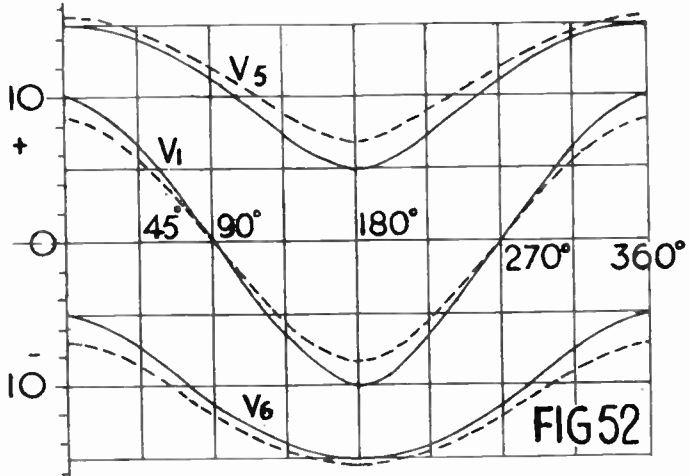
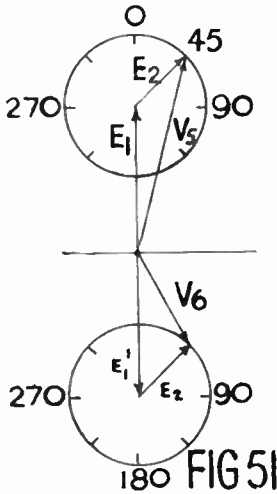

Figs. 49, 50, 51, 52, 53 and 54.—Phase discriminator and indicating system.

made to eliminate the intercoupling and also to provide practical earthing of the rectified signals to permit D.C. amplification.

The coils of the discriminator circuits have been resistance loaded to reduce the Q of the coils, thereby allowing a greater frequency tolerance to the 90 degree fixed phase shift network. To maintain the 90 degree shift between the primary and secondary windings at resonance, the resistance loading is applied in parallel with the primary and in series with the secondary. The distortion of the signals applied to the discriminator must be low, and a reasonable Q must be maintained for filtering.

A linear D.C. amplifier is required and the cathode follower arrangement has been chosen. The diodes never receive a signal less than ten volts and the non-linearity at low signal level is thereby avoided.

6. (iii) *The Effects of Static and Interference*

The effect of static or random noise in the discriminator is to increase the diode signals in proportion to the square root of the sum of the squares of the resultant desired signal and the interference. In Fig. 52 the dash line curves illustrate the effect of a static signal equal in amplitude to the minimum signal level shown for V_5 (5 units) under clear conditions. It can be seen that voltages V_5 and V_6 are unevenly increased and that of V_1 decreased. The voltage of V_2 suffers an equal reduction. The final effect of static is not to produce an erroneous reading but to reduce the field strength of the DeCometer coils. With heavy static the desired signal is swamped both by the action of the A.G.C. and its effect on the discriminator diode. This results in a voltage V_5 which is equal to V_6 , and giving a resultant signal V_1 of zero. The same thing happens to V_2 and there is no current in either of the DeCometer coils. Any residual unbalance may then cause the indicator to slowly drift towards some random indication. Static is not of a steady nature, however, and during the short intervals of reduced level the meter receives the proper indicating torque. The indicator is thus constantly being pulled to a correct reading and is given little time to drift appreciably from its correct reading. Correct meter readings have been given through static that would prohibit the reception of Morse signals.

The effect of C. W. is more serious and less interference of this type can be tolerated. A C.W. signal can be considered to phase modulate the

desired signal. For example, let the C.W. interference be a $\frac{1}{2}$ -cycle different in frequency. At low amplitude the indicator will oscillate at half a cycle giving a mean indication equal to the correct reading. As the amplitude of the interference is increased the swing will increase. Due to the frequency multipliers this swing can exceed a quarter revolution to either side of the correct reading. If the level is set to give a quarter revolution swing to either side of the correct reading and then speeded up by a change of frequency of the interference (until a 10-cycle difference exists) a steady correct reading will be given, but with reduced torque or positiveness of indication. The current reduction in this case would be four to one and any further increase in the interference level would rapidly decrease the operating signals to zero. I.C.W., such as Morse (even of very high speed), permits a meter operating signal during the transmission breaks. With a well-balanced discriminator circuit interference of this type considerably stronger than the operating signals may be tolerated without serious kicking of the indicator needle.

The effect of all types of interference is to reduce the operating torque giving the correct reading, and the correct reading is not disturbed until this torque is reduced by more than two to one. A list of the types of interference in accordance with their harmful effects are: C.W., modulated C.W., I.C.W., Teletyp $\text{\textcircled{R}}$ and static.

6. (iv) *Power Supplies*

The H.T. supply voltage is 145 volts; the valves are operated well under their normal ratings, and the life of the valves should and has been extremely good. The danger of breakdown is minimized by the use of the low voltage and replacement or servicing requirements should be low.

6. (v) *Instrumental Accuracy*

The phase drift of the amplifier during the first half-hour of operation is small, but in general it needs correction. After an hour's warm-up the drift is negligible and a check against the reference once in six or twelve hours is ample safeguard against even small phase drift errors.

The phase readings are not effected by power supply voltage variations within the usual plus or minus 15 per cent of normal. This is to be more or less expected of a unit which has been compensated to permit error free readings for automatic gain changes, allowing input variations of about 30,000 to one. The frequency change of

the reference generator caused by supply voltage variations is less than 0.01 per cent, which is considerably better than is required. At low frequencies of the order of those used for the reference signal, it would seem desirable to use powdered iron in the tuning inductance. This has, however, been proved not to be the case, as the voltage stability of powdered iron is very poor and air cored coils are found to be necessary when voltage tolerance is required. Multivibrators are also critical to line voltage changes, and it is largely for this reason they are not used in the Decca system.

The signal pips of the reference generator are obtained in a three-stage arrangement. The first stage is a stable oscillator whose signal is relatively free from harmonics. The second stage produces a series of highly damped one-megacycle oscillations. The repetition rate of these oscillatory transients is controlled by the frequency of the first stage. The positive peak of the first cycle of each oscillatory transient is amplified by the third or final stage. The output is therefore a series of signal pips of about one quarter micro-second duration repeated at a rate controlled by the first oscillator. With this arrangement the upper limit of supply voltage is limited only by its destructive effect on the life of the valves and the lower limit is that voltage which is required to maintain oscillation.

A push switch is provided on the receiver which shifts the phase of the master channel and is used as a check on the operation of the receiver, and as a means to indicate that signals are being received. This switch to a large extent checks the overall operation of the receiver.

6. (vi) *Ground Station Equipment*

The ground equipment at the master station is simply a crystal-controlled transmitter. The antenna must be symmetrical in design in order to ensure a non-directional radiation. The site must be chosen well clear of long lines or other large obstacles that might interfere with the pattern by setting up secondary radiations. At these frequencies it is difficult to construct an antenna that will radiate more than a small percentage of the input power at resonance, even under conditions of lowest possible ground loss. It follows that there are few natural objects to be found that will act to re-radiate the signal to any considerable extent.

The slave transmitter differs from the master in that it receives its drive signal from a slave drive unit which in turn receives its input from the master signal.

A block diagram of the slave transmitter equipment is shown in Fig. 55. A small receiving antenna picks up the 60 kc/s signal from the master and it is fed through an 80 kc/s rejection filter into a 60 kc/s amplifier. The slave frequency shown is 80 kc/s and the rejection filter is tuned to that frequency. The 60 kc/s amplifier is followed by a frequency divider which reduces the frequency to 20 kc/s. The 20 kc/s signal is passed on to a doubler circuit and thence into a goniometer, which provides a manual phase adjustment of the 40 kc/s output signal. This 40 kc/s signal is passed through selective filters, amplified and passed on to a doubler circuit. The resulting 80 kc/s slave frequency signal is then applied to the driver unit of the transmitter. The output of the transmitter is then fed by transmission line to the aerial coupling coil at the aerial base 200 yards from the transmitter building. This series of units makes up the transmitting channel. If all of the tuning elements could be relied upon to stay absolutely fixed no additional apparatus would be necessary. Over long periods this condition cannot be realised and auxiliary means must be provided to maintain the required phase lock.

The phase lock equipment is essentially that part of a standard receiver which is used to indicate the phase difference of the 240 kc/s signals derived from the 60 and 80 kc/s transmissions. This receiver is fixed in position and will give a fixed reading when a fixed pattern is maintained. It may be used simply as a monitor indicator and the manual adjustment of the phase goniometer provided in the transmission control channel could be constantly adjusted to hold a fixed reading of the receiver. This receiver can be made to give an exact zero phase difference reading when the pattern is correctly phased by setting the phase adjustment of the receiver to a reference reading obtained when the pattern is correctly set as indicated by a receiver situated in an accurately surveyed position. The D.C. voltage output from one of the two output voltages of the double discriminator is then held at zero. A positive voltage results from a phase shift error in one direction and a negative voltage from an error in the opposite direction. By applying this voltage to an electronic reactor circuit the value of the reactance will be made to vary in accordance with the phasing error. When this electronic reactance is correctly connected to the transmission control channel an automatic control of phase is provided. In the actual circuit two reactor valves are controlled by the output voltage of the discriminator

and the ratio of control is about 40 to 1; for example, an error of 40° without the control is reduced to one degree by the control. A meter is provided to indicate the amount of automatic control being applied and by keeping this meter within the indicated limits (corresponding to 20 degrees of phase) by manual phase adjustment of the transmitter control channel, the maximum pattern error is of the order of $\frac{1}{2}$ degree; this corresponds to a time synchronizing error of 0.005 micro-seconds. In practice this manual

The second slave station is similar to the one just described except that the frequency change from 60 kc/s to 90 kc/s is obtained by dividing the master by two and multiplying by three. This gives a $3/2$ frequency of 60 kc/s or 90 kc/s.

Experience has shown that the maximum overall instrumental errors at no time exceed 0.05 microseconds at the present frequency range of 85 kc/s to 127 kc/s. With improved design and care it is possible to substantially reduce these errors.

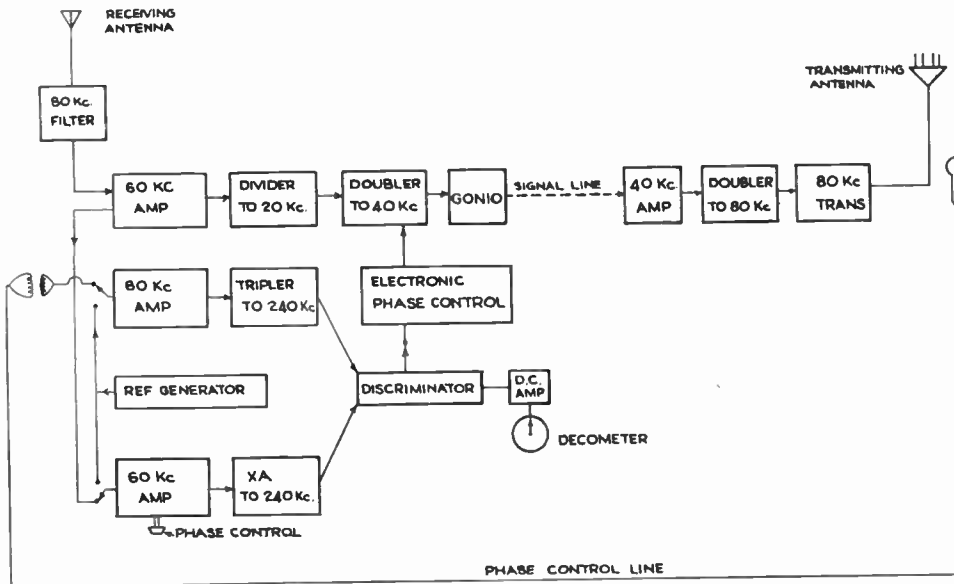

Fig. 55.—
Decca slave
station.

adjustment is usually necessary only once or twice in a twenty-four hour period.

As the control receiver is located only some 200 yards from the transmitter, its reception from its own transmitter is wholly that of the induction field. The phase of the radiated field is dependent on the phase of the current exciting the antenna. A voltage pick-up near the ground and some distance from the antenna may result largely from ground currents which may or may not bear a fixed relation to the antenna current. The signal feed into the 80 kc/s amplifier of the control receiver is therefore obtained from a small pick-up loop located very near the antenna and the signal is transmitted by cable to the receiver.

A standard receiver is used as a monitor at a distant location to keep a check on the transmissions.

6. (vii) *The Effects of Propagation Conditions upon Accuracy*

With ideal propagation, limitations on accuracy would be dependent wholly on the instrumental errors. Unfortunately, the propagation is not always ideal. At the low frequencies under consideration there is no large difference in the propagation over land or over sea, and except for very high mountain ranges the reflections from land are undetectable. During daylight the reflection from the ionosphere has given little to no trouble and until better means of checking are available this daytime error can only be defined as small.

Transmitters set up in Belgium to navigate the Scheldt Estuary into Antwerp, gave interesting data regarding interference due to long cables. Both banks of the Scheldt were lined with barrage

balloons. Interference from these cables began at a height of slightly more than 1,000 ft. and above that height the effects were pronounced and increased rapidly with height. At cable heights less than 1,000 ft. the readings were not altered and the system worked perfectly.

Before trials were carried out there was a good deal of speculation regarding the propagation velocity of the over land and over sea radiation, and the magnitude of the dispersion within the range of frequencies used. Trials, so far, have shown no measurable velocity change with frequency. There is no apparent velocity change over land or over sea. The velocity has been checked by the A.S.E. in co-operation with the R.A.F. This was done by flying around base lines and by interchanging slave frequencies on the same base lines. The value arrived at is 299,250 km. per second plus or minus 40. Further trials are being carried out in order to improve the accuracy of this constant.

The most serious errors are caused by skywave reflection at night. The received signal which is a summation of the ground and sky waves will have a phase which differs from the phase of the ground wave. When the two waves are in phase or in phase opposition the phase error introduced is zero. The error introduced by the extreme condition of phase displacement between the ground to sky signals is an error angle whose sine is equal to the ratio of the sky to ground signal amplitudes. When the sky wave is equal to 50 per cent of the ground wave the maximum error is 30 degrees. When equal to 80 per cent the error is 53 degrees.

For the 80 per cent condition the error expressed in time is 1.7 microseconds at 85 kc/s, 1.3 microseconds at 113 kc/s and 1.2 at 127 kc/s. The worst possible error for a given pair is given by a condition of the maximum error in one direction for one signal at a time of maximum error in the opposite direction for the other. This condition results in a time error for the 85-113 kc/s pair of 3 microseconds and 2.9 microseconds for the 85-127 kc/s pair. This worst condition would be expected for so short a time and at such rare intervals that errors of this magnitude are very seldom realised. The maximum error to be expected in 80 per cent of the readings is about 1.7 microseconds, and 50 per cent of the readings should give errors less than 1.1 microseconds. Trials to date indicate that these conditions are obtained at night at a distance of about 400 miles over land.

No direct experimental value for the reflection coefficient is available for these frequencies. Measurements on 16 kc/s indicate values of 0.12 by day and 0.5 by night. Daytime variations obtained by trials indicate that the coefficient is less than 0.025, and that by night the coefficient rises to about 0.3.

Sufficient data is not available as yet to give accurate data regarding sky wave coefficients nor of the nature of these reflections, to permit an accurate calculation of the phase errors to be expected. For distant points the refraction caused by ground wave attenuation and by variations the dielectric constant of the troposphere may be of sufficient importance to play a major role in the reflection from the ionosphere. The measured value of propagation differs from the velocity of light in vacuum by so much that the complete explanation is hardly expected from a ground effect factor alone. To what extent the troposphere plays a part is subject to speculation.

The propagation characteristics vary considerably with the frequency of the waves used and the limitations imposed on various systems by changes in the frequencies are also variable. The subject of a choice of frequency and its effect on different systems will be dealt with later.

6. (viii) Ambiguity Problems

In order to eliminate ambiguity the Decca system uses a counter to keep track of the number of phase revolutions or lanes as given by the charted grid. One lane is really very narrow and a rather accurate knowledge of position is required in order to set the lane counter correctly at the beginning of its use. When the start of a journey is made within the system this knowledge is at hand. When operating within the overlapping coverage of two chains the required count for entering the second chain is given by the readings of the first chain at the location of desirable change over. In coming into the coverage of a single chain without the aid of sufficiently accurate information the transmissions can be periodically arranged to give lane identification readings which reduce the ambiguity. In a chain using frequencies of 85, 113.3 and 127.5 kc/s the common divisor is 14.2 kc/s. By systematic alterations in transmission, different indications have been obtained to reduce the ambiguity to that of a 14.2 kc/s comparison frequency or 70 microseconds of time difference. This arrangement identifies the lanes in groups of 24 for the 85-113 kc/s pair and 18 lanes for the 85-127 kc/s pair.

There are several possible arrangements for obtaining lane identification by groups. The instantaneous or direct group reading requires an increase in the receiving apparatus. Readings obtained by the number and direction of phase kicks on the Decometers are obtained in a manner similar to amplitude and duration changes of audible signals used for Sonne indications. These readings are obtained without added receiver equipment and were therefore chosen for the early trials. These identification trials were successful, but the time required for a group identification reading is about 20 seconds. By using alternate arrangements which require added receiver equipment, identification readings can be obtained in a very much shorter time. These arrangements have been given full scale experimental trials which proved successful. Any system of identification used should not upset the lane count once it is set.

If minimum of ambiguity were the only factor, the natural choice would be an arrangement in which the wavelength of the repetition or comparison frequency is equal to less than half of the distance between stations. A short base line or a long wavelength would then eliminate all ambiguity (direction of travel identifies the two halves of the hyperbolic lines). The sacrifice in coverage and accuracy, however, is generally too severe to be attractive. The combined use of more than one ratio of base line separation to wavelength allows for a much more favourable solution.

An arrangement using a dual base line ratio for a Sonne system is shown in Fig. 56. In this figure a base line separation of 6 and 14 wavelengths is shown. The block divisioning of the outer circles indicate the arcs of dots or dashes for a fixed phasing of the transmissions. The inner arc is for the operation of the centre and close in pair of stations, and the outer arc is for the centre and outer pair of stations. The ratio of ambiguity for the two alternate transmissions is 3 to 7. Around the full 360 degree pattern, the combined transmissions will result in only four points of ambiguity which is, in effect, no ambiguity at all, as only a short time of travel is needed to obtain a second reading which eliminates the quadrant in question. A linear dot or dash chart shown in Fig. 57 gives the number of dots or dashes from the start of a transmission to the null for both patterns as against bearing position. If this reading obtained happened to be 36 dots for the wide-spaced pattern and 2 dots for the other, the position bearing would be 20° or 290° .

When the spacing of the stations becomes large the lines of position cannot be taken as straight lines radiating from a point. The corresponding lines of position for the two alternate readings will not follow the same trace unless there is no change in the foci forming the hyperbolae. In these cases the phase comparison frequency must be changed rather than the position of the foci as given in the above illustration.

When the envelope or modulation of a transmission is used as the comparison signal many comparison frequencies may be had simultaneously. Figure 58 illustrates a 4,500 cycle signal and its seventh harmonic signal of 31,500 cycles. If these were transmitted separately the lower frequency signal could be used for identification and the higher for the more accurate measure of the time difference. This diagram shows only one of each of the signals to be compared for time measurement. In comparing the two like signals which should be superimposed, the oscilloscope sweep may be increased for the higher frequency comparison and the possible accuracy of measurement by that means can be made practically seven times that of the lower frequency comparison. Figure 59 shows the signal which may be produced by equal amplitude and proper phase arrangement of the first seven harmonics of the lower frequency signal. With this signal almost half the accuracy of the dual signal reading arrangement may be obtained in a single reading, the highest frequency component in both cases being equal.

In the above examples the sky waves will alter the phase of the various signals and will result in errors. The phase distortion takes place at the carrier and side band frequencies and the maximum phase shift of the modulated signals is as great as that for the carrier inside-band signals. For all but very low-frequency modulations, the equivalent time error is inversely proportional to frequency.

The solid line curve of Fig. 60 is the signal resulting from the combined signals representing the first 700 harmonics of a 45 c.p.s. signal at a definite phase and amplitude relation. A signal of this sort is obtained by pulsing the transmitter and is in fact a radar signal. The sky wave produces an orderly arrangement of phase shift in each of the respective harmonic components with the result that a second blip or signal similar in shape to the original is reproduced at a later time. The more practical way of considering this is to realise that the one signal is received so late that two separate signals are received. The simple

reasoning is not fully justified when the pulse length and delay time through the receiver amplifier are both long. This is especially true when the phase delays of the individual side-band signals of the reflected wave are not proportional to their respective frequencies.

phasing or locking control will give satisfactory results. If the modulation signal is used for the final reading and not merely as identification it is desirable to increase the band width to the limit. The higher frequencies are the major factors which control the steepness of the wave slope. Greater

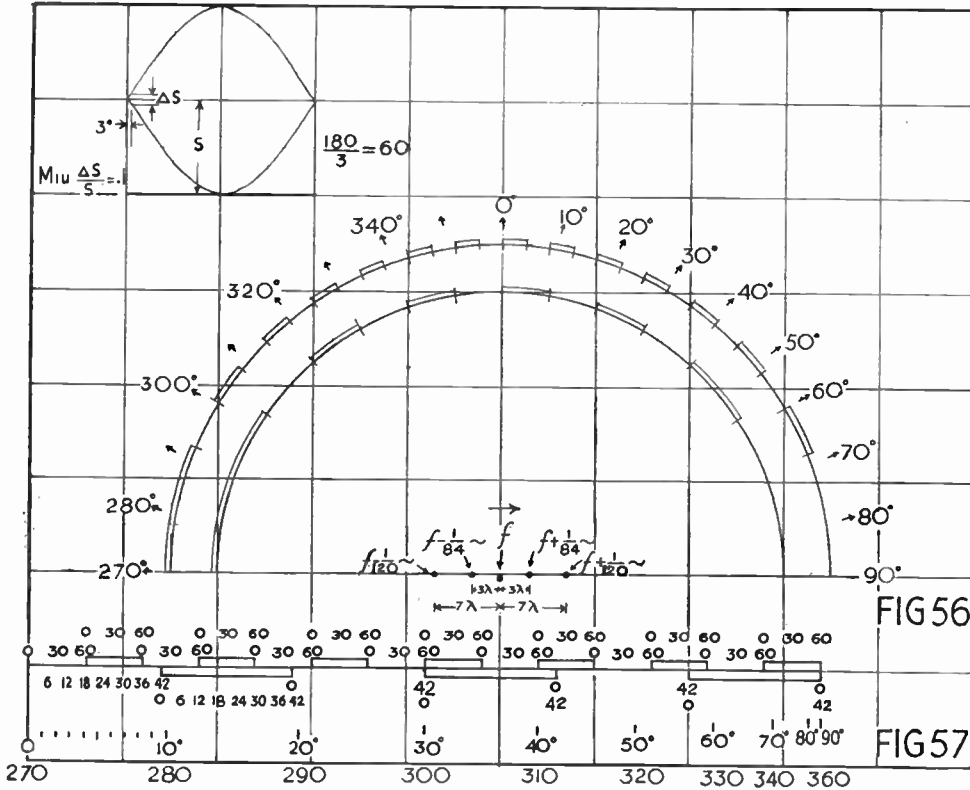

Figs. 56 and 57. —Dual Sonne system to reduce ambiguities and increase accuracy.

Transmission of phase-locked modulation signals can present more difficult problems than that of phase-locked continuous wave transmission. In a continuous wave system the phase of only one signal is to be controlled. In a modulation system comprising more than one modulation frequency a phase lock is a complex problem whose solution lies more in avoiding need for control than in providing control. The phase of a modulated signal is dependent on the relative phase difference of the side-band signals and to a smaller degree on the phase of the carrier. If the circuits involved have a band width which exceeds twice the required frequency range and are designed to give substantially straight phase slope as to frequency for a little greater range than used, then a single

time accuracy is had for greater slopes. If the phasing of the higher side bands is not maintained at the transmitter, the slope and shape of the pulse will be altered and an accurate time match with the second pulse will be difficult and inaccurate.

If transmitted pulse from two stations are identical in shape, the distortion introduced by a single receiver channel will be identical and no receiver phasing error should be expected. If the leading edges of the transmitted pulses are not identical the distortion introduced by the receiver is not expected to give equal distortion and errors are to be expected.

The first twelve components of a short symmetrical pulse are shown in Fig. 61. A linear

phase shift which is proportional to frequency is equivalent to moving all of these wave forms by an equal distance or time. A linear movement or delay resulting from multi-element filter having a steep but linear phase-frequency slope is illustrated by the arrows at the right. A non-linear slope would produce an unequal shift of each frequency and the limit of such a movement for each component is shown by the curves line to the right of the arrows. The shape of the signal given by the summation of the individual components is obviously altered by a non-linear shift.

The greatest single factor controlling the ultimate instrumental accuracy is the comparison frequency or its equivalent. In equi-signal systems this frequency is the transmitted frequency. In the Decca system it is a low order multiple of the

radiated frequency. In modulated systems using sine wave modulation, it is the modulation frequency and for complex or pulse modulation it is generally equivalent to one-half the highest modulation component. The instrumental gain obtained by multiplication as in Decca may be used in sine wave modulated signals. This does not, however, improve accuracy under conditions of sky wave interference errors and it lowers the tolerable limit of C.W. interference from signals well within the band pass of the receiver. There is, therefore, a practical limit to the gain in accuracy which can be obtained by way of multiplication.

The time error caused by sky wave interference is greatest for sine wave modulation systems, and the error is approximately proportional to the modulation wavelength. (It approaches a constant maximum error at very low frequencies.) The reason for this is that for all but the very low frequencies the maximum phase error is independent of frequency.

The wave front of a pulse received via ground wave is not altered by the delayed sky wave signal if its slope is sufficiently steep and sky-wave errors are thus eliminated. For greater distance the delay time is less and greater slope is required. The minimum side-band frequency to give the slope required for 400 miles is approximately 4.5 kc/s and for 1,000 miles 11 kc/s. Assuming a maximum band width equal to 2 per cent. of the carrier frequency the lowest carrier frequency should be 225 kc/s for the 4.5 kc/s modulation and 550 kc/s for the 11 kc/s modulation.

The combination of pulse identified carrier phase comparison was one of the early conceptions of Decca lane identification. The required band width to identify a Decca lane was soon regarded as a practical impossibility. When the pulse carrier frequencies are equal the chances of success are improved, but the extent of the improvement is insufficient to make identification greatly practical although it does just become a possibility. The band width would have to be at least 3 per cent. of the carrier frequency in order to identify a cycle of the carrier frequency. The transmission locking would undoubtedly require constant control by a skilled operator. This control would be most difficult at higher frequencies and at low frequencies the high noise level is more than likely to cause an error reading in pulse matching which will exceed half a cycle of the carrier signal. Unless more than half-cycle accuracy is obtained, the cycle matching becomes useless.

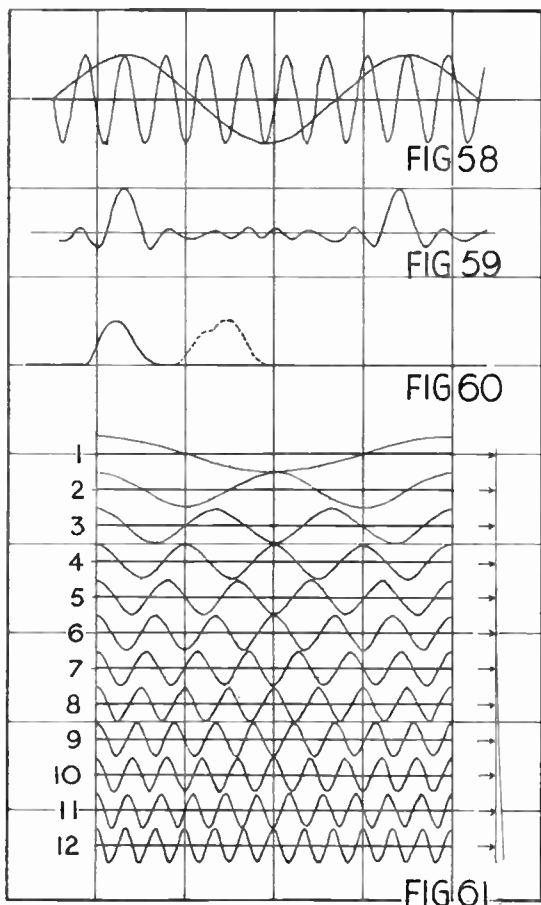

Figs. 58, 59 and 60, 61.—Graphical pulse analysis.

If a system is to be used wholly within the ground range a low frequency is desirable, as the ground wave range is greater at these frequencies and the distance from the transmitters at which the sky and ground waves become equal in amplitude is increased. The gain obtained by lowering the frequency is greater over land than over sea. Reflections and absorptions caused by irregularities in terrain and soil constants are less for the lower frequencies and their effect in pattern distortion is reduced or even eliminated by use of a suitable low frequency. If only air navigation is to be considered the detrimental effects of terrain are overcome by the use of ultra high frequencies. At these frequencies the surface wave falls off rapidly and there is no ionosphere signal reflection to contend with, thus errors caused by terrain and sky wave are largely or completely eliminated. The range is but little more than the line of sight. The allowable band widths at these frequencies are great, and good instrumental accuracy is to be had by pulse systems.

A pattern contains as many hyperbolic lines as there are measurable divisions of the base line. The distance accuracy at close range is dependent on the distance representing a measurable division. The bearing accuracy at long range is dependent on the number of measurable divisions. When a low maximum operating frequency is fixed by propagation characteristics over land, the measurable divisions obtained per unit base line length to be had by pulse transmission is only about 2 per cent of that secured by equi-signal or carrier phase measuring systems. For this reason, low frequency pulse systems are far less accurate at close range than the other two systems mentioned. The length of the base line for a pulse system can be made very large and because of the large number of readable hyperbolae obtained by this means the bearing readings at great distances will compare favourably with short base line equi-signal systems. The Decca system provides fine divisioning of a long base line, and thus possesses both favourable characteristics.

The ambiguity resulting from long base lines in the three antenna equi-signal systems is not the only limitation to practical base line separation. A second limitation is inaccuracy of courses at finite ranges. The approximate radii of the unserviceable area is given by four times the wavelength times the square of the antenna spacing in wavelengths. If a Sonne system were to operate at 100 kc/s with an antenna spacing of five wave-

lengths the radius of inaccuracies would be about 180 miles. At 300 kc/s and three wavelengths spacing it is only 22 miles.

In the Sonne system the base line separation to be used in considering sky wave errors within the ground wave range is the wavelength spacing between outer antennae. Considering this, we are confronted with two contradictory observations. It is stated as an observed fact that along the right bisector of the base line of the Sonne system there is small or no night effect. This indicates a flat reflecting layer. It is also an observed fact that antennae separated by more than five or ten wavelengths receive sky wave signals having independently varying phase relations. This fact has led to the successful use of diversity receivers for reducing night fading, and indicates that the corrugations in the reflecting layer are of a nature that permits different path lengths for the two signals. If the independent variations in path length of each signal is equal to or exceeds one-quarter wavelength, then the maximum possible variation within a cycle is had when the one path is increased and the other decreased by one-quarter wavelength. It is to be expected that the probable variations in path lengths will decrease with increased distances from transmitter to receiver. Without much more experimental data than is now available the question of sky wave effects is unanswerable.

The use of sky waves will probably always be difficult, and it appears that the medium wave pulse system with long base lines is as good an answer to the problem as can be had. The alternative is to extend the ground wave by use of very low frequencies and avoid the problem as far as possible.

7. Conclusion

It is obvious that the field of radio navigational aids is a very complex one. When viewed from all angles it is a field in which many compromises must be made relative to a simple ideal and gains made in one direction are often accompanied by losses in another. The road to an ideal is a difficult and discouraging one. Radio does, however, provide a means of laying down fixed or reasonably fixed lines of position in space, over limited areas, and apart from visual means, which are also subject to many limitations, there is no alternative which will accomplish that all-important result. Radio aids have been giving remarkably good assistance to navigation and more is to be expected from them in future.

CONVENTION DISCUSSION

Captain Hunt : As a pilot I am particularly interested to know whether Decca would function under conditions of precipitation static such as is experienced for lengthy periods on the Atlantic.

Mr. L. S. Vincent (Member) questioned the economics of the Decca system from the commercial aspect under conditions of poor signal-to-noise ratio at the frequencies used, say, under conditions experienced in Far Eastern tropical regions. What is the effect (if any) of "Coastal Refraction" with the Decca system under conditions of a changing coast line which may vary by as much as 20 miles between low and high Spring tides.

Mr. J. C. G. Gilbert (Member) : With any continuous wave phase discriminating transmission it would appear that jamming could completely upset or gravely distort the hyperbolic pattern. This jamming may be accidental or purposeful and on these grounds one of the pulse navigational systems should be preferable. Comparatively small power is required to jam the transmission, and in view of the international unrest it is interesting to consider the economic stability of the Decca system.

Mr. Davies : Having no practical experience yet with Decca I should like to have an explanation of the effect of skywave on the Deccometer. This effect is quite apparent on the usual (C.R.T.) method of presentation used in Gee, Loran, etc. Is this effect quite recognisable particularly to a non-technical operator? The big problem of coastwise navigation involves knowing where the "other fellow" is. This is obviously only covered by anti-collision radar.

Mr. E. R. Friedlaender (Member) : I try to get a picture of the importance of Decca at sea. From discussion and demonstration it is obvious that :

- (1) Conventional navigation is necessary to about 10 m.
- (2) The system is uncertain near port due to cranes, gantries, etc.
- (3) The necessity of anti-collision radar is not sufficiently stressed. Only its inclusion will avoid the laying up of vessels during bad visibility.

Dr. H. P. Williams : One or two speakers have raised the question of the effect of atmospheric noise or precipitation static. It occurred to me that there exists a much more definite manner in which the

Decca Navigator might be put out of action and that is by a valve breakdown. From what I can gather from the zone identification system it seems to me that one might well obtain ambiguous results if the time required for valve replacements or other repairs was of the order of a few minutes or more. It would, therefore, seem that while the Decca system provides a simple method of navigation, it would be unwise for pilots of either ships or aircraft to neglect any of the older methods of bad weather navigation.

Mr. F. Livingstone-Hogg (Member) : Not much has been said about lane identification, which those of us who have been privileged to take a trip in the "N.Y. Navigator" have seen demonstrated. It appears to me, treading on dangerous ground for one having no intimate knowledge of the subject, rather tragic that engineers have produced a number of complex navigational aids to replace the simple compass, sextant, etc., but that we should still be in the position of needing to use them for zone identification at any rate. This fundamental tendency to dependence on old ancillaries is seen in many different branches of development. In listening to lectures on Loran and Gee also, one cannot miss the apparent "blind spots" of each type. I was struck by a remark of Mr. J. A. Pierce, who mentioned that the pulse matching of Loran and Gee was occasionally not accurate enough and that experiments were being made with "cycle matching," by which I understand the Decca phase-comparison principle to be implied.

Dangerous though it may be for an onlooker to make technical suggestions without full knowledge of all considerations, I suggest that the process might with advantage be reversed, and that zone identification might be made by using Gee technique. Suppose a suitably timed "pulse of silence" be made in each carrier at required intervals, these intervals might be used as pulses of carrier as used in Gee or Loran. Obviously, one cannot key an 85 kc/s transmitter with square waves, but if a finite, but known slope was given to the decay and build up, over a definite number of cycles, with silence for a known fraction of a second, it might be possible to make the rough identification needed. A quick calculation, probably based on incorrect premises, makes me suggest that the bandwidth required to accom-

modate the necessary sidebands might be about 200 c/s, which does not appear unreasonable. Doubtless, this would have been done long ago if

it were practicable, and I shall be interested to know wherein the fallacy or impracticability lies.

REPLY TO THE DISCUSSION

Mr. W. J. O'Brien : Captain Hunt and Mr. Vincent have raised the question of the operation of the Decca Navigator under adverse noise conditions. As is explained in the full paper the discriminator circuits give a very good performance in the face of poor signal-to-noise ratios. Receivers fitted with crystal filters provide very narrow bandwidth channels and thereby allow operation through very intense static conditions. It is known that improvements in signal-to-noise ratio in the case of precipitation static may be had by the use of insulated antennae and the application of means to reduce the radiation from objects in its vicinity. Further development along this line is being done by many workers in the radio field. Although really reliable figures for precipitation static and tropical noise levels are not yet available it is anticipated that good coverage will be obtainable in all, or nearly all areas under all conditions.

Mr. Vincent also asks about coastal refraction. Systematic errors of a small order have been noted in some areas and considerable work has been done to account for these errors. We have been looking for coastal refraction effects from the time of the earliest trials of the system but to date there is no positive evidence that they exist. Further checks are being made but the only information to hand is that such errors, if any, can only amount to a few hundredths of a lane.

As Mr. Gilbert points out, the deliberate jamming of the Decca Navigator transmissions would not be very difficult. It is believed that there is little security to be had in any fully-known radio navigation system which is to provide a fix over enemy territory. Security under such conditions lies largely in the secrecy of the system. Accidental jamming, however, is not usually serious as all adjacent transmitters are morse stations and the receivers operate in the intervals between the morse characters.

Mr. Davies asks about the effect of sky wave. This is dealt with in the full paper. He and Mr. Friedlaender rightly state that the Decca Navigator should be used in conjunction with an anti-collision radar set to allow navigation under conditions of zero visibility. It should, however, be

realised that a radar set designed primarily to give anti-collision warning can be made very simple and would be much cheaper than one fulfilling the full maritime radar specification.

Dr. Williams refers to the breakdown of a valve. In an aircraft the chance of replacing a defective valve in flight is small as the receiver is normally treated as a sealed unit. In the marine case, time would be available to make a replacement.

Mr. Livingstone-Hogg has raised a number of interesting points. I believe that the engineering effort which is going into the development of radio navigational aids is not intended to "replace the simple compass, sextant, etc.," but to provide another tool for the navigator's use. These older instruments are fundamental aids to navigation, but in common with other aids, have certain shortcomings. The compass tells you in what direction you are heading, but the important information required is the direction in which you are actually travelling. The speed indicator, likewise, requires additional information to inform you as to the actual number of miles covered per hour. A radio navigational aid tells you where you are. All this information is important and no one instrument will give it all. Errors in one are indicated by cross checks with the others, and all are aids to navigation and aids to one another. The art of navigation is a difficult one and under unfavourable conditions it requires a number of complicated instruments to provide a safe journey.

Zone identification on the Decca Navigator can be carried out with the aid of the compass (the minimum angle between a line in one zone and the same line in the next is 11°), and unless a simple arrangement can be provided the development of a zone identification apparatus might be. If zone identification proves to be necessary the development along the line of pulse technique would undoubtedly be impracticable. The zone corresponds to a time difference of about 70μ secs. It can be shown that a pulse width of less than 300μ secs. would be necessary, which implies a bandwidth of more than 3 kc/s which would be too great at both receiver and transmitter.

NOTICE OF EXTRAORDINARY GENERAL MEETING

NOTICE IS HEREBY GIVEN that an EXTRAORDINARY GENERAL MEETING of the Corporate Members (Honorary Members, Members, and Associate Members) of the INSTITUTION will be held on Thursday, December 11th, 1947, at 6 p.m., at the LONDON SCHOOL OF HYGIENE AND TROPICAL MEDICINE, Keppel Street (Gower Street), London, W.C.1, when the subjoined Resolution will be proposed as a SPECIAL RESOLUTION.

“ That the Articles of Association be altered as follows :

The following Articles shall be substituted for Articles 12, 17 and 25 respectively :

Students

Article 12. A Student shall be a person not under 17 years of age who desires to become a Radio Engineer, has passed the Preliminary Examination prescribed by the Council's Examination Regulations for the time being or such other exempting examinations as may from time to time be approved by the Council under such Regulations, and has satisfied the Council either that he is receiving regular training in Radio Engineering, or that he is receiving full-time instruction in a technical school or college and has received or intends to receive regular training as a Radio Engineer, but who has not yet satisfied the conditions of election to Graduateship of the Institution.

Subscriptions

Article 17. The following annual Subscriptions shall be payable by Corporate and Non-Corporate Members of the Institution, irrespective of the date of election, in the following classes, namely :

	<i>United Kingdom.</i>			<i>Abroad.</i>		
	£	s.	d.	£	s.	d.
Members	5	5	0	4	14	6
Associate Members	3	13	6	3	3	0
Companions	5	5	0	4	14	6
Associates	2	12	6	2	2	0
Graduates	2	2	0	1	11	6
Students (17-25 years)	1	5	0	1	5	0
Students (over 25 years)	1	10	0	1	10	0

A Member, Associate Member, or Companion may compound for his annual subscription by the payment to the Institution in one sum of Sixty Guineas.

Provided that if in the opinion of the Council the financial position of the Institution justifies such a course, the Council may authorise, without calling an Extraordinary General Meeting, the reduction of all or any of the above subscriptions, but that any such reductions shall not permit of a lower subscription than those agreed at an Extraordinary General Meeting of the Institution held on 21st December, 1945.

Notice of Extraordinary General Meeting (Continued)

Constitution of the Council

Article 25. The Council shall consist of (a) The President, (b) The Immediate Past President, (c) 4 Vice-Presidents, (d) The Honorary Treasurer, (e) not less than six and not more than twelve Ordinary members of the Council, and (f) the Chairmen of each Local Section of the Institution which has been approved by the General Council, all of whom shall be British subjects and corporate members of the Institution and whose offices shall be honorary and without remuneration."

These alterations are unanimously recommended by the General Council as a result of proposals made by the appropriate Committees and referred to in the 1946-7 Annual Report of Council which was approved at the Annual General Meeting held on October 9th, 1947.

For the convenience of those Corporate Members who may be unable to attend the Extraordinary General Meeting, a Proxy Form may be completed but must be deposited with the Secretary not less than 72 hours before the time for holding the meeting. Only a Corporate Member may be appointed a proxy; the Chairman of Council has signified his willingness to act in this capacity for any Corporate Member who may so desire.

By Order of the Council,
G. D. CLIFFORD,

General Secretary.

27th October, 1947.

OTHER NOTICES

Development of Sections

Every member of the Institution will shortly receive a questionnaire which is designed to obtain the views of members about the formation and development of sections of the Institution.

Members of the Institution are encouraged to create their own sub-sections and where there is sufficient evidence that a group of members are anxious to form themselves into a section who are able to appoint a responsible Committee, the Council will do everything possible to assist such a section and to foster its development.

The formation of such sections is, however, dependent upon the activity of members and it is hoped therefore, that every member will take the opportunity of expressing his views by returning the questionnaire as quickly as possible.

Graduateship Examination Fees

It has been found necessary to increase the entry fee for the Graduateship Examination to £3 3 0; this increase will be effective from the May, 1948, sitting. Details of the revised scale of fees for various parts of the examination will be published

in the 11th edition of "Membership and Examination Regulations," now in course of preparation.

Amalgamation of the I.Mech.E. and the I.A.E.

The amalgamation of the Institution of Mechanical Engineers and of the Institution of Automobile Engineers took place on April 13th last. The I.Mech.E. was founded in 1847, so that the amalgamation occurs in the year that the Institution celebrates its centenary. The I.A.E. is forty-one years old.

Under the terms of the agreement to amalgamate the Institution of Automobile Engineers will surrender its charter and dissolve the Institution. Its corporate members will become corporate members of the Institution of Mechanical Engineers, being placed as the first members on the register of a newly formed Automobile Division.

Bound Journals for 1946

Enquiries have been received from members about Vol. VI of the Journal. Unfortunately, no date can be given for the completion of the binding, but immediately supplies are received despatches to members will be made as soon as possible.

THE EXPLOITATION OF MICRO-WAVES FOR TRUNK WAVE-GUIDE MULTI-CHANNEL COMMUNICATIONS*†

by

Professor H. M. Barlow, Ph.D., B.Sc.(Eng.)

A Paper read before the 1947 Radio Convention of the Institution held at Bournemouth in May 1947.

Introduction

The use of a wave-guide carrying a modulated micro-wave for multi-channel trunk communications has many attractive features. In presenting a paper on this subject, the principal objective is to stimulate discussion of a project which, while admittedly fraught with many difficulties at the present time, cannot fail, in the author's view, ultimately to achieve success.

The potential value of such a development is enormous, providing as it would do, facilities practically unobtainable by any other means. In a country like this where distances are relatively not large, but in which we have great centres of population, there must inevitably arise a very big demand for independent communication channels between such centres. The possibilities of exploiting micro-waves in this service lead one to expect that the number of independent channels provided by a wave-guide could, without unduly stretching its resources, be numbered in thousands and this compares with the four to six hundred channels obtainable with coaxial lines operated in the region of one megacycle per sec. Furthermore, the trunk communications wave-guide might well offer simultaneous services in the transmission and distribution of electric power, either as an underground cable or possibly as an overhead high tension line.

There is, of course, no denying the fact that in this matter of trunk wave-guide facilities we are taking a peep into the future, but the project is well worthy of close attention. It is of particular interest to assess the magnitude of the problems involved and how far these have a reasonable chance of solution with equipment and knowledge at present available to us. Let us, therefore, look first at the broad aspects of the problem.

* Manuscript received February, 1947.

† U.D.C. No. 621.392 : 621.395.4.029.6.

1. Choice of Micro-wave Carrier Frequency

In wave-guide propagation ultra-high frequency electromagnetic waves are constrained to travel along the inside of a hollow copper tube much as water may be induced to flow along a pipe. The wave-guide will only permit the passage of waves above a certain minimum frequency set by the dimensions of the tube. For practical reasons the wave-guide will normally be filled with air having some degree of humidity, and it so happens that at the frequencies in which we are interested there are two important absorption bands, one for oxygen and the other for water vapour which must be avoided if we are to prevent severe attenuation of the wave due to that cause. The oxygen absorption band occurs at a frequency of 54,600 Mc/s ($\lambda = 0.55$ cms.), and is quite sharp, whilst the water vapour band, which is wider, occurs at a frequency of from 25,000 to 23,000 Mc/s ($\lambda = 1.2$ to 1.3 cms.).

For reasons which will be explained later it is desirable to work at the highest frequency for which devices are, or shortly will be, available to generate the necessary power. Bearing in mind the different factors involved it is proposed, therefore, to concentrate attention on a frequency of 40,000 Mc/s ($\lambda = 0.75$ cms.). This is suitably placed between the two absorption bands to which reference has been made.

2. Form of Wave-guide and Mode of Propagation

Such information as is available on attenuation in wave-guides, arising from losses in the walls, indicates that there is only one form of guide and one mode of propagation along it that can be regarded as a practical proposition for the present purpose. This is what is known as the H_{01} mode in a cylindrical guide. The distribution of the electric and magnetic fields for this particular wave is shown in Fig. 1, and its special virtue lies in the fact that it has an attenuation decreasing pro-

gressively with increase of frequency. Figure 2 gives the attenuation of a cylindrical copper guide $1\frac{1}{2}$ in. internal diameter carrying an H_{01} mode at frequencies from cut-off upwards to 40,000 Mc/s.

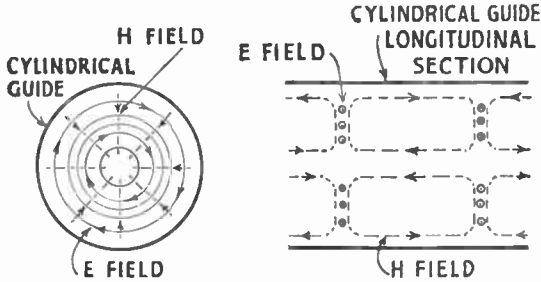

Fig. 1.— H_{01} mode in a cylindrical guide.

Note: Magnetic field represented by dotted lines and electric field by full lines.

Apart from the higher orders of the same mode such as H_{02} , etc., all other known forms of wave in both rectangular and cylindrical guides have a minimum attenuation at a frequency of about double the cut-off value (Fig. 3). This minimum attenuation is, in all cases, too large to permit successful application of any of these other wave modes to trunk wave-guide operation. For many purposes a convenient mode of propagation in a cylindrical guide is the E_{01} wave (Fig. 4A), since

it has circular symmetry, but the H_{11} wave (Fig. 4B) gives a lower minimum attenuation (Fig. 3). Even this is too high for serious consideration of the mode as a vehicle for transmission over long distances.

3. Proposed Scheme for Multi-channel Communications over a Trunk Wave-guide

The introduction of a wave-guide as the communications link between two large centres of population is a logical step from the present coaxial equipment¹, and it is proposed to examine the proposition from that point of view (Fig. 5). In raising the frequency to the proposed wave-guide carrier of 40,000 Mc/s it is convenient to introduce at an intermediate stage of 200 Mc/s, what one might suitably designate, in extension of the coaxial nomenclature, a number of "Super-Super-groups." Thus, if the usual coaxial terminal equipment is employed and a band of frequencies from 0.5 to 2.1 Mc/s is used to give 400 channels at 4 kc/s intervals, we might reasonably group ten of these equipments to form the Super-Super-groups at the intermediate carrier frequency of 200 Mc/s, and therefore provide 4,000 independent channels.

In the schematic diagram (Fig. 5) separate wave-guides are used for "go" and "return" circuits and this is probably desirable in the first place from the point of view of simplicity. At the same time it would appear that there is no insoluble problem in the use of directional couplers as hybrid coils enabling a single guide to function in both directions².

The diagram is largely self-explanatory, but it may be helpful to call attention to two important features. Present limitations in ultra high frequency technique make impracticable effective amplification from a low level at frequencies above about 1,000 Mc/s. Hence, at repeater stations the first stage must be to convert to a lower frequency, and this has been conveniently chosen within the 200 Mc/s band. Successive stages of amplification and re-modulation of a 40,000 Mc/s carrier can then follow. The second point requiring special consideration is the question of carrier frequency stability. In the coaxial system it is the practice to refer all carriers by frequency multipliers and dividers to one master oscillator. Between the

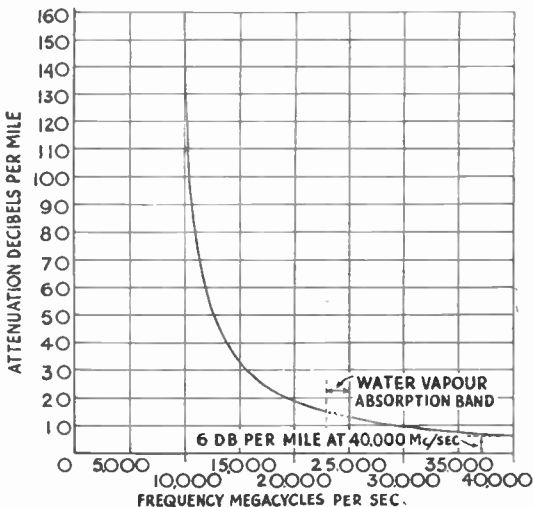

Fig. 2.—Attenuation of H_{01} mode in cylindrical copper guide $1\frac{1}{2}$ ins. inside diameter.

¹Angwin and Mack. *Journ. I.E.E.*, Vol. 81, p. 573, 1937.
²Surdin *Journ. I.E.E.*, Vol. 93, Part IIIA., No. 4, p. 725, 1946.

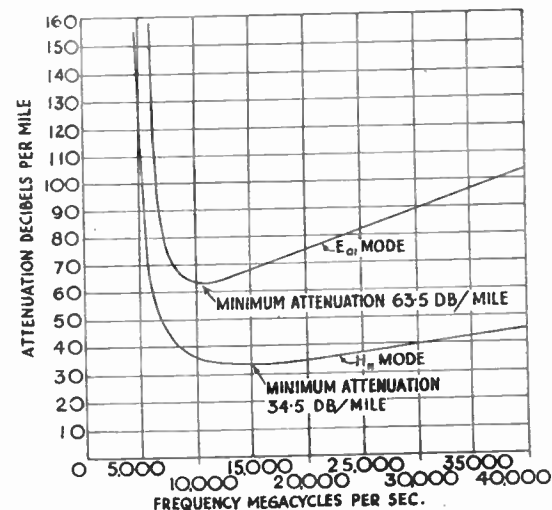

Fig. 3.—Attenuation of E_{01} and H_{11} modes in a cylindrical copper guide $1\frac{1}{2}$ ins. inside diameter.

terminal equipments at the two ends a pilot frequency is transmitted to maintain synchronism, but the need for this arises because the carrier is suppressed in the coaxial line and re-established at the far end. In order to avoid such elaborate stabilizing and synchronizing arrangements it is proposed to apply "automatic frequency control" at each "mixer" stage, so that the local oscillator is automatically adjusted in frequency to give the desired intermediate carrier frequency within narrow limits, no matter how the frequency of the incoming wave-guide carrier drifts about. Some further details of this frequency control will be considered later. With regard to the 200 Mc/s carrier supplies these could, if necessary, be linked to the master oscillator of the coaxial system, and a pilot frequency transmitted between terminal points. Alternatively, it would appear preferable again to use automatic frequency control, and admit the full side-band.

4. Consideration of Individual Problems involved in Wave-guide Scheme

Having now established in outline the kind of scheme proposed, it is necessary to consider more precisely some of the special problems that arise.

4. 1. Wave-guide Construction

Whatever the method adopted in dealing with the wave-guide between terminal points it is clearly most desirable that we should be able to treat it in much the same way as a cable. Thus, the guide

must have a reasonable degree of flexibility without introducing serious distortion of its internal dimensions when bent into an arc. The construction adopted for the outer conductor and protective covering of a form of high frequency coaxial line used successfully during the war seems to offer an excellent solution to this problem. A thin drawn copper tube is enclosed in a stainless steel sheath with a welded seam, fitting tightly over the outside of the copper (Fig. 6). The stainless steel armouring gives a good measure of protection and mechanical strength, without destroying essential flexibility. With a good, smooth surface on the inside of the stainless steel sleeve it might be possible to use internal copper plating instead of a copper tube. It is known that copper plating to a thickness of 0.3 mils. or more is satisfactory as a high frequency conductor, although its resistance and therefore its attenuation are likely to be

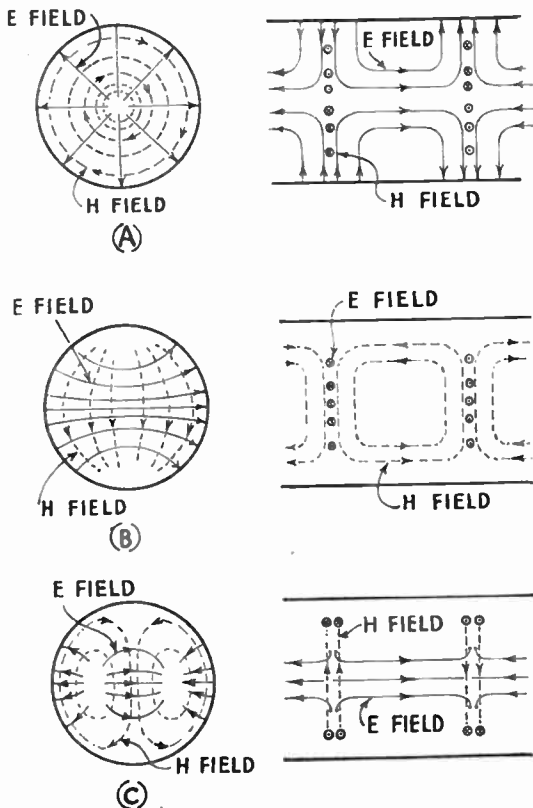

Fig. 4A.— E_{01} mode in a cylindrical guide.
 Fig. 4B.— H_{11} mode in a cylindrical guide.
 Fig. 4C.— E_{11} mode in a cylindrical guide.

about $1\frac{1}{2}$ times that of solid copper³. Since we are dealing with the H_{01} mode of propagation, for which the magnetic field has radial and longitudinal components only, the ultra high frequency currents on the inner surface of the guide walls must be entirely circumferential.

less steel sheath would probably have to be replaced by phosphor bronze or some non-magnetic metal of high tensile strength, and in the case of an underground cable would, of course, require to be insulated. For excitation of the micro-wave in the guide or for extraction of

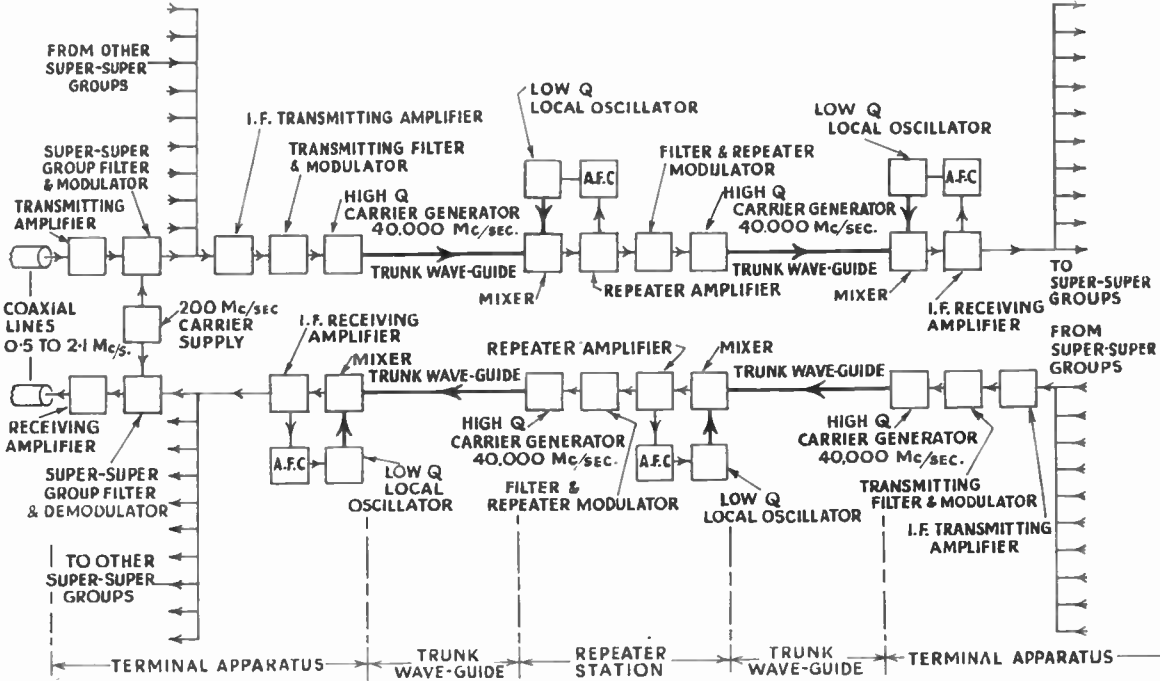

Fig. 5.—Scheme for multi-channel communications over a trunk wave-guide.

Thus, if the guide were made up of a series of rings placed end to end, there should be no serious disturbance of the wave propagation provided, of course, that irregularities are not introduced at the joints between adjacent rings. This suggests the possibility of making up short lengths of flexible guide for terminations or union joints in the manner depicted in Fig. 7. The basis of the joint is the usual half wave-length trap, so that if a gap appears between adjacent rings no serious disturbance results. Flexible wave-guides have been made of rubber pipe with embedded copper gauze forming the inner surface, but this is unlikely to be satisfactory for long lengths. It is necessary also to consider the possible application of the wave-guide as a power supply line. If used for high tension transmission at 50 cycles per sec. the stain-

energy from it, there should be no great difficulty in arranging a short radio link at the terminal points, so that the communications equipment is isolated from the high voltage of such a power supply service.

4. 2. Effect of Ellipticity of the Guide

In general, when a cylindrical wave-guide is deformed the wave being propagated along it will be split into two components, which proceed down the guide with different phase velocities and different attenuations. It so happens, however, that any such effect is negligible when the deformation is along an axis of symmetry of the wave. For the H_{01} mode, therefore, deformation about a diameter of the guide will not cause any splitting up of the wave. This deformation will, however, tend to increase the attenuation of the wave, and if large will destroy the unique feature of pro-

³Milner and Clayton. *Journ. I.E.E.*, Vol. 93, Part IIIA, No. 1, p. 226, 1946.

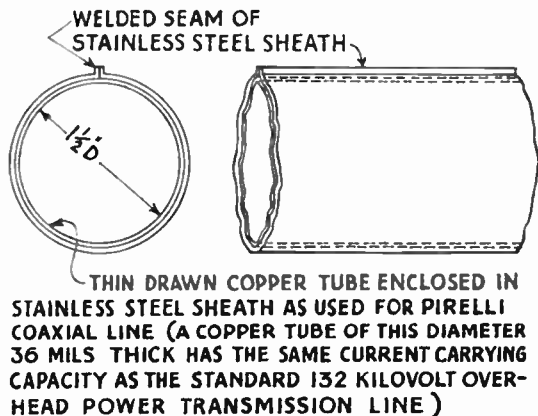

Fig. 6.—Proposed flexible wave-guide as a trunk communications link.

gressive reduction in attenuation with increase of frequency, which is of particular value in this application. The effect of deformations on the attenuation only become serious for eccentricities of 0.2 and over⁴.

4. 3. Elimination of Unwanted Modes of Propagation

The cut-off frequency of the H_{01} mode in a cylindrical guide is the same as the E_{11} mode and larger than both the E_{01} and H_{11} modes. Thus, it is not unlikely that in exciting the H_{01} mode the other modes referred to may make their appearance when the circumstances are favourable. If we examine the H_{01} mode we see that its characteristic field form differs from any of the others in that there is no radial component of electric field.

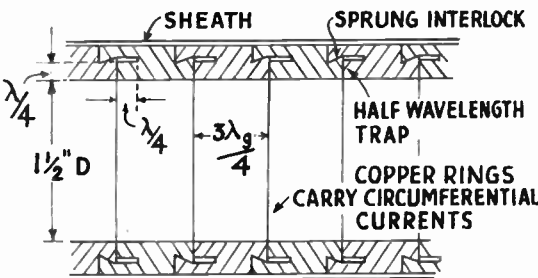

Fig. 7.—Flexible cylindrical guide for H_{01} mode, consisting of interlocking rings placed end to end with half wavelength trap at joints.

Thus, a mesh of radial wires inserted in the guide (Fig. 8) should not disturb the propagation of the H_{01} wave while the three unwanted modes which

⁴ *Microwave Transmission Design Data* p. 86. Published by Sperry Gyroscope Co. Inc., Manhattan Bridge Plaza, Brooklyn, N.Y.

were considered possible intruders will all be reflected by it. In this device we therefore have a means of preventing propagation of unwanted modes, although care must still be taken to avoid local standing waves of these modes.

4. 4. Other Factors Affecting Attenuation of Wave-guide

Mention has been made of a water-vapour absorption band, and the need to avoid the particular frequencies concerned. Quite apart from this there is evidence that moisture deposited on the inside of the guide may, over a wide range of frequencies, have a serious effect on the attenuation. Liquid water may appear at relative humidities less than 100 per cent., and a drying agent, or possibly a water repellent, should therefore be employed inside the guide.

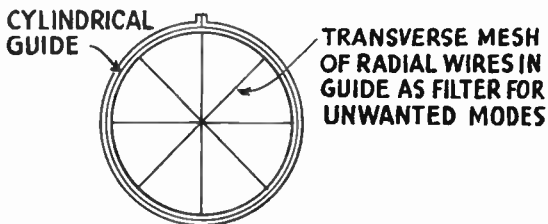

Fig. 8.—Mesh of radial copper wires in cylindrical guide to pass undisturbed the H_{01} mode and reflect the H_{11} mode, the E_{01} mode and the E_{11} mode.

Figure 2 shows the attenuation at different frequencies of the H_{01} mode in a cylindrical copper guide 1.5 in. diameter. If we employ this size of guide at 40,000 Mc/s and allow 50 db fall in power level over any one section, it is clear that the repeater spacing would have to be about 8 miles. This compares favourably with the coaxial system at present in use for which the repeaters are spaced at intervals of about 6 miles. The shielding of the wave-guide is practically perfect so that cross-talk and interference from outside sources or between adjacent guides is quite negligible. It is only at the terminations that special care is required in this respect, and thermal noise therefore determines the lower limit to which the power level can be allowed to drop in the wave-guide itself. Taking given frequencies, say, 40,000 Mc/s and 20,000 Mc/s, it is of interest to follow the change in attenuation with diameter of guide. This is shown in Fig. 9, and it is obvious that a high working frequency is the only way of getting the guide down to a reasonable size without undue attenuation.

4. (5) Generators for Ultra-high Frequencies

Of the two types of valve in use today for the generation of micro-waves the C.W. magnetron is probably capable of the larger output, whilst the klystron lends itself more readily to modulation.

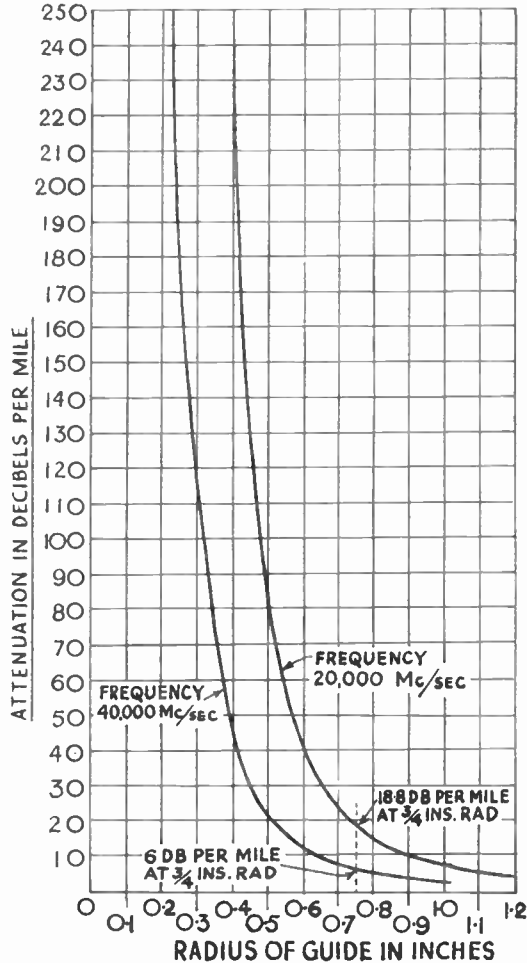

Fig. 9.—Attenuation of H_{01} mode in cylindrical copper guide at frequencies of 20,000 Mc/sec and 40,000 Mc/sec.

To obtain 40,000 Mc/s might, at the present time, require the extraction of an appropriate harmonic with its correspondingly lower power level. There are, however, good grounds for anticipating in the near future the production of generators capable of producing directly frequencies of the order required, and with a reasonable amount of power output.

klystrons to operate at frequencies of 35,000 Mc/s and 60,000 Mc/s are now being built. There are also pulse magnetrons under development for 50,000 Mc/s.

If the klystron is adapted to this purpose, frequency modulation could be safely recommended.

4. 6. Modulation of Klystron Oscillator and Automatic Frequency Control

Variation of negative potential applied to the repeller electrode of a klystron valve causes corresponding changes in the frequency generated. Other things remaining unchanged the larger the negative potential the higher the frequency, and this sensitivity is usually of the order of a few megacycles per volt. Variation of the accelerator voltage will also cause some change of frequency, but it is generally much less marked since it produces two opposing effects. An increase of accelerator voltage increases the velocity of the electrons, and this is accompanied by a tendency to extend the time taken to return. Simultaneously we get a larger potential difference between the cavity and the repeller which operates to return the electrons in a shorter time. Modulation is therefore most suitably carried out through variation of the potential of the repeller electrode. This is also the means by which automatic frequency control can be best applied. The carrier generator and the local oscillator may each suffer drift of frequency, but by using the mixer output frequency through the usual discriminator to control the mean repeller voltage of the local oscillator, the intermediate carrier can be kept of substantially constant frequency. The D.C. output voltage of the discriminator falls as the intermediate frequency rises. Thus, if the micro-wave carrier frequency, which we will suppose is below the local oscillator frequency, decreases, then there is an increase of the intermediate frequency, a fall in the negative potential on the repeller electrode of the local oscillator, with a corresponding reduction of its frequency tending to re-establish the original conditions. The time constant of the A.F.C. circuit must, of course, be long enough to prevent response to modulation frequencies, and the Q of the cavity attached to the local oscillator should not be too high.

In this proposal no attempt has been made to stabilize the micro-wave frequencies. Spurious fluctuations are bound to occur and in order to

keep within reasonable margins there is little doubt that constant voltage power supplies and operation of the micro-wave generator at constant temperature in a thermostatically controlled enclosure would be helpful. A good measure of automatic control can also be provided if necessary through the agency of a high Q resonant cavity. Thus, two cavities with resonant frequencies, one slightly above and the other below the ultra-high frequency carrier can be connected to the wave-guide so as to give, after detection of their separate excitations, a differential control. Alternatively, the Radiation Laboratory of the Massachusetts Institute of Technology has used a single cavity connected to the wave-guide for this purpose. The cavity is purely resistive at resonance, it is capacitive below resonance and inductive above resonance. Thus, there is a rapid change of phase in passing through resonance and this effect may be harnessed to control the frequency of the excitation within such narrow limits as an audio range at 10,000 Mc/s.

4. 7. *Comparison between Services offered by Wave-guide and Lines operated at Lower Frequencies*

In the first place we observe the remarkably low attenuation obtainable with a suitably designed cylindrical wave-guide carrying an H_{01} mode. A copper guide $1\frac{1}{2}$ in. diameter operated at 40,000 Mc/s has an attenuation of only 6 db per mile. The same guide operated at 20,000 Mc/s instead of 40,000 Mc/s has an attenuation about three times as large. This compares with between 6 and 7 dB per mile for the standard coaxial line at 1 Mc/sec. or about 1 db per mile for the usual form of underground telephone cable at ordinary speech frequencies with a conductor size of 20 lb. per mile. Since the wave-guide has such good screening properties we can allow anything up to

60 db drop in the power level over any one section, and therefore at 40,000 Mc/sec. a copper tube $1\frac{1}{2}$ in. diameter will only require repeaters at intervals of 10 miles. The London-Birmingham coaxial line is employed as a means of transmitting a 50 cycles per. sec. power supply to repeater stations in addition to providing communication channels. The same arrangement could be used with even greater simplicity for the wave-guide. There is also the possibility of insulating the wave-guide sufficiently to enable it to be employed for higher voltages in power distribution. As an overhead power line at 132,000 volts 50 cycles per sec. we have to compare with the usual steel-cored aluminium conductor having 30 aluminium strands and seven steel strands each 0.11 in. diameter. This overhead power line has an equivalent copper sectional area of 0.175 sq. in., an overall diameter of 0.77 in., and a tensile strength of about 17,000 lb. To give the same copper section the guide of $1\frac{1}{2}$ in. inside diameter would have to have a wall thickness of about 0.036 in. This is not an inconvenient size. The main problem lies in providing the necessary tensile strength, and because reinforcement in this connection must be over the outside of the conductor, a non-magnetic metal sleeve such as phosphor bronze, would have to be employed. The larger diameter of the guide is an advantage in avoiding corona at the higher transmission voltages, which are likely to come into use in the future.

The number of communication channels offered by a wave-guide of the form considered is very considerable, and as already explained, can be numbered in thousands. For high definition television the arrangement would be particularly valuable. Taking all factors into consideration it would therefore seem probable that the complexity of the equipment required would be fully justified by the services given.

CONVENTION DISCUSSION

Commander (L) J. D. M. Robinson, R.N. (Associate Member) : Is not too much stress being laid on the need for mechanical flexibility of the truck wave-guide? As longitudinal electrical continuity is not necessary, would it not be preferable to construct the wave-guide in rigid section like water-mains? There would be less

risk of mechanical distortion and the practical mechanical limit on the diameter of the wave-guide would be removed.

Mr. E. M. Lee (Member) : What is the absorption band for nitrogen? Would there be any advantage in silver plating the inside of the wave-guide?

Mr. M. M. Levy (Member) : I have read this paper with great interest. Earlier I had the opportunity to assist at Professor Barlow's lectures on wave-guides at University College. These lectures were of great help to me, and I am awaiting with great interest the publication of Professor Barlow's book on the same subject.

Most engineers interested in telecommunications realise the great possibilities of wave-guides, but the merit of Professor Barlow's paper is that it summarizes in a very clear manner the aspects of this problem. While we can only admire the expositions on the trunk wave-guide, I believe there are still considerable problems to be solved before the scheme becomes a practical possibility. We are not yet very familiar with the handling of waves of less than one centimetre and so long as the technique at these frequencies is not well established it will be difficult to estimate what difficulties lie ahead.

In the scheme illustrated by Fig. 5, one difficulty seems to have been overlooked. The group of channels coming from each coaxial line lies in the frequency band 0.5 to 2.1 Mc/s. This group

corresponds to about 600 channels, and to avoid inter-channel cross-talk it is essential that no wave distortion appears during the modulation and demodulation process. In coaxial technique, this is avoided by carrying out all modulation on groups of frequencies whose boundaries are such that harmonics produced by modulation appear outside the selected side-band. Thus, one starts with a group of 12 channels lying in the frequency band 60 to 108 kc/s, and with carriers of 216, 264, 312 kc/s, the successive super-groups 108-156, 156-204 . . . are obtained. Since the harmonics of 60 kc/s are outside the group 60-108 kc/s, the modulation introduces no distortion in the super-group bands. To obtain the same results in the present scheme, it would be essential to start from groups lying say, between 1 and 2 Mc/s.

The question of automatic frequency control has also to be studied very carefully. Any frequency drift is transferred to the super-super-groups and, from there to the super-groups, and finally, to the channels themselves. I have not given this part of the subject very careful thought, but it may be that here is a real difficulty. I welcome Professor Barlow's comments.

REPLY TO THE DISCUSSION

Professor Barlow : Commander Robinson's point that longitudinal electrical continuity is not required for guiding the form of wave chosen and therefore his suggestion that a number of comparatively rigid sections of pipe might be joined end to end without special regard to the joints, is quite a good one especially if we are prepared to forgo the use of the tube simultaneously as a conductor for power supply. Nevertheless, the joints would have to be carefully aligned to avoid discontinuities producing reflections.

Investigations are still proceeding on the absorption bands for gases.

So far very little is known about nitrogen, and I am unable to answer Mr. Lee's query on this subject except to say that the gas exhibits negligible absorption in the micro-wave band of interest for this project. Silver plating the inside of the wave-guide is advantageous in so far as the conductivity of silver is rather greater than that of copper, and therefore the attenuation would be reduced in the

same proportion. For any great length of guide the expense would, however, be prohibitive.

Mr. Levy has called attention to the importance of avoiding inter-channel cross-talk, and to the value of selecting group frequencies so that interference arising from modulation products is reduced to a minimum. In this I concur entirely, but I see no serious difficulty in establishing the desired conditions. Whilst starting with groups lying between 1 and 2 Mc/s would undoubtedly yield a satisfactory arrangement, I am not clear why the alternatives more in line with current practice are regarded by him as unacceptable.

On the subject of A.F.C., any frequency drift in the wave-guide carrier-generator would be accompanied by a corresponding change in frequency of the associated local oscillator. Thus, the output remains unaffected, and the super-super groups continue without disturbance. It seems to me, therefore, that there is no problem in this connection.

GRADUATESHIP EXAMINATION, MAY, 1947

SECOND PASS LIST—OVERSEAS CANDIDATES

Twenty-five candidates appeared for examination throughout all Overseas Centres

Candidates who have passed the complete examination, or having been exempted from part have now passed the remaining subject(s), and are therefore eligible for transfer or election to a grade of membership other than Student.

DOSHI, Kantilal M.	Ahmedabad, India
MAIRAL, Manohar Malharrao	Baroda, India
PORRITT, Brian Longshaw Day	Johannesburg, S. Africa
ROBERTSON, Angus James Eric	Sydney, N.S.W.
SHARMA, Dharm Sheel (S)	Delhi, India

The following candidate has passed Parts I, II and III

MULLICK, Jhangi Ram	Kirkee, India
---------------------	---------------

The following candidates have passed Parts I and II

BROWN, Arthur Malcolm (S)	Brisbane, Australia
LEE, Charles Tet Hien (S)	Singapore
RIESEL, Herbert	Tel-Aviv, Palestine

The following candidate has passed Part I only

HALL, Thomas Charles (S)	Darwin, Australia
--------------------------	-------------------

The following candidates have passed Part II

ALI, Ahmad (S)	Agra, India
EVE, Benjamin John (S)	Sydney, N.S.W.

The following candidates have passed Part III

RAO, P. Laxminarayana (S)	Bombay, India
SINHA, Kailashnath (S)	Meerut, India

The following candidate has passed Parts II and III

ELVEN, Jack Noël (S)	Ealing, London
----------------------	----------------

There are still some results outstanding, and these will be published when available. Meanwhile, all candidates are being notified by post.

THE INSTITUTION'S LIBRARY

The following books have recently been added to the Institution's Library. They are available on loan to all members, and will be posted if required, in which case postage should be refunded when returning the book.

Additions	Index No.
Bendz, W. I. <i>Electronics for Industry</i> , 1947	747
Fink, D. G. <i>Principles of Television Engineering</i> , 1940	715
Flint, H. T. <i>Wave Mechanics</i> . Fifth Edition, 1945	717
Jackson, L. C. <i>Wave Filters</i> . 2nd Edition, 1946	724
Josephs, H. J. <i>Heaviside's Electric Circuit Theory</i> , 1946	718

Lovell, B. <i>Electronics and their Application in Industry and Research</i> , 1947	748
Mills, J. <i>The Engineer in Society</i> , 1945	743
Olson, H. F. <i>Elements of Acoustical Engineering</i> , 1940	725
Poole, J. <i>The Telephone Handbook</i> . Eighth Edition, 1944	726
Ramo, S., and Whinnery J. R. <i>Fields and Waves in Modern Radio</i> , 1944	736
Reich, H. J. <i>Theory and Applications of Electron Tubes</i> , 1944	721
Temple, G. <i>The General Principles of Quantum Theory</i> . Third Edition, 1946	720
Zworykin, V. K., and G. A. Morton. <i>Television. The Electronics of Image Transmission</i> , 1940. Fourth Printing, 1946	737

**THE RADIO TRADES EXAMINATION BOARD AND
CITY AND GUILDS OF LONDON INSTITUTE**

RADIO SERVICING CERTIFICATE EXAMINATION 1947

The first examination held under the auspices of the Radio Trades Examination Board in conjunction with the City and Guilds of London Institute took place in May of this year at various centres in Great Britain. The practical part of the examination was held respectively in London, Birmingham, Manchester, Glasgow and Bristol. There were sixty-five entries. Forty-four candidates satisfied the Board in both written and practical parts. Two candidates were satisfactory in the written examination and will be permitted to re-attempt the practical test, and three candidates were successful in the practical test having already passed the written examination in 1946.

PASS LIST MAY 1947

The following candidates have satisfied the examiners in the entire examination :

BARLOW, Edward	Manchester	MARTIN, Frederick	Bolton
BIRKETT, Frederick I.	Southampton	McCAUL, Samuel	Glasgow
BOLTON, Bramwell	Newton Abbott	McINTOSH, John	Midlothian
BRADLEY, Albert Roy	Gosport	MILESTONE, Harold	Bolton
CALIEAR, George	Whitstable	MOSS, William Leslie	Coventry
COX, Herbert Thomas	Nr. Swindon	MUIR, David M	Glasgow, W.2
CROMPTON, Charles	Huddersfield	NEWMAN, Henry	Ilford
DAVIDSON, Douglas	Ayr	PARKER, Frederick	Mitcham
DRYNAN, David James	Glasgow	PANTON, David	Grangemouth
DUNKLEY, Arnold	Greenford	PAYNE, Dennis George	Bath
EVANS, David	Finsbury Park	PHIPPS, Stewart Alexander	Liverpool
FISH, Norman	Hitchin	POINTER, Edward	Maidstone
FORD, Andrew	Ayre	POLLOCK, Thomas	Rutherglen
FORREST, Michael A	Manchester	SANDER, Peter	N.W.7
GRAY, Henry	Renfrew	SEAR, Norman	Morecambe
GEERE, John	Bolton	SEWELL, John	Cranleigh
HALL, Reginald	Newport	SHAW, Ronald	Uxbridge
HEPWORTH, Benjamin	Yorks	TELFORD, Harry	Bolton
HIGHLAND, Francis C.	Carshalton	TWITY, Kenneth	Darlington
LILLIE, James	Derby	WHITEMAN, Francis C.	London, S.E.24
		WILDING, George Richard	Liverpool

PASSED WRITTEN EXAMINATION ONLY

COYNE, Ernest	N.W.10	CUTHBERT, Peter	Glasgow, S.3
---------------	--------	-----------------	--------------

COMPLETED EXAMINATION FROM 1946

FAIRBAIRN, Harry	Eastbourne	LEWIS, Reginald Whitehurst	Wolverhampton
GLEDHILL, Ronald	Blackpool		