

O.B.M.
The Book Arcade
HOBART

Copyright
No. 56

RADIO AERIAL HANDBOOK



GOOD NEWS

RADIO NEWS, foremost American Radio magazine, can now be obtained direct by post from America; the only sure way of receiving copies regularly.

RADIO NEWS unfolds, month by month, the complete story of radio research and development. Editorially and in presentation, printing and production, it maintains the highest American standards. Each issue contains from 136 to 160 pages *of* news, articles, pictures and advertisements, brilliantly written and illustrated.

Radio technicians, dealers, business and factory executives, radio specialists in the services, amateurs, "hams," officials, research specialists, constructors, all are fully catered for. The scope of RADIO NEWS, in all that matters, is complete.

For a subscription of £1 5s. 0d., inclusive of postage, payable in advance (equal to 2s. 1d. a copy, the postman will deliver a copy at the door every month for a year. For two years the rate is £2 5s. 0d. and for three years, £3 0s. 0d.

Subscription orders may be placed through your radio dealer or newsagent or, in case of difficulty send your order name and full address in BLOCK LETTERS, (please) with remittance covering the period required, to us at the address below.

. . . . **RADIO NEWS**

POPULAR PHOTOGRAPHY, FLYING, PLASTICS.

From the same publishers come these three superb magazines, each completely fulfilling, in its own sphere, the same essential purpose as RADIO NEWS. Informative to the highly skilled operator or technician, yet understandable, and interesting to the amateur : intensely practical, yet never dry or stodgy. Brilliantly written, copiously illustrated and beautiful produced, each magazine maintains the highest standards for which American magazines are famous.

Particulars of subscription rates and facilities on request.

ZIFF DAVIS LIMITED,

GRAMPIANS BUILDING, WESTERN GATE, LONDON, W6

Telephone : SHEPHERDS BUSH 4794

RADIO AERIAL HANDBOOK

By

“RADIOTRICIAN”

No. 56
BERNARDS (PUBLISHERS) LTD.
LONDON • W.6

Copyright 1947

CONTENTS

INTRODUCTION

		Page 4
CHAPTER 1	<i>The Theory of Aerials and Wave Propagation— The Radiated Wave</i>	Page 5
CHAPTER 2	<i>Propagation of Waves and Aerial Directivity ...</i>	Page 11
CHAPTER 3	<i>Transmission Lines and Aerial Coupling— Efficiencies —Standing Wave Ratio— Transmission Line Construction— Untuned Lines and Aerial Matching— “Q “ Bars—The Quarter Wave Transformer— Voltage Fed Aerials—Current Fed Aerials— Correcting Stubs—Single Wire Transmission. Lines—Transmitter Coupling—Single Wire Feeders—Operating—Link Coupling— Air Spaced Twin Transmission Lines — untuned Lines—Tuned Transmission Lines ...</i>	Page 17
CHAPTER 4	<i>Practical Aerials—Quarter Wave Aerials— The Marconi Aerial—Half Wave Aerials— The Zepp Aerial—Long Aerials—Multiband Aerials</i>	Page 45
CHAPTER 5	<i>Directive Aerial Arrays—The Co-linear Aerial—The Broadside Aerial—End-fire Aerials—Combined System Aerials—The “Lazy H “—The Sterba—Parasitic Arrays— Rotating Beams—Aerial Erection— Precautions against Lightning and Electrical Discharges ...</i>	Page 52

Introduction.

Amateur transmitting, suspended at the commencement of the war, has been responsible for many of the developments which go to make the aerial an efficient device.

With the many new uses of radio on the battlefield, it is- a foregone conclusion now that peacetime conditions once more obtain there are new techniques for both the transmitting and receiving experimenter to master.

The aerial, considered as a single unit, has perhaps received less attention from the average amateur than any other section of his equipment, and it is to act as some small counter measure to this attitude that this manual is written.

Owing to the necessary cessation of amateur activities no account of original experiments can be given in these pages but even so it will be quite impossible to collate all the facts and figures relating to the subject.

/

It will be seen that the aerials dealt with are all of the short wave transmitting type, but to the amateur who is interested only in the reception of signals this need be no disadvantage. Remarkably good results, in the past, have been obtained with the most makeshift aerials, but it would, appear that with the new techniques arising the aerial system will require more attention than it has received from the "listener", particularly on the new ultra-short- wave bands.

Aerials work "in reverse" so that a good radiator will also be a good receiver.

Moreover, whilst the formulae given relate equally well to all aerials it is scarcely possible nor indeed desirable to design an aerial for broadcast listening along the same lines as one for efficient high frequency work.

The broadcast listener is, in general, not an experimenter, the radio amateur using the short wave bands almost exclusively and requiring something rather better than the odd length of wire which is sufficient to operate the modern entertainment receiver. It is for this reason that the manual confines itself to high frequency work.

CHAPTER 1.

The Theory of Aerials and Wave Propagation.

To set an electro-magnetic wave around an aerial it is necessary for the wire to carry a high frequency current, and for the output of energy to be as great as possible. For the aerial to be highly efficient, it is necessary that the aerial circuit be resonant, or tuned, to the frequency of operation.

In the conventional tuned circuit of a coil and condenser the reactances of the two components combine at one frequency to make the total reactance of the circuit zero (or nearly so) and clearly any power fed into the circuit at this frequency will develop the greatest possible current. If an aerial shows a similar effect of a resonant frequency, as it does, clearly the current flowing in it will be the highest at this frequency for any given power input, and the strength of the emitted wave will also be high.

This condition of current in an aerial is known as a "Standing Wave" and is often likened to the wave which may be set up in a long rope fastened loosely at one end to a firm support. When the free end of the rope is waved up and down a certain speed of movement will result in a wave that travels completely along the rope. Moreover, small pulls on the end of the rope will be sufficient to keep the rope waving so long as the movements are correctly timed, or, to complete the analogy, are of the correct frequency. If the rope is shortened, the frequency will rise, and vice versa.

It must also be noted that the wave motion is "reflected" from the fastened end of the rope. Pulling the rope tight and giving the end one sharp shake will prove this point for the resulting wave will travel to the end of the rope and then return. The same reflection takes place in the aerial.

Already two points have been noted, then, to set up a standing wave the frequency is closely allied with the length of the rope, and energy is reflected back from the rope's end.

Consider now the rope as being replaced by a length of wire supported in space, with waves of electrical energy applied to one end. A current in the aerial may be considered as an electrical charge moving along the wire.

The speed at which the charge moves is theoretically the speed of light, 300,000,000 metres per second, and so the distance it will cover in one cycle of the frequency at which it is applied is

$$W = \frac{300,000,000}{f}$$

and W is obviously the wavelength in metres. But the charge, as we have already seen, travels along the wire twice, once in each direction owing to the end reflection, if

we desire to set up a wire in which the charge will travel W metres in the time of one cycle the length of the wire will be

$$\frac{W}{2} \text{ or half the wavelength long.}$$

The next fact emerges, then, that the shortest length of wire which will be resonant at a given frequency is a half wavelength long. For a frequency of 1,000,000 cycles per second the resonant length of wire is 150 metres, since W is 300 metres.

In a resonant wire, therefore, the charge moves from the source of energy at one end of the wire, is reflected from the far end and returns to the energised end just as the cycle is complete and a new cycle commences. The charge, therefore, receives a new impetus which sends it off once more, so that it continues to travel back and forth with, of course, a reversal of the direction of the current flow at each reflection. At each moment during a cycle, also, other charges are set off along the wire. Since the voltage of the energising source is varying according to a sine wave law the charges at one instant are slightly different in amplitude to those of the instant previous. As one charge is reflected from the end of the wire, therefore, it meets another charge only slightly lesser or greater than itself. Since the currents are flowing in opposite directions the resulting current at the end of the aerial is practically zero. At other points along the wire, however, the currents flowing in opposition have much greater differences in amplitude. As they have been supplied at widely separated parts of the cycle there is less cancelling up to the centre point of the half wave aerial where the current is greatest. The distribution of current along the aerial may therefore be shown as in Fig. 1.

The voltage along the aerial is distributed rather differently. At the centre point of the aerial where the current is greatest the polarity of the returning charge is of opposite sign to that of the outgoing charge. As the charges are separated by a half cycle, and since they will be of the same amplitude the voltages cancel out. At the ends, however, the voltages are of the same polarity and thus add together whilst the currents are cancelling out. Thus the voltage distribution, as shown in Fig. 2 is greatest at the ends of the half wave aerial and zero in the centre where the polarity reverses.

From these diagrams it can be seen that the current in a half wave aerial would



Fig.1 DISTRIBUTION OF CURRENT ALONG HALF WAVE AERIAL

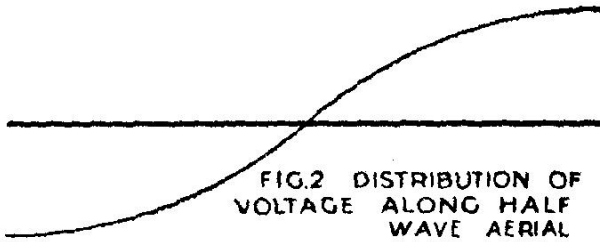

be measured by inserting an ammeter in the wire at the centre point and the voltage would be measured at the ends, probably with a device such as a neon lamp. Any measuring device, of course, would need to be suitable for high frequency work so that a hot wire or preferably a thermo-couple type ammeter would be used. Standing waves are actually detected by instruments in this way, as will be shown later.

Whilst a wire is resonant to a wavelength of twice the length of the wire it is also resonant to harmonics of this fundamental frequency. This means that a wire upon which a standing wave is set up at a frequency of, say, X cycles will have two standing waves upon it at a frequency of $2X$ cycles and three standing waves at a frequency of $3X$ cycles. The value of such Harmonic Operation is at once apparent. For example an aerial suitable for reception in the 40 metre band, the aerial being about 20 metres long, will also be suitable for the 20 metre band when it will work at its second harmonic, the 13 metre band at its third harmonic and the 10 metre band at its fourth harmonic.

Fig. 3 shows the current and voltage distribution over a wire working at its third harmonic. It should be noted that the separation of the current and voltage peaks still remains, and that the peaks are still separated by a quarter wavelength. A maximum or peak of either current or voltage is called a loop whilst a minimum point is known as a node.

The speed of an electrical charge has already been given as 300,000,000 metres per second, but as may be imagined this speed is dependant upon the medium or material in which the charge is moving, the dielectric constant of the material being the determining factor. At high frequencies air is reckoned to have a dielectric constant of one, so that electromagnetic waves move in air at the speed of light in a vacuum which is the figure quoted above. Should the dielectric constant of the medium be increased for any reason the velocity both of a wave or of a change in

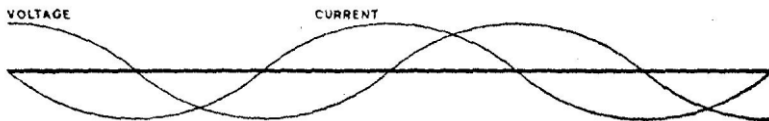

FIG. 3 CURRENT AND VOLTAGE ON AN AERIAL WORKING AT ITS THIRD HARMONIC

the medium will be decreased--that is, the wave or charge will take a slightly longer time to travel the same distance. The overall effect so far as an aerial is concerned is that the relation between the actual physical length and the electrical length of the aerial is changed, and that in order that the charges shall take the same time to traverse the wire--the time of one cycle of the frequency of the supply--the wire must be a little shorter than a half wave long. The effect on the ordinary aerial is known as the "end effect" since the cause is chiefly due to the essential insulation and supports at each end of the aerial. In addition, this capacity at either end of the wire absorbs some power from the aerial, and thus must always be reduced as far as is compatible with a strong and well insulated structure.

The actual effect upon the length of a half wave aerial amounts to a reduction in length of about 5 per cent, and a formula is simply extracted from the first statement,

$$W = \frac{300,000,000}{f} \text{ which gives the length } L \text{ of a half wave aerial in feet as } L = \frac{492 \times .95}{f}$$

where f is the frequency in megacycles. This formula includes the 5 per cent, correction and may obviously be restated as

$$L = \frac{468}{f} \text{ with } f \text{ in megacycles as before.}$$

In the case of a long wire aerial where there are several harmonic working frequencies the reduction in length is considered as applying to the end quarter wave lengths only of the wire,, and the formula becomes

$$L = \frac{492 (n - .05)}{f} \text{ where } n \text{ is the number of complete}$$

half waves in the length of the aerial at f megacycles as before.

The power absorbed by the capacity at either end of the aerial means that some current is flowing and so the current minimum value will fall, not to zero, but to some small finite amount. For the same reason the voltage node in the centre of the half wave aerial will appear as a small voltage which does not fall right to zero. The reversal of polarity takes place at this point.

As the charges move on the aerial they produce "strains" in the surrounding medium, generally known as ether, one strain appearing as a magnetic force and another appearing as an electric force These strains tend to lag in strength behind the forces which produce them. This means that at each alternation of energy in the wire an amount of power will be lost in electro-magnetic forces which are sent travelling outwards around the aerial by the succeeding strains. The whole effect being, so far as the aerial is concerned, a loss of power which may be measured electrically and expressed as a wattage.

Since the current in the aerial can easily be measured, and since the power lost in a resistive circuit can be expressed as $\text{Watts} = I^2 \cdot R$ it will be seen that the transmitted power leaving the aerial can be shown as lost in a resistance.

This fictitious resistance is known as the Radiation Resistance of the aerial and clearly it will vary according to the point on the wire where the measurements are taken. At the end of the half-wave aerial where the current is very small the radiation resistance would appear to be very high, and, in the centre of the half-wave aerial, at current loop, it would appear small.

Actually, at the centre of a half-wave aerial the radiation resistance has a value of about 73 ohms, although as will be shown later this figure is subject to fluctuation.

Besides the power lost in the radiation resistance of the aerial (the useful power loss), there is also a power loss in the actual resistance (often known as the ohmic resistance) of the wire. The ratio of the losses in the two resistances give the efficiency of the aerial, which, as can be seen, is high so far as radiated energy is concerned. The resistance of the wire can be very low compared with the average 70 ohms or so of the radiation resistance, and when stout gauge wire is used the aerial efficiency is above 90 per cent.

It should be noted that the radiation resistance of the half-wave aerial corresponds with the aerial impedance only at the centre point of the aerial, where the impedance is purely resistive. Since the impedance of a circuit is a measure of the voltage divided by the current the impedance will be wholly resistive only when the voltage and current are in phase, and on the half-wave aerial this occurs only at the centre point where the voltage is undergoing a polarity reversal. At other points the impedance includes some reactance.

In a short aerial such as is used on ultra high frequency bands the diameter of the aerial wire can affect the impedance of the aerial to a marked degree, for when the wire diameter rises to more than 1 per cent, or so of the length of the aerial the impedance at the centre point is raised. The net result is that the resonant frequency to which the aerial is tuned is not so sharply defined and so the aerial covers a wider waveband--that is, the frequency response is flatter, a desirable feature for amateur working.

The Radiated Wave.

It has already been shown that the wave radiated from the aerial has both electrostatic and magnetic characteristics, and the two sets of lines of force are at right angles one to the other so that a wave front may be shown as a square lattice work.

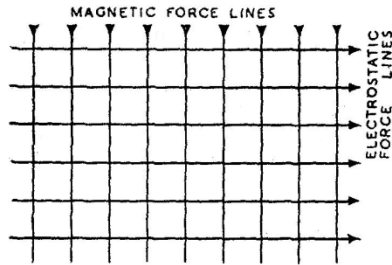

FIG.4 THEORETICAL DIAGRAM OF A WAVE FRONT HORIZONTALLY POLARISED

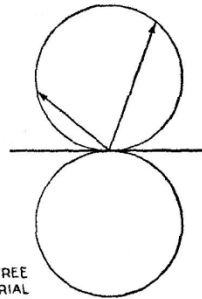

FIG.5 RADIATION PATTERN IN FREE SPACE OF HALF WAVE AERIAL

The direction along which the wave travels is always at right angles to the wave front, and the strength of the wave is conveniently expressed in microvolts per metre--more simply, the voltage induced in a wire One metre in length situated $3Q$ that it cuts the magnetic lines of force. A diagrammatic representation of the wave front is shown in Fig. 4, and this relates to a horizontally polarised wave, where the electrostatic lines of force run horizontally. The polarisation of a wave is primarily due to the setting of the aerial wire, for the wave from a horizontal aerial will have the electrostatic lines of force horizontal, whilst with a vertical aerial they will be vertical, but at an appreciable distance from the transmitter the polarisation of the received wave will probably change in character. Various factors affect this change of angle, particularly reflection from the ionised layers to be discussed later, but if the receiving aerial can be set to correspond to the polarisation of the received wave it will be energised as strongly as possible. Over short distances, and in particular on the ultra high frequencies where working is often confined to horizon distances, the transmitting and receiving aerials should both be in the same plane. For general short wave work it appears that a horizontal aerial is preferable, so far as the receiver is concerned.

The polarisation of the transmitting aerial, like other constructional points, must depend upon the results desired, for the aerial may be arranged in different ways to give different distributions of the transmitted power. & wire in free space, infinitely short, would distribute waves in such a way as to give even, spherical coverage When the wire is extended to a half wave in length the fields due to radiating points a half

wave apart tend to neutralise each other in some directions whilst adding their strengths in others. As a result a radiation pattern is formed, such as that shown in Fig. 5. The central, straight line shows the direction of the aerial, the actual aerial being so small in such a diagram that it amounts to a mere point at the centre of the figure. From this diagram it may be seen that the half wave aerial transmits strongly in directions at right angles to its length, but that from the ends of the aerial radiation is negligible. Such points of minimum radiation are known as nulls whilst the curves denoting radiation are lobes. The field strengths relative to the maximum are deduced by drawing a line from the centre point across the lobe in the desired direction, when the comparison of the length of the lines will give the ratios of the field strengths.

If the aerial could be suspended in space this pattern would extend all round the wire; that, is, any section through the length of the aerial would show the same distribution of radiation. Where an actual aerial is under consideration the pattern varies widely at different angles to the horizontal. Since, as can now be seen the direction and angle of travel from the aerial can be varied in many ways, it is necessary to consider the propagation, or spreading, of the wave through space.

CHAPTER 2.

Propagation of Waves and Aerial Directivity.

It was not until Heaviside and Kennelly both formulated a theory that radio waves were reflected from an electrified layer high in the atmosphere that the long distance reception of signals was understood. The first theory that radio waves followed the surface of the ground was disturbed when signals were received over a distance sufficiently great to prohibit the bending of the waves round the earth's surface, and with the proving of the reflection theory the mystery was solved. A further reflecting layer was later discovered by Appleton, above the Heaviside layer, Appleton's layer sometimes being single and sometimes breaking into two layers, and these layers are now known as the E, the F1 and F2 layers. At times the E layer breaks into two bands also, but it is generally regarded as a single band.

The cause of these reflecting layers is the action of the sun's rays on the attenuated gases of the upper atmosphere in the zone known as the ionosphere. As the name denotes, the air is ionised, that is, electrons are removed from some of the gas atoms. They therefore acquire a positive electrical charge whilst the electron becomes a free negatively charged particle, but whilst this state of affairs exists all through the ionosphere it is particularly so in the layers just mentioned.

The clouds of free electrons make up the layers.

The density of the ionisation in the layers varies considerably over the day, since the ionisation is a sunlight effect, and the two F layers merge into a single layer at sunset, this breaking up once more at dawn.

The average heights of the layers are 70 miles for the E layer, 140 miles for the F1 layer, 200 or more miles for the F2 layer and 180 miles for the F layer formed by the merging of the F1 and F2 layers at night. At times of low ionisation, such as winter, the F1 layer often disappears leaving the F2 layer which descends to a height of about 150 miles.

Fig. 6 shows waves originating from an aerial and their behaviour both at the ground and at the reflecting layers. It will be seen that a wave penetrates into the layer before being bent sufficiently to return towards the earth, the reason for this being that the wave is refracted rather than reflected. The refractive indices of the atmosphere and of the ionised layer differ. The result is that the part of the wave front which first enters the layer commences to travel at a faster rate than that part which has yet to enter the layer with the result that the wave bends round on itself.

It can be seen from Fig. 6 how the ground wave rapidly fades out, being of little value at point A. At point B is a wave reflected from the E layer, giving strong signals, although in the zone between A and B no signals are receivable. This zone A-B, therefore, is known as the Skip Distance, and its boundaries change for every station according to local and day-to-day conditions. If the wave is directed at a higher angle than that which gives reception at point B it will fail to be reflected from the E layer, and so the highest angle which will give return of the wave from an ionised layer is known as the Critical Angle. Waves at an angle above the critical will penetrate the layer and either be lost in space or returned from another layer as in the diagram, where the wave is returned to point C from the F1 layer. This means, however, that the wave has twice passed through the E layer, with refraction both times and also some degree of absorption as well as possible interference from denser ionised clouds.

It is likely, therefore, that reception at C will be both noisy and subject to fading.

Quite often a wave such as that arriving at B is reflected again from the earth's surface so that it makes a double hop to arrive at point D. A wave at a lower angle from the transmitter, however, can reach point D with only one reflection, which will give better reception than the two hop wave, this latter having suffered absorption and other interference at three points. It therefore appears that for ordinary long distance work it, is desirable for the aerial to send forth its energy at a low angle

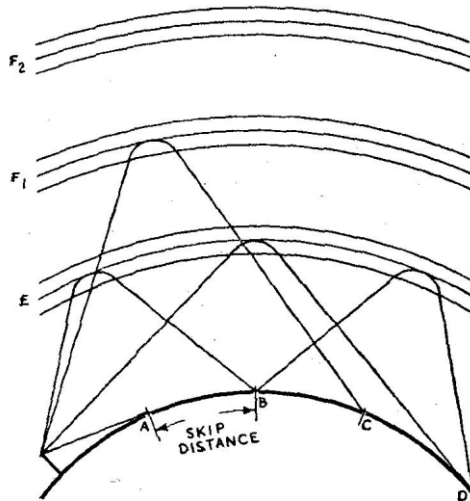

FIG. 6. REFLECTION OF WAVES.

The behaviour of the ionised layer is by no means constant. The most marked long term variation is apparently caused by the 11 year sunspot cycle, which affects the Critical Frequencies handled by the layers. The critical frequency is that frequency, directed vertically, above which the ionised layers will not return the waves, and when sunspot activity is low the critical-frequency is low, and vice versa. Seasonal changes from summer to winter also affect the ionisation of the upper atmosphere, and it will be realised that over long distances a wave might start under conditions of darkness to be received under conditions of light. It will therefore travel between extremes of conditions so far as ionisation is concerned, and the best all round conditions are those obtaining in spring and autumn.

The period of the sun's rotation also gives rise to further fluctuations in the degree of ionisation, the time period being 28 days, the maximum effect being upon the 10 and 20 metre bands, while the day-to-day fluctuations depend, as shown, upon the light and dark conditions of the layers. At night the E layer is much less dense in ionisation and consequently waves pass through it with little attenuation to be reflected from the reinforced F layer so that, in general, night conditions are better and 20 and 40 metre band signals are often so well refracted that a round-the-world echo can be heard on them, the echo time being about a seventh of a second.

Fading, which may occur in different forms at any time can be due to several causes.

Since the layers are not steady but rise and fall, the waves may be split into different components which arrive at the receiving aerial in or out of phase so that they periodically add together and then neutralise each other. Polarisation shifts may occur during refraction, so that even with a wave of fairly steady amplitude the aerial is energised to widely differing degrees, and in large receiving stations a special aerial receiving system is often used, known as the Diversity system. Here several aerials with different polarisations are erected at short intervals, and on fading the receiver is switched, sometimes automatically, from aerial to aerial to combat the changing signal strength.

It is often stated that ultra high frequency signals are received with certainty only over optical distances, where transmitter and receiver can be seen one from the/ other. Recent experiments however have shown that these high frequencies, whilst penetrating the upper layers, are often) refracted front layers of air close to the ground. The dielectric constant suffers a change due sometimes to a meeting of hot and cold layers of air or to water vapour conditions. It appears that very dense ionisations occurring locally in the E layer have also returned Ultra high frequency signals, but this must remain a matter of chance.

Suitable angles for radiation from aerials for long distance work are up to 45 degrees for 40 metres, up to 20 degrees for 30 metres, up to 10 degrees for 10 metres and as low an angle of radiation as possible for higher frequencies.

To understand how an aerial may radiate strongly at a, given angle it is necessary to return to the consideration of the half-wave aerial. As already stated, if such an aerial were erected in free space its radiation pattern would be as shown in Fig. 5, and the pattern would be solid all round the aerial. In a practical aerial, however, this pattern of Fig. 5 must be regarded as the horizontal pattern, or more properly the horizontal polar diagram, since such radiation patterns are drawn to polar coordinates.

A totally different polar diagram is needed to show the radiation of the aerial vertically.

The reason for the difference in the diagrams is readily understood when it is remembered that the earth is a conductor of electricity and thus must be regarded as a reflector of waves. For the purpose of drawing radiation diagrams it is generally reckoned that earth is a perfect conductor, but as this is not actually so there is always an error in the vertical polar diagram. These may be greater or smaller according to local conditions which can only be allowed for by experiment.

This reflection, from the earth, of the radiation of the aerial has many far reaching effects, and it is necessary to see what ultimate result on the radiated power these effects will have.

Fig. 7 shows the paths of waves from the section A of a horizontal aerial. The direct wave, AB, will at some point X be received together with a wave ACD which has been reflected from the earth, and the waves may be in or out of phase depending on the angle of reflection and thus the difference in path length. It must be noted that the wave reflected from the earth has its angle of incidence equal to its angle of reflection; that is, it is reflected in the same way as light from a mirror. The wave CD may thus be regarded as coming from an aerial at E, the same distance below the earth as A is above it. Once again however this factor is influenced by the local conditions, and this "image aerial" is out of phase with the actual aerial by 180 degrees. At any moment the imagined charges on the image aerial are equal but of opposite sign to those on the actual aerial, and this leads to a difference in the effects of (reflection upon horizontal and vertical aerials).

Consider the half wave aerial erected vertically, without any reflection effects. Then the pattern of Fig. 5 is turned through 90 degrees and becomes the vertical free space polar diagram of the vertical aerial whilst the polar diagram for the horizontal radiation is a circle. In a practical vertical aerial with earth reflection, therefore, the horizontal polar diagram is still circular, so that the aerial radiates equally to all points of the compass. Unlike the horizontal aerial, the aerial and its image the phase reversal causes the actual and imagined currents to flow in the same direction.

Returning to Fig. 7 it can be seen that the field strength due to the aerial A at the distant point X can lie between the limits of twice the field strength which would be given by A without reflection, or zero field strength. If the direct and reflected waves are in phase, then they will add and produce twice the field strength of one wave alone. If they are out of phase they will cancel out, and at intermediate phase difference they will produce field strengths between these limits. The most useful vertical polar diagram is a "reflection factor".

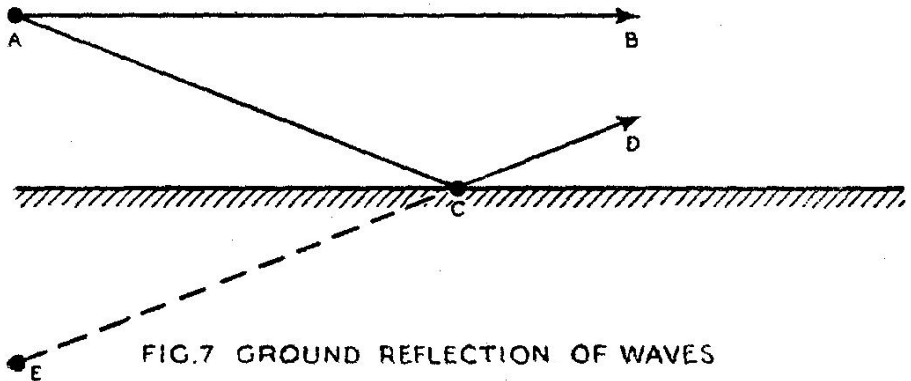

Such factor diagrams can be little more than guides, however, for the reflective values of the ground vary from situation to situation. The image aerial therefore will seldom be theoretically true whilst absorption effects will further distort the picture. For example, a typical factor diagram shows that a vertical aerial is extremely efficient as a radiator of low angle waves. In actual fact however the lowest waves radiated from the vertical aerial, at least in a great number of cases, suffer so severely from absorption that they are lost before ever contributing to the aerial's useful output.

The characteristic which finally decides the radiating angle of an aerial is the height of the aerial above earth. As has been shown this cannot readily be determined with accuracy since the condition of the earth falls short of the presumed ideal. Suffice it to say, therefore, that for all horizontal aeriels together with vertical aeriels an even number of half waves long, the best all round operating heights above ground are either a half wavelength or one wavelength. The latter height gives a rather greater proportion of high angle radiation for local working. If a height of two wavelengths can be obtained even better working should result, but for most amateur frequencies this will be impracticable. It must be remembered that the height of a vertical aerial is measured from the centre of the wire.

The three-quarter wavelength height should be avoided for these types of aeriels, since too much radiation is directed at a high angle, but for the vertical aerial an odd number of half wavelengths long, the three-quarter or one and a half wavelengths heights are most suitable.

If, in place of the unstable earth reflecting surface an efficient reflector is necessary for any reason, it is possible to provide this by covering the surface of the ground below the aerial with a metal net. The net must extend for at least half a wavelength in all directions, and whilst such a restricted area will have little or no effect upon the low angle radiation of the aerial, the device will at least allow the actual aerial height to be established.

In turn this will make known the actual radiation resistance. The radiation resistance of the aerial is also changed by the reflected waves, for those radiated directly to the earth and thus reflected straight up, and past the aerial will induce currents in the aerial in or out of phase with the main currents depending on the aerial's height. Whilst the input to the aerial remains constant, therefore, the aerial current changes with height, the effect being equivalent to a change in radiation resistance. Where the height is roughly .3 of a wavelength the radiation resistance rises almost to 100 ohms (where the half wave aerial radiation resistance is reckoned as 73 ohms) and falls to 60 ohms where the height is roughly .6 of a wavelength. At heights of a wavelength or half a wavelength, however, the radiation resistance is very near to the theoretical value of 73 ohms, and it is recommended that where a horizontal half wave aerial is to

FIG.8 RELATIVE VERTICAL FIELD STRENGTHS ON A HORIZONTAL HALF WAVE AERIAL

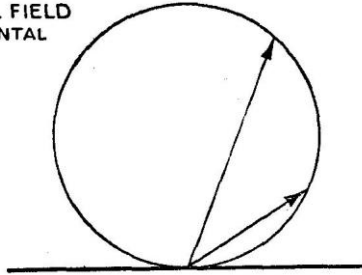

be installed it be erected at a height of one wavelength or, if the frequency is low at a height of half a wavelength.

A further reflection effect is seen with regard to the radiation from the ends of the half wave horizontal aerial, where the horizontal polar diagram appears to indicate that there is no radiation at all. Actually this is misleading, as the diagram of the lobe on the aerial in a vertical direction in Fig. 8 will show. There must be end on radiation from the half wave aerial, although it will be at a higher angle than the broadside radiation. In addition, to this the null is further filled in by reflected vertically polarised waves which travel out at the higher angles in the end on direction of the aerial. The radiation in the direction of the aerial, therefore, is more suited to local and short distance working, but if it is desired to use this end on radiation to the fullest advantage, the aerial may be erected in a sloping position. Where a horizontal half wave aerial is supported one wavelength high at one end sloping down to a half wavelength high at the other end, the radiation is good in all directions except that of the high end.

The height of vertical aerials is measured from the centre of the aerial, and it is interesting to note that in the Marconi aerial the wire may only be a quarter wave long with one end earthed. The resonant half wave length is then virtually completed by the image aerial through reflection.

CHAPTER 3.

Transmission Lines and Aerial Coupling.

In the early days of radio transmission it was soon discovered that the practice of bringing the aerial direct to the transmitter for the purpose of coupling it to the source of R.F. power was inefficient and undesirable.

Clearly there are two points at which a half wave or a longer resonant aerial may be fed with power--either at a current loop or at a voltage loop; points which on

the single half wave aerial correspond to the centre and end of the, aerial respectively. To bring the end of the aerial to the transmitter in order to feed it at a voltage loop means that losses in the surrounding building will be severe, spurious reflections will occur and generally the aerial will need to be brought to a low height. Feeding the centre of the aerial directly at the transmitter is even worse, and so transmission lines, generally known as Feeders, were developed to carry power to the aerial with very little loss whilst the aerial itself can be erected well in the open and at considerable heights, if desired.

A feeder may consist of a single wire, but most often there are two wires to a transmission line, the wires being spaced constantly through their length by a certain fixed distance dependent upon the desired characteristics of the feeder.

The feeder may be used in one of two ways, it may be "TOWED" or "UNTUNED", the tuned feeder being more usually in use.

When high frequency current is fed either to a single or double line of infinite length there is no reflection from the end of the line and consequently no standing waves are set up. These occur only when the line is cut to a certain finite length and so can give current reflection from its end. Even then, if the wires of a two wire line are connected at their ends by a resistance equal to the Characteristic Impedance of the transmission line, the line, so far as the high frequency currents are concerned, will again appear to be of infinite length and again Standing waves will not be set up.

Such a transmission line, where the feeders terminate in a resistance equal to their characteristic impedance and have no standing waves upon them is the untuned line.

Where the transmission line has its feeders terminating in a resistance higher or lower than the characteristic impedance of the line, standing waves will be set up, this line being the tuned or resonant transmission-line. If the terminating resistance is lower than the line's characteristic impedance the end loop of the standing waves will be a current loop. Current loops will also appear at approximately every half wave length of line down to the transmitter, the voltage loops appearing with the usual 90 degree phase difference. If the terminating resistance is higher than the line's characteristic impedance then the end loop of the standing waves will be a voltage loop with voltage loops appearing at half waves down the line, the current loops appearing at the usual 90 degree intervals.

The Characteristic Impedance of the line is seen to be of paramount importance, therefore, and may technically be expressed as the square root of the ratio of inductance to capacity per unit length of line. The value is also known as the Surge Impedance of the line, since it is the impedance which is presented by a long line of the specified type to impulses induced into the line.

Moreover connecting the ends of a pair of feeders through a resistance equal to the characteristic impedance causes the transmission line to present the same impedance across its other ends, no matter how long the line.

The characteristic impedance of a pair of lines, generally known as Z_0 , is determined by the radius of the wires used and the spacing between them. For air insulated feeders

$$Z_0 = 276 \log \frac{X}{Y}$$

where X is the spacing from centre to centre of the wires and Y is the radius of the wire, X and Y must both be in the same units, either inches or centimetres.

Besides being of air spaced wires, feeders can also be constructed of concentric or coaxial cables, where one conductor runs along the centre line of a second tubular conductor. This outer conductor is often woven to give flexibility, the two conductors being spaced internally by several methods ranging from solid rubber insulation to plastic "thimbles". Cables are also made where two conductors are run side by side in rubber insulation with very close spacing, these two conductors sometimes being shielded with a third outer conductor enclosing the whole cable.

When such transmission lines are obtained commercially their surge impedance will be stated; generally they are low and of the order of 100 ohms or less so that they may be coupled to such an aerial as the half wave to give an untuned line.

The characteristic impedance of a coaxial line is given by

$$Z_0 = 138 \log \frac{A}{B}$$

where A is the inside diameter of the outer conductor and B is the diameter of the inner conductor, units again being the same for the two conductors. This formula holds only for lines having a high proportion of air spacing between the conductors, as when small separated spacers are used. When the spacing between the conductors is maintained by a solid dielectric the expression for Z_0 must be divided by \sqrt{K} where K is the dielectric constant of the material between the conductors (2.2 to 2.95 for India Rubber).

The impedance is reduced in a solid dielectric line by reason of the increased capacity between the conductors, and for the same reason the velocity of the wave along the line is also reduced.

The effect of this reduction in velocity is to make a measured length of feeder contain a greater number of standing waves than would be expected by calculation. The solid rubber spaced coaxial cable shows the greatest discrepancy and the twin air-spaced wire feeder the least.

It is not necessary to make calculated allowances for the apparent change in feeder

length, however, so long as the shortest feeder practicable for the work in hand is used. With untuned lines the effect will be neutralised by the matching system and with tuned lines the coupling circuits to be described in a later chapter will handle either a current or voltage loop at the feeder termination. The overall loss of efficiency resulting from the increased feeder capacity will be the most Important effect, and it is for this reason that the shortest possible feeder is advocated.

Twin lighting flex and cabtyre cable have been used as equivalents to twisted line feeders, but their losses are high and they are not to be recommended for outdoor work where weather conditions will rapidly cause perishing and changes in their characteristics. If they are used experimentally they may be reckoned to have characteristic impedances of the order of those given for rubber spaced coaxial line-- that is generally less than 100 ohms.

Where a single wire feeder is used the characteristic impedance will be roughly 500 ohms for a heavy gauge wire, 14 S.W.G. for example. Since standing waves on a single wire would cause it to radiate as strongly as an aerial the single wire line is generally untuned and matched into the aerial where the radiation resistance is of the same order as the line impedance, 500 ohms. Clearly some care is needed in making the adjustment, and further details appear in the discussion of the Windom and VS1AA aerials.

It is one of the greatest advantages of the double wire transmission line that its method of construction prevents it from radiating waves even when it is a tuned feeder. The two wires, spaced as they are by only a fraction of a wavelength, carry equal and opposite currents (except in the case of the Zeppelin aerial, described later, where the currents are not quite equal) and so the radiation from one wire effectively cancels out that of the other. This spacing of the wires should not be greater than a hundredth of the wavelength for good cancellation.

If it is necessary for the feeder to run close to absorbing or reflecting surfaces it is sometimes found that the balance of the currents in the two lines is disturbed, the cause being that one line has a greater capacity to the surface or to earth than the other. In such cases the feeders should be separated by transposition blocks, obtained commercially, by means of which the wires are regularly transposed or crossed. Throughout their length therefore the average capacity of each line to earth or other masses in proximity to it are equal.

In the following sections of the chapter, the efficiencies, methods of use, aerial matching and transmitter coupling details for the two types of transmission line are shown, together with constructional details.

Efficiencies.

Whilst the tuned line is more simple to use and adjust than the untuned line, the losses in the tuned system are greater. A deciding factor of the usefulness of the tuned line is

the length of feeder required to run from the transmitter to the feeding point on the aerial, and where this length exceeds 3 or 3 wavelengths it will be preferable to use the untuned feeder, properly matched into the aerial impedance. A 3 wavelength line even at 20 metres gives a good run, however.

It is common to measure both aerial gain (described later) and transmission line losses in decibels, a 1 dB loss corresponding to 25 per cent, of the power or 12 per cent, of the current or voltage in the line to which the loss refers, 3 dB corresponding to a loss of half the power or 30 per cent, of current or voltage. The losses are generally reckoned in fractions of a decibel per wavelength run of line.

A 600 ohm line, such as has already been mentioned, has a loss of only .1 dB or less per wavelength when the line is untuned; that is when there are no standing waves upon it. The untuned line is therefore suitable for very long runs, even though the loss will rise a little under bad weather conditions or after long use. The same line, with air spaced wires, will increase its loss under the tuned condition to an extent which depends on the standing wave ratio (see the next paragraph). The loss rises perhaps to as much as .5 dB per wavelength run in a. new line and even more with bad weather or age.

When the coaxial: lines with rubber spacing are used the losses are higher still, and these lines are in general unsuitable for runs longer than a wavelength, particularly if they are used as tuned feeders and are thus carrying standing waves.

Standing Wave Ratio.

As has already been explained, a transmission line will have set up along it standing waves of voltage and current unless it is fed into an impedance equal to its own characteristic impedance. Since a usual figure for the characteristic impedance of a line is 600 ohms and the centre point of a half wave aerial presents an impedance to the line of about 73 ohms it will be seen that such a line coupled directly to such an aerial will have standing waves on it, the first loop, that at the aerial end of the line, being a current loop.

The ratio of the mismatch of the two impedances is 600:73 and if the current in the feeders is measured, first at a point of maximum current and then at a point of minimum current (i.e., at a current loop and null, separated by a half wavelength) it will be found that the currents differ one from the other by the same ratio, 600:73 or, being simplified, 8.2:1. A measure of the current ratio in the feeders gives the degree of mismatching between the aerial and the line, therefore, this ratio being known as

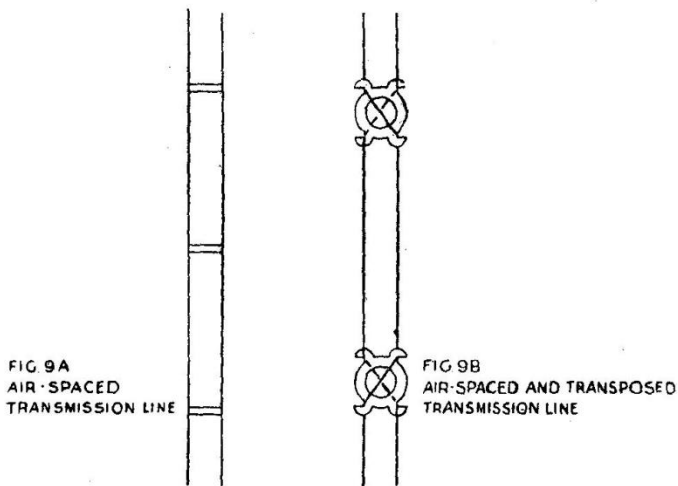

the standing wave ratio, and the figure may be allowed to rise to 10:1 before any disadvantage becomes apparent.

Transmission Line Construction.

The examples quoted in this chapter and elsewhere are based on a feeder impedance of 600 ohms which is a widely used and a satisfactory value. It has the added advantage that a fairly stout gauge of wire can be used with spacers of a convenient length, a good combination being either 16 S.W.G. wires spaced 5" apart or 14 S.W.G. wires spaced 6" apart. It is advisable to use the lighter wire so that stresses and strains especially at the centre of the aerial can be avoided as much as possible. Also for this reason the spacers should be light so far as is consistent with strength and good insulating properties. It is very unlikely that the feeders will need to carry currents which cannot adequately be handled by these gauges of wire.

The wire is best enamelled so that it will be protected from exposure and corrosion.

The spacers between the wires should be obtained commercially, though they can be made of wood. They should be a yard apart along the wires although where transposition blocks are used it might be found necessary, after trial, to decrease this distance to 2 feet. These blocks usually give a smaller spacing than 6" but the wire gauge to give a line of 600 ohms impedance can, of course, be calculated from the formula already given. When transposition blocks are used it is desirable to slightly reduce the spacing but since this is not possible. With the commercial products the same effect can be obtained by using a gauge of wire a size smaller than that calculated. (See Figs. 9a and- 9b.)

line spacers can be made up from three-eighths or half inch hard wood dowelling, the rods being cut to length and having a notch filed across each end face. A small hole should also be drilled near each end. The rods are then treated in just boiling paraffin wax--the wax must not boil hard--by immersing them and leaving till all air bubbles are driven off. When the spacers have been drained they must be allowed to stand until the wax is perfectly hard.

To make up the transmission line the two feeder wires are positioned in the shallow grooves at the ends of the spacers and retained in place with a binding of 20 S.W.G. threaded through the drill holes. At 14 megacycles a transmission line so constructed can be up to three half wavelengths long without support between the aerial and the transmitter, and longer lengths can be supported from wooden posts fitted with stand-off insulators.

Untuned lines and Aerial Matching.

Since standing waves do not appear on a line whose impedance corresponds with the aerial impedance it would seem that all that is necessary is to arrange the surge impedance formula to give a line of, say, 70 ohms to match the ordinary half wave aerial. When the calculations are made it is found, however, that the spacing of the two wires along the transmission line would be very small--the impedance of the line falls as the spacing falls--whilst the wire gauge becomes large. Such a line, with small spacing, generally gives trouble even if only through weight and easily changed characteristics due to the wires twisting nearer still as the feeder swings in the wind whilst insulation will be less efficient in wet weather. The solution is to use the higher impedance line and to match it to the aerial through an impedance transformer device.

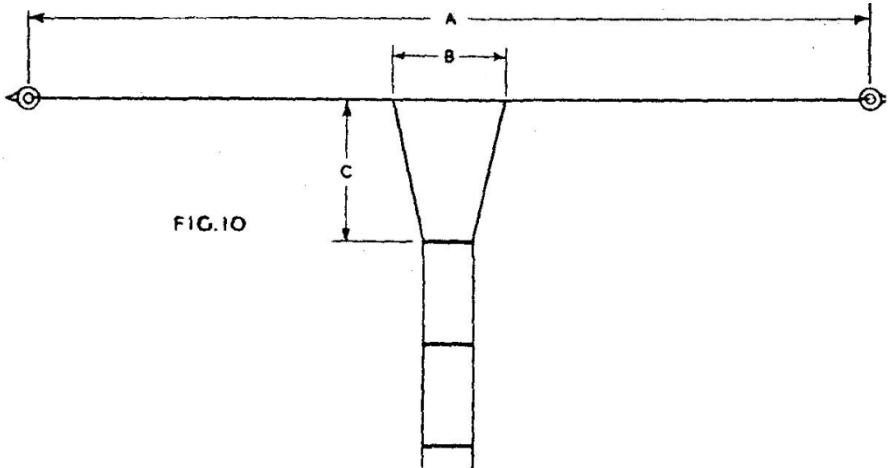

A simple matching section is the Delta match, shown in Fig. 10 It will be seen that the feeder spacing is gradually increased from a definite point, the spacing distance rising until the feeder wires meet the aerial. The fanning out of the feeders in this way clearly will give rise to a gradual change of line impedance over the section where the spacing is rising, the impedance growing higher The line is connected to the aerial in such a way that the impedance is greater than the 73 ohms which would appear as the load if the aerial were cut at the centre and the feeders connected there The two impedances, therefore, are made equal by the fanning out of the wires and it must be noted that the aerial is not cut but that the feeders are tapped on to it.

The aerial length A must be correct, calculated as already explained and tested, if desired, by aerial tuning tests to be described, whilst for a 600 ohm line the two measurements B and C are found from the formulae

$$B = \frac{148}{f}$$

$$C = \frac{123}{f}$$

where both B and C are in feet and f is the working frequency in megacycles. Since the formulae are based on the figure of 73 ohms for the aerial impedance the distances B and C will be slightly inaccurate if for reasons of height or other reflection effects the aerial impedance is different. In any case it is possible to check an untuned transmission line for standing waves, which, of course, should be absent, and to make experimental readjustments in the fanning out of the feeders if the system is not working properly. It may be noted that it is often stated that a standing wave ratio of, say, 2 on a theoretically untuned line can be tolerated

Testing for standing waves on an untuned line can be carried out with either a current or voltage indicator, the device, of course, being one which responds to radio frequency power. The simplest voltage indicator is the neon lamp which will usually light if grasped in the hand with one contact connected to a voltage point. If such a lamp is run over a convenient part of the feeder at least a half wave in length, the lamp either should not light at all or, if it does, the glow should be constant. If the lamp lights at one point and not at another, or if the glow fluctuates, being weak at one point and strong at another standing waves are present on the feeder, and the matching is not accurate.

A similar check can be made by tapping a flashlamp bulb of the 3 volt variety across a length of the feeder line, the connecting points being, say, 2' apart. The bulb will thus act as a shunt to the portion of the line across which it is connected and sufficient current will be passed through it to cause the filament to glow. Again, in an untuned matched feeder the glow should be reasonably constant at all points along the

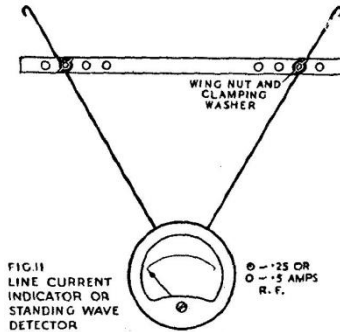

line, but a more definite test is made by developing this idea and using, instead of a bulb, a R.F. milliammeter reading up to, say, .5 amp. The best type of instrument is undoubtedly the thermo-couple ammeter, although almost any instrument used for measuring high frequency current will have an error due to the skin effect on the heater wire. Meters of this type read high to as much as 10 per cent, at frequencies of 14 mcs. and over, but this is of little consequence where comparative readings are generally all that are required.

The meter may be suspended from the line or any other wire under test by stout wire hooks firmly fixed to the connecting terminals on the back of its case, the hooks being spaced to the desired amount by an insulating rod. (See Fig. 11).

Once again the untuned feeder should give constant readings throughout its length when it is shunted by the meter. Peaks indicate standing waves and consequently mismatching. It must be remembered to bare the metal of insulation at the checking points, afterwards protecting it with shellac.

A development of the Delta Match is used with twisted wire feeders, particularly in reception of ultra high frequency signals. The characteristic impedance of twin flex, such as lighting cord, or cabtyre is very roughly 100 ohms, depending on the manufacture. Such a line, it is found, may be connected into the centre of a half wave aerial without the losses rising too much, but a better method is to fan out the two wires a foot or so from the aerial. The aerial itself is cut in the centre, the feeders being connected to the cut ends and these connections are then spaced, and the two halves of the aerial linked mechanically, by an insulator 6" or 9" long. As short a run of feeder as possible should be used to keep the loss low, and it may be mentioned here that a feeder with a characteristic impedance quite close to 70 ohms may be made

by using two lengths of twisted flex in place of a single length. The flexes are wired in parallel by connecting the ends of one wire in the first pair with the ends of the corresponding wire in the second pair, the other two wires also having their ends connected. This feeder is connected to the aerial by again cutting the aerial wire at its centre point and joining the feeders to the cut ends. In this case the halves of the aerial are not separated by the large distancing insulator but are linked by a suitable short insulator, of conventional design.

“Q” Bars.

Fig. 12a shows a half wave line folded to become a double line one quarter wave long. Since the line is still resonant, although its radiation is cancelled out, the voltage and current distribution still hold good. The current, in the diagram, is shown as a full line with a dotted line indicating the voltage distribution. At the top end, therefore, with voltage high and current low, appears a high impedance, and at the bottom, with high current and low voltage appears a low impedance. These relationships still hold when the two quarter wave conductors are not connected across their lower ends, as in Fig. 12b. The device of Fig. 12a is known as the Quarter Wave Transformer, whilst that of Fig. 13b is known as the “Q” match, and is dealt with first.

The quarter wavelength of special feeder, where Q bars are to be used, is made to give an impedance which will match the high impedance, 600 ohms, of a transmission line to the low impedance, 73 ohms, of the half wave aerial, and the matching impedance is determined from the formula

$$Z_o = \sqrt{Rr}$$

Thus for the combination above, 600 ohms into 73 ohms, the formula would become

$$\begin{aligned} Z_o &= \sqrt{600 \times 73} \\ &= \sqrt{43800} \\ &= 209 \text{ ohms as the impedance for the quarter wave section.} \end{aligned}$$

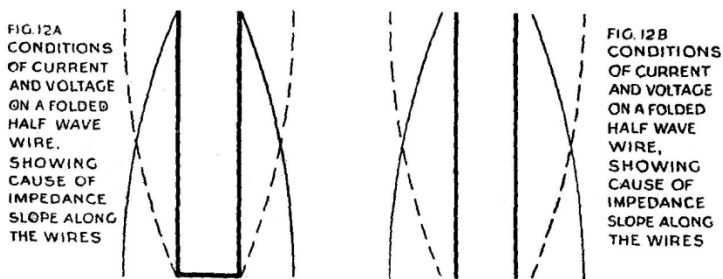

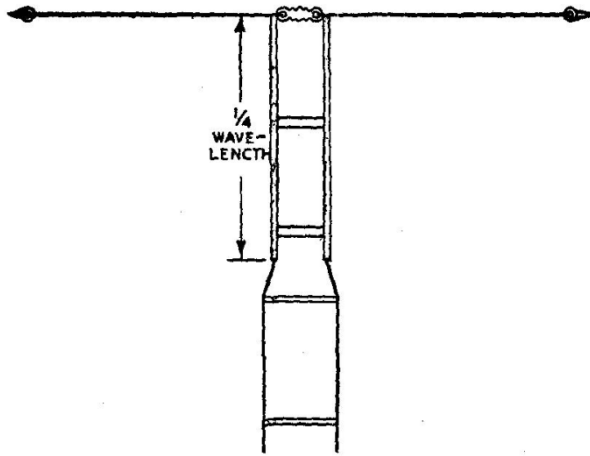

FIG. 13 Q BAR MATCH FOR AERIALS AN ODD NUMBER OF HALF WAVES IN LENGTH

Q bars are generally obtained commercially, cut to length, and given their diameter, usually $\frac{1}{2}$ " since they are made from thin walled tubing, their spacing is found to be, from the formula already given

$$Z_0 = 276 \log \frac{X}{Y}$$

$$\text{or } 209 = \frac{276 \log X}{.025} \quad (Y \text{ is the radius of the tube})$$

$$\text{or } 52.25 = 276 \log X$$

$$\text{and } \log X = \frac{52.25}{276}$$

$$= .1893$$

Therefore from tables of logarithms,

$$X = 1.456, \text{ which is the spacing in inches, taken between centres.}$$

At a frequency of 14 megacycles, therefore, corresponding to a wavelength of 21.43 metres the Q bars will be 5.36 metres long, the metre being 39.37 inches, spaced almost 1.5 inches between the centres of the tubes, Since the Q bars must hang down vertically from the aerial the tubes must be of light construction, preferably of thin aluminium. The spacers between the tubes may be of wood well treated with wax, but since the distance is so small ceramic spacers would be better. The arrangement is shown in Fig. 13.

The Quarter Wave Transformer.

It is necessary, before discussing the properties of the quarter wave transformer to consider the various uses of the matching devices which may be chosen.

In the first place it is clear that the transformer method of matching the line impedance

to the aerial impedance can be used on one frequency only, since the transformer is designed about a certain frequency.

Generally speaking the matching device will give good operation over the band (i.e., the Q bar match in the example above would cover the 14 megacycle band without serious losses at the band limits) but for harmonic aerial operation it is necessary to use a tuned line.

Moreover neither the Delta match nor the Q bar match is suitable for matching a line into a high impedance point or voltage loop. Where the aerial is current fed, the transmission line being led in at a low impedance point or current loop, these two systems can be excellent. Where, however, it is necessary to feed the aerial at a voltage loop, as in various types of aerials to be described later, it is necessary to use the closed type of quarter wave transformer as shown in Fig. 14.

Unlike the other methods of matching, however, the quarter wave transformer is not limited to this one application. If the quarter wave section is opened at the bottom, so that it becomes two separate wires it can then be used as a current feeding match. These two types of transformer are useful for the general transformation ratios which are high--that is where a high impedance line is fed into a low impedance aerial.

On occasions, however, the ratio of the impedances is low, since a large beam aerial might need feeders too long to be tuned. In such cases correcting stubs, developed from the quarter wave transformer are used.

The three methods are outlined below

Voltage Fed Aerials.

Aerial length a whole number of half waves--i.e., 1, 2, 3, etc., WHOLE wavelengths long, the transmission line being fed to the centre of the aerial.

The transformer is made in the same way as the transmission line, and is closed at the lower end by a movable shorting bar or wire which must be readily adjustable. Any clip which is used should be capable of really firm fixing so that it may be set to the correct operating position experimentally and then taped over, both, for weather protection and as additional fastening.

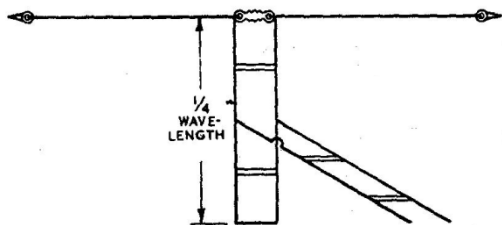

FIG.14 QUARTER-WAVE TRANSFORMER FOR FEEDING INTO A VOLTAGE LOOP. AERIAL AN EVEN NUMBER OF HALF WAVES LONG

The transformer for voltage feeding is shown in Fig. 14 and its method of working, as can be seen, is to match the line impedance to the aerial impedance. This is accomplished by tapping the feeders on to the transformer at a point discovered by trial and error where the voltage to current ratio corresponds to the matching ratio desired

The matching of the system commences with adjusting the aerial, with the transformer in place, to the required resonant frequency. The best method of making this adjustment is to energise the aerial under test inductively from a temporary aerial erected at least a half wave away, and working from the transmitter at the correct frequency. The temporary aerial could be suspended below the aerial undergoing adjustment, but in some cases the method will take up a good deal of space, and it will probably be preferred to energise the aerial directly from the transmitter. The coupling at the transmitter end must be light, and the feeders should be tapped on to the transformer about a tenth of the distance up from the shorting bar.

In either method of adjusting to resonance, the indication is given by a R.F. ammeter shunted across the shorting bar on the transformer, or, if the currents are low, the ammeter may be used in place of the shorting bar. The aerial is hoisted into what will be its final position and the current registered by the instrument noted--it will probably be necessary to read the instrument through binoculars-- and the shorting bar is then readjusted to a new position and the current read again. This entails the lowering of the whole system, and some time will have to be expended on the work.

The shorting bar is finally fixed in the position where the current registered across it is at a maximum, and taped to prevent further movement. The transformer tap is now adjusted to such a position that the transmission line has no standing waves set up along it. For a start, the feeder wires may be tapped on to the transformer about one thirtieth of a wavelength from a current loop, i.e., the shorting bar. The ammeter is removed from the aerial, and used to indicate the presence of standing waves along the feeders by tapping it across a suitable length of the feeder wire, as already described. Alternatively the transmission line can be tested for standing waves by the neon lamp method.

The points along the transformer section where the feeders are tapped in are adjusted until standing waves on the transmission line are eliminated or brought to a very low-ratio. The transmitter coupling to the line is then increased to the optimum amount as the line comes into proper working conditions. If difficulty is experienced in dispensing completely with standing waves it may prove helpful slightly to increase the length of the transformer section by moving out the shorting bar a few inches. A low standing wave ratio will not affect the line efficiency severely, although it should be possible to make the line completely flat.

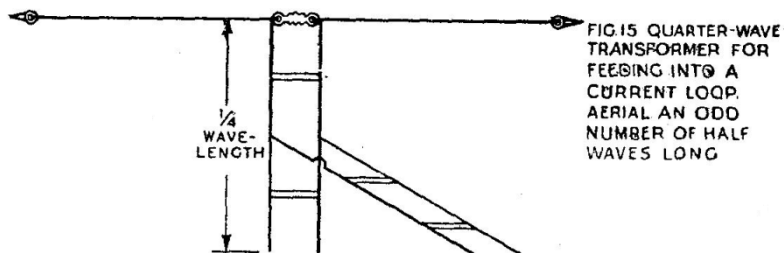

With the line and transmitter working under their correct conditions the last test is to inspect the current in each feeder wire close to the coupling unit on the transmitter. The currents should be the same, and if they differ the transmission line will be transmitting on its own account. Possible causes of out-of-balance currents are reflection effects, a greater capacity to earth along one wire than the other, or sharp bends or kinks at some point in the line. The proposed path of the feeder should, of course, be inspected for possibilities of the first two effects before the aerial system is erected, but if they occur a transposed transmission line should eliminate the trouble.

Current Fed Aerials.

Aerial length an odd number of half waves, the transmission line being fed to the centre of the aerial.

In this case the impedance of the aerial at the point where power is fed in is low, for whether the aerial is one, three or five half waves long a current loop will appear at its centre. The transformer section in this case is open at the bottom end, but in other respects is identical with the transformer already described. That is it is constructed in the same way as the transmission line, and suspended from the centre of the aerial, the feeders being tapped on to it to give a suitable current-voltage ratio.

The aerial again must be brought to resonance either by lightly coupling it to the transmitter or by energisation from a temporary aerial erected a half wavelength or more distant. Since in this case the transformer section has no adjustable shorting bar the aerial is adjusted to resonance by making it a foot or two longer than the calculated figure, and shortening the ends. The arrangement is shown in Fig.15. When the aerial is fed direct for this first operation the feeders should be tapped one tenth of the transformer length down from the top.

It may be said here that the length of the aerial is measured up to and including the loop at the end which passes round the insulator.

Assuming that the egg type insulator is used the aerial wire should be bared for a suitable distance, run round the egg and twisted back upon itself, the joint being well soldered. The loop is then a short circuited loop acting as a straight wire, and the aerial length must be considered as extending up to the extreme curve of the loop.

The resonant point of the aerial is shown, as before, with the help of a R.F. ammeter, but in this case the ammeter is connected across the top of the transformer section, since the current loop appears here, at the centre of the aerial.

The adjustment is made by reducing the length of both sides of the aerial by the same degree a few inches at a time, the Current shown by the ammeter being noted until it passes through a peak. The aerial wires must not be cut exactly to length at each adjustment, therefore, although the loop must be made a good electrical joint each time. A little wire should be left spare so that the length can be increased slightly when the current maximum is passed. Resonance is indicated by the highest current on the ammeter. It will be realised that the operation is tedious, for the aerial must be raised to its working position for each current check, but the work repays care with efficiency.

When the aerial is resonant the transmission line is again tapped on to the transformer about one thirtieth of a wavelength from the current loop Which is now at the top of the transformer, and the ammeter is removed from the aerial The transmission line tap on to the transformer is adjusted until no standing waves are present along the wires, the transmitter loading being brought up to normal working conditions as the line adjustment is correctly made. The currents in the feelers should be checked as already described, and if they are unequal the same remarks apply-- the line is unbalanced in capacity or is kinked at some point.

In both these applications of the quarter wave transformer the match is not perfect since the impedance presented to the transmission line contains a reactive component. That is to say that the impedance is not purely resistive, a condition which, as has been seen, is conducive to the setting up of standing waves on the line. When the transforming ratio is high, however, the effect is not serious but where the aerial fed from the line has an impedance which will cause the matching ratio to fall to 5 or less the correcting stub should be used.

Correcting Stubs.

In order to understand the operation of the correcting stub it is necessary to consider a transmission line connected into an aerial without matching devices so that standing waves are set up.

along the first half wavelength of line, measured from the aerial, there will thus be an apparent impedance slope and if at some suitable point in this length of the line the reactive component could be cancelled out by a capacity or inductance, the equivalent of a quarter wave transformer tapping would be obtained with consequent matching and elimination of the standing wave from that point back to the transmitter.

A correcting stub, Fig. 16, gives this inductive or capacitive effect.

An open stub acts as a capacitive stub, and is used where the current falls in value from the aerial towards the stub; a closed stub acts as an inductive stub and is used where the current rises in value between the aerial and the stub. There are thus two positions in which the stub may be used, and the position nearer to the aerial is the more desirable.

For several reasons, however, the stub is far from simple to construct and adjust. It must be perpendicular to the feeders at the point of attachment which means that some support must be furnished, both, to support the weight and to maintain the correct angle, whilst a good deal of experimental work is necessary to determine both the size of the stub and its precise point of attachment. Since its use can be avoided by aerial design, it is felt that stub matching is best left to the professional and commercial transmitter.

Single Wire Transmission Lines.

Since the impedance of the aerial, due to the standing waves, varies at different points along the aerial, and since the impedance is purely resistive at each single point, it is possible, to match into an aerial a feeder system consisting of a single wire. The feeder will have its own impedance, as usual, depending chiefly upon the gauge of wire and the aerial's surroundings, and it is only necessary to tap this single feeder on to a point along the aerial where the aerial impedance equals the feeder impedance to effect a match between the two.

The adjustment is not simple to make and no hard and fast rules can be laid down since the whole system is influenced to a large degree by reflection whilst the

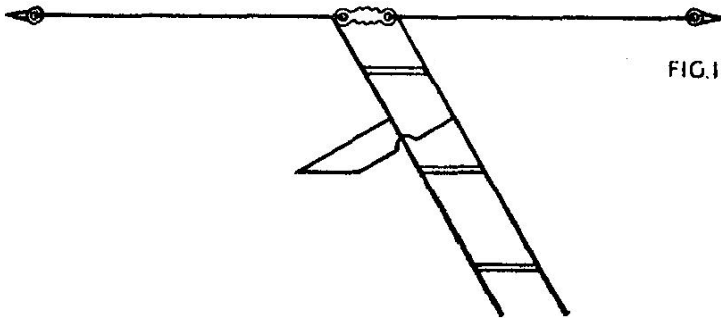

FIG.16 CORRECTING STUB ON TRANSMISSION LINE

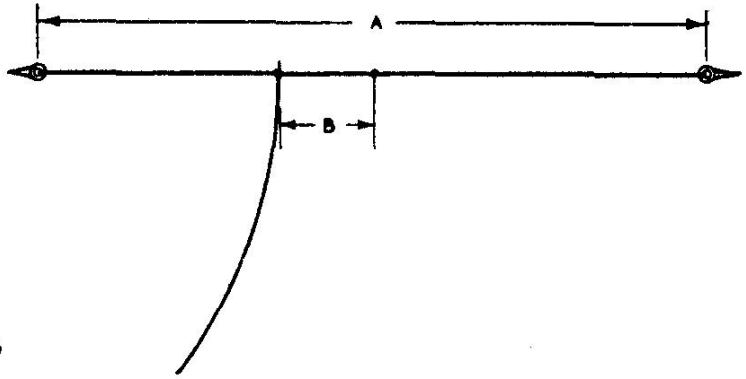

FIG.17 SINGLE FEEDER MATCHING

ground at the transmitter must be of a good conducting type. Over poor or sandy soil the system will probably give poor results

The two important dimensions, as shown in Fig. 17 are the aerial length A and the distance, B, of the feeder tap from the centre point of the aerial. The aerial should first be brought to resonance by energising it from a temporary aerial at least a half wavelength distant, the resonance being indicated as before by an ammeter situated in a current loop of the aerial. The resonance of the aerial is obtained by adjusting the length of the wire which should have been calculated from the figures given, the greatest reading of the ammeter showing the resonant point. Since it is most likely that single wire feeding will be applied chiefly to half wave aerials, this means that the ammeter will be suspended in the centre of the aerial, tapped across a length of the wire since it will not be convenient to cut the aerial.

With the aerial at resonance the ammeter is removed and the feeder is tapped on, the distance, B, from the centre of the aerial depending on the impedance, and therefore the diameter, of the feeder wire, being very approximately one eighth of the aerial length. The point at which the feeder is tapped on, however, must be considered only as a starting point for final adjustment, and the best method of checking the tapping point is to use a pair of ammeters inserted into the aerial or tapped across the wire, one either side of the tap and as close to the feeder aerial junction as possible. When the tap is correct the two meters will indicate the same current and the final test should be the usual standing wave check along the feeder wire itself.

The feeder should leave the aerial at a right angle and be straight for at least a quarter wavelength from the aerial, with no sharp bends at any place.

If the aerial is to be used at more than one frequency it is necessary to make these adjustments at the higher frequency.

J. Macintosh, VS1AA, has developed a single feeder matching system for use on long wire aerials where there are: four or more half waves on the aerial as when a full wave

40 metre aerial is used on 20 and 10 metre bands. The aerial is cut to length according to the figure calculated from the resonant length formula, and the single feeder is tapped, on at a point exactly one third of the aerial length along the wire. The feeder must be of lesser diameter than the aerial wire to obtain correct matching, and where the aerial is 68 or 138 feet long it may be made of 14 S.W.G. wire, the feeder being of 20 S.W.G. Where the same aerial wire is used on a 40 metre half wave aerial, about 33 feet long, the feeder should be of 18 S.W.G.

The main disadvantages of the single wire transmission line are firstly that it always gives a certain proportion of radiation from the feeder and secondly that it is very prone to radiate transmitter harmonics. This can be an asset in some cases but for general amateur work it is most desirable to eliminate harmonic transmission to avoid interference. In addition to those points the earthing of the transmitter and aerial coupling device must be good -- this is dealt with in the next section on transmitter couplings.

Transmitter Coupling.

It may be helpful to the novice to review the operation of a simple transmitter before considering the various methods of coupling the transmission line to the final output, and in Fig. 18 is shown a purely basic circuit of a simple transmitter, without modulation. The tetrode Crystal Oscillator, C.O., provides a controlled R.F. supply in the tuned anode system of the first valve, the Power Amplifier, P.A., consisting of two tetrodes in push-pull being energised through a link coupling unit which is made up of two small coils connected by a length of twisted feeder--ordinary lamp cord is perfectly suitable for the job. This link coupling has many uses, and is often used to connect an aerial tuning system to the final stage of a transmitter.

The transmitter is brought into working conditions by first removing the link coupling between the stages and tuning the anode circuit of the oscillator. The milliammeter in the anode line of the valve will show a pronounced dip in current as the circuit comes into resonance with the crystal frequency. When the C.O. is working correctly the P.A. coupling is restored, and the P.A. circuits tuned, the grid circuit indicator being the milliammeter in the bias lead which indicates the grid-current flowing and the anode circuit indicator being the milliammeter in the anode supply line. As power is taken from the C.O. the anode resonant circuit of the first stage may need some retuning while the current dip will not be so great as it formerly was. The current dip in the plate circuit of the P.A. is very great as the final tuned circuit (the "tank circuit") comes into resonance, and the degree of aerial coupling is adjusted so that as the aerial draws power from the final stage this current dip is decreased until the valves are drawing their rated current at the resonant point.

FIG.18 BASIC
CIRCUIT OF A
SIMPLE
TRANSMITTER

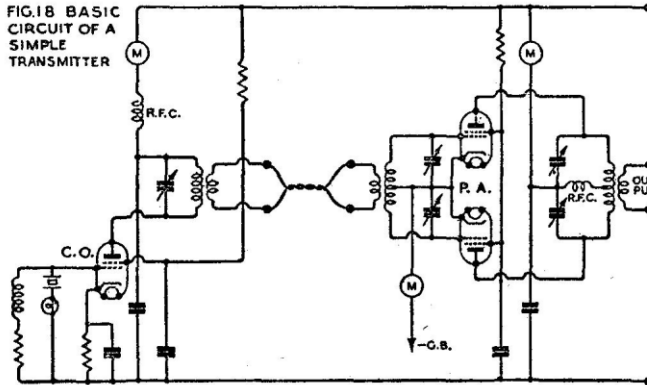

Transmitter--Transmission Line Coupling.

Single Wire Feeders.

As with some other feeder systems it is possible to tap a single wire feeder directly on to the tank circuit of the transmitter, but in most cases this is poor practice. The aerial is at a high potential unless it is isolated from the tank by a condenser. It is therefore liable to harmonic radiation through capacity coupling and also radiates key clicks on C.W. and where the earthing of the tank circuit is defective or poor it is sometimes possible to have a standing wave set up actually on the transmitter itself with consequent danger to the operator, possible instability and the likelihood of high frequency energy being fed into the mains supply.

For these reasons it is not proposed to show direct coupling circuits, since better results can be obtained with quite simple feeder couplers.

Fig. 19 shows the circuit of a single wire feeder coupling, the feeder coil being coupled to the tank through a link coupling. When the feeder coil is directly coupled to the tank coil the coupling should be variable, the general practice being to make the feeder coil swing about a fixed point or to run along insulating bars to and from the tank coil, as shown in Fig. 20. The link coupling is used where the feeder enters the transmitting room via insulators and the feeder coil is situated at this point which is possibly some way distant from the transmitter. In this case the link coupling can be run round the room to transfer energy with very little loss and twisted flex link lines can be used although a better method is to make up a small transmission line with

small spacing between straight vires, especially for the higher frequencies over 14 mcs.

Wherever the feeder coil and condenser are they must be capable of tuning to the transmitted frequency, must be made up of good components suitable for high frequency working with good insulation characteristics and be mounted with good insulation from earth except at the correct earthing point. For low power stations the tuning condenser may be of the normal receiver type, but where the transmitted power is high, double spaced high voltage condensers should be used in the feeder circuit as in the tank circuit. It is always good practice to drive the condenser spindle through an insulating coupling. In general the capacity of the condenser should be kept low, a suitable value being 150 m.mfds., the coil being chosen to suit the capacity.

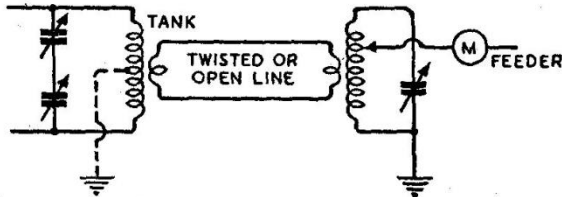

FIG.19 SINGLE WIRE FEEDER COUPLING TO TRANSMITTER
DOTTED EARTH LINE INDICATES POINT OF LOW R.F. VOLTAGE

Operating.

Where the coil is mounted to couple straight into the tank circuit.

Remove the feeder from the feeder coil and swing out this coil to the minimum coupling position, tuning the tank circuit for minimum plate current. Tap the feeder on to a turn fairly low on its coil (i.e., near the earthed end) and bring the feeder coil up to the tank coil, tuning the feeder condenser until the tank current rises, indicating that power is being drawn from the P.A. The tank may need slightly retuning, but if so the degree of variation should be only small. When the two circuits are in resonance it will be found that by moving the feeder tap towards the top end of its coil (away from the earthed end) the current in the P. A. anode circuit will rise, and a point should be found where this anode current rises to the full load current specified for the P.A. valve or valves. The ammeter shown in the feeder is useful as an indicator, but it is not necessary and should be shorted out when the aerial is working correctly.

Link Coupling.

The coils at the ends of a link coupler must always be situated at a point where the R.F. voltage in a circuit is least, this being shown on the tank circuits in the diagrams

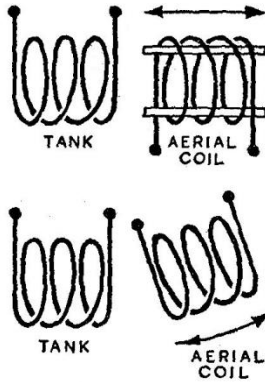

FIG.20 VARIABLE COIL COUPLINGS

by a dotted earth connection. At the feeder end of the coil this is always at the centre of the feeder coil but at the transmitter the link must be situated at the earthed end of the tank coil where the P.A. is single ended and at the centre of the coil where the P.A. has a balanced tank circuit. If the link coil is placed at the “hot” end of the tank coil it will tend to pass on harmonic frequencies via capacity coupling.

The link coil may be wound over the tank or feeder coils, but it is preferable to break these coils at the centre and to accommodate the link coil on the former.

Whilst this means that the link coil is not movable, and so cannot give variable coupling, this variation can be dispensed with by experiment to find the most efficient size of link coil. This system is more robust whilst coil changing is simpler.

The feeder coil can be made up as shown in Fig. 21, and it is convenient to have the feeder coils on a pin base so that they can be interchanged by plugging the whole coil assembly into a valveholder or similar socket. At the transmitter the tank coil can also be made in this manner when a balanced tank is being used. In a single ended tank circuit the link coil can be wound on the bottom of the tank coil former or, if the tank coil is large and self supporting, the link can be mounted at the earthed end on stand-off insulators. The distance between the link coils and the feeding or fed coils should be found by experiment as they will differ for different circuits, but in general the spacing can be kept low--a quarter or eighth-inch spacing between coils is often sufficient.

A rough guide to the size of the link coil is to make the coils a tenth to a third of the size of the tank coil, the proportion rising as the total number of turns decreases, but

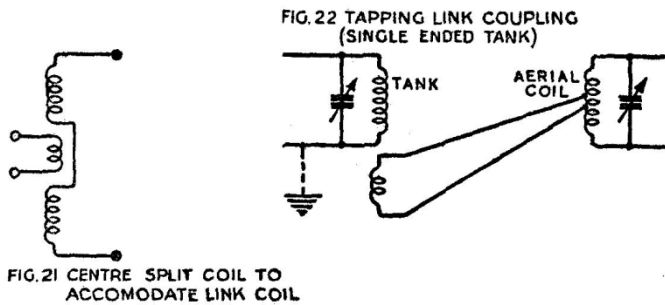

the final selection of size must always be by experiment, the coils at either end of the link coupling being of the same size for the first trials.

Instead of using a coupling coil with the feeder tuning coil it is possible to tap on the link coupling line as shown in Fig. 22, and for whichever method is chosen the method of loading the aerial on to the P.A. stage is as follows.

Disconnect the link coupling line from the feeder coil and tune the transmitter tank to resonance, to give minimum plate current, then recouple the link coil to the line or the line taps to the feeder coil. Tap the feeder on to its coil at a low position and tune the feeder coil with its condenser until the P.A. plate current rises to its highest point. The tuning of the tank circuit should be for resonance although no change, or only a slight change in condenser setting should be necessary. Increase the loading of the aerial on the tank, if required, by tapping the feeder farther up the coil, until the P.A. plate current is at the specified reading for the valves used. If the link coil at the feeder end is dispensed with and the link coupling line is tapped on to the feeder coil, the tapping points can also be used to adjust the load. The line should be tapped on to the feeder coil at one turn either side of the centre turn, when by increasing this distance symmetrically the loading on the P.A. will rise.

Air Spaced Twin Transmission Lines. Untuned Lines.

Here again the feeders may be coupled to the tank circuit in three ways, directly, by a coil placed beside the tank coil, or by link coupling. Direct coupling is only to be recommended where the tank circuit is balanced—that is, has a centre point at earth potential so far as the R.F. currents are concerned—the coupling method being shown in Fig. 23a. The condensers must be at least .0005 mfd.

capacity, with a working voltage well above that of the supply line to the P.A. whilst their capacity for R.F. current carrying is given for an absolutely minimum value by

$$I = \frac{\sqrt{W}}{Z}$$

watts and Z is the line impedance. In practice the condensers should be able to carry a rather higher current than this and in the interests of safety the value thus calculated might be doubled.

The method of directly coupling the feeders inductively to the tank coil is shown in Fig. 23b, the coupling coil being variable with respect to its position beside the tank coil. The size of the coupling coil is best found by experiment, the adjustment necessary being the swinging in of the feeder coil until the P.A. plate current is at its rated value at the resonant point. This system is, perhaps, most useful when used with a single ended tank circuit, the coupling coil being mounted on the "earthy" side of the tank.

Link coupling circuits for untuned feeders are similar to those used with the single feeder wire, the main difference being that the feeder coil is not earthed. The link coils are still placed at low R.F. potential points on both the tank and feeder coils, and the feeders are tapped symmetrically on the feeder coil, as in Fig. 23c. The tank is tuned for minimum plate current with no load from the feeder coil and when the P.A. is at resonance the link circuit is completed and the feeders tapped on to their coil so that the load is light—the tapping points should be close to the centre of the coil. The feeder coil is then tuned to resonance, as indicated by a rise in the P.A. plate current. The feeder tapping points are then moved out from the centre of the coil, the number of turns between each feeder and the centre of the coil remaining equal, until the current registered in the feeder is as high as possible with the P.A. plate current at its correct reading. At this stage it will be as well to compare the currents in both feeder wires. Any unbalance may be due to lack of symmetry about the centre point of the feeder coil but will more probably be due to faults in the transmission line as already detailed—a greater capacity to earth of one line or a sharp bend in the feeders.

The feeder coil and condenser shown in the foregoing diagrams must be suitable for tuning to the transmitter frequency, so that no trouble should be experienced in choosing their values, but the next circuit is rather more elaborate, although of value since it may be used to couple both untuned and tuned transmission lines to the transmitter, whilst with correct operation the system is useful in the suppression of harmonic radiation. The circuit, known as the Pi-section network, is shown in Fig. 24.

The suggested values are .002 mfd. for C, the same remarks applying for voltage rating as before, .0001 mfd. for C1 and C2 except for 80 and 160 metre working, when they may be of .0003 mfd. capacity, whilst both coils are wound 15

turns of 14 S.W.6. on a 2½" diameter former to a length of 3" and tapped every three turns, the approximate settings for various bands being the full coil in for 160 metres, 6 turns shorted for 80 metres, 9 turns shorted for 40 metres and 13 turns shorted for 20 metres. The condensers C1 and C2 should be double air spaced.

The operation of the pi-network is the same for both tuned and untuned lines, and the coupler must be used on a balanced tank circuit.

Disconnect the network and tune the P.A. for minimum plate current, tapping the input condensers symmetrically about the centre of the tank coil afterwards, the

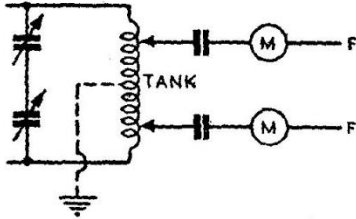

FIG. 23A

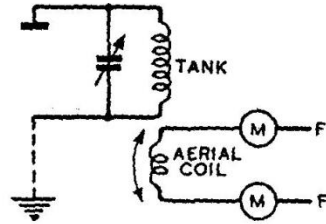

FIG. 23B

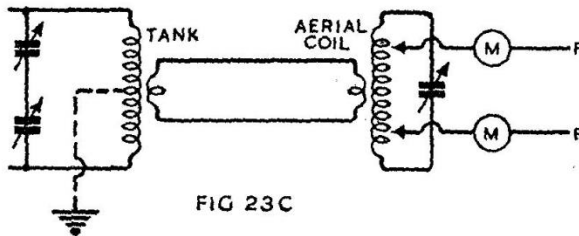

FIG 23C

COUPLING UNTUNED TRANSMISSION LINES TO THE TRANSMITTER

coil taps of the network being set as indicated. When the condenser C2 is set to half capacity and the P.A. is switched on the anode current will be high, and it is reduced by adjusting C1 (rapidly, to avoid overload), until the current falls to the correct working value. If this cannot be obtained, repeat with a new setting of C2, and if at all settings of C2 the current is too high or too low, tap the input condensers higher or lower either side of the tank centre point or try new tappings on the network coils. The tank tuning should not be altered. The aim is to make the minimum plate current obtained by the adjustment of C1 coincide with the correct valve working current, and upon this adjustment depends the elimination or otherwise of the harmonic radiation.

It may be helpful to state that the current in an untuned feeder of 600 ohms impedance would be about .1 amp. for a transmitter output of 10 watts, a 100 watt transmitter increasing this figure to about .3 amp. High currents in the feeders of an untuned line can therefore be regarded as signs of mismatching of the line to the aerial with consequent standing waves, whilst the efficiency of the coupling at the transmitter end may very roughly be checked by testing the feeder coil for heating up. If, after a period of running, the feeder coil is warm a serious waste of power is indicated, and the coupling at both transmitter and aerial should be inspected for inefficiencies and mismatching. A different form of transmitter coupling might help since this condition is sometimes found when feeders have to be coupled close to the centre of the feeder coil to obtain the correct loading.

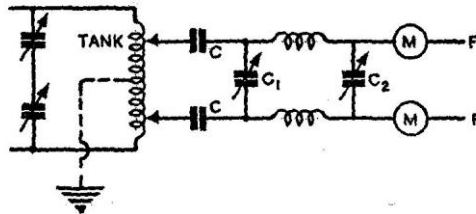
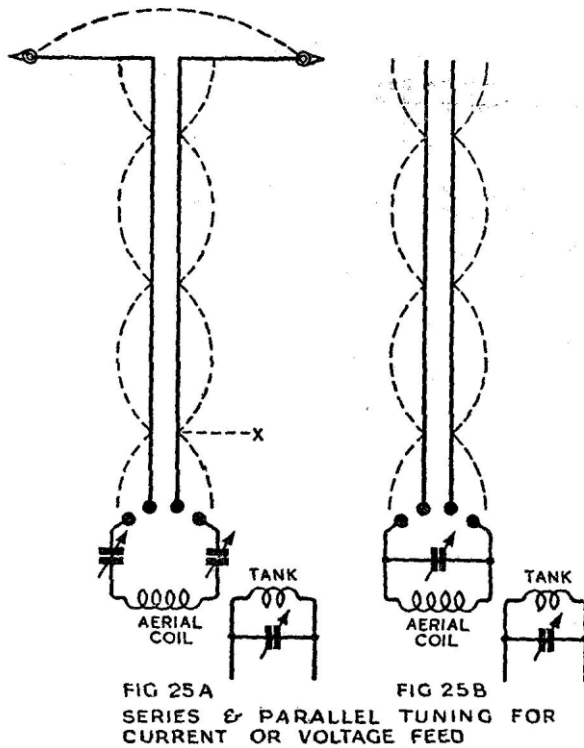

FIG.24 PI-SECTION NETWORK FOR UNTUNED OR TUNED TRANSMISSION LINES

Tuned Transmission Lines.

The tuned type of transmission line is coupled to the transmitter by a tuning unit by means of which the reactive component of the impedance is tuned out and the conditions for standing waves to be set up on the feeder wires are adjusted. The pi-network section described in the previous paragraph is suitable for use with tuned lines as well as untuned lines, but generally a tuning unit is built up which is able to deal with varying types of tuned lines so that changes in the aerial or feeder systems can be met easily, and without need for major adaptation of the circuit.

Preferred practice is to have the tuning unit mounted at the point where the transmission line enters the transmitter room so that the feeders, entering via insulating bushes, run straight into the aerial tuner which is then coupled to the transmitter by links, the link coupling line preferably being an air spaced twin line, the spacing between the wires being small and constant. Twisted wires, such as flex, may be used for short runs, but for any run where the transmitter is working on the 20 metre band (14 mcs.) or at higher frequencies the open wire coupling between links



will avoid losses, and is strongly advised. The line should be run round the wall on stand-off insulators.

Before considering the construction of the tuning unit for coupling the feeders to the transmitter, it is necessary to understand the conditions required to put power into the transmission line. In Fig. 25a a half wave aerial is shown fed at the centre by the 600 ohm transmission line, and since the line is terminated in an impedance lower than its own there will be a current loop present at the junction of the line and the aerial--the correct condition since the centre of a half wave aerial must be current fed. The broken lines in the figure show the current amplitudes along the transmission line, disregarding phases, and at the bottom of the line, which is clearly three half waves long (electrically) is another current loop. If the line is coupled to the transmitter at this point, therefore, it must be fed with current and for this the aerial tuning unit must

be arranged as a series tuning device, as in Fig. 25a.

Suppose, however, that the transmission line shown in Fig. 35a was made a quarter wave shorter. At this point (X) the current is at a very low value and consequently, by the laws already discussed, a voltage loop must appear at this point. The line, then, if it terminates in the aerial tuning unit at point X, needs voltage feed, and for this the tuning unit must be parallel tuned as in Fig. 25b.

To summarise--when the transmission line is an even number of quarter waves long it must be fed in the same way that it feeds the aerial (current-current, voltage-voltage) and where the line is an odd number of quarter waves in length it must be fed in the opposite way to which it feeds the aerial (current-voltage, voltage-current).

Since these are electrical quarter waves, however, and since feeders must fit into the space available, there will be some lines whose electrical lengths are indeterminate. With the unit to be described, however, there should be no difficulty in tuning such lines for it is possible to make the unit series or parallel tuned very simply, the line being tested on both methods of coupling. It is still possible for the line to give trouble in matching, and if the feeders cannot easily be brought into the correct operating conditions the best remedy is to add on or subtract from the line a section one-eighth of a wavelength long. It is the author's opinion, however, that a well set up station will run a transmission line calculated for the preferred method of feeding as accurately as possible, so that nothing is left to chance.

The tuning unit, together with its link coupling coil, is shown in Fig. 26, and it will be seen that the condenser switching is very simply performed with a pair of clips which, when cross-connected give parallel tuning, and when left unconnected give series tuning with the coil.

There were obtainable, pre-war, various manufactured aerial tuning coils which had a movable link coil wound inside the main inductance so that the degree of coupling could be adjusted, and the home constructor might develop

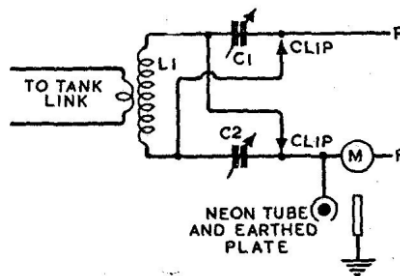

FIG.26 AERIAL TUNING LIMIT

the idea. Since coil changing is necessary when changing from band to band, however, it might be thought more convenient to construct the coil as in the previous example, by splitting the tuned winding and inserting the link coil in the gap. Values for i the tuning unit components are C1, C2. .00015 mfd. ganged, each section, transmitting type condenser, double air spaced.

L1. 160 metre band.

40 turns 22 S.W.G. in two sections, each section $\frac{3}{4}$ "
long with centre space of 20 turns per section.

80 metre band.

22 turns 20 S.W.G. in two sections, each section $\frac{3}{4}$ "
long with centre space of , 11 turns per section.

40 metre band.

12 turns 20 S.W.G. in two sections, each section $\frac{3}{4}$ "
long, with centre space of 6 turns per section.

20 metre band.

6 turns 20 S.W.G. in two sections, each section $\frac{3}{4}$ "
long with centre space of 3 turns per section.

L2. Approximate sizes, to be checked experimentally.

160 metre band, 8 turns 20 S.W.G. in centre space.

80	"	"	6	"	"	"	"	"	"
40	"	"	4	"	"	"	"	"	"
20	"	"	3	"	"	"	"	"	"

The wire used may be enamelled or bare. The coils are all wound on $1\frac{1}{2}$ " formers, preferably of the ceramic type, and should be suitable for all the usual power outputs of smaller transmitters. For powers over 25 watts or so the coils might be wound to have the same inductances .but with greater wire spacing and larger diameter wire. When the tank circuit is changed in waveband changing, the P.A. link coil will also be changed so that it and the feeder unit link coil are of the same size.

The coil sizes above are correct for parallel tuning, the next smaller coil being used for series tuning on the same band.

The meter in the feeder, as shown in Fig. 26 will give a good tuning indication for current when series tuning is used, but with parallel tuning, and thus voltage feeding, its reading will be very low. In this case it is useful to mount a small 100 volt neon tube on the input terminal of the ammeter, one connecting pin only of the bulb being used. If the bulb is given a small capacity to earth it will light at a voltage loop, and this capacity may be introduced by mounting beside the neon lamp a small strip of metal connected to earth, the metal being no closer to the bulb than is necessary to cause the bulb to glow.

The ammeter should be shorted with a clip when the circuit is in correct

operation, and the condenser should be driven through an insulating shaft. There should, be no power in the circuit when the series-parallel changeover is being made.

To tune the unit, disconnect it from the P.A. by breaking the link circuit and tune the P.A. tank for resonance, or minimum plate current. Couple the aerial tuning unit with the tank, and tune either with series or parallel connections to suit the line and waveband until the aerial unit comes into resonance, as indicated by a rise in the P.A. tank circuit and by indication either by the ammeter or neon bulb. Check the plate current of the P.A. so that the coupling of the link circuit can be adjusted, either by swinging of a movable coil or by more or less turns on fixed coils, more turns being required if the P.A. current is low. Keep the link coil at the transmitter of the same size as that at the aerial unit.

As before, the link coils must be in low R.F. voltage positions, at the centre of the aerial tuning coil and at the centre of a balanced tank or at the “earthy” end of a single ended tank circuit. The link coil at the tank, where it is in the centre of the tank coil, may either be wound over this coil or the tank coil may be sectionalised to leave room for the link coil as in the case of the aerial coil

CHAPTER 4.

Practical Aerials.

It is proposed in this chapter to outline details of various aerials suited to different frequency bands, and it is usual to point out that aerial performance depends primarily on the length of the aerial proper. For example, there are several types of half-wave aerial, each with its own name, but the differences all lie in the feeding system which can have very little influence on the radiation pattern of a half wave aerial at a given height, except in so far as one type of feed might be more convenient or suitable in some localities than others. This will be a question of feeding efficiency, however, and not a change in the characteristics of the aerial proper.

Quarter Wave Aerials.

The Marconi Aerial.

It has already briefly been mentioned that the Marconi aerial consists of a vertical quarter wave aerial earthed at its bottom end so that the resonant half wave is completed, in effect, by the “image aerial”. The system is chiefly of use on the longer wavebands where a horizontal aerial a half wave long would be too large both for the space at the amateur’s disposal and for correct erection at an adequate height

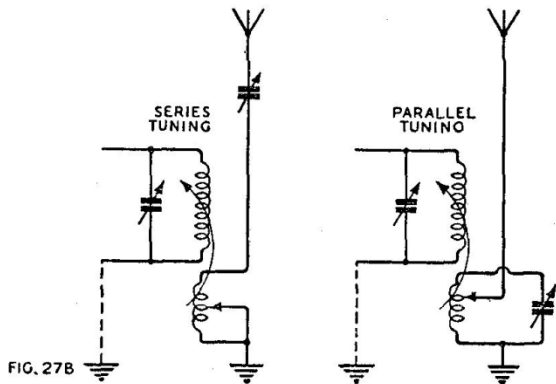
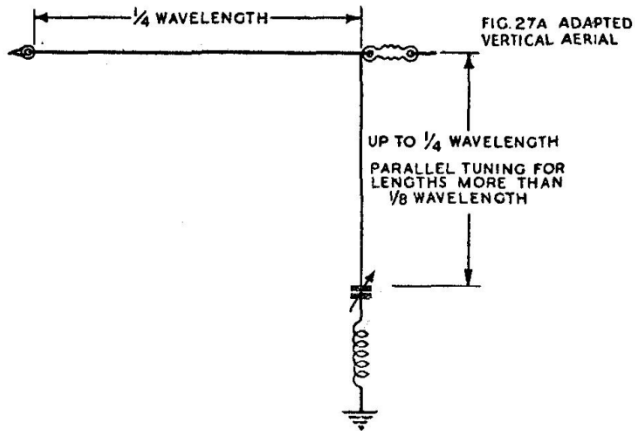

The system, as it stands, however, is not too efficient. Obviously the resistance at the aerial-earth junction must be low, since it is virtually at the centre of a half wave resonant wire and so at the position of a current loop, and the radiation resistance of an earthed quarter wave is approximately 36 ohms only. Thus, if the aerial-earth resistance were reduced to 36 ohms there would still be a power loss of half the total power in the system at this point, leaving only half the power for radiation, and moreover, since the current loop is practically at ground level the vertical wire, with the current falling in amplitude as the wire rises, is not an efficient radiator. For strong radiation it is desirable that the current loop be high—this will mean that the ratio of

the aerial-earth resistance and the aerial's characteristic impedance at the same point will be much larger so that a proportionally larger amount of power will be available for radiation whilst the most strongly radiating part of the aerial will be well above the ground level.

The earthed vertical aerial is therefore best adapted so that it consists of a vertical and horizontal wire, the horizontal length being a quarter wave whilst the vertical length is either a quarter wave or as long as space and constructional facilities will admit, this vertical portion running to earth as before.

This means, also, that the vertical wire will need to run as near as possible to the transmitter and that the earth wire from the coupling coil, whose length must be included with the vertical portion, must be direct and short.

In any locality where earthing conditions are not really good a counterpoise earth is strongly to be recommended.

Figs. 27a and 27b show the arrangement of the system for wavebands of 80 and 160 metres, the method of tuning used on the aerial coupler depending on the length of the vertical wire. For wires of a quarter wavelength the tuning system should be parallel tuned, whilst where the vertical wire is less than one eighth of a wavelength the tuning system is series tuned.

A counterpoise, where used, should be erected on poles insulated from earth and sufficiently high to clear the head, this height necessarily being deducted from the aerial height, and since in the aerial under discussion the main radiation is from the vertical member the counterpoise will be best if it is below the vertical wire. Since the function of the counterpoise is to present a capacity effect to earth the counterpoise should be as large as space will permit although it should be kept of regular shape. Beneath a vertical aerial the counterpoise might well be circular, with wires radiating from the centre to the edge and interconnected to break up resonant lengths which might occur. The "earth" lead will then be connected to the centre of the counterpoise.

The aerial tuning unit, whether series or parallel tuned, will be coupled to the transmitter, and the aerial loading on the final stage will be adjusted as has already been shown. The condenser should be of .0003 mfd. maximum capacity whilst the coupling coil is 20 turns of 14 S.W.G. spaced own diameter on a 3" former, with provision for tapping at every third turn for higher frequency working.

Half Wave Aerials.

The Zepp Aerial.

Besides the various forms of horizontal half wave aerials already described in the foregoing chapter there remains the Zepp aerial, where a horizontal half wave wire is

voltage fed by a transmission line, one end of which is merely left insulated. (Fig. 28.) The feeders are coupled to the transmitter by the usual tuning unit, and are operated as a tuned line--that is with standing waves on the feeders, so that the choice between series and parallel tuning aerial units can be made by referring to Figs. 25a and Fig. 25b.

As well as forming an efficient half wave aerial the Zepp operates well when the aerial is any number of half waves long. Some precautions are necessary, however,

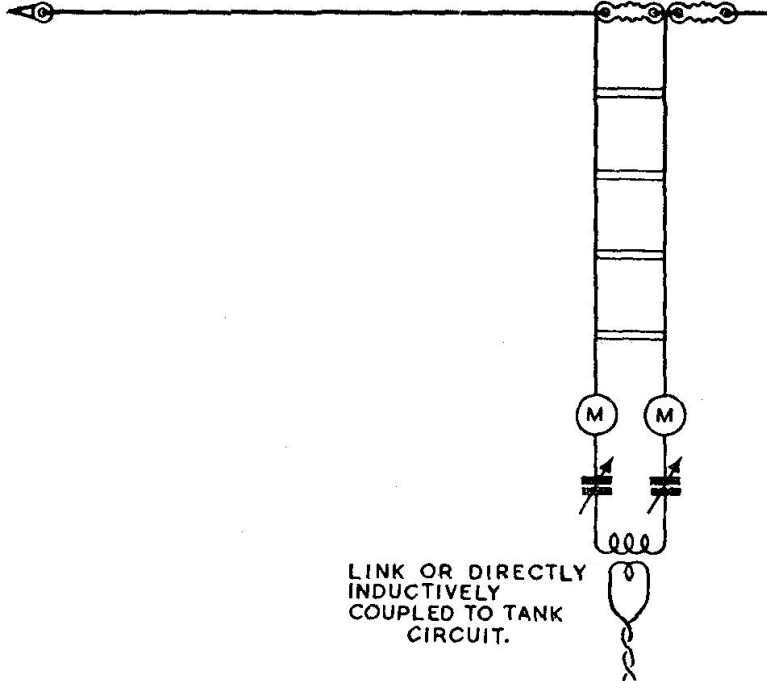

FIG 28 THE ZEPPELIN AERIAL

depending whether the aerial is to be used as a single frequency radiator or is to be worked harmonically.

For example the best length of transmission line with the Zepp arrangement is a Quarter wave, but in harmonic working this becomes a resonant length, which should be avoided if possible. Again, in single frequency working it will be found that the currents in the feeders are not equal, provided that the line and aerial are operating at their optimum adjustments, and when it is desired to make an aerial accurately resonant as for single frequency working, the aerial should be cut a little longer than the length calculated from the formula, and may be finally cut to length by the following method, which depends on the fact that adding an exact half wave

(electrical) length of wire to a transmission line does not change the conditions of the line's operation.

Disconnect the feeders from the aerial and raise them to their working height, suspending them from their insulators. Set the transmitter to its resonant point so that the tank circuit shows the anode current dip, and very loosely couple the aerial tuning unit to the tank. When series tuning is used the feeders on a Zepp aerial carry quite high currents, and ammeters with a range of at least one ampere should be used for safety. Tune the aerial unit to resonance so that the P. A., current rises and the tuning point is well defined and the currents in both feeders are equal, noting all the condenser settings since reference back to the present state will be necessary. Now couple the horizontal aerial to its feeder as in the figure, retuning the aerial coupling unit to the new resonant point. If the aerial has been cut a little long for the frequency used it will be found that the condensers of the aerial coupling unit have to be set at a lower capacity than before, whilst should the aerial by any chance be short, the condensers will have to be set at a higher capacity. The coupling between the P.A. and the aerial coupling unit should not be changed when the aerial is connected to the feeders. The maximum currents in the feeders will be lower, but it should still be possible to obtain a good reading and thus an indication of maximum feeder currents.

Presuming that the aerial is slightly long, lower the wire and cut a few inches off one end. The degree of mistuning in the aerial unit will give some idea of how freely the cut may be made. The aerial is then rehoisted and connected again to the feeders and the aerial coupling unit once again tuned for maximum feeder current--that is, for resonance to the P.A.

This process is repeated until the aerial coupling unit has its condensers set to their original position found with the aerial disconnected from the feeder, when the aerial is at its correct resonant length.

This adjustment is only necessary for accurate work on a single operating frequency, of course. For general work it is sufficient to cut the aerial to the length calculated from the formula.

Long Aerials.

It is proposed to give only a little space to the subject of long aerials, for it is thought that the amateur will have little chance to use them, owing to lack of space. Their main advantage lies in the fact that the long aerial radiates most strongly from its ends whilst it can also be arranged, to act as a harmonic aerial. The long aerial (by which is meant an aerial the horizontal portion of which is a number of wavelengths long) also radiates relatively more power in its favoured direction than does the half wave

aerial, so that it may be said to have a power gain over the shorter aerial. The radiation resistance also rises. For a three wavelength aerial the radiation resistance measured at a current loop is roughly 120 ohms whilst the radiation in its favoured direction (about 20 degrees off from the line of the aerial on either side) is perhaps 50 per cent, greater than would be the case with a half wave aerial under the same conditions.

So far as feeding and adjustments go, the longer aerial is treated in the same way as the half wave aerials already described, except for the fact that it is most suitably fed by tuned feeders and fed at the end of the aerial as is the Zeppelin aerial, or at a current loop.

This ensures that the currents in the sections of the aerial on either side of the feeders when they are not at the end of the wire are out of phase, a necessary condition for the working of the aerial as a long wire proper.

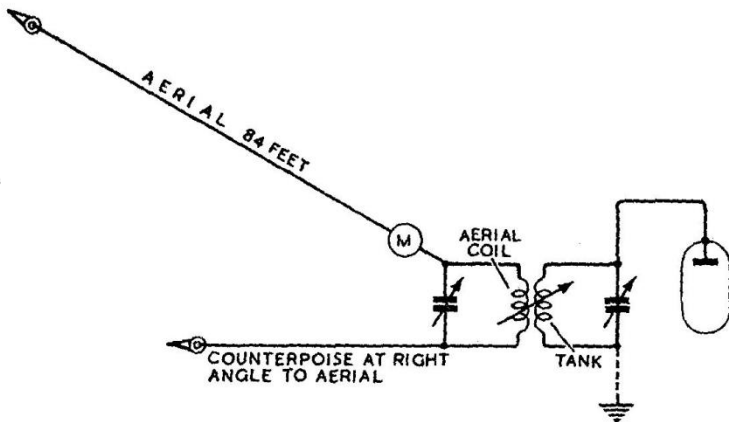

FIG. 29 THE W3EDP MULTI-BAND AERIAL

Multiband Aerials.

Probably of greatest use to the amateur licensed for operating on several bands is the W3EDP aerial, devised by H. J. Siegel the results of whose experiments were first published in QST. The aerial, shown diagrammatically in Fig. 29, appears to radiate most strongly at right angles to its length but excellent all round reports have been obtained even when such an aerial has been used in a badly screened position.

The W3EDP aerial consists of an aerial wire, straight if possible although it may be bent if desired to give a run up to a horizontal top, the height in the case of the original aerial being only twenty feet. The length of the aerial is 84 feet, the end of the wire

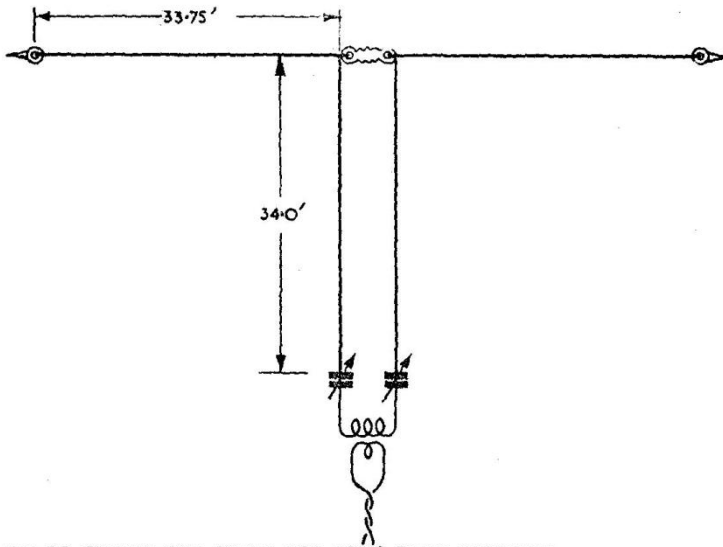

FIG.30 CENTRE-FED AERIAL FOR FOUR BAND WORKING

being brought straight to the aerial coupling coil. The coupling is direct inductive, the aerial coil being mounted beside the tank coil of the P.A. on a swinging support so that the coupling can be varied at will. Contrary to general practice the aerial coil is mounted at the "hot" end of the tank coil to give a degree of capacity coupling, and the system is simplified by using plug in coils which are changed for the various wavebands and which are tuned in each case by a condenser in parallel with the coil.

In place of an earth connection a counterpoise is used, connected to the other side of the aerial coil, the counterpoise consisting either of 17 feet or 6½ feet of wire, depending on the band to be worked. It is important that the counterpoise should be at right angles to the aerial and preferably straight although once again the wire can be bent to fit the space available if necessary.

The aerial is best adjusted by loosely coupling the aerial coil to the tank and tuning for resonance, then by swinging in the aerial coil the P.A. circuit may be loaded up to its correct current. An ammeter in the aerial will show the current, and should this fall off in value before the P.A. loading is correct this may be adjusted by slightly shortening the aerial wire a little at a time to a maximum degree of two feet. The coils, on 2" diameter formers, are wound as follows:--

Waveband.	Counterpoise Length.	Coil Size.
80 metres.	17 feet.	20 turns 16 S.W.G. spaced own diameter.
40 “	17 “	7 turns 16 S.W.G. spaced own diameter.
20 “	6½ “	5 turns 16 S.W.G. spaced own diameter.
10 “	Not used.	3 turns 16 S.W.G. spaced ½”.

The value of the parallel condenser should be .0003 mfd. Already mentioned is the VS1AA aerial with a single wire feeder which may be used for multiband working.

Fig. 30 shows a centre fed aerial where the feeders are made of such a length that the aerial and feeders together are tuned to the lowest frequency it is desired to transmit whilst the aerial is cut to resonate a higher frequency and its harmonics. One example is given.

Each half of the aerial is made 33¾- feet long, the transmission line being 34 feet long. The aerial may then be worked at 80, 40, 20 and 10 metres by coupling it through a tuning unit with series tuning on all bands except the 80 metre band which is parallel tuned. The system is not highly efficient so far as radiated power is concerned since the feeders are made to absorb some part of the power which cannot be radiated, but the aerial is easily constructed by the amateur who desires to work on several bands. The height of the aerial, depending on the feeder length, the line should be as direct as possible.

CHAPTER 5.

Directive Aerial Arrays.

Whilst all aerials, as has been shown, have a preferred direction or directions in which they radiate most strongly they still “broadcast” their power to a considerable extent. For a great deal of amateur work this is convenient, for so many contacts are by chance and the greater the area covered the better, but there are often occasions when an aerial directed towards a certain distant point or having its radiation compressed into a more narrow angle would be a definite advantage.

Directive aerials are generally made up of a number of aerials, or elements, these being most often of half wave resonant lengths, and the manner in which the elements are combined physically and electrically control the preferred direction of radiation. Moreover the directional property can be used either in the horizontal plane, the more usual method of use, and also in the vertical plane in which the directional properties are used to lower the angle of propagation of the wave.

Directional aerials fall into two broad groups, the first in which all the elements are driven with power from the feeders and the second in which the aerial proper is

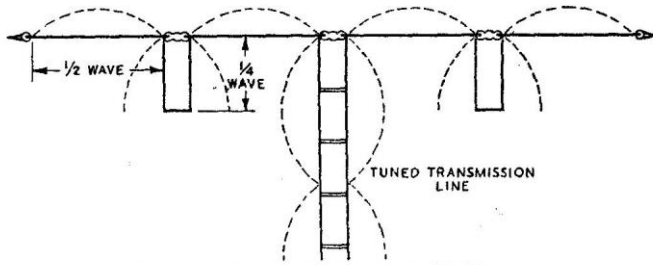

FIG.31 FOUR ELEMENT CO-LINEAR AERIAL VOLTAGE FED

driven whilst the subsidiary elements are excited from the radiation of the aerial and are therefore known as Parasitic elements.

Those aerials in which all elements are driven may further be subdivided into three types, co-linear, broadside and end-fire arrays.

The Co-linear Aerial.

As the name denotes the co-linear aerial is made up of a series of elements arranged end to end in a straight line, each element being a half wave in length. The necessary condition for the proper working of the aerial is that the currents in all the elements are in phase at any given moment, so that the simplest co-linear aerial is the one wavelength long wire voltage fed at its centre.

The co-linear aerial proper, however, is composed of a greater number of elements--three or four being usual-- with matching sections joining the end of one element to the next to act as phase correcting devices. The system may be regarded as a long wire stretched straight for one half wavelength, folded on itself for the next, stretched straight again, etc., and a four element aerial is shown in Fig. 31 with the current distributions shown as dotted lines.

The aerial may be fed as shown, with a tuned transmission line, and since on such aerials the radiation resistance is not so easily determined it is felt that the adjustment of a tuned line will be much simpler than that of an untuned line. A flat or untuned line can be used, however, the feeders being tapped on to one of the shorted quarter wave stubs to give the correct matching into the aerial, the adjustment being similar to that already described in Chapter 3. The tuned line may be run into the aerial in place of any stub, or untuned feeders can be tapped on to any stub, but so far as possible the feed should be in the centre of the aerial. When the aerial is an odd number of elements long the feed can be into the centre of the central element, when the aerial will require current feeding rather than voltage feeding.

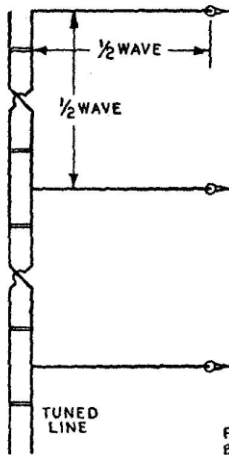

FIG.32A "STACKED" BROADSIDE AERIAL

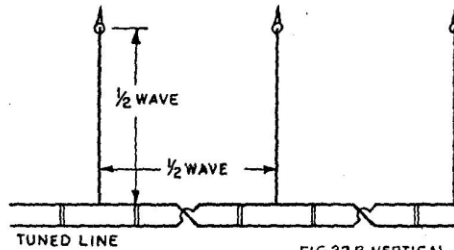

FIG.32 B VERTICAL BROADSIDE AERIAL

Theoretically the co-linear aerial is most efficient when the spacing between the ends of the elements is such that the centre points of the elements are three-quarters of a wavelength apart, but this clearly will give rise to difficulties in the arrangement of the phase correcting stubs. A compromise is generally effected therefore, the elements being spaced by the width of the stubs which, since these are constructed in the manner of transmission lines, will be only a few inches.

A directional aerial naturally gives a gain over a single half wave aerial in the field strengths from either aerial measured in their relative preferred directions for the same input power, the gain being expressed as decibels of field strength. The gain for a co-linear aerial using 3 elements spaced as above is a little over 3 decibels and for a 4 element aerial between 4 and 5 decibels. The maximum radiation from the co-linear aerial is, like that of the half wave aerial, broadside, or at right angles to the wire, and the same aerial height may be used as for a half wave aerial. When the co-linear aerial is constructed vertically, however (not a practical proposition except for high frequencies), the radiation is at low angles and is thus suitable for long distance work in all directions.

The Broadside Aerial.

Both the broadside and end-fire aerials are of similar physical construction but whilst the end-fire aerial elements are fed out of phase the broadside elements are fed

in phase. The broadside aerial may be erected with the elements either horizontal and vertical, as shown in Figs. 32a and 32b, the array being known as the “stacked” array when the elements are horizontal and one above the other.

With three elements as shown the aerial gain is more than 5 decibels, and a gain of 7 decibels may be obtained using four elements whilst, as the name suggests, the radiation is broadside to the aeriels; that is for the diagrams the strongest radiation is perpendicular to the paper. With the elements vertical as in Fig. 36b the directional effect is horizontal, whilst low angle radiation is obtained from the stacked array, the horizontal radiation pattern being equivalent to that of a single half wave aerial.

Both types of aerial should be erected at reasonable heights whilst the stacked array should not be allowed to be at less than a half wave above earth, measuring from the bottom element.

Whilst the aerial may be fed from untuned feeders with a matching section, once again it will be simpler to use a tuned transmission line. The transpositions in the line between elements must be noted in the two figures. These give the phase corrections for the element currents.

End-fire Aerials.

As in the broadside aerial the elements of an end-fire aerial are parallel, but the spacing is closer, generally being one-eighth of a wavelength, whilst the currents in the elements are out of phase. In Fig. 33 is shown what is possibly the most useful end-fire arrangement for it combines with a gain of 4 to 5 decibels the virtue of radiating both at its fundamental and second harmonic frequencies, acting, at the latter, as a four element array, The line of radiation is shown by the arrow in the diagram.

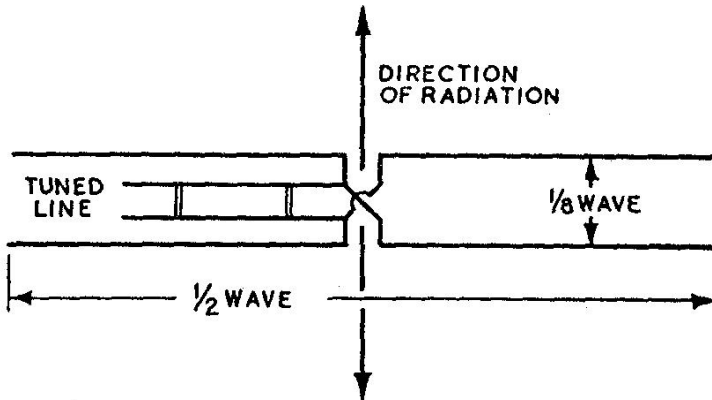

FIG.33 END-FIRE AERIAL

Once again the aerial can be fed both by tuned and untuned transmission lines, but tuned lines will be simpler to use since the adjustment of a matching section will be avoided.

Combined System Aerials. The "Lazy H".

It is possible to combine co-linear and broadside arrays, several such systems having been used with considerable success. One array of this type is known as the "Lazy H", due to its shape, that of a capital H on its side. This is the form that is generally used, although the elements can be vertical if desired. The aerial is shown in Fig. 34. The radiation is broadside to the aerial whilst a gain of perhaps 5 decibels is obtained if the array is erected well in the open and at a good height--at least a half wavelength. The array may be fed, as usual, either with tuned or untuned lines, the latter requiring a matching system, the feed point shown in the diagram giving voltage feed to the aerial.

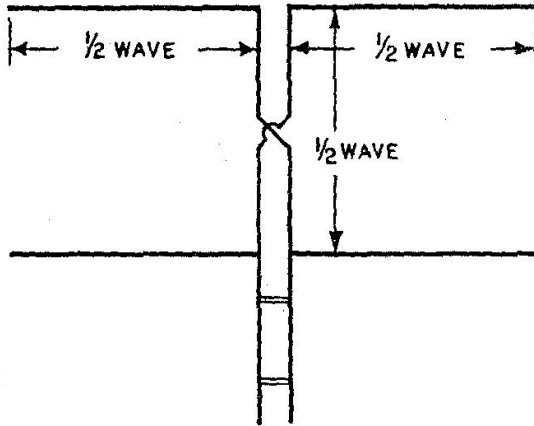

FIG.34
THE LAZY H
ARRAY

The Sterba.

Another combined system aerial is the Sterba array, a more elaborate array which requires some space for its erection. It is often pointed out that such an aerial is a closed circuit and is thus suitable for use in a rigorous climate since it can be easily de-iced by connecting the feeders to a low voltage high current transformer to warm the wire before transmission. The radiation is again broadside, the gain being approximately 7 decibels for the array shown in Fig. 35, whilst another advantage is that if the transmission line is coupled as shown the characteristic impedance of the array is so close to 600 ohms that the feeders may be untuned with only a low standing

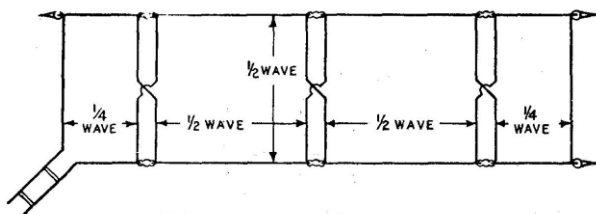

FIG.35 THE STERBA ARRAY

wave ratio. Fewer or more sections may be used than are shown in the figure.

For all these aerials it is sufficient to make the half wave elements the calculated length as obtained from the electrical length formula, but for the half wave phase correcting lines coupling the elements -the length may be found from the formula

$$L = \frac{480}{f}$$

where L is the half-wave line in feet, and f is the operating frequency in megacycles.

Parasitic Arrays.

The directive aerials so far described can hardly be regarded as beam aerials since the radiation, although in a well defined direction, is equal and opposite on either side of the aerial, just as is the case with a half wave resonant. To make an array radiate in one direction on one side of the aerial only, it is necessary to use a reflector behind the aerial, the reflector being parasitically energised in such a way that it cancels or tends to cancel radiation behind the aerial. The effect can further be emphasised by using directors in front of the aerial, spaced so that the wave is reinforced. The system is improved by using directors slightly shorter than the resonant length and reflectors slightly longer than the resonant length. The best all round spacing for the directing elements is one-tenth of a wavelength, and in Fig. 36 is shown an array with both reflector and director, although more directing elements may be used if desired. The reflector should be spaced from the fed element by .15 of a wavelength.

The gain of the array will be in the region of 7 decibels and the method of feeding the resonant aerial as shown in the diagram is by a matching system from an untuned transmission line. This is for the reason that the radiation resistance of a parasitic array falls to a very low value-- possibly below 20 ohms, so that the ratio of mismatch

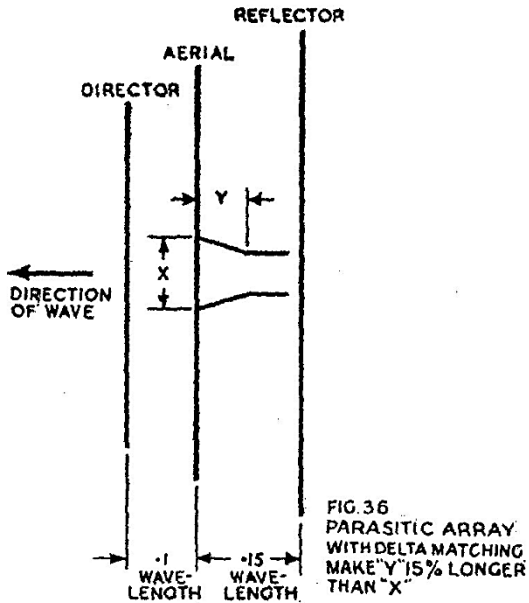

The Delta match is efficient when used with this array, as are the open or closed matching stubs, and the adjustment must be by trial and error. The Delta match is the simplest to operate since it entails no cutting to length of wires. One guide given as to the making of the Delta tap is that the length of the transmission line where the feeders leave their parallel spacing and open out to meet the aerial should be 15 per cent longer than the distance between the two ends of the feeders when they are finally taped on to the aerial.

The length of the director should be about 4 per cent shorter than the resonant aerial length, the reflector being about 5 per cent longer.

As can be imagined the bandwidth permissible on all types of directive aerials is not great, but this is especially so in the parasitic type of array where the energy distribution over the whole system depends on spacing and the resonant qualities of the driven element. Generally speaking, all the aerials will cover the higher frequency amateur bands however, and it is unlikely that the amateur will construct arrays to work on the lower frequencies if on no other account than size, so that little trouble should be experienced on this score.

It must also be remembered that the aerial gain will give contacts at greater distances than those made with the plain aerial, and for this reason it is necessary to use the

the same aerial for reception, for the gain is as effective for reception as for transmission. Some aerial switching device must be used therefore, by means of which the feeders are transferred to the receiver for listening, the most usual method being relay operated switches on the aerial coupling unit. Moreover the input resistance of the receiver must be taken into account in order that a proper match may be made between the line and the receiver.

Rotating Beams.

The sharper the angle of radiation from the directive array becomes so does the area over which contacts may be made become smaller. Longer distances may be worked, but the amateur generally requires to change direction as well, and for the higher frequencies, the 14 mc. band and over, the most practical and simple method is to make the aerial rotate, so that its directive properties can be brought to any bearing.

The difficulties of constructing such an aerial are mechanical rather than electrical, for no change in the characteristics of the aerial are caused by making it rotate. Some method of connecting the feeders must be devised, and in some cases they are brought down to rotating rings to which contact is made through bushes, and the weight of the top members of the aerial is reduced by using the simplest array possible. Suitable aerials for rotating beams are the parasitic arrays or, for energised elements, the Lazy H and the end-fire array.

Then some method of turning the aerial must be arranged, so that the rotation can be controlled from the transmitter room and also controlled accurately as far as compass direction is concerned. Altogether so much depends on the aerial to be used and the location of the transmitter that nothing in the way of hard and fast rules for the design of the rotating aerial can be given.

It might be best first to test the potentialities of the system by using a simple apparatus. A heavy pole to carry the movable head might form the mast, well guyed for strength and steadiness. Many arrays have been made of tubing so that the aerial wires require no end support, the elements being carried on strong stand-off insulators on a small platform, the tubing extending beyond the edge.

Again, light top members such as bamboo poles can be used to carry the wires, whilst, in the case of the "Lazy H" array the platform may be dispensed with and a simple frame be built to carry the elements, the shape being based upon the conventional television aerial.

In any case the platform or frame must be rigidly fixed to a spindle which runs in bearings on the mast, the end of the spindle used for driving the array being fitted with, for example, a bicycle sprocket wheel. A chain drive of sufficient length to drive the wheel through a complete turn can be connected via wire cable to a second length

of chain running over a second sprocket wheel, this wheel being connected with the control handle at ground level. The chain and cable drive will require feeding through small pulleys at the top of the mast to change the direction of the drive from vertical to horizontal, and the platform must be fitted, with stops at the correct positions. The fed element type of directive array need only make a 180 degree turn to cover all directions, but the parasitic array with a reflector will require to turn the whole 360 degrees. When the array is hand driven it will probably be sufficient to allow the feeders enough slack to twist with the aerial, since rotation will be controlled by stops on the platform, so that rotating contacts may be dispensed with. In motor driven arrays, where the aerial will not be reversed in its direction in moving from position to position but will always rotate in one direction, the rotating feeder contacts must be used.

Yet another method of mounting a rotating array is to make the whole mast movable, the aerial being firmly fixed on a correspondingly simpler platform at the top. The mast is pivoted at its base on a steel peg set in concrete and running in a pivot driven into the bottom of the mast, while a second bearing, as strong as possible and as high up the mast as possible, holds the arrangement steady while allowing it to turn. This second bearing may be a strip of steel bent to circle the mast, which should be rubbed to good true shape at the bearing place, the steel ring preferably being bolted direct to a stout wall or else mounted on a substantial post which can be held with guys. With this method the feeder system can once again be simplified so long as stops are furnished to prevent the mast from being turned too far, whilst another great advantage is that the mast can be turned through direct gearing via a crown and pinion, or by a direct cable drive.

Whatever method of drive is used it must be capable of calibration with compass bearings, so that if a ratio of one to one is maintained the control handle can be marked in compass directions. More often, however, the drive is geared down, both to lessen the work of turning the assembly and to make the action steadier. In this case calibration will be more difficult. One method in use is to affix a pointer to the driving cable at some convenient place, the pointer moving along a straight scale which is marked in cardinal points, but here again-the method depends chiefly upon the ingenuity of the user. Some rotating aerials have been made electrically controlled in such a manner that by turning an indicator to the required compass direction the array rotates automatically until it is aligned with the pointer. Other systems have recorded direction by allowing the rotating array to drive the arm of a rheostat which in turn gives varying deflections or the scale of a milliammeter supplied from a small battery, the scale being calibrated in degrees.

For the amateur who desires to use a rotating beam aerial, however, the soundest preparation is to refer to as many periodicals on amateur affairs as may be possible. New ideas and designs are constantly forthcoming on the subject, and much good work can still be done with this type of aerial development.

It is not sufficient to set the aerial on a compass bearing taken from the ordinary Mercator's projection map. Radio waves travel by great circle routes and a good globe *is* a great help to the proper setting of a rotating aerial. An azimuthal map may also be used, one centred about the station's locality or as near to it as practicable. Such a map centred about London would be suitable for stations in the Midlands and all the South Eastern half of England without undue error.

When the aerial is being set by compass, moreover, it must be remembered that the globe or map from which the bearing was obtained refers to true North, whilst the compass indicates magnetic North. The error must be corrected by applying the magnetic deviation correction for the year.

Aerial Erection.

The location of the station will affect the actual construction of the aerial more than any other part of the equipment, and it is often possible to press surrounding features into useful service. Aerials must be erected in reasonably open and clear situations, however, and the position must be reviewed from all points of consideration before the final aerial position is decided upon. Line length must be borne in mind, together with the proximity of large objects, and whilst a single tree might prove a blessing a row of trees might prove a great difficulty to overcome. Steel framed buildings, power cables and gasometers are further stumbling blocks.

Presumably, however, if the position is suitable, one end of the aerial will be carried by the house itself, whilst the other end will be supported upon a mast or tree. If a tree is used the aerial should be kept well away from the branches and held by an extension cable, the two being separated by at least two insulators, and it must be remembered, in such a case, that trees are flexible and liable to considerable movement in wind. One method of overcoming this is to run the aerial extension cable through a pulley lashed to the tree, the aerial weight being borne by a counterweight at the end of the cable so that as the tree moves the cable works on the pulley and the aerial remains taut.

The problem of wind and wind resistance is always before the amateur, and whatever gauge of wire is used for the aerial and transmission line, it should be the hard-drawn type of wire. An aerial of soft wire can be stretched to a surprising-degree, sufficient to ruin its resonant properties with respect to the frequency in use.

Wherever masts are to be used, their shape and type are governed by their height. An ideal mast for heights up to 50 feet is the telephone pole, which requires no guying, but such a mast is very difficult to come by. It is perhaps better to build up a mast suited to the requirements of the station than to compromise on a doubtful article, even though the time and expense involved are sometimes considerable.

For a small mast a single timber can be used, but the height permissible is such that the pole would almost necessarily be mounted on an elevation of some sort--possibly the roof of an outbuilding. Timber of the 4" x 2" type, in pine, will be suitable for heights of 20 feet or less. It may be said here that all wooden masts, of any construction, must be weather protected, whilst good timber, such as pine or deal must be used. Creosote could be used but a good lead paint as used for house painting on exterior work is probably better. At least two coats should be applied, preferably more, and the mast should be kept under, periodical observation so that the protection afforded may not deteriorate. The same precaution applies to the guy cables and fittings. It is far better to take the whole system down, under control, for renovations and repairs than to have it brought down by a gale, with possibly extensive damage.

A single mast, so protected, should be supported by three guys. Guys should be made of wire cable manufactured for such purposes, and they are generally arranged in sets of three, equidistantly spaced round the mast--that is at angles to each other of 120 degrees. The two guys pulling against the aerial are really the working guys, but the third is none the less necessary. Guys must be broken up into lengths which will not resonate at the operating frequency or its harmonics, the method being to run the guys round egg insulators in such a manner that the two loops, whilst insulated one from the other are interlinked. Should the insulator crack under a strain the guy portions will then not part company. The insulators should, of course, be obtained from a reputable company, and their use should be mentioned at the time of ordering so that suitable items are obtained.

The length of each portion of the broken up guy can be made 25 feet, when the cables will be non-resonant at all amateur frequencies from the ten metre band upwards.

One excellent type of mast for heights of up to 40 feet is the A-shaped mast, made from three lengths of 2" x 2", each a little over 20 feet long. If it is not possible to obtain timber of this length the two bottom sections may be made up of two lengths of timber each, but the top section must be made of a single piece. Some odd lengths of wood to act as spacers for the framework will also be required, the arrangement being shown in Fig. 37.

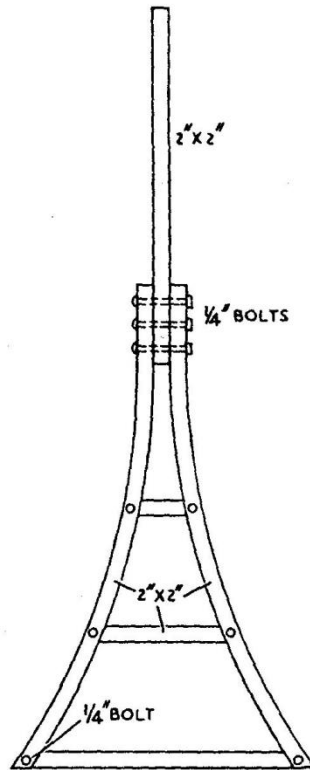

FIG.37 THE 'A' SHAPED MAST

Such a mast is simple to erect for its weight is low in comparison to its strength, and five guys will hold it rigidly in place--three from the top and two from the junction of the frame and upright member, these last two to run to the fore and behind since the splayed bottom of the frame gives good sideways stability.

Several methods of fixing the foot of this mast are possible and it has been erected on flat roofs as well as at ground level. The bottom member can be bolted to stakes well buried in rammed soil, or set on bolts fastened in small concrete beds.

All fittings should be attached to the mast before it is erected, including the halyard through the top pulley which should be chosen so that there is no chance of the rope running off the wheel and jamming. For the halyard, sashcord can be used,

but weatherproof manila rope is excellent for the work. Half inch rope will hold a large aerial.

Galvanised iron wire of 10 or 12 gauge will be suitable for the guys, although a small twisted steel rope, if obtainable, would be better, providing the insulators were of a sufficient size.

Precautions against Lightning and Electrical Discharges.

Since the transmitting aerial will be erected in the open and probably at a good height it is more likely to be a source of danger, so far as electrical storms are concerned than is the ordinary receiving aerial. The chances of any aerial being struck by an actual lightning discharge are, as is well known, very remote, but the aerial might well accumulate a high charge in conditions of static which could damage equipment or injure the operator.

All aerial and feeder systems, therefore, should be fitted with some form of lightning switch and arrestor, a great number from which a choice can be made having appeared on the market. The simplest switch, which should be well insulated and enclosed in a weather proof box at the point where feeders enter the room or building, can be of the two pole two way type, the feeders from the aerial being connected to the arms and thus to earth on one throw and to the aerial tuning unit on the other throw, a spark gap to earth giving protection against discharge whilst the feeders are connected to the apparatus.

Some quite ambitious remote control switches have been made by amateurs, but so long as the device is there, and is of a type which will introduce no R.F. losses, the exact nature of the switch is of small importance. What is needed is a method of connecting the feeders to earth as desired and a spark gap, the apparatus having its earth connections running directly to the ground on the outside of the building.

“TECHNI-GEN”

CONSTRUCTORS' ENVELOPES

Correspondence with many thousands of purchasers of our well-known Radio books has revealed a considerable demand for Radio designs in sheet form, and has indicated the types of sets desired.

The new “TECHNI-GEN” series of Radio Constructors' Envelopes is based upon this information.

Each envelope has an attractive cover design in two colours and contains a broadsheet, size 22½ in. by 17½ in., giving a chassis blueprint, a picture of the set which, in each case, has been built and fully tested, circuit diagrams and explicit instructions.

Lewis George, the well-known Radio designer and author, is responsible for the production of the Series and British component manufacturers have co-operated in developing the designs.

No. 1. **HOW TO MAKE A 3-VALVE PLUS RECTIFIER AC/DC T.R.F. RECEIVER.** For medium waves (200-557 M. only). This receiver is provided with a tone control and a method of using an energised loudspeaker is illustrated and described.

No. 2. **HOW TO MAKE AN “ECONOMY” 4-VALVE PLUS RECTIFIER AC/DC SUPER-HET. RECEIVER.** For medium waves (200-557 M. only). A.V.C. and Tone Control is incorporated.

No. 3. **HOW TO MAKE “ALL-DRY” 4-VALVE BATTERY SUPER-HET. PORTABLE RECEIVER.** For medium waves (200-557 M. only). A.V.C., Tone Control and a Frame Aerial are incorporated. Provision is also made for the use of an outside aerial.

No. 4. **HOW TO MAKE AN AC/DC “QUALITY” RECEIVER.** For medium and long waves. This receiver is suitable for both local station reception and for the more powerful Continental stations. Approximately 8-watts push-pull output is provided.

No. 5. **HOW TO MAKE A 20-WATT “QUALITY” AMPLIFIER.** Separate treble and bass tone controls are incorporated and the output stage comprises two tetrodes in push-pull with negative feedback.

No. 6. **HOW TO MAKE A PORTABLE AC/DC PUBLIC ADDRESS AMPLIFIER.** 10-watts output with provision for mixing two microphone inputs and a gramophone pick-up. A suitable carrying case is illustrated.

Retail price 2s. each

Obtainable from your dealer or, in case of difficulty, write direct

BERNARDS (PUBLISHERS) LIMITED,
GRAMPIANS BUILDING, WESTERN GATE,
LONDON, W.6.

Telephone : SHEPHERDS BUSH 2581.

Printed by Briggs and Grimshaw Ltd., Wright Street, Southport.

BERNARD'S RADIO BOOKS

FOR THE HOME AND AMATEUR CONSTRUCTOR

3.	SERVICES SIGNALLING MANUAL	1/-
4.	RADIO POCKET BOOK	1/-
6.	ELECTRICAL ENGINEERS HANDBOOK	1/-
22.	MANUAL OF RADIO CIRCUITS	2/-
30.	RADIO VALVE MANUAL	3/6
37.	MANUAL OF DIRECT DISC RECORDING	2/-
41.	WIRELESS AMPLIFIER MANUAL	2/-
42.	SHORTWAVE RADIO HANDBOOK	2/-
43.	MODERN RADIO TEST GEAR CONSTRUCTION	1/6
44.	RADIO SERVICE MANUAL	2/6
45.	RADIO REFERENCE HANDBOOK	12/6
48.	RADIO COIL AND TRANSFORMER MANUAL	2/-
50.	INTERNATIONAL SHORTWAVE RADIO STATION LIST	1/-
51.	CATHODE RAY OSCILLOSCOPE MANUAL... ..	2/-
52.	RADIO TUNER UNIT MANUAL	2/6
53.	RADIO CONSTRUCTORS' MANUAL... ..	3/-
54.	RADIO RESISTOR CHART	1/-
<i>In Preparation or Printing—Order Now</i>		
55.	RADIO CIRCUITS HANDBOOK No. 2	2/6
56.	RADIO AERIAL HANDBOOK	2/6
57.	ULTRA SHORTWAVE HANDBOOK	2/6
58.	RADIO HINTS MANUAL	2/6
59.	TELEVISION CONSTRUCTION MANUAL	3/6
60.	RADIO REPAIR MANUAL	2/6
61.	AMATEUR TRANSMITTERS' CONSTRUCTION MANUAL	2/6
62.	CAR AND PORTABLE RADIO CONSTRUCTORS' MANUAL	2/6
63.	RADIO CALCULATIONS MANUAL	2/6
64.	SOUND EQUIPMENT MANUAL	2/6
65.	RADIO DESIGN MANUAL	3/-