

No. 174

6/6

32½p

Transistor Subminiature Receivers Handbook for the Home Constructor

by

CLIVE SINCLAIR

Subminiature Single Transistor Audio Amplifier
High performance RF Transistor Amplifier
World's Smallest Pocket Set
Making Your Own Subminiature Components
Crystal Receiver Plus 2-Transistor Amplifier
Subminiature Reflex Receivers
Ultra Low Consumption 3-Transistor Receiver
4-Stage Receiver Using Deaf Aid Transistors
Regenerative Transistorised Receiver
Wrist Watch Radio Receiver
Match Box Radio Receiver
Very Low Voltage Subminiature Receiver

BERNARDS RADIO MANUALS

FIRST PUBLISHED NOVEMBER, 1951
REPRINTED NOVEMBER, 1952
REPRINTED JULY, 1970

Transistor Subminiature Receivers Handbook for the Home Constructor

We invite all authors, whether new or well established, to submit manuscripts for publication. The manuscripts may deal with any facet of electronics but should always be practical. Any circuit diagrams that may be included should have been thoroughly checked by the author. If you are considering trying your hand at writing this type of book we suggest that you let us have a short summary of the subject you intend to cover. We will then be able to let you know the size of book required and perhaps give you some advice on presentation.

Chapter 2. Components used in transistor circuits
Chapter 3. Transistor Amplifiers
by
CLIVE SINCLAIR

Chapter 4. General Receiver Circuitry 23

Chapter 5. Regenerative Receivers 47

Chapter 6. Reflex Receivers 67

© 1951

BERNARDS (PUBLISHERS) LIMITED
THE GRAMPIANS,
WESTERN GATE,
LONDON, W.6.

Printed by V. Cooper & Co. at Western Gate, London, W.6.
for Bernard's (Publishers) Limited, Western Gate, London, W.6.

FIRST PUBLISHED NOVEMBER, 1961

REPRINTED NOVEMBER, 1962

REPRINTED MARCH, 1966

REPRINTED JULY, 1970

We invite all authors, whether new or well established, to submit manuscripts for publication. The manuscripts may deal with any facet of electronics but should always be practical. Any circuit diagrams that may be included should have been thoroughly checked by the author. If you are considering trying your hand at writing this type of book we suggest that you let us have a short summary of the subject you intend to cover. We will then be able to let you know the size of book required and perhaps give you some advice on presentation.

© 1961

Printed by V. Cooper & Partners Ltd., Flitcroft Street, London, W.C.2,
for Bernards (Publishers) Ltd., The Grampians, Western Gate, London, W.6.

LIST OF ILLUSTRATIONS

INTRODUCTION

Page

12

13

CONTENTS

	Page
Introduction	5
Chapter 1. Techniques used in Home Constructed Receivers ...	6
Chapter 2. Components used in Home Constructed Receivers ...	7
Chapter 3. Subminiature Circuitry Techniques	12
Chapter 4. General Receiver Circuitry	23
Chapter 5. Regenerative Receivers	33
Chapter 6. Reflex Receivers	42

LIST OF ILLUSTRATIONS

	Page
Fig. 1. Unstabilised Common Emitter Amplifier	12
Fig. 2. Stabilised Version of Fig. 1	13
Fig. 3. An Alternative Method of Stabilisation	14
Fig. 4. A Two-Stage R - C Coupled Amplifier	15
Fig. 5. A Two-Stage Transformer Coupled Amplifier	17
Fig. 6. A Two-Stage Choke Coupled Amplifier	17
Fig. 7. A Common Collector Stage Directly Coupled to a Common Emitter Stage ...	18
Fig. 8. Two Directly Coupled Common Emitter Stages	18
Fig. 9. Directly Coupled, Cascade R.F. Amplifier	20
Fig. 10. A Three-Stage, Direct Coupled, Amplifier	20
Fig. 11. A Similar Circuit to Fig. 9 with a Different Form of Stabilisation	21
Fig. 12. Positive Feedback Applied to a Two-Stage, R - C Coupled Amplifier	21
Fig. 13. Positive Feedback Applied to a Transformer Coupled Output Stage	24
Fig. 14. Basic Crystal Set	25
Fig. 15. The Crystal Set of Fig. 14 Connected to a One Transistor Amplifier	26
Fig. 16. Method of Connecting Knob to Postage Stamp Trimmer	26
Fig. 17. Variable Inductance Tuning System	27
Fig. 18. Crystal Set with Two-Stage Amplifier	28
Fig. 19. Simple Two Transistor Receiver	28
Fig. 20. Low Consumption 3-Transistor Receiver	29
Fig. 21. Loudspeaker Version of Fig. 20	30
Fig. 22. Voltage Doubler Loudspeaker Crystal Set	31
Fig. 23. Two Transistor Push-Pull Receiver	32
Fig. 24. Four-Stage Receiver Using Hearing Aid Transistors	33
Fig. 25. Regenerative Detector Receiver	34
Fig. 26. Two Transistor Set with Regenerative Detector	35
Fig. 27. Regenerative Receiver with 2" Loudspeaker	36
Fig. 28. Low Voltage Regenerative Receiver Using Surface Barrier Transistor	37
Fig. 29. Two Transistor Regenerative Using Surface Barrier Detector	38
Fig. 30. Loudspeaker Receiver Using a Surface Barrier Transistor	40
Fig. 31. Circuit of Wrist Radio made by Lel in the U.S.A.	41
Fig. 32. Single Transistor Reflex Receiver	42
Fig. 33. Simplified Single Transistor Reflex Set	44
Fig. 34. Circuit of the "Super-3" Receiver	45
Fig. 35. Loudspeaker Reflex Receiver Using Only 2 Transistors	46
Fig. 36. Two Transistor Reflex Set for use with an Earpiece	47

INTRODUCTION

The increasing complexity of electronic equipment has forced manufacturers to concentrate on reducing the size of their components without any reduction in performance.

Miniaturization has been achieved not only by using smaller versions of standard components but also by the invention and discovery of the new types of components and new assembly methods. Foremost amongst the hundreds of new components is, of course, the transistor which not only reduces the size and power requirements of equipment but at the same time gave a tremendous boost to the research in semiconductors as a whole. This research has resulted in semiconductor switches, transformers, power rectifiers, voltage controlled variable capacitors and newer and better types of amplifier. Most of these components have yet to be exploited to any large degree but many of them show tremendous promise, especially in the fields of higher power and higher frequency devices where the transistor has limitations.

The major recent change of construction method has been the acceptance of printed circuit boards. Nowadays almost every radio and television receiver produced uses printed circuit boards and their use in industry is still more far reaching. The reason for this swing from conventional wiring is simple to understand. The new method offers simplicity and uniformity in construction, more compact assemblies and considerably reduces the number of rejects. In the future it will also provide a method of cheaply and accurately constructing many types of components. Switches, resistors, capacitors, inductances and potentiometers are already being made to remarkably close tolerances.

Still more compact methods of construction are now being used and developed. The micro-modular system, now used in the United States, offers tremendous possibilities for the automatic construction of extremely small and robust pieces of equipment. In this system all the components are made about a third of an inch square and with a thickness varying between a twentieth and a hundredth of an inch. The contacts are brought out to the rim of the disc. In construction the required components are piled on top of one another in the correct order and connections made between them by selectively coating the sides of the resultant block with a conductive material. Using this system the stationary parts of a radio receiver have been made hardly larger than a sugar lump.

A still more compact system is now under de-

velopment both in Great Britain and the United States. In this system, which is usually referred to as solid circuitry, all the components are formed in a solid piece of semiconductor, usually germanium, only about the size of the head of a match. In this tiny space a unit containing 20 components has already been made with considerable success.

The degree of miniaturization just described staggers the imagination and may appear to be carrying things a little too far. However, when one considers that many of the computers of today are already extremely large and that those of tomorrow will probably be hundreds of times as complex such a method appears not only useful but eventually essential. Nor need this degree of compactness be considered an ultimate, one has only to look at the minuteness of an insect which would require literally millions of components to simulate its functions accurately, and one realizes that we are making something comparatively clumsy.

As far as domestic electronic equipment is concerned, miniaturization has been used, but only to a rather limited extent. The smallest radios produced in this country are often called pocket radios by the manufacturers. This they may be if one is referring to overcoat pockets but nevertheless they are too large to be carried comfortably in a normal pocket. In my opinion, a true pocket radio should not only fit into almost any pocket but should fit easily making no bulge and leaving enough space for carrying other, possibly more essential, things. In this book I have described several receivers in this category as well as some slightly larger sets. Some of the sets described are extremely novel particularly the extremely small radios. Despite their reduced dimensions all the radios give sufficient output to be heard comfortably under the conditions for which they were designed. Most of the circuits have never been published before and were developed and tested in the Bernards Laboratory. The components used are all obtainable thanks to the very kind co-operation of the manufacturers concerned. If you have any difficulty in buying whatever components you require your best plan is to ask your local supplier to order them for you. If, for some reason, he is unable to do this you should write to the manufacturer concerned who will either let you know where the components may be bought or will agree to supply them directly.

Where a particular make of component is specified you should, if possible, use that component because that was the type used in the prototype and others may prove unsatisfactory.

CHAPTER 1

Techniques used in Home Constructed Receivers

If one is designing or building a subminiature radio or other piece of electronic equipment there are three basic ways in which space can be saved. First of all, there is the most obvious way, using smaller components. Secondly, one can use a more compact form of assembly by carefully designing the set to leave as little empty space as possible. Finally, and perhaps most important of all, an economical circuit can be used. That is to say, using a circuit which obtains the results normally expected from a radio of its type but with fewer than normal components.

Simplifying circuits and obtaining the maximum performance from a limited number of components is an intriguing pastime. In this the home constructor has far greater scope than the manufacturer because he can afford to spend more time making critical adjustments to the finished radio. For example, a regenerative receiver cannot normally be put on the market because it requires fairly careful adjustment each time it is used, but for the home constructor it is frequently ideal because of its high selectivity, sensitivity and low cost.

For our purpose the various types of circuits that could be used may be separated into six divisions:— Crystal sets — including crystal sets with audio amplifiers; regenerative receivers — meaning receivers in which the first transistor is a regenerative detector; reflex receivers — meaning those receivers in which one or more transistors act as both R.F. and A.F. amplifiers; T.R.F. receivers — meaning, in this case, sets with one or more stages of R.F. amplification but without any reflexing; superhet receivers and finally the super-regenerative type of receiver.

We will deal with each of these types individually to decide which purpose they are best suited for and what their particular merits and demerits are.

The crystal set is simple to build and requires no alignment. It gives first class reproduction and, when suitably designed, can operate on almost any band. On the other hand it lacks sensitivity and selectivity. The lack of selectivity is not so important as it might seem because sensitivity is normally such that only two or three powerful stations can be received and with a well designed coil the set should separate them completely. The low sensitivity is the main disadvantage and severely limits the areas in which the crystal set can be used successfully. In a very strong signal area it is sometimes possible to receive stations well on only a ferrite rod aerial, but normally a good external aerial and an earth are required. When a fixed receiver for the home is all that is wanted, the crystal set may often be very useful, especially

for children, because of the safety and simplicity of operation.

The regenerative receiver has long been popular with the home constructor. For use in subminiature receivers it is almost ideal because of its extreme simplicity. It lends itself well to very small self-contained receivers because it works well with only a very tiny ferrite rod aerial. Using a regenerative detector in the first stage a receiver operating a loudspeaker need only use three transistors and as only one of these is an R.F. type the cost of building such a set is very low. The main disadvantage with a regenerative detector is, of course, its tendency to oscillate if improperly controlled. This means that it must only be used by someone familiar with the properties of regeneration. When a high degree of regeneration is used the quality of reproduction begins to suffer, however, in a pocket set this is usually unimportant because of the limited frequency response of the speaker, but it makes this type of circuit unsuitable for use in radio tuners for feeding tape recorders or audio amplifiers. Preset tuning cannot be used because the tuning is invariably slightly dependent upon the position of the regeneration control.

Another type of circuit has recently emerged to challenge the regenerative detector for supremacy in small home built receivers. This is the reflex which although originally invented many years ago for use with valves, is only really satisfactory when used with transistors. The principle of the reflex circuit is a simple one; The incoming R.F. signal is amplified by the first transistor, demodulated in the normal way by a diode and then fed back to the first transistor for amplification at the audio frequency. To increase the sensitivity of this type of set, R.F. regeneration is frequently used, particularly in very small receivers where the added sensitivity is required to compensate for the small size of the aerial. At first sight it might appear that there is little difference between the regenerative detector and the reflex types of receiver, however, the reflex does, in fact, have several important advantages which will be apparent when the different types of receiver are discussed and described in detail under the section devoted to the circuits themselves.

All the types of receiver so far described are strictly speaking T.R.F.'s, but for the purpose of this book the term T.R.F. has been given a narrower definition. This has been necessary in order to be able to classify the different types of receiver and give the reader an understanding of their most useful application.

As far as we are concerned then, a T.R.F. is that type of receiver which employs one or more stages of R.F. amplification without using reflex

or regenerative detection techniques. To obtain satisfactory reception, using only an internal aerial, with such a receiver, at least two stages of R.F. amplification are required. This means at least three variably tuned circuits the variation being provided by a tuning condenser having three or more gangs. Such a component would be too bulky to include in a subminiature receiver which is what we are concerned with here. On the other hand, if a fixed receiver is required, either as a self-contained unit or to feed a separate tape recorder or amplifier, then the T.R.F. may be useful for an aerial can be used and only a single R.F. stage will be needed. The quality of reproduction in such a circuit will be first class although the selectivity may leave a little to be desired.

From this it may be seen that the only really useful application for this type of set is as a fixed A.M. tuner or receiver where rather more sensitivity is required than a crystal set plus aerial can provide.

The superhet, next on our list, does not, in its normal form, have a great deal to offer to the constructor of subminiature receivers. Transistor superhets usually consist of a frequency changer and two stages of I.F. amplification followed by the usual detector and audio amplifier. This type of circuit uses, in addition to the aerial coil, an oscillator coil and three tuned I.F. transformers. These coils make true subminiaturization virtually impossible with presently available components, so there is little point in discussing the circuit in any detail. Any readers who are interested in transistor superhets will find a detailed discussion of them in "Transistor Superhet Receivers" priced 7/6d. which is also published by Bernards.

Despite the uselessness of the normal superhet

in subminiature construction, the superhet principle may be usefully employed in unorthodox circuitry. For example, one of the main disadvantages of the regenerative detector type of circuit is the dependence of the level of regeneration on the frequency to which the receiver is tuned. This may be overcome by preceding the detector by a frequency changer which will give between 20 and 30db. extra gain as well as enabling the use of a pre-set regeneration control. The frequency changer also isolates the detector from the aerial thereby reducing the possibility of causing unwanted radiation.

Those constructors who are more interested in the short wave and V.H.F. bands than in the ordinary broadcast bands will probably find that the super-regen. is the answer to their prayers. Not only is the super-regenerative receiver the most sensitive type of circuit, exceeding the superhet quite easily in performance, but it also uses few components and is simple to build.

It is, of course, not without its difficulties, but these are mainly matters of adjustment and design rather than construction. When we come to discuss the circuit in detail further on in the book, we will find that there are two main types of super-regen.; the linear and the logarithmic. The latter is simpler to build and construct and has several very useful features but the quality of reproduction is rather poor limiting its use to the amateur bands where high fidelity is unobtainable whatever type of receiver is used.

The super-regen. is particularly useful on the F.M. band where its high sensitivity and broad tuning are a tremendous advantage. At these frequencies the superhet is the only real alternative and for subminiature work this is completely ruled out.

CHAPTER 2

Components used in Home Constructed Receivers

Until quite recently the home constructor who built transistorized equipment was forced to use comparatively bulky components as subminiature equivalents were not available. The situation has now improved considerably however, and a wide range of tiny components can be obtained quite easily.

Aerials and Coils

Because the coil requirements vary so considerably from one receiver to another they must usually be home made. Fortunately ferrite rods are readily available and these are ideal both for ferrite rod aerials and for small coils having high Q's. Ferrite rods are usually available in diameters of $\frac{1}{4}$ ", $\frac{3}{8}$ ", and $\frac{1}{2}$ " and in slabs having a cross section of $\frac{3}{4}$ " x $\frac{5}{32}$ ". The length may be anything from 4 to 8 inches. For very small receivers a shorter length of rod is usually required and the rod may be divided as follows:

Saw or file a groove on either side of the rod at the point at which you wish to break it. Now firmly grip the two ends of the rod and snap it in two. Remember that ferrite is extremely brittle and will shatter if dropped onto a hard surface. For the aerial the ferrite rod should be as long and as thick as the case will allow as the signal pickup is dependent on the size.

When a small aerial coil is required for use with an external aerial a subminiature I.F. transformer may be used. These are usually tuned by means of an internal fixed capacitor of 200pf which should be replaced by a variable capacitor having a similar value. With this arrangement the circuit will tune over the entire medium waveband. The size of this coil assembly may be reduced by removing the surrounding ferrite parts but if this is done the maximum value of the tuning capacitor must be increased to compensate for the loss of inductance.

Tuning Capacitors

Unfortunately, few small tuning capacitors, such as those used by the Japanese, are yet available. However, this difficulty can be overcome by using the postage stamp type of compression trimmer, which, as its name implies, is sufficiently small for use in subminiature receivers. These trimmers are available in values up to about 700pf but for medium wave use a 250pf type should be sufficient. The trimmer is supplied with a 6B.A screw through the centre and turning this screw raises and lowers the plates and thus varies the capacity. To attach a knob the screw should be replaced by a longer one of the same size thread. To the end of this can be bolted a disc of perspex or similar plastic which, when turned, will now control the capacity.

In very small sets it is often preferable to avoid the use of a tuning capacitor by using a fixed capacitor and making the tuning coil variable. This can be done by moving a piece of ferrite or dust iron core up and down inside the coil, thereby varying the inductance.

Resistors

Because of their large size, normal $\frac{1}{4}$ watt resistors are unsuitable for really small construction. They are also unnecessary because the resistors in a transistor set are rarely called upon to dissipate more than a few milliwatts of power. Fortunately very tiny resistors are now available from Arden Limited, under type number Z.1806. These resistors are rated at $\frac{1}{20}$ th of a watt at 80° C., and are really tiny being only 0.2 inches long by 0.063 inches in diameter. Their tolerance is $\pm 10\%$ and they are available in the following values:

56-82	100-820	1K-8.2K	10K-82K	100K-270K
ohms	ohms	ohms	ohms	ohms
	100	1K	10K	100K
	120	1.2K	12K	120K
	150	1.5K	15K	150K
	180	1.8K	18K	180K
	220	2.2K	22K	220K
	270	2.7K	27K	270K
	330	3.3K	33K	
	390	3.9K	39K	
56	560	5.6K	56K	
68	680	6.8K	68K	
82	820	8.2K	82K	

These resistors may be used for all the circuits in this book without being overloaded.

Capacitors

The input and output impedances of transistors are low when compared with those of valves so that coupling and decoupling capacitors must have much higher values if the lower frequencies are not to be attenuated. However, the working voltages are considerably lower so that the capacitors can still be made in very small sizes. As a

rough guide, the coupling capacitor between two common emitter A.F. stages should have a value of about 2 mu.f. With this value there will be a 3db loss due to the capacitor at 80c/s. In small sets, however, the bass frequencies are lost anyway because the speaker or earpiece used is generally incapable of reproduction below about 300c/s. This means that a 1 mu.f. or even a 0.5 mu.f. capacitor could be used if this gave any advantage in size. One of the most important capacitors in a transistor set is the battery decoupling capacitor which is connected across the battery to counteract the effect of the internal resistance rising as it ages. As large a value should be used for this as is possible.

For the radio frequency coupling and decoupling capacitors values of between 0.001 mu.f and 0.01 mu.f. are usually used. These values can be obtained in small sizes using either paper or ceramic as the dielectric. If necessary a value as low as 200pf. may be used, without too great a loss, when coupling between R.F. stages. This may be helpful when space is very limited because extremely small 200pf. capacitors are available and are used in transistor I.F. transformers.

Audio Transformers

To obtain the maximum gain from a cascade A.F. amplifier it is necessary to match the output impedance from one stage to the input impedance of the next. The gain achieved using this form of coupling is about 40db (power) compared with about 20db when R-C coupling is used. The A.F. transformers now available are so small that there is little to choose in size between transformer coupled and R-C coupled amplifiers having similar gain. As the former is usually cheaper, however, it has an advantage. The use of a transformer does introduce some distortion.

The usual turns ratio of an interstage coupling transformer is about 4.5 : 1 but it may be as high as 5 : 1. The inductance of the primary must be high and as this is reduced by the current flowing through it the collector of the transistor which it provides the load should be operated with a current of not more than about 0.5 ma.

The main manufacturers of subminiature transformers are Arden Limited and Fortiphone Limited. For interstage coupling the following types are suitable.

Manufacturer	Type No.	Size in Inches
Arden Ltd.	D.101	0.43 x 0.72 x 0.52
Arden Ltd.	D.217	0.43 x 0.72 x 0.52
Arden Ltd.	D.239	0.43 x 0.72 x 0.52
Arden Ltd.	D.1013	0.315 x 0.53 x 0.425
Arden Ltd.	D.1001	0.315 x 0.53 x 0.425
Fortiphone Ltd.	R.1	0.348 x 0.375 x 0.375
Fortiphone Ltd.	R.11	0.348 x 0.375 x 0.375
Fortiphone Ltd.	S.1	0.25 x 0.375 x 0.375
Fortiphone Ltd.	S.5	0.25 x 0.375 x 0.375
Fortiphone Ltd.	Z.1	0.25 x 0.375 x 0.275

In all the above transformers the primary has a greater D.C. resistance than the secondary and in case of difficulty this will enable you to decide which of the two windings is which.

Subminiature output transformers are also readily available but these depend to a far greater extent on the circuit in which they are to be used. When an output transformer is required in the circuits described in this book, the type to be used is specified and should be adhered to if possible.

Great care must be taken when using more than one transformer in a compact piece of equipment to prevent coupling between them. It is best to separate the transformers from one another as far as is possible and to mount them so that their axis are at right angles.

Volume Controls and Switches

One of the biggest problems in subminiature work has been the purchasing of sufficiently small volume controls and switches. Now, however, suitable types are readily available.

The normal type of volume control consisting of the carbon track mounted in a metal cylinder and controlled by a knob on the end of a spindle is far too bulky for our requirements. Fortunately

two other types are now on the market, the circular rim control type such as those usually found in hearing aids, and the straight sliding type. This latter type consists of a thin straight strip of resistive material with a tiny knob mounted on it which can slide backwards and forwards to form the control. Because of its slim construction it takes up very little space. Both of these types are available with or without switches. In some sets a volume control is not used either because the set is very small and there is no room for one or because the output level is not high enough to warrant it. In this case some means will be required for switching the set on and off without using a volume control. In some circuits it is possible to switch off the set merely by disconnecting the earpiece. When this is not possible it may be necessary to make your own switch because most of those available are a little too large for the type of application that we are concerned with. One fairly simple way to do this is to use a screw which passes through the outside of the case and when turned so that it moves inwards bridges the gap between two contacts thereby completing the circuit. The table below gives a representative selection of the components now available.

VOLUME CONTROLS

Manufacturer	Type Number	Size (Inches)	Preferred Value(s)
Ardente Limited	V.C.1041	0.68 dia. x 0.17	1K to 1Meg ohm
Ardente Limited	V.C.1126	0.68 dia. x 0.17	1K to 1Meg ohm*
Ardente Limited	V.C.1150	0.9 dia. x 0.287	1K to 3Meg ohm*
Ardente Limited	V.C.1226	1 x .125 x .2	5K to 3Meg ohm*
Ardente Limited	V.C.1383	.83 x .125 x .2	5K to 3Meg ohm
Fortiphone Limited	P.S.S.1	1.1 x .16 x .065	50K semi-log.*
Fortiphone Limited	VS.26	0.45 dia. x 0.112	50K semi-log.
Fortiphone Limited	VS.32	0.312 dia. x 0.15	50K semi-log.*

* Indicates that the volume control is complete with switch.

A very neat and fairly small switch is manufactured by Ardente under type No. S.1100. This has a diameter of half an inch and an overall depth of only 0.09 inch. It is a single pole, three position type and could well be used as a waveband switch in a multiwaveband receiver as well as an on-off switch for the set as a whole. The type of construction adopted allows several switches to be stacked on top of one another. Control is by means of a slot in the centre which may either be operated with a screwdriver or by attaching a knob to it.

Loudspeakers

The loudspeaker is probably the most critical component in a small receiver because the performance of the set depends so much upon it. As the size of the cone decreases it becomes harder to obtain a satisfactory performance at the lower frequencies. Furthermore, the sensitivity of small

speakers tends to be poor because a small magnet has to be used. Now sensitivity in the speaker means that the power dissipated by the output stage has to be increased, which in turn, means an increase in the size of the battery. Fortunately, there are now five different types of speaker on the market with performances high enough to fulfil our requirements, these are listed below.

W. B. Stentorian Model P2.585 — diameter 2.5 ins., depth 0.881 ins., handling capacity 300mw., impedance 3 ohms.

This speaker has a plastic chassis which means that a ferrite rod aerial can be mounted behind it without being damped or shielded from the signal.

W. B. Stentorian Model S.175 — diameter 1.75 ins., depth 1 in., handling capacity 200mw., impedance 3 ohms.

The obvious advantage of this excellent little speaker is its very small diameter but the sensitivity is less than the P2.585.

TSL-Lorenz Model LP.70 — diameter 2.75 ins. depth 1.1 ins., handling capacity 500 mw., impedance 10 ohms.

This speaker has the highest sensitivity and best frequency response of any miniature speaker on the market.

TSL-Lorenz Model LP.31 — 4 x 1.5 x 1 inches deep, handling capacity 500mw, impedance 3 ohms.

The unusual shape of the LP.31 makes it very useful for pocket radios having a size of about 4 x 2.5 inches.

TSL Model CMS50 — diameter 2 ins., depth 0.625 ins., handling capacity 50mw., impedance 150 ohms at 800 c/s.

This is a completely new type of speaker which, despite its extremely high sensitivity weighs only about one fifth as much as a comparable electro-dynamic type. When used with a correctly designed circuit no output transformer is required which means a considerable saving in space and expense. The speaker, which has a D.C. resistance of 50 ohms, is connected directly into the collector of the output transistor. If a push-pull output stage is required then the single ended class B type should be used, again without an output transformer. For a really pocketable radio this is the only speaker that can be used because the depth of all the others means the set has to be at least an inch which is rather too bulky. A leaflet on this and the other TSL miniature speakers is available from Technical Suppliers Limited, Hudson House, 63 Goldhawk Road, London, W.12.

However, it should be noted that the CMS50 has now replaced the CMS250 described in the leaflet.

The prices of the speakers mentioned above are as follows:

P2.585 — 22/6d.	S.1.75 — 25/6d.
LP.70 — 25/8d.	LP.31 — 24/7d.
CMS 50 — 17/11d.	LP45F — 25/8d.

(see later chapters)

Plugs, Sockets and Earpieces

As very small radio sets are usually designed for personal use, that is to say for only one person to listen to, there are several advantages in using an earpiece of the type used in hearing aids rather than a loudspeaker. Of course, an earpiece can be included in a loudspeaker set but an earpiece only set has several special advantages which may be listed as follows:—

1. Smaller size and weight.
2. Lower cost.
3. Better frequency response (200 to 4,000 c/s may not seem very good but it sounds excellent on an earpiece).
4. Lower battery consumption.

One way of getting the best of both worlds is to build an earpiece only receiver and an add on unit containing an output stage and a loudspeaker. In this way the earpiece receiver can be used when travelling and then clipped or plugged into the speaker section at home.

Both Technical Suppliers Ltd. and Fortiphone, make a range of earpieces and these are listed below.

Manufacturer	Type No.	Size	Price	D.C. Resistance	Impedance at 1Kc/s
Fortiphone Limited	Series T	0.625 dia. x 0.414 thick	19/3	20	50 (White)
Fortiphone Limited	Series T	0.625 dia. x 0.414 thick	19/3	60	120 (Red)
Fortiphone Limited	Series T	0.625 dia. x 0.414 thick	19/3	250	600 (Black)
Technical Suppliers Ltd.	Series A Crystal	0.875 dia. x 0.4 thick	10/6	—	1 Megohm
Technical Suppliers Ltd.	Series B Dynamic	0.75 dia. x 0.3 thick	10/6	1.5	50
Technical Suppliers Ltd.	Series C Dynamic	0.75 dia. x 0.3 thick	10/6	7.5	20

Batteries

A wide range of small batteries and dry cells is now on the market and the constructor should have little difficulty in finding ones that suit his requirements. The three most useful types are:—

Ever Ready power pack batteries.

Mallory Mercury cells.

Deac nickel-cadmium accumulators.

The latter might be a little difficult to obtain.

The Ever Ready batteries are fairly small and their cost is low. They are available for 6 and 9 volts and are therefore suitable when a comparatively high voltage is necessary. Unfortunately, like all zinc-carbon cells or batteries, their voltage varies with load and time so that they are not very suitable when a very constant voltage is required.

Mallory mercury cells can be obtained in a great variety of sizes down to the size of a shirt button. Each cell has a voltage of about 1.34 which does not alter significantly as the battery ages or with the load. They are very small in comparison to the amount of power they can deliver but they are rather more expensive than the zinc-carbon type. The Deac accumulators have a voltage of 1.25 which remains constant. The power they can deliver per unit volume is less than that of the mercury cells but they are, of course, rechargeable so this may not matter much.

The table below is by no means comprehensive but I think it covers all the cells and batteries of the above mentioned types which are likely to be useful in miniature work.

<i>Manufacturer</i>	<i>Type</i>	<i>Voltage</i>	<i>Size in ins.</i>	<i>Life</i>	<i>Maximum Recommended current drain</i>
Ever Ready	PP3	9	0.68 x 0.68 x 1.9	50 hrs. @ 2ma.	3ma.
Ever Ready	PP3	9	1.03 x 0.68 x 1.9	110 hrs. @ 2ma.	5ma.
Ever Ready	PP4	9	1 x 1 x 1.95	—	7.5ma.
Mallory	RM1	1.34	0.62 dia. x 0.65	1000 M.A.H.	100ma.
Mallory	RM400	1.34	0.45 dia. x 0.125	80 M.A.H.	10ma.
Mallory	RM401	1.34	0.455 dia. x 1.13	800 M.A.H.	100ma.
Mallory	RM450	1.34	0.45 dia x 0.56	350 M.A.H.	40ma.
Mallory	RM625	1.34	0.606 dia. x 0.225	250 M.A.H.	20ma.
Mallory	RM640	1.34	0.620 dia. x 0.43	500 M.A.H.	50ma.
Mallory	TR112	2.6	0.65 dia. x 0.6	250 M.A.H.	20ma.
Mallory	TR113	3.9	0.65 dia. x 0.835	250 M.A.H.	20ma.
Mallory	TR114	5.2	0.65 dia. x 1.065	250 M.A.H.	20ma.
Mallory	TR115	6.5	0.65 dia. x 1.295	250 M.A.H.	20ma.
Mallory	TR152	2.6	0.45 dia. x 1.125	350 M.A.H.	40ma.
Mallory	TR153	3.9	0.477 dia. x 1.693	350 M.A.H.	40ma.
Deac	50DK	1.22	0.63 dia. x 0.23	50 M.A.H.	5ma.
Deac	100DK	1.22	0.98 dia. x 0.226	100 M.A.H.	10ma.
Deac	150DK	1.22	0.98 dia. x 0.246	150 M.A.H.	15ma.
Deac	225DK	1.22	0.98 dia. x 0.334	225 M.A.H.	22ma.
Deac	450DK	1.22	1.65 dia. x 0.28	450 M.A.H.	45ma.

M.A.H. stands for milliampere hours.

Transistors and Diodes

Three different types of transistor are used in the circuits described in this book. The different types are:—

1. Alloy junction.
2. Surface barrier.
3. Drift and alloy diffused.

The alloy junction transistor is the most common type and a great variety of these is available. They are suitable for amplification at audio frequencies and at R.F. frequencies up to about 5 mc/s. For R.F. amplification a transistor specifically designed for this purpose should be used.

For maximum gain a transistor is used in the common emitter mode in which case the current gain will be beta. There will also be a voltage gain because the output impedance is higher than the input impedance but the value of beta does give an indication of the gain likely to be obtained. Thus a transistor with a beta of 50 would have a higher power gain than a transistor whose beta was only 10.

Transistors are sometimes used in the common base mode, usually when the frequency of operation is high in relation to the transistor's cut off frequency. This is because a transistor can amplify

at much higher frequencies in the common base mode than it can in the common emitter mode. Manufacturers usually indicate the frequency capabilities of their transistors by giving the alpha cut off frequency or the maximum frequency of oscillation. The former is the frequency at which the common base current gain is reduced to 0.707 (3db) times its value at 1K c/s. The latter is the frequency at which the common emitter power gain is reduced to one, that is, a power gain of 0 db.

Surface Barrier transistors are made by Semiconductors Limited at Swindon. They usually operate at frequencies up to about 30 mc/s. or rather higher than the average alloy R.F. transistor. They are very useful in small receivers because their gain remains fairly constant down to very low values of collector current and voltage thereby reducing the battery drain. Their efficiency as detectors is particularly good and this makes them useful as regenerative detectors.

Drift and alloy diffused transistors are designed for R.F. applications and types are available which will amplify at 100 mc/s. Their particular advantage is their very high power gain which may be as much as 50 db at broadcast band frequencies.

CHAPTER 3

Subminiature circuitry techniques

The various types of receiver circuit that may be used have already been listed and briefly described. In this chapter general circuitry techniques which apply to them all will be considered in detail.

Transistor biasing and stabilization

For a transistor to operate, it must be supplied with direct currents in the base-emitter and collector-emitter circuits (common emitter operation is all that need be considered here as bias methods used in the circuits in later chapters are generally confined to this system). As the transistor is a current amplifying device, which provides voltage amplification merely because the output impedance is higher than the input impedance, it is usually necessary to design bias sources to supply a definite amount of current rather than a carefully controlled voltage.

The current flowing through the collector-emitter circuit of a transistor will be equal to beta times the sum of the base-emitter current and I_{co} , where beta is the current gain of the transistor and I_{co} is the leakage of current from the collector to the base. Unfortunately this leakage is variable and increases rapidly with temperature,

making compensation necessary except in special cases. Were it not for this the circuit of Fig. 1 would be all that was necessary, but, with a rise in I_{co} , the collector current will rise, increasing battery drain and possibly exceeding the specified limit of the transistor. As a rise in collector current causes an increase in junction temperature, a vicious circle may result in which the collector current rises exponentially until the transistor is destroyed. This dramatic suicide only occurs when the initial collector current is high in relation to the maximum for which the transistor is designed but, with transistors as expensive as they are, the possibility should be borne in mind.

To reduce or negate the effect of the leakage current two general techniques may be used; as the effect of the leakage current from collector to base on the collector current is proportional to the amount that flows through the base-emitter circuit, it may be reduced by connecting a resistor between the base and ground, which amounts to putting a resistor in parallel with the base-emitter circuit thereby reducing the current flowing through it. To compensate for the loss of bias current, R1 would then have to be reduced. If,

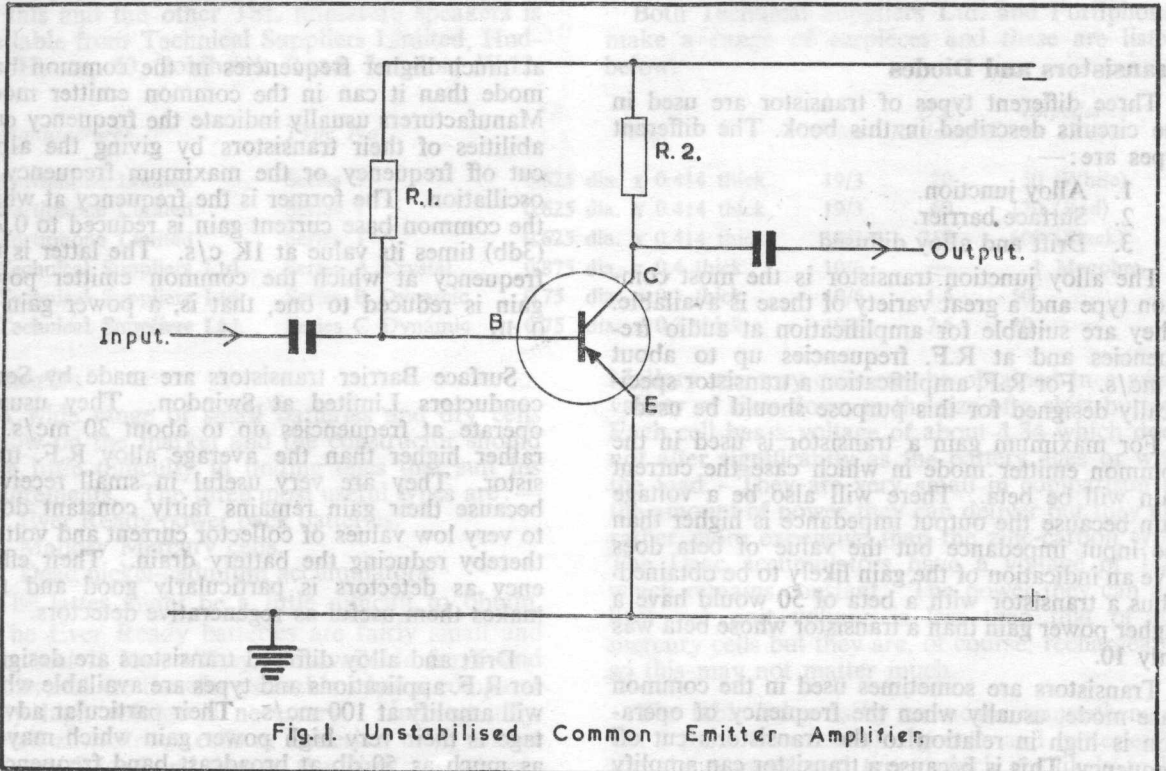

Fig. 1. Unstabilised Common Emitter Amplifier.

as it usually is approximately, the value of the base-emitter resistance is $1K$ then a resistor of this value in parallel with it will reduce the dependence of the collector current on I_{co} by half. As the resistor would shunt the input there would be a 3db loss of power gain and an overall reduction in input impedance.

The second, and more effective, way to improve the D.C. stability is to make the base current dependent on the collector current in such a way that an increase in collector current produces a decrease in base current. This is achieved by negative feedback which, if it is not to result in a serious loss in power gain, is only effective at D.C. The usual method of achieving this is illustrated in Fig. 2. The current in the base-emitter circuit can be determined by the voltage difference between these two electrodes. The voltage on the base is set by the potential divider across the battery formed by R_1 and R_2 and the voltage on the emitter by the value of the collector current and R_4 . If the collector current begins to rise the voltage dropped across R_4 will rise and the potential difference between base and emitter will be reduced. This will reduce the base-emitter current which, in turn, will reduce the collector current. As R_4 is by-passed by C_1 the degenerative effect at audio frequencies is negligible. If you see a circuit of this type, as you will frequently, and wish to know the collector current for which the stage is biased it may be calculated by using the

formula:—

$$I_c = \frac{V R_2}{R_4 (R_1 + R_2)}$$

This will only give an approximate answer but it is quite sufficiently accurate for normal purposes. What is most interesting about this equation is that it does not involve any of the parameters of the transistor itself such as the current gain.

Whilst this circuit is excellent for normal applications it is not very well suited to subminiaturization needs because of the extra components it requires; for although the resistors will not take up a lot of room, the by-pass capacitor is liable to be rather bulky.

When a certain amount of negative feedback at audio frequencies can be tolerated the circuit shown in Fig. 3 may be used for, although the stability of Fig. 2 will not be achieved, there will be a considerable improvement over the performance of Fig. 1. Instead of taking the base bias directly from the negative side of the battery it is taken from the collector of the transistor via R_1 . The cycle of events will now be as follows:— As the collector current rises the voltage dropped across R_2 increases, this reduces the base current which tends to return the collector current to its previous value. This method depends upon the value of the current gain of the transistor.

In simple circuits, where the battery voltage is fairly low and the leakage current of the transistor

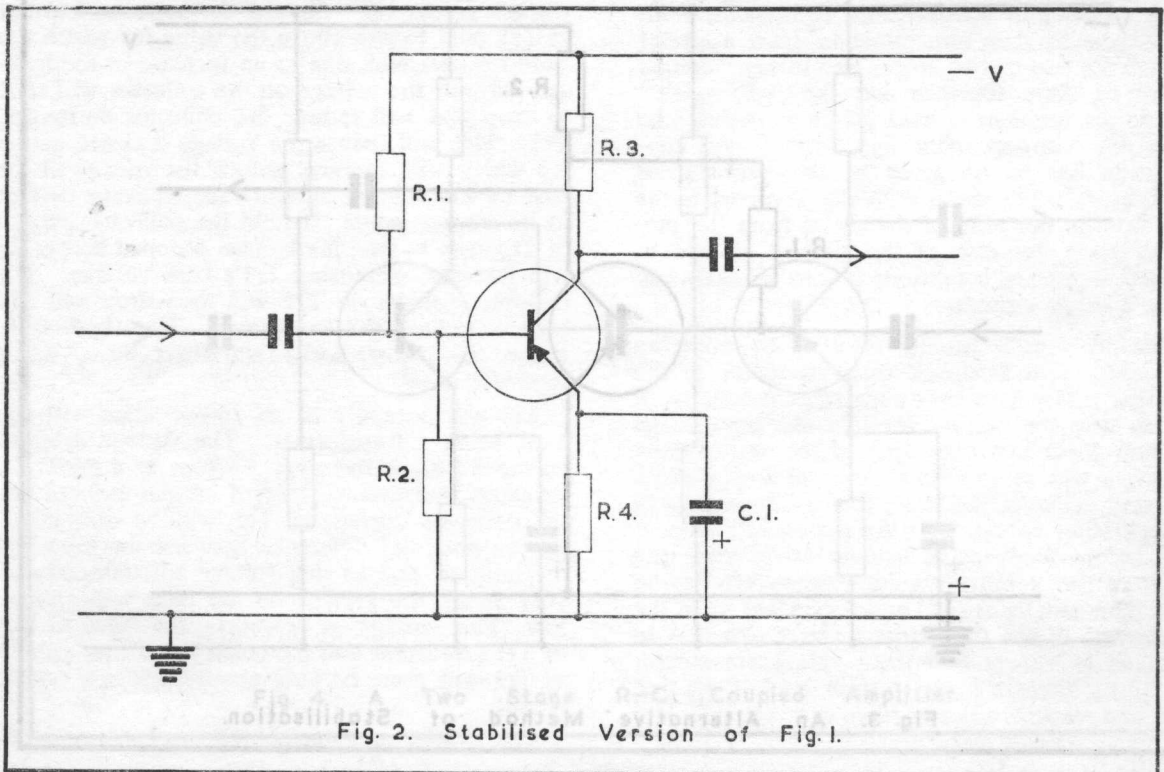

Fig. 2. Stabilised Version of Fig. 1.

is high, the base bias resistor may often be omitted entirely. The collector current will then be unpredictable but this will not usually matter as it is most unlikely to be so low that the gain is very seriously affected, or high enough to cause excessive battery drain or damage to the transistor. It may, however, result in amplitude distortion of the signal and possibly in clipping, the former because transistors are non-linear at low currents and the latter because the signal swing may exceed the maximum possible deviation permitted by the collector current. The low current non-linearity is, of course, an advantage and even an essential feature of the transistor's behaviour when devices such as detectors, mixers and autodyne frequency changers are being designed.

It is sometimes possible to design a circuit in which the bias supplies and stabilization components of several stages are interrelated with a resultant saving of parts. This is usually the case with direct coupled circuits and various examples are shown later in this chapter under the section devoted to coupling methods.

Current Levels

With normal circuitry the collector current of a transistor is set for the optimum value for the type of performance required but, with subminiature

receivers and allied equipment, the power consumption from the battery has to be kept to a minimum and this becomes a factor for consideration in determining the operating current for each individual stage.

The collector current required for optimum gain as an amplifier differs little between transistors of similar mechanical construction but may vary by as much as a factor of 10 between transistors of different type. For example, a normal alloy junction transistor, such as the OC71 gives maximum current gain when the collector current is 3 ma. whilst a surface barrier transistor gives its maximum gain for a current of only 300 microamps. This does not mean that these transistors will not operate at lower current levels however. Far from it, the OC71 will still have a good gain at only 100 microamps and a surface barrier transistor, such as the SB344, will operate with only 10 microamps or even less. At these low current levels, however, the input impedance is considerably higher than normal but, in a resistance-capacity coupled circuit, this may not mean too much loss of power gain. In a transformer coupled stage the loss would be much more significant as this type of coupling depends on the ratio of output to input impedance in a transistor for its advantage over other coupling methods.

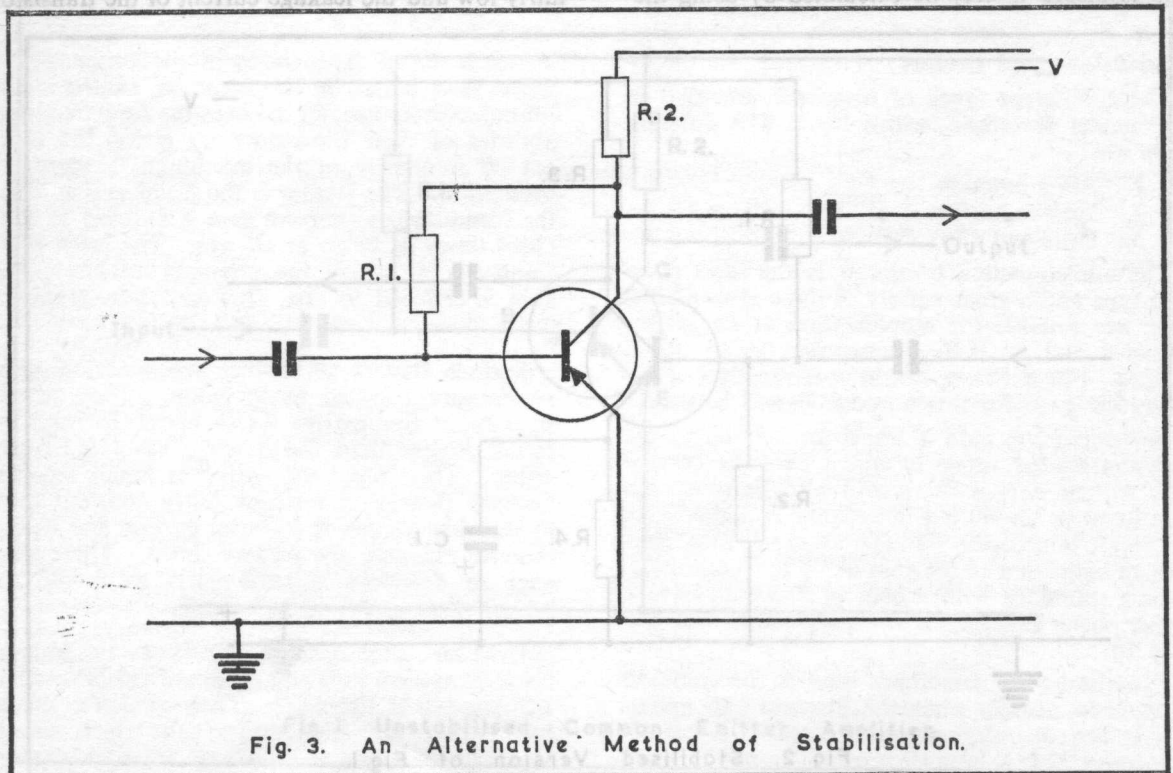

Fig. 3. An Alternative Method of Stabilisation.

Output transistors, such as the OC72, are specifically designed to maintain a constant current gain up to a relatively high level of collector current thereby reducing amplitude distortion in large signal amplifiers. Since current levels in excess of about 4.5 ma. are not often required or obtainable in subminiature receivers it is rarely necessary to use this type of transistor.

When a transistor is used as a detector it must be biased in such a way that the gain given to a negative going signal is significantly greater than that given to a positive going one and for this a very low collector current is desirable. If the detector is to provide regeneration at radio frequencies, however, a compromise has to be made between R.F. gain and detector efficiency. With alloy junction transistors a suitable level of current gain is about 0.25 mA and with surface barrier transistors about 100 microamps usually proves to be the most efficient level.

Because of their high efficiency at low current and voltage levels, surface barrier transistors have considerable advantages over other types when used in subminiature work. Their excellent R.F. characteristics also make them ideal as R.F. amplifiers and regenerative detectors.

Coupling Methods

Transistors may be coupled to one another for

cascade amplification in four different ways, r-c coupling (resistance-capacity), transformer coupling, choke or inductance coupling and direct coupling.

The most commonly used of these is R-C coupling because it is simple, cheap and introduces little distortion. A typical circuit diagram for a two stage R-C coupled amplifier is shown in Fig. 4. Conventional stabilization is used, for the sake of illustration, but any of the other methods of biasing just described would be equally possible and, for our purposes, more appropriate. The gain, per stage, of this type of amplifier is usually between 20 and 25 db and will be high when a high value of collector resistor is used. The value of the interstage coupling capacitor will generally be between 1 and 10 microfarads but, with subminiature receivers, may be as low as 0.1 microfarads because a response below 200 c/s is not usually required.

Transformer coupling has the advantage of considerably greater gain than other types, usually being about 40 db or equivalent to two, cascaded, R-C coupled stages. The distortion introduced by the transformer may be troublesome for some purposes but for our purposes presents no problem. The transformer should be designed so that the primary matches the output impedance of the transistor whilst having as low as possible a D.C.

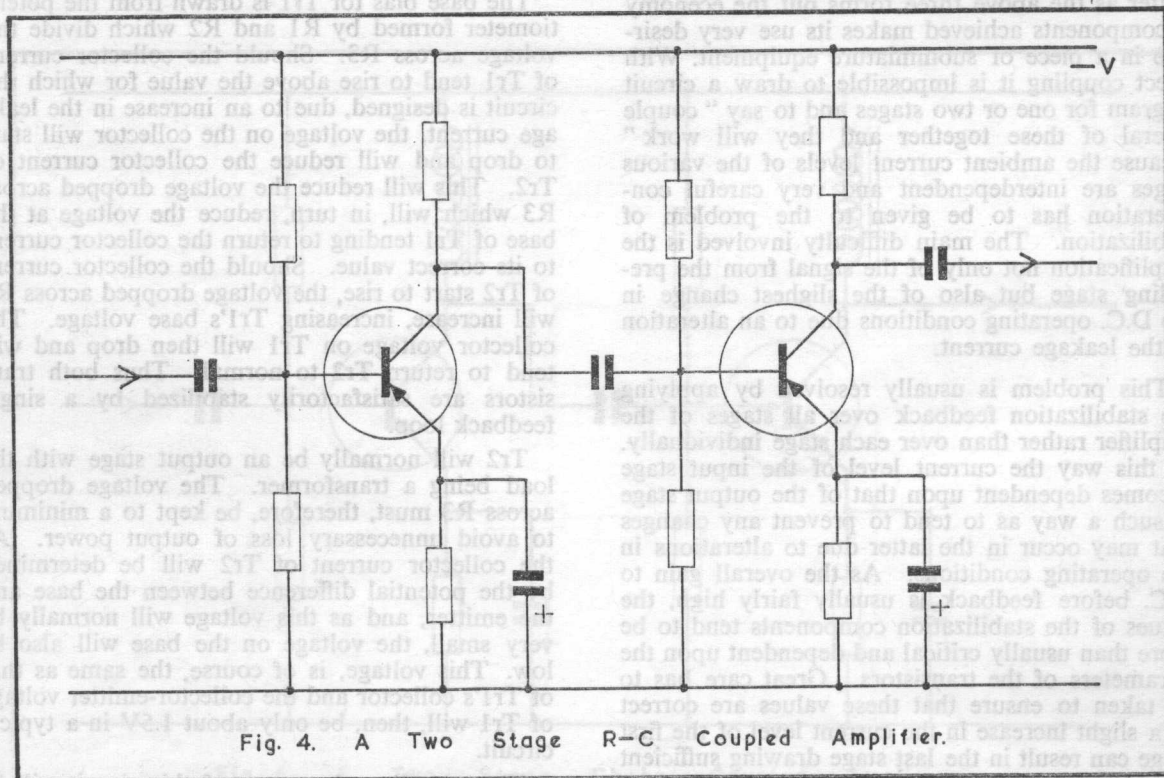

Fig. 4. A Two Stage R-C Coupled Amplifier.

resistance. The turns ratio must be such as to match this output impedance to the input impedance of the next stage. This is usually a matter of matching about 20K to 1K making a turns ratio of 4.5 : 1 about ideal. As a transformer coupled stage can replace two R-C coupled stages from the gain point of view, the size of the transformer need not prohibit the use of this type of coupling. In fact, space may even be saved.

Choke coupling is in between R-C and transformer coupling in both cost and efficiency. It resembles R-C coupling except in that an audio frequency choke replaces the collector resistor. As this choke may have a comparatively low D.C. resistance, the permissible collector current swing in increased and higher signal levels may be handled before clipping occurs. As the load impedance may be increased by use of a suitable inductance a better transfer of power to the next stage is possible. To improve the impedance match between successive stages, the choke may be suitably tapped to provide a low output impedance. It will then act as an auto transformer and there will be little to choose between it and the circuit just described. From the size point of view the choke has little or no advantage over a similar transformer which makes its use rather unattractive.

Direct coupling is nothing like so simple a matter as the above three forms but the economy of components achieved makes its use very desirable in a piece of subminiature equipment. With direct coupling it is impossible to draw a circuit diagram for one or two stages and to say "couple several of these together and they will work" because the ambient current levels of the various stages are interdependent and very careful consideration has to be given to the problem of stabilization. The main difficulty involved is the amplification not only of the signal from the preceding stage but also of the slightest change in the D.C. operating conditions due to an alteration in the leakage current.

This problem is usually resolved by applying the stabilization feedback over all stages of the amplifier rather than over each stage individually. In this way the current level of the input stage becomes dependent upon that of the output stage in such a way as to tend to prevent any changes that may occur in the latter due to alterations in the operating conditions. As the overall gain to D.C. before feedback is usually fairly high, the values of the stabilization components tend to be more than usually critical and dependent upon the parameters of the transistors. Great care has to be taken to ensure that these values are correct as a slight increase in the current level of the first stage can result in the last stage drawing sufficient current to destroy itself.

Fig. 7 shows the straightforward connection of a common collector stage to a common emitter one. The common collector stage has a power gain which is approximately equal to beta or the common emitter current gain and is usually in the region of 15 db. However, the input impedance is roughly the same as the output impedance of a normal common emitter stage so that efficient matching to a preceding stage can be achieved. The second stage is biased in the normal way with the first transistor acting as the top half of the base potentiometer. Variation in the collector level of Tr1 will, therefore, strongly affect the collector level of Tr2. If the input to Tr1 is applied between the base and the emitter, rather than between the base and ground, this first stage will operate as a common emitter amplifier as far as the A.C. signal is concerned. The gain will then be increased but, of course, neither side of the input can be grounded and the signal must be taken from a device having two floating terminals such as the secondary of a transformer. Tr1 could be replaced by an N.P.N. transistor with the positions of the emitter and the collector reversed, in which case the amplifier would again consist of two cascaded common emitter stages.

Fig. 8 illustrates another two stage, direct coupled, amplifier with both transistors operated in the common emitter mode.

The base bias for Tr1 is drawn from the potentiometer formed by R1 and R2 which divide the voltage across R3. Should the collector current of Tr1 tend to rise above the value for which the circuit is designed, due to an increase in the leakage current, the voltage on the collector will start to drop and will reduce the collector current of Tr2. This will reduce the voltage dropped across R3 which will, in turn, reduce the voltage at the base of Tr1 tending to return the collector current to its correct value. Should the collector current of Tr2 start to rise, the voltage dropped across R3 will increase, increasing Tr1's base voltage. The collector voltage on Tr1 will then drop and will tend to return Tr2 to normal. Thus both transistors are satisfactorily stabilized by a single feedback loop.

Tr2 will normally be an output stage with the load being a transformer. The voltage dropped across R3 must, therefore, be kept to a minimum to avoid unnecessary loss of output power. As the collector current of Tr2 will be determined by the potential difference between the base and the emitter, and as this voltage will normally be very small, the voltage on the base will also be low. This voltage, is of course, the same as that of Tr1's collector and the collector-emitter voltage of Tr1 will, then, be only about 1.5V in a typical circuit.

The overall performance of this circuit will be

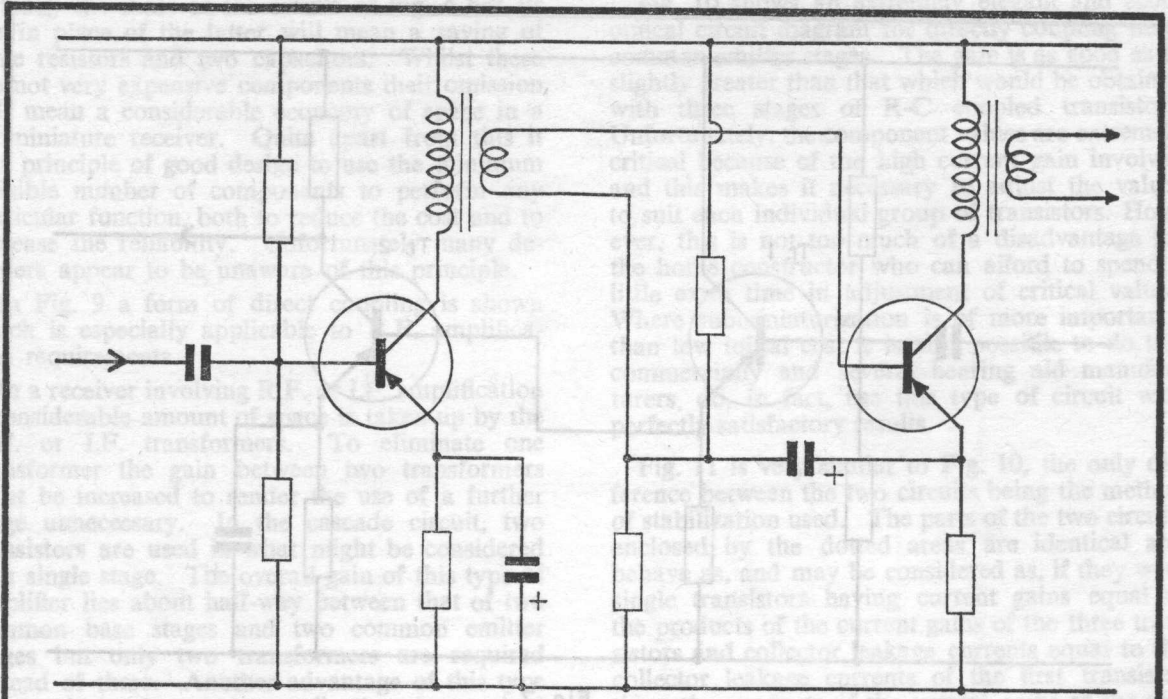

Fig. 5. A Two Stage Transformer Coupled Amplifier.

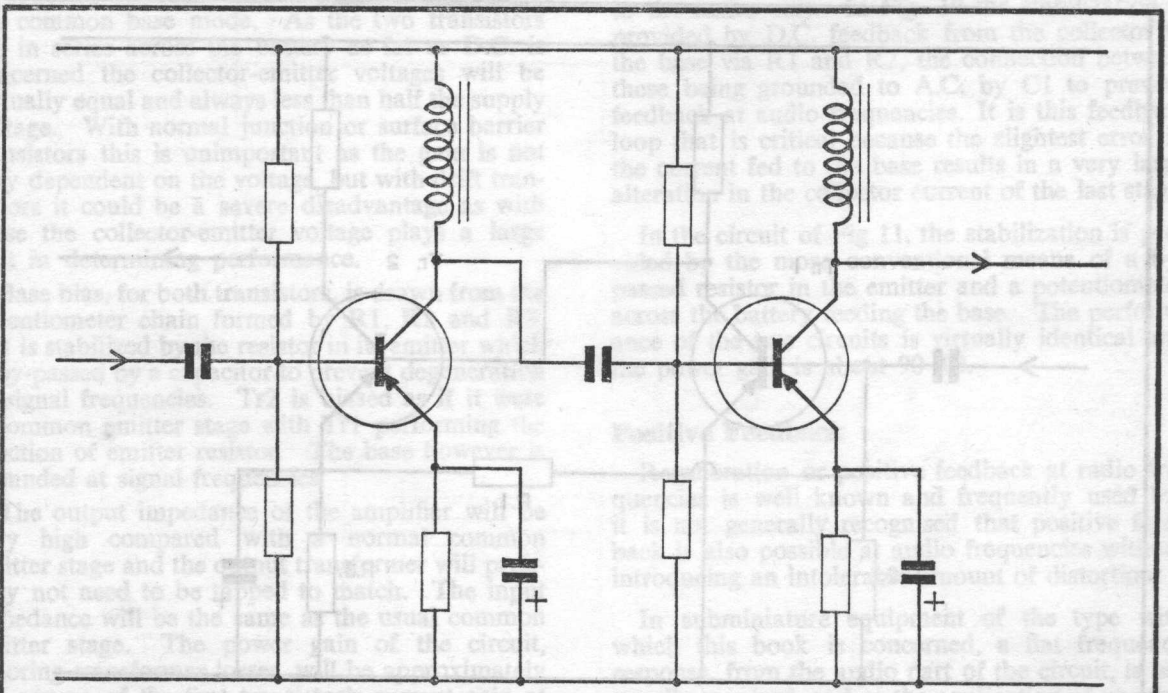

Fig. 6. A Two Stage Choke Coupled Amplifier.

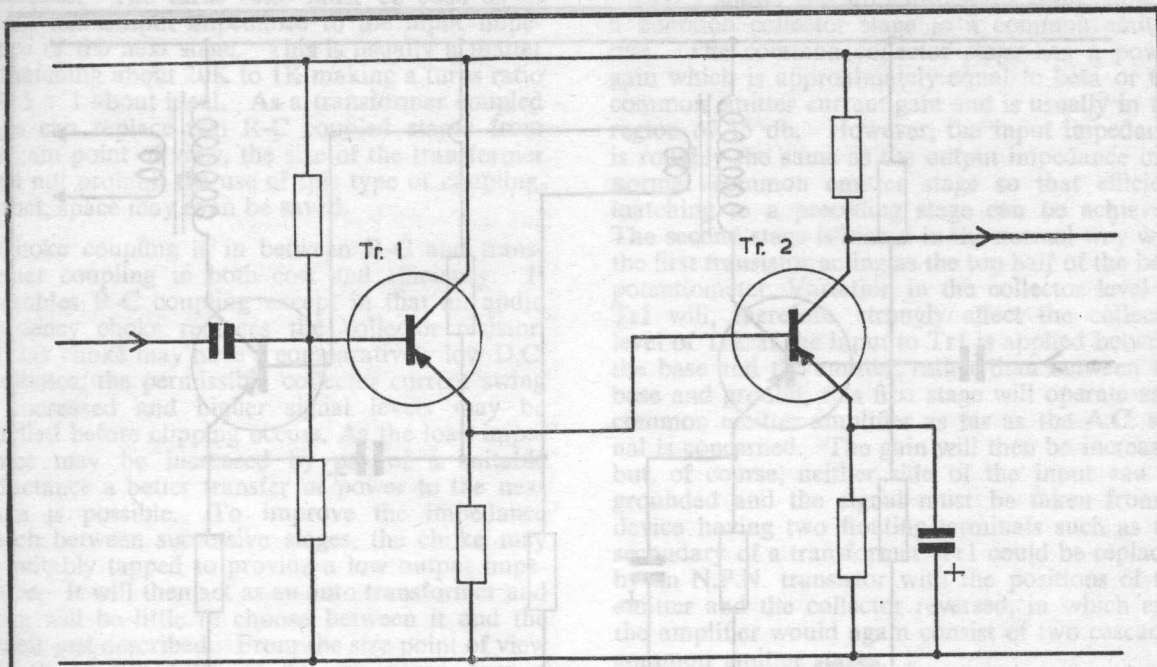

Fig. 7.

A Common Collector Stage Directly Coupled to a Common Emitter Stage.

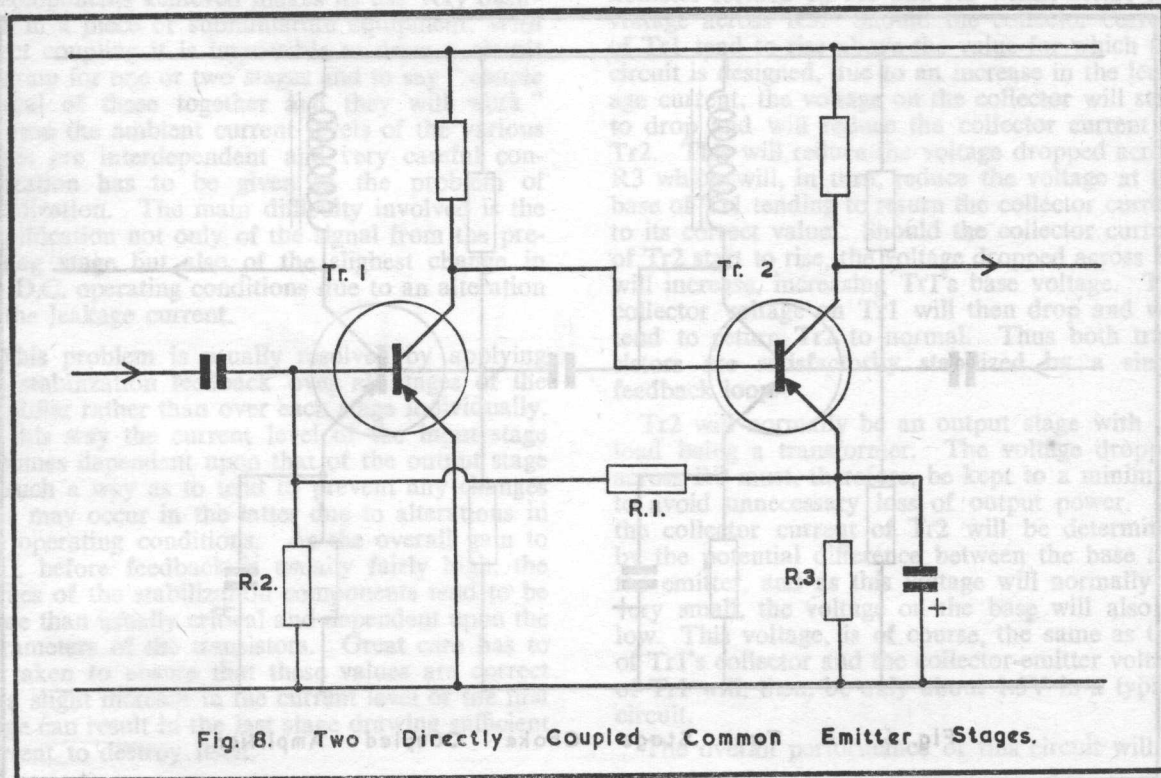

Fig. 8. Two Directly Coupled Common Emitter Stages.

virtually the same as the circuit of Fig. 4 but its use in place of the latter will mean a saving of three resistors and two capacitors. Whilst these are not very expensive components their omission will mean a considerable economy of space in a subminiature receiver. Quite apart from this it is a principle of good design to use the minimum possible number of components to perform any particular function, both to reduce the cost and to increase the reliability. Unfortunately many designers appear to be unaware of this principle.

In Fig. 9 a form of direct coupling is shown which is especially applicable to R.F. amplification requirements.

In a receiver involving R.F. or I.F. amplification a considerable amount of space is taken up by the R.F. or I.F. transformers. To eliminate one transformer the gain between two transformers must be increased to render the use of a further stage unnecessary. In the cascade circuit, two transistors are used in what might be considered as a single stage. The overall gain of this type of amplifier lies about half-way between that of two common base stages and two common emitter stages but only two transformers are required instead of three. Another advantage of this type of circuit is that no neutralization is required which eliminates the need for feedback trimmers to obtain optimum performance.

Tr1 is a common emitter amplifier and draws its collector current through Tr2 which operates in the common base mode. As the two transistors are in series across the battery as far as D.C. is concerned the collector-emitter voltages will be virtually equal and always less than half the supply voltage. With normal junction or surface barrier transistors this is unimportant as the gain is not very dependent on the voltage, but with drift transistors it could be a severe disadvantage as with these the collector-emitter voltage plays a large part in determining performance.

Base bias, for both transistors, is drawn from the potentiometer chain formed by R1, R2 and R3. Tr1 is stabilized by the resistor in its emitter which is by-passed by a capacitor to prevent degeneration at signal frequencies. Tr2 is biased as if it were a common emitter stage with Tr1 performing the function of emitter resistor. The base however is grounded at signal frequencies.

The output impedance of the amplifier will be very high compared with a normal common emitter stage and the output transformer will probably not need to be tapped to match. The input impedance will be the same as the usual common emitter stage. The power gain of the circuit, ignoring transformer losses, will be approximately the square of the first transistor's current gain at the operating frequency times the ratio of the output to the input impedance.

Fig. 10 shows an extremely elegant and economical circuit diagram for directly coupling three common emitter stages. The gain is as good as or slightly greater than that which would be obtained with three stages of R-C coupled transistors. Unfortunately, the component values are extremely critical because of the high current gain involved and this makes it necessary to adjust the values to suit each individual group of transistors. However, this is not too much of a disadvantage for the home constructor who can afford to spend a little extra time in adjustment of critical values. Where subminiaturization is of more importance than low initial cost it is also possible to do this commercially and several hearing aid manufacturers, do, in fact, use this type of circuit with perfectly satisfactory results.

Fig. 11 is very similar to Fig. 10, the only difference between the two circuits being the method of stabilization used. The parts of the two circuits enclosed by the dotted areas are identical and behave as, and may be considered as, if they were single transistors having current gains equal to the products of the current gains of the three transistors and collector leakage currents equal to the collector leakage currents of the first transistor times the products of the current gains of the second two transistors. Considering this unit, then, as a whole, the output will be out of phase with the input because the unit contains an odd number of transistors. Thus stabilization may be applied to the entire unit. In Fig. 10 the stabilization is provided by D.C. feedback from the collector to the base via R1 and R2, the connection between these being grounded to A.C. by C1 to prevent feedback at audio frequencies. It is this feedback loop that is critical because the slightest error in the current fed to the base results in a very large alteration in the collector current of the last stage.

In the circuit of Fig 11, the stabilization is provided by the more conventional means of a by-passed resistor in the emitter and a potentiometer across the battery feeding the base. The performance of the two circuits is virtually identical and the power gain is about 90 dB.

Positive Feedback

Regeneration or positive feedback at radio frequencies is well known and frequently used but it is not generally recognised that positive feedback is also possible at audio frequencies without introducing an intolerable amount of distortion.

In subminiature equipment of the type with which this book is concerned, a flat frequency response, from the audio part of the circuit, is not usually required, and as the application of positive feedback can save a transistor and its auxiliary components, its use can often be justified.

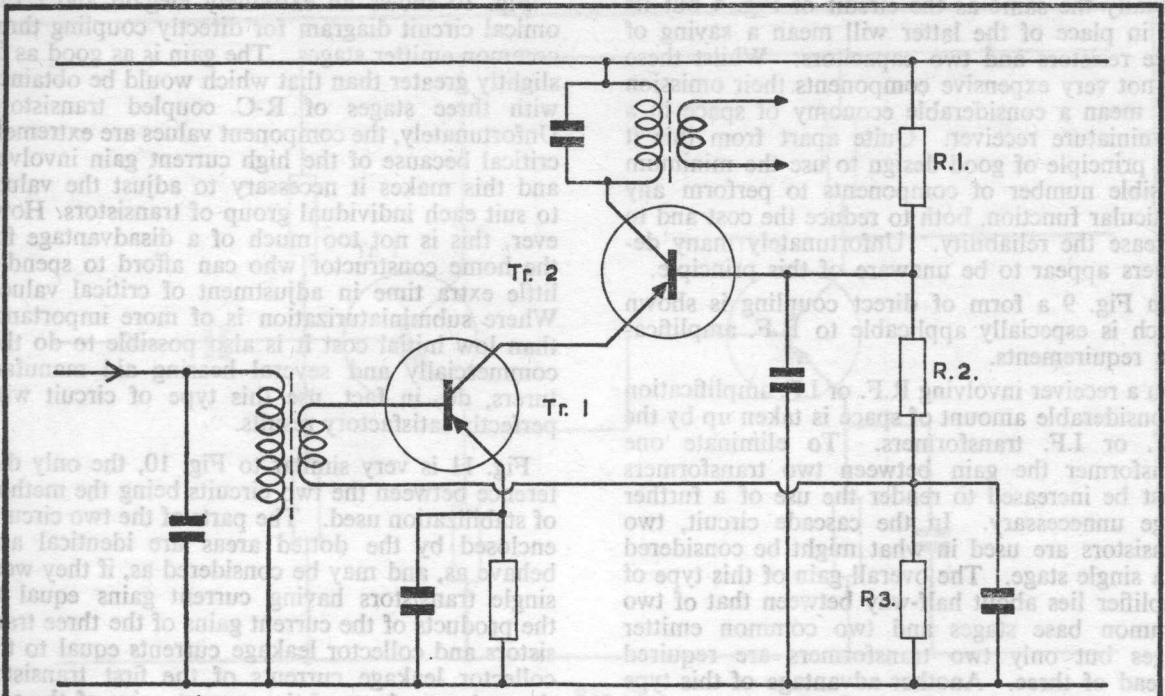

Fig. 9. Directly Coupled, Cascade R.F. Amplifier.

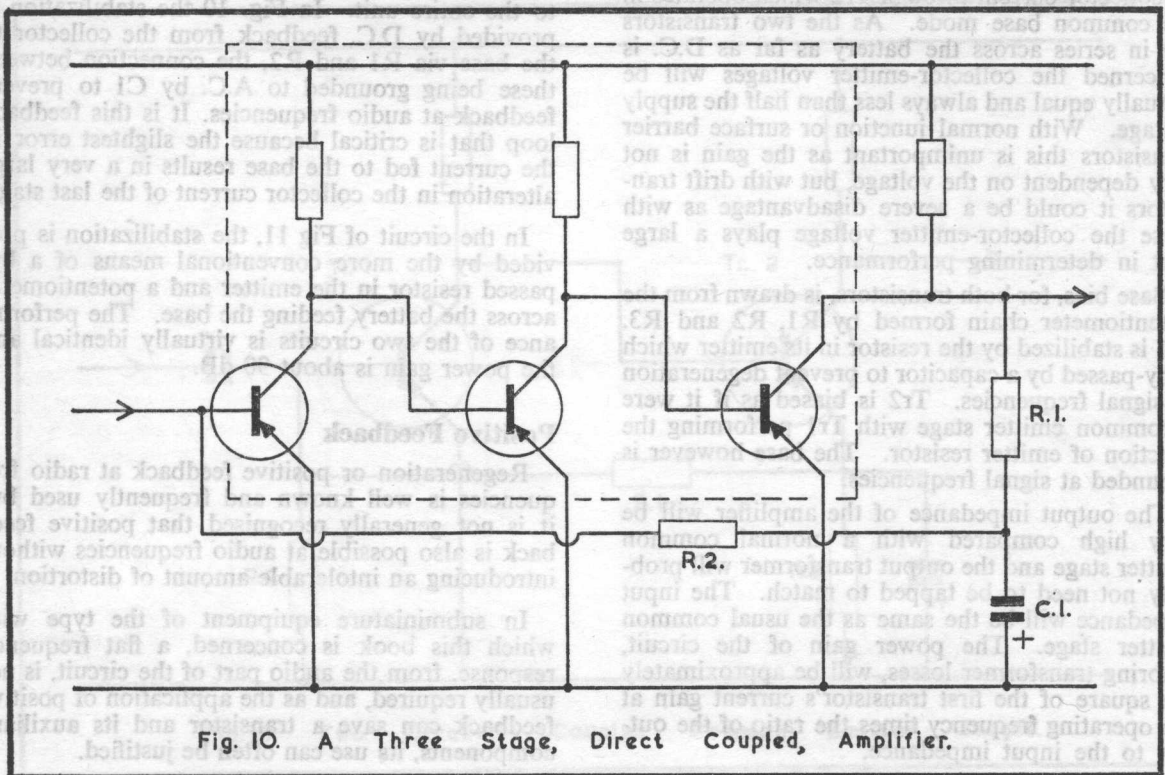

Fig. 10. A Three Stage, Direct Coupled, Amplifier.

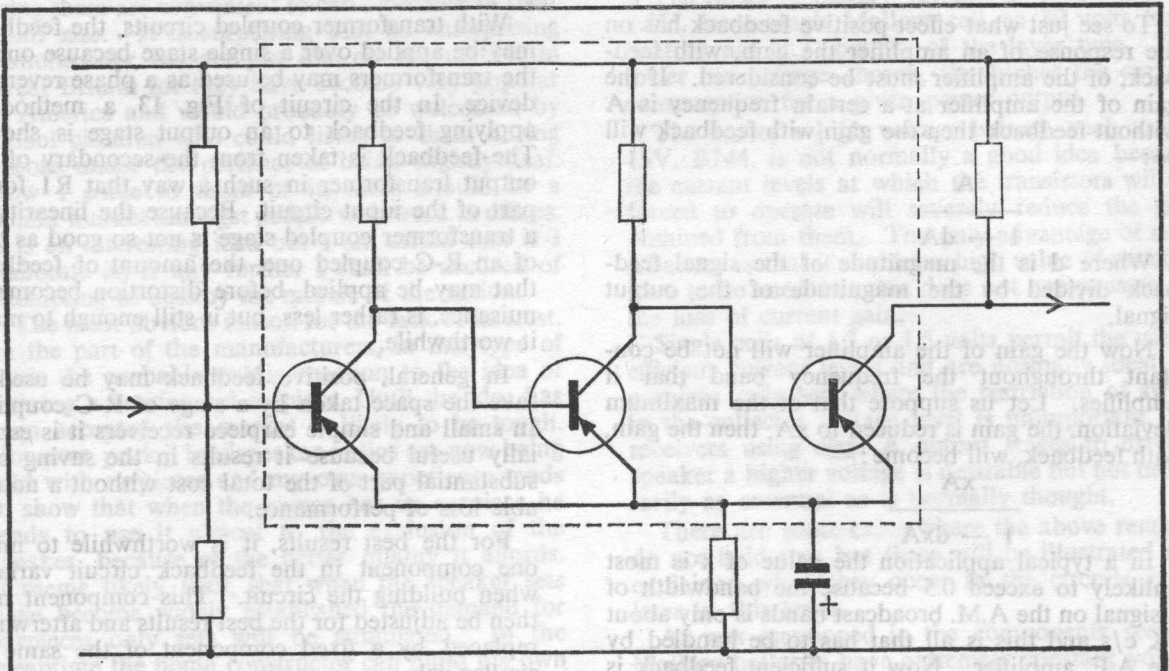

Fig. 11.

A Similar Circuit to Fig. 9. With a Different Form of Stabilisation.

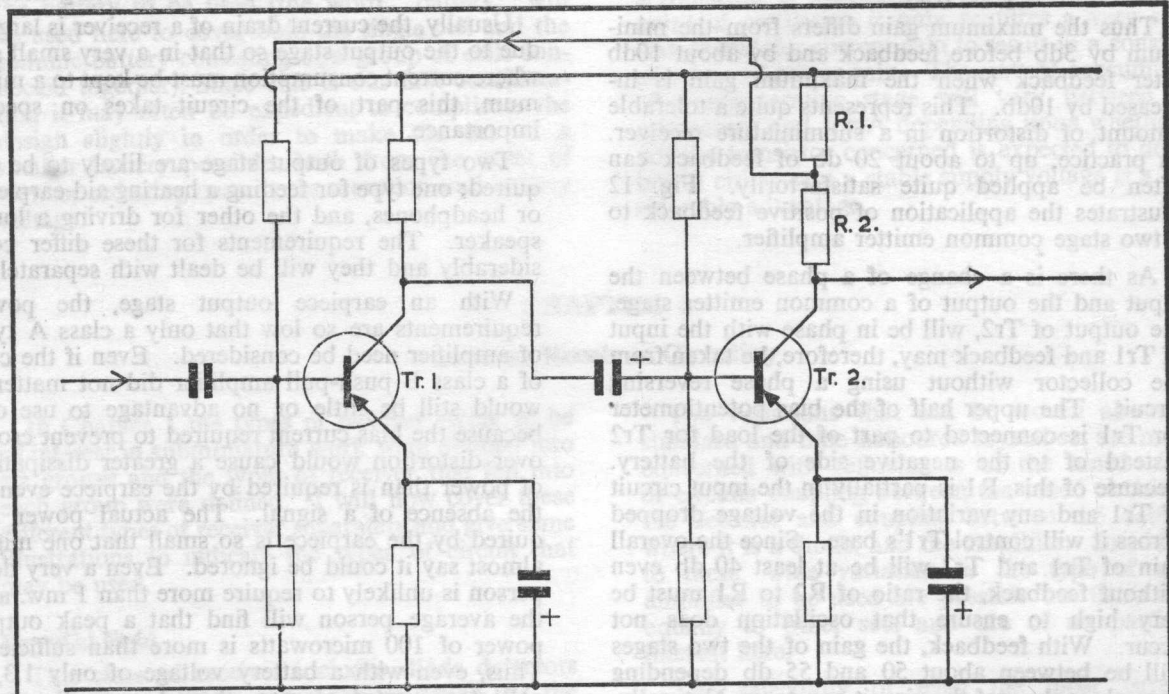

Fig. 12. Positive Feedback Applied to a Two Stage, R-C Coupled, Amplifier.

To see just what effect positive feedback has on the response of an amplifier the gain, with feedback, of the amplifier must be considered. If the gain of the amplifier at a certain frequency is A without feedback then the gain with feedback will be:—

$$\frac{A}{1 - dA}$$

Where d is the magnitude of the signal feedback divided by the magnitude of the output signal.

Now the gain of the amplifier will not be constant throughout the frequency band that it amplifies. Let us suppose that at the maximum deviation, the gain is reduced to xA , then the gain, with feedback, will become:—

$$\frac{xA}{1 - dxA}$$

In a typical application the value of x is most unlikely to exceed 0.5 because the bandwidth of a signal on the A.M. broadcast bands is only about 5K c/s and this is all that has to be handled by the A.F. amplifier. Now if sufficient feedback is applied to increase the maximum power gain by 10db then dA must be 0.9 and the gain at the maximum deviation point will become:—

$$\frac{0.5A}{1 - 0.45} = 0.91A$$

Thus the maximum gain differs from the minimum by 3db before feedback and by about 10db after feedback when the maximum gain is increased by 10db. This represents quite a tolerable amount of distortion in a subminiature receiver. In practice, up to about 20 db of feedback can often be applied quite satisfactorily. Fig. 12 illustrates the application of positive feedback to a two stage common emitter amplifier.

As there is a change of a phase between the input and the output of a common emitter stage, the output of Tr_2 , will be in phase with the input of Tr_1 and feedback may, therefore, be taken from the collector without using a phase reversing circuit. The upper half of the bias potentiometer for Tr_1 is connected to part of the load for Tr_2 instead of to the negative side of the battery. Because of this, R_1 is partially in the input circuit of Tr_1 and any variation in the voltage dropped across it will control Tr_1 's base. Since the overall gain of Tr_1 and Tr_2 will be at least 40 db even without feedback, the ratio of R_2 to R_1 must be very high to ensure that oscillation does not occur. With feedback, the gain of the two stages will be between about 50 and 55 db depending upon the values of the circuit constants. Naturally, the circuit could be designed to provide lower gain but it would then be hard to justify the use of feedback.

With transformer coupled circuits, the feedback may be applied over a single stage because one of the transformers may be used as a phase reversing device. In the circuit of Fig. 13, a method of applying feedback to an output stage is shown. The feedback is taken from the secondary of the output transformer in such a way that R_1 forms part of the input circuit. Because the linearity of a transformer coupled stage is not so good as that of an R-C coupled one, the amount of feedback that may be applied, before distortion becomes a nuisance, is rather less, but is still enough to make it worthwhile.

In general, positive feedback may be used to save the space taken by a stage of R-C coupling. In small and simple earpiece receivers it is especially useful because it results in the saving of a substantial part of the total cost without a noticeable loss of performance.

For the best results, it is worthwhile to make one component in the feedback circuit variable when building the circuit. This component may then be adjusted for the best results and afterwards replaced by a fixed component of the same or similar value.

Output Stages

Whatever type of circuit is used in a subminiature receiver it must have an output stage so that this part of the circuit can be dealt with generally.

Usually, the current drain of a receiver is largely due to the output stage so that in a very small set, where current consumption must be kept to a minimum, this part of the circuit takes on special importance.

Two types of output stage are likely to be required; one type for feeding a hearing aid earpiece, or headphones, and the other for driving a loud-speaker. The requirements for these differ considerably and they will be dealt with separately.

With an earpiece output stage, the power requirements are so low that only a class A type of amplifier need be considered. Even if the cost of a class B push-pull amplifier did not matter it would still be little or no advantage to use one because the bias current required to prevent cross-over distortion would cause a greater dissipation of power than is required by the earpiece even in the absence of a signal. The actual power required by the earpiece is so small that one might almost say it could be ignored. Even a very deaf person is unlikely to require more than 1 mw. and the average person will find that a peak output power of 100 microwatts is more than sufficient. Thus, even with a battery voltage of only 1.3, a collector current of more than 1 ma will not be needed and as little as 100 microamps may be used in special circuits. Modern hearing aid earpieces are very comfortable to wear and radios

using them are convenient to carry because of their small size. It is surprising that no enterprising manufacturer has yet put one on the market in Great Britain for they have become very popular in America and would probably be welcomed by school children who could listen to them during lessons under the pretence of being slightly deaf. Now I come to think of it, there should be a similar market amongst people who work in offices. It is an interesting idea but I am afraid that if I elaborate on it any further I shall be accused of attempting to destroy the morals of the nation.

The most obvious reason for the lack of interest, on the part of the manufacturers, in this type of set is the probable public reaction to the idea of wearing a hearing aid earpiece. Until the idea has been accepted the market is likely to be tough. However, pocket loudspeaker radios are now being sold with earpieces and my own experience tends to show that when the owner has an earpiece he tends to use it almost to the exclusion of the speaker, because of the better quality it affords. It seems likely then, that when the speaker sets have become widely established the demand for earpieces only sets will be stimulated. In the meantime the home constructor can build his own at very low cost.

Battery Voltage

One of the most important considerations in designing and building subminiature receivers is the battery to be used (the word "battery" will be used here to cover both the single cell and the genuine battery consisting of a group of cells connected together). Since size is our first consideration it may often be expedient to complicate the design slightly in order to make the use of a smaller battery possible; both from the point of view of reducing current consumption and battery voltage.

The amount of audio gain that has to be provided depends on the application and the length of the earpiece. For an earpiece on a telephone set the gain is about 20 dB. For an earpiece on a radio set the gain is about 10 dB. The actual size will normally be determined by the size of the tuning components in the circuit.

Crystal Sets

This class of receiver includes diode detectors with A.F. amplifiers and receivers which use the first transistor as a straightforward detector without regeneration.

The range of battery voltages available is from 1.3V, for a single Mallory cell, to 30 volts for a hearing aid H.T. battery of the layer type. The lower the voltage chosen, the higher the current consumption for a given power output.

The use of a high voltage battery, such as the 15V, B144, is not normally a good idea because the current levels at which the transistors will be forced to operate will severely reduce the gain obtained from them. The only advantage of such a battery is that it enables a high value of resistive load to be used but this does not compensate for the loss of current gain.

Single cells of 1.3 or 1.5 volts permit the use of efficient current levels and are normally ideal for earpiece only sets where the restriction of swing in the collector voltage level is unimportant. In receivers using class A output stages to drive a speaker a higher voltage is desirable but not necessarily as essential as is normally thought.

There are some cases where the above remarks do not hold true but these will be illustrated and explained when they occur in the circuits given later in this book.

As was mentioned in the components section, Mallory batteries have extremely constant voltage with life. Their voltage per cell being about 1.3. This is an extremely useful feature in any circuit that employs regeneration because any fall in supply voltage would normally affect the current levels of the transistors, hence their gain and when a transistor is supposed to be operating near the point of oscillation it only requires a very slight loss of transfer current gain to result in a considerable loss of power gain. The current consumption of a regenerative stage will vary between 100 microamps and 1 mA depending upon whether or not the transistor concerned is expected to detect, but in either case a stable supply voltage is a considerable advantage.

CHAPTER 4

General Receiver Circuitry

The variations that can be woven about the standard and time honoured crystal set are mainly concerned with refinements of the tuned circuit or circuits coupling between the tuned circuit and the detector and coupling between the detector, where it is a diode, and the amplifier. In addition to these, wide variation in the type of audio amplifier to be used are possible but these apply equally to other sets and are of no particular interest here.

The selectivity of even the most carefully designed crystal set is bound to be poor because the single tuned circuit is always damped by the

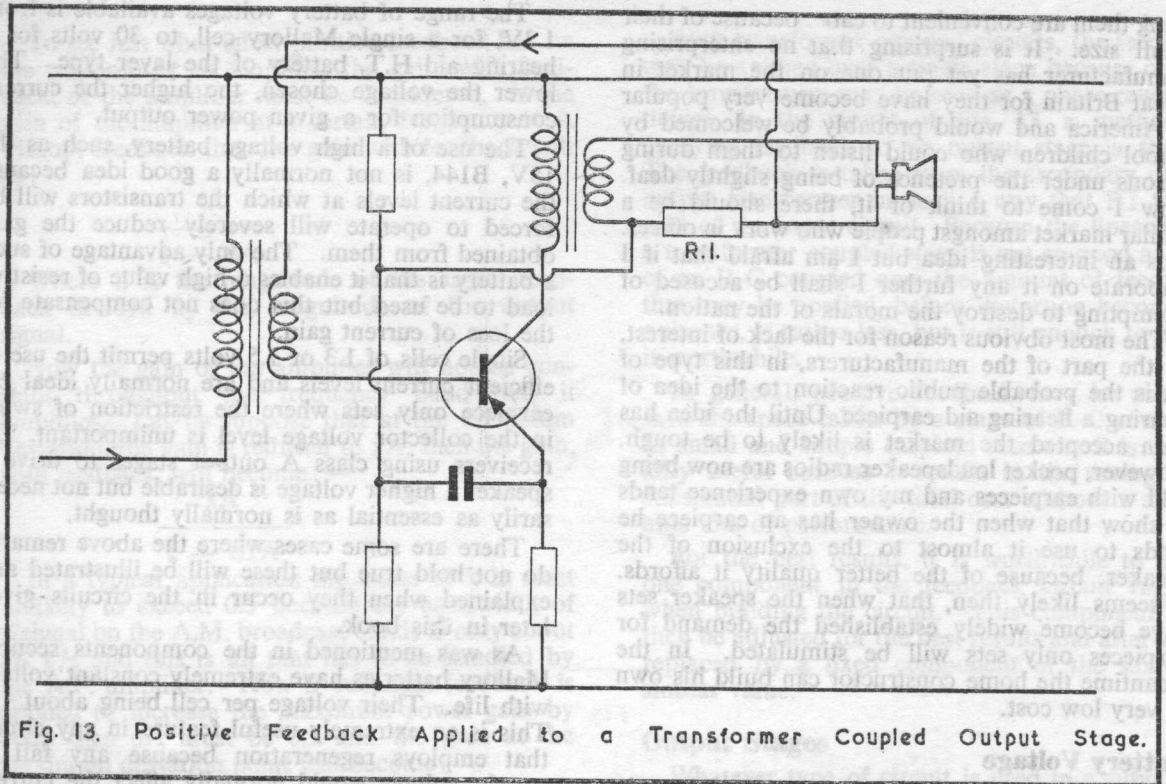

Fig. 13. Positive Feedback Applied to a Transformer Coupled Output Stage.

load, whether it is a diode or a transistor. However, the effect should be minimised by using high Q components for the coil and tuning capacitor and by putting the load across only a portion of the tuned circuit to reduce the damping effect.

While it is possible to operate a crystal set plus amplifier with only a ferrite rod aerial, this can only be done in areas of considerable signal strength. At very low signal strengths a crystal diode conducts almost equally in both directions and the detector efficiency is, therefore, very low. The A.F. output, at such low levels of signal input, is minute and considerable A.F. gain is required to give even a headphone signal. This high A.F. gain also means that the noise level at the output will be high. All in all, then, the crystal set type of receiver is only useful when a reasonable aerial is available and is not worthy of consideration when a true portable is required. When A.F. transistors were the only types available on the market, numerous attempts were made to construct pocket receivers using crystal set front ends. None of these were entirely satisfactory and, now that cheap R.F. transistors are available there is no need to resort to this clumsy and expensive technique.

As we are considering only subminiature receivers here it is worthwhile remembering that a tiny receiver should work well under reasonable circumstances and is of little use if 300 feet of

aerial has to be set up before any signal can be heard. If the set is required for something like a doll's house, however, or as a tiny bedside radio, then the need for an aerial might not matter a great deal.

Simple pocket sets, using a transistor as the detector, can often give sufficient volume using only a piece of wire connected to a telephone, tap or metal pipe as an aerial these have applications where mobility is unnecessary.

The amount of audio gain that has to be provided depends on the application and the length of the aerial. For an earpiece or headphone set, operating on an efficient aerial and earth system, a single stage of R-C coupled amplification is all that is necessary. Where the aerial is not so good a second stage will be required. For loudspeaker operation the diode usually has to be fed into two stages of transformer coupled amplification for a satisfactory volume level.

A basic form of crystal set circuit is shown in Fig. 14. Because of the complete simplicity this type of receiver can be made as small as one likes. The actual size will normally be dictated by the size of the tuning components in the resonant circuit, that is to say C and L. Normal commercial values for these are much too bulky for a really tiny set but suitable miniature equivalents may be home made fairly simply. Instead of using a normal tuning capacitor a postage stamp

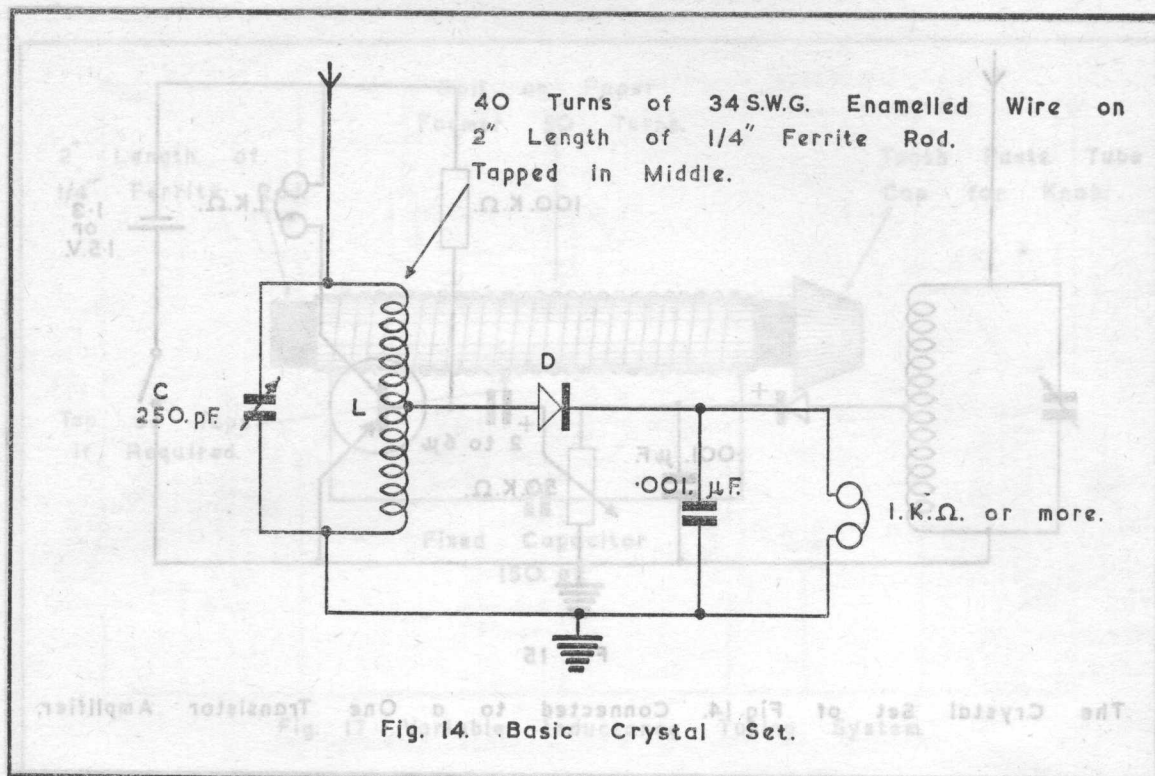

trimmer may be employed. Fig. 16 illustrates one method for connecting a knob to the trimmer, the 6BA bolt, that is normally used to adjust the capacity, is removed and replaced by another about one inch long. On to this is fixed a knob made from a suitable circular piece of perspex with a small hole in the middle by sandwiching it between two 6BA nuts. These must be tightened, very firmly, on to the plastic disc to prevent it from slipping. The excess part of the 6BA bolt may then be sawn off. The coil details are given in the diagram. The 40 turns of 34 gauge wire should be wound onto a single layer of paper wrapped round the ferrite rod.

An alternative, and in many ways better, way of reducing the size of the tuned circuit is to vary the value of the inductance rather than the capacitance. In Fig. 17 a simple method of achieving this is illustrated. The coil is wound onto two or three layers of stiff paper glued together. This assembly is made sufficiently loose to enable the ferrite rod to slide freely in and out of the coil thereby varying its inductance. C then becomes a fixed capacitor having a value of 150 pf.

In Fig. 15 a simple, one stage transistor amplifier has been added to the circuit of Fig. 14 to increase the volume considerably. The actual gain provided by this transistor is about 20 dB which means that the amount of power fed to the earpiece is increased by 100 times. Any audio

transistor may be used, such types as the OC70, OC71 and the red spot type being ideal. The battery voltage may be increased and this will result in a slight increase in volume, but the improvement obtained in this way is generally insufficient to warrant the added size.

Technical Suppliers Limited have recently introduced a really subminiature timing capacitor, type no. 201/1, which may be used in the circuits of Fig. 14 and Fig. 15. This capacitor has an overall size of $\frac{3}{4}$ " x $\frac{3}{8}$ " x $\frac{3}{8}$ " and is available in two values, 250 pf and 365 pf priced at 7/6d. and 8/9d. respectively. The 250 pf type is quite adequate for most circuits, including these, and is listed as type A; the 365 pf capacitor being type B.

For situations where the gain of the circuit in Fig. 15 is insufficient for adequate volume a two transistor circuit may be used. Such a circuit is shown in Fig. 18. Both transistors are normal audio types and the increased gain makes it possible to use the set without an earth and with only a fairly short aerial.

Although this circuit uses only a very few components a much more economical version can be produced without a great sacrifice in performance and with one or two useful advantages. Such a circuit is shown in Fig. 19. In the absence of a signal the base of Tr1 is shorted to the emitter by the secondary of the tuning coil. (TSL $1\frac{3}{4}$ " ferrite rod aerial.) Under this condition the collector

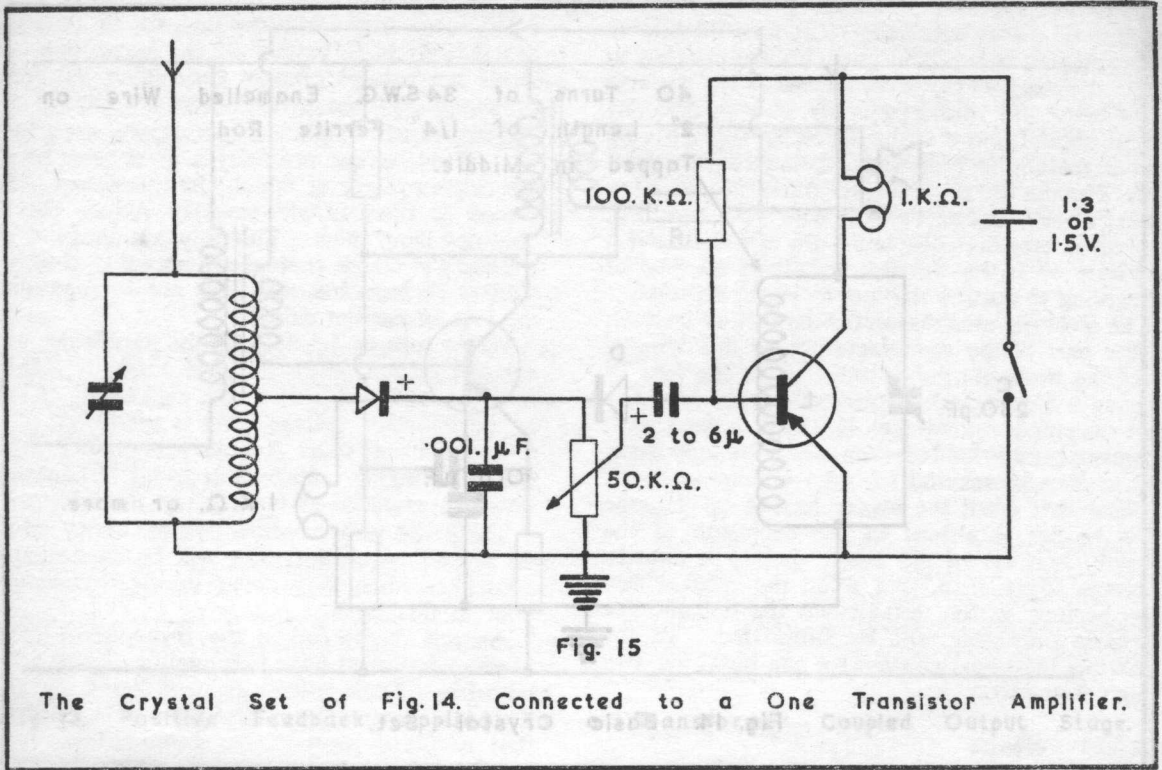

Fig. 15

The Crystal Set of Fig.14. Connected to a One Transistor Amplifier.

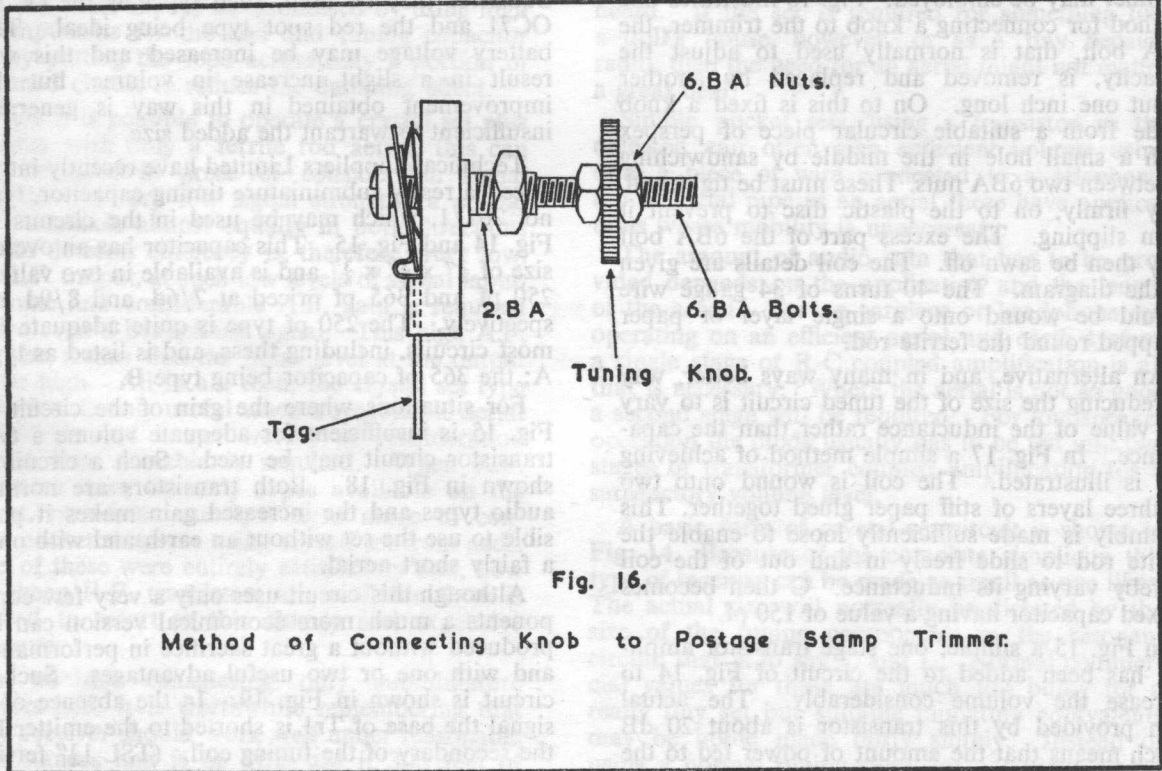
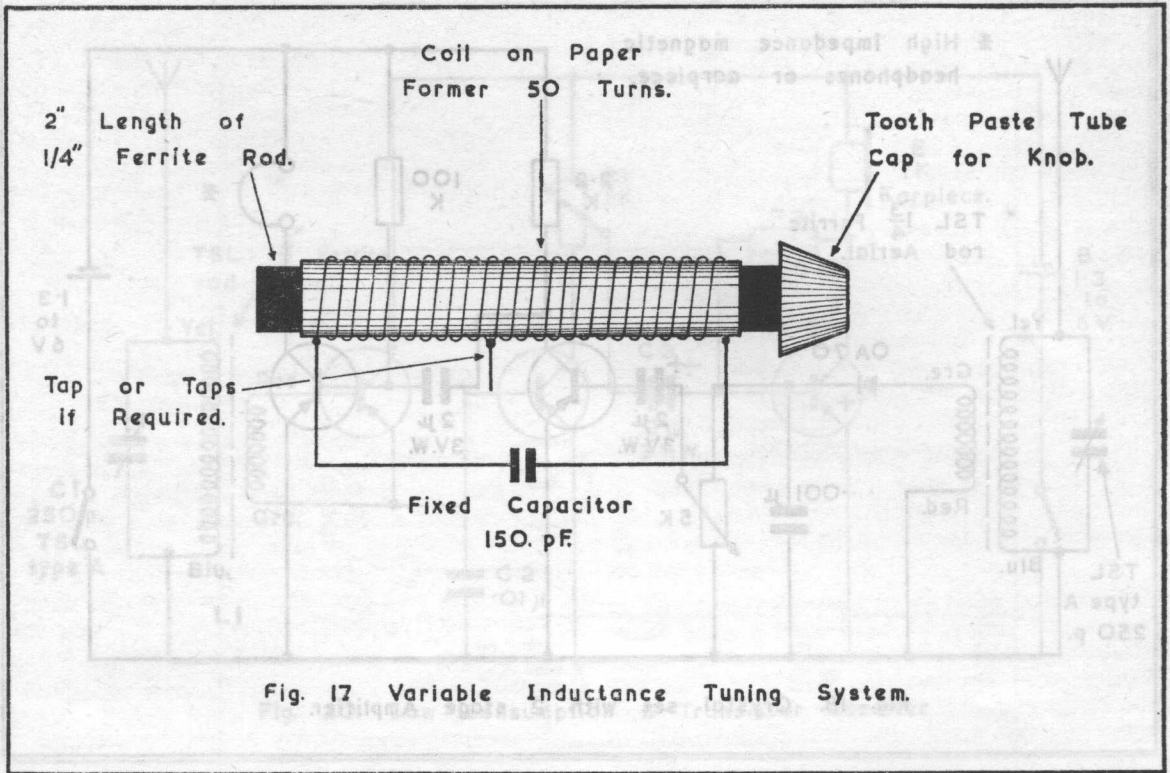

Fig. 16.

Method of Connecting Knob to Postage Stamp Trimmer.



current is only about 5 microamps at the most. This current flows through the base-emitter circuit of Tr2 giving rise to a collector current in this transistor of about 100 microamps. When a positive signal is fed to the base of Tr1, virtually no current will flow because the base-emitter junction will be reverse biased. With a negative signal, however, Tr1 will be forward biased and the signal will be amplified by Tr1 and Tr2 resulting in a comparatively considerable increase in the collector current of Tr2. The current consumption from the battery will be directly proportional to the strength of the signal and will be very much less, for the same output, than would be drawn by any other type of receiver. For this reason, the very smallest size of battery may be used and will have a life of many hundreds, if not thousands, of hours.

Tr1 and Tr2 may, once again, be any small audio types although an improvement in performance is sometimes obtained by using an R.F. transistor for Tr1. The headphones or earpiece should be high impedance types. A crystal earpiece may be used only if it is wired in parallel with an A.F. choke since it does not conduct D.C. With an A.F. choke of a few henries, the performance of a crystal earpiece is excellent.

Fig. 20. Low Consumption 3-Transistor Earpiece Receiver

The addition of an extra stage to the last circuit will increase the range considerably but it is then necessary to add a volume control since the range of volume obtained will also be wide.

The volume control replaces the headphones as the collector load of Tr2. Normally this is not a satisfactory way of connecting this control because steady D.C. runs through it and this can lead to crackling but in this case the current flowing is very slight in comparison to the strength of the signal and no trouble is likely to arise.

The increase in gain afforded by the additional stage is quite considerable and will provide a good signal strength with only a very weak input signal. The use of a transistor rather than a diode improves the performance at very low signal strengths because the efficiency of the transistor does not tail off so badly.

The external aerial should be as short as is needed to provide a satisfactory signal because a long aerial tends to damp the tuned circuit which may cause the stations to overlap. If a long aerial must be used, it may be coupled to the coil via a capacitor of a few pf. Alternatively a couple of turns of thin enamelled wire may be wound

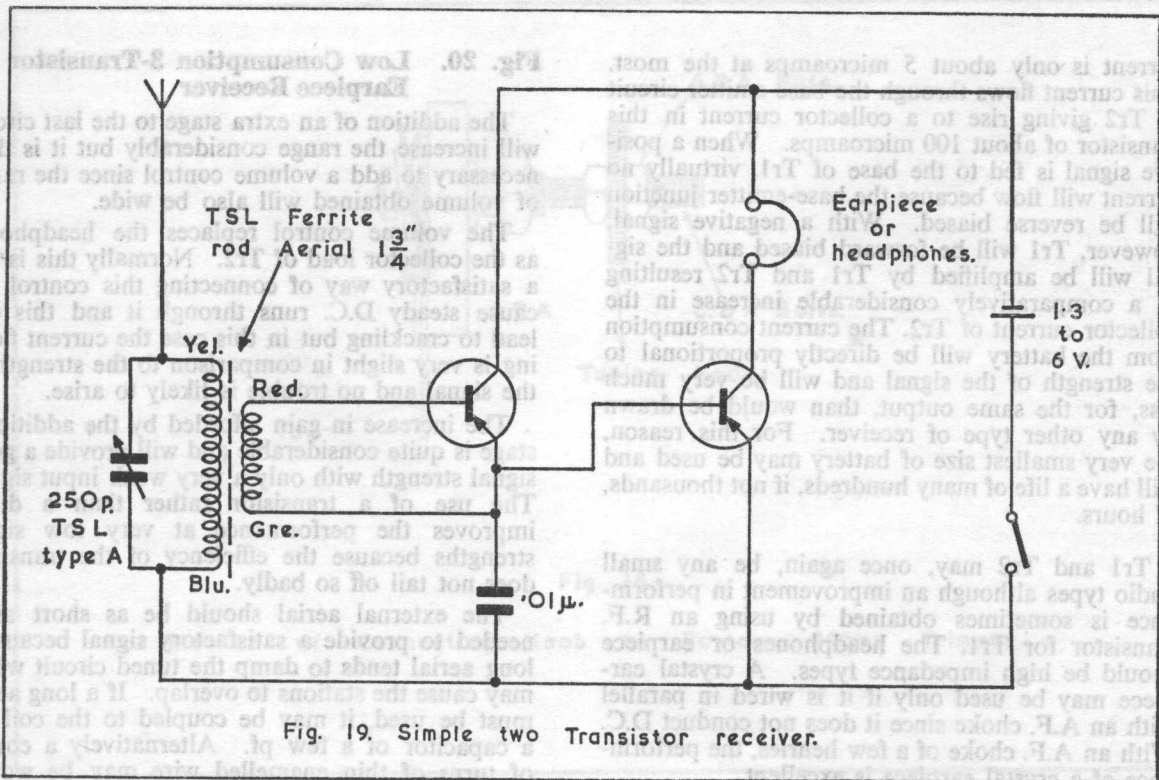
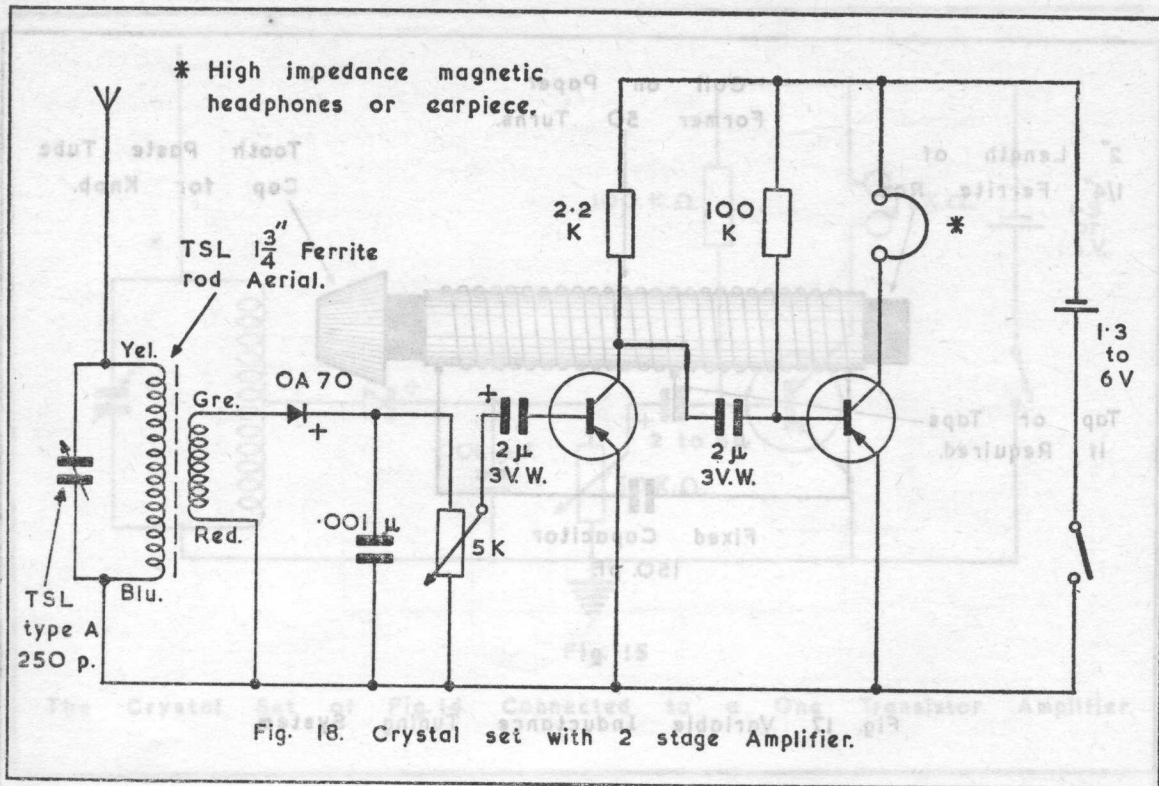

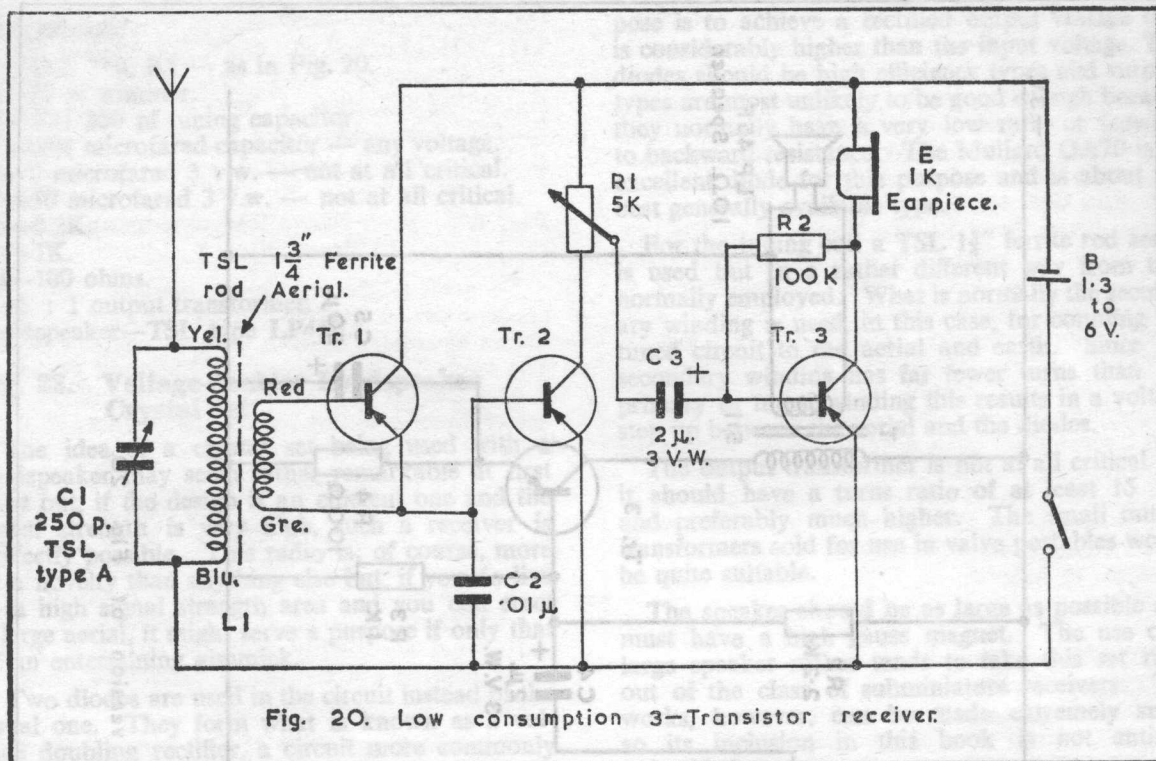

Fig. 20. Low consumption 3-Transistor receiver.

onto the end of the rod nearest the yellow connection. One end may then be taken to earth and the other to the aerial. The battery voltage used is mainly a matter of convenience in this case since an increase in voltage will not result in more than a very slight increase in gain. In general 2.6 or 3 volts, depending upon whether a carbon-zinc or a mercury battery is used, is a reasonable compromise between small size and good performance.

Components

- Tr1—R.F. transistor such as “white spot” or OC44.
- Tr2 & Tr3—A.F. transistors such as “red spot” or OC71.
- R1—5K ohm volume control (preferably semi-log) with switch.
- R2—Select for 1mA collector current in Tr3. About 100K ohms.
- C1—TSL type A tuning capacitor 250 pf.
- C2—0.01 microfarad capacitor — any voltage.

Fig. 21. Loudspeaker Version of Fig. 20

The replacement of the earpiece in Fig. 20 by a loudspeaker and suitable output transformer results in a radio that may be used satisfactory as a bedside receiver.

Since a loudspeaker requires considerably more

driving power than an earpiece this set will require either a larger aerial or a stronger signal than the last one. If it is used as a fixed set, however, the larger aerial need not be a problem. It would be ideal for use in a children’s nursery since there are no awkward controls to operate and there is no danger from high voltage.

The collector current of the output stage is 10mA and the output power is about 10mW. This may not seem very much but the sensitivity of the loudspeaker, an LP45F, is really excellent and the performance it gives with this output is quite sufficient. Since the overall diameter of the LP45F is only 1 1/4” the size of the complete radio need be no more than 2 1/2” x 1.875” x .875”.

The output stage is stabilized by the potential divider and emitter resistor method which ensures excellent stability. The output transformer has a turns ratio of 5 : 1 this value being optimum for the bias conditions. Any value other than 5 : 1 will result in a loss of output power although this may not be noticeable if the deviation is slight.

It would be possible to use the set as a pocket portable if a short aerial with a crocodile clip on the end is not considered too great an encumbrance. The crocodile clip may be connected to any large piece of metal, such as a radiator or window frame, to increase the signal pick-up.

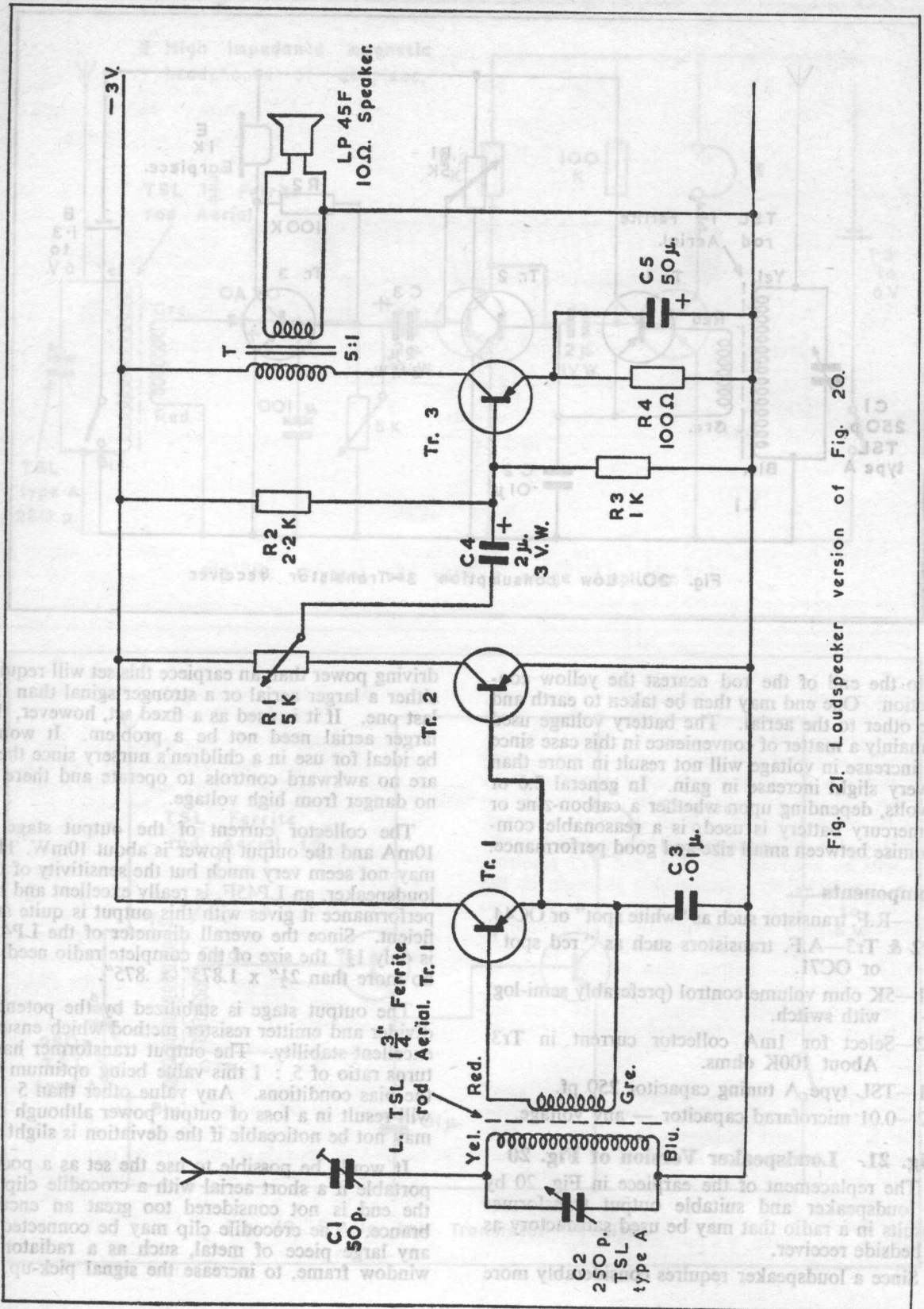

Fig. 21. Loudspeaker version of Fig. 20.

Components

- Tr1, Tr2, Tr3, R1 — as in Fig. 20.
- C1—50 pf trimmer.
- C2—TSl 250 pf tuning capacitor.
- C3—0.01 microfarad capacitor — any voltage.
- C4—2 microfarad 3 v.w. — not at all critical.
- C5—50 microfarad 3 v.w. — not at all critical.
- R2—2.2K.
- R3—1K.
- R4—100 ohms.
- T—5 : 1 output transformer.
- Loudspeaker—TSL type LP45F.

Fig. 22. Voltage-doubler Loudspeaker Crystal Set

The idea of a crystal set being used with a loudspeaker may seem rather remarkable at first sight but, if the design is an efficient one and the signal strength is very high, such a receiver is perfectly possible. This radio is, of course, more of a novelty than anything else but, if you do live in a high signal strength area and you can erect a large aerial, it might serve a purpose if only that of an entertaining gimmick.

Two diodes are used in the circuit instead of the usual one. They form what is known as a voltage doubling rectifier, a circuit more commonly found in mains power supplies, and the main pur-

pose is to achieve a rectified output voltage that is considerably higher than the input voltage. The diodes should be high efficiency types and surplus types are most unlikely to be good enough because they normally have a very low ratio of forward to backward resistance. The Mullard OA70 is an excellent diode for this purpose and is about the best generally available type.

For the tuning coil a TSL 1 3/4" ferrite rod aerial is used but in a rather different way from that normally employed. What is normally the secondary winding is used, in this case, for coupling the tuned circuit to the aerial and earth. Since the secondary winding has far fewer turns than the primary or tuned winding this results in a voltage step up between the aerial and the diodes.

The output transformer is not at all critical but it should have a turns ratio of at least 15 : 1 and preferably much higher. The small output transformers sold for use in valve portables would be quite suitable.

The speaker should be as large as possible and must have a high gauss magnet. The use of a large speaker rather tends to take this set right out of the class of subminiature receivers. The works, however, can be made extremely small so its inclusion in this book is not entirely unjustified.

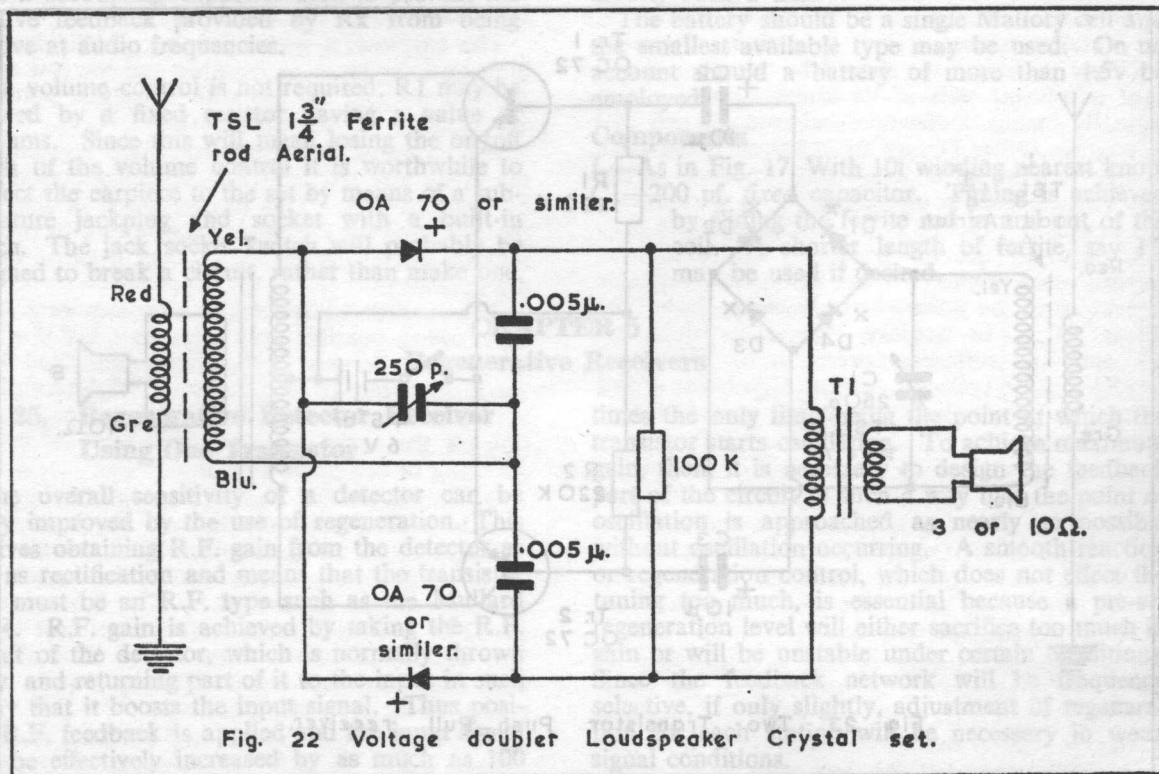

Fig. 22 Voltage doubler Loudspeaker Crystal set.

Fig. 23. Two Transistor Push-Pull Receiver

Another very unusual and interesting set is shown in Fig. 23. This uses a full wave rectifier to supply two oppositely phased signals to two transistors in Push-Pull. The gain of the transistors is sufficient to make this circuit considerably more useful than the last but a good aerial and earth will still be required.

The diodes must be good ones as in Fig. 22. The transistors must be a matched pair to avoid distortion. The output from the transistors is coupled to the loudspeaker via a transformer with a centre tapped primary. The loudspeaker may be an LP45F and the transformer may be any of the small transistor output types now available. Ideally, the output transformer should have a higher turns ratio than normal but by using a 10 ohms speaker a satisfactory match is achieved.

Since the gain of the output stage depends to a large extent on the current gains of the transistors these should be chosen, if any choice is possible, to provide as high a current gain as possible.

Components

- L—TSL 1 $\frac{3}{4}$ " ferrite rod aerial.
- L—Centre-tapped output transformer.
- C1—TSL 250 pf subminiature capacitor.
- C2, C3—10 muf. 3 v.v. electrolytics (value not critical).

D1, D2, D3, D4—Mullard OA70's or similar.

Tr1, Tr2—Matched pair of OC72's or other output transistors.

R1, R2—220K ohms \pm 20%.

S—TSL loudspeaker type LP45F.

B—4.5 or 6 volt battery.

Fig. 24. Four Stage Receiver using Hearing Aid Transistors

To achieve the maximum possible degree of miniaturization in this receiver, hearing aid transistors have been used in a direct coupled circuit. The overall gain is extremely high and the range is only limited by the efficiency of the diode. The use of direct coupling reduces the number of components to a minimum.

Hearing aid transistors are designed for operation from extremely low battery voltages and with low levels of collector current. They also have high betas; that is to say, their current gains are high. These are just the qualities required for a subminiature receiver but, unfortunately, only A.F. types are readily available and R.F. stages using hearing aid transistors cannot be designed using normal techniques.

The collector currents of Tr1 and Tr2 are both about $\frac{1}{2}$ mA. The collector current of Tr3 is controlled by Rx, the feedback resistor, which must

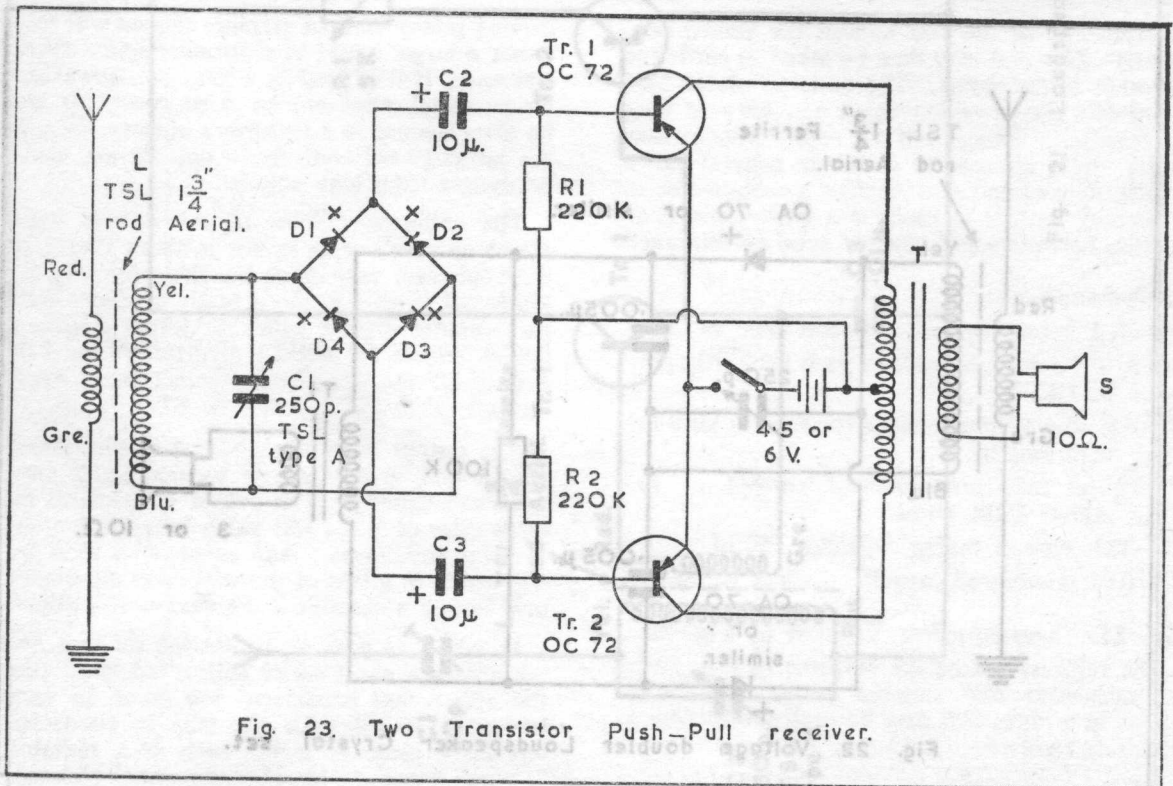

Fig. 23. Two Transistor Push-Pull receiver.

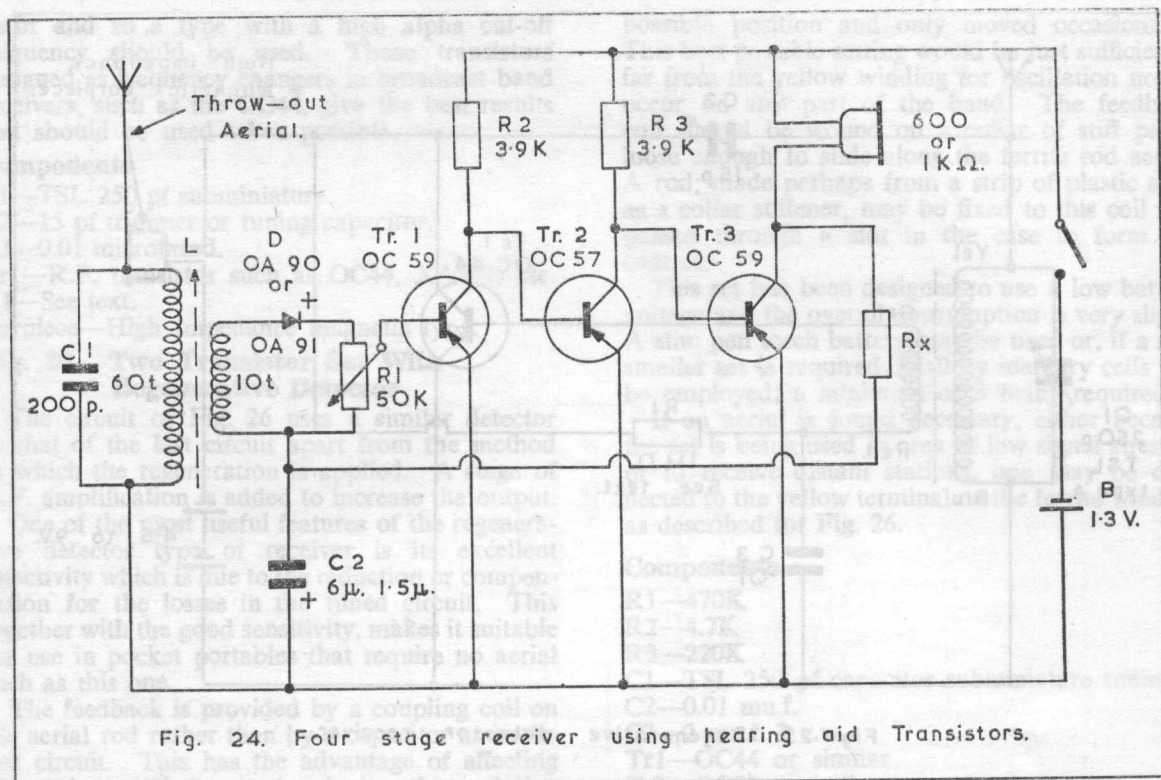

Fig. 24. Four stage receiver using hearing aid Transistors.

be selected to provide a collector current of 1 mA. C2 is a decoupling capacitor used to prevent the negative feedback provided by Rx from being effective at audio frequencies.

If a volume control is not required, R1 may be replaced by a fixed resistor having a value of 5K ohms. Since this will mean losing the on/off switch of the volume control it is worthwhile to connect the earpiece to the set by means of a sub-miniature jackplug and socket with a built-in switch. The jack socket switch will probably be designed to break a circuit, rather than make one,

when the earpiece is plugged in, but it is easy to modify such a unit.

The battery should be a single Mallory cell and the smallest available type may be used. On no account should a battery of more than 1.5v be employed.

Components

L—As in Fig. 17. With 10t winding nearest knob.
 C1—200 pf. fixed capacitor. Tuning is achieved by sliding the ferrite rod in and out of the coil. A shorter length of ferrite, say 1", may be used if desired.

CHAPTER 5

Regenerative Receivers

Fig. 25. Regenerative Detector Receiver Using One Transistor

The overall sensitivity of a detector can be vastly improved by the use of regeneration. This involves obtaining R.F. gain from the detector as well as rectification and means that the transistor used must be an R.F. type such as the Mullard OC44. R.F. gain is achieved by taking the R.F. output of the detector, which is normally thrown away, and returning part of it to the input in such a way that it boosts the input signal. Thus positive R.F. feedback is applied and the input signal may be effectively increased by as much as 100

times the only limit being the point at which the transistor starts oscillating. To achieve maximum gain, then, it is necessary to design the feedback part of the circuit in such a way that the point of oscillation is approached as nearly as possible without oscillation occurring. A smooth reaction or regeneration control, which does not effect the tuning too much, is essential because a pre-set regeneration level will either sacrifice too much in gain or will be unstable under certain conditions. Since the feedback network will be frequency selective, if only slightly, adjustment of regeneration for each station will be necessary in weak signal conditions.

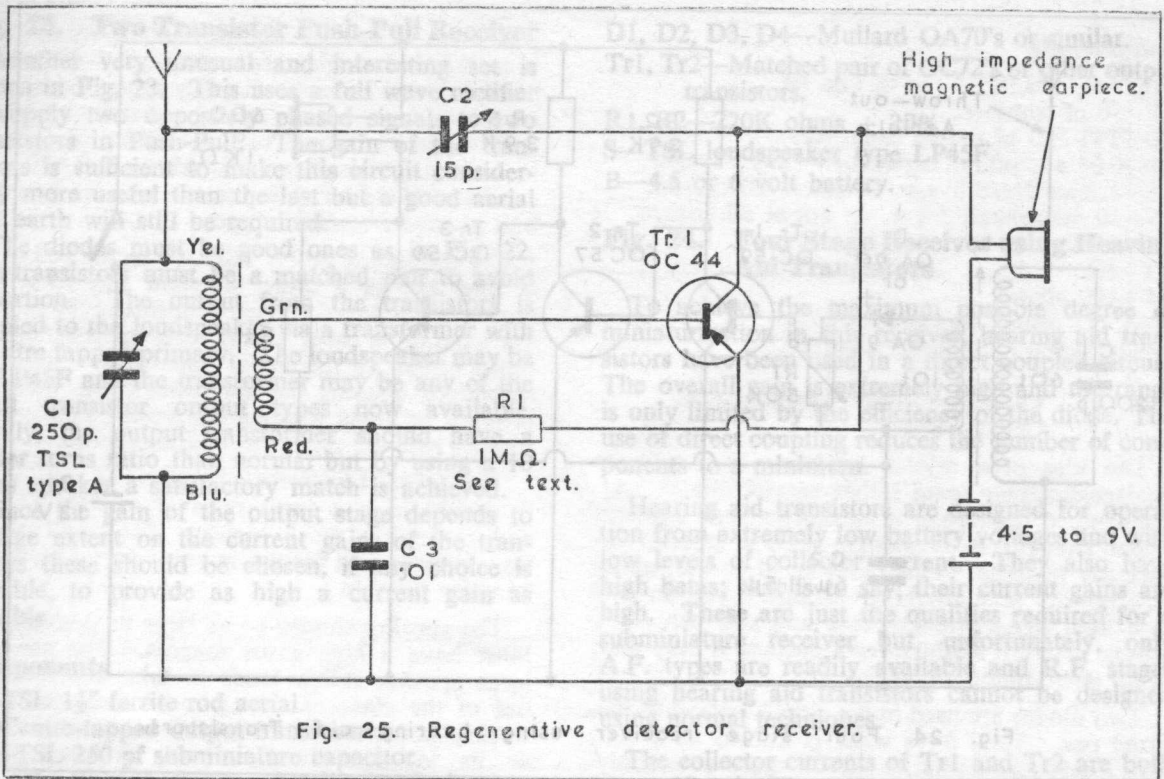

The collector current of a transistor used as a regenerative detector must always be something of a compromise. For maximum detection efficiency the transistor should be operated in the most non-linear part of its transfer curve which normally means somewhere between 50 and 200 microamps (other factors are involved if the knee voltage is used in detection but this form is not very efficient and is unsatisfactory in a regenerative detector). On the other hand maximum R.F. gain normally occurs between $\frac{1}{2}$ and 1 mA or possibly even higher. Thus the actual collector current must be somewhere between these two points so as to achieve reasonable detection efficiency and sufficient current gain. This will usually mean a collector current of between $\frac{1}{4}$ and $\frac{1}{2}$ mA, the precise level depending upon the type of transistor.

Fig. 25 is the circuit of a simple and typical single transistor, regenerative receiver. The earpiece offers sufficient impedance to prevent the R.F. output of the OC44 from being returned and C2 is used to control the feedback to the tuned circuit. In some cases the maximum value of C2 may have to be increased.

The collector current of Tr1 is controlled by R1 which is shown on the diagram as 1M ohm. The circuit will work with this value but, for best results, the value should be selected by trial and error. R1 must not be less than 50K ohms,

however, and is most likely to be best between 250K ohms and 1M ohms.

The earpiece, a magnetic type, should have as high an impedance as possible and the low sensitivity types sold for use with transistor portables are unlikely to be satisfactory.

If it is found impossible to obtain regeneration the green and red leads of the aerial coil should be changed over. This has the result of changing the phase of the feedback since failure to operate may be due to the feedback being negative rather than positive.

The receiver will normally only require a fairly short aerial, possibly only a few feet, but if a long aerial must be used it should be connected via a small capacitor, 10 pf being suitable. Alternatively it may be connected directly to the green connection on the aerial since this will also reduce the damping of the tuned circuit.

Operation of this radio is straightforward but a little trickier than of the sets previously described because of the regeneration control. With C2 at minimum, or nearly minimum, capacity the station required is selected by C1. The capacity of C2 is now increased until the set just bursts into oscillation and is then turned back slightly until oscillation just ceases. C1 may require slight readjustment for perfect tuning.

Satisfactory regeneration and efficient detection depend upon the R.F. performance of the tran-

sistor and so a type with a high alpha cut-off frequency should be used. Those transistors designed as frequency changers in broadcast band receivers, such as the OC44, give the best results and should be used when possible.

Components

- C1—TSL 250 pf subminiature.
- C2—15 pf trimmer or tuning capacitor.
- C3—0.01 microfarad.
- Tr1—R.F. transistor such as OC44, XA104, etc.
- R1—See text.
- Earpiece—High impedance magnetic type.

Fig. 26. Two Transistor Set With Regenerative Detector

The circuit of Fig. 26 uses a similar detector to that of the last circuit apart from the method in which the regeneration is applied. A stage of A.F. amplification is added to increase the output.

One of the most useful features of the regenerative detector type of receiver is its excellent selectivity which is due to the reduction or compensation for the losses in the tuned circuit. This together with the good sensitivity, makes it suitable for use in pocket portables that require no aerial such as this one.

The feedback is provided by a coupling coil on the aerial rod rather than by a capacitor as in the last circuit. This has the advantage of affecting the tuning much less and reducing the variation of feedback with frequency. Unfortunately it is rather harder to control and is best set to the best

possible position and only moved occasionally. This best possible setting would be just sufficiently far from the yellow winding for oscillation not to occur on any part of the band. The feedback coil should be wound on a collar of stiff paper loose enough to slide along the ferrite rod aerial. A rod, made perhaps from a strip of plastic such as a collar stiffener, may be fixed to this coil and passed through a slot in the case to form the control.

This set has been designed to use a low battery voltage and the overall consumption is very slight. A slim pen torch battery may be used or, if a still smaller set is required, Mallory mercury cells can be employed; a minimum of 3 being required.

If an aerial is found necessary, either because the set is being used in area of low signal strength or to receive distant stations, one may be connected to the yellow terminal on the ferrite winding as described for Fig. 26.

Components

- R1—470K
- R2—4.7K
- R3—220K
- C1—TSL 250 pf capacitor subminiature tuning
- C2—0.01 mu.f.
- C3—2 mu.f. 3 v.w.
- Tr1—OC44 or similar
- Tr2—OC71 or similar
- L—TSL 1 3/4" ferrite rod aerial
- Earpiece—high impedance magnetic type.

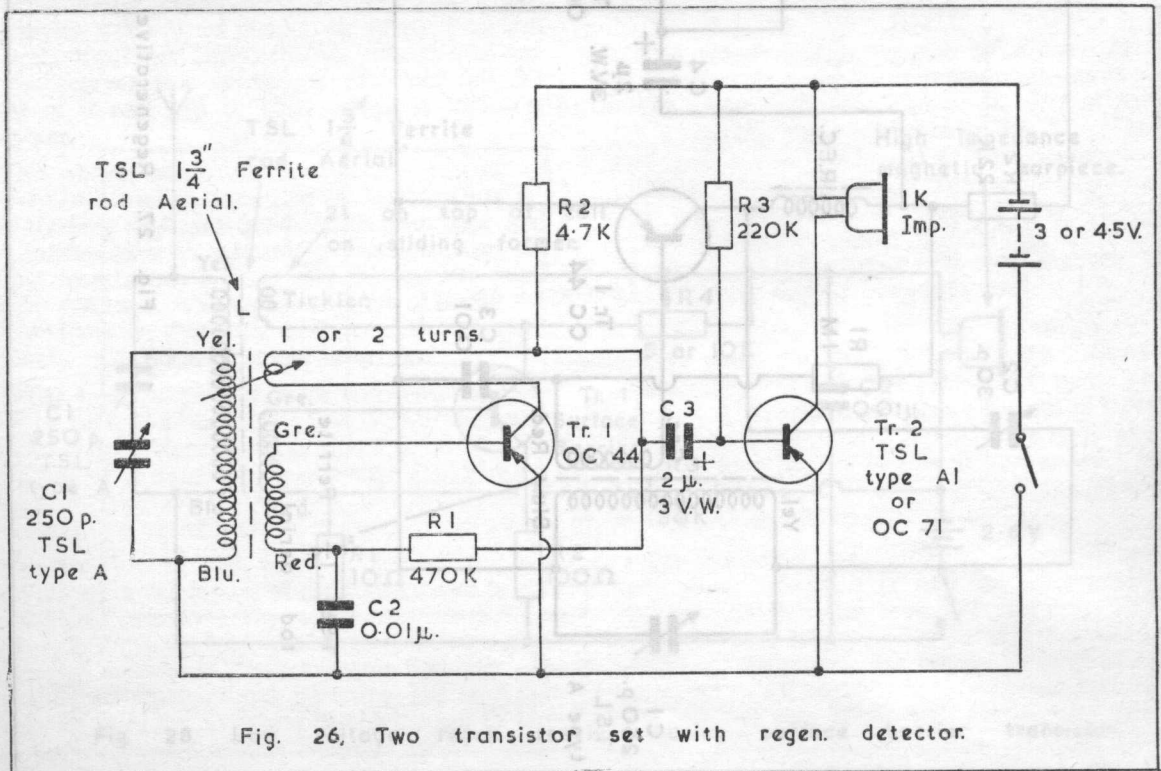

Fig. 26, Two transistor set with regen. detector.

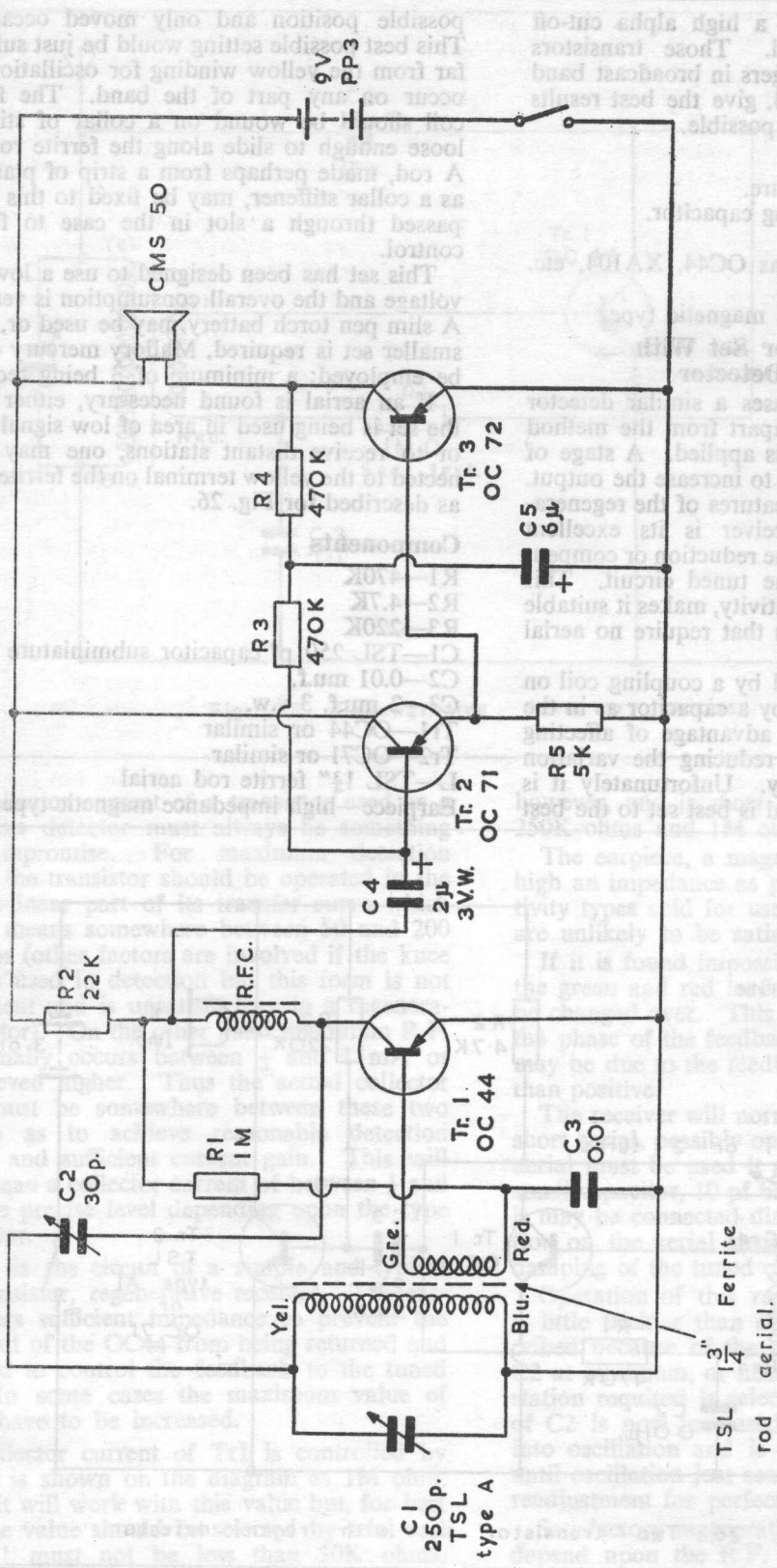

Fig. 27. Regenerative receiver with 2" loudspeaker.

Fig. 27. Regenerative Receiver with 2-inch Loudspeaker

By using the TSL magneto dynamic loudspeaker type CMS50 an extremely small and light pocket set can be made. The CMS50 has an overall diameter of 2" and a depth of only $\frac{5}{8}$ ". Its weight is very much less than for a normal speaker and it requires no output transformer which is an important space saving factor. To achieve a comparable saving of components in the receiver I have used unorthodox circuitry.

The regenerative detector is followed by two directly coupled stages of A.F. amplification the first of which operates in the common collector mode. This would normally mean losing a certain amount of gain compared with two common emitter stages but the output impedance of the first stage is about 20K ohms and this accurately matches the input impedance of the second thus a normal degree of gain is achieved. To obtain a sufficiently high output impedance from the first stage either a high value A.F. choke or a 22K ohm resistor must be used as the load. Normally a choke would be preferable, though much more expensive, because of the limitation a 22K ohm resistor imposes upon the collector current. In this case, however, the collector current has to be low for proper operation and the resistor is no disadvantage.

The collector current of Tr1 is stabilized by the feedback resistor R1 the value of which may need to be adjusted to provide a collector current of about $\frac{1}{2}$ mA. Since the collector resistive load is so high the degree of stabilization is very reasonable.

Components

- R1—1M ohm
- R2—22K
- R3—470K
- R4—470K
- R5—5K
- Tr1—OC44 (or other R.F. type)
- Tr2—OC71
- Tr3—OC72
- Speaker—TSL type CMS50
- C1—250 pf
- C2—30 pf
- C3—0.01 mu.f
- C4—2 mu.f 3 v.w.
- C5—6 mu.f 9 v.w.

Fig. 28. Low Voltage Regenerative Receiver

The excellent performance and considerable component economy of the regenerative detector type of circuit is due to the fact that one transistor performs three functions, namely those of an R.F. amplifier, A.F. amplifier and detector. As has been mentioned before, however, there is a conflict between the need for a low collector current to provide efficient detection and a higher one for optimum R.F. gain. One way to improve this

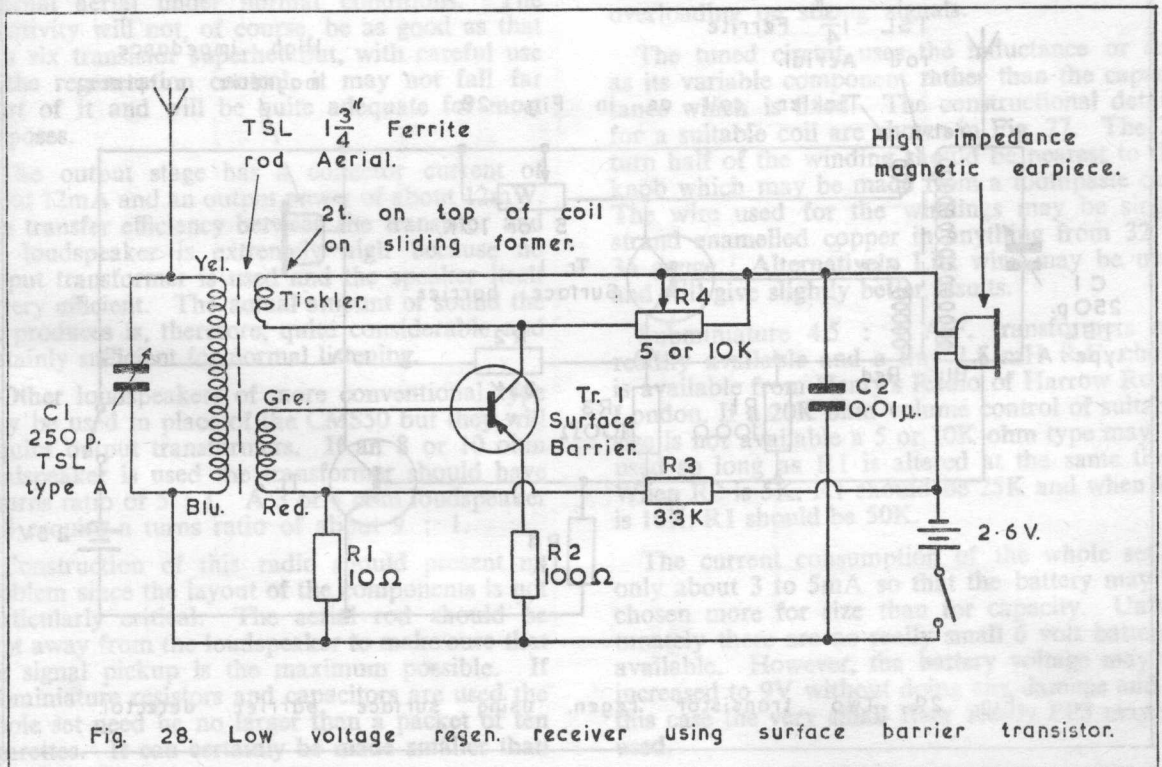

Fig. 28. Low voltage regen. receiver using surface barrier transistor.

position is to use a surface barrier transistor which continues to give good R.F. gain down to remarkably low levels of collector current and, at the same time, makes an efficient detector.

This circuit uses a surface barrier transistor at a collector current of about 90 microamps. Stabilization is provided by the normal potential divided and emitter resistor method. An unusual feature of the circuit is that all coupling and decoupling capacitors have been removed to make the operation of the regeneration control much smoother. To prevent this from reducing the gain too much R1, R2 and R3 are reduced in value considerably. Because R1 and R2 are so low in value they draw 10 times as much power from the battery as does the transistor making the total consumption about 1mA. This is not a great deal but if a really low consumption set is required R1 and R3 may be increased to 100 and 33K ohms with only a very slight loss of gain. Under these conditions the total consumption will be less than 1mA.

The regeneration is applied, as in previous circuits, by coupling the R.F. output of the transistor to a tertiary winding on the aerial coil. Control of the degree of feedback, however, is achieved by shorting the tickler winding with a volume control the methods used previously being unsuitable.

Surface barrier transistors are made by Semiconductors Limited and a wide range is available

to the home constructor. Any type will do since they all have sufficiently high cut-off frequencies for this circuit and the cheapest should be chosen.

Fig. 29. Two Transistor Regen. Using Surface Barrier Transistors

The last circuit is rather limited by its lack of any separate A.F. amplifier stage. This circuit increases the gain by the addition of a single transistor and with the minimum of extra components. Once again no capacitors are used and the regeneration control is extremely smooth.

Direct coupling is used between Tr1 and Tr2 the latter having a collector current of between 1/2 and 2mA depending upon its current gain. The battery should be made up of two Mallory cells in series. If subminiature resistors are used the whole set may be built into a case no larger than a matchbox.

In areas of reasonable signal strength and with careful use of the regeneration control the set will give good results without an external aerial. In any case the external aerial need only be a short one.

Tr2 may be any type of small signal audio transistor but Tr1 must be a surface barrier type.

For those who wish to use surface barrier transistors in any other circuits it should be remembered that they provide their greatest gain at about 300 microamps and that a battery voltage of more

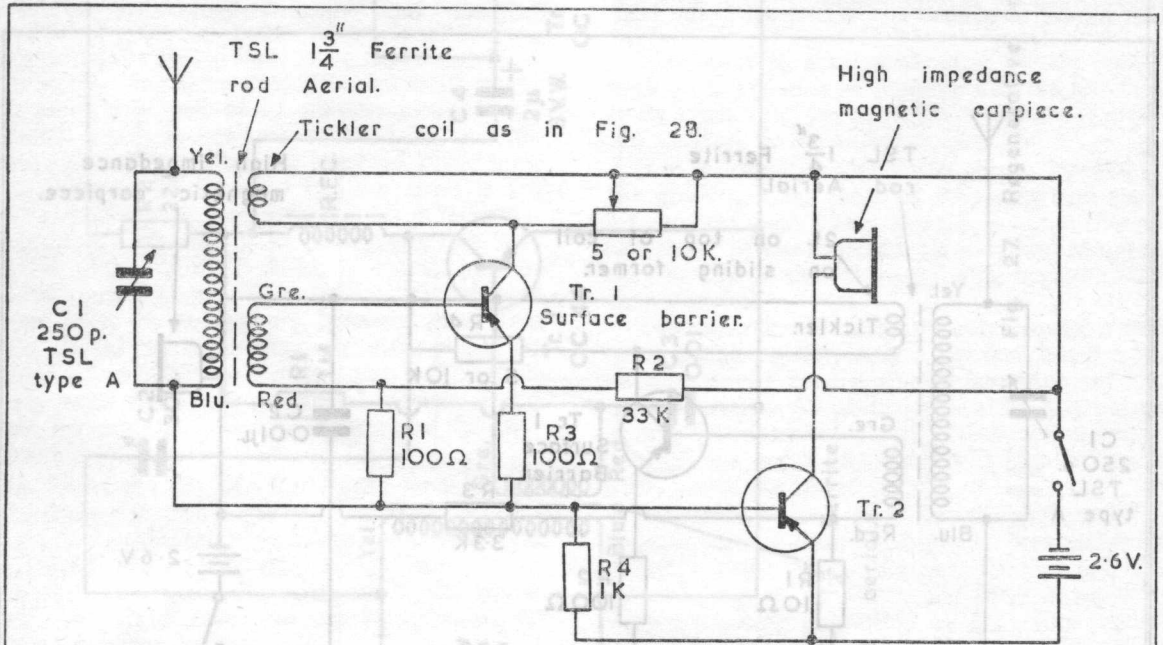

Fig. 29. Two transistor regen. using surface barrier detector.

than 3 volts must not be used. They make extremely good R.F. and I.F. amplifiers, oscillators and frequency changers at frequencies up to about 10 mc/s but their gain is not so high as the alloy diffused transistors now available.

The earpiece used should be a high impedance magnetic type of the sort used with hearing aids. If minimum size is not essential a balanced armature earpiece may be used and will give very good results. Balanced armature earpieces are readily available from shops specializing in government surplus for only a few shillings.

Components

R1—100 ohms
R2—33K
Tr1—Any surface barrier transistor
Tr2—Any audio transistor
R3—100 ohms
R4—1K

Fig. 30. Loudspeaker Version of Surface Barrier Receiver

Fig. 30 shows the circuit diagram of a receiver similar to that of Fig. 29 but with the earpiece replaced by a 1K ohm resistor and an extra stage added to provide sufficient output to drive a loudspeaker to an adequate volume level for personal listening.

This radio, then, is a completely self-contained set which does not require an earpiece or an external aerial under normal conditions. The sensitivity will not, of course, be as good as that of a six transistor superhet but, with careful use of the regeneration control, it may not fall far short of it and will be quite adequate for most purposes.

The output stage has a collector current of about 12mA and an output power of about 12mW. The transfer efficiency between the transistor and the loudspeaker is extremely high because no output transformer is used and the speaker itself is very efficient. The actual amount of sound the set produces is, therefore, quite considerable and certainly sufficient for normal listening.

Other loudspeakers of more conventional type may be used in place of the CMS50 but they will require output transformers. If an 8 or 10 ohm loudspeaker is used the transformer should have a turns ratio of 5 : 1. A 3 or 4 ohm loudspeaker will require a turns ratio of about 9 : 1.

Construction of this radio should present no problem since the layout of the components is not particularly critical. The aerial rod should be kept away from the loudspeaker to make sure that the signal pickup is the maximum possible. If subminiature resistors and capacitors are used the whole set need be no larger than a packet of ten cigarettes. It can certainly be made smaller than

even the smallest commercial set on the market today including the Japanese ones.

The total battery consumption is about 15mA and even quite small cells will give a reasonable life. Two of the tiny RM250 Mercury cells, for example, may be used in series and will last for about 17 hours this being equivalent to the average commercial pocket set running on a PP3.

Fig. 31. Circuit of "Wrist Radio" made by Lel in the U.S.A.

This receiver is included more for its circuit interest than as a constructional project although it may be built by the amateur without too much trouble; all the necessary components being available. It was made by a company called Lel in the United States and, although about 3" x 2" x 1" in size, was described as a wrist radio and supplied with a wrist strap. When it was put on the market it was an ingenious attempt at miniaturization and the circuit is certainly unusual.

The degree of positive feedback is controlled by the 20K ohm volume control which varies the collector current from a few microamps to about 1 milliamp. Two stages of A.F. amplification are used and, since they are transformer coupled, the amount of gain provided is about 75 dB. This is a very high gain indeed for a set of this type and, since the set has no A.G.C. system, may cause overloading on strong signals.

The tuned circuit uses the inductance or coil as its variable component rather than the capacitance which is fixed. The constructional details for a suitable coil are shown in Fig. 77. The 20 turn half of the winding should be nearest to the knob which may be made from a toothpaste cap. The wire used for the windings may be single strand enamelled copper in anything from 32 to 36 gauge. Alternatively Litz wire may be used and will give slightly better results.

Subminiature 4.5 : 1 A.F. transformers are readily available and a tiny 1.5 mH R.F. choke is available from Henry's Radio of Harrow Road, London. If a 20K ohm volume control of suitable size is not available a 5 or 10K ohm type may be used so long as R1 is altered at the same time. When R2 is 5K, R1 should be 25K and when R2 is 10K, R1 should be 50K.

The current consumption of the whole set is only about 3 to 5mA so that the battery may be chosen more for size than for capacity. Unfortunately there are no really small 6 volt batteries available. However, the battery voltage may be increased to 9V without doing any damage and in this case the very small Ever Ready PP3 may be used.

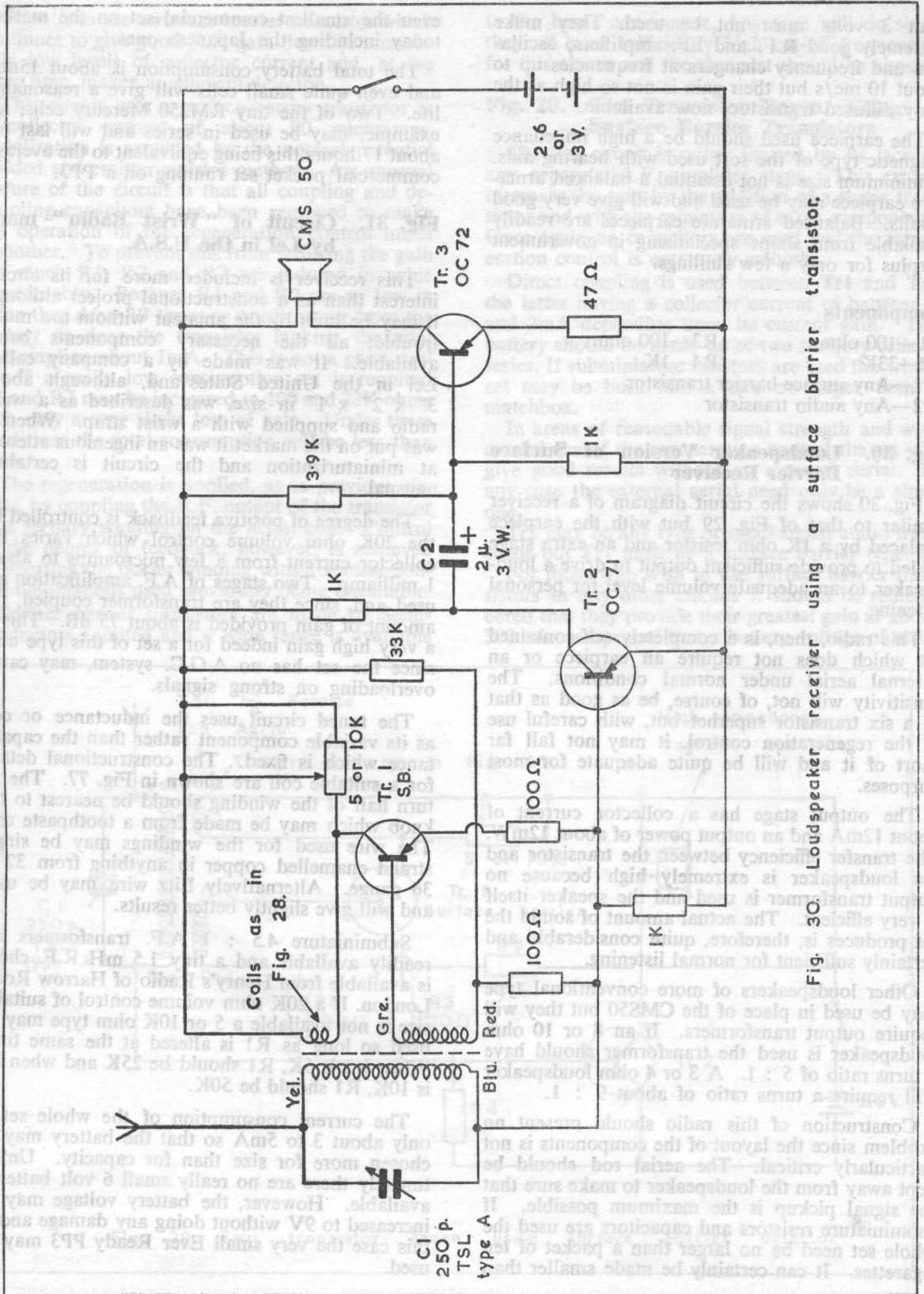

Fig. 30. Loudspeaker receiver using a surface barrier transistor.

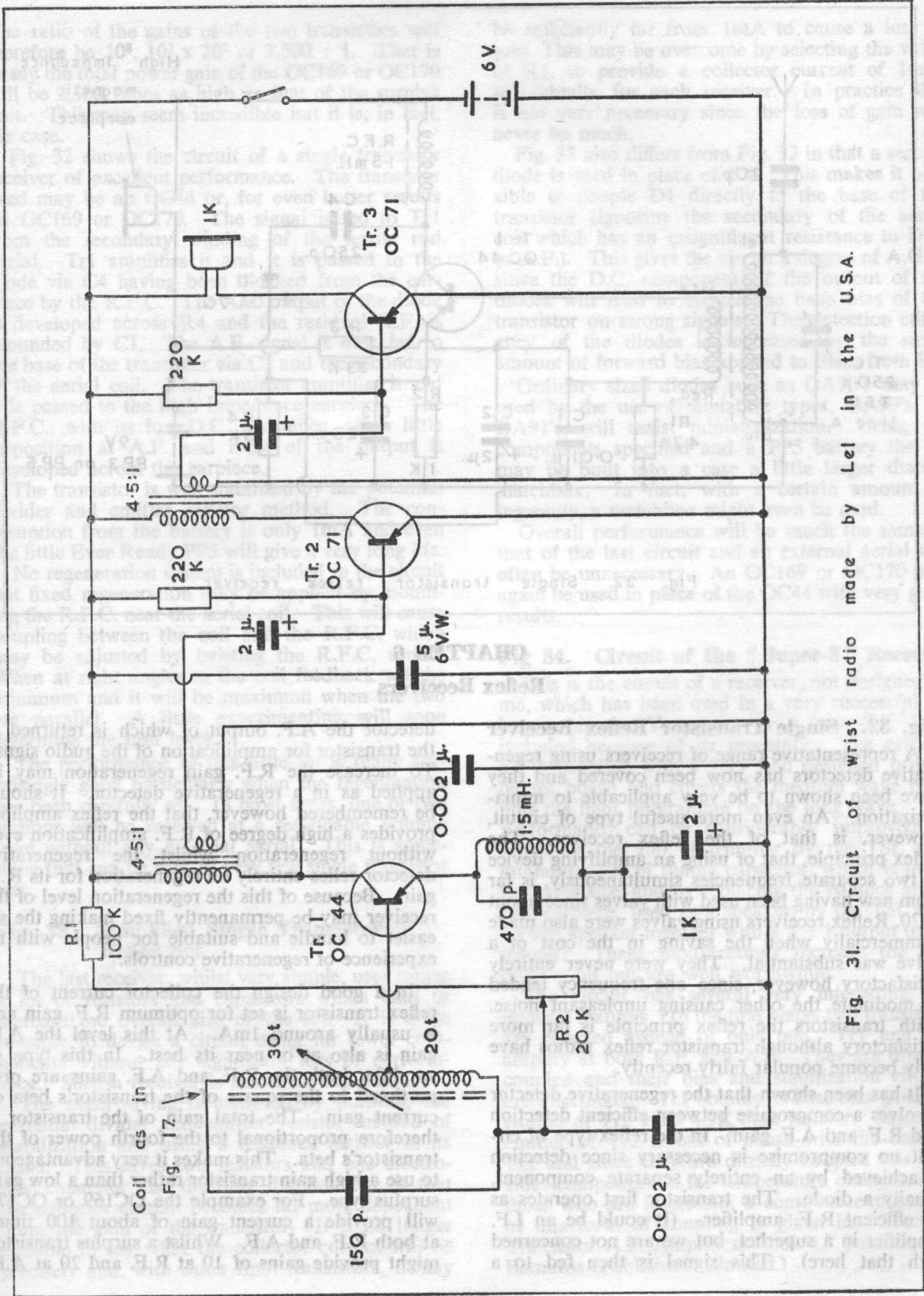

Fig. 31. Circuit of wrist radio made by LeI in the U.S.A.

The ratio of the gains of the two transistors will therefore be 10^8 , $10^2 \times 20^2$ or 2,500 : 1. That is to say the total power gain of the OC169 or OC170 will be 2,500 times as high as that of the surplus unit. This may seem incredible but it is, in fact, the case.

Fig. 32 shows the circuit of a single transistor receiver of excellent performance. The transistor used may be an OC44 or, for even better results an OC169 or OC170. The signal is fed to Tr1 from the secondary winding of the ferrite rod aerial. Tr1 amplifies it and it is passed to the diode via C4 having been blocked from the earpiece by the R.F.C. The A.F. output of the diode is developed across R4 and the residual R.F. is grounded by C1. The A.F. signal is now fed to the base of the transistor via C2 and the secondary of the aerial coil. The transistor amplifies it and it is passed to the high impedance earpiece. The R.F.C., with its low D.C. resistance, offers little opposition at A.F. and most of the output is developed across the earpiece.

The transistor is well stabilized by the potential divider and emitter resistor method. The consumption from the battery is only 1mA and even the little Ever Ready PP5 will give a very long life.

No regeneration system is included in the circuit but fixed regeneration may be applied by mounting the R.F.C. near the aerial coil. This will cause coupling between the coil and the R.F.C. which may be adjusted by twisting the R.F.C. round. When at right angles to the coil feedback will be minimum and it will be maximum when the two are parallel. A little experimenting will soon determine the best level.

The performance of this little set is really surprisingly good particularly when the regeneration has been carefully set. In most areas, one or two stations will be received at a reasonable volume level without any external aerial. This is something that can be said of very few single transistor sets.

Fig. 33. Simplified Single Transistor Reflex Set

The last receiver, whilst very simple, uses rather a lot of resistors and capacitors which tend to increase the overall size of the set. It is quite possible to devise a circuit using far fewer components without any significant loss of performance. Such a receiver is shown in Fig. 33.

The main saving is achieved by omitting the potential divider and emitter resistor method of stabilization and using a feedback resistor in its place. This saves two resistors and one electrolytic capacitor and the only disadvantage is that the collector current becomes far more dependent upon the gain of the transistor. It is no longer possible to say what the collector current will be precisely and, with outer limit transistors, it may

be sufficiently far from 1mA to cause a loss of gain. This may be overcome by selecting the value of R1, to provide a collector current of 1mA, individually for each receiver. In practice this is not very necessary since the loss of gain will never be much.

Fig. 33 also differs from Fig. 32 in that a second diode is used in place of R4. This makes it possible to couple D1 directly to the base of the transistor (ignoring the secondary of the aerial coil which has an insignificant resistance to D.C. or A.F.). This gives the circuit a degree of A.G.C. since the D.C. component of the output of the diodes will tend to reduce the base bias of the transistor on strong signals. The detection efficiency of the diodes is increased by the small amount of forward bias applied to them from R1.

Ordinary sized diodes such as OA70's may be used by the use of miniature types, OA90's, or OA91's, will assist miniaturization. Using the components specified and a PP5 battery the set may be built into a case a little larger than a matchbox. In fact, with a certain amount of ingenuity, a matchbox might even be used.

Overall performance will be much the same as that of the last circuit and an external aerial will often be unnecessary. An OC169 or OC170 may again be used in place of the OC44 with very good results.

Fig 34. Circuit of the "Super-3" Receiver

This is the circuit of a receiver, not designed by me, which has been used in a very successful kit known as the Vancouver or "Super-3". It is included because of its ingenuity. The original kit is supplied with a very well designed printed circuit board and covers the medium wave band plus the light programme on the long wave. The performance can be considerably improved by replacing the 250 pf trimmer by the TSL sub-miniature 250 pf tuning capacitor, which is much the same size, and by replacing the balance armature earpiece, used as a speaker, by the TSL type LP45F speaker together with a 5 : 1 output transformer. These modifications increase the cost quite a bit but are well worthwhile.

The circuit has several very interesting and unusual features. In the first place, two transistors are reflexed instead of only one. Tr1 and Tr2 amplify at both R.F. and A.F. They are directly coupled and their bias and stabilization circuits are interlinked. Tr1 obtains its base bias from the emitter of Tr2 via a 4.7K ohm resistor. Since the emitter of Tr2 is out of phase with the base of Tr1 and since they are directly coupled this provides compensation for temperature changes. (For those who are interested, a complete explanation of this form of coupling is given in "Practical Transistor A.F. Amplifiers Book 1" published by Bernards (Publishers) Limited.)

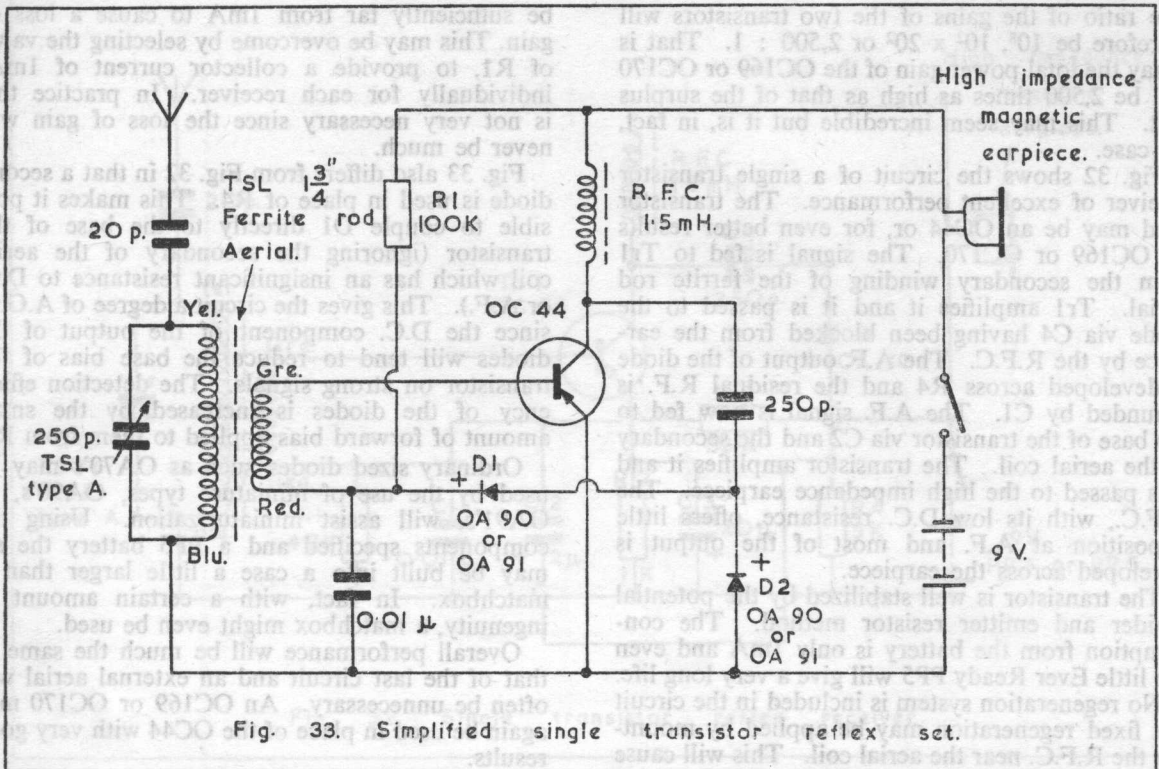

The R.F. output of Tr2 is coupled to the diode by means of an R.F. transformer. This is untuned for the medium wave band but is tuned for the light programme by the 560 pf capacitor on the long wave band. The diode is D.C. coupled to the first transistor and provides a certain amount of A.G.C. as well as the A.F. signal. The A.F. output of Tr2 is fed to a conventional output stage.

In the kit, a certain amount of regeneration is obtained by laying the collector lead of Tr2 close to the base lead of Tr1. The amount of regeneration obtainable in this way is not very great however because the gain of the two transistors varies considerably over the band and there may also be quite a high difference in phase between the two leads. This results in the tuning of the set being rather too broad.

Fig. 35. Loudspeaker Reflex Receiver Using Only Two Transistors

Using the reflex technique it is possible to build a good performance receiver with only two transistors. Japanese radio manufacturers have put such sets on the market and they have been extremely successful, the only trouble being that people have tended to buy them in place of the six transistor superhets, which they closely resemble, and since the latter are far more expensive this has not done the Japanese manufacturers

a great deal of good. The public, on the other hand, have in fact bought sets which, whilst not having anything like the sensitivity of the superhets, will still give very much the same performance on local stations and this is all most people want.

This circuit is similar to the sort the Japanese receivers use except that I have designed it around British components so that it may easily be built in this country.

Like the last receiver described, this set uses an untuned R.F. transformer to couple the first transistor to the diode. For this transformer any transistor I.F. transformer may be used the primary winding being connected to the transistor and the secondary to the diode. The fixed capacitor normally connected across the primary of the output transformer must be removed and any taps on the primary should be ignored.

The output stage uses an OC75 because of its very high gain. The OC75 is not intended as an output transistor but the collector current in this case is only 6mA so that it can be used as one to advantage. To obtain a reasonable output power with only 5mA in the output stage a high battery voltage must be used. In this case an Ever Ready B121 with a voltage of 15 volts has been adopted and the output power is 35mW.

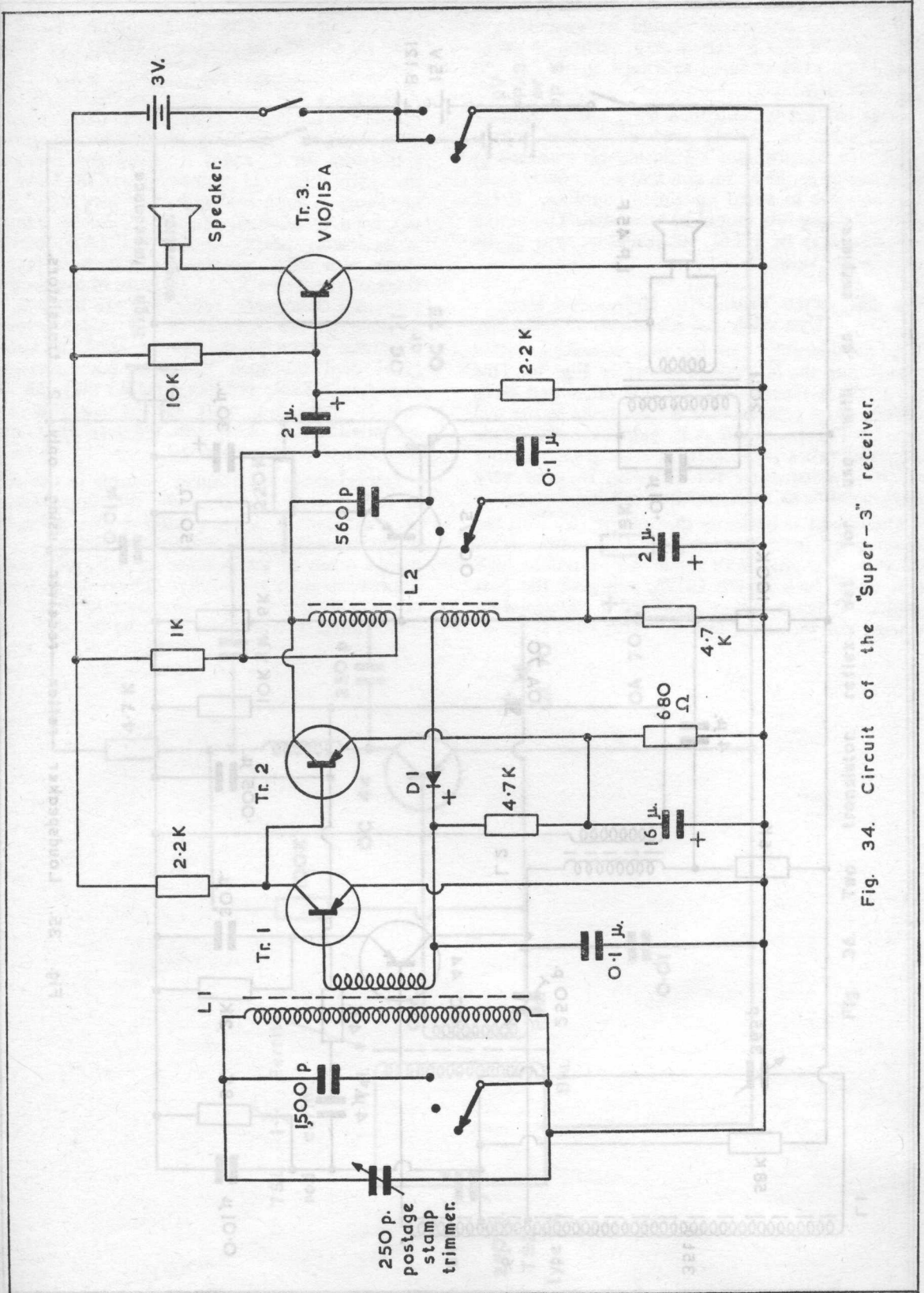

Fig. 34. Circuit of the "Super-3" receiver.

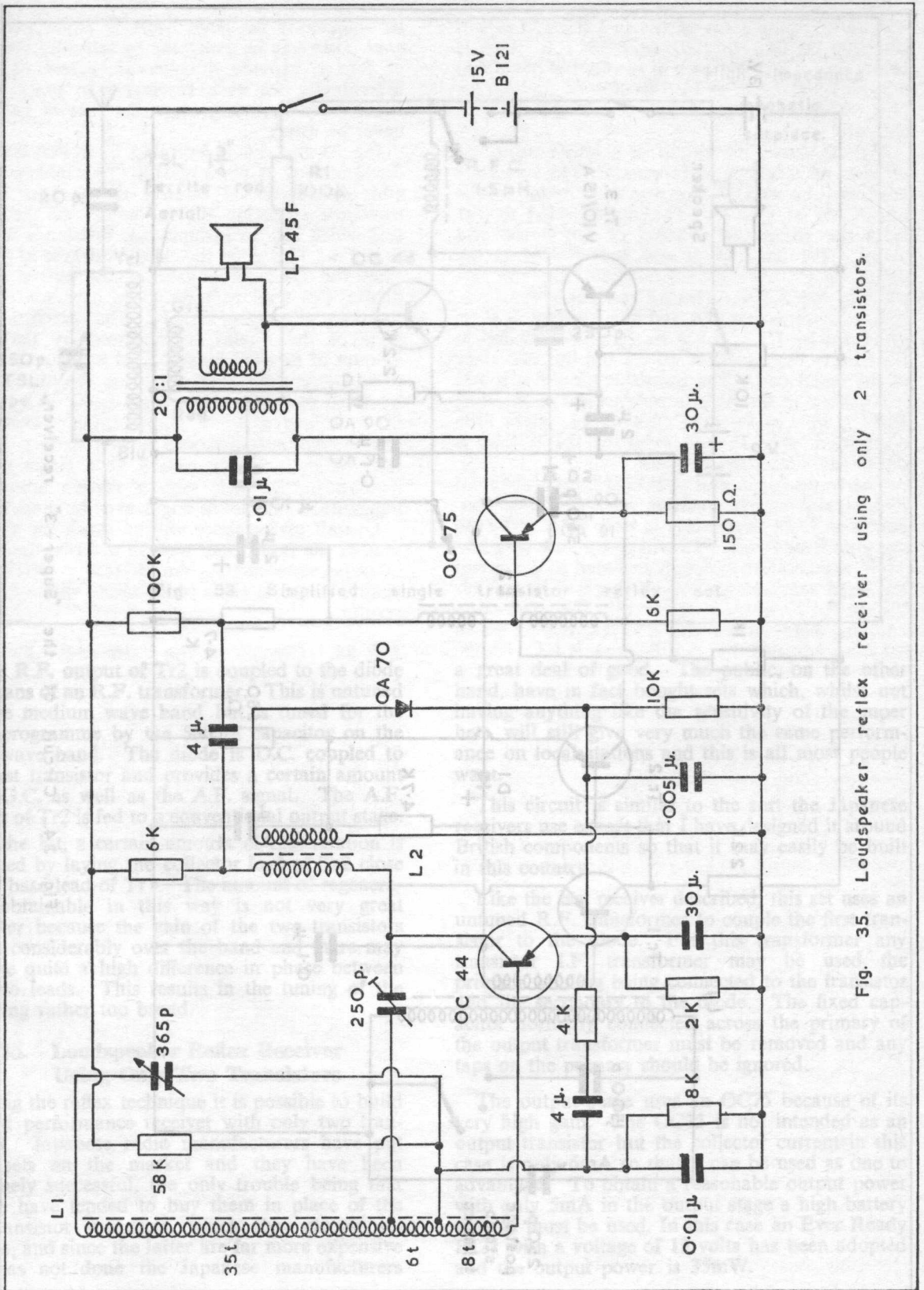

Fig. 35. Loudspeaker reflex receiver using only 2 transistors.

BERNARDS RADIO BOOKS

No.		Price
56.	Radio Aerial Handbook	2/6
57.	Ultra-Shortwave Handbook	2/6
58.	Radio Hints Manual	2/6
64.	Sound Equipment Manual	2/6
68.	Frequency Modulation Receivers' Manual	2/6
83.	Radio Instruments and their Construction	2/6
96.	Crystal Set Construction	1/-
100.	A Comprehensive Radio Valve Guide, Book 1	5/-
103.	"Radiofolder" A. The Master Colour Code Index for Radio and T.V....	1/6
104.	Three Valve Receivers	1/6
121.	A Comprehensive Radio Valve Guide, Book 2	5/-
123.	"Radiofolder" F. The Beginners' Push-Pull Amplifier	1/6
126.	Boys' Book of Crystal Sets and Simple Circuits	2/6
129.	Universal Gram Motor Speed Indicator	1/-
135.	All Dry Battery Portable Construction	2/6
138.	How to Make F.M. and T.V. Aerials, Bands 1, 2 and 3	3/-
141.	Radio Servicing for Amateurs	3/6
143.	A Comprehensive Radio Valve Guide, Book 3	5/-
145.	Handbook of AM/FM Circuits and Components	2/-
146.	High Fidelity Loudspeaker Enclosures	5/-
147.	Practical Tape Recording Handbook	5/-
148.	Practical Transistor Receivers, Book 1	5/-
149.	Practical Stereo Handbook	3/6
150.	Practical Radio Inside Out	4/6
151.	Transistor Superhet Receivers	7/6
153.	Miniature Portable Oscilloscope	2/6
156.	Transistor Circuits Manual, No. 1	2/6
157.	A Comprehensive Radio Valve Guide, Book 4	5/-
158.	Radio, Television, Industrial Tubes, Semiconductor and Diodes Equivalents Handbook (208 pages)	10/6
160.	Coil Design and Construction Manual	5/-
161.	Radio, Television and Electronics Data Manual	3/6
162.	High Fidelity Stereo Gramophone	5/-
163.	Transistor Circuits Manual, No. 2	2/6
165.	Hartley on Hi-Fi, Book 1. Radio Tuners	5/-
168.	Transistor Circuits Manual, No. 4	2/6
170.	Transistor Circuits for Radio Controlled Models	7/6
171.	Super Sensitive Transistorised Pocket Set Construction	3/6
172.	International Radio Stations List	2/6
173.	Practical Transistor Audio Amplifiers	3/6
174.	Transistor Subminiature Receivers Handbook	5/-
175.	Transistorised Test Equipment and Servicing Manual	4/6
176.	Transistor Audio Amplifiers Manual	6/-
177.	Modern Transistor Circuits for Beginners	7/6
178.	Comprehensive Radio Valve Guide Book 5	6/-
179.	Transistor Circuits Manual No. 5	5/-
181.	22 Tested Circuits Using Micro Alloy Transistors	5/-
183.	How to Receive Foreign T.V. Programmes on your Television Set by simple Modifications	5/-
184.	Tested Transistor Circuits Handbook	3/6
185.	Tested Short-Wave Receiver Circuits using Micro Alloy Transistors (MAT's)	5/-
186.	Tested Superhet Circuits for Short-Wave and Communication Receivers using Micro Alloy Transistors (MAT's)	6/-
187.	The TSL Mark "4" Valved F.M. Tuner and its Construction	3/6
188.	Construction of the B.H. High Fidelity "14" watt Audio Amplifier	1/6
189.	How to build the world's smallest transistor radio. The Sinclair Micro 6	1/-
190.	How to build the world's smallest High Fidelity Amplifier	1/6
191.	Practical Car Radio Handbook	6/-
192.	How to build the Sinclair "X10" Amplifier	1/-
193.	"At a Glance" Radio Valve and T.V. Tube Equivalents and Substitution Manual	6/-
501.	ABC's of Magnetism	5/-
502.	ABC's of Missile Guidance	5/-
503.	ABC's of Ultrasonics	5/-
	Resistor Colour Code Disc Calculator	1/6
	Engineers' Reference Tables	1/6