

PEH 383

# Super Sensitive Transistorised Pocket Radio for the Home Constructor

by

**S. C. RYDER-SMITH**

**Full Circuits and Instructions for Building, Operating  
and Servicing this Super Receiver.**

**Twenty-three Diagrams and Plans.**

**Complete stage by stage Building Data.**

**Alignment Instructions.**

**Repairing and Correcting Faults.**

**Parts Lists, etc.**

4769

16

**SUPER SENSITIVE  
TRANSISTORISED  
POCKET RADIO**

**for the**

**Home Constructor**

BY

**S. C. RYDER-SMITH**

**BERNARDS (PUBLISHERS) LTD.**

**THE GRAMPIANS  
WESTERN GATE  
LONDON W. 6**

FIRST PUBLISHED AUGUST, 1961

We invite all authors, whether new or well established, to submit manuscripts for publication. The manuscripts may deal with any facet of electronics but should always be practical. Any circuit diagrams that may be included should have been thoroughly checked by the author. If you are considering trying your hand at writing this type of book we suggest that you let us have a short summary of the subject you intend to cover. We will then be able to let you know the size of book required and perhaps give you some advice on presentation.

© 1961

*Printed by Weatherby and Sons, 182-4 Campden Hill Road, London, W.8,  
for Bernards (Publishers) Ltd., The Grampians, Western Gate, London, W.6*

# CONTENTS

	Page
Introduction . . . . .	5
The Circuit . . . . .	6
Construction . . . . .	9
Power Output stage . . . . .	29
List of Parts . . . . .	30

# LIST OF ILLUSTRATIONS

	Page
Fig. 1 — Transistor lead identification ... ..	6
Fig. 2 — Pocket radio receiver circuit diagram ... ..	7
Fig. 3 — Chassis construction details ... ..	10
Fig. 4 — Glueing the joints ... ..	10
Fig. 5 — Layout of major components ... ..	12
Fig. 6 — Mounting the trimmer ... ..	13
Fig. 7 — Trimmer bending details ... ..	13
Fig. 8 — Station selection switch ... ..	14
Fig. 9 — Mounting switch lever ... ..	15
Fig. 10 — Switch lever position ... ..	15
Fig. 11 — Volume control assembly ... ..	16
Fig. 12 — Battery mounting ... ..	17
Fig. 13 — Aerial mounting ... ..	18
Fig. 14 — Underside lid layout ... ..	19
Fig. 15 — Wiring layout of 1st R.F. amplifier ... ..	21
Fig. 16 — Switch earth line connection ... ..	22
Fig. 17 — Negative line wiring ... ..	23
Fig. 18 — 2nd R.F. detector wiring layout ... ..	24
Fig. 19 — Audio stage wiring layout ... ..	25
Fig. 20 — Tuning capacitor connections ... ..	26
Fig. 21 — Aerial winding details ... ..	27
Fig. 22 — Aerial connection layout ... ..	28
Fig. 23 — Power output stage circuit ... ..	29

## INTRODUCTION

The radio described here is a genuinely pocket-sized transistor radio. A number of pocket radios are available, either in kit form or fully assembled and aligned by the manufacturer. Unfortunately, the majority of these seem to require well reinforced pockets of extremely ample dimensions, or else have inferior performance and finish, which places them in the "toy" class. The design presented here has tried to avoid both of these faults.

To start with the outside of the set, the case used is a cigarette case designed to hold an American style packet of king-size cigarettes. It is finished in pigskin, although this style is available in other leathers, ranging from blue morocco to crocodile skin. This ensures that the appearance of the set is attractive and elegant, and enables a choice of finish to be made to suit individual taste. Also, of course, the fact that the set is housed in a cigarette case shows most clearly how well suited it is to fit in the pocket!

Another drawback with many small radios is that miniature deaf-aid batteries have to be used. This is done in order to obtain the required voltage for driving the radio, while at the same time using as little space as possible to accommodate the battery. A disadvantage with these batteries, however, is that they are moderately expensive to buy, are often difficult to obtain in many localities, and do not have a very large electrical capacity—that is to say, their useful life is not extremely long. To avoid these difficulties, the set described here is powered by two 1.5 volts torch batteries connected in series. These can be bought anywhere, and they cost only 3½d. each. Their useful life is also very good.

As to the circuit, five transistors have been used, and no attempt has been made to cut down on the number of components used where this would lead to a deterioration in the performance. The policy adopted in the choice of a case of obtaining an appearance of good quality has been followed through in the design of the circuit. The objectives of the design have been to achieve a high quality audio output, and also to make the operation in use of the finished set as simple as possible. The set is switch tuned, allowing three preselected stations (Home Service, Light Programme, and Third Programme) to be chosen. This system has the advantage that optimum performance on each programme can be obtained, and the danger of instability which might occur at some frequencies in a compact T.R.F. design is greatly reduced. Another advantage is that the Light Programme transmission on 200 kc/s can be used instead of the transmission on 1 214 kc/s, since the former covers a much larger area of the country than the latter.

For a number of readers, home construction of radio equipment might be a comparatively new hobby. Indeed, this booklet might serve as their first introduction to the subject. For these readers it might be helpful at this point to give a few hints on construction techniques; to discuss the dangers and difficulties involved, and describe how to avoid them.

A good starting point is to discuss the methods of handling transistors, or, indeed, any semiconductor device. It must be emphasised at the start that the active transistor element itself (which is usually very small compared with the complete transistor) can become permanently damaged if it is allowed to get too hot. One way

in which heat can reach it is, of course, through the lead wires when these are being soldered into the circuit.

In order to avoid damage occurring, certain precautions should be taken. In the first place, the soldering iron should not be applied to the lead too close to the transistor, nor should it be held there too long. And, secondly, wherever possible, a pair of pliers should be used to grip the leads between the point where the solder is being applied and the transistor. This acts as a heat shunt and prevents the leads from getting too hot close to the transistor.

However, it should be added that too high a degree of caution is often advocated. The constructor is advised never to shorten the leads of a transistor, so that soldering may always be done as far as possible from the transistor itself. He is also recommended always to use a heat shunt. This is, of course, the safest procedure, and should be followed wherever possible. However, in many cases, it is very restrictive, and, especially in the case of a compact pocket radio, it can make the construction very much harder.

In the circuit employed here, S.T.C. transistors have been used, and, in order to put this problem in its right perspective, it might be of interest to quote the data sheets for their transistors on this subject :

“A heat shunt is unnecessary if a soldering iron at less than 350°C is applied more than  $\frac{1}{4}$ " (6 mm.) from the body for not more than 10 seconds to one lead at a time.”

This gives the limit to which leads may be shortened and soldered without the use of a heat shunt, *where this is absolutely necessary*. When it is not necessary to cut the leads so drastically, they should, of course, be left as long as possible, and a heat shunt should be used wherever it is convenient to do so.

Two other vital points must also be observed to protect the transistor adequately. The first is that the polarity of the battery must be correct when it is connected into the circuit, or the transistor, in certain circuit configurations, might pass too large a current, and be damaged. The second is that the leads must be correctly identified. In most low power transistors, the collector is marked with a spot painted on the case close to the lead. The disposition of the emitter and base leads might vary among different manufacturers, but there is

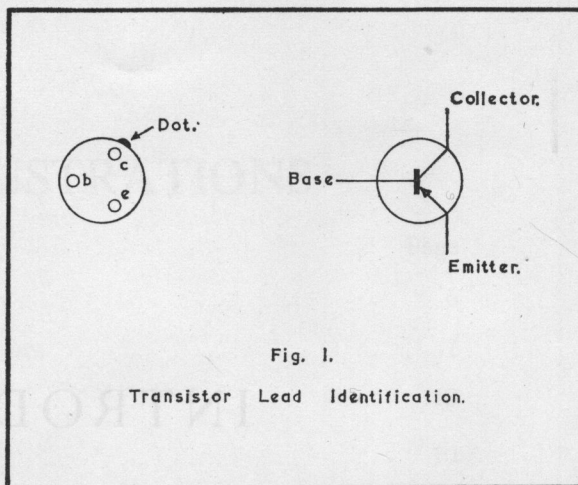

a strong trend to standardise on the arrangement in which the three leads form the points of a triangle, which run collector-emitter-base in a clockwise direction, when viewed from underneath. This is the arrangement adopted by S.T.C. and it is illustrated in figure 1.

Considering other components which will be used, diodes must be treated with the same respect as transistors with regard to both soldering and lead identification. Care must also be taken to avoid over-heating resistors and capacitors when soldering them into circuit. Resistors can change their value, or even become open circuit if allowed to get too hot. Electrolytic capacitors must always be connected into the circuit with the correct polarity, and when one of the miniature low working voltage range is used, extreme care must be taken to prevent them becoming too hot, as they are easy to damage in this way.

### The Circuit

The circuit diagram of this radio is shown in figure 2. The aim of the design is reliability, and quality of audio output. A great difficulty with a radio of this size is that the components must necessarily be placed very close to one another, and the problem of instability occurring due to stray coupling between the components can become acute. The possibilities of rearranging the layout to minimise this danger are also very limited, since the positioning of some of the major components is dictated by mechanical considerations.

Partly because of these considerations of stability it was decided not to attempt either a regenerative

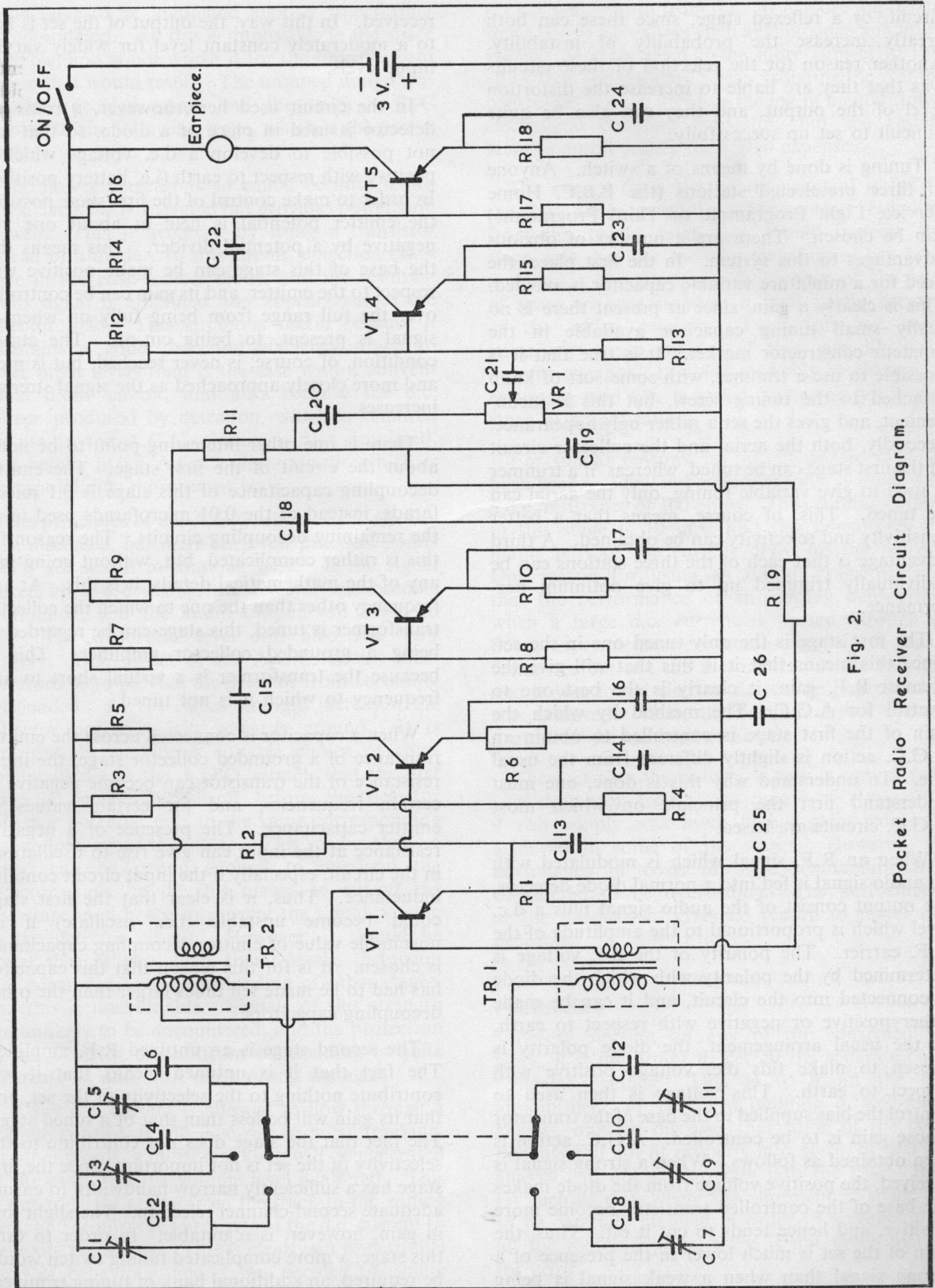

Fig. 2.  
Pocket Radio Receiver Circuit Diagram.



circuit, or a reflexed stage, since these can both greatly increase the probability of instability. Another reason for the rejection of these circuits was that they are liable to increase the distortion level of the output, and they can also be quite difficult to set up successfully.

Tuning is done by means of a switch. Anyone of three preselected stations (the B.B.C. Home Service, Light Programme or Third Programme) can be chosen. There are a number of obvious advantages to this system. In the first place, the need for a miniature variable capacitor is avoided. This is clearly a gain, since at present there is no really small tuning capacitor available in the amateur constructor market. It is true that it is possible to use a trimmer, with some sort of knob attached to the tuning screw, but this is inconvenient, and gives the set a rather ugly appearance. Secondly, both the aerial and the collector circuit of the first stage can be tuned, whereas, if a trimmer is used to give variable tuning, only the aerial can be tuned. This, of course, means that a better sensitivity and selectivity can be obtained. A third advantage is that each of the three stations can be individually trimmed up to give optimum performance.

The first stage is the only tuned one in the set. Since this means that it is this that will give the greatest R.F. gain, it clearly is the best one to control for A.G.C. The method by which the gain of the first stage is controlled to obtain an A.G.C. action is slightly different from the usual one. To understand why this is done, one must understand first the principle on which most A.G.C. circuits are based.

When an R.F. signal which is modulated with an audio signal is fed into a normal diode detector, the output consists of the audio signal plus a d.c. level which is proportional to the amplitude of the R.F. carrier. The polarity of the d.c. voltage is determined by the polarity with which the diode is connected into the circuit, and it can be made either positive or negative with respect to earth. In the usual arrangement, the diode polarity is chosen to make this d.c. voltage positive with respect to earth. This voltage is then used to control the bias supplied to the base of the transistor whose gain is to be controlled. A.G.C. action is then obtained as follows. When a strong signal is received, the positive voltage from the diode makes the base of the controlled transistor become more positive, and hence tends to cut it off. Thus, the gain of the set is much lower in the presence of a strong signal than when a weak signal is being

received. In this way, the output of the set is kept to a moderately constant level for widely varying input levels.

In the circuit used here, however, a transistor detector is used in place of a diode, so that it is not possible to develop a d.c. voltage which is positive with respect to earth (i.e. battery positive). In order to make control of the first stage possible, the emitter potential is held at about one volt negative by a potential divider. This means that the base of this stage can be made positive with respect to the emitter, and its gain can be controlled over the full range from being fully on when no signal is present, to being cut-off. The cut-off condition, of course, is never reached, but is more and more closely approached as the signal strength increases.

There is one other interesting point to be noted about the circuit of the first stage. The emitter decoupling capacitance of this stage is 0.1 microfarads, instead of the 0.01 microfarads used in all the remaining decoupling circuits. The reason for this is rather complicated, but, without going into any of the mathematical details, it is this. At any frequency other than the one to which the collector transformer is tuned, this stage can be regarded as being a grounded collector amplifier. This is because the transformer is a virtual short to any frequency to which it is not tuned.

When a capacitor is connected across the emitter resistance of a grounded collector stage, the input resistance of the transistor can become negative at certain frequencies, and for certain values of emitter capacitance. The presence of a negative resistance at the input can give rise to oscillations in the circuit, especially if the input circuit contains inductance. Thus, it is clear that the first stage could become unstable (i.e., oscillate) if an unsuitable value of emitter decoupling capacitance is chosen. It is for this reason that this capacitor has had to be made ten times larger than the other decoupling capacitors.

The second stage is an untuned R.F. amplifier. The fact that it is untuned means that it will contribute nothing to the selectivity of the set, and that its gain will be less than that of a tuned stage. The fact that the stage does not contribute to the selectivity of the set is not important, since the first stage has a sufficiently narrow bandwidth to ensure adequate second-channel rejection. The slight loss in gain, however, is regrettable. In order to tune this stage, a more complicated tuning switch would be required, an additional bank of tuning trimmers

would have to be used, and another transformer accommodated. All this is impossible in the space available, and is not worth it for the improvement in gain that would result. The untuned design was therefore decided upon, and the stage is R-C coupled to the following stage, which is the power detector.

The power detector is so called because it not only detects the R.F. signal but provides power gain as well. This is achieved by using a transistor instead of a diode. In this circuit, detection takes place in the base-emitter diode, and the resulting audio signal is amplified and appears across the collector load. This circuit is useful because it maintains a good detection efficiency down to lower input levels than is the case with a conventional diode circuit, and also because the d.c. voltage produced by detection, which is required for use in the A.G.C. circuit, is also amplified. This results in an A.G.C. characteristic which is correspondingly more sensitive.

The principles of the A.G.C. circuit have already been discussed, but there are a few practical points which are worth mentioning here. If the signal picked up is too strong, the detector will become overloaded, and the audio output will begin to fall. The distortion level will also rise very sharply. One object of the A.G.C. circuit must therefore be to prevent the detector from becoming overloaded. As the signal strength increases, the collector potential falls towards ground. It is arranged, by making a suitable choice of component values in the A.G.C. circuit, that the first stage is completely cut-off before the detector collector potential falls to the value corresponding to overloading of this stage. This means that no signal can be strong enough to overload the detector, since to do this means to cut-off the first stage, and hence to prevent the signal passing to the detector circuit. However, it should be noted that at very high signal levels, distortion will occur due to the overloading of other stages, and this is unavoidable. Signals of this strength are unlikely to be encountered, and the protection of the detector circuit from overloading is quite adequate to deal with most strong signals.

If any d.c. current is allowed to flow through a volume control, it will give rise to noisy tracking. In other words, a lot of crackling will be generated in the output as the volume level is altered. This is due to slight arcing from the track to the wiping arm, and requires the presence of the d.c. current to generate the arcing. This is clearly an undesirable kind of behaviour, and it was decided to isolate

the volume control from d.c. It is more important to do this in a small set such as this, since miniature volume controls seem to be more subject to this effect than the standard sizes. Isolating the volume control necessarily involves the use of an additional electrolytic coupling capacitor, but the results seem to amply justify the added expense.

The output from the volume control is fed to the first audio amplifier. Transformer coupling from this to the final stage would increase the stage gain, but the use of a transformer has been excluded. This is primarily because of the lack of space to accommodate it, and partly because of the added expense. Transistors are comparatively cheap now, and they are likely to become cheaper. It would probably be cheaper, if any extra gain was required, to use an additional stage of amplification.

For similar reasons, no output transformer has been used. A low impedance earplug is used, with a d.c. resistance of 100 ohms. The standing current in this stage is 10 mA, and this constitutes the major part of the current drain on the battery. One reason for using an output transformer is that the performance of an earplug deteriorates when a large d.c. current is passed through it. Some experiments were made using a 1:1 transformer to cut out the d.c. current in the earplug, and it was found that no detectable improvement was achieved. Thus, the original circuit without a transformer has been retained.

The fact that the battery supply is only 3 volts is a drawback from some points of view. If a 9 volt supply was used, higher gains could be achieved in some of the stages. However, the advantages of cost, life and availability were considered to be over-riding. The performance of the finished set gives no reason to regret this decision.

### Construction

Before starting on any of the constructional work, it is important to get all the separate components together. This is to avoid the disappointment of carefully building a well-made chassis, only to discover that some of the components will not fit properly into place, or that the chassis will not fit correctly into the case. In a set such as this, where the allotment of space has to be carefully planned in order to accommodate all the required parts, there is not much margin for error.

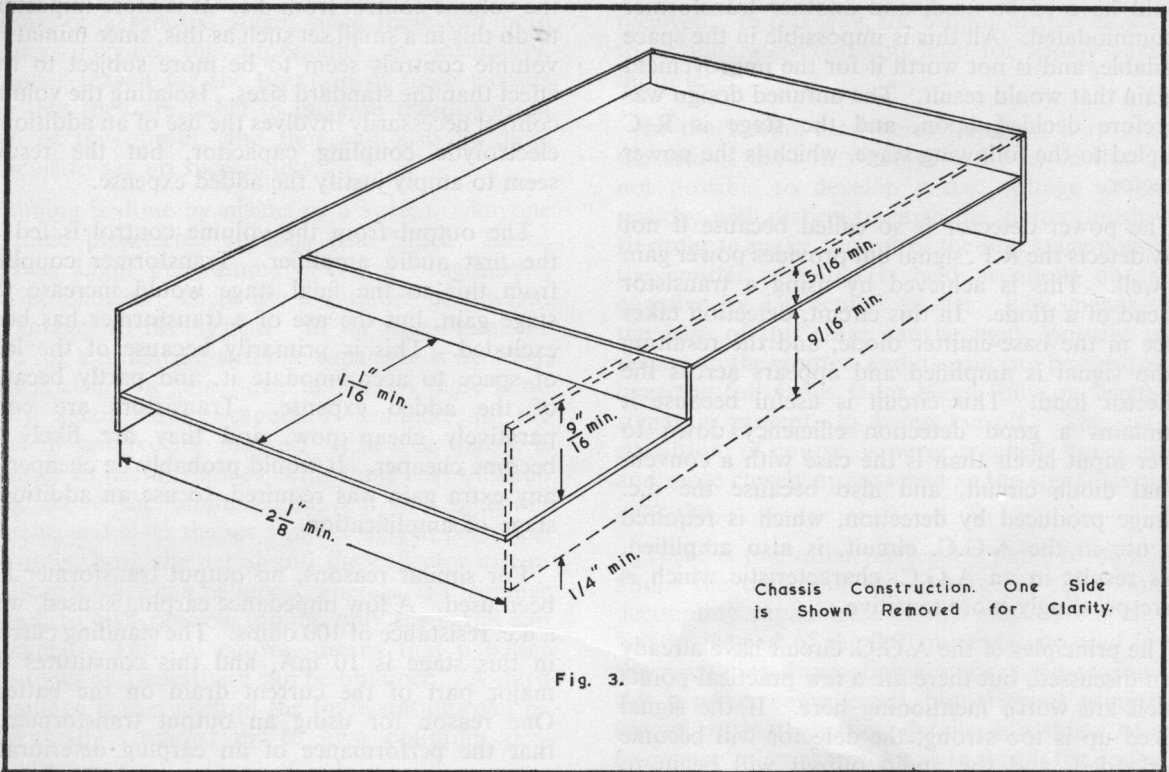

The most important consideration of all, of course, is to see that the finished chassis will fit well in the case. The clearance between the chassis and the case should be such as to allow the chassis to slide in and out without very much force being needed, but the fit must not be too loose, or the set will rattle within the case. If necessary, some small rubber pads may be used to make the housing of the chassis in the case more secure. These would be attached at suitable points to the sides of the chassis to bear lightly against the sides of the case.

The task of fitting the components into the chassis is much less precise. Care must be taken to ensure that there is sufficient room to take all the components in their correct places. It is also important to see that an adequate clearance is left between the set and the chassis when all the components (including the batteries) are in position on the chassis.

The case used in the set illustrated here was bought from Lewis's, the tobacconists, but a number of similar cases can be obtained from other manufacturers. The inside dimensions of these cases will, of course, vary slightly from one to the other.

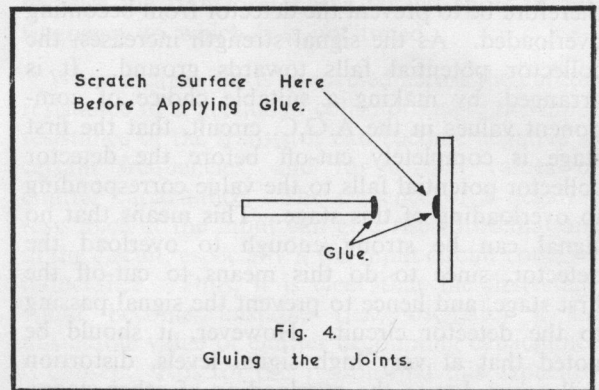

This means that it is not possible to give exact figures for the outside dimensions of the chassis. For this reason, no outside dimensions have been given, and it is left to the individual constructor to determine them for himself to suit the particular case that he buys. The dimensions chosen should be such as to make the chassis a snug fit in the case, as described above.

The dimension that will vary most from case to case is the length from the bottom of the case to the point where the lid opens. This length will

determine how long the chassis should be made, since the top of the chassis has to come flush with the top of the body of the case, when the lid is open.

Figure 3 shows the details of the construction of the chassis. It is made from pieces of bakelite, or similar material, and the pieces are glued together to form the finished chassis. Once the correct dimensions have been found, the individual pieces may be cut and filed down to size. When this has been done, a trial run without any glue should be made to see that the parts fit together correctly. The next step is to glue these pieces together. Although this is a comparatively simple job, it requires care and patience if a good job is to be made of it. In the finished chassis, the joints should be strong and firm, in order to take the strains that will be imposed on them later. The glueing too, should be done neatly, so that there are no blobs or smears of glue left on the chassis when it has been glued together. The type of glue used will probably depend on the type available, but it must be emphasised that a good strong glue must be used. In the set constructed by the author, Araldite was used, and this can be wholeheartedly recommended for this job. The Araldite was allowed to set in a warm oven overnight, and the resulting chassis was found to be extremely strong. It was subjected to a great deal of rough handling during the mounting of the other components, with holes being drilled, and slots filed out, but the joints showed no sign of giving at all.

It will be found that each joint consists of the edge of one piece of bakelite abutted onto the surface of another. The line along which the joint is to be made should be heavily scored to provide a rough surface for the glue to grip on. When all the surfaces have been prepared in this way, a thin line of glue should be applied to the two halves of each joint. This is illustrated in figure 4. When all the joints have been scored and prepared with glue, the chassis should be assembled, and the parts pressed firmly together. The tackiness of the glue will probably be enough to hold the separate pieces together sufficiently to simplify the assembly. An elastic band should be placed very carefully around the whole assembly, to hold it together while the glue sets. At this stage, before the glue has had time to set, any errors in the positioning of the separate pieces can be corrected. Some pieces might not be lying quite level, or they might be too high, or too low. If this is the case, they can now be carefully pushed into the correct position. While this is being done, the pressure

of the elastic band and the tackiness of the glue should be sufficient to prevent the assembly from collapsing. Finally, the chassis should be placed in a low oven, if the glue used sets better when heated, or put in some corner well out of the way, where it will not be disturbed, and allowed to set.

Most people realise that enough glue is essential if a strong job is to be made of a joint, but far fewer seem to realise the importance of not using too much. There are three main reasons why too much glue should not be used. Firstly, the more glue there is, the longer it will take to set properly, and it might never set really well in the centre. And, of course, if the joint is in the centre, it will never achieve its full strength. Secondly, the excess glue will tend to run down the side of the piece being glued, and if it should reach the support on which the article being glued is resting, the two might finish up firmly glued together. Thirdly, the appearance of the finished joint will obviously suffer, and this is important if any pride is to be taken in the finished piece of work.

Once the chassis has been completed, the mounting of the major components may be started. The positions in which they go are illustrated in figure 5, and the positions indicated in this diagram should be followed as closely as possible. The first components to be mounted are the trimmers. These should be carefully removed from the ceramic block on which they are supplied. If the fixing screw in the centre is removed, it should then be possible to remove both metal plates, and the mica sheet between them. All these separate parts should be retained, including the screw and washer, and the ceramic block discarded. The mica washer is fragile, and must of course be treated very carefully. They are also very easy to lose, as they are transparent and hard to locate, except in certain lights. For this reason, it is advisable to keep them all together in a small box, or something of that sort, until they are required.

If the trimmers are to work satisfactorily, the upper plate must be sprung in some way so that it tends to spring away from the lower one. Before discussing how this is achieved, it is necessary to describe the method of mounting the trimmers. This is done by drilling three small holes for each trimmer, one for the solder tag on each plate, and one between these two for the centre screw. The placing of these holes should become obvious from a study of the trimmers themselves, and is illustrated in figure 6. The tag on the upper plate always fits through the hole furthest from the centre line dividing the two rows of trimmers.

TRANSISTORISED POCKET RADIO

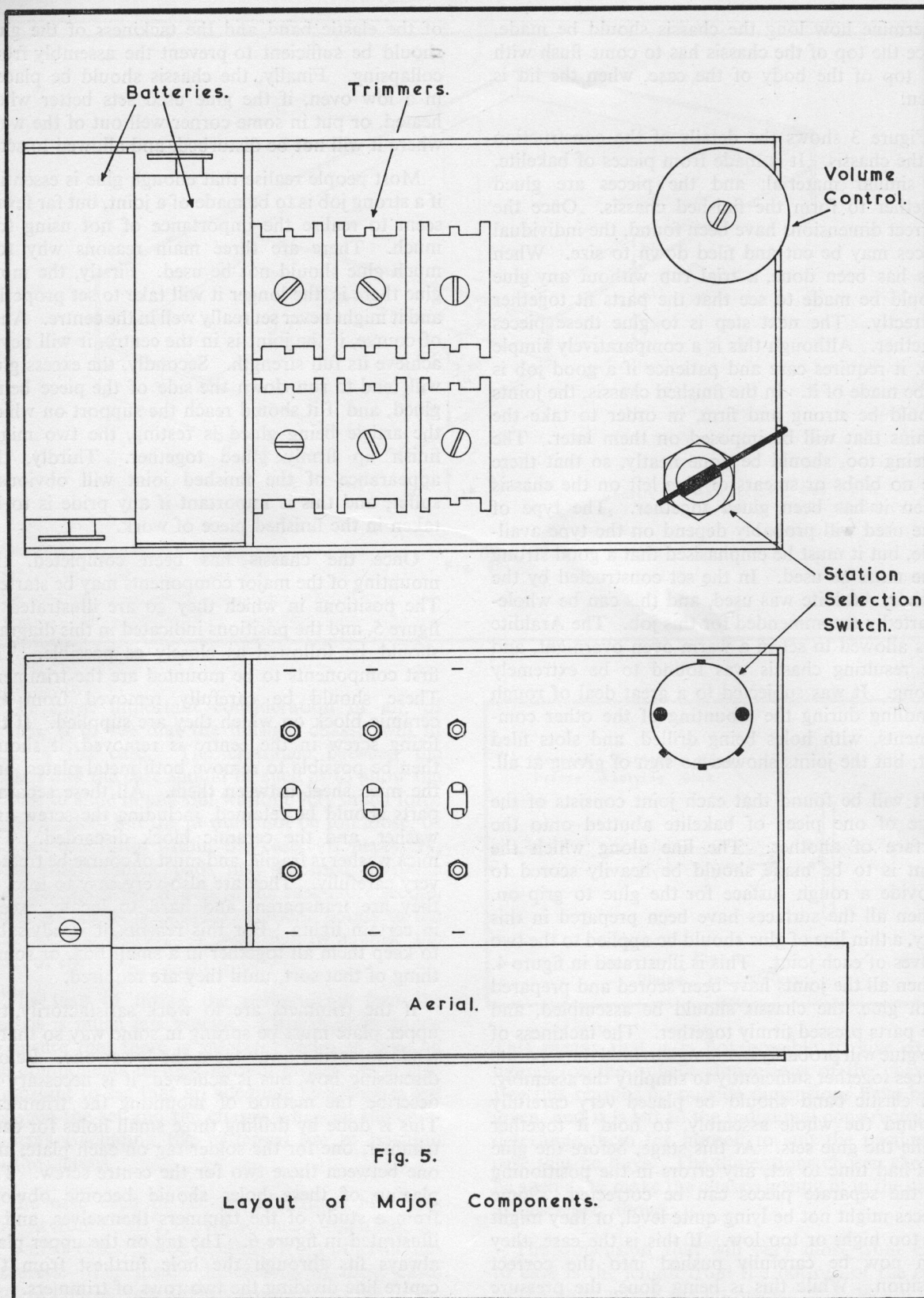
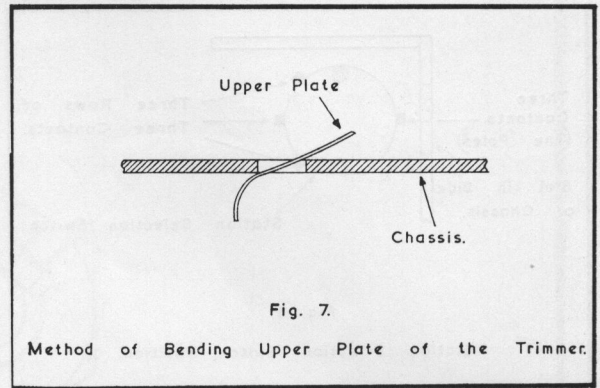
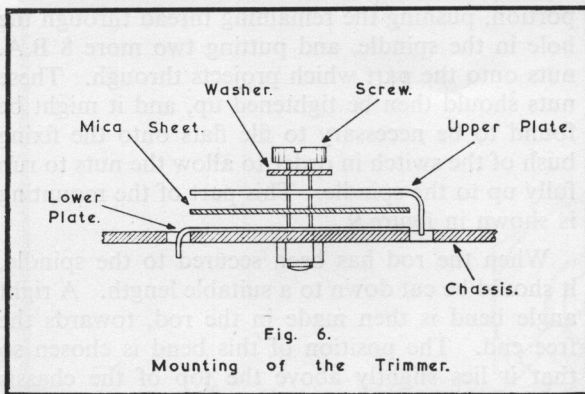

Fig. 5.  
Layout of Major Components.



The method of springing the upper plate from the lower is quite simple, and is shown in figure 7. The tag on the upper plate is bent to form a ledge which catches on the under side of the hole through which the tag passes. This provides the leverage with which the plate can be sprung. It should be held so that it lies above, and at an angle to, the mica sheet and lower plate. The adjusting screw can then be used to vary the distance between the two plates, and a wide range of capacitance can be covered.

The adjusting screw will, of course, require a nut on the other side of the chassis to hold it, and this nut should be firmly glued down to the chassis. When this is done, the screw will serve the secondary purpose of holding the whole trimmer assembly firmly in place. While the nut is being glued down, it is a good idea to bolt it in position. This will ensure that the nut is correctly positioned, and also that pressure is applied while the glue sets. Great care must be taken, however, to see that too much glue is not used, since the screw itself might become glued down, or the threads might become locked together.

Before leaving the trimmers, the solder tags should be cut short, so they project about  $\frac{1}{8}$ " through the chassis. Care must be taken to ensure that the upper and lower plates do not come into contact with one another. If any shorting does occur, then it should be easy to cure it by slightly shifting one or other of the plates. The trimmers should be checked for shorting, of course, over the whole range of their adjustment. In particular, shorting is most likely to occur with the screw down as tightly as it will go, although it is possible for the trimmer to operate correctly here, and yet to give trouble due to shorting at the other end of the range.

The switch should be mounted next. This is a three pole, three way switch. It will be seen from the circuit diagram that only two of the three poles are needed, and the third might seem to be superfluous. However, it can be made to serve a useful purpose. The switch used is one supplied by Ardente, and it was found that if two adjacent banks are used for switching the circuit, there is sufficient coupling between the two tuned circuits through the switch to cause instability. If the two outer banks are used, on the other hand, and the central bank is earthed to provide screening between the two sections, no trouble of this sort is met with.

Two bolts, diametrically opposite one another, pass through the body of the switch to hold the three sections onto the base. It might be found necessary to file these down slightly where they project beyond the end of the switch, in order to obtain the required clearance from the case.

The switch is not operated by a knob, for two reasons. The first is that there is not enough space to fit one, and the second is that in any case, if one was fitted, it would be very hard to turn the switch, when only a part of the edge is available at the outside of the case. The solution to this problem is found in the use of a small rod of silver steel, which is fitted at one end into the spindle of the switch, and is bent at the other to form a convenient handle for finger tip operation of the switch.

The switch should be switched into its middle position, and a hole should be drilled through the spindle as close to the mounting bush as possible, and the spindle cut off a little above the hole. Its size should be 8 B.A. clearance, and its axis should be in line with the diameter joining the two long bolts which hold the switch sections together.

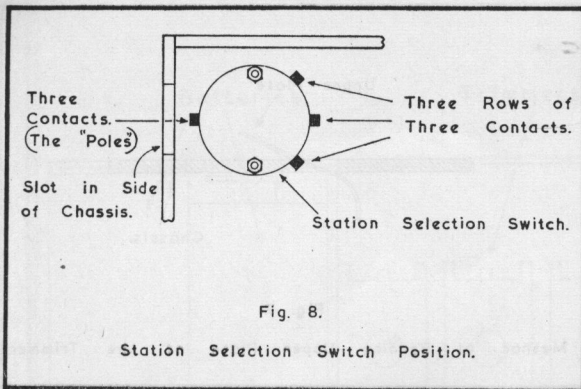

The silver steel rod should be prepared next. A rod of  $\frac{1}{16}$ " diameter is required, and an 8 B.A. thread should be put on one end for a length of about  $\frac{1}{4}$ " to  $\frac{3}{8}$ ". The threaded part of the rod should pass easily through the hole in the spindle of the switch. However, before the rod can be secured to the switch, the switch itself must be mounted on the chassis.

One hole must be drilled in the chassis to take the fixing bush, and another is needed for the locating pin. The diameter connecting the two bolts holding the sections of the switch together should be parallel with the long axis of the chassis, and the separate group of three contacts on the switch should be on the side closest to the side of the chassis. Unfortunately, the closeness of the side of the chassis to these contacts makes it impossible to solder wires to them when the circuit is being wired up. For this reason, it is necessary to file away part of the side of the chassis to allow access to these contacts to be made. In order to make this clearer, figure 8 shows the correct positioning of the switch on the chassis, and the slot filed in the chassis side.

Once the switch has been mounted, the fixing of the silver steel rod can be completed. In order to allow it to move back and forth when in position without jamming against the chassis, a slot of suitable length must be filed in the projecting lip of the chassis front to accommodate it. The length of the slot can be found by experiment: it must be such that when the rod is secured to the switch spindle, it is possible to put the switch into each of its three positions without the rod running against the end of the slot, but it should be very little longer than the minimum length required to achieve this.

The rod is secured to the switch spindle by running one 8 B.A. nut onto the end of the threaded

portion, pushing the remaining thread through the hole in the spindle, and putting two more 8 B.A. nuts onto the part which projects through. These nuts should then be tightened up, and it might be found to be necessary to file flats onto the fixing bush of the switch in order to allow the nuts to run fully up to the spindle. This part of the mounting is shown in figure 9.

When the rod has been secured to the spindle, it should be cut down to a suitable length. A right angle bend is then made in the rod, towards the free end. The position of this bend is chosen so that it lies slightly above the top of the chassis when the switch is in one of its extreme positions. There should be about  $\frac{1}{4}$ " of free rod beyond the bend, and this forms the handle by which the switch is operated. The complete mounting of the rod is shown in figure 10.

The next item to be fitted is the volume control. A number of views of the volume control mounting are shown in figure 11, and these should be studied carefully, and referred to while reading the following instructions.

First, another slot must be filed in the top of the chassis, in the same way that the slot for the switch handle was prepared. This slot is to allow the volume control to project out slightly beyond the top of the chassis, so that it may be operated easily with the finger tip. The length of the slot should be sufficient to allow the volume control to project through it by the required amount without catching against the sides of the slot, but it should only be very slightly longer than the minimum needed for this. Its depth should be just great enough to allow the top of the volume control to clear the case when the set is inserted into it. A small margin must be allowed here, as the head of the screw holding the volume control in place will also have to clear the case. The position in which the slot must be filed can easily be found from the component layout diagram in figure 5, which shows the required position of the volume control.

Before the volume control can be screwed down to the chassis, a small stand-off mount must be made for it. This is needed to raise it to the level of the slot prepared for it. The mount can be made of wood, an odd scrap of Perspex, or, in fact, any piece of material that can conveniently be filed down to the correct shape. The shaping of the mount is done as follows. First, the thickness should be made slightly greater than is needed, so that it can finally be filed down to the correct size when the volume control is ready for assembly.

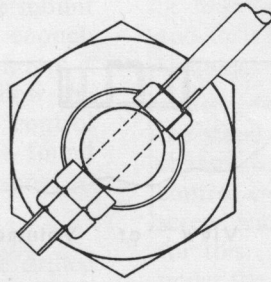
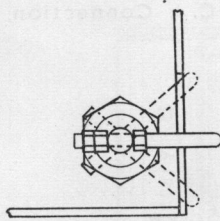
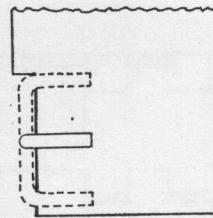

Fig. 9.

Mounting the Switch Lever on the Spindle.



Top View.



End View.

Fig. 10.

The Switch Lever Position.



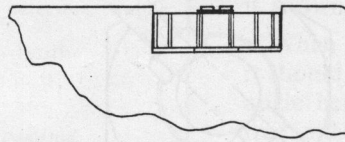

End View of Volume Control.

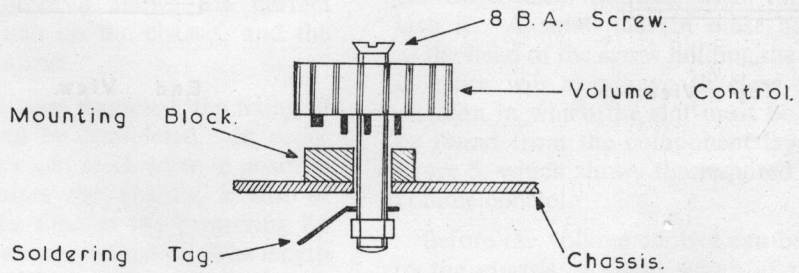
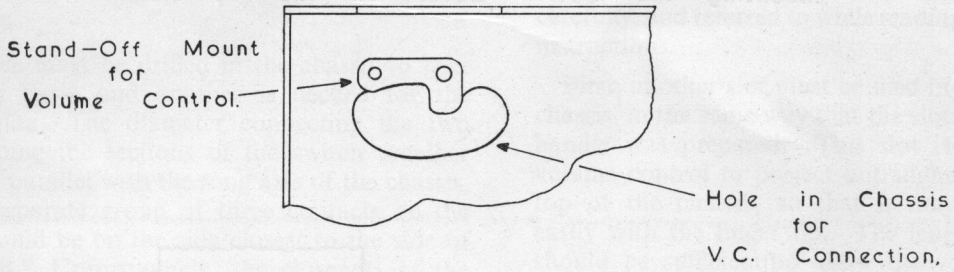

Fig. II.

Volume Control Assembly.

An 8 B.A. clearance hole must be drilled through the mount to take the volume control fixing screw. A second hole will also be needed to take the locating pin on the control. The spacing between these two holes can be found by examining the volume control itself. The shaping of the mount after this is not critical. It must be small enough not to reach the rim of the volume control, and it must be filed back round the holes to allow the four contacts on the under side of the control sufficient clearance from it. This will be found to be important at a later stage when it comes to making connections to these contacts.

An 8 B.A. clearance hole must now be drilled through the chassis to take the screw which holds the volume control in place. To locate the correct place for this hole, the control should be placed on the mount, and put in place on the chassis, so that it lies properly in the slot prepared for it. When it is in place, a needle or a similar sort of tool with a sharp point can be used to mark the chassis through the hole in the centre of the volume control. This mark will clearly indicate the point at which the hole in the chassis should be drilled. Behind this hole (i.e., on the side furthest from the front of the chassis), another, larger hole must be

made. This is to allow access to the volume control contacts to be made from the other side of the chassis. Its shape and size must therefore be made so that all four of the contacts can be reached easily through the chassis. It will probably be found easiest to drill out the bulk of this hole, and then to use a small needle file to do the final shaping.

Before finally mounting the volume control, the stand-off mount should be glued down to the chassis in the correct position. The volume control can then be fixed in position. An 8 B.A. screw with a countersunk head should be used for this. An 8 B.A. solder tag should be placed under the fixing nut on the under side of the chassis, and this forms the connection to the slider of the volume control.

The battery clips made by the author were made from beryllium copper strip. Any other metal which is reasonably springy could also be used, of course. The way in which the batteries lie is shown in figure 12. This figure also shows the way in which the clips are made and mounted. There are three clips in all. At one end, a single clip connects the positive end of the battery A to the negative end of battery B. At the other end,

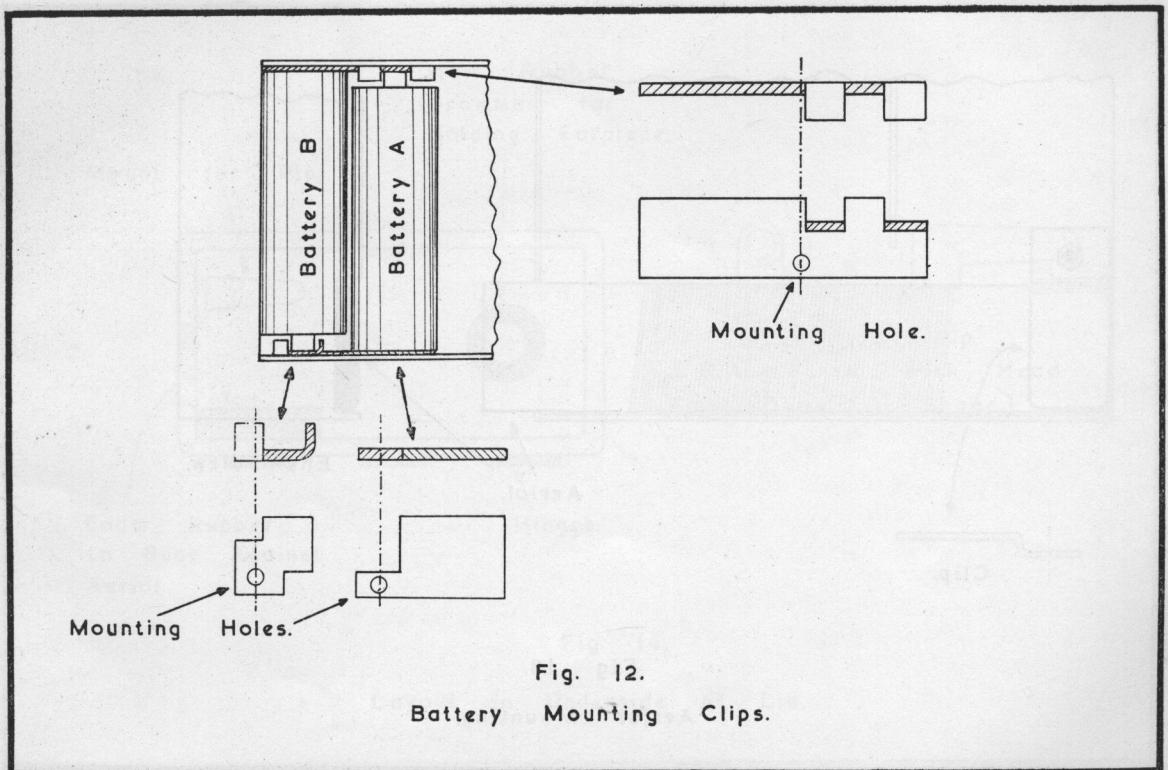

two clips are used, one for the negative end of A, and one for the positive end of B.

The first clip to be made should be the one joining the positive end of battery A to the negative end of battery B. The half of this clip which comes into contact with battery B is flat, and bent slightly away from the chassis so that it is sprung against the case of this battery. The other end of the clip is also bent out slightly to bear on battery A, but it is not flat. Two tabs must be cut in the metal and bent forward (as shown in figure 12). The distance between these tabs must be great enough to allow the positive cap on battery A to pass between them. When this is done, it will be impossible to connect the batteries in with the wrong polarity, so that there is no danger of damaging the circuit by applying a voltage of the wrong sense to it.

The clip is held in place with an 8 B.A. screw. The screw should have a countersunk head, and is mounted so that the head of the screw is flush with the outside surface of the chassis. The length of the screw must be cut down so that it does not project beyond the nut when it is fully tightened. This is done in order to prevent it obstructing the batteries. A further danger is that it might come

into contact with the case of battery A, and, since this would short this battery out, great care must be taken to see that this cannot happen. The screw is positioned slightly off-centre so that it lies under the tab which has been bent over nearest the centre. This is done to ensure that adequate clearance can be found between the batteries and the nut. When the clip has been finished, an 8 B.A. clearance hole should be drilled in the chassis to take the mounting screw, the outside of the hole should be countersunk, and the clip secured in place.

At the other end of the batteries, the negative end of battery A and the positive end of battery B have separate clips. The connections from these clips are taken into the set through two specially drilled holes in the chassis. The clip to receive the positive cap of battery B must have two tabs bent in it, as was done for the positive cap of battery A. The way in which this is done, and also the positioning of the fixing hole is shown in figure 12. The flat clip against which the case of battery A bears has a small projection on it through which the fixing hole is drilled. This is done to allow battery A to lie properly in place. Great care must again be taken to see that this fixing

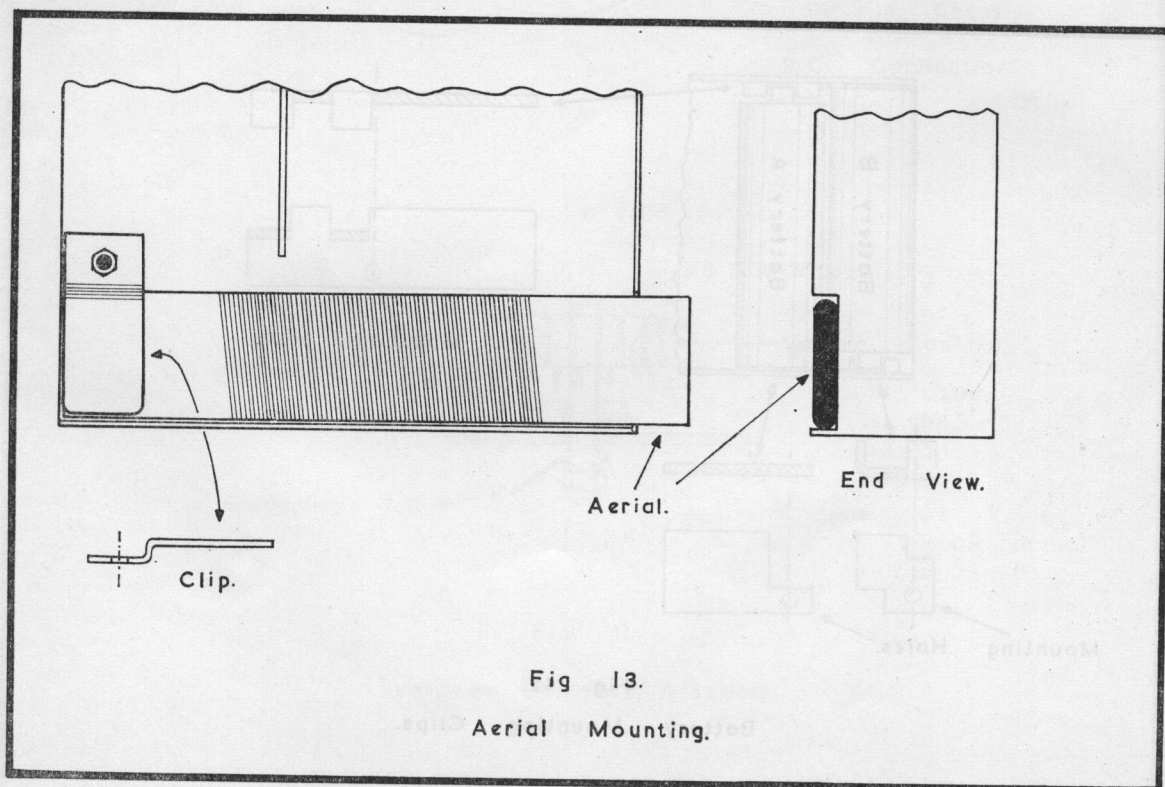

Fig 13.

Aerial Mounting.

screw does not come into contact with the case of battery B.

When these clips have been made, two fixing holes should be drilled in the chassis, and the countersunk on the outside. 8 B.A. countersunk screws are also used to fix these clips in position, and they should be cut short in the same way that the screw at the other end was. Two small holes must also be drilled, one beneath each clip, to allow the battery leads to be taken through to the rest of the set. When these leads come to be connected, they should be soldered onto the clips, and care must be taken to see that the solder does not interfere with the way in which the batteries lie.

After the clips have all been made and fitted in position, two batteries should be inserted. This is to see that they fit correctly, and that they are gripped firmly enough. It might be found to be necessary to adjust the way in which the clips are bent in order to improve their grip on the batteries. The spring action, for example, might tend to push the batteries out of the holder. If this is the case, then they must be bent slightly to ensure that they hold the batteries in properly.

If the clips have been made correctly, it should

now be possible to insert and remove the batteries very easily. In addition, when the batteries are in place, they should be held there quite firmly.

The last major component to be mounted is the aerial. This consists of primary and secondary coil windings, wound on a ferrite slab. It will probably be found easiest if the mounting is arranged with the slab alone, before the coils are put on. The aerial winding can then be done at a later date, and there is no danger of damaging the winding during the mounting.

As the aerial is longer than the chassis, it has to be allowed to project beyond the top. This means that a slot must be filed in the top to accommodate it. When this slot has been prepared, a clamp must be made to hold the aerial in position. This can be made from the same material as the battery clips, as it must be springy and firm. Figure 13 shows the mounting of the aerial, and the method of making the clip should be quite clear from the diagram. A 6 B.A. screw with a countersunk head is used for holding the clamp to the chassis. The hole through the chassis should also be countersunk on the side on which the batteries are fitted. When the screw is in place, its head should lie flush with

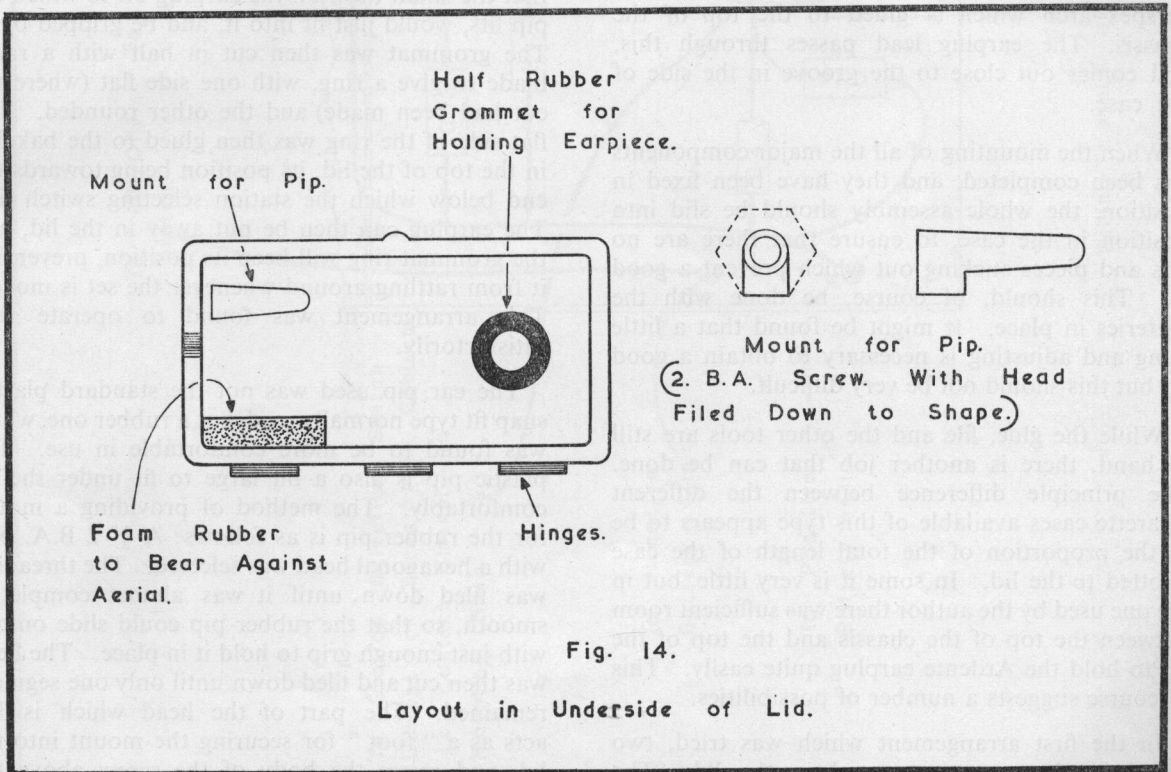

Fig. 14.

Layout in Underside of Lid.

this side, so that it does not obstruct the batteries. The screw itself should be cut short so that it does not project beyond the end of the nut.

There now remains only a few minor items to be tidied up, and the constructional side of the work is finished. A small hole should be drilled in the top of the chassis, centrally between the aerial and the volume control. This is for the earplug lead, and should be just large enough to allow it to pass through. To allow the lead to pass between the case and the lid when the lid is closed, two small grooves must be filed. One groove is in the case, and the other is in the lid, and is exactly opposite the one in the case. When this is done, a small hole should be formed when the lid is closed, and the lead can be brought out through this. The position of this hole, of course, should be in the centre of the side nearest the hole for the earplug lead in the chassis. It is worth preparing these two grooves properly, since it means that the lid can be closed while listening to the set, without any danger of damaging the earplug lead, or of putting too heavy a strain on the hinges of the case. The edges of each groove should be rounded off to avoid the danger of nipping the lead when the lid is closed. It might be thought to be an advantage to include a guide for the lead, as has been done in the set illustrated. This consists of a small perspex arch which is glued to the top of the chassis. The earplug lead passes through this, and comes out close to the groove in the side of the case.

When the mounting of all the major components has been completed, and they have been fixed in position, the whole assembly should be slid into position in the case, to ensure that there are no bits and pieces sticking out which prevent a good fit. This should, of course, be done with the batteries in place. It might be found that a little filing and adjusting is necessary to obtain a good fit, but this should not be very difficult.

While the glue, file and the other tools are still to hand, there is another job that can be done. The principle difference between the different cigarette cases available of this type appears to be in the proportion of the total length of the case allotted to the lid. In some it is very little, but in the one used by the author there was sufficient room between the top of the chassis and the top of the lid to hold the Ardente earplug quite easily. This of course suggests a number of possibilities.

In the first arrangement which was tried, two metal brackets were mounted in the lid. The

earplug lead could then be wound onto these, and sufficient room was left for the earplug itself to be stowed away also. When this was done, and the earplug and lead put in their places, there was nothing externally to show that this, in fact, was not just an ordinary cigarette case.

However, although it might be pleasant to surprise people in this way, it soon became clear that it was much too troublesome to have to wind the lead away every time the set was not in use. After a short time, the lead was simply wound round the outside of the case. When all is said and done, this set is designed to be used as a pocket radio, with as little fuss as possible—it is not intended as a novelty in which a cigarette case is suddenly shown to be a radio. However, the use, if any, that is made of the space in the lid is entirely a matter of personal choice.

The brackets were therefore removed. In their place, a piece of bakelite was inserted to cover the "floor" of the lid, and glued down.

On the Ardente earplug, the projecting pip which fits into the ear can be removed, and this, of course, has to be done before it can be stowed away in the lid. The pip can then be put in separately. A rubber grommat was chosen so that the small bush on the earplug on to which the pip fits, would just fit into it, and be gripped by it. The grommat was then cut in half with a razor blade to give a ring, with one side flat (where the cut had been made) and the other rounded. The flat side of the ring was then glued to the bakelite in the top of the lid, its position being towards the end below which the station selecting switch lies. The earplug can then be put away in the lid, and the grommat ring will keep its position, preventing it from rattling around whenever the set is moved. This arrangement was found to operate very satisfactorily.

The ear pip used was not the standard plastic, snap fit type normally used, but a rubber one, which was found to be more comfortable in use. The plastic pip is also a bit large to fit under the lid comfortably. The method of providing a mount for the rubber pip is as follows: A  $\frac{1}{2}$ " 2 B.A. bolt with a hexagonal head was selected. The threading was filed down until it was almost completely smooth, so that the rubber pip could slide onto it with just enough grip to hold it in place. The head was then cut and filed down until only one segment remained. The part of the head which is left acts as a "foot" for securing the mount into the lid, and raises the body of the screw above the

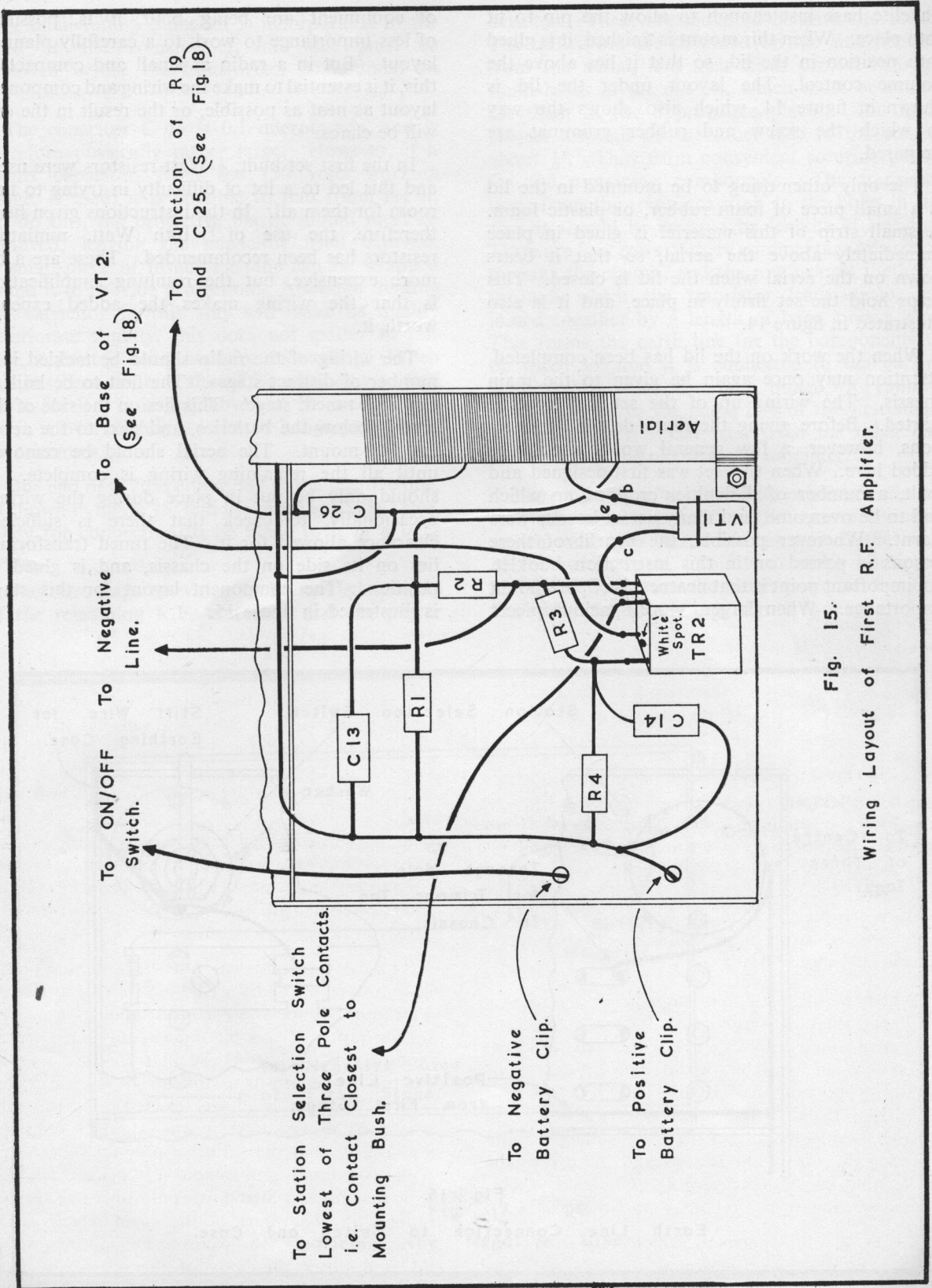

Fig. 15.  
Wiring Layout of First R.F. Amplifier.

bakelite base just enough to allow the pip to fit into place. When this mount is finished, it is glued into position in the lid, so that it lies above the volume control. The layout under the lid is shown in figure 14, which also shows the way in which the screw and rubber grommet are prepared.

The only other thing to be mounted in the lid is a small piece of foam rubber, or plastic foam. A small strip of this material is glued in place immediately above the aerial, so that it bears down on the aerial when the lid is closed. This helps hold the set firmly in place, and it is also illustrated in figure 14.

When the work on the lid has been completed, attention may once again be given to the main chassis. The wiring up of the set can now be started. Before giving the more detailed instructions, however, a few general words should be added here. When this set was first designed and built, a number of difficulties cropped up which had to be overcome, and many useful lessons were learnt. Wherever possible, the benefit of these lessons is passed on in this instruction booklet. An important point is that neatness is of paramount importance. When larger, more spacious pieces

of equipment are being built, it is, possibly, of less importance to work to a carefully planned layout. But in a radio as small and compact as this, it is essential to make the wiring and component layout as neat as possible, or the result in the end will be chaos.

In the first set built,  $\frac{1}{2}$  Watt resistors were used, and this led to a lot of difficulty in trying to find room for them all. In the instructions given here, therefore, the use of  $\frac{1}{10}$ th Watt, miniature resistors has been recommended. These are a bit more expensive, but the resulting simplification is that the wiring makes the added expense worth it.

The wiring of the radio should be tackled in a number of distinct stages. The first to be built is the first, tuned, stage. This lies on the side of the chassis below the batteries, and next to the aerial and its mount. The aerial should be removed until all the remaining wiring is complete. It should only be put in place during the wiring, occasionally, to check that there is sufficient clearance allowed for it. The tuned transformer lies on its side on the chassis, and is glued in position. The component layout for this stage is illustrated in figure 15.

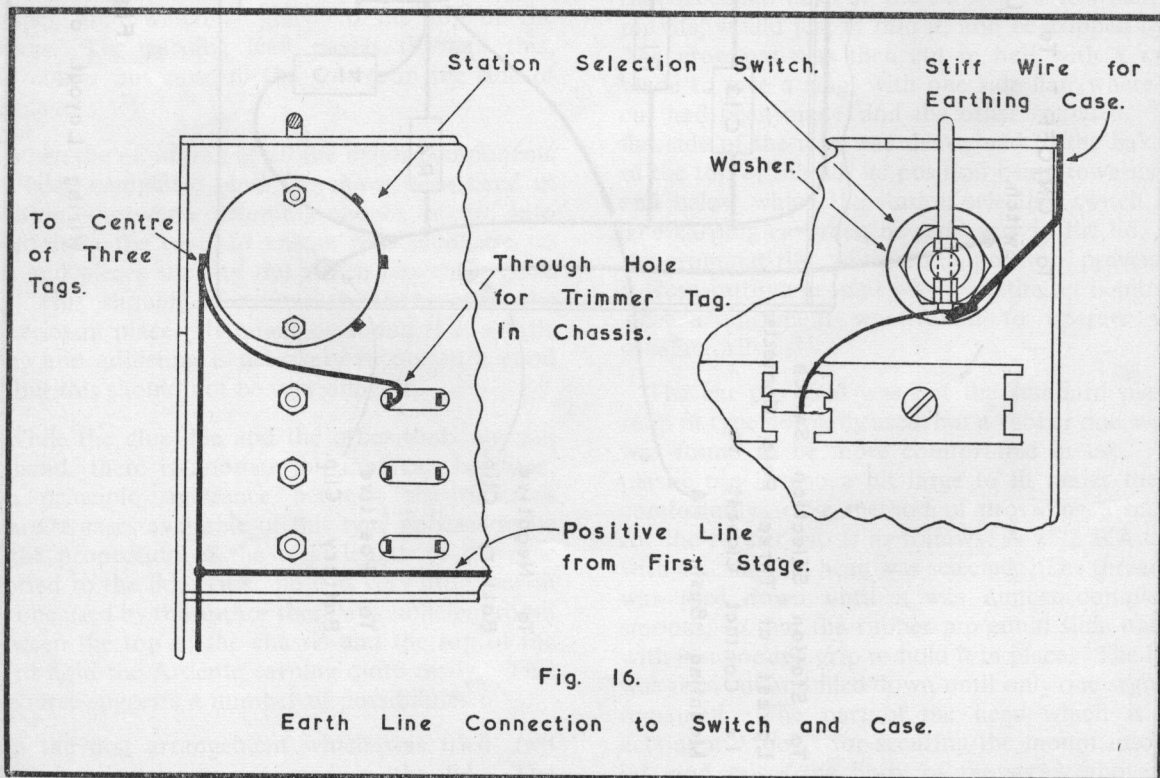

A small tuning capacitor is incorporated in the base of the transformer, and this must be removed before the transformer is mounted on the chassis.

The capacitor C 13 is 0.1 microfarads, and is therefore physically rather large. However, if a Hunts capacitor, from the 150 volts working range, is used, it is possible to find room for it. To do this, the protective plastic mould must be removed, leaving the capacitor itself exposed. A small piece of insulating tape can be wrapped round it to provide protection. Although treating the capacitor in this way will make its quality deteriorate slightly, this does not matter in this case, since it is being used for decoupling. When this has been done, it should be quite easy to find room for it. It might, however, be necessary to move it over slightly, so that it hangs partly over the trimmers.

One end of C 26 is connected to the positive line, as shown in figure 15, and the other end is left free, ready for connection to be made to it in a later stage.

The next stage of wiring to be tackled consists of the remaining R.F. amplifier, and the power

detector. These are mounted beneath the aerial. The transistors are mounted on the side furthest from the aerial, and their leads project through small holes in the chassis, which must be drilled for them in the appropriate places. The leads project through on the other side of the chassis about  $\frac{1}{8}$ ". They form convenient securing points for the remaining components. The transistor leads from the transistor itself to the holes in the chassis should be covered by lengths of sleeving. There are four rows of three trimmer tags projecting through the chassis, and the row nearest the holes through which the transistor leads come, are joined together by a length of bare, tinned wire. This forms the earth line for the components to be wired to, and it is connected to the battery positive through another bare, tinned wire running from one end to the earth line of the first stage. A connection is taken later from the other end for the earth line of the audio amplifier.

The centre tag of the three tags nearest the chassis wall (the switch poles) on the station selection switch must also be earthed, as well as the body of the switch itself. This is done by running a length of wire from the earth point of the first R.F. amplifier to this tag. From the tag, another

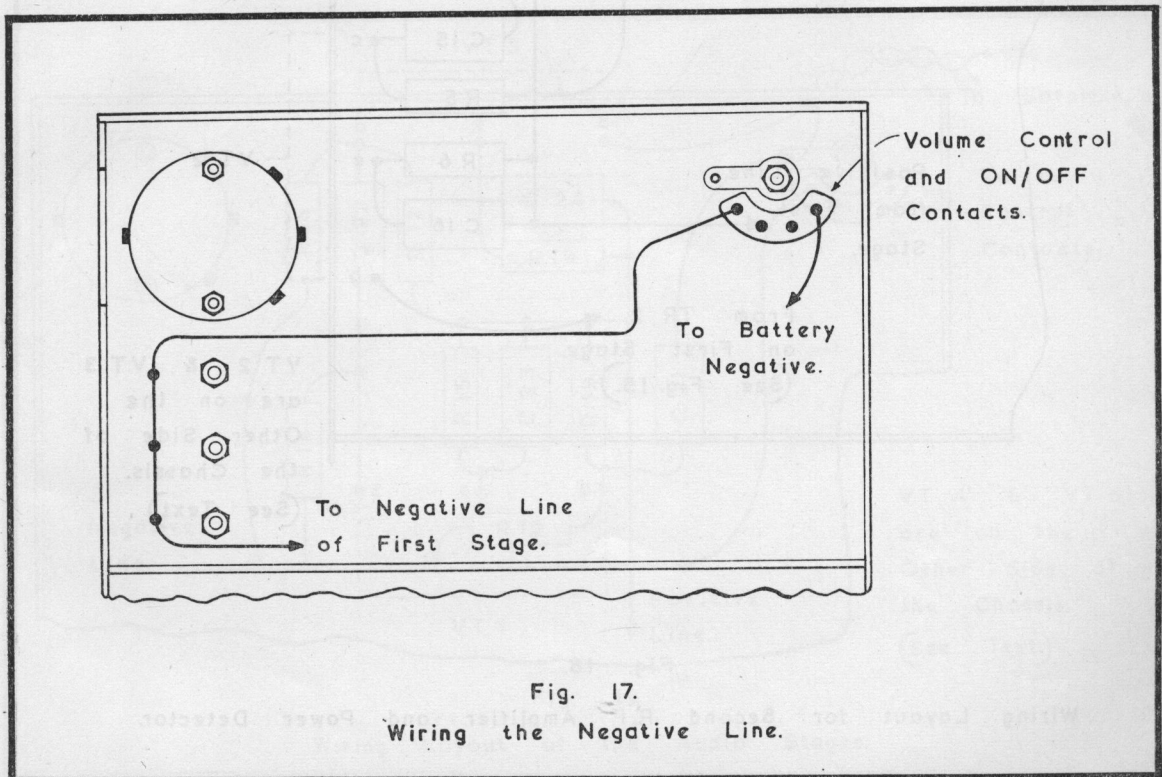

Fig. 17.

Wiring the Negative Line.



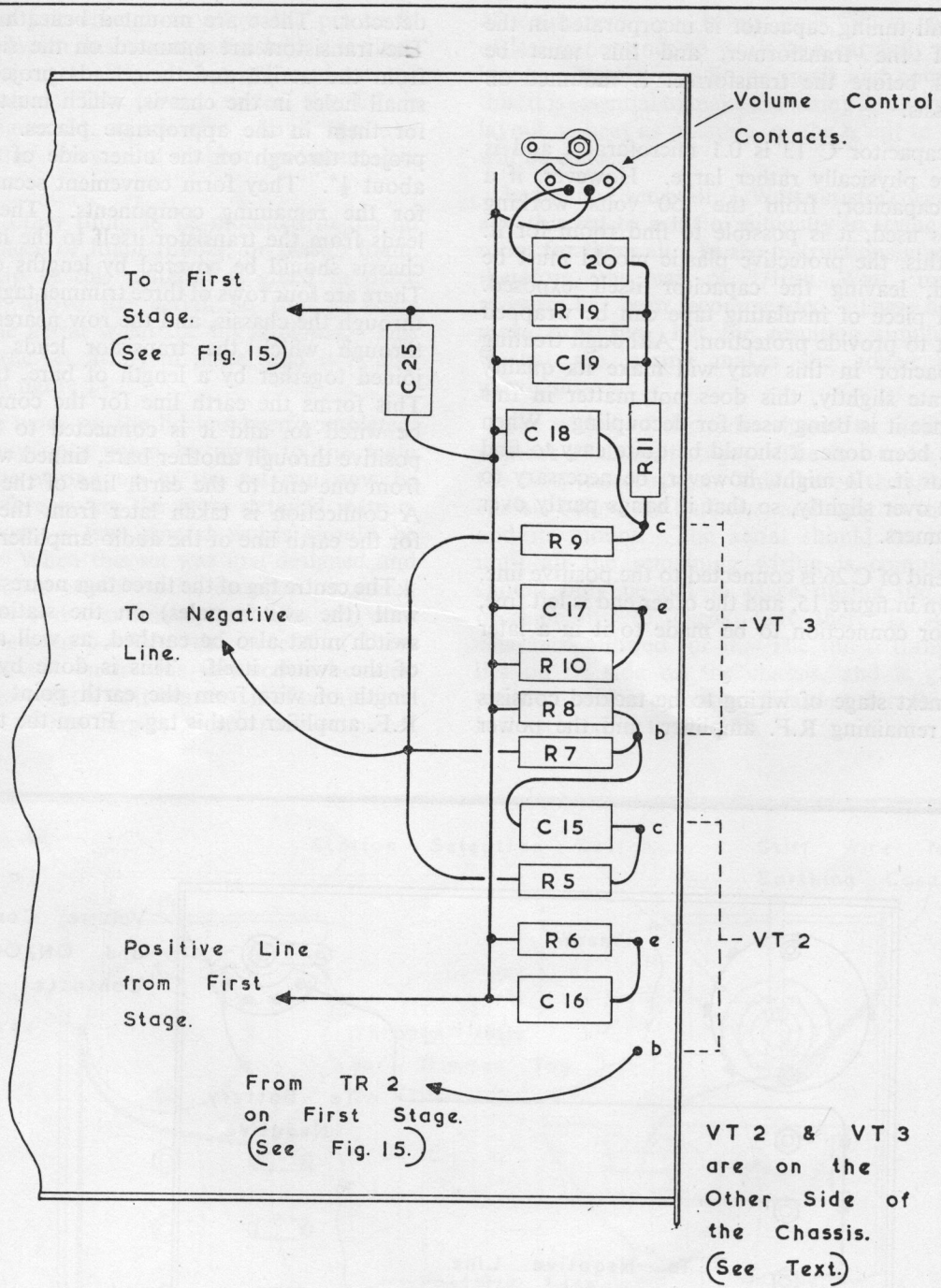

Fig. 18.

Wiring Layout for Second R.F. Amplifier and Power Detector.

wire is taken through the hole between the two nearest trimmers (i.e., the space between their two central tags) to the top of the chassis, where it is soldered to the washer beneath the securing nut of the switch. Also soldered to this point is a piece of stiff wire (part of a paper clip was used by the author). This runs along the side of the chassis to the top, where it is cut off flush with the top. The purpose of this is to make connection with the metal frame of the case, and hence earth it, when the set is put into place. It serves the additional purpose of helping to clip the set in position. The wiring of these earth wires, and also of the case earthing connection, is illustrated in figure 16.

In the first wiring stage, a connection was taken from the battery negative connection to one side of the on/off switch on the volume control. In the second, the battery negative line is completed from the other side of the switch. This is done as follows. The row of three trimmer tags furthest from the aerial are joined together by a length of bare, tinned wire. This wire then runs from the end nearest the station selection switch, across the chassis, and about  $\frac{1}{4}$ " above it, and is eventually connected to the free terminal of the

on/off switch on the volume control. A connection (shown in figure 15) is taken from the other end of the trimmer tags to the negative line connection of the first stage. The wiring of the negative line is shown in figure 17.

The component wiring layout of the second stage is shown in figure 18. It will be seen that there are three resistors which have to be connected to the negative line. These are connected together, and the common point is then connected by a short length of wire to the negative line. The components here are necessarily rather crowded, and some will have to be mounted on top of others if they are all to be fitted in. It is important, however, to ensure that adequate clearance for the aerial is left.

Next, the wiring from the station selection switch to the trimmers should be connected. There are two rows of three trimmer tags left unconnected. The row furthest from the aerial are connected first. They are wired to the bottom bank of three tags on the station selection switch (i.e., to the bank nearest the chassis). The trimmer tag in this row furthest from the switch is connected to the switch tag closest to the trimmers; the centre trimmer tag is connected to the centre

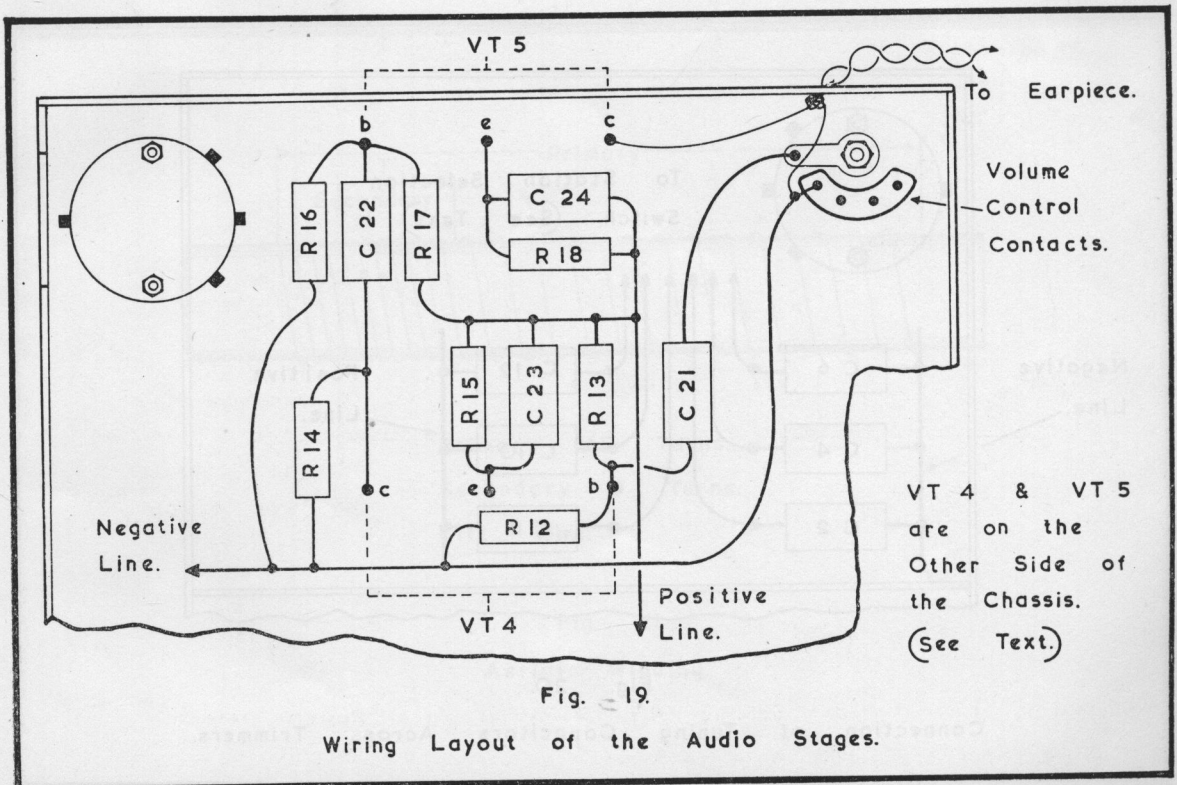

Fig. 19.

Wiring Layout of the Audio Stages.

switch tag, and the remaining trimmer tag is connected to the remaining switch tag.

The same procedure is followed with the remaining row of trimmer tags, but these are connected to the top bank of three contacts on the station selection switch (i.e., the bank furthest from the chassis). The central bank of tags on the switch is left unconnected.

The next stage to be wired in is the audio amplifier. The transistors are mounted on the same side of the chassis as the second R.F. amplifier and power detector. Their leads project about  $\frac{1}{8}$ " through holes drilled in the chassis, as was done before. The component layout of this stage is shown in figure 19. Before starting the wiring of this stage, the lead for the earplug should be threaded through the hole provided for it. A knot should be tied in the portion of the lead which has been threaded through, so that it cannot be drawn out again. Sufficient lead should be left beyond the knot to allow it to be wired into the circuit. The purpose of the knot is to prevent any pull on the earplug lead from outside being transmitted to the actual wiring.

When the audio stage has been completed, the

fixed tuning capacitors can be wired in. These are connected across the appropriate trimmers. Figure 20 shows this.

The final job to be tackled is the aerial. A primary winding of 145 turns is wound onto the ferrite slab so that it leaves about  $\frac{1}{2}$ " of clear ferrite at each end of the slab. The secondary consists of 9 turns wound on one end of the primary. The wire used for both windings should be litz wire. The winding of the aerial is illustrated in figure 21.

The aerial can now be mounted in position, and the primary and secondary leads cut down to a suitable length, and soldered into the circuit. The points at which they are connected is shown in figure 22.

The set is now almost finished. All that remains is to tune the three stations up properly. However, before this is done, some preliminary testing should be done. First, before the batteries are plugged in, and the set switched on, an ohmmeter (if available) should be connected across the positive and negative lines, to check that no short circuits have arisen accidentally during the wiring. The ohmmeter should read about 1 kilohm. The

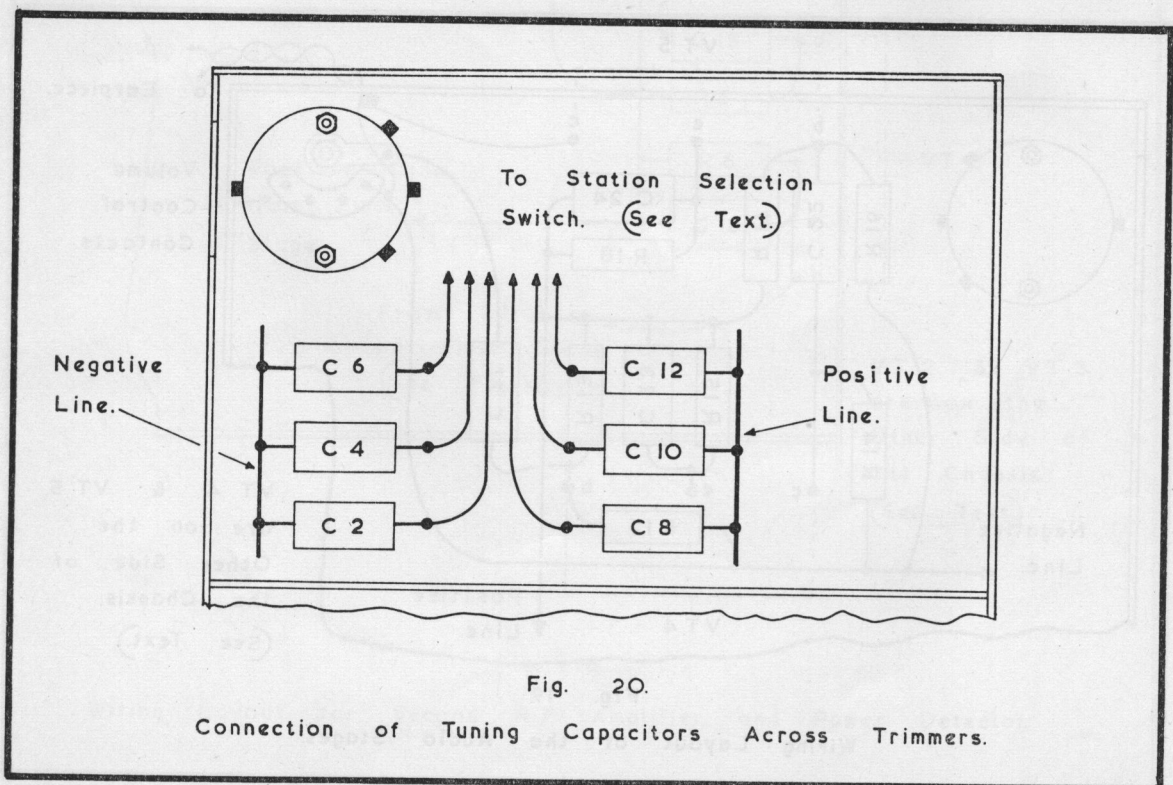

batteries can now be connected to the set, with an ammeter in series. When the set is switched on, the battery current should be about 15 mA. If these tests are satisfactory, then the batteries may be plugged in, and the set switched on. However, if a fault is found, the wiring should be traced out to see where the mistake has occurred, or whether a faulty component is to blame.

Assuming that all has gone well so far, the set should be switched on. It is possible that instability will occur, at least for certain adjustments of the trimmers. If this does happen it can almost certainly be cured by reversing the connection of the aerial secondary.

Before starting to tune up the three stations, an important factor must be taken into account. This is to do with the fact that most cases of the type used here have metal frameworks to strengthen them. The reaction of the framework with the aerial will, to some extent, affect the tuning of the aerial. In other words, a station which is perfectly tuned up before the set is placed in the case will be thrown out of tune when the chassis is placed in the case. This effect is most marked with the Light Programme on 200 kc/s. With the London Home Service, on 908 kc/s, the effect is almost

negligible. For this reason, it is best to start by tuning in the Light Programme, as the initial aerial tuning is achieved by removing turns from the aerial primary, with the aerial trimmer screwed half way down. Turns should be removed, one at a time, from the aerial primary winding, until the Light Programme volume with the set *in* the case is loudest. The station selection switch should, of course, be in the central position (since this is the Light Programme position) while these adjustments are being made. It should be found to be possible to tune the R.F. transformer to the Light Programme by means of the trimmer and tuning slug in the transformer. This can be done with the set outside the case, as the metal framework has very little effect on the transformer tuning (due to the good screening).

Once the correct number of turns on the aerial primary has been found, and the Light Programme is correctly tuned up, the remaining two stations can be tuned up. They are tuned entirely by means of their trimmers. First switch the station selection switch to the Third Programme position, and adjust both the trimmers to give maximum output, with the set outside the case. This will give a good idea of the volume of the programme

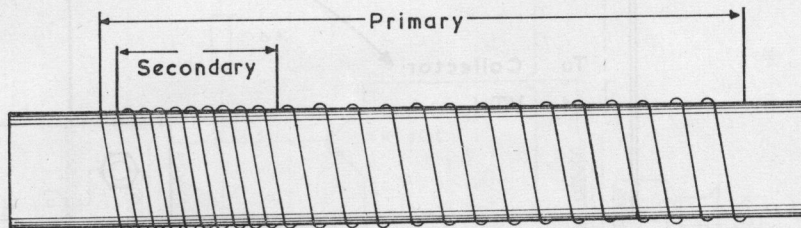

Primary 145 Turns.  
 Secondary 9 Turns.  
 Litz Wire.

Fig. 21.

Aerial Winding.

Top Tag  
(Furthest from  
Mounting) On  
Station Selection  
Switch.

See Fig. 15.---

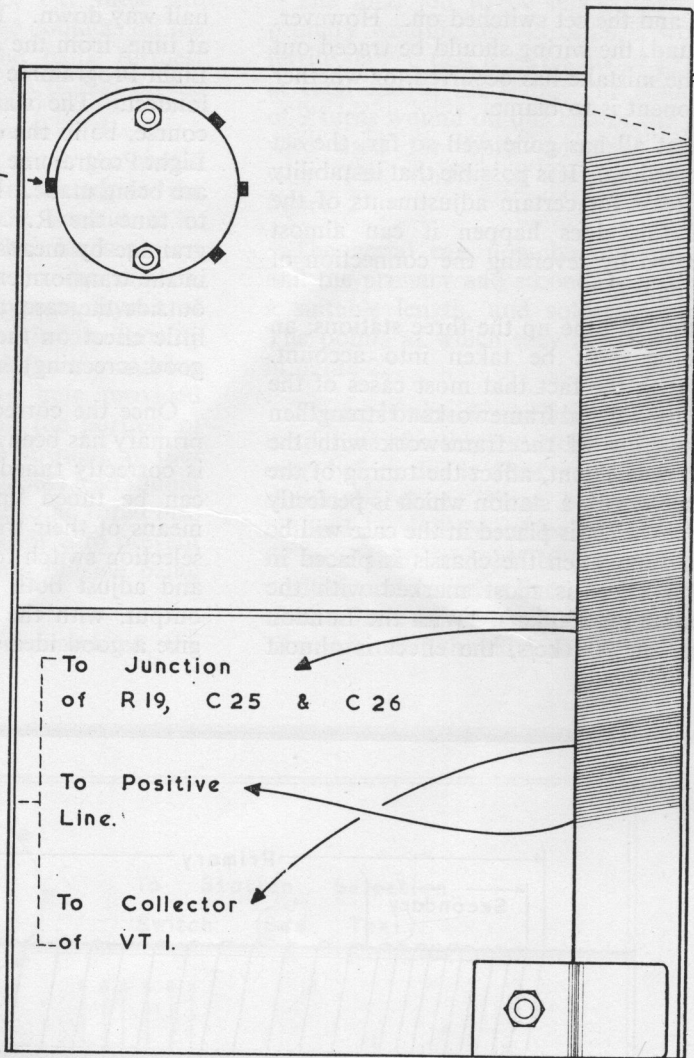

Fig. 22.

Connecting the Aerial into Circuit.

when it is correctly tuned in. Inserting the set in the case will probably reduce the volume slightly. However, if the aerial trimmer is screwed slightly further in, it will be found that the programme can be made to exactly tune in when the set is in the case. The amount of adjustment of the aerial trimmer that is necessary to achieve this can be found by experiment. Finally, the Home Service can be tuned in. As was stated above, putting the set in its case should have no noticeable effect on the tuning of this programme, once the set is fully in place. However, if trouble is experienced, exactly the same procedure that was followed with the Third Programme should be adopted here.

**Power output stage**

There are a number of occasions on which more than one person will want to listen to the radio, and, when these arise, it is useful to be able to hear the output from a loudspeaker. In order to achieve this, an additional power amplifier has to be built in order to provide an adequate drive to the loudspeaker.

The circuit of a suitable power output stage is shown in figure 23. It consists of a conventional

class-B push-pull output stage which is driven through the driver transformer from the output of the radio. The loudspeaker, batteries, and the circuit components should all be built into a suitable cabinet. The only control required is an on/off switch, and there should be a small socket mounted in one side so that the earpiece plug from the radio can be plugged into it, and hence connected to the primary of the driver transformer.

The author did not build up a complete unit, so that no constructional details are given. The circuit, however, has been built up in a lash-up form, and proved very satisfactory. Construction should not present any difficult problems. The layout is not of great importance, since only audio frequencies are being handled, and there should be ample space available for the components.

An extension loudspeaker cabinet would provide the most obvious choice of case for this unit. There is usually quite a lot of space which is not used in these cases, and this could be used to accommodate the battery and circuit components. A hole should be drilled in a suitable place to take the on/off switch, and the mounting of the socket for the earpiece plug from the radio arranged conveniently in the side of the case.

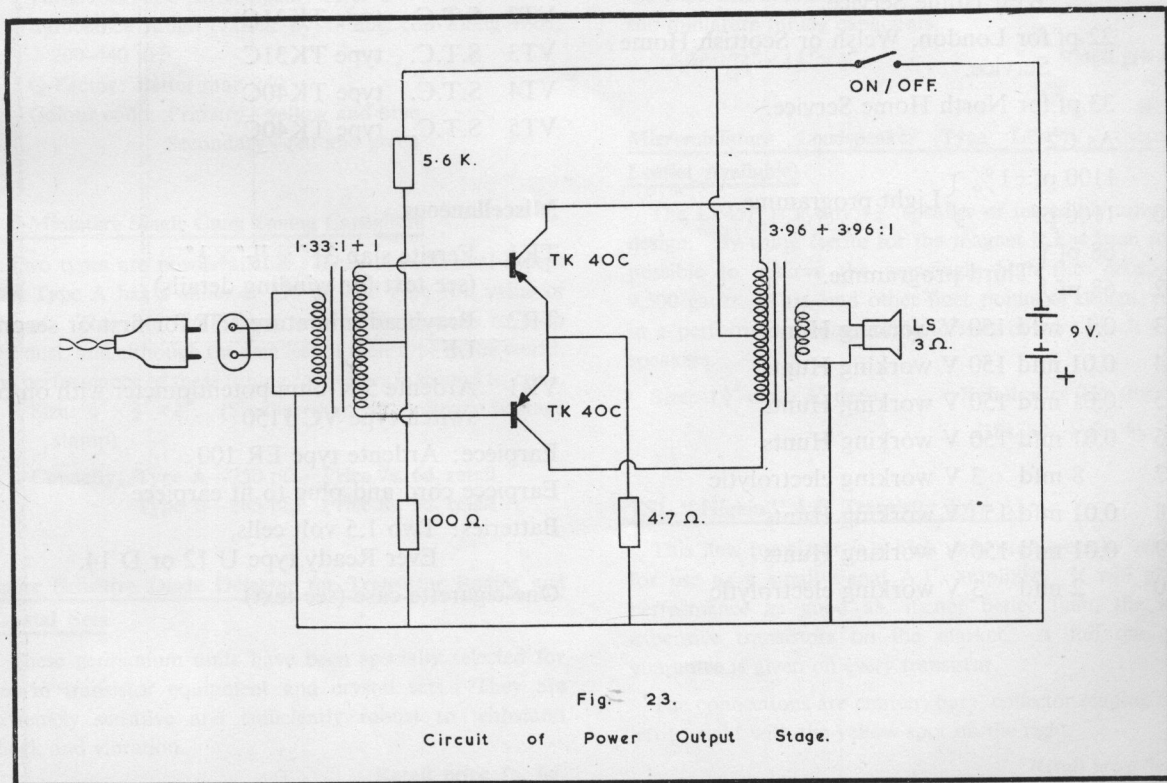

Fig. 23.

Circuit of Power Output Stage.

## PARTS LIST.

**Resistors.** (All resistors are 1/10th Watt.)

R1	1 K ohms	R11	1 K ohms
R2	22 K ohms	R12	18 K ohms
R3	18 K ohms	R13	4.7 K ohms
R4	47 K ohms	R14	2.2 K ohms
R5	2.2 K ohms	R15	1 K ohms
R6	1 K ohms	R16	2.2 K ohms
R7	27 K ohms	R17	1 K ohms
R8	1 K ohms	R18	100 K ohms
R9	4.7 K ohms	R19	8.2 K ohms
R10	100 K ohms		

**Capacitors.** 125V working polystyrene.

C2	15 pf for Northern Ireland, Midland or West Home Service.
	22 pf for London, Welsh or Scottish Home Service.
	33 pf for North Home Service.
C8	As C2
C4	1100 pf $\pm 1\%$ } Light programme.
C10	1100 pf } Light programme.
C6	68 pf } Third programme.
C12	68 pf } Third programme.
C13	0.1 mfd 150 V working Hunts
C14	0.01 mfd 150 V working Hunts
C15	0.01 mfd 150 V working Hunts
C16	0.01 mfd 150 V working Hunts
C17	8 mfd 3 V working electrolytic
C18	0.01 mfd 150 V working Hunts
C19	0.01 mfd 150 V working Hunts
C20	2 mfd 3 V working electrolytic

C21	2 mfd	3 V working electrolytic
C22	2 mfd	3 V working electrolytic
C23	2 mfd	3 V working electrolytic
C24	8 mfd	3 V working electrolytic
C25	2 mfd	3 V working electrolytic
C26	0.01 mfd	150 V working Hunts

**Trimmers.**

(C1, C3, C5, C9, C11.)

3 60+60 pf miniature trimmers  
(compression type)**Transistors.**

VT1	S.T.C.	type TK31C
VT2	S.T.C.	type TK31C
VT3	S.T.C.	type TK31C
VT4	S.T.C.	type TK40C
VT5	S.T.C.	type TK40C

**Miscellaneous.**

TR1	Ferrite slab $3\frac{1}{4}'' \times \frac{11}{16}'' \times \frac{1}{8}''$ (see text for winding details)
TR2	Brayhead miniature IFT for first or second I.F.
VR1	Ardente 5 K-ohm potentiometer with on/off switch type VC 1150
	Earpiece: Ardente type ER 100
	Earpiece cord and plug to fit earpiece
	Batteries: Two 1.5 volt cells, Ever Ready type U 12 or D 14.
	One cigarette case (see text)

## TSL SUB-MINIATURE COMPONENTS FOR THE HOME CONSTRUCTOR

Since the TSL range of sub-miniature components for the home constructor was first introduced we have had many requests for other types of components which were not readily available at the time. We are now able to fill in the gaps and present components which are vastly smaller than any others on the market.

### Sub-Miniature Ferrite Rod Aerial      Retail price 3s. 6d.

This unit has an overall size of only  $1\frac{3}{4}'' \times \frac{3}{4}'' \times \frac{1}{8}''$  yet by using a new type of ferrite of very high gain and first grade Litz wire sensitivity has been achieved which is as good as a normal 6" ferrite rod aerial. Thus, by using this rod, a pocket set can be made having the same sensitivity as a full size table radio. This aerial is ideal for use in any pocket or portable superhet, T.R.F. regen. or reflex circuit. Since the inductance is adjustable, it may be used with any tuning capacitor from 150 pf. to 500 pf. in value.

Size:  $1\frac{3}{4}'' \times \frac{3}{4}'' \times \frac{1}{8}''$

Turns ratio and current gain: 10 to 1

Inductance range (varied by sliding coil along rod):  
200-440 uH

Q-Factor: Better than 240

Colour code: Primary—yellow and blue  
Secondary—red and green

### Sub-Miniature Single Gang Tuning Capacitors

Two types are now available. They are identical except that Type A has a value of 250 pf. and type B a value of 365 pf. They are totally enclosed in plastic cases to keep out dust, and although the smallest of their type in the world, the performance of these tuning capacitors is second to none.

Size:  $\frac{3}{4}'' \times \frac{3}{4}'' \times \frac{3}{8}''$ . (Smaller than an ordinary postage stamp)

Capacity: Type A—250 pf.      Price 7s. 6d. retail

Type B—365 pf.      Price 8s. 9d. retail

### Super Sensitive Diode Detector for Transistor Radios and Crystal Sets

These germanium units have been specially selected for use in transistor equipment and crystal sets. They are extremely sensitive and sufficiently robust to withstand shock and vibration.

Retail price 1s. 6d.

### High Impedance Crystal Earpiece with Jack Plug and Socket

The performance of any receiver can be enhanced by use with one of these earpieces, the quality and sensitivity of which are vastly better than ordinary headphones. Because of their very small size and low weight they are convenient to carry and sufficiently comfortable to be worn for long periods. The earpiece lead is connected to a sub-miniature jack plug and a matching socket, with built-in switch, is included in the price.

Retail price 10s. 6d.

### Miniature Plastic Cases

One of the main difficulties involved in building sub-miniature receivers is the difficulty of obtaining a suitable and attractive case. We have now remedied this situation by making available a clear plastic box. This may be painted inside, in any colour or colours, to produce a durable and attractive finish. Holes may easily be drilled as required and the case will accommodate our new ferrite rod aerial and sub-miniature tuning capacitors.

Size:  $2\frac{1}{4}'' \times 1\frac{1}{2}'' \times \frac{7}{8}''$

Retail price 1s.

### Microminiature Loudspeaker Type LP45F. (Separate Leaflet Available)

The LP45F is a tiny  $1\frac{3}{4}''$  speaker of incredibly advanced design. By using ferrite for the magnet it has been found possible to achieve the amazingly high flux density of 9,500 gauss. This, and other finer points of design, result in a performance comparable to that of very much larger speakers.

Size:  $1\frac{3}{4}''$  dia.  $\times \frac{3}{4}''$  deep.

Retail price 25s. (inc. tax)

(18s. 8d. + 6s. 4d. P.T.)

### TSL "Highgain" A.F. Transistor Type A1

This new transistor is a high gain unit specially selected for use as a small signal A.F. amplifier. It will give a performance as good as, if not better than, the most expensive transistors on the market. A full one year guarantee is given on every transistor.

The connections are emitter, base, collector reading from left to right with the yellow spot on the right.

Retail price 3s. 6d.



FM TUNER. 312-0002

The electrical specifications of this tuner are shown below. A special point to be observed is that the oscillator frequency is above that of the incoming signal, and perfect AFC has been incorporated in the tuner itself. Mechanically this tuner can be supplied either with a reduction worm drive, for self tuning control, or with a cord drive and pulley for attaching to any suitable AM gang where a combined AM/FM receiver is required with only one tuning control.

FM TUNER. 312-0002

Dimensions (pulley drive model):	3.07" × 1.25" × 1.575"	
Dimensions (reduction worm drive model): (5 : 1)	3.95" × 1.25" × 1.575"	(1800° Shaft Rotation)
Transistors T1 and T2 supplied as part of this unit:	OC171's.	
Weight:	4.6 ozs.	
Tuning range (5½ turns):	87.5—108.5 Mc/s.	
Oscillator (frequency tuning range):	98.2—119.2 Mc/s.	
IF:	10.7 Mc/s.	
IF: bandwidth at 6 db down:	350 Kc/s.	
Antenna impedance:	60 ohms.	
IF output impedance:	400 ohms.	
Amplification:	better than 21 db.	
AGC voltage for a ration of 1:100:	1 Volt.	
Image rejection:	better than 30 db.	
IF-rejection (10pF in Antenna lead 1):	better than 60 db.	
Noise:	8 db.	Retail price: 92s. 6d., plus 31s. 3d. Purchase Tax, with pulley drive.
Oscillator voltage at Antenna Terminals:	less than 1 mV.	97s. 6d., plus 32s. 11d. Purchase Tax, with worm drive.
AFC range with ± 1 V AFC voltage:	± 400 Kc/s.	

IF-AMPLIFIER. 322-0002

This IF unit is mounted on a printed circuit board 2.17" by 4.53" long and .95" high. It has three IF stages and a symmetrical ratio detector tuned to 10.7 Mc/s. As illustrated in the diagram, transistor T.1. (OC170) controls the gain of the first IF stage and also functions as an AGC amplifier for the RF stage of FM tuner 312-0002. The voltage available at terminal 5 (IF strip) can be used for AFC and is applied to terminal 5 of the tuner (312-0002).

The range of the AFC, with a signal input of 10 microvolts is ±200 Kc/s, 100 microvolts ±400 Kc/s and above 1 millivolt ±500 Kc/s. An advantage of this wide range is that voltage variations (between 11 and 14 volts) in the power supply, for instance, the car battery, will be automatically compensated when the input signal level is over 50 microvolts.

The FM de-emphasis circuit has not been included in the IF amplifier, thus allowing the designer or user to select the de-emphasis resistor for matching the input stage of the audio amplifier. This method has the advantage of eliminating a double loss in amplification. (All measurements were made with a de-emphasis combination of 10 K-ohm and .005 microfarads and a 10 K-ohm volume control.)

FM-IF AMPLIFIER. 322-0002

Dimensions:	2" × 4.5" × 1"	Retail price: 126s.
Weight:	2.65 ozs.	
T1, T2, and T3 supplied as part of this unit:	OC170's.	
IF:	10.7 Mc/s.	
IF bandwidth at 6db down and 250 microvolts input:	200 Kc/s.	
IF bandwidth at 6 db down and 1 millivolt input:	320 Kc/s.	
Ratio detector with 0.6 volt on primary and ± 22.5 Kc/s frequency deviation.		
Peak distance:	250 Kc/s.	
DC voltage	3 volts.	
AF voltage on 10 K-ohms:	10 millivolts.	
AFC voltage:	±0.5 volt.	
Amplification 1st IF stage:	better than 20 db.	
Amplification 2nd IF stage:	better than 20 db.	

Minimum guaranteed performance standard for combined tuner (312-0002) + IF strip (322-0002)

1.5 Watt Transistor A.F. amplifier type 324-0004.

This 3 stage, push-pull A.F. amplifier was designed to operate from a 12 volt supply with the negative side of the battery at ground potential. It matches the FM tuner and IF amplifier just described and is particularly suited for use in record players, audio systems, intercoms, etc. Full output is available at up to 45°C.

Operating voltage:	12 volts.
Maximum output with 3 ohm speaker:	1.5 watts.
Maximum output with 5 ohm speaker:	1.2 watts.
Input voltage for 1.5 W output:	2 mV.
Input impedance:	2 K-ohm.
Frequency response ± 3 db:	200 c/s to 12 Kc/s.
Size:	2½ × 3 × 1½ ins.
Retail price:	97/6d.

Obtainable from all Radio dealers. In case of difficulty write to:—

**TECHNICAL SUPPLIERS LTD.**

HUDSON HOUSE, 63, GOLDHAWK ROAD, LONDON, W.12

Telephone: SHEpherds Bush 2581 and 4794

Telegrams—Home: Teknika London, W.12. Overseas: Teknika London.

# BERNARDS RADIO BOOKS

No.		Price
56.	Radio Aerial Handbook ... ..	2/6
57.	Ultra-Shortwave Handbook ... ..	2/6
58.	Radio Hints Manual ... ..	2/6
64.	Sound Equipment Manual ... ..	2/6
65.	Radio Designs Manual ... ..	2/6
68.	Frequency Modulation Receivers' Manual ... ..	2/6
73.	Radio Test Equipment Manual ... ..	2/6
83.	Radio Instruments and their Construction ... ..	2/6
86.	Midget Radio Construction ... ..	3/6
96.	Crystal Set Construction ... ..	1/-
99.	One Valve Receivers ... ..	1/6
100.	A Comprehensive Radio Valve Guide, Book 1 ... ..	5/-
101.	Two Valve Receivers ... ..	1/6
103.	"Radiofolder" A. The Master Colour Code Index for Radio and T.V. ... ..	1/-
104.	Three Valve Receivers... ..	1/6
106.	Radio Circuits Handbook, No. 4 ... ..	2/6
107.	Four Valve Circuits ... ..	1/6
121.	A Comprehensive Radio Valve Guide, Book 2 ... ..	5/-
123.	"Radiofolder" F. The Beginners' Push-Pull Amplifier ... ..	1/6
126.	Boys' Book of Crystal Sets and Simple Circuits ... ..	2/6
127.	Wireless Amplifier Manual, No. 3 ... ..	3/6
129.	Universal Gram. Speed Indicator ... ..	1/-
132.	Reactance-Frequency Chart for Designers and Constructors ... ..	1/6
135.	All Dry Battery Portable Construction ... ..	2/6
138.	How to Make F.M. and T.V. Aerials, Bands 1, 2 and 3 ... ..	2/6
140.	T.V. Servicing for Beginners ... ..	4/6
141.	Radio Servicing for Amateurs ... ..	3/6
142.	Modern T.V. Circuits and General Faultfinding Guide ... ..	4/6
143.	A Comprehensive Radio Valve Guide, Book 3 ... ..	5/-
145.	Handbook of AM/FM Circuits and Components ... ..	2/-
146.	High Fidelity Loudspeaker Enclosures ... ..	5/-
147.	Practical Tape Recording Handbook ... ..	5/-
148.	Practical Transistor Receivers, Book 1 ... ..	5/-
149.	Practical Stereo Handbook ... ..	3/6
150.	Practical Radio Inside Out ... ..	3/6
151.	Transistor Superhet Receivers ... ..	7/6
152.	Transistorised Car Radio ... ..	2/-
155.	Portable Transistor Radio and Radiogram ... ..	2/6
156.	Transistor Circuits Manual, No. 1 ... ..	2/6
157.	A Comprehensive Radio Valve Guide, Book 4 ... ..	5/-
158.	Radio, Television, Industrial Tubes and Semi-conductor Equivalentents Handbook (208 pages) ... ..	9/6
159.	Realistic High Fidelity ... ..	5/-
160.	Coil Design and Construction Manual ... ..	5/-
161.	Radio, Television and Electronics Data Manual ... ..	3/6
162.	High Fidelity Stereo Gramophone ... ..	5/-
163.	Transistor Circuits Manual, No. 2 ... ..	2/6
164.	High Fidelity Tape Recorder for the Home Constructor ... ..	2/6
165.	Hartley on Hi-Fi, Book 1. Radio Tuners ... ..	5/-
166.	Public Address Systems ... ..	2/6
167.	Transistor Circuits Manual, No. 3 ... ..	2/6
168.	Transistor Circuits Manual, No. 4 ... ..	2/6
169.	Hi-Fi Transistor F.M. Tuner for the Home Constructor ... ..	3/6
170.	Transistor Circuits for Radio Controlled Models ... ..	7/6
171.	Super Sensitive Transistorised Pocket Set Construction ... ..	3/6
	Resistor Colour Code Disc Calculator ... ..	1/6
	Engineers' Reference Tables ... ..	1/6
	International Radio Tube Encyclopaedia—3rd Edition ... ..	63/-