

Popular Electronic Circuits Book 1

R. A. PENFOLD

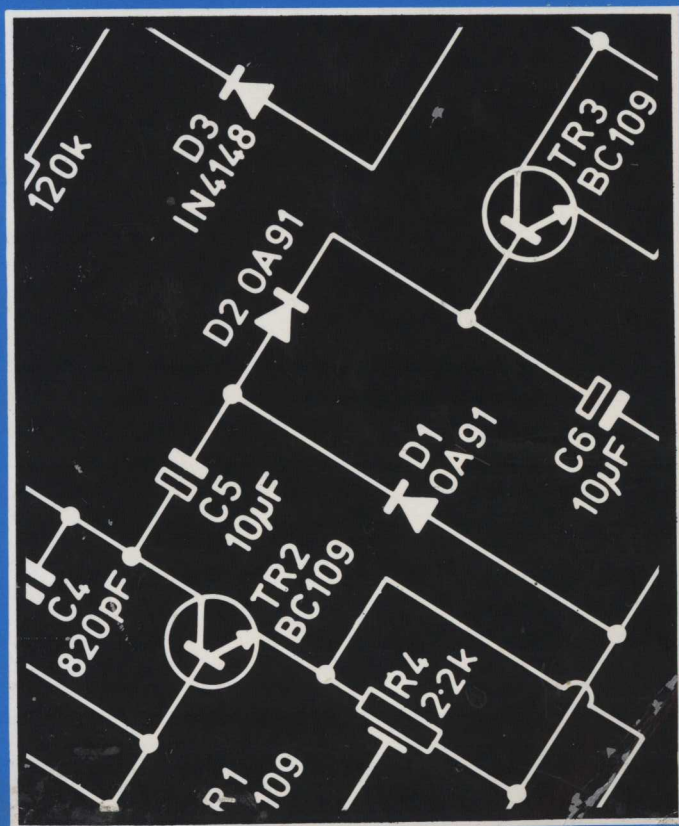

ALSO AVAILABLE

- BP98 Popular Electronic Circuits – Book 2
BP117 Practical Electronic Building Blocks – Book 1
BP118 Practical Electronic Building Blocks – Book 2
BP127 How to Design Electronic Projects

**POPULAR ELECTRONIC CIRCUITS
BOOK 1**

by
R.A. PENFOLD

**BERNARD BABANI (publishing) LTD
THE GRAMPIANS
SHEPHERDS BUSH ROAD
LONDON W6 7NF
ENGLAND**

PLEASE NOTE

Although every care has been taken with the production of this book to ensure that any projects, designs, modifications and/or programs etc. contained herein, operate in a correct and safe manner and also that any components specified are normally available in Great Britain, the Publishers do not accept responsibility in any way for the failure, including fault in design, of any project, design, modification or program to work correctly or to cause damage to any other equipment that it may be connected to or used in conjunction with, or in respect of any other damage or injury that may be so caused, nor do the Publishers accept responsibility in any way for the failure to obtain specified components.

Notice is also given that if equipment that is still under warranty is modified in any way or used or connected with home-built equipment then that warranty may be void.

© 1980 BERNARD BABANI (publishing) LTD

First Published – November 1980

Reprinted – January 1988

Reprinted – February 1990

British Library Cataloguing in Publication Data
Penfold, R.A.

Popular electronic circuits.

Book 1

1. Electronic circuits.

I. Title

621.3815'3 TK9965

ISBN 0 85934 055 4

PREFACE

This book is primarily intended for those who have had some experience of electronic construction, and are capable of building projects working from just a circuit diagram, and without the aid of any constructional information. Most of the seventy three circuits featured are fairly simple and straight forward designs though, and should not be beyond the capabilities of constructors who have limited experience. The circuits cover a wide range of subjects, including audio, radio, test gear, musical effects, household gadgets, etc. There should therefore be a number of circuits of use and interest to most electronics enthusiasts. The circuits are all based on modern and readily available components, and in general are quite inexpensive to construct. Most of the circuits are for devices that, when completed, will form projects in their own right. However, some are really intended as electronic building blocks for use in a larger project or system, and a few fall into both these categories. Where relevant, any special setting up procedures are described.

CONTENTS

	Page
CHAPTER 1. AUDIO CIRCUITS	
50k Mic. Preamp	1
Low Z Mic. Preamp	3
General Purpose Preamplifier	5
High Z Buffer	7
Headphone Adaptor	9
Ambiphonic Adaptor	11
Bench Amplifier	13
Miniature Power Amplifier	15
Simple Mixer	15
Class A Amplifier	19
Headphone Amplifier	21
Peak Level Indicator	23
4½ Watt Amplifier	25
Tone Controls	27
CHAPTER 2. RADIO CIRCUITS	
M.W. Crystal Set	29
M.W. Radio	30
Loudspeaker Version	32
Simple S.W. Radio	34
Preselector	36
Noise Limiter	38
B.F.O.	41
Notch Filter	43
A.T.U.	45
Crystal Calibrator	47
R.F. Probe	49
C.W. Filter	51
CHAPTER 3. TEST GEAR CIRCUITS	
Wideband Preamplifier	55
A.F. Signal Source	57
Continuity Tester	59
Transistor Checker	61
High Impedance Voltmeter	63
Current Meter	65
Audio Millivoltmeter	67
I.F. Alignment Generator	69
X10 Amplifier	71
Bench Supply	73
Logic Probe	75
Add-On Current Limiter	76

AUDIO CIRCUITS

50k Mic. Preamp.

Problems can sometimes arise if one tries to use a microphone with a hi-fi amplifier, or with some mixers, and certain other items of equipment. Microphones give only a low output level, and few pieces of audio equipment have a suitably sensitive input. Most hi-fi amplifiers have an input for a magnetic pick-up, and this may at first seem to have the appropriate input impedance and sensitivity figures to operate well if fed with the output from a high impedance dynamic microphone. However, such inputs are in fact unsuitable due to the inclusion of equalisation in the preamplifier circuit. This would give excessive bass and little treble on the output signal.

The preamplifier circuit shown in Figure 1 can be used to boost the output signal from a high impedance dynamic microphone from about 2mV. R.M.S. to around 500mV. R.M.S. This gives a signal of sufficient amplitude to feed a high level input (Aux., tuner, etc.) on the amplifier, mixer, or whatever. The circuit is also suitable for electret microphones which have an integral step-up transformer.

Tr1 is a JFET which is used in the common source mode. R1 is the gate bias resistor, and as a JFET has an extremely high input impedance (about 1,000 megohms), this also sets the input impedance at the required level. No input D.C. blocking capacitor is needed as the voltage developed across R1 is far too small to be of significance. C5 couples the output from Tr1 to the microphone level control, VR1. C3 couples the output from the slider of VR1 to the input of a common emitter amplifier which utilises Tr2. As Tr1 provides a voltage gain of about ten times or so, Tr2 only needs to give a voltage gain of about twenty times in order to give the required output level. R6 is therefore used to introduce local negative feedback which reduces Tr2's voltage gain to a suitable level. C4 rolls

	Page
CHAPTER 4. MUSIC PROJECTS	
Automatic Fader	79
Tremolo Unit	81
Treble Booster	83
Fuzz Unit	83
A.F. Noise Source	87
Metronome	89
Tuning Reference	91
Simple Organ	93
Audio Modulator	95
CHAPTER 5. HOUSEHOLD PROJECTS	
Doorbuzzer	97
Lamp Dimmer	97
Christmas Tree Lights Flasher	101
Water Activated Switch	103
Simple Burglar Alarm	105
Alarm Generator	107
Simple Timer	109
Telephone Amplifier	111
Telephone Repeater	113
Slide Timer	115
Reaction Game	117
Bent Wire Game	121
CHAPTER 6. MISCELLANEOUS CIRCUITS	
Touch Switch	123
Torch Finder	125
Morse Practice Oscillator	126
Sound Activated Switch	128
Sound Triggered Flash	130
Light Activated Switch	133
Alternative Version	135
Car Cassette Supply	136
Battery Eliminator	138
Flat Battery Indicator	139
Over-Voltage Cutout	140
Under-Voltage Cutout	143
L.E.D. Pendant	143
Rapid Ni-Cad Charger	145
COMPONENTS.	149

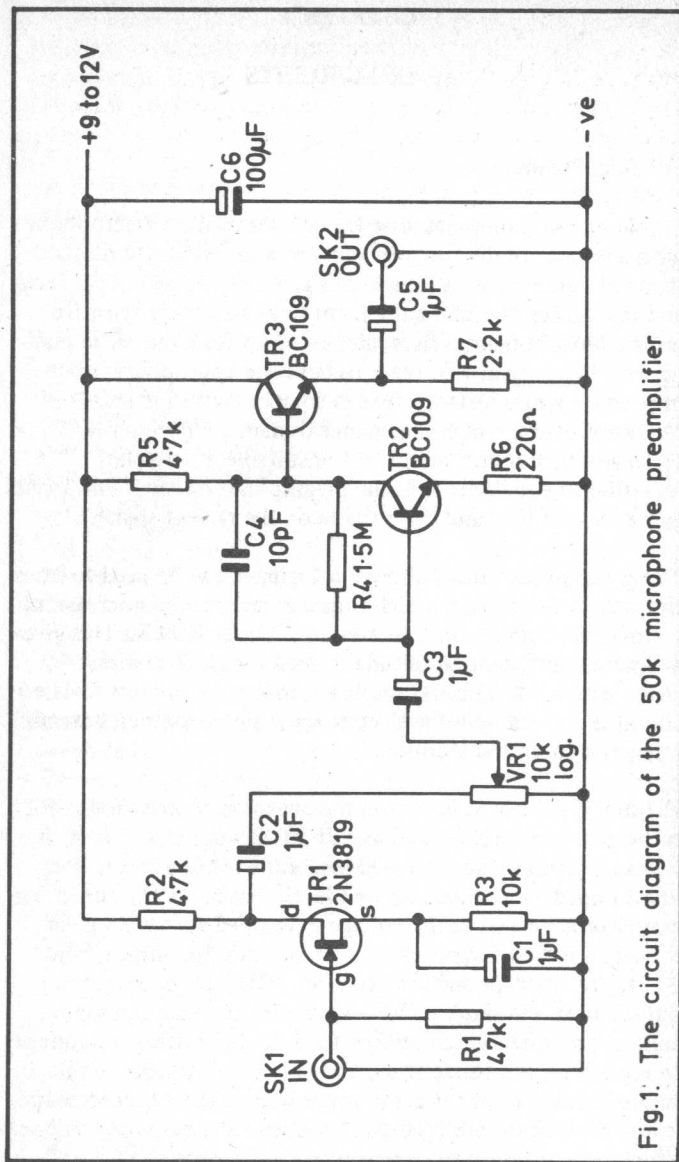

Fig.1: The circuit diagram of the 50k microphone preamplifier

off the high frequency response of the circuit so as to reduce the risk of instability or problems of radio interference breaking through to the output. Tr3 is an emitter follower buffer stage which gives the circuit a low output impedance. C5 is the output D.C. blocking capacitor.

The current consumption of the circuit is approximately 3.5mA, The unweighted signal to noise ratio (relative to an output of 500mV. R.M.S.) is better than -60dB.

Low Z Mic. Preamp.

The circuit described above is, of course, only suitable for use with high impedance microphones, and provides insufficient gain for use with low impedance types. These usually provide an output signal level of about 0.2mV. R.M.S., which is about one tenth of that generated by a high impedance microphone. The circuit diagram of Figure 2 is for a preamplifier that can be employed with low impedance microphones, and should give an output signal of around 500mV. R.M.S. The prototype was found to work well with both 200 ohm (cassette type) and 600 ohm impedance dynamic microphones, but it should also work well with electret types which have a built-in FET buffer amplifier, but no step-up transformer. The unweighted noise performance of this circuit is not quite as good as that of the previous circuit, but is still about -60dB referred to 500mV. R.M.S.

This circuit is really an adaptation of the previous one. The FET input stage uses the common gate mode rather than the common source one. The common gate configuration gives reasonably good voltage gain together with a low input impedance (a few hundred ohms) which matches the microphone reasonably well. The only other change in the circuit is that the emitter of Tr2 connects direct to the negative supply rail and there is no feedback resistor here. This is done to boost the gain of the circuit, which as explained earlier, needs to be about ten times higher for a low impedance microphone.

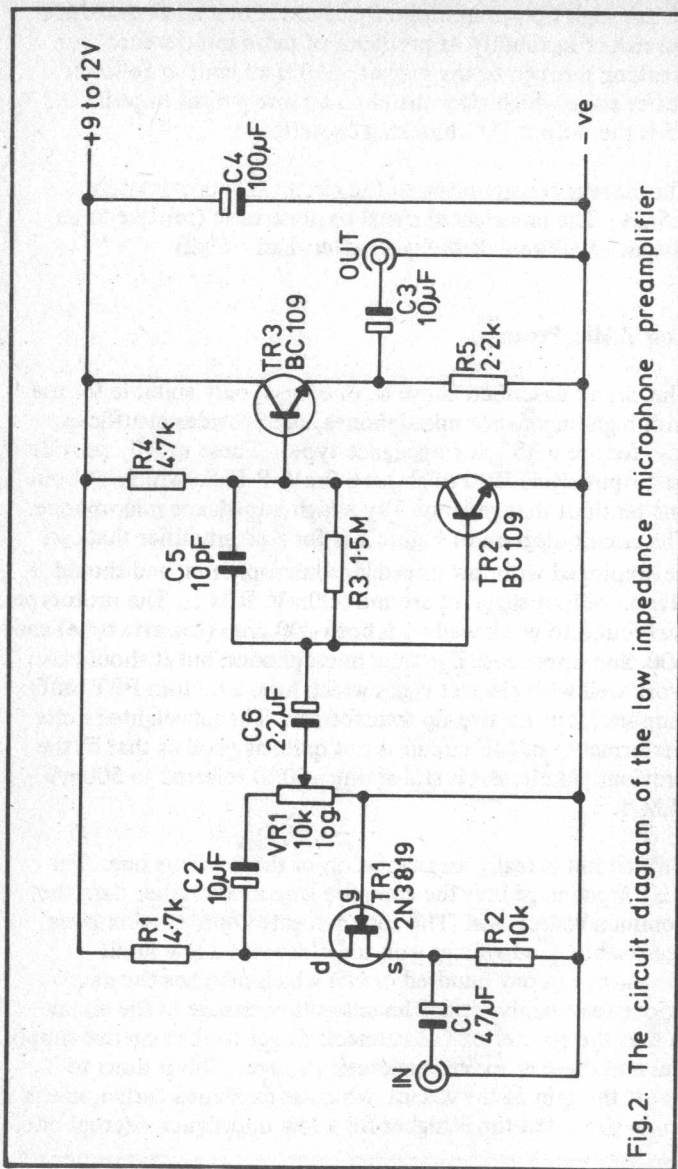

Fig.2. The circuit diagram of the low impedance microphone preamplifier

The current consumption of the circuit is about 3.5mA. The input leads of both the microphone preamplifiers should be screened so as to prevent stray pick-up of mains hum and other electrical interference.

General Purpose Preamplifier

This useful preamplifier circuit has a voltage gain which can be set at any level between five and one hundred times by using a feedback resistor of the appropriate value. The input impedance is high, being typically about 800k, and a low output impedance of around 120 ohms is obtained. The noise and distortion produced by the circuit are both very low. A maximum output signal level of about 6 volts peak to peak can be handled before clipping occurs.

Figure 3 shows the circuit diagram of the unit, and this is a straight forward two transistor, direct coupled arrangement, with both transistors being used in the common emitter mode. R2 provides local negative feedback over Tr1, and provides a convenient point to which overall negative feedback can be applied to the circuit. This feedback is obtained from the collector of Tr2 via D.C. blocking capacitor C3, and the value of Rf determines the amount of feedback that is applied to the amplifier. The lower the value of this component, the more feedback that is applied, and the lower the closed loop voltage gain of the unit. The required value of Rf is found by multiplying the required voltage gain by 560. Thus, a voltage gain of ten times, for example, requires Rf to have a value of 5.6k. It is recommended that the voltage gain should be kept within the limits stated earlier.

C2 rolls off the high frequency response of the amplifier, and is necessary as instability might otherwise occur. The upper -3dB response of the unit is still at about 200kHz even if the amplifier is used at a voltage gain of one hundred times. When used at lower gains the upper -3dB point is pushed proportionately higher. The lower -3dB point is at approximately 20 Hertz incidentally.

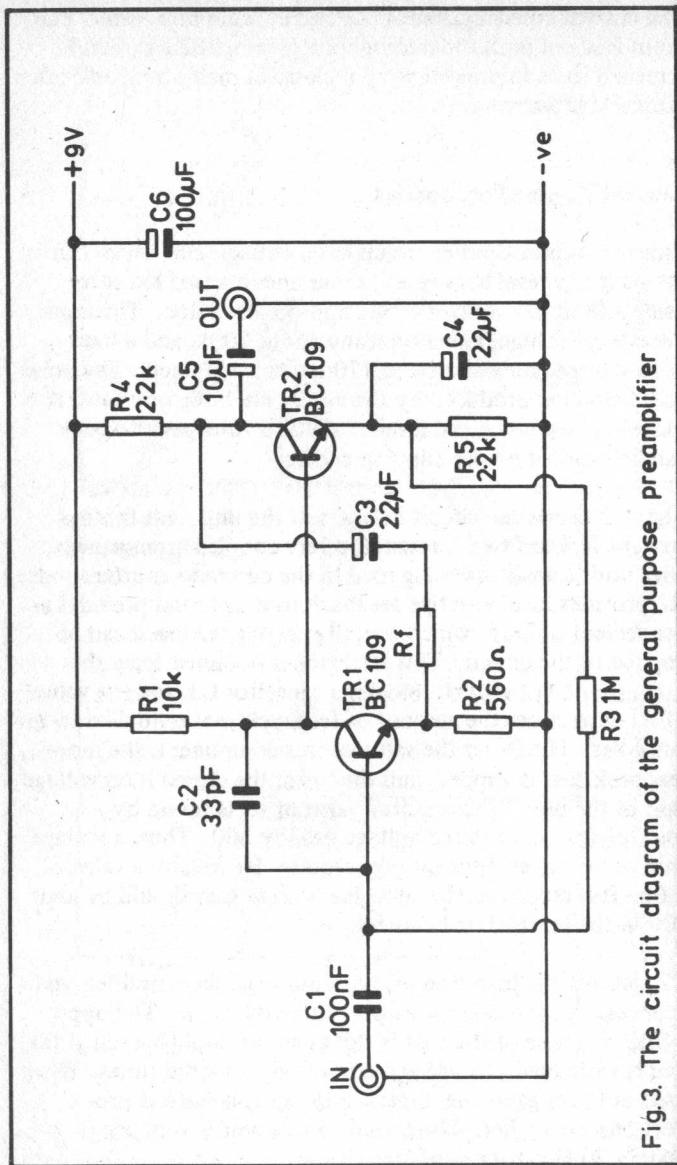

Fig.3. The circuit diagram of the general purpose preamplifier

The current consumption of the circuit is a little under 2mA.

High Z Buffer

It can sometimes be necessary to have a buffer amplifier that will match a high impedance source to a low input impedance. It is also common for items of equipment such as A.C. millivolt meters to have a high input impedance, so that little loading is placed on the circuitry where the signal is being extracted. The circuit of Figure 4 is for a buffer amplifier which has an input impedance of many megohms at audio frequencies, and an output impedance of only a few ohms. It has unity gain up to frequencies of around 4MHz. The levels of noise and distortion generated by the unit are negligible.

The circuit uses an LF351 (or similar BIFET operational amplifier such as the TL081CP), and the JFET input stage gives an extremely high input impedance. The typical input resistance of the LF351 is actually one million megohms. BIFET devices also give extremely good noise and distortion performance. The inverting (-) input of IC1 is connected direct to the output so that the circuit has unity gain from the non-inverting (+) input to the output. The non-inverting input is biased via R3 to half the supply potential by the potential divider formed by R1 and R2. Of course, the output potential is also nominally half the supply voltage. This gives the circuit optimum large signal handling capability. C2 and C3 provide input and output D.C. blocking respectively.

Due to the shunting effect of R1, R2 and R3, the input impedance of the circuit would be reduced to about 15 megohms if it were not for the inclusion of bootstrapping capacitor C1. This couples the output signal voltage (which is the same as the input signal voltage) to the junction of the three resistors. Therefore, any change in voltage at the input is matched by an identical change at the junction of the three resistors. The input signal does not change the voltage across R3, and does not cause any current to flow through R3. Thus R3 appears to have an infinite impedance to the input signal,

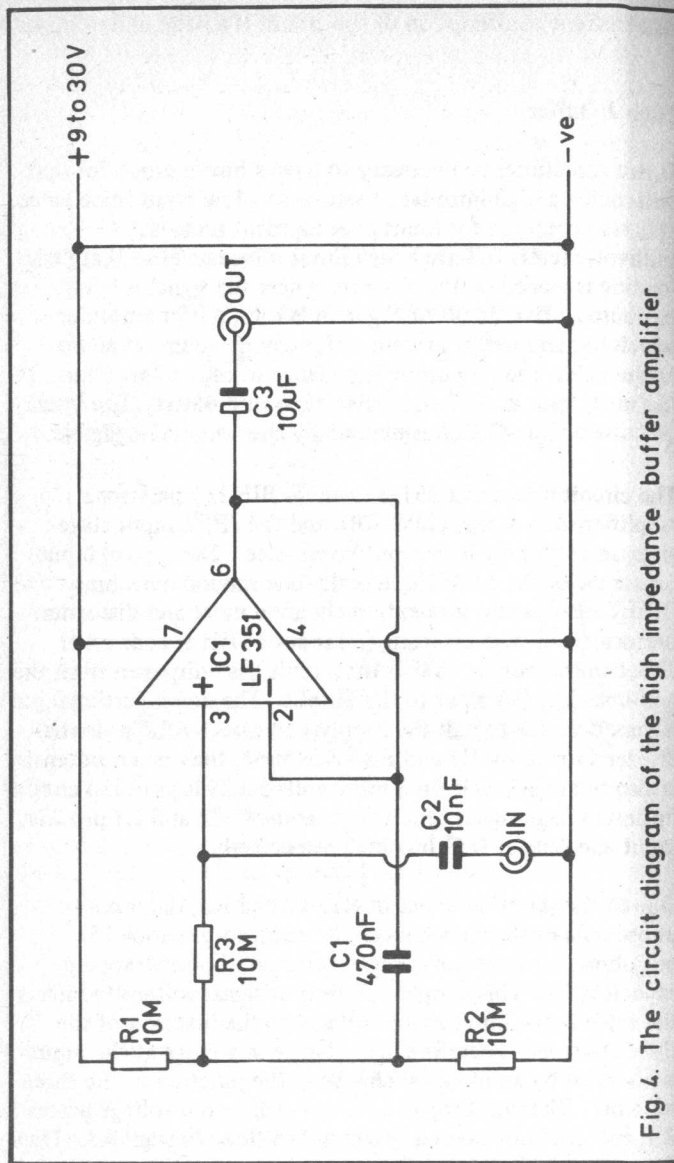

Fig. 4. The circuit diagram of the high impedance buffer amplifier

and has no significant shunting effect on the input. In practice the input impedance of the amplifier will be determined by stray input capacitances, and the frequency of the input signal. Most of the input capacitance will be in the input lead, which must be a screened type in order to keep stray pick-up at a very low level.

The circuit will work well on any supply voltage from 9 to 30 volts, and the current consumption is approximately 2mA.

Headphone Adaptor

With the increasing popularity of stereo headphones it is now quite normal for items of audio equipment to have a headphone socket. However, this is not a feature of all amplifiers and tuner amplifiers, and is absent on many of those built a few years ago.

It is possible to feed headphones from the loudspeaker outputs of an amplifier or receiver, but this is unlikely to give good results. The problem with this arrangement is that most headphones are far more sensitive than loudspeakers, and require only a few tens of milliwatts in order to give good volume. The amplifier is therefore operated with the volume controls set well back in order to give an output power of a suitably low level. However, when the volume control is backed off, the hum and noise produced by the power amplifier is not, and this can result in a rather poor signal to noise ratio. Also, many power amplifiers, especially the solid state class B variety that are so popular these days, do not operate at their best when they are providing extremely low output powers.

A better solution to the problem is to use a simple adaptor, such as the one shown in the circuit of Figure 5, to enable the headphones to be used from the loudspeaker outputs, with the amplifier giving a fairly high output power.

With S1 in the "L.S." position the input signal is coupled straight through to the loudspeaker sockets. This is a very

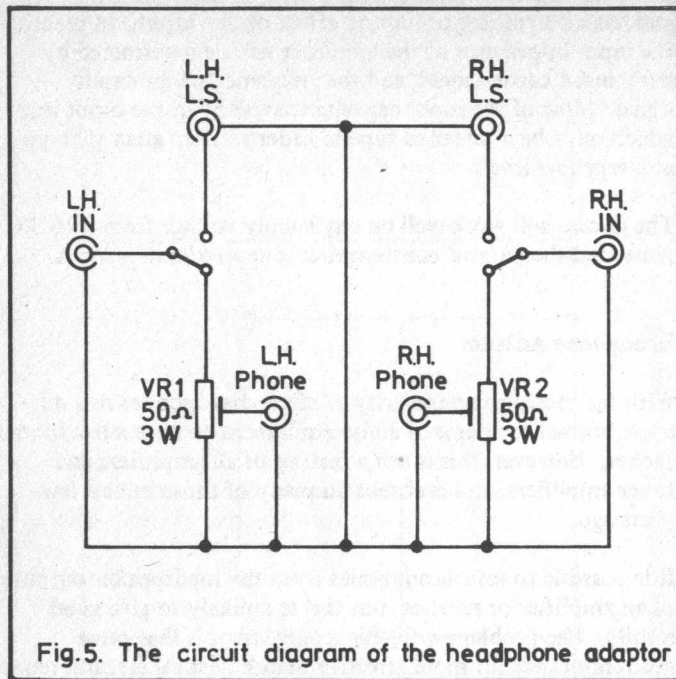

Fig. 5. The circuit diagram of the headphone adaptor

useful feature as it enables the user to easily switch from speaker to headphone operation, and vice versa. When S1 is in the "phones" position, each phone is fed with the input signal by way of a variable attenuator. VR1 and VR2 are adjusted so that comfortable volume is obtained from the phones when the volume control is set in the position that would normally be used for loudspeaker operation. They are also adjusted to give the correct channel balance. The operating conditions of the amplifier should then be such that excellent results are obtained. VR1 and VR2 should place a low resistance across each phone, giving good damping of the phones. VR1 and VR2 should have a power rating of 3 watts or more, and will need to be wirewound components.

Ambiphonic Adaptor

Proper quadraphonic equipment is quite expensive, but quite a good quasi quadraphonic effect can be obtained using an additional set of speakers and a simple passive adaptor of the type described here. The input from the amplifier is fed to the normal (front) pair of stereo speakers in the usual way. The additional set of speakers are situated at the rear of the room, so that the four speakers are, in effect, at the four corners of a rectangle. If we ignore VR1 for the time being, these rear speakers are fed with the difference signal of the two stereo channels. In other words, signals that appear in both channels, which in practice means signals at or near the centre of the sound stage, tend to be largely or even totally cancelled out in the rear channels. This happens because such signals cause similar variations in the voltage across the rear speakers. Signals that only appear in one channel will cause a voltage to be developed across the rear speakers in the normal way, and will be reproduced from the rear speakers. Thus, the general volume level from the rear is somewhat less than that from the front on the main signals.

On many signal sources, and on orchestral records and transmissions in particular, there will be ambience signals present. These are signals which are not picked-up direct from the instruments by the microphones, but are received after they have bounced around the walls and ceiling of the room in which the performance takes place. These reflected signals will either appear in only one channel, or will appear randomly phased in both channels. Some of those that appear in both channels will be out-of-phase, and instead of cancelling out, will add together so that they are reproduced more loudly from the rear channels than from the front ones. This gives the reproduced music a more spacious sound, and can give very realistic results. However, the effectiveness of a unit of this type varies considerably from one programme source to another, but good results are normally obtained with orchestral and other large scale music.

The circuit is shown in Figure 6. Ideally the rear speakers

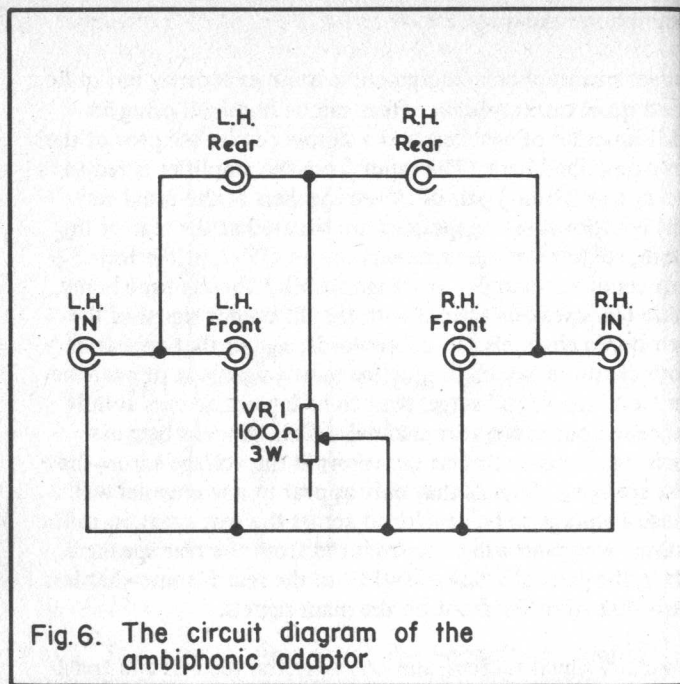

Fig.6. The circuit diagram of the ambiphonic adaptor

should be of the same type as the front ones, but quite good results can be obtained using rear speakers that are of slightly lower quality than the front ones. The front and rear speakers must be of comparable efficiency though. Units of this type inevitably increase the loading on the amplifier, and it is only advisable to use them in systems where the amplifier is kept comfortably within its maximum power output when used in the normal two channel mode. In theory the phasing of the rear speakers is important, but in practice it will probably be found that quite good results are obtained whatever the phasing of the rear speakers. In the basic "Hafler" arrangement, as this system is known, there is a total lack of channel separation in the rear channels. This is overcome to a limited extent by the inclusion of VR1, which can be adjusted to mix a degree of the front channels into

their corresponding rear channels. At maximum resistance VR1 adds very little of the front channel signals into the rear channels, while at minimum resistance the signals at the rear are just the ordinary stereo signals. Best results should be obtained somewhere between these two extremes, probably with VR1 at a little under half resistance (in an 8 ohm system).

Bench Amplifier

A small amplifier with built-in loudspeaker is an extremely useful item of gear to have on the workbench, and can often be helpful when building, testing, or developing radios, audio equipment, and many other types of electronic project. The simple design shown in the circuit diagram of Figure 7 uses just a single I.C., but has a useful sensitivity and a moderately high input impedance, making it perfectly adequate for this application.

It is based on the TBA820M I.C., or the TBA820 device, although the latter has a different encapsulation and pin numbering. The input signal is coupled by D.C. blocking capacitor C1 to volume control VR1, and from here it is coupled direct to the non-inverting input of IC1. No D.C. blocking capacitor is needed here: in fact the volume control is needed to bias the input of IC1. An internal negative feedback resistor is connected from the output of IC1 to its inverting input, and the closed loop voltage gain of the device is determined by a discrete resistor connected from this input to the negative supply rail (via a D.C. blocking capacitor). R1 is the discrete resistor, and gives a voltage gain of about 130 times. This gives an input sensitivity of about 20 mV. R.M.S. for maximum output, and signals of less than a millivolt can produce useable volume. C3, C5, C6 and R3 all aid the stability of the circuit. R2 and C4 provide bootstrapping from the output to the collector circuit of the driver stage of IC1, and this helps to give a high unclipped voltage swing at the output of the amplifier. C7 is the output D.C. blocking capacitor.

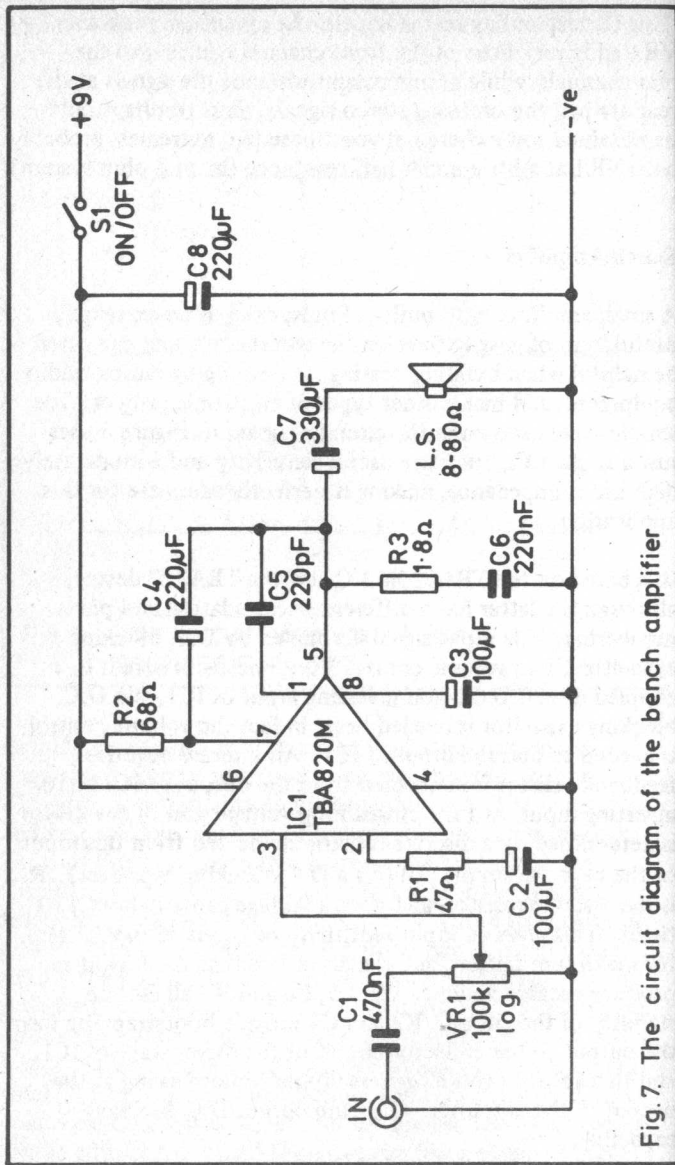

Fig.7. The circuit diagram of the bench amplifier

The TBA820M has a class B output stage which gives a quiescent current consumption of only about 4mA., but the consumption does, of course, increase considerably at high volume levels, especially if a low impedance loudspeaker is used. The maximum output power of the unit depends upon the impedance of the speaker used, and is about 100mW. R.M.S. with an 80 ohm speaker, rising to over 500mW. R.M.S. with an 8 ohm type. The input impedance of the amplifier is fractionally under 100k incidentally.

Minature Power Amplifier

This simple power amplifier uses just one 8 pin DIL I.C. and a very few passive components, and it therefore readily lends itself to minaturisation. The circuit diagram is shown in Figure 8, and as can be seen from this, the I.C. used is the ULN2283B. VR1 is used to bias the input of IC1, and is also the volume control. C1 provides D.C. blocking at the input, while C3 is the output I.C. blocking capacitor. C2 decouples the supply to the preamplifier stage of the device, and thus helps to avoid low frequency instability due to feedback through the supply lines. C4 is the main supply decoupling capacitor. The voltage gain of the amplifier is fixed at a nominal figure of 140 times, and a little under 20mV. R.M.S. is therefore needed at the input to produce maximum output. The maximum output power of the circuit varies from about 100mW. R.M.S. when using an 80 ohm speaker, to approximately 600mW. with an 8 ohm component. The typical quiescent current consumption is 14mA., but the current drain rises somewhat at high volume levels. When using an 8 ohm speaker the peak current drain may exceed 100mA.

Simple Mixer

Most of the cassette decks and recorders currently available do not incorporate any mixing facilities. This is fine if one only wishes to record from a tuner, or produce simple recordings from "live" sources via microphones. It is rather

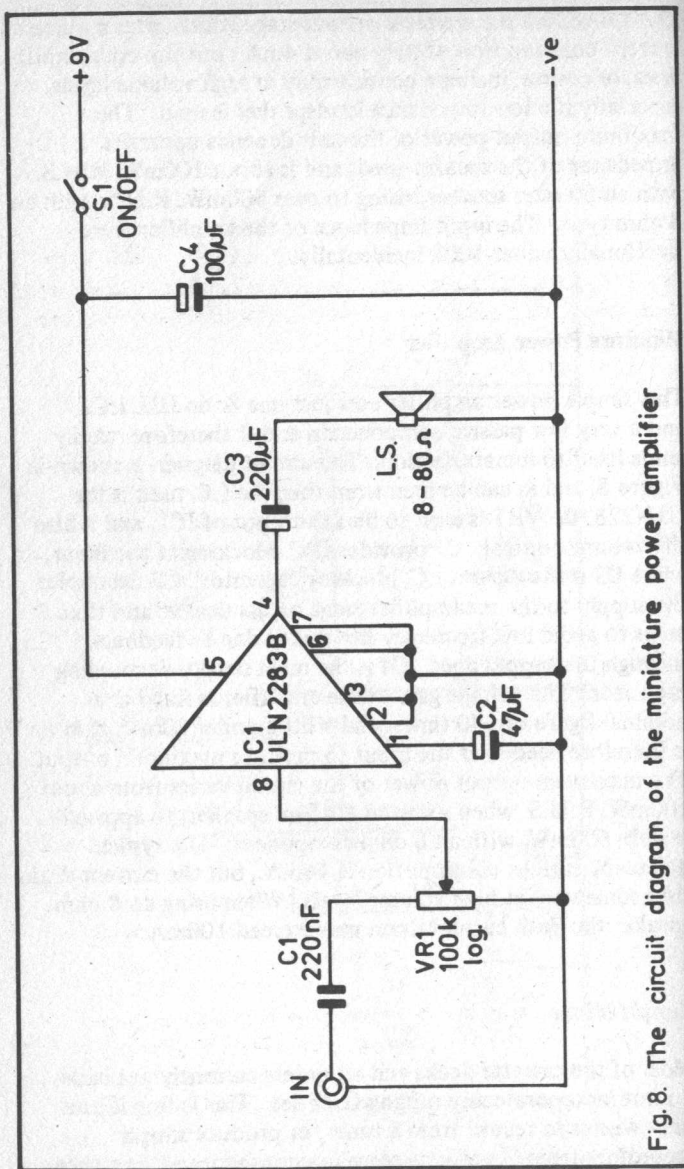

Fig.8 The circuit diagram of the miniature power amplifier

inconvenient for applications such as producing a tape to accompany a slide or cine show, where background music and a commentary are to be simultaneously recorded.

For this type of recording it is really necessary to have at least a simple mixing facility in order to obtain first class results. A suitable circuit for use ahead of a cassette deck or recorder is provided in Figure 9. This should feed a high level input (Aux, Tuner, etc.) and not a microphone input. It will then be necessary to add a microphone amplifier ahead of one input, and two circuits of this type have already been described in this book.

The circuit is basically just a JFET common source amplifier using Tr1, and a direct coupled emitter follower output buffer stage using Tr2. The latter gives the unit a low output impedance. VR1 and VR2 are the two input level controls, and are coupled to the input of Tr1 by way of R1 and R2. These two resistors prevent any significant interaction between the two level controls. R1, R2, VR1 and VR2 also provide the gate biasing for Tr1. There is a 6dB. loss through R1 and R2, but this is more than compensated for by the gain of Tr1. There is in fact a voltage gain of 6db. from each input to the output (with the level controls at maximum). The input impedance of the circuit is a little under 100k., and its current consumption is only about 2.5mA.

Of course, in use one input is fed with the microphone signal via a suitable preamplifier, and the other is fed with the music signal from an amplifier, second tape recorder, or whatever. VR1 and VR2 are then adjusted for the required relative signal levels. For stereo operation two mixers must be built, one to control each stereo channel.

It is possible to increase the number of inputs by adding a D.C. blocking capacitor, level potentiometer, and isolation resistor for each extra channel. However, adding more channels reduces the gain of the circuit somewhat, and the maximum voltage gain will drop below unity if more than four channels are used.

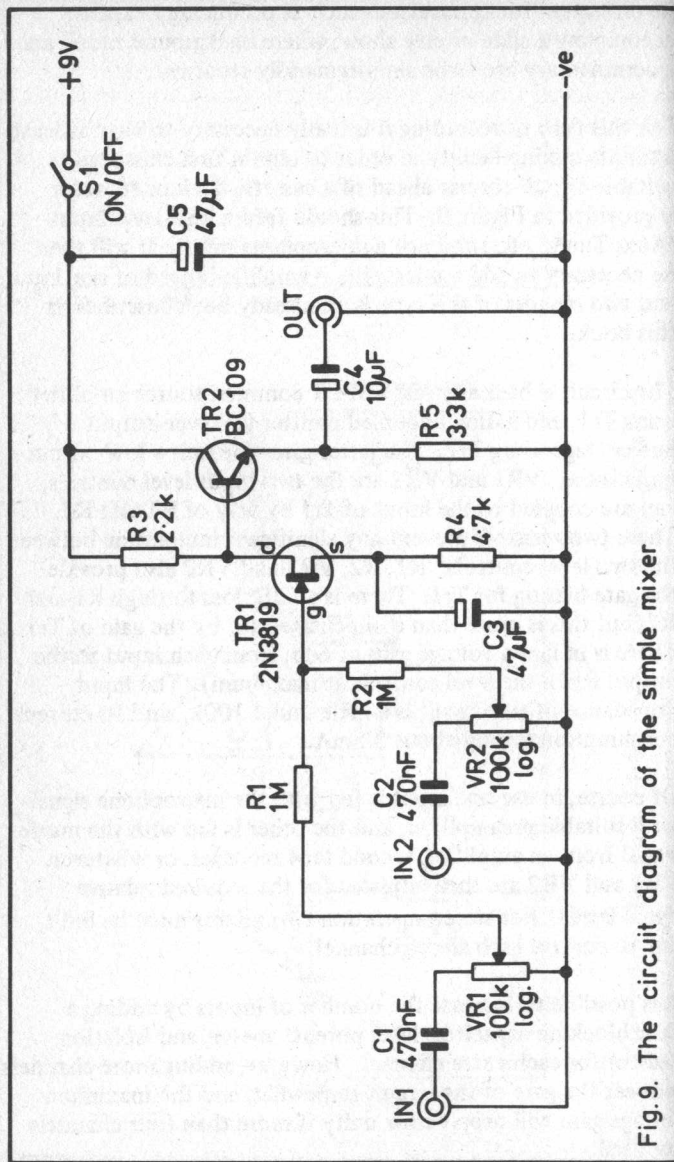

Fig. 9. The circuit diagram of the simple mixer

Class A Amplifier

This is an unusual design which should appeal to the experimentally minded reader. It is a class A amplifier which has a peak output power of about 3.5 watts into an 8 ohm speaker, and it has a direct coupled output. It requires dual (+) 9 volt supplies capable of giving a continuous current of 750mA. or more. It will be apparent from these figures that the circuit is very inefficient, but this is an inevitable drawback of class A amplifiers. On the other hand, class A designs produce no cross-over distortion whater, and the general output quality of this circuit is quite good.

Figure 10 shows the complete circuit diagram of the amplifier. This uses operational amplifier IC1 to drive a VMOS common source amplifier which utilizes Tr1. R4, R5, Tr2 and Tr3 form a constant current generator that forms the drain load for Tr1. This sets the drain current of Tr1 (and the peak output current) at approximately 660mA. A constant current generator load gives better performance and efficiency than using a load resistor.

R3 and R4 form a negative feedback loop which provide overall negative feedback from the output of the amplifier to the non-inverting input of IC1 (not the inverting input, as would normally be the case, because the signal is inverted by Tr1). These set the voltage gain of the circuit at about 15 times, giving an input sensitivity of approximately 350mV. R.M.S. for full output. R2 biases the inverting input (and thus also the output of the circuit) to the 0V. rail potential. It also sets the input impedance of the circuit at a nominal level of 22k. C5 provides D.C. blocking at the input. Of course, there is theoretically no quiescent voltage across the output and no D.C. blocking capacitor is required here. However, in practice there will be a small quiescent output voltage, but this should only be a few millivolts or so, and is of little practical consequence. It is advisable to check that there is a negligible quiescent output voltage before connecting the speaker though, since a constructional error could produce a substantial voltage here, and consequent damage to the

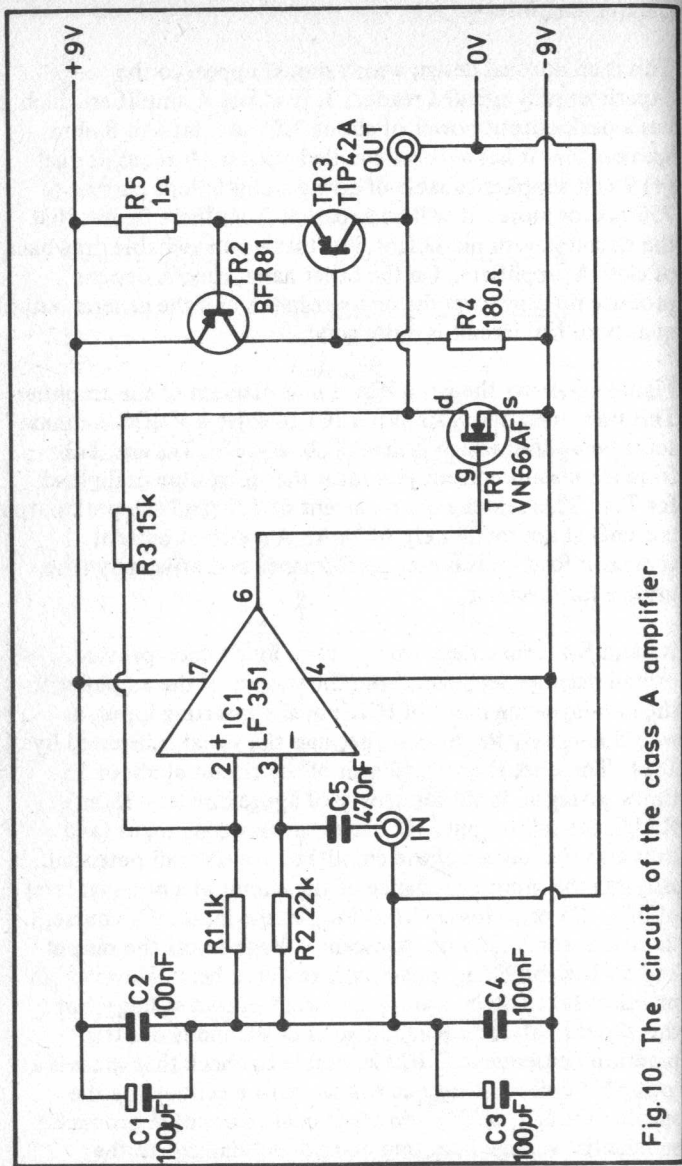

Fig.10. The circuit of the class A amplifier

amplifier and (or) speaker.

Tr1 and Tr3 should be fitted with small, commercially produced, finned, bolt-on heatsinks.

Headphone Amplifier

Although most stereo listening is done via loudspeakers, headphones are becoming increasingly popular, and offer very good quality results for a modest monetary outlay. They also enable the user to listen at high volume levels without causing disturbance to others. This simple stereo amplifier is designed for use with any normal pair of headphones (not special types which require a high drive level and are normally driven from loudspeaker outputs), and can be fed from a tuner, a tape deck, or a ceramic cartridge. The circuit diagram of the amplifier is shown in Figure 11.

Voltage gain is provided by Tr1 which is a JFET used in the common source mode. It provides a low noise level and also produces low levels of distortion. R3 is the source bias resistor and C2 is its bypass capacitor. R2 is the drain load resistor, and gate biasing is provided by VR1, VR2 and R1. VR1 is also the volume control, while R1 and VR2 form a conventional balance control. C1 is the input D.C. blocking capacitor.

Tr2 is used as an emitter follower output stage which gives the amplifier a low output impedance, enabling it to work well even with 8 ohm impedance headphones. C3 is the output D.C. blocking capacitor and C4 is the supply decoupling capacitor. S1 is the on/off switch.

Of course, Figure 11 shows the circuit for just one channel of the unit, and most of the circuitry must be duplicated in the other channel. However, VR2, C4 and S1 are common to both channels. VR1 should be a dual gang component.

The current consumption of a stereo version of the amplifier

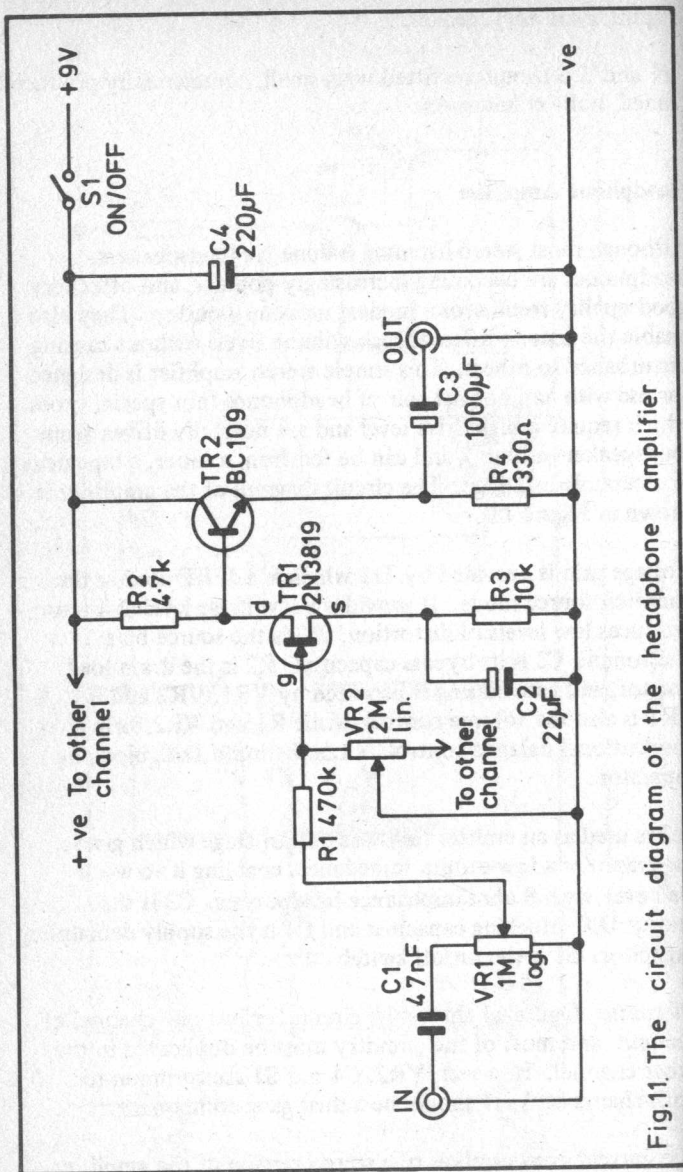

Fig.11. The circuit diagram of the headphone amplifier

is approximately 35mA., and it is advisable to power the unit from a large battery such as a PP9 type.

Peak Level Indicator

A peak level indicator indicates if the peak audio signal level in the monitored equipment (such as a mixer or tape deck) is above or below some predetermined threshold level. Normal VU meters are average reading types which can miss overloads on signals which have a high peak amplitude, but a spikey waveform which gives a low mean amplitude. Peak level indicators are therefore often used in addition to VU meters, but can also be used as the only form of level indicator in situations where the cost of VU meters would preclude their use.

Figure 12 shows the circuit diagram of the peak level indicator. Tr1 is used as a common source amplifier which boosts the input sensitivity of the level detector circuitry to an acceptable level. With R1 at maximum sensitivity the circuit will respond to signals of less than 100mV. R.M.S.

The level detector circuit is based on IC1, which is an operational amplifier employed as a comparator. Its inverting input is biased about 0.6 volts positive by the voltage regulator circuit formed by R4 and D1, while the non-inverting input is biased to the negative rail by R5. Thus, under quiescent conditions the output of IC1 goes low. If peak positive input signals to the non-inverting input of IC1 exceed 0.6 volts, this input is briefly taken to a higher potential than the inverting input, and the output goes high. C4 is then almost instantly charged by way of D3 and current limiting resistor R7 from the emitter follower buffer stage connected at the output of IC1. This discrete buffer stage is needed to effectively give IC1 a high output current capability. C4 now discharges into R6 and D2, with a pulse of light being emitted by the latter, to indicate that an overload has occurred. C4 cannot discharge through R7 and Tr2 since D3 blocks this path. This ensures that a bright and easily

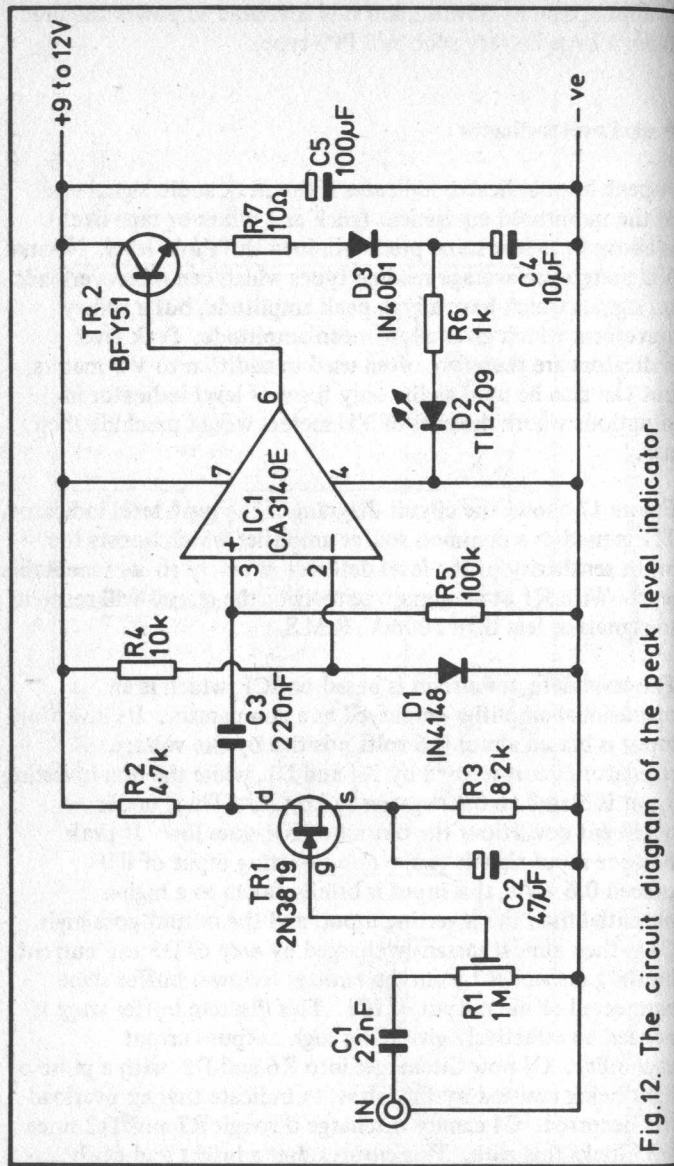

Fig.12. The circuit diagram of the peak level indicator

noticed pulse of light is generated by D2 even if the overload lasts only a fraction of a millisecond.

With the unit connected to the monitored equipment, and a signal at the desired overload indication level fed to this equipment, R1 is adjusted for the lowest sensitivity that causes D2 to light up. The input impedance of the unit is about 1 megohm, and it therefore places little loading on the monitored circuit. The current consumption of the unit is about 3mA., but increases somewhat if D2 frequently operates.

4½ Watt Amplifier

This amplifier will provide an output of about 4½ watts R.M.S. when used with a 20 volt supply and an 8 ohm speaker. It can also be used with a 4 ohm speaker; the output power then being boosted to a maximum of approximately 9 watts. The unit should be powered from a stabilised supply since the maximum permissible supply voltage for the LM383 I.C. used in the circuit is only 25 volts. The supply should be capable of providing 400mA. continuously if the circuit is used with an 8 ohm speaker, or 800mA. continuously if it is used with a 4 ohm impedance load.

The circuit diagram of the amplifier appears in Figure 13. The LM383 I.C. has an internal biasing circuit, and D.C. blocking must therefore be provided at both its inputs. The input signal is coupled from volume control VR1 to the non-inverting input of IC1 by R1 and C1. R2 and R3 are a negative feedback network which set the voltage gain of the circuit at about 32 times. This gives an input sensitivity of about 200mV. into 47k for full output. C2 provides D.C. blocking at the inverting input. R1, R4, C4 and C6 are all needed to aid stability.

The two negative supply connections should be taken to the power supply via separate leads so as to avoid a possible feedback loop and consequent instability. The quiescent current consumption of the circuit should be about 45mA.

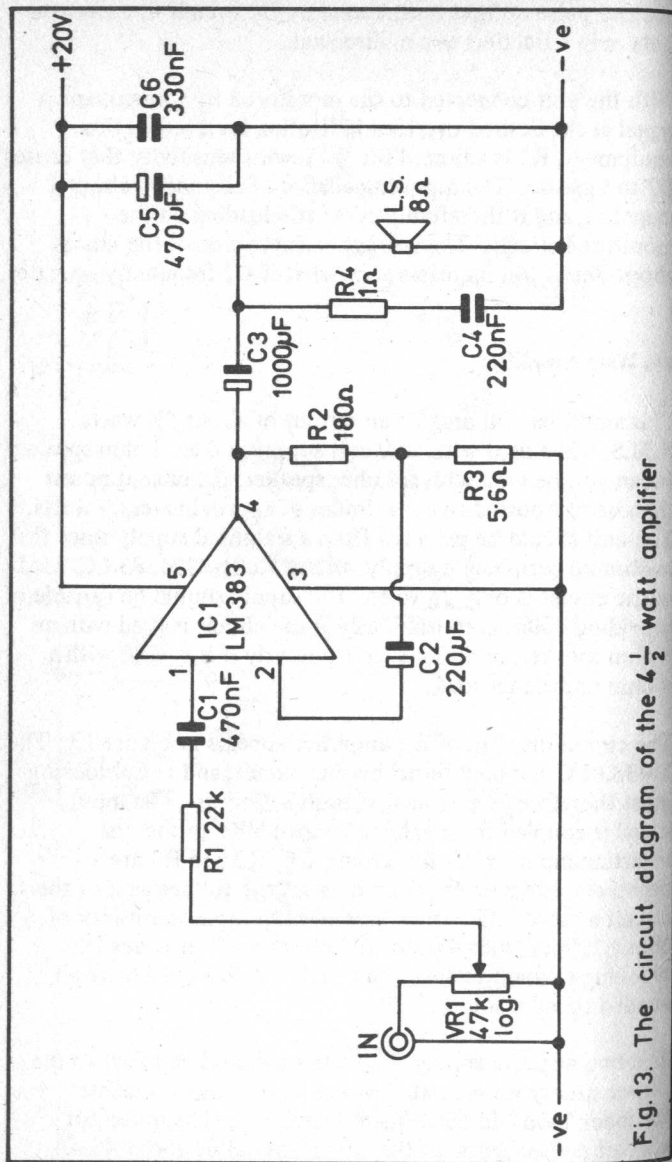

Fig.13. The circuit diagram of the 4½ watt amplifier

The maximum T.H.D. of the circuit is typically only about 0.2%, and so the output quality is quite good. The LM383 incorporates both thermal overload and output short circuit protection. The I.C. should be mounted on a substantial heatsink to prevent it from overheating and shutting down.

Tone Controls

This active tone control circuit can be used ahead of the amplifier described in the previous circuit, or virtually any other amplifier, to provide it with the usual bass/treble, boost/cut tone controls. The circuit diagram of the controls appears in Figure 14.

This is a conventional active circuit having source follower input stage Tr1 to provide a high input impedance, and emitter follower buffer stage Tr3 to give a low output impedance. Tr2 is a common emitter stage, but is has only unity voltage gain at middle audio frequencies due to the feedback provided by the tone control networks. Thus there is nominally unity gain through the circuit as a whole.

At bass frequencies, VR2 and its associated circuitry provide a variable amount of negative feedback, and thus also variable gain. The circuit can provide up to about 12dB. of boost or cut at 100Hz, relative to 1kHz. Similarly, VR1 and its associated components provide a variable amount of feedback at treble frequencies, giving approximately 12dB. maximum boost or cut at 10kHz relative to 1kHz.

The current consumption of the circuit is around 2.5mA. from a 9 volt supply.

M.W. Crystal Set

A crystal set is the most simple form of radio receiver, and requires no battery or other form of power. It relies purely on the energy picked up by the aerial to provide the energy which drives the earpiece or other form of transducer. This has the drawback of requiring a strong signal in order to give reasonable volume, and this means using a longwire aerial, plus an earth connection if possible. Figure 15 shows the circuit diagram of a simple crystal set which covers the medium wave broadcast band.

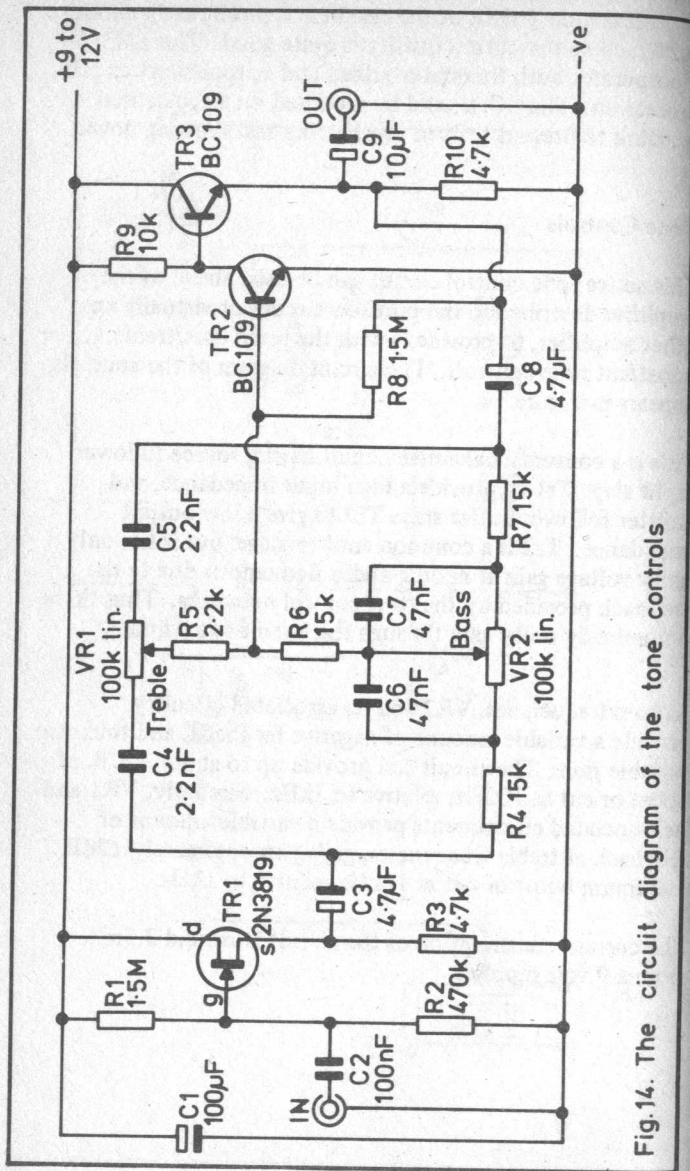

Fig.14. The circuit diagram of the tone controls

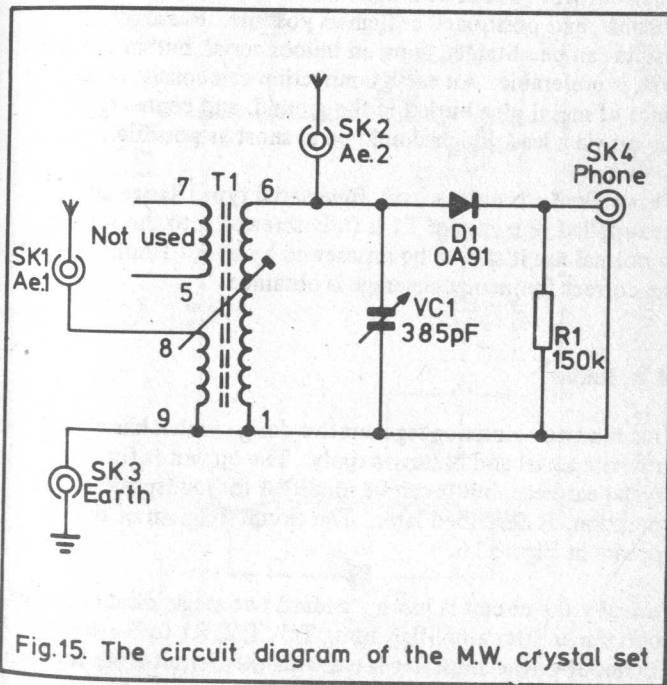

Fig.15. The circuit diagram of the M.W. crystal set

The main winding of T1 forms the tuned circuit together with tuning capacitor VC1. The output from the tuned circuit is coupled direct to a straight forward A.M. detector circuit using D1, R1 and the self capacitance of the crystal earpiece to provide the R.F. filtering. The circuit is only suitable for use with a crystal earpiece. Maximum volume from the set is obtained with the aerial coupled to SK2, so that the aerial signal is injected direct into the tuned circuit. However, if a very long aerial is used it may well be beneficial to use SK1 instead. The aerial signal is then coupled to the tuned circuit by a coupling winding on T1, giving reduced signal strengths, but better selectivity. Of course, the selectivity of a simple set of this type is not very good, but is normally quite adequate. An earth can be connected to SK3.

A suitable aerial for the set merely consists of a length of insulated wire (about 20 s.w.g.) which should be as long as possible, and positioned as high as possible. Reasonable results can be obtained from an indoor aerial, but an outdoor type is preferable. An earth connection can consist of a piece of metal pipe buried in the ground, and connected to the set via a lead which should be as short as possible.

T1 is a Denco transistor coil, Blue aerial type, Range 2T. As supplied, the core of T1 is fully screwed into the former. In normal use it should be unscrewed by about 10mm, so that the correct frequency coverage is obtained.

M.W. Radio

This is a two transistor regenerative design which has a built in ferrite aerial and battery supply. The output is for a crystal earpiece, but it can be modified for loudspeaker operation, as described later. The circuit diagram of the set appears in Figure 16.

Basically the circuit is just a standard two stage, direct coupled, common emitter amplifier, using Tr1, Tr2, R1 to R4 and C2. The input of the amplifier is fed with the output from the

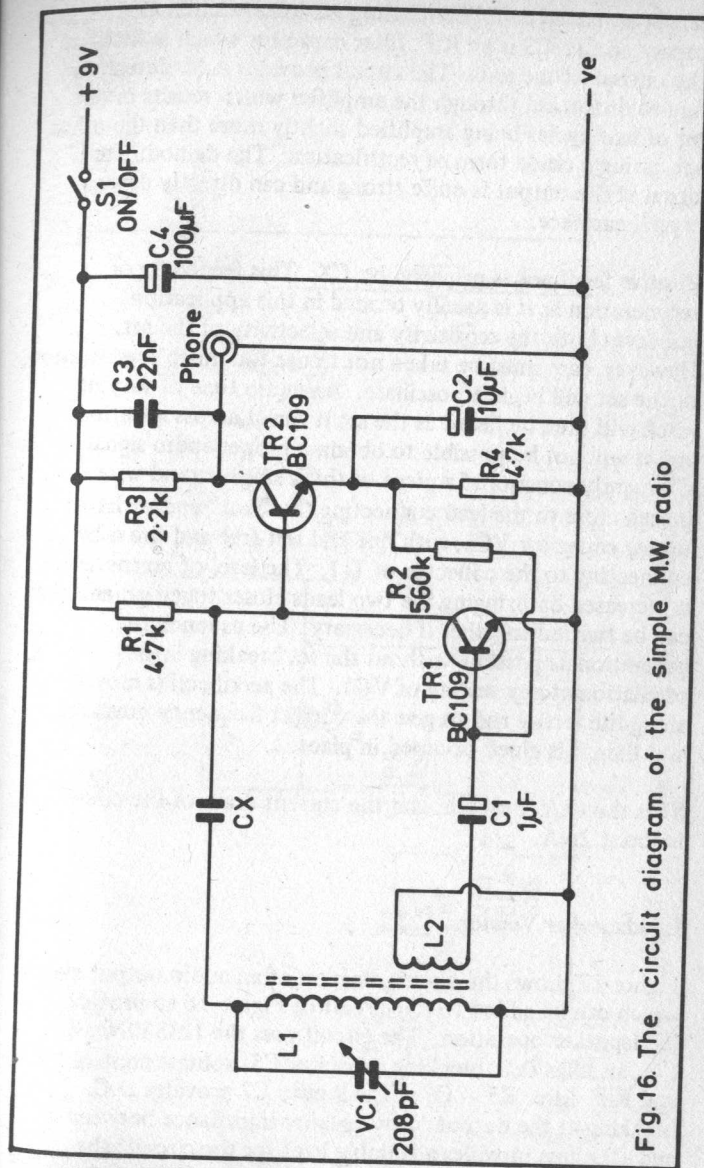

Fig. 16. The circuit diagram of the simple M.W. radio

ferrite aerial via coupling winding L2 and D.C. blocking capacitor C1. C3 is an R.F. filter capacitor which is fitted at the output of the unit. The circuit provides A.M. detection due to distortion through the amplifier which results in one set of half cycles being amplified slightly more than the other set, giving a crude form of rectification. The demodulated signal at the output is quite strong and can directly drive a crystal earpiece.

Positive feedback is provided by CX. This feedback, or regeneration as it is usually termed in this application, improves both the sensitivity and selectivity of the set. However, care must be taken not to use too much regeneration, or the set will begin to oscillate. An audio tone of varying pitch will then be heard as the set is tuned across a station, and it will not be possible to obtain a proper audio signal. CX merely consists of a piece of thick single strand wire placed close to the lead connecting the "hot" end of L1 to tuning capacitor VC1, with one end left free and the other connecting to the collector of Tr1. The level of regeneration is increased by bringing the two leads closer together, and they can be twisted together if necessary. Use as much regeneration as possible without the set breaking into oscillation at any setting of VC1. The aerial coil is moved along the ferrite rod to give the correct frequency coverage, and then it is glued or taped in place.

S1 is the on/off switch, and the current drain of the circuit is about 2mA.

Loudspeaker Version

Figure 17 shows the circuit diagram of an audio output stage which can be added to the circuit of Figure 16 to provide loudspeaker operation. The circuit uses the LM380N audio I.C., and has D.C. blocking capacitor C5, volume control VR1, and R.F. filter R5 - C6 at the input. C7 provides D.C. blocking at the output. Any speaker impedance between 8 and 80 ohms provides a suitable load for the circuit: the

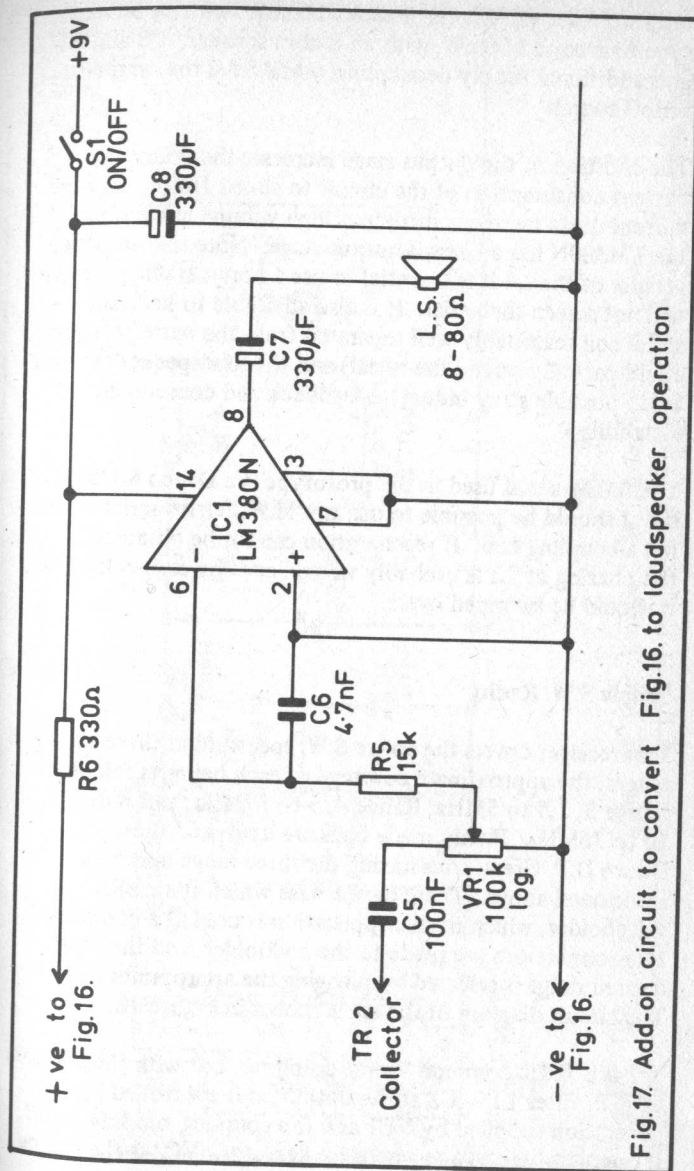

Fig.17. Add-on circuit to convert Fig.16. to loudspeaker operation

output power varying from about 100mW. with an 80 ohm type to around 600mW. with an 8 ohm speaker. C8 and R6 give additional supply decoupling, while S1 is the original on/off switch.

The addition of the output stage increases the quiescent current consumption of the circuit to about 10mA., and the current drain increases further at high volume levels since the LM380N has a Class B output stage. Note that in either version of the set it is essential to use a non-metallic case that will not screen the aerial. It is also advisable to keep the aerial coil reasonably well separated from the battery (which could partially screen the aerial) and the loudspeaker (so as to avoid possible stray inductive feedback and consequent instability).

The ferrite aerial used in the prototype is a Denco MW5FR, but it should be possible to use any M.W. ferrite aerial which has a coupling coil. If regeneration cannot be obtained, the phasing of L2 is probably wrong, and the connections to it should be swapped over.

Simple S.W. Radio

This receiver covers the entire S.W. spectrum in three tuning ranges, the approximate coverage of each being as follows:- Range 3, 1.5 to 5MHz; Range 4, 5 to 17MHz; and Range 5, 10 to 36MHz. Ready made coils are used, and these are Denco D.P. Green coils having the three range numbers mentioned above. These have a base which fits a B9A valveholder, which in this application is used as a coilholder. The connections are made to the coilholder, and then the desired range is selected by plugging the appropriate coil. The circuit diagram of the set is shown in Figure 18.

Tr1 is a JFET common source amplifier, but with the addition of R.F. filter L1 - C2 at the output, and controlled regeneration supplied by VC1 and the coupling winding on T1, it operates here as a regenerative detector. VC2 is the tuning

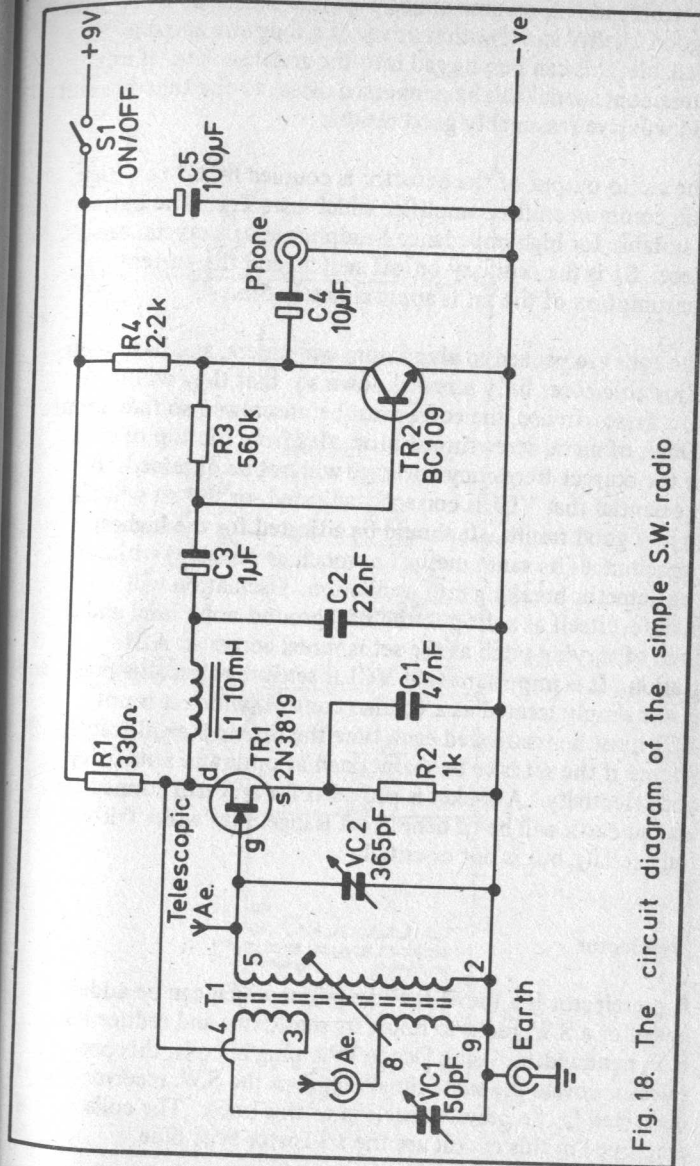

Fig. 18. The circuit diagram of the simple S.W. radio

control, and it is recommended that this should be fitted with a good quality slow motion drive. If a longwire aerial is available, this can be plugged into the aerial socket. If not, a telescopic aerial can be connected direct to the tuned circuit and will give reasonably good results.

The audio output of the detector is coupled by C3 to a high gain common emitter amplifier which uses Tr2. The output is suitable for high impedance headphones or a crystal ear-piece. S1 is the ordinary on/off switch, and the current consumption of the set is approximately 5mA.

The coils are packed in aluminium containers, and have their adjustable cores fully screwed down so that they will fit into these. In use, the cores must be unscrewed so that about 10mm of metal screwthread protrudes from the top of each, or the correct frequency coverage will not be obtained. It is essential that VC1 is correctly adjusted, or the set will fail to give good results. It should be adjusted for the highest capacitance (its vanes meshed as much as possible) without the detector breaking into oscillation. Oscillation will manifest itself as a drop in the background noise level and a tone of varying pitch as the set is tuned across an A.M. station. It is important that VC1 is set just below this point, and is not simply treated as a volume control (which it is not). VC1 must be readjusted each time the tuning is significantly altered if the set is to be maintained at optimum sensitivity and selectivity. A socket is provided for an earth connection, and an earth will be of benefit on Range 3 (as will a fairly long aerial), but is not essential.

Preselector

A preselector is a tuned R.F. amplifier which can be added ahead of a S.W. radio to boost its sensitivity and reduce its R.F. bandwidth. Using Denco B9A plug in coils, this pre-selector covers the same three ranges as the S.W. receiver described in the previous section of this book. The coils employed in this circuit are the transistor type blue

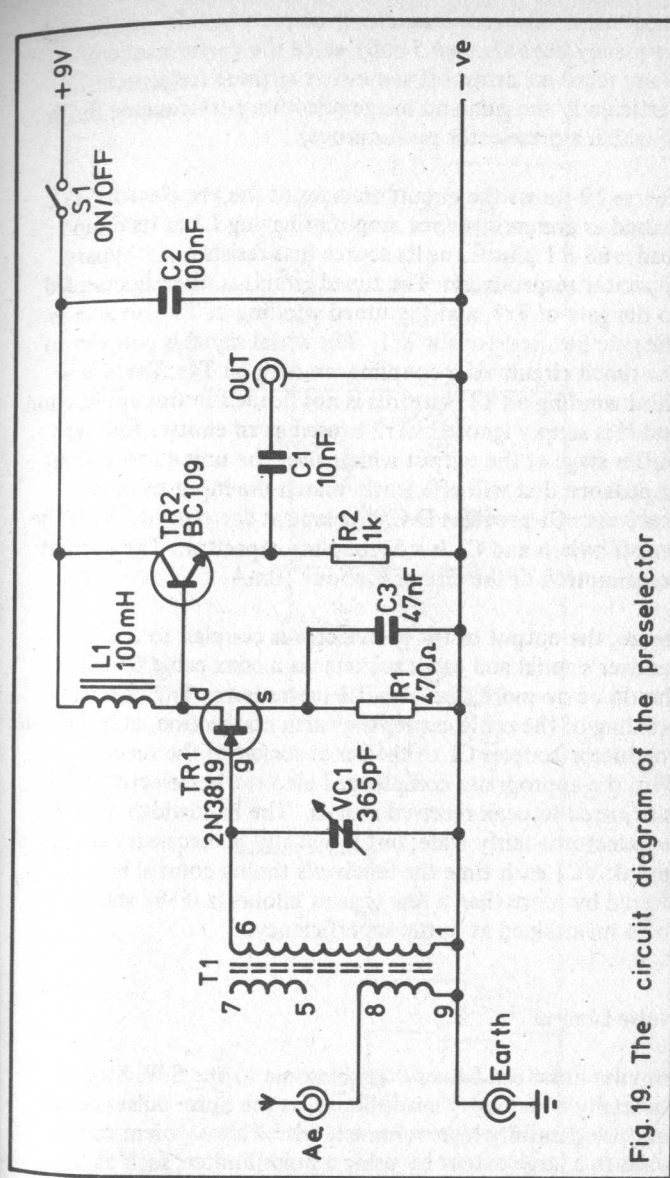

Fig. 19. The circuit diagram of the preselector

aerial coils. The unit is probably of most benefit on the high frequency bands (range 5 coil), since the performance of many receivers drops off somewhat at these frequencies, particularly the gain and image rejection performance (both of which a preselector can improve).

Figure 19 shows the circuit diagram of the preselector. Tr1 is used as common source amplifier having L1 as its drain load, and R1 plus C3 as its source bias resistor and bypass capacitor respectively. The tuned circuit is directly coupled to the gate of Tr1, and the tuned winding of T1 also acts as the gate bias resistor for Tr1. The aerial signal is coupled to the tuned circuit via a coupling winding on T1. There is a third winding on T1, but this is not needed in this application, and it is simply ignored. Tr2 is used as an emitter follower buffer stage at the output which gives the unit a low output impedance that will efficiently match the input of most receivers. C1 provides D.C. blocking at the output. S1 is the on/off switch and C1 is a decoupling capacitor. The current consumption of the circuit is about 10mA.

In use, the output of the preselector is coupled to the receiver's aerial and earth sockets via a coax cable which should be no more than about 1 metre long. The outer braiding of the cable carries the earth connection, and the inner conductor couples C1 to the aerial socket of the receiver. With the appropriate coil plugged into the preselector, VC1 is adjusted to peak received signals. The bandwidth of the preselector is fairly wide, but it will still be necessary to repeak VC1 each time the receiver's tuning control is altered by more than a few tens of kilohertz if the station is to be maintained at optimum efficiency.

Noise Limiter

Impulse noise can be very troublesome to the S.W. listener, especially when using headphones, as the noise pulses often produce painfully high volume levels. This problem can be eased to a large extent by using a noise limiter, such as the

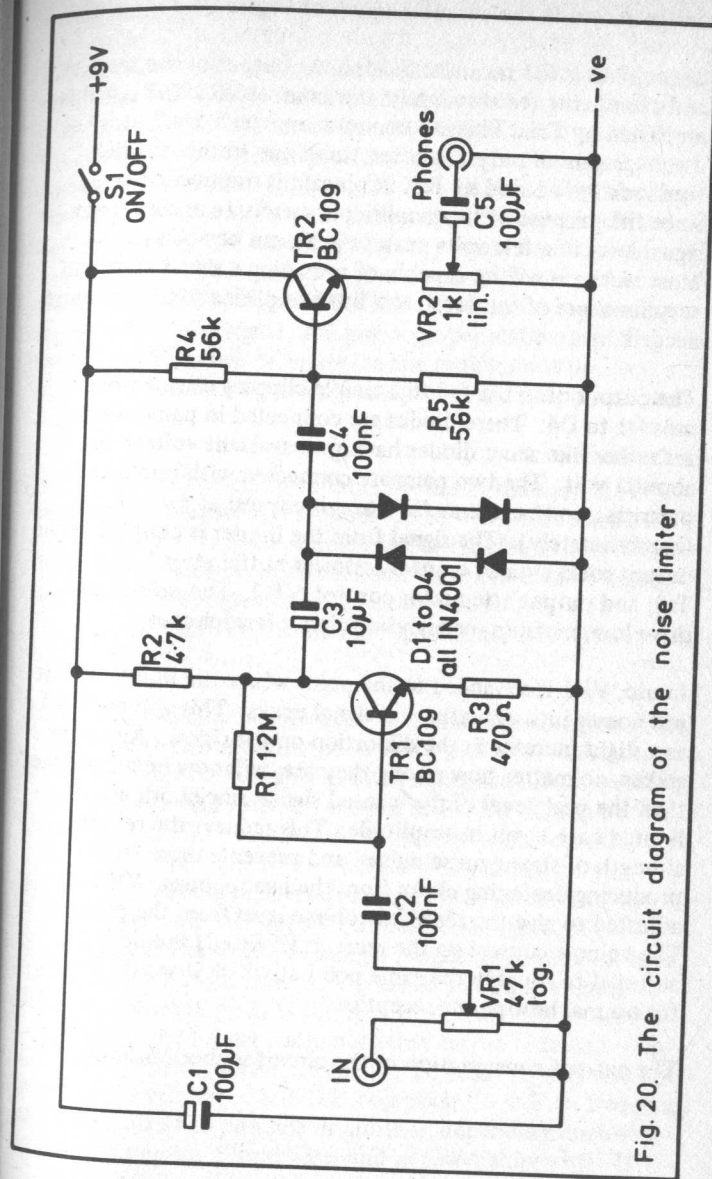

Fig. 20. The circuit diagram of the noise limiter

design shown in the circuit diagram of Figure 20.

This circuit is fed from the headphone output of the receiver, and after being fed through limiter control VR1, the signal is amplified by Tr1. This is a common emitter stage, but is has a voltage gain of only about ten times due to the negative feedback introduced by R3. High gain is not needed here, since the purpose of the amplifier is merely to ensure that a signal level of a few volts peak to peak can be achieved. Most receivers will be capable of providing a signal at, or not very far short of this level, and little amplification is therefore needed.

The output of Tr1 is fed to a simple clipping circuit which uses D1 to D4. These diodes are connected in pairs which act rather like zener diodes having an avalanche voltage of about 1 volt. The two pairs are connected with opposite polarities, so that the audio signal is clipped at ± 1 volt (approximately). The signal from the limiter is coupled to the output socket via an emitter follower buffer stage based on Tr2, and output attenuator control, VR2. The output can drive low, medium, or high impedance headphones.

In use, VR1 is advanced to the point where the limiter circuit just comes into operation on signal peaks. This will be heard as a slight increase in the distortion on the signal. Any noise spikes, no matter how strong they are, will now be no stronger than the peak level of the wanted signal, since both are limited to ± 1 volt in amplitude. This reduces the relative strength of strong noise pulses, and prevents them from producing deafening clicks from the headphones. VR2 is adjusted to give the required volume level from the phones. The volume control on the receiver (if fitted) should be adjusted to roughly the same point at which it would be set for normal headphone reception.

The current consumption of the circuit is about 5.5mA.

B.F.O.

Reception of C.W. (morse) and S.S.B. (single sideband) signals on a superhet receiver requires a beat frequency oscillator (B.F.O.). A B.F.O. is merely an oscillator which operates at the intermediate frequency of the set, and can be tuned a few kilohertz either side of the central I.F. During C.W. reception the B.F.O. produces an audio heterodyne between itself and the incoming C.W. signal, giving the required audio tone. The tuning can be adjusted to give a beat note of the desired pitch. For S.S.B. reception the B.F.O. is used to replace the suppressed carrier signal, and give a proper audio output signal. For this type of reception the tuning must be carefully adjusted to give an intelligible audio output of the correct pitch.

A B.F.O. circuit which is suitable for use at the normal A.M. intermediate frequencies around 455 to 470kHz is shown in Figure 21. This is just a simple Hartley oscillator using Tr1 in the common emitter mode. R1 and C2 are needed to ensure that excessive dissipation in Tr1 cannot occur. S1 is the on/off switch and VC1 is the B.F.O. pitch control. The circuit consumes about 4mA.

It will not normally be necessary to connect the output of the B.F.O. to the I.F. amplifier or detector of the receiver, since stray coupling will probably provide adequate B.F.O. injection. If necessary, a lead from the output of the B.F.O. can be placed near the I.F. circuits of the receiver to increase the level of injection. In order to correctly adjust the core of IFT1, first tune the receiver as accurately as possible to an A.M. station, and then set VC1 at half capacitance. By adjusting the core of IFT1 (using a proper trimming tool such as the Denco TT5) it should be possible to obtain an audio tone that varies in pitch as the core is adjusted. The core is adjusted for the lowest audio note that can be obtained. For C.W. reception the setting of the B.F.O. pitch control will not normally be critical. For S.S.B. reception the B.F.O. frequency should be offset to one side or another, depending upon the mode of reception (upper sideband or lower sideband). It

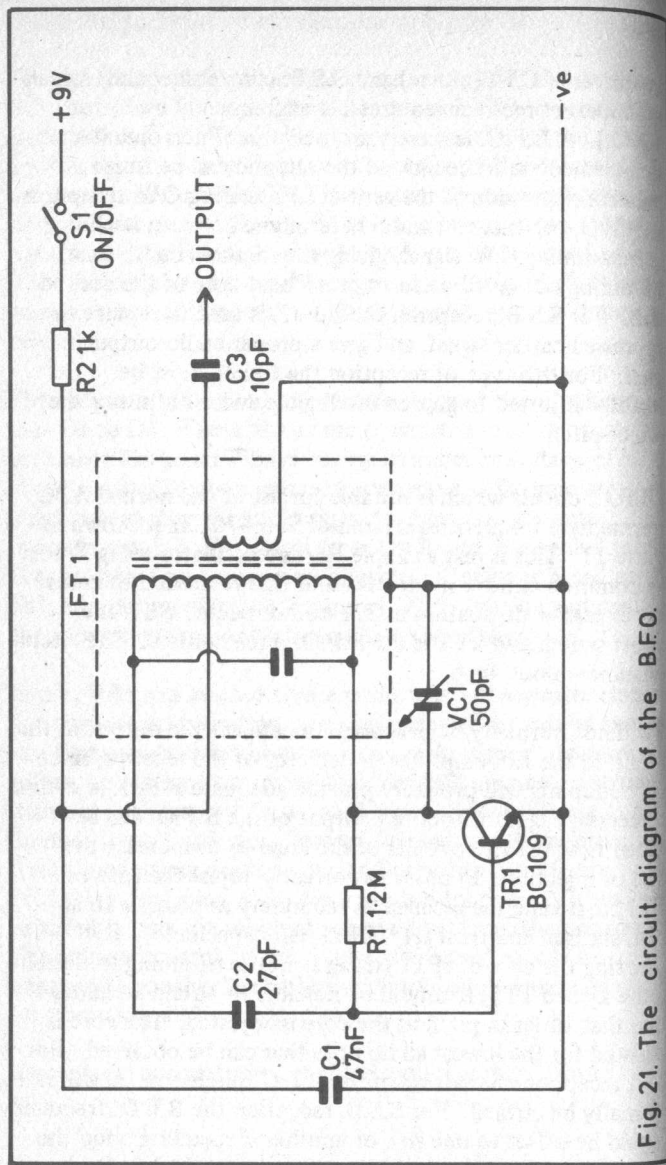

Fig. 21. The circuit diagram of the B.F.O.

will be obvious if the B.F.O. tuning has been offset in the wrong direction, as the received station will drop considerably in strength as the tuning is brought to the point where the correct audio pitch is obtained.

IFT1 is a Denco IFT13/470kHz component, although virtually any A.M. I.F. transformer should work in this circuit.

Notch Filter

One of the most troublesome forms of interference when S.W. listening, especially on the low frequency bands, is the audio heterodyne which is produced by the beat note between two carrier waves, or between a carrier wave and the receiver's B.F.O. This form of interference can be combatted by an audio notch filter having an adjustable notch frequency, so that it can be tuned to null the interfering heterodyne. The design shown in the circuit diagram of Figure 22 has a tuning range of below 100Hz to over 20kHz, and the output is suitable for low, medium, or high impedance headphones. The input is fed from the headphone output of the receiver.

The circuit is quite conventional and uses Tr1 as a phase splitter. The out-of-phase signals at its collector and emitter terminals are fed to a Wien network which has C3 and VR2a as one section, and C4 plus VR2b as the other section. At one frequency there will be zero phase shift through both sections of the Wien network, but at other frequencies there will be some phase shift, and the degree of shift will be different for the two sections. Thus, at the zero phase shift frequency the two outputs from the Wien network will be in antiphase, and therefore cancel one another out. VR1 is adjusted so that they do, in fact, precisely cancel one another out. This gives the required null in the frequency response. At other frequencies there is either no cancelling of the two signals, or only a partial cancelling, and the circuit produces only a very narrow rejection notch so that a minimal amount of the wanted signal is removed. Tr2 and Tr3 are connected as a Darlington pair emitter follower stage which gives the

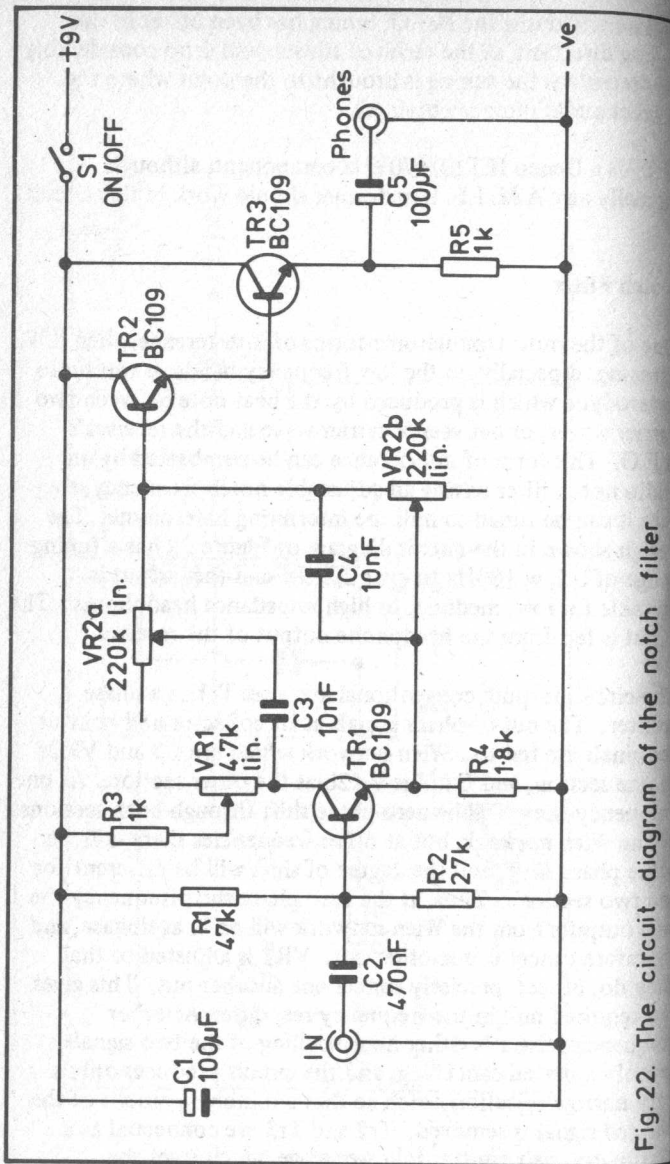

Fig. 22. The circuit diagram of the notch filter

necessary high input impedance load for the Wien network, and a low output impedance to efficiently drive the headphones. The current consumption of the circuit is about 2mA.

In use, VR1 and VR2 are adjusted in turn a few times to obtain the highest possible rejection of the heterodyne, and it should be possible to render it inaudible.

A.T.U.

An aerial tuning unit (A.T.U.) is a very useful accessory for a S.W. receiver as it can increase gain and reduce spurious responses. Furthermore, it is a purely passive device which requires no power source. It is not really accurate to say that an A.T.U. provides gain, since what it actually does is to provide a better match between the aerial and the receiver, and the increased efficiency usually gives an increase in signal strengths of around two "S" points. It thus appears as though there has been an increase in gain, whereas there has in fact been an increase in efficiency and a decrease in the amount of wasted signal. The circuit diagram of the A.T.U. is given in Figure 23.

The circuit is quite conventional, and uses the well known Pi Network arrangement, with a tapped inductor so that virtually any longwire aerial can be correctly matched to any normal S.W. receiver. L1 is an air spaced inductor, and is wound on a 1in. diameter former using a heavy gauge wire (about 18 or 20 s.w.g.) which has enamel insulation. The coil is tapped at 3, 4, 6, 8, 12, 20, 30, 40, 50 and 60 turns, as indicated in the circuit. Small loops in the winding can be produced at these points when winding the coil. The insulation can then be stripped off the loops, and they can be tinned with solder so that connections can easily be made to them. A plastic or ceramic former can be used, or even a wooden former if nothing better can be obtained. It will be necessary to tape or glue the winding to the former to prevent it from springing apart.

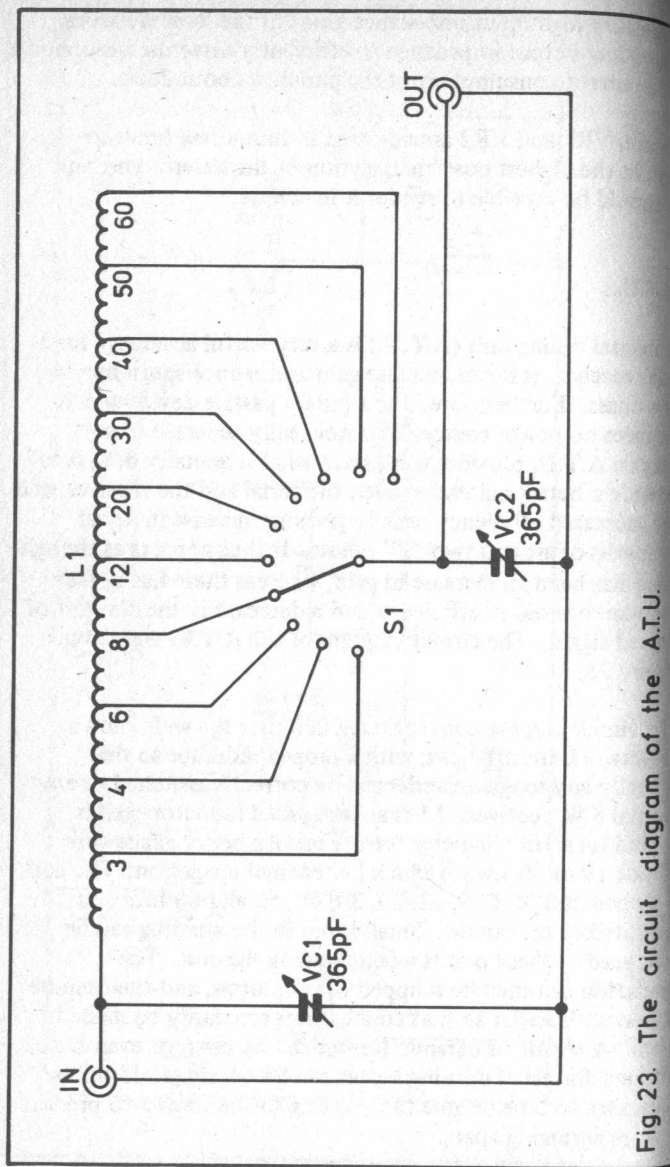

Fig. 23. The circuit diagram of the A.T.U.

The output of the tuner is connected to the receiver via a short coax cable. In use, VC1 and VC2 are adjusted several times in turn to peak received signals, and this procedure is tried at the various settings of S1. This is rather time consuming at first, but one soon gets to know the best settings for each band, and the unit can then be quickly and easily tuned correctly.

Crystal Calibrator

A crystal calibrator is a useful instrument when adding a tuning dial calibrated in frequency, to a newly constructed receiver. It is also useful for checking the calibration of a receiver that has been in service for some time. A calibrator merely generates a signal at a suitable fundamental frequency; 200kHz being used in this case. The output waveform must be such that the output of the unit is rich in harmonic content. Thus, the calibrator does not just produce an output at the fundamental frequency, but also produces outputs at the harmonics. The harmonics are the multiples of the fundamental frequency, and are 400kHz, 600kHz, 800kHz etc. in this case. These provide a series of calibration points at 200kHz intervals throughout the medium and short wave bands.

The circuit diagram of the crystal calibrator is shown in Figure 24. Tr1 is a JFET which is used in the source follower mode, and forms the basis of the oscillator. A crystal oscillator is used, and this gives good accuracy and excellent stability, and requires no setting up adjustments. In effect, C2 and C3 form a tap on the tuned circuit (crystal), and this gives a voltage step up from the source to the gate of Tr1. As Tr1 provides about unity gain, and its source and gate terminals are in-phase, there is sufficient positive feedback to produce oscillation. C4 couples the output of Tr1 to a common emitter amplifier based on Tr2. This gives an output signal having a fast risetime, and rich in the required harmonics. C4 provides D.C. blocking at the output. The only control is S1, and this is simply the on/off switch. The current consumption of the circuit is about 3.5mA.

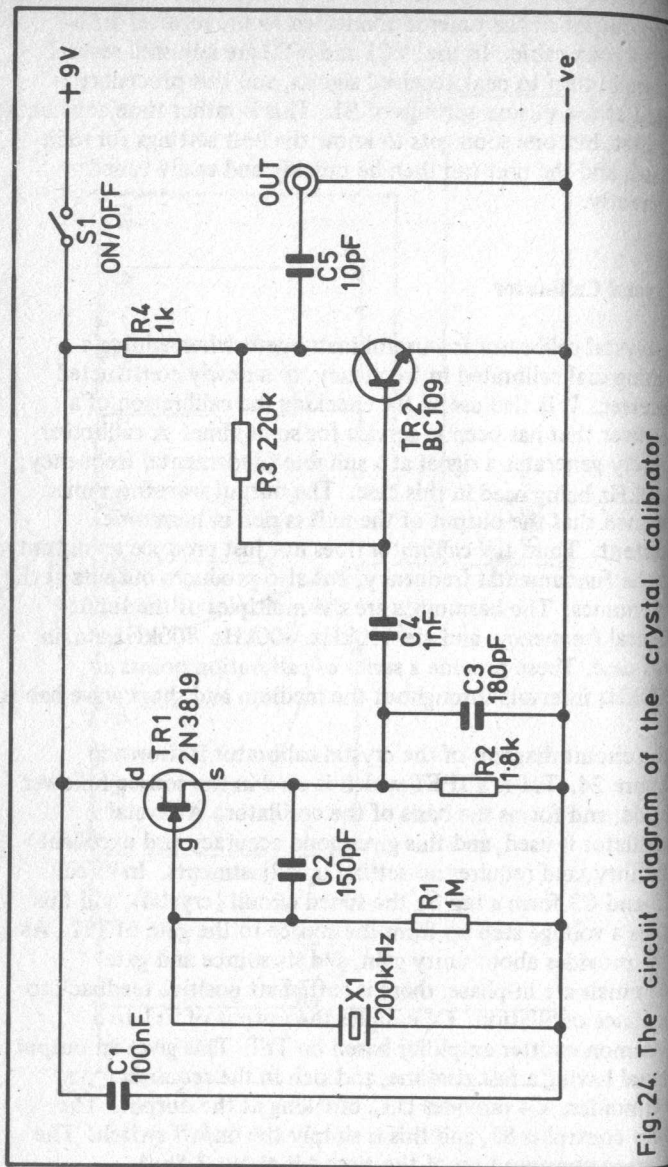

Fig. 24. The circuit diagram of the crystal calibrator

It should be possible to obtain sufficient coupling from the calibrator to the receiver without any direct connection. Simply connect a short insulated lead to the output of the calibrator, and another to the aerial terminal of the receiver, and place the two close together. It is advisable not to use a very high level of coupling, since strong signals could break through on spurious responses of the receiver, giving misleading results. At high frequencies it may be difficult to identify the various harmonics from the calibrator, but a transmission of known frequency can be used to clarify matters. If the receiver is tuned to a station transmitting on (say) 7.1MHz, the harmonics above and below this are obviously 7.2 and 7.0MHz respectively.

R.F. Probe

This R.F. probe is a buffer amplifier and A.M. demodulator which can be used ahead of a bench amplifier (such as the one described in Chapter 1) to enable it to be used for R.F. signal tracing. The circuit diagram of the unit is shown in Figure 25.

Tr1 is a straight forward source follower buffer stage which gives slightly less than unity voltage gain, but provides the unit with a high input impedance of about 1 megohm shunted by roughly 10pf. This ensures that there is minimal loading on the equipment under test. C1 is the input D.C. blocking capacitor. The output from Tr1's source is coupled by C2 to a simple A.M. detector circuit which is comprised of D1, D2, R3 and C3. C4 provides D.C. blocking at the output. S1 is the on/off switch, and the current consumption of the circuit is approximately 1mA. It will respond to frequencies from about 100kHz to over 50MHz.

The circuit can be built into a small metal or plastic case with little difficulty. It is advisable to use the smallest case that is practical, as the unit might otherwise be difficult and cumbersome to use. The probe tip can simply consist of a long bolt (about M3 or 6BA size), and the connection to this can be

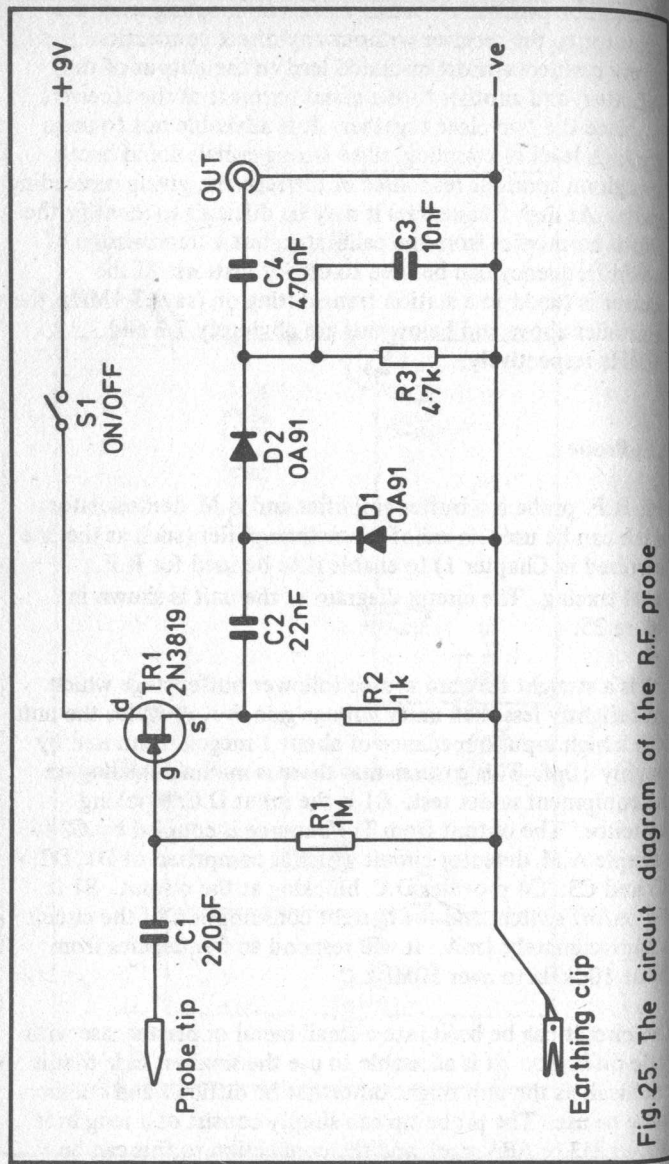

Fig. 25. The circuit diagram of the R.F. probe

made via a soldetag. Of course, if a metal case is used, the probe tip must be insulated from this. A screened lead is used to carry the output signal to the amplifier.

C.W. Filter

Optimum C.W. (morse) reception requires a narrow bandwidth of only a few hundred Hertz at most, but few S.W. receivers are fitted with an I.F. filter having such a narrow bandwidth. This results in C.W. signals being subjected to a higher level of noise and adjacent channel interference than is absolutely necessary. The situation can be substantially improved by using a narrow bandwidth audio filter during C.W. reception. The design featured here takes its output from the headphone socket of the receiver, and its output is suitable for use with high, medium, or low impedance headphones. It has an operating frequency of about 1kHz. The circuit diagram of the filter is given in Figure 26.

The circuit is based on a T notch filter which is comprised of R1 to R4 and C2 to C5. This type of filter gives a narrow rejection notch at its operating frequency, which is the opposite of what is required in this application. The filter is therefore used between the input and output of a common emitter stage based on Tr1. The filter provides almost 100% negative feedback over the amplifier at most frequencies, giving a voltage gain of only about unity. However, at and close to its operating frequency it blocks signals, and provides no significant feedback, enabling Tr1 to produce virtually its full voltage gain.

R5 is used to attenuate the input signal, which would otherwise be high enough in amplitude to overload Tr1 and cause the output signal to become seriously distorted. Tr2 is an emitter follower buffer stage, and this provides the unit with a low output impedance that can drive any normal headphones. C7 and C8 provide input and output D.C. blocking respectively. S1 is the only control, and is the on/off switch. The current consumption of the unit is approximately 5.5mA.

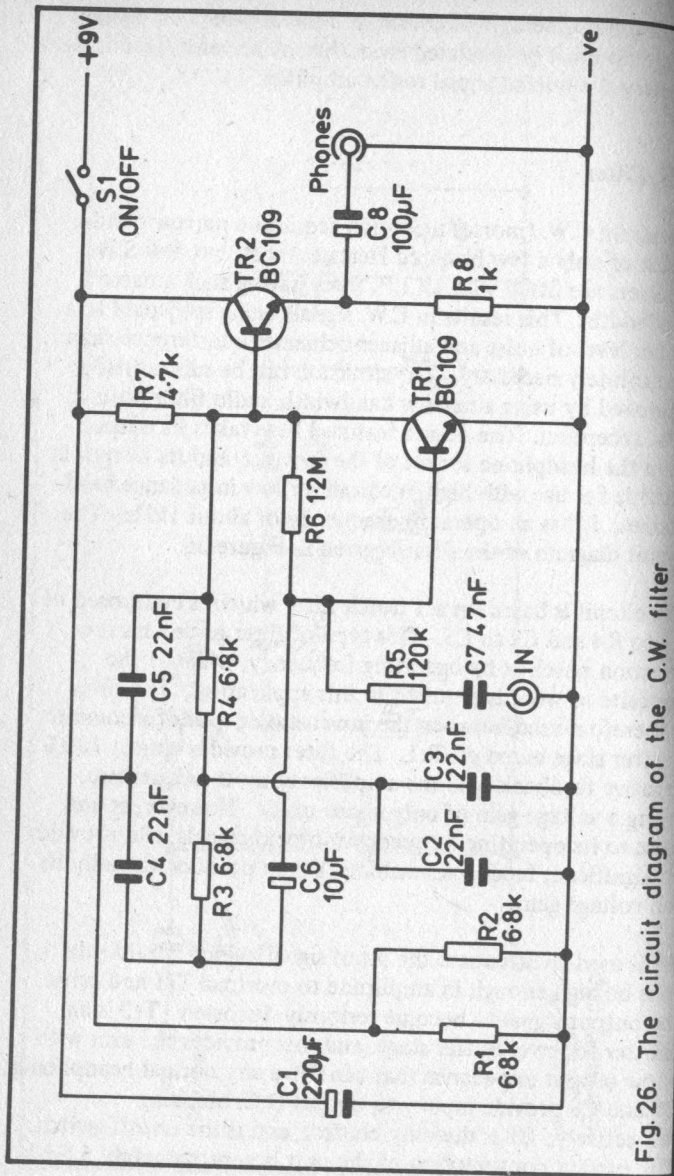

Fig. 26. The circuit diagram of the C.W. filter

Tuning will be somewhat more difficult with the addition of the filter and the decreased bandwidth it provides, but it should provide a very marked decrease in the level of noise and QRM.

C2 to C5 should have a tolerance of 5% or less.

Wideband Preamplifier

This circuit has a nominal voltage gain of 20dB. (ten times) and a frequency response which is virtually flat from about 1kHz to over 20MHz. A useful level of gain is provided at frequencies of up to around 50MHz. The unit is primarily intended as a preamplifier to boost the sensitivity of a digital frequency meter, or an oscilloscope which is being used to display high frequency signals. The circuit diagram of the preamplifier is shown in Figure 27.

Tr1 is used in a JFET source follower input stage which gives the amplifier an input impedance of about 1 megohm shunted by about 10pf. This ensures that the signal source is not heavily loaded. C2 couples the output from Tr1 to the input of Tr2, which is used as a common emitter amplifier. This has a low value collector load resistor (R4) and is operated at a fairly high collector current (about 13.5mA.) so that a flat response is obtained up to about 20MHz. The high frequency response is also aided by the use of a V.H.F. transistor in the Tr2 position, and the small amount of negative feedback introduced by R5. C3 provides D.C. blocking at the output, and S1 is the on/off switch. The approximate current consumption of the circuit is 14.5mA.

As the input and output of the circuit are out-of-phase, stray feedback is unlikely to cause instability. However, it will result in a reduction in the high frequency response of the unit. It is therefore important to use a method of construction that will give low levels of stray capacitance, and a printed circuit or plain matrix board are suitable as the constructional basis of the unit.

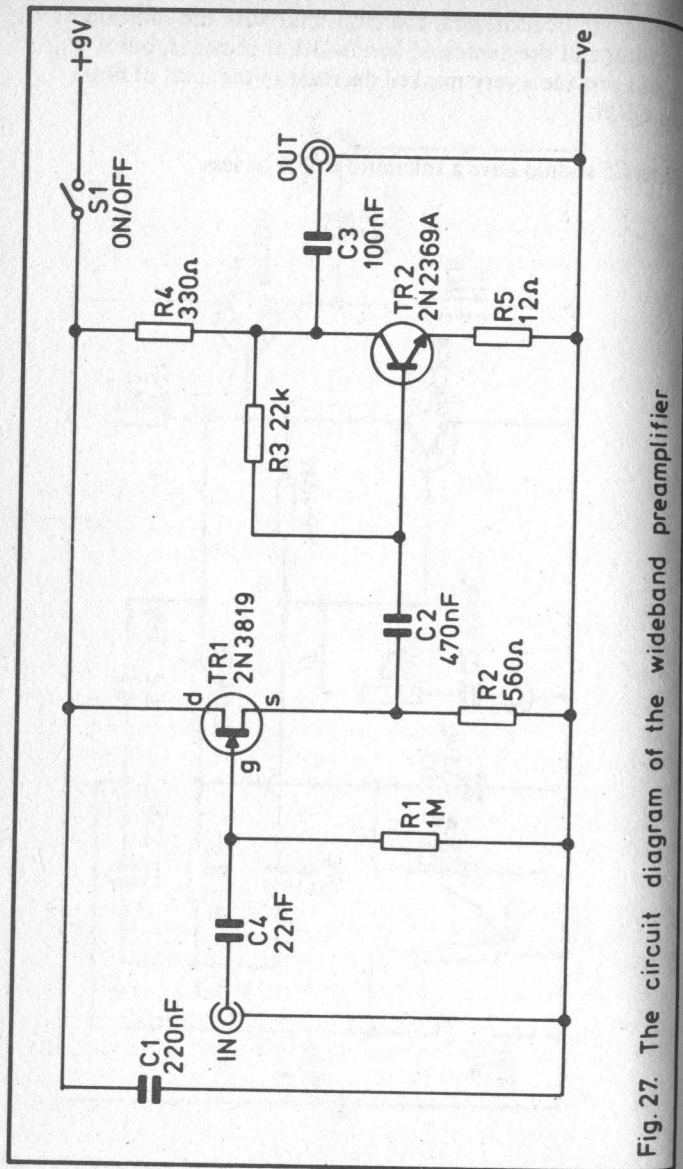

Fig. 27. The circuit diagram of the wideband preamplifier

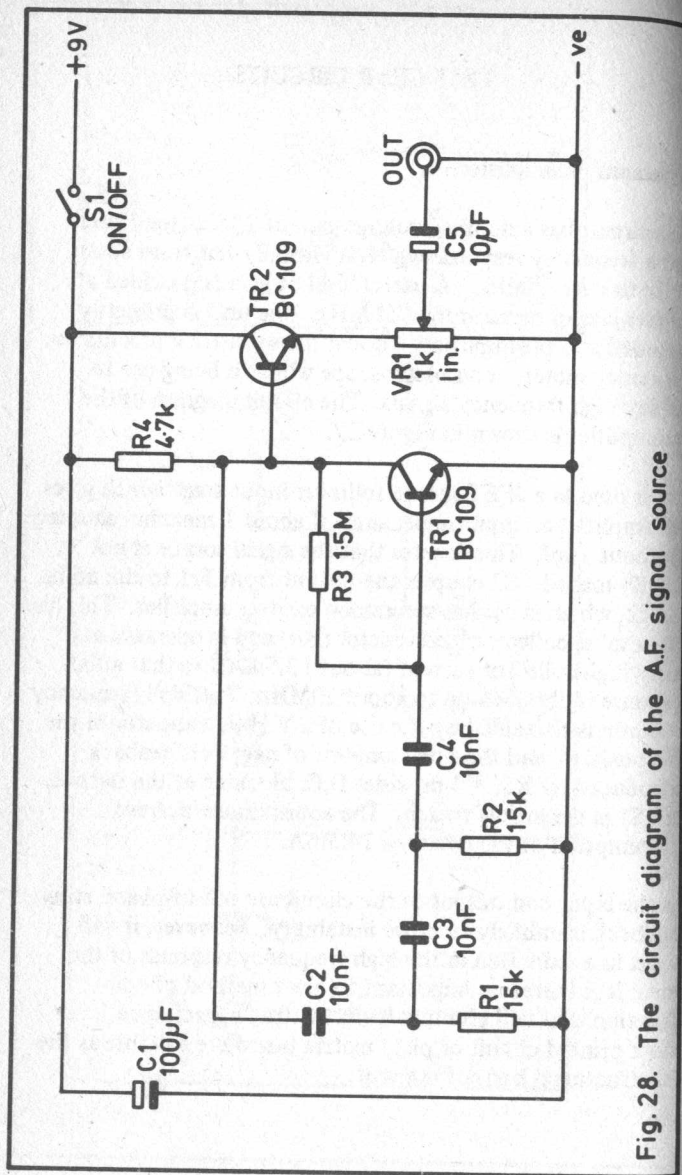

Fig. 28. The circuit diagram of the A.F. signal source

A.F. Signal Source

In order to make sophisticated tests on audio equipment it is necessary to have a high quality signal generator, but for troubleshooting on audio gear an A.F. signal source of some kind is usually all that is needed. This circuit provides a roughly sinusoidal output at approximately 500 Hertz. The peak to peak output voltage is about 8V., and is from a low impedance source, but an output level control that can be used to vary the output amplitude down to zero is fitted to the unit. The circuit diagram of the signal source appears in Figure 28.

The signal is generated by a phase shift oscillator. This uses Tr1 as a straight forward high gain common emitter amplifier, and the feedback is provided by a three stage phase shift circuit. The three stages are formed by C2 - R1, C3 - R2, and C4 plus the input impedance of Tr1. At a certain frequency (about 500Hz in this case) there will be a phase shift of 60 degrees through each section of the phase shift network, giving a total phase shift of 180 degrees. Thus, although the collector and base of Tr1 are 180 degrees out-of-phase, the phase shift network counteracts this, so that positive feedback is produced. Since the gain of Tr1 exceeds the losses through the phase shift network at this frequency, oscillation is produced.

Tr2 is used as an emitter follower buffer stage which reduces the level of loading on Tr1. This is important, as it is otherwise quite likely that a fairly low load impedance across the output would reduce the gain of Tr1 to the point where oscillation ceased. VR1 is the emitter load for Tr1, and is also the output level control. C5 provides D.C. blocking at the output, and S1 is the on/off switch. The current consumption of the circuit is about 5mA.

C2 to C4 should have a tolerance of 5% or better

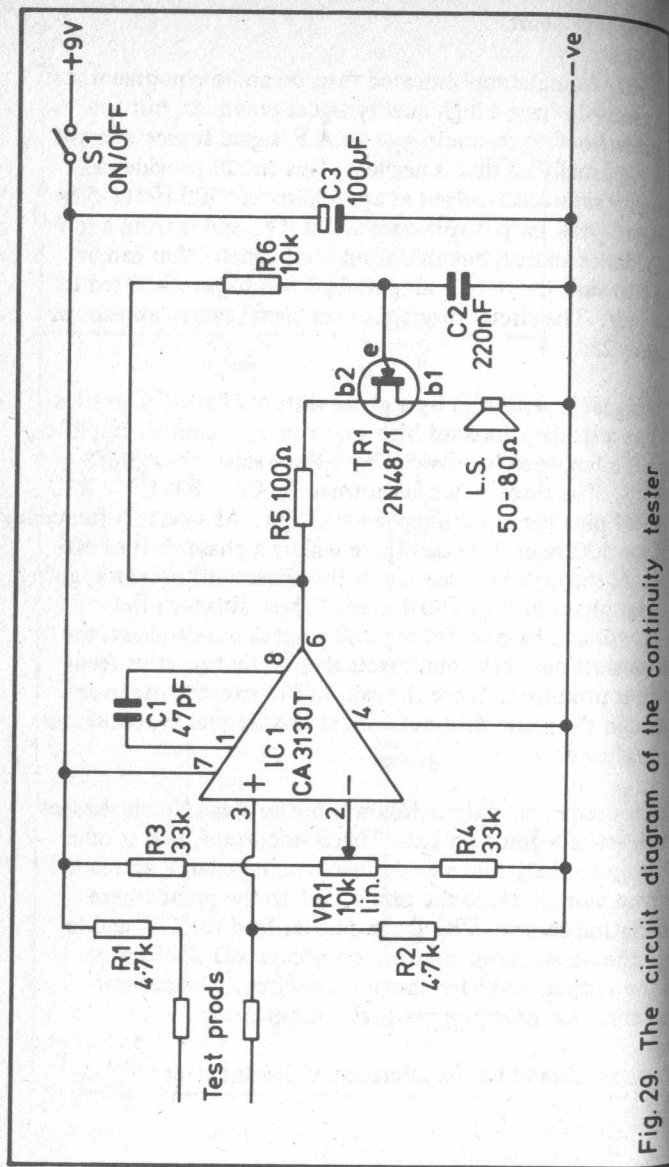

Fig. 29. The circuit diagram of the continuity tester

Continuity Tester

A continuity tester is a very useful item of test gear, and can be used for such things as checking fuses, cables, p.c.b. tracks, and for accidental short circuits on component boards. Many simple designs suffer a couple of drawbacks, one of which is that they indicate that there is continuity even if there is in fact a resistance of tens, or even hundreds of ohms across the test prods. The other is that there is often quite a high current passing through the test prods when there is continuity across them. Admittedly, neither of these are of importance on many occasions, but they can sometimes cause problems.

The continuity tester circuit shown in Figure 29 overcomes both the problems mentioned above, but is still very simple. IC1 is an operational amplifier which is used here as a comparator. With the test prods shorted together, R1 and R2 bias the non-inverting input to nominally half the supply voltage. The inverting input is biased by a potential divider which consists of R3, VR1 and R4. VR1 is adjusted so that the voltage fed to the inverting input is marginally lower than that fed to the non-inverting input when the test prods are connected together. Thus, with continuity across the prods, the output of IC1 goes high, and supplies power to the relaxation oscillator based on Tr1. The output of this is fed to a high impedance loudspeaker which emits an audio tone. With the prods open circuit the non-inverting input is taken to the negative rail potential by R2, the output of IC1 goes low, and no output is produced by the oscillator.

If a small resistance is present across the test prods, a small voltage will be dropped across this resistance. The voltage fed to the non-inverting input is therefore a little lower than when there is zero resistance across the test prods, and is slightly less than the inverting input's potential rather than a little higher. The output of IC1 remains low, and no audio output is produced. When properly adjusted, the circuit will only respond to a resistance of about 3 ohms or less across the test prods. The maximum current through the test points is only about 950 μ A.

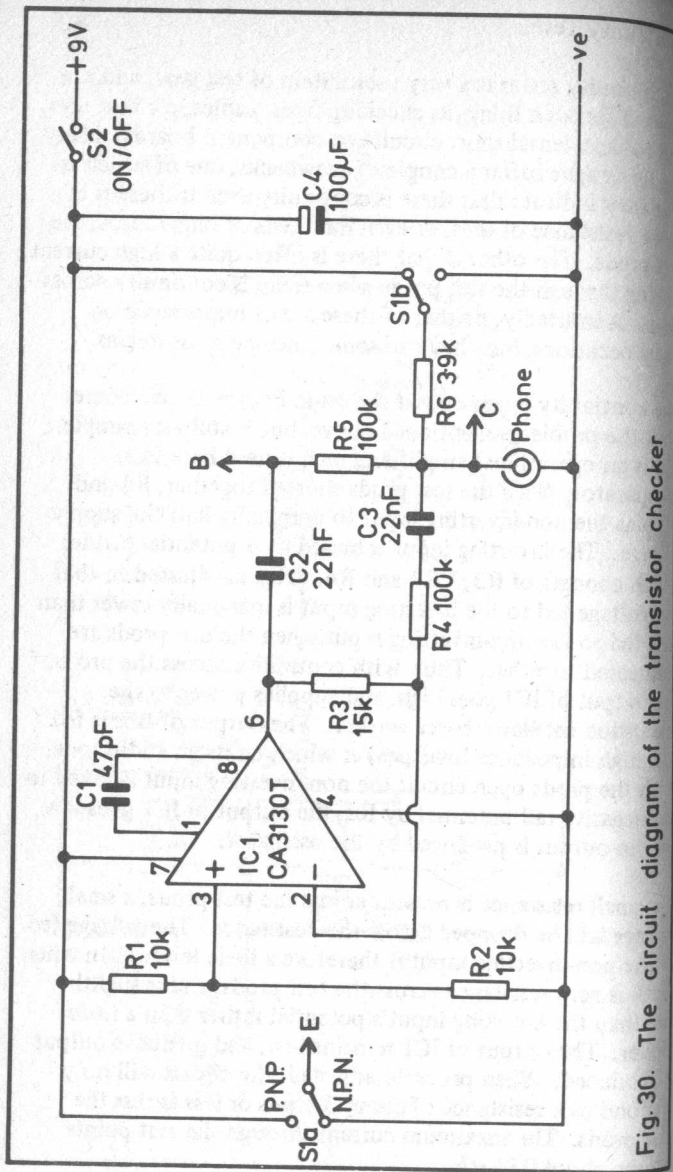

Fig.30. The circuit diagram of the transistor checker

C1 is the compensation capacitor for IC1 and S1 is the on/off switch. The current consumption of the unit is about $300 \mu\text{A}$. with the test prods open circuit, and about 4mA . when they are closed circuit.

In practice, VR1 is adjusted for the highest slider voltage that does not cause the audio tone to cut off (when the test prods are shorted together).

Transistor Checker

This device is intended for use as a quick checker to determine whether or not the test device is serviceable, and it is not designed to measure gain, leakage, or other parameters. The test device is connected to the test socket, and an audio tone will be heard from an earphone if it is functioning properly. The circuit diagram of the checker is shown in Figure 30.

IC1 is an operational amplifier which is connected to operate as an inverting amplifier. R1 and R2 bias the non-inverting input, while R3 and R4 are a negative feedback network which set the voltage gain of the amplifier. In this case there is in fact no voltage gain, and the specified values give a loss of about 17dB.

The device under test is connected as a common emitter amplifier having R6 as its collector load and R5 to provide base biasing. S1 is used to connect the supply to the test device with the appropriate polarity for type being checked (i.e. an n.p.n. or a p.n.p. type). C2 couples the output of IC1 to the base of the test device. C3 couples the output from the collector of the test device back to the input of IC1. As there is an inversion through both IC1 and the common emitter stage employing the test device, positive feedback is provided by C3, and the circuit will oscillate provided the gain through the common emitter stage at least compensates for the losses through IC1. A crystal earpiece receives the output from the collector of the test device, and if the latter is serviceable, produces an audio tone from the oscillations it receives.

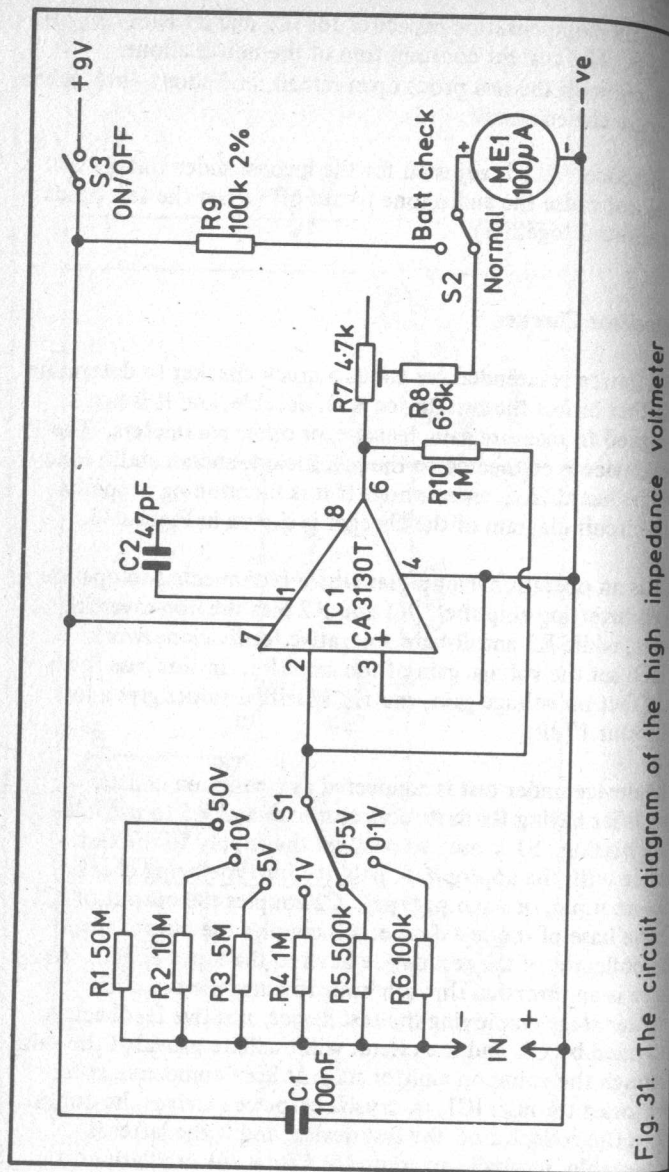

Fig. 31. The circuit diagram of the high impedance voltmeter

On/off switching is provided by S2, and C1 is the compensation capacitor for IC1. The quiescent current consumption of the circuit is only about 500 μA ., and the consumption with a serviceable transistor in circuit is approximately 2mA.

High Impedance Voltmeter

As many readers will be aware, problems can arise when making voltage measurements on high impedance circuits when using an ordinary multimeter to make the measurements. This is simply because the current in the circuitry under test is inadequate to operate the meter movement in the multimeter without a large voltage drop occurring. This results in low, and misleading readings being obtained. This problem can be overcome by using a high impedance voltmeter which uses an amplifier ahead of the meter movement, so that only a very low input current is drawn. The design shown in the circuit diagram of Figure 31 has six ranges (0.1, 0.5, 1, 5, 10 and 50V. f.s.d.), and has a sensitivity of 1 megohm per volt (a normal multimeter has a typical sensitivity of only 20 kilohms per volt).

The circuit is basically just an inverting operational amplifier arrangement driving a voltmeter circuit. The latter is comprised of R7, R8 and ME1: R7 being adjusted for a f.s.d. sensitivity of 1 volt. The negative feedback loop consists of R10 plus whichever of the input resistors is selected using range switch S1. By having six input resistors of different values, six gains and six f.s.d. values are obtained. For example, with R4 selected using S1, the amplifier has unity gain, and a f.s.d. sensitivity of 1 volt. With R5 selected, the gain is increased to two, and only 0.5 volts is required at the input to produce f.s.d. of ME1. With R3 switched into circuit the voltage gain drops to only 0.2 times, and 5 volts is required at the input for f.s.d. of ME1. With S2 in the "batt check" position, ME1 is connected across the supply rails via R9. The latter converts the meter to a 10V. f.s.d. voltmeter which can be used to check the battery voltage. The only other control is on/off switch S3. Although this type of circuit

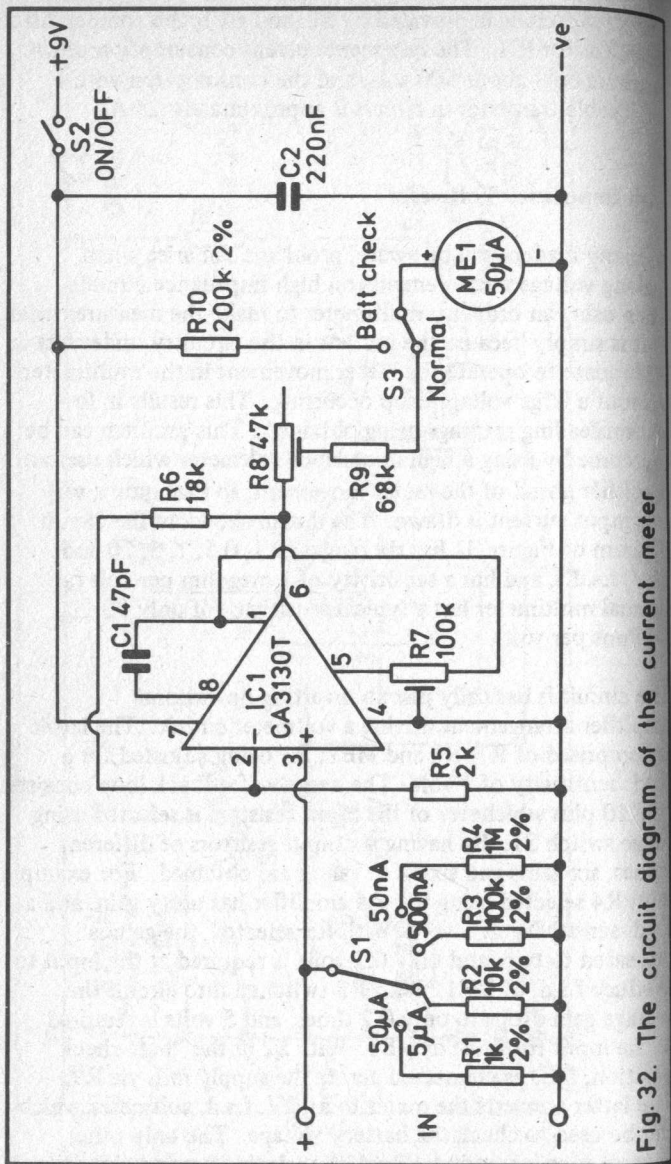

Fig. 32. The circuit diagram of the current meter

would normally use dual balanced supply rails, the CA3130T will work perfectly well in this circuit with just a single supply rail. The current consumption of the unit is only about 500 μ A.

R4, R6, R9 and R10 should all have a tolerance of 2% or better. R1 can consist of five 10M 5% resistors wired in series. R2 can be a 10M 2% component if a suitable component can be obtained. Otherwise, a 5% component of ten 1M 5% or better resistors wired in series can be used. R5 can consist of a 470k 2% or better resistor wired in series with a 30k 5% or better component. The unit is calibrated by connecting the unit to an accurately known voltage (i.e. a 9 volt battery with the exact battery voltage being measured using a multimeter), after switching S1 to a suitable range (the 10V. range if a 9 volt battery is used as the source). R7 is then adjusted to give the appropriate reading on ME1.

Current Meter

An ordinary multimeter does not have very low current ranges, since the sensitivity of the meter movement employed (usually a 50 μ A. type) is inadequate to provide such ranges. This simple circuit enables currents of only a few nanoamps to be accurately measured, and provides four measuring ranges which are as follows:- 50nA., 500nA., 5 μ A. and 50 μ A. f.s.d. The last range is in fact only equal to the sensitivity of the meter used in the unit, but is included to enable the unit to be calibrated against a multimeter switched to the 50 μ A. range. The circuit of the current meter is shown in Figure 32.

IC1 is an operational amplifier which is used in the non-inverting mode, with R5 and R6 setting the voltage gain of the circuit at 20dB. (ten times). R8 and R9 are used in series with ME1 to produce a voltmeter having a f.s.d. value of 500mV. Therefore, just 50mV. is needed at the input of the amplifier to give f.s.d. of ME1. From Ohms Law it can be seen that with R1 switched into circuit by range switch S1, a current of 50 μ A. is needed through the input to produce a voltage of 50mV. across R1 and give f.s.d. of ME1. Higher

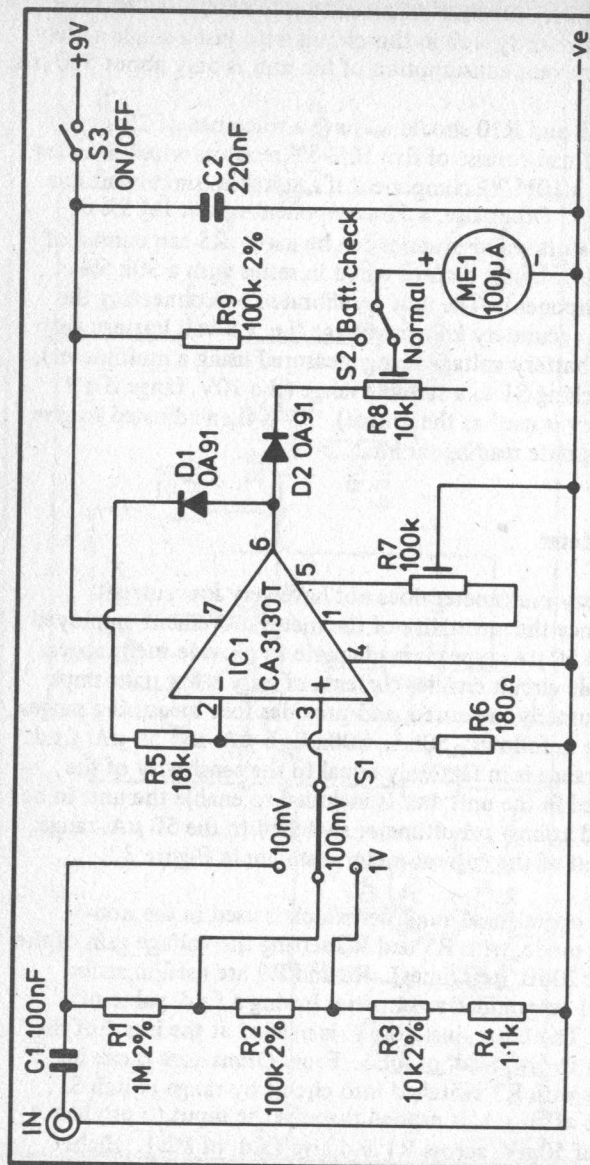

Fig. 33. The circuit diagram of the audio millivoltmeter

value range resistors are used on the other three ranges, giving proportionately higher sensitivity. IC1 has an extremely high input impedance (typically 1.5 million megohms), and despite the high value of the input resistors on the 50 and 500nA. ranges, it does not have a significant shunting effect on them.

R7 is an offset null control for IC1. Initially this should be adjusted with the slider well towards the pin 5 end of its track, giving a strong deflection of ME1. R7 is then adjusted in the opposite direction just far enough to zero the meter. The circuit has a battery check facility, as in the previous circuit. The current consumption of the circuit is approximately 900 μ A.

Audio Millivoltmeter

An audio millivoltmeter is required when making checks on audio equipment for such things as frequency response, gain, distortion etc. This simple design has an input impedance of over 1 megohm, a response which is flat over the audio frequency spectrum, and three measuring ranges of 10mV., 100mV., and 1V. R.M.S. The circuit diagram of the instrument is shown in Figure 33.

IC1 is an operational amplifier used in the non-inverting mode. The output is fed to a voltmeter circuit via diode D2. To compensate for the non-linearity of D2, diode D1 is included in the negative feedback circuit, giving non-linear feedback which counteracts the non-linearity of D2. This gives the unit linear scaling, and obviates the need for recalibration of the meter. R5 and R6 give the circuit a closed loop gain of just over 40dB. (100 times), and R8 is adjusted for a basic sensitivity of 100mV. R.M.S. for f.s.d. of ME1. R1 to R4 form a three stage attenuator which can be used to reduce the sensitivity of the unit to 100mV. or 1V. R.M.S., thus giving the unit its three measuring ranges. S1 is the range switch. Although the attenuator is in a high impedance part of the circuit, it seems to give a flat response at audio frequencies. CI

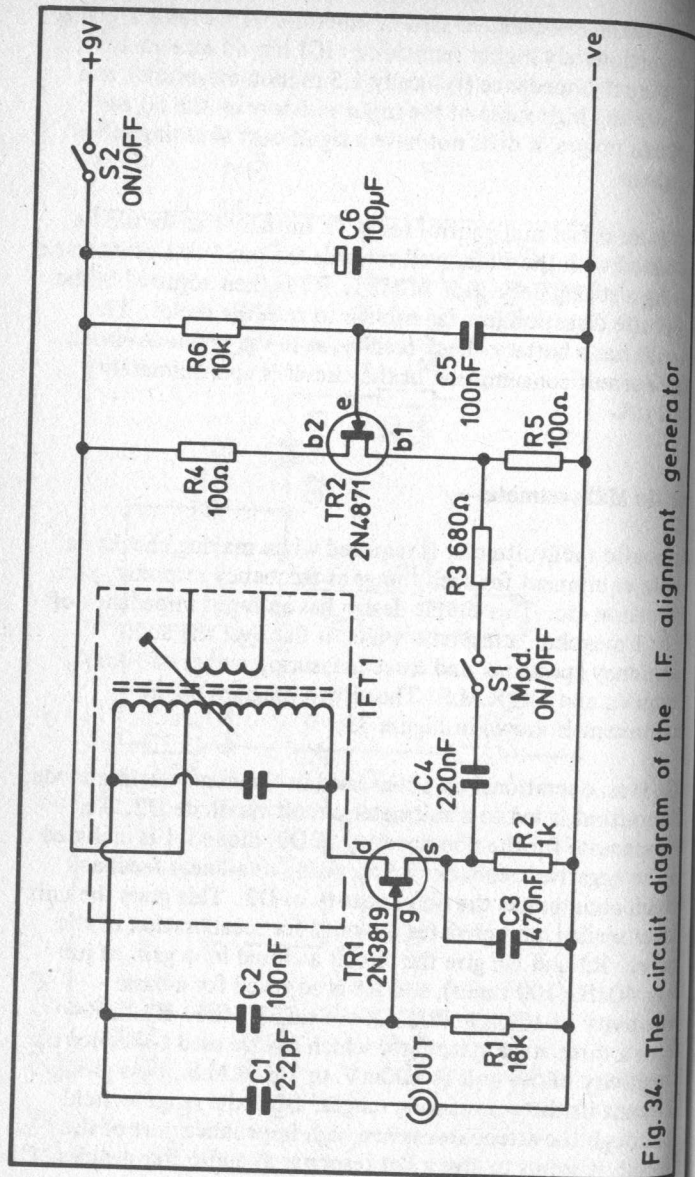

Fig. 34. The circuit diagram of the I.F. alignment generator

provides D.C. blocking at the input. IC1 is operated without any compensation capacitor as it is used here at a fairly high voltage gain, and needs to have a reasonably wide bandwidth and high slew rate. As in the previous two circuits, a battery check facility is included. The current consumption of the circuit is about 900 μ A.

The adjustment of offset null control R7 was covered in the previous section of this book, and will not be repeated here. In order to calibrate the unit a known audio frequency voltage is required, and this voltage should be one that is equal to, or nearly equal to an f.s.d. value of one range of the millivoltmeter. One method of obtaining a suitable voltage is to use an A.F. signal generator or signal source to provide the signal, with a multimeter being used to enable the output to be adjusted to 1 volt R.M.S. Adjust R8 for maximum resistance, couple the calibration signal to the input of the millivoltmeter, and then adjust R8 for precisely full scale deflection of ME1.

I.F. Alignment Generator

An I.F. alignment generator is useful when testing A.M. superhet receivers, realigning them, or when realigning a newly constructed set. This alignment generator provides an output at the standard U.K. I.F. of 470kHz, and has an output which can be either modulated or unmodulated. The circuit diagram of the unit appears in Figure 34.

The 470kHz signal is generated by Tr1 and its associated components. This is a straight forward common source Hartley oscillator, with the primary winding of an I.F. transformer being used as the tuned circuit. The secondary winding is ignored. The capacitor connected across the main winding of IFT1 is an internal component of the I.F.T., incidentally. The output signal is taken from the upper end of IFT1 via D.C. blocking capacitor C1.

If the receiver is aligned using the method where the I.F. trans-

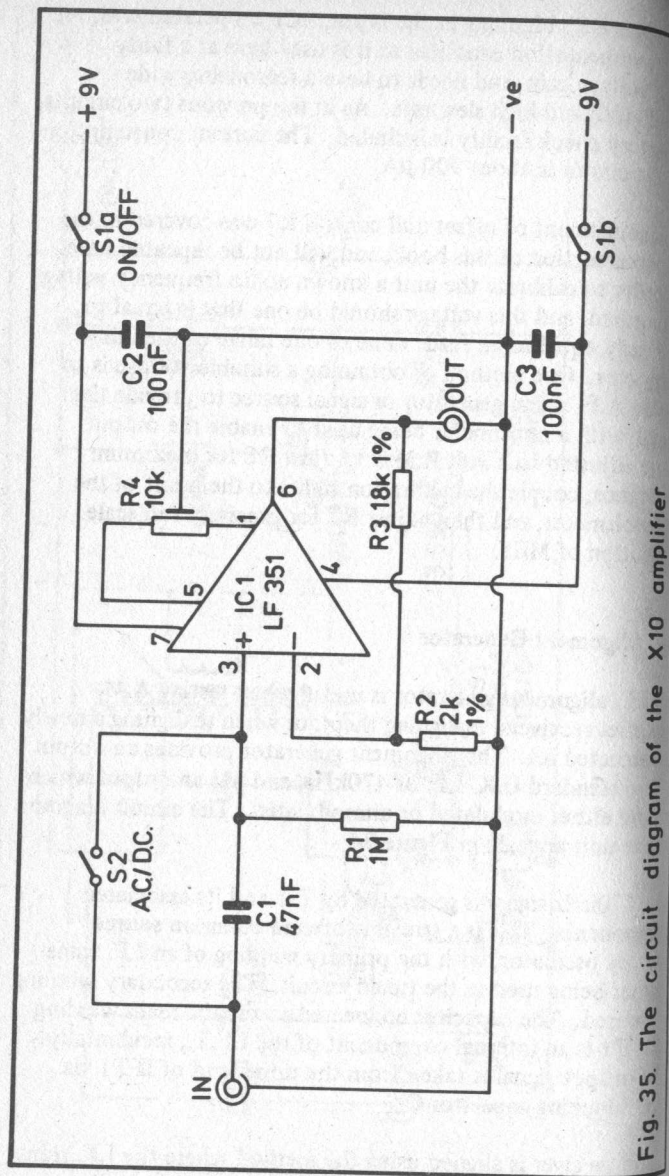

Fig. 35. The circuit diagram of the X10 amplifier

formers are adjusted to give maximum A.G.C. voltage, no audio modulation of the output is necessary. However, it can be very helpful to have the signal modulated when making the initial adjustments to the I.F. transformers, and it is obviously essential to have a modulated output if the I.F. transformers are being adjusted for maximum audio output.

The modulation signal is provided by a unijunction relaxation oscillator based on Tr2. This is quite conventional, and it is the positive pulse output from the base 1 terminal of Tr2 that is used as the modulation signal. This is coupled to the source circuit of Tr1 via R3, C4 and modulation on/off switch S1. R3 and C3 filter out the high frequency harmonics of the modulating signal, which would otherwise give the output signal an undesirably wide bandwidth.

In the absence of suitable test equipment to enable the core of IFT1 to be adjusted for an output at 470kHz, the core can simply be left untouched. The I.F. transformer is pre-aligned, and the output frequency should be adequately close to 470kHz. IFT1 is a Denco IFT13/470kHz component incidentally.

The approximate current consumption of the generator is 3mA. with the modulation on, and about 4.5mA. with it switched out.

X10 Amplifier

This unit is a D.C. coupled amplifier having a voltage gain of 20dB. (ten times). It is primarily intended for use as a preamplifier to increase the sensitivity of an oscilloscope. However, it can also be used to boost the sensitivity of a multimeter switched to a low A.C. or D.C. voltage range. For example, if the output is fed to a multimeter switched to the 5 volt D.C. range, one effectively obtains a high impedance voltmeter having a f.s.d. value of 500mV. (0.5 volts). The circuit has an input impedance of 1 megohm and a response which is virtually flat up to 400kHz. The circuit diagram of

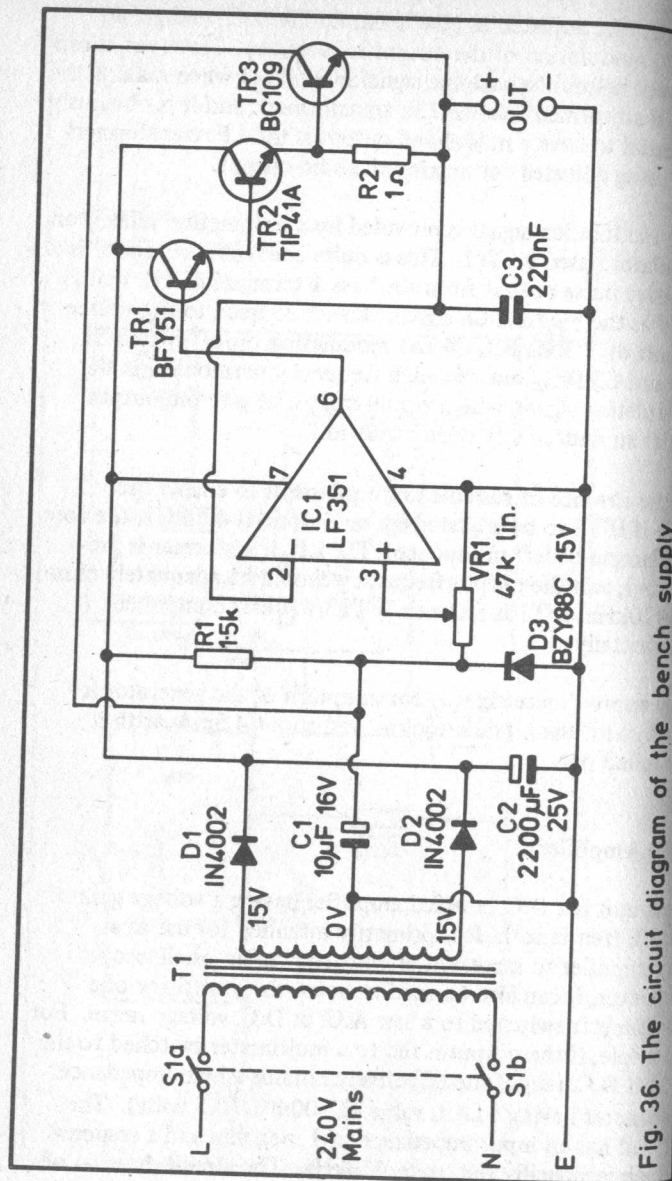

Fig. 36. The circuit diagram of the bench supply

the unit is shown in Figure 35.

A conventional operational amplifier non-inverting circuit is used, with R2 and R3 forming a negative feedback network which sets the voltage gain at 20dB. (the gain is equal to $R2 + R3$, divided by R2). R1 biases the non-inverting input of IC1 to the earth rail and sets the input impedance of the circuit at 1 megohm. The input impedance of IC1 is extremely high (typically one million megohms) as it is a low noise type having a JFET input stage. D.C. coupling is provided at the input when S2 is closed, but A.C. coupling will be provided by C1 if S2 is opened. R4 is an offset null control, and is adjusted to give zero quiescent output voltage. C2 and C3 are supply decoupling components, and S1 is the on/off switch. As is normal for a D.C. operational amplifier circuit, dual balanced supplies are used, and these can be provided by two small 9 volt batteries. The current consumption of the circuit is approximately 2mA. from each supply.

It should be borne in mind that the maximum output the amplifier can provide is about ± 7 volts, or a little under 5 volts R.M.S.

Bench Supply

A bench power supply is undoubtedly one of the most useful items of equipment for an electronics workshop. This design provides an output which is continuously variable from less than 1 volt to approximately 15 volts. The output is well smoothed and stabilised. The maximum output current is a little in excess of 600mA., and current limiting circuitry is included to prevent accidental short circuits or overloads on the output from damaging the unit. Figure 36 shows the complete circuit diagram of the Bench Supply Unit.

T1 is a mains transformer having a 15 – 0 – 15 volt secondary with a current rating of 1 amp or more. Its output is full wave rectified by D1 and D2, with the resultant pulsed D.C. then being smoothed by C2. R1, C1 and D3 form a conventional

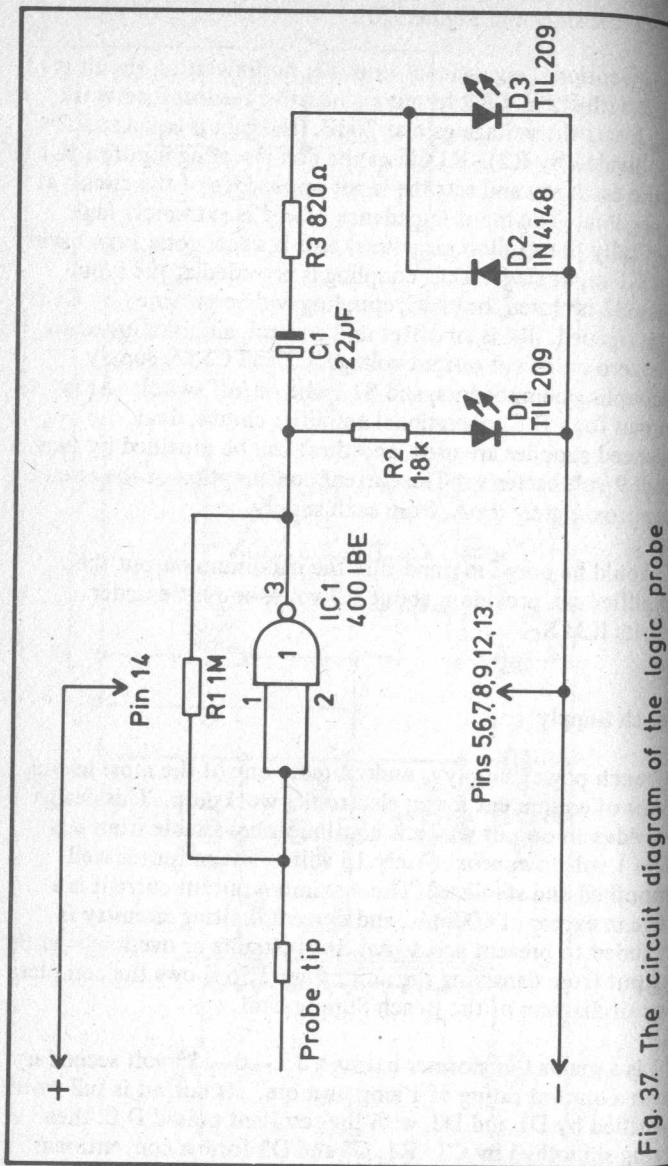

Fig. 37. The circuit diagram of the logic probe

zener stabiliser circuit which gives a nominal output voltage of 15 volts. VR1 is fed with this stabilised potential, and it can provide a stabilised slider voltage of anything from zero to the full 15 volts. Of course, this supply is at only a high impedance, and it is therefore fed to the output via a buffer amplifier that provides unity voltage gain, but a high current gain. This amplifier uses IC1 in the non-inverting mode, with discrete Darlington Pair, emitter follower output stage, Tr1 – Tr2, being used to give the circuit the necessary high output current capability. There is a 100% negative feedback loop from the output to the inverting input of IC1, giving the required unity voltage gain. R2 and Tr3 are used in a standard current limiting circuit. At output currents of more than about 600mA., the voltage across R2 is sufficient to bring Tr3 into conduction. Much of the current which was formerly fed through R1 into D3 is then diverted through Tr3 and the load, causing a reduction in the voltage across D3 (and therefore a similar reduction in the output voltage). With a short circuit on the output, the output voltage reduces to virtually zero, and an output current of only about 650mA. flows. C3 improves the transient response of the circuit, and S1 is the on/off switch.

Tr1 should be fitted with a small clip-on heatsink, and Tr2 should be mounted on a substantial heatsink. VR1 can be fitted with a scale calibrated with output voltages. As this project is mains powered, the normal safety precautions should be observed (e.g. earth any exposed metal work, do not use a case that has a lid or cover which simply unclips).

Logic Probe

A logic probe is simply a device which indicates the logic state present at the point in the circuit which is under investigation, and is an extremely useful item of test gear for anyone who deals with logic circuits. The very simple logic probe circuit of Figure 37 is suitable for use with CMOS and TTL circuits, and indicates whether the test point is at logic 0, logic 1, floating or pulsing.

The unit is based on a 4001BE quad 2 input NOR gate, and only one gate is used. The inputs of the unused gates are tied to the negative supply rail to prevent spurious operation and possible damage to the device. The two inputs of the used gate are wired together so that an inverting action is provided. R1 biases the inverter so that about half the supply potential is present at the input and output of the inverter under quiescent conditions. L.E.D. indicator D1 is fed from the output by way of current limiting resistor R2, and will light up under quiescent conditions, or if the test point is floating. However, D1 will light up at less than full brightness. If the input is taken to logic 0 (low), the output of the inverter will go high, causing D1 to light up at full brilliance. If the input is taken to logic 1 (high), the output of the inverter will go low, and D1 will be switched off. If the input is pulsing, the output of the inverter will obviously be switching from one logic level to the other in sympathy. This alternating signal is coupled by C1 and current limiting resistor R3 to L.E.D. indicator D3, which lights up on positive going outputs. If the input is pulsing slowly, D3 will flash on and off at a rate which is perceivable by the user. On fast inputs D3 will appear to light up continuously. D2 protects D3 against excessive reverse voltages. Of course, C1 blocks D.C. signals so that D3 does not respond to a static input. Due to its simplicity, the circuit will not respond to extremely brief and infrequent pulses.

The circuit takes its power from the supply lines of the equipment being tested. The maximum current consumption is only a few mA., and so the unit does not significantly increase the loading on the supply.

Add-On Current Limiter

Although most modern power supplies incorporate current limiting circuitry to prevent damage to the supply in the event of an overload or short circuit on the output, the maximum output current is still usually quite high. This can result in little protection being afforded to the supplied equipment, and can result in costly damage when experimenting with

delicate components. Some power supply units have several switched current limit levels, or a continuously variable output current limiting level, but this feature is mainly confined to the more expensive and complicated designs. This simple add-on unit can be used when experimenting with expensive or delicate components, and can have a current limit level of anything from less than 1mA. to about 100mA. It can be used with input voltages of between about 6 and 24 volts. There is a voltage drop of about 0.6 volts through the unit, and it will inevitably reduce the regulation efficiency of the supply, since the voltage drop increases somewhat with rises in output current. However, in most applications this will not be a major drawback. The circuit of the unit is given in Figure 38.

This is really just a conventional constant current generator circuit, but in normal use the load will have an impedance which

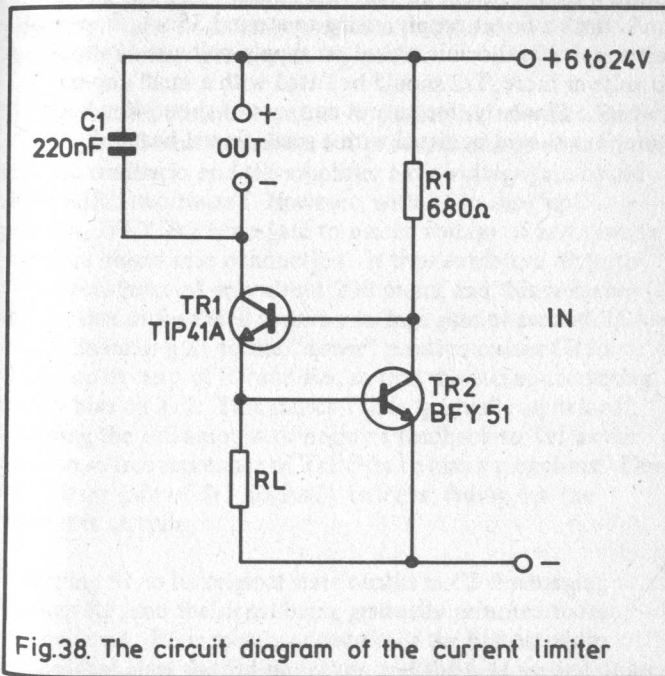

Fig.38. The circuit diagram of the current limiter

is too high to produce this current. The circuit therefore produces an output voltage which is as high as possible, and virtually equal to the input voltage. If an overload should occur, the constant current effect will be produced, giving a reduction in the output voltage so as to prevent an excessive current flow. Tr1 is biased into conduction by R1, causing virtually the full supply potential to be supplied to the load. However, if an excessive output current should flow, the voltage across RL will become large enough to bias Tr2 into conduction. Tr2 then diverts some of the base current for Tr1, causing Tr1 to conduct less heavily, and the output voltage to fall. Thus the desired current limiting action is produced.

The value of RL is 0.65 divided by the required limit current (in amps). For example, a limit current of 50mA. requires a 13 ohm resistor (0.65 divided by 0.05A. = 13 ohms). In addition to the output current, the circuit consumes about 7mA. from a 6 volt supply, rising to around 35mA. from a 24 volt supply. If the unit is used on supply voltages of about 20 volts or more, Tr2 should be fitted with a small clip-on heatsink. Similarly, for output currents of about 40mA. or more, Tr1 should be fitted with a small finned heatsink.

CHAPTER 4

MUSIC PROJECTS

Automatic Fader

An automatic fader is a circuit which fades the audio signal it is processing, without "clicks" or other noises, when a switch is operated. Most circuits of this type, including the one featured here, can be used to "fade" the signal back up to its original level by returning the switch to its original position.

Units of this type are used in the production of electronic music, and can also be used in disco systems where they are used to fade out the music while speech is being broadcast through the system. They can be used in a similar way when preparing a tape to accompany a cine or slide show. The circuit of the unit is shown in Figure 39.

Tr1 is used as a common emitter amplifier, but the inclusion of unbypassed emitter resistor R4 produces a large amount of negative feedback, and the amplifier has a voltage gain of only about 6dB. (two times). However, with S1 in the "up" position, JFET Tr2 has a gate to source voltage of zero, and is therefore biased into conduction. It thus exhibits a drain to source resistance of only about 200 ohms, and this reduces the amount of feedback to give a voltage gain of around 25 times. Switching S1 to the "down" position causes C3 to charge up by way of R5 and R6, so that there is an increasing reverse bias on Tr2. This causes Tr2 to gradually switch off, returning the full amount of negative feedback to Tr1 as the drain to source resistance of Tr2 rises to many megohms. Thus the voltage gain of Tr1 gradually reduces, fading out the signal it is carrying.

Returning S1 to its original state results in C3 discharging through R5, and the signal being gradually returned to its original level. R6 is merely adjusted for the highest slider voltage that gives the fading action, and the fade up and down

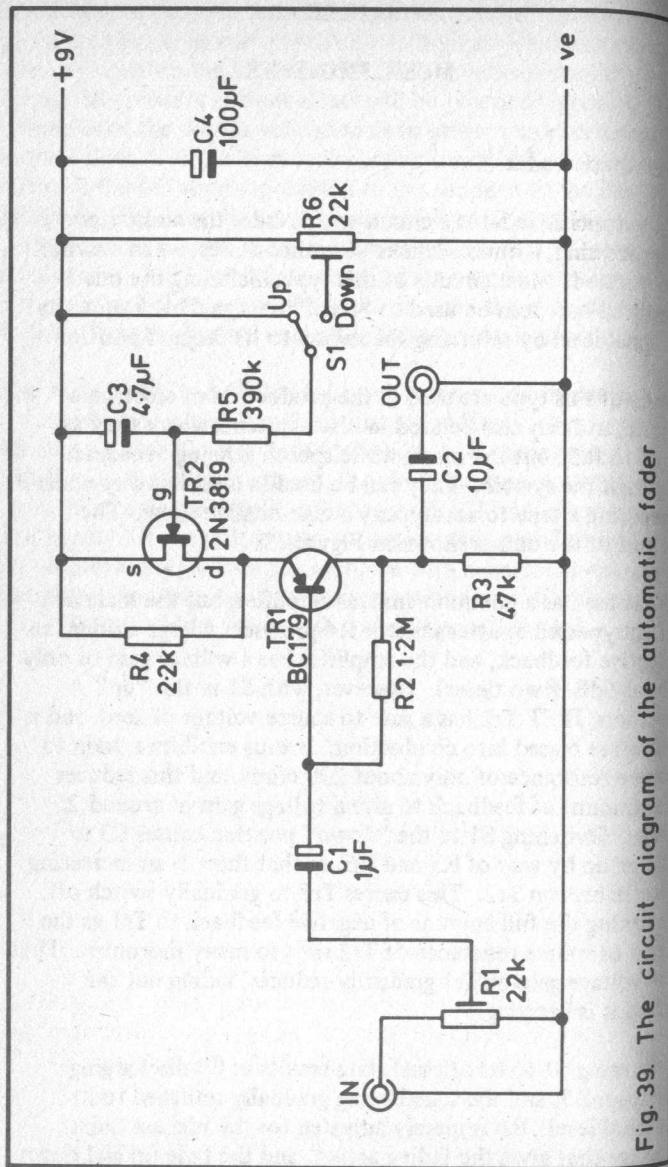

Fig. 39. The circuit diagram of the automatic fader

times should then be reasonably well matched. If the maximum level of fade (which is over 20dB.) is not required, R6 should be adjusted for a slightly higher slider voltage. The fade time is about 1 to 2 seconds, but can easily be altered as it is roughly proportional to the value of C3. In most applications the full gain of the unit will not be required, and a maximum gain of unity will be all that is needed. Variable attenuator R1 has therefore been included in the circuit, so that the gain can be backed off to the required level.

The current consumption of the unit is about 1mA.

Tremolo Unit

The tremolo effect is one of the best known musical effects, and is produced by low frequency amplitude modulation of the input signal. In this unit, the circuit of which is shown in Figure 40, the modulator is based on R4 and Tr2. R6 is adjusted so that Tr2 is biased for a drain to source resistance of about 1k or so. This gives a loss of about 14dB. through R4, but the gain provided by the common emitter output amplifier based on Tr1 largely compensates for this loss, giving a voltage gain of about unity through the unit.

When S2 is closed, the tremolo effect is brought into action, and the sawtooth output from a unijunction relaxation oscillator using Tr3 is coupled by C7 to the gate of Tr2. C4 and R5 form a simple low pass filter which prevent the higher frequency harmonics on this signal from reaching Tr2's gate, and this results in a smoother and more pleasant tremolo effect. The modulation signal raises and lowers the gate voltage of Tr2, causing the drain to source resistance of the device to be varied from a few hundred ohms to several megohms, with consequent increases and reductions in the losses through R4, and the required tremolo effect being produced. The tremolo frequency can be varied by means of VR1 from about 3Hz to 9Hz.

The current consumption of the unit is approximately 3mA.

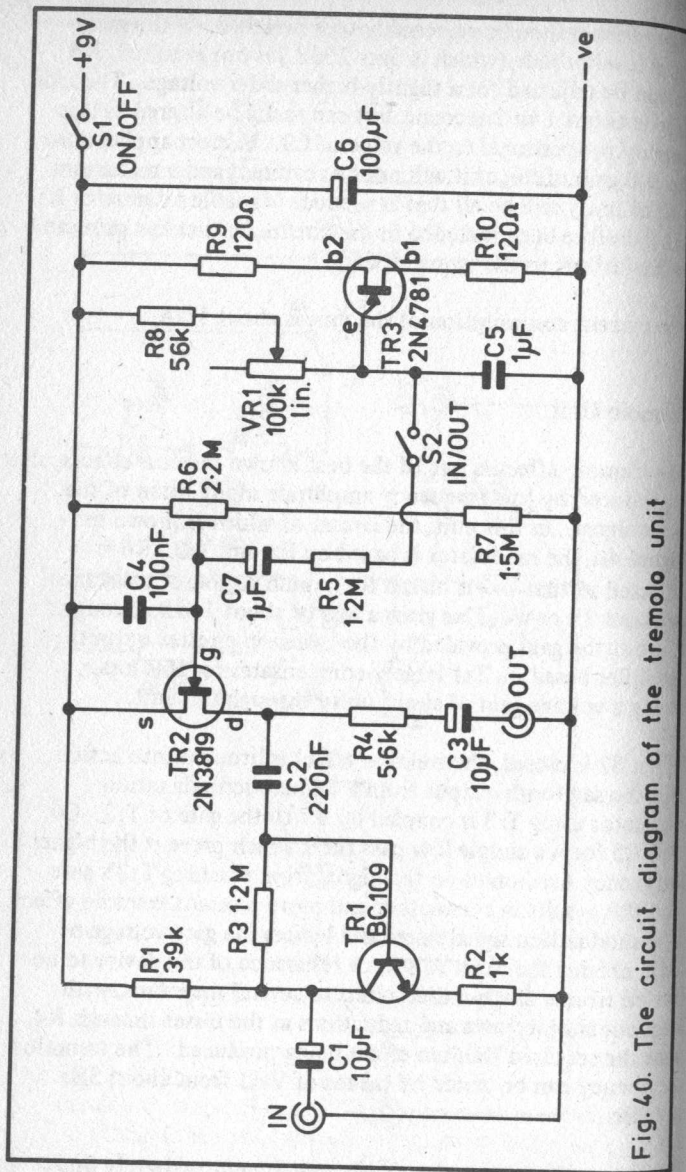

Fig.40. The circuit diagram of the tremolo unit

Treble Booster

Treble boosters are mainly used with electric guitars to give a more "brilliant" sound to the instrument. As the name implies, a circuit of this type merely boosts the treble response of the equipment, boosting the higher frequency harmonics on the signal from the guitar and producing a more brilliant sound. The circuit diagram of the treble booster appears in Figure 41.

The circuit is basically just a straight forward JFET common source amplifier. However, with S1 in the open position, there is no bypass capacitor across source bias resistor R4, and the consequent negative feedback reduces the gain of the amplifier to only about unity. With S1 closed, the treble boost is brought into action. C3 then bypasses R4, but due to the fairly low value of C3 it is only effective at the higher audio frequencies. This gives the unit a response which rises above about 2kHz, giving the required treble boost. Tr1 can provide a maximum gain of only about 18dB., and so there is no need to include a resistor in series with C3 to limit the amount of boost that is applied. C4 rolls off the response of the unit at the highest audio frequencies, and this gives a more pleasant and less harsh sounding output.

The current consumption of the circuit is typically a little under 1mA.

Fuzz Unit

"Fuzz" is another example of a well known and much used musical effect. It is primarily used with the lead guitar, but can sometimes be usefully employed with other instruments. The "fuzz" effect is produced by severely distorting the input signal, so that the harmonics are boosted, and new ones may well be generated. Fuzz units usually have an additional effect of altering the attack and decay characteristics of the instrument. This circuit produces an output that has virtually instant attack and decay, giving an organ-like effect. The circuit

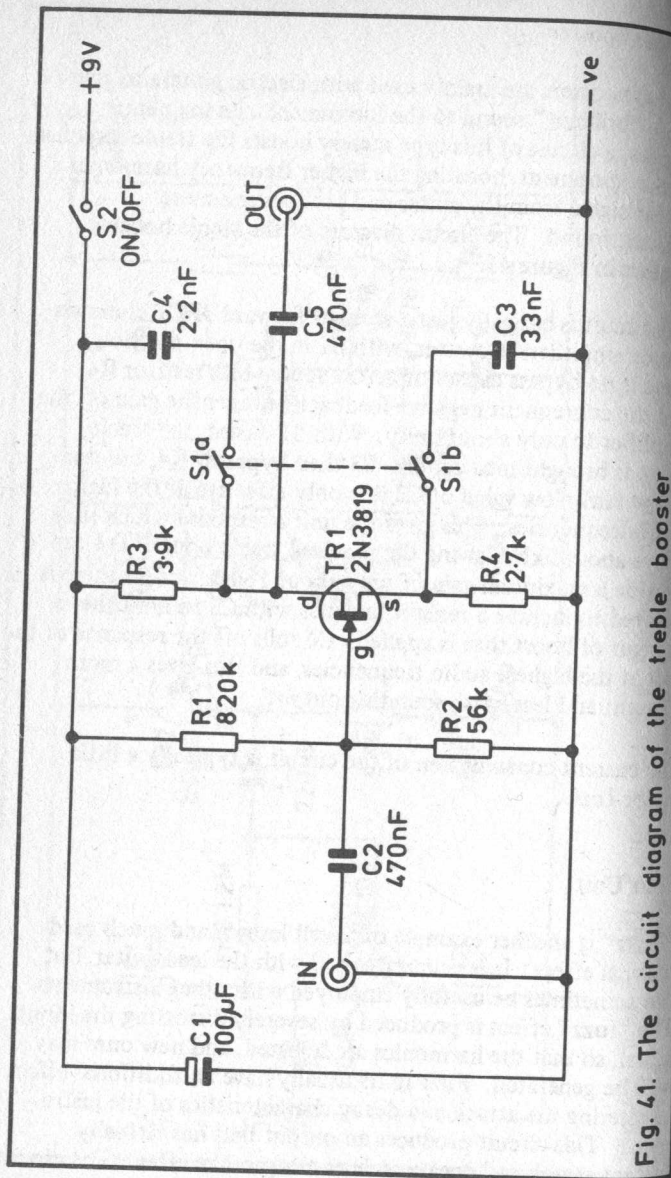

Fig. 41. The circuit diagram of the treble booster

is shown in Figure 42.

Tr1 is used in a common emitter preamplifier stage which boosts the input signal to a level which is sufficient to drive the subsequent stage, which is a Schmitt trigger. C3 rolls off the high frequency response of the preamplifier and helps to prevent instability.

The Schmitt trigger circuit is based on operational amplifier IC1, and is quite conventional in design. R6 and R7 bias the inverting input of IC1 to about half the supply voltage, and R4 is adjusted to bias the non-inverting input to the same level. The output from Tr1 is coupled to the slider of R4 by C4, and the signal from Tr1 has the effect of modulating this voltage at the input frequency. As the voltage here alternates above and below the bias voltage fed to the inverting input of IC1, the output of IC1 alternates between the high and low states as it effectively functions as a comparator. R8 introduces D.C. positive feedback between the output and non-inverting input of IC1, giving a triggering action and a small amount of hysteresis which ensures that the output switches cleanly from one state to the other with no instability under quiescent conditions. Provided there is an input signal of sufficient amplitude (more than a few mV. R.M.S.), a rectangular output signal of the same frequency as the input signal will appear at the output of IC1. Of course, if the input signal does drop to an insufficient level, the Schmitt trigger ceases to function and the output ceases immediately. Thus there is either full output or no output, giving the organ-like effect referred to earlier.

The output level from IC1 is considerably larger than is needed to drive most guitar amplifiers, and so the output is attenuated by R9 and R10. R9 is adjusted so that the volume is approximately the same with the fuzz effect in use, and with S1 switched to bypass the unit. S1 should be a foot operated switch. The only other control is on/off switch S2. The current consumption of the unit is about 3mA.

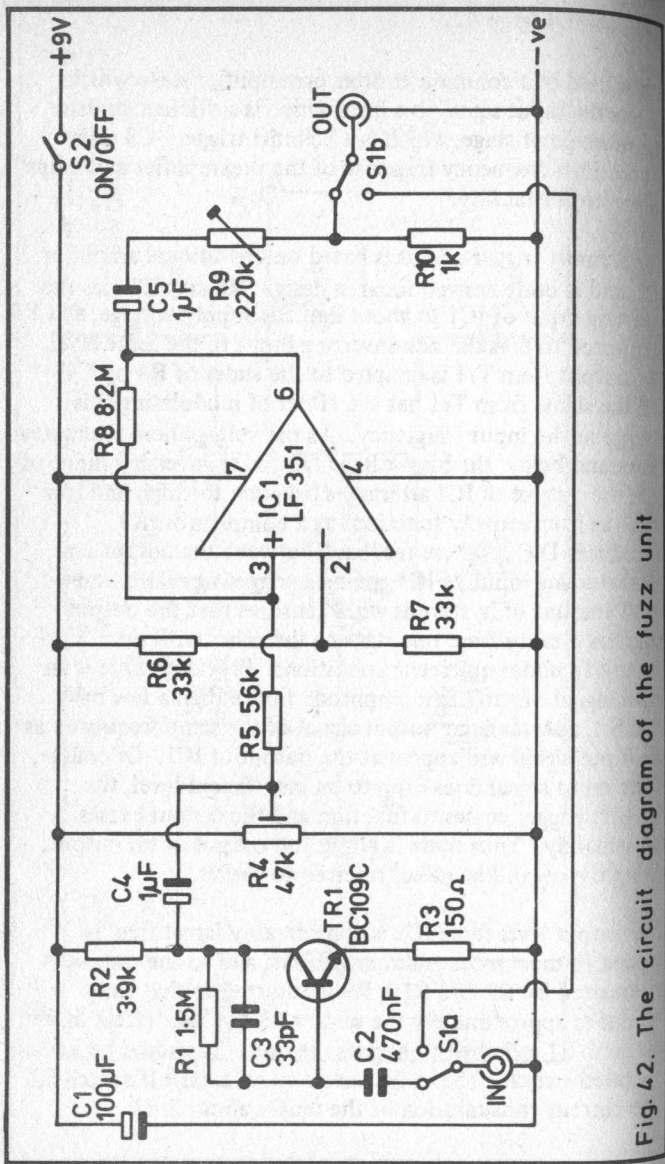

Fig. 42. The circuit diagram of the fuzz unit

A.F. Noise Source

Audio noise sources are used in electronic music to produce a number of special effects, normally in conjunction with envelope shapers and (or) bandpass filters. This simple unit, which has its circuit shown in Figure 43, provides a white noise output of about 100mV. R.M.S., but the exact figure will vary considerably from one unit to another.

The noise generator device is germanium transistor Tr1. This is connected with collector load R1, but without any base biasing. Therefore only leakage current flows through the device, and the precise current flow varies randomly, and rapidly, producing the noise signal. The amount of noise produced seems to vary considerably from one device to another, but a number of germanium p.n.p. transistors were tried in the circuit, and all gave a reasonably high output level. No doubt many constructors will find a suitable component in their spares box.

The output signal from Tr1, although quite strong compared with that from most noise generating devices, is nevertheless still at quite a low level, and in virtually all practical applications it would be inadequate in this respect. IC1 is therefore used as a straight forward inverting mode operational amplifier giving a voltage gain of about 180 times, and this boosts the output to a level which is suitable for most practical purposes. Of course, further amplification can be given to the output signal if an even higher signal level is required. The signal can be boosted somewhat by raising the value of R5, although the frequency response of the amplifier will be inadequate at high audio frequencies if it is increased much, and this would degrade the noise quality.

The current consumption of the circuit is approximately 2mA.

Metronome

This unit provides a "clicking" sound at regular intervals, giving a good simulation of an ordinary mechanical metronome. The beat rate is continuously variable from about 35 to a little under 300 beats per second. The circuit diagram of the metronome appears in Figure 44.

IC1 is an operational amplifier which is connected to operate as a form of Schmitt trigger. The necessary biasing and positive feedback is provided by R1 to R3. The output of IC1 will trigger to the low state if the voltage at its inverting input is taken above $2/3 V+$, and it will trigger back to the high state if the inverting input is taken below $1/3 V+$.

C2 will be uncharged at switch-on, taking the inverting input to the negative supply potential and causing the output of IC1 to trigger to the high state. C2 then rapidly charges to more than $2/3 V+$ via R4 - D1, and R5 - VR1. IC1's output then goes low, causing C2 to discharge through R5 and VR1 only. When the charge falls below $1/3 V+$, IC1's output triggers back to the high state and C2 commences to charge up once again. Thus continuous oscillation is produced, with a series of brief positive pulses appearing at the output of IC1. The mark space ratio of the output is not 1 to 1 due to the inclusion of R4 and D1, which provide a low resistance charge path, but do not provide a discharge path due to the blocking action of D1. This gives C2 a charge time which is very short in relation to the discharge time, with a consequent shortening of the positive output time.

These short pulses are coupled to the loudspeaker by way of an emitter follower buffer stage which uses Tr1. This gives high but very brief pulses of current through the speaker, producing the required "clicking" sound. D2 and D3 reduce the minimum drive voltage to Tr1, which would otherwise be high enough to give a fairly high current through Tr1 and the speaker between output pulses. This would give the unit a rather high current consumption, rather than the consumption of only about 4mA, which is achieved with the circuit with D2

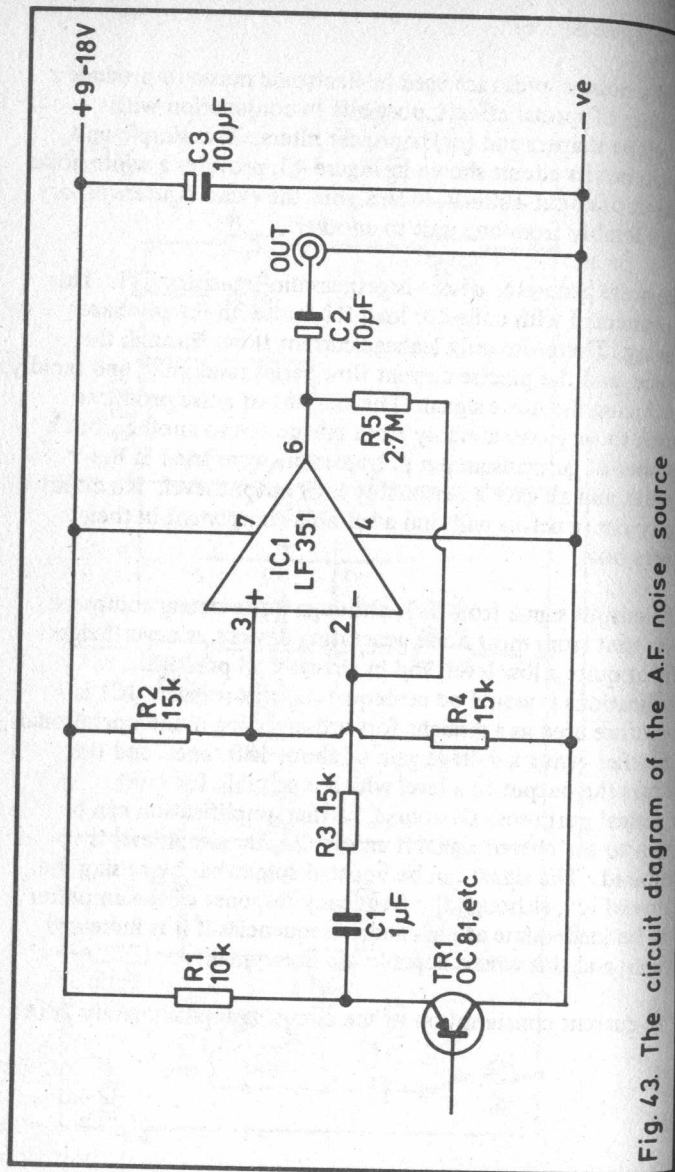

Fig. 43. The circuit diagram of the A.F. noise source

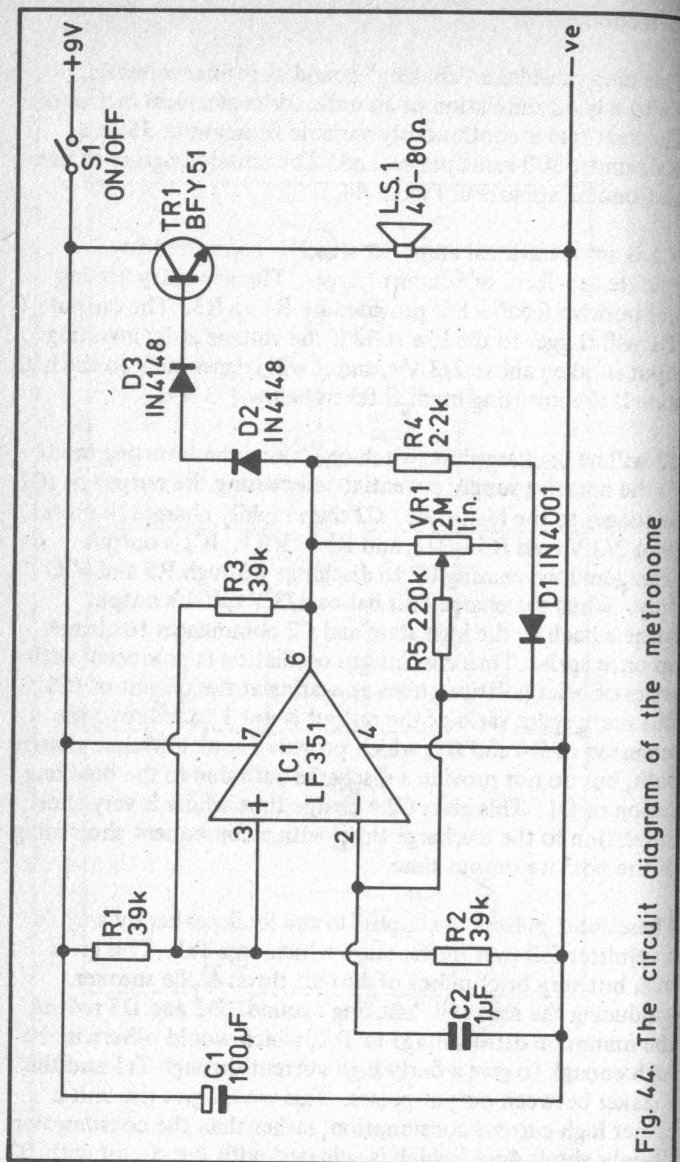

Fig. 44. The circuit diagram of the metronome

and D3 included.

The output frequency of the unit is adjusted by means of VR1, and this should be fitted with a scale calibrated in terms of beat rate. The beat rate is determined simply by counting the number of "clicks" produced in a one minute period (or by counting the number in, say, a 20 second period, and multiplying by three to find the number per minute).

Tuning Reference

This unit provides six switched notes, and these are adjusted to the six notes of a guitar, so that it can be used for tuning purposes. The notes can be adjusted over a wide range, and it should be possible to employ the unit with other instruments. The circuit diagram of the tuning reference is shown in Figure 45.

The circuit is basically the same as that of the metronome project featured previously in this book. However, the timing capacitor (C2) has been reduced in value as much higher output frequencies are required in this application. Also, instead of one variable resistor, the unit has six switched preset resistors, and these are adjusted by ear against a tuned instrument or pitch pipes to give the six required notes. Ideally multiturn trimpots should be used for R7 to R12, but ordinary 0.25 watt preset resistors can be tuned with sufficient accuracy if care is taken. R5 and C3 form a simple R - C low pass filter. This reduces the strength of harmonics on the output, making the fundamental more prominent and making tuning slightly easier.

The current consumption of the unit varies to some extent with variations in the output frequency, being about 5mA. at low frequencies, rising to around 35mA. at high notes. The oscillator is very stable, and a stabilised supply is not necessary.

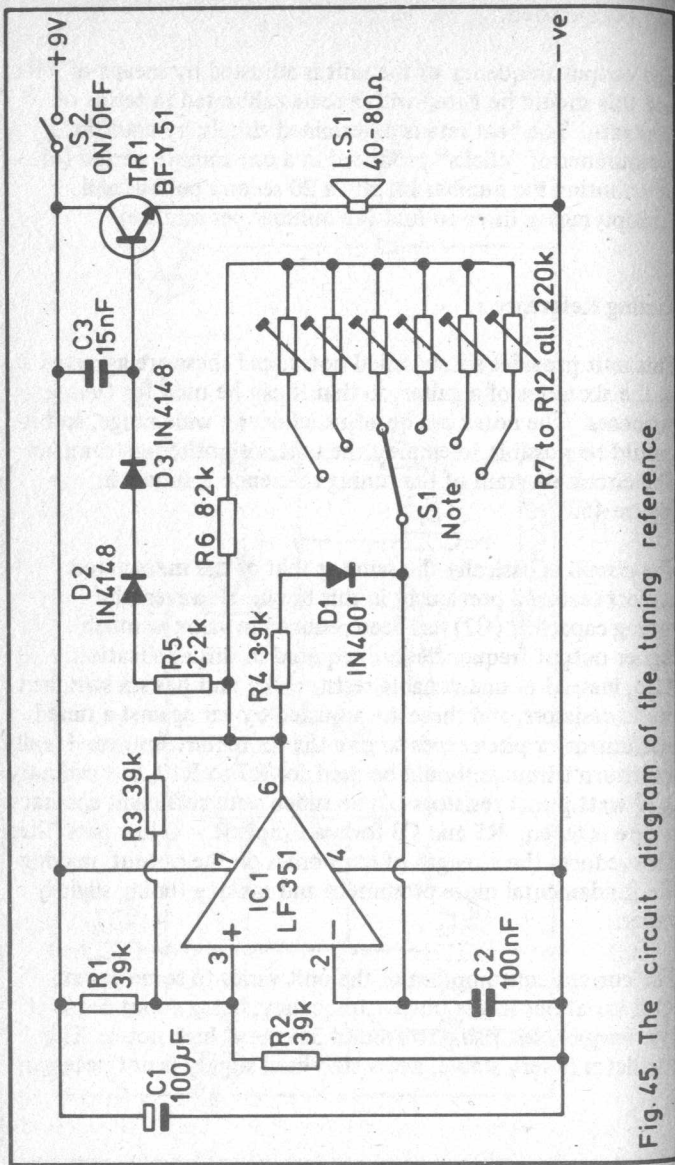

Fig. 45. The circuit diagram of the tuning reference

Simple Organ

This is a simple stylus operated organ which can cover two octaves including semitones. The specified values give one octave either side of middle C. The unit has a built-in vibrato effect which gives a more interesting and musical sound to the instrument when switched into operation. Figure 46 shows the complete circuit diagram of the organ.

The oscillator circuit is based on IC1, and is basically the same as the one used in the previous two projects. However, the discharge diode and resistor have been omitted from the timing circuit, giving a squarewave output rather than a pulsed one. This slightly simplifies the circuit and improves the tone. There are a series of twenty five timing resistors, and these are all preset types which are adjusted to give the appropriate sequence of notes. The required preset is selected using the stylus and keyboard. Printed circuit techniques can be used to produce a suitable keyboard, but any method that gives twenty five contacts of a practical size can be used. The contacts can be arranged in the usual piano keyboard pattern. Of course, in common with other instruments of this type, this one is monophonic (only one note at a time can be played). R8 ensures that the inverting input of IC1 is taken fully positive while the stylus is off the keyboard. This ensures that IC1's output goes low and that only a low quiescent current is drawn by Tr2. The stylus, incidentally, can be a test prod, standard jack plug, or something of this nature.

The vibrato oscillator uses Tr1 in a straight forward phase shift oscillator circuit, operating at just a few Hertz. R5 couples the output from Tr1's collector to the junction of R6, R7 etc. Here it varies the trigger potentials of IC1, with consequent small variations in the output frequency, giving a richer and more pleasant sounding output. S1 can be used to cut the supply to Tr1 and cut off the vibrato effect.

The quiescent current consumption of the organ is only about 7mA., but the consumption rises to about 35mA. when a note is played. It is therefore advisable to power the unit from a fairly large 9 volt battery, such as a PP7 or PP9 size.

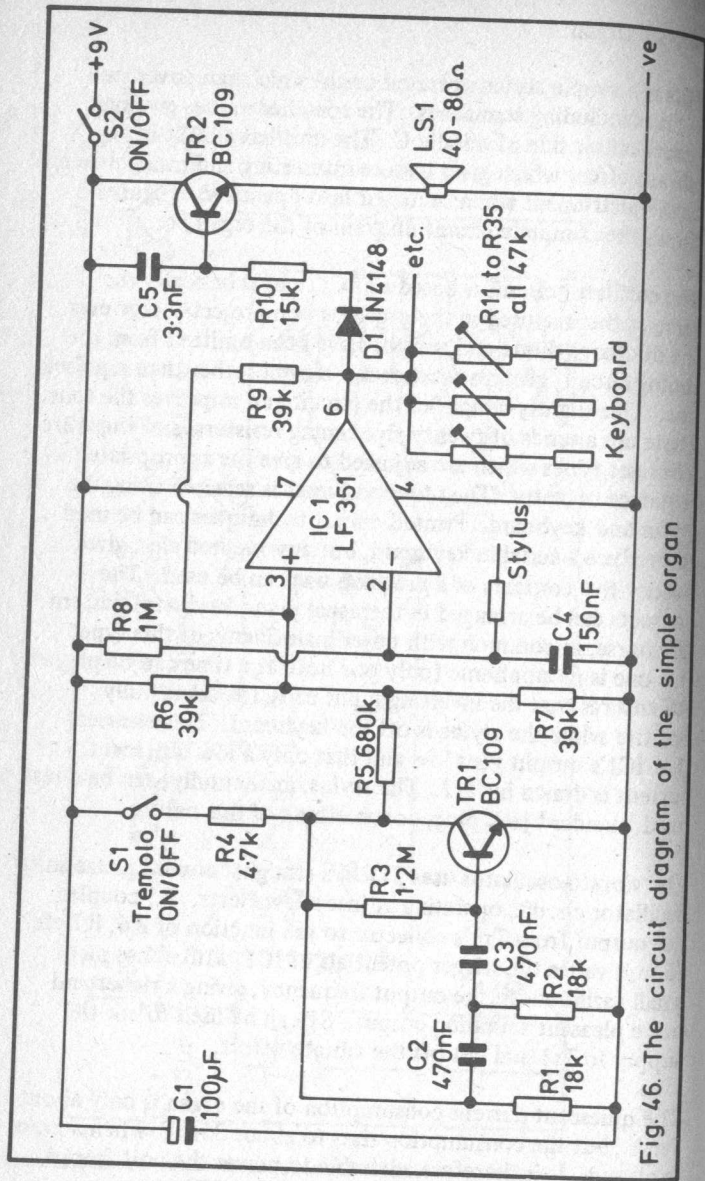

Fig. 46. The circuit diagram of the simple organ

Audio Modulator

An audio modulator enables one audio signal to control another in some way, and a simple amplitude modulator formed the basis of the tremolo unit featured earlier in this book. By using a modulating signal other than a low frequency of low harmonic content, a number of effects other than the tremolo one can be obtained. For example, "computer" type voices can be produced by modulating a voice signal with a low frequency squarewave signal, or an effect like a reed instrument can be obtained by using two tones of just marginally different frequencies. Sophisticated modulators are of the balanced type where only the signals generated by the modulation process appear at the output, and the input signals are phased out. The simple circuit shown in Figure 47 is for a simple unbalanced modulator, although the modulation signal only breaks through to the output at a very low level, giving what is effectively a single balanced modulator. The circuit is very inexpensive to construct and is capable of producing a number of worthwhile effects.

The circuit is basically the same as the modulator section of the tremolo unit described earlier. However, the values have been altered to give a wider modulation range. If R5 is adjusted to give a voltage gain of a little under unity under quiescent conditions, a modulation range of about $\pm 20\text{dB}$ can be achieved. VR1 enables the modulation level to be controlled.

The current consumption of the unit is about 1mA.

Doorbuzzer

This novel doorbuzzer provides an attention-catching sound. It initially produces a low note, but this rises to a much higher maximum pitch over a period of about one second or so. Thus the unit provides a wide range of frequencies, and its output is not easily masked by ordinary background sounds. The circuit diagram of the unit is shown in Figure 48.

The oscillator and output stage is much the same as used in a few of the projects featured in the previous Chapter. However, bias resistor R4 is not taken direct to the positive supply in this circuit, but is taken to a simple C - R timing network consisting of R3 and C2. The negative end of C2 is coupled to a potential divider formed by R1 and R2, so that at switch-on a small voltage is fed to the junction of R3 and R4 even though C2 is uncharged. This small voltage enables the oscillator to function, but at a relatively low frequency. With the supply connected to the circuit C2 quickly begins to charge, causing the voltage at the junction of R3 and R4 to rise towards the positive supply potential, and the output frequency to be swept upwards.

The current consumption of the unit is about 50mA. or so, but as it will only be used intermittently for very brief periods a small (PP3 size) battery should make a satisfactory power source.

Lamp Dimmer

This is a conventional lamp dimmer circuit which can handle loads of up to about 240 watts when used on the standard 240 volts U.K. mains. It should not be used with fluorescent lamps incidentally. The circuit diagram of the lamp dimmer appears in Figure 49.

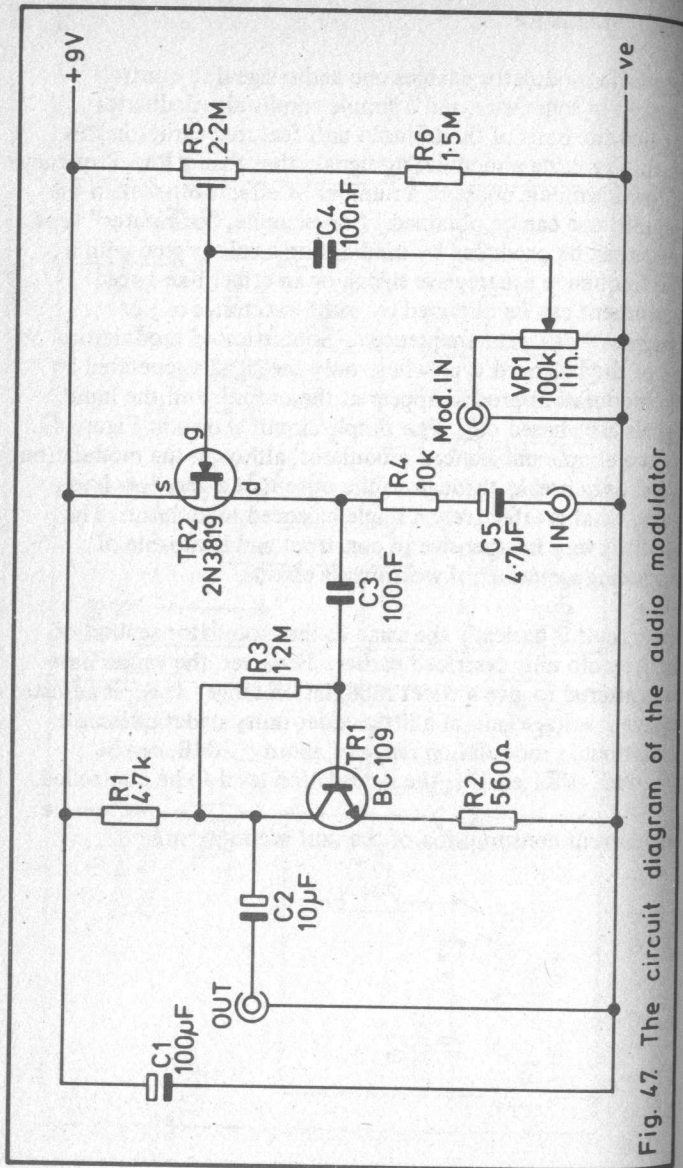

Fig. 47. The circuit diagram of the audio modulator

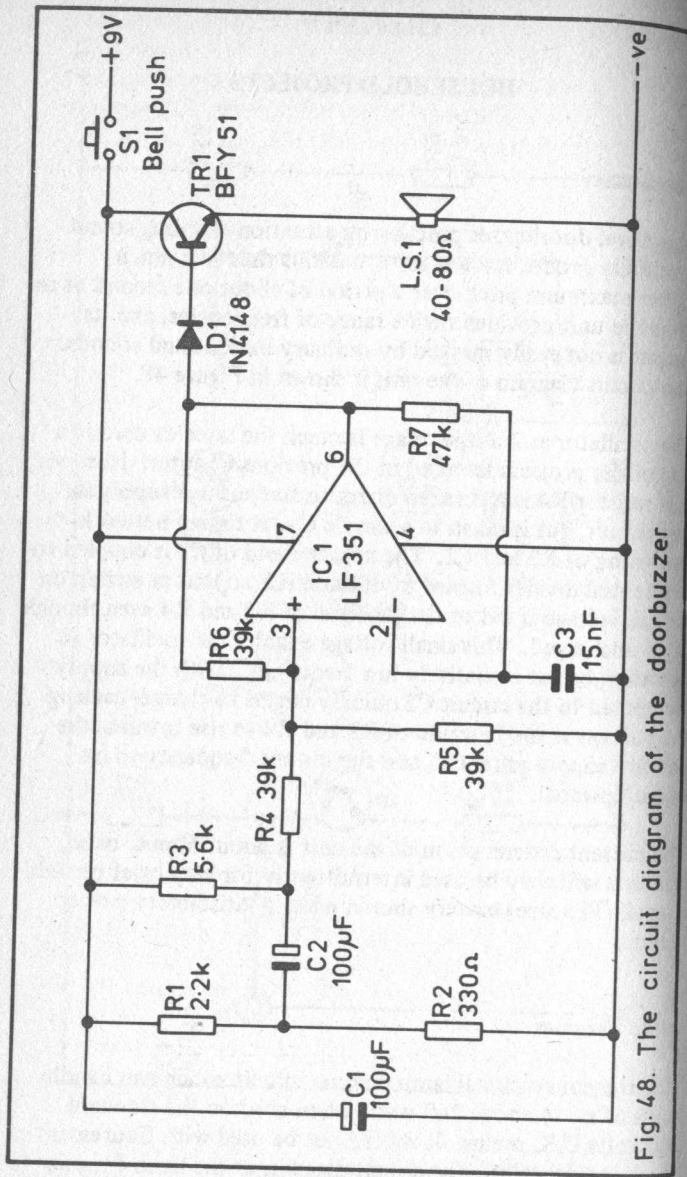

Fig. 48. The circuit diagram of the door buzzer

With VR1 set at or near minimum resistance, C1 charges to the trigger potential of the diac very early in each mains half cycle. The triac is therefore triggered into conduction almost at the beginning of each half cycle, and virtually full power is supplied to the load. There is admittedly a small loss of power as the triac does not switch on at the very beginning of each half cycle, but this is of no consequence in practice as the power loss is extremely small. If VR1 is adjusted for a higher resistance, the charge on C1 does not reach the trigger potential of the diac until later in each half cycle. The power loss does then become significant, and with VR1 at full resistance the triac will not fire at all. VR1 can thus be used to vary the power fed to the load from zero to what for practical purposes can be regarded as full power.

This switching method of power control does have the advantage of wasting very little power in the control element, since the latter is either switched fully on or fully off. It does not rest at any intermediate state, and therefore dissipates very little power. One disadvantage is that a certain amount of R.F. interference is generated due to the fast switching speeds involved, and the high voltages being switched (especially at and around half power). C2 and C3 are included to attenuate the interference generated, and keep it within acceptable limits. Note that these components must be high voltage types capable of withstanding the 240 volt A.C. mains supply.

Normal safety precautions should be exercised in the construction of this project, bearing in mind that it connects direct to the mains and does not incorporate any form of isolation circuitry. None of the circuitry should be touched while the unit is connected to the mains supply, and it should be constructed in such a way that this cannot happen accidentally. Despite the simplicity of the circuit, this is not really a project that should be undertaken by inexperienced constructors.

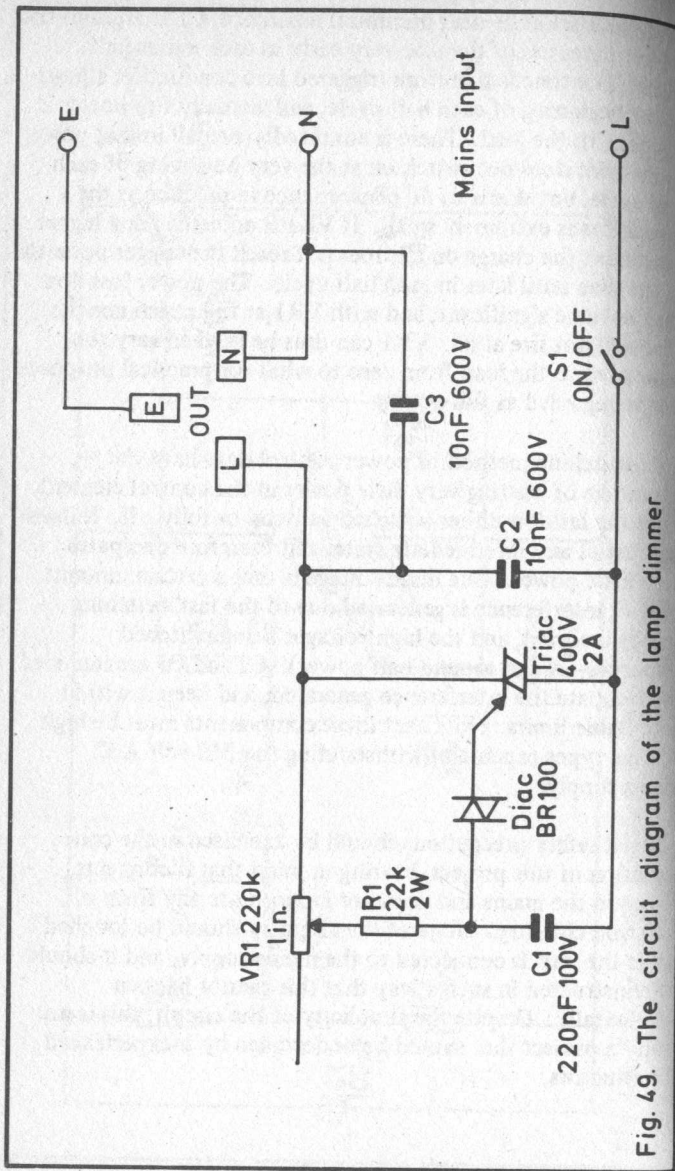

Fig. 49. The circuit diagram of the lamp dimmer

Christmas Tree Lights Flasher

The circuit shown in Figure 50 can be used to control Christmas tree lights to give a much more regular flash rate than is achieved using the normal technique of adding one flashing bulb into the chain of bulbs. The circuit is basically just an ordinary astable multivibrator formed by Tr2, Tr3, C2, C3 and R1 to R4. The relay is used to control the lights via its normally open contacts, and the relay coil is driven from the collector of Tr2 by way of emitter follower buffer stage Tr1. The value of C2 has been made somewhat smaller than that of C3 so that the circuit does not have a 1 to 1 mark space ratio. The collector of Tr2 is "high" for almost five times longer than it is low. Since Tr1 and the relay are switched on when Tr2's collector is high, the "on" time of the lights is longer than the "off" time. This gives a better effect than equal "on" and "off" times, and is usually incorporated in equipment of this type. The flashing bulb method also gives a similar effect.

With the specified values the unit gives an "on" time of about 2 seconds, and an "off" time of a little under ½ second, but these times are easily modified to suit individual requirements as they are roughly proportional to the values of C3 and C2 respectively

The circuit has an average current consumption of about 25 to 30mA., and it could be powered from a large 9 volt battery such as a PP9 type. However, a mains power supply would probably be a better choice if it is to be left running for long periods. The supply does not need to be stabilised or well smoothed. The relay can be any type having a 6/12 volt coil and a coil resistance of about 185 ohms or more, provided it has at least one set of normally open contacts of adequate rating, of course. Be careful to connect protective diode D1 with the correct polarity as both Tr1 and D1 could otherwise be damaged.

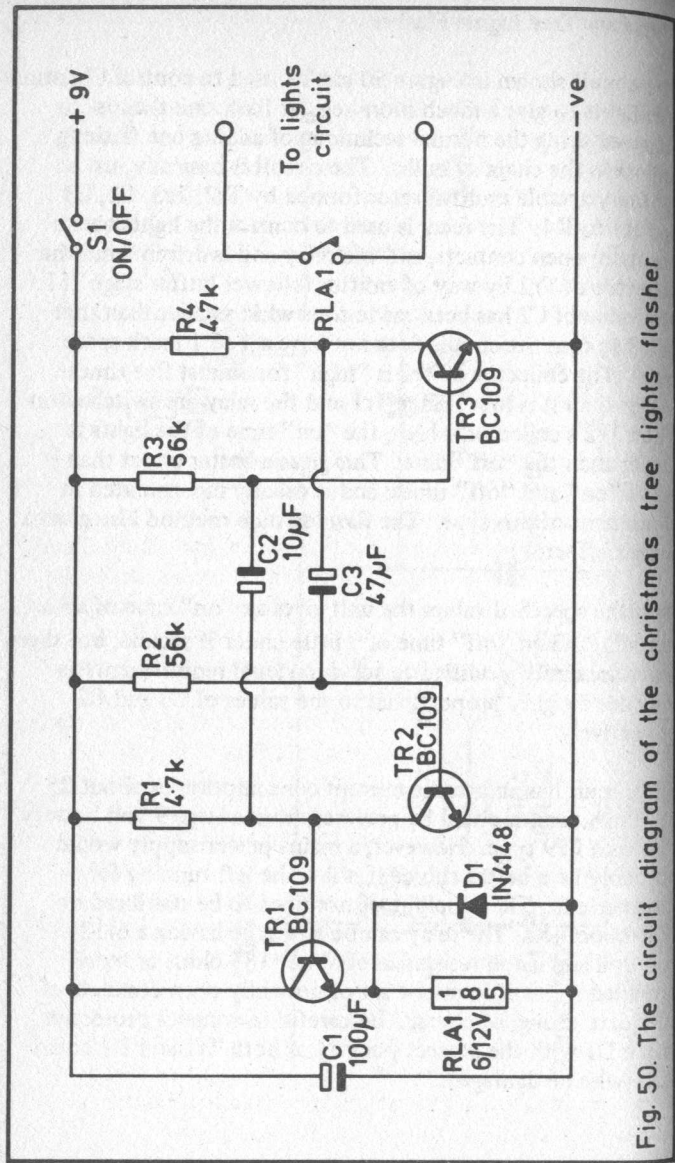

Fig. 50. The circuit diagram of the christmas tree lights flasher

Water Activated Switch

Water activated switches can be used in such household applications as rain alarms, flood alarms, cistern overflow alarms, and even just to indicate that the bath water has reached the required level. Units of this type rely on the fact that tap and rain water are both reasonably good conductors, and can therefore be detected using a sensor that merely consists of two metal electrodes separated by an insulating material. If water bridges the two electrodes the resistance between them falls from an extremely high level to perhaps as little as a few ohms. Figure 51 shows the circuit diagram of the water activated switch.

IC1 and Tr1 are used in a tone generator circuit of the type described in earlier projects in this book, and this part of the unit will not be considered further here. Tr2 is used as an electronic switch connected in the negative supply rail to the tone generator. Under normal operating conditions there will be a resistance of many hundreds of megohms across the sensor, and Tr2 will therefore be cut off and only pass a minute leakage current. This negligible stand-by current makes it possible to power the unit from a small 9 volt battery, as even with continuous operation in the stand-by mode the battery would have its shelf life. C2 is used to filter out any hum and noise which might otherwise be picked up in the wiring to Tr2's base, causing a small but significant stand-by current to flow. R6 is a current limiting resistor which ensures that an excessive base current cannot flow into Tr2 when water bridges the sensor. When the sensor is bridged by water, a strong base current flows through the sensor and R6 into Tr2, so that Tr2 switches hard on and supplies power to the tone generator, causing the alarm to be sounded. In this mode the unit has a current consumption of around 40mA.

The construction of the sensor must be varied to suit the exact application of the unit, and this is really a matter of using ones initiative.

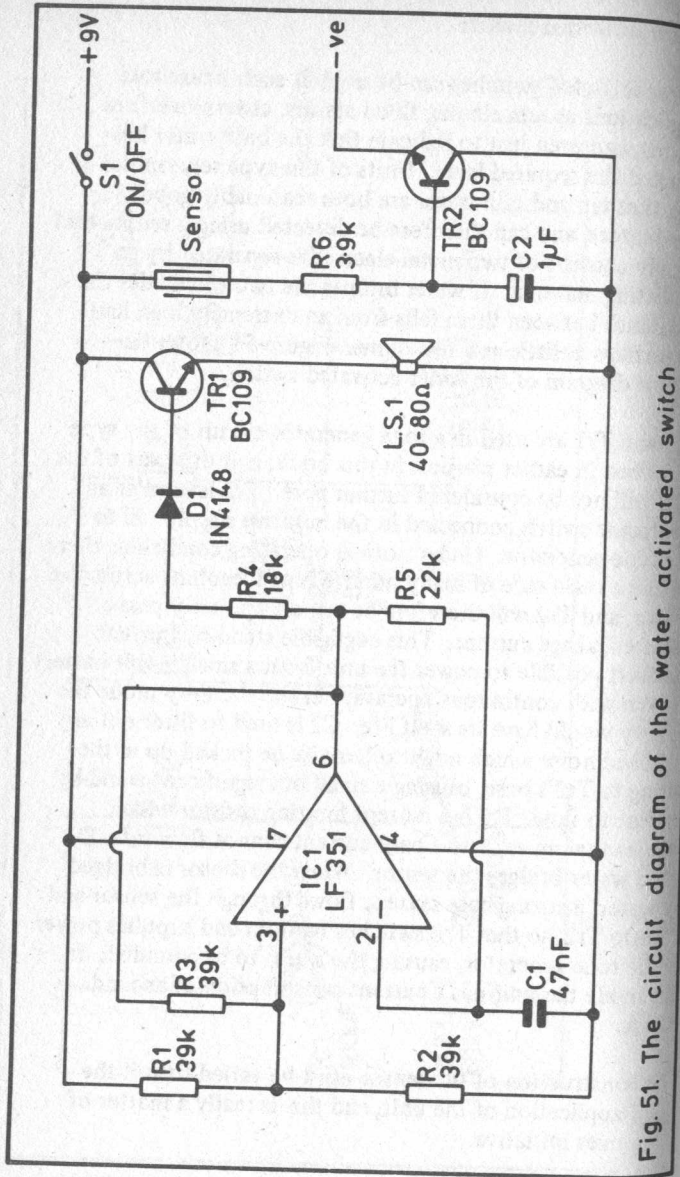

Fig. 51. The circuit diagram of the water activated switch

Simple Burglar Alarm

This burglar alarm can be operated from normally open (N.O.) switches, normally closed (N.C.) switches, or both. The N.C. switches would normally be micro-switches or reed switches; one being fitted to each window or door to be guarded. The N.O. switches could be the popular switch mats. The circuit diagram of the burglar alarm is shown in Figure 52.

The unit is based on three of the four 2 input NOR gates incorporated within the CMOS 4001 device. The inputs of the unused gate are tied to the negative rail to prevent spurious operation and possible damage to the device. Each pair of inputs of the other three gates are wired in parallel so that each gate actually operates as an inverter.

At switch on, C2 holds the input of gate 2 low, sending the output of this gate and the input of gate 3 high. The output of gate 3 therefore goes low, and the positive feedback through R4 latches these two gates in this state. The input of gate 1 is held in the high state by R1 and the N.C. switches, and its output goes low. Therefore, it does not alter the input state of gate 2 due to the coupling through D1 and R3, since both these points in the circuit are initially at the same state.

However, if one of the N.C. switches should open, R2 takes gate 1's input low, sending its output high. The coupling through D1 and R3 does then take the input of gate 2 high, with a corresponding change in logic state through to the output of gate 3. The feedback through R4 then latches gates 2 and 3 in this new state, even if the N.C. switch should now close again and the output of gate returns to the low state. This is due to the inclusion of D1 which permits gate 1 to couple a high signal to gate 2, but blocks the transmission of a low signal. Thus, once it has been triggered, the alarm latches. Of course, if it was one of the N.O. switches that operated, the input of gate 1 could be taken low and the alarm will be triggered just as before.

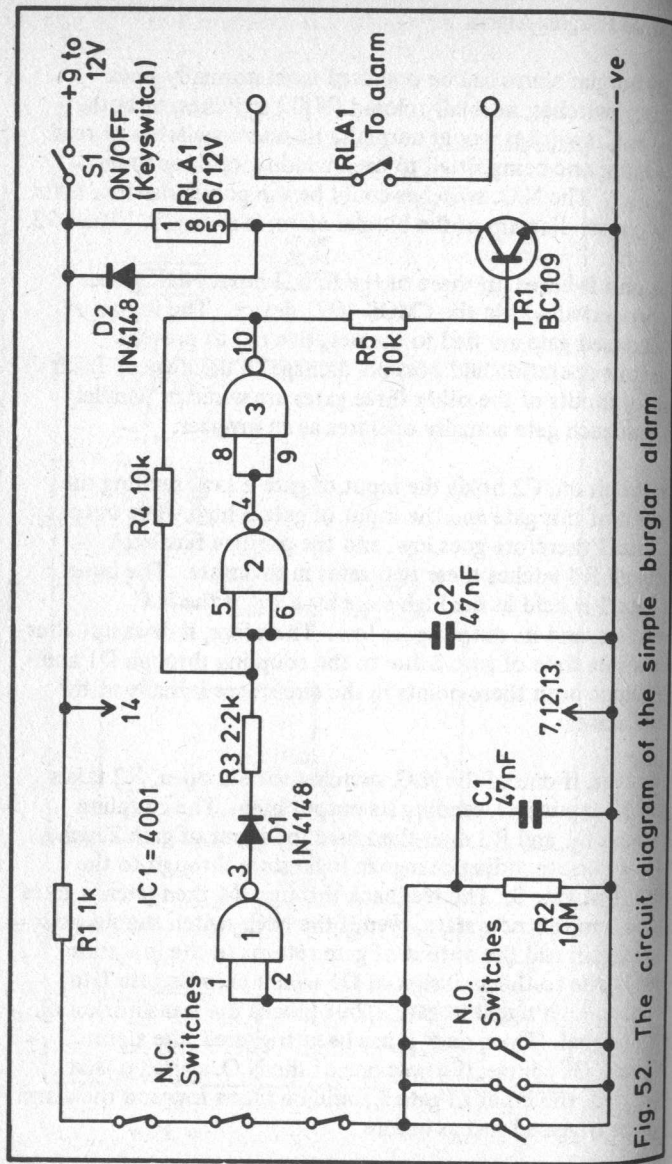

Fig. 52. The circuit diagram of the simple burglar alarm

With the output of gate 3 low, Tr1 is cut off and no significant power is fed to the relay coil. However, when the alarm is triggered and the output of gate 3 goes high, Tr1 is biased hard into conduction by the base current it receives via R5, the relay is switched on, and the normally open relay contacts close and switch on the alarm generator. In this state the circuit has a current consumption of approximately 35mA.

S1 is the on/off switch, and should be mounted outside the protected building so that the occupiers can enter and leave without triggering the alarm. For obvious reasons this should be a key switch, and should be fitted in such a way that it would be difficult for prospective intruders to tamper with the wiring to it. If the N.O. switches are not required they are simply omitted. If the N.C. switches are not required, the left hand side of R1 should be connected direct to the input of gate 1. Although the circuit is shown with three switches of each type, it can have any desired number of N.C. switches wired in series, and any number of N.O. switches connected in parallel. C1 helps to prevent false alarms due to electrical impulses triggering the unit.

Alarm Generator

This alarm generator produces a loud and attention catching two-tone alarm, and is suitable for use with the burglar alarm described in the previous section of this book, or any other alarm circuit where the alarm generator is relay controlled. The equivalent output power of the unit is about 2.5 watts R.M.S. using a 9 volt supply, and 4.5 watts using a 12 volt supply. The circuit diagram of the unit is shown in Figure 53.

It is based on a CMOS 4001 quad 2 input NOR gate, and as in the previous project, the two inputs of each gate are connected in parallel to give an inverter action. Gates 1 and 2 are used in the standard CMOS astable configuration, and the (roughly) squarewave output of the astable is about 2 Hertz with the specified values. Gates 3 and 4 are used in the same type of circuit, but the values of the timing components (R3 and C2)

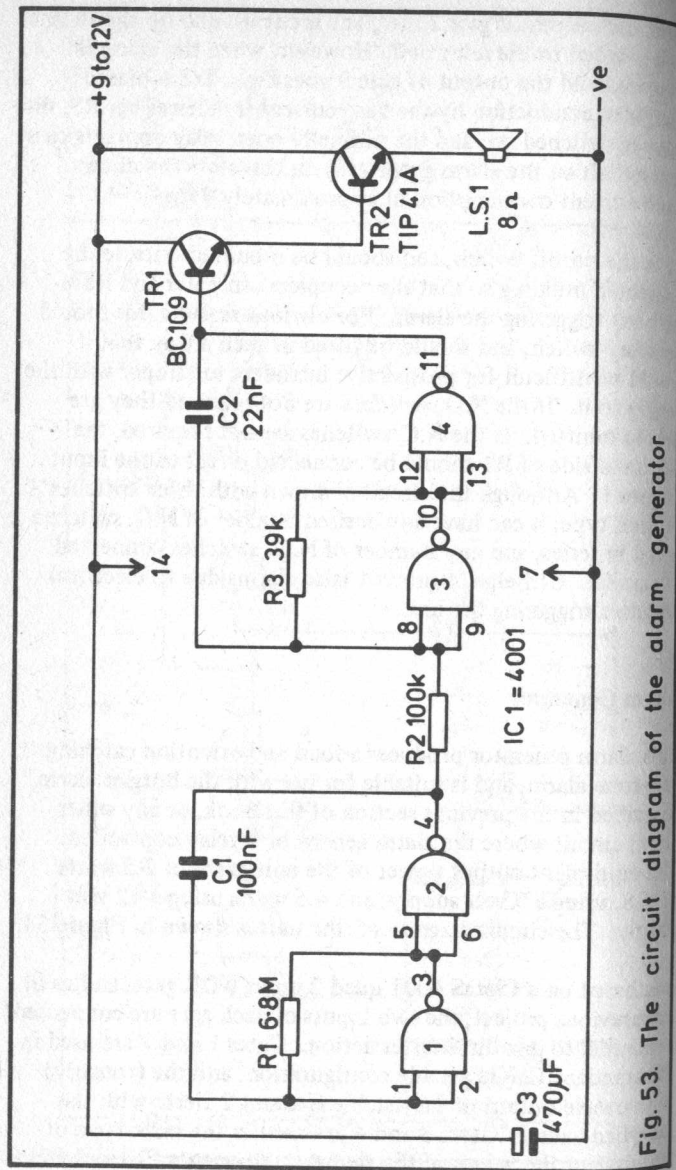

Fig. 53. The circuit diagram of the alarm generator

are much lower, giving a nominal operating frequency of a few hundred Hertz. However, as the output of the low frequency oscillator is coupled to the input of the audio oscillator, the operating frequency of the later changes somewhat in sympathy with the output state of the low frequency oscillator. The output tone therefore switches continuously between two pitches, giving the desired two-tone output. This is far more noticeable than an output at a single pitch.

Tr1 and Tr2 are connected as a Darlington pair, and they are used in the emitter follower mode to give the high output currents needed to drive an 8 ohm speaker at high volume. Make sure that the speaker used is of adequate power rating: miniature types are not suitable for use in this circuit. The current consumption of the unit is about 500mA. or so using a 9 volt supply, and about 750mA. using a 12 volt supply. Tr2 does not dissipate a great deal of power, and it should not be necessary to provide it with any heatsinking.

Simple Timer

This unit is suitable for use as an egg timer, kitchen timer, and similar applications where a very high degree of accuracy is not required. It has a timing range of 30 seconds to a little over 5 minutes. It provides an audible alarm at the end of the timing period. The circuit diagram of the unit is shown in Figure 54.

Operational amplifier IC1 is used here as a comparator. R1 and R2 provide a reference voltage to the inverting input, while the non-inverting input is fed from a C - R timing network which consists of VR1, R3 and C2. Initially C2 will be uncharged, and the non-inverting input will be at the negative supply potential. The output of IC1 therefore assumes the low state. C2 gradually charges through R3 and VR1 until its charge voltage exceeds the reference fed to the inverting input. The output then goes high, providing power to the simple unijunction oscillator which is driven from its output, with an audio tone being emitted from the loudspeaker in consequence.

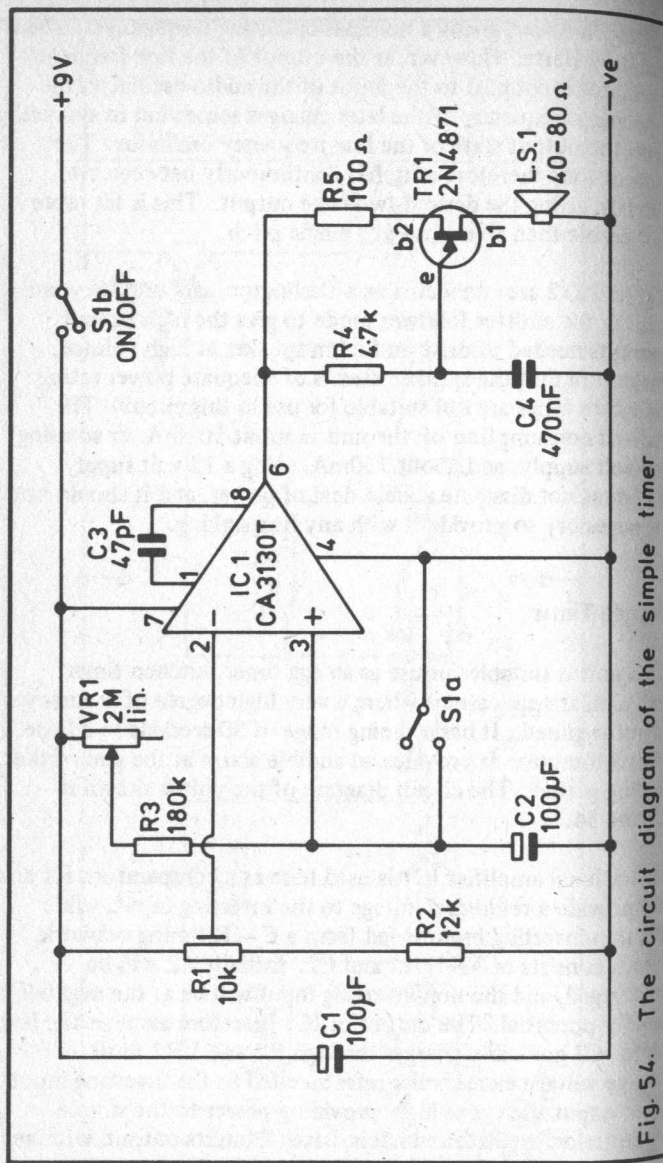

Fig. 54. The circuit diagram of the simple timer

When the unit is switched off using S1, S1a discharges C2 so that the unit is ready to start another timing run when it is switched on again. C3 is the compensation capacitor for IC1.

R1 must be adjusted by trial and error to give the correct timing range. Its slider voltage is increased to extend the timing periods, and reduced to shorten the timing periods. VR1 must have a scale calibrated in terms of timing period marked around its control knob, and finding the settings of VR1 that give the required calibration times is a matter of trial and error. C2 should be a good quality component, and should preferably be a tantalum bead type.

The current consumption of the timer in the stand-by mode is less than 1mA., and the consumption rises to about 4mA. when the alarm is operating.

Telephone Amplifier

A telephone amplifier is very useful when it is necessary for more than one person to follow a telephone conversation, as it gives an output which is strong enough to drive a speaker, thus enabling any number of people to listen to both sides of the conversation. The circuit diagram of a simple telephone amplifier is shown in Figure 55.

It is illegal to make a direct connection to a Post Office telephone, and so the input signal is obtained via a telephone pick-up coil. This coil picks up the electro-magnetic signal which is radiated by an inductive component within the telephone, and converts this signal into an equivalent electrical one. This signal is very weak, and is first amplified by the low noise preamplifier based on IC1. This is a BIFET operational amplifier which gives low levels of noise and distortion. It is used as a straight forward inverting amplifier with the voltage gain set at about 670-times by R1 and R4.

C4 couples the output from IC1 to volume control VR1, and from here the signal is fed direct to an audio power amplifier

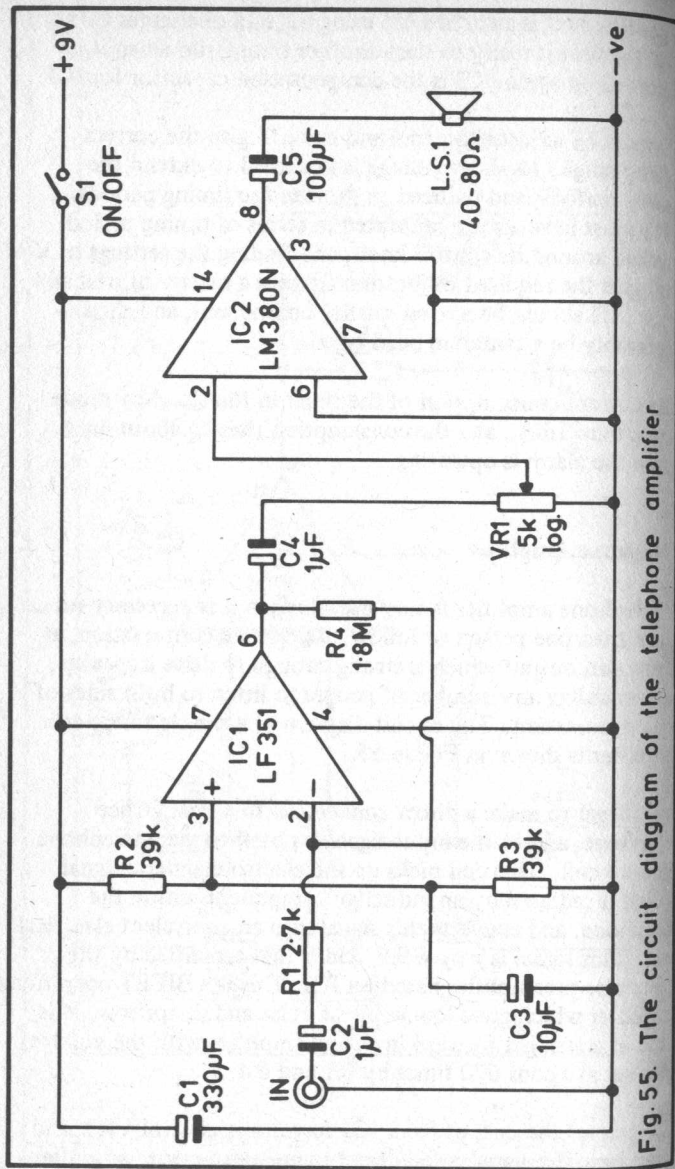

Fig. 55. The circuit diagram of the telephone amplifier

stage based on LM380N audio power amplifier I.C., IC2. No D.C. blocking capacitor is needed at the input of this device if the input is referenced to the negative supply rail, as in this case. The LM380N has inverting and non-inverting inputs, but in this circuit only the non-inverting input is used. The inverting input (pin 6) is connected to the negative rail to prevent stray pick-up of noise here. C5 couples the output signal to the speaker, and an output power of around 150 to 200mW. is available. This is more than adequate to fully drive most high impedance loudspeakers.

The quiescent current consumption of the unit is about 10mA., but the consumption is about two to three times this figure at high volume levels as the LM380N has a class B output stage. The telephone pick-up coil is a ready-made component which has a suction cup that enables it to be easily attached to the telephone base section (little pick-up will be obtained with it fitted to the handset). The best position for the pick-up coil depends on the type of telephone being used, but the optimum position is easily located with a little experimentation. The handset should be kept as far away as possible from the loudspeaker as acoustic feedback may otherwise cause oscillation to occur (with an audio tone being emitted from the speaker in consequence). This may also happen if the volume control is advanced too far.

Telephone Repeater

When working in the garden or an outbuilding, or in certain other circumstances, it is easy to miss the ringing of the telephone. This problem can be overcome by using a telephone repeater which picks-up the sound of the telephone bell using a microphone, and then amplifies the resultant signals to a level that can drive a loudspeaker at good volume. The amplified signal is coupled by a twin lead to a loudspeaker which is placed near the user, where its output will be clearly heard. A unit of this type can also be used as a baby alarm incidentally. The circuit diagram of the telephone bell repeater is given in Figure 56.

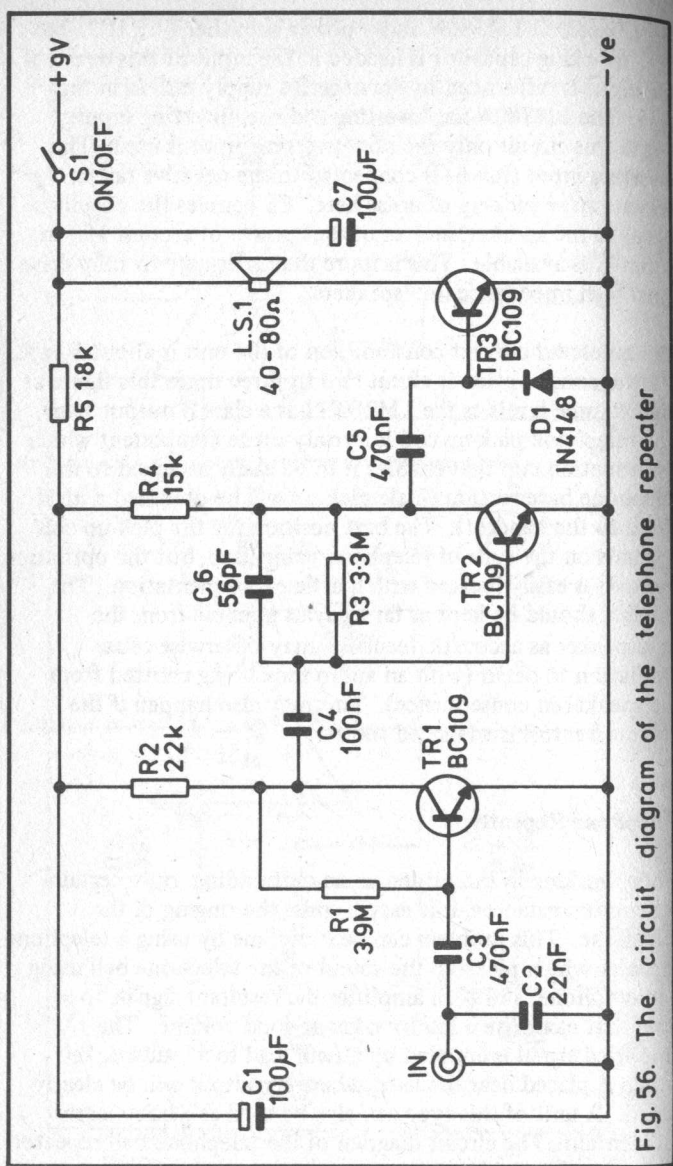

Fig. 56. The circuit diagram of the telephone repeater

The weak signal from a low impedance dynamic (cassette type) microphone is given a considerable amount of amplification by the two straight forward common emitter amplifier stages which use Tr1 and Tr2. C2 is an R.F. filter capacitor which helps to avoid problems with stray pick up of radio signals. C6 rolls off the high frequency response of the circuit and this aids stability.

Tr3 is used as a third stage of common emitter amplification, but it has no bias resistor and passes no significant quiescent current. However, when there is a suitable input signal, Tr3 is switched hard on by positive going half cycles, and it therefore supplies strong pulses of current to the loudspeaker which forms its collector load. Of course, this method gives a very distorted output, but this is of little consequence in this application. The advantage of this system is that with Tr1 and Tr2 operating at very low collector currents, and Tr3 consuming no current under quiescent conditions, the unit has a very low stand-by current of about 500 μ A. This enables it to be run economically from a small 9 volt battery, even if it will need to be used frequently for prolonged periods.

The unit has only one control, and this is on/off switch S1. The prototype was tested with a speaker cable of about 12 metres in length and worked perfectly well. In fact it should operate properly using a speaker cable considerably longer than this. The speaker cable can be an ordinary twin (figure of 8) type, and does not need to be screened as it is carrying a high level, low impedance signal.

Slide Timer

This timer can be used with a projector having a remote control socket to give automatic slide changing at intervals of 5, 10, 15, 20, 25 or 30 seconds. The circuit diagram of the slide timer is shown in Figure 57.

The unit is based on a CMOS 4001 device, with three of the 2 input NOR gates contained in this device being used as

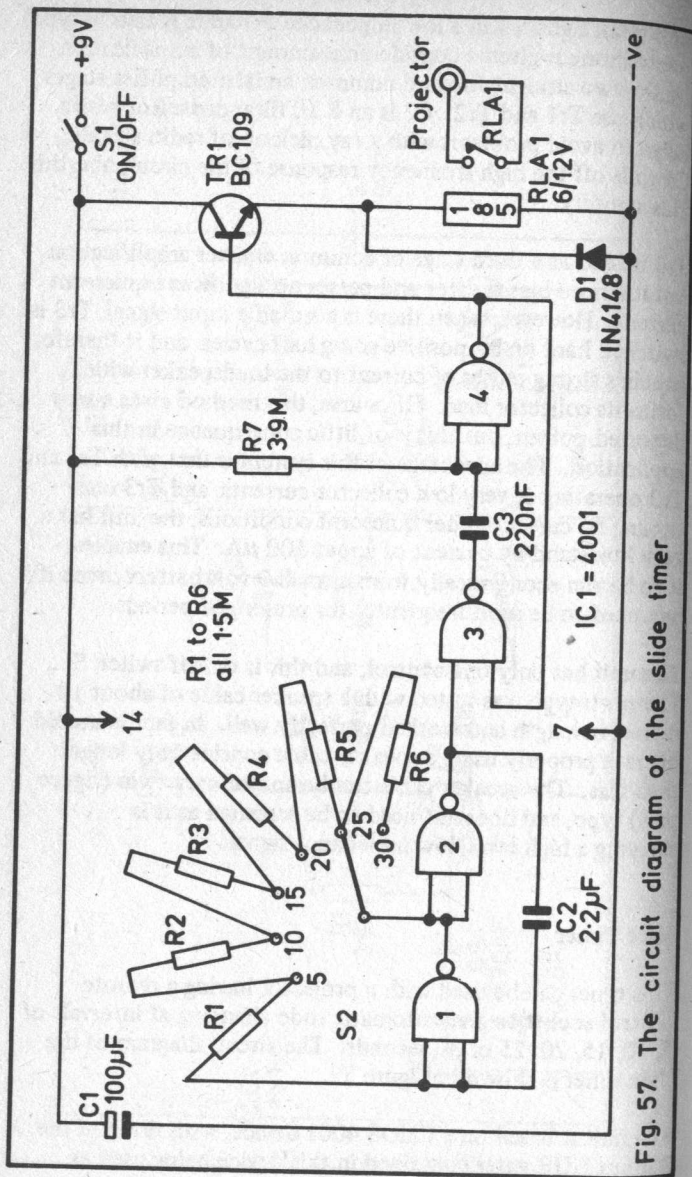

Fig. 57. The circuit diagram of the slide timer

inverters, with each pair of inputs connected together. The remaining gate is used as such.

Gates 1 and 2 are connected in a conventional CMOS astable multivibrator circuit, and the operating frequency of the astable depends on the number of timing resistors switched into circuit using S2. The frequency is approximately one cycle every five seconds with one timing resistor, one cycle every ten seconds with two resistors, one cycle every 15 seconds with three resistors, and so on. This gives the unit six switched time intervals.

The output of the astable is fed to the input of a straight forward CMOS monostable multivibrator which uses the second pair of gates. R7 and C3 are the timing components, and these set the (positive) output pulse length of the monostable at a little in excess of half a second. The monostable is triggered by each positive going input it receives from the astable. The output from the monostable therefore consists of a series of short pulses, the interval between the pulses being controlled using S2.

The monostable controls a relay by way of the emitter follower buffer stage which uses Tr1. The projector is controlled by a pair of normally open relay contacts. When the output of the monostable goes positive, the relay contacts close and operate the slide change mechanism of the projector. The monostable ensures that power is only briefly supplied to the projector by the timer, so that multiple operation of the slide change mechanism is avoided.

The average current consumption of the unit is only in the region of 1 to 3mA.

Reaction Game

This is a simple reaction testing game for two players. The unit has a L.E.D. indicator which is normally in the off state, but switches on for several seconds if a push button switch is

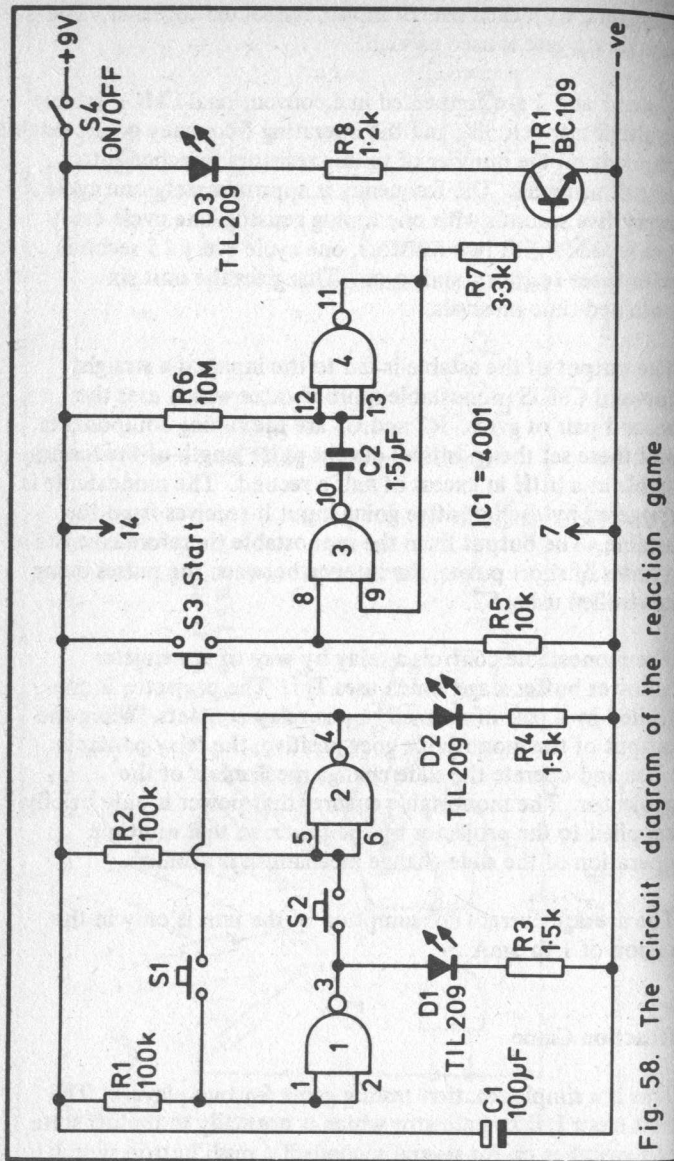

Fig. 58. The circuit diagram of the reaction game

momentarily operated. Each of the players has a push button switch, and the idea of the game is to first switch on the indicator L.E.D., and then each player tries to operate his or her push button switch as soon as possible after the L.E.D. switches off. The winner is the first player to operate his or her switch. A further two L.E.D.s indicate which player was first, thus avoiding any arguments about who was the quicker. The circuit diagram of the unit is shown in figure 58.

The circuit really consists of two separate sections; one to operate the indicator L.E.D., and the other to determine and indicate which push button switch was operated first. The indicator L.E.D. is operated via Tr1 from a monostable multivibrator based on two gates of a CMOS 4001 quad 2 input NOR gate. D3 is switched on by triggering the monostable using S3, and D3 then switches on for about 9 seconds.

The precedence indicator part of the unit uses the remaining two gates of the 4001 (connected as inverters) in a simple bistable circuit. Initially R1 and R2 take the inputs of the inverters high, so that the outputs go low and neither D1 or D2 light up. If, for example, S1 is operated first, the input of gate 1 will be taken to the low output of gate 2, and is therefore forced into the low state. This sends the output of gate 1 high, and D1 lights up to indicate that S1 was the first switch to be operated. If S2 is now operated, it will connect the input of gate 2 to the high output of gate 1, and the logic states at the input and output of gate 2 will not be altered. D2 does not, therefore, switch on. Of course, if S2 is the first switch to be operated, then a similar circuit action takes place, but it will be D2 that switches on and S1/D1 that are blocked.

The quiescent current consumption of the unit is negligible, but the current drain rises to about 5mA. when one of the L.E.D.s is operating.

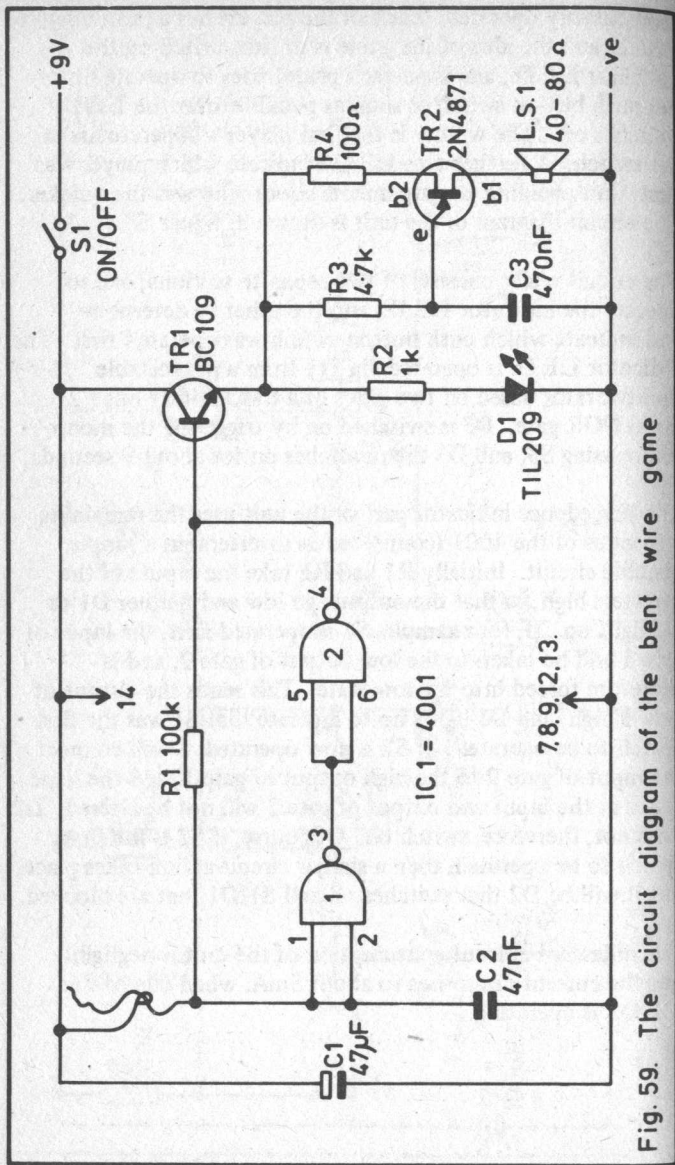

Fig. 59. The circuit diagram of the bent wire game

Bent Wire Game

This is a variation on the old "steady hand" testing game where the competitor has to move a small loop of wire along a piece of wire which is bent into an irregular shape. The idea of the game is simply to move the loop from one end of the wire to the other without touching the two together. The two pieces of wire are connected into a simple circuit which gives an audible and visual indication if they are shorted together, completing a circuit. In the conventional version of the game a light bulb and bell provide the visual and audible indications, but in this circuit they are provided by a L.E.D. and a simple electronic buzzer circuit. It has a slight refinement in that the circuit latches when the two wires are touched together, so that the L.E.D. and buzzer both stay on until the unit is reset (by briefly switching off). This eliminates any arguments about whether or not the competitor did or did not momentarily touch the two wires together. The full circuit diagram of the bent wire game is shown in Figure 59.

Two of the four NOR gates of a 4001 device are connected as inverters and used in a form of simple bistable circuit. C2 ensures that at switch on the bistable latches with the input (pins 1 and 2 of IC1) and the output (pin 4 of IC1) both in the low state. L.E.D. indicator D1 and the simple unijunction audio oscillator driven from the output via emitter follower Tr1 will therefore both be switched off.

The two pieces of wire are connected between the input of the bistable and the positive supply rail. Thus, if the two are shorted together, the input of the bistable is taken high, and it latches in this state due to the feedback through R1. Power is then supplied to both the L.E.D. indicator and audio oscillator.

The unit has negligible quiescent current consumption, but draws a supply current of about 10mA. or so when the L.E.D. indicator and audio oscillator are operating. Two of the gates in the 4001 I.C. are unused, and their inputs are connected to the negative rail to prevent spurious operation and possible

damage to the device. The wire loop and piece of bent wire can be easily fabricated from a fairly thick gauge (about 18 s.w.g.) tinned copper wire, and the level of difficulty involved in completing the game can be controlled by varying the diameter of the wire loop.

MISCELLANEOUS CIRCUITS

Touch Switch

Touch activated switches have the advantage of using no moving parts, and therefore have an extremely long lifespan as they do not wear out. This simple touch switch design is suitable for on/off control of 9 volt D.C. loads drawing a current of up to about 100mA. The circuit diagram of the unit appears in Figure 60.

The circuit is based on a 4001 quad NOR gate package, and all four gates are connected to operate as inverters. Gates 2 to 4 are connected in parallel to give a low output impedance. These three gates are connected together with gate 1 to form a simple type of bistable multivibrator. C1 ensures that the input of the bistable is taken low at switch on, causing the output to assume the low state as well. Tr1 therefore receives no significant base current from the output of the bistable, it is cut off, and passes no collector current to the load which forms its collector load.

If the upper two touch contacts are touched by the user, the skin resistance of the user's finger will be low enough to take the input of the unit high, causing the output to go high as well. When the operator's finger is removed from the touch contacts, R1 will hold the input in the same state as the output. In other words the bistable latches with both its input and output in the high state. Tr1 is then biased hard into conduction by the base current it receives from the output of the bistable via R2, and power is supplied to the load. There is a small voltage drop across Tr1, so that the full 9 volt supply is not fed through to the load. However, Tr1 is a switching transistor, and it should give a voltage drop of less than 0.5 volts even with a load current of 100mA. There are very few applications where this voltage drop will be sufficiently large to have any significant effect on the controlled equipment.

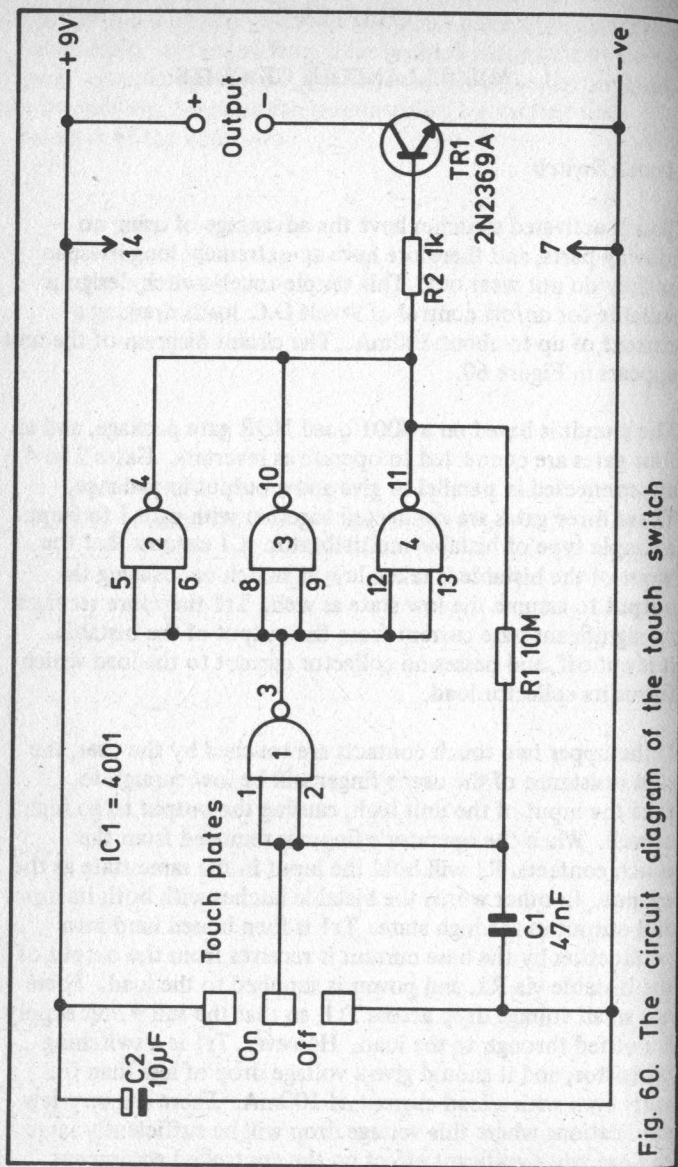

Fig. 60. The circuit diagram of the touch switch

In order to reset the unit to the "off" state it is merely necessary to touch the lower two touch contacts. The skin resistance of the user then takes the input of the bistable low, switching off Tr1 and cutting power to the load. As before, the circuit latches in this state due to the feedback through R1.

In the "off" state the circuit has a negligible current consumption. In the "on" state the consumption is equal to the current drawn by the load, plus a current of about 5.5mA. needed to drive Tr1. Touch contacts can be fabricated from copper laminate board, and ready-made touch contacts are also available.

Torch Finder

This circuit can be added to a 1.5 or 3 volt torch to give a continuous flashing light, so that the torch can easily be found in the dark. The circuit consumes very little power since the flasher circuit itself consumes very little current, and as the L.E.D. is pulsed it is switched off for most of the time, giving a low average current consumption. In fact, the unit draws a supply current of only about 500 μ A., and it does not, therefore, significantly reduce the life of a high capacity torch battery. The circuit diagram of the torch finder appears in Figure 61.

This is based on the LM3909N which is specifically designed for this type of application. Although it might at first appear impossible to run a simple L.E.D. flasher from a 1.5 volt supply (bearing in mind that about 1.8 to 2.0 volts is needed in order to power a normal L.E.D.), it is in fact quite simple to do this. The method used here is to have a form of relaxation oscillator where, in effect, C1 is first charged to virtually the full supply voltage, and is then added in series with the 1.5 volt supply (giving a total voltage of well in excess of 2 volts, which is ample to power a L.E.D.). This total supply voltage is then connected across the L.E.D. indicator (D1) until C1 has largely discharged, whereupon the circuit switches back to its original state and C1 starts to charge up again. An internal resistor of IC1 prevents an excessive L.E.D. current from flowing when C1 discharges.

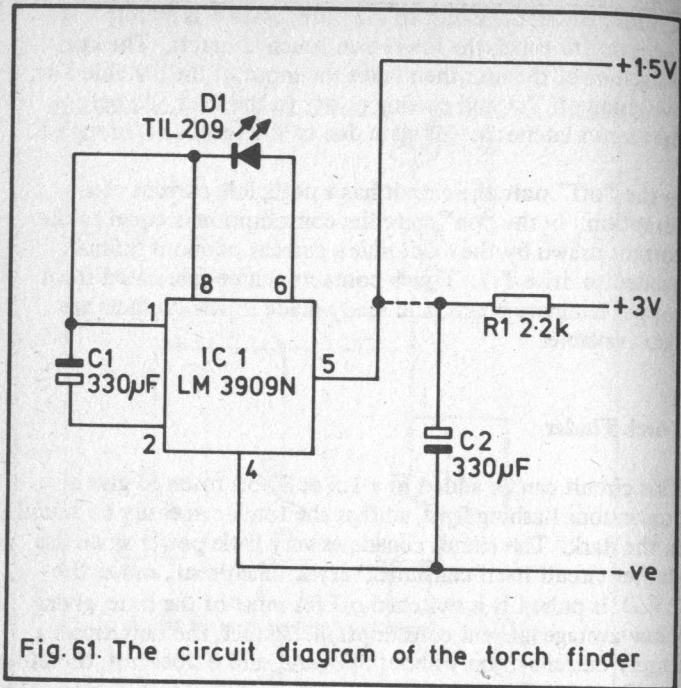

Fig. 61. The circuit diagram of the torch finder

The flash rate is controlled by the value of C1, and is about 2Hz with the specified value.

The circuit can be used on a 3 volt supply, but voltage dropper resistor R1 and decoupling capacitor C2 must then be included in the circuit. The unit will operate as a low current pilot light for 9 volt equipment if R1 is raised in value to about 10k or so.

Morse Practice Oscillator

A keyed audio oscillator is virtually essential for anyone learning to send Morse code, and it is also very useful for receiving practice if used in conjunction with a tape recorder. A suitable design is shown in the circuit diagram of Figure 62.

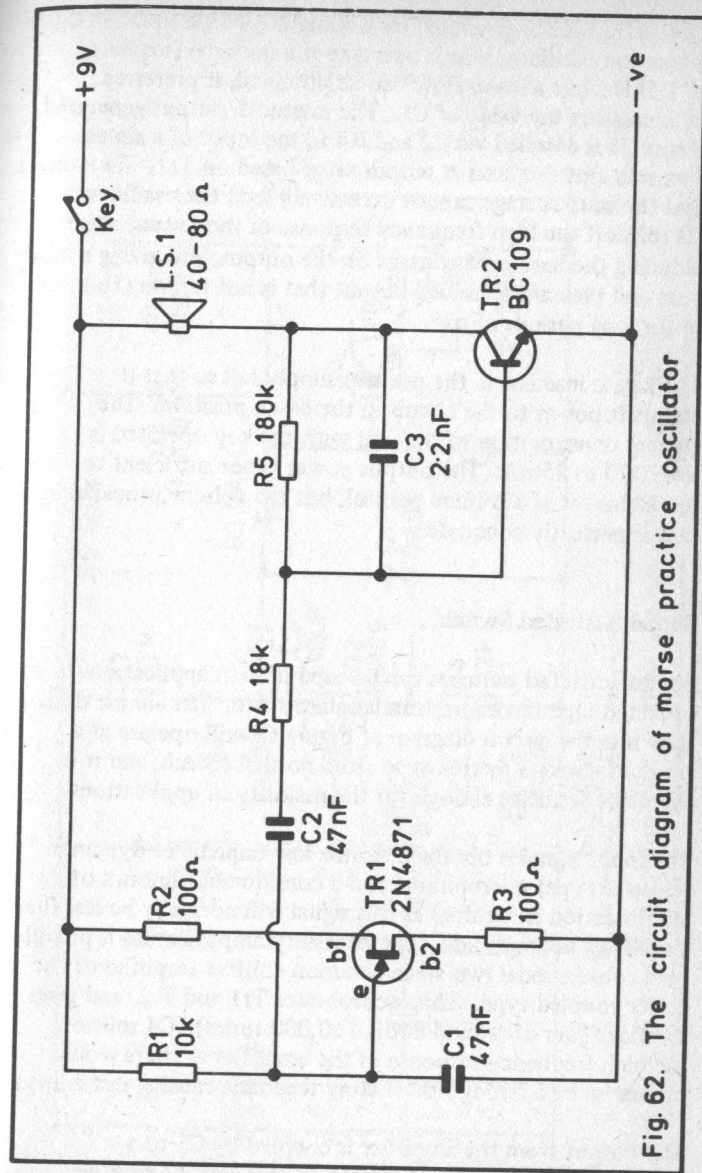

Fig. 62. The circuit diagram of morse practice oscillator

The audio tone is generated by a straight forward unijunction relaxation oscillator which operates at a nominal frequency of 1.5kHz, but a lower note can be obtained, if preferred, by increasing the value of C1. The sawtooth output generated across C1 is coupled via C2 and R4 to the input of a simple common emitter, class A output stage based on Tr1. R4 ensures that the output stage cannot excessively load the oscillator C3 rolls off the high frequency response of the output stage, reducing the harmonic content on the output, and giving a more pure and pleasant sounding output that is not wearing to listen to for long periods of use.

The key is inserted in the positive supply rail so that it connects power to the circuit in the down position. The current consumption of the unit with the key operated is about 20 to 25mA. The output power is not sufficient to warrant the inclusion of a volume control, but the volume provided by the unit is perfectly adequate.

Sound Activated Switch

Sound activated switches can be used in such applications as voice operated tape recorders, burglar alarms, etc. The simple design shown in the circuit diagram of Figure 63 will operate at a range of about 3 metres or so from normal speech, and it is therefore sensitive enough for the majority of applications.

The input signal is obtained from a low impedance dynamic (cassette type) microphone, and a considerable amount of amplification is required as this signal will normally be less than a millivolt in amplitude. The necessary amplification is provided by a conventional two stage common emitter amplifier of the direct coupled type. This incorporates Tr1 and Tr2, and gives a voltage gain of around 80dB. (10,000 times). C4 rolls off the high frequency response of the amplifier as there would otherwise be a strong risk of stray feedback causing instability.

The output from the amplifier is coupled by C5 to a rectifier circuit comprised of D1 and D2, and the positive

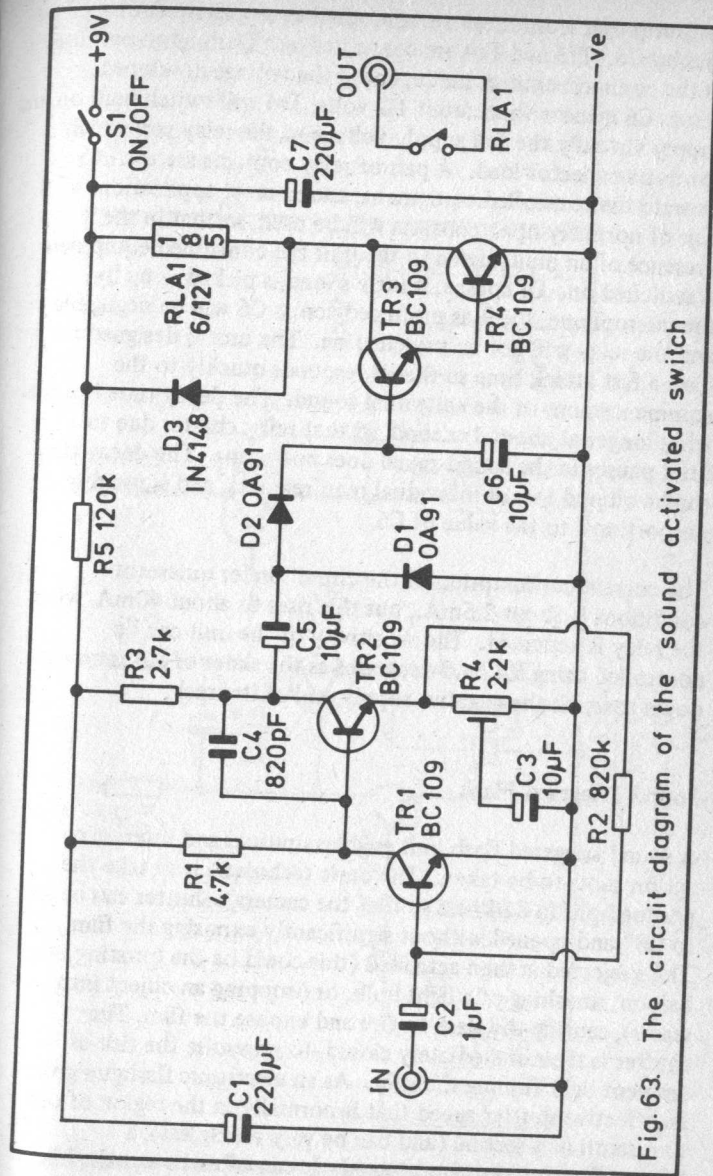

Fig. 63. The circuit diagram of the sound activated switch

output pulses from these are smoothed to a positive D.C. bias by C6. Tr3 and Tr4 are connected as a Darlington pair used in the common emitter mode, and if the voltage developed across C6 is more than about 1.2 volts, Tr4 will switch hard on and supply virtually the full supply voltage to the relay coil which forms its collector load. A pair of relay contacts are used to operate the controlled equipment, and in most applications a pair of normally open contacts will be used, so that in the presence of an input signal to the unit the controlled equipment is switched on. Of course, if little sound is picked up by the microphone, the bias produced across C6 will be negligible and the relay will not be switched on. The unit is designed to have a fast attack time so that it responds quickly to the commencement of the activating sound. The decay time is somewhat longer at about 1 second, so that relay chatter due to brief pauses in the sound signal does not occur. The decay time can be altered to suit individual requirements, and is roughly proportional to the value of C6.

The current consumption of the circuit under quiescent conditions is about 2.5mA., but this rises to about 40mA. when the relay is activated. The sensitivity of the unit can be controlled using R4, and decreases as the slider of R4 is moved down towards the negative supply end of its track.

Sound Triggered Flash

A sound triggered flash unit enables unusual and interesting action shots to be taken. The basic technique is to take the photographs in darkness so that the camera's shutter can be set to "B" and opened without significantly exposing the film. The subjected is then activated (this could be the bursting of a balloon, smashing of a light bulb, or dropping an object into water), causing the flash to fire and expose the film. The shutter is then immediately closed, to minimise the risk of ambient light ruining the shot. As an electronic flashgun gives an effective shutter speed that is normally in the region of one thousandth of a second (and can be very much less), a "frozen" action shot is obtained. It can often be worthwhile

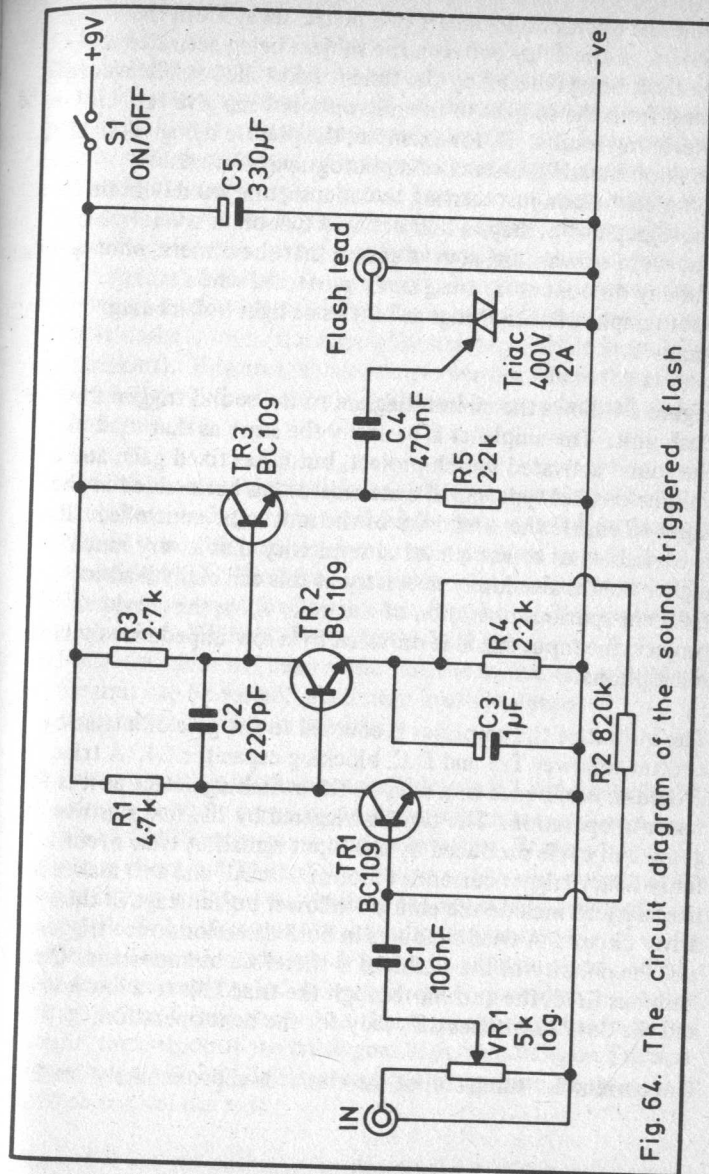

Fig.64. The circuit diagram of the sound triggered flash

using the microphone one or two metres away from the subject, as the delay between the subject being activated and the flash firing (caused by the time it takes the soundwaves to travel from the subject to the microphone) can give very interesting results. If, for example, the picture being taken is of a balloon bursting, instead of a photograph of an almost complete balloon just starting to collapse, one would obtain a photograph of perhaps a half deflated balloon in several pieces. One word of warning, always ensure that the camera, photographer, and any onlookers are adequately protected when taking photographs of such things as bottles or light bulbs being smashed.

Figure 64 shows the circuit diagram of the sound triggered flash unit. The amplifier is basically the same as that used in the sound activated switch project, but it has fixed gain, and a volume control type variable attenuator has been added at the input to enable the sensitivity of the unit to be controlled. It is advisable not to use a level of sensitivity that is very much higher than is absolutely necessary as this can easily lead to frequent spurious operation of the unit. As in the previous project, the input signal is provided by a low impedance dynamic microphone.

The output of the amplifier is coupled to the gate of a triac by emitter follower Tr3 and D.C. blocking capacitor C4. A triac is used in preference to a relay as the switching device as it is far faster in operation. The triac is triggered by the first positive going half cycle produced by the input signal. A triac needs a fairly heavy trigger current of around 20mA., and this makes it necessary to include the emitter follower buffer stage in the driver circuit. A triac conducts in both directions once triggered, and the polarity of the flashlead is therefore unimportant. Once the flash has fired, the current through the triac falls to a low level, and the device switches off ready for the next operation.

The current consumption of the circuit is approximately 7mA.

Light Activated Switch

Switches that are operated by changes in light intensity are useful for many applications, and are amongst the most popular of circuits for the amateur electronics enthusiast. They can be used in such applications as automatic porch light, automatic parking lights, and burglar alarms. The simple design shown in the circuit diagram of Figure 65 can be adjusted over a wide range of sensitivities, giving a switch-over point that occurs in anything from dim light to very bright conditions. It is of the type where a relay is activated if the light falls below the preset threshold level (the type of switch required in most applications). However, an alternative version where the relay is switched on if the threshold light level is exceeded will also be described.

The photo-sensitive cell is a photodarlington transistor (Tr1), and this has a leakage current which varies according to the light level it is subjected to. Increased light level gives increased leakage. The base terminal is simply connected to the negative supply rail to prevent the photocell from being over-sensitive. VR1 and R1 form the load resistor for Tr1, and this resistance has been made variable so that the sensitivity of the unit can be varied. Maximum load resistance corresponds to maximum sensitivity.

The output voltage of the photocell circuitry is fed to the input of a simple Schmitt trigger type circuit which is based on a couple of CMOS gates connected as inverters. If the input voltage is about half the supply voltage or less, the output of the trigger circuit will drop to virtually the negative supply rail potential. Tr2 is then cut off and no significant power is supplied to the relay coil which forms its collector load. If the light level received by Tr1 is low enough to provide a voltage of more than about half the supply voltage to the trigger circuit, the output of the latter goes high, switching on Tr2 and the relay. A pair of relay contacts of the appropriate type are used to control the load.

The quiescent current consumption of the unit depends to some

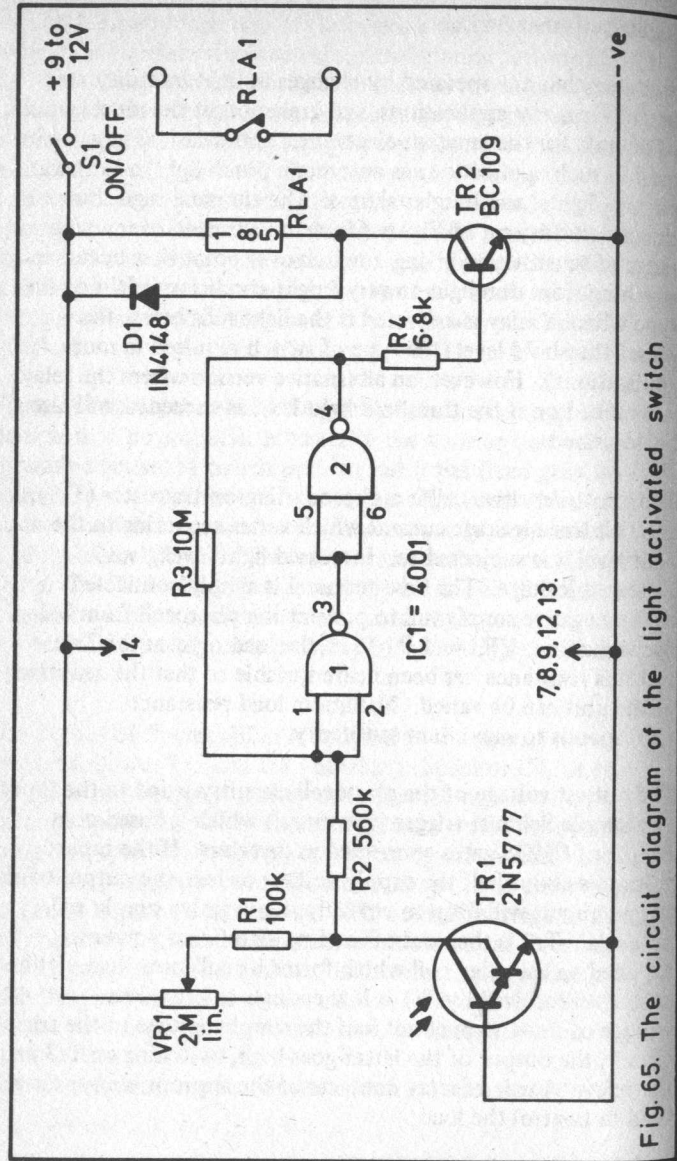

Fig. 65. The circuit diagram of the light activated switch

extent on the setting of VR1 and the light level received by TR1. However, it is normally only about 10 to 20 μA ., although it does rise up to around 1mA. when the light level nears the switching threshold. The current drain is around 35 to 40mA. when the relay is activated.

Alternative Version

Figure 66 shows the necessary modification to make the circuit of Figure 65 switch the relay on when the light level goes above the threshold level. This modification merely consists of connecting one of the previously unused gates of IC1 as an inverter, and adding it at the output of the trigger circuit. Thus, when the relay was previously switched on it will now be switched off, and vice versa, producing the required circuit action.

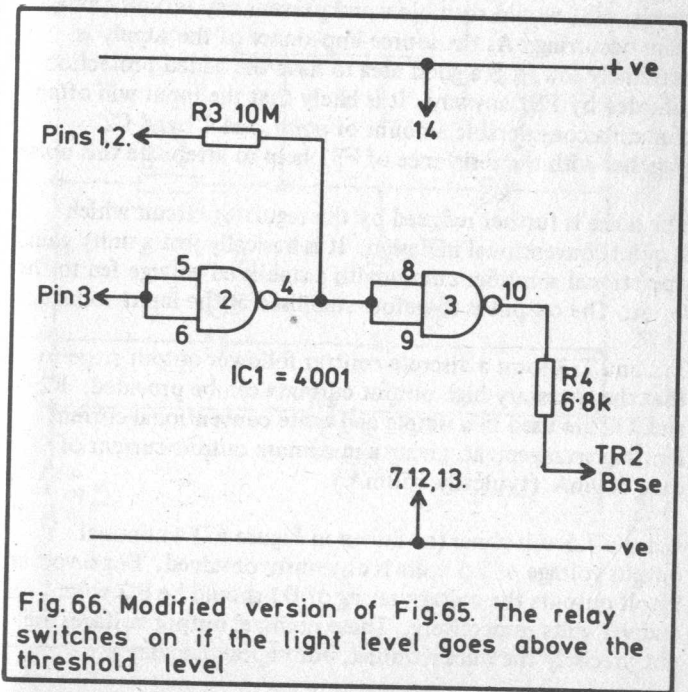

Fig. 66. Modified version of Fig.65. The relay switches on if the light level goes above the threshold level

Car Cassette Supply

When using a cassette recorder in a car it is far cheaper to run the unit from the car battery rather than using internal batteries, and many recorders have a suitable power input socket. However, most cars have a 12 volt battery, whereas cassette recorders normally require a 6, 7.5, or 9 volt supply. A unit such as the one described here is therefore usually needed to drop the 12 volt supply to a suitable level. The circuit diagram of the unit is shown in Figure 67.

The input voltage is first passed through fuse FS1 to smoothing and decoupling capacitors C1 and C2. The fuse is included even though the unit incorporates current limiting circuitry, as in positive earth vehicles it is quite possible that a short circuit could occur between the positive input and the negative output, or direct across the 12 volt supply in other words. FS1 would then blow and prevent any serious damage from occurring. As the source impedance of the supply is extremely low, it is a good idea to have the added protection afforded by FS1 anyway. It is likely that the input will often contain a considerable amount of noise, and C1 and C2 together with the resistance of FS1 help to attenuate this noise.

The noise is further reduced by the regulator circuit which is quite conventional in design. It is basically just a unity gain operational amplifier circuit with a stabilised voltage fed to the input. The output is therefore stabilised at the input voltage.

Tr2 and Tr3 form a discrete emitter follower output stage so that the necessary high output currents can be provided. R2 and Tr2 are used in a simple and quite conventional current limiting arrangement, giving a maximum output current of over 600mA. (typically 650mA).

Using a 7.5 volt zener (as shown in Figure 67) a nominal output voltage of 7.5 volts is obviously obtained. For 6 volt and 9 volt outputs the voltage rating of D1 should be 6.2 volts and 9.1 volts respectively. These nominal output voltages are not precisely the ones required, but in practice they are

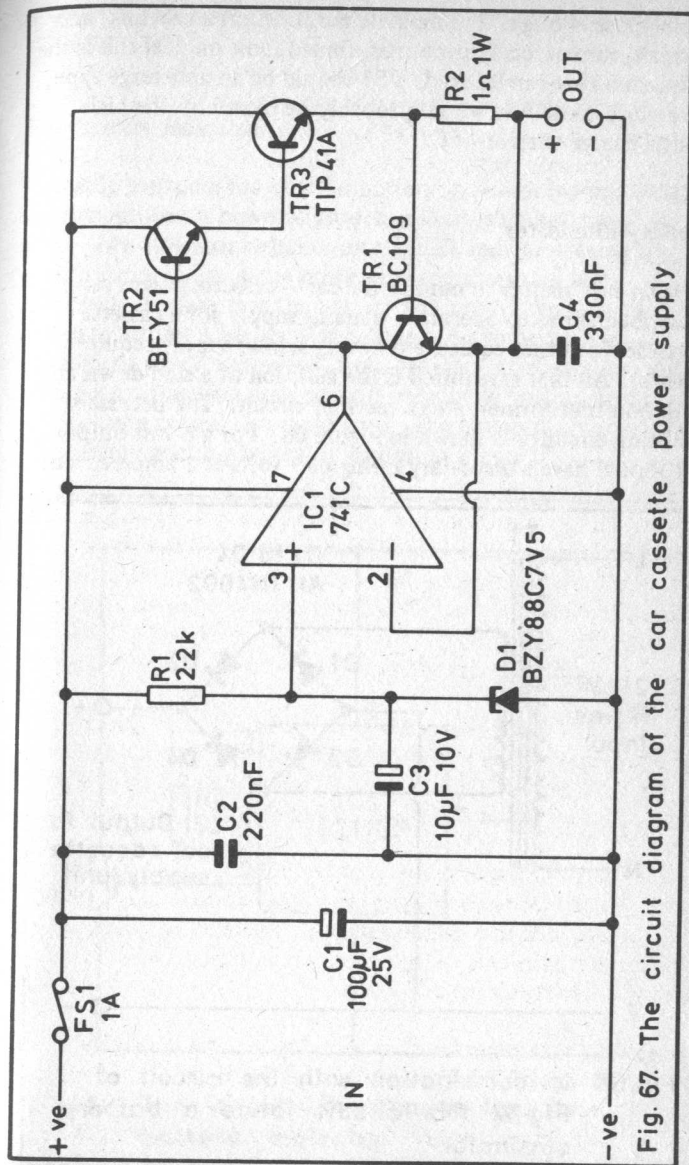

Fig. 67. The circuit diagram of the car cassette power supply

quite close enough. Tr3 must be mounted on a heatsink, and a small, commercially produced, finned, bolt on heatsink is the minimum that can be used. FS1 should be an anti-surge type, as a quick-blow fuse would probably be blown by the high initial charge current of C1.

Battery Eliminator

It is an easy matter to modify the car — cassette power supply described above to operate as a mains supply for a cassette recorder (or other equipment having similar supply requirements). All that is required is the addition of a step-down and isolation transformer, plus a rectifier circuit. The necessary addition circuitry is shown in Figure 68. For a 6 volt output, T1 should have a secondary rating of 9 volts at 1 ampere. For

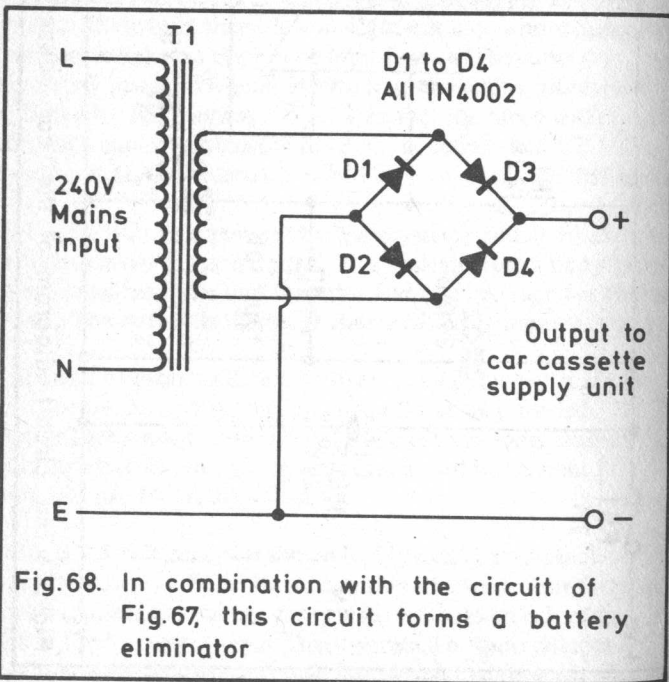

Fig.68. In combination with the circuit of Fig.67, this circuit forms a battery eliminator

a 7.5 or 9 volt output is should have a secondary rating of 12 volts at 1 ampere.

Flat Battery Indicator

Probably the main use of a flat battery indicator is when using equipment that is powered from a rechargeable battery of some kind. The indicator switches on a L.E.D. indicator when the supply drops below some predetermined threshold level, informing the user that the battery will need to be recharged in the near future. Circuits of this type can also be used in equipment which is powered from ordinary dry batteries, and where a malfunction may occur if the supply voltage drops below some critical threshold level. The circuit diagram of the flat battery warning indicator is given in Figure 69.

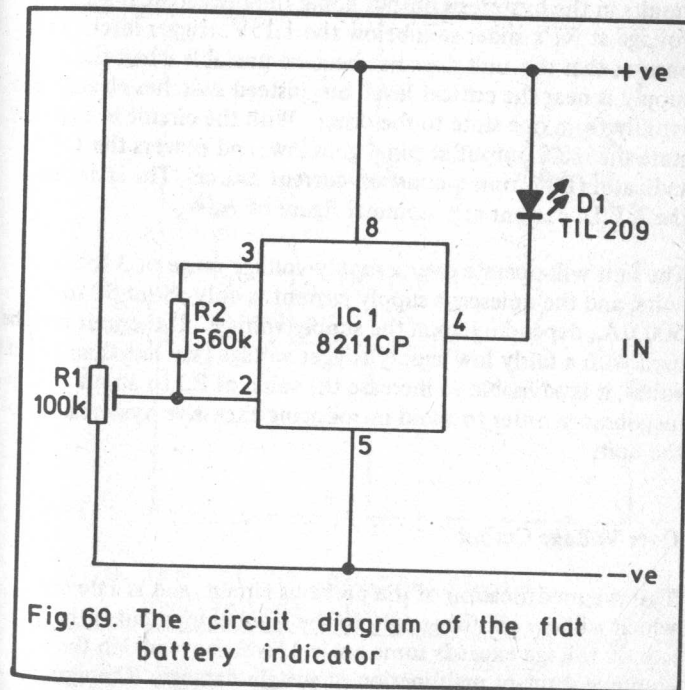

Fig.69. The circuit diagram of the flat battery indicator

This is based on the 8211 I.C. which is intended for precision voltage detection applications. Only three discrete components are required, one of which is R1. This supplies a controlled fraction of the supply potential to one input of an internal voltage comparator of IC1. The other input of the comparator is fed with the output from a precision 1.15V. voltage source. R1 is adjusted so that if the supply voltage drops below the required threshold potential, the voltage at the slider of R1 drops just below 1.15V. Therefore, under normal operating conditions the input voltage to the comparator is more than 1.15V., resulting in the hysteresis output at pin 3 going high and the main output at pin 4 going open circuit. If the supply goes below the critical level, the voltage at the slider of R1 goes below the 1.15V. level, and the hysteresis output starts to go low. Due to the coupling through R2 this results in a reduction in the voltage at the slider of R1. A regenerative action then results in the hysteresis output going fully negative, taking the voltage at R1's slider well below the 1.15V. trigger level. This ensures that the unit does not become unstable when the supply is near the critical level, but instead switches cleanly and rapidly from one state to the other. With the circuit in this new state the main output at pin 4 goes low, and powers the L.E.D. indicator (D1) from a constant current source. The latter sets the L.E.D. current at a nominal figure of 7mA.

The unit will operate over a supply voltage range of 3 to 30 volts, and the quiescent supply current is only about 50 to 500 μ A., depending upon the supply voltage. If the unit is to be used with a fairly low supply trigger voltage (say less than about 8 volts), it is advisable to increase the value of R2 to about 5.6 megohms in order to avoid introducing excessive hysteresis into the unit.

Over-Voltage Cutout

This is a modification of the previous circuit, and is a device which will cut off the supply to the main equipment if the supply voltage exceeds some critical level above which the equipment might malfunction or sustain damage. The circuit

diagram of the unit is shown in Figure 70, and is much the same as the original. However, under normal operating conditions the voltage at the slider of R1 is below rather than above the 1.15V. threshold level, and a strong base current is therefore supplied to Tr1. The latter is thus biased hard on, and supplies power to the load. R1 is adjusted so that if the supply exceeds the required threshold level the voltage at the slider of R1 just exceeds the 1.15V. threshold level, the output at pin 4 goes open circuit, Tr1 is cut off, and no power is supplied to the load.

The quiescent current consumption of the unit is about 7mA. The maximum permissible load current is 100mA., and note that there will be a small voltage drop across Tr1 (although this will normally be only a fraction of a volt).

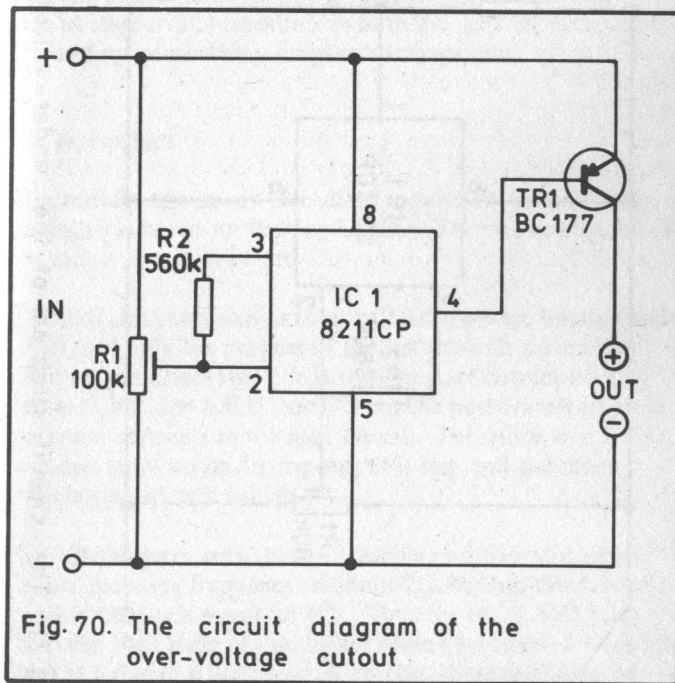

Fig. 70. The circuit diagram of the over-voltage cutout

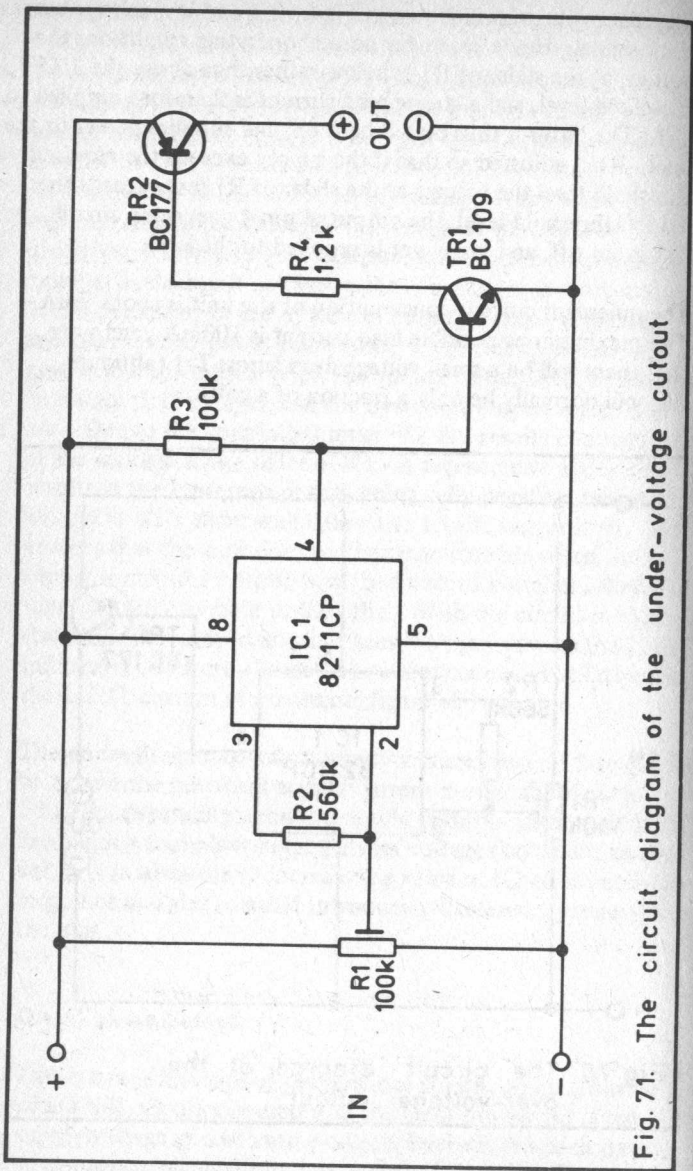

Fig. 71. The circuit diagram of the under-voltage cutout

Under-Voltage Cutout

This unit is basically the same as the flat battery indicator, but instead of operating a warning light it cuts off the supply to the main equipment. The circuit diagram of the unit is shown in Figure 71.

Under normal operating conditions the main output of IC1 will be open circuit, as in the flat battery warning light circuit. However, in this case R3 will bias Tr1 into conduction with IC1 in this state, and Tr1 biases Tr2 into conduction via current limiting resistor R4. Tr2 therefore supplies power to the load which is connected in its collector circuit. If the circuit triggers to the alternative state where the main output of IC1 goes low, the base current for Tr1 is then diverted through the output stage of IC1, resulting in both Tr1 and Tr2 being cut off, and no power being supplied to the output.

L.E.D. Pendant

This novelty circuit can be built as a pendant, brooch, etc., having an array of six flashing L.E.D.s. The circuit diagram of the unit is shown in Figure 72.

The six L.E.D.s are driven from a CMOS 14 stage binary divider (IC2), and only the outputs of the last three stages are used. Each output drives two L.E.D.s via separate current limiting resistors, but one L.E.D. connects to the positive rail whereas the other connects to the negative rail. Therefore, one L.E.D. switches on when its driving output is low, and the other switches on when it is high.

Two CMOS gates are used in an astable multivibrator which has an operating frequency of about 20kHz, and this is used to provide the clock signal for IC2. Thus the two L.E.D.s fed from the 14th stage of the divider chain (the two fed from pin 3) flash at a rate of a little more than 1Hz, those fed from the 13th stage (pin 2) flash at just over 2Hz, and those fed from the 12th stage operate at just over 4Hz. There are various

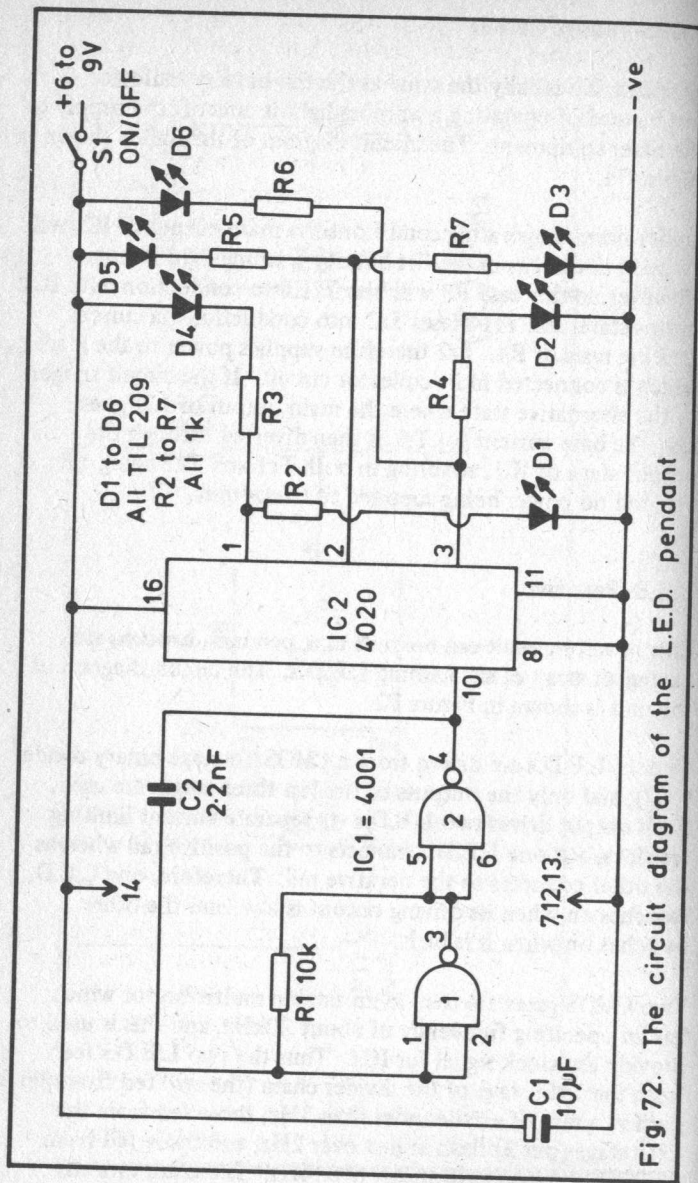

Fig. 72. The circuit diagram of the L.E.D. pendant

ways of arranging the display to give either a regular pattern, or a sort of pseudo-random effect, and the method of presentation is left for individual constructors to decide.

The circuit can be powered from a small 9 volt battery, or from four button cells connected in series (giving a supply potential of about 6 volts). The current consumption is about 14mA. from a 9 volt supply, or 7.5mA. from a 6 volt supply, and these are both average figures as the supply current changes considerably from one instant to the next.

Rapid Ni-Cad Charger

This Ni-Cad charger is primarily intended for rapid charge AA size Ni-Cads requiring a charge current of 150mA., but it can also be used with standard AA size Ni-Cads, or a PP3 size Ni-Cad. Figure 73 shows the circuit diagram of the unit.

T1, D1, D2 and C1 produce a D.C. supply of about 9 volts from the A.C. mains input. T1 6V - 0 - 6V type having a secondary current rating of 500mA. or more.

R1 and D3 form a simple regulator circuit that is used to supply a nominal 0.7 volts to the non-inverting input of IC1. Negative feedback from the emitter of Tr1 to the inverting input of IC1 then stabilises the voltage across RC at this same potential. The emitter current of Tr1 can therefore be set at the required level by giving RC a value that gives this current with an applied voltage of 0.7 volts. Approximately the required figure of 150mA. can be obtained by using a 4.7 ohm component in the RC position. The Ni-Cad cells are actually connected in the collector circuit of Tr1, but this is acceptable since the emitter and collector currents of any reasonably high gain device are practically the same. Ordinary AA Ni-Cad cells need a lower charge current of around 50mA., and this can be achieved using a 15 ohm component for RC. Up to four AA cells can be charged at once in either case, and these should be connected in series. The cells can be mounted in one of the

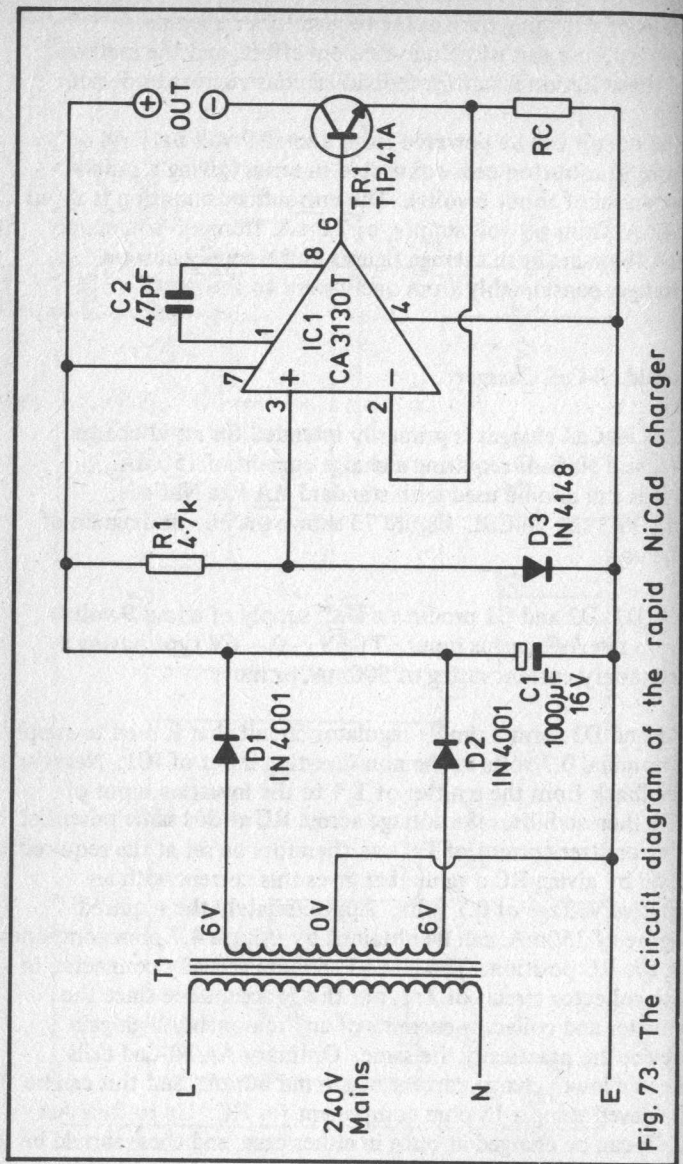
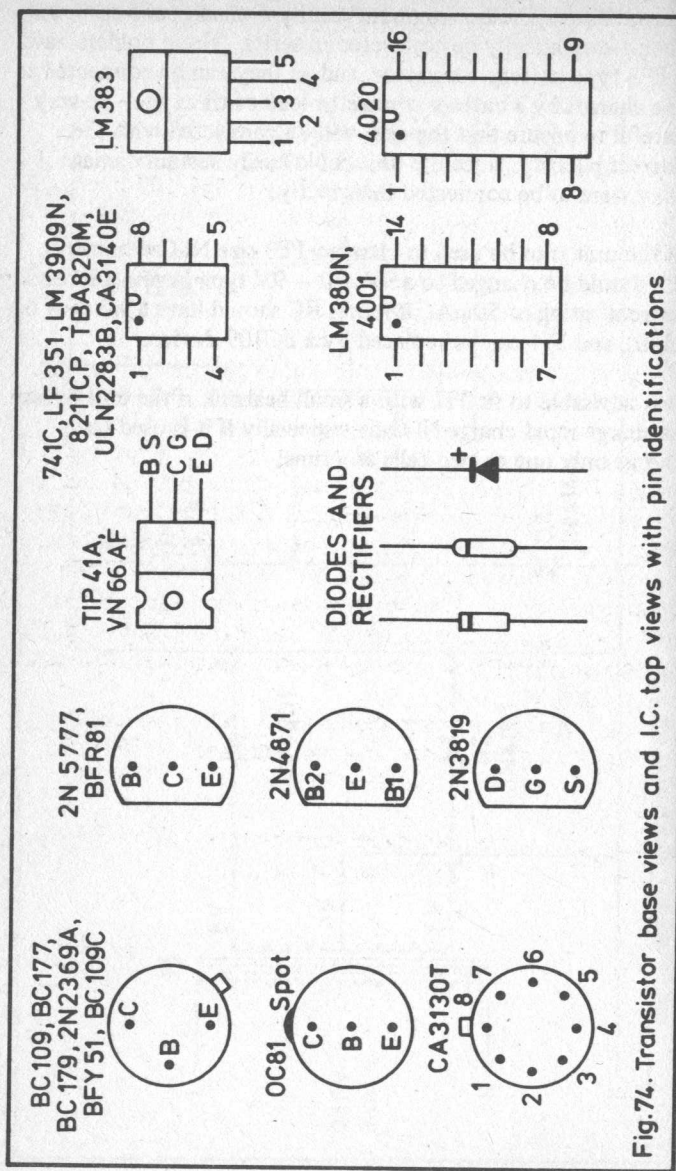

Fig. 73. The circuit diagram of the rapid NiCad charger

plastic battery holders that are readily available, and they will then automatically be connected in series. These holders have a PP3 type battery connector, and so they can be connected to the charger by a battery connector lead of this type. Be very careful to ensure that the cells will be connected with the correct polarity, since the unit could easily sustain damage if they were to be connected incorrectly.

If the unit is to be used to charge a PP3 size Ni-Cad battery, T1 should be changed to a 9V – 0 – 9V type having a secondary current rating of 50mA. or more, RC should have a value of 62 ohms, and Tr1 can be replaced by a BC109 device.

It is advisable to fit Tr1 with a small heatsink if the unit is used to charge rapid charge Ni-Cads, especially if it is used to charge only one or two cells at a time.



Except where noted otherwise, the resistors used in the circuits described in this book are ordinary $\frac{1}{4}$ or $\frac{1}{3}$ watt types having the usual tolerances (5% up to 1M, 10% over 1M). Unless stated otherwise potentiometers are carbon track types, and the circuit indicates whether a log. or lin. type should be used (wirewound types are all lin., since they are only generally available in this type).

Non-electrolytic capacitors can be plastic foil types (polystyrene, polyester, polycarbonate, mylar, etc.) or ceramic plate components where very low values are called for. Variable capacitors can be solid dielectric or air spaced types in the low R.F. circuits, but it is advisable to use only air spaced components in the short wave circuits. Except where the text states that a tantalum bead type should be used, electrolytics can be ordinary p.c.m. or axial types. If in doubt as to the working voltage, use a component having a voltage rating at least slightly more than the supply voltage (minimum working voltages are marked on electrolytics in mains powered circuits).

The semiconductor devices should all be readily obtainable, and the leadout and pinout diagrams for these are shown in Figure 74.

Unless stated otherwise, preset resistors can be 0.1 or 0.25 watt, horizontal or vertical types, as preferred.

Please note overleaf is a list of other titles that are available in our range of Radio and Electronics Books.

These should be available from all good Booksellers, Radio Component Dealers and Mail Order Companies.

However, should you experience difficulty in obtaining any title in your area, then please write directly to the publisher enclosing payment to cover the cost of the book plus adequate postage.

If you would like a complete catalogue of our entire range of Radio and Electronics Books then please send a Stamped Addressed Envelope to.

BERNARD BABANI (publishing) LTD
THE GRAMPIANS
SHEPHERDS BUSH ROAD
LONDON W6 7NF
ENGLAND

160	Coil Design and Construction Manual	£2.50
205	Hi-Fi Loudspeaker Enclosures	£2.95
208	Practical Stereo & Quadraphony Handbook	£0.75
214	Audio Enthusiast's Handbook	£0.85
219	Solid State Novelty Projects	£0.85
220	Build Your Own Solid State Hi-Fi and Audio Accessories	£0.85
222	Solid State Short Wave Receivers for Beginners	£2.95
225	A Practical Introduction to Digital ICs	£2.50
226	How to Build Advanced Short Wave Receivers	£2.95
227	Beginners Guide to Building Electronic Projects	£1.95
228	Essential Theory for the Electronics Hobbyist	£2.50
BP2	Handbook of Radio, TV, Industrial and Transmitting Tube and Valve Equivalents	£0.60
BP6	Engineer's & Machinist's Reference Tables	£1.25
BP7	Radio & Electronic Colour Codes Data Chart	£0.95
BP27	Chart of Radio, Electronic, Semiconductor and Logic Symbols	£0.95
BP28	Resistor Selection Handbook	£0.60
BP29	Major Solid State Audio Hi-Fi Construction Projects	£0.85
BP33	Electronic Calculator Users Handbook	£1.50
BP36	50 Circuits Using Germanium Silicon and Zener Diodes	£1.50
BP37	50 Projects Using Relays, SCRs and TRIACs	£2.95
BP39	50 (FET) Field Effect Transistor Projects	£2.95
BP42	50 Simple LED Circuits	£1.95
BP44	IC 555 Projects	£2.95
BP45	Projects in Opto-Electronics	£1.95
BP48	Electronic Projects for Beginners	£1.95
BP49	Popular Electronic Projects	£2.50
BP53	Practical Electronics Calculations and Formulae	£3.95
BP54	Your Electronic Calculator & Your Money	£1.35
BP56	Electronic Security Devices	£2.50
BP58	50 Circuits Using 7400 Series IC's	£2.50
BP62	The Simple Electronic Circuit & Components (Elements of Electronics - Book 1)	£3.50
BP63	Alternating Current Theory (Elements of Electronics - Book 2)	£3.50
BP64	Semiconductor Technology (Elements of Electronics - Book 3)	£3.50
BP66	Beginners Guide to Microprocessors and Computing	£1.95
BP68	Choosing and Using Your Hi-Fi	£1.65
BP69	Electronic Games	£1.75
BP70	Transistor Radio Fault-finding Chart	£0.95
BP72	A Microprocessor Primer	£1.75
BP74	Electronic Music Projects	£2.50
BP76	Power Supply Projects	£2.50
BP77	Microprocessing Systems and Circuits (Elements of Electronics - Book 4)	£2.95
BP78	Practical Computer Experiments	£1.75
BP80	Popular Electronic Circuits - Book 1	£2.95
BP84	Digital IC Projects	£1.95
BP85	International Transistor Equivalents Guide	£3.50
BP86	An Introduction to BASIC Programming Techniques	£1.95
BP87	50 Simple LED Circuits - Book 2	£1.35
BP88	How to Use Op-Amps	£2.95
BP89	Communication (Elements of Electronics - Book 5)	£2.95
BP90	Audio Projects	£2.50
BP91	An Introduction to Radio DXing	£1.95
BP92	Electronics Simplified - Crystal Set Construction	£1.75
BP93	Electronic Timer Projects	£1.95
BP94	Electronic Projects for Cars and Boats	£1.95
BP95	Model Railway Projects	£1.95
BP97	IC Projects for Beginners	£1.95
BP98	Popular Electronic Circuits - Book 2	£2.25
BP99	Mini-matrix Board Projects	£2.50
BP101	How to Identify Unmarked ICs	£0.95
BP103	Multi-circuit Board Projects	£1.95
BP104	Electronic Science Projects	£2.95
BP105	Aerial Projects	£1.95
BP106	Modern Op-amp Projects	£1.95
BP107	30 Solderless Breadboard Projects - Book 1	£2.25
BP108	International Diode Equivalents Guide	£2.25
BP109	The Art of Programming the 1K ZX81	£1.95
BP110	How to Get Your Electronic Projects Working	£2.50
BP111	Audio (Elements of Electronics - Book 6)	£3.50
BP112	A Z-80 Workshop Manual	£3.50
BP113	30 Solderless Breadboard Projects - Book 2	£2.25
BP114	The Art of Programming the 16K ZX81	£2.50
BP115	The Pre-computer Book	£1.95
BP117	Practical Electronic Building Blocks - Book 1	£1.95
BP118	Practical Electronic Building Blocks - Book 2	£1.95
BP119	The Art of Programming the ZX Spectrum	£2.50
BP120	Audio Amplifier Fault-finding Chart	£0.95
BP121	How to Design and Make Your Own PCB's	£2.50
BP122	Audio Amplifier Construction	£2.25
BP123	A Practical Introduction to Microprocessors	£2.50
BP124	Easy Add-on Projects for Spectrum, ZX81 & Ace	£2.75
BP125	25 Simple Amateur Band Aerials	£1.95
BP126	BASIC & PASCAL in Parallel	£1.50
BP127	How to Design Electronic Projects	£2.25
BP128	20 Programs for the ZX Spectrum and 16K ZX81	£1.95
BP129	An Introduction to Programming the ORIC-1	£1.95
BP130	Micro Interfacing Circuits - Book 1	£2.25
BP131	Micro Interfacing Circuits - Book 2	£2.75

BP132	25 Simple Shortwave Broadcast Band Aerials	£1.95
BP133	An Introduction to Programming the Dragon 32	£1.95
BP135	Secrets of the Commodore 64	£1.95
BP136	25 Simple Indoor and Window Aerials	£1.75
BP137	BASIC & FORTRAN in Parallel	£1.95
BP138	BASIC & FORTH in Parallel	£1.95
BP139	An Introduction to Programming the BBC Model B Micro	£1.95
BP140	Digital IC Equivalents & Pin Connections	£5.95
BP141	Linear IC Equivalents & Pin Connections	£5.95
BP142	An Introduction to Programming the Acorn Electron	£1.95
BP143	An Introduction to Programming the Atari 600/800XL	£1.95
BP144	Further Practical Electronics Calculations and Formulae	£4.95
BP145	25 Simple Tropical and MW Band Aerials	£1.75
BP146	The Pre-BASIC Book	£2.95
BP147	An Introduction to 6502 Machine Code	£2.50
BP148	Computer Terminology Explained	£1.95
BP149	A Concise Introduction to the Language of BBC BASIC	£1.95
BP152	An Introduction to Z80 Machine Code	£2.75
BP153	An Introduction to Programming the Amstrad CPC464 and 664	£2.50
BP154	An Introduction to MSX BASIC	£2.50
BP166	An Introduction to QL Machine Code	£2.50
BP157	How to Write ZX Spectrum and Spectrum+ Games Programs	£2.50
BP158	An Introduction to Programming the Commodore 16 and Plus 4	£2.50
BP159	How to write Amstrad CPC 464 Games Programs	£2.50
BP161	Into the QL Archive	£2.50
BP162	Counting on QL Abacus	£2.50
BP169	How to Get Your Computer Programs Running	£2.50
BP170	An Introduction to Computer Peripherals	£2.50
BP171	Easy Add-on Projects for Amstrad CPC 464, 664, 6128 and MSX Computers	£3.50
BP173	Computer Music Projects	£2.95
BP174	More Advanced Electronic Music Projects	£2.95
BP175	How to Write Word Game Programs for the Amstrad CPC 464, 664 and 6128	£2.95
BP176	A TV-DXers Handbook	£5.95
BP177	An Introduction to Computer Communications	£2.95
BP179	Electronic Circuits for the Computer Control of Robots	£2.95
BP180	Electronic Circuits for the Computer Control of Model Railways	£2.95
BP181	Getting the Most from Your Printer	£2.95
BP182	MIDI Projects	£2.95
BP183	An Introduction to CP/M	£2.95
BP184	An Introduction to 68000 Assembly Language	£2.95
BP185	Electronic Synthesiser Construction	£2.95
BP186	Walkie-Talkie Projects	£2.95
BP187	A Practical Reference Guide to Word Processing on the Amstrad PCW8256 & PCW8512	£5.95
BP188	Getting Started with BASIC and LOGO on the Amstrad PCWs	£5.95
BP189	Using Your Amstrad CPC Disc Drives	£2.95
BP190	More Advanced Electronic Security Projects	£2.95
BP191	Simple Applications of the Amstrad CPCs for Writers	£2.95
BP192	More Advanced Power Supply Projects	£2.95
BP193	LOGO for Beginners	£2.95
BP194	Modern Opto Device Projects	£2.95
BP195	An Introduction to Satellite Television	£5.95
BP196	BASIC & LOGO in Parallel	£2.95
BP197	An Introduction to the Amstrad PC's	£5.95
BP198	An Introduction to Antenna Theory	£2.95
BP199	An Introduction to BASIC-2 on the Amstrad PC's	£5.95
BP230	An Introduction to GEM	£5.95
BP232	A Concise Introduction to MS-DOS	£2.95
BP233	Electronic Hobbyists Handbook	£4.95
BP234	Transistor Selector Guide	£4.95
BP235	Power Selector Guide	£4.95
BP236	Digital IC Selector Guide-Part 1	£4.95
BP237	Digital IC Selector Guide-Part 2	£4.95
BP238	Linear IC Selector Guide	£4.95
BP239	Getting the Most from Your Multimeter	£2.95
BP240	Remote Control Handbook	£3.95
BP241	An Introduction to 8086 Machine Code	£5.95
BP242	An Introduction to Computer Aided Drawing	£2.95
BP243	BBC BASIC86 on the Amstrad PC's and IBM Compatibles - Book 1: Language	£3.95
BP244	BBC BASIC86 on the Amstrad PC's and IBM Compatibles - Book 2: Graphics & Disc Files	£3.95
BP245	Digital Audio Projects	£2.95
BP246	Musical Applications of the Atari ST's	£4.95
BP247	More Advanced MIDI Projects	£2.95
BP248	Test Equipment Construction	£2.95
BP249	More Advanced Test Equipment Construction	£2.95
BP250	Programming in FORTRAN 77	£4.95
BP251	Computer Hobbyists Handbook	£5.95
BP252	An Introduction to C	£2.95
BP253	Ultra High Power Amplifier Construction	£3.95
BP254	From Atoms to Amperes	£2.95
BP255	International Radio Stations Guide	£4.95
BP256	An Introduction to Loudspeakers and Enclosure Design	£2.95
BP257	An Introduction to Amateur Radio	£2.95
BP258	Learning to Program in C	£4.95



BERNARD BABANI BP80

Popular Electronic Circuits – Book 1

- The 73 circuits in this book are primarily intended for those who have had some experience, even if only limited, of electronic construction techniques and are capable of building projects working from just a circuit diagram and without the aid of detailed constructional information or board layouts etc. However, any special setting up procedures thought necessary are included.
 - The circuits cover a wide range of subjects including audio, radio, test gear, musical effects, household gadgets etc. so there should be a number of circuits of interest to most readers. The circuits are all based on modern and readily available components and in general are quite inexpensive to build.
 - This book offers remarkable value for the amount of information that it contains and is a highly recommended addition to the library of all electronic enthusiasts.
 - Also available BP98: POPULAR ELECTRONIC CIRCUITS – Book 2.
-

£2.95

ISBN 0-85934-055-4



9 780859 340557

00295