

# Projects in Opto-Electronics

R. A. PENFOLD

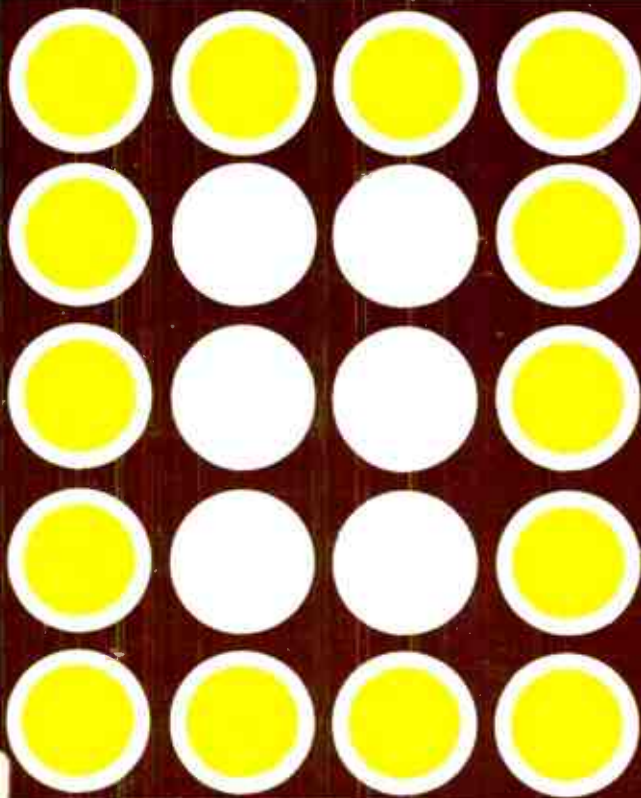



# PROJECTS IN OPTO-ELECTRONICS

## ALSO BY THE SAME AUTHOR

- No. 222 Solid State Short Wave Receivers for Beginners
- No. 223 50 Projects Using IC CA3130
- No. 224 50 CMOS IC Projects
- No. 226 How to Build Advanced Short Wave Receivers
- No. 227 Beginners Guide to Building Electronic Projects
- No. BP49 Popular Electronic Projects
- No. BP56 Electronic Security Devices
- No. BP59 Second Book of CMOS IC Projects
- No. BP65 Single IC Projects
- No. BP69 Electronic Games
- No. BP71 Electronic Household Projects
- No. BP74 Electronic Music Projects
- No. BP76 Power Supply Projects
- No. BP80 Popular Electronic Circuits – Book 1
- No. BP83 VMOS Projects
- No. BP91 An Introduction to Radio DXing
- No. BP94 Electronic Projects for Cars and Boats
- No. BP95 Model Railway Projects
- No. BP96 CB Projects
- No. BP98 Popular Electronic Circuits – Book 2
- No. BP99 Mini-matrix Board Projects
- No. BP103 Multi-circuit Board Projects
- No. BP105 Aerial Projects
- No. BP106 Modern Op-Amp Projects
- No. BP107 30 Solderless Breadboard Projects – Book 1
- No. BP110 How to Get Your Electronic Projects Working
- No. BP113 30 Solderless Breadboard Projects – Book 2
- No. BP117 Practical Electronic Building Blocks – Book 1
- No. BP118 Practical Electronic Building Blocks – Book 2

# PROJECTS IN OPTO-ELECTRONICS

by

R. A. PENFOLD

**BERNARD BABANI (publishing) LTD  
THE GRAMPIANS  
SHEPHERDS BUSH ROAD  
LONDON W6 7NF  
ENGLAND**

## PLEASE NOTE

Although every care has been taken with the production of this book to ensure that any projects, designs, modifications and/or programs etc. contained herein, operate in a correct and safe manner and also that any components specified are normally available in Great Britain, the Publishers do not accept responsibility in any way for the failure, including fault in design, of any project, design, modification or program to work correctly or to cause damage to any other equipment that it may be connected to or used in conjunction with, or in respect of any other damage or injury that may be so caused, nor do the Publishers accept responsibility in any way for the failure to obtain specified components.

Notice is also given that if equipment that is still under warranty is modified in any way or used or connected with home-built equipment then that warranty may be void.

© BERNARD BABANI (publishing) LTD 1978

I.S.B.N. 0 85934 049 X

First Published — February 1978

Reprinted — September 1982

Reprinted — January 1985

Reprinted — February 1988

Reprinted — April 1989

Printed and bound in Great Britain by Mayhew McCrimmon Printers Ltd

# CONTENTS

	Page
<b>CHAPTER 1 – PROJECTS USING LIGHT-EMITTING DEVICES</b>	
What do we mean by “Light”?	7
Light Emitting Diodes	9
Series Resistor	11
Low Power Indicator	12
Peak Level Indicator	13
Stabiliser Circuit	16
L.E.D. Array Driver	17
Audio Compression Circuit	20
Automatic Fader	24
L.E.D. Zener P.S.U.	26
L.E.D. Metronome	29
Seven Segment Displays	31
Logic Probe	33
Heads or Tails	35
Single Display Version	38
Simple Stopwatch	38
Adjustment	41
Lamp Dimmer	41
<b>CHAPTER 2 – LIGHT OPERATED SWITCHES</b>	
Automatic Parking Light	45
Light Detector	47
Darkness Detector	50
Latching Versions	51
Alternative Version	52
Low Standby Current Circuit	53
Variations	56
Infra Red Switch	56
Circuit	59
Receiver	59
Sports Timer	63
Alternative Version	65
Directivity	66

	Page
<b>CHAPTER 3</b>	<b>MODULATED LIGHT TRANSMISSION</b>
Basic Principle . . . . .	71
Circuits . . . . .	74
Receiver . . . . .	78
Using an L.D.R. . . . .	79
Optical System . . . . .	80
Operation . . . . .	83
Infra Red Transmission. . . . .	85
Transmitter Circuit . . . . .	89
Receiver Circuit . . . . .	90
Optics. . . . .	92
<b>CHAPTER 4</b>	<b>PHOTOGRAPHIC PROJECTS</b>
Slave Unit . . . . .	95
Circuit. . . . .	96
Enlarger Exposure Meter. . . . .	98
Calibration. . . . .	101
Phototimer. . . . .	102
Colour Temperature Meter . . . . .	103
Circuit. . . . .	103
Calibration. . . . .	106
<b>COMPONENTS.</b> . . . . .	<b>108</b>



## Chapter 1

# PROJECTS USING LIGHT-EMITTING DEVICES

Although many people tend to take opto-electronic devices and circuits for granted, it is hoped that this book will show even the experienced reader that opto-electronics can be used in a surprisingly wide range of applications.

A large number of devices are included in the light-responsive family, this group including lasers and TV camera tubes, as well as more mundane items such as neon indicators and ordinary filament bulbs. In fact, any electronic or electrical device which responds to light falls under this heading. The purpose of this book is to describe a number of projects which represent practical designs utilising such devices, and which may be of interest to the average electronics enthusiast. This includes designs using ordinary light-emitting diodes (L.E.D.s) as well as more complicated circuits employing similar components in, for example, infra-red transmitters and detectors.

### What do we mean by “Light”?

It would be out of place to discuss this subject at length here, but it could be helpful to the reader to have at least a basic understanding of the true nature of light. Fundamentally, it is a form of electromagnetic radiant energy, rather like radio waves, but at shorter wavelengths than even microwaves. This is shown in Fig.1, which indicates the spectrum of electromagnetic waves. The eye perceives the various frequencies in the visible light spectrum as various colours, shown in Fig.2.

Light is sometimes defined as that part of the electromagnetic spectrum to which the eye is sensitive, but in the field of opto-electronics it is usually taken to include both infra-red and ultra-violet radiation as well. Projects which transmit and detect infra-red are included in this book, but none of the designs are concerned with ultra-violet. To the best of the author's knowledge, suitable devices for experimentation with ultra-violet are not available to the amateur, and there are dangers involved with ultra-violet radiation anyway.

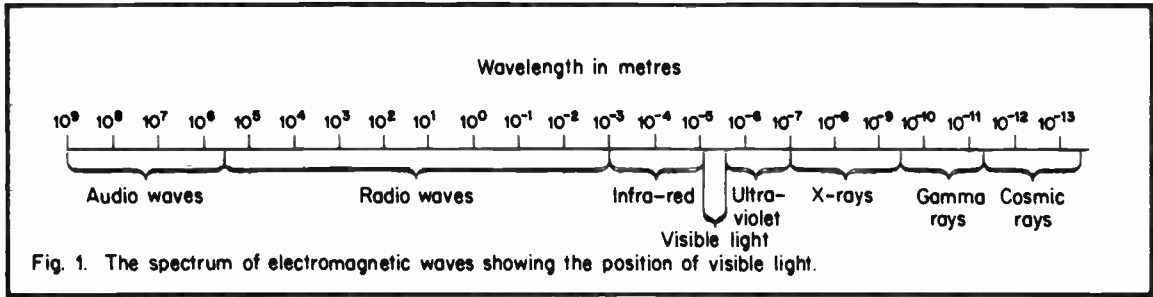

∞

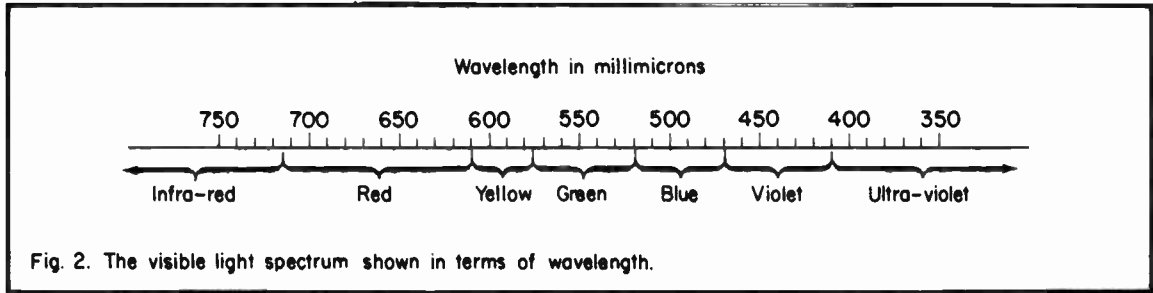

## Light-Emitting Diodes

Light-emitting diodes have been in existence for many years, but it is only comparatively recently that their cost has fallen to a level which makes them a practical proposition for use in amateur designs. They now cost little more than germanium or silicon diodes.

L.E.D.s are not constructed from germanium or silicon, however, they are made from gallium arsenide, and when forward-biased with a current of a few mA they produce a visible glow (except for infra-red types of course, which are covered later). Sometimes catalogues and component lists refer to a L.E.D. by its type number such as TIL209, etc., but there seems to be a tendency now for the size (diameter) and colour to be specified rather than a type number. The two most common sizes are 0.125 and 0.2 in., diameter, and the most common colour is red. However, green, yellow, orange, and clear types are also available. In practice there are few circuits where the use of a particular type of L.E.D. is essential, and in most cases any L.E.D. can be used.

The primary advantage of L.E.D.s over other forms of indicator is that they require very little power. They require an operating voltage of only about 1.7 volts, and the maximum operating current for most small L.E.D.s is 20mA (usually 50mA for the 0.2 in., diameter types). However, most small L.E.D.s will produce quite a bright glow at an operating current of only about 5mA, and a just visible glow at less than 1mA. Thus a L.E.D. indicator will work quite well with an input power of only about 8 milliwatts! Another important feature of L.E.D.s is that they have extremely long working lives.

One practical problem when using L.E.D.s is that it is sometimes difficult to determine which connection is which. L.E.D.s often have leads of dissimilar lengths, and the shorter one is the cathode, but there are some types where the longer lead is the cathode. There are actually some L.E.D.s where there is no apparent way of finding out which leadout is which, short of connecting the device to some form of test circuit.

Care must be exercised when testing L.E.D.s as a forward voltage of only about 2V is all that is needed in order to produce an excessive forward current (only 5 microamps for some devices) and the subsequent destruction of the device. Most L.E.D.s are guaranteed to exhibit reverse breakdown voltages of only about 3–5 volts. Although typical items seem to have a reverse breakdown voltage of something in the region of 20 volts, for some devices the figure is as low as that quoted above.

Most modern test meters incorporate a 1.5, 3, or 4.5 volt battery for use on the resistance ranges, and so it is possible to use such a meter to safely check the polarity of a L.E.D. When connected to the resistance meter, one way round there should be no meter deflection whatever, while there will be a large deflection when it is connected the other way round, and if a low ohms range is used, the L.E.D. will probably light up. When a current flow is produced, the anode leadout is connected to the negative test lead and the cathode is connected to the positive one. If a suitable test meter is not available, the simple test circuit of Fig.3 can be used. Here R1 limits the forward current to the L.E.D. under test to a safe level, and Zener diode D1 limits the reverse voltage to a safe level if the test device is connected the wrong way round. When the L.E.D. under test lights up, test prod 1 is connected to its anode, and test prod 2 is connected to its cathode.

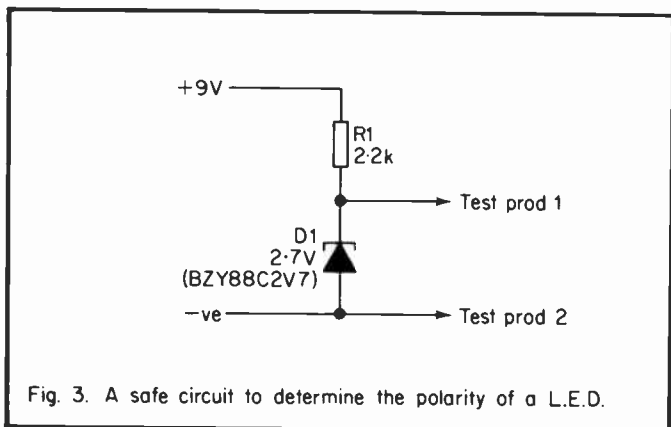

Fig. 3. A safe circuit to determine the polarity of a L.E.D.

## Series Resistor

It is not necessary to provide an accurately stabilised supply voltage for a L.E.D. indicator, even though L.E.D.s do require a supply voltage which is within certain very narrow limits. The reason for this is simply that L.E.D.s act rather like a Zener diode when they are forward-biased, and if fed from a comparatively high supply voltage via a suitable current limiting resistor, they thus stabilise their supply voltage at the correct level.

It is very simple to calculate the required value of this series resistor using the following equation:—  $R = (E - 2)$  divided by  $I$ , where  $R$  is the required series resistance value in ohms,  $E$  is the supply voltage in volts, and  $I$  is the required operating current in amps. Therefore a 700 ohm resistor would be needed for a current of 10mA when using a 9 volt supply, for example  $(9 - 2 = 7, 7 \text{ divided by } 0.01 = 700)$ . In practice the nearest preferred value of 680 ohms would be used.

If a L.E.D. is to be used in a circuit where it is possible for its maximum reverse voltage to be exceeded, a protective diode should be added in parallel with the L.E.D., as shown in Fig.4. The additional diode is used as a low voltage zener which limits the reverse voltage to only about 0.65 volts.

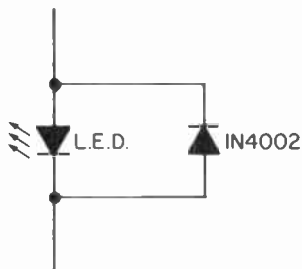

Fig. 4. Using a silicon rectifier to protect a L.E.D. against excessive reverse voltage.

## Low Power Indicator

L.E.D.s are used as various types of indicator, the most common example being the stereo indicator beacon which is fitted to most stereo F.M. tuners. The low power requirement of L.E.D.s enables them to be fed from comparatively simple driver circuitry. This lower power requirement also enables them to be used as on/off indicators on equipment which is powered from an ordinary 9 volt dry battery. Filament bulbs are unsuitable for such applications since they require far too much current. Even the 5mA or so required by a L.E.D. can greatly reduce the life of the battery if the equipment is powered from a small type such as the popular PP3. This problem can be overcome by only pulsing the L.E.D. on briefly at say one second intervals. The L.E.D. obviously consumes no current during the period that it is switched off, and in this way the power consumed by the indicator can be greatly reduced. This does not make the indicator any less effective, since it is at full brightness for the period that it is turned on, and the fact that it is flashing on and off actually makes it more noticeable than if it were on continuously.

The circuit diagram of a simple low power pilot light is shown in Fig.5. This is based on a conventional astable multivibrator circuit. R2 is the base bias resistor for Tr1, and R1 is the collector load resistor. R3 is the base bias resistor for Tr2, and D1 plus R4 are the collector load. C1 and C2 are the cross coupling capacitors, and their values have been chosen to produce oscillation at a frequency of approximately 1Hz. They have also been given values which make the time during which Tr2 is turned on much less than the time during which Tr1 is switched on. Thus the L.E.D. is briefly pulsed on at approximately one second intervals.

The fairly high value of R1 produces a low current consumption when Tr1 is turned on and Tr2 is turned off. This is obviously an essential feature of the circuit as the current consumption would be the same whether the L.E.D. was on or off, if the two transistors had equal collector load impedances in the conventional manner. A current of about 9mA is pulsed through the L.E.D., but the average current consumption of the circuit is only about 1.25mA. C1

provides supply decoupling, and helps to suppress any transients which might otherwise be generated by the circuit and fed to the main equipment via the supply lines.

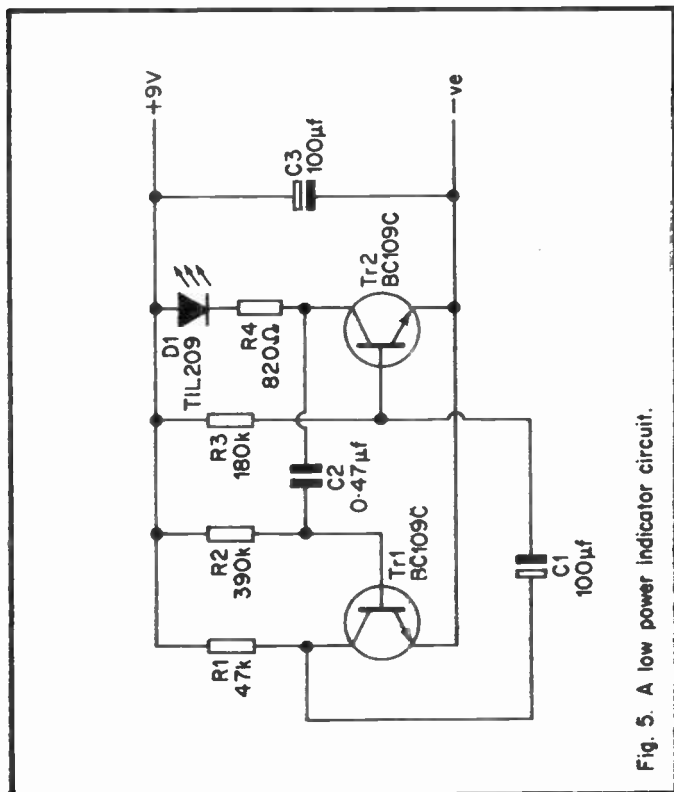

Fig. 5. A low power indicator circuit.

## Peak Level Indicator

L.E.D.s are commonly employed in a device known as a peak level indicator. These were originally used in cassette and tape decks, but now they are often fitted to amplifiers, mixers, disco equipment, etc. The purpose of a peak level indicator is, as its name suggests, to show if an audio signal

exceeds some predetermined peak voltage. When fitted to tape equipment it is used in conjunction with the normal VU meter to ensure that the maximum permissible recording level is not exceeded. An ordinary VU meter is an average reading device, and it does not therefore respond adequately to short spiky waveforms. A peak level indicator on the other hand, will respond just as readily to a very brief overload as it will to a prolonged one.

The circuit diagram of a simple peak level indicator is shown in Fig.6. This consists of two stages, the emitter – follower input stage which uses Tr1, and a conventional monostable multivibrator which uses Tr2 and Tr3.

Dealing with the monostable section first, when the supply voltage is initially applied to the circuit Tr2 will be turned on by the base current it receives via R4. The voltage at Tr2 collector is therefore little more than zero, and Tr3 does not receive any significant base current by way of the potential divider chain which consists of R5, R6 and R7. Tr3 has the L.E.D. indicator (D1) and its series current limiting resistor (R8) as its collector load, and these do not normally receive any current since Tr3 is switched off.

The monostable can be triggered by a negative voltage which is applied to Tr2 base. This causes Tr2 to switch off, which in turn enables Tr3 to obtain a base current and switch on. This results in a current being supplied to the L.E.D. indicator which in consequence lights up.

The circuit does not remain in this stage though, and C3 quickly charges up via R4 until Tr2 begins to turn on. A regenerative action then takes place with the circuit almost instantaneously triggering back to its original state with the L.E.D. off. The values of R4 and C3 have been chosen to produce an output pulse of about 100mS. duration. The monostable is being used here as a pulse lengthener, so that brief input pulses cause the L.E.D. indicator to come on for a length of time which although still only short, is long enough to provide clear indication of an overload.

Tr1 is used as a conventional emitter-follower buffer stage which provides the circuit with a high input impedance (about 300 k $\Omega$ ) and isolates the monostable from the main



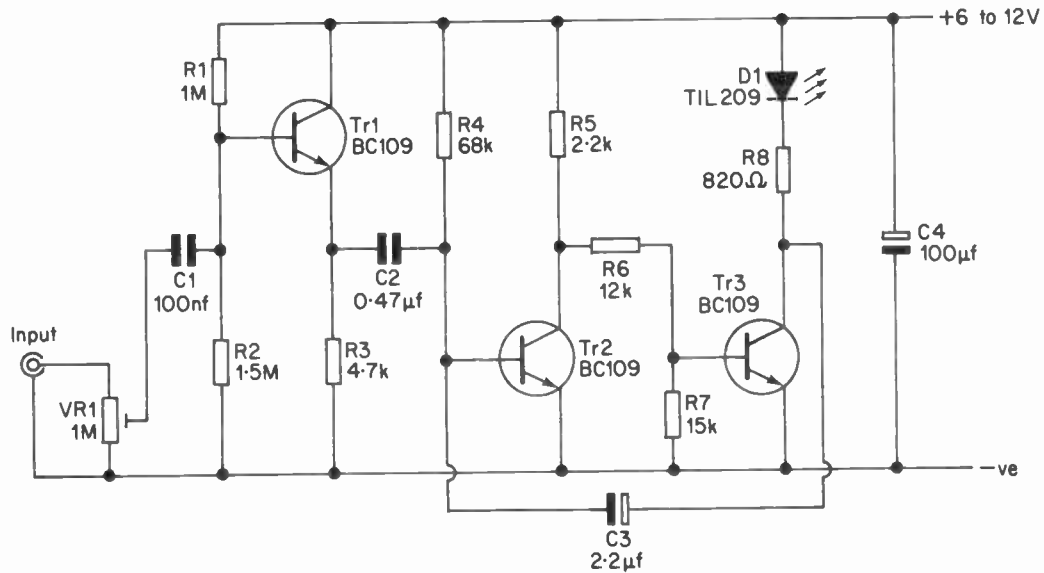

Fig. 6. The circuit diagram of a simple peak level indicator.

equipment. VR1 is a volume control type variable attenuator which enables the sensitivity of the circuit to be adjusted to the required level. It is only necessary to reduce the base voltage of Tr2 by about 30mV in order to trigger the mono-stable circuit, and so the unit has quite good sensitivity. With VR1 set for maximum sensitivity only about 60mV peak-to-peak is needed at the input in order to cause the L.E.D. indicator to light up. With its high input impedance and sensitivity this circuit is compatible with most audio equipment.

What part of the main equipment the peak level indicator is fed from must, of course, be varied to suit the particular circumstances concerned. If it is to be used in conjunction with a VU meter, then it can be driven from the same source as the VU meter circuitry. It should not be fed from directly across the VU meter terminals unless the VU meter is a type which has integral rectifiers. In other words the unit must be fed from a point ahead of the meter rectifier circuit. A screened lead is used to connect the peak level indicator to the main equipment.

Before VR1 can be given the correct setting it is necessary to feed the main equipment with a steady audio signal, such as the output from an A.F. signal source or generator. The amplitude of the signal is adjusted to precisely the minimum level at which the peak level indicator is required to respond. VR1 is then adjusted for the lowest sensitivity which causes the indicator lamp to come on.

## Stabiliser Circuit

The sensitivity of the circuit does vary slightly with variations in the supply rail potential, but this is not likely to be a problem if the unit is powered from a mains P.S.U. Any changes in the supply voltage are then likely to be too small to be of significance. The situation is rather different if the unit is to be battery powered, since the voltage of a 9 volt dry battery can vary by more than 20% during its normal working life. It is therefore advisable to use a stabiliser circuit between the battery and the peak level indicator if this form of power source is to be used. A suitable circuit is shown in Fig.7, and this is a simple emitter-follower series regulator circuit.

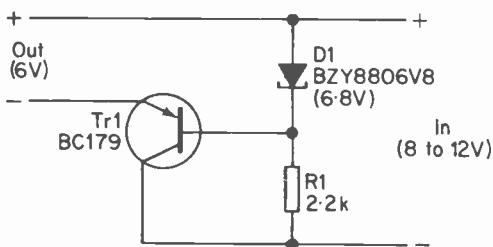

Fig. 7. A simple regulator circuit for use with the peak level indicator of Fig. 6.

## L.E.D. Array Driver

It is possible to take the peak level indicator circuit a stage further, and instead of having just one L.E.D. operating at one level, use several L.E.D. indicators with each one operating at a different threshold point. Some circuits of this type are very accurate and can replace a conventional VU meter. Unfortunately though, such circuits are rather complex and are beyond the scope of this book.

Unsophisticated but less accurate circuits of this type are easy to construct however, and can be very useful. One application for such a circuit would be as a monitor for the output of a disco amplifier. Apart from providing a novel and attractive display, such a circuit would enable the operator to see at a glance whether or not the amplifier was being overdriven.

Integrated circuit L.E.D. array drivers such as the UAA170 and UAA180 are available, and very simple discrete circuits of the type shown in Fig.8 can also be used. This circuit functions in the following manner:— VR1 is the sensitivity control, and unless the output from the slider of this component reaches about 0.6V or more, all five transistors will remain cut off. Each transistor has a L.E.D. indicator (D1 to D5) and a series current limiting resistor (R1 to R5) in its collector circuit, and each L.E.D. will be off until its driver transistor is biased into conduction. When

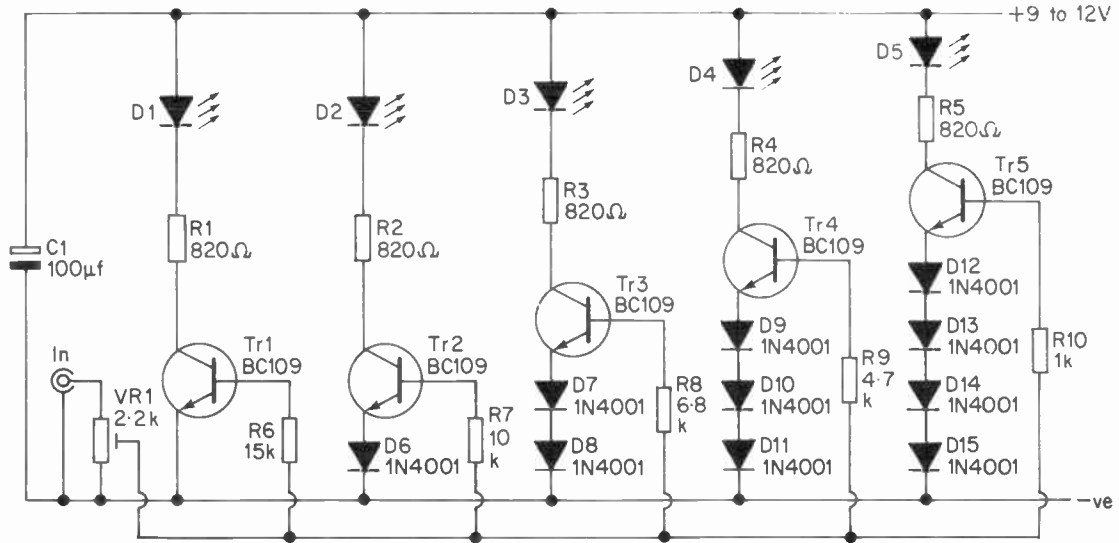

Fig. 8. The circuit diagram of a simple L.E.D. array driver.

the voltage at VR1 slider reaches about 0.6V, Tr1 will be biased into conduction and D1 will light up. However, none of the other transistors or L.E.D.s will be switched on due to the presence of the diodes in the emitter circuits of TRs2 to 5. These diodes act as low voltage zeners, each one having a zener voltage of about 0.6V. Thus the voltage at VR1 slider must reach about 1.2 volts before the base – emitter voltage of Tr2 reaches about 0.6V, and Tr2 begins to conduct. Tr3 and D3 will not come on until the voltage at VR1 slider reaches about 1.8V, and the threshold switch on voltages for Tr4 and Tr5 are 2.4V and 3.0V respectively.

Each transistor has a resistor connected in series with its base terminal (R6 to R10), and these resistors are needed for two reasons. Primarily they prevent the VR1 slider voltage from being limited to the nominal base voltage of one of the transistors. For example, if R7 were to be omitted, the base – emitter junction of Tr2 and D6 would together act as a low voltage Zener, and they would clip the VR1 slider voltage at a level of about 1.2V. This would obviously prevent Tr3, Tr4, and Tr5 from being switched on.

The secondary function of these resistors is to protect the five transistors from damage in the event that the input voltage exceeds their base emitter reverse breakdown voltage. It should be remembered here that although the circuit only responds to positive input half-cycles, the negative-going half-cycles are still present. A transistor will not be damaged by an excessive reverse base – emitter voltage provided the base current is limited. The five base resistors provide the necessary current limiting.

The circuit of Fig.8 is only for one channel, and two of these circuits are required for stereo operation. The same is true of the peak level indicator circuit of Fig.6.

The L.E.D. array, or arrays in the case of a stereo version, can simply consist of a row of five ordinary L.E.D.s. If the stereo version is constructed it is possible to use a ten-segment linear L.E.D. display, or a 'Line-O-Light' display as it is sometimes called. This consists of an array of ten L.E.D.s in a 20 pin DIL package. If this is mounted horizontally with the L.E.D.s at the ends of the row being used as the two D5s, and

those at the centre being used as the D1s, a very novel but nonetheless clear form of display is produced.

The circuit is very easy to set up and adjust. The input of the device is fed from the speaker socket(s) of the monitored amplifier, and there is no need to use a screened connecting cable. A steady audio input is connected to the amplifier which is then adjusted for maximum output. VR1 is then adjusted to the least sensitive position which causes all the L.E.D.s to light up. A minimum input level of 6 volts peak-to-peak is needed in order to drive the unit properly. Any power amplifier of medium or high output should be able to supply this.

The output amplitude is at a level of 20% of maximum, or more when D1 is alight, and D2 to D5 correspond to peak amplitude output levels of 40%, 60%, 80% and 100% of maximum respectively.

## Audio Compression Circuit

Opto-electronic devices can be used in applications which one would not normally associate with them. For instance, a torch bulb can be used as the automatic gain control element of a Wien Bridge sinewave oscillator. Here use is made of the resistance characteristic of the bulb. The resistance of the bulb rises with increasing filament temperature, and it can thus be used as an inexpensive self-heating thermistor. Bulbs can also be used in other audio control circuits such as volume expansion and compression circuits.

The next two circuits are of the same basic type as those mentioned above, but they are a little more modern and sophisticated in concept. They use a L.E.D. and a light dependent resistor (L.D.R., also known as a photo-conductive cell or P.C.C.) to provide an electronically variable resistance. The basic idea is very simple; the two devices are mounted facing one another in a light proof box, and they are placed as close together as possible so that there is good light pick-up from the L.E.D. by the photo-conductive cell. In total darkness the photo-cell will have a comparatively high resistance, and the minimum figure for the ORP12 device

which is used in these circuits is 10 Meg. ohms. When brightly illuminated an ORP12 has a resistance of only about 20 to 100 ohms. It is therefore possible to vary the resistance of the cell by feeding a current to the L.E.D.

In the two circuits which are described below, a small L.E.D. is used, and at a maximum current of only about 9mA. Only a fairly modest amount of light is produced as a consequence, but fortunately the light output from a red L.E.D. is at a narrow range of wavelengths which lie at about the peak of an ORP12s response (about 650 millimicrons). Even so it is not possible to achieve the minimum resistance figure of the ORP12, but a resistance of less than  $1k\Omega$  is obtainable. This provides quite a wide resistance range (less than  $1k$  to more than 10 Meg.) which is more than adequate for most purposes.

It should perhaps be pointed out that these circuits are not put forward for their novelty value (which, admittedly, they do have), but as serious alternatives to more conventional circuits which employ f.e.t.s. or I.C.s. The author has designed and constructed many audio control circuits, and the two described here are competitive with other designs both on grounds of cost and performance.

The first circuit is for an audio compressor, and these units are much used in tape recording and other branches of audio. The circuit can, for example, be interposed between the output of a mixer and the input of a tape recorder in order to ensure that maximum recording level is not greatly exceeded.

The circuit diagram of the compression unit appears in Fig.9. The input signal is applied via C2 to an attenuator which consists of R1 and PCC1. The photo cell is normally in darkness and so exhibits a very high resistance, in comparison to the resistance of R1. There is thus no large signal loss through the attenuator.

Tr1 is used as an emitter-follower buffer stage, and has a high input impedance which does not significantly shunt PCC1. This is obviously an important point as a significant impedance in parallel with PCC1 would render it, and in consequence the circuit, largely ineffective.

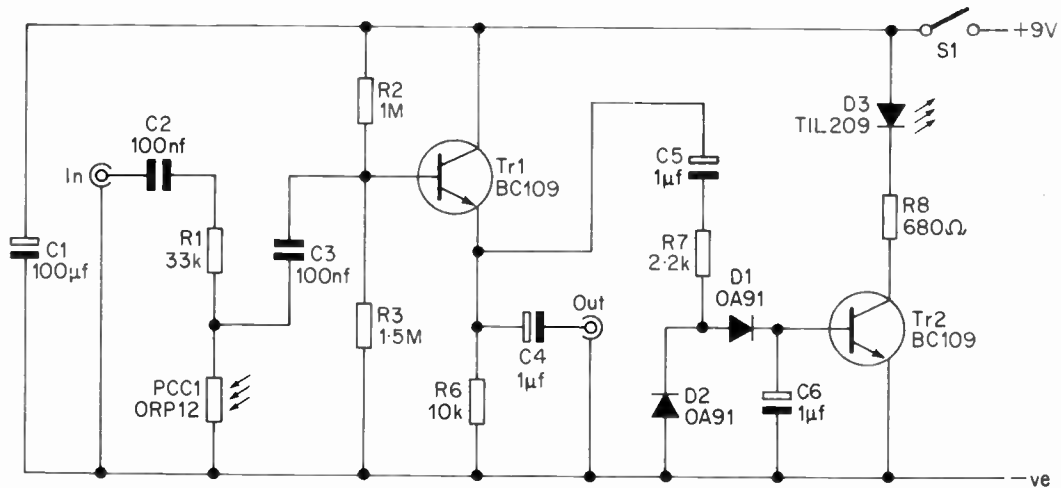

Fig. 9. The circuit diagram of the audio compression unit.



Some of the signal at Tr1 emitter is fed to the output socket. Tr1 is used with 100% negative feedback, and so it adds very little noise and distortion to the signal. The remainder of the output from Tr1 is fed to a voltage doubling rectifier and smoothing circuit which comprises D1, D2 and C6. When the input signal is at an amplitude of about 200 mV. R.M.S. or less the voltage produced across C6 is not sufficient to turn on Tr2.

Signals of more than about 200mV. R.M.S. do result in Tr1 turning on to some degree, and this causes a current to be led to the L.E.D., D3. The greater the amplitude of the input signal, the harder Tr2 is turned on, and the brighter the L.E.D. glows. Of course, the light from the L.E.D. is picked up by PCC1, and the brighter the L.E.D. glows, the lower the resistance of the photo-cell becomes.

This reduction in the resistance of PCC1 results in a large increase in the losses through the attenuator, and so the greater the amplitude of the input signal, the more the signal is attenuated. This tends to limit the output level from the circuit, and this effect can be clearly seen in the graph of Fig.10. Increasing the input signal from 200mV. R.M.S. to 4 volts R.M.S. results in the output rising to only 400mV.

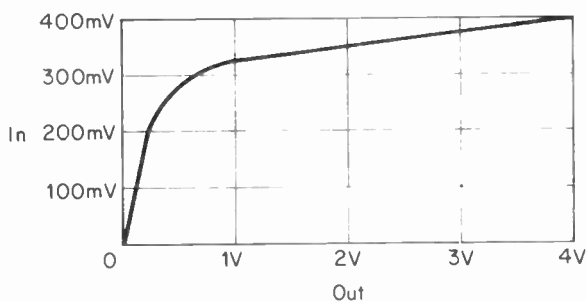

Fig. 10. Graph showing the performance of the prototype compression circuit (voltages are R.M.S. at 1kHz, sinewave).

In other words a 26dB. increase in the input level results in only a 6dB. rise in the output amplitude, and some 20dB of compression is achieved. By critically adjusting the L.E.D. in relation to the photo cell, it is possible to obtain even better results.

The attack time of the circuit is very fast, but it takes about a second for the reduction in gain to decay. This is quite normal with this type of circuit and is known as hysteresis. If required, the decay time can be altered by adjusting the value of C6. The higher the value of C6, the longer the decay time that is produced.

## Automatic Fader

Automatic faders can be used at discos, or during home movie or slide shows. The purpose of the circuit is to mix two audio channels, one of which usually carries a commentary of some kind while the other contains background music. The circuit automatically fades the background music during the commentary

The circuit diagram of the automatic fader is shown in Fig.11. The control input is fed via a preset audio level control (VR1) to the input of an emitter-follower buffer stage. This provides the unit with a high input impedance, and ensures that there is a signal of sufficiently low source impedance to adequately drive the rectifier and smoothing circuit (D1, D2 and C5). As in the previous circuit, the smoothed output from the rectifier is used to operate a simple L.E.D. driver circuit.

R8 and PCC1 form an attenuator at the controlled input, and the output from this is taken to the output socket via C6 and R7. The output from the emitter of Tr1 is coupled to this socket by way of C4 and R5. R5 and R7 form a simple passive mixer.

With an input amplitude of 200mV or less at the control input there is not enough voltage developed across C5 to cause Tr2 to turn on. With control input levels above 200mV. R.M.S. Tr2 does turn on to some extent, and the L.E.D. load will receive power. This causes the resistance of the photo-cell to fall, and the signal loss through the attenuator is increased.

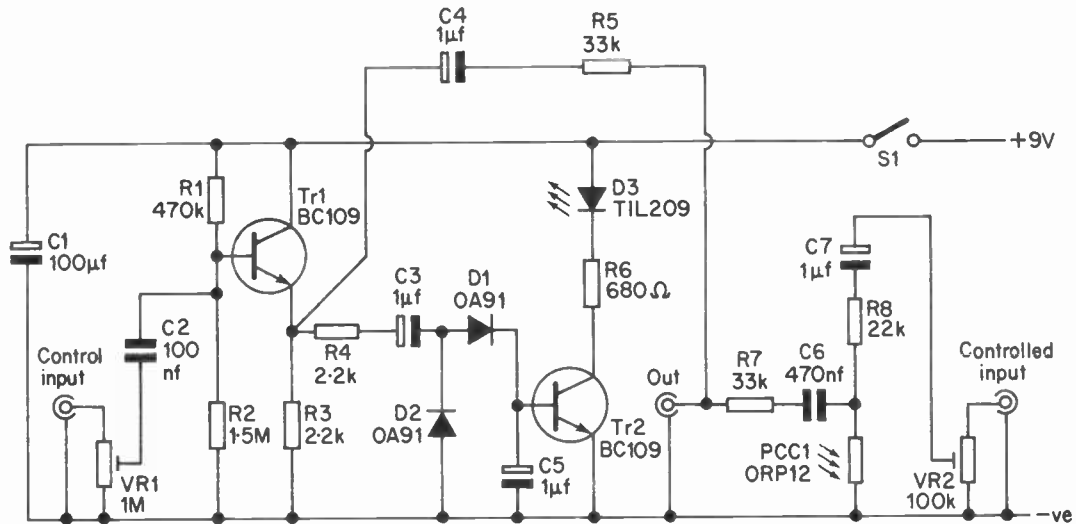
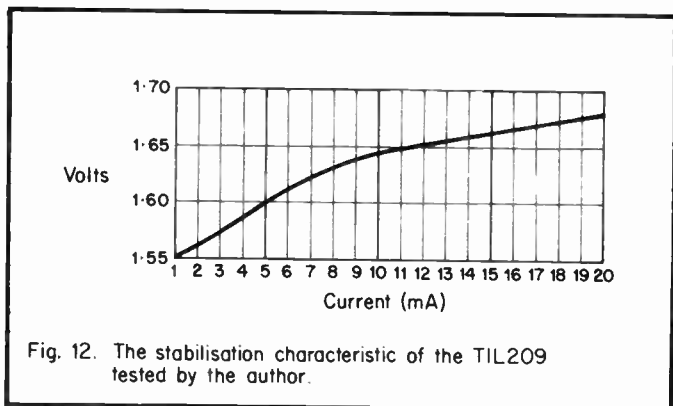

Fig. 11. The circuit diagram of a simple Automatic Fader.

A control input signal level of 350mV, R.M.S. causes a reduction in the controlled signal output level of some 20dB or more. Even when the two input level controls are adjusted for maximum sensitivity there is a loss of about 6dB between each input and the output. Like the previous circuit, this one has hysteresis, and the time constant can be changed by altering the value of C5

### L.E.D. Zener P.S.U.

It was mentioned earlier that a L.E.D. has a forward bias characteristic which is rather like that of a low voltage Zener diode. In fact a L.E.D. can be used as a low voltage (about 1.7V for a TIL209) Zener diode, and will provide excellent results. Of course, it can also be used as an ordinary on/off indicator at the same time.



The graph which is reproduced in Fig.12 shows the voltage produced across a TIL209 L.E.D. for forward currents of between 1 and 20mA. As can be seen from this, very good stabilisation is obtained with a twenty fold increase in current only resulting in a voltage rise of less than 10%. This is better than can be achieved with most low voltage Zener diodes.

Fig.13 gives the circuit diagram of a simple low voltage stabilised P.S.U. which uses a L.E.D. as both a Zener diode and the on/off indicator. This can provide an output voltage

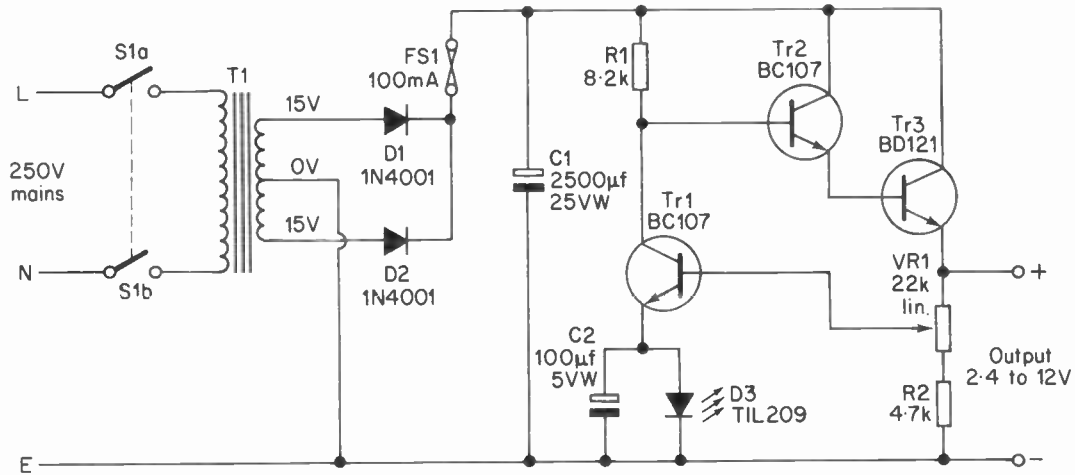

Fig. 13. The circuit diagram of the L.E.D. Zener P.S.U.

of anything between approximately 2.4V and 12V at a continuous current of up to 100mA. A P.S.U. such as this is a very useful item to have in an electronics workshop, especially when small battery operated equipment is constructed or tested. The level of hum on the output is very low, and is less than 1mV at low output currents. Stabilisation is also excellent, and variations in the output voltage are typically less than 200mV between no load and maximum output current.

Apart from the fact that a L.E.D. is used as the zener reference source, the circuit is of a quite conventional nature. S1 in the on/off switch and T1 is the mains isolation and step-down transformer. D1 and D2 are a push/pull full wave rectifier circuit and C1 smoothes the rough D.C. output of these to a very high degree. This smoothed D.C. is then fed to the regulator circuit.

Tr1 is used as a common-emitter amplifier, and it has its emitter held about 1.7V positive of the negative supply rail by D3. C2 smoothes out any hum or noise spikes which are present across D3. R1 is the collector load for Tr1. Tr2 and Tr3 are used as a Darlington Pair emitter-follower, and they are simply used as a unity gain buffer amplifier to reduce the output impedance of the circuit to a low level so that the required 100mA maximum output current can be obtained.

The way in which the regulator circuitry operates is quite straight forward. With VR1 slider at the top of its track, about 2.35V (1.7V plus 0.65V dropped across the base – emitter of Tr1) is needed in order to turn Tr1 on. Thus when power is applied to the circuit the output voltage will rise until it reaches about 2.35V. Although the unstabilised supply rail will then continue to rise in voltage the stabilised output rail will not since any rise here causes Tr1 to conduct more heavily. This causes its collector voltage to fall, which reduces the output voltage back to its original level. It is thus stabilised at 2.35V approximately, with the precise output voltage depending on the zener voltage of the L.E.D. which is used.

As the slider of VR1 is moved down its track, obviously a higher output voltage will be needed in order to produce 2.35V at Tr1 base. The output voltage therefore increases as VR1 slider is adjusted further down its track, with an output voltage of about 12V or so being produced when it is right at the bottom. Again, the precise voltage that is obtained will depend upon the Zener voltage of D3, and in this case it is also affected by the tolerances of VR1 and R2.

The control knob of VR1 can be fitted with a scale calibrated in terms of output voltage, or, if preferred, a voltmeter can be included to monitor the output voltage.

Tr3 must be fitted with a heatsink, but this component has to dissipate only a comparatively small amount of power, therefore a large amount of heatsinking is not required. One of the small commercially produced TO-3 size heatsinks would be ideal.

## L.E.D. Metronome

A conventional metronome generates a 'click' sound by mechanical means, and most electronic metronomes are designed to simulate this sound. However, some electronic metronomes employ an opto-electronic device to produce a visual output, and this does have an advantage over an aural stimulus. A visual output can obviously not be drowned by the sound of the music.

The circuit diagram of a metronome which has a flashing L.E.D. output is shown in Fig.14. This is based on the popular NE555V timer I.C., or one of its many equivalents.

The output of the I.C. is normally high, with no current being supplied to L.E.D. indicator D1, but the output takes up the low state for the periods when C1 is discharging through R2 and pin 7 of the I.C. For those who are unfamiliar with this device it should perhaps be explained that when power is applied to the circuit, C1 begins to charge up via VR1, R1, and R2, and it continues to do so until the potential across it is equal to two thirds of the supply rail

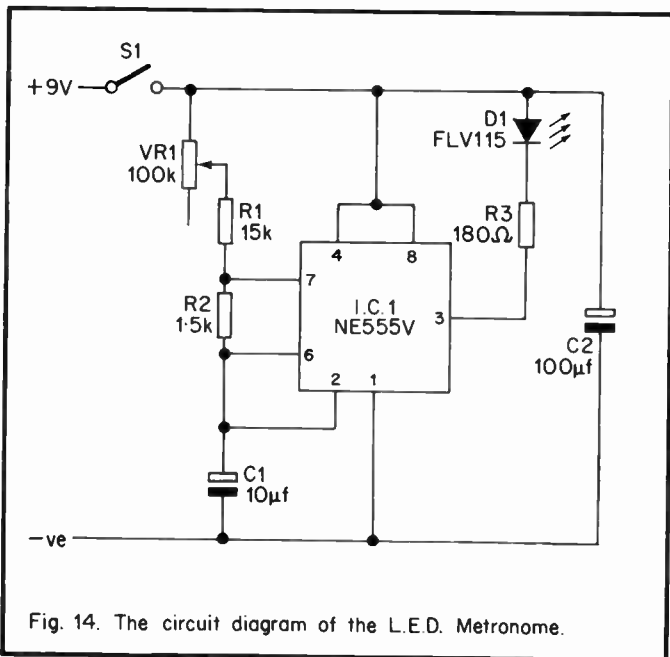

Fig. 14. The circuit diagram of the L.E.D. Metronome.

voltage. C1 then discharges through R2 and the I.C. until the potential across it is equal to one third of the supply voltage. C1 then begins to charge via VR1, R1 and R2 once again, until two thirds of the supply rail voltage is developed across it. The circuit continually oscillates in this way.

This causes the L.E.D. indicator to flash on at regular intervals. It obviously takes longer for C1 to charge up through the relatively high combined resistance of VR1, R1, and R2 than it does to discharge through only R2, and so it is only switched on for brief intervals. VR1 can vary the rate as C1 charges up, and it thus acts as the beat rate control. A range of less than 40 to more than 250 beats per minute is provided by the prototype, but the exact frequency range is subject to quite wide variations between individual units due to the rather wide tolerances of certain components (VR1 and C1 in particular).



Although the L.E.D. is only pulsed on very briefly, it provides a clear indication as it is operated at a current of about 50mA. Note that this must be a large (0.2in. diameter) L.E.D. as most small L.E.D.s are not able to handle such a high output current, and would probably simply burn out.

The control knob of VR1 should be marked with a scale calibrated in terms of beats per minute, and it is quite easy to do this as there is no difficulty in determining the output frequency at various settings of VR1. It is merely necessary to count the number of flashes produced in a period of fifteen seconds, and then multiply this figure by four in order to find the number of flashes per minute. At low frequency settings of VR1 it is better to simply count the number of flashes produced in a one minute period. Using the other method would provide far less accurate results.

## Seven Segment Displays

Seven segment displays are now widely used in digital electronic equipment, and they mostly employ a L.E.D. for each segment, but there are a few alternatives such as the Minitron 3015F incandescent display. Most of the single digit displays such as the DL704, DL707, SLA7, TIL302, etc., are packaged in

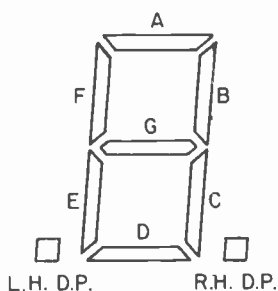

Fig. 15. The arrangement of the segments of a seven segment display.

what is basically a 14 pin DIL package, and they will plug into a standard 14 pin DIL socket. However, the plastic casing is a little wider than is the case for an I.C., and these displays have comparatively long leadout wires rather than pins.

The seven segments are laid out in a figure of eight pattern, as shown in Fig.15. The segments are identified by letters from 'A' to 'G', and this is also shown in Fig.15. Although both right hand and left hand decimal point indicators are shown in the diagram, practical devices have only one or other of these.

The table which is provided below shows how it is possible to obtain all the numerals from 0 to 9 on one of these displays.

Number	Segments Used
0	A, B, C, D, E and F.
1	B and C.
2	A, B, G, E and D.
3	A, B, C, D and G.
4	B, C, F and G.
5	A, C, D, F and G.
6	A, C, D, E, F and G.
7	A, B and C.
8	A, B, C, D, E, F and G.
9	A, B, C, D, F and G.

Very easily resolvable digits are obtained in this way, with the possible exception of the figure 4. This is the least accurate of the ten characters, but in practice it is more easily read than one might think. It is worth noting that with some digital systems segment A is not used when a six is being displayed, and segment D is not used when a nine is displayed. Most systems use tailed sixes and nines though, as this produces a clearer readout.

There are two basic types of L.E.D. seven-segment display, the common anode type and the common-cathode type. As these names imply, either all the anodes or all the cathodes are common to one leadout, while the other connections are taken to separate leadouts.

Usually seven-segment L.E.D. displays are driven by a special type of I.C. known as a seven-segment decoder/driver, and the TTL 7447 I.C. is an example of such a device. This particular device is intended for use with common-anode displays, and the common anode is connected to the positive supply rail. The seven cathodes are then driven from the outputs of the I.C. via suitable current limiting resistors. Some I.C.s are capable of directly driving a L.E.D. display without the need for current limiting resistors, and an example of such a device is the CMOS CD4026AE I.C. This is intended for use with common-cathode displays. When using this type of display the cathode is connected to the negative supply rail and the anodes are fed from the seven outputs of the I.C. It is only possible to use a common-anode decoder/driver with a common-cathode display (or vice versa) if an inverter is used at each output of the I.C.

## Logic Probe

Seven-segment displays are not only used in counter circuits, they are suitable for use in many more simple applications. Two such circuits will be considered here, and then a relatively simple three-digit counter circuit (an electronic stopwatch) will be described.

The first circuit is for a simple logic probe, and the complete schematic diagram of the unit is illustrated in Fig.16. The purpose of a device such as this is to show visually whether the point to which the probe tip is applied is a logic 1, logic 0, or at some indefinite level (either fixed at some point between the two logic states or rapidly switching between the two).

Like most devices of this type, the present one is extremely simple. The unit obtains its power from the equipment which is being tested, and this can be any of the usual types of logic circuit but it must have a supply voltage in the range 5 to 12 volts. Virtually all logic circuits fall into this category.

When the probe tip is taken to a point which is at logic 1, Tr1 will be either fully cut off or only very slightly forward biased. In either case very little current is fed to the four

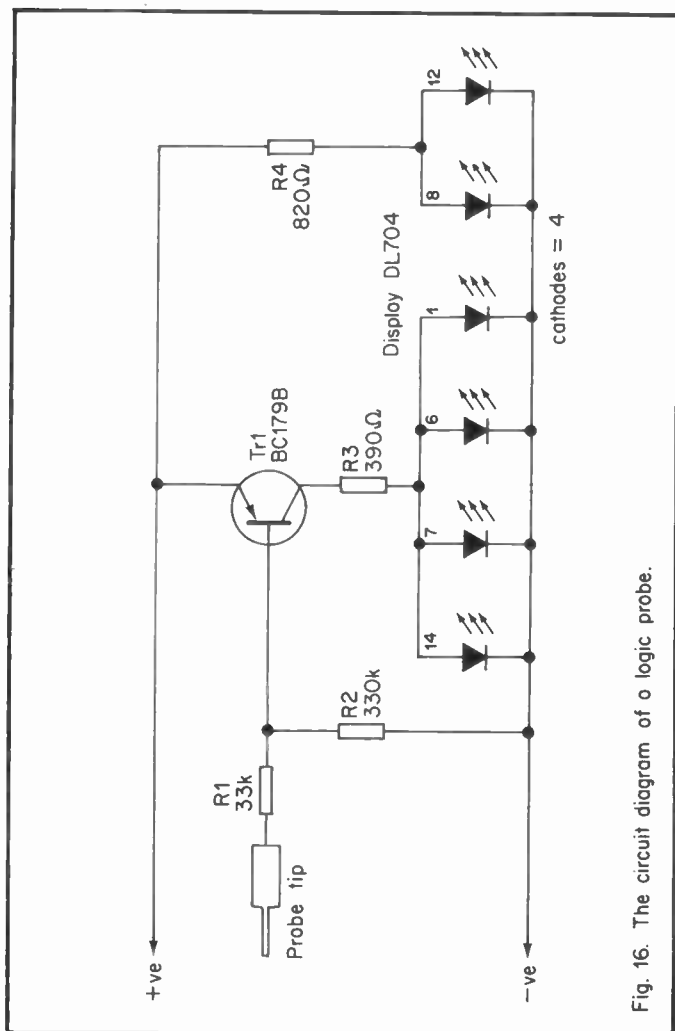

Fig. 16. The circuit diagram of a logic probe.

parallel connected L.E.D.s in its collector circuit. These are the A, D, E and F segments of a DL704 common-cathode display. The B and C segments of this display are fed with current via R4, and a 1 is therefore displayed by the unit.

If the probe tip is taken to a point which is at logic 0, Tr1 will be biased hard on by the base current it receives through R1. This causes segments A, D, E and F to come on in addition to segments B and C, and thus a 0 is displayed by the unit. Therefore the unit produces a 1 when the probe tip is at logic 1, and a 0 when the probe tip is at logic 0.

When the probe tip is at an indefinite state, Tr1 will either be repeatedly pulsed on and off, or it will be partially biased on. If it is left open circuit, or taken to a point which is open circuit, Tr1 will be slightly forward biased by the current it receives via R2. In any of these instances the result will be the same; segments A, D, E and F will be lit rather dimly.

Few components are used in this design, and it is easily constructed into a compact probe type housing. Two flying leads about 500 mm. long are brought out somewhere near the front of the casing, and one of these leads connects to each of the supply rails of the circuits. Terminate these leads in coloured (red and black) crocodile clips so that there is no doubt as to which supply line each lead connects to. The L.E.D. display is mounted on the rear end of the casing.

## Heads or Tails

Although seven segment displays are not designed to display the letters of the alphabet, they can be made to produce a few letters. E, F and L are some obvious examples. This heads or tails circuit is a little unusual in that it does not use two ordinary L.E.D.s which are designated 'heads' and 'tails' in the normal manner, but instead it uses two seven segment displays. Segments C, E, F and G of the other display are used to produce a letter 't' for 'tails'.

The complete circuit diagram of the heads or tails unit is shown in Fig.17. This is based on an NE555V I.C. which is used in the astable mode. The circuit does not actually begin to oscillate until push button switch PB1 is closed. Then C1 charges up via R1 and D2, and it discharges through D1 and R2. As R1 and R2 are of equal value, and D1 and D2 are of the same type, the charge and discharge times of C1 are identical.

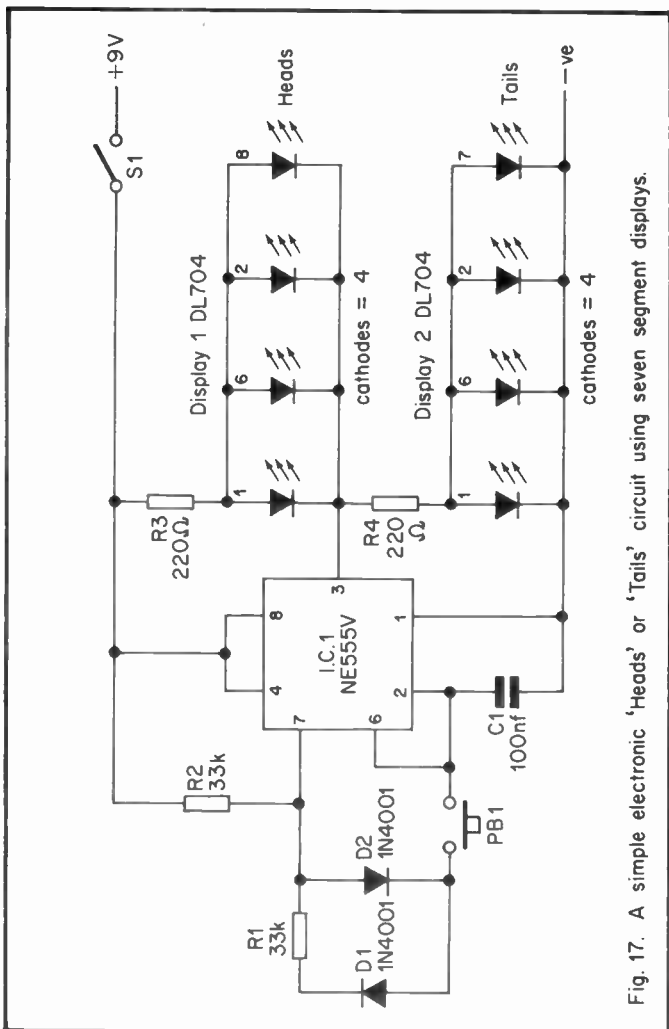

Fig. 17. A simple electronic 'Heads' or 'Tails' circuit using seven segment displays.

A squarewave is therefore produced at the output of the I.C. (pin 3) with the output going positive and negative in turn, for equal lengths of time. While the output is fully positive, R3 and display 1 are in effect, cut out of

circuit since they are short-circuited by the output circuitry of the I.C., although R4 and display 2 will still be supplied with current. While the output is negative it is display 2 and R4 that are effectively cut out of circuit, and power is supplied to display 1.

The circuit oscillates at a frequency of several hundred Hz, and so the operator cannot see the displays flashing on and off as they are doing so at far too fast a rate. Both displays will appear to be on continuously, but they will not be quite as bright as normal.

When PB1 is released and its contacts become open circuit, C1 is no longer able to charge or discharge, and the output latches in whatever state it happened to be in at the instant PB1 become open circuit. There is, of course, no way of predicting which state the output will be in at the moment PB1 is opened, and either display could be the one which remains on. Furthermore, since the output goes high and low for equal periods of time, each display has an equal chance of being the one which happens to remain on. Thus the circuit accurately simulates the tossing of a coin.

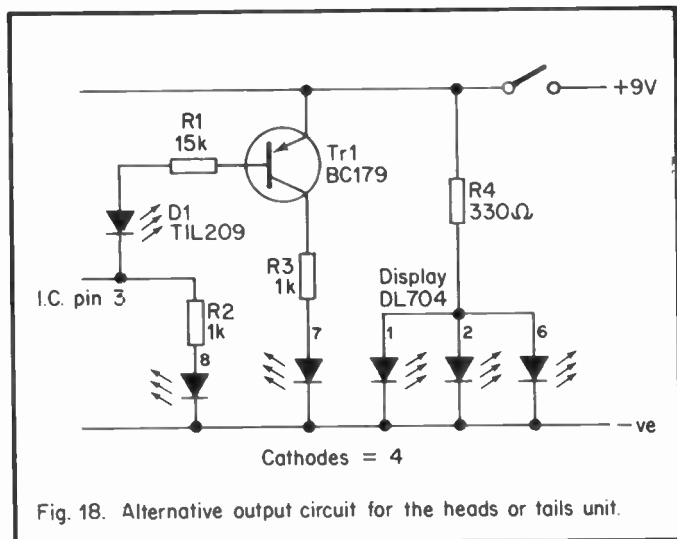

## Single Display Version

The circuit diagram of Fig.18 shows how the heads or tails circuit of Fig.17 can be modified to use a single seven-segment display. Segments E, F and G are continuously supplied with power via R4. When the output of the I.C. goes high, power is supplied to segment C via R2, but segment D receives no current as Tr1 will be cut off. No power is supplied to segment C, but Tr1 is biased hard on and so current is applied to segment D.

Thus an 'h' is displayed when the I.C. output is high, and a 't' is displayed when it is in the low state.

It should perhaps be explained that L.E.D. D1 is used here merely as a low voltage zener diode. It is needed because the output of the I.C. does not go fully positive when it is in the high state. It falls about 2 volts short of the positive supply rail voltage, and so if D1 was not present in the circuit (with its consequent 1.7 volt drop in the base potential of Tr1), Tr1 would be switched on whichever state the I.C. output assumed.

## Simple Stopwatch

The complete circuit diagram of the stopwatch is given in Fig.19. It should be stressed that this circuit is not as versatile or accurate as say, a six-digit crystal controlled circuit, but it can, nevertheless, be used in a number of timing applications and will provide quite a high degree of accuracy if it is set up correctly. The circuit is very simple and is relatively inexpensive. In fact, it costs little more than an electronic analogue stopwatch, and it provides much better resolution and accuracy.

Basically the circuit consists of an NE555V astable section which generates a 10 Hz clock signal, and three CD4026AE Deca counter/divider/7 segment decoder I.C.s which drive three DL704 L.E.D. displays. For the sake of clarity, the three displays are not shown in the circuit diagram.

VR1 enables the clock oscillator to be adjusted to a frequency of precisely 10Hz. The clock oscillator is quite stable as the circuit is not greatly affected by variations in supply rail potential.



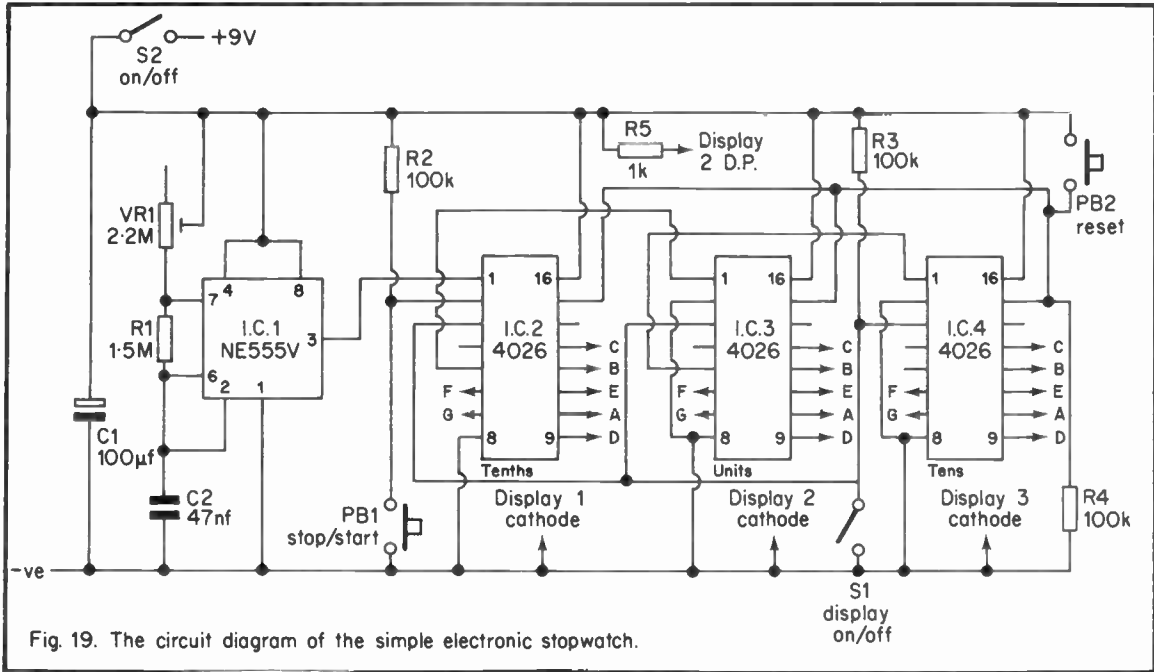

The CD4026AE (or an equivalent device) contains a considerable amount of logic circuitry. Pin 1 is the clock input terminal, and this pin of the first 4026 device (I.C.2) is fed direct from the output of the NE555V oscillator. Thus the display which is driven by I.C.2 goes through a complete count cycle every second, and displays the tenths of a second which have elapsed. A divide-by-ten clock signal is available at pin 5 of the I.C., and this signal is fed to the clock input of the next 4026 I.C. (I.C.3). Therefore I.C.3 cycles through a complete count every ten seconds, and the display it drives shows the seconds that have elapsed. The divide-by-ten output of I.C.3 is fed to the clock input of I.C.4, and so this I.C. goes through a complete count cycle in one hundred seconds, and the display which it is used to drive shows the tens of seconds that have elapsed. Thus the circuit will measure times up to a maximum of 99.9 seconds.

Pin 2 of each I.C. is the clock enable input, and this allows the counter to operate when it is taken low, and disables the circuit when it is taken high. The clock enable input of the first counter is normally taken high by R2, and so it does not operate. This results in the divided clock signal being muted, and so the other two counters do not operate either. Operating PB1 takes the clock enable terminal low and all three counters come into operation. PB1 thus operates as the start/stop control.

The reset terminals are normally taken to the low state by R4, but if PB2 is operated they are all taken high, and the counters are reset to zero. It is only necessary to operate PB2 momentarily to achieve this.

Pin 3 of each 4026 I.C. is a display enable input, and these are normally all taken high by R3. This enables all seven outputs of each I.C. to function normally. If S1 is closed, however, the seven outputs of each I.C. glow, and no power is applied to the display segments. This is a very desirable feature as the circuit will probably be battery-powered, and the life of the battery can be considerably extended if the displays are switched off when not required.

Power is fed to the decimal point of display 2 via R5, and as the DL704 displays have a right-hand decimal point, this puts the decimal point in the correct position. The decimal point is not affected by S1, and it thus operates as an on/off indicator when the display is disabled.

S2 is the ordinary on/off switch, and C1 is the only supply decoupling capacitor that is required.

## Adjustment

If a suitable frequency meter is available, this can be used to determine the correct setting of VR1. Alternatively an oscilloscope can be used, with the 50Hz mains being used as a reference frequency. Presumably anyone with access to such equipment will be familiar with its use, and so a description of the procedure used would be superfluous

In the absence of a source of electronic calibration, it is still possible to attain a fairly high degree of accuracy by using a clock having a seconds hand, or some other form of timepiece as a calibration source. Adjustment of VR1 is then a matter of trial and error, with the object being to get the electronic stopwatch and the timepiece to coincide as accurately as possible.

It is worth noting that the start/stop function of the stopwatch can be controlled by a control voltage at pin 2 of I.C.2, rather than by PB1. This enables the unit to be used as the basis of something like a sports timer with automatic control, and this is considered more fully in the following Chapter.

## Lamp Dimmer

A neon bulb qualifies as an opto-electronic device in two respects. Firstly, and fairly obviously, when fed with a suitably high voltage (about 60 to 90 volts) the neon gas ionises and the device passes a current, which results in light being produced. Secondly, and perhaps less well known, the minimum voltage at which the gas will ionise and the bulb will fire is affected by the amount of light falling on the device. The greater the intensity of the light falling on the device, the more readily it will turn on. This effect is rarely (if ever) used in practical circuits though, and it is often more of a drawback than an advantage.

Neons are frequently used as mains on/off indicators, but they are rarely used in any other role even though they are quite versatile devices. It is possible to use them in a number of circuits which take advantage of the fact that they can be used as an active component and as an indicator light of some kind. Neon circuits were once quite popular, but they have now been largely replaced by I.C./L.E.D. circuits which, although often more complicated, are capable of low voltage operation.

One area in which neons are still quite widely used is as the trigger device for a triac or a thyristor. For example, they are commonly used as the trigger device and on/off indicator in a lamp dimmer circuit. The circuit diagram of such a unit is shown in Fig.20. This can be used to control loads of up to about 250 watts with no heatsink fitted to the triac, and up to about 500 watts if adequate heatsinking for the triac is provided. Apart from being used with lamps, it can also be used as variable speed control for an electric drill, and similar applications. It cannot be used with fluorescent lamps though.

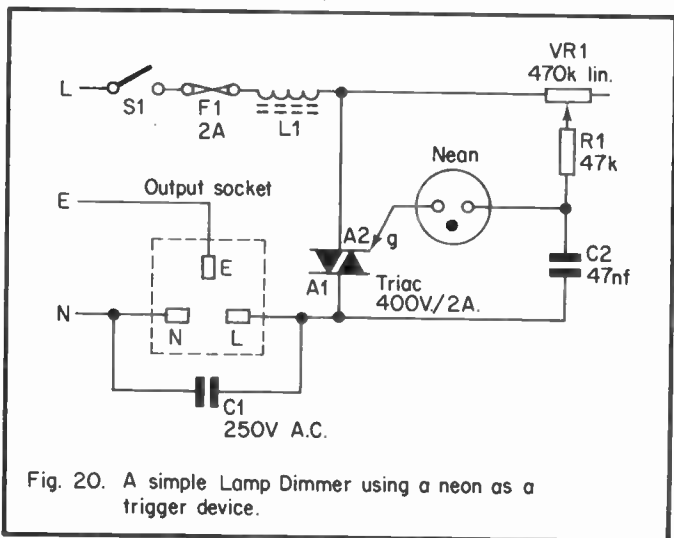

Fig. 20. A simple Lamp Dimmer using a neon as a trigger device.

The circuit controls the power that is fed to the load by chopping off part of each mains half-cycle. At maximum power very little of each half cycle is removed, whereas at half power only half of each half-cycle is fed to the load.

Full power is fed to the load when VR1 is adjusted for minimum resistance. There is then only a relatively low impedance between the mains 'L' input lead and C2, and so the voltage across C2 is virtually equal to the mains voltage. However, the voltage across C1 never reaches much more than the striking voltage of the neon, as when this voltage is reached, the neon fires and provides a trigger voltage to the gate of the triac. The triac then switches on and supplies power to the load. As it turns on it also cuts VR1; R1, C2 and the neon out of circuit by being virtually a short circuit across them. At the end of the half cycle the triac switches off again until early in the next half cycle, when the neon fires again and in doing so switches on the triac.

If VR1 is adjusted to insert a fairly high resistance into circuit, it will be well into each half-cycle before the neon fires and a trigger current is fed to the gate of the triac. The higher the resistance of VR1, the longer it takes for the triac to be switched on. With VR1 adjusted for about maximum resistance the voltage across C2 never reaches the trigger voltage of the neon, and so no power is applied to the load. Thus the setting of VR1 controls the amount of power that is supplied to the load.

S1 is the on/off switch while C1 and L1 are interference suppression components. L1 can be any small suppression choke which has a rating of 2A or more. Note that C2 must have a rating of 250V. A.C. or more, and any value of around 3.3nF is perfectly suitable. The neon bulb must not be a type which has an integral series resistor for 250V mains operation unless this resistor is either removed or short-circuited. VR1 should be a type having a plastic spindle and not a metal one.

The unit can be constructed in either a metal or a plastic case, but any exposed metal (including nuts, bolts, etc.)

must be earthed. Do not touch or work on any of the circuitry while the unit is plugged into the mains, even if S1 is in the off position.

## Chapter 2

### LIGHT-OPERATED SWITCHES

Light-operated switches are used in a wide range of applications, and they are one of the most versatile types of electronic device. A number of light-activated switches are described in this chapter, ranging from very simple but useful units to a much more sophisticated infra-red circuit.

#### Automatic Parking Light

This must be just about the most common application for a light switch. The circuit of such a unit is shown in Fig.21, and as can be seen from this, the unit is extremely simple. It is based on an NE555V I.C. which is used here as a comparator, and not, as is usually the case, as a timer.

With pin 6 of the device connected to the positive supply rail, the output of the I.C. goes high when pin 2 is at a voltage of less than one third of the supply voltage, or low if the pin 2 voltage is higher than this level. The NE555V has quite a high output drive capability, but it cannot supply sufficient output current to drive a parking lamp at the voltage which is involved here. It therefore drives the parking lamp (LP1) via common-emitter driver transistor, Tr1. R2 limits the base current of Tr1 to a safe level. Tr1 will be biased hard on when the output of I.C.1 is in the high state, and it will then supply power to the lamp. When the output of the I.C. is in the low state, Tr1 will be cut off and the lamp will be switched off.

The photocell which is used in this circuit is an ORP12 light dependent resistor, and this device is used in most of the other circuits which are described in this Chapter. This is by no means a new device; in fact there can be relatively few devices that date back as far as the ORP12 and are still in common use. As mentioned in the previous Chapter, the ORP12 has a resistance of more than 10 Meg. ohms in total darkness, but a resistance of only about 20 ohms when brightly illuminated. It thus provides a very large change in resistance for a given change in light intensity when compared with most other L.D.R.s. It also responds readily to a large part of the light spectrum. This makes it suitable for use in a wide range of applications.

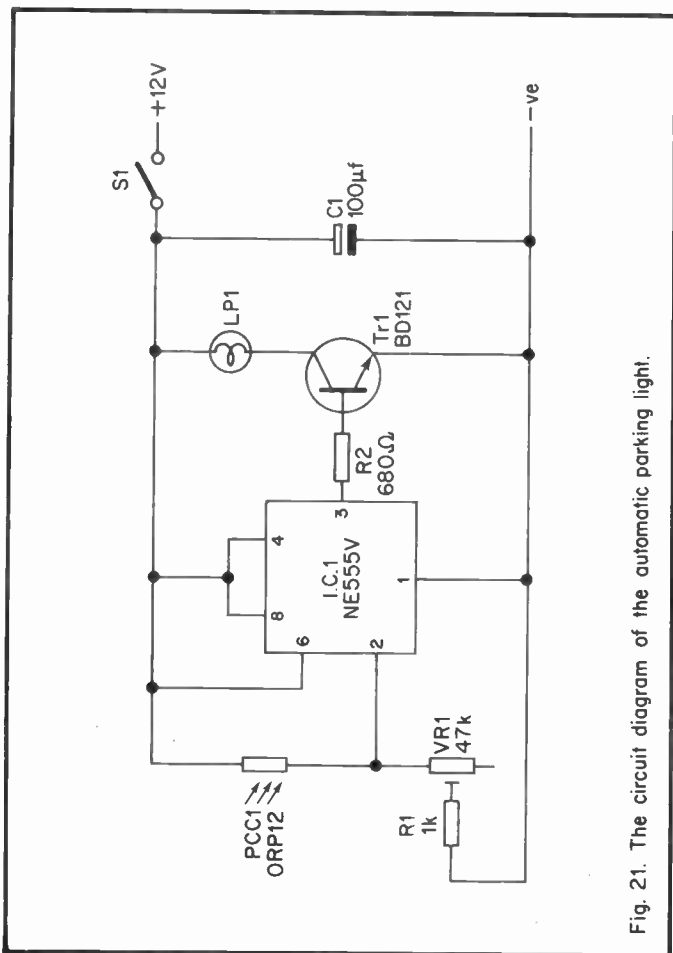

Fig. 21. The circuit diagram of the automatic parking light.

In the present circuit, VR1 is adjusted so that during ordinary daylight the potential at pin 2 of the I.C. is more than one third of the supply rail voltage. As darkness falls though, the resistance of PCC1 will increase, and so the voltage at pin 2 of the I.C. will fall. Eventually conditions will be sufficiently dark to produce a voltage of less than one third of the supply rail potential at pin 2 of the I.C., and then the parking lamp is switched on.



It is an important feature of the circuit that the output of the I.C. can only be high or low, and it cannot remain in any intermediate state. This means that Tr1 is either biased hard on or it is cut off, and in neither of these states does it have to dissipate much power. A small commercial type TO3 size heatsink is all that is required.

The completed unit is very easy to adjust. When dusk falls, the present resistor VR1 is adjusted for the highest resistance which does not cause the parking lamp to be switched off.

It is important that the photocell is not placed where it will pick up a significant amount of light from the parking lamp, as this can result in feedback action which will upset the operation of the circuit.

## Light Detector

The purpose of this type of circuit is to switch on some piece of equipment when the light falling on the photocell goes above some predetermined threshold level. A common application for this type of switch is in a burglar alarm system, where the alarm is tripped if either the intruder switches on a light, or light from his torch falls on the photocell. The circuit diagram of the light detector is shown in Fig.22.

The 741C operational amplifier is used here as a version of a Schmitt trigger. Its output will be high if the non-inverting input is at a higher voltage than the inverting input, and low if it is not. The inverting input is held at about half the supply rail potential by the potential divider which consists of R2 and R3.

The non-inverting input is fed from a second potential divider through R4. The photocell forms one arm of this divider circuit while the combined resistance of VR1 and R1 forms the other. VR1 is adjusted so that under normal conditions the voltage which is fed to the non-inverting input is less than that which is present at the inverting input. This causes the output of the I.C. to normally assume the low state, and so no significant base current is fed to Tr1.

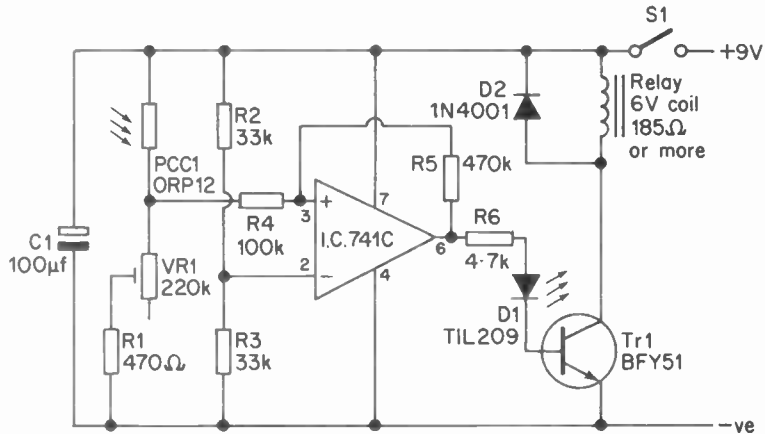

Fig. 22. A simple light detector circuit.

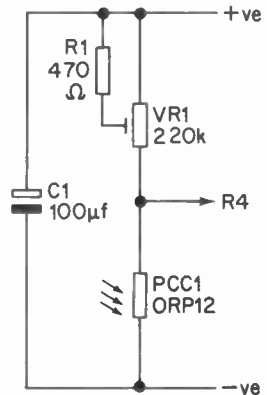

Fig. 23. Modified input to produce a darkness detector.

D1 is used here mainly as a low voltage Zener diode, and it is needed in order to reduce the voltage which is fed to Tr1 base. The low output voltage of the I.C. is about 2 volts, and so without the voltage drop across D1, Tr1 would be biased hard on whichever state the output of the I.C. happened to be in. R6 is a current limiting resistor.

Tr1 has the relay coil as its collector load, and so the relay coil is energised when the output of the I.C. is high. It is advisable to use a relay in the output of a general purpose switch such as this, rather than use a solid state device, as a relay provides complete isolation between the circuit and the load. The unit can therefore be used to control a mains powered load if required.

D2 is the usual protective diode, and this prevents a high reverse voltage being produced across the relay coil as it is de-energised. This voltage is produced by the magnetic lines of force quickly cutting through the turns of the relay coil as the magnetic field collapses. This can generate quite a high voltage which is quite capable of destroying the semi-conductor devices in the circuit, even though it is at quite a high impedance. D2 acts as a low voltage zener diode and clips the voltage generated to no more than about 0.6V.

The action of the circuit when increased light is detected by PCC1 is very straightforward. The increased light falling on PCC1 causes its resistance to fall, and in consequence the voltage which is fed to the non-inverting input of the I.C. via R4 is more than the voltage which appears at the inverting input. The output of the I.C. then swings to the high state and energises the relay coil.

If the ambient light level should happen to take the non-inverting input voltage to a level only fractionally above that at the inverting input, this will cause an increase in the output voltage of the I.C. However, this would not in itself be sufficient to cause the output of the I.C. to swing fully negative. This is an undesirable state of affairs as it could result in Tr1 being slightly forward biased under quiescent conditions, with the circuit having a rather high standby current as a result.

This problem is overcome by the inclusion of R5, which ensures that the quiescent current consumption of the device is only about 2.5mA. If the output of the I.C. starts to go positive, this results in an increase in the potential at the non-inverting input due to the coupling between the two via R5. Of course, this increase in the non-inverting input potential results in a further increase in the output potential, which results in a further increase in the non-inverting input potential. This regenerative action continues until the output is fully positive.

Once the output of the I.C. has gone positive, the current which flows to the non-inverting input by way of R5 tends to hold the circuit in this condition, even if the light level received by the photocell should diminish somewhat. However, this effect only works to a limited degree, and a large fall in the light level will cause the circuit to revert to its original state. It is usual to incorporate this hysteresis into circuits of this type, as otherwise they are likely to be unstable when they are close to the switching point.

The light level at which the circuit is triggered can be varied over a wide range by adjustment of VR1, and this makes the circuit very versatile.

## Darkness Detector

There are many applications where a circuit that will detect a fall in light level is required, rather than one that will respond to an increase in light level. It is an easy matter to convert the circuit of Fig.22 to operate as a darkness detector, and the necessary modification is shown in Fig.23.

As can be seen from this, it is merely necessary to reverse the positions of VR1 – R1 and PCC1. The circuit is again adjusted so that under normal conditions the relay is not energised, but this time an increase in the light level falling on the photocell will cause a reduction of the non-inverting input voltage of the I.C., and so will not significantly affect the circuit conditions.

On the other hand, a reduction in the light level received by the photocell will cause an increase in the voltage fed to the non-inverting input of the I.C., and result in the relay becoming energised. Circuits such as this are suitable for use in an application such as an automatic porch light, where the light automatically switched on at dusk, and off again at dawn.

## Latching Versions

Both the circuit of Fig.22 and the one of Fig.23 can be made to latch using the additional circuitry shown in Fig.24. There are several applications where it is necessary to have a latching circuit, burglar alarms being one example.

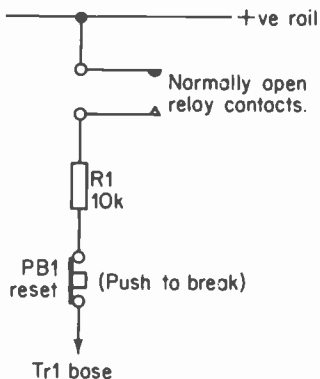

Fig. 24. A simple method of making the circuits of Figs. 22 and 23 latch.

The circuit of Fig.24 uses a pair of relay contacts to supply a base current to Tr1 when the relay coil is energised. Of course, even if the output of the I.C. then returns to the low state, Tr1 will still be biased hard on by the base current it will receive via the relay contacts, R1 and PB1.

R1 is merely a current limiting resistor. PB1 enables the circuit to be reset, and momentarily operating this switch breaks the base bias circuit for Tr1, and turns both Tr1 and the relay off. When PB1 is released and its contacts close again, there will still be no base bias fed to Tr1 as the relay contacts will have opened. Note however, that the reset switch can only work when the output of the I.C. is in the low state.

## Alternative Version

It is only possible to use the circuit of Fig.24 if a spare pair of normally open contacts are fitted to the relay which is employed. If no such contacts are available, the simple modification shown in Fig.25 can be used.

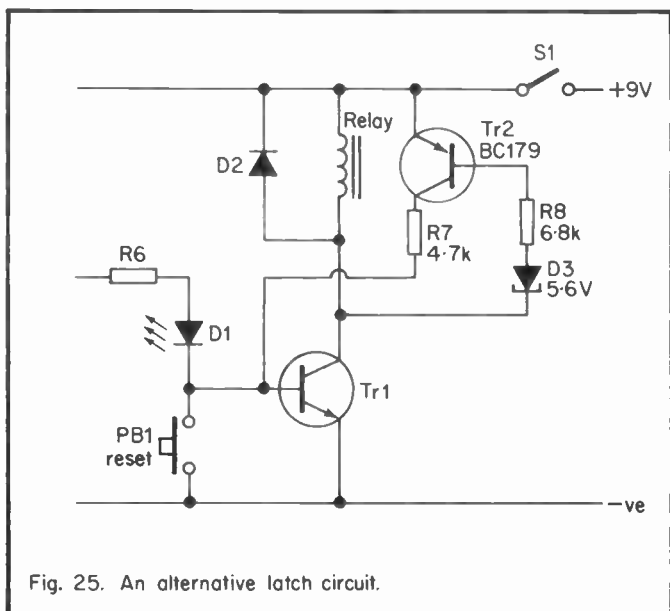

Fig. 25. An alternative latch circuit.

When Tr1 is switched off, its collector terminal will be at virtually the full supply rail potential and so Tr2 will also be switched off. If Tr1 is switched on, its collector voltage

will become virtually equal to the negative supply rail voltage, and Tr2 will be supplied with a base current through D3 and R8. This causes Tr2 to turn on and supply a base current to Tr1 by way of R7. Even if the output of the I.C. then returns to the low state, Tr2 will bias Tr1 on, and Tr1 will bias Tr2 on. The circuit thus latches.

Operating PB1 momentarily short circuits Tr1 base to ground and so switches both Tr1 and Tr2 off. Assuming that the output of the I.C. is in the low state, when PB1 is released and its contacts open, Tr1 will receive no base current and so the circuit will have been reset to its original state.

At first sight it might appear to be unnecessary to have D3 in series with R8. The reason for using this component is that under quiescent conditions there will probably be a small current through Tr1. This means that its collector terminal will not quite be at the positive supply rail potential, and a small forward bias would be supplied to Tr2. This would cause Tr2 to partially switch on and supply more base current to Tr1. This would then conduct more heavily, and a regenerative action would take place with both transistors being quickly biased into saturation.

Due to the presence of D3 this cannot happen, since about 6.2 volts (5.6V plus 0.6V) must be developed across the relay before Tr2 will be switched on.

## Low Standby Current Circuit

When a light switch circuit is to be used in a burglar alarm system, or in some similar application where it will be left connected for long periods, it is often advantageous for the circuit to have a quiescent current consumption which is as low as possible. This enables the unit to be economically powered from batteries. It would, of course, be possible to use a mains power supply unit in many instances, but this is not always desirable. A burglar alarm is a good example of this, as such a circuit could easily be made mains powered, but would then be disabled by a mains failure, or deliberate cutting of the mains supply.

The circuit diagram of a latching light detector circuit which has a low standby current is shown in Fig.26. This circuit is based on a CMOS I.C., and either a 4001 quad two input NOR gate, or a 4011 quad two input NAND gate can be employed. Only two gates are used in this particular circuit, and the inputs of the other gates are simply tied to earth. These unused inputs must not simply be left floating, as this would lead to an increase in the standby current of the circuit, and could even result in damage to the I.C.

The gates which are used have their two inputs connected in parallel, and they then operate as inverters. As can be seen by referring to Fig.26, resistors are used to cross-couple the inputs and outputs of the inverters so that together they form a simple bistable multivibrator circuit. This type of circuit can only stay in one of two stable states. Either the output of inverter 1 is high and the output of inverter 2 is low, or the output of inverter 1 is low and the output of inverter 2 is high.

Under normal operating conditions the output of inverter 2 will be low, and no bias current will be supplied to the base of Tr1 via R5. Tr1 is therefore cut off, and only passes minute leakage currents. The I.C. does not consume any significant current either, since an extremely low static power consumption is a feature of all CMOS logic I.C.s. They only consume a significant amount of power when switching from one output state to the other. Thus the only significant current which flows through the circuit under quiescent conditions is that which passes through PCC1, R1, and VR1. The amount of current that these consume depends upon the setting of VR1 and the amount of light falling on PCC1, but typically the circuit has a standby current of only about 50 micro amps.

The circuit can be made to change state by raising the light level received by PCC1 to a level which causes the voltage at the junction of R1 and R2 to almost the positive supply rail potential. This increases the voltage at the input of inverter 1 to a level which causes its output to change state and go low. This drives the input of inverter 2 low due to the coupling via R4, and so the output of inverter 2 goes high. This holds the input of inverter 1 high due to the coupling through



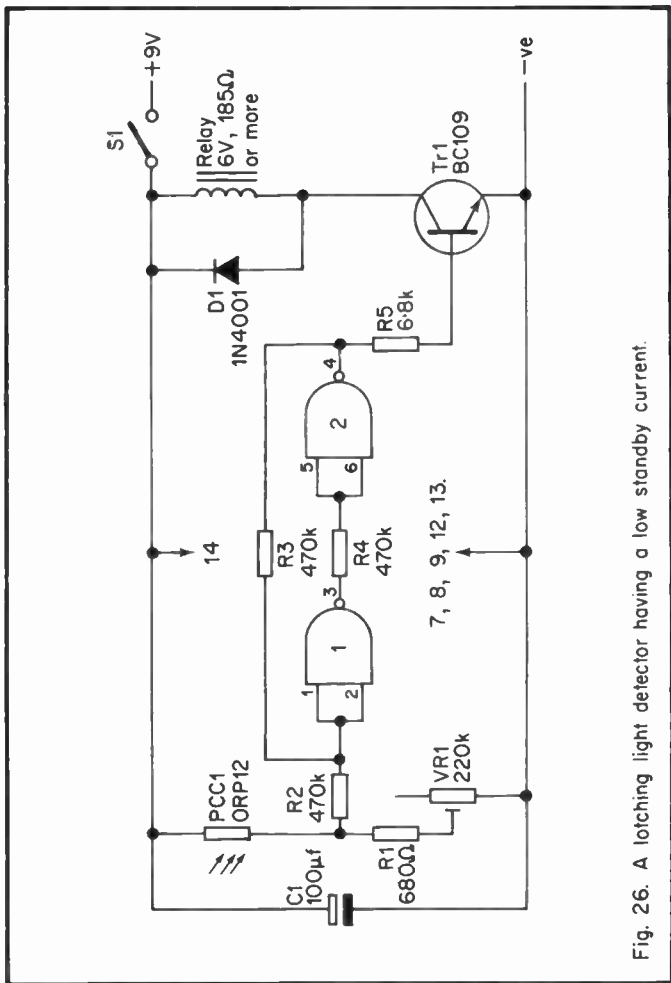

Fig. 26. A latching light detector having a low standby current.

R3, and so the circuit remains in this state even if the light level on PCC1 is subsequently reduced.

With the output of inverter 2 in the high state, Tr1 is biased hard on, and the relay coil is energised.

VR1 enables the sensitivity of the circuit to be varied over a wide range. PB1 is the reset switch, and momentarily operating this takes the input of inverter 1 low, and forces the circuit back into its original state.

## Variations

The circuit of Fig.26 can be converted to a darkness detector by connecting PCC1 between the left hand side of R2 and the negative supply rail, and connecting R1 and VR1 in the position formerly occupied by PCC1.

If a non-latching circuit is required, this can be achieved by reducing the value of R2 to 100k. The two inverters then operate as a form of Schmitt trigger, rather than as a bistable circuit.

## Infra Red Switch

Circuits that operate at infra-red tend to be rather more complicated than their visible light equivalents, but they represent one of the most interesting areas of electronics. It would perhaps be more accurate to call infra-red waves heatwaves rather than lightwaves, but they behave in very much the same way as lightwaves. Infra-red radiation is invisible though, which makes them a little intriguing, and gives them added interest to the amateur electronics enthusiast.

Apart from this, the fact that this form of radiation is not visible can provide practical advantages. For example, there is a type of burglar alarm where a beam of light is aimed at a photocell, and the alarm is triggered if anyone should pass between the light source and the detector. Using an ordinary light beam has the disadvantage that any intruder would probably see the light beam, and have the good sense to avoid it. Using an infra-red beam and detector would overcome this as the intruder could obviously not see the beam, and would be unaware of its presence.

An ordinary broken light beam detector circuit is quite simple, and could employ one of the D.C. circuits described earlier

in this book. An infra-red broken beam detector is rather more difficult to achieve, as although infra-red emitting devices are available to the amateur user, they do not provide a very great output. This means that it is necessary for the detector to respond to very small changes in intensity, and this would be difficult to achieve using a D.C. circuit.

A much more satisfactory method is to use an A.C. technique, and the basic arrangement is illustrated in the block diagram

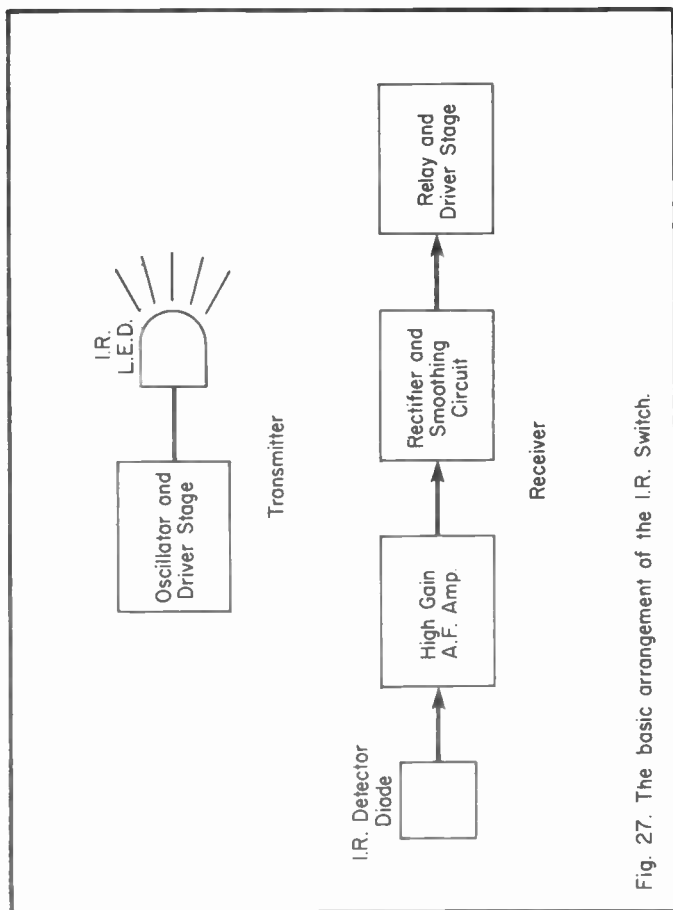

Fig. 27. The basic arrangement of the I.R. Switch.

of Fig.27. The device which is used to produce the infra-red radiation is a type of L.E.D., and this is pulsed on at a frequency of a few hundred Hertz by an oscillator and driver stage.

The pulses of infra-red are picked up by a special type of photosensitive diode, and the resultant electrical pulses are fed to a high gain audio amplifier. The relatively strong output pulses from the amplifier are rectified and smoothed to a D.C. bias which is used to operate a relay via a simple driver stage. The circuit is arranged so that the relay is normally off, and is switched on when the infra-red beam is broken, and the input bias to the relay driver stage is broken. The relay circuit is self-latching so that it is only necessary for the beam to be briefly broken in order for the alarm to be continuously sounded.

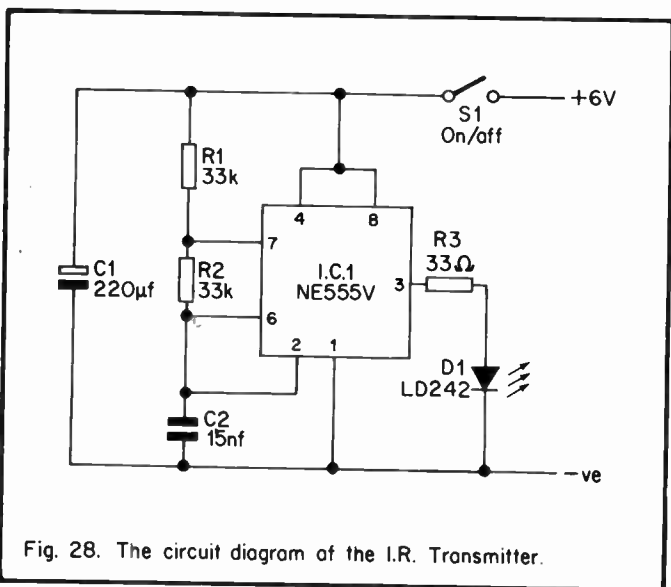

Fig. 28. The circuit diagram of the I.R. Transmitter.

## The Circuit

The circuit diagram of the transmitter is shown in Fig.28, and this is quite simple. Like several of the previous circuits in this book, it is based on the versatile NE555V timer I.C. In this application the I.C. is used in the astable mode, and R1, R2 and C2 produce an output frequency of a few hundred Hertz. There is no need for a discrete driver stage as the NE555V has an integral driver circuit which is capable of supplying the power level required here. The infra-red L.E.D., D1, is therefore driven direct from the output of the I.C. via current limiting resistor, R3.

Note that a supply voltage of more than 6V (nominal) should not be used unless the value of R3 is reduced to a suitable level. There is otherwise a strong risk that the L.E.D. could be over driven and burned out. In use, D1 should feel slightly warm to the touch, but it should not become hot. The current consumption of the transmitter circuit is about 50mA.

The LD242 infra-red L.E.D. can be obtained from Electrovalue Ltd., 28 St. Judes Road, Englefield Green, Egham, Surrey, TW20 0HB. The circuit would probably work using other infra-red L.E.D.s of a suitably high power rating, but the system has only been tried using the specified type.

## Receiver

As one would expect, the receiver is a comparatively complicated unit. Its circuit diagram appears in Fig.29.

Only one type of photocell has been used in the circuits described so far, and this is, of course, the ORP12 cadmium sulphide photo-resistor. This circuit uses a different type of photocell; a special type of silicon diode which responds to infra-red radiation. Photo diodes and transistors can be used as photo-resistive devices, and in many circuits they are, (including some that follow later in this book), but in this instance the photocell is used to generate electricity from the received signal.

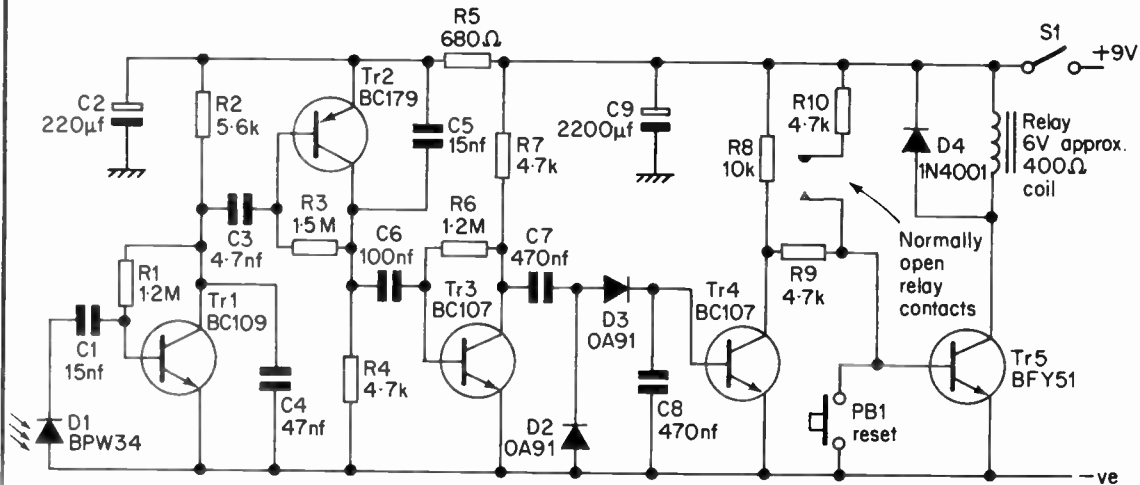

Fig. 29. The circuit diagram of the I.R. Receiver.

Due to the relatively small pick up area of the BPW34 device which is used here, it will not generate much power. It will produce an absolute maximum of about 1mA and under normal conditions it only generates a few microamps. Much of its output is generated from the ambient infra-red level, and the signal produced from the transmitter pulses is extremely small.

A very high level of amplification is therefore required in order to bring these pulses up to a suitable level to drive the rectifier and smoothing network. Three high gain common-emitter amplifiers are used here, and these are Tr1 to Tr3. Three quite conventional capacitively coupled circuits are used, the only unusual components being C4 and C5. These are used to roll off the high frequency response of the circuit which reduces the noise level of the circuit, and reduces the likelihood of instability occurring. The circuit has a very high gain though, and even with C4 and C5 in circuit it is still essential to use a sensible component layout when constructing this circuit.

The signal developed across the photocell is fed into the base of Tr1 via D.C. blocking capacitor C1. It is worth noting that in the A.C. circuit the polarity of D1 is unimportant.

The rectifier and smoothing network consist of D2, D3 and C8. The output signal of the amplifier is fed to this network via C7. A positive D.C. bias signal is developed across C8, and this is fed straight into the base circuit of Tr4. Thus Tr4 is normally biased into saturation, and only a very low voltage appears at its collector. Since Tr5 base is fed from the collector of Tr4, Tr5 is normally cut off. The relay coil is the collector load for Tr5, and so the relay is not normally energised.

However, if the infra-red pulses should cease due to someone passing between the transmitter and the receiver, the bias voltage across C8 will quickly die away, and Tr4 will switch off. This causes its collector voltage to rise to virtually the positive supply rail voltage, and so a strong base bias is applied to Tr5 through R8 and R9. This results in Tr5

turning on and the relay being activated. A pair of normally open relay contacts are used to operate an alarm of some kind.

A second pair of normally open relay contacts are used to connect R10 to Tr1 base. R10 then supplies a base bias current to Tr1 so that even if the infra-red pulses should resume, and Tr4 should turn on again, Tr5 is still switched on and the alarm will continue to sound.

Operating PBI short circuits Tr5 base to earth and switches off Tr5, the relay, and the alarm. This removes the base bias to Tr5 via R10, and so the alarm remains off when PBI is released.

The BPW34 photo diode can be obtained from Electrovalue Ltd., and their address was provided earlier. The range of the system is not very great, being only about 1 Metre or so, but it does not need to be more than this. Normally the system would be installed in a corridor or across a doorway, so that the transmitter and detector would only be about 1 Metre apart.

Alignment of the transmitting and receiving diodes is not too critical as they both operate over a fairly wide angle. Maximum emission/admittance is at an angle of  $180^{\circ}$  to the leadout wires.

The system will work perfectly well in ordinary indoor daylight conditions, or in darkness, but not if strong daylight (i.e. direct sunlight) is falling on the receiving photocell. It is a simple matter to shield it from strong light sources, using a small cardboard tube for instance. Mains powered lighting is also something of a problem since it emits quite a lot of infra-red, and furthermore, it is modulated at 50Hz. The coupling capacitors in the receiver have been given fairly low values so that the circuit does not respond as well to the relatively low frequency of 50Hz as it does to the transmitter frequency. However, the receiver's photocell must still be shielded from strong mains lighting or this will provide a signal which will hold the circuit in the "alarm off" state, even if the infra-red beam is broken. Ordinary daylight will have the opposite affect if it is too strong. It will reduce the sensitivity of the receiver and cause the alarm to sound unnecessarily.



Of course, an infra-red system such as this is far less affected by ambient light conditions than are systems which use ordinary visible light.

## Sports Timer

As was mentioned in the previous Chapter, it is possible to automatically operate the stopwatch circuit of Fig.19 in an application such as a sports timer. A suitable control circuit is provided in Fig.30.

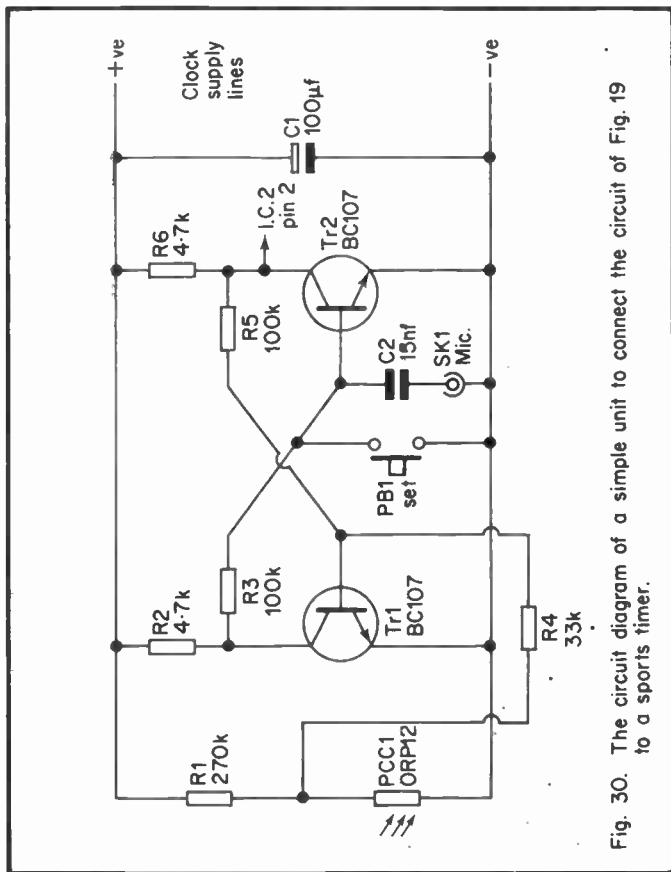

Fig. 30. The circuit diagram of a simple unit to connect the circuit of Fig. 19 to a sports timer.

The purpose of this circuit is to automatically start the stopwatch when the starting gun fires, and stop it when the winning competitor crosses the finishing line. The unit is basically a conventional bistable multivibrator circuit, and when the supply is initially connected, either Tr1 will switch on and Tr2 will switch off, or vice versa. Hopefully Tr2 will be the transistor which is switched off, and so its collector will be at virtually the full supply rail potential. This voltage is fed to pin 2 of I.C.2 in the stopwatch circuit, and it thus controls the start/stop function of the watch. With the collector voltage of Tr1 at virtually the positive supply rail voltage the clock is in the stop condition. If Tr2 collector should happen to be low when the unit has been switched on, then it is merely necessary to operate PB1 which switches Tr2 off and alters the state of the bistable. The watch is then reset to zero, and the set up is ready for use.

A crystal microphone connects to SK1, and this microphone is placed very close to the starting pistol. Although the output amplitude of the signal produced by a crystal microphone is usually only a few millivolts, the sound from a starting pistol will produce an output which is very much greater than this. Positive peaks of this signal should be sufficiently strong to switch Tr2 on, and change the state of the bistable. This takes the collector of Tr2 low, and starts the stopwatch.

The broken light beam technique is used to stop the timer. PCC1 is mounted one side of the finish line, and a torch is shone onto it from the other side. Therefore PCC1 is normally quite brightly illuminated, and will have quite a low resistance. This produces quite a low voltage at the junction of R1 and PCC1, and this voltage is loosely coupled to the base of Tr1 by way of R4. However, as this voltage is at about the same nominal level as that which appears at Tr1 base anyway (virtually zero), and the coupling is only fairly loose, the operation of the bistable will not be significantly affected.

When someone intervenes between the light source and the photocell, the amount of light falling on the photocell will be greatly diminished, and in consequence its resistance

will rise sharply. This results in the voltage at the junction of R1 and PCC1 rising to almost the full supply rail potential, and a bias current flows to Tr1 base through R4. This changes the bistable back to its original state, and a 'stop' control voltage is fed to the timer circuit. Thus the required circuit action is provided, with the timer being started by the sound of the starting pistol, and stopped by the winning competitor breaking the light beam at the finish line.

A crystal microphone is a high impedance device which cannot be used with a long connecting cable. The microphone must therefore be connected to the unit by a cable no more than a few metres long. It is only possible to use a long cable if a suitable preamplifier is interposed between the microphone and the major part of the cable. Using a fairly long cable between PCC1 and the rest of the circuit does not appear to cause any problems.

## Alternative Version

If preferred, both the stop and start functions can be controlled by a broken light beam system. A suitable circuit is shown in Fig.31, and this is largely the same as the previous circuit.

Initially the unit is set up in the same way as the circuit of Fig.30. The triggering of the bistable to start the timer is slightly different though, as instead of a microphone, a photocell circuit is coupled to the base of Tr2.

PCC2 is normally illuminated quite brightly, and the voltage at the junction of PCC2 and R8 is very low. This photocell circuit is coupled to the base of Tr2 via R7, and it normally has no effect on the bistable. When the light beam is broken, PCC2 exhibits a very high resistance and the voltage at the junction of PCC2 and R8 rises to almost the same level as the positive supply rail. This causes a bias current to flow into Tr2 base via R8 and R7, and so Tr2 is turned on and the bistable is triggered to the opposite state. This causes the voltage at Tr2 collector to go low, and the timer circuit is started. The circuit then operates in precisely the same manner as previously.

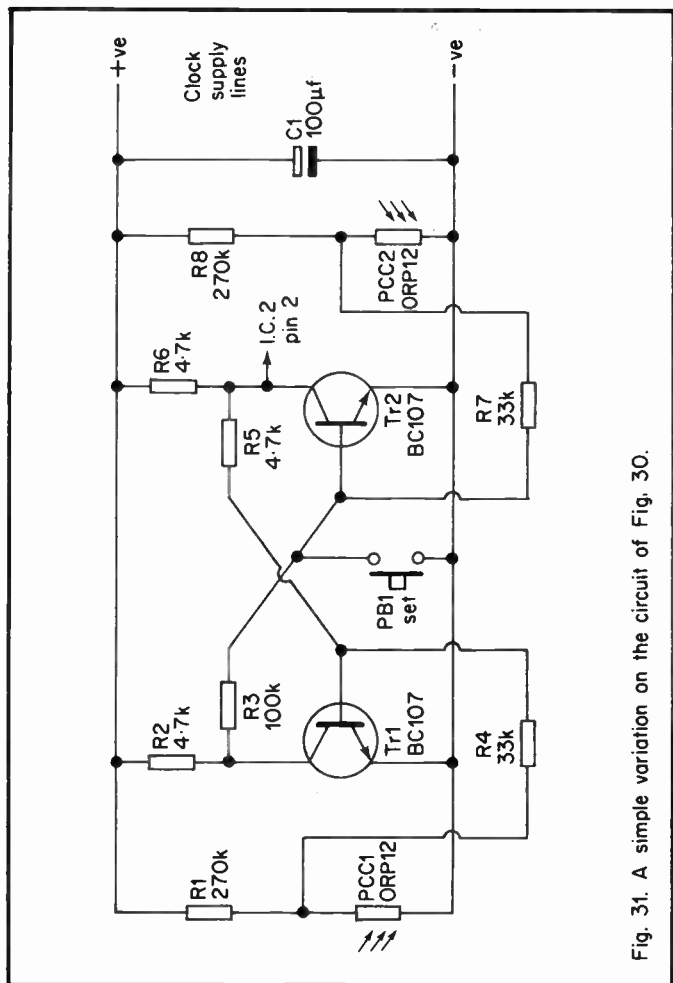

Fig. 31. A simple variation on the circuit of Fig. 30.

## Directivity

Any reasonably powerful torch (a 4.5 or 6 volt type) should provide a light beam which will give a range of several yards, but it is no good simply shining it straight at the

sensitive surface of the photocell. Under ordinary operating conditions there will be quite a high ambient light level, and this would cause the photocell to have quite a low resistance whether anyone was blocking the light from the torch or not. It is necessary to make the photocell highly directional so that it receives a significant amount of light only from the torch.

It is quite easy to achieve this, and it is merely necessary to place a long thin tube in front of the photocell. This tends to block any light from the photocell which is not virtually parallel to the tube. As can be seen from Fig.32, the light from the torch is mostly parallel to the tube and is allowed to pass on to the photocell unhindered. On the other hand, the ambient light is at random angles, and so is largely blocked from the photocell. Thus the photocell will be in almost total darkness if the light from the torch is blocked.

In practice, the tube needs to have an outside diameter of about  $\frac{1}{2}$  in., which is the same as the diameter of the ORP12 cadmium sulphide cell. The inside diameter is not critical, but it should not be less than about  $\frac{3}{8}$  in. as this would result in some of the sensitive surface of the cell being masked. The longer the tube the more ambient light it will cut out, and a minimum length of 18 in. is recommended. It does not really matter what material the tube is constructed from, provided it is extremely rigid. Some form of metal tube would probably be the easiest type to obtain, and steel tubing is used on the prototype equipment.

A good method of securing the photocell to the end of the tube is simply to use a wide band of P.V.C. insulation tape (preferably black). This method produces a strong joint and a light proof seal if the band of tape is kept very tight. If some other type of joint is used, it is essential that it provides a light proof seal. For maximum effectiveness the tube should be painted matt black on the inside.

The alignment of the torch and the tube is surprisingly critical, and it is suggested that the following setting up procedure should be used: with the equipment roughly aligned by eye, a multimeter set to read 10V f.s.d. is connected between Tr1 collector and the negative supply rail. The

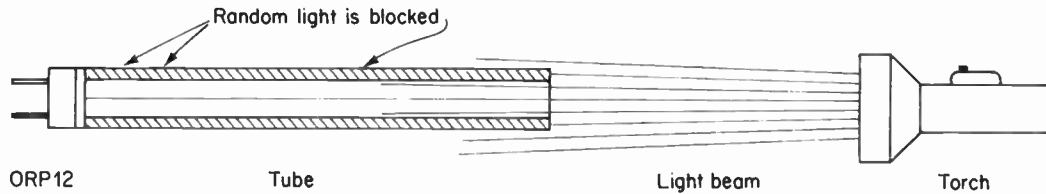

Fig. 32. Using a tube to minimise ambient light pick up.

multimeter should be placed where it can be seen while the alignment of the torch is adjusted. A short crocodile clip lead, or some other form of temporary shorting lead is then connected between Tr2 collector and the negative supply rail.

The multimeter will probably read zero, but by adjusting the torch it should be possible to obtain virtually f.s.d. of the meter. Any setting of the torch which gives almost f.s.d. of the meter should be found to give good results. After the shorting lead and the multimeter have been removed, the equipment is then ready for use.

The torch and the photocell should both be mounted at about body height if the unit is to be used as an ordinary sports timer. They must both be provided with a reasonably substantial form of mounting, to prevent accidental misalignment due to physical damage or environmental vibration.





## Chapter 3

### MODULATED LIGHT TRANSMISSION

This is an area in which a considerable amount of serious research has been done in the past few years. Most of this research has been concerned with the transmission of signals along glass filaments or 'light pipes' as they are sometimes called. These can be used to replace conventional types of cable.

Probably of more interest to the amateur is the transmission of a modulated light signal through the air without the need for any form of interconnecting cable. It must be emphasised right from the start that this type of transmission is only suitable for use over short ranges. Designs of this type for the amateur constructor never seem to claim a reliable range of much more than about 200 feet, and the author's experiments would seem to bear this out. It is feasible to obtain a much greater range than this, but obtaining suitable components and materials for such a system would probably be rather difficult, if not impossible. Here we will only consider systems which can be constructed using readily available items, and which should be well within the scope of the average electronics constructor. They should also provide a good starting point for the electronics experimenter.

#### Basic Principle

The basic principle of this type of system is really very straightforward, and is demonstrated by the diagram which is provided in Fig. 33. The transmitter consists of an audio amplifier which is fed from a microphone. It drives a light bulb at the output, and the output stage must be of the class A type. This means that there is a fairly high current flowing through the bulb under quiescent conditions, and so it lights at about its normal intensity. Speaking into the microphone causes the current through the bulb to vary in sympathy with the applied audio signal, and so the bulb brightens on positive audio peaks, and dims on negative-going peaks.

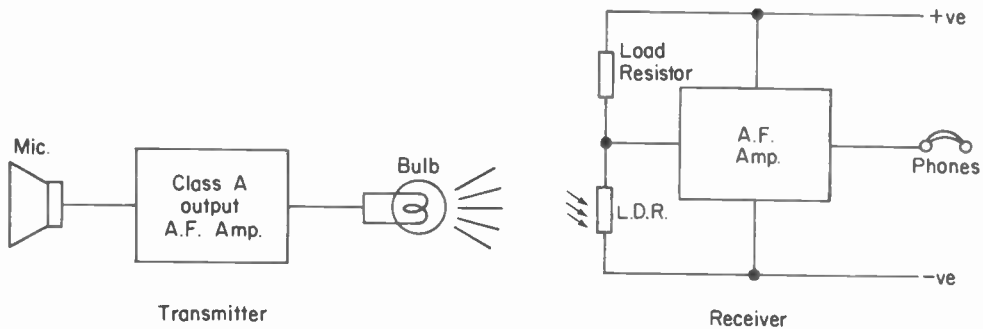

Fig. 33. The basic principle of a modulated light communications link.

The light from the bulb is picked up by a photocell at the receiver, and this cell is connected across the supply lines as one section of a potential divider. As the intensity of the light from the bulb increases, the resistance of the photocell will obviously fall, causing the voltage at the junction of this cell and the load resistor to fall. Reductions in the brightness of the bulb have the opposite effect, and cause a rise in the resistance of the photocell, and hence an increase in the voltage at the junction of the cell and the load resistor.

Thus the audio signal which is fed to the transmitter causes a similar audio signal to be developed at the receiver. Some readers may have noticed that a positive going signal at the bulb generates a negative going signal at the receiver, and vice versa. This is, of course, of absolutely no importance in practice, and it simply means that the signal is inverted between the transmitter and the receiver. The signal which is produced at the photocell is only at a very low amplitude, and it must be considerably amplified before it will drive a pair of headphones satisfactorily.

The quality of the audio output signal of a communications link of this type is not in the Hi-Fi category, but is more than adequate for good voice communication. There are two main causes for the loss of quality. The most obvious one is that there is not very good linearity through the light transmission part of the system, although in practice the linearity seems to be better than one might expect.

Loss of upper frequency response is the other form of quality imperfection of a system such as this. This is almost entirely due to the thermal characteristic of the bulb, which does not heat up and cool down instantaneously. The time it takes is fortunately only very short, and so it will respond quite well up to frequencies of about 5 kHz or so. Above this the frequency response falls away quite rapidly.

For speech communication an upper response of only about 3 kHz at the  $-6$  dB point is usually considered to be all that is needed, and a response which falls short of this would probably be just about satisfactory in practice. In fact most communication systems roll off the upper frequency response

as this does not impair the intelligibility of the signal to any significant degree, and it provides an improved signal-to-noise ratio. Incidentally, the bass frequencies below about 200 Hz are often rolled off for the same reason.

Despite its imperfections, a modulated light transmission and reception set-up of this type is therefore perfectly suitable for the transmission of speech, but is not really adequate to handle music properly.

Many forms of communication link require a Home Office licence, or infringe a Post Office monopoly. To the best of the author's knowledge, this is not so in the case of modulated light transmissions.

## Circuits

The circuitry involved in a modulated light system is not really very complicated, and perhaps rather strangely, it is not the performance of this circuitry which is the main determining factor as to the maximum range which can be attained. In order to attain a reasonable range it is necessary to use some form of optical system to collect the light from the bulb and aim it at the receiver. It is also necessary to have an optical system at the receiver which serves two functions. First, it must collect as much of the light from the bulb as possible, and focus it onto the photocell. Second, it must eliminate as much ambient light from the photocell as possible.

Using no optical system at all, the range of the equipment will be virtually nil under very bright conditions, and only a few feet in darkness. By using a fairly simple optical system a range of about 50 Metres can be attained regardless of the ambient lighting conditions. The description of this system will therefore be split into two parts; first the electronics will be described, and then some suggestions for a suitable optical system will be given.

The circuit diagram of the modulated light transmitter is shown in Fig. 34. This is designed for use with a crystal microphone which feeds the base of Tr1 via C2. Tr1 is used as a common-emitter amplifier, but it has the rather unusual

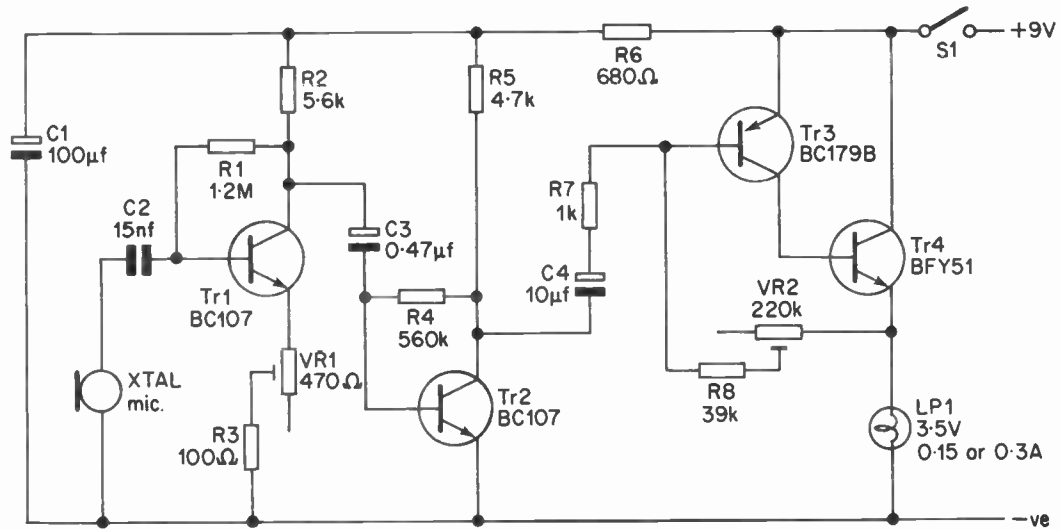

Fig. 34. The circuit diagram of the modulated light transmitter.

feature of a variable and unbypassed emitter resistance. This introduces quite a large amount of negative feedback to this stage which in consequence provides a low noise level and a high input impedance. Normally a crystal microphone would be loaded by an input impedance of about 2 Meg. ohms so that a good bass response would be produced. This amplifier has an input impedance of about 250 k $\Omega$ , and so the bass response is somewhat attenuated. However, as explained earlier, for communications purposes a good bass response is not required, and is usually avoided.

VR1 is a preset microphone gain control, and this varies the gain of Tr1 by altering the amount of negative feedback which is applied over this stage. Tr1 has a voltage gain of about 10 times with VR1 at maximum resistance, and 56 times with it at minimum resistance.

The output signal at Tr1 collector is fed to a high gain common-emitter amplifier (Tr2) by way of C3. A crystal microphone provides an output amplitude of only a few millivolts, and so the high combined gain of Tr1 and Tr2 is needed in order to produce a signal which is adequate to drive the output stage.

A two transistor direct coupled arrangement is used in the output stage. Tr3 is a common-emitter amplifier which has the base/emitter junction of Tr4 as its collector load. Tr4 is an emitter-follower stage which has the light bulb as its emitter load. R8 and VR2 bias the output stage, and they also introduce a certain amount of negative feedback over this part of the circuit, which helps to minimise distortion. VR2 enables the quiescent current through the bulb to be varied. This is adjusted to produce an output current which is equal to the nominal operating current of the bulb used.

The prototype transmitter has been tried with both a 3.5V 300 mA bulb, and a 3.5V 150 mA type, and it worked satisfactorily with either type. Results were a little better when using the higher current type, but the difference between the two was less than one would expect. If a 300 mA bulb is used it is advisable to fit Tr4 with a small clip-on type heatsink.

If a carbon microphone is to hand, it should be possible to drive the output stage direct from this with Tr1, Tr2, and their associated components being omitted. The carbon microphone would then be connected between C4 negative and the negative supply rail. A load resistor of about 5.6 k $\Omega$  in value would be needed between C4 negative and the junction of R6 and C1. Carbon microphones are the type normally fitted to telephone handsets.

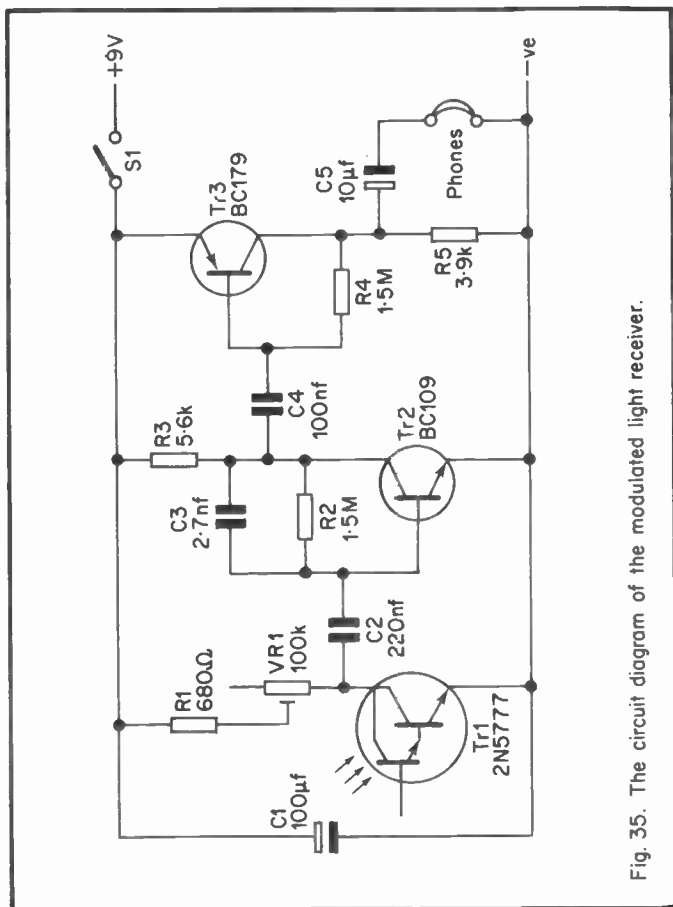

Fig. 35. The circuit diagram of the modulated light receiver.

## Receiver

Fig. 35 gives the circuit diagram of the modulated light receiver. The photocell which is used here is a photo Darlington transistor. As the name implies, this merely consists of two transistors connected as a Darlington Pair, and contained in a transparent plastic encapsulation so that they operate as a photosensitive device. The 2N5777 device specified here accepts light which falls onto the curved side of the case.

In order to use a photo-Darlington transistor as a photo-resistor it is merely necessary to use the collector and emitter leadouts, with the supply being connected with the correct polarity. Thus in this negative earth circuit the emitter is earthed and the collector connects to the load. It is possible to control the sensitivity of the device by connecting a resistor between the base and emitter terminals. The lower the value of this resistor, the lower the sensitivity of the device. In this case the maximum possible sensitivity is required, and so the base is simply left unconnected.

R1 and VR1 form the load resistance for the photocell, and VR1 can be adjusted to optimise results. The best value for the load resistance depends upon the amount of light which is falling on the photocell. Generally speaking, the greater the light level received by the photocell, the lower this resistance should be.

The audio amplifier is quite conventional, and consists of two high gain common-emitter amplifiers which are capacitively coupled via C4. It is designed to feed a pair of high impedance (2000 or 4000 ohms) headphones, or a crystal earpiece, but it seems to work just as well with medium or low impedance headphones. It will also drive a telephone handset insert satisfactorily.

Coupling capacitors of a fairly low value are used so that the circuit does not have a very good bass response. As mentioned earlier, rolling off the bass response does not hinder the intelligibility of speech, and it improves the signal-to-noise ratio. In this case the main source of low frequency noise is likely to be 50 Hz mains hum which can be picked up from mains-powered lighting. This is not likely to be a major problem though.



C3 is used to roll off the high frequency response of the circuit, but this does not affect the audio signal to any great extent. This is simply because the frequencies which are seriously attenuated are higher than those produced by the transmitter, which introduces a high degree of top cut, as explained earlier. By rolling off the very high frequency response, C3 provides a much improved signal-to-noise ratio by reducing background hiss.

## Using an L.D.R.

It is possible to use an L.D.R. such as the ORP12 in a modulated light receiver, but due to the lower sensitivity of an L.D.R. in comparison to a photo-Darlington device, an extra stage of amplification is required. For anyone who would prefer to use an L.D.R., or would like to compare both types of receiver, the circuit of Fig. 36 has been provided.

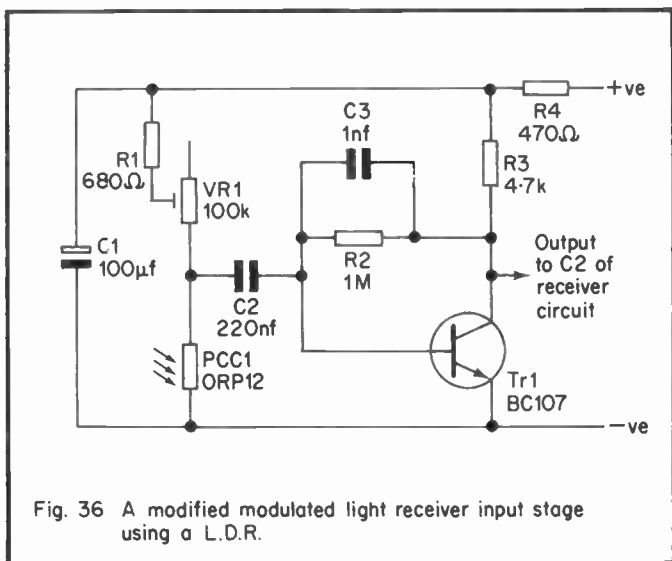

Fig. 36 A modified modulated light receiver input stage using a L.D.R.

This consists of an extra high-gain common-emitter amplifier stage which is fed from the photocell/load resistor network via C2. R4 and C1 are a supply decoupling network. Tr1 collec-

tor connects to the left-hand side of C2 in Fig. 35, and R1, VR1, and Tr1 of Fig. 35 are omitted of course. C3 provides a degree of high frequency roll off and so reduces background hiss. It also reduces the risk of instability, which could otherwise be a severe problem due to the high gain and wide bandwidth of the circuit. Even with the response of the circuit being subject to a degree of roll off at the high frequency end, it is still necessary to use a sensible component layout in order to eliminate the possibility of instability.

As in the previous circuit, VR1 is adjusted to optimise results, and the higher the intensity of light falling on the photocell, the lower the value to which it must be adjusted.

## Optical System

The basic principle of the optical system is illustrated in Fig. 37. To be effective, most of the light from the bulb of the transmitter has to be projected forward to produce a fairly narrow beam of light. This is done by using a reflector to gather up any light which is radiated upward, downward, or to the side, and project it forward.

Most torches seem to produce a quite narrow central beam of light, and so on the prototype the front section of an Ever-Ready 4.5 V torch (the type that takes a 1289 battery) was employed as the reflector and bulb holder assembly. The connections to the torch head are made via a couple of insulated leads, one of which is carefully soldered direct to the pip at the rear of the bulb. The other is soldered to the strip of metal at the front of the on/off switch (which then becomes inoperative and can be ignored). Of course, it should be possible to utilise the reflector assembly from virtually any torch by using a bit of initiative. Car headlamp assemblies are also used in this application sometimes, and there is plenty of room for experiment here.

A reflector which produces a very narrow beam will usually provide the greatest range, as virtually all the transmitted light will be picked up by the receiver. With a wider beam there is a lot of wasted light, since much of it will miss the receiver, and so a smaller maximum range is produced. However, for

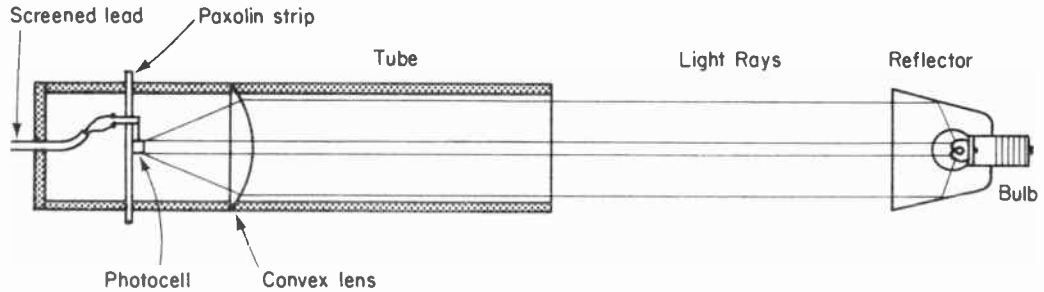

Fig. 37. The basic arrangement of the optical system.

most purposes an adequate range can be obtained using a comparatively wide beam, and this has the advantage that the aim of the light beam is not nearly as critical as when a narrow beam is used.

The receiver is not quite as simple as the transmitter where the optics are concerned, as it is necessary for the receiver optics to be home constructed. It is possible to use a torch reflector at the receiver, with the reflector being arranged so that it picks up the light from the transmitter and concentrates it onto the photocell. In other words, the inverse of that which was used at the transmitter. With a tube painted mat black on the inside added in front of the reflector to minimise the pick up of extraneous light, a system such as this can be very effective, and it is probably the best solution for anyone who does not wish to use a lens.

The basic idea of adding a lens ahead of the photocell is quite simple. Either a plano convex or a double convex lens can be used, and the photocell is placed behind the lens at which is called the focal point. The lens then picks up the transmitted light over its comparatively large surface area, and concentrates it onto the photocell.

One might think that it would merely be necessary to add a tube ahead of the photocell, as in Fig. 32, but unless the transmitter produces an exceptionally narrow beam of light this will not provide a very great range. An ORP12 does not have a very large sensitive surface area, and that of a 2N5777 photo-Darlington device is even less. If neither a lens nor a reflector is used to increase the amount of light which is fed to the photocell, the amount of light pick-up is so small that only comparatively poor results are obtained.

The vital statistics of a lens are its type, diameter, and focal length. In this application a plano convex lens is probably most suitable. This type of lens is flat on one side and curved outwards on the other. A double convex, which curves outwards on both surfaces, is also suitable. Concave lenses are completely unsuitable. The diameter of the lens should be about 1½ to 2½ in., and it should have a focal length of about 2 to 4 in.

The lens is contained in a tube which has the same outside diameter as the lens. The tube should be painted matt black on the inside. By cutting the tube into two pieces, it is possible to glue the two sections back together in such a way that the lens is trapped and glued in position. If the lens is a plano convex type, the curved face should be the one at the front. Try to keep the lens clean and free from finger marks, adhesive, etc. The length of tube which is used ahead of the lens is not too critical, but the longer it is, the more ambient light it will cut out. It is advisable for this length to be at least four times the diameter of the tube.

The photocell is carefully glued to a strip of S.R.B.P., and then this strip is mounted inside the tube. This can be done by cutting suitably sized slits in the top and bottom of the tube, just a little behind the focal point of the lens. The S.R.B.P. strip can then be slotted and glued into place.

A screened lead (which must be reasonably short) is then connected to the photocell. The outer connects to the emitter and the inner connects to the collector. If the version of the unit which employs the ORP12 is used, these leads can be connected either way round. At the receiver circuit board the outer connects to the negative supply rail, and the inner connects to VR1.

Finally, a piece of S.R.B.P. or some similar material is glued in place over the rear end of the tube. A small notch is cut in the edge of this so that there is a suitable exit point for the screened cable. It is a good idea to use some black P.V.C. insulation tape at strategic points on the outside of the tube in order to ensure that it is properly light proofed.

## Operation

When initially trying out the transmitter, VR1 can be set at about half maximum resistance, and VR2 must be set for maximum resistance. If a suitable multimeter is available, this can be used to measure the supply current of the unit, and then VR2 is adjusted to produce a current consumption which is equal to the nominal current rating of the bulb. In the absence of a multimeter, VR2 can simply be adjusted to

produce the normal level of brilliance from the bulb, and the setting of VR2 is not too critical.

Speaking into the microphone should produce some variation in the brightness of the bulb. It is probably best to wait until the system has been set up and is in use before giving VR1 its final setting. It is given the lowest setting which does not cause the transmitter to overmodulate. Any overmodulation will be quite apparent at the receiving end of the system as it will cause considerable distortion.

When the receiver is initially being tested, start with VR1 at about maximum resistance. The system can be tried at virtually point-blank range in the first place, just to ensure that it is working, and then it can be tried over a longer range.

The prototype equipment was initially set up over a range of about 30 yards. It is usually quite easy to aim the transmitter if this is done while it is dark, as it is then possible to see the spot of light produced by the unit. Aiming the unit in the present of a lot of ambient light is by no means as easy.

Probably the best method is to point the light beam as accurately in the right direction as possible, and then with the aid of a helper and the use of trial and error, make the fine adjustments. It is not difficult for the helper to locate the point at which the beam is aimed. By looking at the torch head it is easy to see when it is pointing at you, and you know when your eyes are in the main beam as the torch will appear to be very bright.

Whatever method of aiming the light beam is used, it is probably best to position the receiver to optimise the final results. The aim of receiver is much more critical than one might imagine. If the tube is only a degree or two out of alignment the signal seems to be completely lost, even at short range. However, it is not very difficult to locate the beam and then adjust the aim for maximum signal. Incidentally, maximum signal tends to coincide with minimum background noise rather than maximum volume.

The prototype equipment worked well over this 30 yard range, even in bright sunlight. One slight problem did

arise, and that was that bright sunlight shining at a fairly low angle into the reflector of the transmitter can severely attenuate the signal. This is probably due to the light being reflected to the receiver, and tending to saturate the photocell. This can be overcome by fitting a tube in front of the reflector so that it is shielded from the sunlight. It is quite acceptable to operate the equipment through ordinary window panes as these do not seem to significantly hinder the signal.

As described here, the equipment only provides one way communication. Of course, two way communication can be provided by using both a transmitter and a receiver at each end of the system.

It is difficult to give a maximum operating range for equipment such as this, as it depends on many factors. The prototype was given a quick test (under rather makeshift conditions) over a range of about 55 yards, and it seemed to work quite well. Provided the optical system is reasonably efficient it would seem reasonable to expect a maximum operating range of at least some 50 yards, and a much greater range is presumably possible under very dark conditions.

The setting of VRI in the receiver will probably be found to be of little significance under most operating conditions, but under very bright conditions it should be possible to obtain a substantial improvement in the signal by adjusting this component.

## **Infra-Red Transmission**

Although it is possible to set up an infra-red communications link, for the amateur electronics enthusiast a modulated light link is probably a much more practical proposition where a communications system is needed. Infra-red transmission can be usefully employed by the amateur though, but to provide a high quality very short distance link.

Links of this type can, for example, be used to transmit the sound signal from a T.V. set or a radio receiver. It is then possible for people in the room to pick up this signal on a

special pair of headphones which are equipped with a suitable infra-red receiver. The speaker of the radio or T.V. set is then muted.

The point of this system is that it enables the members of the household who wish to listen to the radio or T.V. to do so without disturbing others. A number of people can listen to the programme (provided an adequate number of headphone sets are available), and there is no need to have a lead trailing from each headphone set to the television or radio receiver.

Most infra-red systems of this type are rather complicated both to construct, and to set up once completed. They also tend to be rather expensive. There are several reasons for this, one of which is the fact that an amplitude-modulated system (such as the system described previously) does not provide adequate quality. Sufficient frequency response could easily be obtained as an infra-red L.E.D., unlike a light bulb, will respond to frequencies of 100 kHz or more, and so will an infra-red detector diode. It is the non-linearity of the system that is the problem. Also, a high quality system would need to have a good bass response, and this would make it very vulnerable to interference from mains-powered lighting. This necessitates the use of an F.M. system. A system such as this must obviously be non-directional, and this usually results in an array of about a dozen L.E.D.s being used at the transmitter, and two or more detector diodes at the receiver. This is also necessary in order to obtain sufficient range. On the constructional side there are obvious difficulties in having to build a complete receiver including battery supply into a pair of headphones.

The system put forward here is much more simple and considerably less expensive than a commercially made infra-red link, but it is admittedly less convenient to use. The main point of it is that it falls within the scope of the average electronics constructor.

The basic arrangement of the system is outlined in Fig. 38. The transmitter is fairly conventional in that it uses the usual voltage controlled oscillator to produce a low frequency F.M. signal from the audio input. The output stage is only used to drive a single infra-red L.E.D., however.



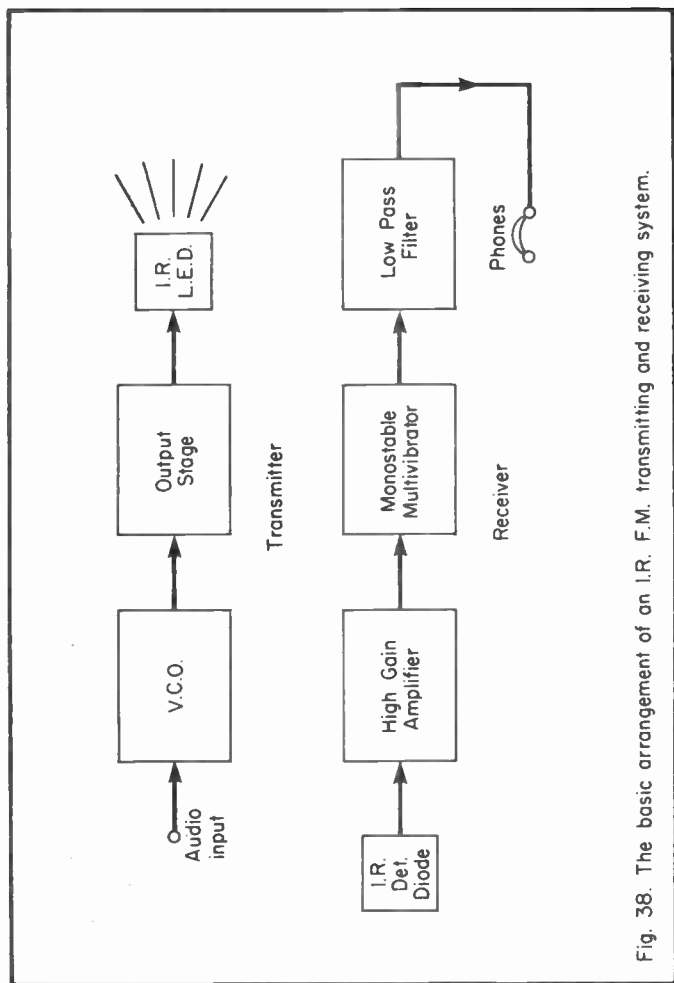

Fig. 38. The basic arrangement of an I.R. F.M. transmitting and receiving system.

The receiver is not designed to be built into the headphones, but is constructed as a separate unit into which the headphones are plugged. The receiver can be placed on the arm of a chair, or in the lap of the user, and it must be aimed towards the transmitter. This is necessary as the receiver must have a

simple optical system in order to provide adequate pick up of the infra-red signal. This optical system does not need to be highly directional, however, and it must be remembered that the transmitter is largely unidirectional. Thus the alignment of this system is nothing like as critical as the modulated light link which was described earlier.

A rather unusual receiver circuit is used, and it does not employ a single tuned circuit. It requires no alignment when it has been completed. The high gain amplifier is an untuned circuit which is very similar in design to an ordinary high gain audio amplifier. The transmitter operates at a nominal frequency of about 75 kHz, and a signal at this kind of frequency is easily handled by a circuit using silicon transistors and resistive loads.

The F.M. detector is a little unusual, and consists of a monostable multivibrator and a low pass filter: this circuit is known as a 'pulse counting F.M. detector'. The monostable is triggered by positive-going signals, and once triggered it produces an output pulse of a fixed length. The purpose of the low pass filter is to integrate these pulses to produce an output voltage which is equal to the average output voltage of the monostable.

The output pulse from the monostable is given quite a short length so that the unmodulated carrier wave produces an output voltage of about a volt or so. If the modulating signal takes the carrier wave lower in frequency, then there will obviously be fewer output pulses from the monostable in a given period of time. As the peak voltage and length of the pulses will remain unaltered, this will result in a reduction in the average voltage of the output signal. The lower the carrier wave is taken, the lower the output voltage will be.

Conversely, if the modulating signal raises the carrier frequency, there will be more output pulses and consequently a higher output voltage. The higher in frequency the carrier is taken, the higher the output voltage of the circuit. The required F.M. demodulation is thus provided by this simple arrangement.

## Transmitter Circuit

Fig. 39 shows the complete circuit diagram of the infra-red F.M. transmitter, and as can be seen from this, it is basically just an NE555V astable circuit. The values of R1 and R2 are chosen to produce a brief pulsed output waveform. Only a short pulse is required in order to trigger the monostable of the receiver, and so there is no point in using a longer output pulse. This would simply increase the dissipation in the I.C. and the L.E.D. to an intolerable level unless the output current were to be reduced. This would obviously reduce the effectiveness of the transmitter. This system of transmitting a series of brief pulses is therefore extremely efficient.

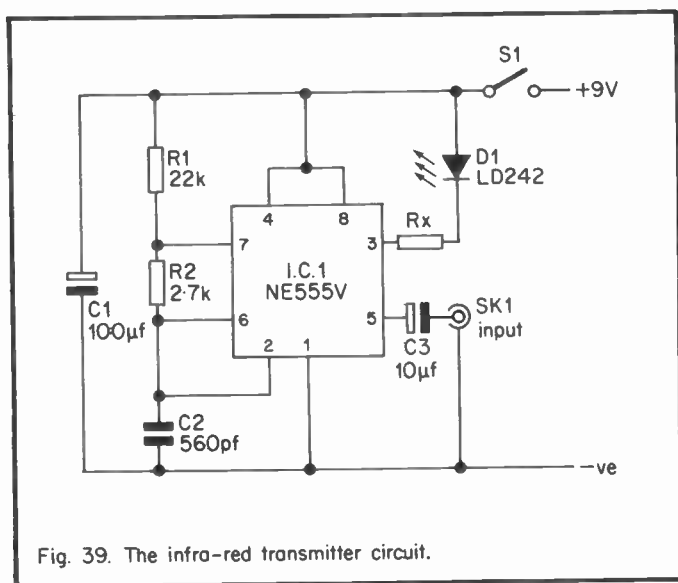

Fig. 39. The infra-red transmitter circuit.

Resistor RX may not be needed, and it will only be required if it is found that in use the I.C. becomes rather hot. It is quite alright if it feels rather warm to the touch, but it should not be allowed to get too hot to touch. If a resistor is needed here, it will require a value of only about 10 ohms, and its value should be no higher than absolutely necessary.

It is possible to frequency modulate the NE555V by applying the modulation signal to pin 5 of the device. C3 provides D.C. blocking at this input. The effect of the modulation is to vary the voltage at which C2 becomes discharged through R2 and the I.C. Positive input voltages raise this trigger voltage, and so lower the output frequency. Negative input voltages lower the trigger voltage and so cause C2 to be discharged earlier. This raises the output frequency. In this way the desired F.M. action is produced.

## Receiver Circuit

Fig. 40 gives the full circuit diagram of the receiver. D1 is the photocell, and it is used as an infra-red battery, rather than a photoresistor. Its polarity is unimportant in this circuit. Two stages of high gain amplification are provided by Tr1 and Tr2, both of which are used in the common-emitter mode. C3 and C5 roll off the high frequency response of the circuit which would otherwise extend well into the R.F. spectrum. This would be undesirable as it would encourage instability.

The CMOS 4047 device which is used in the I.C.1 position can be used in a number of astable and monostable configurations. Here it is connected to operate as a positive-edge triggered monostable. The output pulse length is determined by the values of C7 and R7.

This I.C. has both a Q output (pin 10, and normally low) and  $\bar{Q}$  (pin 11, and normally high) output, both of which are used here. R9 is the load resistor for the Q output, and C10 is its integrating capacitor. R8 and C8 respectively perform the same functions at the  $\bar{Q}$  output. Thus two out-of-phase audio outputs are produced, and the headphones are connected between the two. C9 provides D.C. blocking at the output.

The point of using both outputs is that it provides twice the signal amplitude when compared to the use of a single output. One disadvantage of a monostable circuit is that it is rather insensitive when used as an F.M. demodulator, and quite a high input signal level is needed in order to trigger it reliably.

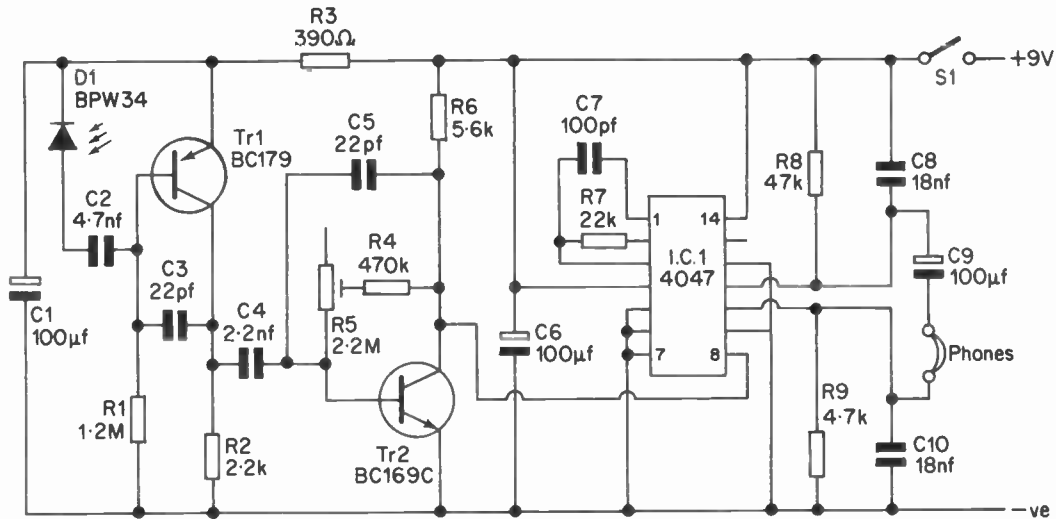

Fig. 40. The circuit diagram of the infra-red F.M. receiver.

On the other hand it provides quite a high output signal level, and this circuit will drive high, medium, or low impedance headphones quite satisfactorily. The best results were obtained from the prototype when it was used with a pair of 8 ohm stereo headphones which were series connected.

R5 is adjusted to provide best results, and when this is correctly adjusted the circuit should have a type of built-in squelch action, with either the signal being sufficient in amplitude to trigger the monostable and an audio output being produced, or with the signal failing to trigger the circuit and no significant output whatever being produced. If preferred, R4 and R5 can simply be replaced with a fixed resistor having a value of 1.5 Meg. ohms.

## Optics

It is not essential to use any optics at the transmitter at all. The LD242 L.E.D. has a built-in lens, which projects the infra-red radiation anywhere in front of the component. In fact it even radiates slightly to its rear. While this makes the transmitter largely unidirectional, it is rather wasteful in most practical situations where the signal which is transmitted at an acute angle will simply be lost. For instance, much of the signal will be radiated towards the ceiling.

It is possible to use a small mirror to aim this otherwise wasted energy forward to where it will be more useful. A better alternative is to use a torch reflector. This will not hinder the infra-red which is aimed well forward by the L.E.D., but it will gather up any other radiation and project it forward. If you place the lens of the L.E.D. in the position which would normally be occupied by the bulb filament, the signal will only be improved over a relatively small area almost directly in front of the reflector. It will probably be better if the L.E.D. is moved back slightly from this position.

The optical system of the receiver can be of the same type as that used in the modulated light beam receiver. Ambient light is far less of a problem in this case, and there is no need to have a long tube ahead of the lens.

One problem with this type of optical system is that it is very directional, although if a lens of about 2 in. or so in diameter is used, more than adequate range should be easily obtained. An interesting and perhaps better alternative is to use a bull's eye type lens. This is rather like a plano convex lens, but instead of having a surface with a regular curve, it describes a parabolic shape, (rounded 'V'). This type of lens has quite a short focal length, and will accept light from a comparatively wide range of angles and focus it onto the photocell. As a result of this it provides an optical system which is not highly critical with regard to directional alignment, and this makes it much easier to set up the receiver and optimise results. It is not quite as efficient as far as signal pick up is concerned, but using no optical system at the transmitter and a bull's eye lens of  $1\frac{3}{4}$  in. in diameter and having a focal length of  $\frac{3}{4}$  in. at the receiver, a range of about 10 feet or so was obtained towards the centre of the infra-red beam. This was reduced to about 8 feet or so at the edges of the beam. This should be adequate for most purposes, but the range can be increased, if necessary, by using a reflector at the transmitter. It is a good idea to do this anyway, as the stronger the signal in the vicinity of the receiver, the less critical the alignment of the receiver becomes and the better the signal-to-noise ratio that is obtained.

While it is not claimed that the system provides true Hi-Fi quality, it certainly seems to sound very good. The system was demonstrated to several people, and they all commented on how good the reproduction quality was. A good test to perform on audio equipment is to play a high level sinewave at a frequency of about 300 to 400 Hz through the system. It is on a signal such as this that the human hearing system will most readily detect any harmonic distortion. When the prototype was subjected to this test, no significant distortion was apparent.

Really, this is no more than one should expect. The transmitter circuit looks deceptively simple, and one should not forget that the NE555V is quite a complicated device which provides a high level of performance in this application. Theoretically the monostable F.M. detector offers perfect linearity, although any practical circuit will introduce a certain (but small) amount of distortion. There is probably

considerable non-linearity between the output of the NE555V I.C. and the input of the 4047 detector, but this is of no consequence. The signal merely consists of a string of pulses, and it is the frequency of these pulses and not their amplitude which determines the output voltage of the detector. This is the main reason for the use of an F.M. system.

An input level of about 4 to 5 volts peak-to-peak is needed at the transmitter in order to fully modulate it. This can be provided from the output stage of most pieces of domestic audio and radio equipment, including such things as portable transistor radios and cassette players. One word of warning must be given here, however. Many items of mains powered domestic electronic equipment do not incorporate a mains transformer, and the chassis of such equipment connects directly to one side of the mains. A severe electric shock can be inflicted by such equipment, and it is very strongly recommended that inexperienced constructors should not tamper with gear of this type. In fact it is probably best for the inexperienced enthusiast to leave all mains-powered equipment alone.



## Chapter 4

### PHOTOGRAPHIC PROJECTS

Photography is a field of interest in which electronics seems to play an increasingly large part. In addition to the many electronic photographic aids which are now available, many cameras seem to have built-in electronic systems of varying degrees of complexity.

This is now quite a broad subject area, and it is not really possible to cover it in detail here. Instead, details of a few photographic projects will be provided.

#### Slave Unit

When a photograph is taken using a single flash gun, it is quite likely to suffer from extremely sharp and rather unnatural shadows. This problem can be overcome by the use of a second flash gun.

One way of firing both flash guns simultaneously is to use an adaptor lead to connect them both to the switch contacts of the camera. The connecting cables can become rather cumbersome though, and a more satisfactory method is to use a photoflash slave unit. This switches on the second flash gun virtually the instant it receives the light pulse from the main gun. There is obviously some delay between the first and second flash guns being triggered, but it is so short that both are fired while the camera shutter is open.

Currently, many photoflash slave units are designed so that they do not require a separate power supply. They either derive their power from the flash gun in some way, or they generate a suitable trigger pulse for the control device (almost invariably a thyristor) from the light pulse. The problem with most of these methods is that they require components which are difficult or impossible for the amateur to obtain.

For example, there is a device which is like a 'photo thyristor', and which can be triggered by a light pulse rather than by an electrical pulse. These can be used as the basis of very simple but effective slave units, but unfortunately (at the time of writing), these devices do not seem to be available to the amateur, except when they become available from dealers in surplus components.

Another problem with most batteryless designs is that they are not always as sensitive as one would wish. This can be overcome by using a stage of amplification in the circuit, but it is then necessary to employ a battery. Slave units therefore have to be a compromise between various factors. The unit described here was primarily designed to provide a high degree of sensitivity, as this gives the unit optimum versatility, and minimises the chances of it failing to operate at some vital moment due to lack of sensitivity.

## The Circuit

The circuit diagram of the photoflash slave unit is provided in Fig. 41. The initial trigger pulse is generated across the photo-Darlington device, Tr1. Under normal ambient lighting conditions about 1 volt or more is produced at the junction of Tr1 collector and R2. The basic sensitivity of the 2N5777 device is such that this condition would not be met unless its sensitivity were to be reduced, as the device would be saturated. R1 is therefore included in order to reduce its sensitivity to the required level.

When Tr1 receives the pulse of light from the main flashgun its resistance will quickly fall, and so a negative pulse is generated at its collector terminal. This pulse is fed to the base of Tr2 by way of D.C. blocking capacitor C2. Tr2 operates as a high gain common emitter amplifier, with R4 as its collector load resistor and R3 providing the base bias.

The negative input pulse at Tr2 base causes a much larger output pulse to be generated. A common-emitter amplifier provides a 180° phase shift between its input and output, and so a positive going pulse is generated at Tr2 collector.

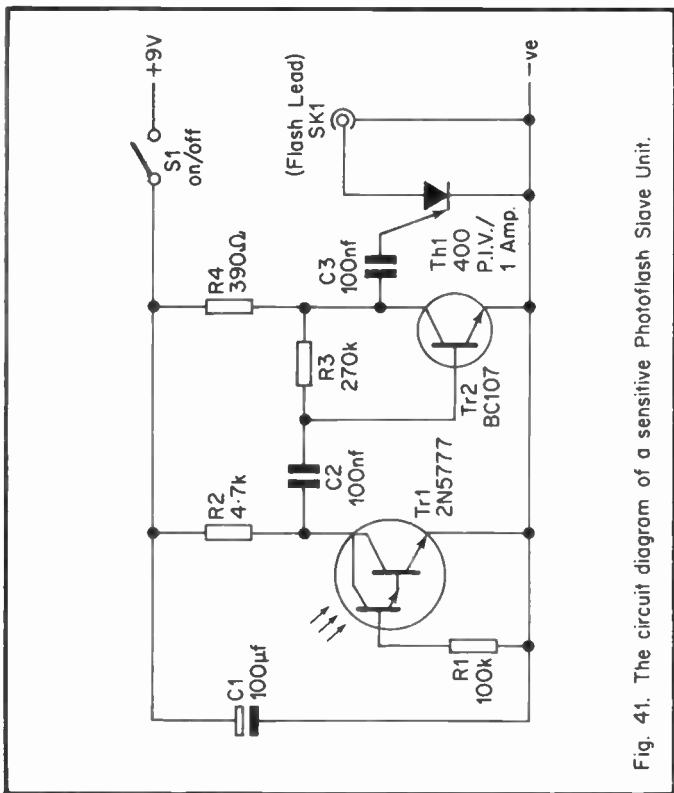

Fig. 41. The circuit diagram of a sensitive Photoflash Slave Unit.

This pulse is fed to the gate of TH1 via C3, and it switches the thyristor on. This results in a virtual short circuit being placed across the flash lead, and in consequence the second flash gun is fired. A thyristor will only remain on while it is passing a significant current, or a suitable gate signal is present. Thus, the device switches off once both flash guns have been fired, and the circuit is then ready to be activated by the next pulse of light.

R4 may seem to have a rather low value, but this is necessary as a thyristor has quite a low input impedance, and requires a comparatively high trigger current. The two coupling capacitors (C2 and C3) have fairly low values so that the circuit will

readily respond to the fast pulse produced by the light from the main flash gun, but it will not be activated by normal changes in the ambient light level, which happen comparatively slowly.

In use it is essential that the flashlead is connected to the thyristor with the correct polarity. The negative lead connects to the negative supply rail of the circuit, and the positive lead connects to the anode of the thyristor. The unit should not be damaged if the flashlead is connected with the incorrect polarity, and so, if necessary, the correct polarity can be found using trial and error.

The circuit is very sensitive, and indoors it can be triggered by a small electronic flash gun at a distance of about 25 feet, regardless of which direction the flash gun is pointed. If used out of doors the unit will inevitably be slightly less sensitive, since it will obviously not be possible for it to respond to light which has been reflected to the photocell via the walls and ceiling. It is possible for exceptionally bright ambient light conditions to saturate the photocell, but this is rarely, if ever, likely to manifest itself. The susceptibility of the unit to this problem can be decreased by decreasing the value of R1. However, doing this will result in some loss of sensitivity.

Probably the best way of making the connection between the flash gun and the slave unit is to use a flash extension lead. One end of this connects to the plug on the flash gun, and the plug at the other end of the lead is removed so that it can be connected to the flash unit. An alternative method is to change the plug on the flash gun for an ordinary electrical type, such as a 2.5 mm jack plug.

A matching socket is then fitted to the slave unit. Although cheaper, this method has the disadvantage that the flash gun is then incompatible with any camera.

## Enlarger Exposure Meter

This is a device which enables the correct enlarger exposure to be determined without the use of test strips. It is really just a

circuit for the measurement of light intensity, but the unit is not calibrated in terms of actual illumination level. The subject of calibration is dealt with more fully later on.

The circuit diagram of the enlarger exposure meter is shown in Fig. 42. This uses either a CMOS 4001 quad 2 input NOR gate, or a CMOS 4011 quad 2 input NAND gate as the only active component. Only two of the gates are used, and the inputs of the other two are grounded. The two gates which are used have their two inputs connected in parallel so that they operate as inverters. The two inverters are wired in series so that they operate as a high gain direct-coupled amplifier.

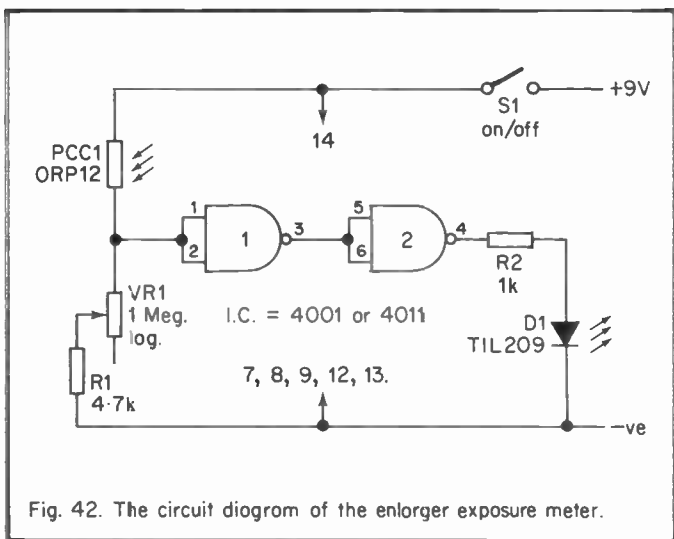

Fig. 42. The circuit diagram of the enlarger exposure meter.

The output of this amplifier feeds a L.E.D. indicator (D1) via a current limiting resistor (R2). When the output of the amplifier goes high the L.E.D. is switched on, and when it goes low it is switched off. An intermediate state will cause the L.E.D. to light up to some degree, but there is only an extremely narrow range of input voltages which will generate an intermediate output state.

A potential divider circuit is connected at the input of the amplifier. Light dependent resistor PCC1 forms the upper section of this, and VR1 plus R1 form the lower part. The control knob of VR1 is fitted with a calibrated scale, and this component is adjusted to the point at which the L.E.D. indicator comes on. The high gain of the circuit gives a very well defined point at which the L.E.D. comes on, and it is almost impossible to locate a setting at which the L.E.D. is only partially illuminated. With VR1 set at the switch on point, a reading can be taken off the dial.

This changeover point occurs when about half the supply voltage is present at the input of the amplifier, which in turn occurs when the resistance of VR1 and R1 is approximately equal to that of PCC1. Of course, the resistance of PCC1 depends upon the intensity of the light to which it is subjected. The brighter it is illuminated, the lower the setting of VR1 will need to be in order to reach the L.E.D. switch-on point. The unit can thus be used as a form of light level meter.

It would not seem to be necessary to stabilise the supply voltage of this unit. Changes in supply voltage do result in some variation in the output voltage of the potential divider, but this seems to be almost exactly matched by a change in the input voltage at which the amplifier goes from one output state to the other.

For the circuit to function correctly it is absolutely essential that the amplifier provides a very low level of loading on the photocell circuitry. This is achieved by the use of a CMOS logic I.C. as these devices have the incredibly high typical input impedance of 1 million Meg. ohms. The amplifier therefore places no significant load on the photocell circuitry.

It should be noted that it can take a cadmium sulphide light dependent resistor (such as the ORP12) a couple of seconds or so to fully respond to a change in light level. The attack time of these devices is quite short, and it is the decay time which is the problem. Because of this it is necessary to take one's time when making a measurement, so that the photocell is given adequate time to fully respond.

Although VR1 is a logarithmic potentiometer, it is actually used here as an antilog. type. This gives more uniform spacing between the dial calibrations than if a linear type were to be used. It is the centre and left-hand terminals of VR1 (when viewed from the rear) which should be used.

## Calibration

In use, the meter is placed on the enlarger baseboard, and a diffuser is placed under the lens so that all the light from the lens passes through it, that is, in accordance with the integration principle.

The most simple method of calibration is to give VR1 a purely arbitrary scale of letters or numbers. For any particular type of paper one determines the correct exposure time and aperture (for a normally exposed negative) by means of test strips in the normal way. Then, without removing the negative or altering the aperture, one places the meter and diffuser in position, switches on the enlarger, and rotates the knob of VR1 until the L.E.D. is just extinguished. The scale reading can then be written on the paper packet.

For new negatives, one keeps the exposure time constant and corrects the exposure by adjusting the lens aperture to the point where the L.E.D. is extinguished. It may be found useful to determine two scale settings for two exposure times (say 10 and 30 seconds) for each type of paper, to cater for small and large prints. Alternatively, as several modern enlarging papers have a constant speed for all grades (except in some instances for the hardest grade, which requires double the exposure of the others) one can make test strips at various light levels, finding the point at which the L.E.D. goes out for each level. The scale is then calibrated directly in exposure times for the one type of paper.

If a different type of paper is used occasionally for any reason, it is possible to determine, again by test strips, a multiplication factor by which the scale readings must be corrected for the new paper. In other words, if it is found that the correct exposure for a certain negative and degree of enlargement is say, eight seconds, and the meter indicates ten seconds, then

the scale times indicated by other negatives must be multiplied by 0.8.

## Phototimer

The circuit diagram of Fig. 43 is for a very simple type of photographic timer. The purpose of the unit is merely to radiate a pulse of light from a L.E.D. indicator at one second intervals.

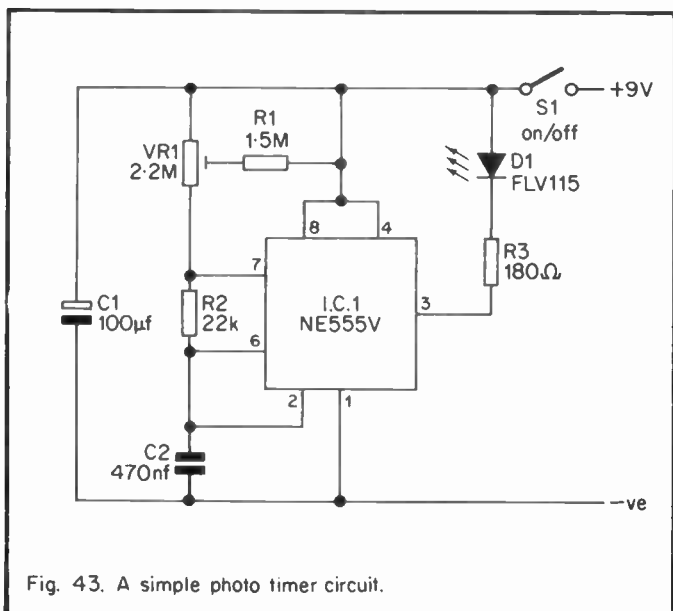

Fig. 43. A simple photo timer circuit.

It is possible to employ the device as a very simple enlarger timer. If, for example, a ten second exposure time is required, the unit is turned on and then as any flash occurs, the enlarger is switched on. After ten more flashes have been produced, the enlarger is immediately switched off.

The unit can be used in other applications, such as night-time photography where long exposure times are required. No doubt it could also be used in applications outside the field of photography.



There is little point in giving a detailed circuit description as this is basically the same as the metronome circuit of Fig. 14, and it is also similar to the two infra-red transmitter circuits. With the aid of a clock or watch which has a seconds hand, VR1 is adjusted to produce a flash rate from the L.E.D. of one per second. Stabilisation of the supply voltage is not necessary as the frequency of an NE555V astable circuit is not greatly affected by variations in supply voltage.

## Colour Temperature Meter

A colour temperature meter is quite a simple device which will indicate any bias towards one or other end of the light spectrum in the prevailing lighting conditions. To look at it another way, it compares the amount of red light with the amount of blue light that is present.

The information it provides can be very helpful to the photographer as it enables him (or her) to compensate for an excess of blue or red light by using suitable camera filters. It should perhaps be pointed out that although one might think that the human eyesight mechanism would be capable of readily detecting changes in colour temperature, this is not exactly the case. The eye tends to automatically compensate for changes in lighting conditions, and this makes quite large changes in colour temperature seem comparatively small.

Of course, a colour film or colour reversal film responds to the actual lighting conditions and not to how they appear to be to the photographer. Thus, for instance, a photograph which is taken indoors using an ordinary tungsten lamp as a light source may well have a considerable red bias unless some compensatory action is taken. Similar experiences with a red or a blue hue can occur when outdoor shots are taken, although this is perhaps less of a problem as this can often be used to increase the effectiveness of a photograph.

## The Circuit

The complete circuit diagram of the colour temperature meter is provided in Fig. 44. An I.C. operational amplifier type

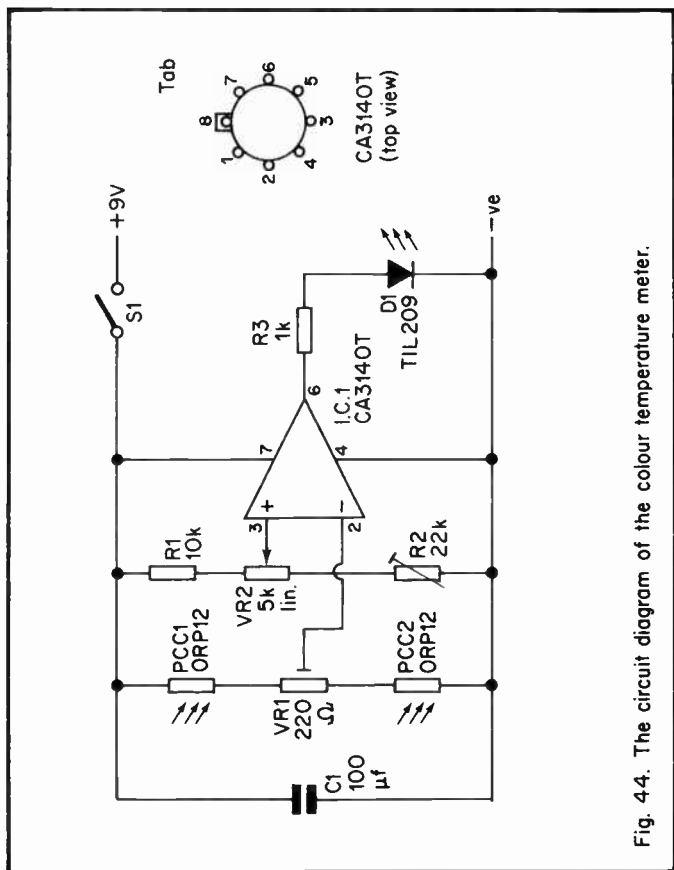

Fig. 44. The circuit diagram of the colour temperature meter.

CA3140T is used as the basis of the project, and it is used here as a comparator. The inverting input is fed from a potential divider which has PCC1 and the upper part of VR1 as its upper arm, and PCC2 and the lower part of VR1 as its lower arm. A red filter is placed over PCC1 and a blue filter is used over PCC2. VR1 performs two functions, one of which is to provide current limiting. This is necessary, as when brightly illuminated, the combined resistance of the two photocells is only about 40 ohms. The second function

is that of compensating for any mismatch in the photocells when they are brightly illuminated. It is also necessary to compensate for any mismatch when the photocells are only rather dimly illuminated, and this is achieved by physical means. This process is described more fully later on. This mismatch compensation must be used as otherwise the unit will respond to changes in light level much more readily than it will respond to changes in colour temperature.

The comparator circuit is used to drive an L.E.D. indicator via current limiting resistor R3. The output of the comparator will go high if the non-inverting input is taken to a potential which is higher than that at the inverting input, and low if the input states are reversed. The non-inverting input is connected to a potential divider which consists of R1, VR2, and R2, and which is connected across the supply lines.

In practice, VR2 is adjusted to find the point at which the L.E.D. indicator changes from the 'on' to the 'off' state, and then a reading is taken off the scale which is marked around the control knob of VR2. In other words it is used in much the same way as 'Enlarger Exposure Meter' which was described earlier. Of course, this changeover point occurs when the voltage at VR2 slider is the same as that appearing at VR1 slider, and the comparator circuit is really being used as a sort of simple voltmeter which measures the voltage at VR1 slider.

The voltage at VR1 slider depends upon the red and blue colour content of the light falling on the photocells. If the amounts of red and blue light are precisely the same, then half the supply voltage will appear at VR1 slider. If the light has a strong red bias, then PCC1 will have a much lower resistance than PCC2, and the voltage at VR1 slider will be higher than half the supply voltage. The stronger the red bias, the higher this voltage.

Similarly, if the light has a blue bias this will result in PCC2 having a lower resistance than PCC1, and the VR1 slider voltage will fall to less than half the supply voltage. The greater the blue bias, the lower the potential at VR1 slider. Thus VR2 can be calibrated in terms of colour temperature rather than voltage.

Under dull lighting conditions the photocell resistances can be quite high, and so it is necessary for the comparator circuit to have an extremely high input impedance in order to make sure that it does not have a detrimental effect on the photocell circuit. The CA3140T I.C. has an input impedance of 1.5 T ohms and so obviously draws no significant input current. Other operational amplifiers such as the popular 741C may not prove to be suitable for use in this circuit.

C1 is the only supply decoupling capacitor that is required, and S1 is an ordinary on/off switch.

## Calibration

Construction of the unit should be quite straightforward, but note that the two photocells are mounted on the outside of the case, and they should be close together. A short piece of paxolin tubing (or similar) about  $\frac{3}{4}$  in. in diameter is glued in place around each cell, and it is advisable to paint each piece of tube matt black on the inside. The coloured filters will eventually be glued in position over the top of each tube, but this is not done until some initial adjustments have been made.

Start with VR2 at a central setting and R2 set for slightly less than half maximum resistance (i.e. about 10 k $\Omega$ ). With the photocells brightly illuminated, say by bright sunlight or being held close to a 100 watt lightbulb, adjust VR1 to the switching point of the L.E.D. indicator. Then with the unit in less bright conditions, perhaps indoors during daylight, mask one of the photocells slightly in order to bring the circuit back to the condition where the inputs to the comparator are balanced. Return to bright lighting conditions, and readjust VR1; finally, return to dull conditions to readjust the photocell masking, and continue this process a few times until the circuit remains balanced, or very nearly so, whether it is in bright or dull conditions.

The point of this procedure is to make the unit insensitive to changes in light level. It is inevitable that the point at which VR2 balances the two inputs will change slightly with changes in light level, but it should be possible to make this effect insignificant.

Probably the best way to mask off the appropriate photocell is by using Bostik Blue-Tack or plasticine. Trial and error is used to find the cell which requires the masking.

Small discs of blue and red cellophane are used for the coloured filters, and large sheets of this material can be obtained from stationers. There are other possible materials which can be used here, and there is plenty of room for experimentation. However, be careful not to make the filters too dense, as this seems to prevent the unit from operating correctly. More than one layer of cellophane is required for each filter, and on the prototype two layers of blue cellophane and three of red cellophane were used.

This may need to be altered slightly on other units, and the filter densities are adjusted to produce a scale which is neither too cramped nor so broad that an inadequate range of colour temperatures is covered. It is also necessary to ensure that all the required colour temperatures fall within the range of VR2, although adjusting R2 can correct small errors in this respect.

A range of known colour temperatures is needed in order to provide VR2 with a meaningful scale, and the following table should help here.

<i>Source</i>	<i>Colour Temperature (degrees Kelvin)</i>
Candle	1,900
100W filament lamp	2,800
250W filament lamp	2,900
500W projector lamp	3,200
Photoflood lamp	3,350
Direct sunlight (at noon)	5,000
Overcast sky (not heavily overcast)	6,900
Light from clear blue sky	about 10,000 to 25,000

A detailed description of the way in which the unit and camera filters are used really goes beyond the scope of this book, and further information can be obtained by consulting a photographic text book.

## Components

The resistors used in the projects described in this book are all conventional  $\frac{1}{4}$ ,  $\frac{1}{2}$  or  $\frac{1}{8}$  watt 5 or 10% tolerance types. Presets can be standard or subminiature carbon types, horizontal or vertical mounting. Potentiometers are carbon track types, and either logarithmic or linear, as shown on the circuit diagram.

Non-electrolytic capacitors can be plastic foil types (polystyrene, polyester, etc.) and neither their working voltage or tolerance is critical in the circuits which are given here. If in doubt about the minimum suitable voltage for an electrolytic capacitor, choose one which has a voltage which is at least a little higher than the supply voltage.

The leadout diagrams for the semiconductors used in these projects are shown in Fig. 45. The only devices which need any comment here are the CMOS I.C.s. Different manufacturers use slightly different type numbers for these. For example, a 4001 gate can have any of the following type numbers: CD4001AE (R.C.A.), HBF4001AE (National Semiconductors) and MC14001CP (Motorola). The suffixes are also different on some versions. Many retailers simply refer to these devices by their basic type number. In the circuits described here, any device which is obtained through normal retail sources should be suitable.

Some care must be taken when handling CMOS devices as they can be damaged by high static voltages. They are normally supplied in some form of protective packaging, such as conductive foam or aluminium foil, and they should be left in this until they are to be used. For the more expensive devices it is advisable to use an I.C. socket. The cost of a socket is hardly justified for use with the 4001 and 4011 gates, and these should be soldered into circuit using a low leakage soldering iron with an earthed bit.

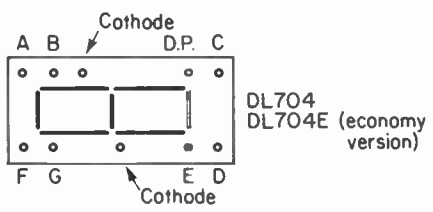
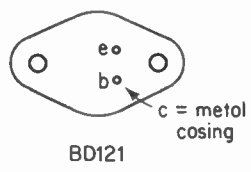
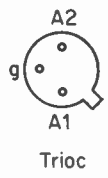
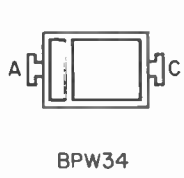
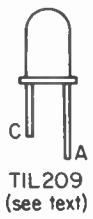
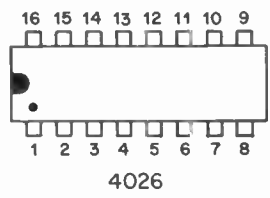
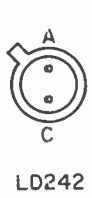
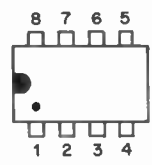
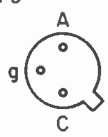
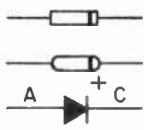
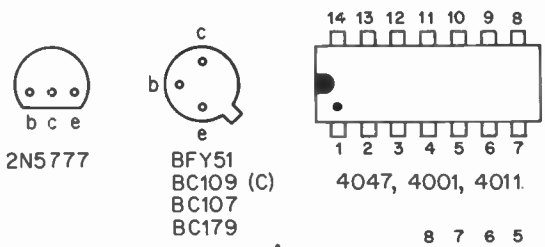

Fig. 45. The leadout details of the semiconductor devices used in the projects described in this book.

## *Notes*



Please note overleaf is a list of other titles that are available in our range of Radio and Electronic Books.

These should be available from all good Booksellers, Radio Component Dealers and Mail Order Companies.

However, should you experience difficulty in obtaining any title in your area, then please write directly to the publisher enclosing payment to cover the cost of the book plus adequate postage.

BERNARD BABANI (publishing) LTD  
THE GRAMPIANS  
SHEPHERDS BUSH ROAD  
LONDON W6 7NF  
ENGLAND

205	First Book of Hi-Fi Loudspeaker Enclosures	95p
221	28 Tested Transistor Projects	1.25p
222	Solid State Short Wave Receivers for Beginners	1.25p
223	50 Projects Using IC CA3130	1.25p
224	50 CMOS IC Projects	1.25p
225	A Practical Introduction to Digital IC's	1.25p
226	How to Build Advanced Short Wave Receivers	1.95p
227	Beginners Guide to Building Electronic Projects	1.50p
228	Essential Theory for the Electronics Hobbyist	1.25p
RCC	Resistor Colour Code Disc	20p
BP1	First Book of Transistor Equivalents and Substitutes	1.50p
BP6	Engineers and Machinists Reference Tables	75p
BP7	Radio and Electronic Colour Codes and Data Chart	40p
BP14	Second Book of Transistor Equivalents and Substitutes	1.75p
BP24	52 Projects Using IC741	1.25p
BP27	Chart of Radio Electronic Semiconductor and Logic Symbols	50p
BP32	How to Build Your Own Metal and Treasure Locators	1.95p
BP33	Electronic Calculator Users Handbook	1.50p
BP34	Practical Repair and Renovation of Colour TVs	1.25p
BP35	Handbook of IC Audio Pre-amplifier & Power Amplifier Construction	1.95p
BP36	50 Circuits Using Germanium, Silicon and Zener Diodes	1.50p
BP37	50 Projects Using Relays, SCR's and TRIACs	1.95p
BP39	50 (FET) Field Effect Transistor Projects	1.75p
BP40	Digital IC Equivalents and Pin Connections	2.95p
BP41	Linear IC Equivalents and Pin Connections	2.95p
BP42	50 Simple L.E.D. Circuits	1.50p
BP43	How to Make Walkie-Talkies	1.95p
BP44	IC555 Projects	1.95p
BP45	Projects in Opto-Electronics	1.95p
BP46	Radio Circuits Using IC's	1.35p
BP47	Mobile Discotheque Handbook	1.35p
BP48	Electronic Projects for Beginners	1.95p
BP49	Popular Electronic Projects	1.45p
BP50	IC LM3900 Projects	1.35p
BP51	Electronic Music and Creative Tape Recording	1.95p
BP52	Long Distance Television Reception (TV-DX) for the Enthusiast	1.95p
BP53	Practical Electronic Calculations and Formulae	2.95p
BP55	Radio Stations Guide	1.75p
BP56	Electronic Security Devices	1.95p
BP57	How to Build Your Own Solid State Oscilloscope	1.95p
BP58	50 Circuits Using 7400 Series IC's	1.75p
BP59	Second Book of CMOS IC Projects	1.50p
BP60	Practical Construction of Pre-amps, Tone Controls, Filters & Attn	1.45p
BP61	Beginners Guide to Digital Techniques	95p
BP62	Elements of Electronics - Book 1	2.25p
BP63	Elements of Electronics - Book 2	2.25p
BP64	Elements of Electronics - Book 3	2.25p
BP65	Single IC Projects	1.50p
BP66	Beginners Guide to Microprocessors and Computing	1.75p
BP67	Counter Driver and Numeral Display Projects	1.75p
BP68	Choosing and Using Your Hi-Fi	1.65p
BP69	Electronic Games	1.75p
BP70	Transistor Radio Fault-Finding Chart	50p
BP71	Electronic Household Projects	1.75p
BP72	A Microprocessor Primer	1.75p
BP73	Remote Control Projects	1.95p
BP74	Electronic Music Projects	1.75p
BP75	Electronic Test Equipment Construction	1.75p
BP76	Power Supply Projects	1.75p
BP77	Elements of Electronics - Book 4	2.95p
BP78	Practical Computer Experiments	1.75p
BP79	Radio Control for Beginners	1.75p
BP80	Popular Electronic Circuits - Book 1	1.95p
BP81	Electronic Synthesiser Projects	1.75p
BP82	Electronic Projects Using Solar-Cells	1.95p
BP83	VMSD Projects	1.95p
BP84	Digital IC Projects	1.95p
BP85	International Transistor Equivalents Guide	2.95p
BP86	An Introduction to Basic Programming Techniques	1.95p
BP87	Simple L.E.D. Circuits - Book 2	1.35p
BP88	How to Use Dp-Amps	2.25p
BP89	Elements of Electronics - Book 5	2.95p
BP90	Audio Projects	1.95p
BP91	An Introduction to Radio DX-ing	1.95p
BP92	Electronics Simplified - Crystal Set Construction	1.75p
BP93	Electronic Timer Projects	1.95p
BP94	Electronic Projects for Cars and Boats	1.95p
BP95	Model Railway Projects	1.95p
BP96	C B Projects	1.95p
BP97	IC Projects for Beginners	1.95p
BP98	Popular Electronic Circuits - Book 2	2.25p
BP99	Mini-Matrix Board Projects	1.95p
BP100	An Introduction to Video	1.95p
BP101	How to Identify Unmarked IC's	65p
BP102	The 6809 Companion	1.95p
BP103	Multi-Circuit Board Projects	1.95p
BP104	Electronic Science Projects	2.25p
BP105	Aerial Projects	1.95p
BP106	Modern Op-Amp Projects	1.95p
BP107	30 Solderless Breadboard Projects - Book 1	1.95p
BP108	International Diode Equivalents Guide	2.25p
BP109	The Art of Programming the 1K ZX81	1.95p



**BERNARD BABANI BP45**

---

# Projects in Opto-Electronics

- Any electronic or electrical device that responds to light may be considered to come under the heading of Opto-Electronic devices.
  - Although many people tend to take Opto-Electronic devices and circuits for granted, it is hoped that this book will show even the most experienced reader that they can be used in a surprisingly wide range of applications.
  - The purpose of this book is to describe a number of projects which may be of interest to all electronics enthusiasts. Included are simple circuits using ordinary light-emitting diodes (L.E.D.s) as well as more sophisticated designs such as Infra Red Transmitters and Detectors, Modulated Light Transmission and also Photographic projects etc.
  - Also available BP194: MODERN OPTO DEVICE PROJECTS.
- 

