



85p

**TWO
TRANSISTOR
ELECTRONIC
PROJECTS**

BY

F. G. RAYER, T.Eng.(CEI), Assoc.IERE

R

Includes 28 Practical Designs

le Historie v/d Radic

BABANI PRESS

No.30

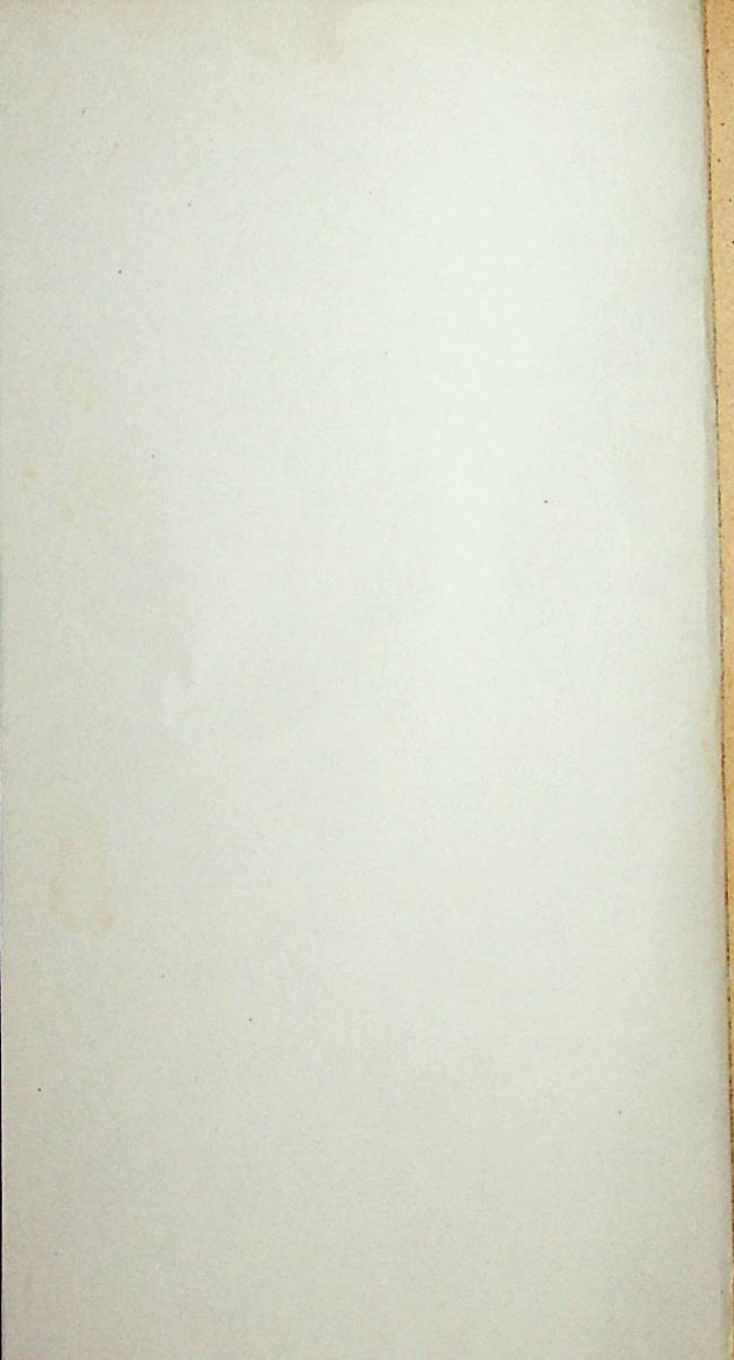

BIBLIOTHEEK
N.V.H.R.

TWO
TRANSISTOR
ELECTRONIC
PROJECTS

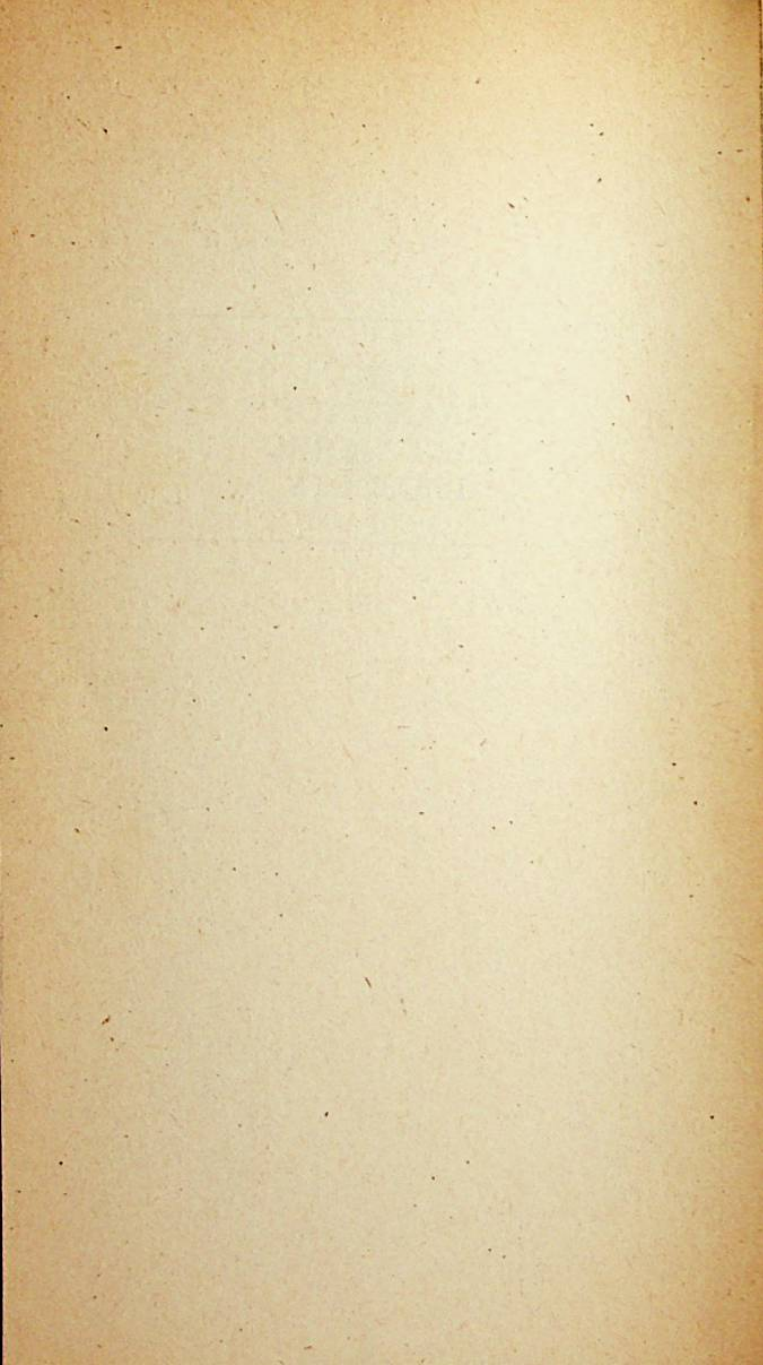

BIBLIOTHEEK
N.V.H.R.

TWO
TRANSISTOR
ELECTRONIC
PROJECTS

by

F. G. RAYER, T. Eng.(CEI), Assoc. IERE

BABANI PRESS

The Publishing Division of
Babani Trading and Finance Co. Limited
The Grampians
Shepherds Bush Road,
London W6 7NF
England

Although every care is taken with the preparation of this book the publishers or author will not be responsible for any errors that might occur.

© 1976 BABANI PRESS

L. S. B. N. 0 85934 033 3

First Published - May 1976

Printed and Manufactured in Great Britain by
C. Nicholls & Co Limited

CONTENTS

PART 1

Multivibrator Circuits	8
NPN/PNP Transistor Polarity	8
Code Practice Set	13
Door Tone Unit	15
Door Siren	16
Audio Trouble Shooter	18
Model Mini-Flasher	23
Double Blinker	24
Polarity Protector	25
Bridge	26
Metronome	30
Minano	32

PART 2

Values and Tolerances	35
Alternatives and Ratings	35
Controller for Models	37
Variable Power Supply	38
Priority Indicator	42
Lie Detectors	44
Automatic Light	48
Touchlight	52
Handy Intercom	54

PART 3

VHF Generator	58
10.7MHz Generator	61
Megahertz Marker	63
HF Bands Amplifier	66
Superhet Tuner	69
TRF Tuner / Receiver	75
Push - Pull Amplifier	78
Dual-Boost Mixer	80
Audio Pre-Amplifier	82
Impedance Buffer	84
2-Transistor AF Amplifiers	86
Equivalent Semiconductors	89

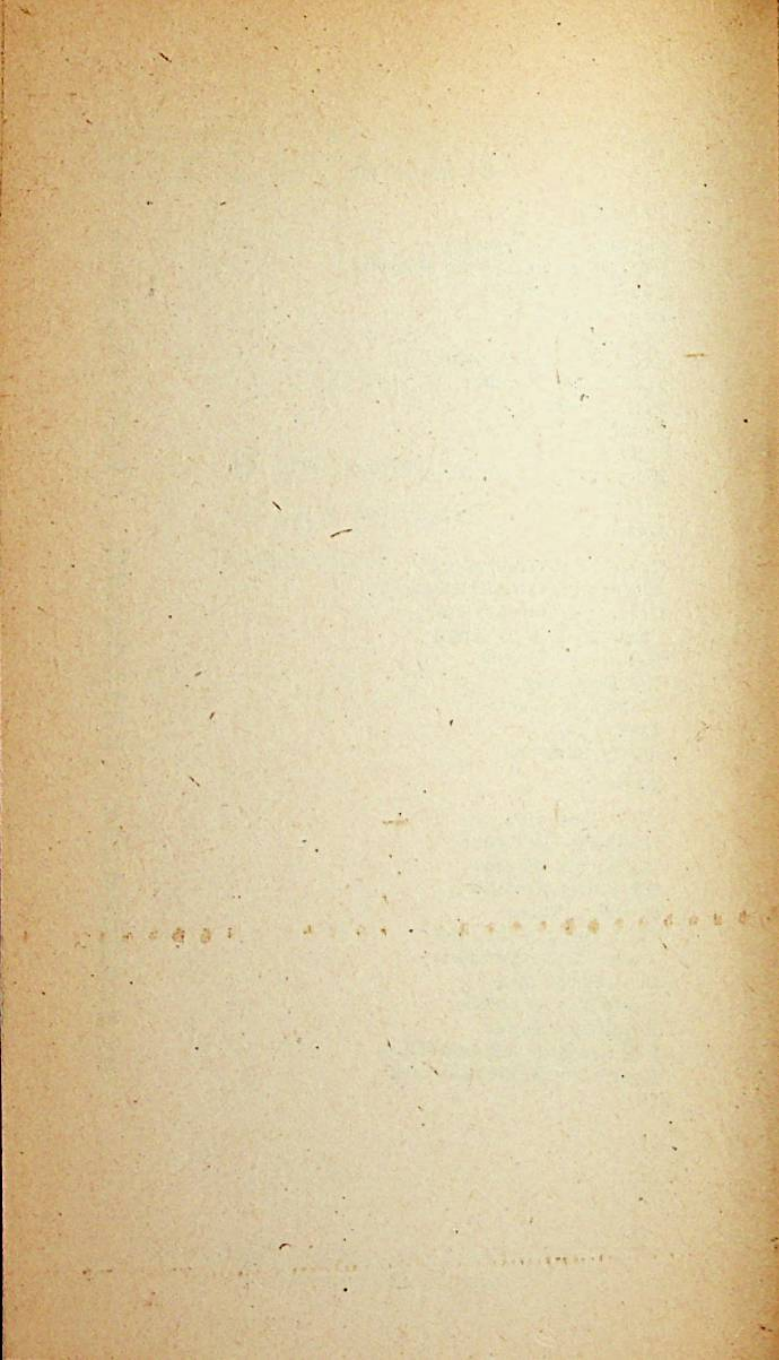

A wide range of projects can be constructed using only two transistors, and this book contains a selection of useful and interesting devices. Some are self-contained, for use alone, while others are intended to operate in conjunction with other equipment. All will be found straightforward to make, and in some cases there is considerable latitude in component values.

For The Beginner

All the items described are by no means for the beginner, but as an aid to the constructor who is just starting to learn about radio and electronics, the first item is covered in full detail. This will prove of aid in translating a theoretical circuit into terms of actual components, and will also illustrate various methods of assembling small units of this type. In addition, the particular device described — a multivibrator — can later be employed in various forms, for a test probe, musical tone generator, capacitance bridge, code oscillator, and other devices, with component values adjusted to suit, where necessary.

The ways in which tag strips or tagboards, perforated boards, and printed circuit boards can be used will be of assistance when making up later circuits.

Also, in view of the large numbers of alternative transistors available, the beginner will need to remember the basic difference between NPN and PNP transistors, if he intends to substitute one for the other in any circuit.

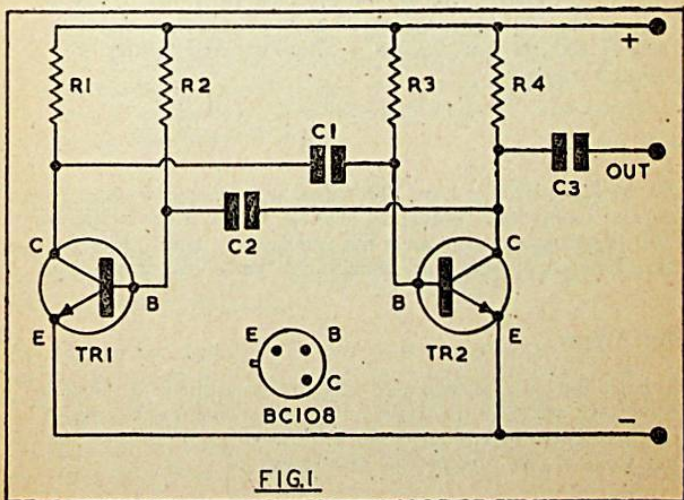

Multivibrator Circuit

Fig. 1 is the circuit of a basic multivibrator which in one form or another finds application in numerous items of equipment. The output available from TR1 collector C is coupled to TR2 base by C1, while TR2 collector is coupled to TR1 base by C2. R1 and R2 provide collector and base currents for TR1, while R3 and R4 supply base and collector currents for TR2.

TR1 and TR2 conduct alternatively, and with this cross-coupling arrangement the circuit is not stable in either condition, and so continues to run freely. Each transistor in turn drives the other into conduction, and is then cut off. The frequency at which this happens is determined by the resistance/capacitance time constant of the coupling – that is, by the values of the resistors, and C2 and C1.

By a suitable choice of values, the frequency can be arranged to be anything from a few beats a second (or lower) up to many kilohertz. The circuit can thus be used in flashing and timing devices, as well as tone generators and audio oscillators.

C3 is a coupling capacitor, to take the output to later circuits. These may consist of a test prod, headphones, an amplifier, or even a loud-speaker, according to the actual equipment in which the multivibrator is used.

Circuits similar to Fig. 1 may operate from a very low voltage, such as a single 1.5V dry cell, and draw a very small current of only a few milliamperes. Or voltage and values can be arranged so that high collector currents flow, for greater output or direct lighting of indicator lamps.

NPN Polarity

The transistors in Fig. 1 are NPN types, and the emitters have a negative supply line. Though BC108s are shown, many alternative NPN transistors can be used in this and similar circuits. Provided substitutes are of NPN type, the negative "earth" line is retained.

PNP Polarity

In order that no confusion need arise, the same circuit is shown in Fig. 2, but with PNP transistors. The emitter line is now positive. Again, a typical type of transistor is indicated (AC128) but other transistors of PNP type may be substituted.

It is quite often possible to make use of transistors already to hand, by substituting other types than those shown. But it is essential to

remember, when doing this, that the emitter line must be negative for the NPN types, but reversed for the PNP types, as in Figs. 1 and 2.

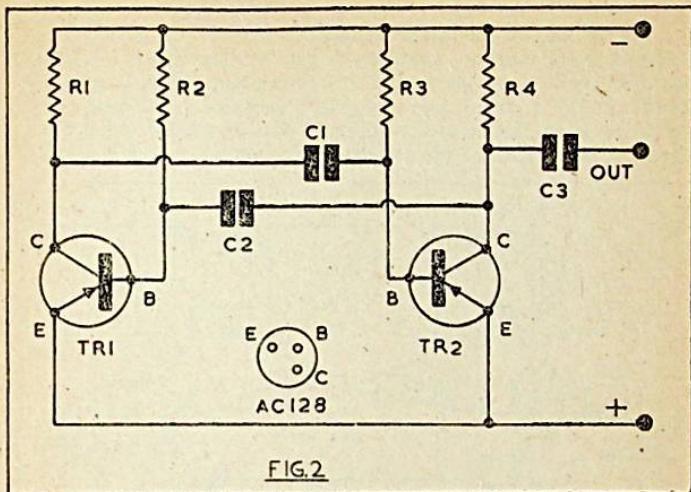

If a battery is connected in the wrong polarity to a circuit such as that in Fig. 1 or Fig. 2, no damage may arise if transistor currents are limited to safe values by the resistors R1 to R4. But in many cases this will not be so, and then immediate destruction of the transistors is likely.

It is recommended that a black flexible lead is used for negative, and a red lead for positive, with all circuits, and that these are fitted with the correct battery clips (rather than croc clips or other interchangeable means of connection). This will avoid difficulty or damage from a mistake in connecting the supply.

Tagboard Assembly

The way in which this or other circuits is assembled may depend on the space available for it, or on personal choice, or even on what materials are available.

Fig. 3 shows the circuit in Fig. 1 wired on a tagboard which here has two rows, each with four tags. This is very convenient when small size is not essential, and for experimental purposes, as components can be easily changed. If Fig. 1 is compared with Fig. 3, it will be clear how the theoretical circuit (Fig. 1) has been wired in practical form (Fig. 3).

Tagboards and tagstrips are available in many sizes, and will be found of great use in numerous circuits given later. Long strips or boards can be cut down with a hacksaw or other small-toothed saw. Tagstrips usually have some longer tags, shaped as brackets, and these are suitable for mounting the wired unit. But if it is to be fixed to a metal panel or chassis, note that the mounting tags will have to be used to provide an electrical return here. With boards like that in Fig. 3, one or two screws or bolts through the insulated part of the board can be used, with extra nuts or washers under the board, to raise it clear of the chassis or panel on which it is fixed.

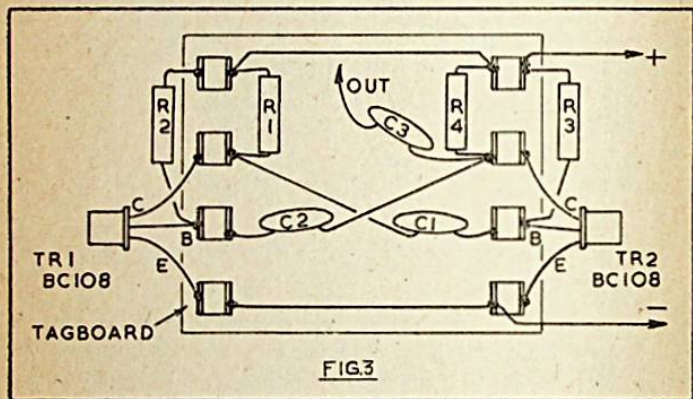

Perforated Boards

Ready perforated insulated boards can be obtained in many sizes, or smaller pieces are readily sawn from a larger board. The boards generally used have holes in a 0.1 in or 0.15 in matrix. The 0.1 in matrix allows smaller assemblies, but the 0.15 in matrix is probably better when space is not important, as it allows a little more between connections.

Fig. 4 shows the circuit in Fig. 1 assembled on a piece of perforated board. Fig. 4 is the top of the board, carrying the components only. The board is then turned over, and the connections shown in broken lines are added. In many places the wire ends of components can be used for connections. Elsewhere, use 22 or 24 swg tinned copper wire, snipping off the excess length of resistor and other leads. Connections can often be placed so that no insulation is necessary. But if leads may touch each other, or a metal chassis, slip on 1 mm or small sleeving, to avoid contact.

The board is mounted with screws or bolts with spacers or extra nuts. Flying leads can be soldered on for positive, negative, and output. Or pins may be pushed into the holes here, or short projecting wires can be arranged, so that external connections can be soldered on. If pins are used, obtain these for the type of board employed, or they may

not fit satisfactorily. They are best put in with a pin-insertion tool – this allows a pin to be held and pushed in to the correct depth.

Another type of perforated board has foil conductors running along the rows of holes. It is then necessary to arrange components to make use of these, and to remove the foil with a drill or spot face cutter where a connection is *not* required.

Printed Circuits

These can be used for the experience and interest they provide, or as a means of making up several copies of the same unit. Fig. 5 is the foil side of a printed circuit board also suitable for the multivibrator. Components all go on the other side of the board. Component positions are not shown, because they are the same as in Fig. 4. It will be seen that the foils provide connections which replace the wires in Fig. 4.

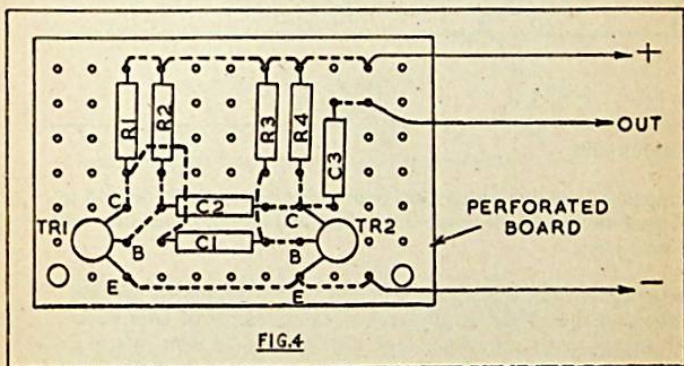

Printed circuits are made on copper clad board. The foil is protected where conductors are needed, by paint or varnish, and the board is immersed in a solution which dissolves the remaining copper. After washing, the board is drilled for component leads.

The easiest method to start is probably to obtain one of the printed circuit board etching kits which are available, as this will contain all the necessary items.

The foils can be marked with an etch-resist pen, which is used in a similar way to a felt-tip pen, to cover over all those areas of copper to be left intact. The usual etching solution is ferric chloride. This should be stored and mixed as directed in the instructions provided with such kits. The board may have to be left in the solution for up to half an hour or so, or until all the unwanted copper has gone. It is then washed in running water, dried, and drilled.

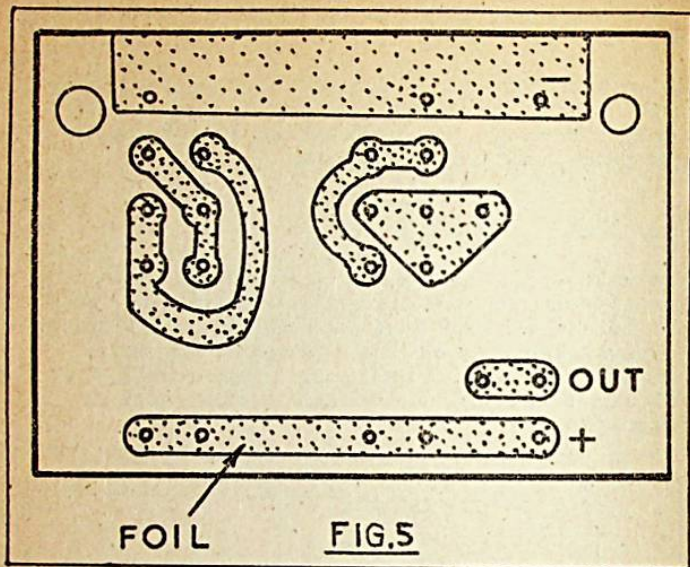

Later Circuits

Component values have not yet been indicated, as these depend on the purpose for which the multivibrator will be used, and they will be seen later.

The actual way in which such a circuit can be assembled has also been covered in detail, as guidance to the assembly of later circuits. This means that these details need not be repeated later, where units can be wired from the theoretical circuit only, or from a suggested layout and wiring plan.

Cases

Though suitable cases are indicated for some units, it will be clear that there is room for considerable choice here. With some units (such as a tuner with internal ferrite rod) an insulated box is necessary, but it is often possible to make use of ready-made metal or plastic boxes, or to fabricate a suitable box from thin wood. Occasionally a metal case is necessary for screening, but details are given when any particular type of cabinet or box is required.

Code Practice Set

It is only necessary to connect phones, Morse key, and battery to the multivibrator, to provide a code practice set which will be of great use to enthusiastic short wave listeners, and those who are intent upon eventually having a transmitting licence.

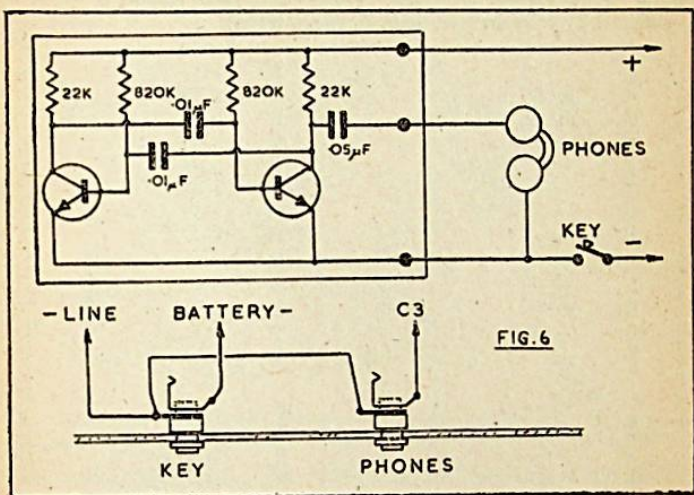

Fig. 6 is the complete circuit. For convenience, the multivibrator and battery are fitted in a box carrying two jack sockets. These are wired as shown, to take plugs for the key and phones. The type of high or medium impedance headset used for SW listening will do very well, but any phones can be employed, including crystal earpieces. An on-off switch is not necessary as current is only drawn when the key is down.

Values for Code Practice Set:

R1	22k
R2	820k
R3	820k
R4	22k (all $\frac{1}{4}$ w 5% or 10%)
C1	0.01uF
C2	0.01uF
C3	0.05uF
TR1	BC108
TR2	BC108

As it is scarcely possible to get started on learning the code without a copy of it, this follows. In length, a - is equal to three •s, while a space of three •s is left between letters of a word, and a space of five •s between words. The space between the -s and •s forming a letter equal one • and during early practice it is best to form each letter rapidly, but to leave longer spaces between letters. The "sound" of letters is then similar to that heard when keying is speeded up by reducing the delay between letters.

A.	•-	N	-•
B	-•••	O	----
C	-•-•	P	•-••
D	-••	Q	---•-
E	•	R	•-•
F	••-•	S	•••
G	---•	T	-
H	••••	U	••-
I	••	V	•••-
J	•---	W	•-•
K	-•-	X	-••-
L	•-••	Y	-•-•-
M	--	Z	---••
1	•-----	6	-••••
2	••-----	7	-----••
3	•••-----	8	-----•••
4	••••-----	9	-----•-•
5	•••••	0	-----

More Multivibrator Projects

The frequency and power output of the multivibrator can be adjusted between wide limits, by selecting suitable component values, and by modifications to the transistors and operating voltage. So almost similar circuits can be used in quite a wide range of projects where some form of tone generator or audio oscillator is needed.

With the multivibrator circuits which follows, it may not be necessary to employ the particular transistors, or exact component values shown. Generally, some change to the frequency or output will not be very important. This means that it would often be possible to use transistors or other items to hand. When this is done, and results prove to be satisfactory, there is no point in changing to the transistors or exact values indicated. On the other hand, if a circuit modified in this way does not operate, or is unsatisfactory then it is likely that the transistors actually fitted are not a sufficiently near type or equivalent to those shown, or that some other values have been changed too radically.

Door Tone Unit

This will replace a door buzzer or electric bell. It runs from a low voltage, direct current supply. This is most conveniently obtained from a battery, which will have a long life, since the current drawn is small, and intermittent.

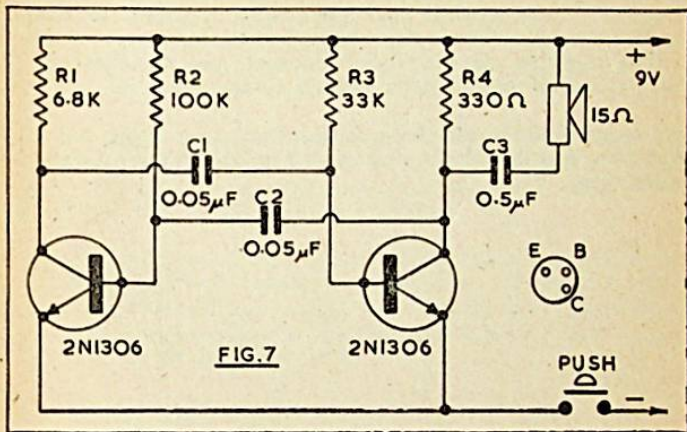

FIG. 7

Fig. 7 shows the circuit. The collector of one transistor of the multi-vibrator is coupled to the speaker by C3. A 15 ohm unit is not essential here, though a very low, or very high, impedance speaker will cause some reduction in volume. A $3\frac{1}{2}$ in diameter or similar small unit will allow the whole device to be housed in a small case, which will also take the 9V battery. If this is to be made of $\frac{1}{4}$ in thick wood, front and back can both be 4×5 in. The sides may then be 5×2 in, with $3\frac{1}{2} \times 2$ in pieces for top and bottom. Joining edges should be sanded smooth, and dust brushed off so that they may be cemented together with a woodworking adhesive. If necessary, the edges and joints can be sanded after the adhesive is hard, and the case may be painted, varnished, or covered with material as used for kitchen shelves and similar purposes. The back should be fixed with screws only, so that the battery can be replaced.

A larger speaker will of course be in order, if to hand, and the case can be increased in size to accommodate it. A larger speaker can be expected to provide some increase in volume, compared with a unit having only a small cone.

The device is probably best hung out of the way fairly high on a wall, but it can be free-standing. In some circumstances, a free-standing unit, with a length of thin twin flex and a push of the type used with flexible cords, will be handy for the use of anyone temporarily confined to bed, or for similar purposes. Modern ready-made cases which

will house the speaker, oscillator board and battery, can be obtained, and will not be out of place in a living room.

For ordinary use, run twin bell wire connections from the transistor emitters and battery negative. Because of the low current thin bell wire is suitable, even with long runs of wiring. Wire can be obtained in various colours, to match decorations, and it is usually fixed with insulated staples. It can be fitted neatly and inconspicuously along skirting or picture rails, and around doorways, using the easiest and most convenient route from the tone unit to the bell push.

Bell wiring should be completely isolated from mains wiring, and should not pass through the same conduit or other fittings as does mains wiring.

Door Siren

The circuit in Fig. 8 has similar uses, but it can be arranged to give a more powerful and penetrating sound. It can also be easily adapted to give distinguishing tones for two or more pushes.

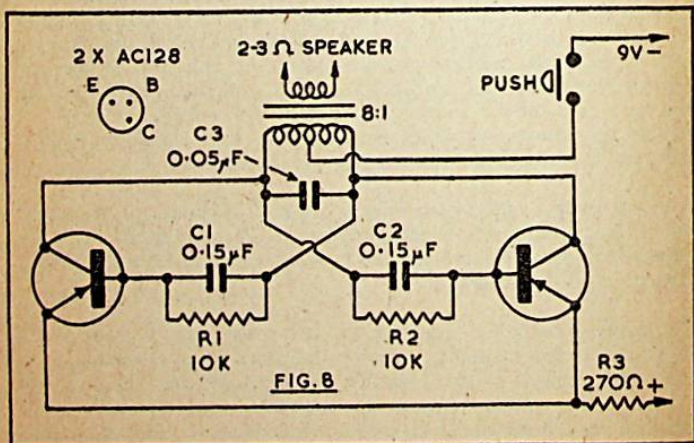

The primary of the transformer provides the collector load, and each transistor drives the base circuit of the other, via the capacitors and parallel resistors C1/R1 and C2/R2.

A transformer as used for loudspeaker coupling in the push-pull output stages of receivers and amplifiers is required. Preferably it is of non-midget type. The ratio is likely to be around 8:1, but this is not essential. However, the transformer and loudspeaker have considerable influence on the volume and tone obtained. It is better to use a ratio higher than 8:1, or an 8 ohm speaker, rather than modifying the circuit by using a transformer of lower ratio, with a 2 ohm speaker.

The tone may be changed by modifying the value of C3. Larger values lower the pitch. R1 and R2, and the capacitors C1 and C2, may also be the subject of experiment. If a quite large speaker is used, it is possible to obtain considerable sound output.

A case or baffle is required. The baffle is a plain board, with an aperture of suitable diameter to match the speaker cone. The board should be at least 10 x 12 in and may well be larger. If hung in the corner of a room it can be of such a width that the speaker is accommodated in the space behind it. A PP9 battery is suitable.

Double Doors

The tone is also changed if the value of R3 is altered. So it is only necessary to use an alternative value for R3 in series with a second push, to obtain two distinctive tones. This is handy when two doors are in regular use as it indicates where a caller is to be found, and it may also be convenient in other circumstances.

The bell-push, battery, and R3 are in series, and it makes no difference to operation whether the push is in the negative lead as in Fig. 8, or in the positive circuit to R3. The second resistor can be 470 ohm, or can be found by experiment. If the runs of wiring to the pushes are completely separate, the additional resistor can be fitted in the unit itself. But if the circuit runs to one push, then on to the other, wiring will be simplified by placing the additional resistor at the second push, in a recess unit it.

Three or more tones may be obtained by fitting three resistors of different value. A simple way to find suitable values here is to connect a 2 k wire-wound potentiometer or variable resistor. Adjust this to a suitable tone, measure its value with a meter, and fit a fixed resistor of this value.

Audio Trouble Shooter

Quick tests of audio circuits can be made with an audio oscillator, and signal generators have an audio output, which is often used for this purpose. It is possible to check speakers and their connections, individual stages of an amplifier, or the audio stages of a receiver, or other equipment of similar type, by this means.

It will be found convenient to have a prod or probe which itself contains an audio oscillator, for tests of this kind, and the circuit in Fig. 9 is suitable for this purpose. It operates from a small single dry cell, so that all the components can be fitted in a cylindrical case.

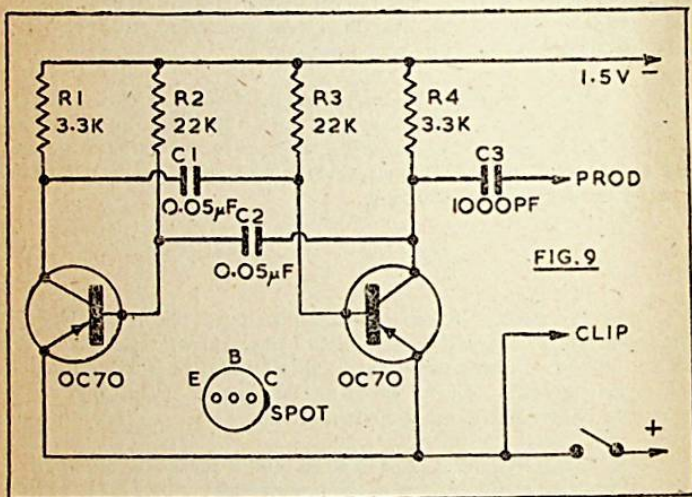
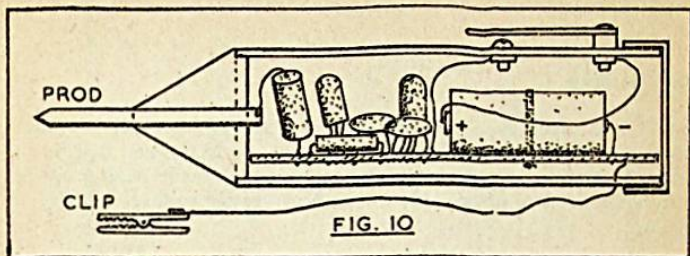

FIG. 9

The resistors may of course be small, fractional-watt components, and C1 and C2 may be low-voltage capacitors. If only low-voltage transistor equipment will be tested, C3 may also be of low voltage (say 15V). But if valve equipment, or equipment having higher potentials will be tested, C3 must be chosen to suit, and be of adequate voltage rating. A 500V capacitor will usually be suitable for all but high-power circuits such as large amplifiers and modulators.

The case can be made from paxolin tube, or can be an insulated plastic container such as is used for some small household items. The conical end can be made from wood, and the prod is a screwed rod, held with nuts, or is any convenient metal point fitting tightly in the central hole.

Components are assembled on a small insulated board, which fits as in Fig. 10. The dry cell can be held with elastic or string, and the battery will have a very long life, as current drain is under 1 mA. The bottom of the cell, or zinc case, is negative.



A flexible lead fitted with a clip forms the earth return connection. Test the oscillator before fitting it in the tube, either by touching the prod on an audio circuit, or by connecting headphones from prod to clip.

The case "switch" is devised from a metal strip and screws, and the oscillator is automatically switched off when this is released. Note that leads must be long enough to allow the connections to be made before the board is fitted from the conical end of the tube, together with the cone and prod.

Testing

There is naturally no danger of shocks when testing low voltage, battery operated equipment. Many receivers and amplifiers of popular type run from an internal 9V or similar battery, and this low voltage is harmless.

Other equipment, which is designed for battery/mains use, will have a power supply which provides a low voltage to replace the battery. If this supply is in proper order and correctly connected, there should be no danger of mains voltages at the receiver or amplifier circuits, though they will be found at the primary side of the isolating transformer.

With mains-operated valve equipment, high tension potentials will be present. These may be from about 200V or so for small receivers and amplifiers, up to 450V or more for large equipment. Accidental or careless contact with these circuits is very dangerous.

Greatest care of all is necessary with mains equipment in which HT and other voltages are obtained directly from the mains, with no isolating transformer. The chassis, and any metal parts, may be "alive" and dangerous to touch.

The service engineer or advanced constructor will, of course, be aware of the ways in which shocks may arise, and will work in the correct way to avoid them. Otherwise, tests should only be made on low-voltage, battery operated equipment, where no danger of shocks is present.

Stage by Stage

Fig. 11 is a typical amplifier. TR1 is the pre-amplifier stage, TR2 the driver, and TR3/4 the push-pull output stage. It is assumed that no output is obtained, and that a meter test has been made from positive to negative lines, to assure that a suitable operating voltage is in fact available.

Tests are made by working backwards from the loudspeaker. A few quick tests might take in a whole stage at a time. As example, if the clip is attached to the positive line, and the prod applied to point A, the amplified tone should be heard in the speaker. If so, this proves that the output stage is operating. But if no tone is heard, investigations can be confined to the output stage.

Assume the tone is heard with the prod at A. It can then be moved to B, to take in TR2. If the tone now ceases, this stage is not working. Remember to work systematically backwards from the speaker. When the point where the fault arises is passed, signals cease to be heard from the speaker.

Where necessary, test points can be much closer together, to help localise the fault. As example, if the tone is heard with the prod on the base lead B of TR2, the prod can be moved to the foil C, and along the foil to D. If the tone is heard at C, but not at D, the foil is probably cracked here. In the same way, the prod can be touched on the actual capacitor lead at C3, to assure there is not a dry joint, and on to the other side of the capacitor at E and then on to F, to test the capacitor and conductor from E to F.

Further tests would be G, H, I and J, taking in TR1, C1, and the volume control, and connections to it.

If amplified signals were heard with the prod at A, individual tests of T2, the speaker, or connections to it, etc., would not be necessary. Otherwise, tests proceed in a similar manner to those already described. With the prod and clip taken directly to the speaker, sound output will be extremely low, as there is no amplification, but if necessary it is an easy matter to test the actual speaker leads, then contact at the sockets S, and foil or other conductors to the secondary of T2. T2 may be checked, if necessary, by taking the prod and clip to its primary. A further test point would be base of TR3 and TR4.

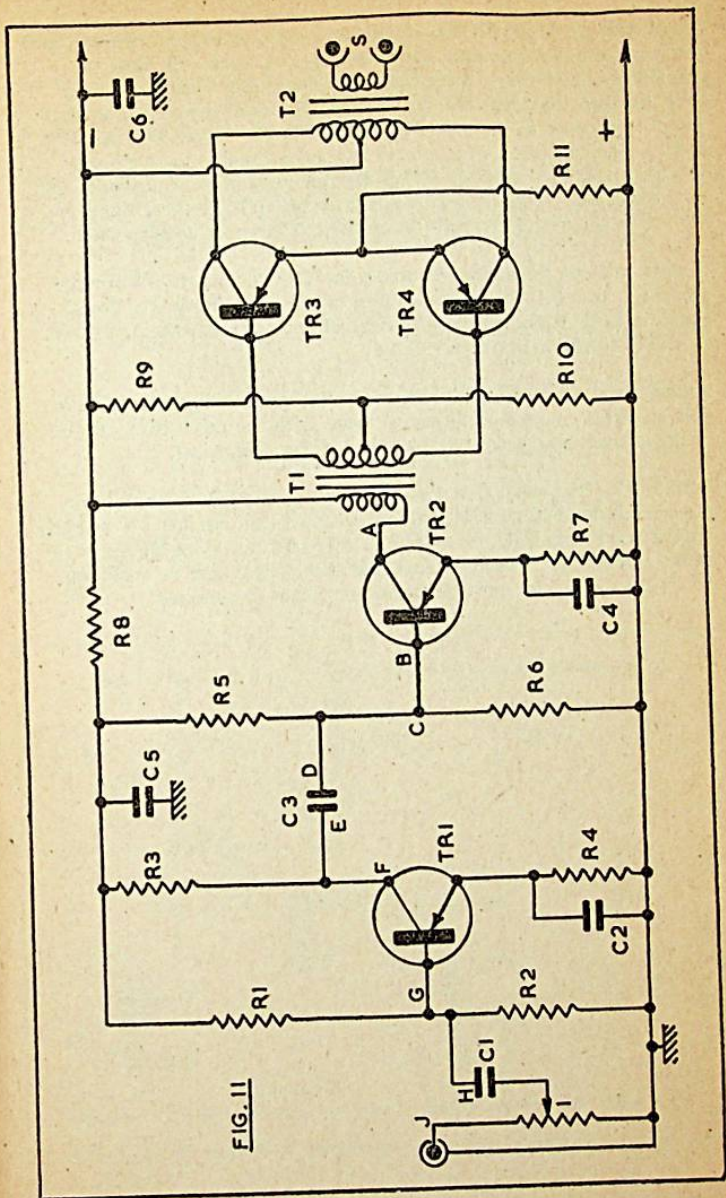

FIG. 11

These tests may indicate the exact fault — for example, a broken foil, bad joint, or open-circuited capacitor. If not, they will show the actual stage which is at fault, and individual component and other tests are then made for that stage only. Suppose signals are heard with the prod at A, but not with it touching B. Stage TR2 is not functioning, and the actual reason has to be found. Lack of base voltage might be caused by R5 or R8 open-circuited or disconnected, or C5 shorted. A meter would similarly test R7. If these items and R6 are in order and correctly connected, TR2 must be suspected.

Similar individual tests can be made for TR1, if this stage were not working. In brief, the faulty section of the amplifier is first found by audio tests as explained, then individual tests of components etc. are confined to the faulty section only.

Audio leads can be similarly checked, with their connectors. If a high-gain amplifier, or pre-amplifier, is tested with the prod, turn gain down, to avoid overloading the output stage of the equipment.

With a valve amplifier, first tests could be at the grid of the output stage (or individual control grids with a push-pull circuit). If an audio output were obtained, this would be followed by taking the prod to earlier circuits. It should be repeated that proper care to avoid any possibility of shocks must be taken, as already mentioned.

Model Mini-Flasher

The versatile multivibrator can be adjusted so that it runs at a very low rate, and collector current is sufficient to light a lamp. One application of this type of circuit is shown in Fig. 12.

The purpose of this device is to replace a mechanical switch in a toy lighthouse, car, signal, or for any similar position where a regularly flashing light is wanted. By using a 6V 0.1A or 0.06A bulb, current consumption is kept low. Such bulbs are used for dial lights, and other purposes.

C1 and C2 are of very large value, giving a periodicity of about 1 second on and 1 second off. The circuit will operate from 3V to 6V but with a 6V bulb 5V or 6V will be required for good brilliance. The operating current may well be obtained from a battery already used to drive a motor or other items.

Overall current drain of this circuit is less than with that of a similar bulb burning continuously, so it can also find uses in various indicator circuits where low battery drain is required. Small bulbs which are suitable include 3.5V 0.15A, 6V, 0.1A, 0.06A and 0.04A, 12V 0.1A, and 6V 70mA types. The choice may depend on the available operating voltage.

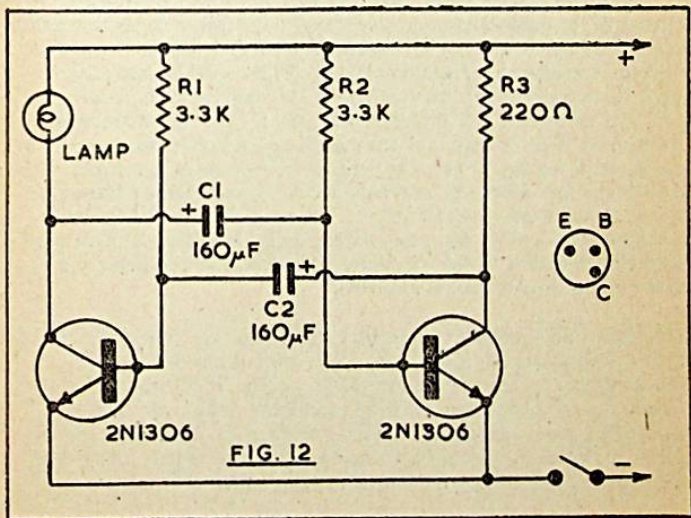

Double Blinker

This circuit may be scaled up to operate a pair of 12 volt 6 watt lamps, and is then forms a useful "accident" device to place near a halted car at night. One application would be to warn oncoming drivers when changing a wheel.

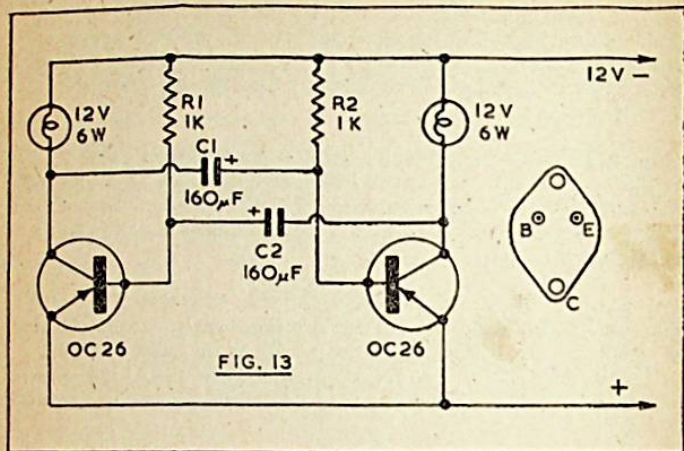

The circuit for this device is shown in Fig. 13. Here, two OC26 transistors are used, but other types may be substituted, provided they are able to handle the current required. With 12V 6W lamps, the collector currents are around $\frac{1}{2}$ ampere. This would be reduced to about $\frac{1}{4}$ ampere (or 250mA) with 12V 3W lamps. Car-type lamps, with holders to suit, will be most convenient. The lamps are most conspicuous if placed about 1 ft or more apart, either side by side, or one above the other. The most convenient method of construction is to fit the lampholders and multivibrator to a board with a hinged leg so that it can stand almost vertical. The multivibrator should be in a metal or other protective case, with a twin flexible lead. This may have clips to attach to the car battery, or may have a suitable plug when an accessory socket is available.

With the OC26 transistors, the metal base forms the collector contact. In this application, additional heat sinks are not needed, so the transistors can be bolted to an insulated board. If they are fixed to a metal case or plate, they must be electrically insulated. This is arranged by having clearance holes for emitter and base pins, and by placing a thin mica washer between transistor and metal. Insulating bushes are also necessary on the two fixing bolts.

It is important to watch that the correct polarity is used, and the leads and clips should be clearly marked. Vehicles may have either a positive or negative chassis. If the polarity is not known, it can be seen by looking at the accumulator, or by using a meter to check polarity at an accessory socket.

Polarity Protector

The importance of using the correct polarity with a transistor circuit should not be overlooked. Where the equipment is run from a dry battery, and leads have non-reversible clips to suit the battery, no danger can arise. It is only necessary to take care to fit the clips to the leads properly in the beginning.

But on some occasions the polarity is less clear, or the chances of connecting the equipment wrongly are very real. An example of this is when using the Double Blinker, and attaching the clips to the accumulator.

With some transistor equipment, quite high values of resistors are present, and these will limit the current in the transistors to a low value, even if polarity is wrong. When this is so, no actual damage may arise to the equipment, unless there are electrolytic capacitors or other polarity-sensitive items.

However, with many circuits an exceedingly high current can flow if the polarity of the supply is wrong. This may destroy the transistors instantly. In this case, even a momentary contact with a supply of wrong polarity can badly damage a unit which was in perfect order.

For these reasons, some form of protection is worth while in circumstances where current will not be limited to a safe value in the event of a wrong connection being made. This is most easily arranged by placing a diode in one supply circuit, as in Fig. 14.

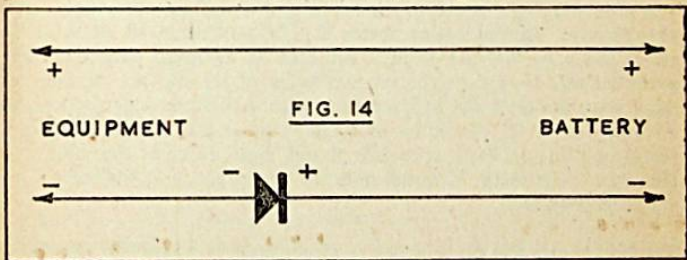

The diode conducts in one direction only, so it interrupts the supply when the polarity is wrong. When such a diode is fitted, wrong polarity simply means that the equipment does not work, and is corrected by reversing the supply connections. The diode must be of suitable voltage and current rating, and silicon power-rectifier diodes are suitable. A typical diode is the 1N4001, of 50V 1A rating, but other diodes are satisfactory. The diode should not introduce an unnecessarily high voltage drop when passing current in the wanted direction. If there is any doubt about its polarity, due to lack of information, connect it that way round which provides normal operation of the equipment, from a supply of known and correct polarity.

Bridge

A multivibrator provides a convenient unit for supplying the input to a measuring bridge, such as may be used to find the values of capacitors. With only a few extra components, a very handy bridge can be made, and it can be used to check the values of colour-coded capacitors, or those without markings.

Fig. 15 will clarify the way in which a bridge of this type is used, and is able to show the value of unknown components. First, the direct current bridge A may be considered, as its operation is very straightforward and easily understood.

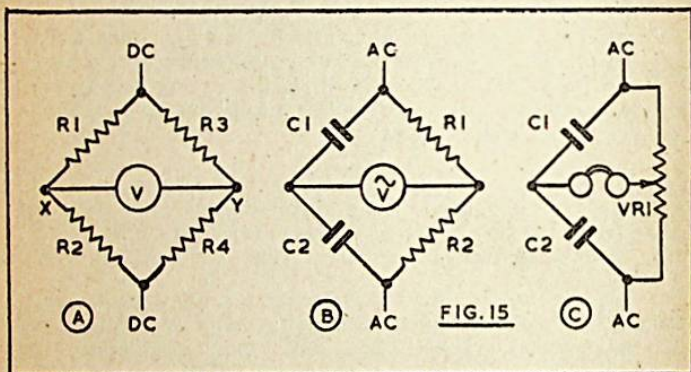

The points DC of the bridge are taken to a direct current supply, such as a battery. The indicating device in a DC voltmeter, V. R1 and R2 are in series, so that the point X will take up a certain potential. This potential will depend on the relative values of R1 and R2. In the same way, the potential at Y depends on the relative values of resistors R3 and R4. If R1 should be the same value as R3, and R2 also be the same value as R4, then points X and Y would be at the same potential. The meter V would indicate no voltage, and the bridge would be balanced.

The bridge can also be balanced in circumstances where the relationship between the values of R1 and R2 matches that between R3 and R4. This state of balance can be expressed in various ways one of which is as follows:

$$R2 = \frac{R4}{R3} \times R1 .$$

From this, if any three of the values R1, R2, R3 or R4 are known, the remaining value can be found.

The DC bridge can only work with resistors. It could be assumed that the value of R1 is not known, but it could be found if R2, R3 and R4 were known.

At B, an alternating current input is used, and the indicating instrument is suitable for this type of supply. C1 and C2 replace R1 and R2. The capacitors C1 and C2 have reactance, which falls as the capacitor value increases. (The capacitive reactance in Ohms of a capacitor = $1/2\pi fC$, where 2π may be taken as 3.14×2 or 6.28, f is frequency in Hertz, and C capacitance in farads.)

It is now possible to find the value of capacitor C1, for example, by varying C2, or (more conveniently) by changing the relative values of R1/R2.

At C, the AC input is an audio tone, and the detecting device is a pair of headphones. C1 may be the unknown capacitor, and C2 is of known value. Resistors R1 and R2 are the upper and lower sections of the potentiometer VR1. It is now possible to balance the bridge by rotating VR1 until the audio tone ceases to be heard. VR1 can be fitted with a scale, from which the value of C1 can be read.

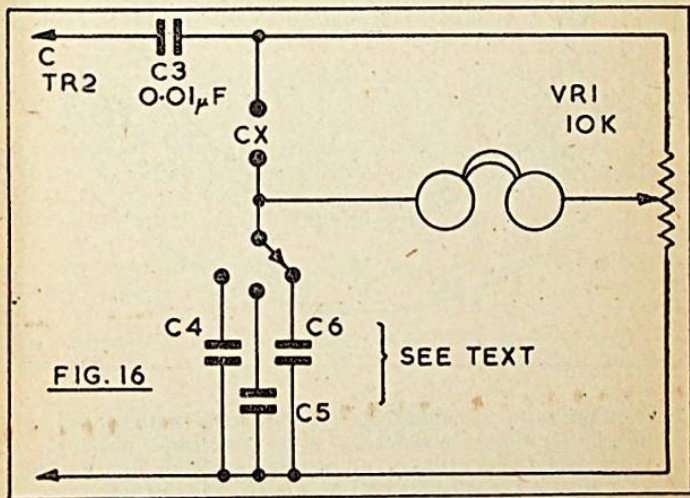
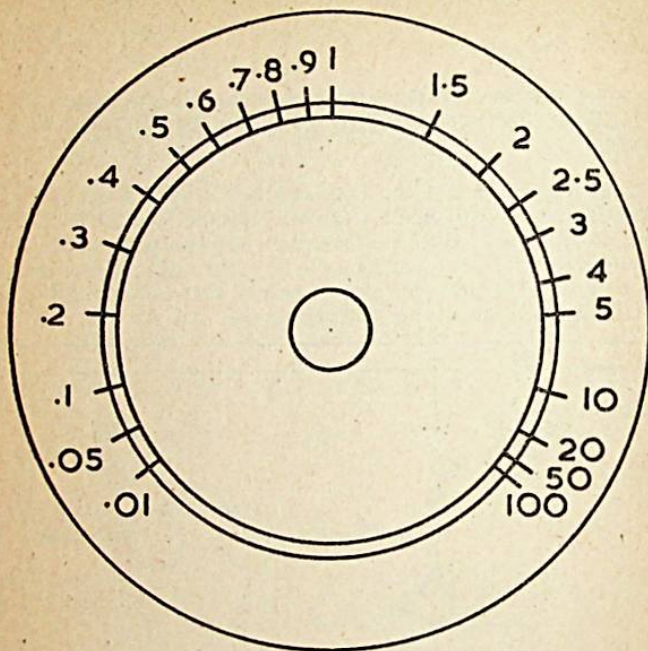

Fig. 16 is the practical bridge, receiving input from a multivibrator, one collector being connected to the coupling capacitor C3. A fairly strong, high tone is most suitable, as it will be best heard with low value capacitors. A suitable audio oscillator can employ the multivibrator circuit first shown, with 10k collector resistors, 100k base resistors, 0.01uF coupling capacitors, and a pair of OC71 transistors. Other circuits to supply a tone could of course be used.

VR1 must be a linear potentiometer. For ordinary use, which will consist in quick checks of capacitors whose values need not be critical, a precision potentiometer is not required. For these purposes, it is also in order to use the scale shown in Fig. 17.

FIG. 17



Values on this scale are multipliers. Thus the actual markings will be read directly for a range in which $1\mu\text{F}$ is the central scale marking. This range results from fitting a $1\mu\text{F}$ capacitor at C_4 , in Fig. 16. The unknown capacitor is placed at C_X . Values may then be read from $0.01\mu\text{F}$ up to $100\mu\text{F}$ by turning the control knob of VR_1 until the null is obtained, and reading from the scale.

Markings become crowded, especially at the extreme maximum values, and so it is best to provide several overlapping ranges. In Fig. 16, these are obtained by the 3-way switch. As example, if C_5 is $0.1\mu\text{F}$, then 1 on the scale is $0.1\mu\text{F}$, 2 is $0.2\mu\text{F}$, 5 is $0.5\mu\text{F}$, and so on. In the same way, 0.1 on the scale is one-tenth of $0.1\mu\text{F}$. That is, $0.01\mu\text{F}$. This will be clear, in use, if it is remembered that the scale markings are *multipliers*, except for that range which employs a $1\mu\text{F}$ capacitor, and has a reading of 1 in the mid-scale position.

C6 will provide a further range, for smaller values. The smallest internal capacitor recommended is 100pF. The bridge cannot be used successfully for very small capacitances (say under about 25pF) because the tone becomes very weak, and stray capacitances in the switch and wiring upset calibration.

When checking paper, mica and similar capacitors, a sharp null or silent point is obtained, unless the capacitor is leaky. Leaky capacitors, and electrolytic capacitors, do not give a complete null, but a point where the tone in the headphones falls in volume, but is still audible.

Best results will be obtained with a medium or high impedance headset (around 250 ohms to 4k). It is possible to use a single earpiece, but the tone, and correct setting for VR1, may be less easily heard.

The unit should be assembled with two terminals, to take the unknown capacitor CX. When the single scale is to be for all ranges, the capacitors C4, C5 and C6 should be of close tolerance. That is, 1 per-cent or 2 per-cent.

For the best possible accuracy, each range can be individually calibrated, and marked with actual values. A number of 1 per-cent capacitors will be required to do this. They are fitted at CX, and VR1 is adjusted, and the null point is marked. Additional markings can be obtained by using various combinations of capacitors in parallel and series. As example, two 0.1uF capacitors in series will equal 0.05uF, while if they are placed in parallel the value equals 0.2uF.

For two capacitors in parallel, merely add their values. So 1000pF and 500pF in parallel would be $1000 + 500 = 1500\text{pF}$.

When capacitors are placed in series, their overall value may be found from:

$$C = \frac{C1 \times C2}{C1 + C2}$$

With two 0.5uF capacitors, this would be $0.5 \times 0.5 / 0.5 + 0.5 = 0.25/1$, or 0.25uF.

When a reasonable number of markings have been provided, others can be filled in by estimating their position. When checking the values of capacitors, remember that exact values are seldom needed in audio, by-pass and similar circuit positions, and the variations of 10 per-cent can be expected with foil capacitors, and 20 per-cent or more with electrolytics.

Capacitor values are given in uF, nF, and pF, which are 10^{-6} , 10^{-9} , and 10^{-12} respectively. Thus, as example, $0.001\text{uF} = 1\text{nF} = 1000\text{pF}$. The "multiplier" is sometimes used as a decimal point. So 4n7 would be 4.7nF, or 4700pF. Once the bridge is made, it will be found of immense help in clearing up points of this kind, or for giving a check on colour-coded or other capacitor values.

Metronome

A metronome is an instrument which provides regular ticks or beats, and its purpose is to set the correct tempo for a musical performance. When used in this way, it provides a regular beat so that speed is not varied by the performer during practice, and it also enables a correct performing speed to be found. In the case of rapid and difficult pieces, a performer may have to work up to the correct speed.

A piece of music may have the speed indicated on it in terms of the number of notes of given length per minute. Or one of the musical terms indicating the correct speed may be found at the top or beginning of the music. These terms cover from slow, to fast speeds, and represent a particular number of beats per minute. Those most generally required are as follows:

Largo	46
Largetto	50
Adagio	54
Andante	60
Andantino	66
Moderator	80
Allegretto	100
Allegro	116
Vivace	126
Presto	144
Prestissimo	184

These speeds also indicate the general nature of the beat. As example, *Vivace* means "in a lively manner". The conventional musician's metronome has a pendulum with adjustable weight, which is set to produce the wanted beat frequency. The circuit in Fig. 18 produces a similar result, by electronic means.

It is a form of directly coupled oscillator, using one PNP transistor (OC71) and one NPN transistor (BC108). Coupling back from the collector of the BC108 to the base of the OC71 is by C1, with the speaker providing the collector impedance. The rate at which C1 charges, and thus the frequency of the circuit, depends on the total resistance of R1 and VR1 (as well as the value of C1).

With the values shown, it should be found that the circuit can be adjusted between about 44 beats per minute, and 200. These may be counted with a watch with seconds hand. Should spreads in the transistors, or other factors, make adjustment necessary, the beat frequency may be lowered by increasing the value of C1, or raised by reducing the value of this capacitor. As leakage through an electrolytic capacitor will upset working, a suitable capacitance here is best obtained by placing two 0.5uF paper capacitors in parallel.

Reducing the value of R1 will increase the maximum frequency, which is obtained with VR1 set for minimum resistance. In a similar manner, increasing the resistance value lowers the periodic frequency.

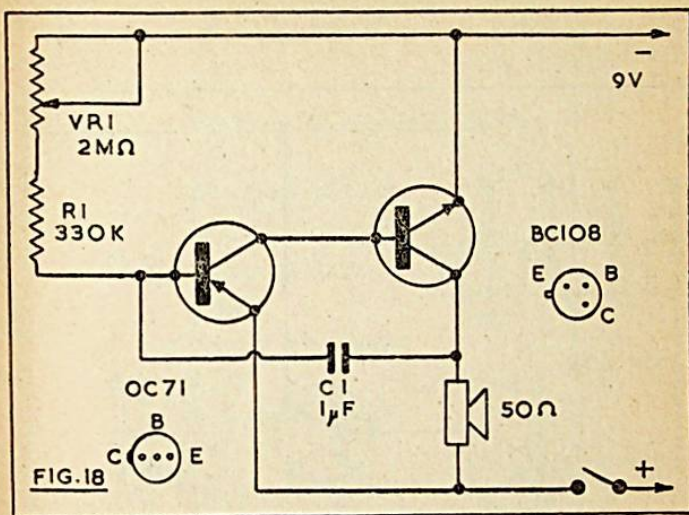

The few components can be assembled on a small tag strip. Place VR1 and the on-off switch on the case front. If a separate switch is fitted, this has the advantage that VR1 can be left at any wanted setting. A nicely varnished wooden case is probably best, as it also provides a soundbox effect, to increase volume. The bottom should be covered with felt or otherwise arranged to prevent scratching furniture or a piano top.

Provide a scale for VR1, which is fitted with a control knob with pointer. First check that the required range of speeds will be available. Speeds can then be marked, for various settings of VR1, by counting the beats with a watch. Actual markings may most conveniently be those given in the list.

Minano

The Minano or mini-piano actually produces an organ-like tone, rich in harmonics, and of quite pleasing character. An instrument of this type can be fun to play, either solo or accompanied. It can produce only one note at a time, and this simplifies playing, as there is no question of producing chords or of sounding two or more notes at the same time.

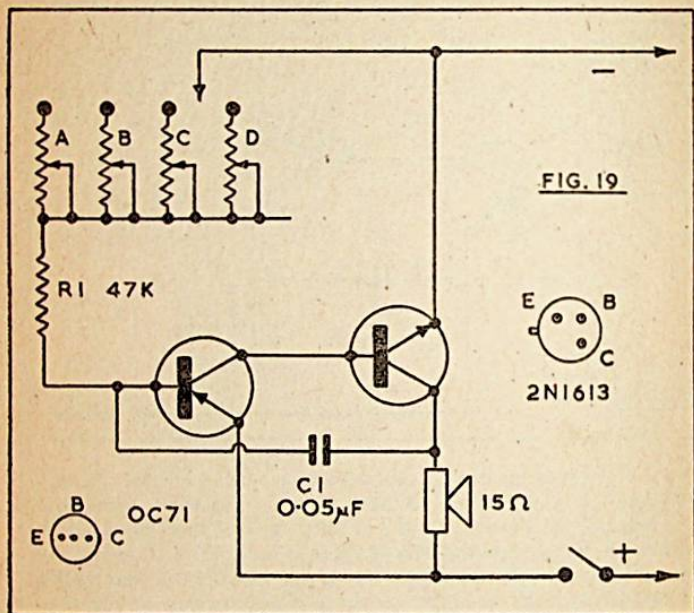

In Fig. 19 the circuit has feedback by C1 to the base of the OC71 to produce oscillation. The frequency depends on C1, and the total resistance in circuit from the OC71 base to negative line. R1 is the minimum circuit value which requires to be present at all times, for the highest wanted note. For lower notes, extra pre-set values A, B, C, D, and so on, are introduced. The frequency falls, as the resistance here is increased. A compass of about two octaves, centred on Middle C, is convenient, and this embraces frequencies from 128 to 512 Hertz, or cycles per second. (There are actually several ranges of frequencies in use, the best known of which are probably Standard and Concert Pitch, and these vary slightly in terms of actual frequencies for a given note.) For such a scale, values of up to about 100k will usually be satisfactory. By using a series of inexpensive miniature pre-sets, each note can be tuned individually, and cost is not excessive.

FIG. 20

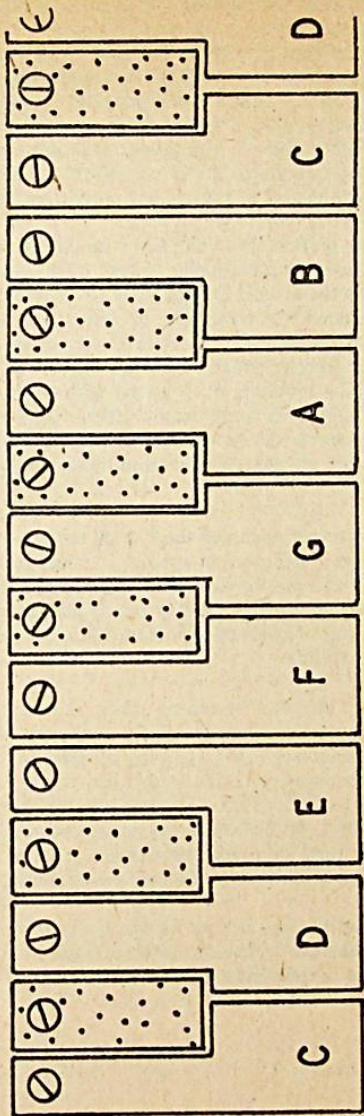

A keyboard, showing a little over one octave, can be seen in Fig. 20. If the notes are actually to be played by depressing them, as with a piano, each natural note, with its clearance space, can be 23mm wide. The black notes (sharps and flats) are situated as illustrated. Such a keyboard can be made, with a little patience, by cutting strips of metal for the notes, and mounting them on a baseboard. Wire all the notes together, and to negative. A round-headed screw situated under the front of each key completes the circuit when the key is pressed. These screws will be connected to the pre-set potentiometers A, B, C, D etc.

Another popular method is to employ a metal rod on a flexible lead, which is put into contact with the "keys". The latter may then be much smaller, as the fingers do not have to be accommodated, and there is also no need for movement, as with the spring metal strips. Such a contact keyboard can be made in various ways. One of the most easy is to place a screw, with fairly large washer, for each note. Notes are then played by touching the washers with the rod point. For those who like making printed circuit boards, this offers an easy way of obtaining note shapes similar to those in the diagram. It would also be an easy matter to cut the shapes from thin metal, with each screwed in place.

The finished keyboard occupies the top of the box, which also carries the tone generator, battery, and speaker. A reasonably efficient speaker will give enough volume for domestic playing, with two 9V batteries to provide an 18V supply. However, it is not necessary to have 18V, or to use the exact speaker impedance shown, though lower impedances are likely to reduce volume.

After testing, the question of tuning arises. The simplest way to obtain a scale in which pitch rises progressively — though not necessarily with correct musical intervals — is to employ a meter set to indicate k-ohms, and clipped from negative to the return line of all the pre-sets. The instrument is not switched on. The pre-sets are then adjusted with a screwdriver, so that the resistance falls progressively, from left to right. Press one key in turn, or touch the contact prod on a key, and adjust it. When this has been done, tones will form a rising sequence.

To obtain musical tuning, a piano or similar instrument is most convenient. It is necessary to adjust the pitch of each note until it is heard to agree with the corresponding piano note.

Values and Tolerances

With electrolytic capacitors, near preferred or easily obtained values will normally be quite suitable. This means, as examples, that if 2uF, 5uF, and 50uF capacitors were indicated, 2.2uF, 4.7uF and 47uF capacitors could be fitted instead. In a similar way, where the "round" values are not available, it is perfectly in order to fit 470uF instead of 500uF, or 6.8uF instead of 6uF, and so on.

With most circuits, a 9V supply will be used, so capacitors need only be for this voltage. However, 10V, 12V and higher rated capacitors will often be commonly available, and would be used. The actual voltage rating is not important, provided it is not lower than the voltage which will exist across the component, in use.

In a similar manner, the preferred and readily available resistor values will normally be used. These are 10, 12, 15, 18, 22, 27, 33, 39, 47, 56, 68, and 82, with all their multiples 1, 100, 1000, 10k, 100k, etc. and so on. Only occasionally are values outside this range required, but if they *are* specified for a circuit they should be used. In addition, there is seldom any need for values of closer tolerance than 5 per-cent. Again, if a closer tolerance is indicated for a circuit, it may be assumed that it is necessary, for correct working.

In transistor equipment, $\frac{1}{4}$ watt or $\frac{1}{2}$ watt resistors can be used in most circuit positions. Where a low wattage is not adequate, the necessary minimum wattage is usually indicated. Larger wattage components may of course be fitted. If necessary, a substitute for a 1w resistor is to connect two $\frac{1}{2}$ watt resistors of twice the value in parallel.

Alternatives and Ratings

Transistors shown are suitable types for the circuits in which they are used. This does not mean that other transistors cannot be fitted, as quite the opposite is generally the case. Numerous transistors of comparable or similar type can operate satisfactorily, and if surplus or other devices are to hand, they can often be utilised. In low power amplifying or similar stages, there is generally no need to check that the ratings of substitute transistors will not be exceeded, as voltage and current will be low. But elsewhere it may be wise to check that no maximum rating is going to be exceeded.

It should prove helpful to note the important ratings of a typical transistor in detail. These ratings are for the BC108, which is a general purpose device.

Device Type: NPN. This means that its emitter circuit will be negative as it is of NPN type, as described, so it is not a replacement for any PNP type, for the reasons explained.

Collector Dissipation: 300mW or 0.3 watt. This is $V \times I$, and allowance is naturally made for the voltage drop in any resistors. If the actual emitter-to-collector voltage, multiplied by the collector current expressed as a fraction of an ampere, exceeds 0.3, then the transistor is over-run. Current or voltage must be reduced.

Collector Current: 100mA. This means that collector current should not be over 100mA. If voltages are high, the limiting factor will be collector dissipation, so maximum current will be under 100mA. On the other hand, with low voltages the limit is set by this rating, as with 100mA flowing, collector dissipation will be under 300mW. So *neither* rating should be exceeded.

Current Gain: 240 at 2mA. This is the current gain of an average device at 2mA, in a common emitter circuit. Gains may be given for various currents, and may be lower with surplus or sub-standard devices. Most circuits operate satisfactorily with a considerable variation in gain, to accommodate spreads in transistors. In some cases using a device with much less gain (as in an oscillator) may result in unsatisfactory working, or complete failure of a circuit.

f_T . (This is the frequency at which current gain has fallen to unity, common-emitter.) 300MHz. This gives an indication of the maximum frequency at which a device may be able to operate. The actual limit is lower than the f_T . It explains why transistors intended particularly for audio or low frequency circuits, with a low f_T , are not likely to prove successful in radio frequency circuits.

There are also maximum voltage ratings of 30V CB, 20V CE, and 5V EB these being the maximum for collector-to-base (CB), collector-to-emitter (CE) and emitter-to-base (EB) with the unused lead open-circuited.

Lists showing similar or comparable types are found in some transistor data books, but cannot be expected to show all possible substitutes. In such cases, a possible substitute may be compared by checking its characteristics against the operating conditions which will actually exist in the circuit.

Controller for Models

This unit can be placed between the supply and model, for the dimming of low voltage bulbs, or speed control. The most probable use is the speed control of a model train. It is of course possible to control such a model by placing a variable resistor in series with the supply, but this can present the problem that the resistor or potentiometer fitted must be able to carry the required current. This means that an inexpensive component as used for radio and similar purposes is not suitable.

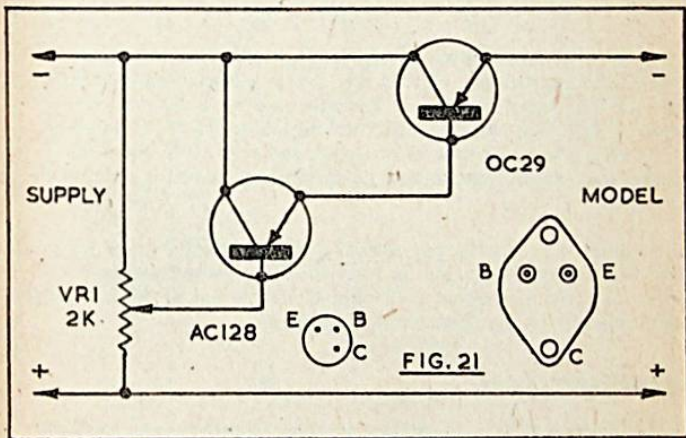

Fig. 21 shows the basic circuit, which will be adequate for many models. VR1 is across the supply, and its adjustment allows any wanted voltage to be taken to the AC128 base. The emitter voltage of this transistor closely follows the base potential, so that the OC29 base voltage is similarly controlled. The AC128 is included to reduce the current load on VR1 - the AC128 base current is not likely to exceed 0.1mA, while that of the OC29 may be over 5mA. The OC29 emitter circuit provides the controlled output for the model.

The transistors shown are PNP types. It is in order to use NPN transistors instead, if to hand. Remember polarity must then be reversed.

Maximum current which may be drawn is limited by the transistor dissipation. This is at its highest when the model is receiving a much reduced or low voltage. However, things are balanced out to some extent because the model will draw less current as its voltage is reduced. Maximum collector current for the OC29 is 10 amperes, but maximum dissipation is 30 watts, with a heat sink to keep case temperature below 45°C. The dissipation in the transistor is the product of the voltage dropped in it and current flowing. As example, if it is reducing the

supply by 10V and 1A is drawn — dissipation is $10 \times 1 = 10$ watts. It is thus essential to use a reasonably good heat sink for other than small voltage drops, or low current, or the transistor will grow very hot to the touch, and may be destroyed. It is usually convenient to employ a metal box as heat sink. Note that the collector is common to the box, unless the insulating washers and bushes available are used to provide electrical insulation.

The circuit is best assembled in a suitable box which can have VR1 on the top or front. Sloping-front cases are available, and will do well here.

A fuse may be placed in one circuit (e.g., positive line) to afford protection if shorts arise. A reversing switch is also often incorporated in a train speed controller. For this purpose, a 2-way 2-pole switch of sufficient current rating, and with a central "off" position, can be used. Take negative to one pole, and positive to the other, crossing over connections so that polarity to the model is reversed by the switch.

If necessary, such circuits can control high currents, by using transistors fitted to large heat sinks, and in parallel. To equalise transistor currents, a resistor of about 0.22 ohm should be put in the individual emitter circuits of the power-control devices.

Variable Power Supply

A supply which is fully adjustable, and able to provide any low voltage likely to be required, is extremely useful for operating all kinds of equipment. A straightforward circuit which can be arranged to suit most needs is shown in Fig. 22.

The mains transformer T1 provides complete isolation from mains circuits. Current is drawn from a 3-pin plug, fitted with a 2A or other low-rating fuse. An earth terminal is provided on the supply, common to the mains earth conductor E. The positive and negative output terminals of the supply can be left floating, or either may be connected to this earth terminal, where equipment has a positive or negative ground.

Regulation is by the Zener diode ZD1. Voltage for this diode is derived via the rectifier diode D5, and resistor R3. C3 and C4 are smoothing capacitors. The voltage control potentiometer VR1 allows any wanted potential to be taken to the base of TR2. TR2 functions as an emitter follower, its emitter voltage following the base voltage. A reference voltage for the base of TR1 is thus obtained from the Zener regulated potential across VR1. The capacitors C1 and C2 are sometimes termed "electronic smoothing". They remove hum from the base of TR2 and TR1. This means that residual hum voltages present at the collector of TR1 are suppressed in the emitter or output circuit.

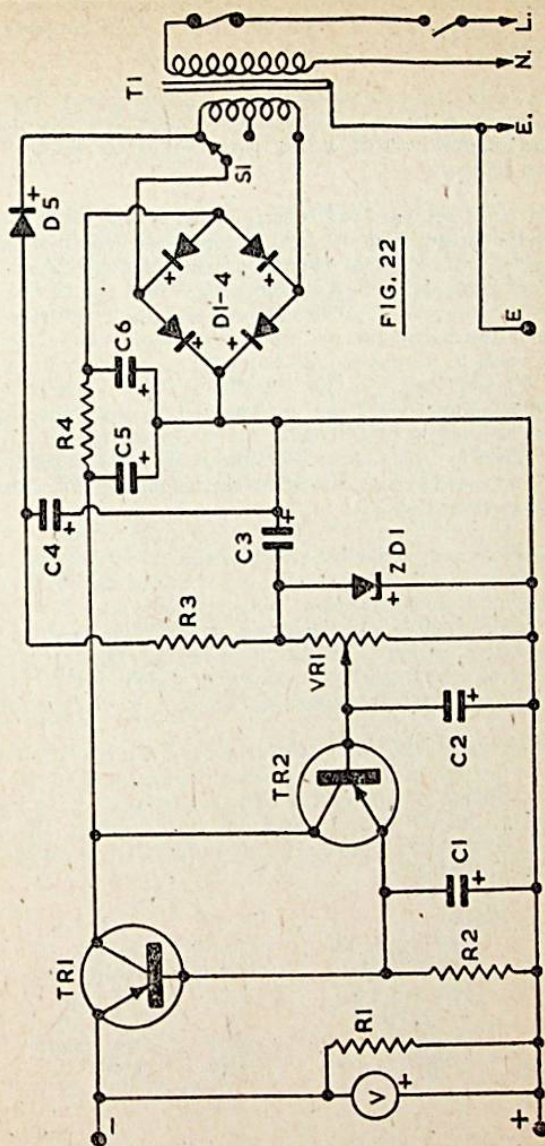

FIG. 22

R1 provides a permanent load, and the voltmeter V shows the output voltage. It is thus merely necessary to rotate VR1, to obtain the wanted voltage.

Operating current for external equipment is obtained from the full-wave rectification circuit D1-D4. Here, separate power diodes can be used, or a single full-wave rectifier of this type. C5, C6, and R4 are for smoothing purposes.

Switch S1 is not necessary with a small power supply, but it considerably simplifies heat-sinking and greatly reduces the dissipation in TR1, at low voltages. As example, assume that the unit could provide up to 24V, but that only 3V output is required. The extra 21V is "dropped" or lost in TR1. With small currents, this is not very important. But if the current demand is heavy, the dissipation in TR1 is large. It would be no less than 21 watts if 1 ampere were drawn ($V \times I = W$), and is still 10.5 watts at 500mA. This means that the operating conditions for TR1 are most arduous for *low* voltage outputs, dissipation and heating of TR1 falling, as the output voltage is increased. To avoid this high dissipation in TR1 when only low voltages are wanted S1 transfers the rectifiers to a lower voltage tapping on T1. This gives much cooler running for TR1.

The same circuit can be used for small or large power supplies. If most items are operated from 9V or similar dry batteries, there is little point in planning for a maximum output voltage of more than 12V to 15V or so. This will also suit car-radio receivers, or amplifiers requiring a 12V supply, as well as smaller items. But if much larger equipment is handled, it is worth planning for a maximum of 24V or 30V. This will accommodate most transistor equipment likely to be encountered.

The second limiting value will be the maximum current which can be drawn from the supply. Small, dry-battery equipment is not likely to require over 500mA, so a ½ ampere rating is adequate. For a medium size supply, a rating of 1A or 2A would be more suitable. The main items upon which difficulty may arise, when high current ratings are in view, are T1, and TR1.

15V 500mA Supply

T1	18V ½A or 1A	D1-5	1N4001
C1-4	220uF 25V	C5, 6	1000uF 25V
R1	150 ohm 2w	R2	1.5k ½w
R3	470 ohm ½w	R4	5 ohm 10w
V	0-15V	ZD1	18V 400mW
TR1	OC29	TR2	OC76

30V 1A Supply

T1	50V 1A tapped	D1-4	1N4002
D5	1N4003	C1-4	220uF 100V
C5, 6	1000uF 100V	R1	330 ohm 4w
R2	3.3k 1w	R3	1k 2w
R4	5 ohm 12w	V	0-30V
ZD1	33V 1w	TR1	OC29
TR2	ACY39		

With the smaller supply, TR1 is mounted on 1/16th aluminium, 7 x 7in or a metal case or chassis with equal or larger thermal capacity. For the larger supply, the Lektrokit LK-1131 sink is suitable. Note that the transistor base must be insulated from the sink, unless the latter is itself insulated from the case and chassis, as this forms the collector circuit.

Suitable voltmeters may be arranged from a 1mA meter. The 0-15V range will require a 15k 1 per-cent series resistor, and the 0-30V range will require a 30k 1 per-cent series resistor. A fuse may be placed in one output circuit. It is essential that S1 is of a type which does not short adjacent contacts when operated.

For higher currents, TR1 may be duplicated, connecting two transistors in parallel, with individual low-value emitter resistors (0.22 ohm) to equalise currents.

Modifications and simplifications to this circuit, which are practical especially for lower voltage and current ratings, can be made. R3 may be supplied from C5, omitting C4 and C5. If a centre-tapped secondary is used, only two diodes are necessary. Voltmeter V may be omitted, a calibrated scale being fitted to VR1, with the aid of an external meter temporarily connected to the supply.

Priority Indicator

There are various games and competitions, participated in by both children and adults, in which it is necessary to indicate which person or team had priority. The game of snap is typical of this, as the first person to cry *snap* on seeing a pair of cards, gains the cards played. Similarly, in various quiz and puzzle competitions, the first person able to indicate that he is able to provide a correct answer wins the point.

With a very short interval, or apparently simultaneous answers or calls of *snap* there is difficulty in deciding who actually was first. Arguments about this can be avoided by using an electronic means of indicating priority. Each competitor (or team) has a bell-push or push-button switch, and two indicator lamps show which switch was closed first. In this way, all doubt is removed. It is also possible to have tests to find who has the shorter reaction time. For this, competitors press their button as quickly as possible when a pre-arranged event arises. In its simplest form, this can be the presence of similar cards on packs dealt by a third person, but various other tests can be devised.

The priority indicator circuit in Fig. 23 requires very few components, and it can easily be assembled on a small tagboard or insulated panel.

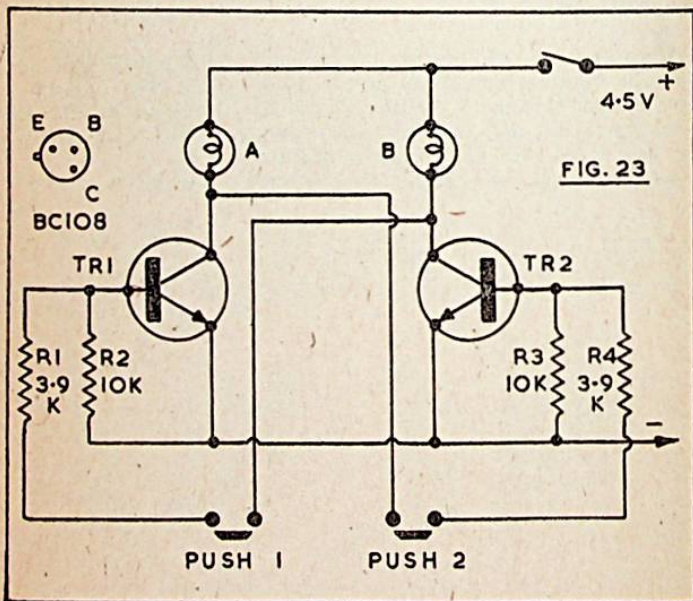

Both the push switches are normally open. In these circumstances each transistor base is held negative by resistors R2 and R3, and collector currents are negligible. Both indicator lamps A and B are thus extinguished.

Suppose that Push 1 is closed first. Positive bias is applied to the base of TR1 through R1, Push 1, and lamp B. As a result TR1 conducts, its collector current flowing through lamp A. So this lamp lights. Should Push 2 now be depressed, the base circuit of TR 2 is completed through R4 and Push 2 to lamp A. However, as lamp A is lit the junction point for Push 2 has moved negative, and this later operation of Push 2 does not cause lamp B to light.

Should Push 2 be operated first, naturally lamp B lights. But the circuit is captured by the first operator, and only his lamp can be lit, and it will remain so while the push is held down. For all practical purposes the operation of the circuit is instantaneous.

The unit can be placed in a box which has the push-switches fitted, or these can be on flexible leads. Pushes mounted towards opposite ends of a shallow box which can rest flat on the table, will be convenient for two players competing in snap or similar games but the flexible leads with pushes will be of advantage where the competitors do not sit close together. Push 1 and bulb A can be red, and Push 2 and bulb B green.

The transistors indicated have a maximum collector current of 100mA. If two 6V 40mA or 6V 60mA bulbs are used, current is easily within this rating. Such 6V 0.04A or 0.06A bulbs, once largely used for cycle dynamo rear lights, are easily bright enough for indicator purposes, and they allow the whole unit to run economically and make transistors of larger rating unnecessary.

Lie Detector

When a person deliberately tells an untruth, physiological changes occur at the time, or in advance in anticipation of the question which cannot be truthfully answered. These changes may be to respiration, pulse-rate, and conductivity of the skin. The latter is a process similar to flushing, in that the subject cannot normally control it.

A lie detector device can thus be one which indicates any small change in skin conductivity, so that the person operating the device can decide that a lie has been spoken.

The circuits here should be regarded as experimental, and not too much reliance should be placed on results obtained. There are two main reasons for this. First, though the most sophisticated machines had a vogue, especially in the USA, "evidence" from their use was not generally a sole or important deciding factor in assessing a person's probable guilt. Secondly, tests made in the home with such devices will be in the nature of a game, and the subject will not be under the emotional stress which may be assumed to exist when a real crime, perhaps of a serious nature, is being investigated. It is suggested that experiments should at least go so far as trying to enhance the subject's psychological or emotional involvement in the replies, as described later.

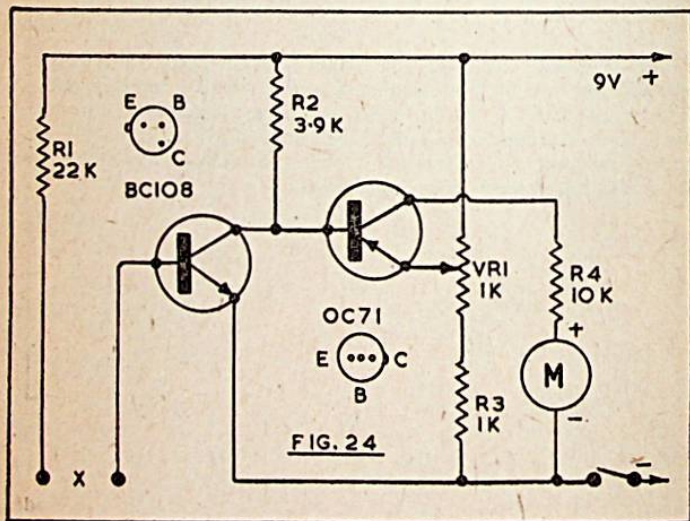

The circuit in Fig. 24 has two transistors as a DC amplifier, with indicating meter M. Sense electrodes are connected to terminals X. The resistance at X, combined with R1, will result in a particular level of collector current in the first stage. The voltage drop across R2, and thus the base potential of the second stage, will depend on this. VR1 allows the emitter potential to be set so that a small collector current flows through the meter. A 1mA instrument can be used, and R4 is to limit current under all conditions so that the meter is not damaged. With the circuit adjusted in this way, any small change in conductivity at the points X will deflect the meter reading.

The circuit can be easily assembled to fit a small box, with battery. There may be some actual operating advantage in having the unit present a sophisticated appearance, while a large meter will in any event allow small changes in current to be more readily seen.

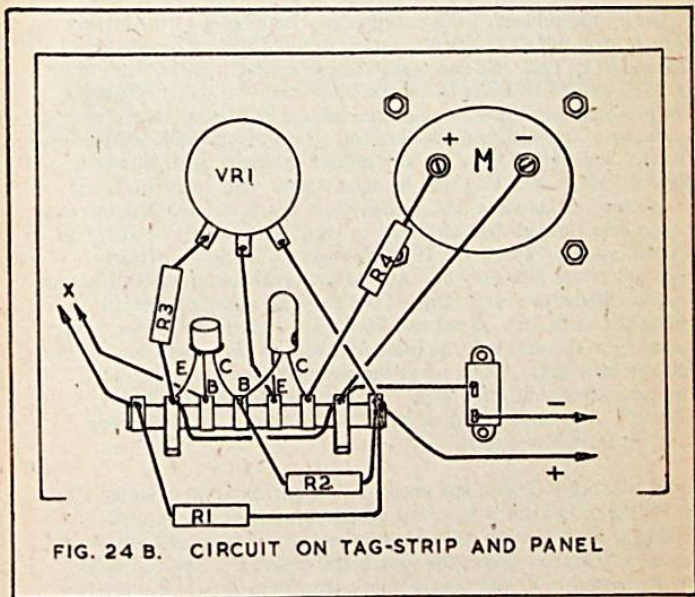

FIG. 24 B. CIRCUIT ON TAG-STRIP AND PANEL

Insulated leads pass from terminals or sockets X to the electrodes. These can be small squares of copper foil (or other similar metals) taped to the subject's palm. A conductive jelly ought to be used here to obtain the best electrical contact between subject and electrodes, but will probably have to be omitted. VR1 should be set so that touching or moving the electrodes causes a large meter deflection.

Questioning

As interrogation is not by a circle of shirt-sleeved cops under arc lights while the subject lies to save his life, a little indirect pressure needs bringing into the affair. Small wagers, to win or lose (e.g., sweets for children) are suggested. To avoid difficulty if a child lies about the lie, creating a situation which can never be definitely resolved, the true answer should be written down by the subject, in advance, for reference afterwards. A questionnaire may be arranged in several ways. One of the simplest is to use cards numbered from 1 to 10. These are placed upwards, in sequence, in front of the subject. The subject secretly chooses one. He is directed to reply "No" *every time* to the question "Did you choose this number?" so that one reply must be a lie. The cards are taken quite slowly in order, as a build up of tension could arise in the subject as the card chosen is approached.

A belief by the subject in the machine may be helpful to the interrogator. It may be felt justified in trying to build this up by deception, initially. At its best, this can make the subject feel that he will not be able to lie as effectively as he thinks, under test. At worst, it may make him feel that there is some other means of finding the lie, which may increase his emotional involvement. An ordinary pack of cards may be used. One method is to ask the subject to take a card, look at it, and replace it. He is then told that he must answer "No" each time, and that the tone of his voice will change when this is untrue. The investigator then goes through the pack card by card, held so that he alone can see them, asking, "Was it the 10 of Spades . . . or the 2 of Hearts . . ." and so on, as the case may be. Any of the usual conjurer's methods may be used to know the card. One of the simplest, often effective, is to separate the cards into 26 red and 26 black. Then if the subject takes his card from the first half, he must replace it in the second half of the pack, and vice versa. Then, when the wrong colour turns up, the investigators hesitate, then says, "Ah, your voice changed, it was that card". The cards can then be put away unseen, after selecting ace to 10, for the real tests.

Fig. 25 is another circuit, less sensitive, but not requiring a meter. A high resistance headset is best, but other reproducers can be used, including a small speaker with transformer, or a speaker of the highest impedance available. Here, the tone heard depends on the resistance between terminals X, and ranges from a slow plop-plop to a quite high audio note. Results are likely to be less easily noted than with the meter circuit, and depend somewhat on the investigator's ear, and placement and size of the electrodes, and thus the resistance at X.

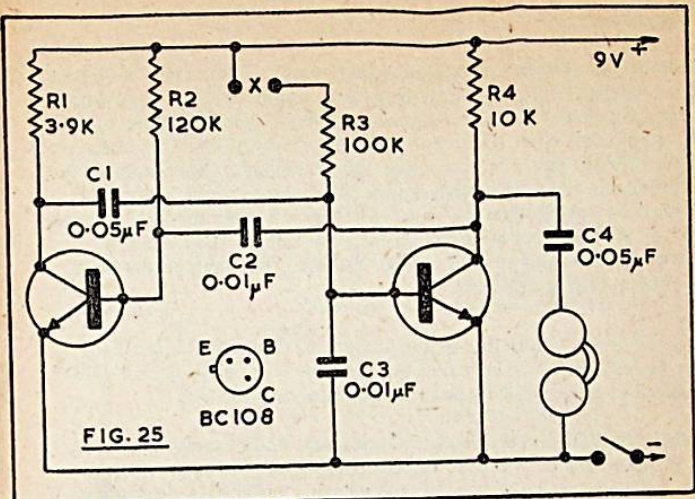

Automatic Light

This device switches on a lamp when general illumination falls below a pre-arranged level. It can be battery or mains operated, and this depends somewhat on the actual purpose in view. A mains run unit is convenient when the circuit is used to control a child's bedroom light or night-light, as it can then run at negligible cost, coming on only during the hours of darkness. The device could be used to switch on vehicle lights, and would then run from the 12V accumulator. A relay is provided, able to carry current for the usual parking lights, and it is of course, essential that the parking lighting conform with regulations.

Fig. 26 is the circuit for mains operation. The ORP12 is a light-dependent resistor. Its value can be quite low, when light is falling on it, but rises to 100k or so in darkness or poor light.

When the LDR is sufficiently illuminated, its low resistance value holds the base of the first amplifier negative. Collector and emitter currents are negligible, so there is virtually no voltage drop across R2, and the base of the second transistor is also at negative potential. When light falls on the LDR and its resistance is low, the setting of VR1 does not have much influence on working. But when illumination is reduced, the value of the LDR rises. The level at which the circuit comes into action can thus be pre-set by adjusting VR1. When the base of the first stage is sufficiently positive, emitter current flows, causing a voltage drop in R2, and thus moving the base of the second stage positive. Collector current flows through the relay windings, to operate the relay contacts.

If the circuit is operated from a battery supply, this is connected to the positive and negative lines indicated. C1 and the rectifier circuit are then unnecessary. The circuit will operate satisfactorily with less than 12V. The relay coil resistance is not too important provided the relay operates satisfactorily, and a relay of 150 ohms or higher resistance is recommended. A 250 ohm to 500 ohm relay will be found to operate satisfactorily, and will limit collector current to a lower level.

T1 may be a 240V/6.3V transformer, with a secondary rated at 1A or larger, and a 6.3V 0.5A bulb can then be used. Four 1N4001 rectifiers may be used, or anything suitable for the low voltage. The lamp is lit directly from the secondary.

Most relays require substantially more current to close them, than to hold them closed, and C1 should prove adequate to avoid any buzzing of the relay. If not, it may be possible to adjust the relay tension so that it closes more easily.

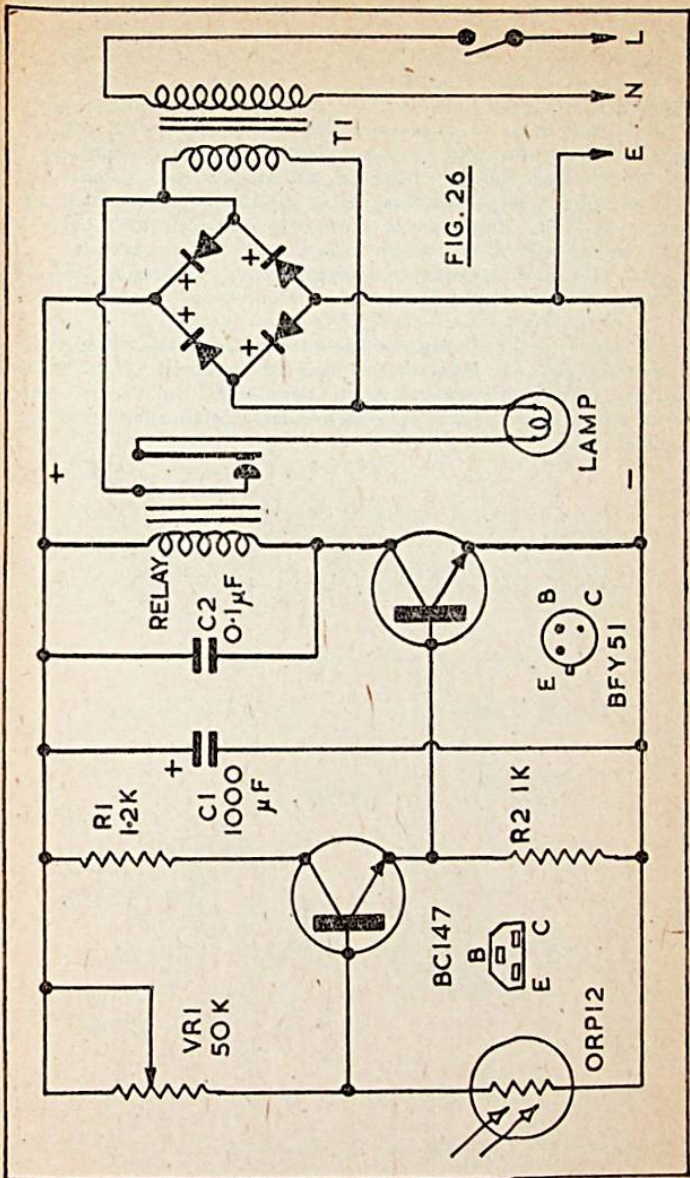

Provided the relay has mains voltage contacts, it may switch on a table lamp or other room light. This is sometimes used as a kind of anti-burglar device.

When constructing the unit, remember that light from the lamp, of whatever kind, must not fall on the LDR, or the device will fail to operate correctly for obvious reasons. With a child's room light, a box may be used with the LDR facing the window, and the bulb at the front, positioned so that stray light from it is not sufficient to operate the LDR. Another way to overcome this difficulty is to build the unit with a twin output socket, into which the lamp is plugged. The latter can then be equipped with a long flexible lead so that it is clear of the LDR.

It will be noted that the negative line is earthed, and this will include a metal box, if used. However, provided the transformer T1 is double-insulated, earthing is unnecessary, with an insulated case or box. The device can then be operated from an adapter, where no earth is available.

Low Drain LDR Unit

The circuit in Fig. 27 will operate from a small 4½ volt dry battery supply. The most economical type of lamp should be used – a 6V 0.04A bulb is satisfactory.

By placing the LDR as shown, operation is reversed, compared with the previous circuit. That is, the lamp is now illuminated when light falls on the LDR. R1 is fixed, no provision being made to adjust sensitivity.

The whole circuit can be constructed as a novelty, with power from three 1.5V cells, with the bulb on top. It may then be lit by striking a match and holding this near the LDR. General illumination must be low enough to avoid operating the circuit, and it should work reliably with the match 6in. or so away. The device can be arranged to resemble a small oil lamp or candle. If the LDR is so positioned that the lamp illuminates it with sufficient strength when lit, the device will stay on until the light falling on the LDR is interrupted by the hand, or the unit is switched off.

A further use for the circuit is to extend the lamp circuit to an indicator bulb which may be at any distance, or to extend the circuit leads to the LDR in this way. This will allow the presence, or the putting on, of another light, to be monitored, without any actual circuit connection.

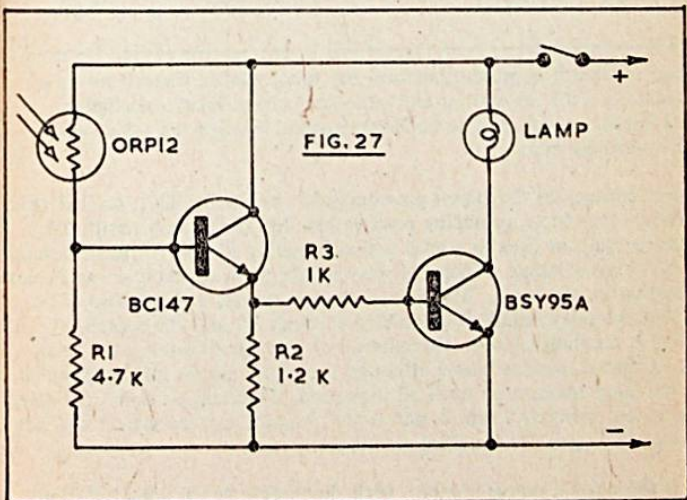

Touchlight

Everyone must have had the experience of fumbling for a bedside switch in the dark. The low-voltage bedside light using the circuit in Fig. 28 is particularly suitable for children, and is operated by placing the fingers on plates or contacts provided for this purpose. It is thus something of a novelty, as well as being useful.

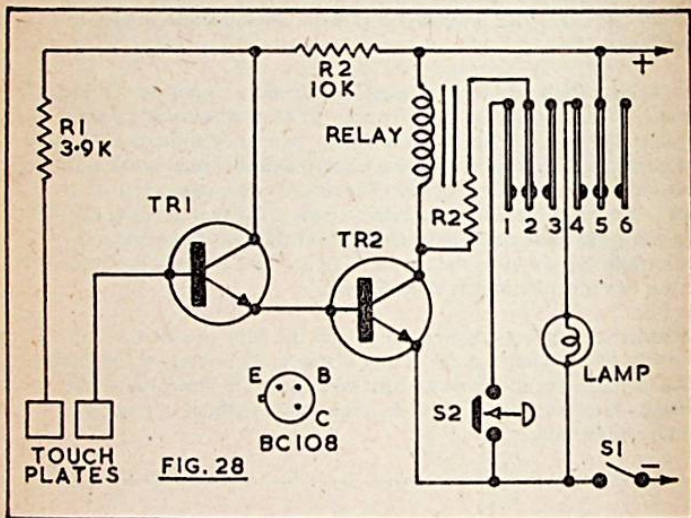

When no circuit is present between the touch plates, there is no base current for TR1, so emitter and collector current here is negligible. TR2 is also cut off, and so collector current through the relay winding is virtually zero.

Finger contact on the plates provides base current for TR1, so that this transistor conducts, providing positive bias for TR2. As a result, TR2 collector current rises to a level which is mainly limited by the resistance of the relay winding. When the relay is energised, contacts 4 and 5 close, switching on the lamp. The second set of contacts 1 and 2 also close, so that the relay circuit is completed through R2 and the switch S2, which is normally closed. Completion of this circuit latches the relay on, so that it remains closed although the plates are no longer touched. So the lamp remains on until S2 is pressed. Once this is done, the relay is released, contacts 1 and 2, and 4 and 5 open, and the circuit can only be operated again by touching the plates.

S1 is the normal on-off switch. With the lamp off, the actual current depends on individual transistors, and any leakage between the plates, but may be only a small part of a milliampere. This imposes very little drain indeed on the battery.

A 2-pole 2-way relay is required. Its actual coil resistance is not too important, but should not be lower than about 300 ohms. (This is to limit the current through TR2. Actually, a relay of less than 300 ohms can be used, provided a resistor is placed in series with it, so that TR2 collector current cannot exceed 100mA. Such an arrangement is less sensitive than using a higher resistance relay.) The value of R2 is similarly not important, and it can usually be a few hundred ohms. It need only allow sufficient current to flow through the relay to hold this closed until S2 is operated. It is an easy matter to try two or three values here, and to use the highest which keeps the relay closed.

As the lamp is switched on by the relay, it can be of any suitable type for the operating voltage. A 6V or 6.3V 0.3A or 0.15A bulb will give a reasonable light, with a 6 volt supply. If only a relatively weak "Night Light" is wanted, a 6V 0.1A or 0.06A bulb can be used, for more economical running.

The whole device occupies a plastic or wooden box, and this may have a miniature Edison screw holder with a small globe. The touch plates can be flat strips, separated by a narrow space, and running along near the front of the case. S2, which has to be pressed to put the light out, can be behind the strips.

It will be noted that relay contacts 3 and 6 are not used, but these will normally be present on a standard relay. A small size is not essential, the larger surplus relays with a coil resistance of several hundred ohms will do very well, and are reliable and robust.

Handy Intercom

This equipment provides 2-way contact between rooms, upstairs-to-downstairs, or from house to garden workshop, with push-button calling from either end. It is also an amusing loudspeaking telephone for children, as well as having utility as a baby-cry listening device.

Fig. 29 is the circuit of the whole equipment, which consists of a main or master unit, and a remote unit, connected by a twin extension lead.

S1 and S2 are a 2-way 2-pole spring loaded push switch, with its contacts normally as shown. S3 is the master unit on-off switch, and S4 the remote unit calling button. To simplify working, S1/S2 is marked "Press to Call or Talk". S3 is marked "On", and S4 "Press to Call".

In operation, if the remote user wishes to call, he pressed S4. This completes the battery negative circuit through the primary of the transformer T1 in such a way that feedback causes an audio tone in the master unit speaker. The master operator closes S3 to switch the intercom on. Speech in the remote speaker is then amplified and heard in the master unit speaker. To communicate the other way, the master operator presses S1/S2, so that his loudspeaker operates as a microphone, and amplified speech is transmitted to the remote unit.

Should the person at the master unit wish to call the remote user, he presses S1/S2, causing the tone to be heard in the remote loudspeaker. He then listens for a reply. C5 allows audio signals to pass but blocks direct current. Each person should say "Over" after speaking, so that the press-button at the master unit can be operated to allow a smooth flow of conversation each way. In practice, the actual use of the push buttons will be obvious.

The audio amplifier is assembled on an insulated board about $3 \times 3\frac{1}{2}$ in size, and can use the layout in Fig. 30. Perforated board can be used, or a plain paxolin panel can be drilled for the parts.

The transformers each have a centre tap, which is not used. Points MC are tags secured with $\frac{1}{2}$ in. bolts. Extra nuts on these will allow the amplifier to be fitted in the metal case, and joints or bare leads must be clear of the metal. To simplify connections to the change-over switch, colour coded leads may be soldered on as shown.

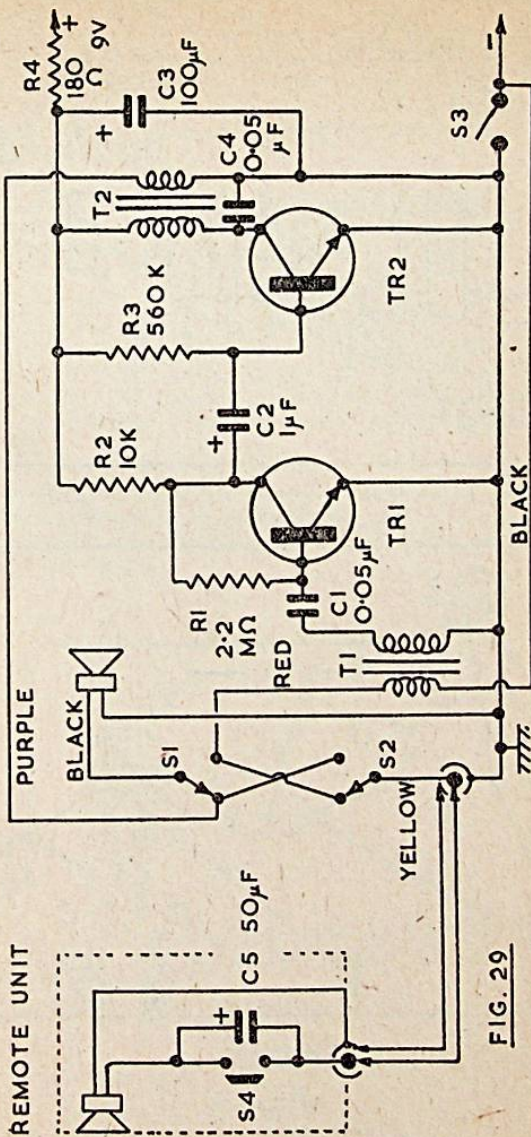
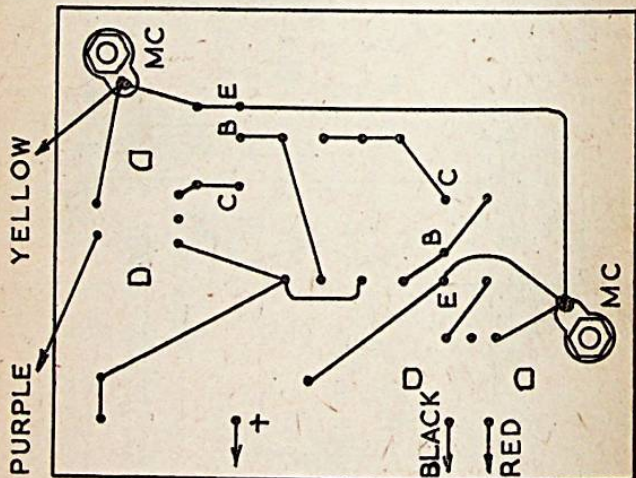
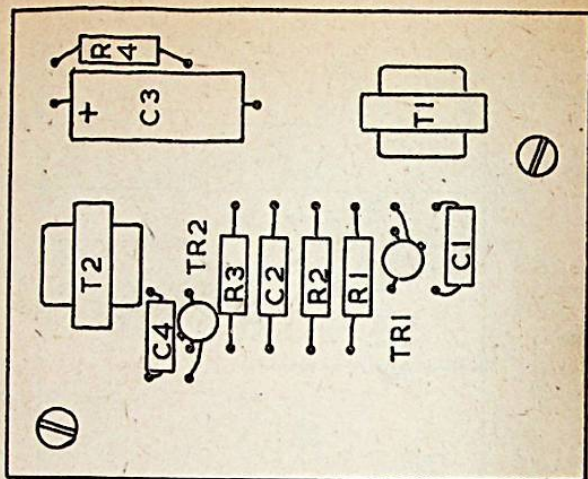

FIG. 29

FIG. 30



Any small metal case able to accommodate the amplifier, battery and speaker would be suitable, and a box about 4 x 4 x 3in. is large enough. The speaker unit can be fitted behind a 2in. diameter hole, covered with gauze or perforated metal. S1/S2 can be fixed to the left of this, with S3 above. The outlet jack is convenient for plugging in the extension lead, and it is fitted to the back of the case. A bracket shaped from scrap metal can be bolted on here to hold the battery securely inside.

When connecting the switch, note that section S1 transfers the master unit speaker from input (T1) to output (T2) circuits, while S2 similarly switches over the remote speaker.

The remote unit is housed in a case about 3 x 3 x 1in., with the speaker behind an aperture covered as explained. The inner and outer contacts of the jack plugs are used as shown. It will normally be found that the extension lead can be 2 ampere or similar flex, or twin bell wire, and that a screened lead is not necessary. Connections should not be transposed because of the electrolytic capacitor in the remote unit.

When first testing the units, have them in different rooms, or keep the loudspeakers separated, or feedback may cause howling. Do not speak too loudly or near the units, as this may cause overloading and poor speech quality.

Components:

Main Unit

R1	2.2 megohm
R2	10k
R3	560k
R4	180 ohm
C1	0.05uF
C2	1uF 6V
C3	100 uF 10V
C4	0.05uF
TR1	BC109
TR2	BC108

T1 and T2 Home Radio (Mitcham) type TR60 transformers.

S1/S2 2-pole 2-way spring loaded push switch.

S3 slide on-off switch

2½in. 3 ohm speaker, jack socket, case etc.

Remote Unit

C5	50uF 10V
S4	Push "on" switch
2½in. 3 ohm speaker, jack socket, case etc.	

VHF Generator

When testing VHF equipment, the lack of a signal source for these frequencies can prove to be inconvenient. The generator shown in Fig. 31 avoids this difficulty, and is easily constructed from readily available components. Its coverage is approximately 75–150MHz, so it includes most of the frequencies likely to be required, including the Amateur 144MHz band.

The VHF oscillator is amplitude modulated, but with a tuned oscillator of this type, AM introduces enough frequency modulation of the signal for FM purposes.

The BF200 functions as carrier oscillator. The upper frequency limit of this device is 550MHz, but it will be found that with inductance/capacitance constants of the type used here that it is not easy to sustain oscillation above about 200MHz. The upper frequency limit also depends somewhat on the individual device, as well as wiring layout. If a higher limit than this is required for some test purposes, VC1 should be reduced to about 5pF. It is also necessary to reduce the size of L1.

C2 should generally be satisfactory as conditions are less exacting for the proposed 75–150MHz band. Having C2 unnecessarily large can prevent oscillation.

The BC108 serves as modulator. The audio transformer connections shown are for the R.S. T/T3. Other driver transformers, with a ratio of about 3:1 or so, should operate with the same circuit. If no audio tone is obtained, connections to the primary (1 and 2) may have to be reversed, to obtain the correct phase of feedback. One half secondary couples modulation to the VHF oscillator.

Layout

The most important feature is likely to be the layout of the components in the BF200 stage, as long connections will prevent the higher frequencies being reached, or prevent oscillation. It is convenient to build this stage separately (Fig. 32) so that components can be grouped closely around VC1. A tagboard is drilled for VC1, and C3 and the transistor are connected with very short leads.

L1 is wound with 18swg or other stout wire, and has four turns, with an outside diameter of $\frac{1}{2}$ in. Turns are spaced so that the whole winding is $\frac{7}{8}$ in. long. The ends are soldered directly to VC1 and C3. L2 consists of one turn of insulated wire, near L1, as shown. Too tight coupling may prevent oscillation.

FIG. 31

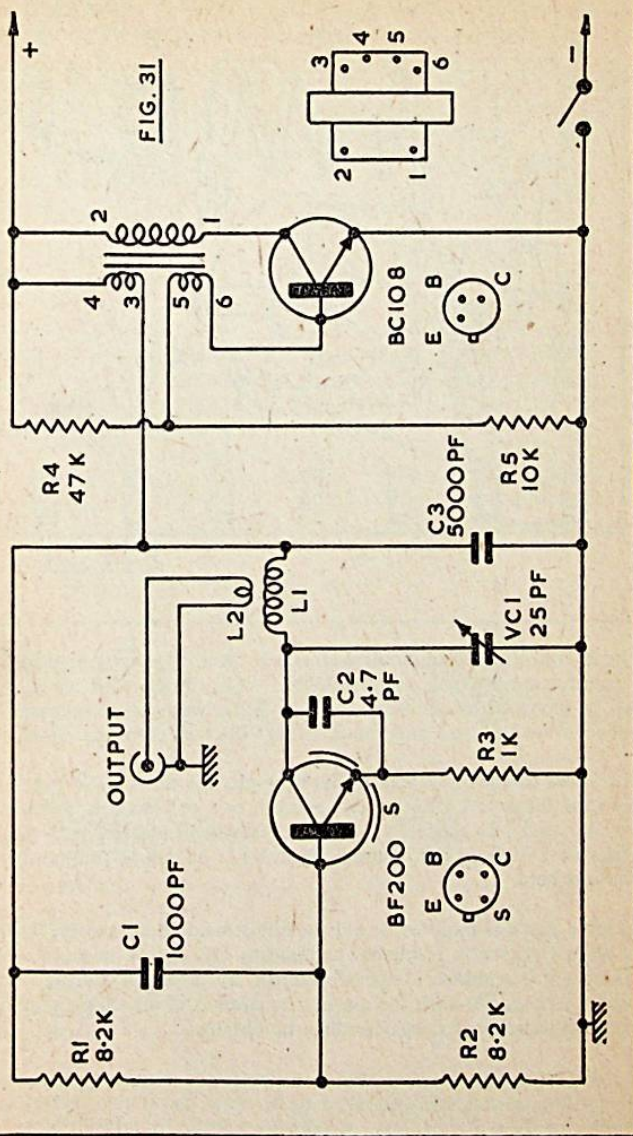

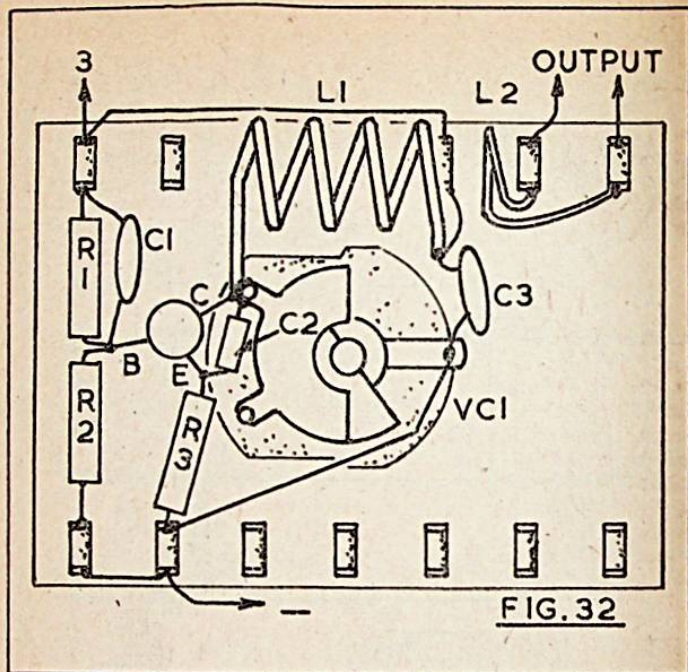

The BC200 shield lead is not connected. Miniature ceramic disc capacitors are probably most suitable. When the board is wired, it can be mounted by the bush of VC1. Extra washers are necessary between the tagboard and panel, so that the tags clear the metal.

If a lower frequency is wanted (as example, for the 70MHz band) then the turns of L1 can be compressed, or a coil with more turns may be used. To raise the maximum frequency, reached with the plates of VC1 fully out of mesh, stretch L1, or reduce the number of turns here.

Where a signal is required to aid the adjustment of a receiver, converter or other equipment, frequency calibration may not be necessary. If calibration is required, it can be obtained by tuning in the signal at known frequencies with the aid of a receiver, and drawing a graph, from which other readings can then be obtained.

It will also be found practicable to calibrate the oscillator with a Lecher line, as this will only need to be up to about two metres in length, for these frequencies. Resonance will be found by observing a meter placed in the positive circuit to L1, and the line is coupled to L1 by a single turn loop. A small change in meter reading will be

seen as a shorting bar is moved along the line, and the distance between two such points should be taken with a metric rule. The frequency in MHz = 15,000/cm. Three or four checks, at well separated frequencies, will allow a graph to be drawn to cover the full range of the oscillator.

Where it is necessary to take the output to particular receiver or converter points, for testing, the whole generator, with its battery, should be enclosed in a sealed box, with a screened lead from the co-axial socket. Screening is in any case recommended, to avoid interference with VHF receivers near by.

10.7MHz Generator

The VHF generator does not include the intermediate frequency usual with VHF receivers, and a 10.7MHz signal source can be used to check the working of these stages. A generator for this purpose can easily be made from the circuit in Fig. 33. An AF117 is used as RF oscillator, and the frequency is determined by L1 with the parallel capacitor C3. These are selected so that the core of L1 allows the frequency to be adjusted to that needed. Oscillation is maintained by the feedback winding L2. R1 and R2 set base bias conditions.

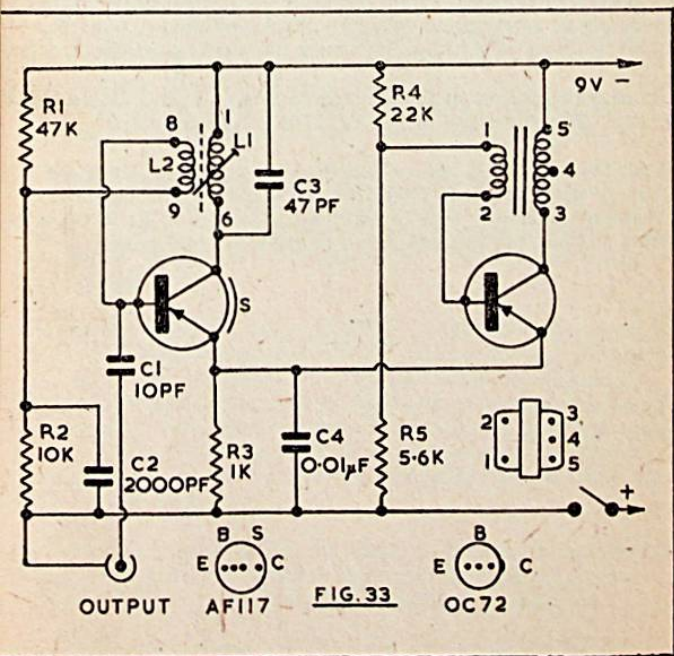

The OC72 functions as audio oscillator, the windings of the audio transformer being phased to achieve this. Common emitter coupling of the oscillators provides amplitude and frequency modulation of the RF signal.

The unit is best constructed to fit a metal box, the battery being included. All the components except L1/2 can be fitted to a small insulated board, which is afterwards fixed to the box lid. Place extra nuts or spacers on the securing bolts to give clearance to connections and joints under the board. Fit the on-off switch, output socket, and L1/2 to the box lid or front. The adjusting screw of the coil projects for frequency setting purposes. The coil used is a Denco *Valve Type* "Blue" Range 4. As its fixing bush and nut are plastic, the nut should be tightened with the fingers only. The pins are counted in a clockwise direction from the space, as when counting tags on a B9A type valveholder.

Many driver transformers, as used to couple the output stage in small amplifiers and receivers, can be expected to function satisfactorily in the AF oscillator stage. The original secondary is employed as the primary, from collector to negative line. The original primary (1, 2) now acts as secondary. If no audio tone is obtained with an alternative transformer, connections to these tags should be reversed. Should the audio tone obtained with a substitute be unsatisfactory, a capacitor can be placed across either winding — a value of about 0.01 μ F to 0.05 μ F is suggested initially. Increasing the value lowers the frequency.

Alternative transistors of similar types to those shown could probably be used. The shield lead of the AF117 is left disconnected.

To set the core of L1, place a lead from the output socket of the generator near the input of the 10.7MHz amplifier of a receiver, and rotate the core to tune in the signal. The core of L1/2 is locked with a 6ba nut, but this should not be tightened too severely.

Megahertz Marker

When exact calibration of a receiver such as that of communications type is required, a harmonic crystal marker is generally used. In fact expensive receivers and transceivers often have such a device permanently incorporated, so that it can be switched on at any time to check dial readings. A harmonic marker can also be employed to calibrate a home-built short wave receiver, or to check or calibrate a signal generator.

Devices of this kind use a crystal controlled oscillator, in a circuit able to provide harmonics of the crystal frequency. These harmonics, or multiples, allow the same crystal to give numerous calibration points.

The marker shown in Fig. 34 uses a 1MHz crystal, and thus provides calibration points at 1MHz and harmonics of this frequency. That is, 2MHz, 3MHz, 4MHz, and so on, up to a limit set by the coverage of the receiver itself, or its sensitivity and thus its ability to tune in the harmonics. Most general coverage short wave receivers tune up to about 30MHz, and with these the marker will be utilised over the 1-30MHz range. For Amateur reception, the 2MHz harmonic will show the higher frequency end of the 160m, or 1.8-2.0MHz band. Higher harmonics show the low frequency ends of the 7, 14, 21 and 28MHz bands (40, 20, 15 and 10m).

The BFY51 is used as the crystal-controlled oscillator. The collector coil is a Denco Range 1 "Yellow" Valve Type, its pins being counted in a clockwise direction, as when numbering valve pins. It is probable that other coils could be used here. The smaller winding serves to couple signals to the output socket, via the isolating capacitor C2.

This oscillator should be found to start readily with crystals of normal activity. If not, changes to the value of C1, or to R1, may help a sluggish crystal. With oscillators of this type, a pre-set capacitor is occasionally provided in the position of C1, but this is not likely to prove necessary.

The second stage is the audio oscillator or modulator, the transformer connections being shown for the R.S. T/T7 transformer. This has a ratio of 9.2 (centre tapped) : 1. The ratio is not too important. Should alternative components be tried here, remember that it may be necessary to reverse connections to one winding, to obtain oscillation. If needed, some adjustment of the tone produced can be obtained by altering the value of C4. Extremely high, or very low, tones are less satisfactory.

S1 is the usual on-off switch. S2 allows modulation to be switched off, as an unmodulated carrier is preferable for some purposes, especially with a receiver having a beat frequency oscillator.

An insulated box or case could be used, as it is not absolutely essential that the oscillator is screen.

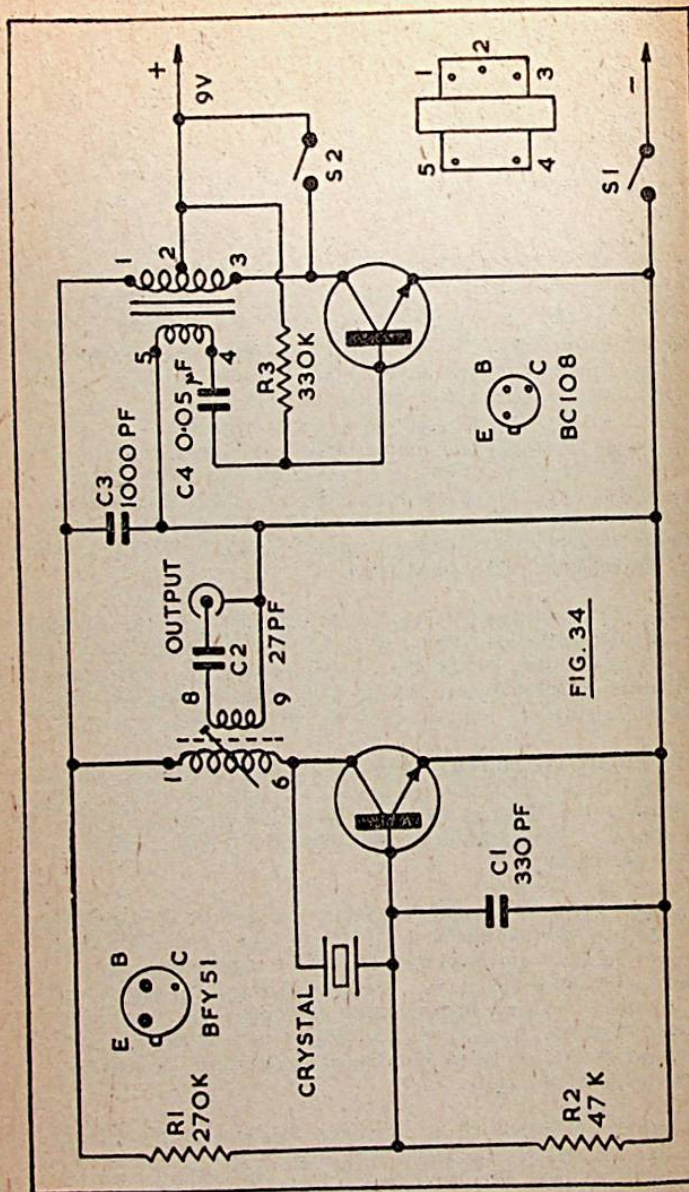

FIG. 34

Marker Use

Output is coupled into the receiver aerial socket. For low order harmonics, it is sufficient to place a short lead in the output socket and run this near the aerial lead or socket. But as the higher harmonics grow progressively weaker, tighter coupling may be needed for these. This can be arranged by plugging a short lead into the receiver aerial socket, and twisting this a few times round the marker output lead. Both wires should be insulated. The strength at which harmonics is received will naturally depend also on the sensitivity of the receiver. The actual strength of the input to the receiver is not very important, provided it is of sufficient level to be tuned in, yet not so strong as to overload the receiver.

With S2 open, the tone should be heard at 1MHz intervals throughout the receiver tuning range. With S1 closed, the signal should operate the S-Meter (if fitted) and provide a heterodyne, if the BFO is on.

To check calibration of a calibrated receiver, compare the dial markings with the marker harmonic tuning positions. Provided the correct usual procedure is employed, trimming can be adjusted to bring readings on to the right frequencies.

If the receiver is home-constructed or has no calibration, it is necessary to discover the frequency of one harmonic. This may be done by marking the harmonics for one band, then locating one actual frequency by reference to an Amateur band, or known station. All the markings for that band can then be counted off, each way, and frequencies can be indicated for them.

To calibrate a signal generator, use a receiver to tune in both generator and harmonic, and transfer the harmonic reading to the generator scale.

It is possible to check the crystal itself by tuning in the standard frequency transmissions, usually best heard on 5MHz. If the 5th harmonic of the unit does not coincide with sufficient accuracy to this, the crystal may be "pulled" a little one way or the other by introducing a small pre-set capacitor in series with it, or in parallel. Usually, however, the accuracy will be such that any difference in tuning position will be so small that it cannot be observed on the receiver tuning scale.

HF Bands Amplifier

The performance of most receivers can be improved on the high frequency bands up to 30MHz by fitting a tuned amplifier. The greatest benefits usually obtained are increased sensitivity, and better freedom from second-channel interference. Reception of very weak signals can be considerably improved, especially with those receivers which have only a single RF stage, or no such stage at all.

In the case of second-channel interference, a very worthwhile improvement is likely. With a superhet, the oscillator is generally operating on a higher frequency than that of circuits tuned to the wanted signal.

As example, if the wanted signal were on 14MHz, and the receiver intermediate frequency is 470kHz, the oscillator would be working on 14,470kHz. In these circumstances, a signal 470kHz higher in frequency than 14,470kHz would also be passed to the IF stages. This unwanted frequency is the second-channel, and is at 14.9MHz in this example. Where the receiver is tuned to 14MHz, its *signal-frequency* circuit may be quite unable to reject 14.94MHz. This is why second-channel interference grows more troublesome, as the frequency is increased. In this example, it would result in 19m SW commercial broadcasts being heard when tuning the 20m Amateur band. Such interference can only be removed by increasing the selectivity of the receiver before the mixer, or by raising the IF. For various reasons both these solutions are generally impracticable, in popular receivers. As a result, though second-channel interference may be completely absent at lower frequencies, it becomes more and more troublesome, as the frequency is raised.

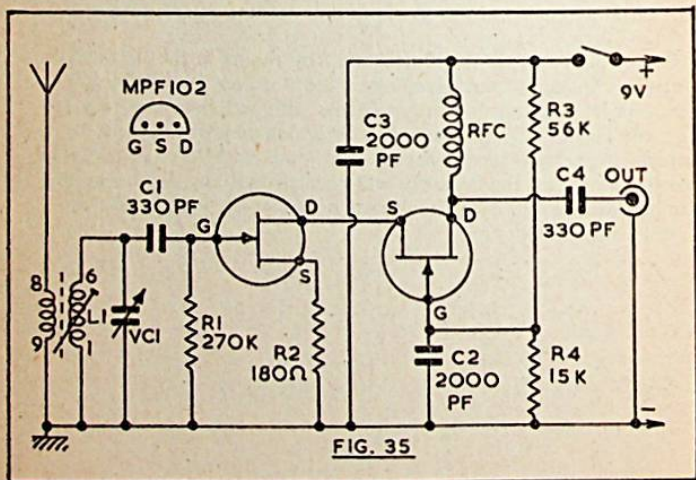

FIG. 35

The circuit in Fig. 35 uses two FETs in cascade, and this arrangement is normally stable, with a reasonable layout. Tuning of L1 is by VC1, and signals are applied to the gate of the first FET. The drain of this device goes to the source of the second FET, resulting in good isolation of input and output circuits. The second FET gate is effectively grounded by C2. Signals are developed across the RF choke, and taken to the receiver by C4.

It is preferable to build the unit in a metal box or case. The FETs and adjacent components can be assembled on an insulated board, mounted on a metal plate or chassis. L1 and associated input circuits items and wiring can then be above the chassis, and the RFC and output circuits are screened from them, below the chassis.

Exact frequency coverage obtained with particular coils will depend on the capacitor, and core setting. However, Denco "Blue" *Valve Type* coils will be found suitable. With a 150pF capacitor, Range 4 can be expected to cover about 8–21MHz, and Range 5 about 14–36MHz. A single coil will thus do for the Amateur HF bands. Second-channel interference grows progressively less troublesome as the frequency is reduced, and is not very likely to be a nuisance under 8MHz except with receivers having only one tuned circuit before the mixer. If required, Ranges 3 and 4 may be used for these lower frequencies, wiring being to a B9A holder, in which the coils can be inserted.

A small reduction drive is helpful on VC1. Its scale can be calibrated by peaking up signals and marking to agree with the receiver scale (taking care to avoid the unwanted second-channel responses which will arise with VC1 in a smaller capacitance position).

The RFC should be about 1mH to 2.6mH. The lead from the output socket to receiver aerial terminal need only be screened if the equipment is unstable, and this lead should be as short as possible.

Output circuit tuning can be added, as in Fig. 36. The main advantage of this arises in the presence of the additional tuned circuit, which will further reduce second-channel signals. It also allows better impedance matching to many receivers, so that gain is slightly higher. The second coil is of the same type as L1, and its smaller winding acts as a coupling inductance for the receiver aerial circuit.

For operating convenience, a 2-gang capacitor is now preferred. A small trimmer should also be connected across each section (30pF will be suitable). Both tuned circuits can then be aligned. To do this, adjust the *trimmers* at a high frequency (ganged capacitor nearly fully open) and the *cores* at a low frequency (capacitor nearly closed). After repeating this a few times, the circuits should tune correctly together.

FIG. 36

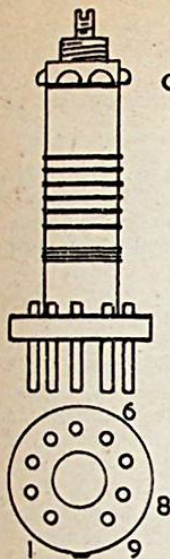

CIRCUIT FOR
TUNED OUTPUT

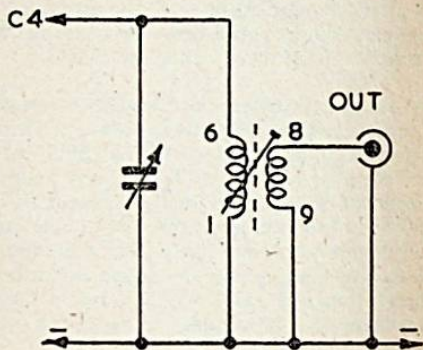

The use of the coils as plug-in units is also shown, and this method avoids switching, and simplifies band-changing. The coil cans provided by the manufacturer can be used as screens, where the layout makes this necessary to avoid instability or whistles due to the RF amplifier oscillating.

Superhet Tuner

Where a tuner offering the increased selectivity and ease of tuning of the superhet is required, the circuit in Fig. 37 will be suitable. As there is only a single intermediate frequency stage, construction is simplified, but a double-tuned IFT in the first position, and silicon transistors, resulting in an adequate performance.

The ferrite aerial winding L1 is tuned by VC1, and TR1 base is supplied by the coupling winding L2. R1 and R2 set base bias conditions. L3 is the oscillator coil winding tuned by VC2. The series padder C3 is required so that L1 and L3 tuned correctly with a constant frequency difference of 465kHz, so that mixing in TR1 provides a 465kHz output for the IF amplifier.

VC1 and VC2 are the sections of a 208/176pF ganged capacitor. Trimmers T1 and T2 may be integral with this component. Alternatively they may be separate items when a ganged capacitor without trimmers is used. Each trimmer may be 50pF or 60pF. The circuit provides medium wave coverage, but long wave coverage can be added as shown later, without changes to other parts of the circuit.

IFT1 and IFT2 can be obtained pre-aligned — that is, already adjusted to 465kHz by the maker. This greatly simplifies initial setting up of the tuner. Later, the IFT cores can be slightly turned as found necessary to give maximum signal strength. These adjustments compensate for stray capacitances in wiring, etc.

Diode D1 demodulates the signal to provide an audio output, and this is taken off at the wanted level by the volume control VR1. The diode also provides a negative bias, which rises with increased signal strength. This bias reaches the IF amplifier base via R5 and the IFT secondary, to provide automatic volume control. Its effect is to reduce gain with strong signals, so there is less change in volume when tuning in various transmissions, than would be so if no AVC were provided.

A 6V or 7.5V supply is adequate. If a 9V supply is available, the tuner may be operated from this, a 470 ohm resistor being placed in the positive supply lead.

Adjustments and Trimming

The usual base coupling winding L2 provides rather tight coupling for a transistor offering high gain, and if it is found that oscillation accompanies all signals, or arises especially at the high frequency end of the band, a turn or two may be removed from L2. Or a resistor may be connected between L2 and C1. Fit the lowest value which prevents oscillation — probably about 100 to 470 ohm.

FIG. 37

BC107 (2)

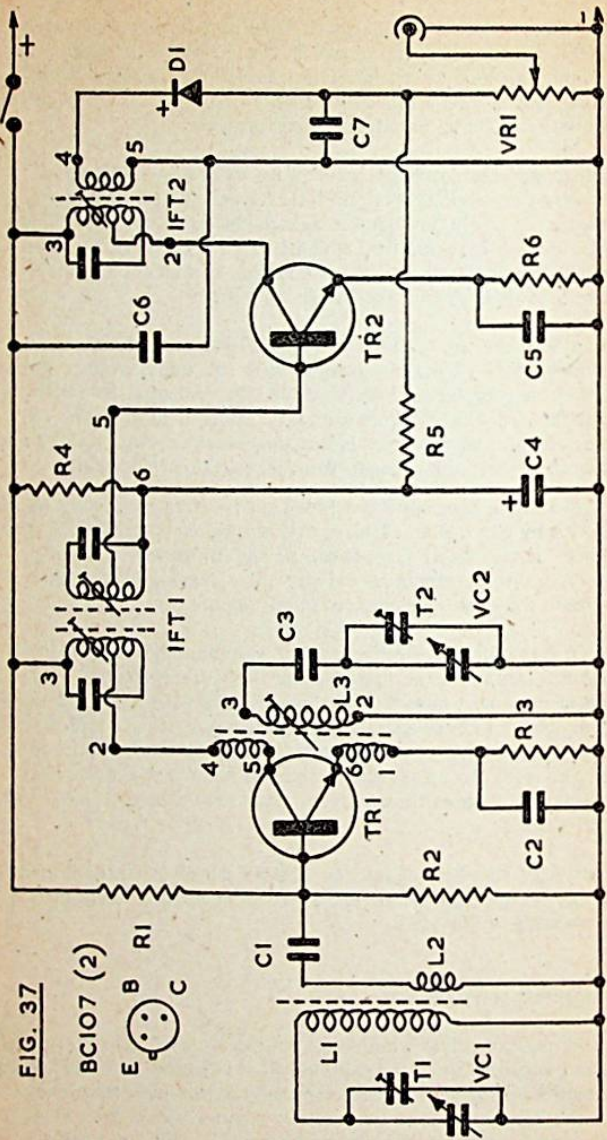

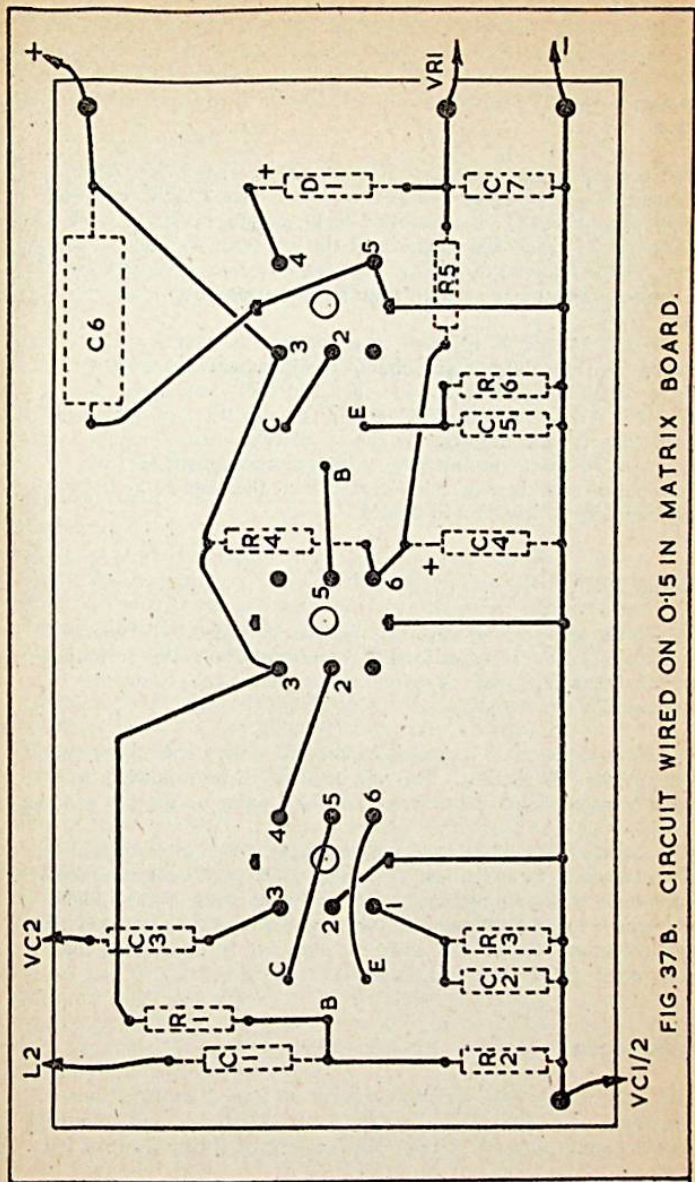

FIG. 37B. CIRCUIT WIRED ON 0.15 IN MATRIX BOARD.

To align aerial and oscillator tuning, set T2 about half closed. Tune in a signal with VC1/2 nearly fully open, and adjust T1 for best volume. Now tune in a signal with VC1/2 nearly fully closed, and move L1 on the ferrite rod, for best volume. Repeat both these adjustments a few times.

Band coverage is about 1600 to 550kHz. If necessary, the highest frequency tunable can be increased by unscrewing T2 (this calls for re-adjustment of T1). On the other hand, should modification of the frequency reached be required at the low frequency end of the band, this is achieved by slightly adjusting the core of L3 (L1 must be re-positioned on the rod afterwards, to restore alignment).

The IFT cores may be adjusted, as mentioned, using a correctly shaped tool to avoid breaking them. If adjustments are made by ear, it is best to set VR1 at maximum, and find weak signals, as these will not operate the AVC circuit. Due to the AVC action, strong signals make adjustments appear relatively flat, though a meter can be placed in one battery lead, and alignment may be directed towards securing the *lowest* current (corresponding to maximum signal level at the diode).

Adding LW

Fig. 38 shows how long wave coverage can be added. MW and LW sections of L1 are in series for LW reception. The switch introduces an extra capacitor, with T4, across the oscillator coil, to modify coverage for LW reception.

The LW winding must be placed on the rod so that it is in the same sense as the MW winding. This will be achieved by following the maker's instructions. L2 now goes to the tapping on the LW winding.

MW alignment should be as already explained, with the switch at M. Then switch to L, and adjust T4 so that 200kHz LW comes at about the middle of the tuning range. Subsequently adjust T3 at a higher frequency, and the LW winding on the rod at a lower frequency, for best reception. Should LW alignment prove to be impossible, the core of L3 may be wrong positioned.

Construction

This circuit lends itself well to assembly on a small insulated board, which can carry all items except the ganged capacitor, and combined volume-control/on-off switch. These are fitted to the front of the case.

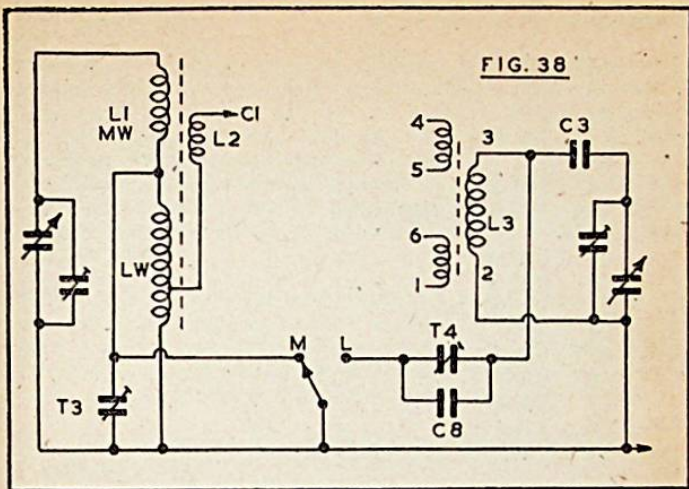

Fig. 37B shows underside wiring, and placement of components. Holes should first be drilled for the oscillator coil and IFTs. These are mounted by their screening can tags, which are connected to the "earth" line. Plain paxolin could be used, about 4 x 2in., with small holes drilled for resistor and other leads.

Flying leads are provided for circuits to L2 and from C3 to the oscillator section of the gang capacitor, which is returned to the negative line. The ferrite rod is best supported by a mount cut from wood or other insulated material.

Pins or leads are fitted to take to positive and negative supply circuits, and to the volume control. The board cannot be tested until VR1 is connected as it completes the base circuit to TR2. Remember to add a resistor of about 470 ohm to 1k in the positive circuit if the supply is derived from a 9V supply also operating an amplifier.

BF194 and BF195 transistors can work well in this circuit. Any difficulty such as instability of the amplifier is unlikely, but may if present be cured by placing a resistor of a few hundred ohms in series with L2, or between osc. coil pin 4 and IFT1 pin 2, or between 5 and base of the IF amplifier.

Components for Superhet Tuner:

R1 56k
R2 10k
R3 1.8k
R4 56k
R5 27k
R6 680 ohm
VR1 5k log pot with switch

C1 0.01uF
C2 0.01uF
C3 175pF 1%
C4 8uF
C5 0.1uF
C6 0.25uF
C7 0.01uF
C8 150pF 2%
VC1/2 208/176 gang with trimmers

TR1 BC107
TR2 BC107
D1 OA81

L1 (MW and LW) with L2: Denco MW/LW-FR5 ferrite rod
L3 Denco TOC.1
IFT1 Denco IFT18/465
IFT2 Denco IFT14

T3 60pF
T4 60pF
2-way switch

TRF Tuner/Receiver

The "straight" receiver, also called a TRF or Tuned Radio Frequency receiver, is of much simpler type than the superhet. With a superhet, incoming carrier and local oscillator frequencies are mixed, to produce a totally different frequency, which passes to the intermediate frequency amplifier. This is then demodulated, and amplified. These circuit complications, and the need for alignment of aerial, oscillator, and IF stages, are absent from the TRF. If it has no radio frequency amplifier, the TRF has only one tuned circuit, and there are no alignment adjustments to make.

A TRF receiver may be less sensitive than a superhet, and is usually less selective. But by using regeneration, sensitivity can be raised to a very good level. Selectivity can also be good enough for the interference-free reception of a reasonable number of the more powerful signals, especially with a ferrite rod aerial, so this type of receiver is quite practical.

Fig. 39 is a 2-transistor TRF circuit which can provide headphone reception, or can be used to feed an amplifier. The circuit is of reflex type, in which TR1 provides both RF and AF amplification, and it is capable of very good results. An OC44 is indicated here, and it is not easy to find an alternative which proves as satisfactory in the silicon range.

Aerial

This is winding L1, tuned by VC1. A ready-manufactured Litz medium wave winding (as used for a superhet) will be found very satisfactory here, and the base coupling winding L2 will be present. VC1 will usually be 208pF, for this type of aerial winding. It is in order to use a 200pF or 250pF capacitor, or the 208pF section of a 208/176pF superhet tuning capacitor.

Alternatively, this winding can consist of sixty-five turns of 26swg enamelled wire, closely side by side, near the end of a $5 \times \frac{3}{8}$ in. ferrite rod. Secure the ends with adhesive or thread. L2 is then wound on the "earth" end of L1, and has six turns. The gauge used for L2 is not important. VC1 can be of similar value to that described. Modification to the value of VC1 will alter the tuning range, but have no effect on performance within the frequencies covered.

Regeneration

Signals pass from L2 to the base of TR1. Radio frequencies are blocked by the RF choke, and reach the diodes D1 and D2 via C2. These diodes provide detection or demodulation, and the *audio* signal reaches TR1 base through L2. Audio signals pass the RF choke, and

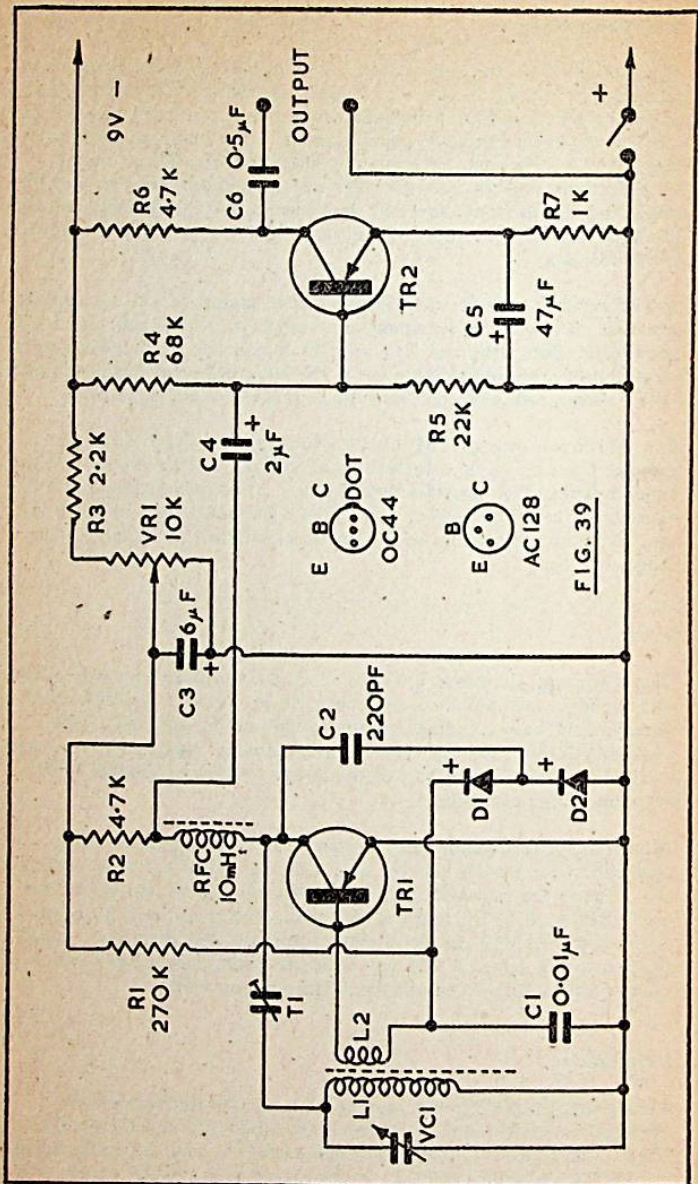

FIG. 39

the audio signal voltage is developed across the collector resistor R2, and passes to the audio amplifier via C4.

The trimmer T1 provides feedback of RF from TR1 collector to L1, so that regeneration can be obtained. T1 has to be of low value. It can be devised by twisting together two insulated wires, or a 30pF trimmer can be fitted. The voltage reaching TR1 is adjusted by the regeneration control VR1, and T1 should be set so that oscillation is just obtained, with VR1 near maximum.

If no regeneration is obtainable, reverse connections to L2. Though VR1 is a panel control, it is *not* operated in the way usual with an audio gain control, and must not be set automatically at maximum. Instead, it is carefully advanced until a whistle *just* arises, when tuning through a transmission. It should then be backed off very slightly. Maximum sensitivity is slightly before actual oscillation begins, and wrong adjustment of VR1 will give extremely poor results.

When a signal is tuned in, the diodes provide a positive voltage for TR1 base, and this has an "automatic volume control" type of action, which contributes to the stability of the circuit. Here, OA81 diodes can be expected to be satisfactory, though similar types could be tried if to hand. With some diodes, the value of R1 can be modified with advantage.

Audio Amplifier

TR2 is a straightforward amplifier, with base operating conditions set by R4 and R5, and emitter bias by R7. R6 is the collector load, so that the output may be taken to phones, a crystal earpiece, or by means of a screened lead to a separate amplifier.

If phones of about 250 ohms to 2k are to be used, and the circuit is not required for use as a tuner, then R6 and C6 can be omitted. The phones are then connected from TR2 collector to negative. A crystal earpiece cannot be used in this way. As working conditions now depend somewhat on the resistance of the headset, it may be worth modifying the value of R4, or R5, to obtain best results.

A receiver of this kind is readily constructed to fit a small plastic or other insulated box. For a very small receiver, VR1 can be a miniature edge-operated control. A linear potentiometer is best here, but not essential. A PP3 battery is adequate, and even further reduction in size is possible by fitting a 250pF compression capacitor for VC1.

Push-Pull Amplifier

The 2-transistor output stage in Fig. 40 may follow the original output stage, or can be used with other circuits of similar type. It is very easy to provide correct operating conditions, as these do not depend on other stages. A further advantage of this is that various output transistors can be used, which is generally not so with directly coupled stages.

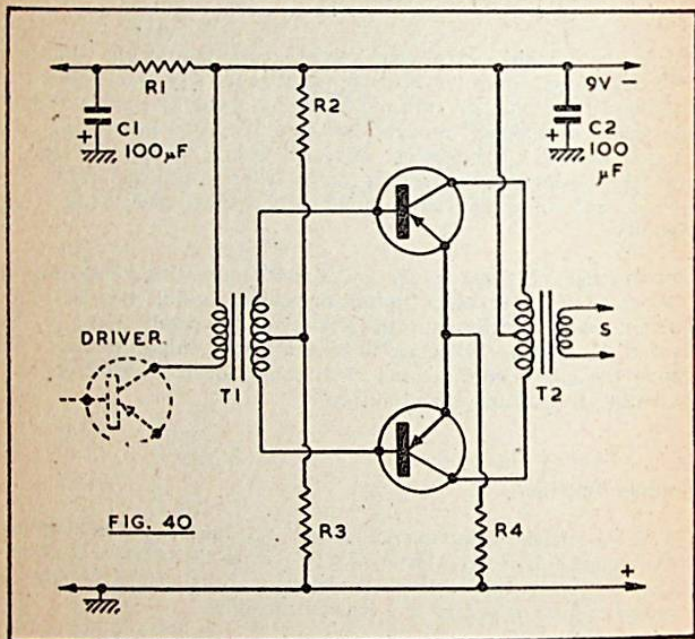

T1 is the driver transformer, and its primary provides the collector load for the previous audio amplifier. The centre-tapped secondary drives the output transistors in push-pull, one conducting when the other is cut off. Base operating conditions are set by R2 and R3. R4 is an emitter resistor, to limit emitter current.

T2 combines the outputs, to operate the speaker. With such output stages the resting, or no-signal current is quite low. Current rises as volume is increased. Current will depend on the actual transistors and exact operating conditions, but can be around 5–10mA or so with no signals, or at low volume, this rising to peaks of 30–60mA or so with volume considerably increased.

Current drawn by the output pair can be found by placing the meter between the negative line and centre-tape of T2. Alternatively, place the meter in one battery lead, allowing for current drawn by the other

part of the circuit. If current is very low, and there is objectional distortion, the base bias point is not sufficiently negative. This is corrected by reducing the value of R2, or increasing the value of R3. Where current is too heavy, R2 should be increased, or R3 reduced. In fact, some circuits have a pre-set resistor in one of these positions. When this is not provided, R2 and R3 should be individually selected, or should be 5 per-cent values, correct for the transistors employed.

Such a circuit may employ small transistors, and give an output of up to about 250mW, with economical running. Or larger transistors may be used, to secure an output of 500mW to 1 watt. Naturally the full output is only obtainable when the input signal, or drive, is sufficient.

R1 and C1 are to decouple the earlier stages, to avoid instability, and similar troubles. R1 may often be 1k, and C1 may be 100uF. The value of R1 may depend on the current required by earlier stages, but is not generally critical.

Transformers T1 and T2 may be miniature components for low power, but a larger component will be required for T2 if the higher output power is to be obtained *Driver and output transformers of these types are readily available. The best ratio for T1 will depend on the driver transistor, and output transistors. The ratio for T2 depends on the transistors, operating conditions, and speaker. It will be found that often a perfectly adequate performance is obtained with transformers of somewhat different ratio from that specified.

A matched pair of output transistors is most satisfactory, but two of the same type will generally be adequate, though they may be less ideally suited for use together. PNP transistors, as shown, allow the output stage to have a positive "earth" line, to match the receiver. If a negative line is required, to suit other equipment, NPN transistors can be substituted.

Operating conditions for the *driver* stage, connected to T1, may depend on the power expected, and output transistors. In the values given, R5 is from base to negative line, R6 from base to positive line, and R7 is the emitter resistor.

R2	4.7k	T1	5.5:1 + 1
R3	82 ohm	T2	4.6 + 4.6:1
R4	4.7 ohm		3 ohm speaker
R5	68k		Driver: AC128
R6	22k		Output: 2 x AC128
R7	1k		Max. output: 500mW
Positive "earth" line			

R2	1.2k	T1, T2, speaker, as above
R3	100 ohm	Driver: BC108
R4	4.7 ohm	Output: 2 x BC108
R5	15k	
R6	47k	
R7	1k	
Negative "earth" line		

Dual-Boost Mixer

With audio equipment it is useful to be able to mix the signals from two sources, such as tuner and pick-up, or from a microphone and pick-up, or alternative pick-ups. The circuit in Fig. 41 will do this, and it also provides a useful extra degree of gain for each channel, when wanted.

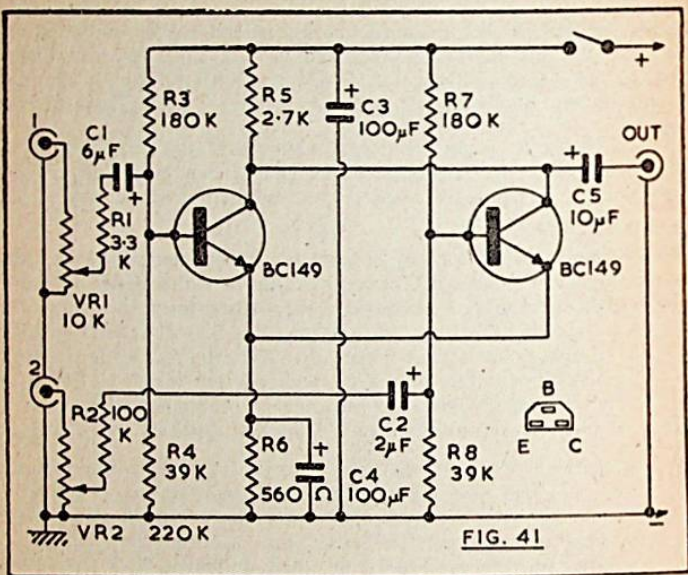

FIG. 41

Input (1) is for relatively low impedance sources, and VR1 is the individual level control for this. Input (2) is more suitable for high impedances, and has the gain control VR2.

Each input has its own individual amplifier, and R5 is a common collector load for these, output being via the isolating capacitor C5. A separate on-off switch is preferable to combining this with VR1 or VR2, as these controls can then be left at pre-determined settings.

A 9V supply is convenient, and if a separate battery is provided for this it will avoid any likelihood of hum or other troubles introduced from a power supply. However, other voltages can be used, and if the mixer is run from a battery or power-pack already supplying the main amplifier, then a resistor of about 1k (or as appropriate for the main amplifier voltage) should be placed in the positive lead. This will avoid coupling of mixer and main amplifier through the power circuits.

Perforated board is probably most suitable for assembly. All the components except the sockets, switch, and level controls can be mounted on this.

The actual type of socket used for the inputs and output can be chosen to match up with other equipment. Alternatively, 3.5mm jack sockets will be convenient. Screened leads will run to plugs which are inserted in (1) and (2). A screened lead should be made to take the output to the main amplifier input.

It is almost essential that the unit is placed in a metal box to complete screening. Various folded sheet metal and die-case boxes are easily obtained, or something similar can be improvised. It is large enough to accommodate the battery. Whether or not the mixer proves satisfactory in use without a screening box depends on the likelihood or otherwise of pick-up from nearby AC or other circuits, including the main amplifier speaker and power circuits. If the mixer runs from the main power supply, a twin lead with plug for positive and negative power circuits should be provided, so as not to rely on the brading of the output circuit lead for the negative return.

Audio Pre-Amp

An amplifier is only capable of giving its full rated output when there is sufficient power to drive it. Some popular and relatively inexpensive amplifiers are intended for certain specified inputs, which are of a high enough level. No difficulty arises with these. But when other inputs, of lower level, are used, full volume is no longer obtained, even with the amplifier gain control at its maximum setting.

In these circumstances, a pre-amplifier can be placed between the microphone (or whatever source of signals is in use) and the main amplifier. This boosts the level of signals, so that the main amplifier receives an adequate input, and can if required again provide its full rated output power.

A pre-amplifier should contribute little distortion or noise of its own, and very good results can be obtained by using two transistors with feedback, as in Fig. 42.

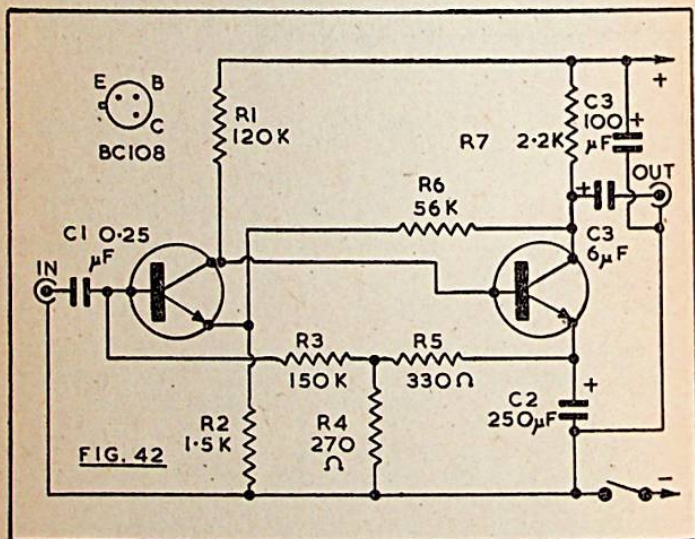

This pre-amplifier has a high input impedance. This can be an important factor, as explained later, especially with high fidelity equipment. The output is at low impedance, and can be taken to most amplifiers with satisfactory results. The amplification obtained depends somewhat on actual transistor samples, and on the supply voltage, but is around 30dB.

The most important point to bear in mind when constructing this circuit is the need for screening, together with the provision of a hum-free, decoupled supply. If the pre-amplifier is run from its own battery, included in the case, there will of course be no danger of hum or instability from this. But when current is drawn from the main amplifier, it must be well smoothed, with a decoupling resistor in the positive line, if required. The unit is intended for operation in conjunction with a main amplifier providing an 18V supply. However, lower voltages are in order, though gain will be reduced.

There are two feedback circuits – one via R3 and R5 to the first transistor base, and the other via R6 to emitter. The values shown should be used, as they also set the direct current operating conditions of both stages.

Input and output sockets can be 3.5mm, or to suit the other equipment. It is in order to include a volume control at the input socket, if this item is required. A 250k potentiometer is suitable for this. A screened output lead should be prepared to connect the output socket to the main amplifier input. The on-off switch is of course not required if power is drawn from the main amplifier.

Impedance Buffer

If a high impedance unit such as a crystal microphone is operated into a low impedance circuit, some loss of quality results, due to loading by the low impedance. Whether or not this is important depends on the degree of loading, and on the results expected. For much general purpose work, it may well be felt that satisfactory results are being obtained, even with a crystal pick-up or other high impedance unit working into a low impedance circuit. But for high fidelity equipment, this would not be considered satisfactory.

Transformers were once often used for impedance matching. These allow any required impedances to be matched, and do not introduce a very important loss of power. But they cannot be expected to have a flat frequency response, and may easily pick up hum voltages, even when screened, besides being expensive items.

An alternative to the transformer is a resistance pad, which enables the unit to work into a high impedance. As example, if a high impedance input is required with a transistor amplifier of low impedance, it might be achieved by placing a high-value resistor (commonly 220k to 1 megohm) in series with the unit, or at the amplifier input after a high-resistance volume control. Unfortunately this loses a considerable proportion of the available signal voltage. Matching by this means is not similar to that of a transformer, where losses are small. As a result, the amplifier may prove to have insufficient gain, though it provides enough output power when used with a low impedance input unit.

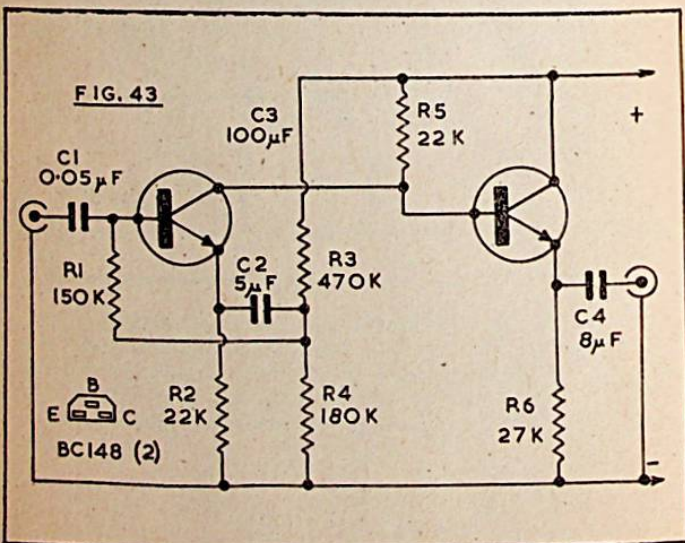

The 2-transistor buffer in Fig. 43 can help overcome such difficulties. It has a high impedance input, but a low impedance output. Its gain is 1 — that is, output is approximately the same as input, despite the impedance transformation.

Once again, this should be constructed to occupy a metal box, which provides screening, and is common to the negative line. If the unit is operated from its own batteries, a switch is necessary in one battery lead. Otherwise, similar considerations apply as to the earlier circuit, as regards a hum-free, decoupled supply. This circuit is also intended for 18V.

2-Transistor AF Amplifiers

A 2-stage audio amplifier able to give modest but quite useful volume can be made with few components. It can be utilised with a tuner, or with other equipment where headphone volume is to be raised to that suitable for a loudspeaker.

The circuit in Fig. 44 has two high-gain NPN transistors. Audio input is via C1, and R1 provides base current for this stage, R2 being the collector load. C2 couples signals to the output stage. C2 couples signals to the output stage.

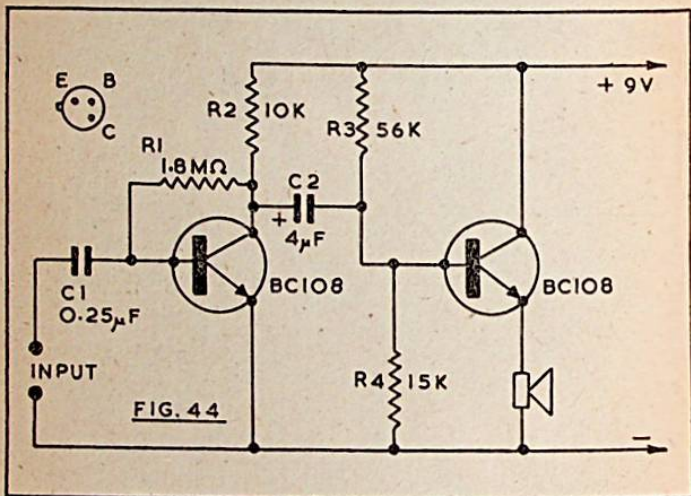

Base bias in the output stage is from R3 and R4. This transistor operates as a grounded collector amplifier – the collector is not actually connected to the “earth” or ground line, but is grounded as regards audio signals through the battery, which has negligible impedance.

For general purposes, a 15 ohm speaker is most satisfactory, but it will be found that speakers of up to about 75 ohms may be used. Current drain is around 25–30mA with a 15 ohm speaker, falling to 10–15mA with a 75 ohm unit. The circuit can also be used as a headphone amplifier, and is widely tolerant of the headphone impedance or DC resistance. Headsets of up to about 1.5k DC resistance can be used, current then falling to only 2–3mA.

Maximum sound output and best reproduction will be achieved with a reasonably large speaker – say 3 x 5in, 4 x 7in., or 5in. in diameter. For personal listening, a 2½in. unit can be fitted. It is almost essential that the speaker have a cabinet or baffle, whatever its size, and this can be a plastic or metal box, or can be made from wood.

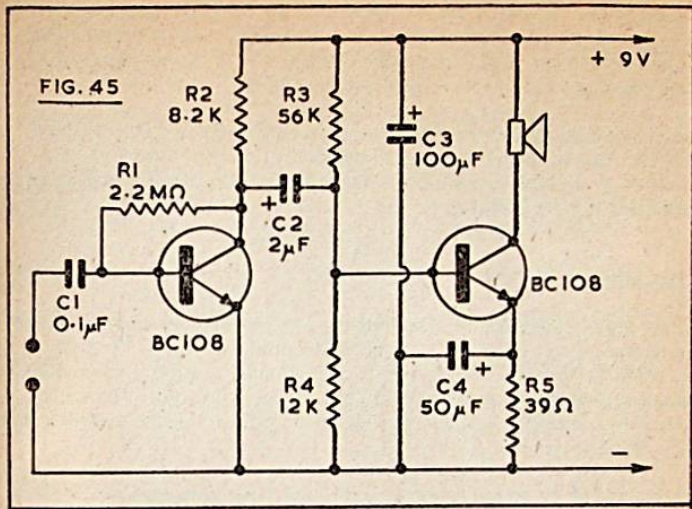

Fig.45 is a somewhat similar circuit, except that emitter bias for the output stage is provided by R5, and the speaker is placed in the collector circuit. A 15 ohm speaker is again suggested, though impedances up to about 75 ohms can be used. Current drain is about 15–20mA, with a little more gain, but distortion from overloading can arise more quickly if the input is too great.

Other transistors can be used in these circuits, but it may be necessary to change the values of some resistors. Where equipment already in use has a positive ground line, PNP transistors can be fitted instead. An OC71 will then do as pre-amplifier, with an AC128 for output, R1 being about 100k, and R2 about 4.7k. Do not overlook that the polarity of electrolytic capacitors must be changed, with the positive ground line.

When transistors other than those shown are to be fitted, the performance of the first stage can be checked by placing medium or high impedance phones from C2 to ground line. A meter should be put in series with R2. It will then be clear how changes to the values of R1 and R2 influence gain, and current drawn by this stage.

With the second stage, power-handling capacity can be increased, at the expense of increased current drain, by increasing the value of R4. Operating conditions here are thus a compromise between the volume wanted, and current drain permissible, though current must never be so high that the transistor is over-run, and this sets a quite low limit with the BC108 and transistors of similar types. Approximate dissi-

pation in the transistor can be found by measuring the emitter/collector voltage, and multiplying by the collector current. The emitter/collector potential is lower than that of the battery, due to the voltage lost in collector and emitter loads (loudspeaker and R5).

As example, suppose current is 20mA, from the 9V supply. R5 and the 15 ohm speaker drop approximately 1V, so that dissipation is $8 \times 0.02 = 0.160\text{w}$ or 160mW. This is well within the 300mW rating listed for this transistor.

Instability

When an amplifier is added to existing equipment, any unwanted feedback from output circuits to input will cause instability. That is, continuous howling, whistles, or similar sounds, possibly only beginning when volume is increased or gain controls are advanced. The more stages the amplifier has, and the higher its gain, the more probably does this trouble become.

It is avoided by screening input leads, and positioning speaker leads so that signals are not coupled back into earlier stages of the equipment. If a common battery supply is being used, the circuit to earlier stages should be decoupled, to prevent signal voltages travelling back into them and thus reaching the amplifier input. Suitable decoupling is usually provided by adding a resistor of about 330 ohm to 1k or so in the supply circuit, with a capacitor of 100uF or larger from the resistor to ground line.

EQUIVALENT SEMICONDUCTORS

To help our overseas readers the following list of possible equivalents is shown below:-

AC128	CV9778, OC74-318, NKT281, 2N467, 2SB222-415, AC117-124-153, GET110, NKT302, SFT232, 2N659-1373-1384-1926-2001-2431-4106, 2SB370, SK3004, RS276-2005.
ACY39	CV9475, NKT243, ACZ10, 2N652-2303-2801.
AF117	2N642, 2SA155, AF102-105-127-133-137, BFX48, BSW19-73, GM1213B, NKT603F, SFT354, SK3006, 2N2273-2635-3324-4916-5354, RS276-2003.
BC107	CV9780, AM251, BC147-167-207-317, MPS6566, SK3020-3122, ZTX107, TT107, RS276-2009.
BC108	CV10541, AM252, BC148-168-208-318, MPS6520, SK3020, ZTX108, TT108, RS276-2009.
BC109	CV10769-10806, AM253, BC149-169-209-319, MPS6521, SK3020, ZTX109, TT109, RS276-2009.
BC147	BC171-182/L-207-317, MPS6566, SK3020, RS276-2013.
BC148	BC172-183/L-208-318, MPS6520, SK3020, RS276-2009.
BC149	BC184/L-209-173-319, MPS6521, SK3020, RS276-2009.
BF200	BF162-173-225-271-311-314, SE5020/1/2/3/4, SK3018, 2N616-2708-3288-3693, RS276-2011.
BFY51	CV7723-7726-10827-11238, BFX51-68A, BFR19, BSX45/X, BSY46-85, SK3024, 40347, 2SC708, ME6102, 2N2193/4-2218-2410-3053-3252-4046, RS276-2009.
BSY95A	CV7648-9379, BC108A, BSX51-73-91, BFX96, BSY20-58-62, ME9022, SK3122, 2SC321, 2N744-914-1708-2218-2369-5187, RS276-2011.
MPF102	E305, SK3116.
OA81	AA117-118-132-144, AAZ15, OA91-95-161, SD38, 1N38-56-476-618, 1S33.
OC26	CV8560, NKT452, 2N257-297-458-553-1021, 2SB3, AD130-131-138-140-149, OC28, SK3009, TF80, T1156-3027, 2N174-1073-2870, RS276-2006.
OC29	CV7083-8356, NKT402, 2N457, 2SB86-425, AD150, ASZ16, AUY21, OC28-35-36, SK3009, T13028, 2N174-1073-2870, RS276-2006.
OC44	CV5710-7003, OC170-171-410-613, 2N1303, 2SA15, AF101-117-126, ASY55, AC191, BC126, NKT211, SFT358, SK3005, 2N36-1191/2-1352-1373-1384, RS276-2003.
OC70	CV5457, OC303-602, NKT214, 2N279-1305, 2SB75, AC122-125-151-163, ACY27-34, ASY27, BC213-206A, BSX36, SK3003, 2N1193-1352-1375-1384-2429, RS276-2004.
OC71	CV5712-7005-8344, OC70-304-604, NKT214, 2N280-1305, 2SB77, AC122-125-151-163, ACY35, BSX36, OC3041, SK3003, 2N1193-1352-1375-1384-2429, RS276-2004.
OC72	AC122/3-125/6-131-151 IV-152-162-191, BC126-213-206A, NKT211, SFT353, SK3003, 2N282-1190-1352-1371-1384-1991-2431, CV5713-7006-8440, RS276-2005.

OC76	CV8314, OC307-6025, 2N284-1305, NKT212, 2SB89, AC128-131-151-152, ACY28, ASY58-76, BC126-213-260A, SK3004, 2N394-1191-1352-1371-1384-1991, RS276-2004.
ORP12	RS276-116, LDR03, RPY25.
1N4001	BY127, EM502, RS276-1101 /1135, 1S100.
1N4002	BY127, EM502, RS276-1102 /1136, 1S100.
2N1306	CV7350-10686, NKT736, 2N634-635-636-1891-1993-1994-1995, ASY26-29, BSX19-20, RS276-2001.
2N1613	CV7440-8843, BFY33-34-67, BSY44, 2N698-699-717-1711-1889-1890-1893, BFY41, BSX45/6, BSY53, MPS6530, 2SC708, 2N2101.

N. B. Although equivalent semiconductors may have similar electrical properties, physical dimensions may be different and this must be born in mind if space is tight and for mounting details.

Remember polarities if replacing PNP with NPN types and vice versa. Also see notes on pages 35 and 36.

If in doubt always be advised by your local dealer for suitable equivalent semiconductors.

NOTES

NOTES

BIBLIOTHEEK
N.V.H.R.

BERNARDS & BABANI PRESS RADIO AND ELECTRONICS BOOKS

BP1	First Book of Transistor Equivalents and Substitutes	40p
BP2	Handbook of Radio, TV and Industrial & Transmitting Tube & Valve Equiv.	60p
BP3	Handbook of Tested Transistor Circuits	40p
BP4	World's Short, Med. & Long Wave FM & TV Broadcasting Stations Listing (International Edition)	60p
BP5	Handbook of Simple Transistor Circuits	35p
BP6	Engineers and Machinists Reference Tables	30p
BP7	Radio and Electronic Colour Codes and Data Chart	15p
BP8	Sound and Loudspeaker Manual	50p
BP9	38 Practical Tested Diode Circuits for the Home Constructor	35p
BP10	Modern Crystal and Transistor Set Circuits for Beginners	35p
BP11	Practical Transistor Novelty Circuits	40p
BP12	Hi-Fi, P.A., Guitar & Discotheque Amplifier Handbook	75p
BP13	Electronic Novelties for the Motorist	50p
BP14	Second Book of Transistor Equivalents	95p
BP15	Constructors Manual of Electronic Circuits for the Home	50p
BP16	Handbook of Electronic Circuits for the Amateur Photographer	60p
BP17	Radio Receiver Construction Handbook using IC's and Transistors	60p
BP18	Boys and Beginners Book of Practical Radio and Electronics	60p
BP22	79 Electronic Novelty Circuits	75p
BP23	First Book of Practical Electronic Projects	75p
BP24	52 Projects using IC741 (or Equivalents)	75p
BP25	How to Build Your Own Electronic and Quartz Controlled Watches & Clocks	85p
BP26	Radio Antenna Handbook for Long Distance Reception & Transmission	85p
BP27	Giant Chart of Radio Electronic Semiconductor & Logic Symbols	60p
BP28	Resistor Selection Handbook (International Edition)	60p
BP29	Major Solid State Audio Hi-Fi Construction Projects	85p
BP30	Two Transistor Electronic Projects	85p
BP31	Practical Electrical Re-wiring & Repairs	85p
100	A Comprehensive Radio Valve Guide - Book 1	40p
121	A Comprehensive Radio Valve Guide - Book 2	40p
126	Boys Book of Crystal Sets	25p
129	Universal Gram-Motor Speed Indicator (Combined 50 & 60 ω model)	10p
138	How to Make Aerials for TV (Band 1-2-3)	25p
143	A Comprehensive Radio Valve Guide - Book 3	40p
150	Practical Radio Inside Out	40p
157	A Comprehensive Radio Valve Guide - Book 4	40p
160	Coil Design and Construction Manual	50p
161	Radio, TV and Electronics Data Book	60p
170	Transistor Circuits for Radio Controlled Models	40p
177	Modern Transistor Circuits for Beginners	40p
178	A Comprehensive Radio Valve Guide - Book 5	40p
183	How to Receive Foreign TV Programmes on your Set by Simple Modifications	35p
196	AF-RF Reactance - Frequency Chart for Constructors	15p
200	Handbook of Practical Electronic Musical Novelties	50p
201	Practical Transistorised Novelties for Hi-Fi Enthusiasts	35p
202	Handbook of Integrated Circuits (IC's) Equivalents and Substitutes	75p
203	IC's and Transistor Gadgets Construction Handbook	60p
204	Second Book of Hi-Fi Loudspeaker Enclosures	
205	First Book of Hi-Fi Loudspeaker Enclosures	
206	Practical Transistor Circuits for Modern Test Equipment	
207	Practical Electronic Science Projects	
208	Practical Stereo and Quadrophony Handbook	
209	Modern Tape Recording Handbook	
210	The Complete Car Radio Manual	
211	First Book of Diode Characteristics Equivalents and Subs	
213	Electronic Circuits for Model Railways	
214	Audio Enthusiasts Handbook	
215	Shortwave Circuits and Gear for Experimenters and Rad	
216	Electronic Gadgets and Games	
217	Solid State Power Supply Handbook	
218	Build Your Own Electronic Experimenters Laboratory	
RCC	Resistor Colour Code Disc Calculator	

bliotheek Ned. Ver

The Grampians, Shepherds Bush Road, London W6 7H
Telephone: 01-603 2581/7296