

75p

THE COMPLETE CAR RADIO MANUAL

BY F. C. PALMER

R.Tech.Eng, M.I.P.R.E., A.M.I.E.T.

Including

Aerials

Installation

Suppression

Fault Finding

etc. etc.

R

de Historie v/d Radio

BERNARDS (publishers) LTD

No. 210

THE COMPLETE

CAR RADIO

BIBLIOTHEEK
N.V.H.R.

MANUAL

BY

F. C. PALMER

BERNARDS (publishers) LTD

The Grampians
Shepherds Bush Road
London W6 7NF

Although every care is taken with the preparation of this book the publishers will not be responsible for any errors that might occur.

© 1975

I. S. B. N. 0 900162 44 9

First Published March 1975

Printed in Great Britain by C. Nicholls & Company Ltd.

C O N T E N T S

Preface	Locating Short Circuits	5
Chap. 1	Fundamental Considerations	7
Chap. 2	Car Radio Aerial	9
Chap. 3	Preliminary Installation Factors	13
Chap. 4	Selection of a Car Radio	17
Chap. 5	Car Radio Receiver Design	18
Chap. 6	Classification of Car Radio Installation	19
Chap. 7	Introduction to Radio Interference Suppression	21
Chap. 8	Procedure for Suppression Interference	24
Chap. 9	Brake and Tyre Static Suppression	32
Chap. 10	Testing Aerials for Faults	38
Chap. 11	Testing Speakers for Faults	41
Chap. 12	Car Radio Voltage Droppers	44
Chap. 13	Car Radio Faults and their Correction	45
Chap. 14	Difficult Rear Speaker Mounting	50
Chap. 15	Illustrated Installations for Various Cars	52
Chap. 16	The Car Battery	82
Chap. 17	Charging the Batteries	84
Chap. 18	Operation of Batteries in High and Low Temperature	87
Chap. 19	Poor Reception and Dirty Terminals	88
Chap. 20	Testing Car Batteries	89
Chap. 21	British Local Radio Stations - B. B. C. and Independent.	95

INTRODUCTION

Many motorist use their cars for frequent long journeys, and there is no doubt, that a properly installed car radio will give added pleasure, as well as relieving the strains of driving.

An ever increasing number of cars, and transport vehicles of various kinds, are being fitted with car radio for this reason and that this number is going to increase in ratio, that is, of course, linked with the production of such motor vehicles.

The maintenance of the electrical equipment in motor cars, is a highly skilled task, therefore, the motor vehicle electrician must be a capable technician, his skill and knowledge being further sharpened by the complexity of the electrical equipment being added to the motor vehicle. Despite all this an additional task given him, is the one of fitting a car radio.

It is the aim of this book to show the car owner or mechanic how he can assist to a large extent in the fitting of car radios, of preventing interference and the saving of time which, in these times of high labour costs, is a desirable wish.

For the radio service engineer, it is hoped that he will find the whole of the book of use and perhaps in common with the motor vehicle electrician he will come to realise that the fitting of a car radio is just not a matter of a few nuts and bolts with brackets to be placed into position

Motor vehicles are expensive, let us do the job right.

F. C. P.

The author would like to express his gratitude to the following firms: -

The **EXIDE BATTERY COMPANY** for material on car battery maintenance and testing.

Joseph **LUCAS LIMITED** for material on Car Radio Interference Suppression, from their own **PUBLICATION**

RADIOMOBILE LTD for the use of technical material from their installation sheets and on their car radios etc.

Taylor **ELECTRICAL INSTRUMENTS LTD** for data on radio servicing equipment.

Locating Short Circuits

It may happen during the course of dash-board removal, etc. that one of the wires may become trapped, thus resulting in a short circuit to earth. Unless the battery is quickly disconnected, much damage can occur, since the car battery possesses considerable current capacity - amperage - the loom may be burnt out or even a fire break out. A method of locating such short circuits must be of great help and such a method is given.

With reference to the diagram given, A and B, are two bulbs of say 6 volts at 3 watts, which means that the two lights will take 1 ampere from the battery if the battery is a 12 volt one.

The resistance is of 6 ohms and must be rated at 6 watts, the single pole switch is to remove from the circuit the resistance R should the battery be one of only 6 volts capacity.

A fuse F is provided and should not be greater than 1.25 amp and MUST be connected as shown for additional safety as will be explained.

H is the wiring harness and it may be assumed that at X we have a short circuit, X may be anywhere within the car or coach.

The light A, is the one used to indicate when the short has been found since when the fault is found it will go OUT.

The arrow heads at C and D should be terminated by strong crocodile clips and whilst the terminals at C MUST be connected between the battery terminal and its output lead, D may be connected to any part of the chassis within the car, the light D being used as an inspection lamp and will not go out when the fault is found.

The fuse F is vital since the terminal leads from the lights to the battery must be long enough to move about etc should the lamp leads themselves become trapped the fuse will blow, thus giving protection against a hot wire burning the upholstery.

Let an example show how the system works. A short is found, so we connect the terminals C BETWEEN the points shown on the circuit diagram, since the output lead will have been disconnected upon the discovery of the short circuit. We now have a controlled short so to speak only 0.5 amp due to the short will flow via lamp A, and result in no damage. Lamp B when connected to chassis via clip D will cause a further 0.5 amp to flow but lamp B may be regarded as being connected ACROSS the battery as shown with the dotted lines and does not interfere with the system of short circuit location or the function of lamp A. The electrician can now move the wiring within the car until the flickering of the lamp A shows he is near the point of short circuit. Whatever he does, the current cannot be greater than that taken by lamp A, even if he puts on another short circuit in error, but the lamp A will continue to glow until all short circuits are cleared. Some calculations are given if required for other battery voltages. Lamp B may be left out completely, but is useful as an inspection light.

The rule is for the calculation of resistance.

$$\frac{\text{Voltage present} - \text{Voltage required}}{\text{Total current consumption in amps}}$$

For six volt bulbs (lamps A and B) on a 12 volt battery.

$$R = \frac{12v - 6v}{1A} = \frac{6}{1} = 6 \text{ ohms}$$

$$\text{Watts} = I^2 R \text{ or } v^2/R = 6 \text{ watts}$$

For 12 volt bulbs working from a 24 volt battery

$$\frac{24v - 12v}{1A} = \frac{12}{1} = 12 \text{ ohms}$$

$$\text{watts} = I^2 R \text{ or } V^2/R = 1^2 \times 12 = 12 \text{ watts}$$

These calculations take into consideration both lamps, A and B and that each lamp gives 3 watts output.

The whole unit may be made up into a small box, lamp A could have a red or amber glass fitted to show this was the location light and lamp B just plain glass. The switch should be of heavy duty to pass lamp.

The leads should be of good quality rubber covered and of low resistance.

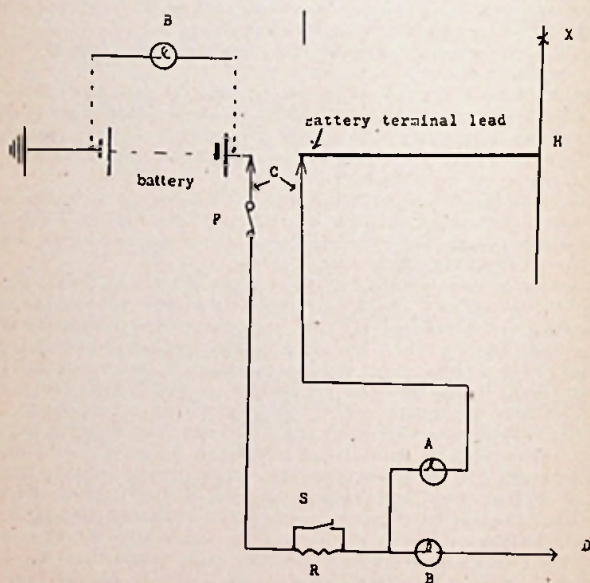

Circuit diagram for short circuit location.

CHAPTER 1

Fundamental Considerations

It appears to be the practice when a car radio is required to fit a portable receiver. At first inspection, there seems to be no real reason why this should not work, a car radio aerial socket is provided, considerable advertisement in the various technical journals all gives one the impression that all will be well.

Now it must be understood, that the radio signal reaches the frame aerial etc, through the plastic or wood case of the receiver. In a large town, where perhaps, the local transmitter is a few miles distant from where the portable is being operated, such receivers give a reasonable performance. This is because the signal strength of the transmitter, is strong enough to overcome the many forms of interference present with in the car.

When the portable receiver is now operated away from the local transmitter, many forms of interference will make their way through the case of the receiver, and be of sufficient intensity to make radio reception vary between very poor to not worth listening.

The causes of the interference comes from the dynamo, the ignition coil or plugs, the windscreen wipers, petrol pump and other electrical systems of the car. Such forms of interference will be given detailed treatment when we come to interference suppression.

During the course of many years, the author has been brought into contact with many of these car radio portables, and it is impossible to reduce the source of such interference without very extensive bonding of the wiring loom, the cost of which renders it beyond the realms of practical consideration.

Therefore, in this book only a properly constructed car radio is considered and even then, we may still have problems of interference suppression to contend with. However, due to the quite different manner of construction, this problem is not as great as it would be in the case of portable receivers.

One further observation to make is, that the various sizes of such portables, do not lend themselves for ease of fitting to cars, where space is extremely limited.

Continuing with our fundamental considerations, we shall give some attention to the construction of a car radio and thus see where it differs from that of a portable receiver.

We note that a car radio receiver case is made of metal, this is to prevent any interference from reaching the tuned circuit within. The input lead, which should be fused, is fed through a filter to remove any source of interference which may reach the tuned circuits from this lead which after passing into the radio can radiate ignition pulses into the tuned circuits, if it were not for the filter circuit specially designed for this purpose.

It will be necessary to explain some terms to the motor vehicle electrician with which he may not be conversant.

The term "impedance" can be likened in importance to the "timing" of cars so that the plugs fire at the correct time.

Whilst the term "aerial trimmer matching" can also be likened in importance, to "correct mixture" of air and petrol in the carburettor if either "timing" or "correct mixture" is not present the performance of any car will be greatly impaired.

Wing mounting, manually controlled extension, fully retractable

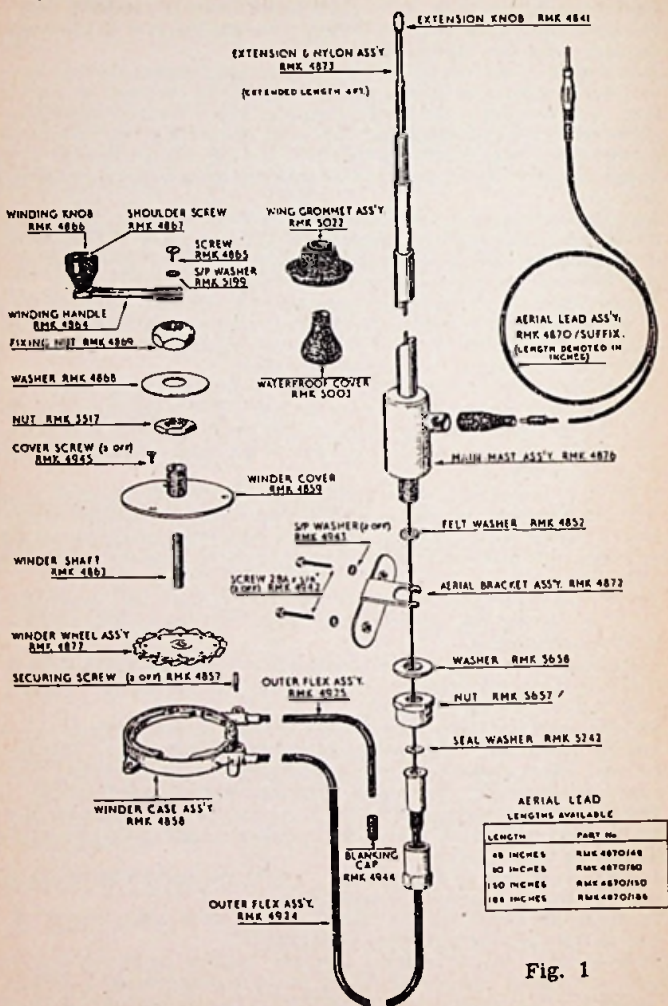

Fig. 1

Aerial trimmer matching will be seen to be of very great importance when car radio aerials are considered.

Since many portable receivers do not have any provision for the matching of the car radio aerial to the receiver, this results in poor signal gain and fading.

This in addition to many other factors, which will become apparent as we go on, makes the portable receiver unsuitable for installation into a car.

CHAPTER 2

The Car Radio Aerial

With all car radios, it is of course necessary to fit an aerial so that signals may be picked up and fed to the receiver. This receiver is as stated, enclosed within a metal box, so that ignition interference etc. may not reach the exposed leads within and be reproduced at the speaker.

There are several types of aerials, which may be mounted on to the wing or to the roof of the car. The actual position depends to a large extent upon the type of car and the recommended position of the aerial given in the installation instructions supplied by the car radio manufacturer.

Some aerials when fitted to the wing have a certain length always exposed whilst other aerials which are called fully retractable may be pushed down into the main section of thicker dimensions. This type of aerial is restricted to cars which have sufficient space under the wing or wheel arch. It must not be so mounted that the aerial mast when fully retracted can come into contact with the wheel also allowing for the body of the car to depress on its springs etc, when going over a bump or when the car is fully loaded with passengers.

That this precaution is vital needs no further comment as to the consequences which would result if it were not adhered to.

The fully retractable aerial may be further extended in facility with the use of a hand winding mechanism which operates within the car. The raising of the various sections of the aerial is achieved by means of a perlon drive. This perlon drive is placed about a winding pulley which is entirely enclosed.

The various lengths of the perlon drive is also enclosed within a cable so that dust and grit etc, would not collect to the perlon drive and obstruct the operation of the winding mechanism. A winding handle is provided to either raise or lower the aerial.

The above method may be further extended by the replacement of the hand winding mechanism for that of an electric motor, all other factors being the same. The switch employed for this purpose is the "self-centring" type, where the "off" position is at right angles to the plane of the switch.

It is usual to connect the switch and position it so that when the switch toggle is moved in an upward direction, the aerial is raised, and of course, when the toggle is moved in a downward direction the aerial sections are lowered into the main mast. This system is essential for night operation of the aerial since it may not be possible to know if the aerial is being lowered especially if one is driving into the garage where the aerial may strike against the roof beams etc. thus causing the mast sections to bend. In such cases, it will not be possible to straighten them out in the manner required.

Wing mounting, electrically operated, fully retractable

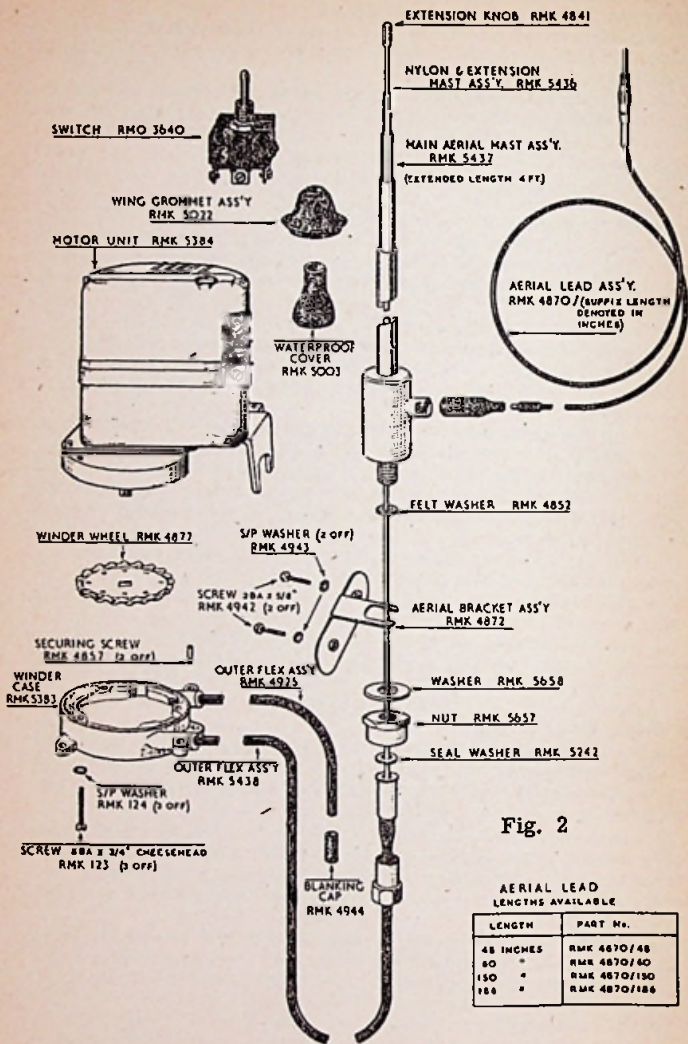

Fig. 2

AERIAL LEAD LENGTHS AVAILABLE

LENGTH	PART No.
48 INCHES	RMK 4870/48
60 "	RMK 4870/60
150 "	RMK 4870/150
186 "	RMK 4870/186

Withdrawal of the hand from the switch, results in the electric motor being switched off.

This method means that the desired height of the aerial sections may be decided by the motorist to suit the signal strength conditions in any particular locality.

With such aerials however a word of warning is necessary under no circumstances should the mast if in the extreme lowered position be pulled up by the metal sections of the aerial with the hand. Or, if the aerial sections are in the raised position - to any extent - be pushed downwards in a like manner, i. e. by hand. To do so would bring about the kinking of the perlon drive which is so hard that it cannot be smoothed out again thus resulting in the perlon drive having to be replaced.

In addition, it will require the removal of the entire aerial either the electrically operated aerial or the hand operated aerial in order for the perlon drive to be removed and the new drive fitted. It also means that there will be a labour charge which may have to be met by the garage etc. if this was down on their premises.

There are some slight modifications to the aerials shown in Figs (1) and (2) which indicates the hand operated and the electrically operated aerial respectively but in general they represent the usual type of aerials being fitted of their class.

A further word of advice with such aerials is necessary, they should only be fitted to cars where provision has been made for their installation. The Jaguar 2.4, 3.4 and 3.8 Mk II cars are the usual cars for the fitting of the above type of aerials. This position is in the drive-side scuttle, where a metal bracket welded to the chassis of the car has been positioned by the manufacturer.

This bracket retains in position the main mast assembly which is in electrical contact with the braid of the aerial lead.

It is essential that a good earth be provided at this point if interference is to be avoided. The main mast assembly houses the other sections of the aerial and protrudes just beyond the surface of the car wing and is held firmly in position by a rubber grommet which also acts as a seal against water.

In every case, however, there is a recommended aerial for each type of car in addition to which its correct position is given in the fitting instructions for the installation of the car radio.

Whenever possible, provided that the driver's view is not obstructed, the author favours the fitting of aerials on the drive side wing either front wing or rear wing.

This reduces the effect of fading due to high walls or hedges etc. since with aerials fitted to the passenger's side, the possibility of their being broken by low laying branches is ever present. In addition, there is more mud etc. on the nearside of a road than on the crown which means that an aerial fitted to the nearside of the car and exposed to the front wheel will have considerable mud and water forced up around it which will cause the aerial lead - with its waterproof covering - to be subjected to more wear and tear than otherwise.

Selection of Aerials

Great care is required in the selection of a car radio aerial. There appears to be a great number of various types of aerials which range from very good to very poor design.

These aerials are unsuitable because the capacity of the aerial lead

does not bring them within the range of the car radio aerial trimmer, the importance of which has been given. This will result in the impedance of the aerial lead not being matched to the impedance of the receiver aerial circuit.

A consequence of this inability is the signal to noise ratio being very low and may also cause a hiss in the reproduction of the signal at the speaker which can be objectionable.

Examination of such aerials also reveals that the aerial plug is split somewhat in the manner of a banana being peeled so that the aerial lead carrying the signal to the receiver is exposed and not covered by the braid which should be screening it.

This will, of course, result in interference from many of the electrical systems of the car such as electric clock, ignition, windscreen wiper.

With regard to the type of aerial which employs either stickers or suction pads for its mounting on to the car wing, or windscreen these cannot be considered to be a true car radio aerial. This is because its very method of construction disregards the most elementary knowledge of preventing interference via the aerial mainly by ensuring that there is an efficient earth under the aerial fitting bracket, with which the screened cable is in electrical contact with the wing or other portion of the metalwork of the car body, i. e. the roof.

The type of aerial which has a large washer instead of sharp raised points (see Earth Bracket Fig. 3) will also give poor earthing to the screened cable, again resulting in aerial interference.

The above aerials are those which the author has had a fair amount of experience with and when replaced have cleared up to 80% of car radio interference problems.

The effect of a poorly designed aerial and its replacement by an efficient aerial has to be experienced to be appreciated with the increased gain and interference free reception.

Extension Leads

With some cars it is necessary for the aerial to be fitted at the off-side rear of the car. In such circumstances it will be clear that an extension lead is required.

Now it must be clearly understood that a car radio aerial extension lead is NOT a length of T. V. coaxial cable.

The practice of cutting a perfectly good aerial lead in half and then joining a length of T. V. cable between the two lengths is quite useless for the following reasons.

On every good quality car radio is an aerial trimmer, this trimmer has been previously stated and its function explained.

Most trimmers will vary from 10 to 120pf, others from 10 to 80pf. It will be seen therefore that if the capacity which is presented to the trimmer falls outside that which the trimmer can adjust, correct matching cannot be achieved with poor gain etc. resulting. The capacity of aerial leads is about 10pf per foot and the capacity of extension leads will, of course, vary with length of which 126 inches in length can be expected with most extension leads.

However, to achieve the correct matching of the aerial together with the capacitance of the extension lead, the extension lead has a condenser within the plug. This brings the capacity of the aerial lead, together with its extension lead, within the range of the trimmer on the receiver. It

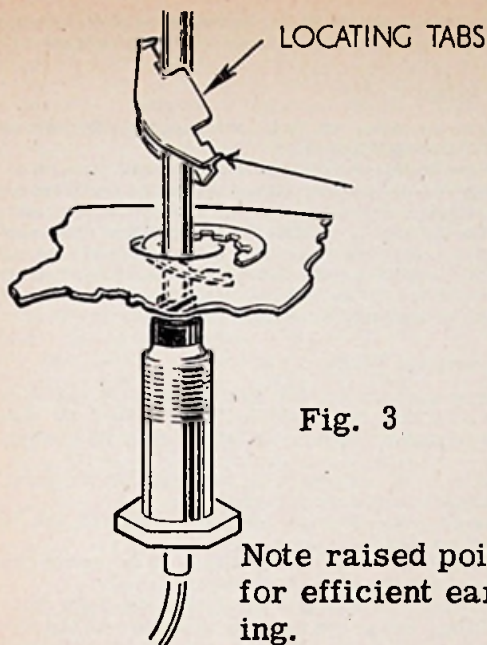

Fig. 3

Note raised points
for efficient earthing.

will now be obvious why T. V. coaxial cable cannot have the desired results since its excess capacity cannot be adjusted by the aerial trimmer.

Some aerial extension leads or aerials that have a continuous lead do not contain a condenser within the plug in order to reduce the excessive capacity due to the lead.

In such cases, these are quite unsuitable for the purpose that they were manufactured, the only thought which comes to mind here, is, why?

One type of aerial that has so far not been mentioned is the under-slung type. This may be fitted under the car running board or in the absence of the running board - not seen on the modern car today - to the chassis.

These aerials are only suitable for areas where the signal strength is good as the metal work of the vehicle above will in most instances restrict the amount of signal reaching such aerials due to the screening effect of the car body.

It is, therefore, wise to use only those aerials that are supplied by the manufacturer of the car radio, as this will ensure that the capacity of the aerial lead will be sufficient for the aerial trimmer on the car radio to be adjusted for the correct setting achieving the best results.

This means, increased sensitivity, or the reduction of hiss, so that the desired signal will be received without any background interference.

Trimming the Aerial

The method which the author adopts for obtaining the best possible results in aerial trimming is as follows:

First only use one section of the aerial mast above the wing, then tune the receiver to a station near 200m. Adjust the aerial trimmer for maximum volume i. e. the peak setting. Then raise other sections as required. The idea is to obtain the best possible results under poor conditions. Some receivers may have two aerial trimmers. One being for the Long wave, this should be adjusted after first adjusting the trimmer for the M. W. band. The trimmer for the L. W. may be adjusted for the Light Wavelength on 1,500m.

CHAPTER 3

Preliminary Installation Factors

Most cars have an aperture provided for the radio control unit which should be used if the radio lends itself to that end. Many car radios do not which is as good a reason as any for not taking such radios into stock.

The aim should be to add neatness to the completed job, the radio looking as an integral part of the dash on the car.

Speaker provision is also a standard feature on most cars, but not for the same type of speaker in all cases.

This may be fitted either in the roll top dash or on the rear parcel shelf and sometimes in the passenger's side kick panel.

The completed installation must give a pleasing finish to the rest of the car with care being taken so that the radio when removed at a subsequent date for re-installation into a new car, will not detract from the general appearance of the car.

Any radio aperture blanking panels should be given to the owner so that when the removal of the radio takes place, this may be refitted thus adding to the appearance of the vehicle and, of course, its sales value which must always be kept in mind.

The aerial also is of importance, apart from such points given in Chapter 2 with some cars critical measurement is very often necessary, if damage is to be avoided to the bodywork of the car. This is to say, that a hole may be started by the use of a drill to find that directly under this point chosen for the aerial position, there is a metal strut etc. and further work in fitting the aerial to that point is not possible.

This means that an unsightly hole has been made, which will prove difficult to repair and, perhaps, even more difficult to explain to the motorist why this was done at all?

The motorist is entitled to feel that when someone agrees to install a car radio for him that this will be carried out by qualified staff who should be fully aware of such dangers.

For this reason, a car radio installation should not be lightly undertaken unless the persons delegated for this task have specialised knowledge of the many factors involved.

Should the work be carried out in a slipshod manner, it will reflect very much upon the prestige of those concerned

There is no lack of other important considerations to be taken into account. For instance, should the car bonnet open away from the windscreen it is better to fit the aerial on the offside rear. This will reduce the risk of the bonnet radiating ignition interference, after the earthing efficiency of the hinges has been impaired due to subsequent rusting.

The screening effect of the car bonnet can be appreciated if the car radio is switched on with the bonnet at first in the closed position and the engine started. Then, to open up the bonnet with the engine again being started. No attempt should be made to open up a car bonnet with the engine turning since it may be possible for one's fingers to be caught in the blades of the fan. This experiment indicates that efficient car radio suppression is only made possible with the bonnet down and that the car is of metal construction. The practice of the car manufacturers using fibre glass for the body work of motor cars is fatal to efficient suppression. Also, one wonders if the H. T. suppressor cable fitted to the ignition system of motor vehicles under the Wireless Telegraphy Act of 1949 is as efficient with these fibre glass constructed vehicles as with the all metal constructed motor vehicles.

Therefore, it must be clearly understood that should any interference reach the aerial directly or indirectly, the normal method of suppression will not be of any consequence.

It is not necessary to state that motor vehicles are very expensive costing upwards to three thousand pounds or more. This is further evidence for allowing only those with the requisite experience and knowledge to fit car radios.

So far, it has been the author's wish to bring to the attention of those responsible in any way for car radio fitting or sales that it is not just a matter of fixing a few brackets and then fit the car radio into position.

The fitting of car radios require careful planning and one of the best ways in which this may be fully illustrated is to consider the fitting of a car radio to a new car which the customer has not yet taken delivery.

It will be shown how such an apparently easy task can have its own complications and how they may be prevented.

Before a new car is handed over to the customer, it has what is called in the motor trade, a "pre-delivery".

This means that the engine, timing, brakes etc are subject to examination in order that anything not correct may be put in working order before it is taken delivery of by the owner.

The car has to be cleaned and polished with the vacuum cleaner being brought into action within the car. In addition, the owner may require several accessories to be fitted so that it will not be necessary for him to bring his car into the garage at a later date, and be deprived of the use of the car.

The electric clock is not a standard feature on every car neither is the heater or windscreen washer. Fog lamps may be desired, should the owner reside in that part of the country where fog is frequent or if he should travel extensively.

In such cases, switches will be required to operate the accessories, in the instance of the fog lamp, the switch must be fitted near the driver for ease of manipulation.

Such accessories appear to be quite normal and there does not appear to be anything which could cause interference to radio. Examination of the various accessories that may be fitted will reveal that unsuspected problems may accrue, taking time and trouble to correct. Let us assume by way of example that a new car has been sold and a new radio is to be fitted.

The aerial and the car radio have each been fitted not overlooking to adjust the aerial trimmer. The petrol pump, dynamo, ignition coil, suppressor condensers have each been connected to their respective components.

Should the installation have been carried out by those firms which are equipped for car radio installation work, the engineer will after making sure that there is no interference present to reduce the effective signal to the radio, depart to another job. Then and it is always then, it is found that an electric clock is also to be fitted. In consequence, it may be necessary for the radio to be removed for this task to be achieved.

The direct result of this will be for the complaining by the owner of electric clock interference and why did the engineer fail to suppress this! In addition, various other interferences may present themselves if the radio is not put back correctly.

This means that the mechanic may not appreciate the need of an efficient earth as it is applied to radio engineering.

The fog lamp leads, if a fog lamp is fitted, may have the leads passing tightly over or near the metal cover of the radio.

This will induce ignition interference into the receiver unit by induction. It is not unknown for a panel carrying many leads to be fixed just under the radio unit or for switches to be fitted above the radio unit through the dash with the wires connected to them laying on top of the radio metal case.

All this after the radio has been fitted, therefore, it is obvious that close co-operation is necessary between the salesman and the person to whom falls the task of car radio installation work.

Since most of the work is the concern of the motor vehicle electrician, he more than anyone is in the best position of preventing such errors.

Preventing Interference

- (1) When new cars are sold and a radio is to be fitted, the motor vehicle electrician should insist that all the pre-delivery work is first carried out.
- (2) Then with the salesman concerned with the sale, he should find out any accessory that may be required.
- (3) If it is not clear where the radio is to be fitted, he should examine the installation instructions and find out!
- (4) After finding out where the radio goes he must make sure that any wire is kept clear of the radio unit and, also, see that no other wires are placed near due to the accessories.
- (5) In most cases, an electric clock **MUST** be fitted before the radio, therefore, see that the electric clock has a suppressor connected to it or the radio unit will have to be removed.
- (6) **NEVER** use the radio brackets or any finishing panel etc. as an instrument panel or you will cause severe interference and also leave holes after removing switches from such panels in order to remove the

interference caused by their being close to the radio unit.

(7) NEVER join lengths of aerial lead together with the usual insulation tape, it won't work! Use a good aerial and the proper extension lead.

(8) Carry out the installation instructions for suppression of the particular car you are working on - it saves trouble.

(9) See that apart from the cleaner, no one else works on the car, or else you may have your work undone.

Full treatment on interference problems is given in a later chapter.

CHAPTER 4

The Selection of a Car Radio

In the previous chapter we saw how the addition of the usual type of accessories can result in interference or the loss of time and trouble because an electric clock was not fitted before the radio unit.

In this chapter we consider factors just as important because the customer will possibly rely upon your choice of a car radio and if it is a poor choice, the customer will not be very pleased or hold a good impression as to your ability.

Therefore, when it is considered that it would be a good idea to hold a number of car radios, for resale, certain questions require answering. Is the radio of a reputable make? Does it have provision for alternative polarity with the many types of cars on the road today both British and continental, there is always the possibility that a change in radio receiver chassis polarity being necessary.

This, of course, being when the owner of a British car then decides to change it for a continental one.

The latter car is almost of negative chassis polarity however there is a tendency for British manufactured cars to revert to negative chassis polarity today.

Under these circumstances, the question of being able to change the polarity of a car radio is a vital one, from the car owner's point of view and also from the trade side since the correct choice of a car radio with such facilities ensures good will. Should a car radio be taken into stock with one type of operating polarity only, could it be converted to operate on the other polarity? Also, what would the cost be if it was returned to the manufacturer for this purpose?

Would the customer enjoy having to pay the cost of such work especially if a friend of his has a car radio, the polarity of which, can be changed within a matter of minutes.

Other important considerations spring to mind are the provisions made within the various cars such that the car radio will lend itself for ease of installation.

Some garages hold an agency which are in a position to supply radios for their make of cars. They also provide service for the radios should such be required from the agency car radio department at the car factory.

It must be understood, however, that these radios are of course constructed for the manufacturer's own vehicles and due to their size and other features, do not lend themselves for readily fitting to other makes of cars.

Of course, they are not intended to do so, it is a product made for the customers of their respective vehicles and this they achieve in a high degree.

Then there are other makes of car radio which vary in size and shape also, unfortunately, in reliability. To be correct, they are strictly car radios, but they never appear to conform in the slightest manner, with the car radio fitting facilities provided within the cars.

Other points soon make themselves felt, the height of these radios are too much for the aperture on the car, the radio controls are either one third up from the bottom of the radio unit, or about one third down with respect to the height.

The controls are also set too far apart from each other so that it would be necessary to file or cut the radio aperture for its installation. After which it may not be possible to hold the radio panel in position should the radio be taken out at a later date.

A further point of consideration is that the speaker required for any particular car, i. e. the size and shape can of course vary from car to car.

With some car radios, the fitting kit may consist in almost every instance of a speaker to be mounted on to a baffle board despite that the speaker provision on the car may require a speaker entirely different from that provided.

Therefore, in the selection of a car radio, it will be necessary for each point to be given due consideration so that trouble may be avoided in the future.

There are three points which may serve as a guide (1) Ease of installation within every car (2) Polarity change over provided without difficulty (3) Note the various cars on the road today and see which radio is recommended by the car manufacturers.

CHAPTER 5

Car Radio Receiver Design

There has been great progress in the design of car radio receivers over the past eight years. Whilst technical advance has been maintained one of the most important developments resulting from such advancement is the reduction in the physical size of the control units and the amplifier units to the total abolition of the latter unit.

This has followed from the introduction of transistors in the output stage of car radios which has due to its ability of giving considerable power amplification rendered the vibrator power pack with its bulky components obsolete.

Such car radios had special 12 volt valves in the control unit with a transistorized power output. The dimensions of a manually operated car radio of this type were height 2 inches, width 7 inches and depth 7 inches.

The press button receiver control units had the same dimensions but had in addition an amplifier unit whose size were 2.3125 inches x 2 inches x 7 inches.

Further progress resulted in the all transistor car radios and a reduction in size. Here the control unit and what was the amplifier unit is incorporated within a single unit, the dimensions being, height 2 inches, width 7 inches and depth 6 inches. Other important factors followed from such progress.

The chief of these being the reduction in the current consumption taken from the car battery. To appreciate this, a car radio with the vibrator power system would take 2.5 amperes whilst a transistorised powered car radio would require 1.2 amps. The equivalent all trans-

sistor car radio, the current would only be just under 1 ampere. The fully transistor car radios are available for either 6 volt or for 12 volt working with polarity change over being provided. Some transistor radios are either for 6 volt working only, alternative polarity but not dual voltage.

With all transistor car radios i. e. either fully transistor or with a transistor output stage great care is necessary. This care is required in the event of the car chassis being of opposite polarity to that which the car radio is adjusted to operate from. Unless this precaution is taken, the transistors are very likely to be destroyed. The press button car radio is produced either for class A operation i. e. a single output transistor or for class B i. e. two transistors in the output stage in push-pull.

Their respective outputs are 3 watts for the single transistor output receiver and 8 watts for the push-pull receiver.

A point to appreciate with regard to vibrator car radios with an amplifier unit is that the amplifier unit may be fitted anywhere within the car. Some cars have provision for the amplifier unit under the passenger's seat whilst others can have the unit mounted in the boot of the car.

Of course, it will be obvious that such cars will be of early date since the vibrator unit is almost obsolete now.

Clearly the position of the amplifier unit in such models of car radios is important as a large cable may be required for the amplifier unit if it were taken from one car and refitted to another car where the longer cable was necessary.

The dimensions of such amplifier units are height 3 inches, width 7.0625 inches and depth 8.5625 inches.

Many of these car radios are still in good working condition and as they give very good reception the owner will not be very keen to part with it for a new one unless the design of the car is such that the control unit cannot be fitted into the radio aperture provided.

CHAPTER 6

Classification of Car Radio Installations.

Car radio installations fall into three distinct classes and it is necessary for these to be known.

(1) A completely new installation which consists of a new radio suitable for the vehicle in which it is to be fitted, one or more speakers, and the recommended aerial for the car.

(2) A radio previously used in one car to be removed and refitted to another car of perhaps different make or to a car of the same make but different model.

(3) A radio again previously used in one car to be removed and refitted to a new car of the same make and model.

Let us now consider how these various installations can differ from each other and in what respect.

In (1) above, we can order up a suitable radio, the price of which has been stated by the customer with the correct installation kit which contains the speaker, all necessary suppressors and the correct aerial for that particular car.

This should not present any difficulty provided that those points given in Chapter 3 are kept in mind.

With regard to (2) above, we shall again require the necessary installation kit with the possibility of a speaker, the old speaker may be the

same type as required and, of course, can be used again. An aerial may also be required, this depends upon the agreement undertaken between the salesman and the customer. It may be decided to leave the old aerial on the car.

There is also the chance that the aerial would not fit to the new car anyway, i. e. a roof aerial from say a Rover car would not normally be fitted to say a Hillman Super Minx. The reason for this is the lining on the latter car may not allow itself to be removed for the fitting of a roof aerial. A further point on (2) is that the speaker will always be taken out but if it should have been fitted to the rear parcel shelf it is considered correct to leave the speaker bezel in place. This is done to prevent unsightly holes from being left and detract from the sales value of the vehicle.

Lastly, (3) above is what is regarded as a straight swop. The fitting kit from the old car may be removed and of course used in the new vehicle, to keep down costs.

With the exception of the aerial if it is a roof type, the reason for this is because of the disturbing of the roof upholstery after some years of exposure to the sun.

It is not recommended to remove the suppressor condensers from any car for use into another. The reason for this is partly theoretical which will be further explained.

When a condenser is connected to a dynamo or to the coil, the characteristics of dynamos and the ignition pulses from the ignition coils vary from car to car.

The insulation resistance of the condenser or better the dielectric is subjected to a strain but adapts itself to this variation either from the dynamo or the coil when the condenser is new.

To refit such condensers to other vehicles is very much like using a spring that has been subjected to a certain type of movement for that which is entirely different, i. e. either from a quick compression to a slow one or vice versa.

The spring will break and it has been known for condensers thus removed to be suspected of causing a short-circuit in circumstances which is puzzling in the extreme.

To put it more clearly the short-circuit MUST have been caused by the condenser dielectric breaking down yet when tested was found in order yet no other cause was possible under the circumstances.

Of course, whatever the installation, the points given in Chapter 4 regarding the polarity of the vehicle and that of the receiver must always be taken into consideration.

There is one important factor to consider here if a radio has been in a car for two to three years, it may have its gain reduced due to the various trimmers having moved from their peak position due to vibration. In such cases, it is worth while for the radio to be re-aligned by the usual testing equipment of the radio engineer before it is installed into the new car.

A chat with the customer will indicate if he feels that the radio is as good as when he had it first fitted or if he feels that it would be a good idea to have the radio checked over first.

CHAPTER 7

Introduction to Radio Interference Suppression

The problems associated with the limitation of radio frequency interference caused by electrical equipment fitted to vehicles can be sub divided into the following four categories.

- (a) For minimum interference with domestic radio and television and short wave communication apparatus not associated with the vehicle.
- (b) For reception of L. W. and M. W. signals by equipment carried in the vehicle.
- (c) For reception of V. H. F. signals in the vehicle (f. m. car radio).
- (d) For the use of V. H. F. radio communication apparatus carried in the vehicle.

The above categories represent progressively greater suppression requirements and economic considerations are naturally of considerable importance in determining acceptable standards. Could all vehicles be suppressed to a standard that was suitable for category (d) then the remaining categories would be automatically catered for.

This arrangement would, however, be quite out of the question from an economic point of view, and it is therefore necessary to compromise by determining levels of suppression which will result in adequate performance, this of course being dependent upon the nature of the equipment that it is required to carry in the vehicle and yet be economically acceptable.

With regard to category (a) this is the subject of legislation in the United Kingdom under the Wireless TELEGRAPHY ACT 1949. Under this act, all vehicles leaving the manufacturer are required to carry the amount of suppression equipment which is necessary for compliance with the Regulations (that is, to limit the interference producing field to 50 microvolts per metre at 10 metres distance over the frequency band - 40 - 70 megacycles per second). Under the same Regulation, the user is obliged to maintain the original ex-works standard of suppression. In other countries, legal standards of suppression are also coming into being and in general the requirements appear to be more severe than those in the United Kingdom.

The remaining categories are not the subject of legislation but are a matter for arrangement between the manufacturer and the user. As the requirements become more severe, the degree of suppression necessary to ensure satisfactory performance from the radio equipment will increase.

Causes and Sources of Interference

It is not possible to carry out any efficient suppression of electrical equipment in vehicles without first knowing the causes and the sources of such interference.

The sudden variations or interruptions in the current taken by electrical apparatus will produce electromagnetic fields capable of causing interference with radio reception.

Such changes occur in the normal operation of many items of equipment on a motor vehicle among them being the ignition system, machines having commutators, such as generators, windscreen wiper motor and fan motors and the vibrating contacts of current and voltage regulators, petrol pumps and temperature gauge transmitters. Even the fan belt on a car has been known to result in interference which was very

much like dynamo interference.

The radio frequency energy associated with the operation of all these devices is distributed over a very wide frequency spectrum. Interference can be caused at the lowest radio frequencies of 100 or 200 kilocycles per second up to frequencies of hundreds of megacycles per second.

The major source of interference from a petrol engine motor vehicle is the ignition system, the interference field from which increases with frequency to a maximum in the region of 40 - 50 megacycles per second and this value may be maintained up to at least 600 megacycles per second.

Serious interference can be caused by ignition systems at ranges of a quarter mile or more, this is not surprising when the magnitude of the oscillating current in an ignition system is considered. The radiation arises from the current in the capacity component of the ignition spark. The secondary capacitance of an ignition system including sparking plug, cable, distributor, etc., is of the order of 50 - 100 picofarads. When a plug fires, the energy stored in this capacitance which is probably charged to a voltage in the region of 10 kilovolts, is discharged through the plug gap in the form of an oscillatory current lasting for less than a microsecond but with a peak value which may reach 200 amperes or more. Some of the energy is radiated from the high tension system and also from the low tension wiring due to mutual coupling with the high tension circuit.

The interference from other items of vehicle electrical equipment is in general troublesome to radio equipment carried on the vehicle itself or on other vehicles in close proximity.

Nevertheless, some screen wiper motors and regulators do produce appreciable interference fields at a distance from the vehicle and can cause trouble with television reception if left un-suppressed.

The interference field radiated from a vehicle depends on other factors in addition to the item of equipment which forms the source. Considering the electrical equipment of the vehicle, the layout of the installation and the length and positioning of the wiring can have considerable influence on the "noise" factor, that is to say, the field. Then again, the effectiveness of the screening resulting from the construction of the vehicle has a pronounced effect but one which is extremely variable and unpredictable since it depends on the manner in which the various metal panels are in contact with each other from an electrical point of view.

This in turn depends on whether joints are welded and how well or the number and positions of the bolts, if bolted, how much paint is in the joint and whether serrated washers are used. The effect of the body work may also vary with frequency due to lack of electrical continuity which may allow resonances in the vehicle panelling.

Suppression components

From what has been given regarding the causes and sources of interference, it will be obvious that some steps must be taken with the view of reducing such interference.

For our purposes, efficient suppression is mainly required for reception on the L. W. and M. W. and the two fundamental circuit elements most used for suppression purposes are resistance and capacitance.

The use of the former is confined almost exclusively to the high tension of ignition systems where its effectiveness and low cost make its application universal. By the use of one or more resistors in the ignition circuit, suppression that is adequate to meet the statutory requirements can be achieved.

The Resistor

Resistors used in an ignition circuit operate under onerous mechanical and electrical conditions. They have to withstand considerable vibration and must be proof against splash from petrol, oil and water. In addition, they are subject to temperature changes and high electrical stress; transient voltages comparable with the plug voltage appear across the series resistor when the sparking plug gap breaks down. The dimensions must be such that internal and surface discharges due to the high voltage across the resistor are eliminated otherwise rapid breakdown occurs.

The resistors manufactured by Lucas are of solid carbon type made from a special mixture with appropriate filling and binding material and conform to the requirements of electrical and mechanical stability called for in British Standard No 833.

The simplest form of resistive suppression by means of a single resistor in the coil-to-distributor high tension cable has been reduced in cost and simplified even further by the development and use by Lucas of the resistive high tension brush.

This brush now incorporated in virtually all Lucas distributors consists of three parts bonded together. The two ends are of low resistance brush grade carbon while the long centre portion is of highly resistive material which forms the suppression resistor.

Resistive High Tension Cable

One other form of resistive suppression which has been the subject of experiment for many years but has only been used on a large production scale for the last few years is resistive ignition cable. Outwardly, this is similar to ordinary high tension cable but the conductor consists of material such as silk, rayon, cotton, or nylon treated with carbon to render them then conductive to the desired degree.

The chief attraction of this method of suppression is low cost. In addition, improved suppression is usually obtained at very high frequencies when compared with "lumped" resistors.

Capacitors

Capacitors are suitable for suppressing low tension electrical components and their capacitance value is normally one microfarad. As a general rule, capacitors must be positioned as near to the component which requires suppressing as possible.

It should be connected with the minimum length of cable thus avoiding excessive lengths of unsuppressed wiring or undesirable inductance in the capacitor circuit. This point is frequently neglected but is most important if the capacitor is to be used to its best advantage over as wide a frequency range as possible.

CHAPTER 8

Procedure For Suppressing Interference

Compliance with the United Kingdom statutory regulations regarding interference with domestic radio and television and other short wave apparatus can be usually achieved by a simple degree of suppression in the ignition high tension circuit.

Since the 1st July 1953 all cars manufactured after this date will be found to have been suppressed appropriately before leaving the factory. The effect of ignition interference on television screens is well known with its "snowflake" appearance. As many television owners are aware, the interference caused by an unsuppressed car can completely upset the receiver.

On many vehicles a single resistor of 10,000 - 15,000 ohms fitted at the distributor end of the coil-distributor high tension cable or the Lucas resistive distributor brush referred to in Chapter 7 will provide adequate suppression. The resistive brush is NOT interchangeable with non-resistive types, the diagram shown in Fig. 4a shows its position with respect to the high tension circuit of the vehicle. If additional plug resistors or resistive cables are fitted then the legal requirements in the United Kingdom are met this being indicated in Fig. 4b.

For maximum effectiveness, the resistors should be located as near as possible to the points of sparking, that is, closely adjacent to the sparking plugs or to the moulded distributor cap.

At this point, mention must be made of the negligible effect of resistors on engine performance. It was at one time commonly thought that since the appearance of an ignition spark with resistors in circuit is of reduced brightness, its ability to ignite the mixture in the combustion chamber is correspondingly reduced. However, the energy stored in the capacitance of the spark plug itself, is more than sufficient for all normal ignition purposes and this is obviously unaffected by the presence of the resistor. Any cases of engine operation being adversely affected have invariably been shown to be due fundamentally to some undesirable condition such as incorrect mixture adjustment or an electrical fault shown up by the addition of resistors.

Moreover, the 100 per cent use of resistive suppression for several years on spark-ignition engines has brought no report of adverse effects on ignition performance. In the somewhat rare instances of interference from equipment other than ignition preventing the required level from being attained, further suppression may be necessary. This is likely to apply more particularly to screen wiper motors and generator control regulators. Therefore, further suppression on such sources of interference will be described in a later chapter.

Reception of Long and Medium Waves

The reception of long and medium wave signals by receiver carried in the vehicle. This, of course, means a properly constructed car radio and since most receivers fitted to the motor vehicle are designed for the reception of the above wavebands, we shall consider means of locating such interferences which would if left unsuppressed, prevent the receiver from giving satisfactory reception.

A simple test to determine whether interference originates externally or within the vehicle may be applied.

Should interference persist with the vehicle stationary, engine

Fig. 4
 Stages in the
 suppression of
 the ignition
 system

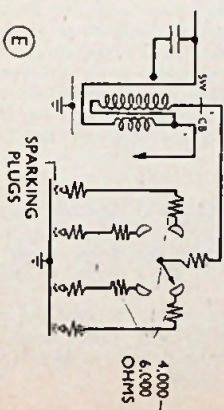
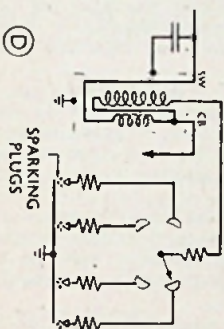
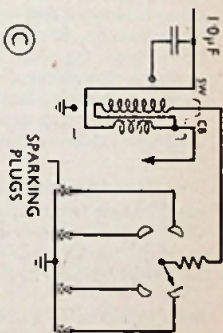
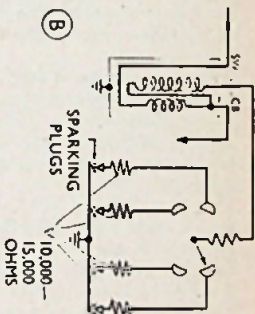
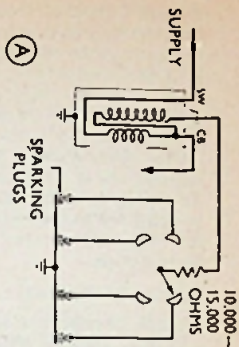

stopped and all electrical equipment except the radio switched off, then the source is external.

However, such statement requires qualification on some vehicles, such as transporters, a thermo-switch may be fitted to some device to indicate the temperature of the water in the radiator. When all electrical equipment has been switched off, a clicking sound resulting from the "thermo-switch" as it cools down will be heard on the radio. Therefore, it will be seen that care must be taken in locating sources of interference.

To continue, if the interference ceases, the source is internal and is being fed to the radio either through the power lead, or through the surrounding case, due to inadequate screening of the set, i. e., by induction.

Ignition Interference

Ignition interference with car radio reception can be recognised by a regular clicking which varies in frequency with engine speed and becomes a continuous buzzing noise at high speeds. To reduce this interference, proceed as follows, assuming that the vehicle is already equipped with the minimum suppression of one resistor or resistive brush at the distributor end of the high tension cable from the coil.

A suitable degree of suppression is such that noise etc, is inappreciable when listening to the weakest station that the set will receive at entertainment value. However, we may also determine a suitable degree of suppression if the noise etc is reduced to about twenty per cent of its original value when the receiver is tuned between stations.

This is in fact the more severe test since the weakest station may be far stronger than some stations according to the district in which the receiver is operating. The interference is, however, not dependent upon the geographical position of the receiver and the transmitter as it would be in the former instance.

To reduce or eliminate ignition interference, first fit a one-microfarad capacitor between the ignition primary coil, that is, the supply terminal (S. W.) and earth. This is shown in Fig. 4c. It is most essential to ensure that a good earth contact is made with all capacitor suppressors. Such capacitor fitted at the S. W. terminal is often useful in bypassing noise currents flowing into the battery supply lead and so to the rest of the car wiring. Should interference still persist, fit further resistors, first at the plugs Fig. 4d and if necessary, finally at the distributor cap cable outlets to each plug Fig. 4e. Alternatively, resistive cables can be used in place of plug and distributor outlet resistors.

Generator Interference

Interference from the generator can be recognised as a whine or growl which varies in pitch with engine speed. The remedy is to connect a one-microfarad capacitor between the output (or larger) terminal and the earthed frame of the generator, Fig 5 shows the method of connection.

In the cases of insulated return machines, a capacitor between each output terminal and frame should be used. Under no circumstances, must a capacitor be connected to the field, i. e. (smaller) terminal or damage to the regulator may result.

Control Box Interference

Interference with car radio emanating from the control box can be recognised by periods of continuous crackle and is caused by normal regulator action. This interference can only be eliminated or reduced by electrical filtering - no attempt should ever be made to remedy it by the indiscriminate fitting of any capacitors or by tampering with the regulator contacts.

Compensated voltage control boxes are available in which suitable filter circuits are incorporated Fig. 7 or the filter unit illustrated in Fig 6, may alternatively be connected closely adjacent to an existing unsuppressed c. v. c. control box. Each of the filter units given in Figs 6 and 7 are made by Lucas.

Windscreen Wipers

The low to medium pitched whine from motor-driven components such as windscreen wipers can be usually reduced or eliminated by connecting a one-microfarad capacitor between the insulated supply terminal and earth. In some cases, it is only necessary to earth the case of the windscreen wiper motor to a convenient earth on the chassis of the vehicle from the case of the windscreen wiper motor.

Electric Clock Interference

The interference caused by an electric clock is of course recognised by the regular "ticking" of the clock.

Such interference can be eliminated by the connection of a one-microfarad condenser to the supply terminal at the rear of the clock and the other end to the clock fixing bracket which is earthed. The capacitors used for clock suppression are covered in insulating material so to avoid the risk of short-circuits that would possibly result from a metal clad condenser.

In order that such suppression methods should have a reasonable chance of success, it is vital that the aerial and the car radio are installed correctly and connected in accordance with recognised practice.

Persistent Ignition Interference

It may well be that after carrying out the measures which has so far been given that ignition interference is still present.

In order to locate the source from which the interference is reaching the receiver, remove the aerial. Should the ignition interference now cease it is being picked up in one or two ways.

It is either being picked up by (1) bonnet radiation or (2) by induction into the aerial at some point where the aerial lead is passing very close to the H. T. tension cable of the ignition coil.

With regard to possibility (1) a short braid covered in insulating material and connected to the bonnet near the side that the aerial is fitted and then earthed to the firewall of the car will prevent this. It is due to the bonnet not making an efficient earth with respect to the body of the car, when it is in a "closed" position. With reference to possibility (2) some aerals when fitted are routed within the engine compartment and may pass very close to the H. T. cable of the coil. The interference is caused by induction of the aerial screening due to the H. T. that is present. If the aerial can be moved away from the H. T. cable and the coil moved also away from the aerial lead, considerable reduction of ignition will be achieved. One such vehicle in which possibility (2) has been known is the Hillman Super Minx.

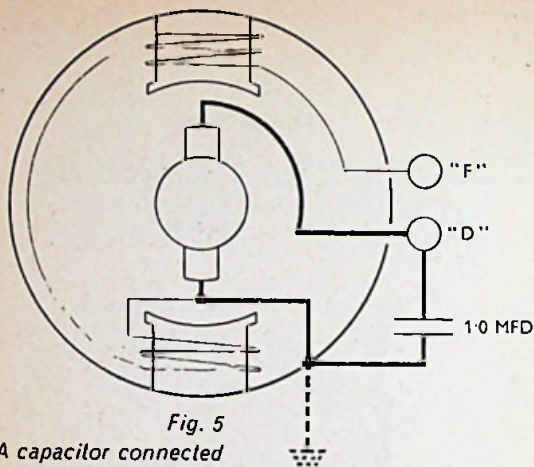

Fig. 5
A capacitor connected
between the generator
output terminal and
earth for suppression
of generator
interference

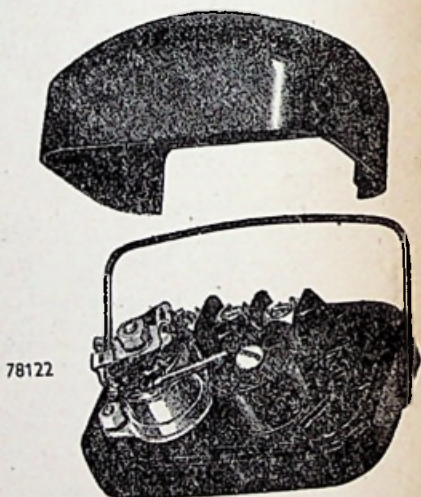

Fig. 6 *Filter unit for unsuppressed*
compensated voltage
control box

Fig. 7 Compensated voltage control box with in-built filter unit

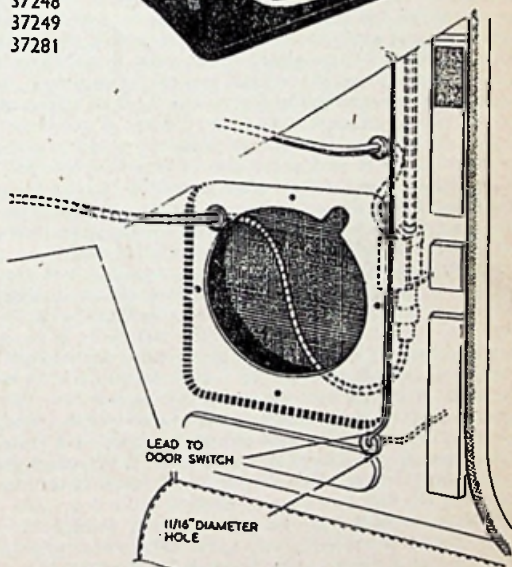
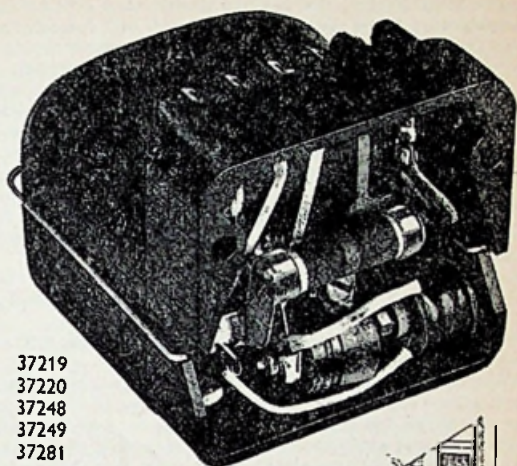

Fig. 8

Further assistance in the elimination of persistent ignition interference, is to fit an additional capacitor to the S. W. terminal of the ignition coil, this will make the total capacitance at this point two-microfarads. It may well be, however, that even with the aerial removed from the car radio aerial socket, that ignition interference still persists. If this interference is not caused by induction it will indicate that the filtering components within the receiver and which are connected in the power lead to the receiver are not quite sufficient for this purpose. Such filtering components are usually comprised of a choke in series with a High Frequency choke through which flows the supply to the receiver. On each side of the iron core choke are two condensers of about 0.01 microfarad, to remove any interference which may pass the high frequency choke which itself has a 0.001 microfarad condenser connected the condensers in each case are connected to earth. The most essential task with such filtering components is to keep them at the end of the receiver chassis, just where the power lead comes into the receiver case.

It is quite futile to allow a length of the power lead to reach well within the receiver thus radiating interference all around, before it is connected to the filtering system provided.

Such a condition of wiring will render the filtering system of no avail and may as well be not there.

With reference to the receiver it will be appreciated that the case itself will screen the coils within from any source of interference. This is providing that the screws which hold the case on are well tightened and making a good earth contact. If this should be otherwise, interference will be induced into the receiver. In order to add to the filtering components in the event of continual ignition interference, an additional filter choke may be connected in series with the fuse holder and such chokes are extremely efficient. Due to the manner of construction, however, it may not be possible to add an additional choke in series with the first as the windings of each choke may be in series opposing instead of in series aiding thus the total effectiveness of the two chokes may be very much less than with one choke. It will be seen then that this possibility may also affect the efficiency of the filtering components fitted within the receiver should such external chokes be added.

On some cars, the aerial may result in ignition interference being induced into it. Considering the fully retractable aerial which is fitted in the drive side scuttle. Such an aerial may be fitted to the Jaguar range of cars i. e. 2.4, 3.4 etc. Now on such cars there is an exposed wire which is connected to a switch behind the driver's door so that when he opens the door an interior light come on. Such wire runs very nearly parallel to the aerial mast and with the engine running various interference can be induced into the aerial mast and of course into the receiver. The remedy here is to route the wire outside from where it normally runs, so that a portion of the steel kick side panel is therefore placed between it, and the aerial mast. The wire is then brought in through a hole at the bottom of the kick panel for connection to the door-light switch. The method is shown in Fig 8 or, alternatively, the wire may be fed through a section of old aerial cable, the outer covering acting as an insulator against short-circuits the inner braid acting as a screen covering for the lead. To enable this to be efficient, it is essential for each end of the braid to have an earth connection or it will radiate interference into the aerial mast itself. With further reference to all types of aerials,

ensure that the earthing sleeve is present around the aerial plug before connecting the aerial to the receiver since if it is absent, the aerial screening braid at that end will not be correctly earthed - if at all - resulting in all sources of interference from dynamo, ignition and clock interference.

Petrol Pump

The interference caused by the petrol pump can be quickly identified by the regular clicking heard from the receiver; since this can only be heard with the ignition switched on, this action must be done. Should the carburetter be empty when the ignition is first switched on, the clicking from the petrol pump will at first be rapid as it carries out its task of filling this vital component, then gradually slowing as the carburetter becomes filled. To suppress the petrol pump, a one-microfarad capacitor should be connected to the supply lead at the pump and earthed to the petrol pump mounting bracket.

Fan-Belt

One would not expect any interference from a fan-belt but should the fan-belt become very worn it will cause static electricity which is very much like a faulty generator i. e. like a rustling noise due to worn brushes. In order to detect this type of interference which is rare, first disconnect the leads which go to the dynamo and start the engine with the bonnet closed.

Should the noise stop, it could of course be due to the dynamo brushes being worn or dirty and require cleaning if the noise continues then replace the leads to the dynamo and remove the fan-belt. Start up the engine once again, with the bonnet always closed, if the noise ceases then a new fan-belt should be fitted correctly adjusted and the engine started again.

Electric Wiring Connections

A considerable amount of interference which is due to poor wiring connections is frequent, such wires not tightened down by the screws on the switch, will result in crackling noises being picked up by the receiver due to intermittent electrical contact.

It is also vital to prevent the addition of any anti-thief device from being fitted near to the receiver case, or to the aerial.

Unusual Source of Interference

The manner in which a car radio can pick up all types of interference is remarkable, indeed it would appear that if the radio on the car is working correctly then the rest of the vehicle is also correct.

A radio was fitted into a good class car of well known make, the owner of which complained of crackling on the radio whenever he wished to turn left. It did not matter if the car was turning to the right or going over rough road, the crackling only resulted when he was making a left hand turn.

It was considered that perhaps the weight of the vehicle was "thrown" on to the front left inner wheel and also thought that perhaps the "king-pin" was somewhat lacking in lubricant and causing static electricity to form due to friction.

This was checked but the vehicle was returned to the manufacturers and the owner was notified that he had a cracked half-shaft which when

replaced no further crackling was heard on the radio from left hand turns, an interesting phenomena.

Electric Horn

This somewhat unusual form of interference is quite startling, since it is heard from the speaker with amplification. The interference is caused by the horn being mounted on the front sub-frame which is electrically insulated from the body panels. The remedy is a short bonding strip connected between centrally mounted horn fixing and radiator reservoir tank mounting bolt which is in the engine compartment behind front bumper.

This interference may be found on Austin 1100, M. G. 1100, Morris 1100 and Princess 1100.

CHAPTER 9

Brake and Tyre Static Suppression

This although a serious interference to car radio reception is important to warrant a chapter on its own. For this reason, it was not included in Chapter 8. The instructions given here are for the vehicles, Austin 1100, MG.1100, Morris 1100 and Princess 1100

Front Disc Brake and Tyre Static

Two attachment brackets are included for mounting a brush holder assembly on the brake caliper in order that the brush may bear on the face of the disc. Use the two longest brush holder assemblies. It is necessary to fit an earthing bond from the bracket fixing to the wing inner valance. Note that the brackets are attached to the brake calipers by one of the dust cover securing bolts, which is the ONLY bolt authorised by B. M. C. for this purpose. The method of assembly is shown in Fig. 9.

The brush holder should be assembled to the bracket as shown in the inset to Fig 9 with the fibre washer under the nut.

The bracket is designed to provide the necessary clearance for the face of the brush holder from the disc and the square spacing washers should not be used. When fitting the bonding strap, observe Fig. 9 and note that a loop is left at both ends to allow for swiveling movement of the wheel assembly and also for vertical movement of the suspension.

Finally, secure the bond as shown to prevent flapping. The plastic sleeves have been fitted to the brackets to damp our brush squeal and should not be removed. It is essential that all paint should be removed around the fixing bolt to ensure a good earth.

It is also essential that the fixing bolt should be tightened securely before replacing the wheel.

Rear Brake and Tyre Static

Due to the very small clearance which exists between the edge of the rear brake drums and their backplates, the fitting of brush holders in this position as given on the leaflet supplied with RMR 1013PG Anti-static Kit is almost impossible. The following method has now been approved.

Note: the kit given in this chapter is RMR 1016PG Anti-Static Kit for the stated vehicles. The kit stated above RMR1013PG is used on such cars as the Morris 1000, A35 (see later).

These kits are obtainable from any Radiomobile stockist and NOT from Radiomobile Ltd direct.

Remove the rear wheel and rear wheel bearing caps thus exposing the ends

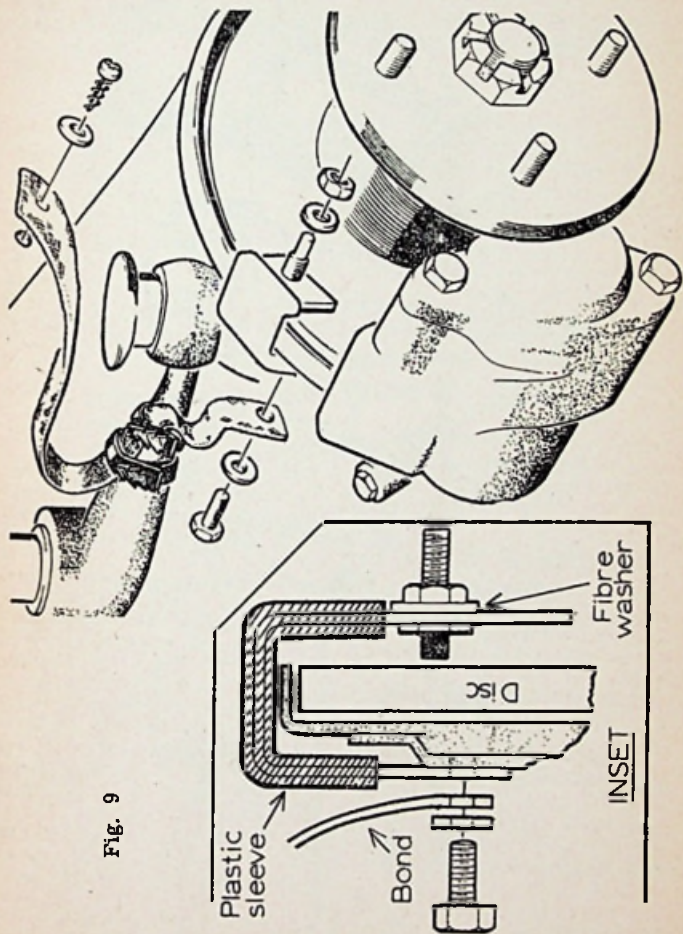
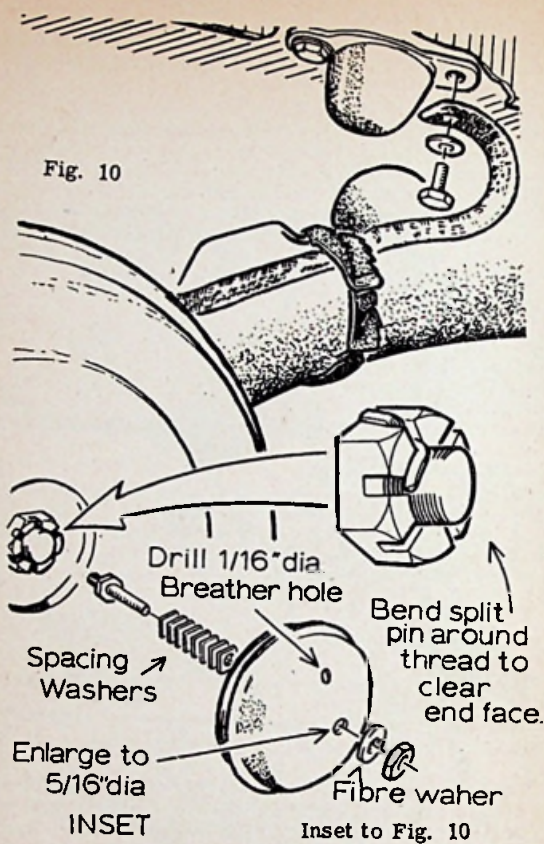

Fig. 9

Fig. 10



of the stub axles. The bent over end of the axle split pin should be moved so that it lies closely round the threaded portion of the stub axle, leaving the axle end face clear.

Examine the end face and ensure that it has no burrs or torn metal and is relatively smooth, this ensures reduced brush wear. Drill out the small breathing holes in the centre of the bearing caps to 5/16 inch diameter and also drill 1/16 inch diameter replacement breathing holes through the caps approximately one-half inch away from the original position. Assemble the short brush holders with spacing washers under the heads of the holders and secure with fibre washers and nuts as shown in Fig. 10.

Note

The number of spacer washers used must be ascertained individually for each rear wheel. The correct position being such that 1/32 inch clearance (thickness of one spacer) exists between the end of the stub axle and the face of the brush housing when the bearing cap is fully "home" in the bearing tube. It is essential that only the short type brush holders are used in this situation due to limited clearance between bearing cap and outer "hub" cap on N.G. and Princess models. Ensure that the end face of stub axle is free of all lubricant and carefully refit bearing caps.

Earth wheel assemblies to body using the bonding straps 5/16 inch washers and nuts. Secure bond to swinging arm with the "fir tree" cleats as shown in Figs 9 and 10. Replace wheels etc. ensure that the wheel nuts are tightened and road test.

Alternative Treatment for Brake Static

This alternative treatment for the various forms of static interference, i. e., either due to tyre or the brake linings may be used for whicles such as the Morris 1000, the A35 Van or the Wolseley 1500 and similar types which are subject to this form of radio interference.

The method of treating such cases is as follows:-

- 1) Remove wheels and drums at front and/or rear of vehicle as necessary.
- 2) Carefully decide mounting position of brush assembly. In many cases, a suitable location will be found on either side of back-plate bottom centre as in Fig. 11. (Never fit at bottom centre). Ensure adequate clearance when wheel is at full lock and under all conditions of suspension.
- 3) Press modelling clay into back plate recess at mounting position and temporarily replace brake drum to make impression in modelling clay, Fig 12A and Fig. 12B.
- 4) Remove drum and drill 5/16 inch hole in back plate. Hole should register with centre of brake drum flange. This may be seen with reference to Fig. 12C.
- 5) Clean area around hole and blow out all swarf, etc. To prevent rust, apply smear of petroleum jelly around front and faces of hole.
- 6) Fit assembly as shown in Fig. 12D, rectangular packing washers, as supplied should be fitted to allow

- 6) Fit assembly as shown in Fig. 12D, rectangular packing washers, as supplied should be fitted to allow 1/32 inch clearance between front face

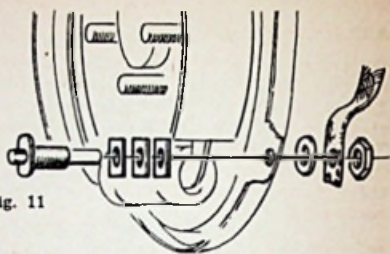
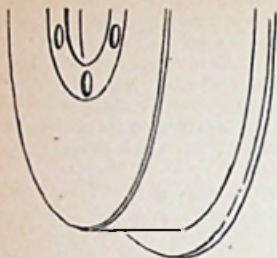

Fig. 11

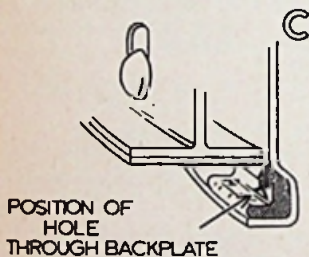
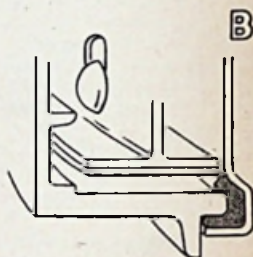
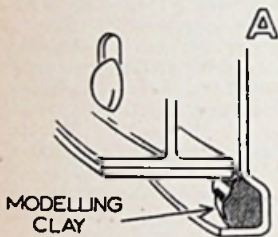
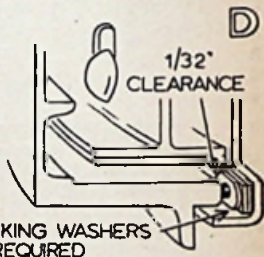

Fig. 12



of brush holder and brake drum.

7) Smooth-off the face of the drum flange, employing fine cut file, large enough to file flat across diameter of flange. Finish with fine emery cloth wrapped around file. If this is not done, brush wear will be excessive.

8) Thoroughly clean brake drum and replace.

NOTE

In certain cases, there may be residual interference which can be treated by means of a bond connected between back plate and chassis. One end of the bond may be attached to brush assembly and the other end to the nearest convenient point to chassis. Ensure that both ends of attachment are cleaned to bare metal. Bond material should be woven copper braid, $\frac{1}{4}$ to 1 inch wide.

CAUTION

It is essential that the close collaboration of a skilled motor mechanic in the dismantling and reassembly of wheels and brake drums is obtained.

Additional Precautions

With reference to Fig. 12D to ensure that there is a clearance, first rotate the drum fully by hand and then remove.

Looking at the face of the brush holder, make quite certain that there is no streaks across the face, if there are, then the clearance is not sufficient. This would result in a small piece of metal being forced across the hole, thus preventing the brush from making contact with the drum flange. It only requires one brush not to make contact for the static to be still present.

Location of a Brush Not in Contact

Some vehicles may have the above static treatment for the elimination of brake static that is, the interference is only present when the brakes are applied. Should this be the case, and assuming that the brushes have been fitted but for reason, one of the brushes is not making contact. It will be necessary for this brush to be found. It is a tedious task to remove ALL the wheels in order to find just one brush, so by the adoption of the following method we can at least reduce it to (a) either the front wheels or the rear wheels i. e. one wheel at front or back, not making contact with its drum flange at the brush.

Therefore, first take the car out for a road test and apply the foot brake this action will result in the static interference being heard on the radio which must of course be switched on.

Then apply the handbrake, if the static interference cases, the interference is caused by one of the front wheels, if on the other hand it continues, it is the result of one of the rear wheels having a poor contact between drum flange and brush.

It is possible to check in this manner since the hand brake only operates the rear wheels whilst the foot brake operates all the brakes, the front wheels being known to cause static with the operation of the foot brake.

When to Test or Carry Out Static Test

Since the interference known as rolling static is only present when the vehicle is in motion, it may disappear when the brakes are gently applied which is, of course, quite distinct from brake static, which is only present due to the brakes being applied.

However, the former interference may also disappear on a damp or wet day, since the atmosphere conducts the static electricity and prevents it from building up to an interference potential. The latter form of interference i. e. brake static may also behave likewise or still be present whatever the weather conditions it being very unpredictable. Since all forms of interferences given above are present on a dry day, it is best to carry out any test for static interference of all kinds on such a day. If it were done on a damp or wet day and one of the brushes did not make contact etc. this would not be known until the motorist used his car on a dry day.

It is very important that during the carrying out of any brake static treatment to remove any signs of OIL on the brake drums as this will impair the efficiency of the brakes and the vehicle must not go on the road

until this has been remedied.

Such cases usually occur if the oil seal on the rear axle leaks, allowing oil to come on to the linings.

CHAPTER 10

Testing Aerials for Faults

It will be appreciated that the length of a car radio aerial is restricted by circumstances and, therefore, it is most essential that the aerial is as efficient as possible.

One of the principle causes of poor signals being received on a car radio is due to the aerial being defective in one way or another. We shall examine some of these defects and how to remedy them.

For such testing, it is necessary to have a meter which will indicate resistance up to 20 megohms. Anything less will be found to give poor indications as to the true state of an aerial.

Should the motorist complain of poor reception the very first task is to check the aerial for insulation with respect to the chassis of the vehicle. With such a meter of resistance range given above, the aerial should be removed from the car radio aerial socket and with the resistance range set to read up to maximum; the leads should be connected as follows to the aerial; the lead to the centre of the aerial plug which is the signal path from the outside aerial mast to the receiver and the other lead to the braid of the aerial or to a convenient point on the vehicle chassis. Taking great care not to have the hands anywhere near the leads which would result in a false indication being given by the meter, ensure that there is no deflection of the pointer on the meter over its scale.

It has been found through experience that a slight movement of the pointer can result in a background hiss, which is absent when the aerial is replaced. Therefore, the critical point seems to be reached when a deflection is observed on the ohm meter range. Any other deflection which tends to indicate that the insulation is lower, i. e. 10 megohms, is further evidence for replacing the aerial with a new one. Don't forget that whenever an aerial is refitted to adjust the car radio aerial trimmer for maximum volume at 200 metres with just one section of the aerial mast pulled up from its housing.

Should however the meter indicate that the aerial insulation is in order, the next step is to check that there is a signal path from the aerial mast to the centre pin on the aerial plug. For this test, the meter should be switched to a range of very low resistance, i. e. down to indicate resistance of 1 ohm.

To carry out this test, first clean the aerial mast with chrome cleaner, to ensure a good connection for the meter lead during the test. Connect one meter lead to the aerial mast with its crocodile clip and the other lead to the centre pin of the aerial plug—not forgetting to zero the meter first and then check for resistance. The reading should be not more than 1 ohm with most aerials, a comparison may be obtained if in doubt, by checking the reading with that against a new aerial.

At the same time with the ohms range still to very low, the braid of the aerial may be tested for an efficient earth by connecting one lead to the aerial braid and the other to the metal chassis on the receiver, a reading of 1 ohm here would be fair but must not be exceeded. This will enable any interference due to a poor earth connection on the aerial to be cleared up.

Should such tests reveal nothing incorrect, but the gain is still poor, then the aerial should be connected to the receiver again and the aerial trimmer adjusted as stated previously. This adjustment may make all the difference which would indicate that the trimmer had not been previously adjusted to the aerial. The fault may come to light by the motorist having been in a strong signal area, coming to a district where the signal was not as strong, the poor aerial adjustment then being in greater evidence.

Intermittent Reception

Cases of intermittent reception can be traced to a faulty aerial. Such aerials may be tested by catching hold of the aerial mast, bending it slightly and allow it to vibrate by releasing it quickly.

Such action may result in intermittent signals or a crackle being heard on the radio, which should of course be switched on. This would indicate a fault at the base of the aerial mast where an intermittent contact would reveal itself due to the vibrating action of the aerial mast.

Testing Extension Leads

Some aerials are, however, fitted to the off-side rear on a car, therefore, in the event of poor signal gain or no signals at all, this means that an extension lead may be fitted.

There are aerials with a complete lead from the aerial mast to the receiver and should it be possible to obtain a reading on the ohm meter from the aerial mast to the centre pin of the aerial plug, the aerial requires replacing due to the fact that the aerial trimmer on the receiver would not be able to allow for this excessive capacity for correct matching as previously stated. The most important factor to remember about extension leads, is that they will have a capacitor within the aerial plug if they are of reputable manufacture. Consequently, it may not be possible to obtain a reading for continuity due to its presence.

If it were possible to obtain a reading and it is known for the extension lead to possess a capacitor, this would of course indicate that the capacitor was leaking.

In many cars with the extension lead fitted under the carpets etc. it is possible for moisture due to condensation to find its way into the joint between aerial lead plug and the extension lead aerial plug socket.

This may be tested by the ohm meter, the probe of one lead being connected to the aerial extension lead hole and the other lead connected to the earth, i. e. to the braid of the extension lead. Any reading here indicates that the lead has moisture within it and must be changed. When it is suspected that the extension lead is open-circuit, the only way for this to be tested is to replace it with another lead.

If this course shows that the original extension lead is faulty; after connecting to the aerial lead and then to the receiver, the capacitance of the new extension lead must be matched to the receiver by adjustment of the car radio aerial trimmer.

The reason for this, should require no further explaining, it is essential for it to be carried out.

It will have been seen that the aerial can result in poor performance being received on the car radio, whilst the radio may be in good working order.

This means that one must not be in too much of a hurry in removing a car radio receiver and it also means that the aerial on the car should

always be tested first when complaints of poor reception are received from the motorist.

Testing Roof Aerials

It will be appreciated that cars which are fitted with a roof aerial cannot be tested in a convenient manner in the way a wing aerial can be tested. The method of testing such aerials is by comparison with another aerial not necessarily a roof aerial.

Should the comparison aerial indicate that the signals are much better received with it than with the roof aerial, it is clear that something must be wrong.

Do not forget, however, to adjust the aerial trimmer before taking comparison tests. Since the position of the trimmer may be such that although it is incorrect for the roof aerial, it may be very nearly correct for the comparison aerial.

One must be very careful in testing roof aerials as it means the removal of the "header panel" and care must be taken not to disturb the upholstery within the car more than necessary.

One other precaution requires stating, some cars have an interior light incorporated with the interior driving mirror. Therefore, when the header panel is removed, it is at first necessary to remove the mirror in order to achieve the removal of the header panel. The car battery **MUST** be disconnected before any work is carried out. Should it become necessary to replace the roof aerial and there is an interior light incorporated with the driving mirror, there will be a possibility of severe ignition interference being induced into the aerial fixing bolt through the light supply leads being pushed into close proximity with the aerial fixing bolt when the header panel is replaced.

Such leads must be directed away from the aerial fixing bolt as much as possible and if possible may be screened in the cases of severe interference with aerial lead in the manner given in Chapter 8. Apart from the Rover motor cars, which has such interior light incorporated with the driving mirror (Rover 2000) but which can be arranged so that interference can be eliminated by careful positioning of the wires, it follows that it is not a good idea to fit a roof aerial where there is an interior light fitted in the header panel just above the interior driving mirror due to the risk of such interference resulting. The importance of the aerial being matched to the receiver has been given many times. There are cases however during an installation when it is not possible to adjust the aerial trimmer after the receiver has been fitted. Those cases are when the trimmer is positioned (a) under the receiver chassis or (b) at the side and (c) on top of the receiver chassis.

The system here is to first fit the aerial temporarily connect the receiver to speaker, power, and the aerial then adjust the aerial trimmer for matching. After which, disconnecting the battery once again, the rest of the fitting can be dealt with.

Also, remember that it is essential for the vehicle to be resting on its wheels, and not on jacks during aerial trimming.

This is because the capacitance of the vehicle with respect to the earth acts as an counterpoised earth and is taken into effect during the aerial trimming operation.

An excessive amount of solder on the extreme end of the aerial plug

will cause the aerial socket connection to "open up" thus resulting in a possible source of intermittent reception.

All unwanted solder should be removed with emery paper.

CHAPTER 11

Testing Speakers for Faults

If we can consider the aerial as being the first step in our search towards determining the cause of poor reception we must certainly regard the speaker as being the second step.

We have, therefore, two essential components to test before we can even think of removing the radio receiver from its mounting. It must also be remembered that this stage of fault location is mainly applicable to the Motor Vehicle Electrician whose knowledge of radio is of course limited; in the same manner as the radio service engineer's knowledge of the electrical equipment in a motor vehicle will be limited.

Even so, the vehicle electrician can with commonsense apply certain methods to the location of "external faults" to the car radio and this will now be given.

Poor Volume

Instances of poor volume may be due to the speaker being mounted within a recess, such as behind the passenger's trim panel near the feet which does not have any holes provided to allow the sound waves from the speaker to come through with sufficient force.

The remedy here is to cut a suitable size hole and then cover this with a speaker bezel for neatness and to protect the speaker cone. A further case of poor volume is that some cars have glass wool or other such material placed in such hollow parts of the vehicle to prevent "drumming" i. e. road noises which have a resonant effect within these hollows and are consequently amplified. What happens is that some of the material may have been fitted just above the speaker and with constant vibration of the vehicle has fallen down on to the speaker on to the speaker cone and thus preventing it from vibrating in a normal manner with the signals being fed to it from the receiver. The remedy here is obvious.

In some cases, it will be found for the speaker cone to become fixed i. e. , not subject to any movement this being the case of speakers fitted on to the rear parcel shelf.

The reason for this is due to objects being placed on the rear parcel shelf such as sweets or hair lotion. If the hair lotion bottle leaks or with constant heat from the sun the sweets will after a time, melt and drip down on to the speaker cone. This will in time become quite hard like glue and prevent the cone from functioning in its usual manner.

Another cause of poor volume is for the speaker cone to have perished, so that the cone behaves in a concertina manner. A rare cause of poor volume may be the result of the magnet on the speaker being weak, in this respect, care must be taken not to drop speakers on to hard surfaces since this can result in the magnet being weakened.

No signals

Apart from a faulty receiver and this is not even considered at this stage, an open connection to the speaker or the leads coming off the speaker tags, will of course prevent the speaker from working. In addition, a common fault with speakers is that the speech coil going open

circuit, will render the speaker useless and it will need to be replaced. A further cause of a faulty speech coil is one of moth balls being left on the rear parcel shelf on a hot summer day, melting and stripping the insulation from the speech-coil windings. This in effect made the coil as useful as a length of wire, no magnetic field could now surround the coil to operate the cone due to the normal attraction and repulsion action when the speech-coil becomes an electromagnet, varying in accordance with the signal currents from the receiver output stage.

Distortion

A speaker will result in distorted reproduction of the signals if the cone is out of centre. This will cause the speech coil to rub against the magnet.

It may in time if allowed to continue, wear the coil, so that it becomes open circuit.

Intermittent Reception

A speaker will cause intermittent reception if there is an intermittent break in the speech coil. Such faults can be extremely difficult to locate as they will continue to give a good contact over a period then go open circuit.

Testing Equipment

Any cases of the speech coil going open circuit will be quickly revealed with the ohm meter since when it is set to read low values of resistance, it will (a) fail to move across the scale, the pointer of the instrument also (b) if the speech coil is in fact no more use than a length of wire due to stripping action of some liquid falling on to the cone etc., fail to give a clicking action from the speaker, although it WILL indicate that there is a circuit. With the resistance range set to read higher ranges of resistance, this clicking action will not be heard. This is because with the lower range of resistance, more current flows from the ohm-meter's internal batteries which has the effect of magnetic action on the speech coil and will therefore produce the clicking sound heard on the speaker.

Of course, in the absence of an ohm-meter, the only other alternative is to use a speaker known to be in good order.

This is in fact essential in order to locate a faulty speaker which is distorted so that a comparison may be made.

A suitable testing speaker with other components is given in Fig. 13. With the aid of the "balance control" the two speakers can be listened to independently and the results noted.

If we consider the above speaker testing procedure to be in relation to those receivers which are of vibrator powered, we can also add to the list of speaker faults dampness. THIS is very essential as apart from causing the cone to collapse and resulting in distortion, it can with other types of car radios, result in the fuse being blown. This will, however, be given later.

Speaker Plugs and Extension Leads

It has been shown how two components, the aerial and the speaker can result in a number of faults also it has been made clear that these essential components must first be checked before taking out the receiver for further examination.

Connect suspected speaker here

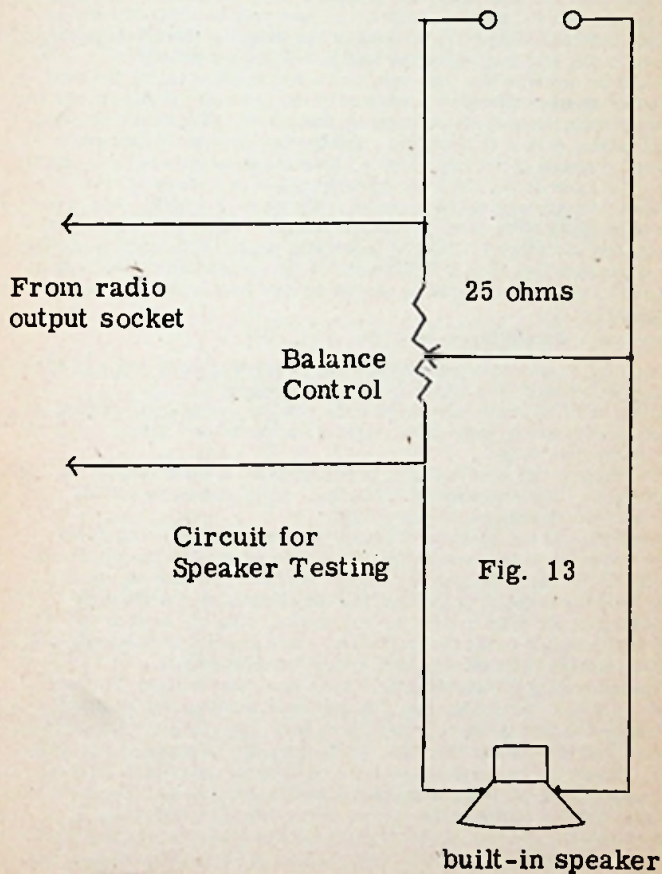

Circuit for Speaker Testing

Fig. 13

Two other possible sources of faulty reception in one way or another, are the speaker lead and the speaker plug.

With reference to the speaker plug an excess amount of solder on its pins will "open up" the speaker socket and result in a loose contact giving intermittent reception, either when the car is going over rough road or during the normal vibration caused by the engine. A poor soldered connection to the speaker plug pins also will give intermittent reception or dirty pins likewise. The speaker connecting leads can suffer from poor soldering so that the wire is actually held by the flux and not in contact with the solder.

The speaker which is fitted to the rear parcel shelf will require a fairly long lead and this can give a greater risk of such leads becoming trapped under the metal portion of the rear seat or under the driver's seat. Continual friction of the seat or the weight of the driver pressing down on the lead may cause the lead to become cut through.

Should the leads to the rear speaker be suspected of having been cut the test speaker should be connected to the receiver, if signals are received when the radio is switched on, the speaker plug should be replaced making sure it is clean etc., and the test speaker connected to the rear terminals of the lead, first disconnecting the mounted rear speaker. If signals do not reach the speaker, we have a faulty speaker lead. Should however signals be received, then we have a faulty rear speaker such faults being those previously stated. This method again assuming that the receiver itself is in working order. With some motorists it is possible that they have carried out the installation themselves in which a faulty join covered by insulating tape may be found.

CHAPTER 12

Car Radio Voltage Droppers

Some car owners have possessed a car radio over many years of vibrator power system working from six volt supply.

Again, they may have purchased a six volt car radio of all transistor design each having previously owned a car the battery supply being in each case six volts.

The common link between them is having paid for their respective receivers, they now want to install their receivers into a vehicle whose battery voltage is twelve volts.

Assuming that the question of vehicle polarity has been considered and either (a) it does not matter since the new car has the same polarity as the old or (b) polarity change over can be achieved, we are left with the problem of the best method of connecting a receiver working on six volts to a twelve volt supply. The one method that we do NOT adopt is to tap the car battery since this would cause one-half of the battery to be working at a greater current supply.

It is interesting to receive orders for a car radio dropper "its only for a six volt radio" they say, "do you know what current it takes" I reply; and this is where it is vital to know how much current it does take, because without this data, no dropper can be supplied with safety. Should the required information be unknown the only method is to connect the car radio to a six volt supply and with a good quality ampere meter measure the current consumption in amperes. To show how the dropper can be calculated from this data, we will work out two cases (a) for a vibrator car radio and (b) for a transistor car radio each requiring only six volts.

Car Radio Dropper Calculations Vibrator Receiver

Let us assume that the above type of car radio requires six volts at 4 amperes, this is a common figure for such receivers and we wish to operate this from a battery supply of 12 volts.

$$\begin{aligned}\text{Hence } R_d &= \frac{\text{Voltage Supply} - \text{Voltage Required}}{\text{Current taken by receiver in amps}} \\ &= \frac{12 - 6}{4} \\ &= \frac{6}{4} = 1.5 \text{ ohms}\end{aligned}$$

It is also necessary to calculate the wattage dissipated by a current of 4 amperes flowing through a resistance of 1.5 ohms

$$\begin{aligned}\therefore W &= I^2 R \\ &= 4^2 \times 1.5 \\ &= 16 \times 1.5 \\ &= \underline{24 \text{ watts}}\end{aligned}$$

The dropper should be mounted on a special bracket, away from any of the car wiring and never near the petrol supply. It should also be given plenty of air space for cooling purposes.

Transistor Receiver

$$\text{Again } R_d = \frac{\text{Voltage supply} - \text{Voltage Required}}{\text{Receiver Current in Amperes}}$$

Now a transistor receiver takes very nearly 1 ampere the actual current on some being 0.9 ampere. We will take the latter figure so that some decimal calculations can be given

$$\begin{aligned}\therefore R_d &= \frac{12 - 6}{0.9} = \frac{6}{0.9} \\ &= \frac{60}{9} = 6.7 \text{ ohms approx.} \\ \text{Wattage dissipated} &= I^2 R = 0.9^2 \times 6.7 \\ &= 0.81 \times 6.7 \\ &= 5.427 \text{ watt}\end{aligned}$$

The nearest wattage six watt will be required.

CHAPTER 13

A Faulty Car Radio Receiver : Notes : For The Motor Vehicle Electrician

This chapter concerns itself with providing information to the motor vehicle electrician so that he will be in a better position to judge what his main course of action should be.

In this respect whenever he is requested to look at a car radio receiver, particularly with transistor receivers of all types i. e. whether fully transistorised or with a transistor output stage to make quite certain that the receiver had been working satisfactory in THAT PARTICULAR CAR this is most vital since it has been stated that such receivers MUST have the correct polarity connected to the receiver ch-

assis. What may have occurred is for the owner to have removed the receiver from one car with a positive chassis and refitted it to the present car which has a negative polarity the fault here being obvious.

However, if some assistance can be given to the vehicle electrician, he can decide whether to remove the receiver and send it to a car radio engineer for examination.

We will give certain symptoms of car radio faults with their possible internal component faults. It must be stated that a faulty aerial or speaker will NOT be considered here, since these two parts have been dealt with previously.

Receiver Dead, Fuse Not Blown

Here it can be decided if the on/off switch is working by noting if the dial lamp is functioning, provided of course that the dial lamp has always previously worked just recently, otherwise the absence of the dial lamp lighting would be most misleading. With vibrator powered car radios, the usual signs of hum coming from the vibrator unit, will indicate that supply voltage is reaching the receiver providing that the vibrator unit is not contained within an amplifier unit which is fitted say in the boot or under the car bonnet in which case it may not be possible to hear the vibrator hum. If on the otherhand, the vibrator unit is silent byt the dial light shows that voltage is reaching the receiver then we have the possibility of (a) a faulty vibrator unit, (b) a broken connection carrying power to it thus preventing the vibrator unit from working.

What would be indicated, however, is a fault in the H. T. section of the receiver if the vibrator is synchronous, or a fault in the L. T. section of the receiver if the vibrator is non-synchronous. The former type of vibrator unit is self rectifying and does not require a rectifier valve to change the A. C. voltage to D. C. whilst the latter type does. It should also be further explained that with the former type of vibrators it is usual for a fault on the H. T. to prevent them from working or to result in their replacement. It could well mean that the lead which provides the working voltage in the first instance may have broken away from the vibrator holder due to vibration.

The actual conclusion is that we have a fault in the power unit as a whole from whatever cause.

No hum or dial light would indicate that the on/off switch is faulty or a lead has broken away from its tags or a bad soldered connection to the switch. This would mean that we would have to remove the power unit for examination or the on/off switch which means the control unit being removed from the car.

Should the vibrator indicate its working by the characteristic hum and the dial lamp lighting also gives its support that voltage is being fed to the receiver then we may have a faulty valve say a rectifier valve if used or a resistor across the smoothing condenser gone high, a faulty speaker output transformer. If the wavechange switch on the receiver shows that there is some life, it may mean that the aerial connection within the receiver is broken - a common fault - or again, it may indicate that some section of the High Frequency stage of the receiver is at fault. In such cases, the receiver will have to be removed from the car for further examination on the bench by an engineer with the necessary testing equipment.

Further to our discussion of the set being dead, and the fuse being in fact, we consider such symptoms with regard to the transistorized receiver. Such radios are those whose output stage consists of a transistor, some transistors being the OC26, AD140 and the OC19, there are others. Such receivers do not have the vibrator so that we are unable to listen to the characteristic hum from this unit in order to know that the power unit is working.

If the output stage of such receivers are in working order, a characteristic "thump" from the speaker will indicate that the output transistor is functioning as the receiver is switched on. Should no signals be received even with this sign of the output stage being reasonably working, we suspect a faulty valve or intervalve condenser broken from its tag etc.

The voltage supply to a transistor receiver is very low being restricted to the battery supply, therefore, should a resistor supplying voltage to the valve anode be higher than it is suppose to be, the valve will receive very little voltage to enable it to function. With such receivers, the intermediate frequency coils seem to break down more than in the conventional vibrator receiver. Should the "thump" which indicates that the output transistor stage is working be absent, we suspect a faulty transistor, driver transformer, or output transformer.

In such circumstances, the receiver will require the attentions of a radio engineer in order to locate the fault.

Signals Very Weak

Considering this heading in regard to the vibrator receiver, the weak signals may be the result of a resistor in the detector stage gone very high i. e., from 220,000 ohms to over 2 megohms. Thus preventing the full amplification of this stage being utilized since the high resistance will prevent the anode of the valve from obtaining its normal voltage supply. An example being a valve requiring say 70 volts only getting 30 volts.

Some car radio receivers, employ a metal rectifier in order to convert the alternating current to direct current. Whilst other car radios may use a rectifier valve for the same purpose. With regard to the latter form of rectification the loss of electronic emission from the valve will prevent it from carrying out its function.

With the former method of rectification we do not have electronic emission but a copper oxide device which will allow current to flow freely in one direction but will prevent current flowing the the opposite direction. It is therefore a rectifier and carries out the same function as the valve rectifier but with different principles involved.

Should either of these rectifiers break down for any reason, there will be no H. T. voltage at the reservoir condenser to operate the receiver. Therefore, the receiver will be dead to radio signals, but this may not prevent the vibrator from working with its characteristic hum. This means that even with the hum present, we need not have any A. C. voltage being rectified due to the various forms of rectifiers having broken down in some manner. However, to return to our main case of weak signals, this may be due to the efficiency of the rectifier being reduced in some way in the case of the valve rectifier it may be reduced emission so that the H. T. is low. Some figures are instead of 250 volts D. C. at the reservoir condenser, it may be only 150 volts which, although sufficient to allow signals to be received will be too low to enable the receiver to work at its usual level of volume. There are

many faults which can result in a receiver giving weak or poor output and again it is a task for the radio engineer to locate the faulty stage and part.

With regard to the transistor receiver which employs valves and the output transistor, this latter output system does away for the need of a vibrator and its associated components. Here again, the causes for very weak signals being received are valves, output transformers driver transformers and the output transistor itself not to say dry solder joints.

In addition to the attention of the radio engineer, it will be necessary for him to be provided with the necessary data on the particular receiver which will be found in the service sheet for the receiver supplied by the manufacturer.

Signals Distorted.

This may be due to faulty components, valves where applicable or transistors. It may also be due to the receiver being out of adjustment which could in fact also be given under the previous head for weak signals.

Once again the only course is to remove the receiver for bench examination by the radio engineer.

Volume Control Distortion

With vibrator receivers, the distorted effect caused by the volume control being operated, indicates that this component must be replaced.

With transistor receivers of all types i. e. fully transistor or hybrid transistorised receivers, the operation of the volume control if faulty will also cause the signals to distort.

This is due to the "carbon track" on the control having become worn thus requiring the entire control to be replaced. In addition, with transistor receivers of all types sometimes the "carbon track" will become "open circuit" and it depends at which end of the control the break occurs since the movement of the control "centre arm" may allow the break to be of no consequence but as soon as the position of the control is such the "open circuit carbon track effect" will be more pronounced with distortion resulting.

It must also be understood that volume controls also include the on/off switch and in addition there may be a tone control. Should the tone control and the volume control be of one complete unit, the entire unit must be removed. In this respect it must be appreciated that with both controls, we have a number of wires to remove and reconnect with the live leads going to the one/off switch. Here is a wonderful chance to mix up the various wires with unfortunate results when the time comes to "switch on". It is far better therefore to leave volume control replacement to the engineer since the soldering must be carried out by the use of "radio solder" and NOT with corrosive flux.

A poor soldered connection may also cause distortion as the connection fails to make contact with the tag of the control.

Fuse Blown

Cases of fuse blowing, should be examined in regard to the type of car radio one is dealing with. For instance with the vibrator car

radio the fuse holder is usually a metal container. In such cases, it is VITAL for the fuse to have a cardboard sleeve around it, thus preventing it from short-circuiting (a) to the metal container and in turn (b) to the chassis of the car via the metal fuse holder. It should also be noted if the fuse removed is of a higher rating amperes than normal that is to say, assuming that the normal fuse is 5 amperes and the one removed is one of 10 amperes also the possibility of any short circuit of the nature given above is not possible, it seems that we have a serious fault within the receiver causing the fuse to blow. Considering the vibrator receiver, if the fuse is replaced with the CORRECT rating in amperes and upon switching the radio on the fuse blows without the initial sound of the vibrator being heard, we may conclude that we have a faulty vibrator unit.

A further cause of fuse blowing in common with all types of car radios, is for the power lead connected to the receiver to have become trapped between the fixing brackets the pressure of tightening the brackets have eventually cut through the wire insulation, thus presenting a source of fuse blowing between the receiver and the fuse. With such receivers, water reaching the speaker would not result in the fuse blowing, provided however that the speaker is mounted away from the control unit.

With regard to transistor receivers, water on the speaker may result in the blowing of fuses if the output transistor has an auto-transformer, since this lead is usually LIVE with respect to the car chassis and receiver chassis.

Trapped speaker leads or faulty transistor output stage can all contribute to fuse blowing which means testing on the bench by the engineer for its cause. The fuse holders on transistor receivers are, however, mainly plastic holders therefore the need for a cardboard sleeve over the fuse does not arise.

Changes in Level of Volume

At times a receiver will give good output and all at once will drop in volume. This can happen though the car is at rest or the receiver playing on the bench prior to an installation. Such faults may be the result of a condenser breaking down in the intermediate transformers or any intervalve condenser.

The valves may have a faulty electrode within or in the case of transistor receivers, a faulty transistor can also result in changes of volume. Any connection which improves the response of the receiver can if making a poor connection result in the level of volume changing. In such cases, the receiver will need to be given an examination by the engineer.

Do not forget to examine the power leads for poor connections as this would result in the amount of voltage being supplied to the receiver to alter in value thus bringing about a change in the volume. It must be remembered that such changes are only when it is known for the reception at a particular place to be good, i. e. the changes in volume stated above are NOT the result of fading due to the movement of the car along roads with high hedges etc.

Receiver Plays, Then Signals Stop

Assuming that there is no faults with the receiver supply, the usual cause of receivers playing then stopping or "cutting" out can be traced to faulty condensers in the intermediate transformers, driver transformers going

open-circuit, defective output transistor or the output transformer likewise.

Faulty valves can develop internal faults as they warm up causing the grid to short-circuit to the cathode etc.

Such faults are tedious to locate since in many instances, the receiver after cutting out will all at once come on again and we have an intermittent fault to locate. This being a task for the radio engineer with his testing instruments.

Intermittent Reception Over Rough Road

This fault is self evident, it means that we have a poor connection somewhere within the receiver which is making an intermittent contact as it is subjected to the vibration of the car going over the rough road. This means that the receiver must be removed from the car and examined by the engineer for a poor connection.

Taking a Look Around

From what has been so far given, the principle task of the motor vehicle electrician will be to prevent interference which in itself is a very important one.

Other factors however show that with commonsense such faults as aerials and speakers can be carried out by him with little trouble. When it comes to the internal parts of the radio receiver, it is best to allow a radio engineer to examine the cause of any such faults that may be complained of.

The next best thing however is to have some idea of what might be a fault within the receiver so that the vehicle electrician can give the motorist an idea of what may be involved.

The vehicle electrician is restricted to the extent that even if he possessed the knowledge for radio servicing, the amount of work in this respect carried out by his garage would perhaps hardly justify the expense of special testing equipment necessary for efficient servicing.

However, for his benefit and for the service engineer, a number of installation sheet instructions for various cars are given and they are to be regarded as an excellent example of providing the necessary information to ensure good results and preventing damage to the vehicle through drilling in the wrong places.

CHAPTER 14

Difficult Rear Speaker Mounting

Many cars have provision for rear speakers on the rear parcel tray. The metal shelf is usually cut to make this task as easy as possible although care must be still taken.

However, the odd difficult rear speaker mounting can occur and one in particular was made much more difficult than usual as the result of a demister apparatus situated in the boot of the car and directly underneath the speaker provision.

This allowed only some 3.5 inches clearance and it was obvious that the cutting out of the speaker hole to its correct size would have to be achieved from within the car itself.

In addition, the speaker position had a recess so it was essential for the speaker to fit exactly into this recess.

The general picture is shown in Fig. 14 whilst Fig. 15 shows the

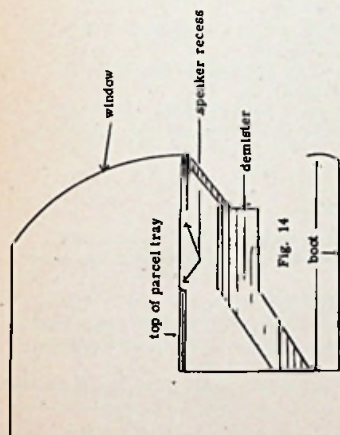
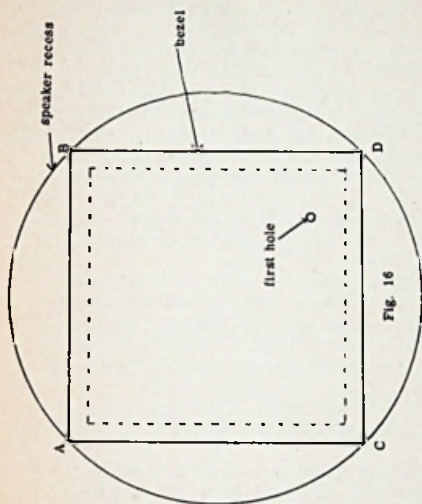

demister outlet

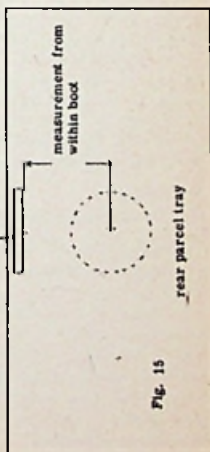

demister outlet

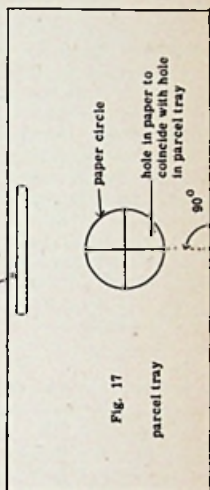

rear parcel tray viewed from within the car, the dotted circle indicating the speaker recess underneath the parcel trim well out of sight and its position we have to locate correctly.

From within the boot, we endeavour to measure from the centre of the recess to the rear of the window as accurately as possible.

Then from within the car, we use this measurement to make our first hole, a right-angled drill being required here.

What we wish to achieve is to drill through the centre of the recess - which is circular - first time but this is more than we can expect.

What we **MUST ACHIEVE** however is to see that our hole comes within the dotted line shown in Fig. 16 which will be eventually removed thus leaving an aperture within the dotted enclosure for the speaker to work etc., this aperture being then covered by the speaker bezel for neatness. In this instance, the speaker was an exact fit into the recess, therefore, the next step was to cut a piece of paper or cardboard, the exact size of the speaker and offer it up from within the boot into the recess.

Firmly pressing the piece of paper or cardboard, the size of the speaker up against the recess, a hole will be made in the paper etc. due to the jagged metal about the hole.

Taking this paper within the car and placing it on to the rear parcel shelf so that the hole in the paper coincides with the hole previously made, a general direction will be given as to the centre of the recess from within the car. Also, if the paper is first divided into quadrants, the intersection of the two diameters will give the exact centre of the recess.

It is clear that the circle must be in the centre of the parcel tray, also with care the circle can be lined up with respect to the window and the rear seat, Fig. 17.

If a hole is now drilled at the centre of the paper circle or disc, it should once again be offered up from within the boot, to see if the mark made by the hole comes at the intersection of the diameters i. e. two such disc can be cut out for this method.

When this has been achieved, the four holes for the speaker bezel can now be marked off, A / B / C / D in Fig. 16.

The circle can be used for this purpose by placing the bezel legs on to the paper and marking off on to the parcel trim.

Care must be taken to see that the speaker bezel is fitted as squarely as possible on to the tray and remember that the bezel legs **MUST** come within the recess aperture.

CHAPTER 15

Illustrated Installation Instructions

The installation of car radios require essential fitting instructions, without which damage may be caused to the car through drilling in the wrong places.

The information given here is provided by Radiomobile Ltd, London, and is taken from their own installation sheets which each Accredited Dealer receives to assist him in the installation of car radio receivers manufactured by Radiomobile Ltd.

It will be appreciated that only a few vehicles can be given in a book this size, since to include ALL vehicles would require a book many times the size of this one.

Apart from the practical advantages of including such data, there are

many terms in the motor trade which the radio service engineer will not be familiar with and it is hoped that such cars that are shown will include sufficient terms for the radio engineer to become acquainted with for future work.

It must be clearly understood that the measurements that are given here relate to the products of Radiomobile Ltd, i. e. , for the mounting of aeri-als, speakers, and car radios. Products of other manufacturers may differ in the size hole required for the fitting of their aeri-als, speakers and car radios.

The usual size hole required for wing aeri-als are 7/8" dia., for roof aeri-als, 5/8" dia. This may be achieved by the "Q-Max" chassis cutter used in radio construction, the latter size being excellent for wing mirror fitting. For vehicles with 'double skin' a wing aerial may be fitted by using a No. 3 Enox cutter in a drill.

It is hoped that the following information will prove instructive to the vehicle electrician and the radio service engineer and hobbyist.

In ALL CASES OF FITTING CAR RADIOS, FIRST DISCONNECT THE BATTERY, there is no SECOND CHANCE if the wiring burns out due to a short circuit.

Vehicle : Triumph Vitesse & Herald
Saloon, Convertible, Estate
Car & Coupe

Introduction : This instruction covers both right and left hand drive cars.

Warning: Before connecting to power supply, ensure that the polarity of the radio is made "POSITIVE GROUND". Damage to transistors is inevitable if polarity is incorrect.

Radio & Speaker : The radio and speaker assembly is mounted under the centre facia.

Aerial : A rear aerial may be mounted on the right side above the luggage compartment lid on the saloon and coupe and on the right side tail fin on the estate car.

Rear Speaker : A rear speaker may be fitted to either the saloon, coupe or estate car but NOT to the convertible as the folding hood occupies all available space when stowed.

Note : All cars are now fitted with suppressed ignition H. T. cables and suppressed distributors. These cables are marked "suppressed" or "Resistive". On NO account should these cables be cut or screw-in type suppressors used as ignition circuit failure will result.

Front Aerial Mounting : Note : A trepanning type cutter is needed.

- (1) Drill a 7/8" dia. hole as shown in Fig. 18
- (2) Fit aerial to panel ensuring aerial lead is routed into vehicle under facia through circular hole which is below and slightly forward of aerial position.

Rear Aerial (Saloon & Coupe)

- (1) Cut a 7/8" dia. hole at position shown in Fig. 19.
- (2) Assemble aerial to body
- (3) Route aerial lead over wheel arch
- (4) Remove rear seat and route aerial lead as shown in Fig. 20.
- (5) Replace seat
- (6) Refit carpets

Aerial Mounting (Estate Car)

- (1) Remove the two trim panels inside the right side tail fin

Fig. 18

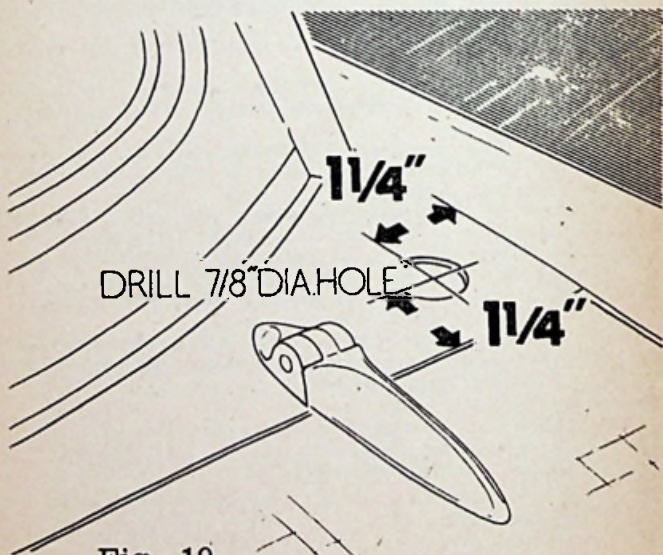
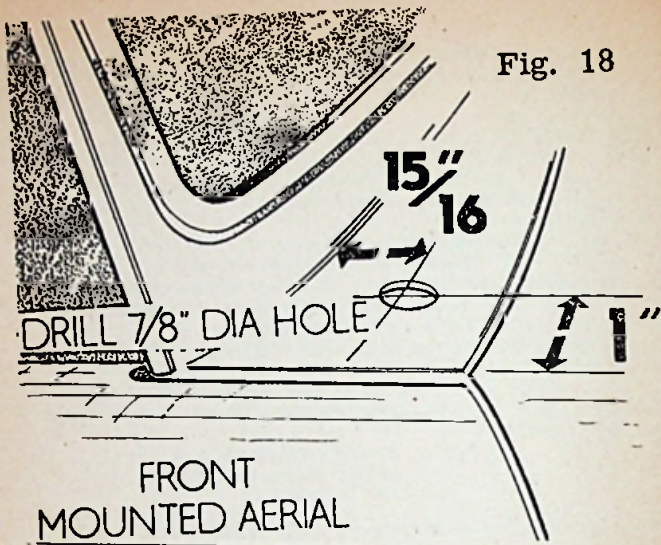

SALOON-REAR MOUNTED AERIAL.

Fig. 20

©
RUN LEAD
BELOW DOOR
SILL, UNDER
CARPET, TO
RADIO UNIT

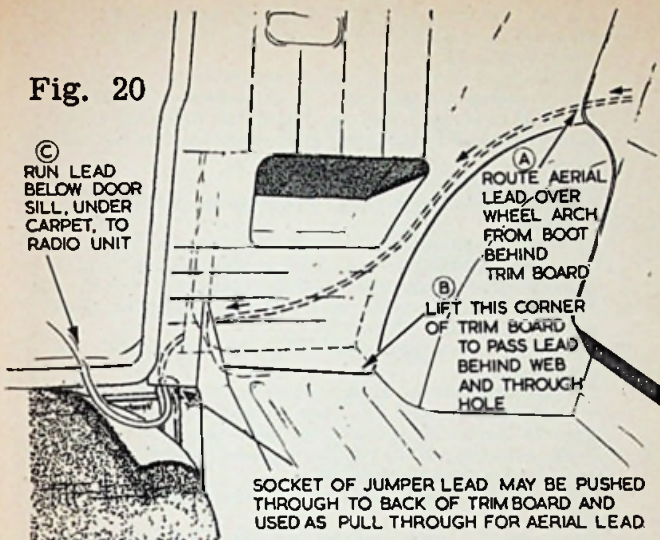

SOCKET OF JUMPER LEAD MAY BE PUSHED THROUGH TO BACK OF TRIM BOARD AND USED AS PULL THROUGH FOR AERIAL LEAD

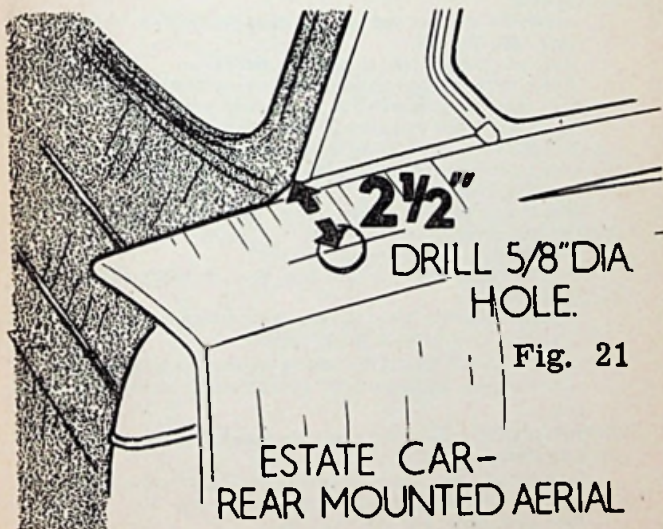

Fig. 21

ESTATE CAR-
REAR MOUNTED AERIAL

- (2) and over the wheel arch (held at top by spring clips). Mark Off and cut a 5/8" dia. hole in tail fin at position shown in Fig. 21.
- (3) Clean to bare metal area around hole inside car
- (4) Remove screw and lead and fit aerial assembly to hole. Adjust mast to vertical position, remove assembly and lock mast in position by tightening grub screw found under rubber washer.
- (5) Assemble aerial to fin
- (6) Route aerial lead over wheel arch as shown in Fig. 20.

Radio Unit Mounting

- (1) Fit front mounting and trim finisher plates (remove blue protective covering) between front of case and radio escutcheon secured by nuts under pull off type knobs - See Fig. 22.
- (2) Fit lower support bracket to rear of tray on gear box tunnel using the two outer PK screws.

Note : The middle PK screw holds the backing plate and should not be removed.

- (3) Loosely assemble the upper support bracket to the lower bracket using the wing nut, plain and shake proof washers.
- (4) Unscrew the two PK screws from the underside centre of the fascia, ensuring that the two flat spire nuts above the fascia stiffener brackets are retained.
- (5) Secure radio assembly to fascia using these fixings. See Fig. 23.
- (6) Secure upper mounting bracket to underside of radio using hexagon screw, plain and shakeproof washers.

Speaker Mounting

- (1) Assemble speaker and bezel to speaker housing with 4BA fixings. See Fig. 24.
- (2) Connect speaker lead to speaker and radio.
- (3) Route battery lead through main wiring harness grommet in bulk head and connect to A. 1 terminal on the regulator box.
- (4) Connect battery and aerial leads to radio.
- (5) Switch on radio. Tune to a weak signal on medium wave, 1.2 mc/s (250 metres) approximately and adjust aerial trimmer for maximum volume.
- (6) Mount assembly as shown in Fig. 22 and 23.

Rear Speaker Mounting (Saloon & Coupe)

- (1) Lift out rear seat cushion
- (2) Detach right hand rear side trim pad and cubby box spring clips on rear.
- (3) Position speaker bezel to dimension shown in Fig. 25 and drill four holes for bezel stubs 5/32" dia.
- (4) Mark with soft pencil the outline of bezel on trim pad and cut a rectangular aperture 3/8" less all round inside the marked area.
- (5) Fit bezel to front of trim pad and speaker to rear secure with fixings provided.
- (6) Connect speaker lead to speaker, routing to radio location as shown for the rear aerial lead in Fig. 20.
- (7) Refit trim panel and seat cushion.

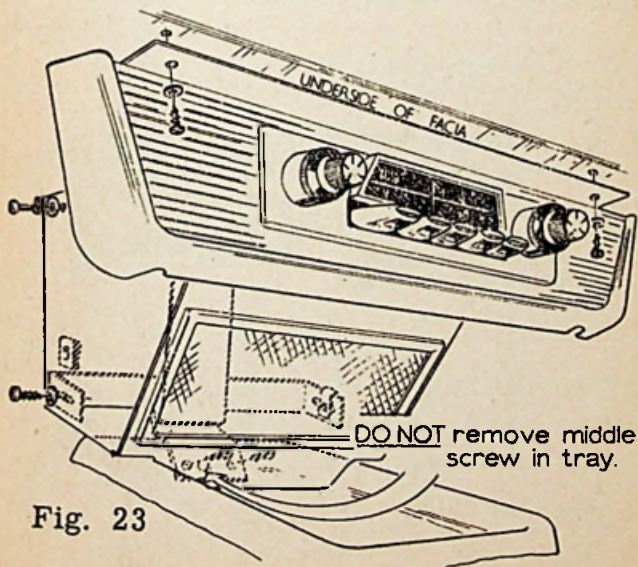
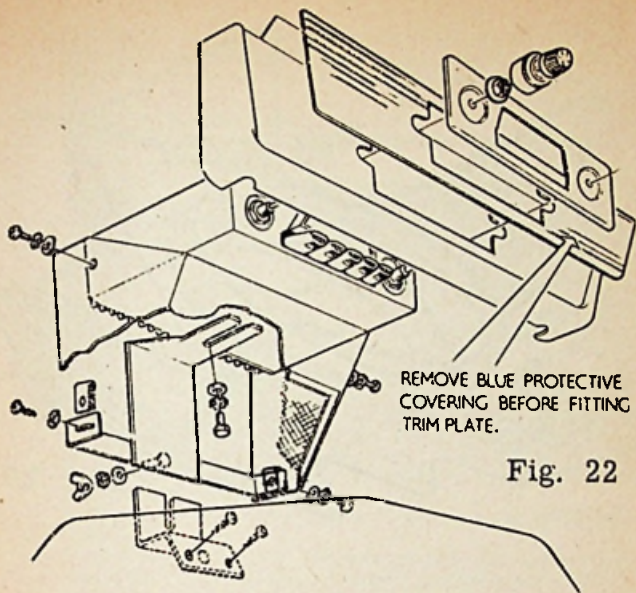

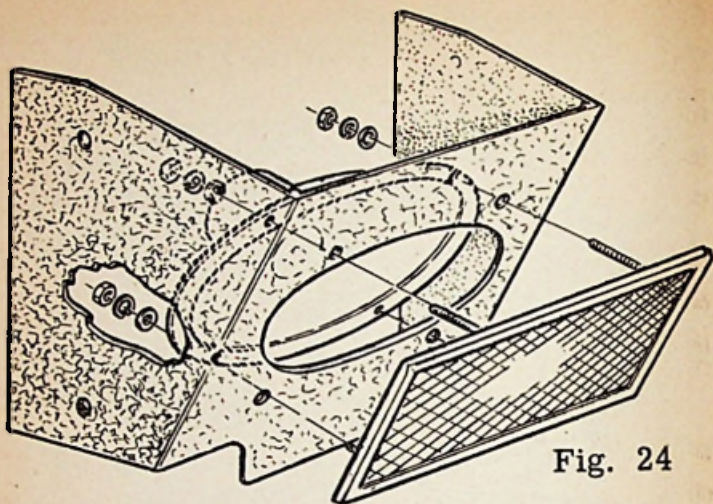

Fig. 24

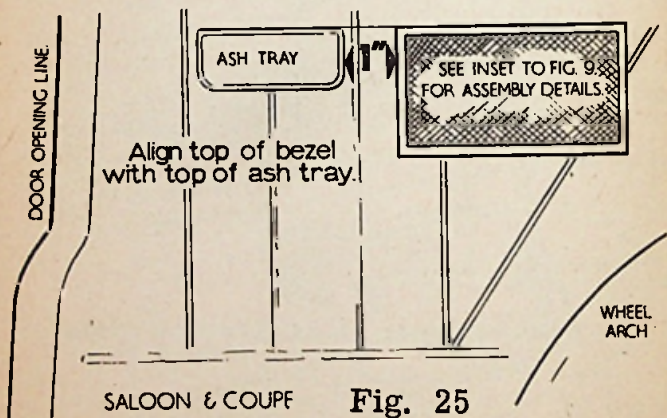

Fig. 25

- (8) Connect leads from front and rear speakers also speaker lead from radio to the balance control, as shown in Fig. 27.
- (9) Secure control to hole provided in right hand side of speaker board.

Rear Speaker Mounting : Estate Car

- (1) Detach side trim pad from luggage compartment spring clips on rear. See Fig. 26.
- (2) Position speaker bezel to dimensions shown in Fig. 26 and drill four holes for bezel studs 5/32" dia.
- (3) Mark with a soft pencil the outline of bezel on trim pad and cut a rectangular aperture 3/8" less all round inside the marked area.
- (4) Fit bezel to front and speaker to rear of trim pad secure with fixings from kit.
- (5) Connect speaker lead to speaker and route over wheel arch behind trim panel to the underneath of rear seat.
- (6) Refit side trim pad to luggage compartment.
- (7) Unscrew two screws from flexible flap on heel board in front of rear seat cushion and drill a 5/16" dia. hole through metal heel board. (This will prevent lead being trapped when seat is folded down).
- (8) Route speaker lead through from below rear seat fitting grommet provided secure seat flap.
- (9) Route speaker lead forward under floor coverings and up to radio location.
- (10) Connect leads from front and rear speakers also speaker lead from radio to balance control connect as shown in Fig. 27.
- (11) Secure control to hole provided in right hand side of the speaker board.

Suppression All Models

It is vital to scrape to bare metal at all points at which an earth connection is made. This is essential in the interests of efficient suppression.

- (1) Connect a 1 mfd capacitor to the "SW" terminal on ignition coil. Earth to coil mounting bracket.
- (2) Connect a 1 mfd capacitor to the large terminal (BROWN LEAD YELLOW TRACER) on the dynamo. Earth to dynamo mounting bolt.

Vehicle : Humber Super Snipe Mk V. / Humber Hawk Mk IV.

Introduction : The instructions give details of fitting a rear speaker to the above vehicles.

Rear Speaker Mounting:

- (1) Remove rear seats
- (2) Remove rear squab held by PK screws at the base and hook brackets at the top.
- (3) Remove rear trimmed parcel tray
- (4) Locate semi-pierced circular aperture on right hand underside of trimmed parcel tray. Cut and trim aperture and pierce four pre-marked holes about aperture for fixing studs of loudspeaker bezel and grill as shown in Fig. 28.
- (5) On Super Snipe, V only, remove circular pre-cut felt on metal parcel tray to expose aperture.
- (6) Replace trimmed parcel tray.
- (7) Connect loudspeaker lead to loudspeaker. Assemble loudspeaker, baffle board, loudspeaker bezel and grille to

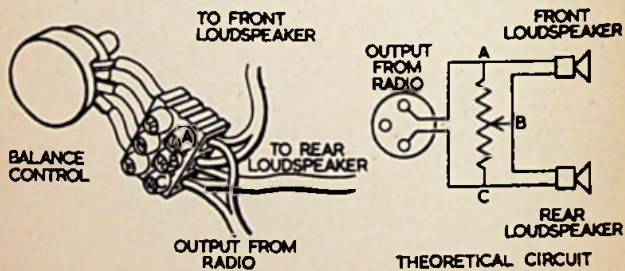
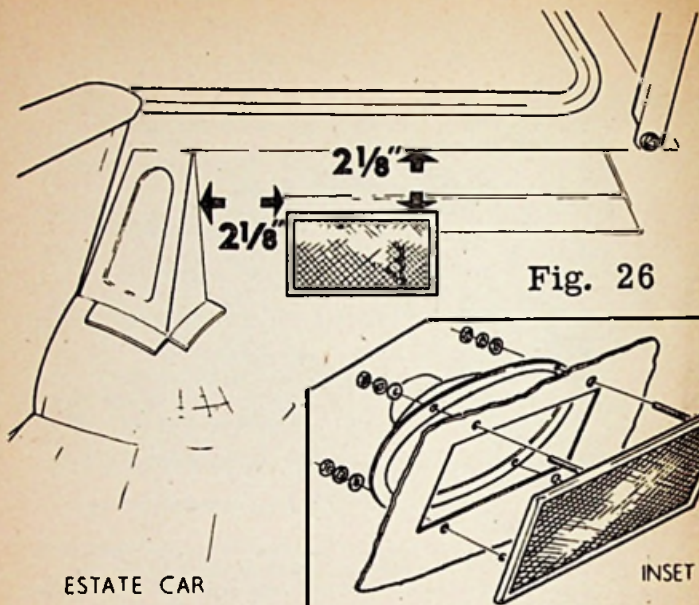

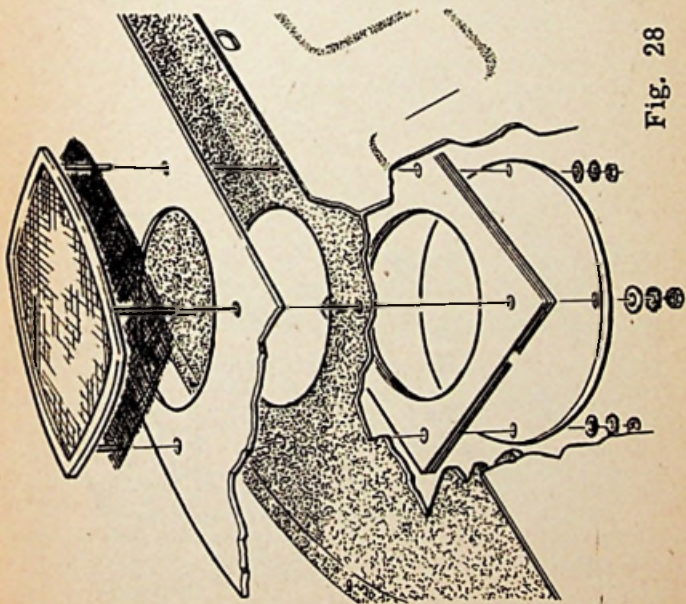

Fig. 28

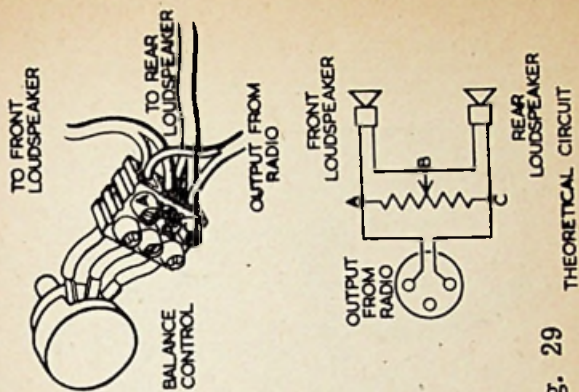

Fig. 29

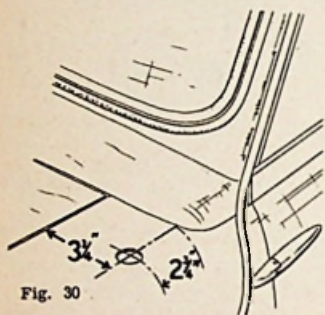

Fig. 30

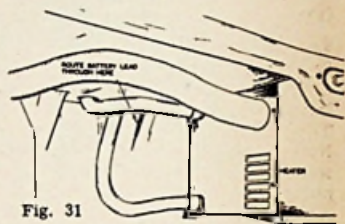

Fig. 31

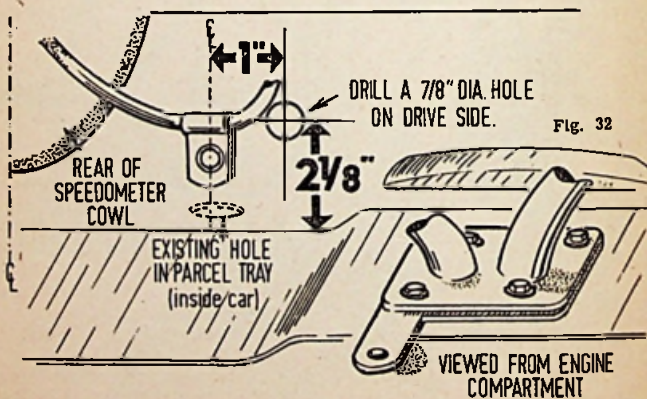

Fig. 32

metal parcel shelf and trimmed parcel tray as shown in Fig. 28.

- (8) Route loudspeaker lead from boot into car and down over wheel arch to floor of car. Continue routing lead under carpet and up behind bulkhead trim to front edge of facia panel on off-side of steering column.
- (9) Connect front loudspeaker lead, loudspeaker lead from receiver and rear loudspeaker lead to balance control. See Fig. 29.
- (10) Assemble balance control to small mounting bracket provided and secure bracket to front edge of facia on the off-side of the steering column.
- (11) Replace rear squab and rear seats etc.

Vehicle : Austin Seven

Saloon, and Special De Luxe (850) / Countryman Van and Pick-up (850) Cooper.

Introduction : This instruction covers both right and left hand drive cars. The illustrations show right hand drive.

Note : Before connecting battery supply ensure that the polarity of radio is made "POSITIVE GROUND". Damage to transistors is inevitable if polarity is incorrect.

Aerial : The aerial is mounted on the passenger's side front wing.

Radio Unit : The radio unit is suspended from the undersurface of the front parcel tray, between the steering column and the side of the body on all vehicles EXCEPT those equipped with a FRESH AIR HEATER. In these cases, the radio is mounted at the left hand side of the vehicle irrespective of driving position.

Speaker Notes : On the saloon versions, the speaker is fitted below apertures provided in the rear parcel shelf. The speaker on the Countryman, Van and Pick-up is mounted in the left hand trim finisher panel (irrespective of drive position) above the front parcel tray.

Aerial Mounting (and battery lead routing) :

- (1) Drill a 7/8th inch dia. hole in the passenger's side front wing as shown in Fig. 30.
- (2) Assemble aerial to panel.
- (3) Route the aerial lead through the 1/2" dia. hole in the wing valance (holes are provided in both valances) the hole at the left hand side being adjacent to the windscreen wiper motor into engine compartment using small black grommet provided.
- (4) Route aerial lead through wiring harness clips at top of bulk head and over top of bonnet hinge to centre of bulkhead.

Note : At this stage, routing of the battery lead should take place a length of fairly stiff wire as a pull through will assist this operation.

- (5) Route battery lead through aperture shown in Fig. 31 and into engine compartment; through grommet hole which will be found in the centre of the engine rear mounting member.
- (6) Route aerial lead into vehicle by the same path and fit soft rubber round shouldered grommet (which may be cut for ease of fitting) provided. Note : To simplify the aerial lead routing on the above vehicles, a 7/8" dia. hole may be drilled through the engine bulkhead in the position shown in the

Fig. 33

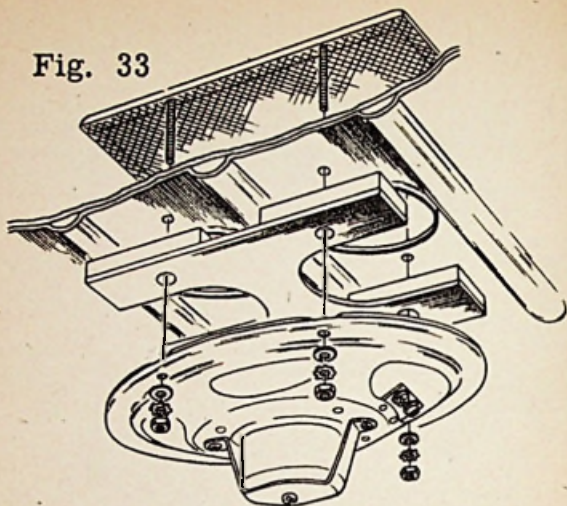

REMOVE ASHTRAY *ADD*

Fig. 34

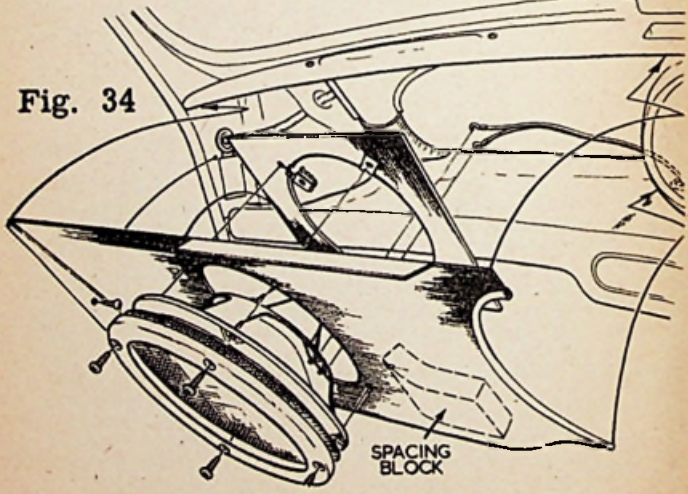

illustration given, Fig. 32, to protect the cable use the large grommet supplied. The hole may be drilled at either side of the speedometer cowl, and will enable a 60" aerial lead to be used in all circumstances. Two holes are provided through the front parcel tray, one below each side of the speedometer cowl which may be used for lead routing.

On vehicles using the "three instrument" cowl, this may be detached for easier access to bulkhead by removing the four small Phillips head screws from it's face. Note: Suppression Resistive type H. T. leads are fitted to the engines of the above vehicles, therefore, plug suppressors, cut lead suppressors etc. must not be fitted otherwise arcing may take place inside the cable. To simplify the battery lead connection, this may be taken to the spare male blade on the back of the ignition switch except where the new large heater is fitted which makes this connection inaccessible.

Saloon Speaker Mounting (Rear)

- (1) Route speaker lead to centre line of bulkhead (positioning lead to avoid interference with pedal movement) down to floor tunnel (underneath the floor covering) and along the right hand side of the tunnel to the front seat floor stiffener.
- (2) Route the lead over stiffener (close to hinge of right-hand seat) and along floor tunnel to rear seat.
- (3) Temporarily remove rear seat cushion
- (4) Drill a 7/8" dia. hole through front section of rear seat pan, 5" to rear of front edge, on centre line of car.
- (5) Route speaker lead through this hole using large grommet provided. Continue rearwards over seat pan and to left hand side of car. Route lead into luggage compartment through existing $\frac{3}{4}$ " dia. hole behind lower edge or rear squab using grommet provided.
- (6) Pass lead through cable clips up the side of the petrol tank.
- (7) Locate holes provided in metal panel of rear parcel shelf, see Fig. 33. Note : On some variations of the saloon, a sheet of felt wadding is adhered to the underside of the rear shelf. The wadding must be cut away to expose the speaker holes and to clear the speaker chassis.
- (8) Cut away the sections of trimmed pad which are visible through the two larger holes.
- (9) Pierce through trimmed pad the four holes for speaker bezel studs.
- (10) Connect lead to speaker
- (11) Assemble bezel, packing piece and speaker to parcel shelf as shown in Fig. 33. Secure with fixings provided.
- (12) Secure speaker lead to floor tunnel, seat pan etc. , with self adhesive tape provided.
- (13) Refit seat cushion

Countryman, Van and Pick-up, Speaker Mounting (Front)

The speaker is mounted in the left hand trim finisher panel (irrespective of drive position) above the front parcel tray.

- (1) Temporarily remove ash tray from rail above speedometer, also P. K. screw from left hand end of trim panel.
- (2) Gently ease curved centre end of trim panel over plastic switch at left of speedometer.

BRACKET POSITIONS AND
RADIO UNIT POSITIONS
ON VEHICLE WITH RIGHT
HAND DRIVE BUT
WITHOUT FRESH AIR
HEATER

DRILL THREE 7/32" DIA. HOLES

INSET
A

NOTE
POSITION
OF BRACKET
BEHIND COLUMN
SUPPORT

INSET
B

NOTE LONG
BRACKET AT REAR

Fig. 35

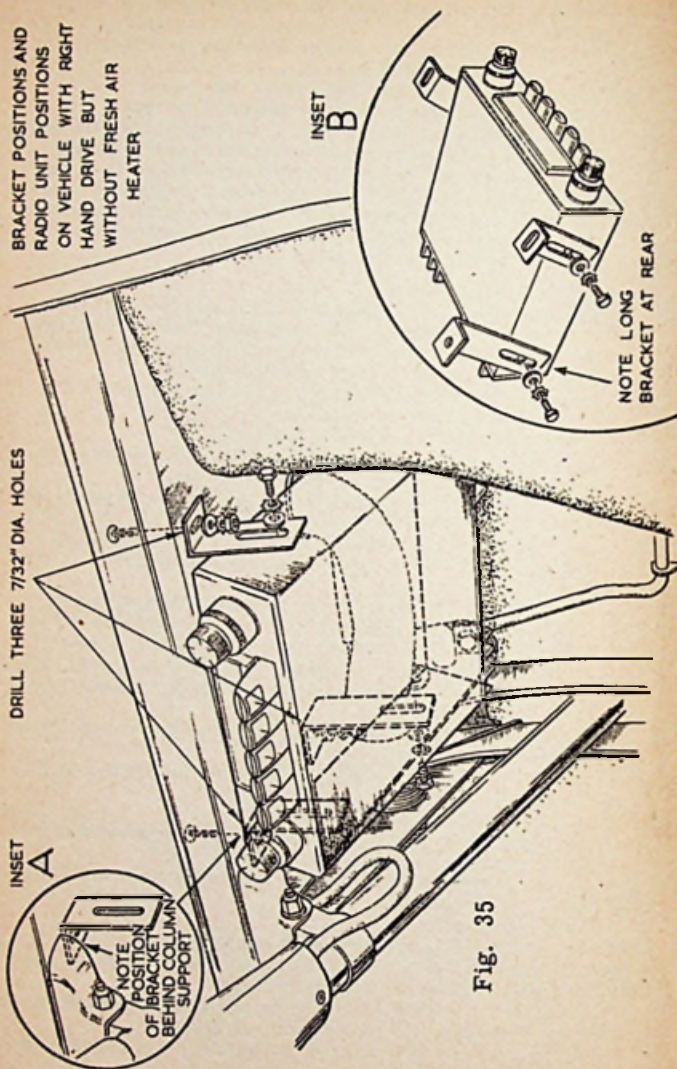

- (3) Mark a position on left hand trim panel, $10 \frac{3}{4}$ " from centre of left hand end crease, to meet a position $4 \frac{7}{8}$ " up from where the panel meets parcel tray. Measurements taken on surface of panel.
 - (4) Using a small sharp tool (bradawl, pricker, etc) pierce a small hole through trim panel in marked position.
 - (5) Using tool as a lever and other hand inside curved end of panel at side of speedometer carefully bulge panel outwards towards edge of parcel tray.
 - (6) Gently remove panel by sliding it towards centre of parcel tray and pulling outwards over dial of speedometer - see fig. 34.
 - (7) The speaker position is marked by semi-pierced holes on back face of the panel.
- Note: Early production vehicles did not have this facility and a $5 \frac{5}{8}$ " dia. hole must be marked on panel using small hole previously pierced as a centre point. See Fig. 34 for position of $5/32$ " dia. fixing holes and use speaker as a marking template.
- (8) Pierce holes in panel as indicated by markings.
 - (9) Fit spire nuts to speaker board - See Fig. 34.
 - (10) Assemble speaker and mounting components to panel as shown in Fig. 34.

Note : Lift corner of fabric spacer black to allow speaker support board to lie against back face of panel.

- (11) Fit grommet provided on to speaker lead and connect lead to speaker terminals.
- (12) Route lead and grommet downwards through hole (under trim) in parcel tray at left hand side of speedometer.
- (13) Refit trim panel/speaker assembly to vehicle in a similar reverse manner to that used for removal.
- (14) Refit P. K. fixing screw and ash tray.
- (15) Route speaker lead to radio unit position (see "Introduction")
- (16) Fit grommet to hole in tray

Radio Unit Mounting

- (1) See 'Introduction' regarding Fresh Air Heaters and radio position.
- (2) Assemble brackets to radio unit as shown in Fig. 35 inset B.
- (3) Offer up to underside of drive side front parcel tray between steering column bracket and body side panel.
- (4) Adjust brackets to bring their top surfaces flush with under side of tray.

Note : The front mounting bracket nearest to steering column should be immediately behind column support bracket (see Fig. 35 inset A). The opposite rear corner of unit should be against the body side trimming.

- The radio unit should be fitted with the fascia at right angles to the centre line of the car as it is not possible to fit it parallel to the parcel tray front edge.
- (5) Mark position of three fixing holes on underside of parcel tray using radio assembly as a template.
 - (6) Drill $7/32$ " dia. fixing holes through metal and trim.
 - (7) Route connecting leads to radio unit position (cleats provided in kit) and connect to radio unit.

- (8) Route battery lead (see "Aerial Mounting" for lead routing) to right hand side of engine compartment and connect to spare male blade (A. 1 terminal) on regulator box. Position lead to avoid interference with movement of bonnet hinge.
- (9) Tune receiver to weak signal on 1200 kc/s (250 metres) approx and adjust aerial trimmer for maximum volume.
- (10) Fit three chrome screws (heads uppermost) through parcel tray trim and metal.
- (11) Attach radio assembly to tray with washers and nuts provided.
- (12) Adjust unit in brackets spacing front of unit down from tray to ensure that dial is visible from driving seat.
- (13) Secure all fixings.

Suppression

It is important in the interest of efficient suppression to scrape to bare metal each point at which an earth connection is made. The distributor incorporates a built-in resistor in the main H. T. lead. Connect a 1 mfd capacitor to the following terminals.

- (1) "S. W." (white lead) on ignition coil, earth capacitor to coil mounting bolt.
- (2) Output on dynamo (brown lead with yellow tracer), earth capacitor to dynamo mounting bolt.
- (3) Supply (white lead) on petrol pump (this unit is located under the left hand rear of the body). Connect small tag of earthing lead supplied to earth terminal on petrol pump.
- (4) Connect small tag of other earthing lead to small cheesehead screw on terminal end plate (motor body) of the windscreen wiper motor. Earth other end of lead to hole provided in gusset plate immediately forward of wiper motor.

Vehicle : Morris Minor 1000 Saloon / Tourer and Traveller

Introduction : This instruction covers both left and right hand drive cars.

Note : Before connecting to power supply ensure that the polarity of the radio is made "POSITIVE GROUND". Damage to transistors is inevitable if polarity is incorrect.

Aerial:

The aerial is mounted in the wing on the drive side of the car.

Radio Unit :

The radio unit is mounted underneath the driver's side glove box in the case of saloon models and underneath the passenger's side glove box in the case of tourer models.

Speaker Notes:

The loudspeaker is located at the rear of the passenger's side of the parcel tray.

Aerial Mounting :

- (1) Remove screw holding parcel tray to scuttle on drive side of car.
- (2) Remove trim pad covering scuttle
- (3) Drill a 7/8" dia. hole in area shown in Fig. 36 (inset 'A').
- (4) Drill a 7/8" dia. hole in wing to dimensions given in Fig. 36.
- (5) Assemble aerial as shown in Fig. 36 (inset 'B') and route lead through hole in scuttle using grommet provided.
- (6) Ensure that mast is vertical and tighten assembly.
- (7) Route aerial lead over top of facia reinforcement panel and replace trim.

Fig. 37

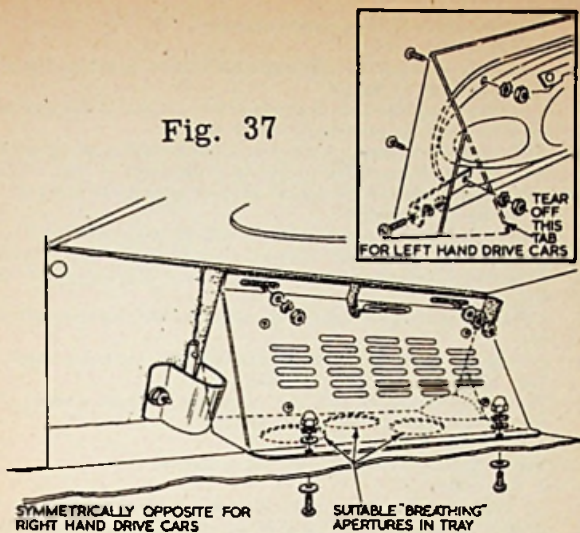
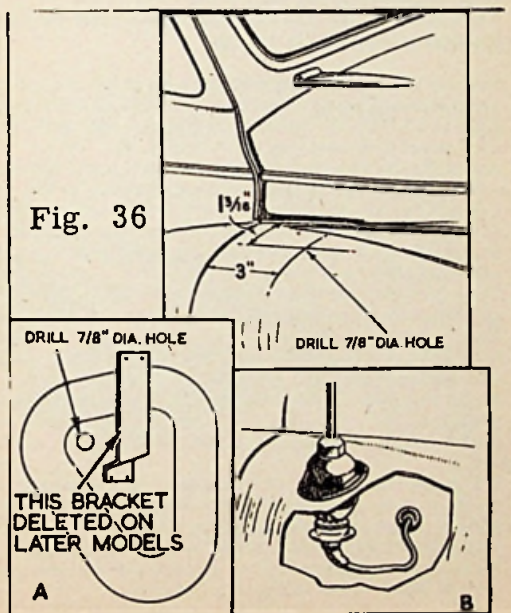

Fig. 36



(8) Replace screw securing tray to scuttle.

Loudspeaker Mounting

- (1) Assemble loudspeaker and angle bracket to mounting board as shown in Fig. 37 (inset).
- (2) Temporarily place unit in position on parcel tray against scuttle trim panel on passenger's side of car.

Note : Left hand drive cars. A portion of the mounting board must first be cut off along the line of cuts indicated in Fig. 37. (Inset). Clearance for the bonnet release is given by the slot in the top of the board.

- (3) Mark area of tray covered by the unit before removing it.
- (4) Cut suitable "breathing" aperture in tray inside the area to be covered by the unit - three $1\frac{1}{2}$ " dia. holes are suggested. See Fig. 37.
- (5) Connect loudspeaker lead to loudspeaker and replace unit on tray.
- (6) Secure top flange to bulkhead utilising existing holes shown in Fig. 38. piercing through insulation.
- (7) Pierce two holes through tray and secure bottom flange to tray with screws and domed nuts provided.

Radio Unit Mounting

Ensure correct polarity to radio, see "Introduction"

Saloon and Traveller

- (1) (a) Assemble the three brackets to the drive side facia reinforcement panel using No. 10 UNF screws washers and nuts provided as shown in Fig. 39.

Note: The position of the holes provided in the panel for attachment of these brackets is indicated in Fig. 39.

Tourer:

- (a) Remove ashtray from passengers side of the car and refit in symmetrically opposite position provided on drive side.
- (b) Drill two $7/32$ " dia. holes in passengers side facia reinforcement panel to dimensions given in Fig. 40.
- (c) Assemble the three brackets to the panel using No. 10 UNF screws, washers and nuts provided as shown in Fig. 40.
- (2) Connect aerial, loudspeaker and battery lead to radio unit.
- (3) Drill a $7/8$ " dia. hole in bulkhead near to control box.
- (4) Route battery lead through this hole using grommet provided and connect to "A 1" terminal.
- (5) Tune receiver to a weak signal on 1200 KC/s (250 metres) approximately and adjust aerial trimmer for maximum volume.
- (6) Assemble plastic heading to flange above control unit position as shown in Figs. 39 and 40.
- (7) Mount unit in brackets using No. 10 UNF screws and washers provided.
- (8) Adjust unit in brackets and tighten fixings.

Suppression:

Note : It is important to keep all wiring i. e. ignition and capacitor leads as short as possible and to scrape to bare metal each point at which an earth connection is made. The distributor incorporates a built-in resistor in main H. T. lead.

- (1) Fit a 1 mfd capacitor to dynamo - main output terminal, (yellow lead). Earth to dynamo fixing bolt.

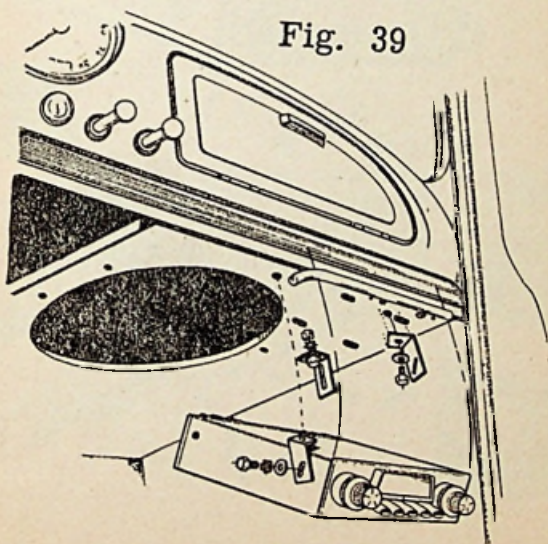
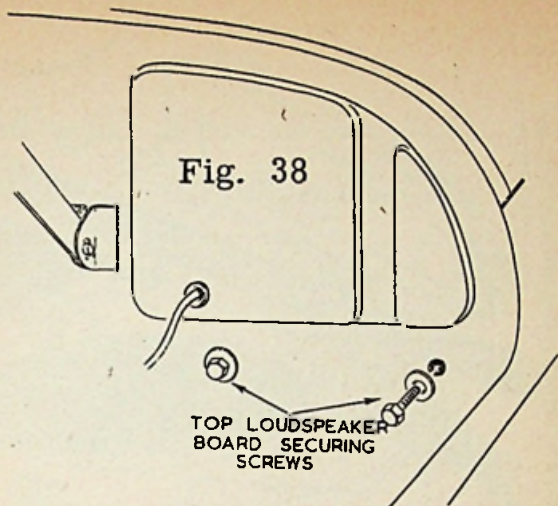

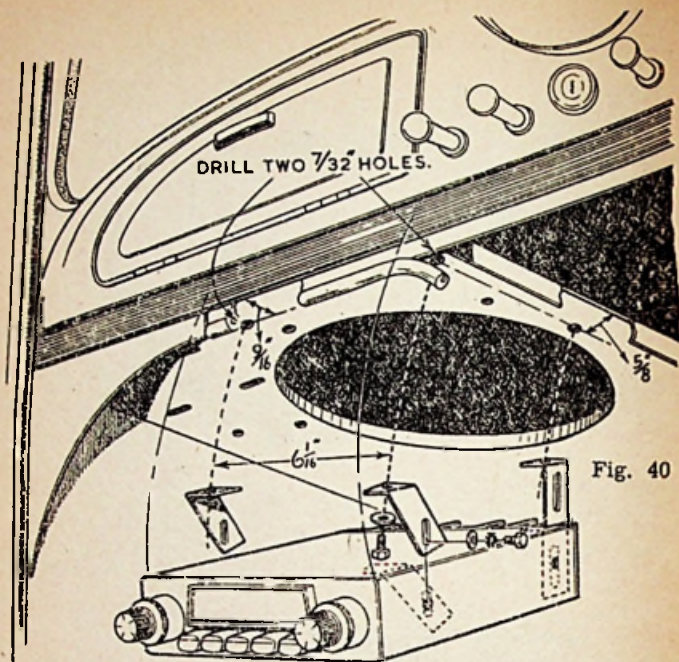

SYMMETRICALLY OPPOSITE LEFT HAND DRIVE

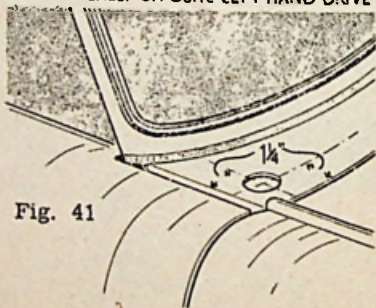

SYMMETRICALLY OPPOSITE LEFT HAND DRIVE

Fig. 42

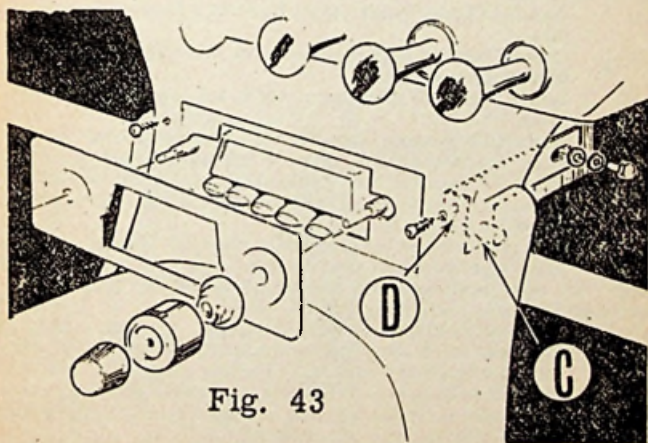
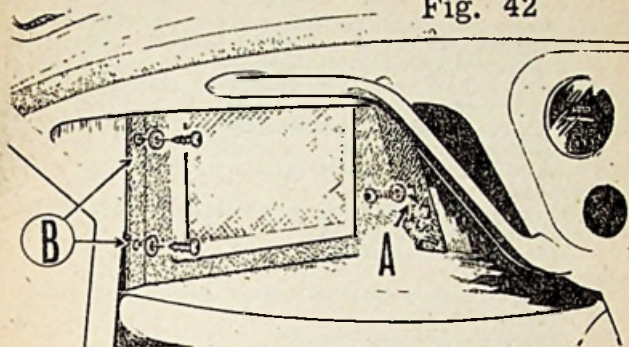

Fig. 43

- (2) Fit a 1 mfd capacitor to 'SW' terminal on coil (white lead). Earth to coil mounting bolt.
- (3) Fit a 1 mfd capacitor to petrol pump (white lead). Earth to pump mounting bolt.

Vehicle : Triumph Spitfire 4

Introduction : This instruction covers both right and left hand drive cars.

Warning : Before connecting to the battery supply, ensure that the polarity of radio is made "POSITIVE GROUND". Damage to TRANSISTORS is inevitable if polarity is incorrect.

Radio Unit : The radio is mounted in the aperture provided in the fascia bracket.

Speaker Note : The speaker is mounted across the corner of the passenger's side parcel tray.

Aerial Notes : The aerial is mounted on the drive side scuttle.

Aerial Mounting :

- (1) Mark off and cut a 7/8" dia. hole in the drive side scuttle at position shown in Fig. 41.
- (2) Assemble aerial to scuttle.

Speaker Mounting

- (1) Assemble speaker and bezel to board, secure with nuts and washers provided.
- (2) Connect speaker lead to speaker.
- (3) Fit assembly to bulkhead and secure with existing screw and washer 'A' in Fig. 42. holding parcel tray to bulkhead.
- (4) Mark off and pierce holes 'B' in tray and secure assembly with PK screws and flat sprie nuts provided.

Note : Early production vehicles had a passenger's parcel shelf which had less depth; for these models, the lower edge of the speaker board (the semi pierced portion) must be neatly removed.

Radio Mounting :

- (1) Remove blanking panel and its spire nuts from radio aperture.
- (2) Connect battery supply lead to spare accessory terminal on back of ignition switch.
- (3) Detach radio unit escutcheon held by nuts under pull off type knobs.
- (4) Route battery supply, speaker and aerial leads from behind fascia, out through radio aperture and connect them to radio.
- (5) Switch on radio and turn ignition key to left, tune to a weak signal on medium wave 1.2 Mc/s (250 metres) approx. and adjust aerial trimmer.
- (6) With gear lever in top gear, ease radio unit through aperture push radio along gear tunnel to heater position (if fitted).

Note : On early production cars one or both parcel tray rails may require shortening to clear radio unit.

- (7) Fit faceplate behind aperture in casting, as shown in Fig. 44.
- (8) Fit folded spire nuts to radio brackets as shown in Fig. 44.
- (9) Fit radio brackets from behind casting as shown in Fig. 43. (bracket studs to engage holes 'C' in lugs provided in vehicle.)
- (10) Slide radio along gear tunnel and engage spindle brushes through slotted aperture in faceplate.
- (11) Attach brackets to rear of radio with 10 UNF fixings provided.

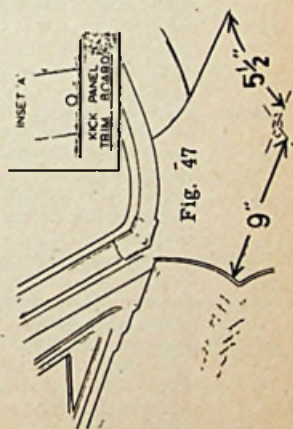
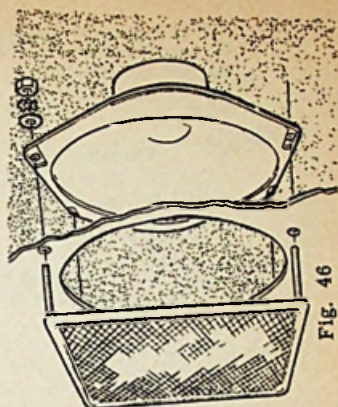
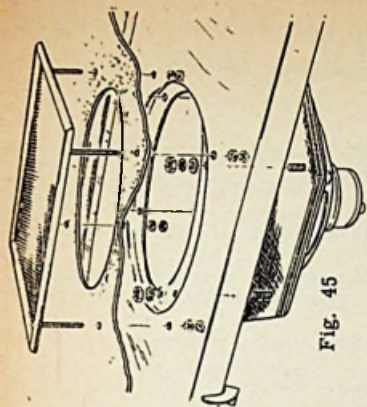
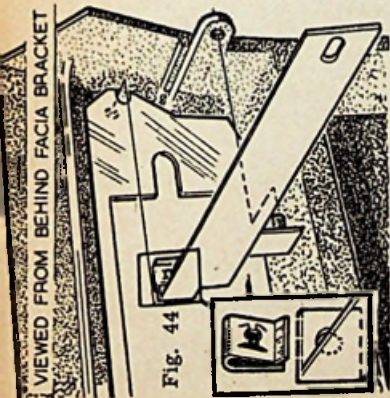

- (12) Lift rear of radio and secure brackets to casting with chrome PK screws at 'D' Fig. 43.
- (13) Re-fit radio escutcheon, spindle nuts, anti-friction washers and knobs.
- (14) Tighten radio rear fixings.

Suppression :

- (1) Fit a 1 mfd capacitor to 'SW' terminal on ignition coil. Earth under coil mounting bracket.
- (2) Fit a 1 mfd capacitor to dynamo output terminal. Earth under mounting bolt.

Note : It is vital to clean to bare metal all points at which an earth connection is made.

Warning : This vehicle is fitted with suppressor cables and these must not be cut or plug suppressors fitted otherwise ignition failure will result.

Vehicle : New Vauxhall Victor / Standard / Super / De luxe VX4/90 and Estate Car

Introduction : This instruction applies to left and right hand drive cars. The illustrations show the right hand drive conditions.

Note : Before connecting to battery supply ensure that the polarity of radio is made "POSITIVE GROUND". Damage to transistors is inevitable if polarity is incorrect.

Radio Unit : The radio unit is mounted in centre dash.

Aerial : A whip type aerial is mounted on drive side wing.

Speaker : The loudspeaker is fitted in prepared position in rear parcel shelf with the exception of the estate car version which takes the loudspeaker in the rear quarter trim panel forward of spare wheel position.

Loudspeaker Mounting Saloon :

- (1) Remove rear seat cushion and backrest held by four tabs along lower edge and hook brackets at top.
- (2) Mark off on undersurface of rear shelf trim board, outlines of loudspeaker aperture and outer bezel fixings.
- (3) Remove trim board and cut to marked outline. Pierce four marked bezel fixing holes.
- (4) Starting from position of loudspeaker socket, route cable behind bulkhead trim and under carpets to rear bulkhead. The lead should be routed along main harness and secured under existing clips.
- (5) Pass lead through rear bulkhead and attach to loudspeaker. Secure loudspeaker assembly to shelf using fixings supplied. See Fig. 45. Using cable clips provided secure lead to shelf flange.
- (6) Replace parcel shelf trim board, and fit bezel/grill assembly to shelf using fixings supplied. See Fig. 45. Replace seat cushion.

Loudspeaker Mounting (Estate Car)

- (1) Remove spare wheel.
- (2) Remove screws securing rear quarter waist rail trim above spare wheel position. Remove trim.
- (3) Remove screws securing adjacent quarter trim panel board and remove trim board.
- (4) Place loudspeaker grille symmetrically over ellipse marked on back of trim board and mark off position of bezel and fixing studs.

- (5) Cut an aperture $\frac{1}{2}$ " inside marked outline and pierce fixing holes.
- (6) Route loudspeaker lead from radio position under carpet, beneath rear floor and attach to loudspeaker. Secure lead to members using clips supplied.
- (7) Mount bezel/grille and loudspeaker on board and secure to board using fixings supplied. See Fig. 46.
- (8) Refit trim board and waist rail trim.

Aerial Mounting

- (1) Mark off a position on off-side wing as follows and drill $7/8$ " dia. hole. See Fig. 47.
- (a) 9" forward or rearmost edge of wing at windscreen pillar.
- (b) $5\frac{1}{2}$ " outwards from engine edge of wing.
- (2) Assemble aerial to wing.
- (3) Drill a $9/16$ " dia. hole in kick panel immediately above top edge of kick panel trim board. See Fig. 47. Inset 'A'.
- (4) Route aerial lead through panel and fit grommet in hole.

Power Supply

Remove cover from fuse box -top right hand corner of bulkhead - locate "Radio" connection and connect lead to terminal on saloon side of bulkhead. Replace cover.

Radio Unit Mounting

- (1) Carefully lever blanking panel away from centre dash and remove patent fixings from stud holes.
- (2) Attach smaller spire nuts to side flanges as shown in Fig. 48.
- (3) Attach mask to radio unit - do not fully tighten fixings - See Fig. 48.
- (4) Attach larger spire nuts to bracket foot and secure bracket to radio unit rear undersurface fixing as shown in Fig. 48.
- (5) Offer assembly into aperture as shown and dress mask against dash to best advantage. Transfer rear bracket position to undersurface of dash flange and mark off a point in centre line of bracket and 1" from edge of dash flange.
- (6) Carefully remove assembly from dash and fully tighten fixings.
- (7) Drill a $\frac{1}{4}$ " dia. hole in position marked on dash flange.
- (8) Connect aerial, loudspeaker and power supply leads to radio unit - passing leads out through aperture in dash.
- (9) Aerial Trimmer. Tune to a weak signal around 250 metres, adjust aerial trimmer for maximum volume.
- (10) Mount assembly in dash-securing mask to fascia with chrome drive screws supplied. Attach rear bracket to dash flange using No. 12 drive screw provided.

Suppression

- (1) Connect a 1 mfd capacitor to charging terminal of generator and mount capacitor under adjacent fixing screw. See Fig. 49.
- (2) Connect a 1 mfd capacitor to "SW" terminal of the ignition coil and mount capacitor under coil fixing screw. NOTE :- Clean to bare metal all surfaces in contact with capacitor fixing lugs.

Vehicle : Triumph TR4

Introduction : This instruction covers both right and left hand drive.

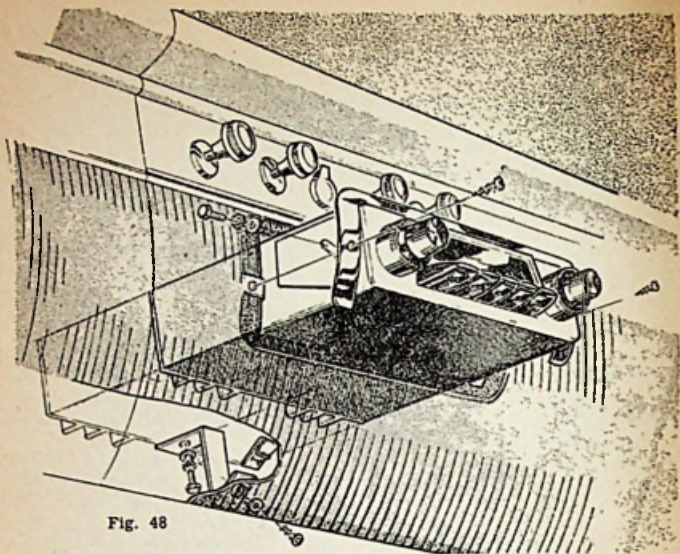

Fig. 48

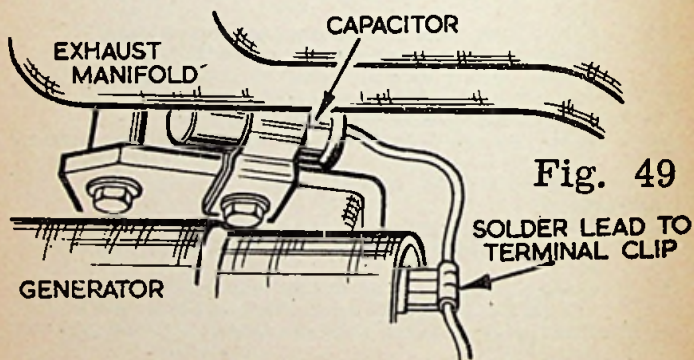

Fig. 49

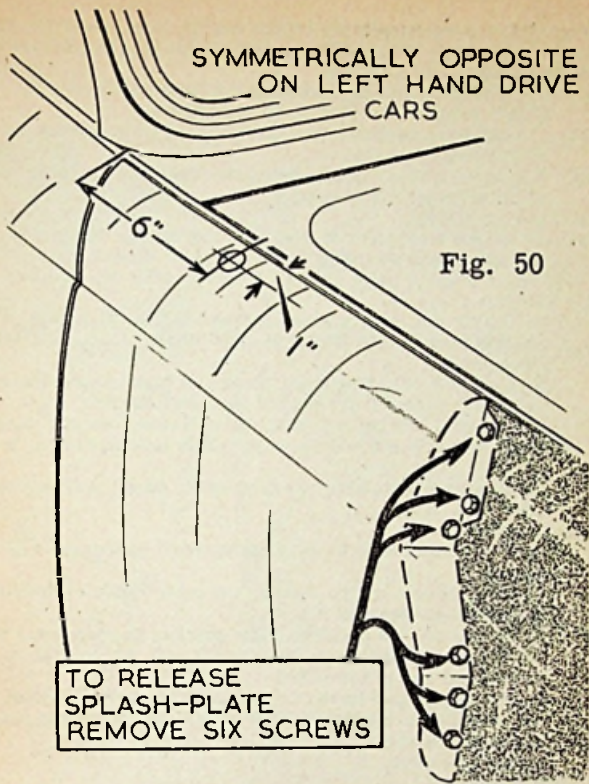
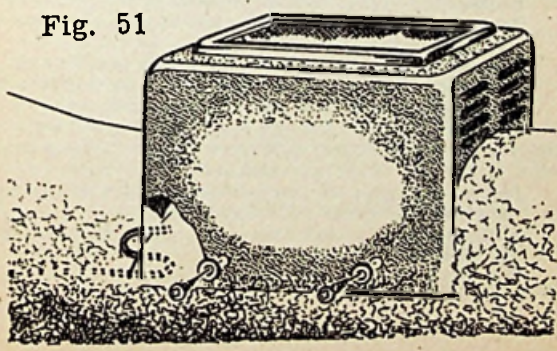

Fig. 51



Warning: Before connecting to the battery supply, ensure that the polarity of radio is made "POSITIVE" ground. Damage to transistors is inevitable if Polarity is incorrect.

Radio Unit: The radio unit is mounted in the aperture (TRIMMED OVER) which is provided in the fascia bracket.

Speaker : The speaker assembly is mounted on the transmission tunnel between the seats.

Aerial : The aerial either semi or fully retractable type is mounted on the drive side front wing.

Aerial Mounting NOTE:

If a trepanning type hole cutter is used, the "top fitting" types of aerial may be installed without detaching the splash plate shown in Fig. 50. This may be achieved by using an Enox Cutter in drill; No. 3 cutter being required.

- (1) Cut a 7/8" dia. hole in wing as shown in Fig. 50, a notch must be filed in edge of hole to allow fitting of fully retractable aerials.
- (2) Drill a 9/16" dia. hole from interior of car through extreme top of kick panel, 8" forward of door seal rubber.
- (3) Route aerial lead through wing and kick panel into car using small loop of scrap wire through hole in kick panel as a "pull-through".
- (4) Assemble aerial to wing, fit grommet to aerial lead hole in kick panel.

Speaker Mounting

- (1) Slide both seats fully forward and tip them up towards wind-screen.
- (2) Connect speaker lead to speaker and place speaker assembly in position as shown in Fig. 51.
- (3) Check that all seat positions clear speaker housing drill four 1/8" dia. holes through housing and tunnel, secure with drive screws and washers provided.
- (4) Route speaker lead forward under carpets on transmission tunnel, round fascia bracket on floor of car and up to radio location under carpets.
- (5) Re-position seats.

Radio Unit Mounting

- (1) Route battery lead through main wiring harness grommet in bulkhead and connect to A. 1. terminal on voltage regulator.
- (2) Remove escutcheon from radio, held by nuts under pull off type knobs.
- (3) Connect speaker, battery and aerial leads to radio unit, switch on radio, tune to a weak signal on 1.2 mc/s (250 metres) approximately and adjust aerial trimmer for maximum volume.

Note : The radio faceplate provided in all TR4 cars supplied to North America will not accept Radiomobile receivers and it should be replaced by faceplate, Part No. 19-001 provided in the radio kit, as follows:

- (A) Remove and retain the four nuts and screws holding the faceplate to dash edge and floor dash bracket.
- (B) Fit the faceplate provided using the original fixings. See Fig. 52. Inset 'B'
- (4) Cut trim cloth away from radio aperture.

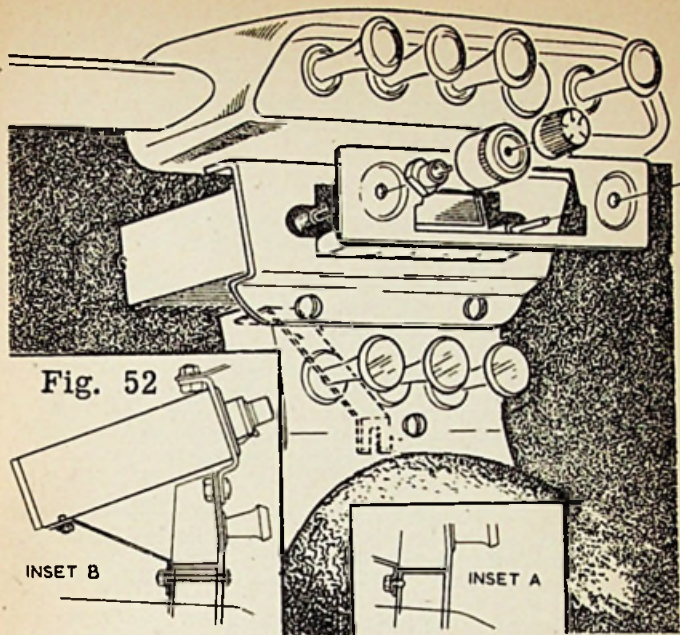

Fig. 52

- (5) Remove millboard blank from aperture and ALL trim cloth and masking tape from back of radio bracket, if not done this will cause difficulty in fitting spindle nuts.

Note: On heater lifted cars the heater cables, both electrical and mechanical may have to be re-routed around the radio unit.

- (6) Lift radio into position behind aperture and refit escutcheon, spindle nuts, anti-friction washers, and knobs.

Note: Discard the plastic spindle nuts from push button models and fit the special nuts from kit as shown in Fig. 52.

- (7) Pierce trim, secure rear support bracket to radio and facia bracket as shown in Fig. 52. Inset 'B'.

Note: The hole in front of the facia bracket is not provided on early production cars but a tapped 10 UNF hole is provided behind the bracket. In these cases secure the support bracket with 10 UNF x 3/8" screw and washers as shown in Fig. 52. Inset 'A'.

Suppression: It is vital to clean to bare metal all points at which an earth connection is made.

- (1) Fit a 1 mfd capacitor to 'SW' terminal on ignition coil. Earth to mounting bracket.
 (2) Fit a 1 mfd capacitor to dynamo output terminal. Earth under mounting bracket.

- (3) Connect a 1 mfd capacitor to the 'B' terminal only (marked on paxolin panel) of the 10 volt instrument stabiliser unit which is located at the extreme top, forward corner of the right hand kick panel inside the car. Earth to mounting bracket.

Warning : These vehicles are fitted with Suppressor Type Ignition H. T. Cables. Any attempt to cut these and fit plug suppressors will result in ignition failure.

CHAPTER 16

The Car Battery

It is essential that the materials used in the manufacture of lead-acid batteries are of a very high standard of purity in order to ensure satisfactory performance and long life.

With this in view, the quality of the materials used by reputable battery manufacturers is carefully controlled and continually checked to avoid the introduction of harmful impurities.

It is just as important to ensure that harmful impurities are not introduced with the dilute sulphuric acid when the batteries are filled initially or with the water used for subsequent topping up in service.

The following, therefore, is intended as a general guide to the maximum acceptable impurity levels for this acid and water when its quality is outside the direct control of the battery manufacturer.

Acid

The standard of purity required for acid in lead-acid batteries is detailed in British Standard Specification 3031 : 1958 entitled "Sulphuric Acid for use in Lead-Acid batteries". Briefly, this specification lays down the following maximum impurity levels for acid of 1.215 specific gravity at 15.6° C. (60° F).

<u>Impurity</u>	<u>Maximum Concentration Parts per million by weight</u>
Ammonia	50
Arsenic	2
Chlorine	7
Copper	7
Iron	12
Manganese	0.4
Nitrates & Nitrites	5
Sulphur Dioxide	5
Total Residue	150

The dilute acid should be clear and colourless when viewed through a column 12" deep. The specification can be applied equally to acid of any standard of 1.215 at 15.6° C (60° F).

The British Standard Specification also covers in detail tests for detecting the actual level of the above impurities.

Water

In general, any impurity introduced into the cell with the topping up water remains there whilst the water itself is removed by electrolysis, leaving the cell as hydrogen and oxygen and by evaporation. Thus, regular use of water containing impurities results in a build-up of these impurities which will remain throughout the battery's life. If they become excessive, premature failure can occur so that it is particularly important to work to cer

tain minimum purity levels for the topping-up water to ensure that the build-up is not too great.

In practice, the following maximum impurity levels have been found satisfactory for topping-up water.

<u>Impurity</u>	<u>Maximum Concentration Parts per million by weight</u>
Ammonia	10
Arsenic	3
Chlorine	15
Copper	10
Iron	10
Manganese	0.1
Nitrates & Nitrites	10
Total fixed residue	250

The water should be clear and colourless when viewed through a column 12" deep. It should be neutral to litmus.

The actual levels of these impurities in water can be determined in a similar manner to that described for sulphuric acid in British Standard Specification 3031 : 1958.

If the water meets the above specification, irrespective of its origin, it is permissible to use it for topping-up of lead-acid batteries manufactured by EXIDE. Generally speaking, there are three main sources of water which meets the specification, they are as follows:-

Mains Tap Water

The mains tap water supply in many areas is perfectly suitable for topping-up batteries without any prior treatment.

However, the quality can vary from time to time and occasions may arise, particularly in time of drought, when excessive impurities are found in water which normally meets the required standard of purity. It is, therefore, advisable to make fairly frequent checks on the impurity levels.

Distilled Water

Until recent years, distillation has been one of the most economical and convenient means of obtaining water for topping-up purposes, when the initial supply is insufficiently pure.

Under normal circumstances distilled water meets the purity requirements but it is advisable to check the still output at regular intervals to ensure that it is satisfactory.

Deionised Water

This water is purified by the ion-exchange principle whereby chemicals in a purification unit react with the impurities in the feed water so that they are in effect to a large extent retained in the unit whilst the "De-ionised" water is passed on.

Although the purity of this treated water can vary according to the purity of the feed water, it is often purer than one-distilled water. In general, it can be considered that deionisers will adequately treat all drinking water making it suitable for battery use. However, only a certain amount of water may be passed through these units before the chemicals are expended and require regeneration. It is, therefore, particularly important that some positive means is provided for determining when this point is reached.

Some equipment are fitted with conductivity meters and others have automatic stop devices which operate before the water reaches an unacceptable quality.

There are a number of miniature deionising units on the market today sold as car accessories, which are intended to handle relatively small quantities of water for topping-up car batteries.

With these units, the chemicals are discarded when expended and replaced by a refill capsule. Unfortunately, this type of deioniser often relies on a rather indistinct colour change to signify that the chemicals have been expended and a careful check must be made regularly if it is to be ensured that no unpurified water leaves the unit.

If the feed water for any deionising unit is known to contain an excess of a particular impurity or an unusual impurity not normally encountered it is advisable to discuss the matter with the equipment supplier. The cost of purifying water by ion-exchange depends on the quality of the feed water but in practically every case, it is cheaper than by distillation.

Other Water

Water obtained from other sources, such as rain water collected on a clean, non-metallic surface may be equally suitable for topping-up. It is often quoted that the water obtained when defrosting a refrigerator is suitable for topping-up purposes. Theoretically this water has been purified but, in practice, there is a danger of impurities having been introduced as the water comes into contact with metallic parts of the refrigerator. Apart from this, other impurities could be introduced as the purification has not been carried out under controlled conditions. It is, therefore, particularly advisable to have a sample analysed to establish its suitability for topping-up purposes and for further checks to be made at regular intervals.

CHAPTER 17

Charging Car Batteries

Under normal operating conditions an automotive battery is automatically charged from the vehicle's generating system and it is important that this is correctly adjusted in order to obtain the maximum performance and life from the battery.

Occasionally, however, it may be necessary to recharge the battery from an external source, known as Bench Charging, if it becomes discharged due to abnormal operating conditions.

The following cover the basic points of this auxiliary charging at both low and normal rates and from Fast Chargers.

General

The lead-acid battery is an electro-chemical energy storage device in which charging and discharging is accompanied by a change in chemical make-up of the active components within the cells. This chemical change is reversible, so that the energy taken from the battery on discharge can be replaced simply by passing direct current through it in the reverse direction.

For this "recharge", the positive and negative terminals of the battery should be connected respectively to the positive and negative terminals of the charging equipment.

During charge, the voltage across each cell will be greater than its open circuit voltage, i. e., in excess of approx. 2.1 volts per cell. This ex-

cess voltage is in effect required to push charging current through the battery. As the state of charge of the battery increases during re-charge the voltage across each cell increases and with the normal recommended charge current flowing, eventually rises to about 2.6 to 2.7 volts per cell for a new battery or 2.4 to 2.5 volts per cell for one which has been in service for some time.

Although the level of the electrolyte within each cell will rise slightly, especially towards the end of charge, due to the presence of gas bubbles in the electrolyte, it is advisable to top up the cells with pure water if the levels are low before commencing recharge. This ensures that the topping-up water and electrolyte are thoroughly mixed during gassing.

The temperature of the battery rises during a recharge due to electrochemical effects and it is important that it should not exceed 52°C (125°F). Otherwise, permanent damage to both the battery and charging equipment may result.

The cells should not gas too vigorously during charge as this causes loosening of the active material on the surface of the plates. High temperatures and very vigorous gassing are usually signs that the charge rate is too high but it should be understood that at charging currents approximating to those recommended by the battery manufacturer, fairly active gassing does take place as the recharge nears completion.

Normal Rate Charging

It is preferable that auxiliary charging should be carried out at the manufacturer's recommended current which is usually a value in amperes equivalent to 7% / 10% of the battery's nominal ampere hour capacity at the 20 hour rate. This current is the most suitable one for applying throughout the recharge as it will cause neither over-vigorous gassing nor excessively high temperatures unless ambient temperatures are unduly high.

Charging can be commenced at higher currents providing that they are reduced to not more than the normal recommended one when gassing commences or temperature reaches 52°C (125°F).

It is customary to continue a normal rate charge until cell voltages and electrolyte specific gravities remain constant over five successive hourly readings.

If the battery has operated on the vehicle in a discharged condition for some time before the Bench Charge is given, it may not be fully recoverable. If this is found to be the case, the advice of the manufacturer should be sought, even though the chances of a complete recovery might be limited.

Fast Charging

Fast chargers have become quite popular in recent years mainly because they enable garages to give a prompt recharge service to the motorist. They are not usually intended for complete recharging of the battery but more as a means of bringing the battery to a state where it will operate the vehicle's electrical equipment.

The occasional boosting of a healthy battery from a reputable make of fast charger will not appreciably affect its life or performance, providing electrolyte temperature and gassing are taken into consideration. The vast majority of fast chargers are capable of bringing the battery to about 90% fully charged over a period of about one hour and in this state it will be suitable for replacing on the vehicle.

An unhealthy battery can be readily damaged by a high charge current particularly if it is sluggish or sulphated after standing for a lengthy period in a discharged condition or with low electrolyte levels. A high charge current would cause violent gassing from the start and a very rapid rise in temperature with subsequent damage to the battery. It is, therefore, particularly important to check the condition of the cells before a fast charge. If hydrometer and high rate discharge TESTER readings are erratic, the battery is probably unsuitable for fast charging and in this condition, it should be given a Normal Rate Charge.

Fast charging should be always considered as an emergency measure and not a substitute for normal recharging. In particular, it is essential that initial charges should be given in strict accordance with the battery manufacturer's instructions.

Basically, there are two current/voltage characteristics which can be used for Fast Chargers, one approaching the Constant Current type and the other Constant Potential.

Constant Current Fast Charging

In actual practice, there is a slight taper on the current so that typical figures would be, say, 100 amperes tapering to 80 amperes or 80 amperes tapering to 60 amperes during the recharge of a battery. With this type of charger, it is highly desirable to incorporate an automatic means of limiting the length of fast charge. This may take the form of a thermal switch inserted in one of the battery cells and immersed in the electrolyte. It is arranged to cut off the charger when the temperature reaches a pre-determined figure preferably not higher than 52°C (125°F).

The thermal switch system has the advantage of being based directly on the battery temperature which is the most important factor involved but it may mean that the battery is gassed vigorously for a longer period than necessary when the ambient temperature is low. Whilst the system affords partial safeguard against overheating of badly sulphated batteries, the risk of damage is not entirely obviated.

An alternative is to provide the charger with a time switch which will terminate the charge after a pre-determined time.

This switch is pre-set according to the state of discharge of the battery as established by hydrometer readings.

The time switch system may allow the battery to reach an excessive temperature before it operates, particularly in high ambient temperatures. It is, therefore, desirable to check the temperature occasionally whilst fast charging with time switch control.

Constant Potential Fast Chargers

These chargers are self-regulating to a large extent, and consequently, more fool-proof. The relatively high current at the start of the charge tapers off as the battery voltage rises on charge until a pre-determined voltage is reached, whereafter the voltage remains constant and the current tapers off more sharply. By leaving the battery connected to the Fast Charger, it can be brought safely up to a higher state of charge than with a Constant Current Fast Charger where the current is considerably higher towards the end of charge.

It can be seen that Constant Potential Fast Chargers have a great advantage in that the battery is safe guarded to a large extent by the

tapering current characteristic. However, it is still important to check battery condition prior to charging as definite protection for an unhealthy battery is not always ensured.

Low Rate Charging

Low rate chargers have an output of 1 or 2 amperes and are capable of fully charging a discharged battery over a period of, say, two or three days. They are, however, primarily intended for periodic charging of idle batteries to ensure that they are ready for immediate service or as a supplementary charging source when a vehicle is doing insufficient running to maintain the battery in a reasonable state of charge.

It is important that once the battery has reached a fully charged state it should not be left on charge even though the charging current is low as unnecessary deterioration would occur.

Battery manufacturers usually specify a minimum charging current of not less than $\frac{1}{4}$ normal for low rate charging. Lower currents restrict the amount of gassing on charge to less than desirable and the conditions approach "Trickle Charging".

Trickle Charging

Trickle Charging is a term often confused with low rate charging. The former refers to charging at a very low current which is just sufficient to balance the normal open circuit losses of the battery and consequently maintain it in a fully charged state.

In fact, the current would be insufficient to charge up a discharged battery. The design of and materials used for the starter battery have been based on conditions experienced in vehicle operation and to trickle charge a battery of this type would cause deterioration of the plates and progressively increasing open circuit losses. In other words, a battery which has been taken out of service will be far more satisfactorily maintained by Normal or Low Rate Charging at 1 or 2 monthly intervals than by attempting to balance the open circuit losses by continuous trickle charging.

CHAPTER 18

Operation of Batteries in High and Low Temperatures

Low Temperatures

There is little danger of the acid freezing in a battery which is operating under normal conditions. Even in an appreciably discharged state of 1.140 at 15°C. the acid electrolyte would not freeze until about -13°C., whilst in the fully charged state of 1.280 at 15°C. the temperature would have to fall as low as -68°C. before freezing occurred. However, some extra care should be taken during a cold spell -1°C. Water near to freezing point should not be used for topping up and it is and it is advisable to top up immediately before the battery is to be charged to ensure that the acid and water are thoroughly mixed. The energy demand on the battery is heavier during cold weather than at normal temperatures. As well as more power being required for engine starting, the battery is usually called upon to operate such accessories as heaters and demisters. At the same time an inherent characteristic of storage batteries is that their electrical output is reduced at low temperatures. A battery which will function satisfactorily in summer may fail to start the engine in the winter. These considerations make it all the more important to see that the battery is fully charged and properly maintained during cold weather.

High Temperatures

When a battery is operating frequently in situations or climates where air temperatures frequently exceed 32°C . (90°F), it is advisable to work the battery with a lower specific gravity acid than that ordinarily employed. This helps to offset the adverse effects of high temperature on battery life.

"Low gravity" acid having a specific gravity 30 points (0.030) lower than normal is used, i. e. 1.240 to 1.255 at the end of charge as compared with 1.270 to 1.285 for normal gravity acid.

The desirable maximum temperature at any time is 52°C . (125°F). If this temperature is frequently exceeded the life of the battery will tend to be shortened.

The capacity of the battery is slightly reduced when "low gravity" acid is used but this is offset largely by the higher working temperature.

When not in use, storage batteries do not hold their charge indefinitely but gradually lose some of it due to internal chemical action. This loss is accelerated at high temperatures and by external leakage of current if the battery is wet and dirty. The battery should, therefore, preferably be stored in a cool, dry place.

If the battery is allowed to remain in a low state of charge for long periods, the plates may be harmed beyond complete recovery. If, therefore, a battery is to be taken out of service for a time, the following procedure should be followed :-

- (a) Disconnect the battery from the electrical system of the vehicle.
- (b) Check the level of the acid in the cells and adjust to the recommended level by the addition of pure water.
- (c) Give the battery a Bench Charge.
- (d) Clean and dry the battery top. Clean the terminal post and apply a light film of petroleum jelly.
- (e) At least every two months, and again before putting into service, give the battery a Bench Charge. When the battery is stored in tropical conditions charge every month.
- (f) If acid is spilled or if surrounding parts are wet with acid, wipe over with a rag dipped in a dilute alkaline solution e. g., dilute ammonia, then wipe with a rag wet with clean water, then dry.

Safety

Never bring a flame, lighted cigarette or pipe near the battery at any time, especially during or shortly after a charge.

Care should also be taken that a spark is not caused by accidentally shorting the battery to chassis of the vehicle with a spanner or other tool. The danger of an explosion occurring is very remote indeed, but the risk is greatly reduced if the vent chamber cover or plugs are tightly in position. Care should be taken to see that the holes in vent plugs do not become obstructed by dirt.

CHAPTER 19

Poor Reception and Dirty Terminals

The car radio receiver does not enjoy constant power supply in the same manner as the mains domestic receiver.

When it is remembered that the car battery has to supply power to the

petrol pump, the windscreen wipers, electric clock, traffic indicators, heater, a cigar lighter, headlights, foglight, ignition system, in addition to the car radio, it must be surely, the heart of the electrical system on a motor vehicle.

Since a vibrator receiver requires more current than a transistorised or all transistor receiver, corroded or dirty terminals will have a greater effect on the operation of the receiver.

For instance, a receiver which requires 3 amperes at 12 volts, will only receive some 9 volts, if there is a resistance of only 1 ohm between the battery terminal and the battery post or between the earthing terminal and the car chassis.

This will result in weak reception, since the H. T. of the receiver at the rectifier cathode will be low. To consider the effect of a 1 ohm resistance, we may take the "step up" ratio of the vibrator transformer as 1 : 20 that is, for 1 volt in the primary winding, we get 20 volts at the secondary winding, the voltages being of course alternating in each case. Hence, if we should reduce the voltage to the vibrator transformer primary by 3 volts due to dirty terminals etc. we would also reduce the resultant A. C. voltage for subsequent rectification by 60 volts, a serious loss!

With regard to the transistor type of receivers, a d. c. resistance of 3 ohms, due to dirty terminals, would reduce the voltage from 12 volts to about 9 volts at the receiver, assuming the usual current consumption of 1 ampere at 12 volts. It will be obvious that, if the receiver cannot have its correct working voltage applied to it, the normal current consumption is not possible. Even so, the loss of voltage to the receiver is serious enough to result in weak reception being experienced. A quick test of the state of the battery can be made by switching on the headlights or wipers. If the former are dim and the latter moves very slowly, it would appear that the battery voltage is very low. The engine of the car can be started and if the lights become brighter and the wiper moves with greater speed the charge of the battery is indeed very low. Such conditions would result in the volume of the car radio being good when the car is being driven at speeds and low or weak when the engine is just ticking over.

In such cases, it may be that the dynamo is not charging correctly due to a faulty regulator, this must be checked by the motor vehicle electrician to ensure that both are working correctly.

It follows then, that no matter how efficient the aerial may be, or how high the sensitivity of the receiver, it will all be of no use unless the battery is kept up in tip-top condition.

A high resistance voltmeter is practically useless for car battery testing and a meter which provides a "load" test is to be desired since if the voltage falls below a certain value during such test, indicates that the battery although having been fully charged has an internal resistance higher than normal. It is usual to test the battery cell by cell.

In the following chapter means of testing batteries will be given with an instrument designed for this purpose.

CHAPTER 20

Testing Car Batteries

One of the most efficient methods of testing the condition of car batteries is provided by the "Exide" 'Double-Check' battery tester. This instrument ensures that the batteries so tested are capable of doing their job and in effect provides bench testing facilities on the car.

Description

The 'Double-Check' tester consists of a meter and a test prod and has been specifically designed to enable the general condition of a battery to be assessed without removing it from the car.

The meter and test prod are inter-connected by a 6 ft cable long enough to enable the customer to hold the meter whilst the serviceman tests the battery.

The meter is housed in a shock-proof resilient rubber moulding. The design of the instrument is such that the test prod can be slipped into the handle of the rubber housing when not in use whilst the handle is so shaped that it may be placed upright on the car wing or bonnet or hooked on to the top edge of a window or door during the test.

Purpose

The 'Double-Check' tester enables the serviceman to assess the condition of the battery in the following order:-

- | | |
|-----------|--|
| Check (1) | The state of charge |
| Check (2) | The performance at normal discharge rates: having done this, he may then - |
| Plus | Check the charging circuit |

The Meter

The meter on the 'Double-Check' tester is a highly sensitive instrument. The basic voltage scale is electrically expanded over the range of 1.7 to 2.5 volts, giving an accuracy of approximately one hundredth of a volt in this range.

The accuracy thereby achieved enables the tester to make use of open circuit voltage in determining the state of charge of the battery. The readings obtained on the scale marked BATTERY CONDITION - OPEN CIRCUIT are comparable to specific gravity readings taken by a hydrometer. By pressing the red button in the handle of the test prod a low current load is brought into circuit, and readings are obtained on the scale marked BATTERY CONDITION - DISCHARGING giving an indication of the ability of the battery to give satisfactory service. A check on the flow of current through the battery from the car generator is given on the third scale marked CHARGING CHECK.

Again, the accuracy of the instrument enables an assessment to be made of the ability of each cell to accept an adequate charge.

The Test Prod

The test prod is connected to a meter by 6 ft. of PVC covered cable and incorporates the 'on load' resistance which is put into circuit by depressing the red button in the handle.

The points of the test prod are angled to reach awkwardly placed batteries and are also adjustable when necessary to enable batteries of different sizes to be tested.

Firm pressure should be used to ensure that good contact is made with the inter-cell connectors. If the meter needle indicates 'Reverse Polarity', pressure on the button switch fitted at the top of the instrument will enable the readings to be obtained without having to reverse the position of the test prod. When this push button is released the instrument reverts to its original polarity.

CHECK ONE

Testing State of Charge

For this test, readings are taken on the scale marked BATTERY CONDITION - OPEN CIRCUIT its purpose is to evaluate the state of charge of the cells in the same way as a hydrometer reading.

Test

(1) Before beginning to test the battery, turn ON all the vehicles lights for a period of about half to one minute. Then switch OFF. This is important to stabilise the cell voltages.

(2) With the engine's lights and accessories switched OFF, apply the test prod points firmly to each cell in turn. Note the readings on the BATTERY CONDITION - OPEN CIRCUIT scale,

Assessment

(1) If all the cell readings fall in the 'FULL' (green) band and are within three divisions of each other, the battery is adequately charged and serviceable.

(2) If the cell readings are within three divisions of each other, but fall in the 'RECHARGE' (red) band, the battery is in need of a charge.

(3) If the cell readings vary by more than three scale divisions, the battery is suspect and check TWO - TESTING UNDER LOAD, may confirm this.

Check TWO

Testing Under Load

For this test, readings are taken on the scale marked BATTERY CONDITION - DISCHARGING and its purpose is to measure accurately the voltage of each cell under load in order to indicate possible failure in service.

Test

(1) Put the discharge load into circuit by depressing the red button in the prod handle.

(2) Apply the test prod to each cell in turn and after approximately five seconds note the reading on the scale marked BATTERY CONDITION - DISCHARGING

Assessment

(1) If all the cell readings are in the 'GOOD' (green) band the battery is serviceable.

(2) If any cell readings are in the 'FAILING' band or are falling rapidly towards 'FAILING' the battery should be given a bench charge or replaced.

N. B. The decision whether to replace a battery or to restore it by recharging will be influenced by its age. The age of a battery may be obtained from the owner or from the manufacturer's code markings.

(3) If the battery is of comparatively recent manufacture and recovery seems possible, it should be fully charged and allowed to stand for twelve hours then re-tested as above. If any cells then give a reading in the 'FAILING' band the battery should be replaced.

NOTE : Provided checks ONE and TWO indicate a healthy battery, you may if desired proceed with the CHARGING CHECK.

THE CHARGING CHECK

For this test, readings are taken on the scale marked Charging Check, and its purpose is to indicate whether the battery is receiving and/or accepting an adequate charge.

This test can only be made on vehicles fitted with automatic voltage regulators and must be carried out with the discharge resistance out of the circuit, i. e. without depressing the red button in the prod handle.

Test

- (1) Switch on all lights for three minutes (unless CHECK ONE has shown the battery to be in a discharged state).
- (2) Switch off lights, start engine and keep it running at a moderate speed (i. e. at engine speed equivalent to 30 m. p. h. in top gear).
- (3) Apply the prods to one cell. The meter reading should increase slightly and then remain constant. This constant reading is the true indication.
- (4) The prods may then be applied to each cell in turn.
- (5) As each cell is tested note whether the readings on the CHARGING CHECK scale fall into low, normal or high bands.

Assessment

- (1) Whilst assessing these readings the results of check ONE and check TWO must be borne in mind.
- (2) An abnormally 'low' reading on all cells on the CHARGING CHECK scale may indicate that the regulator is set too low; a slipping fan belt; a badly corroded terminal on the battery or a fault elsewhere in the charging circuit etc.
- (3) If Checks ONE and TWO indicate a healthy battery, an abnormally 'high' reading on the CHARGING CHECK scale may mean that the regulator setting is too high. (A false 'high' reading would also be obtained if the battery is fully charged and not slightly discharged through the vehicle's lights at the beginning of the Charging Check).
- (4) If Checks ONE and TWO indicate a deeply discharged battery, the readings in the CHARGING CHECK scale will be consistently low. The meter reading will rise steadily for some time before remaining constant.
- (5) If checks ONE and TWO indicate a failing battery, the CHARGING CHECK readings on the cells will be erratic and will indicate that the battery is not able to accept the charge current satisfactorily and therefore emphasizes the approach of the end of the battery's useful life. NOTE : The Tester must not be used for re-setting voltage regulators.

During the preparation of this book, there has been some additional electrical equipment added to Coach and Transporter vehicles which will require suppression. Such suppression methods are given below for reference.

BONDING

An earth should always be connected between the amplifier case and the body of the vehicle and where a radio is fitted the radio case should also be bonded to the vehicle.

PETROL ENGINED (IGNITION COIL) VEHICLES

EARTH RETURN ELECTRICAL SYSTEM

Coil Connect a 1 mfd condenser to the switch terminal of the coil (S. W.)

Generator Connect a 1 mfd condenser to main terminal of the generator and mount under the generator mounting bolt.

PETROL ENGINED VEHICLES (PETROL INJECTION)

TREAT AS DIESEL ENGINED VEHICLES

DIESEL ENGINED VEHICLES E. R. E. S.

Connect a 1 mfd condenser to B terminal on control box and mount capacitor on adjacent body metal work. Connect a 1 mfd condenser to D terminal on control box and mount capacitor on adjacent body metal work.

DIESEL ENGINED VEHICLES, ISOLATED ELECTRICAL SYSTEM

Connect a 1 mfd condenser to B + terminal on central box and mount capacitors on adjacent body metal work. Connect a 1 mfd condenser to B - terminal. Connect two 1 mfd condensers from D to D + terminal on control box.

WINDSCREEN WIPER MOTORS. HEATER FAN MOTORS

VENTILATION FAN MOTORS

- (A) Earth Return Systems
- (1) Bond wiper motor case to body and 'earthy' terminal of motor.
- (2) Connect a 1 mfd condenser across motor terminals
- (B) Isolated Wiring Systems
- (1) Bond motor case to adjacent body metal work
- (2) Connect a condenser 0.5 to 1 mfd. between + VE terminal of motor and case/or - VE terminal and case/or both.

ELECTRICAL CLOCKS

Connect a 0.25 mfd condenser across clock supply terminals at clock.

INSTRUMENT VOLTAGE STABILISERS

Connect a 1 mfd condenser between terminal marked "B" only and case of stabiliser.

ELECTRIC MAGNETIC SPEEDOMETERS

- (1) Bond speedometer transmitter body to vehicle chassis
- (2) Connect a 1 mfd condenser to + VE supply terminal of speedometer transmitter and mount capacitor on transmitter body.
- (3) Repeat '2' for - VE supply terminal.
- (4) It may be necessary to fit a 1 mfd condenser between - VE busbar in body junction box and vehicle body metal work adjacent.

TEMPERATURE TRANSMITTERS, BUZZERS, TRAFFICATORS

Connect a 1 mfd capacitor across supply terminals or from one or both terminals to adjacent body metal work.

FLUORESCENT LIGHTING

- (1) The aerial must be sited as far away as possible from the nearest lamp and from any cable form.
- (2) All leads from ballast units to lamps must be wired in screened cable.
- (3) The screening must be connected to each lamp fitting and earthed to vehicle body metal work at ballast unit.
- (4) Ballast units must be earthed to vehicle body metal work at ballast unit.
- (5) Where integral lamp/ballast unit fittings are employed, the wiring to any slave lamp must be wired in screened cable as in (3).

Where ballast units cause trouble, a 200 mfd condenser an electrolytic should be connected across supply terminals of ballast unit or between either/or both terminals and earth.

THE ELECTRO SPEEDOMETER

The wiring loom to the transmitter has five wires, these are then separated into two sections, one of three, and one of two wires. The section of two wires is the positive and negative supply.

NOTE : Ensure that waterproofing of the transmitter is not affected and that no whiskers of wire touch the transmitter case, since this will result in interference and cause incorrect readings of the instrument.

A. C. GENERATOR

The interference may be suppressed by a choke in either lead to the receiver isolated supply and in difficult cases by decoupling the chokes with a 64 mfd 40 volts working capacitor.

N. B. Care must be taken with regard to the polarity of these capacitors.

BRITISH LOCAL RADIO STATIONS

Town	Station		BAND		
			MW m	VHF kHz	VHF MHz
Birmingham	Radio Birmingham	BBC	206	1456	95.6
Birmingham	Sound Broadcasting	IBA	261	1151	94.8
Blackburn	Radio Blackburn	BBC	351	854	96.4
Brighton	Radio Brighton	BBC	202	1485	95.3
Bristol	Radio Bristol	BBC	194	1546	95.5
Carlisle	Radio Carlisle	BBC	397	755	95.6
Carlisle	Radio Carlisle	BBC	206	1456	-
Chatham	Radio Medway	BBC	202	1485	95.8
Derby	Radio Derby	BBC	269	1151	96.5 Main
Derby	Radio Derby	BBC	-	-	94.2 Relay
Edinburgh*	Radio Forth	IBA	194	1546	96.8
Glasgow	Clyde Radio	IBA	261	1151	95.1
Hull	Radio Humberside	BBC	202	1485	96.9
Leeds	Radio Leeds	BBC	271	1107	92.4
Leicester	Radio Leicester	BBC	188	1596	95.1
Liverpool	Radio Merseyside	BBC	202	1485	95.8
Liverpool*	Sound of Mersey	IBA	194	1546	96.7
London	Radio London	BBC	206	1456	94.9
London	London Broadcasting	IBA	417	719	97.3 Now
London	London Broadcasting	IBA	261	1151	97.3 Later
London	Capitol Radio	IBA	539	557	95.8 Now
London	Capital Radio	IBA	194	1546	95.8 Later
Manchester	Radio Manchester	BBC	206	1456	95.1
Manchester	Piccadilly Radio	IBA	261	1151	97.0
Newcastle/T	Radio Newcastle	BBC	206	1456	95.4
Newcastle/T*	Metropolitan Broad- casting	IBA	261	1151	97.0
Nottingham	Radio Nottingham	BBC	197	1523	95.4
Oxford	Radio Oxford	BBC	202	1485	95.2
Plymouth*	-	IBA	261	1151	96.0
Sheffield	Radio Sheffield	BBC	290	1034	97.4 Main
Sheffield	Radio Sheffield	BBC	-	-	88.6 Relay
Sheffield*	-	IBA	194	1546	95.2 Main
Sheffield*	-	IBA	-	-	95.9 Relay
Southampton	Radio Solent	BBC	301	997	96.1 Main
Southampton	Radio Solent	BBC	188	1596	- Relay
Stoke on Trent	Radio Stoke	BBC	200	1500	96.1
Swansea*	Swansea Sound	IBA	287	1167	95.1

* Not Yet Open

The following IBA stations will follow in due course: Belfast / Blackburn / Bournemouth / Bradford / Brighton / Bristol / Cardiff / Coventry / Huddersfield / Ipswich / Leeds / Nottingham / Portsmouth / Reading / Teesside / Wolverhampton.

BBC = British Broadcasting Corporation
 IBA = Independent Broadcasting Authority