



BABANI PRESS No.16

**HANDBOOK OF
ELECTRONIC
CIRCUITS
FOR THE
AMATEUR
PHOTOGRAPHER**

R
BY
BABANI
de Historie v/d Radio

60p



HANDBOOK OF
ELECTRONIC
CIRCUITS
FOR THE
AMATEUR
PHOTOGRAPHER

BY

B. B. BABANI

BABANI PRESS

The Publishing Division of
Babani Trading and Finance Co Limited
The Gramplains
Shepherds Bush Road
London W6 7NF

Although every care is taken with the preparation of this book the publishers will not be responsible for any errors that might occur

The compiler of this book wishes to express his most sincere thanks to 'ELECTRONICS AUSTRALIA' the leading radio, T.V. and electronics magazine published in that continent, and to Syndication International Ltd., their agents, for permission to use much of the material in this book which appeared originally as articles in that magazine.

© 1974

I.S.B.N. 0 85934 016 3

First Published January 1974

CONTENTS

Photographers Test Meter	5
Equipment Facilitates Time Lapse Photography	13
Simple Photographic Timer	16
Projection Lamp Protector	18
Enlarging Exposure Calculator	23
Enlarging Exposure Meter	25
Light Triggered Flash Unit	27
Solid State Dark Room Timer	28
A Timer and Sequencer for Slide Projectors	30
New Solid State Photographic Timer	42
Electronic Flash - The Complete Unit ...	50
Constant Current Battery Charger	71
An Electronic Photographic Metronome with Accented Beat	72

TO HELP OUR EUROPEAN AND AMERICAN READERS
WE INCLUDE HEREWITH A FULL EQUIVALENTS AND
INTERCHANGEABILITY LIST OF THE SOLID STATE
DEVICES USED IN THE CIRCUITS SHOWN IN THIS BOOK.

BA100. BAX16. BAY18. BA108-127-128-147-188-216-217-218-219. OA129. 52J2.
OA91-81-161. AA117-132. IN60A-63. SFD108.
AC127-141-176-179-181-185-186. NKT781. RS276-2001. 2N647-1304-1308-2430.
2SD96. SK3010.
AC128-117-153-180. NKT302. RS276-2005. SFT232. SK3004. 2N659-1373-1384-1926-
2001-2431-4106. 2SB370.
OC74. AC125-151-152-180-192. BC126-213-260. NKT264. RS276-2005. SK3003.
2N1193-1352-1375-1501-1924-1991-2431-2613.
BC108-148-168-208-318. MPS6520. RS276-2009. SK3020. ZTX108.
EM401. AD4001. IN3193-4002. BY126/100. BA219
EM404. OA210. BY113-116-127-134-143-151N. IN4004. BY126/400.
EM4005. BY126/50
2N3569. 40408. SK3020. RS276-2009. MPSA05. MPS6531.
AC125. AC122-136-151-152-162-170-173. NKT302. SK3004. RS276-2005. SFT353.
2N1189-1192-1305-1352-2163-2428/9-2613. 2SA202. ORP12. LDR03. RPY25.
2N3638/A. MPS3638. TIS50. SK3025. RS276-2021. 2N5447.
2N3565. BC108-130-172-183-208-238. MPS6514-6565. SK3020. TIS98. 2SC485.
RS276-2009.
40669. SC141D
OC24. AD148-149. AUY19. RS276-2006. SK3009. 2N157-1022-2869-3615.
ASZ16. AD138/50. ADY23. AUY21-28. SK3009. RS276-2006. TI3028. 2N513-1146-3615.
BYX10. BA133. BAY90.
OA610. OA210-620. BY100-113-116-127-134-143-151. IN540.
OA202. OA131. BA148. BAY21-45-88. BAX16.
OAZ213. OA126. RF12. BZX79/C12. BZY83-C12/D12. BZY88-C12. Z12K. ZF12.
ZG12.
AD149. AD140. ADY27-28. NKT405. RS276-2006. SK3009-3013. 40051. 2SB425.
2N514-1530-2143-2836.
40265. SK3016.
2N2160. 2N2646. TIS43.

If readers experience any difficulty in obtaining the
components or speakers mentioned in the text of this
book, they should be guided by their Radio Parts
Dealer who will recommend the best make to use as
an alternative.

PHOTOGRAPHER'S TEST METER

This little project, which we have dubbed a Photographer's Test Meter, is suitable for a number of tests which a photographer may wish to make in the field. In addition, it may find use in other than photographic situations.

Basically, it is a multi-range voltmeter plus low resistance ohmmeter. It will check the conditions of both AA and D size cells, by correctly loading them while they are connected across the voltmeter. It also has a 1.5 and 22.5 volt range on which there is no load. Therefore, other batteries can be tested, including the 22.5 volt types commonly used in flashguns.

The low resistance ohmmeter is a very handy and worthwhile addition. Besides testing connections, leads, contacts etc., it will tell you whether or not a flashbulb is OK without actually firing it. This test passes enough current along the filament to tell you whether or not it is intact, without supplying enough current to heat (and therefore 'fire') it. The "red/blue" dot test included in flashbulbs is handy to tell you if the oxygen has escaped from the envelope, but will not give any indication of the state of the filament.

This meter is robust enough to be dropped into a photographer's carry bag, and taken out into the field for on-the-spot measurements. As well as this, it can be used around the home for checking the state of batteries in such things as transistor radios, tape recorders, etc. Besides, it will give the builder the opportunity to make a cheap test meter, and give valuable practical and theoretical knowledge in the operation of meter shunts and multipliers.

Besides the practical tuition given by the construction of this project, it will help if the reader understands why he is putting the parts where he is. So we thought it best to explain how the meter works.

The basic moving coil meter may be used as a voltage measuring device (voltmeter), as a current measuring device (ammeter) or as a resistance measuring meter, or ohmmeter.

By the use of so-called shunts we can convert the basic movement of such a meter into a ammeter which will measure many times its marked value. As an example, we need only take a multimeter. Most modern multimeters have a basic movement of 50uA FSD. In other words, it takes 50 microamperes of current to move the pointer over to its full scale deflection. But most multimeters will measure at least 500 milliamps - some go as high as 10 amps or more.

This is possible because the coil of wire in the meter has a fixed amount of resistance. In our case, it was 100 ohms. Also, there is another 100 ohms in series – the reason for which we will explain a little later. This makes 200 ohms of resistance in the actual path of the current through the meter.

If we put some resistance across the 200 ohms, the current will split up in the inverse ratio of the two resistances.

For example if we put 200 ohms across it, the ratio will be 1:1 and the meter will read half scale when 1mA flows in the circuit. It is this principle which is used on the ohmmeter range of our test meter.

However instead of reading current from an external source through an internal load the ohmmeter does the opposite. It effectively indicates the current drawn from an internal source by an external load. Instead of amps or milliamps, the scale is calibrated in ohms.

What we are doing is supplying a current which will make the meter read FSD (1mA). This is set by the 1k pot when the meter is unloaded. Then, we load the meter by putting across it the unknown flash lamp cable or cord. Depending on the resistance of the load, the current will split in the inverse ratio of the meter and load and reduce the meter deflection by a certain amount. If the load is shorted, virtually all the current will flow through it and the meter reading will drop to zero.

To use the meter as a voltmeter, we use what are called "multipliers". These are resistors placed in series with the meter. If we wish to measure 10 volts with a meter of 1mA FSD, all we need do is ensure that the resistor is the right value to allow a current of 1mA to flow from a 10V supply. Ohm's law will give us this resistance: $R=E/I$ or $10/.001$. Therefore, the correct resistor in this case is 10k. If the supply drops to 5 volts with a 10k multiplier, the meter will read half scale, and so on.

We used a 0-1mA meter for two reasons – the first is that they are cheap and easy to come by, especially from ex-disposals sources. It may be that many readers already have a meter of this type lying around which could be pressed into service.

The second reason is that, by simple association, the multipliers for a 1mA meter are very easy to remember. Using Ohm's law enables us to work out these values for any meter, but we do not need to do this for a 1mA meter if we remember that the correct multiplier will be the full scale voltage times 1000ohms. Therefore, to turn a 1mA meter into a 1.5V FSD meter the multiplier is 1.5k. Similarly, for a 300 volt meter, we would need 300k – and so on.

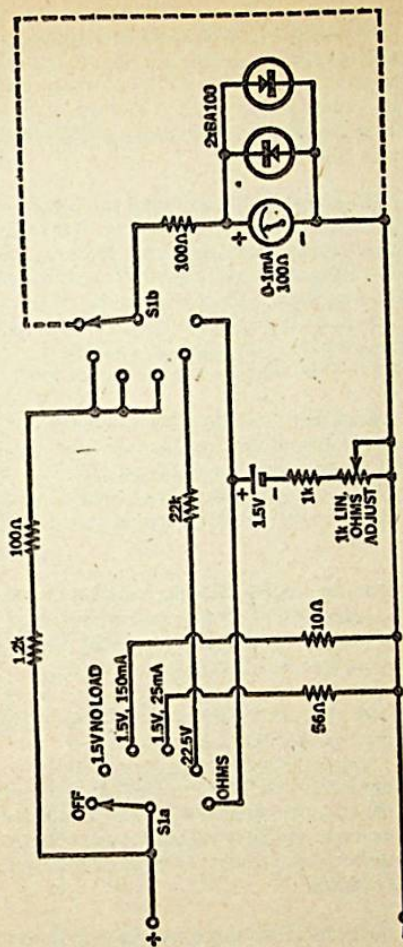

Circuit diagram of the Photographer's Test Meter

The resistors in this project should have a 5% tolerance. The main reason for this is that any wider than this would introduce an unacceptable amount on inaccuracy to the meter. Most 5% resistors manufactured these days have a much closer tolerance than 5%. It is rare to find one much worse than two or three percent at the most. On the 22.5V range a 5% resistor would allow a maximum voltage spread of 21 to 23 volts this is quite accurate — enough. However, a 10% would allow a range of 19.8 to 24.2 volts — which is a little too much.

If the required FSD voltage is not equivalent to a preferred value resistor, it is quite acceptable to use the nearest 5% type. Remember, however, that for low values the meter resistance must be taken into account. In other words, a six volt meter should have a 6k resistor, but the nearest 5% value is 6.2k. However, there is already 200 ohms on the circuit, so a 5.6k resistor would be better. The multiplier is then effectively 5800 ohms which is close enough to 6k. Use of a 6.2k would have resulted in a nominal resistance of 6400 ohms — which is a little too high.

You may have noticed that there are three 1.5V positions on our test meter. The reason for these is simple. There are a number of different sizes of 1.5V cells, ranging from the small "penlight" up to large telephone batteries. Each battery is able to supply a different amount of current, and its ability to supply the current is a good indication of its state.

To check these batteries properly, it is necessary to load them by the correct amount in order to see how they will behave when in use. A discharged battery may give its full 1.5V unloaded, but on even a light load may drop to less than half this figure.

We have selected two very commonly used batteries, the "penlight" and the type used in torches, tape recorders, etc.

Battery manufacturers recommend a certain drain for their batteries for testing, and it is this recommendation which we have based our load resistors on. For example, Penlight batteries require 25mA drain and torch size 150mA. Our load resistors are 10 ohms for the torch size and 56 ohms for the Penlight.

There are many other small batteries which we may want to test from time to time. These include other types of 1.5V cells, and others such as the 1.2V NiCd batteries commonly used in photoflashes.

In order to be able to do this, we have provided a third 1.5V position, which we have deliberately left unloaded. The intention here is to use this position to measure the batteries when they are actually in use. The voltage read should be a good indication of the expected battery life.

RIGHT The meter scale and panel layout:

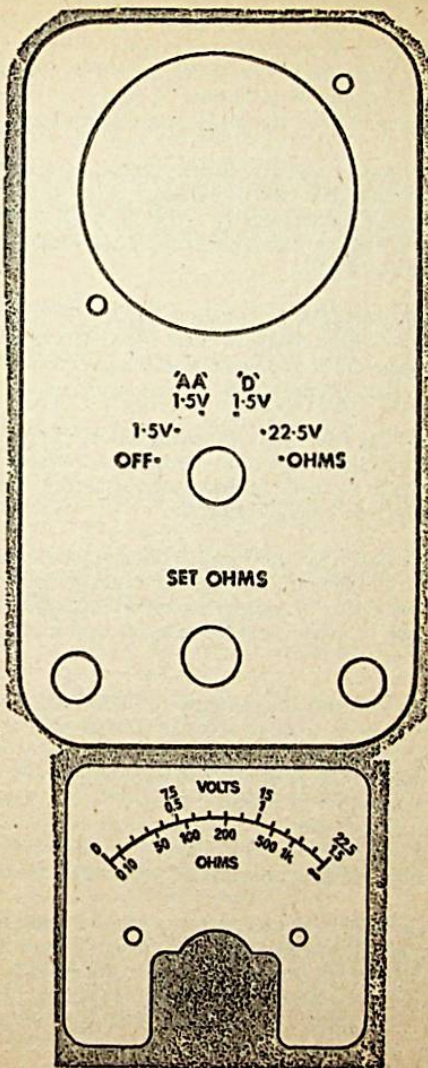

The other voltage position, 22.5V, may be omitted if desired. It may be that the reader would have more call for a six volt test than a 22.5V. In this case, simply change the 22k resistor to a 5.6k unit. It may be loaded or unloaded as desired. The correct test current for a six volt lantern battery (Eveready 509 or similar) is 250mA. This requires a load resistor of 24 ohms, 2W. A 27 ohm will give a test current of 220mA so this should be acceptable in most circumstances.

To test, say, the voltage across the battery and/or the storage capacitor, of an electronic photoflash, two of the ranges can be changed. Most photoflashes have a battery around 6 – 8 volts. A 10k resistor could be substituted for one of the 1.5k. This would turn the range into a voltmeter with an FSD of 10V.

Similarly, a 500k multiplier could replace the 22k. This would make the voltmeter have an FSD of 500 volts. Most electronic flashes have an HT rail of between 400 and 500 volts – 450 is a very common figure. If the voltage is higher than 500, the resistor to suit should be used.

One point to keep in mind while measuring the HT of an electronic flash – the internal impedance of the dump capacitor is very low – which means that it is capable of delivering a lethal shock if touched. Treat these capacitors with due respect.

On the circuit diagram, we have shown a dotted line between the S2a "OFF" position and the negative side of the meter. This is an option which may be included if the reader so desires. Its purpose is to provide some useful electrical damping of the meter when it is being carried around.

The meter movement acts as a generator of EMF when it is shaken or vibrated. (It is, after all, a coil of wire free to move in a magnetic field.) When this EMF is loaded by connecting a short circuit or low resistance across it, the current that flows helps to stop the meter movement from moving. If you have ever tried to turn the shaft of any generator (such as a bicycle generator) with the output terminals shorted together, you will know just how much harder it is than when the terminals are open circuited. Exactly the same principle is involved with the meter.

As this meter is likely to be used by many whose interest is primarily photographic, rather than electronic, we thought it might be wise to incorporate some sort of overload protection. We did this by including a 100 ohm resistor in series with the meter, and placing two BA100 diodes across it, as shown on the circuit diagram. This quite adequately protects the movement from all but the severest overloads.

The 100 ohm resistor prevents too high a current from flowing through

the diodes. If the voltage across the meter movement rises to exceed the turn-on voltage of the BA100 diodes (in either direction) one of them will turn on and safely shunt the current past the meter. In normal use, the leakage current of the diodes does not upset our calculations at all, as it is insignificant compared to the current which flows through the meter.

Including this protection does increase the total effective meter resistance to 200 ohms, as noted earlier, and this affects the lowest voltage ranges. This explains why we have shown a 1.3k multiplier for the 1.5V ranges. With the meter resistance of 200 ohms, the total resistance with a 1.5k multiplier would come to 1700 ohms — an error of about 9%.

On the 22.5V range, it makes very little difference. If anything, it merely brings the pointer closer to being on the scale than it would otherwise have been.

We had thought of putting the tester in a small metal box, but for various reasons decided against this. We eventually settled on a small off-white plastic box.

The only other major components in the unit are the 11 potentiometer (a standard line), and two banana sockets and the battery and holder. Incidentally, readers should obtain the meter, box and switch from their normal parts suppliers, and should not apply to the companies mentioned, who are wholesalers.

For the connecting leads, we used some polarised light duty "figure 8" wire, with alligator clips one end and banana plugs the other. On the meter proper, we used matching banana sockets in red and black, to mark the positive and negative terminals.

The alligator clips and banana plugs should also be red and black to prevent the user from connecting negative to positive.

To physically hold the battery in place, we soldered a small tool clip — size eight — onto the back of the pot. This holds the battery firmly, and fits quite comfortably into the space allowed.

We also had to devise a way of connecting to the battery. The way we overcame this problem will very likely make the purists shudder! We soldered the leads directly to the battery case. We did this in the face of information from the battery manufacturers themselves who strongly recommend against doing this. All we can say is — if there was a holder for single "penlight" cells, we would have used it. But there was not.

So we took the only way out. In doing so, we might point out that the same battery has now been "in situ" for over two months, and shows no signs of deterioration or damage.

The best place to start construction is in drilling of holes — for the meter (1-13/16" or 46mm) the switch and pot (3/8" or 10mm) and the terminals (5/16" or 8mm). The hole for the meter can be made by drilling a circle of holes slightly less than the required diameter, and widening with a file.

Before placing the switch in position, solder the resistors across it. It is much easier to do this now than later. Also, the clip to hold the battery must be soldered in place on the back of the pot.

Then fasten the pot, switch and terminals in place, and connect the required wiring between them.

The meter can now be screwed in and connected. The two BA100 diodes can be left until last, Use a pair of pliers to act as a heatsink when soldering.

If you are sure the wiring is correct, switch the switch to the ohms position. With nothing in the sockets, the meter should show a high reading. Adjusting the pot should bring the meter onto the infinity reference mark. Now, connect the test leads to the sockets and short the alligator clips together. The meter should drop to zero.

The maximum useable resistance of the meter appears to be approximately 2000 ohms. Beyond this, relatively large changes in resistance produce insignificant changes in pointer movement. This does not worry us; however, because the meter is primarily intended for use as a "go/no go" test for leads, connections, contacts, etc, and for flashbulb testing.

To test the condition of a battery, hold it on the test meter for about thirty seconds. In this time, any "surface charge" which it may have will have drained away, and the reading you get will be accurate.

With the two sizes of 1.5V batteries and a 22.5V battery, you should find that the meter registers high up the scale when on its respective setting.

To check flashbulbs, simply hold the test leads on the contacts and note the reading. If low, the bulb is ok. If the meter remains at its maximum, it is open circuit. If there is any reading between these two extremes, the bulb is suspect, because it is normally not possible for a good flashbulb to have much resistance.

YOU WILL NEED THESE PARTS

Resistors: (1/2W, 5%)

1 x 10 ohms

1 x 56 ohms

2 x 100 ohms

1 x 1k

1 x 1.2k

1 x 22k

1 x 1k linear potentiometer.

MISCELLANEOUS

1 x 2 pole, 6 position switch

1 x plastic box, 2-11/16in x 4-7/8in x 1-5/8in (68 x 129mm x 41mm)

1 0-1mA meter, 100 ohms

2 x BA100 diodes or similar

1 x "Terry" tool clip, size 8

1 x 1.5V "AA" size battery

2 x banana sockets (red and black)

2 x banana plugs (red and black)

2 x alligator clips (red and black)

1/2 yd light duty polarised figure 8 flex

2 x knobs to suit

1 x front panel label

1 x meter scale.

Hookup wire, insulated sleeving, solder, etc.

EQUIPMENT FACILITATES TIME-LAPSE PHOTOGRAPHY

This rather unusual idea should interest anyone who has an ambition to experiment with time-lapse photography.

The device is a variable rate switching clock for time-lapse movie photography, a photographic method of changing very slow movement to everyday rates, i.e., plants may be shown to grow bloom and wither, crystals to grow, erosion to occur, etc.

The method of operations is as follows:—

(1) The clock, with a rotating circuit board on the minute hand spindle, and with an overhead pick-up contractor, periodically operates the transistorised switch function, switch 1.

(2) The transistor switch closes relay 1, a small capacitor delay being incorporated to minimise inductive arcing on the circuit board and also chattering of relay 1

(3) As relay 1 closes, it closes relay 2 — a heavy duty relay which switches four photoflood lamps into a series state.

(4) Relay 3 closes approximately $\frac{3}{4}$ second later, being controlled by a 1000uF capacitor and a 5K variable resistor.

(5) When relay 3 closes, it closes relay 4, switching two of the lamps off and the remaining two across the full supply voltage. At the same time, the capacitor across relay 5 begins to charge, the relay closing about $\frac{1}{20}$ th second later; this delay gives time for the lamps to reach full intensity before the next operation.

(6) On closing, relay 5 operates the camera solenoid, driving the camera forward by one exposure.

(7) For periods of less than one exposure per 12 seconds, the clock and relays 1, 2, 3 and 4 and the delay capacitor of relay 5 are switched out of circuit, the photoflood lamps remaining on. A supplementary pulse generator, controllable from one exposure per 6 seconds to three exposures per second is used to drive relay 5 directly. With the two facilities, the equipment has a range of one exposure per hour to three exposures per second.

It is necessary for artificial light to be available for much of the type of work encountered. It is also preferable that the lamps be treated electrically as kindly as possible to give reliability and to avoid colour temperature change occurring too rapidly due to burning at full power for too long a period. Although four lamps are in use, only two are allowed to run at full temperature but the four are rotated periodically.

The power supply is fairly conventional using the three low voltage windings of a typical valve radio transformer in series, giving 24 volts rectified and smoothed in the usual manner. A 24 volt battery pack is used for field use.

The Relays used are 1,000 ohms, 12V, P.O. type, which lend themselves well to delayed action control and are easily converted, if need be, to the required change-over contacts for each stage.

The technique of increasing the supply voltage and using resistance and capacitance to achieve a time delay works well, the values depending to some extent on the particular relays used.

Relays 3 and 4 should have contacts capable of handling 240VAC at up to 10A.

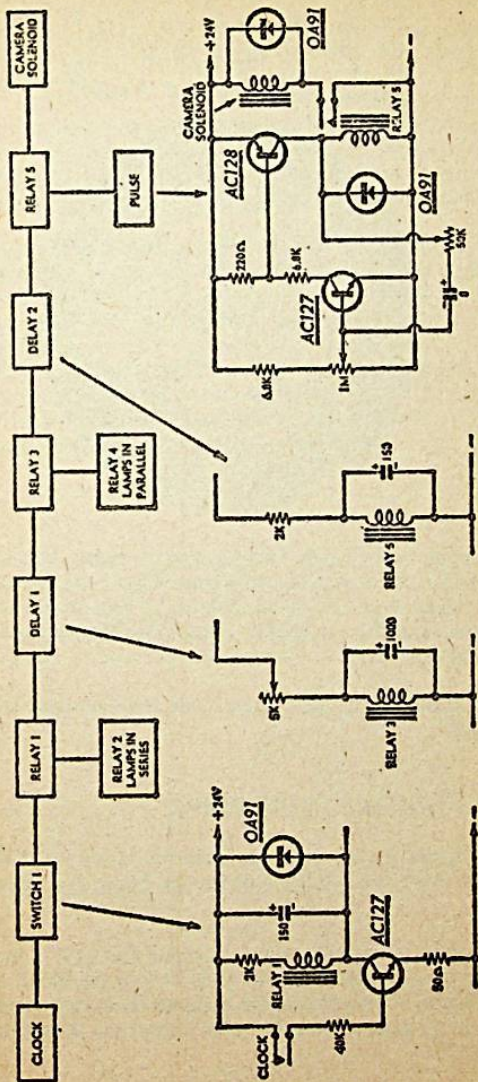

Sketched below is the pattern on the printed board, containing 300 lines in the outer ring, 120 and 60 lines in the next, 24 and 12 in the next, then groups of 4, 2 and 1.

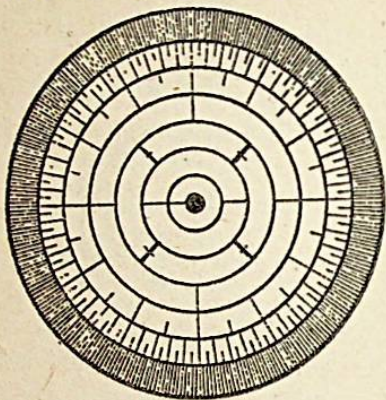

The 24V supply is also handy for operating the camera solenoid. This may well be located at some distance from the control unit and the effects of voltage drop have to be minimised if reliable operation is to be secured. The diode across the solenoid winding stopped erratic operation of the system.

The solenoid is my own design but suitable types are available commercially.

A SIMPLE PHOTOGRAPHIC TIMER

Here is a simple timer which can make life much easier for anyone who plays "octopus" in a darkroom, trying to do several things at once.

Operation of the circuit is as follows: Assume that S1 is in the re-set position, as shown. When switch S3 is closed (on) the 400uF capacitor, charges to the full battery potential. Meanwhile, the two transistors are drawing very little current, the relay is open and the exposure light is therefore off.

When S1 is moved to the "operate" position, the charge across the capacitor causes the first (NPN) transistor to conduct heavily. This creates a large voltage drop across its 3.3K collector resistor, which forward biases the second (PNP) transistor, closing the relay and operating the exposure light. (S2, by the way, allows the light to be switched on manually).

As the charge across the capacitor leaks away through the two resistors, a position is reached where both transistors cease to conduct and the relay drops out. The rate at which the capacitor discharges and therefore the length of the exposure depends on the setting of the two variable resistors.

I elected to use a potentiometer as the timer control mainly for reasons of economy. A 50K switch pot, serves the purpose and doubles as an off-on switch. The tab pot. sets the minimum exposure, while the main pot. is calibrated against a stop watch,

The power supply comes from a large 4½ volt battery. The relay proved something of a problem, requiring contacts to switch 240V while still pulling in reliably at 15.20mA. A simply modified a miniature relay by fitting a set of heavy duty contacts.

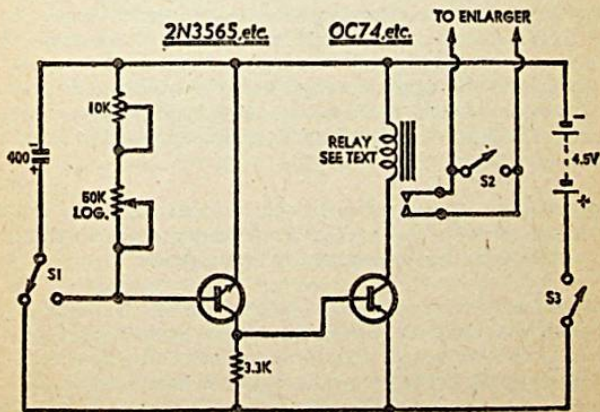

PROJECTION LAMP PROTECTOR

Here is a unit that should prove a boon to people who operate projectors and other equipment using high wattage lamps. It will remove the risk of failure at switch-on and increase the life expectancy of the lamps.

Most people who operate film projectors are familiar with the problem of lamp failure at the moment of switch-on. It is an irritating situation to say the least. There is an annoying delay while the lamp is changed — assuming there is a spare on hand — and the annoying thought of the money to be spent on a replacement, which can be considerable for the higher wattage types.

The reason for this failure at switch-on is that incandescent lamp filaments have a very low resistance when cold compared to their resistance when hot. The ratio of hot and cold resistances for typical tungsten filament lamps is around 15:1. For example, a 300 watt lamp will have a resistance of 13 ohms when cold and 190 ohms when hot. Similarly, a 1,000 watt lamp will have a resistance of 4 ohms when cold and about 60 ohms when hot. This large difference in hot and cold resistance means that the current through the lamp at switch-on will be many times larger than in normal operations. The current drawn by a 300 watt lamp will have a peak value of 26 amps during the first half cycle of the applied 240 volt AC mains supply. Similarly, a 1,000 watt lamp will draw 84 amps.

The whole point of all these figures is that a current-carrying conductor has an associated magnetic field which is proportional to that current and the force on parallel current-carrying conductors is proportional to the product of the currents in the conductors. Most projection lamps have their filaments arranged in parallel and it is the forces due to magnetic fields generated by the surge currents at switch-on which are the main cause of their destruction. The high surge current will also cause hot-spots which make the filament more vulnerable to damage from the forces described above.

Having established the cause of catastrophic failure in projection lamps (and it is a catastrophe as we noted at the beginning of the article) we can now describe the methods to prevent these failures.

The risk of damage due to surge currents is highest with those lamps which run directly from the mains supply. This is because the mains supply has a very low impedance and can maintain 240 volts across a virtual short circuit. The problem is not nearly so serious with those lamps which run from a step-down transformer because the transformer will saturate before it can deliver currents much above its rated output. Some projectors are run with a resistor permanently connected in series with the supply and this will also afford protection from surge currents.

The simplest method of reducing surge current is to use a high power series resistor of suitable value which can be manually switched out of circuit a few seconds after switch-on. The drawback of this method is that the warm-up procedure might be inadvertently forgotten — with disastrous results.

Another method is the use of series thermistors — their negative temperature coefficient of resistance compensates for the positive temperature coefficient of the incandescent lamp. The initial high value of the thermistor prevents any surge and the operation is completely automatic, meaning that the user does not have to worry about any special switch-on procedure.

The main drawback with thermistors is that the maximum current rating available for general use is 2 amps which limits the load they can protect to about 500 watts. At the time of the above-mentioned article it was suggested by the manufacturers that higher wattage loads could be protected by parallel thermistors provided they were thermally bonded together. However, thermistor parameters cannot be controlled closely enough during manufacture so that even though two thermistors may be at the same temperature they will not necessarily have the same resistance. This means that parallel thermistors will not equally share the current — and that they both fail eventually.

Another drawback involves the situation — admittedly rather rare — where the lamp is switched off for a short period and then switched on again. Depending on the type used, the thermistor may take from six to ten minutes to cool adequately, during which time it can provide only partial protection.

What is needed then is a foolproof automatic device which will enable incandescent lamps of any power rating to be operated from the mains without risk of failure due to surge currents. The device described in this article is suitable for loads up to 1,200 watts — or higher with a small modification.

The heart of this warm-up unit is the Triac, a development which provides a simple means of controlling AC power where rectification is not required. Although its internal operation and construction are complex it can be regarded as behaving like a pair of thyristors connected in inverse parallel, sharing a common gate electrode and common case.

Similarly, a thyristor can be regarded as a controllable silicon rectifier which, when forward-biased, can be triggered into conduction after which it normally stays "on" until the supply voltage is removed or reversed in polarity. Thus the output from a thyristor will be DC.

The Triac used in the prototype was an SC40-D which has an RMS conduction rating of 6 amps. For triggering on either half cycle the SC40-D requires a 3V signal of either polarity applied between the gate electrode and terminal A1. Note that, since the Triac is a bi-directional device, it has no "cathode" or "anode" as such but the two end terminals are referred to as "anode 1" and "anode 2."

As the Triac is basically an "on-off" device it is not used as a variable series impedance power controller (as are the switched resistors and thermistors described above). The only means by which it can be used to provide a gradual control of power is to use it as a rapid switch which conducts a variable amount of current on each AC half cycle — by adjusting the instant during the half-cycle when it triggers into conduction.

The oscillograms should help in understanding Triac operation. They represent the voltage across the load taken at low power and a fairly high power. In the first case the Triac is conducting late in each half-cycle and in the second case it is conducting early during each half-cycle, thereby delivering most of the available power to the load. Thus, by varying the triggering point, the Triac may be used to vary the power to a load continuously from zero to "full-on." Zero power corresponds to the triggering being delayed until the half cycle has ended, i.e., the available voltage from the supply is zero.

The method of varying the triggering point used here is referred to as "phase control." This involves feeding the gate electrodes with a sharp pulse whose phase, relative to the AC, can be varied. This is done quite simply by means of a capacitor connected across the Triac in series with a variable resistor. The capacitor will charge during each half-cycle of the applied AC because of the voltage across the non-conducting Triac. The time it takes to charge will depend on its value and that of the series resistor.

The Triac is fired by applying the capacitor's charge to the gate electrode. This must be done via a voltage-sensitive device — one which conducts only when a certain voltage is applied. Varying the resistor in series with the capacitor controls the phase of the pulse delivered to the Triac gate because it determines the instant at which the capacitor voltage reaches the firing voltage of the breakdown device.

In some low power applications where a relatively small trigger pulse is required a neon lamp can be used as the breakdown device. The SC40-D Triac requires a larger triggering current than can be delivered by a neon lamp and for this reason General Electric have developed a special three-layer symmetrical breakdown diode, the "Diac," for the purpose of triggering Triacs. The Diac is an open-circuit until the applied voltage rises to its breakdown voltage, when it becomes a low negative resistance.

The ST-2 Diac has a breakdown voltage of approximately 32V in both directions, and is able to carry a peak discharge current of 2 amps. It will easily provide the 3V triggering voltage for the SC40-D Triac when discharging a 0.1uF capacitor.

Referring to the circuit of the warm-up device, the 0.1uF capacitor is the timing capacitor and the 220K resistor is the charging resistance which initially determines the power delivered to the load. Since the 220K resistor and 0.1uF capacitor have a relatively long time constant the triggering point for the Triac will be rather late in the AC half cycles, as represented by the first of the two oscillograms. Thus the power delivered to the load will be only a fraction of that available. Any surge current will take place over an extremely short time and will be small due to the low voltage and so the load, the projector lamp, will be adequately protected.

As can be seen from the circuit diagram the voltage applied to the load is also applied across a 6V 50mA lamp in series with a 6.2K 15 watt resistor. This lamp, since it is being fed at "constant current," takes a significant time, a little less than one second, before it starts to glow. It is positioned over the LDR which is connected in parallel with the 220K resistor. Initially the LDR has a very high resistance so that the 220K resistor alone determines the triggering point of the Triac. However, as the 6V lamp begins to glow it decreases the resistance of the LDR to a value of around 1000 ohms so that the triggering point of the Triac is advanced to very early in the AC half-cycles and full power is applied to the load.

This means that the actual time of operation at low power is very short — of the order of one second. This is quite sufficient to warm the filament to its nominal resistance value so the full power can be applied. It should be noted that not all the available power is applied to the load due to the fact that the Triac is "off" for a very small part of each cycle. This power loss is negligible and we have not shown a voltage oscillogram of the "full power" operation as this would be merely a sine wave with a small blip at the start of each half-cycle.

All that remains to be explained is the purpose of the three 0.01uF capacitors and the small inductor, L1. These are for interference suppression; as may be seen from the oscillograms the Triac switches "on" extremely rapidly. This rapid rise time in the waveform is radiated as interference, a "buzzing" noise, to nearby radios and amplifiers unless it is suppressed. With the three bypass capacitors, and L1, the interference is quite low and is audible only during the first "second" after switch-on.

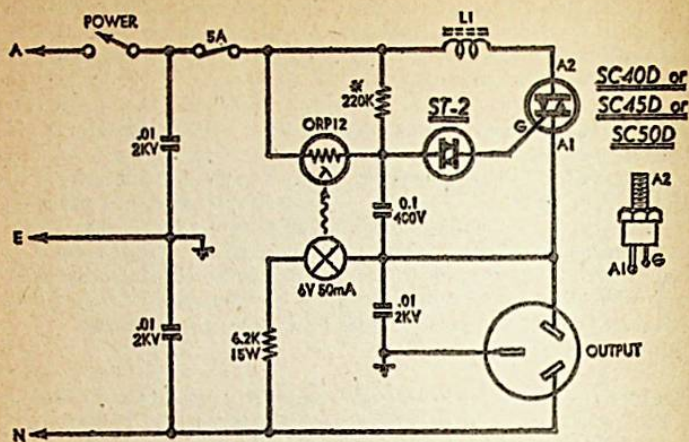

L1: 50T, 18 B&S ENAMELLED COPPER WIRE,
CLOSE-WOUND ON 2-1/2" LENGTH OF
3/8" DIA. FERRITE ROD.

^{OR} MAY NEED ADJUSTMENT

CONTROLLED WARMUP UNIT FOR PROJECTION LAMPS

larger fuse would provide little protection. If this order of load is contemplated it may be possible to use a 5A fuse, since they will usually take a small overload, but there is then the risk of premature fuse failure which, in nuisance value, is nearly as bad as a lamp failure.

For those readers who wish to "soft-start" larger loads, e.g., a bank of flood-lamps, we suggest alternative Triacs to the SC40-D. The SC45-D is suitable for loads up to 2,400 watts and the SC50-D up to 3,600 watts. Both these Triacs have identical triggering requirements to the SC40-D and can be used as direct replacements for it. The ratings of the fuse and the switch would have to be increased.

It may be possible to build this unit into the projector it is to be used with, but the LDR must be shielded from all light apart from that emitted from the 6-volt lamp. If it is to be used with a movie projector incorporating sound reproduction the output from the Triac must not be applied to the power transformer for the amplifier, as the gated sine wave input may generate large spikes which could cause damage to the Triac or the amplifier components.

PARTS LIST

- 1 Metal box, 6in x 3½in x 2½in.*
- 1 Triac silicon controlled AC switch; SC40-D for 1,200 watt loads, SC45-D for 2,400 watt loads; SC50-D for 3,600 watt loads.*
- 1 Diac symmetrical breakover diode, ST-2.*
- 1 3-pin power socket*
- 1 screw-in fuseholder and fuse rated to suit Triac (see text).*
- 1 220K ½-watt resistor.*
- 1 6.2K 15-watt resistor, square cross-section, IRC PW-15.*
- 3 0.01µF/2KV ceramic capacitors.*
- 1 0.1µF/400V polyester or paper capacitor.*
- 1 light dependent resistor, ORP12 or similar.*
- 1 DPST power switch with each section rated at 3 amps or switch to suit Triac used.*

MISCELLANEOUS

- 1 piece of aluminium for Triac heatsink, mains cord clamp, length of 10-amp 3-core power flex and 3-pin plug, 4 rubber feet, 13-lug tagboard, 2 ¼in fibre rod spacers, blind-tapped 1/8th Whit. each end. Rubber grommet, 3/8in diameter.*
- 1 2½in length of 3/8in ferrite rod, few feet of 18G enamelled copper wire, and plastic insulation tape.*
- Connecting wire, solder, screws, nuts, etc.*

ENLARGING EXPOSURE CALCULATOR

Amateur photographers are constantly seeking ways to measure the light projected on to the enlarger baseboard, in an effort to avoid the time wasting chore of making test strips. This design has the advantage that it requires no expensive meter and is cheap and simple to construct.

In photographic enlarging it is very helpful to have some means of determining the time of exposure to give a proper graduation of tones from shadow to highlight. It is also necessary to know which paper grade is best suited to the type of negative being printed.

The unit to be described is run from a low voltage transformer, is easy and cheap to construct, with parts relatively easy to obtain, and provides an extremely accurate means of measuring the actual "light value" being projected on to the enlarging easel.

It can be constructed in a small metal box housing both the transformer and circuit board, with the LDR on a probe, or the transformer can be located in a place out of reach and the small circuit board, lamp and LDR build up as a probe with only the 6.3 volt leads attached.

Operation of the device is based on adjustment of the lens stop until a point is found where the indicator lamp is extinguished. Based on this broad principle, there are two methods which may be employed to determine exposure.

In the first method, the probe can be placed in the path of the light corresponding to what would be a black in the print, or shadow area, and the exposure needed for a satisfactory print determined experimentally. Once this is done, the time used for this print will be the same for all prints, whatever the degree of enlargement, simply by adjusting the lens stop until the globe goes out. A very small movement of the stop will light or extinguish the globe.

When setting up the unit, focus up for a print about postcard size and adjust the 30K pot, control so that the lamp will operate using a small stop (f11). It will then be found that as the print size is increased so also will the size of the stop, without changing the exposure time.

The grade of paper can be determined by first taking a reading of the brightest part of the negative in the same manner as above. Then move the probe to the darkest part, open the lens until the globe just lights, then close it until it just goes out. The number of stops difference will indicate the contrast of the negative.

The best practice, of course, is to expose and develop all negatives to a consistent contrast, thus minimising the need to use more than one grade of paper. However, allowance must still be made for the wide differences in contrast which occur between different subjects.

In the second method the light is measured after diffusion. A swing around holder is mounted under the lens and fitted with some diffusing material such as grained astrofoil and accommodate the LDR and lead out wires to keep them flush with the surface. A thin piece of white plastic or formica is then cut to the shape of the base and a small hole $\frac{3}{16}$ " to $\frac{1}{4}$ " is drilled to coincide with the LDR. This is affixed to the base with plastic cement. The lead may be plastic covered shielded cable or small twin flex, used in much the same way as the red filter fitted to some enlargers. The probe is placed in the centre of where the image will fall on the easel and a reading of the average illumination then results. A test print also will be necessary in this case. A contrast check cannot be made using this method.

It must be emphasised that no light, other than that from the enlarger, must fall on the probe, otherwise a false reading will result.

The probe can be made using black plastic or wood. A recess is made to accommodate the LDR and lead out wires to keep them flush with the

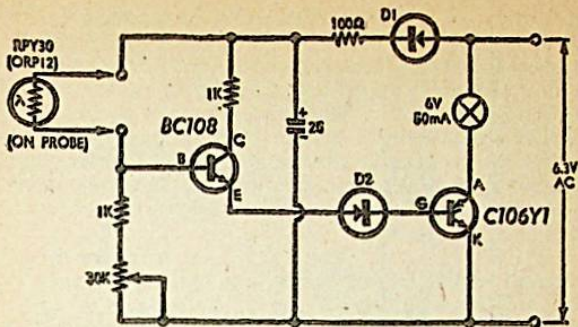

The circuit is simple and uses only a few low-cost components. A small lamp serves in place of a meter.

surface. A thin piece of white plastic or formica is then cut to the shape of the base and a small hole $\frac{3}{16}$ " to $\frac{1}{4}$ " is drilled to coincide with the LDR. This is affixed to the base with plastic cement. The lead may be plastic covered shielded cable or small twin flex.

ENLARGING EXPOSURE METER

Amateur photographers may be interested in this latest suggestion for an enlarging exposure meter. The author claims that many of the objections to previous designs can be overcome by using the more sensitive cadmium selenide light dependent resistor.

The use of a CdSe LDR in lieu of a CdS appears to overcome most of the previous objections to this type of a darkroom aid. The LDR is certainly small enough and sensitive enough to handle all the negatives I have, measuring the darkest "important" part. The sensitivity is also adequate in the blue region for evaluation of colour negatives through narrow cut tri-colour filters. Unfortunately, the variation between individual LDR's of this type (MKB5H, available from Proops Bros. London) is enormous; the second LDR 1 obtained recently appears to be only suitable for measuring the brightest part of the negative. This method seems to be gaining popularity and may be as good as the other. The response time of both units is quite satisfactory and very much superior to the "fast response" CdS cells such as ORP63.

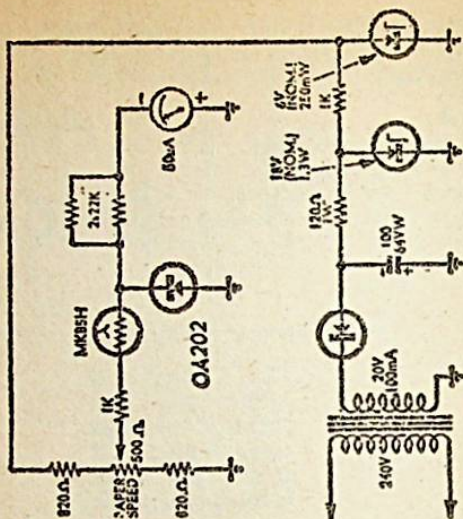

The main feature of this circuit is the use of relatively high sensitivity cadmium selenide (CdSe) photo cell in place of the more conventional cadmium sulphide unit. The cadmium selenide cell also has improved sensitivity at the blue end of the spectrum. Availability of these cells may be a problem.

We have published the above circuit and comment as an item of general interest to those readers who have been seeking a satisfactory solution to the problem of determining enlarging exposure. However, while the CdSe cell appears to have some advantages over the CdS cell, it leaves some objections unsolved and creates at least one new one of its own. Increased sensitivity and rapid response time are in its favour, as is spectral response which appears to be in the blue region. Against this is an apparently very wide spread of characteristics.

LIGHT TRIGGERED FLASH UNIT

"From a circuit published in 'Camera Magazine,' January, 1967, I made up a slave unit with some modifications. After trying several guns, I found it necessary to change the polarity of the flash nipple, so a change-over switch was added. The circuit shown will fire an electronic flash gun or B/C gun by means of the flash from the gun on the camera with no interconnecting wires. It is most effective using a B/C gun on the camera and electronic on the slave, although two electronic guns work quite well.

"The SCR (thyristor) used must have a voltage rating higher than the trigger voltage of the flash gun, but the current rating need not be great. The ones I have used were 50V, 3A and 100V 5A, and both have been satisfactory. Sue to the capacitor, the slave will not fire except by rapid increases of light and works well in high ambient light. The polarity changeover switch for the flash nipple is necessary as guns may have the connecting cable of either polarity. A battery switch is not needed as the current drain is extremely low if the unit is stored in the dark when not in use."

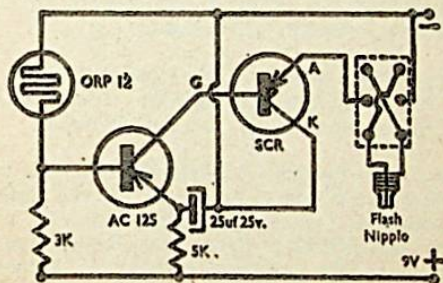

SOLID STATE DARKROOM TIMER

Electronic timers, whether for photographic or any other application are always of interest to the experimenter, particularly as there are a number of ways in which the end result may be achieved.

The enclosed circuit is of a timer for use with a photographic enlarger. It gives times from 2 to 100 seconds in two ranges. Accuracy is around 1% at full scale and much better at shorter times, regardless of mains voltage.

Power is obtained from the mains using a miniature transformer and half wave rectifier, and regulated by a 12 volt zener across a 500uF capacitor.

With the power switched on the 50uF timing capacitor charges to the regulated voltage via relay contacts RL1 and the 3.3K resistor. When push button S2 is closed the relay coils are energised and contacts RL2 apply power to the appliance. At the same time contacts RL1 transfer the negative supply rail from the timing capacitor to the transistor emitters.

The timing capacitor now has its negative plate connected to the base of TR1 and its positive plate to point "A" on the voltage divider network consisting of the 3.3K and 2.2K resistors across the supply rails. This point is at about 4.8 volts positive with respect to the negative rail and the emitter of TR1. As a result there is a negative bias on the base of TR1 equal to the difference between this voltage and the voltage on the capacitor, or about 7.2V when the capacitor is fully charged.

The reason for this arrangement will be explained in a moment.

Because of this bias TR1 is in a non-conducting state and TR2 is biased to saturation by the 68K bias resistor. Therefore the relay remains energised when the push button S2 is released.

As the timing cycle commences the timing capacitor begins to discharge through the 0.5M timing control pot, the 0.5M resistor in series with it (unless shorted out by the switch S1), and the 15K resistor.

When the voltage across the timing capacitor falls to a value equal to that at point "A" there is no voltage on the base of TR1 and the latter is approaching conduction. This actually happens about 0.7V later, whereupon the forward bias on TR2 is reduced, The latter no longer conducts, the relay drops out, and the appliance is switched off. At the same time, the 50uF timing capacitor is charged in readiness for another cycle.

The reason for the positive bias voltage at point "A" can now be explained. It ensures that TR1 is switched into conduction at a point in the capacitor's discharge cycle where it is still discharging at a reasonably fast rate so that, as a result, the change from non-conduction to conduction is rapid and unambiguous. This contributes to stable timing.

Even so I found it necessary to add the OA202 diode and the 10M resistor because the emitter base leakage of 1 or 2 microamps equals the discharge current of the timing capacitor at 90 seconds. Because the diode is reverse biased during the discharge period, such leakage is eliminated. The additional voltage needed across the diode, also postpones the time when TR1 goes into conduction. These components give an additional 10 to 15 seconds at the top end of the range.

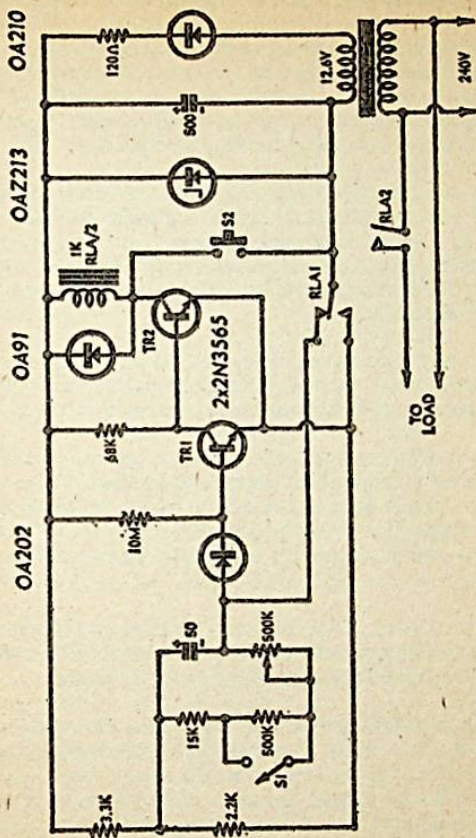

The 15K resistor in the capacitor discharge network sets the minimum time. Both the 0.5M resistor and 0.5M pot in the remainder of this network are shunted with high value resistors – 3M in my case – to adjust the ranges.

The timer was built in a 3in by 4in box. I used a refrigerator door switch for S2, connected via a short length of flex to avoid shaking the enlarger when switching.

A TIMER AND SEQUENCER FOR SLIDE PROJECTORS

Here is a device which will sequence a slide presentation at a rate predetermined by the narrator, giving him a few seconds warning that a slide change is about to occur. It can operate an automatic projector directly or give an appropriate change signal to a manual operator. A further use of the timer is as a camera pulser for time-lapse movies.

The problem which the device is intended to cope with is a fairly familiar one; a devoted colour slide photographer — of which there are many in the community — is invited to show his slides to an interested group of people — a social group, a church group, a hobby class or such like. The slides may be flower or animal studies, scenic gems, a tour, or a coverage of some scientific subject.

The exhibitor very carefully selects his slides, counts them, mentally rehearses what he plans to say about each one and works out that it should take the next hour, or whatever his allotted time may be.

But alas, his careful planning counts for little at the actual presentation. He may talk at such length about the early slides that an hour sees him only half-way through. He may continue to ramble on, to the embarrassment of the audience, or suddenly discover that he has to forget the rest of the slides or push them through so hurriedly that their value is largely lost.

The reverse can happen, of course, the lecturer being so apprehensive about talking too long, or boring the audience, that he hurries through the presentation, quite unnecessarily and to its detriment.

The slide enthusiast who owns a timer can be saved from this kind of embarrassment. Knowing the time available for presentation, he can select a suitable number of slides and set the timer to sequence them at a suitable rate. He can prepare and rehearse his commentary so that it fits into the allotted time. At the actual screening, the slides will come up at the same rate, automatically disciplining any tendency to become too talkative or too terse in front of an audience.

The device can also be boon to a compere or chairman needing to cope with a lecturer whose abilities or tendencies are unknown. Before proceeding begin, and without embarrassment, he can reach agreement with the lecturer on the time available and the number of slides to be shown. The sequencer can be set for the appropriate presentation rate, thereafter providing a powerful incentive to the lecturer to suit his remarks to the time available.

To be sure a device which allots an exact predetermined projection time

to each slide might be criticised as too "mechanical" and it would be quite redundant, both for the expert lecturer, and the person who is able to pre-record his commentary on tape. In fact, it is not intended for such people but rather for those — in the majority — who cannot reply either on expertise or on pre-recording.

What is more, it is not nearly as impersonal as might appear at first glance. The device switches on a signal light a few seconds before each slide change is due, so that the lecturer can round off his remarks or merge them smoothly into the next commentary segment.

Where a large number of slides have to be put through in a limited time, they can be shown at the rate of about 4 per minute. The other extreme, a very leisurely rate, would be 1 per minute. A good average figure is 3 slides per minute, which means a change every 20 seconds.

It is suggested that the warning light be set to come on 6 seconds before each change so that the "average" sequence would be: change — initial period 14 seconds — warning light for 6 seconds — change.

If interest in a particular slide does warrant more time or less than the automatically selected value, the lecturer can operate one or other of two switches to delay or hasten the change. This over-ride facility will not change the total screening time unduly, provided the lecturer uses the buttons only when necessary and for both purposes: accelerate as well as delay!

When the "Advance" button is pressed the normal timing cycle of the unit is terminated and the device immediately cycles the projector or signals the projectionist. If the Advance button is held down continuously the projector control circuit will remain closed and this will cause many automatic projectors to cycle continuously.

Pressing the delay or "Repeat" button does not interfere with the basic timing cycle but simply inhibits closing of the output control contacts. When the signal light comes up, indicating an impending change, the lecturer needs only to hold the Repeat button down until the light goes out and no impulse will reach the projector or projectionist. If the Repeat button is held down continuously, the lecturer can hold a slide for as long as he desires. The slide will change at the end of the cycle during which the button is released or the change can be initiated immediately by pressing the Advance button.

The basic circuitry can be adapted to meet a variety of situations. In the unit as pictured, the timing control, the over-ride buttons and the signal light are all in the one box which can be placed handy to the lecturer, so that he will be aware of the signal light, even when looking at the screen.

The unit as shown needs to be connected to a power point and a two-wire lead runs away to the projector position, serving the same purpose as a two-wire lead from an ordinary press button. This can close the control circuit to an automatic projector, or to a signal light near a manual projector, if the projectionist is in a separate booth.

Obviously enough, various facilities can be deleted or transferred elsewhere leaving the lecturer with nothing at all, or just a light to warn him of an impending slide change. Different constructors may have their own ideas of how things should be arranged.

A programmable unijunction transistor, or PUT for short, is the basis of the slide timer circuit. Essentially, the PUT is a four layer NPNP device similar to a normal thyristor or silicon controlled rectifier, but having an anode gate rather than a cathode gate.

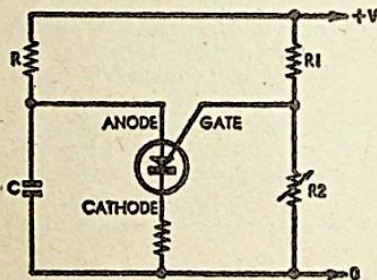

Figure 1

The above diagram shows how a programmable transistor is used in a basic timing circuit. By varying bias applied to the gate electrode the device can be programmed to fire at a particular anode voltage.

In simple terms, it differs from the thyristor in that it can be programmed to turn on when a specific anode voltage is exceeded, rather than cathode voltage. The anode voltage at which it turns on is determined by the voltage, applied to the gate electrode.

Thus a PUT can be used with a capacitor charging network to perform a timing function, as shown in figure 1. When the capacitor charges to a required anode firing voltage the PUT conducts and discharges it through a current limiting resistor in series with the cathode.

Provision to vary the time cycle can be made in two ways. The time constant of the RC combination may be varied, by varying either R or C,

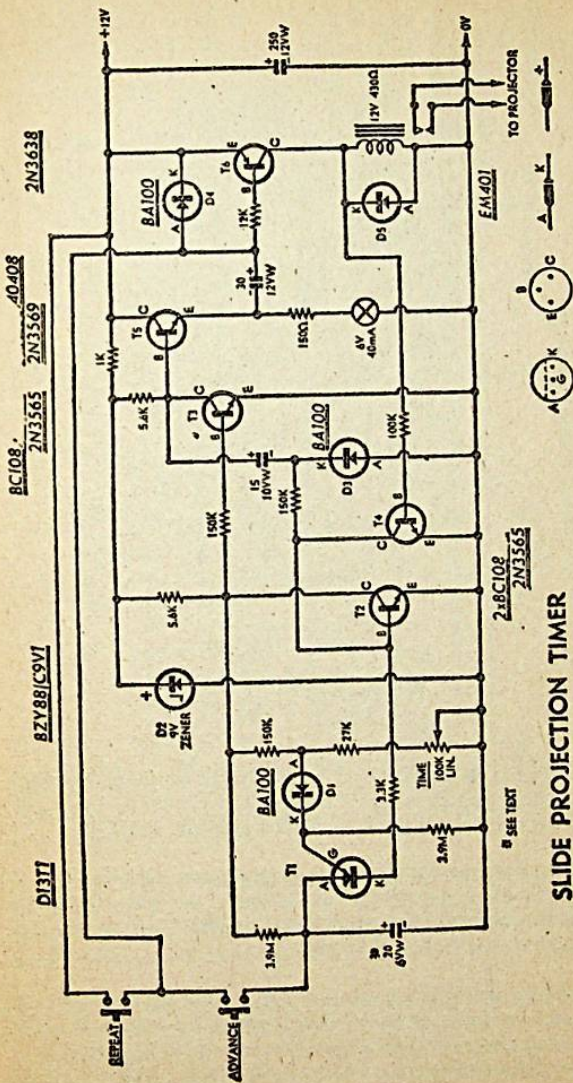

SLIDE PROJECTION TIMER

The slide timer circuit diagram is shown above. On the diagram a relay is shown as having one pair of closing contacts, required for projector operation, but other contacts may be provided and used for other functions.

The wiring diagram for the Veroboard, at right shows the positions and wiring of all the components mounted on the board. Also shown in the diagram are the various take off points for the leads to warning lamp, push buttons and potentiometer.

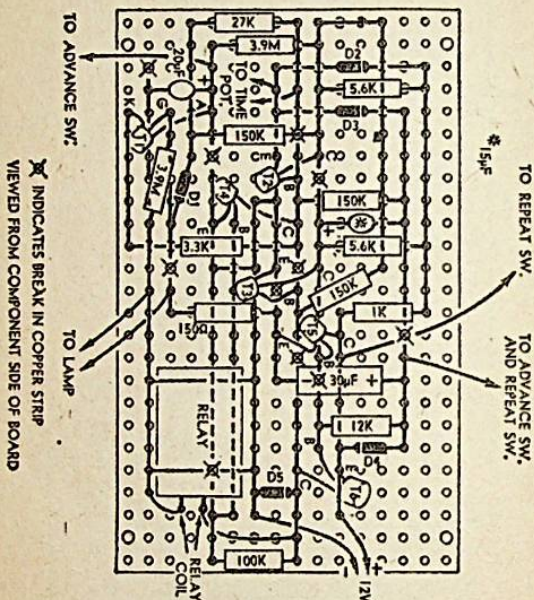

or both, or we alter the anode firing voltage by varying the gate voltage. The latter is much the neater way and can be easily provided by making resistor R2, part of the gate potential divider network, variable.

Essentially, the charging rate of a capacitor is exponential, charging rapidly at first and then tapering off as the voltage increases. So that the time control function might be reasonable, it is desirable to change this to more nearly approximate a linear law.

The simplest approach is to use only the early part of the charging cycle, where the law is more nearly linear. Thus we might arrange for the PUT to breakdown at only one-third of the voltage to which the capacitor would charge if allowed to complete the cycle. We may further improve

PARTS

- 1 Metal box (see text).
- 2 Miniature push buttons.
- 1 Pilot lamp, 6V 40mA
- 1 Speaker socket with plug.
- 1 Miniature relay, 12V 430 ohms (see text).

TRANSISTORS

- 1 Programmable unijunction transistor, type D13T1.
- 3 BC108, 2N3565 or similar
- 1 40408, 2N3569 or similar.
- 1 2N3638 or similar.

DIODES:

- 1 BZY98/C9V1.
- 3 BA100, or similar low power silicon diode.
- 1 EM401, or similar power diode.

RESISTORS

- 1 100K linear potentiometer.
- 2 3.9M, 3 x 150K, 1 x 100K, 1 x 27K, 1 x 12K, 2 x 5.6K, 1 x 3.3K, 1 x 1K, 1 x 150 ohms.

CAPACITORS

- 1 250uF 12VW electrolytic.
- 1 30uF 12VW electrolytic.
- 1 20uF.6VW tantalum electrolytic.
- 1 15uF 10VW tantalum electrolytic.

POWER SUPPLY COMPONENTS

- 1 Miniature power transformer, 240V to 12.6V at 150mA.
- 1 BZY94/C12 zener diode.
- 1 EM401 diode.
- 1 150 ohm 1 watt resistor.
- 1 200uF 18VW electrolytic capacitor.
- 1 Length of mains flex and plug (see text).

the linearity if the current which is charging the capacitor is derived from a constant current source. This is approximated if we use a large value of charging resistor R. We could introduce the constant current characteristic of a transistor if the linearity was critical, but such a step is not justified in this case.

If the resistor R is larger than a certain critical value the PUT will come out of the conducting mode when C is discharged. If R is less than the critical value the PUT will latch up, i.e., it will remain in the conducting mode while ever anode voltage is applied.

Thus the basic circuit of figure 1 can be made to have either of two operating modes. Using the larger value of R it becomes a regenerative relaxation oscillator-type timer, delivering pulses at a regular pre-determined rate. Using the smaller value, it becomes a "one shot" timer

which has to be manually reset.

From the elementary circuit of figure 1 we have developed two practical circuits. The main one, featuring all the facilities, we have discussed is shown on this page. A simpler version, still suitable for projector or other functions, is shown.

In both circuits the resistor R is quite large, 3.9M in one case and 4.7 in the other, while the timing capacitor is 20uF. Because small charging currents are involved it is essential that the capacitor should have very low current leakage. Hence it is necessary to use a tantalum dry-electrolyte capacitor; regular electrolytic capacitors are not suitable.

Typical of all silicon junctions, the voltage between the anode and gate of the PUT will vary with temperature. To make the firing voltage less dependent upon temperature a silicon diode is included in series with the gate electrode.

By exploiting the temperature characteristics of the silicon diode, which is similar to that of the PUT we effectively compensate for temperature changes. A 3.9M resistor connected to the negative rail provides the diode with the necessary forward bias.

The complete timing cycle really consists of two smaller timing cycles, operating consecutively. Thus, we use the PUT circuit to provide the major timing cycle of, say, 14 seconds. The completion of this cycle is then used to initiate a minor cycle, say 6 seconds, at the end of which a total of 20 seconds has elapsed, and the slide change function is initiated. The purpose of the minor cycle is to turn on the warning lamp.

The complete timing cycle may be varied over a range from 15 seconds or 4 slides per minute, to 1 slide per minute. It would be possible to increase both the minimum and maximum times available by increasing the value of the 20uF timing capacitor. In addition, the total range over which the timer can be varied could be increased by increasing the value of the 100K potentiometer.

Timing for the minor cycle is provided by means of a monostable multi-vibrator. This circuit uses two transistors, T2 and T3, with the usual base-to-collector coupling for one transistor, but with an RC time constant network for the other.

In combining these two circuits we must arrange, first, for the major timer to initiate the minor cycle at the end of 14 seconds and, second, for the minor timer to disable the major timer during the 6 second period, so that it does not commence a new 14 second cycle until the end of the minor cycle, i.e., after a total of 20 seconds.

A SIMPLIFIED GENERAL-PURPOSE TIMING CIRCUIT

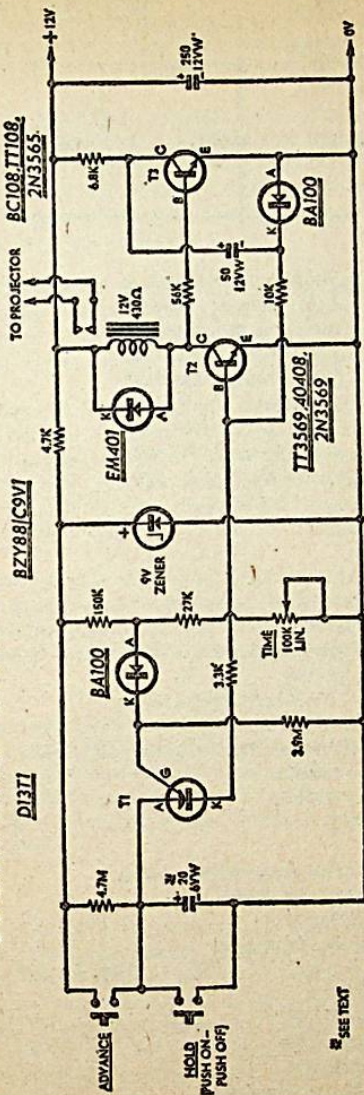

SEE TEXT

Shown above is the circuit diagram of a simplified timer produced by pruning the slide timer circuit. The simplified device is intended for general purpose timing, but will also function as a slide timer.

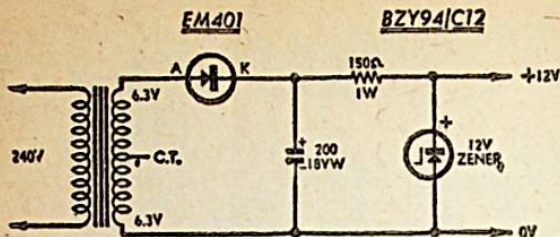

Shown at right is a 12V power supply which is suitable for use with either of the timing circuits described here. In some cases the AC supply may be derived from the projector.

PARTS LIST

- 1 Metal box. (See text)
- 1 Miniature push button.
- 1 Miniature push-on push-off switch.
- 1 Speaker socket with plug.
- 1 Miniature relay, 12V 430 ohms (See text).

TRANSISTORS

- 1 Programmable unijunction, transistor, type D13T1.
- 1 BC108, 2N3565 or similar.
- 1 40408, 2N3569 or similar.

DIODES

- 1 BZY88/C9V1.
- 2 BA100, or similar low power silicon diode.
- 1 EM401, or similar power diode.

RESISTOR

- 1 100K potentiometer, linear taper.
- 1 4.7M, 1 x 3.9M, 1 x 150K, 1 x 56K, 1 x 27K, 1 x 10K, 1 x 6.8K, 1 x 4.7K, 1 x 3.3K.

CAPACITORS

- 1 250uF 12VW electrolytic
- 1 50uF 12VW electrolytic.
- 1 20uF 6VW tantalum electrolytic.

The complete circuit function is as follows. Initially, T2 is cut off with collector at supply potential, and the PUT timer commences. After a set time the PUT discharges the timing capacitor into the base of T2, switching it into saturation, whereupon its collector voltage drops. As a result, T3 is cut off and its collector voltage rises toward supply potential.

With T3 collector near supply potential, the emitter follower (T5) conducts and lights the 6V lamp. Also the 15uF capacitor, which should also be a tantalum type, commences to charge through a 150K resistor into the base of T2. Thus T2 is held in saturation until the capacitor has charged to a point — after about six seconds — where its charging current will no longer saturate T2.

At this point T2 is turned off and, as a result, T3 is switched on and its collector voltage falls with T5's emitter following it and extinguishing the lamp. Whenever the multivibrator is in its timing mode, voltage at T2's collector is very low and the PUT circuit is disabled.

As the T5 emitter falls to the negative supply rail potential, it creates, in conjunction with the associated 30uF capacitor, a differentiated pulse which is applied to the base of T6. This activates the relay in the collector circuit of T6. The 12K resistor in series with the base of T6 ensures that the relay will be held closed for a few seconds; long enough for the projector mechanism to engage and lock up for a complete cycle.

There are several diodes in the circuit, including a power diode across the relay winding to protect its switching transistor against high voltage transients. Depending upon switching speed, quite high voltages can be developed across an inductive load causing irreparable damage to the transistor.

Two other low power diodes are used in conjunction with the 15 and 30uF electrolytic capacitors. The diode connected to the 15uF capacitor ensures reliable multivibrator timing irrespective of the use of the advance button, while the other diode allows the relay to be operated a number of times in succession, without having to wait for the 30uF capacitor to recover.

Essentially the advance button is simply required to energise the relay and engage the changer mechanism. This could be easily done by connecting the resistor at the base of T6 to the negative supply rail via a suitable button. While this method would advance the projector it would not negate the timing cycle already in progress, so that the projector would again be activated when the timing cycle ended. What is required is that the relay should be closed and both timing circuits returned to their start-of-cycle conditions.

This has been arranged by reason of the advance button's position in the circuit and the inclusion of an additional transistor, T4. When the button is closed the 12K resistor at the base of T6 is connected to the PUT anode. Thus current is able to flow through the base-emitter junction of T6, turning it on and energising the relay. The same base current flows through the 12K resistor into the 20uF timing capacitor, charging it almost instantaneously and firing the PUT.

Once the PUT fires the capacitor is completely discharged, thus returning it to the start-of-cycle condition. However, to ensure that T2 is not turned on by the discharge current, so initiating the six-second timing period, a transistor is connected from the base of T2 to the negative rail. This transistor (T4) is switched into saturation at the instant the relay is energised because its base is connected to the collector of T6, via a 100K resistor.

If the timer happens to be in the six-second warning cycle T2 will have already been turned on, but the device will still advance the projector and return both timing circuits to their starting condition. When T4 is switched on, its saturation voltage is less than the base emitter voltage of T2, and T2 is simply switched off.

Thus, the projector can be instantaneously advanced at any part of the timing cycle without upsetting the following cycle or producing any anomalous effects. However, if the advance button is held on, the relay will remain activated and the projector will advance slides in rapid succession until the button is released.

Operation of the repeat button is somewhat simpler, circuit wise, simply inhibiting the switching pulse to T6 base. The button is actually wired from positive rail to the 12K resistor and 30uF capacitor junction. It will be noted that this junction point is common to both buttons, so if they were made remote from the unit only three wires would be required, rather than four, as might be expected.

When using the repeat button it is necessary to hold it closed until the 6-second warning lamp goes out, otherwise T6 will receive a normal pulse from T5 emitter and engage the relay. Once the lamp has gone out the timer will automatically commence another cycle, whether the button remains held down or not.

Although we have only shown one pair of normally open relay contacts, this being all that is required to operate automatic and semi-automatic projectors, we actually used a relay which had a two pole change-over set. The miniature relay was a 12V 430 ohm unit.

The timer's current requirements will depend in the main, upon the warning lamp and relay, the rest of the circuit requiring only a few

milliamps. However, operation of the lamp and relay is intermittent so the average power requirement will be quite modest.

For the prototype, we included a mains power supply using a small transformer. It has a 12.6V centre tapped winding which, when applied to a half wave rectifier, gives about 17V. A zener diode is then used to establish a 12V supply for the timer. Note that a 250uF capacitor across the zener diode is necessary for the correct operation of the unit.

With some later-generation projectors, the necessary low AC voltage could be obtained from the lamp transformer; this may vary between 12 and 24V depending upon the projector type. If 12V RMS is available the supply circuitry may be used, unaltered. But, for 24V RMS the 150 ohm 1 watt resistor should be increased to about 330 ohms with a 4 watt power rating. Also, the rating of the 200uF electrolytic should exceed 34VW.

Alternatively, if low voltage is not available from the projector and a mains supply at the control point is considered inconvenient, the small power transformer could be mounted in the projector housing. A four-core cable between sequencer and projector, carrying low-voltage AC and the changing mechanism voltage would obviate the need for a second cable. In some cases the low-voltage supply from the projector and changing mechanism voltage could be common, in which case it may be possible to use only three-core cable, but this will depend upon the particular projector.

The prototype sequencer was wired on a section of Veroboard, with the exception of power supply components which were wired on a tag strip. The miniature relay was attached to the board by two straps, made from 22-gauge tinned copper wire, which also served as "jumpers" for the negative rail.

The completed board assembly was housed in a small die-cast metal box measuring 4-5/8 x 3-5/8 x 2-1/8. The interior-assembly is shown in the accompanying photograph, giving a clear indication of the position of the transformer and other components. The potentiometer, push-buttons and warning lamp were mounted on the lid, the lamp being held firmly in place with a rubber grommet. A speaker plug-and-socket combination was used to connect the projector to the relay contacts,

After completion of the timer it was apparent that there would be more applications for a regenerative timer than just a slide-changer. In addition to intermittent operation of lights on Christmas trees and in display windows, a timer could be used in "time-lapse" photography and exposure timing. In such applications a warning lamp facility would probably not be required.

In order to fulfill some of these requirements we are presenting a second circuit which has been pruned from the design used in the slide timer. As it happens, thus much-simplified circuit can be used as a slide timer without the full facility of the previous device.

It simply consists of the basic PUT timing circuit together with a monostable circuit incorporating a relay. The monostable circuit provides a time delay to hold the relay closed for a few seconds, allowing time for associated mechanism to engage. The relay holding time may be increased, if required, simply by increasing the 10K-50uF time constant.

Again a diode is used with the time constant network, and a protection diode is wired across the relay winding. Also the 20uF timing capacitors is a tantalum electrolytic while the 50uF capacitor may be a regular electrolytic. Again a 12V supply is required; the supply circuit shown is suitable.

On the circuit diagram we have shown two buttons labelled "advance" and "hold". In a similar manner to the previous circuit, the advance button charges the timing capacitor very rapidly causing the PUT to fire and activate the relay. However, the hold button simply shorts out the timing capacitor preventing the PUT discharging into the base of T2 and activating the relay.

The range of this timer is between 7 seconds and 1 minute 8 seconds, but this may be conveniently varied by altering the value of the charging capacitor proportionally. Increasing the capacitor will logically increase the maximum and minimum timing periods. However, to increase the overall range of variation, the 100K potentiometer may be increased in value, as determined by individual experiment.

If an electric clock with a sweep second hand is available it may be conveniently used to time the operation of both circuits. The only proviso is that the clock should start instantaneously without manual assistance. By connecting the clock in series with a set of normally closed relay contacts it can be operated as an electronic stop watch.

NEW SOLID STATE PHOTOGRAPHIC TIMER

Here is a constructional project with features to appeal to many of our readers — including those with no interest in photography. It is all solid state, mains-operated, and used a new integrated circuit timer element.

Why build a photographic timer? Most professional photographers who do their own enlarging and film developing just count the seconds for their development and exposure times. But the less practised amateur who wants a precise control of his development and enlarger exposure times generally needs some sort of reliable timer. All he has to do then is push a button and the timer takes over, operating a bell or switching the power off after the required interval.

The timer to be described here is basically for enlarger use, but can be adapted for other purposes. It is built in a sloping-front metal case, with a three-pin mains socket on the side to power the enlarger. On the top is a push-button to start the timer. Two toggle switches are provided on the front panel: the left toggle is the on-off switch; the right toggle is to switch the timer in or out of circuit — if it is out of circuit the enlarger stays on continuously. Lastly, there is a handspan dial with eleven positions, marked in seconds from 2.8 to 90.

The dial calibrations increase in 1, 1.414, 2, 2.828 . . . sequence, ie, a geometric progression with the square root of 2 as the multiplier ratio. This means that to double the exposure time, the dial must be "clicked up" two divisions. This is a more logical arrangement than a linear scale for photographic work. Each step on the scale is equivalent to "half a stop" on a camera lens. (On a camera lens iris, the stops are an indication of the effective lens diameter and each increase in stop setting doubles the exposure value.)

Since the enlarger is to be used in a darkroom some illumination of the dial setting is necessary and this is provided by back-lighting the appropriate number on the dial using a small neon lamp. A red filter in front of the neon lamp removes the violet emission which is "bad news" for photographic work.

Refer now to the circuit. It may be split into three sections: the integrated circuit timer element, its DC supply, and the AC switch to control the mains supply to the enlarger lamp. Treating the last first, the AC switching is done by a Triac instead of a relay, in line with modern circuit practice. It is cheaper than a 240VAC rated relay and is more reliable. The Triac is DC gate controlled so that when "on" it is conducting continuously and hence generates no RF interference — in contrast with phase-controlled Triac circuits.

Since the Triac operates at mains potential, the whole circuit operates at mains potential. It is therefore not a circuit for those who like to potter about while the power is applied!

To save money, we have dispensed with step-down transformers and obtain the low voltage supply directly via three 5.1k/10W resistors in parallel. A single diode, 220uF 16VW capacitor and a 12 volt zener diode provide the 12 volt DC supply for the timer. The three resistors dissipate a total of about 15 watts, so that the case becomes hot after a period of operation, but this is no cause for alarm. The resistors are running at 50 per cent of power rating to limit their surface temperature. However they will run at about 100 degrees Celsius above ambient, so don't touch them!

The timer section is based on the Signetics 555 timer integrated circuit. This can be used in a variety of circuit configurations but we shall only

describe the mode used here. The schematic diagram of the 555 is shown in Fig.1.

In the mode of operation used here, the 555 functions as a one-shot multivibrator, ie, it delivers a DC pulse for a set time interval and then latches off until triggered again.

Initially, the external capacitor C at pin 7 is held discharged by a transistor inside the IC. Applying a negative trigger pulse to pin 2 toggles the flip-flop via a comparator. The flip-flop then performs two functions: it turns off the internal transistor which holds C discharged; and it drives the output at pin 3 to its high state, which is almost equal to the supply voltage.

Capacitor C now charges via resistor Ra towards the positive supply rail Vcc. When the voltage across the capacitor equals $2/3 V_{cc}$, the comparator connected to pin 6 toggles the flip-flop so that it reverts to its initial state. This turns on the internal transistor to discharge the capacitor via pin 7, and drives the output voltage at pin 3 to its low state (zero volts). Note that once the sequence of events has been started by the trigger pulse at pin 2, further trigger pulses have no effect until the output at pin 3 reverts to zero.

Thus the length of the DC pulse delivered from pin 3 is a function of the time constant RaC so that

$$T(\text{SECS}) = RaC \times 1.1$$

where Ra is in megohms and C is in microfarads.

Since the input impedance at pins 6 and 7 is very high (of the order of tens of megohms) very long time delays can be obtained – up to one hour. A DC voltage at pin 5 can be used to vary the pulse length over a range of 3 to 1.

If the timer is used as a free-running multivibrator (by connecting pins 6 and 2 together) pin 5 can be used as a frequency modulation control.

The time interval is independent of supply voltage variations because the charge rate and threshold level of the comparator at pin 6 are both directly proportional to the supply.

Refer now to the main circuit diagram. Although the timer is not affected by large supply variations, we use a zener stabilised supply to ensure that the Triac is always provided with adequate gate current and to prevent the supply exceeding 15 volts which is the maximum rating of the 555. Current drain of the timer module varies from about 10mA, when the output is in the zero state, to 60mA when it is supplying gate current to the Triac.

Negative trigger pulses are provided by shorting out the capacitor connected to pin 2. It is normally kept charged up by the 100k resistor connected to the 12V positive supply rail. The value of the capacitor is not critical – it

eliminates any sensitivity of the circuit to negative "spikes" on the mains.

A 50uF 6VW tantalum capacitor is used for the timing function. Do not use aluminium foil electrolytic capacitors. Their leakage is too high and varies widely with temperature as does their capacitance.

Where a smaller capacitance unit is to be used in this circuit, polyester or other plastic dielectric capacitors are suitable.

When calculating the values of resistor for each of the eleven timing intervals, we assume that the timing capacitor is exactly 50uF and that the timing interval is exactly equal to RaC seconds. The capacitor tolerance is actually - 20pc to 50pc. The discrepancy is taken care of by the calibration trimpot connected to pin 5. If resistors with 5pc tolerance are used, the worst case accuracy on any range is within 10pc, once calibration is done.

This order of accuracy is more than adequate for most photographic work. If better is required, a resistor string with 1pc resistors could be used.

A 560 ohm resistor is used to connect pin 7 to the 50uF capacitor, to limit discharge current. A 150 ohm resistor connected from the output pin 3 to the Triac gate sets the gate current at just over 50mA.

S2 is a double-pole, two-position switch to switch the timer out of circuit and run the enlarger continuously. One pole switches the mains supply to the timer and thus cuts power dissipation in the 10W resistors to nil. The other pole switches the gate of the Triac. In the non-timer mode, it is gated on by a 100 ohm/½ watt resistor connected to the A2 terminal. In this mode, the Triac switches on in each half-cycle when the voltage from A2 to A1 rises above two or three volts, so that no RF interference is produced.

Some readers will inevitably want to use less sensitive Triacs than those specified. By "less sensitive" we mean Triacs requiring more gate current. As it stands, the circuit is not suitable for Triacs other than the two specified. It could be made suitable by reducing the value of the supply dropping resistors and the value of the 150 ohm gate resistor. But this would raise the dissipation of the unit to a point where the case would become too hot.

An alternative approach is to use a step-down transformer to provide the low voltage supply. This is more efficient, but more costly. All the same, many readers will perhaps have on hand a 12V transformer capable of supplying the necessary 100mA or so. A single rectifier diode feeds a 500uF/25VW capacitor and the DC is then fed to zener diode in the same way as before. The gate resistor from pin 3 of the IC to the Triac can now be reduced to 82 ohms to provide just over 100mA of gate current. Note that the whole circuit still operates at mains potential, so the transformer should have good insulation between secondary and core.

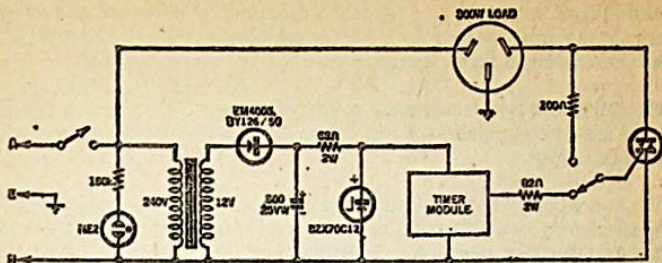

The circuit for the alternative version of the timer, which uses a stepdown transformer in place of the dropping resistors.

CONSTRUCTION: As stated earlier, the timer is built in a sloping front case measuring 5 x 5 x 5 inches. It has a liberal pattern of ¼ inch diameter holes drilled in the bottom and rear panels to provide ventilation. The three 10W resistors are mounted on the rear panel on a pair of tagstrips, together with the diode and 180k resistor supplying the neon pilot. If you cannot obtain 5.1k resistors as we used, another parallel resistor combination to give 1.7k should be used – say, four 6.8k/10W in parallel.

On the front panel is the eleven position switch which has ten resistors wired around it. The neon is “swung” from a three-way tagstrip which also fastens the piece of red perspex to the panel. For the selector dial we used an ordinary “handspan” perspex dial. To the rear we glued a circular piece of glossy white paper carrying the dial markings. These were done with Letraset rub-on lettering.

Readers who cannot obtain a handspan dial will have to make their own from a circular piece of perspex and a suitable knob, glued together.

The rest of the components are mounted on 2-inch square printed wiring board, designated 73d1. It is not specifically designed for the timer circuit but for more universal use. In fact it is intended for wiring up any small circuit with a dual in-line package IC, of up to 16 pins.

We call it a DIP board and we predict it will become very popular with the hobbyist and all who have occasion to experiment with IC's. It does not have holes drilled in the copper pattern, although there is no reason why there should not be, apart from cost and time. We visualise that it will be used with the components on the copper side, to simplify de-soldering, particularly with the IC. If desired, two eight-pin IC's could be used on the

same board; there are plenty of pads to accommodate components. There are pads to accommodate up to four trimpots, if necessary. We hope they will aid readers in their experiments with IC's.

The DIP board is mounted using two insulated stand-off pillars to provide good insulation at mains voltages. These pillars are expensive but must be used for safety.

The two wires to the push-button switch at the top of the case should not be allowed to touch the resistors at the rear, otherwise their insulation will be burnt. Readers who wish to start the timer with a foot pedal need only run two wires in parallel with the push-button. The contacts are normally open. All switches should be rated for 240V operation.

Mains cord termination is important. The cord should be passed through a grommited hole in the side of the case and anchored by a clamp. The earth lead is terminated to a solder lug screwed to the chassis. This earth lug also terminates the earth wire from the three-pin mains output socket. The active and neutral wires are terminated on a three-way insulated terminal block, as shown in the wiring diagram.

Once the phototimer is complete it may be connected to a suitable lamp load of less than 300 watts and switched on. In the timer mode, the lamp should not light until the push-button is pressed. In the non-timer mode, the lamp should be on continuously. If not, the circuit is incorrectly wired or the Triac is faulty.

The timer can be calibrated using a stopwatch or clock second-hand. Use the longer time intervals and adjust the trimpot to give the smallest average deviation on a number of settings. Note that the timer should be disconnected from the mains – pull the plug out of the wall socket – each time an adjustment is made. Remember, the circuit is at mains potential.

Longer or shorter timer intervals than those we have selected may be easily obtained. Just calculate the timing components using the expression given earlier. For example, a 1 megohm resistor and 1 μ F capacitor give a 1 second interval. A 100 μ F capacitor and 10M resistor gives a 1000 second interval. Use tantalum or polyester units for the timing capacitor.

THE PARTS YOU'LL NEED

- 1 sloping front case, 5 x 5 x 5 inches, with ventilation holes.*
- 1 SPST 240VAC switch*
- 1 DPST 240VAC switch*
- 1 pushbutton 240VAC switch with "normally open" contacts*
- 1 Eleven position wafer switch*
- 1 three-pin mains socket*
- 1 DIP board, 73d1*
- 1 Triac, 40669 or SC141D*

- 1 Signetics 555 timer IC
- 1 BY126/400 or similar silicon diode
- 1 BZX70/C12 zener diode
- 4 rubber feet
- 1 length of three-core mains flex, plug and clamp.
- 1 handspan dial
- 1 solder lug
- 2 7-lug tagstrips
- 1 8-lug tagstrip
- 1 3-lug tagstrip
- 1 3-way terminal block
- 1 NE-2 neon lamp
- 2 1 inch insulating pillars, blind tapped $\frac{1}{8}$ in Whit. each end
- 1 220uF/16VW electrolytic capacitor
- 1 50uF/6VW tantalum capacitor
- 1 .0033uF capacitor, polyester or polystyrene

RESISTORS

(5pc tolerance, $\frac{1}{4}$ or $\frac{1}{2}$ watt unless specified)

- 3.5.1k, 10W, 1 x 100 ohm/ $\frac{1}{2}$ watt, 1 x 150 ohm/ $\frac{1}{2}$ watt, 1 x 180k/ $\frac{1}{2}$ watt.
- 560k, 330k, 270k, 220k, 120k, 100k, 82k, 68k, 56k, 47k, 33k, 27k, 1k,
- 560 ohm, 390 ohm (one of each)

MISCELLANEOUS

Piece of red perspex, screws, nuts, hook-up wire, solder.

Note: resistor wattage ratings and capacitor voltage ratings are those used for our prototype. Components with higher ratings may generally be used, provided they are physically compatible. Components with lower ratings may also be used in some cases, providing ratings are not exceeded.

ELECTRONIC FLASH – THE COMPLETE UNIT

This is the second of the practical articles on the construction of an electronic flash unit. It covers flash tubes, reflectors, trigger circuits and their assembly; storage capacitors, batteries, circuit modifications for "half-power"; a carrying case and the assembly of the components into a complete unit, and typical performance figures.

Before discussing the assembly of the complete unit it is necessary to consider a number of essentially practical matters concerning the components and hardware, such as flash tubes, reflectors, main storage capacitors trigger circuits etc.

We have had an opportunity to test three different makes of flash tube during our experiments; two imported and one locally made. Availability of at least two of these, one local, appears to be good at the time of writing, with the position of the third one not yet clear.

Regardless of the type used, the following precautions should be observed to ensure good tube life. Due to what appears to be a distinctly non-linear characteristic of the discharge resistance of these tubes, it is desirable to include some form of current limiting device in series with the tube to restrict the very high peak current which flows at the moment of ignition. A small amount of resistance, such as normally provided by the lead from the main unit to the flash head, is generally sufficient.

Most tubes are polarised, or have a definite anode and cathode, and this point should be clarified at the time of purchase. Usually the cathode is the larger of the two elements, sometimes in the form of a wire spiral wrapped around the main lead wire, and sometimes as a flattened extension of the lead wire.

Another point to consider is whether the tube can be expected to fire reliably on reduced voltage, assuming that this method of reducing power is to be employed. We will have more to say about this later. In some cases it may be necessary to modify the trigger circuit so that it operates at the same energy level, regardless of whether the main storage capacitor is charged to the higher or lower voltage.

The reflector, one of the main components, which have proved a problem in the past, should be readily available from at least one source, in at least three varieties, by the time this article appears. We have also had an opportunity to try an imported unit.

Two of the three reflectors already available are four-inch diameter types of anodised aluminium, with a special "grained" surface which appears to give high efficiency and even coverage. One is sold blank for use with

whatever tube the constructor may have available, while the other is specially designed for use with an imported tube handled by the same firm. In fact, a reflector, tube, protective plastic cover, terminal board, and metal housing can be purchased as a unit, ready for wiring if so desired.

The third reflector is a larger — 6 in diameter — unit, which can also be supplied complete with tube, etc., if required. According to the makers the larger area gives an increased light output equal to about 1/3 stop—a useful amount if the slightly larger size is no objection.

For the smaller reflectors the best position for the tube appears to be as close as practicable to the apex of the reflector. For the larger reflector the centre of the tube should be about $1\frac{1}{2}$ in from the front plane of the reflector.

Where the tube has to be mounted in a blank reflector, the best approach appears to be to first drill a $\frac{1}{8}$ in diameter hole in the apex of the reflector and pass through it a $\frac{1}{8}$ in counter-sunk screw, with the head "inside" the reflector. This screw is retained by a nut and serves the dual purpose of supporting a tag strip (which, in turn, supports the tube) and retaining whatever kind of housing is to be used for the whole assembly. For this latter reason the screw may need to be several inches long.

Two large holes are then made either side of the apex hole to accommodate the legs of the flash tube. The best way to make these appears to be to initially drill two small holes, just large enough to take the lead wires, then enlarge the holes with a fine round file until they are large enough and in the correct position to pass the glass tube.

The tag strip is secured between two nuts on the apex screw and the tube lead wires are trimmed to a suitable length and soldered to convenient tags on the strip. Try not to bend the wires near the glass.

A fourth hole will be necessary to pass the trigger lead, and this should be made large enough to accommodate a nyllex insulating sleeve. Since the voltage is quite high it would be best to use two pieces of sleeving, one large enough to suit the trigger lead and another piece large enough to encompass both.

Next to be considered is the main storage capacitor. The original 100 joule design envisaged using a total of 800uF operating at 500 volts, and some small stocks of locally made capacitors of this general type were located. In accordance with normal practice, these were in 400uF (50 joule) units, two being used in parallel for 100 joules.

A study of the catalogue showed that there was available a 500uF plus

500uF, 450V unit, measuring only 2.5 in diameter and 4.5 in high, or a total of 100 joules in the same space needed for 50 joules in most of the capacitors we had seen. It seemed ideal for a 100 joule unit.

The slightly lower operating voltage of these capacitors does not present a problem in itself, the power supply being easily adjusted, by means of R8, to deliver this voltage. However, it may make the system less suitable, in some cases, to any method of light reduction involving reduced operating voltage. We will have more to say about this later.

The trigger circuit is relatively simple, but its operation is worth discussing. The resistors R9 and R10 form a voltage divider across the main supply, with about 150 volts at the junction. During the charging cycle C4 is charged to the voltage at the junction, the circuit being completed via the primary winding.

When the camera contacts are closed R10 is short circuited and C4 is connected directly across the primary winding. The resultant heavy discharge produces a high voltage pulse in the secondary winding, which ionises the gas in the flash tube.

The circuit is simple enough in concept, but involves a number of compromises in practice. In particular, it is necessary to ensure that, on the one hand, the circuit operates at an energy level high enough to ensure reliable firing in all circumstances but, on the other hand, does not impose an unnecessarily heavy load on the camera contacts.

This particular circuit was evolved by Mr Longfoot, of the Philips organisation after careful study of all the factors, and on the basis of considerable overseas research, and appears to be a very satisfactory compromise. Later we will discuss the alternative circuit developed by Mr. Longfoot, using a thyristor, aimed at reducing contact current even further.

Trigger transformers should be available from the same manufacturers who are supplying the oscillator transformer, but one is also available from one of the tube and reflector suppliers. Although not to the Philips specifications, it appears to be similar and a perfectly satisfactory unit.

As intimated earlier, the flash unit was designed around a battery made from readily available nickel-cadmium cells. Six cells are used, giving a nominal voltage of 7.2. For the benefit of those not familiar with them a brief summary of their characteristics may be helpful.

These cells are completely sealed, and the chemical action is entirely self contained. This means that they need no maintenance in the chemical sense, it being only necessary to charge them correctly in accordance with

quite simple instructions.

For the user's convenience as much as anything, it is desirable to keep them on charge at all times, and this is quite permissible provided a suitable "trickle" rate is selected. On the other hand, they will not suffer any permanent damage if they are left for long periods without the benefit of such a charge. They will suffer internal discharge in such circumstances, and it may be necessary to re-cycle them two or three times in order to restore full capacity. This could be inconvenient, but no permanent damage would result.

The manufacturers recommend that these cells be charged at a constant current equal to the 10 hour rate (1/10 of the amp hour figure) for 14 hours to fully charge a battery. However, no serious harm would result if this rate was continued for several hours more up to, say, another 14 hours.

After that, the cells may be kept in a near full charged condition by trickle charging at between the 50 hour and 100 hour rate (1/50 or 1/100 the amp hour figure).

For example; a 1 amp hour cell should be fully charged in 14 hours at a charge rate of 100mA. After that it may be maintained in condition by a trickle charge of between 5 and 10mA.

These cells have a long working life and an almost indefinite shell life, making them ideal for the amateur photographer who may use them only intermittently with long periods of idleness in between.

The working life is markedly effected by the nature of the discharge/recharge cycles. Shallow cycling will give much longer life than deep cycling and the figures for half discharge/recharge cycles would normally be about three times those for full discharge/recharge cycles. Shallower cycling will give even better results. For this reason it is wise to choose a battery with a capacity in excess of requirements, other than on an occasional or emergency basis.

For this project there are a number of button type cells available, of varying amp hour capacity, which will enable the individual constructor to select a size to suit his requirements. Typical of these is the Eveready cell, which is just under 2in diameter, .394 in thick, weighs 2 oz, and has 1 amp hour capacity. Six of these make a stack 2.5 in high (after allowing for inter-connecting leads) and weighing 12 oz.

Larger versions of the same cell have 2 amp and 3 amp hour capacity respectively.

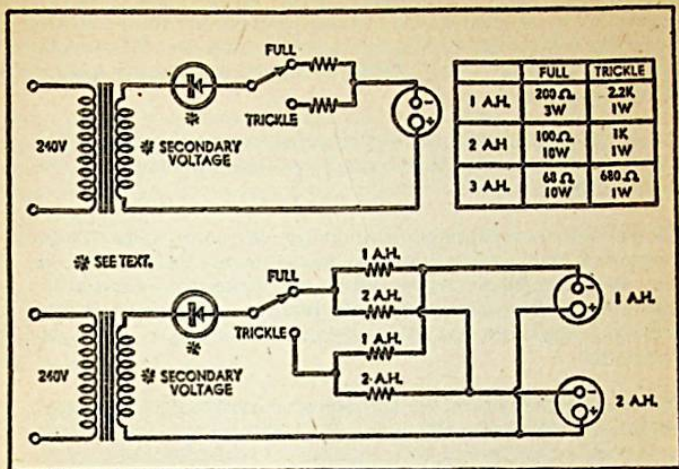

Two versions of a simple charger circuit. The upper circuit is designed to charge a single battery, for which the resistors are selected to suit. The lower circuit will charge two batteries, of differing capacity if necessary.

Reducing power by reducing voltage. R8 should be adjusted for the lower voltage and R8a for the higher voltage. The dotted circuit is optional and is intended to retain the same triggering energy for both voltage levels. It requires one extra lead to the flash head.

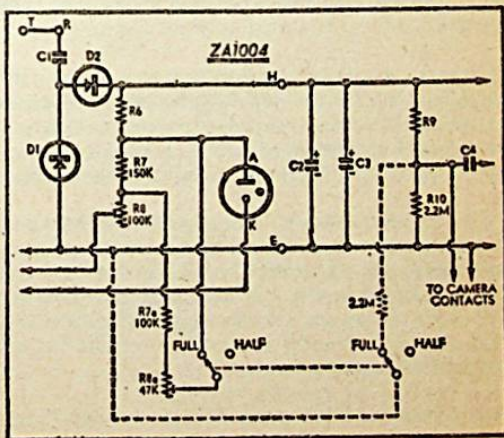

The size of battery selected will depend on the type of work the photographer intends to do. Figures taken by Mr Longfoot when he developed this power supply indicates that a 1 amp hour battery will give about 50 flashes by the time the charging rate has risen from 15 to 30 seconds, while a 2 amp hour battery will give 100 flashes for the same increase in recycling time.

(It may be possible to shorten this time by progressively reducing R3, as suggested last month, but this number of flashes would seem to be the practical limit.)

On this basis we would suggest that the type of photographer who limits his work to purely personal pictures, and will seldom need to take more than about two dozen shots at a session, will be adequately served by a 1 amp hour battery. This offers lowest first cost and minimum weight consistent with minimum cycling depth on most occasions, giving good battery life.

For the type of photographer who does occasional professional jobs, requiring not more than 100 flashes, the 2 amp hour version would be a good compromise, while a high proportion of professional work, may well call for a 3 amp hour unit. The latter could be backed up by a spare battery, of any suitable capacity, should this seem advisable. In this case, the battery should be so fitted that it can be changed with a minimum effort. We have selected a case size and layout which will accommodate any of these three batteries.

The cells are fitted with terminal tabs (signified by the "T" in the type number) and a complete battery is made up by soldering short lengths of hookup wire, which may be bared if necessary, between the appropriate terminals.

To secure the cells into a stable stack may call for a little ingenuity. As a temporary measure we tried strapping them with plastic insulation tape, but this is rather messy and has a tendency to "creep" or "slide". Later we managed to "scrounge" a scrap of shrinking plastic tube (from a source which must remain nameless) and this does an excellent job.

For those not familiar with the material, it has the unique property of shrinking quite substantially when heated, gripping whatever it contains and retaining this shape after it cools. In our case we inserted the battery stack inside a short length of tube, supported the battery between the tips of the fingers, and held the whole assembly in a stream of hot air from a domestic hair dryer. A radiator can also be used, but may be rather uncomfortable on the hands.

In doing this job it is important that undue heat is not applied to the

battery, and the quicker it can be done the better. Normally, it should not take more than a few minutes. When the main portion of the tube has been shrunk, the surplus ends may be trimmed if necessary, then heated and folded under, "grocery parcel" fashion to seal both ends. Naturally, suitable connecting leads will need to be fitted before the plastic.

Unfortunately, we have not been able to arrange a suitable supply of shrinking plastic, in small quantities, though we are still trying. An alternative approach is a cardboard tube of suitable diameter, possibly plugged at one end with a disc of light plywood or Masonite, held with Araldite or something similar.

Connection to the battery is made via a two pin polarised socket. There is a convenient commercial unit available, in black moulded bakelite, similar in general style to the popular four-pin miniature speaker socket. A similar socket is mounted on top of the complete power pack into which the charger may be plugged.

In any electronic flash unit it is highly desirable that some means be provided to reduce the light output by at least two to one. The main reason for this requirement is that there are only two ways to control electronic flash exposure; by means of the lens diaphragm or the amount of light generated by the flash. The lens diaphragm frequently has insufficient range when faced with a combination of close working and high speed film.

However, there are other advantages. In many cases the lower light output is quite sufficient for the job in hand, in which case there is little point in using more light simply because it is available. The lower output will halve the recycling time and increase the number of flashes available at a charge, while the higher output is still available for the difficult shots.

There are two popular methods of reducing light output; by reducing the amount of capacitance in the circuit, and by reducing the voltage to which the capacitor is charged. Both have their advantages and disadvantages, and the constructor can make his own choice.

Reducing capacitance is probably the easiest and, since it maintains the normal operating voltage, there is no problem of tube reliability at reduced voltage. Assuming the total capacitance for 100 joules is made up from two capacitors, it is simply a matter of switching one unit in or out as required to give 50 or 100 joules.

However, some care is necessary here. Switching a discharged capacitor across a charged one is virtually equivalent to placing a short circuit across the charged unit, and the resultant discharge current will completely

wreck the switch.

We overcame this problem in a previous design by using a three position switch with the centre position arranged to connect a suitable value resistor between the two capacitors. This will nearly equalise the two charges in about one second, so that it is only necessary to pause briefly in the mid-position to avoid any serious "splat." Even if a "straight through" change is attempted, the degree of splat will be small.

For 450 or 500 volt operation a resistor of between 250 and 300 ohms works extremely well, and we suggest that it be a 3W wire wound type for maximum reliability. The manner of connection is shown in the accompanying circuit.

The main disadvantage of reduced capacitance is that it shortens the flash time. Typical tubes give about 1/1000 second effective exposure when working at 100 joules, and this does not seriously encroach on the reciprocity failure region of most emulsions. However, with only half the capacitance at the same voltage, exposure time would be nearer 1/2000th second and the reciprocity failure could be serious. Moreover, the effect may not be constant from one emulsion type to another.

Maintaining the same value of capacitance and reducing the voltage (by a factor of .707 for a two to one energy drop) has the advantage that the exposure time will tend to lengthen rather than shorten and is more likely to approximate the two to one ratio in terms of exposure.

On the other hand, some tubes may not fire reliably at the lower voltage, which may well be outside the manufacturer's recommendations. If this mode of operation is contemplated, first determine whether the tube is suitable, by monitoring the capacitor voltage with a meter and switching off the battery supply when the selected lower voltage has been reached.

Flash the tube several times and, if possible, check it in the dark, since cranky tubes often fail in this environment. If the tube seems reliable it will probably be worth while going ahead and arranging the power supply circuitry to give either of two voltage levels, as selected.

If it seems only marginally unreliable, it might be possible to overcome this by modifying the trigger circuit. The idea is alter the divider network (R9 and R10) by means of the same switch wafer that selects the required voltage level, so that the trigger capacitor (C4) is always charged to the same voltage, regardless of whether the main storage capacitors are charged to a high or low voltage.

We have not had an opportunity to actually try this arrangement, but we suggest that it could be done as shown in the accompanying circuit, using

The trigger circuit modified by the addition of a thyristor. The additions are simple, involving only two half watt resistors in addition to the thyristor. The circuit reduces the contact current from several amps to about 25 milliams.

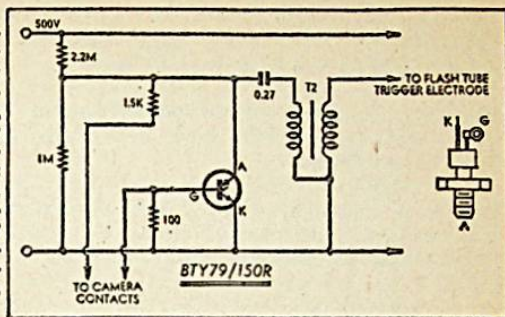

Reducing power by capacitor switching. The 300 ohm resistor equalises the charge on the two capacitors, to minimise contact damage.

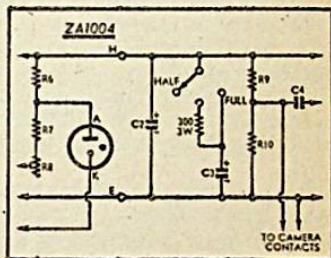

A side elevation showing how the major components are arranged in the case, and how 1, 2, or 3 amp hour batteries may be housed. The 3 amp hour arrangement is a little unconventional, but perfectly practical.

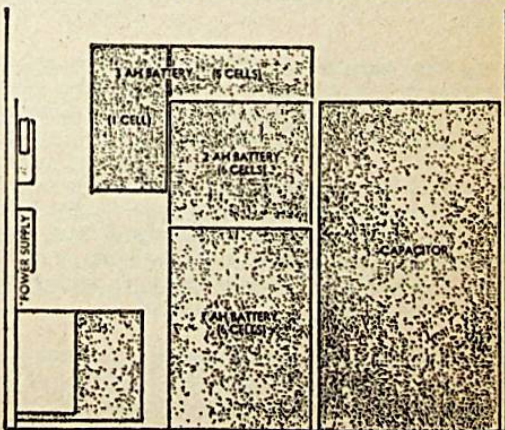

an extra wire between the power pack and the flash head.

For a 500 volt system the "half power" voltage will be 350, and for 450 volts, 325. Arranging the power supply to peg at either voltage, as selected, is not particularly difficult. Remove the 47K pot (R8) and the associated 100K resistor (R7) and put these to one side for the moment. Now replace R8 with a 100K pot and R7 with a 150K resistor.

With this configuration it should be possible to adjust the new R8 so that the supply pegs at 325V. If not, it may be necessary to try other values for R7, but this is unlikely.

To restore the higher voltage condition the discarded 47K pot (R8a) and 100K resistor (R7a) are connected in series and connected across the new R7 via a switch. With the switch closed, adjust R8a until the supply pegs at 450V.

In case this shunting arrangement may seem a little strange, in place of a straight out alternative network, we should point out that it was chosen because it is easiest to add to printed wiring. Even so, the additional components have to be accommodated and the most convenient arrangement seems to be to provide small tag strips on the underside of the case lid, close to the switch involved. This general arrangement would be equally suitable for either switching system.

After considering all the likely requirements of home builders, we designed a case which we feel will suit most of them but which, at the same time, is quite compact. It measures 7in x 2-5/8in x 5 1/4in high, is made from light gauge mild steel, and should be available with a durable Hammertone finish.

The printed wiring board is mounted against one end of the case, transformer end down. It is held by three countersunk 1/8in screws passing through the three mounting holes provided in the board, and held clear of the metal by three 1/4in long spacers.

To facilitate fitting the board it is a good idea to make the three retaining nuts captive on the board. This is best done with a small quantity of Araldite smeared around the outside edge of the nut and allowed to flow onto the board. Since the Araldite is used only to retain the nut, no great stress is imposed on it: The same technique can be used to fit captive nuts to the capacitor clamp, as discussed later.

Before mounting the board it is necessary to ensure that all the ancillary leads are fitted and, ideally, lead off from the top of the board, rather than underneath. This is quite simple in most cases but, should underside connections be necessary, there is room to bring the leads out.

The battery occupies the approximate centre of the case, with the main capacitor at the opposite end. Provided the battery is enclosed as already described, there seems to be little point in going to a lot of trouble to secure it, but it can be packed with small pads of plastic foam.

The height of the case is sufficient to accept either the 1 amp hour or 2 amp hour batteries as a single stack. The 3 amp hour is a little too large to be accommodated in this way, but five cells can be mounted in the main stack, with the sixth mounted beside it in the space near the printed board and above the transformer.

The main storage capacitor is secured by means of a 2½in diameter clamp mounted on the bottom of the case.

As with the printed board, it is held by two countersunk screws, this time through the bottom of the case, in conjunction with two captive screws. These can be made captive by soldering, but we found it much easier to use Araldite.

All the controls and the inlet and outlet sockets are mounted on the lid of the case. Nearest to what may be termed the "front" is the four-pin socket into which plugs the flash head. This is the capacitor end of the case. Behind it, where it can be easily seen by the user, is the neon indicator, then the "ON-OFF" switch, the "HALF-FULL" switch, and, finally, the two-pin charger input socket.

Incidentally, both the sockets are available in either above-chassis or under-chassis mounting types, and we suggest you make sure you get the under-chassis mounting types, for best appearance and simplicity of mounting in this application.

Two tag strips are mounted along with these sockets. One supports the "half power" components, either the 300 ohm equalising resistor or the 100K resistor and 47K pot, according to the circuit employed. The other provides terminals for the neon which is most easily supported in a rubber grommet mounted in the lid of the case.

It may be necessary to modify the mounting foot of these tag strips in order to accommodate them alongside the socket and it may even be worthwhile soldering the foot to the metal socket support, to facilitate the whole assembly. The older, more robust type of tag strip would appear to be preferable here.

The "ON-OFF" switch is worthy of some comment. In its simplest role this need be nothing more than a single-pole two-position type, but we elected to fit a two-pole, five-position type in anticipation of one of the refinements previously discussed. Initially only one pole need be used, with its associated

contacts so wired that four of the five positions all represent "ON".

Later, the second half may be wired so that successive positions connect appropriate resistors across R3 to reduce its value and off-set the lengthening recycling time as the battery discharges. Values will probably have to be determined experimentally, as in the case of the original R3, and should be based on retaining the 15 second re-cycling time. A logical arrangement is for the first "ON" position to represent the maximum value of R3, and to be used for, say, the first 25 flashes. Subsequent positions may also be selected on a number-of-flashes basis.

The "HALF-FULL" switch is a single-pole three-position type. The mid position will serve a useful function only if it is employed to switch capacitors but, in the interest of uniformity of any etched label that might be produced, we suggest that the same switch be used regardless of the type of "half power" circuit used.

Incidentally, we strongly recommend the use of pointer knobs, as distinct from indicating knobs, for both these switches, in order that their position will be immediately evident, even in the dark.

The charger socket is almost self-explanatory. Wired in parallel with the internal battery plug, it enables the battery to be charged by simply plugging in an external charger.

The finished unit is particularly neat and compact and, with a 1 amp hour battery, weighs a mere 4lb 8 oz. It can be carried for long periods without fatigue and all the controls are readily to hand.

Finally, a few words about performance, in the photographic sense. Naturally, this is dependent, a good deal on the efficiency of the tube and reflector used, but our best results to date have been very gratifying.

We tested the light output by photographing a fixed subject, first with a No.1 expendable bulb to provide a reference, then by the electronic flash at various apertures. The subject was 15 feet from the camera and there was very little light reflection from adjacent walls.

The expendable bulb exposure was as recommended by the maker; f11 at 1/25 second. The electronic flash exposures ranged f5.6 to f22, using a high shutter speed to minimise the effect of any residual light, which was at a negligible level anyway.

The film, Ilford FP3, was processed for the normal time and the negatives compared. The electronic flash negative which most nearly matched the expendable bulb negative was then selected, and identical enlargements made from each, varying only the enlarging exposure time to achieve the

best possible match between the two prints.

The result was both gratifying and a little surprising. We selected the f11 negative as being the closest to the expendable bulb negative and, on comparing the enlarging exposure time, it was found that the electronic flash negative needed marginally more exposure than the bulb negative; indicating that the electronic flash was producing at least as much light, and probably a trifle more, than the bulb.

On this basis we could safely use a guide number of 160 for ASA125 (FP3) film on "full power", or about 125 for the "half power" condition, and this is very good indeed. This was using a locally made 4in reflector with an imported tube, but the 6in reflector will give a better performance again.

Next we hope to discuss a simple battery charger and the use of a thyristor in the trigger circuit.

An essential requirement for our electronic flash unit is some form of battery charger and, as mentioned a suitable socket has been provided on the unit to permit the charger to be plugged into the battery with a minimum of effort.

There is not a great deal to such a charger, but those points which govern its design are worth considering. First, it has to satisfy two basic requirements as far as the battery is concerned, (a) to fully charge the battery in the shortest possible time—consistent with safety—and (b) to provide a trickle charge on a full-time basis once the battery is charged, to offset internal losses and ensure that the battery is always at full capacity and ready for use.

As far as the owner is concerned, it should be simple to use, so that the battery is given the right treatment almost automatically but, at the same time, it should not use any more components than are strictly necessary in order to keep the cost at a reasonable level.

Thus, while it would be possible to design a charger which would automatically adjust itself to the battery's requirements at all times, this would necessarily be a relatively complex arrangement. For the time being at least, we felt that a simpler arrangement, providing two charge rates selected manually according to a simple rule, would suit the majority of readers.

The manufacturers recommend constant current charging as the safest arrangement for a nickel-cadmium battery, and this also has the advantage that it is relatively easy to provide. The simple basis is to start with a source of charging voltage considerably higher than necessary, then add resistance until the required current value is obtained. With its own high value of

internal resistance, the charger becomes relatively insensitive to changes in the effective resistance of the external circuit.

In practice an AC supply of about 30 volts, plus a simple half-wave rectifier and the necessary series resistance, works out very well and will supply nearly constant current over the full charging cycle. A two position switch selects either the "FULL" or "TRICKLE" condition.

In adjusting any charging circuit for use with nickel-cadmium cells the major requirement is to ensure that the 10-hour charging rate is not exceeded when the battery is fully charged. Even if a so-called constant current circuit falls somewhat short of this ideal, allowing the battery to charge at a somewhat higher rate when it is well discharged, no harm will result provided the charge drops to the 10-hour rate at the completion of the charge.

Similarly, no harm will result if the battery is left on charge, at this rate, for relatively long periods, i.e., several days, after the battery has reached full charge. Thus, if in doubt about the battery's condition, it is better to over-charge.

To keep the battery in a fully charged condition until the next time it is required, a trickle charge rate somewhere between the 100-hour rate and 50-hour rate is recommended. This may be continued indefinitely.

Relating these figures to practical conditions, a 1AH battery should be charged at 100mA for 14 hours to fully charge it, after which it may be kept in good condition with a trickle charge of about 10mA. For a 2AH battery these figures become 200mA and 20mA, and for 3AH, 300mA and 30mA.

In practice, considering the kind of service involved with the flash unit, it is likely that the battery will be only partly discharged on most occasions, in which case it will be sufficient to charge it overnight, i.e., 8 to 10 hours, which will still provide a small margin of overcharge for good measure.

In fact, this forms the basis for a simple rule on which to base the battery's care: Charge overnight at the "FULL" rate, then switch to "TRICKLE" until the battery is used again. If the battery has been fully discharged add another 12 hours at the "FULL" rate.

Coming to the more practical side, we were fortunate in being able to obtain, "off the shelf" a 30V, 600mA transformer which is a standard line with at least one manufacturer. It is physically small, relatively inexpensive, and should be readily available.

This transformer, although rated at a nominal 30V, delivers a somewhat

higher voltage than this on light load. This appears to be due to the fact that it was designed to deliver a fairly heavy current on an intermittent basis and must deliver the specified 30V under these conditions. In fact, this is all to the good since it brings the charger closer to the constant current ideal.

The rectifier may be any one of a wide variety of silicon types currently available. The main requirement is a Peak Inverse Voltage (PIV) rating of 75 volts or higher and a current rating at least equal to the likely maximum charge rate under any conditions.

Typical types would be the Mullard OA610 (100V PIV), OA620 (200V), or the OA210 (400V). All these are rated at 500mA which should be more than adequate, and the only difference is the price, which increases with the PIV. However, even the OA210 is quite moderately priced. It may also be the most readily available.

The case is the same as that used for our car battery charger described in May of this year. It measures 4in x 4in x 2½in and is quite large enough to house the transformer and the few small components involved. A good idea of the layout can be obtained from the accompanying photograph.

The series resistors for both charge rates will have to be selected according to the size of battery used in the flash unit, and suggested values for 1AH, 2AH and 3AH types are given in the circuit. However, it would be a good idea to check these with a meter if one is available.

In this regard, the following point concerning the behaviour of the popular moving coil-meter when measuring rectified current should be noted. Where half-wave rectification is employed, a moving coil current meter will read only .636 of the RMS current. Thus, to set the system for 100mA, the meter should read 63.6mA.

The circuit as shown is intended to provide a single function device, designed to suit a particular battery, and this approach goes a long way toward making a simple, near foolproof system. However, it could happen that a particular user may have more than one battery for use with his flash unit and, more importantly, batteries of different size.

It is quite conceivable, for example, that a 1AH battery which appears to be adequate initially, may have to be supplemented later by, say, a 2AH type, both batteries being kept available for use if necessary. In this event, the charger should be capable of handling both batteries.

The most satisfactory arrangement appears to be simply to fit two output leads from the charger, one for each battery. Each should be fitted with a similar two pin polarised plug, and each marked according to the size battery it is intended to charge. Internally, each pair of output leads is wired to its

own resistor network, appropriate to the battery size involved. This is shown in the accompanying circuit.

It will be fairly obvious that this arrangement will permit only one mode of operation at a time, i.e., either "FULL" or "TRICKLE" for both batteries, but not "FULL" for one and "TRICKLE" for the other. However, this is unlikely to create too many problems.

It also means that, to some extent, the two batteries are connected in parallel with one another, whereas parallel connection of nickel-cadmium batteries is emphatically not recommended by the makers. However, considering the relatively large amount of resistance in circuit between the batteries they should be well enough isolated not to present any problem.

This twin battery facility need not be built into the charger immediately. It may be made up, initially, to suit a single battery, the extra circuitry being added if and when a second battery is acquired.

One point to watch if a second charging circuit is fitted, or even where a single 3AH battery is involved, is the dissipation of the dropping resistors in the "FULL" charge circuits. These will get quite warm, and some form of ventilation should be provided.

The best scheme seems to be to drill about four $\frac{1}{4}$ in holes under the tag strip, with a similar pattern in the lid directly above it. Four rubber feet should be fitted to raise the box clear of the bench and allow a free flow of air. The two feet on the side where the holes are drilled may need to be set back from the edge by about one inch.

A final suggestion for the two-lead arrangement is to provide a dummy two-pin socket on the front of the charger, into which may be plugged any lead which happens to be unused. This will avoid any risks of short circuit involving a live naked plug.

Another method of battery charging is worthy of consideration, if only because of its simplicity. This is from a car battery (12V) and required only a plug to fit the flash unit, a series resistor, and a plug to fit the car's cigarette lighter or other suitable outlet socket.

This arrangement is not suggested as a substitute for the mains supply, but rather as an addition to it. It could be useful in any circumstances where a mains outlet was not available or convenient to use. Nature photographers camped away from civilisation is one example, while professional photographers, travelling from one assignment to another, could put back at least of the energy used for the previous job.

As before, the governing factor in selecting the series resistor is the charge

rate for a fully charged battery, which should not exceed the 10-hour rate. In arriving at this, it must be remembered that the voltage of a car's electrical system is normally somewhat higher than the nominal 12 volts.

As a basis for experiment we suggest a 60 ohm resistor for a 1AH battery, 30 ohms for a 2AH battery, and 20 ohms for a 3AH. A 3-watt wire wound resistor would be adequate in all cases.

In verifying charging current from the DC source, the figure would be as read on an ordinary moving coil meter.

A desirable feature in any flash system—electronic or expendable bulb—is that it not unduly tax the camera contacts. Unfortunately, by their very nature, both impose a fairly severe load on these contacts and it is more or less inevitable that these will give trouble eventually, if they are not periodically serviced. For this reason, anything which will lighten this load is well worth considering.

It should perhaps be emphasised that the electronic flash trigger circuit is not necessarily "harder" on contacts than the expendable bulb, but it is almost certainly true that the owner of an electronic flash unit will make many more exposures by this means than he would if he were forced to use expendable bulbs. So, in this sense at least, there is more justification for contact protection when electronic flash is used.

One of the most satisfactory ways of providing this protection is to interpose a thyristor or Silicon Controlled Rectifier (SCR) between the contacts and the trigger circuit. In very broad terms the thyristor is a three-terminal unit similar to a transistor, in that it is a solid state device, but with characteristics more like the thermionic device called a thyatron.

The three terminals are the anode (connecting to the positive side of the system), the cathode (to the negative side), and the "gate". Assuming the gate to be disconnected for the moment, the application of voltage between the anode and cathode will result in virtually no current flow, apart from a very small leakage current.

However, the application of a small positive voltage to the gate electrode (relative to the cathode) will result in the anode-cathode circuit suddenly changing from a virtual open circuit to a very low resistance path. What is more important, due to a regenerative effect within the thyristor structure, this low resistance path remains after the voltage has been removed from the gate electrode. To restore the open circuit condition it is normally necessary to reduce the cathode-anode current to a very low value.

Having digested this explanation, look at the modified trigger circuit shown here. The thyristor is connected between the 0.27 μ F capacitor and the

negative line in exactly the same position previously occupied by the camera contacts.

In the "at rest" condition, the thyristor gate is returned to the cathode via a 100-ohm resistor, putting it at essentially cathode potential. Under these conditions, the thyristor presents an open circuit between anode and cathode, similar to the open circuit camera contracts prior to firing.

The camera contacts now form part of the gate circuit so that, when they are closed, the gate is connected to a point on the divider network composed of the 2.2M, 1.5K and 100-ohm resistors. This point is a few volts positive with respect to the thyristor cathode.

Under these conditions the thyristor "fires" or changes abruptly from non-conduction to the conducting state. The 0.27 μ F capacitor now discharges through the trigger transformer primary circuit exactly as before, firing the flash.

The important point about all this is that the camera contacts are now required to handle only the gate current, something between 25 and 50mA, as compared with several amps with the normal circuitry. Under the new conditions it would be reasonable to expect the contacts to have an almost indefinite life.

Fitting the thyristor and the few extra components does not present any serious problems, and the individual can make his own decisions about the purely physical arrangements. The thyristor terminal connections are shown on the circuit.

However, there is one aspect of the circuit which should be noted. The camera contact terminals are now both above "earth" (if we take this as being the negative rail) compared with the previous arrangement where one of these connected directly to the negative rail. Since cameras invariably have one contact connected to frame, some precautions are necessary to ensure that we do not finish up with unwanted voltages between different parts of the system.

The main requirement is to ensure that no part of the electrical system, either low voltage or high voltage, connects to the metal frame of either the carrying case or the flash head. In most respects this does not present a problem and, in fact, the system was built on the assumption that this would not be necessary.

The only real problem concerns the main storage capacitors. In common with most metal can electrolytic capacitors these exhibit considerable leakage between the negative electrode and the can. While this can be ignored with the conventional trigger circuit it could lead to minor compli-

cations with the thyristor circuit, since there could be a slight difference in potential between the flash head/camera combination and case.

Any risk of this is best overcome by insulating the can of the electrolytic from the carrying case. We were able to do this very conveniently by means of another short length of the shrinking plastic which we used to encase the battery. This was a fairly close fit over the can and made an excellent job.

Assuming that the individual must do the job himself, it should not be too difficult. Plastic insulation tape, wound spiral fashion, should do a good job, but it would be as well to apply two layers near the bottom, where the clamp is fitted. The bottom of the can must also be treated in some manner.

The end result of this small extra effort is well worthwhile. Some idea of the improved trigger circuit can be obtained from the figures already quoted, but the most impressive demonstration is the practical one. With the thyristor in circuit it is virtually impossible to detect any spark, even under subdued lighting conditions, when the trigger circuit is closed; a performance which contrasts markedly with the conventional trigger circuit.

Finally, a few words about the photograph at the beginning of this article. Our aim was to capture a "pose" which was characteristic of the butterfly stroke and, initially, we imagined that this would require only a high shutter speed and bright sunlight.

Since things happen much too fast to allow focusing "on the run", we planned to make the best possible estimate of distance, then provide as much depth of field as possible to offset minor errors.

But a couple of dry runs revealed a number of problems. No matter how carefully the swim was planned, it was virtually impossible to ensure that the required "pose" would occur at any nominated distance. And, at a shutter speed of 1/500 second and a stop around f8 to f11, the depth of field just wasn't good enough. The smallest stop, f22, was closer to our requirements, but would have produced a hopelessly under exposed negative.

It was at this point that the idea of supplementing the sunlight with flash was considered. It was calculated that, at the estimated distance of 10ft, the full output of the flash would be sufficient, at f22, to provide a reasonable exposure in its own right. If the sunlight helped a little, so much the better.

The idea worked extremely well. Three exposures were made, one being very similar to the one reproduced and one being less satisfactory only in

the pictorial sense.

This story emphasises one of the most important uses for electronic flash; as a supplementary light out of doors to fill in shadows, work against the light, and help stop action. Once you have used it in this role you will wonder how you ever did without it.

PARTS LIST

- 1 Metal case, 7in x 2 5/8in x 5 1/2in, with lid.
- Shoulder strap and fittings.
- 1 trigger transformer.
- 1 500 + 500uF 450V electrolytic capacitor with clamp type K4167.
- 1 0.27uF 250V polyester capacitor.
- 1 2.2M 1/2W resistor.
- 1 1M 1/2W resistor.
- 1 Flash tube.
- 1 Reflector and cover.
- 1 1 x 3 switch (or 2 x 3, see text),
- 1 2 x 5 switch.
- 1 4-pin miniature socket (under-chassis mount).
- 1 4-pin plug (to suit).
- 2 2-pin miniature sockets, polarised (underchassis mount).
- 2 2-pin plugs (to suit).
- 2 tag strips, 8 terminal SM28.
- 2 pointer knobs.
- Spacers, grommets, screws, nuts, washers, etc.
- "HALF POWER" COMPONENTS.
- 1 300 ohm 3 W resistor
- or
- 1 150K 1/2W resistor.
- 1 100K miniature pot.

PARTS LIST

- 1 Case 4 in x 4 in x 2 1/2in.
- 1 Transformer. Pri. 240V, sec. 30V approx. (see text).
- 1 Rectifier. Type OA610, OA620, OA210, or similar.
- 1 200 ohm, 3W resistor (1AH), 100 ohm, 10W (2AH), 68 ohm 10W (3AH).
- 1 2.2K, 1W resistor (1AH), 1K 1W (2AH), 680 ohm 1W (3AH).
- 1 2-position toggle switch.
- 1 3-lug, 5-lug, 6-lug tagstrip, length of 3-core mains flex and plug, length of 2-core polarised figure-of-eight flex for charging lead, 1 2-pin plug, 4 rubber feet, 3 grommets, nuts, bolts, washers, strap for mains flex, solder hook-up wire.

CONSTANT CURRENT BATTERY CHARGER

This circuit has been adapted for use as a charging unit for use by professional photographers who use many wet cell batteries for powering electronic flash units. The new charger has saved having several chargers and spare batteries can be kept fully charged, even in cases where flash units have chargers built in. Most of the batteries are 3.5AH rating but there are 4, 6 and 8 volt systems. This constant current charger is set to

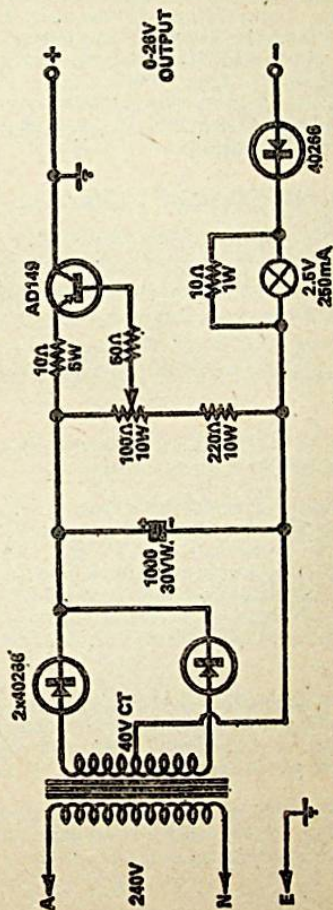

slightly less than the 10 hour rate, to 300mA. Because of the constant current, several batteries can be connected in series, irrespective of the voltage of each battery. The unit is short-circuit proof and gives a "charge" indication.

A standard full wave supply is used with a 100uF filter capacitor. Calibration may be done with a moving coil voltmeter across the 10 ohm emitter resistor. The voltage measured across the resistor is read off the meter in terms of current according to Ohm's law. Also, the voltage drop across this resistor bucks the forward bias set by the 100 ohm preset potentiometer, thus tending to keep the current constant. The unit may be adjusted by means of the 100 ohm potentiometer so that it will cover an approximate range of from 500mA to 50mA, the latter making it suitable for use with small nickel cadmium cells. However, before charging very small nickel cadmium cells, the charging rate should be checked and should not be exceeded.

AN ELECTRONIC METRONOME WITH ACCENTED BEAT

This new electronic metronome has a potential interest for two distinct reader groups: Readers with a musical background can use it as a conventional metronome to measure or to govern musical tempo; those more interested in photography can use it in the darkroom to tick off the seconds. Its novel feature — an "accentuate" facility, which can emphasise particular beats in a regular tempo.

Most readers whether musically inclined or not, will at some time or other have heard or seen a conventional metronome.

Traditionally, it involves a pyramidal shaped case, containing a clock-work escapement mechanism. A spindle emerging from the base end supports an upright steel "pendulum" about 7 inches long, carrying a brass weight which can be locked in any desired position. When set in motion, the pendulum oscillates from side to side at a rate governed externally at least, by the position of the sliding weight. In so doing, it produces an audible click, which can serve as a guide to musical tempo, or beat.

The physical laws behind the mechanical metronome are traceable at least as far back as Galileo but there is a record of a pendulum system used for the actual determination of musical tempo being created in Amsterdam, in 1815, by a man named Winkel.

This was seen and later copied in Paris by Johann Maelzel, who then proceeded to sell the instruments under his own name. Winkel took the matter to law and established himself as the true inventor but Maelzel had become so identified with the device that it became known commonly as "Maelzel's Metronome"

The term is, in fact, the basis for the "M.M." endorsement which appears on some music, indicating the tempo at which the composer considers that it should be played.

The tempo range covered by a mechanical metronome is commonly between about 40 and 200 beats per minute, the rate being shown by comparison with a calibrated scale on the body of the metronome behind the pendulum.

In this electronic age, many people who might not otherwise buy or build a mechanical metronome are attracted to the idea of building up an electronic equivalent—a device which will produce audible clicks at a regular rate, adjustable over a suitable tempo range.

Various devices have been produced along these lines, transistor circuitry lending itself particularly well to the application.

This particular unit used a single transistor in a blocking oscillator circuit feeding its output, as desired, to loudspeaker or phones. Like its older mechanical counterpart, the one-transistor metronome produced simple clicks.

Provided one is not deterred by additional circuitry, it is quite possible to develop a transistor metronome so that it will accentuate certain clicks in the sequence to stimulate the down-beat at the beginning of each musical bar. It is only a matter of adjustment to produce an accentuated sound on every beat, one in two, one in three, one in four, and so on, up to at least one in ten.

This facility can extend the usefulness of the device quite markedly in a musical sense. It also means that it can be used in a darkroom to deliver 1-second pulses, with an accentuated pulse each 10 seconds!

The accentuate facility is normally achieved by diverting some of the energy from the regular pulse to charge a storage capacitor, each pulse raising the charge across the capacitor by a specific increment. The idea is often described by the term "staircase", because a plot of voltage against time looks just like the profile of a staircase.

When the charge reaches a specific level, it normally triggers some kind of flip-flop or breakdown circuit, which generates the accentuate pulse and also returns the storage circuit to the bottom of the staircase!

We were reminded of the general technique by a circuit which we saw in a magazine which had been reprinted from an overseas source. This was duly built up and it certainly worked but close checking after the demise of a transistor revealed that there were current and voltage spikes at certain points in the circuit which seemed clearly to transgress the component ratings.

This was in fact verified by electrical laboratories who were able to suggest modifications which would bring the operating conditions more into line.

In the meantime, however, we had taken up our own line of investigation, based on the use of unijunction transistors (UJT's) and came up with a design which seemed to do the job very nicely. It uses more active devices than the Philips circuit but is simpler and cheaper in other respects.

The unit can be set to any pulse repetition rate between about 46 and 160, with the facility of accentuating each beat or any one beat in up to 11.

The basic beat rate could be expanded, easily enough, to cover a wider range but we felt that there was an advantage in limiting the range and thereby making adjustment somewhat less critical. In fact, virtually all the music we checked on, while thinking about metronomes, appeared to have a basic beat lying between 65 and 130-crotchets per minute.

Looking at the circuit of the new design it may be seen that it employs seven semiconductor devices—two unijunction transistors, two medium-power germanium transistors, two silicon planar transistors and a silicon diode.

The basic beat output of the unit is produced by the circuitry associated with transistors T1 and T2. Unijunction T1 is used as a simple relaxation oscillator driving T2 as a power switch in series with the speaker. The unijunction may be either a 2N2646 or a 2N2160, while T2 should be a medium-power NPN germanium type AC127, 2N647 or similar.

The characteristics of a unijunction transistor are such that virtually zero emitter current flows until the emitter potential rises to a certain value between that of the base-1 and base-2 electrodes. Hence in the present circuit the initially discharged 2 μ F capacitor commences charging to the plus 9V supply potential via the 1M speed pot, the 820K resistor and the 220K resistor.

This charging will continue until the capacitor voltage rises to the point where the unijunction emitter reaches its conduction level. The unijunction then immediately conducts, discharging the 2 μ F capacitor and supplying a current pulse to the 69 ohm resistor in series with its B1 electrode.

The cycle of events then repeats itself, with the 2 μ F capacitor again charging up to the unijunction conduction voltage, the latter conducting, and so on. Hence the unijunction is made to deliver a series of pulses to the 68-ohm resistor. The 1M pot in the capacitor charging circuit controls the rate at which the capacitor recharges each time, and hence controls the pulse repetition rate.

The base of T2 is connected directly to the B1' electrode of the unijunction so that until the unijunction goes into conduction the former is cut off and negligible current flows through the speaker. However, when the unijunction delivers an output pulse T2 is driven into full conduction. The speaker is thus briefly connected across the 9V supply, in series with the 82 ohm resistor. A current pulse thus flows through the speaker to produce a "click".

Accentuation of selected beats from the output produced by T1 and T2 is performed by the remainder of the circuitry, employing T3, T4, T5, T6 and D1. The operation of this section of the circuit is as follows:

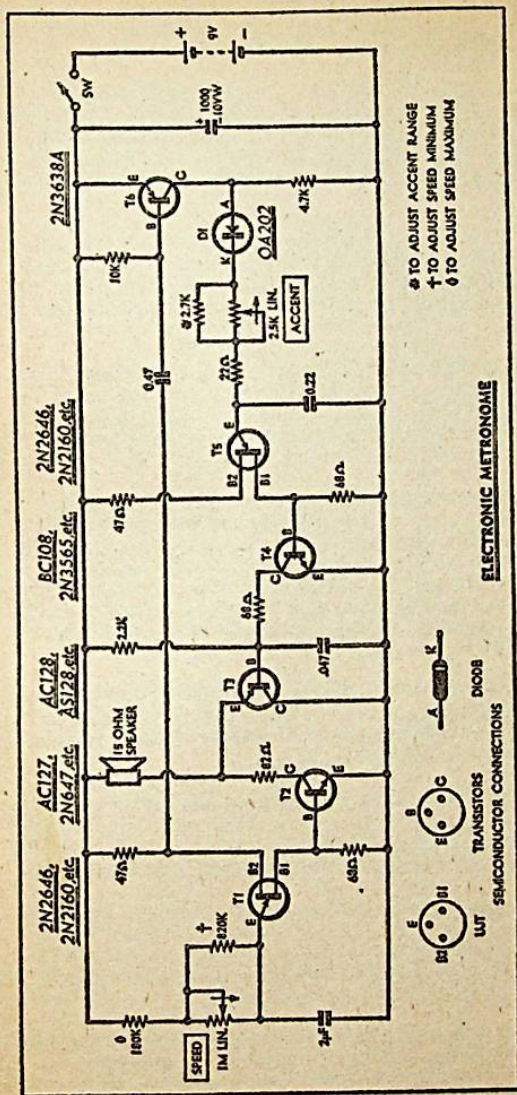

Circuit of the new metronome, with adjustable accented beat. Actually, T1 and T2, with the associated circuitry, would make up into a simple conventional metronome. The 82-ohm resistor could be decreased to a minimum of 22 ohms for a louder tick, or increased to make the tick softer.

When the unijunction T1 conducts, its B2-B1 current momentarily increases. As a result of the 47 ohm resistor in series with the B2 electrode, this causes the latter electrode to be driven briefly negative with the respect to the plus 9V line. Thus there is available at the B2 electrode a train of negative-going pulses at the basic beat rate.

PNP silicon transistor T6 (2N3638A or similar) is normally cut off, as its base is returned to its emitter at the plus 9V line via a 10K resistor. However, the negative pulses from T1 are fed to its base via the .47uF capacitor. As a result, T6 is driven into full conduction and delivers a plus 9V pulse to its 4.7K collector resistor, on the arrival of each pulse from T1.

Unijunction T5 is connected in a very similar fashion to T1, with a capacitor—this time .22uF—connected from emitter to the common negative line. However, the charging resistance connects in this case to the collector resistor of T6, via diode D1, rather than to the plus 9V line as before.

As a result of this the capacitor does not charge spontaneously, but only in short bursts corresponding to the plus 9V pulses fed to the 4.7K resistor by T6. The extent to which it charges during each pulse is controlled by the charging resistance, which may be varied by adjustment of the 2K pot marked "Accent".

Between pulses, the charge on the capacitor remains substantially constant. D1 prevents the charge from leaking away via the 4.7K resistor, while the emitter circuit of T5 presents an extremely high resistance until the unijunction conducts. Hence the capacitor voltage tends to rise in "staircase" fashion, each step corresponding to one beat at the basic rate. The height of the steps will depend upon the value of charging resistance—the lower the resistance, the higher the steps and vice-versa.

As before, the capacitor voltage will rise until the emitter of T5 is taken to the unijunction conduction level. When it reaches the level T5 conducts; this discharges the capacitor and delivers a current pulse to the 68 ohm resistor in the B1 lead of T5.

Just when T5 conducts will depend upon the height of the "steps" of the capacitor voltage, for the steps are occurring at the basic beat rate. Hence by adjusting the "Accent" pot it is possible to make T5 conduct on the arrival of any desired number of basic beat pulses.

With the pot set fully clockwise, the effective charging resistance seen by the capacitor is only 22 ohms. This value is such that the "step" produced by only a single basic beat pulse is sufficient to raise the emitter of T5 up to conduction level. Hence T5 conducts more or less in tandem with T1, at the basic beat rate.

As the pot is turned anticlockwise, the charging resistance seen by the .22uF capacitor increases. Hence it charges less on each pulse, and the "steps" are reduced in height. Thus increasing numbers of pulses will be required to "contribute" to each conduction of T5.

As the Accent pot is turned anticlockwise, it will accordingly be found that T5 will conduct first on every second basic beat pulse, then on every third, then on every fourth, and so on. With the values shown, the fully anticlockwise setting will result in T5 conducting on every 11th basic beat. Hence the pot may be calibrated in terms of the number of basic beats corresponding to each T5 conduction.

Transistor T4 is driven from the output of T5 in identical fashion to the way in which T2 is driven from the output of T1. However the output of T4 is not used to operate the speaker directly, but is used to drive transistor T3 which in turn connects to the speaker.

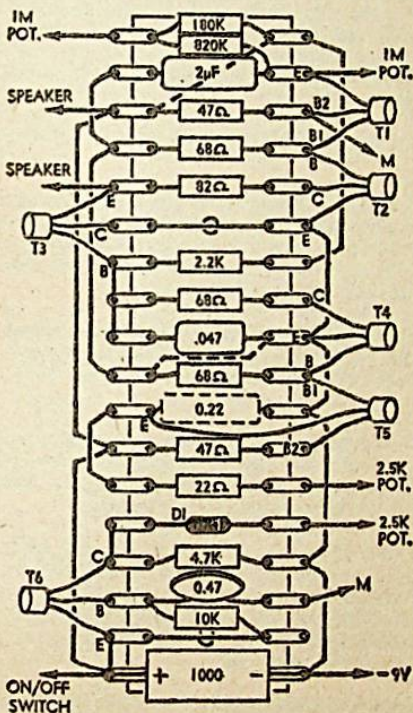

This is done to permit the pulses from T4 to be "stretched" so that they can produce a speaker output "click" which is significantly higher in energy than those provided by T2. The stretching is performed by the .047μF in the base circuit of T3, in the following way:

PNP transistor T3 is virtually an emitter follower, with the speaker as its emitter load. With T4 non-conducting, T3 is cut off by the +9V applied to its base via the 2.2K resistor.

When T4 is driven into conduction by T5, it takes the base of T3 towards the negative supply line via the 68 ohm resistor. This causes T3 to conduct heavily, and it causes an additional burst of current to pass through the speaker.

The base of T3 cannot rise immediately to +9V when T4 returns to the cut-off state following the end of the pulse, because the .047uF capacitor must re-charge via the 2.2K resistor. Hence the conduction of T3 and the current pulse through the speaker is prolonged, effectively "stretching" the pulse and increasing the energy of the speaker output.

Adjustment of the Accent pot allows the "stretched" pulses to be superimposed upon selected pulses from the basic beat, so that they accentuate the pulses selected. Hence, simply by adjusting the Accent pot, one is able to produce accentuation of every click, or so on. The accentuation rhythm is substantially independent of the basic beat rate selected by the speed pot.

Having considered the operation of the circuit, let us now turn to its construction.

Our prototype is housed in a biscuit tin case, measuring 6½in x 4½in x 2in. This relatively small size is such that the unit may be held in one hand and it may be easily moved about. As it is battery operated, there is no external cable and it may be perched on any convenient surface, either lying on its back, or resting on one edge.

The construction is reasonably simple, with all components and sub-assemblies being fixed to the front panel. The box proper is simply used as a protective cover. All these details can be seen from the photographs.

More specifically, the speaker, On-Off switch, battery, Speed and Accent controls are mounted directly on the front panel. With the exception of the 2.7K resistor which shunts the Accent control, all the other components are mounted on the tag board.

Perhaps a good place to start would be the tag board. All the wiring details are given in the diagram, which is quite easy to follow, either independently, or in conjunction with the circuit diagram. A board with a minimum of 20 pairs of tags is required, although it will be noticed that we have used a board with 23 pairs of tags, the unused ones being allowed to overhang each end.

The job will be easier if all the resistors are soldered in first, followed by the capacitors. Remember to mount the 0.22uF capacitor underneath. Then all the interconnecting leads should be next, leaving all the semiconductors until last.

Components should be kept close to the board. Transistor leads should be shortened where necessary, so that the tops do not extend to more than one inch above the board. This is necessary, to make sure that all components will clear the back of the case.

And here a word of warning to constructors who have not had much experience with semiconductors and small components generally: Be careful not to overheat these items during soldering. It is possible to damage or even ruin transistors, particularly if they are heated excessively.

When the board is completed, it can be put aside for the time being. The speaker is fixed to the panel with four screws and with a piece of extruded aluminium between it and the panel. This will protect the cone and gives the unit an improved appearance. Held under one of the speaker screws is a bracket which clamps the battery in position. We made one up out of a piece of scrap aluminium. When screwed up, it should hold the battery firmly. It is also wise to wrap a piece of plastic sheet around the battery before fixing it in place. This precaution will prevent any possibility of the case becoming short-circuited to the panel.

The On-Off toggle switch is mounted above the speaker. As space is at a premium here, the switch is mounted such that it operates horizontally rather than the more common vertical mode. The Speed and Accent controls are mounted with their respective lugs facing each other. At this point, the 2.7K resistor may be connected across the Accent control.

To avoid an awkward job later on, it would be wise to solder the positive lead from the battery clips to the switch. Another short lead should also be provided, from the other lug of the switch. This latter lead will later be run to the positive rail on the board.

Next comes the matter of fixing the board assembly to the rest of the unit. The board should be mounted such that it is no more than one inch from the panel. The end of the board, which is over the Accent control, is actually fixed to this control. We made a "U" piece out of 16 gauge tinned copper wire. From under the board, the ends of the "U" were pushed through the eyelet holes next to the 180K resistor. The closed end of the wire was soldered to the back of the control and the other ends were then soldered to the board, to give the correct amount of spacing from the panel.

At the other end of the board, we fashioned a simple bracket from a piece of tin plate. This was fixed under the nearest screw on the speaker, and the other end of the bracket was then screwed to one of the centre row of holes on the board. Alternatively, it may be possible to fix a stout solder lug under the speaker screw and use another piece of heavy tinned copper wire, more or less the same as was done at the other end. In any case, the main criterion is to make sure that the board is held firmly in place.

To complete the wiring, it is only necessary to run leads from the switch, battery, speaker, speed and accent controls, to the wiring board. Having done this, a careful check should be made to make sure that there are no wiring errors. Particular attention should be paid to transistor leads and the polarity of the battery and electrolytic capacitor.

With all this in order, the switch may be turned on, and the builder will be rewarded with a series of clicks from the speaker. Just what the rate will be and how often a click will be accented, will depend on the initial setting of the controls.

Turn the speed or rate control fully clockwise, to the fast position. The number of clicks should be counted and checked on a watch, over a period of one minute. The prototype unit gives 160 clicks and provided yours falls between about 150 and 160 it could be considered as satisfactory.

Now turn the speed control fully anticlockwise, to the slow position. The number of clicks should be checked again. The prototype gives 46 clicks per minute and if yours gives between about 50 and say 46, it could be considered as satisfactory.

If your unit gives rates outside these arbitrary limits, or if you wish to alter them to suit your own purpose, then this can be done without difficulty. To increase or decrease the maximum speed, the 180K resistor should be reduced or increased in value, respectively. Similarly, to increase or decrease the minimum speed, the 820K resistor should be reduced or increased in value, respectively.

Having satisfied ourselves that these speeds are as required, we can now turn our attention to the accent click. With the accent control turned fully clockwise, every click should be accented. Now turn the accent control to 2, and every second click should be accented. Continue this check right through to 11. It may be possible to turn the control beyond this point and so get an accent on each twelfth click. During this test, it will be noted that the transition from one number to the next may not occur exactly midway between the numbers on the panel. However, they should work out fairly well.

It is not likely that there will be any trouble getting an accent on every click, with the control fully clockwise. However, there may be a gradual drift from our typical calibration as the control is turned anti-clockwise. If the accent is less than one in 11 at this point, then it will be necessary to increase the value of the 2.7K resistor which shunts this control. Conversely, the resistor should be decreased if the accent is greater than one in 11.

Although we have given details how to make any adjustments, more than likely this will not be necessary. The unit may now be screwed into the box and your metronome is ready for use.

Parts List

1 Box 6½in x 4½in x 2in, with biscuit tin lid

1 3in speaker with 15 ohm voice coil

1 SPST toggle switch

1 1M linear potentiometer

1 2.5K linear potentiometer

2 Knobs

1 Miniature tag board, 20 pairs of tags

1 9-volt battery, type No. 216

Extruded aluminium for speaker, bracket for battery; hookup wire, solder, screws, nuts, etc.

CAPACITORS

1 .047uF low voltage plastic

1 0.22uF low voltage plastic

1 2uF low voltage plastic

1 0.47uF 25V ceramic

1 1000uF 10VW electrolytic

SEMICONDUCTORS

2 2N2646, 2N2160

1 AC127 2N647

1 AC128, AS128

1 BC108, 2N3565

1 2N3638A 1 OA202

RESISTORS (½ watt, 5 per cent tolerance)

1 22 ohms

2 47 ohms

3 68 ohms

1 82 ohms

1 2.2K

1 2.7K

1 4.7K

1 10K

1 180K

1 820K

BIBLIOTHEEK

N.V.H.R.

BERNARDS AND BABANI PRESS RADIO BOOKS

BP1	First Book of Transistor Equivalents and Substitutes	40p
BP2	Handbook of Radio, TV and Ind. Tube and Valve Equivalents	40p
BP3	Handbook of Tested Transistor Circuits	40p
BP4	International Handbook of the Worlds Short Wave, Medium and Long Wave Radio Stations & FM & TV Listings	35p
BP5	Handbook of Simple Transistor Circuits	35p
BP6	Engineers and Machinists Reference Tables	20p
BP7	Radio and Electronic Colour Codes and Data Chart	15p
BP8	Sound and Loudspeaker Manual	50p
BP9	38 Practical Tested Diode Circuits for the Home Constructor	35p
BP10	Modern Crystal and Transistor Set Circuits for Beginners	35p
BP11	Practical Transistor Novelty Circuits	40p
BP12	Hi-Fi, P.A., Guitar & Discotheque Amplifier Design H/Book	75p
BP13	Electronic Novelties for the Motorist	50p
BP14	Second Book of Transistor Equivalents	95p
BP15	Constructors Manual of Electronic Circuits for the Home	50p
BP16	Handbook of Electronic Circuits for the Amateur Photographer	60p
BP17	Radio Receiver Construction Handbook using IC's & Transistors	60p
96	Crystal Set Construction	8p
100	A Comprehensive Radio Valve Guide - Book 1	30p
121	A Comprehensive Radio Valve Guide - Book 2	30p
126	Boys Book of Crystal Sets and Simple Circuits	18p
129	Universal Gram-Motor Speed Indicator	8p
138	How to make F.M. and T.V. Aerials - Bands 1/2/3	18p
141	Radio Servicing for Amateurs	20p
143	A Comprehensive Radio Valve Guide - Book 3	30p
146	High Fidelity Loudspeaker Enclosures	40p
147	Practical Tape Recording Handbook	30p
149	Practical Stereo Handbook	30p
150	Practical Radio Inside Out	40p
156	Transistor Circuits Manual - No 1	15p
157	A Comprehensive Radio Valve Guide - Book 4	30p
160	Coil Design and Construction Manual	30p
161	Radio, TV and Electronics Data Book	25p
163	Transistor Circuits Manual - No 2	15p
168	Transistor Circuits Manual - No 4	15p
170	Transistor Circuits for Radio Controlled Models	40p
173	Practical Transistor Audio Amplifiers - Book 1	20p
174	Transistor Subminiature Receivers	32½p
175	Transistor Test Equipment and Servicing Manual	25p
176	Manual Transistor Audio Amplifiers	40p
177	Modern Transistor Circuits for Beginners	40p
178	A Comprehensive Radio Valve Guide - Book 5	30p
183	Hcw to receive foreign TV programmes on your set b simple modifications	
191	Practical Car Radio Handbook	
195	High Fidelity 14 Watt Amplifier Design Chart	
196	AF-RF Reactance-Frequency Chart for Constructors	
197	Inexpensive Push-Pull Amplifier Construction Chart	
200	Handbook of Practical Electronic Musical Novelties	
201	Practical Transistorised Novelties for Hi-Fi Enthusiasts	
202	Handbook of Integrated Circuits (IC's) Equivalents & I	
203	IC's and Transistor Gadgets Construction Handbook	
204	Second Book of Hi-Fi Loudspeaker Enclosures	
RCC	Resistor Colour Code Disc Calculator	

Bibliotheek Ned. Ve

BABANI PRESS & BERNARDS (PUBLISHERS) LIM

The Grampians, Shepherds Bush Rd, London W6 7NF Tel: 0181 275 7172