



TR File.
(2)

ENGINEERING DIVISION
MONOGRAPH
BRITISH BROADCASTING CORPORATION

No. 12
AN IMPROVED 'ROVING EYE'
by
T. Worswick, M.Sc., A.M.I.E.E., and G. W. H. Larkby



BBC ENGINEERING MONOGRAPH

No. 12

AN IMPROVED 'ROVING EYE'

by

T. Worswick, M.Sc., A.M.I.E.E., and G. W. H. Larkby

(DESIGNS DEPARTMENT, BBC ENGINEERING DIVISION)

APRIL 1957

BRITISH BROADCASTING CORPORATION

FOREWORD

THIS is one of a series of Engineering Monographs published by the British Broadcasting Corporation. About six are produced every year, each dealing with a technical subject within the field of television and sound broadcasting. Each Monograph describes work that has been done by the Engineering Division of the BBC and includes, where appropriate, a survey of earlier work on the same subject. From time to time the series may include selected reprints of articles by BBC authors that have appeared in technical journals. Papers dealing with general engineering developments in broadcasting may also be included occasionally.

This series should be of interest and value to engineers engaged in the fields of broadcasting and of telecommunications generally.

Individual copies cost 5s. post free, while the annual subscription is £1 post free. Orders can be placed with newsagents and booksellers, or BBC PUBLICATIONS, 35 MARYLEBONE HIGH STREET, LONDON, W.1.

CONTENTS

<i>Section</i>	<i>Title</i>	<i>Page</i>
	PREVIOUS ISSUES IN THIS SERIES	4
	SUMMARY	5
1	INTRODUCTION	5
2	WEIGHT OF EQUIPMENT	5
3	DISPOSITION OF APPARATUS AND CREW	6
4	THE VEHICLE	7
	4.1. General	7
	4.2. The Generating Set	8
	4.3. Camera Mountings	8
	4.4. Additional Fittings	9
5	CAMERAS AND ASSOCIATED EQUIPMENT	9
6	RADIO LINKS	10
	6.1. General	10
	6.2. Static Arrangement	11
	6.3. Roving Arrangement	11
7	THE BAND V FREQUENCY-MODULATED VISION LINK	12
8	AERIAL STABILIZER	13
9	SOUND AND TALKBACK EQUIPMENT	14
10	MULTIPLEX EQUIPMENT	15
	10.1. Music Channel—Roving Eye to Receiving Base	15
	10.2. Engineering Control or Speech Channel—Roving eye to Base	15
	10.3. Engineering Control or Speech Channel—Base to Roving Eye	16
11	SIGNALLING	16
	11.1. Roving Eye to Base	16
	11.2. Base to Roving Eye	17
12	PRODUCTION TALKBACK—BASE TO ROVING EYE	17
13	MAINS LOCKING	17
14	BASE EQUIPMENT AND VEHICLE	17
15	CONCLUSION	18
16	REFERENCES	18
	APPENDIX	18
<hr/>		
	A RECENT SUGGESTION FOR IMPROVEMENT IN TELEVISION TECHNIQUE	19

PREVIOUS ISSUES IN THIS SERIES

No.	Title	Date
1.	<i>The Suppressed Frame System of Telerecording</i>	JUNE 1955
2.	<i>Absolute Measurements in Magnetic Recording</i>	SEPTEMBER 1955
3.	<i>The Visibility of Noise in Television</i>	OCTOBER 1955
4.	<i>The Design of a Ribbon Type Pressure-gradient Microphone for Broadcast Transmission</i>	DECEMBER 1955
5.	<i>Reproducing Equipment for Fine-groove Records</i>	FEBRUARY 1956
6.	<i>A V.H.F./U.H.F. Field-strength Recording Receiver using Post-detector Selectivity</i>	APRIL 1956
7.	<i>The Design of a High Quality Commentators' Microphone Insensitive to Ambient Noise</i>	JUNE 1956
8.	<i>An Automatic Integrator for Determining the Mean Spherical Response of Loudspeakers and Microphones</i>	AUGUST 1956
9.	<i>The Application of Phase-coherent Detection and Correlation Methods to Room Acoustics</i>	NOVEMBER 1956
10.	<i>An Automatic System for Synchronizing Sound on Quarter-inch Magnetic Tape with Action on 35-mm Cinematograph Film</i>	JANUARY 1957
11.	<i>Engineering Training in the BBC</i>	MARCH 1957

AN IMPROVED 'ROVING EYE'

SUMMARY

The Roving Eye is the popular name for a television camera vehicle built by the BBC in 1954 in an attempt to introduce a new technique for television outside broadcasts.

The name was an apt one, describing the original intention behind its construction, which was to produce a vehicle capable of carrying a television camera and the associated equipment to permit pictures and their sound accompaniment to be broadcast whilst it was moving unimpeded by connecting cables.

Since Roving Eye I was built in the winter of 1953-4, a great deal of experience has been accumulated and this has been embodied in a new design—Roving Eye II—which is described and illustrated in this Monograph. Several novel features are incorporated, including a 45-ft telescopic mast which, when the vehicle is stationary, gives it a working radio range of about 10 miles from a good receiving site.

1. Introduction

The BBC's original Roving Eye fulfilled the requirement for freedom of movement but subsequent experience has shown that from the point of view of an efficient television service it has a much more important, if more mundane, function to perform in addition to its roving feature. This function is that of a complete self-contained television mobile control room which can go rapidly to site, remain for a short time to do a broadcast, and then move on. Examples of this use are short inserts into the 'Sports-view' and 'Panorama' type of programme. To carry out such modest programmes with a normal full-sized outside broadcast unit would be very cumbersome and wasteful.

The outcome of the experience gained with Roving Eye I has been the design of a new vehicle, Roving Eye II.

The broad specification of this vehicle was that it be a two-camera control room complete with its own power supply, radio link, aerials, etc. It must be able to carry out certain broadcasts in a much more modest and direct way than a normal outside broadcast mobile control room. And it must be able to transmit pictures and sound by radio when static and also when roving.

The operating crew must be kept to a minimum on the score of economy.

A good example of the direct way of carrying out a broadcast with the Roving Eye is a contribution from an exhibition hall. Here the Roving Eye may enter the hall and ascend in the lift to the gallery to within a few yards of the exhibit under review and the cameras can be run out with the minimum of fuss and effort.

To fulfil this need the Roving Eye should be as small and as light as possible. Smallness and lightness run counter to the amount of equipment to be carried and the thinking and argument behind the compromises adopted may be of interest.

2. Weight of Equipment

Of all the factors involved the selection of the power supply arrangements has the most impact on the total weight of the apparatus in the vehicle.

One possibility is to use the standard a.c. supply of 240-V 50-c/s single-phase and use mains-driven equipment throughout. When roving this power must be supplied by a prime mover. This has the great advantage that the equipment throughout can be standard and that when the vehicle is stationary it can often make use of the public electricity supply, which saves wear and tear on the prime mover. The standard equipment can if desired be removed from the vehicle and used in conjunction with other equipment. However, the penalty of heavy mains transformers in practically every piece of apparatus has to be paid with this arrangement.

An alternative would have been to use, say, 24-V d.c., and have equipment specially designed for this. By connecting the valve heaters in series parallel and using rotary machines to provide H.T. supplies a useful reduction in weight would have been obtained. Against this must be set the fact that new equipment would have had to be developed almost throughout. Also the vehicle would be completely dependent on the prime mover and could not fall back on public power supply when standing still.

A further choice would have been to use a 110-V 400-2000-c/s a.c. supply, which would reduce the weight of the generator on the prime mover as well as all the transformers in the power supply unit. Again, however, the use of the public supply mains would be precluded.

A number of other factors also come into the balance, such as simplification of maintenance, and so the final choice for power supply was standard 240-V 50-c/s single-phase a.c. in spite of the greater weight.

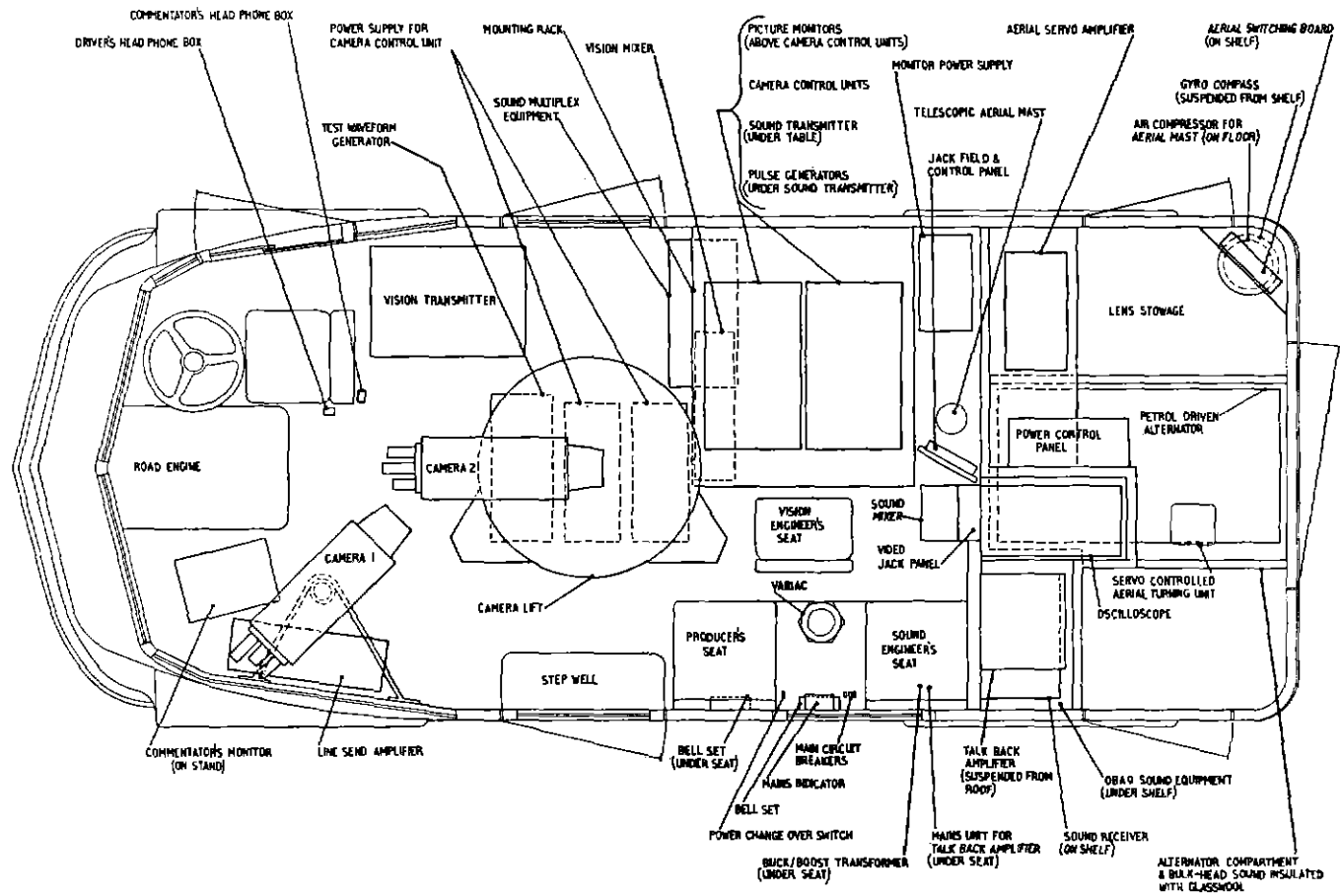

Fig. 1 — Plan of vehicle showing layout of apparatus and position of operators

The decision to use standard mains-driven equipment fixes the sizes of the apparatus to be installed. In the case of the camera, by choosing an older model it was possible to save some weight as compared with the most up-to-date design.

On a normal mobile control room much equipment is duplicated to guard against breakdown. Although this policy cannot be readily applied to a Roving Eye the compromise adopted was that, when stationary and working with line connections for vision and sound, the vehicle has sufficient reserve equipment available to ensure that one camera could send pictures to line. There is a corresponding duplication of an amplifier in the sound equipment, but this does not add appreciably to the bulk of the equipment carried.

3. Disposition of Apparatus and Crew

Considerable thought was given to the layout and placing of the apparatus in the vehicle and the seating of the operators to give the greatest convenience of working and at the same time the optimum packing of equipment.

It was reckoned that the normal personnel of the Roving Eye when in operation would be as follows:

1. Driver.
 2. 2 cameramen, each of necessity behind his own camera.
 3. 1 commentator when needed.
 4. 1 vision operator
 5. 1 sound operator
 6. 1 producer.
- Some of the functions of these two overlap as detailed below.

The positioning of the last three calls for some discussion.

The vision operator is concerned primarily with the operation and adjustment of the camera channels and so he must be placed directly in front of the two camera control units. He may also require to operate the steerable aerial while roving.

The sound operator must have his microphone mixing arrangements directly in front of him. He must be able to operate conveniently on the control line terminations when the vehicle is stationary. Also he must be able to see the picture monitors displaying the camera and the radio check receiver pictures.

When roving, because the sound requirements are likely to be more simple, the sound operator should be placed so that he can relieve the vision operator of some duties if

desired. For this reason most of the controls are so placed that both the vision and sound operators can reach them with equal facility.

Finally the producer has to have his camera mixing panel directly in front of him. He also must have a good view of the camera and radio-check picture monitor screens.

The precise grouping is shown in the plan view (Fig. 1) and also in the photograph (Fig. 2).

It is essential that these three people should operate as a team and their placing so close together aids this.

4. The Vehicle

4.1 General

The vehicle itself has to fulfil a number of requirements as regards its size, mechanical design and construction, and riding qualities. To itemize all the needs would be tedious and only the more important are discussed here.

When the Roving Eye is travelling during a broadcast

vibration of the cameras must be kept as small as possible. Shaking due to the general movement of the bodywork is not out of place because it adds to the viewers' sense of being in motion, but vibration due to the road engine or the power-supply generator is objectionable. For this reason a diesel motor was ruled out because at certain speeds there is a tendency to resonate at a low frequency. This vibration cannot be filtered out without elaborate camera mounting arrangements. A petrol engine, which is much smoother in this respect, was therefore preferred. The ideal chassis would probably be one with the engine and wheels entirely beneath the floor, giving a flat surface on which to construct the bodywork. Such a chassis of the right size was not available with a petrol engine so the choice fell on a Karrier Bantam chassis in which the engine is mounted well forward and low down and only small wheel boxes are required above floor level.

Although the apparatus contributes a large part of the total weight of the vehicle it is important to keep the body-

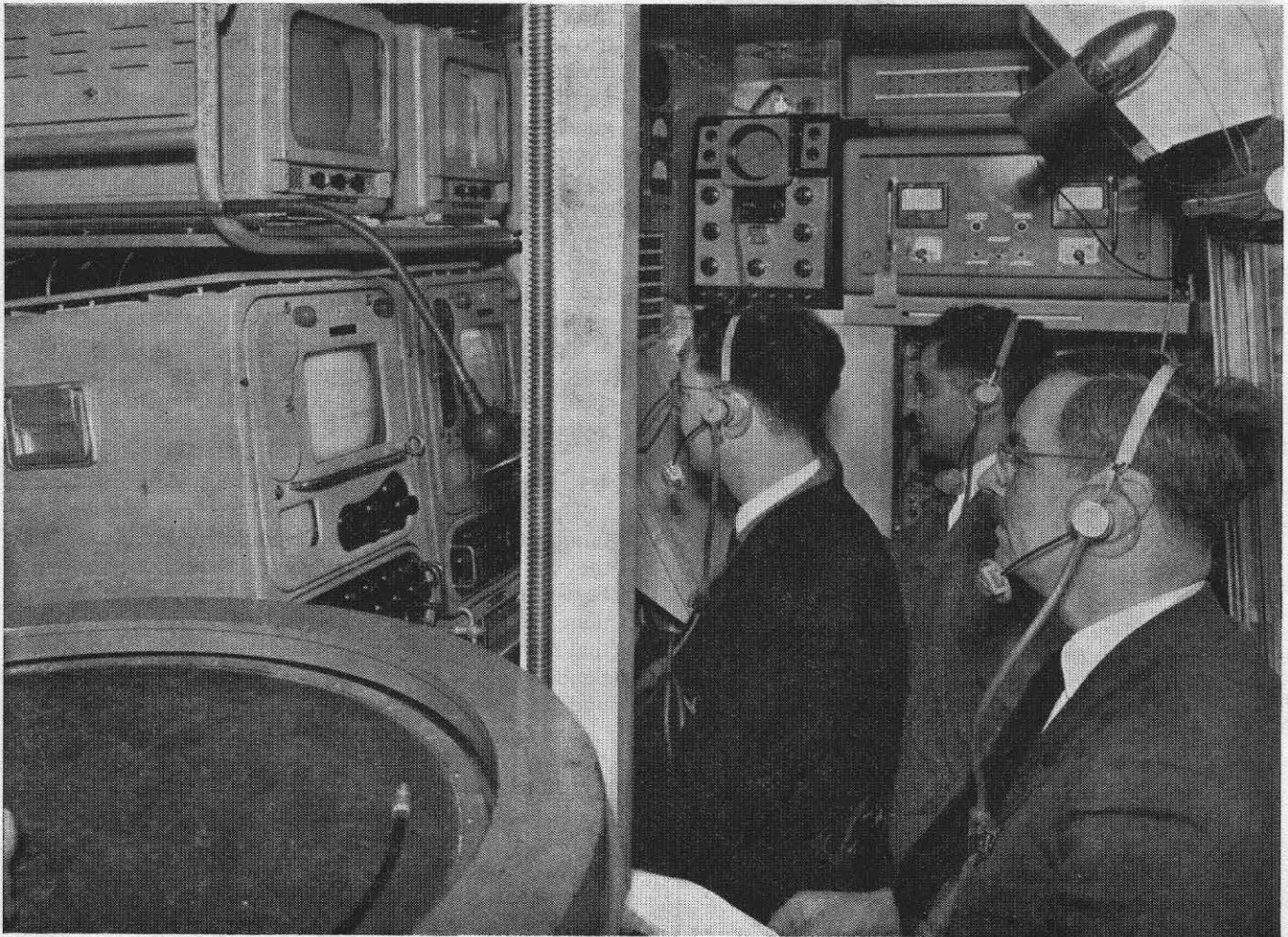

Fig. 2 — View of interior of van showing operators and producer

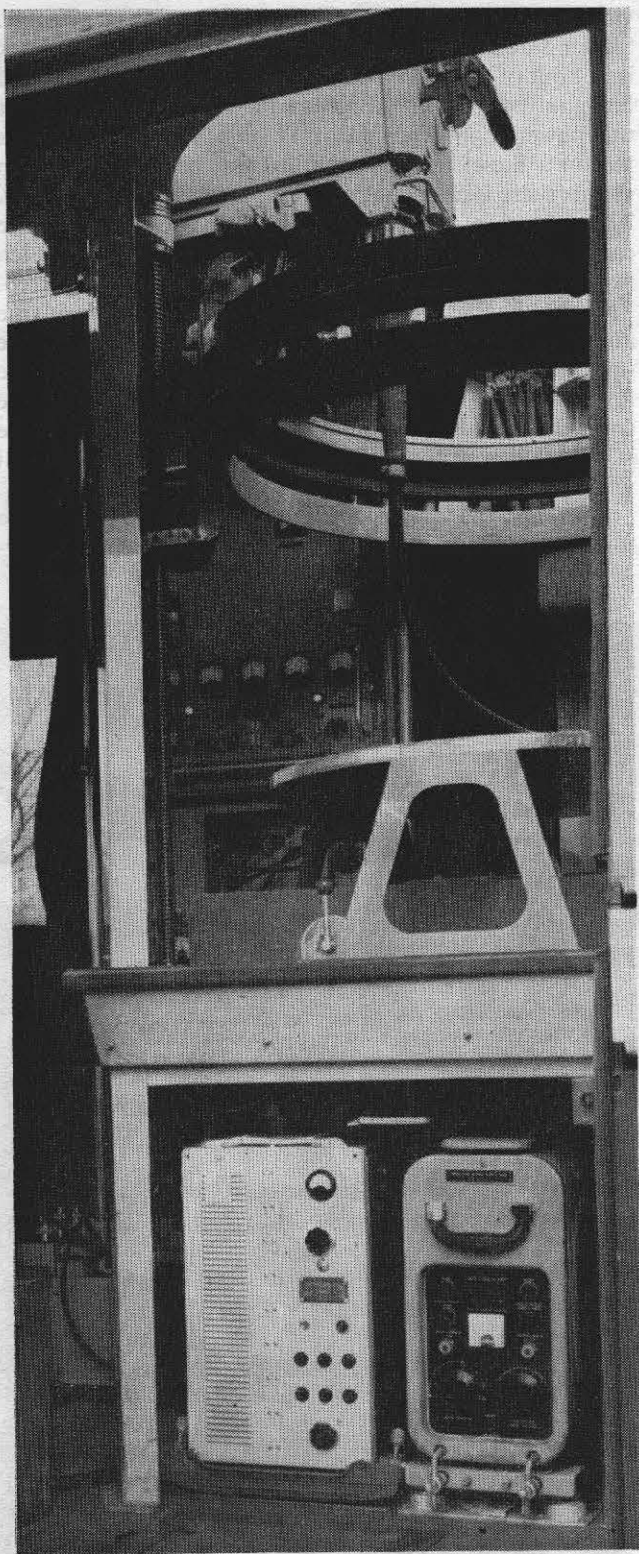

Fig. 3 — Interior looking through main access door showing camera lift. Vision transmitter in background and power supplies and test waveform generator under lift

work as light as possible. To this end welded aluminium construction is used throughout for the frame and aluminium and moulded fibreglass panels for the skin.

The overall size is given in the Appendix.

The riding of the vehicle needs to be smooth. With the full load of equipment careful adjustment of spring leaves and shock absorbers has made it very satisfactory.

4.2 The generating set

The fact that speech will on occasion be broadcast from the vehicle itself requires that the level of the acoustic noise in the van should be low. The two chief contributors to this noise are the road engine and the petrol-electric set, which supplies the power for the television apparatus. When in motion a slight amount of noise from the road engine is of little consequence because it is an appropriate 'effect' which is consonant with the moving picture. When the van is static, however, the nature of the programme may be such that the operators need to work with little extraneous noise in order to be able to devote close attention to the sound component of the programme. Under these conditions noise and vibration from the petrol-electric set would be disturbing. To obviate this the body is divided in two by a partition over the rear wheels. This partition is constructed of Hardec panels separated by a glass-wool lining. In the rear compartment is the petrol-electric set, mounted on resilient supports. A removable box lined with acoustic board is built round the sides and top. This arrangement effectively deals with sound transmitted direct from the rear to front compartments. To reduce engine noise passing outside the vehicle and into the front compartment via the window or camera aperture a small acoustic labyrinth is fitted to the cooling-air inlet at the bottom of the petrol-electric set compartment. With these precautions all that can be heard in the front compartment when the petrol-electric set is running on full load is a slight hum.

4.3 Camera mountings

The mounting of the television cameras presented certain problems. Both cameras should be mounted so that they can be used when the vehicle is in motion; both must be readily removable for use remote from the van. Because there are only two cameras with no spares it is desirable that it should be possible to energize and test them inside the body of the van so that any fault-finding can be done under cover, if need be whilst the vehicle is in motion.

One camera position is over the near-side front-wheel box where it can get a view direct forward through the windscreen or at right-angles to take kerb-side interview shots. For this latter requirement the near-side window drops clear. This camera can be serviced *in situ*.

The second camera has more elaborate supporting arrangements. In Roving Eye No. 1 the camera was mounted on a machine-gun ring which is lifted flush with the roof, the cameraman standing through the ring with his feet about 2 ft 6 in. below the roof. The camera lenses were about 18 in. above the roof. With this arrangement the

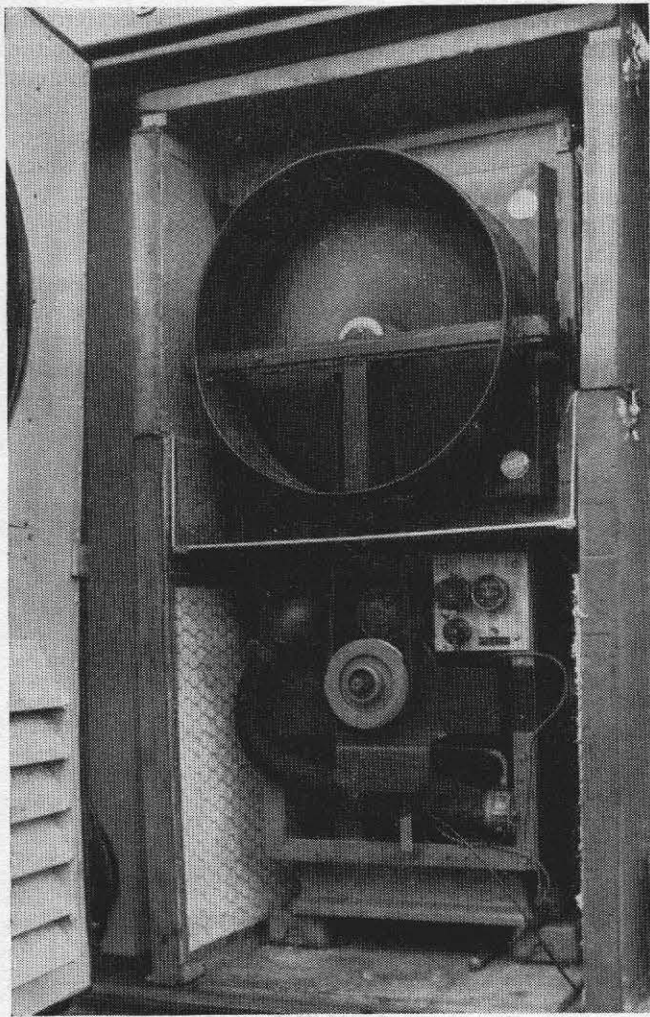

Fig. 4 — Rear engine compartment showing petrol-electric set

camera can swing to look all round the vehicle, and because the gun ring swivels with it to the near or off side of the van fairly steep downward shots are possible, e.g. to look on the pavement or in shop windows etc.

It was felt that similar facilities were wanted for Roving Eye II. The camera is mounted on a machine-gun ring which is supported on three large nuts on three vertical lead screws about 3 ft long hanging from supports in the roof. A circular aperture in the roof permits the gun ring to ascend to roof level by turning the lead screws with a small electric motor. A further rectangular aperture cut in the roof permits the camera, which overhangs the gun ring, to pass through.

In the DOWN position the camera is about 3 ft above floor level and so is conveniently placed for servicing. In the UP position it is clear of the roof. The cameraman stands on a table 3 ft from the floor. Below the table is stowed the lift motor as well as electronic equipment. This is an elaborate and weighty camera mounting which oc-

cupies volume at a position in the vehicle which prevents a spacious internal layout. However, on balance it is considered worth while.

The internal arrangement is shown in plan in Fig. 1. The photographs, Fig. 2 and Fig. 3, show more details of the internal arrangements.

4.4 Additional fittings

On some broadcasts it may be necessary to mount vertical scaffolding poles adjacent to the vehicle to carry cables or lamps or to form a rail. A simple clamping arrangement is therefore fitted whereby four standard 2-in. scaffolding poles can be mounted, two on each side of the van, supported entirely on the van so that if need be the van can move with the scaffolding in position.

As discussed later, a telescopic mast which can rise to a height of 45 ft is fitted. When this mast is erected it is essential that the vehicle should be stationary and level. Horizontal box-section cross members are welded to the chassis behind the front and behind the rear wheels and into the ends of these members can be inserted hydraulic jacks which have 6-in. square plates on their feet. By extending the jacks appropriately the van can be levelled.

Six access doors are fitted both for the personnel and also to permit easy installation and removal of equipment.

5. Cameras and Associated Equipment

For a general-purpose equipment such as the Roving Eye the image orthicon camera is the only choice as its sensitivity enables it to cope with all kinds of lighting conditions with a minimum of fuss. New developments such as miniature cameras of the photo-conductive type are attractive because of their small size, weight, and power consumption, but the light required for satisfactory operation of these is much too great to permit their use on general outside broadcast work.

Standard 3-in. image orthicon Marconi Mark IB cameras are used because they are smaller and lighter than the new 4½-in. image orthicon Marconi Mark III. The cameras are not modified in any way for the Roving Eye application, thus they can be readily interchanged with other similar equipment if required. Each camera has a four-lens turret and an electronic viewfinder.

The panning head on which the camera is mounted has an ingenious cam arrangement which gives the effect of supporting the camera at its centre of gravity. This gives good camera stability and ease of operation even when the vehicle is in motion.

A simple two-channel vision mixer unit is provided, which gives facilities for cutting and dissolving between camera 1 and camera 2 and cutting only to an external non-synchronous source such as a remote camera. A circuit diagram of the mixer is shown in Fig. 5.

All important video cabling is brought to a coaxial interception panel adjacent to the sound fading panel so that for testing, or in an emergency, cross plugging can be carried out.

The output from the two-channel mixer is fed to a line-

sending amplifier for cable broadcasts and to the vision transmitter for radio broadcasts. Spare outputs are provided to feed monitors for commentators etc., when required.

The line-sending amplifier accepts the unbalanced video signal and from a three-stage push-pull amplifier gives a balanced output of 2 volts from a source impedance of 100 or 180 ohms to match into the vision cable. Two identical amplifiers are mounted in one box with separate power units. A common monitoring circuit to feed a remote oscilloscope for checking is also fitted.

6. Radio Links

6.1 General

When the Roving Eye is transmitting pictures and sound

while in motion radio links are essential to connect it to the broadcasting network. When the Roving Eye is static the links can be by cable or by radio. The use of cable demands in most cases foreknowledge of the outside broadcast, which is often available. If there is inadequate warning of the outside broadcast then the use of radio links which require the minimum of setting up is a necessity.

There are therefore two requirements for the radio links, which are slightly different:

- (a) To provide links while roving, in which case the distance from the receiving base will not be very long, say 2-3 miles maximum, and
- (b) To provide links while the vehicle is static, when the maximum range possible from the receiving site is desired, say 10-15 miles.

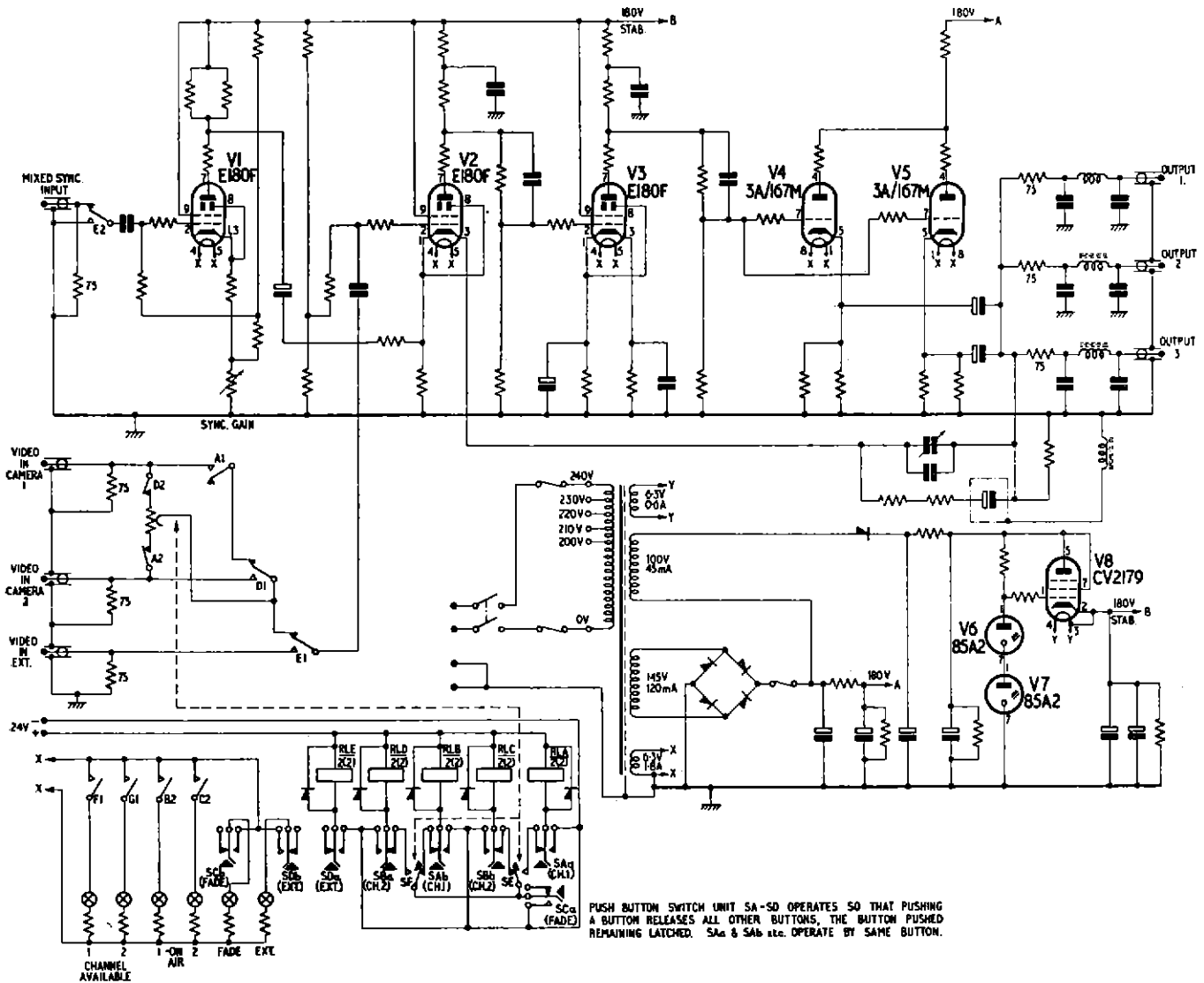

Fig. 5 — Circuit diagram of two-channel mixer

6.2 Static arrangement

If the requirement (b) can be satisfactorily fulfilled then the Roving Eye would become a powerful instrument for 'on the spot' types of broadcast.

Let us first consider the vision link. For long-distance (20-40 miles) links the usual method is to use frequencies in the s.h.f. band, 4,000 to 7,000 Mc/s, but these demand an optical transmission path. For Roving Eye work, where the path may be obstructed, these frequencies are not suitable.

A much lower frequency, say near 200 Mc/s, would be very much more suitable. However, this band is now allocated to Television Broadcasting. The next available space is in Band V, between 600 and 700 Mc/s. Propagation at these frequencies is not as good as at 200 Mc/s but much better than at s.h.f. A suitable equipment using a frequency-modulated signal in Band V had been designed by the BBC as an outside broadcast starting link. It has a nominal carrier frequency of about 660 Mc/s with a deviation of 6 Mc/s and a power output of about 20W.

Using aerials with a gain of 10 dB at both sending and receiving ends this link has given first-class signals over a 40-mile optical path. Over the more normal obstructed path a range of 10-15 miles is possible.

To achieve this range it is essential that both sending and receiving aerials are high. This is no problem at the receiving end if it is a fixture. The masts of the main television transmitting stations can make admirable reception points. At the Roving Eye end of the link a high aerial is not so easy to realize without the risk of increasing the vehicle size more than is wished. A 42-ft extensible pneumatic mast is built into the vehicle body with its base about 1 ft above the roadway. The vision aerial is mounted on a short vertical extension from the top of the mast so that when extended the aerial is supported at 45 ft above the roadway. This raises the aerial clear of most buildings in a suburban area but in the heavily built-up areas of, say, Central London it would be inadequate; in such circumstances it would probably be necessary to carry the aerial to the roof of a suitable neighbouring building.

The pneumatic mast comprises seven sections which telescope one into another. Air at a pressure of about 30 lb. per square inch is supplied from a small compressor and the mast can be raised to its full height in about two minutes. The telescopic sections have a cup type of seal and once erected the compressor is cut off and the mast will stay extended for several days if required. The mast can be rotated from inside the vehicle to point the aerial in the right direction.

Fig. 6 shows the vehicle with the mast erected.

Similar range requirements apply to the sound link and the sound aerial is carried on the same mast.

6.3 Roving arrangement

When the vehicle is roving the aerial height at the van must be low to avoid obstacles such as bridges. It would be simplest to use an omnidirectional radiator on the van, but then multipath effects would be likely to be objec-

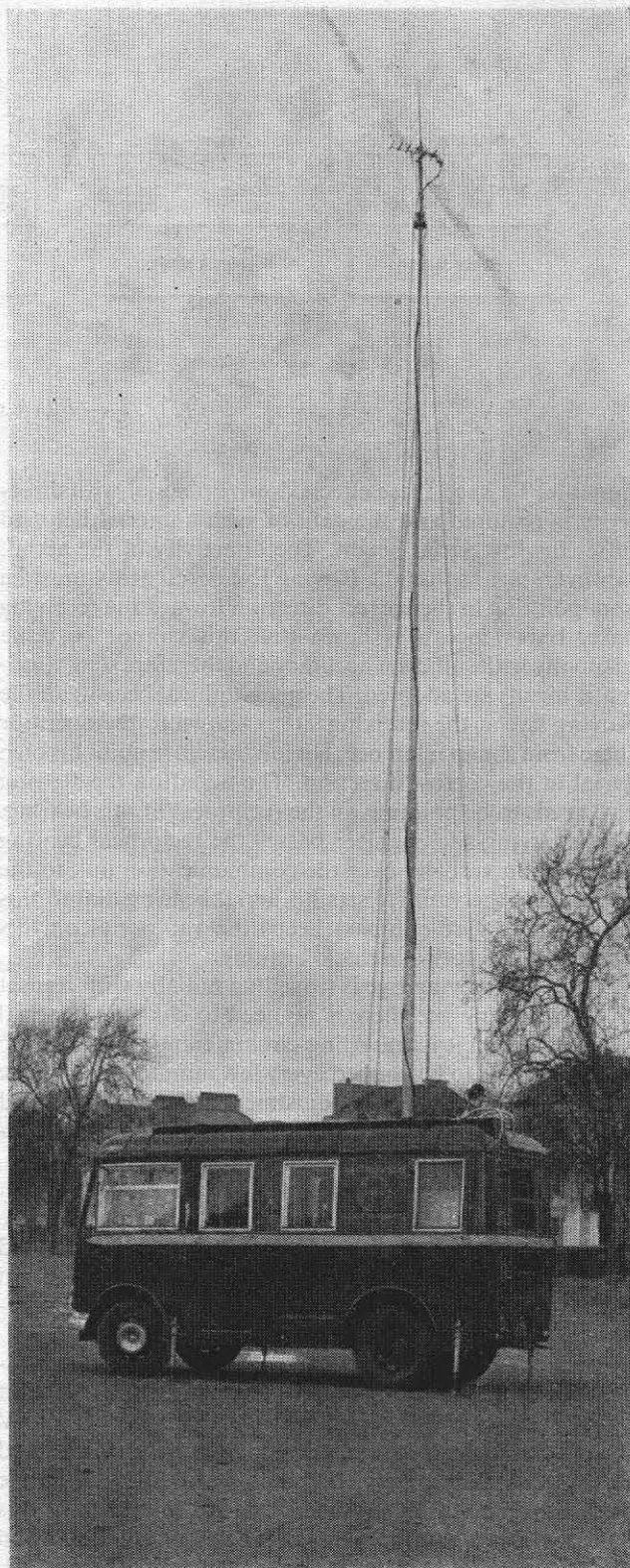

Fig. 6 — Vehicle with 45-ft pneumatic mast erected and levelling jacks in position

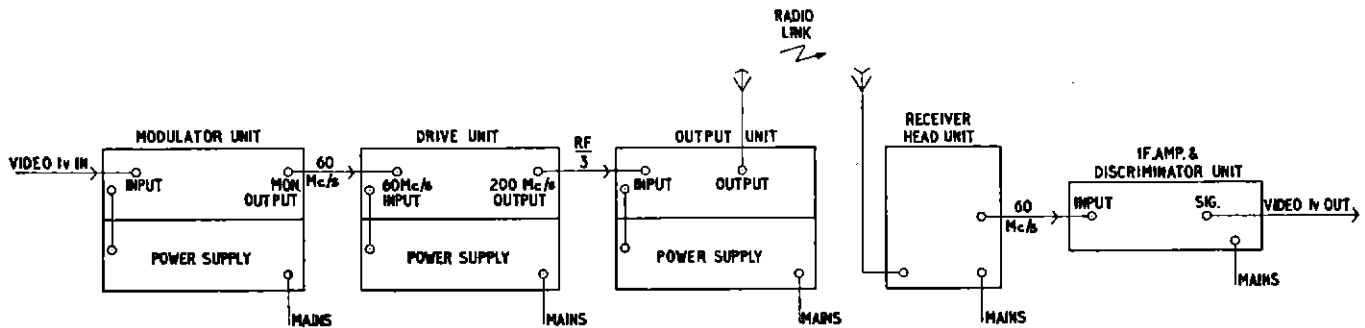

Fig. 7 — Block schematic of vision link

tionable. To keep these effects down an aerial with directivity is required and the gain of such an aerial helps to offset the low aerial height. The directivity of the aerial, however, means that the Roving Eye aerial array must be kept pointing in the correct direction toward the receiving base. Experience has shown that this cannot be done manually with sufficient accuracy and therefore semi-automatic means are adopted. The geographical bearing of the Roving Eye at the receiving site is known to the operator there from a map reference. He can therefore point his own aerial in the correct direction. The aerial on the Roving Eye needs to be pointing on the reciprocal of this bearing. The receiving-site engineer passes the reciprocal bearing information verbally over the communication link to the engineer in the van. He sets his aerial bearing dial to this value and a gyro-compass keeps the van aerial on this bearing regardless of vehicle heading.

When the Roving Eye is travelling radially with respect to the receiving site there is no need to change the aerial bearing. When it is travelling circumferentially a bearing correction has to be applied every few minutes. In practice it is found that the manual adjustment and gyro-controlled stabilizing arrangement works very well. The gyro-compass and aerial stabilizer are described later.

The other links are required for two purposes:

- (a) To carry the sound contribution to the programme (to avoid confusion this is called 'the music'), and
- (b) To provide two-way engineering and production speech channels from the Roving Eye to the receiving site both when roving and when static.

The choice of carrier frequency is governed by the availability of suitable equipment for frequencies which might be used. Since the vision carrier frequency is in Band V it would be logical to put the sound links in the same band so that common arrays etc. could be used. At the time of this project suitable transmitters and receivers for this band were not available or in sight so another solution had to be adopted. This is to use frequencies in Band I, which is allocated to Television Broadcasting, but to choose the frequencies in such a way that interference with local viewers is not caused and with distant viewers is avoided because of the geographical separation. For this

reason if the Roving Eye moves from one part of the country to another it has to change the operating frequencies of its sound links.

A frequency-modulated signal is used in the sound links so that for equivalent performance a lower carrier power is used than would be the case with an amplitude-modulated signal. This helps to keep down the risk of interference with television reception in Band I.

The actual number of radio channels for the sound is kept to two, one in each direction, and on to these are multiplexed the various music and speech channels. The multiplexing equipment is described in the section on sound equipment. The sound radio links are of conventional design available commercially and are therefore not described in detail.

When the van is roving each sound link has a separate whip aerial on the roof. When the van is static the incoming and outgoing sound links are joined to a common feeder and aerial through a splitting filter. The aerial rises from the top of the 45-ft mast.

7. The Band V Frequency-modulated Vision Link

The block schematic of the vision transmitter and receiver is shown in Fig. 7.

The video signal is applied to the modulator, which comprises some low-level video stages, an oscillator, and a reactance modulator. The output is a f.m. signal at 60 Mc/s with a peak deviation of 2 Mc/s and a power of about 1 mW. The output frequency is 60 Mc/s at the bottom of the synchronizing signals and rises towards peak white.

The modulator output is applied to the drive unit where a gain stage raises its level to 100 mW. This unit also contains a crystal oscillator at about 80 Mc/s (using an overtone crystal) whose output frequency is doubled, delivering 100 mW at about 160 Mc/s. These two signals are fed into a mixer and the wanted output signal is selected in a power amplifier which delivers about 4W on a frequency of about 220 Mc/s, the peak deviation still being, of course, 2 Mc/s.

The output from the drive unit is now fed to the output amplifiers in the third unit which contains the penultimate

and final output stages. The penultimate stage has unity gain but multiplies the frequency by three. The final stage then magnifies the signal to a power level of 18W for delivery to the aerial feeder and array. After the frequency tripling in the penultimate stage the final output signal therefore is about 660 Mc/s with a peak deviation of 6 Mc/s.

Each stage comprises an 'inverted lighthouse' triode mounted between resonant cavities. The valves are connected in a common grid circuit, and are air-blast cooled. In order to keep down the weight of the cavities use is made of duralumin elements which are silver plated for good conductivity.

The receiving aerial feeder is kept fairly short to reduce losses and is connected to a weather-proof receiver. This contains a local oscillator and a crystal mixer, followed by a pre-i.f. amplifier to give an output at about 60 Mc/s which then passes down a multiple cable to intermediate frequency amplifiers and a discriminator which delivers a final output of 1 volt at video-frequency into 75 ohms.

The oscillator in the head unit uses an 'inverted light-

house' triode in a $\frac{1}{4}\lambda$ -resonant cavity and special precautions are taken in the design of the cavity to reduce frequency drift due to change of temperature.

A further point of interest in the overall design of this equipment is the use of electronic smoothing on the power supplies to keep down the weight and size of the apparatus.

8. Aerial Stabilizer

When the van is roving the high pneumatic mast is not used at all. The vision aerial is supported on a 5-ft pole near the rear. This pole is rotated by turning gear tied to a gyro-compass through a servo mechanism.

The aerial stabilizing arrangements:

- (a) keep the aerial pointing in the direction set by the operator irrespective of the movement of the vehicle
- (b) provide power to turn the aerial in any direction at the will of the operator.
- (c) indicate to the operator the direction in which the aerial is pointing
- (d) indicate the direction in which the vehicle is travelling.



Fig. 8 — Roving Eye ready to rove

These conditions are achieved by coupling a distant-reading gyro-compass through a simple servo amplifier into a power-turning unit.

A block diagram of this arrangement is shown in Fig. 9. The directional information is fed from the gyro-compass by means of an 'M'-type transmission, i.e. a switched d.c. system using a combination of polarities, positive, negative, and neutral, on a three-wire network to produce a field rotatable in steps of 30° in a repeater motor.

The compass information is fed direct to an indicator and this gives the magnetic heading of the vehicle. This

motor. As the motor is geared to the transmitting magslip rotation will cause the error signal to decrease until the receiver magslip MS1 assumes a null position. Feedback is obtained from the generator IG and is proportional to speed. This prevents the system hunting.

Should the operator require to alter the aerial bearing at any time he causes a motor MR1 to turn the rotor of the differential magslip. This causes an error signal to appear across the receiver magslip MS1 and so turns the aerial.

Any change in direction of the vehicle causes the gyro to turn the 'M' motor on the receiver magslip MS1. This

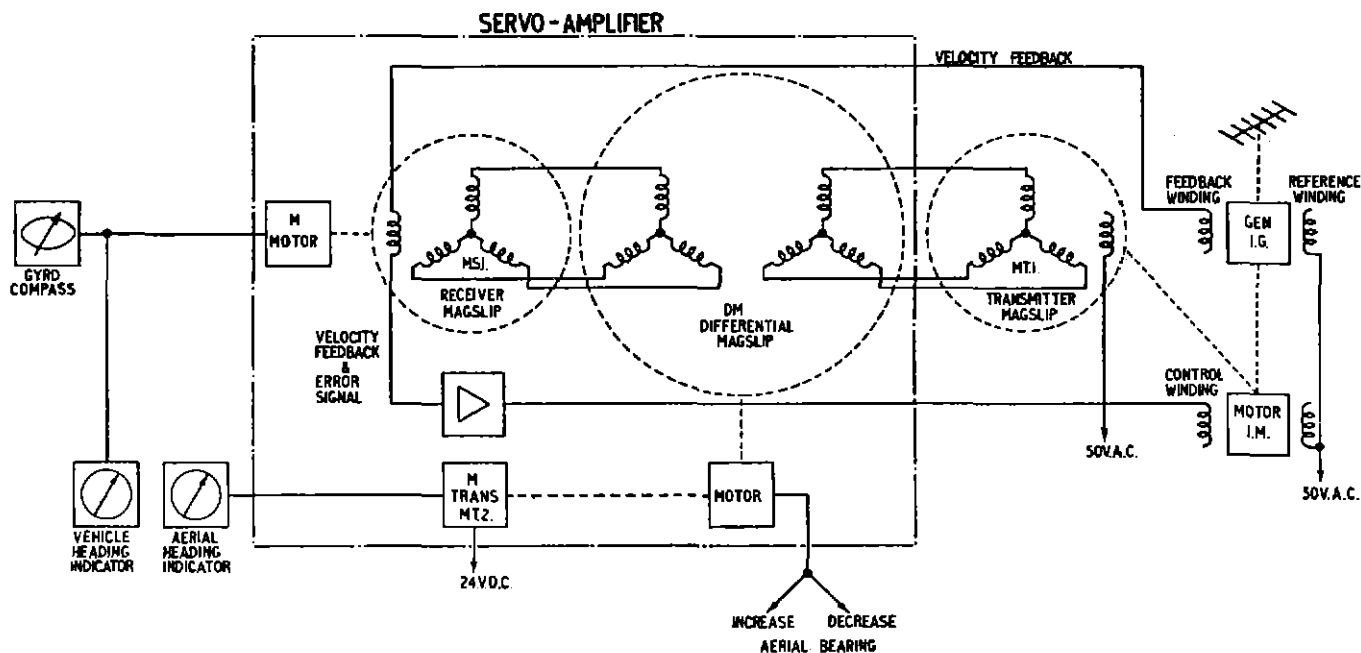

Fig. 9 — Schematic of gyro-controlled aerial

information is also fed into an 'M' motor in the servo amplifier. This motor is connected to a magslip MS1 via suitable gearing. The aerial-turning unit consists of a two-phase induction motor IM directly coupled to an induction generator IG. These are geared in turn to a magslip transmitter MT1 and the aerial. The motor, generator, and magslip are all excited from a 50-V 50-c/s supply. It can be seen from Fig. 9 that the transmitter and receiver magslips are connected together via a differential magslip DM. This allows the operator to increase or decrease the aerial bearing. The action of the whole unit is as follows. Let the aerial be at any random position. Then the phase and the amplitude of the voltage developed across the receiver magslip rotor (MS1) is proportional to the angle of the rotor of the transmitter magslip MT1 and this depends on the position of the aerial. This error signal is fed to the amplifier which in turn excites the control winding of the

again causes an error signal to appear and thus offset the change in angle of the vehicle.

Another indicator is driven by a separate 'M'-type transmitter MT2 coupled to the differential magslip. This gives the bearing of the aerial direct. The whole system is set up by aligning the aerial with the vehicle, reading off the heading from the master indicator on the gyro, and then manually setting the two indicators in the operator's position to the master bearing.

The two dials showing the vehicle heading and aerial bearing can be seen at the top of Fig. 2.

9. Sound and Talkback Equipment

The programme sound apparatus is essentially the standard BBC OBA/9⁽¹⁾ Outside Broadcast equipment. A maximum of eight microphones can be used with low-level mixing. This means that a single amplifier suffices, thereby

saving space. A second amplifier acts as a spare and can be used for other purposes such as group mixing if desired.

A trap-valve amplifier gives three separate outputs which can be used to feed

- (a) the sound transmitter or the music line
- (b) the loudspeaker amplifier in the van, and
- (c) local public address or other requirements in a 'static' O.B.

There is a small amplifier for driving the loudspeaker in the van and, by means of relay switching, this can be used for driving an external loudspeaker (see below).

The power for this equipment is normally derived from the 240-V mains, although there is provision to derive it from the 24-V battery through a rotary transformer in emergency.

All standard types of microphone can be used but a lip microphone⁽²⁾ is often preferred as it is sensitive to the commentator's speech and is insensitive to external noise. Using such a microphone the commentator can place himself behind the driver, directly over the road engine, and give a clear commentary unmarred by heavy engine noises.

There is provision for a number of programme and engineering control lines which can be extended to the producer or to an engineering position in the front of the van. By a switching arrangement the vision and sound operators can also talk on the control lines using the head and breast sets which they normally use on the vehicle talkback system, thus leaving both hands free.

The talkback or intercommunication equipment has to fulfil several requirements. It supplies all the usual facilities in the way of talkback from producer to all personnel, camera control engineer to cameraman, sound operator to all personnel, etc., which are now customary in all full-scale mobile control rooms. It also provides for the introduction of talkback from a remote point by cable, or by radio, so that when the Roving Eye is a satellite to a main mobile control room the 'main' producer can give instructions to all personnel in the Roving Eye. When the vehicle is roving the vision and sound operators only, in the van, require to talk via the control link to the base. There is therefore provision for this to be done without involving the other Roving Eye personnel. When the sound radio links are used the producer can talk to the receiving base by using the music circuit in one direction and the production talkback circuit in the other to give a 4-wire channel. This channel can be extended 2-wire from the receiving base to a distant studio centre on a telephone line if required. Since the music circuit is used this facility is only available at times when the programme is not actually in progress.

On certain types of static broadcast, e.g. theatre shows, it is necessary during rehearsals for the producer to talk to artists at a remote point, such as the stage, through a loudspeaker. There is provision whereby the producer can press a button which transfers the Roving Eye loudspeaker amplifier input to the talkback circuit and connects its output to the loudspeaker at the remote point.

The equipment for all these facilities is housed in a unit mounted at the top of the sound equipment and all important circuits are brought up to jacks on the front panel, which is within easy reach of the sound operator. With this arrangement the maximum flexibility is achieved and cross-plugging to obtain different facilities is possible. A spare amplifier is also included.

The H.T. and L.T. power supply for this unit is housed in a separate box under the sound operator's seat. This box also contains the 24-V supply for operation of all the relays and polarizing of carbon talkback microphones. This separate 24-V unit is used in preference to the vehicle 24-V battery so that the equipment may be used out of the van when desired.

10. Multiplex Equipment

The various music and speech channels are superimposed on the radio links by a frequency division multiplexer.

Fig. 10 shows a schematic of the multiplexing apparatus. This has several novel features and so will be described in some detail.

10.1 Music Channel—Roving Eye to Receiving Base

The music or programme from the sound equipment is applied through an impedance matching pad (Pad 1) to the low-pass filter LP1. This filter has a cut-off frequency of 8,250 c/s and gives an excellent response up to 8,000 c/s. The band restricted music then passes through the matching pad (Pad 2) and the amplifier AMP1 to the output to the sound transmitter, thence by radio to the receiver and to the receiving terminal of the multiplex equipment. At the receiving terminal the music passes through the low-pass filter LP2 to an impedance matching pad (Pad 6) to an amplifier which feeds into a hybrid transformer T3. This gives two isolated outputs so that the load on one does not react in any way on the other output. One output feeds to a music line, the other is used for monitoring. As described below, the first output can be switched to give a 2-wire production control circuit.

10.2 Engineering Control or Speech Channel—Roving Eye to Base

The engineering control speech from the intercommunication unit in the Roving Eye passes via the transformer T1 through an attenuator (Pad 3) to a limiter. This limiter consists of silicon junction diodes connected across the speech circuit. The speech is then passed through a pad (Pad 4) to the modulator. This modulator is fed with a 10-kc/s carrier signal from the oscillator OSC2. The output of the modulator then passes through the attenuator (Pad 5) to the band-pass filter BP1 which passes a frequency spectrum from 10,000 to 13,700 c/s, thereby selecting the upper sideband only of the modulator output. This upper sideband then passes via the impedance matching pad (Pad 2) and the amplifier AMP1 through the radio transmitter and receiver to the receiving terminal where it is accepted by the band-pass filter BP2. From the filter BP2 it passes via an attenuator (Pad 7) to a demodulator

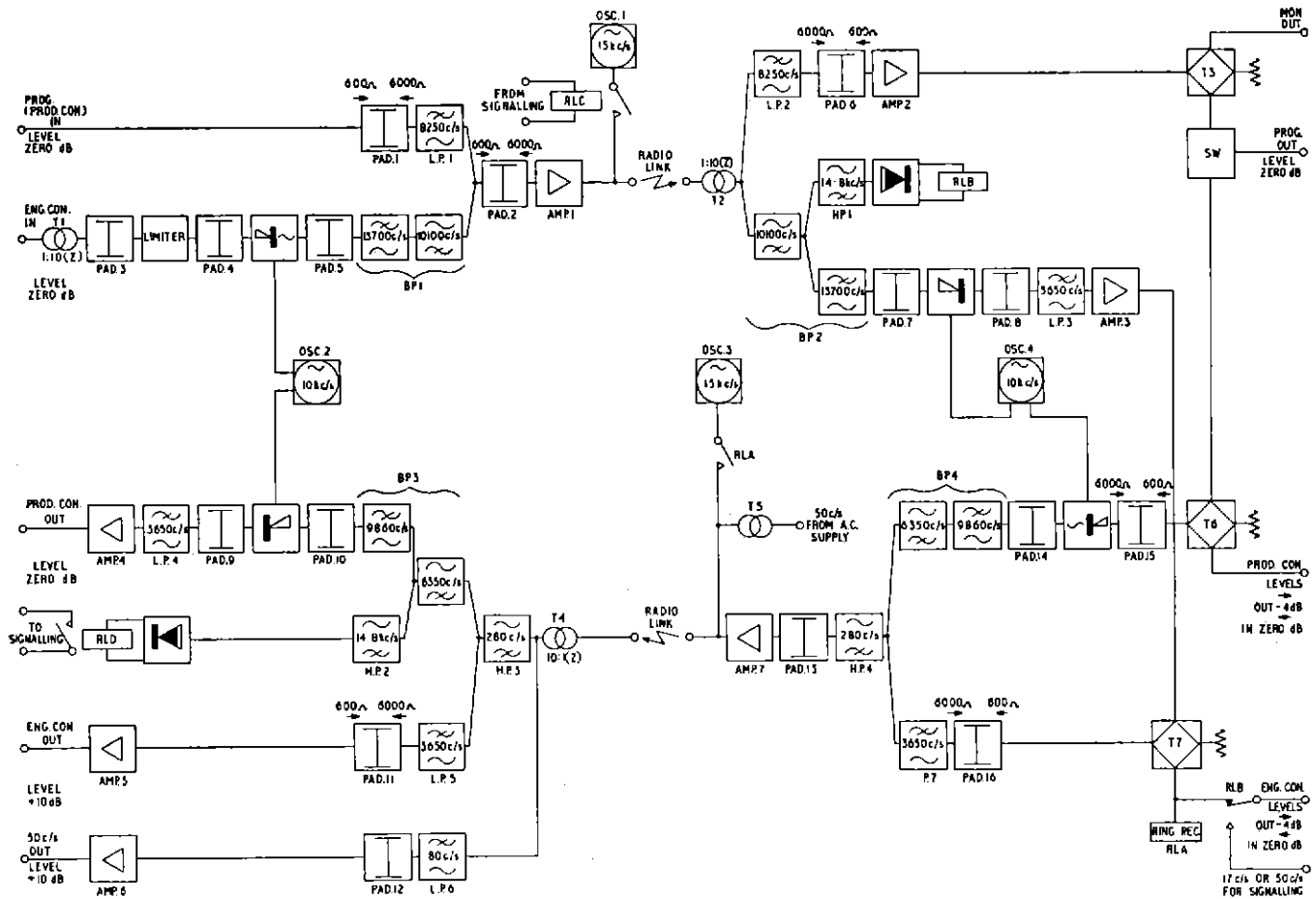

Fig. 10 — Schematic of multiplexing equipment on sound links

which is supplied with a 10-kc/s carrier from the oscillator OSC4. The output from the demodulator passes through the matching pad (Pad 8) to a low-pass filter LP3, which has a cut-off frequency of 3,650 c/s, and thence to the amplifier AMP3, whence it goes to a hybrid transformer T7. It will be noted that the overall frequency spectrum of this speech channel is approximately 100–3,600 c/s, which conforms to C.C.I.F. requirements for good intelligible speech quality.

10.3 Engineering Control or Speech Channel—Base to Roving Eye

Engineering control speech from the base to the Roving Eye passes from the hybrid transformer T7 through the matching pad (Pad 16) to a low-pass filter LP7 whose cut-off frequency is 3,650 c/s. From here it goes through the high-pass filter HP4 (cut-off frequency 280 c/s), a further matching pad (Pad 13) to the output amplifier AMP7, to the radio transmitter and receiver through the high-pass filter HP3 (cut-off frequency 280 c/s), to the low-pass filter LP5 and through a matching pad (Pad 11) to the amplifier AMP5. The output of this amplifier feeds

into the intercommunication system in the Roving Eye. It will be noted that the frequency spectrum of this channel is approximately 300–3,600 c/s, which is similar to that of the Roving Eye to base channel. The two engineering speech channels are reduced to a 2-wire circuit at the receiving terminal so that an ordinary 2-wire telephone instrument can be used or, if desired, the circuit can be extended on a normal telephone control line to a distant studio centre. Signalling is provided over the radio link so that the studio centre using magneto ringing can call the Roving Eye or the Roving Eye can call the base or studio centre. The signalling is provided by a separate narrow-band channel above the two speech (or music and speech) channels already commoned on the radio link.

11. Signalling

11.1 Roving Eye to Base

The relay RLC is energized by the operator in the Roving Eye and so applies a 15-kc/s signal from the oscillator OSC1 to the input to the transmitter, whence it passes to the receiver and the receiving terminal. Here it is selected

by the high-pass filter HP1 and applied to a tuned detector which operates the relay RLB whose contacts apply 17-c/s or 50-c/s ringing current to the control circuit.

11.2 *Base to Roving Eye*

The magneto ringing current from the base or the distant studio centre operates the relay RLA whose contacts apply a 15-kc/s signal from the oscillator OSC3 to the transmitter input. This passes to the receiver and to the Roving Eye terminal where it is selected by the high-pass filter HP2 and the tuned detector to operate a relay contact which gives an alarm in the Roving Eye vehicle.

12. Production Talkback—Base to Roving Eye

Production talkback speech from the base to the vehicle may be required when the Roving Eye is working as a satellite to a normal mobile control room but using its radio links, e.g. on the far side of a racecourse in order to cover the starts of races. This channel therefore is derived as follows.

The production talkback channel is similar to the engineering speech channel from Roving Eye to base except that the lower sideband is transmitted to minimize cross-talk between the two channels.

At the receiving terminal by operation of the switch SW there is the facility to use the music circuit and the production talkback circuit as a 4-wire speech channel during rehearsals and this can be extended 2-wire to a studio centre if desired through the hybrid transformer T6. By this means although using radio links the Roving Eye producer can talk right through to the studio centre. During transmission, of course, this facility is not available.

13. Mains Locking

Even when the Roving Eye is on the move it is desired to hold the frame frequency of the television signal in step with the public supply mains. A 50-c/s signal from the public supply at the receiving base is applied to the transmitter input. At the receiver output in the Roving Eye terminal it is accepted by the low-pass filter LP6. An amplifier AMP6 raises it to a suitable level to use as a reference signal in the television waveform generator.

There are several details of interest in the design of the multiplex equipment.

First, the impedance of the filters is pitched at 6,000 ohms to keep down the physical size and weight of the condensers. Small Ferroxcubes, Type LA1, are used for the coils. Cowan-type modulators and demodulators are used and almost all impedance transformation is done in resistive pads, the gain being made up in standard plug-in amplifiers all adjusted to the same gain setting for interchangeability.

The amplifiers are energized by two separate power units and should one power unit fail the other can carry the essential service of the music channel and the engineering control.

There is built-in level measuring apparatus so that the equipment can be checked without external equipment.

14. Base Equipment and Vehicle

The base equipment is usually carried and housed in a Karrier Bantam vehicle similar to the Roving Eye itself, the body length being increased by 18 in. An engine-driven alternator set is fitted at the rear in a sound proofed compartment. The driver is partitioned off in a normal forward cab giving a middle section devoted to operations and storage for various items of equipment. This operations section has doors which when open give a 6-ft clearance for loading purposes. Fitted under the floor are two adjustable ramps to facilitate the loading of equipment. Lashing points are also provided both in the floor and walls for securing any loose equipment whilst travelling. External scaffolding securing points are similar to those on the Roving Eye.

The transmitter and receivers, together with carrier and monitoring equipment, are fitted to two removable tables, which for transit purposes are secured by aircraft quick-release pins to the floor and walls. These tables are designed to fold flat when removed so that they can easily be carried up narrow stairs should it be necessary to establish a receiving point in a building. A work bench fitted with storage drawers is also provided in the operations compartment.

The power-supply changeover arrangements, together with overload circuit-breaker protection and the 'live and neutral reversed' indicator are similar to those in the Roving Eye. A motor-driven compressor is fitted to pump the 45-ft pneumatic mast which can carry the receiving aerial.

When the aerial is used on, say, a roof, remote from the base equipment, the actual Yagi is mounted on a short vertical spindle projecting from the case housing the turning mechanism and remote control of aerial turning is thus provided. See schematic in Fig. 11. A control Selsyn is electronically coupled to two slave Selsyns, one of which drives the aerial mast via a suitable step-down gear-box, while the other drives a cursor on a map table. The spindle of the cursor is arranged to pass through a point on the map which corresponds to the geographical position of the receiving site. This map has a compass rose giving both the bearing of any object and its reciprocal. This enables the operator to give a bearing directly to the Roving Eye over the talkback link without having to do any calculation.

A microswitch fitted to the aerial turning unit is operated by a cam on the aerial mast so that a lamp indicator on the map panel operates when the aerial is pointing in one particular direction. During the setting up period this aerial direction is noted so that it can readily be used to check that the aerial and the map cursor are in step. Isolating switches are provided to enable initial alignment to be achieved between the map and the aerial.

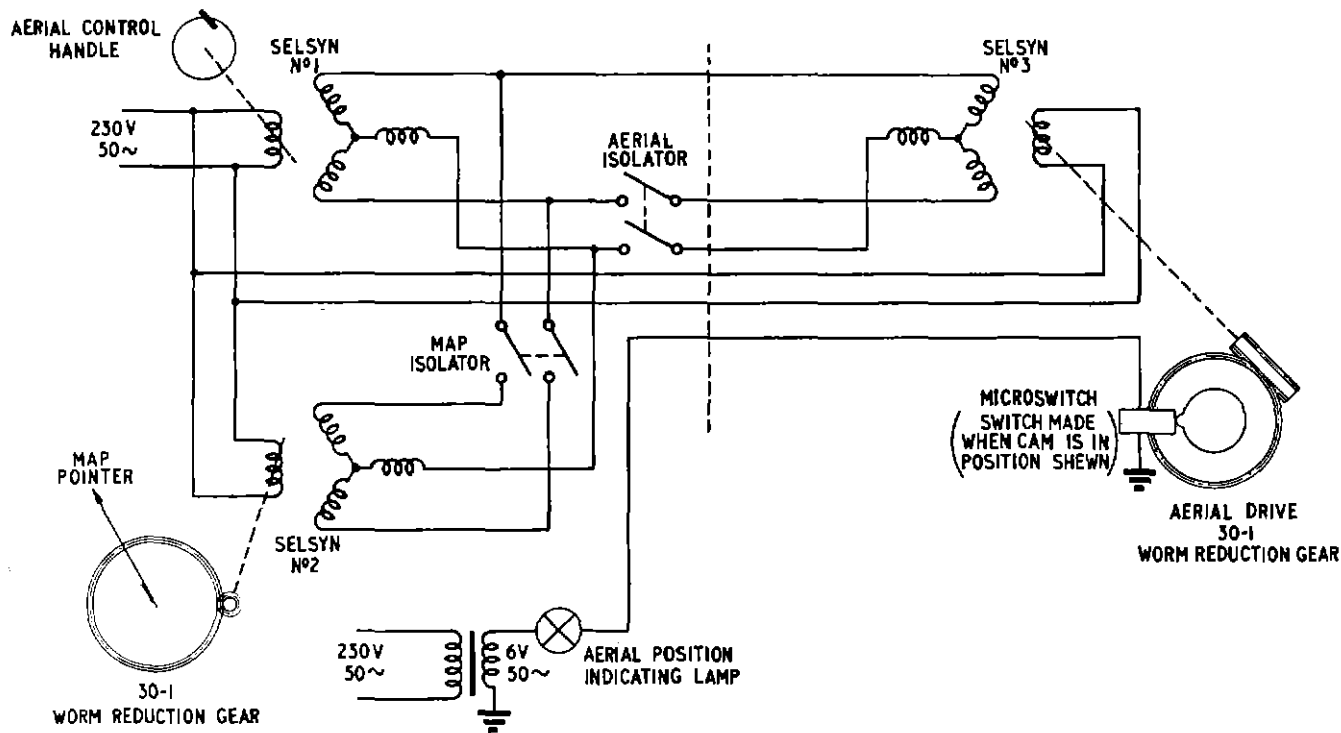

Fig. 11 — Schematic of base aerial-turning system

15. Conclusion

The project described above probably represents as good a compromise between weight, size, and performance as can be achieved with the apparatus available today. To make a major improvement in any of these factors probably calls for new techniques as, for example, a thorough-going application of transistors to as much of the equipment as possible. Lighter camera apparatus is undoubtedly needed but is not at present available in a form giving the required sensitivity, performance, and flexibility. Re-design of apparatus to consume less power would show a two-fold improvement, in the weight of the equipment consuming the power and also in that of the prime mover to supply it.

16. References

1. Berry, S. D. *New Equipment for Outside Broadcasts*, BBC Quarterly, Vol. VII, No. 2, Summer 1952, pp. 120-8.
2. Harwood, H. D. *The Design of a High-quality Commentators' Microphone Insensitive to Ambient Noise*, BBC Engineering Monograph No. 7, June 1956.

APPENDIX

Table of Dimensions and Weights

Overall length	17 ft 6 in.
Overall width	7 ft 1½ in.
Overall height	9 ft 8 in.
Overall height of 'Roving' Mast	14 ft
Overall height of pneumatic mast and aerial	45 ft
Weight of vehicle unladen	2 tons 15 cwt
Weight of vehicle with all equipment	4 tons 15 cwt

A RECENT SUGGESTION FOR IMPROVEMENT IN TELEVISION STUDIO TECHNIQUE

A METHOD OF PROVIDING AN 'IN-SHOT' WARNING FOR TELEVISION OPERATORS

by

JOHN R. GREENWOOD, B.Sc.

Engineering Training Department, BBC Engineering Division

A difficulty commonly encountered in television and film studios is that of preventing the appearance of microphones and similar unwanted objects in the final picture.

This is particularly true of television studios where the camera viewfinder covers only the transmitted picture area and in consequence provides no indication of available leeway between the picture itself and surrounding obstructions.

It is suggested that one method of overcoming this difficulty would be to fit each camera with an ultra-violet generator whose radiation pattern angle subtends a slightly larger angle of view than that of the camera lens.

Microphone booms etc. would be fitted with an ultra-violet detector arranged to actuate a warning, such as a red lamp, in the field of view of the operator in charge of the microphone boom.

Only one ultra-violet source would be allowed to radiate at any one time, this being the one mounted on the active camera.

A microphone (or the nose of a second camera) coming to within a few feet of the angle of view of the active camera would be subjected to ultra-violet radiation and the operator would then receive prior warning of his proximity

to the picture angle and would be enabled to take due care or even retreat if need be.

An additional facility which could be fitted to the active camera would be a set of warning lamps on either side of and at the top of the camera viewfinder coupled to pick-ups set at strategic positions on the boundary edges of the set or backcloth. These would warn the operator if he panned or tilted the camera dangerously close to the boundary of the set on the broadcast picture.

The following recommendations are thought to be significant.

1. Should the lack of sensitivity of the pick-up device entail the use of radiations having ultra-violet content much in excess of that contained in strong sunlight, it is suggested that a U-shaped active tube be used to spare the actors the risk of detrimental effects on their health.
2. It is suggested that a gas-filled discharge tube be used in the pick-up circuit, running with an applied a.c. potential just insufficient to cause ionization in the absence of ultra-violet light and so arranged that ultra-violet radiations will initiate ionization and subsequent magnification of current flow.
In this instance it is suggested that an applied a.c. potential be used to save the operator from having to reset the warning system when he had returned to a 'safe' position.
3. The relay circuit should be in control of the warning circuit, the relay energizing current being that flowing through the pick-up tube.

