

# BBC ENGINEERING

Number 85 January 1971

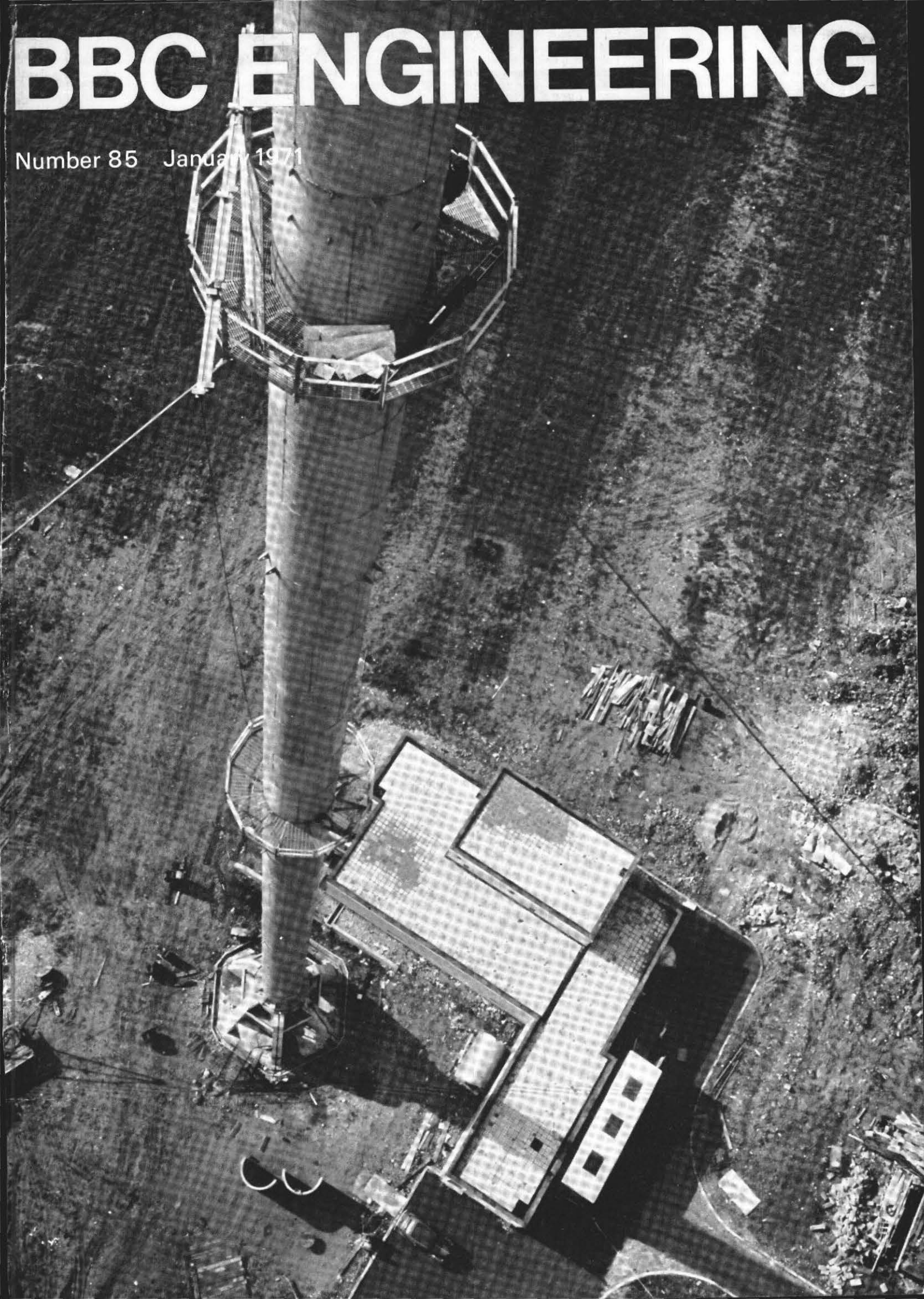

# BBC Engineering

including Engineering Division Monographs

A record of BBC technical experience and developments  
in radio and television broadcasting

Published approximately four times per year by  
**BBC Publications**,  
35 Marylebone High Street,  
London, W1M 4AA  
SBN 563 10440 6

Edited by  
BBC Technical Publications Section,  
Harewood House,  
Hanover Square,  
London, W1A 1AA

Printed by  
The Broadwater Press Ltd,  
Welwyn Garden City,  
Herts

Price  
8s. (40p.) or \$1.00 per issue post free  
Annual Subscription  
30s. (£1.50) or \$4.00 for 4 issues post free

Articles are copyright © 1970 by the  
British Broadcasting Corporation  
and may not be reproduced in whole  
or part without written permission.

*Cover illustration:*

The cover photograph (taken while constructional work was in progress) shows the mast and buildings of the Waltham unattended u.h.f. television transmitting station, which transmits on three channels and is designed to accommodate a fourth channel. Articles in this issue describe the systems of monitoring and standby operation used by the BBC for transmitting stations of this type.

## Contents

Editorial: The Unattended Operation of u.h.f. Broadcasting Transmitters	2
<b>Principal articles:</b>	
Multiplex System for Standby Operation of u.h.f. Television Transmitters R. W. Leslie	4
Technical Monitoring of Transmitters and Programme Links R. W. Holmes	10
The Choice of Primary Colours for Colour Television C. B. B. Wood and W. N. Sproson	19
<b>Short Items:</b>	
New Automatic Monitor for Television Transmitters	37
Joystick Control Unit for TARIF	37
Valves Sought by the Engineering Museum	38
Automatic Modification of Receiving Aerial Polar Diagrams	38
Receiving Aerials for Satellite Broadcasting	38
Computer Storage of Ground Profile and Population Density Data	38
<b>Contributors of the Principal Articles</b>	39
<b>Index to <i>BBC Engineering</i> 1970</b>	40

The major contributions are preceded by individual lists of contents.

## The Unattended Operation of u.h.f. Broadcasting Transmitters

Current BBC plans for u.h.f. coverage of the United Kingdom aim at commissioning nearly sixty main stations and about 450 relay stations by 1980, and these will serve about ninety-eight per cent of the population. Subsequently, additional low-power relay stations will be required to bring the population coverage up to a figure more nearly approaching 100 per cent. All these transmitting stations are designed for the transmission of BBC-1, BBC-2, ITA, and a fourth programme, as yet unallocated, from a common site using a common mast. Co-siting, of course, means that certain technical facilities are shared but the BBC and ITA each plan, install, and operate their own transmitting equipment. It would be most uneconomic to staff each of the stations in this large transmitter network and from the outset, therefore, the BBC equipment has been designed for unattended operation.

The technique of unattended transmitter operation is by no means new to the BBC. The first unattended transmitters were installed in the United Kingdom as long ago as the 1940s and operated at powers of up to 1 kW in the medium frequency band. In 1952, unattended operation was extended to high-power equipment and two 100 kW medium frequency transmitters, operating in parallel, were installed at Daventry for the Third Programme. This was followed in 1955 by the planning of the BBC network of v.h.f./f.m. stations on an unattended basis and the design of unattended 405-line television stations operating in the v.h.f. band. The BBC-1 and BBC-2 u.h.f. transmitter network involves a more extensive application of unattended working than anything previously achieved, either in the United Kingdom or elsewhere. The long experience of the BBC in the planning, installation, and operation of unattended broadcast transmitters in the lower frequency bands has consequently proved of great value in the planning of the u.h.f. network.

Although unattended transmitter operation requires complex equipment and sophisticated design methods the basic principles can be stated quite simply:

- (1) The transmitting equipment must be sufficiently stable and reliable to maintain a satisfactory performance for a long period without adjustment.
- (2) Equipment must be provided that will monitor the performance of the transmitting equipment so that corrective action can be taken when required.

The first requirement is, of course, common to any system of unattended operation but the second requirement can be

met in a number of ways and, broadly speaking, there are two basic approaches which can conveniently be termed 'remote control' and 'automatic control'. In a remote control system the operation of the transmitters at a number of sites is controlled manually by an operator at a central control point. The monitoring equipment at each transmitting station provides the operator with information regarding the state of the transmitters, via a telemetry system, thus enabling him to decide upon, and take, appropriate action in the event of a fault or an unacceptable drift in performance. In an automatic control system, on the other hand, the monitoring system associated with each transmitter detects and locates faults or drifts in performance and then automatically takes the appropriate corrective action. For example, in the event of an unacceptable fall in transmitter power the monitoring equipment would automatically change over to the standby transmitter condition. Although the automatic system deals with faults without the aid of an operator, some control staff are required at the central point. In the event of a fault, a signal is sent to a manned centre reporting the occurrence and nature of the trouble, so that a technical maintenance team can proceed to site and effect the necessary repairs. An important feature of the system is that information on the state of the transmitters need not be sent to the manned centre unless a fault or an unacceptable drift in performance has occurred. It is not necessary, therefore, to provide permanent circuits linking each transmitter to the manned centre.

The remote control and automatic control systems represent two extremes in the philosophy of unattended operation. It is possible to design systems intermediate between the extremes, where some functions (for example, the starting-up and shutting-down of the transmitters) are made automatic and other functions (for example, changeover to the standby condition) are dealt with by remote control. Long experience in the field of unattended transmitter operation has enabled the BBC to engineer a completely automatic system for all the BBC-1 and BBC-2 stations involved in the u.h.f. coverage plan. The system has been adopted, as it ensures a very high standard of service to the viewer at minimum cost.

The standard of service provided by an unattended transmitter network obviously depends to a large extent on the provision of a really effective monitoring system. The system must be able to detect faults accurately and take any necessary executive action; it must not, on the one hand, ignore unacceptable deteriorations in performance or, on the other hand, take action when small, but acceptable, drifts in performance occur. To meet this need, the BBC has developed,

---

over a number of years, an extensive range of automatic monitors for the various television and radio transmitter networks of the BBC. The design and function of these monitors varies considerably but they can be divided into the two broad classes of 'absolute' and 'comparator' monitors. An absolute monitor is arranged to measure the more important characteristics of the signal and alarm when predetermined performance limits have been exceeded. A comparator monitor, on the other hand, compares the signal being monitored with a reference signal and takes action only if the difference exceeds a predetermined level. The complexity of the monitoring arrangement adopted varies with type of transmitting station concerned.

A considerable proportion of the population of the United Kingdom is already served by unattended BBC-1 and BBC-2 transmitting stations, which operate with a small number of centralised staff. Eventually, however, a very large number of

transmitting stations will be required to provide complete u.h.f. coverage of the United Kingdom and, even with the latest designs of transmitter and monitoring equipment, the maintenance costs of the network will be high. Work is continually in progress, therefore, to produce improved designs of equipment that will reduce the maintenance effort required. The aims of new transmitter designs will be to reduce and simplify maintenance, and to provide improved stability and reliability. An effective monitoring system must be inherently reliable and must make measurements that are correlated as closely as possible with the subjective quality of the transmitted picture. Current development work therefore aims at greater simplicity and reliability by the increased use of integrated circuit techniques. Studies are also being made which will lead to a better understanding of the relationship between objective impairments and the subjective quality of the transmitted picture.

# Multiplex System for Standby Operation of u.h.f. Television Transmitters

R. W. Leslie

Transmitter Planning and Installation Department

UDC 621.396.712 621.396.41

**Summary:** A description is given of the current BBC system of standby operation in u. h. f. television transmitters. For normal working, the vision and sound transmissions are each handled by one klystron output amplifier but when a fault occurs in either klystron amplifier, the system is automatically switched to enable the remaining output amplifier to carry both the sound and the vision transmissions. This arrangement offers important advantages over the alternative system in which the vision and sound transmissions are each carried, during normal working, by two transmitters in parallel.

## Contents

- 1 Introduction
- 2 An investigation into possible systems
- 3 The selected system
- 4 Economics
- 5 Conclusion
- 6 References

## 1 Introduction

The planning of the engineering requirements of a transmitting system must provide for a standard of reliability and a quality of service which will satisfy a critical public. At the same time costs must be kept low to minimise the total capital expenditure required to build the complete transmitting network.

To achieve higher reliability and to avoid breaks in radiated programmes the BBC pioneered, about thirty years ago, a system of operating medium frequency sound broadcasting transmitters in parallel. In 1956, when the new television station for the London area came into operation, the system was extended to Band I television transmitters and the high reliability of this station led to the desire to extend the principle to the u. h. f. network transmitters.

Problems associated with phasing transmitters operating at frequencies higher than the 60 MHz or so of Band I were progressively overcome so that the first group of u. h. f. stations was also able to use transmitters operating in parallel. These stations commenced service in 1964 with equipment using large numbers of thermionic valves in the low-power stages to drive identical water-cooled klystrons in the respective output amplifiers for the sound and vision signals.

In 1965 a new phase in the development of u. h. f. broadcasting was being planned and by this time the conditions differed from those which had applied previously. Solid-state devices had become firmly established in many applications in radio engineering and the development of techniques suggested that their extension to higher frequencies and at higher powers would continue at a rapid rate.

Furthermore, to produce stations in the quantities needed and in the time available, the new transmitters would require careful design to ensure that they could be installed rapidly and brought into service by a minimum number of highly-skilled and experienced engineers. The equipment had, of necessity, to operate in a more stable manner than earlier equipment and to be reliable enough to permit stations to operate for considerably longer periods without attention.

It was therefore necessary to consider whether, in view of the new conditions, there were better and cheaper ways of building stations than by using parallel-operated transmitters.

## 2 An Investigation into Possible Systems

A study was made of ways in which stations might be engineered and a few possibilities were examined in detail. Assessments were made of probable equipment and building costs, of the efficiency and reliability of the systems and of the operational convenience. In particular, the possibility of providing the normal service with one klystron amplifier for vision and another for sound was considered as an alternative to the parallel mode of operation.

It was assumed at this stage that solid-state driver transmitters could be developed which would be capable of driving the output vision klystron directly (i.e. without an intermediate amplifier) for powers of at least 10kW. This was expected to confer an improvement in reliability and to extend the period during which the equipment could operate without requiring attention. Previous designs of u. h. f. driver transmitters included large numbers of thermionic valves, commonly more than eighty.

One consequence of improved reliability is that less use is made of reserve facilities and therefore arrangements may be acceptable which would not be so if the reserve condition had to be brought into use more frequently. In addition, if the normal service is provided by a single transmitter (instead of a parallel pair), the number of times the reserve facility is likely to be needed is approximately halved because of the reduction in the amount of equipment normally in use. In addition to considerations of reliability a new system had to

be cheaper than parallel-operated equipment while at the same time providing a comparable reserve power capability.

These requirements can be met by the system using one klystron amplifier for vision and another for sound, which will be referred to as the multiplex system. A switching arrangement enables either amplifier to be driven from a spare driver transmitter and to handle the combined sound and vision signals and to handle the combined sound and vision signals at reduced power in the event of a fault on part of the equipment. This system is attractive because it avoids the delay whilst reserve power amplifiers warm up: moreover, a substantial part of the reserve system is normally in use and is therefore known to have been satisfactory immediately prior to the change-over. The cost is appreciably less than for a conventional parallel arrangement. After taking these and other factors into account it was concluded that the multiplex system offered an overall advantage.

The use of a klystron to handle simultaneously the sound and vision signals had been suggested previously<sup>1</sup> and had been incorporated in the design of certain manually-operated transmitters used on the continent of Europe. In the present arrangement, however, the complete system was to operate automatically.

### 3 The Selected System

Fig. 1 gives a block diagram of the multiplex system adopted.

Duplicate driver transmitters for both sound and vision are shown and are arranged so that one set is normally in use while the other is connected to a unit which combines the low-power sound and vision signals and feeds the combined signal to a change-over switching system at the input of the klystron amplifiers. In the event of a fault on the working sound or vision driver transmitter or on either of the klystron amplifiers, change-over to the spare equipment takes place. At the same time a healthy klystron is selected and connected directly to the aerial feeder instead of passing through the high-power combining unit. The klystron amplifiers are identical and each has its own power supply and cooling equipment. During the

switching operation a short break in transmission of about five seconds takes place but the number of occasions when this is likely to occur is small, because of the high reliability of the solid-state driver transmitters and the long life normally available from klystrons.

The correction circuits in the reserve vision drive are adjusted to settings which differ from those in the working equipment to take account of the changed part of the klystron characteristics which apply when it operates as a common amplifier. The characteristics of klystrons of the same type are similar and a satisfactory performance is obtained on a single set of adjustments irrespective of which amplifier is being driven.

Because of the high reliability of the drive equipment it is not considered necessary to increase the complexity of the arrangement by making these automatically interchangeable. Manual plugging facilities are, however, included which permit their duties to be interchanged should this be necessary.

For the system to perform satisfactorily particular attention was paid to three requirements:

- (1) The system by which the performance of the equipment is monitored and faults detected must be reliable and arranged to minimise complications. Some of the monitoring functions have been produced as part of the transmitting equipment, while the equipment for the overall monitoring system has been developed by the BBC Designs Department.\*
- (2) Previous experience showed that faults associated with mechanical relays accounted for the greatest number of failures on transmitting stations apart from those caused by thermionic valves. The logic and control circuits for the normal operation of the equipment and selection of appropriate reserve conditions on instruction from the monitoring equipment were therefore developed to be as simple as was considered practicable and to use solid-state techniques where possible.
- (3) The r.f. switches must operate with very high reliability and must be capable of manual operation. In addition, it must be simple and quick to change a switch in the event

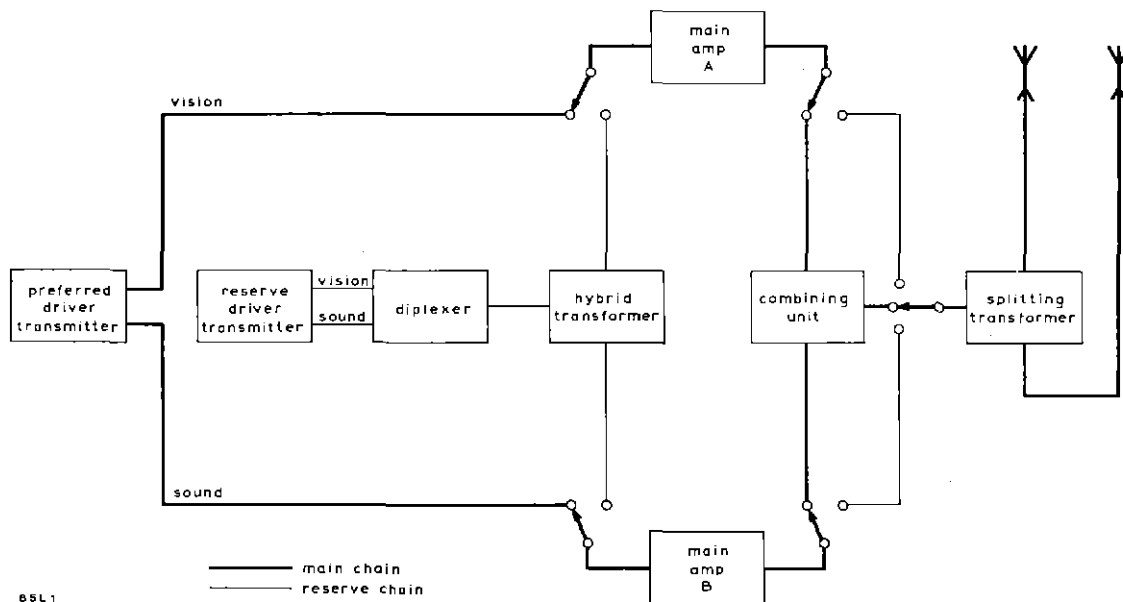

Fig. 1 Typical transmitter block diagram

of a failure. The mismatch introduced by the switches must be small to meet the requirements of the u.h.f. colour service and to permit replacement of a faulty switch without readjustment of the feeder matching arrangements. On the larger transmitters a power handling capacity of 40kW peak vision plus 8kW sound carrier at frequencies up to 854MHz was necessary. The cross-talk between the route in use and the other positions was required to be about 50dB to permit servicing of a faulty amplifier without causing a discernible disturbance on the radiated programme.

The r.f. switches from one manufacturer are based upon a conventional concept while another uses a mechanically-operated U-link arrangement.

To reduce maintenance needs the transmitters have been designed to minimise the number of blowers and cooling fans; this also increases reliability because every essential fan requires interlock circuits and these are liable to give trouble. Great attention has been directed towards the reduction of acoustic noise so as to avoid disturbance to people living near stations in quiet situations. This reduction of noise is also of benefit to the staff who maintain stations and necessarily spend a high proportion of their working time visiting sites.

The cooling system for the transmitters has been designed to eliminate the need for additional plant to ventilate the building. The heat radiated by auxiliary equipment can be extracted via the transmitter cooling plant or warm air from the transmitters can be re-circulated within the building in cold weather.

Klystrons, with four external cavities, are used for all transmitters because considerable operational experience on earlier transmitters has shown them to have long lives. Instead of pumped water cooling, however, vapour-phase cooling is used to obtain the advantages of the reduced amount of coolant needed and the reduction in pump requirements. A further advantage is that protection against freezing in cold weather can be achieved without using anti-freeze solutions. These solutions often necessitate special drainage and disposal arrangements to comply with local authority requirements and impose additional maintenance duties on operational staff. When evaporative cooling is used, the system can be so arranged that the condensate drains back into the building when the system is not in use. The central reservoir can be heated or lagged as necessary to avoid freezing.

Close attention was paid in the design of the equipment to ensuring that minimum time would be spent at site on mechanical installation, adjustment, and subsequent testing before taking service.

As far as practicable the cabling for installations is pre-fabricated and used for the works tests. By setting up the apparatus at the manufacturer's works in the same relative positions as employed at site and using the prefabricated connection system it has been possible to eliminate many of the discrepancies which frequently take place between results recorded at works and those subsequently found at site. All the equipment is arranged and fitted in simple buildings and ducts in floors are unnecessary. Typical layouts used for a 10kW and a 40kW installation are shown in Figs. 2 and 3.

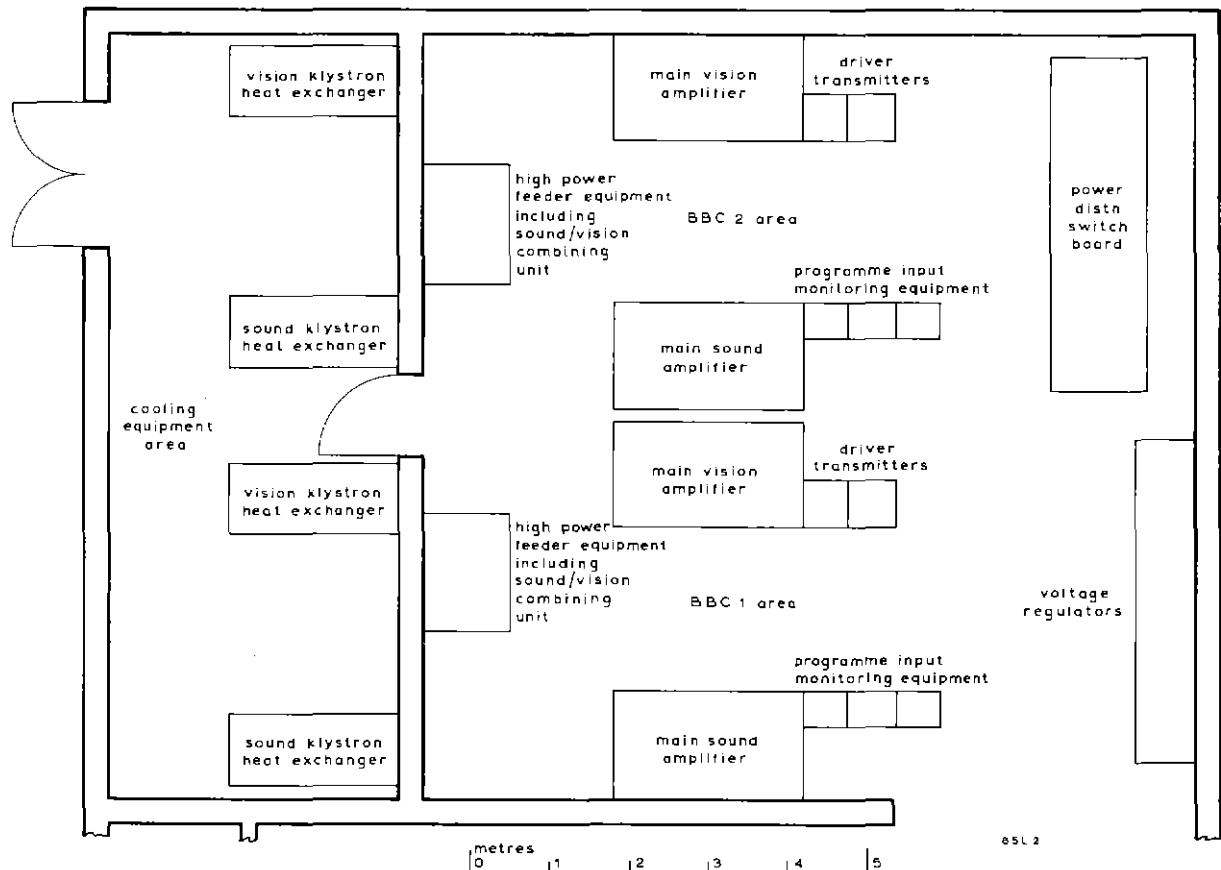

Fig. 2 Typical 10kW multiplex transmitter hall layout

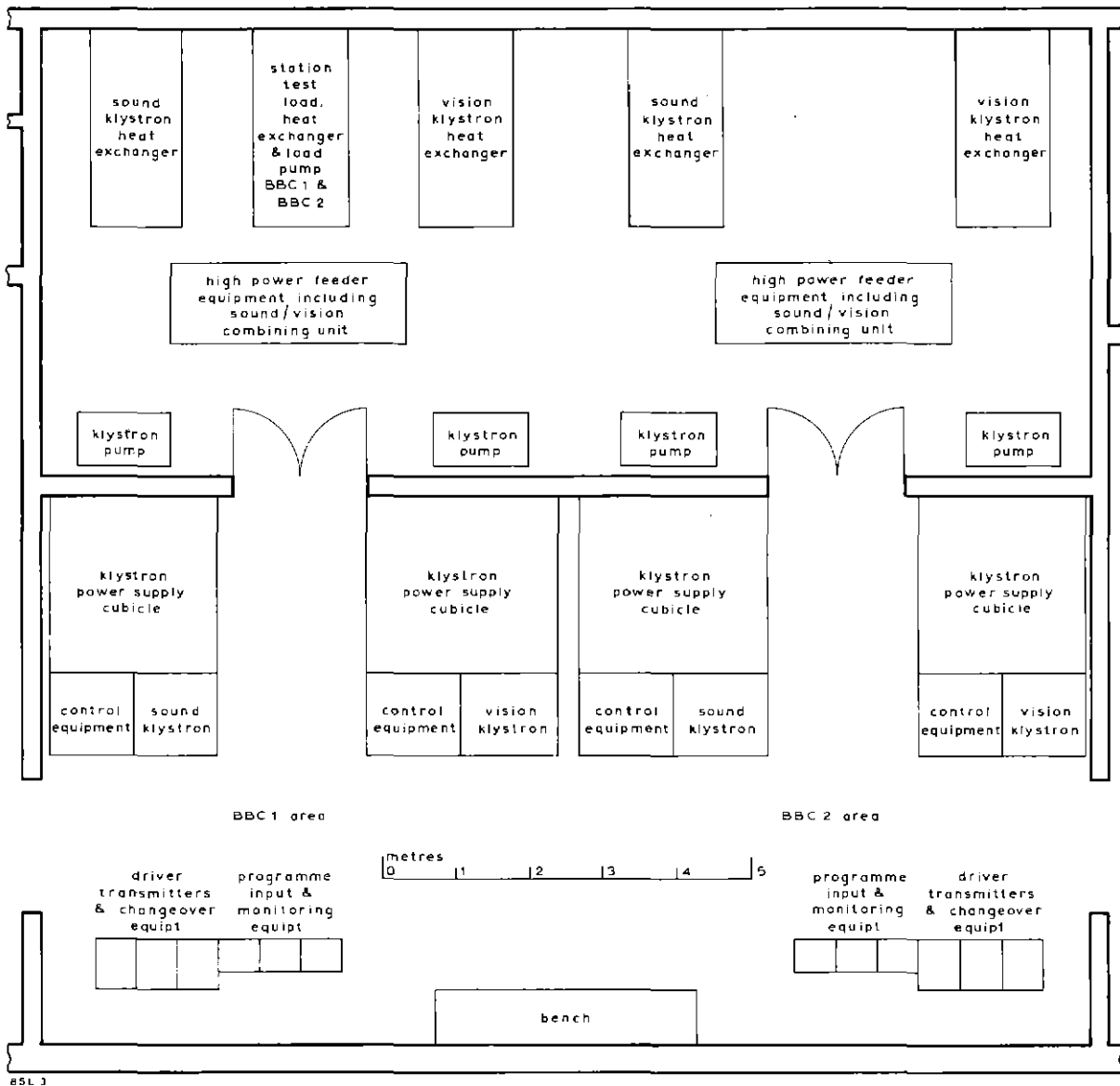

Fig. 3 Typical 40kW multiplex transmitter hall layout

The multiplex system of operation does not impose any restrictions on the performance of the transmitter on high power. However, on reduced power, when one klystron handles both the sound and vision signals, problems due to *intermodulation in the klystron amplifier* arise.

The output for this mode of operation is restricted by the presence of these intermodulation products (i.p.'s) in the output, and for 625-line colour the limit is set by the beat pattern of approximately 1.57 MHz, caused by the sideband from the chrominance signal beating with the sound carrier. The amplitude of the resulting pattern on the picture display is a function of the amplitudes of the vision carrier, vision upper sideband, and sound carrier. Consequently, the subjective severity of the pattern varies with the picture content of the programme. For specification purposes, the level of the pattern is measured in terms of the i.p. arising from a standard test signal comprising three c.w. tones at levels of  $-8\text{dB}$ ,  $-7\text{dB}$ , and  $-17\text{dB}$  for the vision and sound carriers, and vision sideband signal

respectively, where the amplitudes are relative to the vision carrier level at the tips of the synchronising pulses.

For the PAL system with a sound/vision intercarrier spacing of 6 MHz, an i.p. level of  $-50\text{dB}$  causes a 'just perceptible' impairment of the picture under ideal viewing conditions. However, all BBC transmitters operate with the intercarrier spacing offset by  $-400\text{Hz}$  which permits the i.p. level to be raised to  $-47\text{dB}$  for the same impairment. In order to allow a margin for additional impairment due to similar distortion in domestic receivers, the BBC specification for transmitters and transposers, operating normally, sets the limit for i.p.'s at  $-52\text{dB}$ . Some relaxation of this figure is permissible under emergency conditions because such operation is infrequent and its duration is a very small proportion of the total transmission time.

The performance of multiplex equipment in the reserve condition is a compromise between the conflicting requirements of maximum output power and minimum impairment



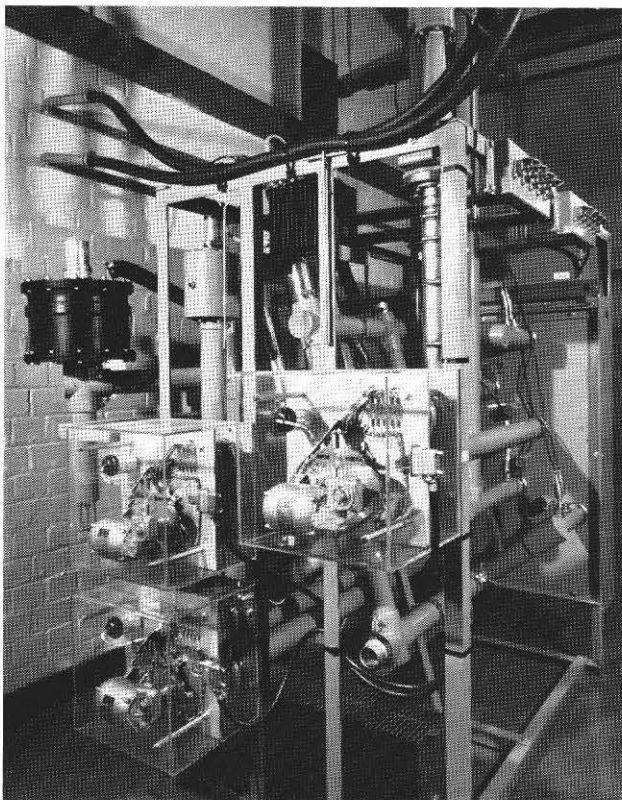

Fig. 4 10kW sound/vision combining unit and switching frame showing motorised switches

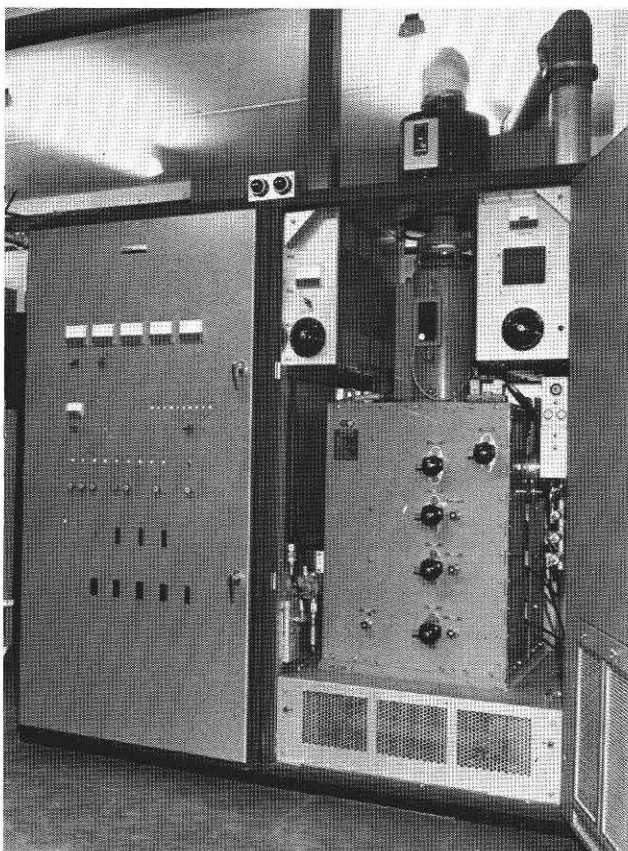

Fig. 5 Interior of 40kW klystron amplifier showing four-cavity klystron tuning controls and 6½ in. coaxial r.f. output feeder

of picture quality. The current BBC specification for transmitters to operate with a vision to sound power ratio of 5:1 requires the output power in the reserve condition to be not less than 7dB below the normal output and the level of the i.p.'s not to exceed -48dB. For systems with a vision to sound ratio of 10:1 the power would be reduced by approximately 5½dB\* for the same level of i.p.'s.

Although the intermodulation performance of individual klystrons varies considerably, there is rarely any difficulty in meeting a specification requirement of -48dB for i.p.'s at the reduced output of 7dB. A high proportion of klystrons can be operated at significantly higher power levels and with care in setting up the equipment a reduction of only 5dB is practicable in many cases.

The reduction in power output in the reserve condition is relative to the nominal rating of the equipment but the full rated output of the transmitter is not always needed to produce the required radiated power. As a result, it is often possible to have a smaller power reduction for the reserve condition than is practicable with a simple parallel system.

#### 4 Economics

Investigation into various possible arrangements for u.h.f. transmitters indicated the two most suitable arrangements, which satisfy the technical requirements for reliability, performance, and power of reserve equipment, as the parallel arrangement and multiplex.

Compared with the normal arrangement, the multiplex system has the lower capital cost because it saves one high-power sound/vision combining unit and two klystron amplifiers, and needs no automatic r.f. phasing equipment. In addition, the space needed to accommodate the plant is less and this in turn results in slightly lower building costs. Multiplex transmitters, however, require automatic high-power r.f. switches with additional logic and control circuits, also the d.c. output from the h.t. rectifiers must be greater. Nevertheless, the price of multiplex equipment is usually between 15 per cent and 20 per cent less than for the parallel system, depending on the power of the equipment.

Running costs, too, are usually less than for parallel operation. The precise saving depends on a number of factors, the most important of which are the replacement costs of the klystrons and the price of electricity. The klystron replacement costs are less for multiplex because the arrangement uses only two tubes instead of the four in parallel equipment. However, the electricity costs are usually higher because the klystron in the sound/signal amplifier operates at an efficiency of around 18 per cent, whereas in a parallel system at least 30 per cent is normally achieved.

The overall saving in running costs is significant and can be

\* This figure is arrived at in the following way:

Consider a common amplifier operating with a 5 to 1 vision to sound ratio. If the amplitude of the sound signal is reduced so that a 10 to 1 vision to sound ratio exists (i.e. a 3dB reduction), the pattern will also be reduced by 3dB. If both sound and vision signals are now increased by 1½dB the pattern will increase by 4½dB since sound, vision, and subcarrier amplitudes have each increased by 1½dB. Compared to the original 5 to 1 vision to sound ratio condition, the pattern has therefore increased by 1½dB (4½dB - 3dB). The vision power, however, has also increased by 1½dB, and thus the 10 to 1 ratio permits operation at a reduction of 5½dB with respect to normal power.

in the order of £3000 per annum for a 40-kW transmitter operating for 5000 hours per year and using klystrons with average lives of 10000 hours. If longer lives could be achieved the saving would become progressively less and eventually the advantage in running costs would be with parallel equipment.\*

## 5 Conclusion

The detailed setting-up and alignment of the transmitters for multiplex operation is more complex than for a conventional arrangement because both klystron amplifiers must be tuned for broad-band operation over a range of 8 MHz and the reserve driver transmitter must be adjusted to be capable of driving either klystron amplifier in the reserve condition. There is no difficulty in meeting these requirements if the whole equipment is taken out of service while adjustments are being made, but if the operation is to be done while radiating programme the situation is more complicated.

There are no problems either in locating or mending faults on any unserviceable part of the multiplex equipment while the service is being maintained by the reserve facilities. Difficulties do arise, however, in carrying out final tests and adjustments when the equipment is restored to normal service: these difficulties are not confined to multiplex type transmitters.

Setting up the reserve driver transmitter to feed either klystron as a common amplifier has been found to be simple because the de-rating used for the reserve condition requires little, if any, pre-correction for linearity, or for differential phase and gain to be applied to achieve an adequate performance. A disproportionate degree of care and patience is needed, however, to obtain performance to the full specification standards from each klystron.

To eliminate difficulties of this kind the use of insertion test signals has been extended so that the signals not only permit measurements of performance to be carried out while radiating programme but can be used to allow adjustments to be undertaken without interrupting service. A portable insertion unit has been developed which accepts any of the usual transmitter test waveforms such as pulse and bar, staircase and sideband analyser sweep, and inserts the waveform as an additional test signal in the field synchronising period. Observations and measurements can then be made at the output of the transmitter while adjustments are optimised.

\* Current indications, based on more than one million running hours, suggest that the mean life is likely to exceed 15000 hours.

Experience of some thirty multiplex transmitters with output powers ranging from 10kW to 40kW has confirmed the predicted advantages and has not resulted in unexpected difficulties of a technical or operational nature.

As additional transmitters are commissioned and further experience is gained, scope for the inclusion of new ideas to improve stations and to reduce maintenance requirements will arise. At the present time a method of providing a direct meter indication of the magnitude of the intermodulation products generated by a klystron amplifier is nearing completion. Insertion test signal techniques are being employed to simplify the setting-up of the reserve output to the highest possible power compatible with the maximum allowable intermodulation product level.

It may also prove practicable to raise the power rating of the reserve arrangement by providing pre-correction for the chrominance beat pattern in the reserve drive.

Scope exists, too, for considerable improvement in the efficiency of the klystron carrying the sound signal. At present the efficiency can be made about 18 per cent by lowering the beam supply and applying bias to the modulation anode when operating as the sound signal amplifier. It is attractive, however, to provide a simple switchable tuning control on one or more of the klystron cavities to obtain a narrow band response with improved efficiency that can be changed to the wide-band condition when required. So far, however, the results have not been sufficiently consistent to merit the arrangement being generally included when the increased complexity is taken into account.

Improvements which can be made must be judged against any increased capital cost which may result and also with the effect that the proposed improvement may have on the maintenance requirements of the equipment. Reliability is not only of prime importance to provide viewers with the best possible service but is also a major factor in determining the cost of maintaining a large modern transmitting network.

## 6 References

1. British Patent 785544.
2. Shelley, I. J. and Smart, D. L., 'Automatic Measurement and Control Using Insertion Test Signals'. IEE Conference Publication Number 69.

# Technical Monitoring of Transmitters and Programme Links

R. W. Holmes, B.Sc. (Eng.), A.C.G.I., M.I.E.E.

Senior Engineer (Planning and Special Projects), Transmitter Department.

UDC 621.396.712 621.396.664

**Summary:** The article reviews BBC practice in monitoring its domestic transmissions from the days of 2LO\* to the present time. Details of the equipment used are not included as these have been dealt with in the various references indicated in the text.

## Contents

### 1 Introduction

### 2 Factors to be considered

- 2.1 Basic requirements
- 2.2 Types of monitoring
  - 2.2.1 Aural/Visual monitoring
  - 2.2.2 Automatic failure monitors
  - 2.2.3 Automatic comparison monitoring
  - 2.2.4 Automatic absolute monitoring
- 2.3 Action taken
- 2.4 Factors which determine the type of monitor to be installed
  - 2.4.1 Cable feeds and radio feeds using modulation and demodulation processes
  - 2.4.2 Translators

### 3 Monitoring policy

- 3.1 Aural/Visual monitoring
  - 3.1.1 Source
  - 3.1.2 Intermediate and end of chain
  - 3.1.3 Low-power unattended transmitters

### 3.2 Automatic monitoring

- 3.2.1 Individual programme links in the distribution chain
- 3.2.2 Transmitters
- 3.3 Communication of information
  - 3.3.1 Passive telephone indicators
  - 3.3.2 Active telephone indicators
  - 3.3.3 Remote alarms using reception of radiated transmissions

### 4 Practical systems

- 4.1 Radio
  - 4.1.1 Monitoring at source
  - 4.1.2 Monitoring at destination
  - 4.1.3 Transmitter monitoring systems
  - 4.1.4 Monitoring station
- 4.2 Television systems
  - 4.2.1 Video monitoring: u.h.f. transmitter
  - 4.2.2 Video monitoring: v.h.f. transmitter
  - 4.2.3 Sound monitoring: u.h.f. transmitter

### 5 Conclusions

### 6 References

## 1 Introduction

A distinction should be made between the technical monitoring of transmitters and programme links, which is the subject of this article, and other types of monitoring which the BBC performs. Frequency measurement and the technical monitoring of overseas transmitters are carried out at the Tatsfield Receiving Station, while the content of transmissions from overseas is monitored at Caversham.

In the early days of radio broadcasting when there were only a few transmitters, technical monitoring was simple, as it could be carried out by staff at a number of points in the programme chain. Their function was to listen, to report, and to take action on any abnormalities in the transmission. Normally these duties were undertaken at the programme source, at the output of the transmitter, and at certain intermediate control points on the distribution chain between studio and transmitter. Telephone communication was provided between each monitoring point to allow rapid location of the trouble.

This system also permitted faults to be reported back to the programme source so that suitable apologies could be made to listeners. With the advent of the television service this policy was expanded to include visual as well as aural monitoring and was continued until it was largely replaced by automatic methods.

It was recognised that this form of monitoring was tedious and wasteful of manpower as a man could sit for days listening to and/or watching a programme without having to take action. The development of new techniques and the rapid advancement in electronics during and after the Second World War led to the automation of certain monitoring functions.

With the expansion in the 1950s of the number of medium frequency Home Service stations and the start of the v.h.f./f.m. radio services, the provision of staff at all stations would have been most expensive in terms of man-power. Systems were therefore developed for operating transmitters automatically with no staff normally in attendance. Equipment was installed in duplicate or triplicate so that failure of any one part would not necessitate a complete shut-down of the station. The r.f. output power was derived from paralleled transmitters such

\* The London 2kW medium-wave transmitter from which regular British broadcasting was started in 1922.

that failure of one would still permit radiation of the programme on reduced power.<sup>1</sup>

Transmitters were switched on and off by mains-wound, clockwork-driven time switches and monitoring equipment was provided to detect failures and to compare the output signal with the input. These monitors were given executive action to switch to reserve equipment or to switch off according to the nature of the fault. *Absolute monitors* were used to detect failure of the programme or of the output carrier; *comparison monitors* were used to detect less drastic deterioration in signals caused by faults in lines.<sup>2</sup> Both types of monitor are described later in this article.

The v.h.f./f.m. radio transmitters (except Wrotham) were co-sited with television transmitters. As staff were available it was necessary only to provide an alarm to warn them when an automatic monitor had taken action so that an investigation could be undertaken. Provision was also made for quality monitoring by providing a special room designed for this purpose. The unattended m.f. transmitters, however, were at sites remote from the manned stations, and monitoring equipment was designed to feed information into the normal Post Office exchange telephone system so that staff at the manned station could ring the transmitter and hear a coded signal which indicated the state of the equipment. Dependent on the code heard they would know whether the transmitter was radiating normally or whether a visit was necessary to repair a fault.

With the further rapid expansion of radio and television in the early 1960s the number of unattended transmitting stations increased substantially and the problem of monitoring such stations became a more significant factor in system design. New methods had to be found to maintain performance standards and to indicate faults immediately they occurred.

In 1965 a committee was set up to examine monitoring requirements in the light of experience, to decide the best use that could be made of equipment already in existence and under development, and finally to lay down a broad policy for future developments in monitoring techniques and programme distribution. Decisions on these points were particularly important because the second television service was about to be introduced.

## 2 Factors to be Considered

### 2.1 Basic Requirements

There are three basic requirements of any monitoring system:

- (a) the detection of faults
  - (b) their correction and
  - (c) the communication of information regarding the state of unattended equipment to a manned point.
- (a) can be further subdivided into faults causing a complete failure, either through loss of programme incoming to the transmitter or a shut-down of the transmitter itself, and secondly impairment of the transmitted programme due to distortion, wrong programme material, cross-talk from other sources, or noise at objectionable levels.

### 2.2 Types of Monitoring

Monitoring can be aural/visual or automatic and can be subdivided into four main classifications:

#### 2.2.1 Aural/Visual Monitoring

The staff carrying out aural and/or visual monitoring are available either to take, or to arrange for, any necessary corrective action. For sound the monitoring can be continuous on one programme or sequential on a time basis on two or more programmes. With vision it is normal to monitor one programme in both sound and television continuously, but where there is a second programme the picture is continuously displayed on a monitor which is observed from time to time. This is known as secondary monitoring. The sound of the second programme is monitored occasionally.

In theory, aural or visual monitoring meets all the basic requirements but in practice they have their limitations.

#### 2.2.2 Automatic Failure Monitors

For audio signals a monitor is used which detects the presence of an audio signal and which remains energised until the level falls to below  $-17$  dB with reference to zero level for a predetermined time (40, 80, or 120 seconds).

Video monitors have been designed to detect line or field sync pulses. They operate instantaneously when the sync-pulse level falls below the required level and are independent of picture content. For frequency-modulated transmissions continuity monitoring is carried out over radio paths by the use of a low-level pilot tone. The frequency of this tone was originally 20 kHz but with the introduction of the stereo service using a 19-kHz pilot tone it was necessary to change the monitoring tone frequency to 23 kHz to prevent any mis-switching of stereo receivers.

In some cases the absence or presence of the parent-station carrier frequency is used instead of pilot tone for relay transmitter starting and closing. This has the disadvantage, however, that it is possible for noise to maintain an output from the receiver after the parent station has closed down, thus keeping the relay on power.

Fig. 1 shows a typical pilot-tone system. The tone is injected into the audio chain at one transmitting station at a level of  $-30$  dB with reference to zero level. With 17.4 dB of pre-emphasis at 23 kHz this produces a deviation of approximately 4.5 kHz at the transmitter output.

At the receiving station the pilot tone is detected at the output of a receiver. The tone can be used to start and close transmitters or to change programme sources. If it is to be used on the following path the tone is filtered out from the programme using a low-pass filter and re-inserted later in the audio chain from a local source.

One further parameter that is monitored on a failure basis is carrier-frequency power. The monitor is usually situated at the output of the transmitter but in installations where there are translators followed by power amplifiers, the output of both translator and amplifier are monitored for carrier failure.

#### 2.2.3 Automatic Comparison Monitoring

This type of monitor generally compares the signals at two points in the transmission chain where they should be alike, such as the output and input of a transmitter as shown in Fig. 2(a). A programme channel may be monitored by transmitting data derived from the signal at the sending end and

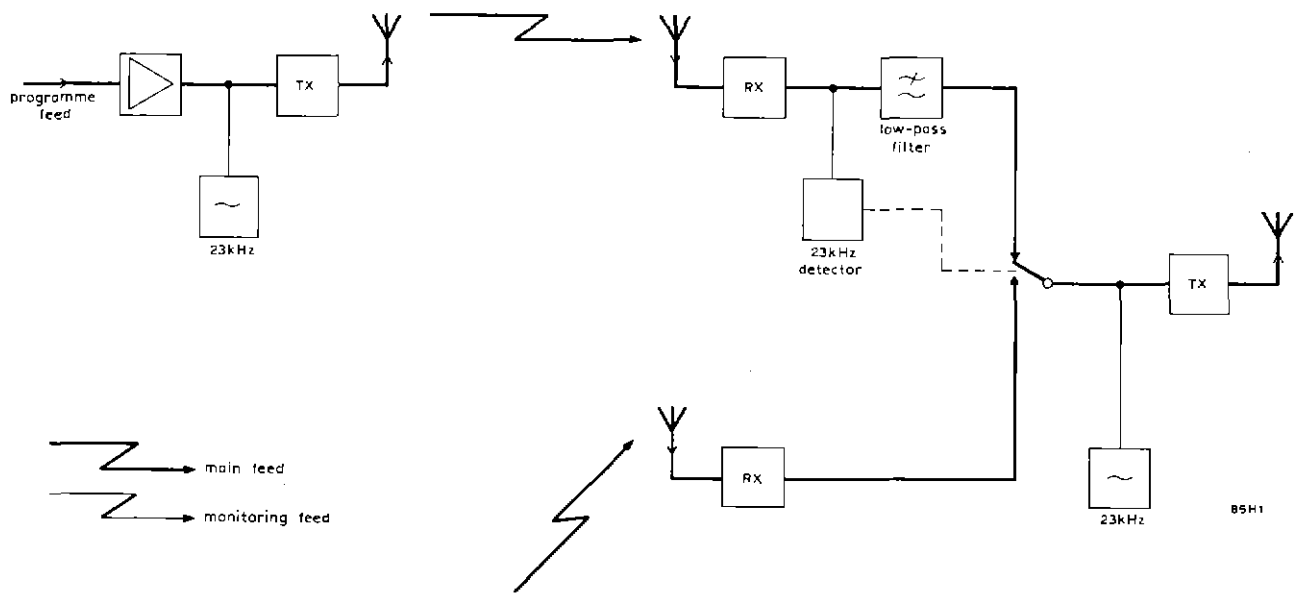

Fig. 1 Typical pilot-tone monitoring system

comparing it with similar data obtained from the signal at the receiving end. The data from the sending end can be transmitted on a separate channel as suggested in Fig. 2(b) or can be combined with the programme material on the main channel.

Instead of comparing signals at two points in the transmission chain, the outputs of two transmitters can be compared at a remote point using radio reception as indicated in Fig. 2(c). Basically, this type of monitor processes the programme signal by rectification with selected integration and discharge time-constants. Frequency response weighting networks are included to correct for the subjective response to different frequency components. Earlier equipments used analogue circuits but later versions used analogue/digital conversion techniques (1) (3) (4) (5) (6).

#### 2.2.4 Automatic Absolute Monitoring

Although described as an absolute monitor this type of equipment is really a comparison monitor in the sense that measurements made at the receiving end are related to a known fixed standard. The television waveform proves to be ideal for such monitors since the field blanking interval can be used to carry standard test signals; measurement of these signals at appropriate points in the transmission chain will reveal any significant changes in the video signal parameters. Two forms of Television Automatic Monitor exist, a simple version known as the *Minor* and a more complicated type known as the *Major*.

The *Minor*, now obsolescent, measures the overall maximum amplitude of the signal with reference to a fixed voltage and noise. The latter measurement is made on any spurious signal occurring within the line synchronising pulse.<sup>7</sup> The *Major*, on the other hand, measures a number of parameters covering both monochrome and colour components of the insertion test signal.<sup>8</sup> It has two sets of limits, one set adjusted to give warning when maintenance limits are reached and another more widely spaced set which initiate corrective action when they are exceeded. Apart from monitoring transmission per-

formance this monitor has also been designed to facilitate routine measurements as each measuring unit has a voltage analogue output which can be read on a digital voltmeter.

#### 2.3 Action Taken

The action taken by automatic equipment depends on the type of station. The equipment either raises an alarm indicating a fault which requires investigating or (as at unattended stations) it takes executive action to change programme sources, to switch to a reserve equipment (low-power operation) or, where transmitters are operated in parallel, to switch off the faulty unit.

#### 2.4 Factors which determine the type of Monitors to be Installed

The choice of monitoring system for a particular station is often a compromise. Factors taken into account are:

- (i) Reliability of equipment.
- (ii) Possibility of reducing the number of routine visits by maintenance staff to unattended stations resulting from provision of more detailed information at a remote monitoring station.
- (iii) The method of feeding programme to a station, i.e. line, video cable, s.h.f. link, re-broadcast reception from another transmitter with demodulation to audio or video, or re-broadcast reception without demodulation.
- (iv) Population served by the station.

##### 2.4.1 Cable Feeds and Radio Feeds using Modulation and Demodulation Processes

In practice the weak links in the chain are the distribution of programmes at audio or video by cable and processes involving modulation or demodulation, and it is here that distortion, cross-talk and noise can be introduced. The greater reliability and stability of solid-state devices, however, have eased this problem.

### 3 Monitoring Policy

Monitoring policy is based on the assumption of full monitoring at the source. Elsewhere at transmitters and at certain intermediate points in the distribution network automatic and/or aural/visual monitoring is used.

#### 3.1 Aural/Visual Monitoring

##### 3.1.1 Source

Aural/visual monitoring is carried out on all programmes at source, the latter being defined as the point from which the distribution system is fed. This covers both national networks and regional opt-outs.\*

##### 3.1.2 Intermediate and End of Chain

Aural/visual monitoring is also made on each programme at certain selected points and at the end of the main distribution chain. Subject to the particular shortcomings of human monitoring, this provides overall quality checks on the distribution network and allows quick identification of the faulty section and its correction.

##### 3.1.3 Low-power Unattended Transmitters

Where signals can be received at a manned station, a commercial receiver is installed in the control area and occasional checks are made. Reception may not always be of high quality but it nevertheless gives a reasonable indication of the performance of the remote transmitter. Where reception is impossible, monitoring is carried out on a routine basis by mobile engineers whenever they are in the service area. Local dealers also co-operate in reporting faults.

#### 3.2 Automatic Monitoring

##### 3.2.1 Individual Programme Links in the Distribution Chain

Main sound and vision links serving a population of greater than a million people are automatically monitored for both quality and failure using comparison monitors for sound and absolute monitors for vision. As these links are usually between staffed points an alarm is sufficient to draw attention to a fault which can be corrected.

Some main links, however, terminate at unattended stations, and here the monitors take executive action to change programme sources, the reserve source usually being a re-broadcast receiver.

Sound and vision links serving populations of less than one million are fitted with failure monitors. Where these terminate at unattended transmitters the failure monitors take executive action to switch to an alternative source. Quality monitoring is carried out by aural or visual check at the end of the chain.

Apart from a monitoring function, failure monitors are often used for starting up and closing down transmitters. Timing delays to prevent unnecessary close-downs due to short breaks are built into the transmitter control circuits.

\* Programmes which are broadcast only by one or more transmitters in a particular region, and which differ from the programmes distributed at the same time on the national network.

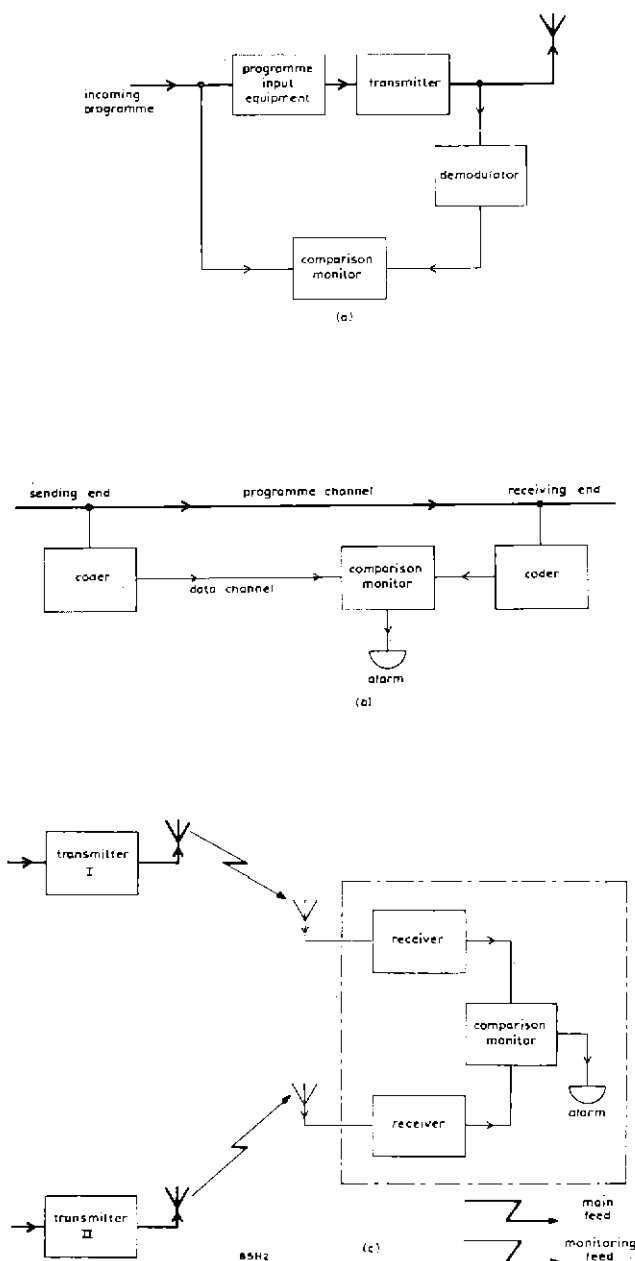

**Fig. 2** Comparison monitoring  
 (a) Comparison of two points in the transmission chain  
 (b) Comparison using a separate data channel  
 (c) Comparison of the outputs of two transmitters using radio reception at a remote point.

#### 2.4.2 Translators

In translators where the received r.f. signal is frequency-changed without being demodulated, the problems are simpler. The most likely fault is a complete failure of the r.f. output due to either the loss of the incoming signal or failure of the equipment.

There are times when fading of the received signal introduces noise into the transmission or abnormal conditions cause co-channel interference on the received signal.

As a rule, both these effects are difficult to deal with on a translator type of installation without demodulating equipment, but they last for comparatively short times.

### 3.2.2 Transmitters

Transmitters serving large areas of population are monitored automatically unless they are at the ends of programme chains when aural/visual monitoring is employed. If the station is unattended then the monitor has executive control for switching off faulty transmitters or bringing standby plant into use. Information of any action taken is communicated to the nearest staffed station.

At attended stations the monitors may have executive action or they may merely operate an alarm to warn staff that action is required.

At smaller stations monitoring is carried out according to the equipment installed and its geographical location. Action is taken accordingly and warning given to a staffed station as appropriate.

### 3.3 Communication of Information

It is necessary to install some method of providing staffed centres with information about the state of the equipment at remote sites. This information can be conveyed immediately to an attended station or stored on site and the store interrogated at intervals.

Except for the very low-power stations (i.e. 10 watts or less) a device known as a Telephone Indicator Panel is fitted in conjunction with the Post Office exchange line. This can be either 'active' or 'passive' respectively according to whether staff at an attended station are alerted automatically or as the result of a telephone call which they have had to initiate. Active telephone indicators can be subdivided into those which produce an alarm at the attended station – the latter then having to take action to interrogate the store – or those which having raised an alarm automatically pass on information regarding the state of the unattended site.

#### 3.3.1 Passive Telephone Indicators

When a telephone call is made to an unattended station, after a few pulses of ringing tone the telephone at the station is disconnected and the indicator is connected to the line. This then transmits in a simple code of dots and dashes information about the station. A dot indicates that the particular equipment being interrogated is normal and a dash that it is abnormal. The code is broken into groups with gaps in between to make reading easier, e.g. on a station transmitting three services there are four groups, one group for the transmitting equipment for each service and the fourth covering common plant such as emergency power plant, feeder gassing, etc.<sup>1</sup>

In earlier equipment the information was stored by means of relays but in later equipment solid-state logic circuits are used. Two further refinements have been added, firstly, that before the code is sent to line, a recorded announcement is made identifying the station and secondly that it is no longer necessary to send all the coded information if all is well.

Using the previous example each of the three service groups could consist of four items which with the general group of two makes a total of fourteen dots if all is well: in the new system this is reduced to four dots. Only if a fault exists is more information provided about the faulty service.

*Sequence of signals when all three services and common plant are in order.*

Code	Meaning
Dot	Service 1 in order
Pause	
Dot	Service 2 in order
Pause	
Dot	Service 3 in order
Pause	
Dot	Common plant in order

*Sequence of signals when there is a fault on Service 2.*

Code	Meaning	
Dot	Service 1 in order	
Pause		
Dot	Service 2 {	
Dot		Main modulator in order
Dash		Reserve modulator in order
Dot		Transmitter A faulty
Pause	Service 3 in order	
Dot		Transmitter B in order
Pause	Service 3 in order	
Dot		Common plant in order

#### 3.3.2 Active Telephone Indicators

When a fault occurs at an unattended site with an active telephone indicator, it triggers off the indicator which initiates a telephone call to the staffed centre.<sup>9</sup> When this call is answered the indicator identifies the calling station and the receiving station acknowledges the call by sending a tone back down the line. This switches in the code indicator and information is sent in simple code exactly as with the passive indicator. This form of monitoring is useful where it is impossible to receive the transmission radiated from the unattended station. It has the disadvantage that it can be balked if exchange lines are busy and it cannot make a connection.

A variant of this method is used where the sound transmitter is frequency-modulated and can be received at the staffed station. A 23-kHz pilot tone is normally radiated by the unattended transmitter. When a fault occurs the tone is cut to raise an alarm and is then pulsed with the coded information as in previous examples.

#### 3.3.3 Remote Alarms using Reception of Radiated Transmissions

There are two additional systems which are used to raise an alarm at the attended station to warn the staff that something has happened at the remote point and that the passive telephone indicator should be interrogated.

One method is to arrange for a milli-second break or dip in the carrier to occur when a fault appears. A detector at the attended station registers this and gives an alarm.

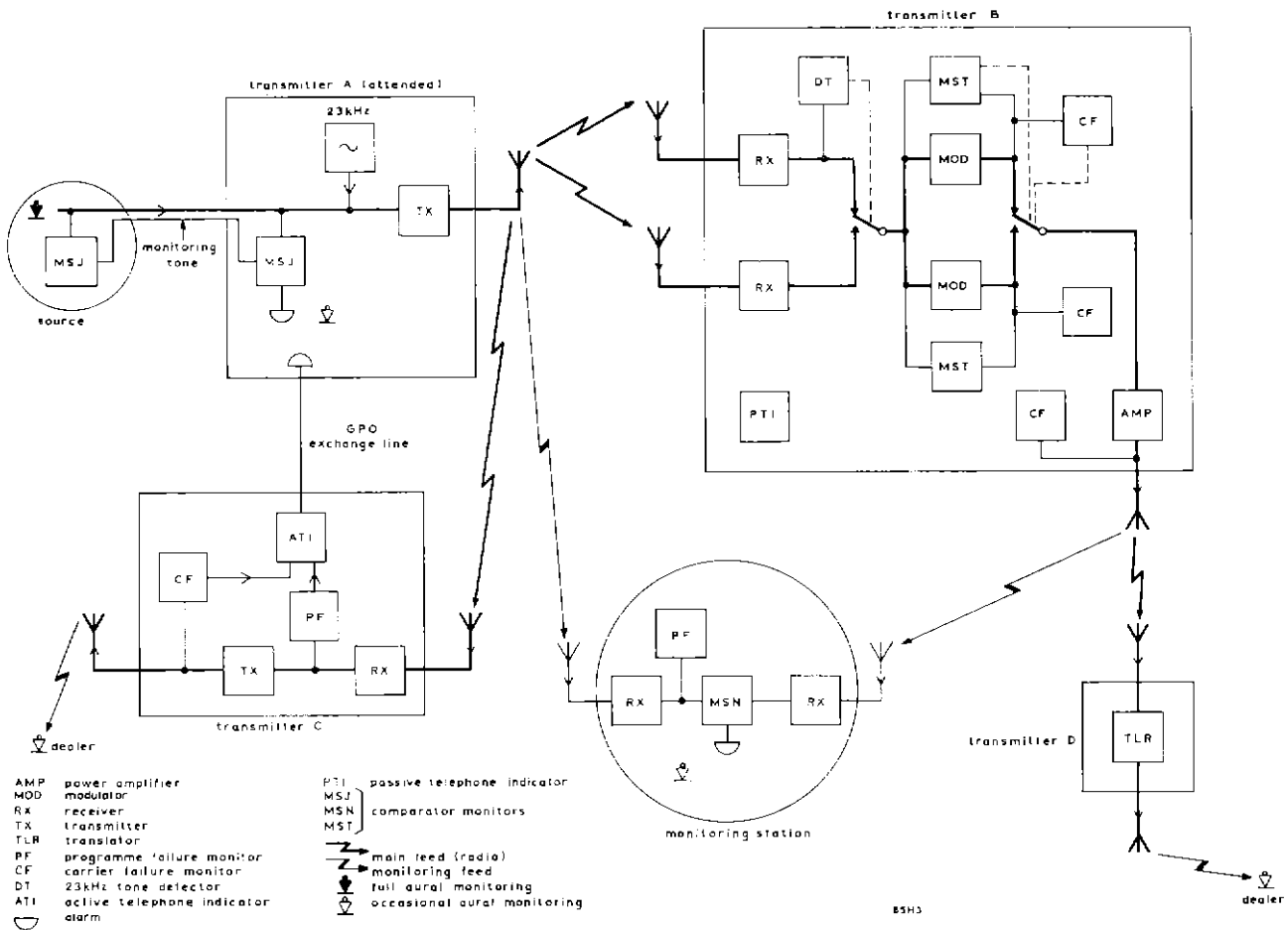

Fig. 3 Typical monitoring arrangements for a v.h.f./fm radio system

The second method used for u.h.f. translators is for an inter-carrier detector to be provided at the attended site.

#### 4 Practical Systems

Two planned systems are now briefly described, one covering an exclusively radio programme and the other a television system for both sound and vision.

##### 4.1 Radio (Fig. 3)

This is a v.h.f. frequency-modulated transmission system.

###### 4.1.1 Monitoring at Source

The source is fully monitored aurally.

###### 4.1.2 Monitoring at Destination

The line feed to an attended transmitter is monitored by a sound monitor major (MSJ) which compares signals at the sending and receiving ends. Information from the sending end is sent to the receiving stations by the use of two tones superimposed on the programme. Either or both of those tones can be present according to the conditions prevailing. In a line with a nominal bandwidth of 10kHz these tones are 10.6 and 10.8kHz. Their level is kept very low to prevent interference with the programme and they are filtered out before the programme is transmitted.

##### 4.1.3 Transmitter Monitoring Systems

###### (i) Transmitter A

Occasional listening is carried out by staff.

###### (ii) Transmitter B

This is an unattended station fed by radio from Transmitter A. Duplicate receivers are provided, changeover being effected by the absence of a 23-kHz pilot tone inserted at the programme input of transmitter A (Detector DT). Transmitter equipment at B is monitored by a sound monitor transmitter (MST) which compares the programme input with the demodulated output from the modulator. This has executive action to change to reserve equipment. Carrier-failure detectors (CF) are also provided on the outputs of the modulators to monitor the output power. Executive action is again provided on the working circuit to change over to the reserve equipment. The power amplifiers which are in parallel are monitored by carrier-failure monitors. If the output falls below a predetermined level the appropriate amplifier is switched off.

###### (iii) Transmitter C

This unattended station receives programmes from Transmitter A, the receiver being monitored by a programme-failure monitor (PF).

The transmitter itself is covered by a carrier-failure monitor (CF). As this station cannot be received at a



remote point an active telephone indicator (ATI) is fitted. Information from the programme- and carrier-failure monitors is fed into this. Ringing-out facilities are provided by a Post Office Exchange line to Transmitter A.

(iv) *Transmitter D*

This is a low-power (10W) translator. No automatic monitoring is provided but local dealer contacts cooperate in reporting major faults.

4.1.4 Monitoring Station

This is a transmitting station which does not radiate the programme being monitored. It is well situated, however, to receive both transmitter A and transmitter B. A sound monitor minor (MSN) is therefore fitted to compare the A and B transmissions. This provides adequate monitoring of transmitter B.

An additional programme-failure monitor (PF) is provided on transmitter A to cover complete failure of A which is not shown up by the comparison monitor.

Occasional manual monitoring of both sources is also provided.

4.2 Television Systems

Figs. 4 and 5 show the video monitoring for 625-line u.h.f. and 405-line v.h.f. systems respectively, while Fig. 6 shows the associated sound monitoring.

4.2.1 Video Monitoring: U.H.F. Transmitter

Fig. 4 shows an unattended u.h.f. station fed from a programme distribution system. There is no separate audio feed,

the latter information being carried in digital form in the sync pulses of the video waveform using a PCM system called Sound-in-Syncs<sup>10,11</sup>. The incoming Post Office feed is monitored by a video monitor (MVJ) which measures both monochrome and colour parameters of the test-line signal and gives an alarm when any of these are outside the prescribed limits.

Following the monitor is the sound-in-syncs decoder which separates the audio information from the video. The video signal then passes through a corrector which adjusts the luminance and chrominance gains within specified limits to produce a constant input to the transmitter. A sync detector at the output of the corrector is used for starting and closing down the transmitter.

At this point the video passes into the programme change-over relay, the other side of which is fed from a reserve source, in this example a re-broadcast receiver. The output of the relay contact then feeds the transmitters. The overall performance of the station is monitored by a second video monitor which is normally fed from a demodulator connected to a probe on the aerial feeder.<sup>12</sup>

If this monitor registers a fault, i.e. one of the parameters is out of limits such that a degraded picture is being transmitted, it triggers a logic unit. This then switches the monitor input to look at the main input (programme feed), the reserve input (re-broadcast feed) and then back to the output. During this process it measures all the parameters in each condition and stores the information before taking action.

If the fault is still present when the monitor switches back to the transmitter output, the monitor takes action based on the information stored in the logic unit. If the main feed is faulty the monitor switches the transmitter input to the reserve

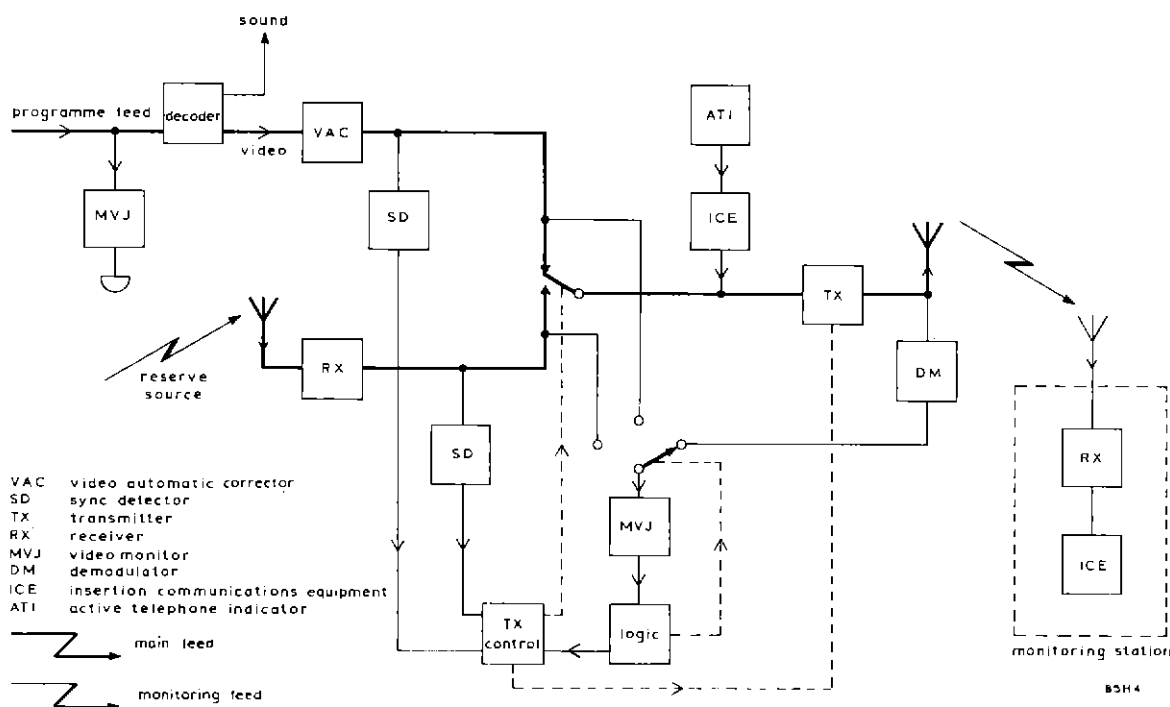

Fig. 4 Video monitoring system for a u.h.f. transmitter

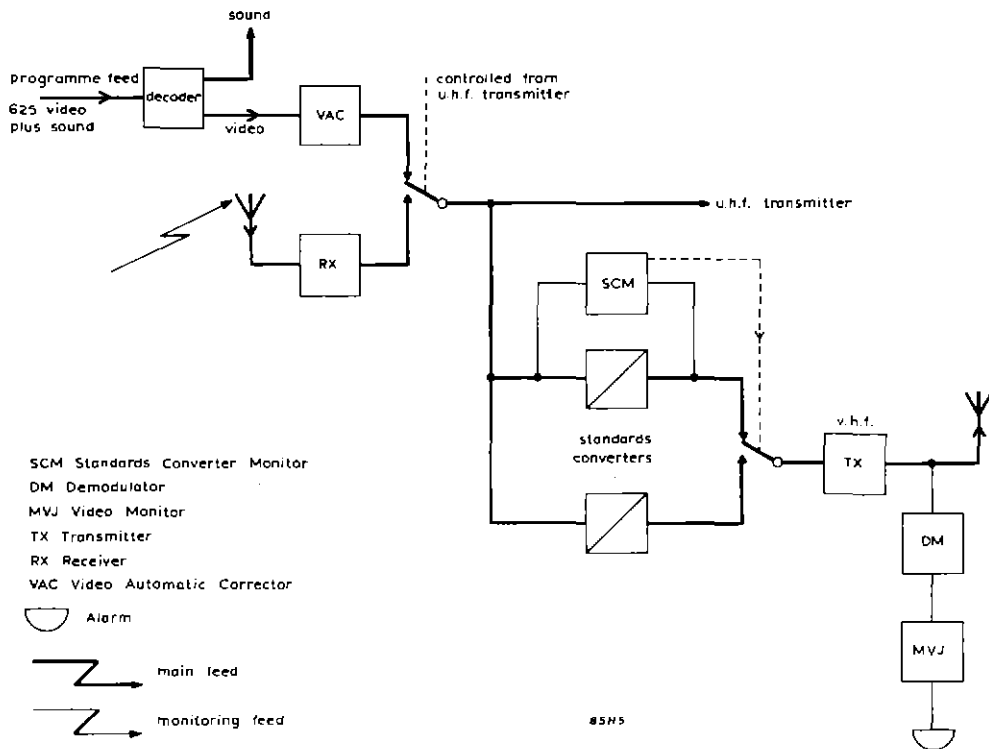

Fig. 5 Video monitoring system for a v.h.f. transmitter co-sited with a u.h.f. transmitter

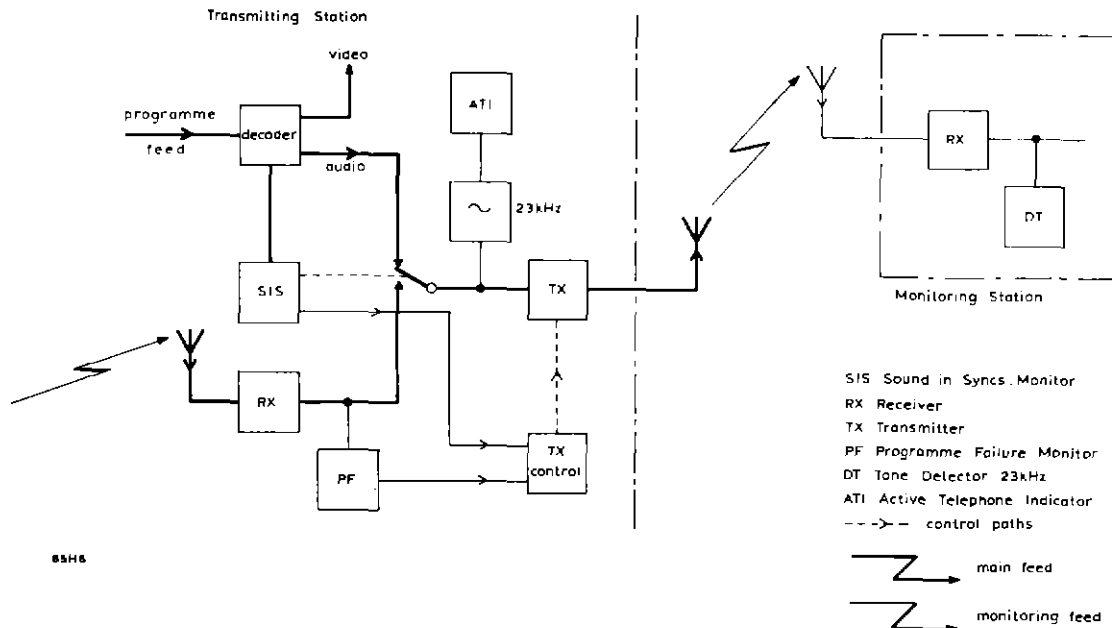

Fig. 6 Sound monitoring system for a u.h.f. transmitter

feed. If, however, the feeds are both within tolerance but the fault persists, the monitor switches the transmitter to a low-power condition using one klystron as a common sound and vision amplifier.\* Should both programme feeds be faulty, the monitor takes no action and the main feed is selected. Where two transmitters are in parallel the monitor sequence includes both individual transmitter outputs and the inputs.

\* This standby arrangement is described in the article on page 4 of this issue.

Its action on a transmitter fault is to 'throw away' the faulty transmitter.

As this system is for use at an unattended station, information must be fed back to a staffed station. This can be achieved by inserting information into the field blanking period of the transmitted signal using Insertion Communications Equipment (I.C.E.). The latter is in turn fed from a Telephone Indicator Panel as described earlier. The necessary information is then decoded at the remote monitoring point.

#### 4.2.2 Video Monitoring: V.H.F. Transmitter (Fig. 5)

V.H.F. transmitters are normally co-sited with u.h.f. installations and only the monitoring of the v.h.f. part need be considered here.

The video output from the source changeover relay is fed in parallel to the u.h.f. transmitter and to the v.h.f. transmitter via a standards converter.

The converter is monitored by its own particular equipment (SCM) which can activate the changeover system to bring in the reserve converter.

The output of the v.h.f. transmitter is watched by a video monitor via a demodulator fed from a probe on the aerial feeder. This (MVJ) is similar to that described for the u.h.f. transmitter, except that it deals with 405-line monochrome waveforms and is therefore simpler in design.

As shown in the diagram, it is connected permanently to the output and merely gives alarms, the transmitter being manually controlled.

#### 4.2.3 Sound Monitoring: U.H.F. Transmitter (Fig. 6)

As described in 4.2.1 the incoming programme feed carries audio and video information which is decoded to give separate video and sound outputs. Built into the decoder is a monitoring system (SIS) which checks that the decoder is working correctly. This monitor is fed into the transmitter control circuits for starting and closing sequences and also controls the programme changeover relay. The reserve source is derived from a receiver which in turn is monitored by a programme-failure monitor (PF).

As described previously all fault indications are fed into a telephone indicator which can either transmit information using ICE as described in 4.2.1 or, as shown in Fig. 6, by pulsing a 23-kHz oscillator, the output of which is superimposed on the programme.

This 23 kHz raises an alarm at the remote monitoring point, and then gives a read-out of the state of the station being monitored.

## 4 Conclusions

The development of automatic monitoring systems has enabled a vast number of new transmitting stations to be built without a proportionate increase in the number of staff re-

quired to operate and maintain the transmitters. In the last five years the number of stations has increased by 56 per cent to 225, and the number of services transmitted has increased by 167, while the number of staff has increased by 13 per cent.

The improvement in methods of signalling information back to staffed centres from unattended stations will lead to a better deployment of the mobile maintenance teams. The teams will be able to plan their work in advance by distinguishing the stations that require an urgent visit from those that, although still operating satisfactorily, are in need of attention. The combination of remote monitoring and signalling systems can be so engineered that performance measurements of unattended stations are always available at a staffed control centre.

## 5 References

1. Wynn, R. T. B., and Peachey, F. A. The Remote and Automatic Control of Semi-Attended Broadcasting Stations. *Proc. I.E.E.*, 1957, 104, Part B, No. 18, p. 529.
2. Peachey, F. A., Toombs, R., and Gunn-Russell, C. BBC New Automatic Unattended Transmitter Technique, Part 1. *Electronic Engineering*, Oct. 1952, p. 446.
3. Peachey, F. A., Toombs, R., and Gunn-Russell, C. BBC New Automatic Unattended Transmitter Technique, Part 2. *Electronics Engineering*, Nov. 1952, p. 490.
4. Peachey, F. A. Automatic Monitoring. *BBC Monograph*, No. 62, April 1966, pp. 10-12.
5. Carey, H. G., and Hoare, U. R. Sound Automatic Monitor Major. IEE Conference Publication No. 25, pp. 42-4.
6. Finn, S. H., and Bowhay, A. G. T. Television Transmitter Automatic Monitor. IEE Conference Publication No. 25, pp. 45-7.
7. Bower, A. H. B. Television Automatic Monitor Minor. IEE Conference Publication No. 25, pp. 48-9.
8. Shelley, I. J., and Williamson-Noble, G. E. Automatic Measurement of Insertion Test Signals. *IERE Conference Proceedings*, No. 18, pp. 159-70.
9. Chorley, J. M., and Miller, M. J. The BBC Automatic Fault Reporter. IEE Conference Publication No. 25, pp. 37-41.
10. Shorter, D. E. L., Chew, J. R., Howarth, D., and Sanders, J. R. Pulse-code Modulation for High-Quality Sound-signal Distribution. *BBC Monograph*, No. 75, Dec. 1968.
11. Chorley, J. M., and Shorter, D. L. PCM Sound-in-Syncs Operational Systems for Video Distribution and Contribution Networks. IEE Conference Publication No. 69, pp. 166-9.
12. Shelley, I. J., and Smart, D. L. Automatic Measurement and Control Using Insertion Test Signals. IEE Conference Publication No. 69, pp. 249-52.

# The Choice of Primary Colours for Colour Television

Part I: C. B. B. Wood, M.B.E., Head of Image Scanning Section, Research Department

Part II: W. N. Sproson, M.A., Head of Physics Section, Research Department

UDC 535.6.08 621.397.132

**Summary of Parts I and II:** The chromaticities of the colour phosphors used in the receiver display tube are a fundamental part of the specification of a colour television system and the colorimetric design of a camera or film scanner cannot be undertaken without this knowledge. The chromaticity co-ordinates specified by the NTSC in 1953 now have little practical meaning since phosphors have changed considerably and signal originating devices are designed to suit current production displays. Moreover, the recent introduction of a linear matrix in the design of modern colour cameras and other picture sources has increased the importance of a close match between the receiver phosphors and the spectral analysis of the picture source, since the matrix makes an approximation for the effect of the negative lobes in the ideal camera spectral sensitivity curves, and the inclusion of these lobes in the effective spectral analysis makes the matching more critical. A UK Working Party, set up under CCIR National Study Group 11, examined the situation in the United Kingdom and made recommendations that led to a change in the receiver chromaticities specified for PAL System I in that country.

Part I reviews the phosphors which have been available since 1953 and describes the performance appraisals which led to the Working Party's decision. The advantages and disadvantages of alternative proposals are discussed, and the recommendations are given in the conclusions. Part II gives a quantitative colorimetric basis to the observations and experiments described in Part I. There is an analysis of the effects of slight departures from the design set of phosphors such as are encountered in presently-available colour television receivers and the colour reproduction given by cameras designed for the original NTSC set of phosphors is also considered. It is concluded that slight changes in chromaticity co-ordinates are permissible but that the colour quality now obtainable from a camera designed for the NTSC primaries is very unlikely to be acceptable.

## Part I: Factors underlying a proposed revision of the chromaticity specification for Pal System I

### Contents

- 1 Introduction to Part I
- 2 Colour Fidelity
- 3 United Kingdom Proposal
- 4 Performance Appraisals
  - 4.1 Camera designed for PAL System J primaries with existing receiver phosphors
  - 4.2 Other proposed cameras with existing receiver phosphors
- 5 Consideration of Results
- 6 Possible Courses of Action
- 7 Conclusions
- 8 Constitution of the Working Party

### 1 Introduction to Part I

Most colours occurring in nature can be matched metamERICALLY by the addition of three suitably-chosen primary colours. A few, however, cannot be matched by means of a

simple additive mixture and it is necessary to describe the match as being between a mixture of the unknown colour with one of the primaries on the one hand and a mixture of the remaining two primaries on the other. In this case the amount of the primary mixed with the unknown colour is considered as a negative quantity. All colours can be matched with any three primaries if negative quantities are included, but in practice the three colour primaries of an additive system are usually chosen to minimise the occurrence of negative quantities.

In a colour television system the gamut of colours which may be reproduced is limited to those falling within a triangle drawn on the CIE chromaticity diagram, the apexes of the triangle being the chromaticities of the three primaries. The choice of primaries for a colour television system is essentially limited by colorimetric considerations of the spectral characteristics and efficiencies of available phosphor materials and this has always been the case. It is, of course, obvious that the colorimetric design of a colour television camera

which is required to analyse the scene into its colour components and produce colour separation signals for transmission is primarily determined by the chromaticities of the reproducing primaries available at the receiver.

In the period 1949–53 the National Television System Committee of the United States of America gave serious consideration to the choice of suitable primaries for a colour television system. The literature of that period contains a number of proposed sets of chromaticity co-ordinates based mainly upon the silicate phosphors which were at that time the only suitable ones available. By September 1951, Panel 7 of the NTSC had recommended a set of primary chromaticities; these were promulgated publicly by the NTSC on 2 February 1953 and were reiterated in the Report of the Chairman (Mr A. V. Loughren) of Panel 13 of the NTSC dated 8 July 1953. This document states:

'The gamma corrected voltages  $E'_R$ ,  $E'_G$ , and  $E'_B$  are suitable for a colour picture tube having primary colours with the following chromaticities in the C.I.E. system of specification:

	x	y
Red (R)	0.67	0.33
Green (G)	0.21	0.71
Blue (B)	0.14	0.08

and having a transfer gradient (gamma exponent) of 2.2\* associated with each primary colour† (eighteenth meeting, Motion 9).'

\* At the present stage of the art it is considered inadvisable to set a tolerance on the value of gamma. This portion of the specification will not be enforced pending a further determination thereof.

† The voltages  $E'_R$ ,  $E'_G$  and  $E'_B$  may be respectively of the form of  $E_R^{1/\gamma}$ ,  $E_G^{1/\gamma}$ , and  $E_B^{1/\gamma}$ , although other forms may be used with the advances in the state of the art.

## 2 Colour Fidelity

The optimum colour reproducer would use primaries so chosen that lines joining their CIE co-ordinates encompassed the most important part of the area of the CIE colour diagram. Suitable primary colours were suggested by Hardy and Wurzburg<sup>1</sup> but regrettably cathode-ray tube phosphors having this performance with suitable efficiency have yet to be discovered. It was pointed out in an appendix written by D. W. Epstein<sup>2</sup> to the petition of RCA before the Federal Communications Commission, dated 25 June 1953, that for good colour reproduction it is necessary that the tristimulus values or trichromatic coefficients of the subject and of the reproduction be the same.‡ In order to reproduce faithfully all those chromaticities of the original scene which lie within the colour triangle of the receiver primaries, it is necessary to control properly the relative amounts of the primaries at every point of reproduction. This imposes special requirements on three spectral sensitivity curves that are used in the camera for making the trichromatic analysis of the original scene. The theoretically-required camera sensitivity curves have regions where the sensitivity is negative. D. W. Epstein

‡ Although this is fundamentally true, it does not take into consideration some of the practical circumstances in colour television practice which arise when the viewing conditions of the original scene and of the reproduction are different, e.g. luminance level, picture surround, white point, scale size, etc.

goes on to show that any departure from the camera spectral sensitivity, as calculated for a given set of receiver reproducing primaries, must result in some lack of fidelity. The negative portions of the ideal camera spectral sensitivity curves depend rather critically on the choice of receiver primaries but the positive portions may vary only slightly for a wide choice of receiver primaries.

Although all this was understood and so clearly documented very early in the history of colour television, successive designs of colour television display tube paid very little heed to the matching of the colour display with the camera analysis. For more than ten years, following the publication of the NTSC specification in 1953, it was probably of minor importance that the manufacturers of shadow-mask tubes chose phosphors more on account of their brightness than on account of their conformity with NTSC chromaticities. During this period the effective spectral sensitivity of television cameras was limited to the positive portions of the ideal responses and the errors present because of this limitation were not substantially changed by making changes in the chromaticities of the display phosphors. However, the introduction of the linear matrix<sup>3</sup> into the practical design of colour television cameras has meant that they are now given an effective spectral sensitivity which includes an approximation to the negative sensitivities as well as the positive portions of the curves and although the overall fidelity of the television system has been much improved, the importance of a match between the camera and the receiver has become much more pronounced.

Reference to Fig. 1 shows the extent to which the chromaticities of shadow-mask tube phosphors have changed since 1953. Each move to achieve a greater brightness has resulted in a reduction of the gamut of colours which may be reproduced. Some of these were not necessarily bad exchanges since the subjective excellence of colour reproduction must include an adequate luminance level and improvements in brightness were initially more important than the ability to portray extreme colours.

The way in which the camera has followed the changes in reproduction primaries appears to have been rather haphazard. As already stated, a camera having positive-only effective spectral sensitivity characteristics is not particularly critical of discrepancies between its effective spectral analysis and the chromaticity co-ordinates of the phosphors used in the display tube in the receiver, but when linear matrix techniques are employed this becomes very much more important. The coefficients for the linear matrix have to be computed and chosen with considerable care since they exercise a powerful total effect upon the colorimetry of the system and indeed are at least as important as the shapes of the positive portions of the characteristic. Generally speaking, matrix values have been calculated and verified experimentally by reference to the chromaticities of phosphors used in the colour television monitors which happened to be in existence at the time of the choice. Hence, almost none of the colour television cameras at present in service with broadcasting organisations throughout the world conform to the original NTSC chromaticities but are based in an imprecise manner upon some other values more or less relevant to an existing colour monitor. Furthermore, the effective colorimetric performance of any given television camera must be considered not only on its spectral

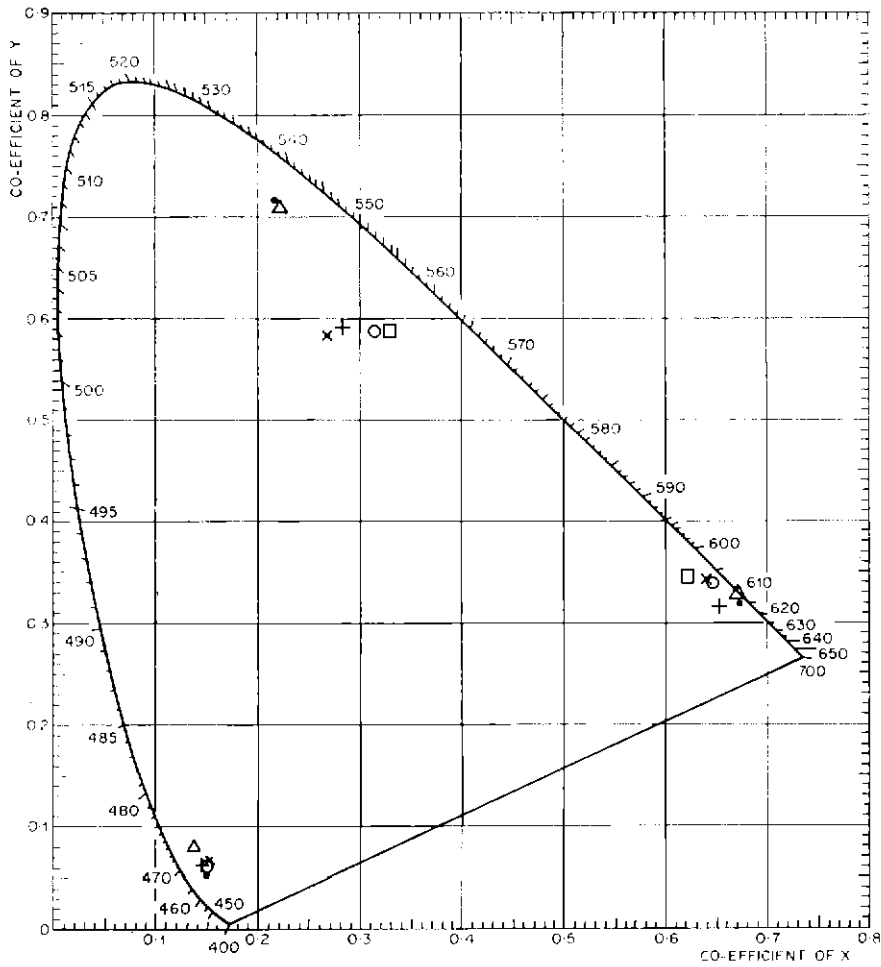

**Fig. 1** Receiver chromaticity co-ordinates  
 △ NTSC primaries 1951-3  
 • Phosphate phosphors circa 1953  
 x Sulphide phosphors  
 + Rare earth 1968  
 o Current production 1969-70  
 □ Complementary shift phosphors 1970-1

analysis characteristic and the linear matrix of its primary signals but also upon the gamma and the white point of the signals as transmitted.

It is therefore not correct to suggest that the chromaticities originally specified by the NTSC in 1953 have remaining relevance and the regrettable fact is that our present colour television cameras cannot be said to conform to any uniform specification at all.

### 3 United Kingdom Proposal

Recognising the unsatisfactory state of affairs wherein colour television cameras used in broadcasting were not colorimetrically related to receivers by anything other than a somewhat empirical approach and that the 1953 NTSC specification was obsolete in respect of receiver and camera colorimetry, a Working Party, set up by the United Kingdom CCIR National Study Group 11, Sub-group 11A, undertook a study

of the situation. It was found that although the trichromatic coefficients of the shadow-mask phosphors had moved quite a long way from those of the original NTSC specification, receivers in current production and the great majority of receivers being used by the public had reproduction primaries falling within a fairly small group of characteristics as plotted on the CIE chromaticity diagram. It therefore seemed rational to examine the spread of chromaticities in normal use and the effects of this spread upon the fidelity of the reproduced picture when the camera had been designed to match a given receiver.

It was not considered sufficient merely to find some mid-point in the chromaticities of existing receivers and to base the colorimetric design of the camera upon that. It was felt that provision should be made as far as possible to take advantage of future improvements in phosphors and this involved some prediction of the course that these improvements might take. The problems were discussed with major pro-

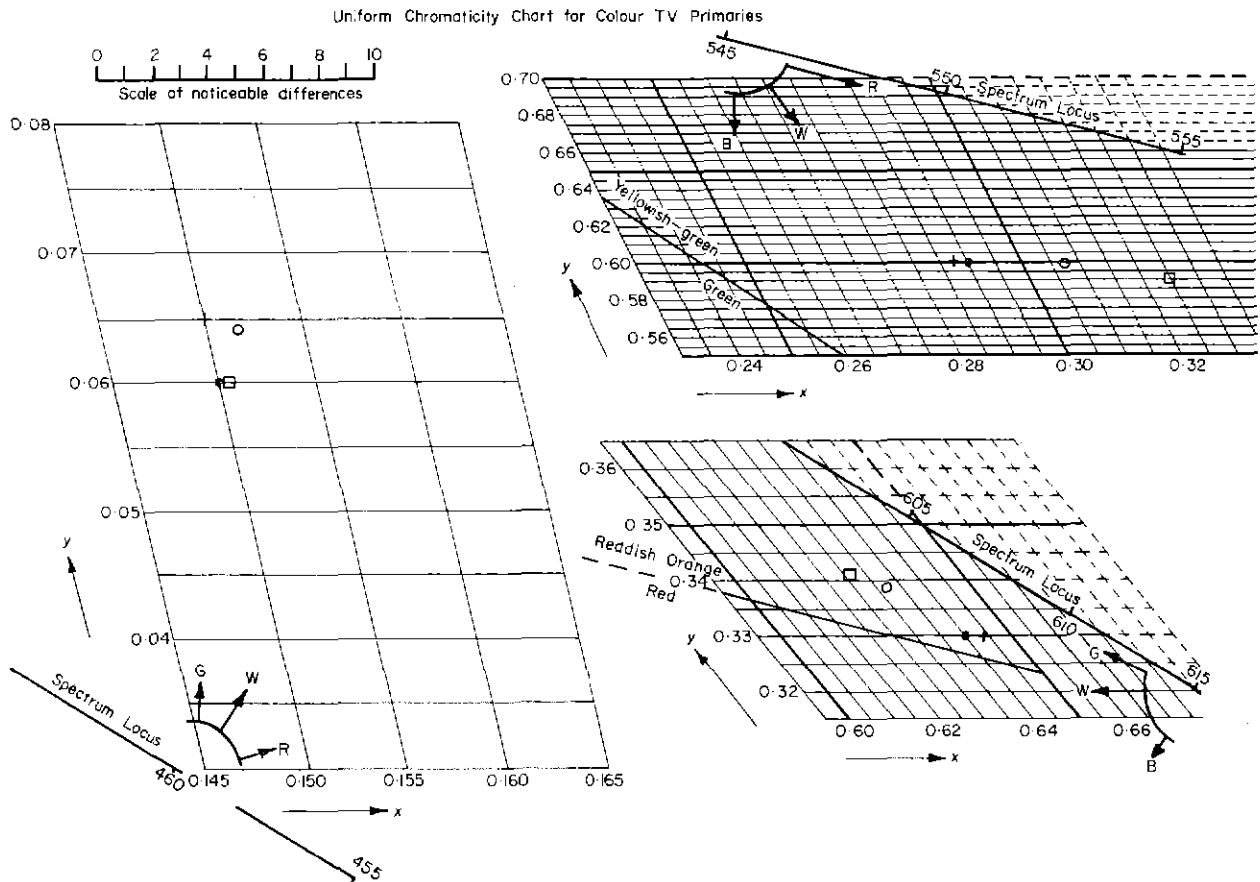

Fig. 2 Uniform chromaticity chart for colour TV primaries

- PAL System 1
- + Receiver phosphors 1968
- o Receiver phosphors 1969-70
- Complementary-shift phosphors 1970-1

ducers of colour phosphors and shadow-mask tubes and their advice was sought on the choice of a set of chromaticity co-ordinates to be used for camera design such that they would not be too far from those of existing receivers and yet were strategically placed to take advantage of possible improvements in phosphor technology. The willing co-operation of the organisations consulted, both with the Working Party and with each other, made possible an agreement on a chroma-

ticity specification which could be adopted for PAL colour television System I.<sup>4</sup> This was as shown in Table 1.

Reference to Fig. 2 will show the relationship between typical receiver phosphors and the points chosen as the design-basis of cameras to be used in the UK television broadcasting.

#### 4 Performance Appraisals

It was, of course, necessary to examine, by calculation and by subjective test, the performance of this camera when used in conjunction with a number of existing, practical display tubes. The colorimetric performance resulting from a given relationship between the chromaticity characteristics of the camera and those of the receiver can be calculated for each set of circumstances and it is also possible to set up practical experiments to permit subjective judgements. Accordingly, the Working Party set out to determine the importance of discrepancies between the effective analysis characteristic of the camera and the reproduction primaries. These were examined over the spread of receivers known to be in existence: if the discrepancies between the camera and the phosphor chromaticities were too great, then the colour fidelity of the system

TABLE 1  
Chromaticity Co-ordinates for PAL System I

	x	y
Red (R)	0.64	0.33
Green (G)	0.29	0.60
Blue (B)	0.15	0.06

Receiver white point: Illuminant  $D_{65}$   
Gamma\* of RGB displays: 2.8

\* It should not be assumed that the gamma of the transmitted signals would be 1/2.8. In practice a value of approximately 0.45 is found to give subjectively the best overall contrast law for average television viewing conditions.

overall would be found to be significantly degraded. At the same time, however, it was clearly realised that it is possible for the broadcaster to choose only one set of receiver primaries as a basis for the transmission and that all other receivers not having those primaries must display a less accurate picture, although the loss in fidelity might be so small as to be negligible.

#### 4.1 Camera Designed for PAL System I Primaries with Existing Receiver Phosphors

A camera whose colorimetric design was based upon the PAL System I receiver chromaticities was, in the first instance, considered in conjunction with three different types of receiver display phosphors. One set of receiver phosphors considered was close to the PAL System I chromaticities and was representative of the rare earth phosphors generally in use in 1968. A second set of phosphors was suggested by shadow-mask display tube manufacturers as being representative of current production in 1969-70, while a third set of phosphors used was typical of those proposed for production in 1971. In the latter case a complementary shift of the chromaticities of the red and green phosphors had been employed: this is found in practice to permit a much greater shift of both the red and the green points for a given degradation of the picture than would have been possible had only one of the two points been moved. The complementary shift, although reducing the size of the triangle of possible colours, does not cause the severe distortion of skin tones which is noticed when, for example, the green phosphor is moved in the direction of yellow, while the red is unchanged. Chromaticity points relevant to the considerations are given in Table 2.

TABLE 2  
Chromaticity Co-ordinates of Typical Phosphors in Current Use

	Red		Green		Blue	
	x	y	x	y	x	y
1968 Rare earth	0.644	0.330	0.288	0.600	0.150	0.065
1969-70 Current Production	0.632	0.339	0.307	0.597	0.152	0.064
1970-1 Complementary Shift	0.627	0.341	0.325	0.590	0.150	0.060

The Working Party and several groups of observers, totaling twenty observers in aggregate, then appraised the colorimetric performance of the system under the three sets of conditions: (1) when the receiver phosphors were a very close match for the camera design; (2) when the current production tube was in use; and (3) when the proposed complementary shift group of phosphors was in use. A number of different types of skin tones were appraised, together with a number of general scenes and a flag containing the EBU

standard fabrics.<sup>5</sup> The results using the EBU Quality Scale\* for subjective grading are given in Table 3 below:

TABLE 3  
Subjective Grading of Typical Phosphors  
PAL System I Camera  
(EBU Quality Scale)

	Skin Tones	General Scenes	Saturated Colours
1968 Rare earth (PAL System I) phosphors	1.2	1.3	1.2
1969-70 Current production	2.1	1.3	1.5
1971 Complementary shift	3.0	1.3	2.0

It will be seen that the effect of discrepancies between the camera and the phosphors was reflected in the observers' judgements of colour quality but that so far the error had not assumed serious proportions. It therefore remained to be established whether much greater discrepancies between the camera and the receiver could be tolerated.

#### 4.2 Other Proposed Cameras with Existing Receiver Phosphors

It was thought that it would be interesting to observe the effect of basing the calculation of colour analysis and matrix coefficients for a modern colour camera upon the original NTSC chromaticities. It was also noted that the proposal made by the Netherlands and tabled at the meeting of CCIR Study Group 11 in Geneva, September 1969<sup>6</sup> had suggested a compromise between the original NTSC specified chromaticities and those of a typical 1968 colour television receiver. The Working Party then examined the colour performance of three different cameras when they were used in connection with existing receiver phosphors. The camera characteristics were based upon:

- (1) The values for PAL System I
- (2) The Netherlands compromise proposal
- (3) The original NTSC chromaticities 1953

The values of these chromaticity co-ordinates are shown in Table 4.

In the practical experiment, only a single colour monitor was used, equipped with current (1969-70 production) phosphors which were intermediate in the previous set of tests between the 1968 rare earth phosphors and the proposed shifted red/green for 1971 production. All three camera conditions were examined in random order on the single monitor, using once again a wide variety of skin tones with some general scenes and the EBU test fabrics. The results were as shown in Table 4.

\*EBU Quality Scale I

- |               |               |
|---------------|---------------|
| 1 Excellent   | 4 Rather poor |
| 2 Good        | 5 Poor        |
| 3 Fairly Good | 6 Very poor   |



**TABLE 4**  
Chromaticity Co-ordinates upon which the Colorimetric Design of the Camera was Based

	<i>Red</i>		<i>Green</i>		<i>Blue</i>	
	x	y	x	y	x	y
PAL System I Camera	0.64	0.33	0.29	0.60	0.15	0.06
Netherlands Proposal	0.66	0.33	0.25	0.65	0.145	0.07
NTSC Specification	0.67	0.33	0.21	0.71	0.14	0.08

**TABLE 5**  
Subjective Grading of Camera Performances  
1969-70 Phosphors  
(EBU Quality Scale)

	<i>Skin Tones</i>	<i>General Scenes</i>	<i>Saturated Colours</i>
PAL System I Camera	1.9	1.2	1.2
Netherlands Proposal	4.3	3.2	2.9
NTSC Specification	4.6	4.1	3.4

These indicate that a change in the trichromatic coefficients used for the camera design from those that are near to a typical receiver to those that are based upon the original NTSC phosphors or to the Netherlands compromise proposal will cause an unacceptable degradation of the picture.

Hence it would seem from the results of this experiment that it is fortunate that camera manufacturers have disregarded the NTSC specification for chromaticity and have based their camera designs upon a realistic assumption of the chromaticities of modern colour television receivers.

### 5 Consideration of Results

It is necessary at this stage to consider whether the results of calculation, supported by a subjective test, are sufficient evidence upon which to base a decision concerning the chromaticity coefficients to be adopted in the specification of the colorimetric design of a television camera. It should be noted that in the subjective tests described in the previous chapter, the monitors were in every case lined up to track accurately over the grey scale balanced to illuminant  $D_{65}$ . Furthermore, the saturation control of the decoder was set up in accordance with the established practice for broadcast quality monitors using a carefully calibrated colour bar test signal. Given that the object of colour television broadcasting is to provide for the viewer an acceptable picture for the majority of subjects transmitted, rather than aiming only at objective accuracy, it might be possible to adopt some set of chromaticity characteristics for the camera other than those related to existing

receivers in the hope that the viewer would, by misadjustment of the chroma-control and the white point of the receiver, achieve subjectively satisfactory skin tones which are, after all, the most sensitive indications of poor colour fidelity. Such a step would, however, by the inclusion of a subjective receiver balance, undermine the ability of the broadcasters and the receiver manufacturers to achieve an engineering specification for colour reproduction. A practical examination of proposals to readjust balance and saturation of the receiver shows that they are not, in fact, acceptable remedies. With a camera designed to suit NTSC chromaticities and a modern receiver, an increase of approximately 45 per cent in chrominance signal level is found necessary to bring the saturation of colours subjectively into the right area and this would have serious implications on the effect of interfering signals, cross-colour, and service area. With a camera designed in accordance with the Netherlands proposal, the corresponding increase in chrominance signal level is about 40 per cent. Moreover, the shift of white point required to make skin tones relatively acceptable renders many other colours noticeably incorrect.

Any attempt to adopt chromaticity coefficients for the camera which were not close to practical, realisable phosphors would in any case cause great difficulty to the television broadcaster. Even if the empirical readjustment of colour balance and saturation could be tolerated and achieved in a retrospective operation concerning the 1.5 million receivers already installed in Europe, such a procedure would be quite intolerable in broadcasting control rooms. A standard and objective method of setting up monitors and cameras is essential and it would be necessary either to have control room monitors with phosphors to match the chosen characteristics for the camera or alternatively it would be necessary to fit each monitor with a matrix. An operation upon the gamma-corrected signals can only give approximate correction and a rigorous treatment would require three linearising circuits for the decoded colour separation signals, followed by a linear matrix and three gamma-correcting circuits. The likelihood of such an arrangement proving economical or satisfactory seems very remote.

At the same time, however, the Working Party were anxious not to overlook the fact that a set of phosphors giving a larger gamut of reproduced colours than those in current production, and also having good efficiency, might one day be devised.

### 6 Possible Courses of Action

It might be argued that the present situation in Europe is relatively satisfactory and that no action is necessary. The spread of chromaticities in receivers at present being offered to the public appears to be sufficiently small to give no serious degradation of the pictures transmitted from a typical modern television camera. Any new receiver appearing on the market would be judged by its performance when used in connection with existing broadcasts and any new camera would likewise be judged by its performance when used in connection with existing receivers. Existing specifications of standard chromaticity co-ordinates would remain notional and of no practical significance.

The excellence of the PAL system in giving freedom from colour errors arising in the transmission path relieves the

viewer of any need to make adjustments to colour balance or hue on changing from one station to another. It is therefore very desirable that all broadcasting networks which may be received by any particular receiver should have uniform chromaticity characteristics in their output signals. This means that the networks should use identical colour monitors for balancing their transmissions and have totally objective methods of lining up both the monitor and the camera. Furthermore, all cameras must have their analysis characteristics and matrix coefficients based upon a recognised set of reproduction primaries. Hence it is very desirable to have a meaningful and rigorously observed standard of transmission from the point of view of colorimetry in any country where there is more than one network. The same argument could be extended to all countries taking part in the Eurovision network.

If it is decided that some action should be taken, then the possible courses are as follows:

- (1) The UK proposal, as adopted in PAL System I, to base the colorimetric design of the camera upon chromaticities near to those of existing receivers, or alternatively,
- (2) To adopt chromaticity co-ordinates for the camera design which are not related to existing receivers but describe a set of phosphors not yet invented which would be more satisfactory from the point of view of colour gamut and efficiency than those existing.

The advantages of Course (1) are:

- (a) that it gives the best possible picture on all existing receivers
- (b) that practical standard colour monitors can be used in broadcasting control rooms to assist in ensuring a standard output from all networks
- (c) that it is substantially in line with existing practice and therefore requires no expensive re-equipment.

The disadvantage of Course (1) is that in the event of a new set of phosphors being invented which gave a greater gamut than those for which the camera is designed, incomplete advantage could be taken of this improvement. The implications of this are dealt with in Part II.

The advantage of Course (2) is that any new set of phosphors invented might be closer to the chosen chromaticities than those adopted under Course (1) and the door is not closed to this improvement. The disadvantages of Course (2) are:

- (a) that it will not be possible to obtain practical control room monitors having phosphors to match the chromaticity coordinates chosen for the camera design
- (b) that the picture quality on all existing receivers will be degraded even though steps are taken to readjust the receivers for colour balance and saturation
- (c) the ability to have objective setting-up methods has been lost
- (d) the precise direction and magnitude of any improvement of phosphors is not predictable and hence the new values chosen for the chromaticity co-ordinates can only be guesswork.

## 7 Conclusions

In making its original recommendations, the Working Party

of UK CCIR Study Group 11, Sub-group 11A, concluded that:

- (1) It was desirable to revise\* the specification for the chromaticity co-ordinates of PAL System I colour television to ensure uniformity between networks
- (2) the existence of a very large number of colour receivers having substantially similar chromaticity characteristics weighed heavily in favour of choosing co-ordinates to give the best possible picture on these receivers
- (3) there was no indication of any receiver becoming available which had reproduction primaries substantially different from those of existing receivers. It was noted that any receiver having very different colorimetric characteristics would inevitably be incompatible with those existing and the broadcaster could do no more than choose one set of chromaticities for his transmission
- (4) it is important that broadcasters should have uniform colour monitors which were a good match for the chromaticity characteristics chosen for the camera, hence the necessity of choosing camera characteristics which are related to practical monitors
- (5) the choice of chromaticities for a camera not related to existing receivers or monitors must inevitably result in down-grading the picture quality obtained by existing receivers
- (6) the likelihood of being able to estimate accurately chromaticity co-ordinates of a new set of phosphors yet to be invented is very small and the advantage of the immediate adoption of any estimated value in advance of their realisation is minimal
- (7) in the event of a new set of phosphors being invented which were substantially better than those in existing receivers it would then be possible to reconsider the specification of cameras and at an agreed date change to the new specification. In this way Course (2) would then be implemented without, in the meantime, degrading the performance of all existing receivers but with the advantage of knowing precisely what chromaticity co-ordinates should be adopted to match the new phosphors.

## 8 Constitution of the Working Party

The members of the Working Party set up by Sub-group 11A of UK National CCIR Study Group 11 were:

Mr B. R. Rogers	BREMA (Rank-Bush-Murphy)
Dr G. B. Townsend	ITCA (Thames Television)
Mr M. S. Tooms	ITA
Mr C. B. B. Wood, Chairman	BBC

In addition, Mr W. N. Sproson, BBC Research Department, was co-opted to give advice on the theoretical aspects of colorimetry. Messrs W. W. Wright and G. C. Playford of Thorn Colour Tubes Limited collaborated in experiments, measurements, and the supply of experimental prototype tubes, while Messrs T. Jacobs and A. Ciuciura of Mullard Limited, Mr C. W. Thierfelder of RCA Corporation and many others were consulted.

\* This resulted in the phosphor specification given in Reference 4.

## Part II: A theoretical study of the colorimetric consequences of the choice of display colours

### Contents

- 9 Introduction to Part II
- 10 Ideal Colour Analysis
- 11 Colour Analysis of a Practical Camera
- 12 Effects of Mismatch between Camera and Display Monitor ( $\gamma = 1$ )
  - 12.1 Camera designed for PAL System I: display on three different sets of phosphors ( $\gamma = 1$ )
  - 12.2 Cameras designed for NTSC, Netherlands, and System I phosphors viewed on the 1969-70 current phosphors ( $\gamma = 1$ )
- 13 Effects of Mismatch between Camera and Display Monitor ( $\gamma = 1.26$ )
  - 13.1 Camera designed for PAL System I: display on three different sets of phosphors ( $\gamma = 1.26$ )
  - 13.2 Cameras designed for NTSC, Netherlands proposal, and System I with display on 1969-70 current phosphors ( $\gamma = 1.26$ )
- 14 Conclusions
- 15 References
- 16 Appendix

### 9 Introduction to Part II

The ideal spectral responses of the red, green, and blue channels of a 3-tube colour camera\* are primarily determined by the chromaticities of the display phosphors and each channel (Fig. 3) characteristic has a major positive response and two subsidiary regions. For the green channel the subsidiary regions are both negative, for the red channel there is a substantial negative region (peak at about 510 to 520nm) and a small positive region in the blue part of the spectrum, and the blue channel has a subsidiary negative region in the green and a very small (usually negligible in practical terms) region in the red which may be positive or negative.

The ideal analysis characteristics enable objectively accurate colour reproduction to be achieved for all physically-realizable colours, i.e. all colours having chromaticity co-ordinates within the colour triangle defined by the phosphor primaries; the objectively-accurate colour reproduction is a metameric match (not a spectral power match) but this feature is common to all modern colour reproduction processes.

The ability to phase invert electrical signals and hence to produce negative lobes in the spectral sensitivity curves of a colour camera was realised at least twenty years ago but it was not until the invention of the plumbicon camera tube that it became practicable to apply this idea. The two most

\* The case of a 4-tube camera is in some ways similar to that of a 3-tube camera but there are additional complications: the colouring channels closely resemble the RGB channels of the 3-tube camera but the choice of l, m, n coefficients to form the unity-gamma low-bandwidth luminance signal is a function of the display phosphor characteristics. It has been thought better to restrict this paper to a consideration of a 3-tube camera because it is more fundamental in terms of basic colorimetric considerations.

important features of the plumbicon tube for this purpose were:

- (1) a signal-to-noise ratio, using a well-designed head amplifier, well in excess of minimum requirements (i.e. in excess of 40dB)
- (2) a linear transfer characteristic.

Prior to the advent of the plumbicon tube, it was usual to use spectral sensitivity characteristics which were an approximation to the major positive lobes of the ideal curves. The absence of negative lobes was partially compensated by making the analysis curves slightly narrower so that the overlaps between the curves were rather less but the crossover wavelengths (at which the green and red channels have the same sensitivity, on the one hand, and the blue and green channels have the same sensitivity, on the other hand) were kept constant. If only the major positive lobes are used, a change in the chromaticities of the display phosphors has relatively little effect on the optimum colorimetric analysis and no special attention to the camera analysis is needed if the display phosphors are changed.

Within the past three or four years it has become usual to apply a  $3 \times 3$  matrix to the RGB linear output of the 3-tube colour camera\* and in this way better colour pictures have been produced because the analysis is a much better approximation to the ideal than was previously possible. This improvement in colour quality is achieved with two consequences:

- (a) a slight loss of signal-to-noise ratio in the displayed pictures because noise power is added when signals are subtracted
- (b) the need to adhere fairly closely to the phosphor chromaticities for which the  $3 \times 3$  matrix was computed.

If this second feature is ignored and the colour display is not the intended one, the matrix may impair the pictures and produce a colorimetrically less pleasing picture than if no matrix were used. The reason for this is that a change of phosphor primaries has a considerable effect on the shapes and positions of the subsidiary lobes (negative and positive) although, as noted above, relatively little effect on the shapes of the main lobes. This matter will be dealt with quantitatively in the following sections.

### 10 Ideal Colour Analysis

The ideal colour analysis characteristics are derived from:

- (1) The chromaticity co-ordinates of the R, G, and B display primaries.
- (2) The chosen white point, e.g.  $D_{65}$  together with fundamental data about the colour matching characteristics of the average human eye (1931 CIE standard observer). For the NTSC primaries\* the quantitative relation is expressed most conveniently by the matrix equation:

\* Linear matrices have also been applied to the colouring channels of a 4-tube camera but this is not discussed for the reasons already stated in the footnote on the left of this page.

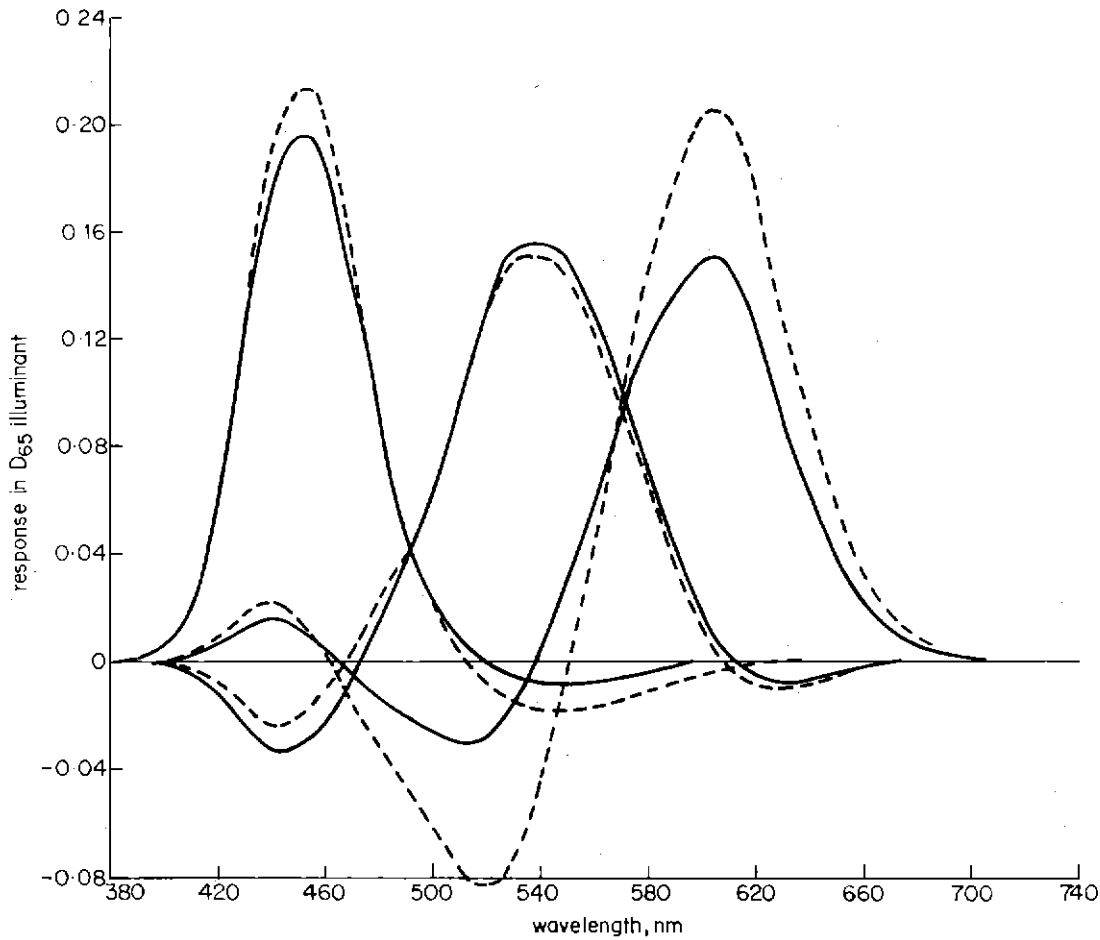

**Fig. 3** Ideal analysis for two sets of display primary colours  
 ——— NTSC set of primaries  
 - - - - System I set of primaries

$$\begin{bmatrix} R \\ G \\ B \end{bmatrix} = \begin{bmatrix} 1.972 & -0.549 & -0.297 \\ -0.954 & 1.936 & -0.027 \\ 0.063 & -0.129 & 0.981 \end{bmatrix} \begin{bmatrix} X \\ Y \\ Z \end{bmatrix} \dots 1$$

This equation gives values of RGB outputs (in linear signal condition) necessary to match (using a hypothetical unity-gamma tube) any colour whose XYZ tristimulus values are known. If the XYZ values are made to take the values appropriate to spectrum colours of wavelength 380 to 770 nm at (say) intervals of 10 nm, the ideal analysis curves are obtained. Fig. 3 shows the result of this computation and includes the effect of the incident illuminant ( $D_{65}$ ) thus making the three curves of equal area.\*

No practical camera has been given exactly these sensitivity curves because more than three sensors would be required (nine for perfect agreement, apart from an XYZ analysis) but a reasonable approximation to this set of curves can be achieved with a practical 3-tube camera and a suitably computed  $3 \times 3$  matrix (see Section 11).

\* If the camera sensitivities to equi-energy illuminant are plotted the areas are not equal but in the ratio 1.126:0.955:0.915. Multiplication by  $D_{65}$  makes the ratio 1:1:1.

A camera designed to match the System I display primaries<sup>1</sup> has ideal analysis curves given by matrix equation (2):

$$\begin{bmatrix} R \\ G \\ B \end{bmatrix} = \begin{bmatrix} 3.073 & -1.403 & -0.475 \\ -0.970 & 1.877 & 0.042 \\ 0.074 & -0.235 & 1.068 \end{bmatrix} \begin{bmatrix} X \\ Y \\ Z \end{bmatrix} \dots (2)$$

The result of substituting the XYZ values of the spectrum colours and additionally including the spectrum of the illuminant ( $D_{65}$ ) is also shown in Fig. 3 (dashed lines). This shows that the subsidiary lobes of the two sets of curves (NTSC and System I) are appreciably different and the most important parameters have been summarised in Table 6 (page 28).

### 11 Colour Analysis of a Practical Camera

The limitation of three tubes (or three colouring tubes in a 4-tube camera) implies that, at best, a good approximation to the ideal curves is the most that can be achieved in a practical camera using a  $3 \times 3$  matrix. Fig. 4 shows the extent to which a real camera can approximate to the ideal analysis for a camera designed to match the NTSC primaries. The negative lobe of the green channel response in the blue part of the

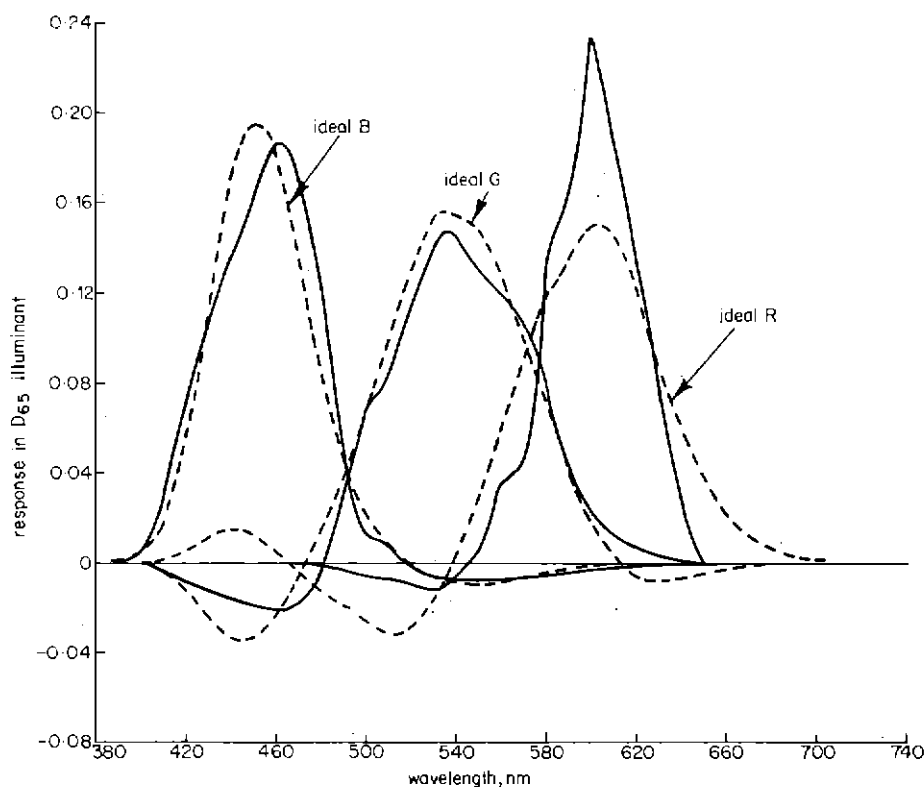

Fig. 4 Effective analysis of a camera designed for NTSC  
Ideal analysis for NTSC primaries is also shown

TABLE 6  
Comparison of Ideal Analysis for Two Sets of Phosphors

	Wavelengths of peaks			Positive Crossovers				Principal Negative Sensitivities					
	$\lambda_R$	$\lambda_G$	$\lambda_B$	$\lambda_{BG}$		$\lambda_{GR}$		$\lambda_{BG}$ of neg. red		$\lambda_G$ of neg. blue		$\lambda_B$ of neg. green	
	nm	nm	nm	nm	Amplitude	nm	Amplitude	nm	Amplitude	nm	Amplitude	nm	Amplitude
NTSC	603	534	452	492	0.042	572	0.095	512	-0.032	550	-0.090	444	-0.034
System I	604	535	452	492	0.043	570	0.092	520	-0.084	550	-0.190	443	-0.024

spectrum and the negative lobe of the blue channel in the green are both fairly good approximations to the ideal. The least satisfactory feature is the negative green part of the red channel response which occurs at the wrong wavelength (peak at 530nm instead of 512nm) and is given a low amplitude because of the wavelength mismatch. The wavelength mismatch is inevitable because this negative lobe is achieved by phase inverting and attenuating the output from the green channel (peak 535nm). In spite of these deficiencies the colorimetric performance of this camera is computed\* to be

\* Since monitors with NTSC phosphors no longer exist, computation is the only means of assessing this camera and monitor combination.

very good when feeding a monitor with NTSC phosphor primaries.

The analysis characteristics of a 3-tube camera with a matrix computed to suit System I phosphors are shown in Fig. 5 together with the ideal characteristics. Again there is a lack of precise matching of the subsidiary lobes. The negative lobe of the red channel has increased (ref. the NTSC camera) and is perhaps more closely followed but the small positive lobe (in the blue region) is given a slight negative value by the computer optimisation programme used to determine the coefficients of the  $3 \times 3$  matrix. The negative lobe of the blue channel is closely followed. The negative lobes of the green channel are very imperfectly followed in that the short wave-

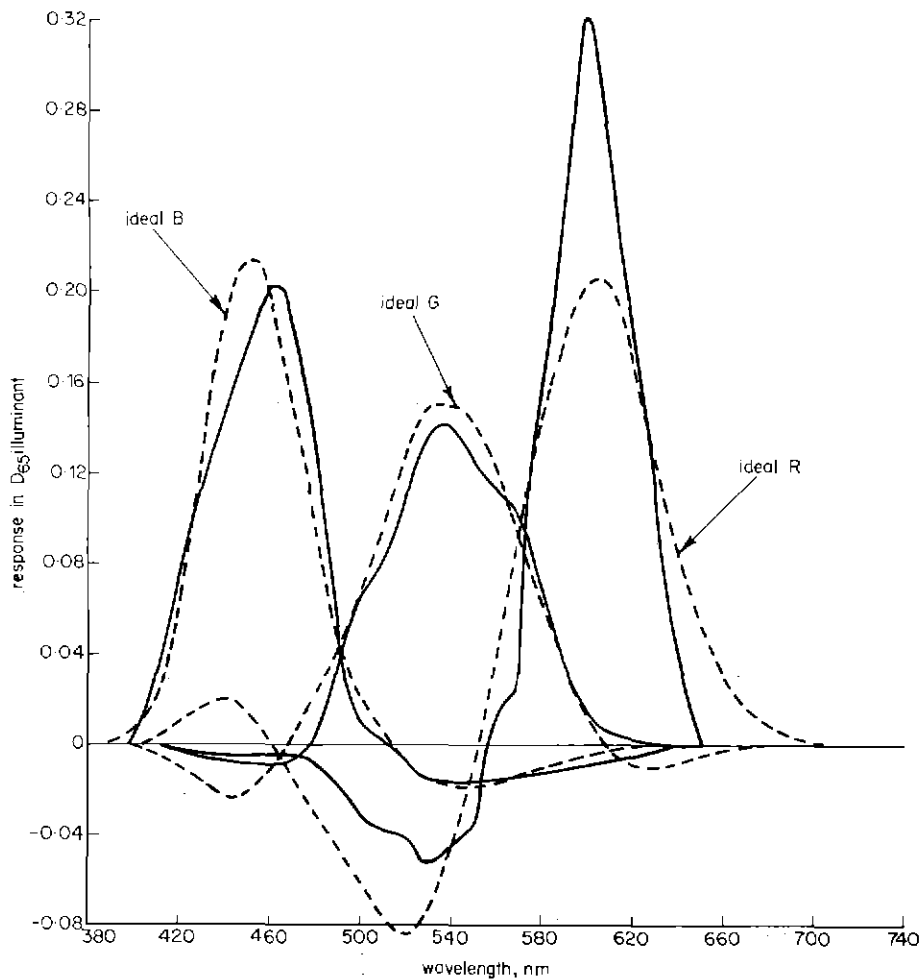

Fig. 5 Effective analysis of a camera designed for System I  
Ideal analysis for System I primaries is also shown

length one is given less than half the correct amplitude (with some wavelength mismatch) and no attempt is made to follow the negative lobe with a peak wavelength of 630 nm. Despite these imperfections, the computed and observed colorimetric performance of this camera with a monitor having the System I display phosphors is fairly good. For the standard twenty-six test colours<sup>7</sup> which have now been used for many colorimetric studies the average chromaticity error is 3.1 j.n.d. and the luminance error 1.8 j.n.d. The corresponding figures for the NTSC phosphor display used with the 'NTSC camera' is 2.9 j.n.d.s chromaticity error and 1.9 luminance error. The slightly lower figure for the chromaticity error is due to the larger gamut of colours given by the NTSC phosphors. Within the area on the chromaticity diagram common to both sets of phosphors the reproductions are identical.

The derivation of analysis characteristics, the computation of the optimum  $3 \times 3$  matrix and the computation of colour and luminance errors discussed so far have assumed an overall transfer characteristic (from scene to display monitor) of unity gamma. It is normal practice to use a gamma-correction law in the camera of index 0.45 and the display monitor has a typical gamma of index 2.8. This gives an overall gamma of 1.26. The effect of this departure from unity gamma will be considered in Section 13.

## 12 Effects of Mismatch between Camera and Display Monitor ( $\gamma = 1$ )

### 12.1 Camera Designed for PAL System I: Display on Three Different Sets of Phosphors ( $\gamma = 1$ )

There is a constant search for improved and better phosphors, usually with a view to producing a brighter picture and it has to be acknowledged that in terms of presently available display tubes there are some variations of chromaticity co-ordinates. These have been classified in Part I into (i) System I phosphors; (ii) 1969-70 current phosphors; (iii) 1970-71 complementary shift phosphors.

The chromaticity co-ordinates of these three sets of phosphors are given in Table 7 and plotted on the 1960 CIE-UCS diagram in Fig. 6.

The effect of using a camera designed for PAL System I with the above three sets of phosphors has been computed for the twenty-six test colours and two of the groups into which these colours may be classified; the results are summarised in Table 8.

Although Table 8 shows less errors for skin tones than for the other groups of colours, it was shown in Section 4 (Part I) that observers are much more sensitive to changes in skin tones and for this reason, five of the skin tones have been

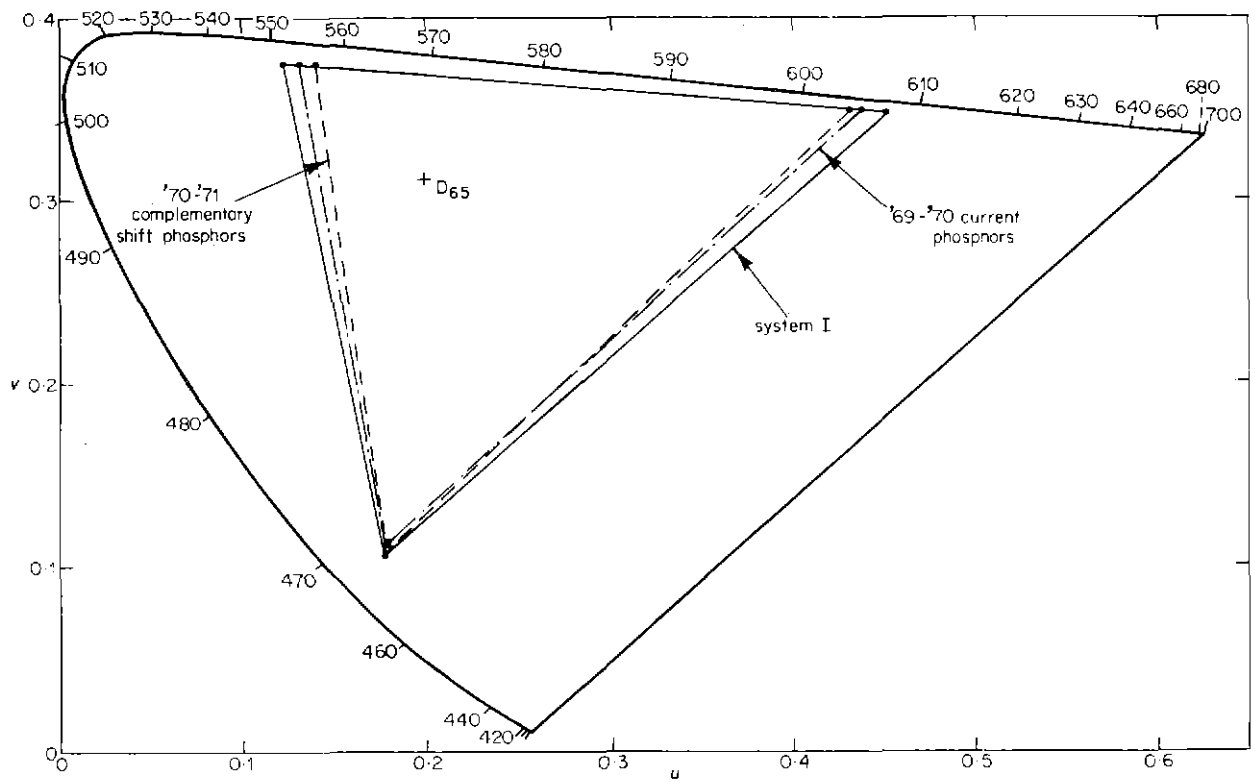

Fig. 6 Chromaticity co-ordinates and colour gamuts of three sets of phosphors

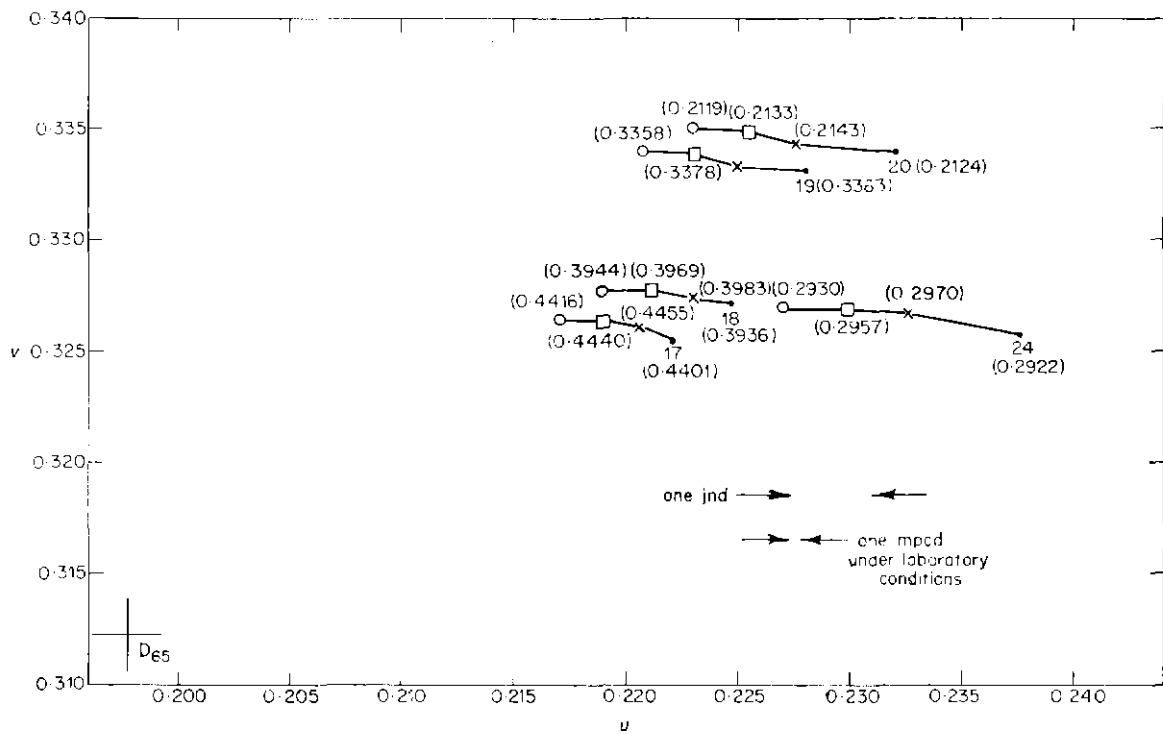

Fig. 7 Reproductions of five skin tones (test colours 17, 18, 19, 20, and 24) using camera designed for System I

- original chromaticity
  - x System I display
  - 1969-70 current phosphor display
  - 1970-1 complementary shift phosphor display
- Numbers in brackets are relative luminances  
Overall gamma = 1

TABLE 7

	Red		Green		Blue	
	x	y	x	y	x	y
System I	0.64	0.33	0.29	0.60	0.15	0.06
1969-70 current phosphors	0.632	0.339	0.307	0.597	0.152	0.064
1970-1 complementary shift phosphors	0.627	0.341	0.325	0.590	0.150	0.060
	u	v	u	v	u	v
System I	0.451	0.349	0.121	0.374	0.175	0.105
1969-70 current phosphors	0.436	0.350	0.129	0.375	0.176	0.111
1970-1 complementary shift phosphors	0.430	0.350	0.138	0.375	0.175	0.105

TABLE 8  
Computed Performance of PAL System I Camera with Three Different Sets of Phosphors

	System I		1969-70 Current Phosphors		1969-70 Complementary Shift Phosphors	
	Chromaticity errors j.n.d.	Luminance errors j.n.d.	Chromaticity errors j.n.d.	Luminance errors j.n.d.	Chromaticity errors j.n.d.	Luminance errors j.n.d.
All Colours	3.1	1.8	4.1	1.7	4.8	0.9
Skin Tones	1.1	0.5	1.6	0.3	2.2	0.2
Saturated Colours	6.3	3.9	8.0	3.7	9.2	2.1

plotted on the 1960 CIE-UCS chromaticity diagram (Fig. 7).

The magnitude of the chromaticity j.n.d. chosen in this paper and other BBC Research Department Reports dealing with colorimetry is shown graphically in Fig. 7 and has a magnitude of 0.00384 units on the 1960 CIE-UCS diagram. This is intended to represent a just noticeable difference under the viewing conditions which generally apply to colour television where judgements are often made on a memory or plausibility basis. Under the best laboratory conditions\* much smaller colour differences can be perceived and the magnitude of the minimum perceptible colour difference (m.p.c.d.) is about 0.0004 which is also shown in Fig. 7. The larger unit (j.n.d.) is thought to be more realistic for most colour television judgements, but it is realised that circumstances can arise where the j.n.d. is rather large and should not be too literally interpreted as a just noticeable difference. The size of

\* And also conditions applying in matching textiles, spraying of large panels in the car industry, and several other practical conditions.

the luminance j.n.d. is based on a 2 per cent difference in luminance between adjacent identical colours (or neutrals). This is approximately correct at the higher end of the luminance range but is too small a unit for dark greys and near blacks. As pointed out in Section 12.2, luminance j.n.d.s do not play any very significant role in the present study.

The direction of the colour shifts shown in Fig. 7 are similar for all skin tones, i.e. in the green to blue-green direction as one proceeds, from the original colour, to that rendered by the System I phosphors, to the 1969-70 current phosphors and finally to the 1970-1 complementary shift phosphors. In most cases the magnitude of the shift is sufficiently small to be scarcely noticeable (although the direction of shift would not be acceptable if the magnitudes were greater). The shifts in the saturated colours are greater but Table 3 in Part I shows that they cause less impairment to the observer.

### 12.2 Cameras Designed for NTSC, Netherlands, and System I Phosphors viewed on the 1969-70 Current Phosphors ( $\gamma = 1$ )

There has been some reluctance on the part of administrations to alter the specifications of the phosphor chromaticities from the original specification. The PAL System I phosphor chromaticities<sup>7</sup> are very close to those at present in use and those contemplated for use in the next year or two (Fig. 6). Nevertheless, no one can be absolutely certain in which direction the chromaticities of new phosphors might move and some engineers might hope for a return to phosphors with chromaticities close to those of the original NTSC specification. As a possible compromise, there has been a Netherlands proposal<sup>6</sup> for chromaticities mid-way between those of the original NTSC phosphors and the current phosphors.

It is pertinent to enquire what would be the effect, on present receivers, of transmissions which are optimised for the NTSC and Netherlands set of phosphors. The introduction (Section 9) suggested in the final paragraph that a mismatch was very undesirable but did not give quantitative results. It is the purpose of this Section to present quantitative results and these show that the effects are far from trivial. Table 9 summarises the results for the twenty-six test colours, sub-grouped as in Table 8.

TABLE 9  
Pictures from Three Cameras Displayed on 1969-70 Current Phosphors

	System I		Netherlands		NTSC	
	Chromaticity errors j.n.d.	Luminance errors j.n.d.	Chromaticity errors j.n.d.	Luminance errors j.n.d.	Chromaticity errors j.n.d.	Luminance errors j.n.d.
All Colours	4.1	1.7	5.8	1.6	6.7	1.6
Skin Tones	1.6	0.3	3.0	0.3	3.8	0.3
Saturated Colours	8.0	3.7	10.6	3.4	12.0	3.0

At first sight it might appear that little harm has been done. For all colours the average colour error has increased from 4.1 for the System I camera to 6.7 j.n.d. for the NTSC camera (with the Netherlands proposal giving 5.8 j.n.d.). The most critical group, as previously mentioned, comprises the skin



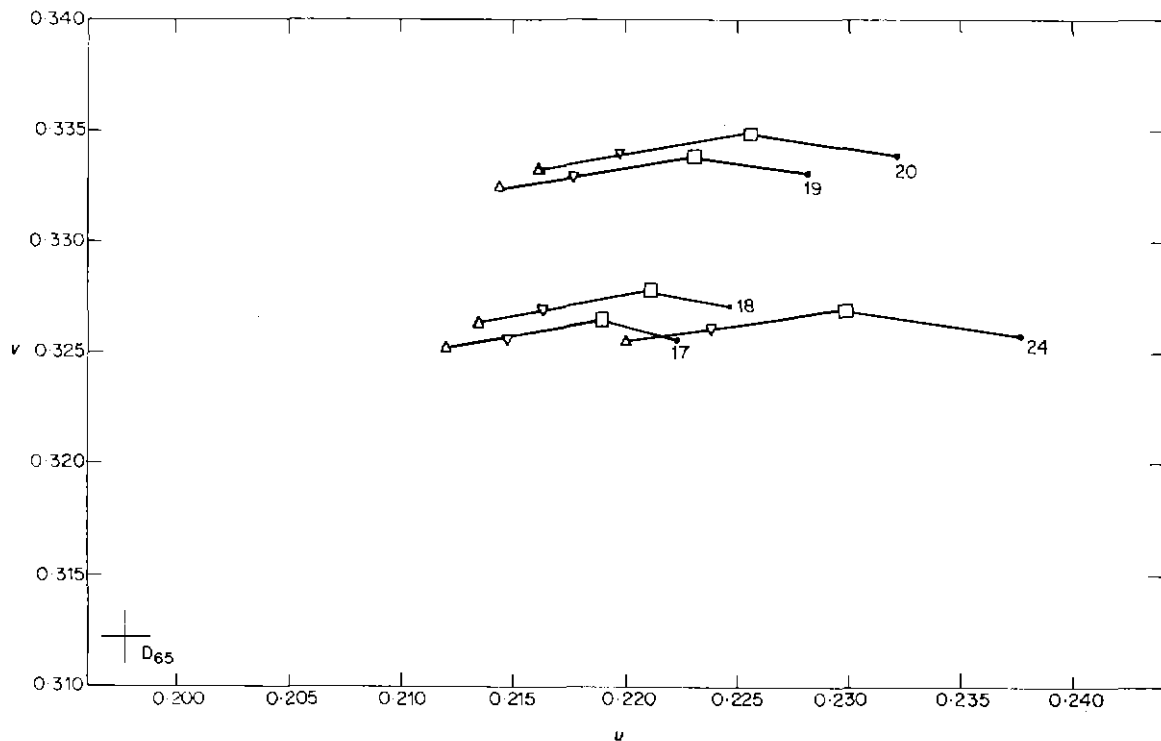

**Fig. 8** Reproductions of five skin tones (test colours 17, 18, 19, 20, and 24) as displayed on current 1969-70 phosphors

- original chromaticity
  - reproduction with camera designed for System I
  - ▽ reproduction with camera designed for Netherlands proposal
  - △ reproduction with camera designed for NTSC
- Overall gamma = 1

tones and here there is an increase from 1.6 j.n.d. for the camera designed to suit System I to 3.8 j.n.d. for the NTSC camera (with the Netherlands proposal giving 3.0 j.n.d.). The direction of the changes (Fig. 8) is again in the green/blue-green direction, which is less acceptable than a change in the direction of red, and whereas the changes shown in Fig. 7 are sufficiently small not to matter unduly, those shown in Fig. 8 are too large to be ignored.

For saturated colours the increase from 8.0 j.n.d. (System I camera) to 12.0 j.n.d. (NTSC camera) is probably less troublesome because the correct colour relationships between the colours are maintained although the absolute accuracy leaves something to be desired.

Little mention has been made of the luminance errors so far. These seem to be fairly small, particularly for skin tones, and more to the point, do not change appreciably with a change of camera design.

The results presented in this sub-section and the previous one (i.e. Sections 12.1 and 12.2) are probably of more significance for the theory of colour rendering in colour television than for its practice because of the assumption of an overall linear transfer characteristic ( $\gamma = 1$ ). The effect of an overall transfer characteristic of index 1.26 will be given in Section 13 and the results of the subjective tests described in Part I will be repeated for comparison.

### 13 Effects of Mismatch between Camera and Display Monitor ( $\gamma = 1.26$ )

#### 13.1 Camera Designed for PAL System I: Display on Three Sets of Phosphors

Experimental evidence has been given in Section 4 (Part I) that the effects of mismatch are much more noticeable when the subject-matter includes skin tone as a reasonably large proportion of the total field. For this reason and in the interests of simplifying the presentation, Section 13 will be restricted to consideration of five typical skin tones.

As in Section 12.1 a 3-tube camera designed for System I phosphors has been assumed and the reproduction on three monitors using different sets of phosphors have been computed. Fig. 9 shows the chromaticities of the reproductions when the overall gamma has an index of 1.26. A difficulty of interpretation or errors has to be considered. The reproduced chromaticities are now of higher chroma (saturation) than the originals, together with slight hue shifts. This enhancement of chroma appears to be acceptable to most viewers and in fact Table 3 (Part I) shows that the reproduction of skin tones using 1968 rare earth phosphors (which correspond closely to PAL System I) achieved a very high grading. The five skin tones used in the calculation were not identical with the

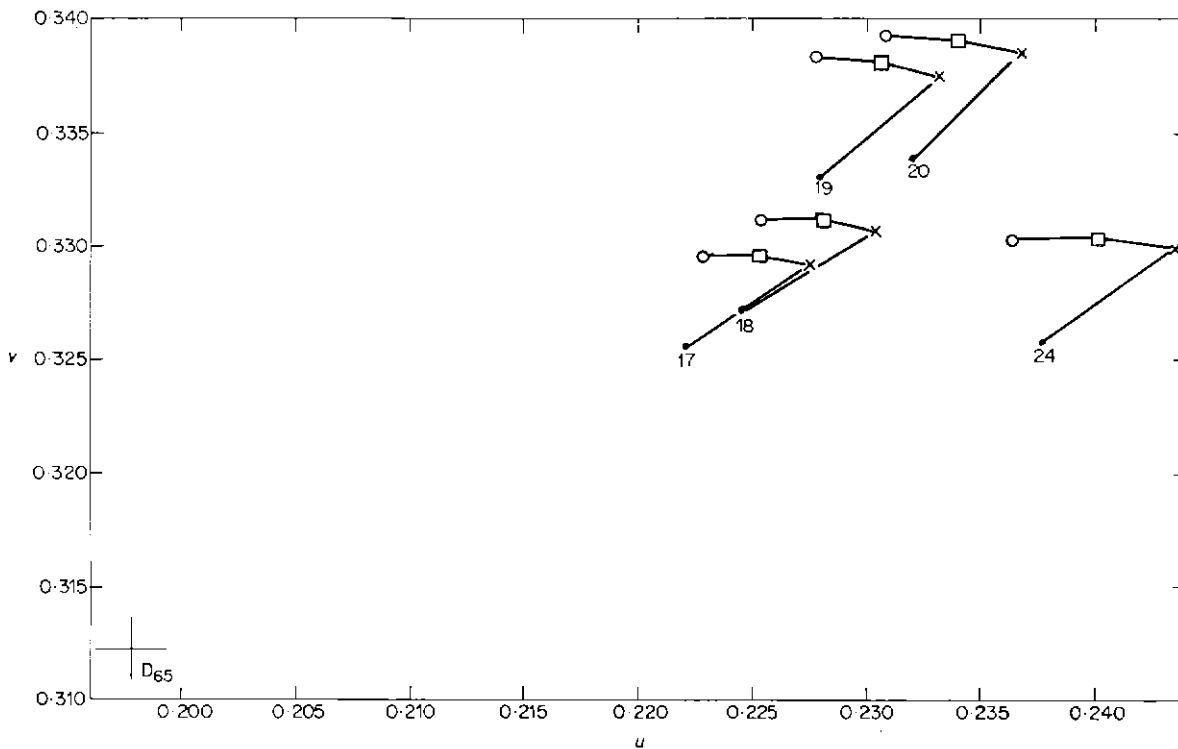

**Fig. 9** Reproductions of five skin tones (test colours 17, 18, 19, 20, and 24) using camera designed for System I

- original chromaticity
  - × System 1 display
  - 1969-70 current phosphor display
  - 1970-1 complementary shift phosphor display
- Overall gamma = 1.26

models actually used in the test but are believed to be typical of different types of Caucasian skin tone. Table 10 gives the average calculated colorimetric shifts in j.n.d. units together with the average gradings given in the experimental trial.

TABLE 10

PAL System I Camera. Overall  $\gamma = 1.26$

Computed colour differences from System I display when using other phosphors and subjective gradings of different phosphors

Phosphors	Computed Colour Difference from System I Display j.n.d.	EBU Scale I Gradings (Skin Tones)
1968 rare earth (PAL System I)	0	1.2
1969-70 Current	0.7	2.1
1970-1 Complementary Shift	1.5	3.0

It will be observed that a change of 0.9 in EBU grading corresponds to 0.7 j.n.d. On this basis a change of 1 EBU

grade corresponds to about 0.8 j.n.d.\* The 1970-1 complementary shift phosphor produced a chromaticity shift (from the System I phosphor) of 1.5 j.n.d. and a change in EBU grading of 1.8 grades. Apart from giving some information as to the relevance of the j.n.d. scale, the subjective experiment is important in its implications, viz. that under the condition of a camera designed for System I, the reproduction on present-day phosphors is 'good' and that on the 1970-1 complementary shift phosphors is 'fairly good' for the most critical subject-matter and under conditions where a simultaneous comparison is made.

It will be noticed that, in the above discussion, the reference picture has been taken to be the one given by System I phosphors and not the original. This corresponds to the practical situation where the precise colouring and complexion of the subject is nearly always unknown; what is asked for is the appearance of reality, pleasantness, and plausibility of picture. On these grounds it might be thought that relatively large errors could be tolerated, but this is not found to be true of skin tones even though the preferred reproduction may not be an exact match to the original.

\* This is a specific example of the general point made in Section 12.1 that the j.n.d. unit used in this paper is a relatively large one. Clearly the EBU quality scale gives a finer grading on skin tones.

13.2 Cameras Designed for NTSC, Netherlands Proposal, and System I with Display on 1969-70 Current Phosphors ( $\gamma = 1.26$ )

Following Section 12.2 the reproductions of the five chosen skin tones have been evaluated when viewed by cameras adjusted to suit NTSC, Netherlands proposal, and System I phosphors and replayed on one monitor, namely that using 1969-70 current phosphors. The overall gamma is in excess of unity (1.26) and typical of modern television practice. Fig. 10 shows the computed chromaticities.

The System I camera gives a result which is slightly oversaturated and with a hue shift (reference the original) in the yellow direction. These chromaticities are identical with the corresponding points of Fig. 9. Reference to Section 13.1 shows that, on average, this reproduction is 0.7 j.n.d. from the System I reproduction. This is a new starting-point for the second set of subjective trials, although it is now graded (on the EBU quality scale) on its merits with no implication that it ought to be regarded as grade 1; in fact it was graded at 1.9 (see Table 11). Fig. 10 shows that appreciably greater shifts of chromaticity are now involved, although the direction is very similar to that applying in Fig. 9. The average magnitude is given in Table 11 together with the subjective gradings from Table 5 (Part I).

TABLE 11

Cameras designed for NTSC, Netherlands proposal, and System I phosphors with display on 1969-70 current phosphors ( $\gamma = 1.26$ )

Computed colour differences relative to System I cameras with System I phosphors, and subjective gradings for each combination

Camera Designed for	Computed Colour Difference ref. System I Display j.n.d.	Subjective Assessment EBU Scale 1 (Skin Tones)
System I	0.7	1.9
Netherlands Proposal	2.55	4.3
NTSC	3.65	4.6

Whereas the changes of chromaticity produced by the different phosphors (Section 13.1) were such that the worst grading was 'fairly good', the situation with a change to an 'NTSC camera' gives a grading of 4.6 (this is between 'rather poor' and 'poor') and produces a change of 3.65 j.n.d.s in an unfavourable direction, i.e. green to blue-green.

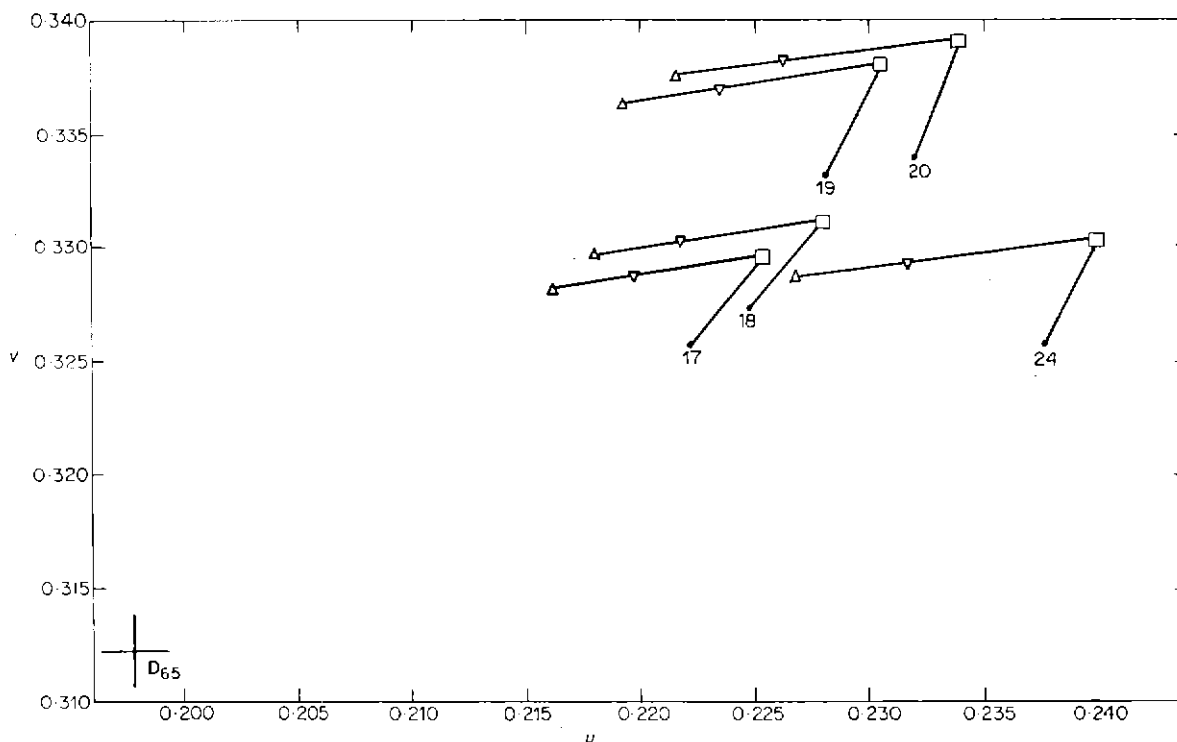

Fig. 10 Reproductions of five skin tones (test colours 17, 18, 19, 20, and 24) as displayed on current 1969-70 phosphors

- original chromaticity
  - reproduction with camera designed for System I
  - ▽ reproduction with camera designed for Netherlands proposal
  - △ reproduction with camera designed for NTSC
- Overall gamma = 1.26

The Netherlands proposal is only slightly better on subjective grading, viz. 4.3: the computed colour error is 2.55 j.n.d. There is evidence of a non-linear relationship between objective chromaticity errors and subjective assessment, but this is clearly to be expected for the more gross chromaticity distortions. The relationship (using the camera designed for System I with the display on System I as the reference point) is shown in Fig. 11 and it would seem that a linear relationship applies up to about 2.5 j.n.d.s of computed colour difference; for greater chromaticity errors the relationship flattens out but this is in a region where the subjective gradings are in the 'rather poor' to 'poor' classes between grades 4 and 5.

How bad the picture may be permitted to become is perhaps a matter for debate, but unless one is prepared to accept inferior standards of performance, the use of a camera designed either for NTSC phosphors or the Netherlands proposal is unacceptable with display tubes containing current phosphors.

#### 14 Conclusions

Chromaticity errors have been evaluated both for a hypothetical system of unity gamma and for a practical system

with a gamma of 1.26. In the latter case it has been shown that there is good correlation between the practical tests using the EBU quality scale and the average chromaticity shift computed for five skin tones. It would appear that whereas the changes observed (and calculated) for a range of phosphors covering System I, 1969-70 current phosphors and 1970-1 complementary-shift phosphors is within reasonable bounds even under critical test conditions and with critical subject-matter, a change of camera analysis to suit the original NTSC phosphors produces unacceptable rendition of skin tones on present-day phosphors. The Netherlands proposal to choose chromaticities mid-way between NTSC phosphors and those of present-day tubes does not substantially alter the subjective grading of the picture and is still unacceptable.

#### 15 References

1. Hardy, A. C., and Wurzburg, Jr, F. L. 1937. The theory of three-colour reproduction. *Jour. opt. Soc. Am.*, 1937, 27, pp. 227-40.
2. Epstein, D. W. Colorimetric analysis of RCA colour television system. *RCA Rev.*, 1953, XIV, 2, pp. 227-58.
3. The use of a linear matrix to modify the colour analysis characteristics of a colour camera. BBC Research Department Report No. T-157, Serial No. 1965/50.

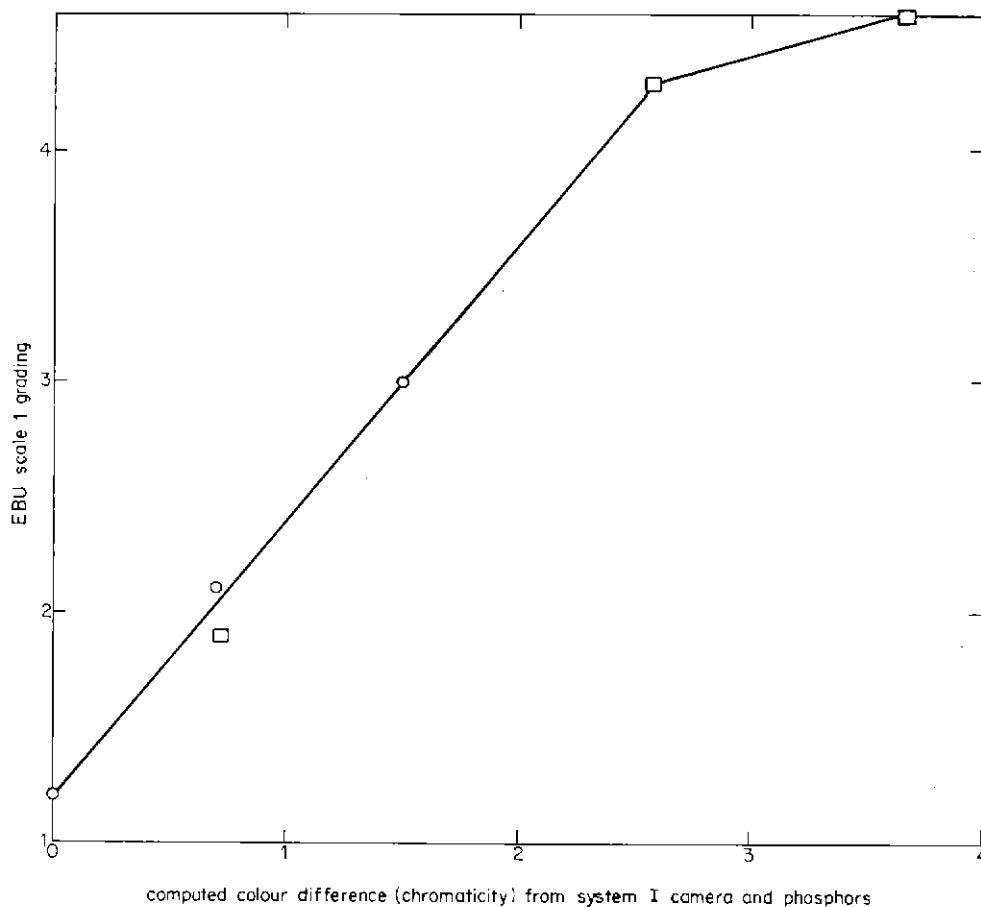
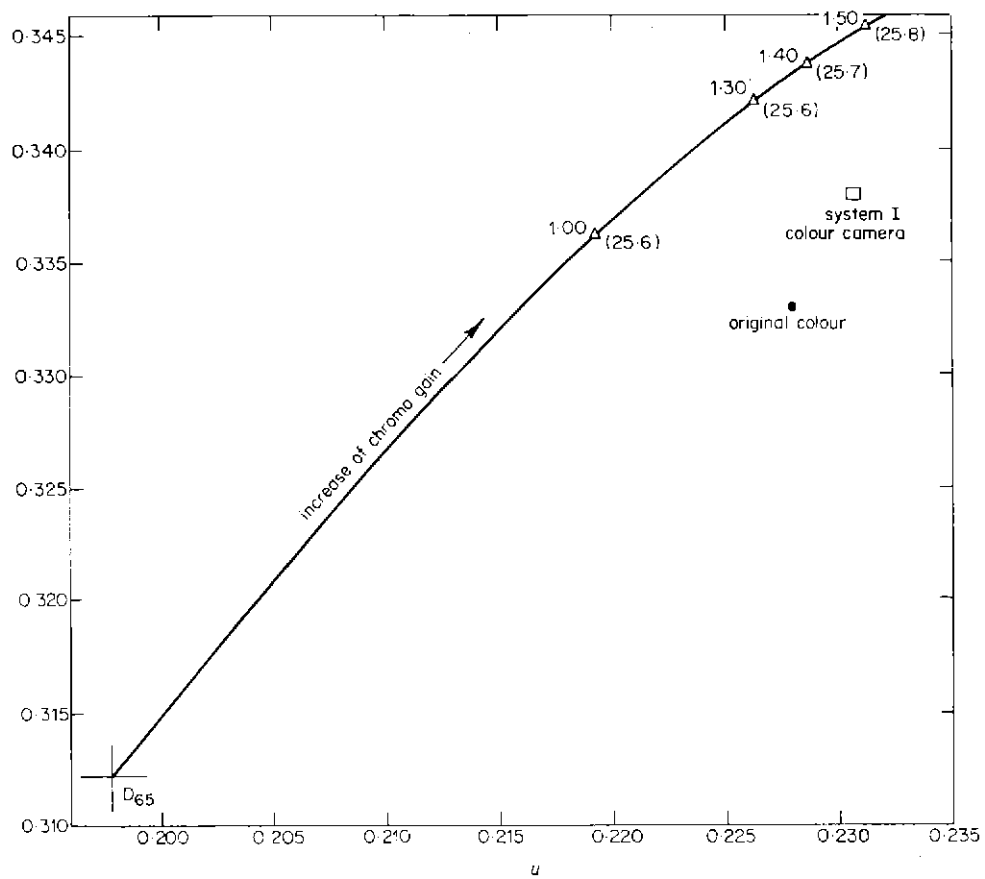

Fig. 11 Skin tones: relation between subjective and objective measurements (gamma = 1.26)

- subjective test No. 1
- subjective test No. 2



**Fig. 12** Effect of increasing chroma on skin colour No. 19  
 Chromaticity using NTSC camera and 1969-70 display phosphors  
 The figures in brackets are the relative luminances in percent  
 The figures 1.00, 1.30, etc., are the chroma gains

4. Characteristics of Colour Television Systems, CCIR Document XI/1038, 13 November 1969.
5. Townsend, G. B. 1963. Coloured fabrics for use in colour television test scenes. *J. Telev. Soc.*, 1963, **10**, 7, pp. 208-12.
6. CCIR Document XI/194, 3 September 1969.
7. Sproson, W. N.  $3 \times 3$  matrices for use with plumbicon colour cameras using three tubes. BBC Research Department Report No. PH-15 (1967/59).

## 16 Appendix

The possibility was mentioned in Section 5 of Part I that the errors produced by mismatch of the camera and the display phosphor could be substantially overcome by increasing the chroma gain. A theoretical investigation of this for test colour No. 19 (which has chromaticity shifts very close to the mean for the five selected skin colours) has been undertaken and the result for an overall gamma of 1.26 is shown in Fig. 12. The chromaticity shift with reference to the System I display can clearly be altered by increasing the chroma gain but the error

is never very small (minimum of 1.5 j.n.d.) and at this minimum point the hue error is in the green direction. If the chroma is further increased by 45 per cent as determined in the practical trial mentioned in Part I the hue error is probably less objectionable but the saturation has now appreciably exceeded that which is usually helpful in giving a more pleasant, 'larger-than-life' appearance. A further possibility is a change of relative RGB gains in the receiver (although few, if any, domestic receivers permit such an adjustment) to correct the skin colour at the expense of the white-point balance. If this is applied to the picture with 45 per cent excess chroma gain, the effect on the white point is considerable (4.2 j.n.d.s in the blue direction) and it is thought that this shift of white point would affect the subjective appearance of all colours.

This theoretical study confirms the practical test with the 'NTSC camera': additionally it should be pointed out that these adjustments represent severe departures from an objective line-up procedure.

## Short Items

### New Automatic Monitor for Television Transmitters

UDC 621.396.712 625.396.664

The system of standby operation of unattended u.h.f. television transmitters, in which the standby condition is obtained by applying both sound and vision signals to a common power amplifier, has been described in the article on page 4 of this issue. Designers Department have developed automatic monitoring equipment which is suitable for installation with this system, since it satisfies two operational requirements:

- (1) To monitor transmission performance to enable alarms to be given when preset deviations from the ideal performance are detected, and to take appropriate executive action when necessary, and
- (2) to facilitate routine measurements of transmission performance.

The equipment comprises a measuring unit, MN2M/513, and a control unit MN2M/518. The function of the measuring unit is to produce outputs in the form of analogue voltages corresponding to the magnitude of certain parameters of the insertion test signal on the input wave-form, e.g. bar amplitude and pulse amplitude. These voltages can be displayed on a digital voltmeter and are an aid during circuit alignment.

In the control panel each analogue voltage is applied to a limit device which provides for two 'Caution' (i.e. high and low) and two 'Urgent' limits which can be individually preset. The outputs from the limit devices can be grouped to give a common alarm when any of the measured characteristics are outside tolerance.

A switching module within the control unit enables the monitor to make measurements at more than one point in a system. It is possible, therefore, to measure the quality of the transmitter output, and should this fall outside tolerance, to examine the quality of the signal on main and reserve inputs to the transmitter. As a result of these sequential measurements control signals can cause the transmitter input to be switched from main to reserve video feed or for the transmitter to be switched to reserve condition, or both, if this should prove necessary.

When the reserve video feed is in use, the monitor will sequence every four minutes and will change back to the main video feed as soon as this is found to be satisfactory.

The measuring unit and control unit each occupy panels measuring  $5\frac{1}{4}$  in. by 19 in.

### Joystick Control Unit for TARIF\*

UDC 778.534.2 621.397.132

The Joystick Control Unit, UN3/530, is intended for use in

controlling TARIF equipment, EP1/503. Two joysticks are required, for gamma and gain adjustment respectively, and a control unit, UN1/627, is required to link these units to the TARIF equipment and to provide power and auxiliary switching routes.

In general, the unit can be used wherever single-handed differential control of three interrelated voltages is required. Typically these would be the red, green, and blue colour-separation voltages from cameras or telecine machines. The control-knob on the joystick also rotates to give a further 'Master' operation.

The unit comprises six photocells arranged at  $60^\circ$  intervals round the inside wall of a box. Opposite cells are connected in series to give a bridge configuration, and the cells are illuminated by a small lamp mounted on the operating arm within the box. Compensation for the different cell-sensitivities can be made by moving the cell holders vertically on the wall of the box. A concentric spindle permits the knurled control-knob to operate the 'Master' control which is also mounted inside the box.

\* Television Apparatus for Rectifying Inferior Film.

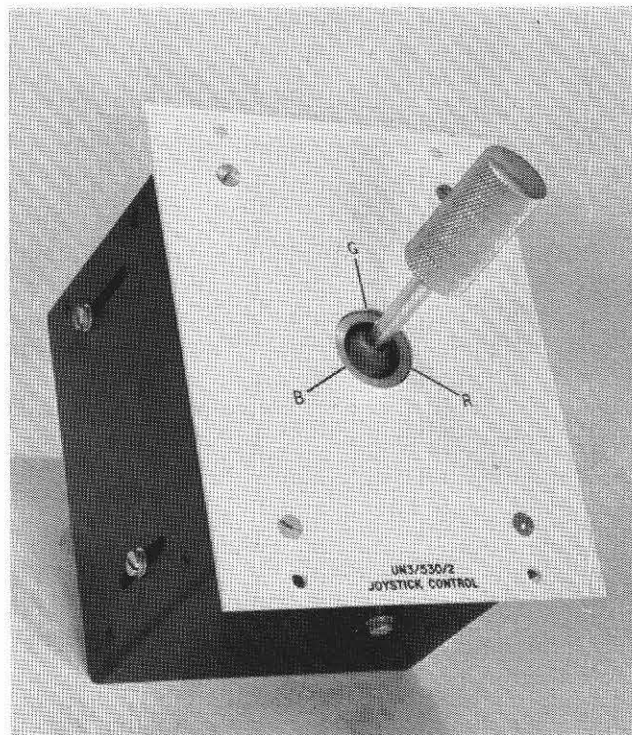

### Valves Sought by the Engineering Museum

The transfer of exhibits for the BBC Engineering Museum from Wood Norton to Bristol is now complete and the various pieces of equipment are being sorted and documented.

As might be expected much of the apparatus originally incorporating valves is now without these and it is desired to fit them in position before placing the units on show.

The types most urgently required are: Marconi DEV and DEQ, these valves were sausage-shaped, roughly cylindrical, and had contacts at the top, bottom, and sides; LS/5 and Mul-lard types 737G, 767G, PM.256, PM.2DT, and PM.2NM.

The valves in question do not need to be usable, they merely have to be mechanically sound. Should anyone have any examples of these early types, or know where any exist, will they please contact Mr P. E. F. A. West at: Broadcasting House, Whiteladies Road, Bristol BS8 2LR.

### Automatic Modification of Receiving Aerial Polar Diagrams

UDC 621.396.67.012.12

Research Department has carried out a feasibility study of an adaptive receiving system for use at u.h.f. television relay stations that receive their programme feed by picking up a main transmitter. This adaptive system operates by continuously monitoring the signal-to-interference ratio of the received signal and automatically adjusting for best results the way in which the aerials of an array are combined. By this means the horizontal radiation pattern of the receiving aerial array is made to have minima on the bearings from which interference is being received.

At the remoter sites at which interference to the rebroadcast link (RBL) is likely to be troublesome, a system of this type could offer several advantages over the use of a conventional fixed receiving aerial array. It compensates automatically for changes in h.r.p. arising from changes in the aerial or feeder characteristics such as might be caused by temperature variation or wind damage. It can also take account of sources of interference that were not envisaged when the receiving aerial was designed, or which might arise under exceptional propagation conditions.

The results obtained from the experimental equipment in Research Department have yet to be fully evaluated. However, there is every indication that such a system may well be technically satisfactory and economically viable at some sites where the level of interference would be too great for a conventional RBL installation. A brief description of the system was contributed to the International Broadcasting Convention 1970 (IEE Conference Publication No. 69, p. 64).

### Receiving Aerials for Satellite Broadcasting

UDC 396.677.31 621.396.946

Preliminary studies are being made by interested countries

and international bodies, such as the C.C.I.R. and E.B.U. on the possible systems of television broadcasting from satellites. The more immediate application of this type of broadcasting may be to developing countries where large areas with scattered population have to be served. Nevertheless, because of continued pressure on available frequency bands, satellite broadcasting is likely to come also to developed areas as it would provide the best means of exploiting the centimetric band (11.7 to 12.7GHz) at present allocated to broadcasting and links on a shared basis.

Research Department has contributed to two aspects of this subject recently. It has investigated a new type of aerial design for microwaves consisting of a flat panel with an array of slot elements formed by printed-circuit techniques. The aim was to investigate unconventional forms of aerial that might permit relatively low-cost receiving aerials to be produced on a large scale. This would clearly be of great importance in the economics of a satellite broadcasting system. Aerials of this type may also have application to radio-links such as those used for Outside Broadcasts. The aerial is described in Research Department Report 1970/27.

The second contribution has been to consider how many programmes might be provided to each viewer by satellite broadcasting within a specified frequency band in the 12-GHz region. This involved a theoretical study of the assignment of frequency channels and satellite positions for multiple services both on an idealised basis and for an example such as the provision of national services to each country in Europe. It was concluded that at least a 120-MHz portion of the band would be needed for each choice of programme, the system giving the maximum economy in the use of the band being one employing frequency modulation and using channel widths of about 24 MHz. This work is described in Research Department Report 1970/38 and in a contribution to the International Broadcasting Convention (IEE Conference Publication No. 69, p. 71).

### Computer Storage of Ground Profile and Population Density Data

Topographical data are at present being obtained by Research Department in a form suitable for computer storage for the purpose of field-strength prediction. In particular it is now hoped that, in co-operation with the nationalised power industries, a data bank can be prepared, giving ground heights on a 0.5-km square grid for the UK. Secondary information required for this includes the density of population in any area and it is likely that this information will be of value in obtaining population counts.

It is intended to derive population numbers for a regular matrix of areas (of 0.5-km squares based on the National Grid) which will be available for computer processing. Present population counts must be derived from maps of enumeration districts, which are of irregular shape, and to assist in the transfer of information from maps to the digital store a trace reader will be used.

## Contributors of the principal articles



**Robert Leslie** joined the BBC from school in 1930 as an engineer's assistant at the Aberdeen transmitting station. After a period in Belfast on studio and outside broadcast duties he transferred to the television outside broadcasting unit in London in 1938. During the war years he worked on various transmitters and served with the BBC war reporting unit in Italy.

In 1948 he joined the Planning and Installation Department and has since been engaged on the development of automatic broadcasting stations. He became Head of the Transmitting Station Section in 1969.



**Ronald Holmes** graduated in electrical engineering at Imperial College. After service in the R.N.V.R. he joined the BBC in 1946 at the Skelton h.f. transmitting station.

In 1951 he transferred to the Drive Section in Transmitter Department Head Office where he was concerned with carrier frequency generation and frequency measurements. In 1962 he moved to the Transmitter Section, working at first on m.f. transmitters and later taking charge of the Low Power Relay Stations and Projects Unit.

In 1968 he was appointed a senior engineer in charge of the Planning and Special Projects Section of Transmitter I Department. Since then he has been involved in various aspects of radio and television programme feeds, transmitter monitoring, stereo, local radio, and transmitter automation.



**William Sproson** is a graduate of Christ's College, Cambridge, and a Fellow of the Institute of Physics. He joined the BBC in 1950 to work on colour television after spending three years with Dufay Chromex (manufacturers of the last of the additive photographic colour processes).

In his present position as Head of Physics Section, Research Department, he is responsible for optics, colorimetry, and acoustics. He has also been involved in several external committees, serving on the committee of the Colour Group\* on two occasions; as secretary of the Optical Group (Institute of Physics and Physical Society) for three years; and at present on two National Illumination Committee panels on colorimetry and colour rendering and also the panel organised by the Scientific Instrument Research Association on assessment and specification of image quality.



**Charles Wood** was training as a mechanical engineer before World War II but joined the BBC Research Department in 1946 after serving in the Signals (Radar) branch of the Royal Air Force throughout the war. He has been concerned entirely with television since joining the BBC and has played a prominent part in the 'image scanning' aspects of all the major engineering developments in the BBC Television Service since it restarted after the war, especially in connection with cameras and the applications of film in television. In 1967 he was awarded the President's Prize by the B.K.S.T.S. for his paper on Colour Film for Colour Television, and in 1968 he was given the Royal Television Society Parr Award for improvements in colour film reproduction. He became a Fellow of the S.M.P.T.E. in 1970, and was awarded the M.B.E. in the 1971 New Year Honours List.

\* Originally the Colour Group of the Physical Society. Now the Colour Group (Great Britain) Limited.



# Index for 1970

---

## Number 81 (January)

Editorial: Colour on Three Channels  
Experience in the Operation of Colour Studies.  
*C. R. Longman*  
BBC Television News – Alexandra Palace and the Television  
Centre Spur. *H. C. J. Turner*  
Twelve Years of Video-tape. *J. Nash*  
Progress in the Use of Pulse-code Modulation for High-  
quality Sound Links. *D. E. L. Shorter*

## Number 82 (April)

Editorial: From Iconoscope to Plumbicon  
Lord Jackson of Burnley  
New Teaching Techniques at the Engineering Training  
Centre. *H. Henderson*  
The Design and Production of Prototype Thin- and Thick-  
Film Circuits. *D. J. Walker*  
A Receiver for Measuring the Radiated Harmonics of u.h.f.  
Television Transmissions. *N. H. C. Gilchrist*  
A Non-Synchronous Method of Demodulating Amplitude-  
Modulated Signals with Asymmetrical Sidebands.  
*K. Hacking*  
Satellite Broadcasting Service Areas. *J. W. Head*

## Number 83 (July)

Editorial: F.M. Broadcasting after Fifteen Years  
Tests of Mixed Polarisation for v.h.f. Sound Broadcasting.  
*J. G. Spencer*  
Modernisation of the BBC Telegraph System with an  
Automatic Data Exchange. *D. V. Lywood*  
Solid-state Video Switching Matrix. *W. T. Shelton*  
Permissible Bass Rise in Talks Studios. *N. F. Spring* and  
*K. E. Randall*

## Number 84 (October)

Editorial: The External Services of the BBC  
The Use of Single-sideband Transmissions for Programme  
Links to Overseas Relay Stations. *D. I. Price*  
The BBC Central Computer Complex. *R. C. Evens*  
ANCHOR – A New Electronic Character Generator.  
*R. J. Taylor* and *R. H. Spencer*  
A Printed Panel Aerial for u.h.f. Relay Stations. *G. H. Millard*  
Automatic Source and Aerial Selection at Skelton Short-wave  
Transmitting Station. *G. Oxley*

# BBC Engineering Monographs

1	The suppressed frame system of telerecording	June 1955
3	The visibility of noise in television	October 1955
4	The design of a ribbon-type pressure-gradient microphone for broadcast transmission	December 1955
5	Reproducing equipment for fine-groove records	February 1956
6	A vhf/uhf field-strength recording receiver using post-detector selectivity	April 1956
7	The design of a high-quality commentator's microphone insensitive to ambient noise	June 1956
8	An automatic integrator for determining the mean spherical response of loudspeakers and microphones	August 1956
9	The application of phase-coherent detection and correlation methods to room acoustics	November 1956
12	An improved 'Roving Eye'	April 1957
13	The BBC Riverside television studios: The architectural aspects	July 1957
14	The BBC Riverside television studios: Some aspects of technical planning and equipment	October 1957
15	New equipment and methods for the evaluation of the performance of lenses for television	December 1957
16	Analysis and measurement of programme levels	March 1958
18	The BBC colour television tests: An appraisal of results	May 1958
19	A uhf television link for outside broadcasts	June 1958
20	The BBC's Mark II mobile studio and control room for the sound broadcasting service	August 1958
22	The engineering facilities of the BBC monitoring service	January 1959
23	The Crystal Palace Band I television transmitting aerial	February 1959
24	The measurement of random noise in the presence of a television signal	March 1959
25	A quality-checking receiver for vhf/fm sound broadcasting	June 1959
26	Transistor amplifiers for sound broadcasting	August 1959
27	The equipment of the BBC television film studios at Ealing	January 1960
28	Programme switching, control, and monitoring in sound broadcasting	February 1960
29	A summary of the present position of stereophonic broadcasting	April 1960
31	The power gain of multi-tiered vhf transmitting aerials	July 1960
32	A new survey of the BBC experimental colour transmissions	October 1960
33	Sensitometric control in film making	December 1960
34	A mobile laboratory for uhf and vhf television surveys	February 1961
35	Tables of Horizontal radiation patterns of dipoles mounted on cylinders	February 1961
36	Some aspects of optical lens performance	April 1961
37	An instrument for measuring television signal-to-noise ratio	June 1961
39	Twenty-five years of BBC television	October 1961
40	The broadcasting of music in television	February 1962
41	The design of a group of plug-in television studio amplifiers	April 1962
42	Apparatus for television and sound relay stations	July 1962
43	Propagation factors in short-wave broadcasting	August 1962
44	A Band V signal-frequency unit and a correlation detector for a vhf/uhf field-strength recording receiver	October 1962
45	Vertical resolution and line broadening	December 1962
46	The application of transistors to sound broadcasting	February 1963
47	Vertical aperture correction using continuously variable ultrasonic delay lines	May 1963
48	The development of BBC internal telecommunications	May 1963
49	Apparatus for measurement of non-linear distortion as a continuous function of frequency	July 1963
50	New methods of lens testing and measurement	September 1963
51	Radiophysics in the BBC	November 1963
52	Stereophony: The effect of cross-talk between left and right channels	March 1964
53	Aerial distribution systems for receiving stations in the l.f., m.f., and h.f. bands	July 1964
54	An analysis of film granularity in television reproduction	August 1964
55	A review of television standards conversion	December 1964
56	Stereophony: The effect of interchannel differences in the phase/frequency and amplitude/frequency characteristics	December 1964
57	Drop-out in video-tape recording	June 1965
58	Sine-squared pulse and bar testing in colour television	August 1965
59	The acoustic design and performance of a new free-field sound measurement room	September 1965
60	Colorimetric analysis of interference in colour television	February 1966
61	Sporadic E ionisation and television interference	March 1966
62	Automatic monitoring	April 1966
63	The design of transmission lines and single-stage switching circuits for a line-store standards converter	August 1966
64	Data for the acoustic design of studios	November 1966
65	Tristimulus spot colorimeter	December 1966
66	VHF aerial gain calculation using tables of mutual resistance between the radiating elements	February 1967
67	Pulse sound: A system of television sound broadcasting using pulses in the video waveform	March 1967
68	Recent research on studio sound problems	July 1967
69	A survey of the development of television test cards used in the BBC	September 1967
70	The dynamic characteristics of limiters for sound programme circuits	October 1967
71	The programme effects generator	November 1967
72	Colour sensitometric parameters in colour film telerecording	March 1968
73	Sonic booms and other aircraft noise in studios	April 1968
74	The non-linear characteristics of klystron amplifiers	June 1968
75	Pulse-code modulation for high-quality sound-signal distribution	December 1968
76	The variable inductance frequency modulator	December 1968
77	The automatic control of sound-signal level in broadcasting studios	March 1969
78	Aspects of high-quality monitoring loudspeakers	September 1969
79	F.M. deviation: Calibration and measurement by edge coincidence techniques	December 1969
80	An automatic method for the measurement of reverberation time	December 1969

Copies of BBC Engineering Monographs are available at 8s. (40p.) or \$1.00 a copy, post free, from BBC Publications, 35 Marylebone High Street, London W1M 4AA.