

© MPE © 1978 © K... © C3P

BBC ENGINEERING



Number 110

July 1978

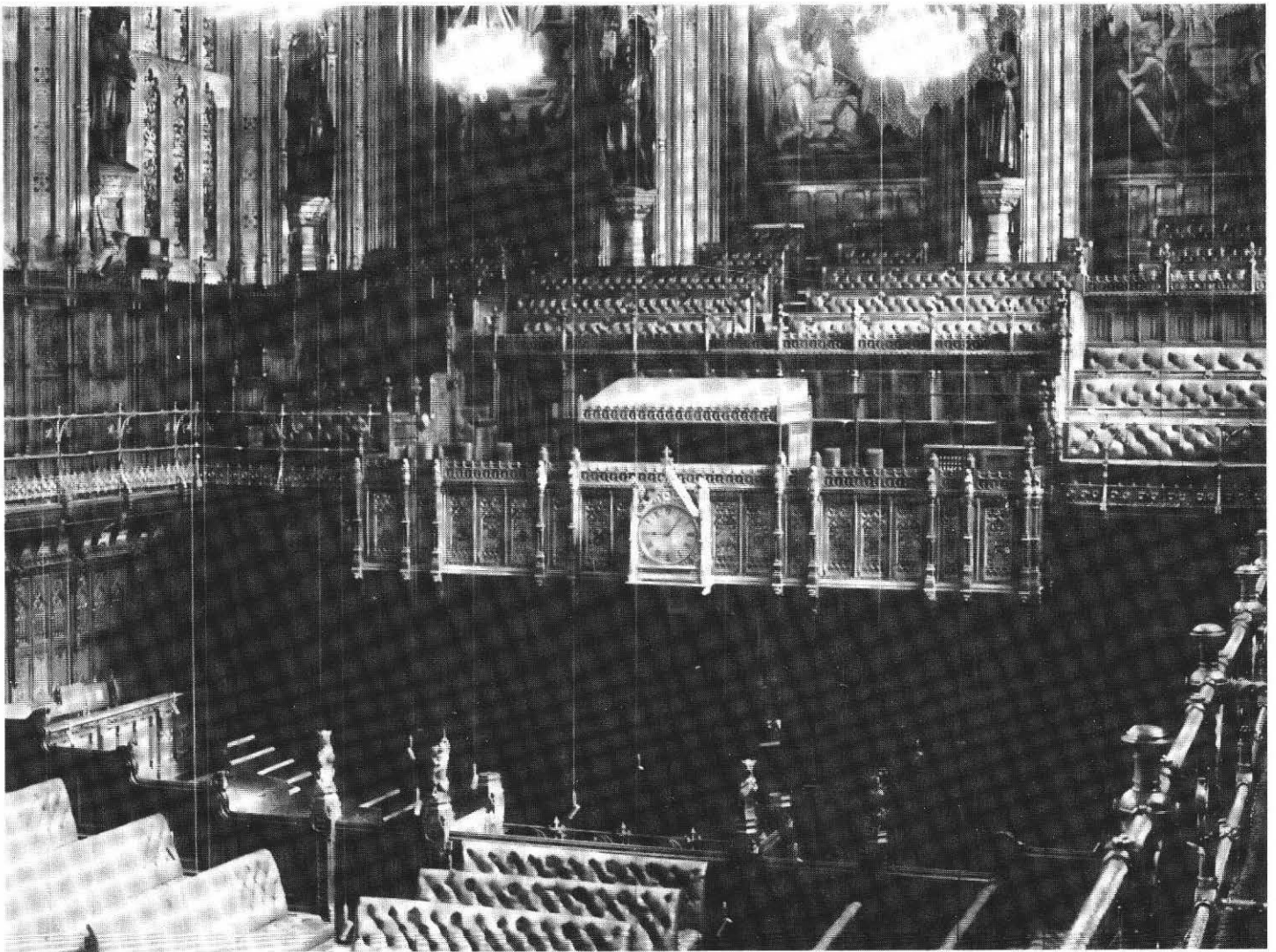

BBC Engineering

including Engineering Division Monographs

A record of BBC technical experience and developments
in radio and television broadcasting

Published approximately four times per year by
BBC Publications,
35 Marylebone High Street,
London W1M 4AA.
ISSN 0308-2369
ISBN 0 563 17655 5

Edited by
BBC Engineering Information Department,
Broadcasting House,
London W1A 1AA.

Printed by
The Yale Press Ltd,
London SE25 5LY.

Price
80p or \$2.00 per issue post free.
Annual Subscription
£3.00 or \$8.00 for 4 issues post free.

Articles are copyright © 1978 by the
British Broadcasting Corporation
and may not be reproduced in whole
or part without written permission.

Contents

Notebook	2
Principal articles	
Television Training at Woodstock Grove K. Angold-Stephens, R. Burden, R. Hammett, and J. Symons	5
Broadcasting Parliament R. W. Newrick	11
Introducing Digits E. R. Rout	17
Making Better Connections T. N. J. Archard, J. A. Fox, and D. D. Gunn	23
Contributors to this issue	27

Part of the interior of the House of Lords is shown on the cover. The broadcast commentary box is at the front of the Press Gallery, behind the clock. An article about broadcasting the proceedings of Parliament begins on page 11.

Notebook

New BBC Engineering publications

The first two of a new series of BBC Engineering publications are now available.

CEEFAX — its history and the record of its development by BBC Research Department collects together the eleven Research Reports which were produced between March 1974 and November 1977 and which describe the progressive development of the system. The reports are introduced by a *History of CEEFAX* which summarises the technical steps which led to the Broadcast Teletext Specification of September 1976. The Specification forms an appendix to the new book.

Although CEEFAX has been the subject of a number of articles in the technical press, the new book is the first detailed complete account of its technical development.

CEEFAX is available, price £15.00, from BBC Engineering Information Department, Broadcasting House, London W1A 1AA.

The *History of CEEFAX* mentioned above is available as a pamphlet free of charge from the same address.

The second new publication is *General purpose television colour camera channel* (BBC Specification TV 1248, December 1977). To quote from its Preface, the specification

'... sets out, as far as possible, the features of general-purpose television camera channels required or preferred by the BBC. It does not deal with portable or ENG cameras.

'Operational practices vary between one

broadcasting organisation and another and national and climatic circumstances can also influence the requirements for a broadcast camera. When studying this Specification therefore, it should be noted that the emphasis put on particular features is determined by the standards, practices and circumstances of the BBC. . . . the document is intended primarily as a guide to manufacturers and as a yardstick against which actual cameras offered may be assessed and discussed.'

Separate sections of the Specification deal with Mechanical Requirements, Lenses and Lens Controls, the Vision System, Communications and Signalling, Camera Cables, Viewfinder, Colour Analysis and Colorimetry. Appendices deal with Scene Illumination, Standard Test Colours, the Camera lens, Camera Tubes, the Colour Display, etc.

General purpose television colour camera channel is available, price £10.00, from BBC Engineering Information Department, Broadcasting House, London W1A 1AA.

Retirement of Dr. George Monteath

George Monteath, OBE DSc(Eng) FInstP FIEE, Head of Research Department, retires on 1 September after thirty-one years of service.

George Monteath graduated from Imperial College in 1939 and spent the war years as a radar officer in the Royal Air Force. It was in 1947 that he joined the BBC Research Department and for the next ten years he was engaged on theoretical and development work on transmitting aerials. Among many of his ideas which have stood the test of time in service are the Daventry mast radiator for the Radio 3 MF service and the use of slots cut in a structural cylinder to form a transmitting aerial which is part of the mast.

He was Head of Transmitter and Aerial Section from 1959 until in 1961 he became Head of Television Group. Here he was concerned with the introduction of 625-line television and colour, sound-in-synchs, line-store and field-store standard conversions. His penetrating understanding made significant contributions to solving the problems of interpolation in standards conversion and it was he who suggested the use of pulse-code-modulation for sound-in-synchs.

In 1967 George Monteath returned to Radio Frequency work as Head of Radio Frequency Group. The major concerns during his time in that post have been the expansion of the UHF transmitter network and the

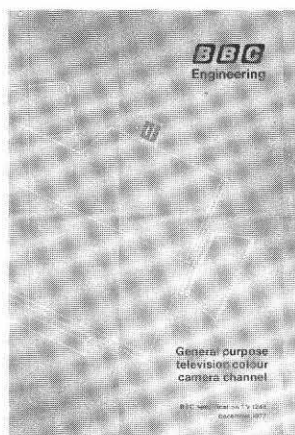
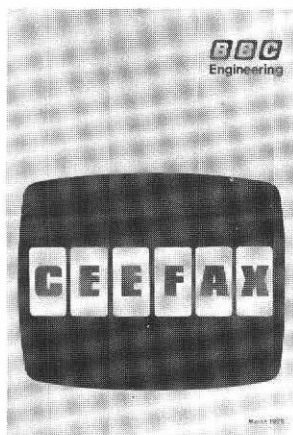



Charles Sandbank

George Monteath

reorganisation of LF/MF broadcasting. He has been Head of Research Department since May 1976.

George Monteath's degree of D.Sc.(Eng.) was awarded by London University in August 1977 for published work in telecommunications. This work includes many papers and a book 'Application of the electro-magnetic reciprocity principle' (Pergamon 1973).

The new Head of Research Department is to be Charles Sandbank, B.Sc. DIC FInst.P FIEE, who is at present Head of Advanced Systems and Defence, Standard Telecommunication Laboratories. He takes up his new post on 4 September.

Charles Sandbank graduated from London University in 1953 and joined the Brimar valve department of STC as a production engineer. In 1955 he was awarded a post-graduate fellowship at Imperial College which resulted in the award of the DIC.

He returned to valve development at STC and later transferred to the transistor division where in the early sixties he led the team which developed the first semiconductor integrated circuits in Europe. Since 1969 he has been manager of the Advanced Communications Systems Division, where he has been heavily involved with the development and application of optical fibre line transmission technology and radio systems, particularly in the defence communication and navigational aid fields.

Experimental digital audio transmissions

The BBC has recently carried out a series of test transmissions from the Pontop Pike transmitting station to explore the possibilities of broadcasting digitally-coded audio signals in Band I as a future public service. This is one of the possible new forms of broadcasting suggested by the BBC to the Annan Committee.

The tests were the initial phase of an investigation into the reception of digital signals under various listening conditions, such as with a whip aerial in a car, a fixed dipole in the home or a ferrite rod inside the receiver. The latter could, with modern materials, provide an efficient aerial for VHF portable receivers. It is hoped to find answers to questions on how effective digital transmissions might be when used for a very-high-grade sound programme service, or for a reliable alternative to the present medium-wave service which has a limited range at night because of the overcrowding of the band. Indeed, several signals or types

of signal, including new data services, could be transmitted together using the time-division-multiplex methods which digital operation makes feasible.

The Pontop Pike service area was chosen for the tests because of the varied nature of the terrain, which includes hills and densely-developed townships.

Other applications for transmissions of digital sound transmissions may be for low-capacity links to distribute stereo programmes to VHF transmitters in remote areas.

The experimental transmissions were on a frequency of 47MHz and used a 4-phase differential phase-shift-keying system to send the digital signals at a bit-rate of 704kb/s. Measurements were made mainly objectively (in terms of eye-height, noise margins, etc.) but also subjectively with the transmission of two high-quality audio signals.

The coding and modulating equipment was that used last year on radio outside broadcasts to relay live stereo concerts from Cardiff and Lancaster over a microwave link to connect with Post Office circuits to London. (See *BBC Engineering 109, page 4*).

Wenvoe MIC



The article about automatic operation of the BBC's transmitter network in the last issue of *BBC Engineering* (number 109, April 1978) dealt with the Monitoring and Information Centres (MICs) but a satisfactory photograph of an MIC was not available when the article went to press. We have received enquiries from readers who have wondered what an MIC is like and so are glad to be able to print this picture of the new Wenvoe MIC. As described in the article mentioned above, the MIC is built into a small room which is furnished functionally and provided with windows and air conditioning to minimise operator fatigue. Acoustic treatment and subdued lighting enable sound and vision transmission quality to be critically assessed.

NICAM — what does it mean?

The Editor has been taken to task by a colleague in the Designs Department over the stated meaning of NICAM in our last issue (*BBC Engineering 109, page 2*). Our colleague claims that he, some four years ago, coined the acronym NICAM, having in mind the words Near-Instantaneously Companded Audio Multiplex. On reflection we agree that those words are more accurately descriptive of the system and so, from now on, they are what NICAM stands for.

Research Department Reports

BBC Research Department has recently published the following reports.

- 1977/45 The relationship of VHF car radio reception quality to field strength at 10 metres
- 1977/46 The CSI 1 kW metal-halide discharge lamp: measurements and predicted effects of intensity ripple using sinusoidal lamp excitation
- 1978/1 A method for measuring echoes in the multipath propagation of v.h.f. signals
- 1978/2 Sampling frequencies and structures for solid state image sensing in broadcasting
- 1978/3 The masking effect of background noise
- 1978/4 Idle-channel noise in p.c.m. sound-signal systems
- 1978/5 An improved correlation audio combiner for use with h.f. diversity receivers
- 1978/6 Automatic colour control using a micro-processor
- 1978/7 Computation of groundwave attenuation over irregular and inhomogeneous ground at low and medium frequencies
- 1978/8 Channel Islands link for BBC television programmes: the Alderney receiving installation
- 1978/9 A digital telecine processing channel
- 1978/10 Digital aperture correction
- 1978/11 Electronic-news-gathering: the effect of multipath propagation
- 1978/12 A proposed method of data transmission from uhf relay stations for remote monitoring
- 1978/13 Computer programs for vhf interference prediction using a terrain data bank
- 1978/14 The use of a programmed computer to perform real-time companding of high-quality sound signals
- 1978/15 An experimental 4-phase d.p.s.k. stereo sound system: the effect of multipath propagation
- 1978/16 An experimental simple digital field-store synchroniser for System I television

A subscription to BBC Research Department Reports, of which about 35 are published each year, costs £25.00. Further information and subscription forms are available from: *Research Executive, BBC Research Department, Kingswood Warren, Tadworth, Surrey, England.*

Television Training at Woodstock Grove

K. E. Angold - Stephens C Eng., B Sc. (Eng.), MIEE

R. Burden

R. Hammett, LRAM

J. Symons, C Eng., B.Sc. (Eng.), MIERE

Television Staff Training

Summary: Many different types of training course are run by the BBC to train various categories of staff in a wide range of television production techniques. The courses include a high proportion of practical work in studios.

This article describes the facilities installed for this purpose at Woodstock Grove. It is not necessary for the equipment to give full broadcast quality but it is important that it should be capable of use in the same way as fully professional installations and that quality limitations should not be sufficiently serious to detract from the student's (or the instructor's) ability to make judgements and take decisions.

- 1 Introduction
- 2 Courses
 - 2.1 Overseas Course
 - 2.2 Introduction to production training
 - 2.3 General Production Course
 - 2.4 Film Direction course
 - 2.5 Studio Direction course
 - 2.6 Production team workshop
 - 2.7 Background to programme production
 - 2.8 Specialist courses
- 3 Main Vision facilities
 - 3.1 Cameras
 - 3.2 Captions
 - 3.3 Production gallery
 - 3.4 Videotape
- 4 Main Sound facilities
 - 4.1 Studio installation
 - 4.2 Sound desk
- 5 Communications
- 6 Lighting
- 7 Telecine
- 8 Studio 3
- 9 Miscellaneous
- 10 Conclusion

reaching the position of Producer. The BBC could successfully train staff in this way because it had gradually built up its large television operation over a period of more than 20 years. Overseas countries wishing to implement or expand a television service very rapidly were in a quite different position — they needed to provide a nucleus of trained Directors and Producers in a very short time indeed, a requirement that could only be satisfied by a full-time training course.

After approaches from many overseas countries and following discussions with the British Council, the BBC agreed to establish a television production training facility. A room of area 100 square metres, previously used as a canteen, was made available at the BBC's Woodstock Grove premises in West London and adapted as a television studio. Woodstock Grove is not far from the BBC Television Centre, which is a considerable advantage because not only do students receive some of their final training at the Centre, to get the feel of using a main production studio, but television camera and sound crews from the Centre serve on many of the exercises held at the Woodstock Grove studios so that students get experience of working with professional crews.

It is not surprising that after the training facilities at Woodstock Grove were opened they attracted the attention of BBC staff as well as overseas administrations, and since 1971 the scope of the training operation has been extended to include directors, production assistants, and researchers from within the BBC as well as overseas students. In fact in 1976 about fifteen times as many BBC students passed through the Centre — 500 as opposed to 32 — but many of the BBC students were on short introductory courses so these figures do not reflect the true division of the work load. This is more fairly shown by the fact that of the 112 course-weeks scheduled for 1978, 26 will be devoted to two courses for overseas students i.e. just under one-quarter of the total.

1 Introduction

The Woodstock Grove Television Training Studio was opened in 1966 to provide training for overseas students, particularly those from developing countries. Remarkable as it may now seem, it was not deemed necessary at that time to provide special training facilities for BBC television production staff — they received most of their training 'on the job', usually progressing through various grades before



Fig. 1 A training exercise in progress in the colour studio.

The teaching complement at Woodstock Grove comprises nine production instructors, including the Head of Television Training, and four technical instructors. In addition to lecturing it is the responsibility of the technical instructors with the aid of two technical assistants, to set up and maintain all the equipment. This maintenance requirement places an additional load on the technical staff, but the amount of technical back-up required on many of the training exercises is minimised by the extensive use of video cassettes. The load on the technical staff is also reduced to some extent during the less advanced exercises because the students themselves often operate the camera, lighting, sound, and vision functions; this gives them an insight into the craft as well as the art of television production.

About half of the instructors are temporarily seconded to Woodstock Grove, for periods from a few months up to three years, from operational areas of the Corporation. This ensures that the techniques and methods taught to students correspond with current operational practice.

2 Courses

2.1 Overseas course

This is a thirteen-week course for 16 students. It is run twice each year, and is open only to applicants with a reasonable command of English and who are sponsored by governments or broadcasting organisations. An economic

fee is paid for each student, normally by the organisation sponsoring him, although in some cases grants are available from British Overseas Aid funds. The courses are always over-subscribed, so not all applications can be accepted.

The course covers most aspects of television production including the grammar (ground rules) of television production, drama, light entertainment, news and current affairs, interviewing, programme planning, research, film techniques, videotape editing, sound, lighting, and special effects.

2.2 Introduction to production training

Basic courses take various forms according to the requirements of the students. These may, for example, be secretaries or clerks who require a knowledge of the television service, research assistants, or newly appointed members of a production team.

2.3 General production course

A four-week course designed to give all-round knowledge of the BBC's production processes is attended by members of programme departments who are at an early stage of their television production work.

2.4 Film direction course

Production assistants, assistant producers and

producer/directors who need to be proficient in the direction of complex film sequences can attend a four-week course.

2.5 Studio direction course

A four-week course similar to the film direction course is run for producer/directors who need to be proficient in the direction of complex studio sequences or complete studio programmes.

2.6 Production team workshop

A one-week course has been established to bring together engineering and programme services staff to practice for one week the skills of studio direction and production.

2.7 Background to programme production

The second week of a two-week course designed to provide an appreciation of radio and television production methods deals with television and is run at Woodstock Grove. It is intended for staff who support the production processes but rarely get into the studios.

2.8 Specialist courses

In addition to the training described above there are more specialised courses. The frequency with which these are run depends upon both demand and the availability of resources.

3 Main vision facilities

The main disadvantage of the studio is its low ceiling which limits the height of the fixed lighting grid to only 3.5 m. On the other hand, once a student has mastered the art of lighting a difficult scene in the face of this restriction, he can be sure that he will have few problems in a production studio.

The studio was originally equipped for black and white working with three EMI 201 vidicon cameras, 16 mm telecine, and vision and sound mixing facilities. It was re-equipped for colour in 1975.

3.1 Cameras

The studio is now equipped with three Link 110 colour cameras similar to those recently used in the re-equipment of Studio 6 at the Television Centre. The cameras are fitted with servo-operated Varotal 23 lenses which offer a 10:1 zoom but, being 'hard-wired', are non-interchangeable.

3.2 Captions

A reminder of past days is the caption camera which comprises an EMI 201 camera with a four-lens turret and CCU (camera control unit) together with an illuminated carrier for 12" x 9" (30 x 23 cm) stills.

The studio also has facilities for 35mm transparencies using a caption projection unit (CPU), which has two

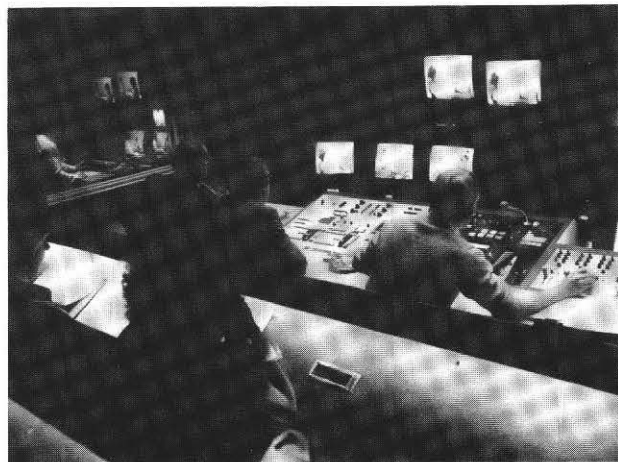

Fig. 2 The studio's production gallery. Tiered seating with dimly lit desks allows students to watch the production processes and to make notes. The sound control area is beyond the window at the left of the picture.

Carousel projectors to allow in-shot cutting between slides, or cross-fades which can be adjusted to take up to twelve seconds to complete. The CPU, once loaded, is remotely controlled from the production gallery.

3.3 Production gallery

In the gallery, normal vision operator controls are available for the camera exposure and colour balance. Unlike a production studio, camera controls, lighting, telecine, VTR remote controls, communications, and even remote sound facilities have all been made accessible from one position for economy of technical manpower. Switchable monitoring is provided.

The centrepiece of the production desk is the vision mixer. To cater for beginners, parts of this can be switched off and covered up, leaving a six-channel A/B mixer. Channels 5 and 6 are both selective, by press-button inter-field switching, to five other sources, and may also be declared non-sync. Twelve patterns of wipes are available with the mixer in the 'simple' condition.

In the fully operational mode, the mixer's other half is an effects unit with C/D banks separately source selected. The effects output appears on the A/B banks as a seventh source. Normal colour-separation and caption overlay facilities exist, together with separate keying arrangements for inlay working, soft-edge switching, and spotlight effects. A particularly useful facility in view of the low ceiling is electronic vignetting by means of a wipe key.

The output stages of the mixer include a further overlay switch operated through an 'insert caption' button. Sources to this switch are selectable and include the 'Videograph' — a forerunner of Anchor, the BBC's electronic character generation system. The appearance of Videograph, or any other script, can often be improved by the use of a black-edge generator associated with the 'downstream' key.

Sources to the caption key switch are also duplicated to a colour synthesiser. Separate RGB controls are infinitely variable for both foreground and background colouring in addition to normal preset button selection. The synthesised



Fig. 3 The videotape area with two cassette machines and full monitoring and editing facilities. The machines can be operated locally or remotely controlled from the studio.



Fig. 4 The sound control desk is separate from the vision and lighting control area (which can be seen through the window in the partition).

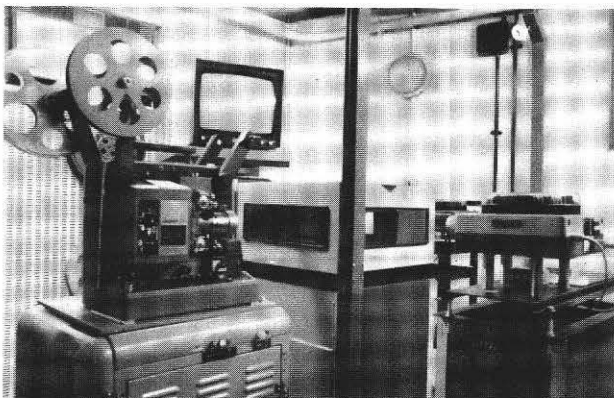

Fig. 5 The multiplexer which permits the use of the two 35 mm transparency projectors or the 16 mm film projector. One of the slide projectors is almost hidden by the multiplexer.

output is available to channels 5 and 6 of the mixer.

The mixer electronics, together with vision distribution, matrixing, monitoring, pulse generation and camera control units are housed in a separate apparatus room. Here, vision line-up and routing is undertaken to fulfil the day-to-day requirements of the training studio.

3.4 Videotape

The main videotape recording equipment comprises two Sony VO2850 video cassette recorders, both fully capable of editing. A purpose-built console houses the machines, each of which has independent source selection and comprehensive monitoring facilities. Both machines can be remotely controlled from the studio.

4 Main sound facilities

The concept adhered to in the design of the sound installation in the Woodstock Grove studio was to ensure that, as far as the budget permitted, the operational facilities available were as near as possible to those found in the studios at Television Centre, while bearing in mind the special requirements of training. However, since overseas students use the studio as well as BBC staff it was also important to cater for the 'regional' approach to television production. For simple programmes it is possible for a technical instructor to control a tape machine and six channels of the sound desk from the production gallery.

4.1 Studio installation

The studio floor has four wall points each having nine microphone sockets with phantom powering, and the usual feeds of talkback, foldback, programme output, production reverse talk-back, boom reverse talkback, sound talkback tie-lines, and production tele-ringer lines. The boom, as well as having the usual private two-way communications with the sound supervisor, also has a 9" (23 cm) video monitor at operator height. The latter was included, although non-standard, because the restricted floor space limits the number of floor monitors that can be used. The foldback speaker (LSU 10) can be plugged to any wall point but the LSTB speaker (LS 1) is fixed in a position above the gallery window.

4.2 Sound desk

The sound gallery contains a 21-channel four-group sound desk with full equalisation/filtering, auxiliaries (foldback, echo, independent), and pre- and post-fade monitoring on each channel. Most of the desk can be hidden from view using two plastic covers to simplify operation for non-technical staff and students. The desk uses the 'floating-group' principle such that any of the 21 modules can be selected as either a channel or a group. The groups are then selectable to main and/or main-clean-feed (MCF) faders on the centre panel of the desk. Button selection on each channel puts an independent output of that channel to MCF without need of an 'independent' jackfield, and each module has a separate buffered output on the jackfield for

greater flexibility in routing. Although not a requirement of television training at the moment, the desk is capable of stereo working, should the need arise. Channel divert points are available before the fader on the jackfield for the insertion of two effects units (telephone-distort etc.) and four compressor-limiters. Two loudspeaker monitors follow PPMs, selectable to 'line-out', 'desk-out', or the outputs of 24-position monitor switches. Between the loudspeakers are a black and white switchable preview monitor and a small colour monitor connected permanently to 'studio-out'. The latter is a domestic-type receiver fed from a small UHF modulator.

As well as the usual tone-to-line, transmission, and rehearsal switching and auxiliary relay changeover facilities, the commercial-recording practice of 'slate' (sound talkback) to groups, main or MCF lines have been provided for. The centre panel also includes control of the production telephone ringer, (auto or manual ring, and selection of the effects units either manually or through slave relays from the vision mixer for use in, say, telephone conversations where 'distort' has to follow the 'on-air' camera but 'off-air' microphone. Simple echo is obtained from a spring reverberation unit, but for more ambitious work the desk can be connected by music lines to an echo room or plate at the Television Centre.

The audio recording equipment includes two twin-track reel-to-reel machines, a twin-track tape-loop cartridge machine, and a cassette recorder.

5 Communications

The communication system is built round a simplified version of the BBC solid-state communications matrix unit. Reversible communication is possible between most combinations of director/producer, cameras, boom, technical manager, sound supervisor, floor manager, telecine, and videotape. Radio talkback is also available separately to the floor manager. Good quality microphones are provided in the control gallery position (e.g. sound supervisor, producer's assistant, director/producer, and technical manager) for maximum intelligibility on the talkback system, a particularly important consideration when the students' native language is not English. A separate engineering intercom connects technical areas with certain key offices around the building.

Two video and three music circuits connect Woodstock Grove to the Television Centre. This allows the studio to work in either direction with areas in the Centre or further afield.

6 Lighting

Thirty lighting outlets, all of which can be directly patched to a dimmer, are available in the studio, six at floor level and the rest supported from a fixed lattice grid. All outlets are $2\frac{1}{2}$ kW except for three 5 kW outlets at floor level which can be used for a ground row of lamps to light the cyclorama. The main hard-light sources are 2 kW Fresnel pole-operated spotlights while the softlights are switchable between $2\frac{1}{2}$ and $1\frac{1}{4}$ kW. These are supplemented by pups, profile spotlights,



Fig. 6 The control area for Studio 3. The studio can be seen through the window.

top cyclorama, and ground row lighting when required.

Students are expected to rig lighting for specific productions, but every effort is made to keep this time-consuming activity to a minimum by employing a configuration at the start of a course which is flexible enough to cope with all but the major training exercises.

The lighting controller's position is on the main production control desk adjacent to the vision operator's position at the right-hand end of the control desk and is therefore within reach of the remote colour balance controls for the cameras, monitoring and monitor line-up patterns, and remote monitor brightness control. The vision controller and lighting controller share a high-quality preview monitor and line-up oscilloscope.

7 Telecine

The three-tube vidicon colour telecine machine used at Woodstock Grove incorporates a multiplex arrangement that enables three picture sources to be used. The multiplexer utilises front-silvered mirrors that are dropped into place to direct light from the selected source to the camera. At present the three sources comprise two 35 mm slide projectors (see section 3.2) and a 16 mm film projector which has sep mag, comopt, and commag (separate magnetic, combined optical, and combined magnetic sound track) facilities and can run from a still frame. All three projectors can be remotely controlled from the vision mixer's position on the production control desk.

Electronic control of picture quality is effected by fixed electronic masking, which provides basic colour correction, an image enhancer (aperture correction), and four switchable gamma positions. A BBC 'joy-stick' TARIF (Television Apparatus for the Rectification of Indifferent Film) controller is provided at the vision operator's position in the production control room.

8 Studio 3

Studio 3, usually designated the 'workshop', is a first-stage studio which allows simple training in production for staff new to television. The studio has been designed so that it can be used without any technical staff in attendance — all the



Fig. 7 Students watching an illustrative programme in one of the lecture rooms.

vision, lighting, and sound equipment is switched on simply by the operation of two mains switches.

The studio has a floor area of 50 square metres and is fitted with a cyclorama round three of the four walls. A fixed lighting plot is employed, using lanterns mounted on a scaffold grid. Dimming facilities are provided by a 10-channel $2\frac{1}{2}$ kW thyristor unit.

The studio is equipped with three black and white cameras mounted on simple pedestals and fitted with manually controlled 10:1 zoom lenses. The cameras have automatic gain control which, in conjunction with the fixed lighting plot, allows beginners to concentrate on using the cameras without being distracted by technical refinements.

A separate control area is used to accommodate a simple five-channel vision mixer with associated monitors, a 35 mm

caption scanner, a Sony cassette videotape recorder, a six-channel sound mixer, and a $\frac{1}{4}$ " sound recorder. The videotape machine is used both to record the studio output and to insert brief recorded items into studio exercises. Studio 3 is equipped with the usual talkback and communications facilities.

9 Miscellaneous

In addition to the studios, various supporting areas are required. There are storage areas for properties and scenery, technical maintenance areas, and a film editing area.

There are four lecture theatres and the facilities available include video cassette replay as well as the usual projection arrangements.

10 Conclusion

The Woodstock Grove television training centre economically provides an environment in which television production staff can obtain valuable experience of current methods and techniques. Although originally set up to train students from foreign broadcasting organisations in BBC methods, the centre nowadays applies roughly three quarters of its training to BBC staff.

To ensure that the methods taught are up to date the permanent training staff are augmented with staff transferred for short periods from their normal work in television production.

Broadcasting Parliament

R. W. Newrick, C Eng., MIERE

Studio Capital Projects Department

Summary: Ever since its inception, the BBC has reported in news bulletins items from the proceedings of both Houses of Parliament, and for over 30 years a formal daily report (Today in Parliament) has been broadcast. That traditional indirect reporting is now being augmented by direct radio transmissions of the actual proceedings, either live or recorded.

Continuous recording is carried out whenever either House is sitting so that any item can be selected for insertion in a subsequent programme. Commentary boxes in each House allow a correspondent to add explanatory or descriptive comments for live broadcasts. A Central Broadcasting Control Room has been equipped in the Palace of Westminster itself, and a Central Technical Area, two small studios, and recording and editorial areas have been established temporarily in a nearby building (Bridge Street): these will be replaced by permanent installations in the Norman Shaw South building when it is completed.

- 1 Introduction
- 2 Pre-existing facilities
 - 2.1 Sound re-inforcement
 - 2.2 Annunciators
 - 2.3 Division bell
- 3 Derivation of primary signals
- 4 Commentary boxes
- 5 Commons editorial area
- 6 Installations at Bridge Street
 - 6.1 Central Technical Area
 - 6.2 Recording
 - 6.3 Studios
 - 6.4 Editorial area
 - 6.5 Television studio
- 7 Aspects of operation
- 8 Conclusion

1 Introduction

Experimental broadcasting of Parliament took place from 9th June to 4th July 1975 but it was not until a great deal more discussion had taken place that approval was finally given to broadcasting on a permanent basis. Parliament has still not agreed to allow television broadcasting of its proceedings. The radio operation began on 3rd April 1978.

The Joint Committee on Sound Broadcasting recommended, and Parliament accepted, that the BBC should be 'agent of the broadcasters' and be responsible for originating the signal and distributing it to the other

approved organisations such as Independent Radio News (IRN), the Central Office of Information, and the Press Association. In addition to the basic signals conveying the proceedings of the two Houses, provision was required for commentaries and for recording.

The main technical and editorial areas had to be set up in temporary accommodation because the Norman Shaw South building, in which they are to be permanently housed, will not be ready for two years.

2 Pre-existing facilities

Certain facilities of the Palace of Westminster had been established to assist in the smooth running of both Houses, without any thought of the needs of broadcasting. Nevertheless, they have proved convenient to the broadcasters.

2.1 Sound reinforcement

Both chambers are equipped with comprehensive Tannoy sound reinforcement systems. In the Commons, for example, microphones hang over the Members' benches and near the Speaker's chair and Despatch Boxes. An operator with experience of the procedures of the House and skill in recognising individual Members selects the appropriate microphone by means of a panel of push buttons: the output of that microphone is connected to the main amplifying chain which feeds, via a frequency shifter, a large number of small loudspeakers mounted in the benches. The frequency shift permits a much higher gain to be used without risk of oscillation, but does not spoil the intelligibility of the signal.

In the Lords there is a similar system operated in the same manner.

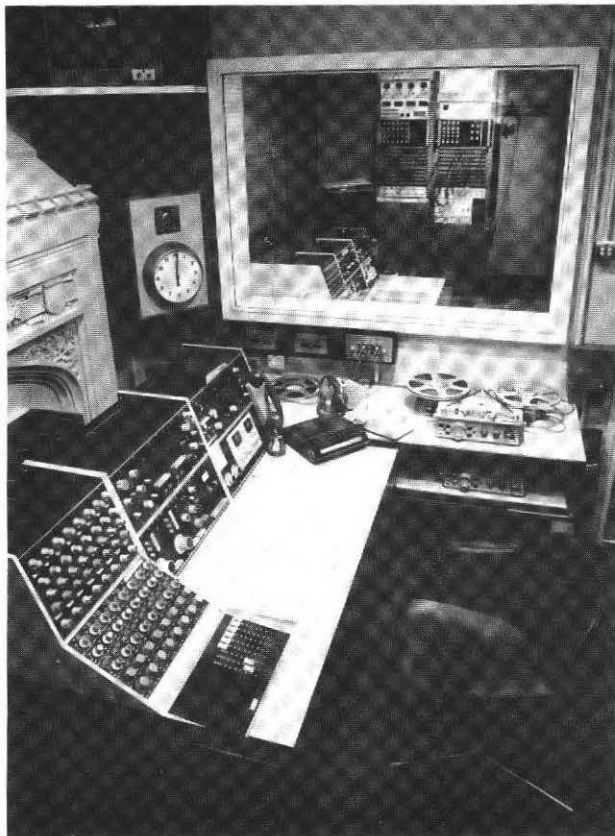

Fig. 1 The control desk in the Lords half of the Broadcasting Control Room. Through the window can be seen a similar desk in the Commons half and, in the background, bay-mounted equipment and a monitoring loudspeaker. The tape machines for emergency recording of the proceedings are next to the partition. The annunciator is in the top left-hand corner of the picture.

2.2 Annunciators

Various parts of the building are equipped with annunciators. These are television monitors displaying information prepared by Palace of Westminster staff, including such items as what debate is in progress, who is speaking, and for how long he has been doing so. Each annunciator can be switched to display either Commons or Lords information. The loudspeaker of the annunciator is silent for most of the time but a chime note signals any change of information in the Lords display while a guitar-string note fulfils a similar function for the Commons.

2.3 Division Bell

Most readers will be aware that bells are sounded to announce the intention of either House to divide — i.e. take a vote. The circuits which cause the bells to ring are distributed to many parts of the building and also to a number of nearby buildings.

3 Derivation of primary signals

The broadcast signals are based on a feed of the sound

reinforcement signal provided by Tannoy. Two feeds are provided (main and reserve) and are, of course, taken from a point in the chain before the frequency shifter: the question of oscillation does not arise in the broadcast case and a frequency shift would merely cause a reduction of quality.

The change from one sound reinforcement microphone to another can produce a discontinuity of atmosphere which could be disconcerting to the radio audience. BBC microphones (normally two) have therefore been suspended from the ceiling of each Chamber to provide a stable ambience. The signal produced by mixing, for example, the sound reinforcement feed from the House of Commons with the Commons ambience is called the Commons Clean Feed.

This mixing is carried out close to both Chambers in Room DK2 (a designation derived from its earlier use by Door Keepers) which is now used as a Central Broadcasting Control Room. In this room also any commentary which may be required can be added to the clean feed, and both clean feed and composite programme passed on to the editorial staff.

Feeds are also available in DK2 from microphones installed in committee rooms. Any such feed may be cut by the Hansard Editor or by the Chairman of the Committee when private session is required.

The Broadcasting Control Room is divided into Lords and Commons areas by a partition which incorporates a double-glazed observation window. Each part is similarly equipped with a control desk of a standard eight-channel outside-broadcast type together with a special unit providing main and independent groups, limiter/compressors with voice over, ring main selections, remote starts for local tape recorders, a digital stop watch, and telephone facilities. When the control desk is in use (e.g. for a live broadcast with a commentary supplied from the box in the appropriate Chamber) both the clean and the mixed feeds are taken from the desk: at other times a simple bay-mounted preset mixer provides the clean feed.

The Commons area also houses the Committee Room Unit and the Lords area houses batteries which allow operation (of both areas) to continue for up to four hours in the event of mains failure. Both areas have tape recorders to permit recording of the proceedings if there should be a mains failure at Bridge Street (see section 5).

4 Commentary boxes

The commentary box in each Chamber is shared by the BBC and IRN.

Commentators (and their assistants) use headsets with independent earphones: the right ear hears the proceedings from the Chamber while the left hears cue programme, which can be overridden by talkback from the control position in DK2. The broadcast microphone is a close-talking capacitor type mounted on a boom attached to the headset. Both boxes are equipped with annunciators, clocks, normal Outside Broadcast signalling and microphone muting facilities, and telephone communications with the main editorial area. Each box can be used for editorial purposes when not required for commentary.

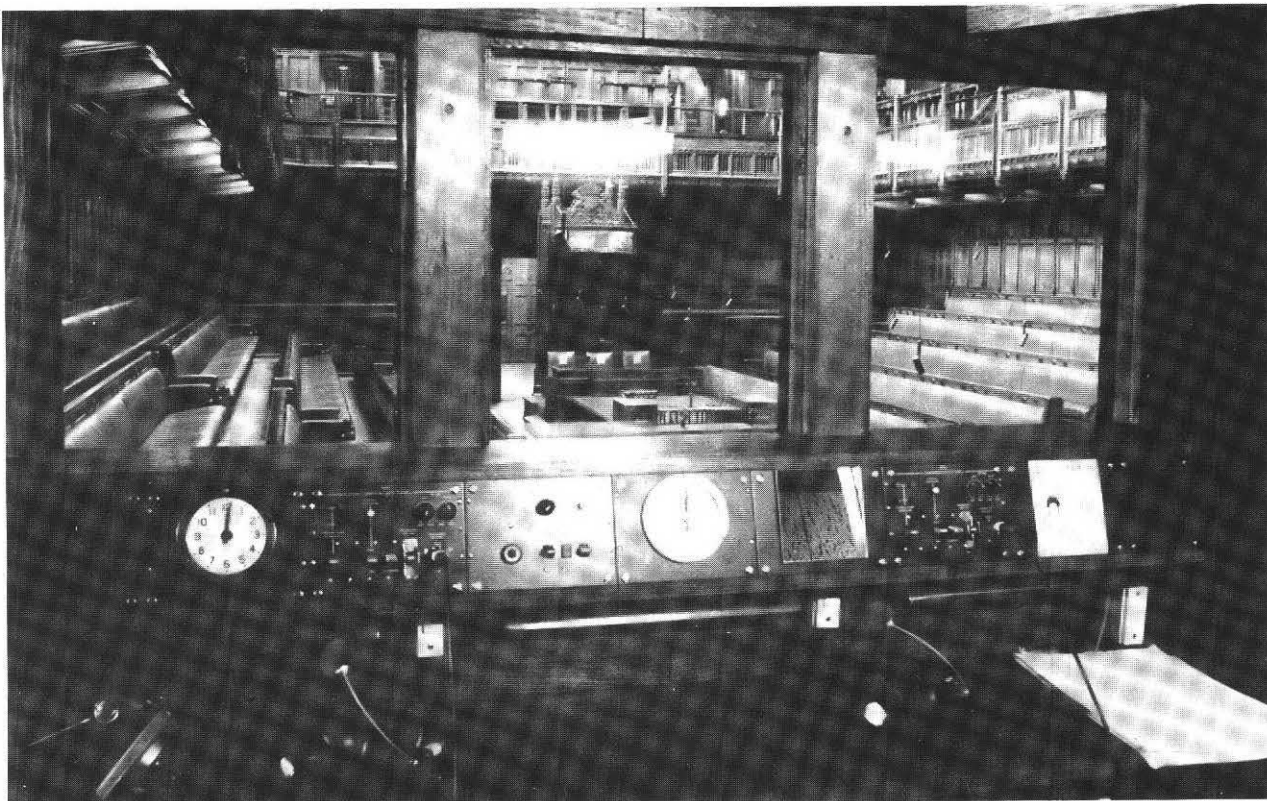

Fig. 2 A view of the Chamber of the Commons from inside the commentary box. The Speaker's chair and Despatch Boxes are visible through the middle window and sound reinforcement microphones can be discerned through the middle and right-hand windows.

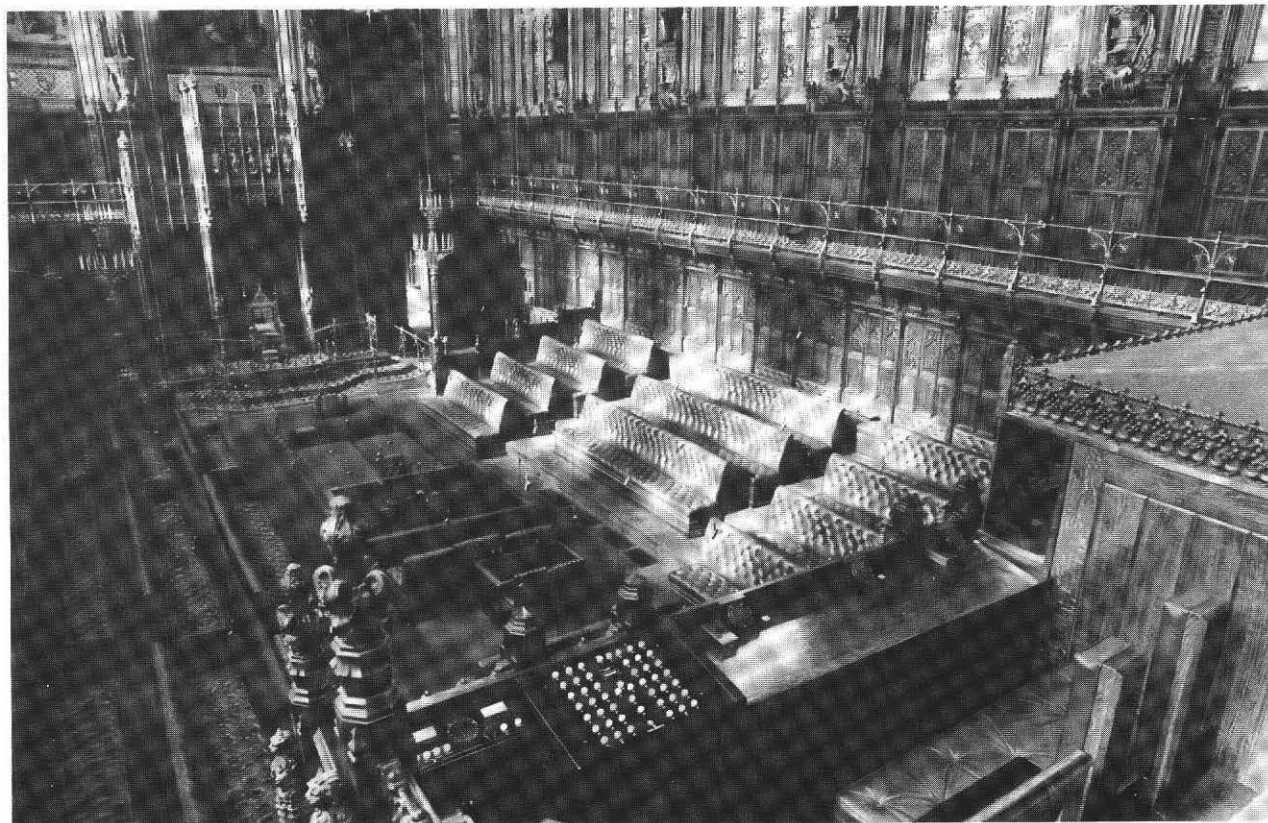

Fig. 3 A view of the Chamber of the Lords looking towards the Throne. The corner of the commentary box can be seen on the right, built in a style to merge inconspicuously with its surroundings. The array of push-buttons in the foreground is the microphone selection panel used by the Tannoy operator.

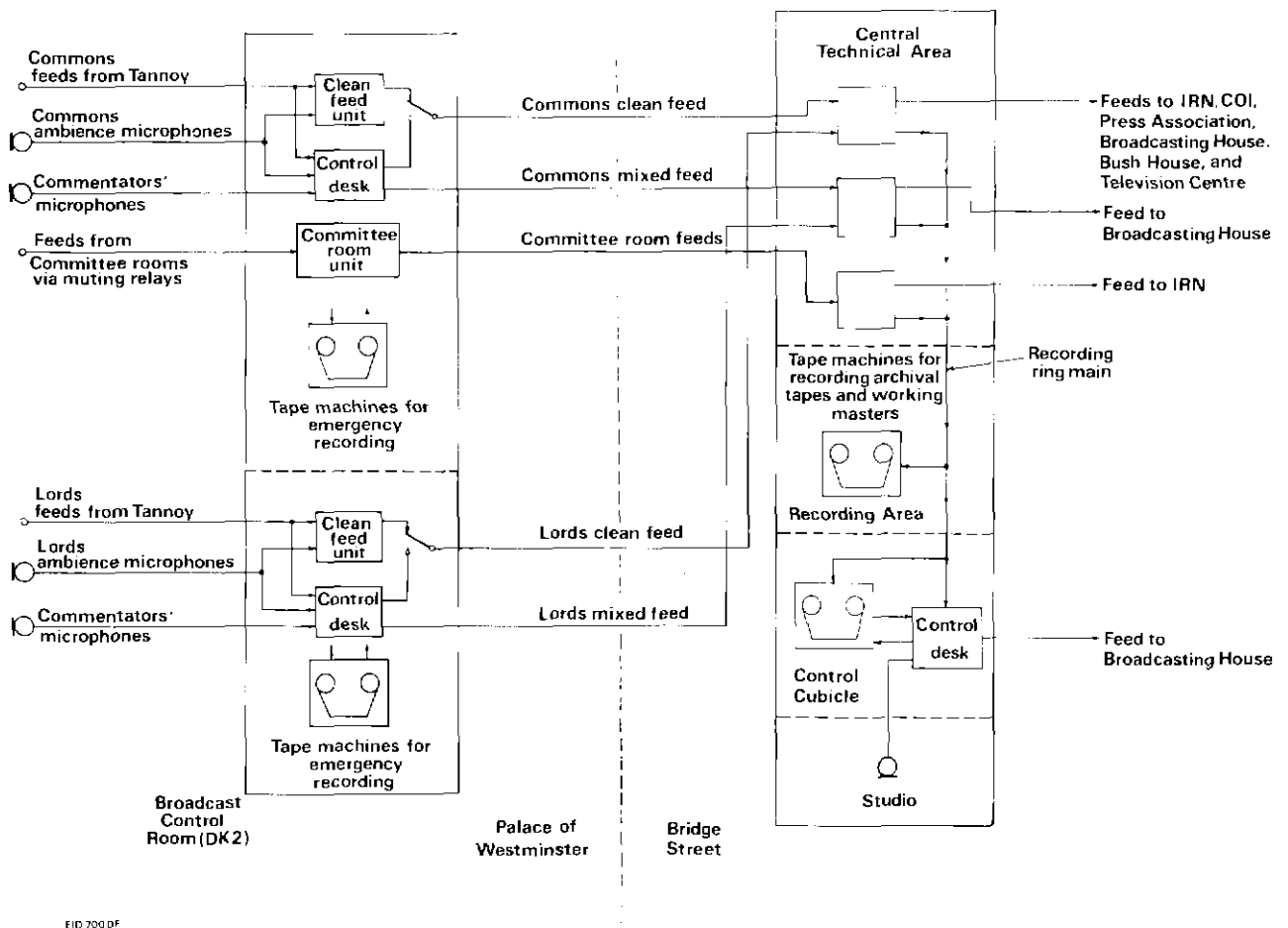

Fig. 4 Principal features of the installation for broadcasting Parliament.

Although each box is intended to accommodate four people (two BBC and two IRN) the constraints in the case of the Lords Chamber have meant that the accommodation is very cramped if all four positions are to be occupied. The Lords box is built at the front of the Press Gallery and has to be low enough to avoid obstructing the view of those behind and have good sound isolation to avoid disturbance to other journalists or to the House itself. At the same time the structure of the Gallery is such as to impose strict limits on the permissible weight.

5 Commons editorial area

In the Upper Press Gallery of the Commons an area has been equipped for six editorial staff. The staff working in this enclosed area can observe and hear the proceedings of the House and at the same time keep in touch with their colleagues in the main editorial area in Bridge Street (section 6.4) by point-to-point telephone to a particular table.

6 Installations at Bridge Street

The temporary accommodation for the remainder of the broadcasting undertaking is in an old building on the opposite side of Bridge Street to the Palace of Westminster.

A Central Technical Area, a recording area, and two small studios, as well as an editorial area and miscellaneous facilities, have been set up there.

6.1 Central Technical Area

All the technical services are based on the Central Technical Area (CTA). Two 'ring main' systems for distributing programme material are fed from the CTA: one is a general-purpose system which distributes the Commons and Lords proceedings and the outputs of three radio receivers, each capable of operating on LF, MF, and VHF bands; the other is for recording purposes and distributes Commons and Lords proceedings and Committee Room outputs.

The CTA is also the switching area for lines to Broadcasting House, Television Centre, Bush House (for External Services), and the Central Office of Information (COI).

No local diesel is available to maintain power in the event of mains failure but sealed lead/acid batteries are installed in the CTA to permit the continued operation of the most important equipment, i.e. the equipment which sends signals to the lines to allow live broadcasts to continue.

A quartz master clock drives a one-second impulse system which feeds slave displays in various parts of the Bridge

Street premises and the broadcasting locations in the Palace of Westminster.

The CTA also houses the equipment for a voice-operated intercom system which has seventeen stations linking most of the broadcasting locations. The system is capable of providing three-way calls and will handle up to three simultaneous conversations.

6.2 Recording

In the recording area twelve trolley-mounted tape machines are used to make continuous recordings of parliamentary proceedings. The machines are organised as six pairs so that each pair can produce a continuous recording. The tape speed is $7\frac{1}{2}$ " per second and so 7" spools will hold sufficient tape for a short overlap on the basis of half-hourly changeover between machines.

The six sets of master tapes so produced are normally divided into two sets of Lords Proceedings and four sets of Commons Proceedings. When a Committee Room output is recorded, only three Commons masters are made. One set of Lords and one set of Commons masters are kept as BBC archive masters and the others are used as working masters by editorial staff (i.e. one set of Lords masters and three sets — or two — of Commons masters).

There are also four semi-professional machines used in two pairs for recording the proceedings of each Chamber at $3\frac{3}{4}$ " per second (giving an hour's net recording on each 7" spool). These tapes are intended for parliamentary archives and MPs' reference, and are handed over daily into the care of the Clerk of the Records.

The recording area cannot continue to operate in the event of a failure of the Bridge Street mains supply. Emergency recording can be carried out in the Broadcasting Control Room (Room DK2) as mentioned in section 3.

6.3 Studios

Each of the two studio suites consists of a small talks studio flanked by two control cubicles. Either cubicle can be used to control the studio, leaving the other one available for editing work. The cubicles of Studio 1 have facilities for five tape machines and those of Studio 2 for three.

The required parts of the master tapes are copied for editing purposes (not cut) and programme-building carried out in these cubicles. The recording ring main is fed to the cubicles so that, if required, the proceedings can be recorded direct.

6.4 Editorial area

The main editorial area is at the heart of the Bridge Street premises. It is made up of four sub-areas or 'tables' devoted to Radio News, Local Radio and Regions, Current Affairs, and Television.

Each table has a feed of the general-purpose ring main so that the Lords and Commons clean and mixed feeds and network radio signals can be selected for listening (by headphones or small loudspeaker). Cassette recorders and semi-professional reel-to-reel machines are available for



Fig. 5 The recording area where six pairs of trolley mounted tape machines produce the six archive and working master tapes. Two pairs of semi-professional bench-mounted machines produce the parliamentary archives.



Fig. 6 The control desk in one of the control cubicles. The small talks studio can be seen through the window behind the desk.



Fig. 7 The main editorial area at Bridge Street.

recording from the ring main or replaying master tapes for programme planning. The tables also bear various telephones: extensions of the Broadcasting House PABX, extensions of the House of Commons PABX, direct exchange lines, and special telephones giving direct access to other editorial areas. They are colour coded and fitted with visual 'ringing'. There are also intercom stations at all the tables.

The editorial area is also linked to the Newsroom at Broadcasting House by a facsimile machine, teleprinters, and a VDU terminal. Annunciators, television monitoring, and a division bell complete the facilities of the editorial area.

The studios and their cubicles, the recording room, and other areas all open off the main editorial area so that rapid access is easy.

6.5 Television studio

A spare room at Bridge Street has been equipped as a simple television studio and will shortly go into service. A fixed camera faces an adjustable chair so that a correspondent can place himself in shot and introduce the selected extracts of the proceedings on audio tape cartridges.

7 Aspects of operation

In order to provide a reliable indication of the time at which any particular part of the parliamentary proceedings took place the signal recorded on one track of the master tape is accompanied by a recording on the other track of a time reference. A simple, readily available, and easily interpretable time reference is the Post Office speaking clock (TIM) a permanent feed of which is taken for the purpose.

Although the voice part of TIM causes no significant cross-talk between tracks, the bursts of tone marking the time every ten seconds are capable of producing an identifiable background on the programme track. For this reason the 'pips' are removed before the feed of TIM is distributed for recording, producing a result known as 'seedless TIM'. The time reference is, of course, invaluable in locating the required portion of a master tape but has no use in a compiled programme and is not copied in the editing procedures.

In an average day when both Houses are sitting the recording area produces about 100 tapes, all of which must, of course, be carefully labelled and stored in an orderly manner. If all the tapes were kept indefinitely a storage problem would be created and vast expense would be incurred. Apart from archive tapes, therefore, short storage times are the rule, and the tapes are then re-used. Ten recordings are permitted per tape before it is discarded and so each tape must be labelled also with the number of times it has been used.

8 Conclusion

The installations used for parliamentary broadcasting have been based on the experience gained during the experimental period in 1975. So far, the results of practical operations appear to be justifying the decisions taken.

Introducing Digits

E. R. Rout, C Eng, MIEE

Head of Designs Department

Summary: This article is not aimed at specialists, but at those engineers who feel that they need a general understanding of the present status and probable future development of digital systems in broadcasting.

The origins and basic concepts of digital techniques are outlined and their present and future application to audio and video equipment in studios and point-to-point transmission systems is discussed. Some of the problems and decisions which face broadcasters are outlined.

- 1 What are digital techniques?
- 2 How can digital techniques help the broadcaster?
- 3 Present-day digital applications and developments.
- 4 Some digital problems.
- 5 The approach to complete digital systems.

1 What are digital techniques?

Audible sounds and visible images originate as acoustic and electromagnetic waves of arbitrary frequency and amplitude. In analogue broadcasting systems they become video and audio signals of defined bandwidth and limited amplitude. Within these defined limits, audio and video signals follow the variations of light and sound picked up by the camera or microphone. Thus conventional broadcast signals attempt to reproduce the original variations of the light or sound; they form an 'analogue' or copy of the original, impaired, however, by noise, distortion and interference.

Digital techniques use numbers to describe video and audio signals. Thus a digital signal is a stream of numbers, changing sufficiently often to give the same subjective impression as a continuous signal and providing sufficient accuracy to avoid visible or audible distortion.

To convert analogue signals to digital signals, an analogue-to-digital converter, ADC, is required. This is, in essence, a special form of digital voltmeter, capable of acting with sufficient speed and precision to satisfy the above requirements. The output is a sequence of measurements, each presented as a number, usually in binary form. Binary numbers have the attraction of requiring only two signal levels, such as one or zero, high or low, thus simplifying circuit techniques and providing a rugged form of signal which can be easily regenerated if impaired by noise or distortion. A digital-to-analogue converter, DAC, is needed to recover the original analogue signal.

Eight binary digits will describe 2^8 or 256 signal levels; thirteen binary digits ('bits' for short) describe 2^{13} or 8192 signal levels. Subjective tests have shown that eight-bit numbers satisfactorily describe video signals and thirteen-bit numbers are adequate for audio signals.

There is a simple rule for deciding how often signals need to be measured or 'sampled' to avoid distortion. The frequency of sampling must not be less than twice the highest frequency in the original analogue signal. For 15 kHz audio signals, an accepted sampling frequency is 32 kHz and for colour television signals a popular figure is three times the colour subcarrier frequency. The latter gives a sampling rate of 13.3 MHz for 625/50 PAL signals with a 4.43 MHz subcarrier and 10.74 MHz for 525/60 NTSC signals using a 3.58 MHz subcarrier.

Since sampling is in essence a modulation process the wanted and unwanted components must be separated. Sharp-cut low-pass filters before the ADC and after the DAC are essential. The cut-off frequencies are as close as possible to the highest wanted frequency in the original signal and high attenuation must be maintained from cut-off to three times cut-off frequency.

2 How can digital techniques help the broadcaster?

Digital techniques offer two principal advantages. First they provide a rugged form of signal which is resistant to noise and distortion and one which can be 'cleaned-up' or regenerated to restore its original condition whenever necessary. These features are particularly attractive in applications such as multi-generation recording or long-distance point-to-point transmission where impairments are inevitable and cumulative. As long as each received 'one' or 'nought' can be correctly identified, logic circuits can recreate the original, noise-free signal.

Secondly they enable techniques and devices developed primarily for computers and data handling to be applied to audio and video signals. Techniques for storing and

manipulating data in digital form are far more sophisticated and economical than their analogue equivalents. Modern, digital, integrated circuits offer high speed and low cost, and this readymade technology can now be applied to video and audio signals provided they are first converted to digital form. In particular, digital techniques offer economical, precise and distortion-free storage, arithmetic, and transmission.

This does not mean that all broadcasting equipment should immediately be converted to digital operation. Some processes will be more cost-effective by analogue methods for some time to come. However, digits already allow many operations to be done precisely, economically, reliably and without loss of quality. It is thus likely that during the next ten to fifteen years, digital techniques will steadily supplant analogue methods and much of the broadcast chain will become digital. Despite this, most broadcast transmissions to the public will remain in their present analogue form for some considerable time, because of existing frequency allocations and the large public investment in receivers. A widespread change-over to digital broadcasting would almost certainly be tied to new transmission media such as broadcasting satellites. Nevertheless, if frequency bands offering channels with bandwidths of the order of a megahertz are available then digital sound broadcasting is possible with current technology.

3 Present-day digital applications and developments

There are two principal areas of broadcasting technology which can benefit from digital techniques at the present time — point-to-point sound transmission and television signal processing which requires the storage of a few lines or fields.

High-quality audio signals are particularly susceptible to noise and distortion and long-distance sound circuits are vulnerable to these defects. Digital transmission overcomes these problems provided suitable bearer circuits can be found. In general terms, digital sound transmission requires greater bandwidths in order to accommodate bit-rates of around 400 kb/sec per channel but can tolerate much higher noise levels. (Up to -23dB peak-signal to r.m.s. noise for binary signals). Such bandwidths can be provided by analogue circuits intended for television transmission and their signal-to-noise ratio comfortably exceeds the minimum required for digital transmission.

Since 1970 the BBC has distributed all television sound signals to transmitters using its Sound-in-Syncs system. This inserts a digitally-coded audio signal in the line-synchronising period of the accompanying television signal. The digital audio signal is removed from the vision signal and converted to analogue form prior to the transmitter modulators.

Since 1972, radio programme-signals have been distributed along main BBC trunk routes in the UK by a 13-channel PCM system using circuits designed for monochrome television transmission. This system uses 13 bits per sample and a total bit rate of 6.336 Mb/s. Using more modern coding techniques, it would now be possible to provide at least 20 high-quality sound channels on the same

bearer circuits. (It is worth noting that the best f.d.m. analogue equipment provides only 12 sound channels in one television bearer). Use of PCM has greatly improved the quality available from BBC stereo VHF/FM transmitters and greatly reduced the manpower needed to maintain and monitor programme distribution.

At least one commercial system offering transmission of six audio signals in digital form is now available.

Digital techniques are also used in current television equipment requiring storage. The first application was to time-base correctors for use with videotape recorders; these are used to remove timing errors in the replay of consecutive line-periods caused by mechanical problems. Early analogue correctors used electronically variable delay-lines which had limited range and accuracy. Digital storage offers much greater precision and cheap, variable delays of several line-periods. The penalty is that a video ADC and DAC are required which offsets this cost saving. Nevertheless all present-day timing-correctors use digital delays.

Television field-synchronisers and standards converters require variable delays of one or more field periods. Such long delays forced designers of early standards converters to use the storage properties of long afterglow cathode-ray tubes and rescan the image with a television camera. Picture quality and stability inevitably suffered. All converters designed since 1970 have used digital storage and digital arithmetic for the multiplications and additions required to provide interpolation between lines and fields. As a result, picture quality and stability are greatly improved and the falling cost of digital circuitry enables modern designs of digital converters to be marketed at acceptable prices.

The same comments apply even more cogently to field synchronisers which are desirable devices but not an essential part of the broadcasting chain. A synchroniser needs a small amount of logic and signal processing but the storage of one or two fields of video accounts for a major part of the cost. With the cost of storage falling rapidly we can expect the price of synchronisers to drop significantly in the near future.

Another luxury article which has come into the market place in the last year or two is the storage-based, television effects generator. This device stores one or two fields of video and has ingenious logic circuits which manipulate the stored data to provide small, inset pictures, variable-size pictures, stop-motion effects, multiple images, etc. Taken to the limit, there seems to be no fundamental reason why any effect which can be conceived, cannot be achieved with combinations of mini-computer, microprocessor and video storage, in the not too distant future.

Video storage and digital control can not only manipulate conventional television pictures, but also originate graphics, cartoons and original paintings. Devices offering useful but limited ability in all these areas have been demonstrated and some have already appeared on the market.

An application of digital techniques which will bring marked improvements of quality and fewer operational problems to both sound and television studio operations is digital recording. In both cases the benefits are greater where several generations of recording are necessary. This need is most common in complex post-production editing.

The BBC and 3M Company (USA) recently announced collaboration in the development of a multitrack, digital audio-recording system. The system, to be marketed in a year or so, will have two principal advantages. The quality of recorded sound will, in terms of noise and distortion, be very high and unaffected by the number of generations. Timing errors will be corrected by a timing corrector, similar in principle to that used in video recorders, and wow and flutter will be zero.

The IBA (UK) have recently demonstrated an experimental digital video recorder using bit-saving techniques and a helically-scanned tape transport. Whilst not yet fully developed, this work clearly demonstrates that digital video recording is possible with moderate consumption of magnetic tape.

Experimental sound control desks and vision-mixers for broadcast studios using digital signal paths have also been demonstrated. However no fully developed, practical, all-digital control desk or mixer has yet been announced.

Digital technology has permitted development of an important device with no precedent in analogue technology. This is the television noise-reducer. By re-circulating the television signal through a field-delay the noise reducer adds together successive fields of wanted video signal and unwanted noise. Since noise is random and the picture is coherent the signal-to-noise ratio is improved, typically by 8 or 9 dB. Moving objects in the scene would be blurred by this technique in a way similar to that caused by excessive camera lag or a long-afterglow cathode-ray tube. However, the ease with which complex logical processes can be applied to digital equipment permits the noise-reducer to intelligently distinguish between moving and stationary objects. Noise reduction is inhibited at moving edges and the overall effect is a reduction of noise without impairment of movement portrayal.

A noise-reducer for the 625/50 PAL system has recently been developed by the BBC.

4 Some digital problems

Previous paragraphs have shown that audio point-to-point transmission and many television studio operations can benefit from the introduction of digital equipment. This section discusses some of the issues which should be considered if digital innovation is to be successful.

There is a problem which is common to all areas where digital equipment for handling video and audio signals is already available. This is caused by the mixture of digital and audio equipments which will be present until the whole broadcasting chain is digital. The digital equipment will be mixed with analogue equipment in random order and at each junction point it will be necessary to convert the analogue signal to a digital signal or vice-versa. Thus ADCs and DACs will proliferate and each will add its own quantising errors.

Most digital equipment uses a number of bits per sample which is sufficient to allow up to four coders and decoders (codecs) in series without a subjectively significant impairment. Care should be exercised in intermingling digital and analogue equipment. For example, a television

signal may soon encounter an analogue video tape-recorder, a digital timing corrector, an analogue switching matrix, a digital standards converter, an analogue video tape recorder, a digital mixer, another analogue video tape recorder and a second digital mixer. This requires four codecs in tandem, without adding digital special effects or digital noise-reduction to the chain.

In practice the example above does not present a serious problem as quantising distortion is only apparent if the noise level in the signal is very low. Two analogue recorders and a camera would almost certainly provide sufficient noise to mask quantising distortion.

However, as noise levels get lower, quantising effects could show up. There are two ways to ameliorate this. The obvious and most attractive way in the long term is to interconnect all digital equipment with digital interfaces and circuits. This is only practicable if most equipment is digital and a digital routing system of the necessary capacity is available. Obviously it will be some time before existing studio complexes can take this course; standard digital interfaces for audio and video equipment will be needed if interconnection is to be easy, and 1978 is not too soon to start the long job of defining, agreeing and standardising.

The second way to avoid accumulation of quantising distortion is to use more bits per sample. Each extra bit per sample doubles the number of codecs that can be put in tandem and thus provides an easy and relatively inexpensive solution. But, unlike the previous solution, it does not save the cost of all those codecs!

Digital equipment for television studios has so far adopted 8 bits per sample almost without exception. However, sampling frequencies vary, those for 625/50 systems being about three times colour subcarrier frequency ($3f_{sc}$) whilst some 525/60 users seem to favour $4f_{sc}$; these frequencies are about 13.3 MHz and 14.3 MHz respectively. A further complication is the convenience of choosing a frequency of precisely three times or four times the colour subcarrier for coding the composite signal in, say, a field-store synchroniser where the signal will only be stored and not processed, whilst for a standards converter a more convenient choice would be an exact multiple of line-frequency to ease the problems of interpolation. To convert a digital signal from one sampling frequency to another is not impossible, but would add a fair amount of complex digital arithmetic to the interfaces. Standards for studio digital interfaces are thus not easy to achieve. The longer we are without them, the more difficult they will be to achieve as designers will choose the most convenient coding parameters for each task.

The problems of standardisation are difficult enough in applications which use linear coding where the only choices are the number of bits per sample and the sampling frequency. When costs are proportional to bit-rate, as in recording and transmission, it is sensible to complicate the coding equipment to save tape consumption or transmission capacity. This is an area where considerable inventiveness has been displayed by numerous workers, the world over. Systems for high-quality sound transmission now use only 320 kb/sec instead of 416 kb/s and television transmission systems have been demonstrated using only 34 Mb/sec

instead of the 106 Mb/sec required by simple linear coding.

Part of the incentive to aim for particular bit rates, 34 Mb/s for example, stems from the fact that most countries of the world will use more and more digital circuits for normal telecommunications traffic within the next decade or so. International standards for digital telecommunication transmission are appearing and much equipment of the future will accord with these standards. It will thus be attractive to base the transmission of broadcast signals around these international standards. The principal agreed bit rates (in Europe) are 64 kb/s, 2048 kb/s and 140 Mb/s. For point-to-point audio transmission only the 2048 kb/s level is of prime interest to broadcasters. The 140 Mb/s level is, similarly, the only one capable of television transmission. It would obviously be attractive to carry as much broadcasting traffic as possible in each of these channels and reducing the bit-rates required by programme signals makes good sense.

Let us deal first with bit-saving techniques for sound recording and point-to-point transmission. Since one of the objectives in digital sound transmission is consistently better quality, our bit-saving techniques must be consistent with high quality. The saving must therefore be made by exploiting known characteristics of hearing and of audio signals. It is well-known that added noise is most audible when the programme level is low; high level programme masks the noise. Furthermore it is well-known that the ear is less sensitive to low frequencies than to frequencies of several kilohertz. Respectively, these two phenomena have resulted in two equally well-known techniques for improving analogue audio transmission, companding and pre-emphasis. These same techniques are used for saving bit-rate in digital audio transmission.

Pre-emphasis is used in the same way, by introducing an analogue network to depress low frequencies and raise high frequencies before analogue-to-digital conversion. Companding is also applied by analogue techniques in the BBC Sound-in-Syncs system. More recently digital audio systems have used digital companding to achieve the same effect, a reduction from 13 bits to 10 bits per sample. The technique relies on changing the value of each bit according to the peak programme level measured in each consecutive interval of, say, one sampling period or one millisecond. At low programme levels the last bit of the 10-bit digital word may represent, say, 1 mV of analogue signal but as the programme level increases it would represent, say, 2 mV, 4 mV, or 8 mV. Thus at low signal levels the smallest level change, or 'quantum', is the same as that of the linear 13-bit PCM system whereas at high levels, where the signal masks the noise caused by the larger quantum, the smallest change is eight times larger. This variation applies not only to the last, or least significant bit, but to all 10 bits which represent each sample of the audio signal.

The latest 10-bit audio coding techniques, the BBC 'NICAM' system for example, provide quality almost indistinguishable from the 13-bit PCM system but enable the bit rate per audio channel to be reduced from 416 kb/sec to 320 kb/sec. Thus a 2048 kb/sec circuit can carry 6 channels instead of 4.

The simple explanations above describe and illustrate the

principles employed in audio bit-rate reduction but do not define any particular system. Most workers agree on the form of pre-emphasis, the sampling frequency and the number of bits per sample. The main differences lie in the method of companding. Some use instantaneous companding of a similar type to that used for digital telephony; this is known as 'A-law' companding. Other systems use near-instantaneous companding, based on the peak signal level in a group of, say, 32 samples. There seems no likelihood that a single audio coding system will be universally accepted in the near future. However, 32 kHz sampling, 10 bits per sample and the form of pre-emphasis are widely agreed, at least in Europe.

Since video bit-saving techniques must exploit characteristics of the eye and the television signal, they are based on quite different principles from those used for audio bit-saving. The television signal has a spectrum which has peaks of luminance energy at multiples of line frequency and peaks of chrominance energy between line harmonics. It thus differs from the continuous spectrum of audio signals. The regular peaks and troughs of the video signal allow filters to be used which have little attenuation at frequencies corresponding to the peaks and high attenuation in the troughs; this type of filter, based on line-period delays, is called a 'comb-filter'.

The process of sampling a video signal is similar to modulation as sidebands are produced around the sampling frequency. Normally the sampling frequency must be at least twice the highest video frequency to avoid over-lap of the sidebands and the original signal. However, both the original signal, and the sidebands produced by sampling, have regular peaks and troughs of energy. It is thus possible to choose a sampling frequency which is less than twice the video bandwidth by arranging for the peaks of energy in the lower sideband to fall in the troughs of the original signal. These spurious or aliasing components can then be removed by a comb-filter. This artifice, known as sub-Nyquist sampling, allows sampling frequencies of twice subcarrier frequency to be used with little degradation of picture quality; this results in an immediate saving of bits per second in the ratio of $3f_{sc}$ to $2f_{sc}$, a reduction of one third. This is a worthwhile step as the bit rate falls from 106 Mb/sec to 70 Mb/sec allowing transmission of two television signals in one standard 140 Mb/sec digital circuit.

A second technique which is popular with those working towards bit-savings for video point-to-point transmission is differential pulse-code modulation, DPCM for short. This technique is well suited to a television signal which in general terms consists of sudden large transients separated by periods in which the signal level changes relatively slowly. In other words most objects in a scene have sharp edges and subtle shadings.

DPCM codes represent a non-linear distribution of quantum steps. These steps are small around zero change, to deal with the subtle shadings, but increase as the sample-to-sample differences increase, thus large transients can be adequately coded. DPCM can be improved in terms of better picture quality for a given number of quantising levels, if changes in level can be predicted. This is done by examining previous sampling periods above and to the side

of the next picture point to be coded. As a result, less information needs to be transmitted, the decoder having an identical prediction system.

Acceptable quality has been obtained by DPCM video-coding systems using five or six bits per sample, that is 32 or 64 quantum-levels. The most common defect stems from the coarse quantum steps used to code large transients. These cause a random twinkling effect on edges of objects, known as edge-busyness.

Using DPCM with 5 bits per sample and $2f_{sc}$ sub-Nyquist sampling in the same system gives a bit rate of about 45 Mb/sec for 625/50 PAL; and three television signals could be sent in one 140 Mb/sec circuit.

A third artifice for reducing the number of bits needed to transmit a television signal is based on the fact that only the video signal in the active line periods is unpredictable; sync pulses, colour burst etc. can all be reconstructed at the receiving terminal provided that critical data such as the timing of the leading edges of the line synchronising pulses and the phases of colour bursts are transmitted. These data could be satisfactorily sent by digital codes occupying only a fraction of the hundreds of bits used to transmit a line-blanking period. Similarly information enabling the field synchronising, blanking and inserted data to be reconstructed would occupy only a few microseconds of a multimegabit-per-second circuit. Assuming that the whole of the line and field blanking periods can be saved, the bits describing picture information can be extended to occupy the whole of the transmission channel, thus reducing the bit rate by a further 24%. This would reduce a bit-rate of 45 Mb/sec to 34 Mb/sec, and permit four television signals to travel in one 140 Mb/sec circuit.

So far so good, but once again the variety of techniques applicable to bit-saving, and the numerous detailed choices within each technique, make the prospect of universal digital video-transmission standards for 525/60 and 625/50 remote. Furthermore no completely satisfactory 34 Mb/sec coding system has yet been demonstrated.

It is necessary to qualify the above simplified discussion of video bit-saving techniques in several ways. The discussion was based on developments aimed at the economical transmission of composite European PAL signals. Similar work is going on in countries using 525/60 NTSC, where the lower video bandwidth makes 34 Mb/sec coding rather easier.

All the methods of video-bit saving, described above in simple outline, code the composite television signal. For international exchanges which involve a change in the colour coding system, there is no need to base digital transmission on the composite form of signal since digital coding avoids the defects which make separate components hazardous in analogue systems. Digital transmission ensures that all three components are free from the amplitude, delay and frequency response errors which bedevil analogue systems. Separate coding of the luminance signal and the two colour components is being seriously considered in Europe as this would avoid the need for transcoding and allow both SECAM and PAL signals to be transmitted in identical form. So far no component coding system has been demonstrated with an overall bit rate as low as 34 Mb/sec.

In the earlier discussion, four television signals in 140 Mb/sec was accepted as an objective. Many broadcasters do not need this facility and would prefer a mixture of video, audio, signalling and communications if offered such a large transmission capacity between two locations. The ease with which digital signals of various kinds can be combined using time-division multiplexing is well proven and one of the great assets of digital methods. Thus a 140 Mb/sec circuit could easily carry three television signals, (120 Mb/sec), twelve high-quality sound signals (4 Mb/sec) and have spare capacity for lots of signalling and communications traffic. The ability to use a circuit in such a flexible way, and the freedom to vary the mix of traffic to match day-to-day or hour-to-hour requirements, depends not on technical issues but on the circuit owners and operators. It does, of course, also depend on the availability of such circuits in the right places and at the right prices; this can be expected towards the end of the 1980s.

5 The approach to complete digital systems

The prospect for the next few years is to introduce digital equipment step-by-step, wherever and whenever it is beneficial to do so. Storage-based television studio equipment, audio point-to-point transmission, audio multitrack recording, vision mixers, sound control desks, video-recording and video point-to-point transmission; this seems a likely pattern for the next decade.

At some point there will be pressure to use digital interconnections, hence the need for standard digital interfaces. Digital routing systems for studios and point-to-point circuits will then be needed and so far little thought has been given to this necessary development.

How rapidly and completely will analogue equipment disappear? Here we break all contact with logic and certainty and resort to personal opinion. One factor must play an important part — finance, in the forms of cost-versus-benefit, budgetary provisions and the write-off of existing equipment. The ability of individual operators and maintenance engineers to assimilate change must be another important consideration; it may be sensible to change certain technical areas to wholly digital operation, leaving other areas wholly analogue as long as is practicable. Indeed the time may come when technical education establishments teach nothing but digital technology and our new recruits cannot cope with analogue equipment.

On the technical front there may be limits to the advance of digital methods. As stated at the beginning of this article, sound and vision signals originate from analogue phenomena and the digital microphone and digital light-sensor may never be developed. It will certainly be difficult to handle signals with large level variations in digital equipment, so microphone amplifiers and the input circuits of sound control desks may remain analogue for some time. Certainly loudspeakers and picture monitors will continue to use analogue drives for a while and even the emergent solid-state sensors for television cameras handle video in analogue form.

It seems that ultimately, audio and video signals could be converted to digital form after initial analogue amplification

and some level control. They could then remain in digital form up to the amplifiers which drive loudspeakers and cathode-ray tubes used for monitoring. They could also remain in digital form throughout the networks feeding transmitters but would revert to analogue form before modulation. How far and how fast we go along this road will depend on people and money.

What is the incentive to convert to digital methods? Earlier in this article it was defined as resistance to noise and distortion and the exploitation of technology developed for non-broadcasting applications. There is another point which has emerged in later sections; it could be inconvenient to add individual items of digital equipment to the broadcasting chain, each justified in itself, but eventually leading to a

minority of interspersed analogue equipment. The main problems could be the embarrassing proliferation of codecs, and the need to choose between a switching and routing system which is either analogue or digital, but not both. At this point the most sensible course could be to eliminate the interspersed analogue equipment. Routing, maintenance and interface problems would thus be simplified.

For many broadcasters this may be the natural course of events. To wait until complete digital installations are the accepted practice means forgoing the benefits which digital equipment can offer to specific items of equipment over the next few years.

Whatever happens, we shall hear more and not less about digital techniques in the 1980s.

Making Better Connections

T. N. J. Archard
 J. A. Fox B.Sc.(Eng.)
 D. D. Gunn

Research Department

Summary: The established techniques of wrapped wire connections and heat-pulse soldering are capable of excellent and economical results but have certain disadvantages in some applications. New tools and methods have been devised in the BBC's Research Department to improve the position.

The developments described in this article are all the subjects of patent applications.

- 1 Introduction
- 2 Wrapped connections
 - 2.1 An improved wrapping bit assembly
- 3 Interconnections within units
 - 3.1 A simpler indexing device
- 4 Heat-pulse soldering
 - 4.1 Automatic temperature control
- 5 Conclusion

1 Introduction

The oldest common method of making electrical connections is probably a simple mechanical clamping of a wire by means of a screw. It is still in widespread use and is perfectly satisfactory for a great variety of applications where the voltage is high enough to break down the thin insulating films likely to appear on the metal surfaces and where the current is low enough to avoid the hot spots that might otherwise result from the rather haphazard distribution of contact pressure.

For lower voltages or higher currents the traditional method of joint-making is soldering. This can exclude insulating tarnish film and provide a contact area larger than the cross-section of the conductor. Soldering is, of course, also common in low-current applications (regardless of voltage) where small, cheap, sound, joints are required.

2 Wrapped connections

In relatively recent times (but still more than 20 years ago) a variant of the clamped mechanical joint was introduced when the first wrapped joint was made. Twisting wires round tags had, of course, been common since time immemorial whenever a poor temporary joint would suffice, but the wrapping technique produced something much better than a slightly less unreliable version of the traditional twist. A special tool wraps the wire under tension round a

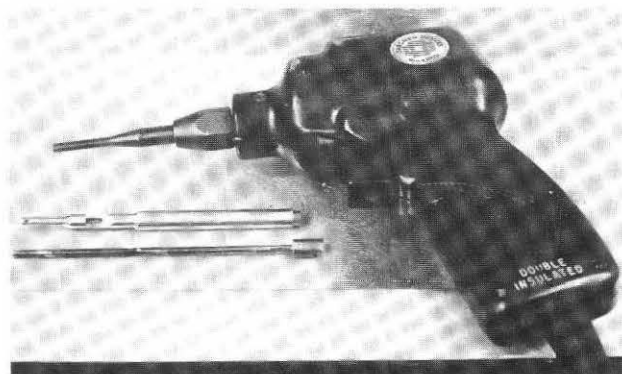

Fig. 1 A wire-wrapping gun fitted with a conventional wrapping bit, shown for comparison with the sleeve and the rotating bit of the improved assembly.

terminal post with sharp corners, producing sufficiently high local pressure to shear or crush the insulating tarnish film and give direct metal-to-metal contact. The technique has found extensive applications where many similar joints must be made in rapid succession and reliability of contact is particularly important.

The technique has not, of course, been without its problems. When simple wrapping tools are used the wire must first be cut to the correct length and suitable lengths of insulation must be stripped from the ends: the operation is rather tedious. More comprehensive tools exist which cut the wire and strip a suitable length of insulation as well as carrying out the wrap. Unfortunately, these usually have one or more serious drawbacks as set out in the first column of the table.

2.1 An improved wrapping bit assembly

An improved bit assembly has been developed which overcomes these problems by the means set out in the second column of the table. The new bit assembly automatically produces a so-called modified wrap — i.e. a small part of the wire that is wrapped round the terminal post is not

stripped — a well-known technique which gives stronger joints.

Further development may be possible: for example a design with a replaceable tip might be produced. The only part of the assembly subject to significant wear is the tip of the bit and it seems needlessly expensive to replace the whole assembly when the tip wear becomes excessive, even though this is normal practice with current tools.

3 Interconnections within units

A very common method of providing interconnections within units in a piece of equipment is by printed circuit boards, and for reasonably large numbers of identical boards the cost of each can be kept low. For small numbers, however, the cost of producing the necessary artwork can make printed circuits unattractive. An alternative method of providing the connections is to use wires attached to terminal posts by wrapping.

Such interconnections can be made manually by an operator who refers to a schedule of connections in the form of a drawing or a list of the co-ordinates of the terminal posts that are to be connected. This approach requires little in the way of preparation and is therefore quite cheap. It gives the operator a very tedious job, however, and the result is therefore prone to errors and omissions which can give rise to expense in correction.

Semi-automatic equipment is available which relieves the operator of the responsibility of finding the correct terminal post for the next wrapping operation. The co-ordinates of the posts concerned are recorded on paper tape and the equipment is controlled by this information, driving a sight over the board to indicate the position where the next wrap is to be made. The joint is then made by the operator using a hand-held wrapping gun. Such equipment can be very effective, but costs several thousands of pounds.

Fully automatic operation can also be provided. The connection information is embodied in a paper tape as in the semi-automatic method, but the equipment drives, instead

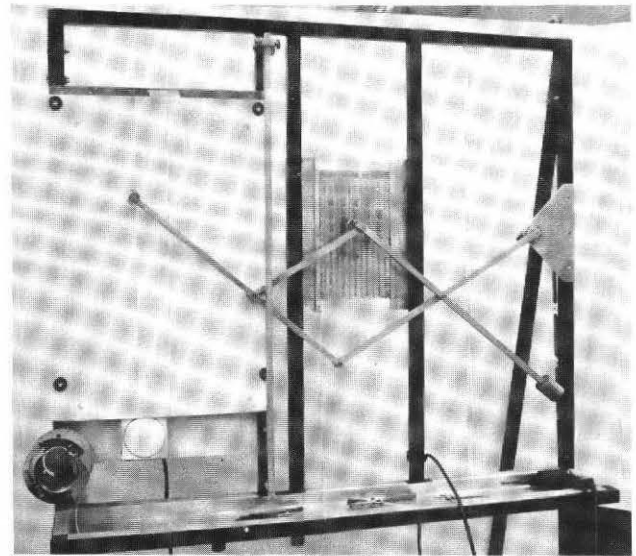

Fig. 2 The pantograph indexing device showing the locating pin head over the drawing at the left and the sight over the terminal post board in the middle.

of a sight, two automatic wrapping guns and makes the joints at both ends of a connecting wire. Equipment of this type costs several tens of thousands of pounds.

3.1 A simpler indexing device

A very much simpler method of locating the required terminal posts has been devised. A drawing of the board on which the connections are to be made is produced at an enlargement of 2:1 with the required connections marked on it. A dyeline print of the drawing is mounted on a baseplate which has been drilled to provide a regular grid of holes at 0.2" spacing both horizontally and vertically (corresponding to the conventional 0.1" grid of mounting boards). The baseplate is lit from behind so that the positions of the holes can be readily observed through the print. The board on

Drawbacks of many conventional wrappings tools	Improvements resulting from use of new bit assembly
Imperfect stripping. Strands of insulation are left inside the wrapping bit (which soon becomes clogged) because the gun motor is used to sever the insulation when it has just started and has little momentum.	Insulation is partially severed by action of operator in pulling wire taut before starting motor. Removal of the insulation remaining in the bit after completion of the wrap is assisted by an ejector consisting of a sliding sleeve and finger.
Risk of mechanical disturbance of adjacent wraps and components by rotating wrapping bit.	Wrapping bit rotates inside stationary sleeve.
Low working rate arising from need to turn tool around to feed wire into face of bit.	Wire is fed into side of tool.



Fig. 3 Making a wrapped connection using the improved bit assembly and the pantograph indexing system.

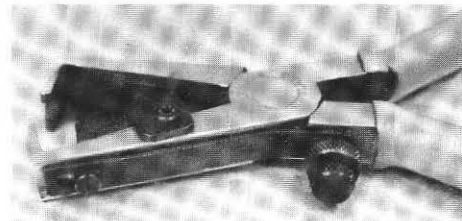

Fig. 4 The modified stripping pliers which make it a simple matter to strip the correct length of insulation.



Fig. 5 Using the modified stripping pliers in conjunction with the pantograph sight.

which the connections are to be made is mounted near the print in an accurately controlled relationship to it. A pantograph linkage moves over the baseplate in such a way that a sight occupies a position over the board corresponding to the position of a locating pin over the print.

The operator moves the locating pin to the position on the print of the first connection to be made and pushes it through the print and into the corresponding hole in the baseplate; the sight then automatically indicates the correct terminal post on the board. The wire can then be wrapped with any suitable wrapping tool. Pushing the locating pin through the print serves two purposes; it eliminates inaccuracy of positioning the pin due to stretching of the print and, by leaving a hole in the print, it provides an automatic record that the connection has been made, obviating the need for any separate record.

A refinement of the technique enables the sight to be used to measure off the required length of wire for each connection. The wire is placed in a notch in the inner rim of the sight when the first wrap of any pair is made. As the sight moves to the position for the second wrap the wire is drawn through the notch and the correct length is then easily cut off and stripped by placing a specially modified pair of

stripping pliers against the face of the sight.

Using this method a sequence of wire connections can be made at speeds directly comparable with those attainable by the much more expensive semi-automatic equipment. Depending on the skill and experience of the operator, each connecting wire (requiring two wrapping operations) takes between 12 and 20 seconds.

4 Heat-pulse soldering

In recent years the making of soldered joints on small 'pads' of copper on printed circuit boards has sometimes been carried out by the heat pulse method. In this technique a tantalum soldering bit with low thermal capacity is heated by electric power for a predetermined time. The virtue of the method is its ability to avoid overheating the pad or adjacent components. The voltage supplied to the bit and the time for which it is switched on are adjustable to accommodate different sizes (and therefore different thermal capacities) of pad and it is important that the adjustments give sufficient heat to ensure that the joint is properly made but not so much that overheating occurs. Establishing the correct

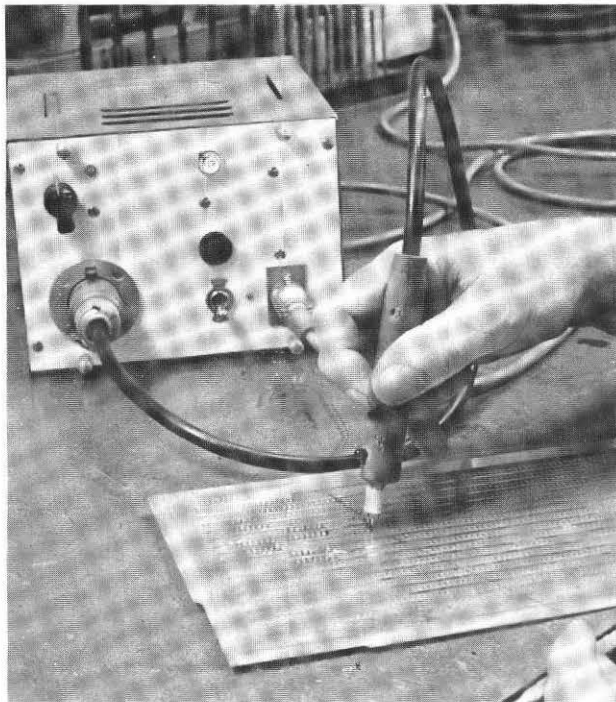

Fig. 6 Making a heat-pulse soldered joint using the new control unit.

adjustments is a tedious process and when dealing with a variety of different pad sizes the frequent re-adjustments open the door to errors and, hence, faulty joints and damaged components.

4.1 Automatic temperature control

An automatic system has been devised which uses a thermocouple junction at the tip of the soldering bit to feed back information about the temperature to a control unit. A differential amplifier drives a solid-state switch so that the power to the bit is cut off when the thermocouple output matches the preset bias on the differential amplifier. The feedback ensures that one setting of the control is satisfactory for a wide variety of solder pad sizes. As a safety measure the control unit incorporates an overriding timer which opens the switch after a certain delay if it has not already been opened by the operation of the temperature-sensing circuits.

5 Conclusion

The equipment described in this article makes joint-making cheaper and more reliable, particularly in low-volume production. It has evoked interest from manufacturers, and the pantograph described in Section 3.1 is already commercially available.

Contributors to this issue



Kenneth Angold-Stephens joined the BBC in 1963 and became an assistant instructor in 1966. He is now a Technical Instructor in the Production Training School. He has been involved in a number of Overseas training assignments and conferences, and has played a major role in the design of a transportable studio installation for use on these occasions. He was also part of the design team for the colour training studio at Woodstock Grove — one of the most advanced in the world — and is co-author of two books on the subject of small television studios.



Tony Archard is Head of Technical Services in Research Department. His responsibilities include the Drawing Office, Model Workshops, and Photographic and Printing Units, and he is consequently connected with all branches of the Department's work. He joined the BBC almost 25 years ago, having perviously been with the Valve Research Laboratories of Standard Telephones and Cables Ltd. His recent specialisations have included developments of printed circuits and related equipment.



Richard Burden joined the BBC in 1963 after being involved in both training and broadcasting — as a Wireless Instructor in the Royal Air Force, and subsequently as a radio presenter. With some experience of the BBC's Television Recording Department, he was attached to the Engineering Training Department before joining the Production School's technical team with which, in addition to his instruction duties, he has helped in the development of a versatile training studio.



J. A. Fox took his degree at King's College London and joined the BBC in 1950. He has been in Research Department ever since, first in Aerial and Transmitter Section and later in Receiver Section. One of his tasks was concerned with the first stereo modulating equipment used by the BBC, at Wrotham. Currently he is in Service Planning Section, where he is responsible for the design and manufacture of a wide range of equipment used by the Section for site tests and surveys of service areas.



David Gunn joined the BBC in 1950 after service in the Royal Navy and a short period with the Post Office. He has been in Research Department throughout his BBC service, and has worked both in the laboratories and in the Model Workshops where he has made a number of important contributions to the mechanical design of equipment. He is at present acting as deputy to Head of Workshops and is supervisor of the internal training programme.

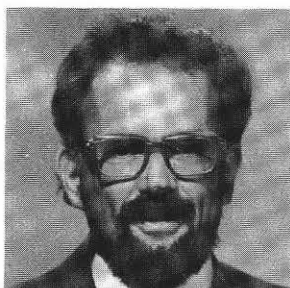

Richard Hammett joined the BBC as a Technical Trainee direct from Grammar School in 1961. During the next four years, half his time was spent working towards a Diploma in Electrical Engineering and the other half working in many engineering areas of the BBC throughout the country. After qualifying in 1965 he spent the next four years at Television Centre in the Studios Base Maintenance Department specialising in the commissioning of sound installations. He became a Technical Instructor at Woodstock Grove in 1969, where his work has included contributions to the setting up of overseas on-site Training Courses with a Production Instructor and the conversion to colour of the main training studio.



Roy Newrick spent six years in industry (the Pye group) and the next three in the RAF where he was concerned with single-sideband transmitters for the Commonwealth Air Force Network. He became a direct-entry engineer in the BBC's Television Service in 1962 but his subsequent career has been mainly in radio. Much of his work in this field was involved with installations in stereo music studios and concert halls, but latterly his main responsibilities have been connected with facilities for news, current affairs, and outside broadcast programmes. He has recently been appointed Head of Sound Studio and Recording Unit in the Studio-Capital Projects Department.

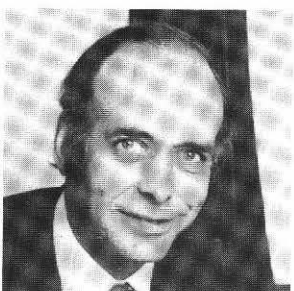

Eric Rout started his career with Pye Radio Ltd, Cambridge, as an assistant in their Research Laboratory and studied electronics at the Cambridgeshire Technical College and the Borough Polytechnic, London. In 1950 he gained an engineer post in the BBC's Research Department at Kingswood Warren where he stayed for twenty-two years.

At Kingswood Warren he was involved in the development of the 625-line European television system, electro-optical standards converters, film telerecording, the application of PCM to high-quality audio and video signals, the development of colour television systems, the first all-electronic standards converters and the Sound-in-Syncs system.

In 1967 he was appointed to the post of Head of Electronics Group in the BBC Research Department, a post which he held until his present appointment as Head of the BBC's Engineering Designs Department in December 1971. He has an active interest in international technical matters, in committees of the ITU and EBU.

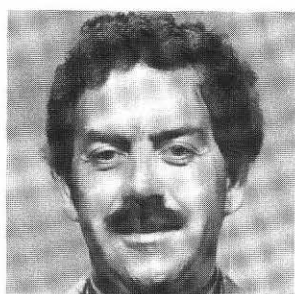

John Symons graduated in electrical engineering at University College, Cardiff. After an initial period in Television Recording Department at the BBC Television Centre, he became an Instructor at the Engineering Training Department at Evesham. In 1966 he became Technical Instructor in the newly formed Overseas Television Production Unit in London, where he is now currently responsible for technical management and instruction on production courses run for both BBC staff and production staff from overseas countries.