

"Amateur Wireless" HALF-CROWN SERIES

2/6

LOUD-SPEAKER CRYSTAL SETS

With numerous
illustrations

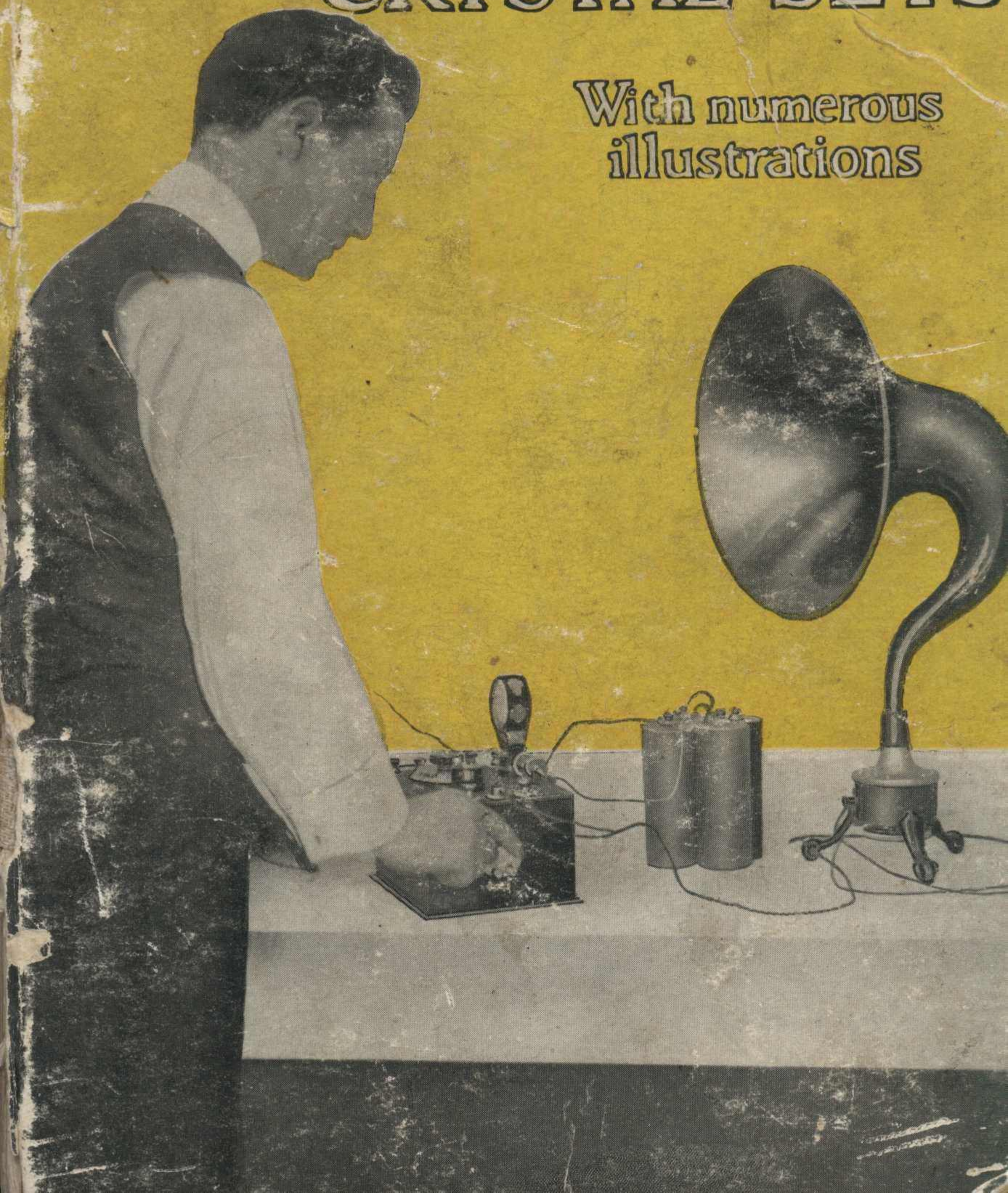

The Best Paper for Wireless Amateurs

Amateur Wireless And Electrics

The Leading Weekly

Devoted exclusively to the interests of Wireless Amateurs; explains the Underlying Principles; Makes the Way Plain to Beginners; Shows them How to Start; What to Do; What to Buy; What to Make, and How to Make It. Gives Expert Replies to Readers' Questions; no matter what the difficulty is, the Reader is helped out of it by Highly Skilled Experts; Wireless Club and Society Fixtures; and the Latest News of Wireless Developments. Fully illustrated by Helpful Diagrams and Photographs.

Every
Thursday

3D.

ON SALE EVERYWHERE

Cassell's, Publishers, London.

Cassell's Pet and Live Stock Series

Each net
1/6

To those who keep pets for pleasure, and live stock for profit—in a small way—this series of little handbooks will prove of the greatest service, and are reliable beyond question.

YOUR DOG ROBERT LEIGHTON.....

Valuable information on the training, feeding, and general treatment of a dog. Also first-aid hints—in fact, everything a dog-owner ought to know.

CANARIES: & HOW TO KEEP THEM.....

F. J. S. CHATTERTON

A guide to the successful keeping and rearing of canaries, either as pets or for breeding purposes.

MODERN PIG-KEEPING.....

H. P. JAQUES

Written primarily for the small man, but anyone who keeps pigs will find this book a valuable guide to making the pig pay.

DUCKS AND GEESE: AND HOW TO KEEP THEM.....

F. J. S. CHATTERTON

What are the best breeds to keep for egg-production, or for table purposes? How should they be housed and fed? These and a host of other important points are dealt with in this book.

POPULAR CAGE BIRDS.....

JOHN ROBSON

Authoritative information and directions on the proper management, keeping, and breeding of these delightful pets.

PRACTICAL RABBIT-KEEPING.....

GEORGE A. TOWNSEND

This book will meet the needs of everyone who "goes in" for rabbit keeping, either as pets or for exhibition purposes.

FOWLS: AND HOW TO KEEP THEM.....

ROSSLYN MANNING

Everyone who keeps fowls, whether in the expectation of profit-making, or merely as a hobby, will find this book a real practical help.

Cassell's

CASSELL'S "WORK" HANDBOOKS

1s. 6d. net each.

For the Handyman, the Expert and the Amateur.
Practical manuals with many helpful illustrations
dealing with almost every subject of interest to
the man who does things himself.

NEW SPRING ISSUES

Practical Upholstery Illustrated.
Electrical Toys and Tricks.
Practical Leather Working.

**Motor-car Overhaul and Adjust-
ment**
Wood Turning Made Easy

Basket Making.
Beehives and Beekeepers' Appli-
cations. [Appliances.]
Bent Iron Work.
Bookbinding.
Boot Making and Mending.
Building Model Boats.
Camera Making. [ing.]
Clay Modelling and Plaster Cast-
ing.
Clock Cleaning and Repairing.
Conjuring Apparatus and How
To Make It.
Cycle Repairing and Adjusting.
Domestic Jobbing. [Building.]
Dynamo and Electric-Motor
Management.
Dynamo and Motor Erection and
Management.
Electric Accumulators.
Electric Bells and Telephones.
Electric Clocks.
Electric Lighting.
Electric Primary Batteries.
Electro-Plating.
Fishing Rods and Tackle, Making
and Mending.
Furniture Repairing.
Gilding, Silvering and Bronzing.
Glass Writing, Embossing and
Fascia Work.
Gramophones and Phonographs.
Handyman's 1,000 Practical
Receipts, The.
House Painting and Decorating.
Household Repairs.
Incubators and Chicken Rearers.
Induction Coils. [Cordage.]
Knotting and Splicing Ropes and
Magneto Repair and Adjustment.

Metal Turning Made Easy.
Miniature Electric Light.
Model Aeroplanes.
Motor Cycles and Side-Cars: Con-
struction, Repair and Man-
agement.
Mounting and Framing Pictures.
Oxy-Acetylene Welding.
Patents, Designs & Trade Marks.
Photography Simplified,
Pianos.
Poultry Houses and Appliances.
Pumps and Hydraulic Rams.
Rustic Carpentry
Sewing Machines.
Simple Lathe and Its Accessories,
The
Small Dynamos and How to Make
Them (including Electric
Motors).
Small Electric Apparatus.
Small Lathes: Making & Using.
Small Workshop Appliances.
Soldering, Brazing and Welding.
Stage Illusions & Entertainments
Tailoring.
Taxidermy.
Ticket Writing and Sign-Painting
Tinplate Work.
Toy Making.
Violin Making and Repairing.
Watch Cleaning and Repairing.
Wireless Telegraphy and Tele-
phony.
Wood Finishing
Workshop Arithmetic. [Workers.]
Workshop Hints for Metal

Send P.C. for Illustrated List of Technical Books.

CASSELL'S—PUBLISHERS—LONDON

**LOUD-SPEAKER
CRYSTAL SETS**

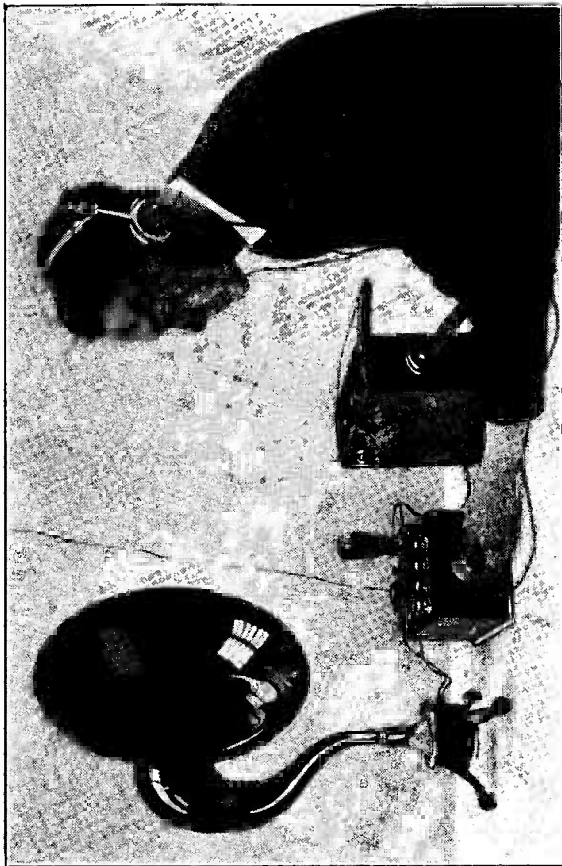

Operating the "Amateur Wireless" Loud-speaker Crystal Set. Any good Crystal Set may be converted to work a Loud-speaker with full volume results. Refer to Chapters 14 to 16.

"Amateur Wireless" Half-crown Series

Loud-speaker Crystal Sets

A Practical Handbook on [Building] the most efficient Crystal Sets, with [a section Fully Explaining the "A.W." Crystal Loud-speaker System

Edited by

Bernard E. Jones

Editor "Amateur Wireless," etc. etc.

With 140 Illustrations

Cassell and Company, Ltd

London, New York, Toronto and Melbourne

First published 1925

Printed in Great Britain

EDITOR'S PREFACE

THE purpose of this book is to explain how to build a number of crystal receivers, all of them simple and of proved efficiency. It is hoped that the text will be found lucid and that in conjunction with the illustrations the reader will find every point fully covered.

A special section of the book deals with a recent development—a system by which a loud-speaker can be operated from a crystal set without the intervention of valves. This system is explained at length, full practical details are presented, and the reader can please himself as to whether he makes a loud-speaker attachment for a crystal set, or whether he builds a set that incorporates in itself the special attachment referred to.

As the Editor of "Amateur Wireless" I answer personally for the success of this loud-speaker crystal system. I have tested it over a number of months, and am positive that if the instructions given in this Handbook are faithfully adhered to, and if care is taken to see that the special microphone button, the *reed*-type phone (not flat diaphragm-type) and other apparatus are in good order, success is ensured.

"Amateur Wireless" will be happy to answer queries on any points referred to in this Handbook, it being necessary that all enquirers should send in with their enquiry a coupon cut from a current issue of "Amateur Wireless."

BERNARD E. JONES.

*La Belle Sauvage,
London, E.C.4.*

CONTENTS

CHAPTER	PAGE
1. CHIEF CONSIDERATIONS IN THE DESIGN OF LOUD SETS	1
2. A SIMPLE VARIOMETER CRYSTAL RECEIVER	12
3. OTHER VARIOMETER CRYSTAL SETS	16
4. CRYSTAL SETS FOR INDOOR AERIAL	25
5. A COMBINED SINGLE-SLIDER AND LOOSE- COUPLED SET	39
6. A SIMPLE FIXED-COUPLED SET	43
7. A SINGLE COIL LOUD-SPEAKER CRYSTAL SET	47
8. LOUD-SPEAKER VARIOMETER CRYSTAL SET.	54
9. LOUD-SPEAKER FOR USE WITH CRYSTAL SETS	56
10. VARIOMETER SET WITH LOADING COIL	60
11. A TAPPED-INDUCTANCE SET WITH LOADING COIL	76
12. AN ALL-WAVELENGTH RECEIVER	88
13. SET WITH AIR-SPACED LOOSE-COUPLED TUNER	94
14. THE "A.W." SELF-CONTAINED LOUD-SPEAKER CRYSTAL SET	101
15. MAKING THE "A.W." SELF-CONTAINED LOUD-SPEAKER CRYSTAL SET	117
16. "A.W." LOUD-SPEAKER UNIT FOR ATTACHMENT TO ANY CRYSTAL SET	129
INDEX	137

LOUD-SPEAKER CRYSTAL SETS

CHAPTER I

Chief Considerations in the Design of Loud Sets

THE successful operation of a loud-speaker by means of a crystal set, formerly the subject of speculation, is now an accomplished fact. The results attained open up a new era for the crystal user, for they are full-volume results, equal—in the neighbourhood of a broadcasting station—to those obtained on a loud-speaker with a two-valve set, there is nothing faltering or hesitant about them, no elaborate apparatus or circuit is required, and every efficient crystal set can be converted in a short time to give the same results. That briefly is the object of this book—to explain the construction of crystal sets known to give loud results, and then to explain the construction of the "Amateur Wireless" self-contained Loud-Speaker Crystal Set, the efficiency and results of which are vouched for by the Editor of "Amateur Wireless."

The advent of the new high-power station at Chelmsford has also made it possible to obtain much louder results than has formerly been the case.

It is no exaggeration to say that ninety per cent.

LOUD-SPEAKER CRYSTAL SETS

of the experiments made by the crystal user are with the object of obtaining increased volume of sound. To this end a multitude of crystals are tried, various tuning arrangements are tested, aeriels are modified and attempts are made to secure general all-round efficiency by attention to constructional details. Whilst attention to all these matters does undoubtedly improve signal strength, sooner or later the conviction is forced upon one that in crystal reception there is a limiting factor beyond which, with our present apparatus and knowledge, it is apparently impossible to proceed.

We hear of remarkable instances of long-distance reception on the crystal, but we never hear of instances of remarkable volume being produced—that is sufficient volume to operate, at full strength, a loud-speaker. True, there are so-called loud-speaker crystal circuits, but the sound from a loud-speaker operated by these is more of a strain to listen to than if phones only were used.

Power for the Loud-speaker.—The conclusion is reached that more power in the form of current is required. How, then, can this power be obtained? We can, of course, obtain it—and very successfully, too—by the use of a valve amplifier, but then the set ceases to be a crystal set in its true sense and becomes a valve set, and we have to recognise the fact that thousands of wireless enthusiasts are wedded to the crystal. The question is how to provide the required extra power in such a way that the necessary apparatus is as simple as the crystal set itself both as regards construction and operation. The cost of the apparatus

DESIGN OF LOUD SETS

and its maintenance must also be trivial. That is the problem.

It has been stated that every efficient crystal set can be made to give loud-speaker results, and it is therefore wise to give some thought and attention to the points making for efficiency, for although many of these factors are old, they do not lose in value by repetition.

Necessary Conditions.—Efficient reception on a crystal is only possible if proper precautions against losses, due to faulty insulation and so on, are taken. The factors which appear to be of chief importance are, firstly, an efficient aerial and earth system; secondly, a good pair of phones; and lastly, a properly designed crystal receiver.

The set itself has been deliberately placed last in order of importance. The circuits employed in most crystal sets are so simple that very little can go wrong with the actual apparatus. Faulty reception is probably due in 99 per cent. of cases to a bad aerial, an inefficient earth or an unsuitable pair of phones.

The Aerial.—So far as aeriels are concerned, the balance of opinion seems to favour a single wire for broadcasting wavelengths, and wherever possible its length should be the maximum allowed.

Aerial Insulation.—Whatever type of aerial is used, great care should be paid to the question of insulation. Two or even three insulators should be used at each end of the wire and a long lead-in tube, the thicker the latter the better.

The lead from the aerial should be kept at least 2 ft.

LOUD-SPEAKER CRYSTAL SETS

away from any walls or other objects. The soldering of all joints is very important, as large losses will result if the connection between aerial and lead-in tube is inefficient.

Position of the Aerial.—With respect to the aerial itself, height is a primary consideration. The aerial should, if possible, be kept well above all surrounding objects, such as trees or roofs, and there should be a clear space between the aerial and the earth below.

Earth Systems.—Equal care must be bestowed on the earth system. An earth system consisting of five or six copper plates $1\frac{1}{2}$ ft. square buried in line at a depth of 4 ft. right underneath the aerial has been found to be at least as efficient as the ordinary water-pipe earth. The lead from the set to earth should be as short as possible, and the same precautions as to insulation must be taken as have been indicated in connection with the aerial. A lead-in tube must be used, and the lead down to earth should be of as large diameter as possible and kept at least 2 ft. away from all walls. It is wise to bury small earthenware pipes over the plates so that on dry days the soil immediately surrounding the plates may be watered. Owners of crystal sets who use gas pipes or water pipes connected only to the water cisterns and not to the main water supply cannot hope to receive distant telephony.

As to the phones, only the very best should be used, 8,000-ohm telephones with adjustable diaphragms.

Insulation.—One of the chief causes of weak signals is faulty insulation. On quite a large number

DESIGN OF LOUD SETS

of inductance coils the brass slider-bars are screwed direct on to the wooden coil ends, and if the latter get slightly damp, as they are likely to, only very weak signals are heard in the phones.

The obvious remedy is to insulate the bars by using ebonite washers and plugs to take the fixing screws. Another method is to cut slots in the coil ends and line them with pieces of thin sheet ebonite

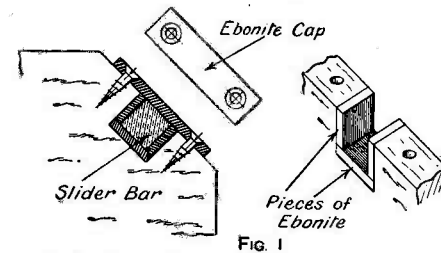

Fig. 1.—Method of Insulating Slider-bar.

as in Fig. 1. The bars can be held in place by sheet-ebonite caps screwed on.

Inductance Coil and Sliders.—A fault with some sliders is that the square holes in the latter are not a good fit for the brass bars on which they slide, and as a result there is bad contact between the top of the springy plunger and the bar.

The obvious remedy is to obtain new sliders which are a fairly tight fit and move them up and down a number of times till they work easily but without shake.

Bad contact is sometimes caused by the brass ends of the springy plunger not being a proper press fit in the ends of the spring.

LOUD-SPEAKER CRYSTAL SETS

This is soon put right by lightly soldering each end of the spring to the brass pieces and carefully filing away any superfluous solder so that the plunger slides smoothly in the hole in the ebonite slider.

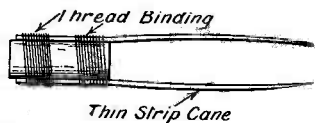

Fig. 2.—Tweezers for Handling Crystals.

The plunger should not be allowed to press too heavily on the coils of the inductance, otherwise the wire soon becomes worn away. The path across the inductance coil over which the plunger travels should be kept scrupulously clean, as should also the tip of the plunger. The tip of the plunger and also the bared winding should occasionally be rubbed lightly with emery-cloth, afterwards removing the dust.

The Detector.—The crystal cup should be mounted on an ebonite base and not on wood, and the crystal must for preference be set in its cup by packing it in silver paper, with perhaps locking screws to hold it in place. Solder is not recommended, as the heat causes the crystal to lose some of its sensitivity. If, however, it is used, Wood's metal or some similar low-melting-point solder should be employed.

When using a catwhisker contact wire see that it is not too thick. Louder signals can often be received by using a very fine wire. No. 34- or 36-gauge wire will be found quite thick enough for most crystals. Some sort of fine adjustment is necessary in order to vary the pressure of the wire on the crystal.

DESIGN OF LOUD SETS

A very slight variation of this pressure often increases the signal strength considerably.

It is important that crystals should not be touched with the fingers. A good plan is to make a pair of tweezers from some thin cane strip as shown by Fig. 2. The crystals can then be changed without touching them with the fingers.

Another thing to be avoided in using crystals is dust. A good plan for keeping the surface of the crystal free from dust is to brush carefully the surface each time the wire contact is moved.

The brush may consist of an ordinary camel-hair brush cut down as shown by Fig. 3. The crystal detector should always be covered up except when adjustments are being made. A small glass jar serves as a cover.

After a crystal has been in use for some time it will probably lose a good deal of its sensitivity. It should not, however, be discarded, but carefully split in half with a pair of cutting pliers. The two fresh surfaces thus formed will often prove to be just as sensitive as the original ones.

Connections.—It is a good plan to solder the ends



Fig. 3.—Brush for Cleaning Crystals.

of the connecting wires underneath the base-board to the projecting terminal stems.

Tuning.—Great care must naturally be taken in tuning and in selecting a sensitive point on the crystal.

LOUD-SPEAKER CRYSTAL SETS

Considerable patience and practice is necessary in tuning.

The following summary raises quite a number of little points which, if overlooked, conduce to poor results :—

- Don't omit to experiment with various crystal detectors.
- Don't heat crystals unless it is absolutely necessary.
- Don't imagine that catwhisker points remain sharp for ever.
- Don't crush together the crystals in a perikon combination.
- Don't expect a crystal to retain its sensitivity indefinitely.
- Don't forget that a small buzzer is useful for adjusting a crystal.
- Don't forget that those cups with three fixing screws are very useful.
- Don't forget that " quick-change " crystal cups save time and temper.
- Don't, when using the three-screw type of cup, crush the crystal to pieces.
- Don't keep on readjusting the crystal once you have found a sensitive spot.
- Don't leave crystals exposed to the atmosphere ; it does not improve them.
- Don't forget that detectors with dust-proof covers are preferable to those without.
- Don't forget that all parts of a crystal detector should be well insulated from earth.

DESIGN OF LOUD SETS

- Don't forget that when using a crystal set the first thing to do is to adjust the crystal.
- Don't clean crystals with petrol, which leaves a film of grease ; use benzine or alcohol.
- Don't be satisfied with always using the same kind of crystal detector ; try different types.
- Don't forget that platinum points for catwhiskers can be obtained from many electric lamps.
- Don't think that the addition of a battery and potentiometer will always give better results.
- Don't forget that most detectors with a catwhisker contact do not need an applied potential.
- Don't despise crystals because you use valves ; they may stand you in good stead one day.
- Don't jam the catwhisker down on the crystal ; a light contact usually gives the best results.
- Don't be satisfied with poor results ; a crystal set may have a range up to 150 miles for broadcasting.
- Don't forget that a crystal is a more efficient rectifier than is a valve and that it gives better tone.
- Don't buy or use detectors in which the catwhisker cannot easily be moved over any part of the crystal.
- Don't forget that some combinations need an applied potential ; that is a potentiometer and a few dry cells.
- Don't judge a crystal by its name only ; nearly all the " patent " crystals are a synthetic form of fused galena.
- Don't forget that copper, brass and graphite can

LOUD-SPEAKER CRYSTAL SETS

sometimes be used very successfully with carborundum.

Don't throw away a crystal if you cannot find a sensitive spot on it ; cut the top away diagonally with a pair of pliers.

Don't think that only a flat steel spring can be used with carborundum ; a rounded or sharp point is just as good.

Don't scrap your crystal detector when you begin with valves ; crystal detectors are necessary in most reflex circuits.

Don't try to adjust a crystal detector in the dark ; you may succeed, but you will most likely only cause bad language.

Don't condemn all crystal detectors because you happen to get poor results at first ; you may get hold of a poor specimen.

Don't forget that the best results are usually obtained with close-grained crystals ; they have more sensitive points.

Don't forget that there are other perikon combinations besides zincite and bornite ; zincite and copper pyrites is another good one.

Don't use two crystals in parallel at once in the same circuit ; it will only cut down signal strength unless they are arranged in opposition for eliminating interference.

Don't use an indoor aerial if you can possibly put one up outside ; an indoor one will usually give good results, though, within five miles of a broadcasting station.

DESIGN OF LOUD SETS

Don't pick up crystals to examine them ; you will not be much wiser afterwards. If you *must* look at them, however, use tweezers, and not your fingers, which are greasy.

Don't forget that different kinds of metal catwhisker can be used with the same crystal ; try some unusual combinations and see what happens. You may discover something useful.

Don't use ordinary solder for mounting crystals ; the temperature at which it melts is likely to affect the crystal. Use Wood's metal or other low fusing-point alloy which is specially made for the purpose.

CHAPTER II

A Simple Variometer Crystal Receiver

THE set shown by Fig. 4 is designed primarily for reception on the broadcasting wavelengths, but two terminals are provided on the panel so that a loading

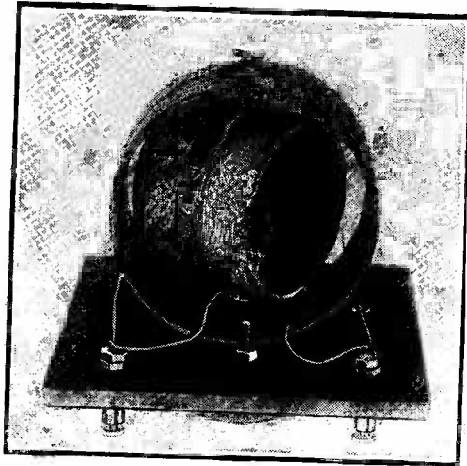

Fig. 4.—Simple Variometer Crystal Receiver.

coil may be used to tune the set to Croydon, the Eiffel Tower or Chelmsford.

Materials.—The materials required are as follows: One piece of ebonite 6 in. by 6 in. by $\frac{3}{16}$ in.; inductance tube 4 in. in length and 4 in. in diameter; and one piece $1\frac{3}{4}$ in. in length and 3 in. in diameter; 2 oz. of

VARIOMETER CRYSTAL RECEIVER

cotton-covered wire about 26 s.w.g.; one ebonite knob; six terminals; one crystal detector and hertzite crystal; 6 in. of $\frac{3}{16}$ -in. screwed brass rod with four nuts to fit.

The Ebonite Panel.—The ebonite panel should be "matted" by rubbing down with fine emery-paper. Then drill the six holes for the terminals and one $\frac{3}{16}$ -in. hole for the centre spindle of the variometer

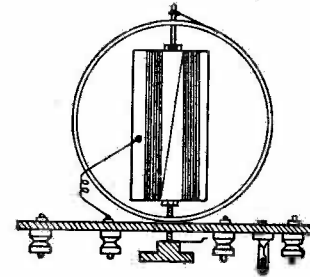

Fig. 4a.—Section of Complete Variometer.

as shown in Fig. 5. The crystal detector may be mounted on the panel in the position indicated.

The Variometer.—The pasteboard tubes must be well treated with hot paraffin-wax or shellac varnish before winding is commenced. The variometer consists of two coils of wire joined in series, one of which is smaller than the other so that it can be rotated inside it. By rotating the inner coil the mutual inductance between the two coils is either increased or decreased, so producing a change in wavelength. Drill a $\frac{3}{16}$ -in. hole through the walls of both tubes midway between the two ends as shown in Fig. 4a.

To wind the stator, start about 1 in. from the

LOUD-SPEAKER CRYSTAL SETS

centre hole and wind on eighteen turns, then cross over to the other side of the spindle hole and wind on another eighteen turns.

The rotor is wound in the same way, but only four-

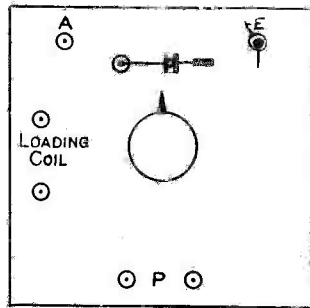

Fig. 5.—Lay-out of Panel.

teen turns of wire are wound on each section, making twenty-eight turns in all. The method of winding is shown in Fig. 4. The rotor may now be mounted on its spindle and fixed tightly to it by four nuts.

Fixing the Variometer.—The variometer is attached to the back of the panel by brass screws, using large brass washers between the screw heads and the paste-board to prevent them from pulling through.

The ebonite knob is then screwed on to its spindle.

Connections.—The connections for the circuit are shown in Fig. 6, and the only point which may present any difficulty is the connection of the variometer itself. This is accomplished as follows. One lead from the rotor is soldered to the brass spindle, the other is fixed to a 6-in. length of flexible wire

VARIOMETER CRYSTAL RECEIVER

which is connected to one of the loading-coil terminals, as shown in the diagram.

From the stator one lead is connected to the earth terminal and the other is connected to a piece of flexible wire which is soldered to the brass spindle.

The aerial terminal is connected to the loading coil terminal which is still free. Thus when the loading coil terminals are shorted by a piece of wire, as when receiving broadcasting, the variometer is in circuit. If a slab or basket coil is connected to the terminals it will be in series with the variometer and will therefore increase its inductance value.

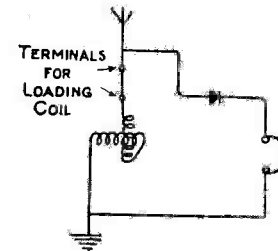

Fig. 6.—Circuit Diagram of Variometer Receiver.

All that is necessary for tuning from 300 to 500 metres is to turn the knob, and for high wavelengths to add a loading coil and turn the knob as for low wavelengths.

It would facilitate tuning-in to the long wavelength signals if a variable condenser of .0003 capacity were connected across the aerial and earth terminals.

CHAPTER III

Other Variometer Crystal Sets

THE set described in this chapter has consistently given excellent results on two sets of phones thirty-seven miles from a broadcasting station and this

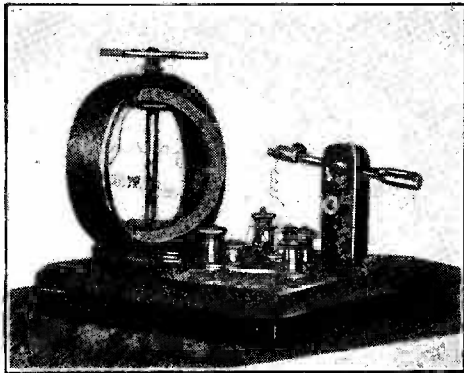

Fig. 7.—Another Variometer Crystal Set.

distance has been more than doubled on favourable occasions.

The Variometer.—The general arrangement is shown clearly in the photograph and the sketches supply the necessary dimensions. The base is of wood or ebonite (preferably the latter) 4 in. square.

The cardboard tubes are 2 in. and $2\frac{1}{2}$ in. in diameter, $\frac{5}{8}$ in. wide, wound respectively with 33 and

OTHER VARIOMETER CRYSTAL SETS

31 turns of No. 36 gauge d.s.c. wire (see Fig. 8). The 31 turns are arranged 15 on one side and 16 on the other of a central strip $\frac{3}{16}$ in. wide, the winding being, of course, continuous; for the 33 turns 16 will be on one side and 17 on the other.

Assembly.—A $\frac{3}{16}$ -in. diameter wooden rod passes through holes drilled at the middle of each ring (the

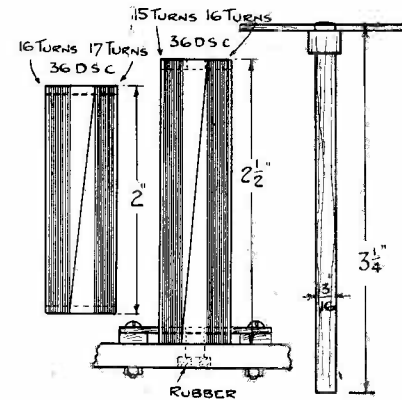

Fig. 8.—Details of Windings and Spindle.

handle of a small paint brush serves admirably for this purpose). A small rubber washer between the rings at the bottom protects the inner coil when the rotor is turned, and small wooden rings glued to the rod inside the coil keep rod and rotor in position as shown in Fig. 8. The outer ring or stator is secured by a wooden strip at the bottom screwed to the base on either side of the ring.

A T-handle completes the variometer, which should now be given several coats of stiff shellac varnish.

LOUD-SPEAKER CRYSTAL SETS

Smooth turning is given by a small rubber washer pushed into the hole in the base through which the spindle passes.

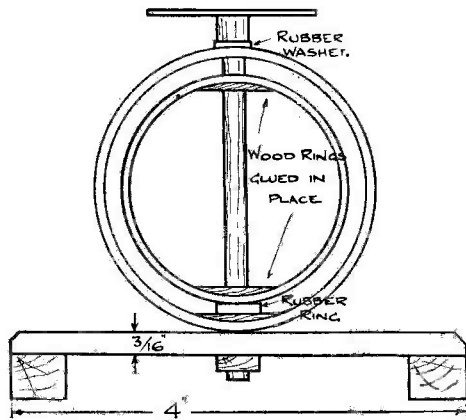

Fig. 9.—Arrangement of Variometer Formers.

The Detector.—The crystal detector is shown by Fig. 9a. It consists of a brass sphere $\frac{3}{8}$ in. in diameter,

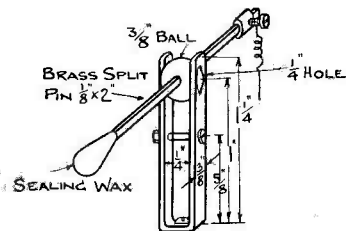

Fig. 9a.—The Detector.

drilled with an $\frac{1}{8}$ -in. hole, through which pass an $\frac{1}{8}$ -in. brass split pin 2 in. long, and the usual brass side strips as indicated. Given a true sphere, the adjustment of this detector is perfect, and success in a

OTHER VARIOMETER CRYSTAL SETS

crystal set depends mainly on the adjustment of the arm holding the catwhisker, which must stay exactly where it is placed without spring or movement.

The split pin can be opened slightly if necessary to make a perfect fit in the hole. A sealing-wax knob at the end for handling and a pinch-screw at the other end for gripping the catwhisker (although this

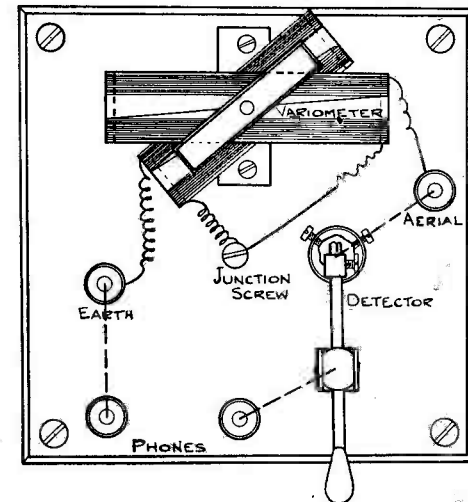

Fig. 9b.—Plan of Complete Receiver.

is not essential) complete the detector. A hertzite crystal and gold catwhisker give excellent results.

COMPACT VARIOMETER CRYSTAL SET

The following relates to the making of a variometer crystal set which differs from the one described in the preceding pages. Figs. 10 to 12 show the instrument. For those who have no facilities for

LOUD-SPEAKER CRYSTAL SETS

turning the various parts, substitutes can be bought in most cases, such as small terminals instead of plugs, etc.

Fig. 13 shows two views of the box and its mountings. This is best made by screwing the sides, top and bottom together and slitting along the line A B so that the top portion forms the lid. This is hinged at A.

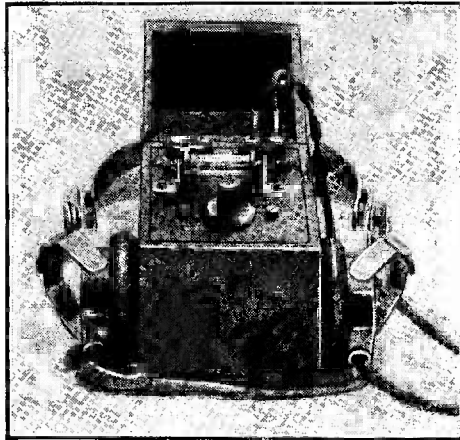

Fig. 10.—Front View of Variometer Crystal Set, showing Panel Arrangements.

The Tuner.—The variometer is shown by Fig. 14. The stator is made from a piece of cardboard tube $2\frac{1}{2}$ in. in diameter and $2\frac{1}{2}$ in. long, well dried and shellac varnished. This is fastened to the ebonite top by two 5 B.A. screws $\frac{9}{16}$ in. long and two ebonite distance pieces. One of these is shown in the figure. The rotor is turned from a piece of hard wood to the dimensions given, and is drilled to take the two

OTHER VARIOMETER CRYSTAL SETS

spindles. These work in holes drilled in the cardboard tube at 180 degrees apart.

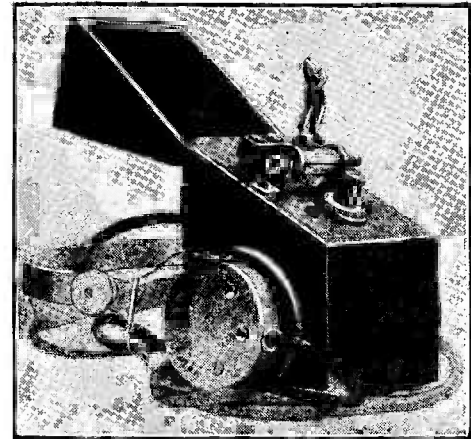

Fig. 11.—Three-quarter View of Variometer Crystal Set.

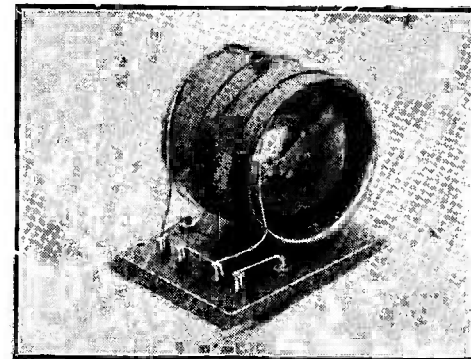

Fig. 12.—The Variometer.

The stator is wound with No. 26 d.c.c. wire in the space provided, that is $\frac{7}{16}$ in. on each side of the centre line. The rotor is wound full with the same wire,

LOUD-SPEAKER CRYSTAL SETS

the ends of which are taken under the nuts on the spindles.

The connections are taken from the spindles by means of strips of copper foil $\frac{3}{16}$ in. wide soldered on

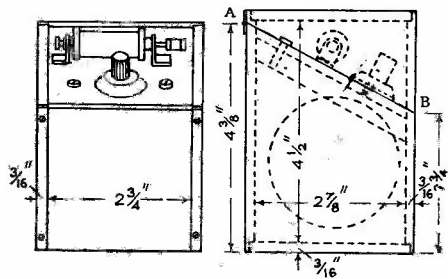

Fig. 13.—Elevations of the Case.

and wrapped round so as to form a spring. The other end of one of these springs is soldered to one end of the stator winding, which is left so as to project about

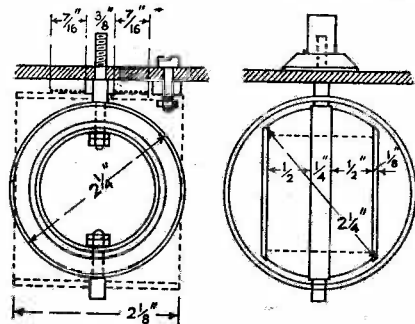

Fig. 14.—The Variometer.

$\frac{1}{8}$ in. beyond the tube. The other spring is likewise soldered to a wire which leads to the detector.

The Detector.—The detector is shown by Fig. 15 but, of course, a detector of another pattern could be

OTHER VARIOMETER CRYSTAL SETS

used equally well. The lay-out of the ebonite panel is shown by Fig. 16, and it is arranged to suit the type of detector shown. The panel should be cut and fitted to the box. The bottom edge may be left square, but the top edge should be filed to suit the case. The

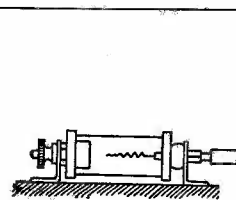

Fig. 15.—The Crystal Detector.

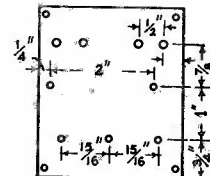

Fig. 16.—Lay-out of Ebonite Panel.

holes in the top are for the earth, aerial and telephone respectively, the centre ones for the detector and the bottom for the variometer. When this has been completed the set may be assembled.

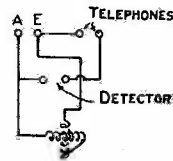

Fig. 17.—Wiring Diagram.

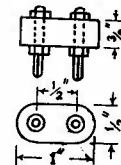

Fig. 18.—Fittings for Aerial and Telephone Connections.

Fixing the Variometer.—The variometer is fastened to the top with the screws provided and the handle knob screwed on. The detector is then fixed down with 5 B.A. screws. The plugs for the outside connections are lightly tapped in with a hammer: on

LOUD-SPEAKER CRYSTAL SETS

no account should these be too tight or the ebonite will split.

Wiring.—The set is now ready to be wired up as in Fig. 17. All connections should be soldered.

All that now remains is to make two fittings as shown on Fig. 18; one of these is used for the aerial and earth connections, the other for the telephones. The body is made of $\frac{1}{2}$ -in. ebonite drilled to take two valve pins.

CHAPTER IV

Crystal Sets for Indoor Aerial

NUMBERS of readers, unfortunately, are unable to erect outdoor aerials.

Designed primarily for use with an indoor aerial, the receiving set described in this chapter will—if

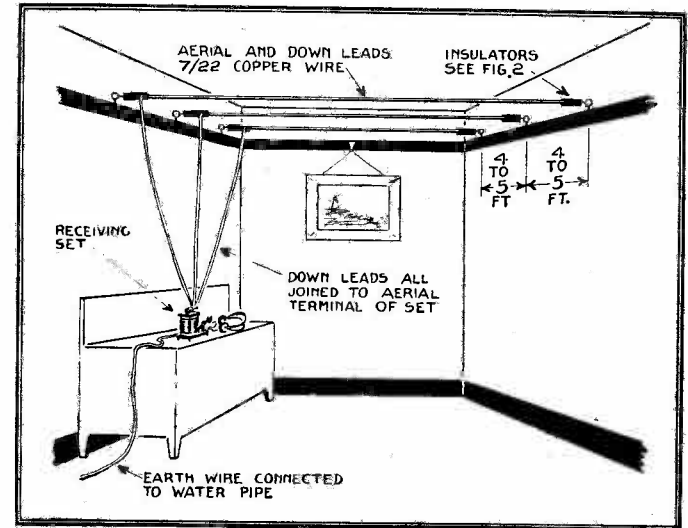

Fig. 19.—Arrangement of Receiver and Indoor Aerial.

carefully made—be found to give excellent results within five miles of a broadcasting station. The aerial—of the type shown in Fig. 19—should, of course, be erected in an upstairs room of the house.

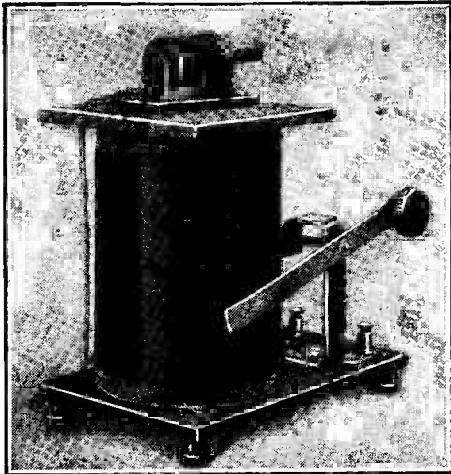

Fig. 19a.—Rear View of Receiver.

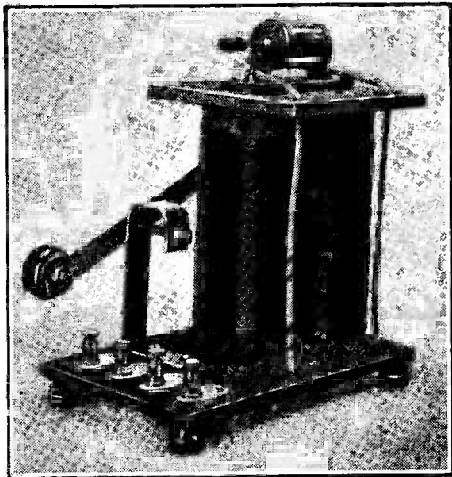

Fig. 19b.—Front View of Receiver.

CRYSTAL SETS FOR INDOOR AERIAL

As practically all details necessary for the construction of the receiver are given in the accompanying diagrams, little need be said with regard to the actual work to be done. Figs. 20 and 21 give all drilling dimensions of the ebonite panel and hardwood square respectively; the latter, after drilling and smoothing with glasspaper, should be given two or three coats of shellac varnish. A No. 2 B.A. nut, as shown in Fig. 22, should be fixed to the under side for the purpose of holding the clamping rod.

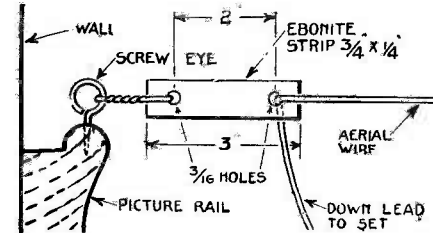

Fig. 19c.—Method of Supporting Aerial.

Winding the Coil.—Winding the inductance is carried out as specified in Fig. 23, the winding former being a cardboard tube, 5 in. long by $3\frac{1}{2}$ in. in diameter. On completion of the winding a portion of the enamel insulation should be removed with emery-cloth so that the slider may make good electrical contact with the turns.

The Slider.—The slider is illustrated in Fig. 24. It consists of a piece of strip brass $5\frac{7}{8}$ in. long drilled to take the 2 B.A. spindle rod and the short 2 B.A. screw for attaching an ebonite knob. In order that smooth contact may be made with the tuning-coil

LOUD-SPEAKER CRYSTAL SETS

winding a slight curvature should be given to the contact end of the strip.

Fig. 25 gives the necessary details for the construc-

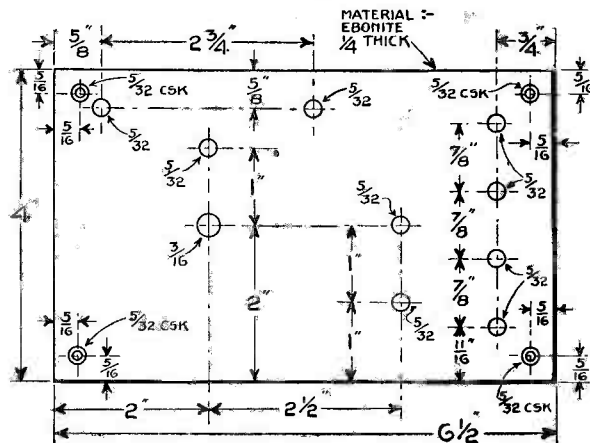

Fig. 20.—Lay-out of Base.

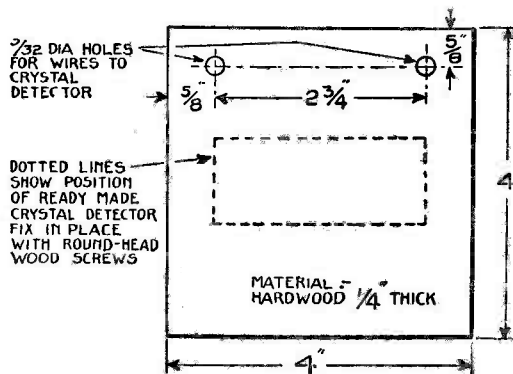

Fig. 21.—Lay-out of Top.

tion of the slider support or bearing bracket. The material used for this part should be fairly stiff

CRYSTAL SETS FOR INDOOR AERIAL

in order that a good pressure can be put on the slider strip.

The assembly of the slider and slider support bracket is shown in Fig. 26; the method of using four

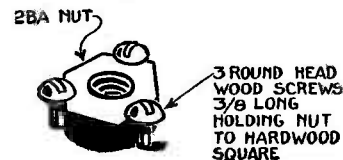

Fig. 22.—Nut for Securing Top Panel.

No. 4 B.A. ebonite knobs as feet in order to raise the panel is also illustrated in this figure.

The Assembly.—A side elevation and plan of the completed receiver—the latter with the hard

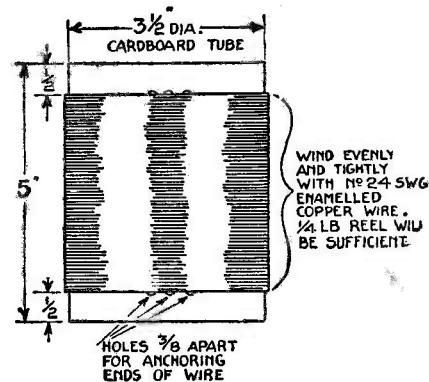

Fig. 23.—Tuning Coil.

wood top removed—are shown by Figs. 27 and 28 respectively.

The Circuit.—Fig. 29 gives the theoretical circuit diagram of the instrument. All connections should be

LOUD-SPEAKER CRYSTAL SETS

made with No. 24 copper wire protected with systoflex or small-bore rubber tubing. The wires to the crystal detector are carried from the under side of the ebonite

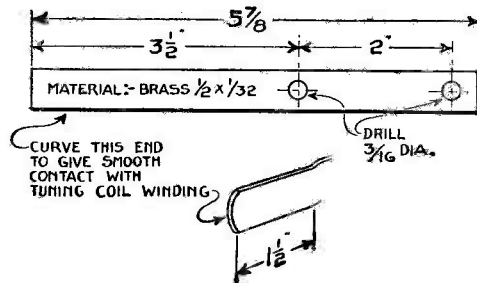

Fig. 24.—Slider Arm.

panel to the terminals of the detector through the $\frac{5}{32}$ -in. holes in the panel and hardwood square.

Fig. 30 shows another circuit for frame aerial

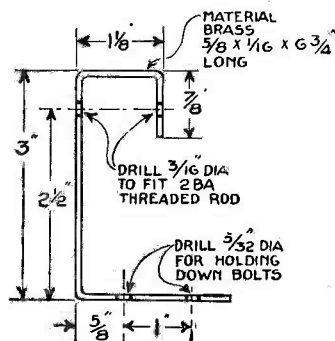

Fig. 25.—Slider Support.

reception; the vernier condenser, though not absolutely necessary, was found to be of considerable advantage, as tuning was at all times very critical,

CRYSTAL SETS FOR INDOOR AERIAL

which is, of course, a feature of frame-aerial circuits generally.

Phones.—Any good make of phones having a resistance of from 4,000 to 8,000 ohms may be used, but care should be taken that the phones are as sensitive as possible. The diaphragm should be very near the pole-pieces without actually touching.

The Detector.—The detector used is an ordinary ball-swivel type fitted with tungstalite crystal; the

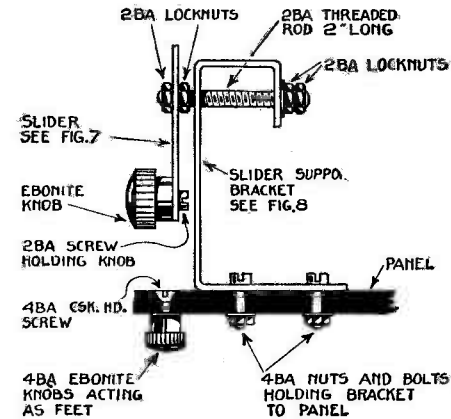

Fig. 26.—Assembly of Slider and Support.

catwhisker (Fig. 31), however, is somewhat out of the ordinary, and consists, as shown by Fig. 31, of a sharp aluminium pointed leg, attached to which is a 4-in. length of No. 32 copper wire, shaped so as to form a flexible connection to the detector arm.

The leg may be cut from an aluminium condenser plate, but the point must be really sharp and presented to the crystal at right angles to its surface.

LOUD-SPEAKER CRYSTAL SETS

The Variable Condensers.—As regards the two variable condensers, the only special point worthy of mention apart from sound mechanical construction and insulation is the necessity of a positive contact to the movable plate spindle.

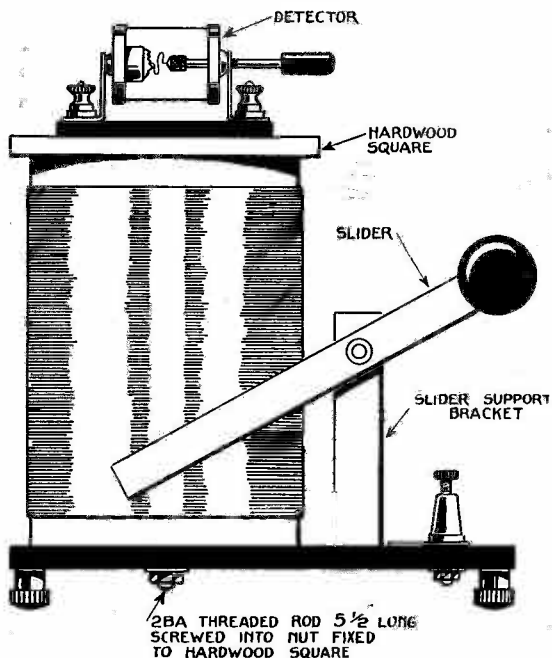

Fig. 27.—Front Elevation of Receiver.

The phone condenser should be of best quality, with mica dielectric.

It is, of course, necessary for good results that all live parts of the instruments be properly insulated either by mounting on ebonite or by ebonite bushes.

CRYSTAL SETS FOR INDOOR AERIAL

The Frame Aerial.—Several types and sizes of frame aerial were tested with a view to finding one

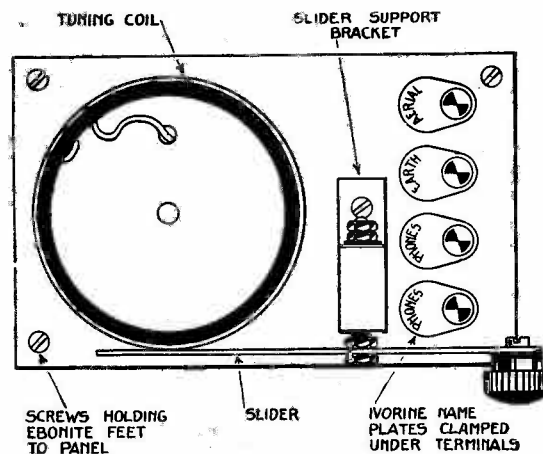

Fig. 28.—Plan of Tuner and Arm.

which gave really good results with the crystal set and at the same time was of simple and cheap con-

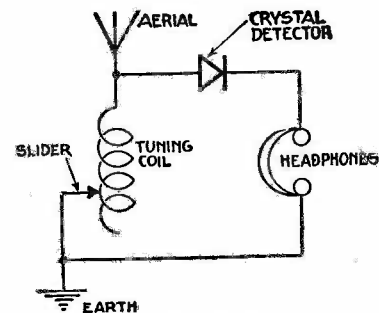

Fig. 29.—Circuit Diagram.

struction. The aerial of which complete constructional details are given in Figs. 32 to 34 is recommended.

LOUD-SPEAKER CRYSTAL SETS

It can be made at a cost of less than five shillings, and can at any time be quickly dismantled by unwinding the wire and folding up the crossbars.

It will be seen that two lengths of 1-in. square-

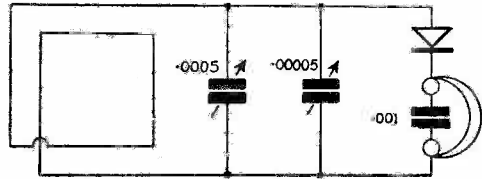

Fig. 30.—Diagram of Frame-aerial Crystal Circuit.

section timber are required for the framework, four ebonite strips 8 in. by 1 in. by $\frac{1}{4}$ in. for the winding insulators, and one strip 4 in. by 1 in. by $\frac{1}{4}$ in. for mounting the four terminals. A $\frac{1}{4}$ -in. diameter bolt

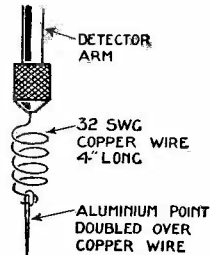

Fig. 31.—Catwhisker.

and nut, and about 130 ft. of copper wire, bare or insulated and of any gauge between Nos. 22 and 26, are also required.

A block of wood about 15 or 18 in. square and $1\frac{1}{2}$ in. thick, with a square hole in the centre in which to fit the leg of the frame, will be found quite satis-

CRYSTAL SETS FOR INDOOR AERIAL

factory for the base. Fig. 35 shows the completed frame aerial.

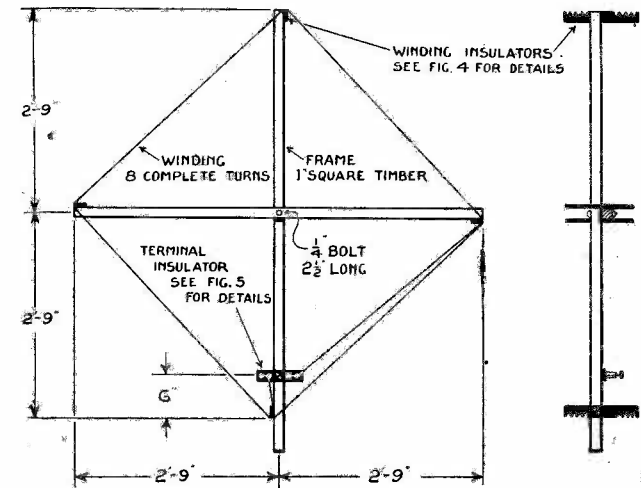

Fig. 32.—Front and Side Elevations of Frame.

Tuning with the Frame Aerial.—Before beginning to tune in, the aerial should, of course, be pointed

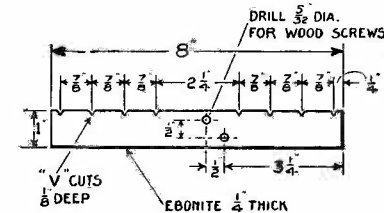

Fig. 33.—Details of Frame Cross Pieces.

approximately in the direction of the transmitting station as shown diagrammatically in Fig. 36, final

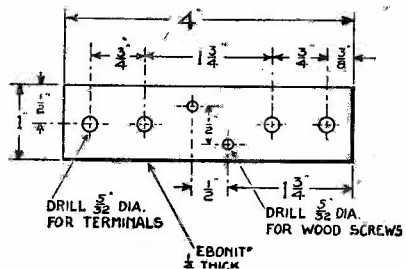

Fig. 34.—Details of Terminal Block.

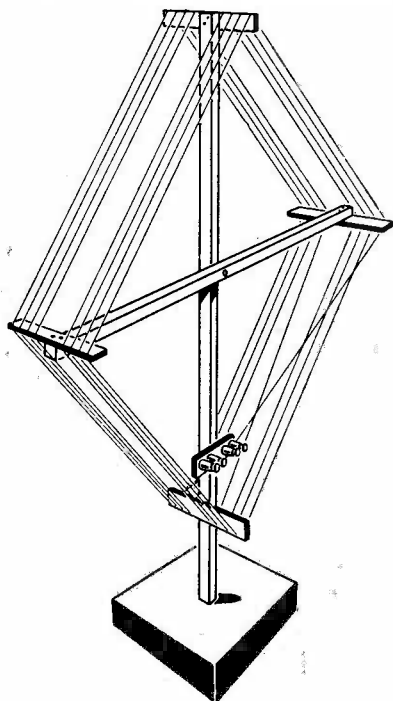

Fig. 35.—Frame Aerial.

CRYSTAL SETS FOR INDOOR AERIAL

directional adjustments being made while signals are being received.

Tuning is best carried out by first setting the vernier condenser with its movable plate half-way between the fixed plates, afterwards bringing in the transmission as loudly as possible with the .0005 microfarad variable condenser.

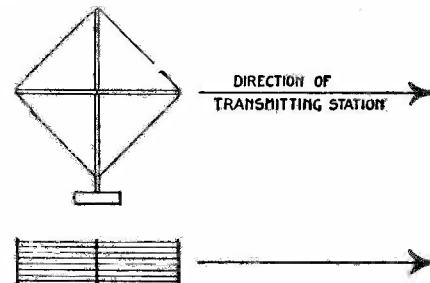

Fig. 36.—Diagram showing Directional Adjustments.

It will then be found that final tuning adjustment can be made by a small movement of the vernier-condenser plate.

In making up the set for use in the reception of broadcast from stations having wavelengths considerably in excess of 365 metres, an extra turn or so of wire on the frame should be given in preference to using a larger condenser.

Results will most likely be found to vary considerably in different rooms of the house owing to the proximity and reflective action of electric-light wires, gas-pipes, water-pipes, .etc.; various positions—including the lower as well as the higher rooms of the house—should therefore be tried in order to find out the best situation for the receiver.

LOUD-SPEAKER CRYSTAL SETS

Experiments may also be made with different crystals and types of catwhisker, while in regard to the last-named component it is suggested that an instrument embodying micrometer adjustment to the rectifying contact would improve the sensitiveness of the set and enable the most to be made of the very small amount of energy being dealt with.

CHAPTER V

A Combined Single-slider and Loose-coupled Set

THIS set consists of two individual sets, a single-slider and a loose-coupled set connected together. When these were connected (Fig. 37) there was a marked difference in the volume of sound. Fig. 38 indicates the connections which were made and also

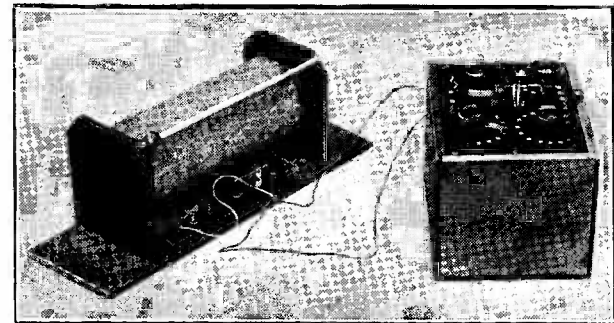

Fig. 37.—Arrangement of Crystal Receiver.

the number of turns. The sets are shown in the photograph.

Operating the Set.—The set is operated as follows: The slider is adjusted to a position that will bring in the desired station. It is then connected to the loose-coupler, which is tuned until the loudest signals are heard. On this set it is necessary to have a tight coupling.

LOUD-SPEAKER CRYSTAL SETS

With the slider it was found that there was a tendency for the contact to slip. In place of the slider a variometer may be used, using the same connections as in Fig. 38; that is, the aerial terminal of the variometer to the aerial terminal of the loose-coupler and the two earth terminals connected. It is not essential to use a loose-coupler, although it is found that the variometer loose-coupler gives the best results. A variometer-slider may be used.

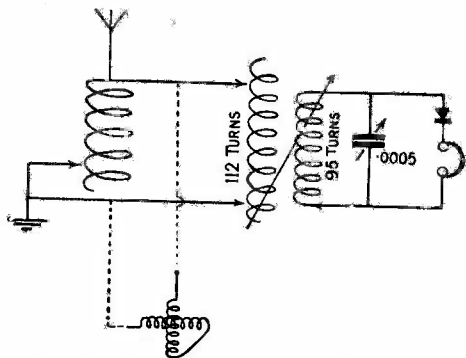

Fig. 38.—Circuit Diagram of "Loud" Crystal Set.

The best detector combination for this set is a piece of hertzite and a very fine copper-wire cat-whisker. No. 42 or even finer wire gives the best results, bearing in mind that a light contact is essential.

Another Set Giving Increased Volume.—Fig. 39 shows a highly-selective crystal circuit that gives signals of considerably increased strength compared with many simple crystal circuits.

For broadcast wavelengths the coils may be solenoids wound on 85-mm. diameter formers. No. 20

A COMBINED SINGLE-SLIDER SET

s.w.g. d.c.c. wire is suitable for winding, but neither wax nor shellac should be used after winding; a layer of waxed paper will keep out the damp without increasing the capacity to any noticeable extent.

For coil A wind twenty turns, and then a further twenty turns with a tap at each second turn. The parallel condenser should have only two moving plates.

For coil B wind eighty turns, and then a further

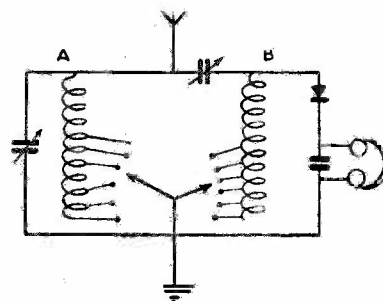

Fig. 39.—Highly-selective Crystal Circuit.

eighty with a tap at each twentieth turn. The series condenser should be .0003 or .0005 microfarad.

The coils must be spaced apart (6 in. is sufficient), as any magnetic coupling greatly reduces the signal strength.

This circuit is hard to tune to get the maximum reception, whether distance or volume. It will be found possible to get good signals in almost any position of the switch arms, but only one position will give the maximum signal strength.

The best position may be found readily if it is

LOUD-SPEAKER CRYSTAL SETS

remembered that tuning should be done with the condenser B at the maximum capacity with the coil B as high as possible; after tuning to this position, reduce condenser B until the maximum is found. It is often advantageous to re-tune A, but the alteration must not exceed one stud.

Cutting Out Morse.—Near the coast it is comparatively easy to cut Morse signals out altogether. To do this, first loosen the coupling by increasing the capacity of the series condenser B until the signals get faint, then retune on coil A, either up or down until the signals go; the switch arm B may then be moved if required to tune in the broadcasting.

It will be noticed that the circuit consists of rejector and acceptor circuits in parallel, and the arrangement gives great selectivity. The increase in signal strength is due to the large number of turns on B giving a higher voltage.

It might be thought that fewer turns are required on A, to compensate for the large number on B, but this is not found to be the case; the correct setting for A is almost the same as for a simple circuit.

It is of the utmost importance that the resistance of the wire be kept down to the lowest possible figure, especially in coil A. Coils wound with 30/42 wire give considerably better results than coils with solid wire.

CHAPTER VI

A Simple Fixed-coupled Set

THE simple type of loud set, shown by Figs. 40 to 43, has been proved by dozens of readers of *Amateur Wireless* to give much louder results than is ordinarily obtained. It is also one of the simplest to

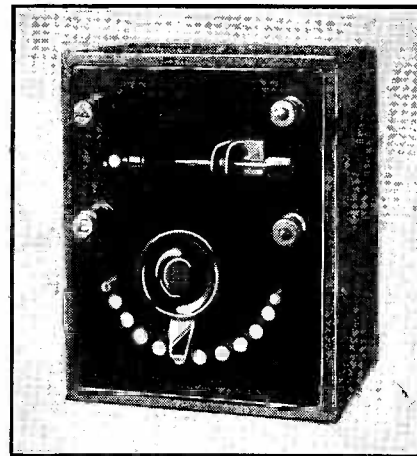

Fig. 40.—The Complete Fixed-Coupled Receiver.

construct, consisting of only a coil of fine wire inside a coil of thicker wire and the usual crystal detector. Providing the size and gauge of wire in the two coils are adhered to, the set can be constructed in any form to receive on wavelengths up to 365 metres.

LOUD-SPEAKER CRYSTAL SETS

The Primary Coil.—The primary or outer coil consists of 40 turns of No. 24 d.c.c. copper wire on a cardboard cylinder 3 in. in diameter and 3 in. long.

The 40 turns take up a space $1\frac{1}{4}$ in. wide, so commence winding at $\frac{7}{8}$ in. from one end of the cylinder to bring the coil central. Twenty turns are first

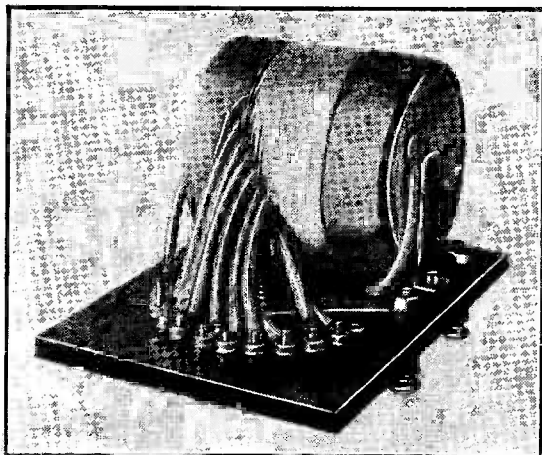

Fig. 41.—Under Side of Panel of Fixed-Coupled Set.

wound, then nine tapings are taken from every two turns of the remainder, making a total of 40 turns.

The Secondary Coil.—The inner or secondary coil has 90 turns of No. 30 d.c.c. copper wire with no tapings, wound on a cardboard cylinder $2\frac{1}{4}$ in. in diameter and $2\frac{1}{2}$ in. long. Commence winding the secondary $\frac{1}{8}$ in. from the cylinder end.

No condensers are needed in this set.

Connections.—The starting end of the primary is connected direct to the aerial terminal. The nine

FIXED-COUPLED SET

tappings and the other end of the coil are connected to the ten contact studs. The switch-arm is connected to the earth terminal. The secondary coil is connected in series with the crystal detector and the phones.

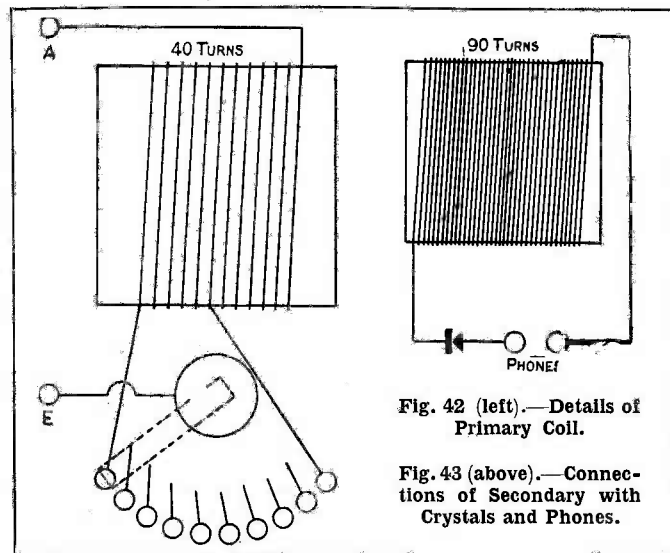

Fig. 42 (left).—Details of Primary Coil.

Fig. 43 (above).—Connections of Secondary with Crystals and Phones.

Mounting the Parts.—The switch and detector are mounted on an ebonite panel $4\frac{1}{2}$ in. by $5\frac{3}{4}$ in. The two coils are kept central one within the other by means of $\frac{1}{4}$ -in. wood discs fitting tightly in the ends of each cylinder.

A $\frac{1}{4}$ -in. hole is drilled in the centre of each disc, through which a piece of wood is pushed to project $\frac{1}{4}$ -in. beyond each end of the primary cylinder.

Two angular pieces of brass slip over the ends of

LOUD-SPEAKER CRYSTAL SETS

this piece of wood and are screwed to the under side of the panel to hold the coils in place.

The Case.—The case is of $\frac{1}{4}$ -in. mahogany, and is of the same inside measurement as the panel and $3\frac{1}{2}$ in. deep. The panel fits tightly into the top of the case and rests upon four wooden blocks screwed into the corners of the case.

Pieces of rubber tubing are slipped over the wires from the tappings to the various connections. These can be seen in the right-hand photograph.

CHAPTER VII

A Single Coil Loud-speaker Crystal Set

THE aim of the author has been to design a simple, efficient and cheap crystal receiver suitable for the reception of broadcast matter and experimental station transmissions, and also one that can be used

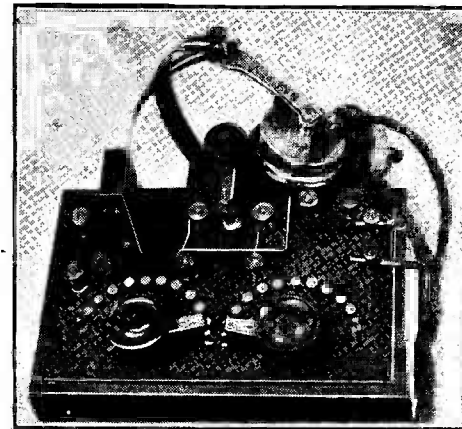

Fig. 44.—Single Coil Loud-Speaker Crystal Set.

for long-wave work if desired. The receiver shown by Fig. 44 has quite successfully operated a loud-speaker at a distance of ten miles from 2 L O. The materials required are :

A half of a pound of No. 22 s.w.g. d.c.c. wire ;
cardboard former $2\frac{3}{8}$ in. in diameter ; twenty contact

LOUD-SPEAKER CRYSTAL SETS

studs; two bar switches; eight small terminals; ebonite 8 in. by 5 in. by $\frac{3}{16}$ in.; pair high-resistance phones, 4,000 ohms total resistance; eight brass wood screws; box to hold the receiver.

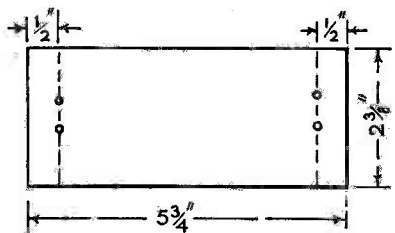

Fig. 45.—Details of Former.

Main Tuning Coil.—First take the cardboard former and cut off $5\frac{3}{4}$ in., and dry, and then give it two coats of shellac varnish. Pierce two holes through the former as shown in Fig. 45, and commence winding on the No. 22 d.c.c. wire.

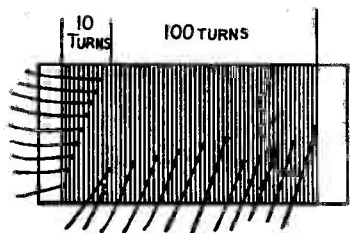

Fig. 46.—Diagram of Tappings.

The winding should be put on evenly, each turn of wire being close to its neighbour, and no kinks should occur during the winding. Tappings must be taken off at every turn for ten turns and one tapping every

A SINGLE COIL SET

ten turns, leaving a length of 4 in. on each tapping. The tappings are shown in Fig. 46.

The Panel.—The ebonite panel should now be prepared as shown in Fig. 47. The sizes of the various holes, etc., are not stipulated, as this will depend upon the gauge of the terminals, screws, studs, etc., used.

Holes should be bored for all the terminals, etc.,

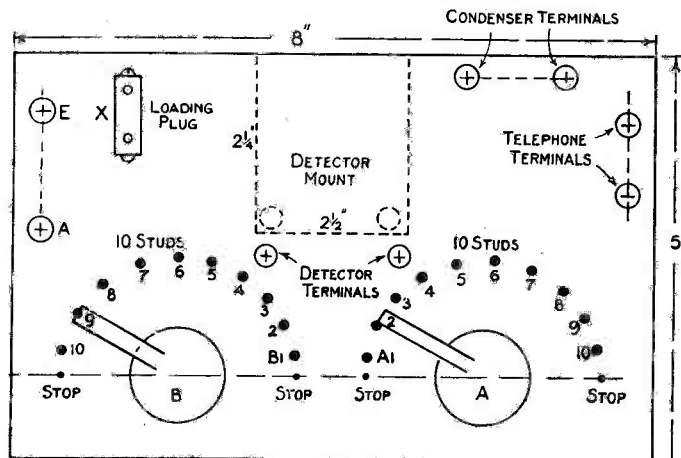

Fig. 47.—Lay-out of Ebonite Panel.

required, and the best way for the amateur to proceed would be to prepare a sheet of paper with the lines drawn in correct scale, paste it to the ebonite, and then work exactly to the lines, taking care that the ebonite is first of all trimmed up to the required dimensions. Position the studs so that the bar switches cannot fall between them.

After the preparation of the panel, the coil is now

LOUD-SPEAKER CRYSTAL SETS

secured to its under side by means of the tappings being affixed to the studs.

The Crystal Detector.—A photograph of the detector is shown by Fig. 48. The materials required are: Two terminals; two brass rods (circular section) $\frac{3}{8}$ in. in diameter; $\frac{1}{4}$ -in. square brass rod; two small crystal cups; three $\frac{1}{8}$ -in. Whitworth screws; two strips of brass (off pocket flashlamp battery); crystals, zincite and bornite; ebonite for base ($2\frac{1}{2}$ in. by $2\frac{1}{4}$ in.).

A sketch illustrating the dimensions and method

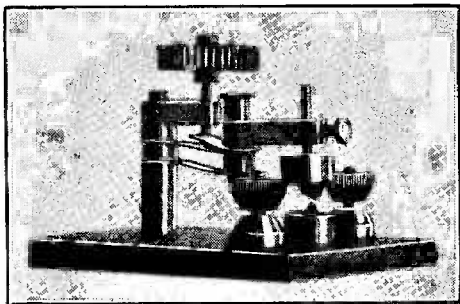

Fig. 48.—The Detector.

of constructing the detector is given by Fig. 49. The zincite crystal is to be put in the upper cup and the bornite in the lower one, a wire from this crystal going direct to the telephones in the completed instrument. Blood-red zincite should be selected and bornite of the deepest blue.

Terminals.—After the detector is assembled and fitted to the ebonite the terminals are wired up on the under side of the ebonite.

Grooves should be cut in the ebonite for the wire to

A SINGLE COIL SET

lie in, and all holes for screws and nuts should be countersunk. The detector may be screwed to the

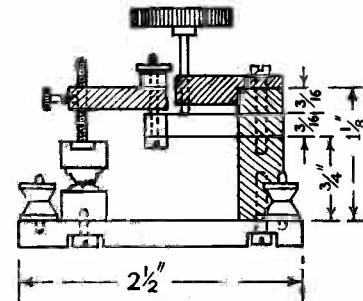

Fig. 49.—The Crystal Detector.

panel, but if desired it can be left loose so that other detectors may be used for experimental purposes.

The detector is wired to the receiver by means

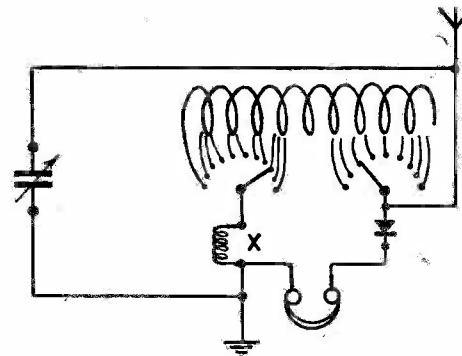

Fig. 50.—Wiring Diagram.

of the two terminals between the bar switches, and thus any other detector may be easily substituted.

Plugs.—In order to extend the range of wavelengths of the set it will be necessary to use loading

LOUD-SPEAKER CRYSTAL SETS

coils, and a coil plug is therefore fitted to the surface of the panel. Two terminals are also provided for the addition of a condenser to tune these coils on the longer wavelengths. The loading plug is shown on the wiring diagram as in Fig. 50, its position being also clearly indicated in Fig. 47.

When the loading plug is not in use it will be necessary to short it by means of an ordinary coil plug, the terminals of which are shorted by means of a piece of wire. The loading-coil plug is secured to the panel from the under side by two $\frac{1}{8}$ -in. screws.

Wiring.—Now that all the components are mounted on the panel it is only necessary to wire it up, but this is not the least important job. All wiring should run in straight lines and never parallel if it is possible to avoid so doing. Bare wire is preferable to insulated wire, and good stiff wire of 18- or 20-gauge is the best to use. A wiring diagram is given by Fig. 50. The wiring is as follows: (1) From aerial terminal to the fine-tuning switch of coil. (2) From fine-tuning switch to bornite of crystal detector and from zincite side of detector to one tag of telephones. (3) From other tag of telephones to coarse-tuning switch, via the loading plug. (4) From terminal of loading plug nearest the telephones to earth terminal. (5) Wires from the fine-tuning switch and the side of the loading plug next to the telephones to the condenser terminals.

The case for the instrument is left to the taste of the reader.

Operation.—Obtain a buzzer (which will give out a high note) and a pocket lamp battery. Sound the

A SINGLE COIL SET

buzzer with the telephones clamped on the head and the switches at A1 and B, then adjust the crystal detector until the sound of the buzzer is heard in the telephones. The switches should then be rotated, the fine switch first, until signals are heard. If none are heard the coarse switch is moved up one stud and the fine switch is run back over the studs to A1. If still no signals are heard the coarse switch is moved to B2, and the same operations carried on until signals are found, after which the detector may be adjusted to its most sensitive point.

Using the Loading Plug.—If Paris time signals are wanted, or any other transmissions on long waves, the loading-plug shorting arrangement is removed and appropriate coils plugged in and a suitable variable condenser connected up to the terminals provided for the purpose.

TABLE OF TUNING COILS WITH CONDENSERS.

Wavelength in metres.	Coil.	No.	Condenser.
180—515	Igranic	L35	.001 microfarad
240—730	"	L50	" "
330—1030	"	L75	" "
700—1000	Burndept	75	.00075 "
450—1460	Igranic	L100	.001 "
950—1450	Burndept	100	.00075 "
660—2200	Igranic	L150	.001 "
1300—2100	Burndept	150	.00075 "
930—2800	Igranic	L200	.001 "
1900—3000	Burndept	200	.00075 "
1300—4000	Igranic	L250	.001 "
2600—4100	Burndept	300	.00075 "
1550—4800	Igranic	L300	.001 "

The capacities of the coils and wavelength given are those quoted by the makers of the coils, and it is left to the experimenter to obtain those suitable.

CHAPTER VIII

Loud-speaker Variometer Crystal Set

THE set here described is similar in every respect to ordinary crystal receivers. The crystal detector is of the vertical-adjustment variety, the catwhisker being pushed on to the crystal. It is not very efficient, as the pressure cannot be regulated easily without the catwhisker breaking up the crystal, but is satisfactory.

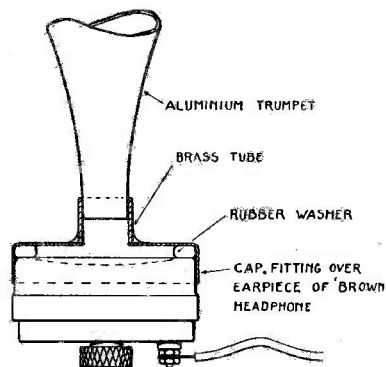

Fig. 51.—The Loud-speaker.

The Loud-speaker.—The loud-speaker (Fig. 51) is of a simple design, and from the results which are obtained it is thought that it works as well as a more expensive instrument. The actual sound-producing part is an earpiece taken from a pair of adjustable

VARIOMETER CRYSTAL SET

phones. A metal cap is fitted over the phone so that a tight fit is made, and a thin rubber washer placed on the inside of the former. An earpiece from an ex-army phone may be used as a cap.

To fix the trumpet to the cap fit a piece of brass tube over the end of the trumpet, and solder that to the cap. The result will be an air-tight joint and a moderately good loud-speaker.

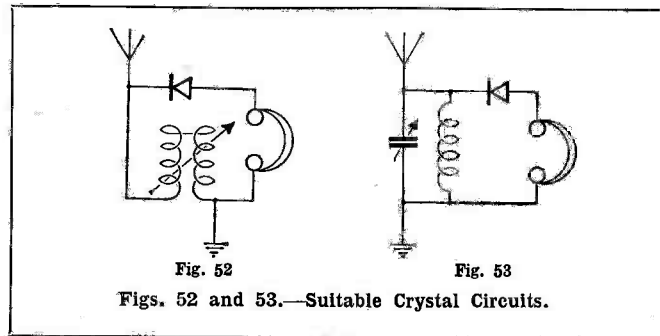

Fig. 52

Fig. 53

Figs. 52 and 53.—Suitable Crystal Circuits.

Connections.—The set is connected in the usual manner, as shown in the diagrams (Figs. 52 and 53), the connections being made with bell wire. In order to get good results from a crystal set, it is necessary to insulate every part with ebonite, and also to keep the crystal free from dust. It can be kept clean by putting a thimble over the cup.

CHAPTER IX

Loud-speaker for Use with Crystal Sets

THE "Crystavox" is a Brown loud-speaker which is capable of working with a crystal set. It is not claimed that signals which are weak with phones will



Fig. 54.—The "Crystavox."

be amplified sufficiently by the "Crystavox" to fill a large hall, but that with signals at fairly good phone strength it will reproduce with sufficient volume to be heard comfortably in a moderate-sized room. The

LOUD-SPEAKER FOR CRYSTAL SETS

general appearance is shown by the photograph Fig. 54, a circuit diagram by Fig. 55, and a sketch of the amplifier portion by Fig. 56.

How the "Crystavox" Works.—In Fig. 55 the microphone is represented by three black lines A, B and C. These correspond to three discs, the centre one of which is movable and rigidly attached to a vibrating

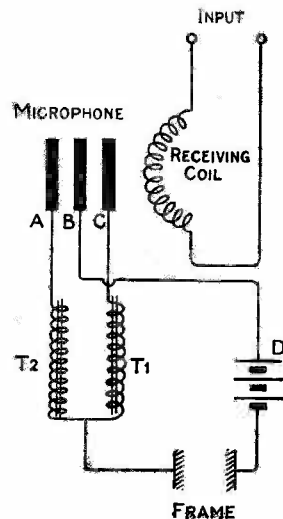

Fig. 55.—Circuit Diagram of "Crystavox."

reed (not shown in the diagram). Fluctuating currents flowing through the receiving coils cause the reed to vibrate and so move the centre microphone disc B, which in turn varies the resistance of the parallel microphone circuits.

When an impulse enters the receiving coils suppose that B is attracted to the right towards C. This lowers

LOUD-SPEAKER CRYSTAL SETS

the resistance of the carbon granules between B and C, and a current for the battery D flows through the coil T1. But as the impulse leaves the receiving coil, B is pushed back towards A and current flows through T2, as the resistance between A and B is lowered.

The Windings.—The windings T1 and T2, shown with iron cores, are placed round the loud-speaker magnets in a special way. Half of each winding is placed round each magnet. Thus for each impulse

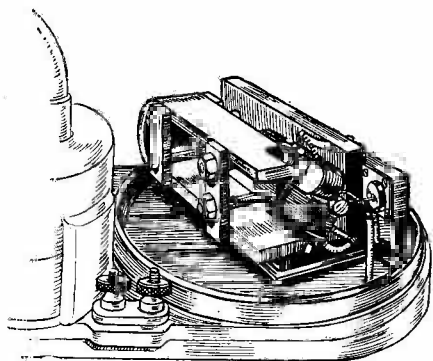

Fig. 56.—Arrangement of Amplifying Device.

passing through the receiving coils there are two impulses through the telephone winding, but this does not give rise to any frequency doubling as might be expected.

General Arrangements.—Fig. 56 shows the general arrangement of the amplifying parts. On the extreme right is the microphone with a needle projecting from it. This is fastened to the centre microphone disc. The vibrating reed and receiving coils can also be seen.

LOUD-SPEAKER FOR CRYSTAL SETS

Each instrument is sent out already adjusted, and in use it is only necessary to connect the phone terminals on the set to the input terminals of the loud-speaker. A 6-volt dry cell is connected in the microphone circuit by means of two other terminals. A 6-volt accumulator should not be used. For final adjustment a small magnet is placed in the knob on top of the case, as see in Fig. 54.

CHAPTER X

Variometer Set with Loading Coil

Range of the Set.—This set (Figs. 57 and 58) has been designed to cover all wavelengths at present used by the British Broadcasting Company, while by the simple addition of a plug-in honeycomb coil of suitable

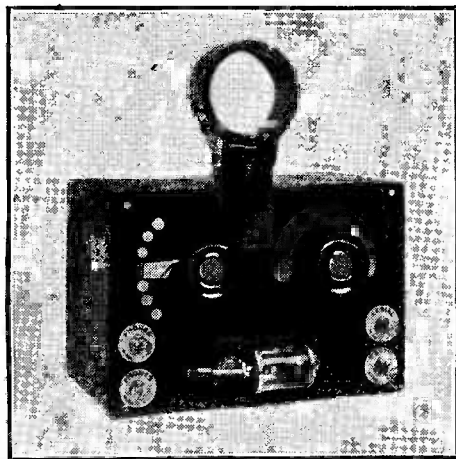

Fig. 57.—The Completed Broadcast Receiving Set.

size, telephony from the new B.B.C. high-wavelength station at Chelmsford, which has a crystal-set range of approximately 100 miles, may be received when this station is working.

The instrument will operate satisfactory within

VARIOMETER SET WITH LOADING COIL

30 miles of existing main broadcasting stations by using a standard 100-ft. outdoor aerial of good height, or within 5 miles of the station using an indoor aerial situated in the upper rooms of the house.

If the set is installed near one of the low-power relay stations, the maximum range for good reception will be in the neighbourhood of 5 or 6 miles, using a full-

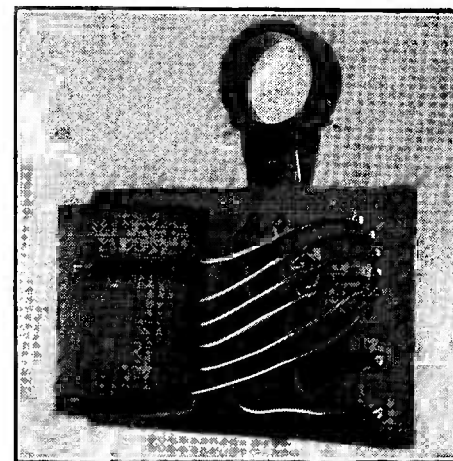

Fig. 58.—View of Underside of Panel showing Wiring.

size outdoor aerial, or from 1 to $1\frac{1}{2}$ miles with an aerial of the indoor type. The circuit is shown by Fig. 59.

Materials.—The material and components are as follows: One ebonite panel $7\frac{1}{4}$ in. by 5 in. by $\frac{1}{4}$ in. thick, and should be quite flat and preferably of dull or matt finish; one crystal detector, complete with hertzite crystal and copper-wire catwhisker, and

LOUD-SPEAKER CRYSTAL SETS

should be of the glass-enclosed type, as shown in Fig. 60; one switch-arm ($1\frac{1}{2}$ -in. radius), complete

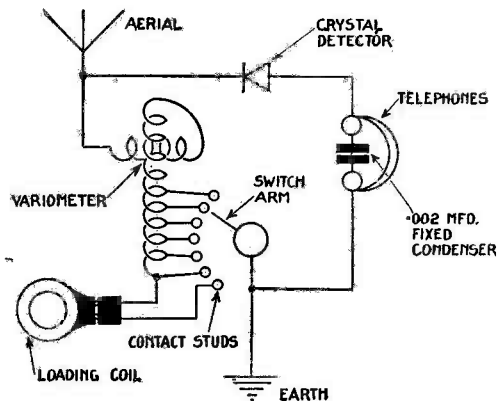

Fig. 59.—The Circuit Diagram.

with ebonite knob, bush, nuts and washers (Fig. 61 shows this component, and the bush should be of the

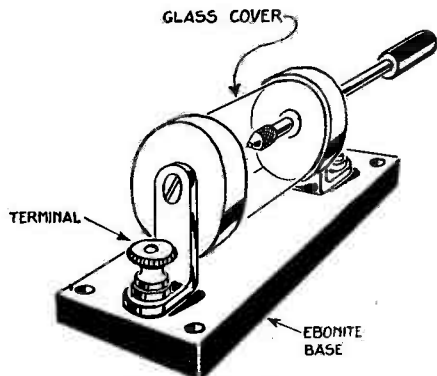

Fig. 60.—The Detector.

type shown in Fig. 62); one fixed condenser of .002 microfarad (Fig. 63, shows this in its general form);

VARIOMETER SET WITH LOADING COIL

one $\frac{1}{4}$ -lb. reel of No. 26 s.w.g. double-cotton-covered copper wire; one plug-in coil holder of the type shown in Fig. 64; one cardboard tube 3-in. outside diameter by 4 in. long (this should be of the thin type, and not

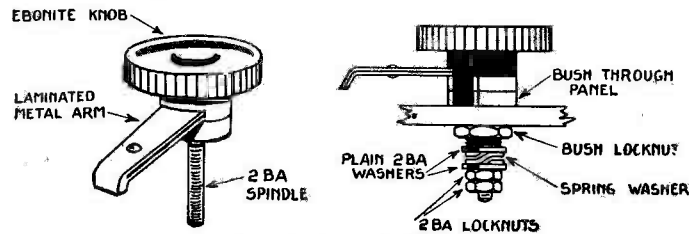

Fig. 61.—Switch Arm.

less than $2\frac{3}{4}$ -in. inside diameter); one cardboard tube 2-in. outside diameter by $1\frac{1}{2}$ in. long; seven $\frac{1}{4}$ -in. diameter brass contact studs, complete with nuts and washers; four brass terminals, preferably of telephone pattern; one ebonite knob screwed 2 B.A. (this com-

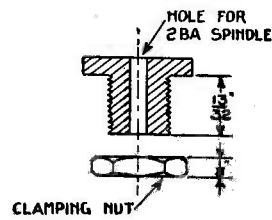

Fig. 62.—Bush.

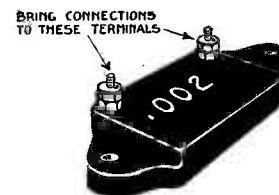

Fig. 63.—Condenser.

ponent should match the knob obtained with the switch-arm, Fig. 61); one semicircular scale 0-180°; one metal pointer to suit scale; one $4\frac{1}{2}$ -in. length of No. 2 B.A. screwed rod (this is for the variometer spindle, and should be quite straight); 1 ft. of thin silk-covered flex; two lengths of large-bore systoflex;

LOUD-SPEAKER CRYSTAL SETS

screws $\frac{3}{4}$ in. long should be used for holding the sections together.

The Ebonite Panel.—The ebonite panel should be

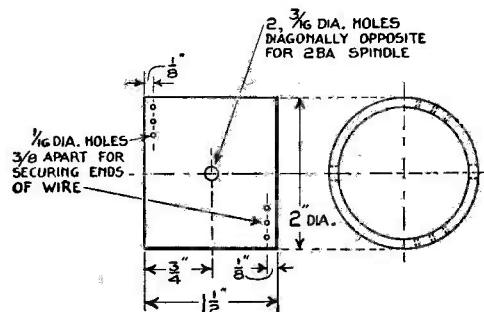

Fig. 67.—Drilling Details of Rotor Tube.

carefully trimmed, so as to be flush with the sides of the box when mounted in position. Drilling is carried out as specified in Fig. 66, and ordinary twist

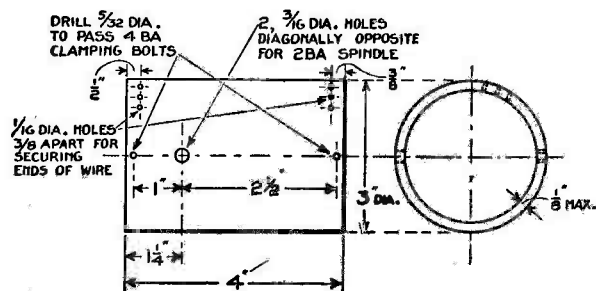

Fig. 68.—Drilling Details of Stator Tube.

drills, as used for metal drilling, will be found best for this work; but too great a pressure should not be applied, or there will be a risk of splitting the panel.

VARIOMETER SET WITH LOADING COIL

The Tuning Apparatus.—This is of the variometer type, which consists in principle of a coil of insulated wire rotatable near a second fixed coil, also of insulated

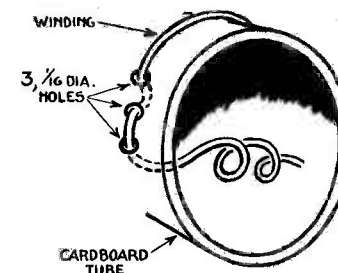

Fig. 69.—Method of Securing Ends of Winding.

wire. The coils are connected in series, that is, the end of the wire in one coil is connected to the beginning of that in the other, and by movement of the movable coil the wavelength of the combined winding is varied,

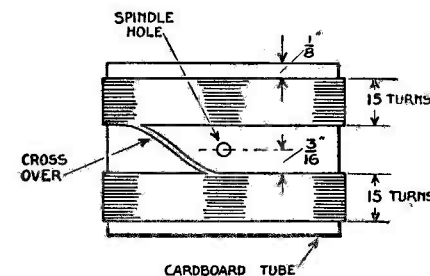

Fig. 70.—Winding Details of Rotor.

thus enabling signals of different wavelengths to be tuned in.

The smaller cardboard tube (2 in. in diameter by $1\frac{1}{2}$ in. long) should be drilled as shown in Fig. 67,

LOUD-SPEAKER CRYSTAL SETS

and the other tube (3 in. in diameter by 4 in. long) drilled as in Fig. 68. These tubes are the formers, on which are wound the two variometer windings.

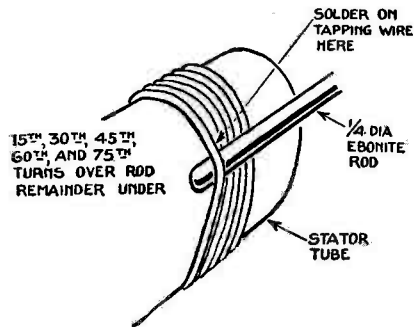

Fig. 71.—Method of Making Raised Wires for Taps.

Begin winding the smaller tube by passing the end of the No. 26 s.w.g. d.c.c. wire through the three

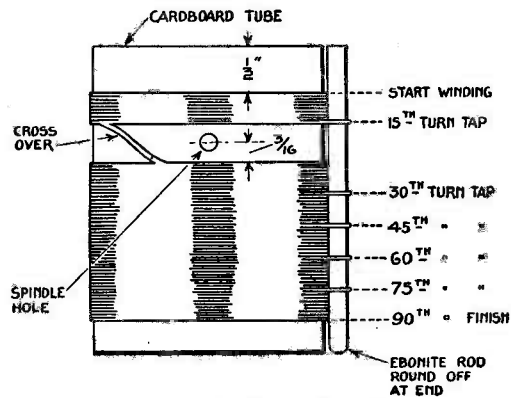

Fig. 72.—Winding Details of Rotor.

1/16-in. diameter holes, as shown in Fig. 69, and wind on 15 turns; then cross over to the other half of the tube

VARIOMETER SET WITH LOADING COIL

and make another 15 turns, the whole 30 turns being all in the same direction and without cutting the wire. On the completion of the last turn the winding should come level with the remaining three 1/16-in. diameter holes, and should be cut and secured through these holes in exactly similar manner as was the beginning end of the coil. Fig. 70 makes the winding of this

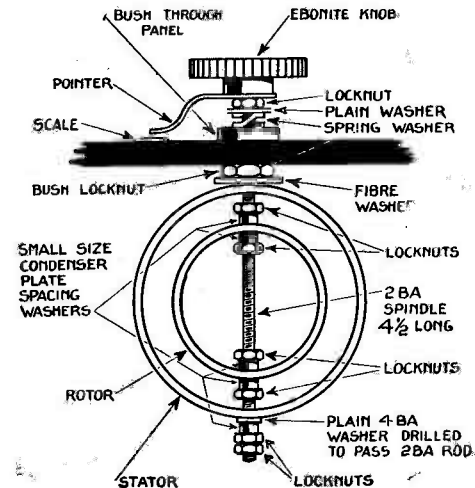

Fig. 73.—Method of Assembling Rotor and Stator on Spindle.

part clear. To complete the rotor, as it is termed, cut off the ends of the wire at each end 3/8 in. from the tube, and after scraping off the cotton insulation, carefully solder a 6-in. length of the thin insulated flexible wire to each end of the winding.

The fixed coil or stator is wound in very similar fashion to the rotor. Beginning at the end nearest to the 3/16-in. diameter spindle holes, secure the end

LOUD-SPEAKER CRYSTAL SETS

of the No. 26 s.w.g. d.c.c. wire through the three $\frac{1}{16}$ -in. diameter holes, and wind on 14 complete turns. Now place the piece of $\frac{1}{4}$ -in. diameter ebonite rod or tube up against the winding in the position shown in Fig. 71, and wind the 15th turn over the rod, so that the wire will stand out from the rest of the winding. After crossing over to the other side of the $\frac{3}{16}$ -in.

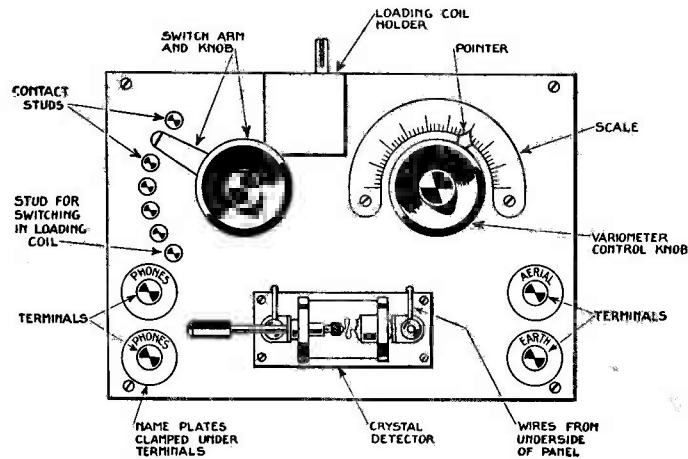

Fig. 74.—Plan View of Panel showing Position of Components.

diameter spindle holes wind on another 14 turns, push the $\frac{1}{4}$ -in. diameter rod forward, and wind over it the 30th turn. Proceed in this fashion until 90 turns are wound on the tube, the 15th, 30th, 45th, 60th and 75th turns being wound over and the intermediate and remaining turns under the rod.

At the last turn the wire should be cut and secured through the remaining three $\frac{1}{16}$ -in. diameter holes, a length of about 6 in. being left for connecting-up

VARIOMETER SET WITH LOADING COIL

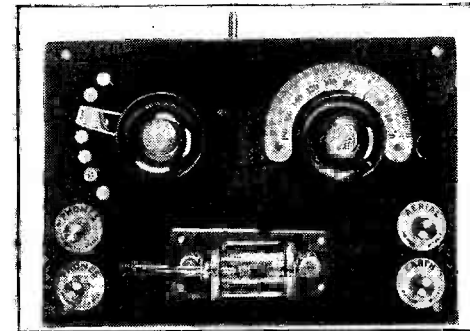

Fig. 75.—View Looking at Front of Panel.

purposes. Fig. 72 shows all details of the stator winding.

To complete, carefully scrape a little of the cotton insulation from each of the raised wires, and solder a 6 in. length of the No. 26 s.w.g. d.c.c. wire to each, thus forming five "taps," as they are termed.

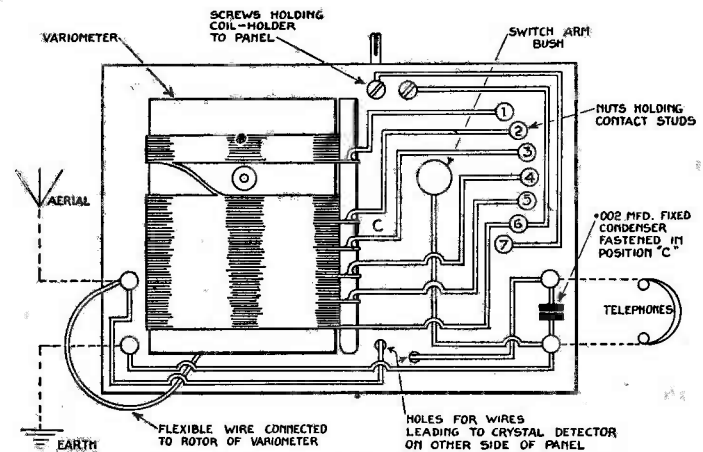

Fig. 76.—View of Back of Panel showing Wiring.

LOUD-SPEAKER CRYSTAL SETS

Both rotor and stator should now be given an application of thin shellac varnish, made by dissolving orange shellac in methylated spirit; winding

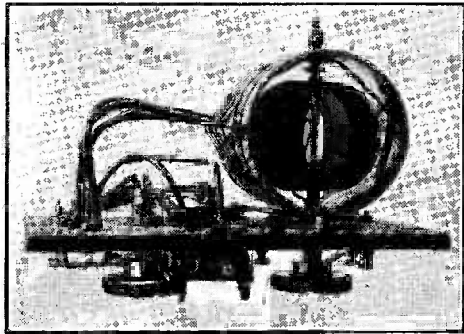

Fig. 77.—View of Under Side of Panel.

and tubes should be well soaked, and then be put aside to dry thoroughly.

The variometer spindle, $4\frac{1}{2}$ in. long, is passed

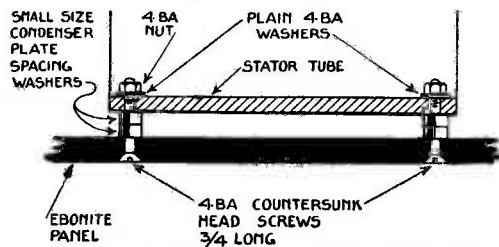

Fig. 78.—Method of Securing Stator to Panel.

through the $\frac{3}{16}$ -in. diameter holes in the rotor and stator, with the addition of locknuts and washers, as shown in Fig. 73. In carrying out this operation care should be taken not to damage the windings in tightening up the locknuts.

VARIOMETER SET WITH LOADING COIL

It should now be possible to swivel the rotor completely round inside the stator, and no trouble will be experienced in this direction if a cardboard tube of the thin type has been used for the stator former.

To complete the variometer solder the end of one of the flexible wires from the rotor to the beginning of the stator winding, that is, the end of the stator winding nearest the spindle.

The assembly of the various parts on the panel may now be proceeded with. Figs. 74 and 75 show the position of the components which come on the outside, while Figs. 76 and 77 show those which are attached to the under side of the panel. To prevent the stator from turning with the rotor, two 4 B.A. screws with four small condenser spacing washers as distance pieces are fixed as shown in Fig. 78.

Fig. 76 shows all the necessary wiring connections, which are made with No. 26 s.w.g. wire covered with insulating sleeving; two lengths will be found ample.

It will be seen that the six wires from the stator of the variometer are connected to six of the switch contact studs, the 7th stud being connected to the coil holder. The remaining connections are clearly indicated in the diagram. The following list will, however, prevent any possibility of mistakes being made: (1) Aerial terminal to crystal and to remaining flexible wire from rotor. (2) Catwhisker of detector to one phone terminal and to one terminal of condenser. (3) Remaining phone terminal to (a) remaining terminal of condenser, (b) centre of switch-arm, (c) earth

LOUD-SPEAKER CRYSTAL SETS

terminal. (4) First tapping wire from stator to contact stud No. 1, that is, the stud nearest the edge of panel. (5) Second tapping wire to stud No. 2. (6) Third tapping wire to stud No. 3. (7) Fourth tapping wire to stud No. 4. (8) Fifth tapping wire to stud No. 5. (9) End of stator winding (turn No. 90) to stud No. 6 and one screw of coil holder. (10) Remaining screw of coil holder to stud No. 7.

The panel completely wired and with all components secured in position should now be fastened to the containing box, and the set tried in actual broadcast reception. It is, of course, presumed that the necessary properly-insulated aerial, wire to water-pipe or metal plate buried in moist ground, and a pair of sensitive headphones of about 4,000-ohms resistance are available, and connected to their respective terminals on the set.

Tuning in.—Presuming the time is that at which broadcast transmission is known to be taking place, put the phones on the head and adjust the crystal detector, so that the end of the catwhisker is just touching the surface of the crystal. Now place the switch-arm so that contact is made with the first stud, and slowly swing the variometer spindle through 180°. If nothing is heard move the switch-arm on to the second stud and again swing the variometer spindle, and continue the alternate adjustment of the switch and variometer until signals are heard. The last contact stud, that is the one nearest the crystal detector, is, of course, only to be used when a plug-in loading coil is in position in the coil holder for

VARIOMETER SET WITH LOADING COIL

the purpose of tuning-in signals from stations of high wavelength. For the ordinary low-wavelength broadcast transmissions, however, no additional coil will be required, as sufficient winding is incorporated in the variometer itself.

Having heard signals, carefully set the variometer control in the position at which the transmission sounds loudest, and readjust the catwhisker to see if any further improvement can be made. Finally make a note of the positions of the variometer pointer and switch-arm respectively, so that the same station can be tuned in without trouble at any future time.

CHAPTER XI

A Tapped-Inductance Set with Loading Coil

IN the set shown by Figs. 79 and 80, tuning is carried out entirely by means of two switch arms, which make contact with two separate sets of studs connected to various turns of the inductance coil. Between each

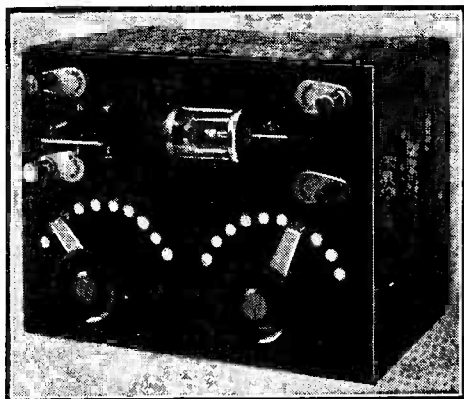

Fig. 79.—Tapped-Inductance Crystal Set Complete.

one of the first sets of studs—on the left-hand side of the panel—one turn of wire is connected, while ten turns are included between each one of the right-hand set of contact studs. It will thus be apparent that as the tens switch arm is moved over its respective studs, the number of turns of the inductance wire will be increased or decreased in jumps of ten, while

TAPPED-INDUCTANCE SET

movement of the left-hand or units switch arm will add or subtract single turns only from the whole, thus enabling the exact number of turns necessary for

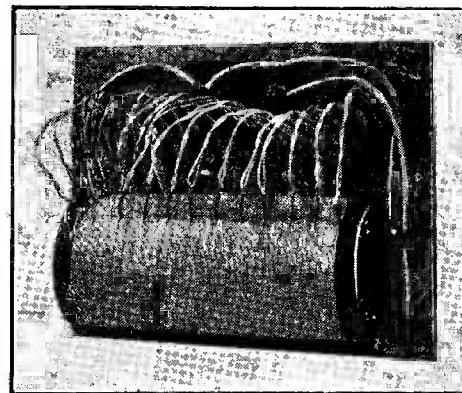

Fig. 80.—Underneath View showing Tappings from Coil.

tuning to the wavelength of the transmitting station to be easily obtained.

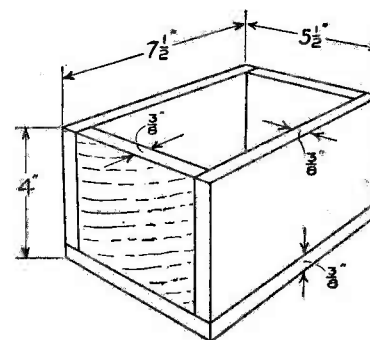

Fig. 81.—The Containing Case.

In addition to the inductance coil incorporated in the set, means is provided for plugging in a loading

LOUD-SPEAKER CRYSTAL SETS

coil, so that wavelengths higher than that of the ordinary broadcast transmission may be tuned to without trouble. This will enable constructors to

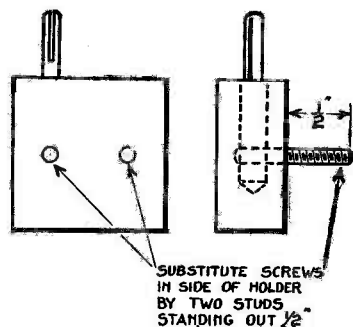

Fig. 82.—Plug-in Coil Holder.

tune in the new B.B.C. high-power station now at Chelmsford.

Materials.—The material and components required are as follows: A polished hard-wood box of the dimen-

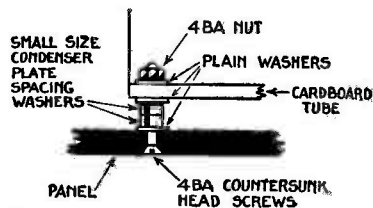

Fig. 83.—Method of Holding Inductance Tube to Panel.

sions given in Fig. 81; an ebonite panel $7\frac{1}{2}$ in. by $5\frac{1}{2}$ in. by $\frac{1}{4}$ in. thick (this should be quite flat and of dull or matt finish); one glass enclosed crystal detector fitted with hertzite crystal and wire catwhisker; two $1\frac{1}{2}$ -in. radius switch-arms, each complete with ebonite knob

TAPPED-INDUCTANCE SET

bush, nuts, washers, etc. (the bush should be of the screwed type fitted with a nut); twenty brass contact studs; one plug-in coil-holder with connecting screws

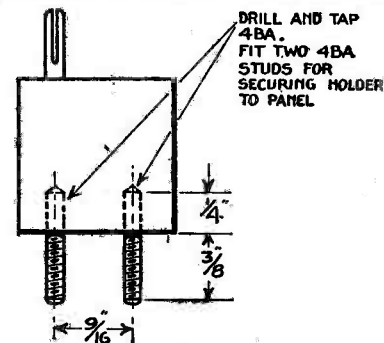

Fig. 84.—Method of Securing Coil-Holder to Panel.

at the front (see Fig. 82); one cardboard tube 3 in. in diameter by $5\frac{1}{2}$ in. long; one $\frac{1}{4}$ -lb. reel of No. 22 s.w.g. double-cotton-covered copper wire; one fixed condenser of .002 mfd.; four telephone pattern terminals;

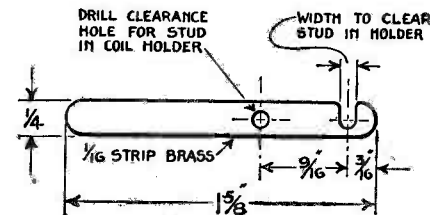

Fig. 85.—Coil-Holder Shorting Switch.

four wood screws for securing the panel to the box; six No. 6 or 8 B.A. countersunk head brass screws for holding the crystal detector and telephone condenser to the panel; four No. 4 B.A. nuts; eight No. 4 B.A. plain washers; four small size condenser-plate spacing

LOUD-SPEAKER CRYSTAL SETS

washers ; one length of large bore systoflex for covering the connections ; two No. 4 B.A. countersunk head screws $\frac{3}{4}$ in. long for holding inductance tube to the panel (see Fig. 83) ; two pieces of No. 4 B.A. screwed rod each $\frac{3}{4}$ in. long for securing the coil-holder to the panel (see Fig. 84) ; two screwed studs each $\frac{3}{4}$ in. long

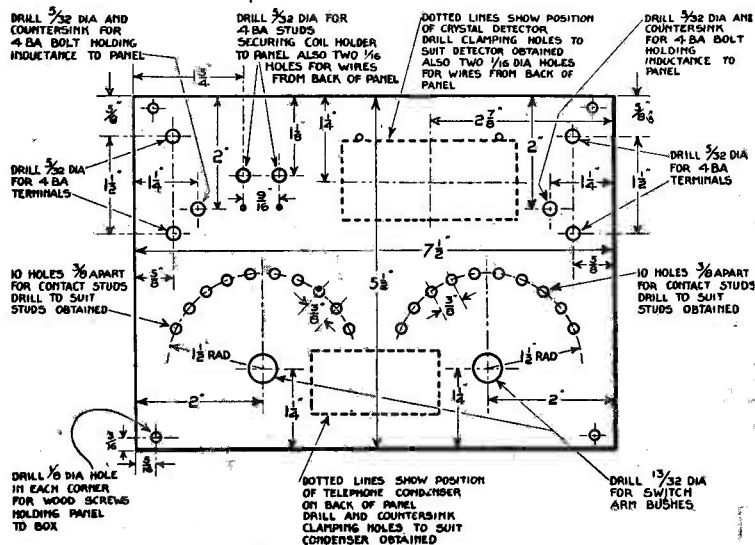

Fig. 86.—Drilling Lay-out of Panel.

to replace the connecting screws in the side of the coil holder, nuts to suit will also be required (see Fig. 82) ; one brass strip $1\frac{1}{8}$ in. long by $\frac{1}{4}$ in. wide by $\frac{1}{16}$ in. thick for the coil-holder shorting switch (see Fig. 85) ; and a small quantity of shellac varnish.

The Case.—The box (Fig. 81) may be of any available hard wood if home constructed, but there is nothing

TAPPED-INDUCTANCE SET

to beat mahogany for good appearance, especially when french polished. If the constructor is not skilled at this method of finishing, quite a passable shine can

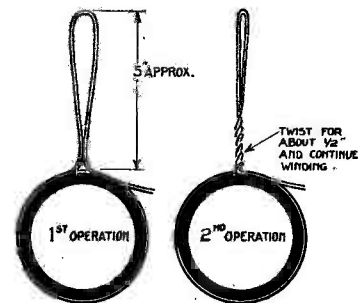

Fig. 87.—Method of Taking Tappings.

be obtained by carefully glasspapering the surface of the wood until every roughness is removed and coating with thin shellac varnish. When this is perfectly dry

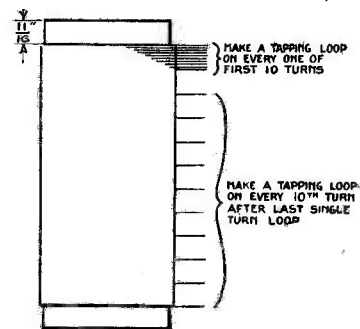

Fig. 88.—Details of Inductance Coil.

the surface should again be smoothed with fine glass-paper lubricated with best linseed oil. After wiping off the surplus oil with a clean piece of soft rag, give

LOUD-SPEAKER CRYSTAL SETS

a second coat of shellac and allow thoroughly to dry. This cycle of operations may be carried out several times until the appearance of the box is satisfactory, the final coat of shellac varnish being left untouched when dry.

The ebonite panel should be tried in position on the box. If the edges do not lie flush with the edges of the box, material should be removed from the panel

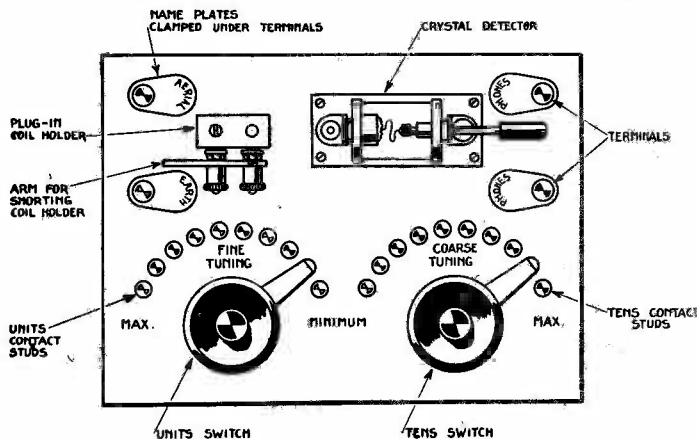

Fig. 89.—Lay-out of Panel.

by means of a sharp flat file of medium cut, afterwards taking out all scratches with a smooth file. A final finish should be given to the edges by means of emery-cloth lubricated with oil.

Fig. 86 gives all drilling details of the panel and calls for no special mention, except that marking-out should be done with a steel scribe or sharp needle, in preference to lead pencil, as marks left by the latter are liable to form electrical leaks.

TAPPED-INDUCTANCE SET

The Tuning Coil.—The inductance of tuning coil is wound on the 3-in. diameter cardboard tube. After drilling the latter as shown in Fig. 92, secure the end of the No. 22 s.w.g. d.c.c. wire by threading through the three $\frac{1}{16}$ -in. diameter holes, wind on one complete turn and make a loop as shown in Fig. 87 (first operation). The loop should then be twisted, as shown in the

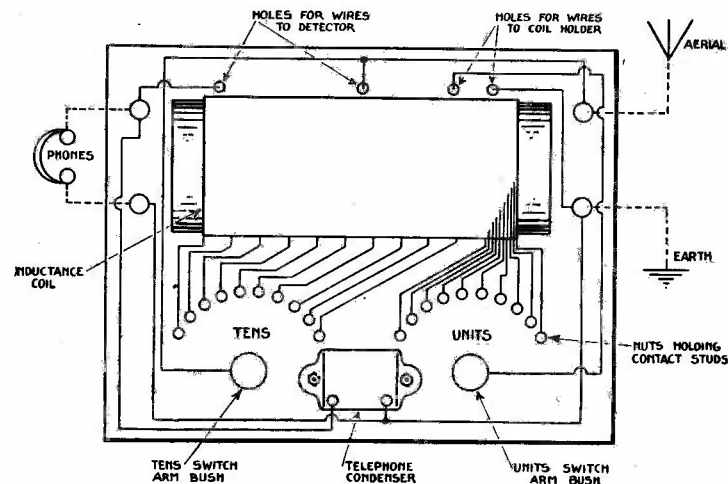

Fig. 90.—Coil Connections.

second operation (same figure), so that it will not come unfastened, and a further turn of wire made on the tube. This turn also is looped and twisted, but in a position about $\frac{1}{8}$ in. past the first. This procedure is carried on until ten turns each complete with a twisted loop have been made. After the last single-turn loop make nine turns of wire without looping. Then at the tenth turn begin the second series and make a

LOUD-SPEAKER CRYSTAL SETS

twisted loop at every tenth turn following until twenty tapping loops have been made. The winding should now have reached the second row of $\frac{1}{16}$ in. diameter holes. Cut and secure the wire through them. Fig. 88 gives all details of the winding.

To complete the tuning coil scrape or burn the

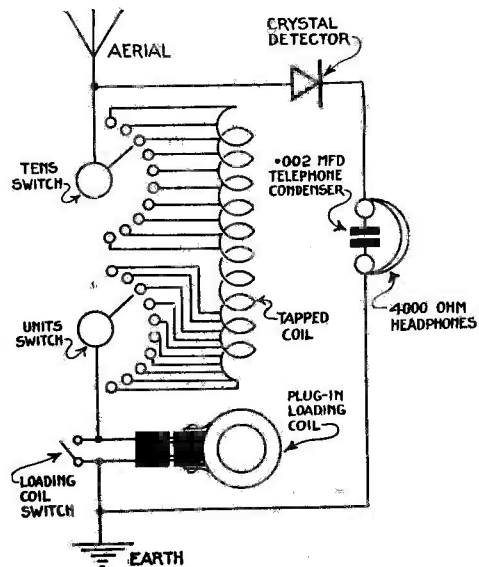

Fig. 91.—Diagram of Connections.

cotton insulation from the extreme end of each tapping, give the whole a soaking of thin shellac varnish and allow thoroughly to dry.

A small modification is required to the plug-in coil holder as explained in Figs. 82 and 84. The base as shown in the last-mentioned figure is to be drilled and tapped 4 B.A. thread, in order that the

TAPPED-INDUCTANCE SET

two small 4 B.A. studs for securing the holder to the panel may be fitted, while the two small screws in the side of the coil-holder are—as explained in Fig. 82—to be replaced by studs.

Fig. 85 gives all details of the coil holder shorting switch-arm. This component may be of thinner material than that specified, if the $\frac{1}{16}$ -in. strip metal cannot be readily obtained. When completed the arm

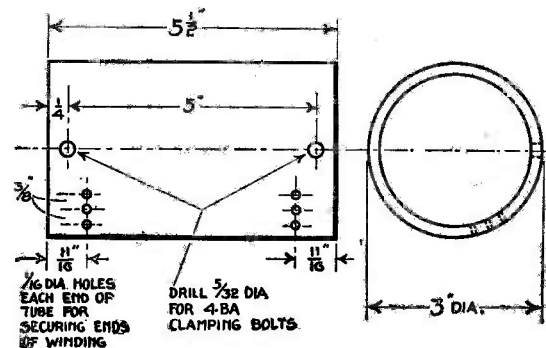

Fig. 92.—Dimension of Coil Former.

should be fitted to the coil-holder as depicted in Fig. 93.

The assembly of the components on to the panel may now be proceeded with. Fig. 89 shows the position of the various parts which come on the outside, while those which are underneath are shown in Fig. 90, which also shows the necessary wiring.

Connections.—With regard to the connecting up of the various components which constitute the set, no difficulty should be experienced if Fig. 90 is carefully studied. The theoretical circuit diagram (Fig. 91)

LOUD-SPEAKER CRYSTAL SETS

can be used in conjunction with Fig. 90, and may prove helpful. The following list of connections, however, should be used by those who have real difficulty in following the wiring diagrams :

(1) Aerial terminal to crystal of detector and bush of tens switch-arm ; (2) catwhisker of detector to one phone terminal and to one terminal of phone condenser ; (3) remaining phone terminal (*a*) to remaining terminal of phone condenser, (*b*) to earth terminal, and (*c*) to one terminal of coilholder ; (4) remaining terminal of coil-holder to bush of units switch-arm ; (5) first ten single-turn tapping loops to the ten contact studs of the units switch ; these connections should be made in rotation—that is, first tap to first stud, second tap to second stud, and so on ; (6) tapping loops Nos. 11 to 20—that is, the tens loops to contact studs of tens switch ; these should also be carried out in rotation—that is, first tens tap to first tens contact stud, second tens tap to second tens stud, and so on.

All connecting wires other than that of the tuning-coil tappings should be covered with insulating sleeving or systoflex ; or small size rubber tubing may be used if available.

The panel complete with all components and correctly wired up may now be fastened to the containing box by means of the four wood screws, and the instrument tested in actual broadcast reception.

Phones.—A pair of good quality 4,000-ohm headphones will, of course, be required, as well as a properly-insulated aerial of suitable size and height, together with means to contact the set to earth.

TAPPED-INDUCTANCE SET

Tuning-in.—Presuming these requirements are fulfilled and the time is that at which the ordinary low wavelength broadcast transmission is known to be taking place, connect the headphones to the phone terminals of the set, and the earth and aerial wires also to their respective terminals. See that the coil-holder shorting switch is in a horizontal position and clamped securely by the two terminal heads. Adjust the crystal detector so that the point of the catwhisker

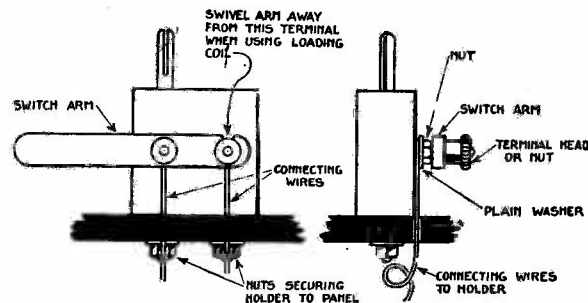

Fig. 93.—Details of Shorting Switch.

is just touching the crystal, and manipulate the tens and units switch arms in the following manner. Place the tens switch-arm so that it rests on the first of the tens studs—that is, the stud connected to the first of the tens tapping loops—and move the units arm slowly over the whole of the units studs. If nothing is heard, move the tens switch-arm to the second of the tens studs, and again slowly swing the units arm over the whole of the units studs. Continue this procedure until signals are heard.

CHAPTER XII

An All-Wavelength Receiver

FOR the construction of the set the following materials and components should be obtained from a reputable dealer.

Materials and Components.—Two pieces $\frac{1}{4}$ -in. hard wood, 4 in. by 4 in. (see Fig. 94); piece matt-finish ebonite, $5\frac{1}{2}$ in. by 4 in. by $\frac{3}{16}$ in. or $\frac{1}{4}$ in.

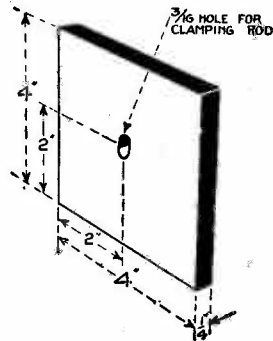

Fig. 94.—End Cheek.

thick (see Fig. 95); $\frac{1}{2}$ -lb. reel No. 24 s.w.g. enamelled copper wire; 1 yard systoflex or small-bore rubber tubing; No. 2 B.A. ebonite knob; cardboard tube $3\frac{1}{2}$ in. diameter by 5 in. long (see Fig. 96); two Meccano 1-in. angle brackets; 1-ft. length No. 2 B.A. threaded rod; five No. 2 B.A. nuts or locknuts; two No. 2 B.A. washers; six terminals (4 B.A.); crystal

AN ALL-WAVELENGTH RECEIVER

detector, complete with good quality crystal and cat-whisker; four $\frac{1}{2}$ -in. countersunk-head wood screws, for fixing ebonite panel to side cheeks; four No. 4 B.A. bolts, nuts and washers $\frac{1}{2}$ in. long, for fixing angle brackets to ebonite panel; length brass strip, $\frac{1}{2}$ in. wide by $4\frac{1}{8}$ in. long by $\frac{1}{64}$ in. thick (see Fig. 100).

Winding the Tuner.—The coil should be first taken in hand, the winding being put on the cardboard tube as evenly and closely as possible. Fig. 96 illus-

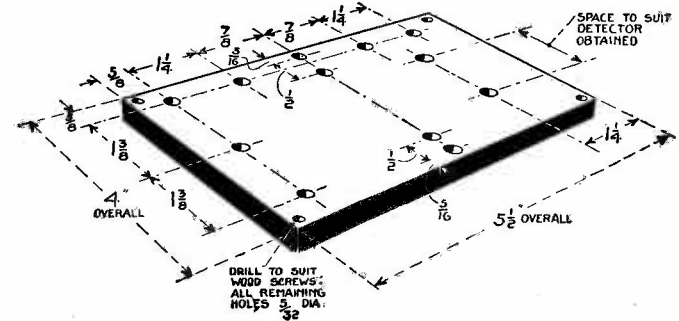

Fig. 95.—Top Panel.

trates this part of the work. Anchoring the beginning and end of the wire should be carefully carried out, so that there will be no fear of the wire coming loose at any time. Perhaps the best method of doing this is to pierce needle holes through the cardboard and thread the end of the wind through them, as indicated in Fig. 97.

After trimming up and drilling the $\frac{3}{16}$ in. diameter centre hole, as shown in Fig. 94, the end cheeks may be clamped in position on the coil by means of a 6-in. length of No. 2 B.A. threaded wire cut from the piece

LOUD-SPEAKER CRYSTAL SETS

obtained, a nut and washer being used at each end for tightening up.

Drilling the Panel.—Fig. 95 illustrates the drilling required in the ebonite panel. All holes should be

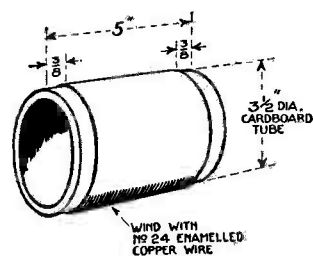

Fig. 96.—Cardboard Former.

marked out with a large needle or engineer's scriber, as pencil lines, unless thoroughly removed with emery-cloth, are liable to detract from the proper working of the completed set.

The exact positions of the holes for the detector will, of course, be determined by the dimensions of the

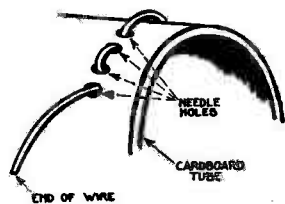

Fig. 97.—Fixing the Wire.

actual component obtained, there being no standardization of the dimensions of this part.

If a detector ready mounted on an ebonite base is purchased, the instrument may be attached to the

AN ALL-WAVELENGTH RECEIVER

panel just as it is. If a little extra work is not objected to, the removal of the small base and remounting on the receiver panel will give a more pleasing appearance to the completed set.

Wiring Up.—Terminals, angle brackets and detector having been securely attached, wiring up as depicted in the circuit diagram (Fig. 98) may be proceeded with,

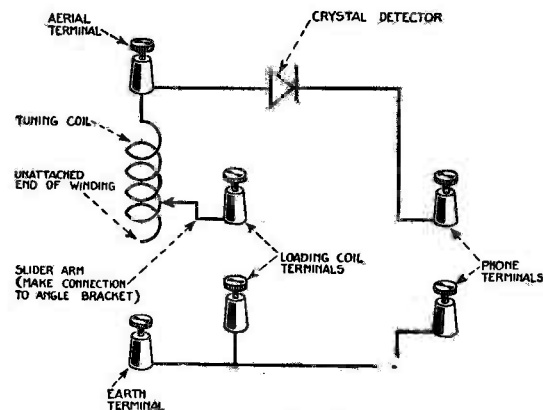

Fig. 98.—Circuit Diagram.

using some of the No. 24 copper wire covered with india-rubber tubing or systoflex. All nuts should be well tightened up, after which the completed panel should be screwed down to the end cheeks of the coil, as depicted in Fig. 99.

The brass slider arm, as shown in Fig. 100, together with the ebonite knob and spindle, can now be fitted into the angle pieces, and locked in position by means of two nuts at the rear end. The spindle (5 in. long) is cut from the remainder of the No. 2 B.A. threaded

LOUD-SPEAKER CRYSTAL SETS

rod. A firm, but not too great a pressure should be maintained between the curved end of the arm and the coil winding. Finally scrape the enamel insulation completely away from that part of the wire which comes into direct contact with the slider arm.

Reception.—Reception of either the local broadcast, if installed within 30 miles of a main transmitting

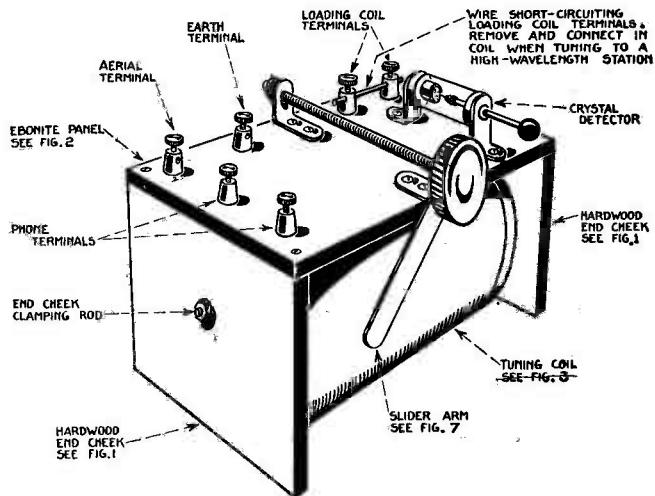

Fig. 99.—Completed Receiver.

station, or the programme from the high-power high-wavelength station is possible with the set. In the former case the two terminals on the detector side of the slider spindle must be joined together with a short piece of copper wire; in the latter the ends of a loading coil containing about 150 turns of wire should be connected to the two terminals mentioned in place of the short-circuiting wire.

AN ALL-WAVELENGTH RECEIVER

Tuning-in.—To listen-in, connect aerial lead-in earth lead and high-resistance (2,000-4,000 ohms) phones to their respective terminals on the panel, as indicated in the circuit diagram (Fig. 98). Presuming the time is that at which broadcast transmission is advertised to be in progress, place the phones over the ears and adjust the detector, so that the point of the catwhisker is seen to be just touching some portion of the crystal; slowly move the slider arm by means of the

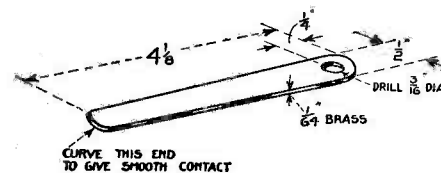

Fig. 100.—Contact Arm.

ebonite knob along the bared portion of the coil winding until signals are heard at their loudest. Finally readjust the catwhisker in case a better rectifying point is available.

If the ordinary low-power low-wavelength transmission is being tuned-in, the loading-coil terminals must, of course, be short-circuited by means of a piece of thick bare copper wire, or proper reception will not be possible, the loading coil being used only during the reception of a high-wavelength station.

CHAPTER XIII

Set with Air-spaced Loose-coupled Tuner

THE success attained with the set shown by Figs. 101 to 104 is beyond question both in aural tests and measurement of the current actually received. By this latter method it was found by comparative tests that an increase of current in the telephones has been

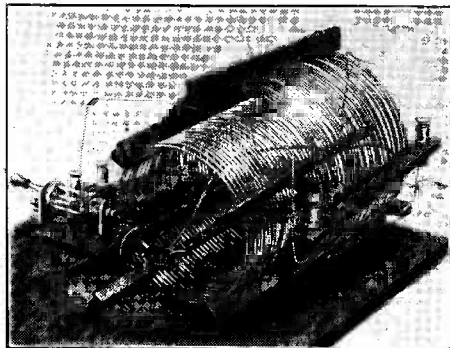

Fig. 101.—View of Air-spaced Loose-coupled-Set.

obtained amounting to 25 to 33½ per cent. over tapped single-coil cotton-covered-wire tuners (without condensers) and 500 per cent. in the case of condenser-tuned coils, which figures are conclusive.

The improvement is entirely attributable to the fact that the utmost efficiency has been obtained by the aid of low-loss coils in the tuner. That these

AIR-SPACED LOOSE-COUPLED TUNER

losses do result on short waves through capacity effects is, of course, well known, and, in fact, it has been

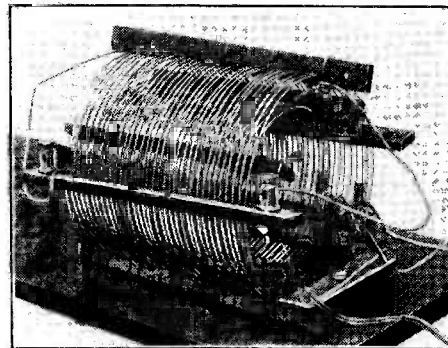

Fig. 102.—Another View of Air-spaced Loose-coupled-Set.

proved on many occasions and is easily demonstrated that unnecessary capacity in coils dealing with radio-frequency currents of a high frequency such as are

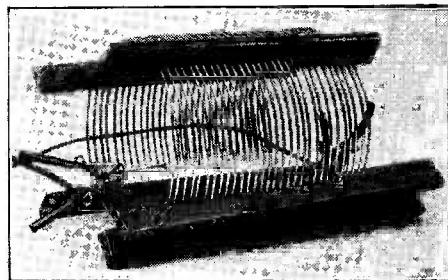

Fig. 103.—Detail View of Tuner.

used on the broadcasting band of wavelengths results in an increase in the H.F. resistance.

It is by paying special attention to these matters that the results referred to herein have been obtained,

LOUD-SPEAKER CRYSTAL SETS

and although the gear shown in the photograph is built up of tinned copper wire for the purpose of the illustration, it is strongly recommended that enamelled wire or bare untinned wire should be used in its stead, as the tin has been found to afford a slight extra resistance to H.F. currents. Enamelled wire is mentioned, as in time bare copper oxidises on the surface and this oxidisation again offers resistance to H.F. currents. If, however, the constructor has the skill and patience to place his coils in an air-tight box of large dimensions this oxidisation will not occur, and the bare copper is the most efficient.

Constructing the Coils.—The material required to construct the receiver is $\frac{1}{2}$ lb. No. 18 bare copper wire, a small piece of ebonite cut into strips, four terminals, a crystal detector and four contact clips, with a bare board 15 in. by $8\frac{1}{2}$ in.

The coils, as may be seen from the photographs, are of the skeleton type, and are composed of bare wire mechanically supported by five strips of ebonite $\frac{1}{2}$ in. by $\frac{3}{16}$ in. by 6 in. for coil A, three strips $\frac{1}{2}$ in. by $\frac{3}{16}$ in. by 5 in. for coil B, with two strips 6 in. long. Considerable patience must be exercised by the constructor in building these coils, and it is most important that the wire is spaced approximately at a distance equal to its own diameter. It is of no use winding bare wire on a former tube spaced with twine, or capacity losses will at once occur. The form of construction advocated here must be adhered to throughout in order to obtain maximum results.

The first matter is to drill the ebonite strips,

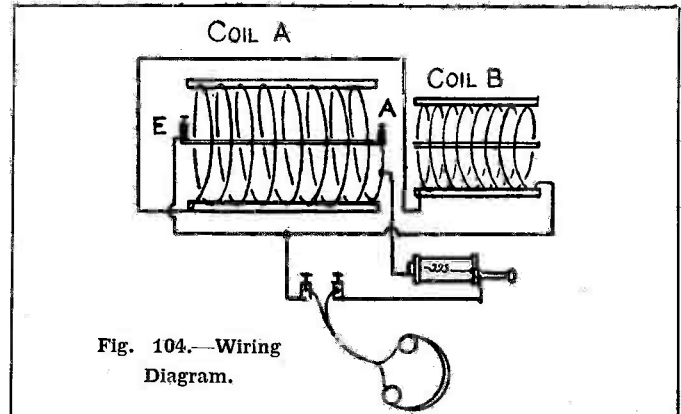

Fig. 104.—Wiring Diagram.

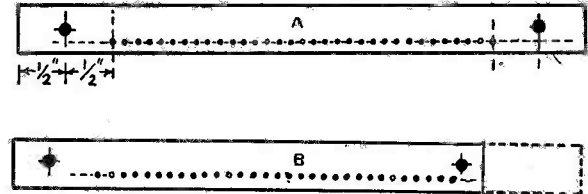
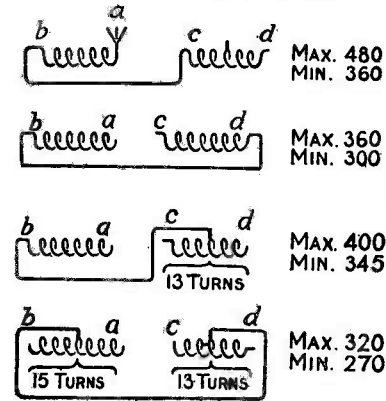

Fig. 105.—Strips for Coils.



LOUD-SPEAKER CRYSTAL SETS

the positions of the holes being as shown in Fig. 105. Strips A are for the outer or large coil and strips B for the inner or smaller coil. All five of the strips may be bored simultaneously by screwing them together. This being done, the bare or enamelled covered wire is prepared for winding in the following manner.

First of all the wire must be stiffened by the simple expedient of attaching one end of the reel of wire to a door knob or fence in the garden and pulling it. As the length of wire is considerable, it may be desirable to do the job in two pieces, cutting each length of wire in half.

Having done this, the wire is next wound tightly on a cardboard former $3\frac{1}{2}$ in. in diameter for the A coil and $2\frac{3}{4}$ in. in diameter for the B coil, 33 and 30 turns for A and B. After each length of wire is wound on the former it is allowed to spring off, and, providing that no kinks have been made in the wire during the winding process, it will be found that the coil has assumed a stiff spiral formation.

The wire is next fed into the holes in the ebonite strips one hole at a time, each strip of ebonite being slid on to the end, and so it is wound until the skeleton formation apparent in the photographs is obtained. Care should be taken that the wire is not kinked or bent from its spiral formation during this process. Having completely fed on the first length of wire, the second is treated in a similar manner and the two lengths are secured together by a soldered connection.

Coil B is not so difficult to wind owing to the

AIR-SPACED LOOSE-COUPLED TUNER

smaller quantity of wire involved, but care should be taken throughout that the copper wire is not kinked, otherwise the coils will assume an untidy and bedraggled appearance. A touch of shellac is now applied all along the ebonite edge and the coil stood to dry, after which it will be found that a rigid structure has been obtained.

The remainder of the construction is comparatively simple, all wiring being carried out in bare wire. The sketch Fig. 106 illustrates the connections in diagrammatic form. The apparatus is mounted on a baseboard of dimensions 15 in. by 8 in.

The Crystal Detector.—The author has carried out a considerable number of experiments with various types of crystal, crystal detectors and catwhiskers, and finds that the best results are obtained with catwhisker crystals when the contact is light and constant. Gold and silver wires have the advantage that they do not oxidise with age, but in the main the wire available is generally too heavy and stiff for the purpose. Brass and copper have also been tried, and as regard the former the same remarks apply. Copper is generally too ductile when the gauge is sufficiently small. The best and most constant results are obtained with Eureka or Constantine resistance wire of No. 36 gauge in contact with a good piece of permanite or hertzite. If this wire is used it will be noticed that a sensitive spot can be found on very poor pieces of crystal almost immediately.

No blocking condensers are shown across the telephone in the receiver, as these have been found by

LOUD-SPEAKER CRYSTAL SETS

the author to result in a loss of current on measurement and certainly do not increase the signal strength in the telephones.

Wavelength of the Receiver.—The range of wavelengths of the receiver described when used on a standard P.M.G. aerial is minimum 270 metres, maximum 480 metres (*see* Fig. 106). If a higher maximum wavelength is desired the B coil may be lengthened and more wire placed on it. Enlarging the aerial, such as lengthening it or raising it, will also increase the wavelength.

With the set and standard aerial loud-speaker results have been obtained a few miles from 2 L O, whilst with two note magnifiers the loud-speaker is unbearable in an ordinary room. By the addition of one note-magnifying valve the signals were audible and readable over the whole of the house and in the garden 40 ft. away in the open-air.

CHAPTER XIV

The "A.W." Self-contained Loud-speaker Crystal Set

THE set described in this chapter, and to which great publicity was given in "AMATEUR WIRELESS," makes use of a microphone button and circuit, both of which are the invention of Mr. Johan Skinderviken.

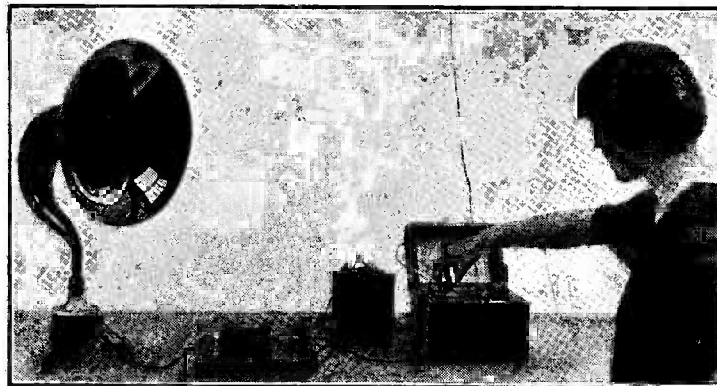

Fig. 107.—Photograph of the Complete Experimental Arrangement.

At the outset it may be stated that in the scheme here presented there is no new principle involved, nor, indeed, any apparatus employing a new principle; the claim is that, due to the modification of well-known principles, it is possible to operate a loud-speaker from any crystal set in any place in which it gives good reception in the phones.

LOUD-SPEAKER CRYSTAL SETS

Results Obtained.—The results to be obtained from the apparatus about to be described, and shown by Figs. 107 and 108, may be stated quite definitely. Within easy range of a broadcasting station and with any standard crystal set that gives good results under normal conditions a loud-speaker can be worked to provide sufficient volume of sound to fill a large room. The quality is quite good with instrumental music.

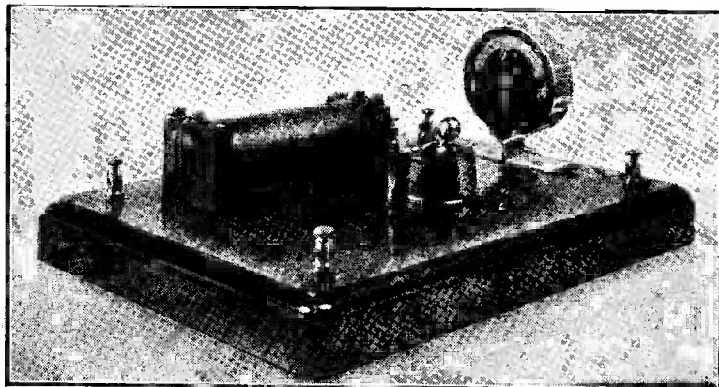

Fig. 108.—Experimental Panel Attachment showing Transformer and Earpiece (without Microphone).

With speech, though this is quite understandable, it is apt to be a trifle gramophonic. As the apparatus is still in more or less of an experimental stage, it is possible that many of our readers who are fond of experiment may be able to improve it to quite a considerable extent.

The initial cost of the apparatus is small, and the working merely comprises that of running four dry cells of the type used for electric bells. The current required

THE "A.W." CRYSTAL SET

from these is approximately 0.1 ampere, which is well within their capabilities. Of course, if preferred, an accumulator may be used in place of the dry cells.

The Principle Involved.—The principle involved is quite simple: The exceedingly delicate currents received by the crystal set are used to operate a microphone relay in the first place. In the relay circuit, which is quite distinct from the receiving circuit, there is a battery and the primary of a transformer; included in the secondary circuit of the transformer is the loud-speaker. A pictorial lay-out of the various parts is shown by Fig. 109.

Component Parts.—Beginning at the left-hand side of the drawing, the ordinary aerial and crystal set will be observed; next comes a telephone earpiece with a small microphone relay secured to its diaphragm (Fig. 110). It will be observed that the crystal set is connected directly to the phone windings in the ordinary way. The microphone relay is attached to the diaphragm of the phone in a way that will be dealt with at length later.

The next components are the switch, four dry cells and transformer. An open-core transformer is shown and this gives good results, but our preference is for a hedgehog transformer with closed core. The loud-speaker is connected to the secondary of the transformer.

The Connections.—The actual connections will be clear upon reference to the circuit diagram (Fig. 111). Commencing at the left-hand side again, the crystal

THE "A.W." CRYSTAL SET

set is connected directly to the phone windings, so that the diaphragm is actuated in the ordinary way.

The next circuit is the relay circuit, and include the microphone relay, the battery and the primary of the transformer. The secondary of the transformer forms part of the right-hand circuit, which includes the loud-speaker.

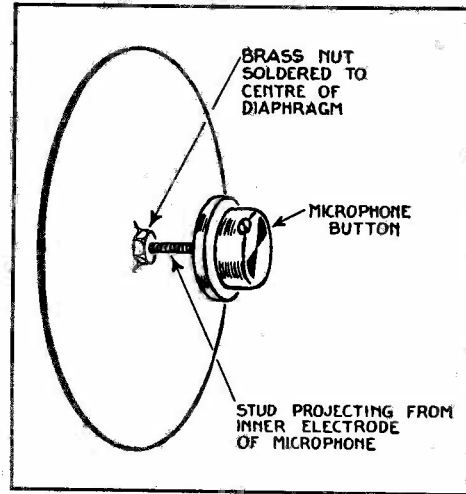

Fig. 110.—Microphone Attached to Earpiece Diaphragm. This arrangement is inferior to that shown by Fig. 114.

The Microphone Button.—Before considering the method of operation of the apparatus in detail it will be well to describe the microphone relay, as it is due to the degree of perfection to which this has recently been brought that the system is capable of producing such satisfactory results. In effect, this relay is a small microphone, but with a difference in its

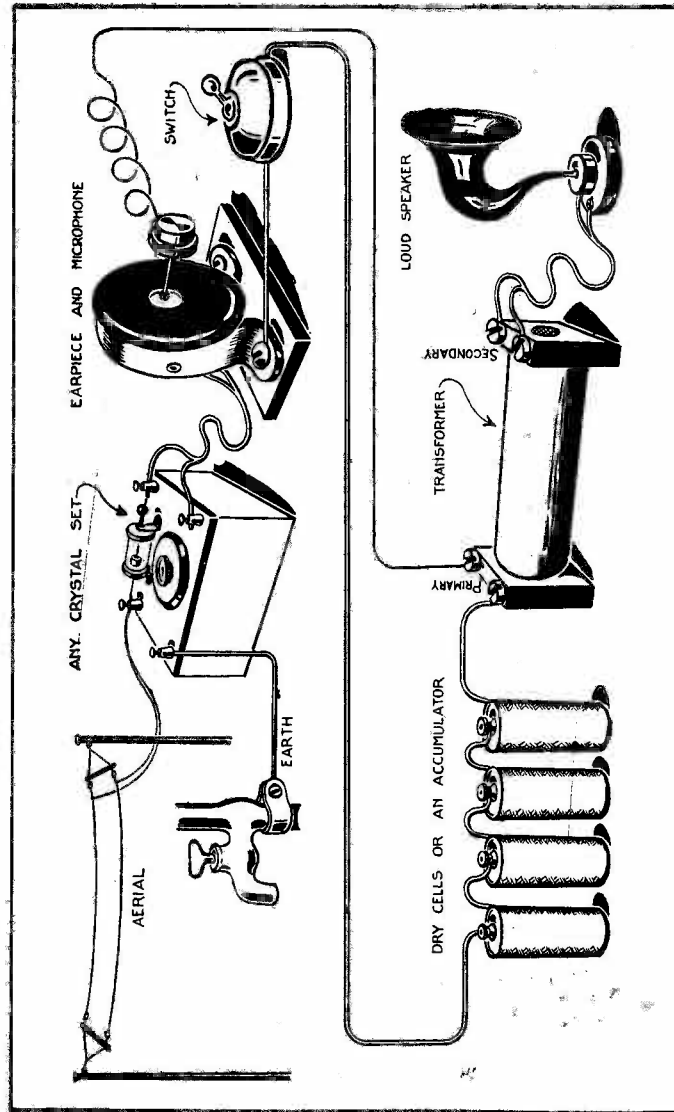

Fig. 109.—Lay-out of "A.W." Crystal Loud-speaker System.

LOUD-SPEAKER CRYSTAL SETS

construction. The ordinary microphone is a fairly substantial piece of apparatus, which has a chamber with a solid back of carbon and a flexible carbon diaphragm as the front. In the chamber are placed small carbon granules, and it is the varying pressure on these, due to the vibrations of the diaphragm caused by the sound waves, which produces fluctuations of the current.

Obviously with this construction the size of the diaphragm must be fairly large in order to be sufficiently sensitive to respond to the sound waves.

In the microphone relay under consideration a somewhat different principle is made use of, this permitting the entire microphone being made in miniature and of such a construction that it is acted upon by vibration instead of by sound waves transmitted through the air.

The reproduced photograph (Fig. 112) shows the instrument, the actual diameter of the shell being little more than that of a sixpence. An enlarged section is shown in Fig. 113 with the parts fully described.

It will be seen that a flexible mica diaphragm is provided, but this is not intended to act as a receiver of the sound waves as does the diaphragm of an ordinary microphone; its purpose is merely to provide a flexible connection between the two poles of the instrument. Supposing, for instance, that the button is attached to a telephone diaphragm or, preferably, the reed of a reed-type telephone (Fig. 114), such as a Brown A-type phone, and then the button is connected up in a simple battery circuit as in Fig. 115.

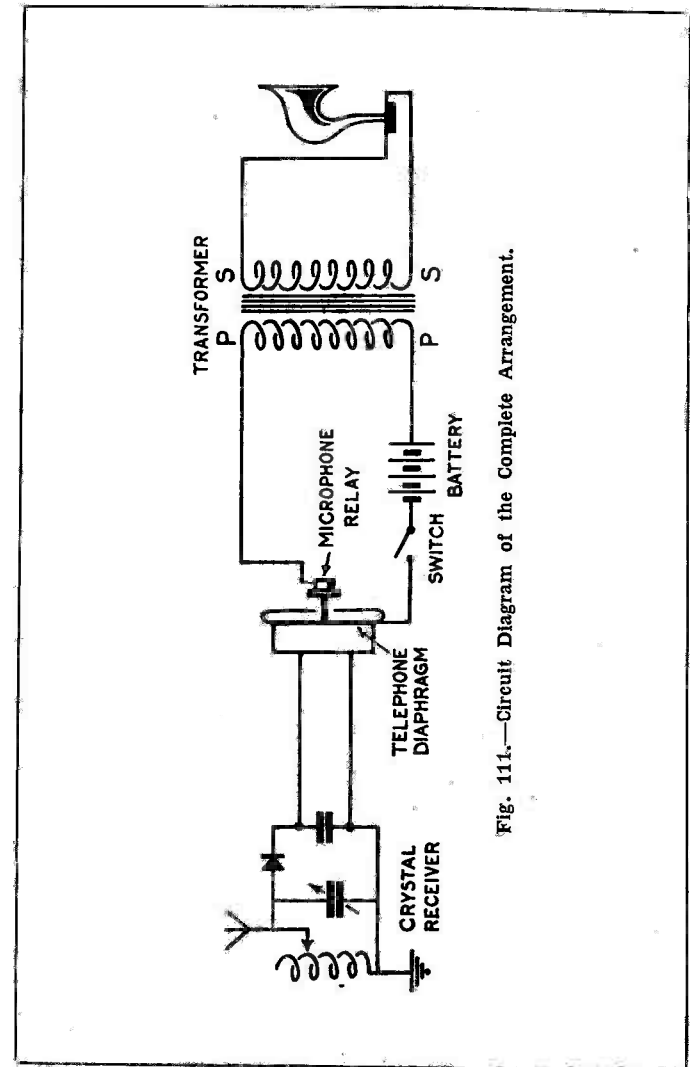

Fig. 111.—Circuit Diagram of the Complete Arrangement.

LOUD-SPEAKER CRYSTAL SETS

Now if the phone diaphragm or reed is caused to vibrate, the centre conical-shaped piece will vibrate with it, but owing to the flexible connection between the centre and outer parts of the microphone and the inertia of the outer part there will be alternate compressions and decompressions of the carbon granules,

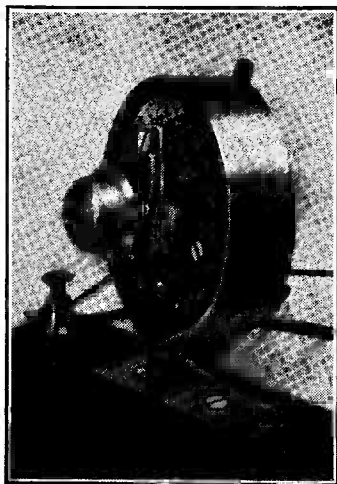

Fig. 112.—Photograph showing Microphone Button Attached to Reed of Brown Phone.

which will vary the amount of current passing in the circuit. The carbon granules occupy the "grey" semicircular chamber shown in Fig. 113.

The Microphone Relay.—The microphone relay used is a new and modified type of Skinderviken microphone button, used in conjunction with a transformer the windings of which have been determined after considerable experiment. Many readers will be

THE "A.W." CRYSTAL SET

acquainted with the old type of Skinderviken microphone button; the present one is similar, but differs in some small but very essential details. It was pointed out earlier that the action of these buttons depends very largely upon the inertia of the body of the instrument.

The exactness of this factor, the flexibility of the diaphragm and the size of the carbon granules in the new button, matters which have been arrived at in

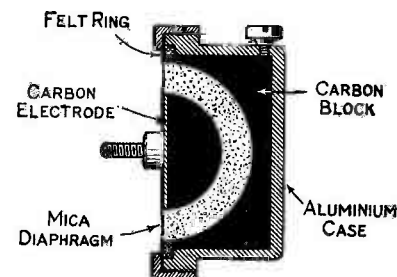

Fig. 113.—Cross-section (double size) through the Skinderviken Button. (In a still later pattern, the felt ring is omitted.)

recent experiments, are the main features that have made crystal loud-speaker work possible.

The new button has an aluminium case, instead of a brass case as formerly used, and the weight of the central moving electrode has been reduced to a minimum by careful experiment. Though the apparatus is so simple, it should be understood that if success is to be attained the instructions must be followed in every detail. In this connection, the first point that requires mention is the type of microphone relay or button to be used.

The Skinderviken button has been on the market

LOUD-SPEAKER CRYSTAL SETS

for a number of years, but it has recently been improved in type, and it is largely the modification of the button that has made the present results possible.

Experimenters, therefore, should not expect to get satisfaction with loud-speaker crystal reception using the *old type* button. The latter, by the way, was made of brass, whereas the new one is made of aluminium, with the cap only of brass, and is generally of lighter construction.

The Transformer.—As the voltage in the relay circuit, using four dry cells, is approximately six, it is evident that this is not sufficient to operate a loud-speaker effectively. As shown in Fig. 111, it is necessary to step this voltage up by the use of a transformer. The ratio of the windings of this transformer depends upon the resistance of the loud-speaker; in order to keep the ratio small it is advisable to use a loud-speaker of low resistance, say 120 ohms, though, of course, a loud-speaker of higher resistance may be used in conjunction with a suitable transformer.

Many different transformers (both open-core and closed-core type) can be tried, but the one which we find gives the best results with a 120-ohm loud-speaker is a hedgehog-type closed-core transformer answering to the following specification: Length between bobbin cheeks, 4 in.; cheeks, $1\frac{1}{2}$ in. square and, say, $\frac{1}{4}$ in. thick. Forming the core of the transformer is an ebonite or paper tube $\frac{7}{16}$ in. internal diameter filled with No. 28 soft-iron wires, 12 in. long, and with the ends doubled over, as shown later. The primary consists of 6 layers of No. 26 d.c.c. copper wire. The

THE "A.W." CRYSTAL SET

secondary consists 5 ounces of No. 34 d.c.c. copper wire.

The dimensions and windings of the transformer were arrived at after a considerable amount of experiment. Transformers of other dimensions will serve, but the results probably will not be so good; also the current consumption may be greater.

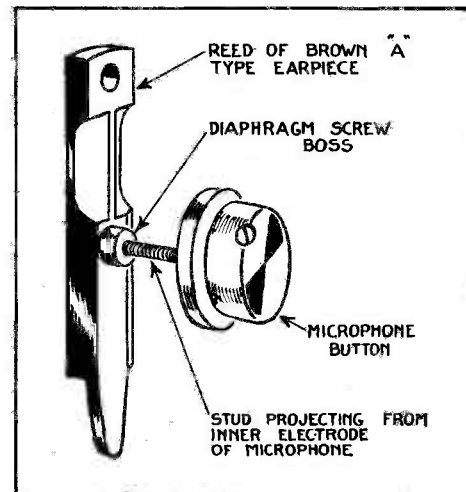

Fig. 114.—Microphone Attached to Reed of Brown Phone. This Arrangement has given the Best Results.

It must be borne in mind that the transformer described is only suitable for a low-resistance loud-speaker—that is, a loud-speaker of 120 ohms.

Attaching the Microphone to the Diaphragm.—Figs. 110 and 114 show the attachment of the microphone to the diaphragm of an ordinary 2,000-ohm earpiece and the reed of a reed-type phone respectively.

LOUD-SPEAKER CRYSTAL SETS

The latter type of phone is decidedly preferable, as the movement of the reed is greater in amplitude than that of the diaphragm. Our best results have all been with the reed-phone, but the other, if the diaphragm be thin and flexible, gives a rendering loud enough for a small room.

It will be understood that the foregoing is only a general explanation of the system, also that the photographs show crude experimental apparatus.

A matter of prime importance is that the telephone

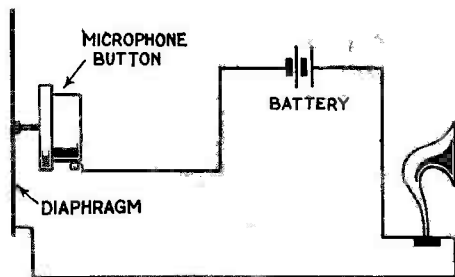

Fig. 115.—An Elementary Microphone Circuit, not including a Transformer.

and microphone relay be insulated as far as possible from vibration. This may be accomplished by placing the whole of the apparatus upon some soft and resilient material or by the use of such material on the phone mount. Spongy rubber, such as used for rubber sponges, is excellent for this purpose.

The lead from the body of the microphone button to the transformer should be of fine wire—say No. 42.

With prolonged use the button will be found to get warm. Should the button become too hot to be touched, it indicates that too much current is passing.

THE "A.W." CRYSTAL SET

Often in this case a light tap will jar it so that the internal resistance is increased and the current reduced. It will also be found that a light tap will often considerably improve reception.

Adjusting the Microphone Button.—In use the button becomes hot, but provided it does not become excessively hot, that is, too hot to touch, this heating is not detrimental. Excessive heat points to too much current passing, and this may be due to too high a voltage, an unsuitable transformer, or insufficient carbon granules in the button. Heating tends to make the carbon granules "pack," with a consequent distortion in reproduction.

The number of carbon granules in the button is of paramount importance, especially in the reception of speech. Experiment is necessary to determine the most suitable quantity, but it may be stated that the button should be what may be termed comfortably full. Should the diaphragm be removed care should be taken before replacing it to see that the rim on which it beds down is quite free from granules. The diaphragm should also be examined to ensure that it is free from cracks. The thickness of the diaphragm has a distinct bearing upon the quality of reproduction. The material used is mica, and it is possible to reduce the thickness by splitting the laminations.

The Phone Earpiece.—Considerations of the resistance of the phone earpiece are, of course, the same as those that apply to phones when used in the ordinary way with crystal sets. The best value is 2,000 ohms for the single earpiece, but 1,000- or 4,000-ohm phones

LOUD-SPEAKER CRYSTAL SETS

are quite suitable. Mention has already been made that, on the whole, better results are obtainable with reed phones, but the diaphragm type is quite satisfactory providing a suitable diaphragm is used.

The Earpiece.—The best type of earpiece is undoubtedly the reed type, but quite good results are obtainable with an ordinary earpiece of good quality. In the former case it will be found that the button will screw directly into the reed, that is, into the hole in the reed normally occupied by the diaphragm securing screw. With the ordinary type of earpiece it is necessary to attach a nut to the centre of the diaphragm. In carrying this out the coating on the diaphragm should be entirely removed by means of emery-cloth; the diaphragm should then be heated uniformly and the exact centre tinned, when the nut can be soldered on quite easily. Any tendency that the diaphragm may have to cockle will be due to unequal heating during the soldering operation. If it is wished to avoid soldering the nut on the diaphragm, it may be attached quite well with Chatterton's Compound or any similar composition. Those who care to experiment may try other means of operating the relay button; for instance, it may be mounted on a light armature placed near to the phone magnets.

Voltage and Current.—Four volts will operate the loud-speaker, but the most suitable voltage is six, and it will be found that four dry cells of the type used for electric bells will answer excellently.

The consumption of current should approximate 0.1 ampere; if it is in excess of this it will reveal the

THE "A.W." CRYSTAL SET

fact by undue heating of the button. It will be understood, of course, that a 6-volt accumulator is equally suitable for supplying the current.

The Crystal Receiver.—Nothing need be said about the actual crystal receiver, as any crystal receiver will serve. It is advisable, in the first place, to tune in on the ordinary headphones, and when assurance has been made that the loudest signals are being received to switch on the current for the relay-loud-speaker circuit.

Indication that this circuit is in operation can easily be obtained by lightly tapping the button, when a loud resonant sound should be heard in the loud-speaker regardless whether any broadcasting is taking place or not.

Extraneous Noises.—It will be found that with this system of loud-speaking operation there is a remarkable freedom from background sounds, the only noises extraneous to the received signals being those due to vibration of the actual instrument.

The extent of these will depend upon the situation of the apparatus, but even where a great deal of vibration is present most of the noise can be obviated by the judicious use of spongy rubber or similar material for vibration insulating purposes. It might be found that in operating an enclosed set such as already described in this book a prolonged howl or whistle is produced, which may be started by the slightest movement of the receiver.

This is due to a reflex action which takes place between the receiver and the loud-speaker. In the

LOUD-SPEAKER CRYSTAL SETS

first place, a slight vibration disturbs the relay button and a sound is produced in the loud-speaker; this sound then reacts upon the containing case of the receiver, which again disturbs the relay, and so the process goes on with a howl that lasts indefinitely.

Fortunately the remedy is simple—merely take steps to prevent the case vibrating either by lining the inside with some soft material, such as felt, or staying the sides with strips of wood.

Success with the new crystal loud-speaker system is assured; as to that there cannot be the least doubt. Indifferent results can only be due to some fault in the components or their connections.

Transformer for High-resistance Loud-speaker.—

No doubt many readers will wish to use the more usual 2,000-ohm loud-speaker and a suitable transformer for this is as follows: Length of core between cheeks, $3\frac{1}{2}$ in.; diameter of core, $\frac{7}{16}$ in.; total length of core wires, 10 in.; primary, 6 layers of No. 20 s.c.c. wire; secondary, 4 oz. of No. 42 d.s.c.

The constructional details are, of course, exactly the same as for the transformer for a low-resistance loud-speaker.

CHAPTER XV

Making the "A.W." Self-contained Loud-speaker Crystal Set

The Complete "A.W." Loud-speaker Receiver.—
The apparatus here described includes the crystal receiver and the accessory loud-speaking arrangements; it is, in fact, complete in itself with the excep-

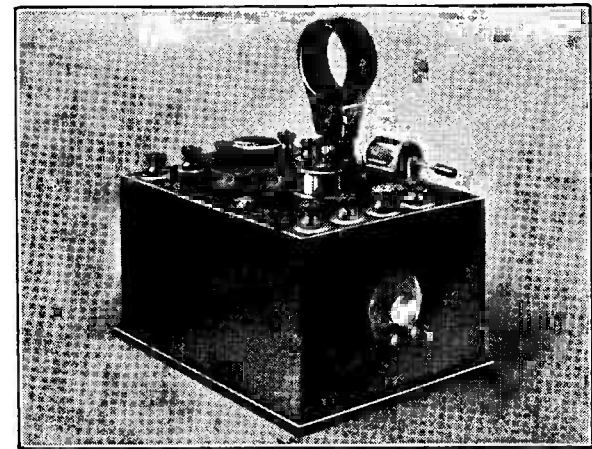

Fig. 116.—The Complete Set.

tion of the four dry cells which supply current to the local circuit. Normally it is intended for ordinary broadcast transmissions, but by simply changing the plug-in coil it may be used for lower or higher wave-

LOUD-SPEAKER CRYSTAL SETS

lengths, including those of the proposed new high-power B.B.C. station.

Materials.—The materials and components required for the construction of the set are as follows: One hard-wood box 8 in. by 6 in. by 4 in. deep, inside measurements; one ebonite panel 8 in. by 6 in. by $\frac{3}{16}$ in. thick; one .0005 microfarad variable condenser of the

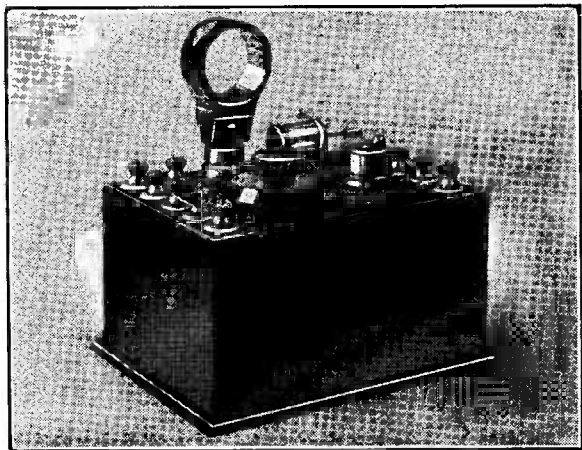

Fig. 117.—Another View of the "A.W." Loud-speaker Crystal Set.

one-hole fixing type; one plug-in coil holder with screws for fixing to panel; one high-resistance ear-piece (a Brown A-type reed phone is recommended); one Skinderviken microphone button; one glass-enclosed crystal detector, horizontal pattern (a copper spear-pointed catwhisker will be found very suitable); fourteen No. 4 B.A. terminals with nuts and washers; ten ivorine name-plates for clamping under terminals (aerial, earth, phones (2), loud-speaker (2), battery

MAKING THE "A.W." CRYSTAL SET

(2)); 5 oz. of No. 34 d.c.c. copper wire; 3 oz. of No. 26 d.c.c. copper wire; $\frac{1}{2}$ lb. soft-iron core wires, 12 in. long; two pieces ebonite 4 in. by $3\frac{1}{4}$ in. by $\frac{1}{4}$ in. thick; small gauge silk-covered flex; systoflex or rubber tubing; two 3-in. lengths No. 2 B.A. threaded rod; six No. 2 B.A. lock-nuts; six No. 2 B.A. washers; two strips $\frac{1}{64}$ -in. brass $\frac{3}{4}$ in. wide by $4\frac{7}{8}$ in. long; one ebonite

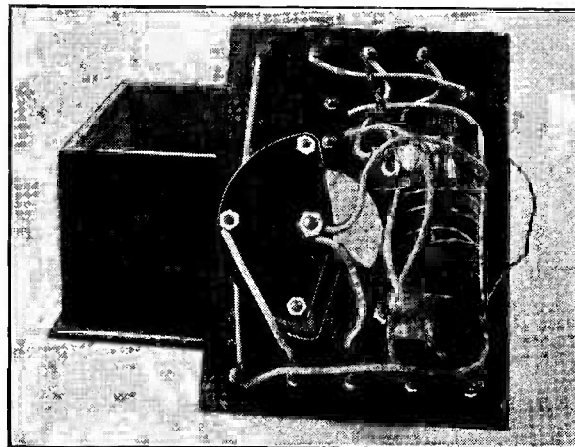

Fig. 118.—Bottom View of Panel.

tube $\frac{3}{8}$ in. bore by $4\frac{1}{2}$ in. long; empire tape 1 in. wide; one ivorine or aluminium indicating arrow.

Drilling the Panel.—Having trimmed the panel to fit the box, drilling should be carried out as shown in Fig. 121. Holes for the crystal detector and switch should be placed to suit the individual components obtained.

A $1\frac{7}{8}$ -in. diameter hole as shown in Fig. 122 is required in the centre of one end of the containing box,

LOUD-SPEAKER CRYSTAL SETS

while the earpiece clamping plate is to be drilled as indicated in Fig. 123.

Drilling is also required in the case of the transformer end cheeks, Fig. 124, and the transformer clamping strips, Fig. 125.

The Transformer.—The winding of the transformer should present no difficulty to readers who possess

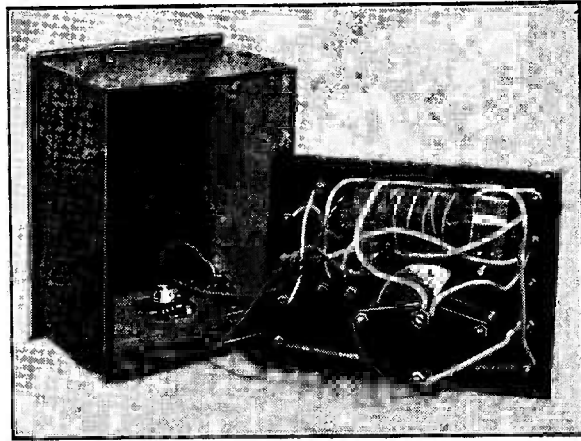

Fig. 119.—View Showing Microphone Button in Position.

a small lathe or breast drill, as the winding bobbin—made by forcing the drilled end cheeks over the ebonite tube—is easily held in a chuck; readers, however, who are not in possession of either of the tools mentioned and wish to wind the transformer themselves should put on the primary coil of six layers of No. 26 d.c.c. wire by hand, then mount the bobbin on a straight piece of No. 2 B.A. threaded rod, using a pair of iron shelf brackets for support bearings and

MAKING THE "A.W." CRYSTAL SET

arranging a step-up gear, and wind on the 5 oz. of No. 34 for the secondary.

The start and finish of both primary and secondary windings should be brought out through small holes drilled in the end cheeks. A layer of empire tape is placed between the primary and secondary windings.

On completion of the transformer windings a good

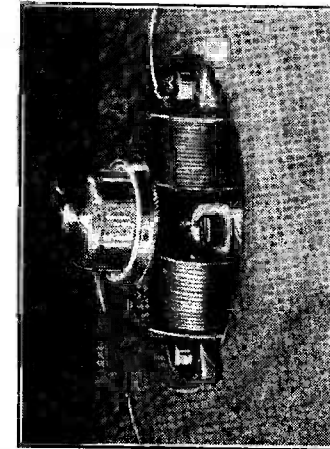

Fig. 120.—The Skinderviken Button Mounted.

binding of empire tape should be put on in order to protect the secondary from possible damage.

The core wires may then be packed in position through the ebonite tube and the ends separated into two branches and bent back over the winding as shown in Fig. 124. The ends overlap to form a closed core; the whole is finally bound with tape or string.

Assembling.—Fig. 126 shows the method of fixing the transformer to the back of the panel, using the

LOUD-SPEAKER CRYSTAL SETS

two No. 2 B.A. studs and brass strips ; care should be taken to see that the movable plates of the variable condenser do not foul the side of the transformer.

The assembly of the detector, switch, terminals, coil-holder, etc., in the positions shown in the plan view of the completed panel, Fig. 127, will present no

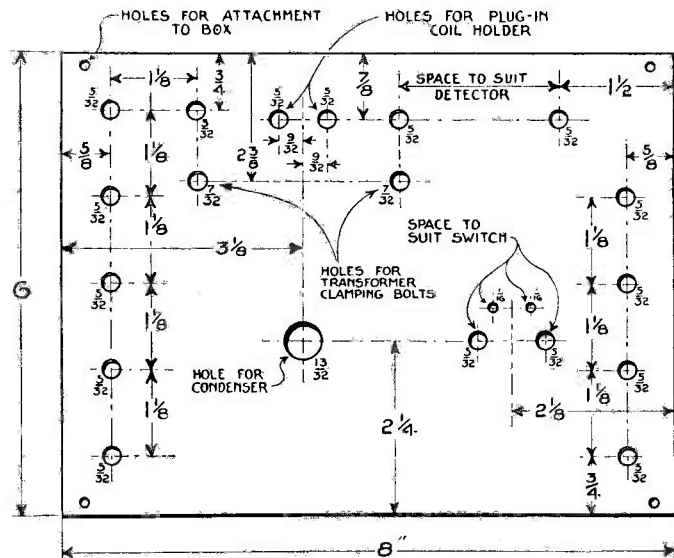

Fig. 121.—Lay-out of Panel.

difficulty ; the legs of the terminals marked " Loud-speaker " and " Phones " must not, however, project more than $\frac{5}{16}$ in. from the back of the panel or they will foul the earpiece clamping plate when this is fixed in position.

The swivel bracket, swivel-bracket stop, cap and diaphragm of the earpiece having been removed, the

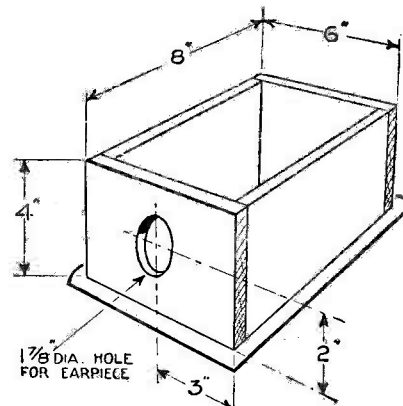

Fig. 122.—Sketch of Case.

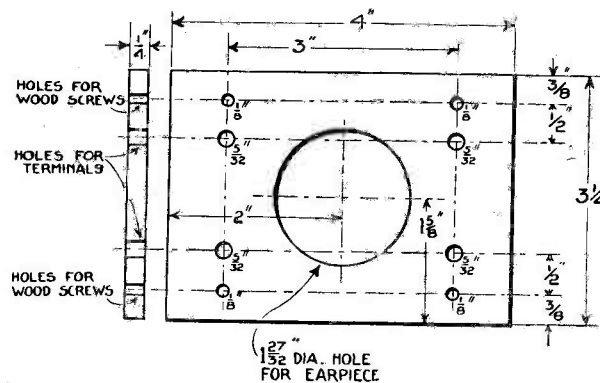

Fig. 123.—Earpiece Clamping Plate.

LOUD-SPEAKER CRYSTAL SETS

latter should be pushed into the large hole in the ebonite clamping plate (Fig. 123) and four terminals fixed in position in the $\frac{5}{32}$ -in. diameter holes.

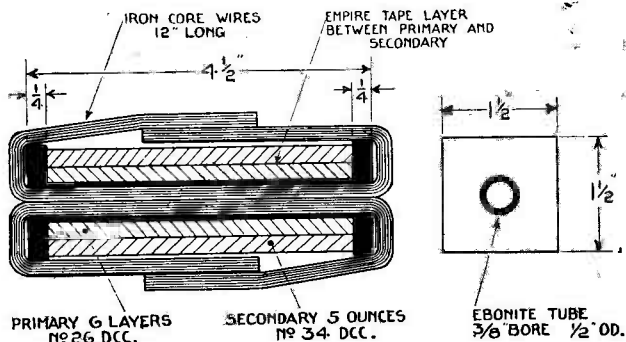

Fig. 124.—Section and Detail of Transformer.

Mounting the Button.—Insulated wires from the two lower terminals are to be connected to the terminal nuts on the back of the earpiece ; one of the remaining

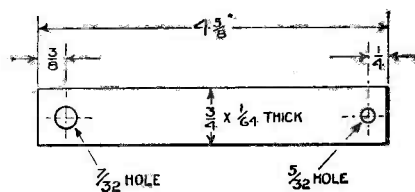

Fig. 125.—Connecting Strap.

terminals should be connected to some portion of the metal case of the phone, the remaining terminal is then joined by a couple of single strands of No. 42 wire (cut from the flex) to the small connecting screw on the body of the microphone button. If a reed-type phone is used the microphone button may then

MAKING THE "A.W." CRYSTAL SET

be screwed direct into the reed, using the hole on the reed formerly occupied by the diaphragm screw. If an ordinary phone is used it will be necessary to solder a nut to the centre of the diaphragm and screw the button into the nut.

To complete the assembly of the phone and clamping plate into the box, push the back of the phone into

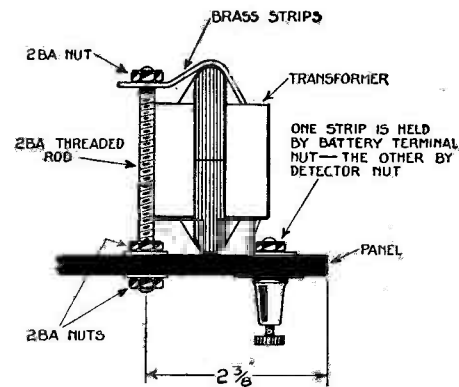

Fig. 126.—Method of Mounting Transformer.

the $1\frac{7}{8}$ -in. hole in the case in such a position that if a reed phone is used the reed hangs vertically in the position in which the phone is normally used. Finally secure the ebonite clamping plate in position by means of four $\frac{3}{4}$ -in. brass wood screws so that the earpiece is held securely to the box as shown in Fig. 128.

Wiring.—Wiring up according to the circuit diagram (Fig. 129) may now be proceeded with, using No. 20 tinned copper wire insulated with rubber tubing or systoflex. The two terminals marked B and C are for

LOUD-SPEAKER CRYSTAL SETS

the purpose of quickly changing the tuning condenser from the series to the parallel position in the circuit or the reverse. Connections from the panel to the earpiece clamping plate terminals are made with silk-covered flex; in making these connections the panel should be placed upside down close to the end of the

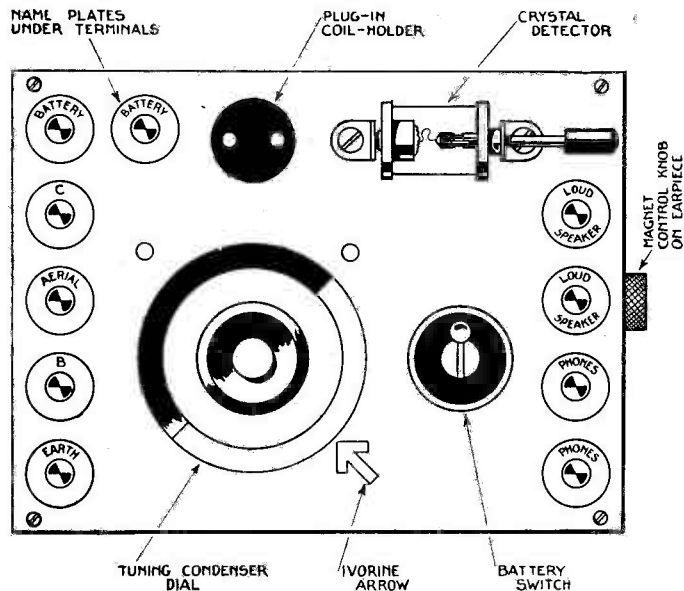

Fig. 127.—Plan of Panel.

box. When attaching the panel to the containing box care should be taken to see that none of the flexible wires touch the microphone button or its flexible connection.

Operation.—To operate the set, connect the aerial and earth in the usual way and a low-resistance

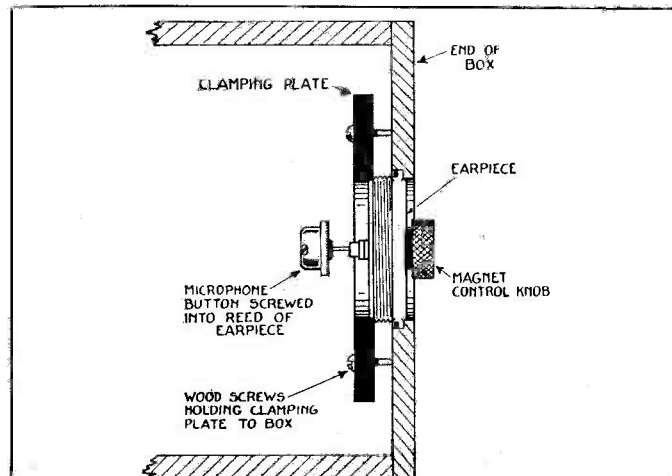

Fig. 128.—Method of Mounting Earpiece.

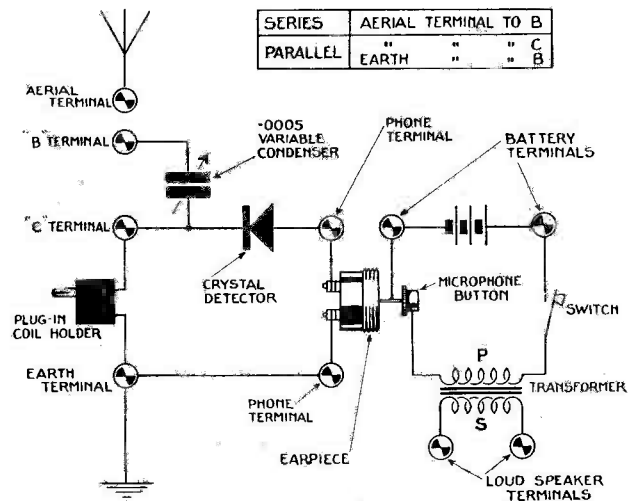

Fig. 129.—Circuit Diagram of Receiver and Amplifier.

LOUD-SPEAKER CRYSTAL SETS

(120 ohms) loud-speaker and four dry cells to their respective terminals on the panel, plug in a suitable coil (basket or honeycomb), and make the necessary connections for the series or parallel placing of the variable condenser, as given in the circuit diagram, Fig. 129. At a time at which broadcast transmission is known to be taking place, switch on the battery, adjust the crystal detector, and tune in on the loud-speaker; finally adjust the earpiece magnets and loud-speaker diaphragm to give loudest signals.

CHAPTER XVI

"A.W." Loud-speaker Unit for Attachment to any Crystal Set.

THIS chapter describes the construction of a loud-speaker unit complete in itself which may be attached to any crystal receiver that gives good phone reception



Fig. 130.—Using the Unit with the new "Amplion" Loud-speaker

at ranges up to about ten miles from a broadcasting station. It is, of course, based upon the principle that has been dealt with in the two preceding chapters.

The components and necessary dry-cells are fitted

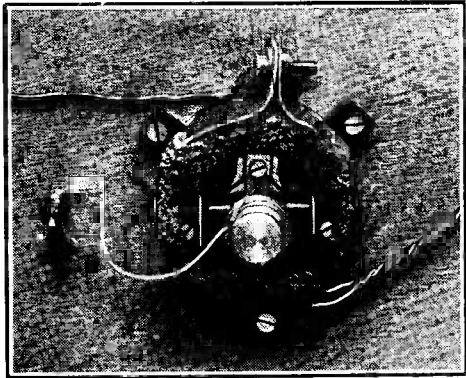

Fig. 131.—View of Receiver and Microphone.

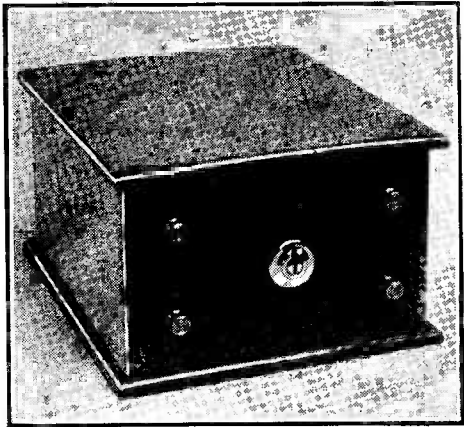

Fig. 132.—Exterior View of Unit.

"A.W." LOUD-SPEAKER UNIT

into a polished hard-wood box of the dimensions shown in Fig. 134. The lid may be hinged to the latter or four dowel pins such as are used by cabinet-makers may be used to keep the top in its correct position, or, again, the reader may simply screw the lid in position.

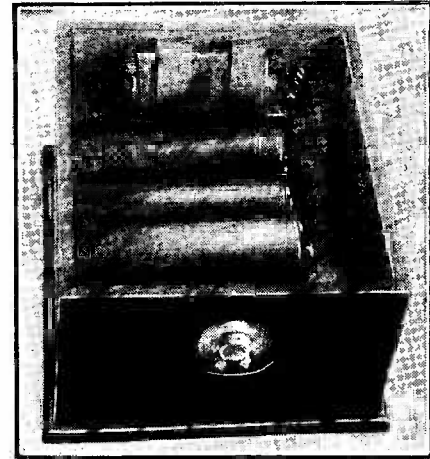

Fig. 133.—Interior View of Unit.

As full constructional details for making the special transformer are given on pages 110 and 116 in Chapter 14, detailed instructions for making this need not be repeated.

Components.—The other components and material required are as follow : Four $1\frac{1}{2}$ -volt dry cells (these may be of any good-quality circular type of not more than 7 in. over-all height or $2\frac{3}{4}$ in. in diameter); one high-resistance earpiece (a "Brown" reed-type earpiece is specially recommended, the ordinary

LOUD-SPEAKER CRYSTAL SETS

diaphragm earpiece giving much inferior results); one Skinderviken microphone button; one switch; four terminals; brass strips for holding transformer and earpiece to box; one No. 4 B.A. bolt and nut for earpiece; clip; one piece of "Sorbo" spongy rubber for packing earpiece (a rubber sponge will serve);

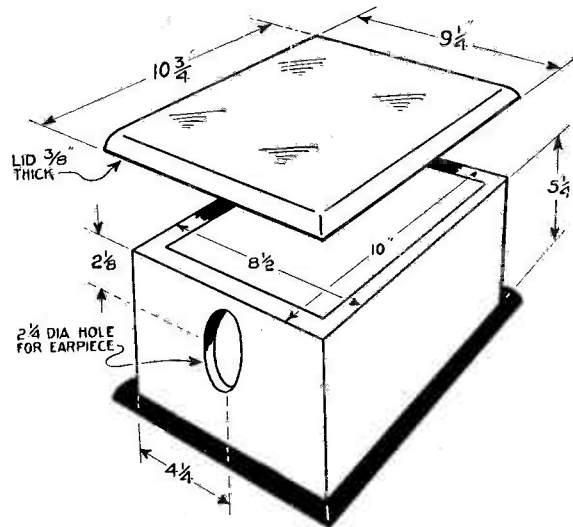

Fig. 134.—Details of Containing Box and Lid.

twin flex for connections; wood screws for attaching earpiece transformer and switch to box.

The Earpiece.—The earpiece, if of the reed type, should be stripped of its swivel bracket, swivel bracket stop, cap and diaphragm and clamped in the brass clip, details of which are given in Figs. 135 and 136. To minimise external vibration as much as possible a strip of spongy rubber should be placed between the

"A.W." LOUD-SPEAKER UNIT

earpiece and earpiece clip, as shown in Fig. 136, before tightening up the latter, sufficient rubber being used to hold the earpiece securely but not too tightly.

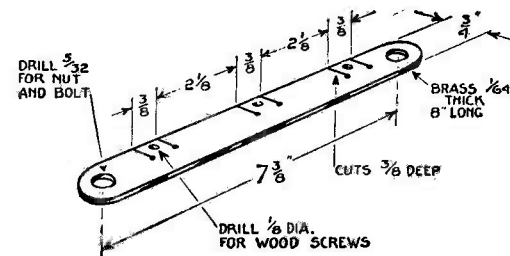

Fig. 135.—Brass Strip for Earpiece Clip.

The earpiece, together with clip and spongy rubber, should now be secured in position in the large hole in the end of the box, three small brass wood

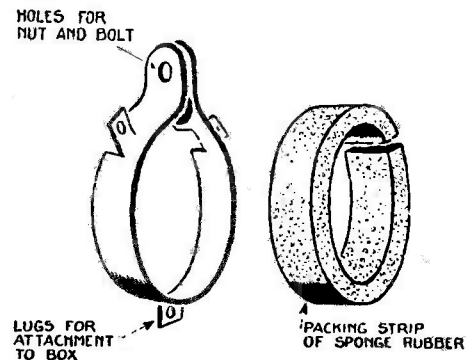

Fig. 136.—Earpiece Clip and Rubber Packing.

screws passing through the lugs in the clip being used for the purpose.

If the earpiece is of the reed type it should be fixed so that the reed hangs vertically.

"A.W." LOUD-SPEAKER UNIT

Terminal Arrangement.—Fig. 137 depicts the arrangement of the terminals and switch on the opposite end of the box and calls for no special explanation. Two brass strips, as shown in Fig. 138, are used for attaching the transformer to the inside of the switch end of the box; to allow room for the dry cells the transformer should be mounted as high as possible.

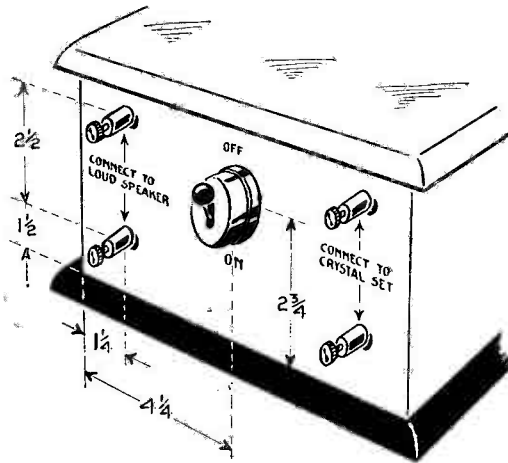

Fig. 137.—Arrangement of Switch and Terminals.

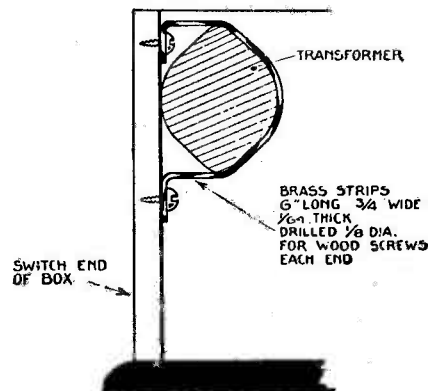

Fig. 138.—Method of Attaching Transformer.

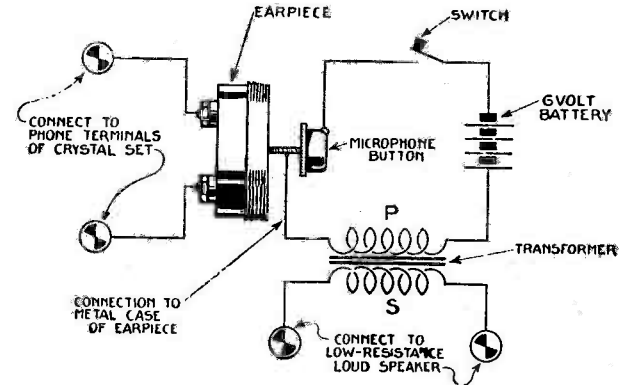

Fig. 139.—Circuit Diagram.

Wiring.—The wiring, as indicated in the circuit diagram Fig. 139, may now be proceeded with, the dry cells and microphone button being placed in position and connected up after the wiring of the other parts has been carried out. Fig. 140 shows the arrangement of the batteries, etc., in the box.

The actual connection to the outer electrode of the button should consist of a couple of 3-in. strands of No. 42 bare copper wire. The end of fine wire where

LOUD-SPEAKER CRYSTAL SETS

it joins the main lead to the switch should be anchored to the side of the box by means of a terminal or wood screw.

In use the phone terminals of the crystal receiver should be connected to the input terminals of the loud-

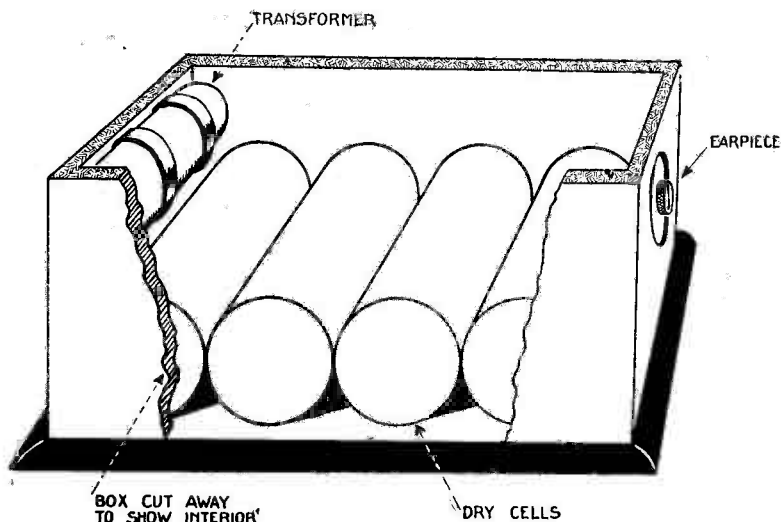

Fig. 140.—Arrangement of Components Inside Box.

speaker unit and the loud-speaker to the remaining two terminals; the switch is then moved to the "on" position and the crystal set tuned in the ordinary way. Any necessary adjustments are then made to the earpiece magnets by means of the control screw projecting through the hole in the end of the box.

INDEX

- AERIAL, frame, tuning with, 35
 — insulation, 3
 —, position of, 4
 —, suitable type of, 3
 Air-spaced tuner, 94
 All-wavelength receiver, 88
- BROWN reed phone, attaching microphone button to, 109
 Brush for crystals, 7
 Burndept coils, 53
- CAPACITY of condensers, 53
 Catwhisker, adjusting, 6
 —, pressure of contact, 6
 —, wire for, 6
 Chelmsford high-power station (5XX), 1
 Coil, air-spaced, 94
 —, holder, plug in, 64, 78
 —, winding, 27, 48, 83, 89, 96
 —, Burndept, 53
 —, for given wavelength, 53
 —, Igranite, 53
 —, tuning, table of, 53
 Condensers, capacity of, 53
 Connections, soldering, 7
 Crystal, action of heat on, 6, 11
 —, brush for cleaning, 7
 —, cup, mounting, 6
 —, "dead," reviving, 7
 —, detectors, 6, 18, 22, 31, 50, 62, 99
 —, "don'ts," 8
 —, mounting, 6
 —, set, all-wavelength, 88
 —, "Amateur Wireless" self-contained loud-speaker, 101, 117
 —, fixed-coupled, 43
 —, for indoor aerial, 25
 —, loud-speaker variometer, 54
 —, single-slider and loose coupled combined, 39
 —, variometer, 12, 15
 —, with air-spaced loose-coupled tuner, 94
 —, with tapped inductance, 47
- Crystals, tweezers for handling, 6
 Crystovox amplifying device, 58
 — circuit, 57
 — loud-speaker, 56
- EARTH systems, 4
 Ebonite, matting, 13
- FIXED-COUPLED set, 43
 Frame aerial, 33
 —, making, 36
 —, tuning with, 35
- IGRANIC coils, 53
 Indoor aerial, sets for, 25
 Inductance coil defects, 5
 Insulating slider-bar, 5
 Insulation, faulty, 4
 — of aerial, 3
- LEAD-IN considered, 3
 Loading plug, using, 53
 Loose-coupled set, with air-spaced tuner, 94
 Loud crystal sets: chief points in design, 1
 Loud-speaker set, 101, 117
 — assembling, 121
 — circuit, 107, 127, 135
 — components for, 103
 — connections, 103
 — materials for, 118
 — microphone, attaching to diaphragm, 111
 — microphone button, adjusting, 113
 — microphone button explained, 105
 — microphone relay, 108
 — mounting the button, 125
 — operating (*frontis-piece*)
 — operation, 126
 — panel, drilling, 119
 — phone earpiece, 113
 — principle of, 103
 — results, 102

INDEX

- Loud-speaker: transformer, 110,
116, 120, 124
— unit attachment, 129
— voltage and current
for loud speaker,
114
— wiring, 125
— unit attachment, 129
— components, 131
— earpiece, 132
— terminal arrangement,
133
— wiring, 135
— for crystal sets, 56
- MICROPHONE button, adjusting,
113
—, attached to earpiece
diaphragm, 105
— reed of Brown
phone, 108
— Skinderviken, 105
— relay, 108
Morse, cutting out, 42
- PHONES, considered, 4
- RECEIVING set (*see* crystal set,
variometer set, loose-coupled
set, etc.)
- SHORTING switch, 87
Single-slider and loose-coupled
set combined, 39
Skinderviken button, diagram of,
109
— microphone button, 105
Slider on bar, method of insu-
lating, 5
— making, 27
Switch arm, making, 53
—, shorting, 87
- TABLE of tuning coils, 53
Tapped-inductance coil set, 47
—, with loading coil,
76
Tappings, method of making,
68, 81
Transformer for "A.W." loud-
speaker set, 110, 116, 120
Tuning, 7, 74, 87, 93
— coils, table of, 53
Tweezers for handling crystals,
6
- VARIOMETER, making, 13, 16, 20, 67
— set, 12
—, loud-speaker, 54
— sets, 16
—, with loading coil, 60
- WAVELENGTH, coils for given, 53
Wood's metal, 6, 11

There's Money in Knowing How!

Knowing how to do "odd jobs" and repairs, and how to make things for the home, means the saving of expense in many directions. Most men could be "handymen" but lack the necessary knowledge.

"The Amateur Mechanic" is the practical weekly which supplies this knowledge in a simple, straightforward manner. Its articles are full of working details and explanatory diagrams, and are written in simple, non-technical language. Every issue contains several pages devoted to solving in comprehensive answers, the various difficulties of readers.

It includes regular weekly pages devoted to the Owner-Driver and his Car, Motor-Cycling and Wireless; Special features are made of Practical Hobbies, Amateur Metal Working, Furniture Making and Domestic Repairs.

3^D
Every
Thursday

*The
Amateur
Mechanic
and Work*

CASSELL'S BUSINESS HANDBOOKS

RETAIL SALESMANSHIP

By Thomas Russell

(President of the Incorporated Society of Advertisement Consultants.)

"Mr. Thomas Russell, the Author of 'Retail Salesman-ship,' always writes in an exceedingly fascinating manner, and this volume, which may be regarded as a standard text-book on retail selling, will be read with interest, not only by the shopkeeper, but by many of his customers."

—FANCY GOODS RECORD.

MODERN WINDOW DISPLAY

By Loughlin M. Feery

(Member of the British Association of Display Men.)

"In 'Modern Window Display,' Mr. Feery, who is well fitted to deal with window dressing, goes very thoroughly into his subject, and with the aid of several excellent illustrations makes his meaning very clear. There is much of interest to boot retailers in this volume."

—SHOE TRADES JOURNAL.

MAIL ORDER METHODS

By Harold W. Eley.

"As a text-book for manufacturers who wish to sell their goods direct to the consumer through the post, and for retailers who wish to increase the area in which they are at present selling, 'Mail Order Methods' is to be warmly recommended."

—ADVERTISERS WEEKLY.

ADVERTISING FOR RETAILERS

By Lionel G. Jackson, B.A.

"In 'Advertising for Retailers,' Mr. Lionel G. Jackson handles his subject in a very thorough and practical way. Although the volume is written for shopkeepers, it is also a good general introductory work on advertising."

—GAMES & TOYS.

RETAILERS' BOOK-KEEPING

By Arthur Buckley, B.Com.

(Chartered Accountant.)

"Every live retailer should secure 'Retailers' Book-keeping.' There is a chapter on Income Tax which will save readers many pounds and much worry."

—NATIONAL NEWSAGENT.

SUCCESS IN SHOPKEEPING

By Ernest H. Butcher.

"'Success in Shopkeeping,' by Ernest H. Butcher, the well-known writer on business topics, is arranged in the form of thirty-one talks with retail traders, and each talk contains something of interest and value to the retailer."

—SPORTS TRADES JOURNAL.

CASSELL'S
Publishers, London

1/6
each, net.

Amateur Wireless Handbooks

A useful
series for
Wireless
Amateurs

1/6 each
NET

Wireless Telephony Explained

CONTENTS: The Electron; Induction and Electro Magnetism; Waves and How They Travel; Inductance and Capacity; Rectification; Amplification; Reaction and Beat Reception; Aerials and Earths; Transmitting Systems; Receiving Sets; Useful Formulæ and Data; Index.

Simple Valve Receiving Sets and How to Make Them

CONTENTS: A Single-valve Set with Basket-coil Tuner; A Single-valve Set with Slide Inductance; A Single-valve Autodyne Receiving Set; One-valve Variometer Set; A Portable Single-valve Set; Adding a Valve; A Two-valve Set; A Three-valve Amplifying and Detecting Unit; The "Amateur Wireless" Unit Set; An Improved Unit Set; Index.

Simple Crystal Receiving Sets and How to Make Them

CONTENTS: A Simple and Efficient Receiving Set; A Single-slider Set; Set with Semi-circular Tuner; Crystal Set with Tapped Single Coil; A Loose-coupled Set; Set with Plug-in Basket Coils; Combined Crystal and Valve Receiver; Some Miniature Receiving Sets; Crystal Circuits; How Crystals Work; Making a Buzzer; Receiving C.W. Signals on a Crystal Set; Converting Low-resistance Phones; The Morse Code; Index.

Wireless Component Parts and How to Make Them

CONTENTS: Components and Their Varied Purposes; Crystal Detectors; Coils, Making and Mounting; Condensers; Variometers and Variocouplers; Resistances or Rheostats; Transformers; Making a Test Buzzer; Index.

Each Book being Well Illustrated
and Thoroughly Practical

Cassell & Co. Ltd. La Belle Sauvage, E.C.4.

ECONOMIC ELECTRIC LTD.

Established

1896.

THE MOST WONDERFUL CRYSTAL, either natural or artificial, is "RECTARITE." Sensitive everywhere—always. A revelation to those who have never used it. No battery required. Only a spiral of 36 gauge brass wire. 1/6 large specimen, sufficient for several detectors. Supplied in sealed glass tube.



WITH THIS DETECTOR "2 LO"
CAN BE HEARD ON
A LOUD SPEAKER
IN LONDON



7/6 7/6

R/22A

MARVELLOUSLY SENSITIVE

We guarantee this detector to be unsurpassed in sensitivity by any other crystal detector at any price. Fitted with our super-sensitive crystal "Rectarite." (No battery required.) Ebonite base 2½ in. by 2½ in. by ¼ in. Ball and socket adjustment, 4-jaw chuck for contact wire, glass dust-shield, finest instrument finish.



THE
"DETECTAVOX"
MICROPHONE.

Specialy constructed for clamping on to the earpiece of any Crystal Receiving Set to amplify the incoming speech, etc.

It is a supersensitive instrument that really does its work.

Price 17/6.

Also makes a wonderfully sensitive Deaf or Detectaphone.

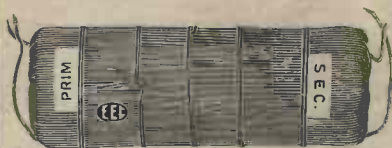

R/57D

MICROPHONE TRANSFORMER.

A really well-made Transformer, suitable for use with the "Detectavox" and other microphones. Price 17/6.

THIS
44
PAGE
RADIO
BOOK

will be
mailed
POST
FREE



on receipt of four penny stamps and mention of this advertisement. REMEMBER the book contains hundreds of illustrations and includes complete sets, components, and all kinds of materials for Radio Set construction. Ebonite, wire, shellac, lacquer, foil, screws, terminals, etc., etc.

Head Office: 10, FITZROY
SQUARE, LONDON, W.1.

Showrooms:
303 EUSTON RD., N.W.1.

Branch Showrooms:
TWICKENHAM.