

HOW TO BUILD TWO ENTIRELY NEW SETS

Amateur Wireless

GREAT SHOW ISSUE 3^d.
And Electrics

Vol. XIII, No. 328

Saturday, September 22, 1928

all that's new in Radio

OLYMPIA

SHOW NUMBER

OLYMPIA

The illustration depicts a large, ornate building with a prominent arched entrance, identified as the Olympia building. A large crowd of people is gathered in front of the building. To the left of the building is a large, vintage-style radio with a prominent speaker. The text 'all that's new in Radio' is written in a cursive font inside the speaker's area. The word 'OLYMPIA' is written in large, bold, blue letters across the top of the illustration, and 'SHOW NUMBER' is written in bold, orange letters below it. The word 'OLYMPIA' is also written in smaller, blue letters on a sign above the building's entrance.

★ RADIO FOR



Simplified Plans and full details of the Mullard Master 3*, the Mullard Master Five Portable, the Mullard H.F. Unit; many special articles and invaluable hints and tips. Make sure of your copy now.

To
The
Publishers,
"Radio for
the Million,"
63 Lincoln's Inn
Fields, W.C. 2.

Please send me
FREE "Radio for
the Million," Vol. 2,
No. 4, with Simplified
Plans of Mullard Master
Radio Receivers.

NAME (Block Letter)

ADDRESS

Mullard MASTER · RADIO

Mention of "Amateur Wireless" to Advertisers will Ensure Prompt Attention

Amateur Wireless

and Electrics

The Leading Radio Weekly for the Constructor, Listener and Experimenter

Edited by BERNARD E. JONES

Vol. XIII. No. 328

Technical Editor: J. H. REYNER, B.Sc.(Hons.), A.M.I.E.E.

SEPTEMBER 22, 1928

B.B.C. At Olympia—A Model Studio—2LO's Modulation—Making Picture Receivers—Astounding Show Figures—Television

B.B.C. at Olympia—Apparatus used in such historic broadcasts as the Boat Race will be shown by the B.B.C. at the forthcoming Exhibition. The development of the microphone from early days to the present time will be demonstrated by a display of various types, from the first Round "mike" to the latest Reiss, including the carbon, magneto and Post Office types.

A Model Studio—The B.B.C. is erecting a model studio at Olympia to show the conditions under which broadcast artistes perform. The model of the London station's control-room and models dealing with such aspects of the B.B.C.'s activities as the Greenwich six-pips time signal and broadcasting to schools should be seen by every visitor. There will also be a series of nine tableaux, entitled "B.C. C.B.C."

2LO's Modulation—"The London station modulates as much of its radiated power as is possible without actual distortion. There has been no change in the amount or method of modulation during recent weeks." So said a B.B.C. engineer when asked to account for 2LO's recent little "wobbles," which have been commented upon by some of our readers. But B.B.C. engineers, like the rest of us, must have summer holidays, and it is more than probable that our usual trustworthy control man has been away.

Making Picture Receivers—The daily Press has interpreted the B.B.C.'s Chief Engineer's statement regarding the home-construction of still-picture receivers rather too literally. What Captain Eckersley meant was that, as far as the B.B.C. is concerned, there will be nothing secret about their experimental picture-broadcast service when it starts in October, and anyone requesting information will be told by the B.B.C. the "essential quan-

OUR NEXT ISSUE

NOTABLE exhibits at the Radio Exhibition will be reviewed next week in our Second Show Number—another big issue packed with special articles that will appeal alike to regular and new readers.

Outstanding Constructional Features will be:

A Three-valver obtaining its H.T. and L.T. supplies from A.C. mains,

A Linen-diaphragm Loud-speaker, representing a revolutionary advance in construction,

A Charging Switch designed by Dr. Fournier d'Albe,

A discussion on some aspects of Gramo-Radio by Our Technical Editor, and

An account of a recent visit to the B.B.C.'s Keston listening post by members of the "A.W." Staff.

ties" of the transmission. A skilled mechanic could, from this information, build some sort of picture receiver, but the B.B.C. are by no means so sure that the average home constructor would be

able to turn the information to advantage. However, ingenious amateurs were not lacking when the first experimental wireless concerts were radiated, and it will surprise us if there are not quite a number of intelligent constructors who manage to resolve the B.B.C.'s chirps into the picture of an isosceles triangle or Uncle André!

Television?—In their announcement regarding picture transmissions the B.B.C. state that so far no practical demonstration of real television has been afforded them. By way of a rejoinder, Mr. J. L. Baird says: "We have given demonstrations to scientists and to men of high standing in the wireless industry, who agree that television has arrived at the point where a public service ought to be instituted without further delay." We already have a public service in the B.B.C., who have clearly shown their willingness to cooperate in any practical wireless development by the alacrity with which they have taken up the Fultograph picture broadcasting system. Why doesn't Mr. Baird give the B.B.C. a demonstration? It is in his interests to do so.

Astounding Show Figures—

Although they are prepared for a bigger show this year, we scarcely think that listeners realise what proportions the Radio Exhibition has now reached. Whereas in 1927 there were 229 stands, occupying about 35,000 sq. ft. of floor space, this year there are no less than 264 stands, covering an area of over 40,000 sq. ft. Moreover, we learn from a reliable source that the number of nails used will be 3,750,000! By the way, listen on Friday evening, September 21, for a relay of Sir William Bull's speech from the Exhibition dinner.

PRINCIPAL CONTENTS

Current Topics	343
The Ace of Twos	344
For the Newcomer	346
My Wireless Den	347
Marconi Royalties	348
Don't Fail to See	348
On Your Wavelength	351
"Q" Coils and How to Use Them	353
Broadcast Pictures in October!	354
Guide to the Radio Exhibition	359
Capt. Round on Ideals in Sets	367
The New-style Baffle Three	376
Without Fear or Favour	380
Sets for Everyone and Every Purpose	382
Our Information Bureau	394

FREE WITH OCTOBER "WIRELESS MAGAZINE"

Blueprint of World's Best Three-valver



The ACE of TWOS

An Entirely New Receiver Incorporating
A "Q" Coil and Pentode Valve
By J. H. REYNER, B.Sc., A.M.I.E.E.

SHORT-WAVE reception is becoming so popular nowadays and so simple that many people who were previously uninterested in this type of reception are now enthusiastic. There is, after all, a great deal of fascination in being able to listen to American programmes, and with suitable apparatus American transmissions can be

consider the term in its widest sense and include the full range from 250 to 2,000 metres. Fortunately, this can easily be accomplished by the use of a "Q" coil, which is a most efficient type of two-range tuner.

A Dual-purpose Set

The question then arose as to how to obtain short-wave reception on the same receiver. The first method which suggested itself was that of changing over the tuning arrangement from "Q" coil to the short-wave coils. This, however, involved switching in the actual oscillating circuit, which has to be very carefully carried out on the short waves. The method was actually tried, and a successful solution evolved, but it introduced rather more complications than I considered desirable in a simple receiver such as I had in mind.

I therefore examined other possible methods of achieving the desired results, and eventually tried the experiment of placing the short-wave coils in parallel with the "Q" coil. This proved perfectly satisfactory. With this arrangement the broadcast windings have the effect of increasing the minimum capacity of the tuning condenser, and we therefore have to make allowance for this effect. Further tests, however, showed that the secondary and reaction windings were the principal offenders, and that by disconnecting one end of each of these windings the self-capacity of the "Q" coil was not troublesome.

This is the method, therefore, which has been adopted in the present receiver. A standard "Q" coil of the magnetic reaction type (QAM) is employed for ordinary broadcast reception, this being wired up to a six-pin base through a push-pull switch. For reception of short waves the appropriate coil is inserted in the six-pin base and the switch is pushed in. This disconnects the grid and anode ends of the "Q" coil windings, leaving the other end of these windings

still connected and leaving the two aerial windings in parallel. The connections of the two positions are as indicated in the skeleton diagram (Figs. 1A and 1B). Repeated trials indicated that this method was perfectly satisfactory, and resulted in no appreciable diminution in the signal strength and only a very minor alteration to the tuning properties of the circuit.

For the short-wave coils, the new Lewcos six-pin coils have been employed, these being wound with strip wire instead of ordinary round wire. This is recognized as being a highly efficient method of coil winding for very high frequencies. The use of Litz wire at such very high frequencies is worse than useless, giving a higher resistance than ordinary solid wire.

The New Pentode Valve

Having satisfactorily arranged the tuning system, the low-frequency amplifying portion has to be considered. At first it would appear that the standard resistance stage followed by one transformer stage would be the best. Experiments have been proceeding, however, for some time with the new pentode valves, and the amplification obtainable from these valves with a single stage was so large, that it was considered desirable to endeavour to make use of the valuable properties. A transformer-coupled arrangement, therefore, was used following the detector valve, a pentode

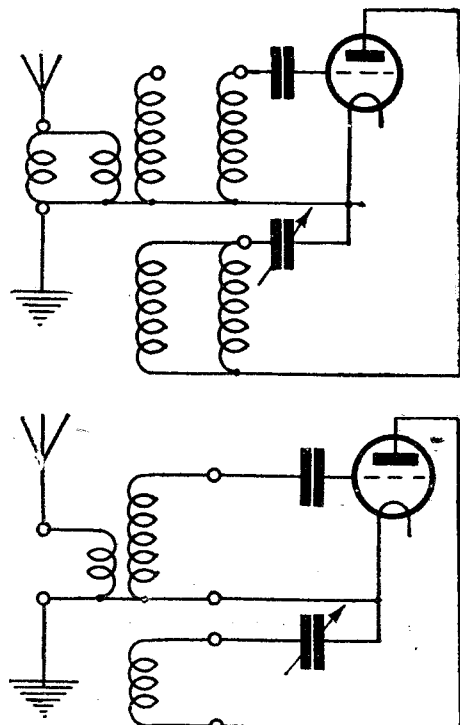

Figs. 1A. and 1B. Diagrams showing "Q"-coil Connections

picked up with almost clock-like regularity by listening on the appropriate wavelength at the right time. Conditions, of course, vary, but in a good 50 per cent. of the cases the transmissions are clear and good.

When I was considering the design of a receiver for this season's show, therefore, it appeared to me that what was required was an arrangement capable of tuning both to the short waves and to the ordinary broadcast band. By broadcasting, we must con-

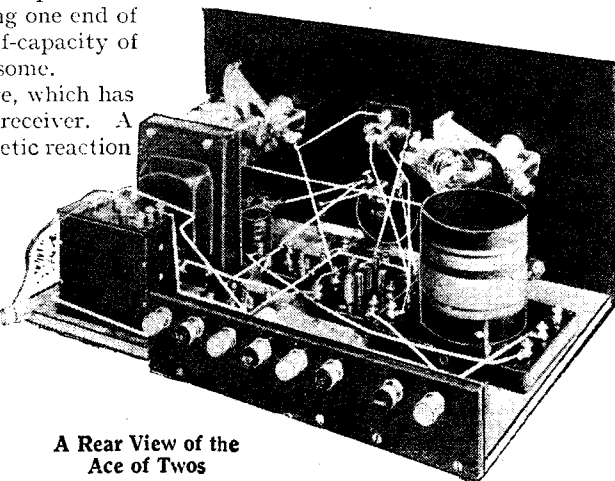

A Rear View of the Ace of Twos

valve being used in the last stage. With suitable precautions this proved perfectly satisfactory and excellent signal strength was obtainable.

Battery Feedback

The precautions necessary are two-fold. In the first place, it is necessary to avoid battery feedback, as with a simple two-

stage amplifier, the last valve of which has such a high amplification factor as the pentode, trouble is likely to arise from this source, particularly when the batteries begin to run down. Distortion and whistling will readily be set up, and some means must be adopted to overcome the difficulty. We can do this either by the use of a choke

The Two-valver with the Three-valve Punch

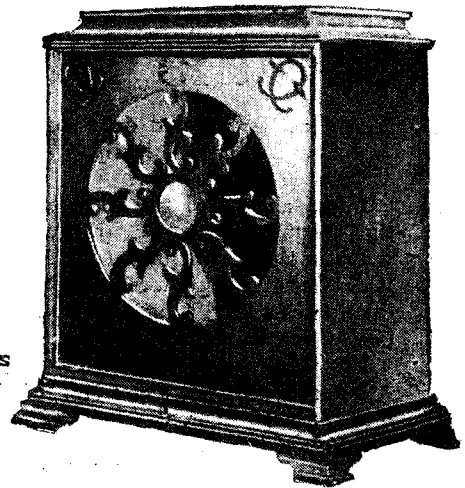

The actual circuit is shown in Fig. 2. The receiver is laid out primarily as a short-wave receiver, the leads between the tuning condenser and the short-wave coil being kept as short as possible in order to avoid the formation of closed loops in the wiring. The "Q" coil is wired in parallel with the short-wave coil, with the exception that the leads to terminals 1 and 6 on the "Q" coil are taken through a double-pole push-pull switch mounted on the panel. These leads are necessarily somewhat lengthy, but as we are dealing here with the broadcast waves and not with the short waves, no bad effects are obtained.

satisfactory short-wave reception it is necessary that a very slow motion should be provided.

J.B. S.L.F. condensers were employed in the original set, the slow-motion drive here being very satisfactory, enabling American stations to be tuned in without any difficulty. A similar condenser, having a capacity of .00015, is used for the reaction control. In order to obtain perfectly smooth reaction, which is absolutely essential for short waves, the grid leak on the detector valve is not taken direct to L.T., but is connected to the slider of a potentiometer connected across the battery. This potentiometer is mounted on the panel so that the best adjustment can be obtained as required.

In the anode circuit of a detector valve, there is first an H.F. choke. Here the new Polar H.F. choke has been employed, since (Continued at foot of next page)

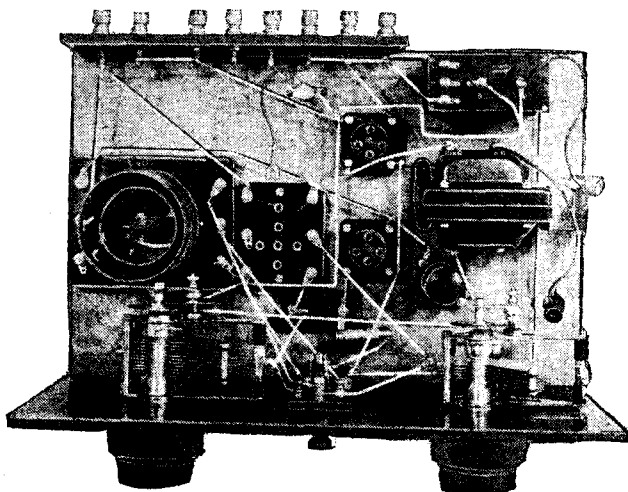

A Plan View of the Ace of Twos

output circuit, or by the use of an anode filter, or both.

With short-wave reception, however, there is a further difficulty to be avoided, that of threshold howl. This is particularly prevalent where the detector is followed by a resistance-coupled stage, and it happens that the use of an anode filter in the detector stage completely overcomes the difficulty. Thus an anode filter overcomes both troubles at the same time, and it was

Right: The Wiring Diagram. Blueprint available, price 1.-.

Below: Fig. 2—The Circuit

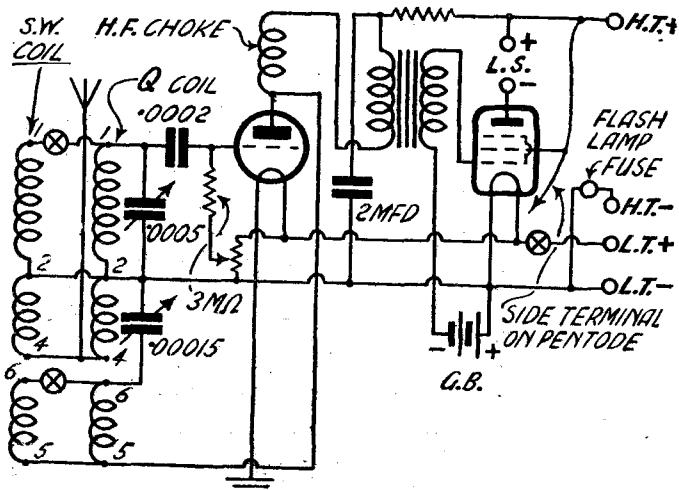

therefore decided to adopt this system in the receiver.

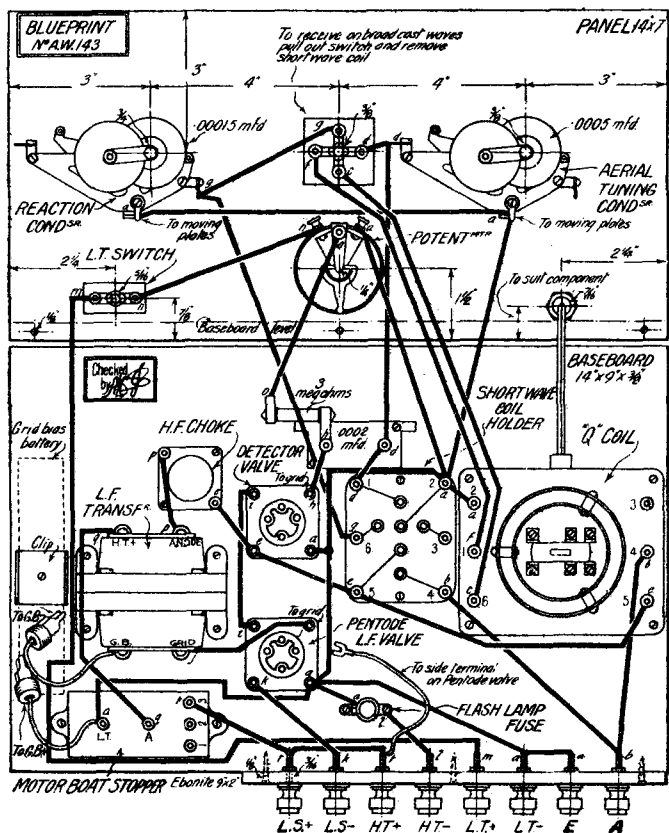

For the Newcomer to Wireless: WHY "POWER" VALVES

I AM rather puzzled over something that has happened lately.

What is the problem?

I had always previously used what the shops call a first low-frequency valve in the last holder of my set, but it did not give quite loud enough reproduction. In fact, I had to use a good deal of reaction.

What did you do?

I bought a power valve and fitted it into the last holder.

And you found?

Why, that instead of being more powerful it was less so. What is wrong?

Nothing at all, except that your set is not quite up to the work that you want it to do and that you have been misled by the word "power." You thought that a power valve would give more amplification than an ordinary one, didn't you?

I don't think it's unnatural to have that idea, do you?

Not in the least, and that's why it's a pity that such a name was ever given to this class of valve. Actually, they have a smaller amplification factor than H.F. or first-stage L.F. valves.

Then what does the "power" mean?

Let's see if we can find out exactly. You realise that impulses brought in by the aerial are very tiny indeed.

Yes. I think somebody once worked out that a fly in crawling over a single window pane expended more energy than that which reaches the average wireless set in a whole evening.

I can't say that I can verify the calculation, but it's probably not very far out. You will see, anyhow, that the

first valve, whether it is a high-frequency amplifier or a rectifier, is called upon to deal with only a very small amount of energy.

What exactly does that mean?

Just this. We may regard wireless impulses as consisting of waves, each of which has a positive crest and a negative trough. In other words, the grid of each valve is made alternately more positive or more negative through the voltage changes delivered to it by an incoming train of waves. In what we may call the early valves of the set, then, the voltage changes are quite small, though they grow bigger and bigger in each succeeding stage.

If a valve receives only a tiny amount of energy it must pass on also only a tiny amount?

That is so. Actually one valve is required to hand on to the next merely voltage changes, for the valve is a voltage-operated device.

Then what about the output stage?

Here matters are very different. The valve has actually got to supply power, since the loud-speaker is a current-operated device. The power is needed in order to move the diaphragm or the coil of the loud-speaker, and these movements must be strong enough to set up powerful sound waves.

I begin to see now. The output valve is the only one which has to deliver power?

Yes; and there is another very big consideration.

What is that?

In order to obtain sufficiently powerful current changes in the plate circuit

of this valve there must be large voltage changes in its grid circuit.

That means that you must have sufficient amplification in front of it?

Yes, but it means something else, too. The output valve must be able to handle those big voltage swings. The ordinary high-frequency amplifier or first-stage low-frequency valve has what is called a high or medium impedance. Such valves can deal faithfully only with quite small grid-voltage swings.

Then the power valve, I take it, is a low-impedance valve?

Exactly, and if we try to use a medium-impedance valve to provide the output to a loud-speaker we obtain poor results. There may be a considerable volume of sound, but it will be unpleasant sound, because we are asking the valve to deal with a bigger input and a bigger output than it is built for.

What does the low-impedance valve do?

It is able to handle both the input and the output necessary for good reproduction, and, further than this, it does not cause a suppression of the lower notes. The only trouble is that it must have quite a small amplification factor, which means that if it is used to replace an existing medium-impedance valve in the last holder one finds, as you found, that the volume of sound is a little smaller.

Why can't we have low-impedance valves with a big amplification factor?

Unfortunately, magnification and impedance are considerably bound up together. You can't lower the impedance without reducing the magnification.

this is both cheap and efficient. It has an inductance of 300,000 microhenries and a self-capacity of only 1.5 micro-microfarad. This renders it equally serviceable on short and broadcast waves. An R.I. & Varley four-terminal transformer follows, giving high amplification with good quality, while a Wearite anode filter is connected in the anode circuit.

This filter serves the purpose, not only of avoiding battery feedback and threshold bowl, as already pointed out, but of reducing the voltage on a detector valve to a lower value, so that the best rectification is obtained. There are threeappings, labelled 1, 2, and 3 respectively, and the best tapping should be chosen for the particular valves in use. For a high-resistance valve tapping No. 3 should be employed. For a medium-resistance valve, such as an H.F. valve, tapping No. 2 may be found preferable.

Components Required

Panel, 14 in. by 7 in. by $\frac{1}{4}$ in. (Becol, Pertinax, Ebonart, Raymond).

.0005-mfd. and .00015 mfd. variable condensers with slow-motion movement (J.B., Polar Ideal, Burndept, Igranic, Ormond).

Panel-mounting potentiometer (Lissen, G.E.C., Igranic).

Filament switch (Bulgin).

H.T. and L.T. switch (Bulgin, Trix, Lissen, Wearite).

"QAM" aerial coil (Lewcos, Wearite, or Finston).

Six-pin base (Lewcos, Wearite, Tunewell, Lissen).

.0002-microfarad fixed condenser (Lissen,

Dubilier, C.D.M., Graham-Farish, T.C.C.).

3-megohm grid leak (Lissen, Dubilier, C.D.M., Graham-Farish, T.C.C.).

Two valve holders (Bowyer-Lowe, W.B., Benjamin, Wearite).

High-frequency choke (Polar, Lissen,

Igranic, Burndept).

Low-frequency transformer (R.I. and Varley, Igranic, Ferranti, Lissen).

"Motor-boat" stopper (Wearite, R.I. and Varley).

Safety fuse.

Grid-bias battery clip (Bulgin).

Ebonite or bakelite strip, 9 in. by 2 in. (Becol, Pertinax, Ebonart, Raymond).

Eight terminals marked: Aerial, Earth, L.T.—, L.T.—, H.T.—, H.T.—, L.S.—, L.S.— (Belling-Lee, Eclex, Igranic).

Baseboard, 14 in. by 9 in. by $\frac{3}{8}$ in. (Camco). Connecting wire (Glazite).

Red wander plug, black wander plug (Igranic, Clix).

Two feet of flex (Lewcos).

Set of short-wave six-pin coils (Lewcos).

(In our next issue Mr. Reyner will describe the actual construction and operation of this remarkable receiver.)

My Wireless Den

A Valve-holder Point: Wiring: To Solder or Not: Faulty Condensers: A Safety Hint

IN my wireless den I spend my days inquiring into this and that, and in testing components and other products sent me by all the well-known manufacturers, just as in "My Wireless Den" I shall every week look into the reasons for this and that theory or practical detail and pass on to my readers—to whom the Editor has already graciously introduced me—the results of my own wireless experience, which now goes back years.

I hope from week to week that my readers will derive advantage from my writings, which I can truly say are based upon what I have proved for myself.

Poor Valve Holders

It is my experience that the anti-microphonic type of valve holder may, on occasion, be the cause of a great deal of trouble. Only a few days ago a set that I was testing refused to function properly. Harsh noises were emitted by the loud-speaker, and it seemed that a wire must be making a poor contact. But, as a matter of fact, the trouble was due to the detector valve holder; for investigation showed that one of the springs, which should have been tightly held by the bolt and nut which carries the terminal, was loose. As a result, every time the valve moved, owing to vibration, the contact was intermittently broken and noises were heard. The trouble was, of course, cured by tightening the nut, but the valve holder had first to be removed from the set.

A Wiring Tip

The average amateur takes a great deal of pride in his wiring, but many make the mistake of using a wire for connecting the various components which is unnecessarily thick. I myself use No. 20 gauge tinned copper with one millimetre insulating sleeving. This wire is sufficiently heavy to carry the filament current of the valves and has the advantage that it is easily shaped. Stray reactions are reduced when thin connecting wire is used instead of thick. This is particularly noticeable in high-frequency amplifiers, where it is well known that the position and length of circuit wires affects stability.

A Safety Hint

In many receivers a variable condenser is employed for varying the amount of reaction. The circuit is usually that shown by the diagram, which shows only the detector valve of the receiver. It will be noticed that in the event of the plates of the reaction condenser touching, current can flow from the high-tension positive through the



Mr. W. James

I have pleasure in announcing a special arrangement by which, starting with this issue, Mr. W. James will contribute to "AMATEUR WIRELESS" a weekly page written from the fullness of his experience on matters of importance and interest to the practical wireless man. Mr. James, who is Wireless Editor to the "MORNING POST" and "SUNDAY EXPRESS," has achieved fame as the designer of the EVERYMAN FOUR and of an even better-known set; he will contribute EXCLUSIVELY (among the wireless periodicals) to "AMATEUR WIRELESS" and "WIRELESS MAGAZINE." I know that readers will be delighted to have the benefit of his weekly advice. THE EDITOR.

primary winding of the inter-valve transformer, the high-frequency choke coil, and the reaction coil itself to the negative H.T. This circuit will have a fairly low resistance, and, as a result, the current will be rela-

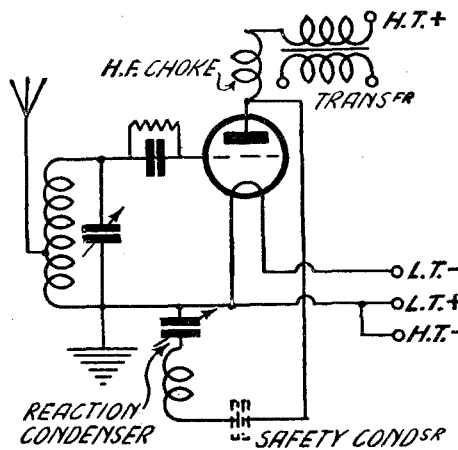

"Safety First" by means of a fixed condenser

tively heavy. The primary winding of the transformer and the high-frequency choke coil may therefore burn out, and if the current is allowed to flow for very long the high-tension supply may be permanently damaged. The danger arising from the plates of the condenser touching may be removed entirely by connecting a fixed condenser in series, as indicated by the dotted lines. This condenser may have a value of four or five times the maximum value of the variable condenser. It stops a flow of direct current, but does not hinder high-frequency currents.

Possible Damage

When a resistance is used in the anode circuit of the detector very little damage can be done. Thus, if the resistance has a value of 200,000 ohms and the high-tension battery is of 100 volts, the current which will flow when the condenser plates short-circuit is half a milliampere. This may damage an anode resistance of the grid-leak type, but should not harm a wire-wound resistance. A safety condenser, therefore, need not be fitted excepting when a grid-leak type of resistance is employed.

No Soldering!

Many receivers which have recently been described, owe their popularity to the fact that all the components are provided with terminals, with the result that no soldered connections have to be made. I have examined a number of these receivers and would draw the attention of component manufacturers to a fault. In many instances it is barely possible to provide good connections because the terminals are so small. It sometimes happens that three wires have to be fastened at one terminal point, and I have noticed on several occasions that the terminal is held by only one turn of the thread. This is most unsatisfactory. Valve holders and fixed condensers are the chief offenders.

A Condenser Fault

Speaking of fixed condensers reminds me that now and again a faulty one is issued. One that came my way a few days ago was incorrectly marked. According to the marking its capacity was .0001 microfarad, but its actual capacity was nearly .0003 microfarad. Fortunately, a component having this fault will usually not affect greatly the performance of a set, although there are, of course, numerous instances where the results may be modified.

The fifth annual Radio World's Fair in Madison Square Garden, New York City, is now being held (September 17 to 22).

RADIO MANUFACTURERS AND THE MARCONI LICENCE

A MEETING of radio manufacturers, consisting of members and non-members of the Radio Manufacturers' Association, held on Wednesday, September 12, at the Hotel Cecil, London, received a report from the Chairman, Mr. A. E. Bowyer Lowe, on the situation created by the Brownie case and subsequent negotiations with the Marconi Company. The Association had attempted to come to an amicable agreement with the Marconi Company, the difficulty of working on a 10 per cent. wholesale basis being emphasized and a sliding scale being suggested. The Marconi Company definitely refused to agree, and informed the Association that they were appealing against the decision of the Comptroller.

Resolution Adopted

The meeting unanimously adopted a resolution proposed by Mr. J. T. Mould, of the Igranic Co., in the following terms: "That this meeting of radio manufacturers having considered the effect of the decision of the Comptroller-General of Patents in the Brownie case and having received Counsel's opinion thereon, hereby resolve

to act in accordance with Counsel's advice and apply to the Marconi Company for a licence on the terms and conditions set out in the Comptroller-General's decision in the said case and, in the meantime, to operate under such terms and conditions notifying the Marconi Company accordingly."

Counsel's Opinion

Counsel's opinion referred to in this resolution is to the effect that the successful result of the Brownie Company's application for a compulsory licence really means that all other manufacturers are enabled to secure the same benefits, even though their licence from the Marconi Company is only determinable by a twelve months' notice, there having been an abuse of monopoly right and the contract being contrary to public policy and therefore void.

The opinion goes on to state: "Manufacturers should immediately write to the Marconi Company pointing out that they are advised that the A2 licence is now void, and demanding a new licence in accordance with the Comptroller's decision in the

Brownie case. If this is refused they should immediately lodge an application for a compulsory licence, and as soon as this has been done they will be in a position to trade under the new rates of royalty laid down. If they are sued for royalties under the old licence, they have a complete defence on the ground that that licence is now void. If they are sued for infringement, the grant of a compulsory licence, which must follow upon their application, will prevent any injunction and there will be no damages, for they will have tendered the royalty rates that have now been laid down as reasonable."

Future Policy

The Chairman announced that the R.M.A. advised their members to act in accordance with Counsel's opinion. Non-member manufacturers might join with them and the Association would bear the cost arising from legal action taken against any firm acting in the way recommended.

As a result of the adoption of the above policy the R.M.A. state that the royalties on receivers sold to the public would be immediately reduced.

Don't Fail to See

AT THE EXHIBITION

BELLING & LEE'S extensive range of engraved terminals, all of which have been considerably reduced in price.

The new range of Mazda receiving valves for 2-, 4- and 6-volt accumulators marketed by British Thomson-Houston Co., Ltd.

The new models of cone loud-speakers by S. G. Brown, Ltd.

The Burndept Ethopower H.T. units and electric sound-box.

E. K. Cole's comprehensive mains units conforming in every detail with the latest I.E.E. regulations.

The trickle charger marketed by the Chloride Electrical Storage Co., Ltd., makers of the famous Exide batteries.

The plug-in coils of H. Clarke & Co. (Manchester), Ltd.

The new upright screen-grid valves and A.C. valves of A. C. Cossor, Ltd.

The triple drum condenser introduced by the Dubilier Condenser Co. (1925), Ltd.

The notable additions to the Edison Swan Electric Co.'s range of Ediswan valves.

The Electron loud-speaker, shown by the Electron Co., Ltd.

The two H.T. units for A.C. mains produced by Ferranti, Ltd.

The Voluvernier volume control of Gambrell Bros., Ltd.

The super-power valve additions to the Osram range of valves marketed by the General Electric Co., Ltd.

Goodman's improved moving-coil loud-speaker assembly.

The Graham-Amplion "Lion" range of improved cone loud-speakers.

The triple range measuring instrument of A. H. Hunt, Ltd.

The Igranic gang condenser and variable wire-wound resistance made by the Igranic Electric Co., Ltd.

Jackson Bros.' efficient variable condensers.

The multitude of connecting links made by Lectro Linx, Ltd.

The headphone portable of E. J. Lever (Trix), Ltd.

The variable condenser and super low-frequency transformer recently introduced by Lissen, Ltd.

The Lewcos short-wave coils and short-wave choke, made by the London Electric Wire Co. & Smith's, Ltd.

The gramophone pick-up introduced by L. McMichael, Ltd.

The new moving-coil loud-speaker units of the Marconiphone Co., Ltd.

The interference-reducing unit made by Met-Vick Supplies, Ltd.

The Mullard screen-grid and Pentode valves of the Mullard Radio Valve Co., Ltd.

The new Phillips cone loud-speaker, shown by Phillips Lamps, Ltd.

The transformers for Westinghouse metal rectifiers, made by W. G. Pye & Co.

The gramophone pick-up produced by R.I. & Varley, Ltd.

Power equipment for mains units made by Regent Radio Supply Co.

The improved lateral action variable condensers made by Ripaults, Ltd.

Simpler Wireless "all-from-the-mains" receivers marketed by Rooke Bros., Ltd.

The new double mounting T.C.C. fixed condensers, made by the Telegraph Condenser Co., Ltd.

Grid bias metal-rectifier units made by the Westinghouse Brake & Saxby Signal Co., Ltd.

Ideal variable condensers of Wingrove and Rogers, Ltd.

"Q" coils made by Wright & Weaire, Ltd.

"Q" COILS AND HOW TO USE THEM

Some of the Applications of the New Coil

By J. H. REYNER, B.Sc., A.M.I.E.E.

SOME time has now elapsed since "Q" coils were first introduced and their advantages are being appreciated by an increasing number of people. The coils have had a good trial under actual practical

For the reader who has not encountered these coils before, a brief description of their properties will be useful. The "Q" coil is specially designed to meet the requirements of broadcasting in this country where it is necessary to receive on two wave-bands of from 250 to 550 metres and from approximately 1,000 to 2,000 metres. Various types of two-range tuner have been devised, these usually operating on the principle of winding sufficient inductance to cover the long range band and short-circuiting some of the turns in order to receive the short waves. This method, however, obviously introduces heavy losses into the circuit, and it was felt that more efficient methods could be adopted to achieve the same results.

former where there are three windings. There is a primary winding, a neutralising winding closely coupled to the primary; and, thirdly, a reaction winding, all these being in addition to the tuning winding

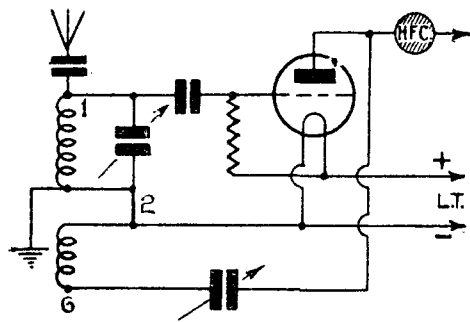

Fig. 1—Circuit employing QA-type Coil

conditions and have proved their usefulness in a variety of ways. One of the most recent applications of the "Q" coil is described in another page of this issue where a standard "Q" coil is used in conjunction with a short-wave coil to cover a range of 20 to 2,000 metres.

The original "Q" coil was a simple tuned winding with a reaction winding added, and this was used in simple aerial circuits. This was followed almost immediately by the split-primary type of coil, and these two types have remained unaltered. More recently it has been possible to introduce further types of

The "Q" coil, therefore, is wound in two concentric sections, both of which are in use the whole time. The sections are

itself. One of the difficulties associated with double-range coils hitherto has been that the coupling windings also required to be changed as well as the tuned winding and the resultant switching was of necessity somewhat complicated. By virtue of the particular construction of the "Q" coil, the same winding is made to serve on both wavebands. Owing to the paralleling of the two sections of the coil, the mutual inductance between the coupling winding and the secondary is smaller in the short-wave position so that the same winding serves on both wavebands. This is a

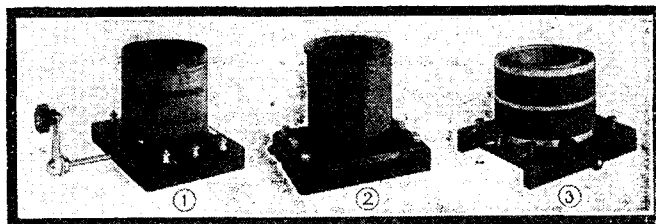

Three makes of "Q" Coil. (1) Lewcos; (2) Colvern; (3) Wearite

placed in parallel for the short wavelengths and in series for the long wavelengths, a self-contained switch being employed to change the connections over as required. By virtue of the particular arrangement of the coils, an astatic effect is obtained on the short waves, so that the interaction between different circuits is minimised, while on the long waves, the field is more or less concentrated, and owing to the lower frequency the magnetic coupling is not so pronounced. Capacity coupling between the circuits is not eliminated, but owing to the astatic effect the amount of screening required is only comparatively small so that the construction of receivers can be simplified.

and the secondary is smaller in the short-wave position so that the same winding serves on both wavebands. This is a

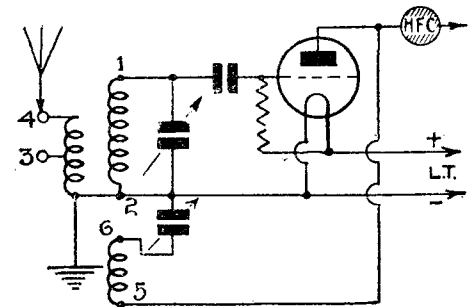

Fig. 3—QAM-coil Circuit

coil and some review of the actual types manufactured together with some applications of the coils will, therefore, be of interest.

It is usually necessary to have one or more windings coupled to the tuned winding on any coil or transformer. A good example of this is the split-primary trans-

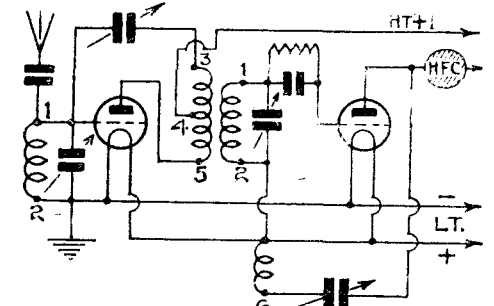
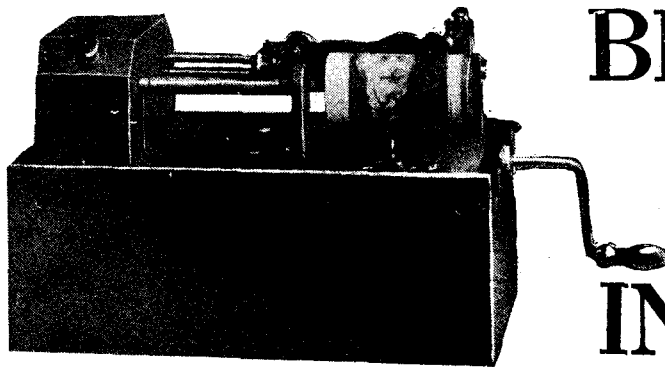

Fig. 4—Split-primary Transformer Coil Circuit

valuable property, for it means that the only switching necessary is the simple series-parallel switch on the secondary and there are no dead end effects whatever.

(Continued at foot of next page)



The Fultograph Receiver

LAST week the B.B.C. issued an announcement to the effect that preliminary experiments in the wireless transmission of still pictures had concluded and that arrangements had been made for a short picture transmission daily from Daventry 5XX outside regular programme hours.

A start is to be made in October. "The material of each transmission will consist of a selection from several subjects," the B.B.C. states. "If and when it is discovered that there is a sufficient public demand for still pictures radiated in this way they will be included in regular programme hours."

The Fultograph system will be used for the series of transmissions beginning in October. It is interesting to recall that last June members of the AMATEUR

BROADCAST PICTURES IN OCTOBER!

The
B.B.C.'s
Experi-
mental
Service
From
Daventry
5XX

WIRELESS Technical Staff were able to witness a highly successful demonstration of the Fultograph at Selfridges, where Captain Ortho Fulton, the inventor of the Fultograph system, personally explained to them the working principle of his method of still-picture transmission by wireless.

From our experience of the system, we can say that listeners possessing a Fultograph receiver (which when available will cost under £20) will be able to pick up extremely clear "line" drawings of whatever subjects the B.B.C. is transmitting.

At the signal "picture transmission" the listener will start his Fultograph—a picture of which is shown herewith—and within 3½ minutes he will be able to take off the cylinder a prepared paper bearing a clear likeness of the transmitted subject.

For the benefit of those unacquainted with the sequence of events, this is roughly what happens when the B.B.C. send a picture. A photograph in the form of a prepared copper foil is wrapped round the cylinder of a Fultograph and rotated about 50 revolutions per minute by means of clockwork. As it rotates a contact needle slowly traverses the cylinder and, in much the same way as the needle in the old-fashioned phonograph, explores the revolving surface from one end to the other.

At the receiving end a contact point is slowly traversing a chemically prepared piece of paper wrapped round a similar cylinder and worked by similar clockwork. Line by line the paper is marked by the electrolytic action of current passing from the needle to the paper to the cylinder underneath.

"Q" COILS—AND HOW TO USE THEM" (Continued from preceding page)

The simplest type of "Q" coil is the QA type. This comprises a simple tuned winding, wound in two sections as just described, and a reaction winding which is designed to give adequate reaction when used in a Reinartz circuit with a .00015 condenser. Where the detector is resistance-coupled, using very high values of anode resistance, a somewhat larger value of reaction condenser is necessary. A suitable circuit for this type of coil is as shown in Fig. 1. It will be seen that the aerial is coupled directly to the coil through a .0001 condenser, or by a smaller condenser if it is desired to obtain a greater selectivity.

The next type of coil is the Reinartz type, which is made in two forms. The first of these is the QAR type, which has the windings of the simple QA type with the addition of an aerial coupling winding. This winding has three tappings giving varying degrees of selectivity and the best tapping should be chosen for the particular conditions obtaining. This type of coil does not supersede the QA coil and in some circuits, indeed, it is less suitable. There are occasions, however, when a separately coupled aerial winding is beneficial, and here the QAR type may be used with every satisfaction.

The second modification of the Reinartz type is known as the QAM type. This is exactly similar to the QAR with the

exception that the reaction winding is entirely separate instead of being connected at one end to the earth end of the secondary

NEXT WEEK:
**FULL CONSTRUCTIONAL
DETAILS OF A
SPECIAL THREE-VALVE
MAINS RECEIVER**

winding. By this means the reaction condenser may be inserted in such a position that its moving plates are at earth potential, which is an arrangement tending to eliminate hand effect and is useful in a

Owing to the demands upon our space in this issue we regret that it has been necessary to curtail some of the "A.W." regular features and in the case of one—the "A.W." Tests of Apparatus—to omit this altogether.

number of cases. This method, for example, is used in the two-valve set described elsewhere in this issue where, from the point of view of short-wave reception, it is essential to have the moving plates of the reaction condenser at earth potential. The QAM type of coil is only provided with two tappings on the aerial coil instead of three. Circuits employing the QAR and QAM types are shown in Fig. 2 and 3 respectively.

The fourth type of coil is the split primary transformer, known as the QSP type. This follows the standard six-pin coil in its connections, the circuit being indicated in Fig. 4. There is a primary winding closely coupled to a neutralising winding, these windings being coupled to the earth end of the secondary coil. Finally there is the reaction winding for obtaining a certain amount of regeneration from the detector valve. It should be noted that in order to obtain the best results from this coil terminal No. 5 should be connected to anode and terminal No. 3 to the neutralising condenser.

(Further uses of the "Q" Coil will be given in our next issue)

During a recent campaign against opium in China a number of Chinese speakers broadcast talks on the evil of the narcotic habit. The talks were broadcast from the Kellogg station in Shanghai.

The National RADIO-EXHIBITION

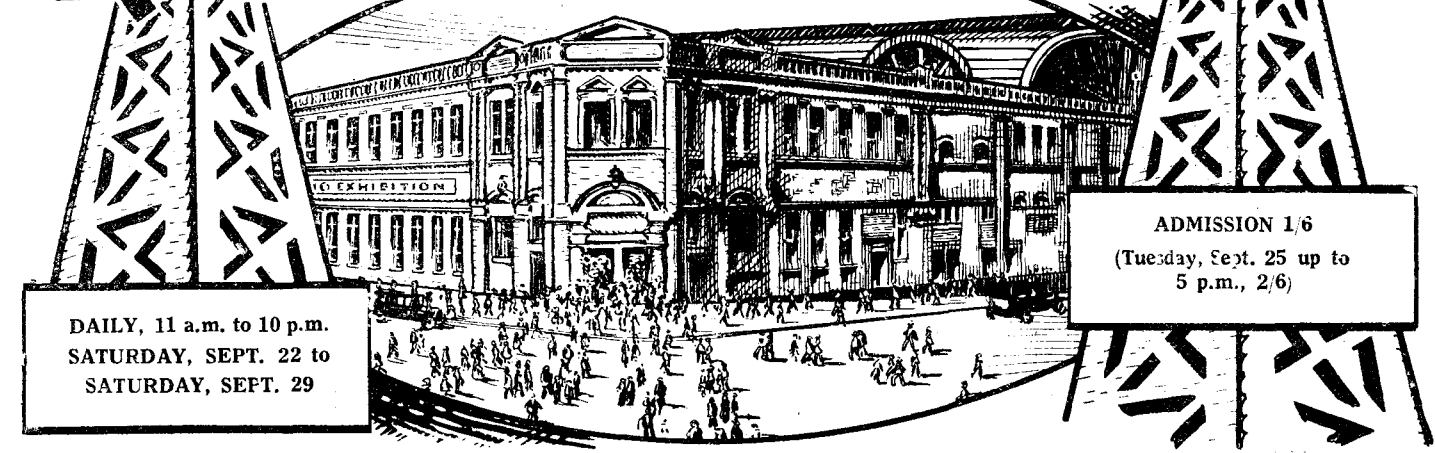

THE present Radio Exhibition is the seventh since the inception of broadcasting and the second to be held under the auspices of the Radio Manufacturers' Association; as each has come round the remarkable developments that have taken place during the preceding year have been apparent. This year's exhibition is no exception.

Progress has been so great that no enthusiast, be he listener or experimenter, can afford to miss a personal visit. Forecasts of the principal lines of

development have already been dealt with in detail in recent numbers of AMATEUR WIRELESS and this issue contains a Complete Guide to the Show; in presenting it we have every confidence that it will be of the utmost value to readers. A hearty invitation is extended to all our readers to visit the "A.W." Stands (Nos. 63 and 66), where we are prepared to give free technical advice and are demonstrating the construction of the famous AMATEUR WIRELESS and *Wireless Magazine* sets.

- Stand 1. J. Dyson, 5 Godwin Street, Bradford.**
Airmax and Godwinex components and accessories, such as H.F. chokes, six-pin coils, indicating terminals, are shown, as well as complete receivers and a neat and handy coil stand for two-pin coils.
- Stand 2. The Beaver Electrical Co., 5 Great Chapel Street, W.1.**
- Stand 3. G. Forster, Carlton House, Lower Regent Street, S.W.1.**
Portables in three types are shown: (1) Advance three-valve portable and transportable receivers, 250-700 metres. Range, 21.0 25 miles, and 5GB 100 miles on loud-speaker. (2)

- Stand 4. Whittingham Smith & Co., 110 Kew Green, Surrey.**
- Stand 6. Radi-Are Electrical Co. (1927) Ltd., Bennett Street, Chiswick, W.4.**
- Stand 7. Standard Wet Battery Co., 184 and 188 Shaftesbury Avenue, W.C.**
Wet H.T. batteries fitted in the new wooden Unibloc containers, giving a 32-cell bank of 48 volts, are the attraction here, where many improvements in this type of battery are notable features.

- work in conjunction with any gramophone and to give either a two-valve or three-valve output. The instrument is entirely self-contained, the loud-speaker portion being in the centre and the amplifier one side and batteries in the other.
- Stands 11, 13, and 14. Baird Television Development Co. Ltd., 133 Long Acre, W.C.2.**
The first of the Baird television receivers are to be shown, further details of which are at present unavailable.

- Stands 19 and 20. Celestion Radio Co., 29 to 31 High Street, Hampton Wick.**
A full range of the famous Celestion loud-speakers are on view, as well as the Celestion Woodroffe gramophone pick-up, which is a first-class instrument fully in keeping with the quality of the Celestion loud-speakers. Owing to its lightness and special damping arrangements, the wear on records is reduced to an absolute minimum.
- Stands 21 and 22. M.P.A. Wireless Ltd., 62 Conduit Street, W.1.**
Loud-speakers and receivers of

ALL THAT'S NEW IN RADIO

- Stand 8. C. Creswick Atkinson, 35b High Street, Bedford.**
A five-valve portable receiver and a three-valve screen-grid receiver are new additions to the Creswick Atkinson range of receivers.
- Stand 9. Mic Wireless Co., White Horse Place, Market Street, Wellingborough.**
Zampa components are on show here, with a *piece de resistance* in the form of a moving-coil loud-speaker. Aerial tuners and a permanent magnet are also included.
- Stand 10. British General Manufacturing Co., Ltd., Brockley Works, S.E.4.**
Special attention is drawn to a gramophone amplifier, an instrument of great beauty, which is designed to
- Stand 12. Sel-Ezi Wireless Supply Co., 6 Greek Street, W.1.**
- Stand 15. Hart, Collins Ltd., 33a Besborough Street, S.W.1.**
- Stands 16, 17, and 18. Halcyon Wireless Co. Ltd., 313 to 319 Regent Street, W.1.**
The Halcyon five-valve portables on view are claimed to give consistently perfect reproduction on long or short waves. Control has been simplified and made sturdier and more fool-proof, so that, in conjunction with the comprehensive calibration charts that are supplied with each instrument, no difficulty should be found in obtaining any of the many British and Continental stations which are within its very wide range.

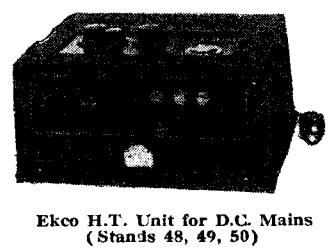

Ekco H.T. Unit for D.C. Mains
(Stands 48, 49, 50)

Advance five-valve receiver, transportable, 250-650 and 1,000-2,800 metres, by means of switch. One-dial tuning. (3) Advance five-valve (screened valve) transportable, 250-550 metres and 1,000-2,000 metres, by means of switch. This also has one-dial tuning.

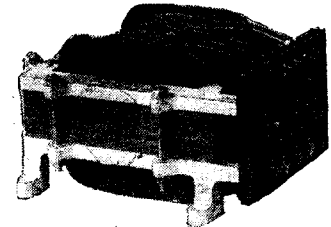

Parmeko A.C. Mains Transformer
(Stand 147)

interest here include the M.P.A. Ethatrope all-electric radio gramophone. At choice this is either a first-class five-valve radio receiver (no aerial or earth needed), or a valve-amplified electrically driven gramophone operating from any make of

(Continued on page 361)

COMPLETE GUIDE TO SHOW

LIST of EXHIBITORS

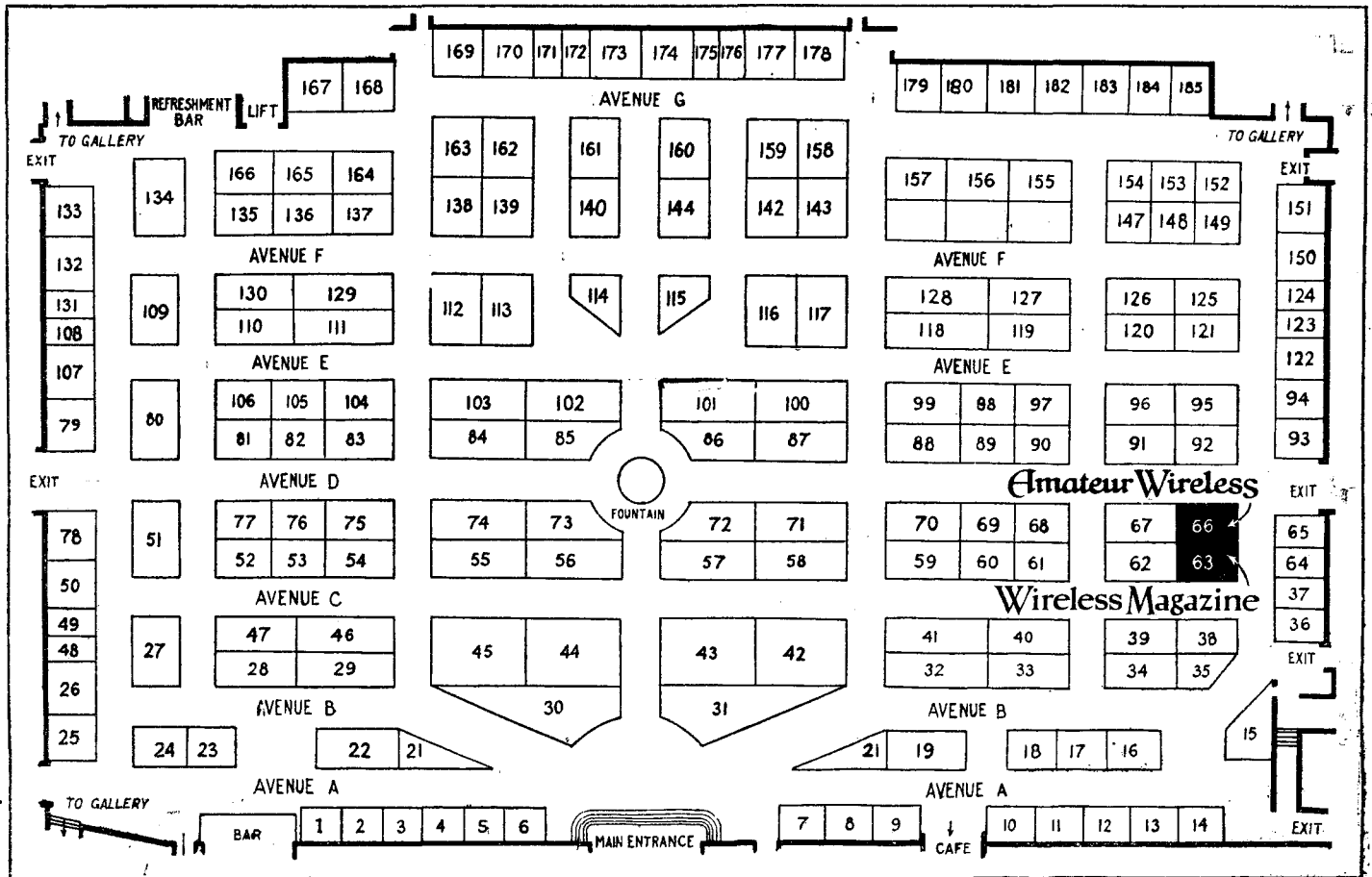

PLAN OF GROUND FLOOR OF NATIONAL RADIO EXHIBITION, NEW HALL, OLYMPIA, LONDON, W.

WHERE TO FIND THE EXHIBITORS—An Alphabetical List with Stand Numbers.

Name	Stand No.	Name	Stand No.	Name	Stand No.	Name	Stand No.
Aeonie Wireless Co., Ltd.	92	Cossor, Ltd., A. C.	116, 117, 231, 250	Hoare & Jagels, Ltd.	82	Peto Scott Co., Ltd.	142, 143
Amalgamated Press, Ltd.	135, 166	Curry's Ltd.	275, 276, 277	Hobday Bros., Ltd.	173, 174	Philips Lamps, Ltd.	94, 122
AMATEUR WIRELESS	63, 66	D.X. Coils, Ltd.	223	Houghton-Butcher (G.B.) Ltd.	136, 137	Portable Utilities Co., Ltd.	144
Atlanta, Ltd.	271	Dayzite, Ltd.	248	Hunt, Ltd., A. H.	273	Pye & Co., W. G.	87, 100
Atkinson, C. Creswick	8	De la Rue & Co., Ltd., Thos.	235	Huntley, Norman	264	R. I. & Varley, Ltd.	56, 73, 222
Automatic Coil Winder & Elec. Equipment Co., Ltd.	150, 151	Dew & Co., A. J.	181, 182	Igranic Electric Co., Ltd.	53, 54, 75	Radi-Arc Electrical Co., (1927) Ltd.	6
Automatic Radio Mfg. Co.	274	Dibben & Sons, William	109	Iliffe & Sons, Ltd.	145, 146, 201	Radio Service (London), Ltd.	207
Axuel Time Switches, Ltd.	293	Dionoid Battery Co., Ltd., The	245	Incorporated Radio Society of Great Britain	227	Redfern's Rubber Works, Ltd.	123
Baird Television Development Co., Ltd.	11, 13, 14	Donotone Loud Speakers	216, 217			Rees-Mace Mfg. Co., Ltd.	268
Baker, A.	172					Regent Radio Supply Co.	62
Bakelite, Ltd.	160					Reid & Co., Louis H.	214
Beaver Electrical Co., The	2					Rialton Radio (Prop. H. & S. Scott, Ltd.)	268A
Bedford Electrical & Radio Co.	35					Ripaults, Ltd.	24
Belling & Lee, Ltd.	220, 221					Rooke Bros., Ltd.	70, 77
Benjamin Electric, Ltd.	171					Sel-Ezi Wireless Supply Co.	12
Bernard Jones Publications, Ltd.	63, 66					Selectors, Ltd.	23
Bowerman, Ltd., George	213					Selfridge & Co., Ltd.	269, 270
Bowyer-Lowe Co., Ltd., The	51					Sells, Ltd.	246
Brandes, Ltd.	118					Shore Mfg. Co., Ltd.	39
British Brunswick, Ltd.	130					Siemens Bros. & Co., Ltd.	164, 165
British Ebonite Co., Ltd.	38					Standard Wet Battery Co.	7
British General Mfg., Co., Ltd.	10					Stapleton, A. W.	211
British Radio Corporation, Ltd.	141					Stevens & Co., (1914) Ltd., A. J.	83, 131
British Thomson-Houston Co., Ltd., The	86, 101					Stratton & Co., Ltd.	34
Brown, Ltd., S. G.	155, 156					Sun Electrical Co., Ltd.	170, 180
Brown, Bros., Ltd.	177, 178					Sylvex, Ltd.	175
Brownie Wireless Co. of G.B., Ltd., The	104					Telegraph Condenser Co., Ltd.	121
Bulgin & Co., A. F.	203, 204					Telsen Electric Co., Ltd.	5
Bullphone, Ltd.	42					Tonex Co., The	266
Burndept Wireless, Ltd.	112, 113					Trader Publishing Co., Ltd.	26
Burne-Jones & Co., Ltd.	96					Trelleborg Ebonite Works, Ltd.	224
Burton, C. F. & H.	184, 185					Triumph Cabinet Works, Ltd.	205
Cahill & Co., Ltd.	176					Truphonic Wireless Co.	134, 260
Camden Eng. Co., Ltd.	152					Tudor Accumulator Co.	249
Carborundum Co., Ltd.	130					Turner & Co.	234
Carrington Mfg. Co., Ltd.	107					Vandervell & Co., Ltd., C. A.	114
Catesby, Ltd.	25					Walker Bros.	154
Cantophone Wireless, Co.	253					Watmel Wireless Co., Ltd.	157
Celestion Radio Co.	19, 20					Webb Condenser Co.	124
Chloride Electrical Storage Co., Ltd.	33, 40, 241					Western Wireless Co.	262
Clarke & Co., (M/c) Ltd., H.	161					Westinghouse Brake, & Saxby Signal Co., Ltd.	78
Cliftophone	176					Whiteley, Boneham & Co., Ltd.	120
Climax Radio Electric, Ltd.	80					Whittingham Smith & Co.	4
Cole, Ltd., E. K.	48, 49, 50					Wilkins & Wright	152
Collinson's Precision Screw Co., Ltd.	91					Williams & Moffat, Ltd.	265
Colonial Wireless Press, Ltd.	202					Wingrove & Rogers, Ltd.	111
Colvern, Ltd.	91					WIRELESS MAGAZINE	63, 66
Cook's Wireless Co., Ltd.	254					Wireless Retailers' Association of Great Britain	259
						Wright & Weaire, Ltd.	251, 252

SEE SETS BUILT AT "A.W.'s" STANDS

COMPLETE GUIDE TO SHOW

STANDS Nos. 23-32

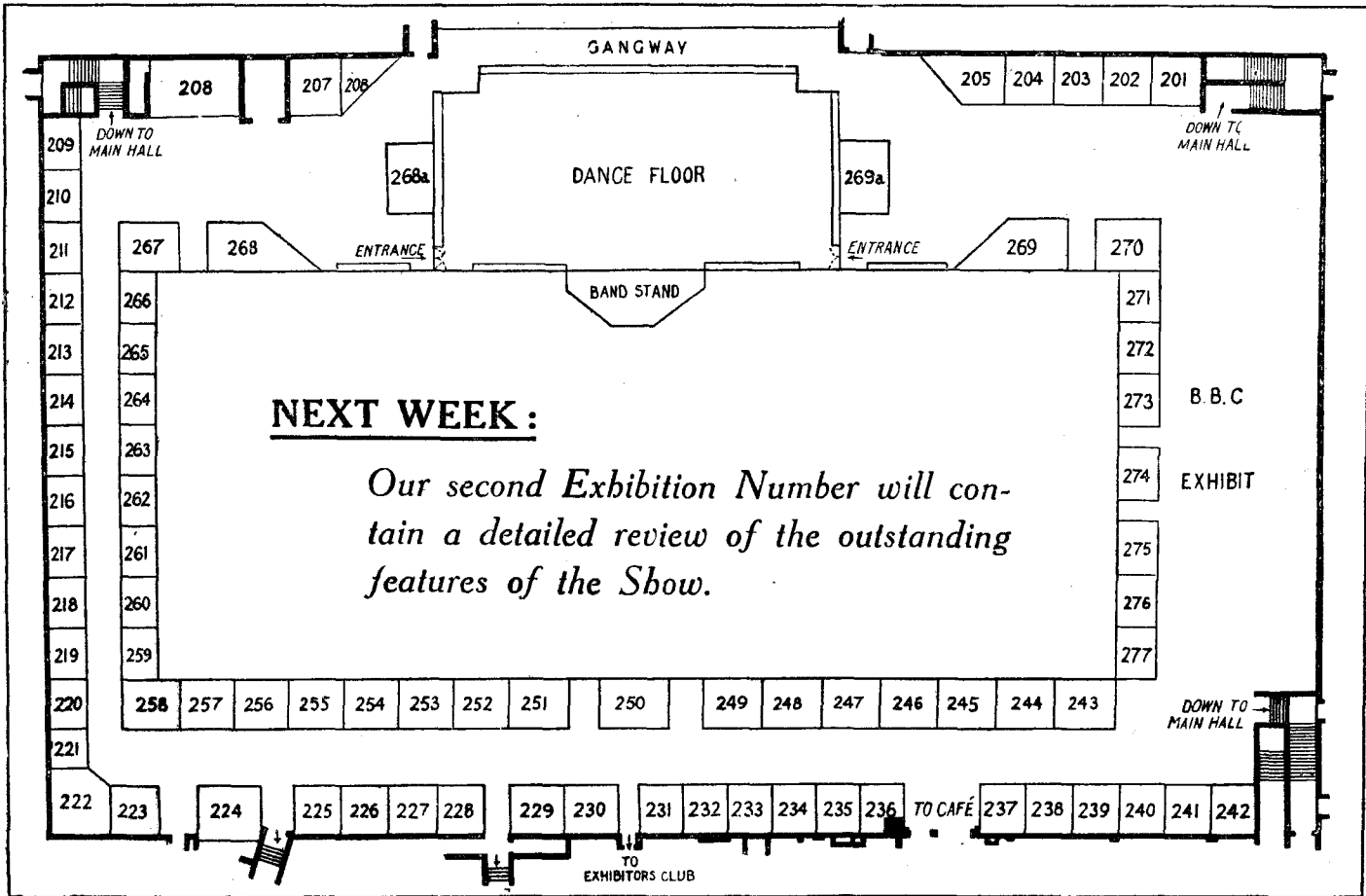

NEXT WEEK :

Our second Exhibition Number will contain a detailed review of the outstanding features of the Show.

THE GALLERY PLAN OF THE NATIONAL RADIO EXHIBITION

(Continued from page 359) record. The M.P.A. screened portable (mains or accumulator driven). M.P.A. complete moving-coil speakers. The result of long research in this field, these speakers give superb results.

Stand 23. Selectors, Ltd., 1 Dover Street, W.1.

In a wide range of portables, the Selector Super stands out. As in the previous models, the super heterodyne type of circuit is employed, and the intermediate frequency stages are

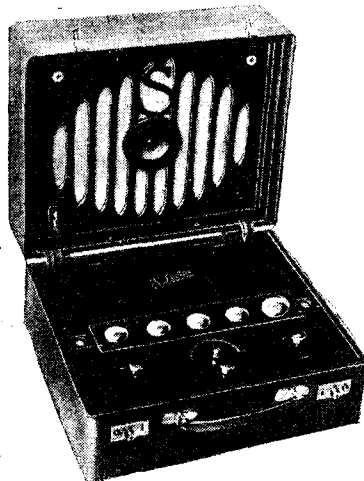

Selector's Attaché-case Receiver (Stand 23)

adequately shielded, thereby entirely eliminating long-wave "pick-up." A large Amplion cone speaker is now

fitted, and the low-frequency stages have been designed to operate it to its best advantage. The voltage of the high-tension accumulator has been increased and correspondingly the volume of reception is greater. The H.T. accumulator has a capacity of 1,500 milliamps and the L.T. 40 ampere hours actual. A ball-bearing turntable is attached to the base of their instrument.

Stand 24. Ripaults, Ltd., King's Road, N.W.1.

This exhibit consists principally of the lateral-action condenser and dual-finish ebonite panels. The lateral-action condenser has recently been very greatly improved, whilst the price has been reduced; the main frame and the runner plate of these instruments are now of die cast metal and the runner rods are of high-grade silver steel. The dual-finish ebonite is of extremely high-grade material.

Stand 25. Catesby's, Ltd., 64 to 67 Tottenham Court Road, W.1.

Stand 27 and 108. Gambrell Radio, Ltd., Buckingham Street, W.C.2.

New components and "mains" receivers are the attraction here. The Gambrell Table Model Two, for D.C. or A.C. mains, gives pure reproduction with simple control. The last word in receiver design is represented by the Gambrell screen-grid four, which works off the mains and brings in a large number of stations by the operation of a thumb control. The Gambrell combinator for A.C. mains is a combined H.T. and G.B. battery eliminator, with trickle-charging unit.

Stand 28, 29, 46, 47, and 225. General Electric Co., Ltd., Magnet House, Kingsway, W.C.2.

The regional scheme and the screen-

grid valve have influenced the design of the new Geophone range of broadcast receivers on view at these stands. Selectivity and sensitivity are the outstanding characteristics of these receivers, which range from three- to six-valvers. Among the new accessories introduced this season, the Geophone H.T. power unit for use on alternating mains will be sure to excite interest. Employing an Osram U5 full-wave rectifying valve, this unit is suitable for all voltages between 200/260 (50 cycles). It has an output of 50 m.a., and a maximum voltage of 180. There are two variable and one fixed output tapplings. There is also an inexpensive Plaque cone loud-speaker. This has an oak base with an old gold centre. Additions to Geophone components include a slow-motion log law condenser.

Stand 30 and 31. Graham Amplion, Ltd., 25 and 26 Savile Row, W.1.

No less than twenty-one types of loud-speakers, ranging from a new and inexpensive swan-neck model to the latest pedestal cabinet model, are being shown by this famous firm. We are now able to reveal the fact that it was Graham Amplion referred to in the Evening News recently, when a "hush hush" cone loud-speaker of an entirely new design was announced. The new principle is embodied in all models of the Amplion Lion range. Readers of "Amateur Wireless" will find a pleasant welcome at Amplion House, next door to Olympia, where demonstrations of all the Amplion models are carried out.

Stand 32 and 41. Metro-Vick Supplies, Ltd., Trafford Park, Manchester.

The most prominent feature of the exhibit is the well-known Met-Vick

five-valve set, three- and four-valve resistance, and resistance-transformer coupled sets. These can be obtained either completely wired up and tested, or, for the constructor, the individual component parts can be purchased with full details for wiring and assembly. In connection with these mains-operated sets, D.C. or A.C., a full range of H.T., L.T., and G.B. eliminators for all periodicities are shown. A lot of the credit for the excellent performance obtained with these mains-operated sets must be given to the Cosmos A.C. valves and rectifying valves, of which there is also a considerable display, as well as of the ordinary battery operated

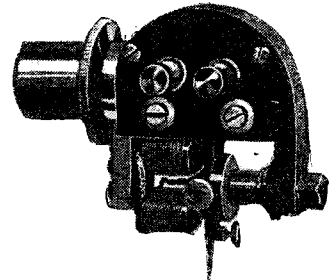

Celestion Woodroffe Pick-up (Stand 19, 20)

valves. Perhaps the exhibit that will attract the most attention, and which will be introduced for the first time at the Exhibition, will be the Met-Vick elastic aerial unit, which provides the equivalent of being able to reduce the length of the aerial from its maximum to zero in infinitely fine gradation, so that the maximum sensitivity and selectivity can be obtained when interference is being

COMPLETE GUIDE TO SHOW

STANDS Nos. 33-52

experienced. Other interesting components are the new skeleton R.C.C. and detector units, moulded anode resistances of guaranteed permanency and the well-known "A.N.P." coils, chokes, etc.

Stands 33, 40, and 241. The Chloride Electrical Storage Co. Ltd., Clifton Junction, near Manchester.

The big range of Exide accumulators includes the new series of Exide patent unspillable cells of special design, with a new form of unspillable device. An entirely new Exide H.T. battery, the WT 10-volt, with a capacity of 10,000 milliampere hours, and the popular WI 10-volt, with a capacity of 5,000 milliampere hours, together with the WJ 10-volt, with a capacity of 2,500 milliampere hours, all of which consist of a five-cell multi-compartment glass container. The

shown, as well as standard-size sheets, rods, tubes, and mouldings. Becol low-loss formers are now made in a good range of sizes. Type 5a former is an improved design, as there are flats between the wings, which enables fittings to be mounted up easily. Becol four- and six-contact formers are shown. These formers are pinless and the form of contact is such that the formers are absolutely foolproof and there is no fear of short circuits.

Stand 39. Shore Manufacturing Co. Ltd., 30 Great James Street, W.C.1.

Stand 42. Bullphone Ltd., 38 Holywell Lane, E.C.

Bullphone horn and cone loud-speakers attract attention, comprising the Nightingale Concert Supreme, cabinet cone, De Luxe model and Concert Grand model. Cone and gramophone units, with an anti-pong

pull switch either long or short waves can be received.

Stand 42a. Electron Co. Ltd., 122 Charing Cross Road, W.C.

Valves are the big interest here, where, in addition to the well-known range of Six-Sixty valves, there is shown the new Six-Sixty Pentode (SS230PP and SS415PP), as well as the new Six-Sixty screened grid valves (SS215SG and SS4075SG). There are also on view the well-known Six-Sixty cone speaker, Six-Sixty cone speaker paper, Six-Sixty cone speaker assembly, and the Six-Sixty turntable.

Stand 44a. Ever Ready Co. (G.B.) Ltd., Hercules Place, Holloway, N.7.

High-tension, low-tension, and grid-bias batteries of both primary and secondary types are shown, including the popular "Winner" type H.T.

chargers, and universal transformers are but a selection of the many new products.

Stands 43, 49, and 50. E. K. Cole Ltd., London Road, Leigh-on-Sea.

Mains units are of great interest at this stand, where the power radio devices are encased in attractive metal cabinets of an artistic, crystalline dark brown finish, which have the appearance of quality leather. The metal case increases efficiency by its "shielding" properties and eliminates any danger of fire. The output sockets are protected and all terminals and leads heavily insulated ensuring absolute safety, so that the device conforms to the latest I.E.E. recommendations. Ekco H.T. units are reclassified into four ranges as regards current output, and the model numbers changed, so that the model number will indicate its range and

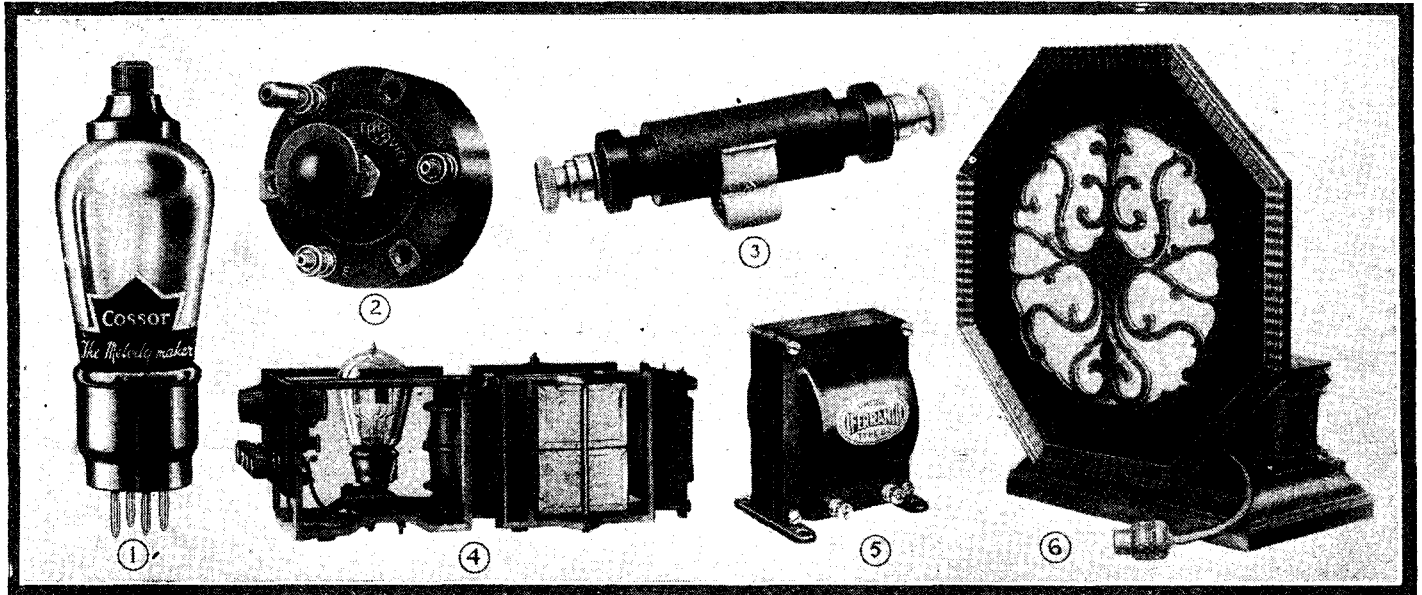

1. New Cossor Screen-grid valve (Stands 116, 117, 231, 250). 2. Met-Vick Aerial Unit (Stands 32, 41). 3. Met-Vick R.C. component. 4. Parmeko Mains Unit (Stand 147). 5. Ferranti Power Choke (Stands 84, 85). 6. M.P.A. Moving-coil Loud-speaker (Stands 21, 22).

WJG 10-volt unit for grid bias is of the same construction as the WJ10 H.T. battery, but provided with 2-volt tappings.

Stand 34. Stratton & Co. Ltd., Balmoral Works, Bromsgrove Street, Birmingham.

Amongst the Eddystone products here the visitor should see the three-valve short-wave screen-grid receiver and kits of parts for the assembly, an improved H.F. choke for 10-3,000-metre work, and a short-wave variable condenser.

Stand 35. The Bedford Electrical and Radio Co. Ltd., 22 Campbell Road, Bedford.

Peerless products such as rheostats and coil formers are augmented at this display by the Peerless complete kit of parts for a moving-coil loud-speaker, which has been carefully designed for ease of construction and to minimise the alteration necessary to the existing amplifying-unit. A four-valve screen-grid transportable ought to be seen.

Stands 36, 37, 64, and 65. F. J. J. Manufacturing Co. Ltd., Cumberland Avenue, Park Royal.

Stand 38. British Ebonite Co. Ltd., Nightingale Road, Hanwell, W.7.

The full range of well-known Becol panels, with matt finish, black, also red and black grained finishes, are

valve-holder are among the accessories, which include an all-wave tuner with a range of 250-2,000 metres. A large knob controls seven tapped wavelengths, and a small vernier controls the reaction coil. "A child can do it," say the makers.

Stand 43. Edison Swan Electric Co. Ltd., 123 and 125 Queen Victoria Street, E.C.4.

Among the many exhibits here is a new range of Ediswan valves, entirely revised and important additions made. The appearance of the valves is somewhat different, a new type of "cap" being used. An important feature of the new Ediswan valves is their marking—not only the filament volts and current, but also the impedance and amplification factor of each valve is etched on the bulb. This feature should appeal strongly to constructors. Other interesting exhibits include the 1929 Ediswan R.C. Threesome. In its up-to-date form, the receiver embodies several striking improvements, and the Threesome should be an even greater favourite than before. The system of plug-together universal coupling units is still employed, but another unit has been developed, to take the place of the present "A" type unit, which has the inductance and reaction windings for both long and short waves mounted on it, so that by means of a simple push-and-

Stand 45. New London Electron Works Ltd., East Ham, E.6.

This firm are making a special feature of Superial Electron wire. The popular aerial, which has now passed the four million mark, is, of course, prominently displayed. Electron extension wire, for economically extending loud-speaker and 'phones in various lengths, Electron earth mat, including 25 ft. wire attached, and Simple-Strip, for the internal wiring of sets without solder, are all of interest.

Stands 59, 60, 61, 63, 69, 70, and 232, 233. Marconiphone Co. Ltd., 219 Tottenham Court Road, W.1.

A large number of new receivers lend considerable interest to this year's Marconiphone exhibit. Special demonstrations of these are given at 30 West Kensington Gardens, near the exhibition. Among the receivers, model 34, a three-valver, provides a wavelength range of 12 to 3,000 metres, and enables American, Australian, and B.B.C. stations to be received. Model 35, claimed as being superior to the usual four-valver and equal to many fives, incorporates a screen-grid H.F. valve, a detector, and a pentode power valve. The receiver may be driven from batteries or entirely from electric mains. The new Octagon cone loud-speaker, the new moving-coil types, the high-tension and all-power units, trickle

type of voltage output tappings—i.e. model 1F10 provides one fixed output tapping, with a maximum current output of 10 milliamperes; model 4F60 provides four fixed tappings, with a maximum current output of 60 milliamperes.

Stand 51. The Bowyer-Lowe Co., Ltd., Radio Works, Letchworth, Herts.

Among the new products we draw special attention to the Pentovox, an inexpensive two-valver with a pentode valve. Then there is the Vox Populi screen-grid Three. Other notable additions to the existing well-known range are the Log Major and Log Minor variable condensers and a new H.F. choke.

Stands 52, 92. J. L. Gottlieb & Co., Ltd., 15 Cromer Street, W.C.1.

On this stand is the new improved model of the R.S.V.P. transportable five receiver, comprising two choke-coupled H.F. stages, followed by detector and two L.F. stages. High-power, long-wave stations can be received at full loud-speaker strength, while good volume is obtainable on the short wavelengths within reasonable range of short-wave stations. Smoothness of the simple control is the keynote of the R.S.V.P. receiver. The R.S.V.P. transportable screened four is a new receiver making use of the new screened valve, and

(Continued on page 365)

COMPLETE GUIDE TO SHOW

STANDS Nos. 53-85

porates a special circuit, which is the result of many months of patient experiment and research.

Stands 53, 54, and 75. Igranic Electric Co., Ltd., 147 Queen Victoria Street, E.C.4.

Many new products are added to this firm's already comprehensive range, such as the dual-impedance coupled R.C. unit, with choice of anode-resistance valve, screened condenser, improved variable resistance, "J" transformer—a light-weight L.F. coupler of exceptional merit, vernier drum control, and wire-wound variable resistances. The short-wavers and portable receiver ought to be seen, as well as the Phonovox electrical reproducing equipment, for use in cinemas and dance halls. Many of the new components to be seen will be incorporated in "A.W." receivers during the coming months.

tors, and an all-from-the-mains eliminator. An improved Interdyne receiver and an all-from-the-mains four-valver for A.C. or D.C. augment a most imposing array that every visitor should see.

Stands 57, 58, 71, and 72. Lissen, Ltd., Friars Lane, Richmond, Surrey.

When visiting the Lissen stand, make a special point of seeing the new Lissen variable condenser and super low-frequency transformer. A combined gramophone and wireless receiver, and a five-valve portable receiver should also be inspected. Among other new lines there is a slow-motion dial made of bakelite, a new cone unit for loud-speakers, cone-speaker diaphragms in paper and other materials, new sizes and types of dry batteries, and a range of valves. The various stages in the manufacture of these valves and characteristic

block with a capacity of 2,500 milliampere hours complete the display.

Stands 76 and 77. Rooks Bros., Ltd., 55 Cardington Street, N.W.1.

The chief feature is a display of "Simpler Wireless" mains sets. These are being built by Simpler Wireless, Ltd., under licence from the inventor, Mr. J. F. Johnston. Two models only are shown, each of which employs three valves. The two models are suitable for 200/240 D.C. supplies and 200/240 A.C. supplies respectively. Both models have exactly the same appearance and dimensions, and each is entirely self-contained. There is no additional external rectifying unit for the A.C. set. Then there is a centre-tapped H.F. choke in a moulded case, an eccentrically tapped L.F. coupling choke, an intervalve L.F. transformer,

a comprehensive range of brass stampings as used by the trade are displayed, with the Lunmet insulated terminal which attracted attention at the last Exhibition.

Stand 80. Climax Radio Electric, Ltd., Quill Works, Putney, S.W.15.

Climax productions are augmented this year by several new lines. Here can be seen the Climax copper earth, fitted with improved cap, Climax Galloy earth, low-loss insulators, shock-absorber set, and lightning arrester. Also the Climax H.F. choke. Then there is the Climax portable receiver.

Stands 81 and 106. S. A. Lamplugh, Ltd., King's Road, Tyseley, Birmingham.

Small accessories, such as volume controls, valve holders, etc., are backed up by a display of a unique system of set construction. By means

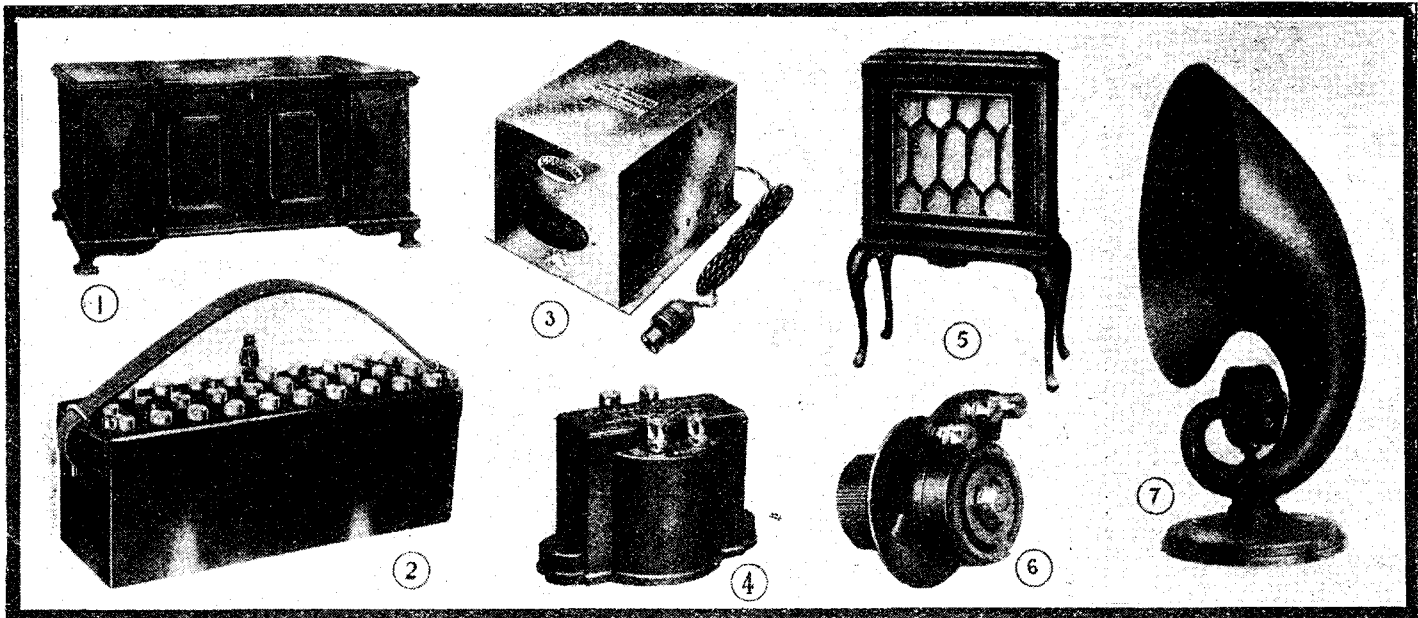

1—Gambrell Mains Receiver (Stands 27, 108). 2—C. A. Vandervell H.T. Accumulator (Stand 114). 3—Dunham Wireless H.T. Eliminator (Stand 257). 4—Igranic, type J, L.F. transformer (Stands 53, 54, 75). 5—Celestion type-24 loud-speaker (Stands 19, 20). 6—Igranic Megostat. 7—Ferranti loud-speaker with exponential horn (Stands 84, 85).

Stands 55 and 74. Langham Radio, 96 Regent Street, W.1.

The latest Langham portable and transportable receiver, the Langham radio speaker, and some useful accessories are to be seen at these stands. Probably the object of greatest interest is the new model Langham transatlantic portable radio and gramophone, which is enclosed in a leather case and incorporates the latest 1929 model Langham transatlantic portable radio receiver, with an electrically reproducing gramophone. This leather-cased model is sold with a canvas cover having pockets for records and a turntable.

Stands 56, 73, and 222. R.I. and Varley, Ltd., 103 Kingsway, W.C.2.

So many new components have been added to the R.I. & Varley range, that our short summary hardly does them justice. See them at the above stands. A new aperiodic tuner, 200-600 metres and 1,000-2,000 metres), seven-pin aerial and H.F. transformers (used in the Explorer Four), an Anti-Mobo unit, new R.C. couplers, push-pull and straight-line transformers, slow-motion dials, and dry rectifier transformers are just a few of the new products. Then there is a gramophone pick-up, a three-valve gramophone amplifier, a volume control, a range of dry-rectifier elimina-

types of each will be explained to the visitor. Other outstanding products include practically every other wireless component that the constructor is likely to require.

a filter choke, six-pin coils and bases, rheostats and vario-fixed resistors. Two models, both entirely new, of the Faradex electrolytic rectifier, are exhibited for the first time.

VISIT "A.W.'S" STANDS (Nos. 63 and 66)

Stand 62. Regent Radio Supply Co., 21 Bartlett's Buildings, Holborn, E.C.4.

Mains units conforming in every detail with the regulations issued by the Institute of Electrical Engineers should be seen by all visitors anxious to utilise their electric-light supply for the working of their receivers. Besides the D.C. models, there is a large selection of A.C. models incorporating the new Westinghouse metal rectifiers. One model, for example, gives 60 m.a. at 190 volts.

Stand 67. Peto & Radford, 50 Grosvenor Gardens, S.W.1.

Listeners who like to know the state of charge of their accumulators should call here and see the patent indicating accumulators, which show the user when the battery is charged, half charged, or discharged. A full range of non-spillable accumulators and a new 20-volt H.T. accumulator

Stand 78. Westinghouse Brake and Saxby Signal Co., Ltd., 82 York Road, King's Cross, N.1.

Types of Westinghouse metal rectifiers that will appeal more especially to the amateur include the 200-volt, 100-milliampere rectifier for H.T. and the ½-ampere and 1-ampere trickle chargers. To these are added two new types, one, the H.T.2, being suitable for an output of 350 volts, 100 milliamperes, for supplying L.S.5A type of valves, or for use in the excitation of the pot magnet winding of moving-coil loud-speakers. An entirely new metal rectifier, having an output of 9 volts 1 ampere, has been produced for 6-volt low-tension eliminators.

Stand 79. London Metal Warehouses, Ltd., Hill Street, S.E.1.

A full range of aerial wire in copper (plain and enamelled), phosphor bronze, and aluminium, together with

of the Lamplugh panel-plate tuner unit and collapsible cabinet, an efficient three-valve set having a professional appearance can be assembled with the greatest ease.

Stand 82. Hoars & Jagels, Ltd., 23 Great Sutton Street, E.C.1.

Stands 83 and 131. A. J. Stevens and Co. (1914), Ltd., Walsall Street, Wolverhampton.

Stands 84 and 85. Ferranti, Ltd., Hollinwood, Lancs.

Audio-frequency transformers (types AF3, AF4, and AF5), licensed push-pull audio-frequency transformers (AF3c, AF4c, and AF5c), licensed push-pull output transformers, OP3c, OP4c, OP6c and a new push-pull output transformer similar in appearance to the OP3c) together with fixed condensers (types C1 and C2), these being of the rolled foil type, not Mansbridge pattern, and having a very low internal resistance and an insulation resistance of not less than 200 megohms at 2 microfarads, are among the many Ferranti products, which include chokes (types B1, B2, and B3), for smoothing purposes, and the B1 for use in choke filter circuits. The eliminator on show is the last word in eliminator design, its total output being in the neighbourhood of 200 volts 100

COMPLETE GUIDE TO SHOW

STANDS Nos. 86-107

milliamps. The design is such that there is a complete absence of interaction between the stages, and mains hum and motor-boating do not occur, even when using receivers employing the finest amplifying arrangements.

Stands 86 and 101. British Thomson-Houston Co., Ltd., Aldwych, W.C.2.
It will come as a surprise to many that the present range of B.T.H.

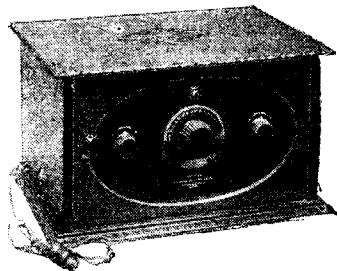

"Simpler Wireless" Mains Receiver (Stands 76, 77)

valves is being augmented by a new range of valves, and all B.T.H. valves in future will be known as "Mazda" valves, after the Mazda lamps, which are made in the same factory at Rugby. The range of Mazda valves on show comprises general-purpose, high-frequency, resistance-capacity, low-frequency and power valves for 2, 4, and 6 volts. In addition, there is a 6-volt super-power valve, which is claimed to give up to 100 milliwatts undistorted output with but 200 volts on the anode. The famous R.K. loud-speaker calls for little comment, as it has already proved itself to be the last word in sound reproduction. This wonderful cabinet instrument is again exhibited as the Senior R.K. loud-speaker. In addition, there are now Junior R.K. loud-speakers, two new models, both known as Junior R.K., one a table grand and the other a *de luxe* model. A gramophone amplifier pick-up and motor are new lines, as are battery eliminators and mains-unit components.

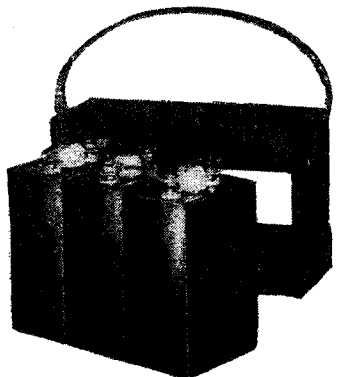

C.A.V. Accumulator (Stand 114)

Stands 87 and 100. W. G. Pye and Co., Granta Works, Montague Road, Cambridge.

Mains-unit components are a speciality of this firm, who are showing a range of products that includes geared condensers, heavy-duty chokes, output transformers, variable high resistances, silent-power transformers, trickle-charged transformers, and antimicrophonic valve holders. The transformers for use with Westinghouse metal rectifiers are specially noteworthy.

Stands 88, 89, 90, 97, 98, 99, 133, and 267. Mullard Radio Valve Co., Ltd., Nightingale Works, Balham, S.W.12.

The exhibits include a complete and comprehensive range of Mullard PM receiving and rectifying valves, including the new screen-grid valves, types PM12 and PM14, and the Mullard "pentone" valves, types PM22 and PM24. These latter are of the five-electrode type, having very large amplification factors. Probably the most interesting introduction to the Mullard range are the new Mullard Pure Music speakers, models "C" and "H." Both these speakers retain the balanced armature principle of construction. In the way of accessories, the Mullard exhibits include the Permaore L.F. transformer, the P.M. H.T. supply unit for A.C. mains, P.M. wire-wound anode resistances, grid leaks, mansbridge type condensers, and fixed mica condensers.

Stand 91. Colvern, Ltd., 150 Kings Cross Road, W.C.1.

A complete range of Colvern tuning inductances, including space-wound six-pin coils, sectional-wound long-wave coils, Colvern dual-range coils, interchangeable ultra short-wave in-

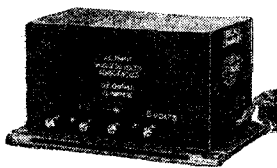

Ferranti Trickle Charger (Stands 84, 85)

ductances, binocular six-pin coils, astatic coils, low-loss inductances for high-frequency interstage coupling, should all be seen by the keen experimenter.

Stand 92. Aeonic Wireless Co., Ltd., South Place, Moorgate, E.C.2.

On this stand is shown the Aeonic transportable five-valve receiver. The employment of a special form of capacity-controlled reaction ensures smoothness of reaction. There are no coils to change and the operation of one switch changes over from the long to the short waves. Purity of reproduction is ensured by special low-frequency coupling and cone loud-speaker, which is built into the cabinet. The Aeonic suit-case five is one of the smallest portable receivers yet produced, and is really "portable" in the true sense of the word. The Aeonic combined gramophone and five-valve wireless receiver is contained in a handsome leather case, measuring 18 in. by 15½ in. by 9½ in. when closed, thus being one of the smallest and most compact combined suit-case instruments on the market.

Stands 94 and 122. Philips Lamps, Ltd., 145 Charing Cross Road, W.C.2.

The new Philips loud-speaker, battery charger, and L.F. transformer should all receive attention from the listener and constructor. The Philips loud-speaker operates upon a system which is independent of the polarity of the windings, and can therefore be connected to a receiving set without regard to the usual plus and minus connections. At the back of the loud-speaker a two-way switch is fitted, by means of which any user can adjust the volume and tone according to taste. The construction of the apparatus is such that it may be adjusted to either stand or be suspended from a wall. The reproduction of both

music and speech from this speaker is of a very faithful order, but regard must be paid to the correct adjustment of the valves in the output stages, by ensuring that adequate grid bias is applied. The Philips low frequency transformer is specially designed to operate with this loud-speaker, and the best results will be obtained if the two are used in conjunction with each other.

Stand 95. Hart Accumulator Co., Ltd., Marshgate Lane, E.15.

Samples of the extensive range of the Hart batteries for H.T. and L.T. supplies. For low-tension circuits, the types designated respectively Magno, Enduro, and RME will attract the attention of listeners. Assembled in specially-moulded pressed glass boxes, these cells are fitted internally with moulded ribs or grooves, extending almost to the bottom of the box and between which the plates rest, the use of bottom blocks in these cells is entirely obviated, and, in consequence, a larger space is available for the collection of any deposit, as also, of course, for a greater volume of electrolyte. The Hart Ray (1250/2500 milliampere-hour capacity) and Rado (3000/6000 milliampere-hour capacity) types of high-tension accumulators constitute further variations of the Ray design, which have been evolved, primarily, to meet the requirements of wireless users to whom economy in table (or floor) space is of importance. Manufactured in 20- and 30-volt units, as standard, the wooden crates into which these cells are assembled are so arranged as to permit of their being placed, if desired, one on top of the other, thus providing a compact unit in a minimum of space.

Stand 96. Burne Jones & Co., Ltd., 288 Borough High Street, S.E.1.

Components of all types, representative receivers, and amplifiers complete a display that ought to be seen by every constructor.



Electron Turntable for Portables (Stand 42A)

Stands 102 and 103. Dubilier Condenser Co., Ltd., Ducon Works, Victoria Road, North Acton, W.3.

The well-known K.C. condenser is shown in two models: either complete with knob, dial, and slow-motion drive, or without these adjuncts. Both models are made in two capacities: .0003 and .0005. Two drum control models, a single K.C. actuated by two drums, for fine and coarse adjustment respectively, and a triple K.C. controlled by three drums, are also shown. A Midget variable condenser, suitable for reaction control, or for use when a neutralising condenser of relatively large capacity is required, and a neutralising condenser, maximum capacity .00005, minimum capacity .000005-6, for baseboard mounting, are included. The popular Dubilier ranges of types 610, 620, and 577 condensers will continue to be marketed, and also the range of B.775 condensers. These latter, however, are also obtainable for higher voltages, if required.

Stand 104. Brownie Wireless Co., Ltd., Nelson Street Works, Mornington Crescent, N.W.1.

The Dominion three-valve on view is contained in a mahogany polished wood cabinet, with vignette front, neatly arranged panel, and terminals for all connections at rear. A special feature is the incorporation of an aerial tuning unit covering

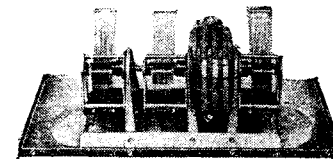

Dubilier Triple Gang Condenser (Stands 102, 103)

wavelengths from 200 to 2,000 metres, and operated by a single selector switch which obviates coil changing. An additional feature which will appeal to all users is the provision within the set of a means whereby, with the aid of a simple pick-up, a gramophone can be instantly plugged in. The Dominion vernier dial, fitted with slow-motion drive, with a reduction ratio of 12 to 1, is fast enough for quick searching and slow enough for fine tuning. Microphonic noises, shocks, and vibration are entirely eliminated with a new Brownie valve holder, which is well moulded in best-quality bakelite material.

Stand 105. Jackson Bros., 8 Poland Street, W.1.

Variable condensers of all types including drum dials and gang condensers, with and without screens, are shown as the exhibit at this stand. Economy of material and compactness of design are noteworthy features of J.B. variable condensers and a close examination of this range will well repay the amateur constructor.

Stand 107. Carrington Manufacturing Co., Ltd., Camco Works, South Croydon.

An assorted range of all types of Camco cabinets for the manufacturer and home constructor are displayed.



Igranite Five-valve Universal Portable Set (Stands 53, 54, 75)

Special features are the Camco portables, moving-coil cabinets, table and pedestal models. A new Camco cabinet named the Popular is introduced. Of course the well-known Camco panels and panel brackets are included in the exhibit.

SHOW GUIDE CONTINUED ON PAGE 373

Captain Round on IDEALS IN SETS

IT is such a change to get away from the factors of cost and size of a set and only constructors will build in the near future. Between aerials and frames I frankly prefer the aerial, because I find that on very

Fig. 2 represents the ideal circuit up to the rectifier and it will be seen that there are six tuning circuits altogether. However, these should be coupled together in pairs at least, even if complete ganging is not attempted.

The tuning of this arrangement will be far above that of the three circuit arrangement of Fig. 1 and separation of stations as close as can be obtained with a

super heterodyne should be possible with the additional advantage of not spoiling quality, because of the property of these

coupled circuits of giving a flat-topped resonance with a sharp side cut off.

It should be noted that I intentionally put a leak of 200,000 ohms across the second condenser of each pair. This resistance will tend to prevent the flat-topped

resonance curve becoming lopsided. Good shielding will be necessary in the receiver and giving oneself ample room is a very good way to make sure of this.

In Fig. 3 I illustrate the circuit I suggest, arranged for both ranges of wavelengths. Some system of switching can be devised to throw over from one pair of coils to the other pair in each compartment.

I suggest coupling the pairs of coils together by placing them end to end; the low-potential ends should be together, but any way of doing this which gives the desired result is all right.

Also I suggest that the long-wave coils can be placed on either side of the condensers well away from the short-wave coils so as to avoid any inter-coupling effects.

Long-wave coils if arranged too near short-wave coils are apt to give rejector effects on certain wavelengths and this may be accentuated if the change-over switch system is arranged so that there is a capacity coupling across the switch. I should arrange for a separate switch in each compartment, the switch

"Each year I like to review the circuits with which I am acquainted; add to all the old knowledge the new knowledge gained during the year and then reconstruct an ideal circuit irrespective of cost and size."

H. J. ROUND

An ideal set of last year, of which I was very fond, consisted

of two screened valves, an anode bend rectifier and two L.F. magnifiers—R.C. coupled as in Fig. 1. This set has two main defects, the first being that the tuning is not sufficiently sharp and the second is that there is a tendency to "motor-boat" in the L.F. stages when using batteries of too high a resistance or when using mains drive. Incipient "motor-boating," long before oscillation takes place, is a common habit of R.C. couplings and later in this article I will show how it is produced and how it can be cured.

The advent of the screened valve with its rather large H.F. magnification was, if anything, a step backwards in tuning, because, before, where we needed four valves to get the same result we automatically put on five tuning circuits and narrowed down our tuning band.

Now we only have three circuits to tune, and three is not really enough under the shadow of 2LO, or worse still, near a high-power station like 5GB.

With the setting up of regional stations, better tuning will be very necessary and some time ago I indicated how double-tuned circuits were a cure for the trouble. I suggested that manufacturers would be wise to make up double-tuned circuits geared and set for home constructors to use. I have not seen any such units yet, possibly the expense is rather heavy, but they will have to be used in the finer receivers which

distant stations, valve hiss is beginning to enter in daylight reception on frames, and the greater E.M.F. given by the aerial

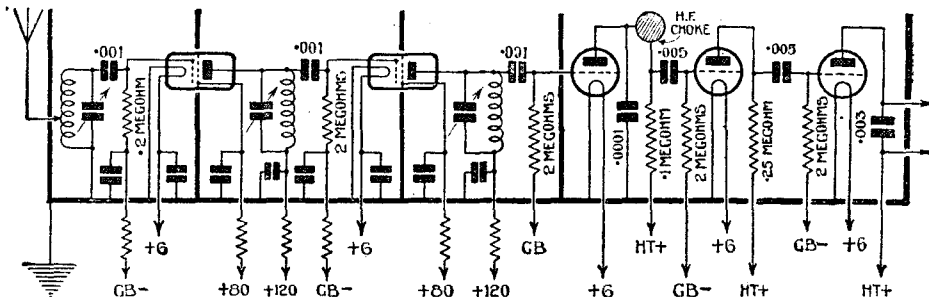

Fig. 1—Last Season's Ideal Circuit.

reduces the amount of amplification necessary and thus reduces the hiss.

Mind I am talking about ideal conditions; next year if I can get equal results with a tiny frame, so much the better.

For my ideal receiver I should be content with two screen-valve H.F. stages and

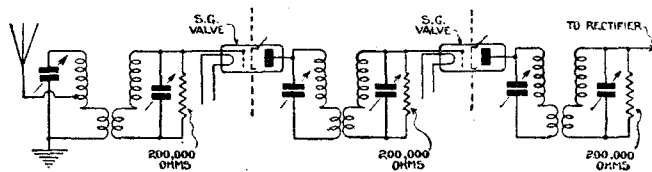

Fig. 2—Skeleton Tuning Circuits in Ideal Receiver.

no reaction, and these stages would be coupled together with double-tuning units which incidentally automatically get rid of the grid leak and condenser arrangements.

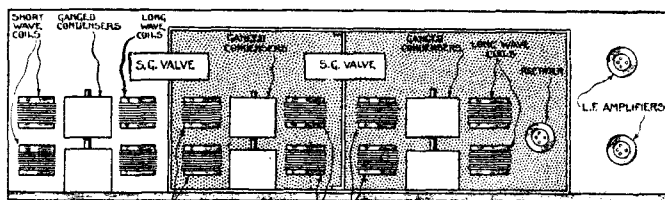

Fig. 3—Layout of Suggested Ideal S.t.

CAPT. ROUND ON "IDEALS IN SETS" (Continued)

shaft could be provided with its control handles on the panel above the condenser knob, and on the switch shaft two contact tongues could be made to connect either to the short-wave or to the long-wave coils (Fig. 4).

All coils I should wind astatically in any convenient style—the short-wave ones being of Litz wire, but this will not be necessary for the long-wave coils.

If the condensers are of log-law type, initial tuning adjustments could be made on them, and variometer coils could be used if the condensers are of another type.

Certain of the circuits have more self-capacity than others, but the chances are that with the later type of screened valve the zero capacities will be nearly equal.

Ganging

All the circuits can be adjusted to go together with the pairs of coils loosely coupled and then the coils of a pair can be brought nearer to a point just where signals are a maximum; nearer together still will weaken signals, and flatten the tuning, although a little overall flatness will tend to maintain the ganging without seriously increasing the pick-up of strong stations well away from the wavelength being received.

Magnetic coupling tends to greater constancy of tuning curve over the wavelength range, as the bumps of the double bumped tuning characteristics remain at about the same distance apart. With capacity coupling, these bumps would get wider apart on the shorter waves.

It will be noted that in the sketch I have placed the rectifier in the last H.F. compartment as against the old practice of putting it with the L.F. amplifier. This rectifier I separate from the next L.F. valve either by a choke or a resistance.

The reason for this change of position is that the rectifier essentially must have H.F. on its grid and if the rectifier is in the L.F. compartment the latter must be heavily shielded, whereas if the resistance or choke separation is provided as shown, H.F. does not get into the last two valves and back to the aerial as it is otherwise apt to do.

Now for the L.F. part of the circuit. This remains more or less the same as before except that precautions are taken against "motor-boating."

A short discussion of "motor-boating" will be of use here. In Fig. 5 a single valve is shown connected to a high-resistance battery where the resistance is represented by R, and the anode resistance of a previous valve is as shown.

Any change of potential across R, due to current flow in the plate circuit is transmitted through A to the grid of the valve, causing distortion; in this case the ten-

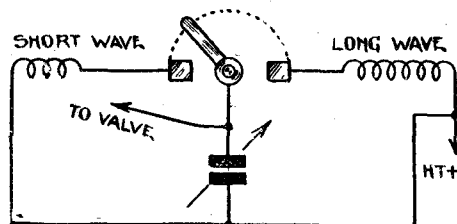

Fig. 4—Switching arrangement from short to long waves. (Two of the blades on the same shaft and four contact pieces)

dency is to reduce the overall magnification on account of the phase relationship of the voltages.

If we take two valves as in Fig. 6, the

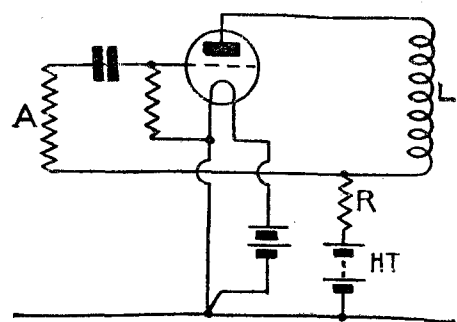

Fig. 5—Negative motor-boating condition

same phenomenon occurs, but the tendency there is to increase the magnification and, in the limit, oscillate if there is any inductance in the circuit.

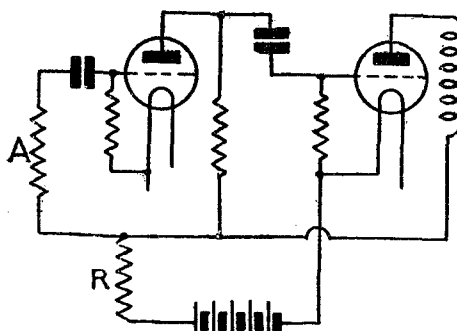

Fig. 6—Double-valve positive motor-boating condition

The cure in both cases is to split the anode resistances and earth them through fairly large condensers at the splitting

place. Fig. 7 shows this arrangement which has been previously described by Mr. Reyner, although I have used this system now for two or three years in standard practice for both smoothing (when using mains) and anti-"motor-boating."

In Fig. 1 it will be seen that the three valves are connected up so that there will be "motor-boating" tendencies owing to the H.T. supply being connected to the tuning coil and thence through the condenser to the grid of the rectifier.

In the new L.F. circuits this bad arrangement vanishes and the "motor-boating" tendency is considerably less.

The Ideal Circuit

As no self-respecting amateur with a really good set will use less than 200 volts on his power valve, I give the final diagram of connections for this set assuming that 200 volts will be used. Carbon or Loewe leaks can be used for the various breaking-down resistances which will be of the approximate value shown.

These resistances will now act as stoppers for H.F. coupling via the fixed leads—thus avoiding the necessity of stopping chokes, etc.

The whole set will operate quite well on the mains, with the addition of a small smoothing choke and condenser, for it is already fairly well smoothed due to the various resistances and condensers.

We have gained stability, quality and ease of tuning, but at the expense of size and cost. At the moment I cannot imagine such a set being put on the market at a reasonable price in a finished form although, of course, the home constructor will not have to spend too much if he is an enthusiast.

THE ULTRA-MICROMETER

THIS instrument is the invention of a Japanese radio-engineer and is designed to measure infinitesimally small movements or displacements. The essential feature of the instrument is a valve-generator with carefully tuned circuits. The movement to be measured is made to produce either a change in the capacity-value of the tuned circuit, or else a change in the eddy-current loss set up in a conductor placed in the field of an inductance coil.

This naturally causes a change in the plate-current output from the valve generator which is first magnified by the amplifying action of the valve, and is then applied to a sensitive recording galvanometer or oscillo-graph tube.

M. A. L.

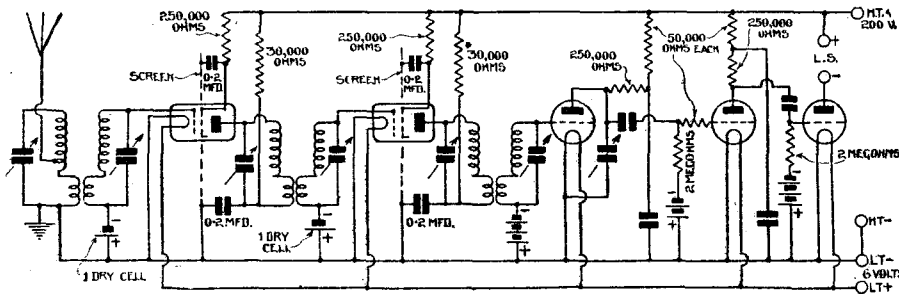

Fig. 7—Suggested Ideal Circuit

COMPLETE GUIDE TO SHOW

STANDS Nos. 109-127

(Continued from page 366)

Stand 109. William Dibben & Sons, Ltd., 82 St. Mary's Road, Southampton.

Multi-valve receivers shown include a five-valve portable receiver known as the Cromwell V, in walnut cabinet, using the new pentode valve and balanced-armature speaker; a three-

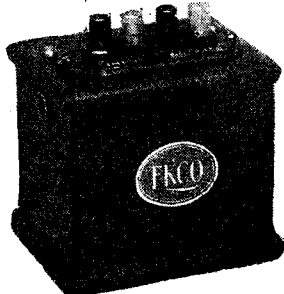

Ekco Transformer (Stands 48, 49, 50)

valve pedestal model known as the Monarch III, self contained, built on very modern lines; a gramophone-cum-wireless receiver incorporating a mechanical gramophone, electrical reproducing gramophone and wireless receiver, occupying no more space than an ordinary gramophone, supplied with either a parabolic-reflector type speaker or moving coil.

Stand 110. The London Electric Wire Co. and Smiths, Ltd., Church Road, Leyton, E.10.

One of the new products shown is the Lewcos H.F. choke, in the design of which the Lewcos engineers have spent considerable time in order to produce a 20-2,000-metre choke of really high efficiency. All the standard Lewcos coils, "Q" coils, and short-wave coils, as well as the famous Glazite wire, are to be seen.

Stand 111. Wingrove & Rogers, Ltd., 188 and 189 Strand, W.C.2.

Variable condensers are the chief attraction. The Polar Ideal slow-motion condenser has an all-round slow motion with a velvet-smooth action, slow motion being obtained by the knob and quick motion by the dial. The ratio is approximately 30:1, and it is made in six capacities. Polar all-brass condenser, known as the

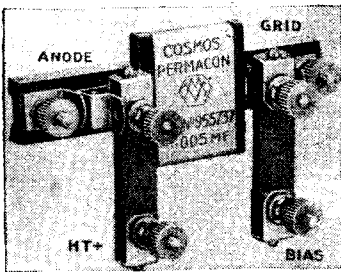

Metro-Vick Skeleton R.C. Unit (Stands 32, 41)

No. 3, was placed on the market in January last, and large numbers have been sold. It is exactly similar to the Polar Ideal condenser, except that it has no slow motion, and it is similarly made in six capacities. Phosphor bronze balls, which have been found specially suitable for ultra short waves, can be fitted in either of the above condensers at an extra price of 6d. and 3d. respectively. Polar drum control condenser is an Ideal

condenser mounted with a parallel to panel arrangement, being supplied with two drums, one for slow and the other for fast motion. Then there is the Polar high-frequency choke, made in two sizes.

Stands 112 and 113. Burndepth Wireless, Ltd., Blackheath, S.E.3.

Receivers, components, and accessories displayed on these stands include portable and transportable screen-grid sets, tapped auto-choke, variable condensers, and filter units and chokes for eliminators. Added to these the cabinet cone loud-speakers, new Ethopower, H.T. eliminator, L.T. battery charger, automatic power control, auto transformer loud-speaker output unit, Ethoplugs, electric soundbox, and volume control and adaptor make a display that ought to be seen by every visitor.

Stand 114. C. A. Vandervell & Co., Ltd., Acton, W.3.

On this stand is a full range of batteries suitable for high and low tension purposes. In the high-tension range will be found the H.M.6. This battery is the latest addition to the C.A.V. products, and makes use of the all-moulded material for the construction of the case. The A.G.M. mass plate cell is intended for receivers having small current consumption not exceeding quarter of an ampere. This cell is supplied in a dry-charged state, so that it only requires

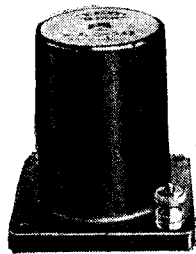

Left: Dubilier H.F. Choke (Stands 102, 103)

Right: Clifphone Balanced-armature Loud-speaker (Stand 176)

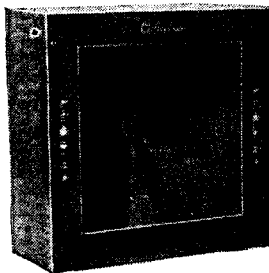

filling with acid to be made ready for use. It holds its charge for extremely long periods. The N.S. non-spillable range of batteries presents a real advance in this class of battery. Whereas many cells depend on their immunity from spilling by employment of acid traps, the C.A.V. battery is filled with a special solidified electrolyte, which, although as effective as ordinary free acid, remains undisturbed whatever the angle of the battery.

Stand 115. Garnett, Whiteley & Co., Ltd., Lotus Works, Liverpool.

A source of attraction is the transportable receiving set. This is a three-valve set using Mullard screened and pentode valves. Lotus portable set is a three-valve set using Mullard screened and pentode valves. Vernier dials, valve holders, jacks, plugs, switches, and vernier coil holders are among the components, which include the Lotus remote controls. There is now a remote control to suit every type of receiving set. The standard type is the one for use with a receiving set using L.T. accumulator and H.T. battery. The eliminator remote control is for a set using L.T. accumulator and H.T. eliminator. The all mains control is for a set working all from the mains.

Stands 116, 117, 231, and 250. A. C. Cossor, Ltd., Cossor House, Highbury Grove, N.5.

Details of this stand are given on a later page.

Stand 118. Brandes, Ltd., Cray Works, Sidcup, Kent.

Complete receivers, accessories, including H.T. and L.T. batteries, are displayed very attractively. Included in the new season's products will be a four-valver, a cone loud-speaker and an L.F. transformer.

Stand 119. Graham-Farish Manufacturing Co., 17 Mason's Hill, Bromley, Kent.

The new R.C. unit should be seen: Audion, type 1, comprising 1-megohm anode resistance, .0004 condenser, and 4-megohm grid leak; Audion, type 2, comprising 100,000 resistance, .006 condenser, and 2-megohm grid leak. A new type of three-valve coupler, in which provision has been made for the inclusion, if necessary, of an H.F. choke between the plate of the first valve and the coupling condenser, is also shown. Other new lines include a variable heavy duty anode resistance, volume control, and variable grid leaks.

Stand 120. Whiteley, Boneham and Co., Ltd., Nottingham Road, Mansfield, Notts.

Apart from the W.B. anti-phonic low-loss valve holder, the main interest here centres on the W.B. popular cabinet patent cone loud-speaker which is moderately priced and pleasing in appearance. Other models of cone loud-speakers complete a noteworthy exhibit.

Electrolytic condensers: These will be of universal interest, as a reliable make of condenser of this type has been eagerly awaited by both trade and public alike.

Stand 123. Redfern's Rubber Works, Hyde, Cheshire.

Ebonart panels, with the new "moire" watered silk surface design,

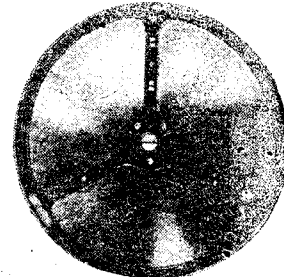

Electron Loud-speaker (Stand 42A)

in black and mahogany, attractive in appearance and almost scratch proof, are shown here, together with Ebonart panels, non-metallic, polished surface one side, in black and mahogany. The new Raven ebonite radio panels, non-metallic surface, polished one side, in black and mahogany colours, also with the new wavy surface design. Ebonite low-loss coil formers and Esonite H.F. choke formers complete a very comprehensive exhibit.

Stand 124. Webb Condenser Co., 42 Hatton Garden, E.C.1.

Stands 125 and 126. Oldham and Son, Ltd., Denton.

Besides a selection of low- and high-tension accumulators, the new high-tension 10-volt blocks of the 2,750 and 5,500 milliamperes capacity will be shown, and also carrying arrangements for building the blocks up in 40- and 60-volt accumulators. A large portion is devoted to a new range of battery chargers, special models being shown for low-tension and high-tension charging on both A.C. and D.C. mains.

Stand 127. Falk, Stadelmann and Co., Ltd., 83 to 93 Farringdon Road, E.C.1.

In addition to the Efesca regenera-

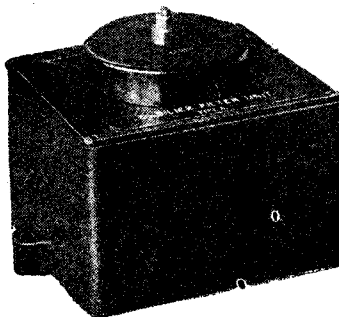

Dubilier Filter Unit Type A (Stands 102, 103)

tive aerial tuner, Efesca anode tuners, Efesca anti-cap switch, and the Efesca L.F. transformer, a new variable condenser designed on logarithmic principle is on view. A good

SHOW GUIDE CONTINUED ON PAGE 375

Look for LOTUS at OLYMPIA!

News at the Lotus Stand! Two new components—two new sets being introduced by Lotus.

There is a new Variable Condenser and Vernier Dial—both typical Lotus quality. The condenser is mid-line and logarithmic. It is made with chemically cleaned special brass vanes and end plates, with ample spacing and ball bearings.

The Lotus Vernier Dial is a slow motion dial with machine geared movement giving a ratio of 14-1. A closely marked satin aluminium dial reading 0-180 fitted to rear, fits flat against panel and a nickel plated cursor is rotated by a small knob round the dial.

The famous Lotus Remote Controls, Buoyancy Valve Holders, Coil Holders, Jacks, Switches and Plugs are also on view.

Come to Stand No. 115

LOTUS COMPONENTS

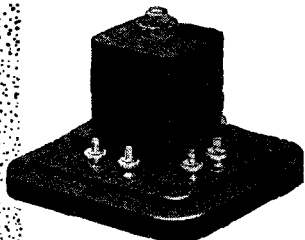
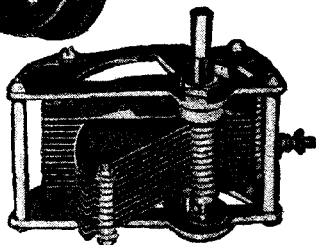
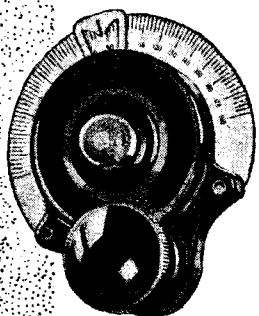

Lotus Relay

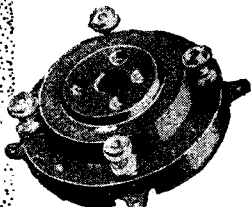

Lotus Valve Holder

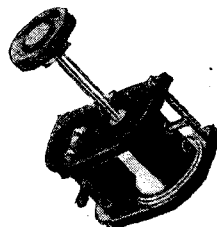

Lotus Coil Holder

PRICES

New Lotus Variable Condenser: '0005, 5/9d.; '0003, 5/6d.; '00025, 5/3d.; '00015, 5/-.

New Lotus Vernier Dial, 4/9d.

The New LOTUS Portable and Transportable Sets

The new Lotus sets are the latest wireless triumph. Using the new Mullard Screened and Pentone valves, the circuit is a combination of latest wireless discoveries and actually makes these three-valve sets capable of five valve results. Transportable models in oak, 30 gns., in walnut and mahogany, 31 gns. Portable models in leather case, 30 gns. Instalment terms.

Write for Booklet

GARNETT, WHITELEY & CO., LTD.,
Lotus Works, Broadgreen Road, Liverpool.

To Ensure Speedy Delivery, Mention "A.W." to Advertisers

COMPLETE GUIDE TO SHOW

STANDS Nos. 128-165

(Continued from page 373)

range of portables completes the exhibit.

Stand 128. L. McMichael, Ltd., Wexham Road, Slough.

The screened Dimic three is a notable feature of this display, which includes the new McMichael gramophone pick-up, of great sensitivity, and, of course, the well-known range of Dimic coils—strongly recommended by the firm as being ideal for screen-grid-Valve work.

Stand 129. Edison Bell, Ltd., Gillingall Road, S.E.15.

Complete receivers and well-designed portables are the main interest at this stand, where the Edison Bell Picnic Portable and Homestead three are well in evidence. A useful gadget is the Edison Bell pick-up arm, which can be used with any gramophone and any make of pick-up, avoiding the necessity of removing the tone arm.

Stand 130. The Carborundum Co., Ltd., Trafford Park, Manchester.

The lines exhibited include the following: Carborundum permanent detectors, stabilising detector units, grid leaks, anode resistances, and R.C.C. units.

Stand 132. Calisky, Ltd., 75 Aldgate High Street, E.1.

Stands 134 and 260. Truphonic Wireless Co., 121 and 123 Rosebery Avenue, E.C.1.

Portable receivers, gramophone and wireless combinations, loud-speaker units, chokes, and H.T. batteries complete an interesting range of exhibits to be seen here.

Stands 136 and 137. Houghton-Butcher, Ltd., 88 and 89 High Holborn, W.C.

As wholesale wireless dealers, this stand will appeal more to the dealer than to the ordinary public. A "Best-seller" competition lends interest to the range of components on view.

Stands 138, 162, and 163. Ormond Engineering Co., Ltd., 199 to 205 Pentonville Road, N.1.

Two-, three-, and five-valve receivers are included in Ormond's display of their well-known products, such as the slow-motion dual indicator dial, logarithmic condensers, and gang condensers. A comprehensive show of the products of the various departments, such as screws, screwed and turned parts and stampings, silver and nickel plating, bakelite mouldings, and cabinet work makes a strong appeal to the constructor. The large working models of the S.L.F. friction-control condenser and dial are again on view.

Stand 139. Eagle Engineering Co., Ltd., Eagle Works, Warwick.

According to this firm, the most interesting exhibit is the new *de luxe* receiver, which is entirely self-contained, requiring neither aerial nor earth, and which operates a coil-driven loud-speaker contained in the instrument. The simple change-over switch allows of either long or short-wave stations being received, or, alternatively, by plugging in a jack, provided in the instrument, gramophone records may be reproduced through the almost perfect amplifier embodied in it.

Stand 140. Formo Co., Ltd., Crown Works, Cricklewood Lane, N.W.2.

An interesting range of components are shown here, including a *de luxe* short-wave condenser outfit that will make a special appeal to the short-wave enthusiast. The compact Formo Densor, a semi-fixed type of special

value in portables, should also be seen.

Stand 141. The British Radio Corporation, Ltd., Weybridge, Surrey. Standard products include the

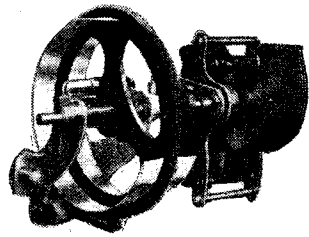

Igranic Vernier Drum Control (Stand 53, 54, 75)

B.R.C. long-range five, employing screen valves, shielded, with a range from 200 to 2,000 metres; the B.R.C. long-range six, incorporating a new H.F. shielded amplifier with screened valves, range 200 to 2,000 metres; and the B.R.C. Radio Exchange, a new broadcast receiver, which will switch to any of eight different programmes; as simple as switching on the electric light. It employs six valves, including screened valves in H.F. stages. This is claimed as one of the most simple receivers. New apparatus includes the B.R.C. three-valve shielded all mains receiver for direct A.C. mains, employing new

Stand 147. Partridge & Mee, Ltd., 12 Belvoir Street, Leicester.

Parmeko accessories for "mains" working are sure to attract attention at this stand, where complete H.T.

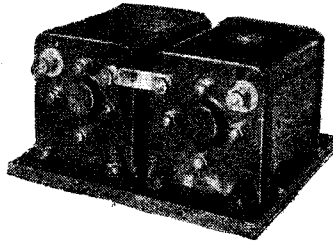

Westinghouse Large Power Rectifier (Stand 78)

eliminators and such accessories as power transformers, heavy-duty chokes, and moving-coil output transformers are displayed. The last-named is specially noteworthy, since it offers exceptional facilities for adjustment of the impedances of the valve and choke. There is one unit for A.C. mains giving 160 volts D.C. at a load of 21 milliamperes.

Stands 148 and 149. A. W. Gamage, Ltd., Holborn, E.C.1.

The exhibit covers a complete range of valve receiving sets to meet all requirements. All new models employ many unique points in design

WATCH AN EXPERT BUILD SETS AT THE "A.W." STANDS

type raw A.C. valves, range 200 to 2,000 metres, single control tuning, gramophone amplifier incorporated.

Stands 142 and 143. Peto-Scott, Ltd., 77 City Road, E.C.1.

New and well-known Keystone components are displayed here, including a screen-grid choke, an H.F. coupling unit, and a drum drive. The Copex universal tuning coil—a new product—is interesting, as by means of a simple switch both wavelength bands are covered. Red Triangle ebonite, in black, polished or matt, and mahogany grain can also be seen in all standard sizes.

and the new listener has been carefully considered, ease of operation being an outstanding feature. A complete range of loud-speakers and useful gadgets will be found, and it is here that an interesting display of Morse practise apparatus is on view.

Stands 150 and 151. Automatic Coil Winder and Electrical Equipment Co., Ltd., Rochester Row, S.W.1.

Stand 152. Camden Engineering Co., Ltd., Bayham Place, Camden Town, N.1.

Stand 153. Wilkins & Wright, Utility Works, Holyhead Road, Birmingham.



Selhurst Moving-coil Loud-speaker (Stand 172)

Stand 144. Portable Utilities Co., Ltd., Eureka House, Fisher Street, W.C.

Added to the range of Eureka products, this firm has on view three long-range portable sets of special interest, since they incorporate the new screen-grid valve in the high-frequency stages.

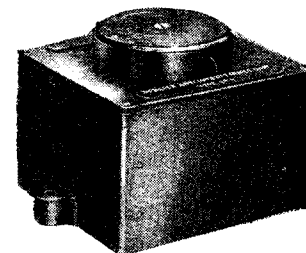

Dubilier Anti-interference Unit (Stand 102, 103)

Constructors should see the new anti-capacity switch, thumb control condensers, thumb control plain dial, thumb control vernier dial, Mite con-

densers, aluminium shielding boxes and panels, and combined drum control with vernier dial, all of which are displayed at this stand.

Stand 154. Walker Bros., St. Joseph's Works, Eramley, Guildford. These woodwork specialists are showing standard products such as portable and ordinary wireless cabinets, and, as a special attraction, licensed cone loud-speakers.

Stands 155 and 156. S. G. Brown, Ltd., Western Avenue, North Acton, W.3.

In addition to their already well-known range of loud-speakers of 71 types, this firm are showing several notable additions, including what is probably the most interesting new-comer, the Cubist moving-coil loud-speaker. A miniature addition of the Mascot loud-speaker, the Duckling, is another moderately priced cone-type instrument that should not be missed. Then there is the Brown low-frequency transformer.

Stand 157. Watmel Wireless Co., Ltd., Imperial Works, High Street, Edgware.

The main item of note is an all-mains receiver, complete with gramophone pick-up, which we hope to review in the near future. All constructors should make a point of seeing the Watmel double-range tuning coil, which abolishes all coil changing.

Stand 158. Fuller Accumulator Co. (1926), Ltd., Woodland Works, Chadwell Heath, Essex.

Stand 160. Bakelite, Ltd., 68 Victoria Street, S.W.1.

A representative selection of bakelite mouldings are shown, including examples of mouldings made from a new bakelite moulding material, which possesses much greater shock-resisting properties.

Stand 161. H. Clarke & Co. (M'c), Ltd., Atlas Works, Easton Street, Old Trafford, Manchester.

Amongst other components, the following are specially attractive. The full series of the new range of all Clarke's Atlas battery eliminators, for both direct and alternating current. Four types of coils, namely, ordinary or general-purpose coils, centre-tapped coils, "X" or double-tapped coils, and new short-wave coils. Resistance-coupling units, fixed condensers. A good assortment of Pirtoid tubing, in the most usual dimensions. In addition to the foregoing there is a good display of insulating materials.

Stands 164 and 165. Siemens Bros. and Co., Ltd., Woolwich, S.E.18.

This company's exhibit is devoted principally to primary batteries for H.T., L.T., and grid-bias purposes. The following batteries will be exhibited: Small capacity, standard type; small capacity, popular type; large capacity, power type; extra large capacity, super-radio battery; high-capacity batteries for portable sets; grid-bias batteries; special batteries for overseas; Crystacel accumulators; L.T. dry cells and batteries. The special section of the stand devoted to batteries for overseas should prove of particular interest to the export trader. There is also a display of ebonite in the form of sheets, rods, and mouldings. A number of samples are shown.

SHOW GUIDE Continued on PAGE 388

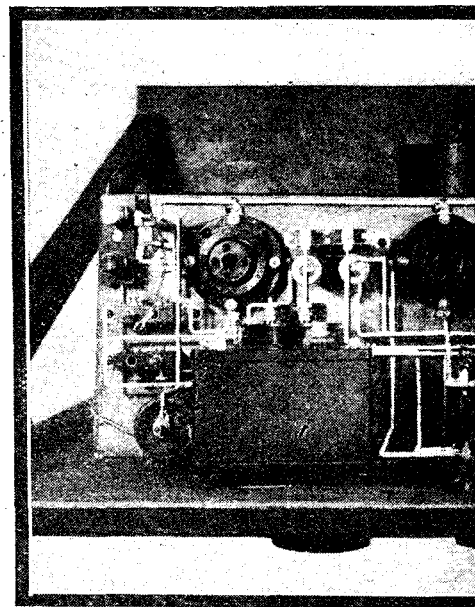
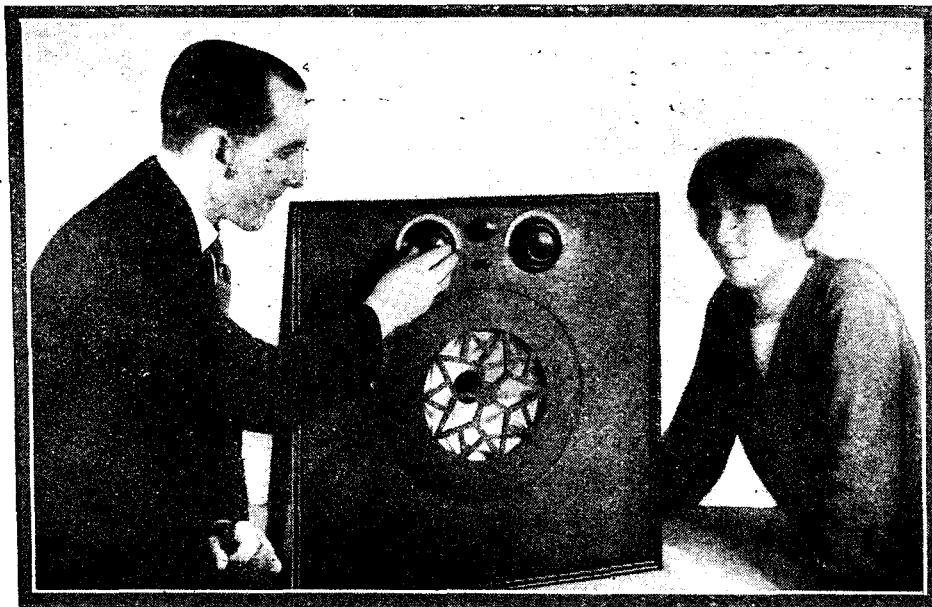

BEHIND the baffle board of a moving-coil loud-speaker is ample room for a complete wireless receiver and its attendant batteries. That is the simple fact we had in mind when designing the special exhibition receiver illustrated and described in this article. From time to time in the past few months regular readers have been given details for the home assembly of moving-coil loud-speakers of various types. On several occasions details have also been given of suitable receivers for operating these moving-coil loud-speakers to the best advantage.

Now, for the first time a combined moving-coil loud-speaker and power-amplifying receiver has been evolved in our constructional department, and is described for the benefit of listeners who seek the best possible reproduction of the broadcast programmes.

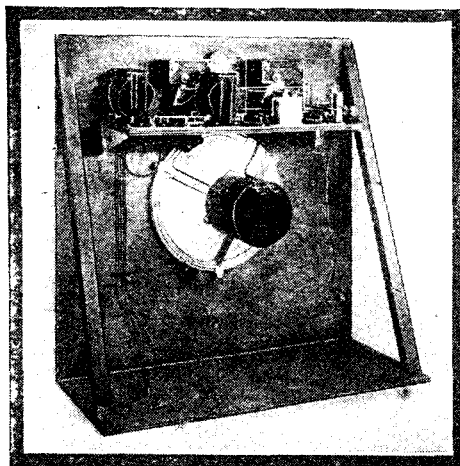

The Eaffle Three without batteries, etc.

The NEW-STYLE

Unique Construction Incorporating a Three-stage Receiver with Par

Self-contained

There are certain undeniable advantages to be derived from the assembly of a self-contained instrument such as we are describing, chief amongst which is the great saving of space, which, incidentally, is some justification for the comparatively large size of the average baffle board.

It is left to the taste of the individual whether the skeleton baffle erection is housed in a complete cabinet or whether the receiver portion alone is protected from dust and interference by means of a small auxiliary cover. The only technical consideration determining the constructor's choice in this matter is that when completely boxed in, the moving coil may sound a little "boomy" on speech, but then many listeners prefer a slight resonance, so our advice is to follow out the idea to the stage of completion depicted by our illustrations and decide afterwards about the cover.

On the score of appearance the complete cabinet is obviously desirable, though with a good french-polished baffle the original photographed model looks very presentable.

A two-foot baffle board with a centre grille for the moving-coil loud-speaker forms the basis of the assembly. The three-stage receiver is mounted on a wooden baseboard above the pot winding of the moving-coil loud-speaker and the various batteries are

arranged on the base support of the baffle board.

We should like to emphasise the simplicity of the actual constructional work involved in making this receiver, but before going into the constructional details a general theoretical survey is desirable.

The first thing to be decided was what type of receiver could be relied upon to give the best possible results in conjunction with the moving-coil loud-speaker. Quite

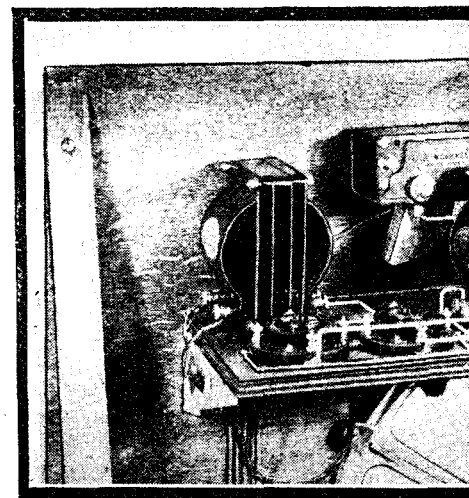

This photograph shows the actual re

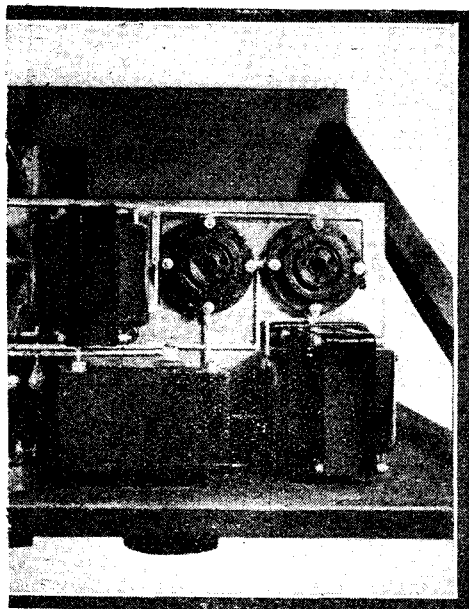

BAFFLE THREE

Parallel Push-pull Valves — By THE "A.W." TECHNICAL STAFF

Obviously, purity of reproduction was a big factor to be considered, but that was by no means all, for to get the most out of a moving-coil loud-speaker we have to take advantage of the fact that a great volume of sound can be produced without overloading this particular type of reproducer. Purity with power was what we were after—a combination we have achieved in this receiver.

Of the three available forms of low-

frequency amplification, namely, transformer coupling, resistance-capacity coupling and choke coupling, the transformer is usually voted for power and the resistance-capacity system for purity. Improved valves and transformers have greatly diminished any striking difference between the two systems, so that we can now obtain considerable amplification from a resistance-capacity amplifier just as we can obtain extraordinarily pure reproduction from a transformer.

Output Arrangements

In our view the choice of coupling device is of less importance to-day than the selection of a suitable output arrangement to deal with the amplified signals. It would seem obvious that, to obtain great power variations we must provide a large power valve in the final stage. With the recently announced reductions in the price of super-power valves this presents no difficulty to the listener of average means. But the real obstacle is not in the power valve, it is in the power supplied to that valve. Here the average listener draws the line and decides to sacrifice volume in order to keep down the size of his high-tension battery to modest proportions.

Readers will now see that what we really require is some system that will give us a

great power output with only a small high-tension battery. The solution of this part of the problem is in the use of push-pull low-frequency amplification.

Here we may point out that the particular system referred to has not received anything like the attention from enthusiasts that it deserves. The belief has grown up that the

chief use of push-pull amplification is in getting super power results with an ordinary power valve. That is quite true, but many miss the real point which is that small power valves require only a comparatively small *maximum* H.T., say 120 volts.

This means that two small power valves connected in a push-pull circuit can handle between them a signal voltage which, were one super-power valve used, would necessitate at least a 200-volt supply. Here, then, is the means whereby the average



Receiver. A plan view is shown above

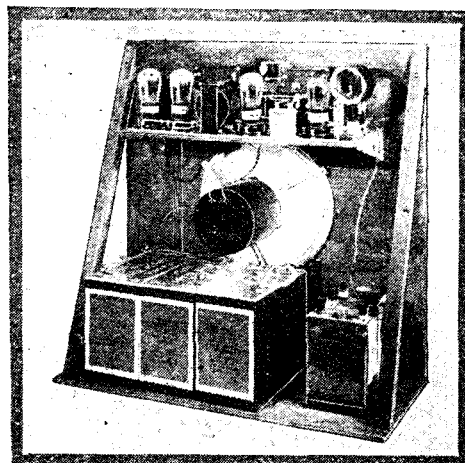

Rear View of Complete Receiver

“THE NEW-STYLE BAFFLE THREE” (Continued)

listener who, with some justice, protests against a greater H.T. supply than 120 volts, may enjoy a majestic volume of reproduction, hitherto associated with what

the two grids of the push-pull valves. The primary of this transformer connects with the preceding valve in the usual way. The two anodes of the push-pull valves are

secondary it will be clear that at any given instant the voltage on the grid of one of the power valves will be rising whilst the voltage on the grid of the other is falling.

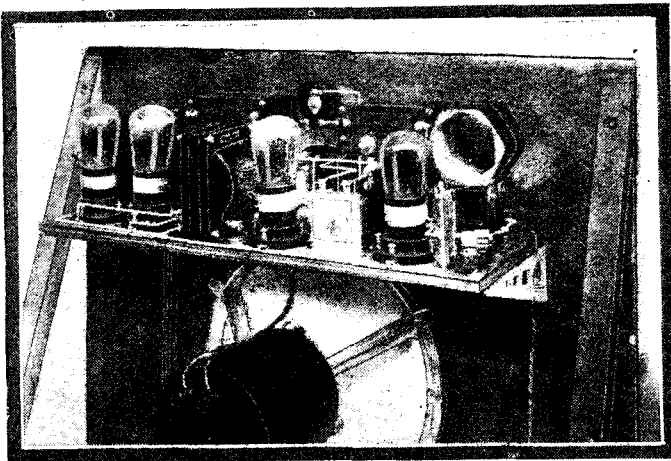

This photograph clearly shows the arrangement at the back

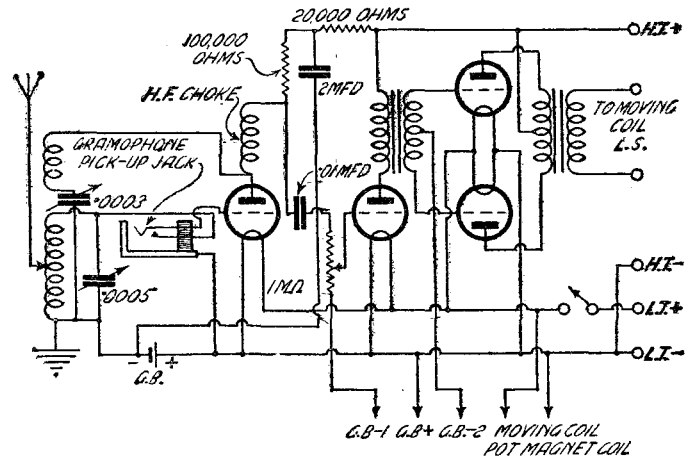

The Circuit using Parallel Push-pull Valves

he considers unreasonably high voltages of supply.

not connected in parallel. One anode goes to one end and the other anode to the other

The extreme limits of voltage variation with which the two valves are called upon

Push-pull Coupling

A brief explanation of the principle of push-pull amplification will, perhaps, enable the reader better to appreciate the system. Two valves and two special tapped transformers are involved. The main push-pull coupling transformer differs from the usual coupling transformer only in that it has a centre-tapped secondary winding.

The two outers of this secondary are connected to the grids of what we can term the push-pull valves—identical power valves of the DEP 215 type. The centre-tap of this secondary supplies the common grid bias feed through the two halves of the winding to

end of the primary of the output transformer, which is

to deal are cut down by half, due to the fact that the centre point of the secondary of the transformer is common to the filament of each valve.

Thus by splitting the voltage before it is applied to the last stage and combining the output from the two valves again, after it has been amplified, we are able to deal with large signal voltages without overloading. The amplified outputs of each power valve combine again in the primary of the output transformer and are then passed to the secondary and so to the loud-speaker.

In practice two power valves with 120 volts H.T. will deal with much larger signal variations than two such power to both halves of the

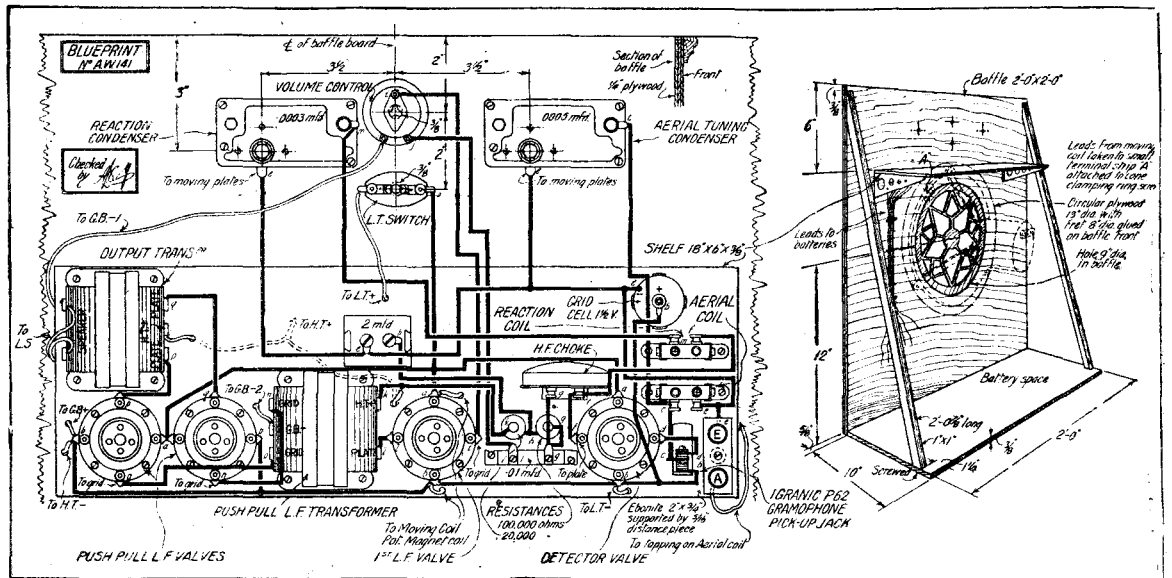

The Wiring Diagram with Push-pull Valves. Blueprint available, price 1/6

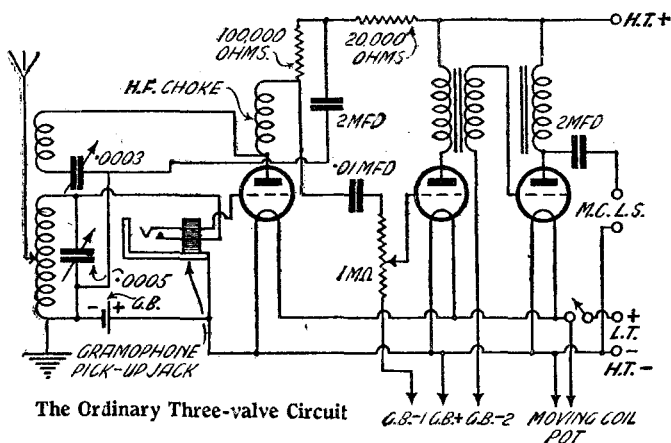

The Ordinary Three-valve Circuit

G.B.-1 G.B.-2 MOVING COIL POT

(Continued on page 410)



Mention of "Amateur Wireless" to Advertisers will Ensure Prompt Attention

WITHOUT FEAR OR FAVOUR

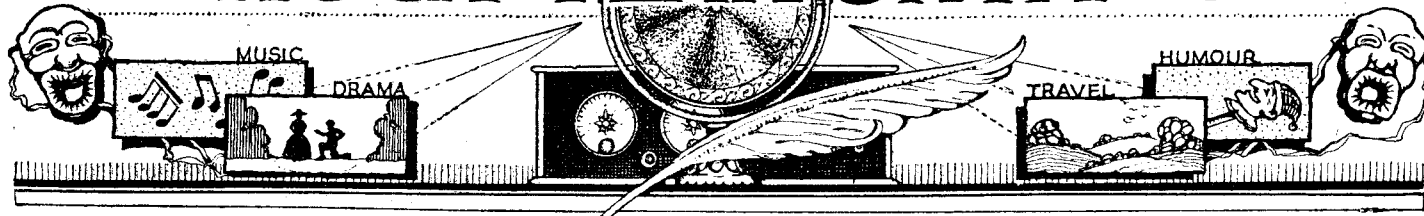

A Weekly Programme Criticism by Sydney A. Moseley

I SUPPOSE we must still award the palm to Sir Henry Wood and his Symphony Orchestra. What finer concert could we conceive than the Thursday popular, with such old favourites as the First *Peer Gynt*, or the Unfinished Symphony or Mendelssohn's "A Midsummer Night's Dream"?

The Proms. would be lost without them.

Two experiments by the B.B.C. must be singled out for detailed mention, although I must leave the "Princess Who Lost a Tune" for possible mention at some other time, when, I hear, it is to be put on again.

I propose to examine rather fully the *Kaleidoscope*, because it was officially announced as "an experiment." Let us see whether it was a successful experiment, and if so, whether the B.B.C. would be justified in putting on similar plays.

Kaleidoscope is described as a "Rhythm representing the life of a Man from Cradle to Grave." It was written by Lance Sieveking who, if I mistake not, is Mr. Lancelot de Gilberne Seiveking, a young member of the B.B.C. staff who was once a worthy member of the Programmes Dept.

(I am glad by the way he has adopted a shorter nom-de-plume; his real name is a bit of a mouthful).

Let me say that I suspected the title. *Kaleidoscope* is oft-times an excuse for incoherence and patchwork. Indeed the author's ambitious efforts to thread together a number of incidents in a lifetime, sometimes gave this impression. (By the way, I noticed that with all the incidents mentioned, there was little mention of work. Alas! heroes in plays and books don't seem to do anything so trivial).

Yet he disarmed criticism by drawing pretty fully on some choice tit-bits from the most popular of authors and composers.

Who is going to cavel at a production which gives one Grieg and Galsworthy, Chopin, and masters, whose melodies are hummed in every household?

Yet Mr. Seiveking gave us something to think about between whiles. The idea itself somewhat suggested the Rake's Progress and, after all, nothing so very original happened to his Boy, Youth, and Man.

He told us nothing. Yet an author who finds the flimsiest of excuses to give us such beautiful prose, verse and music may not only be forgiven but encouraged in his experimenting.

The *Kaleidoscope* was sometimes too insistent. When a man sees his wife drowning, his mind is no longer kaleidoscopic. It is arrested and drawn towards the dramatic channel. No matter what sort of a scamp he may be, the sense of tragedy must be uppermost. It would be unnatural to be otherwise. He wouldn't be thinking of jazz or wait until Handel's "Largo" was half-way through before exclaiming "Take my coat."

Nor would he make this exclamation at all. Such a careless type of individual would throw his coat off and risk the dust.

The cast as a whole played up to the high artistic level of the production, which must have entailed a vast amount of detailed work. For this, the author deserves every credit for, so far as the listener could tell, the production passed off without a hitch.

A word, however, about the length of the cast.

There were in the speaking parts nine males and females. There were in addition four soloists, a pianist, The Parkington Quintet, The Wireless Chorus with Stanford Robinson as Chorus Master, Jack Padbury's Cosmo Club Dance Band and the Wireless Orchestra conducted by John Ansell.

Now I want to know how much this experiment cost. On the face of it there seems to have been an almost reckless disregard of money. Of course, in order to achieve success for its experiments of its own prodigy the B.B.C. might well have employed the Queen's Hall Orchestra, the Albert Hall Orchestra, Sousa's Band and National Chorus.

Let us have another of these experiments by all means, but go slow on the till, Lance, me lad!

Sir William Bragg's Presidential Address to the British Association was interesting to listeners from many aspects. First the subject matter, second the clear enunciation—even when he was tired.



WIRELESS ON MANOEUVRES

Royal Signals Corps Wireless Section, attached to the 2nd Division working their "A" set in a country lane near Pulborough.



SPECIAL EXHIBIT
 ON OUR
STAND 110
 NATIONAL RADIO EXHIBITION
 OLYMPIA
 September 22—29
 OF THE
"ACE OF TWOS"
 WITH
 LEWCOS "QAM" COIL

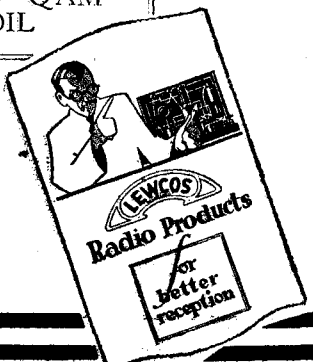

Use the LEWCOS "QAM" Coil with the "Amateur Wireless" two-valve receiver—"The Ace of Twos"—and get perfect reception on the broadcast band from 200 to 2,000 metres, without troublesome coil changing.

By merely plugging in suitable "Lewcos" short-wave coils, the "Ace of Twos" will also receive short-wave stations, including several American and the principal British and Continental transmissions.

Don't forget to visit Stand 110 at Olympia and examine this set with "Lewcos" coils for yourself.

from all good Radio Dealers

LEWCOS
 REGD.
"QAM" COILS

THE LONDON ELECTRIC WIRE COMPANY AND SMITHS LIMITED, CHURCH ROAD, LEYTON, LONDON, E.10
 Telephone: WALTHAMSTOW 2531
 Telegrams: "LEWCOS, PHONE LONDON"

Advertisers Appreciate Mention of "A.W." with Your Order

COMPLETE GUIDE TO SHOW

STANDS Nos. 167-217

(Continued from page 375)

Stands 167 and 168. East London Rubber Co., 29, 31, and 33 Great Eastern Street, E.C.2.

A full range of the latest type screen-grid valve receivers, screen-grid portables, together with all first class components, and H.T. elimina-

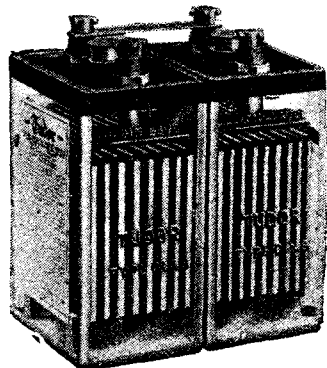

Tudor 4-volt Glass-case Accumulator (Stand 249)

tors comprise the display of these two stands.

Stands 169 and 170. Ellison & Hillman, 123 Albion Street, Leeds.

Special attention is devoted here to high- and low-tension mains units, trickle chargers, A.C. valves, and other devices for operating receivers direct from the mains. A full range of moving-coil loud-speakers, together with accessories, are shown, as well as short-wave receivers.

Stand 171. Benjamin Electric, Ltd., Brantwood Works, Tariff Road, W.

In addition to the Clearer Tone valve holder, of which one and a half million are in use, this well-known firm is showing the Vilro holder, a smaller and cheaper edition of the Clearer Tone. Both types are from now on supplied with soldering tags already tinned. A new battery switch, with double-pole contact and soldering tags, and a similar switch with terminals for easy wiring, will interest the set builder. The listener should see the improved earthing device, claimed as being 60 to 80 per cent. better than the ordinary water-main earth.

Stand 172. A. Baker, 89 Selhurst Road, S.E.25.

Two permanent-magnet moving-coil loud-speakers and five electromagnetic types are on view at this interesting stand. All models incorporate a new centring device that is claimed to overcome all the usual drawbacks.

Stands 173 and 174. Hobday Bros., Ltd., 21 to 27 Great Eastern Street, E.C.2.

See Us Building Sets at Our Stands

A comprehensive range of all the leading makes and types of wireless apparatus are shown by these wholesalers, whose display will be of interest principally to the trade.

Stand 175. Sylvex, Ltd., 41 High Holborn, W.C.1.

As manufacturers of wireless crystals, this firm is exhibiting Sylvex and Reactone synthetic-type crystals, as well as the Sylvex permanent detector and cone washers. The latest line will be Sylvex cone

material, made of Pertinax and claimed as being stronger and better than fabric cones.

Stand 176. Cliftophone and Records, Ltd., 95 Park Street, S.E.1.

The new Cliftophone "armature" speaker on view here claims a number of advantages over other instruments hitherto considered good. It is of the cone type, the cone being of special manilla paper, not reinforced with cane or wood. But the cone has no point, being truncated, the end to which power is applied thus being a circle more than 6 in. in circumference, and so fitted to take the shock delivered by the armature, which latter is, in fact, a diaphragm with metal cone.

Stands 177 and 178. Brown Bros., Ltd., Great Eastern Street, E.C.2.

As wholesale distributors, this firm are showing all the principal makes of

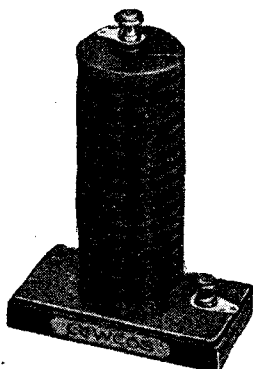

Lewcos H.F. Choke (Stand 110)

high-class components, receivers, and accessories.

Stands 179 and 180. Sun Electrical Co., Ltd., 118 Charing Cross Road, W.C.2.

As wholesale distributors, this firm are showing a representative range of receivers and components.

Stands 181 and 182. A. J. Dew and Co., 33 and 34 Rathbone Place, W.1.

A representative range of wireless receivers, accessories, and components, including the Fidelity Four receiver, as supplied to many educational authorities for use in schools, make this stand one of interest to the listener.

Stands 184 and 185. C. F. & H. Burton, Progress Works, Walsall.

A complete range of condensers, including straight line, mid-log, and neutralising condensers are shown. The most interesting exhibits are new types of condensers, valve holders, dials, and resistors.

Stands 203 and 204. A. F. Bulgin

and Co., 9, 10, and 11 Cursitor Street, E.C.4.

Among the many new lines is a direction locator, comprising a neat wallet containing two maps and a special compass fitting. Full directions are given how to locate the direction of aerials of all the largest broadcasting stations of northern Europe. Regarding the remainder of the exhibits, these comprise a large range of Bulgin push-pull switches, station logs, dial indicators, miniature

panel-mounting instruments, including voltmeters, ammeters, and milliammeters, cast aluminium panel brackets, short-wave tuners, short-wave chokes, high-frequency chokes, safety mains plugs, cable plugs, neutralising condensers, both base-board and panel mounting, gramophone pick-up adapters, grid leak holders, six types of grid-bias battery clips, lead-in spring wire contacts, Ivorine labels of various types and a large selection of soldering tags of unique types.

Stand 205. Triumph Cabinet Works, Ltd., 548 Holloway Road, W.7.

"A.W's." Stands are Nos. 63 & 66

Wireless-receiver cabinets are the line here. Most of the business is mass production to customer's own specification.

Stand 206. Maintan Manufacturing Co., 126 Portland Road, Hove, Sussex.

Battery eliminators in all-metal containers, for A.C. and D.C. mains working, are shown. Special stress is laid on the fact that a fixed resistance is used for each H.T. tapping to ensure absence of hum.

Stand 207. Radio Service (London), Ltd., 105 Torriano Avenue, N.W.5.

This firm deal with high- and low-tension accumulator hire. Visitors living within twelve miles of Charing Cross who desire such a service should call here.

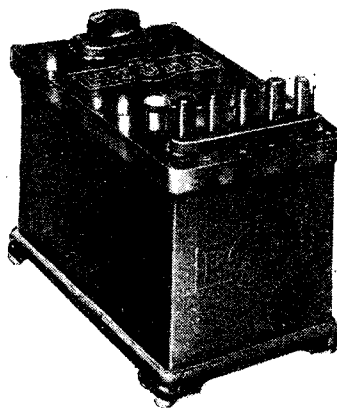

Mullard H.T. Eliminator (Stands 88, 89, 90, 97, 98, 99, 133, 267)

Stand 208. London Electric Stores, Ltd., 9 St. Martin's Street, Leicester Square, W.C.2.

As wholesalers, this stand is not showing any specialities, though attention is drawn to two catalogues which are being distributed.

Stands 209 and 210. London Radio Manufacturing Co., Station Road, S.W.

The Orphean three-valve portable with the latest types of valve should be seen at this stand, where cabinet cone speakers and the Orphean gramophone pick-up are displayed.

Stand 211. A. W. Stapleton, 19a Lorrimore Buildings, S.E.17.

Unique in its construction, the Lorientat multiple fixed-resistor unit on view is deservedly popular with

constructors. There is also the Lorientat—a potentiometer constructed on similar lines to the Lorientat. Another component is the Lorientat, for D.C. charging, especially interesting to visitors who have D.C. mains installations.

Stand 212. R. F. Graham & Co., 45 Cambridge Road, Kingston-on-Thames.

The chief exhibit is the Norbex crystal detector, although for constructors there is also a range of plugs and numerous types of valve sockets.

Stand 213. George Bowerman, Ltd.,

10 and 12 Ludgate Hill, E.C.4.

This firm are showing Bowerman's loud-speaker and a cone unit for which great claims are made. Purity, volume, and adaptability are three features of the unit, which is assembled entirely without screws, so that it cannot develop a rattle or shake loose.

Stand 214. L. H. Reid & Co., 32 Victoria Street, S.W.1.

Gripso bakelite indicating terminals, with changeable labels, spade ends, pin ends, wander plugs, horizontal plugs, hook ends, the sleeves of which are made in various colours to match the labels, used with the bakelite terminals referred to above, are included in a display of components, as well as expanding earth clips, grid-leak holders, sockets, and couplers.

Stand 215. Hart Bros., Electrical Manufacturing Co., Ltd., 4 Queensway, Ponder's End, Mdx.

Harbros Easyfix flex, battery cords, loud-speaker leads, and instrument wires are displayed.

Stands 216 and 217. Donotone Loud-speakers, 40 Farnival Street, E.C.4.

Here the Donotone loud-speaker, which has been further improved and is entirely different from any other make, is shown. Purity of tone, together with ample volume, is the claim. It is supplied in various designs and finishes.

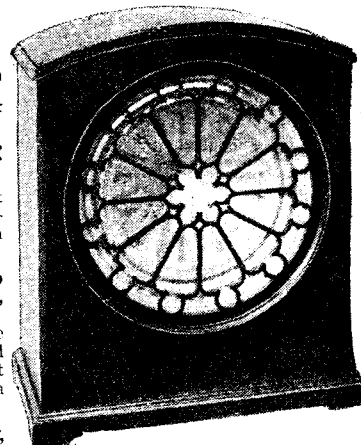

Orphean Super Cabinet Cone Loud-speaker (Stands 209, 210)

SHOW GUIDE CONTINUED ON PAGE 391

COMPLETE GUIDE TO SHOW

STANDS Nos. 218-265

(Continued from page 388)
Stands 218 and 219. J. J. Eastick and Sons, Bunhill Row, E.C.1.

Everyone visiting the Exhibition should obtain a copy of the new Eelex booklet, giving the fullest details of Eelex terminals. All the various designs of Eelex treble-duty terminals, spades, plugs, pin and eyes are exhibited. Another interesting exhibit is the Eelex lightning switch, that positively ensures the safety of the house and set during a thunder-storm.

Stands 220 and 221. Belling & Lee Ltd., Queensway Works, Ponder's End.

These stands are again devoted almost exclusively to indicating terminals. There are no actual new models, but the following new indications, in order to meet the requirements of the latest developments in radio, have been added: Pick-up, screen, held, mains plus, mains minus, A.C. mains. The outstanding feature of the exhibit is the tremendous reductions in price, which will come as a great boon to all those constructors who have long coveted the terminals, but have thought them to be rather too high in price.

Stand 223. DX Coils Ltd., 542 Kingsland Road, E.8.

DX short-wave coils are a big attraction here, where the constructor is catered for with plug-in coils and a new low-frequency transformer. The new transformers are made in four models, 3-1, 2-1, 1-1, and 25-1, all inexpensive, but quite dependable.

Stand 224. Trelleborg Ebonite Works Ltd., Union Place, W.1.

Turned and machined components and accessories manufactured from Trelleborg's genuine ebonite, including panels, formers, bobbins, switches, lead-in tubes, bases, blocks, are well displayed.

Stand 226. The Lithanode Co. Ltd., 190 Queen's Road, S.W.8.

Unspillable L.T. accumulators in celluloid containers of special construction, combining the old-fashioned woven glass battery filling with the ordinary free electrolyte in such a way as to reduce sulphating, are a feature here. These batteries, used under the instructions given, are entirely unspillable.

Stand 228. J. R. Wireless Co., 6 and 8 Rosebery Avenue, E.C.1.

"Buy the coil with the purple winding" is the slogan at this stand, where sovereign products such as six-pin coils, H.F. choke, slow-motion dial, and coils for the Cossor Melody Maker are shown.

Stands 229 and 230. W. & T. Lock Ltd., St. Peter's Works, Bath.

In addition to their new lines, this firm are showing their well-known American cabinets with open fronts, also American pattern with double doors or drop-front pattern. There is a good display of high-grade ebonite panels in keeping with the high quality and finish of the cabinets.

Stand 234. Turner & Co., 54 Station Road, N.11.

Here are displayed the deservedly popular Tunewell plug-in coils, standard, centre-tapped, and "X" types, as well as six-pin coils, and a non-dead-end tuner covering all wavelengths. In spite of their great efficiency, the Tunewell range of coils are marketed at extremely moderate prices, bringing them well within the means of all constructors. An H.F. choke is a new product which we hope to test in the near future.

Stand 235. Thomas De La Rue and Co. Ltd., 90 Shernhall Street, E.17.

The exhibit comprises a very comprehensive display of bakelite, fire-proof and plastic mouldings. These are produced by modern multi-way methods, at the rate of many thousands per week, from hardened steel dies. This demands the applica-

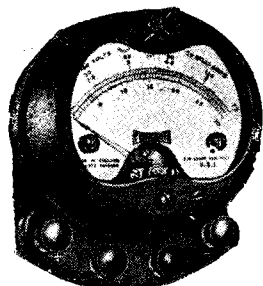

Ferranti Triple-range Meter (Stands 84, 85)

tion of over sixty grades of material, and the moulding-in of metal components.

Stand 236. Lectro-Linx Ltd., 254 Vauxhall Bridge Road, S.W.1.

Constructors should make a point of seeing the many connecting devices shown by this firm, who specialise in patent spade and pin connections, as well as wander plugs and distinguishable terminals of all types.

Stands 237 and 238. Enterprise Manufacturing Co. Ltd., Merton Road, S.W.18.

This firm are showing cabinets of their own manufacture, trickle chargers, H.T. eliminators, and motor generators and rectifiers, supplemented by all proprietary lines.

Stand 239. The K.T.B. Manufacturing Co. Ltd., 210 Hammersmith Road, W.6.

Loud-speaker students should see the Waveola horn at this stand, consisting of a series of tubes of varying diameters connected to one another

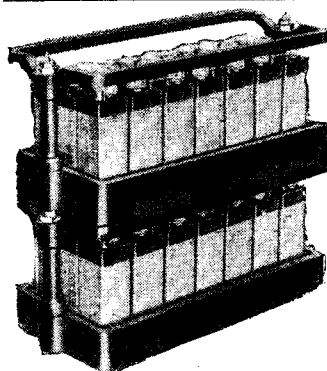

C.A.V. High-tension Accumulator (Stand 114)

by patented deflecting elbows. As a result, the sound waves are conducted round the corners without obstruction, and a clean and pure tone is obtained. A Waveola horn of from 6 to 8 ft. in length can be fitted into quite a small cabinet.

Stand 240. C. D. Melhuish, 8 Great Sutton Street, E.C.1.

H.F. chokes, fixed condensers, combined grid condenser and leak, are on view; also an "intensifier," which, when connected to any receiver, whether valve or crystal, will, it is claimed, increase the volume, at the same time making the

set more selective and purifying the reproduction. Specimens of cabinets which have been treated with the C.D.M. finish should be seen. With this finish any desired plain colour can be produced, or a marble or granite finish. The finish is similar to that of high-class piano cases.

Stand 242. The Eeconsign Co., 94 Jermyn Street, S.W.1.

Bijou outfits are shown—principally of interest to advertisers.

Stand 243. Newton Bros. (Derby), Ltd., Alfreton Road, Derby.

Small rotary transformers, H.T. and L.T., for both transmitters and receivers, and small motor generators are the exhibits here. Many of the machines are as used by the B.B.C., G.P.O., and other bodies.

Stand 244. S. W. Lewis & Co. Ltd., 39 Victoria Street, S.W.1.

Runbaken battery chargers and testers are the main interest here.

Stand 245. The Dionoid Battery Co., Ltd., Victoria Works, Prince of Wales Road, Sheffield.

Dionoid H.T. and L.T. accumulators of a particularly compact and solid design are the main items of appeal.

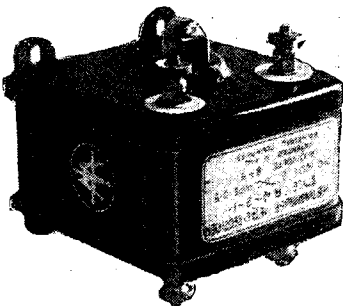

Westinghouse Metal Rectifier (Stand 78)

Stand 246. Sells Ltd., 168 Fleet Street, E.C.4.

The chief media available to wireless advertisers is shown, as well as some of the products which the firm are advertising, together with the advertising matter designed and produced for the purpose of increasing the sales of these products.

Stand 247. Empire Electric Co., 10 Fitzroy Square, W.1.

Stand 248. Dayzite Ltd., 18 and 19 Lisie Street, W.C.2.

This firm is showing a fine assembly of parts for making electrically impulsed coil-driven speakers, and their new motor generator, delivering both high and low tension from the mains, doing away with all accumulators, is an innovation which must be seen to be realised. They are showing a full range of the new Pentavox power valves, together with the Bowyer-Lowe two-valve Pentavox receiver, and full range of power units to draw the current supply direct from the mains, both for A.C. and D.C.

Stand 249. The Tudor Accumulator Co. Ltd., 2 Norfolk Street, W.C.2.

This firm makes its debut at Olympia with a comprehensive range of high- and low-tension batteries, covering no less than sixty sizes and types. An interesting exhibit is a complete power unit, comprising a

bank of H.T. units, and a low-tension battery with rectifier for trickle charging from A.C. mains.

Stands 251 and 252. Wright and Weaire Ltd., 740 High Road, W.17.

Switches, coil holders, tuning units, including "Q" coils, are the standard Wearite products to be seen here, as well as a new series of plugs and jacks, high-frequency chokes, wire-wound fixed condensers. A high-frequency unit employing a screen-grid valve, so designed that it can be connected up to any standard detector and L.F. circuit should make a strong appeal to those who want to improve the DX qualities of their receivers.

Stand 253. The Cantophone Co., 310 Regent Street, W.1.

The radio gramophone is the big feature, described by this firm as the musical invention of the century. With two loud-speakers, this instrument has been found sufficiently powerful to provide dance music for a large hall.

Stand 254. Cooks' Wireless Co. Ltd., 23 St. Helen's Street, Ipswich, Suffolk.

Receivers on view include the two-valve Popular, in which provision is made for accommodation of all batteries in back of cabinet, thereby making a totally enclosed job.

Stands 255 and 256. E. J. Lever (Trix) Ltd., 8 and 9 Clerkenwell Green, E.C.1.

All the Trix products well known to all readers, such as the five-valve portable, Portette, loud-speaker, H.F. choke, fixed condenser, log condenser, valve holder, resistance, coupling unit, three-base, H.T. batteries, and one-way pull-and-push switch, are well displayed for the attention of the listener and constructor. The new Trix portables should be inspected. There is a one-valve headphone model of special merit.

Stand 257. C. S. Dunham, Elm Works, Elm Park, S.W.2.

Among the exhibits are Simplicity two- and three-valve sets designed with the idea of obtaining the highest possible efficiency with extreme simplicity of operation. New products include the mains units, which are made in two types, a large model for sets requiring more than 25 milliamps and a small model for the average two- and three-valvers. The Dunham all-wave tuner is also shown.

Stand 258. W. J. Henderson & Co. Ltd., 351 Fulham Road, S.W.10.

Five- and four-valve portables, with the new screen-grid valve, high-tension eliminator, and a new battery switch, complete a good display of receivers and sundry accessories.

Stand 262. Western Wireless Co., 9 High Street, Ealing, W.5.

Leading makes of receivers and components are exhibited by this firm, who specialise in Marconiphone apparatus on deferred terms.

Stand 263. Axuel Time Switches Ltd., 45e The Mall, Ealing, W.5.

Stand 264. Norman Huntly, 35 Clerkenwell Green, E.C.1.

Norma products, as for example, the Norma midget log condenser, H.F. choke, and push-pull switch, are the main attraction.

Stand 265. Williams and Moffat, Ltd., Ladypool Road, Sparkbrook, Birmingham.

FREE TECHNICAL ADVICE AT "A.W.'s" STANDS

COMPLETE GUIDE TO SHOW

STAND NOS. 266-277

Seen at this stand is an ungeared condenser, with ball-bearing spindle, of extremely rigid construction and free action, rigid build, with mass of metal reduced to a minimum. For use with this condenser, and also to be used in conjunction with other makes of plain condensers, a new *vernier dial* is available in two different gear ratios. A drum drive condenser complete with front panel cover plate. A noteworthy feature of this is that the cover plate serves as a drilling template for the two holes (excluding the slot through which dials operate), which serve to hold both the condenser and the plate to the panel.

Stand 266. The Tonex Co., Tonex Works, Walker Street, Blackpool.

The Tonatuna is the main item—an all-wave coil covering two wavelength ranges, 240-520 metres and 1,100-2,000 metres, when tuned with a .0005-microfarad variable condenser. Wound on a ten-rib former, it is claimed that this coil is ultra-efficient.

Stand 268. Rees Mace Manufacturing Co., Ltd., 39a Welbeck Street, W.1.

Here can be seen a pentode three-valve receiver incorporating one stage of aperiodic, H.F., detector, and pentode, in portable form, with double-cone loud-speaker, etc. Also a Baby Five of the same dimensions as the pentode three, incorporating two aperiodic, H.F., detector, L.F. and power, choke-coupled H.F., transformer-coupled L.F., complete with loud-speaker, etc.

Stand 268a. Rialton Radio, 21a Barbican, E.C.1.

Here are displayed the Rialton portable four-valve pentode set, the Rialton portable four-valve screen-grid and pentode set, and the Melva transportable five-valve screen-grid set. This firm has a demonstration room at No. 3 Hammersmith Road, (above Olympia Motor Co.), right opposite the hall, and visitors are cordially invited to "listen-in" and hear the reproduction and volume of these sets.

Stands 269 and 270. Selfridge and Co., Ltd., London, W.

The chief exhibit will be a display of the new Cleartron valves, including the new 2-volt series.

Stand 269a. Goodmans, 27 Farringdon Street, E.C.4.

Parts for the home assembly of high-class moving-coil loud-speakers are shown here, where the visitor should see the Centrex stand and frame, enabling correct tensioning and vernier centring to be obtained. Simple accessories for the construction of moving-coil loud-speakers include 6-volt .5 ampere pot windings, oiled silk and leather for suspension and moving coils of high or low resistance.

Stand 271. Atalanta, Ltd., 1 to 3 Brixton Road, S.W.9.

Particularly designed for wireless assembly, the Atalanta screw-driver, box spanners, chuck, and collets will undoubtedly appeal to constructors. A new line is the Atalanta construc-

tor's set of tools, mounted in a wooden rack that can easily be fastened to the wall.

Stand 272. E. Paroussi, 10 Featherstone Buildings, High Holborn, W.C.

Screening boxes and partitions of all shapes and sizes, together with screened-grid valve holders, are the specialities at this stand, where the intending constructor of a screened-grid valve receiver should find plenty to interest him.

Stand 273. A. H. Hunt, Ltd., H.A.H. Works, Tunstall Road, East Croydon.

Small gadgets such as safety fuse plug, wall jack, loud-speaker jack, and grid-bias battery clip are the main interests here.

Stand 274. Automatic Radio Manufacturing Co., Gosford Road, Beccles.

Automatically tuned receivers are a unique feature at this stand. In the receiver shown six stations are possible, as each of the three selector switches constitute virtually two switch means. Thus any one of the six stations corresponding to the tapplings may be received by merely moving a switch. Moreover, if the wavelengths of the stations are fortunately chosen, it will be possible to tune in any intermediate wavelength by means of the variable tuner provided, should of course it be desired to do so.

Stands 275, 276, and 277. Curry's, Ltd., 24 to 28 Goswell Road, E.C.1.

Stands 116, 117, 231, and 250.

A. C. Cossor, Ltd., Highbury Grove, London, N.W.

The chief interest at these stands centres in the new Cossor Melody Maker, which incorporates the new Cossor screen-grid valve and the new Cossor L.F. transformer. The improved Cossor valves, different in shape, with six glass walls to their bulbs to stop ringing and other microphonic noises, and having their electrodes suspended at an angle of 45 degrees, are also shown for the first time. Further details next week.

Continental Stations Adopt Fultograph System

Following on the adoption by the B.B.C. of the Fultograph system of still-picture broadcasting, we learn that the high-power Austrian station is to begin a service using the same system on October 1. Later, the long-wave Radio Paris station is to follow suit.

The National Broadcasting Company of America furnishes programmes for fifty-five stations and controls approximately 5,000 miles of permanent lines.

CARBORUNDUM RADIO PRODUCTS

STILL LEAD FOR PURITY OF RECEPTION

CARBORUNDUM

Permanent Detector

Stabilising Detector Unit

Grid Leaks and Anode Resistances

R.C.C. Unit

for purity of reception and general efficiency

OBTAINABLE AT ALL DEALERS

Carborundum Radio Products

are now acknowledged to lead the way in the present-day demand for purity of reception.

Not only do they give wonderful reception, but they will improve your set to a remarkable degree.

The high standard of quality associated with all Carborundum Products will be found in these components.

See them at our Stand No. 130 at the National Radio Exhibition and note their outstanding superiority over similar components of other makes.

Illustrated literature gladly sent on request.

THE CARBORUNDUM CO., LTD.
TRAFFORD PARK . . MANCHESTER

OLYMPIA STAND No. 130

The New Cossor Melody Maker

BETTER TONE

LONGER RANGE

ENORMOUS VOLUME

KNIFE EDGE SELECTIVITY

The Greatest Step Forward in the History of Radio

Now! A wonderful new Cossor Melody Maker—more powerful, more handsome, more selective and costing even less than its famous predecessor.

Send at once for the FREE Constructor Envelope (containing a 32-page book and a large 8 page chart) which tells you all about it—how it will cut out your local station—how it works on a small frame aerial—how it will bring you programmes from at least 23 stations—everything there is to know about the most sensational Receiver ever offered to the public.

Even if you know nothing about Radio you can build the new Melody Maker in 90 minutes. It's as simple as Meccano—no drilling—no soldering—no blue print. Nothing like it has ever been known in the history of Radio. Post the coupon to-day.

SIMPLE AS MECCANO

LOWEST COST

Fill in this coupon Now!

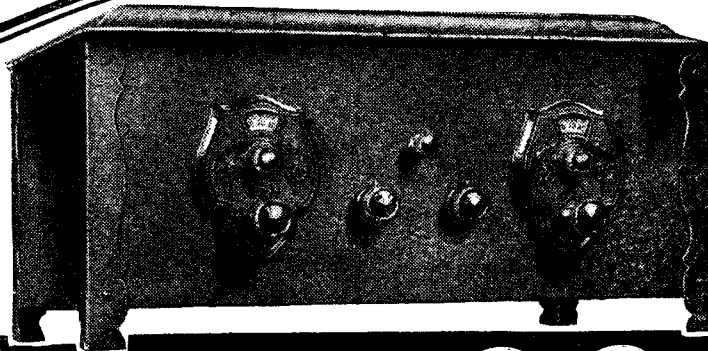

Built in 90 minutes

Please send me one of your Constructor Envelopes which gives full details of the New Cossor "Melody Maker."
Name.....
Address.....

A.W. 22, p. 28

Advt. A. C. Cossor, Ltd. Melody Dept., Highbury Grove, London N.5.

CA 3848

Please Mention "A.W." When Corresponding with Advertiser



OUR INFORMATION BUREAU

RULES.—Please write distinctly and keep to the point. We reply promptly by post. Please give all necessary details. Ask one question at a time to ensure a prompt reply, and please put sketches, layouts, diagrams, etc., on separate sheets containing your name and address. See announcement below. Address Queries—AMATEUR WIRELESS Information Bureau, 58/61 Fetter Lane, London, E.C.4

Mains Hum and Extension Leads.

Q.—I have recently wired my house for loud-speaker extensions to several rooms and now find that I experience a decided hum from the electric-light mains. This did not happen before running the extension leads, and I am wondering if there is any way in which the trouble may be obviated without doing away with the extension leads.—S. A. (Mitcham).

A.—The use of a choke filter circuit between the receiver and the loud-speaker extension leads may obviate some of the trouble, but this cannot be guaranteed to overcome the difficulty entirely. You should try rewiring the extension leads so that they do not run parallel to any of the electric-light wiring in the house. At the same time, if the extension leads have to cross or run near to the house wiring, then they should cross at right angles or run at as large an angle as possible. Failing this, we are afraid that the only complete remedy is to do away with the extension leads or move the receiver and extend the aerial lead-in and earth wires as required.—C. A.

Old-type H.F. Transformers.

Q.—I have several of the old four-pin type H.F. transformers and as these are of no use for present-day circuits I am wondering whether

they could be used in any way as H.F. chokes. Can you advise me in this matter?—F. D. (Glasgow).

When Asking Technical Queries

PLEASE write briefly and to the point

A Fee of One Shilling (postal order for preference) must accompany each question and also a stamped, addressed envelope and the coupon which will be found on the last page.

Rough sketches and circuit diagrams can be provided, but it will be necessary to charge a special fee (which will be quoted upon request) for detail layouts and designs.

A.—The H.F. transformers you mention may possibly have too much natural capacity in the windings to be of any use as H.F. chokes. In any case only a Daventry waveband trans-

former, with the two windings joined together in series, would have sufficient inductance to act efficiently. You may try out the arrangement, but if the capacity of the windings is at all large, little or no choking will be obtained.—C. A.

"Near and Far Three-Four."

Q.—I have built the "Near and Far Three-Four" receiver and, although the last three valves gave good results at first, I find that I have never been able to get the H.F. valve working. Now I am getting very little volume from the last three valves and am wondering if my having used components other than those specified is the cause of the trouble? Can you help me in this respect?—D. A. (Wincanton).

A.—If you have not used the actual type and make of change-over switch for the H.F. valve in this set then it accounts for the whole of your trouble. The switch you are using, being of a different type from that specified, does not perform the duties required of it and quite possibly, at the same time, short circuits the H.T. battery. If you will get the type of switch we recommend and see that your H.T. battery is not run down we feel sure that you will get good results.—C. L.

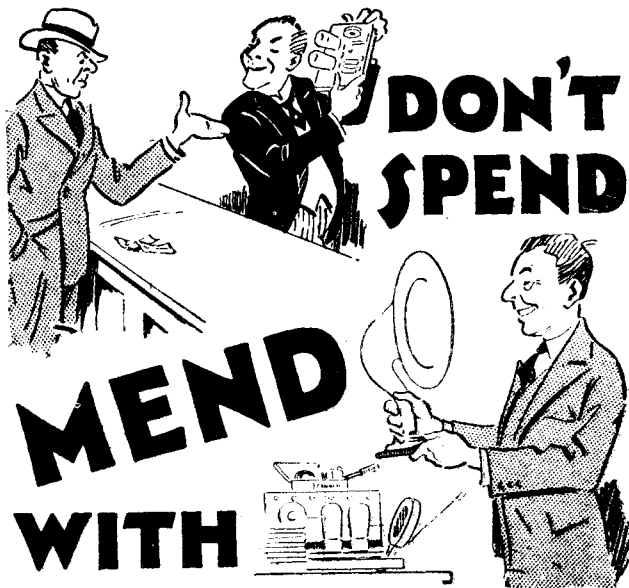

DON'T SPEND

MEND WITH FLUXITE

-simplifies all soldering

All Hardware and Ironmongery Stores sell FLUXITE in tins, price 8d., 1/4 and 2/8. Another use for Fluxite—Hardening Tools and Case Hardening. Ask for leaflets on improved methods.

FLUXITE LTD.,
(Dept. 326)
Rotherhithe, S.E.16

FLUXITE SOLDERING SET—complete
7/6
or LAMP only, 2/6

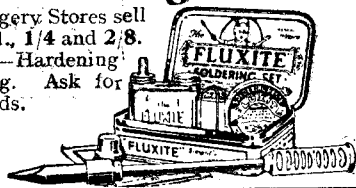

THE SIMPLE SWITCH

The improved Benjamin Switch insures your batteries against waste. Definite 'snap' action, double contact and ease of wiring and fitting are its outstanding features.

It is the switch you have been waiting for—fit it in your set this season. Price

1/3

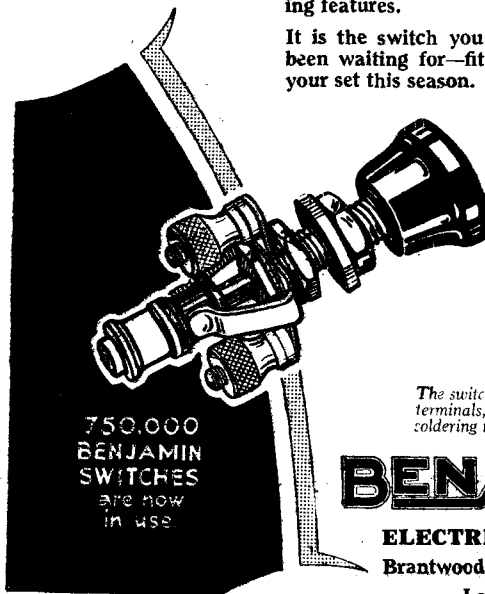

The switch may be obtained without terminals, but with ready-fitted soldering tags. Price 1s.

BENJAMIN

ELECTRIC LIMITED.
Brantwood Works, Tottenham
London, N.17

750,000 BENJAMIN SWITCHES are now in use

THIS VALUABLE BOOK FREE!



Post Coupon To-day

The recently published Columbia brochure, "Why Radio is better with Battery Power," which is being given away to all readers of this journal, is packed full of useful information and is invaluable to every Radio man.

Don't miss this unique opportunity, but fill in the coupon now.

"Why Radio is better with Battery Power" solves all H.T. difficulties. Columbia experts have given you the benefit of their many year's experience in this book.

Don't fail to obtain it!

Columbia RADIO BATTERIES

To

J. R. Morris,
15, Kingsway,
London, W.C. 2.

Please send me a copy of "Why Radio is Better with Battery Power."

NAME.....

ADDRESS.....

A.W.

Within the Reach of All

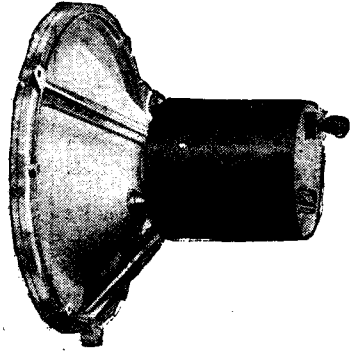

MOVING COIL REPRODUCTION FOR ALL

Thousands of wireless enthusiasts have longed for a Moving Coil Speaker but—well, there was always the question of expense. Now, however, GOODMAN'S have made such remarkable strides in the design and construction of Moving Coil Speakers that it costs little, if anything more to build your own Moving Coil Speaker than to purchase a good ordinary Loud-speaker.

That wonderful quality of reproduction, that depth of tone in the bass notes, that almost uncanny realism is now within the reach of all.

GOODMANS "NEW JUNIOR" MOVING COIL SPEAKER KIT

Produced to meet a demand for a GOODMAN'S product at a competitive price. The last word in up-to-date construction, it has been specially designed to reduce the Constructor's difficulties of assembly to a minimum. The new design of Spider, with an easy and permanent centring device, Cone paper cut to shape, and a cleverly designed Moving Coil, eliminate practically any possibility of error in construction. The coil is sectionally wound, is light, and unaffected by moisture or heat. The Magnet Pot is the already well-known Minor Model, and is remarkably powerful although consuming only 1/2 amp. at 6 volts. Lugs are provided for fixing to the Cabinet or Baffle Board.

Complete Equipment for 6 Volts £3 : 10 : 0

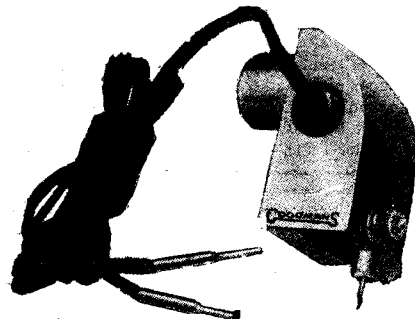

THE GOODMAN PICK-UP

This remarkable new Pick-up costing only 18/6 is now available. It will bear comparison with any other on the market, regardless of cost.

Beautifully finished in nickel case—light in weight—light on the record. Remarkably faithful reproduction of both high and low frequencies. Volume adjustable on the Instrument.

Write for your supply of illustrated leaflets, giving full particulars, or, better still, come and see our wide range of Loud-speaker Components at the

NATIONAL RADIO EXHIBITION STAND 269A

GOODMANS

27 FARRINGDON ST. LONDON E.C.4

Telephone : CITY 4472

Advertisers Appreciate Mention of "A.W." with Your Order

CHIEF EVENTS OF THE WEEK

LONDON AND DAVENTRY (5XX)

Sept. 24 Vaudeville programme.
 " 25 Military band concert.
 " 26 *Maritana*, an opera by Wallace.
 " 27 *The Golden Threshold*, an Indian song-cycle.
 " 28 Prom. Concert.

DAVENTRY (5GB)

Sept. 25 *Followers*, a play by Harold Brighouse.
 " 26 Prom. Concert.
 " 27 Symphony Concert.
 " 28 Excerpts from *Aida* (Verdi).

CARDIFF

Sept. 27 A programme of "Syncopation, Songs, Skits, and Sketches."
 " 29 *Our Programme*, by the Bristol Listeners' Club.

MANCHESTER

Sept. 26 Municipal band concert, relayed from the bandstand, Southport.
 " 29 *Follies of 1928*, relayed from Blackpool.

GLASGOW

Sept. 28 A concert of music set to Shakespeare's plays.
 " 29 Scots variety programme.

ABERDEEN

Sept. 25 Inverness Gaelic Mod Prizewinners' Concert (Junior Section), relayed from the Wesleyan Central Hall, Inverness.

BELFAST

Sept. 24 Variety programme.
 " 27 A Hubert Parry programme.
 " 29 *Four-in-Hand*, a revue. Book and lyrics by John Watt. Music by Claude de Ville.

Rothermel, Ltd., regret that they are not exhibiting at the National Radio Exhibition, but cordially invite listeners to visit their showrooms at 24-26 Maddox Street, W.1.

"Amateur Wireless and Electrics." Price Threepence. Published on Thursdays and bearing the date of Saturday immediately following. Post free to any part of the world: 3 months, 4s. 6d.; 6 months, 8s. 9d.; 12 months, 17s. 6d. Postal Orders, Post Office Orders, or Cheques should be made payable to "Bernard Jones Publications, Ltd."

General Correspondence is to be brief and written on one side of the paper only. All sketches and drawings to be on separate sheets. Contributions are always welcome, will be promptly considered, and if used will be paid for. Queries should be addressed to the Editor, and the conditions printed at the head of "Our Information Bureau" should be closely observed. Communications should be addressed, according to their nature, to The Editor, The Advertisement Manager, or the Publisher, "Amateur Wireless," 59-61 Fetter Lane, London, E.C.4.

BROADCAST TELEPHONY

(Broadcasting stations classified by country and in order of wavelengths).

Kilo- Metres	Station and Call Sign	Power Kw.	Kilo- Metres	Station and Call Sign	Power Kw.	Kilo- Metres	Station and Call Sign	Power Kw.
GREAT BRITAIN								
24	12,500	Chelmsford (5SW) 20.0	299.7	1,001	Agen	401	748	Cork (5CK) 1.5
252.1	1,100	*Bradford (2LS) 0.2	317.4	945	Marseilles	315.8	946	Turin (testing) 0.5
273	1,099	*Sheffield (6FL) 0.2	340.9	883	Le Petit Parisien, Paris	333.4	900	Naples (Napoli) 1.5
276	1,083	*Nottingham (5NG) 0.2	353	859	Algers (PTT) 2.0	400	750	Bolzano
277.8	1,080	*Leeds (2LS) 0.2	370	811	Radio L.L., Paris	449	668	Rome (Roma) 3.0
288.2	1,041	*Edinburgh (2EH) 0.2	389.5	770	Toulouse (Radio) 5.0	546	549	Milan
294.1	1,020	*Stoke-on-Trent (5ST) 0.2	416	721	Grenoble (PTT) 1.5	303.9	971	Zagreb (Agram) 1.25
294.1	1,020	*Swansea (5SX) 0.2	435	690	Kabat (Radio Maroc) 2.0	460	652	Belgrade
294.1	1,020	*Dundee (2DB) 0.2	445.7	673	Lille (Radio Flandres) 0.25	566	530	Laibach (testing) 5.0
294.1	1,020	*Hull (6KH) 0.2	476.9	629	Paris (Ecole Sup. PTT) 0.7	270.4	810	Bergen
297	1,010	*Liverpool (6LV) 0.2	1,765	270	Lyons (PTT) 1.0	412	728	Notodden
306.1	980	Belfast (2BE) 1.5	1,850	162	Radio Paris 3.0	435.4	689	Fredriksstad
312.5	960	Newcastle (5NO) 1.5	2,650	113	Radio Carthage (Tunis) 2	448	670	Rjukan
326.1	920	Bournemouth (6BM) 1.5	14.84	20,270	Kiefel Tower (FL) 8.0	461.5	650	Oslo
353	850	Cardiff (5WA) 1.5	37.65	7,998	Nauen (AGAI) 20.0	500	620	Porsgrund
361.4	830	London (2LO) 3.0	41.45	—	Doeberitz (AFK) 5.0	400	750	Aalesund
384.6	780	Manchester (2ZY) 1.0	67.65	4,434	Bergedorf (AFL) 3.0	566	530	Hamar
400	750	*Plymouth (5PY) 0.2	51	5,882	Stettin	2,011	142	Bergen
405.4	740	Glasgow (5GC) 1.2	236.2	1,270	Nurnberg	270.3	1,110	Lemberg (under construction) 10.0
491.8	610	Daventry EX (5GB) 24.0	242	1,239	Muenster	343	874	Posen (Poznan) 1.5
500	600	Aberdeen (5AB) 1.5	250	1,200	Cassel	422	711	Kattowitz
1,601.8	387	*Daventry (5XX) 25.0	252.1	1,190	Kiel	426.7	703	Wilno
AUSTRIA								
253.8	1,182	Linz	254.2	1,180	Danzig	567	529	Cracow
272.7	1,100	Klagenfurt	272.7	1,100	Bremen	1,111	270	Warsaw
277.8	1,080	Salzburg (under const.)	272.7	1,100	Dresden	250	1,200	Oporto
283	1,060	Innsbruck	275.2	1,190	Cologne	1,000	300	Leningrad
284	1,020	Graz	283	1,060	Kaiserslautern	1,453	209	Moscow
350.7	841	Vienna	277.8	1,080	Hanover	1,703	176	Kharkov
517.2	580	Vienna	297	1,010	Koenigsberg	272.7	1,090	Oviedo (EAJ19) 0.5
576.9	520	Vienna	303.6	988	Breslau	277	1,070	Barcelona
BELGIUM								
220	1,360	Chatelineau	323.2	928	Gleiwitz	272.7	1,090	Barcelona (EAJ19) 0.5
250	1,314	Schaerbeek	330.4	908	Leipzig	277.8	1,080	Cartagena
265	1,130	Louvain (under construction)	356.3	819	Stuttgart	324.3	825	Almeria (EAJ18) 1.0
275	1,090	Ghent	379.7	790	Hamburg	335	895	San Sebastian (EAJ3) 0.5
508.5	590	Brussels	396	757	Aachen	345.2	169	Barcelona (EAJ1) 3.5
DENMARK								
337.4	189	Copenhagen (Kjobenhavn)	400	750	Frankfurt-Main	375	160	Madrid (EAJ7) 2.0
972	308	Soro	429	699	Langenberg	400	750	Cadiz (EAJ3) 0.5
1,153.8	160	Kalundborg	471.6	636	Berlin	422.6	745	Salamanca (EAJ22) 0.55
FRANCE								
40.2	7,463	Lyon (PTT)	483.9	620	Munich	422	711	Bilbao (EAJ9) 1.0
45	6,666	Agen	535.7	560	Augsburg	434.3	690	Seville (EAJ5) 1.0
61.5	4,878	Radio LL (Paris)	560	530	Freiburg	260.0	1,150	Malmö
158	1,899	Beziers	577	520	Zeesen	278.8	1,076	Trollhattan
176	1,700	Tourcoing	1,250	240	Norddeich	316.7	947	Falun
210	1,428	Chambery	1,839	164	Berlin (News)	416.7	720	Goteborg
223.4	1,313	Biarritz	2,525	119	Berlin (News)	454.5	660	Stockholm
230	1,304	St Etienne	2,900	103	"	545.6	550	Sundsvall
238.1	1,260	Bordeaux (Radio Sud-Ouest)	4,030	70	"	720	416	Ostersund
239.5	1,253	Nimes	18.4	—	HOLLAND	1,190	252	Boden
244	1,229	Juan-les-Pins	31.4	—	Kootwijk (PCLL) (Wed. 13.40 B.S.T.)	1,383	217	Motala
245.7	1,221	Toulouse (PTT)	340.9	880	Hilversum	410.5	731	Berne
253	1,185	Montpellier	1,771	180	Scheveningen (ANRO)	500	600	Zurich (testing)
254.2	1,180	Rennes	1,875	160	Huizen (after 5.45 to 6.0 p.m.)	585	510	Zurich
267.3	1,122	Lille (PTT)	1,875	160	Huizen (after 6.40 p.m. and on Sundays)	683	441	Lausanne
268	1,118	Strasbourg	1,950	154	Scheveningen-haven	760	305	Geneva
273	1,098	Limoges (PTT)	519.1	940	Dublin (2RN)	1,031	290	Basle
285	1,048	Bordeaux	IRISH FREE STATE					
291	1,030	Radio Lyon	Dublin (2RN) 1.5					
299.4	1,002	Vitus (Paris)						

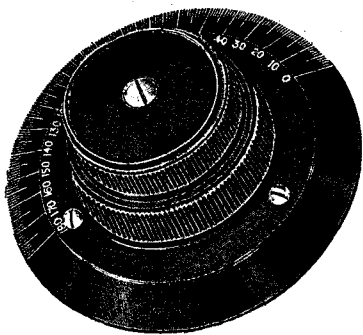

PATTERN W.170

Our plain Dial, with its 70-1 ratio, is still a favourite with listeners everywhere. The design is neat and the mechanism first class. Fits all condensers.

PRICE 7/6

"Utility"

The Perfect Dials

Ask your wireless dealer to show them to you, and particularly note the smooth action... absence of backlash... the vernier adjustment... and the fine appearance of the product. A "Utility" Micro Dial will completely satisfy you... and remember that each is sold with the fully protective "Utility" Guarantee.

May we send you a List of "Utility" Guaranteed Components? They include No Capacity Change-over Switches, Logarithmic and Square Law Condensers, and many other items that will interest you

We are Exhibiting at THE RADIO EXHIBITION Sept. 22-29 STAND 152

WILKINS & WRIGHT LTD HOLYHEAD BIRMINGHAM

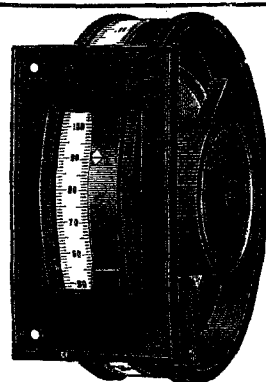

NEW THUMB-CONTROL DIAL

The last word in Dials! Fits all condensers. Coarse and fine adjustment are provided and the movable, engraved scale makes correct maximum and minimum positions easy to determine.

PRICES

Thumb Control, Vernier Dial 12/6
 Thumb Control, Plain Dial 3/-
 Bakelite Finger Plate only 2/-



TOMMY HANDLEY, the popular wireless comedian, will be heard in the vaudeville programme to be broadcast from 5GB on October 6. Mason and Armes (entertainers at the piano) and the Dominoes Dance Band will also take part in this entertainment.

"Twenty Years On" is the title of a debate between Mr. and Mrs. Clough Williams Ellis, which will be broadcast from 2LO on September 22.

Part of the opening concert of the season, given by the National Orchestra of Wales, under the direction of Warwick Braithwaite, in the Assembly Room, City Hall, Cardiff, will be broadcast by the Cardiff station on October 2. The soloists will be Dorothy Bennett (soprano) and Evlyn Howard-Jones (piano).

5GB will relay a concert given by the City of Birmingham Orchestra under the direction of Dr. Adrian G. Boulton, from the Town Hall, Birmingham, on October 4. Dushkin, the well-known violinist, will play Beethoven's "Violin Concerto (Op. 61)," to the accompaniment of the orchestra. A fantasy entitled "Columbine," by Reginald Arkell, will follow. Music will be provided by the Midland Pianoforte Trio.

Cardiff and Daventry 5XX will relay an all-Welsh concert by the Carnarvon Choral Society, from the Pavilion, Carnarvon, on September 20. Mr. D. Elliot Alves (the Mayor of Carnarvon) will give an address. The soloists will be Owen Bryngwyn (bass), Nansi Richards (harp), Leila Megane (contralto), and Walter Glynn (tenor).

"Siamese Cats—and Some Islands" is the title of a talk to be given by Mr. Compton Mackenzie, the well-known novelist, from the London studio on September 24.

A novel item, down for broadcast from the Manchester studio on September 22, is entitled "Both Sides of the Microphone," or, as the author, L. du Garde Peach, calls it, "An Unpardonable Intrusion into the Listeners' Homes."

The Ulster Players will be heard by Belfast listeners in a comedy entitled *Loaves and Fishes*, to be broadcast on October 1. The cast includes James Mageean, W. R. Gordon, James Hodgkin, Charlotte Tedlie, and the author, Charles K. Ayre.

(Continued on next page)

The Latest Thing!

A LINEN DIAPHRAGM LOUD-SPEAKER

will be described

NEXT WEEK



BULGIN
RADIO PRODUCTS

The choice of critics.

56 PAGES

CRAMMED full of the most interesting facts concerning Bulgin Components and Gadgets. Illustrating and describing all our well-known lines and many new ones to be seen for the first time at our Stands, Nos. 203-204, at Olympia.

This catalogue, including a Manual of Instruction, is the most complete set-constructing guide ever published. Call at the Stands and ask for one.

A. F. BULGIN & CO., Radio Manufacturers
9, 10, 11 Cursitor Street, Chancery Lane, E.C.4 Telephone: Holborn 2072

Something entirely New!

AT OLYMPIA

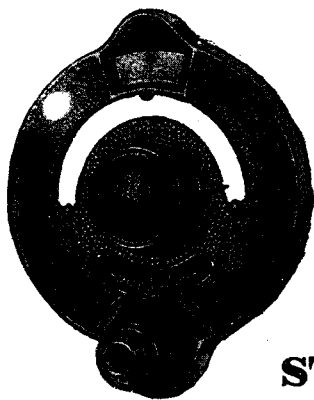

STANDS

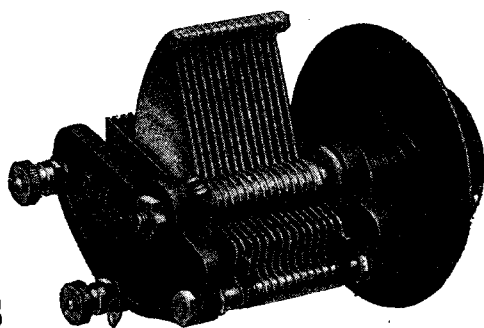

184 & 185

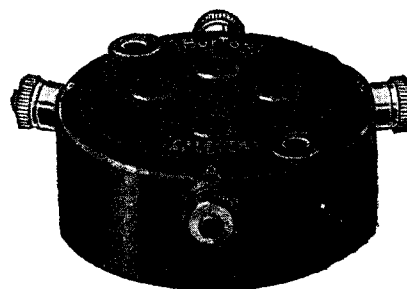

REGD. TRADE MARK.



REGD. TRADE MARK.

C. F. & H. BurTon, PROGRESS WORKS, WALSALL, ENG.

RUPERT COLLINS & CO.

You will Help Yourself and Help Us by Mentioning "A.W." to Advertisers

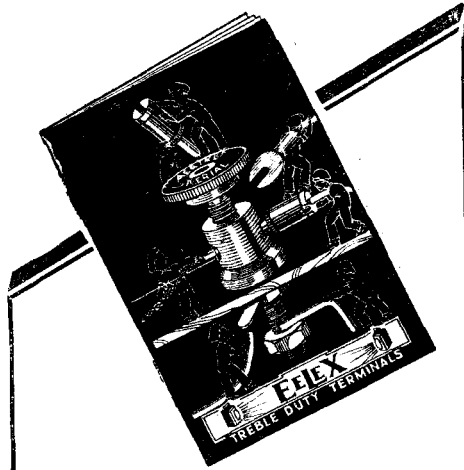

WRITE FOR THIS FREE BOOKLET

and learn all about the EELEX gnomes of efficiency and how by using EELEX TREBLE-DUTY TERMINALS you can make these accessories the centre of industry in your set.

This interesting little booklet also gives you full particulars of other Eelex accessories that will save you pounds. Every constructor should write for a copy—a postcard will bring it to-morrow.

Bad Terminal Connections are often the cause of losses and bad reception. Safeguard yourself by using



TREBLE-DUTY TERMINALS

the terminal with indicating top you can plug into.

DON'T FORGET TO VISIT STANDS 218 AND 219
in the Gallery
Wireless Exhibition, September 22-29

J. J. EASTICK & SONS
EELEX HOUSE,
118 Bunhill Row, Moorgate St., LONDON, E.C.1

Radiograms

(continued)

Artistes taking part in the Queen's Hall Promenade Concert to be broadcast by 5GB on October 3 are Adila Fachiri and Jelly d'Aranyi (violin solos), Astra Desmond (contralto), Eric Green (tenor), and Robert Murchie (flute).

On October 6 Mr. Stanley Dark will visit the Cardiff station, when he will give a talk entitled "And That Reminds Me." Mr. Dark is well known as an actor, author, and producer, and has appeared in many films.

Ida Gilbert (recitations), Louis Pecskaï (solo violin), Jack Colley (entertainer), and the Clef Trio (vocal selections) will be heard in the variety programme from 5GB on October 1.

Miss Eleanor E. Helme will give an eye-witness account of the English Ladies' Golf Championship from the 2LO studio on October 6.

The bulletin of market prices for farmers, compiled by the Board of Agriculture for Scotland, which has up to the present been a regular broadcast from all Scottish stations on Fridays at 6.45 p.m., will, from September 24, be given on Thursdays at 6.30 p.m., and the series of special talks to farmers, by Mr. Peter Reid, the first of which will be on October 5, will be given at 6.30 p.m. every Friday.

A programme built up round Richard Hughes's short play, *Congo Night*, will be broadcast by Glasgow on October 2. This play is typically African, and relies on its "atmosphere" for the dramatic effect. Herbert Thorpe (tenor), Harry Brindle (baritone), Barbara Laing (pianist), and the station orchestra will contribute suitable items to this entertainment.

The Polish Government announces the erection, in the near future, of a short-wave station in the neighbourhood of Gdingen (near Zoppot). This transmitter will also be used on the telephony service between Gdingen and Warsaw, as this line is at present over worked.

In anticipation of a regular Transatlantic aircraft service, a short-wave wireless telephony transmitter has been installed at Hamburg with the call-sign AEM. The plant is sufficiently powerful to assure a transmission of approximately three thousand miles during daylight and over five thousand miles at night.

The International Broadcasting Union, at its recent meeting at Lausanne, Switzerland, recommended that all radio stations broadcast communications in Esperanto, the "international language," as often as possible. Results of a survey showed that 168 stations in various countries were sending out messages in Esperanto.



COMPONENTS

ARE USED IN ALL FAMOUS SETS

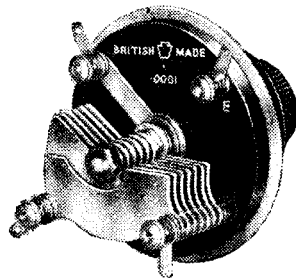

KEYSTONE "MIDGET" REACTION CONDENSER
Ideal for many positions where a small capacity condenser is required. An aluminium shield prevents hand-capacity effects and a special paper bearing gives a beautifully smooth movement. Accurately designed and rigidly constructed, this Keystone condenser is backed by the usual Keystone guarantee of efficiency.
Price, .0001, 5/- .00005, 4/6



KEYSTONE "HIGH-LOW" H.F. CHOKE
The unique form of winding in this choke renders it suitable for practically all sets. It has a very high inductance—self capacity negligible. One-hole fixing. Suitable for all wave lengths from 20—2,000 metres.
Price, 3/6

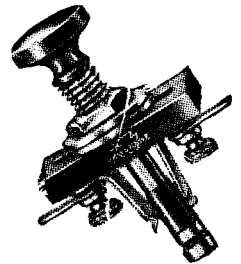

KEYSTONE PUSH-PULL SWITCH
One-hole fixing. Perfectly smooth yet positive action. Fitted with terminals for easy connections. Highly nickel-plated.
Price, 1/3

VISIT US AT STANDS Nos. 142-143
RADIO EXHIBITION—OLYMPIA—SEPTEMBER 22-29

SPECIAL COILS FOR SPECIAL SETS

From time to time we design entirely new coils for use in sets described in the various wireless papers. As it is practically impossible to catalogue all these, we invite customers to let us know their requirements, when we shall have pleasure in advising them as to the most suitable coils for their requirements.

SPECIAL COILS FOR THE "TWIN WAVE" FOUR—1 complete set, £1 10 0

PETO-SCOTT CO. LTD 77 CITY ROAD, LONDON, E.C.1 and 62 HIGH HOLBORN, LONDON, W.C.1

The Amplion Secret

Moving coil quality
without batteries, mains
connections, or special
transformers

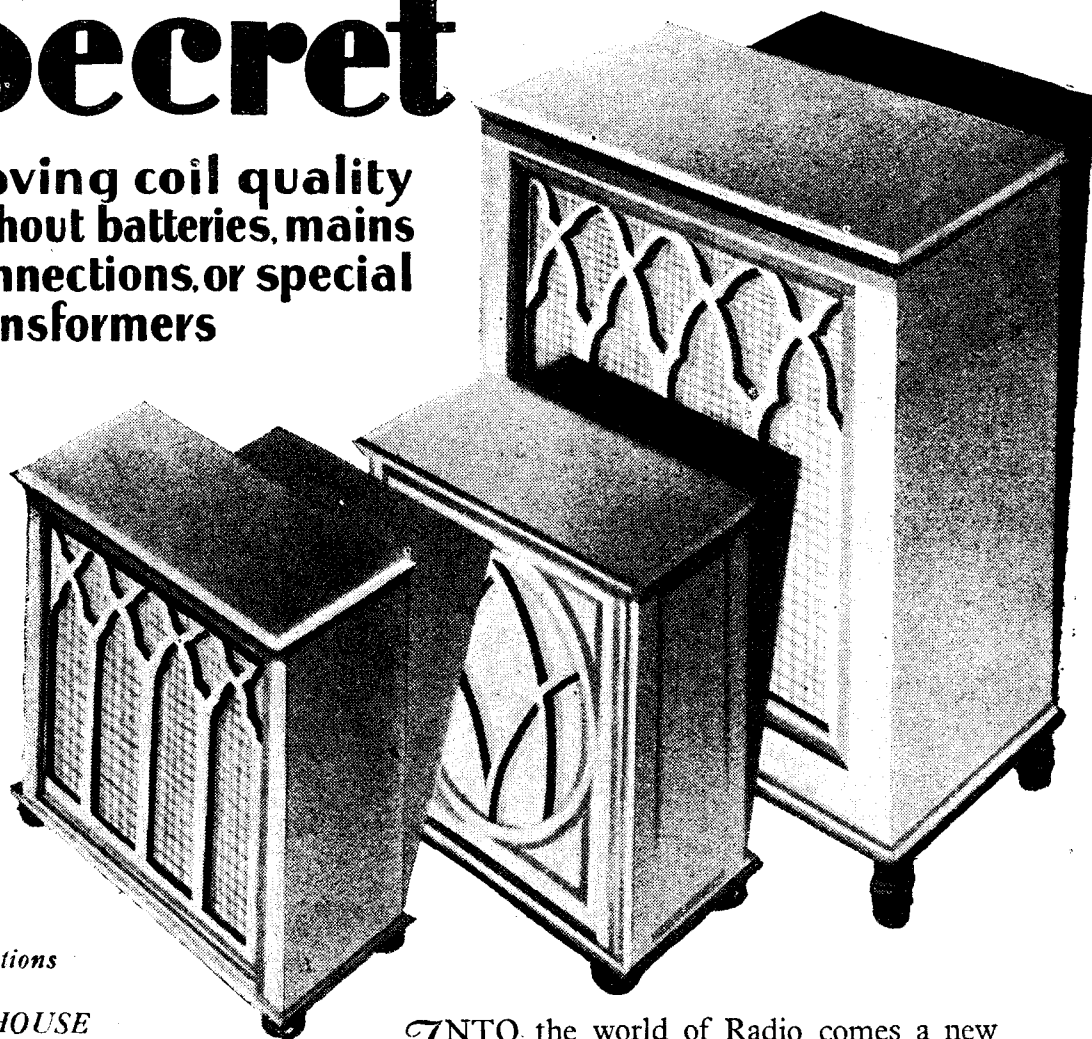

Demonstrations
at
AMPLION HOUSE
next door to
—OLYMPIA—

AMPLION

INTO the world of Radio comes a new speaker, the Amplion "Lion" . . . a unique instrument which gives to listeners a new experience, a better appreciation of radio programmes.

How closely radio at last approaches the "real thing" is left to listeners to judge. Hear the Amplion "Lion" at Amplion House, next door to Olympia, or at your dealer's. Compare it critically with the best you have previously heard. You will be amazed.

"Lion" Speakers. Chassis £6 and £8. Cabinet Models £9 10 0 to £42. Standard Cone and Horn Models from 35/- to £5.

STANDS 30 & 31, NATIONAL RADIO EXHIBITION



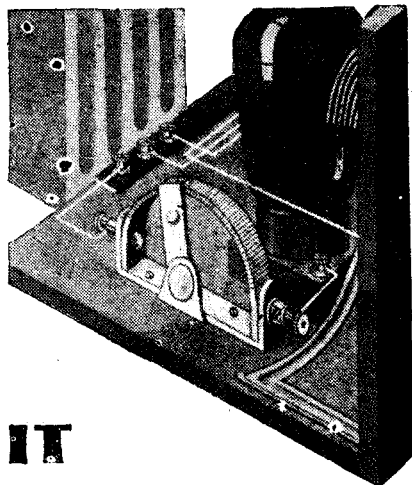

**IT
STANDS
OUT**

**THE
"PEERLESS"
VARISTOR**

This useful component is a baseboard Rheostat made in seven types, viz., 3, 6, 10, 15, 20, 30, or 60 ohms. It is suitable for controlling all makes of valve. Each type is wound with best resistance wire and is fitted with phosphor-bronze adjustable arm. Terminals are fitted in a convenient position for wiring.

Price all types, **1s. 3d.** each.

**"PEERLESS"
MASTER SWITCH**

As is well known, when using a battery eliminator a very high potential is placed across the condenser when the current is broken suddenly. Gradual current control is therefore essential and the master switch has been designed to fulfil this purpose. It cuts off both high and low tension.

Price **2s. 9d.**

**"PEERLESS"
FIBRE COIL FORMER**

Supplied in a small package containing the necessary parts; these can be assembled in less than a minute as it is only necessary to insert the narrow strips of insulating material in their correct slots cut in the end pieces: Quite rigid and will not buckle.

Sizes:

2" x 1 1/4", 3 1/2" x 2 3/8", 2" x 2 3/8", 3 1/2" x 1 3/4"

Price **1s. 4d.**

Stand 35, OLYMPIA

**THE BEDFORD ELECTRICAL
AND RADIO CO., LTD.**

22 Campbell Road - BEDFORD

LONDON:
21 Bartlett's Bldgs.,
E.C.4

GLASGOW:
113 St. Vincent St.,
C.2

"The NEW-STYLE BAFFLE THREE" (Continued from page 378)

valves could deal with were they paralleled in a simple way.

The Circuit

The complete circuit of the receiver is shown by the diagram. If we consider the push-pull valves as one there are three successive valve stages, detector, resistance-capacity-coupled amplifier and push-pull amplifier.

Our real reason for using resistance-capacity coupling after the detector is that we had no other choice because we had already decided to utilise the anode-bend system of rectification. For those who require a moderate power output we give a modified circuit diagram on page 378 with a simple transformer-coupled stage of L.F. amplification.

Anode bend rectification followed by resistance-capacity coupling will ensure purity of reproduction, and the unmutated signals can then be passed on to the efficient power handling push-pull amplifier.

As regards circuit details the best way will be to summarise them as follows:

Tapped aerial coil, of the simple plug-in type shunted by .0005 variable condenser.

Reinartz reaction, comprising a plug-in coil coupled to the tuning coil in series with a .0003-microfarad variable condenser, the series arrangement being connected between earth and the anode of the detector valve.

Gramo-radio

Gramophone reproduction is provided for by the insertion of a simple jack in the grid-filament circuit of the detector valve. The grid end of the tuning coil is taken to one contact, the grid to another and the remaining contact goes to earth. When the pick-up plug is withdrawn the grid is brought into contact with the grid end of the tuning coil. When the plug is inserted the gramophone pick-up is connected across the grid-filament of the valve and the tuning coil cut out of circuit.

For anode bend grid bias a separate 1 1/2-volt cell is wired between the earth side of the tuning coil and L.T. minus.

Resistance-capacity-coupling values: The anode resistance is 120,000 ohms, split into two sections of 100,000 and 20,000 ohms. Between the junction of the two resistances and earth is connected a 2-microfarad fixed condenser. By splitting the anode resistance in this way and providing a by-pass condenser as shown any tendency on the part of the amplifier to "motor-boat"—that is, to generate a series of popping noises—is effectively prevented. A .01-microfarad coupling condenser is used and a 1-megohm grid leak. The high-frequency choke between the anode of the detector valve and the coupling condenser side of the 100,000 ohms resistance is, of course, necessary for Reinartz reaction.

Battery supply: A single H.T. plus terminal gives a common high-tension feed to all four valves. The 120,000 ohms

resistance in the detector anode circuit cuts down the maximum supply to a reasonable value for detection. In the low-tension positive lead is filament on-off switch controlling the filament supply to all four valves. No filament rheostats are incorporated in any of the four filament circuits.

Volume control: Some means of varying the intensity of the output other than by detuning is desirable in a first-class receiver. A high-resistance potentiometer serves the purpose. Its connections are simple. One end of the resistance is connected to the grid side of the coupling condenser between the detector and first amplifying valve. The other end goes to G.B.—. The grid of the second valve is taken to the slider of the potentiometer so that the input to this valve is varied according to the position of the slider along the resistance.

Having dealt at some length with the theoretical considerations that guided us in the design of the receiver, we now propose to give the intending constructor some useful hints on its assembly. First of all here is a full list of the components required together with suitable alternatives.

Components Required

.0005-microfarad variable condenser (Burndept, Lissen, Polar "Ideal," Igranic, J.B.).

.0003-microfarad variable condenser, for volume control. (Burndept, Lissen, Polar "Ideal," Igranic, J.B.).

1-megohm volume control (Gambrell).

Filament switch (Lotus, Trix, Benjamin, Lissen, Wearite).

Four valve holders (W.B., Benjamin, Bowyer-Lowe, Ashley, Igranic).

Two single coil holders (Lotus, Lissen).

High-frequency choke (Igranic, Lissen, C.D.M., Burndept, R.I. and Varley).

Pick-up jack (Igranic P62).

1 1/2-volt cell (Ever Ready UWr, Lissen).

Clip for cell (Bulgin).

Two terminals marked Aerial and Earth (Belling-Lee, Eelex, Igranic).

Ebonite or bakelite strip, 2 in. by 3/4 in. (Raymond, Becol, Pertinax, Paxolin).

.01 microfarad fixed condenser (Hydra, Dubilier, Lissen, Graham-Farish).

100,000 ohms and 20,000 ohms resistor (Igranic).

2-microfarad fixed condenser (Hydra, Lissen, Dubilier, Graham-Farish).

Push-pull transformer (Ferranti type AF5(c)).

Output transformer (Ferranti type OP3(c)).

Six yards single flex (Lewcos).

Three black wander plugs, two red wander plugs (Clix).

Red spade terminal, black spade terminal (Clix).

Baffle-mounting moving-coil loud-speaker (Goodmans', B.T.H., Baker).

(Continued on page 412)

"Simpler Wireless"

Faradex COMPONENTS

Mains Radio RECEIVERS

ALL "FARADEx" components intended for use in connection with electric lighting mains have been specially designed so as to conform in every respect with the Regulations for the Electrical Equipment of Buildings issued by the Institution of Electrical Engineers.

"FARADEx" HEAVY DUTY DOUBLE CHOKE

This Choke is capable of carrying up to 120 milliamperes with perfect safety. The windings each of which has an inductance of 20 henries and a resistance of only 130 ohms, may be connected either in series or parallel, or one winding may be placed in each of the leads between the supply and the load PRICE **30/-**

"FARADEx" SINGLE SMOOTHING CHOKE

This is similar in construction to our double choke, but has one winding only. As this choke can safely carry up to 120 milliamperes, it is particularly suitable for smoothing the filament current for valves of the .1 ampere type PRICE **21/-**

"FARADEx" FILTER CHOKE

This Choke is eminently suitable either for smoothing an H.T. supply obtained from the mains or for incorporation in a filter circuit coupling a loud-speaker to the plate circuit of the last valve of a receiver. The D.C. resistance is only 500 ohms while the current-carrying capacity is 50 milliamperes PRICE **7/6**

"FARADEx" POTENTIAL DIVIDER

This potential Divider is constructed on entirely new lines, many novel features having been introduced. It may be obtained with a total resistance of either 10,000 or 20,000 ohms and is suitable for use in all types of H.T. battery eliminators PRICE **7/6**

"FARADEx" M.R. CONDENSERS

These Condensers have been expressly designed and manufactured for "mains" work and each condenser is tested for capacity, tension and disruptive strength, and insulation resistance.

750-volt test..	1	2	4	8 mfd.
PRICE ..	3/-	4/-	6/9	12/3
500-volt test				
PRICE ..	2/6	3/6	5/3	11/-

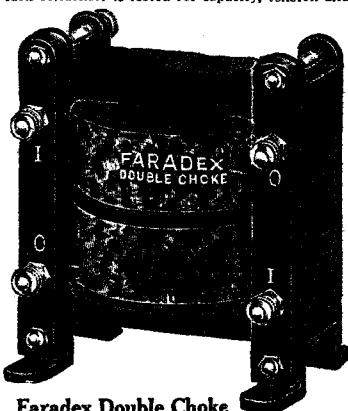

Faradex Double Choke

"FARADEx" MAINS TRANSFORMER

The primary winding is tapped to suit either 100/110 volts, 40/60 cycles A.C. mains, or 200/240 volts, 40/60 cycles A.C. mains. There is a large centre-tapped secondary giving 250 volts on either side of the tapping, and a small centre-tapped secondary giving up to two amperes at six volts across the outside terminals.

This Transformer is suitable for use in eliminators intended to give a D.C. output of up to 60 milliamperes at 200 volts PRICE **35/-**

STANDS

76 & 77

OLYMPIA

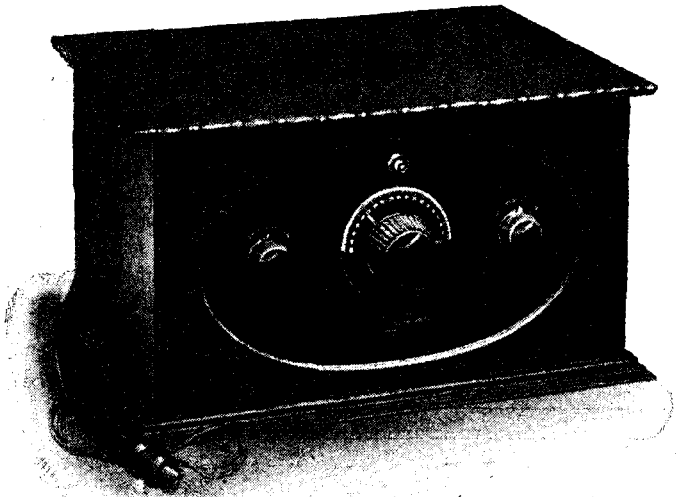

Patent Nos. 289217 and 290032.

Readers of AMATEUR WIRELESS have followed with keen interest the series of articles dealing with the "Simpler Wireless" system which has appeared in this periodical during the past eighteen months. Hundreds of them have actually built, with great success, the various "Simpler Wireless" sets which have been described. The information that "Simpler Wireless" sets are now being manufactured commercially, under licence from the inventor of the system, to the inventor's own design and under his personal supervision, will therefore be of particular interest to readers of this journal.

These receivers, while working on exactly the same principles as those already described in AMATEUR WIRELESS, have been much improved in many ways. All the "live" parts of the sets are totally enclosed and the sets comply in every respect with the I.E.E. regulations relating to wireless sets working from the mains. For the benefit of new readers it may be stated that the "Simpler Wireless" system was invented by J. F. Johnston, then a member of the AMATEUR WIRELESS Technical Staff, and was incorporated in numerous receivers described in these pages. The chief features of the system are the simplicity with which all the current can be obtained from the lighting mains (no "battery-eliminators" being necessary) and the wonderful reproduction due to the unique "direct coupling between the valves." Send for literature.

PRICES :

Three-valve set as illustration, in Jacobean oak cabinet, including Cossor valves. For 200/240 volt D.C. Supplies	16 gns.	Marconi Royalties paid.
For 200/240 volt 40/60 cycles A.C. supplies	21 gns.	

Either of the above sets may be obtained in a polished mahogany cabinet at an extra cost of 1 guinea.

ROOKE BROS LTD

55 CARDINGTON STREET
LONDON, N.W.1

Telephone . . . Museum 8819

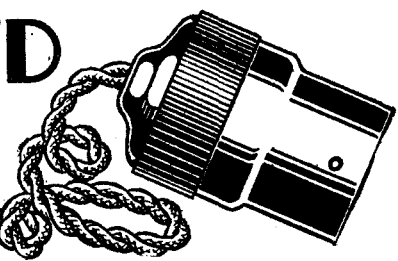
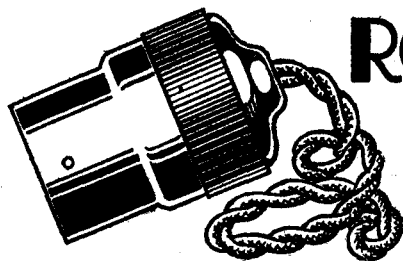

Advertisers Appreciate Mention of "A.W." with Your Order

REVISED PRICES. FIT TUNEWELLS

We are pleased to be able to pass on to the public the reductions made possible by the enormous demand created for these coils.

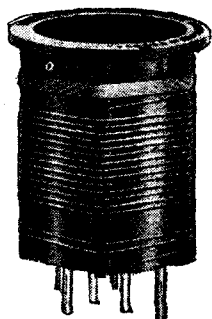

Mullard Master
Three, Three-
Wave Two, etc.
Low and B.B.C.
Wavelength
3/11 each.
High-Wave
5/3
Split-Primary
H.F. as previous
Formers
2/3 and **3/6**

What a satisfied "A.W." reader writes:

"Your coils are simply wonderful value. They are more efficient and altogether superior in every way to others at nearly double the price."

Coils for all 6-pin or plug-in circuits, from all live dealers or direct Post Free from:

TURNER & CO.
54 Station Rd., N.W.11
SEE US at STAND 234

"Zampa"

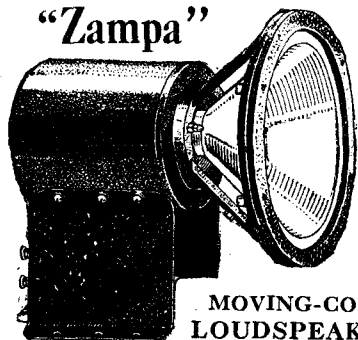

MOVING-COIL
LOUDSPEAKER

The "Zampa" is an entirely British instrument, scientifically and soundly constructed, unequalled in its quality of reproduction.

Most economical to use, as it only consumes .5 amp. at 6 volts. The moving coil is wound to 1,500 ohms. Over-all measurements are: Height 9 1/2", Width 8 1/2", Depth 9".

Remember the "Zampa" is a complete, assembled unit. It gives absolutely natural, clean and crisp reproduction and yet is sold at the following low price:

To work off 6-volt accumulator or Trickle Charger from A.C. Mains Including Step-down Transformer **£5 17 6**

The Zampa Regenerative Aerial Tuner This excellent tuner has been designed to meet the requirements of the Home Constructor. The method of reaction ensures perfect balance and control over the 250-2,000 metres range.

PRICE 13/6

Obtainable through all Dealers

MIC WIRELESS CO.

White Horse Place, Market Street
WELLINGBOROUGH

"The NEW-STYLE BAFFLE THREE" (Continued from page 410)

Complete baffle board (Camco).

Pair of angle brackets (Raymond).

Two slow-motion dials (Burndept, Bowyer-Lowe, R.I. and Varley).

6-volt 40-80 accumulator (Ever Ready, C.A.V., Ediswan).

Super-capacity high-tension battery (Three Ever Ready "Super One" 45-volt or two Ripaults Orange label 60-volt).

16-volt grid-bias battery (Ever Ready, Lissen, Ripaults).

The best advice we can give the intending constructor is—buy a full-size blueprint, an inexpensive, but almost indispensable, constructional guide. Price 1/6, post free, this can be obtained from Blueprint Department, AMATEUR WIRELESS, 58-61 Fetter Lane, E.C.4.

As already mentioned, the receiver is mounted above the loud-speaker pot winding. The reaction and tuning condensers, together with the volume control and filament rheostat, are mounted on the front of the baffle board at the top, the baffling serving in place of the usual ebonite panel. The remaining components are mounted on a baseboard supported at right angles to the baffle by means of two substantial angle brackets.

The blueprint shows the full-size layout of the top of the baffle and the baseboard. The complete baffle arrangement is depicted by an additional sketch on the blueprint which should prove very helpful.

The baffle should first be drilled to take the variable condensers, etc., which can then be mounted in position. Next, the baseboard is fitted by means of the brackets.

The output push-pull transformer is mounted at the extreme left-hand end of the baseboard, looking from the back as in the blueprint. The other push-pull transformer occupies a fairly central position.

On the extreme right is a small horizontally-mounted terminal strip carrying the aerial and earth terminals.

The grid cell for anode bend is mounted in the small clip just to the right of the tuning condenser.

The grammo-radio jack is mounted vertically by drilling a clearance hole in the baseboard and securing the jack with its one-hole fixing nut.

When all the components have been carefully and securely fitted in position they can be wired together before fitting the moving coil loud-speaker frame behind the grill.

Several wiring points call for some comment. As far as possible wiring is carried out with stiff lengths of Glazite wire, but there are four groups of flexible leads as well.

(a) The H.T. +, H.T. -, G.B. +, G.B. - 1, G.B. - 2 leads are taken from the components involved through small clearance holes drilled in adjacent portions of the baseboard to a clamping strip of ebonite

just under the left-hand corner of the baseboard; thence in a neat bunch of five leads to a similar clamping strip at the bottom of the baffle, where the leads diverge to the high-tension and grid-bias batteries.

(b) The L.T. + and L.T. - leads are taken through a hole at the other side of the baffle down to the accumulator.

(c) The two leads from the output terminals of the output transformer are led through a hole in the panel bracket to the two terminals mounted on a strip on the loud-speaker frame.

(d) Two flexible leads are taken through a hole in the baseboard near the first L.F. valve holder to the two terminals on the pot magnet of the loud-speaker. Incidentally it will be seen that by this means the accumulator supply to the valve and pot winding is controlled by the filament on-off switch on the baffle.

When wiring the two resistances of the resistance-capacity coupler see that the metallic side of the 100,000 ohm resistance is connected to H.T. plus. These particular resistances are shielded and the metallic shield is connected to the metal ends of the resistances. It is essential that the low potential end of the resistance be connected to H.T. plus, and not to the anode.

Values For The "New-style Baffle Three" (Recommended 2-volt Combinations)

Make	Detector	1st L.F.	Push-pull Valves
B.T.H.	B210H	B210L	B215P
Cosmos	SP18/B	SP16/G	SP16/RR
Cossor	210RC	210LF	Stentor 2
Ediswan	RC2	GP2	PV2
Marconi	DEH210	DEL 210	DEP215
Mullard	PM1A	PM1LF	PM2
Osram	DEH210	DEL 210	DEP215
Six-Sixty	SS210RC	SS210LF	SS215P

All that remains now is to fit the moving-coil loud-speaker behind the grill of the baffle board, which is done by means of three substantial wood screws passing through the three holes provided round the periphery of the aluminium frame.

Having connected the two sets of flexible leads to the moving-coil and pot winding, as already explained, preliminary tests can be effected by connecting up the specified high-tension, low-tension and grid-bias batteries and inserting one or other of the recommended valve combinations.

£300 A YEAR FOR YOUR SPARE TIME!

Wonderful New Invention YOU can Make and Sell under My Patent!

REALLY, genuinely, you can make at home and in your spare time a sum of extra money up to £300 per year. The work is of fascinating interest. It will open up to you new ideas, new vistas of money-making; provide many of those luxuries and necessities which you have so long wished for, and give you occupation just at those hours when time is apt

to hang heavily on the hands. Let me hear from you NOW before somebody else is granted the licence and the extra income that can so easily become yours.

Simply fill in and forward the coupon below and, by return of post, I will send you every particular with which you may wish to be acquainted. It

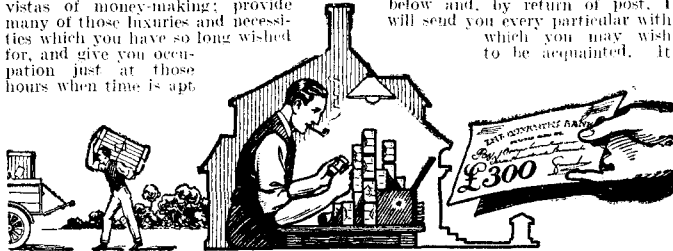

IN THE COMFORT OF YOUR OWN HOME YOU CAN DOUBLE YOUR INCOME.

The work is a delight. You can keep at it just as long as you like each day or week. No "plant" or expensive machinery is needed. A spare-room or even the kitchen table can serve as your profit-making "factory" and the children can help too!

is those who seize opportunities who succeed. Take this opportunity NOW.

to hang heavily on the hands.

Others are doing this by working my enormously successful patents. Why not you? It costs you nothing to write for full particulars, and you can then see for yourself exactly what you can do.

My patents are in very great demand in the field of wireless and electricity—so much so that

I GUARANTEE

your profits, and further guarantee to protect you against any infringement or interference with your market. Only a limited number of licences are issued under my Royal Letters Patent, in order to ensure a fair market for

"MAKE-MONEY-AT-HOME" COUPON

To THE ENGLAND-RICHARDS CO., 125, King's Lynn, Norfolk, LTD.

Sirs.—Please send me at once, and FREE, full details as to how I can Make Money at Home in my spare time. I enclose 2d. stamp for postage.

Print your name and address boldly in Capital letters on a plain sheet of paper and pin this coupon to it.

Amateur Wireless, 22 p. 28.

WRITE OR CALL FOR OUR 1928-1929 CATALOGUE

Just published containing particulars and details of all the latest lines exhibited at the Wireless Exhibition. 70 pages of Wireless and Gramophone accessories that are in everyday use by all experimenters, constructors and amateurs. Send 6d. to cover cost of postage for your copy—FREE to callers.

It always "pays to go to Day's" for all wireless accessories and parts.

|| STAND 248 ||
GALLERY, WIRELESS EXHIBITION, SEPTEMBER 22-29

WILL DAY LTD.

(the best in the west)

19 LISLE ST., LEICESTER SQUARE, W.C.2

Phone: Regent 0921 and 0922 Grams: Ticks, Westrand, London

A MANUFACTURING ACHIEVEMENT

WEILO

"PLUS-POWER" TRANSFORMER

Sets the standard of to-morrow

EVERY preconceived notion of Transformer value swept away. These guaranteed Transformers are wonderful value! Built up to a standard that has hitherto sold at 25/-, these instruments with extra large core have a purity of maximum amplification that excels anything else obtainable.

GUARANTEED TWO YEARS

TRANSFORMERS
"POWER" Heavy Type Shrouded 11/6 Model No. 10
HEAVY Shrouded Type 8/6 Model No. 3
CHOKES
10 Henries, 20 milliamps. 8/6
13 Henries, 30 milliamps. 10/6
20 Henries, 50 milliamps. 18/6
220 ohms. D.C. Resistance.
STOCKED BY GOOD CLASS DEALERS

Telephone Victoria 8472
S.W. LEWIS & CO LTD
3 Lines. 39, VICTORIA STREET, LONDON, S.W.1
Telegrams Eslewick, South London.

This Wonderful New Circular Motion Anti-Microphonic VALVE-HOLDER

NO matter how much you may jar your set, the circular motion of vibration of the NEW CASON ANTI-MICROPHONIC VALVE HOLDER guarantees safety to your valves. They will not swing sharply to and fro, but will rotate smoothly and without the least strain. Again, this wonderful device is so finely sprung that it ensures perpetual valve-motion, a necessity to the best reproduction.

CASON ANTI-MICROPHONIC VALVE HOLDERS
are guaranteed to be made of only the highest grade mouldings, insulated parts and springs.
Ask your dealer, or write for particulars NOW!

16 ONLY

CASON MOULDINGS, CHISWICK RD. LR. EDMONTON, LONDON, N.9

Again—more than 30 New Products this Season

Come and See all our New

COMPONENTS

SETS

ACCESSORIES

GRAMOPHONE ELECTRICAL
REPRODUCTION APPARATUS

at

STANDS 56 & 73

National Radio Exhibition

Olympia, Sept. 22-29

Discuss your particular problems with our Technical experts, or if you cannot come to the Exhibition, write for our 1928-29 Catalogue—it will give you full particulars of our new lines.



VOLUME CONTROL
6/6

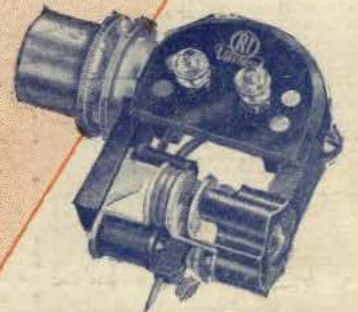

GRAMOPHONE PICK-UP
employing Compound Mass
Suspension
£3 : 3 : 0



H.T. BATTERY
ELIMINATOR
£10 : 5 : 0



ANTI-MOBO R.C.
COUPLERS. Incorporating
Anti-Mobo X, 25/-
" Y, 25/-
" Z, 25/-

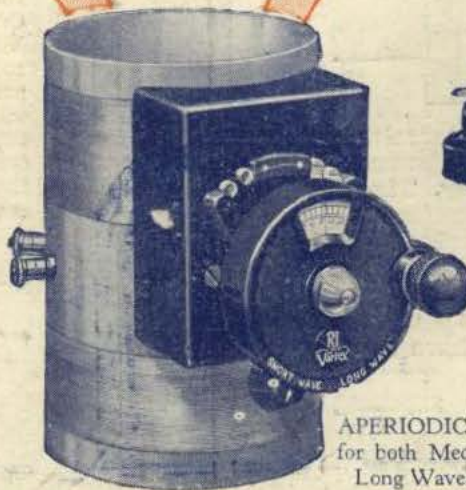

APERIODIC TUNER
for both Medium and
Long Waves, 25/-

**STANDS
56 & 73**

THE MARK OF BETTER RADIO



Kingsway House, 103 Kingsway, London, W.C.2.

Telephone: Holborn 5303.