

# Amateur Wireless And Electrics

OUR  
FIRST  
NUMBER

No. 1

SATURDAY, JUNE 10, 1922

Price 3d

## Our Chief Contents

	PAGE
<b>A MID-ATLANTIC GREETING FROM SENATORE MARCONI</b> With Photograph of Senatore Guglielmo Marconi ... ..	3
<b>BROADCASTING (Illustrated)</b> What It Means: What To Expect ... ..	3
<b>THE THERMIONIC VALVE (Illustrated)</b> A Notable Discovery of Modern Science ... ..	4
<b>HOW TO START WIRELESS (Illustrated)</b> Wave Length: Broadcasting: Obtaining the Licence ... ..	5
<b>THE MARCONIPHONE (Illustrated)</b> Some Advance Particulars of the Four Sets ... ..	6
<b>BREVITIES FOR VALVE USERS</b> Hints on What To Do and What Not To Do ... ..	6
<b>CONCERNING THE AERIAL (Illustrated)</b> Types of Aerial: Wave-length: Capacity ... ..	7
<b>EINSTEIN AND RELATIVITY</b> How the Einstein Theory is Linked Up with the Valve ... ..	8
<b>SOME AMERICAN SUGGESTIONS (Illustrated)</b> A Loud Speaker: Novel Detectors, etc. ... ..	9
<b>AN OFFICIAL RECEIVING SET AND HOW TO MAKE IT</b> Complete Details of Probably the Simplest Serious Crystal Set Yet Devised ... ..	10 & 11
<b>WHAT WIRELESS TERMS MEAN</b> Technical Words Explained in Popular Language ... ..	12
<b>OUR INFORMATION BUREAU (Illustrated)</b> Expert Replies to Readers' Questions ... ..	14
<b>MEMORISING MORSE (Illustrated)</b> A Simple Method of Visualising the Code ... ..	14
<b>RADIOGRAMS</b> The News of the Week ... ..	16
<b>FORTHCOMING EVENTS</b> Wireless Club and Society Fixtures ... ..	16
<b>WE PRESENT THREE RECEIVING SETS</b> Competitions with Valuable Popular Prizes ... ..	16
<b>Mr. WILLIAM LE QUEUX CONGRATULATES US</b> A Message from the Well-known Wireless Amateur ... ..	16

Phone: MUSEUM 1055.

# ECONOMIC ELECTRIC LIMITED

10 FITZROY SQ., Head Office and Mail Orders.  
LONDON, W.1. Branch: Twickenham.  
303 EUSTON RD. Showrooms.

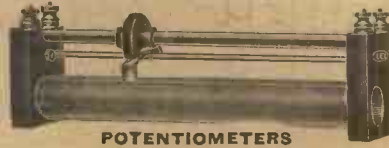

POTENTIOMETERS

## WIRELESS

the greatest of the most fascinating sciences is, or

all hobbies and a part of all will be

## YOUR HOBBY

On this page illustrations Special Radio contains 32 pages, photographs, interesting data the novice, the the professional. instruments or you have pages. Write Mailed for 4d.,

we give seven taken from our List, which con-grammed with diagrams, and —apparatus for enthusiast and Don't buy your materials until studied its post free.

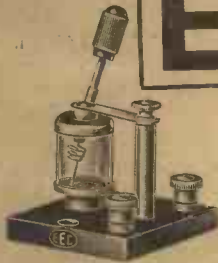

CRYSTAL DETECTORS

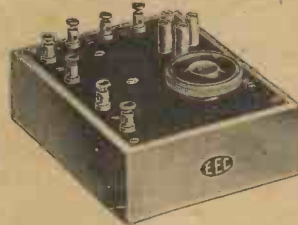

VALVE PANELS



RECEIVERS



CRYSTAL RECEIVING SETS

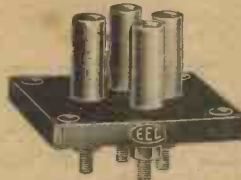

VALVE HOLDERS

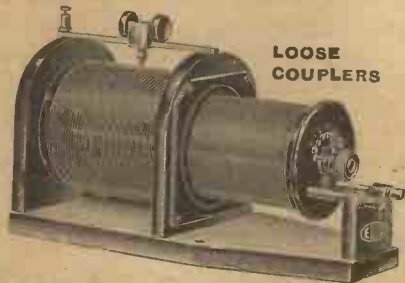

LOOSE COUPLERS



# THE ÆTHERCEPTA (No. W99)

THE WIRELESS TELEPHONE RECEIVING STATION EVERYBODY IS RECOMMENDING

(Originally marketed 1912 ; sales over 3,000)

PRICE £9 10 0

READY FOR ERECT-ING

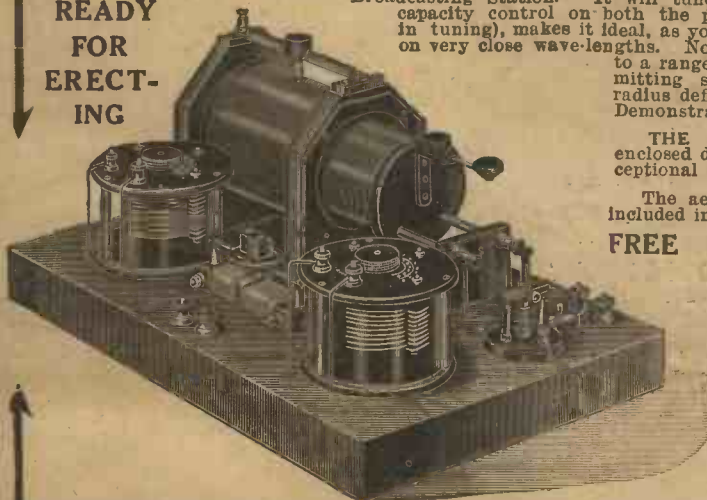

THE illustration does not do justice to the beautiful finish of this set, which is, without doubt, the finest instrument that can be recommended for the reception of "Broadcasting" when you reside within a 40-mile radius from a "Broadcasting Station." It will tune from 250 to 2,000 metres, with wonderful efficiency, and having variable capacity control on both the primary and secondary circuits (which perhaps involves a little more skill in tuning), makes it ideal, as you can select stations when perhaps two or more stations are operating on very close wave-lengths. Not only will you hear the above, but many more, stations of interest up to a range of 1,000 miles, this range, of course, depending upon the power the transmitting stations use. On actual tests carried out in London the Broadcasting radius defined above is established, and we invite you to hear such tests at our Demonstrational Room.

THE ÆTHERCEPTA is priced at only £9 10 0, complete with improved type enclosed detector (no potential needed), and nothing extra is needed, except in exceptional cases where short masts are desired.

The aerial we recommend is 100 ft. long, about 35 ft. high, and the material is included in the price.

**FREE ADVICE** for your Individual Case, and Personal Instructions upon operation willingly given by post if you cannot call.

If you are interested in wireless matters the MITCHELL CATALOGUE, 48 pages, profusely illustrated, should be in your possession, and is sent on receipt of 6 penny stamps.

Pioneers of the No. 1 Home Wireless Set at £5 complete. The "Overseas" Wireless Set, The "Radiocert" Wireless Set, and hundreds of standardised instruments in use throughout Great Britain and Ireland.

# MITCHELL'S ELECTRICAL & WIRELESS, LIMITED,

Postal Address : McDermott Road, Peckham, S.E.15.

Main Retail Stores : 185, Rye Lane, Peckham, S.E.15.

Telephones : Retail—New Cross 1540 ;

Demonstrational Room : 182, Rye Lane, S.E.15.

Wholesale and Shipping—New Cross 1541.

**GREAT BRITAIN'S GREATEST WIRELESS STORE.**



# Amateur Wireless

and Electric

No 1

June 10, 1922

## BROADCASTING

What it Means :: :: What to Expect

**WEEKLY PROGRAM**  
**RADIO-PHONE SERVICE**  
WESTINGHOUSE ELECTRIC & Mfg. Co.  
STATION W J Z, NEWARK, N. J.

MON., DEC. 12th, TO SUN., DEC. 17th, 1921.

This program can be heard by any one with suitable radio receiving apparatus within a radius of 100 miles of Newark.

The service is absolutely free.  
Tune Instruments for 360-meter waves

**REGULAR CONCERT**

DAILY, 8:30 to 9:35 P. M.

**MONDAY** - - - Mme. May Peterson, Prima Donna Soprano, Opera Comique, Paris  
**TUESDAY** - - - Or-Ke-Non-Ton, Indian Baritone; Messrs. Bertram Haigh and Ralph Brown, French horns; Miss Anita Wolf, Pianist  
**WEDNESDAY** - Mme. Gretchen Hood, Prima Donna Soprano, Theatre de la Monnaie, Brussels  
**THURSDAY** - - Miss Helen Davis, Soprano; M. Cliff Young, Pianist  
**FRIDAY** - - - Westminster Orchestra  
**SATURDAY** - Dance music  
**SUNDAY** - - Miss Ethel Mackey, Soprano and Miss Mary Emerson, Pianist. Sacred Music

**OTHER FEATURES**

General News - Newark Sunday Call News Service, daily, 7:55 P. M.  
Children's Hour - "Man-in-the-Moon" stories, by Miss Josephine Lawrence © Newark Sunday Call Tuesday and Friday, 7:00 P. M.  
Hourly News Service - Newark Sunday Call; weekdays, every hour from 11:00 A. M. to 7:00 P. M. on the hour.  
Radio Amateurs' Night - Thursday 7 P. M. J. B. WALKER editor Scientific American  
Weather Forecast (Official Gov't) - Daily, 11:00 A. M., 5:00 and 10:03 P. M.  
Marine News - Marine Engineering Service, weekdays (except Saturdays), 2:05 P. M.  
Official Arlington Time - Daily, 9:55 P. M.



(Program subject to change)

A Typical American Broadcasting Programme.

THE amateur wireless world, and indeed the public generally, are more or less impatiently awaiting the outcome of the discussions between the Postmaster-General and the broadcasting firms (wireless apparatus manufacturers). Everybody interested is anxious to make a start.

We all know that the word broadcasting has come to have a special meaning in connection with wireless telephony. Transmitting stations will send out interesting programmes of news, music, lectures, etc., and all the receiving sets within a working radius will

"Whether radio, or radio-telephony, is or is not going to work a greater revolution in human life than any invention in the world's history remains to be seen. That it is astounding almost to incredibility as it stands is certain; and no less certain is it that its possibilities are not yet even to be guessed at."

In England we hardly know anything of what is already the daily plaything of some millions of people in the United States. The whole thing is a growth of only a few months. It began, so far as the public interest is concerned, in October or November of last year, since when the manufacturers of receiving apparatus have sold close upon 1,000,000 sets and it is believed that the home-made sets number another 500,000.

There is no village in the British Isles so poor or unfriended that it will not be able to afford, or find a patron to give, the necessary receiving instrument in the village institute or hall or necessary room.

The villager and every remotest farmhouse should receive (not occasionally, but every night) as good singing, as good opera, as good dance music, as good a lecture, or as good a survey of the news as any millionaire in London can buy. It is entirely practicable, and close at hand.

One wonders whether, in the near future, there will be private orchestras for dances or concerts any more. If a central orchestra gives better music than can be hired elsewhere, why should a grand piano and four or five musicians clutter up the dancing floor? Shall we go any more to hear public speakers, or will they (as has been done in America) address their audiences from their libraries, talking into a transmitter?

"The Times" New York Correspondent's Prophecy.

### A Mid-Atlantic Greeting from Senatore Marconi



Senatore Guglielmo Marconi, G.C.V.O., LL.D., D.Sc., M.I.E.E. Born in Italy, April 25, 1874; first experiments, 1895; following year came to England and took out his first patent. Has received well-merited honours from many governments and universities.

#### The Message

Office of origin.—Radio S.Y. Elletra via K.D.K.K. 30 — 1300 — Devizes.

Editor, "Amateur Wireless," Caspeg, Cent., London.

My heartiest good wishes for most complete success of "Amateur Wireless."—G. Marconi.

reproduce the programmes. The possible developments must be enormous. What are they?

The subject is peculiar in that it has no precedent in this country. The United States has had a broadcasting service for about the past twelve months, and it will be instructive to note the conditions there. A year ago the wireless enthusiasts of the States consisted of a mere handful, engaged almost entirely in the scientific aspect of the subject, and content to hear the Morse-code clicks and to realise that they were receiving signals from many hundreds of miles away. Wireless telephony came almost as a revelation to them when some discovered that they occasionally received gramophone music—music only of a sort, it is true. As wireless telephony developed and

became practicable it made its appeal even to the less scientifically inclined, with the result that, late in 1921, there were said to be about 200,000 receiving sets in use. It is somewhere near the truth to say that at present considerably more than a million sets have been installed. So great is the demand for apparatus in the United States that one more vast new industry is being developed there. Already, we are told, there is about a hundred broadcasting stations in daily operation, and the broadcasting includes everything that can provide interest or entertainment. A typical programme is reproduced in the first column of this page.

Broadcasting has created a rather anomalous position. You purchase a receiving set and without further payment receive unlimited enter-

tainment; that is, you get a gramophone with a difference, for which no records are required and whose reproductions are always up to date. Presumably, the broadcaster is to be recompensed by the sale of the apparatus, but a difficulty occurs here, for much of the apparatus is not patented and can be made and sold by anybody. So far the broadcasting firms have been recuperated by their enormous sales of apparatus, but these conditions cannot continue indefinitely. The wireless public is receiving its enter-

tainment free, but demands good quality stuff, and to a certain extent the reputations of the great electrical undertakings are bound up in the quality of their efforts—"they that live to please must please to live." The whole question is interesting and awaits solution.

Wireless telephony has passed through about the same period of development as the phonograph had when it was first placed on the market. With the latter the results were crude to a degree, but even at the present time, with wireless tele-

phony in its infancy, the results equal the gramophone as regards tone and articulation, though not so consistent; however, improvement is noticeable week by week.

Future developments, both from a scientific and social point of view, can only be guessed at. Certain it is that we may expect many improvements in technical details and immense development socially. In this connection some paragraphs from the *Times* special correspondent in New York, reproduced on p. 3, can be read in the nature of prophecy.

## THE THERMIONIC VALVE

THE most remarkable of all wireless appliances, and possibly one of the most notable discoveries of modern science, is the thermionic valve, sometimes styled the ionic valve or the audion, or, most usually, simply the "valve." To this appliance must be ascribed the meteoric development of wireless telephony.

At an early date it is intended to devote attention in these pages to the valve in detail, this brief reference only being for the purpose of bringing it to the notice of those readers who have had no previous acquaintance with wireless matters.

In construction and appearance, the valve may be best described as a modified electric lamp, as will be evident from the illustration. The internals consist of what are termed the filament, the plate, and the grid, all of which may be clearly seen in the smaller photographs. With different makes there is variation in their design, but in each case these elements fulfil the same purpose. The filament is the exact counterpart of a filament in any small-size electric lamp; the plate is a small plate of metal, usually in the form of a cylinder surrounding the filament; and the grid is a small spiral of wire or actually a wire grid placed between the filament and the plate.



The Valve Complete.

and it emits from its surface minute negative charges of electricity called electrons, which are subject to the usual laws of electrostatic repulsion and attraction, which will be entered into fully in a later

caused to vary by means of the third electrode or grid by varying the potential of the latter with respect to the filament. If the grid is strongly negative to the filament, it tends to drive the emitted electrons back into the filament, despite the attraction of the positively charged anode. As the negative grid potential is decreased, electrons begin to flow through the spaces in the grid to the anode. The variation in potential, of course, is obtained with the incoming signals.

This is the simplest aspect of the valve. Its most remarkable properties are evidenced in other ways, of which the space in this present issue will not permit of more than brief mention. It will act as an amplifier, permitting of strong currents being impressed upon feeble ones; it will act as a detector, and also as an oscillator or transmitter.

It has been called the modern Aladdin's lamp, but, truth to tell, it is more wonderful than the author of "A Thousand and One Nights"—and he was not without imagination, was he?—ever dreamed!

**Three Sets of Apparatus as Prizes.**—We direct our readers' particular attention to page 18, on which will be found an announcement of a prize competition in which we are offering valuable prizes.



Bulb Removed



Plate Removed



Plate and Grid Removed

Thermionic Valve with Horizontal Elements.



Bulb Removed



Plate Removed



Plate and Grid Removed

Thermionic Valve with Vertical Elements.

In use, the filament of the valve is heated by current (usually from an accumulator) in exactly the same manner as is the filament of an ordinary electric lamp,

issue. The metal cylinder or anode, being maintained at a potential positive to that of the filament, attracts the electrons. The flow of electrons, however, may be

A Good Handbook for all who make their own apparatus is the "Work" handbook "Wireless Telegraphy and Telephony and How to Make the Apparatus." 160 pages, 1/6 net.



# HOW TO START WIRELESS

**Wireless Amateurs.**—There are really three distinct classes of wireless amateurs. Firstly, there is the enthusiast who has no technical knowledge, merely making use of a receiving set for the purpose of listening to concerts. Then there is the amateur who buys a receiving set, with which he listens to anything and everything he can hear. And lastly, there is the experimenter, whose set is never complete, and whose interest in wireless never diminishes. He makes as much apparatus as he can, and buys as little as possible.

If the reader is about to become a wireless enthusiast, he will be able to judge from the preceding paragraph to which category he belongs. If it is only desired to listen to the special broadcasting programmes of speech and music in the area in which he lives, it is merely necessary either to buy or make a very simple set. This set would be designed to receive only the one particular broadcasting station. If it is desired to listen to broadcasting stations from other areas the set would need to be much more sensitive, but it need not have a greater wave-length range, a matter, however, which will be dealt with later.

At the present time there are not very many receiving sets on the market which cover the wave-lengths used by commercial stations as well as those to be used by the

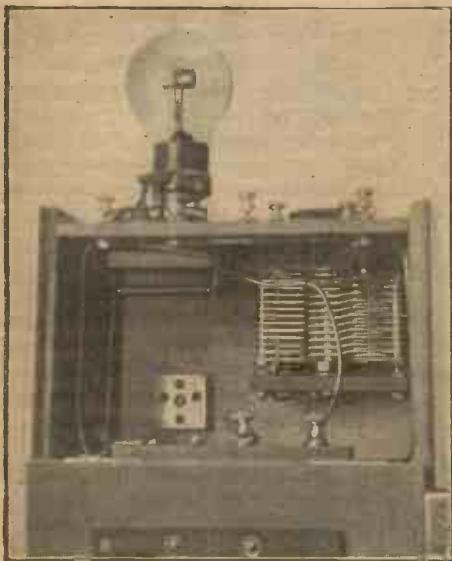

A Simple Valve Receiving Set (Internal View showing Variable Condenser).

broadcasting stations. If, therefore, the reader wishes to receive all types of transmission he should consider this point very fully before purchasing any apparatus, and if he is quite a beginner he will be well advised to obtain the help of a friend

who has already had some experience in wireless work.

**The Meaning of Wave-length.**—The wave-length of a wireless station does not

shall use wave-lengths ranging between 350 and 425 metres. Therefore, to receive these stations the apparatus must be able to tune to these wave-lengths. This, of



A Crystal Receiving Set with Loose Coupler.

refer to the distance to which it can send. This depends upon the power used by the transmitter and the sensitiveness of the receiving apparatus. For example, a station working on a long wave-length may be heard a few miles away, while another working on a short wave-length may be heard across the Atlantic. Wave-length has an electrical meaning.

When a stone drops into a pond a number of little rings travel across the surface of the water. These rings are in reality little waves in the water, and it will be noticed that the distance between each ring is the same. Now, this distance between the crest of one wave to the crest of the next is called the wave-length. Wireless communication is carried out by means of waves, not in water, but in what is known as the ether. The waves, of course, are set up at the transmitting station by electrical means. To prevent the message from one station mixing up with the message from another each station transmits on a different wave-length, and by adjusting the receiving apparatus it is possible to pick up any particular station. This process of adjusting the receiver is known as "tuning," and, therefore, to pick up a certain station it is necessary to tune the receiver to the wave-length which is being used for transmission.

## The Broadcasting Stations.

Wave-lengths are measured in metres, the French equivalent of the yard, or, to be more exact, approximately  $39\frac{1}{4}$  in. The Postmaster-General has provisionally arranged that the broadcasting stations

course, is a very limited range, and the necessary apparatus would only need to be of very simple construction. If it was desired to receive a large number of broadcasting stations from various parts of England the apparatus would be more complicated, as it would have to be more sensitive.

**Other Stations.**—Wireless communication makes such rapid advances that what is written to-day is almost out of date tomorrow. However, the wave-lengths which are in everyday use range from about 150 to 23,000 metres. Speaking generally, the lower the wave-length the more critical is the process of tuning, and hence a beginner usually finds more difficulty with the shorter wave-lengths. This refers to wave-lengths below about 200 metres, and therefore it will be seen that the broadcasting wave-lengths of 350 to 425 metres will present no difficulty whatever.

A certain number of qualified amateurs are allowed to transmit for experimental purposes with very low power, and they are allotted a wave-length of either 180 or 440 metres. Between these two figures there are a few ships and coast stations working on 300 metres, and then there will be the broadcasting stations between 350 and 425 metres. The next wave-length of interest is 600 metres, as it is responsible for nearly all the ship traffic. It is possible to hear ships working with the shore stations at almost any time of day or night. A very fascinating wave-length is 900 metres, as this is allotted for aircraft work. The pilots of all the aeroplanes on the Paris air route are directed by wireless

telephony from the aerodromes, with which they are in touch throughout the flight.

Every Sunday afternoon a concert is given from Holland on 1,070 metres; this, however, is not very strong in England, and very sensitive apparatus is required to receive it plainly. Sometimes telephony is sent out both from Paris and Königswusterhausen on wave-lengths between 2,000 and 4,000 metres.

Other items of daily interest are weather reports and time signals. These are transmitted in Morse code at slow speed, and it is possible to follow each dot and dash, the final one marking the time at which the signal is due to be sent.

*Types of Transmission.*—Wireless messages can be sent by three different methods. These are the "Spark System," "Telephony," and the "Continuous-wave System." Spark and telephony can be received on extremely simple apparatus, provided that the transmission is powerful enough. To receive continuous wave, or C.W. as it is usually called, it is necessary to employ thermionic valves. This necessitates the use of batteries, and hence there is a slight cost in upkeep. It is almost impossible to receive a large number of distant spark and telephone stations without the use of valves, since the valve is not only extremely sensitive, but it can also be made to amplify the strength of the received signals.

Powerful spark signals and telephony, such as would emanate from a near broadcasting station, can be received with what is known as a crystal detector.

#### How to Obtain a Licence.

All wireless communication is controlled by the Postmaster-General, and therefore before any apparatus can be set up for receiving signals it is necessary to obtain permission from the Post Office. At the present time it is practically impossible to give any definite information on the subject. Up to the time of writing the procedure has been to apply to the Secretary, the General Post Office, London, for particulars regarding the issue of a permit to install wireless receiving apparatus. However, it is expected that very shortly (perhaps even when this appears in print) it will be possible to obtain a permit from any post office. T.

## OURSELVES

WE make our bow to the reader. We have no apology to make for our appearance. We are just what we profess to be—"Amateur Wireless and Electrics"—a weekly paper at the complete service of every wireless amateur in the country. We exist to help. Our mission is to "provide the amateur with practical information, with hints and with kinks, with bright readable matter on the all-absorbing subject of wireless, to keep him up to date with the movement, to answer any questions which he addresses to us, and to bring before him the announcements of the traders in this special industry whose goods he will naturally be pleased to hear about.

There—that is the reason for our existence. Modifying the Prince of Wales's motto, "WE SERVE." Let us serve you! That is all we ask.

# THE MARCONIPHONE

"MARCONIPHONE" is the name given to a series of receiving instruments shortly to be placed on the market by the Marconi Wireless Telegraph Co., Limited, and of which we are able to give some advance particulars. The series comprises the following instruments:

1. Crystal Junior, an inexpensive instrument which has been designed to meet the requirements of the young experimenter, the whole being enclosed in a small box fitted with an adjusting handle.
2. Crystal Type A, a larger instrument capable of fine tuning. The crystal is in conjunction with a special patented circuit.
3. Marconiphone V2, with two valves. A range of not less than fifty miles is guaran-



Marconiphone V2, the Smaller of the Valve Sets.  
The Marconiphone will soon be on the market.

teed with an outdoor aerial. With an indoor aerial a range of not less than ten or twelve miles is obtained. The adjustments are of a simple nature and at the same time capable of fine tuning.

4. Multivalve Marconiphone. With this instrument and an outdoor aerial a range of 100 miles or more is attainable. With an indoor aerial the range is at least fifty miles.

The valve receivers are fitted with a

special type of valve, for which dry batteries can be used in place of the usual accumulators.

The illustration shows the Marconiphone V2.

## BREVITIES FOR VALVE USERS

1. REMEMBER that your receiving apparatus is not a crude collection of switches, but that the operation of every switch should receive due consideration.
2. Turn on your valves slowly.
3. Do not burn them too brightly.
4. Signals are not necessarily stronger the brighter the valves are lighted.
5. Valves are dearer now.
6. Do not let your valves "howl." If you do your next door (wireless) neighbour may report you and there will be a possibility of having your licence cancelled.
7. Remember that by using too tight a coupling you not only spoil your own results but those of other "listeners in" in your neighbourhood.
8. Having roughly tuned in on your inductance and accomplished finer tuning with your variable condenser, bear in mind paragraph 6.
9. It is not sufficient to switch off the filament current. Remember your high-tension battery. It will last for months if you do.
10. When using more than one valve it is important to remember that there is a proper arrangement of the valves. Interchange them from left to right—having tuned in a station such as F.L. who is likely to continue for a time, until you find the best position for each.
11. A good aerial, well insulated, is more than half the battle.
12. The higher the aerial is the better.
13. Get the words "frame aerials" right out of your mind unless you are working for the sake of experiment.
14. Frame aerials are of little or no use to the "listener-in."
15. An outside aerial—if only in a backyard—is better than any indoor aerial.
16. If you are contemplating the acquisition of a receiver it is advisable to purchase a valve set if you can afford it, but a crystal receiver will give quite good results over a short distance and usually can be converted later.
17. The cost of a valve set is not greatly in excess of that of a crystal set, and its upkeep is negligible. C.



# CONCERNING THE AERIAL

FOR use with all ordinary apparatus, such as is likely to be in the possession of the average amateur wireless enthusiast, an outside aerial may be deemed to be essential if the best results are to be obtained.

*Types of Aerials.*—(1) Single-wire aerial having a short lead-in, such as is shown in Fig. 1; (2) single-wire aerial having a long lead-in (Fig. 2); (3) double-wire aerial having a short lead-in (Fig. 3); and

between 3.5 and 4.5. It will be satisfactory to take a value of 3.5 for a single-wire aerial, and 4 for a double-wire aerial in which the two wires are well spaced.

It may be taken for granted that it will be desired to receive wave-lengths much in excess of the natural wave-length of the aerial, such as signals from commercial and long-distance stations. It would appear, therefore, that the longer the natural wave-length of the aerial to com-

effect of reducing the inductance of the aerial as a whole, so that, unless the wires are some distance apart the natural wave-length of the aerial will be only slightly increased. Increasing the value of the multiplying factor to 4 allows for this.

An increased capacity is of great advantage when tuning to long wave-lengths, as less inductance has to be added than would otherwise be the case. At the same time, there is no advantage in having an

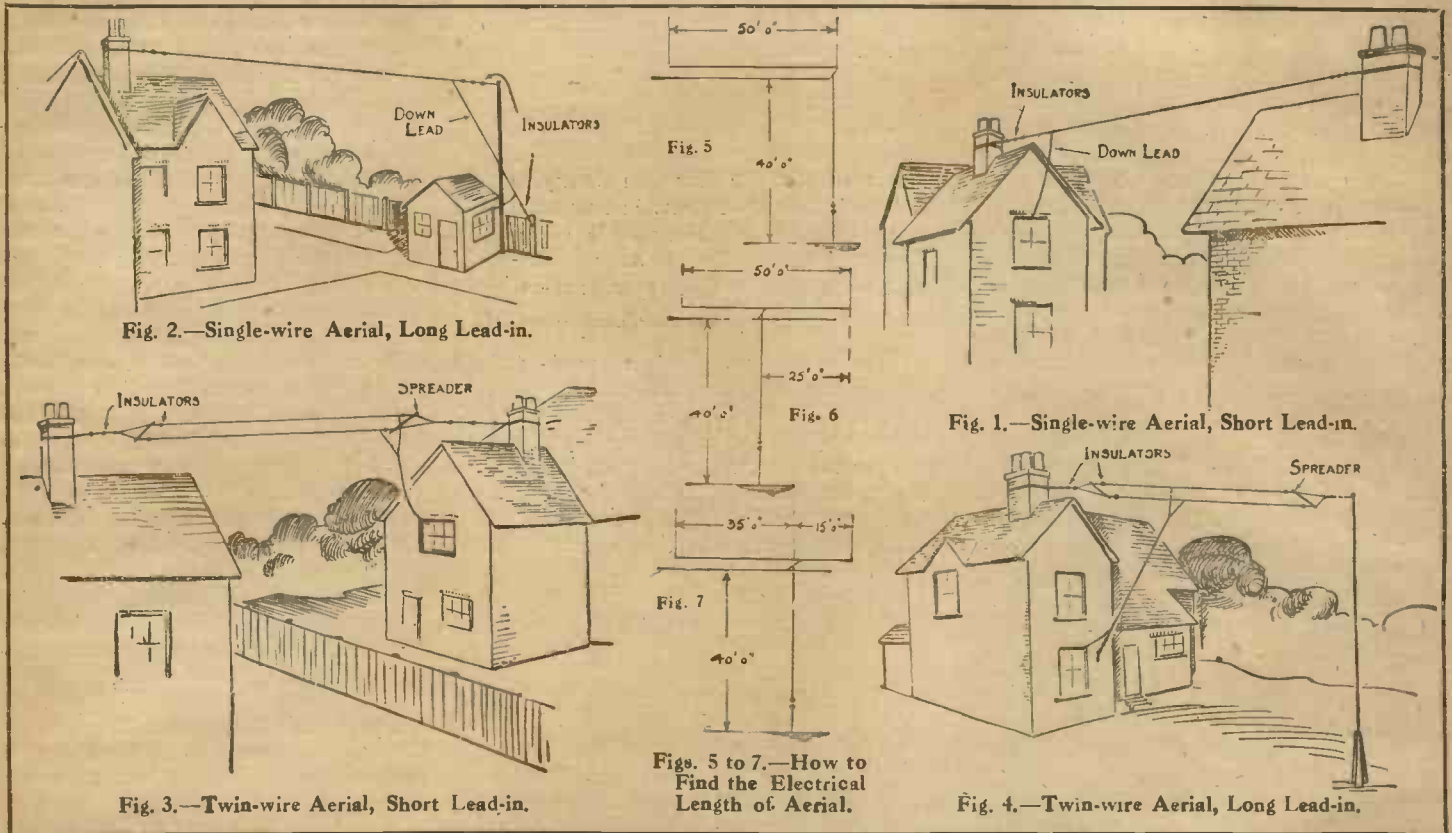

(4) double-wire aerial having a long lead-in (Fig. 4). All these are taken as being either T or inverted L aerials. The umbrella-type aerial is but little used nowadays, scarcely ever by amateurs.

Each of the four examples shown is carried out with a total length of 100 ft. of wire for the single-wire aerial, and 140 ft. where two wires are used.

*Wave-Length.*—The "electrical length" of an aerial, which determines its fundamental or "natural" wave-length, is the distance from earth direct to the end of the aerial wire (see Figs. 5 to 7). The calculations involved in finding the natural wave-length of an aerial are complicated, and the results obtained are often wrong, but a fairly accurate result, sufficient for all practical purposes, can be arrived at by multiplying the electrical length of the aerial by a constant which normally varies

mence with, the less inductance will have to be added to tune in any particular wave.

*Capacity.*—The capacity of an aerial depends on the number of wires and upon the height above the ground. The wave-length of any oscillatory circuit is dependent on the product of the inductance and capacity of that circuit. Therefore, in order to tune a circuit of small capacity up to a given wave-length, more inductance will have to be added than in the case of a circuit possessing a greater capacity.

As a reasonable height is necessary in order that the aerial may be raised above surrounding earth-connected bodies (that is, buildings, etc.), which by absorption would deprive the aerial of energy, the best means of increasing aerial capacity is by increasing the number of wires.

Adding wires in parallel, however, whilst increasing the capacity has the

aerial of very large capacity for reception. With large-capacity aerials, "static" effects are most pronounced and prove troublesome. The weight of a multiple-wire aerial demands very strong "fixings," and with the inevitable sagging of the wires, the effective height is somewhat reduced.

An aerial consisting of two wires, spaced from 4 ft. to 6 ft. apart, will generally prove the most serviceable for all-round experimental reception work. The down-lead from such an aerial should really consist of two wires spaced on a spreader, and connected together just where they enter the instrument room, but a single wire may be used and will prove quite satisfactory.

The many considerations in the choice of an aerial—height, length, etc.—will be dealt with in an article on practical aerial erection to appear in an early issue. T. R.

# EINSTEIN AND RELATIVITY

THE chief thing about Einstein's theory of relativity is its criticism of the manner in which scientists have thought of space and time. They have not thought much of these things—none of us have, because they have seemed too obvious to need it. The measurement of lengths and of intervals of time has been supposed to be a common-sense process, and the ordinary foot-rule and the watch have been the foundation for the most refined instruments. Let me first show how common sense has gone wrong.

To measure the length of an object directly, we must go up to it with our ruler, for if it is at a distance perspective will make it seem smaller. Further, if our object is moving—if it is a motor-car, for instance—we must either stop it or else move with it; but in the latter case we can calculate its length if we know its speed and also the speed of the rays of light by which we see it. Thus two things, distance and motion, must be allowed for in estimating a true length.

We must also be sure that the ruler remains of the same length, and if it should expand a little on a hot day that must be allowed for, if the measurement is to be very exact. All this is common sense. But are there any other influences that may cause our ruler to change its length? There are several extremely minute ones, such as the pressure of the air, and, in the case of an iron ruler, its magnetisation. Forty years ago Professor Fitzgerald of Dublin said that there might be another one—that the ruler might be shortened if it were moving. This is not unreasonable, for the particles of a ruler, as of everything else, are held together by electric forces, and these may alter if the ruler moves: and the ruler is always moving—it spins round with the world in space at a rate of many miles per second. If it happens to be lying east and west, its spinning motion round the earth's axis is in its own direction, and it may become shorter than if it is lying north and south.

## No Importance for the Ordinary Person.

How could so fantastic a notion be tested? Not by measuring it with another ruler, for that too would be shortened by the motion. The only test that has yet been devised and executed successfully has been made on the assumption that a ray of light has a constant speed, and that light could be used to measure the lengths. This was done by Michelson and Morley in 1887, and by others since, and their results do lead to the conclusion that the length of any rod does change if it is moving, and that it is therefore shorter when it is pointing west than when it

points north. The difference is extremely small, and if the rod is one yard long it amounts only to about one-hundred-thousandth of a millionth of an inch. It is entirely negligible for all ordinary purposes, and the Theory of Relativity has evidently no importance at all for the ordinary person. Only by the most delicate and refined of all scientific researches can its effects be noticed.

One further step will show how great is its theoretical importance however. If length depends on speed, we can only say that a rod has a definite, absolute length

*What the author, Robert Lunnon, M.A., B.Sc., says in this article about the relation of the Einstein theory to the behaviour of electrons in a vacuum tube—such as the thermionic valve, for example—will come as a revelation to many electrical experimenters.*

if it has a definite, absolute speed—and there are *no* means of measuring speed absolutely. The speed of a motor-car may be measured relative to the earth, and the earth's speed relative to the sun, and the sun's speed through the stars—but the stars themselves are moving, and there is nothing in the universe that can be said to positively be at rest. Of any body it can only be said that its speed, relative to the observer, is some definite amount, and therefore its length relative to the observer is a definite amount. But it can never be said that a rod has an absolute length—its length is a relative property.

Einstein's argument about time is a little more complex. It will readily be understood that time cannot be measured without reference to distance. To obtain Greenwich time accurately at York, allowance must be made for the time taken by the signal to come from Greenwich to York, and that depends on the distance between the two places. At Greenwich itself, the astronomer could only calculate the time from the stars by allowing for his own motion with the earth—supposing such theoretical accuracy were possible. Hence if absolute measurement of length is unknown, so is that of time.

The heart of the Principle of Relativity is that all measurements of space and time can only be relative, because they depend on speed which cannot be measured.

Sir Isaac Newton believed that there was a standard of rest in the world, namely, a fixed and infinite æther, through which all bodies move. There may be an æther, but we cannot now believe it to be eternally at rest. And we cannot now measure lengths and times

separately. Because they are quite separate and unconnected things in their nature it has been convenient to measure them separately and to say that a yard has nothing to do with a foot. But Einstein's exact thinking has shown that for absolute accuracy this will not serve.

This new point of view has put many difficulties in the way of scientific calculations, because these must all be remade in harmony with this complicated relation between length and time. Most of the work has now been done, and the new results have nowhere been found to conflict with the final test of all theories, viz., actual facts.

The greatest success of Einstein's theory has been in its extension to the force of gravitation. This great force, the laws of which were first partly seen by Newton, has presented an unsolved riddle for centuries. "Thou hast hanged the world upon nothing," said the author of the Book of Job, and despite several brilliant guesses, science has made no progress towards understanding what force this is which keeps the world hanging in space and moving round the sun. The theories proposed hitherto have failed when compared by the tests of exact calculations with the facts of the laboratory. But the new theory has passed all these tests brilliantly, and its author proposed in 1915 a wholly new experimental test. To the astonishment of the scientific world that test, too, was passed successfully in 1918; and it is now essential to regard the arguments as containing much truth,

## A Warping that Cannot be Pictured

We may illustrate the new theory by thinking of a flat cloth with a hollow in it at one point. This hollow will stretch and depress the cloth all round it, and if a marble is rolled anywhere on the cloth, it will turn in its path a little towards the hollow. It will actually roll into the hollow if it travels in that direction and its speed is not too fast; and so the marble behaves as if it were attracted towards the hollow. Einstein's suggestion is that wherever a particle of matter exists it produces a change in the space all round about it, just as the one hollow depresses the whole cloth. We may call it a warping or a curvature of space, but it is beyond the limits of our human faculties to picture what that means.

The idea is only amenable to reason in abstract terms: there is a mathematical equation which states exactly in what way the measurements of space and of time are connected round that particle, and how the connection between them is different from that in empty space. There are still a few scientists who deny that there is any



connection between the measurements of space and time; there are a few more who say that if the connection exists it cannot be affected by the presence of matter. But those who follow Einstein argue that bodies attract one another because of this change they produce in the relation of space and time in the space all about them. The suggestion is entirely adequate, and although the ideas are so strange they are not contradictory to any natural phenomena at all. They also give a complete solution to one of the famous difficulties that has long been outstanding in the realm of science, the discrepancy between the observed and the calculated values for the path of the planet Mercury. The law of Newton had failed in this case, leading to a certain number—532, when the measured amount was 574 (in seconds of arc).

**Where the Theory Leads.**

The new theory leads exactly to this correct result. It extends also from the smallest to the largest of all known masses. It explains the paths taken by high-velocity electrons in vacuum tubes, and it explains the effect of the sun's enormous mass upon rays of light. Ein-

stein argued in 1915 that because the sun is so large it must distort the space all round it very seriously, and if any rays of light came near it they must be much affected by it. When the total eclipse occurred in May, 1918, this could be tested, because some stars were visible quite near to the sun when the sun's own light was obscured. Careful photographs of their position showed that the sun had indeed bent towards itself all these rays of starlight.

Moreover, the amount of the bend was exactly what Einstein had prophesied—172 hundredths of seconds of angle, and no other explanation but his can be given to account for this remarkable fact.

It is not sufficient to say that the light-rays were deflected because they have some mass and weight, like matter. They do indeed possess energy which behaves in many ways like matter, but if the deflection were simply due to their apparent mass, the deflection would have been 86 hundredths instead of 172. It seems to be correct to suppose that the space round the sun is really altered by the sun's presence, and calculations of the path of the ray through space and time must be made with that in mind.

In the illustration of the marble and the dimpled cloth it will be noted that an extra dimension was introduced—the cloth was made to have depth at one place as well as length and breadth. When we speak of space-time curvature, it seems that a similar change must be involved, and that some inconceivable fourth dimension must be added to our world of ordinary space and time. This may be true, but our illustration is not a perfect analogy, and although the full mathematical reasoning is indeed carried on with terms similar to those of a fourth dimension, it should not be taken as a proof of the existence of a new dimension.

**New Suggestions.**

Other extensions of Einstein's theory are also at present without sufficient proof, but their study is one of very great fascination for the modern scientist. There have been new suggestions as to the nature of electricity and others as to the finite extent of the universe, and although their discussion is impossible within the scope of this article, sufficient has been shown of the extent and subject of the theory to prove how far-reaching its influence may be in the future. ROBERT LUNNON

SOME AMERICAN SUGGESTIONS

**A Home-made Loud Speaker**

A SIMPLE method of using a pair of ordinary receivers in conjunction with a gramophone horn is shown in the accompanying illustration. The horn used is a familiar type of gramophone horn, and the cylinder shown is of cardboard or fibre, 7 in. long, and of a diameter suitable for the receivers. A hole is cut in the middle of the tube for attaching the horn. Various methods can be devised for attach-

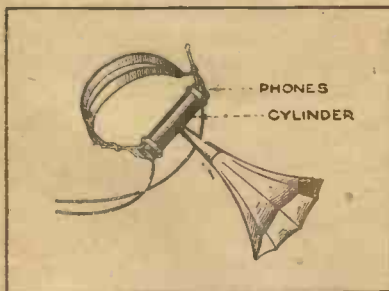

A Home-made Loud Speaker.

ing the horn, but the best method is to rivet a short piece of tubing to the cylinder to make a tight-fitting socket. The 'phones are clamped over the ends of the cylinder, as shown.—*Popular Mechanics.*

**Wire Terminals Made from Eyelets**

PRACTICAL terminals for electric wires that are held on bolt-and-nut binding posts can be made with the eyelets used for binding papers. To make such a terminal, the bare end of the wire is looped once round

the eyelet, which is then crimped in the hand-punch, pressing the metal down tightly against the wire and making a

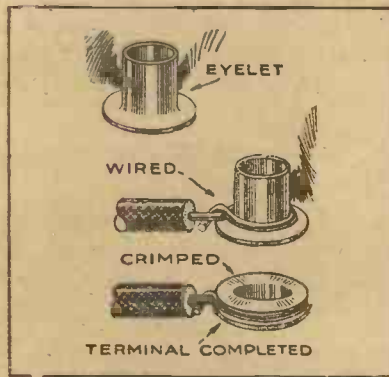

Wire Terminals Made from Eyelets.

terminal that will fit neatly over the screw and give a good contact. If solder is used after crimping a practically solid metal terminal is obtained.—*Popular Mechanics.*

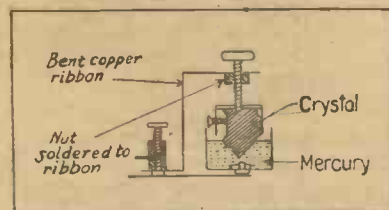

A Novel Crystal Detector.

**A Novel Crystal Detector**

THE illustration shows a novel type of detector made by simply inverting the

crystal cup and partly immersing the crystal in mercury.—*Radio News.*

**Resistance Units from Film Spools**

FINE resistance units for the use of electrical experimenters can be made from old film spools, which can be had from any photographer for the asking. The resistance wire is wound on the spool, the ends being soldered to the metal flanges. A holder, such as the one shown in the drawing, is used, and consequently all the re-

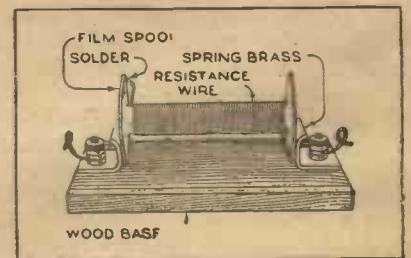

Resistance Units from Film Spools.

sistance spools must be of the same length. By winding a number of spools with a varying number of turns of resistance wire, and marking the known resistance on them, it is a very simple matter to substitute one spool for another by inserting it between the clips, in the same manner as a cartridge fuse. The ends of the spools bearing against the clips are polished bright, to provide a good contact, and the clips should press tightly against them.—*Popular Mechanics.*



# AN OFFICIAL RECEIVING SET AND HOW TO BUILD IT

A SERIES of experiments was recently conducted by the American Bureau of Standards (the American equivalent of the National Physical Laboratory) with the object of determining how cheaply and easily a practicable crystal receiving set could be made. As the result a circular (L C 43) was issued giving the precise constructional details, and we here reprint them. The illustrations are due to "Popular Radio," an American publication.

In this receiving set there are five essential parts: the aerial, lightning switch, ground or earth connections, receiving set, and telephone receiver or receivers, and the construction of each is described under the respective headings.

The set is subdivided into two parts, the "tuner" and the "detector."

**The Aerial, Lightning Switch, and Earth Connections.**—The aerial is simply a wire suspended between two elevated points, and should not be less than 30 feet above the ground with a length of about 75 feet. (See Fig. 1.) It is not important that it be strictly horizontal. It is, in fact, desirable to have the far end as high as possible. The lead-in wire from the aerial itself should run as directly as possible to the lightning switch. If the position of the adjoining buildings or trees is such that the distance between them is greater than about 85 feet, the aerial can still be held to a 75-foot distance between the insulators by increasing the length of the piece of rope (B) to which the far end is attached. The rope (H) securing the aerial insulator to the house should not be lengthened to overcome this difficulty, because by so doing the lead-in wire (J) would be lengthened.

The parts will be referred to by reference to the letters appearing in Figs. 1 and 2.

A and I are screw eyes sufficiently strong to anchor the aerial at the ends. B and H are pieces of rope  $\frac{3}{4}$  in. or  $\frac{1}{2}$  in. in diameter, just long enough to allow the aerial to swing clear of the two supports. B is a piece of  $\frac{3}{4}$ -in. or  $\frac{1}{2}$ -in. rope sufficiently long to make the distance between E and G about 75 feet. A single-block pulley may be used, but is not really essential.

E and G are two insulators which may be constructed of any dry hard wood of sufficient strength to withstand the strain of the aerial; blocks about  $1\frac{1}{2}$  in.  $\times$  2 in.  $\times$  10 in. will serve. The holes should be drilled, as shown in Fig. 1, sufficiently far from the ends to give proper strength. If wood is used the insulators should be boiled in paraffin wax for about an hour. If porcelain wiring cleats are available they may be substituted instead of the wood insulators. If any unglazed porcelain is used as insulators, it should be

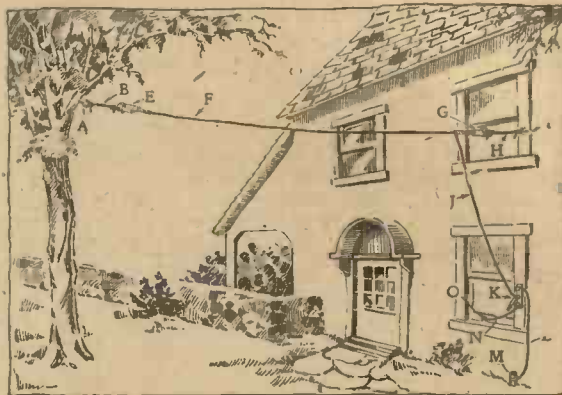

Fig. 1.—The Aerial and its Supports and Connections.

boiled in paraffin wax in the same way as the wood. The wire for the aerial may be No. 14 or 16 copper wire either bare or insulated. The end farthest from the receiving set may be secured to the insulator (E) by any satisfactory method, being careful not to kink the wire. Draw the other end of the wire through the other insulator (G) to a point where the two insulators are separated by about 75 ft.; twist the insulator (G) so as to form an anchor as shown in Fig. 1. The remainder of the wire (J) which now constitutes the lead-in or drop-wire should be just long enough to reach the lightning switch.

K is the lightning switch for the purpose of protecting the system from lightning. This switch may be an ordinary porcelain-base, single-pole double-throw battery switch. The lead-in wire (J) is attached to this switch at the middle point. The switch blade should always be thrown to the lower clip when the receiving set is not actually being used and to the upper clip when it is desired to receive signals.

L is the earth wire for the lightning switch; it may be a piece of the same wire as used for the aerial, of sufficient length to connect the lower clip of the lightning switch (K) to the clamp on the earth rod (M).

M is a piece of iron pipe or rod driven 3 ft. to 6 ft. into the ground, preferably where the ground is moist, and extending a sufficient distance above the ground in order that the ground clamp may be fastened to it.

N is a wire leading from the upper clip of the lightning switch through the porcelain tube (O) to the receiving set terminal marked aerial.

O is a porcelain tube of sufficient length to reach through the window casing or wall. This tube should be mounted in the casing or wall so that it slopes down towards the outside of the building. This is done to prevent ingress of rain.

The receiving set installed in some part of the house is shown by Fig. 2. P is the actual receiver which is described in detail later. N is the wire leading from the aerial terminal of the receiving set through the porcelain tube to the upper clip of the lightning switch. This wire, as well as the wire shown by Q, should be insulated and preferably flexible.

## WHAT THE LETTER REFERENCES MEAN

A, screw-eye  
B, rope supporting aerial  
E, insulator  
F, aerial  
G, insulator  
H, rope supporting aerial  
I, screw or screw-eye  
J, leading-in wire or drop wire  
K, lightning switch  
L, earthing wire  
M, earthing rod  
N, insulated lead from lightning switch to receiver

O, porcelain tube passing through wall or window framing  
P, receiver  
Q, insulated flexible lead from "earth" terminal receiver to water-pipe or other "earth"  
R, tuning coil  
S, crystal detector  
T, telephone headpiece  
U, twisted tapping wire  
V, right-hand switch-arm bolt  
W, switch contacts  
X, set-screw type of telephone terminal  
Y, left-hand switch-arm bolt  
Z, buzzer

A piece of ordinary lamp cord might be unbraided and utilised for these two important leads.

Q is a piece of flexible wire leading from the receiving set terminal marked earth to a water-pipe, heat-

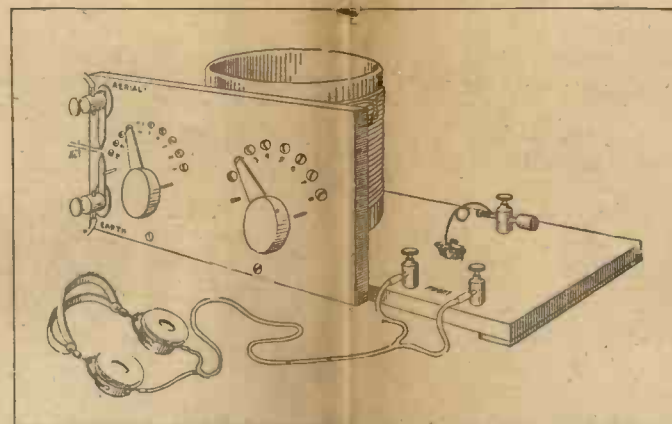

Fig. 4.—View of the Receiver.

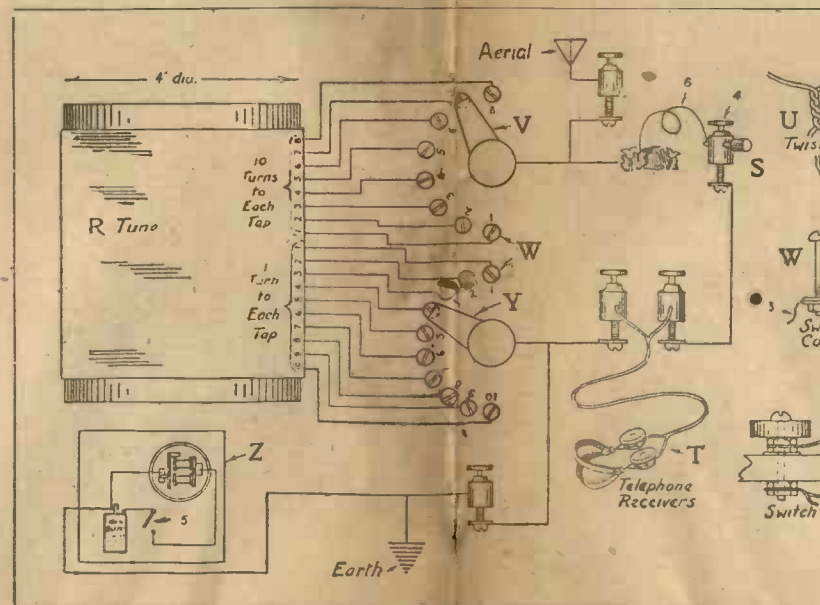

Fig. 3.—The Receiving Set in Complete Detail.



# HOW TO MAKE IT

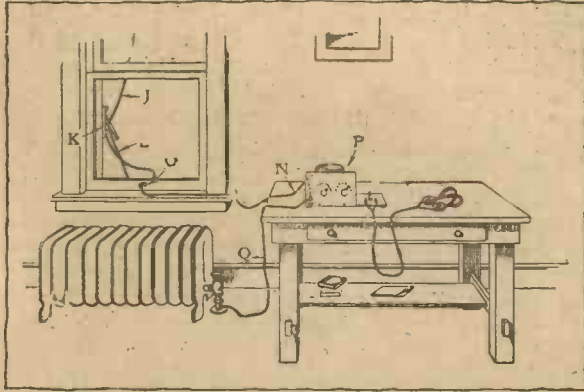

Fig. 2.—The Receiver and its External Connections.

ing system or some other metallic conductor to ground. If there are no water-pipes or radiators in the room in which the receiving set is located, the wire should be run out of doors and connected to a special earth below the window, and which may consist of a few yards of wire netting buried a few inches deep in damp soil.

The detector crystal and telephone will have to be purchased. The tuner and certain accessories can be made at home.

**Tuner.**—This is a piece of cardboard or other non-metallic tubing with turns of copper wire wound round it (see R, Fig. 3). Its construction is described in detail later.

**Crystal Detector.**—The construction of a crystal detector (S, Fig. 3) may be of very simple design and quite satisfactory. The crystal, as it is ordinarily purchased, may be unmounted or mounted in a little block of metal. For mechanical reasons the mounted type may be more satisfactory, but that is of no great consequence. It is very important, however, that a good crystal be used. It is probable also that a galena crystal will be the most satisfactory.

The crystal detector may be made up of a tested crystal, three wood screws, a short piece of copper wire, a nail, setscrew type of terminal, and a wooden knob or cork. The crystal is held in position on the wooden base by three brass wood-screws, as shown in Fig. 3. A bare copper wire may be wrapped tightly round the three brass screws for contact. The assembling of the rest of the crystal detector is quite clearly shown in Fig. 3.

**Telephones.**—It is desirable to use a pair of telephone receivers connected by a head band, usually called a double telephone headset (T, Fig. 3). The telephone receiver may be of any of the standard commercial makes having a resistance of between 2,000 and 3,000 ohms. The double telephone receivers will cost more than all the other parts of the station combined, but it is desirable to get them, especially if one intends to improve the receiving set later. A single telephone receiver with a head band may be used, though it gives results somewhat less satisfactory.

**Accessories.**—Under the heading of accessory equipment may be listed terminals, switch-arms, switch contacts, test-buzzer, dry battery, and boards on which to mount the complete apparatus. The terminals, switch-arms and switch contacts may all be readily purchased. There is nothing peculiar about the pieces of wood on which the equipment is mounted, except that they should be soaked in melted paraffin wax for an hour or two.

**Winding the Tuner.**—Having obtained a piece of cardboard tubing 4 in. in diameter and about  $\frac{1}{2}$  lb. of No. 24 (or No. 26) double-cotton-covered copper wire, start the winding of the tuner. Punch two holes in the tube about  $\frac{1}{4}$  in. from one end, as shown at 2 on Fig. 3. Weave the wire through these holes in such a way that the end of the wire will be quite firmly anchored, leaving about 12 in. of the wire free for connections. Start with the remainder of the wire to wrap the several turns in a single layer about the tube, tightly and closely together. After ten complete turns have been wound on the tube hold those turns snugly while a tap is taken off. This tap is made by forming a 6-in. loop of the wire and twisting it together at such a place that it will be slightly staggered from the first tap. This method of taking off taps is shown quite clearly at U (Fig. 3). Proceed in this manner until seven twisted taps have been taken off at every ten turns. After these first seventy turns have been wound on the tube then take off a 6-in. twisted tap for every succeeding single turn until ten additional turns have been wound on the tube. After winding the last turn of wire, anchor the end by weaving it through two holes punched in the tube, much as was done at the start, leaving about 12 in. of wire free for connecting. It is to be understood that each of the eighteen taps is slightly staggered from the one just above, so that the several taps will not be bunched along one line on the cardboard tube. It will be advisable, after winding the tuner, to dip it in hot paraffin wax.

**Upright Panel and Base.**—Having completed the tuner to this point, set it aside and construct the upright panel shown in Fig. 4. This panel may be a piece of wood approximately  $\frac{1}{4}$  in. thick. The position of the several holes for the terminals, switch arms and switch contacts may first be laid out and drilled. The aerial and earth terminals may be ordinary  $\frac{1}{8}$ -in. brass screws of sufficient length and supplied with three nuts and two washers. The first nut binds the bolt to the panel, the second nut holds one of the short pieces of stiff wire, while the third nut holds the aerial or earth wire, as the case may be. The switch arm with knob (shown at V,

Fig. 3) may be purchased in the assembled form, or it may be constructed from a thin slice cut from a broom-handle and a bolt of sufficient length equipped with four nuts and two washers together with a narrow strip of thin brass somewhat as shown. The switch contacts (w, Fig. 3) may be of the regular type, or they may be brass bolts equipped with one nut and one washer each. The switch contacts should be just sufficiently near each other so that the switch arm will not drop between the contacts, but also far enough apart so that the switch arm can be set so as to touch only one contact at a time.

The telephone terminal should preferably be of the set-screw type, as shown in Fig. 3.

**Wiring.**—Having constructed the several parts just mentioned and mounted them on the wood base, the next matter is to connect the several taps to the switch contacts and attach the other necessary wires. Scrape the cotton insulation from the loop ends of the sixteen twisted taps as well as from the ends of the two single wire taps coming from the first and last turns. Fasten the bare ends of these wires to the proper switch contacts as shown by the corresponding numbers in Fig. 3. Be careful not to cut or break any of the looped taps. It would be preferable to fasten the connecting wires to the switch contacts by binding them between the washer and the nut, as shown at 3 (Fig. 3). A wire is run from the back of the terminal marked "earth" (Fig. 3) to the back of the left-hand switch-arm bolt (v), thence to underneath the left-hand binding post marked

"phones." A wire is then run from underneath the right-hand terminal marked "phones" to underneath the binding post 3 (Fig. 3), which forms a part of the crystal detector. Take a piece of No. 24 bare copper wire about  $2\frac{1}{2}$  in. long and twist one end tightly round the nail passing through binding post 4; its other end will rest gently by its own weight on the crystal. The bare copper wire which has been wrapped tightly round the three brass wood screws holding the crystal in place is led to and fastened at the rear of the right-hand switch-arm bolt (v), thence to the upper left-hand binding post marked 'aerial. As much as possible of this wiring is shown in Fig. 3.

**Operation.**—After all the parts of the set have been constructed and assembled the first essential operation is to adjust the little piece of wire, which rests lightly on the crystal, to a sensitive point. This may be accomplished in several different ways; the use of a miniature buzzer transmitter is very satisfactory. Assuming that the most sensitive point on the crystal has been found by the method described later, the rest of the operation is to get the radio receiving set in resonance or in tune with the station from which one wishes to hear messages. The tuning is attained by adjusting the inductance of the tuner. That is, one or both of the switch arms are rotated until the proper number of turns of wire of the tuner are made a part of the metallic circuit between the aerial and earth, so that together with the capacity of the aerial the receiving circuit is in resonance with the particular trans-

mitting station. It will be remembered that there are ten turns of wire between each of the first eight switch contacts and only one turn of wire between each two of the other contacts. The tuning of the receiving set is best accomplished by setting the right-hand switch arm on contact (1) and rotating the left-hand switch arm over all its contacts. If the desired signals are not heard, move the right-hand switch arm to contact (2) and again rotate the left-hand switch arm throughout its range. Proceed in this manner until the desired signals are heard.

**The Test Buzzer.**—As mentioned previously, it is easy to find the most sensitive spot on the crystal by using a test buzzer (z, Fig. 3). The test buzzer is used as a miniature local transmitting set. When connected to the receiving set, as shown at z, Fig. 3, the current produced by the buzzer will be converted into sound by the telephone receivers and the crystal, the loudness of the sound depending on what part of the crystal is in contact with the fine wire.

In order to find the most sensitive spot connect the test buzzer to the receiving set as directed, close the switch 5, Fig. 3, set the right-hand switch arm on contact point No. 8, fasten the telephone receivers to the binding posts marked 'phones, loose the set-screw of the binding post slightly and change the position of the fine wire (6, Fig. 3) to several positions of contact with the crystal until the loudest sound is heard in the 'phones, then tighten the binding post set-screw (4) slightly.

## WHAT WIRELESS TERMS MEAN.—I

### Some Technical Words Explained as Correctly as Popular Language Allows

**EARTH.**—An essential part of an aerial system. Such a system consists of two parts, the aerial wire and the earth wire, the two forming a condenser (to be defined later), which is charged (in the case of a transmitting station) to a high voltage in order to set in motion waves in the ether, and, in the case of a receiving station, receive the waves. The earth usually consists of a network of wires or metal plates buried in the earth and connected together. In the case of an amateur station, a suitable earth may be obtained by connection to a water-pipe or an earth pin driven in the ground.

On ships use is made of the iron hull of the vessel.

**LOOSE COUPLER.**—A type of tuning coil very popular with amateurs, and one of the most efficient for general use. It employs the principle of mutual induction. Two coils are used, one capable of sliding inside the other, thus making the coupling, or the degree of proximity of one coil to the other, variable. Owing to the induction effect between the two coils good selectivity of tuning is attainable.

**CAPACITY.**—The property which a condenser has of receiving and holding a charge of electricity. Capacity is deter-

mined by the size of the plates, the distance between such plates and the nature of the substance filling the space between the plates (the dielectric). It is calculated by a formula based on these factors. Roughly, capacity is the electrical value of a condenser. The term is also used to indicate the total output from an accumulator or primary cell.

**INDUCTANCE.**—The property a conductor has tending to prevent the starting, stopping, or variation of the flow of an electric current in it. This property is greatly increased when the conductor or wire is in the form of a coil. The moment a current starts to flow a magnetic field is created round the wire, which induces a current in the opposite direction to that which has commenced to flow. This induced current momentarily obstructs the real current, which obstruction, however, is quickly broken down. This induced current is called "back" E.M.F. (Electromotive Force). The same effect is caused by the stopping of the current, the induced current tending to maintain the flow.

**PRIMARY.**—That part of a loose coupler which contains the thicker wire. It is usually the outside tube and is directly connected to the aerial, earth,

variable condenser, and in some valve receiving currents to the grid of the valve. It is made variable by means of a slider or switch. The term also refers to the input winding of transformers, induction coils and similar instruments. The gauge of wire used for the primary winding depends upon the gauge to be used for the secondary and the purpose the instrument is to serve.

**SECONDARY.**—The inner wire-wound tube that slides inside the primary of a loose coupler. It is usually wound with finer wire, and has a switch fitted at the end. It is connected in the crystal and telephone circuit of a crystal receiver, and is used as a reaction coil in some simple valve circuits. The term also refers to the output winding of transformers, induction coils, etc. Sometimes the windings of primary and secondary are very close together, at others they are a considerable distance apart. An instance of the former is the modern high-frequency transformer used in wireless, where both windings are wound together. In referring to the ratio of transformers the terms 1 to 5 or 1 to 10 are used, indicating that the secondary has 5 turns to 1 of the primary or 10 to 1 as the case may be.



## WIRELESS TELEGRAPHY & TELEPHONY.

**W**E can supply all your requirements—complete installations of various types capable of universal reception or the smallest component part or piece of material.

All apparatus is of the finest quality—the product of years of experience and numerous experiments, combined with the finest workmanship and material obtainable. Critical comparison with any other makes is invited.

*Illustrated Catalogue 7d. post free.*

RADIO SUPPLIES (Dept. 9), 236 High Holborn, London, W.C.1

Telephone: MUSEUM 6894.

### THE BOOK YOU WILL EVENTUALLY WANT FOR REFERENCE

*Written by an Expert for the Amateur*

# WIRELESS IN THE HOME

By N. P. HINTON, B.Sc., of the Post Office Engineering Department

**T**HIS book is intended as a guide for all who contemplate installing wireless apparatus. It tells the amateur how to install the apparatus and gives the best advice on its selection and purchase. The style is simple, technicalities are avoided, and everything that will smooth the way for the amateur and help him to grasp the main principles of wireless, so as to be able, after perusal, to receive messages, has been included.

**CONTENTS:** Apparatus — Aerial — Earth — Inductance — Condenser — Detector — Telephone — Triode — Broadcasting — Wireless Waves — Transmitting Station — Wireless Telegraph Systems — Wireless Telephony Transmitting Station — Reception — Tuning — Detection — Interference and Atmospherics — Miniature Generator — Frame Aerials — General Reception.

**WELL BOUND**

**HANDY SIZE**

**PRICE 2/- Net.**

**ALL WHO WISH TO KNOW MORE ABOUT WIRELESS** should read

CONTINUOUS WAVE WIRELESS TELEGRAPHY. By B. E. G. Mittell. 2/6 net.  
 DIRECTIVE WIRELESS TELEGRAPHY. By L. H. Walter. 2/6 net.  
 GUIDE TO THE STUDY OF THE IONIC VALVE. By W. D. OWEN. 2/6 net.  
 WIRELESS TELEGRAPHY. By W. H. Marchant. 7/6 net.  
 MARINE WIRELESS POCKET BOOK. By W. H. Marchant. 6/- net.

OF ALL BOOKSELLERS

SIR ISAAC PITMAN & SONS, Ltd., Parker Street, Kingsway, W.C.2

# OUR INFORMATION BUREAU

Expert Replies to Readers' Questions Without Charge. All Readers in Difficulty should Avail Themselves of This Service

## Converting Crystal Receiving Set to Single Valve Set

Q.—I have completed and obtained signals on my crystal receiving set, and now wish to use a valve; please advise. M.P.N. (17)

A.—M.P.N.'s set consists of the following components: Primary coil, 12 in. by 5 in., wound with about 500 turns of No. 24 s.w.g. enamelled copper wire and fitted with slider. Secondary coil, 12½ in. by 4 in., wound with 650 turns of No. 34 s.w.g. d.c.c. copper wire, arranged to slide completely inside primary coil if necessary, and provided with twelve tapplings and suitable tuning switch. Variable condenser, capacity about .0003 mfd.; zincite-bornite detector, and 8,000-ohm Brown's telephone receivers with usual blocking or telephone condenser. The arrangement illustrated with a "French" or R-type valve forms a two-circuit or inductively coupled set which will give excellent signals combined with selectivity. An additional inductance coil (shown at R in diagram) is required to form a reactance coil to be coupled to the secondary inductance. Suitable dimensions would be as follows, but they need not be rigidly adhered to, and some little experimental work may be required before the most satisfactory proportions are arrived at. Former tube, 3½ in. in diameter by 4 in. or 5 in. long (so as to slide inside the secondary coil if necessary to obtain tight coupling with it), wound with No. 34 s.w.g. d.c.c. copper wire, or nearest gauge, and divided into three sections with three-point switch, so as to be able to use varying amounts of inductance to insure self-oscillation over the whole range of wave-

lengths if possible. For grid leak, employ a piece of ordinary slate pencil, say 1½ in. long, mounted between small clips of springy brass and brought to correct resistance value under

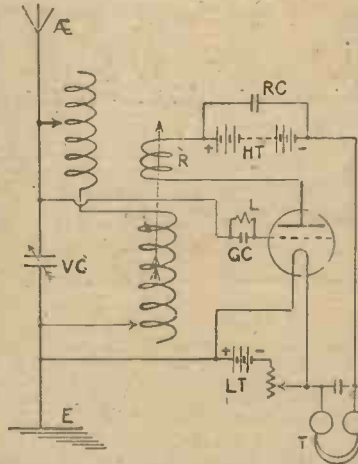

Converting Crystal Receiving Set to Single Valve Set.

actual working conditions by drawing pencil lines from end to end with a soft graphite black-lead pencil. Leak is shown at L in the diagram. A suitable grid condenser GC may consist of three pieces of tinfoil (or copper foil), each 1 in. by 1½ in., separated by thin mica

(say .005 to .01 in. thick) of good quality. Mount this between temporary ebonite clamps and try in the set, sliding the inner foil to vary the capacity until best results are obtained, when the condenser may be fixed permanently by means of soft brass strips bent round the ends of the foils and squeezed tight with a pair of pliers. A small variable condenser across the reactance coil often facilitates self-oscillation and improves general action of the set.

## Obtaining Transmitting Permit

Q.—What are the necessary conditions for obtaining a transmitting permit?—S. E. D. (6)

A.—The principal difficulty in obtaining a transmitting permit appears to be in connection with the reason for desiring to install a transmitting station. According to official information, the mere desire to communicate with other amateur stations is insufficient to warrant the issue of necessary permit. Applicants must desire to carry out some stated experimental work which necessitates the use of a transmitting station; for example, "direction-finding" experiments, in which a fixed transmitting station could be used in conjunction with a portable receiving set. The power allowed to successful applicants is limited to 10 watts and the wave-length to 180 metres. The regulations regarding the dimensions of the aerial are identical with those governing receiving aerials, namely, single wire 100 ft., two or more wires 140 ft. of wire, all measurements to include the "down-leads," and maximum height above ground 100 ft.—CAPACITY.

# A METHOD OF MEMORISING MORSE

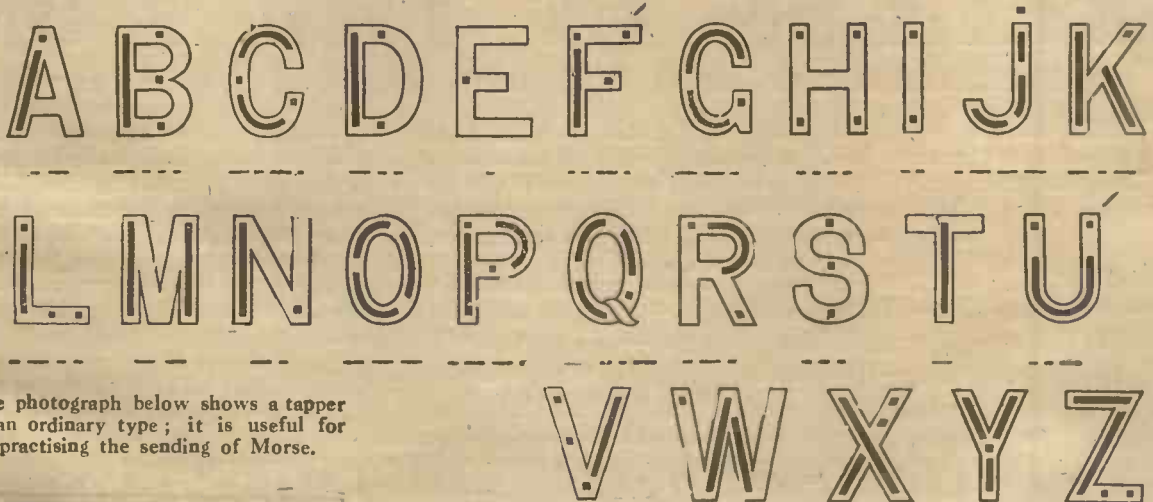

The photograph below shows a tapper of an ordinary type; it is useful for practising the sending of Morse.



The above illustration shows a method of memorising Morse. The code is learnt rapidly simply by visualising the code letters as superimposed upon the alphabetical letters. On thinking of any letter the mind conjures up a mental picture of it and of the dots and dashes of the Morse code lying on it and actually forming part of its shape. The twenty-six letters can be learnt in as many minutes, but only practice, practice and yet more practice at sending and receiving can make perfect.



The Electrical Wonder Book  
for Wireless Workers

# ELECTRICAL ENGINEERING

*The Book that tells you all about  
Wireless Telegraphy*

**ELECTRICAL ENGINEERING** deals with the whole Science of Electricity and describes every practical application in the Commerce and Industry of to-day. It explains all the elementary principles, and shows their practical application in the design, construction and operation of every electrical appliance in modern practice—power, light, traction, etc.

It explains everything in Electrical Science that is difficult to explain in the simplest language. It has been written by practical men for practical men. That is one reason why it is the best book of its kind. Another reason is that it is practical. It tells you the why and how of everything. It includes everything in Electricity.

**IT IS THE BOOK THAT IS INDISPENSABLE  
TO EVERYONE INTERESTED IN  
THE LATEST WONDERS OF ELECTRICITY**

*It treats fully and practically with all the elements of  
Wireless Telegraphy:—*

All about Aerials, Wave-lengths and Tuning.

All about Transmitters and Transmitting Systems.

Detectors, Receiving Systems, Syntony, etc. Thermionic Valves, etc. etc.

**WRITTEN IN SIMPLE UNDERSTANDABLE LANGUAGE**

- ALL ABOUT
- Generators
- Dynamos
- Motors
- Transformers
- Balancers
- Boosters
- Testing Instruments
- Armatures
- Commutators
- Winding Schemes
- Brush Gears
- Controls Resistances
- Switchboards
- Accumulators
- Lighting
- Heating
- Power
- Telegraphy
- Signalling
- Telephony
- Wireless etc. etc.

**THE MOST  
WONDERFUL  
ELECTRICAL  
INVENTIONS  
OF THE  
PRESENT DAY  
MADE  
AS CLEAR  
AS DAYLIGHT.**

No other work has dealt with the subject so clearly or so simply, yet it is the most PRACTICAL work published.

**SEND FOR  
FREE BOOKLET**

*giving full details  
regarding price and  
terms of payment*

To THE WAVERLEY BOOK CO., LTD. (A.W.N Dept.),  
96 Farringdon Street, London, E.C.3.

Please send me, free of charge or obligation, your Free Descriptive Booklet explaining contents, etc. of "Electrical Engineering" with specimen pages and pictures and particulars as to your terms for small monthly payments, beginning thirty days after delivery.

Name.....  
*(Send this Form, or a post card)*

Address.....

A.W.N., 1922.....

## RADIOGRAMS

The possible influence of broadcasting on the music industry was discussed at the recent Music Industries Convention, and one speaker uttered a warning that it might supplant home music to a certain extent and decrease the demand for pianos and gramophones. The chairman, however, gave it as his opinion that the more good music people get from broadcasting the more they will want from gramophones and pianos.

Mr. Marconi's yacht, the *Elletra* (from which he sent us his greeting), is fitted with triple sets of receiving and transmitting apparatus, which are said to be an advance on anything at present in use afloat or ashore. The three transmitters are a 3-kilowatt valve set, a 1½-kilowatt quenched-spark set, and a ¼-kilowatt quenched-spark set. Mr. Marconi will make final tests of a system by which a ship could pick up the position of another ship exactly, and so steer straight for her. A ship in distress could signal others directly to her, while vessels proceeding in fog could avoid collision.

A rather novel suggestion for the frame aerial given by the wireless contributor of the *Pall Mall Gazette* is to insert four pegs in each of the corners of a door and wind the wire round these. As the door can be swung through an arc of about 180 deg., this permits the adjustment of the aerial to the most suitable position.

Directional wireless is perhaps the most immediate aim of experimenters. Already some small advance has been made in this direction, and one New York inventor actually claims to have succeeded in limiting transmission to one selected receiving station, though no proof is forthcoming.

We understand that a provisional agreement has been made between the Metropolitan Vickers Electrical Company and the Radio Communication Company for the joint establishment and operation of wireless telephone broadcasting stations throughout Great Britain.

Experiments in wireless transmission underground have recently been made. A receiving set was taken into a cave about a quarter of a mile in any direction from its mouth. Here a 50 ft. aerial was suspended, and with a small apparatus signals were received clearly from several high-power transmitting centres.

A most important use to which wireless is being put is in the detection of icebergs in the North Atlantic. Ice patrols are employed to look out for icebergs, and the position and size of them is broadcasted.

### Mr. WILLIAM LE QUEUX,

a Member of the Institute of Radio Engineers, one of the early amateur experimenters in wireless and the owner of one of the finest amateur Wireless Telephony installations in Great Britain, sends us a kindly message of congratulation:



Photo: C. Vandyk, Ltd.

"Wireless is the most fascinating subject today, and to the enterprise of the House of Cassell in establishing 'Amateur Wireless' the whole country will be much indebted. Its object is to put the public *au fait* with everything connected with radio, explain its mysteries, and show how wireless telephony may be enjoyed in the home at small expense. I am glad to see that it is not to be too technical but written for everyone to understand. The establishment of this new journal marks another milestone in Britain's progress, and it should be heartily supported not only by every amateur but by everyone interested in voices from the ether."

We are making arrangements to describe and illustrate Mr. Le Queux's fine apparatus in an early issue of "Amateur Wireless."

## FORTHCOMING EVENTS

Will wireless club and society secretaries kindly send us their fixtures for inclusion under the above heading?

**Dewsbury and District Wireless Society.** At the Club Rooms, South Street, Dewsbury, June 8, 7.30 p.m. Lecture by Mr. H. F. Yardley: "Amplification on Short Wave Lengths."

**Wireless Society of Highgate.** At the Highgate Literary and Scientific Institution, June 9, 7.45 p.m. Lecture by Mr. J. Stanley: "Elementary Theory of Wireless Telegraphy and Telephony" (first part).

**Leeds and District Amateur Wireless Society.** June 9, 8 p.m. Lecture by Capt. F. E. Whitaker, R.E.: "Reception of Wireless Telephony."

**Wireless Society of Hull and District.** June 12, 7.30 p.m. Lecture by Mr. W. J. Featherstone.

**Wireless Society of London.** At the Institution of Electrical Engineers, Savoy Place, Victoria Embankment, W.C., June 14, 6 p.m. Address by Sir Oliver Lodge, F.R.S.

**North Middlesex Wireless Club.** At Shaftesbury Hall, Bowes Park, June 14, 8 p.m. Lecture by Mr. L. C. Holton: "The Towns-end Wavemeter and How to Use It"; also a demonstration of telephony for beginners.

**The West London Wireless and Experimental Association.** June 15, 8 p.m. Lecture by Mr. F. E. Strudt: "Interpretation of Wireless Circuits."

**Derby Wireless Club.** At the "Court," Alvaston, June 15, 7.30 p.m. Lecture by Mr. E. F. Clarke: "Alternating-current Experiments in Relation to Wireless Telegraphy."

## COMPETITIONS FOR ALL READERS

### THREE WIRELESS RECEIVING SETS AS PRIZES

WE offer as a prize in each of the following competitions a well-made wireless receiving set manufactured by one or other of our advertisers, the approximate value of each set to be at least seven guineas.

**Competition No. 1.**—A wireless set is offered for the best article of about 1,500 words, written from your own personal knowledge and experience, and calculated to help or interest your fellow amateurs. Illustrations will in most cases be regarded as a feature of merit. Articles should be written in simple language and be as bright and informative as possible, and the subject may be anything that you think wireless amateurs would care to read about. Should we publish any article that does not win the prize we shall pay for it.

**Competition No. 2.**—Another set is offered for a brief description (with illustration if necessary) of the *most novel and useful* item in wireless apparatus—in its design, material, make, electrical connections, etc. etc. The novelty must be original—not copied from any source whatever.

**Competition No. 3.**—The third receiving set will be presented for an ideal broadcasting programme of twelve items. You can enter for this competition on a penny postcard. Simply write down in column form twelve items that you consider would make an ideal programme.

**Rules.**—The Editor's decision in any and every case is final. There is no appeal from it. The copyright of all competition efforts published by us will be ours. All entries to be in by Friday, July 7 and to be addressed to

THE EDITOR,  
"Amateur Wireless,"  
La Belle Sauvage,  
London, E.C.4.

There is a chance for EVERYBODY in these three competitions. Set about your effort at once. The prizes are valuable and well worth trying for.

## ANNOUNCEMENTS

"Amateur Wireless and Electrics." Edited by Bernard E. Jones. Price Threepence. Published on Thursdays and bearing the date of Saturday immediately following. It will be sent post free to any part of the world—3 months, 4s. 6d.; 6 months, 8s. 9d.; 12 months, 17s. 6d. Postal Orders, Post Office Orders, or Cheques should be made payable to the Proprietors, Cassell & Co. Ltd.

General Correspondence is to be brief and written on one side of the paper only. All sketches and drawings to be on separate sheets.

Contributions are always welcome, will be promptly considered, and if used will be paid for.

Communications should be addressed, according to their nature, to The Editor, The Advertisement Manager or The Publisher, "Amateur Wireless," La Belle Sauvage, London, E.C.4.



# The Leading Firm



# for Amateur Supplies

We have 10 years' Wireless Experience.

ALL-IN SERIES, No. 1.

## SET OF PARTS 15/9 **Valve Panel** SET OF PARTS 15/9

Set includes :-Ebonite Panel, matt finished, 7" X 5", and drilled. "Velvet" Filament Rheostat. Grid Condenser and Leak. Blocking Condenser. Systoflex. V. Holder Terminals. Set of Ivorine Tablets and Blue Print. Polished Mahogany Cabinet to fit, 3/6.

## THE BROADCASTING TUNER

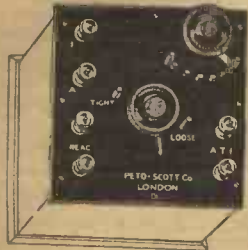

Complete set of parts. Require only fitting together. All holes drilled. Wiring diagram supplied. Complete ... 18/6 Cabinet to fit ... 4/9

10 times more efficient than a coil and slider.

NOTE.—The Broadcasting Tuner and Single Valve Panel together with Valve, Phones and Batteries, make a complete station, which will get all the speech and telephony going.

SEND 6d. for our ILLUSTRATED CATALOGUE with List of Stations.

## The PARAMOUNT

Crystal Receiver, 35/- Head Phones from 35/-

## SINGLE VALVE RECEIVER

£2 17 6 Finished. or Sets of parts ready to assemble, 28/6 Cabinet, 3/6

VALVE EXTRA

## A FEW SUNDRIES for the Constructor.

- The "Velvet" Filament Rheostat is well constructed and of great value to all who build their own apparatus ... 4/-
  - Set of Ivorine Tablets, +HT-, +LT-, A.T.I., REAC, TEL, A, E, set of 7 ... 1/2
  - Ivorine Scales, superior quality, 0"-180" (not cheap printed one) ... 1/6
  - Solid Turned Ebonite Valve Holder with plain legs ... 1/6
  - Grid Leak (Sphinx) and Condenser, mounted ... 5/-
  - "Velvet" Laminated Switch Arms with Lacquered bush and nuts ... 2/6
  - Studs and 2 nuts ... per doz. 1/6
  - Valve Legs and Nuts, lacquered ... per set 1/-
  - Valve Holders with Flange, "A" Type ... 1/9
  - Engraved Ebonite Dials and Knobs ... 4/6
- All orders over £2 post free. Trade Enquiries invited.

## CONDENSER VALUE

Complete Sets of Parts for VARIABLE CONDENSER ready to assemble.

No Drilling or Fitting required.

'0015	'001	'0005	'0003	'0002	'0001
27/-	21/-	14/-	11/-	8/-	7/-
Cabinets—					
4/9	4/6	4/3	4/-	3/9	2/9

The above are supplied with Ivorine Scale for panel mounting or engraved Ebonite top 4" X 4 1/2" for box mounting. We can substitute Ebonite Bevelled dial in place of scale for 3/6 extra.

PLEASE STATE WHICH YOU REQUIRE.



# PETO SCOTT, The Condenser King, 7 Featherstone Buildings, HIGH HOLBORN, W.C.1

(Turk up by No. 63 High Holborn.)

Also at 17 Frome Road, Wood Green.

## C. S. SWAN, 191, BISHOPSGATE, E.C.2. Near Liverpool St. Station. PHONE: BISHOPSGATE 1155.

- |  |   |
|--|---|
| 15 Volt H.T. Units ... 3/3                   | Leading in Tubes ... 6d. to 2/6             |
| Filament Switches for Panel Mounting ... 3/9 | Microphones with replaceable Insets ... 2/6 |
| Grid & Blocking Condensers 2/6 & 3/-         | Crystals in cups ... 9d.                    |
| Aerial Insulators ... 6d.                    | A. Type Valve Holders ... 1/9               |

New & Ex-Government Wireless Apparatus in Stock

## BUILD YOUR OWN WIRELESS SET

Everything in Stock from a nut to a Complete Set. Prompt Deliveries—Lists Two Stamps

ELECTRICAL SUPPLY STORES, 5, SKIRCOAT MOOR ROAD, KING CROSS, HALIFAX.

SHEET, ROD AND TUBE stocked in qualities suitable for all Wireless work.

KNOB (Moulded), various patterns stocked. CONDENSER SCALE BLANKS. ENGRAVED DIALS with Knob.

# EBONITE

(HARD RUBBER)

WHOLESALE ONLY

AMERICAN HARD RUBBER CO. (BRITAIN) LTD., 13a, FORE STREET, LONDON, E.C.2.

Telegrams: "Eboniseth, Ave., London. Phone: Central 12754.

## Visit our Show Rooms and have Leading High Quality Receiving Sets Demonstrated

MARCONI TINGEY'S BORNDIPT

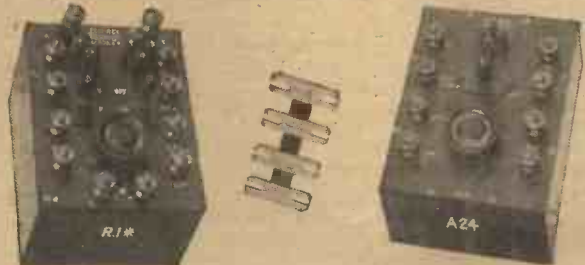

WATES BROS., 13-14, Ct. Queen St., Kingsway, W.C.2 Phone: Gerrard 576. Telegrams: ZYWATESENG, OX., LONDON

## ACCUMULATORS FOR WIRELESS

4 Volt. 24 amp. £0 14 0	6 Volt. 30 amp. £1 10 0
4 " 40 " 1 2 6	6 " 40 " 1 16 6
4 " 60 " 1 7 6	6 " 60 " 2 5 6
6 " 20 " 1 5 0	

We have a small consignment of 6 volt 20 amp. Hart Wireless Accumulators in tin carrying cases. Complete at 19/6.

THE EUSTON IGNITION CO. 329, EUSTON ROAD, LONDON, N.W.1

Phone, Museum 5034

# WIRELESS AT HOME

Everybody's Guide to receiving wireless news, concerts, and messages.

6<sup>D.</sup> NET



Percival Marshall & Co., London

This is the little book which is making Wireless easy for everybody. On sale everywhere. Don't miss getting your copy. Price 6d.; post free, 7½d.

## WIRELESS BARGAINS

Wireless Bargains are advertised in "THE MODEL ENGINEER" every week. The best paper for buying and selling all kinds of Electrical Apparatus, Tools, Models, and Workshop Equipment of all kinds. Hundreds of advertisements to choose from. Published every Thursday. Price 4d.; post free, 5½d.

## WIRELESS FOR BEGINNERS

A new section on Wireless for beginners is now starting in "JUNIOR MECHANICS AND ELECTRICITY," the best paper for novices. Published monthly. Price 3d.; post free, 4d.

**PERCIVAL MARSHALL & CO.,**  
66 FARRINGDON ST., LONDON, E.C.4.

# Everything for Wireless

DIRECT FROM THE ACTUAL MANUFACTURERS  
WE CAN SUPPLY ALL YOUR REQUIREMENTS

A FEW ITEMS FROM OUR LARGE STOCK:

Single-valve Panel ... ..	25/-	Multiple (five-stud) Switch ...	5/6
Multiple-switch Panel (three-way)	15/6	Switch Arms with 1½ in. dia. Ebonite Knob ... ..	2/3
Valve Holders ... ..	2/6	Switch Studs and Nuts ... ..	2/- doz.
Filament Resistance ... ..	5/-	Terminals with Screws and Washers ... ..	2/3 doz.
Condenser Vanes (fixed or movable) ... ..	1/6 doz.	1½ in. dia. Ebonite Knob ... ..	8d.

Best quality insulating materials only used. Satisfaction or Money Back.  
Apparatus made to customers' own designs. Trade Inquiries Solicited.

**D.S.S. ENGINEERING CO.,**  
Alma Road, Windsor.  
*Phone: Windsor, 356.*

## SCIENTIFIC APPLIANCES

HENRY J. DALE. W. HOLLINS.  
11 & 29, Sicilian Avenue, Southampton Row, London, W.C.1.  
Top of Kingsway. In Centre of London. Corner of Bloomsbury Square.

ELECTRICIANS. OPTICIANS. MECHANICIANS.

ACTUAL MANUFACTURERS at our Works, East Street, W.C., thus saving all intermediate profits.

The Store for all Electrical and Scientific Material

WIRELESS & RADIO MATERIALS,  
PARTS and FITTINGS

Immense Stock constantly adding to, and Making; Specially for the Amateur to Build up a Set Complete and Perfect.

EBONITE. BATTERIES. AERIALS.  
INSULATED WIRES. CRYSTALS.  
ENGRAVED DISCS. MICA. HANDLES.  
SWITCHES. TERMINALS. STUDS.

Scientific Appliances, 11 & 29, Sicilian Avenue, London, W.C.1.

VALVES. 'PHONES.  
Call and see us. View our Show Windows. Send for List post free 2d.

Splendid Value in  
Second-hand Appliances

Every Branch of Optical  
and Applied Science

## Sensational Reductions

**OOJAH SLAB INDUCTANCES**, set of eight, 10/-, post 9d.  
300 to 30,000 metres  
**OOJAH BASKET INDUCTANCES**, set of seven, 7/-,  
post 6d. For broadcasting all Telephony wave-lengths  
**THE SCIENTIFIC TUNING STAND**. This, with our set  
of Oojah Basket Coils, make an ideal loose coupled Tuner  
**THE POPULAR H.T. BATTERY**. 36 v., 4/9. 54 v., 7/-.  
72 v., 9/-

WE ARE THE SOLE AGENTS FOR  
OOJAH COMPONENTS in S.E. LONDON

**SCIENTIFIC SUPPLY STORES,**  
8, NEWINGTON CAUSEWAY, LONDON, S.E.1.  
Phone, HOP 4177

## Wireless Equipment Limited

Telegraphic Address: Wirequip, Westcent, London  
Phone: Gerrard 6785

Manufacturers of All Classes of Wireless Apparatus

THE above Company wish to bring to the notice of their many clients, their Change of Title and Address.

**WIRELESS EQUIPMENT LIMITED**  
(late The Wireless Equipment Co.)

have opened Offices at

90, CHARING CROSS ROAD, W.C.2  
to which address all communications should be sent.

Our further Advertisements in these pages will be of interest

Experimental Stations—2 OM, 2 KF, 2 BZ  
Retail Agents—HAMLING CLAPP & CO., 110, Strand, W.C.2  
Offices—90, Charing Cross Road, London, W.C.2

## THAT BOOK YOU WANT ON WIRELESS OR ANY OTHER TECHNICAL SUBJECT

Foyles have it or will quickly obtain it.  
1,000,000 Vols. (Second-hand and New) on Technical and every other conceivable subject in stock.  
Books sent on approval. Write for Catalogue (free) mentioning requirements. Books Purchased.

**FOYLES, 121, Charing Cross Rd., London.**

## ACCUMULATORS for WIRELESS

HIGHEST QUALITY. ABSOLUTELY NEW.  
Accumulators at Lowest Possible Prices.

4 v. 40 amp. ...	18/6	6 v. 40 amp. ...	26/3
4 v. 60 " ...	21/6	6 v. 60 " ...	31/9
4 v. 80 " ...	28/2	6 v. 80 " ...	37/3
4 v. 100 " ...	30/-	6 v. 100 " ...	41/6

### SPECIAL OFFERS

2 volt 16 amp. ACCUMULATORS in ebonite cases (5 plates), absolutely new:

1 only, 3/9 post free. 4 to 6, 3/- each, carriage forward.  
2 or 3, 3/6 each, post free. 7 & over, 2/9 each, carr. forward.

4 volt 20 amp. ACCUMULATORS in celluloid cases, absolutely new:

Only 11/9 each, postage 1/-

**F. YATES & SON, 144, CHURCH ST., KENSINGTON, W.8**

Phone: Park 4276 **QUALITY & ECONOMY** Write for lists enclosing stamp for postage.



# Teach Yourself Wireless Telegraphy

Mr. E. J. BARNARD, Welling, Kent, writes:—

"I think I ought to tell you how much I value 'THE AMATEUR MECHANIC.' It has proved of great assistance in a variety of jobs, and especially as to the article on WIRELESS TELEGRAPHY. I constructed an instrument entirely according to the instructions, and was rewarded with success on the first trial. Sunday last was for me a red-letter day, as I succeeded, with the same instrument, in picking up the telephonic message from London to Geneva at 9.40 a.m. Considering that my aerial is only 42 inches long and 18 inches high, I think these are grounds for self-congratulation. I may add that until I became interested in the article in your 'AMATEUR MECHANIC,' I had not the slightest elementary knowledge of Wireless Telegraphy."

## "THE AMATEUR MECHANIC"

In Simple, Non-technical Language, with  
"How-to-do-it" Pictures and Diagrams

Presents over 400 Practical Lessons

INCLUDING

HOW TO BUILD SHEDS, outhouses, poultry-houses, etc.—HOW TO CURE DAMP WALLS, LEAKY ROOFS, AND SMOKY CHIMNEYS—HOW TO MAKE GARDEN FRAMES, GARDEN FURNITURE, AND PATHS—HOW TO MEND WINDOWS, AND TO MAKE, MEND, AND STRENGTHEN LOCKS AND BOLTS. TO CLEAN, OVERHAUL, AND REPAIR MOTORS AND MOTOR-CYCLES—TO INSTALL WIRELESS TELEGRAPHY, ELECTRIC LIGHT, ETC.—TO WORK IN EVERY KIND OF METAL—TO ETCH ON BRASS—TO WRITE ON GLASS—TO BUILD A BOAT, A CANOE, A CANVAS CANOE, ETC.—TO PAINT AND PAPER A ROOM—TO SOLE AND HEEL AND PATCH BOOTS AND SHOES—TO MAKE A PAIR OF HAND-SEWN BOOTS—TO RESTORE COLOUR TO OLD BROWN SHOES—TO MAKE HOUSEHOLD FURNITURE—TO RESEAT CHAIRS—TO UPHOLSTER SOFAS, ETC.—TO INSTALL A SPEAKING TUBE—TO CLEAN A STOVE—TO REPAIR BICYCLES—TO REPAIR WATER-TAPS—TO VARNISH A VIOLIN—TO REPAIR THE PIANO—TO MAKE A PADDED CHAIR FROM AN OLD CASK—TO STUFF

ANIMALS AND BIRDS—TO DRESS FURS—WOOD INLAYING—TO PREPARE WORKING DRAWINGS—TO RENOVATE A GRANDFATHER CLOCK—TO MAKE GARDEN ARBOURS, ARCHES, SEATS, SUMMER-HOUSES, ETC.—TO USE METAL-DRILLING TOOLS—TO RENOVATE MIRRORS—TO MEND CHINA—TO DO FRETWORK—TO LIMEWHITE POULTRY-HOUSES—TO DO GOLD-PLATING AND SILVER-PLATING—TO CLEAN A WATCH—TO MEND KEYLESS WATCHES AND ORDINARY WATCHES—TO DISTEMPER CEILINGS AND WALLS—TO MAKE PICTURE-FRAMES—CURTAIN FITTINGS—METAL CASTINGS—TO CLEAN PAINT OFF GLASS—TO CLEAN BOILERS—TO FIX AN ANTHRACITE STOVE—TO RE-GILD AND RESTORE PICTURE-FRAMES—HOW TO USE SPANNERS—TO MAKE DOORS AND WINDOWS DRAUGHT-PROOF—TO PAINT WALLS—TO DO NICKEL-PLATING—TO CURE NOISES IN HOT-WATER PIPES—INDIA AND GLUE VARNISHES—TO MAKE PLASTER-CASTS, ETC., ETC.

## THIS IS SOUND MONEY-SAVING KNOWLEDGE

Mr. BEARD, Long Eaton, writes:—

"I intend that 'THE AMATEUR MECHANIC' shall be a free gift to me; for, by taking advantage of your instalment plan, I can see how to easily save the money on house repairs alone, as I find that quite a number of jobs I had intended putting out are treated of in the work, and by no means beyond my limited capacity (with your writers at my elbow). . . . Once again to thank you. . . ."

*Post this Form at once for full Particulars*

(Send this form or a postcard.)

**FREE**   
**A BOOKLET**

To tell you all about "The Amateur Mechanic." It shows pages and pictures from the actual work.

To THE WAVERLEY BOOK CO., Ltd. (A.W.E. Dept.),  
96 Farringdon Street, London, E.C.4.

Please send me, free of charge or obligation to order, your Free descriptive Booklet, explaining contents, etc., of "THE AMATEUR MECHANIC," with specimen pages and pictures, and particulars as to your terms for small monthly payments beginning thirty days after delivery.

NAME .....

ADDRESS .....

A.W.E. 1922 .....





WE GIVE AWAY THREE SETS :: THE VALVE SIMPLY EXPLAINED

# Amateur Wireless And Electrics

ALREADY  
A GREAT  
SUCCESS

No. 2

SATURDAY, JUNE 17, 1922

Price 3d

## Leading Features of This Issue

	PAGE		PAGE
How the Valve Works ... ..	23	Winding Honeycomb Coils ...	29
Finding the Positive Pole ... ..	24	Progress of Amateur Wireless	30-31
Set Made in 30 Minutes ... ..	25	What Wireless Terms Mean ...	32
Starting Wireless ... ..	26	"Blind Spots" ... ..	33
Some American Ideas ... ..	27	Benchwork in Ebonite ... ..	34
More Concerning the Aerial ...	28	Competition for all Readers ...	36

Information Bureau, Radiograms, Club Doings, etc.

## BURNDEPT

### WIRELESS APPARATUS

LONDON OFFICE & SHOWROOMS  
15 Bedford Street, Strand, W.C.2.

### The Ethophone No. 1.

(Trade Mark)

*This Instrument has been specially designed for the reception of Broadcast Music, Speech, etc.*

It can be used with satisfaction by two listeners at the same time. Receiving radius 25 to 40 miles of transmitting stations.

A special arrangement is included which permits reception of time signals from Paris. **This set, complete** and ready for use, includes one good set of High Resistance Phones, Coil of Aerial Wire, Insulators and complete instructions. No knowledge of Wireless required to operate.

Price **£8 0 0** Packing and Postage free.

*Everything in the Ether is yours with certainty  
IF YOU USE*

### BURNDEPT WIRELESS APPARATUS

Wireless Music, Song & Speech in the Home

### THE SET DE LUXE.

The Burndept Ultra IV. Receiving Set.



ILLUSTRATED CATALOGUE, post free, 6d.; returnable with first order. This gives full details of our complete one to four valve Receiving Sets. Prices from £21.

BURNDEPT LTD., Manufacturers of Wireless Apparatus, AERIAL WORKS, BLACKHEATH, LONDON, S.E.3.

Phone: MUSEUM 1055.

# ECONOMIC ELECTRIC LIMITED

10 FITZROY SQ., Head Office and Mail Order  
LONDON, W.1. Branch: Twickenham.  
303 EUSTON RD. Showrooms.

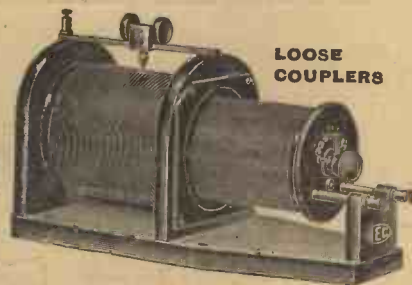

## WIRELESS

the greatest of the most fascinating sciences is, or

### YOUR

On this page illustrations Special Radio contains 32 pages, photographs, interesting data the novice, the professional, instruments or you have pages. Write Mailed for 4d.,

all hobbies and a ting of all will be

### HOBBY

we give seven taken from our List, which con-grammed with diagrams, and —apparatus for enthusiast and Don't buy your materials until studied its for a copy. post free.]



## DAVIS & TIMMINS, LTD.,

34a, York Road, King's Cross, N.1.

### SCREWS AND TERMINALS

for WIRELESS SETS.

:: ASK FOR ILLUSTRATED LISTS. ::

### COMPLETE WIRELESS RECEIVING SETS

Capable of clearly receiving "Broadcast" Speech, Music, and general Morse messages

### CRYSTAL SETS and VALVE SETS

Prices, £7 0 0 and upwards according to distance one desires to receive from

### ALL ACCESSORIES FOR WIRELESS IN STOCK

Send for ILLUSTRATED CATALOGUE, 4d. post free It gives details of all we can supply

Showrooms open 8 to 8; Saturdays, 8 to 1 p.m.

### W. R. H. TINGEY, Specialist in Wireless

Offices and Showrooms:

92, QUEEN STREET, HAMMERSMITH, W.6  
Office and Works Telephone: 1916 Hammersmith

TELEPHONE DOUBLE HEAD SETS. Suitable for 2,000 and 4,000 Ohms in stock. Also wound to any specification.

Complete Crystal Receiving Sets, including Receiver ... (guaranteed) £4 12 6

Winding wires, resistance, copper. Aerial masts and wires. Bare, silk and cotton covered. Ebonite. Terminals. Stamp for List.

P. H. BOYS & CO., 187, Goswell Road, E.C.1

Absolutely Up-to-Date

## Wireless Telegraphy and Telephony

And How to Make the Apparatus

An Entirely New Work

By E. Redpath

### NOTE ITS CONTENTS:

General Principles; Experiments; Tuning and Resonance; Transmission and Reception; Various Detectors; Thermionic Valves as Detectors, Amplifiers and Generators; Making Single-circuit Receiving Set, Short-wave Receiving Set, Valve Panel and a Five-valve Amplifier; Wireless Telephony; Arrangement and Erection of Aerials; Index.  
87 Illustrations Eighteenpence Net

The House of Cassell

LA BELLE SAUVAGE, LONDON, E.C.4



# Amateur Wireless

## and Electrics

No 2

June 17, 1922

## HOW THE "VALVE" WORKS

### A Water Analogy That Makes Its Action Clear

**ANALOGY** usually provides a simple means of explaining rather abstruse principles, and in this and subsequent articles it is proposed to illustrate the working of the three-electrode valve by comparing it with a hydraulic device shown in Fig. 1.

#### A Hydraulic Device.

In the figure *v* represents the valve itself, and it is fitted with a rose *F* (such as is used on a garden watering-can), a funnel *P* and rotating fan *G*. This fan has a number of vanes, only two of which are shown in the drawing, so that when it is stationary it prevents water from being driven from *F* to *P*. Another fan or pump is driven by the 10-h.p. motor *A* at a constant speed, and the piping is so arranged that a continuous circulation of water may be driven round the circuit at a very high speed in the direction indicated by the arrows. The fan *G* is driven by a 1-h.p. variable-speed motor, and tends to pump in the same direction as *A*.

This completes the apparatus for the purpose of analogy. It is doubtless unsound mechanically, but will serve as an illustration of its electrical equivalent.

Start up the motor *A*. If it were not

funnel *P*, and returned through the pipe to the pump. Now start the motor *B* and run it at the same speed as *A*. The fan *G* now ceases to interfere with the stream of water particles, and continuous and steady current circulates in the system.

What will happen if we vary the speed

flow of water will follow suit. Thus variations of its speed may be used to control the flow in the main circuit, although the pump *A* is meanwhile running at a constant speed.

We should note two important properties of our valve. Firstly, it only works one way; and secondly, the effect produced by the big motor *A* is controlled by the small motor *B*.

#### The Valve Explained.

The electrical vacuum valve is shown in Fig. 2. Here *F* is the "filament," a strip of fine wire which is rendered white hot by means of an accumulator. Its purpose is to spray out into the valve a stream of electrons when these are put under pressure by the battery *A*. Its action is thus similar to that of the rose in Fig. 1. The battery *A* consists of a fixed number of dry cells and maintains a comparatively high difference of electrical potential between *F* and the "plate" *P* (which is merely a small piece of sheet metal). This battery would cause a current to flow from *F* to *P* in the form of a stream of fine spray of minute electrons but for the interference of the "grid" *G*. *G* usually takes the form of a piece of



Thermionic Valve with Upright Electrons.

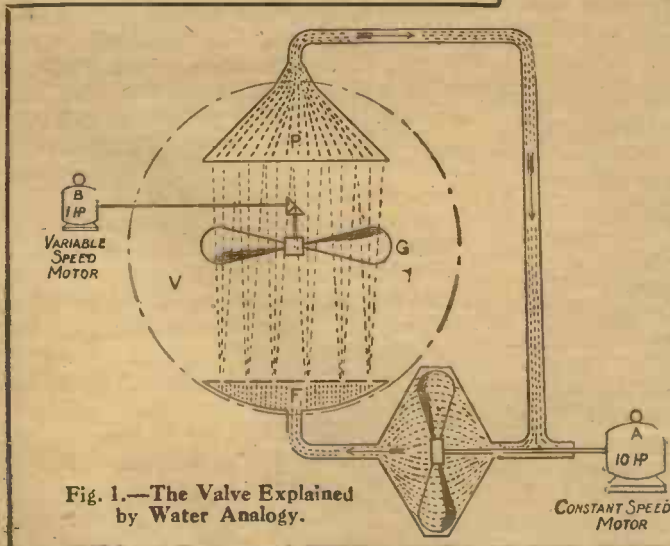

Fig. 1.—The Valve Explained by Water Analogy.

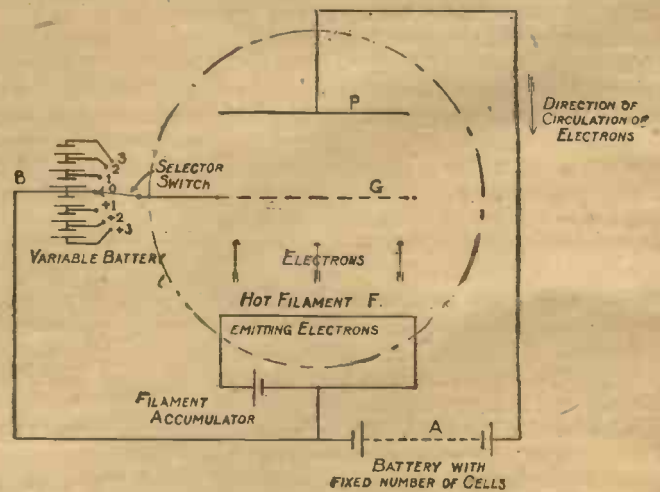

Fig. 2.—The Passage of Electrons in the Valve.

for the interference of the blades of the fan *G* a fine spray would be driven upwards across the valve, caught in the

of *B*? If it is increased the circulation will obviously be assisted, whereas if it is slowed down and ultimately stopped the

metallic gauze or a spiral of wire, and its electrical potential may be regulated; that is, rendered lower than, equal to, or

higher than that of F by means of the variable battery B.

The effect of varying the potential of G is similar to that of varying the speed of the small motor in Fig. 1. Starting with the switch on stud O, which puts G at the same potential as F, the passage of electrons across the valve, and consequently also in the rest of the large battery circuit, is unimpeded. By moving on to 1, 2, and 3 in turn the potential is lowered, and the grid now acts as did the fan G when its speed was slowed down—it interferes with and finally stops the flow altogether. On the other hand, if the switch is moved to studs +1, +2, and +3 in turn the effect is to assist the passage of the electrons and increase the current.

Thus, exactly as in the water analogy, a small variation of the condition of G may be made use of to control the output of power of the large battery A. A numerical example may help us to grasp the value of this effect. The valve experimented on was one such as is commonly used in receiving circuits. The battery A consisted of about sixty dry cells, giving a total potential difference between filament and plate of ninety volts. When the potential of the grid was made two volts lower than that of the filament the current was completely stopped. It was then gradually raised until equal to that of the filament when a current of 160 millionths of an ampere was found to be flowing in the main circuit. Raising it

still further until it was two volts higher than the filament, increased the current to 500 millionths of an ampere.

This property of the vacuum valve is of immense importance in wireless work, and may be made use of in a number of different ways. It is proposed to illustrate a few of these in subsequent articles by means of the hydraulic analogy used above.

One point in connection with the direction of the current in the main circuit of the valve has been left until last in order to avoid confusion. It may be shown experimentally that it is necessary to put the carbon terminal of the battery to the plate and the zinc terminal to the filament for it to operate in such a manner as described.

Conventionally the carbon is the *positive* pole of the battery, and current flows in the external circuit from it to the *negative* or zinc pole. This convention was decided upon in the early days of electrical science before the properties of electrons had been investigated. It is now known that the passage of the latter (which constitutes a flow of current) takes place in the *opposite direction*, either freely across a vacuum, as in the valve, or from molecule to molecule of the wire, as in the rest of the circuit. To be consistent with the convention the plate potential must be regarded as positive to that of the filament, and we should show the current as passing in the opposite direction to that indicated by the arrows. SIGMA.

of potassium nitrate. When cool, immerse in it pieces of white filter paper and dry in the dark.

A simple galvanometer can always be made to show the polarity of wires, but it is necessary to first determine in which direction the needle moves with a current of known source. If used on high-voltage mains a lamp resistance should always be placed in circuit.

### Liquid Pole-finders

Another class of apparatus is the liquid pole-finder, which consists of a glass tube containing a liquid and provided with two electrodes as shown in the illustration. Normally the solution is colourless, but on passing a current through it a reddish purple colour will be observed at the electrode connected to a particular lead. The explanation is that when an electric current is passed through a neutral solution containing some salt of potassium or sodium, the metal is liberated at the negative electrode. This (potassium or sodium) at once reacts with the water, producing hydrogen gas and potassium or sodium hydrate.

The presence of the alkali at the negative electrode may be demonstrated by having in the solution some chemical indicator, for example, phenol phtalein. This, with neutral or acid solutions, is colourless, but with alkaline liquids is of a reddish-purple colour. Hence a reddish-purple liquid round the negative electrode would show the formation of the alkali. On, however, shaking the liquid, the acid formed at the positive electrode, and the alkali formed at the negative electrode, in equivalent quantities, re-combine; a neutral solution is produced and the colour is discharged.

Suitable solutions may be made up in the following manner: (1) In 1 oz. of distilled water dissolve 2 gr. or 3 gr. of sodium sulphate, and add a few drops of a 1 per cent. solution of phenol phtalein dissolved in alcohol. Normally this solution is colourless. On passing current through the solution a reddish-purple colour will be observed at the electrode connected to the negative power lead.

(2) In place of the phenol phtalein add to the sodium sulphate solution one drop of a 1 per cent. solution of methyl orange dissolved in alcohol. The solution is of a yellow colour normally in neutral or alkaline solutions, and red in acid solutions. Therefore, on passing current through the solution, the presence of the acid at the positive electrode is indicated by a red colour at the electrode connected to the positive power lead.

The first solution, being colourless normally, is to be preferred. The electrodes may be of copper, 1 in. apart.

It is welcome news to learn of the new valves coming along, which operate on a single dry cell with a current consumption of  $\frac{1}{4}$  ampere.

## WHICH IS THE POSITIVE?

THERE are many occasions when it is desirable to determine the polarity of a source of electric current, as—to mention one only—when charging accumulators from the mains. There are many methods of doing this, some of which require special means, such as the use of a small piece of apparatus purposely designed for this purpose or the use of pole-finding paper.

### Use a Glass of Water

A simple plan where high-voltage mains are concerned is to dip the two wires in a glass containing very dilute acid (vinegar and water will do) when bubbles will rise from the negative wire. Care should be taken to keep the wires fully 1 in. apart, and it is advisable that the current, if of high voltage, should pass through a lamp, which will act as a resistance.

Another method requiring no apparatus, and suitable for any voltage up to 500, is to take a potato and after removing a portion of the skin to insert the ends of the two wire leads. The distance the wires should be apart will depend on the voltage; the lower this is the closer should they be to each other. It will be found

that the positive wire will turn the potato green, whereas the negative wire will not make any mark at all. The time necessary for the result to show will never exceed one minute and will depend on the voltage.

### Pole-finding Paper

Pole-finding paper can be purchased or made. Made as below, it needs to be moistened and touched with the ends of the two wires, which should be about  $\frac{1}{4}$  in. apart, the positive pole producing a brown

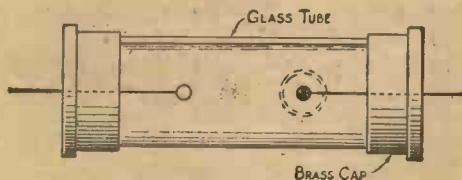

The Liquid Pole-finder.

spot. Mix 1 oz. of best starch with distilled water to form a thick creamy paste and stir in boiling water until the starch becomes translucent. Add the greater part of a pint of water in which has been dissolved  $\frac{1}{2}$  oz. of potassium iodide and 1 oz.



# A Receiving Set Made in 30 Minutes

## A Prize-winning Set that Costs Two Shillings

QUITE recently a competition was instituted by "Science and Invention" (New York) for a receiving set that could be made from odds and ends which were likely to be lying about in any home, and which, in addition, could be very easily constructed. More than 900 entries were received, the competitors being persons of all ages and both sexes, which shows the widespread interest that exists in the subject.

The winner was a youth of twenty-one, his apparatus being declared by the adjudicators to be the simplest outfit that can possibly be made. Though the total cost works out at less than two shillings, without the telephone receivers, assurance is given that the apparatus is quite practical and will work well. A knife is about the only tool necessary for its construction. The following is the inventor's own statement of the manner in which the apparatus can be made:

"The materials required are as follow:

- 1 paper container (4 in. in diameter)
- 13 paper-fasteners (small size)
- 2 paper-fasteners (large size)
- 3 paper clips
- 2 oz. No. 26 enamelled copper wire
- 1 small piece of silicon or galena
- 1 common pin.

"Take the container and punch nine holes 1 in. down from the top  $\frac{1}{2}$  in. apart. Into each hole push a paper-fastener. With pen and ink number each fastener from right to left, 1 to 9. Alongside of hole No. 1 push two fasteners with a paper clip underneath—mark GND (ground or earth). Half an inch down from GND,

"Next pull the wire tight and commence winding the coil. The total number of turns is seventy, and a tap is taken off at each of the following turns: The 15th, 20th, 25th, 30th, 35th, 40th, 45th, 55th, and the 70th.

"Fig. 1 shows how to tap the coil. The important things to look out for are that the coil is wound as tight as possible, and that the enamel is scraped off the wire, where it makes connection with the fasteners. The 15th turn is contact No. 1, the 20th No. 2, etc. The next job is the switch that moves over the contacts. Fig. 2 shows how this is made. Take one of the large fasteners, push the ends through the side of the cover close to the lid. Bend one end down flush with the side and push the other end through the top and bend over.

"Put the cover back on the container, and bend the end of the fastener so that it rides over the contacts easily when the cover is turned, but be sure that it touches each of them. Break off the surplus end.

"The other large fastener is pushed through the lid opposite the switch, and is bent, as shown in Fig. 2, so that it can hold the small crystal. A short piece of bare wire (about No. 24 will do) and a pin acts as the contact; the pin is fastened to

"String the wire the greatest length possible and attach the outer end to a tree or other eminence at least 30 ft. high. The other end of the wire enters the house and is attached to the switch button marked ANT. A short piece of rubber



The Set and Its Maker.

tubing should be slipped over the wire where it passes through the wall.

"A good ground or earth can be had by connecting a wire to the nearest water-pipe. Scrape the pipe until it is bright for a length of about 2 in., then wrap several turns of the wire tightly round it.

"To operate the set, bend the contact wire so that the pin rests on the crystal. Move the pin over the surface until a signal is heard; at the same time move the switch over the contacts, and leave it on the one that gives the clearest result."

### CAMARADERIE!

THERE is a wonderful "good fellowship" among wireless amateurs. It is a part of the game. We indulge our hobby for our own enjoyment, but are never happier than when helping our fellow amateurs. They find a deal of pleasure in helping us.

We can give a special point to that. The finest chance any amateur can have of passing on to his friends any little hint or kink that he has found of service is to send it to "Amateur Wireless." All his brother amateurs can benefit from it then. *And we pay him for his trouble.* EVERYTHING specially written and contributed to this paper is paid for. That is something worth remembering when an idea comes to you and you find by experiment that it works. Let us have it, that everybody may benefit.

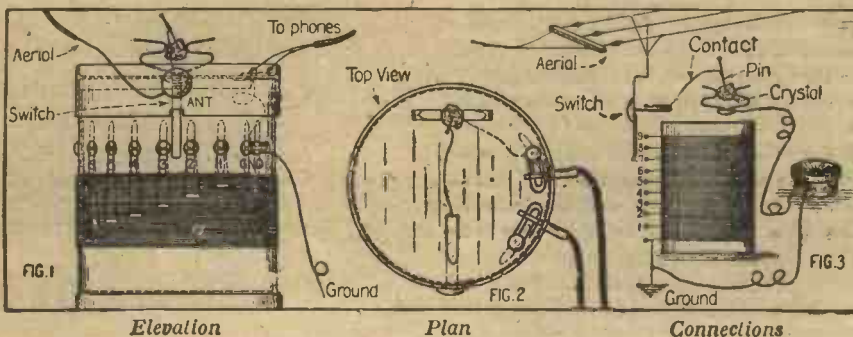

Working Details of the Set.

punch a small hole; this is the starting point of the coil.

"Take the wire and push the end through the hole. Wrap the end round one of the fasteners GND (on the inside of the container). Be sure that where the wire touches the fastener the enamel has been scraped off or else a poor connection will result.

one end of the wire and the other end is wrapped round the end of the switch that is bent over (see Fig. 2).

"Fig. 3 shows the diagram of connections.

"For the antenna  $\frac{1}{2}$  lb. of No. 18 bare copper wire will do. This will give about 100 ft. of wire. Two porcelain cleats will also be required.



# STARTING WIRELESS.—II

HOW SIGNALS ARE SENT;  
SELECTING A SIGNAL;  
TUNING CIRCUITS.

## How Signals are Sent.

AS stated earlier, all wireless communication is carried on by means of waves in what is known as the ether. Reverting again to the analogy of waves in water, suppose we drop a stone into a pool of water, a number of little rings are set up which radiate in all directions from the

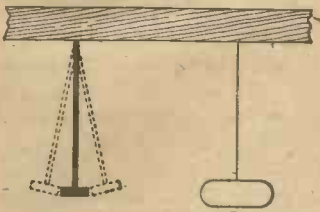

Fig. 2.—Diagram Explaining Inductance.

point at which the stone was dropped. These rings are really miniature waves set up on the surface of the water, and if a cork was floated in the pool, when the waves reached the cork they would cause it to bob up and down.

This provides a very good idea of what happens when a wireless message is sent out. The falling stone producing the waves in the water is analogous with the transmitter producing the waves in the ether. The cork, of course, resembles the receiving apparatus, which is only affected when the wave falls upon it. It would be observed as the rings travelled across the surface of the water that the distance between any two consecutive crests was always the same, and also that they all travelled at the same speed. This distance



Fig. 4.—Variable Condenser.

between the waves is the wave-length, and the rate at which they travel is the velocity.

Fig. 1 shows a wave diagrammatically, and it will be seen that in one second the wave repeats itself twice, that is, it makes three oscillations. Obviously there is always a definite relation between the wave-length and the number of oscillations

in one second or, as it is more usually called, the frequency.

Although Fig. 1 represents a wave such as would be set up when the stone fell into the water, it is very similar to a wireless wave. The great difference is that all wireless waves travel at the enormous speed of 186,000 miles in one second, and this means that consequently the frequency must be very high.

**Selecting a Signal.**—No doubt the reader may wonder what bearing the preceding paragraph has upon the reception of wireless signals. Each wireless station transmits a certain length of wave, and unless the receiving apparatus is tuned to the particular wave-length employed by the sending station it is not possible to receive it. A wireless receiver really consists of two distinct parts. The first part of the apparatus is used to make the receiver receptive of any particular wave-length,

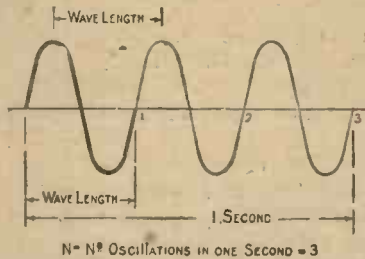

Fig. 1.—Diagram Illustrating Wave-length.

while the second part makes use of the electrical energy which is set up in the first part, when it is in tune with the distant transmitting station. It should be understood that the sending station does not radiate any electricity, but merely sets up waves in the ether, which, if they are properly utilised, may be made to produce an electrical effect at the receiving station.

The first part of the receiving apparatus is frequently referred to as the tuner. This again may be considered as two parts, which are called electrically the inductance and the capacity respectively. The inductance in a wireless receiver usually consists of a coil of insulated copper wire wound round an insulating tube. Capacity can be regarded as a reservoir on each side of an incomplete circuit, the apparatus employed more usually being referred to as a condenser, it having the property of storing up electrical energy and giving it out again when desired.

**How the Wave-length is Determined.**—When we considered the falling stone it was noted that any particular wave-length always corresponded to a particular frequency; in fact, one varies inversely as the other. Hence, instead of always thinking of a wireless message as being sent on a definite wave-length, we might always

consider it as being sent at a definite frequency. Having grasped this point, a simple analogy will show that altering inductance and capacity alters the frequency and therefore the wave-length.

Inductance in an electrical circuit is very similar in action to mass in a mechanical arrangement, while in the same way capacity resembles a spring. Suppose we

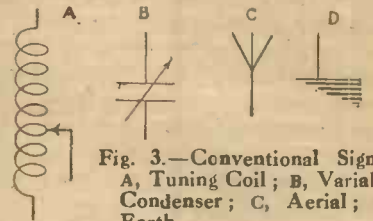

Fig. 3.—Conventional Signs: A, Tuning Coil; B, Variable Condenser; C, Aerial; D, Earth.

clamp a 2-ft. rule at one end and fix at the other a 4-lb. weight, and by the side of this a similar arrangement is fixed up consisting of a 2-ft. length of clock-spring, to which is attached a 40-lb. weight. This is shown quite clearly in Fig. 2. If the 4-lb. weight is pulled to one side the 2-ft. rule will bend, and if suddenly released it will spring backwards and forwards at a very great speed. In other words, the rule and weight are setting up waves in the air at a very great speed. We say, therefore, that the frequency is high, and this, of course, corresponds to a short wave-length.

If, now, we pull the 40-lb. weight and clock-spring to one side and release it we shall find that it will swing from side to side at a very slow speed; that is, the frequency of oscillation is low and corresponds to a long wave-length. Mass and



Fig. 5.—Variable Condenser.

springiness correspond to inductance and capacity respectively, and thus it is evident that if either or both of these quantities be increased the frequency is lowered and the wave-length increased. Therefore, we come to the following conclusion: To receive a wireless signal on any particular wave-length we simply have to vary either our inductance or capacity, or both, until



we get the correct proportions to correspond to the frequency which it is desired to receive. Since it is only possible to receive one frequency at a time, it is obvious that if each station sends on a different wave-length only one message at a time will be received. This explains, of course, how a number of different stations may all send at the same time without interfering with each other.

**The Tuning Circuits.**—It has been shown that the essentials to the tuning part of the receiver are an inductance and a capacity, or, as they are more usually referred to in a wireless receiver, a tuning coil or inductance and a tuning or variable condenser. Both these are usually made

variable, and they are always as shown diagrammatically in Fig. 3. The tuning coil, as mentioned before, consists essentially of a coil of insulated copper wire wound round a non-metallic insulating cylinder, which may be made of ebonite or cardboard. In order to make the amount of wire to be used variable, it is usual to fix up some form of sliding contact to move along the length of the cylinder, the insulation on the wire, of course, being removed at the line of contact. An alternative method is to tap the winding at varying intervals, bringing the tappings to a multi-point switch.

The variable condenser consists essentially of two areas of metal plate, so

arranged that one can be moved up to, or away from, the other. In order to make the arrangement compact the condenser is very frequently of the rotary-vane type. There are two sets of semicircular vanes, each vane being spaced from the other by a distance of about  $\frac{1}{4}$  in. One set is fixed, and the other is mounted on a shaft in such a way as to allow the movable vanes to swing between the fixed ones without the two sets touching. The other form of variable condenser consists of two metal tubes separated by a thin sheet of mica, celluloid, or even waxed paper. The tubes are of such a size that the inner one is just capable of moving in and out of the larger (see Figs. 4 and 5). T.

## :: SOME AMERICAN IDEAS ::

### A Universal Detector

THE materials required for this detector are a ruling pen; three pieces of  $\frac{1}{4}$ -in. copper tubing each  $1\frac{1}{4}$  in. long; two small terminals; two  $\frac{1}{8}$ -in. brass machine screws  $\frac{3}{4}$  in. long having hexagonal nuts  $\frac{1}{2}$  in. in diameter; one piece of spring brass wire about  $2\frac{1}{2}$  in. long; base,  $2\frac{1}{2}$  in. by 5 in. by  $\frac{5}{8}$  in.

To one end of each piece of copper tubing solder the brass hexagon nuts. This should be done so that the machine screw

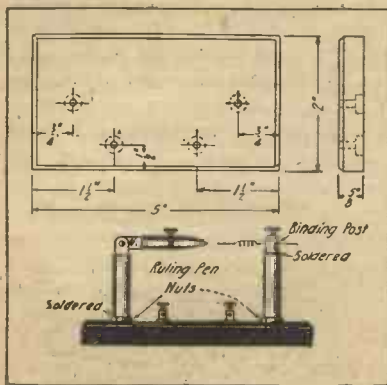

A Universal Detector.

can pass up into the tubes. On the other end of one of the tubes solder the ruling pen, which must have a joint, so that the pen will point horizontally when the tube is vertical. On the end of the other tube solder a small terminal. For the contact point use the brass wire, which should be filed to a point at one end. The wire should be bent into a spiral for about  $\frac{1}{2}$  in.

To assemble, screw the tubes to the base by drilling an  $\frac{1}{8}$ -in. hole. The mineral which is to be used should be put into the ruling pen, which can be tightened by means of the thumb screw.

The remaining two terminals are fitted on the block, as shown in the illustration. —Radio News.

### A Simple Variable Condenser

PROCURE a piece of hard wood or ebonite about  $6\frac{1}{2}$  in. long by 2 in. wide. Obtain two test tubes, one 6 in. long by  $\frac{3}{4}$  in. in diameter; the other the same length or a little longer and a trifle narrower, so that it will slide inside the first. The tubes must be covered with tinfoil on the outside, as shown in the drawing. The bare ends of the tubes, which will be about  $\frac{1}{2}$  in. on the round end and 1 in. on the open end, should be covered with a varnish made by dissolving red sealing-wax in alcohol. Fasten the large tube to the base by a brass clamp (C) in figure, and connect this by a wire to the terminal.

Procure an 8-in. length of No. 24 d.s.c. wire and force a short piece of the bare end under the foil of the small tube. To obviate the danger of this pulling out it

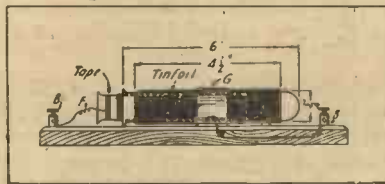

A Simple Variable Condenser.

may be fastened with a small strip of tape; the other end is to be connected to terminal (B). By pulling the inner tube out the capacity is diminished, and by pushing it in the capacity is increased.—Radio News.

### The ONLY Book

that contains "how-to-make" details of apparatus that has actually been made and used, that gives 160 pages of absolutely reliable "wireless" information for 1/6 net, that combines simple theory with working practice.

The "Work" Handbook,  
"Wireless Telegraphy and Telephony: And How to Make the Apparatus."  
CASSELL & Co., LTD., Ludgate Hill, London, E.C.4.

### A High-speed Key.

THE vibrating type of key was first used by operators to attain great speed, and is really a great improvement over the old-fashioned type of key.

The base is supported on ebonite feet to permit the wires to be run on the underside. The blade can be made from any of various materials, such as hack-saw blades and the like, although an artist's spatula, as shown in the drawing, makes an ideal blade. Two strips of ebonite are cut to form an insulating handle, which is held together by small screws, so placed as not to come into contact with the blade. A  $\frac{1}{8}$ -in. hole is drilled near the other end of

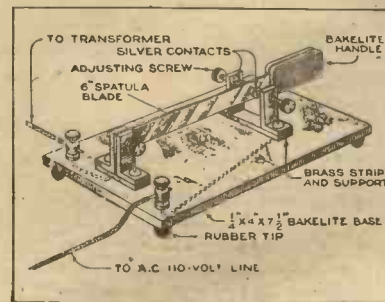

A High-speed Key.

the blade, which is supported between brackets of the type shown; these are formed from  $\frac{1}{8}$ -in. sheet brass, and the blade is securely fastened between them by a screw. The front brackets are made of the same dimensions as those holding the blade at the rear. These brackets are mounted on a brass strip, and each is provided with a knurled-head screw. Silver contacts are soldered to the tips of these screws and to the blade.

The wiring is clearly shown in the drawing. A switch is not needed, because, if the contact points are adjusted to a uniform distance from the blade, it will not come into contact with them when not in use.—Popular Mechanics.



# MORE CONCERNING THE AERIAL

**T**YPES of aerial in use may be classed as follow:

**Single-wire Aerial with Short Lead-in.**—The horizontal component of this aerial is, say, 50 ft. high, and the instruments are in an upper room, 30 ft. above ground level; the lead-in will be comparatively short, namely, 20 ft.

It will be supposed that the horizontal wire is 80 ft. long and the down-lead to instruments 20 ft. The natural wave-length of such an L aerial would be—(80 ft. + 20 ft. + length of earth lead, say, 30 ft.)  $\times$  constant 3.5 = 455 ft., or 142 metres. This would certainly prove quite a serviceable aerial, provided a good "earth" is obtained and the resistance of the earth lead kept as low as possible. The disadvantage is the length of the earth lead.

**Single-wire Aerial with Long Lead-in.**—As the lead-in is much longer, the horizontal component is correspondingly reduced to conform with the length of wire specified.

It is supposed that the instrument room is on the ground floor: Horizontal wire 50 ft., height 50 ft., lead-in 50 ft. The natural wave-length of this aerial would be 3.5 times (50 + 50) = 350 ft., or 109 metres. This is 37 metres less than that of the first example, but, on the other hand, this aerial has the advantage that the whole of the electrical length is properly situated for absorbing the energy of incoming waves.

If the instruments were transferred to a room 15 ft. above ground level this would allow of a further 15 ft. being added to the length of the horizontal wire. The natural wave-length would then be 3.5 (65 + 35 + 15) = 402.5 ft., or 125 metres.

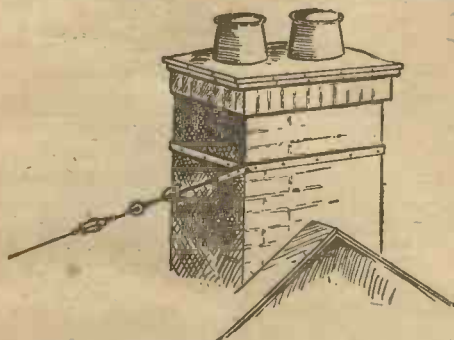

Fig. 1.—Aerial Attached to Chimney-stack.

The natural wave-lengths can easily be estimated for other variations of length and height.

**Double-wire Aerial with Long Lead-in.**—The total length of wire is 140 ft. In order to gain the fullest advantage from the extra 40 ft. of wire, it will be better

to utilise the same in the horizontal component, leaving the down-lead a single wire as in previous cases.

With a height, say, of 40 ft. and a length of 50 ft. this will give an aerial having a natural wave-length of 340 ft., or 106 metres.

*The Editor suggests that this article be read in conjunction with "Concerning the Aerial" on page 7 of the first number, in which article will be found illustrations of the types of aerial here mentioned.*

**Double-wire Aerial with Short Lead-in.**—This is a variation of the foregoing, unless the effect of transferring the instrument to an upper room is considered.

From what has been stated it will be evident that, for a given quantity of wire, an L-type aerial will have a greater natural wave-length than a T-type aerial. The necessity for making connection to the exact centre of a T-type aerial will also be apparent, as otherwise the aerial would be badly balanced electrically, having, in effect, two natural wave-lengths slightly different from one another.

In many cases the erection of an aerial presents the most troublesome problem of the installation of a set of apparatus, for conveniences do not always exist for it to be entirely supported on the premises where it is intended that the apparatus should be, and this perhaps means erecting a post or mast, or availing oneself of the goodwill of a neighbour who will permit of one end of the aerial being attached to his premises.

**Erection.**—It is impossible to lay down hard and fast rules regarding the erection of aerials for amateur experimental purposes as conditions vary, but a few trials will quickly show which arrangement gives the best results in any particular circumstance.

An aerial should be kept as far away as possible from buildings, trees and telephone wires, and if wires or metal spouts are unavoidably adjacent the aerial should be disposed at right angles to them if this is possible.

Both electrically and mechanically, stranded or "braided" copper wire is the best for aerials, but single, hard-drawn copper or phosphor-bronze wire of, say, No. 16 S.W.G., will be found good enough for all purposes. Old telephone wires make a very satisfactory aerial and may often be obtained cheaply. Iron wires should not be used if the best results are desired.

In insulating a small aerial take particu-

lar care, remembering that the total energy picked up does not leave much margin for leakage. There is no need, however, to employ massive insulators; quite small insulators of the "reel" pattern, coupled up in series of three or four, will be quite satisfactory. The down-lead from the aerial should be kept as far as possible from the walls of buildings, etc. Insulated wire is not necessary. It may be an advantage in the case of a station on the sea coast where bare copper wire quickly corrodes.

Two methods of fastening the supporting wires to brickwork, such as a chimney, or corner of a building, are shown by Figs. 1 and 2. The first necessitates the use of a band composed of two pieces of iron that entirely encircle the stack, and should only be necessary when extra strength is required or there is some difficulty in carrying out the plan suggested by Fig. 2. With the latter the iron fastening is in two pieces, a bolt being passed through the projecting pieces.

**Earth Connection.**—As a rule an earth connection, by means of a stout copper wire (single or stranded) to the nearest water-pipe will be found most convenient and, in general, quite satisfactory. If a single wire is employed it should not be smaller than No. 16 S.W.G., and should be soldered or tightly clipped on to the cleaned water-pipe as near to the latter's point of entrance to the building as possible.

If the aerial is being erected in a more or less open space, however, and away from any water-pipes, several long lengths of bare copper wire—some beneath the aerial and others radiating away from the instrument room—should be laid in small trenches in the ground (say 10 in. or 12 in.

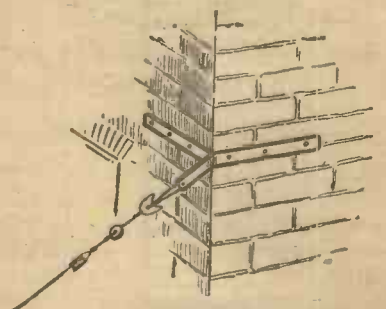

Fig. 2.—Aerial Attached to Corner of Building.

deep), and covered over with soil. Alternatively, a single length of wire netting (not necessarily new) may be merely laid out on the ground beneath the aerial, secured temporarily in place by means of heavy stones, and readily removed when not in use.

T. R.



# HONEYCOMB COILS

A SIMPLE METHOD OF WINDING THEM

**E**FFICIENT tuning coils of the basket type can be wound by amateur wireless experimenters in quite a simple manner which will be found equally useful for spark, continuous wave, or telephonic reception in the following manner. Practically the only expense involved is the initial cost of the wire and a small quantity of orange shellac varnish.

**The Former.**—The necessary former for winding these coils can be made up by first securing a wooden cylindrical disc measuring about 2 in. in diameter and ½ in. wide as shown by Fig. 1. This disc must be divided and marked off into seventeen equal parts round the periphery. The best method of doing this is to cut a strip of paper the same width as the edge and just sufficiently long to go round the circumference of the disc. The paper strip can then be marked off into seventeen equal parts quite easily whilst flat (see Fig. 2) and then be gummed on to the edge of the disc.

Next procure thirty-four ordinary pins and press two into each division opposite to each other (see Fig. 3).

**Winding.**—All that is now necessary is to wind on the wire. No. 32 gauge double- or single-silk-covered copper wire is suitable. Of course, a larger gauge wire can be used, but where space is to be considered the smaller gauge is preferable.

then to the inside across to pin No. 5 on opposite side, round the outside of pin No. 5, then to the inside across to pin No. 9 on the opposite side, round the outside of pin No. 9 to the inside, and so on

receive. It is a good plan to count the number of turns wound on, and this can be done quite easily by marking an arrow head on the disc opposite pin No. 1, one turn being recorded each time this pin is passed.

As a guide, it may be mentioned that in actual practice it has been found that a number of these coils having windings ranging from forty turns to 1,200 turns give a wave-length range of from 300 to 25,000 metres with a suitable aerial tuning condenser in the circuit.

When the desired number of turns has been wound on the former the free end of the wire should be temporarily twisted round the last pin and cut after leaving, say, 10 in. spare. A small quantity of shellac varnish should then be poured into a flat tin and the whole coil and former laid into it for a few seconds to allow the varnish to soak in. The coil should then be removed and suspended by the wire for a few minutes to drain, after which it must be thoroughly dried either in front of a fire or in a moderately heated oven. When dry the wire will be found to be quite rigid and the pins can be easily withdrawn and the coil removed from the disc. As a precaution it is advisable to bind the coil at intervals of 1 in. with fine thread to prevent the outside ends from slipping.

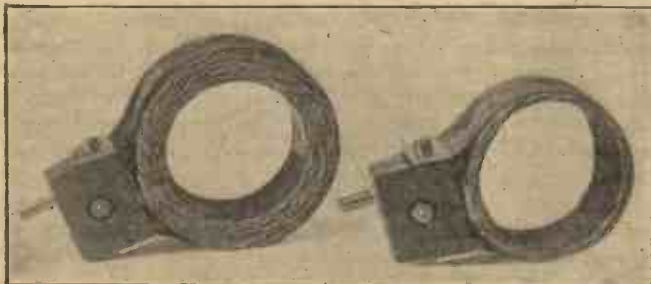

Fig. 6.—Mounted Honeycomb Coils.



Fig. 7.—Honeycomb Coils in Use as Tuner.

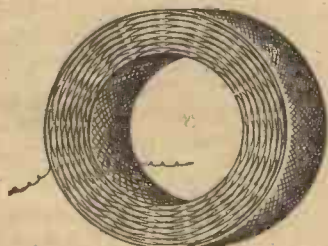

Fig. 5.—Finished Coil wound by method explained in this article.

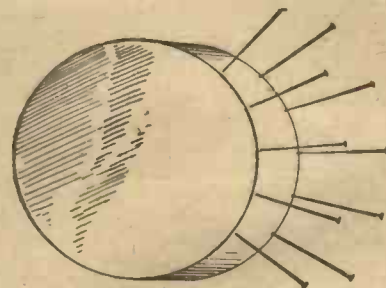

Fig. 3.—Pins Inserted into Disc.

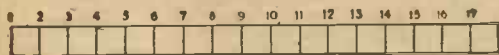

Fig. 2.—Divided Paper Strip.

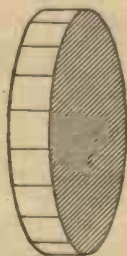

Fig. 1.—Wooden Disc.

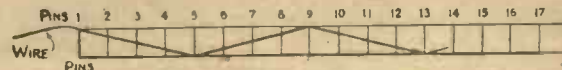

Fig. 4.—Method of Winding.

To wind the coil, take the bobbin containing the wire and place it upon a suitable support, so that when the wire is pulled it will unwind quite readily. Now take the former in the left hand, the wire in the right hand, and after leaving a sufficient length from the end, say 10 in., commence to wind it on as shown diagrammatically by Fig. 4; that is, commencing with pin No. 1 pass round on the outside,

throughout the whole winding of the coil, going forward to the fifth pin ahead each time on each side alternately. The first layer should lie flush against the edge of the disc. If the pins are numbered the operation will be facilitated.

By this means a coil of any size up to about 1 in. in width and of comparatively low self capacity can be wound, according to the wave-length range it is desired to

The finished coil will have the appearance shown by Figs. 5 to 7. If desired the two 10 in. ends can be taken to suitable plugs or studs of a tuning switch to facilitate the insertion of the coil in the receiving circuit.

D. F. U.

[In a later issue we are illustrating a little machine specially designed for winding honeycomb coils.—ED.]



# AMATEUR WI



End View of "Amateur Mechanic" Crystal Set.

IN view of the great interest now being taken in wireless-telegraphy, and more especially in wireless-telephony, by British amateurs a brief outline of the developments and particulars regarding the present position as far as the amateur is concerned will, it is considered, prove of service to the numerous readers who contemplate taking up the hobby for the first time.

During the years 1911 to 1913 a comparatively small number of amateurs in this country took an interest in the study of radio-telegraphy and constructed more or less successful receiving stations. In some cases low-power transmitting apparatus was also constructed, making use, as a rule, of accumulator batteries as a source of power supply in conjunction with spark or induction coils.

Considerable difficulty was encountered in those early days owing to the lack of literature giving concise theoretical and practical information regarding the apparatus, and the experimenter was obliged to spend both time and cash on trial-and-error methods until something definite was arrived at on which the design and construction of further apparatus could be based.

**Early Apparatus.**

Appreciating these difficulties from actual experience, the present writer prepared a series of constructional articles describing in a manner since proved to have been readily understood by the absolute novice exactly how to make a serviceable receiving set. The articles in question were published in our contemporary "Work" in 1913, and immediately enabled numbers of interested amateurs to construct successful receiving stations, the set becoming known as the "Work" Long-distance Receiving Set."

Later, the original articles, together with a special historical and theoretical introduction (prepared at the suggestion of the Editor of "Amateur Wireless"), appeared in the "Amateur Mechanic" (see

page 19 of our last issue), from which publication the set became known as "The Amateur Mechanic' Receiving Set." Altogether some hundreds of these receiving sets have been constructed, very often by beginners having little or no knowledge of electrical matters.

**The War.**

With the formation of amateur wireless associations at various centres throughout the country the number of radio experimenters commenced to grow rapidly, until the outbreak of war in August, 1914, put a stop to all such activities.

All essentially "radio" apparatus was sealed up and later removed by the Post Office authorities, and radio, from the point of view of the amateur experimenter, became a dead letter.

As the war continued considerable development took place in connection with radio apparatus, both at sea, on land, and in the air. This in turn created a demand for operators and mechanics, and as the "time factor" was very important, and training had to be limited as much as possible, volunteers who already had some knowledge of the essential apparatus were especially valuable.

In this connection it is to be recorded to the credit of the British amateur community that large numbers of more or less experienced amateur experimenters enlisted in some branch of the Imperial forces, whilst not a few made the great sacrifice.

Of the progress of wireless, as made in the Services during the continuance of hostilities, it is impossible to give here even an outline. To trace how various improvements were effected in the spark transmitting and receiving apparatus available for the specific requirements in the field and the watchers in the air, with the subsequent displacement of much of such apparatus due to the introduction of the three-electrode thermionic valve, together with later developments in connection with "direction finding," involving the use of "frame" and other special types of aerials and radio-telephony, would take up much more space than can be spared for this article.

**After the War.**

Shortly after the cessation of hostilities radio apparatus in custody of the Post Office authorities was released for return, and the Postmaster-General issued regulations regarding the installation and operation of experimental radio transmitting and receiving apparatus.

Briefly these regulations (they are not given fully) were as follows:

1. Preliminary application had to be made to the Secretary, G.P.O., London, who supplied a form containing numerous questions relating to age, nationality, etc., of the applicant, together with a number of tech-

Smaller circles represent area included within a 50-miles radius. Dotted larger circles, with Birmingham as centre, indicate areas within 100, 150 and 200 miles respectively.



nical and other questions concerning the proposed installation—that is, type of transmitting and/or receiving apparatus, diagrams of proposed circuit arrangements, source of power, etc., and wave-length which it is proposed to employ for transmission. Usually, the wave-lengths granted were 180 metres for spark, C.W., and wire-

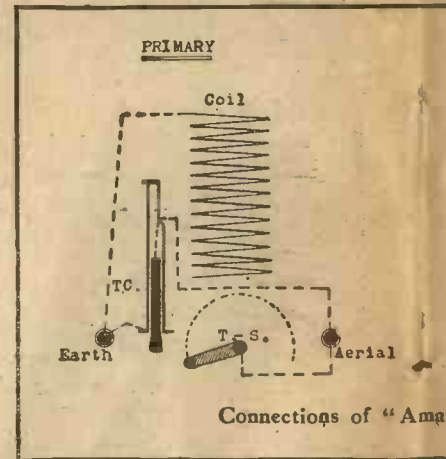



# WIRELESS—1911-1922

Map of Proposed Broadcasting Stations



3. Full particulars, together with sketch of proposed aerial, which was limited in dimensions as follows: Maximum length of wire to be employed—for a single-wire aerial 100 ft., and for an aerial consisting of two or more wires a total length of wire not exceeding 140 ft., which in both cases included the "down-lead" from aerial proper to the "leading-in" insulator at the instrument room. It is understood, however, that for receiving purposes only an increased length of wire may be erected by special arrangement with the authorities.
  4. Transmission was permitted between stations, as stated in paragraph 2. above, but actual transmission was limited to a period of two hours per day, the actual times being selected by the applicant.
  5. Licensing fees are payable as follows: Receiving station only, 10s. upon application and 10s. per annum subsequently. Complete transmitting and receiving station, £1 on application and £1 per annum subsequently.
- In both cases the fee is for twelve months, commencing from the actual issue of the "permit."
6. In the case of transmitting stations the applicant has to satisfy the Post Office authorities, by examination or otherwise, with regard to knowledge of apparatus and regulations; also, he must be able to transmit and receive Morse at a speed of at least twelve words per minute.

During the last two years the number of amateur radio experimenters in the British Isles has increased enormously, and at present is in excess of 10,000 and increasing daily.

With the present improved facilities for obtaining efficient apparatus or components and instruction regarding the theory and manipulation of these (such as is provided by a journal of this description specially arranged to cater for the requirements of the amateur), together with the increased number of commercial transmitting stations now in operation, the difficulties of the present-day amateur (or intending amateur) are greatly reduced whilst the interest is increased.

Undoubtedly the greatest stimulus which amateur radio has received so far is the announcement made by the Postmaster-General on May 4 last with regard to radio-telephone broadcasting stations.

The successful reception of radio-telegraphic signals from far distant stations, though in itself an interesting accomplishment, is scarcely complete unless the receiving operator is *au fait* with the international Morse code, which for many amateurs, especially perhaps those who take up the hobby rather late in life, proves a considerable obstacle. To all such experimenters, therefore, the introduction of radio-telephony on a fairly comprehensive scale, with the reception

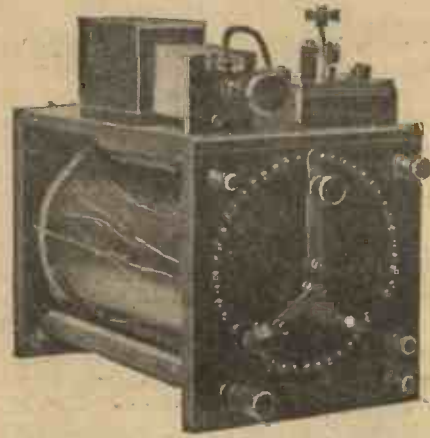

General View of "Amateur Mechanic" Crystal Set

of the actual speech or music, must very strongly appeal.

Up to the present it has been possible for amateurs in the British Isles to receive radio-telephony from the following stations:

**CROYDON.**—A ground station transmitting speech to, and receiving from, aeroplanes *en route* to the Continent, and working on a wave-length of 900 metres at various times throughout the hours of daylight.

**THE HAGUE.**—A private station operated by the Nederlandsche Radio-Industrie, transmitting a programme of music, etc., on Sunday afternoons and Thursday evenings on a wave-length of 1,050 metres.

**EIFFEL TOWER.**—Radio-phone station recently commenced to transmit speech and music in the early evening of most weekdays on a wave-length of 2,500 metres.

**WRITTLE (ESSEX).**—A private station operated by the Marconi Telegraph Co., Ltd., transmitting speech and music for half an hour on Tuesday evenings. Wave-length originally 700 metres, now altered to 400 metres.

CHELMSFORD.

MARCONI HOUSE.

POLDHU.

Stations operated by the Marconi Co., occasionally transmitting upon various wave-lengths for experimental purposes.

With the addition of occasional reception from some of the well-equipped amateur radio-phone stations, the transmissions from the above-mentioned stations are already available for reception by amateurs in this country; but as the power employed at such stations is by no means large, somewhat sensitive apparatus is required for successful reception, unless, of course, the distance separating the transmitting and receiving stations is comparatively short.

The Postmaster-General, in his announcement, stated: "I have decided to allow the establishment of a number of radio-telephone broadcasting stations. The country will be divided roughly into areas centering on London, Cardiff, Plymouth,

less-telephone transmission, and (if required) 1,000 metres for continuous-wave telegraphy and radio-telephony only.

2. Full particulars of stations not exceeding five in number, with which it is desired to carry on experimental work, together with written expression of willingness to cooperate from the owners of such.

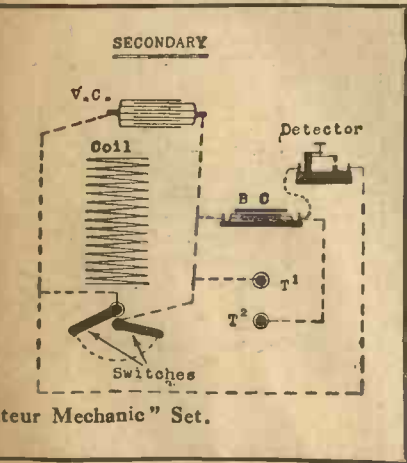

"Amateur Mechanic" Set.



Manchester, Birmingham, Newcastle, Glasgow (or Edinburgh, but not both), and Aberdeen.

One or more broadcasting stations will be allowed in each of these areas. The power of these stations will be  $1\frac{1}{2}$  kilowatts, and they will have wave-lengths allotted which will not interfere with each other.

The normal hours for broadcast transmissions will be from 5 to 11 p.m., except on Sundays, when there will be no limit. Regulations will be made regarding the class of news to be transmitted. The facilities for obtaining permits for reception will be simplified, and in the future it will be possible for anyone desiring to install a receiving set to go to any post office and obtain a licence for ten shillings.

It will be seen at once that when the scheme outlined becomes operative (and in this connection it is understood that no time is to be lost in getting to work) the repertoire of a wireless receiving set will be enormously increased, whilst the comparative nearness of the transmitting stations, and the increased power to be used, will considerably simplify the apparatus at the receiving stations.

Until some of the proposed new radio-telephone stations actually commence operations, enabling trials of receiving apparatus to be made, it is not possible to state with exactitude what receiving apparatus will be essential at various distances from any particular transmitting station. From some of the numerous paragraphs, etc., appearing in the daily press regarding this subject readers might be led to think

that most expensive apparatus is required, whilst from others that reception can be satisfactorily effected by means of a telephone receiver, a coil of wire, a piece of cork and a bent pin (!), which is certainly not the case, although Morse signals from powerful commercial transmitting stations (such as the Eiffel Tower time signals) can be received with very crude apparatus if skilfully manipulated.

In general these extreme cases will require to be modified to meet the requirements of the average amateur experimenter according to whether speech, etc., clearly audible in one or two pairs of good telephone receivers (headgear type) will be considered satisfactory, or whether it is desired to entertain a company by means of a "loud-speaking" telephone with trumpet attachment. In the former case it is thought that for distances up to about 50 miles quite good reception will certainly be possible, and up to 100 miles most probable, by means of an efficient crystal receiving set used in conjunction with a good outdoor aerial consisting of one or two wires from 60 to 100 ft. in length, suspended upon suitable insulators at a height of not less than about 35 ft.

In the latter case (that is, with loud-speaking telephone) the addition of at least two three-electrode valves, and of course a good "loud-speaker," will probably be found necessary, whilst to enable similar signals to be received from all of the proposed new stations will doubtless make a further valve (or two) necessary.

Between (a) reception of clear but not loud music, etc., in, say, two good pairs of headgear telephones from stations

within a radius of 50 to 100 miles, and (b) clear and fairly loud reception, per "loud-speaker" from all of the stations within a radius of, say, 400 to 500 miles, there is scope for many different arrangements of apparatus, depending only upon the knowledge and constructive ability of the experimenter and/or the depth of his purse; but in general readers are advised to follow carefully the theoretical and constructional articles which will appear in this journal, and having decided upon a type of apparatus best suited to their particular requirements, proceed either to construct or purchase this, bearing in mind the desirability of being able at a later date to make such additions as will improve the performance of the apparatus without the necessity of discarding much (or any) of the original set.

Simultaneously the necessary official permit should be obtained and the erection of the *best possible aerial* proceeded with, the essential points being (a) good average length, (b) greatest obtainable height, (c) excellence of insulation, and (d) the avoidance of close approach of the aerial wire or down-lead to earth-connected bodies, buildings, etc.

The map given on p. 31 shows the distribution of the proposed new broadcasting stations, whilst the circle drawn round each shows the area within a 50-mile radius. The dotted circles with Birmingham at the centre indicate areas covered within a radius of 100, 150 and 200 miles respectively, and will afford a good indication of the receiving range required to permit good reception from various stations. E. REDPATH.

## WHAT WIRELESS TERMS MEAN.—II

### Some Technical Words Explained as Correctly as Popular Language Allows

**AMPLIFIER.**—An instrument consisting of a number of valves coupled together used in conjunction with a receiving instrument for the purpose of magnifying or amplifying the signals after reception. Amplifiers may be either of radio-frequency or audio-frequency (see *these terms*), and the nature of the coupling between the valves may be transformer or resistance (see *also these terms*), hence the terms transformer-amplifier and resistance-amplifier. Three valves is usually the maximum for a low-frequency amplifier owing to the tendency of the valves to howl, due to "reaction" effects between the several transformers.

**REACTANCE COIL.**—A coil which is placed in the plate circuit of a valve set and coupled to the grid circuit, or primary coil, in order to produce reaction between the two coils, the effect being to amplify signals. It is reaction that produces the oscillations which blend with the incoming oscillations and produce the beat frequency, enabling continuous wave signals to be received. In a two-coil valve circuit it is the secondary coil of a loose-coupler. For receiving short waves the reaction coil should have more turns

of wire than the primary. For receiving long waves, the reverse is the case.

**IMPEDANCE.**—The property which a wire possesses of offering apparent obstruction to the passage of an alternating current. Analogous to inductance but not the same. Simply explained it may be stated thus: Inductance offers obstruction to the passage of a direct current, but is almost immediately overcome, and then the current flows. With alternating current, changing direction at high speed, the obstruction is not overcome before the current changes direction and is again obstructed, the result being it never gets through at all.

**COUPLING, INDUCTIVE.**—Where two coils are in a position to produce mutual induction they are said to be inductively coupled.

**COUPLING, LOOSE.**—When two tuning coils, such as the primary and secondary of a loose coupler, are very far apart they are said to be "loose coupled." In the reception of telephony it is necessary to have very loose coupling in order to prevent the valve oscillating, and so distorting the speech. In a crystal circuit loose coupling is employed to tune out

stations which are causing interference. For instance, if two signals are coming in together, the one strong and the other weaker, and the coupling is loosened, the effect will be to reduce the strength of both—the weaker one then will not be heard, but the louder one will continue to be heard alone.

**COUPLING, DIRECT.**—When one instrument is connected to another, such as a transformer to a valve, with nothing else intervening they are said to be directly coupled. The converse is the case when a condenser or other instrument is interposed between the two.

**COUPLING, TIGHT.**—When two coils are close together, or, in the case of a loose-coupler, when the smaller coil is entirely enclosed in the larger, the coupling is said to be tight, and the mutual inductance of the two coils is at the maximum. Signals will then be at their strongest with a crystal set. With a valve set, however, tight coupling is to be avoided for many reasons, one being that the valves will howl and probably be damaged. Further, if an auto-heterodyne circuit is used—that is a two coil valve circuit—considerable radiation of energy will result with consequent interference with other stations.



## "Blind Spots"

ALL wireless amateurs are aware that the presence of conductors, buildings, hills (particularly those containing mineral deposits), trees, etc., have considerable effect on the reception of wireless waves, an effect that has generally been ascribed to absorption, or the using up of the power in the production of currents in the obstacle. Recent experiments, however, have shown that, in addition, distortion of the waves takes place, that is, that it tends to bend round the object, and that, therefore, there will be certain positions in the vicinity where the facility of reception differs. It has been demonstrated by the apparatus shown in the photographs that the distortion sometimes was as much as 50 deg., while at greater distances the distortion became less until at points about 2,000 ft. away the distortion was entirely gone. This means that after passing a distorting structure the waves straighten out again and are not erroneous in their direction until other obstructions are met.

The distortion or bending of the waves is also found to differ when the transmitting station uses different frequencies or wave-lengths. The wave-length, which is subject to greater bending, depends upon the actual dimensions of the object which is causing this change in direction.

Another interesting point is that it was shown that the distortion caused by a given object is greatest when the waves which are passing by it are of the same length as those which would naturally be sent out by that object if it were used as the antenna of a transmitting station.

## Radio-frequency or Audio-frequency?

MORE and more attention is being paid to radio-frequency amplification, although radio-frequency continues to predominate. The difference between these two methods is that radio-frequency amplification consists of building up the intercepted radio energy before impressing it on the detector, which in turn makes this energy capable of actuating a telephone or other device. Audio-frequency, on the other hand, is used to build up the audible frequency current issuing from the detector. As many types of detectors only begin to function when the intercepted wave strength has reached a critical point, it stands to reason that very weak waves will not be detected, and no amount of audio-frequency am-

plification can help matters, since there is nothing to amplify. On the other hand, even with extremely weak signals it becomes possible to pass them through one or more radio-frequency amplifiers to be built up before being introduced to the detector. Then, if desired, the output of the detector can be passed through several

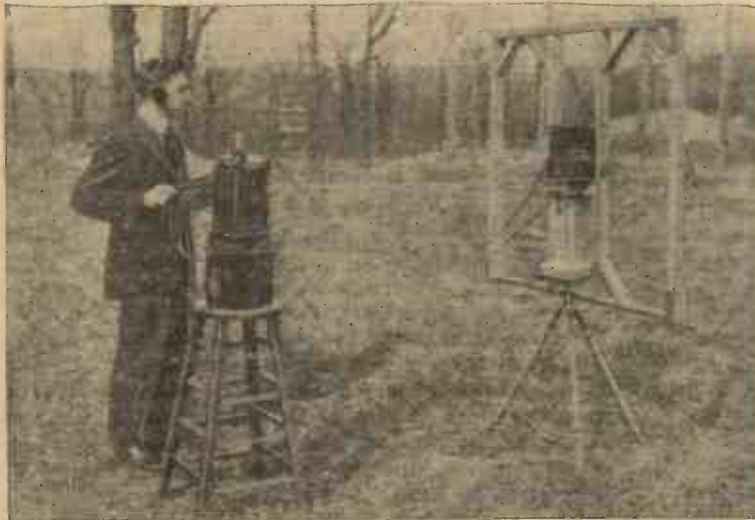

"Blind Spots": Direction Finder Obtaining Exact Position of Passing Waves.



"Blind Spots": Direction-finder Frame Sighting Transmitting Station.

stages of amplification, with the object of obtaining maximum audibility.

## CORRESPONDENCE

### SOME FREAK RESULTS

SIR,—Some people require many expensive instruments in order to receive signals. It is quite a hobby with me to see what results can be obtained using as little apparatus as possible, and in the course of these experiments I have naturally come across many "freak" results.

Using an indoor aerial 10 ft. long and a set consisting of a crystal and single slide inductance, I have repeatedly received North Forelands, and can read ships in the Channel regularly. As I live at Bexhill-on-Sea, which is about fifty-five miles from G.N.F., I consider this no mean result, and it only shows what can be done with the "old-fashioned crystal."

Using the same set with the G.P.O. single-wire aerial, I have heard at various times most of the spark stations of Great Britain. Most of these long-distance messages were received at night, as they then seem to be much stronger than in daylight.

But it is with a valve that one gets the most surprising results. I can read Paris regularly without any aerial at all, and with only one valve. Whilst using the same valve, but with an aerial, I have repeatedly heard the American C.W. stations and ships with the standard Marconi sets far out in the Atlantic. Once, whilst listening in for Croydon's telephony, I heard a very feeble carrier-wave. On tuning it in and loosening the reaction at first I heard nothing, then I heard Renfrew calling up Pulham; his speech was heard distinctly for about five minutes, after which it waned and died out. I think this must be nearly the record for receiving telephony on one valve.

Have any of your readers who possess three- or four-valve amplifiers tried using a friend as an aerial? Quite strong signals may be received if a person touches the aerial terminal, especially if he wears rubber on his shoes.

F. H. M.

Bexhill-on-Sea.

[We shall be pleased to have other readers' experiences of a similar nature.—Ed.]

## WE OFFER OUR THANKS

to everybody who has sent us his hearty congratulations and good wishes. We did well with our first issue and went a long way towards selling two reprint editions. We ask our readers to mention us to their wireless friends. For every little help we RECEIVE, ever so much more are we able to GIVE. One other request: Will our readers always write to us when in difficulty!



# ELECTRICAL BENCHWORK

Ebonite Turning, Knurling, Milling, Drilling, Tapping and Bending

THE chief difficulty met with in working ebonite is presented by the fact that two of its constituents are sulphur and an abrasive material (the presence of the former being essential, and of the latter

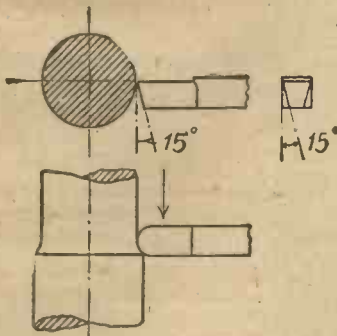

Fig. 1.—Rough-turning Tool in Use.

accidental, but observable even in the best ebonite); these give ebonite the property of rapidly corroding all steel tools used on it. Thus the methods of working described later, which do not involve steel edge tools, will be useful, as they are not universally known.

## Turning.

Ebonite is, on the whole, an easy substance to turn, but the following points are well worthy of attention as being conducive to expedient working. The tools used are similar to those employed in brass turning, in that they have little or no top rake. The two principal forms are the roughing tool (Fig. 1) and the plain finishing tool (Fig. 2). The former is round-nosed, has a large clearance (about 15 deg.), so that a fairly heavy feed may be used, and has no side rake, thus making it possible to use it in both directions. These two matters are of considerable importance in fast working. The question of the kind of steel used for the roughing tool is a matter of little moment, as the finest high-speed steels appear to wear almost as quickly as low-grade carbon steels. In any case it is necessary to grind the tools more frequently than in working any other material, and even then the edge is allowed to become considerably worn before grinding, otherwise the turner would spend all his time at the emery wheel. A usual practice is to use a double-ended tool to save time.

The roughing-out should be taken to within as fine a limit as possible, to save the edge of the finishing tool, which should be kept keen with an oilstone. The type of tool shown in Fig. 2 is sufficient for general purposes, but for work which has

to be faced on the right and left, such as coil formers, a square-nosed tool as in Fig. 3 is more convenient. The angle between the edge of the tool and the surface of the job should be very small (about 1 deg. or 2 deg.), as shown in the plan in Fig. 2. Ebonite is turned dry, both for roughing and finishing, at a speed easily found by experiment.

## Knurling.

Knobs for condensers, switches, plugs, and many other things are always knurled. The application of this process to ebonite is different from that of brass, in which case the work is run at ordinary high speed, as for turning, and the knurling wheel applied directly to the surface, very often by hand. For ebonite, on the

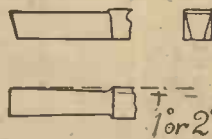

Fig. 3.—Square-nosed Turning Tool.

other hand, the lathe must be run very slowly (either on the back gear or by hand), and the knurler, which must be fixed in the slide-rest, applied slowly, from one end, and very slightly canted so as to work on the advancing edge alone. This is shown in Fig. 4. As in turning ebonite, no lubricant is used.

## Milling.

This is an operation which with ebonite should be avoided whenever possible, as the cutters (which are expensive) are found to require grinding or renewing so often. However, it cannot be avoided in some cases, and to save the cutters as far

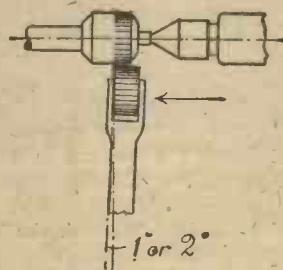

Fig. 4.—Method of Knurling.

as possible, they should be run as slowly as for cast-iron, the feed being light. Sometimes water is used as a lubricant, but it is doubtful whether it is effective.

## Drilling.

Twist drills are the only satisfactory type to use on ebonite. The best lubricant to use for drilling is tallow. This is especially necessary when drilling a long

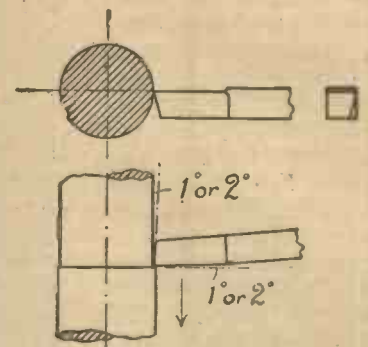

Fig. 2.—Finishing Tool in Use.

hole, as the drill is liable to seize up in the hole. The same speed may be employed as for drilling brass, and the drills should be ground as for wood.

## Tapping.

There is no special difficulty in tapping ebonite if good machine-relieved taps are used, with tallow as a lubricant. Care should be taken in starting, and the tap must be cleared very often, or else a stripped thread results.

## Bending.

Thin ebonite may be bent like india-rubber when heated, and when cooled will retain its new shape, but this property is not made much use of in practice, as it is rather difficult to obtain the correct temperature without destroying the nature of the material. Some readers may have noticed the ring-shaped formers used for valve filament resistances; these are sometimes made from bent ebonite rods by heating in boiling water, but a more usual practice is to use Erinoid. In any case, it is as well to know of this property, as it can occasionally be made use of to advantage.

M. S. S.

[Other processes will be given in a later article.—ED.]

## Do You Like Work?

NO? But have you seen "WORK," the weekly journal for all interested in Handicraft? It is full of practical information, and the Publishers, CASSELL & CO., Ltd., La Belle Sauvage, Ludgate Hill, London, E.C.4., will be glad to send you a specimen copy gratis & post free.



# ACCUMULATORS for WIRELESS

HIGHEST QUALITY. ABSOLUTELY NEW.  
Accumulators at Lowest Possible Prices.

4 v. 40 amp. ...	18/6	6 v. 40 amp. ...	26/3
4 v. 60 " ...	21/6	6 v. 60 " ...	31/9
4 v. 80 " ...	28/2	6 v. 80 " ...	37/3
4 v. 100 " ...	30/-	6 v. 100 " ...	41/6

## SPECIAL OFFERS

2 volt 16 amp. ACCUMULATORS in ebonite cases (5 plates), absolutely new:

1 only, 3/9 post free. 4 to 6, 3/- each, carriage forward.  
2 or 3, 3/6 each, post free. 7 & over, 2/9 each, carr. forward.

4 volt 24 amp. ACCUMULATORS in celluloid cases, absolutely new:

Only 11/9 each, postage 1/-

**F. YATES & SON,** 144, CHURCH ST., KENSINGTON, W.8  
(1 minute from Notting Hill Gate Station).

Phone: Park 4276 **QUALITY & ECONOMY** Write for lists enclosing stamp for postage.

## ALL PARTS FOR MAKING YOUR OWN SETS

A. E. G. & Telefunken Valves	10/6	Inductance Tubes, 12" x 3"	6d.
Egg Insulators, small	9d.	So. Brass Rod, 12" x 1/4" x 1/4"	9d.
Reel	4d.	Sliders with Plunger	1/-
Condensers Vernier, 3-plate	5/-	Enamelled Wire, per 1/2-lb.	1/8
Filament Rheostats, Flat	1/6	Crystals, Assorted	6d.
" " Panel mtg.	4/-	Studs and 2 Nuts, per doz.	1/6
Lead-in Insulators	2/6	Terminals with 2 Nuts	3d.
Switch-arms, Laminated	2/6	Transmitters with Cords	5/-
Ebonite Knobs, best	7d.	L.F. Transformers	27/-

PANELS, TUNERS, CONDENSERS, ETC. ETC.

Visit our Showroom and get fixed up at once.  
DEMONSTRATIONS DAILY.

THE **ESSEX WIRELESS CO.,** 499, GROVE GREEN RD., LEYTONSTONE, E. 11.  
Telephone—WANSTEAD 749. (1 min. from Station, G.E.R.)

## THE WIRELESS CRYSTAL OF TO-DAY AND THE FUTURE

# "HERTZITE"

SIMPLE TO USE. NO BATTERY REQUIRED  
Price 2/6 post free

UNSOLICITED TESTIMONIAL:  
The piece of "Hertzite" sent some time ago has given splendid results. This evening I card Mozambique (4,250 miles from Johannesburg) on it—S. C. PLEASS, Johannesburg.  
We can give you the best Wholesale Terms for all Crystals

## "ORA" VALVES, 15/- post free

### RUSSELL-SHAW

38, Great James Street, Bedford Row, W.C.1  
(From Holborn through Brownlow Street, or Hand Court)

## ALL READERS

are invited to send for our CATALOGUE of

MODERN WIRELESS INSTRUMENTS, ACCESSORIES and MATERIALS

RADIO, ELECTRICAL & MECHANICAL SUPPLIES.  
**SCIENTIFIC SUPPLY STORES**  
8, NEWINGTON CAUSEWAY, LONDON, SE1.

# HAMBLING CLAPP & CO

## WIRELESS SPECIALISTS

ALL WIRELESS ACCESSORIES IN STOCK

## Visit OUR Showrooms

No obligation to purchase, but a splendid opportunity to do so if you wish

Register your Name for a Copy of our NEW ILLUSTRATED CATALOGUE  
READY SHORTLY. POST FREE, 3d.

110, STRAND, LONDON, W.C.2

Visit our Show Rooms and have Leading High Quality Receiving Sets Demonstrated

MARCONI TINGEY'S BURNDIPT

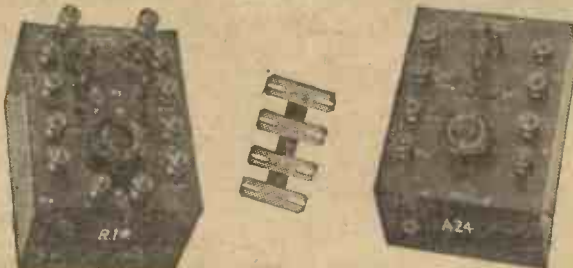

**WATES BROS.,** 13-14, Ct. Queen St., Kingsway, W.C.2  
Phone: Gerrard 576. Telegrams: ZYWATESENG, OX, LONDON

## SCIENTIFIC APPLIANCES

HENRY J. DALE. W. HOLLINS.

11 & 29, Sicilian Avenue, Southampton Row, London, W.C.1

Top of Kingsway. In Centre of London. Corner of Bloomsbury Square.

ELECTRICIANS. OPTICIANS. MECHANICIANS.

ACTUAL MANUFACTURERS at our Works, East Street, W.O., thus saving all intermediate profits.

The Store for all Electrical and Scientific Material

WIRELESS & RADIO MATERIALS, PARTS and FITTINGS

VALVES. 'PHONES.

Call and see us. View our Show Windows. Send for List post free 2d.

Splendid Value in Second-hand Appliances

Every Branch of Optical and Applied Science

Scientific Appliances, 11 & 29, Sicilian Avenue, London, W.C.1.

## Get Your TOOLS from Us

We specialise in Electricians' Requirements. Write or call. The Chancery Lane Tube Station gives all London access to us, and is only one minute away, just across the road to Chancery Lane and a few doors down brings you to

# POND TOOL CO

67, 69, 70, CHANCERY LANE, W.C.2.

SPECIAL LINES IN

Wire Gauges, 0 to 26, S.W.G., 2/9; Hand Vices, 4 in., solid steel, 2/-; Hand Drill, taking all drills, 0 to 1/2 in., 7/6; Combination Pliers, 6, 7 or 8 in., 2/-; Hack Saw, with 2 blades 1/6; Measuring Slide Rules, 3 in., 2/-; Blow-lamps from 2/6; all post free. We have a large stock of Drills, Files, Taps and Dies, Bolts and Nuts, Wood Screws, Solder Irons, etc. All goods sent on approval against cash, money returned if not satisfied.

Write for our List 6d., refundable on first order



# OUR INFORMATION BUREAU

Expert Replies to Readers' Questions Without Charge. All Readers in Difficulty should Avail Themselves of This Service

## Necessity for Aerial

Q.—Is it necessary to have an outside aerial with a simple type of apparatus or can an indoor aerial be used?—H. B. (19)

A.—Indoor aerials, when used by an experienced operator in conjunction with good apparatus, can be made to give quite good results, but for a beginner a regulation outside aerial is much to be preferred. Reception on a "frame" aerial is quite out of the question unless three-electrode valves are employed.—CAPACITY.

## Tubular Condenser for Receiver

Q.—I should be obliged for particulars of a tubular condenser, which I desire to use in place of a rotary vane type condenser in a receiving set.—F. D. (10)

A.—A tubular condenser is, in general, quite as effective as the rotary type, provided the maximum capacity required is not too large. Their great advantage lies in the comparative simplicity and ease of construction. There are two or three arrangements which give good results, but the following will, it is hoped, suit querist's requirements. Obtain a hard-wood roller of approximately the following dimensions: length 6 in., diameter  $1\frac{1}{4}$  in. Make the cylindrical surface quite smooth with glass-paper and cover this surface to within  $\frac{1}{2}$  in. of one end with tinfoil, which is to be attached to the wood by means of shellac varnish. Leave a small tab of foil projecting over the uncovered end of the roller, and through this pass a small wood screw with large washer so as not to tear or break the foil. To the head of this screw is to be soldered subsequently a flexible wire connection. Procure a sheet of mica, or, if this cannot be obtained, a piece of tracing cloth, or even a sheet of stout typewriting paper, and wrap round the roller over the foil. If mica is used, the original sheet must be split so as to obtain the thinnest possible mica for the condenser, otherwise it will break when wrapping round the roller. Again use shellac varnish to attach the mica or paper, and after giving the whole a good coat of varnish leave to set. The great advantage in using mica lies in its high dielectric value, thus giving to the completed condenser a greater maximum capacity. Next procure a metal tube into which the roller and foil will just fit. Probably such a tube will not be available, so make, or have made, a suitable tube from thin brass sheet or tinplate. The roller with foil forming the inner plate slides in and out of the metal tube, the latter forming the outer plate of the condenser, whilst the dielectric consists of the mica, tracing-cloth, or paper placed over the foil upon the roller. Mount on any convenient base and provide with two terminals, one connected to the metal tube and the other, by means of a length of flexible conductor, to the foil. A further suggestion which querist may try if he desires is to use a glass tube such as straight lamp-glass, with foil pasted upon outside and roller with foil, as described above, sliding inside. Or a metal tube may form the inside plate.—CAPACITY.

## Using Valve to Produce Oscillations at Audible Frequency

Q.—Please give me information with regard to the production of oscillatory currents at audible frequency by means of a valve or valves.—H. D. (23)

A.—From querist's letter it is not quite clear

whether the production of an audible note in the telephone receivers of a valve circuit is the only object which he has in view, but if so it may readily be accomplished as shown in the accompanying diagram, in which the anode circuit is shown to include an inductance shunted by a variable condenser, whilst the

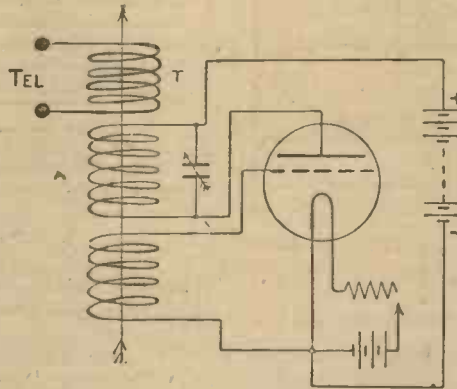

Using Valve to Produce Oscillations at Audible Frequency.

grid circuit contains a further inductance (the reactance coil, in fact) closely coupled to the anode coil. The telephone receivers are placed in an entirely separate circuit consisting merely of the coil T, which is inductively coupled to the anode coil A. No grid condenser or leak is necessary in this arrangement, and as a rule it will operate satisfactorily with an anode volt-

age of about 18 to 24 volts. The variable condenser should be of large maximum capacity if a fair control of the note is desired whilst all three inductances may conveniently consist of old induction-coil, secondary sections having a large number of turns of fine wire. If at first trial the resultant note is too high, even with the condenser full in, an improvement may no doubt be effected by placing the inductances together on an iron core consisting of a bundle of soft-iron wires.—CAPACITY.

Q.—Could you tell me if Glasgow is to have a broadcasting station?—J. A. R. (101)

A.—The Postmaster General stated that either Glasgow or Edinburgh (but not both) would be permitted to have a broadcasting station, and, therefore, for the present the matter is in abeyance.

Q.—I desire to communicate with a friend 75 miles away by wireless. Please say how this can be managed.—W.S. (117)

A.—The Post Office regulations forbid this, a licence for transmitting only being granted in cases where it is shown that it is required for work of an experimental nature. Moreover the applicant, to be successful, is required to prove by test that he has a very thorough knowledge of the subject generally, in order that there will be no risk of his causing interference.

Q.—Please give the address of the York wireless club.—RECRUIT (116)

A.—The address of the Hon. Sec. of the York Club is 16, Wentworth Road, York

## COMPETITIONS FOR ALL READERS

### THREE WIRELESS RECEIVING SETS AS PRIZES

WE offer as a prize in each of the following competitions a well-made wireless receiving set manufactured by one or other of our advertisers, the approximate value of each set to be at least seven guineas.

**Competition No. 1.**—A wireless set is offered for the best article of about 1,500 words, written from your own personal knowledge and experience, and calculated to help or interest your fellow amateurs. Illustrations will in most cases be regarded as a feature of merit. Articles should be written in simple language and be as bright and informative as possible, and the subject may be anything that you think wireless amateurs would care to read about. Should we publish any article that does not win the prize we shall pay for it.

**Competition No. 2.**—Another set is offered for a brief description (with illus-

tration if necessary) of the most novel and useful item in wireless apparatus—in its design, material, make, electrical connections, etc. etc. The novelty must be original—not copied from any source whatever.

**Competition No. 3.**—The third receiving set will be presented for an ideal broadcasting programme of twelve items. You can enter for this competition on a penny postcard. Simply write down in column form twelve items that you consider would make an ideal programme.

**Rules.**—The Editor's decision in any and every case is final. There is no appeal from it. The copyright of all competition efforts published by us will be ours. All entries to be in by Friday, July 7 and to be addressed to

THE EDITOR,  
"Amateur Wireless,"  
La Belle Sauvage,  
London, E.C.4.

There is a chance for EVERYBODY in the these three competitions. Set about your effort at once. The prizes are valuable and well worth trying for.



The Leading Firm



for Amateur Supplies

We have 10 years' Wireless Experience.

ALL-IN SERIES, No. 1.

SET OF PARTS 15/9 **Valve Panel** SET OF PARTS 15/9

Set includes :- Ebonite Panel, matt finished, 7" X 5", and drilled. "Velvet" Filament Rheostat, Grid Condenser and Leak, Blocking Condenser, Systoflex, V. Holder Terminals. Set of Ivorine Tablets and Blue Print. Polished Mahogany Cabinet to fit, 3/6.

THE **BROADCASTING TUNER**



Complete set of parts. Require only fitting together. All holes drilled. Wiring diagram supplied. Complete ... 18/6 Cabinet to fit ... 4/9

10 times more efficient than a coil and slider.

NOTE.—The Broadcasting Tuner and Single Valve Receiver, together with Valve, Phones and Batteries, make a complete station, which will get all the speech and telephony going.

The **PARAMOUNT**

Crystal Receiver, 35/-

Head Phones from 35/-

**SINGLE VALVE RECEIVER**

£2 17 6

Finished.

or

Sets of parts ready to assemble, 28/6

Cabinet, 3/6

VALVE EXTRA

We are the Pioneers of sets of parts to build your own sets.

A FEW SUNDRIES for the Constructor.

- The "Velvet" Filament Rheostat is well constructed and of great value to all who build their own apparatus ... 4/-
- Set of Ivorine Tablets, +HT-, +LT-, A.T.I., REAC, TEL, A, E, set of 7 ... 1/2
- Ivorine Scale, superior quality, 0"-180" (not cheap printed one) ... 1/6
- Solid Turned Ebonite Valve Holder with plain legs ... 1/6
- Grid Leak (sphinx) and Condenser, mounted ... 5/-
- "Velvet" Laminated Switch Arms with Lacquered bush and nuts ... 2/6
- Studs and 2 nuts ... per doz. 1/6
- Valve Legs and Nuts, lacquered ... per set 1/-
- Valve Holders with Flange, "A" Type ... 1/9
- Engraved Ebonite Dials and Knobs ... 4/6

All orders over £2 post free. Trade Enquiries invited.

**CONDENSER VALUE**



Complete Sets of Parts for VARIABLE CONDENSER ready to assemble.

No Drilling or Fitting required.

'0015	'001	'0005	'0003	'0002	'0001
27/-	21/-	14/-	11/-	8/-	7/-
Cabinets—					
4/9	4/6	4/3	4/-	3/9	2/9

The above are supplied with Ivorine Scale for panel mounting or engraved Ebonite top 4 1/2" X 4 1/2" for box mounting. We can substitute Ebonite Bevelled dial in place of scale for 3/6 extra.

PLEASE STATE WHICH YOU REQUIRE.

SEND 6d. for our ILLUSTRATED CATALOGUE "A" with List of Stations.

**PETO SCOTT**, The Condenser King, 7 Featherstone Buildings, HIGH HOLBORN, W.C.1 (Turn up by No. 63 High Holborn.)

Wireless is attracting all men. The Amateur is entering the field in great numbers, and he wants to know all about it. He will require Material, Parts, Tools. He will also want to sell surplus material.

**"Amateur Wireless"**

is out to cater for this class of reader, who will be eager for knowledge and bargains. To meet him, use the Sale and Exchange columns, which he is sure to search. Rate 3d. per word, 3s. minimum, prepaid. Latest date Saturday mornings.

ADDRESS:

THE ADVERTISEMENT MANAGER  
"AMATEUR WIRELESS,"  
LA BELLE SAUVAGE  
LUDGATE HILL LONDON E.C.4

## RADIOGRAMS

A matter that is now being given consideration in London is the erection of "aerials" over blocks of flats.

■ ■ ■ ■ ■

The question as to whether "wireless" is music was raised by the licensee of an hotel, who desired to know if it was necessary for him to have a music licence if he put in a wireless set in connection with the broadcasting scheme. The magistrate advised the applicant to wait until he had his set ready.

■ ■ ■ ■ ■

The Meteorological Office are to carry out tests which will have special reference to the collection of reports by wireless of the weather in the areas of the Azores and Bermudas.

■ ■ ■ ■ ■

Is it not about time that experiments with railway wireless were resumed? Although licences were given so long ago as 1920 the railway companies have not availed themselves of the privilege.

■ ■ ■ ■ ■

About 10,000 receiving licences have already been applied for.

■ ■ ■ ■ ■

Some interesting experiments have been made by the Paris police in connection with the application of wireless telephony to the work of maintaining order. Two large covered motor vehicles have been equipped with necessary wireless receiving and transmitting apparatus. During the experiment, carried out some ten miles from the city, one of these vehicles was brought to a standstill, and the reply to an experimental message was received from the Prefecture in Paris.

■ ■ ■ ■ ■

The Brown microphone relay is a modification of the type used by the Royal Air Force and the Admiralty. On the aerial side it has a resistance of 4,000 ohms, and has a transformer mounted on a separate base with condenser, suitable for telephones of 120 ohms resistance. Whereas the current consumed with tube amplifiers is considerable, the current required for the microphone relay is minute, being approximately only 25 milliamperes supplied from a 6-volt dry battery.

### PREPAID ADVERTISEMENTS.

**Wireless Telephony.**—Required immediately, wireless lecturer, with marked ability to give bright, informative lectures to prospective users and amateurs. Good remuneration will be paid. Give fullest particulars of experience when writing, enclosing copies of testimonials.—Box 18,929, Samson Clark & Co., Ltd., 52, Gt. Portland St., W.1.

### AGENTS WANTED

for supplies for cash, for AMATEUR WIRELESS OUTFITS; first class position, large city in Scotland.

Box No. 1, c/o "Amateur Wireless," La Belle, Sauvage, Ludgate Hill, London, E.C.4

It is interesting to note that many devices are being introduced for service as loud-speakers. One is a simple horn provided with two arms that terminate in soft rubber caps. The ordinary pair of telephone receivers clamps right over the two arms, so that the sound must then pass up through and be amplified by the horn. Another device takes a single receiver, which is placed in the base. Receivers are being made provided with special coupling members so that they may be fastened to the usual phonograph tone arm, for amplifying the sound.

©~~~~~©

## CLUB DOINGS

### North Middlesex Wireless Club

(Affiliated with the Wireless Society of London).  
Hon. Sec.—E. M. SAVAGE, "Nithsdale," Eversley Park Road, Winchmore Hill, N.21.

THE 92nd meeting of the club was held at Shaftesbury Hall, Bowes Park, N., at 8 p.m., when the chair was taken by the President, Mr. A. G. Arthur. After the minutes had been read by the Secretary, the chairman called on Mr. D. Macadie to give his lecture on "Direct Current Measuring Instruments, Their Design, Construction and Use."

Mr. Macadie had brought to the hall a large number of measuring instruments, both ancient and modern. These were displayed on the lecture table. He started with the ordinary

Will Amateur Wireless Clubs  
please keep us informed of  
their activities.

linesman's galvanometer, and explained the various types that were in use. The lecturer said that it was now considered preferable to use instruments that read direct in volts or amperes on an instrument that gave a purely arbitrary reading, and showed examples of these instruments of the moving-coil, hot-wire, and the electrostatic types, and by means of large clear diagrams attached to the blackboard he explained the characteristics of each.

He then passed on to the measuring of resistance, and explained in detail the principles of the well-known Wheatstone bridge and the method of using it. His description of the method by which plugs were removed in certain ways, which had the effect of inserting various resistance coils of known value, and enabling readings to be taken over a large range, was followed by members with great interest. Mr. Macadie then explained the action of the megger testing generator, and on the suggestion of Mr. Holton, the club's aerial was tested as a demonstration, and it was satisfactory to learn that the resistance was all that could be desired.

A very interesting instrument was the "Avometer," which was one of Mr. Macadie's own design. By an ingenious arrangement it was made to read amperes, volts, and ohms, as required.

### Glasgow and District Radio Club

(Affiliated with The Wireless Society of London).  
Hon. Sec.—ROBERT CARLISLE, 40, Walton Street, Shawlands, Glasgow.

At a recent meeting held in temporary premises at 11, Elmbank Street, a very fine lecture was given by Mr. A. F. Stevenson, on "Cable Engineering." It was fully explained how the various types and grades of cable were manu-

factured and tested, and the lecturer exhibited numerous examples. Mr. Stevenson held the close attention of his audience throughout, and afterwards answered a number of questions.

At the last two meetings a lecture on "Capacity and Inductance" was given by Mr. M. McLennan. With the aid of blackboard diagrams and some figures in simple arithmetic Mr. McLennan made the subject clear to those members of the audience who had only a very elementary knowledge of electricity. Some clever analogies were introduced, but the outstanding feature was the particulars given of how to make sets capable of receiving waves from 200 to 25,000 metres. The details given included dimensions of formers, gauge of wire, capacities of condensers, etc

### Leeds and District Amateur Wireless Club

(Affiliated with the Wireless Society of London).

Hon. Sec.—MR. D. E. PETTIGREW, 37, Mexborough Avenue, Chapeltown Road, Leeds.

A GENERAL MEETING was held at the Leeds University on May 26th, Mr. G. P. Kendall, B.Sc. (Vice-President), taking the chair at 8 p.m. The Chairman called upon Mr. T. Brown Thomson to deliver a lecture entitled "Types of Valves."

Mr. Thomson commenced his paper with an exposition of the electron theory of matter, showing its particular applications to the study of vacuum tubes as used in wireless work. He emphasised the necessity for the amateur to attain a thorough knowledge as to what his valves require, if maximum efficiency is to be derived from the apparatus. He explained the two main properties of valves, namely their uni-directional and non-uniform conductivities. Two electrode valves or diodes were then considered, the characteristic curve and other features being examined carefully. The lecturer then explained the principle of the three-electrode valve or triode, showing very clearly the function of the third or control electrode. Characteristic curves of various valves, including such tubes as the French "S," the British "R," "Q," A.E.G. types, and the De Forest Audion, were exhibited, explained and compared in detail.

## FORTHCOMING EVENTS

**Wireless Society of Highgate.** At the Highgate Literary and Scientific Institution, June 16, 7.45 p.m. Lecture (Part II) by Mr. Stanley: "Elementary Theory of Wireless Telegraphy and Telephony."

**West London Wireless and Experimental Association.** Demonstration by Mr. F. O. Read of the "Ultra IV" Receiver.

**Wireless Society of Highgate.** At the Highgate Literary and Scientific Institution, June 23, 7.45 p.m. Lecture and demonstration by Mr. F. L. Hogg: "The Construction of a Valve Receiving Set."

**Leeds and District Amateur Wireless Society.** June 23, 8 p.m. Discussion on Direction Finding.

## ANNOUNCEMENTS

"Amateur Wireless and Electric." Edited by Bernard E. Jones. Price Threepence. Published on Thursdays and bearing the date of Saturday immediately following. It will be sent post free to any part of the world—3 months, 4s. 6d.; 6 months, 8s. 9d.; 12 months, 17s. 6d. Postal Orders, Post Office Orders, or Cheques should be made payable to the Proprietors, Cassell & Co. Ltd.

General Correspondence is to be brief and written on one side of the paper only. All sketches and drawings to be on separate sheets.

Contributions are always welcome, will be promptly considered, and if used will be paid for.

Communications should be addressed, according to their nature, to The Editor, The Advertisement Manager or The Publisher, "Amateur Wireless," La Belle Sauvage, London, E.C.4.



# Teach Yourself Wireless Telegraphy

Mr. E. J. BARNARD, Welling, Kent, writes :

"I think I ought to tell you how much I value 'The Amateur Mechanic.' It has proved of great assistance in a variety of jobs, and especially as to the article on WIRELESS TELEGRAPHY. I constructed an instrument entirely according to the instructions, and was rewarded with success on the first trial. Sunday last was, for me, a

red-letter day, as I succeeded, with the same instrument, in picking up the telephonic message from London to Geneva at 9.40 a.m. Considering that my aerial is only 42 inches long and 18 inches high, I think these are grounds for self-congratulation. I may add that until I became interested in the article in your 'Amateur Mechanic' I had not the slightest elementary knowledge of Wireless Telegraphy."

In  
Simple,  
Non-  
Technical  
Language

# The Amateur Mechanic

With How-  
to-do-it  
Pictures  
and  
Diagrams

## Presents Over 400 Practical Lessons

including

**How to Build Your Own Sheds, Outhouses, Poultry-houses, etc.—How to Cure Damp Walls, Leaky Roofs, and Smoky Chimneys—How to Make Garden Frames, Garden Furniture, and Garden Paths—How to Mend Windows and to Make, Mend and Strengthen Locks and Bolts.**

To clean, Overhaul, and Repair Motors and Motor-Cycles—To Install Wireless Telegraphy, Electric Light, etc.—To work in every kind of Metal—To Etch on Brass—To Write on Glass—To make Hektographs—To Build a Boat, a Canoe, a Canvas Canoe, etc.—To paint and paper a room—To sole and heel and patch boots and shoes—To make a pair of hand-sewn boots—To restore colour to old brown shoes—To make household furniture—To re-seat chairs—To upholster sofas, etc.—To install a speaking tube—To clean a stove—To repair bicycles—To work in metal—To colour metals—To repair water taps—To varnish a violin—To remedy damp walls—To repair the piano—To make a padded chair from an old cask—To stuff furs—To stuff and mount birds—

Wood inlaying—To prepare working drawings—To renovate a grandfather clock—To make garden arbours, arches, seats, summer-houses, etc.—To use metal drilling tools—To renovate mirrors—To mend china—To do fretwork—To limewhite poultry houses—To do gold-plating and silver-plating—To clean a watch—To mend keyless watch and ordinary watches—To distemper ceilings and walls—To make picture-frames and frame pictures—Curtain fitting—Metal castings—To clean paint off glass—To clean boilers—To fix anthracite stove—To re-gild and restore picture frames—How to use spanners—To make doors and windows draught-proof—To paint walls—To do nickel-plating—To cure noises in hot-water pipes—India and glue varnishes—To make plaster casts, etc. etc.

## This is Sound, Money-Saving Knowledge

Mr. JAMES W. HALL, of Woodbridge Road, Ipswich, writes :

"Since purchasing your Book I have fitted new sash cords to three windows in my house, repaired two grandfather clocks, fitted a new spring to a cheap German clock, repaired a wrist watch, fitted rubber soles to my everyday boots, distempered and papered an office, fitted up a bench in my workshop, and am

now building a summer-house in my garden from odd pieces of wood and old orange boxes, also sundry other repairs too numerous to mention—all from instructions in your work; and I am 64 years of age. You can make what use you like of this letter, as I think you ought to know how I appreciate it. If ever in doubt, consult THE BOOK."

Post this FREE Form at Once 

**FREE** 

A BOOKLET to tell you all about  
"THE AMATEUR MECHANIC"

It shows pages of Pictures from  
the Actual Work

Over 105,000 Sets have been sold to date.

To THE WAVERLEY BOOK CO., LTD.,  
(A.W.G. Dept), 96, Farringdon St., London, E.C.4.

Please send me free of charge or obligation to order, your Free descriptive Booklet, explaining contents, etc., of "THE AMATEUR MECHANIC," with specimen pages and pictures, and particulars as to your terms for small monthly payments, beginning thirty days after delivery.

NAME.....  
(Send this form on a postcard.)

ADDRESS.....

A.W.G. 1922.....

# WHY PAY POUNDS FOR A SET OF LATTICE WOUND INDUCTANCES?

You can easily make as many as you wish for the price of the wire only by possessing a

# LOKAP LATTICE COIL WINDER

### DIRECTIONS FOR GENERAL USE OF THE "LOKAP" WINDER.

Screw the machine down firmly to the table or bench, making sure that the set screws holding gears and cams are tight. Have the bobbin with the wire upon it behind you, mounted in any convenient way, so that when winding is commenced it has a fairly free feed. Pass the end of the wire through the small hole in the BRASS FEEDING DEVICE on to the pin on the drum. Hold the wire as shown by the illustration, keeping the forefinger on to the end of the CAM SHAFT, so as to assist the spring, tension being unconsciously applied by the wire passing through the fingers. Start the winding two or three times, if it is your first attempt to use the machine, to grasp its working principles. A slip on the first layer is not at all detrimental but helpful, as will be seen later. Continue winding until you think the coil is large enough, maintaining the tension on the wire, drop a little hot sealing-wax or Chatterton's Compound on to the finishing end, and wait a few seconds until you are sure this end is being held securely, then cut off. TO REMOVE FINISHED COIL FROM THE DRUM, pass a piece of thin strip or twine through the slots on drum and tie off, do not use undue pressure or you will spoil your handiwork, then carefully slide off the drum. THE COMPLETED COIL can be used as it is, or preferably, soak well in hot paraffin wax or shellac varnish it. When dry it is ready for use. If coil has been wound too tightly, and difficulty is experienced in removing from drum, carefully pull the end of the commencing winding, thus taking out one or two turns, and it will easily come away.

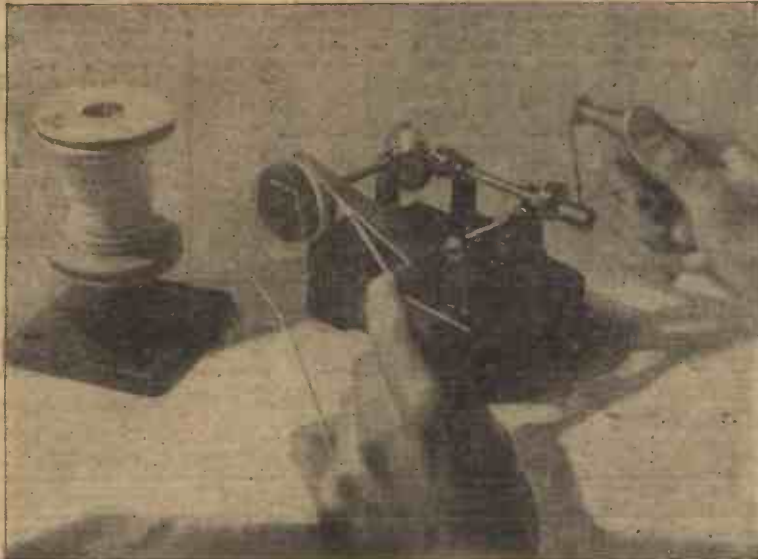

### INSTRUMENT WIRES.

All wire wound on bobbins free. Postage extra.					
S.W.C.	S.C.C.	D.C.C.	Sgle.Silk.	Dbl.Silk.	Emd.
12	1/10	1/11	4/-	5/4	1/6
14	1/11	2/-	4/-	5/4	1/9
16	2/-	2/1	4/2	5/6	1/10
18	2/1	2/2	4/4	5/6	1/11
20	2/2	2/3	4/8	6/2	2/6
22	2/6	2/11	5/-	6/8	2/8
24	3/-	3/6	5/6	7/4	2/8
26	3/7	4/1	6/8	8/2	3/2
28	4/4	4/7	7/2	9/-	3/6
30	5/-	5/6	8/-	10/-	3/10
32	6/-	7/3	9/2	13/-	4/2
34	7/-	8/3	11/6	14/-	4/4
36	8/8	10/2	14/-	15/6	4/8
38	11/3	13/2	16/-	19/-	5/3
40	15/-	18/-	18/6	22/6	16/6
42	17/3	21/-	31/6	34/-	9/-

Price, 25s. (Including set of Three Cams). Post Free U.K. Foreign 5s. extra. Being sturdily built, with ordinary care it will not wear out.

All orders of 1 lb. or over wound on reels free. For less than 1 lb.-reel 8d. extra.

# THE ÆTHERCEPTA (No. W99)

THE WIRELESS TELEPHONE RECEIVING STATION EVERYBODY IS RECOMMENDING

(Originally marketed 1912; sales over 3,000)

PRICE  
**£9 10 0**

READY  
FOR  
ERECT-  
ING

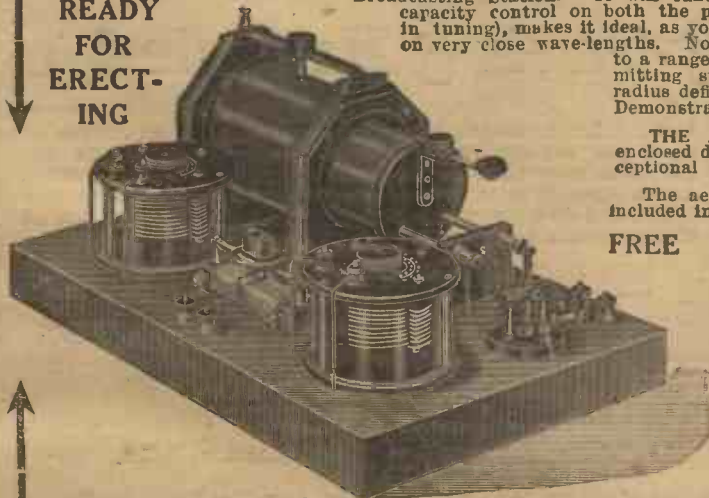

THE illustration does not do justice to the beautiful finish of this set, which is, without doubt, the finest instrument that can be recommended for the reception of "Broadcasting" when you reside within a 40-mile radius from a "Broadcasting Station." It will tune from 250 to 2,000 metres, with wonderful efficiency, and having variable capacity control on both the primary and secondary circuits (which perhaps involves a little more skill in tuning), makes it ideal, as you can select stations when perhaps two or more stations are operating on very close wave-lengths. Not only will you hear the above, but many more stations of interest up to a range of 1,000 miles, this range, of course, depending upon the power the transmitting stations use. On actual tests carried out in London the Broadcasting radius defined above is established, and we invite you to hear such tests at our Demonstrational Room.

THE ÆTHERCEPTA is priced at only £9 10 0, complete with improved type enclosed detector (no potential needed), and nothing extra is needed, except in exceptional cases where short masts are desired.

The aerial we recommend is 100 ft. long, about 35 ft. high, and the material is included in the price.

**FREE ADVICE** for your Individual Case, and Personal Instructions upon operation willingly given by post if you cannot call.

If you are interested in wireless matters the MITCHELL CATALOGUE, 48 pages, profusely illustrated, should be in your possession, and is sent on receipt of 6 penny stamps.

Pioneers of the No. 1 Home Wireless Set at £5 complete. The "Overseas" Wireless Set, The "Radiocert" Wireless Set, and hundreds of standardised instruments in use throughout Great Britain and Ireland.

# MITCHELL'S ELECTRICAL & WIRELESS, LIMITED,

Postal Address: McDermott Road, Peckham, S.E.15.

Main Retail Stores: 189, Rye Lane, Peckham, S.E.15,  
Demonstrational Room: 182, Rye Lane, S.E.15.

Telephones: Retail—New Cross 1540;  
Wholesale and Shipping—New Cross 1541.

**GREAT BRITAIN'S GREATEST WIRELESS STORE.**



A NEW CRYSTAL DETECTOR :: WE PRESENT THREE WIRELESS SETS

WELL  
ILLUSTRATED

# Amateur Wireless And Electrics

No. 3

SATURDAY, JUNE 24, 1922

Price 3d

## CHIEF CONTENTS OF THIS NUMBER

	PAGES
SOMETHING NEW IN CRYSTAL DETECTORS . . .	50-52
UNEXPECTED CAUSES OF WEAK RECEPTION . . . . .	43
STARTING WIRELESS: Aerial and Earth, Receiving Signals, Detectors	44
WIRELESS IN THE TROPICS . . . . .	45
MOUNTING SLAB INDUCTANCES . . . . .	46
ELECTRONS AND WIRELESS . . . . .	47
WIRELESS BETWEEN INDIAN SAHIBS . . . . .	47
NEW WIRELESS BILL . . . . .	48
ELECTRICAL BENCHWORK: Ebonite Grinding, etc. . . . .	49
"AT THE CALL OF G N F" . . . . .	52
DETECTOR MADE FOR ONE SHILLING . . . . .	52
THE PRIMARY BATTERY AND CURRENT FLOW . . . . .	53
WHAT WIRELESS TERMS MEAN . . . . .	53
MAKING TELEPHONE RECEIVERS SUPER-SENSITIVE . . . . .	54
A BRIEF HISTORICAL NOTE . . . . .	54

*Information Bureau, Radiograms, Club Doings, etc.*

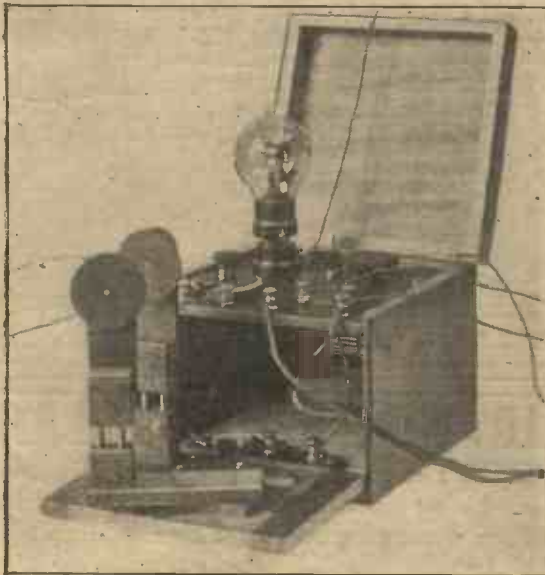

*An Amateur's Single-valve Set; note the variable condenser underneath the panel and the slab-coil holders in front; the coils are not shown. In this issue, amateur methods of mounting slab coils are explained.*

# ECONOMIC ELECTRIC LTD.

If You Require  
**Wireless  
Apparatus**

Send 4d.  
To-day for the  
"E.E.C." List



**NOTE**  
32 PAGES AND  
OVER 200  
ILLUSTRATIONS  
INCLUDING  
**CRYSTAL  
& VALVE  
RECEIVING  
CIRCUITS**



## WARNING!

The wireless boom has been the signal for a number of inexperienced, and in some instances, unscrupulous persons to jump into the business.

## DEAL WITH A FIRM WHO KNOWS

"E.E.C." have 25 years Electrical including 15 years Wireless Experience.

Head Office: 10, FITZROY SQUARE, LONDON, W1.

Telephone: MUSEUM 1055.

New Showrooms: 303, EUSTON ROAD, N.W.1.

Branch Showrooms: TWICKENHAM.

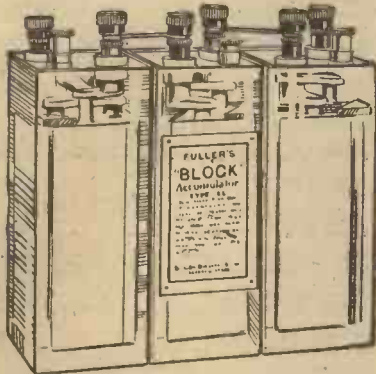

## INSIST ON HAVING A FULLER "BLOCK" TYPE ACCUMULATOR

FOR YOUR WIRELESS SET!

The only Accumulator on the market that will hold its charge from 12 to 18 months when not in use.

4-volt 40 amp. hours, £1 12 6, plus 1/3 carriage  
6-volt 40 " " £2 8 9, " 1/6 "

Note:—These prices are 33 1/3% below those of the actual makers.

8,000 Sold. 20,000 still in stock.

Descriptive and Instructive Pamphlet on request from—  
**The CITY ACCUMULATOR Co. (Dept. 14),**  
79 Mark Lane, E.C.3 (Tel. No. Avenue 91)

ALSO SUPPLIED BY—  
Selfridge & Co., Ltd., Wireless Section; A. W. Gamage, Ltd., Wireless Dept.; Barnsley British Co-operative Society, Radio Section; Richard and Co., 153, Fleet Street, E.C.3.  
**AGENTS WANTED IN ALL PARTS.**

## PETO'S POPULAR PARTS



### The "SPHINX" COIL HOLDER

as shown on illustration  
**2/9 each**

WE CAN ALSO SUPPLY WITH BAND MOUNTING as illustrated in article on page 29, June 17th issue

## CONDENSER VALUE

Complete Sets of Parts for VARIABLE CONDENSER ready to assemble.

No Drilling or Fitting required.

'0015 27/-	'001 21/-	'0005 14/-	'0003 11/-	'0002 8/-	'0001 7/-
Cabinets— 4/9	4/6	4/3	4/-	3/9	2/9

The above are supplied with Ivorine Scale for panel mounting or engraved Ebonite top 4 1/2 in. X 4 1/2 in. for box mounting.  
We can substitute Ebonite Bevelled dial in place of scale for 3/6 ext a.

PLEASE STATE WHICH YOU REQUIRE.

ILLUSTRATED CATALOGUE No. A/W., 6d.  
24 PAGES. LIST OF TRANSMITTING STATIONS.  
Details of all Accessories the Amateur Needs.

**PETO SCOTT (The Condenser King),**  
7, Featherstone Buildings, High Holborn, London, W.C.1.  
(Turn up by No. 63.) Also at 17, Frome Road, Wood Green.

## Visit our Show Rooms and have Leading High Quality Receiving Sets Demonstrated

MARCONI TINGEY'S BURNDEPT

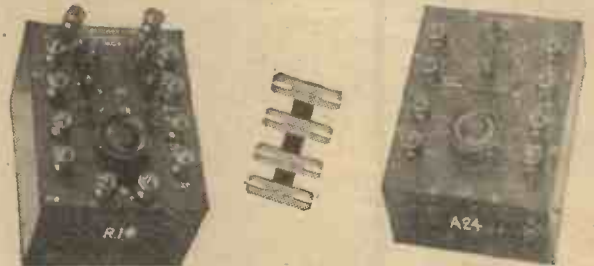

WATES BROS., 13-14, Ct. Queen St., Kingsway, W.C.2  
Phone: Gerrard 576. Telegrams: ZYWATESENG, OX., LONDON

## COLLOY WIRELESS INSTALLATIONS

FREE Demonstration in your home if in London area. Let our expert call and advise you. We install free and give working instruction. Provinces, stamp for list.

All component parts stocked at lowest prices

4, CLONMELL ROAD, S. TOTTENHAM



## "THE WHISPER - PHONE"

WONDERFUL NEW SENSITIVE MICROPHONE

Detects whispered conversation from a distance. Strongly magnifies Wireless Signals and Telephony. More sensitive than a Crystal Detector. For constructing Detectaphone, Deaf-phone, Loudspeaking Telephone. Magnifies the ticking of a watch. PRICE 6/9 ONLY, post free. All illustrated leaflets sent with Instrument. Send stamped envelope for leaflets only.—CHARLES ADOLPH, TAYLFORTH and CO., Works, 12, Leverington St., Clerkenwell, E.C.1.

Actual diam. 2 1/2 in. Fine black enamelled. 3 ft. Best braided cord attached.



# Amateur Wireless

## and Electrics

No 3

June 24, 1922

### Unexpected Causes of Weak Reception

WHEN dealing with such high-frequency currents and potentials as are used in wireless work, we shall often be led astray unless our notions of inductance and capacity are enlarged to take in quantities which in power circuits would be completely negligible. We are apt to get into the habit of regarding inductance as being existent only in specially-wound coils, and of capacity as residing only in variable condensers, and to forget that, "like the poor," they are always with us. For wherever we have a conductor carrying current there is inductance, and if that conductor is insulated from surrounding objects there is capacity also. They are our very good servants if properly arranged, but if we overlook them at any point we may often be left guessing as to why signals are poor and faint.

#### A Classic Experiment.

Both inductance and capacity tend to impede the passage of oscillating or alternating currents, the extent to which they do so being governed by the frequency. This point is well illustrated by the classic experiment with a Leyden jar. If such a jar is charged by means of a Wimshurst machine, for instance, and then discharged by a piece of wire bent into the shape shown in Fig. 1, it will be noticed that a

air-gap G, which it virtually short-circuits, and its inductance would be regarded as negligible; but with the high-frequency current, which constitutes the discharge of

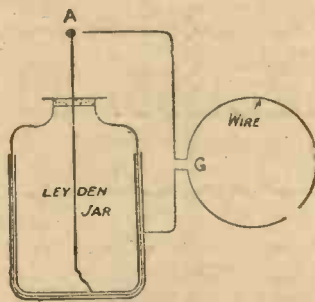

Fig. 1.—Experiment with High-frequency Current.

the condenser, the matter is entirely reversed, the air-gap then offering the path of least resistance.

We are made aware of one of the peculiarities of our high-frequency currents in the above experiment by the outward and visible sign of the spark, but similar effects may vitiate the efficiency of our receiving sets without giving us such warning if we are not aware of the possibilities.

Generally speaking, overlooked capacities are most likely to prove troublesome,

#### A Trouble and Its Elimination.

Supposing we have connected up such a set, consisting only of aerial, tuning inductance, telephones and silicon crystal rectifier as shown in Fig. 2. It will be noticed that the 'phones and the part of the detector in which the crystal is mounted (this usually being bulkier than the part which carries the point) are connected to the aerial end of the inductance. Now, when we place the 'phones on the head we considerably increase their capacity to earth—that is, the windings of the magnets form one plate of a condenser while the head of the operator forms the other, and this second plate is naturally, to a greater or lesser extent, earthed. In addition, the more bulky part of the detector may have a by no means negligible capacity to earth. These two incidental capacities are represented in Fig. 3 by Ct and Cs. In effect, by arranging the apparatus in this way the detector has been "shunted" by a condenser Ct + Cs in the manner shown in Fig. 4, and much of the incoming high-frequency current will take this by-pass path in preference to doing useful work in the detector.

By altering our connections to those shown in Fig. 5 the trouble is eliminated, as Ct + Cs now shunts the 'phones (where it will actually be of assistance), and the

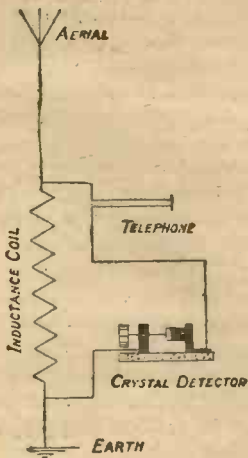

Fig. 2

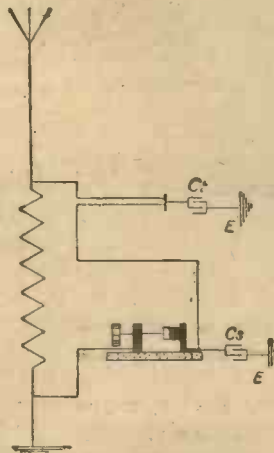

Fig. 3

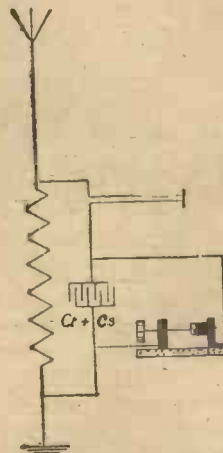

Fig. 4

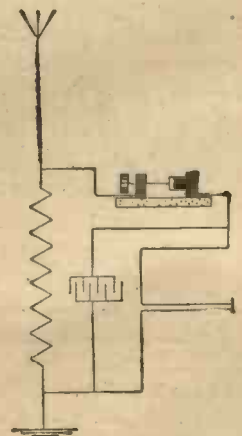

Fig. 5

Figs. 2 to 5.—Arrangements of Apparatus showing the Different Effects of Capacity and Impedance.

spark appears at G as well as at A. To a low-frequency current the circular loop would offer much less impedance than the

and as an example we can profitably study the effect of this on a simple crystal receiving set.

whole of the high-frequency current must pass through the detector.

Another case of a stray capacity being

usefully employed is that of the flexible leads commonly used with telephone receivers. Here we have two insulated conductors twisted tightly together and having, from the high-frequency point of view, a considerable capacity between them. The effect is obviously the same as if a condenser had been connected across the receivers in shunt, and, in fact, it usually renders any additional "blocking" condensers unnecessary.

Frequently that part of the receiving circuit which contains the 'phones has to deal with both high, or radio-frequency, and low, or speech-frequency, currents. To currents of radio-frequency the inductance of the windings of the 'phones offers a large impedance, and they mostly avoid this part of the circuit and take the alternative path offered by the condenser just mentioned, whereas to currents of speech-

frequency the 'phones offer by far the lesser impedance. Consequently the cur-

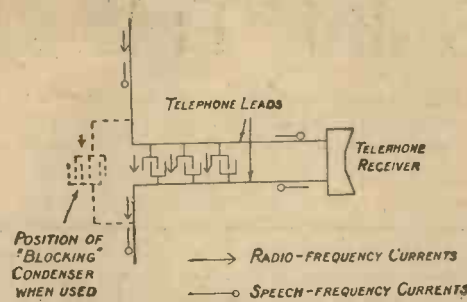

Fig. 6.—Diagram showing Distribution of Currents.

rent distributes itself in the manner shown in Fig. 6, the radio-frequency and speech-frequency current being clearly indicated. SIGMA.

as would be the case with a sliding contact. With very short waves even this grading would not be fine enough, and it is therefore necessary to use a variable condenser. On the other hand, when tuning to very long wave-lengths it is equally essential to employ a variable condenser.

**How the Energy is Utilised.**

Suppose that we have tuned our receiver to a particular station, and that we now wish to receive the message. Every time a wave falls upon the aerial it causes an electrical oscillation to be set up across the inductance. This means that across the inductance (and therefore the capacity, whether it is the aerial alone or with an additional variable condenser) a very small electrical potential (that is, a pressure) will be set up. But since this is produced by an oscillation it will be an alternating potential, and, of course, at a very high frequency. All that it is necessary to do, therefore, is to make use of an alternating potential at a very high frequency.

If a telephone receiver was to be connected across an electrical pressure, such as a battery, there would be a little click in the receiver. An alternating current is one which is continually changing its direction, and therefore if we were to connect the telephone across an alternating-current supply we should get a series of clicks which, if they were rapid enough, would produce a musical note. Now we have an alternating potential across the receiving inductance; but even if we were to connect a telephone to this we should still be no nearer solving the problem, for it must be remembered that the potential is varying at a speed of thousands of times a second, so fast that the telephone diaphragm could not possibly move at the speed. If some device could be inserted in the telephone circuit that would only allow the current to pass one way each time a signal was sent there would be a click in the telephone, since there would practically then be a direct current.

Signals from what is known as a spark station consist of a number of little trains of waves with a comparatively long interval between each, say a thousandth of a second. Therefore each signal will produce a number of rapid clicks which will be heard as a musical note.

**Detectors.**

The apparatus connected in series with the telephones is the detecting device. The crystal detector can be used for the reception from spark stations and of telephony. The other apparatus now generally employed for detecting wireless signals is the thermionic valve, which has the advantage of being able to magnify the strength of the signals and also receive continuous wave signals.

PAUL D. TYERS.

**STARTING WIRELESS.—III**

AERIAL AND EARTH; RECEIVING THE SIGNALS; DETECTORS.

THE object of the aerials is, of course, to pick up the signals and convey the electrical energy to the receiver. Perhaps we may best understand the action of the aerial as follows: The aerial consists of one or more insulated wires raised above the surface of the earth; this, it should be remembered, is also an electrical conductor. Hence the aerial wire and the earth form a condenser, since they consist merely

to the earth. It is obvious, then, that what we really have is an inductance connected across a condenser.

We have now explained the essential requirements for receiving messages, but we have not yet considered how we can utilise the electrical energy now at our disposal. However, before dealing with this point it is necessary to revert to the variable condenser previously mentioned.



Two Detector Components—the Crystal and the Valve.

of two conductors separated from each other. The aerial at the transmitting station has various electrical currents and pressures produced in it which cause the ether to become strained. This sets up waves in the ether which, falling upon the receiving aerial, cause various other electrical pressures to be produced. In practice it is usual to connect the "lead-in" from the aerial to one end of the tuning inductance, the other end being connected

Since it is possible to tune to any wave-length by varying proportions of capacity and inductance, the inductance could be fixed and the capacity be variable, or the capacity fixed and the inductance variable. Now the aerial is a fixed capacity, and therefore it is possible to tune in a station by merely varying the inductance. However, the tuning must be critical, and, therefore, if only the inductance is variable it must be very finely graded, such

"Upright Electrons."—These are not a startling discovery by the Editor of "Amateur Wireless," but simply a rather absurd mistake made by the printer. The inscription to the photograph on p. 23 of our last number should be "Thermionic Valve with Upright Electrodes."



# WIRELESS IN THE TROPICS

**L**EAVING England, our first port of call was at St. Vincent, in the Cape Verde Islands, a small and uninteresting group of volcanic islands, situated some hundred miles west of Bathurst, West Africa. The only point of interest was the unusual type of wireless station which was to be seen erected practically on the seashore; this, on investigation, proved to be a British Army wagon set equipped with an 80-ft. umbrella aerial. There are few places I have visited that appeal less to me than St. Vincent, and I was not sorry when our two days' stay there came to an end.

The next town of interest, from a wireless point of view, which we called at was Cape Town. This has for its wireless work the station at Slang Kop. This station, opened in May, 1911, filled a much-needed want, as it is one of the three existing stations now open for ship and shore communication, the other two being those at Port Elizabeth and Durban, Natal. The station at Durban was removed from its original site in September, 1913, to the position it now occupies, some four miles inland near Isipingo.

Leaving Durban, we straightway headed up the Mozambique Channel, and after a further voyage of a week passed Zanzibar. The island possesses a small station open for ship and shore work, and there is also another station on the Island of Pemba.

Mombasa was next investigated after disembarking at the Port of Kilindini, and the wireless station there proved very instructive. When it is remembered that this station is only about  $4\frac{1}{2}$  deg. south of the equator, the reader will surely not envy the operators on duty! One set consists of a 5-kilowatt transmitter of the synchronised-spark type, having a spark-frequency of about 600 sparks per second; the note emitted is musical and high-pitched, which makes reception through the atmospheric disturbances which in this country are always prevalent easier. The station is also fitted with a  $1\frac{1}{2}$ -kilowatt plant for shipping work; this has a range of some 350 miles. The surroundings are tropical to a degree, and from the entrance to the Harbour of Kilindini present a very striking aspect. Close by is the railway station, which is the starting-point of the Uganda Railway, which terminates at Kisumi, on Lake Victoria Nyanza, some 500 miles from the coast, the capital, Nairobi, being about half-way up. The country around this district is probably one of the finest there is for big game shooting, and practically every type of African animal, reptile and bird is to be found there. One of our chief enemies

was the white ant. The favourite pastime of this creature is to eat up everything it can get at, especially leather.

We had with us small portable wireless



Raising Derrick of Mast at Dar-es-salaam.

sets, both transmitting and receiving, with which much heavy work was carried out. When it is remembered we made a journey mostly on foot from Kilima Njaro, the highest mountain in Africa, to a spot some hundred miles south of Dar-es-salaam, with a  $\frac{1}{2}$ -kilowatt spark set, through plain, bush, forest, over mountains, through

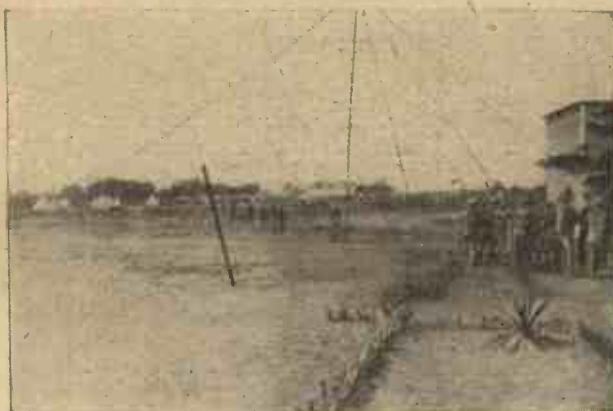

Raising a 120-ft. Steel Mast at Dar-es-salaam.

swamps, twice being almost surrounded by bush fires, and in one case even having to abandon our set and provisions, the reader will agree no doubt that wireless, under some conditions, can be as exciting as it is interesting.

Results were astonishing when it is

recalled that at this particular time our set had only an input of  $\frac{1}{2}$  kilowatt; in one instance we were easily able to hold good communication over a distance of eighty-four miles for several days, whilst on shifting our station to a position among the mountains we were actually unable to communicate twelve miles with the same set and power.

Of atmospheric conditions I shudder to think; the sets were provided with static leaks between the aerial and earth connections, but these seemed to have little effect. On many nights, particularly in the dry season, communication was quite impossible. The best illustration I can give the reader is to ask him to imagine himself in a greenhouse and a bucketful of tinctacks being poured on to the glass roof from a considerable height; he may then have some faint idea of the noise amidst which we had to endeavour to read our messages.

At Dar-es-salaam before the war there was a large wireless station capable of direct reception from Nauen, Germany. This had a transmitting range of some 3,000 miles, which enabled traffic to be sent to a station at Kamina, in Togoland, West Africa, which relaid it direct to Germany. On August 9, 1914, only five days after the declaration of war, the British forces completely destroyed the German station at Dar-es-salaam and thereby cut the colony off from the Fatherland. When the writer visited this station it wore an aspect of desolation and complete destruction, the high aerial mast being broken off near the base. What remained of the station was used later by our troops as a store for the British Wireless Section when in possession of the town itself.

Leaving Dar-es-salaam, our next destination was the Persian Gulf via Bombay; we then soon picked up the call well known to operators in that part of the world, namely, VWB, and a few days later we were living as respectable citizens of Bombay. Our stay there terminated abruptly, and we were soon away for more work. Shortly afterwards we landed at Bussara, or, as it is better known to many, Basrah. Here one at once noticed the great masts of the 30-kilowatt Marconi station that stands close to the river. This station is used with

low power for ship communication work and also for Press and long-distance work on full power. VTC, the call letters of the Basrah station, were always welcome to us, as later on this station proved to be our directing station after we had erected an 8-kilowatt C.W. station at Bagdad and



moved some 350 miles to the north-east to a position about eighty miles south of the Caspian Sea. Here another C.W. station was erected, a few brief details of which may be of interest. The prime mover was a 14-h.p. two-cylinder water-cooled engine which drove an 8-kilowatt Newton generator at 80 volts. By this current a motor-generator set was run supplying a 400-volt direct current for a Poulsen arc, the power being delivered to a 120-ft. aerial. When the transmitting key was down energy was supplied to the aerial system, and when up the current was diverted through a balanced-capacity system, thus emitting no spacing wave. This station was a link

or relay station between Basrah, Bagdad, Baku and Tiflis.

After the lapse of a few months we were again at sea, and after passing through the Gulf of Oman our course was steered for the Suez Canal. Aden was passed close by, and again our eyes were directed to the station which lies well to the west of the town, but we did not stop there. Passing on we entered the Straits of Bab-el-Mandeb and to the Red Sea. When the passage through the Suez Canal is made at night, a small steam-generating set is hoisted on board, and connected to any available steam-pipe, the turbine and dynamo are put into operation, and a powerful arc

lamp swings from the mast, and a searchlight in the bows of the ship shows up the banks of the canal to the navigator on the bridge.

There are a number of wireless stations in the vicinity of Port Said, including, of course, Port Said itself, which handles the bulk of the sea traffic in that neighbourhood. Close by is the station of Abu Zabal, situated on the outskirts of Cairo, the second of the Imperial stations, which may be plainly heard in England working to Leafield (GBL), that much-dreaded high-power station near Oxford which, to coin a phrase, literally "breeds harmonics."  
A. C. CHATWIN.

# MOUNTING SLAB INDUCTANCES

THE method of mounting slab coils, shown in the accompanying illustrations, was originally devised in order to use these coils in conjunction with the

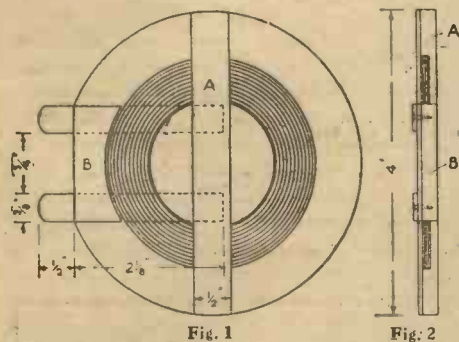

Figs. 1 and 2.—Two Views of Coil Mounted on Holding Disc.

apparatus described in "The Amateur Mechanic," but, of course, it will lend itself equally well to other types of apparatus. It has the great merit of requiring very few tools to carry out, and most of the work can be done with a fretsaw.

The dimensions will depend on the sizes of the coils to be used, and they must be modified accordingly. Those given were intended for coils with an inside diameter of 1 1/2 in. and an outside diameter varying from 1 7/8 in. to 3 1/4 in. The thickness varies from 1/16 in. to 1/4 in.

In Figs. 1 and 2 the coil is shown shaded. It is mounted on a disc of 1/8 in. three-ply wood, and is held in place by a strip of wood shown by A, which will vary in thickness according to the thickness of the coil it is to hold, the strip being cut on the under side to fit the coil. Another piece of wood cut to the shape shown is attached at B. Two strips of 3/8 in. by 1/4 in. brass are fixed to the back by screws passing through the three-ply into the pieces of wood A and B; A is also fixed by screws at the ends.

The ends of the coil are led through the three-ply wood, and are soldered to the

two brass strips at the back. All the coils are mounted in the same manner, care being taken to see that they are central and that the brass strips are the same distance apart in every case.

Fig. 3 shows a side elevation of the stand for holding the coils, and a coil is also shown in position. The coupling adjustment is obtained by varying the angle between the A.T.I. and the reactance coil, the latter being mounted on hinges for that purpose.

The base of the stand is hollow to allow of the wires being led to the terminals. It may be made entirely of 3/8 in. mahogany. In the middle of one end is fixed an upright support for the fixed coil; this may also be made of mahogany, suitable approximate dimensions being 4 in. by 1/2 in. by 3/8 in. This upright is shown

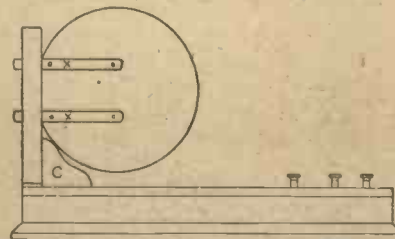

Fig. 3.—Side Elevation of Stand for Holding Coils.

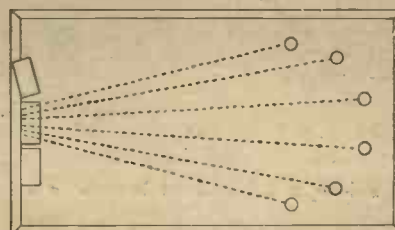

Fig. 6.—Underneath Wiring Connections.

brass strips on the coils are a loose fit. Small brass strips (these may be cut from flash-lamp battery contacts) bent at right angles are fixed by small screws in the slots as shown at D (Fig. 5); when these are fixed the coil should be a spring fit into the slots between the brass clips. Wires are then led from the clips down the back of the support to the two middle terminals.

Two other supports are made exactly similar to A, and are attached to it by hinges through which the electrical connections are made, all joints being soldered at the points marked X in the drawings. Figs. 4 and 6 show the wiring connections. No. 28 gauge d.c.c. wire will be suitable for these; the stand is shellac-varnished after the wiring is fixed.

If desired, the stand may be made to

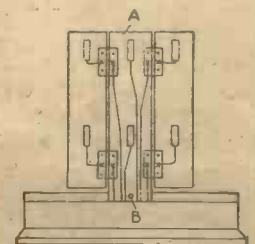

Fig. 4.—Back Elevation of Stand showing Wiring Connections.

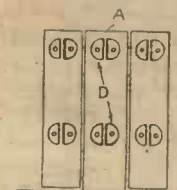

Fig. 5.—Positions of Brass Clips.

at A in Fig. 4, and is fixed by one screw B (Fig 4); it also has a strengthening support C (Fig. 3). The upright should have two slots mortised in it, into which the

hold only two coils, but it is worth the extra trouble to make it for three, as it is then possible to experiment with various circuits.  
B. M. W.



# ELECTRONS AND WIRELESS

NO one has ever given a clearer explanation of the modern uses of wireless than Professor Fleming gave last Christmas-time to an audience of children at the Royal Institution. He devoted one of his six lectures to a careful explanation of what is sometimes called the electron theory of electricity, but it was very noticeable that he did not treat it in the least like a mere theory. He stated it quite simply as an answer to the question, "What is electricity?"

Anyone who heard those lectures and thought about them afterwards must have wondered whether the veteran electrician could possibly have made all those children understand the experiments he showed them if he had not started by telling them about electrons. There was another thought that would keep on intruding itself, and that was, Could Dr. Fleming have made his wonderful "valve" if the electron had not been as real to him as he made it to the young people?

It is not given to all of us to be mathematicians, so the writer of this article has no intention of trying to explain the methods by which the size and weight of an electron have been measured. He would make an awful mess of it if he made the attempt. He wants rather to say something about how the discovery was made, to say what an electron is thought to be,

and to tell a little of the way it explains some of the otherwise mysterious phenomena of electricity. The example of Dr. Fleming is so good that we may all be sure that amateur students of wireless telegraphy and telephony will understand what they are doing none the less for a little electron lore.

### Electron Lore.

First of all, then, what is an electron? It is a particle of electricity. It bears the same relation to an electric current that a molecule of water does to the river Thames. It has been described as the smallest thing on earth. Before its discovery, the smallest or, at any rate, the lightest thing we had any knowledge of was an atom of hydrogen, whose diameter has been estimated as about one twenty-fifth millionth of an inch. A hydrogen atom weighs about 1,600 times as much as an electron. So much for weights and sizes. It is right that we should know them, but such figures are so far beyond the grasp of human thought that we shall not refer to them again.

One thing has not yet been mentioned, the most important thing of all. The electron is a particle of negative electricity. This is rather curious. We are not in the habit of considering negative quantities as very real things. The diffi-

culty arose in this way. Somewhere about 600 B.C. Thales of Miletus wrote that the substance called amber (*elektron*) had the power, after it had been rubbed, of attracting dust and other light particles. About A.D. 1600 Dr. Gilbert found that many other substances had the same property. He called them, after the Greek name for amber, electrics. Hence the word electricity. Symmer and Du Fay, working independently, a century or so ago found that there were two kinds of electricity, positive and negative, but it was Franklin who decided which was which. He called the charge of electricity excited on glass by rubbing it with silk positive, and that produced on amber or resin by rubbing it with fur negative. Franklin knew nothing about electrons, so when he suggested that electricity was an imponderable fluid he thought only of positive electricity. The negative state was a deficiency of positive fluid. These facts are well known, but we must keep them in mind if we are to realise how great a change was made by the discovery that the "corpuscles of electricity" or electrons were negative.

About forty years ago the late Sir William Crookes began his famous series of experiments on the structure of matter, or rather on the structure of material atoms. The original Crookes tube was simply a

(Continued on next page.)

## WIRELESS BETWEEN INDIAN SAHIBS



Photographs by permission of Marconi's Wireless Telegraph Co., Ltd.  
His Highness the Maharajah Ranjitsinhji, Jam Sahib of Nawamagar, speaking by wireless telephone from Jamnagar to Mandvi across the Gulf of Cutch, a distance of 70 miles.

His Highness Maharao, Sahib of Cutch, receiving the message.



tube of glass with metallic electrodes fused through its ends. Before using it, the air was pumped out of it as completely as possible. This exceedingly high vacuum ought to have formed an insulator, but when he joined up the metallic ends with an induction coil he obtained a remarkable set of effects. Some kind of radiation was set up, but, strangely enough, all the rays started from the negative pole and none from the positive. One of the effects of these rays was that they made the glass of the tube glow with a dim light where they struck it. He then made similar tubes of various patterns. Most of these had the positive electrode placed at one side instead of at the end. This made no difference to the direction of the rays. They ignored the positive electrode altogether and flew straight across the tube to the glass opposite, making it glow as before.

#### **Crookes Tubes.**

Two of his patterns of tube are of special interest. First is one in which two horizontal glass rails were placed. The rails, as he called them, were like thin glass wires stretching from one end of the tube to the other, and on them was balanced a wheel, like a minute model of the paddle-wheel of a steamer. The negative electrode was placed in such a position that its rays fell on the upper vanes of the paddle. The object of this tube was to discover whether the rays consisted of material particles or not. If they did, they would have enough momentum to turn the wheel. The experiment was brilliantly successful, so much so that the spinning wheel, moved by flying electrons, was exhibited on many occasions, and hundreds of copies of the apparatus have been made.

The second pattern was of quite a different kind. The electrodes were placed at the ends of the tube, but a glass partition with a small hole in the middle of it was placed across the inside of the tube just in front of the negative electrode. This prevented all excepting a thin stream of rays from finding their way into the main part of the tube. Inside this main part of the tube, right along the path of the stream of rays, Sir William placed a piece of card that had been coated with luminous paint. When the rays were allowed to pass, their path along the card was marked by a luminous line. Now, if the rays were of the same nature as a current of electricity they would be deflected by a magnet, and, as was expected, the streak of light could be bent about, attracted or repelled exactly as though it was a current flowing in a wire.

Sir William Crookes did not call his discovery by the name of electrons. He preferred to speak of his rays as radiant matter, but in using the word matter he was careful to point out that he got exactly the same effects whether the gas which had been in the tube before it was exhausted was oxygen or carbonic acid or

any other gas instead of air. It might be thought that a few particles of the original gas were left behind and were the material part of the rays. If so, then all gases must have been resolved from the same substance in his tubes.

#### **Electrons and Atoms.**

In the forty odd years that have passed since the Crookes tube was devised a great swarm of investigators has pounced down on the original idea, and our knowledge has advanced steadily. For the greater part it has gone along two lines. One of them has been to find out what part the electron takes in the constitution of a material atom, and the other has been concerned with the part it plays in the phenomena of electricity. The two are so close together that it is difficult to separate them. The discovery of radium solved many problems with regard to the first, but that is such a fascinating story that it is best, in this short article, to let it alone, with the remark in passing that radium, as it decays, gives off rays that answer all the magnetic tests of Crookes's radiant matter. It gives off electrons.

Material atoms, then, contain electrons. Some of these are quite loosely bound to the central part of the atom, so they are easily passed on at times from one atom to the other. When the old Greek philosopher rubbed his bit of amber on what passed in those days for a shirt-sleeve some of the electrons passed on to his shirt. Somewhere inside each molecule of the amber there were corpuscles of positive electricity that had kept the electrons in position by their attraction until they suffered violence. When the amber lost some of its electrons it became positive in its nature, and attracted the electrons in the dust to such an extent that they carried the dust with them back on to the amber.

This is the first mention of positive corpuscles that has been made here. They are slowly unfolding their properties, but, excepting in a remote way, they have very little to do with the science of electricity, so they will not be mentioned again.

#### **How Electrons Behave.**

When electrons are crowded together their mutual repulsion is gigantic, so it is no wonder that, when they get the opportunity, they fly apart with enormous velocities. When they move they cause disturbances in the ether. As a rule, they are moving in tiny orbits around the centre of a material atom, but their paths may be changed in many ways. One of these ways has been used in the thermionic valve. It has been found that when a metal is heated strongly electrons escape.

Now see how readily this fact explains one of the commonest of natural phenomena, that is, the earth's magnetism. The sun is at a very high temperature. Electrons are flying out from its atoms into space. Constant streams of them must be passing through the outer parts of our atmosphere. Now, these streams do not

pass the earth so rapidly that the spinning motion of the earth is negligible.

The course of the electrons as they pass us is therefore a spiral one. If the electrons are units of electricity, then we have a spiral current of electricity continually running, always in the same direction, round the world, and everybody knows that when a current is sent through a wire spirally round a piece of iron an electromagnet is formed. Is it any wonder the earth behaves like a magnet?

#### **Electrons and Wireless.**

Go back again to the remark made just now that when electrons move they make disturbances in the ether. It is one of the commonest ways of explaining the transmission of messages by waves to make an analogy between the ether and a still pond. Float a cork at one side of the pond and float another on the other side. If you hit one of the corks it will bob up and down, ripples will be formed in the water, and in a little while the ripples will make the other cork keep time with the one you hit. It is dangerous to follow an analogy too far, but it is fairly safe to believe that the electrons pulsing rhythmically backwards and forwards in the aerial of, say, the Eiffel Tower send waves through the ether that will make the electrons confined in any distant conductor bob up and down like the distant cork. Of course, the conductor in which they are confined may be out of tune. When they rise with the wave they may get a check by the wave beginning to fall before they reach the end of their tether. Then the response of the distant aerial will be next to nothing.

FRANK T. ADDYMAN.

## **New Wireless Bill**

SOME further proposals concerning wireless telegraphy and telephony have been framed, and under the name of the Wireless Telegraphy and Signalling Bill have been introduced in the House of Commons.

The Bill authorises the Postmaster-General

To make regulations regarding the granting of licences;

To require persons engaged in the working of wireless telegraphy to be provided with certificates;

To provide for preventing interference with the working of wireless telegraphy by the generation or use of etheric waves for any purpose other than the transmission or reception of wireless messages.

The Bill makes it an offence to send or attempt to send a message or communication of an indecent, obscene, or offensive character; or send or attempt to send a signal of distress of a false or misleading character, or a false or misleading message as to a vessel in distress; or improperly to divulge the purport of any message sent or proposed to be sent by wireless telegraphy.



# ELECTRICAL BENCHWORK

Ebonite Grinding, Lapping, Burning, Finishing and Engraving

## Grinding.

THIS process is very useful for making rectangular panels, such as panels and bases. As an example, Figs. 5 and 6 show the method of making small rectangular switchblade holders. The blanks are cut up about  $\frac{1}{8}$  in. larger than required from sheet of the required thickness with a circular saw (which, by the way, should be of a coarse cut and not the same as that used for brass). Then a lathe or lapping machine is set up with the table and dish-shaped emery wheel as shown in Fig. 5. One long side of all the blanks is first ground off, using a fence or guide as shown. Next, the guide is set so that the parts are nearly to size, allowing for lapping, when the other long side is ground. The ends are treated in a similar manner, but by using a cross guide, set at right angles, as in Fig. 6. The wheel should be perfectly true, or the edges ground will be ribbed, necessitating much more lapping afterwards.

It is hardly ever necessary to grind on the flat, as ebonite sheets of the required

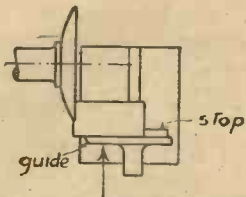

Fig. 6.—Grinding End of Piece of Ebonite.

thickness are usually procurable, but if so the dish-shaped wheel may be mounted in the chuck of an end-milling machine, or profile, and the parts held in the vice. A rather coarse wheel should be used for this work, as a fine one soon gets clogged. The speed should be fairly high, as for tool grinding.

## Lapping.

Flat surfaces may be lapped on either an ordinary circular lap or a finisher, in a similar manner to brass. Sometimes lapping is used as a finish, in which case a straight "grain," such as obtained with the finisher or roll-type lap, is desirable, the surface being oiled. All surfaces that have been ground, as just described, have to be lapped (as in Fig. 7) before finishing.

## Burning.

A useful process which is applied specially to making square holes in ebonite is burning. An iron or steel drift of the required size is made, with a blunt point. This is fitted to the tail stock of

a small lathe, as shown in Fig. 8, and a suitable stove rigged up for heating it. A bunsen burner enclosed in a tin box will do for this. The parts to be drifted out have previously been drilled out to the

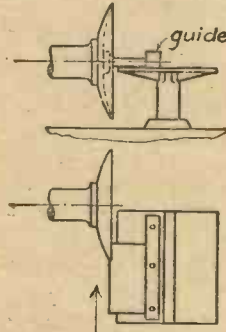

Fig. 5.—Grinding Side of Piece of Ebonite.

same size as the square to be cut, and are placed against a flat plate with a hole in the centre fixed in the chuck of the lathe, while the tailstock head is pushed up so that the drift enters the hole and burns its way through, as shown in the figure. Too great a force is liable to split the work, but the process should not be unduly prolonged, otherwise the hole will be made too large. The best temperature for the drift is found by experiment.

The only disadvantage of this process and that of grinding is that they both make a horrible smell (burning sulphur and burning india-rubber being combined), which to those unused to it is unbearable. The writer practically lived in such an atmosphere for many months at one time, and almost began to like it, but to most people it is highly offensive. The best plan is to work near a window when grinding or burning ebonite, and arrange an electric fan to carry out the dust and fumes.

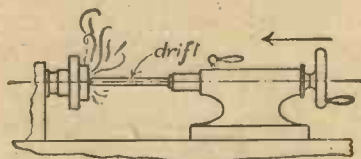

Fig. 8.—Drifting a Square Hole.

## Finishing.

There are several kinds of finishes which may be given to ebonite, each of which has its particular use. The easiest to obtain is the dull polish, or "egg-shell" surface, in which the work is first rubbed with F emery paper, then flour paper, then with an oily rag, and finally with a clean rag. Turned work may be treated thus in the lathe at high speed,

while flat surfaces are best rubbed with a rotary motion on emery paper on a surface plate. For the edges of panels, etc., the most convenient method is to place a sheet of emery on a surface plate, and on top of this a block with a straight-edge, against which the work is held, the edge of the latter being rubbed to and fro on the emery; a straight "grain" is produced by this method.

To produce a high polish bath brick and water is used, on a lap made of thin felt for flat surfaces, or in the lathe for turned work. A high speed is maintained, and the work should never be allowed to become dry. This gives a polish sufficient for most purposes, but, if desired, a still higher finish may be obtained with rottenstone and water. The best way of applying the abrasives is to keep them in a flannel bag (which effectually sifts them) and dust them on to the surface of the work. This bright finish is the best and

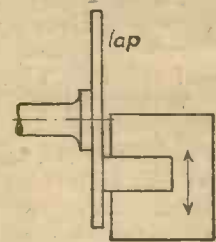

Fig. 7.—Lapping Ebonite.

most lasting surface, and looks well for all panels, knobs, pillars and scales which are exposed to view.

Another method sometimes employed to give a finish to ebonite is to lacquer the surface, a process which is not to be recommended except for small or intricate parts which are difficult to polish.

## Engraving.

The amateur cannot hope to produce the beautifully regular lettering seen on ebonite instruments, for this is accomplished by engraving the letters with a pantographic machine, and afterwards filling them with white or coloured paste. The nearest approach to this to be obtained without a machine is arrived at by painting the letters in white enamel with a fine brush, but this process is extremely laborious and seldom gives good results.

M. S. S.

Every Reader of "A.W." should have at hand for reference a copy of the "Work" Handbook, "Wireless Telegraphy and Telephony: and How to Make the Apparatus," 1s. 6d. net.



# SOMETHING NEW CRYSTAL DETECTOR



Photograph of Complete Detector and Potentiometer.

IN spite of the fact that valves are becoming widely used by amateurs, crystal detectors still have their uses, especially in small sets where low cost is the first consideration. One of the objections to crystal detectors is the fact that when it is desired to change the crystals or experiment with new combinations quite a considerable time is lost in getting the new crystals in position. With the instrument described in this article the time lost in changing is reduced to a minimum, while the appearance, if carefully made, will enhance the value of the most expensive set. With regard to the cost of material, the only item worth mentioning is the ebonite for the base; ebonite is getting cheaper, however, so that the cost of the whole instrument should not exceed 7s. 6d.

The instrument consists of a main ebonite base, carrying an adjustable resistance and a pair of plug sockets. The crystal combinations are mounted on small subsidiary bases fitted with special plugs which fit into the sockets on the main base.

Figs. 1 and 2 show the general design of the main base, Fig. 3 being one of small detector stands fitted with the plug connectors. The reference letters refer to the same part in each case.

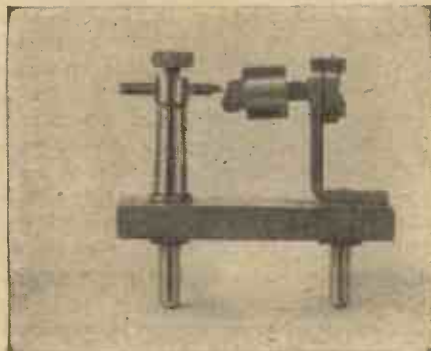

Horizontal Detector.

improved by having all the sides and angles of the corners milled dead true. Failing this, the sides should be filed true, a set square being used to get the job as accurate as possible. The surface of the ebonite should be finished off as described in the latter part of this article and the position marked (on the under side) for the holes to take the terminals T, the potentiometer knob K, and the plug sockets P.S.

It might be as well here to remind the reader that the appearance of the nicest piece of apparatus may easily be spoiled by having a terminal on a knob mounted out of truth. Many amateur mechanics use their eyes too much in this respect; the result of guesswork is seldom satisfactory. A pair of engineer's dividers are the things required for accurately marking the holes for drilling, and a little care exercised will materially add to the appearance of the finished instrument.

The terminals T fitted at one end of the main base B in Figs. 1 and 2 are a standard pattern, and may be purchased from advertisers of electrical sundries ready polished and lacquered. The writer has improved his by drilling a hole in the screw portion and fitting a small ring made of german silver wire as shown in the sketch. This prevents the terminal nut from being screwed right off, although allowing it sufficient play to clamp the connecting wires, etc.

The plug sockets PS which carry the crystal sets are mounted on the opposite end of the base, the dotted lines in Fig. 1 indicating the space occupied by the small ebonite blocks carrying the various crystals. Small plug sockets of a suitable pattern, together with a supply of the necessary plugs for the crystal sets may be purchased from large dealers in electrical and telephone supplies, the usual finish being a dull nickel. This can be removed from the flange of the plug socket, however, by polishing with fine emery cloth while the socket is revolved in the lathe.

It may then be lacquered to make it in keeping with the finish of the terminals T.

A nut on the under side of the base keeps the plug socket in position, a few threads being left to enable the connections to be soldered thereto. On the question of soldering care should be taken to see that all joints are soldered quickly and properly the first time, so that no undue heat reaches the ebonite.

Four small ebonite feet are required, and these should be turned up on the lathe and drilled and countersunk to take small screws which secure the feet to the base B. If they are made  $\frac{3}{8}$  in. long by  $\frac{1}{2}$  in. diameter they will raise the base sufficiently to enable the fittings on the under side to clear the table by  $\frac{1}{8}$  in.

The potentiometer (Fig. 4), consisting of the resistance R, the contact finger C, and the knob K, should now be constructed, its purpose being to vary the potential or voltage across the crystal. The knob K is turned up from ebonite and polished with

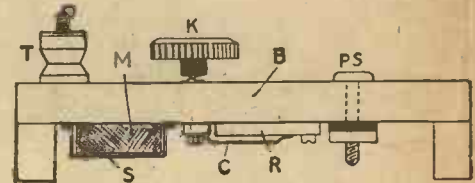

Fig. 1

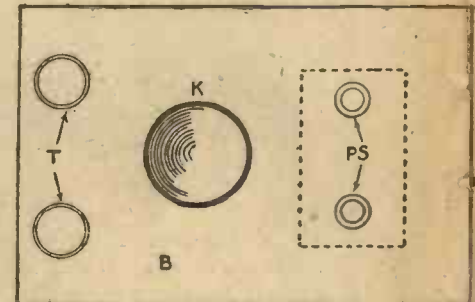

Fig. 2

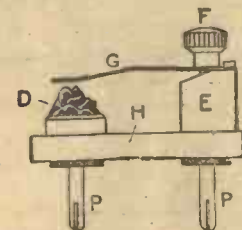
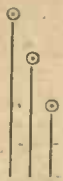

Fig. 3

Figs. 1 and 2.—  
and Plan  
Fig. 3.—De  
Fig. 4.—Po  
Fig. 5.—Mo  
Fig. 6.—Diagram



# INSTRUMENTS



## Making a Novel Instrument with Quickly-removable Crystals :

turns and fine emery cloth while in the lathe. If desired, the knob may be purchased ready-made quite cheaply.

The complete moving contact is shown in Fig. 5, the plate RP serving as a terminal for connecting up in addition to providing a smooth surface for the contact C to move on. Before the movable portion of the potentiometer is fitted to the base a spring washer should be slipped on directly under the knob K, as shown in Fig. 1; this has the effect of making the contact more firm over the resistance and remaining in place after the adjustment has been made. The contact C should be made of phosphor-bronze strip if this is obtainable, as it retains its springiness for a considerable time and thus provides a good contact with the resistance.

The resistance R is built on a strip of ebonite, measuring 3 in. long by 1 1/8 in. wide by 3/16 in. thick. Four holes are drilled in the extreme corners to provide means of fixing to the base B. The re-

sistance consists of No. 36 S.W.G. enamel-covered resistance wire, wound closely on the ebonite former, the ends of the wire being secured by slipping them through holes in the ebonite and pressing two small metal strips, bent up to form clips, over to further secure them. The whole coil should then be soaked in shellac varnish in order to keep the turns of wire firmly in position. The insulation must now be carefully removed where the contact C is to touch the turns of wire; this can best be done with a small piece of emery-paper or by gently scraping with a pen-knife, great care being taken to ensure that no turn of the resistance coil is damaged or broken during the operation. It will, of course, be understood that it is only necessary to remove the insulation from the wire where the contact C is arranged to pass over. The potentiometer battery is mounted on the under side of the base B, as shown in Fig. 1, M being the battery and S the strap which holds it in position. As the current required is exceedingly small, a battery such as is used in the very small type pocket lamps will be quite suitable.

In order to avoid the complication of a switch to control the battery and prevent it running down through the resistance R, a small clip should be made to clamp on one of the battery contact strips and to easily be recoverable when it is required to break the circuit. The next point for consideration is the question of crystal combinations. As explained in the commencement of this article, the idea is to provide a means of rapidly changing from one combination to another. The combinations may consist of zincite-bornite, carborundum-steel plate, galena-graphite, etc., all mounted on small blocks as shown in Fig. 2, fitted with plugs P for the purpose of rapidly connecting the crystals to the main base B.

The crystal set shown in Fig. 3 is a carborundum crystal D set in a cup in direct contact with one of the plugs P, screwed through the ebonite base H. The other plug has an extra long thread on the upper portion which passes through the small ebonite block E and the steel plate G into the adjusting knob F. It will be



Another Photograph showing Different Detector in Place.

noticed that the ebonite block E is filed off at an angle under the plate G, and it will be obvious that any pressure applied by screwing the knob F down will cause the plate G to press on the crystal, the amount of pressure being instantly variable. The adjusting knob F is of polished ebonite, and the plate G is a piece of clock spring softened at one end for drilling, and polished with fine emery paper.

Various other crystal sets should be made up, the crystals being mounted in small brass cups and provided with means of adjustment. The point requiring most care will, of course, be the position of the plugs in the base H. Unless these are all exactly the same distance apart it will be impossible to make them fit nicely into the sockets on the main base B. The most effective plan is to make a small metal template with two holes, the correct distance apart, accurately drilled in it. The small bases carrying the crystals should all be made the same size, and the template be used to guide the drill for making plug holes.

It is a good plan also to make up a small cabinet of polished wood to hold the various crystal sets and keep them free from dust and damage. The bottom of the



Vertical Detector.

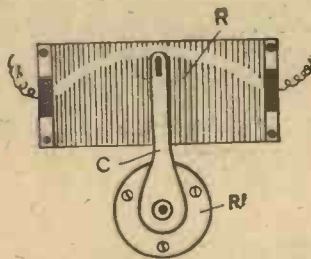

Fig. 4

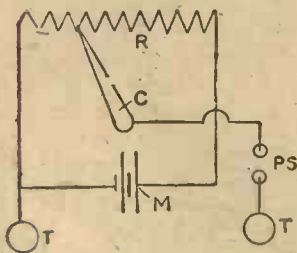

Fig. 6

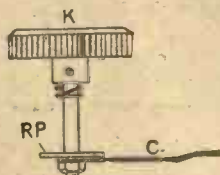

Fig. 5

Side Elevation of Base. Detector Unit. Potentiometer. Moving Contact. of Connections.



cabinet should have a block with a number of pairs of holes drilled in it to take the plugs P. The diagram of connections is shown in Fig. 6, where it will be noticed that all the wiring is practically confined within the limits of the base B, the only connections necessary outside being by means of the two terminals T, thus considerably simplifying the connecting-up to the other apparatus.

It is a good plan to solder all connections where possible; the work is then permanent and more satisfactory in every respect. A few notes on finishing the main base B and the smaller bases H may be of use to many.

The sides of the base, after being filed or milled up square, should have all file

marks removed by drawing the file along the surface, the file being held at right angles to the direction of movement. A piece of FF emery cloth, wrapped round an old file, or a piece of smooth wood, should now be used to produce a grain on the ebonite. It is most important that the emery cloth should be continually moistened with turps, otherwise the heat generated will draw the sulphur in the ebonite and cause a pitted surface to appear.

The finishing should be done with very fine emery cloth. The top of the base may either be left as originally purchased, with a highly polished surface or a matt surface obtained with turps and fine emery paper. Another finish, having a matt surface, may be obtained by laying a sheet

of fine emery cloth on a small flat surface, wetting it with turps and rubbing the base round and round, constantly changing the direction.

The final finish is given by means of a polishing cloth and a little tallow, care being taken to ensure that no metal dust has been picked up by the polishing cloth off the bench.

The knobs K and F should be polished while still in the lathe, practically the same process being used, with the exception, of course, of the fact that they will be revolving at a high speed in the lathe. Excessive heat must be guarded against by using plenty of turps all the time, and not allowing the work to revolve at too great a speed.

A. W. HULBERT.

## "AT THE CALL OF GNF"

HOW time flies! On a rainy and altogether miserable night in March, 1920, when behind a pipe of favourite baccy we had become reminiscent, my friend, with sudden inspiration, said, "Let's build a wireless receiving station." Just one of those happy spontaneous ideas to make one feel eternally grateful. We were enthusiasts from that moment, being in an excellent position to put the idea into effect. But a few months before we were Service operators, my friend in the R.A.F. and I in the Signal Service. The ensuing days, pending official sanction to erect the station, produced many an interesting hour while we pegged away at a design for the receiver.

We decided to use a circuit employing a crystal rectifier, the possibilities of which, with efficient handling, we considered excellent. On an auspicious night the official permit arrived and our real operations commenced. The aerial was our first consideration, and on the Sunday morning we allotted to the erection of the mast, stays and aerial, much interest, and probably a good deal of speculation was aroused in our neighbours.

We were very modest with our aerial, erecting a single wire 60 ft. long, plus insulators. The house end was attached to the roof, and the other to a mast only 18 ft. high. The mast was a present from an interested friend. In those days, before the advent of multi-valve amplifiers, rendering the use of outdoor aeriels optional, a high aerial was a great objective, but never a complaint have we lodged against our diminutive antenna.

Came the great day to "listen in," and in passing I will remark that our station was in part purchased from a manufacturer and in part made up at home, a method which saved us quite a considerable outlay, wireless gear in 1920 being at a prohibitive price.

We surveyed the set with much satisfaction. Indulging in a little self-praise, we commended ourselves on the neatness of the arrangements, but—would it give signals? Theoretically, yes; but might there be some minor detail hidden from our eyes which would cause negative results? Aerial and earth leads connected and head 'phones on, we sat down, half expectant, half doubtful. I moved the slider of the tuning inductance over a wide wave-length range, but not the faintest buzz of a Morse signal, not even a crackling atmospheric gladdened our ears. Re-adjustment of the crystal detector to a point of good sensitivity with the aid of our buzzer brought no results. Fifteen minutes passed and the ether remained silent, as silent as we ourselves were.

We overhauled the set, suspecting a faulty connection. The result was an O.K. report. We donned the 'phones again, hardly with optimism. A minute or two elapsed while we were jumping to anything that (in our imagination) resembled a signal. Suddenly—and it is impossible to describe the feeling of elation and success—deep-noted signals became clearly audible. A handshake, a mutual word of congratulation, and we read the call sign of the station transmitting GNF, GNF, GNF. A hasty reference to the call letters list gave it as the North Foreland station. With the advent of one, other stations, both ship and shore, graced our aerial with their signals, till in the evening we culminated our success with the reception of the famous Paris station FL and the great Marconi station at Poldhu.

Since that memorable occasion we have made GNF our pet station in deference to our initial success, but, like other things wireless, GNF has changed with the passing months. The old deep spark note has given way to a sharper, more

musical one; it provides excellent practice for Morse code enthusiasts when transmitting navigation warnings. Likewise our original simple set has given way to something more pretentious, but with many of the old parts embodied in the new.

Added zest was given to our experiments when we succeeded in hearing a faint voice emanating from Croydon aerodrome, the only wireless telephony we heard for many months. What a comparison with to-day, when any evening provides its quota of interesting telephony transmissions! Now London is to have its own "broadcasting" station.

But in spite of all that is new and welcome, a memory of a great day in 1920 will be rekindled at the call of GNF.

SPARKKS.

### A Detector that Costs a Shilling

A READER sends a sketch of a novel detector made from a domestic clothes-peg. He avers, from practical experience,

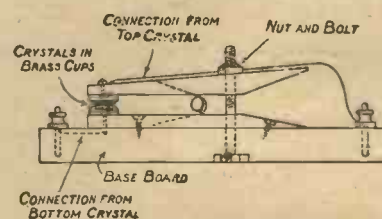

Detector made from Clothes-peg.

that it works exceedingly well. The drawing reproduced is sufficiently explanatory not to require further description.

The Economic Electric Co., of 10, Fitzroy Square, London, W.1, sends us an excellent catalogue of wireless supplies.



# The Primary Battery and Current Flow

THE commonly understood meaning of the word battery in connection with electrical apparatus is that it is an arrangement for producing electricity by chemical means. There is another word, however, used in the same connection, and the indiscriminate use of either is apt to lead to confusion in the minds of some people. This word is cell, and, obviously, when a single unit is referred to it is the more correct, for actually the term "battery" implies two or more cells connected together. However, now it frequently means nothing more than a single cell. The primary battery or cell is the most easily available source of electricity, and in its simplest form it consists of a sheet of zinc and a sheet of copper placed a little distance apart in a vessel containing dilute acid, as here illustrated. When the two plates are connected by an external wire a current of electricity will flow along the wire.

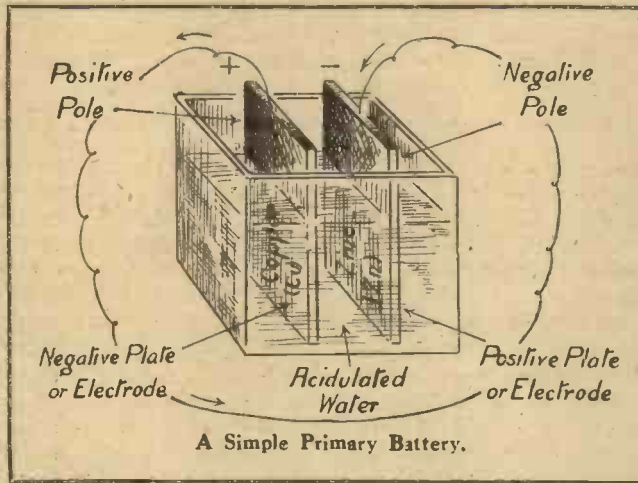

what it was at starting. The zinc and copper have become changed, more or less, to zinc and hydrogen, with the result that the difference of potential (otherwise the pressure of the current) drops by about 25 per cent. In addition, the presence of the

stance that is entirely without resistance. In general, good conductors of heat are also good conductors of electricity. The conductivity of a substance is its capability of conducting an electric current.

An insulator is any substance that offers much resistance to the passage of an electric current. Theoretically there is no substance that is a perfect insulator—that is, there is none that offers so great a resistance as to obstruct entirely the passage of a current of electricity.

The amount of current that flows through a conductor is measured in amperes; the pressure, difference of potential, or electro-motive force (E.M.F.) is measured in volts; and the resistance which it has to overcome is measured in ohms. Thus, the ampere is the (practical) unit of quantity; the volt, of pressure or E.M.F.; and the ohm, of resistance. Any one of these three can be determined when the two others are known by a simple rule known

The copper plate is termed the negative electrode and the zinc plate the positive electrode, and in theory the current always flows from the copper to the zinc outside the cell, and from the zinc to the copper inside, thus completing the circuit as shown. The parts of the plates outside the liquid are referred to in the reverse sense to what the immersed portions are, for the copper or negative plate is spoken of as having the positive pole or terminal, and is always indicated by the positive (+) sign, whilst the zinc plate provides the negative (-) terminal.

There are hundreds of different types of primary batteries and many different electrodes are used, but the same principle holds throughout:

When a cell has been working for some time, the "couple," as the two different metallic plates are known, is no longer

hydrogen increases the resistance to the passage of the current, and the yield of energy is still further reduced. This deterioration of the cell is known as "polarisation," and in the many attempts made to eliminate or, at least, minimise it have been produced most of the great variety of primary batteries known to-day.

There are certain elementary matters regarding the flow of the electric current that have a distinct bearing on the use of any type of battery or other source of electric current. Although not accurate in the light of present-day knowledge, it is convenient to assume that electricity flows in a metallic conductor somewhat in the sense that water flows through a pipe.

An electrical conductor is any substance that offers but a slight resistance to the passage of an electric current. There is no perfect conductor—that is, there is no sub-

stance that is not in the least formidable and may be expressed in the following way:

Amperes = volts divided by ohms.

Current = E.M.F. ÷ resistance. It follows from this, that

Volts = amperes multiplied by ohms.

Ohms = volts divided by amperes.

A simple method of committing this important rule to memory is to let the letter E represent volts (E.M.F.); C, amperes (current); and R, ohms (resistance). Then memorise the following simple expression:

$$\frac{E}{C \times R}$$

(E divided by CR multiplied together).

If any two of the above factors are known, the third is obtained by simple division or multiplication; cross out the required factor, and the remainder of the expression indicates the quantity. VOL.

## WHAT WIRELESS TERMS MEAN.—III

Some Technical Words Explained as Correctly as Popular Language Allows

**MICA.**—A common insulator used in the making of small condensers. It is a mineral substance, semi-transparent, and is obtainable in sheets which can be split up into a number of thinner sheets. It is placed between the plates of the condenser in order to insulate them from one another.

**SLAB COILS.**—A closely wound, circular coil of very fine wire, having a high self-capacity, and therefore of considerable utility on long wave-lengths. These coils are not efficient on short wave-lengths on account of self-capacity.

**POLARITY.**—Electricity is said to "flow," and that flow is said to take place from one pole through the circuit and back to the other pole.

**JIGGER.**—A term seldom used now. An arrangement of coils taking electricity in at one end and passing it out at the other at a different pressure. So called because it "jigs" up the current.

**AERIAL (or ANTENNA).**—A system of wires (usually elevated in the open air) used for the radiation or reception of wireless waves. There are various types

of aeriels. With modern high-power valve receivers the aerial frequently consists of a few turns of wire wound on a frame. Trees have been successfully used as aeriels.

**INSULATOR.**—A term applied to all materials which prevent the passage of electric currents. Ebonite, porcelain, distilled water, air, rubber, glass and similar substances are insulators. Electric wires covered with rubber or tape are said to be "insulated." There is no such thing as an insulator of magnetism.



# Making Telephone Receivers Super-sensitive

It will have occurred to many who have dismantled a pair of receivers and studied the action that the nearer the diaphragm is to the magnets without actually touching, the more sensitive the receivers will be.

This is correct up to a certain point; at the same time, there is a certain critical position where the instrument works most satisfactorily under all average conditions. It may be mentioned here that the following remarks refer to telephones of the ordinary pattern, not to the adjustable patterns.

The thickness of the diaphragm is a most important point, and one upon which the whole success of the instrument depends. If the receivers have been specially made for wireless work they will be fitted with diaphragms of much thinner sheet than those in ordinary commercial telephones, which are designed to work with a comparatively large current.

The diaphragms of wireless 'phones vary slightly in thickness from No. 31 Brown and Sharpe gauge, which is .010 in., to No. 35 B.S., which is .005 in. If the reader has rewound his own 'phones (a somewhat troublesome operation), he would do well to fit diaphragms of the gauge mentioned above in order to reduce the effort required to set the diaphragm in vibration. It might be as well here to explain the action of the wireless 'phone before proceeding further. If the earpiece is unscrewed and the diaphragm lifted off it will be found that the permanent magnets endeavour to hold it tightly in place. It will also be noticed that the extensions on the poles of the magnets form a cone on which the fine windings are wound. Now, when no current is passing the permanent magnets will tend to draw the diaphragm towards them, so that, were it possible to look at it sideways through a magnifying glass, it would appear to sag towards the centre.

When a current flows round the coils, according to the direction, so will it either assist or neutralise the effect of the permanent magnets, so that the diaphragm will either sag more or fly back to its normal position. The effect of the current being intermittent will cause the diaphragm to vibrate at a certain period, the sound emitted being given out through the earpiece either in the form of speech or spark signals.

Now, the strength of these sounds will depend entirely on what force is used to attract the diaphragm. As magnetic attraction falls off quickly when acting through a space, however small, it will be seen that it is an advantage to keep the distance between the diaphragm and the poles of the magnets as small as possible.

The writer experimented with several methods of adjusting telephones in this way, and the most successful is described here. A sheet of glass, some 2 ft. square, was obtained, and a piece of FF emery-paper stuck on with seccotine. The 'phones are now connected up to a set for test and the earpieces and diaphragm removed. One of the receivers is now held in the hand and rubbed, with a circular motion on the emery surface, on the edges carry-

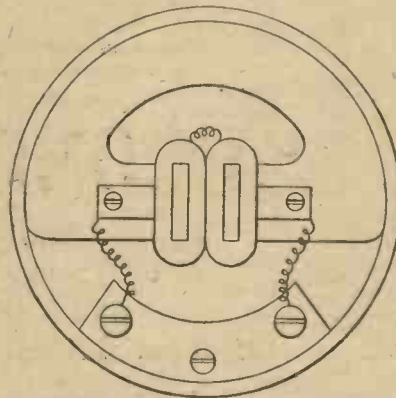

Internal Diagram of Ordinary Telephone Receiver.

ing the diaphragm. This process will naturally reduce the height of the case by a small amount, thus bringing the diaphragm a shade nearer to the magnet

poles. The receivers should be replaced on the ears and tested frequently, only one receiver being connected up at one time. This process should be repeated in turn with the other receiver until it is considered that they are as sensitive as it is possible to make them. Should it happen that one of the diaphragms is found to be too near the magnets the distance may be increased again by taking a small amount off the tips of the pole-pieces with a file.

With a little practice it will be possible to get both receivers extremely sensitive, so sensitive, in fact, that they must never be directly connected across a battery, otherwise there is a chance of buckling the diaphragm.

One method of testing 'phones is to get a sixpence and a penny, lay them on a sheet of glass and put a drop of water between them, touching the edges of both coins. If the flexible leads from the 'phones are placed on the coins a distinct click will be heard, the two dissimilar metals and the water acting as a battery.

It might be as well to mention here that the above remarks regarding the thickness of the diaphragms only applies to high-resistance 'phones; in cases where low-resistance 'phones are used in conjunction with a telephone transformer a diaphragm of thicker metal can be used, as the instrument is then more or less current-operated. H.

## A BRIEF HISTORICAL NOTE

JUST eighty years ago (in 1842) the first wireless message was sent. Morse was able to signal without any connecting wire from one side of a river to the other, but this was not wireless as we know it to-day. He used the water as a conductor for the current. The same idea served other experimenters. Still others used the induction method, and strung up a mile of wire on one side of a stream so that current flowing through it would induce a current in a similar range of wire on the opposite side of the stream. Scores of experimenters contributed to the problem of electrical communication between places not metallically connected, and among them: Clerk Maxwell, Hughes, Hertz, Lodge, Fleming and Branly, are great names.

In 1895, Marconi, the greatest of them all, experimented in Italy on the Hertzian-wave principle, his object being to transmit wireless signals by means of electric oscillations of high frequency. He was encouraged to come to London, where, in the following year, he lodged what is generally regarded as the first British patent for wireless telegraphy.

By 1900 so great had been Marconi's success that the use of wireless telegraphy was becoming general. In that year Marconi took out the most important of his early patents, No. 7,777 of 1900, the Poldhu high-power station was begun, and wireless messages had been sent by this time over distances as great as eighty-five miles. Two years later Marconi introduced his moving-wire magnetic detector, which was a very great improvement over the coherer as used by Branly and other experimenters; on board the *Philadelphia* the great Italian inventor received signals from Poldhu, 2,099 statute miles away. Since that date the development has been amazing, particularly since 1914, when the military needs of so many nations gave wireless telegraphy a fillip.

Last year messages were sent from Carnarvon to Australia, a distance of 12,000 miles, and a sensational achievement of amateur wireless was to transmit messages from the United States and to receive them in Great Britain and in Holland.

One of the greatest factors in modern wireless has been the use of the thermionic valve invented by Dr. Fleming in 1904.





# GET THE BEST!

BE READY FOR "BROADCASTING"

# DICTOGRAPH HEAD-SETS

These will be found unsurpassed in distinctness, sensitiveness and fine tonal qualities.

Years of experience in making the world-famed Dictograph Telephone Products, Transmitters and Receivers, ensure results

# SECOND TO NONE

They are the best for all amateurs, professionals and commercial purposes.

**TRADE SUPPLIED**

**DICTOGRAPH TELEPHONES Ltd.**  
AURELIA ROAD, CROYDON, SURREY.

## HEADQUARTERS

FOR

## WIRELESS SUPPLIES

In addition to our own wide range of Wireless Specialities we carry stocks and can give prompt deliveries of the Leading British Makers.

Send us your enquiries and we shall be pleased to quote.

Illustrated Catalogue  
Post Free 6d.



# MAKE YOUR OWN WIRELESS SETS!

<p><b>CONDENSER UNIT</b> 5 and 0.1 P Simple and efficient. .005 to .0005 m.f.d., 3/- per set. Set of three mounted on Ebonite base. Price 12/6. 6 values can be obtained simply by lifting one end of any condenser.</p> <p><b>CRYSTAL DETECTOR</b> 3 Cup type ... 21/- Single Cup type ... 8/6</p> <p>"<b>EXCENTRO</b>" <b>CRYSTAL DETECTOR</b> Described in <i>Wireless World</i> Dec. 24, 1921. Price, 16/-</p> <p><b>SKELETON BUZZER</b> Extremely sensitive for Crystal Testing, 2/6</p>	<p><b>INDUCTANCE TUBES</b> Impregnated. Length 12 in.</p> <table border="1"> <tr><td>Dia.</td><td>...</td><td>Dia.</td><td>...</td></tr> <tr><td>2½</td><td>... 6d.</td><td>4</td><td>... 1/-</td></tr> <tr><td>3</td><td>... 8d.</td><td>5</td><td>... 1/6</td></tr> <tr><td>3½</td><td>... 10d.</td><td>6</td><td>... 2/-</td></tr> </table> <p><b>SMALL CONDENSERS</b></p> <table border="1"> <tr><td>.0004</td><td>...</td><td>3/6</td></tr> <tr><td>.0005</td><td>...</td><td>3/6</td></tr> </table> <p><b>ANODE RESISTANCES</b></p> <table border="1"> <tr><td>50,000 ohms</td><td>...</td><td>3/6</td></tr> <tr><td>80,000 ohms</td><td>...</td><td>3/6</td></tr> </table> <p><b>VARIABLE ANODE RESISTANCE</b> 20,000 to 100,000 ohms. 7/6</p> <p><b>FILAMENT RHEOSTAT</b> 7/6</p>	Dia.	...	Dia.	...	2½	... 6d.	4	... 1/-	3	... 8d.	5	... 1/6	3½	... 10d.	6	... 2/-	.0004	...	3/6	.0005	...	3/6	50,000 ohms	...	3/6	80,000 ohms	...	3/6	<p><b>CONDENSER PARTS</b> FIXED AND MOVING VANES, 3/- dozen.</p> <p><b>CENTRE ROD</b>, 4½ in., 4/6 each.</p> <p><b>LAMINATED SWITCH ARMS</b>, 2/6</p> <p><b>VALVE SOCKET</b>, 1/9</p> <p><b>VALVE SOCKET TERMINALS</b> 1/3 per set of 4</p> <p><b>CONTACT STUDS</b> Small size, 2/- dozen Large " 3/- "</p> <p><b>AERIAL INSULATOR</b> 2 in., 1/3</p>	<p><b>AERIAL WIRE</b> Per 100 ft.</p> <table border="1"> <tr><td>3/20</td><td>...</td><td>4/-</td><td>7/23</td><td>...</td><td>5/-</td></tr> <tr><td>3/19</td><td>...</td><td>4/6</td><td>8/18</td><td>...</td><td>6/6</td></tr> <tr><td></td><td></td><td>7/20</td><td>...</td><td>7/6</td><td></td></tr> </table> <p><b>REGULATING SCREW</b> 1/-</p> <p><b>EBONITE KNOBS</b>, 1/- and 1/6</p> <p><b>INSULATED SLIDERS</b>, 1/-</p> <p><b>KNIFE SWITCHES</b></p> <table border="1"> <tr><td>S.P. 1 way</td><td>...</td><td>1/9</td></tr> <tr><td>S.P. 2 "</td><td>...</td><td>2/4</td></tr> <tr><td>D.P. 1 "</td><td>...</td><td>3/9</td></tr> <tr><td>D.P. 2 "</td><td>...</td><td>5/-</td></tr> </table> <p><b>GRID CONDENSER and LEAK</b>, 7/6</p>	3/20	...	4/-	7/23	...	5/-	3/19	...	4/6	8/18	...	6/6			7/20	...	7/6		S.P. 1 way	...	1/9	S.P. 2 "	...	2/4	D.P. 1 "	...	3/9	D.P. 2 "	...	5/-	<p><b>BLOCKING CONDENSER</b>, 5/-</p> <p><b>GRID LEAK</b>, 3/-</p> <p><b>PLUG CONNECTOR</b>, 2-Pin, 1/6</p> <p><b>SINGLE RECEIVER</b> With Head Band and Cord</p> <table border="1"> <tr><td>120 ohms</td><td>...</td><td>24/-</td></tr> <tr><td>500 "</td><td>...</td><td>27/6</td></tr> <tr><td>1,000 "</td><td>...</td><td>30/-</td></tr> <tr><td>2,000 "</td><td>...</td><td>32/6</td></tr> </table> <p><b>DOUBLE RECEIVER</b> With Head Band and Cord</p> <table border="1"> <tr><td>1,000 ohms</td><td>...</td><td>35/-</td></tr> <tr><td>2,000 "</td><td>...</td><td>37/6</td></tr> <tr><td>4,000 "</td><td>...</td><td>45/-</td></tr> </table>	120 ohms	...	24/-	500 "	...	27/6	1,000 "	...	30/-	2,000 "	...	32/6	1,000 ohms	...	35/-	2,000 "	...	37/6	4,000 "	...	45/-	<p><b>BROWN'S LOUD SPEAKER</b> Type H. 2 £3 0 0</p> <p><b>HIGH TENSION BATTERIES</b> 15 volts ... 3/6 Variable Type, 36 volts, Tappings, every 3 volts, 7/6</p> <p><b>ACCUMULATORS</b></p> <table border="1"> <tr><th>Volts</th><th>Amps</th><th></th><th></th></tr> <tr><td>4</td><td>40</td><td>...</td><td>28/-</td></tr> <tr><td>4</td><td>60</td><td>...</td><td>35/-</td></tr> <tr><td>6</td><td>40</td><td>...</td><td>42/-</td></tr> <tr><td>6</td><td>60</td><td>...</td><td>52/-</td></tr> </table>	Volts	Amps			4	40	...	28/-	4	60	...	35/-	6	40	...	42/-	6	60	...	52/-
Dia.	...	Dia.	...																																																																																																					
2½	... 6d.	4	... 1/-																																																																																																					
3	... 8d.	5	... 1/6																																																																																																					
3½	... 10d.	6	... 2/-																																																																																																					
.0004	...	3/6																																																																																																						
.0005	...	3/6																																																																																																						
50,000 ohms	...	3/6																																																																																																						
80,000 ohms	...	3/6																																																																																																						
3/20	...	4/-	7/23	...	5/-																																																																																																			
3/19	...	4/6	8/18	...	6/6																																																																																																			
		7/20	...	7/6																																																																																																				
S.P. 1 way	...	1/9																																																																																																						
S.P. 2 "	...	2/4																																																																																																						
D.P. 1 "	...	3/9																																																																																																						
D.P. 2 "	...	5/-																																																																																																						
120 ohms	...	24/-																																																																																																						
500 "	...	27/6																																																																																																						
1,000 "	...	30/-																																																																																																						
2,000 "	...	32/6																																																																																																						
1,000 ohms	...	35/-																																																																																																						
2,000 "	...	37/6																																																																																																						
4,000 "	...	45/-																																																																																																						
Volts	Amps																																																																																																							
4	40	...	28/-																																																																																																					
4	60	...	35/-																																																																																																					
6	40	...	42/-																																																																																																					
6	60	...	52/-																																																																																																					



# OUR INFORMATION BUREAU

Expert Replies to Readers' Questions Without Charge. All Readers in Difficulty should Avail Themselves of This Service. We Send Many Replies by Post

## Failure to Obtain Signals

Q.—I should be glad of advice concerning my wireless receiving apparatus, from which I am unable to obtain a signal.—A. D. (90)

A.—The following items should be carefully attended to. (1) Dismantle apparatus and carefully inspect for (a) corrosion due to being stored in a damp place; (b) broken leads or other disconnections; (c) bad connections of wires at terminals or contact studs, and (d) faulty insulation. (2) Reassemble set and test by means of a buzzer in series with a cell, for (a) continuity of windings; (b) switches or sliders making good contact at all points; (c) short-circuits in condensers; and (d) general insulation between various points and circuits. For the last-named item, the 220-volt. house supply and an 8-candle-power lamp are most useful, care being taken always to have the lamp in series with the supply and one of the testing leads. The aerial described by querist should give quite good results, especially on the shorter wave-lengths, but the aerial lead mentioned should be removed from close proximity to the wall. Presumably the 6-ft. galvanised earth plate is buried in a damp situation. A direct connection to a water-main or house-supply pipe would improve matters. If this latter is unobtainable, bury another similar plate at some distance from the first one and measure the resistance between the two through the earth (so as to indicate if the resistance is high) by means of a 4-volt. accumulator and a small lamp.—CAPACITY.

## Interference

Q.—How can one be sure of not causing interference with other stations?—F. E. M. (95)

A.—There is, of course, no possibility of interference being caused by a receiving station which employs either a crystal detector alone, a crystal detector with additional amplifiers, or even with a valve detector, provided the receiving set is not made self-heterodyning by introduction of a reactance coupling between the anode and grid circuits of the valve. Reception of continuous waves is carried on by the interference-beats set up between two independent oscillatory currents. That is to say, the received waves set up oscillations in the receiving aerial and aerial circuit, which oscillations are, as it were, superimposed on other oscillations generated in the set itself. So that when the receiving set is "oscillating," as it is called, the aerial is actually radiating C.W. at the particular wave-length to which the aerial circuit is tuned. If when this is the case the tuning switches, etc., be moved so as to vary the wave-length of the aerial circuit possibly over wide limits, the emitted wave varies accordingly. A second receiving station, especially if near by, would, if the receiver were also "oscillating," receive the transmission from the first station; also, when this occurred, the first station would hear the beat note due to the radiation from the second. At each station the sound would be similar to, though probably not so strong as, a distant transmitting station "tuning up." Therefore, if such a note is heard when varying receiving adjustments, listen carefully and refrain from further adjustments for a time. If the note varies up and down, the other station, now identified as a near-by receiver, is endeavouring to tune querist's C.W. either in or out, and this particular adjustment had better be abandoned

for a time. On no account chase the note up and down the scale, a most annoying performance indeed to the operator to whom interference is being caused.—CAPACITY.

## SHORT ANSWERS

J. F. J. (Wavetree).—(1) The apparatus described in the Handbook "Wireless Telegraphy and Telephony" represents the latest practice, and, moreover, it has all been constructed and used, and you could be quite sure in making any of it that it would work. (2) Outside aerials are always advisable whenever possible, though with such a set as you contemplate you would still get good results with an indoor or even a frame aerial. The roof has a screening effect. A few feet will not make any appreciable difference.

E. C. (Dublin).—An advertisement in this

journal would no doubt secure you a purchaser for the wireless books, etc.

F. C. L. (Balham).—We are obliged for your suggestion, though we regret that we cannot adopt it at present.

L. H. (St. Albans).—An article on the construction of a single-valve receiving set will appear in an early issue.

W. J. M. (Co. Down).—In succeeding issues you will find that all the information you require and as outlined in your letter will be given.

A. G. E. (Shepherd's Bush).—An article on rewinding ordinary watch-type receivers will appear in an early issue. The usual resistance is 2,000 ohms each; we do not consider that the construction of 8,000-ohm receivers is within the capabilities of an amateur.

Receiver (Earl's Court).—An article on rewinding receivers will appear in an early issue.

## RADIOGRAMS

**A**N American bootblack has installed a wireless receiver, together with a large sound magnifier, on his stand. Customers are entertained with concerts and news.

In order to eliminate head resistance and produce a clearer and more constant tone for transmission from aeroplanes, a generator driven by a single-blade propeller has been tested. This generator is carried on a special mounting on the side of the fuselage, and preliminary trials indicate that better results may be had with this type.

A musical programme has recently been heard about 2,800 miles from the sending station.

Anent the supposition that fairy stories will be broadcasted at the children's bedtime someone asks: "Who is going to answer all those questions which make the telling of a fairy story such an exercise in patience and ingenuity?"

Marriage by wireless is the latest "stunt" in the American radio world.

In the States it is possible to hear a church service on a Sunday—the sermon, the congregational singing and the organ. One can almost hear the money rattling on the collection plate.

More "freak" receiving sets are announced, the latest being contained in a coconut-shell.

Experiments with the employment of wireless telephony between moving trains and between a moving train and a fixed point are being carried out in many countries. One method is to fix antennae on to a coach, and also between two telegraph poles by the side of the line.

For those who desire to practise the Morse code, gramophone records are available which dictate the code, the abbreviated figures and punctuation signs.

It is, of course, well known that until recently wireless conditions in the States were very chaotic. As an example, a sermon which was being broadcasted from a church to some smaller missions was deliberately jammed by an atheist.

A reduction in the rate for deferred wireless messages via Marconi, from Great Britain and Ireland to the Eastern zone of Canada, from 4½d. to 4d. per word, is announced. At an early date the reduction will also apply to messages handed in at post-office counters.

According to a recent statement of the Postmaster-General, there is no reason why a beginning with broadcasting should not be made this summer.

It is possible in Leeds to-day to sit in the barber's chair, and while having a hair-cut or shave to listen to the scattered wireless messages of England and the Continent "caught" on the red and white pole poised outside the shop.

(Continued on page 58)



The Electrical Wonder Book  
for Wireless Workers

# ELECTRICAL ENGINEERING

*The Book that tells you all about  
Wireless Telegraphy*

**ELECTRICAL ENGINEERING** deals with the whole Science of Electricity and describes every practical application in the Commerce and Industry of to-day. It explains all the elementary principles, and shows their practical application in the design, construction and operation of every electrical appliance in modern practice—power, light, traction, etc.

It explains everything in Electrical Science that is difficult to explain in the simplest language. It has been written by practical men for practical men. That is one reason why it is the best book of its kind. Another reason is that it is practical. It tells you the why and how of everything. It includes everything in Electricity.

IT IS THE BOOK THAT IS INDISPENSABLE  
TO EVERYONE INTERESTED IN  
THE LATEST WONDERS OF ELECTRICITY

*It treats fully and practically with all the elements of  
Wireless Telegraphy:*

All about Aerials, Wave-lengths and Tuning.

All about Transmitters and Transmitting Systems.

Detectors, Receiving Systems, Syntony, etc. Thermionic Valves, etc. etc.

**WRITTEN IN SIMPLE UNDERSTANDABLE LANGUAGE**

- ALL ABOUT**  
Generators  
Dynamos  
Motors  
Transformers  
Balancers  
Boosters  
Testing  
Instruments  
Armatures  
Commutators  
Winding  
Schemes  
Brush Gears  
Controls  
Resistances  
Switchboards  
Accumulators  
Lighting  
Heating  
Power  
Telegraphy  
Signalling  
Telephony  
Wireless  
etc. etc.

THE MOST  
WONDERFUL  
ELECTRICAL  
INVENTIONS  
OF THE  
PRESENT DAY  
MADE  
AS CLEAR  
AS DAYLIGHT.

No other  
work has dealt  
with the subject  
so clearly or  
so simply, yet it is  
the most  
PRACTICAL  
work published.

**SEND FOR  
FREE BOOKLET**

*giving full details  
regarding price and  
terms of payment*

To THE WAVERLEY BOOK CO., LTD. (A.W.N Dept.),  
96, Farringdon Street, London, E.C.3.

Please send me, free of charge or obligation, your Free Descriptive Booklet explaining contents, etc. of "Electrical Engineering" with specimen pages and pictures and particulars as to your terms for small monthly payments, beginning thirty days after delivery.

Name.....  
(Send this Form or a post card)

Address.....

A.W.N. 1922.....

(Continued from page 56)

A conference of linguistic experts from the various universities in the United States has been summoned to consider the advisability and practicability of establishing a universal language for the purpose of international communication by wireless.

Already in the back gardens of the London suburbs one may see aerials of all kinds.

## CORRESPONDENCE

### Who Will Recompense the Broadcasters?

SIR,—Having become very keen on wireless matters, I fail to see who is to pay for the broadcasting. I note in your first number you mention that the firms broadcasting will be recompensed by the amount of apparatus sold. This does not seem to me to be an ideal arrangement. What about all the small firms making fittings and the amateurs who make their own sets? Unless we get a huge combine (which does not seem possible) it will fall to the lot of the large firms to find thousands of pounds every year, which expense will have to be added to the selling prices of sets and fittings, while the firms not sharing this cost will be able to sell at a cheaper rate. Would it be possible to add a fixed amount to the cost of the licence—say 5s. or whatever is necessary—which amount to be paid over by the G.P.O. to the firms broadcasting, the firms on their side to guarantee a certain amount of news, etc., weekly at fixed hours?—F. W.

London, S.W.

## FORTHCOMING EVENTS

**West London Wireless and Experimental Association.** June 22. Demonstration by Mr. F. D. Reed of the "Ultra IV" Receiver.

**Liverpool Wireless Society.** June 22, 8 p.m. General exhibition and discussion on home-made wireless apparatus.

**Wireless Society of Highgate.** At the Highgate Literary and Scientific Institution, June 23, 7.45 p.m. Lecture and demonstration by Mr. F. L. Hogg: "The Construction of a Valve Receiving Set." June 24, Field Day, outing to Ken Wood. June 30, 7.45 p.m., at the Highgate Literary and Scientific Institution, lecture (Part III) by Mr. J. Stanley: "Elementary Theory of Wireless Telegraphy and Telephony."

**Leeds and District Amateur Wireless Society.** June 23, 8 p.m. Discussion on Direction Finding.

**North Middlesex Wireless Club.** At Shaftesbury Hall, Bowes Park, June 28, 7.30 p.m. Elementary lecture for beginners. 8.30 p.m. Lecture by Mr. W. Gartland: "The Miscellaneous Applications of the Thermionic Valve."

**Lowestoft and District Wireless Society.** The society proposes to hold an exhibition of wireless and other gear on August 3 and 4 of this year. Hon. Secretary, L. W. Burcham, Gouzeau Court, Chestnut Avenue, Oulton Broad.

**Newcastle and District Amateur Wireless Association.** July 3, 7.30 p.m. Annual general meeting for election of president and officers.

## CLUB DOINGS

### Brighton Radio Society

*Hon. Sec.*—MR. D. F. UNDERWOOD, 68, Southdown Avenue, Brighton.

At a meeting of this Society recently held at the residence of Mr. Magnus Volk, vice-President, a most interesting and instructive paper was read by Mr. Norman R. Phelps, entitled "Inductance and Methods of Tuning," during the course of which the lecturer lucidly explained the various methods adopted to receive short-wave telephony, etc.

Many useful diagrams were given on the blackboard for the benefit of members.

### North Middlesex Wireless Club

(Affiliated with the Wireless Society of London). *Hon. Sec.*—E. M. SAVAGE, "Nithsdale," Eversley Park Road, London, N.21.

THE 93rd meeting of the Club was held on Wednesday, June 14th, at Shaftesbury Hall, Bowes Park, N., the chair being taken by the President, Mr. A. G. Arthur. The Secretary announced that it had been arranged to hold elementary classes for beginners, commencing at 7.30 on ordinary meeting nights, for one hour. Mr. L. C. Holton read a paper on "The Townsend Wavemeter and How to Use It." He explained how waves were produced in water, and compared these with those produced in the ether in wireless work. He made clear the fact that wave-length is independent of range of transmission. He also explained the meaning of the terms frequency and amplitude. The lecturer explained that the wavemeter was used in a number of ways, but one of its chief uses was to measure the incoming waves at a receiving station. He gave a demonstration of this, and explained how to use the charts supplied with the meter.

### The Wireless Society of Dorsetshire

*Hon. Sec.*—E. T. CHAPMAN, "Abbotsford," Serpentine Road, Poole, Dorset.

AN interesting side show of the Royal Victoria and West Hants Hospital Pageant and Bazaar, held at the Winter Gardens, Bournemouth, on May 30th and 31st, was the demonstration of wireless telephony and telegraphy given by Mr. E. T. Chapman, A.M.I.R.E., with a Burnlept Ultra IV. Receiver kindly loaned by Dr. T. Morland Smith.

The programme included special transmissions of music from the Eiffel Tower by kind permission of General Ferrie, in addition to the usual daily music bourse and weather forecasts broadcasted by the same station. The audiences were also much interested in hearing speech from Croydon, Lympne, and other aerodromes with aircraft flying to and from Paris and Amsterdam. A local amateur was kind enough to transmit music by kestraphone and is to be congratulated upon his station (2FX), and achievements.

## PREPAID ADVERTISEMENTS.

Receiver, valve, two condensers; good music from Hague, £5. Headgear and transformer, 30s. Marconi unit, including valve, £3 17s. 6d. Other items. Call Saturday.—113, St. James' Rd., Upper Tooting. 11s

A Sensitive Telephone Receiver is a good investment. We have splendid aluminium watch-type receivers, 80 ohms, 4s. 6d.; also first-class ebonite watch-type, 150 ohms, 7s. All quite new, with braided cords. Postage, 3d.—Charles Adolph and Taylforth, Works, 12, Leverington Street, Clerkenwell, E.C.1. 12s

Get it from K.E.W.S.—Crystal receiver, £2; valve sets from £2 2s.; aerial wire, 2s. enamelled, 7s. 6d. per 100 ft.; 24 enamel, 2s. 8d. per lb.; other prices on application. Aerials erected and sets installed. Lists, stamp. Inquiries—K. E. Wireless Service, 10, Glenview Rd., Lewisham. 13s

Wireless.—Complete sets or spare parts. Everything the amateur needs. State your requirements. Advice free.—Davies, 75, Dale St., Liverpool. 14s

Wireless.—Make your own apparatus; 18 connection diagrams. 2s. 6d.—Edwards, 38, Chancery Lane, W.C.2. 11s

## COMPETITIONS FOR ALL READERS

### THREE WIRELESS RECEIVING SETS AS PRIZES

Closing Date, Friday, July 7th

WE offer as a prize in each of the following competitions a well-made wireless receiving set manufactured by one or other of our advertisers, the approximate value of each set to be at least seven guineas.

*Rules.*—The Editor's decision in any and every case is final. There is no appeal from it. The copyright of all competition efforts published by us will be ours. All entries to be in by Friday, July 7 and to be addressed to

THE EDITOR,

"Amateur Wireless,"

La Belle Sauvage,

London, E.C.4.

**Competition No. 1.**—A wireless set is offered for the best article of about 1,500 words, written from your own personal knowledge and experience, and calculated to help or interest your fellow amateurs. Illustrations will in most cases be regarded as a feature of merit. Articles should be written in simple language and be as bright and informative as possible, and the subject may be anything that you think wireless amateurs would care to read about. Should we publish any article that does not win the prize we shall pay for it.

**Competition No. 2.**—Another set is offered for a brief description (with illustration if necessary) of the *most novel and useful* item in wireless apparatus—in its design, material, make, electrical connections, etc. etc. The novelty must be original—not copied from any source whatever.

**Competition No. 3.**—The third receiving set will be presented for an ideal broadcasting programme of twelve items. You can enter for this competition on a penny postcard. Simply write down in column form twelve items that you consider would make an ideal programme.

## When Will You Send Your Effort?

## ANNOUNCEMENTS

"Amateur Wireless and Electric." Edited by Bernard E. Jones. Price Threepence. Published on Thursdays and bearing the date of Saturday immediately following. It will be sent post free to any part of the world—3 months, 4s. 6d.; 6 months, 8s. 9d.; 12 months, 17s. 6d. Postal Orders, Post Office Orders, or Cheques should be made payable to the Proprietors, Cassell & Co. Ltd.

General Correspondence is to be brief and written on one side of the paper only. All sketches and drawings to be on separate sheets.

Contributions are always welcome, will be promptly considered, and if used will be paid for.

Communications should be addressed, according to their nature, to The Editor, The Advertisement Manager or The Publisher, "Amateur Wireless," La Belle Sauvage, London, E.C.4.



# WIRELESS SETS FOR AMATEURS

## The NEWTONIAN RECEIVING SET

52/-

Consists of Material for making your own set, including Detector, Aerial, Receiver, etc., and full instructions.

APPLY MANUFACTURERS:

**NEWTONS,**

Dept. A.W., 13/15, Whitecomb Street, London, W.C.2.

**DON'T MAKE** haphazard purchases till you have sent for our CATALOGUE of

RADIO, ELECTRICAL & MECHANICAL SUPPLIES.  
**SCIENTIFIC SUPPLY STORES**

NEWINGTON CAUSEWAY,  
LONDON, S.E.1.

WIRELESS  
INSTRUMENTS,  
ACCESSORIES  
and  
MATERIALS

We stock everything for the Experimenter who wishes to build his own Set.

# WIRELESS INSTALLATIONS

CRYSTAL RECEIVER, complete | VALVE RECEIVER, complete  
Aerial, 'Phones, etc. . . . £4 | All Accessories, etc. . . . £8  
Range, 200—2,800 metres | Range, 300—20,000 metres

Valves, Wire, Insulators, Batteries,  
in fact *Everything Wireless*, from

G. D. HINKS, Wireless Department, HARDINGTON, YEOVIL  
WRITE FOR LISTS

# FOR TOOL BARGAINS

CALL or WRITE TO-DAY to;

Before buying elsewhere compare our prices. Remember, we have the Largest Stock of Tools to select from in London. We guarantee you satisfaction, so you can safely shop by post. Bargain List sent post Free.

GEORGE ADAMS, D.P.T. A/W, 255-B, HIGH HOLBORN,  
LONDON, W.C.1.

# THAT BOOK YOU WANT ON WIRELESS OR ANY OTHER TECHNICAL SUBJECT

Foyles have it or will quickly obtain it. 1,000,000 Vols. (Second-hand and New) on Technical and every other conceivable subject in stock. Books sent on approval. Write for Catalogue *10s (free)* mentioning requirements. Books Purchased.

FOYLES, 121, Charing Cross Rd., London.

TELEPHONE DOUBLE HEAD SETS. Suitable for Crystal or Valve  
2,000 and 4,000 Ohms in stock. Also wound to any specification

Complete Crystal Receiving Sets,  
including Receiver ... (guaranteed) £4 12 6

Winding wires, resistance, copper. Aerial masts and wires. Bave, silk and cotton covered. Ebonite. Terminals. Stamp for List.

P. H. BOYS & CO., 187, Goswell Road, E.C.1

# C. S. SWAN,

191, BISHOPSGATE, E.C.2.  
Near Liverpool St. Station.  
PHONE: BISHOPSGATE 1155.

15 Volt H.T. Units	3/3	Leading in Tubes	6d. to 2/6
Filament Switches for Panel Mounting	3/9	Microphones with replaceable Insets	2/6
Grid & Blocking Condensers 2/6 & 3/-		Crystals in cups	9d.
Aerial Insulators	6d.	A-Type Valve Holders	1/9

New & Ex-Government Wireless Apparatus in Stock

# ---CQ Std bi for ERICSSON PHONES



WHEN you instal your wireless set—crystal or valve—you'll get maximum results if you fit Ericsson Phones—clarity, sensitivity, strength of signals and absence of "click." Specially suited to telephony.

Ericsson Phones embody the accumulated experience of telephone manufacture for a generation.

Easy to the head, light and comfortable. The magnets never lose their strength and "shorts" are non-existent.

Write for Particulars

The BRITISH L.M. ERICSSON MANUFACTURING Co., Ltd.

Head Office:

60, Lincoln's Inn Fields, E.C. 2

# Ericsson Telephones

# DAVIS & TIMMINS LIMITED

34a, York Road, King's Cross, N.1

# SCREWS and TERMINALS for WIRELESS SETS.

:: ASK FOR ILLUSTRATED LISTS. ::

# SCIENTIFIC APPLIANCES

HENRY J. DALE. W. HOLLINS.

11 & 29, Sicilian Avenue, Southampton Row, London, W.C.1.

Top of Kingsway. In Centre of London. Corner of Bloomsbury Square.

ELECTRICIANS. OPTICIANS. MECHANICIANS.

ACTUAL MANUFACTURERS at our Works, East Street, W.C., thus saving all intermediate profits.

The Store for all Electrical and Scientific Material

WIRELESS & RADIO MATERIALS,  
PARTS and FITTINGS

VALVES. 'PHONES.

Call and see us. View our Show Windows. Send for List post free 2d.

Immense Stock constantly adding to, and Making; Specially for the Amateur to Build up a Set Complete and Perfect.

Splendid Value in  
Second-hand Appliances

EBONITE. BATTERIES. AERIALS.  
INSULATED WIRES. CRYSTALS.  
ENGRAVED DISCS. MICA. HANDLES.  
SWITCHES. TERMINALS. STUDS.

Every Branch of Optical  
and Applied Science

Scientific Appliances, 11 & 29, Sicilian Avenue, London, W.C.1.

