

*Amateur*

# RADIO

**For all two-way radio enthusiasts**

**The Icom ICu4E UHF Hand-held  
FM Transceiver:  
A User Review**

**Construction:  
A Fast Ni-Cad  
Charger**



**On Test:  
The New Low-loss Coaxial Cable from  
Westlake and the PX02 Pulse Generator  
and Marker Unit**

**NEW BEARCAT**

**IT'S HERE AT LAST!**

Bearcat's latest high technology scanner is now available in this country. It covers 10 mtrs, 6 mtrs, Airband, High Band, UHF and 950MHz. The UBC 200XLT is the handheld scanner with the latest facilities - 850-950MHz in 12.5KHz steps, 200 memories in 10 Banks.

Super LCD Backlight for discreet listening in the dark, detachable Nicad pack, CW charger @ **£249.00** (£5.00 P&P).

**ONLY LIMITED STOCKS AVAILABLE  
OUR NEXT DELIVERY IS IN  
TWO MONTHS**

**RAYCOM**

COMMUNICATIONS SYSTEMS LTD

TEL: 021-544 6767

**SUMMER SPECIAL OFFERS**

**WHILE STOCKS LAST**

Icom ICR7000 + Royal 1300 .....	<b>£899.00</b>
Icom IC3200E 25W Dual Band Mobile .....	<b>£399.00</b>
BJ200 Mk2 Handheld AM/FM Scanner .....	<b>£199.50</b>
Sony ICF2001 D SW Receiver plus Airband .....	<b>£289.00</b>
Sony ICF7600DS Super SW Receiver .....	<b>£199.00</b>

**SCANNERS**

YAESU FRG9600 from the company who specialises in fitting extra options, as supplied to Government departments and professional bodies. We also upgrade existing models, please call for more details, prices, delivery and information.

Yaesu FRG9600 Basic Model Improved 'S' Meter + Sens .....	<b>£465.00</b>
Yaesu FRG9600/RWC Mk2 60-950MHz 'N' Connector Fitted .....	<b>£495.00</b>
Yaesu FRG9600/RWC Mk3 HF 100KHz-950MHz plus Mk2 Spec. ....	<b>£595.00</b>
Yaesu FRG9600/RWC Mk5 HF 50KHz-950MHz Active Mixer .....	<b>£625.00</b>
! Yaesu PAL Video Unit for above .....	<b>£27.50</b>
Icom ICR7000 25M-2GHz superb quality professional Rx .....	<b>£859.00</b>
Icom ICR7000/AH7000 Receiver plus Matching Discone .....	<b>£937.50</b>
Kenwood RZ 1 New 500kHz-950MHz Wide and Narrow AM/FM .....	<b>£139.00</b>
Fox VHF-UHF Multi Function Mobile Scanner FM only .....	<b>£139.00</b>
Uniden-Bearcat UBC 50XL VHF-UHF 10ch. H/held Scanner .....	<b>£95.00</b>
Uniden-Bearcat UBC 70XL VHF-UHF 20ch. Miniature H/held .....	<b>£179.00</b>
Uniden-Bearcat UBC 100XL VHF-UHF-Airband H/held Scanner .....	<b>£189.00</b>
Uniden-Bearcat UBC 175XL VHF-UHF-Airband Desk-Top .....	<b>£175.00</b>
BJ200 Mk2 VHF-UHF-Airband-Military Airband H/held .....	<b>£199.50</b>
AOR 2002 25-550, 800-1300MHz Desk-Top/Mobile AM/FM .....	<b>£469.00</b>
Sony Air 7 Top Quality VHF-Airband Handheld Scanner .....	<b>£245.00</b>
Package deal on above Mk3/5 FRG9600 c/w AH7000 discone, G5RV, PA4 AC PSU, complete receiving station HF-UHF including delivery UK mainland. Add £100.00 to above price.	

**PACKAGE DEAL AVAILABLE ON ALL MAKES.  
IF IT'S GOOD, WE STOCK IT!**

**A new concept in Amateur Radio . . . uniden 2830**

It's here at last! A beautifully-made processor-controlled full feature 10w (20w PEP) multimode transceiver with LCD readout and all functions necessary to work DX with Sporadic E and in the forthcoming sunspot maxima and also for transverting to the VHF and UHF bands. Work out the facts . . . how much is a Two Metre Multimode? How much is the Uniden 2830 Ten Metre Multimode and a 2 metre transverter? With the Uniden 2830 you can have two bands for the price of one, with 10 watts on each band and all modes including CW. ★ S.A.E. for copy of Review.

**Features**

- ★ All modes, AM/FM/USB/LSB/CW
- ★ LCD readout of frequency/functions
- ★ CW with Sidetone
- ★ FM bandwidth compatible with VHF/UHF
- ★ 10Watts continuously variable o/p AM and FM
- ★ Scanning feature, up and down steps on mic.
- ★ Selectable frequency steps, 10kHz, 1kHz, 100Hz.
- ★ Ten metre band selectable in 500kHz steps
- ★ Build-in VSWR meter and protection circuit
- ★ Superb receiver sensitivity -3uV FM

Just TEN of the many reasons for choosing the UNIDEN 2830

THIS PRODUCT IS EXCLUSIVE TO RAYCOM, WE ARE THE U.K. DISTRIBUTOR. WHOLESAL ENQUIRIES WELCOME

10 metre band amateur transceiver



**£279.00**  
£10.00 post and packing

Matching transverters  
2M transverter £169.00  
6M transverter £189.00  
Package Deal: 2M + 2830 ..... **£399.00 Post £10**

**HANDHELDS**

\* = Extended Receiver coverage available, call for details.

YAESU FT27R/FN84A 2.5W (5W) DUAL BANDER. C/W CHRGR	<b>£395.00</b>
*YAESU FT23R/FBA10 2.5W (5W) 2MTRS	<b>£229.00</b>
*YAESU FT73R/FNB10 2.5W (5W) 70CMS C/W CHARGER	<b>£259.00</b>
*ICOM MICRO 2E 2.5W 2MTR HANDHELD WITH CHARGER	<b>£209.00</b>
CTE1600 (SAME AS ICOM IC2E) C/W NICAD CHARGER	<b>£179.00</b>

Many other types of handheld stocked, please enquire

**SHORT WAVE RECEIVERS**

Yaesu FRG8800 Short Wave 100KHz-30MHz all Mode + Mem.	<b>£589.00</b>
Yaesu FRG8800/FRV8800 as above with VHF Conv. fitted	<b>£679.00</b>
Icom ICR-71 Top Grade Communications Receiver	<b>£799.00</b>
Sony PRO80 HF/VHF Handheld Scanner c/w accessories	<b>£345.00</b>
Sony 20010 Short Wave/Airband Receiver	<b>at £349.00</b>
Sony SW1 Micro Short Wave Receiver	<b>£249.00</b>

Many more makes and models in stock. PLEASE CALL FOR PRICES. DELIVERY COSTS and any advise or information, or send large SAE. (Insured post and packing £10.00. Carrier £12.50)

**YAESU FT 747GX**

**£649.00** including our FREE fitted MOD Board!

We improve the reciprocal mixing performance by up to 15dB which gives you receive performance of higher priced rigs! Only available from Raycom, buy it elsewhere if you want SECOND BEST! YAESU IS STILL BEST VALUE FOR MONEY!

ALL CURRENT YAESU AND ICOM HF RIGS STOCKED, CALL FOR A DEAL!

**MOBILES**

YAESU FT211RH 45W 2MTR MOBILE WITH FREE 1/4 WAVE ANT	<b>£299.00</b>
YAESU FT212RH NEW 45W 2MTR MOBILE DVS FEATURE OPT	<b>£349.00</b>
*ICOM IC28E 2MTR 25W MOBILE WITH FREE 5/8 ANTENNA	<b>£359.00</b>
Ailinc Dual Band ALD-24E	<b>£445.00</b>
ICOM IC48E 70cm 25W	<b>£428.00</b>
ICOM IC3200 Dual Band 25W	<b>SPECIAL £399</b>

Compare our prices!  
Many other types and makes stocked, please enquire.

**PORTABLES**

FT290RMK2 2.5W MULTIMODE STANDARD ACCESSORIES	<b>£399.00</b>
FT290RMK2 2.5 WATT M/M AS ABOVE C/W NICADS CHRGR	<b>£425.00</b>
FT290RMK2/FL2025 (STD) WITH 25W LINEAR AMPLIFIER	<b>£489.00</b>
FT690RMK2 2.5W MULTIMODE STANDARD ACCES	<b>£399.00</b>
FT690RMK2 6MTR 2.5W M/M AS ABOVE C/W NICADS CH	<b>£425.00</b>
FT790RMK2 NEW 70CM 2.5W MULTIMODE DUE OUT SOON	<b>£499.00</b>

**ANTENNAS & ACCESSORIES**

NOW AVAILABLE AT RAYCOM: CUSHCRAFT, BUTTERNUT, HY-GAIN ANTENNAS, JAYBEAM, TONNA, MET, HAM-M ROTATORS, Call for full details, prices, availability and delivery costs.

ICOM AH7000 SUPER 250-1300MHz DISCONE **£79.50**  
G5RV HALF SIZE HF ANTENNA ready to use .... **£16.50**  
G5RV FULL SIZE HF ANTENNA ready to use .... **£18.50**  
GBKW-TYPE 7.1MHz TRAP DIPOLE KIT SO239 **£24.50**  
GBKW-TYPE as above for use with 75 OHM .... **£23.50**  
GBKW-TYPE 2X 7.1 TRAPS ONLY. LESS CABLE **£9.95**  
RAYCOM AIRBAND-VHF SIX ELEMENT DISCONE **£12.50**  
RAYCOM DISCONE VHF 60-600MHz BE.S0239/COAX **£29.50**  
SUN KG209 SE2M 5/8 MOBILE TILT-OVER 259 **£14.50**  
RAYCOM CAST GUTTERMOUNT C/W SO239/COAX **£8.50**  
GAMMA TWIN 2 METRE SLIM JIM KIT inc. instr. **£14.50**  
RAYCOM/RWC HB9CV 2 METRE 2E MINI BEAM **£12.50**  
RAYCOM/RWC HB9CV 70CM 2E MINI BEAM .... **£8.95**

The above popular products POST FREE.  
(UK mainland only)

**ROYAL 1300 WIDEBAND DISCONE**

Following the huge success and popularity of the 25-1300MHz, wideband discone antenna - Icom AH 7000 & Welz - Diamond D109 with transmit facilities on VHF-UHF amateur bands, Raycom decided to persuade a UK manufacturer to make a "BRITISH COPY!" at a very competitive price!

COMPLETE WITH PROFESSIONAL CABLE & CONNECTORS AT ONLY £59.50 P&P £5.

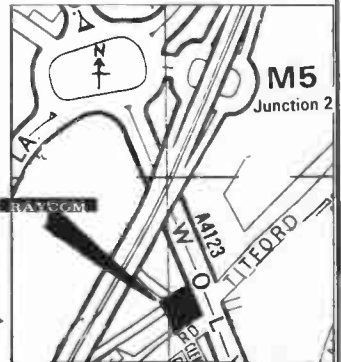

CALL IN, EASY TO GET TO, EASY PARKING

Opening hours 9am-5.30pm 6 days, late nights Thursday & Friday till 7pm. We stay open later!

**ORDERING INFORMATION**

ALL PRODUCTS WE ADVERTISE ARE NORMAL STOCK ITEMS. OUR NEW MAIL ORDER DEPARTMENT CAN NOW DESPATCH MANY ITEMS SAME DAY, BUT PLEASE ALLOW UP TO 14 DAYS. DELIVERY TIME IS SUBJECT TO CARRIAGE METHOD. IF ORDERING BY MAIL PLEASE INCLUDE CARRIAGE AND STATE YOUR DAYTIME TELEPHONE NUMBER. ALL PRODUCTS OVER £750.00 CARRIAGE FREE. PLEASE ALLOW TIME FOR PERSONAL CHEQUES TO CLEAR. PLEASE CALL BEFORE ORDERING AND FOR MORE INFORMATION

PLEASE TEL: 021 544 6767

**RAYCOM COMMUNICATIONS SYSTEMS LTD.**  
**INTERNATIONAL HOUSE, 963 WOLVERHAMPTON ROAD**  
**OLDBURY WEST MIDLANDS B69 4RJ**  
Telephone 021 544 6767. Fax 544 7124. Telex 336483 Identi-G

**RAYCOM gives you MORE PURCHASING POWER!**



FOR FAST SERVICE PHONE IN YOUR ORDER WITH ANY MAJOR CREDIT CARD OR IN MOST CASES WE CAN OFFER YOU INSTANT CREDIT OF UP TO £1,000.00 (SUBJECT TO STATUS. RAYCOM ARE LICENSED CREDIT BROKERS, APR 29.8%, SUBJECT TO VARIATION. FREE CREDIT ON CERTAIN PRODUCTS AT M.R.P. PRICES, 50% DEPOSIT AND SIX MONTHLY PAYMENTS. PLEASE TELEPHONE FOR MORE DETAILS AND APPLICATION FORMS.

**NEW INFOLINE 0836 282228**  
available 5-9pm (weekdays only)



FOR THE BEST IN AMATEUR RADIO

THROUGH OUR CONTINUOUS AND VALUED CUSTOM, RAY WITHERS COMMUNICATIONS LTD. HAS MOVED AND EXPANDED TO ENABLE US TO OFFER YOU EVEN BETTER SERVICE AND PRICES - STILL WITH THE RAYCOM GUARANTEE, BEST EQUIPMENT, BEST SERVICE, BEST PRICES, BEST BACK-UP, AND PLENTY OF PARKING FACILITIES AND EASIER TO GET TO! WE NOW BOAST THE BEST CENTRAL FACILITIES IN THE COUNTRY, WHY NOT POP ALONG AND SEE THE LATEST TRANSCEIVERS, SHORTWAVE/SCANNING RECEIVERS AND ACCESSORIES? MOST OTHER PRODUCTS ADVERTISED IN THIS MAGAZINE ARE AVAILABLE AT RAYCOM, AND DON'T FORGET OUR EXCLUSIVE PRODUCTS AND MODIFICATIONS!



# Amateur RADIO

**Editorial:**

Iain Mackenzie  
Penny Phillips

**Advertisement  
Manager:**

Marian Vidler

**Advertisement Executive**  
Maria Smith**Subscriptions:**  
01-684 9542**Publisher:**  
Peter Williams**On sale:**

Last Thursday of the  
month preceding cover  
date

**Next issue:**

Cover date November, on  
sale 27th October 1988

**Published by:**

Amateur Radio  
Magazines,  
Sovereign House,  
Brentwood, Essex.  
CM14 4SE, England  
(0277) 219876

**Printed:** In England**ISSN:** 0264-2557**News Trade Sales by:**

S M Distribution,  
6 Leigham Court Road,  
Streatham, London.  
SW16 2PG  
Tel: 01-677 8111

Whilst every care is taken when accepting advertisements we cannot accept responsibility for unsatisfactory transactions. We will, however, thoroughly investigate any complaints. The views expressed by contributors are not necessarily those of the publishers. Every care is also taken to ensure that the contents of *Amateur Radio* are accurate, we assume no responsibility for any effect from errors or omissions.

© Copyright 1988  
Amateur Radio Magazines

**6 Straight & Level**

The latest news, comments and developments on the amateur radio scene

**9 The Icom IC-u4E Hand-held Transceiver**

Ken Michaelson conducts a user review

**11 Angus McKenzie Tests . . .**

. . . the new low-loss coaxial cable from Westlake and the PX02 pulse generator and marker unit

**14 Constructing a Fast Ni-Cad Charger**

Steven and John Goodier show you how to construct a charger which is safe, cheap to build and a very worthwhile addition to the shack

**20 DX Diary**

Don Field, G3XTT, with this month's DX news

**23 Scrounger's Notebook**

Thomas E King, VK2ATJ, with some advice on getting something for nothing

**28 Multiband Dipoles**

In the second part of his series on the dipole aerial Ken Williams considers multiband dipoles

**33 Second-hand**

Pye Compacts, dual conversion superhet receivers, front ends, Honda generators. Hugh Allison tells you more

**35 Short Wave Listener**

Trevor Morgan, GW40XB, looks at sunspots and filtering systems and gives the latest update on award winners

**37 On the Beam**

Glen Ross, G8MWR, with the latest microwave news and some thoughts on a novice licence

**39 Project Book**

Martin Williams discusses decibels

**40 50MHz**

Ken Ellis, G5KW, with the latest developments on 6m

**42 The Codar AT5 Transmitter**

Richard Q Marris, G2BZQ, takes a look at this rig. If you can buy one second-hand you should find it excellent value for money, as Richard reveals

---

**SERVICES****25 Subscription Order Form****45 Free Classified Ads****47 Newsagent Order Form****50 Advertisers' Index****50 Advertising Rates and Information**



PHONE  
0474 60521

# P.M. COMPONENTS LTD

SELECTION HOUSE,  
SPRINGHEAD ENTERPRISE PARK, SPRINGHEAD ROAD,  
GRAVESEND, KENT DA11 8HD

TELEX  
966371  
TOS PM

## INTEGRATED CIRCUITS

AN103	2.50	LA4430	2.50	AL1327Q	1.10	TA7609P	2.50	TC4760	2.50	IDA4500	2.95
AN124	2.50	LA4481	2.50	SN7474	1.80	TA7611AP	2.50	TC4800	2.50	IDA4650	2.95
AN214	2.50	LC7130	3.25	SN7472	0.85	TA7629	2.50	TC4800	6.95	IDA5003	3.15
AN236	1.95	LC7131	5.50	SN76023N	3.00	TAA310A	3.50	TC4800	1.95	TEA1099	1.35
AN239	2.50	LC7137	8.50	SN78110N	0.90	TAA320A	3.50	TC4900	2.50	UPC41C	3.50
AN240P	2.50	LM322K	4.95	SN78115N	1.25	TAA350A	1.95	TC4940	1.85	UPC566H	2.95
AN247	2.50	LM322N	4.95	SN78131N	1.30	TAA550B	1.95	TDA440	2.20	UPC575C2	2.75
AN250	2.95	LM360N	1.50	SN76226DN	2.50	TAA570	1.95	TDA1001	2.95	UPC10001H	2.75
AN262	1.95	LM380N8	2.95	SN76227N	1.05	TAA6320S	2.95	TDA1006A	3.95	UPC1020H	1.95
AN264	2.50	LM3837	2.95	SN76228N	2.95	TAA661B	1.95	TDA1010	2.15	UPC1024H	2.95
AN271	3.50	LM380N	3.50	SN76533N	1.05	TAA700	1.70	TDA1035	2.50	UPC1025H	1.50
AN301	2.95	LM1011	3.15	SN76560N	1.15	TAA930	2.95	TDA1037	1.95	UPC1025H	1.95
AN303	3.50	M5155L	2.95	SN76660N	0.90	TAA120AS/B/C	1.00	TDA1044	2.15	UPC1028H	1.95
AN313	2.95	M51513L	2.30	STK011	7.95	TAA120AS/B/C	1.00	TDA1180	1.95	UPC1032H	1.95
AN315	2.25	M51521L	1.80	STK014	7.95	TA/5B/T/U	1.00	TDA1200	2.95	UPC1158H	1.80
AN316	3.95	MB3705	1.50	STK015	8.95	TBA395	1.50	TDA1237	1.70	UPC1167C2	0.75
AN331	3.95	MB3712	2.00	STK018	7.95	TBA398	0.75	TDA2000	1.95	UPC1181H	1.95
AN342	2.95	MB3756	2.00	STK025	11.95	TBA440N	2.55	TDA2020	2.95	UPC1182H	1.25
AN352L	2.95	MC1307P	2.00	STK032	7.95	TBA480Q	1.25	TDA2150	2.95	UPC1185H	2.95
AN612	2.15	MC1310P	1.95	STK078	11.95	TBA510	2.50	TDA2151	1.95	UPC1191V	1.80
AN632	3.95	MC1327	1.70	STK085	8.95	TBA510Q	2.50	TDA2152	1.95	UPC1350C	3.95
AN740	3.50	MC1327Q	0.95	STK415	6.95	TBA520	1.10	TDA2530	1.95	UPC1353C	2.95
AN745	3.50	MC1351P	1.75	STK435	8.95	TBA520Q	1.10	TDA2541	2.15	UPC1360	2.95
AN7145M	3.95	MC1357	2.35	STK437	7.95	TBA530Q	1.10	TDA2541	2.15	UPC1365C	3.95
AN7150	2.50	MC1358	1.85	STK439	7.95	TBA540	1.25	TDA2582	2.95	UPD2114L	1.95
AN7151	2.50	MC1358	1.85	STK439	7.95	TBA540	1.25	TDA2582	2.95	UPD2114L	1.95
BA521	3.35	MC1496	1.75	STK461	11.95	TBA540Q	1.25	TDA2582	2.95	UPD2114L	1.95
CA1352E	1.75	MC1723	0.90	STK463	11.95	TBA550Q	1.25	TDA2582	2.95	UPD2114L	1.95
CA3086	0.45	MC3357	2.75	STK0015	7.95	TBA590C	1.45	TDA2582	2.95	UPD2114L	1.95
CA3129E	1.95	MC3401L	2.80	STK0029	2.95	TBA590Q	1.45	TDA2582	2.95	UPD2114L	1.95
CA3131EM	2.50	MC3410E	2.95	STK0039	7.95	TBA570	1.00	TDA2582	2.95	UPD2114L	1.95
CA3140s	2.50	MC14518CP	7.50	TA7072	2.85	TBA673	1.95	TDA2582	2.95	UPD2114L	1.95
CA3140T	1.15	ML231B	1.75	TA7073	3.85	TBA720	2.45	TDA2582	2.95	UPD2114L	1.95
ETT16016	2.50	ML232B	2.50	TA7106P	1.80	TBA750	1.95	TDA2582	2.95	UPD2114L	1.95
HA1137W	1.95	ML239	2.95	TA7120P	1.65	TBA750	1.95	TDA2582	2.95	UPD2114L	1.95
HA1156W	1.95	MSM5807	0.75	TA7120P	1.65	TBA750	1.95	TDA2582	2.95	UPD2114L	1.95
HA1306	1.50	MSM5807	0.75	TA7130P	1.50	TBA800	0.95	TDA2582	2.95	UPD2114L	1.95
HA1322	1.95	SAA1025	7.25	TA7130P	1.50	TBA800	0.95	TDA2582	2.95	UPD2114L	1.95
HA1339A	2.95	SAA1251	4.95	TA7146P	1.80	TBA800	0.95	TDA2582	2.95	UPD2114L	1.95
HA13665M	2.75	SAA500A	3.95	TA7146P	1.80	TBA800	0.95	TDA2582	2.95	UPD2114L	1.95
HA1406	1.95	SAA5020	0.75	TA7203	2.95	TBA820Q	1.45	TDA2582	2.95	UPD2114L	1.95
HA1551	2.95	SAB3210	3.95	TA7204P	2.15	TBA890	2.90	TDA2582	2.95	UPD2114L	1.95
LA1201	0.95	TA7204P	2.15	TA7204P	2.15	TBA920	1.65	TDA2582	2.95	UPD2114L	1.95
LA1230	1.95	SAS5708	1.75	TA7205AP	1.15	TBA920	1.65	TDA2582	2.95	UPD2114L	1.95
LA2301	0.95	SAS80	2.85	TA7206	1.95	TBA950/2X	2.25	TDA2582	2.95	UPD2114L	1.95
LA4101	0.95	SAS890	2.75	TA7227P	4.35	TBA990	1.49	TDA2582	2.95	UPD2114L	1.95
LA4102	2.95	SL901B	7.95	TA7228P	1.85	TBA990Q	1.49	TDA2582	2.95	UPD2114L	1.95
LA4143	2.95	SL901B	7.95	TA7310P	1.90	TCA270	1.50	TDA2582	2.95	UPD2114L	1.95
LA4031P	1.95	SL1310	1.10	TA7313AP	2.85	TCA270SQ	1.50	TDA2582	2.95	UPD2114L	1.95
LA4400	3.50	SL1327	1.10	TA7314P	2.95	TCA850	2.50	TDA2582	2.95	UPD2114L	1.95
LA4420	3.50	SL1327	1.10	TA7321P	2.25	TCA850	2.50	TDA2582	2.95	UPD2114L	1.95

## SEMICONDUCTORS

AC126	0.45	BC1821B	0.10	BD237	0.40	BF493	0.35	MRF453	17.50	TV106	1.80
AC127	0.20	BC183	0.10	BD242	0.65	BF595	0.25	MRF456	26.50	TV106/2	1.80
AC128	0.25	BC183L	0.09	BD246	0.75	BF597	0.25	MRF455	17.50	ZRF0112	16.50
AC128K	0.32	BC184BL	0.09	BD376	0.32	BF39	0.25	MRF475	2.95	2N1100	6.50
AC141	0.25	BC204	0.25	BD379	0.45	BF40	0.25	MRF477	14.95	2N1308	1.35
AC141K	0.30	BC207B	0.25	BD410	0.65	BF81	0.25	OC166	2.95	2N1171	0.30
AC142K	0.45	BC208B	0.20	BD434	0.65	BF88	0.30	OC23	9.50	2N2219	0.25
AC176	0.22	BC212	0.10	BD437	0.75	BF90	0.35	OC25	1.50	2N2626	0.20
AC176K	0.31	BC212L	0.09	BD437	0.75	BF90	0.35	OC26	1.50	2N2905	0.40
AC187	0.25	BC213	0.09	BD438	0.75	BF42	0.35	OC28	5.50	2N3053	0.40
AC187K	0.28	BC213L	0.09	BD510	0.95	BF43	0.35	OC29	4.50	2N3054	0.50
AC188	0.25	BC214	0.09	BD518	0.75	BF10	0.55	OC32	5.50	2N3055	0.52
AC188K	0.37	BC214C	0.09	BD520	0.65	BF11	0.75	OC42	1.50	2N2702	0.12
AD142	2.50	BC217L	0.09	BD534	0.95	BF16A	1.15	OC44	1.00	2N3703	0.12
AD149	0.70	BC223B	0.15	BD535	0.45	BF91	0.80	OC45	1.00	2N3705	0.12
AD161	0.90	BC238	0.15	BD587	0.95	BF29	0.30	OC71	0.75	2N3706	0.12
AD162	0.80	BC239	0.15	BD588	0.95	BF29	0.30	OC72	2.50	2N3708	0.12
AF106	0.80	BC251A	0.15	BD588	0.95	BF29	0.30	OC72	2.50	2N3708	0.12
AF114	1.95	BC252A	0.15	BD698	1.50	BFX85	0.32	OC75	1.50	2N3733	2.50
AF121	0.80	BC258	0.25	BD701	1.25	BFX86	0.30	OC81	1.00	2N3773	9.75
AF124	0.85	BC258A	0.30	BD702	1.25	BFX88	0.35	OC84	1.50	2N3792	1.35
AF125	0.35	BC284	0.30	BD707	0.90	BFY18	1.35	OC139	12.50	2N4427	1.95
AF126	0.85	BC300	0.30	BD732	1.45	BFY50	0.72	OC171	5.50	2N4444	1.15
AF127	0.85	BC301	0.30	BD732	1.45	BFY50	0.72	OC200	4.50	2N5294	0.42
AF150	0.40	BC303	0.25	BF115	0.35	BFY90	0.35	OC201	6.50	2N5294	0.42
AF178	1.95	BC307B	0.09	BF119	0.65	BLY48	1.75	OC205	10.00	2N5296	0.45
AF239	0.95	BC327	0.10	BF127	0.39	BR100	1.45	RC2008B	1.45	2N5485	0.45
AY102	2.95	BC338	0.10	BF154	0.20	BR101	0.45	R2009	2.50	2N5496	0.95
BC107A	0.11	BC347A	0.13	BF160	0.27	BR103	0.65	R2010B	1.45	2N5A329	0.95
BC107B	0.11	BC478	0.20	BF178	0.25	BR303	0.95	R225	0.65	2SA715	0.55
BC108	0.10	BC527	0.30	BF178	0.25	BR303	0.95	R225	0.65	2SA715	0.55
BC109	0.10	BC547	0.10	BF178	0.25	BR303	0.95	R225	0.65	2SA715	0.55
BC109B	0.12	BC548	0.10	BF181	0.29	BR100	0.45	R2008B	1.45	2N5485	0.45
BC109C	0.12	BC549A	0.10	BF182	0.29	BT106	1.49	RCA16334	0.95	2N5496	0.95
BC114A	0.09	BC550	0.14	BF183	0.29	BT116	1.20	RCA16335	0.85	2N5496	0.95
BC115	0.55	BC557	0.08	BF184	0.35	BT119	3.15	RCA16572	0.85	2N5496	0.95
BC116A	0.85	BC558	0.10	BF185	0.28	BT120	1.05	SKE5F	1.45	2N5106	0.50
BC116B	0.85	BC559	0.10	BF185	0.28	BT120	1.05	SKE5F	1.45	2N5106	0.50
BC119	0.24	BDY33A	16.50	BF195	0.11	BU105	1.05	2K621V	0.45	2N5112A	0.95
BC125	0.25	BDY115	0.30	BF197	0.11	BU108	1.89	T6027V	0.45	2N5112A	0.95
BC125B	0.25	BDY124P	0.69	BF199	0.16	BU125	1.25	T6036V	0.55	2N5112A	0.95
BC139BC	0.20	BDY131	0.42	BF199	0.16	BU126	1.25	T6036V	0.55	2N5112A	0.95
BC140	0.31	BDY132	0.42	BF200	0.40	BU204	1.95	T9011V	0.75	2N5112A	0.95
BC141	0.25	BDY135	0.30	BF201	0.30	BU205	1.30	T9015V	2.15	2N5112A	0.95
BC142	0.21	BDY136	0.30	BF201	0.30	BU205	1.30	T9015V	2.15	2N5112A	0.95
BC147B	0.10	BDY137	0.32	BF256LC	0.35	BU208D	1.85	THY15/85	2.25	2N5112A	0.95
BC148A	0.09	BDY138	0.30	BF257	0.28	BU326	1.20	THY15/85	2.25	2N5112A	0.95
BC149	0.09	BDY139	0.32	BF259	0.28	BU326S	1.80	TIP25	0.42	2N5112A	0.95
BC153	0.30	BDY140	0.30	BF271	0.28	BU407	1.25	TIP29C	0.42	2N5112A	0.95
BC157	0.12	BDY144	1.10	BF271	0.28	BU407	1.25	TIP29C	0.42		





# P.M. COMPONENTS LTD

## SELECTRON HOUSE

### SPRINGHEAD ENTERPRISE PARK, SPRINGHEAD ROAD GRAVESEND, KENT DA11 8HD

# TELEX

## 966371

### TOS PM

# PHONE

0474 60521  
FAX NO.0474 333 762

### A SELECTION FROM OUR STOCK OF BRANDED VALVES (Cont'd)

DL35 2.50	ECL85 0.95	GY501 1.80	OM5B 3.00	R19 2.50	VR105/30 2.50	4-250A 85.00	6CA7 3.50	7Y4 2.50	35A3 3.95	5704 3.50
DL63 1.00	ECL86 0.95	GY802 1.50	OM6 1.75	R1169 55.00	VR150 2.50	4-300 21.50	6CB5 1.50	8B8 2.50	35A5 4.50	5718 6.15
DL70 2.50	ECL805 0.95	GZ32 2.50	ORP43 2.50	RS559 9.50	VU29 4.50	1000A 425.00	6CD6GA 4.50	8B10 2.50	35C15 2.50	5725 2.50
DL73 2.50	EF37A 2.80	GZ33 4.50	ORP50 3.95	RG1-125 4.50	VU39 2.80	4B32 35.00	6CF6 1.95	8B05 1.95	35LGT 2.00	5726 2.50
DL91 3.95	EF39 1.80	GZ234 2.50	P61 2.50	RG1-240A 1.50	W21 4.80	4B35S1B 1.50	6CG7 4.50	8C05 1.95	3523 1.95	5727 2.50
DL92 1.25	EF40 4.80	GZ237 4.50	PABC80 0.75	RG3-250A 1.50	W61 4.80	125.00	6CH6 6.95	8E8B 1.95	35Z5GT 3.50	5749 2.50
DL93 1.10	EF42 3.50	H3C90 1.95	PC86 0.75	RG3-1250A 35.00	W77 5.00	4B25 1.00	6CL5 3.95	10D2 1.25	38HE7 5.95	5750 1.85
DL10 2.80	EF50 2.50	HF93 2.50	PC97 1.10	RG3-250A 35.00	W79 1.80	4C28 25.00	6CL8A 1.50	10D7E 2.50	40KD6 5.50	5751 2.95
DL13 1.50	EF54 4.80	HL41 3.50	PC900 1.28	RPK2K25 62.50	X24 4.50	4C35 145.00	6CM7 2.95	10DX8 2.50	47 8.00	5811A 3.25
DL16 10.00	EF55 4.95	HL90 3.50	PC984 0.40	RPY18 2.50	X41 4.80	4CX125C 1.50	6CS6 0.75	10EB8 1.95	50A5 1.50	5823 6.50
DM70 3.95	EF70 1.20	HL13DD 3.50	PC985 0.75	RPY43 2.50	X66/X65 4.95	Emac 180.00	6CS7 0.95	10EW7 2.95	50B5 1.95	5829WA 9.50
DM160 6.50	EF73 3.80	KT8C 7.00	PC986 0.70	RPY82 2.50	X76 1.95	4CX250B 45.00	6CW4 8.00	10F1 0.75	50C5 0.95	5840 3.50
DOP-067 9.50	EF80 0.58	KT33C 3.50	PC989 0.70	RR3-250 15.00	XK24 1.50	4CX250B 65.00	6CX8 2.50	10G6 1.95	50C6DG 1.95	5842 11.00
DY86/87 0.75	EF85 0.60	KT36 2.00	PC805 0.70	RR3-1250 35.00	XC25 1.50	4CX250K 1.50	6D08 1.00	10H1 1.95	50EHS 1.50	5863 95.00
DY802 0.85	EF86 2.25	KT45 4.00	PC806 0.80	S6F17 5.95	XF50 1.90	4CX250K 115.00	6D18 1.00	10I3 55.00	50J76 2.95	5886 13.95
ES5L 49.50	EF86 Mullard 4.80	KT63 2.00	PC807 0.80	S6F33 28.65	XF50 1.90	4CX250R 125.00	6D26 2.50	10J1 1.95	50K2 1.95	5894 39.50
ES60C 12.50	EF86/CV4085 4.80	KT66 USA 9.95	PC808 0.85	S11E12 35.00	YG1-2500 75.00	4CX350A 1.50	6DQ5 8.50	10K6 1.95	50L75 3.50	5899 4.50
ES6F 18.50	EF89 1.80	KT66 GEC 25.00	PC809 0.70	S109/1K 15.00	YD1100 75.00	4CX350A 425.00	6DQ5 8.50	10L1 1.95	50M5 1.95	5963 2.15
ES80L 29.50	EF91 1.95	KT67 9.00	PC810 1.25	S130P 8.95	YD1100 75.00	4CX1500B 4.50	6E5 3.95	12A15 1.95	50N1 1.95	5963 1.75
ES81C 5.50	EF92 2.15	KT77 Gold Ion 11.85	PC811 1.85	S130P 8.95	YD1100 75.00	4CX1500B 4.50	6E7 2.95	12A16 1.95	50O1 1.95	5965 2.15
ES82CC 4.80	EF93 1.80	KT77 Gold Ion 11.85	PC812 1.85	SC11/200 5.00	YD1100 75.00	4CX1500B 4.50	6E8 2.50	12A17 1.95	50P1 1.95	5965 2.15
ES83CC 4.80	EF94 1.80	KT81 7.00	PC813 0.85	SC11/200 5.00	YD1100 75.00	4CX1500B 4.50	6E9 2.50	12A18 1.95	50Q1 1.95	5965 2.15
ES8F 3.50	EF95 1.95	KT88 USA 10.95	PC814 0.65	SC11/140 6.00	YD1100 75.00	4CX1500B 4.50	6EA 2.50	12A19 1.95	50R1 1.95	5965 2.15
ES8C 9.80	EF96/CV4085 5.00	KT88 18.00	PC815 1.20	SC11/140 6.00	YD1100 75.00	4CX1500B 4.50	6EB 2.50	12A20 1.95	50S1 1.95	5965 2.15
ES8C 7.95	EF97 0.80	KT88 18.00	PC816 1.20	SC11/140 6.00	YD1100 75.00	4CX1500B 4.50	6EC 2.50	12A21 1.95	50T1 1.95	5965 2.15
ES8CC 3.50	EF98 0.90	KT88 18.00	PC817 1.20	SC11/140 6.00	YD1100 75.00	4CX1500B 4.50	6ED 2.50	12A22 1.95	50U1 1.95	5965 2.15
ES8CC Mullard 4.80	EF99 0.80	KT88 18.00	PC818 1.20	SC11/140 6.00	YD1100 75.00	4CX1500B 4.50	6EE 2.50	12A23 1.95	50V1 1.95	5965 2.15
ES8CC 4.80	EF103 0.75	KT88 18.00	PC819 1.20	SC11/140 6.00	YD1100 75.00	4CX1500B 4.50	6EF 2.50	12A24 1.95	50W1 1.95	5965 2.15
ES90C-01 6.95	EF104 0.85	KT88 18.00	PC820 1.50	SC11/140 6.00	YD1100 75.00	4CX1500B 4.50	6EG 2.50	12A25 1.95	50X1 1.95	5965 2.15
ES90C 7.95	EF131 4.50	KT88 18.00	PC821 1.50	SC11/140 6.00	YD1100 75.00	4CX1500B 4.50	6EH 2.50	12A26 1.95	50Y1 1.95	5965 2.15
ES90F 7.95	EF800 11.00	KT88 18.00	PC822 1.50	SC11/140 6.00	YD1100 75.00	4CX1500B 4.50	6EI 2.50	12A27 1.95	50Z1 1.95	5965 2.15
ES91H 4.80	EF804S 19.90	KT88 18.00	PC823 1.50	SC11/140 6.00	YD1100 75.00	4CX1500B 4.50	6EJ 2.50	12A28 1.95	50A1 1.95	5965 2.15
ES92CC 3.95	EF805 28.00	KT88 18.00	PC824 1.50	SC11/140 6.00	YD1100 75.00	4CX1500B 4.50	6EK 2.50	12A29 1.95	50B1 1.95	5965 2.15
ES99 6.95	EF806S 28.00	KT88 18.00	PC825 1.50	SC11/140 6.00	YD1100 75.00	4CX1500B 4.50	6EL 2.50	12A30 1.95	50C1 1.95	5965 2.15
ET130L 18.80	EF812 0.65	KT88 18.00	PC826 1.50	SC11/140 6.00	YD1100 75.00	4CX1500B 4.50	6EM 2.50	12A31 1.95	50D1 1.95	5965 2.15
ET180CC 9.80	EF1200 1.50	KT88 18.00	PC827 1.50	SC11/140 6.00	YD1100 75.00	4CX1500B 4.50	6EN 2.50	12A32 1.95	50E1 1.95	5965 2.15
ET180F 5.80	EF1200 1.50	KT88 18.00	PC828 1.50	SC11/140 6.00	YD1100 75.00	4CX1500B 4.50	6EO 2.50	12A33 1.95	50F1 1.95	5965 2.15
ET182CC 9.00	EF1200 1.50	KT88 18.00	PC829 1.50	SC11/140 6.00	YD1100 75.00	4CX1500B 4.50	6EP 2.50	12A34 1.95	50G1 1.95	5965 2.15
ET182CC 9.00	EF1200 1.50	KT88 18.00	PC830 1.50	SC11/140 6.00	YD1100 75.00	4CX1500B 4.50	6EQ 2.50	12A35 1.95	50H1 1.95	5965 2.15
ET182CC 9.00	EF1200 1.50	KT88 18.00	PC831 1.50	SC11/140 6.00	YD1100 75.00	4CX1500B 4.50	6ER 2.50	12A36 1.95	50I1 1.95	5965 2.15
ET182CC 9.00	EF1200 1.50	KT88 18.00	PC832 1.50	SC11/140 6.00	YD1100 75.00	4CX1500B 4.50	6ES 2.50	12A37 1.95	50J1 1.95	5965 2.15
ET182CC 9.00	EF1200 1.50	KT88 18.00	PC833 1.50	SC11/140 6.00	YD1100 75.00	4CX1500B 4.50	6ET 2.50	12A38 1.95	50K1 1.95	5965 2.15
ET182CC 9.00	EF1200 1.50	KT88 18.00	PC834 1.50	SC11/140 6.00	YD1100 75.00	4CX1500B 4.50	6EU 2.50	12A39 1.95	50L1 1.95	5965 2.15
ET182CC 9.00	EF1200 1.50	KT88 18.00	PC835 1.50	SC11/140 6.00	YD1100 75.00	4CX1500B 4.50	6EV 2.50	12A40 1.95	50M1 1.95	5965 2.15
ET182CC 9.00	EF1200 1.50	KT88 18.00	PC836 1.50	SC11/140 6.00	YD1100 75.00	4CX1500B 4.50	6EW 2.50	12A41 1.95	50N1 1.95	5965 2.15
ET182CC 9.00	EF1200 1.50	KT88 18.00	PC837 1.50	SC11/140 6.00	YD1100 75.00	4CX1500B 4.50	6EX 2.50	12A42 1.95	50O1 1.95	5965 2.15
ET182CC 9.00	EF1200 1.50	KT88 18.00	PC838 1.50	SC11/140 6.00	YD1100 75.00	4CX1500B 4.50	6EY 2.50	12A43 1.95	50P1 1.95	5965 2.15
ET182CC 9.00	EF1200 1.50	KT88 18.00	PC839 1.50	SC11/140 6.00	YD1100 75.00	4CX1500B 4.50	6EZ 2.50	12A44 1.95	50Q1 1.95	5965 2.15
ET182CC 9.00	EF1200 1.50	KT88 18.00	PC840 1.50	SC11/140 6.00	YD1100 75.00	4CX1500B 4.50	6F0 2.50	12A45 1.95	50R1 1.95	5965 2.15
ET182CC 9.00	EF1200 1.50	KT88 18.00	PC841 1.50	SC11/140 6.00	YD1100 75.00	4CX1500B 4.50	6F1 2.50	12A46 1.95	50S1 1.95	5965 2.15
ET182CC 9.00	EF1200 1.50	KT88 18.00	PC842 1.50	SC11/140 6.00	YD1100 75.00	4CX1500B 4.50	6F2 2.50	12A47 1.95	50T1 1.95	5965 2.15
ET182CC 9.00	EF1200 1.50	KT88 18.00	PC843 1.50	SC11/140 6.00	YD1100 75.00	4CX1500B 4.50	6F3 2.50	12A48 1.95	50U1 1.95	5965 2.15
ET182CC 9.00	EF1200 1.50	KT88 18.00	PC844 1.50	SC11/140 6.00	YD1100 75.00	4CX1500B 4.50	6F4 2.50	12A49 1.95	50V1 1.95	5965 2.15
ET182CC 9.00	EF1200 1.50	KT88 18.00	PC845 1.50	SC11/140 6.00	YD1100 75.00	4CX1500B 4.50	6F5 2.50	12A50 1.95	50W1 1.95	5965 2.15
ET182CC 9.00	EF1200 1.50	KT88 18.00	PC846 1.50	SC11/140 6.00	YD1100 75.00	4CX1500B 4.50	6F6 2.50	12A51 1.95	50X1 1.95	5965 2.15
ET182CC 9.00	EF1200 1.50	KT88 18.00	PC847 1.50	SC11/140 6.00	YD1100 75.00	4CX1500B 4.50	6F7 2.50	12A52 1.95	50Y1 1.95	5965 2.15
ET182CC 9.00	EF1200 1.50	KT88 18.00	PC848 1.50	SC11/140 6.00	YD1100 75.00	4CX1500B 4.50	6F8 2.50	12A53 1.95	50Z1 1.95	5965 2.15
ET182CC 9.00	EF1200 1.50	KT88 18.00	PC849 1.50	SC11/140 6.00	YD1100 75.00	4CX1500B 4.50	6F9 2.50	12A54 1.95	50A1 1.95	5965 2.15
ET182CC 9.00	EF1200 1.50	KT88 18.00	PC850 1.50	SC11/140 6.00	YD1100 75.00	4CX1500B 4.50	6FA 2.50	12A55 1.95	50B1 1.95	5965 2.15
ET182CC 9.00	EF1200 1.50	KT88 18.00	PC851 1.50	SC11/140 6.00	YD1100 75.00	4CX1500B 4.50	6FB 2.50	12A56 1.95	50C1 1.95	5965 2.15
ET182CC 9.00	EF1200 1.50	KT88 18.00	PC852 1.50	SC11/140 6.00	YD1100 75.00	4CX1500B 4.50	6FC 2.50	12A57 1.95	50D1 1.95	5965 2.15
ET182CC 9.00	EF1200 1.50	KT88 18.00	PC853 1.50	SC11/140 6.00	YD1100 75.00	4CX1500B 4.50	6FD 2.50	12A58 1.95	50E1 1.95	5965 2.15
ET182CC 9.00	EF1200 1.50	KT88 18.00	PC854 1.50	SC11/140 6.00	YD1100 75.00	4CX1500B 4.50	6FE 2.50	12A59 1.95	50F1 1.95	5965 2.15
ET182CC 9.00	EF1200 1.50	KT88 18.00	PC855 1.50	SC11/140 6.00	YD1100 75.00	4CX1500B 4.50	6FF 2.50	12A60 1.95	50G1 1.95	5965 2.15
ET182CC 9.00	EF1200 1.50	KT88 18.00	PC856 1.50	SC11/140 6.00	YD1100 75.00	4CX1500B 4.50	6FG 2.50	12A61 1.95	50H1 1.95	5965 2.15
ET182CC 9.00	EF1200 1.50	KT88 18.00	PC857 1.50	SC11/140 6.00	YD1100 75.00	4CX1500B 4.50	6FH 2.50	12A62 1.95	50I1 1.95	5965 2.15
ET182CC 9.00	EF1200 1.50	KT88 18.00	PC858 1.50</							

# STRAIGHT &

# LEVEL

## NATIONAL SOUND & VISION '88

This event takes place from Friday 30th September to Sunday 2nd October 1988 inclusive. Held at the picturesque Last Drop Village, Bromley Cross, Bolton, this annual show is now in its eighth year. Amongst this year's exhibitors are: Pioneer, Linn, Creek, NAD, Rotel, Wharfedale, Studio Power 'Hayden Labs Denon Dual Sennheiser', Ariston, Marantz, Heybrook, Revox, Yamaha, Kenwood, Audio Technica, Celestion Acoustic Research, Cambridge Audio, A&R Cambridge, Revolver Meridian, KEF, Philips, Mission, Haymarket, Sony, Panasonic, Technics, Maxell, Amstrad, JVC, Goodmans, Hitachi, Grundig, Aiwa, Sharp, TDK, Beyer, Target, Canon, Scotch 3M, CD Distribution, Apollo and Hunt P2.

Opening times are 12.00noon-8.00pm on Friday, 10.00am-7.00pm on Saturday and 10.00am-6.00pm on Sunday. The admission fee is £1.

Car parking is free and additional Park and Ride facilities will be available on Saturday and Sunday.

Further details are available from the show co-ordinator, George West, on (0204) 31423.

## BEACON/REPEATER REPORT

Following information published in Straight & Level in the August issue of *Amateur Radio* (DTI News) the DTI would like to make it clear that the monthly beacon/repeater report that it produces is sent *only* to the RSGB. The RSGB circulates this document throughout its organisation and therefore, for information on the current status of your application, you should contact your local repeater group. Details of the groups in your area may be obtained from the RSGB, Lambda House, Cranborne Road, Potters Bar, Hertfordshire EN6 3JE.

We apologise to those concerned for any confusion caused.

## COMPUTER INTERFACE

A new multi-function computer interface, the CIL6580, is now available from CIL. The interface has all the functions of the original PCI6380 (data acquisition - 16 bit A-D, waveform generation - 16 bit D-A, relays and input/output ports) plus automatic IEEE and RS232 interface control, a full range of thermocouple inputs for temperature

measurement and expandable bus control. Even with all these functions the emphasis is on simplicity and optimum reliability at low cost.

The CIL6580 is priced at £595 for the bench mounted model and is sold with a five year guarantee.

Further details from: CIL, 4 Wayside, Commerce Way, Lancing, Sussex BN15 8TA. Tel: (0903) 765225.

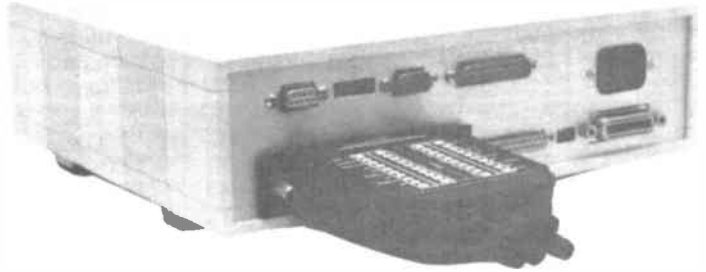

## NEW CONNECTORS AND SWITCHES

A recent distributional deal has brought Rendar, the Bognor-based audio and power component specialist, new ranges of low-cost, good-quality connectors and switches.

The new ranges include jack sockets and plugs for general use (6.3, 3.5 and 2.5mm) and a gold plated range for higher specification equipment. Panel and PCB-mounting sockets are complemented by straight, right-angled and in-line plugs. DIN and Phono plugs and sockets

with comprehensive variations on body materials and design can be supplied. DC-power connectors include plugs and sockets to suit all currently popular needs.

Switches in the new range include push-button, toggle and rocker types, which are suitable for a wide range of applications. Many audio cable assemblies are also held in stock.

For further information, contact: Gez Smith, Rendar Ltd, Durban Road, South Bersted, Bognor Regis, West Sussex PO22 9RL. Tel: (0243) 825811.

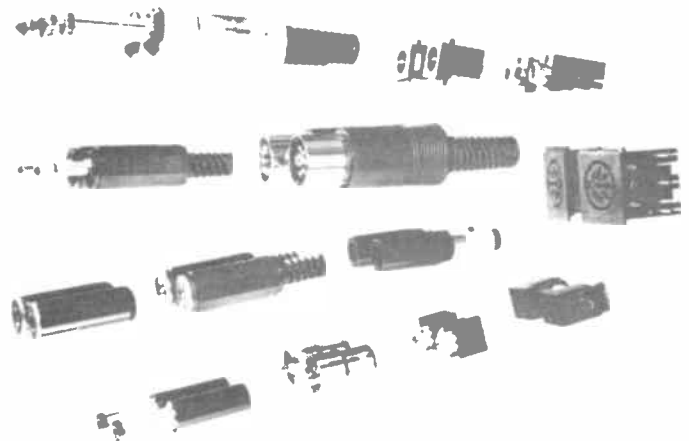



# All the latest news, views, comment and developments on the amateur radio scene

## OPPORTUNITY KNOCKS

The weeks following A level results can be fraught with disappointment – but you do not need a degree to get into electronics or software engineering.

There is now an opportunity for women aged 18-25 to be paid whilst training for a career in this area of work. It is TESS – the Technician Engineer Scholarship Scheme and it is run nationally by the Engineering Industry Training Board.

TESS is a two-year BTEC course at colleges in Blackpool, Crawley, Edinburgh, Lincoln and Sunderland. Recruitment is now under way for an October start. The approach is practical and relevant to industry, with industrial placements to practise and extend the skills acquired during the basic training.

Students will be paid £70 a week in the first year, rising to £82 per week in the second. In addition, all college and training fees are paid by the EITB.

To be eligible, you should:

- be female;
- be aged between 18 and 25 years when the course starts;
- have obtained an O or CSE level pass in mathematics, physics, (or related science programme) and English;
- have studied for an A level or BTEC course or a Scottish Higher or SCOTVEC course.

In addition to satisfying these criteria, you should also be able to demonstrate an aptitude for technician training and the motivation to succeed in the electronics industry.

For further details about TESS, or other EITB initiatives for women, contact Catherine Eaton, the national co-ordinator, on (0922) 743123 or write to her at: *Engineering Industry Training Board, Centre House, Rookery Lane, Aldridge, West Midlands WS9 8QR.*

## SPECIAL EVENT STATION

Thornbury and District Amateur Radio Club, G4ABC, is operating a special event

station, GB75OLD, from Friday 30th September to Sunday 2nd October.

The event takes place at Oldbury-on-Severn Nuclear Power Station, near Bristol, to celebrate the 75th anniversary of the RSGB and the 21st anniversary of the power station.

The station will be operational on Friday evening and from midday on Saturday through to 6pm on Sunday on all bands including ATV. Special event QSLs will be available for SWLs. Visitors to the power station are welcome from midday to 5pm on Saturday and 11am to 5pm on Sunday.

The route will be signposted from the M5 southbound, junction 14 and the M5 northbound, junction 16. Initially, look for signs to the A38 and Thornbury. Car parking is free.

## VERULAM ARC

On 11th October the Verulam Amateur Radio Club is having an activity evening and on 25th October Robin Hewes, G3TDR, is giving a talk entitled '70cm NBFM Transmitters'. Both meetings start at 7.30 for 8pm and visitors are welcome. The venue is the Royal Air Force Association Headquarters, New Kent Road, off Marlborough Road, St Albans.

For further information, contact Hilary, G4JKS. Tel: St Albans 59318.

## A TIP FOR REPAIRS

Cirkit Distribution now stocks the Cooper Weller Pyropen range of professional butane gas operated irons, supplied in three sizes for a wide variety of field applications, with a number of tips and other accessories.

The Weller WSTA1 Pyropen is a cordless, butane gas operated soldering, brazing and hot air tool with temperature controlled by varying the gas flow. Especially suitable for the servicing of electronics, radio and telecommunications equipment

in inaccessible locations, the lightweight (96g) iron does not require batteries or electricity. Supplied with a 3.3mm soldering tip and protective plastic cap, it may also be specified in a metal carrying case with 3.3mm soldering tip plus 5.7mm hot blow tip, torch ejector, spanner, tool support clip, cleaning sponge and operating manual.

The Pyropen will operate for up to three hours continuously on one filling and is ready to solder in 30 seconds. Temperature may be easily adjusted to suit the application, to a maximum soldering temperature of 500°C, hot air temperature of 700°C and torch temperature of 1,300°C (all approximate). Accessor-

ies include a selection of twelve tips and hot blow nozzles for heat-shrink or SMD work, plus butane gas refills.

A self-igniting version, the WSTA4, is also available. It is fitted with a tapered needle tip and hot air nozzle, and is supplied complete with a plastic protective cap and an operational manual.

The WSTA2 Pyropen Jr is a mini soldering, brazing and hot air tool. It is supplied complete with a 0.5mm tapered needle soldering tip, aluminium protective cap and operational manual.

For further information, contact: *Cirkit Distribution Ltd, Park Lane, Broxbourne, Hertfordshire EN10 7NQ. Tel: (0992) 444111.*

## PENNINE AWARD

This award is sponsored by the East Lance Amateur Radio Club. It is open to radio amateurs and SWLs on a 'heard' basis. Only call signs count. The call signs 'P', 'M' and 'A' can be used, but only one contact or 'heard' will be allowed.

QSL cards are not required, but a certified/verified copy of log entries, listed in chronological order, must accompany all claims.

Only stations worked/heard in the Ordnance Survey Map area SD 62, 63, 64, 72, 73, 74, 82,

83 and 84 count towards the award.

The award is issued in four grades: bronze, silver, gold and shield. Certificates are issued for the first three categories.

Claims can be submitted for either 160m or 2m, but the two bands cannot be mixed.

When making a claim, use one side of the log sheets only and get it verified by two licensed amateurs.

For further details, contact: *Mr P Drew, G1OPV, 20 Russell Street, Accrington, Lancashire BB5 2NF.*

## QUALIFICATIONS

Stations based, mobile, portable or alternative in the designated area

	160m	2m
Bronze	30 contacts or heard	60 contacts or heard
Silver	60 contacts or heard	100 contacts or heard
Gold	100 contacts or heard	150 contacts or heard
Shield	150 contacts or heard	250 contacts or heard

Stations based, mobile, portable or alternative outside the area

	160m	2m
Bronze	15 contacts or heard	30 contacts or heard
Silver	30 contacts or heard	60 contacts or heard
Gold	50 contacts or heard	100 contacts or heard
Shield	75 contacts or heard	150 contacts or heard

# STRAIGHT & LEVEL

## NEW QTH

The Grafton Radio Society, based in North London will be moving to a new club QTH as from October.

The new venue will be Holy Trinity Church Hall, Stapleton Hall Road, London N4. Meetings will continue to be held on the second and fourth Friday of each month.

The events' diary gets off to a good start at the new QTH with a talk and demonstration by KW Ten-Tec on 14th October; a talk on the RFI in industry by Brian Bond, G3ZKE, on 28th October; a night on the air on 11th November and a talk on enamelling by Don Bell, G4ILU, on 25th November.

For more details, contact Rod, G0JUZ, tel: 01-368 8154.

## STARS

The Stourbridge and District Amateur Radio Society are celebrating their 50th anniversary this year. They have been allocated a special call sign, GB5OS, which has been running since 5th

September and will run until 3rd October.

## RADIO COMMUNICATION SECURITY

Hagen Cy-Com, the Redditch based data and communications security experts, are promoting their solution to selective calling for portable radio communications.

The Sigtec low-power, miniature 5-tone selective calling encoder/decoder, type S1515, is primarily designed for use in two-way radios. Measuring just 40mm x 20mm x 7mm, the S1515 accommodates most internationally recognised standards including '6-tone reset' and will fit almost any portable radio.

Some of the S1515's many features are: lower power consumption, simple programming, 100,000 address codes, channel busy transmit inhibit, time out timer, international group call and auto reset.

For further information, contact: *Hagen Cy-Com, 16 Colemeadow Road, North*

*Moons Moat, Redditch B98 9PB. Tel: (0527) 61053.*

## PCB TRACK REPAIR KIT

Flowlyne (UK) Ltd have just introduced the Linc 500 Printed Circuit Board Track Repair Kit, incorporating Easitrack, a patented laminate combining pre-tinned copper with a permanent temperature resistant adhesive. The peel-off, self-adhesive tracks and pads give low-cost, fast, 'as new', permanent repairs.

The kit is compact and easy to use. It comes complete with 15ml solvent and applica-

tion brush; 15ml laquer with application brush; a scalpel knife; a curved specialist blade; a preparation brush; an aluminium oxide dressing stick measuring a compact 3 x 13 x 100mm, which causes no electrical resistance or static build-up; a pair of forceps; an instruction and specification card and Easitrack insulator, consisting of three sizes of track.

The complete kit costs £54.50 plus VAT and postage and packing from: *Flowlyne (UK) Ltd, Unit B35, Sanderson Centre, Lees Lane, Gosport, Hampshire PO1 3UL. Tel: (0705) 511444.*



# C.M.HOWES COMMUNICATIONS



**Eydon, Daventry,  
Northants NN11 6PT  
(mail order only)  
Phone: 0327 60178**

## EASY TO BUILD KITS

### SWB30 - SWR/POWER INDICATOR/LOAD

The **HOWES SWB30** kit enables you to build an essential piece of station test equipment easily and at reasonable cost. The SWB30 not only indicates SWR and RF power, but also features a power attenuator that reduces the level of radiated tuning signal and provides an excellent match to your transmitter at all times whilst the antenna or ATU is being adjusted. A resistive bridge circuit is used to give accurate, repeatable results over a wide frequency range.

- \* Nominally flat response in SWR and power modes from 1 to 200MHz.
- \* Smart, custom made moving coil meter unit.
- \* Power handling suits radios of 1 to 100W RF output, provided a tuning signal of less than 30W is used.
- \* Unit can double as a 50 ohm "dummy load" at 15W continuous.
- \* Ideal companion for the HOWES CTU30 all HF bands ATU kit.

**SWB30 kit: £12.50**

**Assembled PCB module: £17.30**

### ASL5 - DUAL BANDWIDTH RECEIVE FILTER

On today's crowded bands, high quality filtering makes all the difference. You can upgrade the performance of almost any radio by the addition of the ASL5 filter kit. It simply connects in line with the external 'speaker' or 'phones' output of the set, giving a CW bandwidth of 300Hz (-6dB) and sharp roll-off for speech modes typically 50dB down at 3.3kHz - a big improvement to the performance offered by a normal crystal IF filter as fitted to most receivers and transceivers. This kit offers a very cost effective and worthwhile improvement. Suits all the popular rigs, Yaesu, ICOM, Kenwood etc. 12 to 14V DC operation.

**ASL5 kit: £14.90**

**Assembled PCB module £22.50**

### DcRx DIRECT CONVERSION COMMUNICATIONS RECEIVERS

The **HOWES DcRx** receivers have become the popular choice of both the beginner looking for a low cost start into the hobby, and the experienced operator building a low power (QRP) station. These little sets offer amazing performance for simple equipment. Versions are available for each of the following bands: 160, 80, 40, and 20/30 metres. They can also be combined with some of our other kits to form transceivers. Tuning capacitors to suit all but the 160m version are available at £1.50 each; you need two per receiver. Modes: SSB and CW.

**DcRx kit: £15.60**

**Assembled PCB module: £21.50**

### Other HOWES KITS include:

	Assembled	
	KIT	PCB
<b>CTX40</b> and <b>CTX80</b> QRP Transmitters for 40 and 80m	£13.80	£19.90
<b>MTX20</b> 10W 20m CW Transmitter	£22.90	£29.90
<b>CVF20</b> <b>CVF40</b> , <b>CVF80</b> VFOs to suit above Txs	£10.40	£16.90
<b>CSL4</b> CW/SSB Filter for DcRx	£9.90	£15.90
<b>DCS2</b> Signal Indicator Meter/Driver for DcRx	£6.80	£10.60
<b>CV220</b> and <b>CV620</b> 2 and 6m to 20m Rx converters	£17.50	£23.90
<b>XM1</b> Crystal Controlled Frequency Marker	£16.80	£21.90
<b>ST2</b> Side-tone/Practice Oscillator	£8.80	£13.50
<b>AP3</b> Automatic Speech Processor	£15.90	£22.80
<b>CM2</b> Quality mic with VOGAD	£11.90	£15.90
<b>CTU30</b> All HF bands ATU for Rx or 30W Tx	£27.90	£33.90
<b>TRF3</b> Short wave broadcast TRF Receiver	£14.80	£20.20
<b>HC220</b> and <b>HC280</b> 20 and 80m Transverters from 2m	£52.50	£83.50

All kits include PCB and all board mounted components, plus full clear instructions. Help, advice and sales are only a phone call away, but please send an SAE for a copy of our free catalogue.

UK P&P is £1.00 per order. Delivery normally within 7 days.

**73 from Dave G4KQH, Technical Manager**



# THE ICOM IC-u4E

## UHF HAND-HELD FM TRANSCEIVER

by KEN MICHAELSON G3RDG

The opportunity to review this little hand-held transceiver gave me my chance to operate on 70cm. Although I have worked 2m for a number of years, I have never operated higher in frequency. It was a very pleasant surprise to experience the operating efficiency of the users and the absence of QRM.

The IC-u4E is one of the smallest hand-held transceivers I have seen, measuring only 58mm x 140mm x 29mm (WHD). These measurements exclude projections. It is also very light, weighing only 340g. The case is made of high impact black plastic. A brief technical specification is shown in the table.

The IC-u4E is fitted with a very short 'rubber duck' type of antenna and is approximately 50mm long terminating in a BNC plug. This must be inserted into the BNC socket on the top of the unit. The review item's Ni-Cad batteries had to be charged before any operation could take place. This was easily accomplished, as a suitable battery charger (model BC-26E) is supplied with the unit, which merely has to be plugged into any ac outlet. It has a sensible length of lead coming from it, terminating in the usual 2.1mm power plug.

The actual unit itself, however, has a continental 2 pin type plug on its base. As it is impossible to plug this into a current 13 amp modern socket a 'Heath Robinson' arrangement of various plugs had to be made. A new owner could cut off the plug and replace it with a standard 13 amp type.

### Controls

A careful reading of the instruction manual is necessary before working the unit. There are controls on all four sides of the case. Starting from the back we have two slide switches, the upper one giving high or low power, while the lower one is a three way, covering duplex +, simplex and duplex operation (for accessing various repeaters). On the left hand side (with the unit facing upwards) there is the 'push-to-talk' switch and to its right there is a frequency lock so that if you accidentally touch any of the frequency controls they will not function. You have to remember to switch it off, however, otherwise you may think the unit has ceased working as I did on one occasion at the start!

Below the frequency lock there is a white on/off button controlling a light for the display. This light will only operate when the set is switched on. Below this, there is a slide catch, which enables the whole battery pack to be slid off, towards the right of the unit. It is not necessary to do this normally, as the batteries can be charged without removing anything.

The only items on the front face of the IC-u4E are the combined microphone

and an indicator which glows red when the unit is being charged. On the right there are three sockets: external microphone (2.5mm), external speaker (3.5mm) and the charging socket (a female 2.1mm to accept the charging lead plug).

Having gone right round the case, I am only left with the top face to discuss; this is where the majority of the controls are situated. There are four 'two-way, centre off' switches at the front, which operate the frequency setting and memory. They are referred to as digit up/down switches in the instruction manual. To the left, there is a small black knob controlling

the squelch level. While to the right, there is a small button which operates the tone call for repeaters. In the review IC-u4E this is set at 1750Hz and has to be pressed to access them. Above right of this range of controls is the BNC socket for the insertion of the antenna and to its left is the display area. This shows the last digit of 433 to 439MHz, eg 3 to 9. This is followed by a decimal point and then the actual frequency which is selected in hundreds, tens and units of kHz in steps of 12.5kHz. Below this, a line is shown which increases in thickness towards the right. In receive it acts as an S meter and in transmit, it is shown as a power level indicator. It is marked 1, 5 and 9 as an indication of S points in receive and as an indicator of RF power (out) when transmitting. When using low power only three segments appear, but in high power all the segments are shown. On the left of the display area, a small indicator glows red when the unit is in the transmit state and below it, there is a little button marked CHK which allows

### Technical Specifications

Frequency coverage	IC-u4AT (USA version) 440.000 to 449.995MHz IC-u4A (Australian version) 430.000 to 439.995MHz
Version under review	IC-u4E (European version) 430.0000 to 439.9875MHz
Frequency resolution	IC-u4A/T 5kHz IC-u4E 12.5kHz
Antenna impedance	50ohms unbalanced
Usable temp range	-10°C to +60°C
Frequency stability	±10ppm at 0°C to +60°C
Current drain at 8.4V dc	Receiving : Power saving approx 8mA : At max audio Max 170mA Transmitting : High (1.0W) Max 700mA : Low (0.1W) Max 350mA
<b>Transmitter</b>	
Output power	High 1.0W Low 0.1W
Emission mode	16K0F3E
Modulation system	Variable reactance frequency modulation
Max frequency deviation	±5kHz
Spurious emissions	More than 60dB below carrier
<b>Receiver</b>	
Receiving system	Double conversion superheterodyne
Intermediate frequencies	1st 23.15MHz 2nd 455kHz
Modulation/Acceptance	16K0F3E
Sensitivity	Less than 0.25uV (-12dBu) for 12dB SINAD
Squelch sensitivity (Threshold)	Less than 0.1uV (-20dBu)
Spurious response/rejection ratio	More than 60dB

the operator to monitor the input (transmit) frequency during repeater operation. Or for that matter, whenever one is working duplex. The knob which operates the volume and actuates the on/off switch is on the left. Both this and the squelch control have little red marker lines on the top surface to give the user an idea of their positions.

Now to a description of how to tune the rig. First of all, the frequency is set by two black coloured keys, marked 1M and 100k. The right hand beige coloured key is marked 10k/SCAN. This is moved away from you to increase the frequency, or towards you to decrease it. The scanning is in 12.5kHz steps for the E version.

There are ten memories available but no actual write key (or something marked) for you to know that the frequency has been accepted. The number of the memory channel in use is shown on the display and when the memory recall key is moved either away or towards the user, the channel number is increased or decreased. The memory takes whatever the frequency setting is at the time, to be the correct channel setting. A bit confusing, I think.

If you accidentally press any of the other three keys, thus altering the frequency, then the channel frequency on that number is automatically altered. Therefore, care must be taken not to touch the frequency setting keys. When you want to operate into various repeaters, the offset frequency has to be entered.

#### Memory channels

On 70cm the offset (input) frequency of repeaters in this country is +1.600kHz above the nominal figure. To do this, the set has to be turned off and the three way switch on the back moved to +DUP. Then the light switch has to be pushed on and held, while the power is turned on. The light switch is then released and the existing frequency offset is displayed. This frequency may then be altered in the usual manner with the three digit up/down switches. After this has been done, pressing either the PTT switch or the CHK button will enter the frequency into the memory. As I mentioned earlier, the offset frequency can always be checked by pressing the CHK button. Of course, if the offset were below the

nominal frequency, the three way switch would be moved to -DUP. For normal two way contacts, the switch should be in the centre, SIM, for simplex.

When I started to operate the IC-u4E, I was unable to get any result indoors. Although it was possible to hear one or two repeaters faintly, it was not possible to access them. This is obviously due to the very low power used, the screening of the house and also to the relative inefficiency of the antenna. However, when I took the rig up to Hampstead Heath (trying to get my first access), I got into NK in Wrotham on 433.100MHz. I also had a successful QSO with a mobile going round the M25, aiming for Seven-oaks. Achieving this on 1W was a very creditable performance. The same ease of access was available into LW, NS and NW. The audio quality was considered satisfactory by those operators whom I contacted.

As far as the actual operation of the IC-u4E was concerned, I found it very fiddly indeed. It is obvious that my hands are too big for this sort of rig. All four two-way switches controlling the memory and frequency had to be operated by my finger nails! The squelch control measures approximately 7mm in diameter and moving it often accidentally knocks the memory channel switch, much to my irritation.

The actual setting up of the ten memory channels is reasonable enough if one does it carefully, but changing from one memory channel to the other has to be done cautiously, as other switches can also be moved by accident.

However, there is no doubt about the efficiency of the unit. When operated in a situation where there is not too much screening, the 1W performs very well. Those whose hands are smaller than mine would have no difficulty in operating the controls.

I took the IC-u4E for another walk on Hampstead Heath and had a number of simplex contacts (apart from the repeaters) and found it to be a very interesting experience of 70cm. I am quite sure that an owner of this little rig will derive much pleasure from using it.

The price of the rig at the time of going to press, including the battery charger and a hanging strap is £279.00 (VAT inclusive). Thanks to Icom (UK) Ltd, Sea

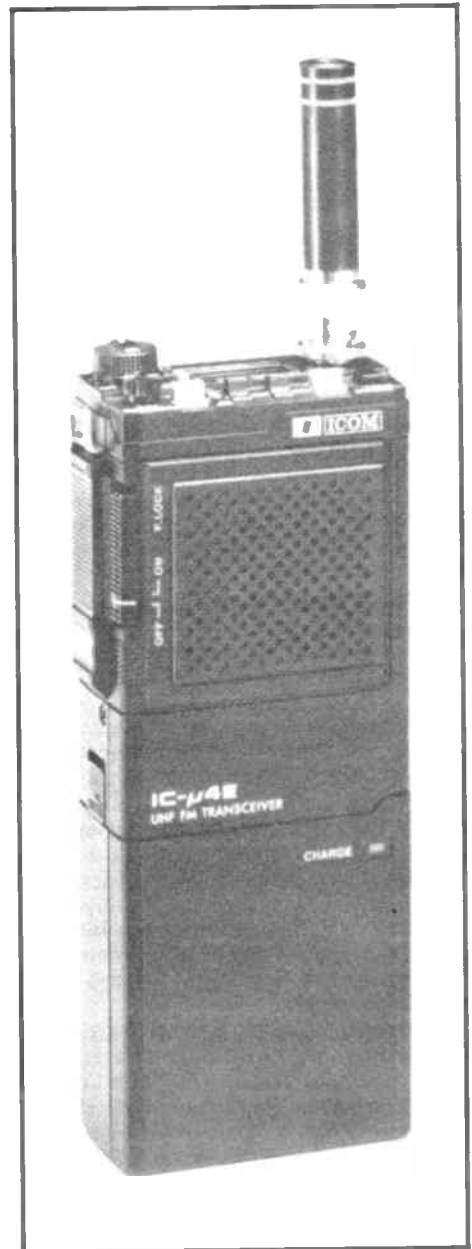

The Icom IC-u4E

Street, Herne Bay, Kent CT6 8LD, (telephone 0227 363859) for the loan of the reviewed unit.

Please note that the rig illustrated above is the reviewed IC-u4E, not the one pictured on the cover.

## L F HANNEY

77 Lower Bristol Road, Bath, Avon  
TEL: 0225 24811

Your electronic component  
specialist for Avon,  
Wilts & Somerset

Closed Thursdays

## QRP KITS AT QRP PRICES!

### 80m CW TRANSCEIVER DTR3

Compact and lightweight, an ideal QRP rig for 3.5MHz CW. Great for /P and holiday operation!  
A COMPLETE KIT - includes ALL Hardware, VFO, Audio Filter, RIT, Sidetone etc and fully detailed building instructions.

**£76.25**

including postage or ready  
built and tested £126.50

Also included in our Kit Range	FULL KIT	PART KIT
*CARLTON 3-band RX for 80/40/20m	£83.00	
TU1 Mk2 Antenna Tuning Unit	£26.80	£24.50
TU2 Mk2 ATU with SWR Bridge	£48.00	£32.70
TUA 1: SWR Bridge	£14.50	£8.50
AP2 AUDIO FILTER	£11.50	£8.50
AP3 BASIC AUDIO FILTER BOARD	£8.50	
CM1 CAPACITANCE METER	£22.50	£14.00

REMEMBER The 'FULL' kits are COMPLETE in every detail and come with FULL instructions. The 'PART' Kits consist of the PCBs and all board mounted components plus, of course, the detailed Instruction Manual. All prices include postage.

For full details of these and the rest of the range, send a SAE to:  
LAKE ELECTRONICS, 7 MIDDLETON CLOSE, NUTHALL, NOTTINGHAM NG16 1BX  
or ring Alan, GADVW on (0602) 362509



# ANGUS MCKENZIE

## TESTS

### THE NEW LOW-LOSS COAXIAL CABLE FROM WESTLAKE

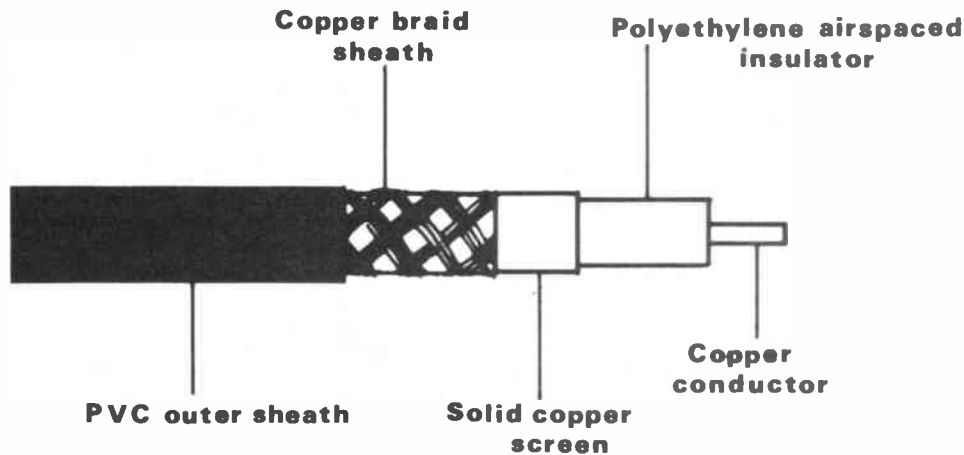

W H Westlake has been supplying various coaxial cables to radio amateurs both at rallies and via the post for many years, and has gained an excellent reputation for his good prices. He has been stocking Pope H100, made in Holland, for many years, and whilst this has been a very recommendable cable, it is generally agreed that it is a very awkward cable to interface with N type plugs. The main problem is that H100 has slightly too small a diameter of 9.5mm, whereas N plugs, as normally supplied, have an entry designed for URM67 and RG213, each of 10.3mm diameter. Some amateurs have reported water damage to the cable, with water creeping in where the plug has been soldered on to the coax. They have also found that H100 was not pliable enough.

Westlake are now marketing a new coax made by Radex Volex, a UK company, which offers a few advantages over Pope H100. The new cable, Westflex 103, is the same diameter as URM67, so it is very easy to put N plugs on to it. The loss characteristics as measured in my lab show it to be very similar to H100, any differences being within experimental error, or at most, differences that one would expect to measure from different batches of the same cable. For example, we measured a loss on 144MHz of 1.15dB per 25 metres, including two N type plugs. This would represent a loss of below 4.6dB per 100 metres, the manufacturer's actual specification being 4.5dB. The plot shows the typical losses up to 400MHz as checked by the Marconi spectrum analyser, but also includes slight measurement inaccuracies at the UHF end. Please note that the plot represents the loss of 25 metres, plus two N type plugs and one back-to-back adapter.

There was insufficient time to check the coax on microwave, but the manu-

facturer's specifications do show that losses might be marginally less than those of H100. It is very clear that this new coax is to be strongly recommended for use on VHF, UHF and lower microwave frequencies.

#### Internal construction

The inner conductor is 2.7mm diameter as opposed to 2.5mm required for insertion into the centre pin of an N plug. This means that you will have to have a nice sharp file handy to decrease the diameter of the inner by just 0.2mm. This should only take a minute or so, and baring the copper in any case is a good idea, as it will help make a good contact with the pin when solder is applied.

I collared two friends of mine recently, G3NQR and G3JIP, with Allan doing the soldering and Joe doing the timing to see how long it would take to put N plugs on to the cable. Allan took 15 minutes for the first plug and just 10 minutes for the second one. He said that if he got into the swing of it, he might be able to manage

seven minutes after many attempts, but it would get very monotonous! He found it much easier to cope with than the old H100, and the end result felt far more secure.

The dielectric is rather different on the new coax, and is of the five cell semi-air-spaced type, similar to that used in many makes of low-loss TV coax. Pope H100 dielectric is a tube, inside which is a plastic spiral which holds the inner centrally. The outer conductor is of copper leafing covered with the usual mesh and the outer covering is of PVC rather than polyester.

#### More pliability

The combination of all these differences allows Westflex 103 to be slightly more pliable than H100. Furthermore, whereas H100 is rather like an extremely stiff rubber rod, 103 has the consistency of very thick Plasticine and tends to stay in the new position when bent.

I also found that it seems to bend much more easily round a small radius. However, it is important to note that it is still not the ideal cable for turning loops, and you will have to have a very large loop indeed around a motor if you want to avoid problems. Therefore, I would still recommend RG213, etc, for shorter turning loops, even if the loss is slightly higher.

#### Manufacturer's loss specifications

The following loss measurements were provided by Henry Westlake for 100 metres of cable, excluding connectors. 10MHz - 0.9dB, 30MHz - 1.7dB, 100MHz - 3.2dB, 144MHz - 4.5dB, 432MHz - 7.5dB, 1GHz - 13dB and 3GHz - 27.8dB. I have no reason to doubt any of these figures, which tied in well with my brief measurements.

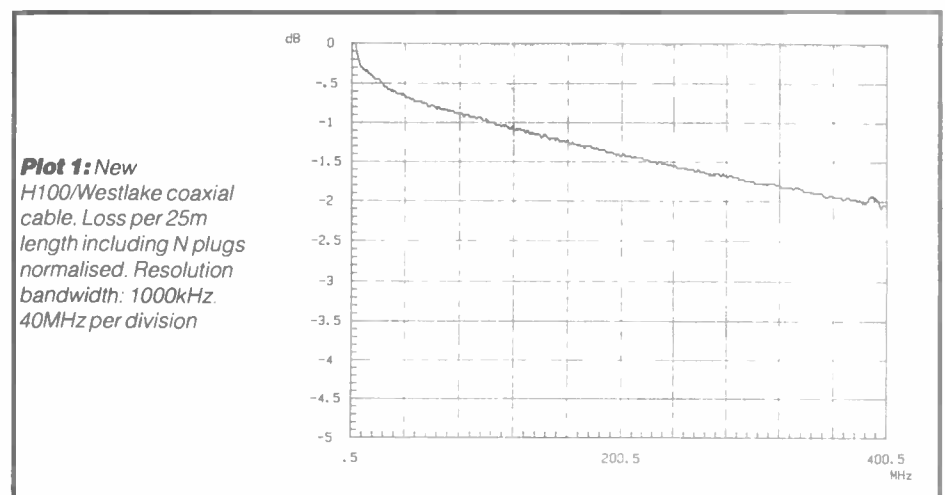

## Conclusions

The price of the new Westflex 103 is 95p per metre, an increase of 15p per metre over the old H100. An introductory special offer of £80 per 100 metres has been given by WH Westlake and in order

to avoid carriage charges, why not purchase the cable at a rally which Westlake are attending. I regard this coax as extremely good value for money, and I feel sure that it will become just as popular as its older counterpart.

Many thanks to Westlake for supplying 25 metres of coax for my tests, and to both Allan G3NQR, and Joe G3JIP, for their help in soldering the N plugs on to the coax. WH Westlake is at Clawton, Holsworthy, Devon. Tel: (0409) 253758.

# THE PX02 PULSE GENERATOR AND MARKER UNIT

It was during early June that I first heard from Roy Harrod, G3RWN, asking me to review this remarkable little pulse generator; both for this magazine and for *Radial*, the magazine of the Radio Amateur Invalid and Blind Club.

You might rightly wonder what on earth you can do with a pulse generator. As there are dozens of uses for one like this, I will suggest quite a few in this review for starters. The unit costs £39.50 (add a further £1.50 for postage and packing). The pulse generator is available from Tor Electronics, Strathallan, Whitworth Road, Darley Dale, Matlock, Derbyshire DE4 2HJ.

The PX02 has two controls and a phono output socket. The on/off slider switch can be switched to one of two positions: frequency X 1 or frequency X 10,000. This switch is complemented by a six position rotary giving frequencies of 0.1Hz, 1Hz, 10Hz, 25Hz, 50Hz and 100Hz, so you can get all decades from 0.1Hz to 1MHz, including 250kHz and 500kHz as a bonus when using the X 10,000 range. The actual pulse generator chip circuitry is dc coupled into an emitter follower, giving a source resistance of around 560 ohms to the output which is dc coupled. The unit can be used to give logic switching for testing digital equipment, but I would suggest that most purchasers would use the unit for generating test pulses covering both the audio and RF spectrum.

## Use as a frequency marker

The actual review sample gave frequencies that were correct to around 2Hz per million, although the actual specification is somewhat wider than this, depending on the particular chip installed in the sample. Thus, by 30MHz the review sample was around 60Hz out, or 300Hz in error by the 2m band. I would suggest that this is excellent for use on HF, but not quite accurate enough for marking meteor scatter frequencies on 144MHz, for example. By the time you get up to the 2m band, the harmonics will be extremely weak and you will need to directly couple-in to get an accurate zero beat.

Plot 1 shows the unit feeding into a 50 ohm load, plotting the markers from 0Hz to 50MHz. Whilst the levels at LF are very high, between 1 and 25mV with markers every MHz, you will see that by the top

end of HF they are very much weaker. If you use capacitive coupling into the receive section of a receiver, then this will have the effect of reducing the LF levels with the appropriate value of capacitor, whilst not having so much effect on HF. Don't forget, however, that you need higher levels on LF and when trying to use the marker here, you should use the attenuator on your receiver.

Having found a MHz point, you can then tune upwards or downwards with the pulse generator switched to one of the other ranges, eg 100kHz, to find your appropriate 100kHz point. You can then go down to 10kHz steps by counting carriers up or down. You will always have to be careful to ignore any beats caused by various marker frequencies beating

with spurious reception frequencies on the receiver, eg image, or products from the local oscillator.

In addition to checking the calibration on an analogue tuning receiver, this unit will be a godsend for blind amateurs and short wave listeners who cannot afford one of the new receivers with a digital speech read-out.

Plot 2 shows the comparative levels over the same range, with the pulse generator driving a 1m long piece of coax into a very high impedance Marconi probe. In this case, the level of the fundamental 1MHz is 1.4V RMS, but the actual level on the generator's output would be even higher and reach the claimed 5 volt peak for various logic testing.

**Plot 1:** G3RWN crystal pulse generator. 1MHz fundamental loaded 50 ohms and 0dB is -20dBm. Resolution bandwidth: 30kHz · 5MHz per division

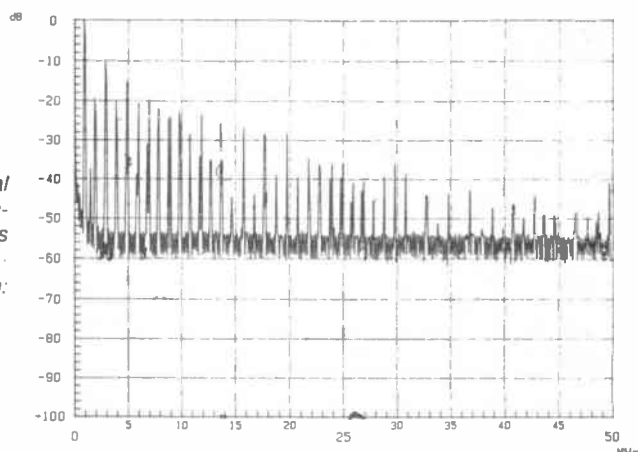

**Plot 2:** G3RWN crystal pulse generator. 1MHz fundamental into Hi Z 0dB is 1.4V. Resolution bandwidth: 30kHz · 5MHz per division

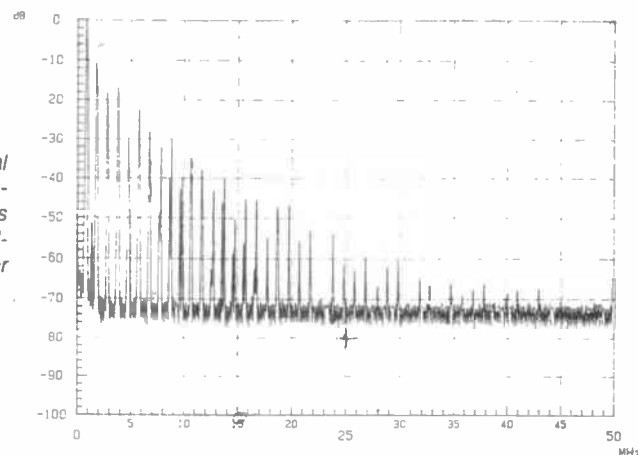



### Continuity testing

If you switch this unit to one of the lower frequencies, say 50 or 100Hz, or even 1kHz, you will not only get typical pulse harmonics, but a series of carriers at 1MHz intervals having superimposed AM sidebands which are pulsed. Whenever you tune a receiver, you will hear the pulsing noise and thus you can use it to peak up circuits by ear or by using an S meter. Since the level at any one frequency is fixed, this procedure will be a lot more reliable than trying to peak up tuned-in RF signals from an antenna. You can easily feed the output through a capacitor on to parts of the circuit to see exactly what is going on.

You can also use it as a continuity checker or to identify audio or RF cables, by allowing it to feed one end of a mystery cable whilst you search for the pulses at the other end! This can also be very useful for blind enthusiasts, as I am always losing cables in my spaghetti maze around my shack!

### AGC line testing

Most HF receivers now on the market have a switchable AGC line-time constant, but very frequently the slow speed is not enough to maintain the proper dynamic range of the transmission. If you are relaxing back to a 40 or 80m QSO and chinwagging to a strong station, then you don't want the receiver to be pumping away at you all the time. If you take one of these units to the shop, select the 0.1Hz range and tune in at 2 or 3MHz, you will see the signal going up and down every 5 seconds, with the complete cycle lasting 10 seconds. The even harmonics of 1MHz are noticeably weaker than the odd ones, so you can choose the level you require for your tests, using the receiver's antenna input attenuator if necessary. You can also choose the one second rate to check the fast AGC speed, as the level should completely recover in less than 0.5 seconds. You can also listen for AGC bounce, for it is AGC overshooting and a

slow attack time that causes many receivers to produce audio distortion on speech transients. Try comparing the S meter readings on the 1Hz and 0.1Hz ranges and listen for the cleanness of the beat note immediately the level starts to shoot up. I noted around 16dB difference at 3MHz between the on and off levels. Incidentally, it would be simple enough for you to measure it on a calibrated receiver and use this to check your friends' receivers. I have come across the odd S meter that may well shoot from below S1 to S9 when you apply this test! My TS-940S shifts around four S points, which seems just about right to me.

### Noise blanker testing

This is an amazingly useful gadget for checking noise blanking action, both on SSB and AM. It is better to do the testing on lower frequencies as the RF output level is much higher. However, I did a lot of checking on the 14MHz band and found that the unit allows you to test anything from occasional click blanking to repetitive pulse blanking up to 100Hz. I was interested to see how similar the two switchable noise blankers were on the TS-940S and how effective the noise blanking level control was. Using noise blanker 2 it was possible to almost eliminate 50Hz repetition pulses, which were unsufferable without blanking. You will find the unit very useful if you want to modify your blanking circuitry, although it is a pity that the pulses were so attenuated by VHF. I have to admit that this unit could have been invaluable to me over the years when I have been testing noise blankers, for in the past I have either had to wait for passing traffic, or take ages setting up my own pulse generator in the lab.

### Performance and ergonomics

I did not detect any significant drift of the fundamental frequency of more than one part in a million over long periods. Output levels were consistent, but I feel

that Tor Electronics should provide an alternative output with a lower source impedance, and a switchable capacitor which could help the VHF output level (thereby reducing the output at LF). The unit requires a single PP3 battery and the current drawn from it is very low, so it won't require changing very often. I left it switched on for a whole weekend once and I am still using the original battery after six weeks!

The unit is housed in a small plastic case, measuring approximately 105 x 55 x 20cm and weighs only 125gms. Although it is well made, you will find it frustrating that all the components have been painted black and cannot be identified. The unit will have to go back to the manufacturer for any repairs, which will be annoying if you are on an HF DX-pedition to Pitcairn Island! Furthermore, no circuit diagram is enclosed.

I have a personal dislike of phono sockets being used for RF and would have preferred a BNC, but it should be easy to change the socket if you need to. The battery rattled around a bit inside the case but this can be easily fixed.

### Conclusions

I can imagine the faces of enthusiastic junk sellers at rallies, when an owner of one of these gadgets pulls it out of the hat and connects it to a receiver bearing the legend 'working but needs slight attention'. You might even be able to recover the cost of the unit on one purchase at a rally! I have found the unit absolutely invaluable for quickly checking the 'silent' bands during a magnetic storm! I recommend purchase of the unit if it is what you want. I hope that Roy Harrod will be encouraged to produce some more goodies in the future.

Finally, this would be a superb present for a blind amateur who would probably use it a great deal for many more purposes than I can think of at the moment. Many thanks to G3RWN, for providing the review sample for testing.

## G4ZPY PADDLE KEYS

Britain's leading High Quality Hand Built Morse Key Manufacturer

PUMP (Straight) KEY	Brass £26.00 & £30	Nickel £31 & £35
SINGLE PADDLE KEY	Brass Std £42.00	Deluxe £44.50
Nickel on Brass	Std £47.00	Deluxe £49.50
TWIN PADDLE KEY	Brass Std £48.00	Deluxe £50.50
Nickel on Brass	Std £53.00	Deluxe £55.50

60. VARIATIONS OF THESE KEYS ARE AVAILABLE. Some to Order.

IAMBIC ELECTRONIC KEYS (with Auto Inter-Character Spacing) £40.00  
1K PEP BALUNS 3.5-30 Megs £15.00  
10-70 Megs £16.50, P&P UK: - KEYS £3.00  
IAMBICS AND BALUNS £2.00

SAE for further details to

41 Mill Dam Lane, Burscough, Ormskirk, Lancs L40 7TG  
or Phone: 0704 894299

Start training now for the following courses. Send for our brochure — without obligation or Telephone us on

REF: AR

06267 79398



NAME .....

Telecoms Tech  
271 C & G

Radio Amateur  
Licence C & G

Micro-processor

Introduction to  
Television

Radio & Telecommunications Correspondence School  
12 Moor View Drive, Teignmouth, Devon TQ14 9UN

# CONSTRUCTING A FAST NI-CAD CHARGER

by Steven Goodier G4KUB and John Goodier G4KUC

Rechargeable nickel cadmium batteries (Ni-Cads) have been freely available for some time now and most radio operators who own portable equipment are bound to own a set. Portable transceivers such as hand-helds are usually supplied with a sealed pack which can be recharged in about 14-16 hours using a conventional charger. Sooner or later, most people will feel the need for a second set of Ni-Cads which can quickly replace the exhausted pack when out portable. Unfortunately, spare batteries can cost an arm and a leg; checking a recent price list shows a price range of between £25 for a medium power pack right up to a staggering £46 for a 12V 600mAH high power pack.

Fortunately for us, most manufacturers produce an empty case which can be filled with the popular AA size of battery. These packs are usually intended to take long life alkaline batteries which can give a very long life when carefully used. The total voltage of the pack when using six batteries will be about 9V. When using the popular Yaesu FT-209RH, the batteries will produce about 2.3W output. The only disadvantage when using this type of cell is that, once they are exhausted, they must be replaced with new ones. Therefore, they tend to be very expensive in the long run.

A much better alternative is to purchase a set of rechargeable batteries which can be used over and over again. Using Ni-Cads is very cost effective and the total cost of a spare pack for an FT-209 using six AA size batteries is in the region of £18 including an empty case. In fact, the empty case costs more than the set of Ni-Cads! Voltage requirements of most hand-helds are quite wide and most will run happily on the lower voltage produced by the spare pack.

## Ni-Cads

Nickel cadmium cells were produced to replace dry batteries in medium and high current applications. Most Ni-Cads have a minimum life of at least 500 full charge/discharge cycles and with reasonable care it should be possible to achieve a 750 to 1000 charge and discharge cycle. There is a number of myths connected with the charging of Ni-Cads and I have read many conflicting articles regarding the charging of such cells. Most of these articles totally contradict each other with respect to what is good and bad for the average rechargeable battery.

When a Ni-Cad is fully discharged the voltage drops to around 1.2V compared to about 1 to 0.8V for normal cells. At room temperature, using normal charging conditions, the voltage increases

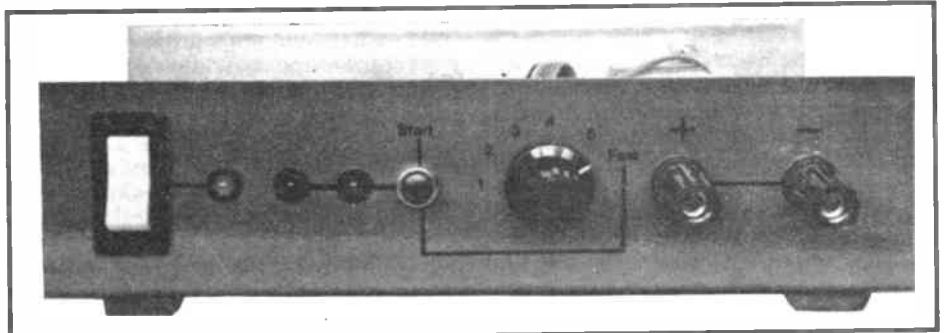

The front panel

from an initial 1.2V to an end of charge voltage of around 1.45V. In a new alkaline battery the voltage is at least 1.6V, so when Ni-Cads are connected in series there is a slight voltage difference when compared with normal dry cells, but under normal conditions this should have no effect on the equipment to be powered.

The efficiency of a rechargeable battery is the amount of electricity you get out compared to the amount of electricity you need to put in for a full charge. Most good quality nickel cadmium cells will have an efficiency of about 70% for a charge of 14 hours. Most modern day Ni-Cads have a very low internal resistance, typically 0.01 ohms for a 1AH cell and can provide high discharge currents for a very short time.

Due to their very low internal resistance, Ni-Cads should never be shorted together. Damage can result to the cell for a number of reasons such as, furious overcharging, very rapid discharging and reverse charging. Furious overcharging and reverse charging can result in the internal generation of gas which if exceeding the pressure rating of the cell can cause it to explode. Therefore, modern cells are fitted with a re-sealing one way safety vent that opens at about 200 psi and closes again at about 175 psi. These vents are used to relieve any excess internal pressure caused by a fault or abuse to the cell, any loss of gas represents a loss of electrolyte and hence cell performance. It must be said, however, that a cell really needs some abuse before it reaches the stage of gas discharge or the danger of an explosion.

## Charging Ni-Cads

All rechargeable batteries are charged at a constant current for a set amount of time. For most cells the maximum charge current that can be indefinitely applied is C/10 where C is the nominal capacity of the cell in amperes per hour. For example, a normal AA size battery with a nominal capacity of 500mAH can be charged at 50mA for 14 to 16 hours for a

full charge, but if left on charge longer, say for 48 hours, no damage should occur; although it is not recommended that Ni-Cads are overcharged on a regular basis. Working out the charge rate from the formula given above is very simple; just take the nominal capacity of the cell in mA per hour and divide it by 10 to produce the charge rate in mA per hour.

As already stated, the traditional way to charge Ni-Cads is to leave them connected to a constant current source for between 14-16 hours. This is fine if you are in no hurry to use your batteries but it can be a little inconvenient if you wish to use your transceiver within the next couple of hours. The alternative is to fast charge the cells. As the name suggests, this means charging the Ni-Cads at a much higher rate, thus dramatically reducing the time taken to produce a fully charged pack. An acceptable charge rate would be C/1 and for an AA size cell this would be 500mAH for one hour continuously. In other words, charging a pack of AA Ni-Cads at a rate of 500mA would reduce the charging time from 15 hours down to just one hour.

Ni-Cads can be charged at a much higher rate than C/1. In theory, cells can be charged at a rate which is equal to 10C (10 x the nominal capacity). As an example, charging 500mAH cells at 10C would require a constant charge current of 5 amps, and the time taken to charge the cells fully would be approximately five minutes. Another example is charging a 4 amp/hour cell at 8C; the charging time is again five minutes, but this time the charging current is 32 amps!

If you study *Figure 1* you can check the charge rate against the time taken to charge the cells fully. Battery chargers which can charge at a very fast rate (under ten minutes) often have sophisticated monitoring circuits which can detect when the cells are fully charged, thus protecting the Ni-Cads from being damaged.

Even charging at 1C is not without its dangers, for example, it would be unwise



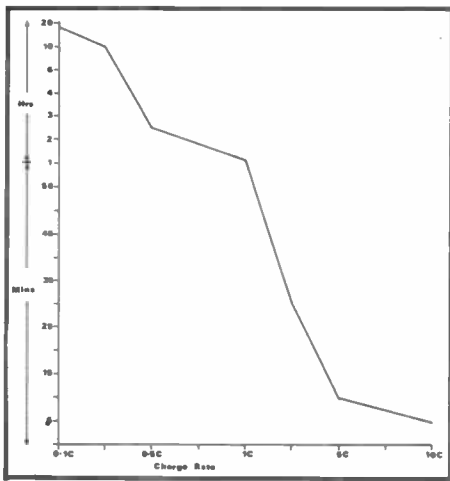

**Fig 1:** Graph showing charging time against charge rate

to start charging the pack and then forget about them for the next 24 hours. As already stated, overcharging can cause a build up of gases within the pack which could damage the cell and, in exceptional circumstances, cause an explosion. So if this method of charging is to be employed, then a number of safety features must be included in the charger design.

### Design considerations

Having decided to build a charger, I wanted to be able to fast charge the batteries, but still keep the option open of charging Ni-Cads at their nominal rate. The type of batteries I use most are the AA and sealed packs usually found on hand-helds, both usually charge at 500 to 800mAH.

The charger must also have a number of safety features when fast charging. I didn't want a continuous high current charge so I decided to pulse charge the Ni-Cads when in the fast charge position. Pulse charging will alternate between a 'high' and 'medium' charge rate for about one hour. With these specifications in mind, I constructed a charger with the following features:

1. 240V mains operated, with most of the components on a single printed circuit board to make construction simple and straightforward.
2. Able to charge a number of different types of Ni-Cads, including: PP3, AAA, AA, C and D size. Charging rates are selected from a front panel switch.
3. Able to fast charge a pack of AA size Ni-Cads in one hour using pulse charging of 480mAH (low) and 550mAH (high).
4. Impossible to select fast charging without first starting a one hour timer. After one hour, fast charging stops and switches in a trickle charge resistor, or switches to the normal charge rate of 50mAH for AA size batteries.

### Circuit description

Figure 2 shows a block diagram of the charger. On first inspection this looks quite complicated, but in practice it can be split into a number of small stages. There are three main sections in all, these are: the charger circuit including the fast charger, pulse generator and the one hour timer.

Figure 3 shows the circuit diagram of the charger and the power supply for the pulse generator and timer. T1, BR1 and C1 form a simple unregulated dc supply of about 28V across C1. LED3 is used as an 'on' indicator and can be left out if you decide to use a mains on/off switch with a neon lamp fitted. IC1 is a 7805 voltage regulator which is wired to form a constant current generator. The common pin of IC1 is wired to the output of the charger and by doing so, a 5V drop is forced across one of the charging resistors R8 to R15, depending upon the position of the selector switch SW3. R8 to R15 are the resistors which actually set the charging rate, their values are determined by using ohms law  $R=V/I$ . For example, the value for the resistor to charge at 50mAH is simply  $5/0.05 = 100$  ohms, the 5 used in the formula is the 5V of the regulator and the 0.05 is the charge current of 50mA.

### Fast charging

When SW3 is placed in the fast charge

position R13 is selected, you can either set the value of this resistor for a trickle charge of about 5-10mA or, as I did, select it to produce about 50mA which is the nominal charge rate for an AA size cell.

To start fast charging you must press SW2, which is a push to make switch. This will short the relay contacts RL1a and place voltage, which is tapped off C1, onto the input of IC2. The job of IC2 is to provide a 12V regulated supply both to the pulse generator and the one hour timer. Once the relay RL1 is energised, R13 is switched out via RL1b and the fast charge resistors R14 and R15 are switched in. Because the relay is now energised SW2 can now be released and a constant unregulated supply is placed onto the input of IC2, which will remain there until RL1 drops out after one hour.

R14 and R15 are the fast charge resistors. For an AA size battery the value of R14 is 10R, this provides a constant current of about 480mA. R15 is placed in parallel with R14 but is switched out of circuit by the transistor

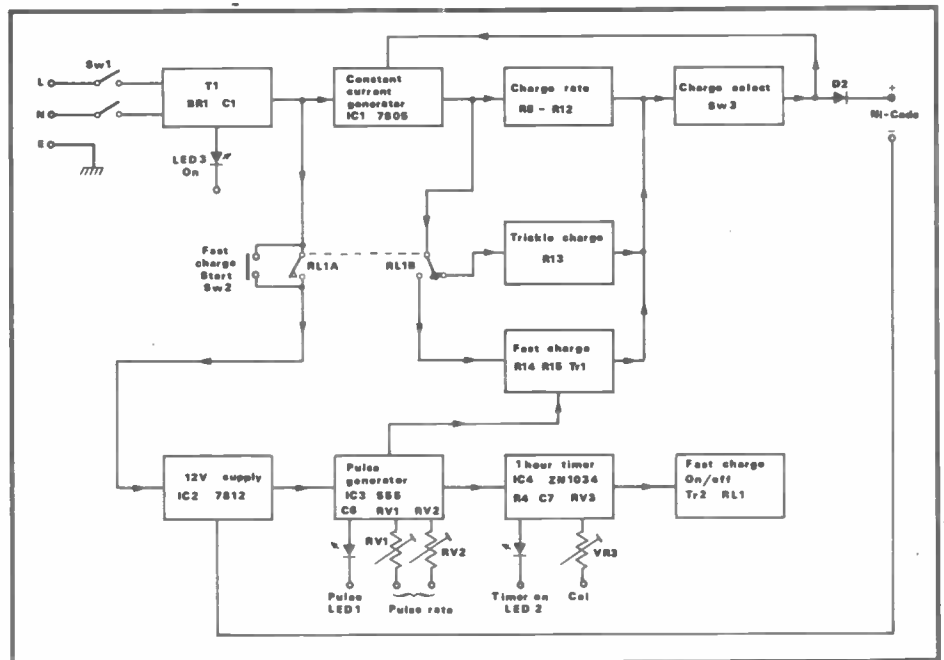

**Fig 2:** Block diagram of the Ni-Cad charger

**Fig 3:** Diagram of the charging circuit, fast charge transistor TR1 and 12V power supply for timer and pulse circuit

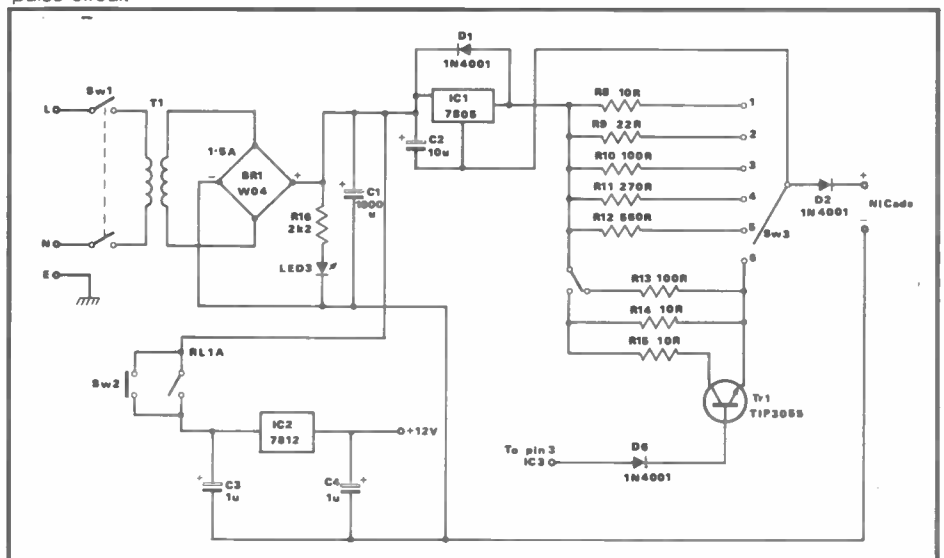

TR1 which is a TIP3055. When a pulse arrives at the base, TR1 is switched on and allows current to flow through R15 to the Ni-Cads. If the value of R15 is lower than that of R14, then the constant current supply to the batteries will increase for as long as TR1 is switched on, R14 and R15 are in parallel and the current supplied is also limited by the resistance of TR1. In practice, we found that the circuit was self-regulating depending upon the discharged state of the batteries. When the Ni-Cads were completely dead the fast charge current was around 550mA and this fell as the pack became charged. D6 is needed to prevent any voltage flowing back down to the pulse generator and timer circuit when they are not in use.

### Pulse generator

The job of the pulse generator is to continually switch TR1 on and off at regular periods. The generator is based around IC3 which is a 555 timer wired in the astable mode (the circuit is shown in Figure 4). Astable simply means a circuit which will oscillate as long as power is supplied to it. In our case, the on state is very long and the off state is short. Power is applied to it as soon as RL1 is energised by pressing SW2.

C6 is the timing capacitor and is charged via R2, VR1 and D4 and discharged via VR2, R3 and D3. The effect of charging and discharging C6 in this manner is to provide a long 'on' pulse, which can be varied by VR1 and a short 'off' pulse which can be varied by VR2. The output from pin-3 is applied to the switching transistor TR1 via D6 and this controls the fast charging of the Ni-Cads. When fast charging is taking place, LED 1 lights in sympathy with the high output and switches off again when the output goes low.

### Timer circuit

An important part and safety feature of this design is the inclusion of a timer. This will start as soon as fast charging begins. Once the timing period has finished, it will switch in a trickle or nominal charge resistor. We first tried a number of timing circuits based on the 555, but these proved to be highly inaccurate over a one hour period. Our attention turned towards the ZN1034E precision timer IC.

This device has many benefits over the 555 which is a suitable IC for short timing periods only. Instead of depending upon the sole accuracy of capacitors and resistors for the timing period, this chip uses an on board precision oscillator whose frequency is determined by a capacitor and resistor. Pulses from this oscillator are fed through a 12 stage binary divider which changes the state of the outputs at pins-2 and 3 after 4095 counts. To maintain accuracy the device has an on board 5V regulator. A calibration pin may be connected between pins-11 and 12 for precise adjustment of the timing period.

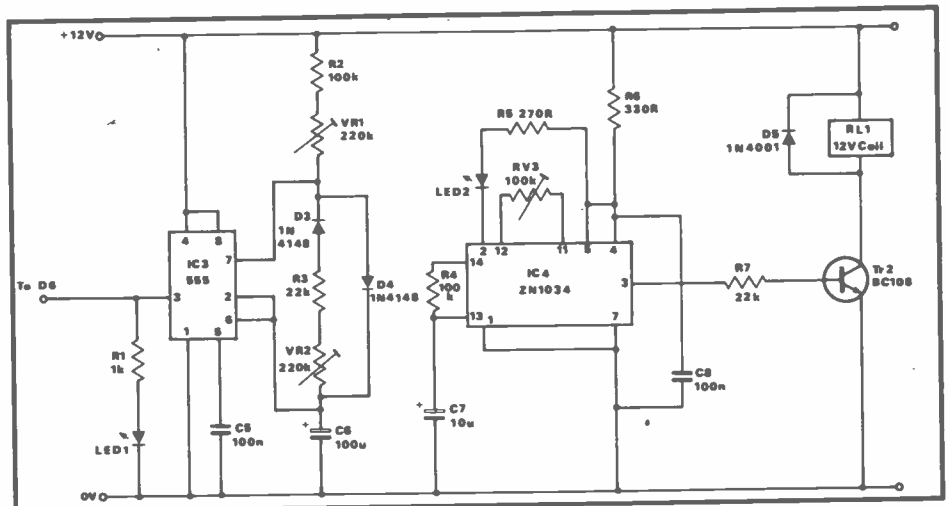

Fig 4: Diagram of the pulse generator and timing circuit

Figure 4 also shows the circuit diagram of the timer which is based around IC4. Pin-1 is the trigger and since it is wired to ground, the timing process begins as soon as power is applied to the circuit. Both the pulse generator and timer are supplied from the voltage regulator IC2 but since the ZN1034E has its own 5V regulator built in, R6 is needed to limit the current into the chip. R4 and C7 set the frequency of the internal precision oscillator and by changing their value, the timer can be made to time over a period of below a second to over a week. With the values chosen and with the calibration pins-11 and 12 shorted together the timing period will be about 49 minutes. By adding a 100K calibration pot VR3, the period can be increased to one hour and 15 minutes or any point between.

As soon as the timing period starts, pin-3 switches high and turns on TR1 which in turn energises RL1. RL1 has two jobs, first it keeps a continuous supply on the input of IC2 via RL1a, thus supplying voltage to the timer circuit itself and the

pulse generator. Secondly, it switches in the fast charge resistors R14 and R15 via RL1b. LED2 lights when the timing process is in operation. Once the timing process has finished, pin-3 goes low and RL1 drops out removing the supply voltage to IC2 and switching back into circuit R13. The timing process cannot begin without first pressing SW2 and it cannot start again without pressing SW2. This simple feature effectively stops the charging process repeating itself and gives protection from overcharging. Repeat accuracy of the timer is to within a few seconds so it is ideally suited to our application.

### Construction

Construction of the Ni-Cad charger is very simple and most of the components are mounted on a single printed circuit board measuring 130 x 80mm in size. Figure 5 shows the components overlay and foil pattern. Start by making the printed circuit board. To do this you will need the usual PCB pen and acid etc. Before you start to mount the compo-

Fig 5: PCB overlay and foil pattern along with the lead-outs of the semi-conductors used

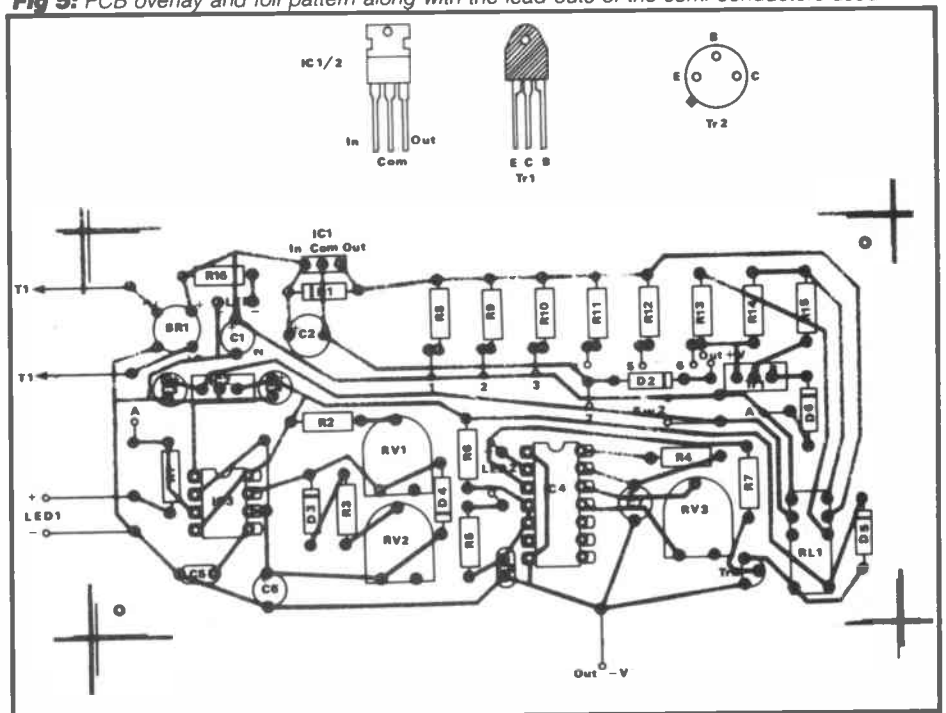



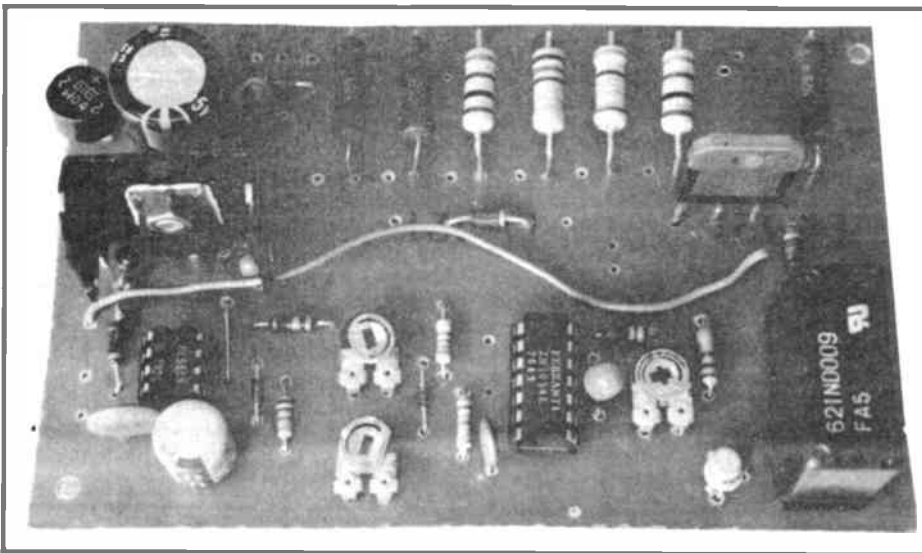

Close-up of the completed printed circuit board

nents make sure that the copper side of the board is clean and free from grease. Start by mounting all the resistors including the three preset pots. The charging resistors R8 to R15 are mounted about 5mm above the board to allow air to circulate around them. Even though R14 is rated at 7W and is reliable, it still runs considerably hot when fast charging. For long term reliability R14 can be replaced with a 10R 25W aluminium clad resistor (available from Maplin) which is bolted to the back panel of the case. If you choose to use this type of resistor then use flying leads to connect it to the board. This component is shown in the final wiring diagram (see Figure 6).

Next, mount the capacitors, taking care to insert the electrolytics the correct way round. There are six diodes to solder into place and a bridge rectifier, double check you have mounted these components the correct way round. Do not forget the wire link close to IC3, R2 and D3. Use IC holders for IC3 and IC4. Once these are soldered into place we can move on to IC1, IC2, TR1 and TR2. The lead out information for all the semiconductors is shown in Figure 5. Since IC1 runs quite hot it must be mounted on the back panel (this acts as a heatsink). Solder a length of three way ribbon cable to its position on the PCB, this can then be soldered to the appropriate pins on the IC. IC2 needs a small heatsink and this is best attached to it before soldering into place. When it is correctly mounted the metal back is facing the smoothing capacitor C1. Some of the bottom fins of the heatsink may need removing due to the closeness of C3 and C4.

TR1 needs no heatsink and this is simply soldered into place, but again, take care to solder it the correct way round with the metal back facing the relay RL1. TR2 is a small BC108 transistor and is mounted close to RL1, the emitter points to the bottom edge of the board. There is a length of wire which links the output of IC3 to D6, this runs across the board and is marked 'A' on the overlay. Lastly, solder into place the relay RL1. You may have to slightly enlarge the mounting holes to get this component to

fit. That completes the construction of the charger board.

### Housing the charger

The choice of box to mount the mains transformer, PCB and other components is up to the constructor, I used a vinyl covered box type WB3 size 203 x 127 x 51mm (Maplin LH38R). As you can see from Figure 6, there are a number of components to mount on both the front and back panel. Start by marking the position of the PCB and transformer on the bottom of the case, the PCB is secured at either corner by 6BA stand-offs. The front panel has three switches, three LEDs and two output terminals, the positions of these components are not critical so you can mount them in any order you wish, but I would advise that

the mains switch is left in the position shown.

On the back panel mount of IC1 and R14 (if you have decided to use a 25W resistor), the mains cable is passed through a grommet and the earth wire must be bolted to the metalwork of the case, the live and neutral wires then pass onto the mains on/off switch and then onto the transformer. It is possible to use a double pole mains switch fitted with a neon indicator for SW1; if you decide to use this type of switch then LED3 and R16 are not needed. In the prototype, I used a single pole mains switch (see Figure 6) but double pole types are available from Maplin Electronics.

When you have drilled and cut all the necessary holes, you can paint and label the box. I used a blue car body paint spray and then labelled the front panel with rub-on transfers which can be obtained from art shops, W H Smith or other stationery shops. Take care to label the switch positions on SW3 correctly (these can be checked using Table 1). I simply labelled the charge selector switch 1 to 5 and then 'fast', and stuck a note of the charge rates on the bottom of the box for reference.

### Final wiring

Figure 6 shows the wiring diagram of the Ni-Cad charger, it is best to use ribbon cable for the connections to SW3 and the other components on the front panel; you will find that this type of cable is easy to handle and it keeps the wiring neat and tidy. Maplin Electronics sell a ribbon cable which is rated at 1.4 amps per core and this is suitable for most of the wiring apart from the mains. To make wiring up easy to follow I have numbered all the connections, so it is just a matter

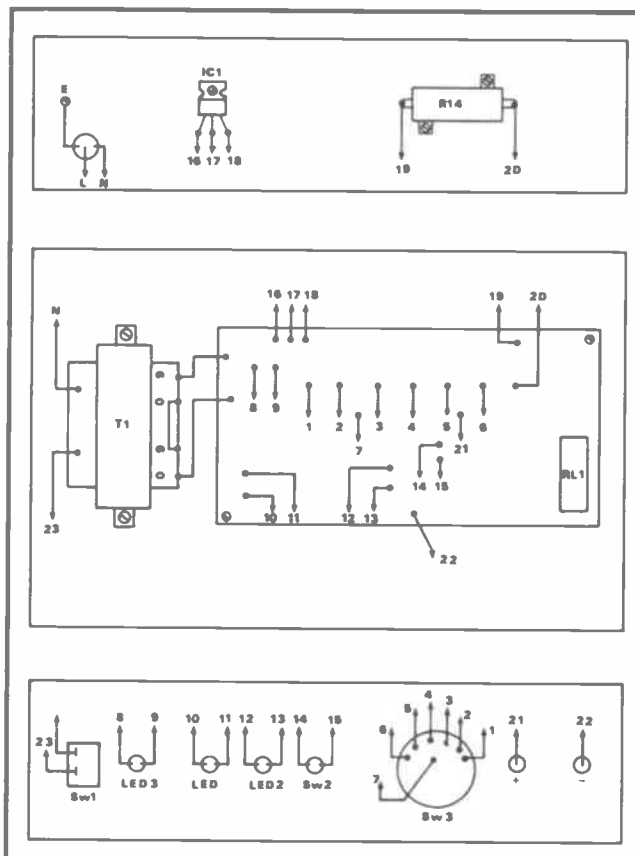

Fig 6: Internal wiring of the charger unit

of joining number to number; you should have no problems doing this.

I found it was best to wire the printed circuit board up to most of the components before it was mounted into its final position in the box. The mains transformer has two secondary windings which are both marked 0-9 and these must be wired together to form a single 0-18V 500mA output. To do this, connect the 9V from one winding to the zero volts of the other. It is then a simple matter of making the remaining connections to the mains transformer R14 and the mains switch SW1. Double check all the wiring so that we can move on to testing and setting up the unit.

### Testing and setting up

First make sure that the mains plug is fitted with a low amperage fuse of about 3 amps, next connect a voltmeter set to read 50V across the output. Set SW3 to position one and turn the charger on, if you have fitted LED3 this should light. The voltmeter should read approximately 28V and switching through the six positions of SW3 should not alter the reading. Before testing the charger with a set of Ni-Cads, we will first set up the pulse generator and timer circuits.

### Pulse generator

The pulse generator and timer will work in any position chosen on SW3, but it will only fast charge batteries in position six. Set VR1 and VR2 fully anti-clockwise and then press SW2, as soon as this switch is pressed, RL1 should pull in and LED1 and LED2 should light. LED 1 indicates the pulse rate and with the two preset resistors set fully anti-clockwise, LED1 will flash at a constant rate.

VR1 controls the pulse 'on' time (LED lit) and VR2 controls the 'off' time (LED off). VR1 can be set to give an 'on' time of approximately 8 to 35 seconds. I set VR1 to give an 'on' time of about 25 seconds. I then adjusted VR2 to give an 'off' time of 5 seconds, you should find that the swing on VR2 will give an 'off' time of between 2 and 21 seconds. Keep the circuit running for about five minutes and then check the timings again, you will probably find that some very slight adjustment will be needed. You can set the pulse 'on' and 'off' rate to whatever you feel is necessary and the example given above is only a guide and seemed to work out well in the prototype.

### Timing circuit

The next stage is to set up the timer and this is done with the calibration pot VR3. If you have an accurate ohms meter, set VR3 to read about 35K across pins-11 and 12 of IC4, failing that, set VR3 to about the 11 o'clock position. The only way to set the timer accuracy is to leave it running for an hour and time it with a stop watch or clock. To start the timer press SW2 (this will also activate RL1) and the pulse generator; both LED1 and LED2 will light. LED1 should flash at the preset levels set up previously, but LED2 will stay lit for the full hour.

When the timing period is over RL1 will drop out and both LEDs will go out, as soon as this happens, check the time and

adjust accordingly. To increase the time adjust VR3 to give more resistance (clockwise) and to decrease the time period adjust VR3 anti-clockwise. The swing of the calibration pot should give a timing range of between 49 minutes and 1 hour 15 minutes. Once set, the ZN1034E is very accurate and each timing period should be within a few seconds.

### Testing with Ni-Cads

When you have successfully carried out all the above tests, we can then connect a set of Ni-Cads to the charger. I would advise you to use a set of six 500mAH AA size batteries because all the charging positions can be tested using these. A total cell voltage of above 12V should not be charged using this charger. Different sizes of Ni-Cads can be used for testing, including the 12V sealed packs usually supplied with hand-helds, but take care if you are using a lower rated cell such as a PP3 or AAA, as these will charge at a lower rate.

Before switching on, connect a current meter in series with the positive lead as shown in Figure 7. Set SW3 to position one and switch on the charger (refer to the Table below Figure 7 which shows the expected charge rates for the six positions of SW3). Switch through the different ranges and check that the charge rates are correct, there may be slight variations in your readings to those shown in the table below. This will be due to the resistance of the current shunt used in your meter and the tolerance of the charging resistors.

The next stage is to test the fast charge position. I would advise you to use six AA cells to do this. Start by turning the selector to position six, your current meter should show about 53mA, or the expected current if you have changed the value of R13. When you press SW2 to

start fast charging, the reading on your meter should increase to about 480mA up to 550mA, depending upon the state of your cells. If your batteries are completely dead then the reading will almost certainly be over 500mA. The charge rate will alternate as the pulse LED switches on and off. When the LED is out, the charge current will drop to around 480mA and then climb again when the LED switches back on. If all seems well then your Ni-Cad charger is ready for use.

### Ni-Cad charger in use

The Ni-Cad charger can be used to recharge a variety of different cells (for their associated charge rates, charge times, switch positions of SW3 and the values of the charge resistor, see the table below. It is best to charge Ni-Cads in series and a number of battery holders are available from Maplin Electronics who also stock a large range of rechargeable batteries. The average time taken to recharge Ni-Cads at their nominal rate is between 14 and 16 hours.

With the values shown in the circuit, it is only possible to fast charge AA size cells in packs of six, or 500mAH packs found on hand-helds. Having said that, however, the unit will fast charge packs of a lower amperage, but care must be taken not to overcharge these as a shorter charge time is needed. Alternatively, packs of a higher amperage may be charged, but these will take subsequently longer than one hour. It should be possible to charge the new 1.6 amp packs found on the new Kenwood range of hand-helds in about three hours. A 12V pack will fast charge at a rate of about 370mAH and it was found that the higher the total pack voltage, the lower the fast charge rate would become. Because of this, you may have to fast charge 12V packs for a little longer than one hour to

CELL SIZE	CHARGE RATE	CHARGE TIME	SWITCH POSITION	RESISTOR VALUE
D	500mA	16 HOURS	1	R8 - 10R
C	228mA	16 HOURS	2	R9 - 22R
AA	50mA	16 HOURS	3	R10 - 100R
AAA	18mA	16 HOURS	4	R11 - 270R
PP3	9mA	16 HOURS	5	R12 - 560R
FAST	500mA	1 HOUR	6	SEE NOTES

### NOTES

1. Fast charging is set by resistors R14 and R15. R13 is a trickle charge resistor and can be set to provide about 5 to 50mAH. The value of R13 or any of the above resistors can be found by using ohms law, for example:

$$R = V/I \text{ for } 10\text{mA} \quad R = 5/10\text{mA} = 500\text{R}$$

Where: R = Charge rate resistor

I = Charge rate in mA

V = Voltage of the regulator IC1 ie 5 volts

It is worth noting that the fast charge rate will drop as the pack becomes full. This is due to the resistance change in the Ni-Cad pack.

2. The charge rate as shown for D and C size batteries is correct as recommended in the RS data sheet **Batteries R/2854**. Low amperage batteries such as the 1200mAH type sold by Maplin Electronics need only a 120mAH charge rate, so it may be necessary to change the values of R8 and R9 to obtain the correct charge rate. For C size 1200mAH batteries change R9 to a 33R 3 watt resistor.



## COMPONENTS LIST

### Resistors

R1 – 1K	R9 – 22R 3W
R2 – 100K	R10 – 100R 1W
R3 – 22K	R11 – 270R 1W
R4 – 100K	R12 – 560R 1W
R5 – 270R	R13 – 100R 1W (see text)
R6 – 330R	R14 – 10R 7W (see text)
R7 – 22K	R15 – 10R 1W
R8 – 10R 3W	

VR1 – 220K	VR2 – 220K
VR3 – 100K	

### Capacitors

C1 – 1000uF 35V single ended	<b>Maplin FF18U</b>
C2 – 10uF 35V tant	
C3 – 1uF 35V tant	
C4 – 1uF 35V tant	
C5 – 0.1uF disc ceramic	
C6 – 100uF 25V single ended	<b>Maplin FF11M</b>
C7 – 10uF 16V tant	
C8 – 0.1uF disc ceramic	

### Semiconductors

IC1 – 7805 5V 1 amp regulator	<b>Maplin QL31J</b>
IC2 – 7812 12V 1 amp regulator	<b>Maplin QL32K</b>
IC3 – NE555 timer	<b>Maplin QH66W</b>
IC4 – ZN1034E precision counter timer	<b>Maplin UF32K</b>
TR1 – TIP3055 power transistor	<b>Maplin QH56L</b>
TR2 – BC108 or equivalent	<b>Maplin QB32K</b>
BR1 – WO4 bridge rectifier 1.5 amps	<b>Maplin QL40T</b>

D1, D2, D5, D6 – 1N4001
D3, D4 – 1N4148

LED1 – 5mm RED	<b>Maplin WL27E</b>
LED2 – 5mm ORANGE	<b>Maplin WL29G</b>
LED3 – 5mm GREEN	<b>Maplin WL28F</b>
LED HOLDERS (3 off)	<b>Maplin YY40T</b>

### Miscellaneous

T1 – 0-9 0-9 500mA transformer	<b>Maplin WB11M</b>
SW1 – Single pole single throw	<b>Maplin FH30H</b>
SW2 – Push to make	<b>Maplin YR67X</b>
SW3 – Rotary switch 1 pole 12 way	<b>Maplin FF73Q</b>
RL1 – Double pole relay 12V coil	<b>Maplin YX98G</b>
Heatsink for IC2	<b>Maplin FG55K</b>
Terminal post RED	<b>Maplin HF07H</b>
Terminal post BLACK	<b>Maplin HF02C</b>
Vinyl covered box type WB3	<b>Maplin LH38R</b>
Stick on Rubber Feet	<b>Maplin FD75S</b>
Ribbon Cable 1.4 amp 1m	<b>Maplin XR06G</b>
6 re-chargeable batteries type AA	<b>Maplin YG00A</b>
9V battery box	<b>Maplin HQ01B</b>
PP3 clip	<b>Maplin HF28F</b>
Printed Board	
Printed circuit board pen	<b>Maplin HX02C</b>
Ferric Chloride	<b>Maplin XX12N</b>
Nuts, bolts, hardware etc	
R14 10R 25W resistor if used	

All the components for this project are available from Maplin Electronics. To make ordering easier, I have listed the Maplin order codes. A full range of resistors and capacitors are also available. A copy of their catalogue is available from W H Smith or direct from Maplin Electronic Supplies Ltd, P.O. Box 3, Rayleigh, Essex, SS6 8LR. Price £1.75

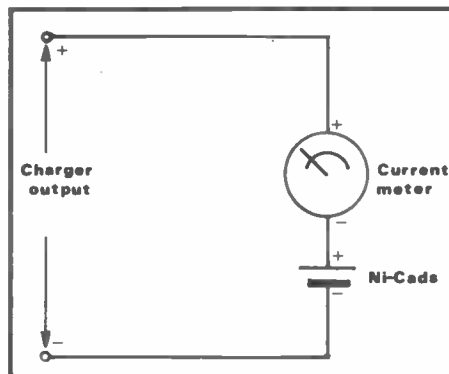

SWITCH POSITION	OUTPUT CURRENT
1	494mA
2	228mA
3	53mA
4	23mA
5	13mA
6	53mA

**Fig 7:** Set-up for checking each charge rate and a list of expected outputs

obtain a full charge.

For lower amperage batteries, the fast charge resistors R14 and R15 may be changed in value to obtain the correct one hour charge time. To modify the design to fast charge higher rated packs in one hour, the transformer, bridge rectifier, C1, IC1 and the fast charge resistors will all have to be up-rated to handle the higher charge rate.

The charger is very easy to use; just select the range to suit the pack to be charged and connect the Ni-Cads across the output. To fast charge, select the fast charge position on SW3 and then press the START button SW2, the Timer LED and the Pulse LED will light and then after one hour the charger will automatically switch to a trickle charge, causing the lights to go out. *Care must be employed at all times when dealing with rechargeable batteries, and overcharging at a high rate must be avoided.*

### Conclusion

The charger has been in regular use for some time and has been a very worthwhile addition to the shack. Ni-Cad batteries can die with very little warning and to be able to recharge them in one hour instead of the usual 15 hours is very beneficial. It now means that if you are planning a day out and you have forgotten to charge your batteries the night before, a full pack can be ready within the hour.

With a little thought the charger can be modified to fast charge at a higher or lower rate and the timer can be altered for almost any time period required. Most people should be able to complete the project with little difficulty and I am sure you will obtain full use from this charger. The approximate cost of construction including a box is around £25, which is relatively cheap when compared to other fast chargers.

# DX DIARY

News for HF operators compiled by Don Field G3XTT

The portents continue for some excellent propagation this autumn. As I write this in the late evening on August bank-holiday weekend, 10m is full of stations from North, Central and South America as well as South Africa. I suspect that during the CQWW SSB Contest later this month, it could well be possible to work over 100 countries on 10m over the weekend, just as it was in the early '80s.

Talking about possibilities, there were some interesting statistics in DX News Sheet recently. Tom, GW3AHN, is reported, since the beginning of 1988, to have worked 100 countries on 28MHz, 100 on 24MHz, 150 on 21MHz, 50 on 18MHz and 120 on 14MHz. Alan, G4NXG, has worked 160 countries this year, all from his car! And G3EZZ is reported as having worked 195 countries in two years using just an indoor dipole!

August brought us some interesting DX activity including CY9DXX from St Paul Island (worked in the UK on 160-15 metres); P40R from Aruba; a big effort from T5GG by some visiting Italians; a splendid operation by HD8DZ from the Galapagos (worked in the UK on 10 through 40 metres, including RTTY); further operation by C9MKT; more activity by TN4NW and a brief operation from South Georgia (the first from there for many years) by VP8BRR. In addition, there was plenty to please those who chase islands, oblasts, etc, as well as those who simply enjoy a good rag-chew.

Talking about rag-chewing, I took the 2 metre box on a camping holiday in August, and found it hard to raise people for a QSO. Although many folk seem to monitor S20 or the local repeater, they will often only reply to their mates. This is a phenomenon I have observed before in several different parts of the country. Contrast this with HF, where it is always possi-

ble to get a QSO and often a very interesting one at that. Many HF operators may have only a smattering of English, but there are plenty more who will be happy to chat for hours on end about every subject under the sun. And with the higher bands coming back into use as the sunspots return, this is often possible with low-power, modest antennas, and very little QRM.

## What's new?

Latest reports indicate that the Lynx DX Group now has visas for the Yemen, but the operators have missed their opportunity to take leave. However, the visas are valid

until 25th October, so they are hoping to re-schedule their trip for early October. Keep a sharp ear to the bands for this one. Meanwhile, a station signing 4W0CRC has been quite active. The operator really does appear to be in the Yemen and claims to have permission to operate, but whether there will be any supporting paperwork still remains to be seen.

The number of operations notified for the October and November CQWW contests is increasing rapidly. The table summarises all those I know of at the time of going to press. Many of these operations will be extremely well

equipped and should be very easy to work. For example, the P40V group is going for a new multi-multi record, so they should be operating simultaneously on all bands with big antennas and lots of power. The operators promise to QSL all contacts automatically via the bureau, and a certificate will also be available if you work them on at least four bands.

I think we sometimes forget the scale of some of these operations. US groups such as this think nothing of chartering an aircraft to ship tons of gear and antennas to a remote island to mount a major contest operation. Even the Russians get in on the act, with some very big operations in recent years from UG, UF, etc. Anyway, it's good to see some UK operations in the pipeline for this year, with G4JVG heading for VK9Y, G3PFS in S7, G4FAM scheduled to be in CT3, and some other possibilities which have yet to be formally announced. Because of the efforts some of the contest groups put in, the CQWW contests are a good opportunity for QRP operators to boost their scores. It's amazing how far you can get with low power when the distant station is receiving you with a big monoband yagi!

Mind you, not all DXpeditions go smoothly, so there is no guarantee attached to these contest operations. There is a story doing the rounds of the DX press at the moment regarding WB4PJW's effort to operate from the Turks and Caicos Islands a while back. Jeff thought he had all the loose ends tied up before he went. On arrival, after discovering that the weather was hot and humid and the hotel had no air conditioning (a must for our American cousins!), he found that the officials who would issue his licence were on holiday until the Tuesday, the Monday being a national holi-

## CQ WW SSB Contest Operations

A35 by OH2BAZ	
CT3 by G4FAM?	SA
CR9BZ by Finnish group	MM
HB0 by Bavarian group	MM
HC8 by NE8Z	
HK0 by HK3MAE?	
J3 by W8KKF and W6CDR	MS
J52US by OH2BH	SA
OZ9EDR (first OZ on 160 SSB)	
PJ1B by US group	MM
PJ1W by N4WW and NX4N	MS
P40A by N1GL	SA
P40T by KB2HZ	S (15)
P40V by AI6V et al	MM
PY0F by PS7KM et al	MS
S7 by G3PFS	
VK9YG by G4JVG	
YJ8 by OH1RY	
XX9 by WB4FLB	
ZF2ML by WB2P	
8P9X by K3KG K3ZR K4FJ	

## CQ WW CW Contest Operations

GU by G group	MS
HK0 by HK3MAE?	
J52US by OH?	SA
KC6 (East) by KX6DS	
LX by Bavarian group	MM
SV5 by W6OSP	
VP2MDC by K1TN	
VP2MW by AA5DX	

Key: MM = Multi-Multi

MS = Multi-op, single Tx

SA = single-op, all-band

S (band) = single-op, single-band

(only shown where known)



day. Come Tuesday the officials concerned denied ever having heard of him! By this time Jeff had also gone down with one of the local bugs and had a temperature of 103.

After a few more days and some expensive 'phone calls to the main island of the group, Jeff eventually tracked down someone who would issue him a licence. A few days of operating followed, until the trip home where he was hospitalised for a further week. And there were no photographs to record the happy events on VP5 because - you've guessed - Jeff's camera also packed up during the trip!

I'm sure this story is by no means untypical, but it doesn't seem to stop budding DXpeditioners trying their hand. However, when you hear the moans and groans from the DX fraternity when a DXpedition doesn't deliver quite what was promised, it's worth remembering that life isn't always a bed of roses at the sharp end.

Of course, sometimes things just fall into place. The DX Bulletin recently carried an interesting account by I8YGZ of how the 3X0A operation from Guinea became a reality. Pino was given the opportunity of taking a team of technicians to Guinea to set up a comms network for the local health service. Like any good radio amateur he spotted the potential for some amateur radio operation and started investigating possibilities. In the end Pino himself was unable to go, but Franco, IK8DYD, was able to join the team of technicians who went out and managed to persuade the authorities to issue him a licence once he was in the country.

When Franco first turned up on the air he was shunned by many DX operators who thought him a pirate. This was mainly because there had been no advance publicity. However, once Franco was on the air Pino put in an immediate call to the RSGB's DX News Sheet and word soon got around (the DXers' grapevine always works at lightning speed on such occasions!).

Franco's operation wasn't the easiest, what with work commitments and frequent power blackouts, but he was on the air enough to notch up over 3,700 contacts. What's more, having breached the dam, he and others were later able to return to Guinea for an

exclusively ham radio operation as 3X0A/A from the Los group of islands off the Guinea coast.

#### Other forthcoming DX

To start the month off, VE2UMS/VE2 should be active from Zone 2 on 1st/2nd October on 10 to 80 SSB and CW. On 20 they will alternate between SSB and CW roughly every two hours. On 20m they will also announce from time to time the other bands currently in use. Check the following frequencies: 3785, 7025, 7085, 14025, 14185, 21025, 21185, 28025 and 28525kHz. QSLs to the VE2 bureau.

If you are looking for the Falkland Islands, look out for the RAF Club station, VP8RAF (what else?). It is active every Sunday on 21295kHz from 1700 to 1800GMT.

C9MKT's next operation should take place over the weekend 21st-23rd October. Keep an ear open around 21400kHz. That same weekend, K5MK/4 will be active from Cat Island (NA82 for Islands on the Air). Check 25 and 62 on CW and 14330, 21330 and 28630 on SSB.

By now SM7PKK should be on tour in the Pacific. He will operate from 5W1 until 10th October, then as SM7PKK/KH8 until 24th October, from ZK2 until 7th November, A3 until 24th November, 3D2KK until 13th December, and from ZK1 from 25th March until 4th April next year. He will run barefoot to a vertical antenna so don't expect massive signals. Check 5 up on CW, and 3795, 7095, 14195, 21295 and 28595 on SSB.

Also in the Pacific, KX6DS, who has been very active from the Marshall Islands, plans an operation from the Eastern Carolines from 20th-28th November. Dave prefers CW and suggests you look for him on 3505, 7005, 14030, 21030 and 28030kHz.

#### Prefixes

Some rather curious prefixes cropped up again recently. These included HD4, TV75, 8J2, 8J4, 8J5, EK0, 4C2 and U5 to name but a few. Perhaps the oddest, though, was P0PJ from the Netherlands Antilles. This seems to defy the ITU prefix allocations, so perhaps a mistake was made when the call was issued. It certainly wouldn't be the first time.

#### RTTY

Some RTTY equipment has been donated to the oper-

ators on Pitcairn Island, so we could be seeing some activity from VR6 soon on this mode. Even China is now on RTTY, with a couple of UK stations reporting QSOs with BY9GA. There has been lots of other interesting RTTY activity recently, with UK stations reporting contacts with HZ1AB, 6W6JX, FO5LQ, JY9IU, V85WS and others. SU1DR should be active on RTTY and AMTOR by the time you read this. And TG9VT says he is active on AMTOR from 0400GMT on 14074 and on RTTY from 1230 to 1430GMT daily on 14090 or 21090kHz.

#### YL award

The Young Ladies Relay League (YLRL) celebrates its 50th anniversary next year and is offering a special award to mark the occasion. To qualify, you need to work 50 YLRL members during 1989. Applications should be sent to Joan Gibson, KG1F, RR1 Box 1465, Waterbury, VT 05676, USA by the end of 1990. They should include a list of QSOs with date, time, call sign, report, band and mode, plus a signed declaration that you have observed the rules of the award and your local licence conditions. The fee is \$4 or five IRCs.

#### Contests

As well as the CQWW events, don't forget the RSGB 21/28MHz 'phone and 21MHz CW contests, which give UK stations a chance to be DX for a change. Then there are the VK/ZL/Oceania contests, with the SSB leg on 1st/2nd October and the CW leg a week later. The weekend after that the WA-Y2 contest takes place - work stations in the DDR on SSB and CW. Into November and there is the RSGB 1.8MHz contest to look forward to, plus the OK DX Contest (rules much the same as the CQWW, but both CW and SSB simultaneously) on 13th November.

#### St Paul Island

Earlier I said that CY9DXX was active during August from St Paul Island. This is an odd 'country' because it lies in the Gulf of St Lawrence, surrounded by the rest of Canada. St Paul consists of two main islands and a number of rocks, and has claimed many ships over the years. Around the turn of the century it was home to about 40 people, with its own cannery, school and telegraph office, but now the only permanent



Bob Cox, K3EST, one of the organisers of the CQWW Contests

resident is the lighthouse keeper.

Like its near neighbour, Sable Island, St Paul qualifies for separate DXCC country status by virtue of its separate administration. Both islands are administered directly by the Federal Department of Transportation. The DXCC rules have changed since then, of course, but Sable and St Paul remain on the DXCC list as interesting anomalies from the past.

Various amateur call signs have been used from St Paul over the years. The first was VY0A, round about 1970 if I remember rightly. Since then CY9SPI has been issued to the island for use by 'all' operations, though the latest operators seem to have got round this one. Just as well, because the use of one call by successive DXpeditions has created all sorts of confusion as far as QSLing is concerned. The same is true of Sable Island which was allocated the call sign CY0SAB.

Finally, more congratulations are due this month, this time to Ian, G4LJF, who becomes the latest UK amateur to achieve 5-band WAZ. Ian has a super station, but his work as an airline pilot takes him overseas for long periods, so this award, as with other recipients, represents the culmination of lots of effort and perseverance. John, G3BRD, is also to be congratulated on achieving DXCC on topband. And Roger, G3KMA, made number two slot world-wide with the new 10m single-band DXCC award, with 315 current countries confirmed on the band. Many of us would like that total regardless of band! W4DR led the pack with 317 confirmed. Roger was the only European in the top ten. 73 de Don, G3XTT.

- ★ 2m/70cm
- ★ 25 Watts output
- ★ Full duplex operation
- ★ 21 Memories
- ★ 2 Call channels
- ★ Priority channel
- ★ Dual VFO's
- ★ 12.5 & 25kHz steps
- ★ Memory Scan
- ★ Programme Scan
- ★ Memory Skip

**£449 inc vat**

**ALD-24E**

## ALINCO DUAL BANDER



This transceiver could transform your operating habits! It contains completely separate 2m and 70cms transceivers, permitting full duplex operation. To the un-initiated, this means you can transmit on 2m whilst receiving on 70cms, or vice versa. The built-in duplexer means a single antenna socket with a full 25 watts output on both bands. Measuring only 5.5"x2"x6.5" it is the ideal mobile rig. Its comprehensive memory and scanning facilities provide rapid access to both

simplex and repeater channels on 2m & 70cms. Using the dual VFO's you can instantly switch between 2m & 70cm and the single knob tuning provides simple and quick frequency selection. The large LCD readout incorporates an S-meter and is back lighted. If you are looking for a completely self contained 2m & 70cm station, then look no further. At this price it has to be a bargain. For further details of this amazing transceiver, send today for the full colour brochure.

## OUR FAMOUS FREQUENCY MANUALS!

### UK LISTENERS CONFIDENTIAL FREQUENCY LIST 5th EDITION

This publication has now sold well over 3500 copies since it was advertised only a few months ago. Now the recent updated version is selling even better. No self respecting listener should be without a copy. If you enjoy exploring the short wave bands then this publication will add to your enjoyment. It covers the hf spectrum from 2 to 30 MHz and gives details of transmissions outside the amateur bands. Specially designed for the UK and European listener it sets out in a very easy way a comprehensive list of hundreds of interesting transmissions that will keep you occupied for days on end! Only a fraction of the cost of other similar publications it contains details of Marine, Air, Military, Embassy, Press and News agencies. Many listings have time schedules included together with comprehensive RTTY details. It tells you the frequencies used by civil and military aircraft whilst flying the Atlantic, when and where to pick up the press bulletins, long distance marine traffic etc and much more. Send today for your copy of this worthwhile publication.

**NEW 1988 EDITION £6.95 p&p 90p**

### 4th EDITION VHF-UHF AIRBAND FREQUENCY LIST

This frequency manual is without doubt the most comprehensive list of VHF/UHF aircraft listings available in the UK. Of vital importance to the airband enthusiast or indeed any keen VHF/UHF listener it sets out in a very easy to follow manner full details of a whole host of stations. Every known UK airfield frequencies, etc. Included are Civil, RAF, USAF, MOD, Naval fields on both VHF and UHF bands. There are also air to air frequencies, the Red Arrows frequency, and much more. Send today for your copy and find out just how much you have been missing!

**£5.95 p&p 90p**

### THE COMPLETE UHF-VHF FREQUENCY GUIDE 26-2000 MHz

**New 1988 Edition.** Many listeners have asked for a guide to the wide VHF/UHF spectrum and to meet this request we have recently published this frequency manual. It covers the range 26 to 2000 MHz and has been specially prepared for the UK listener. Anybody who has used a scanning receiver will know that the wide frequency range involved means that it is difficult to know exactly where to listen. This guide takes all the guessing out of monitoring. It lists all the services throughout the spectrum together with both simplex and duplex frequency splits. If you've spent your hard earned money on a scanning receiver or are considering buying one you'll find that this publication contains a wealth of information that has previously remained un-published!

**£5.95 p&p 75p**

### HF OCEANIC AIRBAND COMMUNICATIONS 1988 EDITION.

Prepared in response to many requests for more information about the air traffic on the hf bands this little guide sets out to explain to the beginner how the hf band works in relation to air traffic. It contains full details of the world aircraft frequency bands in the range 2 to 23 MHz together with control frequencies and those commonly used for Oceanic control. Also included are many VOLMET frequencies, the Search and Rescue frequencies used by RAF helicopters and Nimros, the Hf RT network, London Company frequencies, European control centres etc. An ideal companion for the hf airband listener. Send today for your copy.

**£3.50 p&p 70p**

**WATERS & STANTON ELECTRONICS**

18-20 MAIN ROAD, HOCKLEY, ESSEX - 12 NORTH STREET, HORNCHURCH, ESSEX.  
MAIL ORDER TO: 18-20 MAIN ROAD, HOCKLEY, ESSEX TEL: (0702) 206835





If you enjoy buying your station in nice neat surroundings then don't read this article! If, however, you have the spirit of adventure and are willing to invest a bit of time then you might pick up a few pointers on a new 'hobby' as well as some FM VHF gear, carpet for the shack, bamboo for that quad, parts for a linear and countless other goodies.

# SOMETHING FOR NOTHING

## ... a Scrounger's Notebook

by Thomas E King VK2ATJ

### Scrounging

This even sounds like a word hams invented, but it isn't. According to one popular unabridged definition, to *scrounge* is 'to gather together by foraging; to seek out; to borrow, especially a small item one is not expected to return or replace.' According to the 1984 unabridged King definition, scrounging is the 'pleasurable art of collecting useful and often priceless articles of everlasting amateur use by ingenious, yet completely legitimate, means.'

Before entering the world of 'formal scrounging' it's best not to tell anyone, especially your family, of your desires as they might not be able to withstand the shock. If you are a married scrounger keep the ham shack locked and avoid telling your wife that you're planning to take up a new hobby. Marriage stability is often shaken when an XYL learns the truth about her husband. If you are contemplating marriage, reconsider your intentions.

You will also have to admit to yourself that you really are a pack rat and that you will be of credit to the scrounging profession as well as do justice to all of your finds, including attempts at repair if practical. Only as a last measure are you to box up items and store them in the shack or, at worst, the attic or garage with a note attached to fully describe the contents so you don't have to dig through dozens of similar boxes!

### The fun begins at home

In over 20 years of dedicated scrounging I have found only one basic requirement, other than an inquisitive and persistent nature common to all foragers. The only tools of the trade are a thick notebook and ready pencil carried at all times to note down possible equipment/parts, sources for scrounging ideas. In the serious business of scrounging, memory is not enough!

Your main researching will be done using telephone directories. Start with the yellow or white classified pages and let your mind roam and your fingers do the walking over the various possible classifications. Good listings to jot down

with firms and addresses are: taxi companies; electronic equipment and supplies agencies; radio and television stations; radio communication equipment and system distributors; authorised repair stations for commercial equipment; surplus stores; pawn shops; automobile service stations; city municipal services, such as telephone, gas, power and water companies; radio and TV repair shops and second-hand stores.

After you've done that, you might start checking listings for fire departments, road maintenance boards, weather bureaux, forestry and conservation services, railroads, electrification commissions, implement companies, closed circuit TV installations (such as factories, etc), moving van lines, hospitals, lighthouses, delivery services, construction companies, airports, second-hand stores and, finally, law enforcement agencies (such as the motorway patrol and city police, etc).

Noting down so many addresses can be a large task if you happen to live in a metropolitan area with dozens of radio/TV repair shops, a score of electronic suppliers and a multitude of utility offices. So a priority approach is needed unless you are a truly dedicated scrounger with lots of time and patience.

If you live in a small city then your first telephone list of 'scrounge possibilities' will not take long to compile. Additional aids are as close as your public library. More libraries have other local, regional and some national directories which are invaluable for further research. It's quite easy to spend many pleasant hours looking through directories of the larger cities, considering the categories mentioned and day-dreaming of the possible results.

### Go out and get it

Armed with your trusty notebook full of addresses three paths lie ahead. You can either visit everyone on your list, 'phone them all or dig out the typewriter and write to all of them.

Virtually all firms in small towns and villages can be contacted directly. Personal contact with these smaller businesses is only hampered by transportation and available time. If you are known in the community then a personal visit will not only be an advantage but an

asset as a less formal approach is needed. Business people in small towns will often go out of their way to help.

Personal contact can also be used in small towns close to home. Whenever possible try and squeeze in a stop or two at a service shop or commercial equipment repair station, as well as the friendly neighbourhood second-hand store. Because of the probable lack of time, however, it may be better to contact the larger firms in such nearby cities by telephone or for longer distances, a short letter. For instance, for that particular city, a few calls to the town's council offices will usually check that category off your list.

Finally, equipment manufacturers, out of town radio and television stations and other city municipal offices, can fall into this category as well. You might also want to contact all airports with authorised commercial equipment service shops within 200 miles.

### The scrounge approach

It makes little difference which means of approach is used when it actually comes to making the initial contact. Certain moves always reign supreme, however, when establishing contact for the first time. Brevity, courtesy and appreciation should be at the top of anyone's list. Remember that you are asking a favour from a person that you have probably just met (or possibly might never meet).

Your introduction, whether spoken or written, should include the facts: your name and call sign and a statement that you are an amateur radio operator (or soon-to-be amateur, are interested in amateur radio, or whatever) and that you enjoy building or experimenting.

If contacting by letter my first sentences after introducing myself are: 'I am writing to enquire of the possibilities of obtaining any old radio or communications equipment and/or parts. As an amateur radio operator I am looking for items that might be used for parts or converted for ham use.' In the closing sentence I usually add that I would appreciate any help that they might be able to give and also that I would like to know if they have information of any other outlets for such parts and/or equipment.

With a personal visit it's possible to be a little less formal and I often use something like the following: 'Hello, I'm Tom, VK2ATJ, a ham radio operator from Sydney. I was wondering if you might have any old radio equipment and/or parts laying around and gathering dust, that you might be interested in disposing of?' As unimaginative as this may sound, it's brief, gets the point across, doesn't leave someone wondering what you want and, best yet, it works (variations on the above are acceptable, however).

A few statements on what to expect is in order at this point. Don't be surprised at anytime and don't get your hopes up too high over a potential scrounge. Also never refuse anything unless it's been under water more than 30 years and in some instances that still wouldn't matter!

I have got down to the final moment of making a real find only to get a four valve radio with the line cord cut off and all the valves gone. However, many unexpected finds have been made when the anticipation level was relatively low and nothing more than a four valve radio was expected to begin with.

#### What to expect

Many hams may think of their neighbourhood radio and TV repair shop as one of the best possible sources for goodies. They are great, and over the years such service shops have provided a gold-mine for me in the form of my first FM VHF rig, an 80ft aluminium tower, several pieces of test equipment, commercial pre-amps and antique radios, to name only a few goodies.

Radio and TV service shops can fill up with unclaimed stuff which after a period of several months to many years, are usually thrown out or heaped in the attic, basement, or back room. There have been instances where service shops have either closed or thoroughly cleaned house, and knowing that I wanted anything electronic or related, have brought this to my attention. Repair shops can also tell you whose commercial equipment they have worked on and/or who used commercial equipment; this can lead to other possible contacts.

Radio and TV stations must keep their transmitters operating at maximum efficiency. This means that final output valves are often thrown away after a set number of hours have been reached. In amateur service these valves would last forever. If you've ever dreamed of the ultimate linear but can't afford the valves...

Any mobile service requiring radio communication is also a source of equipment. Often it's easiest to use the 'club scrounge approach' when contacting large companies using mobile radio equipment. This is particularly true of county and state agencies. My first experience with these agencies was through a 'permanent loan' of many two piece low band FM units to a radio club in eastern Kentucky when I was portable 4.

This allowed the first activity on 6m in that part of the state. So, as a club project you might consider contacting some of the agencies listed earlier. Don't forget gas, water, power and telephone companies. It won't hurt.

Actually, anything on wheels is a possible source. Radios get worn out in all radio dispatched vehicles eventually. Radio users can come in all shapes and sizes from pizza delivery vans, taxis and even cement companies which are contracted to the local airport.

What can you expect when you least expect it? Just relax and accept what's offered.

Many possibilities for getting goodies are right under your nose, especially if you happen to live in a small town. Take a walk some nice afternoon, keeping an eye to roof level. It might be a good idea to start in your own neighbourhood and ask around to see if someone has recently changed antennas. If so, you just might have a chance of obtaining an old television antenna or maybe even a tower and, who knows what else? Some home owners replace antennas and will happily give the old one to somebody who can use it.

Check for usable goodies from demolished houses. If you can strike up an acquaintance with the fellow tearing the place down, so much the better, as you might be able to obtain pipe, lumber, wire, carpet, doors (a nice solid operating table) etc.

Attend all the rummage, garage sales, yard sales and fêtes you can find. It's really surprising what people sell. Remember that most fêtes and rummage sales are heavily publicised as they are a chief fund raiser for churches. Check out these church sales and cash in on old radios, books and accessories which are ideal for the shack, such as carpets, desks, lamps etc.

While you're checking out the local establishments you might try 'ye olde carpet shops' for rug scraps (ever thought of carpeting your operating table? It really is nice) and bamboo (yes, some companies still ship rugs wrapped around bamboo poles. How about a free quad?). Try chemists and department stores for old display stands and cabinets. They make great storage bins for equipment and parts. Don't forget lumber yards for wood scraps, electrical repair shops for old appliances, cinemas for speakers (they make nice mobile speakers when rebuilt) and petrol stations for old car radios.

Next, there's the tip...that unique creation where almost everything ends up at some time. It might not be too appealing to wander among smouldering rubbish, dodging rats and flies. However, not all tips burn their rubbish, as some tips are land fills, so the task of retrieving treasure is not as difficult or hazardous. A number of radio beginners have made their start in the tip. Get a shovel and happy digging!

#### The ad game

Amateurs willing to invest a few pounds in advertising can often realise great benefits. Informal, but attention-grabbing notices such as handwritten sheets on bulletin boards can be posted in laundries, corner grocery stores... anywhere where there is a vacant spot. You might mention that you would take down unused towers and antennas and haul away their old television sets.

Classified advertising can also be effectively used. College newspapers are often a good place to enquire about various electronics articles.

Read the local newspaper noting advertisements in the wanted and sale sections. Make note of auctions (especially police auctions), farm sales, closing-down sales, etc. Electronic gear, fixtures, hardware and much more is often sold at sometimes reasonable, sometimes exorbitant prices (experience will guide you as to the best bargains).

#### Hamfests

Hamfests are a different slice of life. Nothing but a hamfest would tempt you to stay up until midnight packing the car full of gear, get up at 4am or earlier, dress in total darkness so as not to disturb the family, fix yourself a cold cup of coffee, drive for three hours in the dark, search for half an hour to find the hamfest and another 15 to 20 minutes for a parking spot.

Nowhere but at a hamfest would you park next to your neighbour from back home, or go on a self-imposed starvation diet not wanting to queue for ten minutes for a cold sandwich and a beer at 9.30am (of course, if you had arrived five minutes sooner you could have had a free doughnut, a cup of coffee and somewhere to sit).

Only at a hamfest would you wade through mud for six hours to see what the other hams in your town brought. Hamfests are the only institutions where you see grown men haggle over a few pence or swap hundreds of pounds of gear without batting an eyelid. A hamfest is also the only place where when you open the boot to stash some goodies, you've got six guys around you immediately trying to buy your spare tyre.

A hamfest is the only place where you can leave with all the stuff you brought with you, or with a new boot load of goodies and then drive home asking yourself what can be built with 158 1pF capacitors, and when the next hamfest within 500 miles will be.

Hamfests are fun and since they provide relaxation from your daily routine, it should be easy to convince yourself of their emotional benefits. Hamfests shouldn't be the only place where you see the hometown hams, however. Get to know the ones in your own town. Attend and meet with the other hams at your club meetings. If



there isn't a club-start one. You'll soon find that other hams around will help you with a club and will also be ready to trade, buy, sell, barter or whatever. Maybe your club could sponsor an auction (it's a good fund raiser), you'll be able to get rid of some old scrounged stuff in order to make more room for your newly acquired finds.

Get out the call-book for an extended search of the ham about town. It takes a long time to sieve through the 99.43% of hams that aren't local, but the effort is worth it. Not only can you find out what the locals are doing, but you can often find out who is the best troubleshooter or

who has access to a truck for hauling your scrounged tower.

If you are an active ham who still enjoys QSLing, you may have another source for scrounging. With every QSL sent out I always enclose duplicated sheets of radio magazines' past issues, that I am looking for or have to trade. Not only does this method protect the QSL but it also introduces my radio interests and needs to other hams who might be interested in trading. Such sheets can be typed on a master and then duplicated quite inexpensively to keep costs down. Maybe one of the locals you've met has access to a duplicating machine?

**Is there reason for this madness?**

There have been some fantastic success stories in the two decades I have been scrounging. One of the biggest and heaviest things I ever scrounged was a 5,000W AM broadcast transmitter. I had no intention of keeping it, however, as I worked for a year to obtain it for a community college broadcasting programme. Probably the largest thing I have ever scrounged was a 40ft windmill tower with blades and pump still intact, or was it the 80ft aluminium tower?

As you can see, the chase is often more fun than the catch (this can be true with a number of things!).

# LOOK WHAT YOU GET EVERY MONTH IN

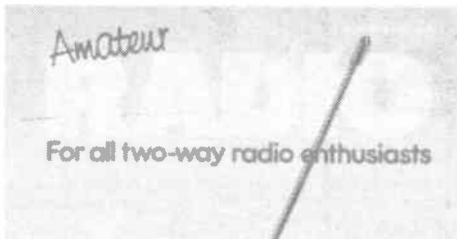

# Amateur RADIO

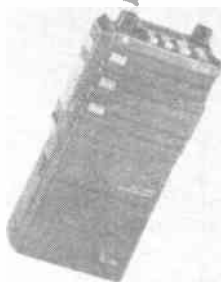

On Test  
The new Low loss Coaxial Cable from Westlake and the PX02 Pulse Generator and Marker Unit

- ★ **DX DIARY** Don Field G3XTT with all the news of rare DX, contests and DXpeditions
- ★ **ON THE BEAM** Glen Ross G8MWR with all the news and comment from bands above 50MHz
- ★ **G3OSS TESTS** Angus McKenzie – the fairest, most comprehensive reviews available anywhere

**MORE NEWS, MORE FEATURES, MORE FUN, MORE STYLE THAN ANY MAGAZINE AVAILABLE ON THE MARKET TODAY**

Make sure of your copy by placing a regular order at your newsagents or by taking out a post free, inflation proof subscription, with early delivery to your door each month

## AMATEUR RADIO SUBSCRIPTION ORDER FORM

To: Subscription Department • Amateur Radio •  
45 Union Road • Croydon •  
Surrey • CR0 2XU  
Tel: 01-684 9542

PLEASE SUPPLY: (tick box) for 12 issues, all rates include P & P

Inland	World-Surface	Europe-Air	World-Air
£23.80..... <input type="checkbox"/>	£25.80..... <input type="checkbox"/>	£29.50..... <input type="checkbox"/>	£34.55..... <input type="checkbox"/>

NAME.....

PAYMENT ENCLOSED: £  -

Cheques should be made payable to Amateur Radio. Overseas payment by International Money Order, or credit card

ADDRESS.....

CREDIT CARD PAYMENT   EXPIRY DATE

.....

/

.....

.....

.....Postcode.....

Signature.....

# ICOM

## NEW! IC-228E 2 Meter FM Transceiver



Actual  
size

### Features:

- Multicolour Liquid Crystal Display.
- 25 Watt output.
- 20 Memory channels.
- Scanning.
- Call and priority function.
- Compact size.
- HM15 microphone supplied.

Take a close look at this easy to use and compact VHF Mobile Transceiver. It's unique orange, red and green LCD highlights the numbers and letters for easy viewing. With a 25 watt output from a custom designed power module and a extra large heatsink, this transceiver does not get too hot under your dashboard

Each of the 20 memory channels can store frequency, offset and direction, in fact all the information to work simplex or a repeater. The memory scan function will scan the memory channels and with the skip function

miss those you choose. The program scan will scan all frequencies between two programmable limits. The call channel ensures that your favourite frequency is within easy reach, and with the priority watch the call channel or memory channels can be monitored every five seconds.

This transceiver provides you with so many features, its small compact size and simple front panel design make it a superb mobile transceiver. See the IC-228E or the IC-228H 45 watt high power version at your local ICOM dealer.

**Icom (UK) Ltd.**

Dept AR, Sea Street, Herne Bay, Kent CT6 8LD. Tel: 0227 363859. 24 Hour.



Count on us!

# NEW! IC-3210E Dual Band FM Mobile



If you are newly licensed or just undecided about which band to operate first, then the new ICOM IC-3210 is just the answer. This dual band FM transceiver is ideally suited for the mobile operator. Transmit on one frequency and receive on the other and you're operating full duplex. It's just like talking on the telephone.

The simple and well laid-out front panel ensures quick and easy operation of all its many functions. A great convenience when driving. Optional accessories available are the UT40 tone squelch board, HS15 + SB mobile microphone and switch box SP8 external speaker and PS45 AC power supply.

#### Features:

- Full crossband duplex.
- 20 double-spaced memory channels.
- Built-in duplexer.
- 2 call channels.
- 4 priority watch functions.
- Programmed, memory and selected band memory scan.
- Variable LCD backlight intensity.
- Tone squelch and pocket beep functions (optional).
- 25 watts output.

**Helpline:** Telephone us free-of-charge on 0800 521145. Mon-Fri 09.00-13.00 and 14.00-17.30. This service is strictly for obtaining information about or ordering Icom equipment. We regret this cannot be used by dealers or for repair enquiries and parts orders, thank you.

**Datapost:** Despatch on same day whenever possible.

**Access & Barclaycard:** Telephone orders taken by our mail order dept, instant credit & interest-free H.P.



# MULTIBAND DIPOLES

by Ken Williams

In last month's article we considered half-wave dipoles. Although they are essentially single band devices, under certain circumstances, they will also operate on harmonics of their fundamental frequency, or even on frequencies totally unrelated to their physical length. Perhaps the best place to start, therefore, would be to consider the characteristics of long dipoles.

## Current distribution

If a dipole is half a wavelength in length, there is a current maximum at the centre where it can be fed with low impedance feeder. Here, the feed impedance is the same as the radiation resistance of about 70 ohms.

If, however, the aerial is doubled in length (or the frequency doubled, which amounts to the same thing) each half of the wire will have its own half-wave current distribution which will be out of phase with each other. So the centre, at which point we fed the half-wave aerial, will now be at the end of each half-wave pattern, ie at a voltage maximum.

The feed impedance will, therefore, be very high and any attempt to feed with low impedance feeder is doomed to failure due to impedance mismatch. There are, however, means of feeding at this point which we will come to later.

Now let us extend the aerial still more until it is three times the length of the original half-wave dipole. Three half-wave patterns will now be set up so the centre is once more at a point of maximum current where it can, again, be fed with low impedance feeder. In this case, however, the radiation resistance is higher than for a half-wave dipole, corresponding to about 100 ohms.

As the aerial is further extended in multiples of a half-wavelength, these effects are repeated. The centre point of

## THE DIPOLE AERIAL PART 2

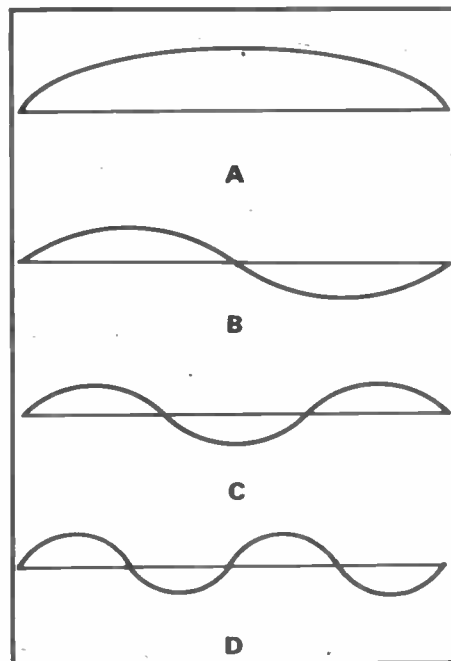

**Fig 1:** Current distribution on an aerial. **A:** Half-wave. **B:** Full-wave. **C:** Three half-waves. **D:** Two wavelengths long. Note that there is always zero current at the ends and that maximum current is at the centre if the aerial is an odd number of half-wavelengths long

aerials of an odd number of half-wavelengths in length presents a low impedance to the feeder and those of an even number of half wavelengths, a high impedance.

Unfortunately, on HF, with the exception of 7 and 21MHz, the amateur

wavebands bear a 2:1 frequency relationship which means that a dipole on one band cannot be operated on the next higher. Again, there are methods of overcoming this which we will come to later.

## Radiation patterns

Each half-wave section of a long dipole will radiate pattern exactly the same as a single dipole. In space, however, these separate patterns will add in amplitude and phase to form the pattern of the complete aerial.

So, in the case of a full-wave aerial, where one half is out of phase with the other, broadside to the wire, the radiation from one half will cancel that of the other and give a null. For a three half-wave length aerial, the radiation from two out of phase sections will cancel, leaving that from the remaining half-wave unaffected.

The patterns for all aerials of an even number of half-waves long will, therefore, show a null broadside to the wire while aerials of an odd number of half-wave lengths long will show a lobe in that direction.

Consider now the signal radiated from one half of a full-wave aerial at an angle of about 45 degrees to the wire in the direction of the other section. Although the radiation from the two half-waves was originally out of phase, by the time the signal has reached a point in front of the other section, it will have travelled half a wavelength and so changed phase. The signal from the two halves will, therefore, reinforce and create a lobe in that direction. Similarly, at some other angles, the radiation will reinforce while at others it will cancel, resulting in two lobes either side of the wire.

If the aerial is longer than two half-wave lengths a similar action will occur,

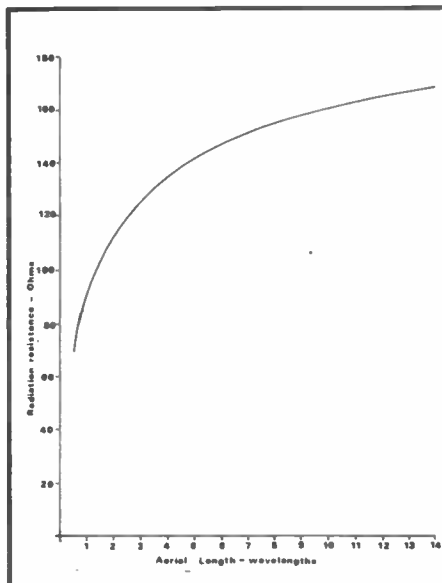

**Fig 2 left:** The variation of radiation resistance with length for a long wire aerial

**Fig 3 right:** Curves representing theoretical gain, of a long wire aerial over a dipole and the angle with respect to the wire of the main lobe

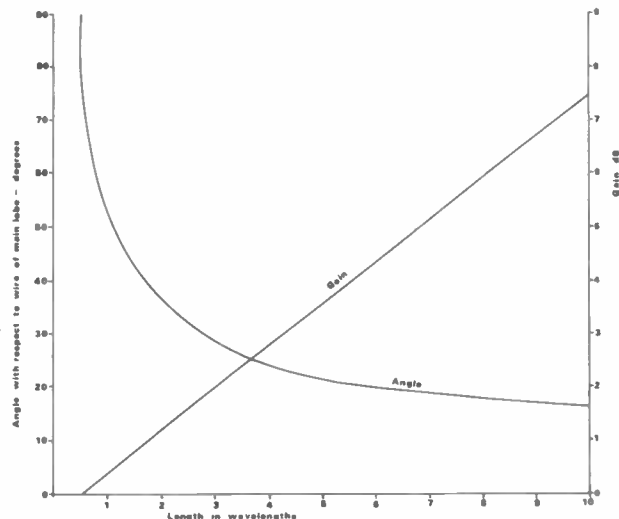



producing a pattern which has the same number of lobes on each side of the wire as the length of the aerial in terms of half wavelengths.

Of these, the strongest lobe is always that which is closest in line with the wire. As the aerial is lengthened, so this lobe strengthens and its angle to the wire decreases. With really long wires, the advantage over a dipole becomes considerable and at an aerial length in the order of 10 wavelengths the gain is comparable with a good monoband beam in the order of 7-8dB.

The other lobes are much weaker but are still of sufficient strength to provide reasonably good all-round coverage.

Many years ago, I had the opportunity of erecting an aerial nearly 800ft long. This was aligned in an east-west direction and on 20m the two westerly lobes were directed at the southern United States and South America while one of the easterly lobes reached over western Australia.

In each of these directions the aerial consistently out-performed my neighbour's beams which included quad loops and commercial multi- and monoband yagis.

### Multiband dipoles

In the previous section, we have seen that an aerial of any number of half-wavelengths will radiate extremely efficiently but, unfortunately, due to the 2:1 frequency relationship between most HF amateur bands, a coaxial fed dipole aerial for one band will be totally mismatched on the next higher. The problem, therefore, resolves itself as one of feeding the power generated by the transmitter to the aerial. Possibly the most simple means is to use parallel dipoles.

### Parallel dipoles

As we have seen, if an attempt is made to operate a dipole on its second harmonic, it will present a very high impedance to the feeder and, due to the mismatch, very little, if any, power will be radiated.

If, however, a second dipole tuned to the harmonic frequency is connected in parallel with the first, this will match the feeder and accept and radiate the signal as if the lower frequency dipole were not present.

When operating on the lower frequency, the shorter dipole will present an impedance of several hundred ohms to the RF signal and accept very little power; the vast majority being radiated by the longer aerial.

We have seen previously that a reasonable match can be obtained between a low impedance feeder and an aerial operating on odd harmonics of its fundamental frequency. The only case on the HF bands, where advantage may easily be taken of this, is operating a 7MHz dipole on its third harmonic (21MHz). Due to the differences in electrical and physical length discussed in last month's article, however, an aerial tuned for optimum on either 7 or 21MHz will not be so for the other. Yet, an acceptable, but not optimum match for

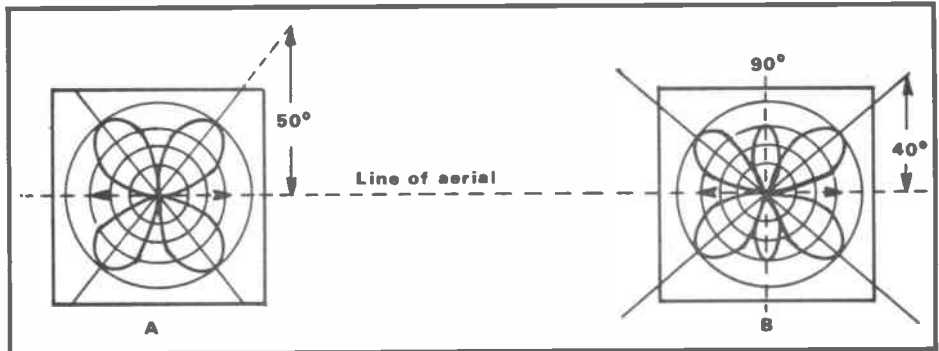

Fig 4: Horizontal polar diagrams of a **A**: 1 wavelength aerial **B**: 1½ wavelength wire

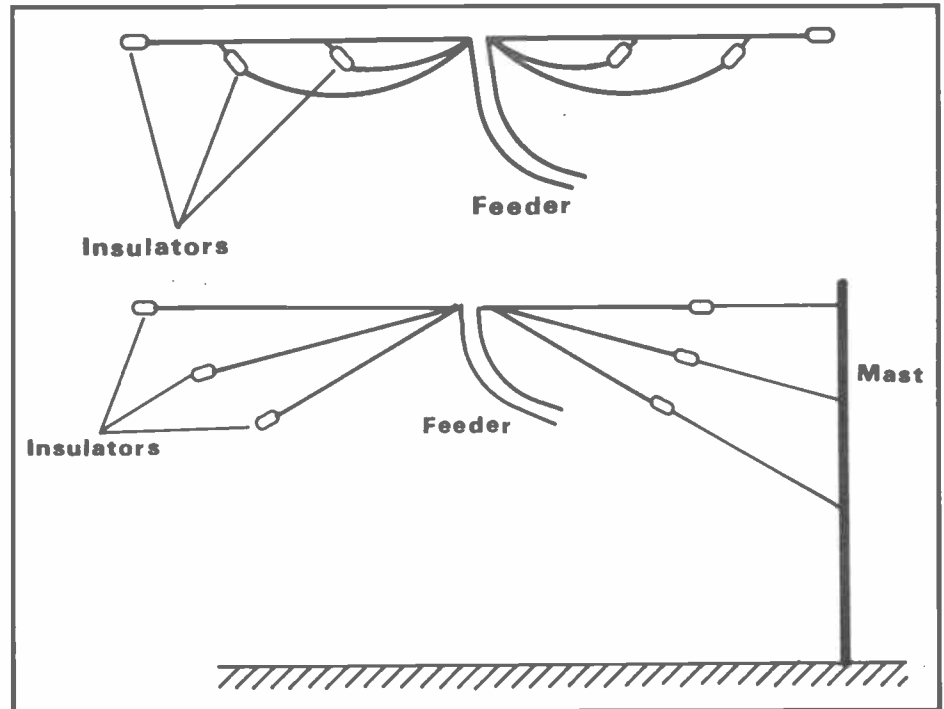

Fig 5: Two ways of supporting parallel dipoles

both bands can usually be determined.

If, therefore, dipoles for 7 and 14MHz are mounted in parallel, acceptable operation on three bands: 7, 14 and 21MHz, is possible. The addition of a further parallel dipole for 28MHz will complete coverage of the major DX bands.

Needless to say, the close proximity of the parallel dipoles will have an effect and if 'text book' lengths are used, they will be found to be in error although they will provide a good starting point. The influence each of the aerials has on the others is largely a matter of their relative spacing with the closer the proximity, the more the effect. In practice, separations in excess of six inches are satisfactory, provided that the aerials are individually optimised for each band.

### The trap dipole

One of the most common multiband aerial systems in use today is the trap dipole. This comes in one of several forms, encompassing two different principles of operation.

In examining the principles of the most simple of these, let us first consider a simple 40m dipole. Here, each leg has been cut and an insulator inserted at the halfway point so the remaining centre portion resonates on 20m.

In this form, the aerial will operate on 20m, with the RF ignoring the section of wire beyond the insulator. By placing short circuits across the insulators, the aerial will now resonate on 40m. If, however, the short circuiting wires are then replaced by switches, when open the aerial would operate on 20 and when closed, on 40.

Similarly, other switches could be added at appropriate places to make the aerial resonate on any desired selection of frequencies.

The use of mechanical switches to change the effective length of the aerial is obviously unwieldy and impractical. Use is, therefore, made of the properties of a parallel tuned circuit.

Basic radio theory tells us that, at resonance, the impedance across a parallel tuned circuit is extremely high but relatively low at all other frequencies. Therefore, if the switches mentioned earlier were replaced by a parallel tuned circuit tuned to 14MHz, on 20m they would act as insulators, but on 40m they would be virtually ignored. The tuned circuits would then be acting as automatic electronic switches and the aerial would operate on both wavebands without adjustment.

The insertion of a parallel tuned trap has a further effect, for the circuit shows

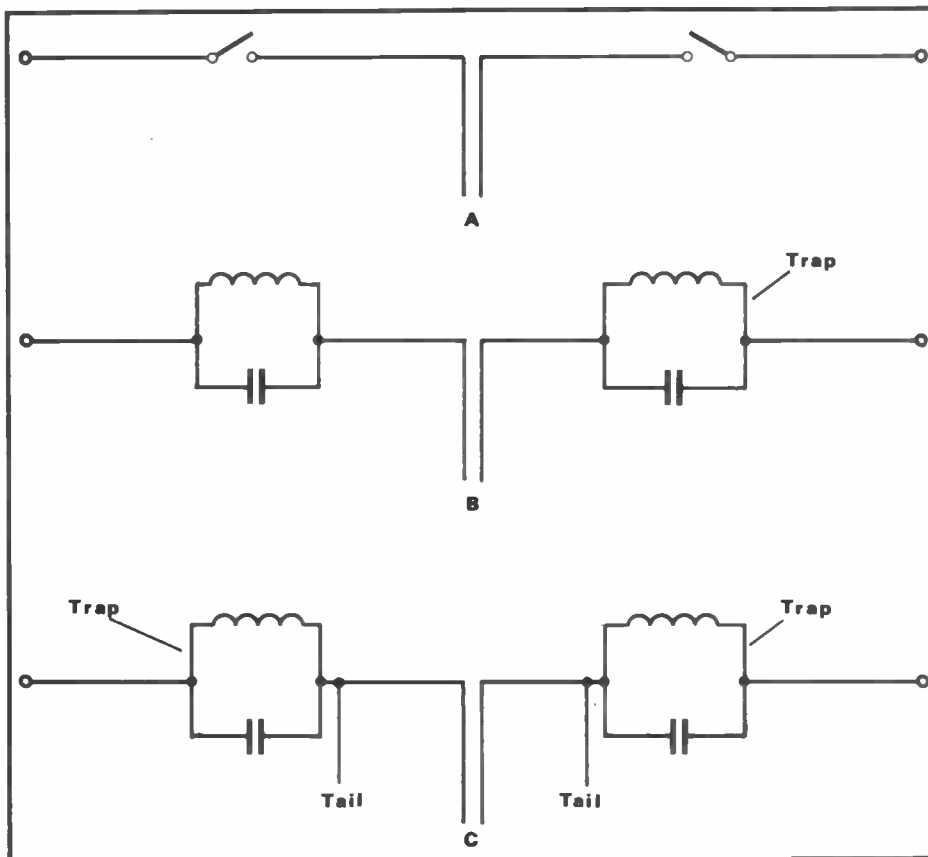

**Fig 6:** Trap dipole. **A:** Action of trap (see text). **B:** Trap dipole. **C:** Modification suggested by Angus McKenzie G3OSS

**Fig 7:** Series tuned trap dipole. **A:** Dipole Resonant on 7MHz. **B:** Dipole loaded to 3.7MHz by inductances L<sub>1</sub>. **C:** Action of series tuned trap. **D:** Circuit of series tuned trap (L<sub>2</sub>C) across loading coil L<sub>1</sub>

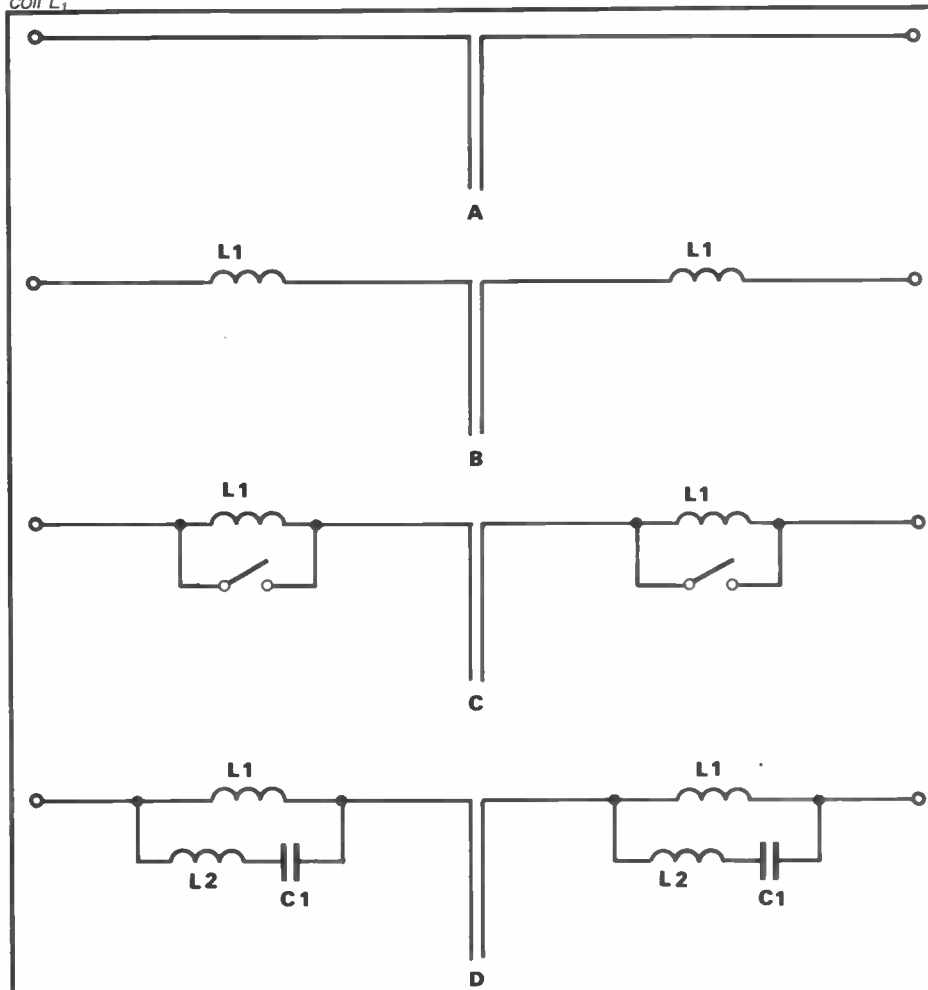

an inductive reactance at frequencies below that of the trap and a capacitive reactance above.

The effect is that the traps tend to 'load' the aerial on the lower frequency of operation. Also, the additional length of wire required beyond the traps to make the aerial resonant on 40m will be less than expected. This length will be affected by the L/C ratio of the trap.

Similarly, if an attempt was made to operate the aerial on its third harmonic (ie 21MHz), the effect of the trap would be an increase in the amount of wire required to achieve resonance.

By careful 'juggling' of the L/C ratio of the 20m traps it is possible to gain an optimum match for the aerial on all three bands.

When in operation considerable RF power flows within the traps and any underrating of components can cause heating and instability. As an example, some time ago the author erected a trap dipole using inexpensive 7MHz traps. These turned out to be very inadequately rated, because when tuning-up on 40m, the change in their resonant frequency, as they became hotter, could easily be seen on the transmitter loading.

I believe Angus McKenzie G3OSS, suggested that the electrical strain on traps could be relieved if, instead of mounting the traps at the highest voltage point, they were placed several feet back along the wire and an equivalent-length to restore resonance was left hanging below the wire. This considerably reduces the voltage on the traps together with consequent heating effects.

It is probable that at this point you are asking how, in view of the foregoing discussion, can a trap dipole operate on five bands or more with only one pair of traps?

The answer to this dilemma lies in the fact that the normal five-band trap dipole is about 102 feet long and operates as harmonic aerial on 10 (seven half-waves), 15 (five half-waves) and 20m (three half-waves) and as a simple dipole on 80m. The only fly in the ointment is 40m, where a high impedance would be presented to the feeder. This is overcome by a pair of 40m traps at an appropriate place to isolate a simple dipole for that waveband.

An additional effect of the traps is to provide some loading to assist the aerial to resonate on 80m and also electrically shorten the aerial on the three higher frequency bands. By careful optimisation of the L/C ratio of the traps and wire lengths, it is possible to present a good match to the feeder on all HF bands.

The other type of trap, which is not yet common on wire aerials, is designed to load the aerial for operation on lower than its natural frequency yet not affect normal operation.

Returning to our simplistic method of using mechanical switches, an inductance is inserted about two-thirds of the distance along each leg of a dipole. This is of such value that it will load the aerial to the next, lower frequency band. A mechanical switch is fitted across the inductance. So, with the switch closed,



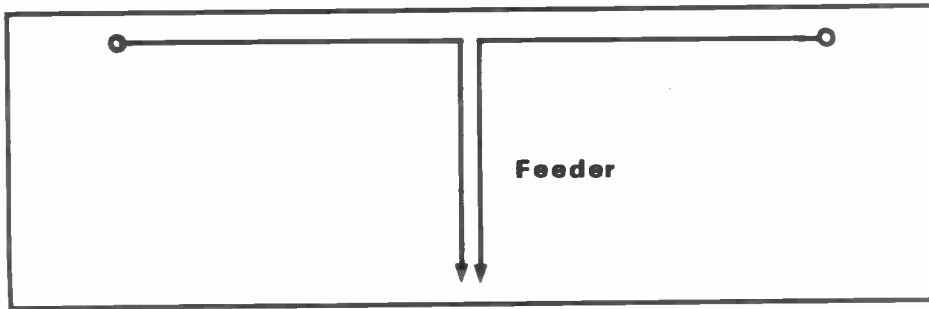

**Fig 8:** The open wire fed dipole. The feeder is most conveniently made from about 16swg enamelled wire spaced 3-6in by spreaders of insulating material spaced 2-3ft. Neither the gauge of the feeder wires nor their spacing are critical

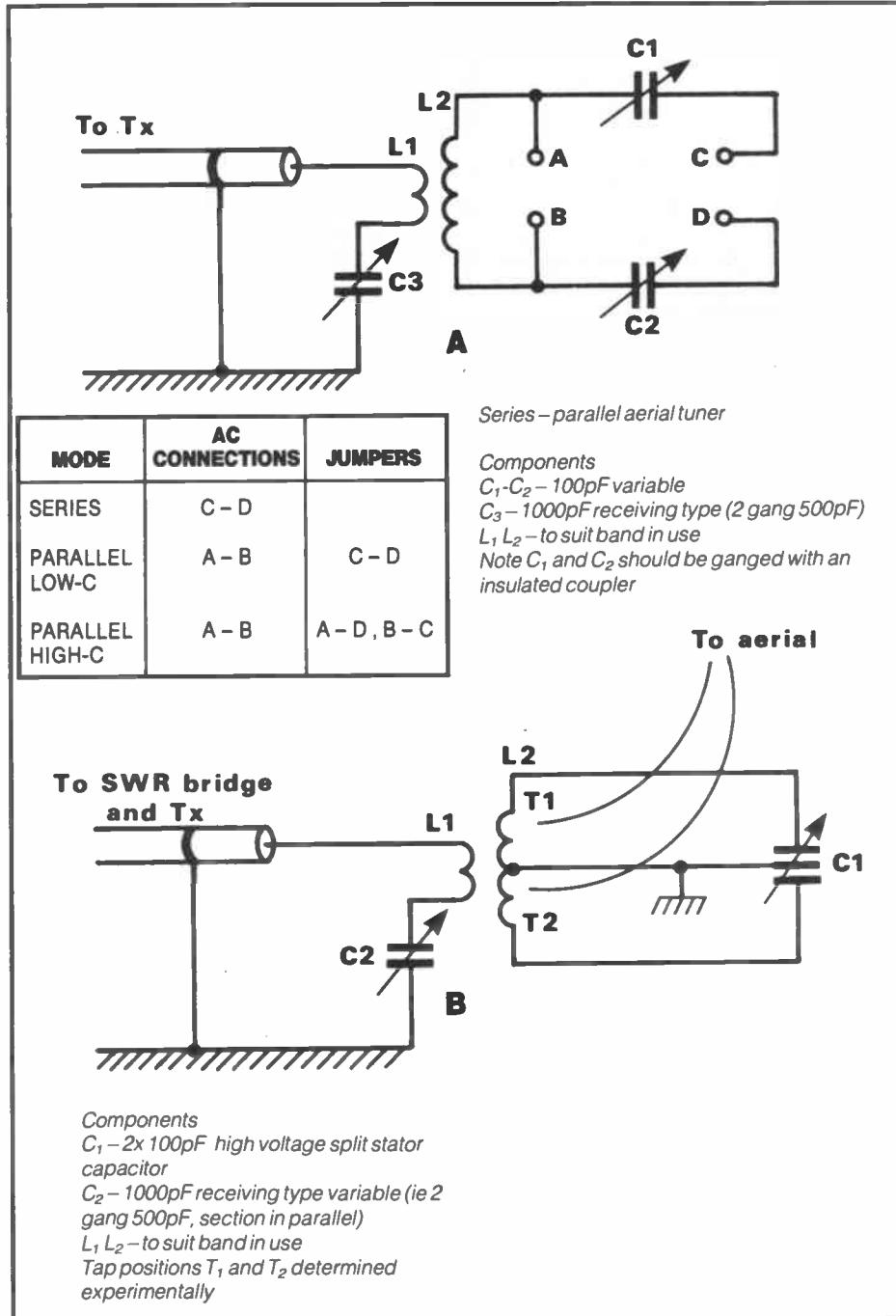

**Fig 9:** Two circuits to match low impedance lines to balanced open wire feeders. Of these B is preferred

the inductance will be inoperative and the aerial will act as a simple half-wave dipole. With the switch open, the aerial will be loaded to the lower frequency band.

To make the switching automatic, the

properties of tuned circuits are, again, brought into use, this time those for a series tuned circuit. While, on resonance, a parallel tuned circuit presents a very high impedance, in contrast, a series circuit presents a low one.

So, if a series tuned circuit is connected across the inductance in the loaded dipole, on the higher frequency the inductance will be effectively short circuited and the dipole will assume its natural resonance. On the lower frequency of operation, the series circuit will present a much higher impedance and the loading inductance will be effective.

With this type of trap, therefore, the whole span of the aerial is effective at all times.

### The open wire fed dipole

The simplest and most flexible all-band aeriels are those using open wire parallel conductor feeders to the centre of the aerial.

The principle of operation is simple. When any wire is excited by RF some form of varying wave pattern will be set up in which a voltage maximum will appear at either end. As the feeder is an integral part of the system, the whole can then be tuned by adding either capacity or inductance to the base of the feeder. When resonance is achieved, a stable standing wave pattern will then be set up. Due to the balanced nature of the feeders, they will not contribute to the radiated signal.

In this brief description it should be noted that there has been no mention of dimensions for, due to the very nature of the system, it will tune to any frequency. If the top is less than a half-wavelength in length at the lowest frequency of operation, the radiation efficiency will be impaired, but this does not become serious until the length is approaching a quarter of a wavelength.

The radiation patterns are similar to those described previously with one important difference. When the top is a full-wavelength long, due to the nature of the feeder system, each half-wave is fed in phase. The radiation from each half will reinforce and, instead of the four lobe pattern, the main radiation will be broadside to the wire. This configuration is known as 'two half-waves in phase' and provides a gain of just under two decibels over a half-wave dipole.

The possible disadvantage of this system is that the impedance presented at the transmitter varies extremely widely from band to band and matching may well be beyond the capabilities of many commercial Aerial Matching Units (AMUs) which are basically designed to deal only with the range of impedances that are normally found on a coaxial feeder.

It would probably be wise to construct an alternative AMU in accordance with one of the circuits accompanying this article.

### The G5RV dipole

The G5RV is possibly the most popular of all multiband aeriels in use in the United Kingdom today. It is, however, a specific configuration of the open wire fed dipole.

By experiment and calculation, the designer realised that with a 102ft top, a low impedance point appeared approximately 32ft down the open wire feeder

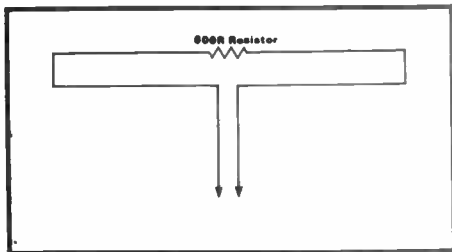

**Fig 10 left:** The G5RV aerial  
**Fig 11 below:** The terminated folded dipole.  
 The length is in the order of  $.35\lambda$  at the lowest frequency of operation and the bandwidth is 2:1

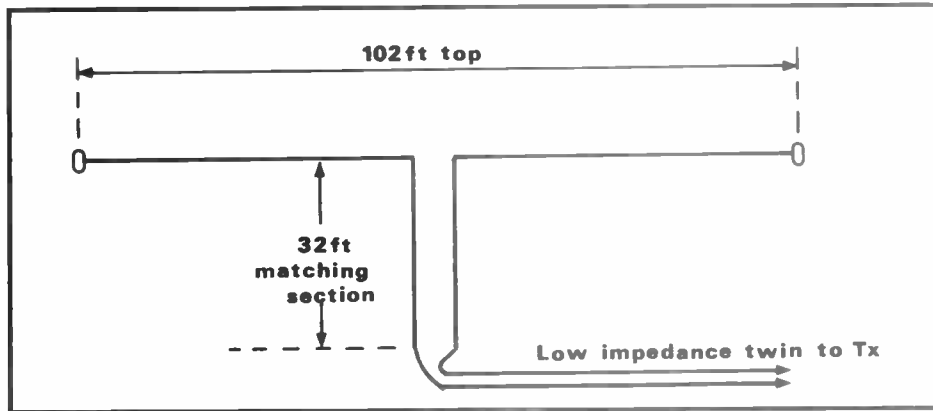

line on each of the pre-WARC amateur bands from 3.5 to 28MHz. From that point, therefore, the open wire feeder could be replaced by a low impedance, preferably twin, feeder which would then exhibit a reasonably low VSWR. The system was particularly effective on 20m.

A more recent version of the aerial replaced the open wire feeder with a

somewhat shorter length of 300 ohm twin. In this case the mode of operation of the aerial is exactly the same, the shorter length being necessary due to the velocity factor of the 300 ohm line.

**The terminated folded dipole**

Many amateurs have the impression that commercial transmitting stations

invariably have massive aerial farms. In some cases this is true but frequently only simple aerials are used.

Most commercial stations, however, have a requirement to transmit over a wide band of frequencies and the convenience of a wide band aerial often outweighs a slight reduction in efficiency. One type of aerial commonly used by small stations is the terminated folded dipole.

This is very similar to a normal folded dipole except that the folded section is split opposite the feed point and a 600 ohm non-inductive resistor inserted. The dipole is fed from 600 ohm open line or by coaxial cable via a matching balun.

The effect of this is that the aerial presents a reasonably constant impedance to the feeder over a wide (more than 2:1) frequency range.

A version of this aerial received some publicity in the amateur press many years ago. It never gained popularity due, perhaps, to the belief that the resistor absorbed half the output power.

Since WARC, however, we have had the availability of five bands between 14 and 30MHz. I believe that, for these frequencies, the terminated folded dipole may begin to find favour, for to construct (say) a trap dipole for all these bands would be extremely complex.

In my last article in this mini-series, I shall be considering the dimensions and fine tuning of half-wave and multiband dipole systems.

# ICS

## EVERYTHING FOR DATA COMMUNICATION BY RADIO

---

**The Best Value Packet Radio TNC on the UK Market**

NEW



PK-88

- ★ Compact size
- ★ Nine front panel status indicators
- ★ NetRom-compatible
- ★ Compatible with PK-87 Host Mode Control
- ★ TTL/RS232 inputs and outputs
- ★ 32K RAM buffer
- ★ Full range of high quality driver software for IBM-PC, Commodore 64 and BBC Computers
- ★ Built in personal mailbox
- ★ Built in HF modem

Only **£109.95** inc VAT  
Post and Packing: £2.50

**The World Standard Multi-Mode Data Controller!**

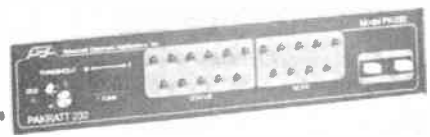

PK-232

- ★ Now with seven modes: AMTOR, Packet, RTTY, CW, ASCII, Facsimile and Navtex
- ★ Superb send/receive facsimile software for IBM-PC and Commodore 64
- ★ Unique SIAM signal acquisition and analysis capability
- ★ Firmware upgrades available for earlier PK-232s
- ★ Excellent Host Mode software support

Still only **£269.95** inc VAT  
Post and Packing: £4.00

Applications assistance always. Send large SAE for further product details. Visitors by appointment only.  
 Prices may vary according to prevailing exchange rates. **Prices include VAT @ 15%**



### ICS ELECTRONICS LTD

PO Box 2, Arundel, West Sussex BN18 ONX  
 Telephone: (024 365) 655 (2 lines) Fax: (024 365) 575





# SECOND-HAND

by HUGH ALLISON G3XSE

## Pye Compacts

A Compact is a 'pair' of pocketphones (a Tx and Rx) in one box. There is the advantage that, as you go from receive to transmit, the receiver is automatically disabled, thus there is no howl round as with a more normal pair of pocketphones. There is the disadvantage that you cannot have listen through if working through a repeater. One big plus is that there is more room to spare inside a Compact case, thus a tone burst can be squeezed in.

Why the sudden write up on Compacts? A trader was shifting hundreds of them at the Brighton rally (excellent do, as always) and he was selling them at the amazing price of two quid each. The normal price of a pocketphone receiver is of the order of two to three quid, the matching transmitter five to seven. A Compact has slowly fallen from thirty sovs ten years ago to about twelve to fifteen nowadays, so two quid is a genuine bargain.

Purely in the spirit of a journalistic investigation I risked life and limb to join in the scrum and buy one. It was in a reasonably grubby condition, but the electronics set up on the local repeater gave no trouble (it never ceases to amaze me how sharp the trimmers are, you have to be careful or you are through the peak) and the case came up a treat after an overnight session in the dishwasher.

It was in a grubby condition but the electronics on the local repeater gave no trouble....

If you are considering trying 70cm and live well in the service area of a repeater, then a cheap Compact is worth considering. Batteries can be picked up (rechargeable) for 10p a go, you will need two, and a charger for a quid. The only other expense is likely to be crystals to get it on the required channel, estimate a fiver or so since 70cm rocks do need to be more stable, thus more expensive. A Compact runs on two yellow pocketphone receive type 9V batteries. They don't use the red pocketphone 18V transmit battery, which is good news 'cos they can set you back a couple of quid.

## Servicing dual superhets

There are two basic types of dual conversion superhet receiver. In one you have, as per a normal single superhet, a front end which may, or may not, have an RF stage, but will have a tuneable oscillator and a mixer. This could produce a fixed IF of, say, 10.7MHz that

**Right:** Honda E300 Generator.  
**Below:** Electroniques front end

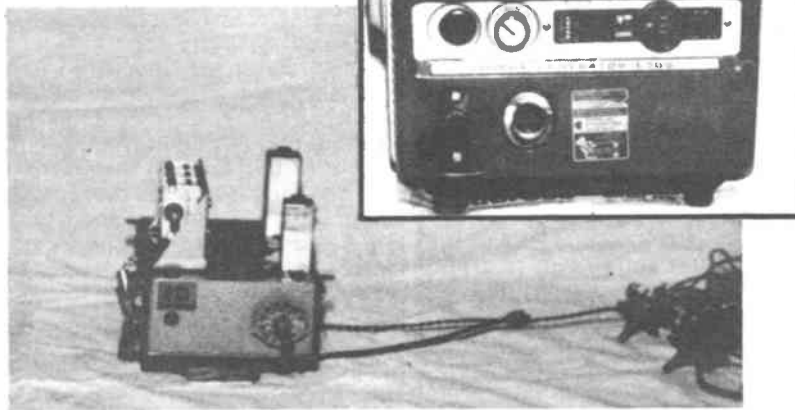

then gets hetrodyned down to the second IF of, say, 500kHz by means of a crystal controlled oscillator.

This crystal oscillator, for our example, might be 10.7-5, ie 11.2MHz, or 10.7-0.5, ie 10.2MHz, or *both*. Why both? To invert the sidebands. This has the advantage that the BFO could be fixed frequency (maybe crystal controlled) and reception of lower sideband (LSB) or upper sideband (USB) is achieved by selecting the appropriate IF mix crystal.

If you have followed me so far it should now be painfully obvious to you what is going wrong with a receiver that will resolve, say, LSB but goes totally dead on USB; one of the conversion rocks ain't oscillating. If I had a quid for every Gelose R209 that I've repaired that has had this fault (the USB/LSB switch goes open circuit) it would pay for a good night out.

Another advantage of this type of dual conversion is that it combines the high first IF, thus giving good image response, with the low second IF where cheaper filters can do amazing things to the overall bandwidth.

## The other type

The other sort of dual conversion receiver I always think of as a single band receiver with a converter in front. Imagine if you will a receiver just tuning 5 to 5.5MHz. If it had an IF of 500kHz then it must have tuneable local oscillator running either 4.5 to 5 or 5.5 to 6MHz (*not both*). In front of this receiver you then stuff the normal converter of crystal controlled oscillator, mixer and RF stage. This converts the band you want to listen to down to the frequency of your receiver. You will need a different crystal for each band, plus different coils in this

converter.

This type of dual conversion receiver, known as a tuneable IF dual conversion superhet, has one glorious advantage. The tuning scale is the same for each band; ie 3.5MHz will be in the same spot as 21MHz, and the tuning length from, say, 3.5 to 3.6MHz will equal that from 21 to 21.1MHz.

Right, so what is wrong with a receiver of this type that quietly (ie at greatly reduced sensitivity) receives the wrong stuff but is tuneable, and gets exactly the same wrong stuff on each band in the same spot on each band? The converter bit isn't functioning. All you are receiving is tuneable IF breakthrough. Since the receiver bit tunes 5 to 5.5MHz on every band, that is what you are hearing.

To repair the above you certainly are not wasting your time checking that the crystals are oscillating (one per band, obviously a set dead on one band smells of a single dead rock). A real favourite is the separates' problem. Here you have a separate receiver and a separate transmitter that can be joined up for single knob working. I've come across problems where the receiver will work on its own but join him up with his transmit friend and all goes quiet. Particularly aggravating if the Tx works OK!

If you give the above a moment's thought, for single knob working the tuneable local oscillator (VFO) and usually the conversion oscillator have to be shipped from one box to the other - normally from the Tx to the Rx. Very often these drives are buffered and if the buffer transistor goes you get the above exasperating fault. If I had a quid...

## Electroniques

The accompanying photograph shows

## SECOND-HAND

a rather uninteresting-looking bit of 'rubbish' which I bought for 10p at a rally. What is it? It's a front end.

Many moons ago, like about twenty odd years back, Electroniques made some super amateur stuff and one of their offerings was a valve front end. This either tuned the short waves, general coverage or amateur bands only, depending on variant. The mechanical inputs were tuning and bandchange, the output was, invariably, a 1.6MHz IF. Most of the ones I've seen recently are a pretty metallic blue colour. After a few years the valves gave way to solid state, again amateur bands only, or general coverage. These front ends seem freely available, second-hand, at most rallies.

Note that with 1.6MHz IF, we are talking of the top end of the medium wave and I've seen a transistor car radio on the end of a valve general coverage front end look a mess but work exceptionally well. A matching 1.6MHz solid state IF strip was also available, resplendent with a two crystal filter. These are occasionally seen at rallies nowadays, around the couple of quid mark. Incidentally, take out one of the two crystals in this strip and replace it with a low-value trimmer capacitor and you have a moderate CW filter. The strip only gave out a few millivolts of audio – straight from the detector – but an audio strip removed from, say, a tape recorder, will take care of speaker driving. Add a BFO and a very reasonable home-assembled receiver becomes a distinct possibility for well under a fiver.

Don't overlook front ends which have been 'built on'. The one photograph came with a right rats' nest of an attempted homebrew dual IF bolted on. In the middle of it was an excellent Collins mechanical SSB filter, a very welcome and unexpected little bonus. I've bought other front ends with all sorts of gash holes in them and gubbins attached; they seem very reliable and all work when relieved of extraneous stuff.

A quid seems tops for one of these excellent front ends. If you don't use it as nature intended, it's still worth that pound to strip down for the variable

capacitor and coil pack.

How well do they work? The photographed 'mess' which went into an Electroniques transistor strip then into a four transistor audio amp, plus BFO, could certainly hear everything that the shack TS-830S could hear on 20m. On 10m the Electroniques receiver could only hear the stronger stuff coming down from a satellite and the '830 very definitely had the edge, but it was quite an acceptable performance for a total cost of £3!

### Honda generator

It's not often you make an impulse purchase that turns out to be indispensable. At the Derby rally, on the flea market, was a sold as not working E300 generator. The seller told me that the starter rope did not engage and there was no compression. Luckily, the spark plug was loose and could be undone by hand. I already knew how to deal with a non-engaging starter rope on these and having got the rope connected to the engine, gave it a pull with my finger on the plug hole – there was compression. The seller wanted a tenner, which seemed reasonable, so I bought it.

---

**... the starter rope did not engage and there was no compression. The spark plug could be undone by hand ... having connected the rope to the engine, gave it a pull with my finger on the plug hole – there was compression ...**

---

The starter rope engagement problem is normally due to the three solder tag-looking things in the starter mechanism. These are situated between two rings. When the engine is running, centrifugal force holds them out. When the engine is stopped, one or more of these solder

tags drops down to engage the starter. The slightest bit of dirt and they won't. The quick cure is a sharp blow to the generator with the palm of your hand, that will normally dislodge one, then you are in business. The long term cure is to open it up and clean it off with meths. *Never ever oil the tags as this will encourage them to pick up dirt.*

Having cured the rope problem it was time to get the engine running. The seller, incidentally, was of the impression that there was no compression 'cos he could not see the piston down the plug hole. I understand that in this engine there is what is called an offset combustion chamber, which apparently helps reduce noise. It also means you cannot see the piston.

Having put in petrol, checked the oil and given it a new plug I reckon I pulled the thing round the garden trying to start it. No go. In desperation, a shot of *Easy start* down the plug hole and it ran like a dream first pull. The funny thing is, it's never needed it again. Full choke and it is up and running first pull, get the choke off quick and it's ready for work, even in the coldest winter.

Uses? It's brilliant. Power cuts, no problem. It will give out 240V mains at a couple of amps. That's enough to run quite a few bulbs. Field days, indispensable. To be honest I prefer to run a mains powered rig on a Honda via a constant voltage transformer, but will run the rig and a light bulb.

The generator will also give out 12V dc. Note, it will not give mains and dc, it's one or the other. Man, does it charge a battery quick! On a freezing cold winter's day an iced up car with a flat battery is up and running within five minutes. In summer, down to the bottom of the garden to the tractor with the flat battery (I must buy a new one sometime), it is up and running in seconds after a quick 'top up' from the Honda.

Second-hand, I've seen general non-workers in the ten to twenty-five quid area. Workers range from sixty (a bargain) to a ton. I've also seen them unsold at £110 and £120, so £100 seems the top price to pay. Super machines!

## MAKE YOUR INTERESTS PAY!

More than 8 million students throughout the world have found it worth their while! An ICS home-study course can help you get a better job, make more money and have more fun out of life! ICS has over 90 years experience in home-study courses and is the largest correspondence school in the world. You learn at your own pace, when and where you want under the guidance of expert 'personal' tutors. Find out how we can help YOU. Post or phone today for your **FREE INFORMATION PACK** on the course of your choice.

Electronics	Radio, Audio and TV Servicing
Basic Electronic Engineering (City & Guilds)	Radio Amateur Licence Exam (City & Guilds)
Electrical Engineering	Car Mechanics
Electrical Contracting/Installation	Computer Programming
	GCSE and 'A' level subjects

Course of Interest: .....  
Name: .....

Address: ..... P. Code: .....  
**ICS** International Correspondence Schools Dept EFSAB, 312/314 High Street, Sutton, Surrey SM1 1PR. Tel: 01-643 9568 or 041-221 2926 (24 hrs)

## AIRBAND LISTENERS!

Our UHF frequency list, apart from being continuously updated now has a new layout, still with the same information on Airfield/ATCC/Range/Ops & Air Refuelling frequencies etc. It is available for **£2.00** inc postage.

The new HP82 Handheld VHF/UHF Airband receiver should be with us now. Please call for details

We also keep in stock a wide range of VHF/UHF 'airband' receivers from the leading manufacturers, along with accessories including VHF/UHF base antennas

For further information please send SAE or telephone for details



### JAVIATION

Carlton Works, Carlton Street,  
BRADFORD, West Yorkshire BD7 1DA

Telephone: 0274 732146 or 639497 (evenings)





# SHORT WAVE LISTENER

TREVOR MORGAN GW40XB

As I said last month, the sun can influence radio wave propagation in many ways. The easy to follow changes, as each zone goes from day to night are important if you wish to log stations from the other side of the globe.

There are also seasonal changes to consider. You will soon find that reception on the lower frequencies is better during winter and reception on the higher frequencies vastly improves during summer.

## Sunspots

However, the most startling and important effect on radio wave propagation is caused by sunspots. These can be seen from the earth using a telescope with a paper screen to collect the image. *Do not look at the sun through a telescope or binoculars.*

Sunspots are not fully understood but they can be seen singly or in groups. When the sunspot count is high, propagation of high frequency radio waves is dramatically enhanced.

Sunspot levels are not necessarily on an eleven year cycle, but this is taken as the average time between the end of one cycle and the end of the next. It is an interesting point that extremely low sunspot levels also herald very cold winters (the so called 'Maunder minimum' in the 17th century saw the River Thames frozen over).

We are, at present, in the 'rise time' of the present cycle (cycle twenty-two) and it has already shown a very sharp rise which, we are told by scientists, could mean an early peak and a very high count. Listeners will already be aware of the superb propagation conditions on 15m and 10m.

Unfortunately for the users of the bands, such conditions also mean overcrowding and intensified interference. With the bands already well loaded, a good filtering system is needed to get the desired signal.

Despite modern technol-

ogy and the virtual necessity of filtering systems, it is only when you pay a very high price for your receiver that you get built-in filtering. Thankfully, all is not lost, as filtering is possible at the audio end of the works and can be obtained at a reasonable price if you do not mind using a soldering iron.

One of the cheapest audio filters is the Maplin DXers Audio Processor, which offers high and low pass filters and an attenuator for less than £10 for the basic components and printed circuit board (the box and knobs cost extra). This one works well, making all the difference on a crowded band. If you want to splash out, the Daiwa AF606K or Datong FL3 filters have variable bandpass and notch filters.

So, what will the filter do for your reception? This depends on the type of filter; the main ones are the bandpass and notch filters. The variable bandpass filter enables you to place an interfering signal outside the range of frequencies covered by the filter. This works extremely well with CW reception and can also work quite well with SSB signals, although some people dislike the 'tunnel' sound created by very narrow filters. The tunable notch filter allows you to attenuate heterodyne 'whistles' close to the desired frequency. A noise limiter can also be used to prevent noise peaks from overriding the wanted signal by clipping them at the level of the peaks of the signal you want to hear.

There are also automatic filter systems which will detect unwanted heterodyne whistles and deal with them very effectively. An all mode active filter system is probably a better buy as it gives you more control over the effect it will have.

The effect of narrowing the pass band of the filter and shifting it, can be seen in *Figure 1*. The interfering adjacent signal is severely attenuated by the filter and is no

longer a problem.

When it comes to winking out a Morse signal from the noise, a trained ear can work wonders. However, the audio filter can be of great assistance and does give the ears a rest during a long session, especially if you are listening to single side band.

The main aid to reception has got to be the aerial. Even if you only have a simple receiver with a telescopic aerial, a length of wire measuring about 60ft, with the first couple of feet wound round a cardboard tube which is slipped over the partially extended telescopic aerial with the rest of the wire left in the open, or the attic, can work wonders. It may cause overloading on some of the strong stations but a lot more can be heard between them. A great deal can be heard on the medium wave bands if you have a mind to listen.

The end fed long wire is the listener's best friend. Couple that with an ex-government tank whip, fed with coax with the screen grounded, and you have every chance of tuning into rare broadcasts. Never be afraid of improvising. Necessity being the mother of invention and an empty wallet will make you think of ways round a problem.

Next month, we will look at some of the strange noises on the bands and how to understand them.

## Award winners

The mailbag has been heavy with award claims, which is not surprising considering the conditions on the higher frequencies.

It is encouraging to see Chris Gibbs of Camberley still

among the hunters and excelling in the Continental awards with three for amateur and three for the broadcast bands. Europe, Africa and Asia represented the broadcast side while North America, Africa and Asia were the amateur fields. Some good catches from Africa included TN8CC (Congo), FH4ED (Glorioso Is), ZD9CK (Gough Is), 7P8CI (Lesotho), 5R8AL (Malagassy), S92LB (Sao Tome) and TZOMAR (Mali). Asia came up with A15AB (Abu Ali), V85GA (Brunei), VQ9QM (Chagos) and 8Q7CL (Maldives). Well done, Chris!

Susan Powell of Pontypridd kept the YLs in the frame by claiming three Continentals for North America, South America and Europe. There was nothing startling in the lists but it is early days yet. Susan lives in a similar location to me so DX is hard to find - but it will come, so carry on, Sue.

Darrell Jacobs of Reading offered two more lists, this time for European Continentals for 10 and 15m. Once again, there was nothing extraordinary to report.

Our first claims from the Eastern area of Europe are from Peter Uhren of Waren in the GDR. Peter claimed Continental certificates for USSR, North America, South America and Asia. There were some good catches in the Asian listing including AT0T, KK7K/DU3, W6KG/4S7, V85DA, XX9MF and K4YT/418. The South Americans included AY4, AZ6, CP8, HD8, P40 and WP4. Peter attends the local radio club in Rostock, operating as Y58WA.

A couple of months ago I heard from Ted Melinosky

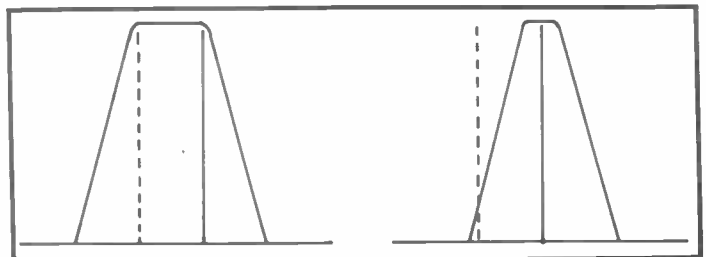

Fig 1

K1BV, about a listing of awards from all countries. I recently received a copy of the *K1BV Awards Directory*, which is a wealth of information. It comes as a package of looseleaf sheets without a binder but it is perforated with three holes so you can provide your own binder, remembering, of course, that it can be updated as new awards become available. The listing features about 830 awards which are on-going, (not due to annual or special events). A list of them is available free to subscribers to the main directory.

The first category is the 'national' type such as DXCC, DIG, DUF, WAC etc. The second is devoted to local and regional awards which require certain stations in areas to be logged, such as logging 25 Brazilian PY1 stations or 40 Swedish SM stations. The third is for awards presented by clubs and individuals.

This comprehensive directory is constantly being updated. The price is £7.40 by surface mail or £9.00 airmail and, to any serious award hunter, is money well spent.

From a few letters I have

received, there seems to be some confusion when writing reports to both amateur and broadcast stations. There are two areas under question. The first is the time. I am often asked whether GMT or UTC should be used on reports. UTC represents the International Time Standard and is, simply, the time which is maintained by an extremely accurate atomic clock. UTC is the accepted method of announcing time and is based on the twenty-four hour clock so there is no AM or PM. Broadcast station schedules are set out on this basis.

However, the GMT time (the time at the Prime Meridian or, geographically, zero degrees) is, for all intents and purposes, identical to UTC time but the term is being dropped for the sake of clarity. So, if you are sending a report to a station, you should quote UTC time, not local time.

#### SINPO

The second query is the reporting code. The SINPO code is only accepted by broadcast stations. Amateurs use a simpler RST code meaning Readability (1-5) and

Signal Strength and Tone. The signal strength is usually shown on your receiver, but meters are only relative. This means that although comparisons can be made between stations received on that receiver/aerial combination, reports would be quite different for other combinations (even at the same location), meters are not very reliable! The tone is graded from 1 to 9. If chirp is present on the note (chirp is noticed as a fast rise or fall on the note), a 'c' is reported after the RST.

An interesting letter came from Stan Clark G6NUO, of Birmingham, who mentioned that he had received a batch of QSL cards for his old BRS number 48815, all correctly addressed. Some had been sent to the ISWL bureau in Oban who had sent them to G4CYW who, in turn, forwarded them to Stan in one of his envelopes. They were a mixed batch from 9L1, 4K0A, 5N22HEM, HG5BNV, VP2MF and other sundry DX stations. So, what's so remarkable about that? All the cards were from 1982!

The annual Scout Jamboree on the Air is due to take place on 15th and 16th Octo-

ber, when Scouts world-wide will be exchanging greetings between groups and individuals. It is not a contest but a way of linking the movement by amateur radio.

There are many listeners who enjoy logging the stations and every year I donate a couple of trophies and some certificates to listeners sending me their logs. This encourages Cub Scouts, Scouts, Guides and Brownies, who are not able to use a transceiver during the JOTA, to take part by listening for the Scouts who are on the air. However, the scheme is open to all listeners and all you need to do is send a copy of your loggings plus 50p (which is donated to charity) to: GB2WFF, 1 Jersey Street, Hafod, Swansea SA1 2HF. The scoring is one point for UK stations, two points for overseas stations, and a bonus of ten points each for GB2GP, GB2COD and GB2WFF. The closing date is 1st Dec 1988.

That wraps it up for this month. Next time we will look at the data scene and how you can log some interesting stations at a reasonable cost and build up your simple station to a monitoring set-up.

# TRAINEE RADIO OFFICERS



Are you looking for a secure shore-based job which offers a rewarding career in the forefront of modern Telecommunications technology... then consider joining GCHQ as a Trainee Radio Officer.

Training involves a 32 week residential course, (plus 6 weeks extra if you cannot touch type) after which you will be appointed RADIO OFFICER and undertake a variety of specialist duties covering the whole of the spectrum from DC to light.

**We offer you: Job Security · Good Career prospects · Opportunities for Overseas Service · Attractive Salaries · and much more.**

To be eligible you must hold or hope to obtain an MRGC or HNC in a Telecommunications subject with an ability to read Morse at 20 wpm. (City and Guilds 7777 at advanced level incorporating morse transcription would be advantageous). Anyone with a PMG, MPT or 2 years relevant radio operating experience is also eligible.

The Civil Service is an equal opportunity employer.  
Salaries: Reviewed Annually, 1987/88 rates shown below:  
Starting pay for trainees is age pointed to 21 years. For those aged 21 or over entry will be at £7,162. After Training an RO will start at £10,684 rising by 5 annual increments to £15,753 inclusive of shift and weekend working allowance.

Write or telephone for an application form to:



**THE RECRUITMENT OFFICE, GCHQ, ROOM A/1108  
PRIORS ROAD, CHELTENHAM, GLOS GL52 5AJ  
OR TELEPHONE (0242) 232912/3**

<h4>OSCILLOSCOPES</h4> <p>TELEQUIPMENT D83. Dual Trace 50MHz Delay Sweep Large Tube.....<b>£350</b> COSSOR OSCILLOSCOPE CDU150. Dual trace 35MHz delay sweep. Dual state portable 8x10cm display. With manual.....<b>now only £180 each</b> Optional Front Protection Cover. Containing 2 Probes &amp; Viewing hood.....<b>£20</b> SCOPEX 4010 Dual Trace 10MHz with manual.....<b>£180</b> S.E. TABS SM111 Dual Trace 18MHz Solid State Portable AC or External DC operation 8 x 10cm display with manual.....<b>£190</b> ICL EQUIPMENT S644 Single Trace 10MHz Solid State with manual.....<b>£90</b> GOULD/ADVANCE OS255 Dual Trace 15MHz with manual.....<b>£225</b> ADVANCE OS250TV. Dual Trace 10MHz with manual.....<b>£190</b> SCOPEX 456 Single Trace 6MHz with manual.....<b>£85</b></p> <h4>MULTIMETERS</h4> <p>AVO 8 complete with batteries &amp; leads.....<b>from £50</b> AVO 8 Mk4 complete with batteries &amp; leads.....<b>£90</b> AVO TEST SET No 1 (military version of AVO 8) complete with batteries &amp; leads.....<b>£60</b> TEST LEADS suitable for AVOMETERS. Red &amp; Black with two cross clips &amp; two Prods (P&amp;P £3).....<b>£5</b> Black 'Ever Ready' case for AVO's. Unused (P&amp;P £4).....<b>£20</b></p> <p>LABGEAR CROSSHATCH GENERATOR Type CH6038-03 Crosshatch/Grey Scale/Blank Restor Mains or Battery..... Unused <b>£18</b> Used <b>£12</b> (P&amp;P £3) FARNELL switched mode PSU +/-12V 5A; 5V 40A (P&amp;P £4).....<b>£30</b> Other switched mode PSU available. Please enquire</p> <h4>STEPPING MOTORS</h4> <p>Type 1. 200 Steps per rev 4 Phase (5 wire) 12/24V Torque 25oz inch (will run on 5V with reduced torque).....<b>£15 ea</b> Type 2. 8/12 Steps per rev. 3 Phase. 12/24V (will work on 5V).....<b>£2 ea</b> 5 off.....<b>£7.50</b> Type 3. NORTH AMERICAN PHILIPS 24 Steps per rev. 4 wire 5V 3.3amps 0-250rpm 0-200 PP's.....<b>£5 ea</b> Type 4. 200 Steps per rev. 120V (3 wire) Torque 25oz inch.....<b>£4 ea</b> Type 7. WARNER 24 Steps per rev 3 Phase (6 wire) 28V. Holding Torque 45oz inch.....<b>£6 ea</b></p> <h4>ISOLATING TRANSFORMERS</h4> <p>240V In - 240V Out 500VA.....<b>£15 each P&amp;P £5</b> 240V In 240V Out 100VA.....<b>£5 each P&amp;P £3</b> 240V In - 24V Out 100VA.....<b>£4 each P&amp;P £4</b></p> <p>Used equipment - with 30 days guarantee. Manuals supplied if possible. This is a VERY SMALL SAMPLE OF STOCK. SAE or Telephone for Lists. Please check availability before ordering. CARRIAGE all units £16. VAT to be added to Total of Goods &amp; Carriage.</p>	<h4>SPECIAL OFFER at only £300 each</h4> <p>Telequipment D755 (Nato approved version of D75). Dual trace. Delay sweep. 50MHz.</p> <p>LEADER IV FM SWEMAR GENERATOR Model LSW-250 2250MHz. Unused (P&amp;P £7).....<b>ONLY £200</b> TWO RF SIGNAL GENERATOR type 90402 100kHz-30MHz. Unused (P&amp;P £7).....<b>ONLY £75</b> COLOUR BAR GENERATOR Type PAL MC101. 8 patterns, pocket size. Rechargeable batteries. Complete with battery charger/mains adaptor. Unused (P&amp;P £4).....<b>ONLY £90</b> COLOUR BAR GENERATOR type PAL MC321 - 8 patterns, video/sound output. Unused (P&amp;P £7).....<b>ONLY £175</b></p> <p>Marconi AF Power Meter IF893A 20Hz 35kHz 20 MW-10W with manual (P&amp;P £7).....<b>ONLY £35</b> Marconi RF Power Meter TF1152V1 DC 500MHz 0.5in 25 watts 50 ohm with manual (P&amp;P £7).....<b>ONLY £45</b> MARCONI ATTENUATOR TF21B2 OC 1MHz 600 ohm 0-1100 in 0.1 Db steps (P&amp;P £7).....<b>£35</b> HATFIELD ATTENUATOR DC 250MHz 50 ohm 0-100 Db (P&amp;P £4).....<b>£90</b></p> <p>AVO TRANSISTOR ANALYSER MK2 (CT446) Suit case style. Complete with batteries &amp; operating instructions (P&amp;P £7).....<b>ONLY £25 each</b> AVO VALVE TESTER CT160. Suit case style. 22 Bases (P&amp;P £7).....<b>ONLY £25 each</b></p> <h4>NEW EQUIPMENT</h4> <p>HAMEG OSCILLOSCOPE 604. Dual Trace 60MHz Delay Sweep. Component Tester - 2 probes. <b>£875</b> HAMEG OSCILLOSCOPE 203.6. Dual Trace 20MHz. Component tester with 2 probes.....<b>£314</b> All Other Models Available</p> <p>BLACK STAR FREQUENCY COUNTERS (P&amp;P £4) Meteor 100-100MHz.....<b>£99</b> Meteor 600-600MHz.....<b>£126</b> Meteor 1000-1GHz.....<b>£175</b> BLACK STAR JUPITOR 500 FUNCTION GENERATOR Sine/Square/Triangle. 0.1Hz 500KHz (P&amp;P £4).....<b>£110</b> Black Star Orion Pal TV/Video Colour Pattern Generator.....<b>£199</b></p> <p>HUNG CHANG DMM 7030 3 1/2 digit. Handheld 28 ranges including 10 amp AC/DC 0.1%. Complete with Battery &amp; Leads. (P&amp;P £4).....<b>£39.50</b> As above DMM 6010. 0.25%.....<b>£33.50</b> Carrying case for above <b>£3</b></p> <p>OSCILLOSCOPE PROBES. Switched x 1; x 10 (P&amp;P £2).....<b>£11</b></p>
<h4>STEWART OF READING</h4> <p>110 WYKEHAM ROAD, READING, BERKS RG6 1PL Telephone: 0734 68041. Fax: 0734 351696 Callers welcome 9am - 5.30pm Mon - Fri (until 8pm Thurs)</p>	





## News and comment from Glen Ross G8MWR

The latest edition of the Backpackers Microwave group's newsletter comes to hand and contains some interesting information. It also slaps my wrist for saying that the editor, G6MEN, is QTHR, when in fact he is not. I plead guilty to this slip-up but my defence is that I knew his address anyway and had not actually checked the callbook, all very naughty. Let's put the record straight, if you want information on the newsletter then please contact Paul enclosing an SAE to: PO Box 32, Shrewsbury.

### The news

The big microwave news for August was the expedition by the Telford group to Snaefell on the Isle of Man, where they were signing GD3ZME/P. This was an opportunity for many people to work a new country, a new square and was most likely a fair improvement on the best distance previously worked. It certainly worked that way for GW1GHZ, who operated from Cadir Berwyn. Their list of contacts included: G8AGN, Merryton Low, at 102kms; G3NKL, Jubilee Tower, at 134kms; G4UQI, Harper Fell, at 168kms and finally GD3ZME at 170kms. As far as the Telford group is concerned, it seems that the best DX worked was to Shining Tor at a distance of 195kms where they found three stations waiting to work them.

### Big noise

GW1GHZ also remarked on the huge signal put out by G8KQW, who has now amassed so many points from the early cumulative contests as to be in a completely unbeatable position. This is very discouraging for those trying to catch up with him, but it does show what can be done with sufficient effort and the determination to travel to find even longer paths. The latest foray by Ian is a trip to the Scilly Isles, where he will try the long sea paths along the South coast. He is hopeful of making a contact to Beachy Head and, if weather conditions are right, he should be successful.

### The low end

In last month's column we commented that our old TV broadcast system caused little trouble to Dutch and Belgian TV viewers. So why were power and aerial systems so restricted? This brought in some very fast comment via Prestel.

Perhaps one of the more telling comments came from G8OIT, who points out that TV transmissions emanating from the Low Countries cause comparatively few problems when searching for weak signals on 50MHz. True, the noise starts to be a bit of a nuisance when the band opens up, but it does not stop us working into such countries as the USA. He asks: 'surely the reciprocal law should operate?'. Well, it is not quite as simple as that due to the different modes and bandwidths employed, and you must also keep in mind that visual interference is always less acceptable than odd background noises on an SSB contact. Even when taking this into account there is still a lot of sense in what he says.

### Students?

We now move on to some deep thinking about something that affects us all. As you will know, there has been pressure for a novice type of licence for many years. The RSGB has, on behalf of all radio amateurs, manfully resisted the urge to get involved until fairly recently. It was something, we were told, that we really did not need. Not only that, but if we gave into pressure and actually produced such a facility it could only result in a lowering of standards. Another point which we were asked to keep in mind was that it would give those nasty CB people, who we have been steadily ignoring for years, an easy way into our hobby. Can you imagine what that would do to our international standing? Somewhere along the line they lost sight of the fact that the vast majority of G6 and a lot of G1 licences had gone to ex CBers and it does not seem to have caused all that much harm. Then they suddenly discovered

that our numbers were in decline and that most of us who were still in the hobby were on the senile side of forty. This was followed by the sudden realisation that, if we did not get some new blood into the hobby pretty quickly, soon there would be no amateur radio or, perhaps even more seriously, no RSGB.

### Panic stations!

Now they have to tread carefully. We all know that the RSGB likes to give the impression of being a serious and learned society. Surely having a few thousand novice members would seriously lower the tone of the whole thing? 'Can't be done, old man. Tell you what, let's call them students'. That way the RSGB can be seen as the good guys encouraging newcomers while at the same time, because the students will have to learn our ways before getting a ticket, the RSGB will be seen to encourage high standards of operating. It looks pretty good so far. Right, that is one problem out of the way, now how do we go about encouraging people who want to get into the hobby?

### Not easy

This needs some serious thought, how do we go about it? Well, in the best traditions of all serious organisations, it is a committee job. The top brass spend a few months thinking about it (while not seeming to get very far in the process) and then decide that the best answer is to pass the problem on to someone else who can set up a 'think tank'. If they do not actually tell people that this think tank exists, they are not likely to get any external input of ideas. The problem with outsiders' ideas is that they are usually at variance with your own thoughts, thus confusing the issue. At the end of the day, the unknown think tank can report back with various ideas. The top brass can then publish the results and receive all the credit for the new system.

### Make it easy

So what ideas has the think tank come up with? The 'mole' has been at work and has come up with the following information. So as not to discourage youngsters who are entering their teens from getting into the hobby, they will only be required to undertake something like a thirty hour training course at a local Tech, radio club or Scout group. This will be followed by a multiple choice RAE style exam of about thirty-five questions which have to be answered over a one and a half hour period. The questions will be suitable for ten year olds to answer and will include such simple stuff as a knowledge of Ohms law and the use of test meters, propagation effects at HF and VHF and a knowledge of aerial theory including Yagi operation. They should also know about the harmonic content of oscillators and the characteristics and uses of the various transmission modes. If you do not believe me have a look at the specimen questions given in the pilot copy of the RSGB's new magazine *DIY Radio*. There is just one more thing to achieve before our ten year old gets his ticket. He has to take a

## You'll learn all about how the Navy keeps in touch.

If you join the Royal Navy as a Radio Operator, you will be trained to use modern ship-borne computers and communications systems, including satellite links. After training you will serve at sea, in a surface ship or submarine, and later you could be based ashore, at home or abroad.

No formal educational qualifications are needed but you will need to pass the Royal Navy Entry Tests.

If you're between 16 and 32, get the facts now - call in at any Royal Navy and Royal Marines Careers Information Office (in the phone book under 'Naval Establishments').

Normally you should have been a UK resident for the past five years.

The Armed Forces are Equal Opportunity Employers under the terms of the Race Relations Act 1976.

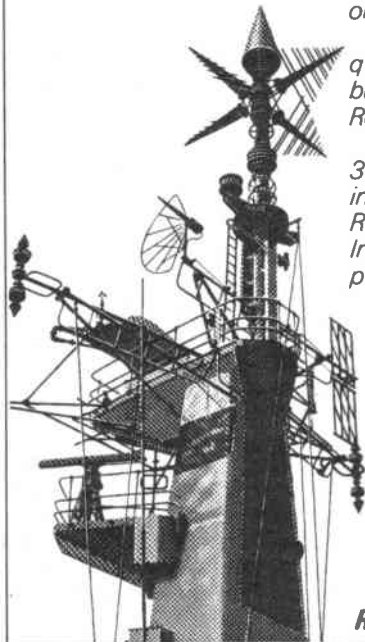

**RADIO OPERATOR ROYAL NAVY**

## TX-3 RTTY/CW/ASCII TRANSCEIVE

The high performance, low cost system

Split-screen, type-ahead operation, 24 memories, clock, review store, callsign capture, RTTY auto CR/LF, CW software filtering and much more. Needs interface or TU. **BBC-B and Master, CBM64** tape £20, disc £22. **Spectrum** tape £35, +3 disc £37 inc adapter board (needs interface/TU also). For **VIC20** we have our RTTY/CW transceive program. Tape £20.

## RX-4 RTTY/CW/SSTV/AMTOR RECEIVE

This is still a best-selling program and it's easy to see why. Superb performance on all 4 modes, switch modes at a keypress to catch all the action. Text and picture store with dump to screen, printer or tape/disc. An essential piece of software for the SWL. Needs interface. **BBC-B and Master, CBM64** tape £25, disc £27. **VIC20** tape £25. **Spectrum** tape £40, +3 disc £42 inc adapter board (needs interface also). The SPECTRUM software-only version (input to EAR socket) is still available, tape £25, +3 disc £27.

## TIF1 INTERFACE

Perfect for TX-3 and RX-4, RTTY and CW Fitters, computer noise isolation for excellent reception. Transmit outputs for MIC, PTT and KEY. Kit £20 (assembled PCB + cables, connectors) or ready-made £40, boxed. State rig. Available only with TX-3 or RX-4 software.

ALSO MORSE TUTOR £6, LOGBOOK £8, RAE MATHS £9 for BBC and CBM64 (disc £2 extra), SPECTRUM, ELECTRON, VIC20

Prices include VAT and p&p, 1st Class inland, airmail overseas, normally by return. Eire, CI, BFPO deduct 13%.

## Technical Software (AR)

Fron, Upper Llandwrog, Caernarfon LL54 7RF

Tel 0286 881886



## ON THE BEAM

Morse test at five words per minute. Now at last he can get on the air and have some fun.

### Top secret

Now this part of the information is extremely confidential, but luck is on our side as the think tank leaks like a sieve. It seems likely that having gone through all the training and the examinations, our young operator is going to be rewarded with a narrow segment, probably on 14MHz (and only a few kilohertz wide) where he will only be allowed to use 4 watts of CW.

To make sure that he cannot get too excited due to working stations outside his own backyard, he will be limited to a simple wire aerial. There is also talk of limiting the height of the aerial to not more than 15ft above ground.

Now, credit where it is due, an experienced member of the QRP club could probably do a fair bit with that sort of allocation, but what sort of results do you suppose a ten year old novice is going to get? Would you go through all that for those results and, if you did make a start, would the results encourage you to stay in the game?

The RSGB will probably move the goal posts and then tell you that I have been mistaken. In my view, this is roughly the way things stand at the moment.

### Straight in

The only way you get people interested in any activity is to give them instant access to it. If you are at a village fair and you show some interest in, say, an archery display, the next thing you know is that you have a bow and arrow in your hands and are invited under supervision, to give it a try. If you enjoy it you are hooked. Try getting a young lad interested in football by telling him that before he can kick a ball, he must spend thirty hours learning the rules and theory of the game and then take a practical test in repairing football boots. Then tell him that all this will only qualify him to play blow football anyway. Stupid? Of course it is, but that is the sort of thing that is being considered for our hobby.

### What now?

Is there a better way? I think so. Why not push for permission to allow people to use the microphone at special event stations under supervision? Allow them not only to send greetings, but to actually hold a conversation with an operator 'Stateside' or wherever. Follow that up by telling them that they can operate under supervision at the local radio club. If young people find that exciting then they will want to join. If they want to join, they will be prepared to do the training and will eventually become a new recruit. We

used to have an 'under supervision' facility years ago. One of the reasons we lost it was because amateurs' wives were found to be nattering away on 80m nets while their husbands were at work.

It's our own fault that we no longer have the facility but it should not be impossible to regain it. It is, perhaps, too much to expect the facility to be returned to individual amateurs, but it should be possible to extend it to club and special event stations. Perhaps the RSGB is working along these lines, I certainly hope so because I feel sure that it is the only sensible solution to our current problems. Please do not expect me to believe that the present proposals are going to work.

### Next time

A report on the latest issues of our various certificates is about due, if you want details of them please send an SAE to me at the address below. The new satellite is now operational and early reports of activity are looking good. Perhaps the best news of all, is that we are just coming into the time of year that sees those lovely extended tropospheric openings on the VHF bands. Your news and comments will be gratefully received at: 81 Ringwood Highway, Coventry, or on Prestel using MBX 203616941. Good hunting.



# PROJECT

# BOOK

by Martin Williams

This month we are going to try and sort out something that probably causes more confusion in our hobby than any other single item. I refer to the term decibel, usually shortened to dB. You find it in all the adverts for new gear, the producers of pre-amplifiers and linears use it as if it were the only thing that matters. Judging by the literature, the only thing that sells an aerial is a higher dB rating than rival makers can claim for their offerings.

This profligate use of dB seems to obtain one of two things; either to impress the customer with 'specimen-ship' as in the Hi-Fi world, or to make the customer think that if the gear has all these dBs attached, it is good quality. They get away with it simply because the average amateur does not understand the term and that the information is frequently given in a meaningless way.

## Derivation

The term originates from the audio field where a Bel is used as a measure of sound intensity. As is nearly always the case, the basic unit is too large to be useful (think of the Henry and the Farad) and is usually divided into ten, thus producing decibels. A fundamental property of the human ear is that its response to variations in sound levels is logarithmic rather than linear and this is what makes the decibel so useful.

## The figures

Because of the logarithmic curve large variations in sound levels can be represented by small changes in numbers. Taking voltages as an example, a change from 1V to 10V would be an increase of 10dB, as would an increase from 10 to 100V. 20dB represents an increase of 100 times; 30dB is times 1000. A change of one million times is indicated by 60dB. The sequence can be continued indefi-

nately. To complete this part of the picture you should also understand that the figures can be used in a negative direction. For example, a reduction in level to one tenth of the original is shown as  $\times 10\text{dB}$ .

## Reference

The next point to understand is that the term dB means nothing when used in isolation. It is simply a ratio between two values, in our case these are normally voltage, current and, from these, power. Unless a reference value is given, no useful information can be obtained from the dB. If I say that a voltage is 10dB up on the original, you will know that it is ten times more than I started with, but you still do not know how much is actually there. If instead I give the level as 10dBV (the V standing for volt), you now know that I am measuring 10V and that I had one volt to start with. The reference level, which is always 0dB, can be anything you care to make it but you *must remember* to indicate what you have used. Hence dBW for 1W, dB $\mu$ V for one microvolt and dBmA for one milliamp reference. In the audio world, the reference voltage is 0.775V which gives a primary reference of 0dB (milliwatt) when used in conjunction with standard 600 ohm audio lines.

## Aerials

A common use of dB is to indicate the gain of an aerial. This is where the fun really begins, as many manufacturers' leaflets are full of non-information. If a maker says that his aerial has a gain of 9dB, does this mean that it has less gain than one quoted at 10.5dB by a rival maker? As you will realise by now, you cannot tell from the information given. It is probable that the second one will get your money because of the higher figure; that is exactly the choice the maker

wanted you to make.

Aerial producers are some of the most optimistic people on earth. The chances are that they are all telling you something not too far removed from the truth, even though they quote the figures in different ways, usually without specifying which figures they are using!

## Problems

The point is that the reference is not quoted. Is it dB over a dipole, over a piece of wet string, or over that thing beloved of aerial makers, an isotropic radiator; once described as an aerial that radiates equally badly in all directions? The point here is that a dipole has a gain of nearly 3dB in its favoured direction when compared to an isotropic radiator. If the maker claiming 9dB is using a dipole reference and the maker claiming 10.5dB is using an isotropic reference then, in practice, the 9dB aerial will provide over 1dB more gain than the 10.5dB one.

## Exceptions

In some cases it is not required to give a reference level, but this is only true where the reference level is obvious or can be reasonably assumed. A good example is a pre-amplifier where the gain may be quoted as 15dB. In this case it can be taken for granted that the reference is whatever signal voltage is coming down the feeder. It is a ratio of input to output volts. A similar case is the linear amplifier where the dB indicates the ratio of input to output watts. In both cases, the equipment is assumed to be linear over its normal working range and that the input is kept below the maximum stated by the makers. If you exceed a certain input level you come into a state known as compression; but that is another story.

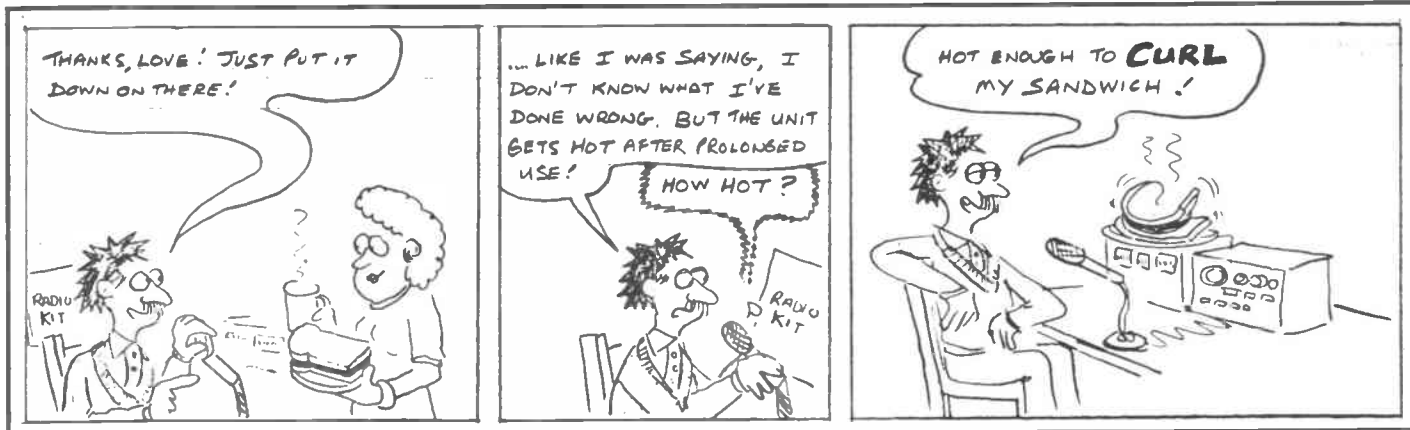

# 50MHz

by Ken Ellis G5KW

After reporting the high Solar Flux of 187 on August 1st in last month's column, the reception of the ZD8VHF beacon which was received over a wide area of the British Isles, has suggested an early start to the TEP season this year. With the Solar Flux nearing 200 at the end of the month, it was no surprise when the first opening of this cycle occurred.

## First two-way QSOs on 50MHz

The first two-way QSOs between British G stations along the south coast and South Africa since November 1947 (between G5BY and ZS1T), took place during the early hours of August 28th. The South African beacons on 28MHz were putting in consistent signals over a wide area of the British Isles and many crossband QSOs occurred on 28/50MHz. From mid afternoon three South African stations ZS6XJ, ZS6WB and ZS6LN started to break through to G stations along the south coast. Stations known to have made it include: G4IGO, G3SED, G8HUY, G3JVL, G8XZO, G4JCC, G8VR, GJ4ICD, PA0RDY, SV2DH and DL9RM crossband. There may have been others not yet reported to me.

On Monday September 5th, the North South path QSOs with Windhoek (Namibia) were reported. ZS3AT and ZS3DM contacted several G stations along the south coast including: G3SED and G3JVL. Further inland, G4IJE and G6BCL of Aylesbury, contacted G3SED and G3JVI at 1743. At the moment, it is not clear who made the 'All time first'. Leroy, ZS6XJ, also had a field day working 8 Gs.

## 50MHz at the crossroads

After I heard ZD8MB and the ZD8VHF beacon on six during July, I wrote to Ray Cracknell, G2AHU (ex ZD2JV) who has helped me in the past with TEP information. Ray kindly wrote two long letters discarding some old theories and gave the latest 'state of the art' based on time delay measurements and CRO displays. This will be fully discussed and illustrated in a book Ray is writing and will be well received I am sure.

Ray Cracknell writes: 'After being asked about reception of ZD8VHF on 50.032, I analysed the reception from Ascension Island in the "May Consolidated Reception Report" using quite a sophisticated propagation program. I centred my calculations on Southampton which is a convenient centre-point for G4UPS and GJ4ICD and for which the latitude and longitude is quoted in every atlas. Re TEP, firstly it is an F layer mode similar to 2 hop F layer with the centre ground reflection cut out.

'At 50MHz, amateurs talk of 'afternoon type' TEP. In fact, the two afternoon type

modes are the normal 2 hop F layer and the F type TEP which can only be distinguished by different time delays. Evening type is associated with the break-up of the F region, which takes place at about 2000 hrs local time when the ionisation resembles several massive 'cigars' along the lines of the earth's magnetic field. These cigars move from west to east and can propagate really high frequencies (144 and 432 at solar max). Since propagation can take place along several cigars, some moving towards and some moving away from the direct Great Circle route, there is a rare old jumble of Doppler shifts, ie 'flutter fading'. Flutter can also occur during afternoon type; generally when both 2 hop and F type TEP are occurring at the same time during multi-path propagation, for example. However, a clean afternoon type signal may be either one or the other, *but not both*.

## Dip Equator

'As far as 50MHz is concerned, it is important to remember that the F region is much denser in the tropics than it is over the UK or Gibraltar. Over the 'Dip Equator', a trough in electron density starts to form after midday and ionisations are drawn away to form intensified high density areas 5 to 15 degrees north and south of the Dip Equator (ie where the lines of the earth's magnetic field are parallel to the surface).

'TEP works best when it is possible to take successive hops from the high density areas. That is when the Dip Equator is crossed at right angles (or plus or minus up to about 40 degrees). It is important to appreciate that these high density areas can give normal F layer reflections as well so that 1 hop propagation from, say, Botswana to Kenya, can be very easy to work at 50MHz.

'As the Dip Equator across Africa lies 10 to 11 degrees north of the Geomagnetic Equator, it is possible for TEP to reach southern England (as it did recently). Scotland and Northern Ireland are well situated for an extra hop by Es (Sporadic E). The only requirement is that there is an Es' patch of sufficient density in the right place. TEP works at low vertical angles and the Es' hop has to take off at the same angle as it arrives (typically, 2-4 degrees). These result in a skip zone and explain why when G2ADR and GM4DGT were working A22KZ, hundreds of us sat in the skip zone glued to our rigs and heard nothing, while 9H1BT in Malta was recording A22KZ successfully working northern England!

'Ascension is interesting in that over the Southern Atlantic, the Dip Equator

goes from north-east to south of the Geomagnetic Equator. Thus, when Ted Collins, now G4UPS was there, he heard KP4EOR on 144MHz. ZD8MB has been able to work Central America from November to March, as well as the Mediterranean area during the equinoctial periods and even in between on 50MHz. Good TEP took place from South Africa as far north as central France in March and April 1988. Intermittent openings are already occurring from ZD to the south coast. Whether these are TEP or two hop F is impossible to say, although the time (typically 1930-1945) is highly suggestive of the peak in early evening F type TEP (this makes a nonsense of talking about evening type TEP since afternoon type is best in the early evening).

'Your letter of August 24th crossed the one I posted yesterday, which unfortunately does not answer all your questions. Thanks for the copy of your latest 50MHz article in *Amateur Radio* magazine and I cannot argue with what you have said. My only suggestion is that we now talk about the Dip Equator which is defined as the line that is equidistant from the Magnetic Poles (the line where there is zero magnetic dip). There is a difference which in the case of ZD8 can be important.

## Propagation

'I certainly agree when you say that "It's not possible to state conclusively the exact details of the mode of propagation". Before attempting to do that we need to know the propagation delay time and even that can be ambiguous. Being dogmatic about any long distance propagation at 50MHz is hazardous, as we learned when we undertook TEP time delay tests. This was designed to prove that TEP took place via the ionosphere (and not by the exospheric mode). Surprisingly, we found three modes of TEP, all via the F region of the ionosphere.

'Ken Osborne, G4IGO's reported reception of ZD8VHF after 2100 on 1st August and at 1800 on 2nd August was very interesting. I have a similar tape recorded report from G4GLT of ZD8VHF on 18th May at 1939 and also at 0559.

'You will note from the 1959 article that TEP does not have to be weak, watery and exhibit flutter. At 50MHz, TEP is capable of propagating very strong signals; provided that there is only one propagation path in operation. The other point of significance is that there was widespread reception in Devon, the South Coast, Leicester and Keele. I should like to make three points that I discuss more fully in my articles "50MHz



at the crossroads”:

1. Mixed mode propagation is common at 50MHz.

2. Always look first at which mode of propagation is possible from each end of the circuit, then see how it can fit in between.

'Re G4IGO's other remarks:

1. All signals coming across the Equator on VHF involve TEP.

2. ZD8VHF is not in the skip zone for TEP (there is no skip zone and stations located on the Dip Equator can work north and south very easily on 50MHz).

3. ZD8VHF's latitude is about 7.55 south and its Geomagnetic latitude is more than 30 degrees south, which is ideal for TEP.

'So what do we propose? I hope to meet Mike Barry, G4MAB/ZD8MB and suggest to him that he takes back a pulsing unit and puts pulses on both beacons. I would also suggest we prepare to re-broadcast them across the bands and that he read off both the outgoing and re-broadcast pulses on a CRO. Signals are obviously good enough for excellent transponding on both bands. Full details will be given as soon as I have seen Mike, if he is willing'. End of appreciation by Ray Cracknell, G2AHU.

#### From the mailbag

Mike Devereux, G3SED, Portsmouth reports: 'Es has continued during August with many good openings to Europe. TEP propagation has been present on a

number of occasions, with at least five good openings to ZD8 Ascension Island being observed in the UK. ZS3AT reports that the reception of both the CT0 and 9H1 Beacons has been good. My log of "heard/worked" during early August includes: 1/08/88 2102. ZD8VHF heard at S7 until 2135, 2130. CT1WW, 2300, CT4KQ. 5/08/88 1915, OX3LX. My first to Greenland, 2055, CT1WW.

#### Stop Press

On Thursday 7th September, the all time first two-way QSO between England and South America occurred. LU7DZ in Buenos Aires had two-way QSOs with eight English stations between 2123 and 2130.

The first QSO was with G1PAM, Plymouth, this was followed with G4GLT, Leicester; G3CCH, Scunthorpe and G4GLT, Leicester. Other first two-way QSOs include: G4VXE, G4AFJ, G4UXB, G3ZYY and G6IXN.

The 'Great Circle' distance of 7057 miles between G3CCH and LU7DZ is a UK 6m record. This means that five continents have now been worked from England leaving only Australasia to be worked for 'worked all continents'. Full details of these developments in next month's column.

#### Other news

Tom, ZS3AT, reports that he heard both CT0WW and 9H1SIX beacons on August 10th from 1643 to 1810.

SM6FZD informs me that Sweden will

be granting 25 special licences for 50MHz from around November this year. SU1ER-CAIRO will operate on 50MHz as soon as the equipment is donated to him. I understand that he cannot obtain it in Egypt, so moves are afoot by the UK 6m group to obtain the necessary equipment for him.

Ken Osborne, G4IGO, writes: 'Reading your article in *Amateur Radio* magazine has prompted this letter. Countries worked on 50MHz include: G, GW, GM, GI, GJ, GU, GD, EI, 9H, CT, PA0, LA, ZB2, PF, SV, W, FP, OH, VE, VO, FF, OX, EA, ZC4, YV0 and CT3 - in 113 grids. The reception of the ZD8 beacon on the evening of 1/8/88 which I discovered at 2101 (and put the alert out) ended with me at 2232 and was by chordal E layer propagation and *not* sporadic E or TEP. All the evidence is there and in my log it was S9 for a very long time'.

Mike, G3SED, reports: 'On Saturday 9th July, the PJ0M DXpedition to Saba Island in the Caribbean worked: GM3POI/A at 2145 and G3SED at 2150. Both contacts were a "first ever" to GM and G respectively. No other QSOs took place; although G3GLT was heard at 2155 that evening'.

Next month, I hope to feature 50MHz in Australia and any other openings we get. There was very little in the mailbag this month due to the postal dispute. We are entering a very exciting period on 50MHz, so keep monitoring.

CUL Ken Ellis, 18 Joyes Road, Folkestone CT19 6NX.

# A FIND TO TREASURE

Place a regular order with your newsagent.

On sale the fourth Thursday of the month.

Each issue is packed with articles and ideas for the enthusiast. . .



# THE CODAR AT5 TRANSMITTER

by Richard Q Marris G2BZQ

The AT5 transmitter was introduced around 20 years ago by the Codar Radio Company of Southwick, Sussex. It represented the first really satisfactory and reliable transition from the older 'built like a battleship' transmitter, to a small and effective instrument for home or mobile use. The company disappeared some years later while the writer was living and working in the USA, and the history of their departure from the scene is unknown. In the meantime, they must have produced many AT5 transmitters.

Older TXers may well have forgotten the AT5, and the younger ones may not have heard of it, however many AT5s are still in use. In fact a local Top Band Sunday morning AM net, some 20 miles away from the writer's QTH, has several participants who use the AT5. If you can find one they are still a good buy.

The AT5 covers the 1.8 to 2MHz and the 3.5 to 3.8MHz bands (Top Band and 80), with AM and CW facilities. The manufacturer's power input ratings are 10 watts AM and 14 watts CW. The writer uses an AT5 on 80 metres CW using only about 10 watts input with an indoor antenna, and happily works over 'our half' of the world.

Very occasionally it has been heard from users on the air that the AT5 'frequency drifts'. The writer has not experienced this - in fact far from it! One AT5 was purchased new from Codar when it was first introduced, and another second-hand one was bought a while ago. After the usual initial valve heater 5 minute warming up period neither have suffered from frequency drift. In fact CW reports have been T9 with no frequency drift either.

One explanation of alleged frequency drift is that the AT5 Tx has been stood on top of the ac PU, which obviously generates some heat, so the two units should be placed side by side. Putting any small VFO transmitter on top of a piece of equipment which generates heat could well produce frequency drift problems.

Others have said that it is difficult to load the AT5 into an antenna. Certainly this is true on 80 metres when using 50 ohm coaxial cable into a 50 ohm antenna, and a minor modification will be discussed later to facilitate this. However, the AT5 was designed to match 75 ohm loading - not 50 ohms!

The following list discusses the problems that you may encounter with a second-hand AT5.

1. Well, if you have to replace a valve then the types used are readily available and just plug into a socket. The writer has never needed to change a valve in an AT5!

2. There is a rotary switch for *net-standby-transmit*. This gets an enormous amount of use in a busy station. An occasional application of a switch contact cleaner is advisable. If this does not work then an offending contact can be gently bent. If all fails, one can presently purchase a replacement switch which is physically compatible, superior to the original switch construction and presumably reliable. Again the writer has never had to change one of these switches, but does occasionally use some switch cleaner, and on just one occasion tightened up a contact by bending it slightly with a small pair of instrument pliers.

## Description and specification

The AT5 consists of two small interconnected units as shown in *Figure 1*: 1. The transmitter type AT5 - 8½in x 4¾in deep x 4¾in high, and 2. The ac power supply unit type 250/S - 8½in x 5¾in deep x

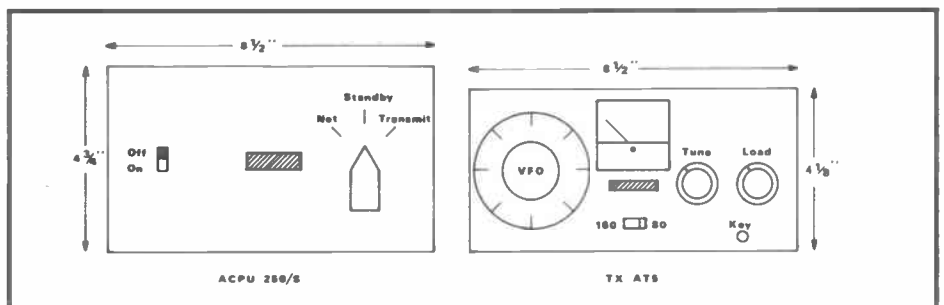

Fig 1: The AT5 transmitter (front view)

4¾in high.

The two units, which should be placed side by side, are interconnected by a multi-plug and lead assembly. This must be treated with care as will be discussed later. There is also a short length of coaxial cable connecting the TX to the S/R switch. A 12 volt dc power unit type 12/MS was also manufactured to enable the AT5 to be used as a mobile transmitter. The writer has no practical experience of this unit, but remembers their clean and robust signals when operating as 160 metre AM mobiles.

*Figure 2* shows a block schematic diagram showing the various stages of the AT5 plus 250/S. *Figure 3* shows the circuit diagram. Component values have been included in case any reader has an AT5 without the handbook.

The VFO employs a type EF80 valve in a Vacker circuit complete with temperature compensating capacitors. This VFO is remarkably stable after an initial 5 minute warm up. The main VFO dial on the AT5 front panel (see *Figure 1*) is calibrated every 20kHz, from 1.8MHz to 2MHz and every 50kHz from 3.5 to 3.8MHz.

If you find one also calibrated up to 4MHz, it is an export model. The calibration is excellent as a guide but actual transmitted frequencies should be checked with suitable measuring equipment.

The second stage uses an EF80 buffer/doubler valve; working as a buffer amplifier on 160 and a frequency doubler on 80. The power amplifier stage uses a 6BW6 and is coupled to the antenna via a Pi-network matching. The specified output impedance is 75 ohms but can easily be matched to 50 ohms, as will be described later under Modifications.

On CW the PA is keyed using cathode keying, and is fitted with a key click filter. When using AM the PA valve is anode/screen modulated. The modulator consists of a two stage high gain twin triode valve type 12AX7 driving the modulator output stage which employs a 6BW6 valve. The microphone has to be of the crystal type, and the ACOS crystal microphone type 40 or the Davidal CM21 crystal microphone were specified by Codar. Modulation peaks can be monitored by a neon indicator which is located underneath the front panel meter. On CW the HT to the modulator is removed by the AM/CW function switch and transferred to the PA stage.

Codar rated the AT5 at a power input of 10 watts AM and 14 watts CW. The latter can be 'wound up' a bit higher. However, the writer runs his AT5 at 10 watts CW for

2 reasons: 1. It is hoped to extend the life of the treasured AT5 by under running it, and 2. Practical tests, using transmitters between 10 and 100 watts input on 80 metres with an indoor antenna have revealed that the reports received from

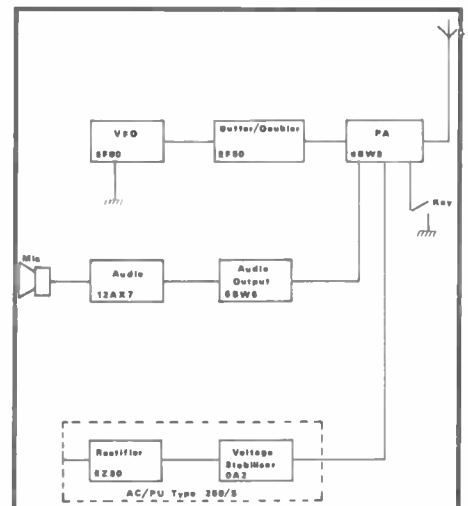

Fig 2: Block schematic of AT5



the same stations using various powers have shown little difference in signal reports, but with an indoor antenna the chances of TV1 go up with the power used!

The mains power supply type 250/S can operate from 200-250 volts ac mains (adjustable). It is believed that other versions were available for export.

The power unit provides both heat and HT voltages to the transmitter together with a standby/netting/transmit switch which includes changeover of the antenna from transmitter to receiver. A bright neon indicator flashes on the front panel when the power unit is 'switched on', and it is most unlikely that one could possibly forget to switch off the AT5 when not in use.

The ratings are: HT2, 250-280 volts at up to 100mA; HT1, 150 volts stabilised, which are applied to the VFO anode and screen; and LT, 6.3 volts, 1.8 amps ac (can be adjusted to 12 volts when used with mobile power unit).

The one black spot on the AT5 is the interconnecting lead between the transmitter and the power unit. At the back of the AT5 and the 250/S there are 9 pin sockets, see *Figure 5*. The connecting lead has a plug at either end! Now if, accidentally, the plug in the socket at the back of the transmitter 'comes out' while the power unit is 'switched on', then three things can/will happen: 1. The transmitter will stop working; 2. If the plug drops onto a metal surface then there will be an almighty flash; and 3. If you come into contact with the plug then you will find yourself the recipient of a very unpleasant electric shock! Remember, there is an HT voltage of 280 volts at 100mA. Whether this would be lethal or not is a matter of conjecture, and the writer does not wish to experiment along these lines, so make certain that the supply lead plug is secure in the back of the transmitter, or better still, securely anchor it.

The circuit of the ac power supply unit 250/S is shown in *Figure 4*. Rear views of the AT5 and 250/S are shown in *Figure 5*.

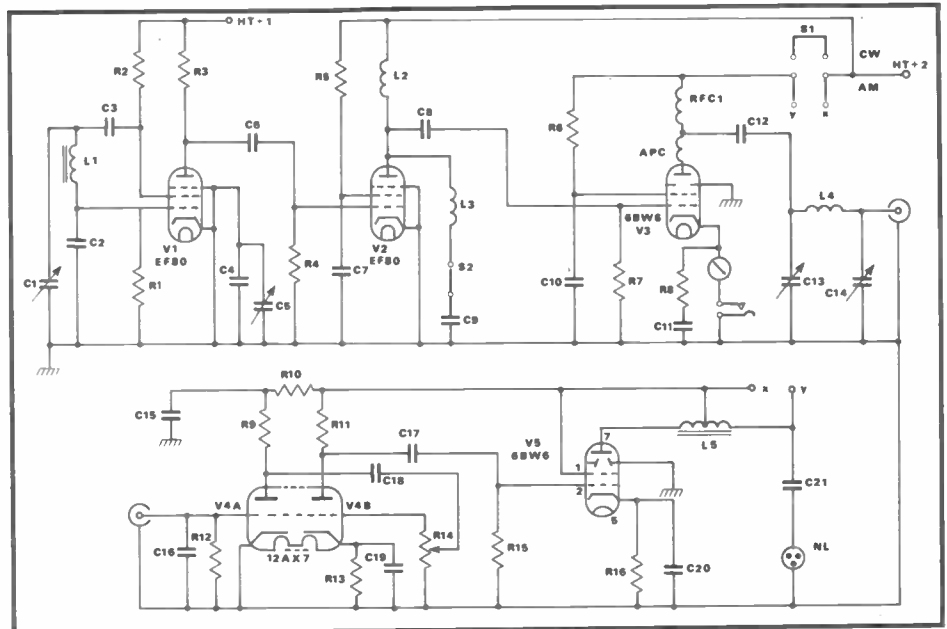
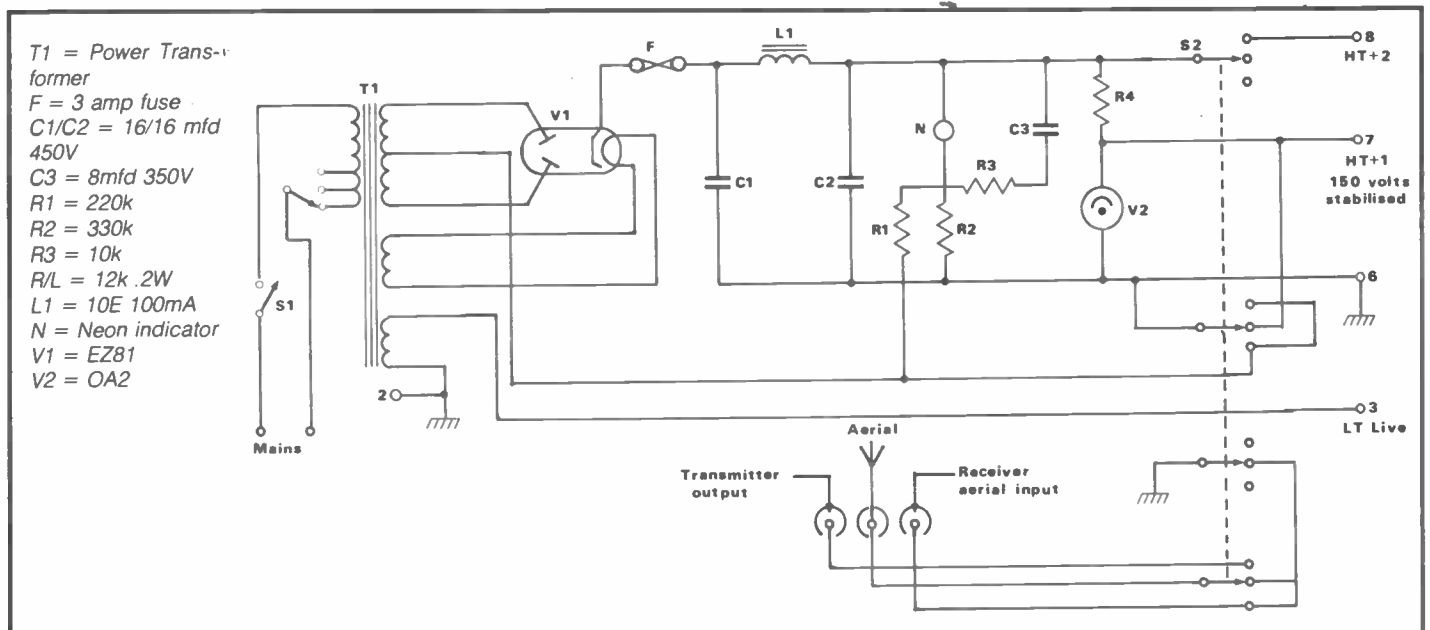

**Fig 3:** Circuit diagram of the AT5

### Key to Abbreviations

NL	Neon Indicator	C14	900 pfd var	R2	100k
APC	Anti-parasitic choke	C15	8 mfd elect	R3	22k
C1	60 pfd var	C16	100 pfd ceramic	R4	56k
C2	2000 pfd polycap 2%	C17	1000 pfd ceramic	R5	22k
C3	270 pfd polycap 2%	C18	.01 mfd ceramic disk	R6	12k 2W
C4	270 pfd polycap 2%	C19	10/25 elec	R7	22k
C5	10/40 pfd Temp Comp	C20	10/25 elec	R8	1k
C6	100 pfd ceramic	C21	1000 pfd ceramic	R9	100k
C7	.01 mfd ceramic disk	L2	RFC 2.5mh	R10	10k
C8	100 pfd ceramic	L3	3.5 MC/S	R11	100k
C9	22 pfd ceramic	L4	Codarcoil T422S	R12	1 meg.
C10	1000 pfd ceramic	L5	Auto-Trans type TL10	R13	1k
C11	.01 mfd			R14	500k var
C12	1000 pfd ceramic			R15	470k
C13	365 pfd var	R1	100k	R16	270 ohm 2W

All resistors 1/2W other than R6/R16 R1/C3/C4/L1/ are in VFO can assembly



**Fig 4:** Schematic diagram of the ac power supply unit 250/S

**Modifications**

1. The question of the dodgy interconnecting lead has already been mentioned. There are four possible alternative courses of action:

- a. Leave it as it is and risk a nasty experience!
- b. Fasten the plug into the back of the AT5 (not 250/S) by means of an adhesive. This is fine **but** it would produce problems if the wires had to be replaced in the future.
- c. Remove the plug and socket and wire directly into the AT5.
- d. Make a clamp to hold the plug in place.

2. The AT5 was designed to match into a 75 ohm load. Many people, including the writer, use 50 ohms.

Looking at the circuit, *Figure 3*, it will be seen that the Pi-network matching consists of L4 plug C13 (365pF) and C14 (365pF). Certainly for 50 ohms, and possibly 75 ohms, C14 should have a large capacity.

Codar appear to have anticipated possible loading problems when using mobile and other very low impedance antennas. They suggested that 'a capacitor of between 500 and 1000pF 250 volt working can be fitted externally across the antenna output socket'. Well, 250 volt working might be all right when properly matched to the antenna, but might well be exceeded in the event of a mismatch. For absolute safety 750 or 1000 volt working is suggested.

In the event the writer has used two 350pF ceramic disc capacitors 2kV working, wired in parallel across C14 inside the AT5 making an additional capacity of 700pF. These are about the size of a 5p piece. 2kV working has been used because they were available, see *Figure 6* for modification, Cx being 350 + 350pF in parallel.

**Conclusion**

The AT5 is a compact reliable VFO controlled low power transmitter, which operates in both the 80 and 160 metre bands using CW or AM.

It is neat and attractive in appearance and can still be purchased at a price comparable with a QRP single band crystal controlled transmitter kit, plus a suitable 12V dc power unit.

The AT5 uses valves which are, in general, more rugged than transistors, and replacement valves can easily be plugged into their sockets. The valves used are of types readily available new, advertised in the pages of various magazines. Often they can also be obtained, either new or used in the surplus market and from old pieces of equipment.

The AT5 is ideal for CW operation in the 80 and 160 metre bands. In addition, it is often heard using AM, on Top Band 'natter nets', and it does not seem beyond the possibility of amateur conversion on a low power SSB rig.

At the G2BZQ QTH the HF CW transceiver with 100 watt + capability is not used on 80 metres these days; it has been found that the AT5 with about 10 watts input (CW) and an indoor antenna will do a similar job, with a greater challenge and less risk of TVI.

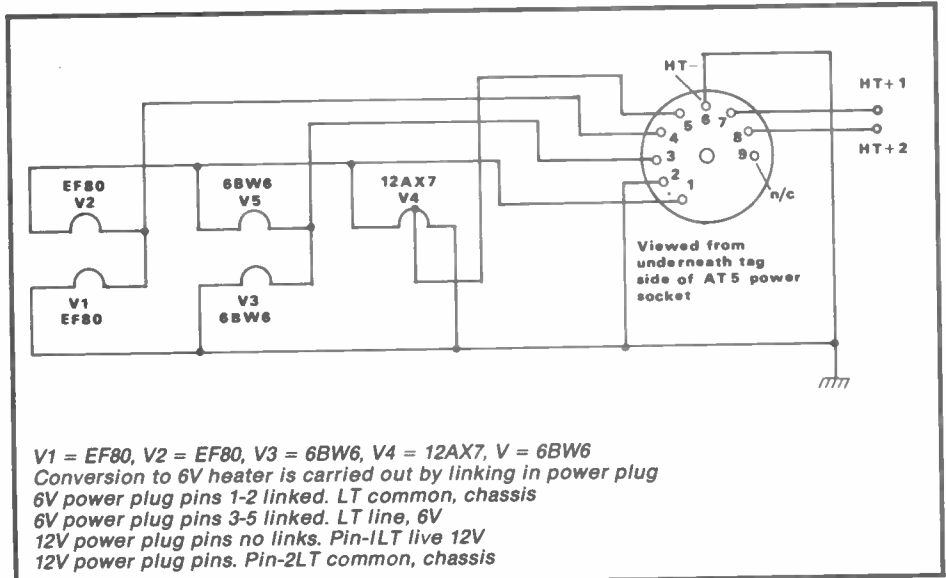

V1 = EF80, V2 = EF80, V3 = 6BW6, V4 = 12AX7, V5 = 6BW6  
 Conversion to 6V heater is carried out by linking in power plug 6V power plug pins 1-2 linked. LT common, chassis  
 6V power plug pins 3-5 linked. LT line, 6V  
 12V power plug pins no links. Pin-1LT live 12V  
 12V power plug pins. Pin-2LT common, chassis

**Fig 4b:** AT5 heater wiring 12V system

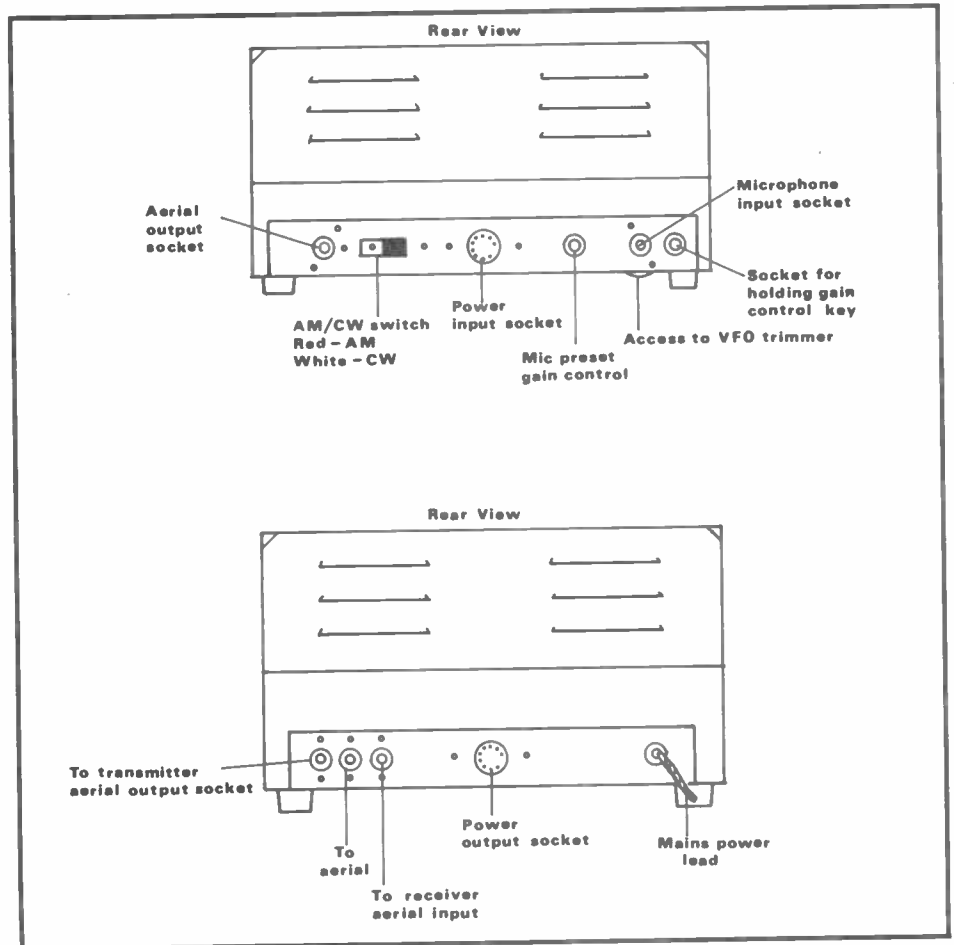

**Fig 5:** Rear view of AT5 and 250/S

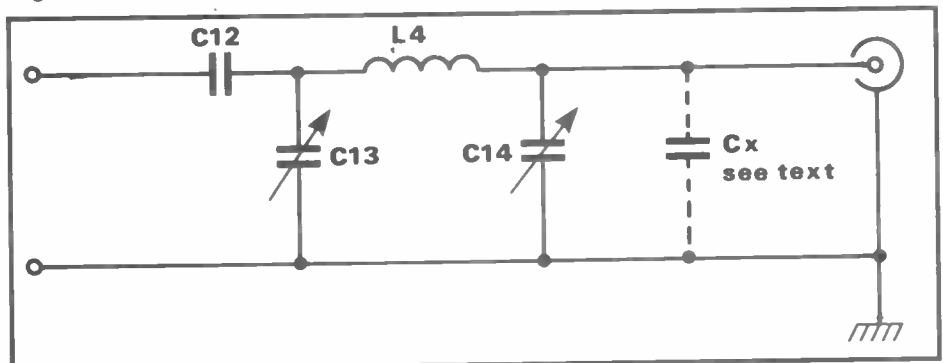

**Fig 6:** Modification to loading circuit



# FREE CLASSIFIED ADS

## FREE CLASSIFIED ADS CAN WORK FOR YOU

We are pleased to be able to offer you the opportunity to sell your unwanted equipment or advertise your 'wants'.

Simply complete the order form at the end of these ads. Feel free to use an extra sheet of paper if there is not enough space. We will accept ads not on our order form.

Send to: *Amateur Radio Classified Ads*, Sovereign House, Brentwood, Essex CM14 4SE

## DEADLINE AND CONDITIONS

Advertisements will be published in the first available issue on a first come first served basis. We reserve the right to edit or exclude any ad. Trade advertisements are not accepted.

## FOR SALE

- Yaesu FT290, 14-ele parabeam and 100W 2m valve linear amp, £350, or swap for HF rig FT707, 101 etc. Buyer must collect. Tel: Ian (0782) 771058
- Sony ICF2001. Marconi Warden 2181 monitor Rx. Marconi Falcon Marine Tx. Rx poss. Manual available. Decca 2000 cat, fixed HF, T/R manual. Tandy DX100 Rx. Tandy 40 ch h/held CB. Pye AM10B complete, £8 + P&P. Pye PF3FMH 150MHz unit, only £6. Offers or exchanges, SAE details. W Symes, 74 Birchen Grove, Luton, Beds LU2 7TW
- Communications receiver 0-30MHz with Trio 9R59DS speaker, handbook, plus ATU, £95 the lot, or exchange for airband radio. Tel: Little Cherrington 202 (Oxfordshire)
- Zetagi B550 mobile linear, as new. Exchange for Yaesu ATU or sell for £165, current list price £220. Maplin RTTY terminal TS1000, sell for £30 or exchange for 11m radio with SSB. Cash adjustment no problem. Tel: John (0734) 411501
- Trio TS430S with FM, excellent condition, £600. Matching PSU also available if required. Buyer collects. TET 15m, 2-ele beam, minus few small bolts, £20. Tel: G3RK (050845) 688, North Suffolk
- Trio TS120S, just been serviced, excellent condition, £395. Victor Communications ATU, 3kW rating, electronic switchable antenna selector and ATU or direct position selector. Just been tested, £150. Tel: Rodney (0689) 58825
- Yaesu 101ZD in immaculate condition. Comes fitted with fan, all manuals, mic and matching SP901 speaker. Recently had full overhaul by ARE, £475, or will exchange for FT707. Must have matching PSU and preferably ATU as well. However, will consider any good HF mobile transceiver. Tel: John (0432) 760845
- Yaesu FT7B HF mobile/base Tx, crystallised for seven bands, complete with PSU. Will pay half of postage if necessary, £295. Tel: (0224) 324808 evenings only, ask for Ian
- Computer Colour Genie EG2000. RTTY/CW type ahead split screen. Tapes, handbook. B/W TV. Tunicator recorder. Offers. Kenwood TS530S, vgc, £520. Suitable spare valves. Twin meter SWR bridge, £10. Oscarbloc SWR bridge, £15. Shure 401B low impedance mic, as new, £15. Tel: Noel G3ZLN (0473) 49139, Ipswich
- Yaesu FT757 GX HF all mode computer aided transceiver, absolute mint condition, little used, £595 ono. SEM Tran Z match ATU with Ezitune, mint condition, £79. Datong D70 Morse tutor, as new, still boxed, £39. For viewing/trial etc, Tel: Leeds (0532) 585806
- Realistic Pro2004 scanner, latest model, boxed, as new, £260 ono. Dressler ARA500 active receive antenna, with all cables, plugs and PSU, as new, half new price at £70. Tel: Hull (0482) 871498 after 6pm
- 60ft tilt-over tower, P60, 3 x 20ft sections, never been used, as new, dismantled, £500 or best cash offer. Also KR600 rotator, never used, still boxed, £200. Mr Chesters, G4NXW not QTHR. Tel: (0335) 70555 or mobile (0860) 541873
- Tono 350 RTTY CW reader, £120. Slow scan TV converter, needs case, £50. Coe AR40 aerial rotator, as new, £50. 10m converters for 70cm 144MHz, 70MHz, 50MHz and VLF. £20 each. Numerous satellite information sheets, £15. Old Cossor scope, £15. Numerous obsolete wireless batteries free. All ono and collect. Tel: Graeme (0642) 318451, 6-7pm
- Yaesu FL2100Z linear amp, in first class condition, new bands, with connecting leads, £575 ono. Tel: D Caplan G3PXC (0256) 58423, evenings
- Broadcast transmitter FM 88 to 108MHz, power output 60W, range 30 miles or more. Hi-Fi audio reproduction, mains or 12V battery operation, light and portable, simple to operate, unused, £180 for quick sale. Tel: 01-949 4888 anytime
- Satellite television system for the home. 1m

- dish mounts easily anywhere. Motorised to receive all current and future satellite channels. Full remote control, connects to normal TV set. Good pictures. Lots of channels already on air: films, sports, news, music videos, kids' programmes, general entertainment, foreign language channels—German, French, Spanish, Italian. Ideal for a foreigner living in UK. Boxed, unused, £530. Can install. Tel: 01-949 4888 anytime
- PK232 AEA multi-mode data controller, plus PC software. Both brand new, never used. Unexpected redundancy forces sale. Bargain, £200, plus post. Contact G0HJC QTHR. Tel: (0844) 51694, Chinnor, Oxon
- Multimode Cobras 148GTL DX. Fully modified, 26.515-28.495, £150 ono. 150GTL standard 26.625-27.855, £120 ono. Both excellent condition, working and suitable for 10m conversion. Reason for sale—'GD' call sign imminent. Howard, PO Box 4, Port Erin, Isle of Man BRS 84881
- Video upper head drum, brand new in original packing, genuine Mitsubishi Model 303, 304. Cost £33, sell £16, post free. Tel: (0274) 881635
- Trio HF, SSB, CW transceiver, TS-130S. Also Yaesu ATU FC-707 80, 40, 30, 20, 17, 15, 12, 10m and through. With dummy load VSWR and power meter, £350. Tel: David (0689) 42157, New Addington, Croydon
- Advance E2 signal generator 100kHz-100MHz. National Rx NC77X, with 240V/110V auto transf if required. EKCO radio U245 and U319A, circa 1955. US radar units from WW2, RT7/APN1 and APS13/34. WS19 leads, headphones, variometer LP and HP control boxes, spare parts case 5C (also early all-metal microphone for WS19). Small RAF parachute 10 AQ113 and oxygen masks 6D2343/6D2298 and 6D1485. WW2 RAF operation room headgear. Tel: Tony Howard (0908) 73114
- Sommerkamp 13.8V HF amplifier, variable to 100W. AM/SSB, built-in pre-amp, plus MMT 144/28MHz transverter. Would exchange for FC-902 ATU or similar. WHY? Any other HF gear considered. Tel: John (02372) 77631
- Icom IC-215 2m, 15 channel portable with NiCads, charger, ¼ wave antenna, manual, £85. Tel: 01-319 0098
- Trio TR2300 2m portable, complete with carry case, charger, vgc, £120. Tel: (0438) 359428
- Yaesu FT-757 Mk2, mint cond, with mic and manual, boxed, £675 ono. Yaesu FT-290R Mk2 with NiCad pack, clip-on 25W linear, mic, carry case, mobile mount, plus mobile scan mic, boxed with manual, £375 ono, or exchange for standard C-500. Brian Newman G4TGN, 8 Cole Gardens, Hounslow TW5 9RJ. Tel: 01-897 3794
- Yaesu FT211RH 2m FM mobile Tx, 5/45W, 6 mths old, £270, or exchange for FT290R in gwo. Tel: Colin, G6W5IT (0407) 50792
- 1155A receiver, original condition, £55. 19 set Zenith, as new, £85. ZCI MkII New Zealand transceiver, as new, £110. US army test set 1-566H, comprising Espy valve tester, multimeter, 20,000 per volt, output meter, Model 103, multi case, leads, adapters, carrying case, £95. Zenith trans-oceanic receiver, 1940 vintage, gwo, £95. Cossor 405 TV pattern generator, £15. 1155 Morse key and navigation switch, £12. Wartime utility radio, £45. Solotron 'scope, CT319, 'scope working but faulty, £28. Derek Carter, G8WVM. Tel: Kidderminster (0562) 752068
- President Jackson, Boxed, immaculate condition, with manual. Also Cobra 148GTL DX, good condition. Serious offers considered. Tel: Kevin (0224) 684004 after 6pm
- Brand new AR88 gearbox, £25 including postage. Tel: (0228) 26436
- DSB80 QRP rig, 2W CW on 80m. Well made, superb case, digital readout, £40. Special power meter, 2m and 70cm hand-held rigs. New, still in box, £10. JAP bug key, new but dust cover is

- cracked, £10. Would swap all for good ATV for HF. Tel: (0603) 406331
- Datong Morse tutor in mint condition (1988), the effective aid to passing the Morse test. RAE books also available. Tel: 01-625 4287
- PRO32 Realistic hand-held, 200 ch scanner, NiCads, charger. Immaculate condition, never used outside, £100. Tel: (0473) 348228
- Scanner, Realistic PRO2004, VHF/UHF, 25-520, 760-1300MHz, 300 channel memory, boxed, manual, £240 cash, or part exchange ham equipment. Keane. Tel: 061-442 8806
- Icom AH7000 discone, £30. Midland 4001, 40 channel for conversion, £15. M12VHO KX2 sky coupler, £25. All ono. Tel: Peter (0553) 841119
- Standard C58, all mode, excellent condition, all boxed and with instruction books. Complete with 25W power amp, mobile slide mount, two sets of NiCads, c/case, rubber duck antenna with charger unit, 5 memos scan and mic control scan, 144.00 to 147.99MHz, simplex and duplex, 2m. The lot for £360, no offers. Tel: Chas, G1YRM (0582) 662863
- Hi-fi acoustic research legend turntable, VMS20 EII, Linn LVV arm, £110 (or £170 with Rega RB300). NAD 3020A amplifier, £50. All excellent condition. Going HF. All letters answered. Write to Mark Cooper, 33 Park View, Royston, Barnsley, South Yorkshire S71 4AA
- WS19 variometer (and also HP version). National NC77X receiver (117V) covers 550kHz-30MHz. PSU for R216. Complete WS31 with headphones and aerial. No 1 aerial mast, 32ft in sections circa WW2, in canvas bag. Signal generator Advance E2, covers 100kHz-100MHz. American midget radio (117V) octal valves MW/SW. Always interested in pre-1960 military radio bits. WHY? Tel: Tony Howard, Milton Keynes (0908) 73114
- FT250, FP250, 240W PEP, mint, reliable, 8-10m, no gadget HF rig by Sommerkamp, with mic and manual. Bargain, first £200 cash secures. All letters answered. Please send an SAE. Write to Frank, 60 Highfield Road, M6 5LA
- Yaesu FT77 line up, including FM, CW narrow FP700 PSU, FV700DM VFO with memories and split FC700 ATU. Absolutely mint, all boxed with manuals, sell for £600, will not split. May take basic rig plus cash. Buyer pays half delivery charge only. Tel: Chris 091-232 8860 between 9am and 12 noon.
- Various radio sets, complete set of trader service sheets, from number 1. Offers? Tel: Stanford-le-Hope (0375) 642803
- Spectrum + 48K, tape recorder, interface, games and monitor. President Adams SSB transceiver (will convert to 10m) and manual. DX100 general coverage receiver. Will swap for good receiver or other radio related items. Please write to Shaun Imms, 18 Lowes Road, Albion Estate, West Bromwich, West Midlands B77 4LN. Will reply to all letters.
- PRO2008 FM scanner 68-88, 144-174, 410-512MHz, 240V, immaculate, £100 ono. Admiralty general coverage receiver, type B40D, superb condition, spare set of valves, AM, FM, SSB, £80. FSK CW reception 640kHz-30.5MHz SEM transmatch with ezitune, good condition, £60. Buyer to inspect and collect B40D. Bring your own crane—weighs 114lb! All letters answered. S P Martin, 24 Collingwood Close, Worle, Weston-Super-Mare, Avon BS22 9PQ
- HRO p/pack, 4 coils, spkr, £50. Trio MC60A desk mic, £45. Goodman 40-40 amp, £25. Amstrad FM tuner, £10. Leak amp and controller, £20. Armstrong tuner-amp, £50. Hammalund HQ170A Rx, good condition DX, £145. Hammalund HQ170 Rx plus pre-amp for 54MHz, £130. SMC73 general coverage receiver, £50. Marconi wattmeter 0-25W, CT419, £15. Home brew 1155 Rx p/pack, £12. BC348m as new, no mods, £75. Yaesu 9600 Mk1, one mod by Withers, unmarked, boxed, £300. Tel: Milton Keynes (0908) 313507





# FREE CLASSIFIED ADS

Bill Batley, W Yorks. Tel: (0924) 471226

- AOR2001 scanning receiver, complete coverage from 25MHz to 550MHz, 20 channel memory and searching facility, excellent condition, £260. Bearcat hand-held scanning receiver, 50XL, as new, in box, £75. Tel: (0443) 422406
- Trio TS180, one memory, £400. Racal dual diversity unit MA168B, with handbook, £45. Minimitter low-pass filter, 30MHz, £10. Pentax ME with F1.7 50mm lens, £95. Hanimex HMG 80-200mm F4.5 lens, £25. Tandberg Model 11, professional portable tape recorder with leather carrying case, excellent condition, £225. Carriage extra. Tel: Halsall (0704) 840328
- Yaesu 709R 70cm hand-held, SW out FNB4 Ni-PCad, charger, case, original packing, mint, £145. Icom 1200E 23cm 10W base/mobile, latest model, mint, £455. Wood & Douglas GP1F 107ub 10GHz WRFM board (unused), plus superb professionally made 'penny' feed, £72. Solfan 10GHz heads (aligned), £8. Kenwood HC10 digital world 'zone' clock, mint, £50. Tel: Paul G4XHF, (0293) 515201
- FT7B, £260 ono. Audioline 10m FM, £45. 5 band vertical 80, 40, 20, 15, 10, £30. Tristar 747, £40 ono. Please write to John G0FGC, 33 Hicks Close, Warwick CV34 5ND
- Yaesu FT757GX, FC757AT (auto ATU) and FP757HD (heavy duty PSU). Boxed as new (4 HF contacts), unused, mobile mounting bracket, £950. Part/ex for basic solid-state HF rig or may split. Standard C58 2m multimode, portable/mobile with aerial, soft case, strap, scanning mic, Ni-Cads, mobile quick mount, mobile mic and manuals, £200 or exchange FT23 2m FM. Hamgear DX PM11 pre-selector/amp powered version, £35. Tel: Garry, (0625) 530200

## WANTED

- Manual BR1565, also Labgear manual LG300. Very urgent, your price paid. M J Gist G4KFX, Sunnyside Cottage, Hugas Three Mile, Stone, Truro, Cornwall TR3 6EQ
- Belcom liner, two Pye W15FM W15U F460 or similar Pye F30 and F460 type cases. W Symes, 74 Birchen Grove, Luton Beds LU2 7TW
- TS-130S (the 100W model), or would consider a TS-120S. Must be in good order. Tel: (0637) 878741
- Could the owner of an RX216 please let me have a copy of the operator's manual? Now that the TV/DX season is with us once more, is there anyone with transport, living in the Essex area of Buckhurst Hill, willing to transport this OM and his gear to his good ground, in the hope of obtaining even better reception? If you are interested, please telephone 01-505 6303.
- Marine crystals 156.400, 156.300, 156.600, 156.700, 156.800, channel 9. All third overtone to fit holder HC25U. Will possibly purchase set if reasonable. F W Nash, 39 Fleet Street, Holbeach, Lincs PE12 7AD. Tel: 22649
- HF beam, 2 or 3-ele. Mr Chesters G4NXW, not QTHR. Tel: (0335) 70555 or mobile (0860) 541873
- Yaesu BBC control EPROM and cable for 9600. Possibly swap for Yaesu CAT interface FIF-232C. Also have Commodore 64 for exchange or sale. Offers. Let me know what you have. Can deliver or

- collect. David Forward, 13 Hobbes Close, Malmesbury, Wiltshire SN16 0DA. Tel: (0666) 823490 after 5pm
- Will exchange FT-250, FP-250, 240W PEP, 80-10m, mint, reliable, no gadget, HF SSB/CW transceiver by Sommerkamp with mic and manual, for either Panasonic RF-6300 or Satellit 3400 Rx. Also wanted: Sony CRF-330K or 320 Rx. Must be in excellent condition. Good price paid. Tel: (061) 743 1570 anytime
- Military radio items before 1960. WHY? Need outer case T1154 and any relevant items. WHY? Need volume knob and pair IF transformers for Eddystone 840C. Tel: Tony Howard (0908) 73114
- HF5 or similar vertical antenna. Tel: John (02372) 77631
- Tx to cover 3.5-3.8MHz SSB. Anything considered. Must be cheap, will pay carriage. Tel: Peter (0287) 34397
- Private collector requires Eddystone Communications receivers. All models wanted. Must be near mint, but your price paid. Also manuals, circuit diagrams and other, and non-functional receivers for renovation or spares. Also wanted: power

- wanted global AT1000 ATU. Tel: 01-556 5131 anytime (East London)
- Pair of high impedance head phones in good condition. Tel: (0532) 686362
- Radio sets: Pre-1960 mains type, old Bakelite EKCOS, any Grundig table models + export Pye's from the 1950's. Old Dynatron Ether Princess radiogram, 1952 sought. Cash paid by private collector WHY? Tel: Stanford-le-Hope (0375) 642803
- Exchange FT7 for QRO TX/RX. Any age but must be working. Anneski, c/o Top Right, 1 Dunphail Road, Glasgow G34 6BX
- Wavechange, BFO Pitch, tone knobs, also tuning scale, black escutcheon for small tuning scale and manual. All for Halicrafters VHF Rx type S27. Good price paid or would buy non-worker for parts. WHY? See for sale ad. Tel: Tony Howard, Milton Keynes (0908) 73114
- R2000 with VHF or FRG8800 with VHF and/or ATU. SP Martin, 24 Collingwood Close, Worle, Weston-Super-Mare, Avon BS22 9PQ
- Sony CRF330K or 320 RX. Good prices paid for mint example. Cash purchaser. Write to Frank, 60 Highfield Road, M6 5LA
- Datong audio notch filter. Tel: Garry, (0625) 530200
- Yaesu FP707 heavy duty PSU or similar. Also FC707 ATU unit or similar. Condition not important but must be in good working order. Cash waiting. Tel: Tony G7BXZ, (0603) 614928
- BATC issue 122, 70cm, ATV, Tx, must be in good working order. £25 offered. Write to M Stevens, 13 Downs Road, Bristol BS9 3TX
- HF transceiver for long time SWL, now Morse test and RAE candidate. Must be reasonably priced as I'm on a low income with young family (ie no more than £250). Would prefer Yaesu but may consider others. Cannot accept radio with 11m and 45m pirate bands fitted. Strictly amateur bands only please. Leighton Smart, 33 Nant Gwyn, Trelewis, Mid Glamorgan CF46 6DB Wales. Sorry no phone
- Diagram for Bearcat 220, model BC220. Have no Rx at antenna end. Will pay all costs. Please help. David Smythe, 27 Cookes Terrace, Galway City, Republic of Ireland
- Service manual or circuit diagram for Realistic DX302 comm Rx. Also, circuit for wide band, low noise GasFET pre-amp covering 3-1000MHz with adjustable gain. Tel: (0207) 544342 after 6pm
- Icom R7000 scanner, Sony Air 7 or 2001D. Datong D370 active aerial. ARE, Morse, RTTY reader. Old Radcoms and other radio books. Tel: (0283) 68439
- Eddystone EC10 MK2 receiver. Non-worker considered but receiver must be complete and in good condition. Mains power pack not essential but manual must be supplied. Reasonable offers to: D J Hall, 97 Clearbrook Close, High Wycombe, Bucks HP13 7BS
- Codar 250/S ACPU, as used with AT5 Tx. Also old ARRL handbooks. AR77E Rx. Also HRO Rx with ACPU and coil packs, unmodified. Please send accurate details, price and condition to: Richard Marris, 35 Kingswood House, Farnham Road, Slough, Berks SL2 1DA

## FREE CLASSIFIED ADS FREE CLASSIFIED ADS CAN WORK FOR YOU

We are pleased to be able to offer readers the opportunity to sell your unwanted equipment or advertise your 'wants'.

Simply complete the order form at the end of these ads - feel free to use an extra sheet of paper if there is not enough space. We will accept ads not on our order form. Send to **Amateur Radio, Classified Ads, Sovereign House, Brentwood, Essex CM14 4SE.**

- supply for R210 (mains). Will collect anywhere in UK. Tel: Dr Jarrett (021) 706 1360 day, (021) 705 7626 evenings
- AOR FM RX covering 156MHz-174MHz or reliable hand-held receiver with usual frequency coverage, ie amateur band, marine etc. Wilkinson Rowena, St John's Road, Wroxall, Ventnor, Isle of Wight. Tel: (0983) 855113
- PLEASE HELP. Information required on Mullard DN7-78 CRT, modifications or improvements for type 13A oscilloscopes, circuit diagram or service sheet for Philips 595 wireless, cheap (including non-working) home-built oscilloscope. Any help much appreciated. Coles, 18 Bilford Avenue, Worcester, WR3 8PJ. Tel: (0905) 56818
- Please could anyone supply handbook or circuit diagram for Trio 7500 2m FM transceiver. Manual or photocopy, expenses covered Tel: G8CTB (0525) 715211 evenings or write to 24 Primrose Close, Flitwick, Beds MK45 1PJ
- Icom R71E in mint condition, cash or p/ex Trio 2000 with VC10 VHF converter and cash. Also

## NEWSAGENT ORDER FORM

*Amateur*  
**RADIO**

To (name of newsagent)

Please order a copy of *Amateur Radio* for me every month

NAME.....

ADDRESS.....

Newtrade distributors: SM Distribution, 16-18 Trinity Gardens, London SW9 8DX. (Tel: 01-274 8611)

## Free Classified Advertisers Please Note

Please ensure that your telephone number (if applicable) and address are included in the appropriate section of your ad.

If you do not wish to have your address published, please include it but state 'not for publication'.

# Amateur RADIO SMALL ADS

## WORKSHOP SERVICE MANUALS

Any Colour/Mono TV, Amateur Radio, Military Surplus, Music System, Vintage Valve Wireless etc, etc..... **£5.00 plus LSAE**  
Any Video Recorder..... **£15.00 plus LSAE**

**FREE** Catalogue Unique Repair and Data Guides for LSAE.

**MAURITRON (AR)**  
8 Cherry Tree Road, Chinnor  
Oxon OX9 4QY

## AGRIMOTORS MERTON CB AND RADIO CENTRE MERTON GARAGE AND POST OFFICE, MERTON. Nr OAKHAMPTON, DEVON EX20 3DZ

OPEN 6 DAYS 9-6 LUNCH 1-2pm  
EARLY CLOSING THURSDAY 1.00pm  
(SUNDAYS BY APPOINTMENT)  
SPECIALIST IN 934 MHz  
SUPPLIERS OF ALL 27MHz AND 934 MHz EQUIPMENT  
AMATEUR ACCESSORIES CATERED FOR  
08053 200

## IAN FISHER COMMUNICATIONS OF STANHOPE

**CB Works, The Market Shop, Market  
Place, Stanhope, County Durham**  
☎ (0388) 528464

Main Distributors of 27MHz CB radios and the  
NEW CEPT models including UNIDEN and DNT.  
Including U.K. and CEPT walkie talkies.

Large stocks of coaxial cable, plugs, sockets and  
adaptors.

Stockists of the new UNIDEN 28/30 Multimode  
Transmitter receiver

All available via mail order. Retail/Wholesale

OPEN: MON-SAT 10.30am-6.00pm

SUN 2.30 - 4.30

RING FOR DETAILS (0388) 528464

## JAPANESE IC's (PART OF OUR RANGE)

AN7178 £2.95, BA5408 £2.20, HA1377 £2.20, HA1392 £2.50, HA1394 £2.95,  
HA1397 £2.75, HA1398 £2.75, HA13001 £2.95, LA4460 £1.80, LA4461 £1.80,  
LA4507 £4.25, LC7137 £4.50, M51517 £2.80, MB3705 £1.80, MB3712 £1.50,  
MB3722 £3.50, MB3730 £2.50, MB3731 £3.50, STK461 £7.50, STK463 £8.40,  
TA7205AP £1.00, TA7222AP £1.30, TA7240 £2.95, TA7241 £2.95, TA7270  
£2.75, TA7271 £2.75, TA7274 £2.95, TA7280 £3.50, TA7281 £2.95, TA7282  
£2.95, TA7283 £2.95, TA7288 £2.95, TA7611 £3.20, UPC575 £1.00, UPC1158  
£2.95, UPC1181 £1.10, UPC1182 £1.10, UPC1185 £2.50, UPC1188 £2.75,  
UPC1230 £2.50, UPC1263 £2.50, UP1277 £2.75, UPC1278 £2.75, UPC1365  
£3.80, UPC1384 £1.95.  
ADD 60p POST AND PACKING AND THEN ADD 15% VAT TO TOTAL  
**T POWELL 16 PADDINGTON GREEN LONDON W2 1LG**  
OPEN MON-FRI 10AM-6PM, SAT 9AM-12 NOON.  
TELEPHONE: 01 723 8248  
ACCESS/VISA. TELEPHONE ORDERS ACCEPTED OVER £5.00

## USED AMATEUR EQUIPMENT?

### I buy, sell and exchange

For the deal you've been looking for, phone Dave, G4TNY,  
anytime on Homchurch (040 24) 57722 or (0836) 201530  
9am-7pm Mon-Sat or send SAE  
Personal callers by appointment please

**G4TNY Amateur Radio**

132 Albany Road, Homchurch, Essex RM12 4AQ

## SMC/TMP ELECTRONICS

Unit 27 Pinfold Workshops



Pinfold Lane,  
Buckley, Chryd



Tel: 0244 849863

For all your amateur equipment and accessories. Open Tues, Wed  
Fri 10am-5pm Saturday 10am-4pm. Other days by appointment

## Selectronic

The UK's leading suppliers of  
934MHz personal radio equipment

203 High Street  
Canvey Island, Essex,  
Tel: 0268 691481  
(Open Mon-Sat 9-5.30)

Amateur radio equipment also in stock

## THE SCIENTIFIC WIRE COMPANY

811 Forest Road, London E17. Telephone 01-531 1668

SWG	ENAMELLED COPPER WIRE			
	1lb	5oz	4oz	2oz
8 to 34	3.63	2.09	1.10	0.88
35 to 39	3.82	2.31	1.27	0.93
40 to 43	6.00	3.20	2.25	1.61
44 to 47	8.67	5.90	3.49	2.75
48	15.96	9.58	6.38	3.69
SILVER PLATED COPPER WIRE				
14 to 30	9.09	5.20	2.93	1.97
TINNED COPPER WIRE				
14 to 30	3.97	2.41	1.39	0.94

Fluxcore

Please add 15% VAT. Orders under £3 add 50p.  
SAE for list of copper and resistance wire.  
Dealer enquiries welcome.

## VHF ACTION RECEIVERS

Specialist hand-compact VHF  
monitor receivers for lo/mid/hi band  
detection + 10/11m.

Hear Ham's, Aircraft, Public-Service,  
Marine, Local 2-Way and much more!  
All 53-176MHz signals, +28-30 Mc Hf  
(11m version also), Squelch, VFO  
facilities etc. International Series,  
Special Price: **£29.50** inc p&p.

Prompt dispatch from:

### TAYLOR RADIO

8 Emmerson Street, Crook, Co  
Durham DL15 8NF. ☎: 0388 763323



Morse made simple. Learn quickly. Everything  
you need on one tape. Includes helpful learning  
tips. £4.75 which includes P&P.

John Hunt G2FSR

4 Warndene Road, Brighton BN1 8NL

# Amateur RADIO

This method of advertising is available in  
multiples of a single column centimetres —  
(minimum 2cms). Copy can be changed  
every month.

### RATES

per single column centimetre:

1 insertion £7.00, 3 — £6.60, 6 — £6.30, 12 — £5.60.

# SMALL ADS

## AMATEUR RADIO SMALL AD ORDER FORM

**TO:** Amateur Radio · Sovereign House  
Brentwood · Essex CM14 4SE · England · (0277) 219876

**PLEASE RESERVE**.....centimetres by.....columns

**FOR A PERIOD OF** 1 issue.....  3 issues.....  6 issues.....  12 issues.....

**COPY** enclosed.....  to follow.....

**PAYMENT ENCLOSED:** (Add 15%VAT).... £ —

Cheques should be made payable to  
Amateur Radio. Overseas payments  
by International Money Order and  
Credit Card

**CHARGE TO MY ACCOUNT**.....  CREDIT CARD EXPIRY DATE  /

COMPANY .....

ADDRESS .....

SIGNATURE ..... TELEPHONE.....

C P I



24v ni-cad battery contains twenty XD type cells, used condition, some cells may be faulty ..... **£12.00**  
 Spring tension gauges, set of 3. 0-4 ounce, 0-16 ounce, 0-6lb ..... **£8.00**  
 Ex Vulcan bomber hitch and roll assembly, contains gears, shafts, bearings etc ..... **£15.00**  
 Range and bearing marker unit, contains bevel gears, servos, shafts etc ..... **£15.00**  
 Ex Government Geiger counter with 3 probes x-ray, alpha, beta ..... **£45.00**  
 Eddystone type 770R VHF receiver, 19-155 MHz ..... **£120.00**  
 Type R210 receiver 2-15 MHz, complete with plug and headphones ..... **£55.00**  
 ITT UHF TX-RX base station ..... **£40.00**  
 ITT 149 MHz VHF transmitter ..... **£40.00**  
 Collins R390A receiver, poor condition **£150.00** Ring for details  
 Readyphone 100 watt, LIN, amplifier, complete with ATU ..... **£75.00**

Prices include postage and packing

**A C ELECTRONIC SERVICE**  
 17 APPLETON GROVE, LEEDS LS9 9EN  
 TELEPHONE: 0532 496048

## TAR COMMUNICATIONS

For all Aerials & Lashing equipment.  
 We are famous for the G5 RB antenna and the 5.7 & 12 element ZL.

For Retail and Mailorder contact:

**TAR COMMUNICATIONS**  
 King William St, Stourbridge,  
 W Midlands DY8 4EY  
 0384 390944  
 NEW GM AERIALS NOW AVAILABLE

## ALAN HOOKER ELECTONICS



42 Netherrall Road  
 Doncaster



Tel: 0302 25690

Large stocks of electronic components

## CRICKLEWOOD ELECTRONICS LTD

FOR COMPONENTS  
 LOTS OF NEW DEVICES  
 LOTS OF LOWER PRICES

Phone for our catalogue: Price £1.00  
 01 452 0161/450 0995 Telex 914 977  
 40 Cricklewood Broadway,  
 London NW2 3ET

## JAYCEE ELECTRONICS LTD

JOHN GM30PW

20 Woodside Way,  
 Glenrothes,  
 Fife KY7 5DP

Tel: 0592 756962

Open: Tues-Fri 9-5 Sat 9-4

Quality secondhand equipment in stock. Full range of TRIO goodies. Jaybeam - Microwave Modules - LAR.



## 2 METRE COLLINEAR UVRAL X2<sup>5</sup>/8over 5/8

An omni directional antenna giving low angle radiation. The ideal base station vertical. Ruggedly constructed for long life

### Technical Specification

Gain	- 6 dB
Impedance	- 50 Ohms
Max Power	- 100 Watts
Length	- 3.14 metres
SWR 144 to 146Mhz	- Less than 1.5
Wind Loading	- 4.8 Kgf at 100mph
Weight	- 1.2 Kgs
Mounting Diameter	- 25mm
Termination	- Free 'N' Socket

N Plug extra, costs **£4.52 inc VAT**

Send cheque or postal order for **£33.96** inc VAT plus **£2.60** postage to:

### BUCKLEYS (UVRAL) LTD

Beta Works, Range Road  
 Hythe, Kent CT21 6HG  
 Tel: (0303) 60127/60128

Various Frequencies Available

**QZVF LOOP ANTENNAS COMPLETE WITH ATU FOR HIGH FREQUENCY HAM BAND TRANSMISSION (SWR One to One 40, 15 and 10 and One Point Five to One 80 and 20) AND SWLS, AND LONG AND MEDIUM WAVE BANDS FOR BCLs.** Loops 21 inches square or triangle. DIY projects. No special skills required. Circuits, Parts Lists with sources of supply and full assembly data. **HIGH FREQUENCY LOOP 80 to 10 Metres CS. LONG AND MEDIUM WAVE LOOP** for BCLs **CS. LONG WAVE, MEDIUM WAVE AND SHORT WAVE LOOP** 1500 to 10 Metres **FOR THE BCL AND SWL CS. SHORT WAVE ATU FOR USE WITH EITHER A LOOP OR LONG WIRE ANTENNA CS. FIELD STRENGTH METER CS. DIY pre-amp LW, MW and SWave CS. SAE for details. Photocopy HRO Manual £4.**

F G Rylands, 39 Parkside Avenue  
 Millbrook, Southampton SO1 5AF. Tel. (0703) 775064

## OMNI ELECTRONICS

stock a wide range of electronic components at

174 Dalkeith Road, Edinburgh EH16 5DX  
 Tel: 031 667 2611

Open: Mon-Fri 9am-6pm, Sat 9am-5pm.  
 Send 2x19p stamps for latest catalogue.

## MRZ MICROWAVE MOBILE ANTENNA

ICOM-BUSINESS/AMATEUR/MARINE/AIR  
 UK AND EXPORT

MRZ COMMUNICATIONS LTD  
 NEWCASTLE UNDER LYME



TEL: (0782) 619658  
 7 DAY SERVICE

★ **PSSS....** ★

**ALL THE SUPER BARGAINS ARE ON THE INSIDE FRONT COVER**

★ ★

## ETESON ELECTRONICS



158 Lower Green,  
 Poulton-le-Fyde, Blackpool  
 Tel: (0253) 885107

Open: 9.30am - 12.30, 1.30 - 5.30. Closed Wed & Sun.  
 Electronic Component Specialists.

A wide range of electronic components, IC's, capacitors, transistors, resistors, plugs and sockets etc.

### BRAND NEW, QUALITY COMPONENTS ONLY £1.00 PER PACK

400 Mixed Resistors, 1/8-1 Watt	5 Copperclad Stripboard, like Vero but no holes, 100 x 125mm
50 Mixed WW & Power Resistors	82x, 0.1" or 0.15" pitch
25 Mixed Pots & Presets	50 OC71 Transistors, long leads
100 Mixed Polyester Capacitors	1 Sound Effects PCB with Data.
200 Mixed Ceramic & Mica Caps	Just add LS & Switches for Siren, train, trimphone, etc. etc
500 Mixed Capacitors, all types	2 Power Resistors, 1 ohm 100W
2000 Solder tags, 45A Hole	10 Clip-on Transistor Heatsinks
10 Slide switches, two types	3 Red LED Displays, 7 segment
25 Mixed Zener Diodes	2 Power Resistors, 1 ohm 100W
12 Mixed W W Potentiometers	10 Clip-on Transistor Heatsinks
20 Transistor Sockets, 4 pin	5 680 uF 50v Electrolytics
1 39,000 uF/250V Electrolytic	5 6800 uF/50v Electrolytics
100+ Hardware eg Grommets, Knobs, Clips, Clamps, etc	3 15,000 uF/25v Electrolytics
	50 Components Mystery Pack

**Quant Packs.** Superb selection of all types of new components. Approx 700 to the pound weight. 1lb @ £5.50, 2lbs @ £5.90, 4lbs @ £5.90. Large stocks of **NEW VALVES** (many RARETIES) and **SEMICONDUCTORS** at unbeatable Prices. Many more component & equipment bargains. Ask for free list. Mail Order Only. Add 85p Postpacking (inc VAT).

KENZEN, 1435 PERRINSHORE ROAD, STIRCHLEY, BIRMINGHAM B30 2JL

## SOUTH WALES

### ELECTRO DISPOSALS

2000 sq ft of surplus equipment and components

UNIT 31, LONLAS WORKSHOPS  
 SKEWEN, NEATH  
 Tel: 0792 818451

Please mention  
**Amateur Radio**  
 when replying  
 to any  
**advertisements**

DISPLAY AD RATES		series rates for consecutive insertions			
depth mm x width mm	ad space	1 issue	3 issues	6 issues	12 issues
61 x 90	1/8 page	£66.00	£62.00	£59.00	£53.00
126 x 90 or 61 x 186	1/4 page	£115.00	£110.00	£105.00	£92.00
126 x 186 or 263 x 90	1/2 page	£225.00	£210.00	£200.00	£180.00
263 x 186	1 page	£430.00	£405.00	£385.00	£345.00
263 x 394	double page	£830.00	£780.00	£740.00	£660.00

COLOUR AD RATES		colour rates exclude cost of separations	series rates for consecutive insertions		
depth mm x width mm	ad space	1 issue	3 issues	6 issues	12 issues
126 x 186 or 263 x 90	1/2 page	£305.00	£290.00	£275.00	£245.00
263 x 186	1 page	£590.00	£550.00	£530.00	£470.00
263 x 394	double page	£1,130.00	£1,070.00	£1,010.00	£900.00

SPECIAL POSITIONS	Covers:	Outside back cover 20% extra, inside covers 10% extra
	Bleed:	10% extra [Bleed area = 307 x 220]
	Facing Matter:	15% extra

DEADLINES		*Dates affected by public holidays			
issue	colour & mono proof ad	mono no proof & small ad	mono artwork	on sale thurs	
Sep 88	28 Jul 88	3 Aug 88	5 Aug 88	25 Aug 88	
Oct 88	1 Sep 88	7 Sep 88	9 Sep 88	29 Sep 88	
Nov 88	29 Sep 88	5 Oct 88	7 Oct 88	27 Oct 88	
Dec 88	27 Oct 88	2 Nov 88	4 Nov 88	24 Nov 88	

CONDITIONS & INFORMATION			
<p><b>SERIES RATES</b> Series rates also apply when larger or additional space to that initially booked is taken. An ad of at least the minimum space must appear in consecutive issues to qualify for series rates. Previous copy will automatically be repeated if no further copy is received. A 'hold ad' is acceptable for maintaining your series rate contract. This will automatically be inserted if no further copy is received. Display Ad and Small Ad series rate contracts are not interchangeable.</p>	<p>If series rate contract is cancelled, the advertiser will be liable to pay the unearned series discount already taken.</p> <p><b>COPY</b> Except for County Guides copy may be changed monthly. No additional charges for typesetting or illustrations (except for colour separations). For illustrations just send photograph or artwork. Colour Ad rates do not include the cost of separations. Printed - web offset</p>	<p><b>PAYMENT</b> Above rates exclude VAT. All single insertion ads are accepted on a pre-payment basis only, unless an account is held. Accounts will be opened for series rate advertisers subject to satisfactory credit references. Accounts are strictly net and must be settled by the publication date. Overseas payments by International Money Order or credit card.</p> <p><b>FOR FURTHER INFORMATION CONTACT</b> Amateur Radio, Sovereign House, Brentwood, Essex CM14 4SE. (0277) 219876</p>	<p>Commission to approved advertising agencies is 10%.</p> <p><b>CONDITIONS</b> 10% discount if advertising in both Amateur Radio and Radio &amp; Electronics World. A voucher copy will be sent to Display and Colour advertisers only. Ads accepted subject to our standard conditions, available on request.</p>

# ADVERTISERS INDEX

J Bull .....	51	Lake Electronics .....	10
P M Components .....	4,5	G4ZPY Paddle Keys .....	13
ICS Electronics .....	32	Radio & Telecommunications	
RN Electronics .....	52	Correspondence School .....	13
GCHQ .....	36	Royal Navy .....	36
L F Hanney .....	10	Stewart of Reading .....	36
C M Howes .....	8	Technical Software .....	33
ICOM .....	26,27	Waters & Stanton .....	22
ICS International .....	34	R Withers .....	2
Javiation .....	34		





### No. 1 LIST BAKERS DOZEN PACKS

All packs are £1 each, if you order 12 then you are entitled to another free. Please state which one you want. Note the figure on the extreme left of the pack ref number and the next figure is the quantity of items in the pack, finally a short description.

- BD1 5 13A junction boxes for adding extra points to your ring main circuit.
- BD2 5 13A spurs provide a fused outlet to a ring main where devices such as a clock must not be switched off.
- BD7 4 In flex switches with neon on/off lights, saves leaving things switched on.
- BD9 2 6V 1A mains transformers upright mounting with fixed clamps.
- BD11 1 6 1/2in speaker cabinet ideal for extensions, takes our speaker. Ref BD137.
- BD13 12 30 watt reed switches, it's surprising what you can make with these—burglar alarms, secret switches, relay, etc., etc.
- BD22 2 25 watt loudspeaker two unit crossovers.
- BD29 1 B.D.A.C. stereo unit is wonderful value.
- BD30 2 Nicad constant current chargers adapt to charge almost any nicad battery.
- BD32 2 Humidity switches, as the air becomes damper the membrane stretches and operates a microswitch.
- BD34 4 8 2 meter length of connecting wire all colour coded.
- BD42 5 13A rocker switch three ways so on/off, or change over with centre off.
- BD45 1 24hr time switch, ex-Electricity Board, automatically adjust for lengthening and shortening day. original cost £40 each.
- BD49 10 Neon valves, with series resistor, these make good night lights.
- BD56 1 Mini uniselector, one use is for an electric jigsaw puzzle, we give circuit diagram for this. One pulse into motor, moves switch through one pole.
- BD59 2 Flat solenoids—you could make your multi-tester read AC amps with this.
- BD67 1 Suck or low operated pressure switch, or it can be operated by any low pressure variation such as water level in water tanks.
- BD91 2 Mains operated motors with gearbox. Final speed 16 rpm, 2 watt rated.
- BD103A 1 6V 750mA power supply, nicely cased with mains input and 6V output leads.
- BD120 2 Stripper boards, each contains a 400V 2A bridge rectifier and 14 other diodes and rectifiers as well as dozens of condensers, etc.
- BD122 10m Twin screened flex with white pvc cover.
- BD128 10 Very fine drills for pcb boards etc. Normal cost about 80p each.
- BD132 2 Plastic boxes approx 3in cube with square hole through top so ideal for interrupted beam switch.
- BD134 10 Motors for model aeroplanes, spin to start so needs no switch.
- BD139 6 Microphone inserts—magnetic 400 ohm also act as speakers.
- BD148 4 Reed relay kits, you get 16 reed switches and 4 coil sets with notes on making c/o relays and other gadgets.
- BD149 6 Safety cover for 13A sockets—prevent those inquisitive little fingers getting nasty shocks.
- BD180 6 Neon indicators in panel mounting holders with lens.
- BD193 6 5 amp 3 pin flush mounting sockets make a low cost disco panel.
- BD196 1 in flex simmerstat—keeps your soldering iron etc. always at the ready.
- BD199 1 Mains solenoid, very powerful, has 1in pull or could push it modified.
- BD201 8 Keyboard switches—made for computers but have many other applications.
- BD210 4 Transistors type 2N3055, probably the most useful power transistor.
- BD211 1 Electric clock, mains operated, put this in a box and you need never be late.
- BD221 5 12V alarms, make a noise about as loud as a car horn. Slightly soiled but OK.
- BD242 2 6in x 4in speakers, 4 ohm made from Radiomobile so very good quality.
- BD246 2 Tacho generators, generate one volt per 100 revs.
- BD252 1 Panostat, controls output of boiling ring from simmer up boil.
- BD259 50 Leads with push-on 1/4in tags—a must for hook-ups—mains connections etc.
- BD263 2 Oblong push switches for bell or chimes, these can mains up to 5 amps so could be foot switch if fitted into pattress.
- BD268 1 Mini 1 watt amp for record player. Will also change speed of record player motor.
- BD275 1 Guitar mic—clip-on type suits must amps.
- BD283 3 Mild steel boxes approx 3in x 3in x 1in deep—standard electrical.
- BD293 50 Mixed silicon diodes.
- BD296 3 Car plugs with lead, fit into lighter socket.
- BD305 1 Tubular dynamic mic with optional table rest.

Most other packs still available and you can choose any as your free one.  
**VERY POWERFUL 12 VOLT MOTORS—1/2nd HORSEPOWER** Made to drive the Sinclair C5 electric car but equally adaptable to power a go-cart, a mower, a rail car, model railway, etc. Brand new. Price £15.00 plus £2.00 postage. Our ref 158.

### OVER 400 GIFTS YOU CAN CHOOSE FROM

There is a total of over 400 packs in our Baker's Dozen range and you become entitled to a free gift with each dozen packs.

A classified list of these packs and our latest "News Letter" will be enclosed with your goods, and you will automatically receive our next news letter.



### NEWLY ADVERTISED ITEMS

**FET CAPACITOR MICROPHONE** Eagle Cl 200 Electret type microphone. An FET amplifier is built in for obtaining an output equivalent to a high class dynamic microphone while retaining the characteristics of a capacitor microphone. External influence by magnetic and electrostatic noise is minimised since no magnets or coils are used. The small size of this microphone and the low power supply needed for its operation makes this microphone a very versatile unit. Electrical specifications are as follows: Output impedance: 500ohms ± 30% at 1kHz. Sensitivity: -65dB ± 3dB (0dB = 1V/uBar at 1000Hz). Frequency response: 50-8000Hz. Price £1 each. Order Ref. BD646.

**SUB-MIN TOGGLE SWITCH** Body size 8mm x 4mm x 7mm SBOT with chrome dolly fixing nuts. 4 for £1. Order Ref. BD649.

**Ex GPO MULTI-RANGE TEST METER 12/C1** Complete in real leather case with carrying handle—this is a 20,000 OPU instrument, with 19 ranges including AC and OC volts—dc current 5mA to 1A, 4ohms ranges up to 20meg— the low ohms range is particularly useful, you will be able to read right down to one ohm and below. This meter also has provision for reading dc current 0-5 amp and 0-25 amp. Meter size 6" long x 3" wide x 2" deep. Leather case has compartment for test leads, prods, and croc clips all of which are included. Can be used in the case. Not new but are in first class condition—tested and guaranteed. Price is £7.00. Order ref 7P5.

**RE-CHARGEABLE NICADS 'D' SIZE** These are tagged for easy joining together but tags, being spot welded, are easy to remove. Virtually unused, tested and guaranteed. £2.00 ref 2P141 or 6 wired together for £10.00 ref 10P47.

**8 TRACK CASSETTE DECK** Complete with cassette holder. In fact, if you have any 8 track cassettes, then with the addition of 2 speakers this unit would play them. As 8 track cassettes are no longer made the units have become surplus, however, they do contain lots of useful parts: motor, tape head and drive, pulley wheels, etc. and a stereo amplifier. Mains operated. Brand new in makers packing. Only £3.00 each plus £1.00 additional postage. Order ref 3P46.

**COMPUTER BARGAIN—MEMOTECH MTX 512 64K RAM** Full size QWERTY keyboard with 57 professional keys and additional 12 dual function keys arranged as a separate keypad with cursor control and editing keys. Auto repeat is standard on all keys. This is a very superior home computer and comes complete with power supply, cassette lead, TV lead and 3 cassette programmes. Brand new in manufacturer's original packing with 250 page Operator's Manual. Price £45.00 plus £4.00 postage.

**STEREO SPEAKERS** Each 10 watts 8 ohm and twin speakers mounted in Walnut-finish cabinets, size 16" high x 10" wide x 6" deep. Front is black Dacron and the finish is very pleasing. Price £7.00 per pair. Extra postage and packing £3.00.

**UNUSUAL MAINS MOTOR** Quite small, measures only 2" x 2" x 1" approx, but is surprisingly powerful. It revs at 3,000rpm and is reversible. It has good length 1/4" diameter spindle. Price £1.00. Our order ref BD640.

### LASER TUBE

Made by Philips Electrical. New and unused. This is helium-neon and has a typical power rating of 9mW. It emits random polarised light and is completely safe provided you do not look directly into the beam when eye damage could result. Do not use in the presence of children unless a diverging lens is fitted. **DON'T MISS THIS SPECIAL BARGAIN!** Price £29.95 plus £3 insured delivery.

### PAPST AXIAL FAN—MANUFACTURERS REF NO. TYP4500N.

This is mains operated. 15 watt rating and in a metal frame with metal blades so OK in high temperatures. Body size approx. 4 3/4" square x 1 1/4" thick. £6.00 each, plus £1.00 postage. Our ref 6P6.

**VERY POWERFUL MAGNETS** Although only less than 1" long and not much thicker than a pencil these are very difficult to pull apart. Could be used to operate embedded reed switches, etc. Price 50p each, 2 for £1.00. Ref BD642.

**FLIP-OVER DIGITAL CLOCK** Quite an eyecatcher, this is mains operated. The figures flip-over per minute and per hour and give a larger than usual visual display. Supplied complete with front and perspex panels to glue together to make its case. £2.00 each. Our ref 2P205.

**STABILISED 15V 2A PSU** kit which mounts on SRB panel. Mains operated. Ideal to drive monitor, etc. Price only £6. Our Ref. 6P7.

**SMOOTHING CAPACITOR 230uF 63V 10A** at 50 deg. C. Can type with mounting bracket. Price £2. Our Ref. 2P206.

**SMOOTHING CAPACITOR 2200uF 63V 5.8A** at 50 deg. C. Can type with mounting bracket. Price £1. Our Ref. BD644.

**10A 100V BRIDGE RECTIFIER ASSEMBLY** comprising 4 diodes mounted on two 4in x 3in sinks with bottom insulators. Price £2. Our Ref. 2P207.

**DO YOU WANT TO MEASURE AC AMPS?** We have found a few more of the 50Hz 0-40A AC 2 1/2in diameter panel meters, made for RAF equipment these are very reliable and robust. Price £5 each. Our Ref. 5P105.

**20A DOUBLE POLE RELAY WITH 12V COIL** complete with mounting brackets. made by the Japanese Omron Company. Price £2 each. Our Ref. 2P173A.

**TOROIDAL MAINS TRANSFORMER** with twin outputs. 6.3V 2A and 12V 600mA, so ideal for FDD power supply. Price £5. Our Ref. 5P122.

**DOUBLE MICRO CASSETTE DECK** made by the Japanese ABS company. This takes two micro cassettes and is complete with motors, solenoids to select the deck to use and record and playback heads. Price £10. Our Ref. 10P49.

**QUICK FIX MAINS CONNECTOR** A must for your workshop. Saves putting on plugs as you just push the wires under the spring clips. Automatically off when lid is up. Price £7.50. Our Ref. 7P5/1.

**BT HANDSET** with curly lead terminating with flat BT plug. Colour cream. Price £5. Our Ref. 5P123.

### NEW ARRIVALS. FIRST TIME OFFERED

**EPSON MINI PRINTER 15011** This is a till roll size printer and uses plain paper. £15 each. Order Ref. 15P14.

**276A EPROM 65K bits.** BBC micro compatible. £3 each. Order Ref. 3P48.

**PIEZO SOUNDER.** Reference PKM11 3-30V operation. 90dB output. 2 for £1. Order Ref. BD647.

## J & N BULL ELECTRICAL

Dept AR, 250 PORTLAND ROAD, HOVE  
BRIGHTON, SUSSEX BN3 5QT

**MAIL ORDER TERMS:** Cash, PO or cheque with order. Orders under £20 add £1.50 service charge. Monthly account orders accepted from schools and public companies. Access and B/card orders accepted. Brighton (0273) 734648 or 293588

### POPULAR ITEMS

Some of the many items described in our current list which you will receive if you request it

**3 1/2in FDD CHINON 80 track 500K.** Shugart compatible interface. Standard connections, interchangeable with most other 3 1/2in and 5 1/4in drives. Brand new. £28.50 plus £3 insured post.

**3in FDD HITACHI HD3055XA** Shugart compatible interface. 500K on 3in disc. Recommended for most Amstrads but interchangeable with most drives. £29.50 plus £3 insured post.

**FDD CASE AND POWER SUPPLY KIT** for the 3in or 3 1/2in. £11.00. Ref. 11P2 for the Chinton, 11P3 for the Hitachi.

**9in MONITOR** made for ICL, uses Philips black and white tube. Brand new and complete but uncased. £16.00 plus £5.00 post.

**ACORN COMPUTER DATA RECORDER REF AF503** Made for the Electron or BBC computers but suitable for most others. Complete with mains adaptor, leads and handbook. £10.00. Ref. 10P44.

**POWERFUL IONISER** Uses mains transformer. Generates approx. 10 times more ions than the normal diode/cap ladder circuits. Complete kit £11.50 plus £3.00 post.

**3 INCH FDD Hitachi ref. HFD 3055XA.** Ideal replacement or second drive in most computers, especially Amstrad 6128, etc. Price £30 plus £3 post.

**FREE POWER!** Can be yours if you use our solar cells—sturdily made modules with new system bubble magnifiers to concentrate the light and so eliminate the need for actual sunshine—they work just as well in bright light. Voltage input is .45—you join in series to get desired voltage—and in parallel for more amps. Module A gives 10mA. Price £1. Our ref. BD631. Module C gives 400mA. Price £2. Our ref. 2P199. Module D gives 700mA. Price £3. Our ref. 3P42.

**SOLAR POWERED NI-CAD CHARGER** 4 Ni-Cad batteries AA (HP7) charged in eight hours or two in only 4 hours. It is a complete, boxed ready to use unit. Price £6. Our ref. 6P3.

**50V 20A TRANSFORMER 'C'** Core construction so quite easy to adapt for other outputs—tapped mains input. Only £25 but very heavy so please add £5 if not collecting. Order Ref. 25P4.

**15A PANEL METER** These have been stripped from Government surplus battery charger units made originally for army use. Unused, tested but of course rather old, diameter 2in can be surface or flush mounted. £3 each. Our Ref. 3P40.

**SWITCH AC LOADS WITH YOUR COMPUTER** This is easy and reliable if you use our solid state relay. This has no moving parts, has high input resistance and acts as a noise barrier and provides 4kV isolation between logic terminals. The turn-on voltage is not critical, anything between 3 and 30V, internal resistance is about 1K ohm. AC loads up to 10A can be switched. Price is £2 each. Ref. 2P183.

**METAL PROJECT BDX** Ideal size for battery charger, power supply etc.; sprayed grey, size 8in x 4 1/4in x 4in high, ends are louvred for ventilation other sides are flat and undrilled. Order Ref. 2P191. Price £1.

**BIG SMOOTHING CAPACITOR.** Sprague powerwytic 39,000uF at 50V. £3. Our ref. 3P41.

**4-CORE FLEX CABLE.** Cores separately insulated and grey PVC covered overall. Each copper core size 7/0.2mm. Ideal for long telephone runs or similar applications even at mains voltage. 10 metres £2. Our ref. 2P196 or 100 metres coil £8. Order ref. 8P19.

**6-CORE FLEX CABLE.** Description same as the 4-core above. Price 15 metres for £2. Our ref. 2P197 or 100 metres £9. Our ref. 9P1.

**BULK-HEAD MOUNTING LOUDSPEAKER.** Metal case with chrome grill front and with mounting lugs for screwing to ceiling, 8in. speaker. £10 each. Order ref. 10P43 add £2 post.

**TWIN GANG TUNING CAPACITOR.** Each section is .0005uF with trimmers and good length 1/4in spindle. Old but unused and in very good condition. £1 each. Our ref. BD630.

**13A PLUGS** Good British make complete with fuse, parcel of 5 for £2. Order ref. 2P185.

**13A ADAPTERS** Takes 2 13A plugs, packet of 3 for £2. Order ref. 2P187.

**20V-0-20V Mains transformers** 2 1/2 amp (100 watt) loading, tapped primary, 200-245 upright mountings £4. Order ref. 4P24.

**BURGLAR ALARM BELL—6"** Gong OK for outside use if protected from rain. 12V battery operated. Price £8. Ref. 8P2.

**24 HOUR TIME SWITCH—16A** changeover contacts, up to 6 on/offs per day. Nicely cased, intended for wall mounting. Price £8. Ref. 8P6.

**CAPACITOR BARGAIN—axial ended, 4700uF at 25V.** Jap made, normally 50p each, you get 4 for £1. Our ref. 4P1.

**PIEZO ELECTRIC FAN—**An unusual fan, more like the one used by Madame Butterfly than the conventional type, it does not rotate. The air movement is caused by two vibrating arms. It is American made, mains operated, very economical and causes no interference, so is ideal for computer and instrument cooling. Price is only £1 each. Ref. BD598.

**SPRING LOADED TEST PRODS—**Heavy duty, made by the famous Bulgin company, very good quality. Price 4 for £1. Ref. BD597.

**ASTEC P.S.U.—**Switch mode type. Input set for +230V. Output 3.5 amps at +5V, 1.5 amps at +12V, and 3 amps at +5V. Should be OK for floppy disc drives. Regular price £30. Our price only £10. Ref. 10T34. Brand new and unused.

**APPLIANCE THERMOSTATS—**Spindle adjust type suitable for convector heaters or similar. Price 2 for £1. Ref. BD582.

**3-CORE FLEX BARGAIN No. 1—**Core size 5mm so ideal for long extension leads carrying up to 5 amps or short leads up to 10 amps. 15mm for £2. Ref. 2P189.

**3-CORE FLEX BARGAIN No. 2—**Core size 1.25mm so suitable for long extension leads carrying up to 13 amps, or short leads up to 25A. 10m for £2. Ref. 2P190.

**ALPHA-NUMERIC KEYBOARD—**This keyboard has 73 keys giving trouble free life and no contact bounce. The keys are arranged in two groups, the main area is a QWERTY array and on the right is a 15 key number pad, board size is approx. 13" x 4"—brand new but offered at only a fraction of its cost, namely £3, plus £1 post. Ref. 3P27.

**WIRE BARGAIN—**500 metres 0.7mm solid copper tinned and p.v.c. covered. Only £3 plus £1 post. Ref. 3P31—that's well under 1p per metre, and this wire is ideal for push on connections.

**INTERRUPTED BEAM KIT—**This kit enables you to make a switch that will trigger when a steady beam of infra-red or ordinary light is broken. Main components—relay, photo transistor, resistors and caps, etc. Circuit diagram but no case. Price £2. Ref. 2P15.

**3-30V VARIABLE VOLTAGE POWER SUPPLY UNIT—**with 1 amp DC output. Intended for use on the bench for experimenters, students, inventors, service engineers etc. This is probably the most important piece of equipment you can own (after a multi range test meter). It gives a variable output from 3-30 volts and has an automatic short circuit and overload protection, which operates at 1.1 amp approximately. Other features are very low ripple output, a typical ripple is 3mV pk-pk, 1mV rms. Mounted in a metal fronted plastic case, this has a voltmeter on the front panel in addition to the output control knob and the output terminals. Price for complete kit with full instructions is £15. Ref. 15P7.

**STEREO SPEAKERS** Each 10 watts 8 ohm and twin speakers mounted in walnut finish cabinets, size 16in high x 10in wide x 6in deep. Front is black Dacron and the finish is very pleasing. Price £7 per pair. Extra postage and packing £3. Our Ref. 7P6.

# R. N. Electronics

Professionally designed equipment for amateurs

INTRODUCING  
EXCITING ADDITIONS TO OUR RANGE  
DON'T MISS THE OPPORTUNITY FOR A DX "FIRST"



## 6m TRANSVERTERS

Our market leader 144/50MHz  
Transverter 25w pep **£179 + £4 p&p**

NEW

28/50MHz Transverter 25w pep **£199 + £4 p&p**

★ RN690 Power Amplifier. Add to your dedicated 6m rig 3W drive to give 25w p&p **£75 + £4 p&p**

★ 7dB Switched Attenuator **£22 + £2 p&p**

## Specifications

Drive - 0.5-3w  
Spurii - <60dB  
Second Harmonic - <70dB  
Current - 3.5A typ

2 year guarantee

## 4m TRANSVERTERS

★ 144/70MHz Transverter. 25w pep **£239 + £4 p&p**

NEW

144/70MHz Transverter. 10W pep **£199 + £4 p&p**

NEW

28/70MHz Transverter. 10W pep **£199 + £4 p&p**

★ RN490 Power Amplifier. 25w pep **£75 + £4 p&p**

## RECEIVE CONVERTERS

With your existing 2m or HF equipment these receive converters give you the opportunity to listen in on other bands.

With the switched version you will have the facility for working crossband.

**RECEIVE ONLY CONVERTERS** at **£39 each plus £2 p&p**

2m IF/4m  
2m IF/6m  
2m IF/10m

10m IF/2m  
10m IF/4m  
10m IF/6m

## SWITCHED RECEIVE CONVERTER

**£45 + £2 p&p**

2m TX/RX

2m TX O/P to Transverter etc

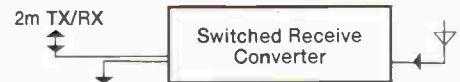

ANNOUNCING  
A NEW DIMENSION IN 2M FM MOBILES

# NAVICO®



## AMR1000

- ◆ 12.5KHz & 25KHz channelling
- ◆ Automatic repeater shift
- ◆ Simple to operate
- ◆ 5w and 25w
- ◆ Dual VFO
- ◆ Reversible front panel

**£247.25 incl VAT + £4 p&p**

## BRITISH DESIGN & MANUFACTURE

## AMR1000S

- ◆ Scanning modes of operation
- ◆ Automatic or manual repeater access tone
- ◆ Programmable functions
- ◆ Memory channels
- ◆ Scan rate
- ◆ Priority channels
- ◆ Plus many more

**£299 incl VAT + £4 p&p**

DESIGNED FOR TODAY'S AMATEUR. VARIABLE MOUNTING POSITION FOR THE MODERN CAR, EASY TO USE YET PROVIDING EVERY FEATURE FOR THE BEGINNER OR EXPERT.

**PLUS** INNOVATIVE HANDS FREE UNIT OUT SOON  
AVAILABLE AT THE LEICESTER RALLY 28/29 OCTOBER ON STAND 54A



from

# R. N. Electronics

37 Long Ridings Avenue, Hutton, Brentwood, Essex CM13 1EE

See us at all major rallies

For details:  
**(0277) 214406**  
**ORDER NOW**