



# RAYCOM OPEN DAY

WITH THE SANDWELL AMATEUR RADIO CLUB  
SUNDAY 3rd JULY 1988

MAJOR DEALERS WILL BE ATTENDING

BRING & BUY ☆ ☆ ☆ ☆ ☆ ☆ ☆ COMPONENTS

FLEA MARKET ☆ ☆ ☆ ☆ ☆ ☆ ☆ ACCESSORIES

CAR PARKING - - - - - TALK IN S22

REFRESHMENTS, LOCAL PUB GRUB  
CANAL WALKS

OPEN 11-00-4.30

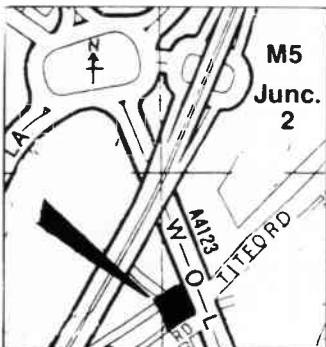

**RAYCOM COMMUNICATIONS SYSTEMS LTD**  
INTERNATIONAL HOUSE, 963 WOLVERHAMPTON ROAD  
OLDBURY, WEST MIDLANDS B69 4RJ  
Telephone: 021-544 6767. Fax 021-7124. Telex 336483 Identi-G

*Amateur*

# RADIO

**For all two-way radio enthusiasts**

**Construction:**

**Build a Transmitter out of the Junk Box**

**Radio Wave Propagation**



**On Test: the Kenwood TM-721E Dual Band FM Mobile Transceiver; Icom WR200 and WR2000 Power Meters and the Diamond Heavy Duty Mag Mount**

# Amateur RADIO



#### Editorial:

Iain Mackenzie  
Penny Phillips

#### Advertisement Manager:

Marian Vidler

#### Subscriptions:

01-760 0409

#### Publisher:

Peter Williams

#### On sale:

Last Thursday of the  
month preceding cover  
date

#### Next issue:

Cover date August 1988,  
on sale 28th July 1988

#### Published by:

Amateur Radio  
Magazines,  
Sovereign House,  
Brentwood,  
Essex,  
CM14 4SE,  
England  
(0277) 219876

Printed: In England

ISSN: 0264-2557

#### News Trade Sales by:

S M Distribution,  
6 Leigham Court Road,  
Streatham,  
London.  
SW16 2PG  
Tel: 01-677 8111

#### Front cover:

The Kenwood TM-721E  
Mobile Transceiver

Whilst every care is taken when accepting advertisements we cannot accept responsibility for unsatisfactory transactions. We will, however, thoroughly investigate any complaints. The views expressed by contributors are not necessarily those of the publishers. Every care is also taken to ensure that the contents of *Amateur Radio* are accurate. We assume no responsibility for any effect from errors or omissions.

© Copyright 1988  
Amateur Radio Magazines

## 6 Straight & Level

The latest news, comments and developments on the amateur radio scene

## 8 Radio Wave Propagation

Alan Malcher gives us an insight into this fascinating subject

## 11 Building the JB80 Transmitter

Richard Q Marris builds an 80m transmitter out of the junk box

## 14 Datasheet

Ian Poole looks at MSA Avantex Series Amplifiers

## 17 Angus McKenzie Tests . . .

. . . the Kenwood TM-721E Dual Band FM Mobile Transceiver, Icom WR200 and WR2000 Power Meters and the Diamond Heavy-Duty Mag Mount

## 22 Bits to Build

George Dobbs continues his series on building a Jandek receiver

## 28 Second-hand Receivers for under £50

Hugh Allison offers advice on six more second-hand receivers

## 31 The WILCO Principle

Roger Williams explains the Williams Inverse Law of Communication

## 33 Realistic Pro-38 and Bearcat BC 50XL

Peter Rouse reviews these budget price hand-helds

## 34 DX Diary

Don Field with this month's DX news

## 36 Short Wave Listener

Trevor Morgan looks at the broadcast bands

## 39 Project Book

Martin Williams provides some information on the various types of low frequency filters

## 40 Second-hand

'There's this funny smell . . .'  
Hugh Allison investigates

## 41 On the Beam

Glen Ross with all the latest news from VHF, UHF and microwaves

## 43 A Beginner's Guide to Packet BBS Operation

Joe Kasser concludes his introduction to Packet Bulletin Board Systems

## 45 Morse Report

Tony Smith takes his bimonthly look at the world of dots and dashes

## 46 50MHz

Ken Ellis with the latest developments on 6m

## SERVICES

### 50 Advertisers Index

### 50 Advertising Rates and Information

#### PUBLISHER'S ANNOUNCEMENT

You may have noticed that *Amateur Radio's* cover price has increased. This had been made necessary because of continually increasing paper and production costs.

As we are publishing a very specialised magazine, appealing to a dedicated band of readers, we are subject to higher unit production costs than other magazines of more general appeal.

Our research indicates that the magazine content is what you have asked for, so in order to continue publishing *Amateur Radio* for you, we need to charge an economic cover price.

I hope you continue to enjoy the magazine.

Best wishes

Peter Williams  
Publisher

VISA  
PHONE  
0474 60521

# P.M. COMPONENTS LTD

## SELECTRON HOUSE, SPRINGHEAD ENTERPRISE PARK, SPRINGHEAD ROAD, GRAVESEND, KENT DA11 8HD

TELEX  
966371  
TOS PM

### INTEGRATED CIRCUITS

AN103	2.50	LA4430	2.50	AL1727Q	1.10	TA7609P	3.95	TCA760	2.50	TDA4050	2.90	AA119	0.06
AN124	2.50	LA4461	3.95	SN7474	1.10	TA7811AP	2.95	TA800	2.50	TDA4160	2.85	BA115	0.13
AN214Q	2.50	LC7130	3.25	TA7623	2.50	TA310A	3.50	TCA800	6.55	TDA9503	3.18	BA145	0.18
AN236	1.95	LC7131	3.50	SN78023N	3.95	TA810A	3.50	TCA900	2.50	TEA1009	1.95	BA154	0.08
AN239	2.50	LC7137	6.50	SN7811SN	1.25	TAA350A	1.95	TCA940	1.85	UPC566H	2.95	BA156	0.18
AN240P	2.50	LMB23K	4.95	SN78131N	1.30	TAA550B	1.95	TDA440	2.20	UPC41C	3.50	BA157	0.30
AN247	2.50	LM324N	2.95	SN78228N	2.95	TAA661B	1.95	TDA1000	2.95	UPC575C2		BA244	0.78
AN250	2.95	LM330N	1.00	SN78227N	1.08	TAA821	3.95	TDA1000A		UPC1000H	2.75	BA301	0.78
AN252	1.95	LM3808N	2.45	SN78227M	1.08	TAA8205	2.95			UPC1000H	2.95	BA302	0.85
AN254	2.50	LM383T	2.95	SN78533N	1.65	TAA700	1.75	TDA1000A	3.95	UPC1020H	1.95	BA313	0.78
AN271	3.50	LM390N	2.50	SN78533N	1.65	TAA700	1.75	TDA1010	2.15	UPC1020H	1.95	BA316	2.95
AN301	3.95	LM1011	3.15	SN78650N	1.15	TAA930	3.95	TDA1020	2.15	UPC1024H	2.95	BA328	2.95
AN303	2.50	M5155L	2.95	SN78650N	1.15	TAA930	3.95	TDA1035	2.25	UPC1025H	1.95	BA321	6.78
AN313	2.95	M51513L	2.30	STK437	7.95	TAA720	1.00	TDA1035	2.50	UPC1025H	1.95	BAV21	0.30
AN315	2.25	MB131L	1.95	STK014	7.95	SA/SB/TU		TDA1035	2.50	UPC1025H	1.95	BAW62	0.19
AN316	3.95	MB3705	2.50	STK015	8.95	TBA231	1.30	TDA1044	2.18	UPC1025H	1.95	BAW62	0.19
AN331	3.95	MB3712	2.00	STK018	7.95	TBA395	1.50	TDA1170	1.95	UPC1028H	1.95	BAW62	0.19
AN342	2.95	MB3756	2.50	STK025	11.95	TBA396	0.75	TDA1180	2.18	UPC1028H	1.95	BB1205B	0.90
AN362L	2.50	MC1307P	1.00	STK032	7.95	TBA440N	2.50	TDA1270Q		UPC1032H	1.95	BT151	7.99
AN512	2.18	MC1310P	1.95	STK078	11.95	TBA480A	1.25	TDA1327	3.95	UPC1158H	1.50	BY126	0.10
AN536Z	1.95	MC1327	1.70	STK085	9.95	TBA510	2.50	TDA1327	3.95	UPC1158H	1.50	BY127	0.11
AN7140	3.50	MC1327Q	0.95	STK415	7.95	TBA510Q	2.50	TDA20002	1.95	UPC1167C2	0.75	BY133	0.15
AN7145	3.50	MC1349P	1.78	STK433	8.95	TBA520	1.10	TDA20002	1.95	UPC1167C2	0.75	BY164	0.48
AN7145M	3.50	MC1350P	1.75	STK435	7.95	TBA520C	1.10	TDA2010	1.95	UPC1181H	1.95	BT176	1.20
AN7150	2.95	MC1351P	1.75	STK437	7.95	TBA530	1.10	TDA2020	2.95	UPC1181H	1.95	BY182	0.58
AN7151	2.50	MC1357	2.35	STK461	11.50	TBA540Q	1.38	TDA2020	2.95	UPC1182H	2.25	BY184	0.35
AS21	3.45	MS1358	1.58	STK463	11.50	TBA540Q	1.38	TDA2150	2.80	UPC1182H	2.25	BY187	0.45
CA1352E	1.75	MC1495	3.00	STK0015	7.95	TBA550Q	1.95	TDA2150	2.80	UPC1185H	1.95	BY199	0.40
CA3086	0.46	MC1723	0.50	STK0029	7.95	TBA560C	1.45	TDA2160	2.95	UPC1185H	1.95	BY208	0.14
CA3123E	1.95	MC3357	2.75	STK0039	7.95	TBA560C	1.45	TDA2252	1.95	UPC1191V	2.95	BY208-800	0.33
CA3131EM	2.50	MC3401L	2.50	STK072	7.95	TBA651R	2.48	TDA2530	1.95	UPC1350C	2.95	BY223	0.90
CA3140S	2.50	MC4106P	2.95	TA7073	3.50	TBA673	1.95	TDA2530	1.95	UPC1353C	2.95	BY298-400	0.22
CA3140T	1.15	MC4518CP	7.50	TA7108P	1.50	TBA720A	2.48	TDA2541	2.18	UPC1363C	2.45	BY299-800	0.22
CA3140T	2.50	MC4518CP	7.50	TA7120P	1.85	TBA750	2.95	TDA2560	2.18	UPC1363C	2.95	BY299-800	0.22
ETT610	2.00	ML231B	1.75	TA7120P	1.85	TBA750Q	2.95	TDA2571	2.95	UPC2000H	1.95	BYX10	6.50
HA1137W	1.95	ML232B	1.75	TA7137P	1.50	TBA810AS	0.85	TDA2581	2.95	UPD2114L	2.90	BYX26-600	1.28
HA1159W	1.80	ML239	2.95	TA7146P	1.50	TBA810P	1.85	TDA2581	2.95				
HA130E	1.95	MSM5807	5.75	TA7176A	2.95	TBA820M	0.78	TDA2610	2.50				
HA1322	2.95	MSM5807	5.75	TA7193P	3.95	TBA820M	0.78	TDA2610	2.50				
HA1339A	2.95	SA11251	7.28	TA7202	2.95	TBA820M	0.78	TDA2610	2.50				
HA1366W	2.75	SA11251	7.28	TA7204P	1.95	TBA820M	0.78	TDA2610	2.50				
HA1377	3.50	SA11251	7.28	TA7205AP	1.15	TBA820M	0.78	TDA2610	2.50				
HA1406	1.95	SAAS510	5.35	TA7206	1.95	TBA820M	0.78	TDA2610	2.50				
HA1551	2.95	SAAS510	5.35	TA7222AP	4.25	TBA820M	0.78	TDA2610	2.50				
LA1201	1.95	SAB3210	3.50	TA7227P	4.25	TBA820M	0.78	TDA2610	2.50				
LA1230	1.95	SAB3210	3.50	TA7272P	4.25	TBA820M	0.78	TDA2610	2.50				
LA3201	0.95	SAB3508	1.78	TA7272P	4.25	TBA820M	0.78	TDA2610	2.50				
LA4101	0.95	SA580	2.65	TA7272P	4.25	TBA820M	0.78	TDA2610	2.50				
LA4102	2.95	SAB590	2.75	TA7272P	4.25	TBA820M	0.78	TDA2610	2.50				
LA4140	3.95	SL901B	7.95	TA7310P	1.80	TBA820M	0.78	TDA2610	2.50				
LA4031P	1.95	SL917B	6.95	TA7313AP	2.95	TBA820M	0.78	TDA2610	2.50				
LA4400	3.50	SL1310	1.80	TA7314P	2.95	TBA820M	0.78	TDA2610	2.50				
LA4420	2.50	SL1327	1.10	TA7321P	2.25	TBA820M	0.78	TDA2610	2.50				

### SEMICONDUCTORS

AA12	0.25	BC182B	0.10	BD237	0.40	BF493	0.38	MRF453	17.50	TV106	1.50
AC126	0.48	BC181	0.10	BD242	0.85	BF595	0.28	MRF454	26.50	TV106/2	1.50
AC127	0.32	BC184B	0.09	BD246	0.75	BF597	0.25	MRF455	17.50	ZRF012	16.50
AC128K	0.20	BC184B	0.09	BD276	0.32	BF838	0.25	RF012	2.90		
AC141	0.38	BC207B	0.25	BD410	0.85	BF881	0.25	RCF147	14.95	2N1308	1.18
AC141K	0.24	BC208B	0.25	BD434	0.85	BF882	0.25	OC18W	2.50	2N1711	0.30
AC142K	0.45	BC212	0.09	BD436	0.48	BF890	1.80	OC25	1.50	2N2626	0.85
AC176	0.22	BC212L	0.09	BD437	0.75	BF981	1.75	OC26	1.50	2N2905	0.40
AC176K	0.31	BC213	0.09	BD438	0.75	BF982	0.28	OC28	1.50	2N3053	0.40
AC187	0.26	BC213L	0.09	BD510	0.95	BF983	0.35	OC29	1.50	2N3054	0.40
AC187K	0.26	BC254	0.18	BD516	0.75	BF984	0.25	OC32	1.50	2N3055	0.52
AC188	0.25	BC214C	0.09	BD520	0.65	BF985	0.25	OC32	1.50	2N3055	0.52
AC188K	0.38	BC214L	0.09	BD524	0.48	BF986	0.25	OC44	1.25	2N3703	0.12
AD142	2.50	BC237B	0.18	BD535	0.45	BF986	0.25	OC44	1.25	2N3703	0.12
AD143	2.50	BC238	0.18	BD538	0.45	BF986	0.25	OC44	1.25	2N3703	0.12
AD149	0.70	BC239	0.18	BD575	0.95	BF987	0.25	OC71	0.75	2N3706	0.12
AD151	0.50	BC251A	0.18	BD587	0.95	BF988	0.25	OC72	2.50	2N3708	0.12
AD152	0.50	BC252A	0.18	BD588	0.95	BF988	0.25	OC72	2.50	2N3708	0.12
AF106	0.50	BC254	0.25	BD597	0.95	BF986	0.25	OC81	1.50	2N3773	2.75
AF114	1.95	BC258A	0.38	BD695	1.80	BF986	0.25	OC84	1.50	2N3792	1.38
AF121	0.60	BC284	0.30	BD698	1.50	BF986	0.25	OC139	12.50	2N4427	1.95
AF124	0.65	BC300	0.30	BD701	1.25	BF986	0.25	OC171	4.50	2N4444	1.18
AF125	0.35	BC301	0.30	BD702	1.25	BF986	0.25	OC200	4.50	2N5294	0.42
AF126	0.85	BC303	0.28	BD707	0.90	BF986	0.25	OC201	5.50	2N5296	0.48
AF127	0.65	BC307B	0.09	BDX32	1.50	BL48	1.75	OC208	10.00	2N5298	0.50
AF139	0.40	BC328	0.18	BDX53B	1.65	BR100	0.48	R2008B	2.25	2N5485	0.48
AF150	0.60	BC328	0.18	BF115	0.38	BR101	0.48	R2009	2.50	2N5496	0.95
AF178	1.95	BC337	0.10	BF119	0.65	BR103	0.55	R2010B	1.48	2SA329	0.95
AF239	0.42	BC338	0.09	BF127	0.39	BR303	0.95	R2322	0.58	2SA715	0.55
AU106	0.95	BC347A	0.13	BF154	0.20	BRC4443	1.18	R2323	0.48	2SC495	0.80
AY102	2.95	BC461	0.35	BF177	0.38	BR939	0.48	R2540	2.48	2SC496	0.80
BC107A	0.11	BC478	0.20	BF160	0.27	BSW64	0.98	RCA16029	0.85	2SC784	0.78
BC107B	0.10	BC527	0.20	BF170	0.22	BSX80	1.28	RCA16039	0.85	2SC785	0.78
BC108	0.10	BC548	0.10	BF178	0.22	BT100A/02		RCA16181	0.85	2SC789	0.78
BC109	0.12	BC549A	0.10	BF179	0.34	BT106	1.49	RCA16334	0.90	2SC931D	0.95
BC109B	0.12	BC550	0.14	BF180	0.29	BT116	1.20	RCA16372	0.85	2SC1034	0.50
BC109C	0.12	BC557	0.08	BF181	0.29	BT119	1.18	S2060D	0.95	2SC1096	0.80
BC114A	0.09	BC558	0.10	BF182	0.29	BT120	1.85	SKE5F	1.48	2SC1106	2.50
BC115	0.95	BC639/10	0.30	BF183	0.29	BU105	1.95	T6021V	0.48	2SC1124	0.95
BC116A	0.50	BCY33A	19.80	BF184	0.35	BU108	1.95	T6027V	0.48	2SC1162	0.95
BC117	0.19	BD124P	0.80	BF185	0.28	BU124	1.25	T6029V	0.48	2SC1172	2.20
BC119	0.24	BD131	0.42	BF194	6.11	BU125	1.25	T6036V	0.55	2SC1173	1.18
BC125	0.25	BD132	0.42	BF195	0.11	BU126	1.60	T9002V	0.55	2SC1307	2.95
BC139B/C	0.20	BD133	0.40	BF197	0.11	BU204	1.55	T9011V	0.75	2SC1364	0.50
BC140	0.31	BD135	0.30	BF198	0.16	BU205	1.3				

# SECOND-HAND

BY HUGH ALLISON G3XSE

Well-made variable capacitors with a swing of say, 30 to 300pf, plus wide spacing between plates, are desirable objects for anyone contemplating a high frequency aerial tuning unit (HF ATU). The plates need the wide spacing if you are going to transmit through them, because of the high voltages involved.  $P = V^2/R$ . Thus 100 watts into 50 ohms means we are talking 70 volts, but let the aerial impedance go up to, say, 300 ohms and we are talking 175 volts.

There are some really weird variables on the surplus market at the moment. I've no idea where they are coming from (I didn't see them at any trade auctions, for example). They are weird because they have a cam on the non-shaft end of the rotating bit. The effect of the cam is to reduce the spacing between the plates as the capacitance increases. I have no idea why this was done. The only theory that has come out of informal seminars held at traders' stalls amongst people in the crowd is that it was done to linearise the rotation/tuning ratio. True, this may well happen, but why not make them of the old fashioned 'snail shell' outline, which did the same job?

The good news is that these capacitors sell cheaply, brand new and boxed they seem to fetch £8 to £10. This may not seem cheap to you if you are thinking along the lines of 'great, but it will arc over at high capacitance values', however, it is not a lot of trouble to remove the cam and bung in a washer or two. I've also met one guy who filed the profile off the cam. It's worth thinking about!

## Talking of building ATUs

Another unusual item for ATUs was seen on a trader's stand at the Leeds rally, and on other tables at other rallies since. These were massive roller coasters, like, *big man*. The coil was eighteen inches long and nigh on six inches in diameter, and all in heavy silver plate too. The mechanical drive came in via a bevel gear system from the input shaft so, unusually, the shaft was at right angles to the coil. I promise you, if you can arc over one of these roller coasters you are really running some urge! At £14, these mechanical delights are seriously underpriced. Couple one of these with a pair of the 'funny' variable capacitors above (suitably modified) and you have an ATU that will deal with any power level and last a lifetime for a very reasonable thirty quid or so.

## Rally prices

In response to several recent queries which I have received, the following table is a rough and ready guide to the price of a basic six foot table at some assorted amateur radio rallies.

Leeds (White Rose)	£12.50
East Suffolk (revival)	£10
Brighton (with early payment discount)	£11.25
Anglian (Colchester)	£5
Drayton Manor (MARS)	£20
BATC (Crick)	£18
Spalding	£9
Doncaster	£10
Bury (Manchester)	£9

## There's this funny smell . . .

So says a 'friend' standing at the door with a scope in his hands. As he recounts his tale of woe about how the EHT voltage multiplier chain had blown its last rectifier, I'm busy plugging it in and turning it on. Sure enough an overpowering whiff of ozone comes out. The hapless owner goes on to say that he had changed the said rectifier and had run the scope up, covers off, with no trouble at all. He had then put on the covers, whereupon the smell had appeared, plus a fizzing noise.

Our hero now made an almost literally fatal mistake; with the cover off, in a darkened room and with the scope on, he tried to put the cover on whilst looking for the source of the smell and noise. As he got the cover about half an inch from the scope, *crack*, the EHT arced over to the cover he was holding and gave him the mother and father of electric shocks, causing him to say 'oh bother' or similar. His next move was to bring it round to me.

I explained that if he is going to work on EHT power supplies whilst they are on, he must at least earth the cover with a decent earth strap before holding it. I then had a look at the rectifier he had changed. Who had fitted the new rectifier and left a bit of its lead-out wire sticking out of the joint? This was causing a corona. It just took a few minutes to cut an eighth of an inch off the lead-out and re-flow the joint so that there was a good smooth ball of solder there. End of problem.

On the subject of scope EHT power supplies, I've had a spate of incorrectly repaired ones where the owner had simply changed one fault for another. Quite a lot of scopes have something like a 2N3054 in a free-running, transformer-coupled oscillator. As well as the feedback winding there is a high voltage (and hence high impedance) winding that goes to the voltage multiplier. The rectifiers in the chain are selenium or similar old technology stuff. Incidentally, these can be impossible to measure on an Avo as there are often dozens of diodes inside, all in series, say half a volt or so drop across each, and your 15V battery in the Avo on ohms is insufficient

to bias them. The only way to check out the chain is to carefully work your way up it with a well-insulated probe and a voltage multiplier on the Avo, or a dedicated electrostatic voltmeter. Remember that the capacitors down to earth in the chain are far more likely to go a short than the rectifiers. These capacitors are not a lot of pfs, often only 500pf.

What often happens is that, if the rectifier goes, the owner fishes around and fits a silicon 25kV diode from, maybe, a colour telly as a replacement. The EHT still doesn't work, the reason being that the afore-mentioned selenium 'stick' rectifiers are high impedance even when on. Wop in a silicon low impedance job and the free running oscillator will not start up, 'cos it loads it too much. The trick is either to fit a massively overrated silicon diode - say 45kV - or three or four ex-telly 25kV ones, in series. In either case you now have lots of silicon diodes in series (a 45kV diode probably has several lower voltage ones, in series, inside it, a 25kV one, two or three). This is now of high enough impedance to allow the oscillator to start and run. Personally I prefer to use one 45kV job rather than two or three lower voltage ones in series, since the joints cause a corona. Isn't this where we came in?

## RTTY to television converter

This is a Microwave modules box of tricks that goes between the speaker of your receiver and a television (or monitor) and allows reception of RTTY. Sure you can make your beloved home computer do this nowadays, and this has probably forced down the second-hand price of the Microwave Modules box; more of this in a moment. The big, big advantage of the MM box is just that, its box. The thing is contained within the larger flavoured die-cast box and the screening is excellent. Side by side in the shack, connected to a TS830S, the Microwave Modules converter chucked out about an 'S' point of noise on 14.080MHz, a programmed for RTTY Sinclair spectrum (early 48K job) chucked out an S8 signal. The MM box was able to resolve many more stations, and does it well too.

The MM box allows a vast range of RTTY 'speeds' (rates to its followers), unfortunately not automatically selected, but it does work well. I had a lot of fun around 10MHz with it, reading about what would be in tomorrow's papers etc, as well as reading amateur traffic.

Price-wise the converter used to hold its value well, about the ton, this seems recently to have fallen to about half that, say fifty or sixty quid. I would certainly recommend one to any listener who wanted to have a dabble.



# STRAIGHT & LEVEL

## RAYCOM'S ROYAL 1300

The Royal 1300 antenna now manufactured in Birmingham on behalf of Raycom is a copy of an original Japanese design, but having improved features such as Military Specification UR67/RG213U Coaxial cable and Military Specification 'Greenpar' N connectors. As a vertical Transmit/Receive antenna for the 2m, 70cm, and 23cm bands, it is ideal for general monitoring and FM operation. The Royal 1300 is also supplied with 15m of coaxial cable and two N type connectors. It costs £59.95 (including VAT).

For further information write to: **RAYCOM Systems Ltd, International House, 963 Wolverhampton Rd, Oldbury, Warley, West Midlands B69 4RJ.**

## MINIATURE ENCLOSED RELAYS

STC Electronic Services has introduced the PED Series 15 relay for ac or dc operation. These miniature enclosed plug-in relays feature single, double or 4-pole changeover contacts which are suitable for switching resistive loads up to 16A, 250V ac or 24V dc (single); 10A, 250V ac or 24V dc (2-pole); and 5A, 240V ac or 24V dc (4-pole).

Typical contact switching time including bounce is 9ms for operate and 8ms (ac) or 4ms (dc) for release. Offering a mechanical life of  $20 \times 10^6$  operations (minimum) and an electrical life expectancy of 100,000 operations at the maximum rated load, standard devices are available in 12V dc, 24V dc, 110V ac and 240V ac versions.

Mounting is via a clip and socket assembly for plug-in connection.

For further details, contact: **The Relay Group, STC Electronic Services, Edinburgh Way, Harlow, Essex CM20 2DF. Tel: (0279) 26777.**

## MASS TERMINATION ASSEMBLIES

Mass termination assemblies (MTAs) are complete PCB interconnection systems,

now available from STC Electronic Services.

They dispense with the need for wire stripping and crimp height control, allow a variety of wire sizes and types to be terminated in a single step and offer a reduction in labour of between 50-95%, depending on the application.

Housed in 94V2-rated thermoplastic polyester with a contact pitch of 0.100in and 0.156in and an operational current rating of 4A, the system is colour coded by wire size.

The MTA 100 Series accepts wires from 28 to 22AWG whilst the MTA 156 Series accommodates 26 to 18AWG. Headers are available in straight or right-angled versions, with or without friction lock and polarisation. Mating is possible with all available 0.100in-post header assemblies.

For further details, contact: **The Connector Group, STC Electronic Services, Edinburgh Way, Harlow, Essex CM20 2DF. Tel: (0279) 626777.**

## MORE THAN 20MHz

Available from ECW (Electronic and Computer Workshop), the 20MHz 3031 single trace oscilloscope allows in or out of circuit testing of FET, bipolar and zener active devices and of passives such as capacitors and inductors. This extends the range of applications far beyond that of a normal oscilloscope.

The input sensitivity is 2mV/div up to 10V/div, in 12 switched steps. Rise time is 17ns. The timebase is adjustable from 40ns/div to 0.2s/div and the trigger circuit can operate with signals of up to 25MHz. Its dimensions are 240 x 317 x 125mm, it has a clear 9.5cm rectangular CRT display and costs £199 (excluding VAT) or £242.65 mail order (including VAT and post/packing).

Further details can be obtained from: **Electronic and Computer Workshop Ltd, Unit 1, Cromwell Centre, Stepfield, Witham, Essex CM8 3TH. Tel: (0376) 517413.**

## DIALOGUE SUPERVISOR

Now available from Dialogue is a new family of supervisory circuits to reduce the complexity and component count of microprocessors which monitor power supplies and batteries.

Four devices are available: the Maxim MAX690, 691, 692 and 693. All feature a precision voltage monitor with pretrimmed voltages of 4.65V (690/691) or 4.40V (692/693). They are offered in 8-pin (690/692) or 16-pin (691/693) packages.

The main device functions are a reset output during power up/down and brownout conditions; battery back-up switching for low power logic; a reset pulse if the optional watchdog timer has not been toggled within a specified time; and a 1.25V threshold detector for power fail, low battery or power supply monitoring other than +5V.

Additional features offered by the 691/693 include write protection of a CMOS RAM or EPROM; adjustable reset and watchdog time-out periods; separate outputs for indicating a watchdog time-out, back-up battery switchover and low  $V_{cc}$ ; and on-board gating of chip enable signals.

For further details, contact: **Dialogue Distribution Ltd, Wicat House, 403 London Road, Camberley, Surrey GU15 3HL. Tel: (0276) 682001.**

## SCANNERS 2

by P Rouse

This sequel to Peter's original book, *Scanners 1*, fulfils a basic need for an all-embracing guide for scanner users.

*Scanners 1* acted as an introductory text for those new to the hobby, explaining the basics of scanning and giving extremely useful and comprehensive frequency lists.

This new book is aimed at those who have a little more technical knowledge - for instance, there is a section on homebrew equipment which should interest the soldering-iron fan.

Despite the additional

# All the latest news, views, comment and developments on the amateur radio scene

technical examinations the book is written in the same no-nonsense, understandable style that made the first volume so popular. Anyone who has read *Scanners 1* will enjoy this further amplification of the ins and outs of the subject.

To give some idea of the contents, frequency lists for the US are given, aircraft call signs and prefixes, amateur radio prefixes, marine channel allocations and ITU Regional allocations. Fault-finding tips are given, computer interfacing is examined with programs included, and various projects for the construction enthusiast are detailed.

Argus Books Ltd, £9.95. ISBN 0 85242 924 X

## BENCH POWER SUPPLY

Instrumex has made available the Thurlby LB series of low cost, general-purpose laboratory bench power supplies.

Voltage and current levels are set using rotary switches, providing a rapid and accurate means of setting the output. Calibrated vernier controls provide infinite adjustment of voltage and current between each switch setting. Also provided is an output range switch, which allows the user to select a higher maximum output current when using lower output voltages.

The LB series operates in constant voltage or constant current mode with automatic crossover. LED indicators show the operation mode and provide an easy means for measuring the load current.

The LB series has a line stability of less than 0.01% of the maximum output for a 10% line change, a load regulation of less than 0.01% of the maximum output for a 90% line change and ripple and noise levels of less than 1mV/1mA. The design is totally protected against overload conditions. Fully isolated outputs are provided with a maximum voltage between outputs and ground of 300V.

The LB series of laboratory bench power supplies weighs just 3.6kg and measures 155 x 175 x 235mm.

For further information, contact: *Instrumex Ltd, Dorcan House, Meadfield Road, Langley, Berks SL3 8AL. Tel: (0753) 44878.*

## UK LISTENERS' CONFIDENTIAL FREQUENCY LIST

Another regular and popular book, currently in its fifth edition and completely revised.

Layout and presentation have been improved considerably, though the special A4 format is retained by popular demand.

All sorts of interesting frequencies are included and, as the title suggests, some of them are faintly naughty and really, you're not supposed to listen to them. At least, that's what they say...

Indispensable for the SWL, this is a frequency guide pure and simple and the frequencies included have been selected because there is enough detail on the stations (and interest among the readership) to warrant inclusion.

Broadcast stations are featured again, though the numbers are restricted to those which are well-received in the UK. This isn't intended to be an exhaustive guide but it's certainly an interesting one and at £6.95 it's definitely worth having.

Waters and Stanton, £6.95 plus £1 p+p. ISBN 0 9512729 34

## PRACTICAL MIDI HANDBOOK

by R A Penfold

Yes, R A Penfold does it again, this time with PC Publishing - a determined new company that is producing a laudable stream of extremely useful and interesting texts for the radio and electronics enthusiasts.

MIDI stands for musical instrument digital interface, and this book sets out to explore the vast potential of this field. MIDI is a technical subject, so musicians can be

deterred from utilising its flexible and fascinating possibilities.

This book should alter the situation, as it's aimed at the baffled musician who is faced by the mysteries of electronics and computing. All of the basics are detailed, with an emphasis on practical aspects, such as how to interconnect the systems.

This user-friendly text is hot off the press and promises a warm welcome to those who want to conquer the amazing world of digitally-produced music.

PC Publishing, £5.95. ISBN 1 870775 10 4

## PRACTICAL INTRODUCTION TO MICROPROCESSORS

Various microprocessor modules are now available from manufacturers of teaching equipment, but circuit diagrams are also included in an appendix to this text.

The 6802 microprocessor is the basic module examined and, of course, this is ideal for basic experimental work due to its internal clock circuitry and built-in 128 bytes of RAM.

A systems approach to learning is adopted, emphasising the behaviour of the units as functioning blocks rather than details of the devices concerned.

The advantage of this approach in a fast-changing field is obvious - devices change internally very swiftly, but the function itself remains important. As will this book!

Longman Publishing, £8.95. ISBN 0 582 00611 2

## INTRODUCING DIGITAL AUDIO

Another PC Publishing text, this book is again involved with digital music reproduction.

As CD players are currently enjoying a huge upsurge of popular interest, doubtless those amateurs who have already explored audio circuitry would like to find out more about this system and

DAT (digital audio tape).

This book fills the knowledge gap for the technician and amateur, looking at principles and methods rather than the mathematics behind the processes.

This is a fascinating and very readable book, echoing the pragmatic values of the publishers. It is sensitive to the needs of the technically-minded but basically amateur enthusiast, and one can only applaud this series of books.

To find out more about current texts, contact PC Publishing, 22 Clifton Road, London N3 2AR.

PC Publishing, £5.95. ISBN 1 870775 05 8

## ERRATUM

In last month's issue of *Amateur Radio*, we inadvertently reviewed the wrong issue of the *World Radio Handbook*. The 1988 edition is published by Pitman Publishing, 128 Long Acre, London. We apologise to Mr Aleck Kitching, the International Marketing Director of Pitman Publishing, for any embarrassment caused.

## RF CHOKES

Please note the following corrections to the 'Practical single-layer RF chokes' article in the June edition of *Amateur Radio*.

Page 33 First column

Line 6:

" $3\frac{3}{16}$ " should read " $\frac{3}{16}$ ".

Para 5:

$C_s = 0.3a + 1.4r$  (a and r in inches)  
and  $C_s = 0.0118a + 0.055r$  (a and r in mm)

Para 6: formula should read:

$$L = \frac{25330}{(f_{res})^2 \times C_s}$$

$C_s$  is in pF

Line 3: second column:

delete the whole line

"and so  $\frac{a}{r} = \frac{3}{0.25} = 12$ "

Para 4 third column:

Add at end of 4,

"and so  $\frac{a}{r} = \frac{3}{0.25} = 12$ "



# Radio Wave Propagation

by Alan Malcher G4TPM

When I first became a radio amateur, I held the callsign G6OFF and was a keen 2m operator. I could regularly be heard calling CQ DX on the SSB portion of the 2m band in the early hours of the morning. 'One more CQ call and I'll go to bed,' I would tell myself. Two hours later, still no reply. I used to wonder whether I was the only radio amateur foolish enough to stay awake at this unearthly hour, or perhaps it was my rig that was at fault. Then, suddenly, the band would burst into life with Continental stations all calling CQ DX. The lift had begun.

Radio wave propagation can be a fascinating subject. A basic understanding can prove to be of enormous benefit to both radio amateurs and short wave listeners alike. Although this article covers certain aspects studied for the RAE examination, I make no apology since many short wave listeners and individuals studying for the RAE may find it clarifies the subject further.

Before we discuss propagation, we must first understand how radio waves behave under normal atmospheric conditions. So, let us first look at VHF/UHF and microwave propagation.

## VHF/UHF/microwave

These radio waves behave entirely differently from their high frequency counterparts. Radio waves (radio magnetic radiation) that fall within this area of the radio spectrum move horizontally to the face of the earth. Their horizontal movement causes them to quickly decay when reaching the horizon (Figure 1).

The rapid decay makes it necessary to erect antennas as high as possible when operating on the 2m and 70cm bands. Professional engineers often refer to these frequencies as line of site, due to their limited range. However, as you will learn later, this statement is not always true.

## Tropospheric ducting

This phenomenon is a regular cause of 'over the horizon' signal enhancement but, unfortunately, this form of disturbance is short-lived. Cooling of the earth's surface after a warm to hot day causes radio waves to skim across the surface like a flat stone skimming across a still pond. This can result in radio waves travelling up to approximately one to 200 miles with relatively good signal strengths. The earth expels the warm air very quickly, thus a contact under these conditions can suddenly be lost without any prior warning.

The serious VHF operator who is equipped with even a modest-sized directional antenna is advised to note any directions in which he thinks this

form of propagation is present. Eventually, after careful monitoring over a period of months, it will be possible to beam in the directions in which this tropospheric ducting is known to occur. The strength of the ducting is dependent on the terrain, as well as the weather conditions, so it goes without saying that certain areas are more susceptible to this form of propagation than others.

When I lived in Middlesex, I noted that on several occasions, I was able to work into Cornwall by what appeared to be ducting. Following my own guidelines, I made a note of the direction, weather conditions and signal strengths and, using the information, I was able to continue working into Cornwall and the surrounding areas on regular occasions. This is not a foolproof method of obtaining long distance contacts but it should be regarded as just an aid for judging the conditions.

## Sporadic E Ionisation

This, to my mind, is the most exciting form of propagation. Under good conditions an opening of this type can truly provide DX performance from mobile stations and stations running low power with simple antennas. It is not unknown for sporadic E to provide a communications path over thousands of miles. Although I cannot claim to be one of the fortunate few who have achieved this, I have worked into southern Spain whilst running 10W and using a collinear antenna situated approximately 20ft above the ground, experiencing signal

strengths of 5/9 plus 20dB both ways. This was all achieved on FM.

Sporadic E consists of sheets of ionised particles that reflect radio waves. These sheets may be small, isolated regions or may cover thousands of miles. They can form over either land or sea due to the fact that they are random in nature, ie they can form anywhere. It is not possible to predict just where these ionised sheets will form. However, given the necessary information, and making observations which will be discussed later, it is possible to predict when conditions are suitable for the formation of such sheets and a rough indication of their possible size.

## Finding the openings

Having collated the information necessary to predict whether ionisation might be present, how do you find out the whereabouts of the sheets (referred to as openings), bearing in mind their random nature? A lot of the time, needless to say, we find the openings purely by accident. Many times I have tuned around the 2m and 70cm band and suddenly found a mobile Continental station. That has been the first indication that conditions were good. However, to save tuning right through the band whilst turning your beam through all points of the compass, the following procedure is recommended.

Buy a small notebook and note the types of propagation and meteorological conditions required for that form of 'over the horizon' signal enhancement. When you ascertain that conditions are suitable for sporadic E, say, tune into and beam towards the beacons listed in the many RSGB publications.

Numerous radio beacons are located within the UK and on the Continent, which automatically transmit their call-signs at slow speed in CW, followed by RTTY. It might be interesting to note that as this CW transmitted from a beacon is

**Fig 1:** 1 - Escape wave; its frequency is too high to be reflected by the ionosphere and is lost in space. 2 - Normal one skip to receiving station (see figure 2). 3 - Ground wave which decays once it reaches the horizon. NB. Although Station B is near to Station A, it will not be able to receive that station's transmission because it is located within the skip zone.

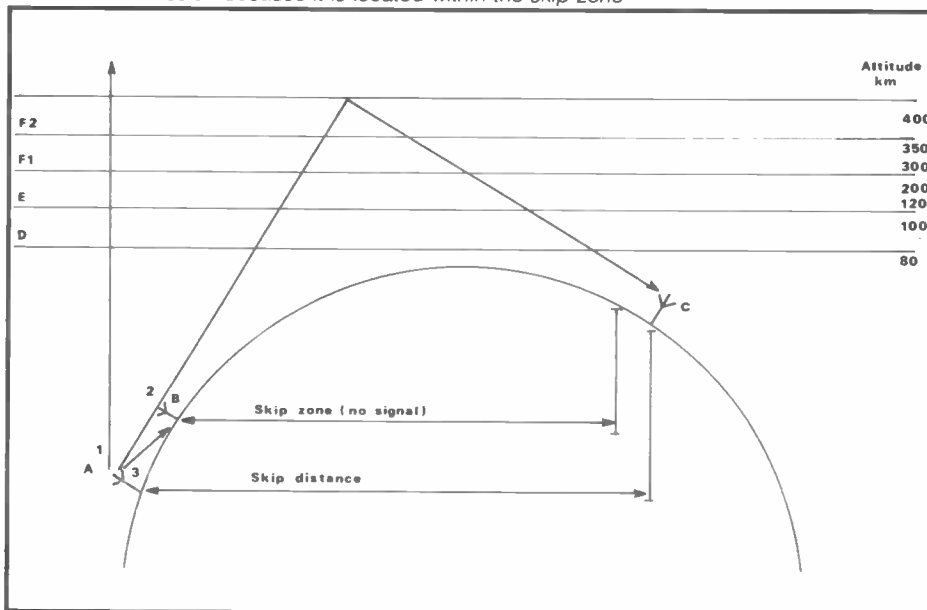

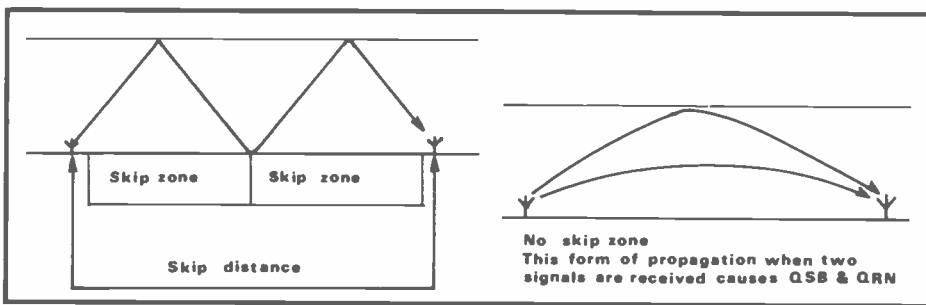

**Fig 2**

automatic (ie produced by logic circuits), this will be perfect Morse that your home computer or CW decoder should have no problem decoding. Unfortunately, the beacon frequencies, callsigns and locations are too numerous to be included in this article and users are advised to purchase a current list from the RSGB and, of course, keep the list next to the notes on propagation.

**Solar activity**

There is always a lot of talk among radio enthusiasts about solar activity. Unfortunately, there are also a lot of myths and misunderstandings. It's true to say that the sun plays an important role when it comes to radio communications and affects all of the radio spectrum. Let us look, therefore, at those solar activities which contribute so much to every-day communications.

Sunspots are mentioned quite often, so I think it would be a good idea to discuss them first and then move on to other related activities. A sunspot can be described as any temporarily cooler region appearing from time to time as a dark spot on the sun. 'Time to time' here means a 28-day cycle, with the sunspot cycle reaching maximum activity every eleven years.

The study of solar activity can be a complicated affair. For the purpose of this article, it is only necessary to say that sunspot activity is associated with increased ionisation within the lower atmosphere around the earth's surface. Solar flares can be detected as a large flame extending many miles from the solar surface. These flares emit high intensity protons, argon, nuclear charged oxygen and other gases that are collectively referred to as a solar wind. This solar wind eventually reaches the earth's atmosphere and ionises its layers. The degree of ionisation is dependent upon the magnitude of the solar wind.

These solar disturbances are repeated approximately every 28 days and rise to a climax every 11 years. Since the sun has a gaseous structure, its rotation varies in speed. For this reason, the time scale for solar disturbances should be treated only as a guide. Unlike the earth's rotation of one revolution every 24 hours, the sun's rotation cannot accurately be used to determine a time scale.

**High frequency**

The high frequency band, often referred to as short wave, consists of electromagnetic waves that behave entirely differently from their UHF/VHF

counterparts. These waves travel horizontally from the transmitting aerial until they hit an ionised layer within the outermost region of the earth's atmosphere. These ionised particles reflect the wave back towards the earth's surface, resulting in the signal (radio wave) travelling thousands of miles away from where it originated. This can occur several times, thus enabling the signal to be received anywhere in the world.

With this form of propagation, it is possible that a station could be received in, say, Australia but another radio amateur or short wave listener located a few miles from the originating station receives strong signals from Australia but cannot hear the originating station. This is depicted in Figure 3. Radio wave B, the transmitted signal, does not fall anywhere near station C although, in reality, with most HF signals there will be a very small amount of ground wave associated with the signal. A ground wave can be considered as a very weak signal that behaves like a VHF signal but decays much more quickly.

**SIDs and MUFs**

SIDs, sudden ionospheric disturbances, often occur on the HF bands and can last for a matter of hours or a few days. SIDs affect the earth's reflective layers and stop all propagation by these layers. In severe cases, this results in bands being completely dead, although some very local contacts may be obtained via ground wave. Only one band may be affected but, very occasionally,

all bands can be either severely degraded or closed.

SIDs occur when the ionised layers contain too much ionisation and, instead of reflecting the radio wave, absorb and attenuate all radio signals that strike its surface. There will often be one or more bands that are not affected and the highest of these frequencies is referred to as the maximum usable frequency (MUF). For example, if 3.5MHz is the only frequency where reliable communications can be established, the MUF is 3.5MHz.

**Auroras**

Auroras are to be found in the northern hemisphere and are large layers of ionised particles within the troposphere (Figure 4). These also reflect VHF signals and surprising results have been obtained on the 2m band. Just 10 watts of power and a small directional antenna can produce good DX contacts far into the Continent. Since these auroras take place in the Northern Hemisphere, it goes without saying that you must be beaming to the north for your signal to be reflected. It can appear quite strange to a new operator to be transmitting towards north and working a DX station to the south.

**Ghostly whisper**

Due to the intermittent nature of ionisation, all signals via an aurora result in fluctuation and all speech takes on what can be described as a ghostly whisper. Although the signal quality is poor, signal strengths are normally high. This phenomenon is a regular occurrence especially during the summer months. During these periods, it is advisable to occasionally beam towards the north to see if you can hear any strange sounding signals which may be the result of an aurora.

In an article such as this, it is only possible to scratch the surface of radio wave propagation but I hope that the areas covered will assist you in working DX. So, the only thing left to say is '73s and I'll catch you on the bands'.

**Fig 3:** A - Although here the signal has been reflected from the trail of meteors, the same principle occurs under sporadic E conditions. B - While beaming a signal north towards an aurora, the final direction of your signal cannot be estimated. C - Elevated duct - the signal is lifted over the horizon. D - Surface duct - this occurs as the land surface cools

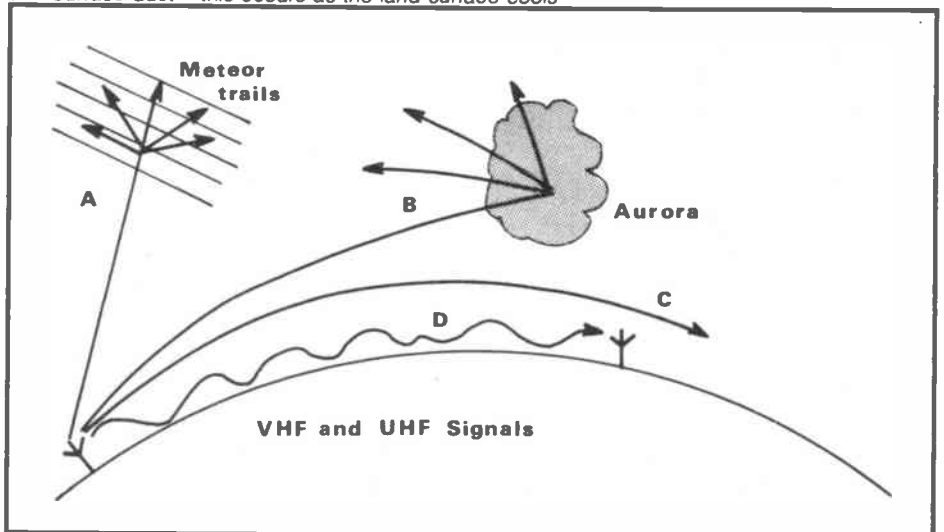

# KW ARGOSY II

**NOW MADE BY KW IN THE UK**



**ARGOSY II** - 100 WATTS SSB/CW MOBILE,  
PORTABLE OR HOME STATION

## CENTURY 22 NOW MADE BY KW IN THE UK

50WATT, 6 BAND CW TRANSCEIVER COMBINING EXCELLENT PERFORMANCE, RELIABILITY, OPERATIONAL SIMPLICITY AND LOW COST

### ALSO FROM KW

THE PARAGON 200W SYNTHESIZED TRANSCEIVER, THE CORSAIR II 200W TRANSCEIVER FRITZEL BALUNS, HF BEAMS & VERTICALS NOW IN STOCK - FROM CUSHCRAFT, BUTTERNUTT, HYGAIN, MFJ PACKET RADIO UNITS AND ATUs ETC HYGAIN ROTATORS, VHF BEAMS & VERTICALS

### KW COMMUNICATIONS LTD

VANGUARD WORKS, JENKINS DALE, CHATHAM, KENT ME4 5RT  
TEL: (0634) 815173 TELEX: 965834

**EPA  
SUPER  
FUND**

## £'s CAN BE YOURS £'s

- GOVERNMENT DICTATES CLEAN UP OF DUMPSITE & ALL WASTE PRODUCERS
- NEW PRODUCT CAN SAVE WASTE GENERATORS MILLIONS OF POUNDS
- FROM THE DRY CLEANERS, PETROL STATION, PAINT SHOP TO BIG DUMP SITE
- HELPS WATER CLEAN UP

### WE SUPPLY:

- TRAINING SCHOOL
- RECOGNISED PRODUCT
- APPROVED TECHNOLOGY
- LABORATORY BACK-UP
- TOTAL ENGINEERING

AREAS ARE LIMITED LEAD SOURCES PROVIDED

GET YOUR PART OF THE \$8,000,000,000 SUPER FUND

INVESTMENT REQUIRED - FINANCING AVAILABLE

## ECOLOGY RECOVERY CO

16787 BEACH BLVD.

HUNTINGTON BEACH, CA 92647 U.S.A.

MR J E RODGERS

- CALL (714) 536 0757 - FAX: (714) 960-9728

## Matmos Ltd

1 Church Street, Cuckfield, West Sussex RH17 5JZ  
Tel: (0444) 414484/454377

## Computer Appreciation

30/31 Northgate, Canterbury, Kent CT1 1BL  
Tel: (0227) 470512

**TA/ROYAL OFFICE MASTER 2000 DAISY WHEEL PRINTERS.** Our purchase of nearly 2000 of these printers direct from West Germany enables us to offer them at enormous savings!

Features include:

- \* 20 cps operation
- \* Full DIABLO 630 and IBM compatibility
- \* CENTRONICS compatible parallel interface
- \* 132 column with variable pitch capability including micro proportional spacing
- \* Subscripts, superscripts, bold type, underline etc.
- \* Manufactured to highest standards (rigid steel chassis etc) in West Germany
- \* 6 month full guarantee
- \* Ribbon & typewheel included
- \* by Europe's largest typewriter manufacturer

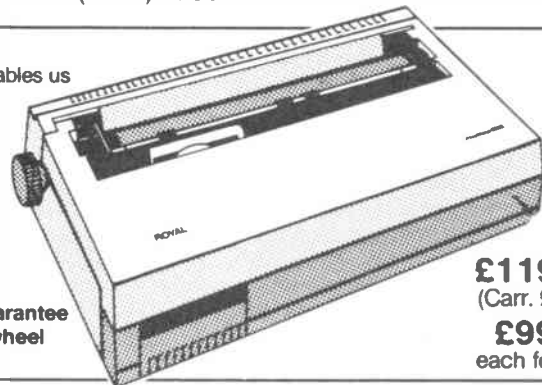

**£119.50**  
(Carr. £5.00)

**£99.50**  
each for 5 +

**PANASONIC Model JU-363 3 1/2" Disc Drives.** Shugart interface, 1/2 height, 1 megabyte double sided double-density 80 track, low component. Will interface to just about anything. (A quantity discount of at least 20% is available for 10 + off).



**£59.50**  
(Carr. £3.00)

**ITT SCRIBE III PROCESSING SYSTEM.** Professional system originally selling at around £6000 without printer. Colour leaflet available.

**SOFTWARE INCLUDES** - DATABASE \* AUTOMATIC LETTER WRITING \* HELP FILES \* BASIC \* PROGRAMMABLE COMMANDS \* MATHS/ ACCOUNTS FUNCTIONS \* FULL EDITING  
**HARDWARE INCLUDES** - 128k SCREEN/ WORKSTATION \* DUAL DSDD SHUGART 5 1/4" DISC DRIVES

**£290.00**

**DUPLEX Model M100 Monochrome Monitors.** With 12" high resolution green screen & composite video input. Equivalent to other models such as ZENITH & PHILIPS.

**£39.50**  
(Carr. £5.00)

**PLESSEY Model T24 V22/V22 bis 1200/2400 Baud MODEM.** Compact automatic modem featuring the latest technology & the highest data rate over the ordinary phone system. Features:

- \* Software available for IBM PC & compatibles & MATMOS PC
  - \* High speed PRESTEL compatibility
  - \* Auto call & auto answer
  - \* New low price
- Now  
£169.00**  
(Carr. £5.00)

**VICTOR SpeedPac 286 IBM PC ACCELERATOR.** Half-wide 80286 accelerator card for IBM PC or PCXT, VICTOR VPC, and compatibles. Features 8KB cache memory & 7.2MHz 80286 processor. Offers AT/Personal Systems 2 performance for a fraction of the cost. Runs up to 7.5 times faster.

**£139.00**

### Please note:

We have only a few 3" HITACHI SSDD drives left at **£24.95**. Cases now available for 3" drives at **£4.99** (single) and **£7.99** (dual). VAT and carriage must be added to all items. New TRANSDATA 307 originate/ answer acoustic couplers available at **£14.95**.

# Building the JB80 Transmitter

by Richard Q Morris G2BZQ

The JB80 is a highly efficient rugged and simple, low power CW 80m transmitter. Because of crystal control, with stabilised HT, plus a buffer stage between CO and PA, it should produce a clean CW performance. The fact that it uses valves and not transistors is of no importance as the target was reliability

JB80 is an acronym for Junk Box 80m Transmitter. It is a low-power, reliable, quality CW Tx which can easily be built by the new, and not-so-new Txer.

Every item used was found in the junk box - ie bits and pieces, many long forgotten, located in various parts of the QTH and garage, having been stored away in boxes and cartons. All these had been accumulated over the years from old gear; components and chassis which had long ago been purchased, or scrounged, because they looked as though they might come in useful some day. How many amateurs, with a junk box, small or large, can remember what is in it? Or remember where something has been carefully stored?

A long-promised 'junk box clean-out' was ruthlessly planned and executed. Needless to say it was abortive in as much as nothing was thrown away, but I realised that there were enough parts to build at least 2 or 3 spare transmitters; plus all kinds of other gear! Well - a spare Tx is a 'must' to keep you on the air, if the first Tx breaks down. Murphy's Law will no doubt ensure that when you have a spare Tx, then the main Tx will never break down anyway!

The JB80 was designed around available components. I had fun building the transmitter and was pleased to see it working.

Many amateurs will have some, if not all of the necessary parts, which are readily available from advertisers of surplus or new components. Other parts can be found by scrounging from old G9JOE down the road.

The circuitry is simple as the JB80 uses valves. They are readily available and can be overrun and abused. If they give up the ghost, you just pull 'em out and plug in a replacement. Valves that were designed during the First World War are still in use, so accordingly, they must be considered reliable and worthy of use.

The JB80 has been assembled into two units of approximately equal size. These are the Tx and the ac power supply. The two units are interconnected with a cable/plug/socket assembly; as a result the ac PU can be used with other Tx's.

However, the circuits and layouts

described can be amalgamated into one self-contained chassis/cabinet as a Tx, complete with integral power unit. Dimensions are shown, but are not critical, and any suitable chassis/cabinet(s) can be used for the project. No real attempt at miniaturisation has been made. The object was reliable and easy to build. An appendix can be found at the end of this article suggesting alternative valves, components and ideas which might be used.

## Circuit description

The JB80 can be used as a 10/12W input Tx. It is used with a 10W input, but seems to be quite happy running at 15W input CW. Conventionally tried circuitry has been used throughout, and signal strength with stability, quality and reliability has been the target. Only one stage - the PA - has a tuning control.

The circuit(s) are shown in Figure 1 (a and b). Each circuit terminates with 4 power connection points A, B, C and D, which have to be joined together. This

valve (V1) (B9A valve base), in a simple Pierce Colpits crystal oscillator. FT243 crystals have been used, however, any other available types are suitable. The crystal socket is mounted on the front panel of the Tx. The CO is fed with a stabilised HT supply of 150 pV. This is a bit of a luxury with a crystal valve type oscillator, but does ensure very clean and stable signals.

The next stage is a buffer amplifier with another EF80 valve (V2). This is an extra stability refinement, giving some extra drive to the PA.

The power amplifier uses a 6BW6 valve (V3) (B9A base) which is rated at 11-12W input according to an old copy of the ARRL handbook. It is supplied with 250/280V HT positive. On the prototype, this is actually 270V. The PA uses a well tried and proven circuit. A conventional Pi-network output tuned circuit is used to match 50-75 coaxial feedline to a suitable antenna.

The PA stage is cathode keyed with suitable key click suppression. A 100mA

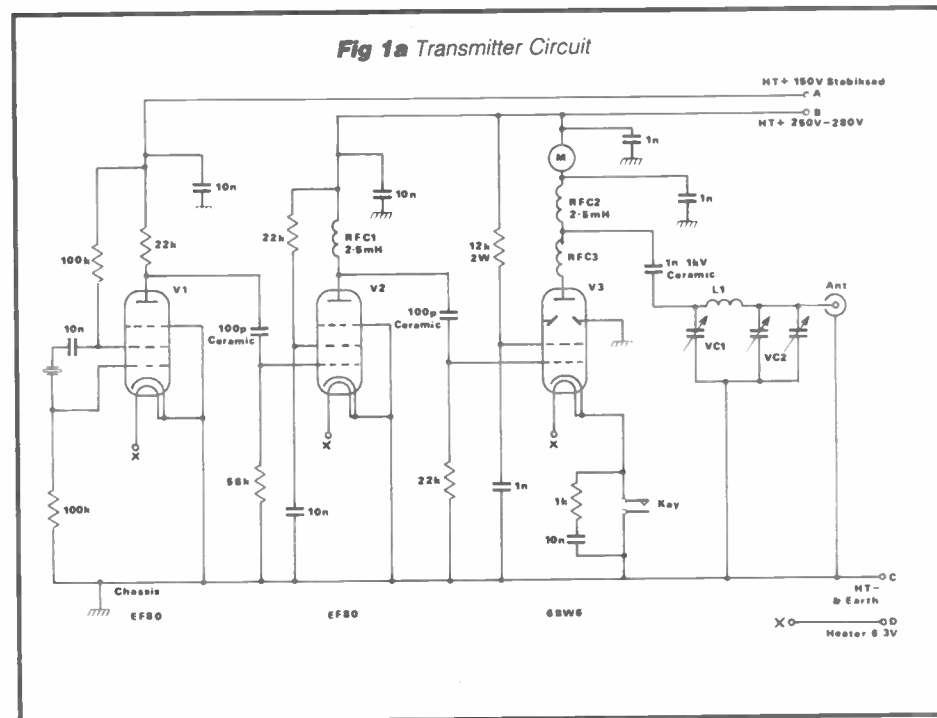

can be done with a cable/plug/socket arrangement (the socket *must* be in the rear of the power unit), plug on the cable end from the Tx). Alternatively, the two circuits can be shunted together and the whole thing built on one chassis as a combined unit (Tx plus PU).

The Tx (Figure 1a) consists of a crystal oscillator stage, a buffer amplifier and a PA output stage. The power unit consists of a rectifier valve and voltage stabiliser.

The crystal oscillator uses an EF80

meter is wired into the anode circuit for tuning and loading purposes and monitoring the anode HT current. If you know the HT voltage on the anode circuit, and multiply it by the anode current, then you have the PA power input.

The ac power unit provides 250/280V dc HT, plus a stabilised voltage of 150V DC for the crystal oscillator. It consists of a mains transformer (T) in a full wave rectifying circuit using an EZ81 rectifier

valve (B9A base). The two LT windings required for the valve heaters should be 6.3V ac each, with a minimum of 1 amp and 1.5 amp ratings respectively. Variations of this transformer will be discussed further later.

The HT is smoothed by means of a 10H 100mA choke and two 16mfd electrolytic capacitors (min 450V working). An OA2 voltage stabiliser (B7G base) is used to provide the 150V HT line. A small 6V dial light bulb is wired into the heater circuit and panel mounted, to show when the power unit is switched on.

S2 is the Standby/Transmit (and NET) switch. When the switch is 'open' the HT to the Tx is 'off'. When S2 is closed (with morse key open) only the crystal oscillator is running, which can be used for netting on the Rx, if this is required. Press the morse key 'down' and this brings the PA into action. Make certain that your Rx input is suitably protected before pressing the key. S2 can naturally be a pair of contacts on an S/R relay or switch, which would also change over the antenna from Tx to Rx. However, whatever arrangement is used, do remember that there is approximately 300V HT between the switch contacts and chassis (earth). The Rx input must be protected against the 'full blast' from the Tx. HT voltages, like mains voltages, must be treated with respect, as they can give you a nasty shock which is often lethal!

### Construction

The prototype JB80 was built into two small ventilated metal cases. Each has a chassis of dimensions approximately 8in x 4in x 1in with front panels of 8in x 4in.

Figure 2 shows the layout of the chassis and panels. Once again they can be shunted together, side by side, to form one combined unit (Tx plus acPU). As an alternative, there seems to be no reason why the two units should not be combined into one chassis, with one panel, with the power unit being located behind the Tx. Dimensions are not critical, and any convenient chassis/cabinet combination can be used, although metal cabinets should be well ventilated.

The layout of the main components can be seen in Figure 2 and details of their position will vary depending on the actual components used.

All resistors are 0.5W rating, except where otherwise indicated on Figure 1 (a and b). Capacitors are 350V working (minimum) unless otherwise stated. Good quality capacitors should be used; ceramic if possible and certainly where indicated on the circuit. Decoupling capacitors should be connected as close as possible to the points to be decoupled, and earthed directly to the nearest point of the chassis and securely fixed with solder tags.

The main PA tuning inductance L is wound on a 1in length of 1in diameter plastic tubing; parentage unknown. Thirty-five turns of 24 SWG enamel copper wire are wound on to the tubing, with spacing of a wire diameter between turns.

RFC3 is a simple anti-parasitic choke, consisting of 7 turns of PVC covered

single core hook-up wire, wound on to a 0.125 diameter rod, then removed. The result is self-supporting.

All wiring has adequate insulation, and is firmly secured. This is essential when dealing with ac mains and HT voltages. Switches S1 and S2 are good quality products operating well within their voltage ratings.

### Testing and operation

With the Tx and acPU linked together

but it should be possible to pick up the crystal oscillator on an Rx. Before doing this it is a good idea to check the stabilised HT volts (150V) with a suitable meter.

With both variable capacitors at minimum capacity, S2 is closed to apply HT volts to the PA stage. Pressing down the morse key will produce a meter reading, and VC1 should be quickly rotated for the minimum current dip on the meter (resonance). VC2 should be increased

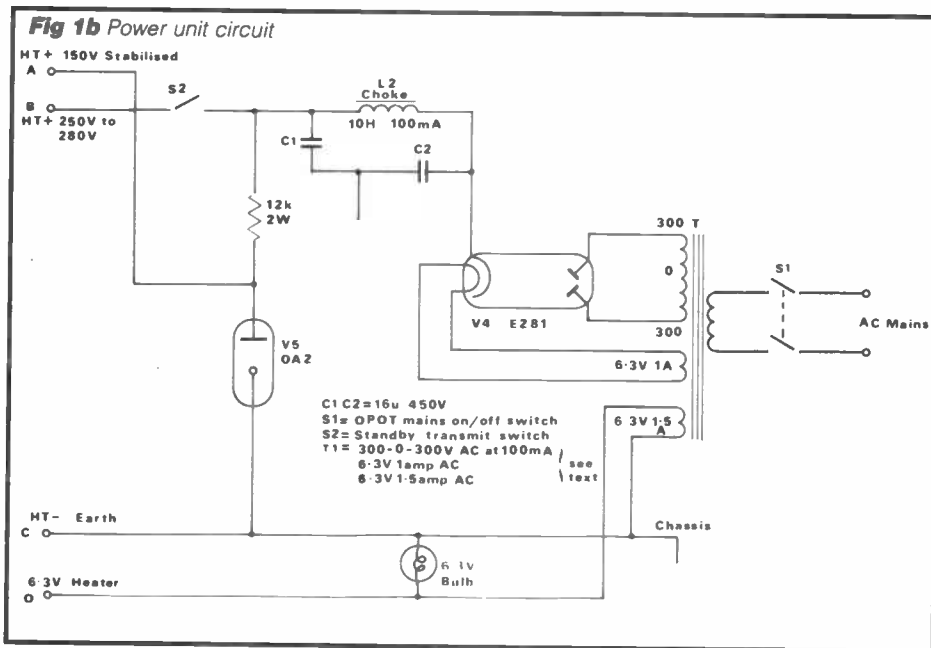

with the cable/plug assembly, a 3.5MHz band crystal is plugged into the Xtal socket mounted on the front panel, and a 10W (minimum) dummy load (50 ohm impedance), is plugged into the antenna socket. Then all is ready to switch on. Switch S2 is put into the 'standby' position (ie contacts open). On switching the power unit switch S1, the dial light should come on and there will be no reading on the meter. Off load HT voltages should be initially checked with a suitable voltmeter.

With S2 switched on, and more key 'open', there will be no meter reading,

until a reading of about 40mA appears on the meter. Retune VC1, for minimum dip, and if necessary increase VC2 again to get back to 40mA. If the HT is 250V then 40mA anode current is 10W input; and if the HT is 280V, this gives just over 11W input.

The stability and CW note can be 'key checked' with the Rx and the RF gain turned well down, and the transmitter operating into a dummy load. The CW note should be found to be absolutely clean, sharp and no chirp. This is entirely due to the use of a crystal oscillator with stabilised HT, and a buffer stage

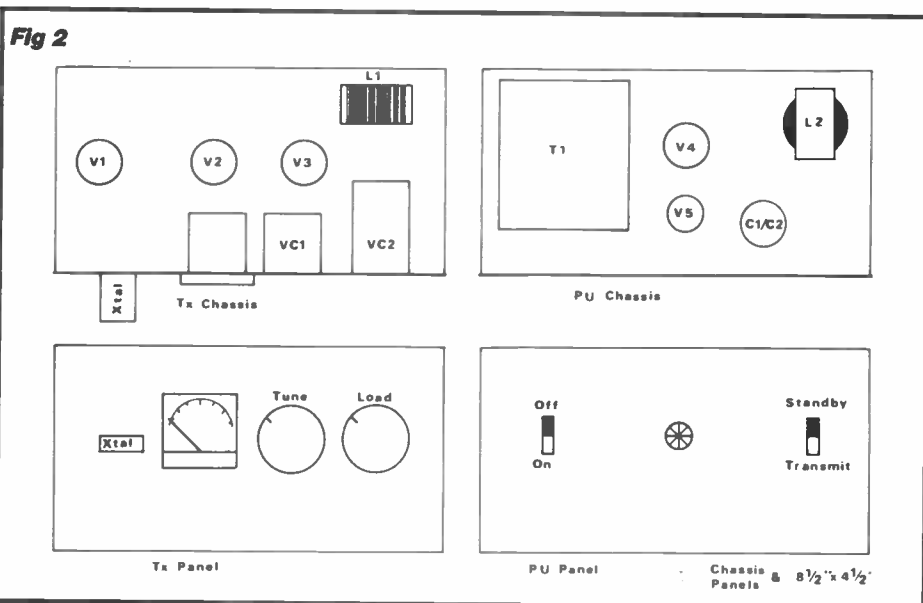

between the CO and PA stages.

Initial loading into the antenna is identical to that of the dummy load, but if the antenna impedance is very low, it may be necessary to connect a ceramic disc capacitor (say 1kV working for safety) across VC2. Capacities of say 500 or 750pf should suffice.

If the PA is loaded to 50mA then this will represent 12W input (250V HT) and 13W (270V HT). The actual HT voltage obtained, depends on the mains transformer used: the dc resistance of Choke L2 and the EZ81 rectifier.

#### APPENDIX – Possible alternative components and ideas

1. *Valves.* EF81 valves have been used for the first two stages. Alternatives might well be EF91, 6AM6, 6F12 and Z77; all using B7G bases. A check would be needed of the published voltage ratings, and resistor values changed if needed.

The 6BW6 is an excellent valve for the PA stage. It could be replaced with a type 5763 (B9A base) which is also an excellent PA valve for a low power transmitter. Possibly an EL84 could be tried, but the writer has had no experience with it. In theory it looks all right.

The 6BW6 could also be replaced with octal valve types 6F6 or 6V6, but a careful pre-check would be necessary to make certain the height could be accommodated. It might be necessary to increase the panel height slightly. Do check the voltages and resistor requirements against valve data.

The above ideas are for any constructor who is interested in experimenting.

2. *VCs.* The variable capacitors used, are a 365pf for VC1 and a 2 gang 365pf (two sections wired in parallel to give 730pf) for VC2. VC1 could be reduced to about 250pf. There are 2 gang  $\times$  125pf VCs advertised which, if wired in parallel, will give 250pfs. On the other hand, there are plenty of 2 gang  $\times$  500pf per section capacitors advertised, or obtainable from old Rxs. With the two 500pf sections wired in series, we have 250pf in total. If 250pf is not quite large enough, then a 50pf ceramic disc fixed capacitor of adequate voltage rating, could be wired across to increase the overall capacity. The permutations possible are endless, as long as good quality air spaced capacitors are used.

VC2, as specified, can be replaced with a 2 gang 500pf per section air spaced capacitor (in parallel to give 1000pfs).

3. *Transformer T.* T is the mains transformer which has two valve heater windings (6.3VAC) plus a 300 – 0 – 300 100mA section. Using a good quality transformer with the EZ81 rectifier and a 10H choke, the combination should produce an HT voltage of 270V at 100mA. The dc resistance of the choke will vary from manufacturer to manufacturer, and transformers are wound to a tolerance in voltage, depending on quality and the manufacturer. The manufacturers might well dispute this point. This means that the HT voltage, may be between 250V and 280V, depending on the load.

If a 300 – 0 – 300 100mA transformer cannot be located, then 275 – 0 – 275 or 250 – 0 – 250 100mA can be used. The result will be lower HT voltage (less Tx power), but still a very useful low power Tx of 7W to 9W input. If such transformers are used then it may be necessary to experiment with the value of the 12k 2W resistor in series with the OA2 stabiliser; to adjust the correct voltage.

4. *The Final Tx.* As has been mentioned the Tx and acPU can be built as separate inter-cabled units, or combined into one unit. In the latter case, a lot of work could be saved by stripping down an old valve communications Rx which would provide a ventilated cabinet. Only a new aluminium panel would be needed to be fitted.

Before stripping down such an Rx, have a good look at the circuit and specifications. For example, a Heathkit RG-1 Rx (and other Heath types) has a built in transformer, rectifier, smoothing choke and power unit giving 250V HT at 90mA, plus an OA2 voltage regulator (150V HT). By stripping out everything except the power unit, some of the B9A valve holders, the main lead arrangement and the co-axial antenna socket, we are well on the way to a Tx if we fit a new front panel. Check if the audio output valve is suitable for the PA valve. The S meter, with shunt resistor, could be used for HT current measurement. Such circuitry is typical of many of the older valve communications receivers, which would also yield many of the required resistors and capacitors.

## The Archer Z80 SBC

The SDS ARCHER – The Z80 based single board computer chosen by professionals and OEM users.

- ★ Top quality board with 4 parallel and 2 serial ports, counter-timers, power-fail interrupt, watchdog timer, EPROM & battery backed RAM.
- ★ **OPTIONS:** on board power supply, smart case, ROMable BASIC, Debug-Monitor, wide range of I/O & memory extension cards.

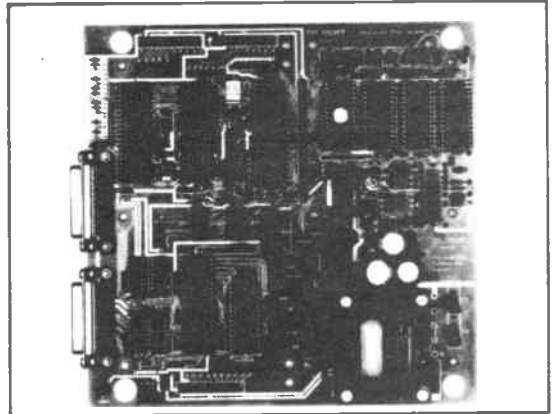

## The Bowman 68000 SBC

The SDS BOWMAN – The 68000 based single board computer for advanced high speed applications.

- ★ Extended double Eurocard with 2 parallel & 2 serial ports, battery backed CMOS RAM, EPROM, 2 counter-timers, watchdog timer, powerfail interrupt, & an optional zero wait state half megabyte D-RAM.
- ★ Extended width versions with on board power supply and case.



# Sherwood Data Systems Ltd

Sherwood House, The Avenue, Farnham Common, Slough SL2 3JX. Tel. 02814-5067

# DATASHEET

## Ian Poole Investigates MSA Avantex Series Amplifiers

UHF frequencies are no longer as difficult for constructors as they used to be. In years gone by the very mention of frequencies above three hundred megahertz or so sent shivers running through many a radio amateur. In fact to the majority of people these frequencies used to be synonymous with Maxwell's Equations and plumbing.

Fortunately this is no longer the case. Many developments have taken place which have made the design and construction of circuits at these frequencies very much easier indeed. In fact in certain instances designs have become almost as easy as using operational amplifiers at audio frequencies.

One of the developments which has made this possible is the advent of the monolithic microwave integrated circuit, and in particular the Avantek MSA series of amplifiers. They are a range of fixed gain amplifiers which are easy to use, require a minimum of extra components around them, and considering their performance are quite cheap. In fact their cost has come down to the level where they can be considered by the home constructor wanting to dabble at frequencies up to 1GHz or more.

### Specification

The MSA amplifiers are silicon devices which are manufactured using a process known as 'nitride self alignment ion implantation'. This process enables the integrated circuits to be manufactured to a very high degree of accuracy and allows the components on the chip to be defined particularly well.

The actual circuit used in the MSA amplifiers is shown in Figure 1. At first sight it may appear to be quite simple. This apparent simplicity hides the large amount of

development which went into perfecting these devices to make them very easy to use. In fact they have both shunt and series feedback included in the circuit making them totally stable - a factor which is one of their major advantages.

There are several types of MSA amplifiers, each having a different value of gain or noise figure. In turn each type can be obtained in a number of packages, the more expensive ones enabling the full performance to be achieved at higher frequencies. However, for amateur use the cheaper packages are usually more than adequate.

All of these variations are reflected in the part number of the device. The first two numbers define the basic amplifier, ie, its gain, noise figure and so forth as shown in Table 1. Then the final two figures give the type of package as seen in Table 2. From these two tables it can be seen that an MSA0304 would have a gain of 12.5dB, a noise figure of 6dB and would be in a 4-pac plastic package. This is a similar type of package to that used for some RF transistors like BFR91s, etc.

### In use

The circuits using these amplifiers are remarkably simple. The only external components which are required are a capacitor at the input, one at the output, a current limiting resistor and an optional choke, as shown in Figure 2. No special matching is required because they already possess an input and output impedance of 50 ohms.

The input and output dc blocking capacitors are chosen to give no appreciable reactance at the lowest frequency of operation. A typical value would be 100pF. The calculation of the bias resistor is equally simple. It is the voltage drop across the resistor divided by the current drawn by the device.

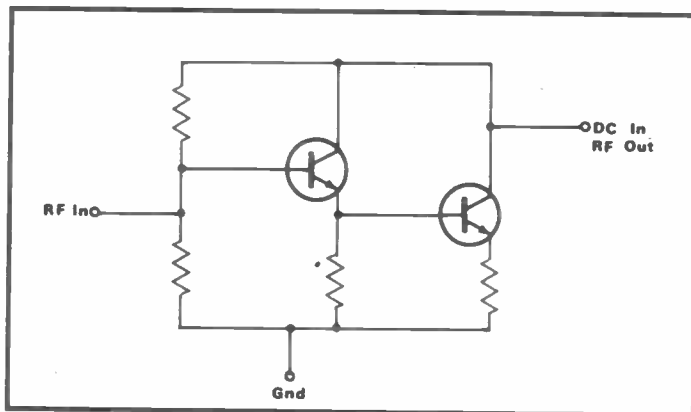

Fig 1 Internal schematic diagram for MSA Series amplifiers

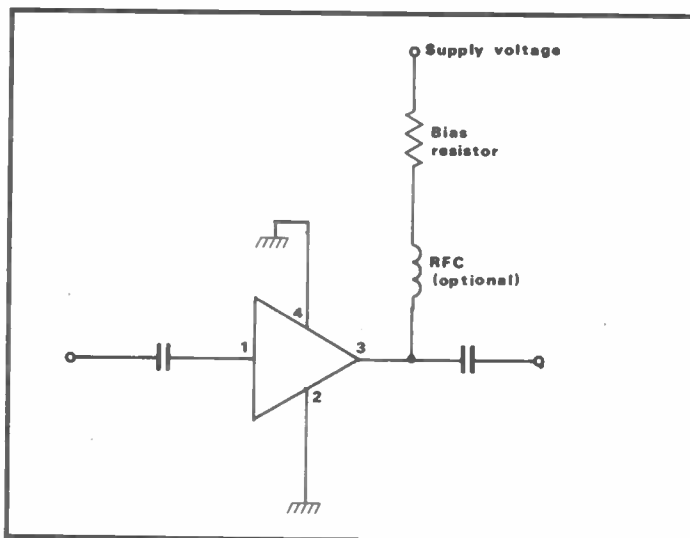

Fig 2 A typical circuit using an MSA amplifier

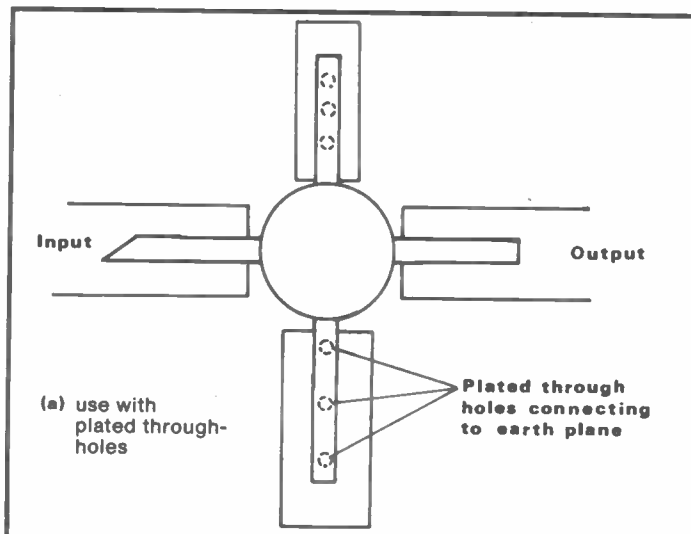

Fig 3 Earthing arrangements must be good to maintain a high frequency response

Often a twelve volt supply is used. So taking an MSA0104 as an example, it will draw 17mA and will have 5 volts across it for normal operation.

Using this information, the value of the resistor needed will be  $(12-5)/0.017 = 411$  ohms, or to take the nearest preferred value 390 ohms. Its heat dissipation also needs to be worked out. This is simply  $VI$  or  $7 \times 0.017 = 0.119$  watts. In this case, it is best to choose a quarter watt resistor so that it operates well inside its capability.

As far as the circuit board is concerned it should obviously be double sided, then one side can be used as an earth plane and the other side used to carry the tracks. It is worth noting that the two earth leads from the device should be taken to the earth plane by the shortest possible route. This must be done if the high frequency response is to be achieved.

This can be done in a couple of ways. For the lucky few who are able to use plated through-holes it is suggested that two or three holes are made as close as possible to the device, as shown in *Figure 3a*.

Alternatively, for the majority of us, wire links can be made through the board as shown in *Figure 4*.

#### Final comments

These ICs may not be 'run of the mill' components in the same way as ones like the 741 or 555. Even so, being easy to use and producing very good results, it is almost certain

### MSA Series Amplifiers

Type	Max Usable Frequency	Gain at 0.16Hz (dB)	Noise Figure (dB)	Device Voltage	Device Current (ma)
MSA 0104	3.5	18.5	6.0	5	17
MSA 0204	4.0	12.5	6.5	5	25
MSA 0304	3.5	12.5	6.0	5	35
MSA 0404	2.5	8.3	7.0	5.3	50
MSA 0135 MSA 0170	4.5	19.0	6.0	5	17
MSA 0235 MSA 0270	4.5	12.5	6.5	5	25
MSA 0335 MSA 0370	4.5	12.5	6.0	5	35
MSA 0435 MSA 0470	3.8	8.5	6.5	5.3	50
MSA 0635 MSA 0670	4.0	20.5	3.0	3.5	16
MSA 0735 MSA 0770	4.0	13.5	4.5	4	22
MSA 0835 MSA 0870	6.0	32.5	3.0	7.8	36
MSA 0185	4.5	18.5	6.0	5	17
MSA 0285	4.5	12.5	6.5	5	25
MSA 0385	4.0	12.5	6.0	5	35
MSA 0485	3.6	8.3	7.0	5.3	50
MSA 0685	4.0	20.0	3.2	3.5	16
MSA 0785	3.8	13.5	5.0	4	22
MSA 0885	6.0	32.5	3.3	7.8	36

Table 1

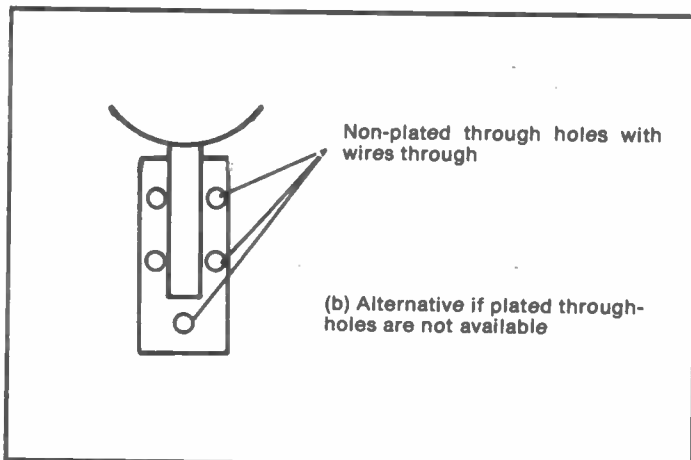

Fig 4

that they will be seen more and more.

For anyone wanting to obtain some; the MSA0104, 0204, 0304 and 0404 are available from the RSGB at around £5 a time. They should also

start to appear in the lists of other stockists. Hopefully the increased sales will mean that their prices will fall and they can be used as much as 741s, 555s and other cheap and plentiful ICs.

#### MSA Device Packages

Last two digits of device number

Package type

-04  
-35  
-70  
-85

4-pac plastic  
Micro-x  
70mil hermetic  
85mil plastic

Table 2



# NEVADA

**THE UK'S SCANNER SPECIALISTS**  
**Just arrived Black Jaguar MkIII**

*With additional features*

Switchable between AM/FM  
 Base & mobile charging  
 Frequency range -  
 26-30MHz 60-88MHz  
 115-178MHz 210-260MHz  
 410-520MHz

**£235**

**100 XL  
 Bearcat**

Hand held scanner  
 with 16 channels  
 Memory scan covering -  
 66-88 Mhz, 118-174 Mhz,  
 405-512 Mhz  
 Complete with carrying case  
 earphone and charger unit

**£189<sup>99</sup>**

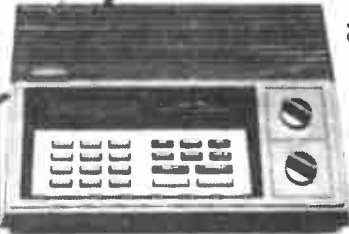

**Bearcat 175 XL BASE**

Base station scanning Rx  
 with 16 channel memory scan  
 covering 66-88Mhz  
 118-174 Mhz 405-512 MHz

**NEW LOW PRICE**

**£179<sup>99</sup>**

**50 XL  
 Bearcat**

A super NEW low cost  
 handheld scanner with  
 10 memories and covers -  
 66-88MHz 136-174MHz  
 406-512MHz

**£99<sup>99</sup>**



**Bearcat 800 XLT**

40 Channel Base Scanner  
 Covers 29-54MHz, 118-174MHz,  
 406-512MHz 806-912MHz.  
 Complete with AC adaptor

**£257**

**NEW 580 XLT  
 Bearcat**



100 Memory channels covers:  
 29-54 MHz, 118-174, 410-512 MHz

**£225** Requires 12V DC supply

**70 XLT  
 Bearcat**

Pocket size scanner  
 with 20 memory scan  
 covering 66-88 Mhz,  
 118-174 MHz, 406-512 MHz  
 Complete with carrying case,  
 earphone and charger unit

**£179<sup>99</sup>**

**NEW BUMPER CATALOGUE**  
 Includes £2 Voucher  
**£2**

**USE YOUR CREDIT CARD FOR IMMEDIATE DESPATCH**

**HOTLINE (0705) 662145**

**NEVADA COMMUNICATIONS**  
 189 London Road, North End,  
 Portsmouth PO2 9AE. Telex: 869107

## Universal Semiconductor Devices Ltd

UNIT 4, SPRINGFIELD ROAD,  
 CHESHAM, BUCKS HP5 1PW  
 TEL: 0494 791289; FAX 0494 791296; TLX 837707 usdcog



WE OFFER ONE OF THE LARGEST RANGES OF SEMICONDUCTORS  
 AT HIGHLY ECONOMICAL PRICES. THE FOLLOWING SEMICONDUCTOR TYPES ARE  
 AVAILABLE FROM STOCK. IF WE DON'T STOCK WHAT YOU NEED THEN WE CAN GET IT  
 FAST FROM OUR FACILITIES IN WEST GERMANY AND USA UPON REQUEST

**TRANSISTORS -**  
 BIPOLARS - GERMANIUM AND SILICON  
 SMALL SIGNAL  
 POWER  
 DARLINGTONS - ALL SHAPES AND SIZES  
 VHF/UHF DEVICES - ALL SHAPES AND SIZES

**FETS - POWER MOSFETS  
 UNJUNCTIONS**

**DIODES - GERMANIUM AND SILICON  
 RECTIFIERS AND BRIDGES  
 OPTO-ELECTRONIC DEVICES  
 LEDS OF ALL SHAPES AND SIZES**

**THYRISTORS AND TRIACS - ALL  
 SHAPES  
 SIZES  
 RATINGS**

**INTEGRATED CIRCUITS  
 CONSUMER - DIGITAL/ANALOGUE  
 MICROPROCESSORS AND PERIPHERALS  
 IC SOCKETS**

**JAPANESE COMPONENTS - VAST RANGE OF DISCRETES AND CONSUMER IC'S  
 CATALOGUE - PLEASE SEND £1 CHEQUE, POSTAL ORDER OR STAMPS FOR OUR 1988  
 CATALOGUE. SUPPLIED FREE OF CHARGE TO COMPANIES WHEN REQUESTED ON AN  
 OFFICIAL LETTERHEAD**

**SPECIAL DISCOUNTS AND PAYMENT TERMS ARE AVAILABLE TO OEM'S, SCHOOLS,  
 COLLEGES, UNIVERSITIES, GOVERNMENT INSTITUTIONS, COMPUTER FIRMS,  
 ELECTRONIC REPAIR FIRMS AND DISTRIBUTORS**

PLEASE ENQUIRE FOR QUANTITY DISCOUNTS

**WE WELCOME TELEPHONE, TELEFAX AND TELEX ENQUIRIES**

**WE  
 SUPPLY  
 SEMI  
 CONDUCTORS  
 FOR  
 SATELLITE  
 TV**

## R. N. Electronics

**Professionally designed equipment for Amateurs**



**2/6m TRANSVERTER £179**  
 25w pep - £4 p&p

The superb audio qualities of this  
 transverter have proved it to be a market  
 leader. If you are looking for a low cost  
 high performance way of getting on the  
 exciting 6m band, this offers 25w pep when  
 used with your own 2m transceiver input  
 up to 3 watts or use with 7dB attenuator  
 (10w i/p) **£22 - £2 p&p**



**2/4m TRANSVERTER £239**  
 25w pep - £4 p&p

Yet another first from R N Electronics  
 meeting the same high specification as  
 our 6m transverter.  
 Second harmonic -70dB  
 Spurious -60dB  
 Complete with 5 switching options and full  
 operating manual



**RN690 pa £75**  
 25w pep - £4 p&p

Not enough power from your dedicated 6m  
 rig?

This power amplifier has the same high  
 standard of filtering as our transverters.  
 Don't wait until you miss those DX  
 contacts to stations with more power -  
 order now

**NEW \*\*\* 10m RECEIVE CONVERTER. IDEAL FOR CROSSBAND WORKING**  
**£39 or with switching £45 - £2.00 p&p**

SO CONFIDENT ARE WE THAT  
 YOU WILL BE PROUD TO OWN  
 ONE OF OUR TRANSVERTERS  
 THAT WE OFFER A FULL 2 YEAR  
 GUARANTEE

See us at all major rallies ALL PRICES INCLUDE VAT

**37 Long Ridings Ave, Hutton,  
 Brentwood, Essex CM13 1EE.  
 Tel: 0277 214406**

# ANGUS MCKENZIE

---

# TESTS

---



## THE KENWOOD TM-721E DUAL BAND FM MOBILE TRANSCEIVER

To have both 2m and 70cm in one rig is a very great advantage, but to be able to transceive on one of the bands whilst simultaneously monitoring the other is an even greater asset. However, it is no good adding all these excellent facilities if they are difficult to use, requiring you to study the manual for hours, followed by many days of experimentation before you can select the required function quickly. My job as a reviewer is not just to test a rig in the lab to compare it with the ideal, but perhaps just as important, my job also entails using the equipment to find out all its good and bad points in general operation. There are some rigs I just hate within a matter of minutes, whereas others greatly impress me by their good ergonomic design, and this rig comes into the latter category.

### The TM-721's features

The rig covers the 2m band from 144 to 146MHz, and 70cm from 430 to 440MHz. There are two basic tuning controls, a large knob being provided for the main band, whilst a very small one provides the tuning for the sub band. Both knobs rotate in click steps, which are factory set at 12.5kHz for 2m and 25kHz for 70cm. The microprocessor can easily be programmed from the front panel to provide 5, 10, 12.5, 15, 20 or 25kHz steps, a separate choice being available for each of the bands. Negative and positive repeater shifts are independently programmable for the two bands, and the memories can also store tone burst on/off as well as repeater shift etc.

Of the 14 memories on each band, 10 follow the normal sequence from 0 to 9 (mem 1 is also a priority channel), whilst four lettered ones, A-D, are for special purposes. A and B set the lower and upper limits of a band scan, whilst C and D are provided for different Tx and Rx frequencies as required for any special operation.

Inserting a frequency, shift and tone on or off from the VFO into the memory is fairly simple, although you do have to do each step in five seconds, which could be a danger if you are doing it while driving

the car. Selecting memory or VFO modes is more logical than usual, and there is also the facility of putting any memorised frequency etc into the VFO.

The main channel is provided with a dual concentric rotary with one half acting as a squelch control whilst the other is 13V dc on/off and Rx gain. Two slider controls, both working from left to right, are provided for operation with the sub-band, one being sub-band squelch whilst the other is a centre indented balance control which allows you to vary the audio feed levels between the two bands through to the output amplifier and loudspeaker. I very much preferred this idea to separate gain controls for the two bands, but I feel sure that some will prefer it the other way!

### Front panel buttons

In addition to the main and sub tuning knobs, there are two little buttons for changing MHz up or down on the main band. Other miniature buttons are provided to switch 1750Hz auto tone burst on or off, VFO, memory recall/memory input, a function to enable second functions, scan/lockout, priority, reverse repeater, channelling steps, main band selector, sub-band on/off, sub-band 20dB audio mute, high or low power/display dim, and automatic band control (transfers the sub-band to the main one when squelch is opened). A slide switch can select frequency lock, and two sliders are provided for audio balance between main and sub-bands and sub-band squelch.

### Front panel display

The LCD gives the main tuned frequency in fairly large digits, whereas the sub-band is displayed in slightly smaller numbers. The display was clear and easy to see, and all the main and sub-band indicators and various status displays are helpful.

The microphone socket on the front panel is wired to the standard Kenwood convention, and has eight pins. The supplied hand mic has just PTT and up/down buttons, but the socket can also

provide an audio feed to a headphone, and dc volts for energising various microphones (current limited to 15mA). The mic socket also provides frequency control information for use with the RC10 remote control, and dab hands at interfacing might well be able to add some fun facilities here!

### Rear panel and case

We were delighted to see that Kenwood had got away from chassis mounted antenna sockets, which can be very difficult to use if you want to take the rig in and out of the car frequently. The TM-721 is fitted with an N socket for 70cms and an SO239 socket for 2m, both as line sockets at the ends of short coaxial flying leads. The 13V dc lead is fused in the positive only, and is terminated in a special Kenwood dc plug, a long extension lead being provided. The only other connection on the back is a counter sunk 3.5mm jack socket for an external speaker.

A rather crude mobile mount bracket is supplied, the rig having to be screwed into it at the sides with four short bolts, which are coloured black. I mention the colour, since Fiona commented that if one of these is dropped, you are likely to have a very frustrating time trying to find it on the car floor. However, a much better bracket is available, type MB-11, as an optional accessory, which allows you to just push and clip the rig into place. The internal loudspeaker is in the top of the rig, which I much prefer to one underneath, but a mobile loudspeaker, type SP-50B, is available as another optional extra.

### The RC-10 remote control option

This remarkable unit allows separate insertion of the required frequency, remote tuning and memory channel selection, 16 key auto patch (not applicable in UK), volume control, squelch on/off and a facility to allow duplex operation. Bearing in mind that this rig offers a memory to VFO facility, and that when in the memory mode you can find memory 0 as there is a loud 'pip' at this

point when it is reached, the RC10 allows the rig to become a recommended one for use by the blind, despite the fact that it does not have a speech frequency read-out.

However, the RC10 option is very expensive, costing around £170 inc VAT. It is in the form of a telephone type hand set with the pad on it, and PTT and three position earpiece volume switch on the side. It clicks into a cradle which can be situated where required. A flying lead from the cradle is another socket either for use with the 721's hand mic, or with a second compatible rig (TM-221 or 421) for additional duplex operation.

If you are interested in the remote control option, I strongly recommend you to look at it before committing yourself, as it may not do quite what you want in the way that you want it to. For example, I was surprised that I could not find any way of remotely changing the actual main band. Duplex operation, accessed by pressing 'function 1', (not listed in the RC10 book), produced the receive frequency as the main display and Tx frequency on the sub, whilst the Tx frequency, or Rx when Tx is released, was indicated on the remote unit's own frequency display.

#### Subjective tests

Of all the dual band mobile rigs that I have so far used from all companies, I have no doubt that this is my top recommendation because of its superb ergonomic design, as well as its excellent performance in almost all areas. I could not fault any of its facilities, and in general use not only was the receiver excellent on both bands, producing very good audio quality from well modulated signals, but its transmission quality was also judged to be very good by listeners.

There were some excellent thoughtful ideas put in, for example, the provision of 'beep' tones of various frequencies produced by different button pushes. An excellent example of this is that three different frequencies are produced in succession as you cycle round the shift button, the lowest beep corresponding to minus repeater shift, the middle beep for simplex and the highest one for positive shift. Low and high power are signified by low and high tones.

Of course, I noticed this immediately, as I am blind, but I suggest that many a driver operating the rig will find these beep tones very useful indeed once he or she gets the hang of them. They will allow him to concentrate on the road ahead while changing power or something else on the rig. I am therefore all the more disappointed that Kenwood have omitted an optional speech read-out, but I have recently heard from Kenwood in Japan that such read-outs will be re-introduced again in the future.

I very much liked the provision of the separate banks of memories for the two bands, allowing much more flexibility. The front end seemed to be particularly good, sensitivity being noticeably better than usual on both bands, whilst selectiv-

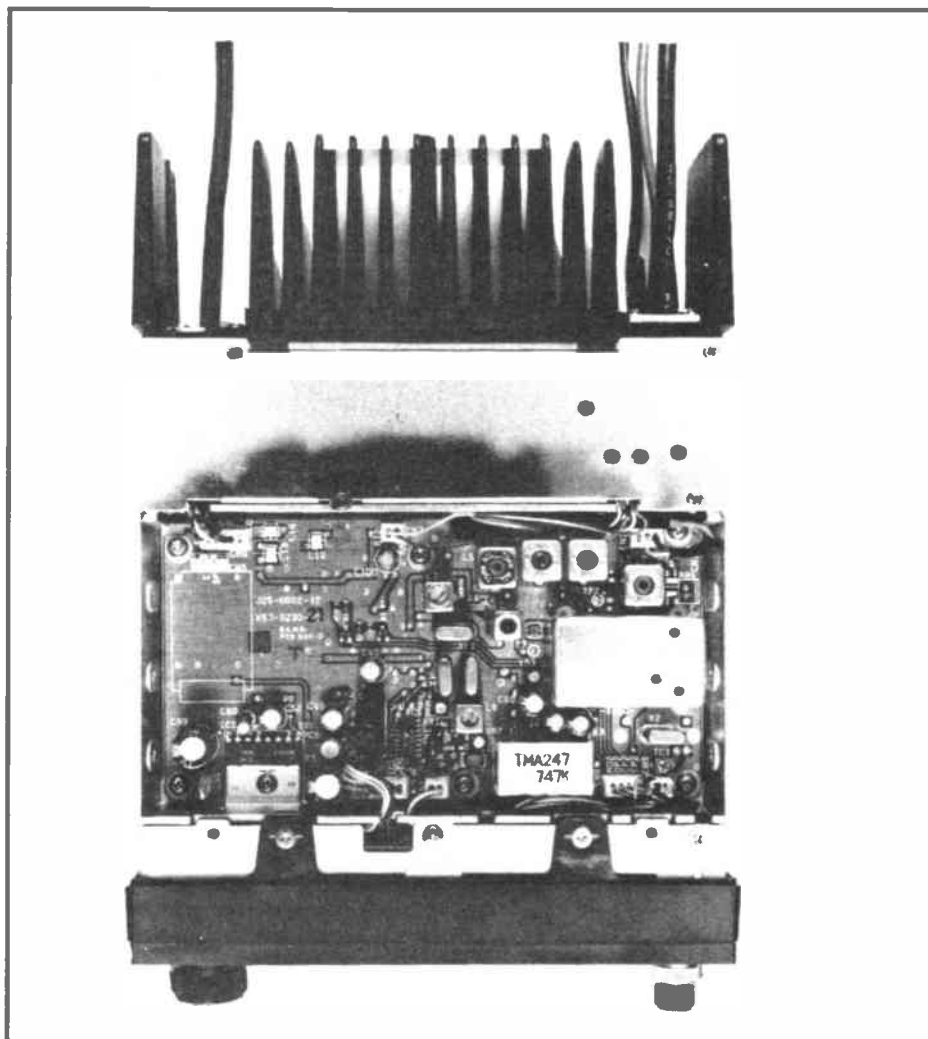

ity was adequate for 12.5kHz channelling. Kenwood has installed an F filter on this model, having approximately 12kHz bandwidth for 6dB down. Audio quality from the built-in speaker was quite acceptable, and was very good from an external one.

#### Crossband working

Many stations like to monitor a frequency on one band whilst working on another, a typical example of this being the monitoring of a local repeater on 70cms to see who comes up, whilst remaining in QSO on 2m. There was no confusion in operating this facility, for you could actually tune up and down the sub-band whilst in QSO on the main one.

The provision of single button pushes for changing over the main and sub-bands, and for turning the sub-band off in a hurry, is an extremely strong point for this rig. I very much liked the idea of a single push 20dB audio mute button for the sub-band allowing you to ignore, but not lose, sub-band monitoring. This was a lot quicker and easier than varying the main/sub-band audio balance control. The audio outputs of both bands on Rx mix to the same speaker except for the remote control feed from the mic socket which is of the main band only.

Time and time again I checked for any degree of desensing when listening to

the sub-band and turning the transmitter on and off on the main. Both the 2m and 70cm RF input stages gave superb rejection of out of band signals, and therefore I did not note any desensing problem other than on a harmonic etc.

For most of the tests I was using an Icom discone together with a Revex band duplexer. The Icom discone has such a wide response, that many a rig can be overloaded by it, but I had no trouble with this one on either band. The memory to VFO function is useful as it enables you to select your favourite nominal frequency for both the main and sub-bands separately, and then vary channels on either without any problem.

Quite frequently when in QSO on the national RAIBC frequency of 145.35MHz, I scanned up and down the 70cm repeaters. This was extremely effective. Even more effective was to put the RAIBC net and emergency frequency of 145.35 on the sub-band, whilst in QSO on 70cms. The only problem I had was caused by the very occasional amateur in the London area who was not aware of the frequency being used very frequently by disabled and blind amateurs. However, I cannot imagine any user wanting to monitor 145.5 on the sub-band in the London area, as it would be interrupting all the time and drive one potty!

## Laboratory tests

The TM-721's RF sensitivity on 144MHz was extremely good, only 0.11µV emf/2 being required for 12dB sinad sensitivity. This confirms my impression that this rig is one of the most sensitive ones available, and in the same class as the superb TR751E multimode. Perhaps more surprising is that the rig is very nearly as sensitive on 432MHz over the whole band, and this is where you really will notice the difference between this rig and some of its competitors.

I criticised the RF input intercept points of the TW4100E, this rig's immediate predecessor, when I reviewed it in September 1987. The 4100E was not at all good on 70cms, but the TM-721 has an input intercept point some 10dB better, and certainly good enough for all normal purposes. The 2m intercept point was also good by comparison, being around 3dB better than its predecessor, although one or two other competitive rigs are slightly better.

FM selectivity was adequate for 12.5kHz channelling, whilst at 25kHz spacing it was excellent, achieving quite a remarkable figure which was noticeably better than the earlier model. We noted 14dB difference between S1 and 9 on both bands on the signal strength indicator. There are single and double plus indications over 9, the latter requiring an average of only 6dB more RF than S9, and so the S meter did not cover a wide enough dynamic range, although better than quite a few.

Audio distortion was quite acceptable, and normal for an F filter, whilst the maximum output into an 8 ohm speaker was quite a healthy 2.9W, increasing usefully to 4.8W into 4 ohms, which is a little more than usual.

Capture ratio measured well, showing that the rig discriminates fairly well between stronger and weaker signals on the same frequency. Limiting action was excellent on both bands, so that the audio output from weak and strong signals was virtually identical. The receiver's response followed a 750µsec de-emphasis curve quite accurately from 500Hz to 2.5kHz. Below around 400Hz bass roll-off was very rapid, which is just what is needed to achieve maximum intelligibility from a mobile installation, whilst higher frequencies were rolled off above 2.5kHz moderately steeply, 5kHz being -16dB ref 1kHz from a pre-emphasised transmission. I suggest that this is an excellent compromise, and somewhat better than usual.

No reciprocal mixing problems were noted, and the performance was well matched across the whole of both bands. When the receiver is squelched, it took around 0.5A standing current, so don't leave it on over the weekend by mistake and expect to make a fast getaway on Monday morning!

## Transmitter tests

Power output was well maintained across the whole of 2m, whilst on 70cms it was slightly below spec at 430MHz, but

## Laboratory Tests on Kenwood TM-721E

### 144MHz section

RF input sensitivity, level for 12dB sinad	
144.025 MHz	-125.5dBm
144.95	-126
145.975	-126

RF input intercept point, 100kHz spacing	-13dBm
1MHz spacing	-12dBm
2MHz spacing	-9dBm
4MHz spacing	+6dBm

FM selectivity +/-12.5kHz	+15/+12dB
+/-25kHz	+75.5dB

### S meter

S1	-116dBm
S3	-110
S5	-107
S7	-105
S9	-102
S9+	-100
S9++	-97

Capture ratio	4.3dB
---------------	-------

Limiting threshold for -3dB audio output	-129.5dBm
--	-----------

Audio distortion	between 1.5 and 2.5% typically
------------------	--------------------------------

Max audio output for 10% THD 8 ohms 2.9W 4 ohms 4.8W
--

### Transmitter Tests

Typical output power from 13.8V DC supply	48W at 7.6A 4.8W at 2.7A
---	-----------------------------

Frequency accuracy	within 10hz
Max deviation at 1kHz	4.7kHz
Absolute maximum deviation	5kHz at 500Hz audio
Typical Tx distortion	1.1% at 4kHz deviation
Typical dynamic range	40dB

### 433MHz

RF input sensitivity level for 12dB sinad	
432.025MHz	-125.5dBm
433.4	-125.5
435.975	-125.5
439.975	-125

RF input intercept point	
100kHz spacing	-16dBm
1MHz	-15
5MHz	-12
10MHz	+9

### Transmitter Tests

Typical output power from 13.8V DC supply	33-37W at around 8.6A 5W at 3A
---	-----------------------------------

Other results as 144MHz section

Dimensions W x H x D 150 x 50 x 219mm

Weight 1.8kg

above it at the top end of the band. When low power was switched on, the rig typically gave around 5W on both bands. The rig took around 7.6A on 2m on high power, and this increased to around 8.5A

on 70cm despite the lower maximum output. When switched to low power, current on Tx was typically around 2.7 to 3A. No troublesome harmonics nor spurious were noted whilst testing the rig.

FM deviation was very accurately set, and the toneburst was on frequency and also correctly deviated. However, the deviation would have to be lowered for 12.5kHz channelling standards, but this should not be difficult. Frequency accuracy was extraordinarily good, and having pointed out that an error of only 10Hz was noted after four hours' use, what more need be said about frequency accuracy and drift characteristic?

The transmitted response was reasonably flat from the 3dB down points of 300Hz and 3.4kHz, LF attenuating rapidly whilst HF rolled off somewhat more gently to be 10dB down at 5kHz. This is rather a wider response on Tx than on Rx, but should be perfectly acceptable

unless you are driving a very rumbly vehicle. The mic amp gain was set just about right for speech around 2 inches from the mic. The transmitted dynamic range was around 40dB. Transmitted distortion was 1.1% at 4kHz deviation, and less at lower deviations, and this clearly resulted in the good audio reports.

### Conclusions

This is a very well designed rig, and surprisingly simple to use, despite its complex facilities. It clearly follows on from the TM-221 and 421, and has made me curious as to the reason for Kenwood introducing their TW4100E which was originally so over priced, but which was

sold off at quite a bargain price earlier this year.

This rig is quite a lot better than the TW4100, and yet it is cheaper, which is quite something these days. It can be modified to give talk through when in the duplex mode, as could its predecessor, but once the modification has been done, it is much easier to access that mode than on the 4100. I can thoroughly recommend this rig, I could find no apparent snags, and priced at just under £700 including VAT it should sell well.

Very many thanks to Lowe Electronics for loaning me the review sample, including the RC10 remote controller, and yet again, thanks to my XYL, Fiona, for all her hard work.

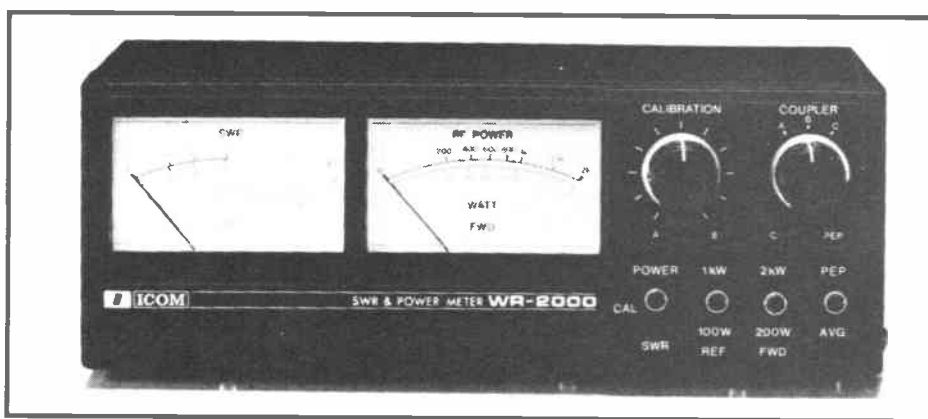

## ICOM WR200 AND WR2000 POWER METERS

There are two power meters available in the Icom range, the WR200 and WR2000. They are identical in every way except for the actual power ranges. The WR200 was sent for review with the WRC150, the remote directional coupler covering the frequency range 1.8 to 150MHz, the maximum throughout power being 400W PEP. This particular model is one of four that are available for the meters, the others being the WRC-54 (1.8 to 54MHz, rated at 2kW PEP at HF), the WRC450 (covering 140 to 450MHz at 200W PEP max) and the WRC1300 (covering 1200 to 1300MHz at 40W PEP max). The WRC54 is normally supplied with the WR2000 meter which has power ranges ten times higher than the WR200.

### Facilities

The WR200, supplied with the WRC150, can be switched to give forward power ranges of 20 to 200 fsd on the right hand meter, whilst the left one can be switched to read reflected power of 10 or 100W fsd, or standing wave ratio. A series of up/down switches select the mode of operation (power, SWR CAL or SWR READ), forward power range, reflected power range, and PEP or average power. A rotary knob sets the required deflection for SWR reading when the mode switch is in the CAL position.

A three-position rotary switch can select any one of three remote directional couplers, allowing a very flexible

metering system with the directional couplers left permanently in circuit.

The meter scaling is quite clear, and the model is very easy to use and is also very reliable. An external voltage between 11 and 15V dc is required to be inserted into an appropriate socket in the back (lead supplied), this voltage only being needed for PEP measurements and for lighting up the scales.

For reading SWR, a minimum of only around 3W is required to obtain a full scale deflection in the CAL position, and thus this meter is somewhat more sensitive than some of its competition. The WR2000, however, requires around 30W for SWR reading, which will mean that you will have to exceed the maximum licensed carrier power on 1.8MHz for SWR reading!

### The four different couplers

The WRC54, normally supplied with the WR2000, can take up to 1kW continuous carrier at HF, 1.5kW for CW and a maximum of 2kW PEP on SSB. It is downrated on 50MHz to 300W carrier, 450W CW and 600W PEP. This head is thus suitable for the WR2000's 200W and 2kW forward power ranges, with reflected power ranges of 100W and 1kW. The WRC54 is not specified for use above 54MHz, and is fitted with SO239 sockets on the coupler.

The WRC150, rated from 1.8 to 150MHz, is also fitted with SO239 sockets. At HF

and VHF, the maximum throughput powers are 200W carrier, 300W CW and 400W PEP. This coupler is also suitable for both the meters provided you watch the maximum throughput power.

The WRC450 copes with 144 and 432MHz bands, but I am rather surprised that it is fitted with SP239 sockets rather than N types. Power ranges are 100W carrier, 150W CW and 200W PEP on both bands.

Finally, the WRC1300 covering 1200 to 1300MHz is fitted with N type sockets, and has the very restricted power ranges of only 20W carrier, 30W CW and 40W PEP, and for this reason is only practicable for the WR200.

### Subjective test

I first of all checked that just under 3W forward power was required to obtain full-scale deflection on the 'calibrate' position for measuring standing wave ratios on both 1.8 and 26MHz. Power readings correspond to within 10% of readings obtained from a standardised power meter which I have used for some years. I was particularly pleased that peak envelope power readings on CW, and compressed or uncompressed speech, read extremely accurately. You will find that CW that might be peaking, say, 100W PEP might only read 30W on a line of dits if the meter is switched to the average reading position. On speech, average power would under read even more, and it is for this very reason that I consider a PEP meter almost essential for any shack employing SSB transmitters. You will almost always be putting out more power than you realise on speech, and the well known 'wahlo' or long whistle of indeterminate pitch, may well give you a real peak power which is 10 or 20% below the values that you would get from uncompressed speech.

This effect is particularly marked from valve linears in which the HT supply holds up the voltage on normal speech peaks, thus preserving the real full peak envelope power whilst a continuous current drain on a whistle etc decreases the HT voltage. This is because the power supply capacitors cannot cope with the current demand in most cases, and thus the voltage is lowered. The

actually SWR readings appeared to be accurate throughout, and it was useful to be able to switch the sensitivity of the reflected power meter independently from the forward power meter.

### Conclusions

The WR200 is a most recommendable power meter for use with rigs giving up to 200W PEP output, as the PEP readings were very accurate and it was possible to measure SWR using a very low power output to the antenna. This will be very useful when matching the antenna to the rig with an antenna tuning unit. You can

also, of course, carry out matching very quickly by using the forward and reverse power indications. I very much liked the provision for accepting up to three directional couplers.

The WR200 costs £108 inc VAT, and includes the WRC150, and this seems a very reasonable price for such a high calibre instrument. The WR200, incidentally, costs £119.

The meter would have been a lot more useful if it had incorporated three rather than two power ranges, especially as many of the competing models cover the wider power range. If you choose the

WR200, you will find it rather difficult to take measurements on the 1.8MHz band as your carrier will be well below one tenth of full scale if you are to remain legal. I would personally like to see ranges of 15W, 150W and 1.5kW to cover all normal power testing, with the highest power range perhaps available as 500W as an option, which would be more appropriate for use with the Icom IC2KL 500W linear, and the UK licence regulations! Nevertheless a very recommendable meter, available from Icom UK and their agents. Many thanks to them for the loan of the review sample.

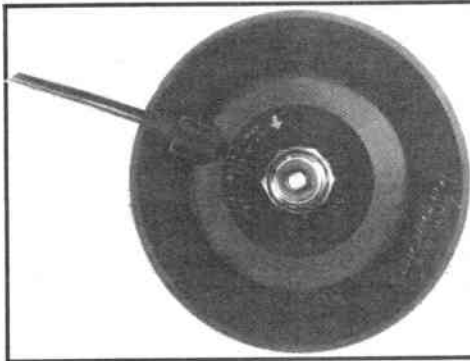

## THE DIAMOND HEAVY-DUTY MAG MOUNT

When I reviewed a new dual band mobile antenna for 2m and 70cm very recently, I commented that the performance of the gutter mount that I had been using for some time was far from acceptable, so I substituted a Nevada 934MHz antenna mag mount with the new Hokushin dual band antenna. The Nevada 'Maspro' mag mount turned out to have only 0.5dB loss on 2m and 1dB on 70cm, showing the benefit of the use of superb coax and an excellent SO239 socket. Unfortunately, not only was the mag mount sold only with the 934MHz antenna, but as that band has now more or less hit the dust, Telecomms of Portsmouth are no longer importing it. I therefore felt it important to have a look at a typical mag mount, and with Geoff Stanton's help. I was able to test the Diamond heavy duty mag mount that he supplied for review.

The actual cable length of the Diamond

as supplied is 3.8m, and although the cable is not terminated, a PL259 plug is supplied with the mag mount. The first thing that we tested was the system's SWR by using a 50 ohm dummy load screwed on to the mount. With 16W going up the lead from a very accurate 50 ohms source, we were not able to see any return power on 433MHz. Neither was their evidence of return power on the 1W range of the Bird through line wattmeter; so the SWR was as near 1:1 as makes no difference. This was better than the gutter mount lead, which had been 1.4:1.

The loss of the lead on 144MHz, including very high quality N type adaptors, was 0.9dB, and the loss on 433MHz was 1.7dB. This is apparent on UHF, although not significantly so. As the Maspro had almost half the loss, it is possible that the Japanese do not pay enough attention to the optimum design of some accessories. To give the

Diamond its due, it is extremely well made, having a very strong magnet. The Maspro lead was some 80cm shorter than that of the Diamond, but this would only account for a very small difference.

Having tried many different mag mounts in the last 20 years or so, I have never known one to fall off the roof of the car. I have no doubt whatsoever, that using a mag mount in the centre of the roof gives consistently better results than a gutter mount, due to the mag mount's ground plane action. Although there is no metal contact between the plastic coated base of the mount and the roof of the car, the mount's, large diameter does provide quite a high capacity to the car body; hence effectively earthing the mount to the car at RF.

### Conclusions

I can recommend the Diamond mag mount as a useful mobile accessory, which is removed far more quickly than a gutter mount at the end of a journey. Another advantage of a mag mount over a permanent installation, is that the car's resale value remains unaffected by roof holes which are necessary with a fixed system. I hasten to add that mag mounts are not suitable for heavier antennas, including HF ones, because of their higher leverage in windy conditions. The Diamond range of accessories are imported by Waters and Stanton Ltd of Hockley, Essex, and are stocked by most amateur radio equipment dealers, priced at £23.95 inc VAT.

## G4ZPY PADDLE KEYS

Britain's leading High Quality Hand Built Morse Key Manufacturer

PUMP (Straight) KEY	Brass £26.00 & £30	Nickel £31 & £35
SINGLE PADDLE KEY	Brass Std £42.00	Deluxe £44.50
Nickel or Brass	Std £47.00	Deluxe £49.50
TWIN PADDLE KEY	Brass Std £48.00	Deluxe £50.50
Nickel of Brass	Std £53.00	Deluxe £55.40

60. VARIATIONS OF THESE KEYS ARE AVAILABLE. Some to Order.

IAMBIC ELECTRONIC KEYS (with Auto Inter-Character Spacing) £40.00  
 1K PEP BALUNS 3.5-30 Megs £15.00  
 10-70 Megs £16.50, P&P UK: - KEYS £3.00  
 IAMBICS AND BALUNS £2.00

SAE for further details to

41 Mill Dam Lane, Burscough, Ormskirk, Lancs L40 7TG  
 or Phone: 0704 894299

## MAKE YOUR INTERESTS PAY!

More than 8 million students throughout the world have found it worth their while! An ICS home-study course can help you get a better job, make more money and have more fun out of life! ICS has over 90 years experience in home-study courses and is the largest correspondence school in the world. You learn at your own pace, when and where you want under the guidance of expert 'personal' tutors. Find out how we can help YOU. Post or phone today for your **FREE INFORMATION PACK** on the course of your choice.

Electronics	Radio, Audio and TV Servicing
Basic Electronic Engineering (City & Guilds)	Radio Amateur Licence Exam (City & Guilds)
Electrical Engineering	Car Mechanics
Electrical Contracting/Installation	Computer Programming
	GCSE and 'A' level subjects

Course of Interest: \_\_\_\_\_  
 Name: \_\_\_\_\_

ICS Address: \_\_\_\_\_ P. Code \_\_\_\_\_  
 International Correspondence Schools Dept EF568, 312/314 High Street, Salford, Surrey SM1 1PR. Tel: 01-643 9568 or 041-221 2926 (24 hrs)

# BITS TO BUILD

## THE JANDEK RECEIVER – Part 2

### The VFO

The circuit of the JD004 VFO is shown in *Figure 2 (a)*. The oscillator, Tr1, is a JFET transistor in a Colpitts arrangement. The oscillator is capable of operation on bands between 1 and 15MHz using appropriate values of inductor L1, with a variable capacitor or varicap diode or a combination of both. Tr2 is a source follower buffer with a stage gain of less than unity. Tr3 provides amplification of the signal, filtering via a pi network through L2, resulting in a 300mV RMS signal designed to feed a 50-ohm load.

The chart of VFO frequency coverage values shows how the circuit may be used on any band from 160 to 20m. The value for C1 is nominal and depends upon the method used to tune the frequency range. Probably the simplest method is to connect a variable capacitor between points 1 and 2 on the circuit.

A facility has been provided to use varicap tuning; a double varicap device, the BB204, can be connected with the common cathode lead to point 3 and the anodes to points 1 and 2. Point 3 provides a variable voltage, derived from the stabilised 8 volt line at IC1, and controlled by a potentiometer connected at points X, Y and Z. The possibilities of varicap tuning are fully discussed in the Jandek documentation. Two BA102 varicaps can be used in place of the BB204. Suitable spacings are provided on the printed circuit board for either device.

It is not possible to get adequate frequency coverage using varicap tuning on 160m, so my receiver used a variable capacitor in the arrangement shown in *Figure 3*. This uses a 75pF variable capacitor, with extra capacitive padding, in two switched ranges to give the whole band in two equal segments (1.8 – 1.9 and 1.9 – 2.0MHz).

This has the advantage of using a common value of variable capacitor and also gives easy tuning, with the band being covered by two complete sweeps of the capacitor. Generally, I do not like switching frequency-determining components, but the circuit is at low frequencies and proved to be very stable in this configuration. I also added two BA102 varicaps and the potentiometer arrangement shown in *Figure 1 (a)* to allow fine tuning.

The printed circuit board provided by Jandek is a good quality fibreglass tinned board, complete with terminal pins for the output. Jandek also provide the frequency determining components, excluding the variable capacitor, according to the band ordered.

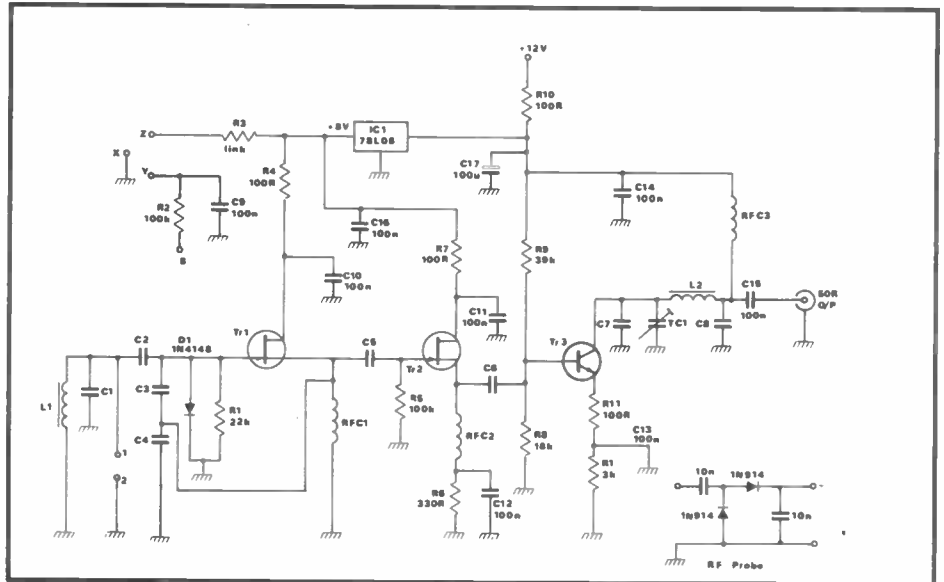

Fig 2a VFO circuit diagram

### VFO Parts List

#### Resistors (all 0.25W):

R1	22k	R2	100k	R3	link	R4	100R	R5	100k
R6	330R	R7	100R	R8	18k	R9	39k	R10	100R
R11	100R	R12	3k0						

#### Capacitors:

C9 to C15 inclusive: 100nF ceramic  
C16 100µF 25V electrolytic

#### Semiconductors:

D1	1N4148
Tr1, Tr2	BF256C FET
Tr3	2N2222
IC1	78L08 voltage regulator

#### Miscellaneous:

C1 to C8 inclusive and TC1 (see additional notes)  
RFC1 to RFC3 inclusive (see additional notes)  
L1 and L2 (see additional notes)  
10x1mm terminal pins  
Printed circuit board

The only likely problem in building the VFO is the winding of the inductors L1 and L2. Both are wound on toroid formers, which are provided together with the wire. L2 for 160m requires 90 turns of thin wire to pass through the hole of the toroid: each pass through the hole represents one turn. In practice the easiest way to cope with this number of turns is to thread the wire onto an embroidery needle and 'sew' it through the hole. Do it standing up... and keep counting!

The VFO can be tested by applying an RF probe and voltmeter to the output. It is best to put a load, say a 56 ohm resistor across the output for this test. A suitable circuit for a simple RF probe is shown in *Figure 2 (a)*. This probe should be connected to a low voltage range on a multimeter via a screened lead. An analogue (needle indicator) meter is required, as the next stage is to adjust the trimmer capacitor TC1 for maximum output.

The prototype VFO is surprisingly stable, even lying loose on the bench,

## VFO Frequency Coverage Values

Component	Band				
	160m	80m	40m	30m	20m
C1	60-180 (56)	60-120 (56)	47-53 (39)	33-35 (22)	18-23 (10)
C2	1000	560	220	150	120
C3	2200	1000	470	330	270
C4	2200	1000	470	330	270
C5	82	39	22	15	10
C6	22	22	22	47	68
C7	150	82	56	39	33
C8	2200	1800	1200	820	680
TC1	5-65	5-65	6-25	6-25	6-25
RFC1	1mH	470μH	220μH	100μH	100μH
RFC2	1mH	470μH	220μH	100μH	100μH
RFC3	100μH	47μH	27μH	27μH	27μH
L1	52 turns 30swg T50-6	37 turns 26swg T50-6	27 turns 24swg T50-6	22 turns 22swg T50-6	18 turns 20swg T50-6
L2	90 turns 36swg T50-2	59 turns 30swg T50-2	36 turns 26swg T50-2	30 turns 26swg T50-2	26 turns 24swg T50-6

be heard on the receiver. The receiver calibration may be used to calibrate the VFO ranges from 1.8-1.9MHz and 1.9-2.0MHz. If a frequency counter is available then calibrating and range setting is much easier. Simply couple the output to the counter and adjust accordingly.

The VFO is the most complex and potentially difficult module to build, although the prototype produced no problems. After the VFO - it's all downhill!

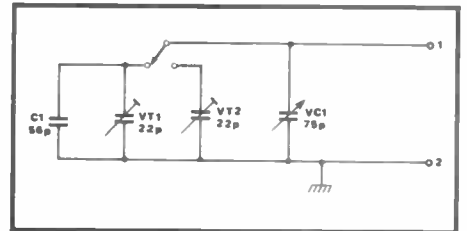

Fig 3 Frequency coverage for 160m

### Parts List

In 2 Bands: 1.8-1.9MHz and 1.9-2.0MHz  
 C1 = 5pF (polystyrene)  
 VT1 and VT2 = 2-22pF foil trimmers  
 VC1 = 75pF airspaced variable  
 (Moving plates/spindle must be connected to ground)  
 S1 = single pole changeover toggle switch

### The product detector

The product detector is designed around the popular MC1496 mixer IC. The MC1496 is a cross-coupled double-balanced mixer device capable of good local oscillator rejection and having some gain. The circuit of the product detector is shown in Figure 4 (a), with the layout in Figure 4 (b).

The VFO is injected at points A and B. The VFO input is via two capacitors (C4 and C5) and should be connected to the VFO with screened lead, if possible miniature 50 ohm co-ax. The centre is joined to point A and the braid to point B. The braid should be grounded at the output of the VFO.

The radio signal is injected at C1 and the resultant audio output comes via C8. The input radio signal requires filtering to prevent overloading by strong adjacent signals, which is provided by the double-tuned front end circuit.

The double-tuned front end circuit is shown in Figure 5 (a), with the layout in Figure 5 (b). The circuit, usually called a bandpass filter, consists of two tuned circuits (L1 and C4, and L2 and C5). The tuned circuits are loosely coupled by C2, with C1 and C3 coupling the input and output.

The front end parts list shows how the circuit can be applied to a receiver on any amateur band from 160m to 20m. The inductors, L1 and L2, are commercial coils made by Toko. The input is designed to be fed by an antenna with 50 ohm impedance, and the output matches the 500 ohm input of the product detector circuit.

This front end circuit is designed for bandpass filtering without the need for re-adjustment in use; there are no

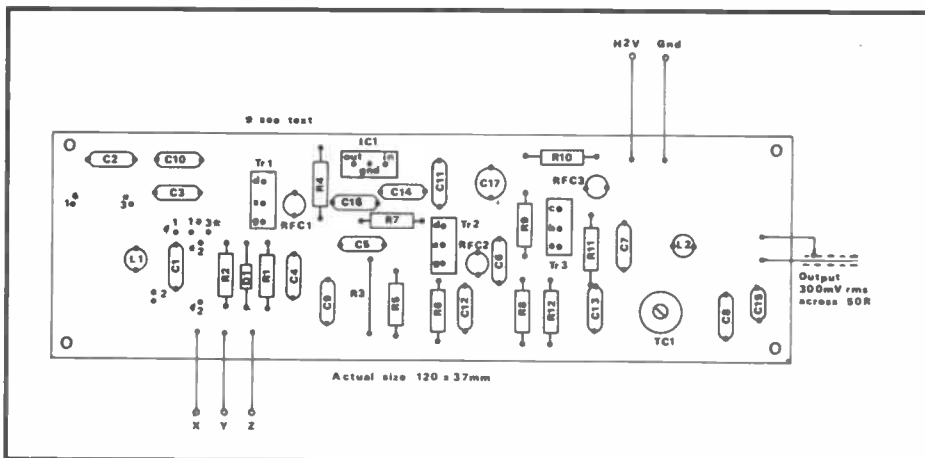

Fig 2b VFO layout

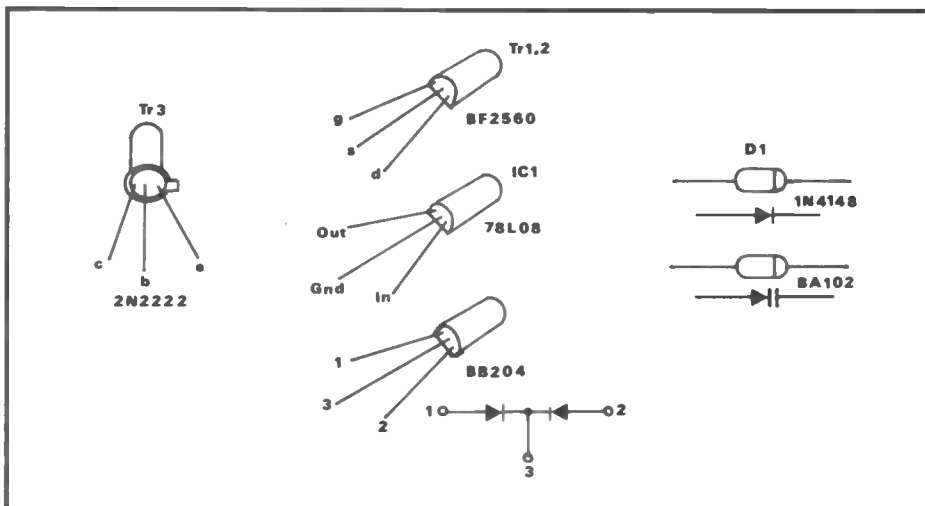

Fig 2c Semiconductor lead identification

and VT1 in the Figure 3 configuration should enable the two segments of the band to be covered, with a very slight overlap.

The frequency of the VFO may be checked using a receiver which covers 1.8 to 2.0MHz. As the variable capacitor is tuned across its range, the signal should



# BITS TO BUILD

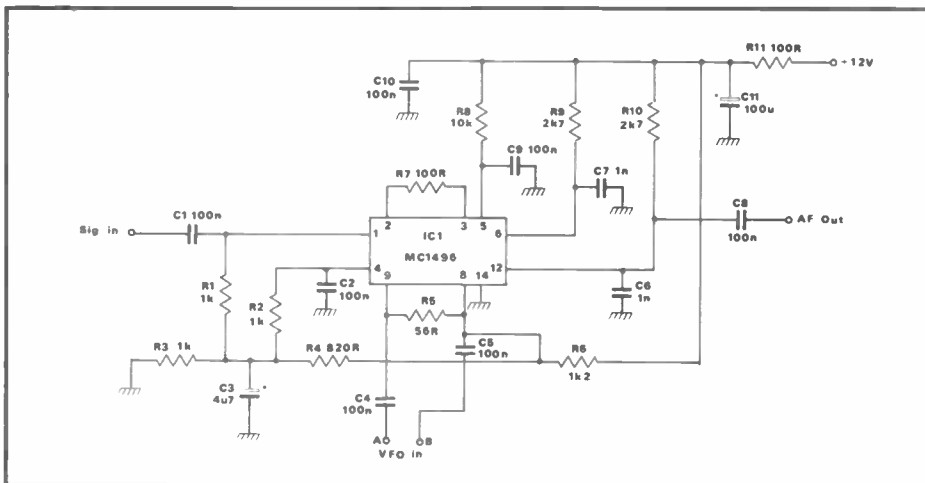

Fig 4a Product detector circuit diagram

## Product Detector Parts List

### Resistors (all 0.25W):

R1	1k0	R2	1k0	R3	1k0	R4	820R	R5	56R
R6	1k2	R7	100R	R8	10k	R9	2k7	R10	2k7
R11	100R								

### Capacitors:

C1	100n ceramic	C2	100n ceramic
C3	4 $\mu$ 7 63V electrolytic	C4	100n ceramic
C5	100n ceramic	C6	1n0 ceramic
C7	1n0 ceramic	C8	100n polyester
C9	100n ceramic	C10	100n ceramic
C11	100 $\mu$ 25V electrolytic		

### Miscellaneous:

MC1496 IC  
8x1mm terminal pins  
Printed circuit board

alternative is to increase the value of C2 to increase the bandwidth of the filter. This may cause overcoupling and pass-band ripple, but this may be acceptable in a simple receiver. In fact I increased the value of C2 to 100pF and obtained acceptable results on 160m.

The front end module can be set up in advance of its use in the receiver if the constructor has an RF signal generator and an RF voltmeter. Inject a signal into the input, terminate the output with a 470 ohm resistor and the RF voltmeter. The cores on L1 and L2 are rotated to maximum output. A few adjustments ought to be made at either end of the band and in the centre, to give the best compromise settings of the cores.

Take care with the brittle cores – use the correct trimming tool rather than a hefty screwdriver. I suppose I ought to have followed this procedure, but in practice I used the method that I guess most readers will use. That is, to peak signals using the cores when the front end is installed in the working receiver.

### Audio output stage

The advantage of building the audio output stage next is that it can be used to test the product detector and front end in conjunction with the VFO. Although ideally there should be additional audio pre-amplification between the product detector and the audio output stage, a receiver of reduced sensitivity can be made with the modules shown in Figure 1 (b).

The circuit and layout of the audio output module is shown in Figure 6 (a and b). The module is a 'stand-alone' amplifier capable of some 2 watts of audio output to a standard 8 ohm loudspeaker. The prototype gave a maximum output of 0.7 watts for a signal of 50mV RMS at 1kHz. The frequency response of the amplifier is set by C1/R1/C2 which could be changed to taste, but the quoted -3dB bandwidth of 165Hz to 8kHz is about right for our application.

The LM380 IC used in this module is not my favourite. It is very popular, but I have found examples to be noisy and prone to instability. This circuit is adequately decoupled with C7 and C4 and this, with the input filtering and output network (R2/C5), uses the LM380 to advantage. Even so a stable, ripple-free power supply is required, with well screened leads to the input and volume control connections. Overloading this circuit will cause instability and the characteristic 'leave me alone' squeal.

### Testing the modules

Once the modules described so far have been built, it is possible to make up the receiver circuit shown in Figure 1 (b). As mentioned above, this combination will lack some sensitivity because extra audio amplification is required between the product detector module and the audio output stage. When I tried this combination hooked up on the bench, though, I was surprised at the good account it gave of itself.

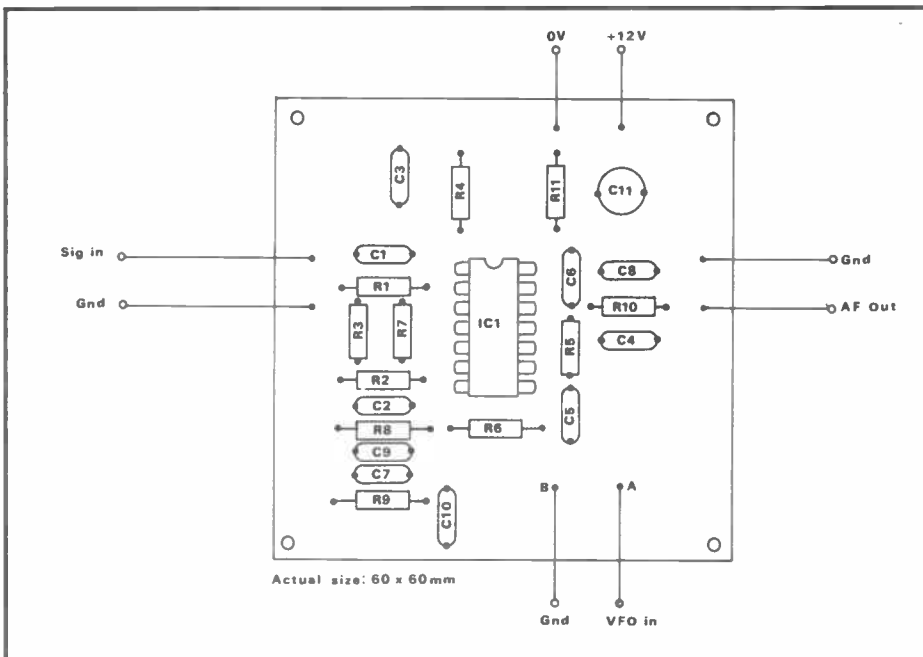

Fig 4b Product detector layout

variable capacitors. The values shown provide a flat coverage of the bands above 40m, but on 160m and 80m the bandwidth is limited. The constructor

may decide to peak the filter at the centre, or on a favoured portion, of these bands and make do with the fall-off at either end of the tuned range. Another

# BITS TO BUILD

Figure 1 (b) shows how to join up the modules and the relative placings of the terminations on the board layouts. Use screened leads for input and output connections to all the boards. If the front end board is laid adjacent to the product detector board, a couple of short wires can easily link the boards, although I used screened lead. Ideally, miniature 50 ohm coaxial cable should be used for these interconnections, but it is expensive and not always easy to obtain. Before I bought a large reel of splendid, flexible 50 ohm sub-miniature co-ax for next to nothing at a radio rally, I always used cheap screened lead designed for audio applications. It might not be the ideal stuff, but for short runs between boards it serves the purpose well.

The antenna input is designed for 50 ohms, so unless the constructor is fortunate enough to have a full 160m dipole an ATU will be required to match the typical amateur 'bit of wire' to the input. In practice, just putting the station antenna - whatever it is - onto the input will yield some signals.

Now is the time to adjust the cores in L1 and L2 of the front end board for maximum output, and to adjust the frequency coverage of the VFO now that it is connected to the product detector. If it is daytime and/or summer don't expect 160m to be full of amateur signals, but there will be commercial signals and 'warbles' within the band.

By now the possibilities of the Jandek modules will be apparent. Next month I will examine the building of the audio filter modules to complete the receiver. There are two: JD002-S for SSB reception and the JD002-C for CW. Either can

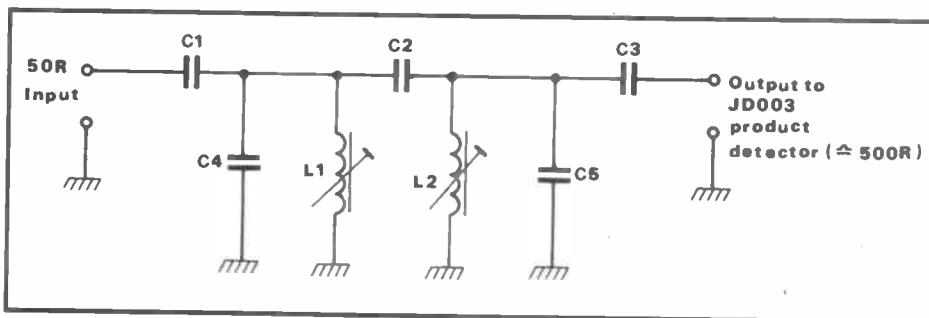

Fig 5a Double tuned front end circuit

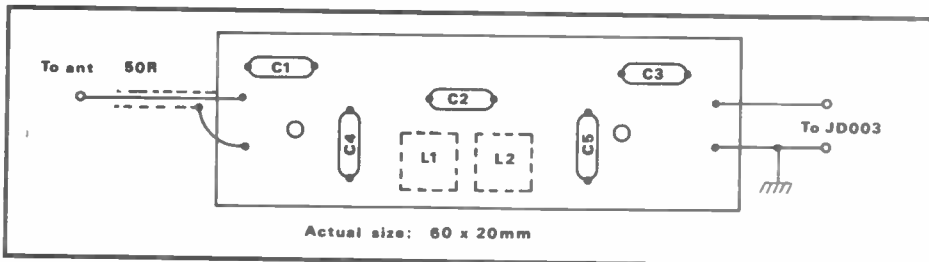

Fig 5b Double tuned front end layout

## Front End Parts List (listed by band)

Band	C1	C2	C3	C4	C5	L1 and L2
JD007 - 160mm	270	68	100	560	680	119ANA5874HM
JD007 - 80mm	82	15	27	220	270	113CNK1369HM
JD007 - 40mm	39	6.8	15	150	180	113CNK1370HM
JD007 - 30mm	22	2.2	6.8	68	82	113CNK1370HM
JD007 - 20mm	15	2.2	4.7	47	56	113KN2K1026HM

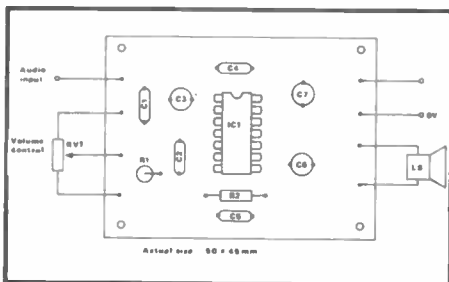

Fig 6b Audio output stage layout

## Audio Output Stage Parts List

R1	22k 0.25W (see text)
R2	2R7 0.25W
C1	100nF polyester (see text)
C2	1nF ceramic (see text)
C3	4μF 63V electrolytic
C4	100nF ceramic
C5	100nF ceramic
C6	220μF 25V electrolytic
C7	220μF 25V electrolytic

RV1 10k log pot

IC LM380N

Plus 8 1mm terminal pins

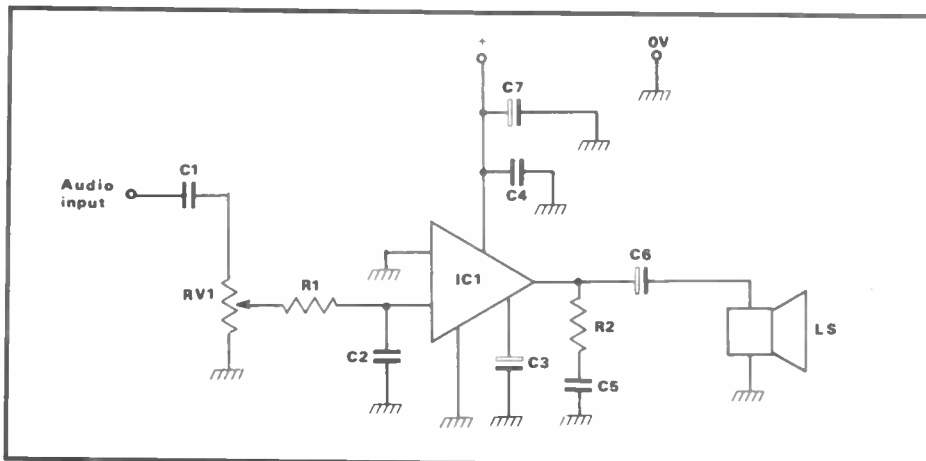

Fig 6a LM380 audio output circuit

be used, although if only one is to be included the SSB filter is probably the better choice because both CW and SSB can be resolved. Using both modules is better still.

### Sources:

These modules are available from: Jandek, 6 Fellows Avenue, Kingswinford, West Midlands DY6 9ET. Tel: (0384) 288900 (weekends and evenings)

### Modules:

JD004 (VFO) at £7.75  
 JD003 (product detector) at £4.25  
 JD005 (front end filter) at £2.85  
 JD001 (audio output stage) at £3.70  
 Postage and packing is £1.00

### Also available

JD002 - S (SSB Audio Filter) at £4.45  
 JD002 - C (CW Audio Filter) at £4.45

A suitable 75pF variable airspaced capacitor may be obtained from: J Birkett, 25 The Strait, Lincoln LN2 1JF. Tel: (0522) 20767

**Part 1 of The Jandek Receiver appeared in the June issue of Amateur Radio and featured figures 1a and 1b. If you would like to obtain a copy, please contact the Back Issues Department at our address on p3.**

# ICOM



## ICOM at the N.E.C.

At this years R.S.G.B. Exhibition the full range of ICOM Amateur Radio Equipment will be on display. ICOM (UK), the official UK importer will have their fully experienced sales team ready to discuss and recommend the ICOM products to suit you.

So come on down to NEC and see why ICOM is number 1. You will find us on stand B6 alongside R.S.G.B., B.C.N.U.

## NEW! IC-32E Dual Band VHF/UHF FM handportable

### Features:

- Full cross band duplex operation.
- 20 Dual band memories.
- Scanning.
- Compatible with ICOM accessories.
- 5 Watt output with IC-BP7 nicad.
- Small size.
- Power saver circuit.

When are ICOM going to produce a dual band handportable? This has been the most asked question about new ICOM products for a long time. The IC-32E is the answer.

This exciting new handportable offers full cross-band duplex operation, and with a built-in duplexer allows single antenna operation. 3 Watt output is standard but with the BP7 high power nicad pack or external 13.8v, 5 Watts can be achieved on both bands. The IC-32E comes packed with features, such as the 20 memory channels which can store both a VHF and UHF frequency in one memory and also simplex duplex condition, offset direction and frequency.

There is a choice of five scanning functions, full programmed memory, memory band and priority. The die-cast frame gives a solid construction featuring rubber gaskets for splashproof operation. The IC-32E is supplied with VHF/UHF a dual band antenna, BP3 battery pack and wall charger. OK, when are ICOM going to produce a new dual band mobile with full cross band duplex? The IC-3210E will be the answer.

**Icom (UK) Ltd.**

Dept AR , Sea Street, Herne Bay, Kent CT6 8LD. Tel: 0227 363859. 24 Hour.

Count on us!

# All Aboard at N.E.C.

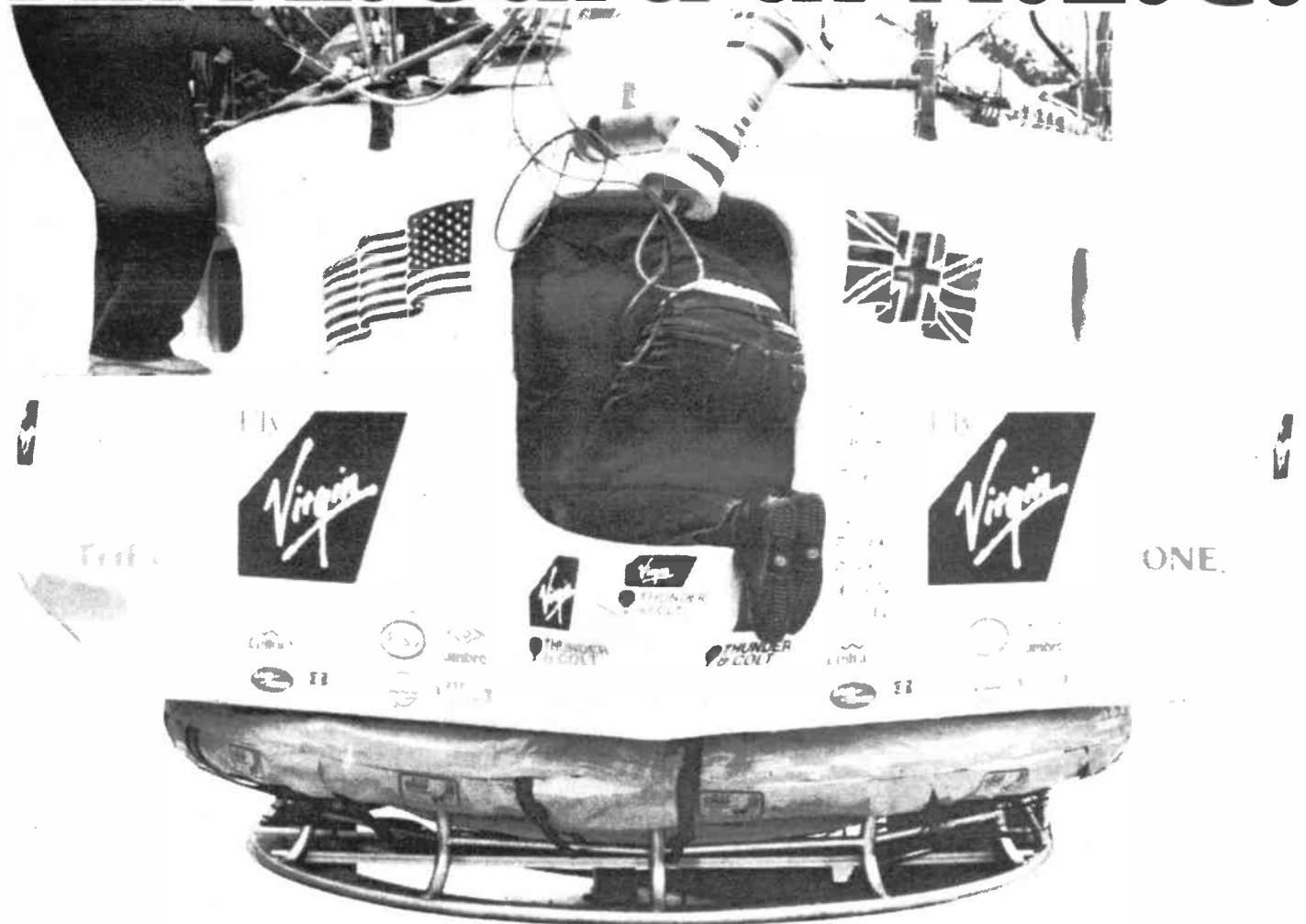

Exclusive this year to ICOM stand at N.E.C. will be the Virgin Balloon Capsule "The Flyer" which was piloted by Richard Branson and Per Lindstrand who used ICOM equipment to co-ordinate the first successful crossing of the Atlantic by Hot Air Balloon.

Climb aboard the capsule and experience the conditions encountered by the two aviators. See how ICOM equipment was utilised for aeronautical communications. Do not miss the opportunity to see the "Flyer"!

**Helpline:** Telephone us free-of-charge on 0800 521145. Mon-Fri 09.00-13.00 and 14.00-17.30. This service is strictly for obtaining information about or ordering Icom equipment. We regret this cannot be used by dealers or for repair enquiries and parts orders, thank you.  
**Datapost:** Despatch on same day whenever possible.  
**Access & Barclaycard:** Telephone orders taken by our mail order dept. instant credit & interest-free H.P.

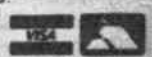

# Second-Hand Receivers

## for under £50

By Hugh Allison G3XSE

### Mohican (Heathkit)

Here we have a classic. This is an early sixties set, hence it has AF series transistors. The same disease that affects EC10s (see above) can nobble your Mohican. It is 12 volt powered, though most will run (just) on a single PP9. It has an RF stage, mixer, separate oscillator, transfilters in the IF (ceramic resonators) plus a varicap-tuned BFO built in. This means there is reasonable general coverage performance up to 14MHz. The transistors in the mixer and RF stages tend to fade out a bit above 14MHz or so. Image rejection is into double figures, just, on 28. So is the sensitivity! It's 10 $\mu$ V for 20dB signal noise on most of the examples I've come across recently. Put it this way – on 17MHz your average CB set will do the proverbial all over your Mohican, sensitivity wise. Dial setting accuracy is a bit hit and miss.

I love the built-in aerial. It's more of a fishing rod than a telescopic. On it acceptable stuff comes in up to 14MHz or so even indoors. After a domestic set

Heathkit Mohican



with a short wave band on it, the Mohican is a move in the right direction, though you could do better.

As I recently stated in the more normal *Second-Hand* column, Mohicans eat their varicap diodes. No sweat though, you just stuff in almost anything diode flavoured. The normal column also prompted loads of letters about the 'spring loaded split gear anti-backlash thingy' on the tuning capacitor. It does seem to have a high failure rate, it seizes up. Again no sweat, prise it back into action with a narrow screwdriver. Take care not to snap the dial cord while you are in there. If it's chewed up the gearing on the variable, move the backlash mechanism to a fresh bit by spacing it out with washers etc.

It is, of course, obligatory to chew up the IF coils in Mohicans. One correspondent has reported a source of near-replacements from Garex, which is good news. Another weak point is the 'S' meter, which goes open circuit. When this happens, the set goes dead in the AVC position.

A tatty, non-working Mohican will set you back about a fiver. Its wonderful handbook should make a kitchen-table repair possible for moderately competent amateurs. Good clean examples are, unfortunately, gaining value. A couple of

years ago £25 was the top price, now it's £35. One didn't sell at Woburn last year at £45, so that is obviously too much. Again, it was originally a kit, so open up your intended purchase and have a look prior to parting with the readies.

### Codar T28

Back in prehistoric times, when operating on two metres meant valve Pye Reporters with acres of heaters damaging your car battery's health, one alternative was to operate mobile on 160 metres (1.8MHz). Codar were quick to spot the market and produced, from a combination of commercially made Mullard modules, their own PCB and a distinctive metal cabinet, a rather nice little receiver.

The product of their endeavours is a nine transistor single superhet dual band receiver (for 160 and 80m), with built in BFO and RF stage. Controls are kept to a minimum but there is a good clear tuning dial that is easy to set to within, say, 5kHz. The frequency stability is excellent and the thing will work down to 9 volts from its recommended 12 (nominal). There is no built-in speaker.

The receiver was designed for mobile use with their AT5 AM/CW transmitter which could be powered up via their inverter, since this consisted of valves.

Codar T28

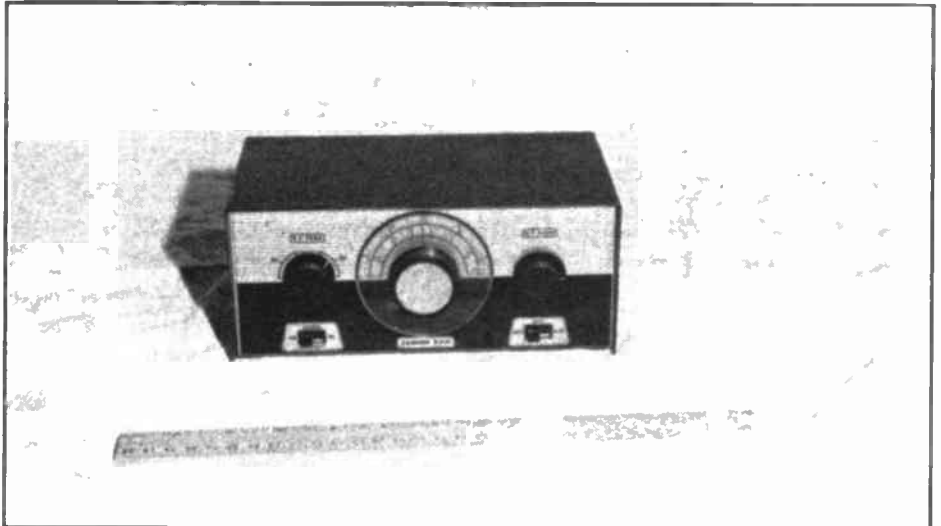

## SECOND-HAND RECEIVERS

Obviously, a mobile whip was the expected aerial, and it is here that the T28 falls over. Wop it on the end of a decent length of wire and you get into blocking and second channel trouble, though an ATU can help appreciably. If you have 30 foot of wire down the garden and an ATU, be prepared to be impressed by what a T28 can pull in on 160 and 80. 100 metres of non-resonant aerial straight up the aerial hole will produce a barrage of rubbish that, in all honesty, isn't there. Make with an ATU and maybe an attenuator, and all will be well.

For amateur use you are restricted. Restricted to 160 and 80 metres. For general coverage broadcast use, it's no use at all. I have seen the odd one in cars at rallies doing what they were designed for, ie mobile top band use, though they are more often coupled up to a homebrew SSB Tx. The saving grace for the T28 is probably the number of 80 to 10 metre rigs about. Amateurs buy T28s to have a listen to the band they are missing, which is top band.

Price-wise, the money depends on the condition. I bought one that had been taken to bits by an ape at Old Warren last year for £1. It took no more than an hour to rebuild it, repair the faults the last repairer had put on it, then fix the original fault—an open circuit track. They are no harder to work on than your average late sixties medium wave transistor radio. In good order, the price depends on condition. £12 would get you a scruff, £20 would be absolute tops for a showroom job. Not bad depreciation for a receiver that cost £15 about twenty years ago! You would have to work at it to lose a great deal of money with one of these.

### Perdio Town and Country

This was a domestic portable, British made, again from the late sixties/early seventies. As well as the more normal medium/long wave it covered up to 4MHz, though some covered medium/long plus 6 to 17MHz. As a nipper I can remember looking admiringly at one in Boots shop window. A portable amateur receiver – the excitement of it! There is

no BFO, but provision is made to switch in an external aerial. This was often used in mobile installations many years ago. A BFO can easily be knocked up for one of these, the IF is around 455kHz so there's no problem.

Performance wise, with respect to blocking, second channel and how it will work on a long aerial, refer to the write up on the T28, as it is identical.

Price wise, well, at the Gandhi Halls bike/musical instrument/radio jumble last year I was given one! The bloke, who was trying to sell a non-worker for a modest 50p was so surprised that I knew the set that he gave it to me! He used to work for Perdio and knew a lot of their history. A worker, bought under more normal circumstances, will set you back £5 to £10, £8 being the average.

There is a lot of interesting stuff between the end of the medium wave (1.5MHz) and about 4MHz. For general listening, plus a round-the-house domestic squark box, it's worth considering. For amateur use it's not mega-useful.

### Astrad

Also known as the Vega, and other things. Quite widely advertised, it can be bought new, even now – this set's ancestry goes back to early seventies Russian sets. We have a big turret coil change for changing bands, and ridiculous mega-ancient looking 'Top Hat' transistors inside. If you don't know what a Top Hatter was, ask your grandad.

Most of the ones I've come across cover LW, MW, then short wave up to about 18MHz. Some then have a VHF section for domestic FM.

Performance is not bad, as a portable. If you tire of mindless DJs and the like there is plenty of other stuff to listen to on one of these. Put in a big aerial and there are second channel and blocking troubles. The other aggro is that there's no BFO. Again, there is a 455kHz IF, so in with a one transistor device or something and CW and SSB become available. It is quite stable, bordering on surprisingly stable. The FM variants are quite sensitive and sound quite pleasant.

Servicing wise, some transistors in some of the variants are in sockets. Arrgh! The bliss of just pulling one out to check it is wonderful. Don't forget that the transistors are leakyish, so backward-biased junctions will show some reading on ohms – 10k and above might be OK.

The turret is the main bugbear. There are silvered studs rotating past fingers. The studs oxidise. The fingers *don't* bend, so leave them alone. To cure an intermittent set just rub over the studs lightly with a plastic pan scourer, and I mean lightly.

The other components inside look a bit weird, but modern stuff will go in as a replacement if you are keen. The components are often marked in Russian, but the layout is easy to follow. Russian electrolytics are not renowned for reliability, especially the 100µF and above sizes as in Rigonda TVs. If you have a dead set that is doing everything except make a noise, it is invariably the dc blocking electrolytic 'twixt output stage and speaker that has gone open circuit. This is a very common failure indeed.

The price, new, will be £20 to £30 dependent on the greed of the seller. Second-hand and working, it should be half that. Non-working, 50p to a quid, two if you must.

It's not bad, add a BFO and you are in for a pleasant surprise as to what it can do with its own aerial and, again, ideal as a round the house portable as well.

### Eddystone S504

Classic Eddystone styling again, dated but timeless (I know that's a contradiction, but you know what I mean). Heavy too, but that's an indication of the reliability. It's built like the proverbial, and will work forever if left alone.

It covers 580kHz, with a built-in noise limiter, BFO, crystal filter and 'S' meter. This is quite a powerful tool, and the S504 will certainly pull them in. The review sample was 5 microvolts for 10dB signal to noise at 28, increasing rapidly as we came down in frequency. Second channel was a moderate 25dB, again at 28. Wop a modern RF pre-amp in front and you can hear it all with one of these.

Tuning accuracy is, admittedly, vague. I'd back one only to 50kHz on the top ranges, so the next most important accessory for you to buy or build is a calibrator. You can just about set the thing to receive the amateur band you want to listen to, but not to any specific frequency within that band. It's no cop for trying to find a broadcast station on 7.410MHz for example, though when you've found it, the set will bring it in.

Talking of accessories, don't try and power anything else off an Eddystone. I'm not saying they will not do it but the very few I've had in not working had burnt out transformer windings due to overloading. Nuff sed?

The filter will 'ring' nicely on CW and is a pleasure to use. I also love the way the band details change in the top left hand

Left: Astrad. Right: Perdio Town and Country

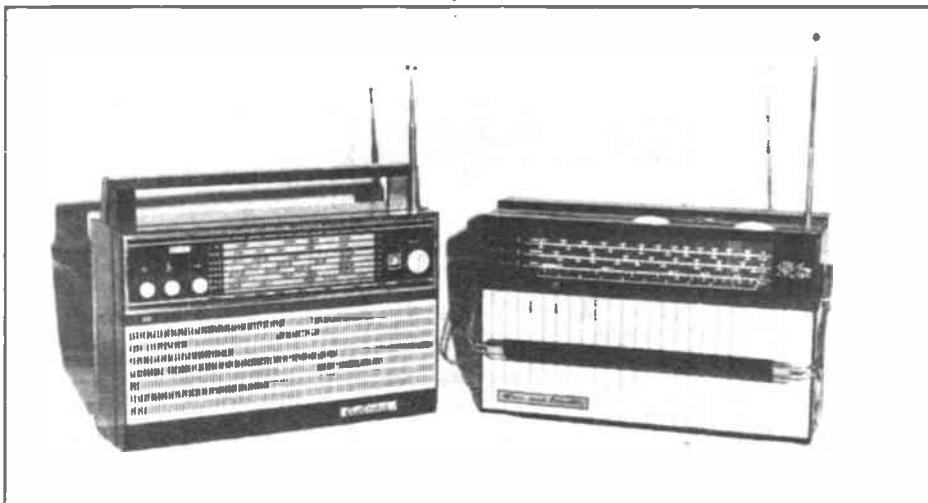

## SECOND-HAND RECEIVERS

'window' (a one inch circle in the dial) to tell you what you are switched to. The set is acceptably stable.

To return to the styling, the thing looks like there is a speaker fitted internally on either side of the tuning dial. There isn't. The external 'matching' speaker shown in the picture can sometimes command amazingly high prices from collectors if in good condition, would you believe £20+? Leave the collectors to it. A period Eddystone might look funny running into, say, one car stereo speaker of modern design, but I'd personally rather do that and have an extra twenty sovs in the wallet.

Price wise S504s cost £40 to £50 in reasonable working condition. I've come across so few duff ones that I cannot comment on the value of a dead 'un; as a guess, say a third of this. Sure there is cheaper about, but it is a reliable, reasonable receiver with some scope for improvement via add-ons. It's worth noting that Eddystone stuff doesn't normally lose its value and, indeed, this receiver seems to have put on a respectable £25 (or doubled its value) in the last 10 years.

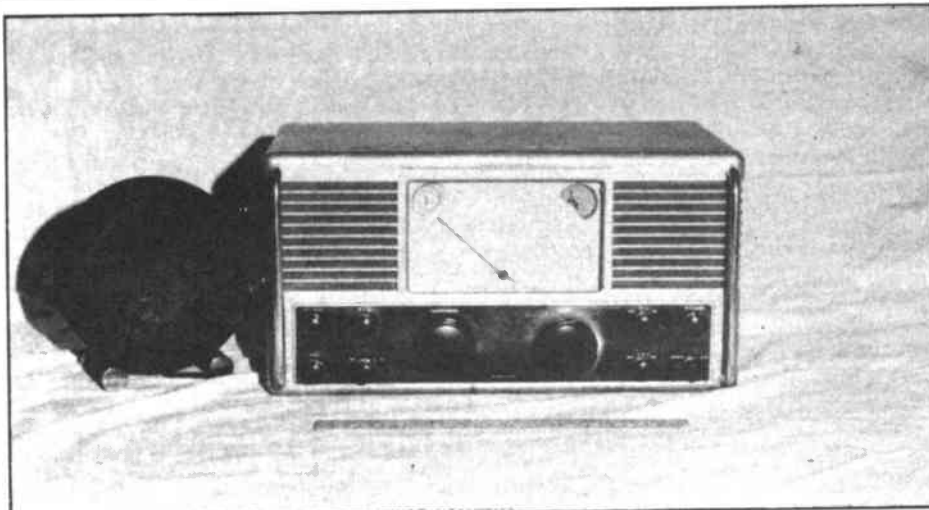

Eddystone S504



Lafayette HA350

### Lafayette HA350

Perhaps I've left one of the best bargains until last. This amateur bands only receiver, with Tx/Rx muting built in, seems quite unknown to your average amateur/listener. I have a sneaking feeling that the uncluttered front panel layout, with the lack of knobs to play with, makes it look a simple machine. Couple this with the now relatively unknown name of Lafayette compared with Trio, Yaesu etc, and perhaps we have an explanation of why examples of this fine receiver often spend the whole day on bring and buy tables without selling. The styling is also, perhaps, slightly odd with the 'big T' in the middle holding the main tuning knob, 'S' meter and tuning scale, but I don't think it looks too weird.

The tuning accuracy is normally spot on, to within a couple of kHz at worst. Stability is excellent, and you can set the dial calibration from the front, if required. There is a built in noise limiter which, in the review sample, works very

well when confronted with pulse type (ignition) interference.

Price wise, these often start off at about £65 but drop to £45 after they haven't sold. Strike then and you have a bargain. The sensitivity of the set will pull in all that's going up to 21MHz, and 28 is only a little down on 'nowadays' standards. Second channel is good so, all in

all, this is a good and easily obtainable bargain.

Don't miss the August issue of **Amateur Radio**, on sale 28 July

### SATELLITE TV RECEIVING EQUIPMENT

#### Dish Spinings

60cm RAW .....	£19.32	80cm RAW .....	£26.59
90cm RAW .....	£28.08	1M RAW .....	£39.85
1.2M RAW .....	£47.04	1.5M RAW .....	£60.78

Feed Horns From £26.74

#### LNB's

KU/BAND from .....	£113.85	C/BAND from .....	£87.98
--------------------	---------	-------------------	--------

Prices include VAT, carriage charged at cost  
For further details contact:

**HARRISON ELECTRONICS**  
Century Way, March, Cambs PE15 8QW  
Tel: (0354) 51289

## DEWSBURY ELECTRONICS

SUPPLIERS

of

KENWOOD - YAESU - ICOM - BENCHERS  
AIRBAND RECEIVERS - SCANNERS - VIBROPLEX  
S.M.K. - C.M.K. - MORSE KEYBOARD

For further details send SAE:

176 Lower High Street, Stourbridge,  
West Midlands, England

Telephone: (0384) 390063/371228

Telex: 336712 SHELTING; Fax: 0384 237367

# THE WILCO PRINCIPLE

by Roger Williams G4PMM

As an amateur of nearly five years standing, it is clearly time I began to impart words of wisdom to others in the hobby. From my excellent vantage point in the middle of the call-book, one previously undiscovered law of radio becomes apparent. This law, the Williams Inverse Law of Communication, or WILCO for short suggests, that the more one becomes involved in amateur radio the less one communicates. One strives to reach the perfect state of using radio equipment without communication at all. Amateur radio is littered with innumerable examples of this law and one of the chief aids in this respect has been the 70cm repeater to which this column is in part devoted.

The first thing to remember, is that repeaters are designed to inhibit rather than facilitate communication. This being the case, the following procedures should be borne in mind to ensure that no communication is possible.

- 1) Before accessing a repeater from a mobile station accelerate to 80mph, open the windows, put a handkerchief in your mouth and then give your call-sign clearly.
- 2) Always leave your tone-burst in and try to complete as much of your over while it's still sounding.
- 3) Always call a single station who you believe won't be listening and preferably one who doesn't have any equipment for the band in question. This will ensure that the box gets maximum use without the tiresome necessity of having to communicate with anyone.
- 4) Never respond to a station that is just 'listening through' or 'listening for any call'. This only encourages mindless use of the box by people experimenting with the amateur medium.

Sometimes, despite all precautions a QSO will break out even on a 70cm repeater. Incidentally, if you're tempted to try to get a contact through an uninhabited box, there is one certain way of doing it; you raise the box and say 'G4PMM listening Delta Mike', and instantly someone will come back to inform you that it's not Delta Mike at all. Something that you knew all along, because there's no such repeater. It doesn't half get people going though, and never fails to get a QSO if you really feel the need for one.

Now where was I? Ah yes, the WILCO principle... this applies on a repeater even if a QSO breaks out, especially on the morning commuter run with a shifting congregation of half a dozen or so stations. The important point to bear in mind is that the sole object is to establish whose turn it is, who is still left in the net and who has signed. You know

the sort of thing 'Round to you Brian, oh no, Brian's signed, pick it up Fred', 'Not my turn, it's Eric then Norman', 'I've just destined, you take it Bill', 'I'm in a bad spot...', and so it goes; Amateur Radio obscuring the art of communication and destroying the English language into the bargain. I ask you 'destinated' What kind of word is that for heavens sake?

The WILCO principle tells us that as soon as a mode of communication becomes established enough for a large number of people to be using it, some bright spark will invent something new, so that communication is obscured and ideally obliterated altogether. The first exponent of the principle was of course Alexander Graham Bell who invented the first telephone. He remained in the blissful state of non-communication until someone invented the second telephone and communication was established. What must he have thought when his telephone actually rang? Chances are he was in the bath, and as the pioneer of the WILCO principle, he would have immediately turned his thoughts to another mode.

Speaking of which, what about CW? A better example of the WILCO principle is hard to find. The proposition here is that only about 10% of the CW sent is actually copied, thereby giving us a 90% WILCO quotient. Here's how the sums add up: Take 80m in the evening, after all someone should put out a call and get into a meaningful QSO. The Inverse Law of Communication applies as follows:

- 1) 20% automatic signal loss for QRM, static etc.
- 2) Next knock off another for the 'F' or format factor. As we know exactly what's coming, we mentally switch off for most of the first over, parts of the second and third, and all of the final. Why waste brain power turning the notepad into the amateur equivalent of estate agents' blurb? you know the sort of thing: FB, SIGE, GD, DX, ES, DES, RES, WID, FGCH, ES, VAC, POS, and so it goes on.
- 3) The 'S' or speed factor. Let's be honest lads, don't most of us send at a speed at or above that which we can comfortably receive? It takes a real effort of will to launch into CW at a reasonably conservative speed. Are we not aware that we invariably never return to people, slower than we send? Therefore, unless we're in the First Class Operator club, a good 30% of CW is being sent faster than our ability to receive! This might be just about OK for a format QSO but once the format goes – oh boy, are we in trouble!

We're now up to about 80% information loss and nearing the ultimate goal of nil

communication. The remaining 20% can be disposed of in a variety of ways, the most popular being the introduction of the Vlad-factor. Now we must all admit a lot of admiration for your average Vlad-in-the-Oblast for attempting feats of construction that would get the better of many of us, but at the end of the day it does sound as if the RF has been trampolining its way around the ionosphere to our disbelieving antennas. I reckon that CCCP stands for 'Chirpy Code Chaps Party'

It is not that difficult to apply the WILCO principle to CW but you'll find it applies all over the place in our hobby. I reckon there's a group of amateurs who sit around proposing ever more bizarre modes of propagation and who fall about laughing when they're taken up. I reckon it's the provisional wing of the RSGB at work. How else can the history of our hobby be explained, except by the existence of a WILCO committee dreaming up ever more difficult ways of lobbing dollops of RF around?

Do you remember those wonderful modulated NM signals we used to hear on the HF bands? Perfect communication! Far too good for the WILCO committee who, after due thought, suggested removing the carrier from our transmissions, thereby making our signals completely unintelligible. Needless to say we fell for it and soon started communicating again.

After meeting at the local pub, our friends finally poured out, just managing to say 'let's try bouncing our signals off meteor trails' before collapsing in a hysterical heap on the floor. Trouble was, people managed to do it! Whatever the WILCO committee comes up with is promptly put into action by our resourceful amateur fraternity. Auroral propagation? No problem! Earth Moon Earth? We fell for that too.

Perhaps we should draw some consolation from the fact that despite the best endeavours of the WILCO committee we nevertheless manage to communicate. Even the suggestion that we put RF in 'packets' hasn't stopped us from opening them to see what's there, even though the mode operates the WILCO principle wonderfully well; by virtue of the fact that it works while you're shampooing the cat or doing the dishes.

At the end of the day there is still communication taking place, but doesn't it seem to you sometimes, on some bands and in some modes, that there is rather less real communication taking place than there ought to be? Perhaps that bears thinking about next time you hear a call on SU 20.



# ECW for KITS

- ▷ **K2622 – AM/FM Antenna Amp.** 22dB gain from 10MHz to 150MHz from this kit. Complete with metal case. 12–15V d.c. supply voltage direct or via coaxial input. 50–75ohm impedance lines. **£12.13** per kit
- ▷ **K2554 – Quality FM Tuner.** Varicap tuning from 85–108MHz. 1.2uV sensitivity, 70dB S/N ratio. AFC, AGC and output for digital frequency display. **£32.02** per kit
- ▷ **K2553 – Stereo Decoder.** Works with K2554 tuner kit, includes stereo indicator signal, stereo on/off and 19kHz filter. Excellent stereo radio reproduction. **£17.99** per kit
- ▷ **K1771 – Short Range Transmitter.** Miniature FM transmitter for short distance communications. Inputs from all mics., pre-amps, etc. 1Megohm input impedance, 5mV sensitivity. 100–108MHz adjustable output frequency. 9–12V d.c. supply. **£9.20** per kit
- ▷ **K610 – LED VU Meter.** VU level display using a 12 LED bar graph. Adjustable input sensitivity for all types of signals. **£15.47** per kit
- ▷ **K1798 – 16 LED Stereo VU Meter.** Stereo VU display, twin 16 LED high resolution bar graph output. Internal adjustable pre-amp to give sensitivity from 100mV to 10V full scale. **£26.75** per kit
- ▷ **K2032 – 3 digit DPM.** Three digit digital panel meter module, +999 to –99mV full scale, zero adjust, overload indication, 1mV resolution and 0.1% linearity. 20uV/°C temperature stability. Compact unit easily built in to other equipment. **£28.54** per kit
- ▷ **K1803 – Universal Preamplifier.** For signal matching, low level input boosting, etc. 40dB gain, adjustable output. 20Hz–20kHz bandwidth. 40mV full scale input. **£6.84** per kit
- ▷ **K2576 – 40W Power Audio Amplifier.** No adjustments necessary and non-critical power supply from 2x6 to 2x18V un stabilised 250mV input sensitivity. 10Hz–50kHz bandwidth. (+/- 3dB). Protected against short circuit and thermal overload. **£18.83** per kit
- ▷ **EXPAND YOUR MICRO! – talk to the outside world with an extensive range of motherboard/function kits.**
- Motherboards include:
- K2615 for Sinclair computers – £41.75
  - K2628 for Commodore 64/128 – £53.36
  - K2640 for Amstrad CPC464, 664 – £50.37
  - K2641 for Standard MSX – £50.37
  - K2642 for BBC 'B' and Master – £54.86
  - K2643 for Amstrad CPC 6128 – £57.04
- Plug-in function boards include:
- K2611 eight channel input card – £28.00
  - K2618 single channel D/A – £34.50
  - K2610 single channel A/D – £37.26
  - K2635 analogue multiplexer – £29.33
- (Others available on request)

## ECW

Prices include VAT & Postage. For your order, please make cheques payable to  
**ELECTRONIC & COMPUTER WORKSHOP LTD**  
 Unit 1, Cromwell Centre, Stepfield, Witham, Essex CM8 3TH. Tel: (0376) 517413



### NEW

## FROM NUMBER ONE SYSTEMS

### NEW

## PCB CAD, FOR THE PC/XT/AT, THAT YOU CAN AFFORD

Have you been putting off buying PCB CAD software?  
 Are you still using tapes and a light box?  
 Have you access to an IBM PC/XT/AT or Clone?  
 Would you like to be able to produce PCB layouts up to 17 inch square?  
 With up to 8 track layers and 2 silk screen layers?  
 Plus drill template and solder resist?  
 With up to eight different track widths anywhere in the range .002 to .531in?  
 With up to 16 different pad sizes from the same range?  
 With pad shapes including round, oval, square, with or without hole, and edge connector fingers?  
 With up to 1500 ICs per board, from up to 100 different outlines?  
 With auto repeat on tracks or other features – ideal for memory planes?  
 That can be used for surface mount components?  
 With the ability to locate components and pads on grid or to .002in resolution?  
 With an optional auto-via facility for multilayer boards?  
 With the ability to create and save your own symbols?  
 That is as good at circuit diagrams as it is at PCBs?  
 That can be used with either cursor keys or mouse?  
 Which, with "Easy Plot" can also output to a pen plotter? (A photoplot driver will be available shortly)  
 Where you can learn how to use it in around half an hour?

That only costs £275.00 + VAT.

Please contact us for further information

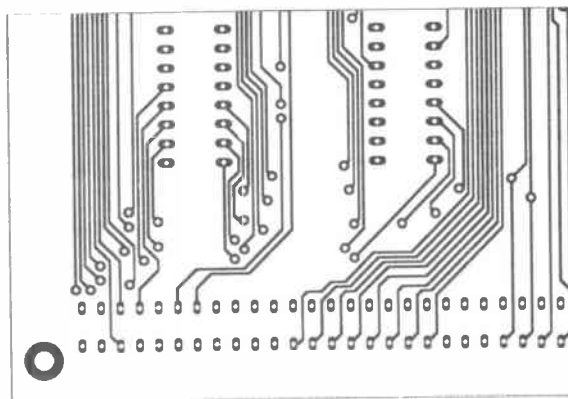

## AFFORDABLE PCB CAD IS HERE!

**Number One Systems Limited, Ref AR**  
**Harding Way, Somersham Road, St Ives, Huntingdon, Cambs PE17 4WR**  
**Tel: 0480 61778**

# REALISTIC PRO-38 AND BEARCAT BC 50XL

Peter Rouse GU1DKD Reviews Two Budget Price Hand-Helds

At the time of writing, the Realistic PRO-38 from Tandy costs £129.95 whilst the Bearcat/Uniden BC 50XL costs £99.99 – a difference of nearly thirty pounds. Why the comparison? Because it is the same set, although a little caution must be exercised in buying the Bearcat model. There are two versions on sale in the UK; the American one with 29-54MHz coverage and the European version which has 66-88MHz coverage instead.

Tandy announced the PRO-38 last summer but said that it would not be available until later in the year. In fact, my own PRO-38 was purchased in the USA, not only because it was a lot cheaper (\$139) but also because I wanted the 29-54MHz band featured on the American version. Even so, the price tag of the British version was tempting in comparison with the going rate for other synthesised hand-helds, and if you price-up a ten channel crystal controlled marine scanner and the cost of the crystals you end up not far short of the cost of the PRO-38, without the convenience of instant re-channelling let alone access to other bands.

## Features

Prices aside, what do we have in this receiver? It is essentially a three band scanner with 10 memory channels all scanned in 1 second whilst employing double superhet principles with IFs at 10.85MHz and 450kHz. Frequency coverage is 66-88MHz (29-54MHz on the American version), 137-174MHz and 406-512MHz and mode is restricted to FM. Indeed anyone hoping to receive AM on the frequencies can forget it. Although it is possible to make out an AM transmission on some FM-only scanners, albeit with distorted audio, it is near impossible on the PRO-38 because the rejection is so good. Delay is not optional, you are stuck with a 2 second pause at the end of each transmission.

With slight variations across each band, the figures quoted for sensitivity were as per the manufacturer's data. The VHF high band and UHF claimed figures are about average bearing in mind the limited space for circuitry. Costs on my own scanner were better than the quoted sensitivity. One slight bugbear is the 5kHz steps for frequency entry at VHF, meaning that you have to put up with slight offset tuning for some British bands where 12.5kHz spacings are used. In practice, this means that some channel allocations may be 2.5kHz off the nearest frequency that you can enter into memory.

## Using the scanner

The PRO-38 is supplied with a 'rubber duck' antenna and belt clip which can be screwed onto the back of the casing. The

antenna is a helix (almost identical to a 2m type) with an additional single wire running up its centre which is meant to act as a quarter wave element at UHF. The fact that the wire runs inside the helix suggests that it could have very little effect when the wire is removed, resulting in little change in UHF reception. Despite quoted sensitivity figures, the choice of antenna means that portable performance peaks at the middle of the three bands. However, the antenna connection is via a BNC socket, so other antennas can easily be attached; particularly for mobile working.

The scanner measures 178mm high by 67mm wide and is fairly slim with a depth of 35mm. It sits comfortably in the hand and a slide-off panel at the back reveals a small plug-in carrier which holds 5 AA Dry cells or NiCads. With the carrier removed (memory is still retained for about 30 minutes) a small switch is revealed, which is used to select dry cells or NiCads. With the switch in the dry cell position, the batteries are automatically disconnected when a 12V power source is plugged into the socket on the scanner's side. In the NiCad position, the 12V supply is regulated to supply a charge current for the cells. This is a highly commendable feature of the set. It means that a simple supply, including a raw 12V vehicle supply, can be used to both power the set and recharge the cells without the expense of an external regulated charger, matched to the voltage and type of NiCads being used. Current consumption is 50mA squelched (a fair bit lower than many hand-helds) and peaks to 110mA at full volume.

The controls consist of rotary squelch, volume and entry keypad. The small LCD display above the pad shows just two digits. To enter a frequency you punch in the figures followed by 'enter'. To check the frequency, you press the 'Review' button and the LCD displays the figures one-by-one at one second intervals before reverting back to the channel number. It sounds an odd way of displaying the frequency but you soon get used to it. There are additional buttons for manual stepping, channel lockout and a key lock switch which disables the keypad so that buttons are not accidentally pushed whilst the scanner is carried around.

## Overall impressions

The set is well made with solid and well moulded plastics. There is no search facility or step up/down in frequency, but then such features would not be expected at these prices. For someone who just wants to monitor a few FM channels the set will satisfy their needs. The only criticisms I can make is that I

would like to have seen a soft case available as an optional extra to stop the casing getting scratched, and the audio is slightly 'thir' (even with an external loudspeaker). It is not a major problem but can make signals a bit difficult to copy in noisy surroundings.

On the other hand I found several features which impressed me. The power supply arrangement is excellent and the standby current consumption is better than a lot of hand-helds. The BNC aerial socket is far more versatile than the screw-in arrangement used on some sets, the scan rate is fast and the set is easy to programme and use.

If this scanner satisfies your needs then the only words of caution I would utter are to be careful if you are buying the Bearcat/Uniden version. Both the American and European versions are on sale in the UK and the Model number is no clue to which is which. Obviously, the version with 66-88MHz will appeal to most scanner users, so if you are ordering by mail it would be wise to telephone the dealer first and confirm which version is being sold.

## Price comparison

Having pressed the point that the Tandy and Bearcat models are identical except for price, I asked Tandy for an explanation. Tandy did not deny that both scanners probably came out of the same factory but said that all their products are manufactured for them to their specification. They added that they insisted on strict controls on uniform specification and quality, and that their products are backed by a nationwide organisation.

All I can say, therefore, is that you pay your money and you make your choice. The PRO-38 is available from Tandy dealers throughout the UK and the BC 50XL is sold through the many radio dealers who stock Bearcat/Uniden products.

## SPECIFICATIONS

### – Realistic PRO-38/Bearcat BC 50XL

Coverage (European model): 66-88, 136-174, 406-512MHz

Coverage (US model): 29-54, 136-174, 406-512MHz

IFs: 10.85MHz (crystal filter), 450kHz (ceramic filter)

IF bandwidth:  $\pm 12$ kHz

Sensitivity (20dB S/N at 3kHz deviation): 29-54MHz = 0.3uV, 66-88MHz = 0.5uV, remaining bands 0.7uV

Selectivity:  $\pm 10$ kHz @ -10dB

Scan rate: 10 channels per second

Delay: 3 seconds (not switchable)

Audio output: 260mW via internal speaker or external speaker/earphone

Antenna input: 50 ohms via BNC socket

Power supply: 7.5V dc from 5 x AA batteries or NiCads or 12V dc external supply for both power and NiCad charge

Current consumption: 50mA squelched, 110mA full volume.

# DX DIARY

News for HF operators compiled by Don Field G3XTT

I am writing this column in the immediate aftermath of the CQ WPX CW Contest. Although I didn't make a serious effort, it was obvious that band conditions were excellent; unlike the SSB leg back in March. Fifteen metres was opening to the Pacific, KL7 and West Coast USA at about 0300GMT, and the path to Japan was open from morning to midnight on both 15m and 20m. On 10m I noted the Far East was opening early in the day and Central America plus the Southern USA late in the day. As for prefixes, there were plenty to choose from, including AT0, AY4, LS1, R1, RL1, RS3, TW6, VO7, XQ1, YY5, ZW4, 4M7, 7S5, 9J0 and 9Y3.

Looking back on May as a whole, I note the W0RLX/KH5 operation from Palmyra Island, worked in the UK on 40, 20 and 15 metres. S9AGD and S9XB, worked in the UK on all five main HF bands; an excellent operation from VK9Y and VK9X by VK6NKG and W7SW (these two made 23,000 contacts from Cocos Island alone, including over 10,000 in the novice segments of 10m and 15m, and made a special effort of checking for UK stations), T32 by some of the KH5 operators en route for home, some loud 15 and 20 metre signals from ZK1XV (VK2BCH, see last month), and much more besides.

Talking about ZK1, I was interested to see from DX News Sheet that Harry G3MCN, made some 6163 QSOs while operating as ZK1XG recently from the South Cook Islands. This included a grand total of 240 G stations which is encouraging, as it gives an idea of the current high level of HF DX activity from the UK. I hope some DX Diary readers were among the lucky ones. Harry commented that the Japanese stations were operating impeccably, with US stations bringing up the rear. The European stations,

however, were so bad that on several occasions he went QRT in disgust.

## Palmyra and Kingman

Now that the KH5 DXpedition is over, it is worth reviewing what went on and some of the lessons which we, as DXers might learn from it. As I said last month, the group made quite an effort for Europe and there were no excuses for missing it. I know of several UK amateurs who made 20m and 40m contacts using verticals and dipoles, so it was by no means essential to have a mega-station to make the QSO. The provisional QSO count was 17,000 from Kingman and 15,000 from Palmyra.

Mind you, the expedition was so active, there was often an issue of priorities. On several mornings of the KH5 DXpedition, the operators were coming through simultaneously on 20 SSB and 40 CW. There was the question of where to put your effort. The answer must be determined by the likelihood of getting through. If you were short of an HF beam, for example, 40m might have been a better bet, especially as propagation at that time tended to favour Western Europe, whereas Southern Europe seemed to be having more success on 20m. This is where good listening comes in. On which band did you hear them making the most UK QSOs?

Good listening, rather than calling incessantly as some stations did, helped in other ways. When I worked the KH5K, for example, they recently changed their listening split from 14130-150 to 14120-150. Many people hadn't heard them announce this, so the band segment 14120-130 was fairly clear for a time and it was relatively easy to get a contact. At times they were also listening outside their announced range, which you could only spot by listen-

ing for the stations they were working.

On SSB, in fact, the operators periodically seemed to use every variation to keep the pile-up within reasonable proportions; listening by numbers, by country, letters, etc. Those who called out of turn simply slowed the whole process down and, ultimately, reduced the probability of a QSO for everyone. So did the inevitable 'policemen' and those who came up on the DXpedition's frequency asking for the DX station's callsign, QSL information, etc. Again, a brief spell of listening would have provided all the information they needed. It also very quickly became clear to those who bothered to listen, that 'tail-ending' (calling on the station's frequency that the DXpedition has just worked) wasn't going to work, as the operators changed their listening frequency each time (usually to a discernible pattern). So those who kept tail-ending were wasting their time.

On CW, the DXpedition operators tended not to announce that they were listening 'UP', which led to some stations (including G's) calling co-channel. A brief listen around would have made it perfectly obvious where they were listening. There was another danger on CW as well. On occasion the KH5 and TY9SI were operational simultaneously near 14025, listening up, and I'm sure some folk who thought they were working the KH5 actually ended up in the TY log. Hardened CW DXers would not have had a problem, but others may have had problems on CW, which may have been lessened by using a memory keyer. In the excitement of the moment the inexperienced operator can easily send his callsign incorrectly, which could be a disaster when it comes to getting the QSL card!

Actually, it's only too easy to make a mistake in the heat of the moment, even on SSB, and call for example on the wrong VFO. Very embarrassing, though it happens to all of us from time to time. And when you do get through after hours of calling, the tension is such that afterwards you can't remember whether you actually gave the DXpedition a signal report! Nevertheless, it isn't cricket to make another contact on the same band and mode, so if you want an 'insurance' contact in such instances, try and catch the DXpedition on some other band or mode.

Short calls with pauses were very much the order of the day. On many occasions I have heard the DXpedition reply to somebody who failed to acknowledge the report because they were still busy calling!

One lesson to be learned was not to assume that a DXpedition will go on to the pre-announced date. The group took longer than expected to get from Kingman to Palmyra (reputedly because they couldn't find the latter!), and then announced the end of the operation earlier than expected. However, never believe what you hear, because having said over the air they would be closing down early on the Thursday, they were then workable for much of the following day!

Of course, all this excitement may have passed you by. To many HF operators a DXpedition pile-up is an unruly scrum, to be avoided at all costs. To the competent DXer, a pile-up actually has form and order and, with a little detective work, can be cracked. With the more common or garden DX you will get a contact sooner or later without trying very hard, so it is easy to ignore the building-up of real DXing skills. However, when a rare one like KH5 comes on, the need for

these skills separates the men from the boys and gets the adrenalin flowing in serious DXers. If a DXer tells you he is cool and laid-back in such a situation, he is either a liar or he must have worked it before and got the QSL!

Incidentally, if you haven't yet looked them up, let me tell you a bit more about these specks of land that the DXers were so worked up about. I included a little information about Palmyra in this column in May of last year, which I haven't repeated here.

Palmyra, an atoll 900 miles south of Hawaii, is named after the American ship which discovered it back in 1802. The island, now uninhabited, although the US had a garrison of some 6,000 there during WWII, is currently for sale and many suggestions have been made for its use; such as turning it into a gambling resort or storing nuclear waste there. The buildings, roads and runway that were built during the war, are in a state of disrepair. One DXpedition came to grief when their plane ran into a tree on landing. The last amateur operation was very brief, by KB1HM/KH5, in 1986, and no European QSOs were made. The last major operation from this DXCC country was AD1S/KH5 from Jarvis Island in 1983 when two of the operators were WA2MOE and W0RLX, who participated in the latest operation. That group made 16,800 contacts with 102 countries, although they were barely audible in the UK and some extremely dubious list contacts took place.

Kingman Reef, 15km by 8km (much of which is submerged at high tide), lies about 35 miles from Palmyra and is believed to have been discovered by an American ship in 1798. However, it is named after Captain W Kingman, who rediscovered it in 1853.

The reason it counts as a separate 'country' from Palmyra and the Jarvis Islands, is that it is under a separate administration. While Palmyra and Jarvis are under the jurisdiction of the US Department of the Interior, Kingman Reef, since 1934, has been under the jurisdiction of the US Navy because of the deep, enclosed lagoon, which was ideal for use as a refuelling stop on trans-Pacific flying boat services. Pan Am used it

for this purpose for about a year for flights between Hawaii and New Zealand, before discontinuing the service in 1938 after a crash near US Samoa.

The last amateur operation from there was AD0S/KH5K in 1981. This group also operated from Palmyra, but the operation was disallowed by the ARRL as they had not obtained landing permission.

To complete the picture, Jarvis Island, from which the 1983 operation took place, is a small (3 by 1.5km) island some 450 miles south of Palmyra. It was discovered by a British ship in 1821, worked by the American Guano Company between 1857 and 1879, annexed by the UK in 1889, and occupied and claimed by the US in 1935. The UK offered no objection and Jarvis has since been used from time to time as a weather station.

The above information on the various KH5 islands has been culled from 'QRZ DX', DX News Sheet of July 1983 and my own files.

### Forthcoming DX

So, enough of these rambles. What is there to look forward to? Well, firstly some operations for island chasers. There will be a major operation from Los Monjes Island off Venezuela from 14-17th July as part of the celebrations commemorating the 165th anniversary (yes, really!) of the Venezuelan Navy. The special callsign YY5M will be used. There will be an award for working the station on at least four bands: from Europe, TV6WAT will operate from the Belle island group from 1-15th July and Y25ZO/P will operate from Rugen Island from 19-29th July. J16KVR, who has already made several IOTA expeditions, will operate from Nago-Shima Island sometime during July and Saki-Shima Island sometime in August. His operations usually take place over a weekend, and he can be found around 21245kHz as soon as the band opens to Japan. 1K1IDC will operate from some of the islands off Mexico, during the period 9-15th July.

As part of the Armada celebrations, the Plymouth Radio Club will air GB4OOA from 21-28th July. N1AME was hoping to operate as VQ9ZM from Chagos, sometime in the period June to September.

KA2CC was planning a late June or early July return to Minami Torishima. By the time you read this, FR4FA/G should be active from Glorioso, and will be there until 31st July. He was quite active in May as FR4DA/J on 15m and 20m, both SSB and CW, so expect a repeat performance. The Greek group who operated last year from Mt Athos are hoping to make a return trip in September, and it is also reported that one of the monks is now licensed as SY2A. JH1FNS is in Kuwait until the end of September, and was hoping to operate the club station 9K2RA. It is almost impossible for foreign nationals to get a personal callsign in Kuwait. Finally, remember that the special callsign EI1000 will be activated again on July 10th.

### Sweden Calling DXers

The weekly bulletin Sweden Calling DXers, which contains lots of interesting HF information, is now put out by SM7DLZ on the HF packet network, and re-broadcast as a 2m packet bulletin in the UK, so if you are equipped for packet operation you might like to look out for this regular bulletin.

### Awards

The Odense Radio Club are sponsoring an award to celebrate their town's 1000th anniversary. European stations need to gain 10 points as follows: contacts with OZ1000 count 5 points, with OZ3FYN and OZ5HCA 2 points and with other stations located in Odense 1 point each. All contacts must be made during 1988. OZ5HCA (Hans Christian Andersen) will be active only from 10-17th July. Applications for the award, to consist of log extract plus fee of 10 IRCs or 5 US dollars, should go (before 31st March 1989) to EDR Odense Div, PO Box 134, DK 5100 Odense C, Denmark.

### Contests

July is a quiet month on the contest scene, the main event being the IARU Radiosport Contest, a mixed mode event, on 9/10th July. The SEAnet (South East Asia Net) CW Contest takes place a week later. Remember also to make an early note of the German Worked All Europe CW Contest, one of the highlights of the summer season.

Have a good summer and remember to take the rig on holiday with you! 73 de Don.

Don Field  
brings more  
DX news in  
the next issue

Write into our  
Editorial  
Office with  
your News  
and Views

# SHORT WAVE LISTENER

TREVOR MORGAN GW40XB

Well, the rally season is upon us again, and the listeners will be in there looking for those elusive parts for their latest 'homebrew' (equipment, that is!) Funny thing is, I often get asked where to get widespaced variable capacitors for antenna tuners. Although the widespaced versions are desirable, if not always essential, for transmitting purposes, they are by no means necessary for antenna tuners for receiving only. The polyvaricon types are easy to obtain, relatively cheap and are perfectly adequate for the purpose.

A more elusive item is varnished copper wire, which old timers would have stripped from redundant transformers. This is probably still the main source but the job of stripping the wire out is time-consuming. Copper wire of reasonable quality can be found at rallies, wound on plastic drums containing about 100m but you may have to search for it.

As regular readers know, I attend a number of rallies during the year on behalf of the International Listeners Association and get to meet quite a few readers in the process. This year, my first rally was the one held here in Swansea and, for the first time, this was held in the Leisure Centre, a great improvement over the previous venue. The larger of the two halls was given over to the main dealers and the size of the premises enabled them to spread their wares and put up good aerial displays. The smaller hall held the bring and buy, the local and national organisations such as repeater groups, RAIBC, WAB, Services groups and the ILA as well as the 'surplus' dealers.

Like last year, there was not a lot of second-hand equipment around. The usual few Racal and Eddystone receivers were seen at the regular prices of between £100 and £175 depending on the model, but there was little else, even on the bring and buy. I'm

afraid that any prospective newcomer to listening would have been hard put to find a cheap beginner's receiver.

Taking the current prices of second-hand receivers of the 'big three' marques, the prices being asked for the Racals does not seem excessive when you consider their quality of construction and reliability. I've never met a disappointed user. Naturally, they are a bit 'spartan' when it comes to gadgetry, but, as I've said many times before, it's the quality of reception that really matters... filters and things can always be added to the receiver if wanted.

Anyway, Swansea ARC gave us a good welcome and the rally was thoroughly enjoyed by our team. Visitors had plenty of room to move around or, as is the habit with rally types, gather in little groups for a chinwag. Thanks to all those who visited the ILA stand and made it all worthwhile. See you at the NEC!

## Broadcast bands

Over the past few years, there has been an upsurge in the interest in shortwave listening. Many of the newcomers have opted to join the amateur bands aficionados but there are many who have made the broadcast bands their hunting ground. In some ways, the broadcast side of listening is easier to get into, as the equipment is simpler and a lot cheaper to buy. However, as with all things, it's a matter of how you use the equipment you have rather than how much you spend on it.

The aim of any radio station is to capture as large an audience as possible and keep it. The programme planners have to find out what sort of audience they are attracting, and, in the case of international broadcasting, what sort of coverage their transmissions have.

Naturally, 'Mr Average' has his own ideas on what he wants to hear and what may be interesting to some people

can be a 'turn-off' for others. With governments having a lot of 'pull' over what is broadcast, it is not surprising that there are political overtones on many broadcasts. Others are of a religious origin, being either set up by an individual organisation (such as the Gospel stations in the USA) or by International organisations (such as HCJB).

Even within these parameters, there is a wide variation in the way the political or religious messages are put across to the listening public and it is interesting in itself to study the subtle ways stations try to put over their 'message' while not being too obvious.

Programme content naturally varies according to the country of origin, but the format is pretty standard. The world news is followed by local headlines and a 'commentary' on a major news item. Usually this is followed by a topical interest subject and, perhaps, a travelogue or piece about local customs. The music content also has set patterns with folk and popular music.

So, with programmes being laid out in such a form, it is easy for the serious listener to make out a standard format for his records. As with amateur listening it is useful, for a number of reasons which we will go into later, to keep a record of what we are hearing. These 'logs', as they are called should contain all the details of the transmission as we hear it. Details of the time, date, frequency, programme content, propagation conditions and so on, can then be referred to at a later date.

Reports from regular listeners let a station know how successful it is. These do not have to be technical but should contain the basic details, your opinion of the programme and its content. It is not a lot of use to the station concerned if you just send them a reception report and a list of what you heard. They want to know what you *really* thought of the programme.

If you want to do the job properly, you've got to be critical without being destructive. If you've got a comment to make about a particular subject, make it clear and to the point. If the station feels the comment to be valid, it will often be taken up in a future programme. Good reports are very much appreciated and are often rewarded with tokens such as badges, pennants, books, and such.

So, what about those 'records' I mentioned? The amateur radio operator is obliged to keep a record of all his transmissions and these 'log books' contain all the information necessary for him, or someone else who has a right, to trace back to any day or time to check his activity at that period. This can be for official reasons, such as in cases of complaints of interference to neighbouring televisions, or for personal interests, such as checking for countries worked or duplicate contacts, etc. However, the log has a more useful purpose.

A correctly kept log book should contain all the details of a particular period that could be of interest to the listener and the station being logged. The arbitrary time, date, frequency mode loggings are obvious, but it is also important to log the propagation and weather conditions and details of the programme. The standard SINPO code (Signal strength, Interference, Noise, Propagation, Overall) report is all right on a QSL card, but fuller details of the type of interference or the depth and time of fading are much better in the log. The programme details can be brief but you should have room for personal comment so that you can refer back to it later.

The average short wave listener will spend, perhaps, a couple of hours a day listening to a range of programmes, but there are more dedicated listeners who spend many hours each day listening to

just one or two stations on a regular basis. These people are known as monitors. Their listening is done to a plan and reports are regularly sent to the stations concerned, giving technical data regarding general reception, inference and overall quality. The SNIPO code of reporting is, usually, abbreviated to SIO and full details of types of interference and, where possible, their sources are given. These monitor stations spend a lot of time and effort getting their equipment working to its best advantage and the aerials trimmed to get the best possible signal. They know when and where to find their 'target' stations and, through experience, what sort of signals they should be receiving.

You do not have to be a monitor to enjoy what the broadcast bands have to offer. As in the amateur side of the hobby, there are awards and contests and you can log countries, islands or specific types of stations. The broadcasters often offer incentives for reports on particular programmes and these are worth looking out for.

Most stations have a letter-box programme and many have special programmes aimed at the serious listener, giving details of propagation forecasts, programme schedules, new stations about to start broadcasting, and so on. Printed schedules are usually freely available if you are interested.

Next month, we'll look at some of these stations in detail and look at just what can be heard even on the cheapest receiver.

**Awards**

Now, to this month's award winners. Firstly, Ian Baxter in Blackburn who sent in claims for the Asiatic Continental Award, logging OD5, TA3, 5B4, YC0, 9K2, ZC4, VU2, XX9, 4S7, BY4, 9M6 and V85 among the entries. Also claimed was the Broadcast Monitor Award with Radio Paraguay, R Togo ORTM Mauritania, R Sus-tatenza, Colombia, SLBC Sri Lanka, R Reloj Costa Rica, Vos de Carabobo, Venezuela, N'Djamena, Chad. ORTN Niamey, Niger alongside many regulars. Some good logging here, and all done with the FRG7700. Well done, Ian!

Darrell Jacobs of Reading is still in there hunting, with the latest claims being for the Asiatic Award with 9K2, EP3, V09, XX9, VU2, BH6, DX3, DU6, YB0, 5B4, TC5 among an interesting list. His claim for the African Award included the SORASD station in Somalia and 3V1, S9Z, 3B8, 5H1, TU2, 3B9, 3D6, C53, C8S and a positive rash of Z86s. With these claims and ones for the USSR and South America awards, the wall must be looking quite pretty at the new QTH. Darrell is now completing his RTTY station, consisting of the Microwave Modules MM2001 decoder, so I expect we will be having claims for that mode in a short time.

Mentioning data modes, brings me to Bill Holt of Leeds, who claimed the first ever Continental award for Europe in Slow Scan Television all on 20m! Bill has the SRX 30, 9R59DS and HA350 receivers with Speccy and C64 computers. Certainly a fine effort, Bill!

Ewald Bartunek of Austria claimed the Gold Prefix Award for 1000 loggings including A2C, A71, AB8, AK9, C5, CO8, CX7, CZ2, FM7, FP0, HK8, HZ1, JH0, J28, PT9, P29, S79, T98, TN8, VK9, XT2, ZD7, 6W8, 7S2 and 9Y4 amongst them. Also, I received his claim for the Broadcast Monitor Award and some very interesting stuff in there too with R Conacy, R Rwanda, R Jamaheeriya, R Garoua, R T Djibouti, R Mogadishu, 4VEH Haiti among them. Well done, Ewald!

Stan Porter of Malawi is also still in the hunt and claimed the certificates for Africa, North America and Asia. Stan monitors Radio South Africa monthly. He recently had the pleasure of a guided tour of RSA with ZS6IN in Johannesburg and thoroughly enjoyed himself looking at all that equipment.

With 10 metres showing its form over the past couple of months, it's not surprising that the reports on loggings emphasize the fact. However, Geoff Hughes of Chelsea has been occupied trying out his 6ft folded dipole and has managed to pull in C31, 5T5, V2S, T77, HP1, 6W6, TU4, 3A2 and many others, so it seems to be doing a fine job.

Peter Bowles has been trying out the AD370 Active Aerial from his QTH in

Peacehaven and has also had good results with DU7, JW8, ZP5, HZ1 and 9Q5 getting into the log, so we have another satisfied listener. Joan Slater in Matlock has been putting the HF125 through its paces and was pleased to have heard all the US states by the end of March! A QSL card has been received from Christmas Island (VK9XP) so she's happy now after a long wait.

A nice letter arrived from Boris Chuistov in the Crimea. Boris is 49 and an ex-marine radio operator and enjoys working CW and SSB using his all home brewed equipment (call UB4JAA) but is just as keen on listening and has 179 countries confirmed.

On the 10m scene, Darrell Jacobs has been logging some interesting stuff including A4XKB, JE8IV, VP8VK (West Falklands), DU2HCO, VK2U, VP8BDA (East Falklands), YC0FEX plus PY1, LU1, ZP5, CX7 and CO7 (Cuba), so things are looking good for the coming months.

Guy Dean of Ringwood has made some interesting loggings lately with VX1AY (Prince Edward Is) on 20m at 1921UTC, ZS6KM on 15m at 2019, 6W6AB on 15m at 1251, VP2MDC on 15m at 1232, A92EM on 15m at 1611, 9T4DR on 10m at 2017, VK5MM on 20m at 2250, LU1DS on 10m at 2017, YV5LAS on 20m at 2153 and JY1 (King Hussein) on 20m at 2138, all around the end of March or beginning of April, which shows how carefully you should listen!

The Gloucester Amateur Radio Society has announced an award which is open to

short wave listeners. There are three classes. Class 1 requires 15 points, class 2 requires 10 points and class 3 requires 5 points. The points can be scored by contacting GARS members (1 point), the club stations, G4AYM and G1AYM (2 points) or any GARS Special event station (2 points). No QSL cards are required but claims should be in log extract form and countersigned by another amateur. There are no band or mode restrictions, entry fee is £2 or 10 IRCs and claims should go to: GARS Award, c/o 7 Bilbury Road, Gloucester GL4 9TS.

Radio Japan has finished renovation work on the YAMATA transmitting site. The station has four 300kW and four 100kW transmitters with 17 antenna units. Reception reports of signals from the Yamata site attract a new range of QSL cards especially designed in celebration. There are two cards depicting a world map superimposed by 'Radio Japan' in Japanese characters, and six new general QSL cards showing views and artifacts.

A new exchange deal with Radio Canada International will enable Radio Japan to use the RCI Sackville site for relaying transmissions to Canada and North America while RCI will be able to use the Yamata site for relay of their programmes to the Pacific area.

Well, that's about it for this month. If you have any news or reception reports, please send them in. Meanwhile have a good month listening.

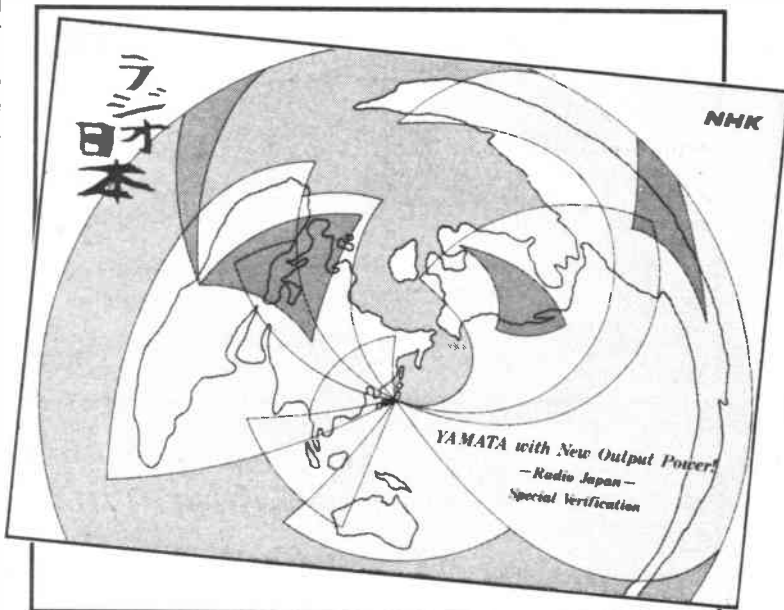

# ICS

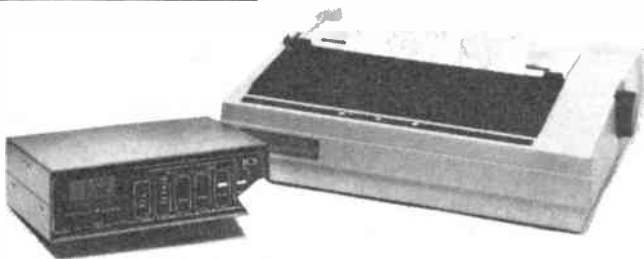

## WEATHER FAX/RTTY/NAVTEX: COMPLETE RECEIVE SYSTEM

Operates with any HF SSB Receiver.  
Easy to use. No computer knowledge needed.  
Fully automatic operation. Built in timer and  
tuning indicator

Gives superbly detailed weather maps, satellite  
cloud cover printouts, printed weather forecasts,  
navigation warnings and news bulletins from  
around the globe

Includes FAX-1 demodulator, mains power unit,  
Epson compatible printer, paper, ribbon and all  
connecting cables. **Nothing more to buy.** Just  
connects to receiver loudspeaker output

**Incredible value at ONLY £399.95 inc VAT**  
Carriage and packing (Securicor) £12.50

Send large SAE for details, print sample and  
product review. Printer and FAX-1 available  
seperately if required

Hundreds of FAX-1s already in use world wide by  
professional and amateur weather forecasters,  
yachtsmen, aviators and enthusiasts. British  
designed and manufactured

## ICS Electronics Ltd

PO Box 2, Arundel,  
West Sussex. BN18 0NX

Telephone: 024 365 590. Facsimile: 024 365 575

12 months parts and labour warranty, Price includes VAT at 15%



# Siskin Electronics

*The RF Data Communication Specialists*



### Pac-Comm

TNC-220 Dual port (HF/VHF) very popular  
PC-110 PC card! Single port, inc software  
PC-120 PC card! Dual port, inc software  
TINY-2 Single port VHF TNC. Great Value  
Micro-2. Low power (40mA), high spec  
DR-200. Dual port digipeater

£ PHONE  
£159.00  
£179.00  
£109.95  
£159.00  
£169.00

### Kantronics

KPC-2 VHF/HF TNC, WEFAX and PBBS inc £159.00  
KPC-4 Dual port TNC, gateway command £298.00  
KAM Packet/CW/RTTY/Ascii/Amtor/WEFAX. KA/NODE and  
PBBS inc £265.00  
MD24 2400 baud modem for KAM or KPC-4. Great value at  
only £59.00

### AEA

PK-88 Low price TNC from AEA  
PK-232 Packet/Ascii/CW/Amtor/RTTY/WEFAX and  
NAVTEX!

£109.95  
£269.95

### Accessories

RS-232 Lead for most computers £9.95  
HF-125 HF Receiver, ideal for FAX as well as RTTY/AMTOR  
etc £375.00

### ICS

FAX-1 Receive weather maps from any SSB receiver to a suitable  
printer

£279.95

### Software

Please contact us to discuss your software needs. We can supply  
a wide range of both public domain and specialist software to get  
the most from your TNC

PO Box 32.  
Hythe, Southampton,  
SO4 6WQ.  
England  
FAX: 04893-5081

**Orders and Information**  
**Phone: 0703-849962**  
**or Cellnet (0860) 616770**

# PROJECT BOOK

by Martin Williams

Sometime ago I wrote a series of articles describing filters for several of the VHF and UHF bands, and following these I have had several requests for information on various types of low frequency filters. These are usually required as a means of sharpening up the selectivity of direct conversion receivers, but they may be used for a wide variety of applications.

## Filter types

Basically, filters can be of four types. First, there is the lowpass type in which all input above a certain frequency is heavily attenuated. Second, highpass types which reverse the previous operation and attenuates all input below a predetermined frequency. The third type is the bandpass which attenuates all frequencies, below and above predetermined frequencies. This is the type commonly used with the receiver already mentioned. The fourth type is the reverse of number three, and is known as the bandstop type. This passes frequencies above and below predetermined frequencies and attenuates all others. The common way to specify the fre-

quency response of a filter is to quote the frequency; or in bandpass and bandstop types, the two frequencies. The response of which is 3dB down at the centre of the passband.

## Filter designs

The traditional design of filters has been based on the use of inductance and capacitance. There are many ways of arranging these elements to get the desired result, but in practice it is usual to select from the following types; each have particular characteristics. The Butterworth design provides a virtually flat response inside the pass band with a reasonably sharp cut-off of the unwanted frequencies. The Chebyshev design is used to get a sharper cut-off response, but this is only achieved by accepting a certain amount of ripple (a slight change of gain) within the pass band. If you want the ultimate in cut-off of unwanted frequencies, you should choose the Cauer-Chebyshev, also known as the elliptical filter. This response however, is gained at the cost of ripple in both the stop and pass bands. The number of ripples in both these types depends on

the number of poles or sections in the filter. At frequencies close to the cut-off point, the Chebyshev types all have some overshoot effects. This, coupled with a high group delay, means that if you want minimum distortion of the signal, you should opt for a Butterworth design. All the points raised so far are clearly illustrated in the various drawings which are below.

## Active filters

All the above filter types usually call for some odd values of inductance, and you frequently end up hand-winding the coils. It should also be kept in mind, that all these designs involve a certain amount of loss in the circuit. A type of filter that gets round the circuit values problem, and can also be made to give some gain is the active filter. This is usually based around 741 integrated circuits. Next month, I will give some designs for these units and also some tables of component values, so that you may design a filter with whatever characteristics you require, without the problems of getting involved in some high power maths.

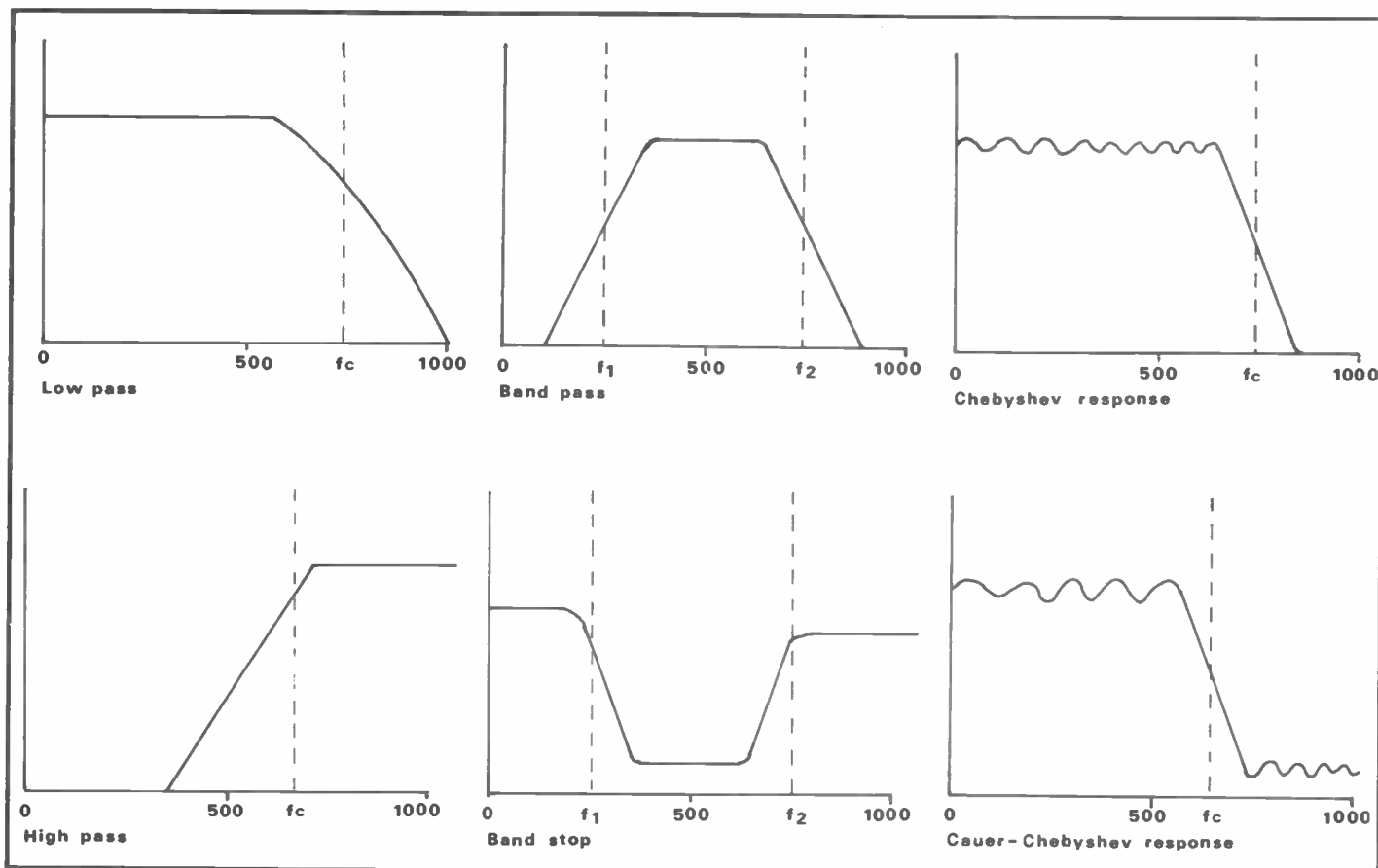



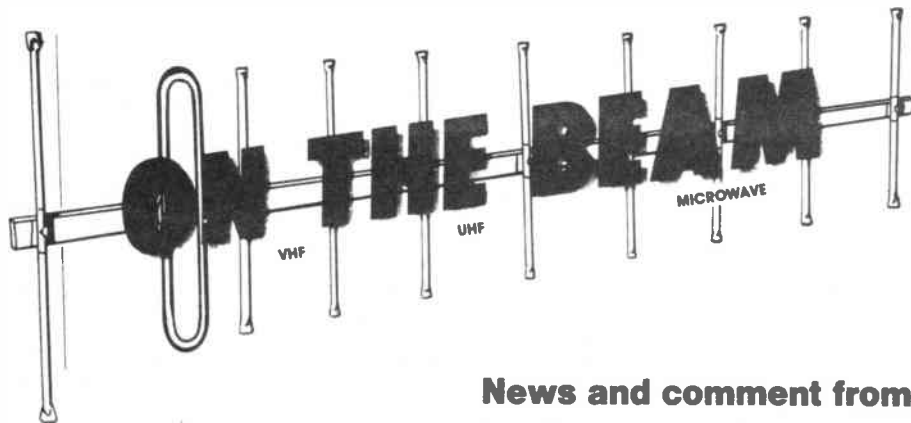

## News and comment from Glen Ross G8MWR

Let us start off this month with a bit of good news. The Finnish authorities have made the six metre band available to amateurs. Precise details are not yet available, although the band will be from 50 to 50.4MHz. Operation will be on SSB and CW only and on a permit holder basis. This is the way we got on the band so it seems likely that, provided there are no TVI problems, a general allocation may be forthcoming in the next year or so.

### Lost in France

Well something certainly went astray. The news was broken that the French amateurs had been granted access to six metres and all the usual people, including Radcom and the RSGB news service, reported the item. Letters started to reach me from knowledgeable people, a particularly useful one coming from G4UPS, saying that the French had not got permission to operate on 50. Several people then reported contacts into France, in fact right down to the South coast which is nice DX if you can get it, and confusion reigned supreme.

### Latest news

Various stories are doing the rounds at the moment, mainly based on the idea that the French amateurs are trying to get a better deal in terms of power and so on. It seems that, although at the time of writing the position is still not completely clear, they have managed to obtain a small increase in the ERP that they will be allowed and have also managed to get the exclusion zone around the TV transmitters reduced to 75km. We will keep you up-to-date as more information is received. Another point to come out of all this is that the position in Belgium is dependent on the outcome of the French negotiations.

### Backpacking

From G6MEN, the infamous 'Captain' Pink, comes the first two issues of a new newsletter aimed at the microwave fraternity. In fact the official organ of the

Backpackers Microwave Group, it is available to all by sending Paul a quantity of SAEs and some news of your activities. The group's latest adventure was climbing to the summit of Cadir Berwyn at 827 metres above sea level for the 10GHz contest on the 15th May. Many contacts were made including five in excess of 100kms. Not bad when running only 7 milliwatts of wide band FM to an 18 inch dish.

### GM to EI

I mentioned last month the 172km contact between Scotland and Northern Ireland that may well be a first on 3cm. Dave Cossor, GM3WIL, has now sent details of the site and the equipment used for the attempt. The site used at the Irish end of the path was Agnews Hill and the Scottish end of the path was located at Holehead in Campsite Fells, about 5km NNW from Lennoxton or 17km NNW of Glasgow. The NGR is NS 617 826 and the locator is I076VC. Power output was about 9 milliwatts from the ubiquitous Solfan head into a two foot dish energised with a Penny feed system. Similar equipment was used at the Irish end.

### Keep at it

When the contact was first tried the results were disappointing with only weak intermittent signals being received. The dishes were carefully aligned with some improvement in the signals, but it was not until the temperature started to drop later in the day that signals eventually came up to the point where a full duplex noise free contact was obtained. Another person reporting the results of tenacity is Harold, G3UYM, who has been trying to get gear running on 24GHz for some time. While operating in the May cumulative from a site on the Long Myndd he managed a first contact with the Telford club station G3ZME operating from the Clee Hills. He has now got his 10GHz best contact up to 120km but a try with Ray, G3NKL, on Fairsnape at 152km would not work on

the day; although this is known to be a workable, if slightly marginal, path.

### Sporadic E

By the time you get to read this we should be into this year's sporadic E propagation and newcomers to the bands are in for a great surprise. The usual mode of propagation on the VHF bands is perhaps best, but not accurately, described as straight there, with no assistance due to reflections such as is the common mode on the HF bands. Sometimes during the summer months the E layer does become dense enough to support reflections of two metre signals and when this happens the potential workable distances can be very high indeed. Up to 3000km have been achieved and even trans-Atlantic contacts have been attempted, although as yet these have not materialised. Contacts into Russia, South into Malta and Greece and even into the North African coast are regularly reported and contacts have been made into Israel.

### Getting results

The most useful equipment needed is plenty of patience. As the name of the mode implies, the events occur at completely random times and there is no foolproof way of forecasting when they will occur. It therefore requires an awful lot of listening round the bands for signals to appear. It does not need a lot of power, being in the right place at the right time is more useful. My own first contact with Malta was made by accidentally switching on the shack receiver and hearing the station come up out of the noise. One call and he was in the bag.

Ten minutes later the world and his wife knew he was there and bedlam resulted. A quick QSY up the band and a couple of Italians were in the log. As an example of what can be done a barefoot FT290 at 2.5 watts into a five element yagi has enabled contacts to be made into Russia and Malta.

### On frequency

A trick to maximise your chances of a contact is one that I have mentioned before but it will stand repeating. Most newcomers call the DX station on the same frequency that they receive him on but a moment of thought will show that this is not the best way to go about it. The problem is that he will have been using his RIT to tune stations and he could be listening up to 10kHz away from where you hear him. How do you beat this problem? Simple, you listen for the station that is already talking to him. When the DX stations reply to him you use your RIT to clarify the DX stations. When it is your turn to call the DX you will be exactly on the frequency he is listening on and will be clearly resolved. The others who do not know this trick will be just monkey chatter to the DX station and will still be wondering why they cannot raise him long after you have got your contact. Simple isn't it?

### Keep it simple

An opening can last anything from a few seconds to all day, because of this

# ON THE BEAM

there is a great demand to work the stations while they are available. Work on the theory that the station you are after is going to be there for a few seconds. Pass the minimum amount of information which usually amounts to your callsign and locator and his report. Speak clearly and slowly so you do not get involved in repeating the information. He will probably return by saying QSL. He is not asking for your card which he will assume you are sending, but is using QSL in its true meaning as 'All received OK'. He will then send you his details to which you reply QSL and then get out of the way fast.

## In and out

You will notice that in the above exchanges there was no mention of your name, the gear you are using, or even the town that you live in. The whole point is to complete the basic contact as fast as possible and then get out of the way so that other stations can get in during the few seconds that he may be available. If you go on waffling for ages you will certainly appear on the list of people we do not like; to say the least!

## Finding it

As the E layer gradually becomes denser, it starts to reflect higher frequency signals than usual so our 50MHz

band will show long distance signals before and indeed more frequently than two metres will. Perhaps the best place to monitor for a possible two metre opening is the FM broadcast band around 90MHz. If this starts to fill up with broadcasting stations all speaking in strange tongues, then there is a fighting chance that 144 may come alive a little later. You can also use this information to give you an idea as to where to point the beam. It is not too hard to tell the difference between, say, a middle European language and Spanish; so getting a good idea where the reflecting layer is situated. By the time the BBC announcers are starting to tell you not to adjust your sets because the problems are caused by continental interference, you can be sure a major event is on the cards and that it is time to get the gear warmed up and ready for the fray.

## Something new

This year should see the possibility of sporadic E propagation to the USA. Some of the stations over there are running a kilowatt to stacked beams and they should put in some fantastic signals. Even if you cannot transmit on the band it would be worth buying a convertor and a simple dipole aerial so as to be able to join in the fun. There is also the possibility that while the Americans have

got the 50MHz beam on Europe they may also take a look on two metres. There are two major ways in which the path could be possible, the first is by a double hop sporadic path in which the signal is reflected to Earth and back up again at around the half way point. The second method is if there is extended tropo-propagation at one or both ends, with a sporadic system in the middle to help things along. The trans-Atlantic path will be made one day and it may be you who does it. If you do you will certainly qualify for one of our special class certificates.

## Close down

Mentioning certificates reminds me to tell you that details of all the various grades offered on the different bands can be obtained by sending me an SAE. This month's quote: 'Is my signal to you any better now that I have switched on the clarifier at my end'? Please keep the news and comment coming to me at 81 Ringwood Highway, Coventry, or, as more of you are now doing, on Prestel 203616941. Good hunting.

Don't miss the August issue of **Amateur Radio**, on sale 28 July

## LOOK WHAT YOU GET EVERY MONTH IN AMATEUR RADIO



- ★ **DX DIARY** Don Field G3XTT with all the news of rare DX, contests and DXpeditions
- ★ **ON THE BEAM** Glen Ross G8MWR with all the news and comment from bands above 50MHz
- ★ **G3OSS TESTS** Angus McKenzie – the fairest, most comprehensive reviews available anywhere

Make sure of your copy by placing a regular order at your newsagents or by taking out a post free, inflation proof subscription, with early delivery to your door each month

## AMATEUR RADIO SUBSCRIPTION ORDER FORM

To: Subscription Department • Amateur Radio •  
1 Clarendon Road • Croydon •  
Surrey • CR0 3ST

Tel: 01-760 0409

PLEASE SUPPLY: (tick box) for 12 issues, all rates include P & P

Inland  World-Surface  Europe-Air  World-Air   
£18.00  £19.90  £26.65  £28.70

NAME .....

PAYMENT ENCLOSED: £  -

Cheques should be made payable to Amateur Radio. Overseas payment by international Money Order, or credit card

ADDRESS .....

CREDIT CARD PAYMENT  VISA   EXPIRY DATE

.....

/

..... Postcode .....

Signature .....

# A BEGINNER'S GUIDE TO PACKET BBS OPERATION

## Part 2

by Joe Kasser

### Files on a WORLI PBBS

When connected to NM8X-3, (WORLI PBBS) it returned the screen shown in *Figure 7a* after receiving a 'W' command. It told me what directories were available. I wanted to look at the 'Equipment Mods' sub-directory, so I sent it to the 'WL' command to get a listing of the 'L' sub-directory. I then received the reply shown in *Figure 7b*.

This listing told me not only what the files are, but how long they are, and also gave me some information about NM8X's hard disk, before giving me back the prompt message. As I wanted to look at the PK-232.MOD file, I sent the command 'DL PK-232.MOD'.

'D' is the command to download a file. It is always followed by the letter code for the sub-directory and the name of the file.

### Uploading files

To upload files to a WORLI PBBS you use the 'U' command with the directory and file name qualifier. In the example shown in *Figure 7*, you are only allowed to upload files in the 'A' sub-directory. To upload a file such as 'G3ZCZ.LAN' to the PBBS you'd have to send the command 'UA G3ZCZ.LAN'

and follow the instructions on how to begin and end the file transfer.

### Files on a WA7MBL PBBS

The WA7MBL PBBS uses the same file directory structure as does DOS (the Disk Operating System). Thus when you send it a 'W' command you will get back a directory/file listing that looks like a DOS listing.

N4QQ uses the WA7MBL software on his PBBS. When I sent it a 'W' command I received the reply shown in *Figure 8a*. You can see that it contains a mixture of subdirectories and files. Subdirectories are indicated by the '<DIR>'. I then sent it the 'WPacket' command and received the directory listing shown in *Figure 8b*. I then sent the 'WNTS' command and received the directory listing shown in *Figure 8c*.

To download a file you'd use the 'D directory/filename' command. Thus the command to download the file 'TUNING.HF' which is located in the 'PACKET' subdirectory is

'D /PACKET/TUNING.HF'.

Don't try to download a subdirectory. You use the 'U' command to upload a file. Send the full file name including the directory you want to put it on and follow

the instructions that the PBBS will give you regarding how to do it.

### Talk to the SYSOP

If you want to talk to the PBBS SYSTEM Operator, you use the 'T' (Talk) command. When it is received, you will probably get a reply telling you that the computer is paging the SYSOP. If the SYSOP is home, and wants to talk with you, a message to that effect will appear on your screen, if not, a 'Not at home' message will appear. On many versions of the PBBS software, if you send a command while the SYSOP is being paged, it will *automatically* cancel the page.

### Software version

Sometimes at connect or 'log on' time you will be told which version of the software the PBBS is running as part of the Welcome message. The version is enclosed in square brackets []. For example, the following version codes were extracted off-the-air.

[MBL313] WA7MBL Version 3.13 as received from GB3HQ.  
[MBL-\$] WA7MBL Version 5.0 (?) received from NA2B.  
[WORLI 4.22] WORLI Version 4.22 as received from WA2PVV.  
[GYQ-CBBS4.4-\$] WORLI/VE3GYQ Version 4.4 as received from WA8OOH-1.  
[GYQ-CBBS4.5-\$] WORLI/VE3GYQ 4.5 as received from N8BMA-1.

If the PBBS does not give you the version when you first connect, and you still want to know, you can use the 'V' command to ask it what version it is running.

Typical off-the-air responses to the 'V' command various PBBS's were,  
WORLI/VE3GYQ V3.22, 2 July 1987  
WORLI/VE3GYQ V4.3, 3 December 1987  
WORLI/VE3GYQ V4.5, 14 February 1988

### Connecting elsewhere

The PBBS also has a built-in facility to let you connect to other stations on other frequencies, using the PBBS as a gateway. There are a number of commands associated with this mode of operation.

The 'J' command allows you to get a 'Journal' list of stations that have been heard by the PBBS on any of its ports. Most PBBSs have more than one port active. This means that they operate on more than one frequency. The second or other ports provide trunking of messages from your local PBBS to other PBBSs as well as HF or VHF access from different LAN frequencies. When you send the PBBS a 'J' command, it will

**Figure 7a** An example of the Root Directory Listing

```
Use W and directory ID:
WA All files must be uploaded to this area EXAMPLE UA Filename
WB Addresses Download only area.
WC ARRL Bulletins Download only area.
WD Basic Ascii Programs Download only area.
WE BBS Information Download only area.
WF Misc. Bulletins Download only area.
WG CRRRL Bulletins Download only area.
WH Humor Download only area.
WI Other Information Download only area.
WJ Msc. Whatever Download only area.
WK Maps Download only area.
WL Equipment Mods Download only area.
WM Pictures Download only area.
WN Model 100 Programs Download only area.
G3ZCZ de NM8X: at 0509z on 880216 B, C, D, H, I, J, K, L, M, N, P, R, S, T, U, V, W, ? >
```

**Figure 7b** The Equipment Mods. Subdirectory Listing.

```
AEA-RF. MOD 1k KPC2CLK. MOD 3k TNCFILTE. MOD 1k
ICOM02. MOD 6k MFJ. MOD 2k YAISU726. MOD 2k
KPC-2. MOD 1k PK-232. MOD 2k
18k of 41396k used, 20552k free.
G3ZCZ de NM8X: at 0511z on 880216 B, C, D, H, I, J, K, L, M, N, P, R, S, T, U, V, W, ? >
```

# PACKET BBS OPERATION

usually reply asking you which port you want the listing of, in the following manner.

From one PBBS you may get back a list such as this one.

Use J and port ID:

JD 145.01MHz.

JE 145.05MHz.

JL Connected

A second BBS on the other hand may give you this one.

Use J and port ID:

JC 145.09MHz.

JD 145.03MHz.

JL Connected

Both PBBSs are configured differently.

When you've seen what frequencies show up on which ports you can ask it for the journal of that port by adding the port identification letter to the 'J', as in 'JC' for example. You will then get back a listing something like this.

listing something like this.

Port C, 145.09MHz.

WD8LIZ 0453

VE3CKU 0447

VE3WZL 0058

K8DD 0040

NM8X-9 1715

VE3RCA 1506

VE3RCA-3 2335

VE3EUK 1539

VE3KGB 1535

N8FTY 1324

To actually connect to someone, you use the 'C' command. You must also define the port letter in the command. So, in the above example, if you had wanted to connect to VE3RCA who had shown up in the journal on port C, you'd send the PBBS the command 'CC VE3RCA'.

The PBBS will let you know that it's trying by sending you a reply which could take the following format.

'Attempting the connection on 145.09MHz. CTRL-W will abort'.

If for some reason the connect request fails, it will tell you so, with a message. A typical message is:

'Connection not established'.

Note that the 'journal' does not distinguish between calls heard directly or via a digipeater. Also, just because a call is in the journal, don't expect the station to still be on-the-air, especially if the journal entry is old. Thus unless you know that the call is local and active on the LAN most of the time, don't be surprised if the connection is not established.

If you just want to see what is happening on the other port, you use the 'M' (Monitor) command. This will cause the PBBS to relay any packets it hears on the specified port. Note you have to tell the PBBS which port to monitor, using something like 'MA' if you want to monitor packets on 'Port A'.

In the early days of packet radio, the PBBS was the only gateway facility that existed to allow crossband connects. These days with NET/ROM and KANODEs readily available, it is advisable not to use this feature, as there is no need to tie up the PBBS as a gateway.

## Obtaining on-line help

Each PBBS contains on-line help information. You can get a list of the commands and features with the 'H' (Help) command. It will instruct you on how to get detailed help on specific commands. Try it. Summary command listing for both types of PBBS are shown in Figure 9.

## Logging off the PBBS

To log off the PBBS send the 'B' (Bye) command. The PBBS will then disconnect and close its files in an orderly manner and set itself up for the next person.

You can disconnect and achieve the same effect, but please do it the polite

way.

## Summary

Lurking on that PBBS disk are electronic mail capabilities, and the electronic newspaper in the form of ARRL, CRRL, AMSAT and many other bulletins. The amount and type of information literally at your fingertips increases daily. This article has been a beginner's guide to using the Packet Radio BBS. It has covered the most commonly used features of the BBS. If you can follow the material presented in the article you will be able to expand your horizons with packet radio and connect to the exciting new world of information and bulletins.

Figure 8a An example of the Root Directory Listing.

USER.DOC	3325	DOWNLOAD.HOW	1110	MAILFWD.HOW	3320	AMSAT
QUERY.TCP	5360	313USER.DOC	27k	DOWNLOAD.D19	1658	COSI12.87
ARRLDX	<DIR>	ARRLPROP	<DIR>	NTS	<DIR>	PACKET
DX	<DIR>	PK232	<DIR>	VKHUMOR	<DIR>	AUTOPATC.T80
AUTOPATC.T40	3366	NETROM	<DIR>			
12118016 bytes free						
N4QQ BBS						

Figure 8b The Packet Subdirectory Listing

AX25L2.LTR	5565	AX25L2.DOC	16K	LLBBS.NGC	3441	TUNING.HF
12118016 bytes free						
N4QQ BBS						

Figure 8c The NTS Subdirectory Listing

KB2HM.NTS	5949	HISTORY.NTS	3559	WA7MBL	2497	LOCAL.ZIP
ZIP.3RN	1553	AREACODE.LTR	4005	ARRLGRAM.NUM	6537	
12118016 bytes free						
N4QQ BBS>						

Figure 9 Summary of the most often used WORLI PBBS Commands

### Mail commands

L - LIST mail headers  
S - SEND a message  
R - READ a message  
K - KILL a message

### File commands

W - WHAT's available (File Directory)  
D - DOWNLOAD a file FROM the PBBS  
U - UPLOAD a file TO the PBBS

### Other commands

B - BYE (Logoff)  
I - Get INFORMATION about this PBBS  
J - Show STATIONS heard or connected  
T - TALK to SYSOP  
NE - CHANGE your 'Expert' status  
V - Show VERSION of PBBS software in use  
? - Get detailed HELP with individual system commands  
H - Get general HELP with all system commands  
Cp - Connect to CALL, using port p  
M - Show what ports are available on this PBBS  
Mp - Watch the packets of port p

### Most often used WA7MBL commands

#### Mail commands

L - LIST mail headers  
S - SEND a message  
R - READ a message  
K - KILL a message

#### File commands

W - WHAT's available (File Directory)  
D - DOWNLOAD a file FROM the PBBS  
U - UPLOAD a file TO the PBBS  
Y - BINARY file transfer

#### Other commands

B - BYE (Logoff)  
I - Get INFORMATION about this PBBS  
J - Show STATIONS heard or connected  
T - TALK to SYSOP  
X - CHANGE your 'Expert' status  
V - Show VERSION of PBBS in use & mail statistics  
? - Get detailed HELP with individual system commands  
H - Get general HELP with all system commands

# MORSE REPORT



## Tony Smith G4FAI takes his bimonthly look at the world of dots and dashes

### CW in Brazil

Last year I had a letter from Gil Penna, PY1AFA, editor of the Brazilian amateur magazine *Antenna-Electronica Popular*. Telling me that there is a number of amateur radio Morse groups in Brazil, he said 'I devote considerable space to Morse matters (we call it Cedabilism) and we occasionally publish special supplements devoted to Morse enthusiasts'. Gil Penna sent me one of these supplements, which unfortunately I couldn't read because it was in Portuguese! It included an interesting list of some 230 CW abbreviations giving their English language meanings, as well as their equivalent in Portuguese, to help Brazilian operators when conducting international QSOs.

I compared this list with a few others. The RSGB's 'Amateur Radio Operating Manual' had 114 abbreviations. ARRL's 'Operating an Amateur Radio Station' had 91, and 'The Secret of Learning Morse Code', by Mark Francis, had nearly 150. So if you work a PY station and don't recognise some of the signals he is sending, you will know why. Just for the record, here are a few of the abbreviations the PY's list and the RSGB doesn't. ABV, abbreviate; BZUZ, because; BTWN, between; CNU, can you; GG, going; GH, good hunting; HLO, HLW, hello; TRI, try; XCUS, excuse; YD, yesterday; 2DA, today; 72, peace and friendship.

### What international language?

Some of these of course, are used by British amateurs even though they are no longer in the 'official' textbooks, but it has set me thinking. Why do we no longer seem to try very hard at international communication when the other operator doesn't speak our language? The age-old claim that you can communicate with others through the international language of Morse seems to be getting a bit thin round the edges nowadays.

You can communicate with a Russian who doesn't speak a word of English – it's called a rubber-stamp QSO – but surely

that's not what it's supposed to be all about? How many internationally understood abbreviations, Q-codes, etc, do you know, and how many does the rubber-stamp Russian know? In both cases, probably only a handful. If we knew more, and used them, there would be fewer rubber-stamp QSOs! It is sometimes said that abbreviations are for the slow operator, who has time to think before using them. The fast operator has less thinking time to spare and therefore tends to use more plain language. If that is the case CW operating must, inevitably, become even more polarised.

The 'international' reputation of Morse really lies in its commercial use, which is fast diminishing. Ships at sea can (in many cases) communicate extensively on specialised subjects without the operators knowing each other's language.

How precise and efficient it was, in the days of aeronautical Morse, to send 'QUQ' in an emergency, anywhere in the world, to mean 'please train your searchlight on a cloud, occulting if possible and, if my aircraft is seen or heard, deflect the beam up wind and on the water (or land) to facilitate my landing'.

Several questions come to mind: Should we continue the way we are, using less internationally understood abbreviations and codes, or should we try to do something about it before one of the unique features of communication by Morse code is lost forever?

Who should do something about it, and what is the real attitude of national societies towards Morse operating in this age of computerised communications? I propose to explore these questions in a later column. In the meantime, if you have any comments or suggestions on the subject, drop me a line. You don't have to agree with me!

### Demonstrations

I have previously mentioned the Morse Telegraph Club in the USA which

demonstrates historical telegraph equipment at museums, preservation railway sites and so on. They link up with other sites, sometimes over great distances, via the public telephone system, recreating the days of the Morse Telegraph and passing greetings traffic for visitors to their telegraph stations.

Tone signals sent down the line are converted to dc at the receiving end to activate electronic switches controlling locally powered sounder circuits. Over short distances it is quite feasible to get the signal into and out of the telephone system by acoustic coupling. Over longer distances, however, a special unit has been devised which uses a conventional approved computer modem to connect to the public telephone system. I would like to explore the possibility of doing something similar in this country. The basic requirements are that it must not be too expensive and must meet all Telecom requirements.

Would anyone with knowledge of such matters care to advise me, or even design an appropriate unit? I have details of the American 'Dial-Up Morse Terminal' as they call it, designed by Ace Holman Jnr for use on the American telephone system. Whether it could be used legally on British Telecom lines, I am unable to say. However, I have details explaining the system, and I can make them available to anyone who would like to help.

Incidentally another group (this time in Australia); the Sydney Morsecodians Fraternity, are planning an ambitious 3,500 mile link next April, between Canberra and the old Alice Springs Telegraph station. With the help of Telecom Australia, old-time telegraphers will re-create part of the great Overland Telegraph, with a terminal station set up in a museum at the southern end of the line. It is hoped that this station will become a permanent feature for use in future historical demonstrations.

### Another good day

As I write, I have just returned from the Yeovil QRP Convention, which gets better every year. G3MYM's talk on 80m propagation was great, showing in both theoretical and practical terms, what it is possible to do with one watt of CW using an average antenna from a typical location.

Following my own talk (on the origins of Morse), members of the audience mentioned a number of lesser known forms of Morse activities. These included decoding Japanese and Russian Morse, flashing light Morse signals between Army tanks on the battlefield, use of the Aldis lamp in the Navy, the heliograph and other matters. I don't know about anyone else but I enjoyed those last few minutes best of all. There's so much information and knowledge held by individuals who were actually involved in such Morse activities. This will unfortunately be lost forever unless the participants record their knowledge or experience for posterity. I hope that I have managed to persuade a few of them at least to do just that.

# 50MHz

by Ken Ellis G5KW

## Sunspots due to give better results

Earlier predictions based on statistics, were for Cycle 22 to be a poor one, but recent reports from various reliable sources, indicate that the solar flux and sunspot numbers are rising faster than originally forecast. This should mean an earlier peak than expected.

## Sporadic E's season has a good start

Although this year's E's season during May was late, this has produced some good openings to the European and Mediterranean areas. This has not been of a general nature, but very patchy with some areas reporting S9+ signals; whilst other areas gave Nil reports. In general, stations in the South came off worst. As is expected with so many new stations operating on 50MHz, QRM has been a serious problem with the big pile-up, once a DX station shows itself. This was particularly noticeable around 50.2MHz with cross-band operators. This will get progressively worse unless we can get stations on 28.9MHz to say that they are looking higher up the band to around 50.25MHz.

## Upward trend in solar flux and sunspot numbers

Once again I am grateful to Geoffrey Roberts G3ENY, for the latest graph and figures of recent conditions, showing a forecast of trends during the current cycle. The duration of a solar cycle is generally accepted to be 11 years, and on this basis we are not due for another peak until 1990-1991. 'Smithy' G8KG (writing in *Radio Communication* May 1988, page 376), well known for his studies and writings on ionospheric phenomena, says:

'Of the past seven cycles, only one lasted more than 10.5 years, the others between 10 and 10.5 years.' He also reports that the magnetic minimum, measured early in 1988, was lower than its predecessor in 1976 (the low point of the previous cycle). It was nevertheless the second most active minimum in the 120 years since the 'AA' index started to be recorded. Smithy continued to state that the cycle is currently rising faster than average, and that we may be in for a whopper. Smithy is certainly not alone in his views.

An article in the *'New York Times'*, talks of a steep and surprisingly early increase in magnetic disturbances on the sun in the last few months, which may have disastrous effects on low-flying satellites. One scientist is quoted as saying that he 'suspects the solar maximum may come as early as the end of the year.' Refer to *Figure 1*. Also see 'Report from

South Africa by Hal Lund ZS6WB'.

## Iceland beacon on 50.057.5MHz

Although reports have not been received about reception of the new beacon, it is understood to be in operation (callsign TF3SIX; power output 50W). A G3JVL-designed  $\frac{5}{8}$  vertical is used to ensure that worldwide reception is possible. The keyer sends the callsign, followed by Iceland, then Locator HP94CC. Acknowledgements to Richard Diamond G4CVI, Jonas Bjarnson TF3JB, Hijodtaekni Radio Society, Mike Walters Nevada Communications Ltd, and South Midland Communications Ltd, for funding the project.

## New Gibraltar beacon

The UK Six Metre Group has funded a new beacon for Gibraltar, to replace the original ZB2VHF beacon on the same frequency 50MHz 35W RF output. The beacon was designed, built and tested by Mike Walters G3JVI. The original PA and regulated power unit was supplied courtesy of Nevada Communications Ltd. A reception report of the original ZB2VHF beacon by G5KW of the Isles of Scilly, appeared on page 46 of this magazine's May 1988 issue. The DXpedition to Gibraltar, referred to last month, arrived on 31st May and within two hours was on the air on Six; callsign ZB2IQ 59/59 for G5KW 1545z.

## Opening on six to Greece

For about 90 minutes on Saturday 28th May, a localised opening occurred to Greece when a few lucky UK stations had a two-way QSO with Costas SZ2DH starting around 1700z. It is unknown who made the first QSO, but stations confirmed as having worked Costos include: G4IJE, G4VNR, G3CCH, G3UVR, GW3LDH, GW8ZCP, GM3WYL and possibly one or two others. Greece of course counts as Asia, so this was very welcome news. Another report mentions two other SV Stations operating at the same time, but as their status is not known, they are not included at present. As far as we know, the club station operated by Costos is the only officially permitted station presently operating. More news about this when known.

Bill Stirling GM4DGT writes: After arriving home from the VHF Convention on Monday evening after a very enjoyable visit, the first DX on Six this morning was G5KW 449 at 0746z.4-4-88. Aurora detected 1136z. RSGB beacons RMK:SIX:NHQ, and OX3VHF were all Auroral. 1518-1842z worked G:GW:EI and PA. I heard LA and GI and worked 42 stations during the opening, but please

would stations keep clear of the DX section, as the clutter makes any QSOs impossible and everyone will miss DX in a case like this.

Mike G3SED reports his first E's opening this year between 1355z and 1604z. 9H1FL Malta contacted G3JVL, G3SED, G3DEZ, G4DBL/A and G3GLK. On 6th May 1988, large aurora openings between 1415z and 1650z were reported. Stations that worked the two-way Six include: GM1LUZ, GM8COX, GM8BZK, G1PAM, G0JHC, GM6VXB, GM3WIL, G3FDW, G18YDZ, G1OPF, GM0FWV, PA2VST, G1MEJ and GM4DGT. Later that evening we had a large E's opening and worked the two-way, including the LA6QBA, 9H1CG, GM4UPL and 9H1BT. Beacons heard were: 9H1SIX, GB3RMK and 9H1BT.

John GW3MHW writes: The E's season seems to have started late this year. At this QTH it started on 27th April, when I found the 49.75 video spreading up into the LF end of the 6m band at 12.00z. I monitored the RTE TV signal on 53.740, and its FM sound was 6MHz higher. It was up on 13th, 14th and 15th May. When there is an enhancement, I experienced considerable trouble from a GW3 and others unidentified, who used FM on 50.200. I struggled to work those G stations who were about 0.1mV and had to close down when these people fired up. I personally would like to see this mode completely banned below 50.5MHz.

The Es on 15th May were outstanding and should go down in history. At 12.12GMT, Es were up to 69MHz. At 14.38GMT, Es were up to 88MHz. Normally, I don't check above this except to hear a local station's 2nd harmonic at 100MHz, which is usually about S3! At 17.37GMT, I did have two-way on Six with PA2VST on 50.120 getting RST 549. This makes my six metre two-way with licensed stations, 21 countries. Spain was not included as I don't know what the official position is there. At 2136 I had two-way QSO with 9H1BT followed by 9H1CG.

To call a new beacon that is operating on FSK, call GJ4HXJ frequency 50.065.5MHz. It runs 10W to a Halo Logic and was designed by GJ3RAX. The final amplifier was donated by G3SED from Nevada Products. The antenna was built and supplied by GJ1TJP. The output filter was donated by BNOS UK.

Old-timer Bill James G6XM, at his new QTH, Okehampton, sent a long letter with some interesting reports of VHF/UHF activity. QSOs outside the UK on Six include: E19Q, GU2HML, GM3WOJ, LA5UBA, LA3EDA, LA8KV/M, CT4KQ and CT1DTQ. On 24th May, Bill

received Norwegian TV on CH2 (Melhuis) and CH3 (Steigen), both had good picture quality. Although the TV was good, there was no sign of any LA activity! I missed out on the Maltese stations, but I could hear stations in Plymouth and Cornwall working them. I am screened by Dartmoor, but that does not explain why I can work Spain, Portugal and Italy! Having Dartmoor on my doorstep, I shall be going portable on 10GHz (3cm) shortly. I find it very satisfying working about 100 miles with 5mw, receiving signals better than on Six. Visitors to the RSGB VHF conventions may recall seeing photographs of some of the well engineered equipment produced by G6XM and the absence of 'black boxes'.

My own activities have had mixed fortunes: as I live in the shadow of the Downs, 300 feet above my QTH, the local TV stations give a poor signal, as a result most of my neighbours use cable TV. Installing a Nevada TC50 DX linear amplifier with harmonic filter seems to have cured my immediate problem. This unit gives a boost of approximately 8dB with input power of 3W and suppresses 2nd and 3rd harmonic radiation by up to 50dB. At £29.95 it is good value for money. I have recently installed a Cushcraft A50-6 six-element beam; boom length 20ft, gain 11.2dBd. KW Communications still have a few in stock, but more are on the way. Since installing the new antenna, I have had some good results and on May

15th, I heard the ZD8 beacon on 50.032MHz at 1747z. A few minutes later I heard on 50.105MHz, a continuous call-sign ZD8MB being sent for over half an hour. I wondered who was calling Mike and not giving his own call? After making a recording, I later discovered that Mike had left his station keyer on the frequency whilst at work. Apparently, I was the first to receive it! We still await the first 'legal' two-way G/ZD8 and two-way QSO.

#### UK Six-Metre Group AGM, 2 May 1988

As the report of the VHF Convention in last month's edition did not mention the Six Metre Group's AGM, here is a brief summary of the meeting.

The chair was taken by Steve Richardson G4JCC, one of the three founder members; Steve had got the group off to a good start by doing the dual role of Club Secretary and Editor of the Six News during the first three years of the group. Steve and the other officers were elected to carry on for another year, confirming the members' confidence in the way the group's affairs had been handled. The Treasurer reported a successful year financially, with a balance of £584.00, and excess income to 1st March of £122.21. The Beacon Fund has received donations from members and supporters, totalling £139.40. Subscriptions remain unchanged at £5.00. Committee members for 1988 are: G3SED, G3UPS, G4IIL, G3UFS and GM4DGT.

During the afternoon, GK5W introduced the President, Sir Richard Davies, to the Chairman and officers of the group. The group has accepted a stand at the Midland VHF Convention to be held at Telford on 4th September.

#### South Africa news

Hal Lund ZS6WB, Editor of 'VHF News', reports that Cycle 22 may be one of the best ever, according to a special report in the *DX Bulletin*. Only one year after hitting the minimum of 12, the smoothed sunspot number has increased to 40. This means that Cycle 22 is increasing at least 50 per cent faster than any cycle and is comparable only to Cycle 19, which peaked with an SSN of 200. If the current trend continues, we could have another peak of 200+ in mid-1989. Earlier predictions based on statistics, were for this to be a poor cycle, but updated ones are based on current numbers and should be more reliable. Get your station and antennas ready now!

A number of European stations have indicated an interest in attempting TEP contacts during the upcoming months, and suggestions have been made that 50.110 be used. We will use 28.885 and 50.110 for co-ordination, but once contact has been made, move from those frequencies.

9H1BT has requested that QSLs be sent DIRECT to him: Paul Galea 9H1BT, 63 Ellul Mercer Street, Dingli, Malta. That is all for this month, good luck.

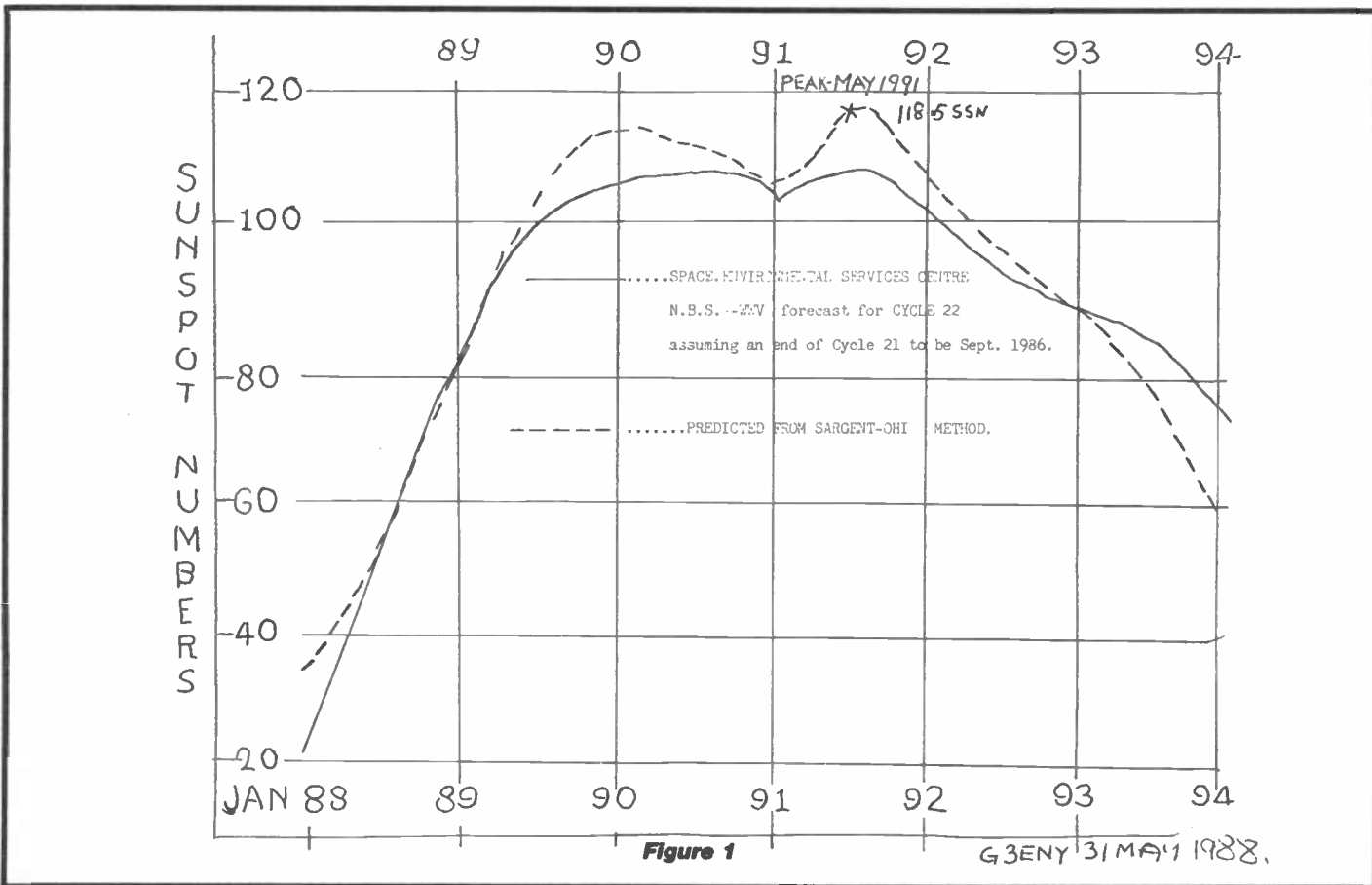

# Amateur RADIO SMALL ADS

## USED AMATEUR EQUIPMENT?

### I buy, sell and exchange

For the deal you've been looking for, phone Dave, G4TNY, anytime on Hornchurch (040 24) 57722 or (0836) 201530 9am-7pm Mon-Sat or send SAE

G4TNY Amateur Radio

132 Albany Road, Hornchurch, Essex RM12 4AQ

## WORKSHOP SERVICE MANUALS

Any Colour/Mono TV, Amateur Radio, Military Surplus, Music System, Vintage Valve Wireless etc, etc..... **£5.00 plus LASE**  
Any Video Recorder..... **£10.00 plus LASE**

**FREE** Catalogue Unique Repair and Data Guides for LASE.

**MAURITRON (AR)**

8 Cherry Tree Road, Chinnor  
Oxon OX9 4QY

Morse made simple. Learn quickly. Everything you need on one tape. Includes helpful learning tips. **£4.75** which includes P&P.

John Hunt G2FSR

4 Warmdene Road, Brighton BN1 8NL

## SUSSEX MOBILE RALLY

**Brighton Racecourse, Sunday 10th July, Family Fun Day starts 10.30.**  
Tel: (04446) 3757 Evenings.

## JAPANESE IC's (PART OF OUR RANGE)

AN7178 £2.95, BA5408 £2.20, HA1377 £2.20, HA1392 £2.50, HA1394 £2.95, HA1397 £2.75, HA1398 £2.75, HA13001 £2.95, LA4460 £1.80, LA4461 £1.80, LA4807 £4.25, LC7137 £4.50, M51517 £2.80, MB3705 £1.80, MB3712 £1.50, MB3722 £3.50, MB3730 £2.50, MB3731 £3.50, STK461 £7.50, STK463 £8.40, TA7205AP £1.00, TA7222AP £1.30, TA7240 £2.95, TA7241 £2.95, TA7270 £2.75, TA7271 £2.75, TA7274 £2.95, TA7280 £3.50, TA7281 £2.95, TA7282 £2.95, TA7283 £2.95, TA7288 £2.95, TA7611 £3.20, UPC575 £1.00, UPC1156 £2.95, UPC1181 £1.10, UPC1182 £1.10, UPC1185 £2.50, UPC1188 £2.75, UPC1230 £2.50, UPC1263 £2.50, UP1277 £2.75, UPC1278 £2.75, UPC1365 £3.80, UPC1384 £1.95

ADD 60p POST AND PACKING AND THEN ADD 15% VAT TO TOTAL  
T POWELL 16 PADDINGTON GREEN LONDON W2 1LQ  
OPEN MON-FRI 10AM-5PM, SAT 9AM-12 NOON.  
TELEPHONE: 01 723 9248  
ACCESS/VISA. TELEPHONE ORDERS ACCEPTED OVER £5.00

## ETESON ELECTRONICS



15B Lower Green,  
Poulton-le-Fylde, Blackpool  
Tel: (0253) 885107

Open: 9.30am - 12.30, 1.30 - 5.30. Closed Wed & Sun.  
Electronic Component Specialists

A wide range of electronic components. IC's, capacitors, transistors, resistors, plugs and sockets etc.

## QUARTZ CRYSTALS and FILTERS

Large numbers of standard frequencies in stock for amateur, CB, professional and industrial applications.

Stock crystals **£5.00** each (inc VAT and UK post). Any frequency or type made to order from **£6.50**.

Phone or SAE for lists.

### GOLLEGE ELECTRONICS

Merriott, Somerset TA16 5NS.  
Tel: (0460) 73718.

## ALAN HOOKER ELECTONICS



42 Nethernall Road  
Doncaster

Tel: 0302 25690



Large stocks of electronic components

## IAN FISHER COMMUNICATIONS OF STANHOPE

CB Works, The Market Shop, Market Place, Stanhope, County Durham  
☎ (0388) 528464

Main Distributors of 27MHz CB radios and the NEW CEPT models including ATRON and DNT.

Including U.K. and CEPT walkie talkies.

Large stocks of coaxial cable, plugs, sockets and adaptors.

All available via mail order. Retail/Wholesale

OPEN: MON-SAT 10.30am-6.00pm

SUN 2.30 - 4.30

RING FOR DETAILS

(0388) 528464

## AGRIMOTORS

MERTON CB AND RADIO CENTRE  
MERTON GARAGE AND POST OFFICE, MERTON.  
Nr OAKHAMPTON, DEVON EX20 3DZ

OPEN 6 DAYS 9-6 LUNCH 1-2pm

EARLY CLOSING THURSDAY 1.00pm

(SUNDAYS BY APPOINTMENT)

SPECIALIST IN 934 MHz

SUPPLIERS OF ALL 27MHz AND 934 MHz EQUIPMENT  
AMATEUR ACCESSORIES CATERED FOR

08053 200

## SMC/TMP ELECTRONICS



Unit 27 Pinfold Workshops

Pinfold Lane,

Buckley, Chwyd

Tel: 0244 849863

For all your amateur equipment and accessories. Open Tues. Wed  
Fri 10am-5pm Saturday 10am-4pm. Other days by appointment

# Amateur RADIO

This method of advertising is available in multiples of a single column centimetres — (minimum 2cms). Copy can be changed every month.

### RATES

per single column centimetre:

1 insertion £7.00, 3 — £6.60, 6 — £6.30, 12 — £5.60.

# SMALL ADS

## AMATEUR RADIO SMALL AD ORDER FORM

TO: Amateur Radio · Sovereign House  
Brentwood · Essex CM14 4SE · England · (0277) 219876

PLEASE RESERVE.....centimetres by.....columns

FOR A PERIOD OF 1 issue.....  3 issues.....  6 issues.....  12 issues.....

COPY enclosed.....  to follow.....

PAYMENT ENCLOSED: (Add 15%VAT).... £ —

Cheques should be made payable to Amateur Radio. Overseas payments by International Money Order and Credit Card

CHARGE TO MY ACCOUNT.....  CREDIT CARD EXPIRY DATE  /

COMPANY .....

ADDRESS .....

SIGNATURE ..... TELEPHONE.....

C P I



**Telephone the advertising department on: 0277 219876 for details**

**VHF ACTION RECEIVERS . . .**  
 Specialist hand-compact UHF monitor receivers for lo/mid/hi band detection + 80Ch 11m.  
 Hear Ham's, Aircraft, Public-Service, Marine, Local 2-Way and much more! All 53-176MHz signals, Squeich, VFO facilities etc. International Series. Special Price: **£27.50** inc p&p.  
 Prompt dispatch from:  
**TAYLOR RADIO**  
 8 Emmerson Street, Crook, Co Durham DL15 6NF. S: 0388 763323

**PSSS....**  
**ALL THE SUPER BARGAINS ARE ON THE INSIDE-FRONT COVER OF THIS MAGAZINE!!**

**Selectronic**  
 The UK's leading suppliers of 934MHz personal radio equipment  
**203 High Street**  
**Canvey Island, Essex,**  
**Tel: 0268 691481**  
 (Open Mon-Sat 9-5.30)  
 Amateur radio equipment also in stock

**JAYCEE ELECTRONICS LTD**  
 JOHN GM30PW  
**20 Woodside Way, Glenrothes, Fife KY7 5DP**  
**Tel: 0592 756962**  
 Open: Tues-Sat 9-5  
 Quality secondhand equipment in stock. Full range of TRIO goodies. Jaybeam - Microwave Modules - LAR.

**2 METRE COLLINEAR UVRAL X2<sup>5</sup>/<sub>8</sub>over 5<sup>8</sup>/<sub>8</sub>**

An omni directional antenna giving low angle radiation. The ideal base station vertical. Ruggedly constructed for long life

**Technical Specification**

- Gain :- 6 dB
- Impedance :- 50 Ohms
- Max Power :- 100 Watts
- Length :- 3.14 metres
- SWR 144 to 146Mhz :- Less than 1.5
- Wind Loading :- 4.6 Kgft at 100mph
- Weight :- 1.2 Kgs
- Mounting Diameter :- 25mm
- Termination :- Free 'N' Socket

N Plug extra, costs **£4.52 inc VAT**

Send cheque or postal order for **£33.96 inc VAT plus £2.60 postage to:**

**BUCKLEYS (UVRAL) LTD**  
 Beta Works, Range Road  
 Hythe, Kent CT21 6HG  
 Tel: (0303) 60127/60128  
 Various Frequencies Available

**THE SCIENTIFIC WIRE COMPANY**  
 811 Forest Road, London E17. Telephone 01-531 1566

SWG	ENAMELLED COPPER WIRE			
	1lb	3oz	4oz	2oz
8 to 34	3.63	2.09	1.10	0.88
35 to 39	3.82	2.31	1.27	0.93
40 to 43	6.00	3.20	2.25	1.61
44 to 47	8.67	5.80	3.49	2.75
48	15.96	9.58	6.38	3.69

14 to 30	SILVER PLATED COPPER WIRE			
	9.09	5.20	2.93	
14 to 30	3.97	2.41	1.39	0.94

Fluxcore

Please add 15% VAT. Orders under £3 add 50p. SAE for list of copper and resistance wire. Dealer enquiries welcome.

**TEST EQUIPMENT**

- HP 864f0B .5-512mhz ..... **£3,550**
- HP 1720 scope 200mhz..... **£750**
- HP 1725A scope 275mhz ..... **£1,975**
- Marconi Counter 2437 ..... **£350**
- Solartron RMS voltmeter ..... **£125**
- Multi-meter PSM37 ..... **£85**
- HP 3437A system voltmeter ..... **£1,500**
- HP 3438A digital Multi-meter ..... **£850**
- Fluke 8800A digital Multi-meter ..... **£120**
- Marconi Apollo HF receiver .r **£450**
- Video system portable Sony camera HVC 4000P with JVC VHS/C compact recorder/player ..... **£500**
- Airlight 62 headset & boom mic ..... **£45**
- Bone Dome Mk 3C, new ..... **(POA)**
- 770U receiver ..... **£165**

**Telephone: 0472 690383**

**Please mention Amateur Radio when replying to any advertisements**

**SOUTH WALES**

**ELECTRO DISPOSALS**

2000 sq ft of surplus equipment and components

**LONLAS WORKSHOPS**  
**SKEWEN, NEATH**  
**Tel: 0792 818451**

**NEXT ISSUE OF**

**Amateur RADIO**

**On Sale Thursday 28th July**

DISPLAY AD RATES		series rates for consecutive insertions			
depth mm x width mm	ad space	1 issue	3 issues	6 issues	12 issues
61 x 90	1/8 page	£96.00	£62.00	£59.00	£53.00
128 x 90 or 61 x 186	1/4 page	£115.00	£110.00	£105.00	£92.00
128 x 186 or 263 x 90	1/2 page	£225.00	£210.00	£200.00	£180.00
263 x 186	1 page	£430.00	£405.00	£385.00	£345.00
263 x 394	double page	£830.00	£780.00	£740.00	£660.00

COLOUR AD RATES		series rates for consecutive insertions			
depth mm x width mm	ad space	1 issue	3 issues	6 issues	12 issues
128 x 186 or 263 x 90	1/2 page	£305.00	£290.00	£275.00	£245.00
263 x 186	1 page	£590.00	£550.00	£530.00	£470.00
263 x 394	double page	£1,130.00	£1,070.00	£1,010.00	£900.00

SPECIAL POSITIONS	Covers:	Outside back cover 20% extra, inside covers 10% extra
	Bleed:	10% extra [Bleed area = 307 x 220]
	Facing Matter:	15% extra

DEADLINES		*Dates affected by public holidays			
issue	colour & mono proof ad	mono no proof & small ad	mono artwork	on sale thurs	
Aug 88	30 Jun 88	6 Jul 88	8 Jul 88	28 Jul 88	
Sep 88	28 Jul 88	3 Aug 88	5 Aug 88	25 Aug 88	
Oct 88	1 Sep 88	7 Sep 88	9 Sep 88	29 Sep 88	
Nov 88	29 Sep 88	5 Oct 88	7 Oct 88	27 Oct 88	

CONDITIONS & INFORMATION	
<p><b>SERIES RATES</b> Series rates also apply when larger or additional space to that initially booked is taken. An ad of at least the minimum space must appear in consecutive issues to qualify for series rates. Previous copy will automatically be repeated if no further copy is received. A 'hold ad' is acceptable for maintaining your series rate contract. This will automatically be inserted if no further copy is received. Display Ad and Small Ad series rate contracts are not interchangeable.</p>	<p>If series rate contract is cancelled, the advertiser will be liable to pay the unearned series discount already taken.</p> <p><b>COPY</b> Except for County Guides copy may be changed monthly. No additional charges for typesetting or illustrations (except for colour separations). For illustrations just send photograph or artwork. Colour Ad rates do not include the cost of separations. Printed - web offset.</p>
<p><b>PAYMENT</b> Above rates exclude VAT. All single insertion ads are accepted on a pre-payment basis only, unless an account is held. Accounts will be opened for series rate advertisers subject to satisfactory credit references. Accounts are strictly net and must be settled by the publication date. Overseas payments by International Money Order or credit card.</p> <p><b>FOR FURTHER INFORMATION CONTACT</b> Amateur Radio, Sovereign House, Brentwood, Essex CM14 4SE (0277) 219876</p>	<p>Commission to approved advertising agencies is 10%.</p> <p><b>CONDITIONS</b> 10% discount if advertising in both Amateur Radio and Radio &amp; Electronics World. A voucher copy will be sent to Display and Colour advertisers only. Ads accepted subject to our standard conditions, available on request.</p>

**Amateur Radio**  
- the monthly magazine for all two-way radio enthusiasts

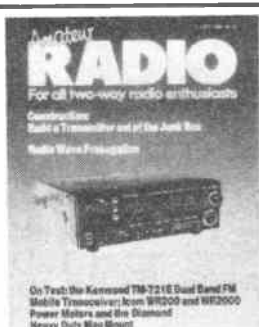

Don't take a chance on being able to get your copy

**AVOID DISAPPOINTMENT**  
Place a regular order with your newsagent

Should you have any difficulties obtaining a copy, phone (0277) 219876 or write to Circulation Department, **Amateur Radio**, Sovereign House, Brentwood, Essex, CM14 4SE.

### NEWSAGENT ORDER FORM

To (name of newsagent) .....

Please order a copy of **Amateur Radio** for me every month

NAME .....

ADDRESS .....

POSTCODE .....

Newstrade distributors: SM Distribution, 16-18 Trinity Gardens, London SW9 8DX. (Tel: 01-274 8611)

## ADVERTISERS INDEX

J Bull .....	51
P M Components .....	4, 5
Computer Appreciation .....	10
Dewsbury Electronic .....	30
Ecology Recovery .....	10
Electronic Comp Workshop .....	32
R N Electronics .....	16
I C S Electronics .....	38
Harrison Electronics .....	30
Icom .....	26, 27
I C S International .....	21
Number One System .....	32
G4ZPY Paddle Keys .....	21
Sherwood Data .....	13
Siskin Electronics .....	38
Telecomms .....	16
KW Ten-Tec .....	10
Universal Semi Conductors .....	16
Waters & Stanton .....	52
R Withers .....	2



## POPULAR BAKERS DOZEN PACKS (still available)

All packs are £1 each, if you order 12 then you are entitled to another free. Please state which one you want. Note the figure on the extreme left of the pack ref number and the next figure is the quantity of items in the pack, finally a short description.

- BD1 5 13A junction boxes for adding extra points to your ring main circuit.
- BD2 5 13A spurs provide a fused outlet to a ring main where devices such as a clock must not be switched off.
- BD7 4 In flex switches with neon on/off lights, saves leaving things switched on.
- BD9 2 6V 1A mains transformers upright mounting with fixed clamps.
- BD11 1 6 1/2" speaker cabinet ideal for extensions, takes our speaker. Ref BD137.
- BD13 12 30 watt reed switches, it's surprising what you can make with these—burglar alarms, secret switches, relay, etc., etc.
- BD22 2 25 watt loudspeaker two unit crossovers.
- BD29 1 B.D.A.C. stereo unit is wonderful value.
- BD30 2 Nicad constant current chargers adapt to charge almost any nicad battery.
- BD32 2 Humidity switches, as the air becomes damper the membrane stretches and operates a microswitch.
- BD34 48 2 meter length of connecting wire all colour coded.
- BD42 5 13A rocker switch three tags so on/off, or change over with centre off.
- BD45 1 24hr time switch, ex-Electricity Board, automatically adjust for lengthening and shortening day. Original cost £40 each.
- BD49 10 Neon valves, with series resistor, these make good night lights.
- BD56 1 Mini uniselector, one use is for an electric jigsaw puzzle, we give circuit diagram for this. One pulse into motor, moves switch through one pole.
- BD59 2 Flat solenoids—you could make your multi-tester read AC amps with this.
- BD67 1 Suck or blow operated pressure switch, or it can be operated by any low pressure variation such as water level in water tanks.
- BD91 2 Mains operated motors with gearbox. Final speed 16 rpm, 2 watt rated.
- BD103A 1 6V 750mA power supply, nicely cased with mains input and 6V output leads.
- BD120 2 Stripper boards, each contains a 400V 2A bridge rectifier and 14 other diodes and rectifiers as well as dozens of condensers, etc.
- BD122 10m Twin screened flex with white pvc cover.
- BD128 10 Very fine drills for pcb boards etc. Normal cost about 80p each.
- BD132 2 Plastic boxes approx 3in cube with square hole through top so ideal for interrupted beam switch.
- BD134 10 Motors for model aeroplanes, spin to start so needs no switch.
- BD139 6 Microphone inserts—magnetic 400 ohm also act as speakers.
- BD148 4 Reed relay kits, you get 16 reed switches and 4 coil sets with notes on making c/o relays and other gadgets.
- BD149 6 Safety cover for 13A sockets—prevent those inquisitive little fingers getting nasty shocks.
- BD180 6 Neon indicators in panel mounting holders with lens.
- BD193 6 5 amp 3 pin flush mounting sockets make a low cost disco panel.
- BD196 1 In flex simmerstat—keeps your soldering iron etc. always at the ready.
- BD199 1 Mains solenoid, very powerful, has 1in pull or could push if modified.
- BD200 8 Keyboard switches—made for computers but have many other applications.
- BD210 4 Transistors type 2N3055, probably the most useful power transistor.
- BD211 1 Electric clock, mains operated, put this in a box and you need never be late.
- BD221 5 12V alarms, make a noise about as loud as a car horn. Slightly soiled but OK.
- BD242 2 6in x 4in speakers, 4 ohm made from Radiomobile so very good quality.
- BD246 2 Tacho generators, generate one volt per 100 revs.
- BD252 1 Panostat, controls output of boiling ring from simmer up boil.
- BD259 50 Leads with push-on 1/4in tags—a must for hook-ups—mains connections etc.
- BD263 2 Oblong push switches for bell or chimes, these can mains up to 5 amps so could be foot switch if fitted into pattress.
- BD268 1 Mini 1 watt amp for record player. Will also change speed of record player motor.
- BD275 1 Guitar mic—clip-on type suits most amps.
- BD283 3 Mild steel boxes approx 3in x 3in x 1in deep standard electrical.
- BD293 50 Mixed silicon diodes.
- BD296 3 Car plugs with lead fit into lighter socket.
- BD305 1 Tubular dynamic mic with optional table rest.

## 5A BATTERY CHARGER KIT

All parts, including case, Only £5 plus £1 postage

## OVER 400 GIFTS YOU CAN CHOOSE FROM

There is a total of over 400 packs in our Baker's Dozen range and you become entitled to a free gift with each dozen packs.

A classified list of these packs and our latest 'News Letter' will be enclosed with your goods, and you will automatically receive our next news letter.



## F.D.D. BARGAIN

3 1/2" Floppy Disc Drive, made by the Chicon Company of Japan. Beautifully made and probably the most compact device of its kind as it weighs only 600g and measures only 104mm wide, 162mm deep and has a height of only 32mm. Other features are 80 track, high precision head positioning, single push loading and eject direct drive brushless motor. Shugart compatible interface standard connections interchangeable with most other 3 1/2" and 5 1/4" drives. Brand new with copy of maker's manual. Offered this month at £28.50 post and VAT included.

**CASE** adaptable for 3 1/2" FDD, has room for power supply components. Price only £4 includes circuit of PSU. Our Ref 4P7

**POWER SUPPLY FOR FDD** 5V and 12V voltage regulated outputs, complete kit of parts will fit into case 4P7 price £8 or with case £11. Our ref 11P2

## 9" MONITOR

Ideal to work with computer or video camera uses Philips black and white tube ref M24/306W. Which tube is implosion and X-ray radiation protected. VDU is brand new and has a time base and EHT circuitry. Requires only a 16V dc supply to set it going. It's made up in a lacquered metal framework but has open sides so should be cased. Offered at a lot less than some firms are asking for the tube alone, only £16 plus £5 post.

## CASE FOR 9" MONITOR

We have arranged with a metal worker to make cases for the 9" Monitor. Delivery promised for the end of May and the price £12 plus £2 post. The case will be made from coated sheet steel, overall size approx 10in x 10in x 7in high which will give ample space for the Power Supply and external controls if you fit them.

## PROBLEM SOLVED!

We have obtained from the manufacturers of the 9" Monitor, the TTL converter which makes it composite input suitable to work with any computer. We have had the printed circuit board made and have all the components and can supply this converter in kit form price £6. Our ref. 6P4.

## AN ALLADIN'S CAVE

We have opened another shop in Hove, the address is number 12 Boundary Road which is between Hove and Portside fairly close to the seaford. When you want to see before you buy and when you want to browse around the special bargains available, this is where you should make for as the Portland Road shop in future will be just mail order. You can of course collect from Portland Road but you should bring in an order complete with reference numbers so that the stores can attend to it easily.

## MINI MONO AMP

on p.c.b. size 4" x 2" (app.) Fitted volume control and a hole for a tone control. The amplifier has three transistors and we estimate the output to be 3W rms. More technical data will be included with the amp. Brand new, perfect condition, offered at the very low price of £1.15 each, or £13 for 12.

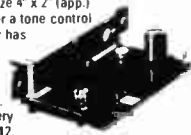

## THIS MONTH'S SNIP

**ACORN COMPUTER DATA RECORDER (CASSETTE).** This is a mono data recorder with switchable motor control intended for use with the Acorn Electron or BBC computers but also functions with almost any other computer and can be used for normal record and play-back of music and speech.

Six key controls give "PAUSE", "STOP" and "EJECT", "CUE/FAST FORWARD", "REVUE/REWIND" and "RECORD", last forward and rewind (100 seconds for C60). Also tape counter with reset button. Input signal range 5mV to 500mV. Input impedance 40k ohm. Can be battery operated but is supplied with a mains adaptor. Brand new still in manufacturer's wrapping £8. Order Ref. 8P18 add £2 postage.

## VENNER TIME SWITCH

Mains operated with 20 amp switch, one on and one off per 24 hrs, repeats daily automatically correcting for the lengthening or shortening day. An expensive time switch but you can have it for only £2.95 without case, metal case £2.95, adaptor kit to convert this into a normal 24hr time switch but with the added advantage of up to 12 on/off per 24hrs. This makes an ideal controller for the immersion heater. Price of the adaptor kit is £2.30.



Ex-Electricity Board. Guaranteed 12 months.

## AKAI RV-UM300 MIDI-RACK

Is a really excellent piece of furniture, ideal to hold your computer or audio equipment. Has three shelves in the upper section and a hinged glass fronted lower section. Height approximately 3ft, width 13 1/2in, depth 14in, on castors, dark walled veneer finish £15 plus £8 for Securcor delivery. Order Ref. 15P11

## MULLARD UNILEX AMPLIFIERS

We are probably the only firm in the country with these now in stock. Although only four watts per channel, these give superb reproduction. We now offer the 4 Mullard modules—i.e. Mains power unit (EP9002) Pre-amp module (EP9001) and two amplifier modules (EP9000) all for £6.00 plus £2 postage. For prices of modules bought separately see TWO POUNDERS.

## 25A ELECTRICAL PROGRAMMER

Learn in your sleep. Have radio playing and kettle boiling as you wake—switch on lights to warn off intruders—have a warm house to come home to. You can do all these and more. By a famous maker with 25 amp on/off switch. A beautiful unit at £2.50.

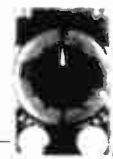

## POWERFUL IONISER

Generates approx 10 times more IONS than the ET1 and similar circuits. Will refresh your home, office, workshop etc. Makes you feel better and work harder—a complete mains operated kit, case included. £11.50+£3 P&P

## J & N BULL ELECTRICAL Dept AR, 250 PORTLAND ROAD, HOVE BRIGHTON, SUSSEX BN3 5QT

**MAIL ORDER TERMS:** Cash, PD or cheque with order. Orders under £20 add £1.50 service charge. Monthly account orders accepted from schools and public companies. Access and B/card orders accepted Brighton (0273) 734648 or 203500

## NEW ITEMS

Some of the many items described in our current list which you will receive with your parcel

**SOLAR POWERED NI-CAD CHARGER** 4 Ni-Cad batteries AA (HP7) charged in eight hours or two in only 4 hours. It is a complete, boxed ready to use unit. Price £6. Our ref 6P3

**50V 20A TRANSFORMER 'C'** Core construction so quite easy to adapt for other outputs—tapped mains input. Only £25 but very heavy so please add £5 if not collecting. Order Ref. 25P4

**FREE POWER!** Can be yours if you use our solar cells—sturdily made modules with new system bubble magnifiers to concentrate the light and so eliminate the need for actual sunshine—they work just as well in bright light. Voltage input is 45 volts in series to get desired voltage and in parallel for more amps. **Module A** gives 100mA, Price £1. Our ref. BD631. **Module C** gives 400mA, Price £2. Our ref. 2P199. **Module D** gives 700mA, Price £3. Our ref. 3P42.

**15A PANEL METER** These have been stripped from Government surplus battery charger units made originally for army use. Unused, tested but of course rather old, diameter 2in can be surface or flush mounted. £3 each. Our Ref 3P40

**SWITCH AC LOADS WITH YOUR COMPUTER** This is easy and reliable if you use our solid state relay. This has no moving parts, has high input resistance and acts as a noise barrier and provides 4kW isolation between logic terminals. The turn-on voltage is not critical, anything between 3 and 30V, internal resistance is about 1K ohm. AC loads up to 10A can be switched. Price is £2 each. Ref. 2P183

**METAL PROJECT BOX** Ideal size for battery charger, power supply etc., sprayed grey, size 8in x 4 1/4in x 4in high, ends are louvred for ventilation other sides are flat and undrilled. Order Ref. 2P191. Price £2.

**BIG SMOOTHING CAPACITOR.** Sprague powerlytic 39,000uF at 50V £3. Our ref 3P41

**HEAVY DUTY CURLY MAINS LEAD.** Can be loaded up to 13A, stretches to almost 3 metres fitted with 13A plug. £3. Order ref. 3P42

**4-CORE FLEX CABLE.** Cores separately insulated and grey PVC covered overall. Each copper core size 7/0.2mm. Ideal for long telephone runs or similar applications even at mains voltage. 20 metres £2. Our ref. 2P196 or 100 metres coil £8. Order ref. 8P19

**BULK-HEAD MOUNTING LOUDSPEAKER.** Metal case with chrome grill front and with mounting lugs for screwing to ceiling, 8in speaker. £10 each. Order ref. 10P43 add £2 post.

**TWIN GANG TUNING CAPACITOR.** Each section is .0005uF with trimmers and good length 1/4in spindle. Old but unused3rd and in very good condition. £1 each. Our Ref. BD630

**13A PLUGS** Good British make complete with fuse, parcel of 5 for £2. Order ref. 2P185

**13A ADAPTERS** Takes 2 13A plugs, packet of 3 for £2. Order ref. 2P187

**20V-0-20V** Mains transformers 2 1/2 amp (1100 watt) loading, tapped primary 200 245 upright mountings £4. Order ref. 4P24

**BENCH ISOLATION TRANSFORMERS** 250 watt 230V in and out with plenty of tappings to give exact volts £5 plus £2. Order Ref. 5P5

**BURGLAR ALARM BELL.** 6" gong OK for outside use if protected from rain. 12V battery operated. Price £8. Order Ref. 8P2

**24 HOUR TIME SWITCH** 16A changeover contacts, up to 6 on/off per day. Nicely cased, intended for wall mounting. Price £8. Ref. 8P6

**CAPACITOR BARGAIN** axial ended, 4700uF at 25V. Jap made, normally 50p each, you get 4 for £1. Our ref. 613

**CLEANING FLUID** Extra good quality—intended for video and tape heads. Regular price £1.50 per spray can. Our price 2 cans for £1. Ref. BD604

**PIEZO ELECTRIC FAN** An unusual fan, more like the one used by Madame Butterfly than the conventional type, it does not rotate. The air movement is caused by two vibrating arms. It is American made, mains operated, very economical and causes no interference, so is ideal for computer and instrument cooling. Price is only £1 each. Ref. BD605

**SPRING LOADED TEST PRODS** Heavy duty, made by the famous Bulgin company very good quality. Price 4 for £1. Ref. BD599

**CURLY LEAD** Four core, standard replacement for telephone handset, extends to nearly 2 metres. Price £1 each. Ref. BD599

**TELEPHONE BELLS** These will work off our standard mains through a transformer, but to sound exactly like a telephone, they then must be fed with 25Hz 50V. So with these bells we give a circuit for a suitable power supply. Price 2 bells for £1. Ref. BD600

**ASTEC P.S.U.** Switch mode type Input set for +230V Output 3.5 amps at +5V, 15 amps at +12V, and 3 amps at +5V. Should be OK for floppy disc drives. Regular price £30. Our price only £10. Ref. 10P34. Brand new and unused.

**APPLIANCE THERMOSTATS** Spindle adjust type suitable for convector heaters or similar. Price 2 for £1. Ref. BD582

**3-CORE FLEX BARGAIN No. 1** Core size 5mm so ideal for long extension leads carrying up to 5 amps or short leads up to 10 amps. 15mm for £2. Ref. 2P189

**3-CORE FLEX BARGAIN No. 2**—Core size 1.25mm so suitable for long extension leads carrying up to 13 amps, or short leads up to 25A. 10m for £2. Ref. 2P190

**CASE WITH 13A PRONGS** To go into 13A socket, nice size and suitable for plenty of projects such as battery trickle charger, speed controller, time switch, night light, noise suppressor, dimmers etc. Price 2 for £1. Ref. BD565

**ALPHA-NUMERIC KEYBOARD** This keyboard has 73 keys giving trouble free life and no contact bounce. The keys are arranged in two groups, the main area is a QWERTY array and on the right is a 15 key number pad. Size is approx 13" x 4" brand new but offered at only a fraction of its cost, namely £3, plus £1 post. Ref. 3P27

**TELEPHONE EXTENSIONS** It is now legal for you to undertake the wiring of telephone extensions. For this we can supply 4-core telephone cable 100m coil £8.50. Extension BT sockets £2.95. Packet of 50 plastic headed staples £2. Dual adaptor for taking two appliances from one socket £3.95. Leads with BT plug for changing old phones. 3 for £2.

**WIRE BARGAIN** 500 metres 0.7mm solid copper tinned and pvc covered. Only £3 plus £1 post. Ref. 3P31—that's well under 1p per metre, and this wire is ideal for push on connections.

**INTERRUPTED BEAM KIT** This kit enables you to make a switch that will trigger when a steady beam of infra-red or ordinary light is broken. Main components: relay, photo transistor, resistors and caps, etc. Circuit diagram but no case. Price £2. Ref. 2P15

**3-30V VARIABLE VOLTAGE POWER SUPPLY UNIT** with 1 amp DC output. Intended for use on the bench for experimenters, students, inventors, service engineers etc. This is probably the most important piece of equipment you can own (after a multi range test meter). It gives a variable output from 3.30 volts and has an automatic short circuit and overload protection, which operates at 1.1 amp approximately. Other features are very low ripple output, a typical ripple is 3mV pk-pk. 1mV rms. Mounted in a metal fronted plastic case, this has a voltmeter on the front panel in addition to the output control knob and the output terminals. Price for complete kit with full instructions is £15. Ref. 15P7

**TRANSMITTER SURVEILLANCE (BUG)** Tiny, easily hidden, but which will enable conversation to be picked up with FM radio. Can be housed in a matchbox, all electronic parts and circuit. Price £2. Ref. 2P52

- ★ 2m/70cm
- ★ 25 Watts output
- ★ Full duplex operation
- ★ 21 Memories
- ★ 2 Call channels
- ★ Priority channel
- ★ Dual VFO's
- ★ 12.5 & 25kHz steps
- ★ Memory Scan
- ★ Programme Scan
- ★ Memory Skip

**£449 inc vat**

**ALD-24E**

## ALINCO DUAL BANDER



This transceiver could transform your operating habits! It contains completely separate 2m and 70cms transceivers, permitting full duplex operation. To the un-initiated, this means you can transmit on 2m whilst receiving on 70cms, or vice versa. The built-in duplexer means a single antenna socket with a full 25 watts output on both bands. Measuring only 5.5"x2"x6.5" it is the ideal mobile rig. Its comprehensive memory and scanning facilities provide rapid access to both

simplex and repeater channels on 2m & 70cms. Using the dual VFO's you can instantly switch between 2m & 70cm and the single knob tuning provides simple and quick frequency selection. The large LCD readout incorporates an S-meter and is back lighted. If you are looking for a completely self contained 2m & 70cm station, then look no further. At this price it has to be a bargain. For further details of this amazing transceiver, send today for the full colour brochure.

## OUR FAMOUS FREQUENCY MANUALS!

### UK LISTENERS CONFIDENTIAL FREQUENCY LIST 5th EDITION

This publication has now sold well over 3500 copies since it was advertised only a few months ago. Now the recent updated version is selling even better. No self respecting listener should be without a copy. If you enjoy exploring the short wave bands then this publication will add to your enjoyment. It covers the hf spectrum from 2 to 30 MHz and gives details of transmissions outside the amateur bands. Specially designed for the UK and European listener it sets out in a very easy way a comprehensive list of hundreds of interesting transmissions that will keep you occupied for days on end! Only a fraction of the cost of other similar publications it contains details of Marine, Air, Military, Embassy, Press and News agencies. Many listings have time schedules included together with comprehensive RTTY details. It tells you the frequencies used by civil and military aircraft whilst flying the Atlantic, when and where to pick up the press bulletins, long distance marine traffic etc and much more. Send today for your copy of this worthwhile publication.

**NEW 1988 EDITION £6.95 p&p 90p**

### 4th EDITION VHF-UHF AIRBAND FREQUENCY LIST

This frequency manual is without doubt the most comprehensive list of VHF/UHF aircraft listings available in the UK. Of vital importance to the airband enthusiast or indeed any keen VHF/UHF listener it sets out in a very easy to follow manner full details of a whole host of stations. Every known UK airfield frequencies, etc. Included are Civil, RAF, USAF, MOD, Naval fields on both VHF and UHF bands. There are also air to air frequencies, the Red Arrows frequency, and much more. Send today for your copy and find out just how much you have been missing!

**£5.95 p&p 90p**

### THE COMPLETE UHF-VHF FREQUENCY GUIDE 26-2000 MHz

**New 1988 Edition.** Many listeners have asked for a guide to the wide VHF/UHF spectrum and to meet this request we have recently published this frequency manual. It covers the range 26 to 2000 MHz and has been specially prepared for the UK listener. Anybody who has used a scanning receiver will know that the wide frequency range involved means that it is difficult to know exactly where to listen. This guide takes all the guessing out of monitoring. It lists all the services throughout the spectrum together with both simplex and duplex frequency splits. If you've spent your hard earned money on a scanning receiver or are considering buying one you'll find that this publication contains a wealth of information that has previously remained un-published!

**£5.95 p&p 75p**

### HF OCEANIC AIRBAND COMMUNICATIONS 1988 EDITION.

Prepared in response to many requests for more information about the air traffic on the hf bands this little guide sets out to explain to the beginner how the hf band works in relation to air traffic. It contains full details of the world aircraft frequency bands in the range 2 to 23 MHz together with control frequencies and those commonly used for Oceanic control. Also included are many VOLMET frequencies, the Search and Rescue frequencies used by RAF helicopters and Nimrods, the Hf RT network, London Company frequencies, European control centres etc An ideal companion for the hf airband listener. Send today for your copy

**£3.50 p&p 70p**

**WATERS  
& STANTON  
ELECTRONICS**

18-20 MAIN ROAD, HOCKLEY, ESSEX - 12 NORTH STREET, HORNCHURCH, ESSEX.  
MAIL ORDER TO: 18-20 MAIN ROAD, HOCKLEY, ESSEX TEL: (0702) 206835

