

Amateur

RADIO

For all two-way radio enthusiasts

'Tiny Tim'
Top Band transmitter

24cm television
- part four

Battle of the beams

Starting a club station

DX Diary

Pass the RAE
painlessly



**ICOM IC02E/Standard C110
2m Handhelds on test**

AMTRONICS (TONBRIDGE) G4 SYZ

THE AMATEUR RADIO SPECIALISTS IN KENT

CLOSED MONDAYS: 9 TO 5.30 TUES TO SAT



FDK

750XX.....	£349.00
725X.....	£219.00
70cm EXP.....	£249.00

FORTOP ^A_T

Converter.....	£26.95
70cm TX.....	£149.00
70cm TX/RX.....	£169.00
24cm TX.....	£199.00

B.N.O.S.

1-100 Linear..	£172.50
3-100 Linear..	£172.50
10-100 Linear..	£149.50
25 amp PSU	£125.45

ADONIS

Safety Mic	£28.95
Safety Mic	£43.25
503 Mic	£47.50
303 Mic	£36.50

STILL A FEW LEFT

package deal
FT790R +
FL7010 amp
bought together
£299.00 inc

FT290R Multimode Transceiver 2m	£269.00
FT790R Multimode Transceiver 70cm	£249.00
SMC 8C 220mA Charger (13A Style)	£8.80
MMB11 Mobile mount	£26.85
CSC1A Carrying case	£4.20
FL2010 2m 10w Amplifier.....	£63.25
FL7010 70cm 10w Amplifier.....	£91.00
FT203R New 2m Handy	£169.00
FT230R 2m Transceiver 25w	£259.00
FT730R 70cm Transceiver 10w	£229.00
FT208R 2m Handheld 2.5w	£199.00
FT708R 70cm Handheld 1w	£179.00
SMC8.9AA Compact charger (13A Style).....	£8.05
NC7 Base charger.....	£32.95
NC8 Base quick charger & psu	£54.05
PA3 DC Adaptor and charger	£15.35
FT77 8 Band RX/TX 100w output	£459.00
FT77S 8 Band RX/TX output	£425.00
FP700 Matching AC PSU	£135.00
FC700 Matching Antenna Tuner	£98.90
FV700DM Digital VFD Unit	£200.00
MKT77 Marker Unit.....	£10.35
FMUT77 FM Unit	£27.20
FT57GX All Modes and Filters Fitted	£685.00
FP757 GX Switched Model PSU	50% duty £149.40
FP757HD Heavy Duty PSU.....	100% duty £162.50
FC757AT Automatic Antenna Tuner.....	£231.50

SPECIAL OFFERS

YAMATO ROTATOR takes up to 8 element 2 metre beam. Uses 3 core cable, in line and neat controller **£40.00**

ALINCO EMR 400 ROTATOR similar spec to KR400. Takes large 2 metre beam etc. **£79.00**, lower bracket **£14.00**

GLOBAL MINI CLOCK Rotate the Globe: London and Country zone time. Special price **£45.00**

FAST MAIL ORDER:

Access, Visa, Postal Order or Cheque. Instant HP with Call sign for callers at the shop.

JAYBEAM — Full range in stock

Including the new 1 ELI TRIBAND 16-15-10 metre Rotary Diopol/and I-Z EU EXTENDER KITS.

MET. Full Range

including the Non Metallic Mastings in 1.5/3 metre sizes.

NEW Fortor 70cm TV Transmitter Kit. **£33.55p.**

ALSO: Poles, Masts, Rotors, Brackets Clamps, Plugs, Sockets, Cable, Tape etc in stock.

WE ALSO SELL:

Met: Welz: KDK: Azden: Drae: Datong: Diamond: Sagant: Amtron kits: DK Tronics ZX software.

SEND LARGE SAE for details on any of the above equipment.



Instant credit. Ask for details when you call or write for a quote. See us at most of the major Rallies: ie Brighton, Longleat, Woburn, Harlow, Vange & Ton Wells.



8 TOLLGATE BUILDINGS, HADLOW RD, TONBRIDGE. TEL: (0732) 361850

Amateur RADIO

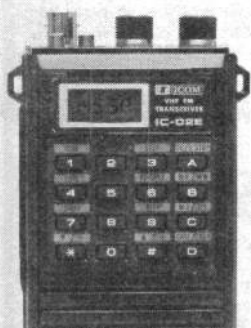

Editor:

Dennis Padfield G1AJQ

Advertisement Manager:

Nicola Dyer

Advertisement Executive:

Anne Brady

Subscriptions: 01-684 3157

Accounts: Clare Brinkman

Publisher: Peter Williams

General Manager:

Alan Golbourn

On sale: Fourth Thursday of the month preceding cover date

Next issue: Cover date June 1984 on sale 24 May 1984

Published by: Amateur Radio Magazines, Sovereign House, Brentwood, Essex CM14 4SE, England (0277 219876)

Printed: In England

ISSN: 0264-2557

News Trade Sales by:

Argus Press Sales & Distribution Ltd, 12-18 Paul Street, London EC2A 4JS. 01-247 8233

Front cover: The two handhelds tested in this month's issue, by Angus McKenzie G3OSS. See page 22. Picture by Jay Moss Powell

Whilst every care is taken when accepting advertisements we cannot accept responsibility for unsatisfactory transactions. We will, however, thoroughly investigate any complaints. The views expressed by contributors are not necessarily those of the publishers. Every care is also taken to ensure that the contents of *Amateur Radio* are accurate, we assume no responsibility for any effect from errors or omissions.

Audit Bureau of Circulations membership applied for
© Copyright 1984
Amateur Radio Magazines

6 Current comment

The Editor's chance to give his own views on recent events in amateur radio

8 Letters

Your news and views on topics of interest to all amateurs

10 Straight and level

Latest developments in the amateur radio scene

12 DX Diary

Don Field G3XTT with last month's DX news

18 When Germany was on the beam

Brian Kendal looks at German wartime radio navigation systems

22 Two handhelds are better than one

Angus McKenzie G3OSS looks at the Icom IC02E and Standard C110

30 On the face of it

Ken Williams takes a look at front panel design

35 RSGB National Convention 1984

A preview of the Birmingham exhibition

36 On the beam

Glen Ross G8MWR with all the latest news from VHF, UHF and Microwaves

39 Making 'Tiny Tim' talk

John Heys G3BDQ with a simple Top Band transmitter project

44 SWL

Information for all short wave listeners from Trevor Morgan

48 Starting your own club station

Tim Wander on the joint approach

51 Early experiments

Glen Ross brings us up to date with his history of amateur radio

52 Newsagents order form

60 Read the b---y question

Bill Sparks G8FBX on passing the RAE without tears

64 Subscription order form

65 24cm ATV - Part 4

Andy Emmerson G8PTH with the penultimate part of his series, this month looking at the new repeaters

68 Club calendar

Latest club news

70 Coming next month

What's in store for you

71 Free classified ads

Sell your unwanted gear

73 Small ads

74 Advertisers index

74 Advertising rates & information

NEW PUBLISHERS

We are pleased to announce that we have bought *Amateur Radio* from its previous owners, Goodhead Publications.

Our policy is to continue the current editorial policy of *Amateur Radio* and our aim is to continually improve the magazine and provide you, the reader, with exactly what you want. We will be pleased to receive your comments which will be invaluable in helping us to plan future issues.

Publication Date

Amateur Radio will continue to be published on the fourth Thursday of the month - so the June issue will be on sale from 24 May.

Don't Miss the Next Issue

Make sure you are not disappointed, ensure you are able to obtain your copy by placing a regular order at your newsagent. Alternatively you could take up a subscription and have your favourite AR magazine delivered to your door before publication date each month (see page 64).

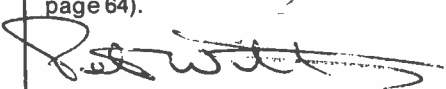
Peter Williams
Publisher

We are pleased to announce that the company has recently been appointed U.K. distributors for the TELEREADER range of equipment. Those of you who have seen TELEREADER products will know that outstanding performance allied with ease of operation are the hallmarks of this particular company. The three models in our range are the TELEREADER CWR685E combined transmitter and receiver and the CODE MASTER CWR610E which not only receives CW and RTTY (Baudot and ASCII) but doubles as a Morse tutor.

The TELEREADER CWR685E has many outstanding features. CW, Baudot and ASCII receive and transmit. RTTY at 45-300 bauds (transmission/reception of both upper and lower case letters). Built-in 5" green phosphor screen with brightness that I have not seen elsewhere.

An external QWERTY keyboard is available in a carrying case and supplied with a choice of metal or plastic faced keys.

6 Memory channels for total memory recall. In addition the character set can be memorized for fast recall.

External Morse code keyer for CW and RTTY. Morse code keyer for CW and RTTY. Morse code keyer for CW and RTTY.

External Morse code keyer for CW and RTTY. Morse code keyer for CW and RTTY. Morse code keyer for CW and RTTY.

special announcement
a new LOWE shop
in Cambridge
Ring Matlock for details



Code Master CW/RTTY model CWR 610E

THE POCKE TRA, A NEW DIMENSION IN PORTABLE AMATEUR RADIO

A RIG FOR YOUR TOP POCKET, THEREFORE PERFECT FOR THE ACTIVE RADIO AMATEUR

*The rig you will forget you are carrying ... With overall dimensions of 140mm high, 69mm wide, 26mm deep and weighing only 260 grams (including aerial and batteries), the LS-20XE fits easily into your pocket giving perfect portable communication.

*Long range communications ... A newly developed dual gate MOS FET is used in the RF stage of the transceiver which considerably improves receiver performance. The internal 50mm diameter speaker ensures clear audio under difficult portable conditions.

*Full coverage of 2 metre amateur band ... The transceiver covers 144 to 146 MHz in 5 kHz steps and has repeater shift and automatic tone burst.

*Switchable output power for extended operation ... In order to extend portable operation, transmission power level is switchable, 1 W, 500 mW and 100 mW, so depending on the terrain and conditions, the most economical level can be selected.

*Simple to operate ... Simplicity of operation is a special feature of this rig and many optional accessories are available. Of major interest is the matching headset SH-2 having built-in vox, this convenient accessory provides simple and safe operation whilst cycling, walking etc.



LS 20XE

£139.00 inc VAT carriage £2.50

Before I buy, I carefully consider the purchase. If the item is not expensive, then probably consideration will not take long, but if the cost is for example, two or three hundred pounds or more, then there are several questions which I would want answering.

what to buy,

The first question is whether to buy ICOM, YAESU or TRIO. Obviously, we are convinced that TRIO equipment is the best. Since we import the equipment, you could accuse us of being biased in this view. However, our opinion is based on many years' experience, and the simple fact that the volume of TRIO sales in the UK is extremely high. Many people are to be found using TRIO equipment, and we are confident that this is its own best advertisement. Why not ask an owner?

where to buy it,

The second question is where to buy your rig or accessory. Ever since the company began, some twenty years ago, our policy has been one of service. No matter how careful a manufacturer may be, equipment can go faulty and it would be wrong to say otherwise. Having said this, a high priority on your shopping list must be the quality of after sales service that you can expect from the company that supplied the goods. Service that can be asked for with confidence and result in your favourite piece of gear being rapidly repaired. Service of this calibre can only be given if sufficient money has been invested by the company in the necessary test equipment and spare parts. A point worth remembering is that test equipment by itself is useless: the company must also have technically able staff. How many amateur radio shops do you know that have eight engineers whose sole job is the repair of your equipment? Who other than LOWE ELECTRONICS have sufficient pride in their facilities and expertise to hold an "OPEN DAY" once a year?

help,

Informative and helpful service is also of major importance. Both the newcomer and the experienced amateur may want to discuss their requirements before making a purchase. They may be seeking advice. They will certainly want to check that the piece of equipment they have chosen does what they want it to do. What a customer does not want is pressure sales. At a LOWE ELECTRONICS shop you will receive advice and courtesy: the service on which we and all members of the staff pride ourselves.

LOWE ELECTRONICS accept the fact that everyone cannot travel to Matlock. To make purchase of equipment easy, we have opened our own shops, all with the same high standards, in Glasgow, Darlington, London and soon in Cardiff - the managers of the shops being hand picked for their abilities. For those who are still too far from a LOWE ELECTRONICS shop, then we have the fastest in mail order. Remember, we are the importers of the majority of the equipment we sell - we don't have to take your order and then obtain the goods. In addition to all these facilities, there are selected approved TRIO dealers who offer the same direct link with the TRIO factory as ourselves. A list of these approved dealers is published regularly by TRIO. Please ring us here at any time for information on your nearest approved dealer.

Lowe Electronics.

Matlock, Lowe Electronics Ltd.,
Chesterfield Road, Matlock, Derbyshire DE4 5LE
Tel: 0629 2817/2430/4057/4995

London Lowe Electronics Ltd.,
Lower Sales Floor, Hepworths, Pentonville Road, London.
Tel: 01-837 6702

Glasgow Lowe Electronics Ltd.,
4/5 Queen Margarets Road, off Queen Margarets Drive, Glasgow.
Tel: 041 945 2626

The North East Lowe Electronics Ltd.,
56 North Road, Darlington, Durham.
Tel: 0325 486121

Yes, we don't give discount. Our price is the price, and takes into account the above services which have to be paid for. But it is much better than getting 5% off "LOWE'S PRICE" and then finding when you have a problem that you may have bought from a rogue.

Not everyone can afford a new piece of equipment. To cater for this need, we prepare a weekly list of what is available both here in Matlock and also at the LOWE SHOPS. This list is sent out with all correspondence and to those who request it. Regarding the SECOND HAND LIST, please contact Matlock for your copy.

Credit is also available. We have for your convenience, the LOWE CARD which not only makes purchasing easy, but each quarter along with your statement are details of the "SPECIAL OFFERS." Ring for a LOWE CARD application form.

So that's it; simple questions which should receive answers before making a purchase, be it an SWR meter or a new HF rig.

TR9130 TWO METRE ALL MODE TRANSCEIVER

This rig is proof, if one needed it, that TRIO do not bring out new models just for the sake of it. The TR9000 is remembered as a classic rig and today people are still asking for second hand ones, even they are a rarity on our S/H shelf. The TR9130 incorporates the improvements that all amateurs asked for: green display, reverse repeater, tune whilst transmitting, higher power, more memories and of course memory scan. TRIO's answer, the TR9130.

TR9130..... £442.52 Inc. VAT



TS780 DUAL BAND BASE STATION TRANSCEIVER

The TS780 is the perfect base station VHF/UHF transceiver for the enthusiastic operator. The rig has all the necessary control functions essential for operating on both today's busy two metre band and the wide spaces of seventy centimetres. Full repeater facilities plus reverse repeater are included and the transceiver has the usual memory channels (10), two VFO's, up/down frequency shift microphone, 1F shift, two priority channels, memory and band scan etc. A superb rig. I have one myself. Ring for a full enthuse!

TS780..... £795.00 Inc. VAT



TR7930 TWO METRE FM MOBILE TRANSCEIVER

Those who have used or owned a Trio TR7800 will know what I mean when I say that Trio, with the introduction of the TR7930 have improved on the unimprovable. The Trio TR7930 improves on the TR7800 by giving a green floodlight liquid crystal display, extra memory channels, both timed and carrier scan hold, selectable priority frequency and correct mode selection (simples or repeater). The most significant change is the liquid crystal display, but closely following this must be the ability to omit specific memory channels when scanning and the programmable scan between user designated frequencies.

TR7930..... £312.11 Inc VAT



R2000 GENERAL COVERAGE RECEIVER

The amateur bands are only a very small part of the radio spectrum, many other transmissions are available for the short wave listener. Broadcast stations provide an alternative source of current information both political and regarding the life style of the country. Fitted with the internal VHF converter the R2000 covers continuously frequencies from 118 to 174MHz giving access to amateur two metre transmissions (am, fm, ssb and cw) plus a lot more. Having 10 memories, memory scan and programmable scan the R2000 provides in one rig the perfect receiver.

R2000..... £421.36 Inc VAT



TS930S HF TRANSCEIVER WITH GENERAL COVERAGE RECEIVE FACILITIES

Much has been said about the TS930G transceiver and it now has a place high in the affection of those amateurs fortunate enough to own one. Indeed it has become the "flagship" of the TRIO range. Providing full amateur bands plus a general coverage receiver (150KHz to 30MHz), the TS930S has every conceivable operating feature for today's crowded frequencies.

TS930S..... £1,150.00 Inc. VAT

**NEW
PRICE**



TR2500/TR3500 HANDHELD TRANSCEIVERS

Two first class hand held transceivers, one for two metres and the other for seventy centimetres. Ten memory channels, band and memory scan, repeater shift, reverse repeater and a low power position make the rigs extremely useful for the radio amateur who wishes to keep in touch with his local scene. A comprehensive range of accessories, base station charger, speaker microphone, mobile mount, etc., can be added to enhance operation. Accessories used with one rig being compatible with the other.

TR2500..... £237.82 Inc VAT
TR3500..... £256.45 Inc VAT



TS530SP HF AMATEUR BAND TRANSCEIVER

A logical progression from the reliable TS520 series the TS530S was the most popular HF rig in the range. I use the term "was" because TRIO decided to cease production and supplies were no more. However, the demand from radio amateurs worldwide for the transceiver has continued and TRIO have re-introduced the rig. A standard HF valve transceiver without the frills but providing today's amateur with all necessary facilities for reliable world wide communications, the TRIO TS530SP

TS530SP..... £638.00 Inc VAT



TW4000A DUAL BAND FM TRANSCEIVER

I have been waiting for this rig for the last three years. Now it is here and I am using one, words fail me. Send for details.

TW4000A..... £469.00 Inc. VAT



just a part of the range

Send 90p for full catalogue

CURRENT COMMENT

Upsurge in QRP activity

The last couple of years have seen a tremendous worldwide upsurge of interest in QRP operation which can only be good news and should be welcomed by all Radio Amateurs. This trend is particularly evident with new licence holders and this must surely encourage good operating techniques and simple home construction. Many would argue that there should be a 'Novice' licence limiting power output to, say, 10W maximum for a period of a few months or a year. I, for one, entirely support this view. After all, when learning to drive a car, you have to prove yourself capable of handling the machine safely and correctly. So why not a similar scheme in Amateur Radio? I am sure most people would agree that the HF bands would be a much healthier place as a result. Of course, QRP has much more to offer than this. Equipment is usually of much simpler design and easy to build which appeals to many potential constructors. The equipment has to be very efficient (as has the antenna!) as power output is much lower than commercial 200W rigs. It is extremely rewarding making contacts in this way, and to think you are achieving it with less power than a pocket torch flashlight!

On each band there are QRP calling frequencies where you will usually always hear enthusiasts chattering away. On CW these are 3.560, 7.030, 10.106, 14.060, 21.060, and 28.060MHz. Have a listen on these frequencies, and if nobody appears to be present try putting out a CQ. Very often another low power sta-

tion will reply as many amateurs regularly monitor these frequencies listening for just such calls.

This leads to the other side of QRP operation - listen carefully. Putting out a haphazard call in the hope of an immediate response might prove frustrating as your signals will be well below the average QRO station and unfortunately some foreign stations tend not to answer if it's going to be hard work copying you. Here your receiver is vitally important. Good sensitivity and selectivity is essential and the use of good filtering and RIT will enhance your success rate enormously. This is why most QRP operators have a high performance receiver separate from the transmitter, the latter only needing to be very simple indeed - see some of the G-QRP Club designs. One problem is that not every amateur knows about the above mentioned frequencies and it can be tiresome to be 'bullied' off your channel by a high-power station. Even so, RIT overcomes this to some extent and the frequencies are always +/- a few KHz. Don't be put off by this since with a bit of practice you will become expert at 'QRM hopping' and a much better operator, too.

Commercial rigs are also available, two excellent and widely used transceivers being the HW8 and the Argonaut. These, and others, provide a good start to QRP if you don't fancy building your own rig. The G-QRP Club is a must to join, and their excellent quarterly publication 'SPRAT' contains articles purely for low-power. They certainly live up to their logo 'Devoted to

low-power communication'.

When conditions are good anything is possible: with only a watt or two output QRP is pure magic. If you haven't tried it yet you are missing out on possibly the most exciting aspect of amateur radio. The QRP fraternity are always keen to help others and you will be made most welcome. Give it a try - you'll love it.

The G-QRP club address is: G-QRP Club, c/o Rev George Dobbs, G3RJV, 17 Aspen Drive, Chelmsley Wood, Birmingham. B37 7QX

BBC Micro owners

If you're tired of waiting ages for programs to be loaded from cassette into your Beeb, there is now a fast, cheap alternative method called the 'PHLOOPY' microprocessor controlled system. It is claimed that this new system gives owners almost all the features of a professional floppy disc system at half the price. It uses interchangeable cartridges which contain a continuous twelve foot loop of 1/4in tape driven at 15 ips. Transfer rate is 10k bytes per second and takes between 3 to 4 seconds to find a file and load or save it, and is as much as 200 times faster than cassettes. It also has a built in error-correction system and there is no risk of data corruption if a cartridge is accidentally removed while in use. Its loop filing system (LFS) uses standard BBC filing system and basic program commands, and the whole system is under computer control with no buttons to press. The only hardware adaption is one interface ROM to be inserted and cut to clearly defined resistors. These are described fully in

the simple to follow documentation included, and it is claimed that full installation should not take more than 20 minutes. 'PHLOOPY' costs £99.00 + VAT, interface £26.00 + VAT and a pack of five cartridges £19.75 inc VAT and P&P. Information from: *Phil Mag Systems Ltd, Tregonigie Industrial Estate, Falmouth, Cornwall, TR11 4RY.*

Germany beaming

The article in this month's issue entitled 'When Germany Was On The Beam' describes German Second World War activities in the field of radio navigation for bombing raids over the UK. It traces the systems they used and the innovations required when these systems were countered. These designs were the forerunner to present-day Electronic Counter Measures (ECM) and Electronic Counter Counter Measures (ECCM). It is a fascinating subject and provides an invaluable insight into how Germany utilised their advances in radio. For readers who are interested in this area of wartime electronic systems, the definitive work on the subject is published in a book by Professor RV Jones (one of the leading exponents in the field) entitled *Most Secret War*. It is comprehensive, very readable and one of those books you can't put down. It covers the pre-war exploits of both sides in radio communication developments, electronic navigation during the war, radar, through to 'Enigma' and other code-breaking devices. The book also includes sections on German rocket designs such as V1 and V2 and how close Germany came to producing a nuclear capability.



FASTER BY PHONE WITH A.R.E. MAIL ORDER



Bernie-can
I send coffee by Mail Order?

Sure-when I arrange it with
American Expresso!

PHONE FOR DETAILS · STOP PRESS · SPECIALS · PHONE FOR DETAILS ·

YAESU SPECIALS

FT 102 9 BAND T'CEIVER
FT 980 HF TRANSCEIVER
FT 757 HF TRANSCEIVER
FT 290R VHF PORTABLE T'CEIVER
FT 790 UHF PORTABLE T'CEIVER
FT 726 VHF-UHF & HF T'CEIVER
FRG7700 HF RECEIVER

ICOM SPECIALS

IC 751 HF TRANSCEIVER
IC 745 HF TRANSCEIVER
IC 2E VHF HAND HELD
IC 4E UHF HAND HELD
IC 02E VHF HAND HELD
IC 04E UHF HAND HELD
IC R70 HF RECEIVER
IC R71 NEW HF RECEIVER

TRIO/KENWOOD SPECIALS

TS 930 HF T'CEIVER GEN COV
TS 430 HF T'CEIVER GEN COV
TR 9130 VHF ALL MODE TCVR
TW 4000 VHF/UHF FM TCVR
TR 2500 VHF HAND HELD
R 600 HF RECEIVER
R 2000 HF RECEIVER

PHONE PHONE · ALL ABOVE ON SPECIAL OFFER · PHONE PHONE PHONE

ICOM STOCK

2005 IC751	* NEW * 100W H.F.	999.00
2008 IC745	* NEW * 100W H.F.	
2010 IC740	100w HF tr	
2020 PSU(int)	230v AC p	
2030 FM(EX242)	FM modul	
2040 KEYSER(EX243)	Keyer mod	
2108 IC730	100w HF tr	
2128 FL30	SSB pass t	
2180 IC720A	100w HF tr	
2200 PS15	230v p.s.u.	
2210 PS20	230v chopp	
2150 FL45	500Hz filter	
2050 FL44	2.4kHz SSB	
2220 FL32	CW narrow	
2230 FL34	AM filter for	
2150 EX202	LDA unit for	
2160 EX203	CW audio filt	
2170 EX205	TRV unit for	
2240 B10	Memory back	
2290 IC2KL	500W solid st.	975.00
2300 IC2KL PSU	Matching 230v AC PSU	258.00
2310 AT100	100 watt HF Auto ATU	248.00
2320 AT500	500 watt HF Auto ATU	348.00
2340 CF1	Cooling fan	28.50
2350 SP3	Matching ext speaker	38.00
2380 HP1	Communication phones	25.00
2378 SM5	Base microphone	29.00
2250 IC-R70	Comms rec 230v AC	PHONE
2280 FM unit	Plug in module	30.00
2270 FL83	CW narrow filter	32.50
2050 FL44	Xtal filter	65.00
2410 IC290H	Multimode 2m 12v DC	438.00
2430 BU1	Back up supply	28.00
2448 IC471	Multimode 70cm	688.00

2450 IC490 Multimode 70cm 12v DC

2480 IC2E

New transceiver—or accessory—in mind?

You'll find A.R.E. first and foremost in everything for the Radio Amateur. Our huge selection of equipment is too big for one ad. In fact, it's big enough for a book—so we've got one ready for you. Send 50p for our new **SPRING PRICE LIST**, out now.

MUTEK STOCK

50MHz low noise switched preamplifier using BF981	37.10
70MHz low noise switched preamplifier using BF981	37.10
70MHz low noise unswitched preamplifier using BF981	22.40
Unboxed version of SLNA 70u	13.70
144MHz low noise switched preamplifier using BF981 (0.9dB noise figure)	37.10
44MHz low noise unswitched preamplifier using BF981	22.40
Unboxed version of SLNA 144u	13.70
Over optimised preamplifier for switching using BF981 FT290R	27.40
5940 TLNA 432s	74.90
5950 TLNA 432u	29.00
5960 TLNA 432ub	29.40
5970 GLNA 432u	PHONE
5980 BLNA 432ub	13.70

CQ TOP BAND

The latest from WPO Communications
160m SSB/CW Transceiver Kit 30w
output, digital display, noise-blanker.
Extremely small. Superb receiver.
Available end June. **PHONE**

TOP SECRET BOOK Confidential Frequency Book Still only £10.95

Always available—leading makes, comprehensive stocks

- MICROWAVE MODULES • MUTEK • FDK •
- WELZ • DATONG • DRAE • BNOS •
- TONNA ANTENNAS • TELE READERS •
- AMTOR • TONO TERMINALS •
- TET ANTENNAS • WRAASE SLOW SCAN & FAX
- ROTATORS • HF BEAMS • ALINCO •

ALSO A VAST RANGE OF GOOD SECOND HAND EQUIPMENT ALWAYS IN STOCK. JUST PHONE IN YOUR REQUIREMENTS.

LONDON ONLY
NEW OPENING HOURS
STARTING MAY 1st
MONDAYS-closed
WEDNESDAYS—open
THURSDAY—late night
FULL DETAILS: TUES, WED, FRI 9.30-5.30
THURS 9.30-6.30 • SAT 9.30-5.00

If the particular item you're looking for is not listed here, call us on 01-992 5767 or 092 52 29881 — Brenda & Bernie pride themselves on being able to supply anything connected with amateur radio.

All orders over £100 are sent carriage-free. For 24-hour Securicor delivery, add £6.00. For orders below £100 add £2, or £1 for books. Beam Antennas are sent by Securicor only.

SIMPLY SEND OR PHONE YOUR ORDER



INSTANT HP AVAILABLE
WRITTEN DETAILS ON REQUEST



24 HOUR TELEPHONE ORDER SERVICE

PRICES CORRECT AT TIME OF GOING TO PRESS



LONDON:
373 UXBRIDGE ROAD,
ACTON,
LONDON W3 9RH.
Tel: 01-992 5765/6

NORTHERN:
38 BRIDGE STREET,
EARLESTOWN, NEWTON LE WILLOWS,
MERSEYSIDE WA12 9BA.
Tel: 092 52 29881

more on your wavelength

AMATEUR RADIO EXCHANGE LTD

L·E·T·T·E·R·S

ON THE DRAKE 2B

I enjoyed your article in an issue of *Amateur Radio* some time ago, describing the 'classic' receiver, the Drake 2B. It brought back 20 years as if it were yesterday.

I still have a Drake Rx and would appreciate your sending me the minor modification mentioned in the article, making the 2B cover the 160 band.

**Roy Prince, G3CAJ,
Stubbingtown**

Ken Williams replies: My Drake 2B as the pictures show, is now rather battered due to the ravages of 10 house moves and too many leaky garden shed shacks but nevertheless it still meets manufacturers' specifications. For my money, it is still the best buy on the secondhand receiver market and I certainly wouldn't part with mine.

Now, to answer your query. The receiver has been modified to top band, but, based on experience, the modification is not a good one, which is why I didn't describe it in the article! The original idea came from an article in Short Wave magazine in the late 1960s. The method used is to disconnect the links on S9R Front and S9B Front between the R switch position and the 80 switch position. Then fit a 600pF capacitor in parallel with a 650pF trimmer in parallel between each A switch tag and the lower end of the 80 metre fixed padder (C1 or C6 as appropriate).

Fit a crystal of frequency between 5.5 and 5.9MHz in the A crystal socket, tune to a very strong signal at about 1.9MHz, set the preselector dial to mid position and peak the trimmers for maximum signal. The weakness of this method is that the RF and mixer grids are tuned with over a thousand pF with consequent reduction in performance. Although the modification is still in the receiver, for top band reception I use a modified Gelson converter which has also been retuned to cover the new WARC bands. Although the Gelson is no more sensitive than the Drake alone, it gives far more bandspread.

UPON FURTHER REFLECTION

Checking through a copy of my recent letter in which I replied to Mr Gillam's letter on 'Reflections' in *Amateur Radio*, I notice the omission of a word that could cause misunderstanding. The omission is in the sentence that begins 'Although, as Mr Gillam says, there can be only one voltage and current on a two-wire line...' The middle words of this should have read '...there can be only one resultant voltage and current...' It is important to make this distinction because there are actually two voltages and currents on a mis-matched line, one produced by the incident wave and another by the reflected wave of electrical energy—their interaction producing a resultant voltage and current standing-wave.

**KE Parker, G3PKR,
Middlesex**

AVANTI SIGMA 4 AERIAL

We write regarding the photo of the Avanti Sigma 4 aerial featured on page 9 of your November issue and BC Curtis's reply in defence of the owner in the March edition. We echo this gentleman's comments regarding the attitude of radio amateur magazines towards CB and although he is quite correct in his synopsis as to why a vertical aerial such as this should have a rotor fitted there is a more simple explanation.

The aerial is the property of our service manager who also had a three element beam 'up the pole' and the rotator was also used in connection with this. Unfortunately, the beam proved to be unsuitable against high winds and had to be removed. Before a new beam could be installed it was necessary to find sufficient time for the operation and as we work long, hard hours here it has not been done yet. In fact, we are so busy that there is not a radio at the other end of the Sigma 4 since there is no time to use it.

Incidentally there is yet another example of what Mr Curtis is talking about immediately following his letter. You have published a photo of a shop in Hastings featuring ladies gowns in the

window and with a sign over saying 'the CB Centre'. In fact the CB centre moved a long time ago to a larger site and are trading, like us, very successfully—the new owners of the shop obviously are busy as well since they have not painted over the sign.

In closing DJR does not need to apologise for his 'snide' comments about the CBER concerned since we of the CB fraternity are rapidly becoming immune to such ill informed remarks. According to the press CB is dead and buried but dealers such as ourselves, with proper workshop facilities, still seem to be thriving.

**Ted Pittman, Ceebee
Electrical**

PASSIVE RESISTANCE?

So Mr Store thinks there is no point in putting a resistor at the end of any aerial wire because there is no current there (Letters, April AR).

Would he like to explain: the unidirectional and rhombic (with terminating resistor); the non-resonant vee (with two! terminating resistors); the Beverage (or wave antenna); the sloping folded terminated dipole?

R Taylor, Henley-on-Thames

BDQ STRIKES BACK

I have just noticed the letter on page 8 of your April issue, from R Store, which suggested that the resistors used at the ends of the wires in my Vee Beam article of February were redundant. Unfortunately, the Editor also apologises for the offending resistors!

It is obvious that Mr Store has little knowledge of antennas and his views are quite simplistic. The ends of *unterminated* wire aeriels are at a very high impedance but even with good end insulation and even in the case of self supporting dipole elements, there is a slight leakage and a tiny amount of current flows there. There are many antenna designs where the end of a wire is either connected to ground or is so connected via a non-inductive resistor. A Vee beam without end resistors is bi-directional. To make the

antenna unidirectional its ends are terminated to ground through suitable resistors. This is difficult to achieve when the antenna is high up from the ground, so a substitute 'artificial' earth in the form of a quarter wavelength of wire is used instead. The end of each leg of the Vee goes to its artificial earth through a resistor. The resistors must be able to dissipate about half of the output power from the transmitter.

May I suggest that Mr Store obtains a copy of L A Moxon's book *HF Antennas for all Locations* in which, on page 199, he will find many examples of this technique as used on single end fed wires and with vees.

The terminating resistors may appear to 'go nowhere' but Mr Store is mistaken to suggest there is something wrong with my article or with the diagrams relating to it.

**John D Heys G3BDQ,
Guestling.**

Q CODES

Magazines such as *Amateur Radio* have a duty to ensure that published information is correct. Bad operating practices and procedures are often caused by 'mis-information' during an amateur radio operator's initial years as a short wave listener or licenced transmitting amateur.

Your March 1984 issue carries an article or section SWL and details the meaning of a selection of Q codes. The article fails to advise that Q codes are used with a question mark to indicate an interrogative message and without to indicate a reply.

Hence QRZ is not 'who is calling me' but 'you are being called by . . .'. 'QRZ?' is, in fact, the correct form for 'who is calling me?'

Some may feel these observations to be splitting hairs but unless the correct form and use of Q codes is stressed we will hear more of the newer licenced operators saying 'QRZ the frequency', or 'QRZ the station calling' etc.

**John Saunders, G3OIU,
Braintree**

L·E·T·T·E·R·S

G-1 APR

Greatly enjoyed your article on 'Underground Aerials'. Only one comment: shouldn't John Heys' call sign be given as G-1APR??

A McClelland
G1FKU/PE, BFPO 28

UK AMATEUR LICENCE

I was interested to read your Leader on the RSGB's request for comments on the UK Amateur Licence.

I agree with your suggestion that the terms of the Licence should be altered to allow third party traffic and I think this should be seen in the context of the users of CB radios. At the moment there are, I believe, some 250,000 licensed CB radio users compared with about 40,000 licensed Radio Amateurs. The latter have all had to take at least one technical examination and many others have also taken the Morse Code Test yet we are not allowed to handle traffic for third parties or to allow our wives and friends to use the microphone, although some years ago this was permitted.

Under the present legislation anybody can go into a post office and pay £10 for a CB Licence and go out and buy 3 sets which can be used not only by himself but by members of his family without any one of them taking any examination to ascertain whether they know how to use the sets. Many of these CB radio enthusiasts perform very useful services such as monitoring traffic conditions and liaising with the authorities to maintaining communications when telephone lines may have been damaged by floods or snow - facilities denied to the licensed amateur unless his help is specifically requested by the proper authorities.

We licensed amateurs are now in a minority as far as radio communications are concerned and although we do have the advantage of many frequencies at our disposal and the possibility of using considerably more radiated power than CB enthusiasts there seems to be little reason why we should be singled out for the restrictions already mentioned.

Many radio amateurs are also keen sailors and yet we are forbidden to use our radios for communication while afloat in tidal waters unless we pay a further licence fee to obtain a Maritime Mobile Licence. I think that less than 50 of these licences have been issued and it would appear to be hardly worth the expense of collecting the extra fees so this is an anomaly that should be removed. CB radios can, of course, be used while at sea.

One final comment - many yachts are equipped with VHF radio telephones and it is now common practice for the owners to also buy a hand held set very similar to a 2 metre set so that whoever remains onboard can keep in touch with any other member of the family who happens to have gone ashore. This practice is illegal according to the terms of the Maritime Radio Telephone Licence but is widely practised and the authorities seem to turn a blind eye to it.

Removal of these anomalies would greatly enlarge the scope of amateur radio and would reduce the, in many cases, very trivial exchanges which one hears over the air. I am sure you will have many other letters in support of this suggestion.

Dr M B Carson, G2AIV, .
Lymington

BLAME THE TRANSMITTER

I feel that all amateurs and SWLs have now reached the crossroads. The 7MHz band to me seems to be the first on the list - the influx of broadcasters on this band has increased a lot recently. It will remain to the future to see whether my suspicions are substantiated. As regards the SW bands, I have recently taken over a RC70 Icom receiver, and it is very good as regards sensitivity, stability, and is remarkably silent, which is a great asset for winking out weak signals.

Unfortunately it falls in line with all other solid-state receivers with respect to selectivity on AM in so far as it is impossible to remove mod splash from any high powered station 5KHz away and in fact mod splash can be heard from even 8KHz. At first glance this

appears to be the fault of the receiver for producing insufficient selectivity, but they are all the same irrespective of price. It is obvious that factors outside the scope of the manufacturer are to blame. One of these of course is the ridiculous separation of 5KHz on the SWL spectrum, which is bad even with moderate dissipation broadcasters, but today SW broadcasting seems to have gone mad, with ridiculous power of as much as 200KW or more.

This approach by thoughtless countries has led to an enormous decline in the number of listeners today on the SW bands. Some form of sanity must prevail in the future if these are to come back. Looking back to the pre-war days when VK2ME on 31.28m using only 10KW unbeamed used to be a regular signal into the British Isles from Australia, I can hardly believe I am in the same world. In the USA, a curb on the dissipation of broadcasting stations on medium and short waves has been in vogue for many years, but in Europe aerial dissipation seems to have gone haywire. Medium wave stations should serve only their particular locality, as in the USA, and not endeavour to make themselves heard half way round the world. On short wave with beaming 50KW should be the absolute maximum. It could be less and still maintain communication, especially bearing in mind my earlier remark regarding the separation of only 5KHz.

G Rose, Waltham Cross

BLAME THE RECEIVER

Thank you for the most interesting magazine produced in this country. The 'Giant Test' April issue confirmed my worst fears about the modern transistorised general coverage receivers.

Having reached the peak of receiver design in the mid-60s, with such models as Hammarlund, Collins etc, along came the scientists, (followed by the cheap-and-nasty brigade) with 'a brand new system'; unfortunately for us the transistors and synthesisers did not make our

receivers 'whiter than white', but rather incredibly dirty. We now have a situation, where unless one is prepared to pay over £1000 for a receiver, the serious listener is now having a standard of receiver thrust at him that would have been considered poor in 1940.

Obviously these remarks do not apply to ham transceivers, but on a general coverage receiver you can't hide the spurious harmonics which jump at you every few turns of the dial, especially below 3MHz.

Does anyone really think that such a lousy report would have come out of a test in 1964 on a HQ145 or HQ180, or even a secondhand AR88? The fantastically high noise level on modern receivers makes listening to weak signals, especially below 3MHz, like listening to the accompaniment of a vacuum cleaner.

Can anyone explain why at least the front ends cannot use miniature valves? Of course the present generation have accepted lousy specifications as normal but it wasn't like that with valves!

There was obviously a purpose for transistors in miniaturisation, especially for computers and space work, but not for the wholesale take-over of general-use receiver design, especially when found to be inferior. There's something crazy when in 1984 we are trying to solve Rx problems that were solved in 1939. What would they have thought if it had been known that 50 years hence, we would have wide open IFs with selectivity filters across the speaker, and front-ends so poor, that 10 foot of wire needs the use of an attenuator. Still they show you the time and tell you the frequency you're tuned to, even though the signal being received is probably a harmonic!

G Trower, Brighton

A DOTTY PROBLEM

Amateur Radio magazine is suffering from the 'mis-print' bug again! Page 43 of the March issue has Morse code printed showing all dots. Most misleading for the beginner.
SW Law, G3PAZ, Croydon

STRAIGHT & LEVEL

All the latest news, comment and developments on the amateur radio scene

SAY AGAIN CALLSIGN?

Further to last month's item from Geoff Brown GJ4ICD on some of the more contentious points in the radio regulations, David Farr G4WUB of Bristol writes with some thoughts of his own on the question of how often you give your callsign:

'My attitude has been to give my callsign at the beginning and end of each over, but a listen round the bands reveals that not everybody would agree with me. Frequently the notion held seems to be that once every fifteen minutes is all that is necessary to comply with the regulations. I've even suffered a lecture from a station much longer licenced than myself who found my use of callsigns an irritation.

A look at my licence suggests that the call is given at the beginning and end of every period of sending (and when frequency is changed). The problem, as you will realise, is to define adequately what constitutes a period of sending.

To me this used to seem fairly clear. My radio is fitted with a PTT. When I key the mike I start a period of sending, and when I release the PTT my period of sending comes to an end (doubtless to the relief of many!). It isn't always this simple though; what about working cross-band, what about using VOX, what about CW rigs with full break-in facility?'

It seems clear that David is correctly following clause 9 paragraph 2 of the Amateur Licence, and yet it is equally clear that many amateurs ignore this rule.

It would be interesting to hear from any amateur who does not follow this practice. If requested we will, of course, respect his desire for anonymity which he displays so frequently on the air!

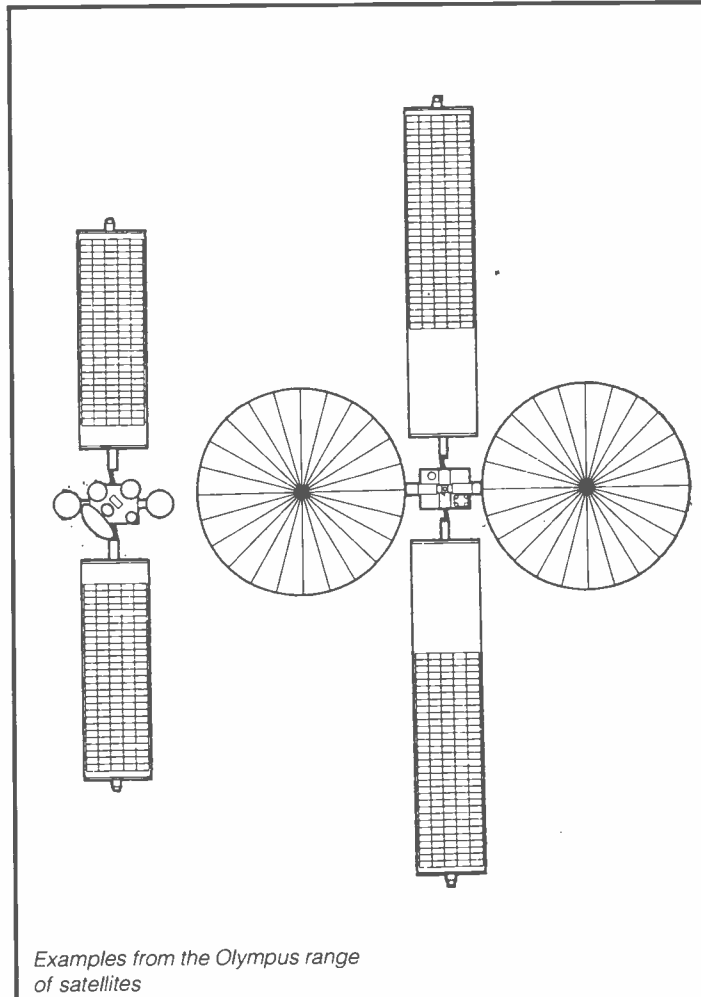

Examples from the Olympus range of satellites

SATELLITES

Due for launch in 1986 is OLYMPUS 1, first in the Olympus series which plans to provide the world's most powerful commercial communications satellites, with primary power ratings of satellites later in the series expected to be twice that of any currently in commercial use.

The overall responsibility for, and major contribution to the series comes from British Aerospace, with some sub-systems contributed by Dutch, Italian and Canadian firms.

The relatively small OLYMPUS 1 will weigh 2,300Kg and be capable of developing 3.5KW from its solar arrays. Launched on an Ariane 3 (the Olympus series is also designed for shuttle launch) OLYMPUS 1 will carry a multi-purpose payload for commercial, TV and telecommunication functions.

Next month's issue of **AR** will include an article by Peter Dodson tracing the history of communications satellites.

MORSE THE PITY

Two new items of interest to those learning or operating Morse have come onto the market.

The first is a program for the ZX81 computer which reads Morse and translates it into script on the VDU. A screened lead from an external speaker or speaker-fed socket on the receiver to the EAR socket on the ZX81 is all that is required, although it may be useful to distance the receiver from the computer and screen the Rx aerial lead, in order to reduce signal interference from the computer and monitor.

The unit also offers variable

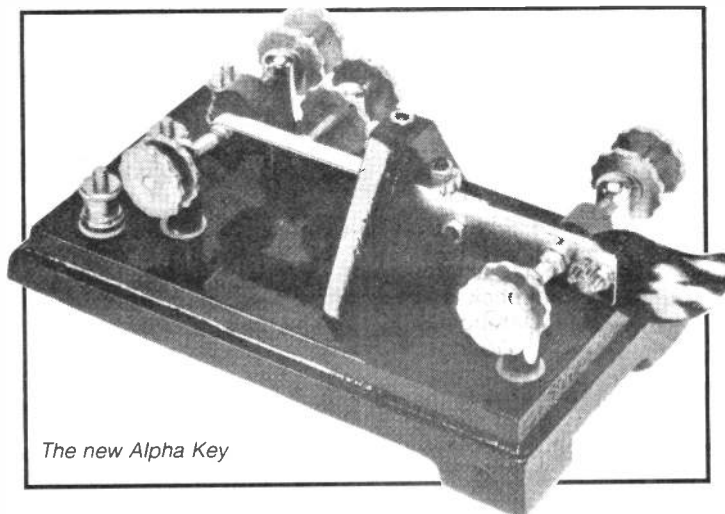

The new Alpha Key

speed so that all received signals can be translated and printed out with proper spacing regardless of operating speed. Further details of this program are available from: *Pinehurst Data Studios, 69 Pinehurst Park, W. Moors, Wimborne, Dorset.*

If you want a machine to write down the Morse you receive, you may well be interested in high-class sending with the new precision-engineered 'Alpha Key' from Sergeant (see photo). These individually made keys are available with cast aluminium or cast iron bases, and feature silvered contact points and a paddle pivoted on ball-bearings for a smooth movement.

The aluminium bases can be personalised as required, and all enquiries should go to: *P Sergeant, 6 Gurney Close, Costessey, Norwich NR5 0HB. Tel: (0603) 747782.*

'Rolls Royce' items like this always provide sore temptation for the penniless amateur, but even if you can't or don't want to pay for them it's nice to see the 'state of the art'.

Next month we hope to feature an article on learning Morse by Dave Green G4OTV.

THE WOODPECKER

Nobody who has listened for more than ten minutes on HF can be unaware of the existence of the Woodpecker. This is of course the loud chopping noise heard over a wide area of any given band, which more often than not makes listening or operating those frequencies completely impossible.

The signal derives from a Russian 'Over-The-Horizon' radar system, which consists of a series of linked transmitters forming a curtain around that country. Stories circulate of huge radar-towers from which these emissions originate, but what is certain is that they can be heard anywhere in the world, blotting out anything up to 500KHz or more at a time.

In view of the enormity of the problem caused by the OTH radar, it is perhaps not surprising that the amateur is starting to fight back, at least in the form of Datong's SRB2 automatic Woodpecker blander. This reduces the level of OTH pulses to that of an ordinary signal, making a desired signal affected by the Woodpecker audible again.

It can only be hoped that this is but a start in the effort to combat one of the most common menaces to enjoyment of amateur radio.

NEW 934MHZ CLUB

A group of 934MHz users and enthusiasts have got together to form The 934MHz Club UK in an effort to encourage and further the use of 934MHz throughout the country and to represent the users of the frequency in connection with representations to the various government bodies concerned with radio communications.

Another aim of the club is to keep all members informed of news and events to take place in the future by means of a quarterly magazine. Other features of the magazine will include details of new equipment and products available for the band, a readers' letter page, technical enquiries and where possible answers, news of DX contests to take place and many other events which it is hoped will be of interest to all members. Other projects on the horizon are a national QSL Bureau for use by members, Club radio log books, QSL cards and other services.

A tremendous response has been received in various parts of the country and club membership already stands at over 100. We very much look forward to hearing from you.

One year's membership costs £5.00, and details are obtainable from: Mrs Glenys Anthony, 4 Austral Way, Althorne, Chelmsford, Essex. Tel: (0621) 741240.

WPO AT RSGB '84

WPO Communications will be exhibiting all their products, including Project OMEGA, and other HF/VHF equipment at the RSGB Exhibition. Also on show will be their latest major kit - a single board, single band HF SSB/CW transceiver, initially with models for 160 and 20m. This will run 50 watts PEP, and has been designed to a high specification for fixed station or mobile use. It features a rugged PA, highly sensitive receiver with true Noise Blanker, and can be bought with or without a matching prepunched case. Price for the basic kit is £165 without case or £219 with case, digital display and all hardware. Another new release will be a

2m PLL VFO kit to go with any 2m crystal controlled rig, or 9-10.7MHz IF strip, priced at £38.50. A matching 7 digit LED display kit will also be featured. (Stand E27).

THE RAC AMATEUR RADIO GROUP SCHEME

Membership of this scheme is open to all amateur radio enthusiasts, and provides membership of the Royal Automobile Club at a discount of £2 below the normal RAC membership subscription rate. Since 1 June 1983 the annual subscription for members of the group scheme has been £16.50.

The group scheme's subscription renewal date is 17 May (World Telecommunication Day) each year, and 11 members renew on the same date. Anyone joining the scheme will pay at the pro-rata rate of £1.37 per month until the next group renewal date. In addition, the RAC

once-only joining fee of £3 is also payable, regardless of the period remaining in the membership year. Radio amateurs who are already members of the RAC and who wish to transfer to the group scheme will not pay the joining fee.

Desirable options are the RAC Recovery Service and the 'At Home' Service, the annual subscriptions for which are £13.50 and £5.50 respectively, annually from date of taking up the option.

No additional subscriptions are payable for a member's spouse.

The scheme is administered by the Royal Automobile Club's Scottish Western Counties Office, 200 Finnieston Street, Glasgow G3 8NZ. The co-ordinator of the scheme is Mr A W Hutchinson, 88 Broomfield Road, Chelmsford, Essex CM1 1SS, from whom application forms may be obtained.

BOOKS

A book entitled *30 Solderless Breadboard Projects - 2* by RA Penfield is now available from Babani. It includes a wide range of construction projects from burglar alarms and timers to games and counters. Of particular interest to the amateur perhaps are his designs for a peak level indicator, monitors for both battery and supply voltage, and a logic tester. The book is ideal for beginners as these interesting, well-explained and well-illustrated projects provide a sound introduction to ICs, veroboard (the makers of which recommend the book) and electronics in general. It costs £2.25.

Another new book is the

Beginner's Guide to Radio by Gordon J King in the Newnes Technical series. This is the ninth up-date of a book first published in 1955, and it continues to provide a basic grounding in radio theory and practice.

It includes chapters on the theories of electricity and radio waves and analyses of the principles of both receivers and transmitters, and their components. It is well illustrated and has an index, which is very useful for a book of this type as it enables it to be used as a source of reference.

Don't be put off by the cover (which shows an AM/FM hi-fi tuner) or the chapter on CB - it is a very useful book.

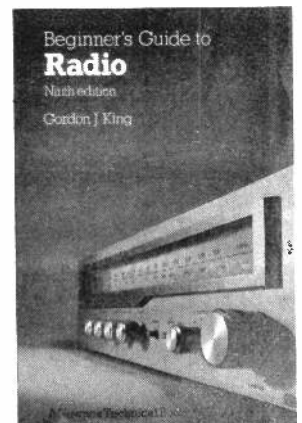
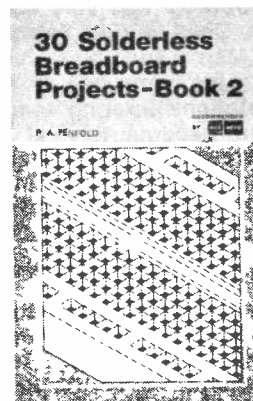



DX DIARY

'News for HF operators compiled by Don Field G3XTT'

I am delighted that so many of the promised DXpeditions eventually appeared on the bands. Firstly, there was the T19 (Cocos Island) expedition, mounted by a group of Costa Rican amateurs and worked in the UK on six bands. QSL to T12CF, Box 4300, San Jose, Costa Rica. Next to appear was the Venezuelan operation from Aves Island as YV0AA, worked on 80-10 metres including the 30 metre band. QSL information appeared in January's *Amateur Radio*.

Later, we had the Kermadec Island expedition, which coincided with some excellent propagation on the HF bands. The group were worked from the UK on 15, 20 and 40 metres. Unfortunately, it seems that their boat sank while they were on the island, which necessitated cutting the expedition short, in order to take advantage of the only alternative transportation available. Hopefully, those of you who needed this one caught them before they went QRT. QSL the New Zealand operators to their home calls. Cards for ZL0AJW/8 go to ZL1BQD.

While all this was going on, Lloyd and Iris Colvin, who I have mentioned before, appeared from Easter Island (CE0A), and subsequently from Juan Fernandez Island (CE0Z). Their QSL route is the YASME foundation (see last month).

A tale of three ships

A notable omission from the above resume is Clipperton

Island. The group who hoped to put this one on the air arrived in Mexico on schedule, only to be met with a run of bad luck. The first boat they had chartered became unavailable at the last minute and a substitute was arranged. This one, in turn, broke down while returning from a trip to Costa Rica. Frantic efforts were made to find a third boat, and there was even talk of hiring a sea plane. Nothing, however, worked out. Thus the would-be DXpeditioners were forced to return home.

It is hoped to re-schedule the operation for later this year or early in 1985. If you are gnashing your teeth at having missed the chance to work this one, spare a thought for the poor operators who travelled thousands of miles at their own expense, only to have to call the whole thing off.

Other news

F6BFN/TT was very active from Chad during February and March and QSLs should go to his home call 1A0KM, the station operating from the Rome headquarters of the Sovereign Military Order of Malta, showed up again on 10/11 March and put an excellent signal into the UK, especially on 160, 80 and 40. QSL to 10MGM.

Speaking of 160, the Italians now enjoy 160 privileges, though there has been occasional 160 metre operation from Italy in the past under special permit.

Activity from China has

been increasing in leaps and bounds. K7JA and VE7BC were active on SSB from BY1PK during March, and the BY4AA station has also been making frequent appearances on both 15 and 20. ZM7VU, operating from the Tokelau Islands, was DL1VU who I mentioned back in the February column. QSLs for this ZM7 operation go to F6DYG. He has been worked on 20 and 15, both SSB and CW.

A sign of the times perhaps is the recent appearance on the bands of N4YD, where the 'operator' has been a TRS80 computer with speech synthesiser! If you don't want to be replaced by a computer, now might be the time to start putting more into your QSOs than a stereotyped signal report, name and QTH.

Finally, if you were quick off the mark in buying this magazine (or better still, if you received it through the post) you should be in time to catch K3UOC on his travels to some of the islands which make up the Netherlands Antilles. His trip started on April 14th and ends on May 1st. QSL to his home call.

WPX and all that

For the contesters among you, the CQ WPX SSB produced some very good 10 metre propagation on the Saturday, with JA, VK and W7 all at good strength in the UK. In addition there was the usual bunch of special prefixes to add interest or confusion, depending on how you look at it.

This contest reminded me that last year my station was operated briefly on the Saturday of the contest by Gary, G4/VE3GCO, who flew back to Canada later that weekend. On arriving home, he went straight on the air and I was able to work him on 20 metres before the contest finished! Gary is one of Canada's leading DXers, and to see why, just look at the photos of his shack and antennae which appear on the following page.

Gary was in fact kind enough to send me some details about himself, and you may be interested to see them. He has always been interested in prefix chasing and has 2220 prefixes confirmed! At the same time, he is always ready to put a new prefix on the air himself and has recently operated with such calls as VE3WCY, CY3WCY, VD3GCO, XK3GCO and CI3GCO.

Gary was licensed back in 1965 and has worked all DXCC countries except Albania and Clipperton, so he is another who will be disappointed that the expedition was called off. He is QSL manager for VP2MF, HS1AMM and ZF1MA as well as all his own call-signs.

On top of all this, he edits *Long Skip*, a newsletter for Canadian DXers, and writes for other Canadian amateur radio publications. He is custodian of the Ontario Bicentennial Award, and publishes and sells the Amateur Radio Awards Directory of the World and the CQ Contest Operating Booklet.



The impressive array of aerials at VE3GCO's QTH in Canada featuring (l to r) a 48ft TH6DXX, a 72ft 204BA and 81ft 402BA and a 14 ele 2m VHF beam



A view of Gary, VE3GCO, one of Canada's leading DXers, in his shack

Countries lists

I have recently received some enquiries from readers about where they can get hold of an up-to-date countries list. I can only assume they haven't been reading *Amateur Radio* for very long, because a copy of the comprehensive list produced by Geoff Watts appeared in the August 1983 issue and also in the *Amateur Radio Yearbook*. However, if you don't have either of those, copies can be obtained directly from Geoff at 62 Belmore Road, Norwich, NR7 0PU, price 75p. Copies of the IOTA (Islands-on-the-Air) directory are also available from Geoff, for the same price. Talking about countries, there has always been immense controversy in our hobby about just what constitutes a country, with everybody having their own particular view on the subject. In view of this, you might find the following of interest.

What is a country?

There is no internationally-agreed convention about what constitutes a 'country' or a 'nation', which is why the

ARRL has had to make what to many appear to be a number of rather arbitrary decisions about what constitutes a 'country' for amateur radio awards purposes. The United Nations has 158 member states, and eleven non-member or observer states. There are a few curiosities in the UN list. For instance, the Ukraine and Byelorussia are counted separately from the USSR in this list, while Moldavia, Lithuania etc, are not. This results from efforts at the time of the UN's formation to give a fair allocation of voting power to the Eastern Bloc. Despite such rather ad hoc rulings, the UN total does give an idea of how many sovereign countries there are in the world.

Having said this, there are many 'dependent' countries with different levels of status and a host of fancy phrases have been invented to describe them. Within our own islands, to take an example with which we are familiar, Scotland has its own legal system, the Isle of Man has its own parliament, Jersey has its own legislature, although

it relies on the UK for its defence and for various other services, and so it goes on. In other words, the degrees of autonomy vary. At the same time, Gibraltar, for instance, is an extension of Britain even down to the bobby on the beat, but surely we wouldn't regard a ZB2 contact as being synonymous with a G contact?

Thus the ARRL have arrived at a set of criteria which lead, at the present time, to the recognition of 315 countries for us to contact. At the highest level the ARRL recognises as separate countries those entities with distinctly separate governments. At the next level, entities with a common government can be classified as separate countries if they are separated by a sufficient amount of sea or of foreign land. Thus Hawaii and Alaska count separately from the USA, the first because of the separation by sea, the second because Canada intervenes.

At one time unadministered areas were allowed to count as countries, which is how the Spratly Islands came to be on the list. This is no longer true. There was also a move at one time to recognise distinctly separate administration as justifying separate country status and this is how Desecheo Island, for instance, slipped on to the list. This rule was quickly rescinded when it was realised that most foreign embassies, military bases, and other odds and ends would pass this test.

It must be clear by now that many of the countries on the list would not be accepted applying the present criteria, but are there because they passed the criteria which applied at a particular point in time. The rules now are very strict and there seem to be very few new 'countries' in the offing. One possibility might be the sovereign base areas of Cyprus which are unique in that they are indeed British Sovereign territory, quite unlike US bases in the UK for instance, which are British through and through and simply leased to the Americans.

So there you have it. The final arbitrators are the ARRL Awards Committee, who take advice from the DX Advisory Committee but have the final right of veto. At the moment

they are considering possible country status for the Pribilof Islands off Alaska, though the prospects of this one getting through must be slim. On another front, however, the Committee has decided that the 1S1CK operation from the Spratly Islands last year will count, which has already led to rumours that a further group of Philippine amateurs may operate from there during the week commencing May 2nd.

Sovereign Military Order of Malta

I mentioned 1A0KM, the call sign of the SMOM amateur radio station, earlier in this column. If you are wondering what, or where, this particular 'country' is, then read the following.

The SMOM is a worldwide Roman Catholic organisation with origins dating back to the end of the 11th century when it was established in Jerusalem as a hospital, initially for pilgrims to the Holy Land but later to serve knights injured in the crusades. Later it became a crusading order in its own right but, nowadays, has reverted to its original role of hospital and other charitable works. Its British branch is the Most Venerable Order of the Hospital of St John of Jerusalem, better known in the guise of the St John Ambulance Brigade.

With the triumph of Islam, the order was forced to withdraw first to Cyprus and then to Rhodes. Later, after a period of homelessness, Charles 5th of Spain granted them Malta, Gozo and Tripoli. Although their stay on the island ended in 1798, they have retained the Maltese connection in their name, but their present headquarters is in Rome and this is where the 1A0KM station is located.

As the name of the order implies, they enjoy sovereign status, and have full diplomatic links with many countries of the world. It is on this basis that the ARRL recognised them as a DXCC country, though a mass of supporting evidence first had to be submitted by the radio amateurs of Rome, who did much of the background work and who now put the station on the air whenever possible.

That's it for this month. Correspondence to me at 63 West Drive, Caldecote, Cambridge CB3 7NY. Good DXing.



South Midlands

* FREE FINANCE • 2 YEAR GUARANTEE

BRANCHES AT: SOUTHAMPTON, LEEDS, CHESTERFIELD

'YAESU' YOUR ULTIMATE CHOICE FOR EQUIPMENT

FT203R YAESU'S NEW COMPACT 2M HANDIE



The ultra compactness of the FT203R is due mainly to Yaesu's chip component circuit board assembly, the chip components being installed automatically by robots. The 203's features include thumbwheel frequency selection, built in S/PO meter, 2.5W RF O/P at 10.8V, (3.5W O/P with FNB4). Vox activated switching is possible when used in conjunction with YH-2. Accessories supplies include FNB3, FTE-2 tone unit, CSC6 case and YHA-14A antenna.

FT203R	2.5W transceiver.....	£169.99 inc
FBA5	Case for 6AA cells.....	£6.50 inc
FNB4	12V Nicad pack.....	£36.40 inc
CSC7	Soft case (when FNB4 is used).....	£6.50 inc
YH-2	Headset/Mic.....	£13.80 inc
MH-12A2b	Speaker Mic.....	£16.85 inc
SMC8, 9AA	Charger (13A style).....	£8.05 inc
MMB21	Mobile mounting bracket.....	£7.65 inc



HANDHELDS FOR 2m or 70cm FT208R & FT708R



FT208R	2m Handheld 2.5W.....	£199.00 inc
FT708R	70cm Handheld 1W.....	£209.00 inc
SMC8-9AA	(13A style) Hand charger.....	£8.05 inc
NC7	Base charger.....	£32.95 inc
NC8	Base quick charger + PSU.....	£54.05 inc
PA3	DC adaptor and charger.....	£15.35 inc
NC9C	Slow charger.....	£8.80
FNB2	Nicad Battery Pack.....	£21.45
FBA2	Battery pack sleeve.....	£3.45
FLC5	Heavy duty case.....	£25.30
MMB10	Mobile bracket.....	£8.05



FT 726R MULTIMODE UHF, VHF, HF



FT726R (2)	Transceiver c/w 2m.....	£739.00 inc
21/24/28	HF module.....	£200.00 inc
50/726	6m module.....	£185.00 inc
430/726	70cms module.....	£250.00 inc
SAT726	Full duplex module.....	£95.00 inc
XF455MC	600 Hz CW filter.....	£39.85 inc

MULTIMODES FOR 6m, 2m and 70cm

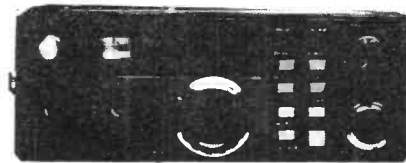

FT690R	Multimode Transceiver 6m.....	£249.00 inc
FT290R	Multimode Transceiver 2m.....	£269.00 inc
FT790R	Multimode Transceiver 70cm.....	£249.00 inc
SMC2, 2C	2.2Ah Nicads 'C' size.....	per set £21.60 inc
SMC8C	220mA Charger (13A Style).....	£8.80 inc
MMB11	Mobile Mount.....	£26.85 inc
CSC1A	Carrying case.....	£4.20 inc
FL6010	6m 10W Amplifier.....	£49.00 inc
FL2010	2m 10W Amplifier.....	£63.25 inc



FM TRANSCEIVERS FOR MOBILE



FT230R	2m Transceiver 25w.....	£259.00 inc
FT730R	70cm Transceiver 10w.....	£229.00 inc
FT720RVH	Transceiver 2m 25W.....	£209.00
FT720RU	Transceiver 70cms 10W.....	£229.00



COMMUNICATIONS RECEIVER



FRG7700

FRG7700	Receiver 0.15-30 MHz AM/CW/SSB/FM.....	£369.00
FRG7700M	Receiver c/w 12 channel memory.....	£435.00
MEMG7700	Memory option.....	£69.00
FRT7700	Antenna tuner/switch.....	£46.00
FRA7700	Active antenna.....	£41.80
FF5	Low Pass filter 500 KHz.....	£10.75

SMC SERVICE

Free Securitor delivery on major equipment. Access and Barclaycard over the phone. Biggest Branch agent and dealer network. Securitor 'B' Service contract at £5.00 Biggest stockist of amateur equipment. Same day despatch wherever possible.



FREE FINANCE

On many regular price items SMC offers Free Finance (on invoice balance over £120). 20% down and the balance over 6 months or 50% down and the balance over a year.

You pay no more than the cash price!!
details of eligible items available on request.

GUARANTEE

Importer warranty on Yaesu Musen products. Ably staffed and equipped Service Department. Daily contact with the Yaesu Musen factory. Tens of thousands of spares and test equipment Twenty-five years of professional experience.

● 2 Year warranty on regular price Yaesu products.

SMC STOCK CARRYING AGENTS WITH DEMONSTRATION FACILITIES

Neath John GW4F01 (0639) 52374 Day (0639) 2942 Eve
Bangor John G13KDR (0247) 55162
Stourbridge Andrew G48JY (0384) 390916

Communications Ltd



**MAIN DISTRIBUTOR: FACTORY BACKED
BUCKLEY, STOKE, GRIMSBY, JERSEY, EDINBURGH.**

'SMC' YOUR ULTIMATE CHOICE FOR SERVICE

FT980



FT980 Transceiver with general coverage Rx **£1265.00 inc**
 SP980 External L/S with audio filter **£58.65 inc**
 SP980P External L/S with phone patch **£74.85 inc**
 FIF80 Computer interface for NEC PC8001 **£99.65 inc**
 FIF65 Computer interface for Apple **£51.35 inc**
 FIF232C Computer interface **£54.80 inc**

FT77



FT77 8 Band Rx/Tx 100W output **£459.00 inc**
 FT77S 8 Band Rx/Tx 10W output **£425.00 inc**
 FP700 Matching AC PSU **£135.00 inc**
 FC700 Matching antenna tuner **£98.90 inc**
 FV7000DM Digital VFO unit **£200.00 inc**
 MKT77 Marker unit **£10.35 inc**
 FMUT77 FM unit **£27.20 inc**

FT7GX THE 'NO OPTIONS' RADIO

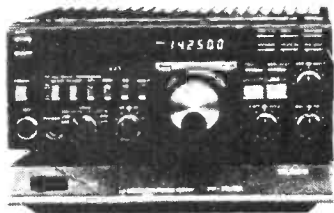

FT757GX All Modes and Filters Fitted **£685.00 inc**
 FP757GX Switched Mode PSU 50% Duty .. **£149.50 inc**
 FP757HD Heavy Duty PSU 100% Duty **£162.50 inc**
 FC757AT Automatic Antenna Tuner **£231.50 inc**

THE BUY OF THE YEAR FT707 8 BAND HF TRANSCEIVER



~~£499.00~~
now only
£425 inc

FP707 matching AC PSU **£125.00 inc**
 FV707DM Digital VFO **£149.00 inc**

FT102 ALL MODE TRANSCEIVER



FT102 Transceiver 9 band **£685.00**
 SP102 External speaker **£32.50**
 FC102 Antenna coupler **£179.00**
 AMFMUT102 AM/FM unit option **£46.75**

FT ONE 'THE ULTIMATE'



FT ONE Transceiver HF All Mode **£1495.00**
 KEYT901 Curtis Keyer **£28.75**
 DCT1 DC Power Cable **£10.35**
 RAMT1 Non volatile memory **£13.80**
 FMUT1 FM unit **£42.85**

LEEDS
 SMC (Leeds)
 257 Otley Road
 Leeds 16, Yorkshire
 Leeds (0632) 782326
 9-5.30 Mon-Sat

CHESTERFIELD
 SMC (Jack Tweedy) Ltd
 102 High Street
 New Whittington, Chesterfield
 Chesterfield (0244) 453340
 9-5 Tues-Sat

BUCKLEY
 SMC (TMP)
 Unit 27, Pinfold Lane
 Buckley, Chwyd
 Buckley, (0244) 549563
 9.30-5.30 Tues-Sat

STOKE
 SMC (Stoke)
 76 High Street
 Talke Pits, Stoke
 Kidagrove (07816) 72644
 9-5.30 Tues-Sat

GRIMSBY
 SMC (Grimsby)
 247A Freeman Street
 Grimsby, Lincs
 Grimsby (0472) 59388
 9.30-5.30 Mon-Sat

JERSEY
 SMC (Jersey)
 1 Dalmont Gardens
 St Helier, Jersey
 Jersey (0634) 77067
 9-6pm Mon-Sat

EDINBURGH
 SMC Scotcomm,
 23 Morton Street
 Edinburgh EH15 2HN
 Tel: 031 657 2430
 10-5 Tues-Fri, 9-4 Sat

**HEAD OFFICE
&
MAIL ORDER**

S.M. HOUSE, RUMBRIDGE STREET, TOTTON, SOUTHAMPTON, SO4 4DP, ENGLAND
 Tel: Totton (0703) 867333. telex: 477351 SMCMM G. Telegram: 'Aerial', Southampton

SCANNING RECEIVER



MS-8400

New from S.M.C. the MS8400 VHF/UHF micro-processor controlled scanning receiver with 40 programmable memory channels, keyboard entry of frequency or command; automatic band search, AM and FM selectable; 4 selectable scanning steps, priority channel, connections for external antenna, DC supply and loudspeaker. Supplied c/w telescopic antenna mounting bracket, etc.

SPECIFICATIONS

Frequency Range: Low VHF 68,000 MHz - 88,000 MHz
Mid VHF 108,000 MHz - 136,000 MHz
High VHF 136,005 MHz - 174,000 MHz
UHF 360,000 MHz - 512,000 MHz
5, 10, 12.5 and 25 KHz VHF (10, 12.5 and 25 KHz UHF)

Scanning steps: 40 programmable memories

Channels: AM or FM selectable

Modes: AM or FM selectable

Scan rate: Approximately 18 channels per second

Scan delay: 2 seconds - Priority sampling: 4 seconds

Audio output: 1.2 Watts

Selectivity: Better than -60 dB @ ±25KHz

Power supply: DC 12V - 16V 0.6A max

Memory backup: 9 volt, battery (PP3)

Antenna: Telescopic antenna or External

Loudspeaker: 2.5" x 4" oval speaker

Size: 190(W) x 250(D) x 85(H) mm

Weight: 1.7kg

£249.00 inc.

Price includes free carriage

10M FM CORNER



Join the many others who have found that operating 10M FM can be a pleasant alternative to the overcrowded 2M band. The SMC Oscar 2 10M gives you 40 channels, channel 1 being 29.310 MHz and channel 40 29.7 MHz, a power o/p of approximately 4 watts and a receive sensitivity of better than 3µV for 12db sinad. Also for your enjoyment when the band opens up, we have incorporated a -100kHz repeater shift (by using the original front panel Hi/Low power switch), so from the car or at home you can enjoy 10M, FM, without having to pay £500 for an HF transceiver.

OSCAR 2 10M FM £49.00 inc

ACCESSORIES	INC	P/P
SMCGP27 1/2 Wave vertical with radials	£24.15	£2.65
SMCVA27 1/2 Wave vertical no radials	£20.70	£2.65
SMC11V11S Glass fibre shortened ground plane	£32.20	£2.65
SMC10SE 10M Mobile whip	£14.95	£2.00
RSL-28b Yaesu 10M mobile whip	£10.85	£2.00
SMCGCCA Gutter mount and cable	£10.35	£2.00
SMCSOCA 4M cable assembly for 10SE	£5.35	£1.50
FLEXI 10 G Whip mobile 10-80M	£49.00	£2.35
MULTI-MOBILE G Whip mobile 10, 15, 20M	£32.20	£1.65
FLEXIWHIP G Whip 10M mobile	£19.21	£1.85
GW BASE Base for all G Whip antennas	£6.10	£1.00
SMCT3170L Twin meter SWR bridge	£16.50	FOC
SMC100LP30 Low pass filter	£6.30	FOC
SMCRU12 4 Amp DC power unit	£14.95	£2.35
04-06 Extension L/S	£16.00	FOC

NB. PRICES INCLUDE VAT AT 15%
and carriage by post or Securicor

KDK KYOKUTO DENSHI CO. LTD.

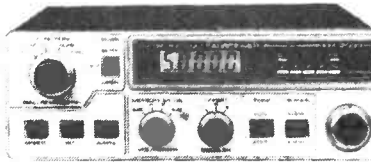

FM2033

144 MHz, 12VDC Transceiver. 25W/5W Hi/Lo (both adjustable). Compact 2 7/16" x 6 7/16" x 7 3/16". 12 1/2 KHz steps (100 KHz fast QSY). Amber LCD 'Sunlight View', Side Lit. Display; 100's of Hz or channel number. Sensitivity <0.2µV for 12dB SINAD. Single knob frequency control "Dial". Endless or non-endless dial options. RIT: 1 KHz steps, V.F.O. + memory. Two 5 slot memories A, B, A + B, A x B. 11th memory instant "call" channel. Memories simplex or duplex channels. Band scanning, programmable limits. Scan halts, squelch + centre zero. Pause on scan halt for 3 seconds. Scan/tune/RIT from microphone ± 600 KHz split, plus cross memory. Repeater input listen by pressing "dial". Setable; steps, tone, splits, limits. Simple controls for safe mobile operation. C/W mobile mount, mic and handbook.

£239.00 inc

NEW

NEW

6M EQUIPMENT

Are you one of the lucky few to obtain one of the 60 new 6M experimental licences or maybe you would just like to listen and give reports.

Here at Totton we have been importing 6M equipment for the dedicated few since 1974 when the FT620 and the FTV650 were state of the art. Today's equipment is much more sophisticated multimode, base stations, mobile and transportable equipment with multi memory facilities, scanning and channelised operation, to name a few of the facilities. Listed below is our current range of equipment and accessories for all your 6M requirements.



FT726F	Main frame unit less modules	£589.00 inc
50/726	6M module for 726F	£185.00 inc
FT680R	6M mobile 10W O/P	£349.00 inc
FT690R	6M transportable 2.5W O/P	£249.00 inc
FL6010	Matching 10W amplifier for 690R	£49.00 inc
50TV	6M module for FTV transvertors	£85.45 inc
MMS50/28	6M down to 10M converter	£29.90 inc
MML50/28S	6M down to 10M converter	£34.90 inc
MMA50V	6M switched pre-amp	£34.90 inc
SLNAS0S	50 MHz switched pre-amp	£37.10 inc
4Y6M	6M 4 ele Yagi	£41.40 inc
2HB6	6M ZL antenna	£19.95 inc
LT606	13 ele Log Periodic 50-500 MHz	£115.00 inc

Carriage on antennas £2.65 extra

MORSE EQUIPMENT

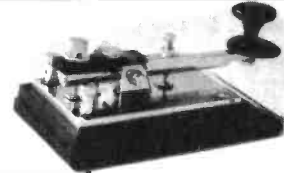

MORSE KEYS

HK703	Straight Key	£28.00	£1.20
HK704	Straight Key	£19.25	£1.20
HK706	Straight Key	£15.90	£1.00
HK707	Straight Key	£15.00	£1.00
HK710	Straight Key	£39.70	£1.75
HK808	Straight Key	£49.70	£1.75
HK711	Key Mounting	£32.15	£1.50
BK100	Mechanical Bug	£24.25	£1.75
MK701	Single Lever Paddle	£27.50	£1.60
MK702	Single Lever Paddle	£28.85	£1.60
MK703	Squeeze Key	£28.30	£1.75
MK705	Squeeze Key	£24.65	£1.75
MK706	Squeeze Key	£21.25	£1.75
1KP60	Lambic	£9.95	FOC
HK802	De Luxe Brass Key	£85.85	£2.00

MORSE EQUIPMENT

KP100	Squeeze CMOS 230/13.8V	£77.05	£2.00
KP200	Memory 4096 Multi Ch Mem Back Up 230/13.8V	£165.62	£2.50
D70	Morse Tutor (Datong)	£56.35	FOC
MMS1	Morse Tutor (M/M)	£115.00	FOC
MMS2	Morse Tutor Advanced	£155.00	FOC

MICROWAVE MODULES - RTTY EQUIPMENT

MM2001	RTTY to Demod./Converter	£189.00	FOC
MM4001	RTTY Transceiver	FOC	FOC
MM4001KB	RTTY Transceiver c/w keybd	£299.00	FOC
MM1001KB	Morse Keyboard	£135.00	FOC
MM1000KB	ASCII CW conv c/w keybd	£135.00	FOC

PRICE INCLUDE VAT at 15%
Carriage as shown

ROTATORS

The finest range: be it Kenpro, C.D.E., Channel Master, SMC, has over 19 models to choose from. Ask the experts for the right model to suit your requirements - it should save you money. Write, phone or call.

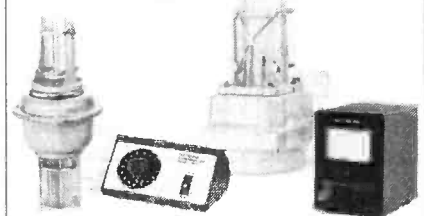

FU200	through 3 Core	Light Duty	£49.95
KP25B	Bell 6 Core	Lighter Duty	£54.91
9502B	Offset 3 Core	Lighter Duty	£57.50
AR40	Bell 5 Core	Medium Duty	£98.90
KR400	Bell 6 Core	Matches KR500	£99.95
KR500	Thro 6 Core	Elevation	£126.50
AR50	Bell 5 Core	5 Position Medium	£113.85
KR400RC	Bell 6 Core	Medium Duty	£118.45
CD45	Bell 8 Core	Heavy Duty	£149.50
KR600RC	Bell 8 Core	Heavy Duty	£167.90
HAM IV	Bell 8 Core	Heavier Duty	£264.50
KR2000RC	Bell 8 Core	Heavier Duty	£333.50
T2X	Bell 8 Core	Very Heavy Duty	£332.35
H300	Bell 8 Core	Digital Readout	£546.25

Control Cable

RC5W	5 Way 40p/mtr	Carriage £1.90
RC6W	6 Way 55p/mtr	Carriage £1.90
RC8W	8 Way 55p/mtr	Carriage £1.90
9523	Support Bearing 9520B F4200	Carriage £2.50
KCO38	Lower Mast Clamp	£12.65 Carriage
KR400	600 etc	£2.50

Prices including VAT and carriage, but carriage on accessories is extra unless sent with rotators

STOCK-CARRYING AGENTS WITH DEMONSTRATION FACILITIES

Stourbridge Andrew G4BJY (0384) 390916

Bangor John G13KDR (0247) 55162

Neath John GW4FOI (0639) 52374 Day
(0639) 2942 Eve

POWER METERS

IN LINE POWER/SWR BRIDGES P.E.P., R.M.S. 1.8-440MHz

The Hansen range covers 30 quality models with top-of-the-line the FS710. This is a flat frequency response, peak envelope power and average in-line wattmeter with many novel features. Notable being the 'power independent' SWR scale - no forward power calibration knob, just direct reading SWR.

FS-500H

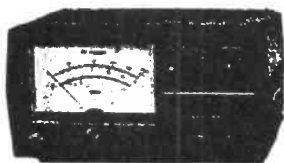

HANSEN				£
FS710H	1.8-60 MHz	15/150/1500W	Pep	97.75
FS710V	50-150 MHz	15/150W	Pep	97.75
FS500HP	1.8-60 MHz	20/200/2000W	Pep	96.60
FS500V	50-150 MHz	20/200W	Pep	96.60
FS500H	1.8-60 MHz	20/200/2000V	Pep	77.80
FS500V	50-150 MHz	20/200W	Pep	77.80
FS300H	1.8-60 MHz	20/200/1000		60.60
FS300V	50-150 MHz	20/200		50.60
FS200	1.8-150 MHz	20/200	Pep	55.95
FS601M	1.8-30 MHz	20/200W	Pep	57.50
FS601MH	1.8-30 MHz	200/2000W	Pep	57.50
FS602M	50-150 MHz	20/200W	Pep	57.80
FS603M	430-440 MHz	5/20W	Pep	56.75
FS210	1.8-150 MHz	20/200W	Auto SWR	59.80
FS301M	2-30 MHz	200/200W		39.50
FS301MH	2-30 MHz	200/2000W		39.50
FS302M	50-150 MHz	20/200W		39.50
FS711H	2-30 MHz	20/200W	Head	41.00
FS711V	50-150 MHz	20/200W	Head	41.00
FS711U	430-440 MHz	5/20W	Head	41.00
HB1	FS711H Coupler			23.00
VB1	FS711V Coupler			23.00
UB1	FS711U Coupler			23.00
FS5E	3.5-150 MHz	20/200/1000W	HF	41.00
FS5S	1.8-150 MHz	20/200/1000W	HF	41.00
FS7	145 & (432 MHz)	5/20/200	144	44.85
SWR3E	3.5-150 MHz	20/200/1000W	HF	26.85
SWR3S	3.5-150 MHz	F/S Meter ant.		26.35
SWR50B	3.5-150 MHz	Twin Meter		26.85
FS20D	3-150 MHz	5/20W		39.85
FS-800	1.8-150 MHz	6/30/150W	JD	115.00
JD110	1.5-150 MHz	10/100W	WELZ	13.80
SP600	1.8-500MHz	20/200/2kW		97.00
				S.M.C.
S3-30L	Mini			8.80
T3-170L	3.5-170 MHz	Relative		16.50

T3-170L

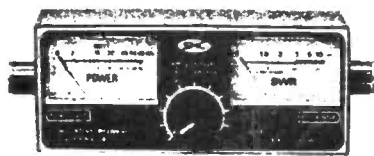

NB: PRICES INCLUDE VAT AT 15%
Carriage free by post



SMC-HS

HF, VHF, UHF ANTENNAS MOBILE VERTICALS

SMC-HS Mobile Elements, tabulated below, feature an inbuilt PL259M connector, which mates with the SQ239M on any of the four standard mounts. This arrangement is ideal for easy removal - band changes, comparative test, car wash, and anti-vandal, system checks from the feed point, portable operation and for ease of garaging etc. All models have fold over bases (either lift and lay or locking collar) except the 78B which has an inbuilt ball in case the mount must be fitted askew.

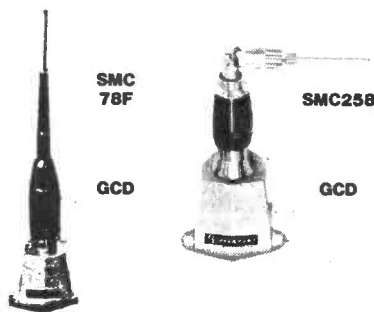

SMC
78F

SMC258

GCD

GCD

SMC-HS MOBILE ANTENNAS

		P&P
SMC6P27/PL	Telescopic 2M PL259 fitting 0dB	£5.75 £0.85
SMCT144h	Telescopic 2M 1/2 wave BNC	£9.20 £0.85
SMC6PT/BNC	Telescopic 2M BNC fitting 0dB1/4	£5.75 £0.85
SMC2H/PL	Helical 2M PL259 fitting	£5.75 £0.85
SMC2H/BNC	Helical 2M BNC fitting	£5.75 £0.85
SMCHS430	70cm 1/2 wave BNC fitting 2.5dB1/4	£7.30 £0.65
SMC2QW	2M wave 0dB1/4 1.6'	£2.53 £1.85
SMC2NE	2M wave fold 3.0dB1/4 4.3'	£7.30 £2.00
SMC2VF	2M wave fold 3.0dB1/4 3.5'	£12.65 £2.00
SMC78F	2M 7/8 wave fold 4.5dB1/4 5.7'	£14.95 £2.50
SMC78B	2M 7/8 wave ball 4.5dB1/4 5.6'	£14.95 £2.50
SMC78SF	2M 7/8 wave short 4.7'	£14.95 £2.50
SMC88F	2M/8 wave 5.2dB1/4 6.5'	£20.70 £2.50
SMC118M	Colinear 2M 11/8 wave fold 7dB1/4 9.7'	£33.35 £2.65
SMC25B	70cm 2 x 5/8 fold 5.5dB1/4 3.1'	£13.80 £2.00
SMC35B	70cm 3 x 5/8 fold 6.3dB1/4 4.7'	£18.40 £2.00
SMC70N2M	Dual band 2M 2.7dB1/4 70cm 5.1dB1/4	£18.40 £2.00
SMCHS770	144/432 Duplexer 50W	£16.50 £1.85
SMC20SE	20M 1.72M 'fold over' 100W PEP	£19.15 £2.50
SMC15SE	15M 1.72M 'fold over' 130W PEP	£15.70 £2.50
SMC10SE	10M 1.72M 'fold over' 200W PEP	£14.95 £2.50
SMC17SE	17M 1.915M 'fold over' 200W PEP	£17.25 £2.50
SMC12SE	12M 1.915M 'fold over' 200W PEP	£15.35 £2.50
RSL-28b	Yaesu 10M mobile whip	£10.85 £2.00
SMCGCCA	Gutter clip 4 mtrs cable	£10.35 £2.00
SMCSOCA	Cable assembly 4M	£5.35 £1.50
SMCSOCAL	Cable assembly 6M	£5.75 £1.50
SMCTMCAS	Trunk mount c/w 6M cable	£9.20 £2.00
SMCSOMM	Magnetic base c/w 4M cable	£10.75 £2.00
SMCSOWM	Adjustable wing mount base	£4.60 £0.90
SMCGCD	Gutter clip deluxe	£5.00 £1.50
SMCBSD	Bumper strap deluxe	£9.60 £1.50
HS88BK	Bumper mounted extension for 144 MHz ant.	£20.30 £2.00

SOMM

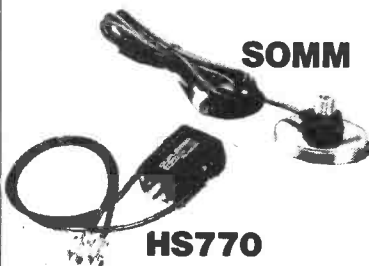

HS770

NB: PRICES INCLUDE VAT AT 15%

HF ANTENNAS

SMC have the greatest range of HF antennas eg. Multi Beams/Quads, over 20 models. Shown below is the sensational new Explorer 14 - contact us for full details.

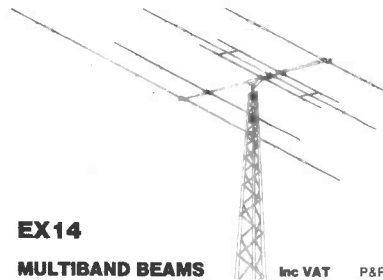

EX14

MULTIBAND BEAMS		Inc VAT	P&P
EX14	Explorer 10-20m	£325.00	£5.95
TH3JN	3 Ele 10-20m	£199.00	£3.50
TH2MK3	2 Ele 10-20m	£169.00	£3.50
TH3MK3	3 Ele 10-20m	£199.00	£3.50
TH5DX	5 Ele 10-20m	£419.00	£6.70
TH7DX	7 Ele 10-20m	£520.00	£8.75
TB3	3 Ele 10-20 Jaybeam	£189.75	£5.90
HQ1	Mini Quad 10-20	£169.00	£4.00
G4MH	Mini beam 1-20	£88.50	£4.50
RA33JNR	3 Ele 10-20 Moseley	£177.10	£6.00
Mustang 2	2 Ele 10-20 Moseley	£177.10	£6.90
Mustang 3	3 Ele 10-20 Moseley	£220.80	£6.90
GQ2E	2 Ele 10-20 Quad	£270.25	£5.40
GQ3E	3 Ele 10-20 Quad	£435.00	£9.20
GQ4E	4 Ele 10-20 Quad	£599.00	£10.00
Hyquad	2 Ele 10-15M dipole 20M	£325.00	£6.00
LP1007	Log Periodic 13-20 MHz	£1707.75	DIST
3Y1015D20	3 Ele 10-20m	£158.70	£5.95
DB10/15A	3 Ele 10-15m	£199.00	£4.80



TB3

MONO BAND BEAMS

		£69.00	£3.50
103BA	3 Ele Yagi 10m	£155.00	£3.95
105BA	5 Ele Yagi 10m	£95.00	£3.50
153BA	3 Ele Yagi 15m	£239.00	£5.90
155BA	5 Ele Yagi 15m	£179.00	£4.90
203BA	3 Ele Yagi 20m	£289.00	£7.30
204BA	4 Ele Yagi 20m	£399.00	£9.40
205BA	5 Ele Yagi 20m	£249.00	£6.50
402BA	2 Ele Yagi 40m		
18TD	Dipole Tape 10-80m		

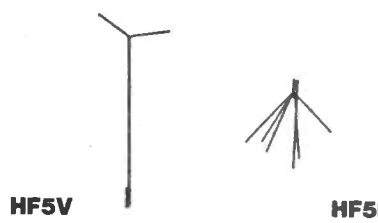

HF5V

HF5R

VERTICALS

12AVQ	Vertical 10-20m	£52.90	£2.75
14AVQ	Vertical 10-40m	£66.70	£2.75
18AVT/WB	Vertical 10-80m	£113.85	£2.75
18V	Vertical 10-80m taped	£36.22	£2.75
C4	Vertical 10-20m	£59.00	£2.65
SMCHF5V	Vertical 10-80m	£39.00	£2.65
SMCHF5R	Radial Kit for above	£38.35	£2.65

TRAP DIPOLE

SMCTD/HP	High Power 10-80m	£45.00	£2.65
SMCTD/P	Portable inc coax	£65.55	£2.65

MOBILE

Tribander	10-20m Slide sw	£27.37	£1.65
Multimobile	10-20m	£32.20	£1.85
Flexiwhip	10m only	£19.21	£1.65
Extra coils	For above to 160m	£6.80	£1.00
Flexiten	2, 10, 12, 17, 15, 20, 30, 40, 80M	£49.00	£2.35
Bases	For above	£6.10	£1.00

NB: PRICES INCLUDE VAT AT 15%
Carriage extra. Mainland rate shown.

Head office
Mail orders
Service & Spares

S. M. HOUSE, RUMBRIDGE STREET, TOTTON, SOUTHAMPTON SO4 4DP, ENGLAND
Tel: Totton (0703) 867333, Telex: 477351 SMCMM G, Telegram: "Aerial" Southampton
See preceding pages for complete addresses and phone numbers of branches

When Germany was on the beam

There was a time, during the second World War, when Germany's bombing accuracy over England was deadly accurate, while at the same time, British bombers often had to resort to jettisoning their loads into the Channel. The big question, was, and is; why?

Here Brian Kendal describes how the Luftwaffe found their targets so easily

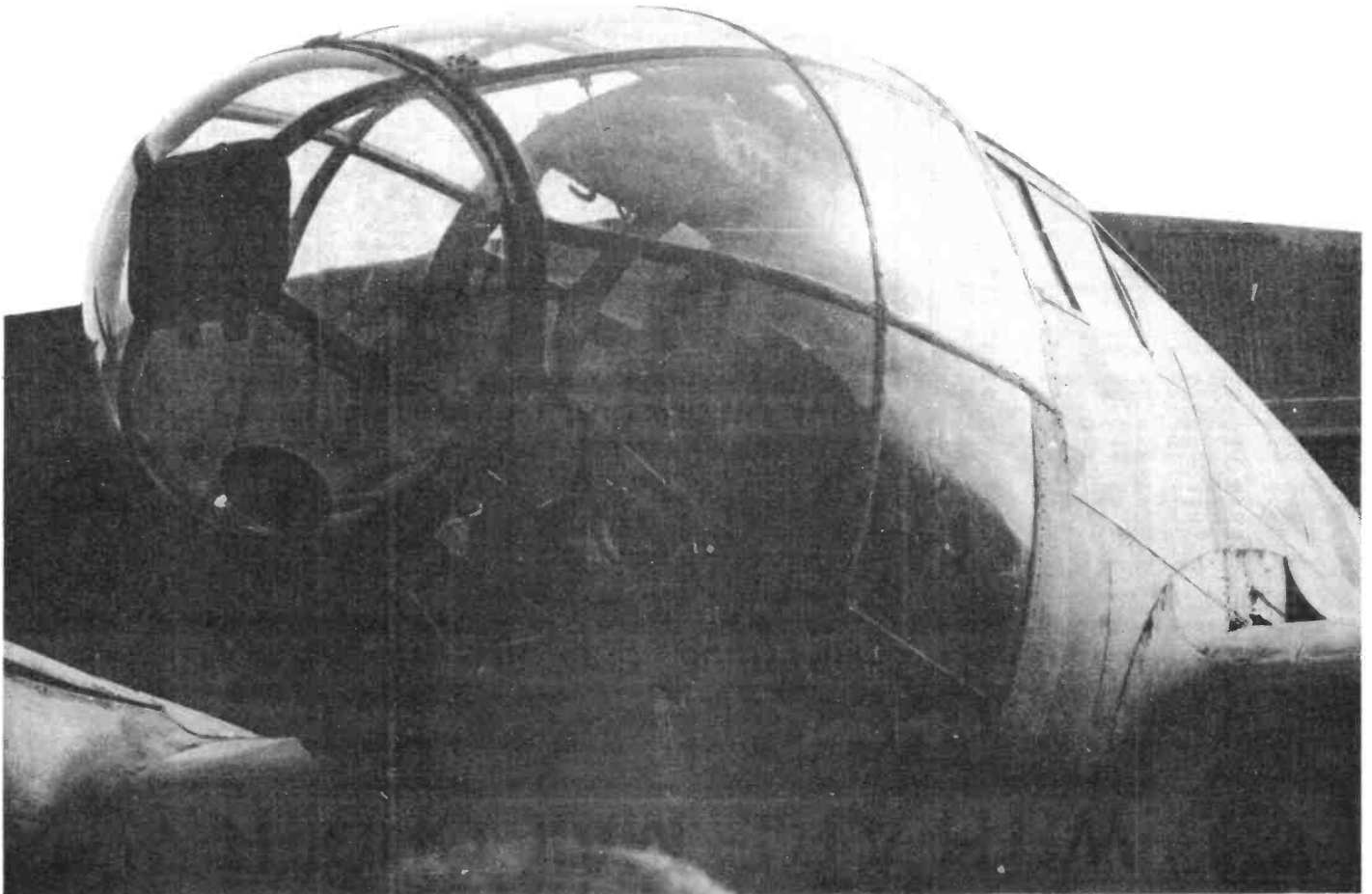

In 1940, the British people were more than a little surprised when the German Luftwaffe launched a series of night bombing raids on the centres of British cities, each with devastating accuracy.

The military were also surprised, for a recent report had shown that at night, RAF bombers, far from bombing with precision, frequently failed to even find their targets over the night skies of Europe. In many cases they either returned with their bomb loads intact, or jettisoned them over the Channel.

The wide difference in results was no reflection on the skill or courage of the RAF crews. It was a direct result of decisions made by the two air forces several years before.

The Luftwaffe opted for the use of radio navigation aids from the outset, and had effective bombing aids available even before the fighting started. The RAF High Command, on the other hand, took the view that any form of radio navigational system could be easily jammed. Consequently, and despite an

incident a few years before in which a whole squadron of Heyford heavy bombers had crashed during a peacetime night flying exercise because of navigational difficulties, the RAF opted for a system of astro and dead reckoning (DR) navigation which they thought adequate.

This, however, was not so. While such techniques might seem satisfactory for highly trained peacetime aircrew flying over brightly lit cities, the wartime situation was completely different. The hastily trained wartime navigators, frequently operating in conditions which would ground the peacetime airforce, found that the darkened terrain coupled with inaccurate meteorological information and accurate German anti-aircraft fire made DR navigation almost impossible.

From the mid nineteen-thirties several German firms had concerned themselves with radio navigation aids, three of which were used in the bombing of the UK. Each of these was broadly based on

the 'Lorenz' landing system, which was in wide use throughout Europe including RAF airfields in the UK.

Lorenz landing system

The guidance signal of the Lorenz system was generated by the effect of a reflector element on the horizontal radiation pattern of a vertical dipole aerial.

A vertical dipole will produce an omnidirectional polar diagram but if a reflector element is introduced, say, to the West of the dipole, the signal strength in that direction will be degraded and to the East, enhanced. If a second such element is now introduced to the East of the dipole and that to the West rendered inoperative by open-circuiting the centre of the element, then the reverse will occur. To the North and South, however, whichever reflector element is in use, the signal will remain sensibly constant and in one narrow sector, due north and south, it will be impossible to tell which reflector is in

WHEN GERMANY WAS ON THE BEAM

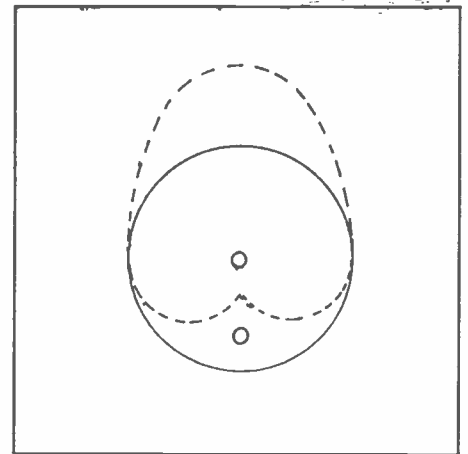
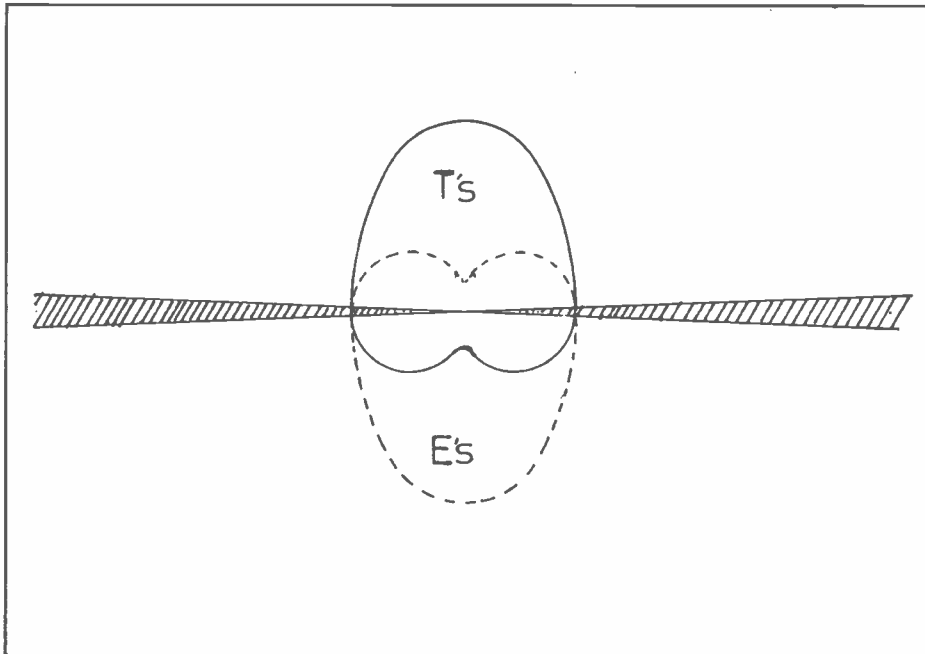

Above: Horizontal polar diagram of a dipole (solid) and dipole plus reflector (dashed)

Left: The 'Lorenz' beam approach showing the Horizontal Polar Diagram (HPD) for each aerial combination. In this case the approach would normally be from the right. The hatched area is the equi-signal zone

use. This is known as the 'equi-signal zone'.

In the practical Lorenz system (known to the RAF as Standard Beam Approach or SBA), each reflector is divided into two equal parts with relay contacts bridging the gap. The relays are arranged such that when one set of contacts is closed, the other is open. So that approaching aircraft can tell from which side of the centreline it is approaching, the control circuitry arranges that one relay is energised for three times the period of the other. The pilot therefore hears a series of morse letter 'T's if approaching from one side and 'E's if approaching from the other. At a later date this system was modified to use other interlocking morse characters such as 'A's and 'N's or 'D's and 'U's.

The system operated in the 32 to 40 MHz band, with distance-from-touch-down information being provided by market beacons on 38MHz.

The British had received intelligence information that beam bombing systems might be used, but had discounted the use of the Lorenz system on the grounds that their experience had shown that the signals had only a very limited range. It did not occur to them that, although the range at normal operating altitudes was only a few tens of miles, at heights of 20,000 ft or more, it increased to nearer 200 miles.

While it was realised that the Luftwaffe must have some type of radio assistance, the form which this took was not known, until the radio equipment of a shot-down Heinkel He.111 of K.Gr.26 was found to be almost intact. A routine specification check revealed that the Lorenz receiver was far more sensitive than was necessary for approach and landing purposes.

As a result of this discovery, an Anson aircraft from RAF Wyton was equipped with a suitable receiver. For two nights the aircraft patrolled the night skies over East Anglia and heard nothing, but on the

third evening, just south of Spalding in Lincolnshire, an unmistakable Lorenz type transmission was heard. They had located a Knickebein transmission.

Knickebein

The Knickebein (which translates to 'Crooked Leg') system was developed from the Lorenz landing system by Telefunken GmbH.

During a series of propagation experiments, the German engineers had discovered that, contrary to the general belief that the range of 30MHz transmissions was optical, in practice it was 30% more and therefore, if the receiving aircraft flew at heights of 20,000ft or more and high power transmitters were employed, usable signals could be received up to 250 miles away.

The method of operation was simple, for the system comprised only two high power Lorenz transmitters with their aerial systems aligned such that the radiated beams intersected over the target. All that was required of the aircraft was that it flew along one beam

and released its bombs when it crossed the other.

The ground stations could be adjusted to give an equi-signal zone about one third of a degree wide ie about one mile width at 180 miles range. This was not sufficiently accurate to attack a small target such as a single factory, but was more than adequate for a larger target such as a town centre. The system also had the considerable advantage that crews were well used to using the Lorenz landing system and in consequence needed no special training to use Knickebein.

Immediately the British discovered the significance of Knickebein, steps were taken to nullify its effect. A large number of electro-diathermy sets were requisitioned from hospitals and modified to transmit 'noise' on the Knickebein frequencies in order to mask the dots and dashes. Later, high power transmitters radiating dashes were brought into action to mask the equisignal zone. Although no attempt was made to synchronise these dashes with those

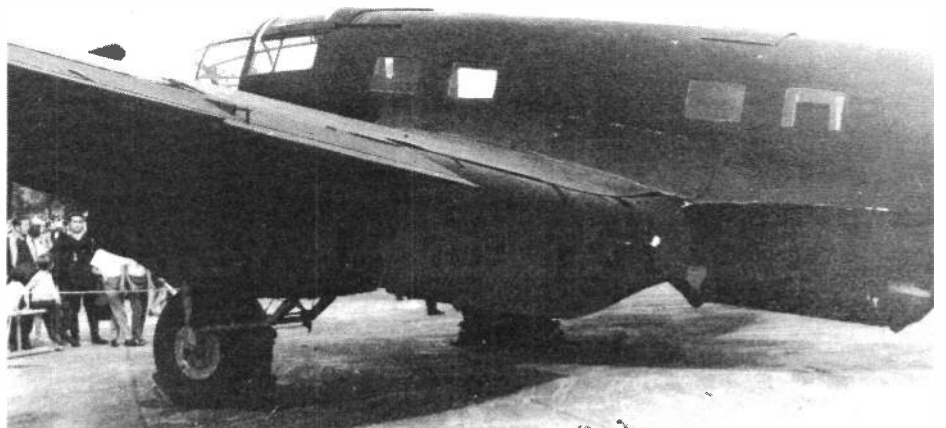

A Heinkel HE 111 as used by KGr100

WHEN GERMANY WAS ON THE BEAM

radiated by the German transmitting stations, on occasions they fell into phase, the effect being to bend the beam, causing the bombing aircraft to wander off track and get hopelessly lost.

Even when not synchronised the jamming was sufficient to cause the German crews to lose confidence in the system. As a result the use of Knickebein was discontinued.

X-Verfahren

Simultaneous with the development of Knickebein, the Lorenz company was concerned with a bombing system devised by Dr Hans Plendl and developed further by Dr W Kuhnold. This aid operated on frequencies in the order of 70MHz and used an aerial system which produced a complex fan of beams, some of which were relatively coarse and others which were as sharp as 0.05 of a degree - very close to the theoretical limit.

The directional information was complex but still basically Lorenz in character. Approach guidance came from a fine beam radiated from one transmitter (called the Marschweg) and similar transmitters provided three cross-beams intersecting the approach beam at distances of 30, 20 and 5km from the target.

The bomber approached the target

along the main navigational beam. On hearing the first of the cross beams the pilot knew he was on course. When the second beam was heard, the navigator pressed a button to start a special clock. This was not unlike a stopwatch except that it had three hands, red, green and black. On pushing the activating button, the green and black hands began moving together, the black following the green by a time corresponding to the bomb's trajectory. On intersecting the third cross beam the button was pushed again, which stopped the moving hands and started the red one. This hand moved at approximately three times the speed of the others and thus, due to the spacing of the cross beams, would reach the position of the black hand at bomb release point. When the red and black hands coincided, an electrical circuit was completed which energised the bomb release mechanism.

The theoretical accuracy of this system was in the order of 100 yards at a range of 200 miles. However, this could be degraded by inaccurate setting up of the ground equipment, poor ballistic properties of the bombs, wrong allowance for wind effects or inaccurate flying.

One of the chief disadvantages of this system was that, unlike Knickebein, the system could only be used by specially

equipped aircraft flown by crews trained in its use. One of the major and most skilled users of X-Verfahren was the crack Kampfgruppe 100 (K.Gr.100) pathfinder squadron which was based at Vannes in Brittany and led many of the raids over the UK.

In answer to the X-Beams (as they were known in the United Kingdom), army radar sets were modified to jam the 70MHz transmissions. These were given the code name of 'Bromide'.

It had been discovered that the Marschweg was being radiated from a site on the Cherbourg peninsular. The intention was to site the Bromide stations on the approach lines to London and other Midland and Northern towns. Unfortunately, on the night of the Coventry 'Blitz' when the Bromides were first used, the modulation frequency had been wrongly set up and they were ineffective. This deficiency was soon rectified after the X-Verfahren receiver from a shot down He.111 of K.Gr.100 was examined. After adjustment of the Bromide modulation frequency, even K.Gr.100 had great difficulty in locating their targets.

Y-Verfahren

By the middle of 1940, intelligence reports were indicating that a third type of aid using only a single beam for both

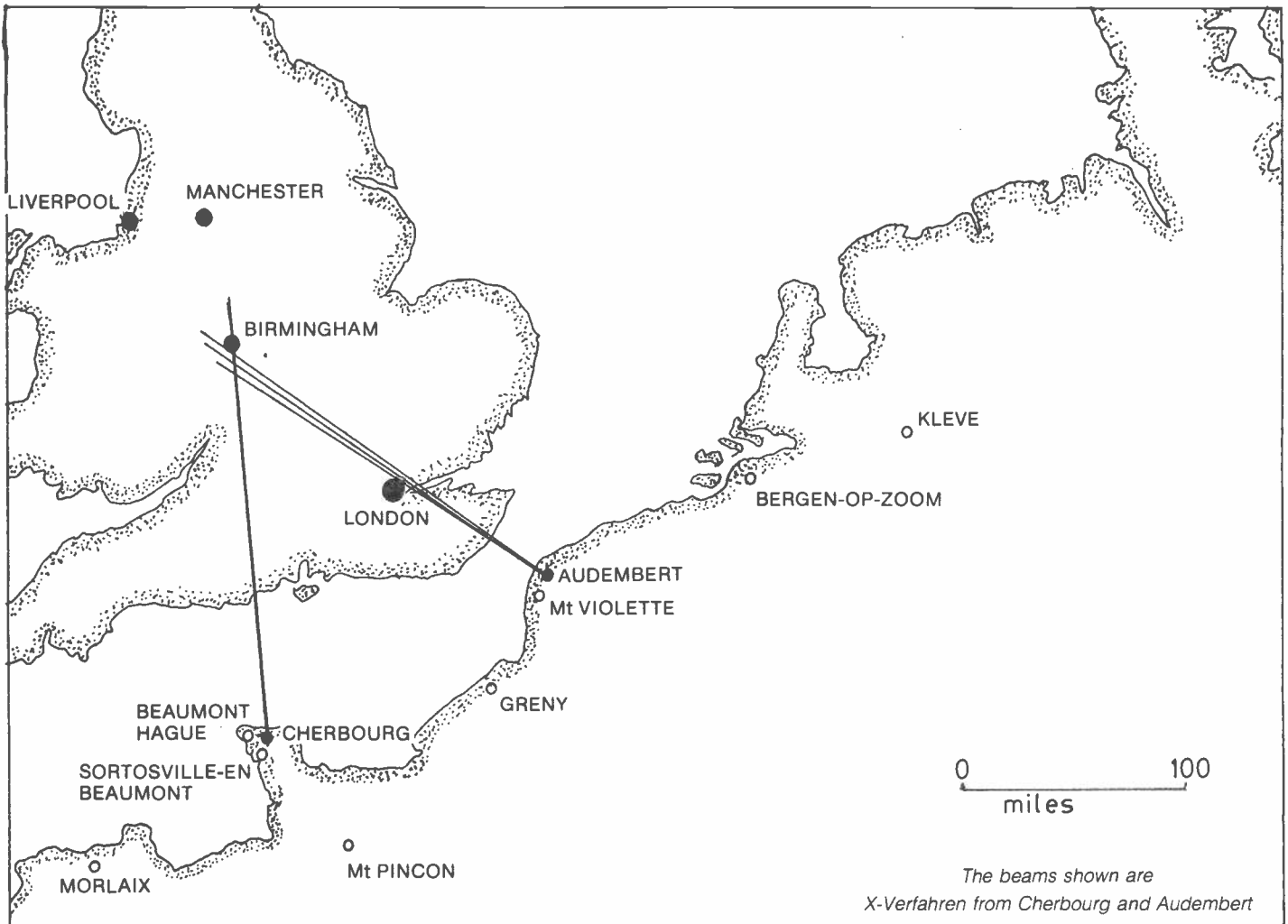

WHEN GERMANY WAS ON THE BEAM

direction and ranging information was about to be introduced into service and in November 1940, the RAF monitoring service heard unusual signals in the 40MHz band.

This was Y-Verfahren, and like its predecessor it was also designed by Dr Hans Plendl. The beam was Lorenz in nature, except that the keying was in the order of 180 per minute and the directional information was conveyed by the relationship of the dots to a synchronising pulse. In the aircraft this was decoded automatically by the receiver which gave a meter presentation to the pilot and also controlled the autopilot which could maintain the aircraft on the beam more accurately than any human hand.

Steady Tone

The range element of the transmission radiated a steady tone which could be keyed to pass instructions to the aircraft in Morse code. When a range check was required, the modulation changed to 300Hz. On receipt of this lower modulation frequency, the aircraft receiver keyed a transmitter and re-radiated the received modulation on an adjacent frequency. At the ground station the difference in phase between the transmitted and received modulations were measured on an oscilloscope from which the aircraft range could be calculated.

This system could give an accuracy in the order of 100 yards at a range of 250 miles.

For once, however, the British had information about an enemy system in advance. There was time to devise more subtle jamming techniques.

The method eventually developed made use of a receiver located at Highgate which was used to pick up the

result was catastrophic to the German raiding bombers. Out of 89 Y-Verfahren sorties over the UK in the first two weeks of March 1941, only eighteen received bomb release information.

An even greater disaster hit the Luftwaffe during the night of the 3rd of May 1941. Three of their Y-Verfahren equipped Heinkels were lost over England. In each instance the beam equipment was recovered intact and, needless to say, rapidly found its way to Farnborough where examination showed that the electronic beam analyser was extremely susceptible to jamming. All that was necessary was to radiate a continuous signal on the beam's frequency. This unlocked the beam analyser and the whole system became inoperative. With this discovery the antidote to Y-Verfahren was available and the system rendered unusable even before it came into full operational service.

'Keying was in the order of 180 per minute'

ranging signal re-radiated from the German aircraft transmitter. This was relayed to Alexandra Palace, where the silent BBC high power television transmitter transmitted the signal on the German ground station frequency. The

Contest

Although this ended the 'Battle of the German Beams', it was not the end of the contest between the radio experts of the opposing nations. The German radio men started to muck up the navigational aids used by the RAF's Bomber Command. This continued to the end of hostilities and forms one of the most fascinating stories of World War 2.

G3WPO HASSOCKS (07918) 6149
G4KEI

20 FARNHAM AVENUE HASSOCKS
WEST SUSSEX BN6 8NS



WPO COMMUNICATIONS

Home construction is on the increase! Or so it appears judging by the demand for our products. It really isn't that difficult once you have attempted that first project — as long as you can solder reasonably well, you are 99% of the way towards completing one of our projects. With comprehensive instructions (we believe the best on the market), clear layouts and high quality pcb's, WPO Communications aims at taking out all the uncertainties in building your own gear. All components needed to complete the project are normally supplied, including pcb's, pots and wire. Our speciality is HF equipment, but we are broadening our range to cover other aspects of the hobby, including some pretty unique projects which have never been offered before. Why don't you have a go at building something — QSO's are more interesting when you say "running a home brew rig here. . . ." Design expertise from Tony G3WPO, Chris G4KEI and Frank G4JST. For HF, our most popular kits are the **DSB80/160 QRP Transceivers**, running 2 watts or more on either 80 or 160M, double sideband or CW and VFO controlled. The basic kit (£37.45) only needs an antenna, PSU (12v) and speaker/mic/key to get on the air, or we have a case (£23.35 inc hardware) and even a digital readout option (£24.10) if you want to go the whole hog! There are now over 500 of these scattered around the world with excellent results. Or try the **UPGRADED DSB2** — with enhanced features such as semi-break in keying, active filter, and the ability to run on any single band from 160 through to 15M (£68 inc VFO — state band when ordering) — at the moment the most popular versions are for 80 and 20 metres, and for cw on 10MHz. This MkII version is driven by the **MINISYNTH PLL single band VFO**, itself available separately at £29.70. It covers any one band from 160 through 10M, with options for i.f.'s of 9 or 10.7MHz (state which), direct conversion, or a 5-5.5MHz version, useful for second VFO etc. **Get that G4CLF/3ZVC board up and running at last.** Both the DSB2 and the MINISYNTH come with a polyvaricon capacitor to keep the cost down — for ultimate stability use an air spaced either from your own junk-box or add £7 to the prices for a top grade Jackson version. Other options are digital displays and a case — write for more details. Still on HF, another very popular line is our **G4DHF TRANSVERTER** — unique kits which will put you 2 metre multimode rig on to 20/15/10 or 160/80/40 metres, both transmit and receive. You just operate the 2M rig as normal but you have HF transceiver operation instead of 2 metres! 2 watts min output will give you plenty of contacts on these bands, and only a 12v supply is needed. The kits have everything else included (except metalwork and the multimode!). Either version priced at £81 including the three conversion crystals needed. Cheaper than an HF Rig! Hear these working at the Rallies this year.

PROJECT OMEGA is now nearing completion. This is our top-of-the-line Kit for a 9 BAND HF SSB/CW Transceiver, engineered by G4JST for best performance without the frills. It isn't cheap but does work as many people can now testify. Professional

NEW — HFSSB Transceiver 160 or 20m — phone for details

appearance case available with anodised, screened and punched panel plus hardware kit options. See our previous ads for more details, or ask to be included on our unique **OMEGA Mailing List** (£1 in stamps). Our newsletter will be sent at intervals (5 issued to date) and keeps you fully informed on the project, with all known mods, hints and corrections to the published articles. Some of the modules are suitable for use with other designs, in particular the **OMEGA PLL VFO** will suit 3ZVC/&CLF i.f. designs. It is low noise, highly stable and covers all Amateur bands in 1MHz segments and is priced at £108 inc all crystals (10.7MHz version). The **ACTIVE FILTER** can be used for any rig needing more selectivity and fits in the audio line at low level — 7 switched selectivity position (£16.65). **QRP PA (3W) suits 3ZVC/&CLF i.f. strips also** (£21.80). The **BROADBAND RF PREAMP** is very popular on its own and will live up any HF receiver, or can again be used with G4CLF type bidirectional signal designs as it used pin diode Tx/Rx switching (£13.50).

Moving to VHF, our **2 METRE TALKBOX FM TRANCEIVER** is proving another best seller kit. A cheap way to get on 2 metres, with our 6 channel receiver and transmitted designs. Both will work independently of the other, or mate them for Transceiver. Rx £39.50, and Tx £32.90, or both together for £68. Crystals not supplied but available from any of the usual suppliers — or go VFO with the new VHF Minisynth. Interested in **6 METRES?** — then try our 6M to 28MHz i.f. converter design — complete pcb kit is only £14. Or, if your 2 metre rig is deaf, try our **2M PREAMP** (very small) at only £5, or the **70CM VERSION** for £6.50.

Have you a **FREQUENCY COUNTER** — then convert it to a **DIGITAL CAPACITANCE METER!** Another unique kit — if you can get at the gate pulse in your counter then try this design priced at £18.20, inc case, 1Pf. — 1000's uF's.

2 NEW ITEMS THIS MONTH! SPEECH PROCESSOR — simple but very efficient design by G4JST using VOGAD, variable clipping + filtering all the right places. Complete kit only £13.90. +12v operation, suitable for FM/AM/SSB, amateur/CB. **VHF MINISYNTH** — by request, our **2 METRE PLL VFO KIT — 2MHz BAND COVERAGE** with options for 144, 133.3 or 135MHz or other outputs (up to 4 selectable 2MHz ranges on the pcb to allow for a repeater shift on Tx and Rx). **Works with our Talkbox for continuous 2M coverage**, and should go with almost any other rig that needs direct 2M injection on Tx, and either 9 or 10.7MHz i.f. offset on receive (or Tx). Very stable and easily buildable. Complete pcb kit with air spaced VFO capacitor **ONLY £38.50**. Crystals are not supplied — 1 needed for each 2MHz range, full details on ordering rapidly are with instructions. Suitable SSB/CW/FM and can be modulated for latter. More details on request.

All prices include VAT and post. We are MAIL ORDER, or collection by arrangement (phone Chris between 10am-11am on Brighton 834478 before coming). Most items ex-stock or allow up to 28 days if not. Post Office COD over £30. Phone Mon-Fri 10-4pm. See you at the NEC (Stand E27), Woburn, Longleat and other Rallies. Access-24hour Answering phone 07918 6149.

TWO HANDHELDS ARE BETTER THAN ONE

Two new handhelds have just arrived onto the amateur radio scene. Here, our chief test reviewer Angus McKenzie G3OSS puts both the Icom IC02E and Standard C110 through their paces.

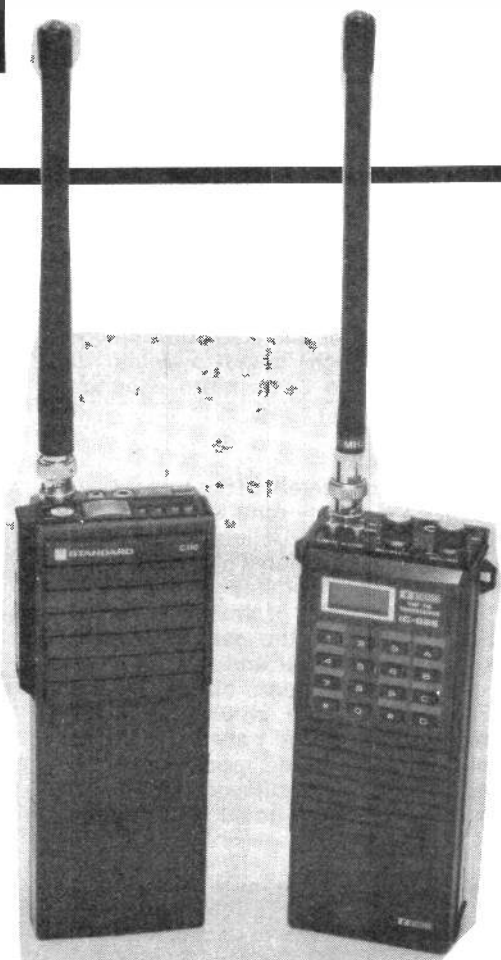

About a year ago, several handhelds were reviewed in this magazine and since then two important new models have appeared, both of which are likely to interest readers. The IC2E has now been given a major facelift and becomes the IC02E. Thumbwheels for tuning have been replaced by a front panel keypad giving more facilities, and the model has been completely restyled; much of the circuitry internally is however, very similar. The Standard C110 is very similar to the old IC2E and AR240 models, but offers a reasonable performance for its modest cost. Both handhelds incorporate repeater shift and toneburst functions, and both have BNC sockets into which various antennas can be plugged.

ICOM IC02E

The IC02E can be supplied with alternative nicad battery packs, and several different chargers are available. The rig normally comes with a BP3 pack which gives 250mA hours at a nominal 8.4V. Also available are the BP2 with 425mA hours at 7.2V, the BP4, taking either plug-in AA type batteries or rechargeables, the BP5 giving 10.8V at 450mA hours, the BP7 giving 13.2V at 425mA hours and, finally, the BP8 giving 8.4V at 800mA hours. The BP2, BP5, BP7 and BP8 batteries can be rapidly

charged. A wall plug charger model BC25U/E can be supplied to give a slow charge for the BP7/8. The mains charger can give slow or fast charging, and this model BC35 is suitable for all the rechargeable packs. A cigarette lighter socket charger model ICCP1 charges at a slow rate and is suitable for BP3, 7 and 8.

Other accessories include a speaker microphone IC HM9, a headset incorporating microphone and headphone type HS10 for use with either a PTT switch box HS10SB or VOX unit type HS10SA. Various cases are available in different sizes to accommodate the rig with battery pack. All the battery packs slide sideways on to the bottom of the rig for easy changing.

When you consider the size of the battery, the rig itself is remarkably small, measuring 116 x 65 x 35mm without power pack. On the top is a BNC socket for the antenna (rubber duck supplied) and two push-buttons for high/low power, and illumination on/off. Two rotaries are provided for variable squelch and volume on/off. Miniature jack sockets are fitted for external power input (up to 13.8V). The basic front panel has an LCD at the top giving frequency and status indication, below which is a 4 x 4 soft touch key pad. This pad allows direct access to frequency in 12.5 or 25kHz

steps, and 10 memories. Below the keypad is the microphone/loudspeaker panel and below this the plug-on battery. Underneath the battery are holes which allow the fast charger automatically to select the appropriate voltage/current, juice being provided on two screws at either side of the battery. On the left side of the rig is a rocker-type press switch, one end operating PTT and the other end toneburst.

I did not like this particularly, and found it tiring to use after a while. There is no way of locking on to transmit unless you use external PTT. Above the PTT switch is a special function enable button, again a rubber covered micro-switch which is not positive enough to feel and awkward to hold while you press the other buttons on the keyboard for dialling repeaters into memory etc. Two eye hooks at the top of the rig are provided for carrying strap and a belt clip is supplied which screws onto the back panel.

Frequency can be inserted by pressing four or five followed by only two more numbers, the rig automatically selecting the nearest appropriate channel. 12.5/25kHz spacings are selected by buttons, which also provide any repeater offset, plus or minus, but in my opinion too much button pressing is necessary

TWO HANDHELDS ARE BETTER THAN ONE . . .

for this, including special function being depressed all the time. Two buttons select up or down channel changing, whilst other functions available are priority (this works on memory 1), tone encoding (US etc models only), reverse repeater shift, beep or not to beep when buttons are depressed, listen on input, dial lock, memory and programme scan and scan stop.

Although 10 memories are available, there is an extremely bad ergonomic snag with them, for unless a repeater shift is put into memory one, memories two to six inclusive will not accept repeater shift. Memories seven, eight, nine and zero operate normally with or without repeater shift. The requirement for inserting repeater shift into M1, immediately stops that channel from being used as a priority simplex one, an asset that would have been strongly favoured by Raynet members and probably most other users.

As if this is not unfortunate enough, you cannot channel QSY from one repeater to another without losing repeater shift immediately unless the repeaters are in memory, so round we go again to the memory one problem. I really think this is a very bad piece of ergonomics and I have checked both of these problems on several rigs which are all the same, so Icom ought to do something about it in future.

It is very useful to go direct from a memory to a nearby frequency by using memory to VFO function, and once I had got used to the pad, I found I liked the rig much more than its predecessor.

In general use I received very good modulation quality reports, and reception was also sensitive and sound quality excellent, especially considering the small speaker. The PTT gadget was also supplied with the loudspeaker mike and this could be very useful indeed, particularly in a car where one would also possibly want to use the headset, which I liked. The earpiece is covered with foam and gave quite good quality, but I really must grumble about the awful plastic contraption which bent my right ear as well as reducing the blood circulation (Icom should put a foam covering on

ICOM IC - 02EFM Received Audio Response

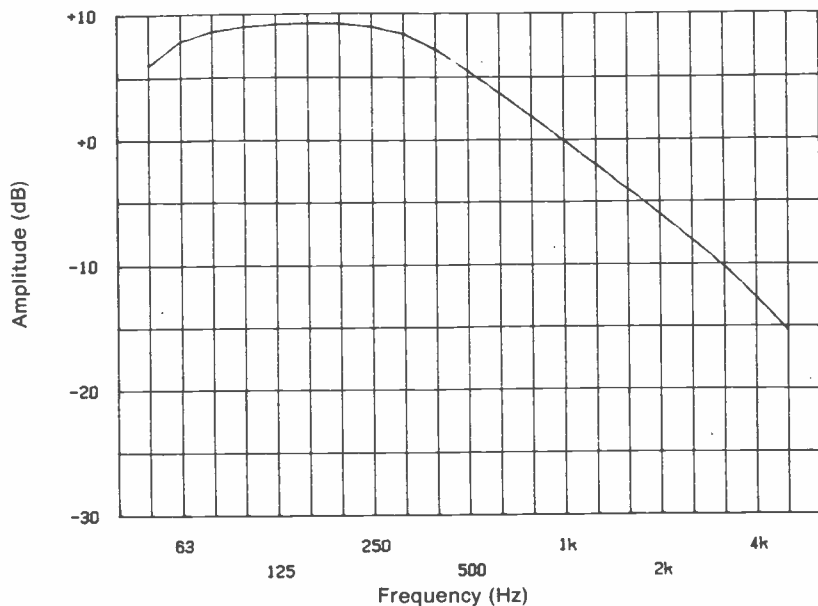

Standard C110 FM Received Audio Response

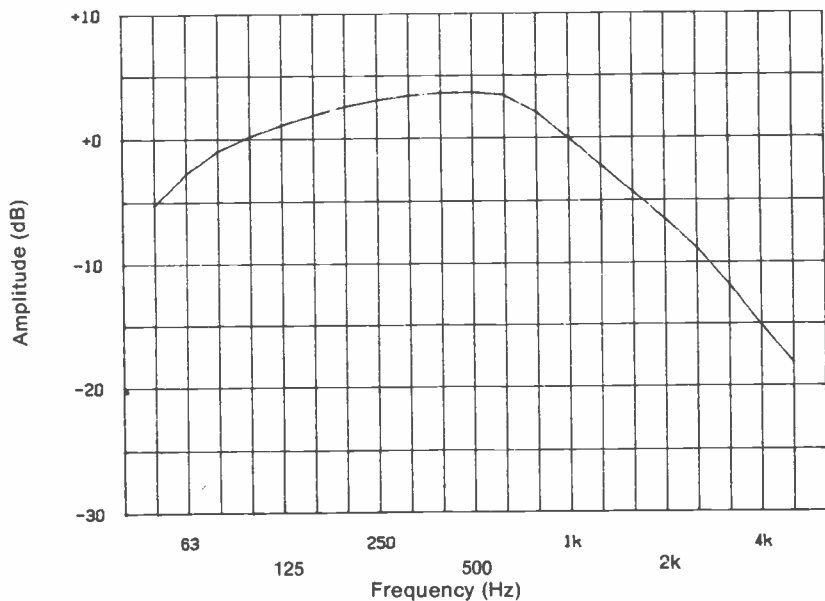

SELECTRONIC

RADIO, TV AND RADIO COMMUNICATION SPECIALISTS

★ 934MHz UHF RADIO EQUIPMENT ★

We have in stock the full range of Reftec equipment, ie, Mobile, base station and handheld Transceiver plus full range of aerials and fittings, etc. Hand held model now available. SAE for full details.

AUTHORISED REFTEC SERVICE DEALER

STOCKISTS OF AMATEUR RADIO EQUIPMENT:

Yaesu, Trio, FDK, Tonna, Jaybeam, Revco etc

* CREDIT TERMS AVAILABLE

For further information please ring: Mike Machin on (0268) 691481



203, HIGH STREET,
CANVEY ISLAND, ESSEX



G6YHB
G6YHC
G4UVJ

BECOME A RADIO AMATEUR

Train now for the Radio Amateur Licence examination. No previous knowledge needed, only a few hours per week of home study for 3 to 6 months. Post coupon now for details or tel. 0734 51515 (24 hr service)



British National Radio & Electronics School Reading, Berks. RG1 1BR



FREE brochure without obligation from:—

British National Radio & Electronics School
READING, BERKS. RG1 1BR

Name

Address

AR/5/846

BLOCK CAPS PLEASE

FRG7 OWNERS ARE GOING — DIGITAL AND SIDEWAYS

And you can join them by using our custom designed DFC70 digital frequency counter. The DFC70 is specifically designed for the FRG7 and gives rock steady read out on all bands with 100Hz resolution. Signal frequency is computed and displayed unambiguously on a state of art LCD display specially made for us in Japan. It is not necessary to drill any holes and only one wire has to be connected to a well marked test point in the receiver.

DFC70 Kit £19.95 Built and tested module £24.95

Will also work with the Lowe SRX30 and Drake SSR/1.

With our new FM7 adaptor module, you will be able to receive sideways modulation (FM as it is otherwise known). Our superb state of art FM detector uses the very latest 3359 chip from Motorola, and has a built in IF filter and a variable squelch control for noise free monitoring. Although specially designed with the FRG7 in mind, it will happily work with other receivers or transceivers with a 455kHz IF amplifier. The FM7 will add a whole new dimension to your listening activities. You will of course be able to follow legal CB contacts but you will also hear the exciting DX being worked by amateurs on 10 metre FM. Used in conjunction with our DFC7 counter, you can accurately tune to a specific CB or amateur channel and so be sure that you will not miss whatever goes on.

Kit Price £9.95 Tested Module £14.95 P&P £1.00 (VAT inc.)

For FM reception on receivers with any IF up to 50MHz, the FM 42 is the answer to all your problems. *Please state frequency required when ordering.*
Kit Price £14.00 Tested Module £19.00 p&p £1.00 (VAT inc.)

TIMOTHY EDWARDS MK2 144 MHz PRE-AMP HEAR IT LIKE YOU NEVER HEARD IT BEFORE

We are proud to announce that the well known RF consultant Timothy Edwards has given us the exclusive marketing rights to his new 2 metre pre-amp. Timothy Edwards RF designs are used by British Telecom amongst others and so you can be sure that this pre-amp will perform to perfection. It employs the incomparable BF981 which has a better noise figure at 2M than the often used 3SK88. Spec. Size (tiny) 34mm x 9mm x 15mm (same as Mk1) Noise figure 1.0db Gain 26db **Kit Price £4.95 (inc VAT & P&P).**

TRANSISTOR

	mHz	PoutW	Pin W	Volts	Price	Not 3SK88 but BF981 Better 2M noise figure -0.6db £1.40
2 N6456	30	60	1.25	13.8	£5 (inc)	(inc) ZTX 501 Gen. purpose PNP 0.5A. 20 for £1.25 (inc)

BARGAINS

NEW LCD COUNTERS

At last a new range of 5 digit LCD counters that will cover up to 200MHz and give 1KHz resolution to 39MHz. Ideal for most short wave receivers using common IFs. Similar to the FC177 but cheaper! Supply voltage 5-15V dc. Will operate on 26 different IF offsets. If this counter range won't do what you want probably nothing will. Works with all of Tony Bailey G3WPO designs, ask for conversion data.

DFC40 0-4MHz £14.95 built DFC41 0-32 MHz £18.50 kit DFC42 0-200MHz £21.95 kit

LNA144. OUR ace RF designer Timothy Edwards has done it again! In line 144MHz RF switched pre amp which needs no modification to any rig. Just put it in the co-ax feed, supply 12V and your deaf rx will have ear ache. Uses the BF981 with a total of 4 tuned circuits for the best out of band rejection. The relays are 50ohm gas filled with earthed metal cans and are good to over 800MHz. This was originally designed for 'British Telecom Satellite Division' hence the provision for gold 14GHz SMC connectors. 1dB noise figure and 18dB gain is guaranteed to improve all standard rigs on 144-146MHz. Will fit in standard diecast box (not supplied). Try one in the car under a wing mounted aerial and be surprised. LNA144 kit £14.95. Built and tested module £24.95.

TONE BURST. Probably the smallest crystal controlled unit available. 1750Hz ± 0.1Hz. Supply 5-15V. Will fit in the tiniest of rigs or even microphones.

TBI Kit £6.50

SHORT WAVE RECEIVER TE206. Superb Russian design specially imported for Timestep. World wide coverage in 8 bands. Upgradable to full digital readout and DX MW reception. TE206 £19.95. Matching 144MHz 2M converter DC144 kit £9.95. DC144 built £16.50. Digital display module DFC206 built £18.50. FM adaptor FM206 kit £9.95. FM206 built module £17.50. Medium wave DX kit MW206 £3.95 MW206 installed from new £6.95.

TOP BAND CONVERTER Listen to the other local nets and DX on 160m with any 2m SSB receiver. Does not need a large aerial and will comfortably out perform most commercial receivers.

UC160 Kit £9.95 UC160 built and tested £16.50

2M MONITOR RECEIVER. A superb design featuring crystal and ceramic filters coupled with the MC3359 and BF981 results in an almost bomb proof monitor. Single channel with squelch and 500mW audio amplifier. No coils to wind and little alignment required. Uses standard crystals from 'PM Electronics'. **MON2M Kit £19.95 Built and tested module £29.95.** For professional use on 18-200MHz built and tested module **£38.50** including crystal.

ULTIMATE 2M MOBILE AERIAL. For those of you who don't want the world to know. Fully automatic professional quality electrically retractable aerial. Can be used manually or will erect when the rig or car radio is switched on. Full duplex design allowing LW-MW and stereo FM to be used simultaneously with 2m. Half wave electrically loaded for superb performance on 144-146MHz. Maximum input power 30W. This unique design can be used with our LNA144 for outstanding results. **DUP2M £29.95.**

934MHz PERSONAL COMMUNICATION TRANSCEIVERS

Quiet and private, Ideal for small business use or give the girlfriend one. Each unit checked by Timothy Edwards on our Anritsu MS62B Spectrum Analyzer and Marconi 2019 Synthesized Signal Generator. Mobile Transceiver **£299.95** Mobile aerial 3dB, mag mount **£26.45**, hole mount **£20.75**. Base 3dB **£15.53**.

All prices include postage and VAT. Send 35p for individual data on any of the above. Mail order only. Please allow up to 28 days for delivery.
TIMESTEP ELECTRONICS LTD, EDMONT ST, GLEMSFORD, SUDBURY, SUFFOLK.
TELEPHONE NO 0787 280154 TELEX 987033 TIMST G



TWO HANDHELDS ARE BETTER THAN ONE . . .

this!) Perhaps if you have very long hair and rest it on your temple you might manage until the gubbins falls off your head.

I found it very useful to have 5W output available from several of the packs, giving this rig a more worthwhile range than usual. The receiver sensitivity was also excellent. On an outside aerial RF IM was poor and so I cannot recommend the rig for base station use in urban areas. It is possible, if you get your knickers in a twist, to transmit far outside the 2m band, and Icom should urgently attend to this. It is all too easy to dial in 6MHz instead of 600kHz shift, and you could cause an awful lot of aggro if you inadvertently do this, apart from your irritation in not getting any QSOs. We found that we could not listen outside the band, but several dealers have found ways of incorporating fun mods both on Rx and Tx to enable the rig to transceive almost anywhere in the VHF range, and other models are available for professional and marine use etc.

The BP3 pack did not add too much weight, and the rig was easy to hold with it. The larger batteries added quite a lot of weight though and this should be borne in mind when selecting the pack. The battery clicks in sideways and is secure although the pushlever to unlock the battery is stiff.

LCD includes a 15-sector signal strength indication, without calibration, but these covered only a very narrow RF level range of 12dB. The first one indicates the presence of broken squelch at a much lower RF level as preset. An inverted triangle shows up when the batteries are nearly exhausted, and other displays include 'L' (dial lock) 'S' (scan) 'T' (Tx), a quaver sign indicating tone encoder, and a +/- sign showing repeater shift in use. The display was difficult to read in broad daylight, but was excellent at night with the light on.

Lab tests

RF sensitivity was confirmed to be excellent, and about the same as that of the IC2E. RF IM was very poor, such that the intercept point, at -32dBm, is one of the worst I have measured, confirming that this rig will have a problem on a large fixed antenna if there are many other stations around. The reciprocal mixing performance was reasonably good, although there did seem to be more than average noise on the local oscillator/synthesiser, especially far out. IF selectivity was checked with both the normal old method, and by my new method detailed at length in the next issue of **AR**. 12.5kHz channel selectivity was very good, and 25kHz excellent. The capture ratio was remarkably good, showing the rig to have a superb discriminator. This will mean that the rig will favour the reception of the stronger of two signals where the weaker one is only a few dB down on the strong one. This is a measurement so frequently ignored that I consider important in the context of band usage.

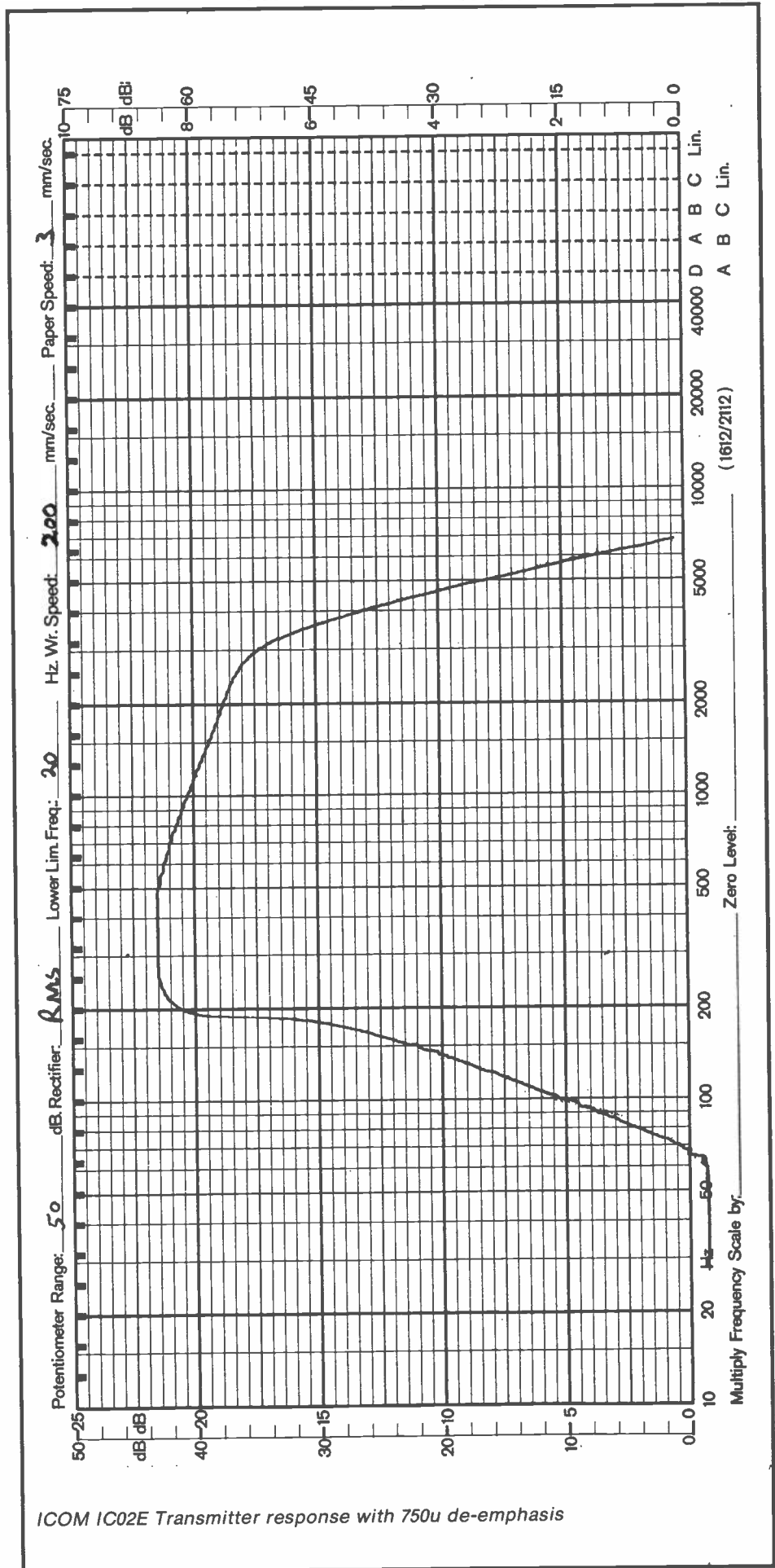

ICOM IC02E Transmitter response with 750u de-emphasis

TWO HANDHELDS ARE BETTER THAN ONE...

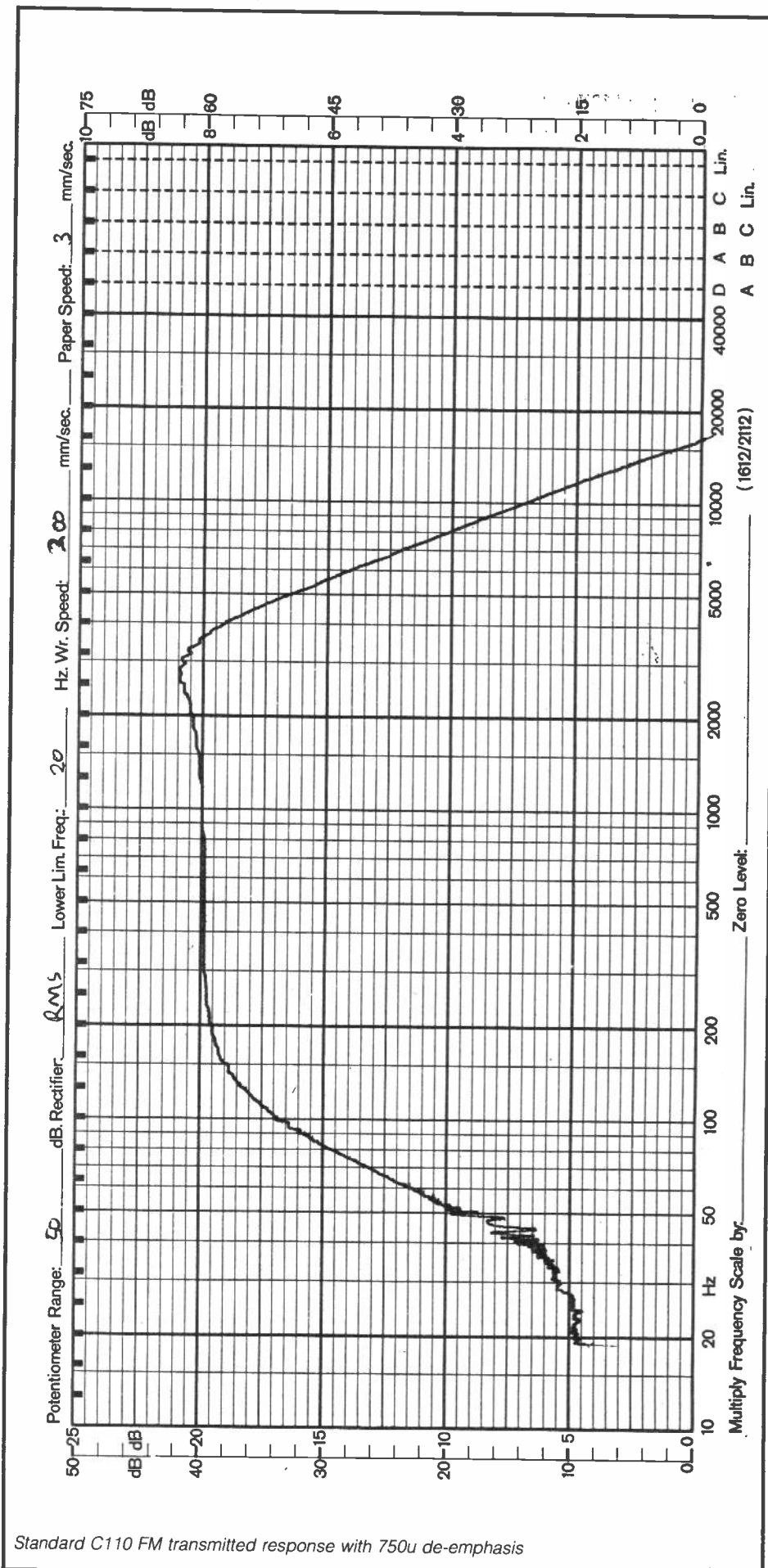

The audio-quieting signal-to-noise ratio at the 12dB sinad point was only a few dB better, and this again shows the discriminator to be good, for a greater difference implies distortion etc. when mod is on, on a very weak carrier. Limiting came on at an extremely weak RF input level, which allows all receivable stations to be audible at the same level depending upon their deviation.

The best obtainable signal-to-noise ratio on a strong carrier was very good, ultimate maximum being approached at 10uV input. The range of the S meter, whilst small, was actually indicating a typical range of signals that would be received when used as a handheld. The audio was quite clean, with distortion better than on many other FM rigs. Maximum audio output was at 0.5W into 8 ohms, which increased to 0.8W into 4 ohms. The internal speaker was surprisingly uncoloured, but its efficiency was not very high, so the maximum volume from it is somewhat limited.

The rig's current consumption was a little high on squelch, and was surprisingly high with full received audio power. On transmit, on full power, current consumption was of course very high, but this did not drop back enough on low power, so you will need the bigger batteries for a day of Raynet work. The squelch sensitivity was amazing, and almost inaudible signals would open squelch, although I would have liked the squelch variation to have been wider. The receive audio response does not fall rapidly enough below 200Hz. Above this frequency, the response follows a reasonably accurate 6dB per octave to 4kHz and then is attenuated rapidly. This is just about ideal for receiving correctly pre-emphasised transmissions.

The transmitted power on the bigger packs was always around 5.5W output, reducing to 0.5W on low power. Even the BP3 gave 5W output, but it wouldn't give this for too long! Those who transmit long overs on FM will justly get their reward here! The carrier frequency accuracy was remarkably good throughout, the repeater shift accuracy being within 10Hz. 2nd harmonic on full power was at -65dB, whilst 3rd was below -68, and these figures are very good for a handheld. On low power, harmonics were below noise. The toneburst frequency was only 1Hz out, and deviation around 4kHz. Peak speech deviation was around 6.5kHz at worst, but typically 4.5kHz, which is still a little high.

The transmitted response from mike jack in to the output of our Marconi 2305 modulation test meter, with 750uS de-emphasis switched in, shows an extremely good steep cut below 200Hz, and flat up to 1kHz, with a gradual slope down to -5dB at 3kHz, above which the roll-off is steeper (see pen charts). Thus both transmitted and received responses match extremely well, and put many other rigs to shame, ironically, including the responses of some other Icom ones.

TWO HANDHELDS ARE BETTER THAN ONE...



Standard C110

This is a much more basic rig which of course costs a lot less. On the top of the rig is a BNC antenna socket (rubber duck supplied). Beside this is an extremely awkward recessed squelch control that you may find very difficult to use. It is tiny and has to be rotated but at least is unlikely to shift too easily. Three edge-wise acting wheels select MHz, 100kHz and 10kHz steps. A button, when depressed, gives a 5kHz offset so you cannot get 12.5kHz steps. The frequency indication is painted onto the switches, and you won't be able to read these in the dark. Jacks are mounted for external mike and loudspeaker. A proper miniature S meter (moving-coil action) displays signal strength. On the front is the loudspeaker/mike and on the side a reasonably positive PTT switch, at the bottom of which is the toneburst section which can easily be depressed at the same time.

The volume control on the top of the left side was very convenient to use and incorporated the on/off switch. On the back panel are three switches selecting high/low power, Rx -600kHz and Tx -600kHz, allowing listen on input as well as normal repeater shift. The rig measures 167 x 65 x 34mm with battery and weighs 470g inclusive. Several accessories are available including mobile and wall chargers (CMC1 and C10/230-1 respectively) and a fast charging unit CSA110E. Two battery packs are avail-

able a complete nicad rechargeable one type CNB110 at 400mA hours, and another pack, which comes with the rig, which can be fitted with AA alkaline or rechargeable cells.

Charging is accomplished by inserting a charging lead plug into the side of the rig or, alternatively, unplugging the pack and charging it externally. The rig has a maximum recommended input voltage of 9.6V and is not suitable or designed for use with 12V, which could cause overheating, damage, a nasty expensive smell and loss of DX reception!

The receiver covers the range 140 to 149.995MHz, and thus picks up quite a lot of entertainment value! The transmitter unfortunately can transmit up to 147.995MHz and in my opinion this is rather bad practice. The case is rather plasticky, and I gain the impression that it could crack rather easily if dropped.

The subjective receive quality on the internal speaker was on the tinny side and rather distorted, although quite a lot of audio power was produced acoustically, showing the speaker to be quite efficient. The rubber duck supplied seemed adequate. The sensitivity seemed good, but I hated the thumb wheels; finding that they lacked positive switch action. I must emphasise that this is very personal, but even so, it is extremely difficult to hunt and peck across the band unless you are looking in 10kHz steps.

Transmit quality was acceptable in the

context of a walkie talkie, but not as good as that of the Icom. Selectivity seemed excellent even in rejecting 12.5kHz offsets. The S meter was far better than that of the Icom, covering quite a useful range. RF IM seemed poor when the rig was used with a fixed station antenna, but in the context of a handheld it is adequate. The speaker mike, whilst having limited LF output, gave much better reproduction and the transmit quality was preferred. It could be clipped onto the belt and was easy to use, its PTT disabling the rig's one.

Lab tests

The RF sensitivity was amazingly good for an inexpensive handheld, actually being slightly better than that of the Icom. Rather surprisingly the figure at the top end of 2m was the best we have measured on any unmodified 2m receiver. RF IM was marginally superior to that of the Icom, the intercept point being 3dB higher, although still very poor. Reciprocal mixing performance was rather poor close in, but slightly better than that of the Icom further out. IF selectivity was very good at 12.5kHz but did not improve enough further out.

The new white noise method showed selectivity to be excellent close in, measurements further out giving similar figures to the old method. The S meter starts moving at around 0.45uV, with S9 at around 4.5uV thus giving a 20dB range. The capture ratio measured quite well,

TWO HANDHELDS ARE BETTER THAN ONE...

but audio distortion was very poor at 3.7% at only 1KHz deviation, rising to 6.5% at only 3KHz deviation, which explained part of the apparent poor audio quality. Maximum audio output power was rather limited. The receive audio response peaked at 500Hz falling too gently at LF, but was about right up to 3KHz. The squelch required only a very weak signal to open it, but it had far too small a range of adjustment, so that almost any receivable signal would open it up which can be a disadvantage. The best attainable signal to noise ratio was slightly better than that of the Icom, and good for a handheld, this being approached at around 20uV. RF/IF limiting was excellent, and the quieting at the 12dB sinad point was about optimum for the system.

When the receiver was squelched the current drain was very low indeed which is a great boon, and to put this into perspective, the squelch current was around one third of that of the Icom. Current rose rapidly with audio passing through, showing that the design is very much in favour of battery life conservation.

The transmitted power output on high was 2.6W, falling to 0.3W on low power. Current drain on maximum power was 0.6A which I think is quite reasonable, falling to 200mA on low power which shows excellent efficiency, much better than that of Icom, which took nearly twice as much for the same output power. RF harmonics were minimal, and no spurious were noted. Peak speech deviation was around 5KHz, although with much yelling and tutting we did achieve 9KHz! Carrier frequency accuracy was incredibly good, and the repeater shift accuracy very good. Tone-burst deviation was about right, and its frequency within 3Hz. The transmitted audio response into 750uS de-emphasis was surprisingly flat from 200Hz to nearly 3KHz, but with a surprising slight rise here. I feel the HF response however, was too extended, the 5KHz output being only -7dB, which could cause slight splatter. This was clearly the cause of the apparent over-deviation under the worst circumstances.

General conclusions

I welcome the addition of both these handhelds. Each in their own way, I think, will become popular. I still rather like the old Yaesu FT208 which is still worth considering, but the IC02E has similar flexibility but is lighter. Whilst being enthusiastic about the IC02E, it is rather expensive, and has the two strange ergonomic features referred to earlier. The Standard seems good value at its price, and is quite a long way ahead of some earlier competition, and it should certainly fit the bill if you want a rig on which you will not want to change frequency too often.

We cannot point to a best buy, as the rigs are different, but each in its own way is recommendable. I would like to thank Thanet Electronics for lending the Icom rig, and Lee Electronics for the Standard.

Both companies have been extremely helpful in providing information about the products. I would also like to thank

my colleague, Mike Hatch G1DEW, for the hours he spent in helping me with the measurements.

FM HANDHELD TRANSCEIVER — LABORATORY MEASUREMENTS

STANDARD C-110 ICOM IC-02E

Receiver Measurements

Sensitivity for 12dB Sinad (3kHz modulation, 1kHz deviation)

144.025MHz	-124.5dBm (0.13µV)	-124.0dBm (0.14µV)
144.950MHz	-124.5dBm (0.13µV)	-124.0dBm (0.14µV)
145.975MHz	-125.0dBm (0.12µV)	-123.5dBm (0.15µV)

Selectivity:

blank carriers off channel to degrade Sinad by 3dB (ref 12dB Sinad)

-/+12.5kHz spacing	42.5/30dB	38/38dB
-/+25kHz spacing	62/62dB	69.5/70dB

Selectivity: second method (see text)

Carriers off channel modulated with filtered white noise (ref 12dB Sinad)

-/+12.5kHz spacing	26/30dB	19/19dB
-/+25kHz spacing	62/63dB	68/67dB
-/+50kHz spacing	76/76dB	79/86dB

RFIM performance: carriers off channel for 12dB Sinad product (ref 12dB Sinad)

50/100kHz spacing	61dB	69dB
100/200kHz spacing	63.5dB	72.5dB

Calculated RF intercept point:

-29dBm (8mV)	-32dBm (5.5mV)
--------------	----------------

Reciprocal mixing performance at 144.05MHz

RF levels required off channel to degrade sinad by 3dB (ref noise floor)

25kHz spacing	74dB	80dB
50kHz spacing	89dB	90dB
100kHz spacing	100dB	95dB
200kHz spacing	102dB	99dB

S meter: RF levels required for the following readings

S1	-114dBm (0.45µV)	(First LCD segment) -103 dBm (1.6µV)
S3	-103dBm (1.6µV)	
S5	-100dBm (2.2µV)	* See text *
S7	-97dBm (3.2µV)	
S9	-94dBm (4.5µV)	
S9+20dB	-87dBm (9µV)	
S9+40dB	Not calibrated	
S9+60dB	Not calibrated	(Last LCD segment) -91dBm (6.4µV)

capture ratio	5.2dB	4.2dB
---------------	-------	-------

Audio quieting (at 12dB sinad)	15.7dB	15.5dB
--------------------------------	--------	--------

3dB limiting point	-128.4dBm (0.09µV)	-127dBm (0.1µV)
--------------------	--------------------	-----------------

Maximum audio output (10% THD into 8ohms)	0.3 watts	0.5 watts
---	-----------	-----------

Audio distortion (125mW into 8 ohms)		
1kHz deviation	3.7%	1.5%
3kHz deviation	6.5%	1.5%

Best obtainable signal/noise ratio		
Unweighted	54.5dB	50dB
CCIR/ARM weighted	54dB	52.5dB

Current drawn on receive (squelch on)	23mA	65mA
---------------------------------------	------	------

Current drawn on receive (-60dBm signal)	30mA	121mA
--	------	-------

Current drawn at 10% THD audio output	154mA	192mA
---------------------------------------	-------	-------

Transmitter measurements

RF output power	low/high	low/high
144.06MHz	0.2/2.6 watts	0.5/5.7 watts
144.95MHz	0.3/2.6 watts	0.5/5.5 watts
145.05MHz	0.3/2.6 watts	0.5/5.4 watts

Carrier frequency accuracy at 144.95MHz	+90Hz	-110Hz
---	-------	--------

Harmonic output (ref fundamental)		
2nd harmonic	-67dB	-64dB
3rd harmonic	-65dB	< -68dB
Peak deviation	5kHz	6.5kHz
Tone burst deviation	3.4kHz	4kHz
Tone burst frequency	1753Hz	1749Hz
Repeater shift accuracy	-190Hz	+/-10Hz
Current drawn on transmit	0.6A/0.2A	1.2A/10.35A (high/low)
Squelch sensitivities		
Minimum	-121dBm (0.2µV)	-119dBm (0.24µV)
Maximum	-128.5dBm (0.09µV)	-132dBm (0.06µV)

INTRODUCING THE **ARE** CLUB

Why you'll want to make it your club.

Ever wished you could have first priority on news about the latest radio equipment? First priority to buy at very special prices—or a 2-year Warranty option?

All this kind of exciting news and

information is now available—on an exclusive priority basis—to members of the Amateur Radio Exchange Club.

We can also arrange for Radio Clubs affiliation—Club Secretaries, please write.

ARE CLUB
PRIORITY:
PRICE OFFERS ON
RADIO EQUIPMENT

ARE CLUB
PRIORITY:
2-YEAR WARRANTY OPTION
ON NEW EQUIPMENT

ARE CLUB
PRIORITY:
NEWS ABOUT THE LATEST
EQUIPMENT

**ALL PRIORITY NEWS AND
OFFERS EXCLUSIVE TO A.R.E.
CLUB MEMBERS ONLY.**

For details of how to join—come into any of the A.R.E. shops. Or phone.



LONDON:
373 UXBRIDGE ROAD,
ACTON,
LONDON W3 9RH.
Tel: 01-992 5765/6

NORTHERN:
38 BRIDGE STREET,
EARLESTOWN, NEWTON LE WILLOWS,
MERSEYSIDE WA12 9BA.
Tel: 092 52 29881

more on your wavelength

Despite all the advances in communications technology over the past 50 years, one aspect of design has remained almost static: that of front panel design. Ken Williams now argues the case for a complete re-think in fascia design

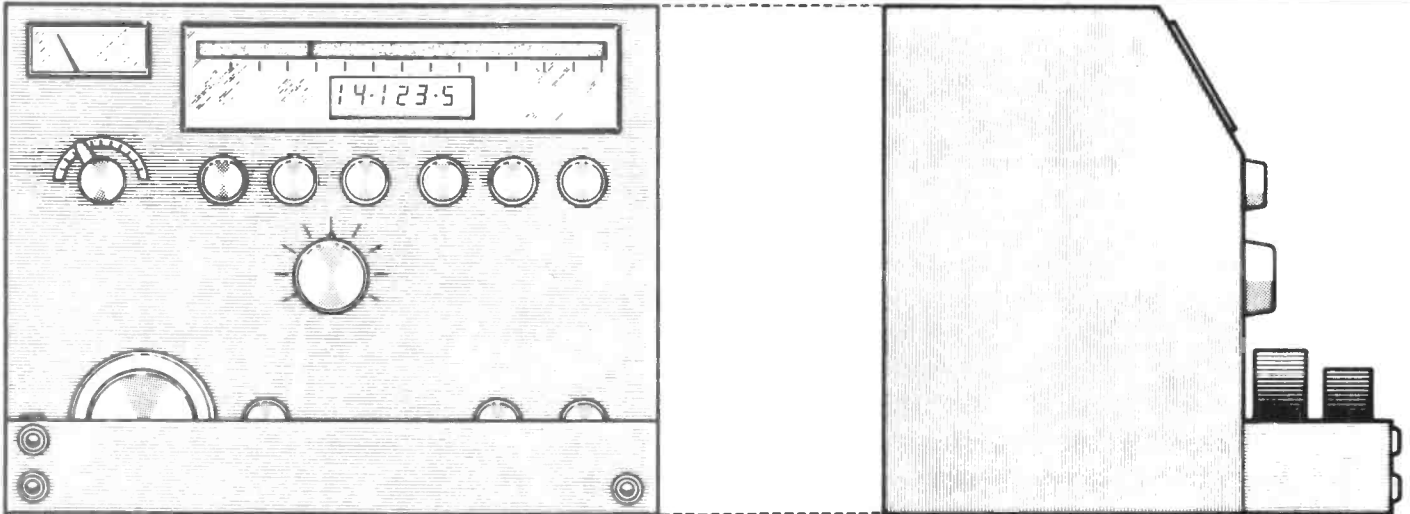

ON THE FACE OF IT

Certainly the layout of almost every bamboo box on sale today looks attractive—but are the controls laid out in such a way as to ensure maximum operational convenience? From my own experience, I would suggest that the design is dictated more by the opinion of the sales staff than by that of experienced operators. Furthermore, I believe this criticism to be as valid for the highly expensive commercial equipment as for the cheapest amateur transmitters and receivers at the local emporium.

Compare equipment available today with that designed forty or more years ago such as the HRO, AR88 or SX28. Apart from a few minor changes due to miniaturisation there has been little if any variation in basic panel design. It is not that I advocate change for change's sake, but in all that time, has anybody considered the relationship between panel design and operational convenience?

This was forcibly brought home to me on field days over several years. The 'prime mover' of the station was a very advanced transceiver designed and constructed by a friend of mine who is not only a long standing G3 but also a circuit designer for one of our most famous communications equipment manufacturers. The performance of the equipment was superb, but to operate it was a pain. The tuning dial and control were mounted so low on the panel that it was not only difficult to see the dial but also impossible to get your fingers around the tuning knob; and when tuning, your hand half-concealed the dial. When adjusting the transmitter output, your wrist covered the tuning meter.

Whilst most commercial equipment is not as bad as this, they still leave much to be desired. Let us therefore examine each aspect of design individually and consider how they could be improved for

both convenience and reduction of fatigue during long operating sessions. Even before this, however, let us look at the case in which the equipment is fitted and ask whether it meets our present day needs.

The equipment case

Traditionally, the classic valve receivers were quite bulky and were therefore designed to fit within the standard 19 inch rack. Even when intended for table top operation, this standard remained, with the chassis and panel being fitted within a more decorative case. Behind the panel, the equipment stretched some 15-18 inches in order to house the multitude of valves, transformers and the ganged tuning condenser (there were no capacitors in those days!)

With the introduction of miniature valves, packaging became more compact and finally semi-conductor techniques brought the necessary case volume down another magnitude in size. Despite this, the original concept of the height to

width to depth ratio of the case remained.

From the original panel size of something in the order of 19 by eight inches, today we are down to about nine by four inches—an area reduction of 75%, yet, with the increasing number of facilities available, far more controls have to be accommodated.

Every control and indication on the panel has therefore to be miniaturised and packed at the highest possible density. With skilled design this can still look quite attractive on the retailer's shelf, but how convenient is it to operate?

Many operators, both amateur and professional, suffer from failing eyesight, which, although corrected to a considerable degree by spectacles, can still cause difficulty in reading the legends above the controls and even the frequency readout. Furthermore, many controls may be difficult to set accurately merely because of their small size.

Even so, these problems could be

Comparison between the available areas of a typical 19 inch rack panel and that of many modern receivers

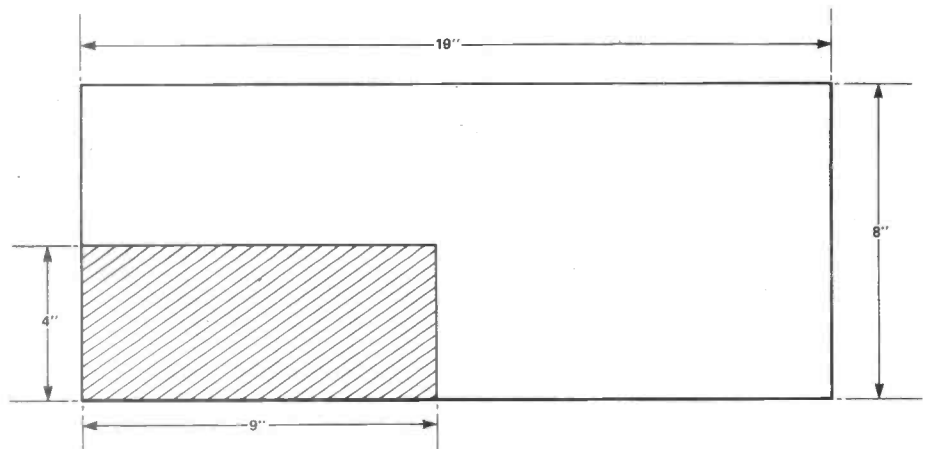

ON THE FACE OF IT

easily dispersed. The average size of many modern transceivers is in the order of nine inches wide by four inches high by 10 inches deep—a volume of about 320 cubic inches. With the capability of mounting modern components at any angle, could not the shape of the case be changed from a horizontal to a more vertical format, perhaps nine inches wide by six inches high by only six inches deep?

The increase in panel area would again make possible the provision of finger sized controls, reasonably sized meters and frequency readouts which are large enough to be read from across the room. The necessary bench area would also be reduced—a boon to those of us with small shacks!

The dominant feature of any receiver or transceiver panel is the frequency readout, so let us now consider its purpose, design and position.

The frequency readout

The purpose of the frequency readout is to give an accurate indication of the frequency upon which the equipment is operating, but how accurate does this need to be and should it be analogue or digital?

Most quality HF receivers manufactured during the past 40 years have been capable of being set to an accuracy of +/- 1kHz by use of their mechanical analogue dials. Modern synthesised equipment often gives a readout to 10 or 100Hz, but despite this it is often interesting to note the divergence of opinion on what frequency a net is operating. Particularly at VHF, the accuracy of readout is almost invariably far higher than the setting accuracy of the equipment. For example: my Icom VHF multimode equipment gives a readout accuracy of 100Hz, yet the specification only quotes an accuracy of +/- 1.5kHz. I would therefore suggest that a readout accuracy of 0.5 or 1.0kHz is more than adequate for all practical purposes. This does not mean, however, that the ability to increment frequency should be reduced to this. The smaller the increment the equipment is able to achieve, the better.

Although all modern equipment use digital readout, is this the optimum? To consider this we must look at the circumstances under which the equipment is used.

To interpret a digital readout, the eyes must accurately focus on the figures, an action which, if continuously repeated, can be very fatiguing towards the end of a long operating session, particularly if the operator is, not to put the point too finely, past the first blush of youth. However, a good analogue dial (remember the Eddystone receivers of the fifties and sixties?) can usually be read with adequate accuracy on peripheral vision and without taking the eyes off the present focus of attention, be it log book, note pad, page three or whatever. A similar comparison can be made between telling the time on a traditional clock and on a modern digital timepiece.

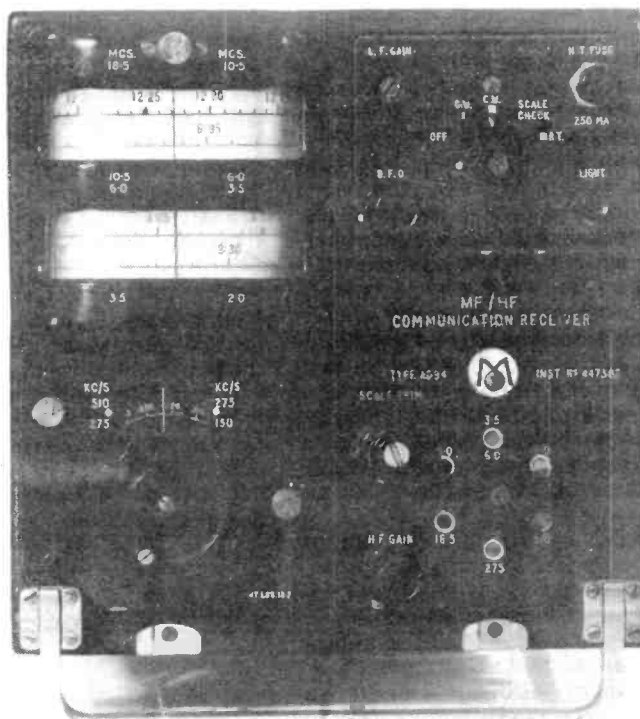

The AD94, a Marconi aircraft communications receiver of the late 1940's. This had a magnificent film type frequency readout which was over 30 ft. long. The LF gain was preset and the positioning of the remaining controls make it very near to the author's ideal



The classic Drake 2B. If the RF and LF gain controls were interchanged, this would almost be the author's ideal receiver for left handed operators

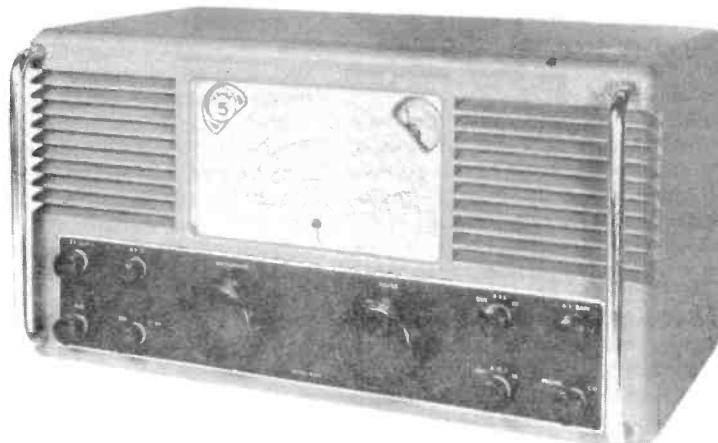

The Eddystone 504 receiver of 1948. This had a large, easily read dial which could be read using peripheral vision only. (Photo courtesy Eddystone Radio)

It would appear, therefore, that the optimum would be a combination of both techniques – a large, well lit analogue dial with a digital readout window of reasonable size for when maximum accuracy is required.

With memories of the beautiful mechanical (and highly expensive) dials of yesteryear, the reader may well ask how such a dial could work in conjunction with modern synthesised techniques where the tuning control merely operates an optical encoder. The answer is that there is no necessity for the dial to be mechanical. It should not be beyond the capability of major manufacturers to construct an LED or LCD bar scale of adequate length which would be both compatible with digital techniques and meet all the other requirements for an analogue scale.

The positioning of the frequency readout is of prime importance, for not only does this provide essential information, it also contributes considerably to the aesthetic appearance of the equipment and consequent sales appeal.

For maximum visibility it must be positioned, as are most readouts, as high as possible on the panel. However, in operation, most are positioned towards the rear of the operating bench, with the operator's eyes located some 15 inches above the operating bench and 18 inches to two feet distant from the dial. The operator is therefore looking down on the readout and in consequence, for maximum visibility and to minimise extraneous reflections, the readout should be angled back such that it is at right angles to the line of sight from the eye. As manufacturers cannot possibly allow for every combination of operator position and bench depth, I would suggest that an angle of 30 degrees would be a reasonable compromise.

The tuning control

In modern equipment the tuning control may be: a rotary knob; up/down frequency incrementing buttons on either microphone or panel; a keypad for entering the required frequency or almost any combination of these. In addition, equipment not including a keypad will have a (usually) rotary band change switch. The bandchange switch or keypad will, in normal operation, be used perhaps only once or twice per hour, so the positioning on the panel will be non-critical.

However, in contrast to this, the main tuning mechanism will be in almost constant use and the form of the control and its position will be of major importance in minimising fatigue.

If a hand held microphone is in use, frequency incrementing buttons located on the microphone would probably be the most convenient, but if the tuning controls are mounted on the panel, consideration must be given to the most ergonomic way in which the equipment can be operated. Consider the case of a right-handed operator. During reception periods his right hand will be occupied in

writing down the content of the received message. Should any minor adjustment of receiver gain or frequency be necessary, these will have to be made with his (or her) left hand. If during these adjustments, the left hand is not to impede the right hand in its task, then these controls must be located towards the left hand side of the receiver.

During periods of transmission, the right hand may be either operating the key or making brief notes of what he (or she) is saying. However, it is unlikely that at this time any adjustment to the transmitter controls will be necessary and in consequence, from this aspect, the position of these controls will be of little importance.

The use of panel incremental frequency buttons is certain to be awkward, for, due to the relative lengths of the

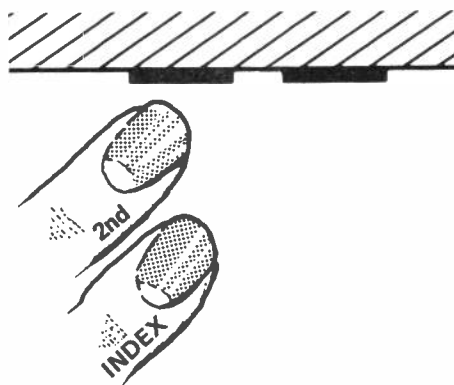

Why panel mounted frequency incrementing buttons will always be awkward to operate

index and second fingers and the need to rotate the wrist, I can see no way in which they can rest comfortably on such controls on a vertical or near vertical-panel. The consequence is that the tuning knob must stay with us a little longer. This must be of adequate size and free turning, for if it is too small or in any way stiff to operate, it will be necessary to grip the knob to achieve rotation – an effort which in a long operating session can add noticeably to fatigue. Even with the most silky controls, it will be necessary to provide a knob of sufficient diameter such that it may be rotated easily merely by the pressure of the weight of the finger on the rim. I would suggest that to meet this requirement, a knob of not less than two inches diameter would be necessary.

With such smooth control, there is no necessity to position the knob so that it may be handled all around its periphery; in fact I would suggest that fatigue could be reduced further by mounting a projection in front of the receiver, covering the lower half of the knob and extended as a rest for the remaining fingers.

In a transceiver in which a 'Receiver Incremental Tune' control is fitted, the same criteria applies to this control as to the main tuning. However, to save space there seems no reason why these two knobs should not be mounted concen-

trically with one of slightly smaller diameter than the other.

A final useful addition to the tuning assembly (and possibly essential if the main tune and RIT are concentric) would be a main tuning lock to avert accidental mistuning. In a mechanically tuned system this could take the form of a friction device or clutch but in digital systems it need merely disable the optical encoder output.

The gain controls

Most equipment have two gain controls: radio frequency gain and audio frequency gain. Although an automatic gain control system is also fitted, most operators find that it is advantageous to carefully control the RF gain as this can dramatically improve reception in bad band conditions. In contrast, once an appropriate audio level has been selected, this gain control need hardly be adjusted. For these reasons, therefore, the RF gain control should be on the left hand side of the receiver for the right handed operator, whilst the location of the audio frequency gain is in no way critical.

Preselector control

The preselector tune control is used to resonate the preselector tuning on the incoming signal. However, the tuning 'peak' is relatively broad and readjustment will only be necessary during wide frequency excursions. Although it would be preferable to have this control positioned near to the main tuning, it is by no means necessary.

No mention has yet been made of the position of the bandswitch, mode, bandwidth, etc. These are rarely varied during an operating session and in consequence, from the operating fatigue point of view, are non-critical. They may therefore be positioned to meet other parameters.

Transmitter controls

The transmitter controls on a transceiver are usually: microphone gain, processing level, power level and power amplifier tune and load. All switching concerned with the transmitter is ganged with the appropriate receiver control. Except during wide frequency excursions, when the PA tune may need slight attention, little adjustment is necessary to any of these after initial setting. The position of these controls may therefore be considered to be non-critical provided that they are positioned such that during adjustment the hand or wrist does not obstruct sight of the tuning meter.

Location of headphones, key and microphone sockets; the main requirement for the positioning of these is to ensure, as far as possible, that the attached leads do not obstruct the operating bench. During R/T transmission, the right hand will be occupied recording information or filling in the station log, thus the microphone will, by necessity, be held in the left

ON THE FACE OF IT

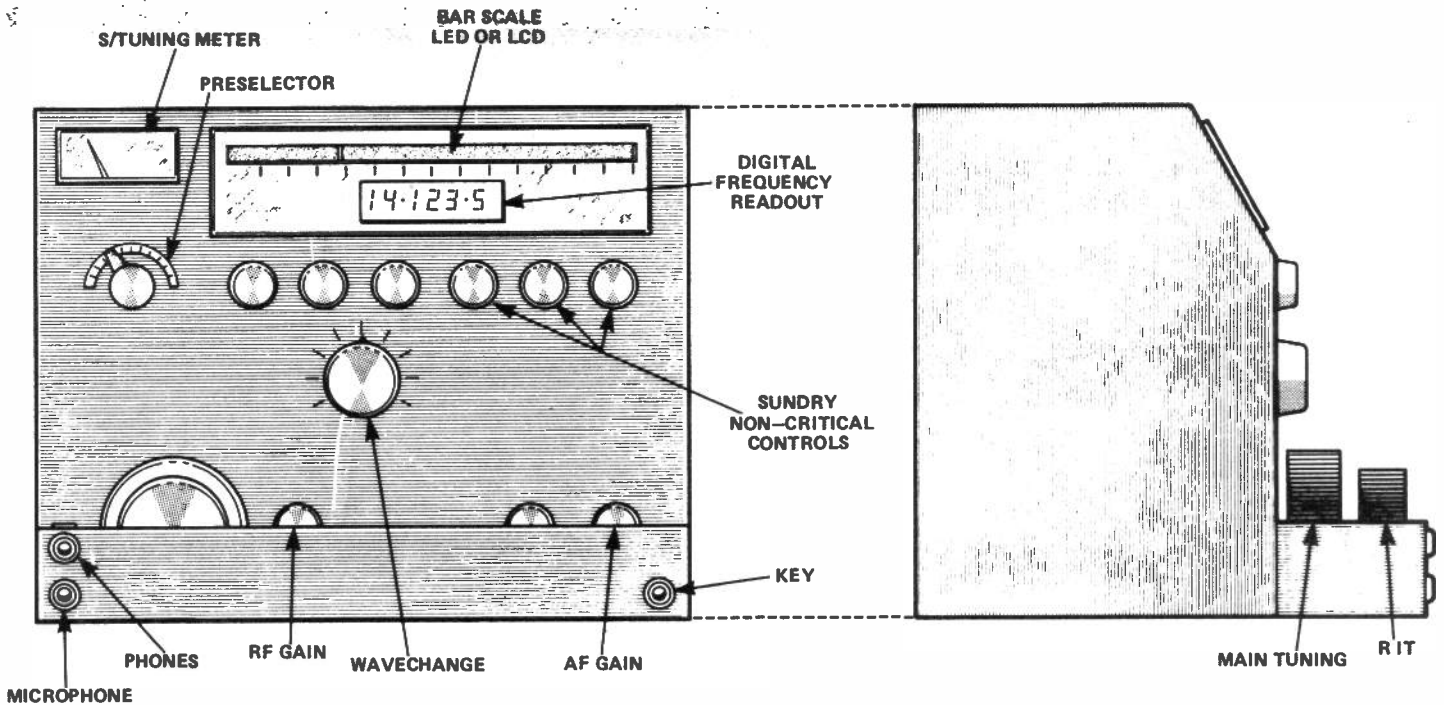

A panel layout for a right handed operator based on the suggestions made in this article

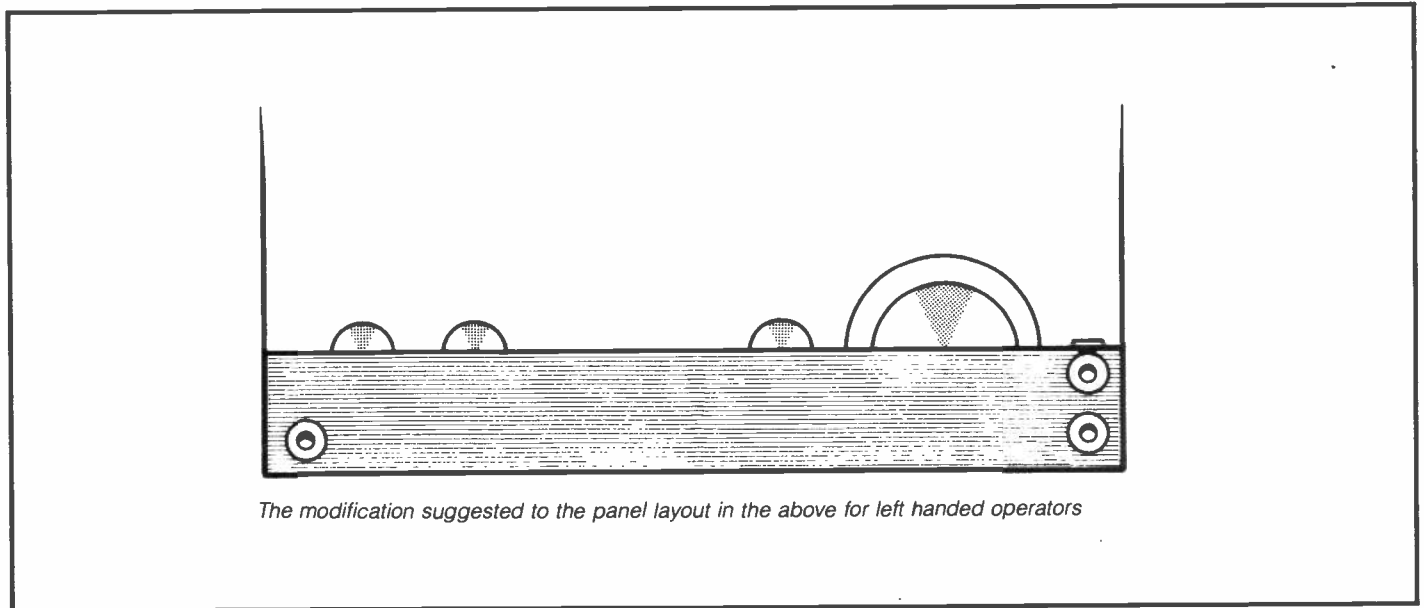

The modification suggested to the panel layout in the above for left handed operators

hand. The microphone socket should therefore be located on the left hand side of the equipment.

The headphone socket should be similarly placed so that the lead does not obstruct the right hand. However, it would be advantageous if a further parallel socket could be fitted at the rear of the equipment in order that, in permanent installations, this could be extended to a bench edge socket. The key will (obviously) be operated by the right hand, thus setting the position of the associated socket to minimise lead length. In permanent installations an additional socket at the rear of the equipment may also prove useful.

The left handed operator

Throughout this article it has been assumed that the operator is right handed. Unfortunately though, a very high proportion (perhaps approaching 40%) are not and they would find that the ideas suggested would act for maximum operating inconvenience. It would therefore be necessary to design the equipment in both left and right handed versions. Despite what may be thought, this should not be an insuperable difficulty, for many controls could remain in the same location whilst most of those whose position is critical, such as the optical encoders or gain controls, are of such a nature that they could be placed

in any position behind the fascia. With a little ingenuity, it should be possible for manufacturers to produce both left handed and right handed versions of the same equipment, even though these would not be mirror images.

Postscript

In this article, I have tried to make an argument for a rethink in the design of equipment front panels – an aspect of design which seems to have remained static for 40 years or more. Even if the reader considers the foregoing to be nonsense, provided that he also asks himself why it is, my object has been achieved.

ARROW

... Give us a ring
Tel: 0245 381673 381626

STOP PRESS NEWS!
ARROW HAVE MOVED TO LARGER PREMISES:
5 The Street, Hatfield Peverel
Nr. Chelmsford, Essex.
(On Main A12 Trunk Road – Own car park)

CHOICE

When you are tempted to a new rig you owe it to yourself to go to a store where you can see the competing models. It doesn't make sense to travel 100 miles or more to see one brand. ARROW STOCK YAESU, TRIO/KENWOOD & ICOM.

COME AND TRY THEM SIDE BY SIDE

HAVE YOU TRIED & COMPARED 2M HANDHELDS IN YOUR LOCAL DEALER?

ARROW HAVE: FT208R TR2500 LS20XE C110/C2E for you to try, together with all accessories plus the 70cm version. (Some more HOT news: Soon the new ICO2E from ICOM, the FT203 from Yaesu and the SK202 from SOMMERKAMP which will really be a winner on price and performance).

DOES YOUR DEALER PUSH HIS CREDIT CARD AT YOU, or does he offer you a choice of payment methods? ARROW will accept ACCESS, BARCLAYCARD, EUROCARD, MASTERCARD, VISA, TRUSTCARD, ALL "CREDITCARD" IN STORE CARDS, and of course we have our own card too. Cheques, Travellers cheques, most major currencies (and we can offer special export schemes saving tax). Or how about interest Free Credit, Normal Hire purchase, No Deposit HP? We will be happy to advise you on the most economic method for your purchase.

EXPERTISE: Everyone claims to have it – we'll rest on our reputation. Not every company can have designed and manufactured transmitters for commercial use including some of the very top names in Show business.

SERVICE: Not just the ability to mend your gear, but a sales system where equipment is tested before despatch, where the sales staff are interested users of the equipment, where we will never refuse to service your equipment "because you didn't buy it from us" or suchlike.

PRICE: With 3 store buying power Arrow buy as competitively as any dealer – bulk buying is the answer to our terrific price deals. **WE BUY BIG – RING US FOR PRICE!!!**

3 UK Locations Nationwide or Mail Order
Peter G3LST or Bob G6AKL at CHELMSFORD
SCOTLAND: Bill G6NHJ 041 339 6445
WALES: John G7BUZL 0248 714657



"PHONE YOUR ORDER FOR TODAY'S
DESPATCH ALL WE NEED IS YOUR
OR NUMBER, SMALL
SPARES – PLUGS – AERIALS – PHONE
FOR A QUOTE FOR THAT NEW RIG!"

OPEN 5 DAYS A WEEK. CLOSED THURSDAYS

C M HOWES Communications

139 HIGHVIEW, VIGO, MEOPHAM
KENT DA13 0UT
Fairseat (0732) 823129

Home construction made easy

Enjoy the satisfaction of building your own equipment with one of our kits. We make construction a pleasure, the right parts, the right performance, and very good instructions. Our kits are designed to be easy to build, even for those with no previous experience of this absorbing side of the hobby.

All kits come complete with all board mounted components, a drilled, tinned, PCB that has the component locations screen printed on it for straightforward assembly (see example below), and full instructions that include a parts list and circuit diagram. The parts list in a HOWES kit details the colour code/markings information for each individual component.

Choose a worthwhile project from our expanding range:-

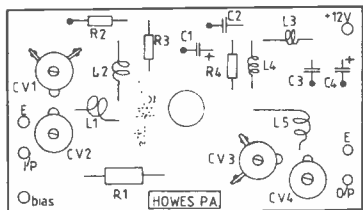

PA Series Linear Amplifiers

These linear amplifiers have been designed for use with the popular portable and hand-held 2 meter rigs. There are two versions available at the moment, one or other will probably suit your radio.

PA2/15 Up to 15W output with a gain of approx 10dB, for hand-helds with up to 1½W output and 1W SSB portables. **Kit £18.90, assembled PCB £22.80.**

PA2/30 Up to 30W output, gain approx 8dB. This unit has been designed to put out a 'clean', narrow signal on SSB with rigs such as the FT290 and IC202. We have not gone all-out for maximum gain, this unit will have plenty of power in hand with these popular rigs, there are too many small 'linears' on the market that try to get too much gain and power out of a 25W transistor with the resultant nasty effects for other band users. Build a linear that will put out a signal you will be proud of. **Kit £22.90, assembled PCB £26.90.** Both the above come complete with preformed inductors, so there is no problem in trying to decipher coil winding instructions! An RF or PTT operated switching unit for the above is available, type **CO1** this uses low-cost relays to give reasonable performance at a sensible price. **Kit £8.90, assembled PCB £11.90.** Yes, there is provision for connecting a pre-amp if you wish.

AP3 Automatic Speech Processor. Kit £14.80, assembled PCB £19.80 This is the excellent processor described by Dave, G4KQH in the September 83 edition of 'Ham Radio Today'. We have sold hundreds and hundreds of these and many customers have come back to buy a second, third or even fourth unit for use with their other rigs. The AP3 uses a combination of compression, clipping, and response tailoring to give you a really 'punchy' signal that enables you to make contacts that may not be possible without it. The unit will run from your rigs' 12V supply or a 9V battery, it turns itself off automatically when not in use, so saving batteries. Clipping level is selectable in 6dB steps, no other operational controls to fiddle with, operation is fully automatic, speak as loudly or quietly as you like, the AP3 will adjust itself. Suitable for high and low impedance mics.

DcRx DIRECT CONVERSION COMMUNICATIONS RECEIVER, Kit £13.95, built £18.90 DcRx is a low cost, easy to build amateur band receiver, designed so that a newcomer to the hobby can build a shortwave receiver with the minimum of trouble. The DcRx is also proving to be very popular with experienced QRP operators.

Two versions of the DcRx are available at the moment, one covering 10 or 14 MHz, and one covering 3.5MHz (80M). The kit comes complete with ready-wound coils and requires very little alignment. You will be amazed how well a simple receiver can work, don't be put off by the low price, this set performs well and is capable of world-wide reception. The DcRx runs from a nominal 12V supply and will drive a loudspeaker or headphones.

Modes: SSB and CW. PCB size 77 by 77 by 25mm approx.

XM1 CRYSTAL CONTROLLED FREQUENCY MARKER Kit £15.60, assembled £19.60. A really useful piece of test equipment, besides helping you meet amateur licence frequency measurement requirements. Our kit has a built in voltage stabiliser to maintain accuracy over a wide voltage range (8 to 24V DC). The XM1 provides marker outputs at 1MHz, 100kHz, 25kHz and 10kHz, these are usable up to 70cm, unlike some CMOS designs. The XM1 has a pulsed ident facility for distinguishing markers from off-air signals on crowded bands. This facility is very useful, and much preferable to tone modulated markers, whose bandwidth becomes larger as frequency increases. If you are going to invest in a piece of test equipment, it pays to go for a good quality design, the XM1 provides this.

ST2 CW SIDE-TONE UNIT or PRACTICE OSCILLATOR Kit £6.20, built £8.90. The ST2 provides a nice sounding sinewave note, either from your key or from the output of your TX by RF sensing. This design should not be confused with cheap and nasty squarewave circuits so common in horrible sounding practice units. We think side-tone, or a practice oscillator should sound like a good off-air signal received on a quality set. Output is up to approx. 1W at 800Hz, a volume control is included.

An SAE will bring you further information on any item.
P&P charge is 60p, please add this to your total order value.
We attempt to keep everything in stock and delivery to within 7 days, but we do sometimes get caught out, no matter how hard we try!



RSGB NATIONAL CONVENTION 1984



As you probably know by now, the 1984 RSGB National Convention will be held on the 28-29 April in Hall 3a of the National Exhibition Centre at Birmingham. It opens at 10am each morning, and entry will cost £2 (children £1).

The NEC is of course well provided with road, rail and air links and, once there, will offer you a wide range of facilities.

What's on

This year's convention promises to be the largest of its kind ever held in the UK, with twice as many exhibitors as last year covering an area of almost 6,000 sq m. As well as the major exhibitors, there will be in excess of 150 tables in the 'flea' market and a series of lectures and discussions on a variety of topics.

There is a total of 58 major exhibitors participating in this year's exhibition. The RSGB will, of course, be there in strength with their complete range of books and other useful accessories on sale. Various other clubs covering all aspects of the hobby will be represented.

Among the major suppliers of equipment, both South Midlands Communications and Lowe Electronics promise something new, while Wood and Douglas will be there with their full range of popular construction kits. Other exhibitors worth visiting will be Microwave Modules and Datong.

Adjacent to the main exhibition will be the 'flea' market, bigger than ever this year with over 150 tables. This highly popular area is always a happy hunting-ground for anyone chasing a bargain, and a fascinating array of new and secondhand items is bound to be on sale.

This year's programme of talks and forums is especially interesting. It includes a one-hour talk for beginners, entitled 'An introduction to amateur radio', given on both days in the morning and afternoon, by the RSGB Education Committee. In addition there will be a discussion with RAE tutors on the Saturday afternoon, a Raynet symposium, talks on VHF and microwaves and an HF Convention on Saturday, including a home-constructors forum organised by the G-QRP Club. Certainly there should be something for everyone in these sessions, for which a finalised schedule will be available at the NEC.

Getting there

For those driving to the exhibition, the NEC is well served by the motorway system and has direct access to major roads for all parts of the country. On arrival, you will find free parking for over 15,000 cars, with a free 'shuttle' bus

providing a rapid link to the main hall.

For those preferring to travel by rail, Birmingham International station is directly connected to the NEC by covered walkways and escalators. The journey from London (Euston) takes only 80 minutes.

The RSGB is offering special fares for members, and those wishing to take advantage of these should see the April issue of *Rad Comm*.

In addition, Birmingham Airport is adjacent to the NEC, with five flights daily from Heathrow and scheduled flights to all the major cities of Europe.

For the family

If you're thinking of taking your family along and want to keep them occupied, Birmingham's New Street station is only 10 minutes away by rail, with the city's

shopping and entertainment facilities at their disposal. Alternatively, the city of Coventry with its magnificent cathedral is also only 10 minutes by rail from Birmingham International.

Facilities

For those with long journeys to make, and for those who wish to take in both days of the convention, a full range of accommodation, from bed and breakfast to hotels, is available. Most convenient perhaps is the Metropolitan Hotel, which forms part of the NEC complex.

Inside the NEC itself, you will find full bar and restaurant facilities, and with a considerable increase in seating this year, there seems to be every chance that, whatever your needs, your visit to the 1984 RSGB National Convention will be a comfortable and enjoyable one.

HOW TO GET THERE

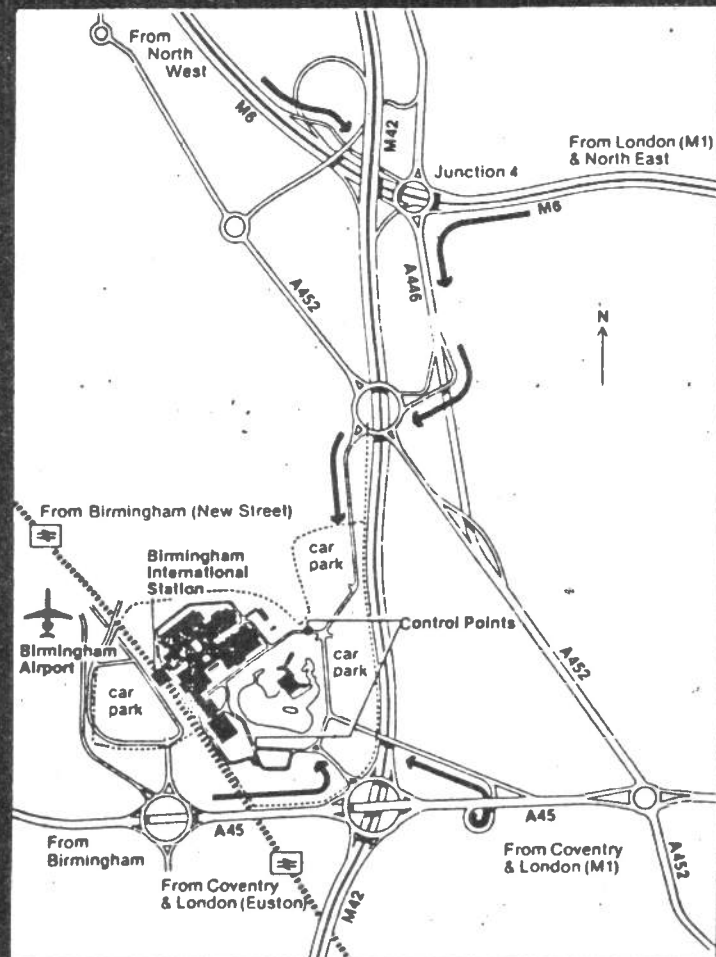

ON THE BEAM

VHF UHF MICROWAVE

By Glen Ross G8MWR
 News and topics of interest for the
 bands above 50MHz

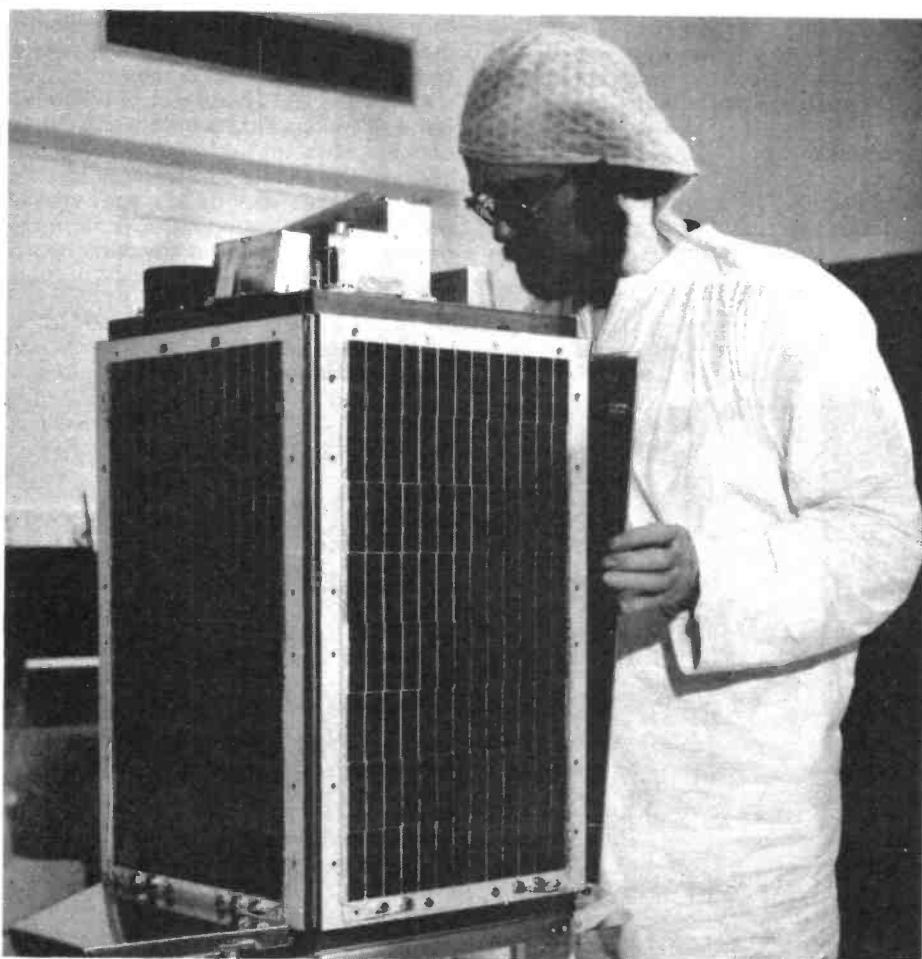

The good news is that UOSAT 'B' was launched with no problems. Strong signals were received during the early orbits that same evening and it looked as though everything was going well. This continued for the first few days but a malfunction occurred on the ninth day aloft and signals suddenly ceased to arrive.

There had been some problems with the first UOSAT when the system managed to block itself by switching on the 145MHz and 430MHz transmitters at the same time. This caused all sorts of problems and was eventually overcome only by the use of prodigious amounts of power being thrown at it from the USA.

As far as I know no-one has ever disclosed just how much was used, but rumours of megawatts ERP have been circulating!

Most of the electronics on the new machine are completely redesigned and it is fairly certain that such a thing could not happen again. As an extra precaution the unit is now fitted with what amounts to a 'reset' button. To put it into computer terms (and after all that is what we are dealing with), if the machine goes into a 'loop' this can only continue for a maximum of twenty one days before the machine resets itself. This will only happen if there is no response to the commands sent to it by the ground

stations. Whilst it was available the signal strength from the satellite was excellent and the timing of the passes, in the morning and evening, was a great improvement over the early afternoon and early morning times of UOSAT A.

The other major advantage is that, because the bird is flying at a greater height, it is available for much longer on each pass.

The repeater scene

Do they QSL, we asked in the last issue? The reply came from Chris Lorek of the GB3PI group with the minimum of delay. Yes they do! But not in the same sense that we spoke about. With his letter he enclosed a sample of the QSL cards of each repeater in the group; the design is most attractive and would grace any collection. They are sent to those who provide a reception report on the repeater signals. They do NOT confirm a contact in the usual manner.

What of the Cambridge group's repeaters? GB3PY in common with several more repeaters is awaiting permission for a site change. When it does move, the new aerial system will be four dipoles spaced around the mast to give omnidirectional radiation. The soak testing of the 23cm unit GB3PS has been resumed following the replacement of the UHF driver system which was giving a wide band output and would not have been welcome if it had appeared on the air. This unit will have a 'Digitalker' system to give you information about your signal.

G6KZG has been doing some clever work to get it to say useful things. 'Overdeviating' is not in its wordbank but 'You; are; over; D; V; eighteen' comes pretty close! Another example of true amateur genius. GB3PT (the first RTTY repeater) has been going strong for five years now. Long term plans for this one include an electronic mailbox facility and the possibility of using it for data transmission. This seems a sensible idea to implement and it is interesting to see that BARTG have now reorganised their magazine and are including both data and AMTOR as regular features.

The South West Hertfordshire group

also have a 23cm repeater on the stocks (GB3BH 1291 Rx, 1297 Tx). Their 70cm unit, GB3HR, has recently been installed on a new site at Stanmore. There were some on-site problems originally but these have now been cleared and very good signals are being reported from around the area. They also provide a 3cm beacon GB3SWH on 10.386GHz which is located at Bushey Heath. More information on these from G4KUJ.

Further north we arrive at Leamington Spa and GB3YJ. This is another one that is waiting for a site move. A lot of work has been done on this repeater over the last few months to clear the various gremlins that had infested it for some time and it is now producing superb results. This is one of the repeaters that does not suffer from the attentions of the 'Yobbo' element. Over in Leicester we hear rumblings of the first dedicated data repeater to come on the air. We would like some more information on this one please, especially on *how* you use it. There is also a proposal for a 10 metre repeater and if this is obtained the group will have a repeater or beacon on nearly all bands from 10 metres to 10GHz and have voice, data, RTTY and TV facilities on offer.

Space shuttle

Those of you who actually heard W5LFL, and not some idiot who thought he would cause some confusion by replaying tape recordings of him (and there were plenty of those about), can get a nice QSL if they send a report to ARRL, 225 Main Street, Newington, CT, 06111, USA.

Bits and bobs

You still have time to get in your request for a 50MHz permit. These should be sent to G3WSN and not direct to the RSGB. Speaking of the RSGB, they have undertaken the mammoth task of judging this year's IARU VHF contest. Something like 2,000 entries are expected! New versions of the French class A and B licence structure have been announced but no details are yet available.

After a long absence from the bands the Polish stations are again active. This is good news, arriving as it does, at the start of the Sporadic-E season. The total number of amateur licencees in Great Britain now stands at well over 50,000. Class B now outnumber class A. Unless you live close to a large town you may well wonder where they all are, as activity seems to be hitting an all-time low in many areas with most people seeming to use the bands simply as a means of personal communication with one or two friends. The art of calling CQ on two metre FM seems to be a dying one. After a series of court appearances over a period of three years, an American ex-amateur has been sentenced to 18 months in jail for, amongst other things, transmitting obscenities and illegal operation. In a way, it would be nice if it could happen over here.

Cable TV systems

The new cable TV networks which are gradually being introduced have caused some concern due to the frequencies involved in the distribution network. The first confirmation of these fears came to light in Milton Keynes where the local system was run on a frequency, would you believe, in the two metre band. Strong signals appeared in the band, as was expected, and these were traced to radiation from distribution systems which were enclosed in *plastic* cases. Presumably no one had told them about the screening effects of metal.

Representations were made to the authorities and, after some work had been carried out, the problem was stated to have been cured. The bad news was that it did not work out to be as simple as that and the problem still plagued many of the local amateurs. Strong words were spoken and the powers that be said that if the problem could not be solved within a few days the whole system would be switched off. Knowing our luck this was hard to believe but *it really happened*. At last we have had a decision in our favour. Whether this will stand for future problems will remain to be seen, but all credit to those who brought about this result. As the system spreads there is little doubt that more people will find themselves facing similar problems. If it happens to you, then waste no time in informing the RSGB as well as the authorities. Let's keep on top of this one while we have the chance.

Parchment

One of the more pleasant sides of the hobby is the chasing of certificates and awards. Some people take this very seriously, whilst others apply for them simply because they discover that they have enough cards in the shoebox to qualify for something. All this leads us to news of some new awards that has just reached us. These are available from Holland.

PACC-VHF award: for working 100 Dutch stations on two metres.

PACC-UHF award: The same but for 70cm.

Both of these can be updated to 900 stations. At 1000 stations you qualify for a 'Supreme' award. **VHF-6** and **UHF-6** awards are for working six countries on 2 and 70 with stickers to 50 countries on two and 30 countries on 70cm. On the higher bands the **PACC-SHF** requires 100 stations on 23cm and the **SHF-6** needs six countries on 1296 MHz. Similar awards are available for operation on 2.3 and 3.4GHz. Details of all these and more can be obtained from J Lourens, Keeweer 13, 6862 CD Oosterbeek, Holland.

From the Microwave Society we have news of their new awards for operation on 10GHz and above. These will be issued for contacts over distances of more than 50Kms on 10GHz and 25Kms on 24GHz. The award can be up-graded in steps of 25Kms on both bands. All contacts must have been made since the

1st January 1984, so giving everyone a clean start. Details from the society at 81 Ringwood Highway, Coventry.

Microwave cumulatives

This seasons 10GHz cumulative contests are being held on the following dates: 13th May, 17th June, 15th July, 12th August and 16th September. Some ideas which were put forward by members of the Microwave Society have been incorporated into this year's contest. For the first time, scoring of the FM and SSB sections will be separated. Scoring contacts can be made on both modes between the same stations and cross mode contacts also count for points but can only be scored as one mode. This should encourage a lot more people who have SSB equipment to make use of it.

Problem in the past has been that many people do not use SSB on the grounds that most paths available can be worked using FM. There will be a lot of newcomers to the band this season and a good turn out of the 'regulars' for the first cumulative would give them a lot of encouragement. See you there?

Anti-social

There is an idea about that the use of an omni-directional aerial is anti-social, due to the fact that you are spreading the RF around in all directions equally poorly, but is this really the case? A little thought will show that it is not. Let us suppose that, for no other reason than to alleviate this 'problem', you invest in a beam. What happens? Your signal, which originally went in all directions, is now directed in front of the beam. Your neighbours behind and to the side of you now suffer less from your signal but what about those on the beam? Your signal within the distance you previously covered is now five to ten times stronger than it was and people living much farther away are now getting signal levels that cause problems! A certain amount of power is produced and, whether you spray it around or beam it in one direction, the footprint of the signal covers the same area. There are, however, many good reasons for using a beam and if you can get one up in the air, even if it is only four or five elements long, you will be rewarded with signals from distances that you could manage before only under lift conditions.

Safety

Two points to bear in mind when organising your gear. Please fit a mains isolating switch of some sort. Make sure it is easily accessible and that your family know how to operate it. It could save you from getting killed. Secondly, clambering around on roofs is not something to undertake lightly. When you are up there fitting the aerials do take care, and always try to have someone with you. How is the leg mending, Paul? Finally, thanks for all your letters containing news and comments of interest. Keep sending them to me at 81, Ringwood Highway, Coventry, CV2 2GT.

HATELY ANTENNA TECHNOLOGY

GM3HAT

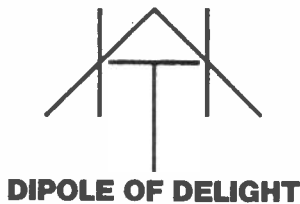

GM3HAT/A

DIPOLE OF DELIGHT

The DIPOLE OF DELIGHT is the familiar name for the new type of antenna with a really effective balance to unbalance (BALUN) feed system recently invented by GM3HAT and now being patented in the major industrial countries.

This antenna has created a lot of interest in amateur and professional circles because practical trials of early production models verify the expected advantages this outstanding antenna possesses attributable to its:-

1. built-in lightweight capacitive BALUN card.
2. ability to achieve multi-resonant behaviour when constructed with multiple wires.
3. rugged behaviour and 800W transmit capability due to there being NO TRAPS.
4. wide bandwidth so that NO ANTENNA TUNER is required.
5. exceptional rejection of local interference such as machine hash, TV timebase noise, and computer pulses.

VERSIONS AVAILABLE

There are presently available seven versions made for the international amateur HF bands, and more will follow. The models are designated by a code which indicates the frequency band (or bands) of operation, defined as being the band across which the antenna has less than SWR of 1.5 to 1. The length of the DD is a full space half-wave at the lowest frequency of operation, and the antenna is fully protected against the weather including a drip-protected SO239 socket (UHF) for connection of the 50 ohm coax required. Due to variability of site length etc, coax is not supplied, but the 5mm types such as URM 76 or 43 are recommended. Larger 10mm cables (such as URM67 and RG8U) can be supported if the antenna is used as an inverted V, or if held by reduced tension. Each antenna is supplied with a helpful USER'S INSTRUCTION SHEET describing the best way to support a DD in any open or cluttered situation, as well as giving hints on how to make a low cost and inconspicuous fixed YAGI with gain at high angles for one hop paths, and how to use an ATU to make the DD work on lower amateur frequencies as a 'T' against Earth.

ECONOMIC and OPERATIONAL ADVANTAGE

As there is no ATU needed, a DD is an ideal first antenna. The DD is superb for amateurs who have, or intend getting, a modern semi-conductor 'NO-TUNE' PA or Linear. To change bands, flick the switch, listen on frequency and speak. Great in a contest. The wide bandwidths allow the user to make contacts away from the over-crowded central frequencies to which trap and coil-resonated antennas are tuned.

In regard to TVI the particular circumstances determine the outcome. The DD is so efficient that it will produce amateur field strengths greater than a traditional dipole. But by virtue of its excellent balance, a horizontally slung DD will produce considerable less vertical induction field (which links to TV downleads) than would an old style coax fed dipole with its unbalance current flowing down the outside of the screen. A DD has a genuine RF Earth point at its centre. Further details on SWR values and specimen input impedance plots on SMITH CHARTS may be obtained for the asking (send SAE or IRC please).

AVAILABLE VERSIONS AND PRICES

The UK Price includes Packing Post and VAT (on 15% at time of drafting).

The DX Price includes Packing Air Mail Post, and currency exchange. Cheque may be written in ANY CURRENCY, equivalent on the day of signature to the amount in £ Sterling at published middle rate.

SPECIFY CAREFULLY VERSION REQUIRED

	UK	DX
DD 7/14/21 length 21m (69ft)	£56.46	£56.00
DD 10/18/24 length 15m (50ft)	£56.46	£56.00
DD 14/21/28L length 10.7m (36ft)	£46.75	£46.00
DD 7/14/21/28L length 21m (69ft)	£58.50	£58.00
DDM 14 length 10.7m (36ft)	£15.98	£15.28
DDM 21 length 7m (24ft)	£11.64	£11.50
DDM 28 length 5.8m (19ft)	£11.64	£11.50

(28L antennas operate in the lower half of the band only, unless an ATU is used)
Money back GUARANTEE if purchaser not satisfied if antenna returned undamaged within one month.

HATELY ANTENNA TECHNOLOGY

1 Kenfield Place, ABERDEEN AB1 7UW
SCOTLAND, UK

Proprietor:- Maurice C Hately, B Sc (Eng), M Sc, MIEE, Chartered Electrical Engineer, (GM3HAT)

(NB We will be Exhibiting at the Anglo-Scottish Rally at Tait Hall, Kelso 6th May)

THE GAMMA TWIN 2 METRE FOLDED 1/2 WAVE ANTENNA

Copyright Gamma Aerial Products 1982

This antenna is based on the very popular and successful "SLIM JIM" design.

The GAMMA TWIN has the following unique features:

★ VERY LOW ANGLE OF RADIATION.

★ ADJUSTABLE RADIATOR.
(140—150 MHz)

★ COMPLETELY WEATHERPROOF CONNECTING BOX

★ VERTICAL FIX DIRECTLY TO MAST

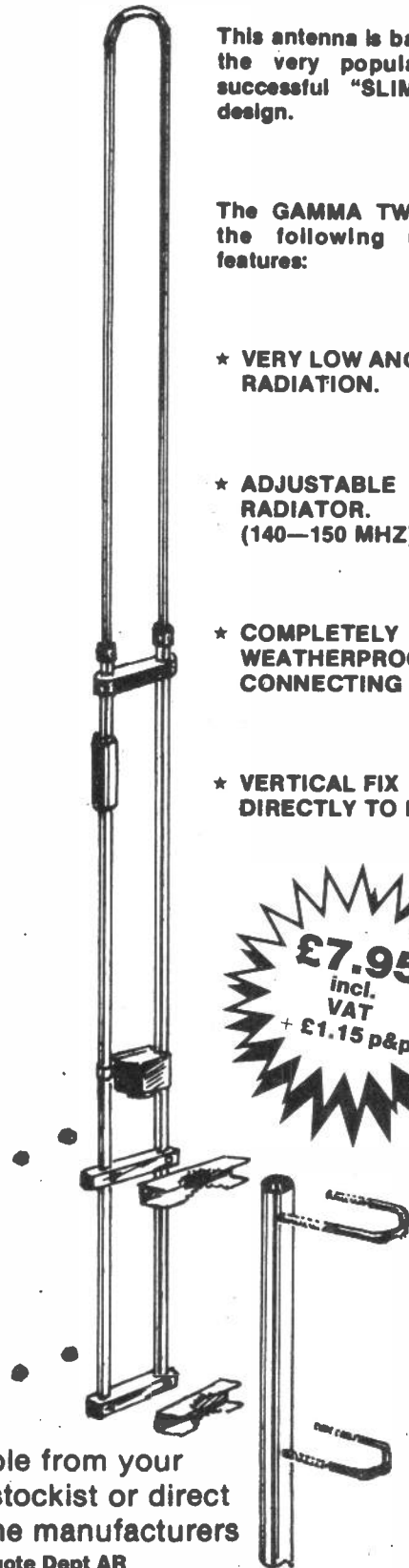

Available from your usual stockist or direct from the manufacturers

Please quote Dept AR

Gamma Aerial Products

MANUFACTURERS OF AMATEUR RADIO & CB ANTENNA

BALDS LANE, LYE, STOURBRIDGE

WEST MIDLANDS LYE (0384) 891132/891474

TRADE ENQUIRIES WELCOME



John D Heys G3BDQ builds this compact top band AM transmitter using easy to obtain components, and ideas from easy to obtain sources! The usual acknowledgements to various RSGB publications...

Making TINY TIM TALK!!

This small and easy to build transmitter was first put on the air on Christmas morning, so when the grey matter later set about thinking of a suitable name for it, 'Tiny Tim' sprang to mind as the only really apt title. On that morning, before both turkey and pudding were set upon the table and consumed, the 100mW output from the little rig allowed G3BDQ to join the stalwarts who regularly appear on the local Sunday morning Top Band Net.

My QTH is about three miles out from the town centre but the RF from Tiny Tim was enough to put out an S8 to S9 signal when on a good antenna.

The writer is not a professional electronics engineer and has always purloined ideas and snippets of circuitry from a variety of sources and references. This is perhaps the design technique used by most real 'amateurs' and in this instance no apology is made for using standard, and to some extent 'ancient' solid-state circuitry. There is not one single IC within Tiny Tim!

TR4 (Fig 1) operates as a crystal oscillator in a circuit devised by G3YUQ

and later described in Pat Hawker's *Amateur Radio Techniques* (RSGB publication). A two-stage microphone amplifier using BC107Bs is also described in that handbook, and it was originally included in the *RCA Solid-State Hobby Circuits Manual*. This pre-amp drives another BFY51 (TR3) which operates as a modulator using the Choke or Heising method of modulation. This part of the circuit was 'nicked' from the modulation section of an RF (no wires) intercom which had originated in Italy and was being sold in kit form!

Two small pieces of 0.1 inch matrix plain veroboard hold the wiring and the components. No doubt a purist would prefer to design and etch suitable boards on copper-faced laminate but the writer finds that plain board offers him greater scope for 'fiddling' with component values and circuit changes. It takes considerable confidence to etch a board and then assemble a prototype when using an untried circuit arrangement.

The circuit

The original G3YUQ oscillator used a

coil wound on a standard 1/4 inch slugged former but the writer decided to try a toroidally wound inductor using a core salvaged from a scrap computer board (circa 1960?). This core has an outside diameter of 20mm and its characteristics remain a mystery. A suitable core can be found in the Amidon series if the junkbox fails (see parts list). TR4 can be obtained for as little as 20 or 30 pence and if 'pushed' when using a good heatsink may be run with up to 27 volts on its collector. At this voltage it should give about 0.75 watt out. With 12 volts the output lies between 100 and 150mW and the input is almost one watt. The efficiency is never high in an oscillator circuit, but by 'playing' with the tuned circuit, reducing the inductance L and increasing C6 to about 500pF, a better match to the transistor output impedance might be gained. The component values used in the oscillator circuit were chosen because a 200pF compression type capacitor was to hand!

The capacitor C7 makes sure that the circuit will oscillate readily and without it in circuit the setting of C6 seemed rather

TINY TIM

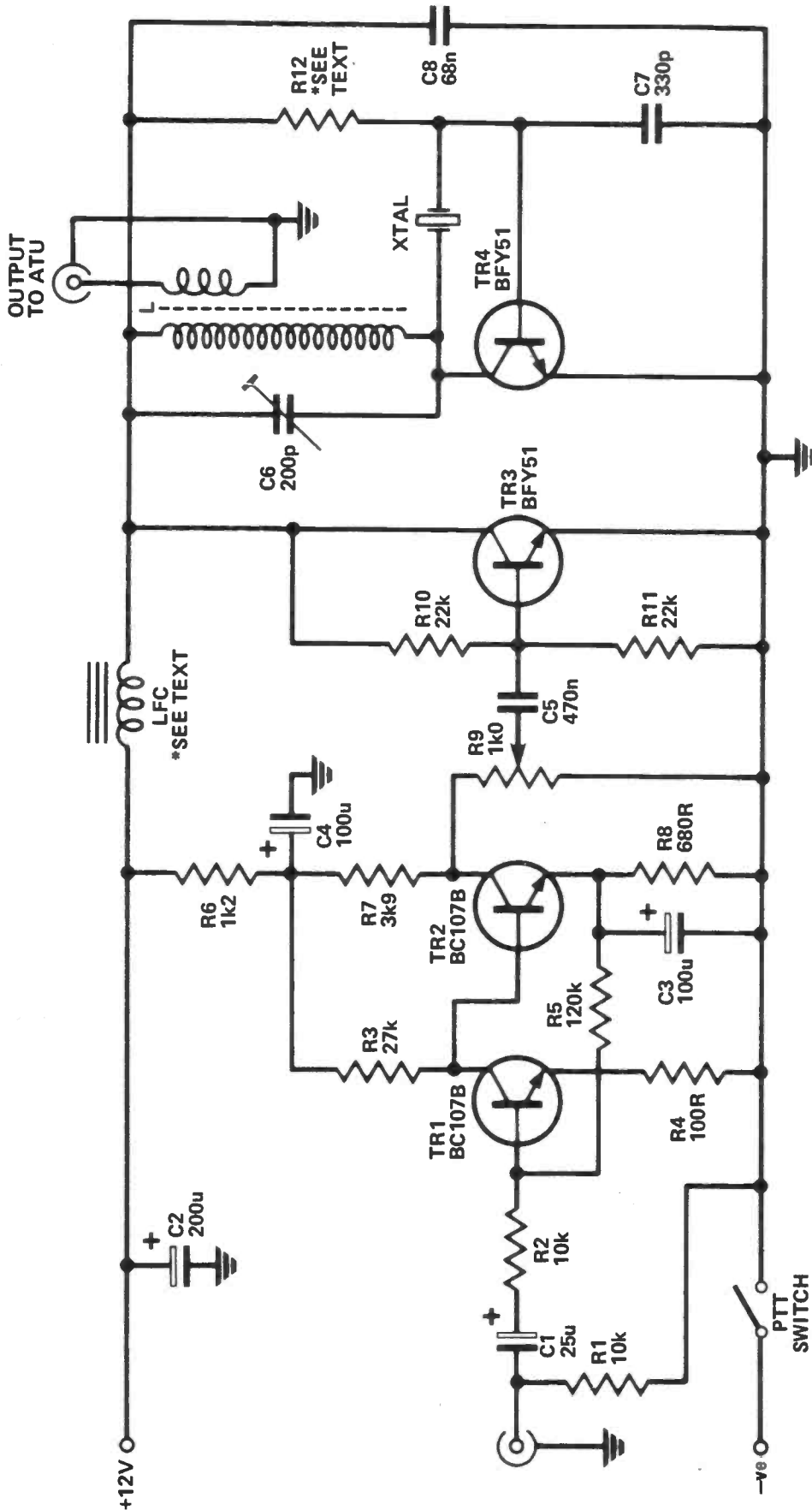

Circuit diagrams of the 'Tiny Tim' AM transmitter. Only four cheap and easily obtainable transistors are used in this circuit.

critical and it was not possible to load up fully into an ATU or dummy load. R12 determines the total transistor dissipation and it is best to at first use a resistor with a value of around 20K ohms. If the oscillator works at a low level using this resistor value then R12 may be reduced in stages until the input power rises to a higher but safe level. In Tiny Tim a 4.7K resistor was the best compromise value but individual BFY51s will have different optimum values for R12. Aim for a resistor which keeps the total input current to the oscillator below 100mA at 12 volts. At this input a clip-on heatsink will be needed.

The AF pre-amp uses cheap transistors costing just pence and it can be driven from most types of dynamic microphone. The writer uses a cheap mike from a CB rig! (see photo). The input resistor R1 suits this particular microphone but it can be changed to work with mikes having a different impedance. A high impedance microphone, say 50K ohms, would work best with an input resistor around 100K, whilst a low impedance type might be best when R1 was as low as 300 ohms. The circuit incorporates some negative feedback and is really quite a hi-fi arrangement. The original RCA circuit employed SK3020 transistors but the humble BC107Bs seem to work satisfactorily.

TR3, the modulator, uses a minimum of components and its base gets its drive via R9, a 1K pot. This pot is a pre-set miniature component and at a pinch could be dispensed with. It is difficult if not impossible to achieve 100 per cent modulation when using choke control and a fixed resistor could be substituted for R9. The choke LFC is just one half of the primary winding of an LT-700 AF transformer. The LT-700 has a total primary impedance of 1.2K ohms and by using only half of this winding (it has a centre tap) the voltage drop to the oscillator and modulator is reduced with no loss in modulation or fall in quality. The modulator BFY51 runs rather warm on long overs and again a heatsink is recommended.

A further advantage in the use of a standard Japanese mike is that such items normally incorporate a PTT switch. This is used in Tiny Tim to switch the negative line to the power supply and could also be used to switch the antenna to Tx or Rx with a relay.

Construction

TR3, TR4 and their associated components are assembled on a 75 x 60mm piece of veroboard. The oscillator should be wired first and then tested. All that is needed for this is a meter to read the current to TR4 and the station receiver tuned to the crystal frequency. A low power flashlight bulb (3.5V 0.15A) may be connected over the output socket and this will prove that some RF is being produced! The receiver 'S' meter will also help in the adjustment of the oscillator. It was found that the tuning of C6 was rather flat and not in any way critical. At

TINY TIM

first a two-turn link coil wound on the earthy end of L was used but later this was increased to four turns with a better power output. It is suggested that as many as six turns might be tried for output coupling. When the value of R12 is being reduced by stages to find the optimum resistance the output will rise until the flashlamp bulb begins to show a red glow.

An ATU is best first roughly tuned using the other station equipment and then final adjustments should be made when the oscillator output of Tiny Tim goes to it. A sensitive RF 'sniffer' using a tuned circuit, diode and microammeter is another useful device to help tuning up. The output is so low that my power meter on its lowest scale (20 watts) did not give any reading so other ways to determine maximum energy must be devised. Don't worry about the SWR! Just tune everything for the most power into the antenna.

Enough space

The actual layout of the parts on the oscillator board is not critical but there must be enough space for the LT-700 and the other modulator components. Much

of the wiring involves just component lead outs and some of the resistors are actually wired under the board. Ensure that the AF gain control is easily adjustable from the top. A single screw through the centre of the board holds it firmly to a stand-off pillar. The toroid is secured to the board with a dab of Holt's 'Clear Weld' epoxy adhesive.

The microphone amplifier is built on a tiny 45 x 45mm square of board. When it is completed a test with the microphone in circuit and a pair of headphones connected to the output (via C5) and earth will quickly demonstrate that no mistakes have been made. At this stage it may be profitable to experiment with the value of R1 and so determine a value for this resistor which best suits the microphone used. When satisfied that all is well the board can be glued into place (see photo) again using Holt's special concoction which seems to set much faster than most 'two-tube' epoxies. The two boards are easily interconnected and a two-wire cable can run out to the power supply which would normally be a standard 12-13.8 volt unit. Tiny Tim has also been used with a PP9 battery but at nine volts the Tx becomes really QRP! A

'surplus' diecast box houses the rig but similar boxes with almost identical dimensions are obtainable from Maplin (Box DCM5007).

The photograph of the inside of Tiny Tim clearly shows the location of the chief components but the heatsinks were removed before the picture was taken. With the exception of the toroid core and the crystal all the parts can be obtained from Messrs Maplin. A copy of their excellent catalogue is advised. It is a source of valuable data and is much more than a mere price list.

Not advised

Many may question the use of AM (ancient modulation?) but on my local Top Band Net everyone uses this mode. Many of the locals have station transceivers which do not cover 160 metres and they are using older valve receivers such as the AR88. AM is not to be advised for other than local working but it is a mode capable of fine copy over a few miles during daylight hours. Get your locals on to Top Band AM for their natter nets and help to reduce the QRM on your VHF Repeater. We don't seem to gather any 'squeakies' on 1950KHz either!

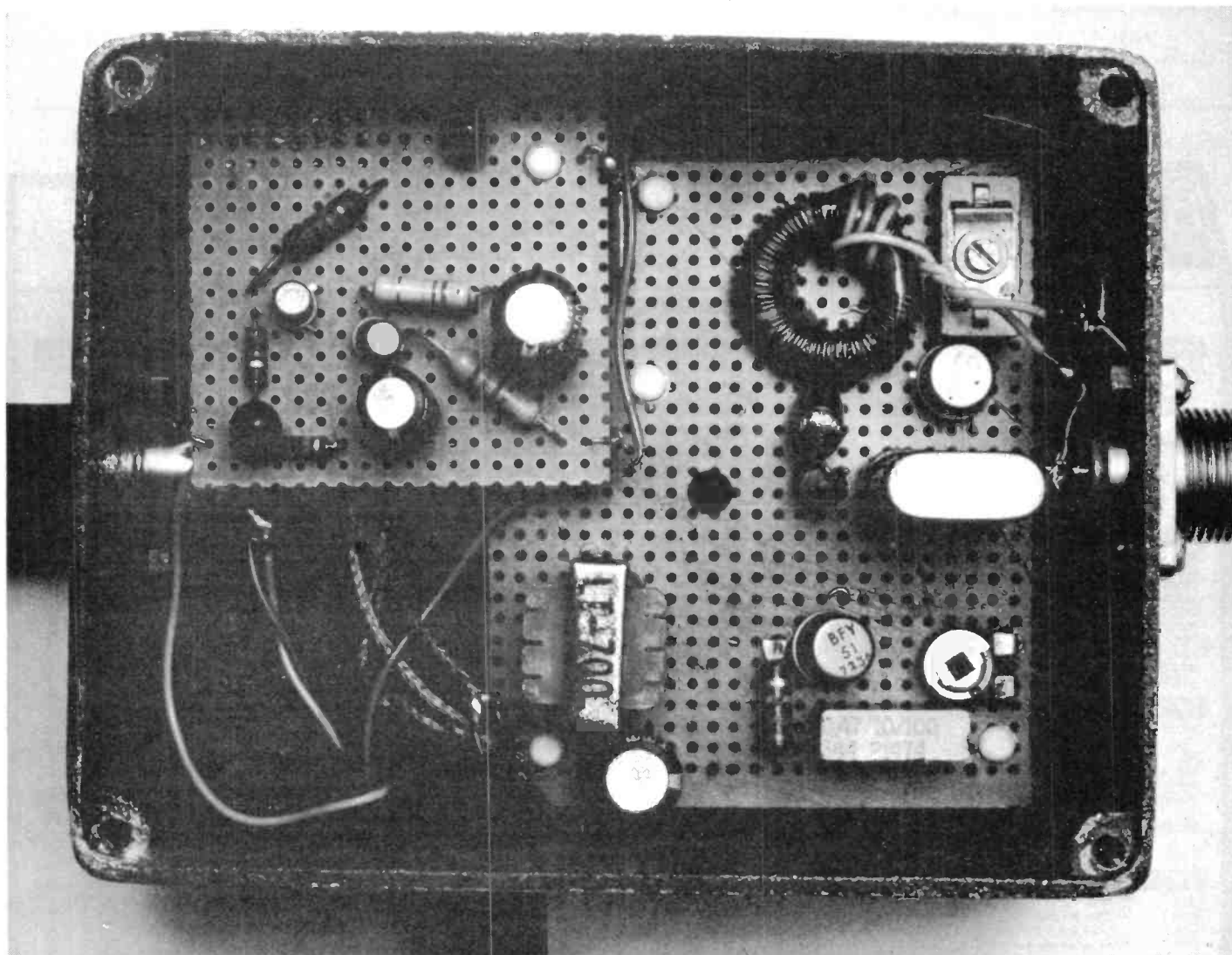

Underside view which clearly shows the layout of the components and the way the two veroboard sections fit in the box. Despite the size of the transmitter there is no crowding of parts on the boards.

TINY TIM

TINY TIM TRANSMITTER PARTS LIST

R1, R2	10K	metal film 0.4W
R3	27K	" " "
R4	100R	" " "
R5	120K	" " "
R6	1K2	" " "
R7	3K9	" " "
R8	680R	" " "
R10, R11	22K	" " "
R9	1K	sub-miniature carbon preset horizontal mounting
R12	Approx 4K9 (see text)	carbon film 1W
C1	25uF	tantalum bead 16V.wkg
C2	200uF	electrolytic 16V.wkg
C3, C4	100uF	" 25V.wkg
C5	0.47uF	Polyester film
C6	100 to 500pF	compression type trimmer
C7	330pF	polystyrene
C8	68n	polyester film
TR1, TR2	BC107B	
TR3, TR4	BFY51	
LFC	Audio transformer type LT700	
L	50 turns 28swg enam. on Amidon toroidal core type T50-2 (SMC-TMP Electronics, Buckley, Clwyd) Link winding 4 to 6 turns, plastic-covered wire.	
Xtal	HC6/U with holder for required net freq. (Messrs. Quartslab Erith, Kent)	
Diecast box	Type DCM5007 116 x 91 x 56mm internal	
Microphone	Standard communications type	
Mike input socket to suit		
Output socket	SO239	

NB: All the components except the toroidal core and the crystal may be obtained from Maplin Electronic Supplies Ltd.

Bredhurst
electronics

BREDHURST ELECTRONICS
HIGH ST, HANDCROSS, W. SX.
(0444) 400786 RH17 6BW



**MAIL ORDER
AND RETAIL**

MON-FRI 9-12.30/1.30-5.00
SAT 10.00-4.00pm

THE COMMUNICATIONS CENTRE OF THE SOUTH —

HF TRANSCEIVERS		£ (c&p)	2M FM TRANSCEIVERS		£ (c&p)	SPEAKERS		£ (c&p)
TRIO	TS930S	1150.00	TRIO	TM201A 25W Mobile	269.00	TRIO	SP230 (TS830. 530)	42.00 (1.50)
YAESU	FT980	1265.00	ICOM	IC27E 25W Mobile	299.00	TRIO	SP430 (TS430)	29.90 (1.50)
ICOM	IC751	1049.00	YAESU	FT230R 25W Mobile	259.00	TRIO	SP120 (TS130. 120)	27.14 (1.50)
ICOM	IC745	839.00	TRIO	TR2500 Handheld	237.00	YAESU	SP102 (FT102)	52.50 (1.50)
TRIO	TS430S	752.00	FDK	Multi 725X 25W Mobile	215.00	TRIO	SP40 Mobile speaker	14.49 (0.75)
TRIO	TS830S	731.00	YAESU	FT208R Handheld	199.00	YAESU	FSP 1 Mobile speaker	12.65 (0.75)
YEAESU	FT102	685.00	ICOM	IC2E Handheld	169.00	WORLD CLOCKS		
YAESU	FT757GX	685.00	ICOM	IC02E Handheld	229.00	TRIO	HC10 Digital	67.62 (2.00)
TRIO	TS530S	638.00	2M MULTIMODE TRANSCEIVERS			ICOM	Globe Clock — LCD readout	55.00 (2.00)
TRIO	TS130S	555.00	TRIO	TS780 2M and 70cm base	795.00	YAESU	QTR 24D — Analogue quartz	34.50 (2.00)
YAESU	FT77	459.00	YAESU	FT26R 2m fitted (70cm optional) base	739.00	ANTENNA BITS		
ANTENNA TUNER UNITS			ICOM	IC271E 25W base	629.00	HI-Q Balun 1:1 5kW pep	9.95 (0.75)	
ICOM	IC-AT500 Auto	369.00	ICOM	IC290D 25W Mobile	469.00	W2AU Unadilla 4:1 Balun	18.99 (1.20)	
ICOM	IC-AT100 auto	269.00	TRIO	TR9130 25W Mobile	442.00	7-1 14/21/28 MHz Unadilla Traps — pair	18.99 (1.20)	
ICOM	AT250 auto	273.00	YAESU	FT480R 15W Mobile	399.00	7-1MHz RAL TRAPS — Epoxy — pair	8.95 (1.50)	
YAESU	FC757 auto	231.00	FDK	Multi 750XX 20W mobile	315.00	Self Amalgamating Tape 10m x 25mm	3.80 (0.75)	
YAESU	FC102 High Power	179.00	YAESU	FT290R Portable	269.00	T-piece polyprop Dipole centre	1.50 (0.30)	
TRIO	AT230	136.00 (2.00)	70 TRANSCEIVERS			Polyprop Strain Insulators	0.50 (0.10)	
TRIO	AT130	95.45 (1.50)	TRIO	TW4000A Mobile 2M/70cm	469.00	Small ceramic Egg Insulators	0.50 (0.10)	
YAESU	FC700	96.90 (1.50)	TRIO	TM401A 12W Mobile	299.00	Large ceramic Egg Insulators	0.75 (0.10)	
WELZ	AC38	69.00 (1.50)	TRIO	TR3500 Handheld	256.00	75 ohm Twin Feeder light duty	per metre 0.16 (0.40)	
YAESU	FRT7700 Short Wave Listening	46.00 (1.00)	YAESU	FT790R Multimode portable	249.00	300 ohm Twin Feeder	per metre 0.14 (0.04)	
HF RECEIVERS			ICOM	IC4E Handheld	219.00	UR67 Low loss coax — 50ohm	per metre 0.60 (0.20)	
ICOM	R70	549.00	YAESU	FT708R Handheld	179.00	UR76 50 ohm coax — dia 5mm	per metre 0.25 (0.05)	
TRIO	R2000	421.00	POWER SUPPLIES			UR70 70 ohm coax	per metre 0.30 (0.05)	
TRIO	VC10 VHF Converter for R2000	113.00	YAESU	FP7579X	149.00 (1.50)	4mm Polyester Guy Rope, strength 400kg	per metre 0.16 (0.04)	
YAESU	FRG7700M with memory	435.00	YAESU	FP700	125.00 (2.50)	WELZ SWR-POWER METER		
YAESU	FRG7700 without memory	369.00	TRIO	PS430S	115.00 (2.50)	SP15M	SWR-Power HF/2M 200W	39.00 (1.00)
YAESU	FRT7700 antenna tuner for FRG7700	46.00	TRIO	PS20	59.95 (2.00)	SP45M	SWR-Power 2M/70cm 100W	55.00 (1.00)
YAESU	FRA7700 active antenna for FRG7700	41.80	ICOM	PS15	119.00 (2.50)	SP250M	SWR-Power HF/2kw	55.00 (1.00)
TRIO	R600	263.00	ICOM	PS20	176.00 (2.50)	SP350M	SWR-Pwr HF/2M/70cm 200W	65.00 (1.00)
VHF RECEIVERS			DRAE	4 amp	34.00 (—) 12 amp 79.50	COAXIAL SWITCHES		
JLL	SX200N	299.00		6 amp	53.50 (—) 24 amp 110.00	SA450	2 Way Diecast SO239 (500MHz)	10.00 (0.75)
AOR	AR2001 25—500MHz	325.00	BNOS	6 amp	48.30 (—) 24 amp 125.00	SA450	2 Way Diecast N plug (500 MHz)	12.95 (0.75)
FDK	ATC720 Handheld Airband	159.00		12 amp	£86.40 (—) 40 amp 225.00	CH20A	2 Way Welz SO239 (900 MHz)	19.50 (1.00)
FDK	RX40 Handheld 141-179 MHz	132.00	NEW AKD WAVEMETER (VHF) £24.50			CH20N	2 Way Welz N plugs (900MHz)	34.50 (1.00)

GOODS NORMALLY DESPATCHED WITHIN 24 HRS — PRICES CORRECT AT TIME OF GOING TO PRESS — E&OE

DEWSBURY

ELECTRONICS

G4CLX

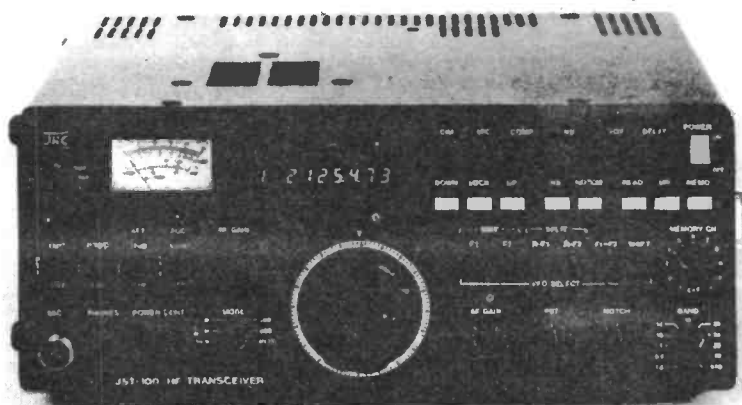

JST100 AMATEUR BAND TRANSCEIVER £998.00

transceivers collect dust

**SEE US AT
NEC. STAND A25**

PROTECT YOURS NOW!!!!

Exclusive to **Dewsbury Electronics** opaque covers for your rig. Made from opaque PVC stitched seams ensure long life. Edged with sewn cotton tape (bias binding). Available for all transceivers, receivers and ancillary units (ATU-VFO) etc.

Only **£1.50** inclusive. State transceiver or other rig identification, eg TS430, TS930 etc.

Allow ten days for delivery.

Postal orders please add 25p post & packing

Access/Barclaycard accepted. Licenced credit broker

GAMMA TWIN

2 METRE FOLDED 1/2 WAVE ANTENNA

Copyright Gamma Aerial Products 1982

This antenna is based on the very popular and successful 'SLIM JIM' design.

The GAMMA TWIN has the following unique features:

- ★ VERY LOW ANGLE OF RADIATION
- ★ ADJUSTABLE RADIATOR. (140-150 MHZ)
- ★ COMPLETELY WEATHERPROOF CONNECTING BOX
- ★ VERTICAL FIX DIRECTLY TO MAST

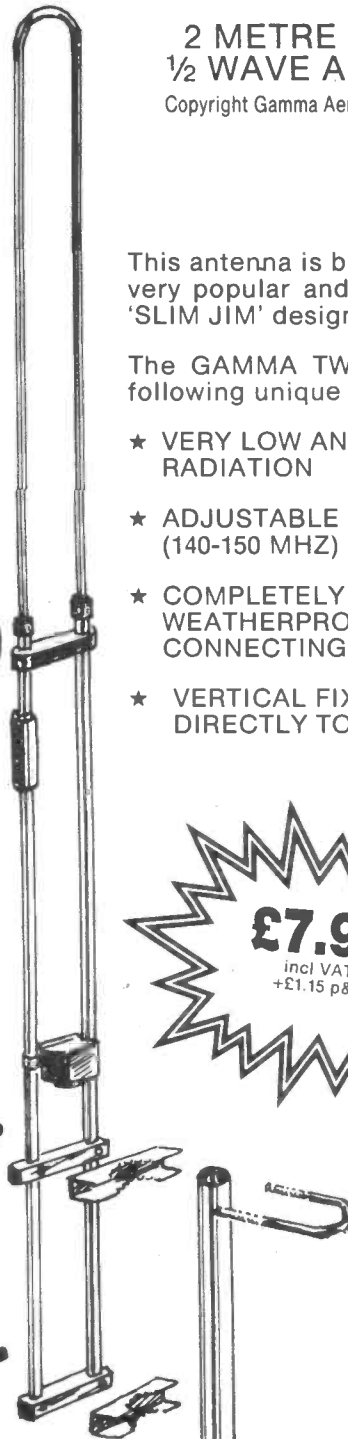

£7.95

incl VAT
+£1.15 p&p

Dewsbury Electronics offer a full range of **Trio Equipment** always in stock.

We are also stockists of DAIWA - WELTZ - DAVTREND - TASCOS TELEREADERS - MICROWAVE MODULES - ICS AMTOR - AEA PRODUCTS - DRAE

Dewsbury Electronics, 176 Lower High Street, Stourbridge, West Midlands.

Telephone: Stourbridge (0384) 390063



Closed Thursday

Instant finance available subject to status
Written details on request

Before we discuss the band of the month, I was interested to note that a number of listeners and, indeed, a few licensed amateurs, have suffered damage caused by high winds bending masts. High winds can wreak havoc with the simple 'long pole' mast and, having suffered such problems myself some time ago, I set out to construct a mast that was easy to handle without help or in an emergency.

My design had to have certain requirements. Firstly the mast had to be easy to construct, as I'm one of nature's misfits with ham bones where there should be fingers. Secondly it must be as light as possible, but sturdy. Finally it should be reasonably easy to raise or lower, using simple equipment.

I don't claim any originality for the idea but confess that I have never seen the design in print. The cost depends on where you get your materials, but buying locally the cost would be around £35 for a twenty-footer or about £45 for a thirty-footer. I have made one of these masts forty-foot high and raised it single handed with a six element 2m quad on top without any problems, so if you intend using it for supporting the end of a trap dipole or a multi-band vertical there should be no problems.

Materials required

If you are making a twenty-foot mast it can be a single length pole, but over that length I would suggest making it up from two equal lengths joined with a 15in jointing sleeve. Required length 2in OD thick walled aluminium (about 1/4in walls) should be OK, plus the following: 3 x three way shock guy wire clamps (non-rotating); 3 x eight inch turnbuckles; 3 x three foot lengths of 1in square section steel or alloy; galvanised steel wire to provide for three straining wires about 5% longer than the mast and, if your mast is more than 30 foot or will carry a vertical or beam, enough for four support guys; 4 x three foot (minimum) angle iron stakes for guys.

Construction

Taking the three lengths of square section, drill holes at one end of each to take the bolts from the guy clamp. Then drill 1/4in hole in the other ends at right angles to

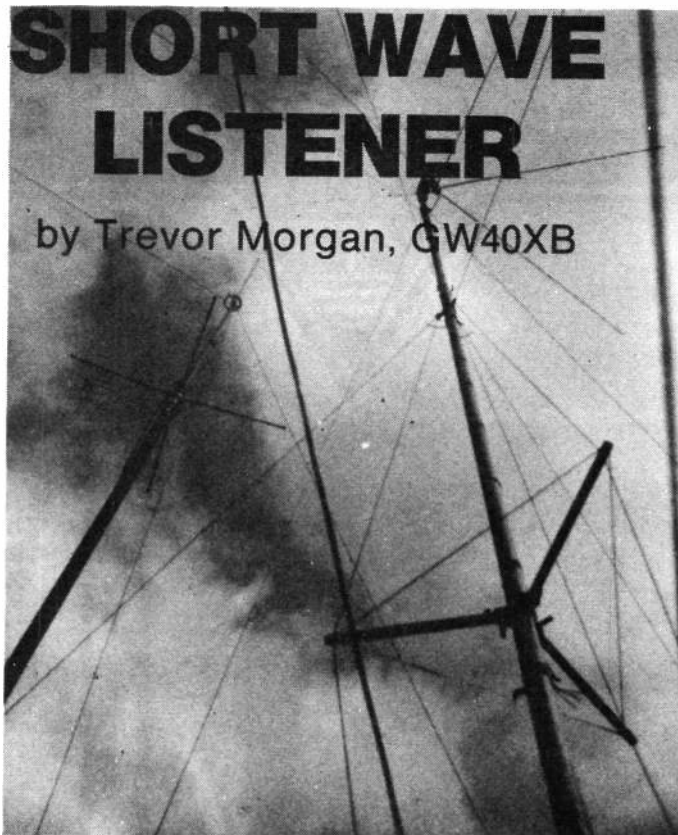

Above: On the right the author's completed mast

the first to take the straining wires. These should be about an inch from the ends. Check the centre point of the mast. If using a joiner, mount the clamp and outriggers just above the joiner, otherwise position it at the centre. Tighten this securely with the outriggers at right angles to the mast. Take the turnbuckles and fit them to the second clamp using the fixing bolts (as in Figure 2) and fit the clamp about 9in from the bottom of the mast. Next, fit the remaining clamp about 18in from the top of the mast. This will allow room to fit the required antenna or a rotator.

Take the galvanised wire and, from the bottom of the mast, take the end through one turnbuckle, making sure that the turnbuckle is fully extended, up through the outrigger on that side and on to the upper clamp. Fix the end securely. My method was to use a round turn and three half hitches and wiring the free end to the wire using a steel wire wrap. Repeat this procedure on the other two turnbuckles pulling the straining wire taut each time.

Using the turnbuckles, bring the straining wires to equal tightness, checking for straightness of the mast all the time. You will find that once tight, even slight turns on the turnbuckles will result in pulling of the mast into a

curve, so this must be checked constantly during construction, and after the mast is erected. Once the mast is upright it will be extremely stable, but checks must be made on the straining wires from time to time due to stretching.

Fixing

The mast can be erected either as a fixed mast or swivel mounted. Figure 4 shows the basic construction of both fixtures but measurements have been left out as these will depend on the site. If using the swivel mounting, you will find that the simplest pulley system will be sufficient, or even a small winch could be used. If erecting the mast as a permanent fixture (quite feasible with a twenty-footer as it can take a ladder leaning against it once securely fixed) a channel to take the bottom end while erecting, will prevent the bottom moving as the mast is raised.

Guy ropes

These should be fitted for safety if the mast is over twenty feet and should be fitted with turnbuckles at the bottom end. Fix them on the top clamp using the same method as with the straining wires and run them out at as wide an angle as possible. Due to the basic construction

of the mast, only four guys should be necessary. It is good policy to run an earth wire from the bottom clamp to ground.

I wouldn't recommend sticking a triband beam on top (how many listeners use them?), but mine did support a six element 2m quad and a five element yagi so it will stand a fair old load. As a support for wire arrays it is superb and it is possible to put a horizontal boom at the top for spacing loops etc. It's open to development, so give it a go!

Picture shows the mast described, built as a twenty-footer with a ten foot extension above the top clamp. The antenna is an HF5V with radials. Total height is 43ft.

Your letters

Thanks to all who have written regarding the column. Judging from your responses we seem to have the formula correct and are being of assistance to many. Please keep the letters coming. Those requiring a detailed reply I will respond to directly but please send a stamp!

Philip Cole writes from Bedminster, Bristol, with a query regarding the reception of CW and RTTY. I covered the subject last month, but it proves how popular this side of the hobby is and I will be dealing with it again, in depth, later this year. Philip uses a Yaesu FRG7700 with matching ATU for reception and is a very keen listener. Keep taking the mag, Philip.

Lawson Smith in Perth, who uses a Trio R600 with a Mizuho Sky Coupler ATU set me a stinker of a problem. He lives in one of those open plan estates and, to prove his point, sent me a photo showing an electricity substation smack up against his pine end! Nasty!

Problem is, that due to the open plan estate, Lawson can't put up a mast in the garden as he ain't got one; his house faces north and he can't hear W land (United States). I'm going to dig into that one, but it shows how some people suffer for the hobby!

From Dave Wilkinson in Ventnor, IoW, comes a letter asking for help in choosing a receiver. He currently uses an Eddystone 840A but wants to upgrade. This is always a problem as tastes differ from person to person so I can only give a one-sided appraisal of

SHORT WAVE LISTENER

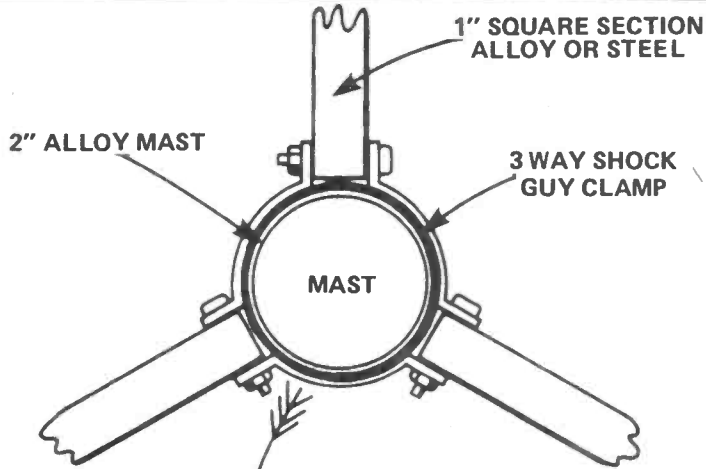

Fig 1

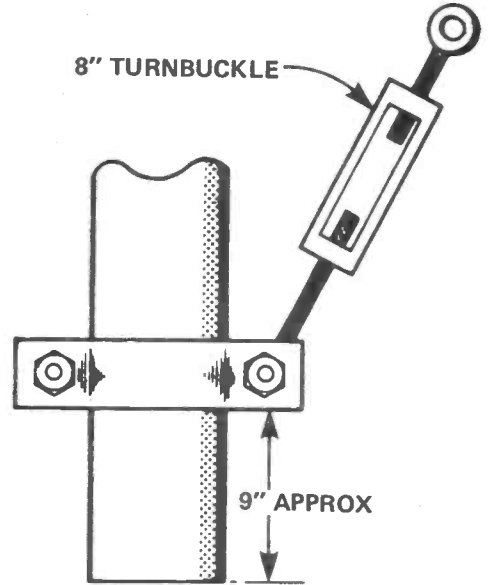

Fig 2

BOTTOM OF MAST

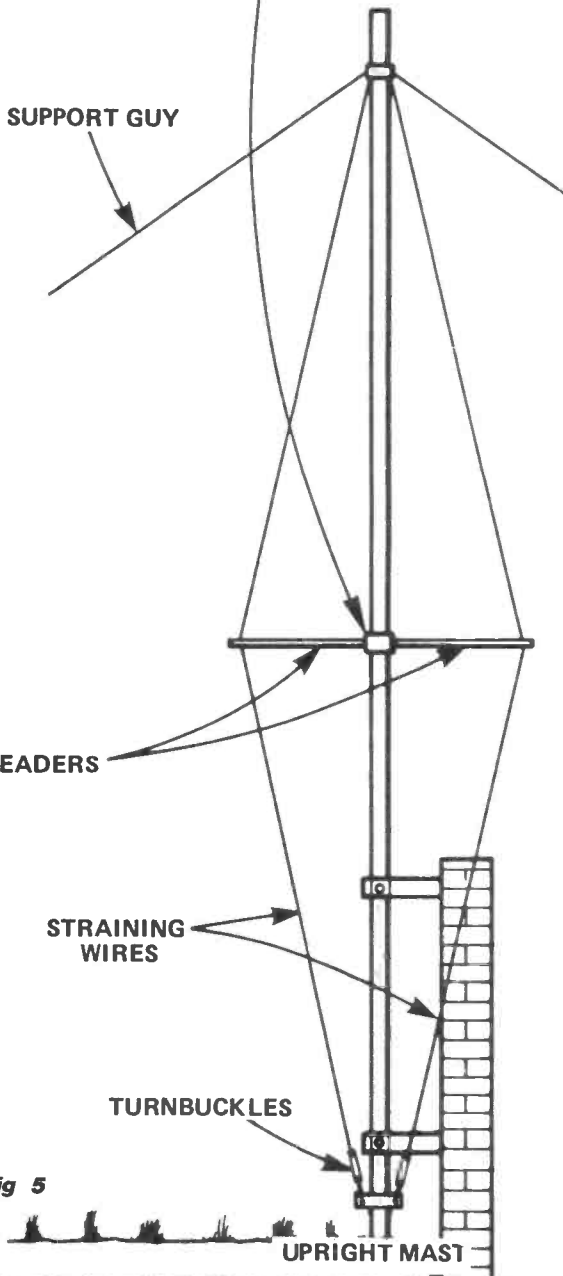

Fig 5

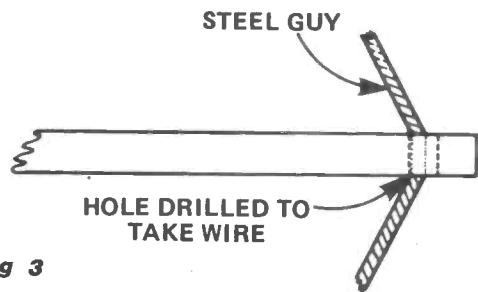

Fig 3

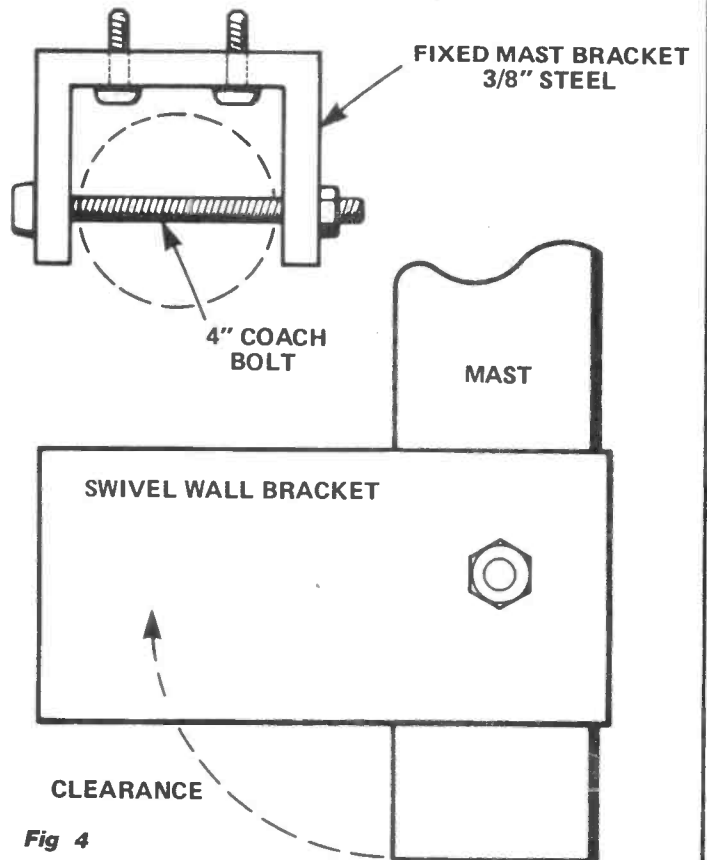
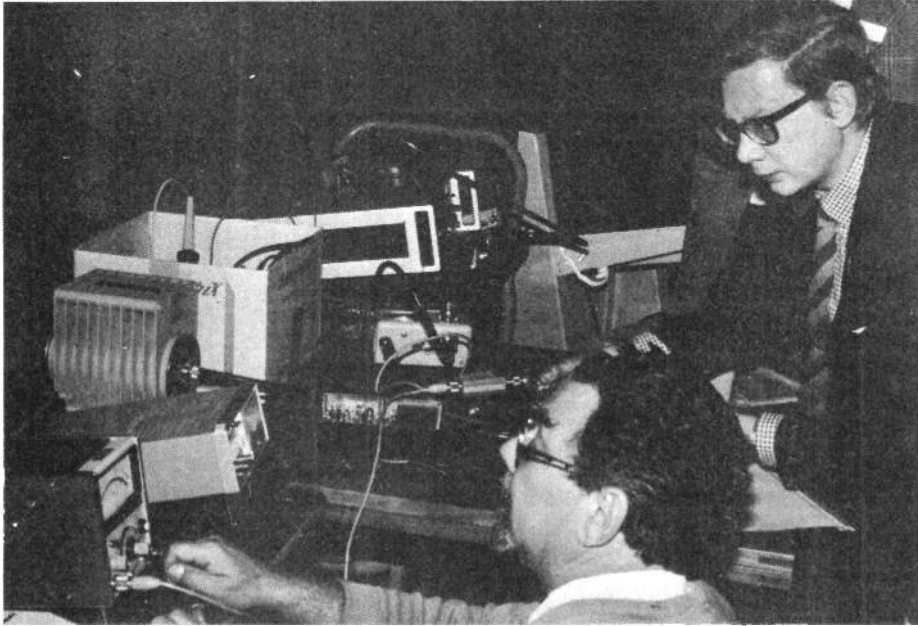

Fig 4

Starting your own CLUB STATION

by Tim Wander BSc, G6GUX



Setting up and testing equipment for a club special event station

Some guidelines and possible pitfalls to starting a radio club at college, school, university or even at home

The upsurge in new callsigns over the past two years must mean that many interested amateurs have not been heard on the air due to the high cost of amateur equipment. A radio club therefore, with equipment for general use, sounds like an excellent idea, but these things don't happen overnight and involve a large amount of hard work.

The first stage in founding a club station is to ensure that enough people are interested, *and that they are prepared to do some work*. With this in mind an enthusiastic committee should be elected. Then the long grind begins.

Authorisation

Unfortunately the modern world is ruled by bureaucracy and seemingly ridiculous regulations. To form any society or club within any institution means that permission must be obtained, often from the most surprising quarters. The first thing to be remembered is that certain departments are totally allergic to RF. This barrier includes any area using computers or audio-visual aids. Departments using public address or hi-fi equipment (drama studios, conference centres etc) should also be avoided.

It may be useful to co-opt a member of staff (look in the physics or electronics

department for lapsed amateurs); they can prove useful allies, especially if documentation has to be signed or someone must take overall responsibility for equipment and premises.

Equipment

The first thing to remember is that everybody's interests are different but a club should obviously serve the majority. SSTV or RTTY can come at a later date. The most important hurdle is finance; students cannot live by beans and eggs alone despite what the adverts say. The average Japanese black box is beyond the reaches of many people and yes, 10m CW for £30 may be great, unless (like our club) Class B calls outnumber Class A by 18 to 2 (neither of whom use CW).

Raising the money

Everybody is trying to raise money for so many good causes; the trick is to keep people interested and, above all:

- Ask anyone who might donate actual money, equipment or materials. These are obviously rare occurrences so elect a treasurer who can be polite!
- Ask anyone who might donate unwanted equipment, fondly known as junk. This need not be RF orientated. There is a lot of old computer and TV equipment around that can be cannibalised or bought at a boot sale.
- Fund-raising activities are numerous but legal requirements must be met. Sponsored events and especially raffles need licences and careful control but can raise surprisingly large sums. Alternatives would be demonstration stations at garden fetes or jumble sales

which involve a lot of hard work but can be great fun.

(d) Contact the nearest radio club and ask for help and advice. There may also be some secondhand equipment for sale.

(e) If all fails, call a club meeting. Get everyone to list all the equipment that members are willing to provide for regular sessions. This can be difficult, but even my own battered rig can stand several club sessions a week.

(f) Remember that the first money comes from membership fees. 30 members at say £4 each can provide a good start for any club.

The shack

The next step must be to bring it all together in the hallowed shack. This should become the focus of the new club, so checks must be made concerning access (especially after hours). All buildings tend to have some deserted cupboard that can be turned into a regular meeting place/coffee hut/DX-chasing shack. Once permission has been received, the station must be installed.

(a) All connections must be safe and secure (especially mains). One sure fire way of becoming unpopular is to burn the place down or electrocute your only Class A. If you don't understand it, don't play with it...

(b) Security is vital; money is scarce; so do not give it away. If the room can be locked up, lock it. If not, fit a lock. Who has access other than club members (ie cleaners)? Ensure that those who have keys lock up afterwards. We found it necessary to restrict keys to just three club members (the committee) who were responsible for the shack.

(c) Keep the shack tidy. Not only does this make it easier to work in but it prevents cleaners cleaning things that they shouldn't (ie computer disks) or moving things that can't or shouldn't be moved.

(d) Ensure that the club is insured, not only against fire and theft but also against accident.

Antennae

Again the 'key' is permission. All amateurs face the potential problem of putting antennae up and getting them to stay up. Authority must be gained from several different sources. Find out who you have to talk to. This may include staff, building or estates departments, safety officers, even insurance companies. There is nothing more irritating than putting up the 15 foot pole, 16 ele

CLUB STATIONS



Operating club stations open to the public can bring good results in terms of publicity as pictures of Lord Mayors and Provosts often find their way into the local papers

antenna, rotator and masthead preamp only to have to take it down because it spoils the view of the gas works.

When permission has been confirmed, check before you put it up that:

(a) It all works, and is robust enough to withstand the elements. It tends to blow harder on the rooftops, and water plus coax equals nasty SWR.

(b) Check it is secure, and if necessary guy it properly and use a steel pole (our 2in aluminium pole bent at an alarming angle one stormy night). If necessary use an alignment bearing and park the rotator after use.

When putting it up wait for good weather. The DX will wait for another day; wet roofs and high winds are not good places to play on. If you can't do it even on a good day, admit it and find someone who can, even if it requires professional help. It should be a once-only job. Once it is up ensure that little children can't swing on it on open-night or that they can't borrow 10 feet of your hard-earned coax, late one night.

Activities

Once you have a station, use it, but ensure you use it properly. Refer to those

licence regulations you read, once upon a time.

(a) Affiliate the club to the RSGB; *Rad Comm* magazine can be shred, **Amateur Radio** can't! The QSL bureau is also useful; get some cards done, preferably with your own eye-catching design. The art department can often help, especially with the cost. Get some envelopes off to the bureau, but remember you've got to send them if you want some back to cover the shack walls.

(b) Get some events going: base stations, demos, regular meetings, rally trips and even CW lessons will get the

CLUB STATIONS



Local club members can provide a useful and enjoyable service by operating a talk-in to local conventions and events

club moving, but ensure that people know what is happening. Try a regular club net or newsletter.

(c) Ensure the club gets publicity, but make sure it is *good* publicity. Tell people what the antenna is; advertise demonstration stations; explain what is going on during operation. Try articles in local newspapers, posters or plain word of mouth.

The first step is always the hardest, but nothing ever gets done unless someone makes a move. Become a founder committee member. It can be great fun, and you can even put a plaque over the door.

Well used

During the past two years at the University of Aston, we have set up (through subscriptions and a student union grant) a well-used and very enjoyable station.

All those who have worked G3UOA or GB8UOA will know us to be nice people (if students) and yes, your QSL cards are in the bureau somewhere.

The founding committee have now moved into the 'real' world where

hopefully we can earn enough pennies to buy a black box, or have time to build our own.

We have moved from an excellent station to a very active club (which will talk to anyone), and amateur radio will never quite seem the same again after two years in a cleaner's cupboard.

Estimated costs

(i) The shack. Hopefully free but offer to pay for locks if necessary.

(ii) Insurance. Around £20-£25 for complete cover (negotiate).

(iii) Antenna. VHF beams from £15 to £35 (try secondhand).

(iv) Coax. Beware cheap imitations; the losses are not worth it. The new L-100 from Westlake looks very interesting; about £8 depending on run.

(v) Rigs. Personally I feel it is a false economy to go for FM only, ie TR2300, unless accompanied by a single sideband rig (consider the new Totsuko TR-2100M at £110). I would also recommend that secondhand equipment provides the cheapest method of getting on the air. Consider a multimode such as a used FT290 for around £190. These are only

suggestions; other more comprehensive items have become available before now.

(vi) Possibly a linear amplifier. Again consider secondhand (ie 25W-£50, 100W-£90+).

(vii) Miscellaneous expenses (eg connectors, postage, preamp, licence and affiliation fees) come to at least £40.

(viii) For HF, antennas are simpler but no less vital. Our G5RV is made from old transformer windings. There are numerous good used rigs on the market with valved PA, of course. We found an FT401 for £200. If this figure is a bit high initially, consider SWL with an HRO/B40 or the like (£25+).

All these estimates provide a ball park figure, somewhere around £400 to provide a complete 2m base station, antenna and operating facility.

This may seem like a very high sum, but with, say, 25 members it's only £16 each for the use of a very good station for three or four years.

Not that members should raise it all of course. Oh, and don't forget exams or course work as well!!!

Early Experiments back to work

Glen Ross G8MWR brings us up to date (almost) with his researches into the history of amateur radio. Last month he began his story in 1580 – finishing off at the beginning of the first World War. This month he takes us all the way to the point when today's call signs were being allocated...

Part 2

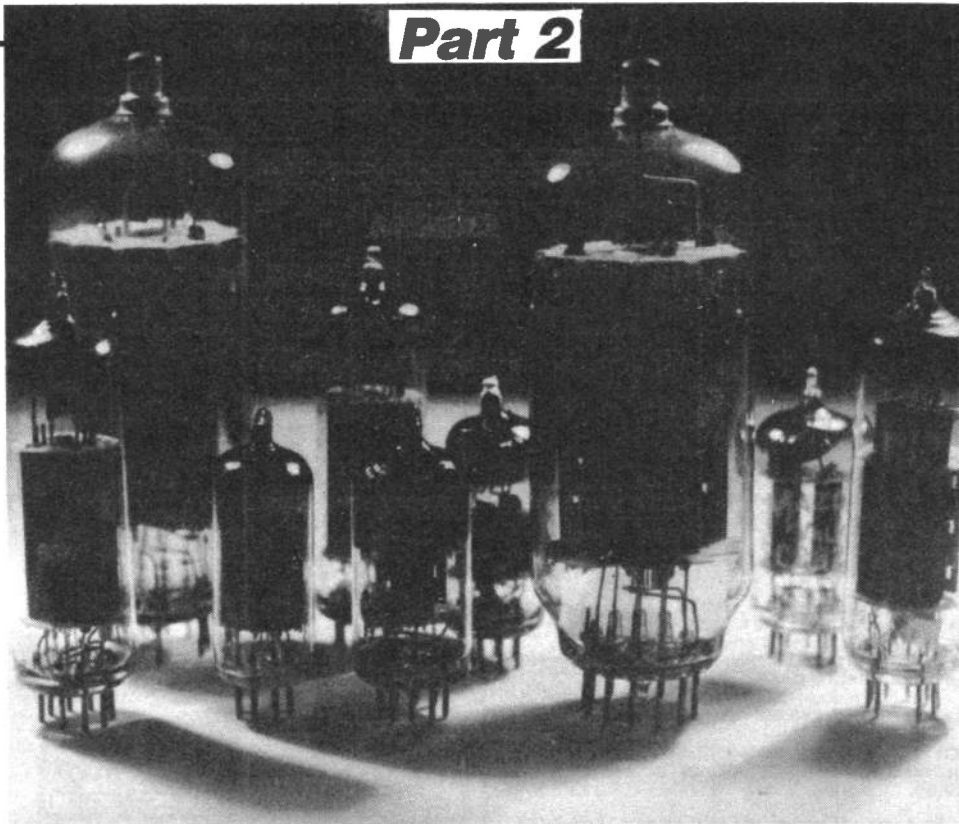

In last month's article we left the amateur world closed down for the duration of the 1st war and all the gear had been impounded. The fond hope had been that once the war was over, the gear would be returned and that things would be back to normal. Things being as they are, it did not work out like that and there was a long delay before operations resumed.

This did not completely stop the amateurs of the day and, within weeks of the war ending, the Leicester Radio club was back at work. In December 1919 the first wireless exhibition was held in London with the prize exhibit being a 500 watt Tx which must have caused a certain amount of drooling amongst the lads.

In October of that year the American amateurs were back on the air but the long-awaited British statement did not arrive until January 1920. Then it was announced that all pre-war permits would be cancelled and a new licence

would be issued. The first of these appeared on April 7th and came in the series 2AA. There was at this time no national prefix and they were not even issued in strict alphabetical order. There was no technical exam, but a Morse test at 12wpm was required. There were at this time no amateur licences; they were all for experimental purposes and you had to justify your need for one to be issued. This continued, in theory at least, right up to 1939. As well as justifying your need for a licence you also had to specify the five other stations that you were going to do tests with!

The permit was available on four different power levels 10, 50, 250 and >250 watts with a sliding scale of fees from one to five pounds. The 10 watt licence was the normal one, the others being issued for special purpose only. The wavelengths you were allowed to use were 3000, 1000, 700 and 180 metres. Aerials were limited to a total length of 100 feet and operation was on CW only,

with severe restrictions on operating time.

Growing up

The amateur population increased at a fairly rapid rate and at the end of the first year 250 permits had been issued. An interesting issue was on July 7th 1921 when a Mr V Watson was given the call 2VW. This is the first example of a personalised callsign, although in later years many of the G2+2 calls had some resemblance to their owners' names. At this time we were still on CW only but many amateurs were pressing for the use of telephony. This resulted in a petition to the PMG for permission to use the mode which was signed by the London Wireless Society (now the RSGB) and 65 other societies. This alone indicates the tremendous interest in the hobby that existed at this time. The big event of the early 1920s was of course the series of transatlantic tests which were featured in an article by John Heys a couple of

GSXBH **R.A.S. (Nottingham)** **GSXUS**
Radio Amateur Supplies
Tel: 0602 280267

Visit your Local Emporium
 Large Selection of New/Used Equipment on Show

AGENTS FOR: **ACCESSORIES:**
F.D.K **Wetx Range**
AZDEN **Microwave Modules**
ICOM **Adonis Mics**
YAESU **Mutek Pre-Amps**

FORTOP ATV **DRAE PSU and Wave Meters**

AERIAL: Tonna, Halbar, New Diamond Range of Mobile Whips
PLUS OWN
'Special' Q.R.P. GW5 HF5 Band Beams
JUST GIVE US A RING
 Monday: CLOSED Tuesday - Saturday: 10.00am to 5.00pm

3 Farndon Green, Wollaton Park, Off Ring Road
Between A52 (Derby Road) & A609 (Ilkeston Road)

WOOD & DOUGLAS

A NEW MODE and a new FREQUENCY?
FMTV has arrived on 24cms
 so get on '24' in '84
 Using some of our new products:-

VIDIF Demodulator Strip
 The apparently hard part made easy. First of all convert the signals from the frequency you are receiving to approximately 52MHz. This could be the first i.f. at 24cms, or using doppler Gunn oscillators, at 10GHz. Feed this 52MHz signal into the VIDIF where it will be amplified, limited and then demodulated in an NE564 phase lock loop. The recovered signal is then amplified and processed to give two 1V ptp standard video signals with the ability to select positive or negative modulation sense. A 6MHz signal is filtered off for audio detection and the phase lock loop gives an a.f.c. signal for front end tracking. There is also an a.g.c. signal which can be used for 'S' meter applications. Everything you need on a single board measuring 5" x 3". There is a minimum amount of setting up, four ocils to adjust and one trimmer capacitor. The video amplifier is fixed value discrete components and needs no aligning. The use of NE592 integrated video amplifiers has been avoided to ensure no degrading of the potential video bandwidth. Once adjusted it will not need touching again. The demodulator is exceptionally linear over approximately 15MHz. This board simply works and works well.

Price in kit form £38.95, £52.65 assembled and tested.

Having removed the headache on receive systems, what of transmit? There are two approaches that you can pursue — high level varactor multiplication and low level direct output. The following products are to be initially offered.

UFM01 UHF Power Oscillator
 This small module (1.6" x 2.5") gives a free running 50mW signal at 400MHz. The dimensioning of the board is such that sufficient deviation is obtained for direct transmission at 400MHz. This can then be reduced by the multiplication factor to final frequency for other bands. There is a minimum video processing circuit to allow direct connection of 1V ptp 75R signals. The board is voltage stabilised to minimise drift. In use the module should be followed by our standard 70L/IN/LT to increase the power to 500mW and then any of our 70FM series amplifiers can be applied to give currently 40W maximum output. For 24cms use, the stability is adequate. For higher orders of multiplication some form of frequency lock will be needed. This could take the form of a skeleton VIDIF without the post detector amplifier.

Price in kit form £17.95, £24.80 assembled and tested.

WDV 400/1200 Varactor Tripler
 Due to appear in early 1984, a BXY35a varactor tripler for 400MHz to 1200MHz. This will be a boxed finished unit suitable for 10W input power levels. Provisional pricing indicates the £40 — £50 range.

Our commercial experiences in wide band FM links have enabled the amateur market to benefit from these exceptional designs. This is only the beginning of the MDTV product range from W & D.

Kits and modules are offered on our usual 'no external hardware' basis just high standard, well designed electronics with a backup you know you can rely on.

Products for MDTV will not be available through our agents due to the experimental nature of their use. Please send your orders direct to W & D and if possible give some detail of the application. This will help us to assess the demand and usage of these state of the art modules.

SEE THESE AND OUR OTHER PRODUCTS ON STAND A2 AT NEC Prices include VAT at the current rate. Please include 75p postage and handling. Please check stock position before ordering although delivery will never usually be more than 28 days. Further details on receipt of a large SAE.

UNIT 13
YOUNGS INDUSTRIAL ESTATE
ALDERMSTON, READING RG7 4PQ
Tel: 07356 5324 Telex: 848702



NEWSAGENT ORDER FORM

Amateur RADIO

To (name of newsagent)

Please order a copy of **Amateur Radio** for me every month

NAME

ADDRESS

Newstrade distributors: Argus Press, Sales & Distribution Ltd, 12-18 Paul Street, London EC2A 4JS. (Tel: 01-247-8233)

GAREX (G3ZVI)

REBISO TR KITS a top-selling line for many years. E12 series, 5% carbon film, 10R to 1M, 61 values, ratings 1/4W or 1/2W (state which).
 Starter packs 5 each value (305 pieces) **£3.10**
 Standard pack 10 each value (610 pieces) **£5.55**
 Mixed pack, 5 each 1/4W + 1/2W (610 pieces) **£5.55**
 Giant pack, 25 each value (1525 pieces) **£13.60**

SR-9 MONITOR RECEIVER 2m FM with 144-146Hz full coverage VFO + 11 Xtal controlled channels; ideal for fixed/M/P use. 12V DC operation. **£47.50** Mains adaptor **£9.50**.

CRYSTALS FOR NR-56, SR-9, SR-11, HF-12, TM-56B All 2m channels from 0 (145.00) to 33 (145.825) incl. also 144.80, 144.825, 144.85 Raynet at **£2.60** (+ 20p post per order). Over 40 popular marine channels for SR-9, etc. at **£3.00** (+ 20p post).

DC/DC TRANSISTORISED INVERTERS 12V input, 400V 200mA output **£9.50**. This is a chassis section cut from used R/T equipment, tidied, fully wired & tested. Free-standing but no luxuries like cabinet. 24v version — same price. SAE for details of this and others in our range.

SPARE PARTS FOR PYE RADIOTELEPHONES
 WESTMINSTER & PF70 SERIES, also Cambridge & Vanguard etc. SAE list

GAREX FM DETECTORS & squelch conversion for Pye R/T equipment Ready assembled, full instructions. Tailor-made, easy-fit design, replaces existing squelch board, with minimum of modifications. For AM Cambridge **£6.30**, for Vanguard AM25B (Valvé RX) **£6.10**; for Transistor Vanguard AM25T **£6.95**.

REVCON
 A superb quality 16-element, all British made, VHF/UHF broadband fixed station aerial from Revco. Ideally suited to SX200 and other VHF/UHF receivers. Covers 50 to 500 MHz.
PRICE £24.95 inc.

MAIN DISTRIBUTOR OF REVCO PRODUCTS
 PRICES INCLUDE UK POST & PACKING & 15% VAT

GAREX ELECTRONICS
7 NORVIC ROAD, MARSWORTH, TRING, HERTS HP23 4LS
Phone 0296 668684. Callers by appointment only

JIL SX200-N
THE SUPERIOR SCANNER

* THE CHOICE OF THE PROFESSIONALS * AM & FM ALL BANDS
 * WIDER COVERAGE: 26-58, 58-88, 108, 380-514MHz; includes 10m, 6m, 4m, 2m, & 70cm Amateur bands.
 * 16 MEMORY CHANNELS WITH DIRECT ACCESS
 * SPECIALLY DESIGNED FOR EUROPEAN MARKET
 * SCAN & SEARCH * SEARCH BETWEEN PRESET LIMITS UP AND DOWN * 12V DC 230V AC OPERATION
 * FACTORY BACKED SPARES & SERVICE, 12 MONTH WARRANTY & ALL IMPORTANT PRE-DELIVERY CHECK BY GAREX, THE MAIN SERVICE & SALES AGENTS.
£299 INC. VAT Delivered

REVCO RS-2000 SCANNER
 * Covers 60-90, 108-180, 380-520MHz (90-108MHz also, by programming tricks).
 * AM & FM ALL BANDS * 70 MEMORIES
 * SEARCH & STORE OF ACTIVE CHANNELS
 * COUNT OF ACTIVITY ON A CHANNEL * ALL THE USUAL SCAN & SEARCH FUNCTIONS * 12v DC & 230v AC OPERATION
£259 INC VAT Delivered

REVCO R5-160FM POCKET SCANNER £249 inc VAT COVERS 26-32, 68-88, 138-176, 380-512MHz. 160 MEMORIES, SCANS, SEARCHES & STORES. WITH NICADS, CHARGER & FLEXIWHIP ANTENNA.

JIL SX-400 PROFESSIONAL SCANNER £598 inc VAT SAE details
 ASK FOR OUR LIST OF SECONDHAND SCANNER BARGAINS



BACK TO WORK

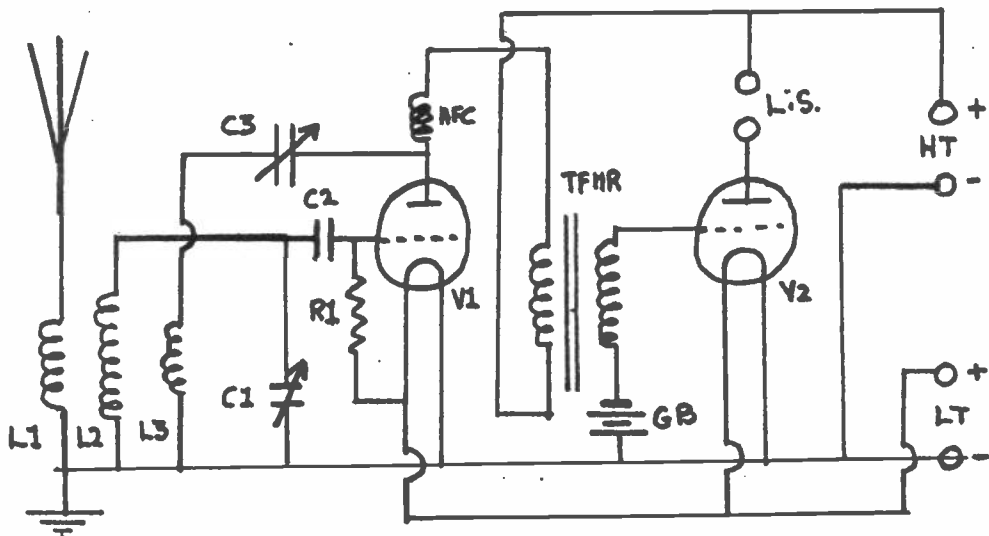

Two valve receiver using 1930 drawing conventions

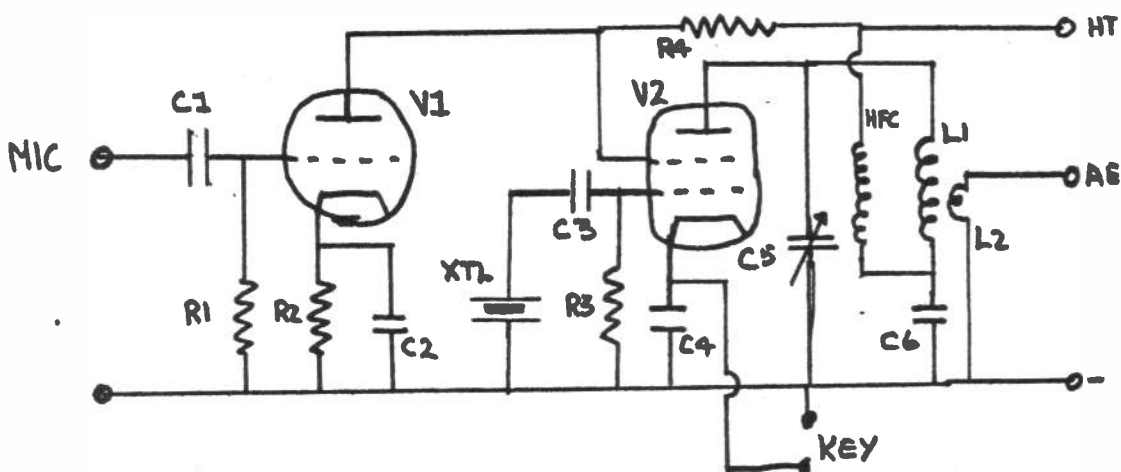

Two valve AM/CW transmitter. With suitable values this could provide 150 watts

months ago, but other things were also happening.

British amateurs thought that they had had a raw deal in the delay in getting new licences but the French did not receive theirs until 1922. By this time worldwide activity had grown to such an extent that prefixes were used to indicate the country the amateur lived in and we added G to the callsign. A lot of countries did not start out with the prefixes that we now know. The USA, for example, used the letter U.

In 1923 Hugh Ryan G5BV became the first amateur radio columnist by starting a regular DX column in *Experimental Wireless* for November 1923, which ran for four years.

Conditions

There had been some changes to the licence conditions by this time. The band at 180 metres had been moved to 200 metres and extra bands had been granted at 440 and 100 metres. Spark transmission was now prohibited, although it remained in use for emergency working by the Royal Navy

right up to the 1939 war. Transmission on 440m was allowed on weekdays only from 5pm to 11pm. 200m was available every day but only between the hours of 6pm and midnight. Only inter-UK working was allowed except by special permission, which then allowed operating to stations in Western Europe only. Judging by the results that had already been achieved by then there was obviously a lot of rule-bending going on.

First contacts

Some notable 'firsts' happened around this period. On the 16th October 1924 G2OD became the first British station to be heard in Australia. He followed this up with the first contact on the 13th November. In January 1925 he made the first two-way with Mexico and in May he was the first British station to be heard in New Zealand. The honour of making the first two-way contact with New Zealand went to a young schoolboy, Cecil Goyder, using the callsign G2SZ on October the 14th but G2OD followed this by making the first daylight contact between the two countries.

Broadcasting

In April 1925 the PMG notified Gerry Marcuse G2NM, that they agreed 'with considerable reluctance' to allow the use of wavelengths of 45 and 23m. To keep to tradition they also specified that transmissions could only be made between 4 and 6.30pm and that the total transmission time was not to exceed 30 minutes in any 24 hour period (and you think you've got problems?).

QSL cards, which were first used by G2UV in 1923, had by now become so popular that the RSGB opened the first QSL bureau (which was run by G6BT). During August 1927 G2NM received permission to 'transmit speech and music for a period of six months from Sept 1st, using one kilowatt on wavelengths of 33 and 23m'. Operating time was restricted to two hours per night. The total number of records used was not to exceed fifty and there was to be no advertising. The first amateur broadcast was made on 11th September 1927 and was beamed towards Australia and New Zealand. Gerry later admitted to using 1.5kW to a 'Zeppelin' aerial on 100

BACK TO WORK

foot masts from his home at Caterham in Surrey. So started Empire broadcasting. No one really thought it could be done but, once it had been demonstrated as being a feasible proposition, the BBC took over the service and G2NM's permission was withdrawn.

Moving on

In 1927, when very few people had gone higher than 100m, G2OD published a design for a 5m beam aerial. This was well before the work done in Japan by Yagi.

International agreement on amateur frequencies came in October 1927 when the bands 1.7-2.0; 3.4-4; 7-7.3; 14-14.4; 28-30 and 56-60Mc/s were allocated. These are more or less the present day allocations. They came into use in Britain on 1st January 1929 but the PMG, true to form, insisted on 'guard bands' 50Kc/s wide at each edge of the bands. This was also the first official use of frequency rather than wavelength.

Enter the YLs

The first YL operator was Mrs Ingram who held the permit IXI before the 1914-18 war. She did not apply for a licence after the war and the first lady to do so was Barbara Dunn who in 1927 received the call G6YL. She was very active until her death a few years ago and always used CW. In 1935 she was joined by probably the best known YL operator ever, Nell Corry, G2YL, who made history in 1935 by working all continents on 10m in a period of only six hours and contacting only British Empire stations. Ever since these two operators there has been a tradition to issue ladies with callsigns including the letters YL.

Into the 30s

March 1934 sees what could have been the start of Raynet when Folkestone amateurs provided communications for the Hyde lifeboat during an emergency. The first aeronautical mobile operation was done by G5CV when he operated on five metres from a glider. Feeling that this was not enough he then climbed Snowdon, again operating on five metres. There were also the first reports of stations using beam aerials on 14Mc/s. Some changes were made to the licence. The guard bands were reduced to 5Kc/s and the lead in from the aerial would not be counted as part of the aerial system.

The big breakthrough was that amateurs were now allowed to operate for a total of four hours a day instead of only two! The RST code was introduced by Arthur Bratten, but the 'S' part of the code only went up to 'S5' instead of 'S9' as now. In 1935 the PMG allowed the use of the 80m band at any time of the year except on weekdays during September (it gets crazier all the time) The reason for this was that military exercises took place during that month and they did not want to suffer. QRM. The amateur was now in the position of having to work out how long he had been on the air that day, what band he was going to use, if it was

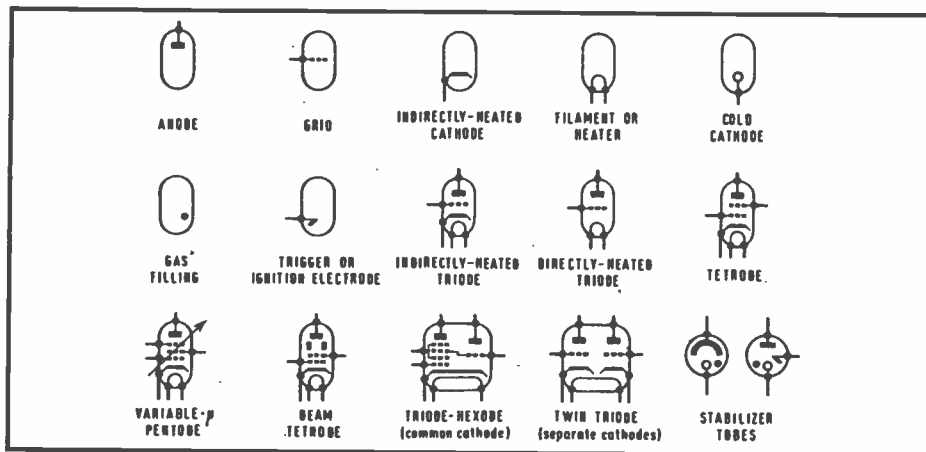

Some early circuit symbols

available at the time he wanted to use it, and even if it was allowed to him in that month. And he still could not call CQ, only test.

Here comes TVI

TVI started on November 2 1936. So did the BBC TV service from Alexandra Palace in London. The frequencies the BBC used were 41.5Mc/s for sound and 45Mc/s for vision. Bearing in mind the broadband nature of TV receivers, these fall nicely as third harmonics of the amateur 20m band. Not only did the viewers receive their nice TV pictures, they also received every amateur within miles, a problem we still have not completely beaten even today.

Another QRT

Four days before the start of the Second World War the BBC 9pm news for August 31 carried the announcement that all amateur licences had been 'determined' and that all equipment would be impounded. It had a familiar ring to it. The first amateur casualties of the war were Jack Hamilton, G5JH, and Ken Abbott, G3YJ, who were killed when their ship, HMS Courageous, hit a mine on September 13, just nine days into the war.

Very essential work was done during the war by the 'Enemy radio signals watch'. This complete system was staffed mainly by amateur operators who were not eligible for war service in any other sphere. The work of this unit has never been well documented but would make interesting reading...Suggestions to the Editor, please.

Round three

After having been knocked out twice by world wars we thought we knew what to expect when activity resumed after 1945. Very few people were really prepared for what happened. To start with, we were near the top of the sunspot cycle; there were servicemen on every little bit of land you can think of and they were eager to begin. Many were the 250 watt military rigs that were fired up on the amateur bands. The writer admits to using a SWB 11 (running 10kW to stacked rhombics at 60 and 90 feet firing into the

UK) on 40 and 20m from Kenya, and I got good reports! On legal limits the writer achieved 100 countries on 10 metres in less than eight hours. I never did get them all confirmed. We will never see that sort of activity again.

New licences

At last the sham of experimental licences was dropped. All the pre-war licences were re-issued to their original holders and those who had held 'artificial aerial' permits were issued callsigns in the G2AAA series. There had been no technical exam before the war, but now the RAE exam was introduced in its fully written up form. Having passed this and the 12wpm Morse test you were issued with a licence in the G3AAA series. True to form, once again there were restrictions. You spent the first 12 months on CW only and with a maximum power of 10 watts. At the end of the year your log was inspected and, if approved, you were allowed on to phone and high power. You could choose your power level at 10, 25 or 150 watts with licences starting at one pound for 10 watts.

Third party traffic was allowed but this facility was very much abused, with wives using the rig while their husbands were at work.

This became so blatant that the facility was withdrawn. I fell foul of this law when I was heard talking in the garden at a friend's shack while he was on the air. Up in front of the court and a fifteen pound fine, big money around 1950.

The amateur involved got a caution from the PMG. Rules were not meant to be broken then. You were also allowed to play one record a day for test purposes. You knew who was on the bands by the music, as much as by the callsigns, you heard.

You were now allowed to call 'CQ' instead of test. The licence structure was still a bit strange. You needed a special permit if you wanted to work mobile and a separate licence and a callsign in the G6AAA series for amateur television. The 144MHz band became available from Jan 1 1949, with a maximum power of 25 watts. And so amateur radio came back to life.

R WITHERS COMMUNICATIONS

584 HAGLEY ROAD WEST, OLDBURY, WARLEY
B68 0BS (QUINTON, BIRMINGHAM)

Tel: 021-421 8201/2 (24 HR ANSWERPHONE)



RWC SPECIAL OFFERS



INSTANT FINANCE AVAILABLE TO ALL LICENCED AMATEURS SUBJECT TO STATUS. VIA LOMBARD TRICITY.

TRANSCEIVERS & RECEIVERS - BEST BUYS P & P

NEW
Kenpro handheld 140-150 MHz 2 watts H/Power out
Includes Nicad pack & charger 3..... **£159.95** £2.00
ALL AVAILABLE KENPRO ACCESSORIES IN STOCK

AM/FM Revco/Gemscan 60 MHz to 515 with airband (extended coverage out soon) only.....	£249.00	£3.50
Hamaster FM 2085-25w 2mtr mobile.....	£179.00	£4.00
FDK Palm II-Ex Demo 6CH 2mtr H/H.....	£119.00	£2.50
FDK Palm II-Ex Demo 6CH 70cm H/H.....	£119.00	£2.50
Blazetone FM200-15w 2mtr PRT Shift.....	£129.00	£3.00
Century 210-AM-FM-SSB Digital		
PLL SW Receiver 0-30mhz.....	£199.00	£5.00
Kenwood/Trio TR3500 UHF/H/N.....	£199.00	£2.50
Kenwood/Trio TR 7950 45W Mobile.....	£319.00	£5.00



R. WITHERS COMMUNICATIONS appointed sole distributors for this exciting range of new antennas, portable, fixed, mobile. SAE for details. Trade enquiries welcome.

ACCESSORIES

NEW

500mhz 7 Digit Mini Frequency Counter.....	£59.98	£2.00
40mhz 7 Digit version of above.....	£39.98	£2.00
Spring Silly Price Rotator Offer 50KG - Koepke Straight Through Rotator.....	£38.95	£2.00
Oskerblock SWR 200 maximum power 2kw. Normal price £59.95		
-3.5-144MHz- 100 to clear at only.....	£39.95	£2.50
Yaesu Mics. MH1B8, YM35, YM49, YM36. All 10% off Regular Prices		
Yaesu FT102 Filters.....	Special	
XF82GA 6khz AM Filter.....	£14.50	£1.00
XF82HSN 1.8khz Narrow SSB Filter.....	£15.00	£1.00
XF82HC 600hz CW Filter.....	£15.00	£1.00
XF455C 500hz CW Filter.....	£39.50	£1.00
XF455CN 270hz CW Filter.....	£39.50	£1.00
Yaesu SP980. Ext LS with Audio Filters (£54.00).....	Special £45.50	£2.50
Yaesu FL110 HF Linear 10w - 100w HF.....	Special £89.00	£2.50
Kenwood/Trio type Mobile Mini Speaker.....	£4.99	£1.00
Diawa Auto ATU CNA 1001 Special Price.....	£139.00	£2.50
Diawa 1.2 k/watt CNW 518 Special Price.....	£189.00	£2.50
Yaesu World Clock QTR 24D only.....	£29.95	£1.50
Diawa CN 510 Cross Needle - HF.....	£39.95	£1.50
Diawa CN 560 Cross Needle - VHF/UHF.....	£49.95	£1.50
Diawa 2030 30 watt FM Booster - 2mtr.....	£55.00	£2.00

PLUS HUNDREDS OF MAIN LINE ITEMS FROM ICOM, YAESU, FDK, KDK, KENWOOD, TRIO, WELZ, DRAE, DATONG, REVCO, MICROWAVE MODULES.

ANTENNAS - REMEMBER IT'S THE ANTENNA THAT MAKES THE STATION!

NEW
A.R.M. TRAVELLING JIM - The exciting new portable Slim Jim..... **£8.99** £1.00

Sun KB-144 Triple 518 Base.....	£29.95	£3.00
Hoxin 8/8 Mobile 88.....	SPECIAL £16.50	£2.00
Sun Double 5/8 KG5 Mobile.....	SPECIAL £11.50	£2.00
Hoxin DC Grounded 1/2 wave mobile complete with cable and mount.....	SPECIAL £10.50	£2.00

TET Beams VHF Special - Enquire - All Tonna & Jaybeam in stock

2mtr HB9CV Over 5000 made to date -.....	£6.99	£2.00
70cm HB9CV Manufactured by RWC - Price held for 4 years!.....	£5.99	£2.00
10mtr HB9CV Complete Assembled or Kit. Full Instructions.....	£29.50	£3.50

ALL TYPES HF AERIALS IN STOCK + 3 types of Discone/Scanner aerials in stock - please enquire.

10 METRE FM MOBILE BASE

'2740' from the company who have converted over '600' units. We have obtained the last 200 units we believe available in the UK. Take this opportunity to obtain any of the following options:-

2740 modified to 6 watt output 29.310 to 29.700 (All units guaranteed brand new).....	£47.50 inc
2740 as above but inc repeater shift.....	£10.50 extra inc
2740 unmodified less crystals.....	£33.00 inc

Crystals for above **£4.75** each plus 50p p&p = 2 req'd plus one for repeater shift.

Suitable 25 watt linear 'Relay Switched' only **£16.50 inc** plus £1.50 p&p

IF Crystal filter **£2.00** inc + 50p p&p

MOD Sheet for above including improved audio also applies to DNT rigs **£1.00** plus SAE

Delux mic ready wired 5 pin din **£3.50** inc plus 50p p&p.

(Also suitable for all VHF rigs)

Delux 10 metre dipole inc wall/loft bracket **£8.50** & £2.50 p&p.

Ray Withers G4KZH says now is the opportunity for all progressive radio amateurs to work real DX for less than £50.00.

Don't Forget We stock almost all Power Transistors/Modules for amateur radios which we import ourselves proving we mean business when it comes to service back-up! - Phone us for your requirements.

'Visit our Shop' - Junction 3 M5 2 mins up the A456 - Full demonstration facilities - All major Brands stocked - something of interest for everyone! - including full Yaesu/Somerkamp range.

Please note all special offers will be dealt with strictly on a first come first served basis. This offer is available only while stocks last. All lines we will be pleased to send mail order.

Please send a SAE for any information you require and our latest s/h list.



SPECIAL
Complete mod kit for LCL 2780/DNT M40 inc 2 x XTALS, 2 x c's XTAL filter full instructions @ £12.95 inc post.

TRIED 10-FM?

What price

HF Equipment

IC-751	All band AM, FM, SSB, CW + Gen Cov Rx. 32 Memories.	1049.00
PS35	Internal switched mode power supply	149.00
SM6	Desk microphone	34.50
HM12	Hand microphone with up/down scanning	16.50
EX310	Voice synthesizer module	39.00
RC10	Frequency controller unit	29.95
CR64	High stability xtal unit	49.95
FL32	9MHz CW/RTTY filter - 500Hz	39.00
FL63	9MHz CW/RTTY narrow filter - 250Hz	39.00
FL33	9MHz AM filter - 6KHz	32.50
FL70	9MHz SSB wide filter - 2.8KHz	35.50
FL52a	455KHz CW/RTTY filter - 500Hz	79.00
FL53a	455KHz CW/RTTY narrow filter - 250Hz	79.00
IC-745	All band SSB, CW, AM (Rx only). Gen Cov Rx. 16 mems.	839.00
PS35	Internal switched mode power supply	149.00
SM6	Desk microphone	34.50
HM12	Hand microphone with up/down scanning	16.50
EX310	Voice synthesizer unit	39.00
EX242	FM unit Tx & Rx	32.50
EX241	Marker unit	15.95
EX243	Curtis keyer unit	39.00
FL45	9MHz CW filter - 500Hz	45.00
FL44a	455KHz SSB narrow filter - 2.4KHz	79.00
FL52a	455KHz CW/RTTY filter - 500Hz	79.00
FL53a	455KHz CW/RTTY narrow filter - 250Hz	79.00
FL54	9MHz CW/RTTY narrow filter - 270Hz	39.00

IC-740	No longer available. Accs still in stock.	
PS740	Internal switched mode power supply	149.00
SM5	Desk microphone	34.50
EX241	Marker unit	15.95
EX242	FM unit	32.50
EX243	Curtis keyer	39.00
FL44	455KHz SSB filter - 2.4KHz	79.00
FL45	9MHz filter - 500Hz	45.00
FL52	455KHz CW/RTTY filter - 500Hz	79.00
FL53	455KHz CW/RTTY narrow filter - 250Hz	79.00
FL54	9MHz CW/RTTY narrow filter - 270Hz	39.00
IC-730	10-80 Mtrs compact transceiver	659.00
PS15	External power supply - 20amps	119.00
PS20	External power supply with speaker - 20 amps	176.00
SM5	Desk microphone	34.50
HM7	Hand microphone with pre amp	14.95
EX202	LDA unit for use with AT100/500	13.50
EX203	CW audio filter	14.50
EX205	Transvertor unit	14.00
EX195	Marker unit	17.00
FL44	455KHz SSB filter - 2.4KHz	79.00
FL45	9MHz CW filter - 500Hz	45.00
FM04	FM unit Tx & Rx	49.00
IC-720A	No longer available. Accs still available.	
PS15	External power supply - 20 amps	119.00
PS20	External power supply with speaker 20 amp	176.00
CF1	Cooling fan for PS20	24.00
SM5	Desk microphone	34.50

FL32	CW narrow filter	39.00
FL34	AM xtal filter	34.00
BC10	Memory back up unit	5.95
FM03	FM unit Tx & Rx	89.00
IC-R70	General Coverage Receiver 0.1-30MHz	549.00
EX257	FM unit	32.50
FL63	CW narrow filter	39.00
FL44a	455KHz SSB filter	79.00
CK70	DC cable kit	5.75
7072	Interface unit to transceive with IC720A	97.50
IC-R71	All mode Gen Cov Rx. k'pad entry, 32 memories	649.00
RC11	Remote control unit for above	T.B.A.
IC-2KL	1KW PEP Linear, auto band switching, complete with -	
2KLPS	Power supply to run 2KL linear	1303.33
IC-AT100	100Watt Automatic antenna tuner	269.00
IC-AT500	500Watt Automatic antenna tuner	369.00
IC-PS30	Systems power supply, 25 amps continuous	229.00
IC-AH1	Mobile antenna, 3.5MHz-30MHz	199.00
VHF Equipment		
IC-271E	Multimode base station, 25w, 32 memories	629.00
IC-271HE	High power version of above, 100w	T.B.A.
PS25	Internal switched mode power supply	89.00
EX310	Speech synthesizer unit	39.00
AG20	Internal receive pre-amp	49.00
SM6	Desk microphone	34.50
IC-290D	25W Multimode mobile, 5 memories, scanning mic	469.00

IC-751, £1049.

The IC-751 now has an interesting and useful addition, a remote push-button frequency selector pad, so you can either twiddle knobs or press buttons.

The IC-751 could be called the flagship of the ICOM range as it features 32 memory channels, full HF receive capability, digital speech synthesizer, computer control and power-supply options. The 751 is fully compatible with ICOM auto units such as the AT-500 and IC-2KL.

Standard features include: a speech processor, switchable choice of J-FET pre-amp or 20dB pin diode attenuator and two VFO's, marker, 4 variable tuning rates, pass band tuning, notch, variable noise blanker, monitor switch, direct feed mixer in the front end, full break-in on CW and AMTOR compatibility.

For more detailed information on this excellent set, please get in touch with us.



IC-R71E, £649.

The best has just been made better! The ICOM IC-R70 receiver has had some important additions made to its specifications and this model is named the IC-R71E. Here are some details:-

100 KHz - 30 MHz all mode (with FM option). Quadruple conversion superhet. IF frequencies 70 MHz 9 MHz and 455 KHz with continuous bandpass tuning and notch filter. Virtually immune from adjacent channel interference with 100 db dynamic range. Adjustable AGC, noise blanker and switchable pre-amplifier. Direct entry keyboard into twin VFO's with 32 programmable memories. Auto squelch tape record function.

Options:- Synthesized voice readout, infra-red remote controller, 12V DC kit, mobile mounting bracket, two CW filters 500 and 250 Hz, FM unit, computer interface, headphones.

The IC-R70 will still be available at £549.00. Ask for a leaflet giving the full details of these two fine receivers.



Thanet ICOM Thanet ICOM Thanet ICOM Thanet ICOM Thanet ICOM Thanet ICOM Thanet ICOM Thanet ICOM Thanet ICOM

perfection!

IC-27E	25W FM mobile, 9 memories, multi-function display	299.00	BC16E	240v wall charger for O2E (BP8/BP7)	9.95	IC-402	SSB portable + CW, 3 watts output	257.00
UT16	Voice synthesizer unit	T.B.A.	BC30	Desk top drop in charger (fast and slow) old packs	56.35	BC15E	AC charger 240v	41.80
IC-25H	45W FM mobile, high power version of old IC25E	359.00	BC35E	Desk charger all packs new & old (fast/slow)	56.35	BC20	DC charger 13.8v	41.80
BU1	Memory back up unit for mobiles	24.50	HM9	Speaker microphone	16.50		DC lead	1.75
	DC leads (flat pin or square 6 pin)	4.50	IC-202S	SSB Portable, + CW, 3 watt output	199.00	LC25	Carrying case	8.25
	DC Plugs (flat 4 pin)	.30	BC15E	AC Charger 240v	41.80	1.2 GHz Equipment		
	DC Sockets (flat 4 pin)	.30	BC20	DC Charger 13.8v	41.80	IC-120	FM mobile, 1 watt output.	
IC-2E	Synthesized hand portable, 1.5 watts	169.00		DC lead	1.75		40MHz coverage mems	439.00
IC-02E	Synthesized hand held, keypad entry, LCD display	229.00		Telescopic antenna	1.50	BT23E	Bit Zero 23e. 1296MHz linear, 1w in -7/8w out	179.00
ML1	10 watt booster unit for 2E	69.00	LC25	Leatherette carrying case	8.25	50 MHz Equipment		
BP3	Standard battery pack	25.00	FA1	Helical screw in antenna	7.50	IC-551	Multimode base station, supplied SSB/CW only	379.00
BP2	Low volts high capacity (long life)	38.00	UHF Equipment			EX106	FM unit	112.00
VP4	Empty battery pack, takes 6 x AA size cells	7.95	IC-471E	Multimode base station, 25watts, 32 memories	699.00	EX107	VOX unit	49.00
BP5	High volts high capacity (high power)	48.00	PS25	Internal switched mode power supply	89.00	EX108	Pass band tune unit	97.50
BP7	High volts high capacity (for use with O2E ONLY)	59.00	EX310	Voice synthesizer unit	39.00	IC-505	Multimode portable, 3/10watt, supplied SSB only	382.00
BP8	Low volts high capacity	49.00	SM6	Desk microphone	34.50	EX282	FM unit	28.50
DC1	12v regulator pack (2E ONLY)	12.50	IC-490E	Multimode mobile, 10 watts, 5 memories	495.00	BP10	Nicad pack	59.00
CP1	12v charger lead for cigar lighter	4.95	IC-45E	FM mobile, 10 watts, 5 memories	329.00	BC15	Charger unit	6.50
FA2	Helical antenna	7.50	BU1	Memory back up unit for mobiles	24.50	LC10	Carrying case	22.50
LC1	Leatherette case (BP5)	5.00		Spare DC leads (flat 4 pin or square 6 pin)	4.50	Mobile Mounting Brackets		
LC2	Leatherette case (BP4)	5.00		DC plugs & sockets (flat 4 pin)	.30	MMB5	Mount for 251E, 451E, 720A, 730	12.50
LC3	Leatherette case (BP3)	5.00	AG1	Must head pre-amp for 471/451/490	49.00	MMB6	Mount for 240	12.50
LC11	Case for O2E (BP3)	5.00	IC-4E	Synthesized hand portable, 1.5 watts	219.00	MMB7	Mount for 245E	12.50
TL1	Heavy duty leather case (all batt packs)	21.27	IC-04E	Synthesized hand held, K pad entry, LCD display	T.B.A.	MMB8	Mount for 255E, 260E	12.50
BC25E	240v wall charger for 2E	6.99	FA3	Flexi 1/4 wave antenna	7.50	MMB9	Mount for 290E, 490E	12.50
BC25U	110v wall charger for 2E (USA)	6.69		Accessories same as IC2E/O2E		MMB10	Mount for 25E, 45E, 120	12.50
						MMB11	Mount for 22U, 24G	12.50



IC-02E, £229.

ICOM introduces the new top-of-the-line IC-02E to compliment its existing line of popular handheld transceivers and accessories. The new direct entry microprocessor controlled IC-02E is a 2 meter handheld jam packed with excellent features.

Some of these features include: scanning, 10 memories, duplex offset storage in memory & odd offsets also stored in memory. Internal Lithium battery backup and repeater tone are of course included. Keyboard entry is made through the 16 button pad allowing easy access to frequencies, duplex, memories, memory scan and priority. The IC-02E has an LCD readout indicating frequency, memory channel, signal strength, transmitter output and scanning functions. New HS-10 Headset, with earphone and boom microphone, which operates with either of the following:— HS10-SB Switch box with pre-amplifier giving biased toggle on, off and continuous transmit. HS10-SA Voice operated switch box, with pre-amplifier, mic gain, vox gain and delay.

IC-271E, £629.

The IC-271E, 2 meter VHF and IC-471E, 430-450 MHz are the 'terrific twins' in Base multimodes at the moment. The design is based upon a new CPU chip that is easy to operate and offers the maximum number of functions available. Power can be adjusted up to 25W on all modes, squelch works on all modes and a listen-input facility has been added for repeater work. RIT shift is shown on the multicolour fluorescent display. 10Hz tuning facilities are included on both machines. Options for the 271E and 471E include - switchable front-end pre-amp, SM6 desk microphone, speech synthesizer announcing displayed frequency, 22 channel memory extension with scan facilities and an internal chopper PSU.



MMB12	Mount for R70, 740, 271E, 471E	12.50	TONO CW/RTTY/ASCII Terminals	RX430	70 cm mast head pre-amp & control box	70.00
MMB16	Mount for 2E, 4E, O2E, O4E	6.95	9000E	Communications computer, RTTY, CW, ASCII, TX/RX		
MMB18	Mount for 751	T.B.A.	550	CW/RTTY decoder, inc CW practice, and CW transmit		
SS1	Shoulder strap for handhelds	7.50	5000E	Communications terminal & k' board, inc AMTOR, VDU.		
Microphones			9100E	As 9000E with amtor		
HM3	4 Pin hand microphone (IC240)	12.50	CRT1200G	High quality video monitor with green display		
HM5	4 Pin hand microphone noise cancelling	20.00	TONO Linears			
HM7	8 Pin hand microphone (IC-24G, 730, 720A)	14.95	MR250W	144-146MHz, 10-15W drive, 180-200W out. RX pre-amp		
HM9	Speaker microphone for hand helds	16.50	MR150W	144-146MHz, 10-15W drive, 120-140W out. RX pre-amp		
HM10	8 Pin microphone with up/down scanning	29.00	MR100W	144-146MHz, 10-15W drive, 80-90W out. RX pre-amp		
HM11E	8 Pin microphone with up/down scanning + tone call	22.50	2M50W	144-146MHz, 1-3W drive, 30-45W out. no pre-amp		
HM12	Up/down scanning mic for new sets (271/471/751/745)	16.50	NEW "G" Series			
SM2	4 Pin base microphone	34.50	2M40G	144-146MHz, 1-3W drive, 20-35W out. RX pre-amp		
SM5	8 Pin base microphone	34.50	2M90G	144-146MHz, 10-15W drive, 70-90W out. RX pre-amp		
SM6	Base microphone for new sets (271/471/751/745)	34.50	2M130G	144-146MHz, 10-15W drive, 110-130W out. RX pre-amp		
Ext Speaker/Headphones/Headsets			4M60G	430MHz, 3-15W drive, 40-60W out. RX pre-amp		
SP3	Matching speaker for ICOM sets	45.00	TONO Pre-amps			
SP4	Mobile speaker with magnetic mount	19.55	RX144	2 metre mast head pre-amp & control box		65.00
HP1	Good quality headphones	28.50				
HS10	Headset and boom mic for ICOM hand helds	18.40				
HS10SB	PTT switch box for HS10	18.40				
HS10SA	VOX unit for HS10	20.70				
ICOM Global digital clock						
	Attractive gold colour, gives time in cities all over the world. Pulsating red LED s. LCD readout with alarm. 195mm	59.00				
					TELEREADER Equipment	
					CWR685E	CW/RTTY/ASCII terminal & k'board, with VDU, TX/RX 730.99
					CWR675E	RX only version of 685E, with inbuilt printer/VDU 599.00
					CWR670E	CW/RTTY/ASCII RX only, use with TV or VDU 349.00
					CWR610	12 pin plug for 670/675/685 6.00
					CWR610E	CW/RTTY decoder, slow morse practice As 610 with adjs baud rate from front panel (45-600) 159.00
					CM40PS	40 character dot matrix printer, 11.5cm paper roll 4.75
					ZENITH Monitors	
					123E	12 inch with green display, good quality 109.25
					122E	12 inch with amber display, good quality 125.00
					TAL, ASP Series System 6 antennas	
					ASP2016	138-512MHz 1/4 wave whip with threaded adaptor 2.56
					ASP3976	66-138MHz 1/4 wave whip with threaded adaptor 5.21
					ASP3936	130-174MHz 1/2 wave whip with barrel/spring, 3dB 18.63
					Mounts for above	
					K57	Fits 1/2 wave, 3/8 inch hole, snap-in type 3.10
					K440	Fits 1/4 wave, 3/8 inch hole, snap-in type 1.55
					K145	Fits 1/2 wave, 3/4 inch hole, snap-in with claw mount 5.43

IC-27E, £299.

This must be the smallest, 2M, FM mobile available today, measuring only 38mm H x 144mm W x 177mm D. IT has all the features that you probably require included in this microprocessor controlled unit. In addition, if you feel lonely and can't find anybody on the band, just press "speech" and the optional built in speech synthesizer will tell you the frequency you are tuned to. This is a boon to the blind operator or to those that tuck their rigs out of sight.

Brief features:- 25/1 Watt output, green LED readout, scanning (memories and programmable limit band scan), priority scan, programmable duplex splits, 25 and 5 Khz tuning steps, 10 memory channels with lithium back up cell, normal and reverse repeater switch, dual VFO, internal speaker and optional speech synthesizer. Just ask for a leaflet and we'll be glad to send you one. Price 299.00 and 39.00 for the optional speech synthesizer.

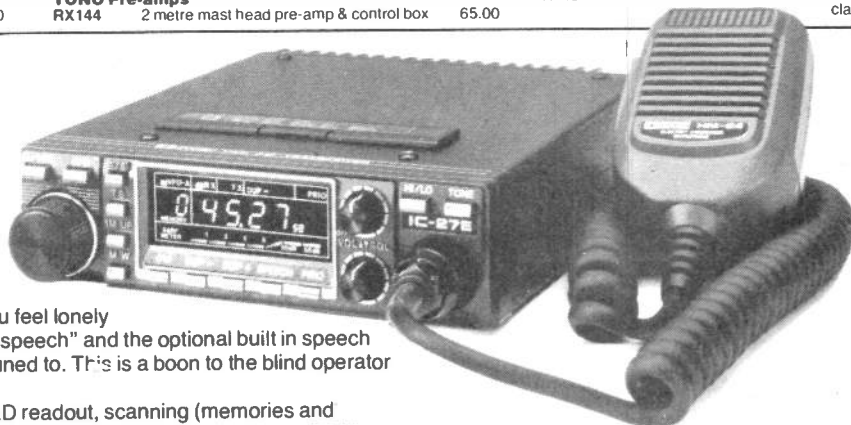

IC-745, £839.

Hearing is believing, the IC745, a new all band HF transceiver with SSB, AM (receive only), CW, RTTY, FM option, and a 100KHz-30MHz general coverage receiver.

The IC745 has a terrific combination of features found on no other transceiver, at such a low price. The IC745 is the only transceiver today that has so many standard features, options and accessories.

The IC745 is yet another superlative set in the ICOM range, see it in our retail shop at 95 Mortimer Street Herne Bay Kent, or contact our Reclver Road address for more information. Your own local ICOM dealer will be able to help you too.



K65	Fits 1/4 wave, 3/4 inch hole, deep claw with 17ft cable	9.31	Mounts for above		
K47	Fits 1/2 wave, 3/4 inch hole, wing mount	7.17	K68	Snap in adaptor for 3/8 inch hole	2.32
KR47	Fits 1/2 wave, 3/4 inch hole, narrow wing mount	12.42	K145	Snap in adaptor with claw fits 3/4 inch hole	5.43
K220	Fits 1/2 wave, magnetic mount with 17ft cable	12.10	K72	Wing mount with 17ft of cable, fits 3/4 inch hole	11.64
K220A	Fits 1/4 wave, magnetic mount with 17ft cable	12.10	K66	Claw mount with 17ft of cable, fits 3/4 inch hole	7.76
M161	Fits 1/2 wave, boot lip mount, needs K57	3.88	K65	1/2 inch deep claw mount with 17ft cable, 3/4" hole	9.31
M161	Fits 1/4 wave, boot lip mount, needs K440	3.88	K220	Magnetic mount with 17ft of cable	12.10
KR193	Fits 1/2 wave, swivel ball mount	4.03	ASPR332E	Gutter clip with 10ft of cable	11.79
K67	Ground plane kit for all whips	16.30	M161	Boot lip mount needs K68	3.88
3000 Series System 6 antennas			KR223	Duraflex noiseless spring	10.86
TAP3006	60-110MHz, 1/4 wave whip with threaded hinge	7.76	K67	Ground plane kit	16.30
TAP3016	110-512MHz, 1/4 wave whip with threaded hinge	7.76	Base station antennas		
TAP3026	144-174MHz, VHF 1/2 wave, 3dB gain, threaded hinge	10.86	ASP655	130-174MHz economy base, 1/2 wave with g-plane	27.94
TAP3676	144-174MHz, VHF 1/2 wave, 3dB gain, with spring	12.42	TAP4009	156-174MHz Colinear, 3dB gain	50.45
TAP3456	420-440MHz, UHF 3dB gain, with threaded adaptor	14.74	ASPD682	160-166MHz Colinear, 4.5dB gain	194.00
TAP3466	450-470MHz, UHF 3dB gain, with threaded adaptor	14.74	ASPE682UK	164-172MHz Colinear, 4.5dB gain	194.00
TAP3696	420-440MHz, UHF 5dB gain, with shock spring	18.63	ASPD700	450-460MHz Colinear, 7dB gain	163.00
TAP3666	450-470MHz, UHF 5dB gain, with shock spring	18.63	ASP2006	156-174MHz Unity gain	47.44
			Low profile/Heavy-duty antennas		
			ASP2001	66-88MHz dome shape, -12db	55.89
			ASP2000	105-108MHz TX - 138-141MHz RX dome shape, -4.5dB	73.74
			ASP2002	162-174MHz dome shape, -3.5dB	55.89
			ASP2021	162-173MHz fin shape, -1dB	55.89
			ASP4005	450-470MHz dome shape, -0.5dB	31.05
			Marine antennas 156-162MHz		
			ASM37E	1/2 wave unity gain, deck mount, with 20ft cable	26.90
			ASM38E	Colinear 3dB gain, deck mount, with 20ft cable	39.32
			ASM77E	1/2 wave unity gain, mast mount, with 3ft cable	19.67
			ASM88E	As above with 60ft of cable	27.83
			ASM98E	Dipole, with deck/bulkhead mount & 20ft of cable	24.21
			TAM1001	1/2 wave unity gain, lightweight whip style	24.84
			TAM1003	Emergency antenna, (CH16) c/w special bracket	23.28
			Mounts/Accessories for above:		
			ASM42	Heavy duty ratchet mount all angles	25.88
			ASM91	Vertical deck mount, fold over	10.35
			K509	Stand off bracket (13cm) for 1001, 1005, 1006, 88E	5.74
			TAM108	Antenna extension rod (1.5m)	31.05
			ASM93	Antenna support bracket	5.16
			CS100	Good quality extension speaker	11.37
			Antenna matching units		
			AMU100	1.5-99MHz 200 watts pep	99.00
			AMU400	1.5-60MHz 400 watts pep	116.43
				Prices include VAT at 15%	
				We reserve the right to change prices without giving prior notice.	
				As well as ICOM equipment, we also stock the following:-	
				TONO & TELEREADER, CUE DEE, DATONG, MICROWAVE	
				MODULES, MUTEK, LAR, WELTZ, YAESU, JAYBEAM, TAL,	
				G-WHIP, DRAE, B.N.O.S., BEARCAT, TRIO and many	
				accessories. Items listed are subject to availability.	

Tono 5000E, £799.

From the famous TONO stable comes the new THETA - 5000E now ready to send and receive AMTOR as well as CW, RTTY, and ASCII.

Features include:- 5" high resolution monitor displaying 400chr. x 16 lines x 2 pages, ARQ/FEC, time clock, Selcal (Selective calling), high speed RTTY demodulator - up to 300 bauds (600 baud using TTL level); 3 shifts (170, 425 and 850 Hz) and two tones (2125 and 1275 Hz); manual or automatic Tx/Rx; Battery back-up memory (72 chars x 7 channels and 24 chars x 5 channels); type ahead correctable buffer memory; Morse code 5 - 100 wpm (variable weights) + autotrack on receive; CW practice feature with random generator; Automatic CR/LF with wrap around display; Automatic letters code insertion; Printer interface; Bargraph LED meter for tuning; TOR A, B and L - the list goes on and on ... Power requirements by the way are AC mains or 13.8v DC.



Please note that we now have a new retail branch at 95, Mortimer Street, Herne Bay, Kent. Give it a visit, BCNU.

Tono 9100E, £699.

The famous TONO THETA 9000E has had AMTOR modes A, B and L added to its functions providing transmit and receive facilities with selective calling on AMTOR, RTTY (with 3 selective shifts and 2 tone pairs), CW with built in practice function and random generator, and ASCII with full Duplex facility. The 9000E requires an external VDU. The battery backed memory covers 256 characters x 7 channels with Channel 6 which is divided into 16 subsections of 16 characters each and Channel 7 into 8 subsections of 32 characters. Any of the subsections may be used individually and messages can be repeated 1 - 9 times from a keyboard command.

Agent: Gordon G3LEQ, or telephone Knutsford (0565) 4040 anytime between 0900 - 2200 hrs.

You can get what you want just by picking up the telephone. Our mail-order dept. offers you: free, same-day despatch whenever possible, instant credit, interest-free H.P., telephone Barclaycard and Access facility and a 24 hour answering service.



Read the B _ _ _ Y Question

A guide to passing the RAE painlessly (almost) by Bill Sparks, G8FBX

The above title will immediately identify the writer to many amateurs in the North Cheshire/South West Lancs region! Many years of experience as a class instructor have convinced me that the majority of failures in the Radio Amateur Examination are due to a misunderstanding of the questions. This is usually brought about by one of two reasons:

1. The time interval permitted for answering the question is rather brief, and consequently the subject is hurriedly scanned rather than carefully studied. The main impact of the question is not fully established.

2. The examinee's inability to appreciate some form of ambiguity in the question as written, this being a failure on the candidate's part to appreciate 'English as she is written'.

The ambiguity referred to does require the application of a certain degree of logical reasoning and this can only be brought to bear in an ordered mind. Where the confines of the exam room create a certain degree of nervousness, this reasoning often becomes difficult to organise. The purpose of these notes is to ensure that the candidate assumes a comfortable and relaxed position in the exam so that full concentration can be brought into play.

This is perhaps an opportune moment to establish the function of the test and the purpose in the examiner's mind in subjecting our hopefuls to the purgatory of the exam room. The purpose of the exam is not to answer either 35 or 60 questions, but to provide a sufficient number of correct answers to satisfy the examining body that you are a 'Person suitably qualified to operate the equipment within the confines of the Amateur Licence.'

Areas of study

In view of this, the importance of establishing a satisfactory pass mark is obvious and this means that a minimum number of questions have to be correctly answered. This also means that if, for example, it was necessary to answer 35 questions in Part 2 to gain a pass mark, then once 35 questions have been answered correctly, the remaining questions are not really significant. Remember that the licence, when it arrives, is not gold, silver or bronze plated, so it is of no significance to the authority whether you get a distinction, credit or a simple pass. The licensing authority is only

concerned with your ability to control the equipment under your supervision to their satisfaction.

So, *choosing* the areas in the syllabus most suited to the student's learning ability (or main interest) is one short cut that can be taken. Another is the obvious necessity of learning those parts of the subject thoroughly to ensure a pass rating, and using the remainder as a sort of bonus.

It must be apparent that the important question must be: 'Do you know how to use the knowledge you have gained in your study?' And can you apply your knowledge in establishing the correct meaning of the exam question, remembering all the time that the examiner could be trying to catch you out?

The May 1983 paper created a considerable amount of criticism, mainly due to the fact that it introduced certain new topics and style; many students felt they had been 'cheated'. They had, but by themselves - not by anyone else. There were no subjects in the questions which were not in the syllabus on pages 21-30 and 33-34 of the original HO book *How to become a radio amateur*. Saying that the RAE exam manual did not cover them, or previous exam papers did not show them, is a weak protest. Also, the RAE exam manual has many failings since it assumes an O-level in physics before starting and its coverage of the basic parameters is very sketchy indeed.

Also, no student should legally have copies of previous papers. These are the property of City and Guilds and all should have been returned after the exam.

DTI manual

The new DTI manual does not include a syllabus, but one is available from the City and Guilds of London Institute, Publication 765. Attention is specifically drawn to page 15, section 3 of this booklet where the differential form of the operational amplifier and the Darlington configuration are mentioned. Very few instructors cover these details. (City and Guilds of London Institute, 76 Portland Place, London W1N 4AA.)

Part 1		
Group a:	Licensing conditions	23 questions 65.7%
Group b:	Transmitter interference	12 questions 34.3%
		<hr/> 35 questions 100.0%

The DTI manual splits the exam into various sub-groups. The total of correctly answered questions is relevant and not the number passed in each group.

In order to be certain of a pass, at least 58% of correct answers should be achieved so that 21 questions need to be answered correctly.

The section on licensing conditions invariably requires an answer which is an extract from the DTI booklet, pages 13-19 new (5-15 old). Providing a careful study is made of these pages then the relevant sentence can often be brought to mind. It must be apparent that a thorough knowledge of (a) will certainly guarantee a pass in Part 1, leaving the questions on transmitter interference as a possible safety margin if answered correctly.

Applying a similar analysis to Part 2:

Group 1:	Operating practices and procedures	5 questions	8.33%
Group 2:	Electrical theory	11 "	18.33%
Group 3:	Semi conductors	9 "	15.0%
Group 4:	Radio receivers	9 "	15.0%
Group 5:	Radio transmitters	9 "	15.0%
Group 6:	Propogation & aerials	10 "	16.66%
Group 7:	Measurement	7 "	11.66%
	Total	60 "	100.00%

From the analysis, and assuming the same requirement as a pass rate, the total can be made up from various combinations of the above. Obviously, (2) is essential (18.33%) since none of the others can be satisfactorily studied without this part. This leaves some 40% to be made up. It can be seen that 3, 4 and 5, if answered correctly, will guarantee a pass, or that 1 plus any from 3, 4 or 5 will also ensure a happy face in late August or early February. The point emphasised here is that if the student can absorb certain subjects, but finds difficulty in other groups, then he or she should concentrate on the groups which are within his or her capability to ensure a high mark, while any other questions guesstimated may be considered again as bonus points.

The important fact to arise from the above is that a thorough understanding of the desired subjects is essential and that this is not the phenomenal task that it is often assumed to be.

For those studying at home a different approach is required from that of the classroom student. It should be noted that the basic principle in studying any subject is to establish certain parameters, the most important ones being those of size or limitation. It is futile to

READ THE B...Y QUESTION

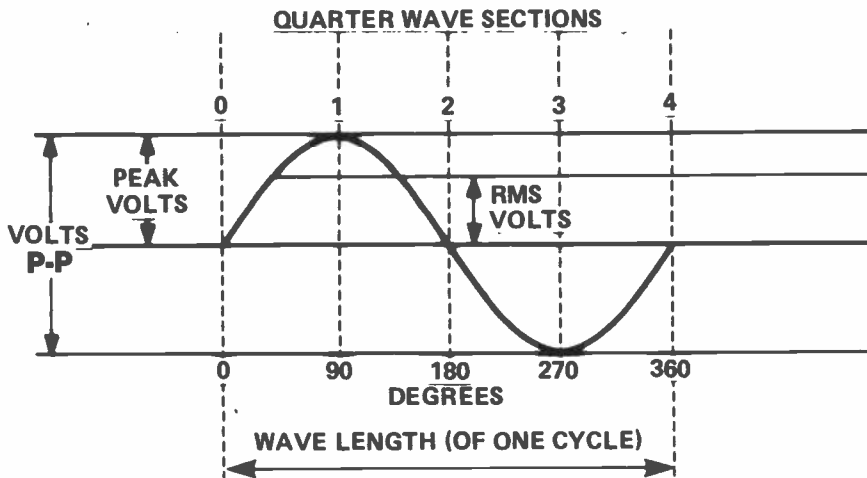

[Figure 1]

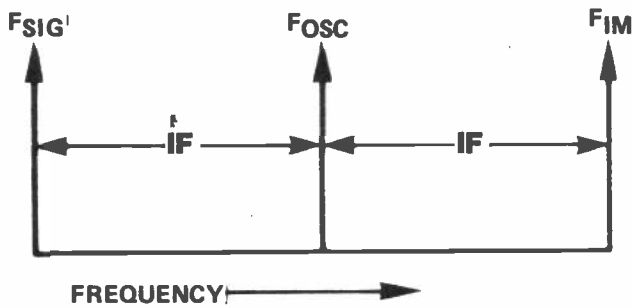

EXAMPLE

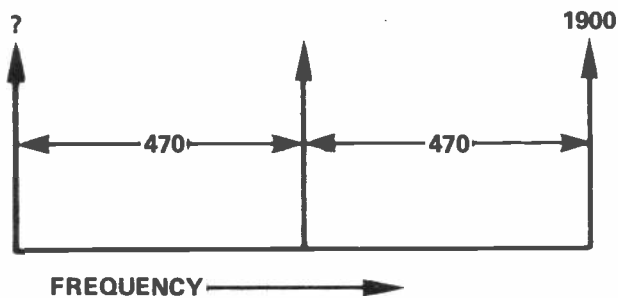

$$? = 1900 - 470 - 470 = 960$$

Figure 2 A typical example of the use of diagrams in answering RAE questions, in this case finding the actual frequency when given only the modulated frequency and IF, by means of the 'toasting fork' method

study any part of the subject that will not be a possible source of questions. Development of any subject can take place once the licence has been gained. Until that date the main objective is to cover the syllabus *only*.

By using a form of critical path analysis and working from the end point to the beginning, a point is reached at which the present limited knowledge is of the required level. By planning the learning from this point, a programme of study can be established and monitored by means of sample questions on the specific subject, which are currently available from the CGI or taken from the back of the *RAE Manual*. The writer uses the KISS routine: Keep It Simple and Stupid. Unnecessary elaboration in a course is not wise since knowledge over and above that required can be confusing. Another check on progress is to mark off the areas of study completed, as indicated in the syllabus shown in the objectives in the CGI manual.

Method of approach

The main difficulty in tackling the course is that the method of approach is often incorrectly adopted. Providing simple basic rules of understanding are adopted it is a relatively easy matter to reduce any problem to a simple form which can be readily understood. This is a vitally important factor in Group 2. Initially, the question is asked and a group of four answers given. Invariably, two answers are obviously wrong; the other two present the problem of deciding which answer is the correct one. One is nearly right and causes some confusion and this is the point at which the student requires a satisfactory understanding of the point under discussion. Usually, a simple application of logic will give the required answer and a typical question is as follows:

An alternative voltage of sinusoidal waveform has a peak to peak value of 500 volts. The RMS value would be:

- (a) 707V
- (b) 353.5V
- (c) 177V
- (d) 141.4V

The suggested approach to answering this question is to sketch a sine wave on the question paper (Fig 1). Show the peak voltage which is immediately seen as 250 volts. This then disqualifies (a) and (b) and leaves a choice of (c) or (d) in the answers. The RMS is known to be $.707^\circ$ of the peak, so $.707^\circ \times 250 = 177$ which is the correct answer.

The correct technique is *always* to either put the relevant formula down on the question paper, or to draw or sketch some suitable diagram or table to portray the point of the question. This shows the examiner that you understand the theory behind the question

Let us now assume that the student has just taken his seat in the exam room and is just about to pick up his question paper.

ATTENTION 10 METRE OPERATORS!

NEW – especially for the 10 Metre users who have converted CB rigs

The AKD 10 Metre Linear Amplifier

- ★ 25 Watts FM out for 4 Watts in
- ★ 50 Watts PEP on SSB
- ★ About 10 Watts out for ½ Watt in (13.8V)
- ★ Automatic RF sensing
- ★ Fully protected output
- ★ Relay switching employed
- ★ Requires nominal 12 volts @ 5 amps (15 volts maximum)
- ★ In-line fused
- ★ 2 year guarantee (including output device)
- ★ British made



£25.50
Incl VAT, p&p

10 Metre RF Switched, In-Line Pre-Amp

- ★ 3SK45 Dual Gate Fet, 15 dB gain
- ★ Fail safe, will handle 10 watts through power
- ★ 2 year guarantee

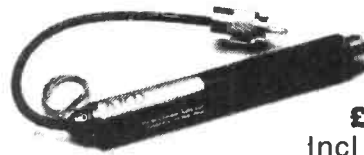

£14.50
Incl VAT, p&p

HIGH PERFORMANCE RF FILTERS SLIMLINE, ATTRACTIVE APPEARANCE

Used by British Telecom, Thorn-EMI, ITT, Telefusion, etc.

Standard range terminated in Belling Lee plug/socket (75ohms) – others to order.

Model TNF2 Tuned Notch Filters (Braid & Inner) for 2, 10, 15, 20 Metres & CB (state which) **£7.50**

The TNF2 range have a very low insertion loss and very high rejection over the band for which they are supplied. They are the best possible answer for aerial borne interference from a single known frequency or frequency band.

Model RBF1-70cms Notch Filter (inner only) **£6.32**

Model BB1 Braid Breaker **£6.32**

Also available, 3 High Pass models and a "Radar Blip" filter for VCRs. Please send A4 or C4 stamped addressed envelope for filters data sheet and price list.

RF FILTERS DIAGNOSTIC KIT

A complete set of the 11 AKD standard RF Filters may be purchased as a Diagnostic Kit. Includes Data Sheet **£38.40**

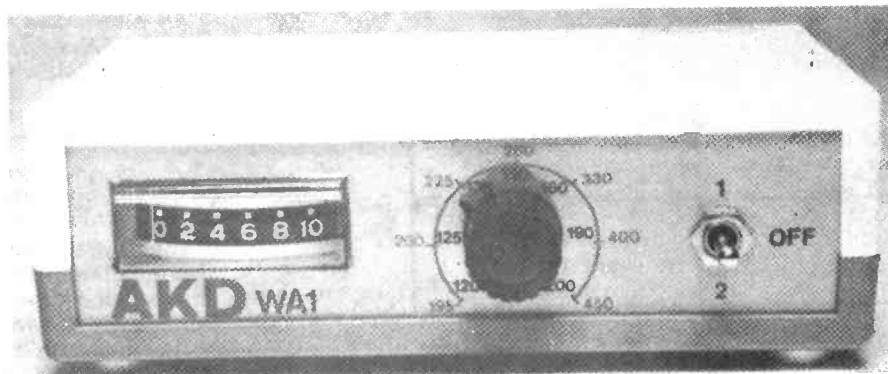

A WAVEMETER FOR VHF/UHF

The AKD WA1 Absorption Wavemeter covers 120-450 MHz in two ranges. It is extremely sensitive and comes complete with a small aerial. It requires a PP3 battery.

£24.95 inclusive of postage & VAT

Direct from the Manufacturer – or from your local Amateur Radio dealer.
Trade enquiries welcome

★ AKD ★ ARMSTRONG KIRKWOOD DEVELOPMENTS
62 Marcourt Road, Stokenchurch, High Wycombe, Bucks HP14 3QU
Tel: 024-026-2360

READ THE B...Y QUESTION

MA

Candidate Name	Date	Paper Number
Name of Centre	Centre Number	Candidate Number

Use HB pencil: Fill in details above
 Write your number in the boxes
 and fill in the same figure in the column
 below each box.
 Mark chosen answer thus:
 To change answer rub out carefully.

0	1	2	3	4	5	6	7	8	9
0	1	2	3	4	5	6	7	8	9
0	1	2	3	4	5	6	7	8	9
0	1	2	3	4	5	6	7	8	9
0	1	2	3	4	5	6	7	8	9
0	1	2	3	4	5	6	7	8	9
0	1	2	3	4	5	6	7	8	9
0	1	2	3	4	5	6	7	8	9
0	1	2	3	4	5	6	7	8	9
0	1	2	3	4	5	6	7	8	9

Fill in your answers in the boxes — WORK DOWN THE COLUMNS

1	26	51	76
2	27	52	77
3	28	53	78
4	29	54	79
5	30	55	80
6	31	56	81
7	32	57	82
8	33	58	83
9	34	59	84
10	35	60	85
11	36	61	86
12	37	62	87
13	38	63	88
14	39	64	89
15	40	65	90
16	41	66	91
17	42	67	92
18	43	68	93
19	44	69	94
20	45	70	95
21	46	71	96
22	47	72	97
23	48	73	98
24	49	74	99
25	50	75	100

Fig 2

Now go back and check your work

Taking the examination

The examination routine is to provide a question paper together with an answer sheet (Fig 2). The answers are checked by computer analysis and it is necessary to mark the answer sheet in a specially registered place to indicate your preference between a, b, c or d. This marking *must* be carried out with an HB pencil and done exactly as shown on the sheet to enable the computer to scan your preference correctly.

The set of columns on the upper right hand area of the answer sheet also require filling-in correctly. This personal data is the only link between you and the computer and a mistake in filling in this section correctly could possibly lose you the exam. Make certain that this area is filled in with your centre and reference number correctly entered, and do not leave this for the last few panic-stricken minutes. Mind you, if you follow the advice in these notes you should not have these panic periods.

The correct technique in taking the examination is to arrive at the centre at least ten minutes before the deadline and make yourself comfortable at the table. Check that you have all the necessary equipment and ensure that you are not likely to require to make any 'calls of nature' in the immediate future. In other words, go before you enter the exam room. You will have already been issued

(probably) with an answer sheet and now is an opportune time to enter your personal data from your exam slip onto the answer sheet before the exam starts. At the start of the exam proper you will be told that you may now look at the question paper, and the first few minutes should be spent in a rapid survey of the paper to check whether there are any 'gift' questions: those that you are confident of answering quickly and correctly. Tick these with pencil and complete your survey.

In answering a single question, a valuable technique is to look at the given answers in reverse order, ie, d-c-b-a, instead of a-b-c-d. This apparently irrelevant fact is not so stupid as it appears since it gets one away from the natural tendency to look at the first answer and say 'that's it' without carrying on and examining all the prospects. Looking at them briefly in reverse order means you should examine all the alternatives. This is a psychologically proven fact and has been practised by the writer's students who definitely find it of value.

After disposing of the easier questions it will be found that more time can be given to the more difficult questions. Upon analysing the time span for paper 2 (a similar analysis applies to part 1) some 1.75 hours is permitted, ie 105 minutes.

Assuming that a pre-planned programme of attack is envisaged, the

timetable would probably look like the following:

1. Examine questions	10 mins
2. Answer questions	70/75 mins
3. Check answers, transfer to answer sheet and check answer sheet information	10/15 mins
4. Check back from answer sheet to question paper	5 mins
5. Reserve time	5 mins

or some similar variation, as discussed earlier.

The important point is not the actual time allocated but the planned form of attack which helps to take a lot of the frightening confrontation complex away. The importance of checking the accuracy of the transfer of information cannot be over-emphasised.

Since the purpose of these notes is to eradicate some of the pitfalls in the exam, it is perhaps a rather significant feature that one should adopt the attitude of the boy scout: Be prepared! The time to prepare is right at the start of the course of study and to plan the course of study around the CGI syllabus if studying at home, or to ensure that the instructor covers all the syllabus points in class.

To adequately cover the course, some 20-22 x 2 hour periods will enable the various points to be discussed broadly, with a further 12 x 2 hour periods of revision, using previously asked questions to illustrate the revision followed by a mock exam and inquest just prior to the main exam.

The order of learning is of importance since various classifications are built up from other groups. The one found to be highly effective is as follows:

(a) Mathematics for RAE students	2 periods
(b) Electrical (DC) theory	2 "
(c) Electronic (AC) theory	2 "
(d) Solid-state devices	3 "
(e) Transmitters	2 "
(f) Receivers	2 "
(g) Aerials and propagation	3 "
(h) Measurements & interference	1 "
(i) Practices & procedures	1 "
(j) Licence conditions and regulations	1/2 "

The suggested periods are subject to variation; obviously the progression is a logical build-up in which knowledge of the preceding group is part of the learning requirement of the successive stage, ie a learning curve is established.

The techniques discussed here have been applied by students under the writer's tuition over the past four or five years with very satisfactory results. The accumulative pass rate is well over 90%, and 100% has been achieved on three occasions. The make up of the classes has been from thirteen-year-old girls to eighty-year-old men (duly separated).

Our aim has been to relieve some of the fears of the exam room and to point out the not-so-obvious pitfalls which may be encountered. Whilst a rigid adherence to the notes is not required, various sections can be of great help in passing the exam with less pain.

73 es GL from G8FBX.

Amateur RADIO

For all two-way radio enthusiasts

DON'T MISS YOUR COPY

With regular features like Current Comment, DX Diary, Straight and Level, Angus McKenzie's equipment review, SWL, Club Calendar and Free Classified Ads, and a host of special features in each issue, make sure you place a regular order for **Amateur Radio** with your newsagent or take out a post free subscription now, while the offer lasts

SUBSCRIPTION BENEFITS

...delivery to your door by publication date each month
 ...inflation proof - price guaranteed for 12 months



On sale NOW at your newsagent

AMATEUR RADIO SUBSCRIPTION ORDER FORM

To: Subscription Department • Amateur Radio •
 513 London Road • Thornton Heath •
 Surrey • CR4 6AR. Tel: 01-684 3157

NAME

ADDRESS.....

.....

..... Postcode

PLEASE SUPPLY: (tick box) for 12 issues, all rates include P & P

Inland World-Surface Europe-Air World-Air
 \$10.80..... \$11.65..... \$18.80..... \$21.00.....

PAYMENT ENCLOSED: £

Cheques should be made payable to Amateur Radio. Overseas payment by International Money Order, or credit card.

CREDIT CARD PAYMENT  

Signature..... AR0584

24cm AMATEUR TV

4

UK repeater licences have now been issued, and already we know of two amateur television repeaters on the air. Andy Emmerson G8PTH takes a close look at the situation as it now stands, and guides us through the details of who, what, with what, and to whom

Time seems to fly as I write these articles, and I am pleased to say that the event we were all waiting for has now happened, and just at the right time for this article!

Yes, the UK repeater licences have now been issued and two TV repeaters are already on the air. So without further ado, let us take a look at what's going on, and at the same time congratulate those people who have been working so hard and so long to make TV repeaters a reality.

Phase one (let's be positive!) of ATV repeaters in the UK covers five units, listed below with their locations and channel number.

GB3UT	Bath	YL49e	RMT1
GB3GV	Leicester	ZM25f	RMT1
GB3TV	Luton	ZL08d	RMT2
GB3VR	Worthing	ZK18b	RMT2
GB3UD	Stoke	ZN79b	RMT2

The frequencies of channels RMT1 and 2 were given in Part 1 but can be repeated here. RMT1 allows either AM or FM in on 1276.5MHz (vision carrier) and radiates AM on 1311.5MHz. RMT2 is an FM-only system with input centred on 1249 and output at 1318.5. With both AM and FM systems operational we will be able to see which system is better under practical conditions, and if FM turns out as predicted we may see at least one of the RMT1 repeaters transferring to RMT2.

Operational

Already on the air are GB3GV (Glenfield Video) and GB3VR (Video Repeater); GV went operational at 1pm on Sunday, 19th February (the first QSO being recorded for posterity) and VR on Sunday 4th March (at least it was due to – I am writing this in advance). The idea of ATV repeaters in the UK was first mooted (and indeed muted!) some six or seven years ago, but practical proposals were only sent to the Radio Regulatory Department some 18 months ago. The fact that we now have these repeater licences is a tribute to the stalwarts in the BATC, RSGB Repeater Management Group and sympathetic ears at the RRD.

The advantages of repeaters are considerable: they will relieve the pressure on 70cm, both for ATV use and in the interests of other users of that band. Lengthy local natter/gawp nets can go on in the sure knowledge that neighbours' TV front-ends are not frying, and the



One of the UK pioneers on 24cm, this is John Wood, G3YQC. Seen here in the 'shack', his QTH is just outside Rugby in Warwickshire. Despite his Midlands location John has had successful contacts with France on 24cm



Crossband 24/70cm working adds a new dimension to ATV. Here F3YX is relaying on 438.5MHz a signal received on 1255MHz from F1MV. These transmissions were picked up by F1DL who in turn relayed them on 1255 to F1BJB who made this recording

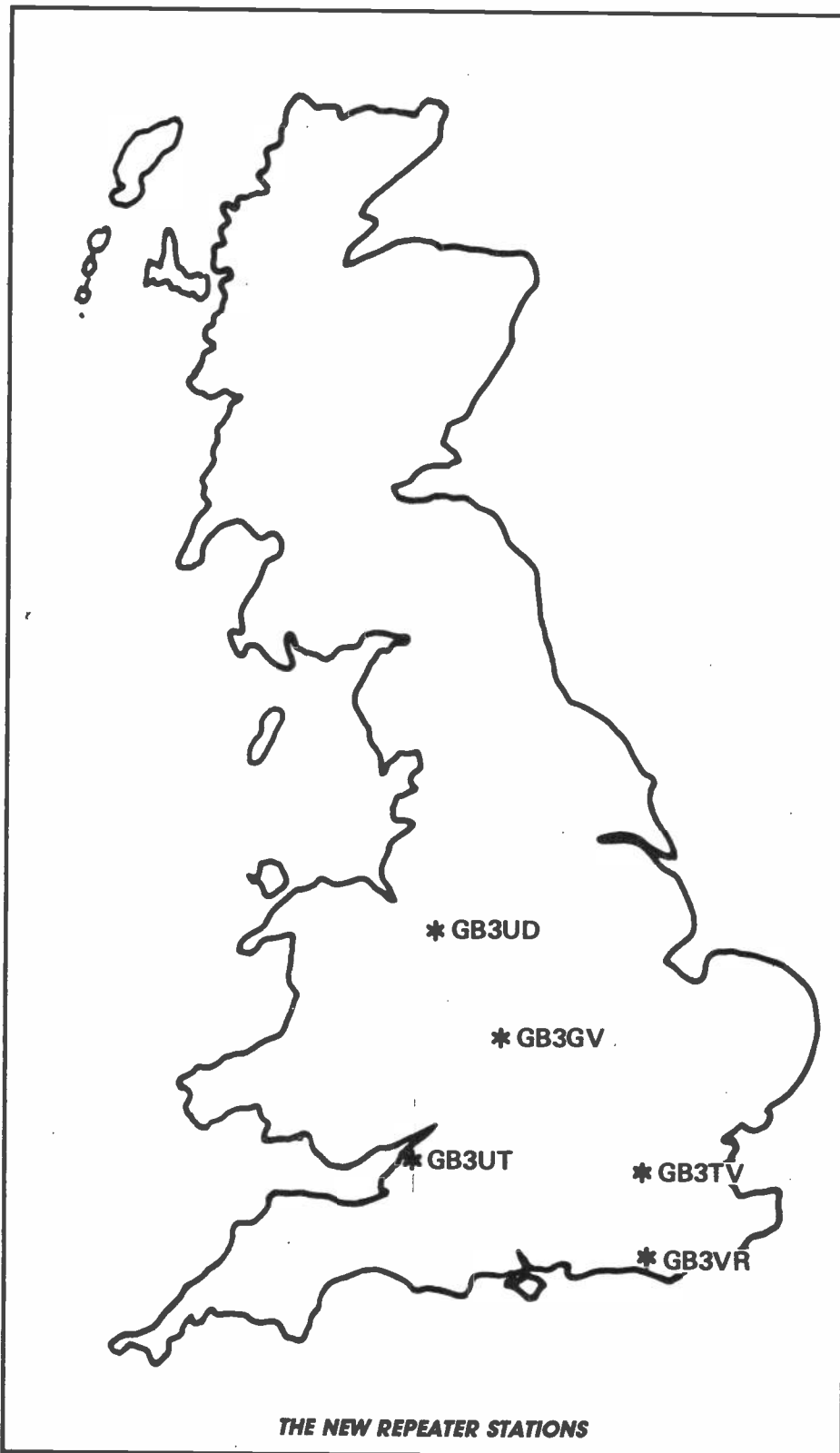

aggr of turning beams every five minutes and someone on the edge missing out will be a thing of the past. Furthermore when you need a signal at 4am to test a new receive converter you have spent all night aligning, you will be able to call up the repeater and carry on twiddling.

The lack of high power on 24cm will not be a major disadvantage within the repeater's coverage area, and it is to be hoped that the lack of constraints will

encourage a higher level of ATV activity. Among the lack of constraints will be the fairly certain knowledge that the 'buzbies' will not be watching, nor will they have the means so to do, but that should not be the instigation for 'late night films' as Roger Bunney once called them. Enough of this frivolity.

Technical details

Because only two repeaters have been completed so far, I am not in a position to

describe all the repeaters in detail, so I have confined this to one 'box'. Whether this turns out to be typical, time will tell. This then is the story of GB3VR.

Following extensive tests of both AM and FM, the latter was found to give far better results. The district covered comprises the Sussex coast, a fairly flat area east and west, but with the South Downs to the north (excluding coverage in this direction). To the south is France and cross-Channel hookups are likely under lift conditions. There is in fact a high level of simplex and crossband activity in the district.

The site chosen for the repeater is at High Salvington, an elevated spot overlooking Worthing. Aerials are centre-fed Alford slots built by G6AIW. These have a gain of around 6.5dBi, with one each for receive and transmit. Both are equipped with the standard three-pole interdigital bandpass filter (see *fig 6* and last month's article) and the receive antenna has a bipolar transistor preamplifier (by G8KOE).

The transmitter was also built by G8KOE and starts off with a Wood and Douglas UFM01 oscillator, left running 24 hours for stability. The power stage is a TRW 'black brick' (the source of Motorola 'blue bricks' has now dried up), producing five watts for a varactor multiplier. The output to the aerials is about 2W and may be increased later.

Modification

The receive side is headed by a Microwave Modules 1296MHz converter, modified by the firm to convert 1249 to 52MHz; this feeds a Wood & Douglas IF strip, which has more facilities on it than the BATC design. This combination is found to be much less noisy than the user method of using a UHF TV tuner. Work on the receiver was put in by G6AIW, with help from Wood & Douglas. The logic, by G8DHE, is based on a Plessey teletext chip and synchronises to incoming video. It also overlays the GB3VR call sign and eventually up to seven pages of information.

For the other UK repeaters we can be briefer. GB3GV, west of Leicester, is also on the air. Last information was that it produced 15 watts to an Alford Slot antenna, with a BBC microcomputer in control. Alford slots are also due to be used at GB3TV, the Luton repeater which will in fact be sited on Dunstable Downs. Coverage tests from this site indicate reception being possible at up to 64km. Logic control is to be based on a 6800 microprocessor.

GB3UT is another AM repeater and is being built by part of the Mendip Repeater Group. Little has been published about this project, though its output is expected to be eight watts to a clover-leaf antenna. The location is co-sited with GB3UB. GB3UD is to be located 366 metres above sea-level near Stoke on Trent and should give some good coverage, even as far as Birmingham. Construction is likely to incorporate Fortop modules.

24cm AMATEUR TV

Activity in the UK...

There are more than two dozen transmitting stations active on 24cm in England, mostly concentrated around the five repeater sites mentioned above. In addition a few stations are scattered across the Midlands and in the London and Solent areas, where the next repeaters may be proposed. A number of stations have had successful contacts with French stations.

...and abroad

Our nearest neighbour, France, has led the activity on 24cm, all FM. Marc F3YX started the ball rolling a few years ago and there are now more than 40 stations on the air. A couple in Belgium have also built equipment, though there is a little doubt about the long-term future of the 24cm band in Belgium. Simplex frequencies are 1255MHz, with 1227 as an alternative for relay operation. There are no TV repeaters in France or Belgium.

In the Netherlands, interest in FM TV is led by Paul Paoson, who has written some articles in *Elektron* magazine. A TV repeater is under construction in Aalten (FM input 1275.0, AM output 1252.5MHz) and another is planned for Eindhoven.

West Germany has the highest activity level in Europe for ATV, and a number of AM 24cm stations have existed for several years. There is some FM activity, championed by Heinz Venhaus DC6MR. Four repeaters have FM capability:

DBOTT, Dortmund, DL48a.

AM input 1242.5.

FM input: 1275.0.

AM output: 434.25.

FM output: 1275.0.

(FM input/output selectable).

DBOCD, Essen, DL46h.

FM/AM input: 1275.0.

AM output: 434.35.

DBOKO, Cologne, DK05f.

AM input: 434.25.

FM output: 1285.5.

DBOYQ, Oberpfalz, GJ22c.

FM/AM input: 1252.5.

FM/AM output: 1285.5.

All frequencies quoted are vision carriers in MHz.

Crossband and relay operation

Back in the far-off days of 15 years ago, when we had a wider allocation of 70cm, I understand the East Anglian ATVers used to link the London area to the Fenlands by a series of relays. Such an achievement would now be difficult if not impossible with our present 'single TV channel' 70cm band, but at 24cm the problems vanish. In France the frequencies 1255 and 1227MHz are in common use for duplex and relay operation. F3YX tells me he made duplex QSOs with F5BH for many years and John G8UWS in Folkestone had an interesting link-up in February 1982 when he worked F1MV (St. Georges, Auxerre - 1255MHz) and F1AQJ (Neuvy-Sautour - 1227MHz) on 70cm! Relay station in each case was F3YX.

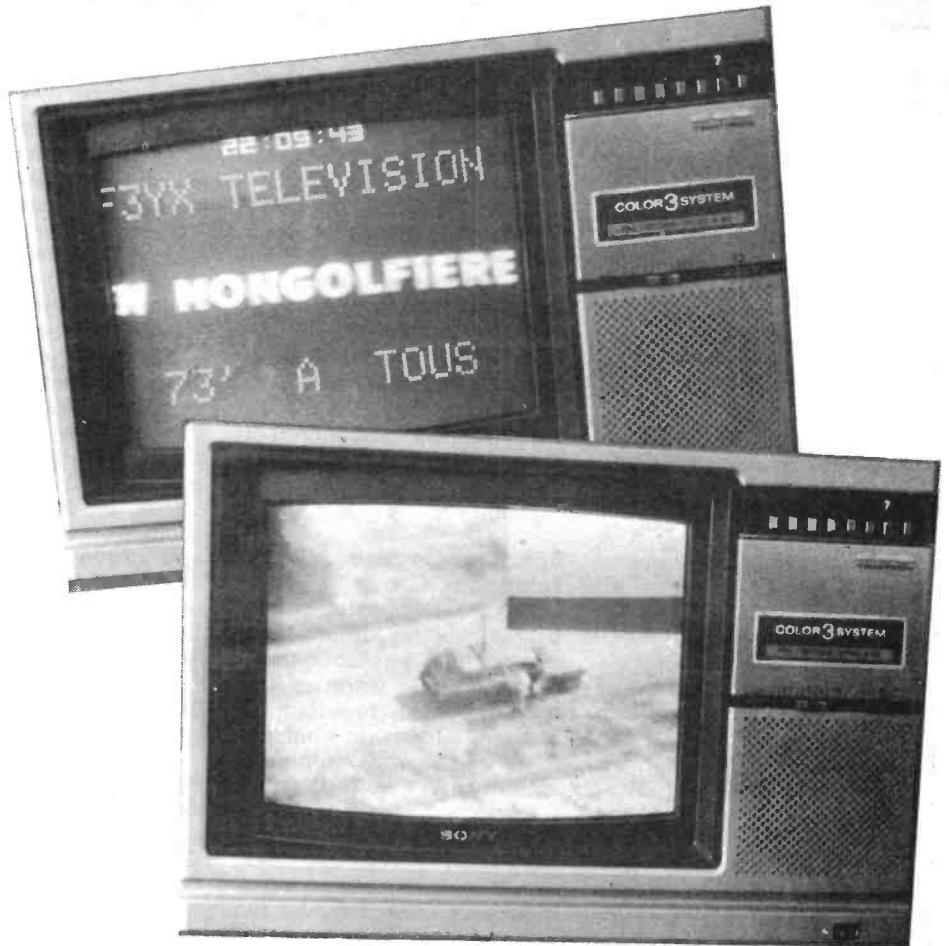

A low power (1 watt) FM transmitter can be used to link a camera and a VCR, as in this example when Marc F3YX went aeronautical mobile in a balloon. In this case another camera in a car on the ground was genlocked to the received signals and the combined pictures retransmitted on 70cm from the car

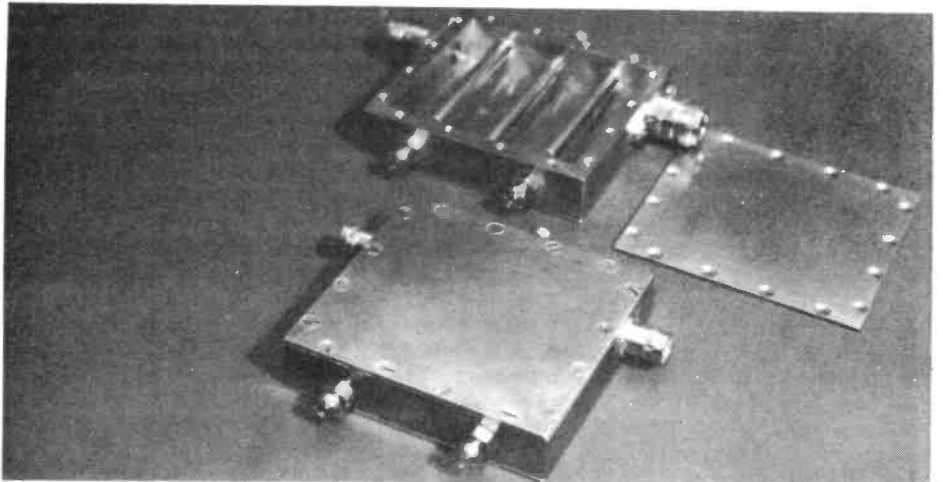

Examples of three-pole interdigital filters made by Cyril James G3VVB. Write to him QTHR for prices

Envoi

For part four, that's it. The next part is scheduled to conclude the series unless we get lots of feedback. We have now covered all the theory and the rest is practical. To a large extent it's up to you to go forth and multiply (with varactors of course) and increase the level of activity. To this end, part five will contain constructional details of a single-tube PA and a broadside colinear aerial. Both are 'easy' to build with tools and materials which should already be avail-

able at home. There are no desperately precise measurements or tolerances, and both the PA and the aerial will cover the whole 23/24cm band. Don't thank me though; thank Rod G8YBC and Roy G6AIW who did the development work.

Footnote: I have prepared an 'activity list' of 24cm ATV stations in western Europe; if you want a copy please send a large SAE to me at 71 Falcutt Way, Northampton, NN2 8PH. I shall also be pleased to hear from other 'activists' with any feedback for these articles.

CLUB CALENDAR

Axe Vale AR Club

The Axe Vale Amateur Radio Club meet on the first Friday of each month at The Cavalier Hotel, West Street, Axminster, Devon. The Cavalier is just west of the Parish Church on the main A35 road. Meetings start at 7.30pm.

The 1984 programme is:

May 4, Aerial Radiation Patterns: How and Why? by G3GC; June 1, The Entertaining Electron; July 6, Visit to IBA, Stockland Hill; August 3, 144MHz Fox Hunt; September 7, Your RSGB; October 5, A Microwave Evening; November 2, AGM and Presentation of Constructor's Trophy; December 7, Annual Dinner.

Stockland Hill Repeater Group

The group has been reformed. At a meeting on 10th February G8AOJ explained to 17 users of the 70cm repeater GB3SH that although the repeater continues to work well there is no money left to maintain or improve the installation.

The repeater equipment was originally purchased by a small group known as the East Devon Repeater Group who were responsible for both the GB3SH (Stockland Hill) and GB3EX (Exeter) proposals.

Subsequently GB3EX has proved fairly easy and inexpensive to maintain; GB3SH however, requiring aerials to be mounted high up on a very exposed site, has not proved so easy. Indeed it is to the credit of G8AOJ that the unit works so well. George had managed the repeater virtually single handed for two years and he felt the time had come to request some assistance. A management group of four was formed. G8AOJ will act as Technical Manager; G3YMK Sec/Treasurer; G4DOQ and G6WZA fulfilling a user liaison role.

It was decided to ask users for a minimum of £5 per year towards upkeep and improvement of the repeater.

Future plans include raising the height of aerials, and improving coverage to the north. Estimated costs to carry out this work are about £300.

All contributions to funds would be welcomed by

G3YMK at 10, Oak Tree Close, Uppottery, Nr. Honiton, Devon, EX14 9QG.

Some GB3SH users would be interested to see if there is support for a 2m repeater co-sited with the 70cm unit. Comments please to any of the GB3SH team.

Exmouth AR Club

The club meets at the 6th Exmouth School Scout Hut on Marpool Hill, Exmouth, on alternate Wednesdays at 7.30pm.

British Amateur Radio Teleprinter Group

This year the Group celebrates its Silver Jubilee. It has come a long way since those days in 1959 when a few pioneers got together to exchange ideas on what was then the new technique of amateur RTTY. Today, the Group caters for most forms of data transmission, ranging from RTTY, AMTOR, FAX, weather forecasting, satellites and telemetry, to the more advanced techniques of digital repeaters, packet radio, computer-to-computer communication, and so on.

The Group Newsletter is published quarterly, and contains around 60 pages of technical, constructional and theoretical features, together with news and items of general interest. The Newsletter also carries a schedule of the RTTY News Bulletin service, which has recently been expanded. The bulletins are broadcast from stations all over the UK on Sundays on 80m, 2m and 20m, and test transmissions are also radiated regularly, to allow amateurs to check their receiving equipment. Bulletins are transmitted in RTTY at present, but AMTOR and ASCII will be added in the near future.

Another service is the sale of publications and specialist RTTY components. One of the most popular books available is 'RTTY The Easy Way', which describes the equipment required to operate RTTY (with full details of terminal units, tone generators, and ancillary equipment), and has been responsible for many amateurs starting up in this mode. The book is available from Mr Ian Brothwell,

G4EAN, 56 Arnot Hill Road, Arnold, Nottingham, NG5 6LQ, at £1.15 including packing and UK postage.

Current membership is around 1300, and is expected to grow rapidly in the next year as interest in data transmission increases, particularly in the microcomputer field. Membership costs £5 per year, in return for which the member receives the Newsletters and can take advantage of discounted prices of publications and components. In addition, several trade suppliers offer discounts to BARTG members. A SAE to Mr John Beedie, G6MOK, 161 Tudor Road, Hayes, Middlesex, UB3 2QG (or a telephone call on 01-561 0010) will bring membership details.

South East Kent (YMCA) Amateur Radio Club

The club's second 'Spring Cleaning Rally' will be held on Sunday, 13 May, 1000-1600, at the Dover YMCA Centre.

A special event station is to be run at the Waldershare Vintage weekend at Waldershare Park on 28 and 29 July. Other Club dates are: Wednesday, 2 May, Natter Nite and film show; 9 May, visit to North Foreland Coast Radio Station (nb 10 members only on this visit). Names to G3VSU asap. Visit will commence at 1900.

Further details of club activities from Alan Moore, G3VSU, 42 Nursery Lane, Whitfield, Dover, Tel: 822738 or Brian Joyner, G8ZYZ, Brimmar, Nelson Park Road, St Margaret's-at-Cliffe, Dover. Tel: 852533

Vale of White Horse AR Society

The Club meets at: The Landsdown Club, Milton Trading Estate, Nr Didcot. Meetings first and third Tuesdays of each month at 7.30pm for 8pm. Club nets: HF, Thursday evenings 7.30 local time 28.750MHz. VHF, Sunday evenings 8.00 local time 145.200 MHz.

75th Anniversary of Scouting in Wallingford. District Commissioner Graham Rix would definitely like the Club to put on a special event station in Lesters Field adjacent to Howbery Park. Gra-

ham has promised date and other details asap. Good opportunity to try for contacts with Wallingford USA. (W1 or W2).

ARTAC International

There can be few British radio amateurs who have not, at some time, been in a situation where they would have liked to ask the station with whom they were communicating to, for example, call his town information centre for details on a point of history, send a short greetings message to a friend or relation or just ask simple route directions for a friend in the radio shack. For British amateurs this is designated by the licensing authorities as 'third-party' and is, in general, forbidden!

British amateurs, for years, have had to remember to be extremely careful to avoid mentioning, over-the-air, anything which could, even remotely, be considered 'third-party'.

Australian amateurs shook off the third-party restriction shackles some three years ago and never looked back.

ARTAC (Amateur Radio Third Party Action Committee) International would like to hear from anyone interested in the removal of this totally unnecessary restriction on the British Amateur Radio Service. Comments to ARTAC at 38 Wattle Drive, Watsonia, 3087, Australia.

BSC Port Talbot AR Society

The GB2SDD Special Event station was very successful with over 1300 QSO's taking place on HF as well as 2m RTTY, 70cm SSB and ATV. Conditions on HF were very good with massive pile-ups on most HF bands. The award is £125 and all entries should be in by 30th June. On QSL all QSO's will receive a QSL card via bureau. If you would like one direct please enclose SAE or IRC's. Reg Woolley, GW8 VHI.

Cambridge and District AR Club

This long-established Cambridge club caters for all those interested in the many facets of amateur radio and meets each week during term-time at 7.30pm on Fri-

CLUB CALENDAR

days in the Visual Aids Room, ground floor, Coleridge Community College, Radegund Road (a turning off the well-known Coleridge Road in the south part of the City).

The following is the future programme of Club activities: April 27, College Closed. Meet at 'Ancient Shepherds', Fen Ditton; April 29, Radio 'Fox Hunt'; May 4, Talk by Martin Mann G4FFO on 'Very Low Frequencies'; May 11, Informal. Morse Class. Operating club station G2XV. May 18, Construction Evening; May 26, Informal. Morse Class. Operating club station G2XV; June 1, College Closed. Junk sale at Comberton Village Hall; June 8, Informal. Morse Class. Operating club station G2XV; June 15, Programme to be announced; June 22, Informal. Morse Class. Operating club station G2XV. All (any age, both sexes) welcome. For information, please contact David Wilcock, Tel: Cottenham (0954) 50597.

Bury Radio Society

Meetings are held at the Mosses Community Centre, Cecil Street, Bury, every Tuesday evening at 8.00pm. Main meetings (as below) are held on the second Tuesday of each month. The remaining meetings are informal. Newcomers are invited to contact the Hon. Secretary, Brian Tyldsley, G4TBT, 4 Colne Road, Burnley, for further information: Tel: Burnley 24254.

Meeting details are as follows: May 8, Confessions II. Clive Hardisty, G8XUR continues the theme of his previous talk 'Confessions of a TV Repair Man'. June 12, Title to be announced; July 3, Surplus Equipment Sale; July 10, Visit to IBA Transmitter Site at Emley Moor; August 14, Fox Hunt.

Stevenage and District AR Society

The best of luck to all those taking the May RAE exams. With all these new licences being issued I can see that two metres is going to become very crowded by the end of the year. Hopefully the overcrowding will result in more activity on 70cm which is an excellent band but one which is sadly underused.

The rally season is now upon us with the following

PICTURES FROM PORT TALBOT AR SOCIETY SPECIAL EVENT



GW4HOQ (on the mike) with GW4LKS operating Special Event station GB2SDD on 20m



GW6MXS operating on 70cm SSB as GW6JC looking on

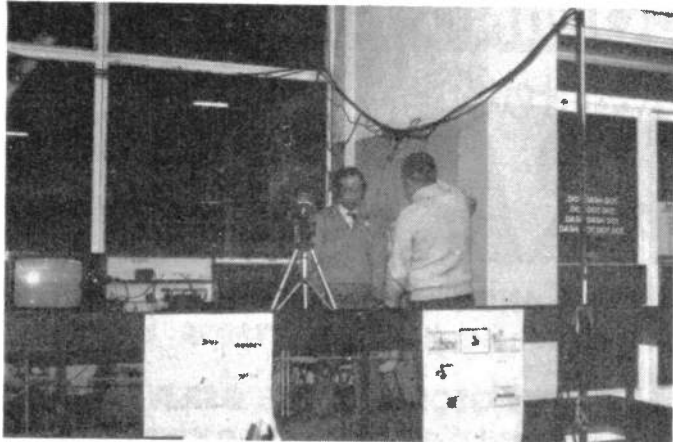

GW8TBG discussing 70cm ATV with a member of the public at the BSC Port Talbot AR Society Special Event

events scheduled: 28-29 April, RSGB National Amateur Radio Exhibition at the NEC in Birmingham. This is one not to be missed. 28 May, Drayton Mobile Rally at Drayton Manor.

Home Counties ATV Club

The Group meet at Richings Park Sports and Social Club, Iver, Buckinghamshire, at 8.30pm every fourth Wednesday in the month. Talk-in is provided on 145.200MHz. Future meetings are as follows: 25 April, Talk on Video

Recorders; 23 May, Talk on Slow Scan TV; 27 June, Outside activity night on 70cm and 23cm TV; 25 July, Slow Scan Operating evening.

We operate both slow and fast scan monochrome and colour television on HF, as well as 70cm, 23cm and 10GHz. So plenty of advice/experience on hand.

Sutton and Cheam Radio Society

The club meets at Downs Lawn Tennis Club, Holland Avenue, Cheam, and Sutton

College of Liberal Arts.

Club nets are - Mondays, 20.00 hrs, SSB 144.390MHz; Tuesdays, 10.30 hrs, SSB 3.770 MHz; Sundays, 11.00 hrs, FM rendezvous on 145.500 MHz.

The Annual General Meeting is at Scola on 4 May.

Other club dates are: 18 May, 'Amateur Satellites', talk by Ron Broadbent, G3AAJ, Sec. of AMSATUK at Downs; 1 June, Subject pending, possibly 'Receiver Measurements', Downs. 2-3 June, 'HF National Field Day' at Legal & General. 15 June, Subject pending at Scola, possibly 'Maritime Radio'. 6 July, Subject pending at Scola. 7-8 July, 'VHF National Field Day' at Leek. 20 July, 'German War Radio Equipment' by Tony Cockle, G31EE, at Downs. 1-2 Sept, SSB Field Day at Legal & General.

The Severn Valley Radio Society

The Society meets every first and third Tuesday of the month, at the Kings Head Hotel, Whitburn Street, Bridgenorth, Salop, at 8pm. Visitors and new members are most welcome. Further details and programme available from the Secretary, Julian Sutcliffe (G6TMP) Tel: 0952 883752.

Nene Valley Radio Club

Details of our May programme are as follows. 2 May, Ladies Night and Buffet; 9 May, Natter Nite; 16 May, Building and Operating HW8 (G3DOT); 23 May, Natter Nite; 30 May, No meeting.

All meetings are held at the Dolben Arms, Finedon, Near Wellingborough, Northants. 8.00pm start.

Farnborough and District Radio Society

Meetings commence at 7.30pm at the Railway Enthusiasts Club, Access Road, off Hawley Lane, Farnborough, Hants. Further information from the PRO, Peter Taylor, on Farnborough 837581. The following meetings have been arranged. 9 May, 'AMSAT-UK' - A talk on latest developments; 23 May, HF Field Day. A preview by G3ZUM and 13 June, Talk on Racal equipment by G3VCX.

Preston AR Society

The 17th Mobile Rally will be held at Lancaster University on 26 August. The rally opens at 11am - 10.45am for

CLUB CALENDAR

disabled persons. There will be trade stands, an RSGB bookstall and the usual 'Bring and Buy'. There will be a 'talk-in' on 144 MHz (22) and 70cm.

There is ample parking within the University which has easy access from the M6 and A6. Leave M6 at junction 33 and proceed north on A6 for two miles.

All enquiries to Godfrey Lancefield, G3DWQ, QTHR. Tel: Preston (0772) 53810.

Radio Club of Thanet

The club meets at 8pm at the Grosvenor Club, Grosvenor Place, Margate, on the second and fourth Tuesdays in the month.

Club activities during May are: 8th, Talk on PCBs by G3DNR; 13th, Fox Hunt; 15th, Visit to HM Coastguard, Dover; 22nd, to be arranged.

Verulam Amateur Radio Club

The Verulam Amateur Radio Club meets at the RAF Association headquarters, New Kent Road, off Marlborough Road, St Albans on the second and fourth Tues-

days in each month. On May 22nd, Rev George Dobbs, G3RJV, will give a talk entitled 'Amateur Radio on a Shoestring'. Visitors are welcome at all Club meetings.

The Radio Amateur Invalid and Blind Club

The Flight Refuelling Amateur Radio Society and the Bournemouth and District RAIBC are once again holding another Hamfest on Sunday, 19th August, at the Flight Refuelling Social Club and Grounds, Merley, Wimborne, Dorset.

Hamfest '84 is an amateur radio (ham) festival and is intended to promote the hobby in all aspects. The event is open to all who are interested in the hobby and any person who would like to find out about amateur radio. The event is being promoted by RAIBC and run as a fund raising project for the group which provides amateur radio equipment and assistance for the disabled.

The main event will be open from 11am to 5pm and will provide a day out for the

disabled and able bodied 'ham' and his family.

Hamfest '84 will be a weekend event and will include such attractions as full camping and caravan facilities on an adjacent luxurious camping complex for the weekend; barbecue refreshment and on-site entertainment for the family - including the model railway rides; an XYL Bonanza, including demonstrations and stalls and, of course, the usual 'junk' and bring and buy stalls. The Radio Society of Great Britain will be in attendance.

Further details can be obtained from Bob Burrows G6DUN., Tel Bournemouth 762828 (day) or Miss E K Howard G4LFM.

Worthing and District AR Club

Guest of honour at the Club's annual dinner was Donald Baptiste CBE, the immediate past President of the Radio Society of Great Britain.

Mr Baptiste, who before retirement from the Home

Office Radio Regulatory Department spent many years involved with the international allocation of communications frequencies, told the Club of some of the humorous moments at international conferences. He also gave a brief insight into the work of the RSGB carried out on behalf of all UK licensed radio amateurs and of some of their achievements during his term as President.

Haverhill and District AR Society

The proposed programme of events for 1984 is: April 27, Video; May 11, Design of Simple Test Equipment; May 25, Construction of GDO; June 8, Talk on Fox Hunts; June 22, Construction of 2m DF Loops; July 6, Fox Hunt; July 20, Club Aerials; Aug 3, Mobile Suppression; Aug 17 Interference; Aug 31, Lightning Protection; Sept 14, Open Evening; Sept 28, HF Operating Procedures; Oct 12, Video; Oct 23, Junk Sale; Oct 26, BARTG; Nov 9, Sudbury Repeater Group; Nov 23, Video.

COMING NEXT MONTH

Amateur RADIO

ANGUS MCKENZIE G8OSS -

reviews yet another handheld, the Yaesu FT203R, and the new Icom R71 Rx

REV GEORGE DOBBS G3RJV -

takes a look at kit assembly for a crystal calibrator

THE VIEW FROM THE TOP -

a history of communications satellites by Peter Dodson

MR MORSE AND ALL THAT

learning Morse without tears by Dave Green G4OTV

PLUS SWL, DX Diary, On the Beam, your letters and all the regular features

DON'T MISS the June issue - on sale 24 May

To be sure of your copy of *Amateur Radio* complete the newsagents order form in this issue or take out a post free subscription

COMING NEXT MONTH

FREE CLASSIFIED ADS

We are pleased to be able to offer readers free classified ads to enable you to sell unwanted equipment or advertise for your 'wants'. Simply complete the order form at the end of these ads, although we will accept ads not on our order form. Feel free to use an extra sheet of paper if there is not enough space on the order form. Send to: **Amateur Radio**, Sovereign House, Brentwood, Essex CM14 4SE.

DEADLINE
Send your ad in now as ads will be inserted in the first available issue on a first come first served basis.

CONDITIONS
We will not accept trade advertisements. We reserve the right to exclude any ad.

FOR SALE

■ Trio TR9130 2m multi mode, as new, complete with mobile mount and SWR meter plus Swan Neck car mike and remote. Need cash for move to HF. £385 ovno. Tel: 01-328-3238

■ AR88D in good working order £50. Buyer must collect from Blackburn Lancashire Tel: 0254 21859 after 4pm

■ Belcom LS102L 26.000 MHz-29.000MHz All Mode mint cond £225. Tel: Plymouth (0752) 778825

■ Everts audio compander model C1 speech processor on both transmit and receive. List price £147 as new only £60 Creed 444 teleprinter 45.5 band or 50 baud £45 Heathkit signal generator 100KHz-110MHz £40. S Haseldine, Leamington, Windley Lane, Weston Underwood, Derbys. Tel: Ashbourne 0335 60755

■ Triax RB20 active aerial 26 - 860MHz own PSU and coax. Twenty inches cross clamps to 2 1/2in mast. Ideal for that scanning receiver £100 on telephone Tim on Brimscombe 882316 near Gloucester.

■ HRO general coverage receiver, plug in coils 50 KHz to 14.4MHz £35 ono the lot, ask for Greg Tel: Colchester (Essex) 330 397

■ FT101 2D Mike TV1 filter hi mound key £550 FTV 901R 2m, 70cm transverter £350 ext speaker for 101 £25.00 telephone Darlington 54772

■ Yaesu FT480R used only few hours as fixed station, brand new condition £285 Drae 4 amp power supply as new £25 Tel: 041-639-2173

■ Yaesu FT100 3.5-28MHz plus 26-28MHz fully inclusive recent full service, immaculate condition, £225 ono consider Sommerkamp 780 DX in part exchange or will swap for quality 70cm/2m multimode transceiver Neil (G1ETM). Tel: Derby 74849

■ RAE Course (ICS) £15 used twice by two successful candidates still in good condition. Phone Eric Coe Bishops Stortford (0279) 54330 evenings

■ Valves KT66's KT88's QQU03/10's QV02/6's 6CH6's etc cheap send for list, or type. Top band AM TX £12 collect. Bellhowell 16mm sound projector £85 or swap 70cm Transceiver, G8BSK 290 Priory Road, St Denys, Southampton SO2 1LS

■ AR-240 handheld absolutely mint condition. Case, helical, charger. £100. Two IC-BP3 battery packs (for IC-2E, IC-4E) brand new, charged once. £21 each. G4BKI not QTHR Tel: Towcester (0327) 51823

■ Blaupunkt Bamberg AM/FM car stereo/cassette with record facility, quadratic equaliser 4 speakers £110. Astronomical telescope £35 Ford push-button car radio £25. Elac 750 record deck with Shure cartridge £35. Fidelity mains taperecorder £10. Require 70cms Transceiver or W.H.Y? Bedford G4NJP QTHR.

■ Sony CRF320 professional receiver 150 KHz - 30 MHz plus FM immaculate. Cost £750 sell £325 swap BBC (B) computer. Also Telerrader CWR 670 E as new cost £300 accept £200 deliver 120 miles. Heath Upper Cumberworth Yorkshire (0484) 606 542

■ Yaesu FRG7 general coverage receiver no mods little used, mint condition, manual circuit diagram etc £140 or offers. Will deliver Devon/Cornwall/Somerset Telephone Plymouth (0752) 862252 (evenings or weekends)

■ Microwave MMS1 Morsetalker 2-20WPM perfect working order £75 Tel: Redditch (0527) 28003

■ FT480R as new £300, rotator light/medium duty £35, Drae VHF wavemeter £20, 5 ELE J beam £8, 13.8V 5A PSU £8, all ono Tel: Farnborough (0252) 514127 after 6pm.

■ Transvert from 2 metres to 70cm. MMT432/144R, 10W out, 1.6 shift, Linear mode. Attenuators to suit 10W or 3W (FT290R) rigs, list price £14.50 each. Plus free 70cm wavemeter mint £130 ono Tel: 01 247 6097 (daytime)

■ Bremi BRL200 Linear Amplifier 200W SSB output little used and in good condition £55.00 plus carriage. Phone Garsington 475 (Oxford)

■ Yaesu FRG7700 receiver, 6 months old. Mint condition £275 Sony Walkman Professional personal stereo and recorder 2 months old £125 (originally cost £200). FDK synthesized airband monitor ATC 720. Two months ago cost £150 accept £100 Tel: 0933 625464 after 6pm

■ Yaesu FR101SD receiver, FL101 transceiver, YO 100 monitor scope, YD-844A mic, ex speaker. £550 ono N Pugh, 5 Back Lane, Nomansheath, Malpas, Cheshire SY14 8DR.

■ Have FRG7 for sale £110 or part exchange for KW103 SWR1 Power meter. Phone Herne Bay 02273 3511 evenings or weekends

■ Grundig satellite 2100 with instruction books. Mint condition Mr A Garner Tel: 01 501 1424

■ SX200N scanning receiver with mains adaptor 26-88 108-180 380-514 MHz in mint condition £220 cash ono. Buyer collects Tel: Medway (0634) 43953 evenings after 6.30pm

■ Realistic DX300 general coverage receiver 0.01-30MHz digital read out AC/DC, AM/USB/LSB £115 Tel: Bourton-on-the-water (0451) 21690

■ Trio TS130S TX/RX. All hf WARC bands 80-10m 100W output excellent mobile or base rig suit beginner or oldtimer. Complete with mobile mount, AC PSU, £399. G3PVX QTHR Phone 01-866-6432 evenings.

■ Frequency meter BC221 US Army 125KHz to 20MHz PMO. Ambit GDO working needs tidying up sell or swap for 2m Cambridge or SW RX. William Doherty, 68 Shelbourne Road, Dublin 4, Rep/of/I Tel: 01 686135

■ VLF Receiver kit from 'Cambridge Kits' £7 extension speaker 6 1/2in dia £1. 'Jaybeam' UGP/2m VHF antenna £4. 'Sigma' 2A Airband Receiver 88-108 MHz plus 112-142 MHz £5. Tel: Newark (Notts) (0636) 73235

■ Daiwa SR92m receiver. Two crystals and VFO to cover 144MHz to 146MHz FM complete with original packaging and instructions £35 ono contact Mr M James GW1FOF on (044 128) 2325

■ FT221R + Mutex front end with 11 fixed chan crystals and manual. Proven performance in many contests £340 144MHz WISL Linear 2 x 4CX250 1W in 400w out offers. FT290R + Mutex front end. Exc cond with nicads, chgr, case, flexiwhip, manual. Orig pkg £220. MML 144/25 25W PA/Preamp to suit above £40 TR7010 2m SSB/CW mobile £75. MMT 432/285 satellite TVTR £95 Trio TX599 + JR599 Tx + Rx 80-10m Tx 160-10m + 2m Rx SSB/CW/AM/FM with CW fltr £280. FT101ZD FM + fan + 12V PSU + CW fltr + man as new £530 MM4000K RTTY with keybd £180 60Ft Versatower less gnd post £325. Akai 4000D stereo reel to reel needs attn £30 TH3 Jnr beam up 2mths £135. Steve Marsh G4BWG. Tel: 088-32-4656 (Surrey)

■ Icom IC251E, mint condition (no mods), six months old. Offers around £400 or would consider exchange for FT290R, nicads and case plus cash adjustment. Write G8YTA QTHR.

■ Trio TS 430S plus PS430 power supply, comes with mic FM board. All filters fitted CW SSB narrow, and AM. Both in mint condition, boxed £700. Will consider part exchange. Tel: (0475) 706451

■ Yaesu FT 290 multimode 2 metre, brand new, used twice. Also swiss Quad wih rotor, all new. Genuine reason for sale £285. Tel: Mid Somer Norton 414329

■ Sait Electronics general coverage receiver, digital readout signal meter, AM SSB CW £100. Consider swap for CB equipment or Why? Tel: Bradworth, N. Devon 435.

■ Icom IC2E with case charger and 2 spare packs + 12V pack £140 ono or swap for FT 290R or standard C58 & cash adjustment. MC 50 desc mic unwanted Xmas gift £25 ono. Radial kit for HF 5V

£25 ono or swap either for Weiz SP15M. GW4RQQ QTHR (GW61TL) T Jones, 6 Lon Ganoli, Menai Bridge, Menai Bridge (0248) 712763

■ Microwave modules MMD OSO/500 frequency counter, 0.45 to 500 MHz with probe £55. G2DAF RX £50 Tel: Dursley 811454 after 6pm

■ Yaesu FRG 7700 receiver with ATV £200 ono also 50 channel scanner, Realistic £80 both boxed, as new. Tel: Lincoln 22524.

■ 2in JVC B/W TV/radio UHF/VHF mains car batteries charger, service manuals useful adaptation mobile DX, little used £50 ono. Letters only please, will guarantee. H S Woodman, Flat 9, 49 Upper Rock Gardens, Brighton BN3 1QT.

■ Drake SW-4A International Short-Wave receiver, direct frequency readout, designed especially for radio New York worldwide, as new £75 Tel: 01-590-9366

■ Bearcat 220FB 18 months old boxed £125 Tel: Derby 833071 (Evenings)

■ DX302 communication receiver, 10KHz to 30MHz SSB, AM, CW, battery, mains or 12V. Digital synthesized, original, packaging, immaculate condition, absolute bargain, cost £289, save £200, sell £90. Keith Tel: Rugby 70363

■ Nag 144XL 250W 2 metre Linear built-in Preamp £325. Yaesu 101ZD WARC bands, mic, fan, AM/FM boards £525. FTV901R transverter £140. FC902 ATU £90, all excellent condition. Tel: 02372-3172

■ Harvard Home base model 407 CBN-40CH, £60 Realistic Tandy TRC 1001 40CH handheld CB, £70 complete. P O'Brien, 12, Church Street, Caernarvon, Gwynedd, Wales. Tel: 5468

■ Lowe SRX30 communications receiver, 500 KHz to 30 MHz with add - on digital display, £100. Tel: Stockton (0642) 762259

■ FRG7 RX with manual, as new, £175 or swap FT290R with case, charger, nicads etc in GWO. Tel: Stevenage 350310. Buyer collects please.

■ MMT432/144R 70cm linear transverter with attenuator to suit FT290R etc, (list £14.50) mint, hardly used, full 10W output on 70cm plus 1.6 shift, £120 ono. Including free 70cm wavemeter. Tel: 01 247 6097 (daytime).

■ RCA AR88 and Marconi CR100 receivers both in good working order + spare valves. RCA AR88, £50 CR100, £40 Skipmaster SK42000 base mike, £10. Call after 6pm please. P Howlett, 41, Preston Road, Toddington, Nr. Dunstable, Beds.

■ Avometer No 8 Mark III with case, £45. AC VCM, £20. Taylor meter, £15. Cybernet 1000 with SWR V/meter, built as home base in case, £45. Tel: 01 672 3372.

■ Moonraker AV-140 vertical + horizontal 10 meter antenna, 10 months old forward gain 14 DBD 16 ft boom. 4 elements, cost new £130, sale price £75. Steve G1EFD Tel: Sunbury on Thames 80917 any time.

■ Wavemeter BC221 mains input, clean original charts, £50. New Audioline 345 CB base station, never used, in original packing, £110. Heathkit HA202 50W 2 metre linear £45. Advance B4B 30KHz-30MHz signal generator, carriage extra. Tel: 0872-862575.

■ Fidelity 1000 FM CB, £20. Car radio cassette player (stereo), auto reverse, MW, LW, FM, £40. Binatone route 66 FM CB, £20. P/button MW LW car radio, £10. Tel: Milton Keynes 316052 Ansa Phone.

■ FDK multi 11 2 metre FM transceiver 10W o/p crystalised most channels, tone burst, auto scan. Ideal starter for 2m, £100. Mustang 2000 FM CB £20, Tel: Milton Keynes 316052 Ansa Phone.

■ Microwave modules MMS1 Morse Talker. Perfect working order. £75. Tel: 0527 28003

■ Yaesu FT101E transmitter receiver 1.8 to 29.9MHz amateur bands, CW, cooling fan, VGC £250. Buyer collects or part exchange video camera VHS with cash adjustment. Tel: Boston Lincs 61952 (evenings)

Amateur RADIO SMALL ADS

G3RCQ ELECTRONICS

Amateur radio equipment bought, sold, exchanged
Tel: Hornchurch (04024) 55733
 Evenings 6-9 and Weekends Or send SAE for up to date lists of used equipment to
65 CECIL AVENUE, HORNCHURCH, ESSEX

G3SRK MORSE KEY (Direct form Manufacturer)

As used by Govt. Establishments in over 60 countries
NOW AVAILABLE TO AMATEUR FRATERNITY
£9.00 inc. VAT and carriage UK
J SYKES, 7 Top o'the Hill, Slaithwaite, HUDDERSFIELD HD7 5UA

HAM HOLIDAY SRI LANKA

WRITE TO SPANGLES TRAVELS
84 TEMPLERS ROAD
MOUNT LAVINIA. SRI LANKA
TELEPHONE 010 941 713437

Amateur RADIO

This method of advertising is available in multiples of a single column centimetres — (minimum 2cms). Copy can be changed every month.

RATES

per single column centimetre:
 1 insertion £7.00, 3 — £6.60, 6 — £6.30, 12 — £5.60.

SMALL ADS

AMATEUR RADIO SMALL AD ORDER FORM

TO: Amateur Radio · Sovereign House
 Brentwood · Essex CM14 4SE · England · (0277) 219876

PLEASE RESERVE.....centimetres by.....columns

FOR A PERIOD OF 1 issue..... 3 issues..... 6 issues..... 12 issues.....

COPY enclosed..... to follow.....

PAYMENT ENCLOSED:..... £ — Cheques should be made payable to Amateur Radio. Overseas payments by International Money Order

CHARGE TO MY ACCOUNT.....

COMPANY

ADDRESS

SIGNATURE **TELEPHONE**

For Publisher's Use — AR0584

Registered No 2307662 (England)

C P I

Ant Products
All Saints Industrial Est
Baghill Lane, Pontefract West Yorkshire
Telephone (0977) 700949

TIGER LY9 70 Cms Antenna

New from Ant Products, a superb addition to the range of renowned antenna, the Tiger LY9 for 70 cms. A light weight antenna with a heavy weight signal. Offering a high 11db gain on a 58 inch boom length. Great for vertical or horizontal mounting. Supplied in matched pairs for the ultimate Oscar station complete with all hardware for mounting with elevation control. Precisely adjustable for angle in order to get the best performance. Also including matching unit for circular polarisation. Right or left hand can be chosen with equal efficiency. Last but not least our famous two year guarantee and full back up service.

Write now for full details
enclosing a SAE plus 25p in stamps

MORSE READING PROGS

Work on clean signals without hardware interface. ZX81 1K UNEXPANDED MEMORY. Translated code, with work and line spacers for easy reading Automatic scroll action **£7.00 incl.**
 Spectrum 16-48k. Scroll action with 10 page scrolling memory, instantly accessible page by page **£8.00 inc.** All types variable speeds feed signal direct into EAR socket.
Pinehurst Data Studios, 69 Pinehurst Park, W Moors, Wimborne, Dorset BH22 0BP.

SOUTH-DOWN RADIO SUPPLIES **40 TERMINUS RD EASTBOURNE**
Tel: (0323) 639351

(opp. Railway Stn.)

Open: Mon-Sat 10-6 (Closed Tues)

Amateur Radio Equipment Yaesu, Icom, Standard, Tonna, Dae, Kenpro, Halbar, Wood & Douglas, Daiwa.

AERIAL BOOSTERS

Next to the set fitting
B45WQ-UNF TV, gain about 20dbs. Tunable over the complete UHF TV band **PRICE £8.70.**
AMPLIFIED SET TOP AERIALS for UHF TV, trebles the gain. **PRICE £11.70.**
 All Boosters we make work off a PP3/006p/6F22 type battery or 8v to 18v DC **P&P 30p PER ORDER.**
ELECTRONIC MAIL ORDER, 82 Bridge Street, Ramsbottom Lancs BL0 9AG. Tel (070682) 3036
 Access/Visa Cards Welcome SAE Leaflets

Complete, full-size sets, any published service sheets £2 +large SAE — except CTV's/Music Centres from £3 + large SAE.
 Manuals from 1930 to latest. Quotations, free 50p magazine, price lists, unique technical publications, for large SAE.
 Repair data/circs almost any named TV/CVR, £9.50 by return.

TIS(AR)

76 Church Street, Larkhall, Lanarkshire ML9 1HE
Phone: 0698 883334

Booth Holdings Bath

See you at Longleat
Sunday June 24th
6 GOLF CLUB LANE
SALT福德, BRISTOL
Tel: 02217 2402
 Open Tues-Sat 9am-9pm
 closes Mondays

G2VF DIY LOOP ANTENNAS

Circuit, Parts List, Assembly data 80 to 10 Metres £5 Long Medium Short Wave 40 to 10 Metres £3 Ideal Caravan and Flat Dwellers.

FG RYLANDS, 39 PARKSIDE AVENUE MILLBROOK, SOUTHAMPTON SO1 9AF

ADVERTISERS INDEX

AKD	62	Low Electronics.....	4 & 5
Amateur Radio Exchange	7 & 29	Microwave Modules.....	Outside Back Cover
Amtronics	Inside Front Cover	PM Components	46-47
Ant Products	73	Pinehurst Data Studios	73
Arrow Electronics.....	34	RAS (Nottingham)	52
BNRES	23	FG Rylands.....	73
Booths Holdings.....	73	Selectronic	23
Bredhurst Electronics	42	South Midlands Communications ...	14-17
WPO Communications.....	21	Spangles Travel	73
Dewsbury Electronics.....	43	J Sykes	73
BNOS Electronics.....	Inside Back Cover	TIS.....	73
G3RCQ Electronics	73	Thanet Electronics.....	56-59
Electronics Mailorder.....	73	Timestep Electronics	24
Gamma Aerials	38	R Withers.....	55
Garex Electronics.....	52	Wood & Douglas	52
Hately Antennas.....	38		
C M Howes Communications.....	34		

Amateur RADIO

ADVERTISING RATES & INFORMATION

DISPLAY AD RATES		series rates for consecutive insertions			
depth mm x width mm	ad space	1 issue	3 issues	6 issues	12 issues
61 x 90	1/8 page	£66.00	£62.00	£59.00	£53.00
128 x 90 or 61 x 186	1/4 page	£115.00	£110.00	£105.00	£92.00
128 x 186 or 263 x 90	1/2 page	£225.00	£210.00	£200.00	£180.00
263 x 186	1 page	£430.00	£405.00	£385.00	£345.00
263 x 394	double page	£830.00	£780.00	£740.00	£660.00

COLOUR AD RATES		colour rates exclude cost of separations	series rates for consecutive insertions			
depth mm x width mm	ad space	1 issue	3 issues	6 issues	12 issues	
128 x 186 or 263 x 90	1/2 page	£305.00	£290.00	£275.00	£245.00	
263 x 186	1 page	£590.00	£550.00	£530.00	£470.00	
263 x 394	double page	£1,130.00	£1,070.00	£1,010.00	£900.00	

SPECIAL POSITIONS	Covers:	Outside back cover 20% extra, inside covers 10% extra
	Bleed:	10% extra (Bleed area = 307 x 220)
	Facing Matter:	15% extra

DEADLINES		*Dates affected by public holidays			
issue	colour & mono display ad	small ad	mono artwork	on sale	
June 84	26 Apr 84*	2 May 84*	4 May 84*	24 May 84	
Jul 84	30 May 84*	6 Jun 84	8 Jun 84	26 Jun 84	
Aug 84	28 Jun 84	4 Jul 84	6 Jul 84	26 Jul 84	
Sept 84	26 Jul 84	1 Aug 84	3 Aug 84	23 Aug 84	
Oct 84	30 Aug 84	5 Sep 84	7 Sep 84	27 Sep 84	

CONDITIONS & INFORMATION		Printed — web-off-set.	Overseas payments by International Money Order.
<p>SERIES RATES Series rates also apply when larger or additional space to that initially booked is taken. An ad of at least the minimum space must appear in consecutive issues to qualify for series rates. Previous copy will automatically be repeated if no further copy is received. A 'hold ad' is acceptable for maintaining your series rate contract. This will automatically be inserted if no further copy is received. Display Ad and Small Ad series rate contracts are not interchangeable.</p>	<p>If series rate contract is cancelled, the advertiser will be liable to pay the unearned series discount already taken.</p> <p>COPY Except for County Guides copy may be changed monthly. No additional charges for typesetting or illustrations (except for colour separations). For illustrations just send photograph or artwork. Colour Ad rates do not include the cost of separations.</p>	<p>PAYMENT All single insertion ads are accepted on a pre-payment basis only, unless an account is held. Accounts will be opened for series rate advertisers subject to satisfactory credit references. Accounts are strictly net and must be settled by the publication date.</p> <p>FOR FURTHER INFORMATION CONTACT Amateur Radio, Sovereign House, Brentwood, Essex CM14 4SE. (0277) 219876</p>	<p>Commission to approved advertising agencies is 10%.</p> <p>CONDITIONS 10% discount if advertising in both Amateur Radio and Radio & Electronics World. A voucher copy will be sent to Display and Colour advertisers only. Ads accepted subject to our standard conditions, available on request.</p>

Take a look at the world's most advanced range of 2 metre Linear Amplifiers

Over 40 years of design experience has gone into what is fast becoming acclaimed as the biggest break-through in linear technology.

Performance and reliability have been designed in, which gives us the confidence to offer a free 5-year warranty. Why not take a closer look at our products and see where value for money really counts.

The LPM144 Range

This sophisticated, but simple to use, range of amplifiers have performance characteristics and extra features previously not available in the UK. The pre-amplifier uses the highly regarded BF981 MOSFET, and an LED bargraph power meter is provided, to highlight only two of the amazing number of features.

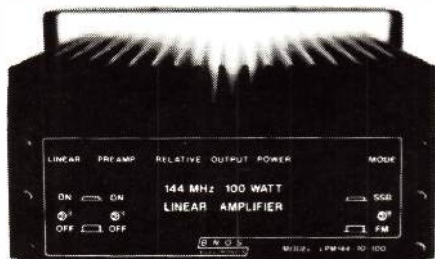

LPM144-1-100	£172.50
LPM144-3-100	£172.50
LPM144-10-100	£149.50
LPM144-25-160	£207.00
LPM144-3-180	£235.75
LPM144-10-180	£235.75

The L144 Range

To complement the LPM range, we have introduced the L series linear-only versions for the amateur who may already be equipped with a good pre-amplifier and power meter. The excellent linear performance is maintained and both RF Vox and hard-wired changeover are standard.



L144-1-100	£143.75
L144-3-100	£143.75
L144-10-100	£120.75
L144-25-160	£178.25
L144-3-180	£207.00
L144-10-180	£207.00

- Linear all mode operation
- Continuous rated RF output power (RMS)
- RF & HARD switched changeover with selectable delay
- Trouble-free RF switching at low drive levels
- Straight-through mode when switched off
- Unique over-drive protection circuit
- Mobile mount on all 100 Watt models

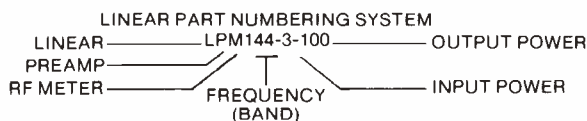

BNOS 'A' Series Power Supplies

12/6A £52.90

- 13.8V, 6A continuous output
- 7A maximum output current
- 10A current meter
- 10A output terminals
- LED shut down indicator
- Fully protected



12/12A £95.45

- 13.8V, 12A continuous output
- 15A maximum output current
- Large 20A current meter
- 15A output terminals
- LED shut down indicator
- Fully protected

12/25A £138.00

- 13.8V, 25A continuous output
- 30A maximum output current
- Large 30A current meter
- 30A output terminals
- LED shut down indicator
- Fully protected

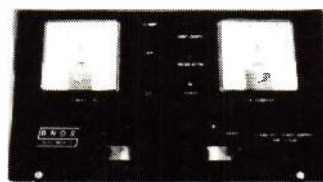

12/40A £276.00

- 13.8V, 40A continuous output
- 50A maximum output current
- Large 50A current meter
- Large output meter
- LED shut down indicator
- LED out of regulation indicator
- Output sensing terminals
- Fully protected

Our Guarantee Our aim is to provide you with high quality products at realistic prices, to give you the best value for your money.

All products that carry our logo are designed and built by our engineers in the UK and carry a full 12-month guarantee, which includes all parts and labour.

We are so confident that our linears are simply the best that we offer to repair your unit at component cost for up to 5 years from date of purchase. That means we will repair, calibrate and return to you free of charge.

All other products sold by us carry our standard 12-month guarantee.

Available direct or from one of our many UK agents — or come and see us at most rallies and exhibitions



BNOS Electronics (Dept AR) Bigods Hall, Great Dunmow, Essex, CM6 3RE

Telephone (0371) 4677 SAE for further details

PLEASE NOTE NEW ADDRESS AND PHONE NUMBER

All prices include VAT. Postage free on all Mainland UK orders, goods normally despatched by return.



MICROWAVE MODULES LTD

AS IF YOU DIDN'T ALREADY KNOW . . .

Microwave Modules Ltd. Is a full time professional organisation, established over **15 years** ago in **1969**, and currently employs over **30 full time**, on site staff based in our two modern, purpose built factories. In addition, a similar number of 'Outworkers' are involved in assembly and mechanical operations.

OUR EXTENSIVE RANGE . . .

Our product range now exceeds **50 individual items** in total and is the widest range available from any one manufacturing company. Our technical resources have enabled us to not only become **the largest and most successful** designer and manufacturer of R F Products, such as **Linear Amplifiers** and transverters, but also designers and manufacturers of **Innovative** microprocessor and digital products such as **The Morsetalker**, MMSI, and the R TY to TV decoder, MM2001.

ALL BRITISH . . .

Every product in our range is designed and manufactured in the UK by our own employees, and wherever possible British Components are utilised.

GUARANTEED . . .

All Microwave Modules Products are **Fully Guaranteed for 12 months**. This includes all semi-conductors and **PA Transistors**. We have built our reputation around our customer service and back-up and it is second to one.

OUR RANGE OF LINEAR AMPLIFIERS . . .



MML144/30-LS

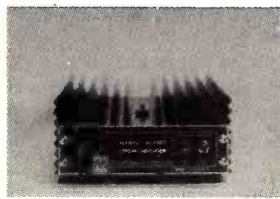

MML144/50-S



MML144/100-LS



MML144/200-S

PRODUCT	INPUT POWER	OUTPUT POWER	MODES OF OPERATION	Pre Amplifier		POWER REQUIREMENTS	RF * VOX	PRICE INC VAT	
				GAIN	NF				
MML144/30-LS	1 or 3W	30W	SSB,	12dB	<1.5dB	13.8V @ 4A	✓	£75 (p&p inc £3)	
MML144/50-S	10W	50W				FM,	13.8V @ 6A	✓	£92 (p&p £3)
MML144/100-S	10W	100W	AM,				13.8V @ 12A	✓	£149.95 (p&p £3.50)
MML144/100-HS	25W	100W					13.8V @ 12A	✓	£149.95 (p&p £3.50)
MML144/100-LS	1 or 3W	100W	CW,			13.8V @ 14A	✓	£169.95 (p&p £3.50)	
MML144/200-S	3, 10 or 25W	200W		13.8V @ 30A	✓	£245 (p&p £4.50)			

* THE RF VOX CAN BE OVERRIDDEN AND HARDWIRED

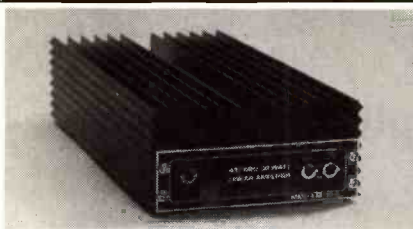

MML432/30-L

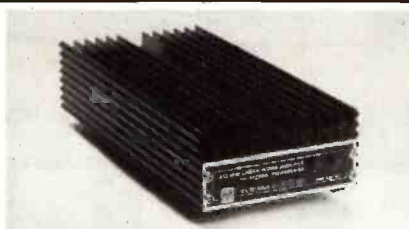

MML432/50

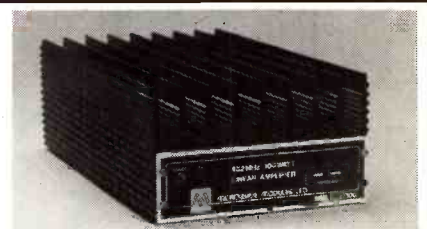

MML432/100

PRODUCT	INPUT POWER	OUTPUT POWER	MODES OF OPERATION	PRE AMPLIFIER		POWER REQUIREMENTS	RF* VOX	PRICE inc VAT
				GAIN	NF			
MML432/30-L	1 or 3W	30W	SSB, FM, ATV, CW,	12dB	2dB	13.8V @ 6A	✓	£139.95 (p&p £3.50)
MML432/50	10W	50W		12dB	2dB	13.8V @ 8A	✓	£129.95 (p&p £3.50)
MML432/100	10W	100W		—	—	13.8V @ 20A	✓	£245 (p&p £4.50)

* THE RF VOX CAN BE OVERRIDDEN AND HARDWIRED.

CONNECTORS . . .

144MHz Products — Our standard connector on these products is SO239. We use a high quality PTFE socket of superior quality, but we are able to supply the choice of BNC or 'N' type at no extra charge. Please specify

432 MHz Products — The MML 432/30-L's fitted with BNC connectors, 'N' type available, please specify. The MML432/50 and MML432/100 both have BNC input sockets and 'N' type output sockets. If this is not to your preference please specify when ordering.

DATA SHEETS . . .

A full printed data sheet is available on each product, and is free on request.

CATALOGUE . . .

A copy of our latest catalogue can be obtained by sending a large SAE (23p) or by sending 40p in stamps to the address below.

RALLIES & EXHIBITIONS . . .

We shall be attending most of the 1984 rallies and exhibitions. Come and see our products for yourself.

AVAILABILITY . . .

Our products are normally available from stock, either direct from ourselves or any of our 75 UK outlets.



WELCOME

MICROWAVE MODULES

BROOKFIELD DRIVE, AINTREE, LIVERPOOL L9 7AN, ENGLAND
Telephone: 051-523 4011. Telex. 628608 MICRO G
CALLERS AE WELCOME, PLEASE TELEPHONE FIRST

HOURS:
MONDAY-FRIDAY
9-12.30, 1-5.00
E & O.E.