

RCA Victor engineer adjusts antenna 600 feet above ground — See cover story, page 5

Communications Feature Issue — See Page 39

JUNE 1962

electronics & communications

The engineering journal of the Canadian electronics industry



Achievement...

This is why Litton Systems (Canada) Limited has grown from *18,000 square feet plant space and 60 employees in 1960 to *92,000 square feet (four plants) and 1120 employees in 1962 . . . proven ability to —

- manufacture complex electronic packages for airborne navigation systems for Canada and Europe,
- build the extremely precise and demanding LN3 inertial navigation stable platform in its entirety — unique in Canada,
- manufacture associated gyros and accelerometers to tolerances at the limit of the art,
- to provide top flight engineering design in several fields including ASW equipment,

in short . . .

by establishing Litton Systems (Canada) Limited as Canada's foremost company in the most advanced areas of space age technology.

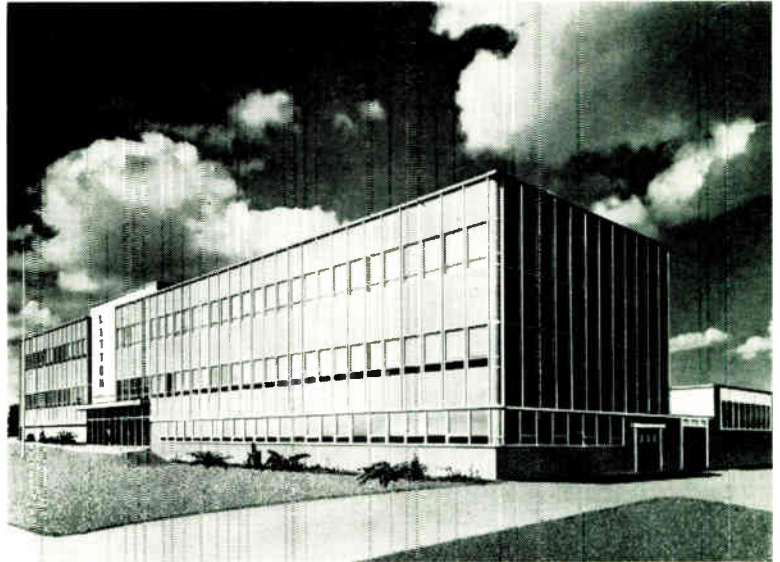

Leadership...

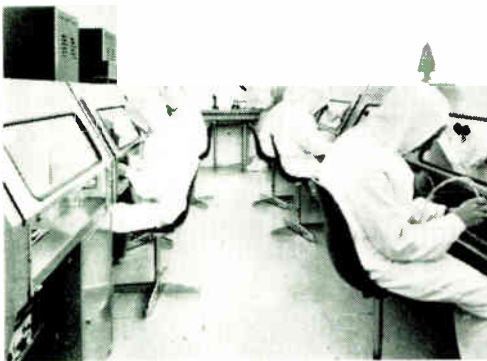

. shown here is an interim clean room at Litton Systems (Canada) Ltd. such facilities are essential for the building of precise mechanisms needed for inertial navigation systems. Though the room shown ranks with the best, even greater standards of environmental control are now demanded.

Therefore, soon to be completed at Litton's Rexdale plant will be a huge new clean room, setting standards second to none in continental North America another example of Litton's insistence on only the highest possible quality

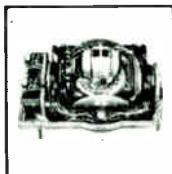

**LITTON SYSTEMS
(CANADA) LIMITED**
Rexdale, Ontario

DIVISION OF LITTON INDUSTRIES
BEVERLY HILLS, CALIFORNIA

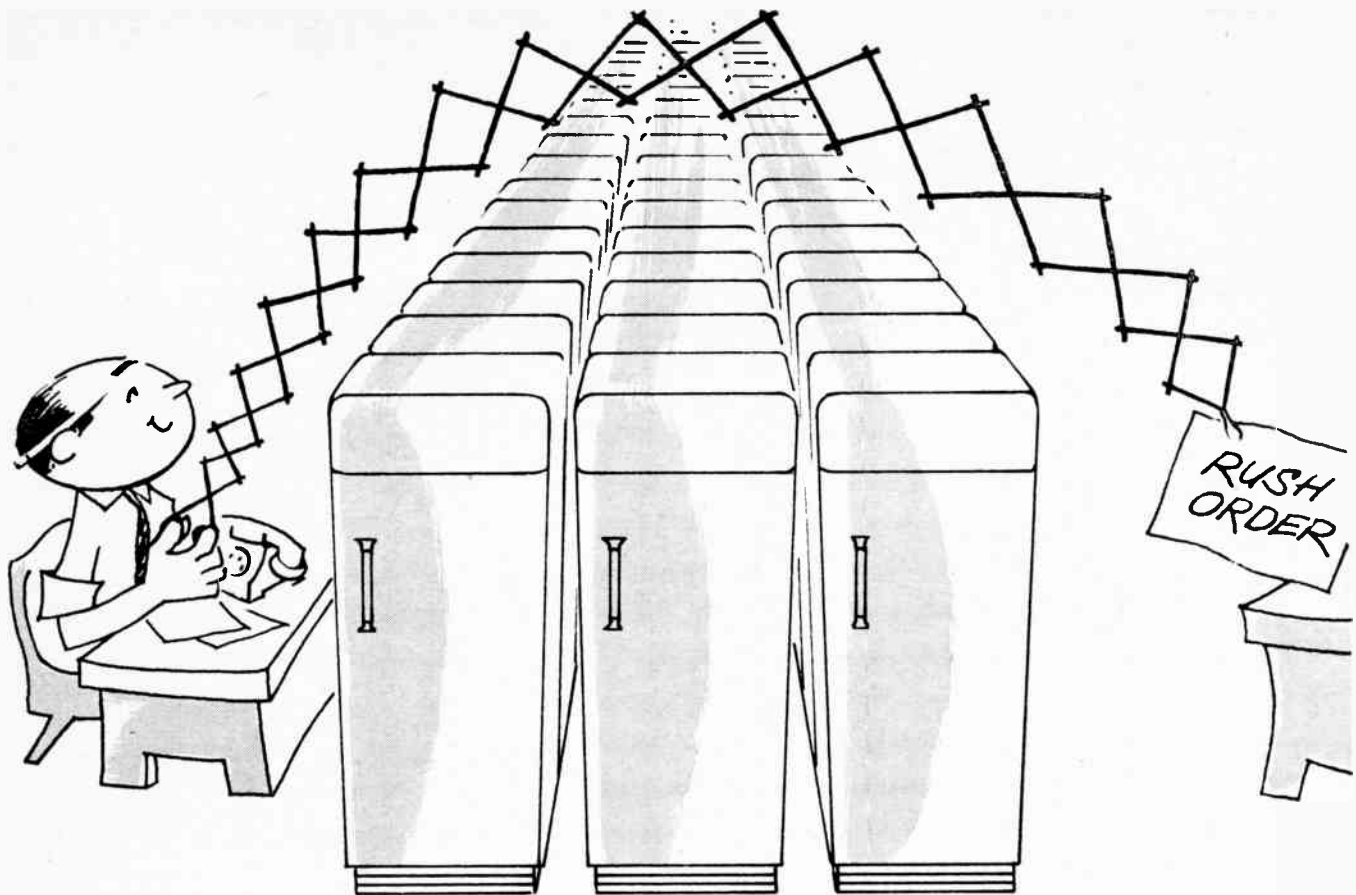

YOUR TUBE ORDER WON'T GET LOST AMONG THE REFRIGERATORS

Our tube department sells just one thing: tubes. From our field representatives to the order-desk men to the shippers, we have only one concern: Marconi Radiotrons. Your order won't be held up by shipments of refrigerators, light bulbs, TV sets or radios.

We're proud that we can "turn on a dime", work fast, and deliver fast on *any* of more than 1,000 tube types in our quick-service stocks across the country. Quality is tops, price is competitive — when service counts, specify **MARCONI RADIOTRONS.**

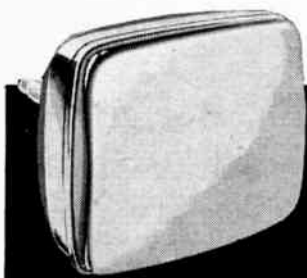
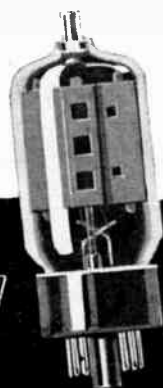

TUBE DEPARTMENT
HOME ELECTRONICS DIVISION
CANADIAN MARCONI COMPANY



Vancouver • Winnipeg • Toronto • Montreal • Halifax

For complete details check No. 12 on handy card, page 83

ELECTRONICS AND COMMUNICATIONS, June, 1962



NEW SUBMINIATURE ADJUSTORIODS* HANDLE BIG JOBS

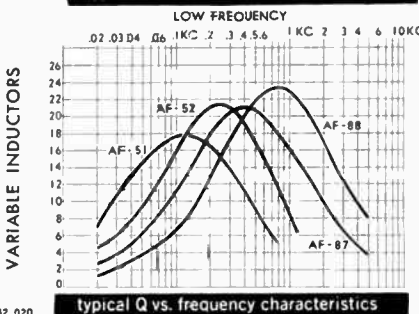
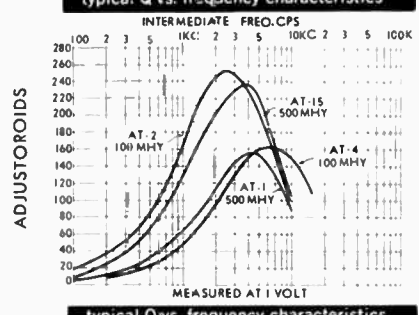
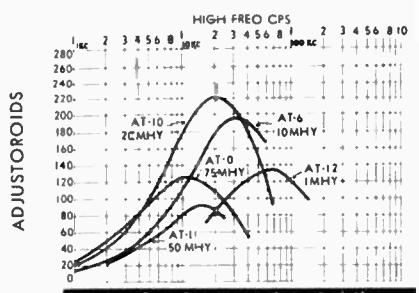

The new subminiature Adjustoroids utilizing an ingenious patented method of magnetic biasing cover a wide range of frequencies, occupy less space and are available at low cost.

New Adjustoroids possess all the outstanding characteristics of non-adjustable toroids including:

Precise continuous adjustment of inductance over a 10% range.

No need for external control current.

Hermetic sealing to meet Government MIL E # 15305-A specifications.

If your Adjustoroid needs can't be met from our stock catalogue, we'll be glad to manufacture to your specifications.

	Length/ Dia.	Width	Hgt.	Wt.	Useful Freq. Range	Mox Q	Mox L in hys
AT-0	1 1/8"		1"	2 oz	1 kc to 20 kc	10 kc	5 hys
AT-1	1 3/4"	1 3/4"	1 1/4"	7.25oz	2 kc to 10 kc	4 kc	15 hys
AT-2	2 3/4"	2 3/4"	2 1/4"	24 oz	Below 2.5 kc	2.5 kc	125 hys
AT-4	1 1/8"		1 1/4"	4 oz	1 kc to 16 kc	6 kc	15 hys
AT-6	1 1/8"		1"	2 oz	10 kc to 100 kc	30 kc	.75 hys
AT-10	1 1/8"		1 1/4"	4 oz	3 kc to 50 kc	20 kc	.75 hys
AT-11	4 5/8"	4 5/8"	3 1/4"	.83 oz	2 kc to 25 kc	15 kc	5 hys
AT-12	4 5/8"	4 5/8"	3 1/4"	.83 oz	15 kc to 150 kc	60 kc	1 hys
AT-15	1 3/8"		1 7/8"	14 oz	Below 5 kc	4 kc	125 hys
AF-51	1 1/8"		2"	5 oz	30 cps to 500 cps	120 cps	1000 hys
AF-52	1 1/8"		2"	5 oz	50 cps to 1 kc	250 cps	1000 hys
AF-87	4 5/8"	4 5/8"	1 1/4"	1.7 oz	90 cps to 2 kc	400 cps	80 hys
AF-88	4 5/8"	4 5/8"	1 1/4"	1.7 oz	.16 kc to 4 kc	800 cps	42 hys



MANUFACTURED IN CANADA BY

EDO (Canada) Limited

P.O. Box 97 Cornwall, Ontario, Canada Phone Wellington 2-6774

SALES REPRESENTATIVE - A. DESKIN SALES CORP.

1091 Sharecrest, Montreal, P.Q. Phone MU 1-0201

Manufactured under license from Bunnell & Co. Inc., Pelham Manor, New York

*PAT. 2,762,020

For complete details check No. 25 on handy card, page 83



an age publication

electronics & communications

The engineering journal of the Canadian electronics industry

Arthur E. Maine, P.Eng., editor
R. C. Poulter, P.Eng., associate editor
Ron Wood, assistant editor
William Bowers, art editor
Jerry Davey, photo editor

H. E. Dallyn, manager
Derek Reynolds, advertising manager
Nevill A. Campling, production manager
Diana King, asst. production manager
Rudy Lengerer, circulation manager

L. R. Kingsland, president
K. E. Gould, executive vice-president
Paul A. Irwin, secretary-treasurer

Published by
AGE PUBLICATIONS LIMITED
450 Alliance Avenue, Toronto 9, Ontario
Telephone RO. 2-7225

Publishers of
Beverage Alcohol Reporter
Restaurants and Institutions
Automatic Heating/Plumbing/Air Conditioning
Food Service Equipment Supplier
Canadian Gas Journal
Vending Age
Product & Design Engineering

MONTREAL
J. R. "Tom" Graham
Age Publications Ltd.
Suite 390, Lafleur Bldg.
6555 Cote des Neiges Road
Montreal 26, P.Q.
Telephone 739-2981

WEST COAST
Dillenbeck-Galavan, Inc.
266 South Alexandria Avenue
Los Angeles 4, California

U.K. and EUROPEAN REPRESENTATIVE
Norman F. Keenan
Regency House
1 Warwick Street
London, W.1, England

Indexed in the Canadian Business and
Technical Index of the Toronto Public Library.

Subscription Rates: Canada, British Possessions
and United States: 1 year — \$5.00; 2 years — \$9.00;
3 years — \$12.00. Foreign: 1 year — \$10.00.

Member Canadian Circulations Audit Board

Authorized as second class mail by the
Post Office Department, Ottawa and
for payment of postage in cash.



PRINTED IN CANADA



contents

JUNE, 1962 Vol. 10, No. 6

- 39** Frequency stabilizers for reflex klystron oscillators
by F. V. Cairns & A. E. Lindsay
- 44** Digital data transmission by telecommunication circuits
by P. Pascali, P.Eng., & D. Atkinson, P.Eng.
- 48** Factors contributing to the isolation in passive diplexers and multicouplers
by Dr. W. V. Tilston
- 51** Portable telephone exchange provides fast service to new communities
by R. W. Robb & G. S. Ballantyne
- 55** A flexible microwave absorbing material
by A. Staniforth
- 58** A new carrier system for light route communications
by J. D. D. Myers & A. Reading
- 61** A reliability program — proven by field service
by F. W. Preziosi
- 66** A new high-quality stereophonic FM receiver
by J. E. Brown
- 69** A short survey of the British microwave industry
by R. C. Glass

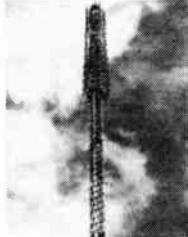

COVER STORY

RCA Victor engineer Hugh Swain makes final adjustments on the Canadian Broadcasting Corporation's new antenna at CBXT-TV, Edmonton, Alberta. Mr. Swain is working at a height of 600 feet above ground on the antenna which is shown at left. Specifically designed and built in Canada by RCA Victor, it will provide CBXT-TV with the most powerful low-band TV signal in North America.

departments

- 15** EIA news
- 26** CRTPB newsletter
- 30** Industry's business
- 33** Industry personnel
- 73** Engineer's file page No. 10
Nomagram relates vacuum-tube parameters
- 76** Product panorama
- 80** International scene
- 83** Technical literature briefs
- 84** Advertisers' index
- 87** Engineer's bookcase
- 89** Letters to the editor
- 92** Defense industry barometer
- 98** Opportunities
- 100** Editorial

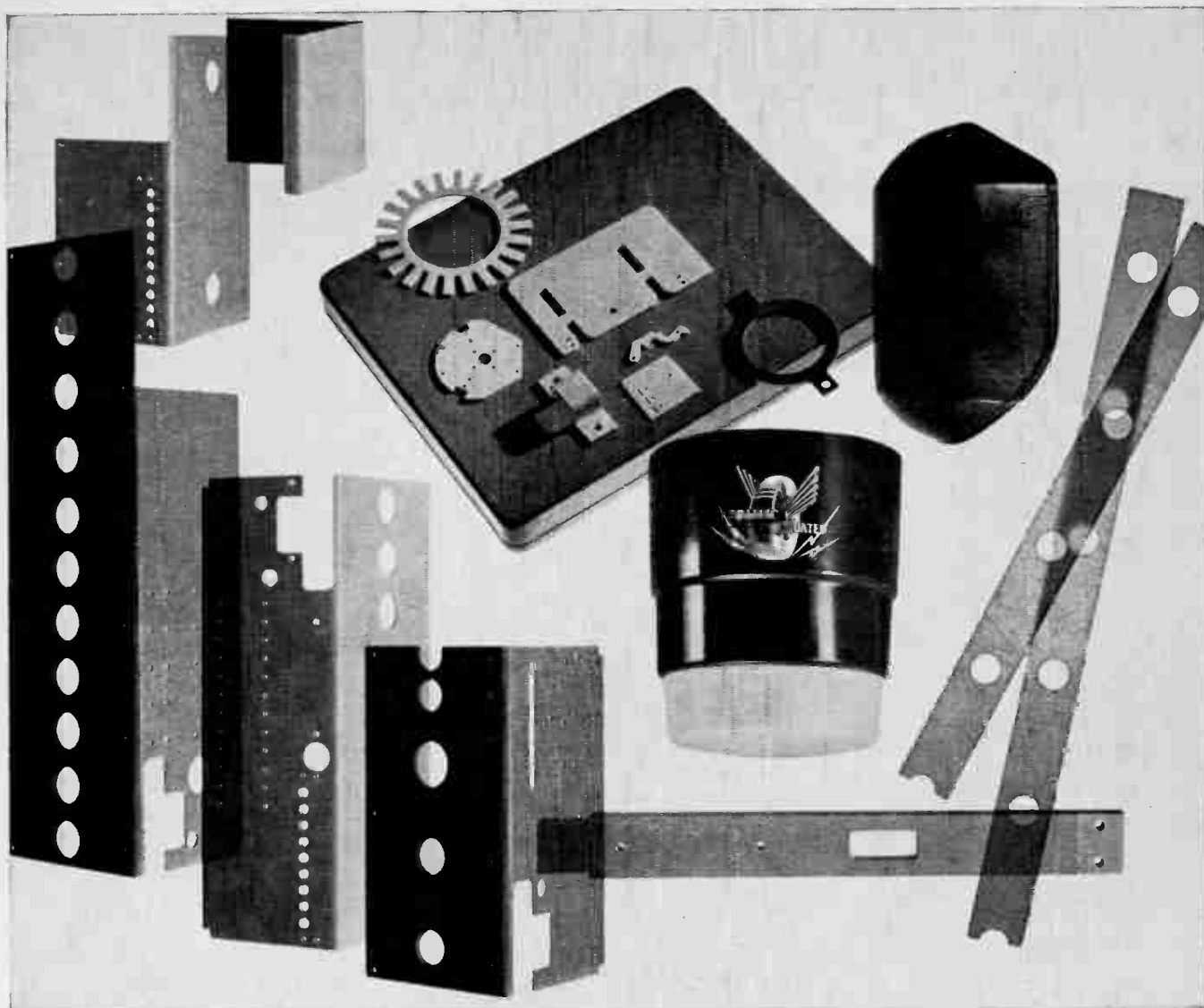

Have you explored the full design potentials of molded polyester-glass?

Few materials offer the designer so many opportunities for product design simplification and cost reduction.

Added to the inherent toughness and strength of polyester-glass are good electrical and thermal properties, weather resistance—and flame retardance if you need it.

Using advanced molding and machining techniques, complex shapes and structures can be produced to reduce product weight or the number of parts, eliminate costly machining or stamping operations, simplify product assembly, improve product performance, life or reliability.

These are the kinds of results our customers are achieving. For a few thought-starters—and facts about National polyester-glass products and molding services—contact your nearby National Sales

Office, or write directly to Dept. CC-4, Toronto, Ontario.

116 Choices: One Source This is the latest count of the different plastics and grades National can offer in your search for the *one best material*. Add to this total the one special grade that can be developed from scratch to meet your particular need. This full range of materials is backed by complete engineering services . . . from application assistance up to and including the delivery of Canadian made, 100% usable, precision-fabricated parts . . . in any quantity, on time!

Call the National Sales Office near you. It's a direct line to single-source help on your current materials problem.



NATIONAL FIBRE CO. OF CANADA

Atlantic & Hanna Avenues, Toronto • 1405 Bishop Street, Montreal

For complete details check No. 47 on handy card, page 83

GET HIGH SPEED AT HIGH CURRENT

WITH PHILCO MADT* ECONOMY!



2N1494, 2N1494A,
and 2N1496 fea-
ture 400 mw Pr in
TO-31 case.



2N1204, 2N1204A,
and 2N1495 fea-
ture 200 mw Pr in
TO-9 case.

Six Philco high current *Micro Alloy Diffused-base Transistors give you extra design latitude

Philco High Current MADT Parameters

	V _{CB0}	P _T	f _T min	V _{CE} (Sat) Max I _C =400 ma I _B =25 ma	C _{ob} Max
Ultra high speed types					
2N1204	20 v	200 mw	220 mc		8 pf
2N1204A	20	200	220	0.7 v	8
2N1494	20	400	220		8
2N1494A	20	400	220	0.7	8
High Voltage types					
2N1495	40	200	150	0.7	6.5
2N1496	40	400	150	0.7	6.5

- ... for line driving
- ... for memory driving
- ... for high current logic.

All six Philco high current MADT's—types 2N1204, 2N1204A, 2N1494, 2N1494A, 2N1495 and 2N1496—give you a high capability-to-cost ratio, outstanding uniformity, and are 100% tested for freedom from avalanche . . . all benefits of Philco MADT automation.

Write for complete information.



Immediately available in quantities 1-99 from your Philco Industrial Semiconductor Distributor



PHILCO
A SUBSIDIARY OF *Ford Motor Company*

government and industrial division

PHILCO CORPORATION OF CANADA LIMITED, DON MILLS, ONTARIO
TRANSISTOR DISTRIBUTORS—ONTARIO—Electra Sonic Supply Co. Ltd., 343 Yonge Street, Toronto • QUEBEC—Canadian Electrical Supply Co. Ltd., 271 Craig St. W., Montreal • NEW BRUNSWICK, NOVA SCOTIA, NEWFOUNDLAND—Commercial Equipment Ltd., King St., Saint John, N.S.

For complete details check No. 50 on handy card, page 83

World Radio History

hot molded carbon potentiometers

for higher stability and smoother noise-free operation

Designed to meet MIL-R-94 Environmental and Test Requirements

Available for immediate delivery at factory prices from your nearby Centralab Industrial Distributor

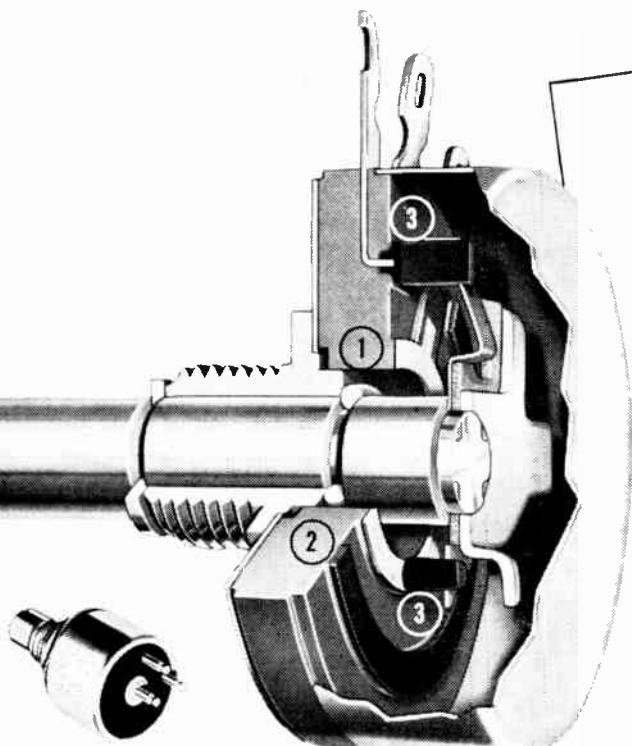

MODEL A (RV4 Style) 2 watt*

Three ways better than other hot molded units

1. Greatly increased high voltage capability, due to the wide clearance between the bushing and the collector track.
2. Greater freedom from contamination of dirt, carbon particles and sealing compounds, due to the elevated resistance track construction.
3. Exceptionally long noise-free operation that actually improves with use, provided by the carbon composition material of which both the collector and pick-off brushes are constructed.

SIZE: $1\frac{3}{32}$ " diam., $\frac{5}{8}$ " deep.** RESISTANCES: linear taper, 50 ohms to 5 MEG, log taper 100 K to 2.5 MEG. CONSTRUCTION: completely enclosed, standard or locking bushing.

MODEL N— $\frac{3}{4}$ watt*

Small size and high rating permits the Model N to be used in place of the 2 watt units in many applications where size is important. $\frac{3}{32}$ " diam., $\frac{1}{2}$ " deep**, completely enclosed construction.

RESISTANCES: Linear taper, 500 ohms to 2.5 MEG, log taper, 100K to 1 MEG.



MODEL P

(RV6 Style) $\frac{1}{2}$ watt*

One piece case spun over insulating base and "O" ring shaft seal provides extreme resistance to environmental conditions. $\frac{1}{2}$ " diam., $\frac{1}{32}$ " deep**, completely enclosed construction.

RESISTANCES: Linear taper, 500 ohms to 2.5 MEG.



MODEL T— $\frac{1}{3}$ watt*

Locking-type trimmer potentiometer designed primarily for printed circuit board use. Can be encapsulated. $\frac{19}{32}$ " diam., $\frac{11}{32}$ " deep**. Open construction.

RESISTANCES: Linear taper, 500 ohms to 2.5 MEG.

Centralab
CANADA LIMITED

ELECTRONICS

106 McMASTER AVENUE • POST OFFICE BOX 400,
AJAX, ONTARIO • TELEPHONE WHITEHALL 2-1540

NOW MADE IN CANADA

ELECTRONIC SWITCHES • VARIABLE RESISTORS • CERAMIC CAPACITORS • PACKAGED ELECTRONIC CIRCUITS • ENGINEERED CERAMICS

For complete details check No. 17 on handy card, page 83

*SOMETHING IN COMMON

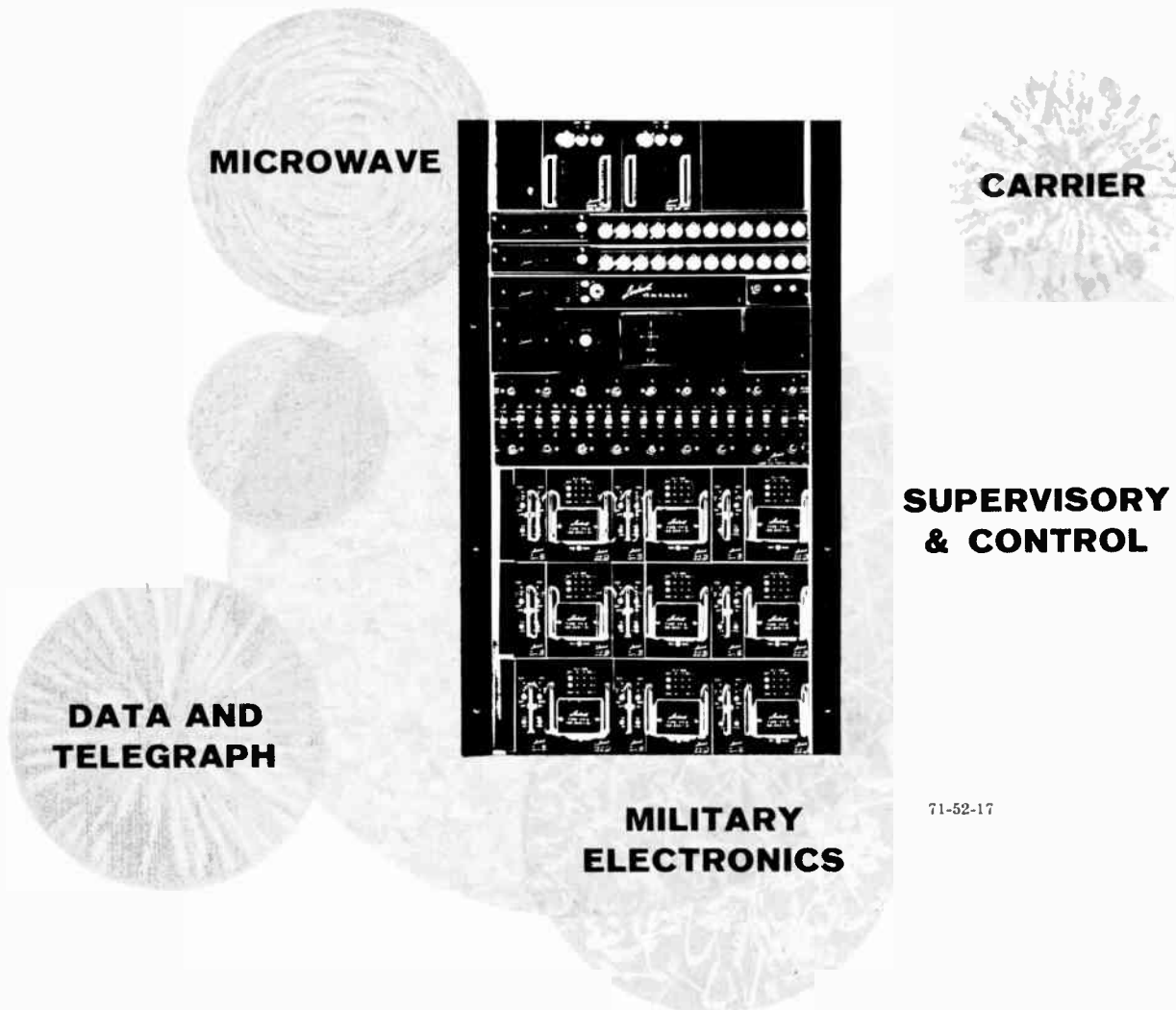

MICROWAVE

CARRIER

DATA AND TELEGRAPH

SUPERVISORY & CONTROL

MILITARY ELECTRONICS

71-52-17

*BUILT-IN QUALITY ... LENKURT'S ANSWER TO EVERY COMMUNICATIONS REQUIREMENT

This achievement results not only from sound principles of engineering design but from a continuous support program of research and development. For information and details on the many long distance communications systems developed by Lenkurt Electric, contact any of our district offices in principal cities across Canada.

LENKURT ELECTRIC

ib subsidiary of GENERAL TELEPHONE & ELECTRONICS INTERNATIONAL

For complete details check No. 41 on handy card, page 83

ELECTRONICS AND COMMUNICATIONS, June, 1962



FROM AUTOMATIC ELECTRIC THE NEXT LOGICAL STEP FOR

The next important step after Direct Distance Dialing is to extend customer dialing to other types of toll calls. This is exactly what Automatic Electric has now done.

The new Type 62 Strowger Automatic Toll Ticketing System incorporates all the proven features of Type 59 SATT, and handles Person-to-Person, Collect, Special Instruction calls (PPCS), and Station-to-Station calls as well.

This means Type 62 equipment can be used either for new installations where both Station and Person calls are to be handled by customer dialing, or to add PPCS service to existing Type 59 systems. In the latter case either system can be expanded independently as required. Although the Type 62 SATT system places no restrictions on choice of access code, two- or three-digit codes are widely used in typical toll centre and tributary installations.

IMPORTANT NEW FEATURES AND BENEFITS

- Called numbers are displayed in panel facing operator, in easy-to-read, illuminated digits.
 - On Person calls, where party may be at a different number, operator can release previously built-up toll connection and key new number without dismissing calling party.
 - Class of call and start of timing are controlled by six classes of pushbuttons:
- | PERSON-TO-PERSON | STATION-TO-STATION |
|-------------------------|-------------------------|
| 1. PAID | 1. PAID |
| 2. COLLECT | 2. COLLECT |
| 3. SPECIAL INSTRUCTIONS | 3. SPECIAL INSTRUCTIONS |
- Operator can change the class of any call at any time before she initiates timing, and either be disconnected automatically when timing starts, or stay the call and cancel accumulated time.
 - Where a customer elects paid service after trying a Station Collect or Person Collect call, Station Paid key permits both recording and timing of call.
 - If operator answers a call where calling number has not been automatically identified, a lamp lights and remains lighted until she has asked for and keyed-in the calling number.
 - PPCS operators are also able to act as regular checking operators on Station calls where required, and while awaiting answers on PPCS calls.

For complete details check No. 7 on handy card, page 83

YOUR REVENUES UP STEPPING



TIME-PROVEN BENEFITS OF SATT

- Cuts handling costs.
- Provides faster completion and recording of calls.
- Encourages more toll calls, increases your revenues.
- Ensures maximum number of trunks during peak hours.
- You get permanent records that can't be erased.
- You can add new equipment as and when you need it.

For the full story on the new Type 62 Strowger Automatic Toll Ticketing System and what it can mean to you, call or write Automatic Electric today. Automatic Electric Sales (Canada) Limited, 185 Bartley Drive, Toronto 16, Ontario. Branches across Canada.

AUTOMATIC ELECTRIC

Subsidiary of

GENERAL TELEPHONE & ELECTRONICS



6217

|U|R|G| All-New HF

System Concept!

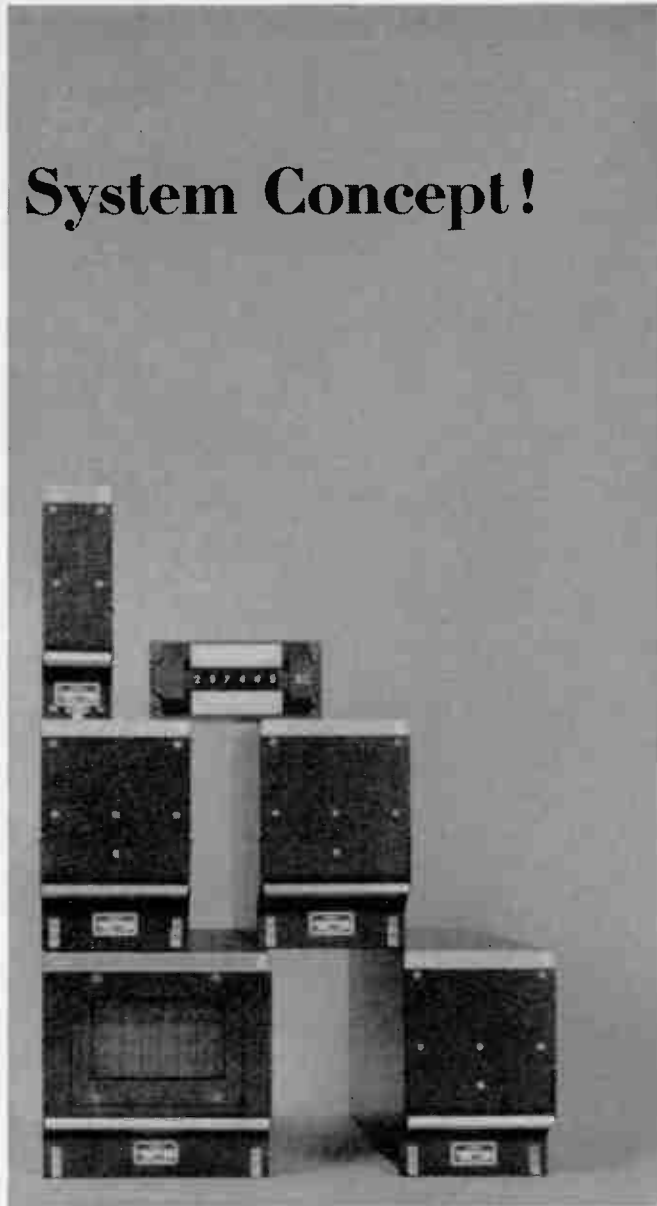
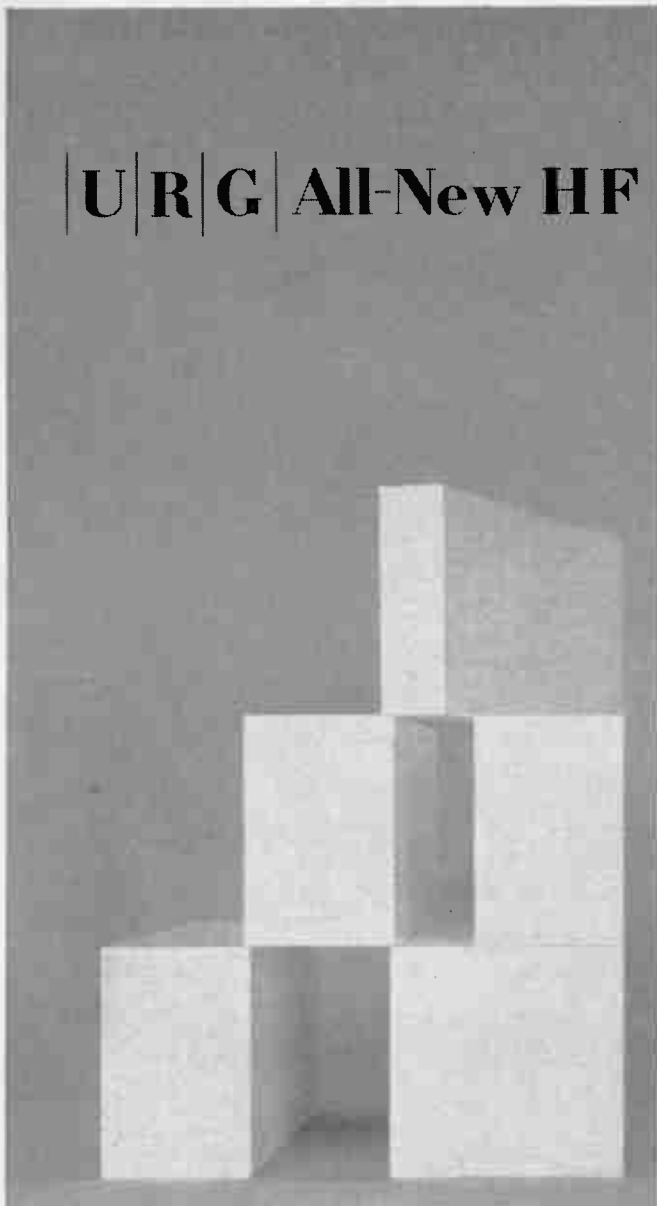

Get maximum flexibility for your expanding communication requirements.

The most advanced answer to your requirements for a growing or changing HF system is Collins' SSB Universal Radio Group. Employing system-oriented modular design, U/R/G will meet *all* requirements . . . from simple local control voice circuits to complex remote control data circuits. It is equally applicable to fixed station, transportable or airborne installations. □ Covering the 2.0-29.999 mc frequency range in either 0.1 or 1.0 kc channel increments, U/R/G offers a choice of power levels, functions and operational modes. Utilizing the latest solid state

circuits, this rugged new system is compact, lightweight, and it features low power consumption. □ Advanced modular packaging allows individual circuit cards to be housed in compact, easily installed units conforming with standard racking. □ This flexibility makes U/R/G the most easily expanded system available to meet your changing communication requirements. □ For a brochure with complete information about Collins' Universal Radio Group, write to COLLINS RADIO COMPANY OF CANADA, LTD. 11 Bermondsey Road, Toronto 16, Ontario.



For complete details check No. 19 on handy card, page 83

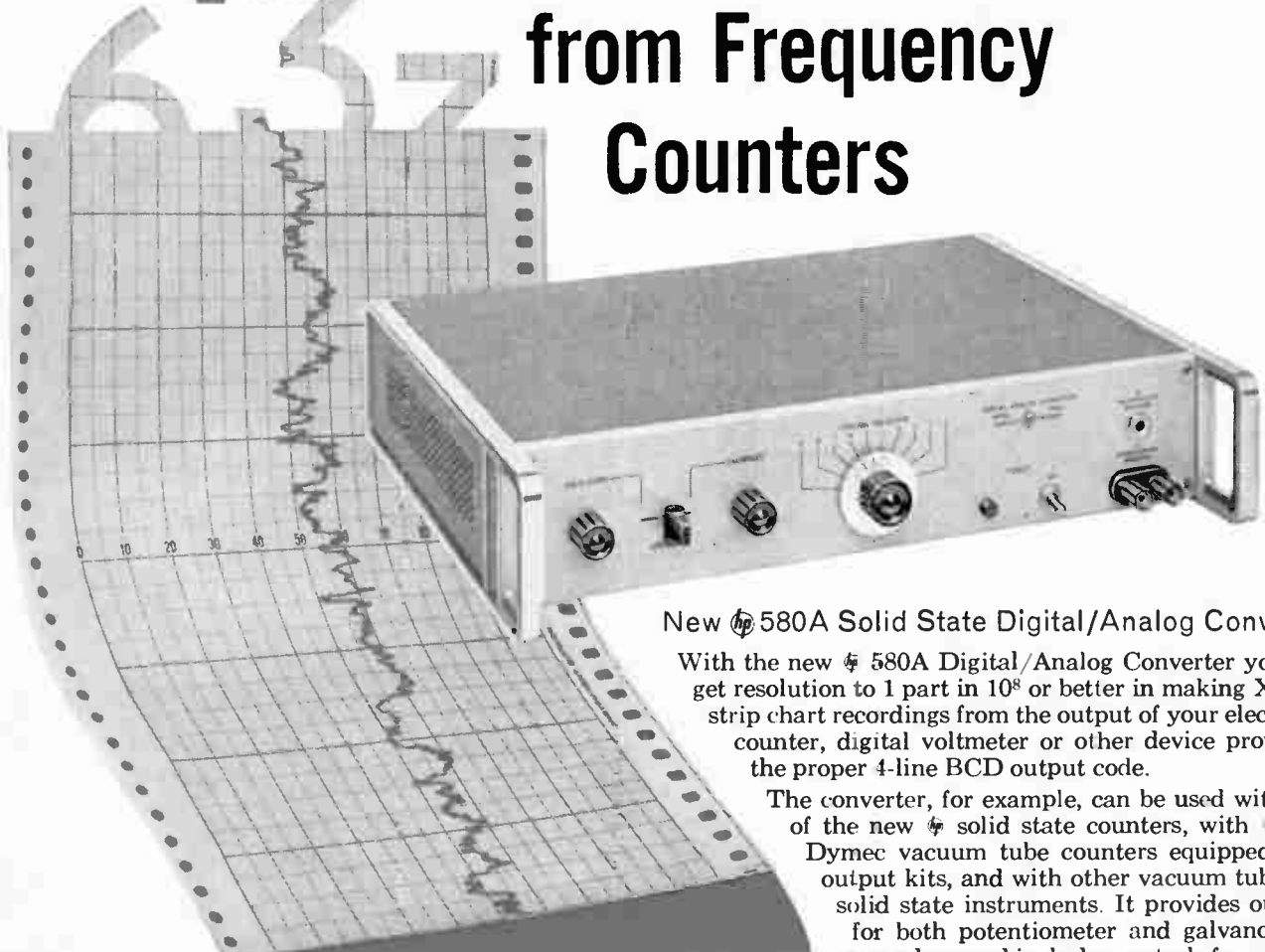

814.

High-Resolution Analog Recording from Frequency Counters



New 580A Solid State Digital/Analog Converter

With the new  580A Digital/Analog Converter you can get resolution to 1 part in 10^8 or better in making X-Y or strip chart recordings from the output of your electronic counter, digital voltmeter or other device providing the proper 4-line BCD output code.

The converter, for example, can be used with any of the new  solid state counters, with  and Dymec vacuum tube counters equipped with output kits, and with other vacuum tube and solid state instruments. It provides outputs for both potentiometer and galvanometer recorders, and includes controls for calibration of the recorders.

Any three successive digits (or the right-hand two) may be chosen for analog output, and selection of the least significant digits produces analog records of extreme resolution and accuracy. For example, recording three righthand digits of nine-column data results in resolution of 1 part in 10^8 . Automatic zero-shift keeps the record "on-scale" at all times.

The solid state  580A accepts 4-line data, which is transferred to storage binary units within the converter on command from the counting source. The stored data is then translated and weighted to provide the proper analog output voltage or current.

HEWLETT-PACKARD (CANADA) LTD.

8270 MAYRAND ST., MONTREAL • 735-2273

Branches:

1762 Carling Ave., Ottawa • Parkway 2-8162

1415 Lawrence Ave., W., Toronto • 249-9196

SPECIFICATIONS

Accuracy:	0.5% of full scale
Potentiometer Output:	100 mv full scale
Galvanometer Output:	0 to 1 ma into 5,000 ohms or less
Driving Source:	Parallel entry 4-line BCD, 1-2-2-4 (9 digits max.) having a swing of 4 to 75 v about a source reference
Command Pulse:	Positive or negative pulse, 20 μ sec or greater in width, 6-40 v amplitude
Transfer Time:	2 msec
Size:	16 $\frac{3}{4}$ " wide, 3 $\frac{1}{2}$ " high, 11 $\frac{1}{2}$ " deep; 15 lbs.
Price:	\$525.00

Data subject to change without notice
Price f.o.b. factory.



For complete details check No. 32 on handy card, page 83

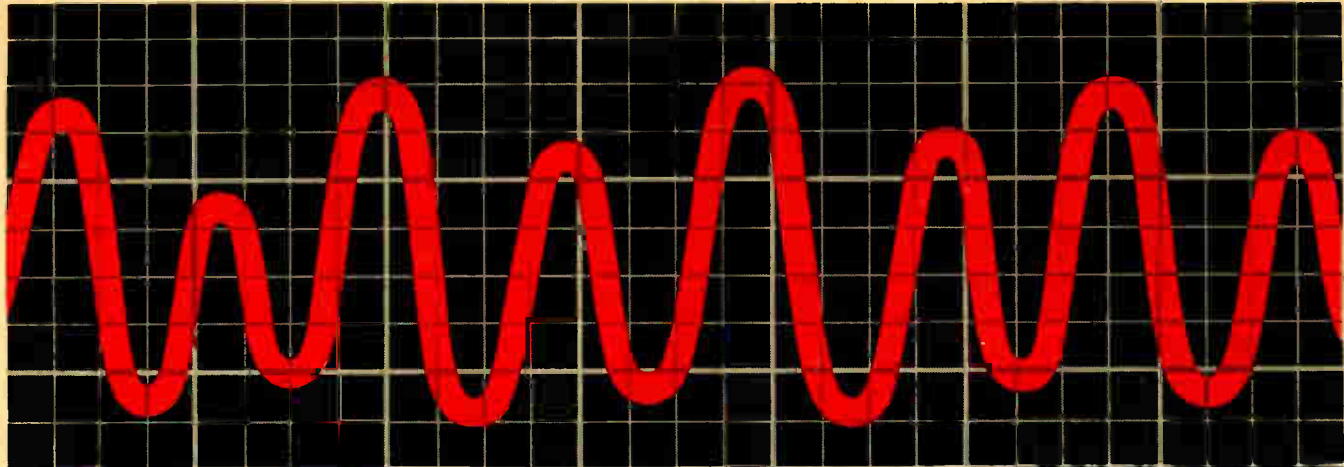

MULTI-PURPOSE COMMUNICATION SYSTEMS



3 KW GENERAL PURPOSE
TRANSMITTER

ITT
CANADA
LIMITED

For complete details check No. 37 on handy card, page 83

A comprehensive range of low and medium frequency transmitters of advanced design for beacon and communication purposes, built to meet the stringent requirements of the Royal Canadian Navy and Department of Transport.

25 WATT BEACON TRANSMITTER

200-415 KCS, CW/MCW/RT, with automatic keyer and with "press to talk" facility.

50 WATT BEACON TRANSMITTER

Frequency range 280-330 KCS, CW/MCW, with automatic keyer.

3 KW TRANSMITTER

Frequency range 100-200 KCW, CW/FSK, will accept keying speeds up to 100 wpm (400 wpm FSK).

3 KW BEACON TRANSMITTER

Frequency range 190-415 KCS, CW/MCW/RT, with automatic keyer.

2 KW TRANSMITTER

Frequency range 100-230 KCS, CW/FSK, will accept keying speeds up to 100 wpm (400 wpm FSK).

All transmitters are supplied with an Antenna Tuning Unit. For dual installations an Automatic Transfer Unit is available.

ITT
CANADA
LIMITED

9600 ST-LAURENT BLVD., MONTREAL

ITT systems cover the whole broad field of telecommunications including: telephone and telegraph, radio and television microwave links . . . designed, manufactured and installed by ITT engineers.

Electronic **I**ndustries **A**ssociation

of Canada

news

by R. T. O'Brien



The Industrial Research Assistance Program

A circular outlining the intent and nature of the Industrial Research Assistance Program has been released by the National Research Council. The circular explains the basic considerations which will govern the operation of the program, which is intended to stimulate the interest of Canadian industry in research and development; to promote the establishment of new industrial research facilities; and to promote the expansion of existing facilities across Canada.

The NRC is responsible for the administration of the plan and will be assisted in adapting the program to industrial needs by advice from the NRC Advisory Committee on Industrial Research. This group is comprised of well-known industrialists representing a wide range of Canadian industries.

New EIA Standards

Some new EIA Standards are available in the RS series: RS-253, dated March 1962, gives the Standard Temperatures For Electrical Measurement and Rating Specifications For Semiconductor Devices. The standard is designed to provide the specification writer with a list of temperatures in common usage and for which testing equipment will be more readily available. It also reduces to a minimum the number of temperatures at which semiconductor device electrical measurements and ratings are specified consistent with electronic equipment requirements.

RS-252 covers Baseband Characteristics of Microwave Radio and Multiplex Equipment. The standard makes it possible to describe the baseband characteristics to allow evaluation of radio and multiplex equipment compatibility. It applies to the characteristics of the transmission path between the Multiplex Baseband Send Terminals and Multiplex Baseband Receive Terminals in both directions of transmission.

RS-255, Simulated Life Test Circuit for Semiconductor Rectifier Diodes describes the requirements which a simulated circuit should meet when life tests require the use of large quantities of power, due to the size of the rectifier diode being tested, while subjecting the rectifier to the same operating conditions as it would see in a normal test circuit.

RS-258 pertains to 50-ohm Semi-Flexible Air Dielectric Coaxial Cables and Connectors. Typical cables included are those having a helical or tubular dielectric supporting the inner conductor and sheathed with a ductile or semi-flexible outer conductor, those having the inner conductor supported with spaced beads and those having a foamed dielectric between inner and outer conductor.

The Electronic Industries Association of Canada
holds its twenty-third Annual Meeting
on June 20-22, 1962,
at the Chantecler Hotel, Ste. Adele-en-haut, P.Q.



The equipment sales are

To be accurate, communication sales seldom start with equipment. They originate with customer requirements: The demand for convenience, for luxury. In the business world, the demand to free valuable executive time from detail, the need to

clear information faster at less cost, the need to control distant operations more precisely, the desire to shave "reaction-time" in competitive selling. □ At "Northern", we apply communications technology to communication requirements. The resulting



call director



speakerphone



pushbutton intercom

For complete details check No. 48 on handy card, page 83



made of.

equipment represents profitable solutions to the vast and profitable market for specialized communications. □ To build your revenue, emphasize these problem-solving products in your sales programmes. All are in immediate supply. From "Northern"

Northern Electric

COMPANY LIMITED



cordless switchboard

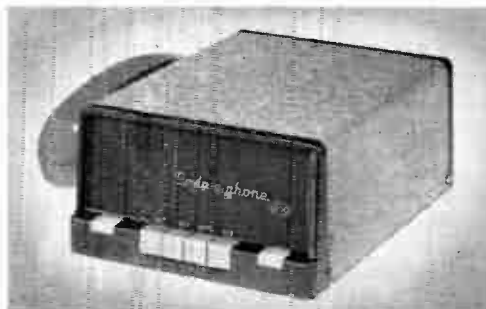

code-a-phoné

World Radio History



home interphone



This untiring electronic secretary[®] can start earning money for YOU now

Here is another sure fast seller and revenue earner in the famous Electronic Secretary[®] line—a low priced telephone answering set for domestic and small business use. It answers the telephone . . . delivers a message . . . receives and records up to 12 incoming messages of 15 seconds duration . . . and stays on duty 24 hours a day. The new unit is known as the Model SP (Short Play) telephone answering set, and it sells for only about half the price of the Model LP (Long Play).

The SP is so simply designed that subscribers can learn to operate it in seconds. Because it uses tape, there are no records to buy or cut,

and messages can be changed anytime. It will function for years without extensive service problems. And with the time and money it saves, and the new business it attracts, it quickly pays for itself many times over.

Cash in on the earning potential of the new SP. Offer it to your subscribers—they'll wonder how they ever got along without it.

For complete details, call or write Automatic Electric—your one comprehensive source for all your "subscriber" needs. Automatic Electric Sales (Canada) Limited, 185 Bartley Drive, Toronto 16, Ontario. Branches across Canada.

AUTOMATIC ELECTRIC

Subsidiary of

GENERAL TELEPHONE & ELECTRONICS



6213

For complete details check No. 8 on handy card, page 83

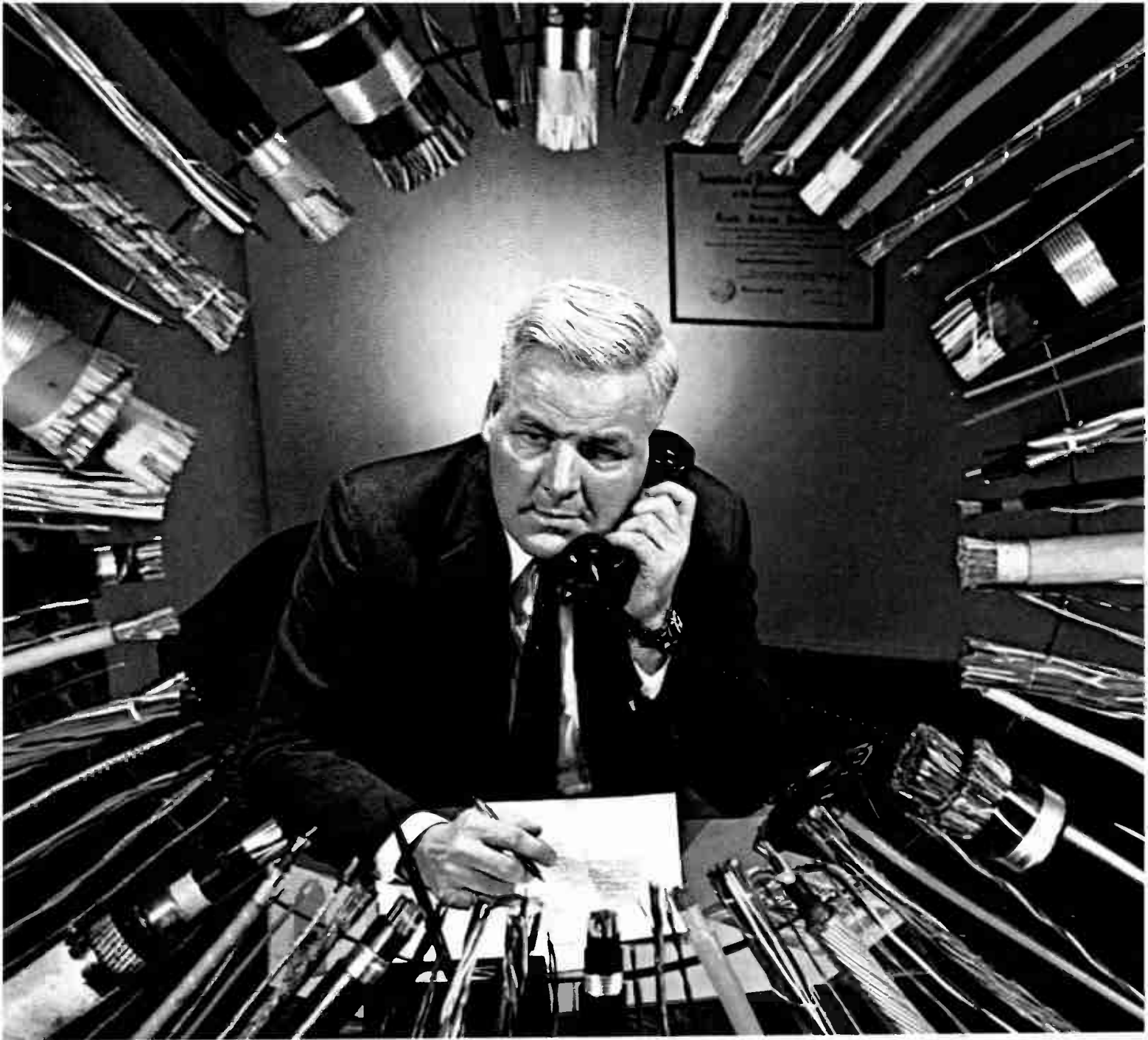

"GET ME PHILLIPS!"

Warehouse stocks strategically located from coast to coast are your assurance of the product you want, when and where you want it. For the finest wires and cables—and the fastest service—say "Get me Phillips!"

Phillips Electrical Company Limited, Head Office—Brockville, Ontario. Branches—Dartmouth, Montreal, Ottawa, Toronto, Hamilton, Winnipeg, Edmonton, Vancouver. The Canadian affiliate of the BICC Group.



WIRE & CABLE

6118

Phillips Telephone Wire and Cable are also distributed in Canada by Automatic Electric Sales (Canada) Limited

HAMMOND

ELECTRICAL-ELECTRONIC CABINETRY

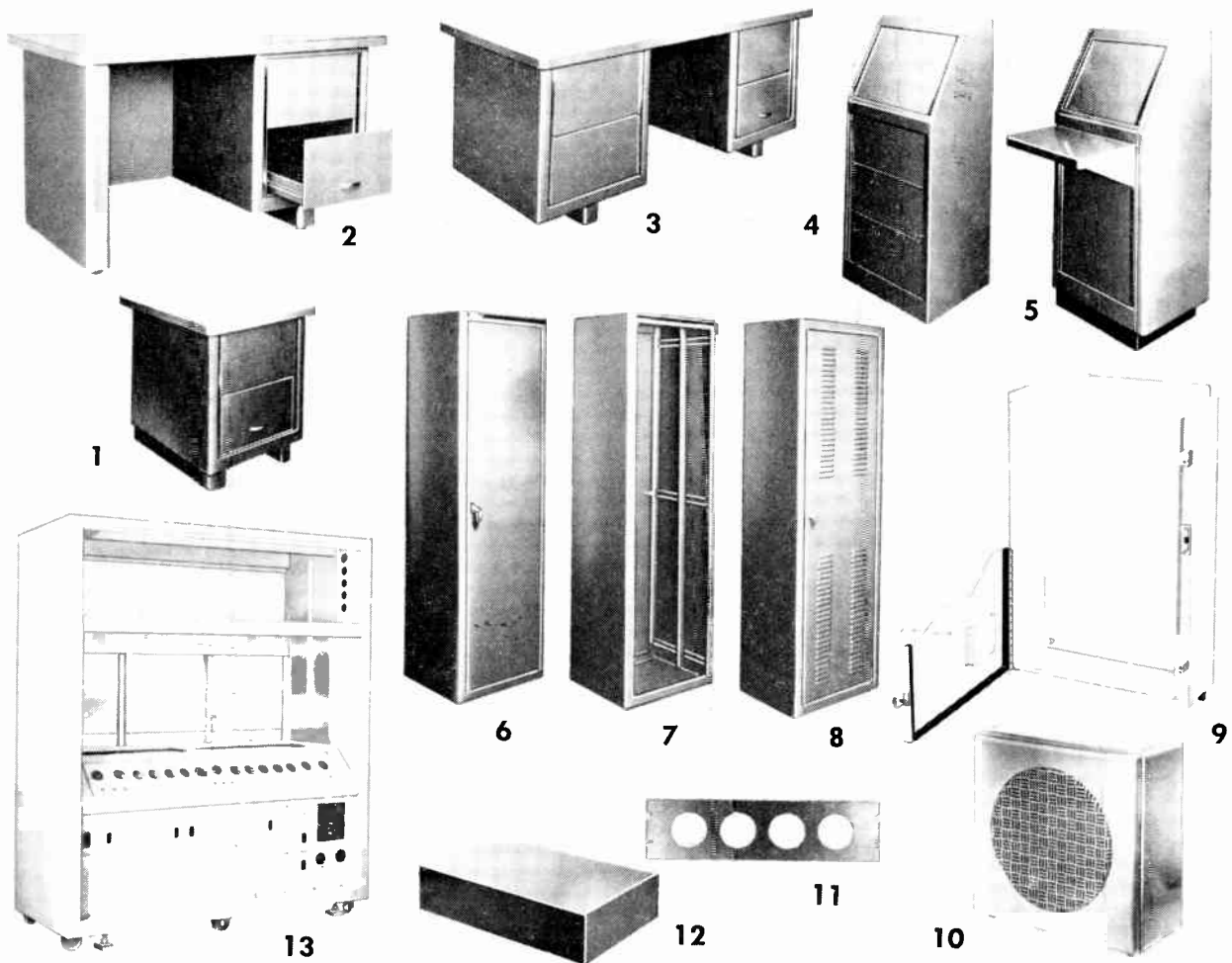

Quality metal work as standard or original equipment

Hammond fabricates precisely made metal work for the electrical-electronic industry. Stocked items include

a wide range of equipment and accessories in a choice of size and finish.

Dies used for nearly 17,000 original metal fabrications are available to produce "specials" to your requirements at an economical price.

- 1 Single pedestal Console.
- 2 Console with pedestal and leg support.
- 3 Double pedestal Console for heavy equipment.
- 4 Standard Modular Console.
- 5 Modular Console with side panels, table attachment and base.
- 6 Cabinet Rack with optional front door.
- 7 Cabinet Rack, interior view.
- 8 Cabinet Rack, rear view.
- 9 Panel Enclosures to N.E.M.A. specifications.
- 10 Speaker Cabinet.
- 11 Meter Panels.
- 12 Chassis.
- 13 Intricate special Cabinet to customer design.

FOR FURTHER DETAILS, ASK FOR CATALOGUE 82

HAMMOND MANUFACTURING COMPANY LIMITED GUELPH, ONT., CANADA

For complete details check No. 31 on handy card, page 83

H/8



ANNOUNCING THE NEW HONEYWELL IRON VANE AC

PANEL METERS

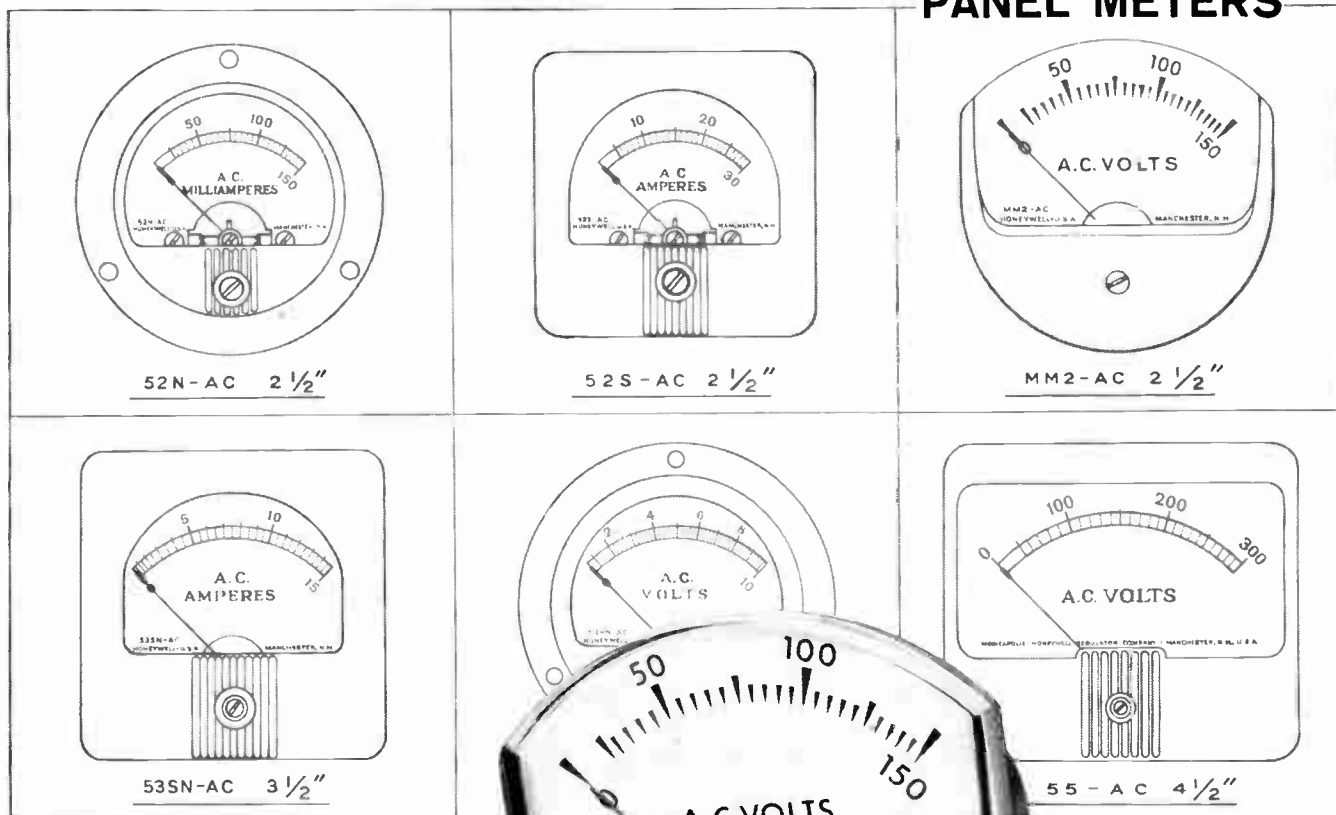

Here are the AC counterparts of Honeywell's popular DC panel meters. Iron Vane AC Meters are perfectly matched to the DC range and are available in both the Medalist and "standard" case styles. This means a minimum of trouble and expense in mounting. And you are assured of harmonious styling in every detail.

Iron Vane AC Meters are designed for a wide variety of commercial applications — including portable equipment, testers, power supplies, generator equipment and medical equipment. The improved moving iron mechanism features magnetic damping, impregnated field coils, and selected fixed and moving iron material to provide long, trouble-free operation.

These meters are available in a wide selection of case styles and colors. Dials can be custom designed with your company name, trade-mark or other data.

For full information, call your nearest Honeywell Office or write Honeywell Controls Limited, Precision Components Division, Toronto 17, Ontario.

Honeywell



Precision Meters

For complete details check No. 34 on handy card, page 83

SPECIFY CANADIAN MARCONI—

DQ58C

WIDE-BAND LONG-HAUL CARRIES 600 TELEPHONE CHANNELS OR TELEVISION TO CCIR STANDARDS

The DQ58C equipment operates in the frequency range of 1750-2300 mcs and carries 600 telephone channels, or one monochrome or colour TV programme over transcontinental distances to CCIR standards. The facility to drop or insert channels can be provided at repeater stations if required.

The newest of modern techniques and components have been employed in order to obtain still better performance from the equipment. The use of slide-in-chassis, printed circuit boards, high performance tubes and modern solid state and ferrite components have all contributed to outstanding performance and reliability.

The DQ58C is the best value on the market in terms of capital cost per channel mile. The operating cost is low, because the DQ58C has low power consumption and low spares replacement cost.

Systems can be supplied for a variety of requirements, including hot or cold standby, twin path or multipath system. Automatic changeover and switching systems are available. Systems can be engineered to provide reliabilities in excess of 99.99%.

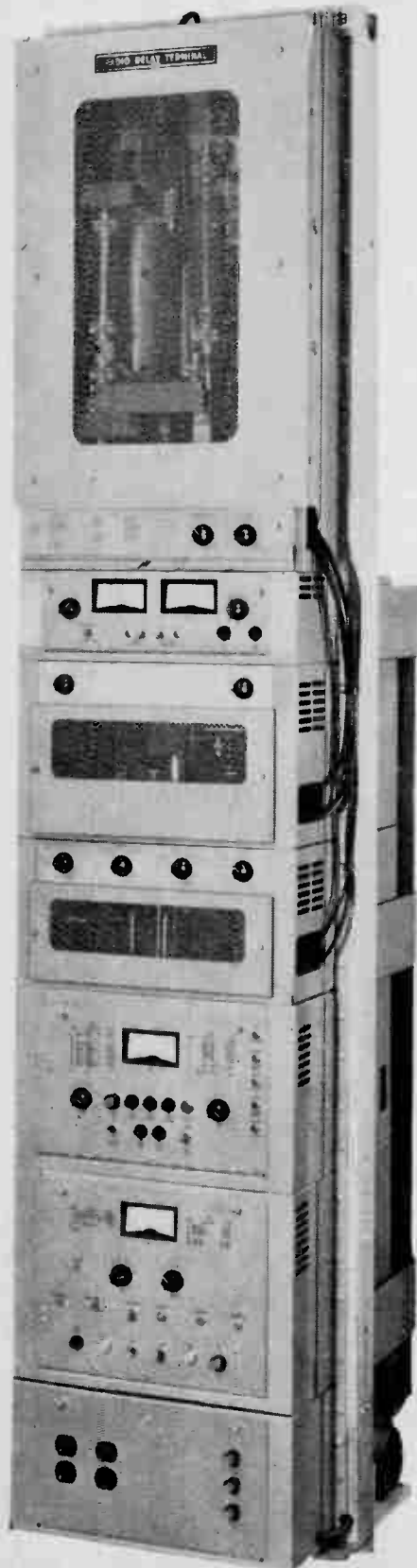

(Side covers removed)

EASE OF ACCESSIBILITY AND REPLACEMENT

Slide-in chassis utilizing printed circuit techniques are used extensively.

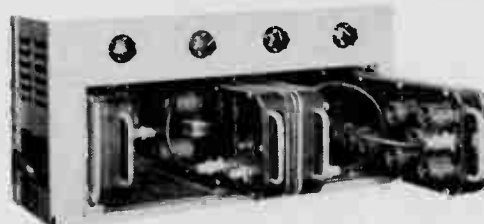

COMPACTNESS

Complete front access, making possible back to back, as well as side by side, arrangement. A complete terminal or repeater equipment is contained in a single 19" relay rack.

10 WATTS OUTPUT FROM A SINGLE TRAVELLING WAVE TUBE

THE USE OF TRAVELLING WAVE TUBES GIVES: HIGH GAIN — A gain of 40 db in a single RF stage.

LOW DISTORTION — Low distortion usually is the determining factor for performance of wide band systems and is easily obtained with travelling wave tubes.

BROAD BANDWIDTH — The RF assembly has a 3 db bandwidth in excess of 35 mcs.

EXCELLENT MATCHING — Input and output standing wave ratio is less than 1.05.

HIGH RELIABILITY — Tube life is in excess of 10,000 hours.

HIGH STABILITY — Tubes require no adjustment during the course of their life.

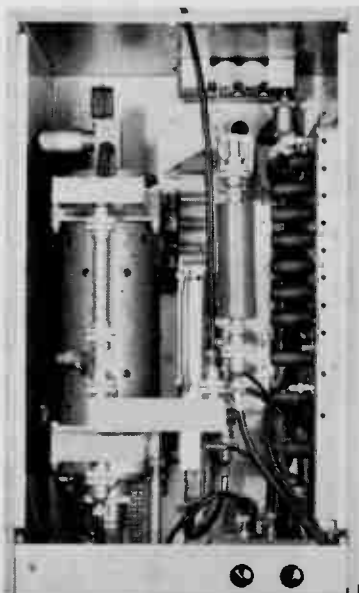

RELIABILITY WITHOUT COMPROMISE

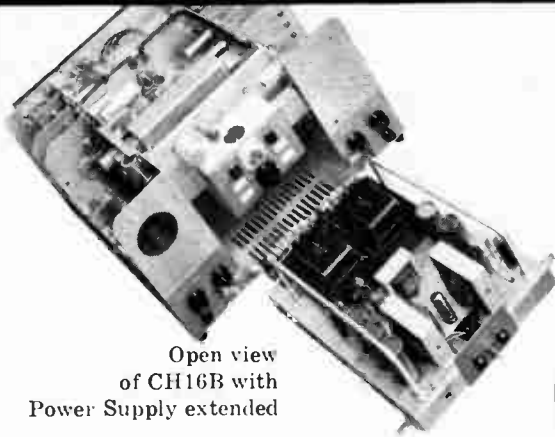

Open view of CH16B with Power Supply extended

CH16B Single Sideband Transceiver



CH16B

A complete radio station! Single Sideband Transceiver

The CH16B single sideband transmitter/receiver is a complete radio station primarily intended for point to point radio communication.

The equipment consists of a single desk mounting cabinet. The top and sides are removable as an integral unit, making the circuitry readily accessible for simplified maintenance.

- The radiated energy in SSB operation is concentrated in one sideband only. This results in a 4 to 1 power advantage over conventional AM operation for a given output rating when used with a SSB receiver.
- The option of operating with different transmit and receive frequencies in each channel is an important advantage not available on most competitive equipment.
- Speech Clipper increases the average transmitted speech power using simple and reliable circuitry.
- Self-contained audio oscillator and meter facilitate tune-up procedure.
- Compatibility in communicating with AM equipment is possible by re-inserting the carrier on trans-

mission, and using on reception, the separate true envelope detection system which is incorporated in the CH16B.

- Silicon rectifiers only are used in the power supply for increased reliability.
- Front panel meter monitors relative power output, PA tuning and PA cathode current.
- Automatic Break-in on CW — Automatic reversion to the transmit condition during key down CW telegraphy operation.
- Simplified Antenna Matching by four automatically switched output terminals, plus optional facilities for automatic remote antenna switching and matching.



Front-Mount Unit
148 - 174 Mc
30 Watts Output
19 lbs.

DT65 30 WATT VHF FM MOBILE RADIO UNIT

The new DT65 is ultra-reliable. It will work more than twice as long as the best of its predecessors, before needing service attention. This singular reliability saves you cash in two ways:

1. Fewer service interruptions mean lower servicing costs.
2. Fewer stand-by units are needed "on the shelf" for maintenance applications, so less capital is required.

The DT65 can operate as anything from a single-channel up to a SIX-channel unit. In addition, it has facilities to add such items as Siren and Loudhailer, etc. Simple adaptors mean that you pay only for the flexibility you need. Just add-in as your needs grow — all the basic wiring is already there. The expansion of your mobile radiotelephone needs will never make the DT65 obsolete.

SPECIFICATIONS AVAILABLE ON ALL UNITS

"MINIPAK" LIGHT WEIGHT FM TRANSCIVER

9 lbs. — 1.3 Watts
RF output
12" x 3" x 8 1/2"

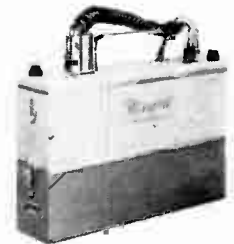

Engineered for the man in the field, this set features long battery life, extreme dependability in the face of hard usage, and light weight.

SPECIFICATIONS

Frequency Range: 150 — 174 Mcs
Frequency Stability: $\pm .0025\%$ 5 Kcs Deviation
 $\pm .005\%$ 15 Kcs Deviation
Sensitivity: .75 microvolts for 20 dB
Noise Quieting — 5 Kcs Deviation.

Units equipped with microphone or handset. Available with Dry Cell, wet battery or long-life nickel cadmium battery power supplies.



CANADIAN MARCONI COMPANY

COMMERCIAL PRODUCTS DIVISION

2442 Trenton Avenue, Montreal 16, Canada



REPRESENTATIVES AND AGENTS LOCATED THROUGHOUT THE WORLD

Records PROVE Reliability of Westinghouse Microscatter

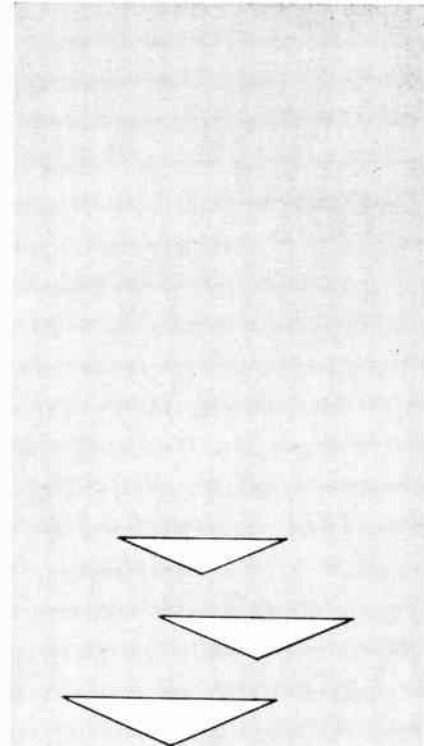
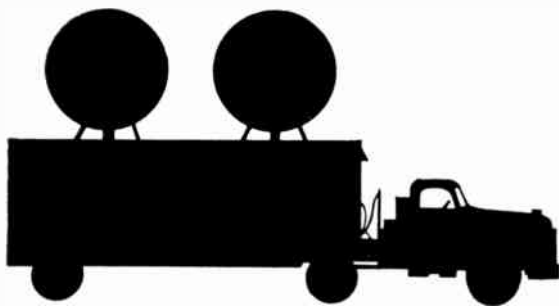

%

MICROSCATTER PERFORMANCE

> 99.99

PROPAGATION CONDITIONS

> 99.97

Scatter path
Average path length...150 miles
Average angular distance...20.5 milliradians
Frequency...4400-5000 mc

Power...2 KW
Diversity...Quadruple
Voice channels...48
Antenna size...10 feet
diameter

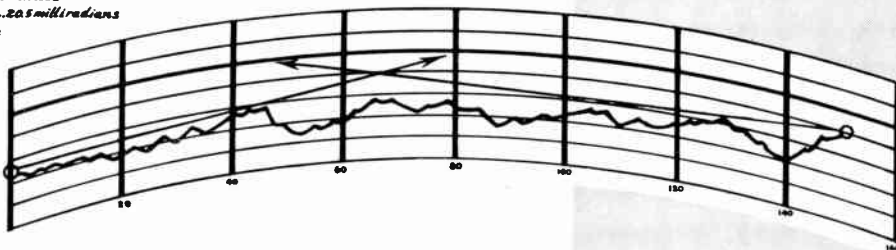

MICROSCATTER equipment reliability: 99.99%! That's the record of performance established by Canadian Westinghouse MICROSCATTER communications equipment for continuous "in service" operation. The above figures are based on a defense agency's records extending over a 20-month period; they graphically illustrate the year-round dependability of MICROSCATTER communications.

The first tropospheric scatter equipment in the 4400-5000 mc band, MICROSCATTER may be operated unattended and independent of commercial power lines. For complete transportability, a full terminal including primary and

standby power generators may be installed in two standard highway trailers.

To receive complete MICROSCATTER application data write to: Canadian Westinghouse Co. Ltd., Electronics Division, Hamilton, Ontario, Canada.

CANADIAN
Westinghouse
Microscatter

ANDREW

HELIAX

THE FLEXIBLE AIR DIELECTRIC CABLE

meets every communication requirement

Production scenes

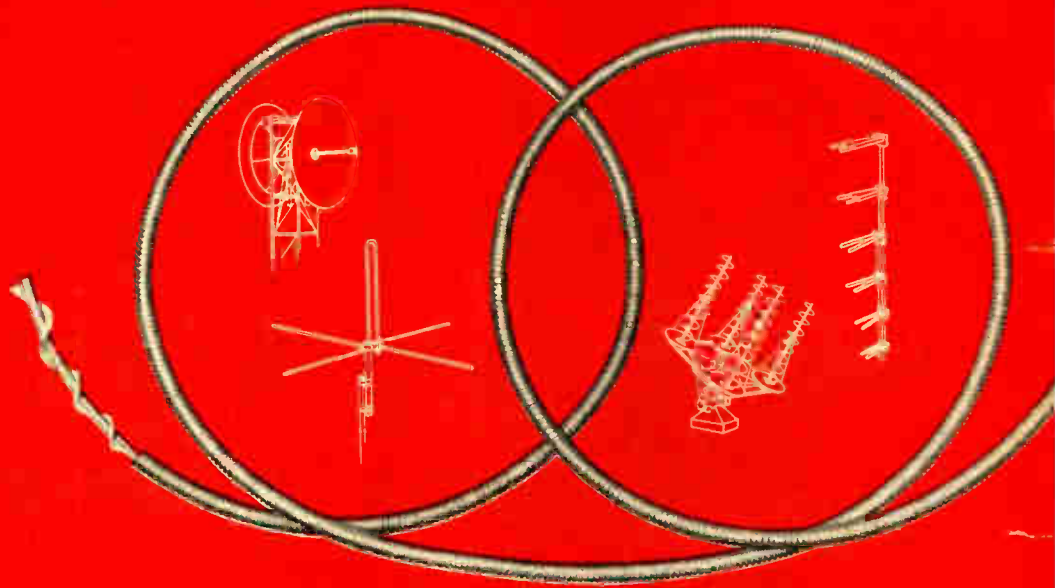

Easiest to install...longest to endure

Produced in the new ANDREW plant facilities, HELIAX is the flexible, low loss, low VSWR coaxial cable for use in all applications from VLF through microwave.

The production cycle in which the copper sheet stock is formed around the cable core, welded and corrugated on a continuous basis is depicted in the film strip. Rolled sheet stock provides considerably closer tolerance tubing than is possible by extrusion or other methods.

HELIAX is the *only flexible* air dielectric cable. This flexibility is imparted by the unique, continuous helical corrugated construction. Bending torque required is about one-half that required for straight wall aluminum or copper tubing of the same size.

HELIAX has the greatest resistance to crushing or kinking. Again this is due to its unique construction. Resistance to physical damage from crushing or kinking forces is about twice that of conventional aluminum or copper cables of comparable size.

HELIAX is the only air dielectric coaxial cable capable of being manufactured in continuous lengths. Critical applications need no longer depend on splicing 1,000 feet or shorter lengths to make up a long cable run. HELIAX affords the only splice free, trouble free air dielectric cable installation.

STANDARD SIZES AND TYPE NUMBERS

SIZE	IMPEDANCE	TYPE NO.
3/8	50	H3-50
7/8	50	H5-50
7/8	75	H5-75
7/8	100	HT5-100
1 1/8	50	H7-50
1 1/8	75	H7-75
1 1/8	100	H7-100
3 1/8	50	H2-50
3 1/8	75	H2-75

ANDREW is your only fully integrated source for complete antenna systems.



HELIAX • RIGID COAXIAL LINES • MICROWAVE ANTENNAS • MILITARY PRODUCTS • FIXED STATION ANTENNAS • FM ANTENNAS

You are invited to write for these ANDREW catalogs.

Andrew
ANTENNA CO. LTD.
606 BEECH STREET • WHITBY, ONTARIO, CANADA

ANTENNAS • ANTENNA SYSTEMS • TRANSMISSION LINES

For complete details check No. 5 on handy card, page 83

SYNTRON

expands line of
RECTIFIERS

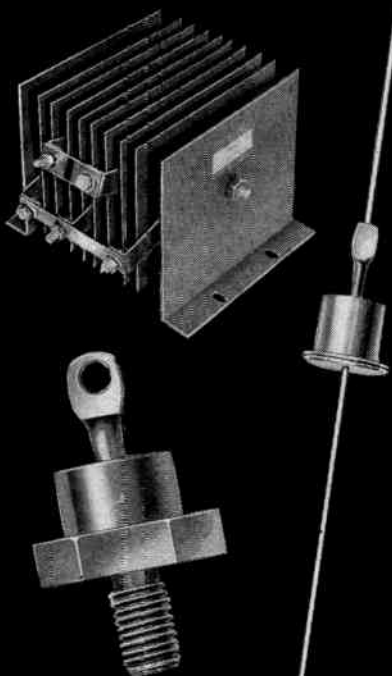

SELENIUM and SILICON RECTIFIERS

Now Syntron offers a complete range of power rectifiers. Manufacturing facilities have been expanded to produce silicon rectifiers in a wide range of capacities. Selenium rectifiers are made to specification from the most complete range of plates manufactured in Canada. Write for data sheets.



SYNTRON (CANADA) LIMITED
DEPT. X, STONEY CREEK, ONTARIO

MADE IN CANADA

For complete details check No. 64

Canadian
Radio
Technical
Planning
Board

newsletter

by R. C. Poulter



To Implement Land Mobile Split-Channeling In All Areas

Effective November 1, 1962, applicants for new systems in the 150.8-174 Mc/s band in any area of Canada will be required to employ equipment type approved under the latest issue of Radio Standards Specification 126, which covers land mobile equipment in this band with 30 Kc/s channel separation.

In order to make possible greater use of the 152-174 Mc/s portion of the radio spectrum the DOT took the first step to implement 30 Kc/s channeling in this band on an area basis on September 1, 1960. At the CRTPB Annual Meeting last December the Department said that in order to make the program of split channeling fully effective it intended to implement RSS-126 with an effective date of November 1, 1962.

The question of a suitable amortization period for existing systems operating at 60 Kc/s channel separation is still to be resolved in co-operation with the Planning Board. Therefore the requirement for all-area implementation of 30 Kc/s channelling is for *new* systems applications.

Special Committee Studies Frequency Tolerance & Stability

A special committee of the CRTPB has been studying frequency tolerance and stability problems in existing equipment and systems with a view to determining the effects on reliability of communication in varying environmental conditions.

With specifications becoming more stringent through the trend towards a greater use of the spectrum by split-channel operations there is an increasing need for equipment and systems to be maintained closer to allowable tolerance and to gain more control over the factors which affect equipment stability.

Vice-President C. J. Bridgland of CRTPB is chairman of the committee which comprises experts acquainted with every facet of study. Each has undertaken to report on a fact-finding assignment with a view to producing what is hoped to be a valuable reference for manufacturers, operators and specification writers alike.

The study ranges through all the aspects of equipment design and development, crystal and oven and other circuitry production techniques, environmental control and compensation, maintenance and adjustment techniques in the field and the degree of degradation which can be tolerated without seriously affecting the efficiency of a user's communication system or interfering with his neighbours' use of the public domain known as the radio spectrum.

Expansion of Emergency Broadcasting Network

The Department of Transport has announced that the Emergency Broadcasting Network will be expanded to include all radio and TV stations in Canada. In a national emergency the network would carry warnings and instructions from federal and regional control studios linked with Army warning centers.

Co-ordinated by the CBC under the control of the Minister of Transport, the network will include private and CBC stations.

In the event of a national emergency, all broadcasting stations in operation at the time would remain on the air and the radio stations which had shut down would be re-opened. All stations would broadcast only official warnings and instructions.



the model 635

combines for
the first time in
one instrument:

- Flat A.C. response to 50 KC/S on both current and voltage ranges.
- Milliohm insertion impedance, virtually constant over the full range of frequency.
- Adjacent Volt and Amp switch positions, plus circuit holding feature, permitting virtually simultaneous comparison readings with four test leads.

This combination of features extends the application of this portable multimeter to include accurate measurements in the low impedance circuits typical, for example, of high fidelity amplifier output stages. In a single instrument the Model 635 accurately fulfils a function formerly reserved for two special single purpose meters.

And it's a versatile general purpose multimeter as well, with many outstanding features —

Single switch operation • Premium accuracy • Mirror scale •
Knife-edge pointer • Spring-loaded jewels • Shielded movement •
Overload protection . . .

And the same quality and ruggedness which have made "Simpson" a byword wherever multimeters are used.



1255 BRYDGES ST. • LONDON, ONTARIO

For complete details check No. 9 on handy card, page 83

MARSLAND

ELECTRO-MECHANICAL ASSEMBLIES

Used in the most complex control equipment being built in Canada today.

If you are building or purchasing electro-mechanical packages and systems of "space age" complexity, you will find it an advantage to know about Marsland Engineering Limited.

- Marsland manufactures high quality components and packages to the most rigid customer specifications as single prototypes or in production quantities.
- Marsland is able to start with a statement of requirement and develop it through all stages to a finished production assembly.

MARSLAND ENGINEERING LIMITED

WATERLOO, ONTARIO

Associate Company: MARSLAND PRECISION EQUIPMENT CO. LTD.
WATERLOO, ONTARIO.



ANTENNA CONTROL

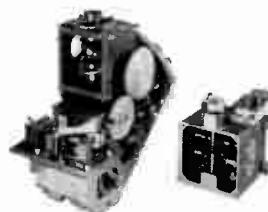

COINCIDENCE FEED ASSEMBLY
4 SPEED GEAR BOX

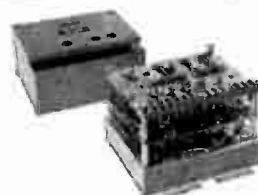

SERVO AMPLIFIER

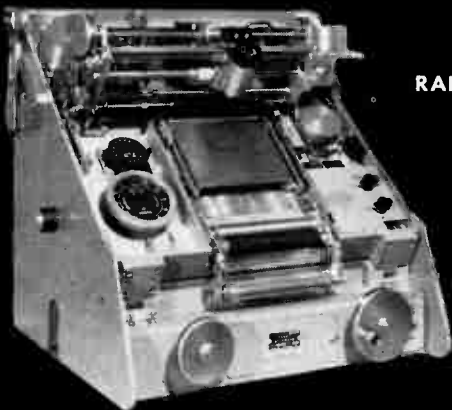

RANGE RECORDER

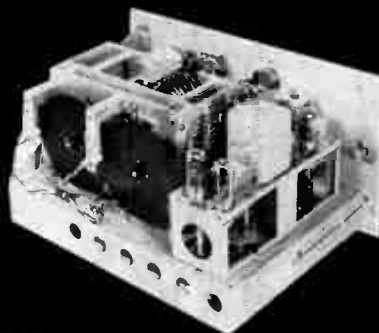

AZMUTH
MARK
GENERATOR

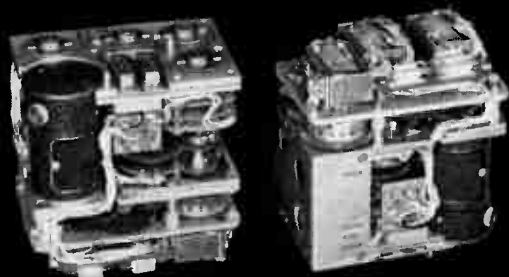

ELECTRO MECHANICAL
TUNING DRIVE



DUAL CHANNEL
PEN RECORDER



GEAR
CASE ASSEMBLY

YOUR SPECIFIC ENQUIRY IS INVITED

Sylvania electronic tubes have the unmistakable stamp of reliability. For example, the new Sylvania 6146A eliminates a major mobile communications problem: fadeout as the battery supply is reduced through engine idling, slow driving speed, or motor shut off. Sylvania 6146A (6.3 type) maintains a 45W output with the battery supply as low as 5 volts. Interchangeable with their prototypes, Sylvania 6146A, 6883A and 6159A, are already producing outstanding results for police and fire departments, taxi companies, airlines, forest rangers, government departments and other users of mobile and portable radio transmitting equipment. For more technical data on Sylvania electronic tubes, contact your supplier, or write: Sylvania Electric (Canada) Ltd., 6233 Cote de Liesse Road, Montreal 9.

SYLVANIA

Sylvania Electric (Canada) Ltd. • A subsidiary of General Telephone and Electronics International Inc.

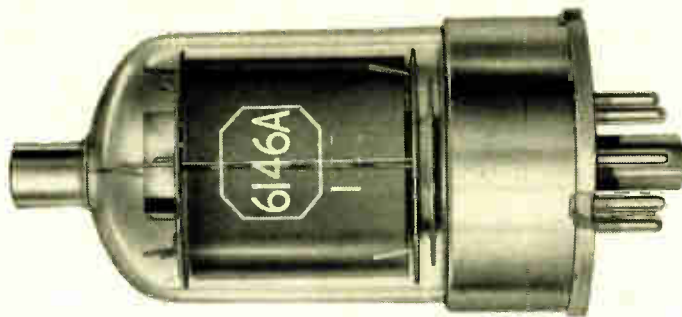

Reserved
for a
Sylvania
tube
!

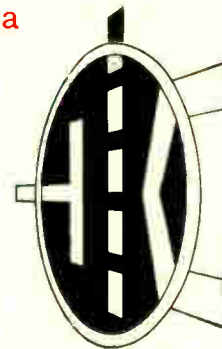

industry's business



Jerrold Electronics (Canada) Ltd. recently moved into their new building at 60 Wingold Avenue, Toronto 19, Ontario. An area of 20,040 square feet provides for complete engineering, production and warehouse facilities, as well as general offices.

Wide acceptance of products dictates TMC (Canada) expansion

T.M.C. (Canada) Limited will be expanding its facilities to more than double the present size of the plant on the River Road, near Uplands Airport, Ottawa, within the next few months. The present premises of 15,000 square feet, will be increased to approximately 32,000 square feet with the major emphasis being on production and production support.

These increased facilities are dictated by the acceptance of T.M.C. single sideband transmitting and receiving equipment and synthesized frequency control systems, generally used by Government and communications agencies throughout Canada and foreign countries.

RCAF approves CAE's F-104 simulator

The first of 30 F-104 Starfighter simulators being built for the RCAF and NATO countries in Europe by Canadian Aviation Electronics Ltd. was accepted by the RCAF late in April. The Air Force's Central Experimental and Proving Establishment report equipment meets all its specifications.

The on-time delivery of the first unit by CAE is extremely important because the on-schedule completion of the remaining simulators, in what will be one of the largest electronic export orders ever filled by a Canadian firm, depended upon acceptance of the first.

The second simulator, for the Netherlands Air Force, is scheduled for delivery early this summer, with models for the RCAF and the air forces of West Germany, Holland, Belgium and Italy following at regular intervals during the next 2½ years.

Licon now represented in east

Ben Manis Associates Reg'd. and Wm. Cohen Ltd., both of Montreal, were made exclusive reps. for Licon Switches & Controls in Quebec and the Maritimes. They will carry stocks of Licon products; address orders and inquiries to 8900 Park Ave., Montreal, P.Q.

CEWA holds 7th annual meeting

At its seventh annual national meeting and convention held in the Royal York Hotel, Toronto, April 16-18, the Canadian Electronic Wholesalers' Association elected C. G. Mann, of Cam-Gard Supply Ltd., Winnipeg, as its president, and M. I. Rosenthal, of

Cesco Electronics Ltd., Montreal, as vice-president.

In addition, directors elected were: C. R. Smith, Capital Sales Ltd., Fredericton, N.B.; Al Ugar, T.V. Radio Wholesale (Ontario) Ltd., Toronto; Bernard Rosenberg, Lee Bern & Company Ltd., Winnipeg; and Fred Fucile, Inter-Comm Supply Company Ltd., Fort William.

Alan G. Johnson of Johnson Electric Supply Limited, North Bay, Ontario, immediate past-president, was appointed chairman of the board, and John T. Rochford, of Toronto, was re-appointed secretary-treasurer.

The National meeting was followed by a Management Seminar, EIA Tube Committee Reception and Industry Dinner. The Association's first annual award of a plaque to the outstanding supplier of the year was presented to D. Lou Harris, president of Atlas Radio Corporation Limited, Toronto, by the Convention and Dinner Chairman, Alan G. Johnson.

Eldon's new plant operational

May 1st saw Eldon Industries of Canada Ltd. move into newly completed premises in Don Mills, Toronto. Electrical and electronic products will be produced and distributed from the new 1315 Lawrence Ave. East site.



Air Marshal Hugh Campbell (left) Chief of the Air Staff, discusses simulator responses with F/L R. Taylor during demonstration of the first F-104 simulator produced by CAE.

Manitoba student wins 1962 IRE Competition

Judges in the 1962 IRE Region 8 Student Papers Competition named R. M. Jell, Electrical Engineering Department, University of Manitoba, as the winner. His paper was titled "The Extraction of Periodic Functions from Quasi-Random Processes".

Mr. Jell has the alternative of the \$100 cash prize or expenses towards a trip to the IRE Canadian Communications Symposium to be held in Montreal in November. In addition, he will receive an engraved plaque to mark his achievement.

Honorable mention was given to a paper — "A Precision High-Current Low-Voltage Power Supply" submitted by R. P. C. Paul, Department of Electrical Engineering, McGill University.

There were four other entrants in the final judging:

D. H. Auston, Elec. Engineering Dept., University of Toronto, "The Modulated Long-Yagi Antenna"; J. B. Milroy, Elec. Engineering Dept., University of Waterloo, "Noise in Ge and Si Semiconductor Devices"; J. W. Oades, Elec. Engineering Dept., University of B.C., "Recent Techniques in VHF Amplification"; R. M. Turnbull, Physics Dept., University of Western Ontario, "Fading of HF and CW Signals on a Trans-Atlantic Path".

The judges, all from the Montreal Section, were:

Allan B. Oxley, Canadair Ltd.; Prof. Alain Breton, Ecole Polytechnique; and Prof. G. W. Farnell, McGill University.

New product line

Belfort Instrument Co., Baltimore, Md., manufacturers of meteorological and photogrammetric instruments, are now represented in Canada by Aviation Electric Ltd., Montreal.

Electronic Marketing represents Hoyt Meter Corp.

F. Segal, general manager of Electronic Marketing Company of Canada Ltd., announced early in May that this company was the exclusive representative of the Hoyt Meter Corp., Cambridge, Mass., for all applications except automotive. Hoyt manufactures a line of meters including ammeters, voltmeters, panel meters and portable meters.

Continued on page 79

SIMPLIFY YOUR PULSE-SAMPLING MEASUREMENTS

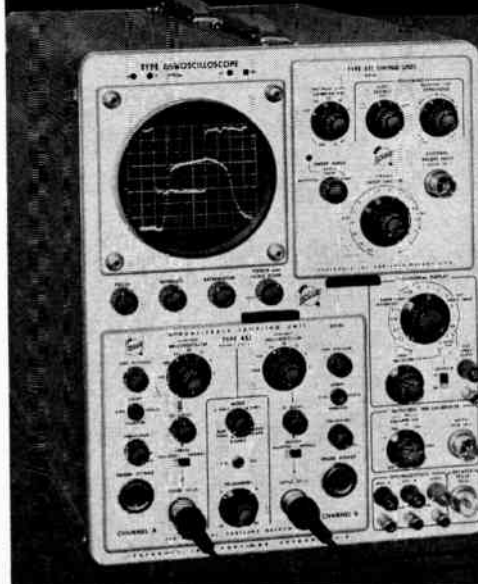

with this **NEW**
Tektronix
Dual-Trace
Oscilloscope



Here's what you can do:

- ... Trigger internally—observe the leading edges of both A and B traces. Matched internal delay lines in both channels assure accurate time comparisons.
- ... Measure pulse risetimes with 0.35 nanosecond response in both channels. Time measurement range extends to 1 millisecond.
- ... Display repetitive signals on 16 calibrated equivalent sweep rates from 1 nsec/cm to 100 μ sec/cm, accurate within 3%. Magnifier provides sweep expansion from 2 to 100 times... time per dot remains the same for digital readout.
- ... Change the probes' signal source without affecting the dot transient response.
- ... Reduce time jitter and amplitude noise, if needed, on the more sensitive vertical ranges and faster sweep rates by means of a smoothing control.
- ... Measure millivolt signals in the presence of a substantial dc component by means of a dc-offset voltage monitorable at the front panel.
- ... Calibrate with amplitude signals available from the front panel. Calibrate with timing signals traceable to National Bureau of Standards.
- ... Show lissajous patterns in addition to single and dual-trace displays and signals added algebraically.
- ... Drive X-Y plotters or similar readout accessories.
- ... Drive external equipment, with fast delayed-pulse output.
- ... Add plug-in units as they come along.

Here's how you do it:

- ① Plug in the power cord and signal source,
- ② Set the controls on the vertical and timing plug in units,
- ③ Take the measurements.

In one compact laboratory oscilloscope you have a complete pulse sampling system with risetime of 0.35 nanosecond. Using the 50 Ω inputs, or the Tektronix passive probe or cathode-follower probe designed for use with the instrument, you can meet most of the general-purpose-measurement demands in repetitive-signal applications.

For complete information on the characteristics and capabilities of this new Pulse-Sampling Oscilloscope, please call your Tektronix Field Engineer.

Type 661 Oscilloscope (without plug-ins) . . . \$1150
Type 4S1 50 Ω Dual-Trace Sampling Unit . . . \$1430
Type 5T1 Timing Unit . . . \$ 750
Probes: Type P6026 Passive Probe . . . \$ 140
Type P6032 Cathode-Follower Probe \$ 160
U. S. Sales Prices f. o. b. Beaverton, Oregon

Tektronix, Inc.

P. O. BOX 500 • BEAVERTON, OREGON / Mitchell 4-0161 • TWX—BEAV 311 • Cable: TEKTRONIX

SERVING THE CANADIAN PROVINCES OF:

Quebec, New Brunswick, Nova Scotia, Prince Edward, Newfoundland:	Manitoba, Ontario:	British Columbia, Alberta, Saskatchewan:
Tektronix Canada Ltd. 3285 Cavendish Blvd., Montreal, Quebec Phone: HUinter 9-9707	Tektronix Canada Ltd. 4A Finch Ave. West Willowdale, Ontario Phone: Toronto, 225-1138	Tektronix, Inc. 236 S.W. 153rd Street Seattle 66, Washington Phone: CHerry 3-2494

For complete details check No. 66 on handy card, page 83



COMMUNICATIONS-DESIGNED

transistors are **7 WAYS BETTER**
 than conventional communications-adapted
 transistors:

PHILCO COMMUNICATIONS TRANSISTORS FOR EVERY FREQUENCY:

- | | |
|----------------|---|
| 2N1788 | } I.F., R.F., Converter service to 10 mc. Typical noise figure under 3 db at 1 mc. 55 db max. gain (over 40 db usable gain). 1.5 pf typical C _{ob} . |
| 2N1789 | |
| 2N1790 | |
| 2N1866 | R.F. mixer and converter service to 30 mc. 25 db min. gain at 10.7 mc. Typical noise figure under 4 db at 10 mc. |
| 2N499 | H.F. Amplifier and oscillator. 22 db gain at 25 mc. Meets all requirements of MIL-S-19500/72A (SIG C). |
| 2N502A | R.F. Amplifier and oscillator. 12 db gain at 200 mc. 6 db noise figure at 200 mc. 30 volt rating. 75 mw power dissipation. Meets all requirements of MIL-S-19500/112 (SIG C). |
| 2N1158A | Medium power oscillator. 35 mw output at 200 mc, and 50 mw at 100 mc. Meets all requirements of MIL-S-19500/113 (SIG C). |
| 2N1742 | } 14 db min. gain at 200 mc. 14 db min. conversion gain at 200 mc. 5 db max. noise figure at 200 mc. 12 db max. conversion noise figure at 200 mc. 1.5 mw guaranteed oscillator output in single-tuned oscillator. |
| VHF Amplifier | |
| 2N1743 | |
| VHF Mixer | |
| 2N1744 | } 1. F. applications from 30 to 60 mc. 21 db min. gain at 45 mc, Typical noise figure under 4 db at 45 mc. |
| VHF Oscillator | |
| 2N1745 | |
| T2028 | } VHF and UHF. 16 db min. gain at 200 mc. 4.5 db max. noise figure at 200 mc. 16 db min. conversion gain. 9 db max. conversion noise figure at 200 mc. 6 db typical noise figure at 450 mc. 13 db typical gain at 450 mc. Typical noise figure under 3 db at 60 mc. |
| Amplifier | |
| T2029 | |
| Mixer | |
| T2030 | } UHF amplifier, oscillator, and mixer service. 8 db min. gain at 1 kmc. 8.5 db typical noise figure at 1 kmc. Coaxial package impedance-matched for 50 ohm insertion. |
| Oscillator | |
| T2351 | |
| 2N1494 | Wideband video amplifier service to 20 mc. 400 mw rating. 220 mc min. fr. |
| 2N1748A | Wideband video amplifier service to 10 mc. 100 mc min. fr. 50 to 150 hrc. 25 volt rating. |
| T2352 | Low level wideband video amplifier service to 100 mc. 300 mc min. fr. Controlled 20 to 60 hrc. |

FUTURE TYPES FOR FUTURE DESIGNS:

APPLICATION

- UHF AMPLIFIER
- RADAR I.F.
- HIGH VOLTAGE VIDEO AMPLIFIER
- VHF VIDEO AMPLIFIER

NEW CAPABILITY

- Maximum Noise Figure of 5 db @ 420 mc
- Maximum Noise Figure of 3 db @ 60 mc
- Delivers 120 volts of video in wideband amplification to 5 mc
- A solid-state video amplifier for wideband systems to 200 mc

1. MORE db PER DOLLAR...
2. INDUSTRY'S LOWEST NOISE FIGURES...
3. INDUSTRY'S MOST USABLE A.G.C. CHARACTERISTICS...
4. ONLY COMMUNICATIONS TRANSISTORS SPECIFIED TO GUARANTEE PERFORMANCE IN PRACTICAL CIRCUITS...
5. ONLY PHILCO GUARANTEES BANDWIDTH SPECIFICATIONS...
6. ALL TRANSISTOR ELEMENTS ARE ISOLATED FROM CASE...
7. PROVEN MADT* RELIABILITY.

*Micro-Alloy Diffused-base Transistor.

For every communications transistor requirement — both today's and tomorrow's — consult Philco. Write for further information and application assistance.



Immediately available in quantities 1-99 from your Philco Industrial Semiconductor Distributor



PHILCO

A SUBSIDIARY OF Ford Motor Company

government and industrial division

industry personnel



E. N. Fowler



A. I. McKay

Two appointments announced by Eldon Industries

Eldon Industries of Canada Limited recently announced the appointments of **Angus I. McKay** as Hi-Fi and industrial sales supervisor in the Province of Quebec, and the Maritimes, and **Eric N. Fowler** as Hi-Fi sales supervisor in the Province of Ontario.

Mr. McKay attended McGill University and served in the Radio Division of the RCAF during the war. He brings to this position a wealth of knowledge in the sales, advertising and sales promotion fields in the Montreal area.

Mr. Fowler is a graduate of the St. Catharines Collegiate Institute. His experience in the promotion of Hi-Fi equipment to dealers and jobbers all across Ontario and Quebec will be a valuable asset to this company.

Atkinson joins Progress Electronics' sales staff

Joseph E. Atkinson has joined the sales staff of Progress Electronics Company Limited, Montreal, P.Q. Mr. Atkinson was associated with the Canadian General Electric Company for the past 9 years in various capacities and has spent the last two years in the Electronic Tube and Semi-Conductor's Sale Division.

Burroughs names Winnipeg and Windsor branch managers

The appointments of **John L. McGavin** as manager of the Windsor branch and of **John P. Bastien** as manager of the Winnipeg Branch of Burroughs Business Machines Ltd. have been announced by J. L. Rapmund, company president.

Mr. McGavin joined Burroughs in July 1948 as a sales representative in Winnipeg where he remained until 1953 when he was transferred to

Toronto as a regional sales promotion representative. In January 1957 he returned to Winnipeg as a zone sales manager.

Mr. Bastien joined Burroughs in November 1952 as a sales representative in Toronto. In March 1957 he was appointed zone sales manager at the same location and in March 1961 he became manager of the Burroughs Branch in Windsor, Ontario.

Szabo appointed at Robertshaw

T. T. Arden, president, Robertshaw-Fulton Controls Company, announced the appointment of **Sylvester (Sy) Szabo** as vice-president and general manager of Robertshaw-Fulton Controls (Canada) Limited.

Mr. Szabo is pleased to reaffirm his executive staff of **E. A. Pike** as assistant general manager & comptroller, **F. H. Barker**, general sales manager, **G. H. Warren** as general plant manager, and **D. F. Weekes** as chief engineer.



S. Szabo



F. Freeborn

New director for Edo (Canada) Limited

R. R. Hind, President of Edo (Canada) Limited, Cornwall, Ontario, announced the election of **Commodore F. Freeborn** to the Board of Directors. Commodore Freeborn is well known in the electronics industry and has recently retired from the post of Naval Constructor-in-Chief, Naval Headquarters, Ottawa.

Macphail re-elected as chairman of WCTC

W. N. Macphail, of B.C. Telephone Company radio engineering department, was re-elected chairman of the Western Canada Telecommunications Council at its annual meeting March 27 in Vancouver.

The council represents manufacturers and users of radio equipment in the western provinces, making co-

ordinated representations to the Department of Transport and industry on development and use of radio.

Other officers elected were **H. A. Hoyles**, B.C. Loggers' Association, vice-chairman; **M. E. Laidlaw**, Vancouver, Western Communications Ltd., secretary; and **H. Mathers**, B.C. Electric Co., treasurer. Directors are **G. G. English**, Pacific Great Eastern Railway Co.; **F. H. Toy**, Pacific Western Airlines; **H. B. Seabrook**, R.C.A. Victor Co. Ltd.; **A. J. Spilsbury**, Spilsbury and Tindall Ltd.; **P. A. Niblock**, Hoyles, Niblock and Associates, all of Vancouver; **G. A. Playfair**, Victoria, B.C. Forest Service; **T. W. Hall**, Calgary, Canadian Electronics Ltd.; and **A. E. Earnshaw**, Edmonton, Alberta Department of Lands and Forests.

Darling becomes Garrett's field sales manager

The appointment of **Bruce D. Darling** as manager of Canadian field sales for Garrett Manufacturing Limited was announced by William J. Pattison, director of sales.

Mr. Darling has been Garrett's representative in Ottawa for several years and will maintain his headquarters there.

Stillings takes over Canadian post

E. R. Stillings takes the position of production manager at Leeds & Northrup, Canada, Ltd. in Toronto. Mr. Stillings has had wide experience gained from long association with the Leeds & Northrup Company in the United States. His knowledge of electronic instrumentation and controls includes steel, automotive, ceramics, power and other industries.

Harskamp made manager of Lee Bern & Co. Ltd.

Lee Bern & Company Limited, electronic wholesalers, with head office located in Winnipeg, Manitoba, have announced the appointment of **Albert Harskamp** as manager of their associate company, Radio Supply Company Limited, at Edmonton, Alberta.

Mr. Harskamp was previously senior salesman of Radio Supply Company Limited and brings to his new position ten years' experience in the electronic industry.

'ENGLISH ELECTRIC'

electronic valves and
tubes for industry
and communications

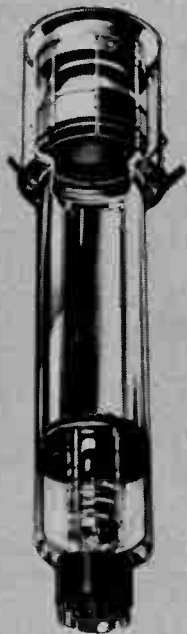

4 1/2-inch image Orthicon

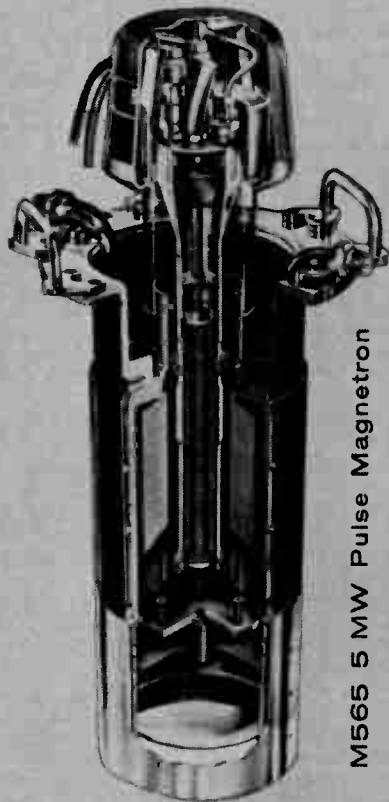

M565 5 MW Pulse Magnetron

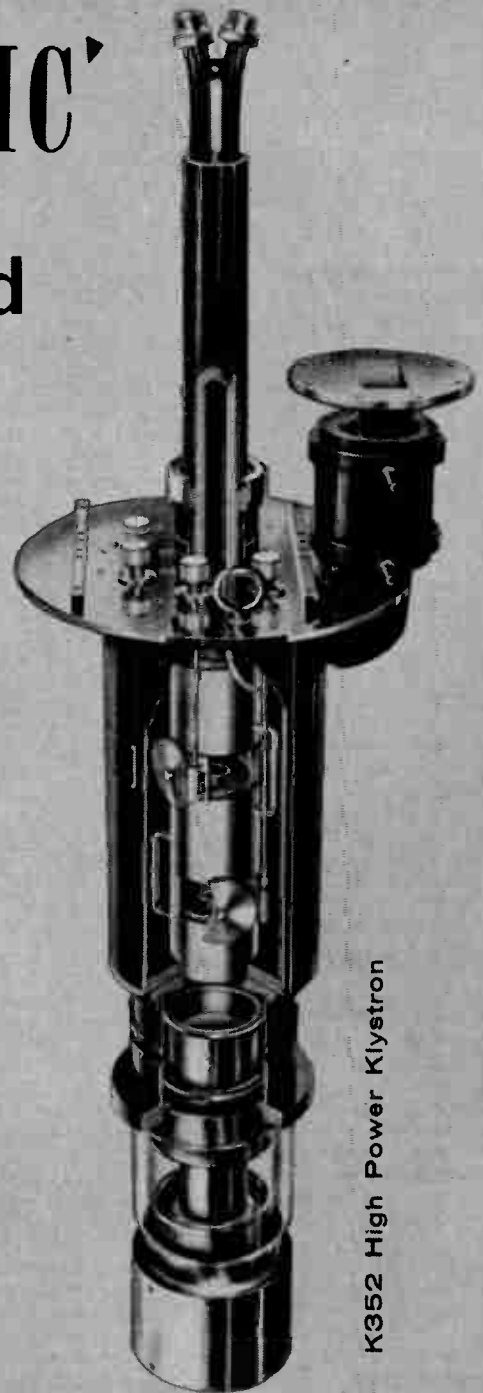

K352 High Power Klystron

Semiconductor Rectifiers
Thermionic Rectifiers
R.F. Heating Valves
Transmitting Valves
Trigger Tubes
Voltage Reference Tubes

Voltage Stabilisers
Image Orthicons
Vidicons
Backward Wave Oscillators
Klystrons
Magnetrons

Pulse Amplifier Valves
Storage Tubes
Thyratrons
Travelling Wave Tubes
Vacuum Capacitors
Cathode Ray Tubes

ENGLISH ELECTRIC VALVE COMPANY (CANADA) LIMITED

24 Ronson Drive, Rexdale, Ontario

TELEX NO. 02-2762

Telephone: 249-8548

Telegraph ENELECAN

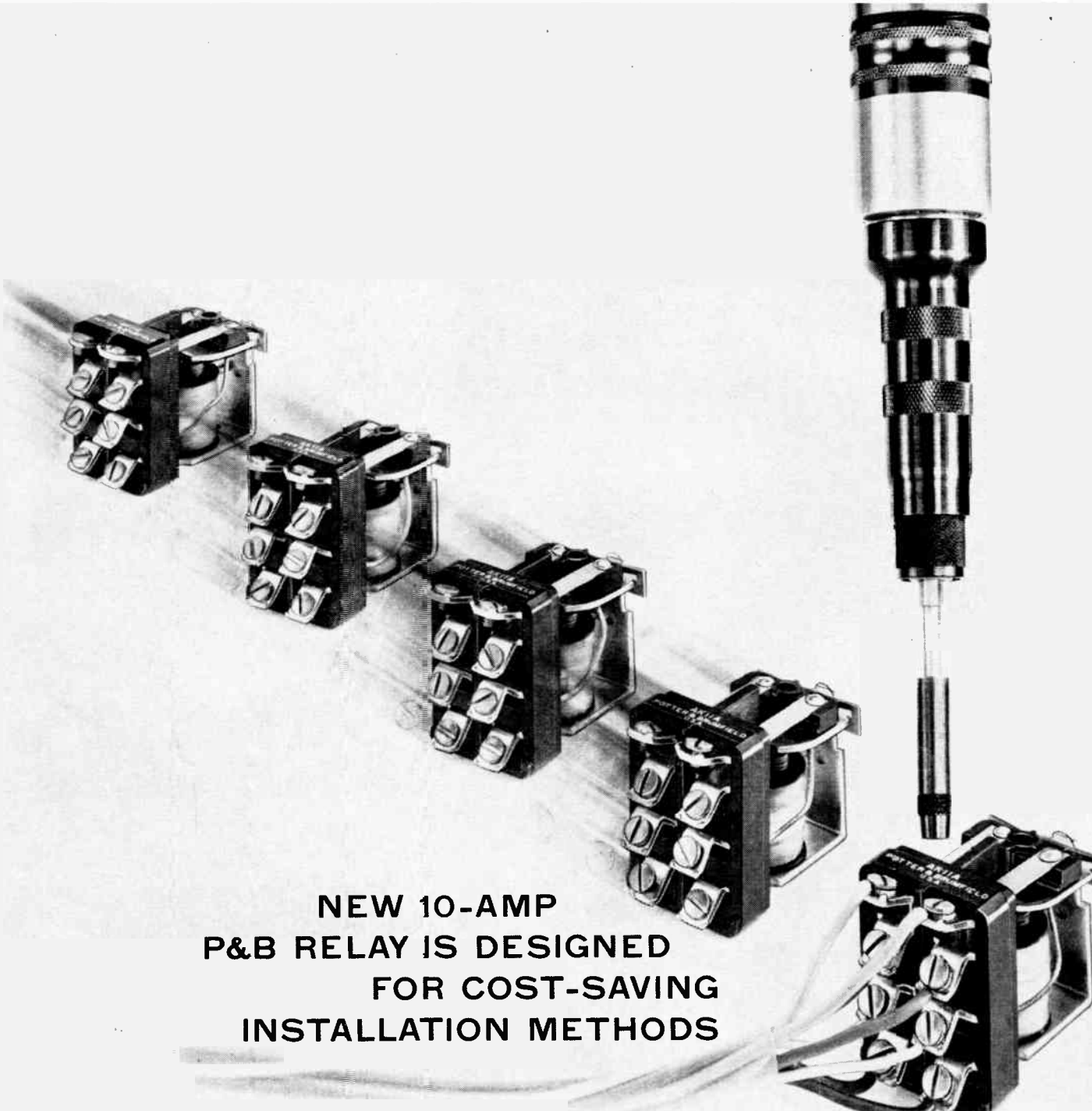

NEW 10-AMP P&B RELAY IS DESIGNED FOR COST-SAVING INSTALLATION METHODS

Fast, labor-saving power screwdrivers can be used to hook up lead wires to the extra stout screw terminals of our new AK Series relays. Thus you save time and money on your production lines.

This new relay is sturdy throughout: its expected mechanical life is 3 million operations and the $\frac{1}{4}$ " diameter contacts are rated at 10 amps at 115V AC non-inductive. Available for either AC or DC power.

Get all the facts today from your P&B representatives or call us direct.



AB SERIES

SIMILAR RELAYS HAVE U/L & CSA LISTING
The AB and the ABC have $\frac{1}{4}$ " quick-connect terminals which can be used for printed circuits. Screw terminal adapters available. U/L and CSA listed for 10 amps at 115V 50/60 cycles.



ABC SERIES

ENGINEERING DATA, AK SERIES

GENERAL:

Insulation Resistance: 100 megohms min.
Breakdown Voltage: 1500 V. rms between all elements.
Temperature Range: AC and DC, -55°C . to $+45^{\circ}\text{C}$.
Weight: Approx. 5 ozs.
Pull-in:
AC 78% of nominal voltage.
DC 75% of nominal voltage.
Terminals: Heavy-duty screw type.

CONTACTS:

Arrangements: Up to DPDT.
Material: $\frac{1}{4}$ " dia. silver.
Rating: 10 amps @ 115 volts or 5 amps @ 230 volts, AC non-induc.

COILS:

Resistance: 35,000 ohms max.
Power: 6.4 volt amps (AC), 2.0 watts (DC).
Duty: Continuous AC or DC (DC coils will withstand 6 watts at $+25^{\circ}\text{C}$).

P&B STANDARD RELAYS ARE AVAILABLE AT YOUR LOCAL ELECTRONIC PARTS DISTRIBUTOR



POTTER & BRUMFIELD

DIVISION OF AMF CANADA LIMITED • OXFORD STREET, GUELPH, ONTARIO

get the
shortest
etching time
with

Hunt Etchants

Whenever Hunt Etchants are used production rates jump — rejections are negligible.

HUNT R. C. E. (Rapid Circuit Etch) is a fast acting, specially balanced etchant for printed circuit board production.

HUNT S. C. E. (Solder Circuit Etch) is the only prepared product formulated to etch solder-plated boards at room temperature without attacking the solder.

Send for **R. C. E. Technical Bulletin 1 & 1A**
S. C. E. Technical Bulletin 3

Philip A. Hunt Company (Canada) Ltd.
TORONTO • MONTREAL • CALGARY

HUNT

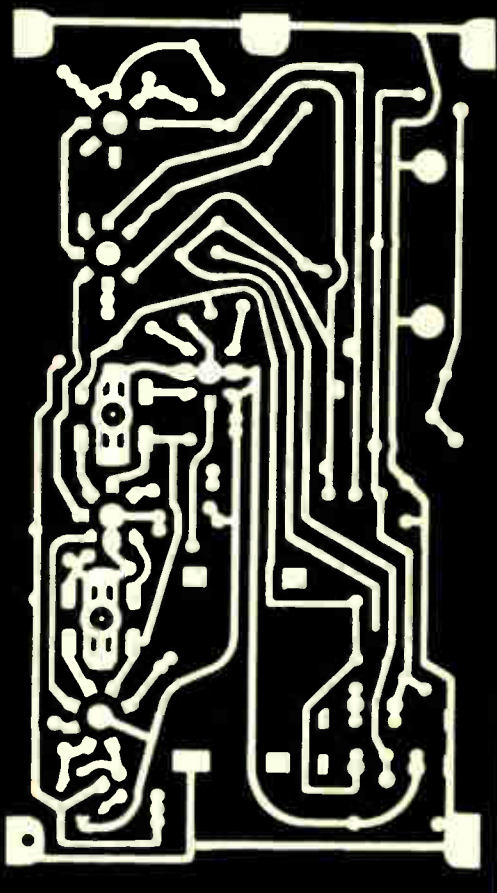

For complete details check No. 35 on handy card, page 83

New

TMC

illuminated
PUSH BUTTON KEYS
with
PRECISE SWITCHING
ACTION

FEATURES

- Small and rugged, keys are supplied in an easily assembled kit ready for immediate mounting. They are available with round or rectangular push buttons in black or white nylon in locking, non-locking or interlocking form.

- Designed to reduce maintenance and increase durability, body construction is of hard nylon, a precision locking track with heavy plating of all metal parts and twin silver contacts on all spring-sets.

- Illuminated lenses can be supplied in white, yellow, green and black which meet colour-signalling code requirements of most electronic equipment.

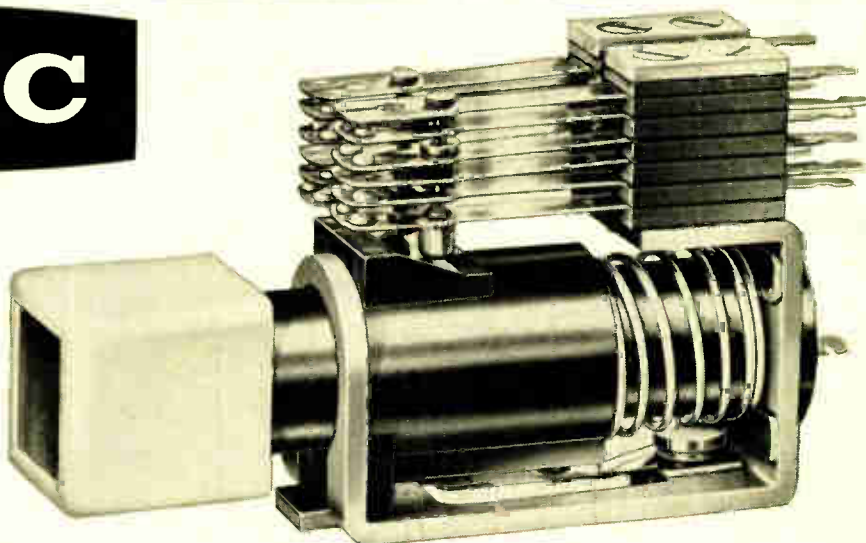

T.M.C.'s illuminated push button keys have many applications in a wide variety of communication and data processing equipment. Equally useful as a neat and compact switching and indicating device in any test or control circuit.

Write for leaflet giving full details to:—

TELEPHONE MANUFACTURING CO. LIMITED

Saxony Building

26 Duncan Street, Toronto, Ont.

Telephone EM. 6-5314

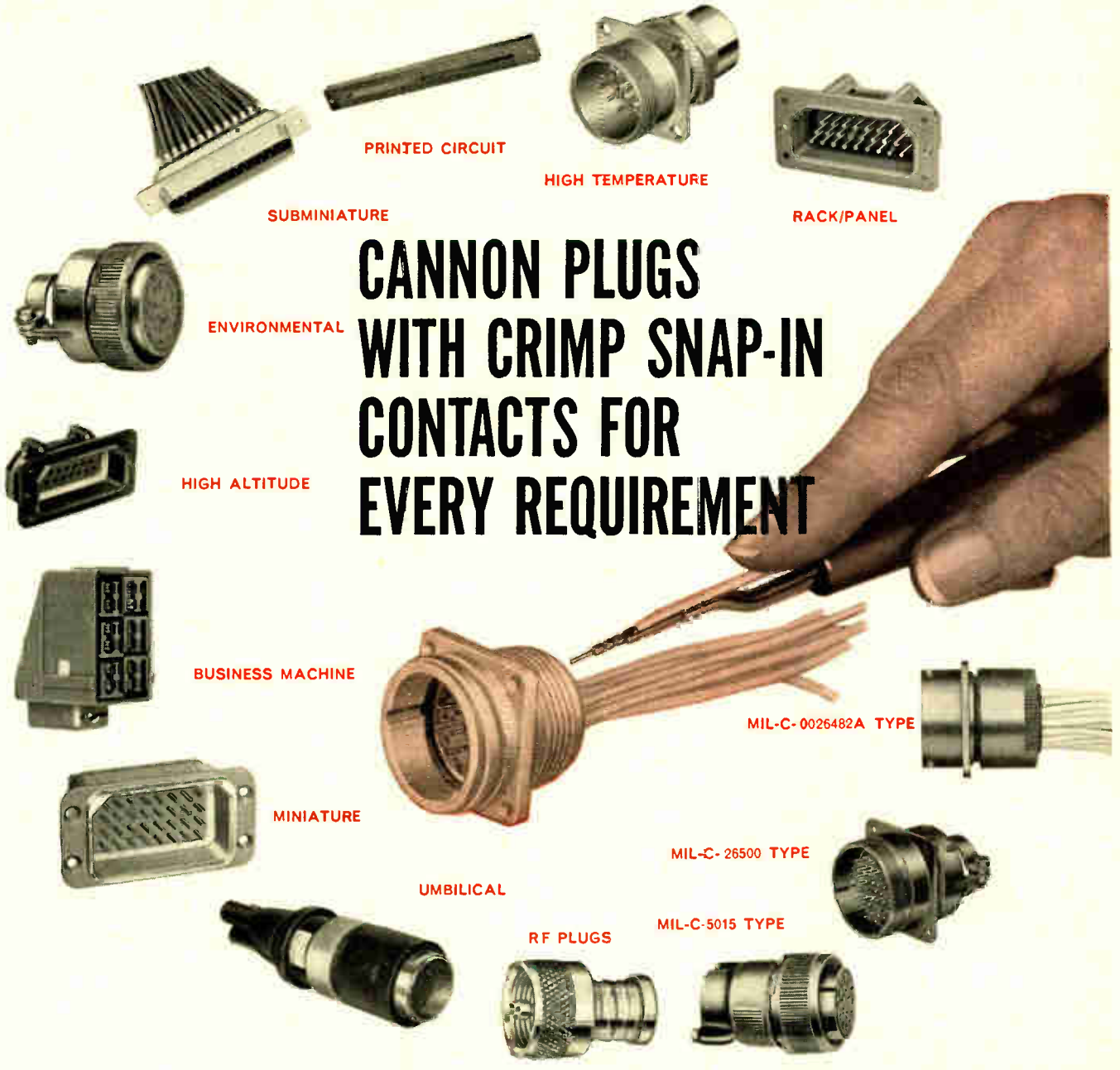

CANNON PLUGS WITH CRIMP SNAP-IN CONTACTS FOR EVERY REQUIREMENT

IMAGINATIVE ENGINEERING For The Space Era

More than 20 years ago Cannon originated the crimp-type plug to fulfill the growing needs of the aviation industry. Since then, our research and development has kept pace with expanding technology, until today we provide plugs with crimp snap-in contacts for every application, every environment. A full range of crimp tools—hand, semi-automatic, automatic—gives you the utmost in flexibility. Whatever your requirements...whether standard solder pot versions or crimp snap-in contacts—consult your nearest Cannon sales office or distributor. For further information, write to:

CRIMPING TOOLS

SEMI-AUTOMATIC



AUTOMATIC



HAND

CANNON ELECTRIC CANADA LIMITED 160 Bartley Drive, Toronto 16, Ontario
 MONTREAL: Montreal Airport, Dorval, Quebec • OTTAWA: 1168 Edgeland Place
 For complete details check No. 16 on handy card, page 83
 ELECTRONICS AND COMMUNICATIONS, June, 1962



6202

Norden is precision

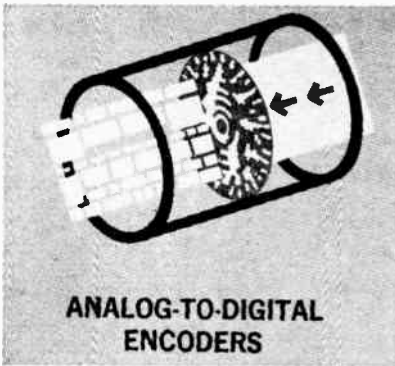

High capacity, high precision make Norden encoders a prime choice for weapons and missile control systems, pipeline data transmission, machine tool positioning, automatic weight logging, a wide range of other military and industrial applications. Pioneers in the field, Norden puts quality first with a rigorous testing program that assures top performance and long life for every Norden encoder you choose.



Pure Binary
External Selection
Contacting
Brush & Disc

Model Number	Total Count	Revolutions For Full Count	Length"	Diameter"
ADC-ST7-BNRY-X	128	1	1 ¹ / ₃₂	1.750
ADC-13-BNRY-X	8,192	64	2 ²⁵ / ₆₄	1.750
ADC-19-BNRY-X	524,288	4,096	3 ³ / ₁₆	1.750
ADC-ST8-BNRY-X (11)	256	1	1 ³ / ₄	1.125
ADC-13-BNRY-X (11)	8,192	32	2 ¹ / ₄	1.125



Pure Binary
† with parity
Self Selecting
Contacting
Brush & Disc

ADC-ST7-BNRY-B	128	1	1 ⁴ / ₆₄	1.750
ADC-13-BNRY-B	8,192	64	2 ²¹ / ₃₂	1.750
ADC-19-BNRY-B	524,288	4,096	4 ¹ / ₃₂	1.750
†ADC-ST8P-BNRY	256	1	1 ²⁹ / ₆₄	3.250
ADC-ST9-BNRY	512	1	1 ² / ₆₄	3.250
ADC-ST10-BNRY	1,024	1	2 ¹ / ₄	6.220



Gray
External translation
Contacting
Brush & Disc

ADC-ST8-GRAY	256	1	1 ¹ / ₆₄	1.750
ADC-ST9-GRAY	512	1	1 ² / ₆₄	2.250
ADC-ST10-GRAY	1,024	1	1 ²⁹ / ₆₄	3.250
ADC-16-GRAY	65,536	64	2 ³ / ₆₄	3.250



BCD
8-4-2-1
‡4-2-2-1
Self Selecting
Contacting
Brush & Disc

ADC-ST3-36BCD	360	1	1 ² / ₆₄	3.250
ADC-3-36BCD	360	3.6	3 ¹ / ₈	2.250
ADC-4-36BCD	3,600	36	3 ¹ / ₈	2.250
ADC-5-36BCD	36,000	360	4 ²³ / ₃₂	2.250
ADC-6-36BCD	360,000	3,600	5 ¹³ / ₁₆	2.250
‡ADC-3-36BBCD	360	3.6	3 ¹ / ₈	2.250
‡ADC-4-36BBCD	3,600	36	3 ¹ / ₈	2.250
‡ADC-5-36BBCD	36,000	360	4 ²³ / ₃₂	2.250
‡ADC-6-36BBCD	360,000	3,600	5 ¹³ / ₁₆	2.250



FUNCTION GENERATOR
Self Selecting
Contacting
Brush & Disc

ADC-4-LAT-BCD	36,000	3,600	6 ¹ / ₈	2.250
ADC-5-LNG-BCD	36,000	3,600	6 ¹ / ₈	2.250
*SIN/COS-BNRY	2° + sign + quadrant	4	5 ¹ / ₈	3.250

NORDEN PRODUCT SALES

CANADIAN PRATT & WHITNEY AIRCRAFT

COMPANY, LIMITED • LONGUEUIL, MONTREAL 23, P.Q.

SUBSIDIARY OF UNITED AIRCRAFT CORPORATION

**U
A**

For complete details check No. 14 on handy card, page 83

Figure 1. Block diagram of the cavity stabilizer.

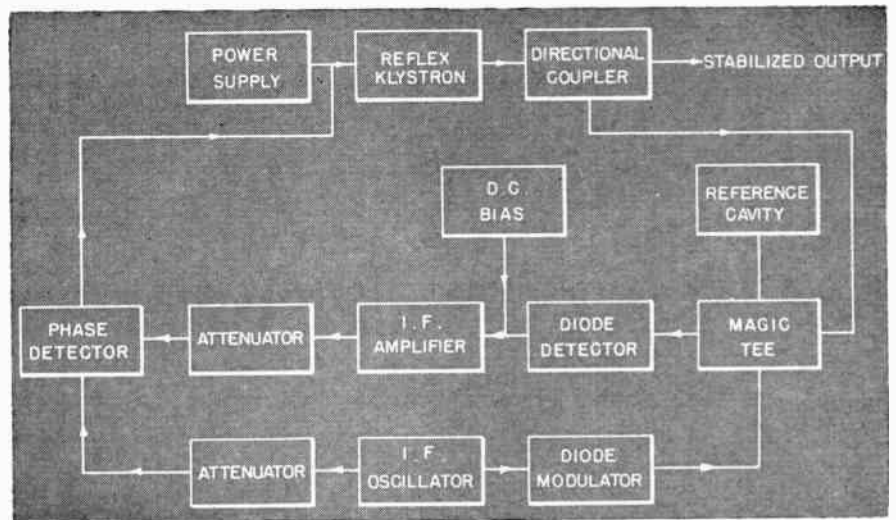

KLYSTRON OSCILLATORS

Frequency stabilizers for reflex klystron oscillators

Developed at NRC, simple closed loop system applied to reflex klystrons gives frequency stability improvement by two to three orders of magnitude

by F. V. Cairns and A. E. Lindsay*

Introduction

Many microwave laboratory measurements can be made more accurately or more conveniently with an oscillator which is two to three orders of magnitude more stable than a reflex klystron with a stabilized power supply. For this application it is desirable to have a stabilizer which is easily assembled and adjusted and which does not consume a significant portion of the klystron power.

The stability of a klystron can be improved by the addition of a high Q external cavity.¹ This method improves the stability by less than two orders of magnitude and consumes a significant amount of the klystron's output power. It is not easy to assemble and adjust for laboratory use.

Techniques for stabilizing a klystron with a cavity and feedback loop^{2,3,4} and by a reference signal and feedback loop^{5,6} are well known and very stable oscillations have been achieved with these devices. We have found that useful improvements in the stability of klystron oscillators can be achieved with simple apparatus of this type. An i-f amplifier, oscillator and phase detector are the only special items which are required. Other components, such as a resonant cavity, magic tee, directional coupler and crystal mounts are standard items found in most microwave laboratories. The stabilization factor should not be expected to equal that of stabilizers, which are tailored to a particular klystron. However, stabilization factors of two to three

orders of magnitude are attainable with most low-power reflex klystrons. The stabilizer is readily adapted to any low-power klystron in any frequency band for which the microwave components are available. It can be easily adjusted and tuned, and can be added to an existing klystron and power supply.

There is little difference in the complexity of the equipment or in the ease of operation between stabilization with a resonant cavity and stabilization by phase locking to a stable reference signal, such as a harmonic of a crystal-controlled 50 Mc oscillator. A klystron phase-locked to a harmonic of a crystal-controlled oscillator is normally the more stable of the two systems because (1) crystal environment is more easily controlled than cavity environment, and (2) the error signal in the feedback loop is a phase difference in the case of a phase-lock stabilizer but a frequency difference in the case of a cavity stabilizer. For this reason, a phase-locked stabilizer will often be preferred. However, a stable reference signal on the desired frequency is not always available and a klystron stabilized by a tunable cavity is more versatile.

Stabilization with reference cavity

(a) Description

A block diagram of a cavity feedback stabilizer is shown in Figure 1. About 1% of the power output of the klystron is coupled into the magic tee discriminator.

*See page 42

When the klystron is oscillating at the resonant frequency of the cavity the reflection from the cavity is small and its phase is adjusted (by path length in the arm of the magic tee) to null phase detector output.

klystron. An amplifier which is satisfactory for a variety of applications is shown in Figure 2. It will be recognized that the gain-bandwidth product has not been achieved with the minimum number of tubes and

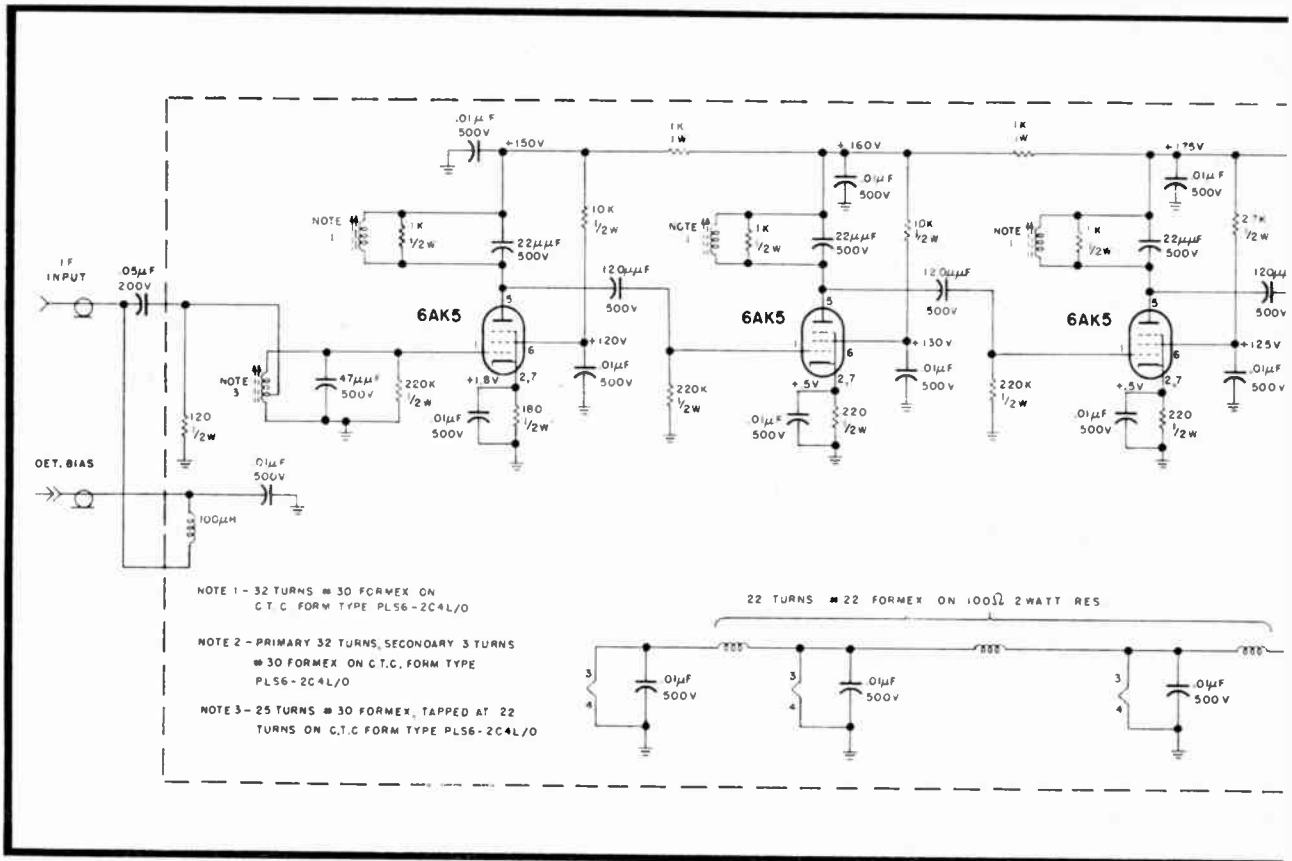

Figure 2. Circuit diagram of the IF amplifier.

Because of the reversal in phase of the reflection from the cavity on opposite sides of resonance, a DC voltage of different polarity is developed by the phase detector as the klystron frequency drifts one side or the other of resonance. This DC voltage is applied to the klystron repeller in such a way as to oppose the change of frequency. A phase-reversing switch has been incorporated into the phase detector to simplify setting up. The detailed operation of this stabilizer is discussed in reference (3). However, it is worth noting that the IF amplifier normally operates at an amplitude minimum and so its dynamic range is not a problem.

A 20 db directional coupler is suitable for coupling the stabilizer to the oscillator. This ensures that a negligible amount of power is used for stabilizing, and that the reactance of the reference cavity does not affect the klystron tuning. It also decouples the stabilizer from the output transmission line, so that stabilization factor does not depend on the load. The reaction of the load on the klystron itself may still be troublesome. If this is so, an isolator should be used. It can be seen that the components, except for the amplifier, oscillator and phase detector, are items of equipment that are usually available in microwave laboratories.

The IF is not critical. It must be high enough to permit an adequate frequency response in the servo and low enough for transistorization of the phase detector. The selected frequency, 10.7 Mc, was convenient but otherwise has no special advantage.

The amplifier gain required depends on the stability factor desired, the Q of the available cavity, the klystron output power and the tuning characteristic of the

that the input and output circuits are not optimum. This amplifier is useful in a stabilizer because it is insensitive to tube changes and to cable lengths at the input and output. The gain is 45 db at 10.7 Mc. This is more gain than necessary for a 2K25 klystron, for example, but in order to accommodate different klystrons and reference cavities extra gain with an

Figure 4. Photograph of the phase detector.

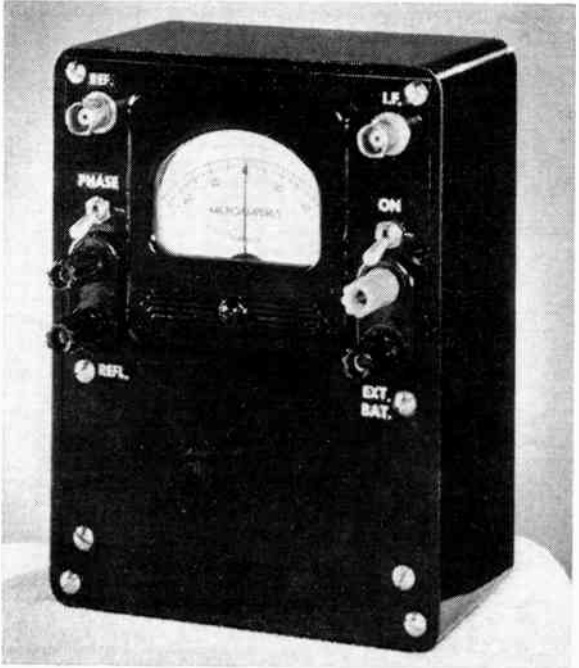

attenuator has been used. The transistor phase detector is shown in Figure 3 and a photograph in Figure 4. The transistor phase detector is isolated from the IF amplifier and oscillator by transformers so that it can

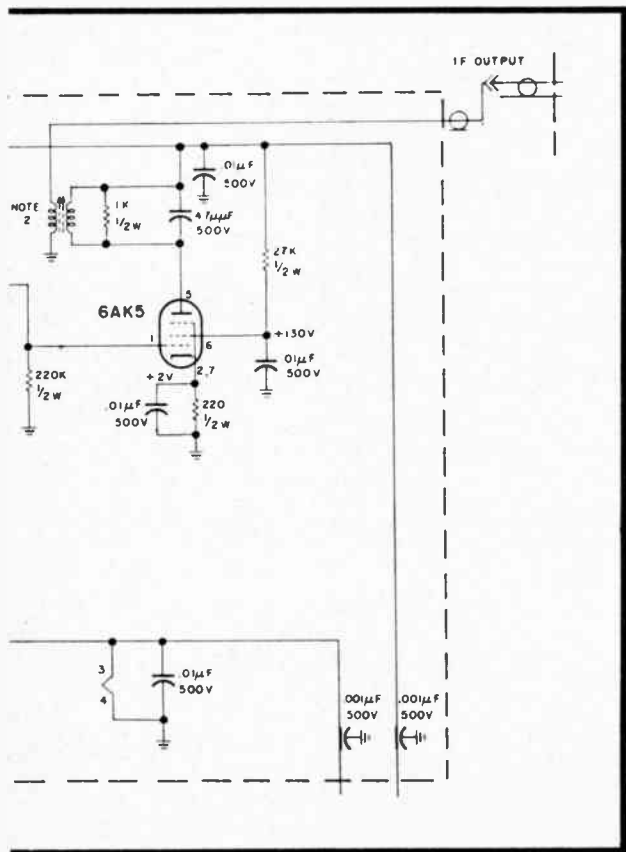

float at repeller potential. The operation of the feedback loop is independent of the repeller voltage of the klystron and the stabilizer may be coupled to any klystron with consideration only for the adequacy of the insulation of the transformers.

The measured gain and phase characteristics of the feedback loop for a 2K25 klystron with a tuning characteristic of approximately 4 Mc per volt are shown in Figure 5. The unloaded Q of the cavity used was approximately 20,000.

(b) Operation and adjustment

The modulator and cavity in the discriminator must be electrically equidistant (or differ by $\lambda/4$) from the magic tee junction for proper operation. These electrical distances do not correspond exactly to measurable mechanical distances. The proper location must, therefore, be determined experimentally. It has been found convenient to estimate the distances and make the final adjustment electrically with a tuning screw in the cavity arm of the magic tee. This method has the disadvantage of reflecting a small amount of power back to the junction of the magic tee. If the amplitude of the reflection is small and it is phased approximately 90° with respect to the reflection from the cavity near resonance, the adverse affect on the stabilizer is negligible.

Setting up is most conveniently done with an oscilloscope (Figure 6). The klystron is swept through the frequency range of interest by the horizontal sweep voltage and the output of the phase detector is applied to the vertical plates. The amplitude of the modulation voltage, the forward bias current on the detector

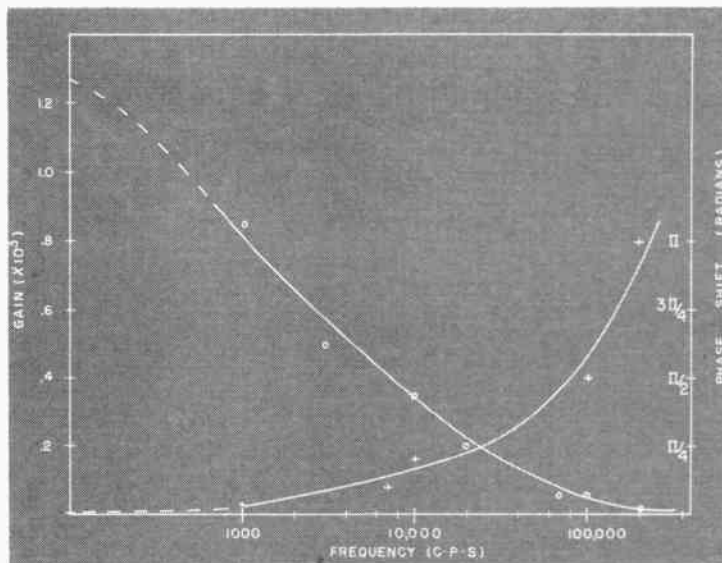
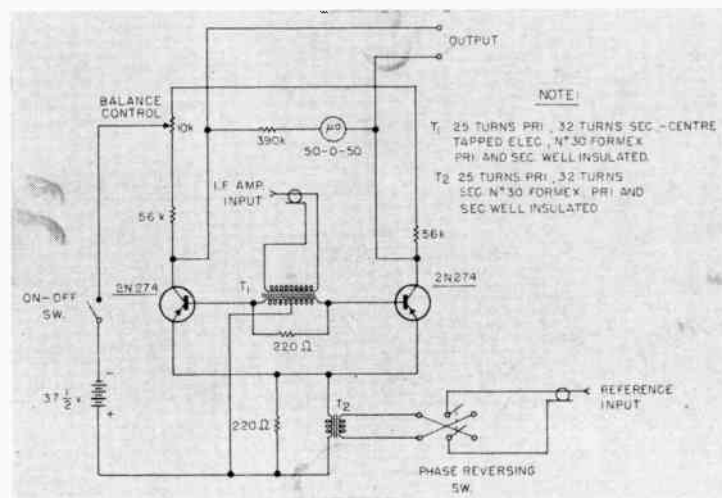

Figure 5. (above) Gain and phase characteristics of the feedback loop. Figure 3. (below) Circuits diagram of the phase detector.



crystal and the penetration of the tuning screw are adjusted to give the best discriminator curve. Figure 7 is an example of the discriminator curve obtained with a 2K25 klystron, and two different reference cavities. The amplitude of the DC voltage is ± 20 volts.

After a suitable discriminator curve has been obtained the feedback loop is closed. Servo oscillation is probable if the output of the phase detector is not filtered. An adjustable RC low-pass filter is used. When set up in this way frequency can be changed over the klystron oscillation mode by a single control, the cavity tuning.

An alternative method of setting up is to insert a phase shifter in one arm of the magic tee (this may limit the single-control-tuning bandwidth) and minimize the output of the IF amplifier as observed on an oscilloscope or detector. The IF is then applied to the phase detector and other adjustments made.

Stabilization with reference signal

(a) Description

A block diagram of a circuit for phase locking a klystron to a reference signal is shown in Figure 8. In this case the phase detector provides a DC voltage which depends on the phase difference between the oscillator output and the reference signal. When a klystron is phase locked to the reference signal, its stability, for many purposes, can be considered to be the same as that of the reference signal.

(b) Operation and adjustment

Setting up a phase-locked oscillator is not appreciably more difficult than setting up a cavity stabilizer. The capture range is limited to the narrowest pass band in the feedback loop, the pass band of the phase detector output filter in our case. Power supply ripple will normally sweep the klystron frequency through this narrow bandwidth. Measurement of the output of the phase detector at power supply ripple frequency with the feedback loop open can be used to indicate the gain of the feedback loop, and thus the performance. A peak amplitude of ± 15 volts was considered to indicate satisfactory operation.

When the feedback loop is closed, attainment of lock is indicated by the voltmeter in the phase detector. As the klystron is varied in frequency in the vicinity of the reference frequency, the reading of this voltmeter changes and when lock occurs the voltage varies with variations in the repeller voltage.

The adjustment of the filter is critical for the reason mentioned in the previous section. However, once a satisfactory combination of resistance and capacity has been determined, the stabilizer operates for long periods without adjustment.

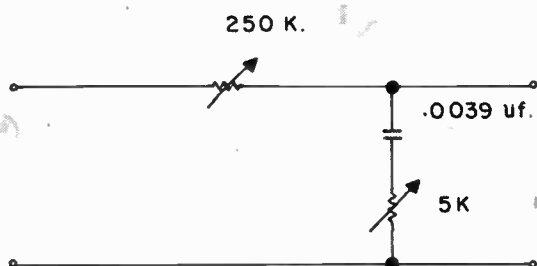

Figure 9. Shaping (lag) network for system stability.

The stabilizers have been tried with a number of X-band and a J-band (6500 Mc) klystrons and attached to a commercial X-band signal generator without difficulty.

Carcinotron stabilization

Carcinotrons have been stabilized with a cavity.⁸ Both of the systems described above were tried as stabilizers for a low power O-type carcinotron. Because the impedance at the line of the carcinotron is much lower than the impedance at the repeller of a klystron, they did not work satisfactorily when the phase detector was floated at line potential. Two suitable methods of operation, with limitations, were found. If the power supply for the carcinotron is floated and the output of the phase detector added between ground and the common terminal of the carcinotron power supply, operation similar to that observed with the klystron is obtained. This system was found useful in the laboratory. An alternative is to apply the output of the phase detector in series with the reference voltage for the carcinotron line voltage regulator in the carcinotron

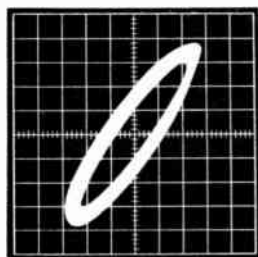

Figure 10. Photograph showing beat between two phase-locked klystrons locked to the same reference signal.

power supply. This method is feasible, but the DC amplifier of the power supply stabilizer becomes part

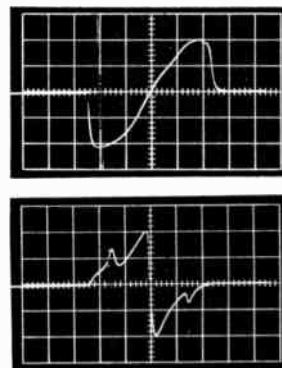

Figure 7. Discriminator curves of cavity stabilizer.

of the frequency stabilizer feedback loop and unless it has the correct characteristics, it will degrade either the stability factor or the frequency response of the stabilizer. Power supply regulators designed without this requirement in mind are not likely to be suitable.

Conclusions

Reflex klystron oscillators can be stabilized with simple equipment. The stabilizers discussed above improve the stability by a factor which depends on a number of parameters, including the Q of the reference cavity or the stability of the reference signal and the tuning characteristic of the klystron. An improvement in stability by a factor of 100 to 1000 is not difficult to achieve. If extremely stable oscillations are required, the oscillator should be made stable initially. This implies a well-regulated power supply and some control of the environment. The approach discussed here leads to a considerable improvement in stability with minimum amount of equipment. The main application is laboratory measurement where ordinary stability is inadequate or inconvenient, but where maximum stability is not necessary. In this application the simplicity, ease of adjustment, and compatibility with an existing power supply are important advantages.

References

1. Rabinowitz, S. G., "Stabilization of Reflex Klystrons by High Q External Cavities", Trans. IRE, MTT-2, No. 3, September 1954, p. 23.
2. Pound, R. V., "Frequency Stabilization of Microwave Oscillators", P. IRE, Vol. 35, p. 45, December 1947.
3. Tüller, W. G., Galloway, W. C., Zaffarano, F. P., "Recent Developments in Frequency Stabilization of Microwave Oscillators", P. IRE, Vol. 36, p. 794, June 1948.
4. Altman, Jerome L., "A Technique for Stabilizing Microwave Oscillators", Trans. IRE, MTT-2, No. 2, p. 16, July 1954.
5. Labin, E., "Theory of Synchronization by Control of Phase", Phillips Res. Rev., Vol. 4, p. 291-315, August 1949.
6. McAleer, Harold T., "A New Look at the Phase-Locked Oscillator", P. IRE, Vol. 47, p. 1137, June 1959.
7. Zimmerer, Robert W., "Transistor Phase Detector for Phase-lock Stabilization of a 30,000 Mc Klystron", Review of Sci. Instruments, Vol. 30, No. 11, p. 1052, November 1959.
8. Hervé, Jacques, Pescia, Jaques and Sauzade, Michel, "Stabilization en Fréquence d'un Carcinotron de Grande Puissance", Comptes Rendus des Seances de L'Académie des Sciences, Vol. 249, No. 16, p. 1486, October 19, 1959.

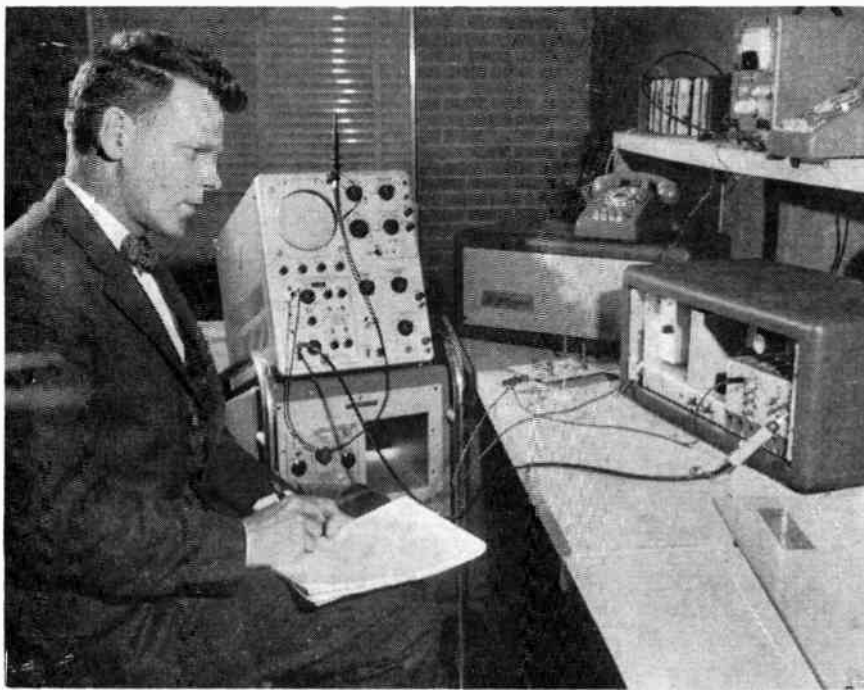

DATA TRANSMISSION

Engineer at Northern Electric's Research Laboratories, Ottawa, makes measurements on Data-Phone used for the transmission of digital data signals over communication message circuits.

Digital data transmission by telecommunication circuits

Article examines the capacity and limitations of regular telephone message circuits when used for the transmission of digital data from business computers

by P. Pascali, P.Eng. and D. Atkinson, P.Eng.*

Introduction

The rapid growth and use of large computing systems and the related field of data processing have increased the business world's requirements for communications between such sources of data.

During the last few years the term data transmission has been taken to mean the transmission at relatively high speeds, over telecommunication facilities, of binary coded information for the purpose of data processing.

Transmission of binary coded information is nothing new to the telecommunications engineer since telegraphy, the first form of electrical communication, made use of binary transmission almost 100 years ago. Present and future data systems will make use of the binary code because of the circuit simplicity and performance.

Every digit or "bit" of information, whether numerical or alphabetical is represented by either of two states, "on" or "off", "yes" or "no", "1" or "0", commonly referred to as "MARK" or "SPACE" respectively. The binary system then represents alphabetical or numerical information by means of only two digits "0" and "1". Representation of numerical quantities above one in the binary system must involve the use of a greater number of digits than are required to represent the same quantity in the decimal system.

For example, the decimal number 67 corresponds to the binary number 100011. Binary numbers are usually read from left to right with the most significant digit (MSD) on the left. To avoid confusion, as the number may appear inverted in a machine, the least significant digit (LSD) is often underlined, i.e., 100011 or 110001 = 67.

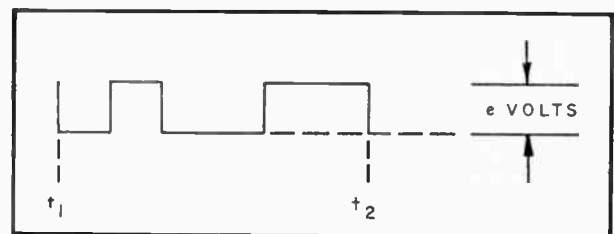

Figure 1. Electrical representation of binary information.

A letter or number is electrically represented as an array of rectangular voltage pulses plotted against time (Figure 1). To represent any kind of information the time interval between t_1 - t_2 is divided into equal time slots, whether it be mark or space. The information is represented not by the total number of marks or spaces but by their sequence of occurrence, and

*See page 46

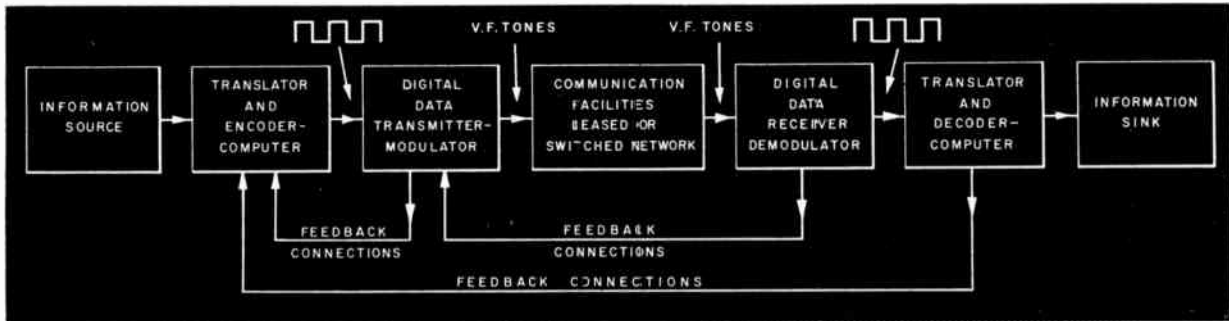

Figure 3. (above) A typical data transmission system employing voice-frequency telephone circuits.

is sent at a fixed "bit" rate. The number of binary digits that can be handled is a good measure of the information capacity of any data system. Since the basic system signal cannot be transmitted at baseband frequency over long distances some type of modulation such as amplitude, frequency or phase is necessary (Figure 2). In AM systems the binary signal is translated into sine wave signals in one of two different amplitudes, while in FM systems the signal takes the form of two different frequencies. When phase modulation is used the signal is represented by either of two different phases.

Error control

The fundamental requirement for a perfect binary data transmission system is to be able to transmit correctly binary information over the telecommunication circuits and to be able to detect the presence or

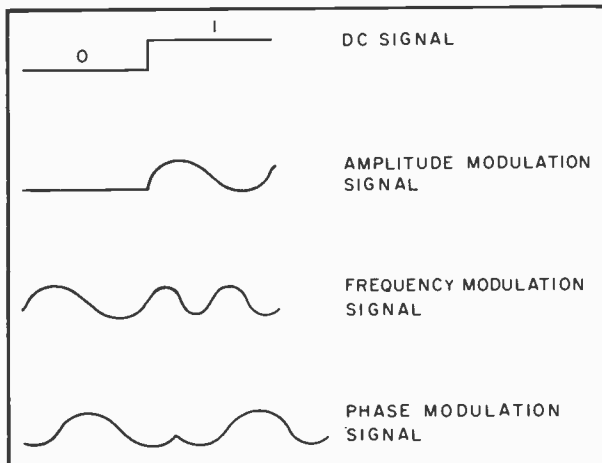

Figure 2. Representation of "DC signals" and modulation schemes for a data transmission system.

absence of a pulse in each of a set of regular discrete time intervals.

Data transmission is different from voice or even telegraph transmission in that:

- The "conversation" is between machines with little or no human guidance into which decision making ability can be built only at a cost.
- The tolerable error rate may be extremely low.

The telecommunication facilities evolved up to now were designed to accommodate speech and telegraph messages which incorporate an appreciable amount of redundancy, i.e. repetition of a message or a word in voice and extra non-information bits in telegraph. This redundancy and other properties, such as the ear's insensitivity to phase delay and impulse noise, were taken into account in the design of the telecommunication circuits, to reach a compromise between "economics" and "perfection". Business machine equip-

Figure 4. (below) Typical characteristics for a telephone network channel.

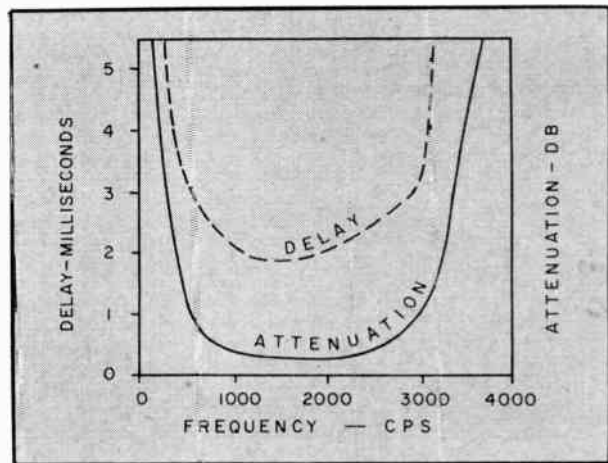

ment has little or no redundancy at all and demands near perfect transmission thus any appreciable phase distortion or impulse noise cannot be tolerated.

While phase distortion or impulse noise does not normally affect a telephone conversation, it is liable to cause serious errors if the same criteria are applied to the transmission of information for data processing. Hence, in adapting the existing telecommunication facilities for high speed data transmission an error control problem arises.

Rather than attempting to achieve the impossible task of providing error free circuits, the problem of errors in high speed digital transmission is being solved by means of error detecting or correcting devices built into the system.

This method allows existing telecommunication networks in which millions of dollars have been invested, to carry data signals with the accuracy required by the data processing users.

In consideration of errors for any data system, a factor of much importance is whether the errors are detected or undetected. An erroneous word which is detected by some device at the receiving terminal of the data transmission system can be rejected before it is inserted into the data processing machinery. An undetected word error is fed into the input machinery and consequently has to be processed in order to reveal its false character. In both cases the original word is lost, but in the second case valuable processing capacity is also wasted. It is important then that error detecting devices be included as part of the transmission and processing system.

There are various methods that can be used to detect and correct errors. The deliberate introduction of redundancy has been used for some time. In this method repetition of characters in error, duplication of channels or equipment can be used.

Most of the recent work on error detecting or error

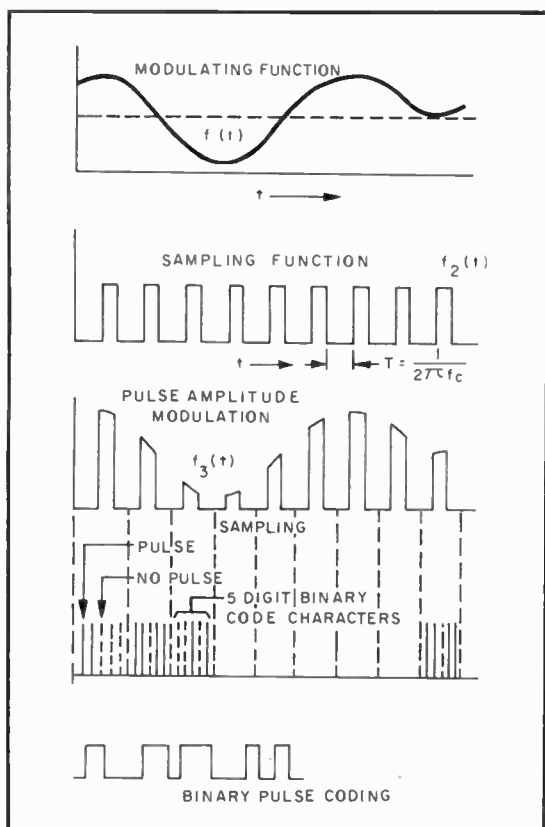

Figure 5. Pulse code modulation. Sampling function and digitizers provide sequence of binary numbers representing instantaneous amplitudes.

correcting codes stems from Hamming's Systematic Parity Check Codes.

Systematic codes may be defined as codes in which each symbol has exactly n binary digits, where m digits are associated with the information while the other $k = n - m$ digits are used for error correction and detection. This produces a redundancy R defined as the ratio of the number of binary digits used to the minimum number of binary digits necessary to convey the same information $R = \frac{n}{m}$.

One disadvantage of either error correcting or detecting methods is that the effective rate at which data can be transmitted is reduced. We may construct a single error detecting code having n binary digits in the following manner:

In the first $n-1$ positions we put $n-1$ digits of information. In the n th position we place either a "0" or "1" so that the entire n positions have even numbers of "1"'s. This is clearly a single error detecting code since any single error in transmission would leave an odd number of "1"'s in a code symbol. The redundancy of these codes is

$$R = \frac{n}{n-1} = 1 + \frac{1}{n-1}$$

since $m = n-1$.

It appears that to gain a low redundancy we should let n become large. However, by increasing n the probability of at least one error in a symbol increases. This type of check used to determine whether or not the symbol has a single error is called parity check and the extra bit added is referred to as the "Parity" bit.

The parity check is required only to determine if an error in transmission has occurred. If so, the block in which the error has been detected is retransmitted.

This form of error control always requires a return path in the transmission system, probably one that can be used simultaneously with the forward transmission.

A significant number of errors, however, occur in adjacent bits in the same transmission. Such errors are normally undetected by simple parity checks and more sophisticated methods such as "Triple Interleave Parity" are used.

Performance of line facilities for data transmission

Broadly speaking circuits of interest for data transmission are the telegraph and telephone type. Generally, the available bandwidth of these circuits varies from 100 c/s to 3000 c/s for telegraph and telephone respectively, though special bandwidths of up to 48,000 c/s can be made available. These circuits can be made available on either a leased point-to-point basis or as part of the Direct Distance Dialing public network.

The leased line facilities are most suitable for the transmission of data between two points similarly equipped for long periods of time. The use of the switched network, however, enables any subscriber to exchange data as and when required with any other subscriber on a continent wide basis.

The switched telephone network

The use of the Switched Telephone Network for data transmission provides the same flexibility for communication between machines as is already provided for communication between people.

PASCALI

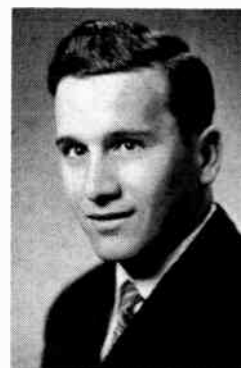

Born in Cyprus, Peter Pascali, P.Eng., CPEQ, graduated from the University of London with a B.A. Sc. in Engineering. Mr. Pascali took a post-graduate training course with Standard Telephones and Cables in London, England. Upon arrival in Canada, he worked briefly with Canadair on telecommunications requirements for the Argus aircraft. He joined Northern Electric Company in 1959 as a systems engineer in toll transmission and was then transferred to carrier telegraph equipment and telegraph testboards. He presently holds the position of systems engineer and is currently associated with data transmission and teletypewriter switching systems.

The question is, to what extent can the present telephone network be utilized for data? At what speeds can data be transmitted, what error rate can be expected and what changes, if any, have to be made to present transmission facilities?

The speed of data transmission possible is, in the first instance, governed by the usable bandwidth of the telephone channel. Theoretically the speed in bits per second is numerically equal to twice the bandwidth in c/s. For a telephone channel of 3000 c/s then a

speed of 6000 bits per second should be possible. However, the theory assumes a flat loss and no delay distortion within the pass-band and infinite loss without. These conditions are not met, of course, by the telephone network. In practice, 1500 bits per second can be transmitted. Speeds approaching 3000 bits per second can be achieved if special modulation schemes are used at the cost of reduced noise tolerance, increased possibility of errors and increased terminal cost. In addition to the attenuation and delay characteristics of the transmission facilities, which will be discussed further on, two other characteristics affect bandwidth and speed; type of carrier and non-linear distortion. If an AM double side band carrier is utilized, the bandwidth and speed is reduced by half. Non-linear distortion also affects the bit rate as second order modulation products may fall within the baseband of the data signal and cause distortion if it overlaps the line signal; therefore, the lower end of the telephone band cannot always be used.

Figure 4 shows typical attenuation and delay characteristics with respect to frequency of the telephone network. These characteristics are shaped by the component parts of the system: non-loaded cable, loaded cable, carrier, multiple connections and cabling runs within switching offices and repeating coils, series capacitors and shunt inductors used for signalling and supervision at switching offices. All these factors considered, data signals can be transmitted in the 1000 to 2600 c/s range over the switched telephone network.

Noise is a factor which must be considered. For voice transmission steady line noise is important; however, for data transmission impulse noise is the key

path. This action prevents the simultaneous two-way operation required in data transmission. A common method of overcoming the problem is to use a signal to switch out the echo suppressor before data transmission begins.

The final problem in using the telephone network is to make the transmission equipment compatible with the customer's data equipment. This is easily done using data sub-sets which change the information from the customer's form to a form suitable for transmission.

With the extensive utilization of common control switching and continuing improvements in the DDD network, the effects of impulse noise on data transmission have been greatly alleviated while the effects of phase and attenuation distortion can be compensated for in the data sub-sets. Tests carried out in Canada, and other countries, indicate that data bit rates up to 1500 bits per second can be accommodated on the switched telephone network with an error rate of 1 in 10^5 to 1 in 10^6 . In fact on a particular commercial application using the data-set an error rate of 1 in 2.5×10^6 has been experienced. At the present time then there is no problem which prevents transmitting data over the switched telephone network. There are few commercial applications that cannot be easily handled. As demands for higher speeds become greater more sophisticated modulation methods will be required and eventually wider bandwidth circuits could be made available.

Future trends

Military demands for data transmission will continue to increase as more sophisticated weapons systems are being incorporated in our defense arsenal. The continuing decentralization of business and industry and the increasing use of computers and business machines for an effective and efficient operation will create a tremendous demand for communication facilities.

Up to now digital data transmission has been applied to information for business machines only. Yet it is in the field of voice communication transmission that digital data will find its greatest application. The advent of information theory has given to us a new way of understanding the fundamentals of transmission of information.

One of the most important ideas involved is that of sampling and the development of Pulse Code Modulation (PCM). The application of the sampling principle reduces the problem of transmitting a continuously varying message, voice for example, to one of transmitting a finite number of amplitude values. By quantizing and binary coding these amplitudes a message can be transmitted in digital form (see Figure 5). These techniques have been proven successful, and systems have already been developed incorporating these new concepts.

References

1. A. A. Alexander, R. M. Gryb, D. W. Nast; "Capabilities of the Telephone Network for Data Transmission"; The Bell System Technical Journal, May 1960.
2. J. M. Wier; "Telephone Circuits: A New Link in Data Communications"; Bell Laboratories Record, October 1960.
3. A. W. Horton, Jr. and H. E. Vaughan; "Transmission of Digital Information over Telephone Circuits"; Bell System Technical Journal, May 1955.
4. R. G. Enticknap and R. M. Lerner; "The Design of Data Transmission Systems"; Lincoln Laboratory Report 25G-0022.



ATKINSON

Dean Atkinson, B.A. Sc., P.Eng., CPEQ, is presently employed as a systems engineer with Northern Electric Company. He is now concerned with data transmission and teletype-writer switching systems. Mr. Atkinson who was born in Toronto, Ontario, received his B.A. Sc. in Engineering from the University of Toronto. He joined Northern Electric in 1959 as a systems engineer with carrier telephone. He subsequently worked in defense projects and toll switching. Before joining this company, Mr. Atkinson worked for two years with Canadian National Telecommunications Limited.

factor. Impulse noise can be caused by either natural phenomena such as lightning or equipment operation such as the operation of switches and switching relays. Although the average power is low for this kind of noise the peak value can be comparable to the energy level of a data signal. It is, therefore, possible for a data signal to be destroyed or a false signal produced.

Echo suppressors, used on the telephone network present something of a problem. When a person is talking the echo suppressor short circuits the return

Factors contributing to the isolation in passive duplexers and multicouplers

... analysis shows that isolation between terminals in a duplexer is composed of several parts ... filter attenuation, impedance mis-match and parallel antenna impedance must all be taken into account ...

by Dr. W. V. Tilston*

Summary

When two or more equipments, operating on different frequencies, are to be joined to a common antenna, a duplexer or multicoupler is used. The necessary isolation between channels may be provided by several different passive filter types. The resulting attenuation between channels may be broken down into various components. The main source of attenuation is that due to the filters alone (i.e. the sum of the attenuations that would result if each filter were located between a matched generator and load). Other sources of attenuation include the "loading" isolation which is due to the power split when two or more channels are coupled to a common antenna, and the mismatch loss which results from unequal generator and load impedances.

Introduction

The wider use of duplexers and multicouplers to join more than one transmitter or receiver to a common antenna has made it desirable to examine the various factors which contribute to the isolation between channels.

A typical duplexer arrangement is shown in Figure 1. The equipment to be connected to terminal number 1 is tuned to frequency f_1 which may travel freely between this terminal and the antenna terminal. Similarly the equipment to be connected to terminal number 2 is tuned to frequency f_2 which may travel freely between that terminal and the antenna terminal.

Filters number 1 and number 2 are used to pro-

vide a certain amount of isolation over the band, between terminals (1) and (2). A description of the procedures for determining this isolation and for choosing a particular filter type appears in the literature¹. It is only necessary here to realize that filter (2) attenuates frequency f_1 by a certain calculable amount and similarly filter (1) attenuates frequency f_2 .

An "attenuation X frequency" curve can be derived for either filter by placing it between a matched generator and load, and measuring the power into the load over the band of frequencies under consideration. One way of presenting this information is shown in

The Author*



Dr. W. V. Tilston received his Ph.D. in applied mathematics at the University of Toronto in 1951. He served with the RCN during World War II, on loan to the Royal Navy as a radar officer. He was also a demonstrator and research assistant at the University of Toronto, and also worked at the Canadian Naval Laboratory in Ottawa. Dr. Tilston has been with Sinclair Radio Laboratories Limited since 1951, and holds the position of Research Director.

Figure 1. Diagrammatic arrangement of typical duplexer.

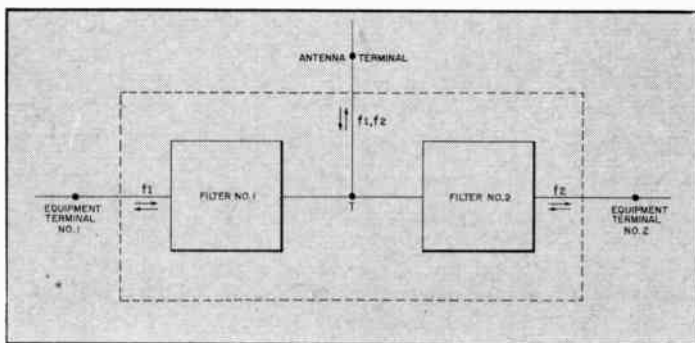

Figure 2. In this figure, filter (1) is assumed to be a band-pass filter. At its resonant frequency f_1 there is a certain amount of loss due to the finite unloaded filter Q. A similar curve could be drawn for filter (2).

In addition to these individual filter characteristics, the isolation between either equipment terminal and the antenna terminal may be measured. The "attenuation X frequency" curve resulting from such a measurement will usually differ only slightly from that described previously for the filter alone since the addition of the other parallel branch does not change the load impedance appreciably except at its resonant

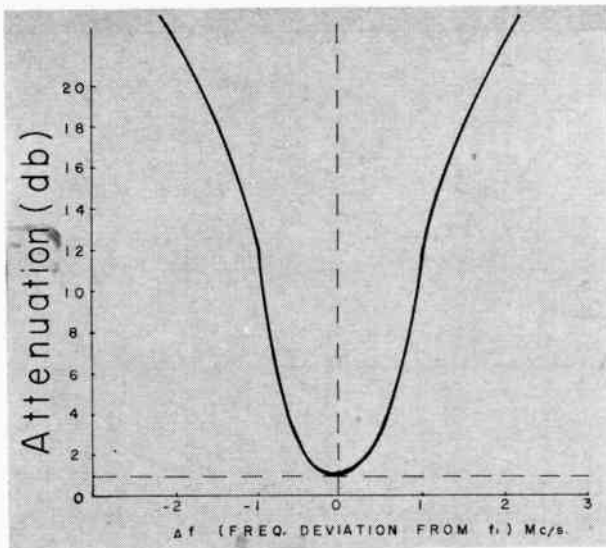

Figure 2. Response curve — Filter Number 1.

frequency. At the latter frequency the load impedance will be halved for a matched equipment terminal so that the isolation is increased at this point.

The isolation between equipment terminals is illustrated in Figure 3. This is not simply the sum of the attenuations from filters (1) and (2), but depends also on the coupling between them as well as on the antenna and load impedances.

While Figure 3 clearly shows the isolation between equipment terminals, it often happens in specifications that only a curve, such as that of Figure 2, is given, with the added statement to the effect that 6 db should be added to the attenuation shown when the filter is used in a diplexer or multicoupler. The reasons for this will now be discussed.

Components of isolation

The contributions to the isolation between terminals (1) and (2) of Figure 1 can be understood by considering the action of the diplexer at three different frequencies.

First let frequency f_1 be considered. At this frequency filter (1) may be neglected since it has a low resonant insertion loss. If the antenna line were removed at the junction "T", then the voltage on frequency f_1 appearing across the transmission line at T from a generator at terminal (1) would be almost equal to the generator voltage since filter (2) presents a high impedance to f_1 at this point. If the antenna line were now reconnected, the voltage at T would be approximately half the generator voltage, since the antenna is assumed to almost match the generator. Since only linear passive networks are being considered the voltage on frequency f_1 which appears at terminal (2) is proportional to the voltage on the antenna side of filter (2), and thus is halved by the addition of the antenna to the circuit. This 2:1 voltage ratio accounts for the 6 db increase in isolation which is added to the filter attenuation. This is strictly only true when the filter presents an extremely large impedance at f_1 and when the antenna and generator impedances are matched.

If a generator at terminal (1) were tuned to frequency f_2 then filter (1) would prevent most of the power from reaching terminal T. (This situation occurs when a transmitter tuned to f_1 is located at terminal (1) and puts out a certain amount of noise on frequency f_2). However any energy on f_2 which does reach terminal T can be considered to be generated by a generator which has a very large internal impedance and hence delivers a constant current when attached to much smaller loads. Thus if the antenna impedance is nearly equal to the load impedance at terminal (2), the current through the load will be halved when the antenna line is attached at T. In this case too there is therefore, a 6 db improvement in the isolation with the antenna attached over that with the antenna removed.

If a third frequency f_3 , to which neither filter (1) nor filter (2), is tuned, travels from terminal (1) to terminal (2) with no antenna attached, then the voltage at terminal T will depend on the exact frequency and type of filter used as will the drop in voltage which occurs at terminal (2) when the antenna is reconnected. This gives a qualitative description of some of the isolation components. These points are brought out more precisely in the following paragraphs.

Network representation of a typical diplexer
A linear passive network as in Figure 4 may be

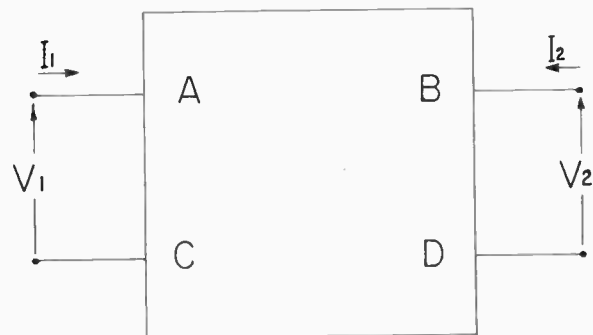

Figure 4. General linear passive network.

represented by the general circuit parameters, A, B, C, D, where:

$$\begin{bmatrix} V_1 \\ I_1 \end{bmatrix} = \begin{bmatrix} A & B \\ C & D \end{bmatrix} \cdot \begin{bmatrix} V_2 \\ -I_2 \end{bmatrix}$$

As far as the isolation between terminals in a diplexer or multicoupler is concerned, the circuits may be represented as in Figure 5. This shows a generator with an impedance R_0 at terminal T_1 and a load of resistance R_L at terminal T_2 .

Filters (1) and (2) are represented by the general circuit parameters (A_1, B_1, C_1, D_1) and (A_2, B_2, C_2, D_2)

Figure 3. Isolation between equipment terminals.

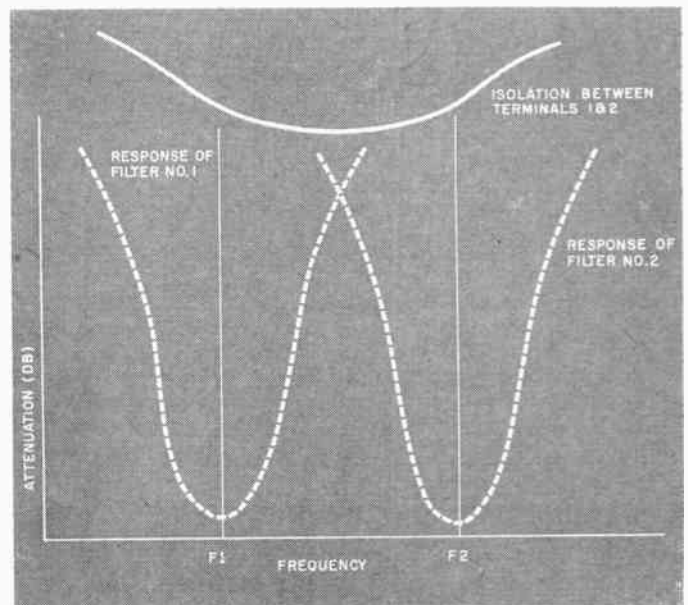

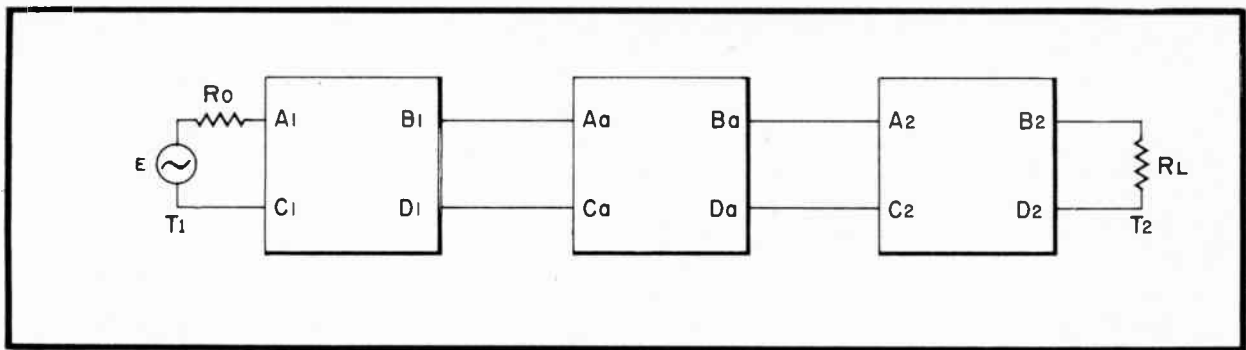

Figure 5. Network representation of a typical diplexer.

respectively while the antenna impedance is described by (A_A, B_A, C_A, D_A) . The latter parameters could also contain any contributions from parallel branches of a multicoupler.

The combined matrix for the two filters plus the antenna is given:

$$\begin{bmatrix} A & B \\ C & D \end{bmatrix} = \begin{bmatrix} A_1 & B_1 \\ C_1 & D_1 \end{bmatrix} \begin{bmatrix} A_A & B_A \\ C_A & D_A \end{bmatrix} \begin{bmatrix} A_2 & B_2 \\ C_2 & D_2 \end{bmatrix}$$

The isolation L between generator and load is then²

$$L = 10 \log_{10} \frac{P_0}{P_L}$$

$$= 10 \log_{10} \frac{1}{4} \left(R_L A + R_0 D + B + R_0 R_L C \right) \left/ \frac{1}{R_L R_0} \right.$$

where P_0 = Power available from the generator.

P_L = Power dissipated in the load R_L .

It proves convenient for some cases to take part of the transmission line system into the antenna network as shown in Figure 6. This shows the antenna admittance Y_A shunted across the transmission line at terminal T , with an eighth-wavelength of transmission line on either side of it. In this case the antenna matrix is given by:

$$\begin{bmatrix} A_A & B_A \\ C_A & D_A \end{bmatrix} = \begin{bmatrix} y & jR_0(y+1) \\ j \frac{(-y+1)}{R_0} & y \end{bmatrix}$$

where $y = j \frac{R_0 Y_A}{2}$

R_0 = characteristic impedance of the transmission line = generator impedance.

If the resonant frequency f_1 of filter (1) is considered, then for this frequency

$$A_1 = 1, B_1 = C_1 = 0, D_1 = 1$$

A useful type of filter which is often employed in diplexers is formed of band-pass resonators coupled in such a way that for "n" resonators in cascade the general circuit parameters are given by:

$$\begin{bmatrix} A & B \\ C & D \end{bmatrix} = \begin{bmatrix} T_n(x) & jZU_n(x) \\ j \frac{1}{Z} U_n(x) & T_n(x) \end{bmatrix}$$

where $T_n(x)$ is a Tschebyscheff polynomial of the first kind and $U_n(x)$ is a Tschebyscheff polynomial of the second kind.

$$Z = \sqrt{\frac{1+x}{1-x}}$$

$$x = \frac{2|f-f_0|}{f_0} \cdot Q_L$$

f_0 = resonant frequency of the resonators.

Q_L = loaded Q of each resonator.

If this type of filter were to comprise filter (2) then:

$$A_2 = D_2 = T_n(x_2)$$

$$\frac{B_2}{Z_2} = Z_2 \cdot C_2 = jU_n(x_2)$$

where

$$x_2 = \frac{2|f-f_2|}{f_2} \cdot Q_L$$

In this formulation the resonant insertion loss has been neglected for simplicity. In practice this would be added to the other factors to form a part of the overall isolation between terminals.

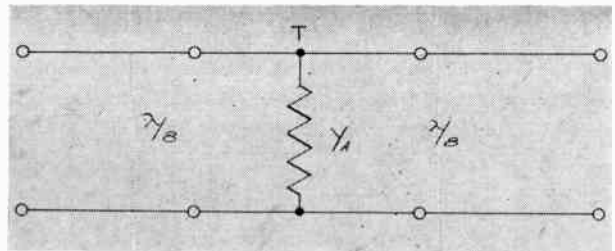

Figure 6. Antenna network incorporating transmission line elements.

The loaded Q of each resonator is made large enough so that the required isolation is achieved at frequency f_1 .

If filter (2), of the type just described, were placed between a matched generator and load then its attenuation at frequency f_1 would be given approximately by:

$$L = 10 \log_{10} T_n^2(x_2)$$

where now $x_2 = \frac{2|f_2-f_1|}{f_2} \cdot Q_L$

It can be shown that for this type of filter the attenuation between terminals (1) and (2) at frequency f_1 is given by:

$$L = L_1 + L_2 + L_3$$

where $L_1 = 10 \log_{10} \frac{1}{2} \left(\frac{R_0}{R_L} + \frac{R_L}{R_0} \right)$

$$L_2 = 10 \log_{10} |Y_A R_0 + 1|^2$$

$$L_3 = 10 \log_{10} T_n^2(x_2)$$

Continued on page 57

Figure 1. Complete automatic telephone exchange on standard flat-bed truck headed for a remote location.

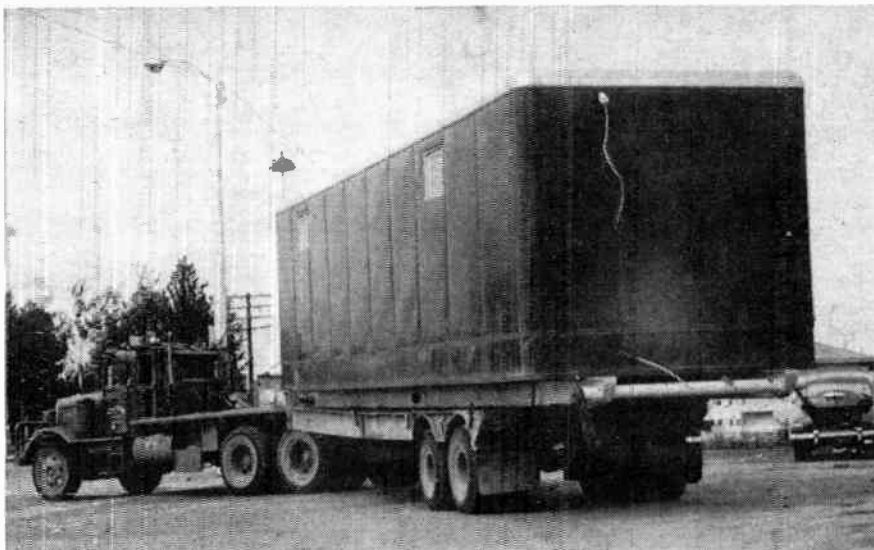

Portable telephone exchange provides fast service to new communities

... portable exchanges have proved highly successful in various Canadian communities and set new patterns where fast installation of telephone networks are needed . . .

by R. W. Robb and G. S. Ballantyne*

Alberta Government Telephones, a provincial government agency (260,000 telephones), provides all public telephone service in the Province of Alberta with two notable exceptions — the City of Edmonton Telephone System (138,000 telephones), municipally owned, and about 960 rural systems (33,000 telephones), which are farmer-owned mutual companies. The A.G.T., however, provides all long-distance service to the 431,000 telephones in the province. Since World War II, new discoveries of oil, natural gas and mineral resources have resulted in both a startling population growth and a rapid industrial development.

This has, of course, resulted in heavy demands for telephone service and has greatly accelerated the installation of unattended automatic exchanges (community dial offices or C.D.O.'s), both to replace outgrown magneto exchanges and to provide service in newly developed areas. In many of the latter cases, however, the location of temporary offices and housing for the construction forces might not coincide with that of the permanent townsite, so that the final exchange location would be difficult to determine in the early stages of development. An example of this situation was the construction of a large paper mill, utilizing natural gas as a fuel supply, at Hinton, Alberta, near two existing townsites, several miles apart. Telephone service was urgently required during the construction period, but the final growth pattern of the community was not immediately apparent.

These circumstances led to consideration of some

form of portable exchange which could be used to provide initial service at a temporary site and which could be replaced later by a fixed installation. It was decided, therefore, to build a portable exchange for Hinton and to use the experience thus gained as a guide to future employment of such units.

Several organizations in Canada have been using mobile buildings to house similar equipment, and many of these were examined. A design used by one of the major oil companies and in certain defense installations was selected as being the most suitable for the A.G.T. This design incorporates a body of stressed steel sheets over a framework of steel channels, with interior lining and insulation, the whole mounted on heavy skids.

A portable building on skids was chosen instead of a mobile trailer on wheels because: (1) It would provide a more steady platform for the equipment; (2) It would be in service most of the time, and only infrequently in transit; (3) Low, flat-bed, tractor-trailers, such as used for the road transport of heavy machinery, were readily available throughout the province on a rental basis. A complete building, in transit, is shown in Figure 1.

Details of building

The two skids supporting the building are 10-inch "I" beams with curved ends and heavy tubular spacers,

*See page 54

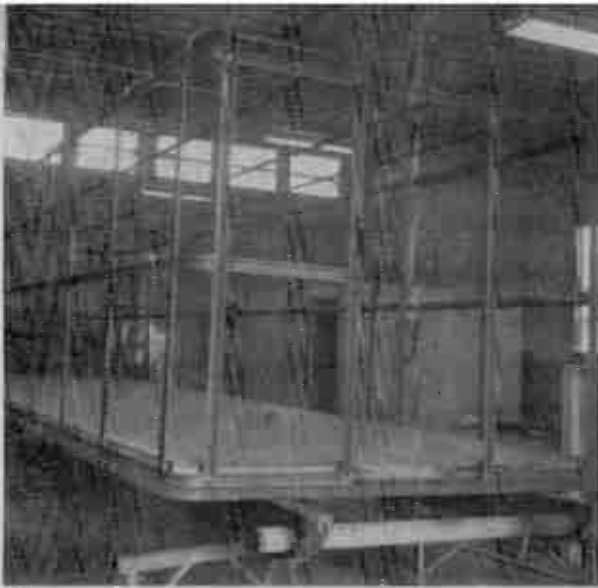

Figure 2. Body framework construction.

providing a rigid foundation. The double wood floor is supported by transverse 4-inch "T" beams, reinforced under the equipment bay locations. The body framework consists of specially shaped steel channel ribs with bolted joints (Figure 2). This framework is covered with sheet steel panels fitted to the vertical channel ribs and held by outer steel channels of smaller section; as these smaller channels are tightened into the main channels by bolts, they stretch the sheet steel panels, thus providing a stressed-skin structure of great strength and rigidity, which is sealed at the joints with weatherproofing compound. This patented construction, known as the "Lindsey" body, is widely used for truck and trailer bodies; the components, of American manufacture, are commercially available in Canada.

The body is lined with plywood on wood battens fastened to the steel channel ribs, and the space between the plywood and the outer sheet-steel skin is filled with glass fibre insulation, and provided with a vapor barrier. A 1½-inch square wood strip around the



Figure 3. Interior view ready for equipment installation.

inside walls, 7 feet above the floor, provides a secure fastening for the auxiliary equipment framework. This strip is plainly seen in the interior view (Figure 3), which shows a completed building, ready for installation of exchange equipment.

A single door at one end is for normal use of maintenance personnel, and a double door at one side provides for the entry of equipment. Small windows, double glazed with Vibrin plastic sheet, are located high on each side, to provide good light without offering a means of unauthorized entry.

A propane gas-fired heater, with forced hot-air circulation, provides adequate heating for the prolonged Alberta winters — even with temperatures as low as 50°F. On the other hand, summer temperatures may rise to nearly 100°F, and for this reason, two electric ceiling-exhaust fans, with automatic shutters, are installed for ventilation. Semi-recessed lighting fixtures are mounted in the ceiling and walls, and power outlets provided as required. The heater-fan motor and controls, ceiling exhaust fans, lights, and

Figure 4. Floor plan arrangement of the portable telephone. Centrally located propane heater provides

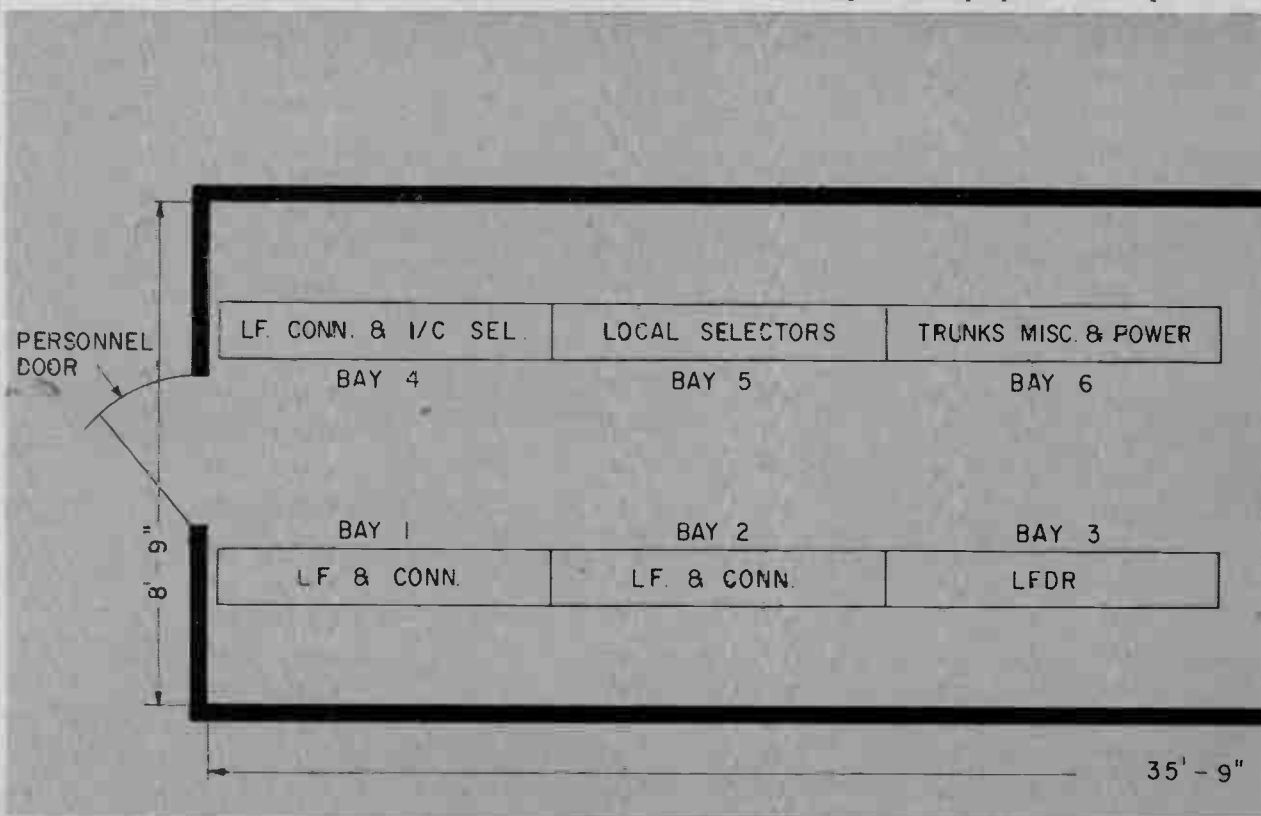

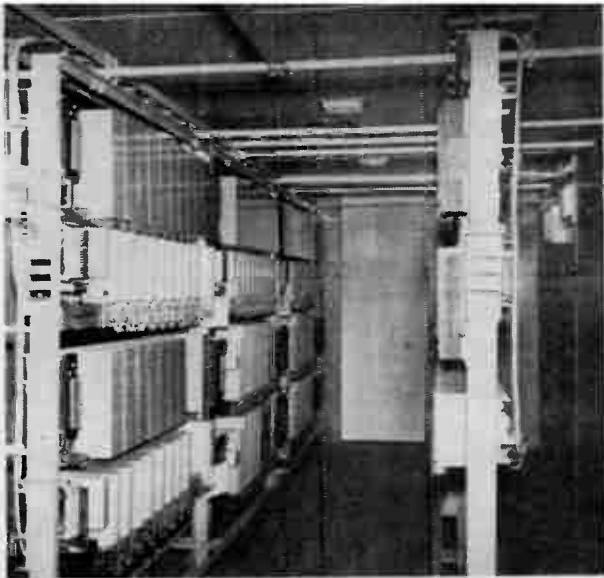

Figure 5. Interior view of exchange showing switch-room arrangement.

power outlets are all wired to a 110/220 volt, 50-ampere service box, arranged for connection to an externally mounted watt-meter and commercial a.c. power supply.

The portable building is 36 feet long, 9 feet wide, and 8 feet high. This provides adequate space for the switching equipment, plus the main distributing frame, power equipment and toll terminating equipment as required; the floor plan arrangement is shown in Figure 4. The building has a capacity of 500 lines, which is considered to be sufficient for most temporary exchange applications.

Standard stocklist units of Type 11 M-A-X equipment were installed in the portable building, at the A.G.T. shops in Edmonton, and the result was the attractive switchroom shown in Figure 5. The flexibility of the Type 11 units was proven by the fact that the only modification required consisted of minor changes in the auxiliary framework, to adapt it to the elongated shape of the portable building. All switches and other jack-in units of equipment were securely held by temporary wood battens, and the storage batteries were

exchange. Equipment is laid out to provide easy servicing, comfortable temperature at 50 below outside.

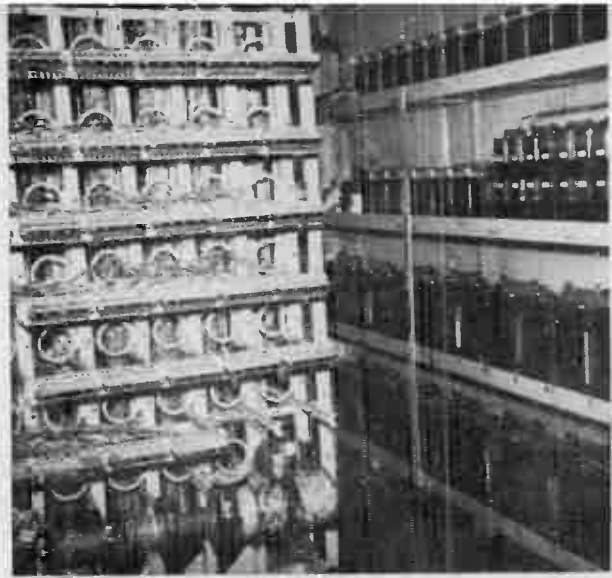

Figure 6. View showing storage battery location.

not mounted but left in their original shipping cartons on the floor.

Transportation and installation at site

The portable building, with equipment installed, was then transported some 200 miles to Hinton by road, using a rented flat-bed tractor-trailer as shown in Figure 1. At two points the building had to be dropped off the trailer and skidded under low overhead bridges; this maneuver was facilitated by use of the power winch on the tractor. Apart from this, no difficulty was encountered and no damage of note to the equipment occurred.

A temporary site adjacent to a highway had meanwhile been selected at Hinton, and the necessary outside cable plant installed. Aerial cable on wood poles was utilized, so subsequent re-routing to the eventual permanent exchange location would be at a minimum cost.

The temporary site was on a new toll route, to which 12 channels of medium-haul open wire carrier

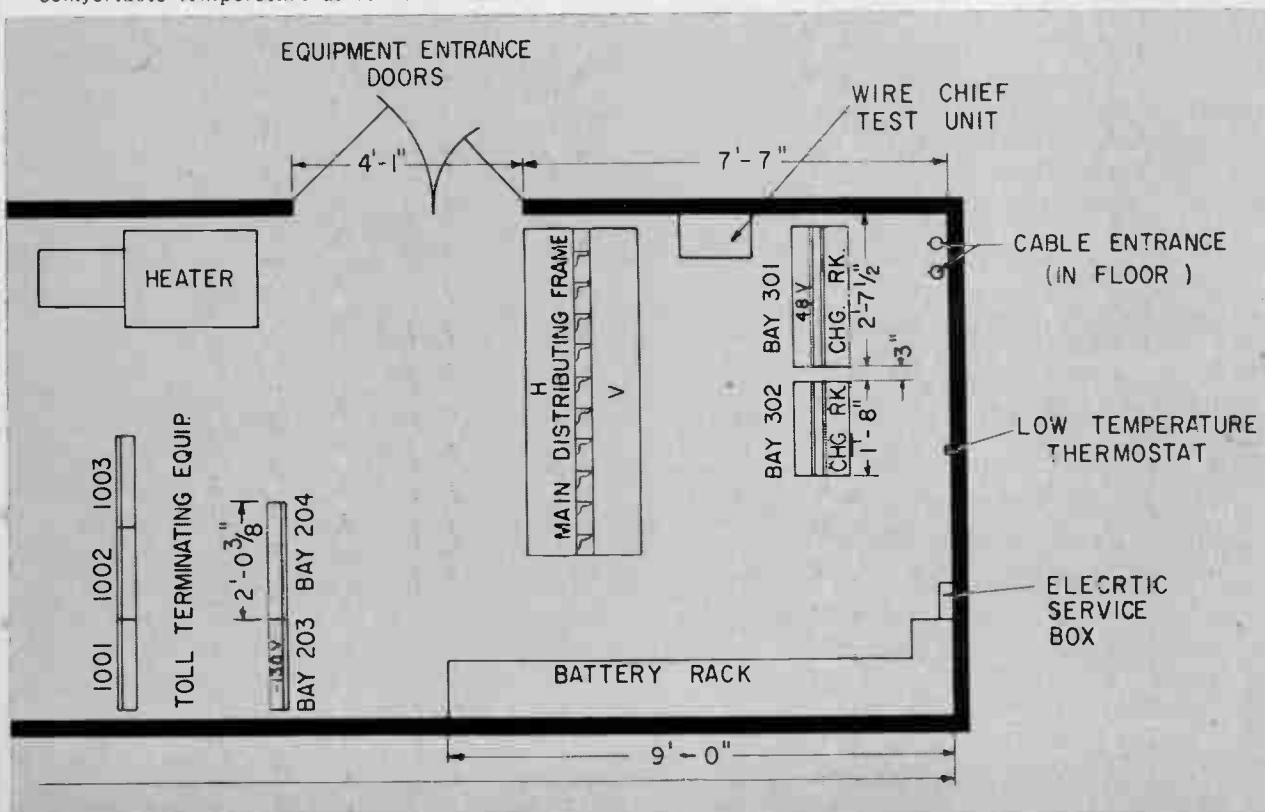

were added, 8 channels of which were used for two-way operator trunks to the controlling toll center at Edson, 55 miles distant. The carrier terminal equipment, with the necessary 130-volt power supply, was also installed.

Upon arrival at Hinton, the portable building was unloaded at the temporary site and levelled, the storage batteries were installed (Figure 6), the equipment was checked, and connections were made to the local a.c. power supply, trunk lines and local cable plant.

Experience gained at Hinton

This portable exchange was in service at Hinton for over two years. The Type 11 M-A-X equipment gave excellent service during this period of rapid growth — which included the installation of a large P-A-B-X with 8 trunks to the exchange. Additional units of Strowger equipment from the A.G.T. stores, quickly and easily installed, were invaluable in meeting traffic demands.

The Authors

Robert W. Robb joined the staff of Canadian (B.C.) Telephones & Supplies Limited, the Automatic Electric installation organization in Canada, in 1942, and for the following ten years was engaged in the installation of automatic telephone equipment throughout western Canada. In 1952 he was transferred to **Automatic Electric (Sales) Canada Limited** as a staff assistant in Telephone Sales at their head office in Toronto. He was appointed in 1954 to his present position of District Manager, at Edmonton, Alberta.

Gordon S. Ballantyne graduated in 1950 from the University of Manitoba with a B.S. degree in Electrical Engineering. He began his communications career in the Engineering Department of the Manitoba Telephone System. In 1954 he joined the staff of **Automatic Electric Sales (Canada) Limited** as Sales Engineer on telephone equipment at Edmonton, Alberta. He is now specializing on carrier and radio equipment sales engineering, as District Manager of **Lenkurt Electric Company of Canada Limited** at Edmonton, Alberta.

In late 1960 a permanent community dial office was installed at Hinton. The portable unit was then moved to Calgary to meet early demands for service for a period of approximately eight months pending the installation of additional dial equipment in the Crescent Heights exchange. It was next moved to Two Hills, Alberta, where it is still in service. Minor changes in equipment quantities and facilities were easily made to meet the requirements of each new location.

When at the original location at Hinton, the heavy traffic to the controlling toll center at Edson indicated the need for greater capacity in the 48-volt power supply. It was also felt that a cable entrance through the end wall, with outside jointing, instead of floor

entry with inside jointing, would be more convenient. These improvements were incorporated in the second portable building constructed, with successful results. This building was installed in a housing area on the perimeter of Calgary, and made it possible to provide service within 10 weeks from conception of the project. While the grade of service provided was naturally poor for a large urban dial area, and involved temporary numbering, nevertheless service was provided quickly, where otherwise nothing could have been done. In this connection it was found desirable to provide full digit-absorbing-type selectors for ultimate flexibility.

Economic aspects

In view of the special nature and purpose of the portable exchange, it was not expected to compete in cost with fixed installations of the same capacity; nevertheless it appears to do so. The portable building is rated as a 20-year structure, as compared to the much shorter life of wheeled trailers, and is very competitive in cost to prefabricated steel buildings. The equipment costs are, of course, the same with the exception of a slight additional expense for modification of the auxiliary framework and battery rack.

There are, however, substantial savings in shipping and labor costs. Transportation of the complete building and equipment at \$0.95 per mile was found to be equal to freight charges for the equipment alone over the same distance, thus saving the cost of freight on a comparable prefabricated building.

Assuming four men spending four weeks installing the equipment in the portable building at the shops in their home area, and only one week in placing the exchange in service at the operating site (instead of 5 weeks at the latter, which would be required in the case of a non-portable installation), there is a saving of about \$5.00 per man per day, or over \$500 for out-of-town living expenses, plus some intermediate travelling expenses.

Acceptability

The introduction of any radical change in established practice is bound to cause some reactions from the personnel involved. The attitudes of staff and subscribers to the portable exchanges were carefully observed and were found to be favorable in all cases. The installers were very pleased that most of their work was performed in their home area, with all shop facilities at hand, as compared with the makeshift and expensive accommodations of a new town. The maintenance personnel found the portable buildings comfortable to work in and the equipment easy to maintain. Subscribers, impatient for service, and accustomed to the usual slow erection of a building and installation of equipment, were surprised and pleased with the speedy introduction of service made possible by the portable exchanges.

Conclusion

The value of these portable exchanges in providing telephone service quickly to new communities seems conclusive. With the addition of a portable, engine-driven, a.c. power supply, they would be invaluable in case of any disaster which interrupted regular telephone service. No abnormal costs are involved in their construction or maintenance, and the reaction of staff and subscribers is most favorable.

Figure 1. Examples of absorbers cut from 1/16" sheet.

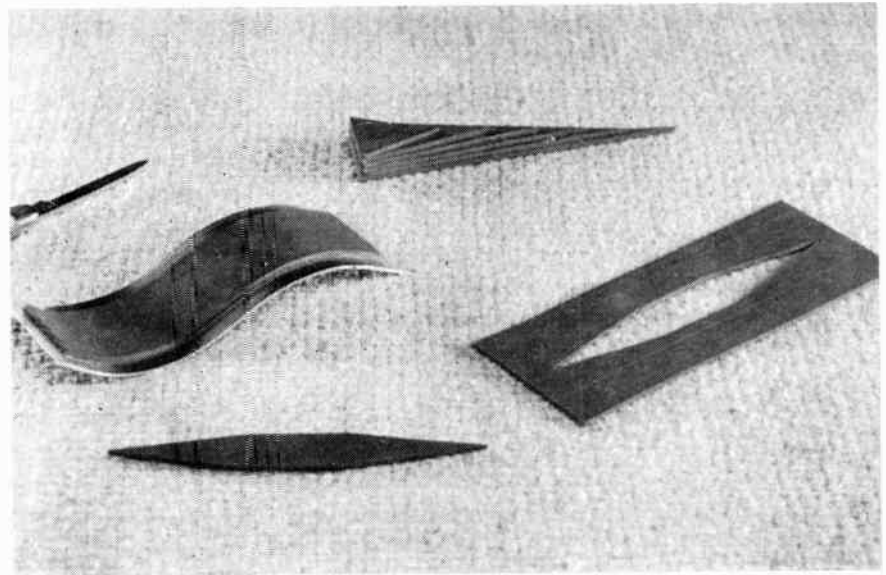

A flexible microwave absorbing material

by A. Staniforth

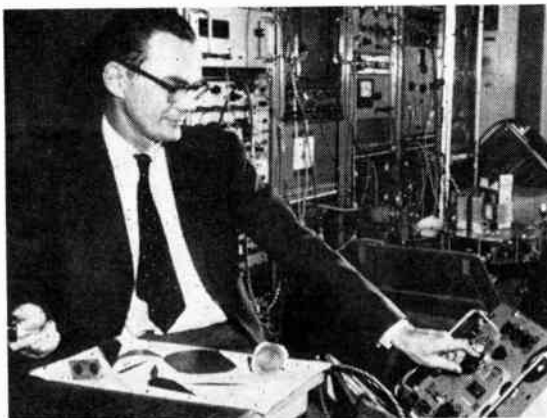

The Author

A. Staniforth was born in Aldersyde, Alberta. He received his B.A. Sc. from the University of British Columbia in 1938. The following year he joined the Canadian Broadcasting Corp. as transmitter supervisor in Vancouver. He left there in 1942 to join the Radio and Electrical Engineering Division of the National Research Council, Ottawa.

Abstract

In experimental work at microwave frequencies an r-f absorber that is flexible and easily cut to a wide variety of shapes is sometimes needed. A material that meets these requirements is described. In addition, the material can be made into gaskets which form a seal against both water and microwaves.

Low-cost material forms excellent radiation absorber and also has desirable mechanical properties

Introduction

In research and development work at microwave frequencies there is sometimes a requirement for an r-f absorber with some special physical properties. Its shape may be such that it cannot be machined or cast easily, or it may be secured to a non-rigid material that would result in breakage of the usual epoxy resin-iron powder mixture. There are now available several flexible casting resins which may be mixed with iron powder to form a microwave absorber material suitable for many applications. Some examples of these are flat loads, attenuators, and gaskets for joints in r-f shields or waveguides.

To make an attenuator or flat load for an application in stripline, a sheet of the mixture may be cast to the desired thickness, after which any shape may be cut out with a knife. If a waveguide tapered load is required, several layers of the material may be cast and stacked. These examples are illustrated in Figure 1. The VSWR of the waveguide load shown in the photograph is about 1.08 at X-band. If this flexible absorber is to be fitted to a curved surface, it may be cast flat and then cemented in place in the shape desired.

A supporting structure in the near field of an antenna may cause undesirable reflections. At X-band frequencies these reflections can be reduced by coating the surfaces with the r-f absorber by direct application or by cutting appropriate pieces from a flat sheet which can then be shaped and secured to the structure.

The flexible property of the material makes it particularly well suited to cementing onto thin sections of photo-etched Rexolite or epoxy-resin fibreglas laminate in microstrip r-f circuits. For example, this r-f absorber makes a very good distributed resistive termination on broadband antennas, such as the flat spiral.

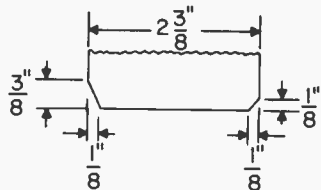
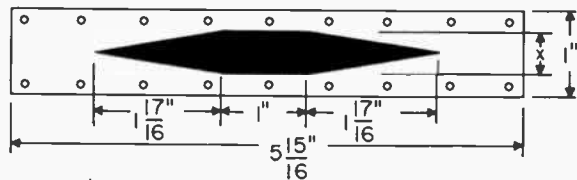

Figure 2a. (above) Shape of waveguide attenuator.

Figure 2b. (below) Shape of stripline attenuator.



Materials in the mixture

The lossy material in the mixture is a fine carbonyl iron powder. The attenuation, or loss, increases as the proportion of iron is increased, but the amount that can be added is limited by the high viscosity. The carbonyl type of iron powder is used in preference to other types, as it is composed of uniform spherical particles which result in a mixture with lower viscosity. Consequently, more iron can be added before a limiting viscosity is reached.

The material used in this laboratory was made by mixing by weight 17% resin and catalyst and 83% iron powder, type GQ-4.² Three types of resin were used in the tests: Stycast #2340M, Stycast #2741,³ and Silastic RTV-521.⁴ The Silastic resin is more flexible than the other materials and is serviceable from -70°F to +500°F. The recommendations of the resin manufacturer were followed in mixing and curing the resin with its catalyst. In all cases, the iron powder was thoroughly mixed with the resin and catalyst, then vacuum pumped to remove excess air before placing in the mold.

The Stycast resin can be cemented to metal and many other surfaces with an epoxy adhesive such as Bondmaster M688.⁵ The Silastic can be cemented to a metal by first coating the surfaces with Primer #4094⁴ and allowing to dry. Then an adhesive Silastic #140⁴ is applied and the pieces pressed together for about 24 hours at room temperature. A satisfactory bond is obtained if the surfaces to be cemented are first cleaned and preferably roughened.

Waveguide attenuator

The characteristics of the flexible absorber Stycast 2340 were compared with those of a rigid absorber made of Hysol #6020 resin with the same proportion of GQ4 iron powder. Flat strips 1/16" thick and shaped as shown in Figure 2(a) were placed in the center of 1" x 1/2" waveguide (RG-52/U) parallel to the electric

field. The attenuation curve of these flap attenuators are shown in Figure 3. There is not much difference in the attenuation of the two materials in X-band guide, although there appears to be less variation in the attenuation of the Stycast across the frequency band 7 to 10.5 kmc/s.

Because of the square shape of the attenuators, the VSWR increased from about 2.0 to 4.0 as the frequency was reduced from 11.0 to 7.0 kmc/s, but as they were used as switches this relatively high VSWR was of no consequence. There is no doubt that tapering the ends would result in a better match to the waveguide.

Stripline attenuator

The same materials were measured in a 50-ohm stripline circuit of dimensions shown in Figure 2(b), together with samples of Stycast 2741 and Silastic RTV521. The attenuation was similar for all types from 1.0 to 2.0 kmc/s but that of the rigid sample was considerably less from 2.0 to 4.0 kmc/s, as shown in Figure 4.

The VSWR's of the various types of material in the stripline unit were found to be similar, but with a slight improvement when using the Stycast resins. The measured values of VSWR varied between 1.1 to 1.4 across the frequency band.

Use as a gasket for a microwave shield

To test the properties of the flexible Stycast 2741-83% iron powder mixture as a gasket material, a pulsed 300 mw X-band oscillator was placed in a sheet metal box. The box was made of 18g. brass with dimensions 12" x 8" x 6", and a cover 12" x 8" secured with screws spaced about 3 3/4". With a rubber gasket 3/32" thick the attenuation was 18 db from inside to outside of the box. Using the flexible absorber gasket, the attenuation

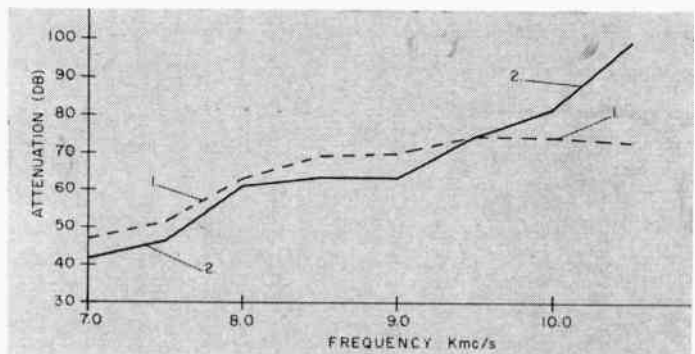

Figure 3. Attenuation of waveguide attenuators. Curve 1 is for Stycast 2340M (flexible) and Curve 2 is for rigid Hysol 6020 material.

increased to 48 db. The r-f leakage could be reduced still further with a well made shield box and cover. However, a poorly fitted cover was used to show that low leakage could be obtained with this gasket material without a good metal-to-metal contact. The use of a flexible absorber gasket results in a joint which has low r-f leakage and is also splash proof.

Waveguide flange gasket

The physical and electrical properties of this material suggested that it might be useful as a gasket in a waveguide flange coupling. The resilience of the material, particularly that of the Silastic 521, is sufficient to make a weatherproof joint at a choke flange. Joints were tested with 100 lb./in.² air pressure under water and all found to be tight. A series of measurements were carried out on several gasket

materials, four samples of each, to compare the leakage of r-f power at a waveguide choke flange. Results are shown in Figure 5. The Stycast 2741 gasket, using a mixture of fine steel wool and carbonyl iron powder GQ-4, resulted in the lowest leakage, being about 13 db better than a gasket of rubber and wire mesh.

The r-f leakage at the junction of two waveguide cover flanges was measured under several conditions at two frequencies, as shown in Table I. These are the mean values of four samples of gaskets.

It can be seen that with no gasket the leakage becomes excessive unless the waveguide covers are screwed tightly together to obtain good electrical

TABLE 1

Condition	8.9 kmc/s	9.7 kmc/s
No gasket		
Tightly coupled	80 db	87 db
No gasket		
.012" spacers, one side only	24 db	27 db
Stycast 2741-83% iron		
1/16" thick	72 db	84 db
Silastic 521-80% iron		
1/16" thick	79 db	93 db

contact. The use of flat gaskets of flexible r-f absorbing material about 1/16" thick reduces the requirement for an electrically clean and perfectly flat cover flange to obtain low leakage of r-f power.

VSWR measurements were made on these waveguide flanges with the different gasket materials, using ordinary laboratory instrumentation. As the VSWR's were all less than 1.15, no significant difference could be found between the various gaskets used.

Conclusions

The foregoing examples indicate that an r-f absorber with a wide variety of uses can be made in the laboratory from a mixture of flexible casting resins and iron powder. It can be cast or cut to the desired shape without the use of machine tools, thus making a suitable material for microwave experimental purposes.

Reference and sources of materials

1. A. Staniforth and K. Steele, "Casting Lossy Microwave Parts in Resin Aids Design Work", Canadian Electronics Engineering, May 1958.
2. General Aniline & Film Corp., Antara Chemicals Division.
3. Emerson & Cuming, Inc.
4. Dow Corning Corporation.
5. Rubber & Asbestos Corporation.

Figure 5. RF leakage at a choke joint in X-band waveguide: (1) no gasket, (2) round rubber gasket, (3) rubber washer with wire mesh, (4) Silastic RTV-521, (5) Stycast 2741 with steel wool and iron powder.

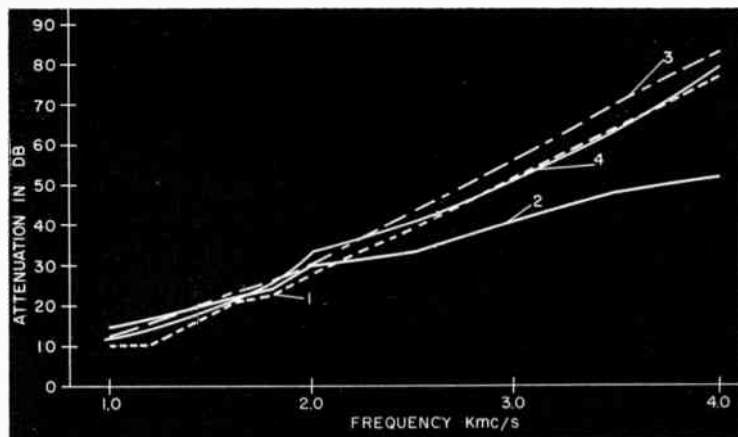
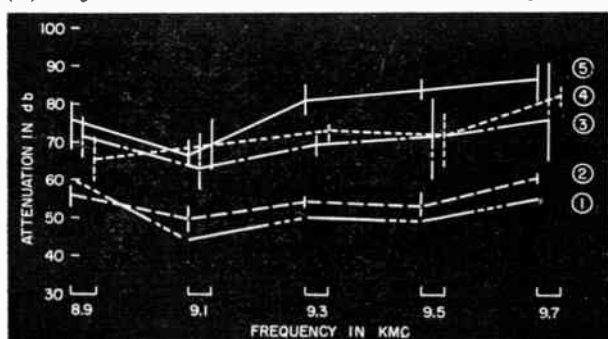

Figure 4. Attenuation of stripline attenuators: (1) Silastic RTV521 — flexible, (2) Hysol 6020 — rigid, (3) Stycast 2340M — flexible, (4) Stycast 2741 — flexible.

Passive couplers

Continued from page 50

Thus the isolation is seen to be composed of three parts.

L_1 is the mismatch loss, and for values of R_L such that:

$$\frac{1}{16} \left[\sqrt{\frac{R_0}{R_L}} - \sqrt{\frac{R_L}{R_0}} \right]^4 \ll 2 \left[\frac{R_0}{R_L} + \frac{R_L}{R_0} \right]$$

it is twice the loss that would occur should there be no antenna or filters between the generator impedance R_0 and the load R_L . For example, if $R_L = 2R_0$, then $L_1 = 1$ db which is twice the reflection loss which results from a voltage standing wave ratio of 2:1.

L_2 is the attenuation gained by placing the antenna admittance Y_A across the line at point T as described previously. If the antenna impedance is matched to the generator impedance then $Y_A = 1/R_0$ and $L_2 = 6$ db.

It is interesting to note that L_2 is the isolation that would be obtained if the antenna admittance were doubled and placed between a matched generator and load.

L_3 is the attenuation that would be obtained if filter (2) were placed between a matched generator and load.

At frequencies other than f_1 or f_2 , where X_1 and X_2 are sufficiently large, it can be shown that if the resonators of the example just given comprise both filter (1) and filter (2) then the insertion loss is:

$$L = L_1 + L_2 + L_3$$

where now

$$L_1 = 10 \log_{10} \frac{1}{2} \left[\frac{R_L}{R_0} + \frac{R_0}{R_L} \right]$$

$$L_2 = 10 \log_{10} |2R_0 Y_A|^2$$

$$L_3 = 10 \log_{10} T_n^2(x_1) + 10 \log_{10} T_n^2(x_2)$$

where

$$x_1 = \frac{2|f - f_1|}{f_1} \cdot Q_L$$

$$x_2 = \frac{2|f - f_2|}{f_2} \cdot Q_L$$

Again L_1 is a mismatch loss as it was previously. L_2 is the attenuation caused by placing the antenna

Continued on page 65

A new carrier system for light route communications

... article describes a versatile transistorized system, capable of fully synchronized operation, using the latest techniques in space saving and reliability

by J. D. D. Myers and A. Reading

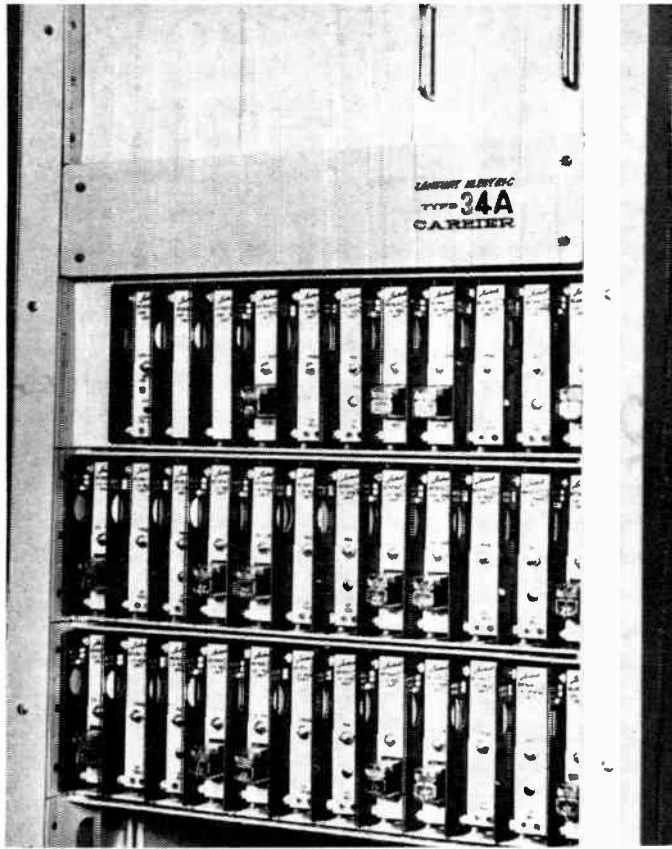

Figure 1. A complete 8-channel terminal equipment.

Introduction

A fully transistorized carrier system, designated Type 34A, has been conceived, developed and is being manufactured in Canada for economical use in systems requiring a small number of channels. Due to the unique design philosophy, a single channel terminal is entirely self-contained, and up to eight channel terminals can be operated without common equipment. A minimum amount of group equipment increases the channel capacity to 24. A standby is provided for the group carrier oscillator, the only circuit capable of affecting more than eight channels.

Individual channel arrangements

Each channel is provided with its own carrier oscillator capable of operating completely independent of external circuitry, and is held synchronized during a call to allow use of the 34A system for highest quality data transmission. In a party line application, the called stations are automatically connected as slaves to the calling station, while for toll circuits, each station transmits a carrier synchronizing tone.

The synchronizing tone is, in fact, the channel carrier frequency inserted after the channel modulator stage, and also serves to provide a medium for signalling and acknowledgment information during the establishment of a call. Attenuated carrier tone is

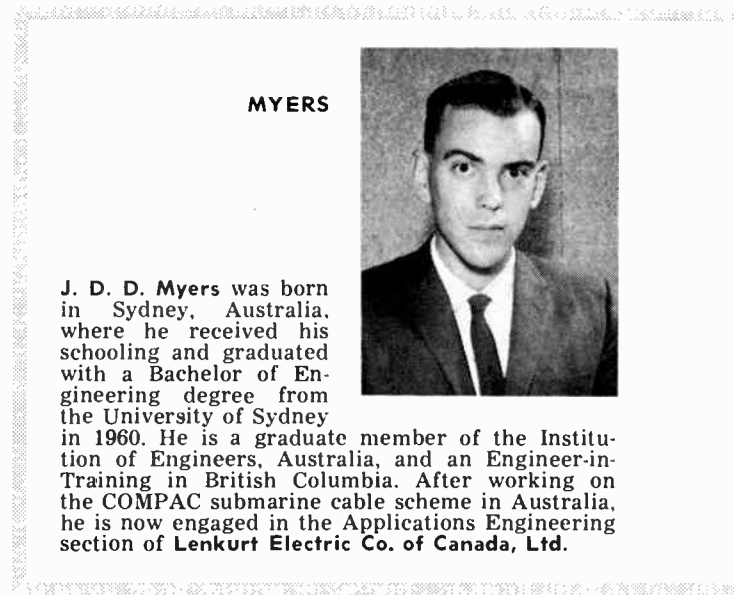
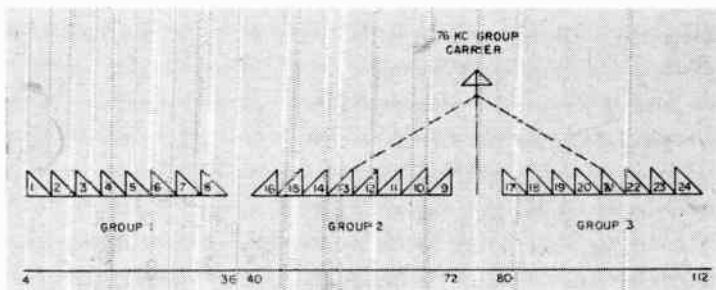

MYERS

J. D. D. Myers was born in Sydney, Australia, where he received his schooling and graduated with a Bachelor of Engineering degree from the University of Sydney in 1960. He is a graduate member of the Institution of Engineers, Australia, and an Engineer-in-Training in British Columbia. After working on the COMPAC submarine cable scheme in Australia, he is now engaged in the Applications Engineering section of Lenkurt Electric Co. of Canada, Ltd.

transmitted from a terminal when the calling party goes "off hook", and pulses if the calling party dials. In a toll circuit when the called party also goes off hook, attenuated carrier tone is transmitted back to the calling station where it is converted into standard E-lead information for exchange equipment.

Universal card mechanics are used throughout the 34A system, and each channel terminal is composed of four plug-in cards interconnected by shelf wiring. Of these, two cards are repeated in each channel of the system and the remaining two cards contain channel bandpass and carrier frequency filters, carrier oscillator, and part of the signalling circuitry.

Figure 2. Diagram showing the modulation plan.

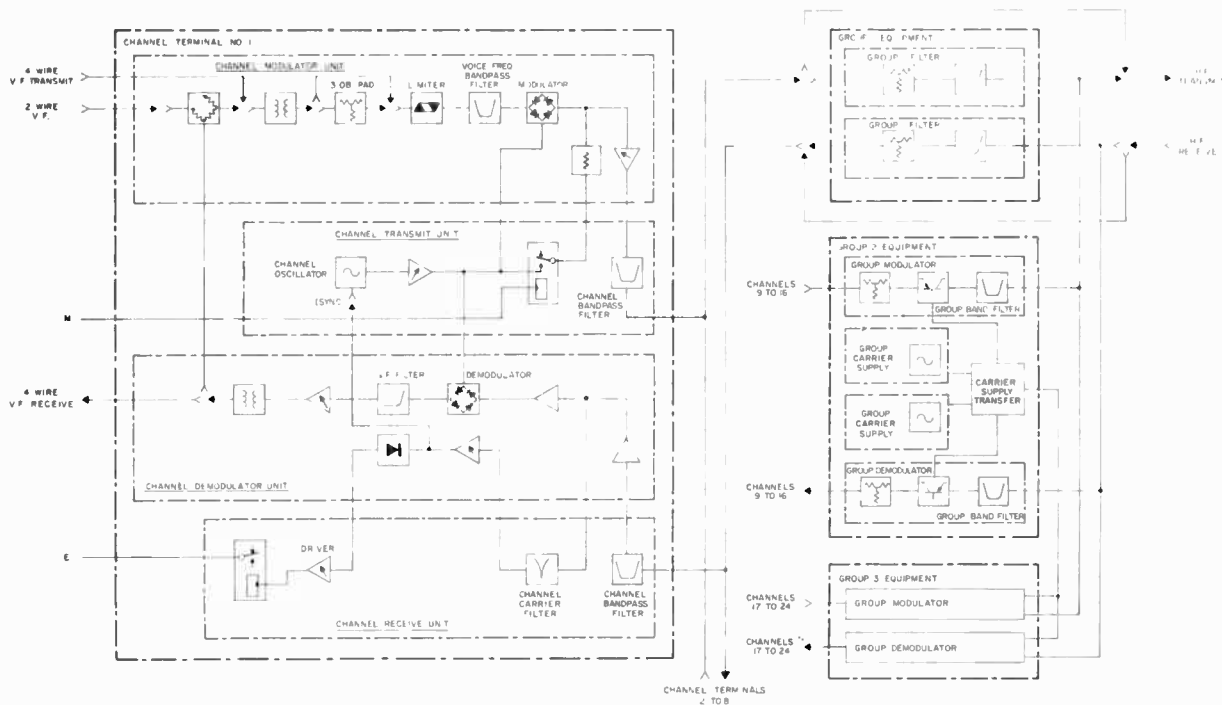

Figure 3. Block diagram of the 24-channel terminal.

Frequency allocation

Details of the modulation steps are given in Figure 2. Eight channels of 350 to 3400 c/s are stacked to make up a basegroup 32 kc/s wide commencing

the first group, while the higher groups require pad, modulator and filter, together with carrier supply equipment and optional standby carrier facilities.

The group equipment is located in the same shelf as the channel terminal units of the group concerned.

Overall system description

A block diagram of twenty-four channel terminal is shown in Figure 3. For clarity, the message, carrier synchronizing, and signalling circuits will be traced separately.

Message circuits

The voice frequency input to a channel terminal appears at the input of the channel modulator unit. When the channel is operated with a 4-wire VF circuit, the transformer is connected to the transmit side of the drop, while for a 2-wire VF drop, a hybrid circuit is provided on the channel modulator unit before the input transformer. From here, the signal passes through an optional pad to a limiter stage. The pad is strapped into the circuit when a -13 dbm level is presented on a 4-wire drop. After limiting, the signal is passed through a bandpass filter to the modulator itself, which is a ring bridge using balanced diodes to obtain minimum carrier leak. From the modulator, the signal passes through an adjustable amplifier, setting the level for transmission, to a channel bandpass filter which removes the upper sideband. The channel bandpass filters are flanking and each presents a high impedance to the line except over its passband, thereby presenting 600 ohm impedance to the line over frequency spectrum of the equipped channels, and allow-

Figure 4. A self-contained 2-channel terminal.

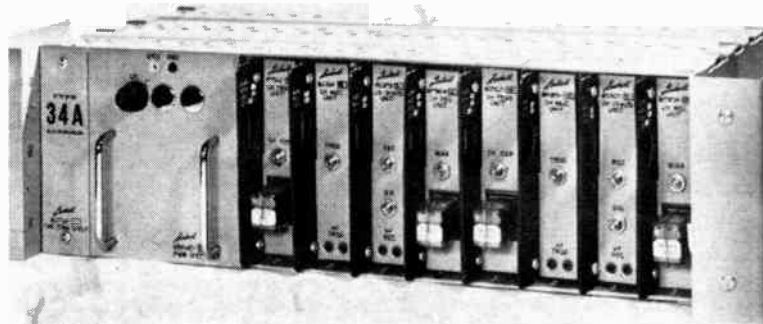

READING

Anne Reading, AMIEE, received her B.Sc. (Eng.) from London University in 1950 and worked with the G.E.C. before coming to Canada in 1954. Since then she has worked with

the Bell Telephone Laboratories, Murray Hill, N.J.; de Havilland Aircraft (Canada) Ltd., Toronto, and in 1959 joined Lenkurt Electric Co. of Canada, Ltd., where she is currently a project leader for carrier, telegraph and similar systems.

at 4 kc/s. Each channel is transmitted as the lower sideband of its channel carrier frequency, the upper sideband being removed by the channel bandpass filter.

For numbers of channels exceeding eight, or when a particular output frequency band is required, two more eight channel groups can be placed on the sidebands of a 76 kc/s group carrier. The highest frequency resulting from this is 112 kc/s occurring when the twenty-fourth channel is used. Channels can be equipped in any order; numerical sequence need not be followed.

Group equipment arrangements

If only channels up to number 8 are used, it is not necessary to use any group equipment. For more than eight channels, a pad and separating filter are used on

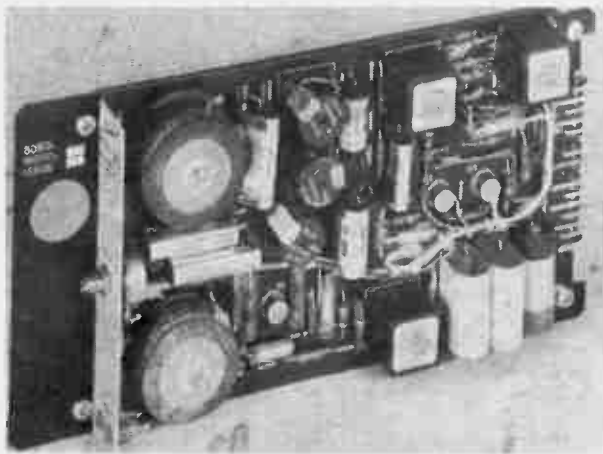

Figure 5. Photograph of a channel modulator card used in the terminal equipment.

ing the outputs to be directly connected without affecting the individual channel levels. When more than eight channels are used, group equipment is required. This consists of an isolating pad and low pass filter for the first group, to co-ordinate levels and restrict the frequency range. The second and third groups are equipped with a pad, a transistor modulator and a group bandpass filter. The carrier supply oscillator is provided with an optional standby unit.

The received signals applied to the group equipment are split into bands by the group band filters and modulated with the group carrier frequency to obtain basegroups. Further selection is carried out by the channel bandpass filters on the channel receive units cards. The signals are then amplified and demodulated in a ring bridge circuit using the channel carrier frequency. An adjustable amplifier is used to bring the modulator output up to drop level. Depending on application, the output VF signals are either fed to the receive leg of a 4-wire drop, or to the hybrid circuit on the channel modulator unit and thence to the 2-wire drop.

Carrier synchronization

The synchronizing signal for each station is obtained from an attenuated carrier tone transmitted by the other during a call. This signal is present in the output of the channel receive unit bandpass filter, is amplified, and picked off in the channel carrier filter. The synchronizing tone is then amplified to a set level and connected to the channel carrier oscillator synchronizing input. Toll operation is with both local and remote stations connected in this fashion; in party line applications, the circuits are arranged to allow the calling station only to transmit the synchronizing tone. This inhibits the called station from transmitting a tone and thereby avoids frequency shift effects due to phase discrepancies between the received signals when more than one synchronizing tone is received.

Signalling circuits

The 34A Channel Terminals accept standard M-lead signalling, operating the channel transmit unit signalling relay. This relay applies attenuated carrier tone to the output of the modulator, which is transmitted and picked off at the remote terminal as described for the synchronizing circuit. The signal supplied to the channel carrier oscillator carries the signalling information, which is picked off, detected, amplified in a

modified Schmitt trigger circuit, and used to operate the channel receive unit signalling relay. This relay repeats the operations of the channel transmit unit signalling relay. When the "off hook" condition causes the transmit relay to operate, the receive relay operates and connects E and F leads at the remote station to indicate a call. Dialing is also repeated, so that the system is capable of full interworking with exchange circuits.

Conclusions

For signalling on toll circuits, when the called station goes off hook, the transmit signalling relay operates and transmits the attenuated carrier tone back to the calling station. This causes the receive signalling relay in the calling terminal to operate and thus provides standard E and F lead signalling. This facility is not used on party line calls due to the necessity of suppressing all carrier tones but that due to the calling station.

Power supply equipment

To render the system as versatile as possible, a series of three interchangeable power supply units have been developed to provide for locations where a filtered source of -24 volts d.c. is not available. These provide suitable filtered output from a 115 volt a.c. line, a -48 volt supply, or from a noisy -24 volt station supply. One such unit is capable of supplying the load of an eight channel terminal. Two smaller units are available for use in the two-channel package shown in Figure 4.

Mechanical construction

A typical card as used in the channel units of the 34A system is shown in Figure 5. All wiring is carried out according to the "Stitched Wiring" method, which uses staples punched through an insulating card to provide a rigid support for components. Internal connections are wrapped and soldered to the legs of the

Continued on page 72

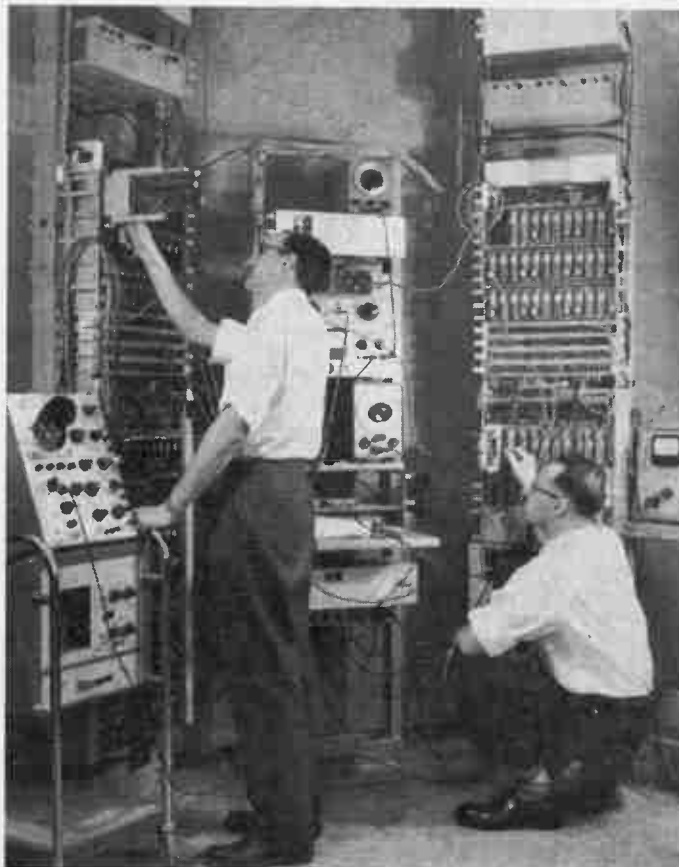

Figure 6. (right) Evaluation testing of two 24-channel terminals at the plant of Lenkurt Electric Co. of Canada, Ltd.

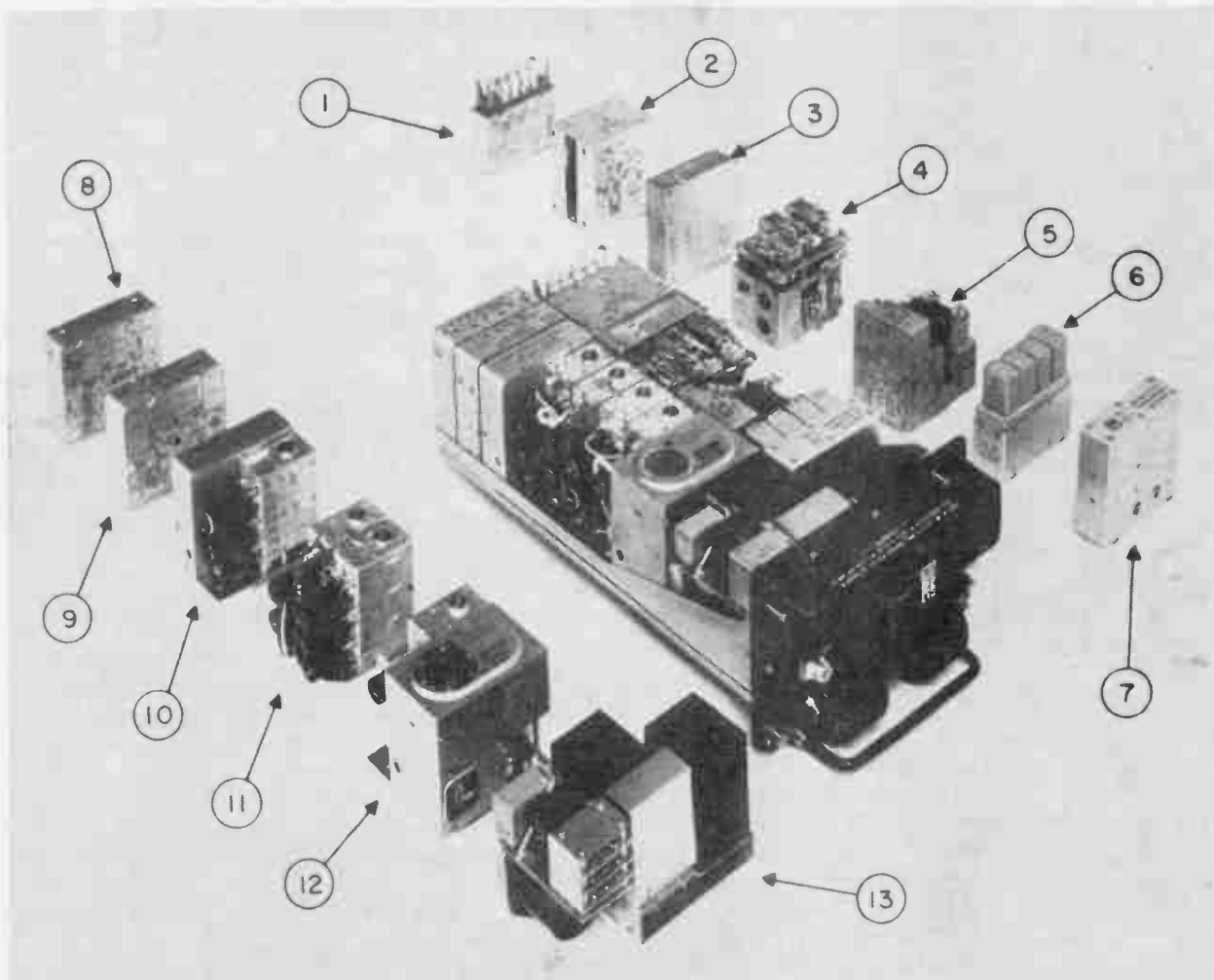

Figure 1. The AN/ARC-552 Airborne Transceiver showing individual modules: (1) 1.85 Mc/s IF amplifier, (2) 20-30 Mc/s IF amplifier, (3) Oscillator unit, (4) Mechanical tuning unit, (5) modulator unit, (6) Relay unit, (7) Rectifier unit, (8) guard receiver, (9) audio amplifier, (10) spectrum generator and amplifier, (11) main receiver RF amplifier and transmitter preamplifier, (12) power amplifier, (13) AC power supply.

RELIABILITY

A reliability program—proven by field service

... article describes a production program for an airborne military transceiver ... concluding notes show high effectiveness of reliability assurance methods employed

(based on a paper presented at the 2nd Canadian Military Parts Symposium — Ottawa 1962)

by F. W. Preziosi*

Summary

This paper provides a brief description of the reliability factors involved in the development and large scale production of a complex airborne electronic equipment for severe environmental service. An existing equipment design was improved in terms of component ratings and application. New components and better components were developed by the industry. A

source approval program was followed in co-operation with CAMESA and the customer to make compliance with specifications more certain, and a rigorous parts and assembly inspection program was used to monitor production. As a result of such attention to components, their application and good assembly practice on a well proved design, a new order of reliability has been achieved.

*See page 64

Introduction

The production program to be described began late in 1955 with the assembly of development models of AN/ARC-52 (XN-4) equipment for test by the RCAF. These tests carried on in the summer of 1956 resulted in the award of a large production contract for equipments and spare modules. There followed a period of intensive effort in development engineering and component study designed to improve the reliability of an equipment which had already demonstrated its capabilities under severe environmental stress. The improved product was designated AN/ARC-552. First production units were delivered in 1958. Since that time in-plant testing and field reports have shown the high effectiveness of the measures taken to improve equipment reliability.

The equipment

Function

The AN/ARC-552 is an amplitude modulated airborne UHF Transceiver intended for use in high performance aircraft where space and weight are at a premium. It provides 1750 crystal controlled channels in the frequency range of 225.0 to 399.9 Mc/s by virtue of a synthesizer employing thirty-six crystals. Rapid selection of any one of the 1750 channels is made possible by the incorporation of an autotuner. The Control Unit provides means for setting up "manual" channels i.e., all four digits of the selected channel or preset channels wherein the digits are stored in a memory drum and only the choice of the channel is required.

Operating characteristics

The performance characteristics of the radio are shown in Table 1.

Table 1

OPERATING CHARACTERISTICS	
Frequency Stability	± 10 Kc/s
Transmitter Power Output	20 watts
Selectivity	Greater than 90 Kc at 6 db Less than 200 Kc at 60 db 5 microvolts mod 30% at $\frac{S+N}{N}$
Sensitivity	1,000 c/s for $\frac{S+N}{N}$ of 10 db
Audio Output	1.0 watt max.
Audio Dist.	Not more than 10%
AVC	± 3.0 db 10 microvolts to 100,000 microvolts
Audio Fidelity	+1, -4.0 db 300 to 4,000 c/s

Physical description

The UHF system consists of a transceiver unit, a control unit, and a shockmount. Figure 1 illustrates the transceiver and thirteen plug-in modules. These modules conform to standardized dimensions as indicated in Figure 2. The block diagram of the transceiver is shown in Figure 3. Maximum use of common circuitry is achieved for the transmit and receive functions. Interconnection between modules is achieved electrically via the main chassis. A mechanical tuning unit module provides the driving source for tuned modules. Coupling is achieved through Oldham couplers on the module and a gear train on the main chassis.

Environmental requirements

The equipment is designed to operate satisfactorily in an environment as detailed in Table 2.

Reliability considerations

At the time when this contract was let, the electronics industry and the armed services in particular had become painfully aware that the reliability of in-

Table 2

Environmental Requirements AN/ARC-552 Equipment	
Temperature:	-55°C to $+55^{\circ}\text{C}$
Altitude:	Sea level to 70,000 ft.
Vibration:	$\pm 10\text{G}$ from 10 to 55 c/s $\pm 2\text{G}$ from 10 to 500 c/s
Shock:	15G in all planes
Humidity:	Up to 95%

stalled equipment fell far short of the minimum acceptable standard for mission accomplishment. This situation had inspired sufficient concern with the factors involved in equipment reliability that theoretical studies had been generated to permit measurement and specification of equipment reliability. However contract demands for reliability in numerical terms had only begun to be required. There had not been enough time for the development of sufficiently dependable parts to meet the increased demands for reliability, although some component manufacturers had begun development of more reliable parts using the statistical approach recommended in the literature.

The contract for the AN/ARC-552 specified that the Mean Time Between Failures should exceed two hundred hours under specified conditions. This demanded that a positive approach be made to the problems of designing reliability into the equipment and

Figure 2. ARC — 552 standardized module dimensions.

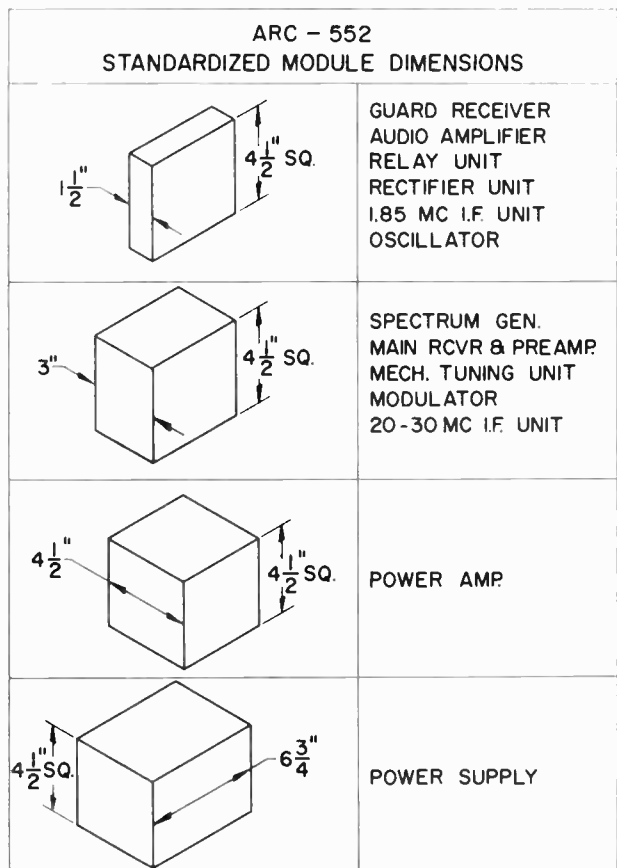

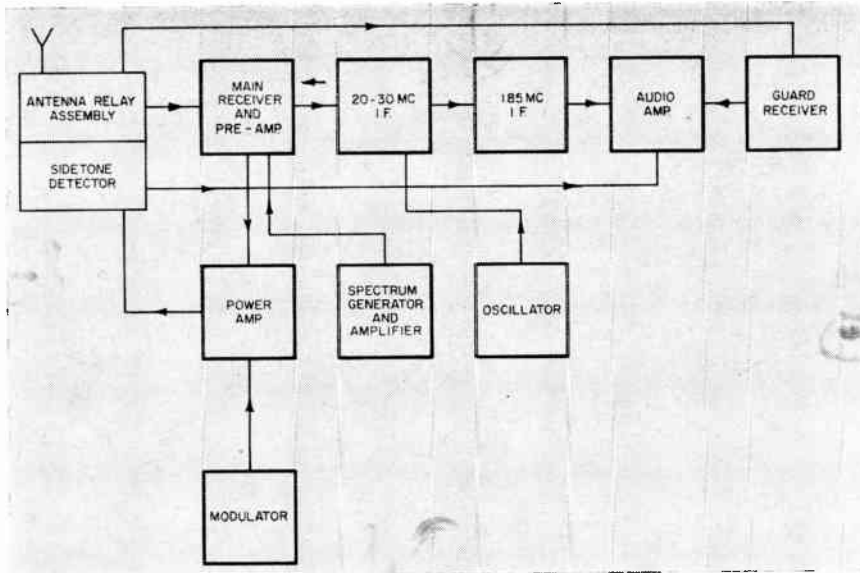

Figure 3. Block diagram of the RT-5011/ARC-552 airborne transceiver.

monitoring the performance of parts and equipment as the work proceeded. The following steps were taken to assure compliance with the reliability specifications.

Circuitry

The AN/ARC-552 continued to employ basic frequency generation techniques and electro-mechanical methods for remote control of tuned circuits which had been proven in predecessor equipments, notably the AN/ARC-27, over a period of fifteen years, and in production quantities of approximately 100,000. In addition, much of the other circuitry was of standard and well-proven design.

Selection of components

During early environmental testing of prototype equipments, actual operating temperature conditions of components were established by extensive thermocoupling of the equipment. In addition, voltage measurements were made at all components to establish maximum voltages and dissipations. This information was recorded in tabular form for all modules and steps were taken to "derate" all components in their respective applications below the maxima laid down in the components specification. It was known that the relationship between the stresses present in the equipment and the stresses imposed on the vendor for life testing would determine the component life in the equipment. However, little was known about inherent vendor ratings. It was, therefore, necessary to lay down an arbitrary stress level and require this of all component vendors. Based on the total number of components in the equipment and the maximum temperatures recorded during thermocouple tests, a life requirement of 1,000 hours at 125°C was imposed.

Derating generally was twofold. First, as many parts as possible were procured to 125°C specification, although the expected ambient was 100°C. Second, a derating factor was applied which depended on prior experience with the vendor. Some examples of derating action taken are as follows:

1. **Composition resistors** were restricted to the RC-20 style and were not permitted to dissipate more than 25 per cent of their nominal ½ watt rating. This assured that body temperature would not exceed the safe limits for the materials used. There have been almost no failures of these parts.

2. **Paper capacitors** were mostly purchased to one of the new high reliability specifications. Before this specification was in effect, the vendor selected by Collins had been producing to the same specification as an internal quality control measure for some time. Because of this vendor's pioneering effort in the techniques of higher reliability applied to production, his ratings were accepted as accurate and the parts were used at up to 75 per cent of these ratings.

3. **Ceramic capacitors** of general purpose type were also purchased from a vendor who used high reliability techniques in manufacturing. His parts also were used at up to 75 per cent of their ratings.

4. **Button mica capacitors** in hermetically sealed enclosures, developed in Canada in co-operation with the Department of Defense Production, were used at 50 per cent rating. Here again, the vendor's capability was well established by tests performed by CAMESA and Collins.

5. **Diodes and rectifiers**, all silicon types, were derated to about 50 per cent.

6. **Electrolytic capacitors**, all plain foil tantalum types, were used so that the maximum conditions of supply voltage together with switching transients, would never exceed the nominal 125°C rating of the capacitor.

Component test and approval program

Due to the large number of new and re-developed components used, and also because of the non-standard parts approval requirements of the contract, an extensive test and approval program was required. At a very early stage in the development, conferences were held with CAMESA and the Department of Defense Production to establish agreement for qualification testing by CAMESA to the increased requirements of the new component specifications.

Collins component approval program consisted of full scale electrical tests under all temperature conditions, life tests and other environmental tests. This program, to produce dependable results, theoretically required that statistical sampling be applied to assure that the 1,000 hour life test requirements had been attained. Since time did not permit sampling and testing on a sufficiently large scale, it was decided to restrict purchasing action for the first production

phase as far as possible to vendors in whom Collins had established some degree of confidence. In later stages of production, other vendors were considered on a competitive basis once they had met test requirements. Component test reports were used as a basis for product improvement when the component failed to comply, or for ordering a limited production run of the parts in the event of compliance. Electrical and environmental testing was then repeated on a sample drawn from this limited order. On successful completion of these second tests, use of the components in production equipment was approved, submission for non-standard parts approval was usually made, and full production was released. A test failure during this qualification or pre-production phase led to further close co-operation between CAMESA, Collins and the vendor, with a view to correcting the trouble or finding another source.

During the production of the equipment, all component parts were inspected for major attributes in accordance with the sampling procedure of MIL Standard 105. Very often 100 per cent sampling had to be invoked during the early days when component production was being debugged. Environmental tests were repeated at intervals where the component reliability was suspected or where changes had been made in parts.

Failures of parts in production testing of equipments were investigated thoroughly and their implications for parts in stock considered. Reinspection was usually carried out in such cases to determine whether the parts could be used as is, or should be modified or rejected.

Component problems encountered

During the component development program difficulties were frequently encountered because the new temperature and performance requirements were ahead of the state of the art. Two examples are given here: Crystals and electro-mechanical parts.

The specifications for crystals called for very close frequency control, special aging procedures for all crystals, and special spurious frequency requirements. Considerable effort in the correlation of frequency measurements was necessary due to the close frequency tolerances specified under wide temperature extremes. It was necessary to develop methods of measurement of spurious modes of oscillation. Actual production of low spurious frequency crystals was a major problem, particularly in the early production phase. Obtaining a sufficient supply of good crystals was a critical matter for some time.

At the time the contract was let, electro-mechanical parts including blowers, motors and relays were all of doubtful reliability under the expected operating conditions. The blowers were required to operate at speeds in the order of 20,000 rpm. At the outset, not much history existed with tiny bearings running at high speeds and high temperatures. No fewer than five vendors' products were evaluated, some of them as often as a dozen times on samples of up to a dozen specimens. This was a costly time-consuming effort. However, by much perseverance and sharing of ideas, one vendor at least succeeded in achieving the mechanical perfection necessary for passing 105°C requirements repeatedly. Another vendor although capable of passing life tests at 125°C, fell short of another specification requirement which prevented use in this equipment.

The motor used to drive the tuning circuits in the radios is a DC machine. Early problems were with brush wear, which resulted in commutator damage and bearing destruction. This was easily corrected, but it was then found that life performance was sporadic unless great care was taken with machining tolerances and assembly practices. This product too has now been built with consistent success, but due to the high performance required, is limited to environments of 100°C under our required duty cycle. Relays also were a problem due to the very high temperatures involved. Contact and spring materials had to be chosen carefully, and mechanical adjustments set accurately. Conventional methods of adjustment were frequently inadequate because of the way materials reacted at high temperatures.

It was found that these electro-mechanical parts demanded workmanship of a very high order to control performance under the severe conditions that existed in the working members of the components.

Apart from state of the art problems, another troublesome area was found to be the general lack of



The Author

F. W. PREZIOSI

Graduated from McGill University in 1948 with B.Eng. in Electrical Engineering (Communications) and is a member of IRE and the Association of Professional Engineers of Ontario. Joined Standard Telephone and Cables Manufacturing (Canada) Ltd., and held position of project engineer until 1955. During this period was engaged in research and development on airborne and ground communications equipment. Joined Collins Canada in 1955 as Senior Project Engineer and was appointed Chief Engineer in 1959 and Director of Research and Development in 1960.

adequate quality control imposed by vendors during the early stages of production. For too frequently, we received the distinct impression that the vendors were not aware that our Receiving/Inspection facility was determined to reject anything that did not conform to the specifications. This condition improved steadily as our vendors came to realize that they too had a stake in this new reliability objective, and that nothing short of whole-hearted compliance with realistic specifications would produce results.

Equipment testing program

As indicated early in this paper contractual requirements dictated a Mean Time Between Failures of two-hundred hours. The equipment testing program imposed by Specification MIL-R-19610 was applied as indicated in Table 3. The following sequence of tests were carried out:

Testing Program Duration	No. of Equipments
20 hours	All
80 hours	2 out of each lot of 25
500 hours	1 out of first 25 1 out of next 100 1 out of next 175 1 out of each additional 500

Reliability Test Requirements of Mil-R-19610

Table 3

Modules

1. Upon completion of assembly and prior to test, each module was vibrated at 2 G at a frequency of 30 c/s for a period of thirty minutes.

2. The module was then baked for thirty minutes at 100°C.

3. Finally the module was processed through the module test position.

Equipments

1. Each equipment was assembled using modules which had been processed through their respective test positions.

2. Then each complete equipment was processed through final test and taking of data.

3. Next the equipment was vibrated for fifteen minutes at 2G, 30 c/s in the operating state and subsequently checked for degradation in performance.

4. Finally, the equipment was placed on twenty hour reliability testing on a duty cycle of five minutes transmit, ten minutes receive, with channel change after each completed duty cycle, once again being checked for subsequent degradation in performance.

5. Where applicable, equipments were processed into eighty hour and five hundred hour reliability testing as indicated in Table 3.

Item	Basis of MTBF	Test Hours	MTBF
1	First prediction based on environmental tests of hand made prototypes of ARC-552.	60 hrs.	
2	Predicted from failure rates in RCA TRIIOO, 1956.	126 hrs.	
3	Predicted from failure rates based on Collins standard practices.	423 hrs.	
4	Measured on 100% 20 hr. break in test.	119 hrs.	38,800
5	Measured in 80 and 500 hour tests, including failures in initial 20 hour period.	407 hrs.	10,580
6	Reported from customer MTBF of whole system during flight in August 1961.	196 hrs.	11,000
7	Reported from customer early in 1962, transceiver only.	440 hrs.	

Table 4

Table 4 provides a comparison of the Mean Time Between Failures predicted and measured in various ways. The items are arranged in chronological order

from the first prediction based on hand-made radios, to the final report based on actual in-flight performance. Figures shown for items 3, 4 and 5 are of particular interest. The Mean Time Between Failures of item 4 shows the effects of "infant mortality" and demonstrates convincingly the need for 100% break-in testing. The Mean Time Between Failures of item 5 includes the effects of failures which occurred during the first twenty hours of operation on the equipments used during these tests. Had these early failures been excluded, the Mean Time Between Failures would have been much higher and would have been more representative of the sort of equipment which is actually delivered to the customer. The correlation between the MTBF of items 3 and 5 is a measure of the success of the engineering effort applied to this program. The correlation between the MTBF of items 5 and 7 indicates that the equipment is withstanding the rigors of service life with little deterioration in performance.

Conclusion

The development and production of this high reliability equipment has been a rewarding experience for all concerned at Collins, in that the application of high standards of design and production, together with the relatively new (in 1956) reliability prediction techniques has produced an equipment which has exceeded the reliability specification by a satisfying margin. A great deal was learned about the practical application of reliability techniques under demanding production schedules. The achievement of the reliability specification alone is a demonstration of the value of a careful and co-operatively planned reliability program. Finally, it would seem significant to note that this order of reliability was achieved without recourse to the very costly sampling techniques and testing programs proposed by the AGREE III Committee.

Passive couplers

Continued from page 57

admittance in the circuit and for $Y_A = 1/R_0$ is equal to 6 db.

L_3 is the sum of the attenuations from the two separate filters.

The restriction has been placed on these latter formulae that Y_A must not be zero.

Conclusions

It has been shown that the isolation between equipment terminals in a diplexer or multicoupler is composed of several parts. Besides the attenuation due to the action of the individual filters there is a mismatch loss caused by unequal equipment impedances and an additional antenna attenuation caused by the parallel antenna impedance.

When all equipment impedances are equal the mismatch loss is reduced to zero. When the antenna admittance matches the generator admittance the added attenuation due to the parallel antenna is 6 db.

References

- (1) W. V. Tilston, "Simultaneous Transmission and Reception with a Common Antenna". Sinclair Radio Laboratories Report — to be published in the 1962 I.R.E. National Convention Record.
- (2) Geo. L. Ragan, "Microwave Transmission Circuits". McGraw-Hill Book Company Inc.

A new high-quality stereophonic FM receiver

New receiver is designed for multiplexed stereophonic transmission and features several novel circuits including an automatic stereo-monaural switch

by J. E. Brown*

Introduction

The receiver is completely new in design and engineered from tuners to speaker systems especially for reception of the new multiplex Stereo FM broadcasts as well as regular FM and Long Distance AM.

Average performance characteristics of the receiver include: FM detector peak to peak separation — 600 KC; FM-IF band-pass selectivity — 225 KC at 6 db. down, and an overall audio frequency response of 50 to 15,000 cps.

The twin cabinet unit, named the Stereo Symphon-aire, provides 24 tuned circuits, 15 on Stereo FM, 11 on FM and 9 on AM, plus automatic frequency control on FM. Circuit features include: tuned RF on both FM and AM; two-stage wide band IF with "narrow skirt" selectivity; a new wide band balanced ratio detector that, with the wide band IF, provides a maximum in tuning ease even on the more critical multiplex stereo signals, and a new AGC circuit, controlling the RF and IF stages, that provides more constant selectivity and tuning characteristics at all signal levels.

The receiver includes a novel circuit that acts as both amplifier and automatic electronic stereo-monaural switch for the multiplex circuit, and four new high-Q coils using a new ferromagnetic cup core design developed by Zenith. The coils function respectively as an input for the 19 KC pilot signal, a frequency

doubler, a 67 KC trap that minimizes SCA interference, and a detector that simultaneously samples the composite (L + R, L - R) signal for the left and right audio information."

The stereo-monaural switch also automatically turns on or extinguishes a stereo signal light located on the front of the receiver.

In comparison to monaural FM where one signal is broadcast, multiplex Stereo FM transmits on one channel a composite of two basic signals—the mon-

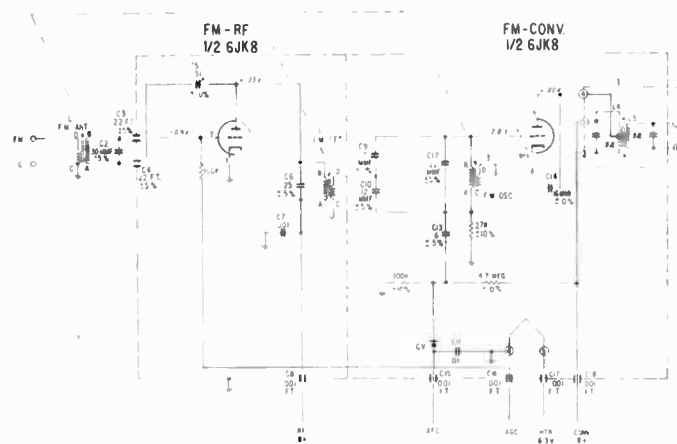

Figure 2. Circuit diagram of the Stereo FM tuner.

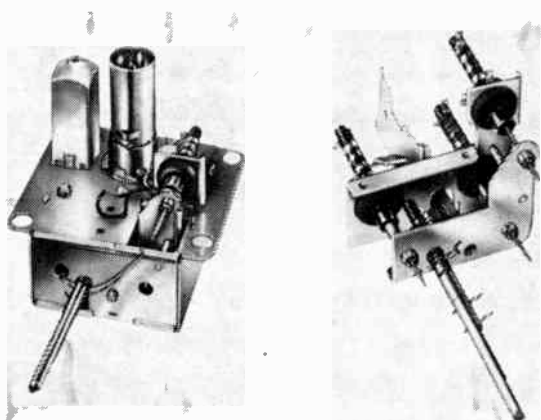

Figure 1. Photograph of the separate Stereo FM tuner. Unit employs Zenith developed 6JK8 low-noise dual triode.

aural (L + R) main carrier and a suppressed sub-carrier containing the stereo (L - R) information, plus a 19 KC pilot signal that enables the receiver to detect the presence of stereo, so that it can then separate the composite signal into LEFT and RIGHT channel information, and route each to the appropriate audio amplifier and speaker systems. As a further complication, an SCA (storecasting) signal may be simultaneously transmitted. Therefore, circuits of a high quality stereo FM receiver must be unusually stable, highly sensitive and selective, and capable of rejecting the SCA signal with which the receiver and the listener are not concerned.

*J. E. Brown is V.P. in charge of Engineering of the Zenith Radio Corporation, Chicago, Ill.

The FM Tuner

Since the Stereo FM tuner requires more sensitivity and selectivity than a monaural FM tuner and must function within prescribed radiation limits, the Stereo FM tuner and AM tuner in the Zenith design are separated units. This eliminates complicated RF circuits, most band-switching as well as other associated circuits that contribute to radiation problems and reduce each tuner's performance.

ate units. This eliminates complicated RF circuits, most band-switching as well as other associated circuits that contribute to radiation problems and reduce each tuner's performance.

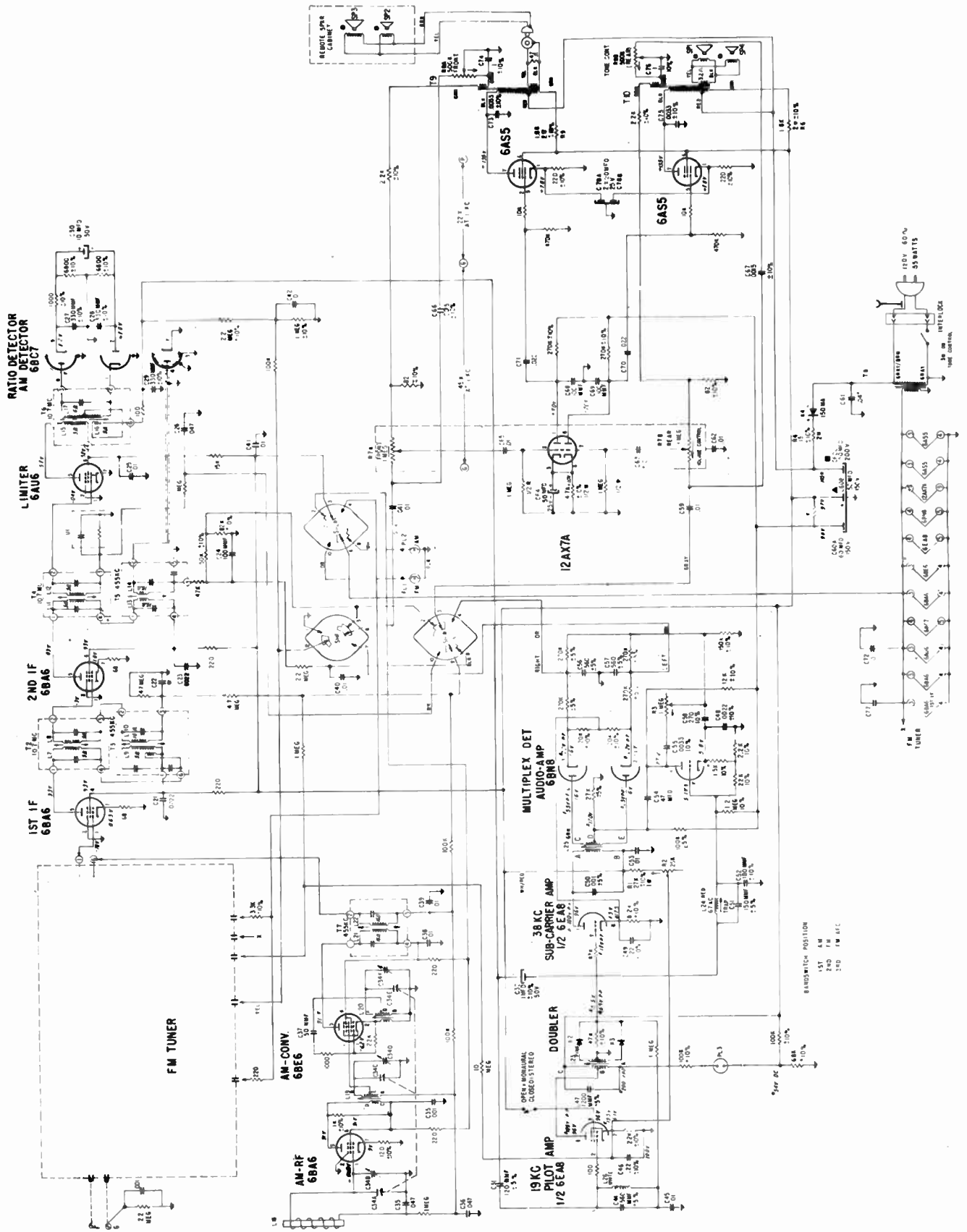

Figure 3. Complete circuit diagram (less FM tuner) of the Zenith Radio Stereo FM receiver.

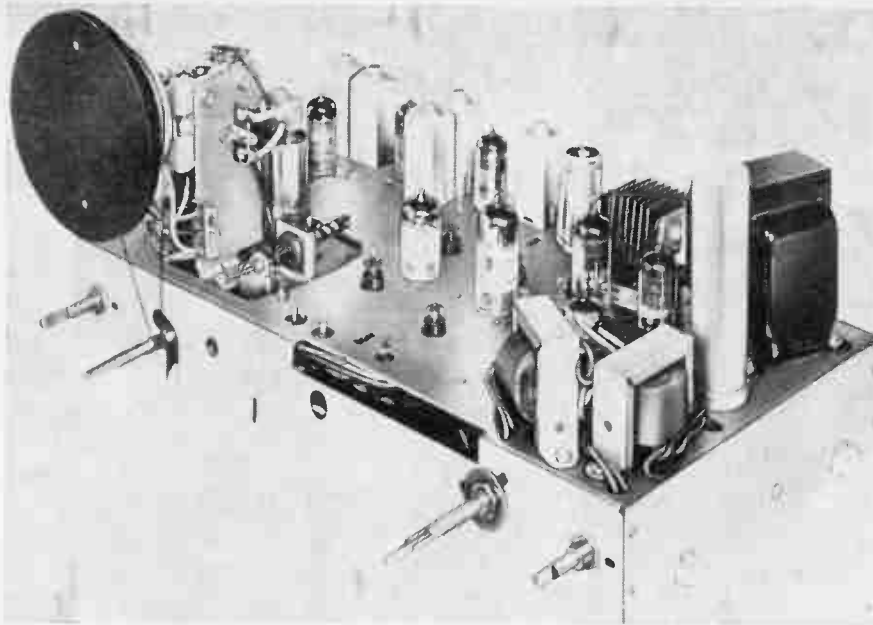

Figure 4. The 12J01 chassis of the Stereo receiver. Circuit features include: tuned RF on both FM and AM, 2-stage wide band IF with narrow skirt selectivity, new wide-band balanced ratio detector and limiter, and three AGC controlled stages.

For FM-RF amplification a 3-gang permeability tuner with a new 6JK8 dual triode tube is employed, the latter being specifically designed for such an application. Combining the advantages of highly stable frame grid construction and a very low noise figure the tuned RF stage significantly reduces interference from undesired signals and sharply improves fringe area reception. A general view of the FM tuner is given in Figure 1 and the circuit arrangement of this portion of the receiver is shown in Figure 2.

The autodyne converter consists of a triode oscillator (1/2 6JK8) with an RF signal coupled into the grid circuit at the junction of the two 12 mmf. capacitors. The RF signal mixes with the oscillator to produce a 10.7 megacycle IF frequency that is fed from the converter plate circuit to the primary of the first FM IF transformer.

The RF stage together with the other tuner circuits, gives the new receiver a sensitivity of approximately 3.5 microvolts for 30 db. quieting when measured in the monaural mode of operation.

The main receiver circuits

A complete circuit diagram of the receiver is given in Figure 3 and reference should be made to this diagram in connection with the following circuit descriptions.

Automatic Frequency Control

To provide maximum tuning ease and to insure freedom from the effects of any possible high frequency oscillator drift, automatic frequency control is provided. AFC is guided by voltages directly related to oscillator frequency shift. This is accomplished by taking DC voltage from the ratio detector and feeding it back to a voltage controlled variable capacitor. This voltage dependent silicon capacitor, connected in the oscillator grid circuit, acts as the frequency controlling device. If the oscillator shifts frequency, this causes ratio detector unbalance and a DC voltage is fed back to the voltage dependent capacitor. This changing capacitance automatically adjusts the frequency of the oscillator circuit to compensate for original oscillator shift. In this manner the receiver is provided with continuous automatic oscillator frequency control that eliminates drift and simplifies Stereo FM and regular FM tuning for the set owner.

An AFC disabling switch is provided to prevent override when the receiver is tuned to a weak FM station within the AFC pull-in range (600 KC) of a strong FM station.

Stereo separation

When stereo is received, the composite output of the ratio detector consists of the following: the 19 KC pilot signal; L + R audio voltage, and two L — R 38 KC side bands. This information is separated, with the 19 KC pilot signal fed to the 19 KC tuned grid-tuned plate pilot amplifier (1/2 of a 6EA8), and the remainder to the 67 KC trap that is needed to eliminate interference from SCA material which the FM station may be simultaneously transmitting with the stereo broadcast.

Automatic stereo-monaural switching

The automatic electronic stereo-monaural switching circuit is centered around the 6EA8 tube. When no 19

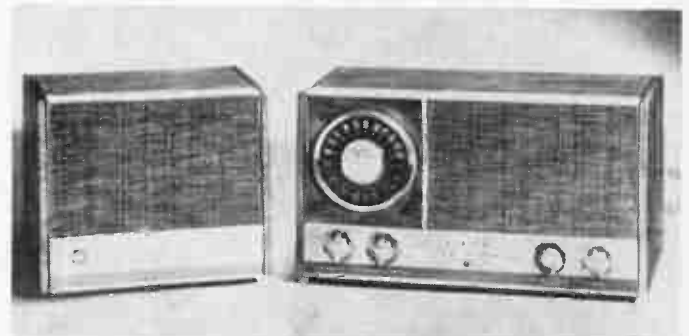

Figure 5. General view of the complete receiver. Main unit carries front panel light to show status of the stereo/monaural switch circuit and both cabinets house woofer and tweeter speakers.

KC pilot signal is present, the tube is muted. The mute voltage is obtained from the B plus line through a 25 K potentiometer and impressed on the cathode of the 6EA8 pentode section. When the incoming 19 KC signal is sufficient to overcome this back bias, it then causes the 6EA8 to conduct and amplify. In the plate circuit of this amplifier, a center tapped 19 KC tuned circuit is used and a pair of diodes that operate as a full wave unfiltered rectifier and act as a frequency doubler. The output of this full-wave rectifier is a series of 38 KC positive pulses.

Gate voltage is then fed back to the grid of the 6EA8 pentode pilot amplifier, which raises the grid to a potential that is within 2 volts of the mute voltage previously impressed on the cathode. This changes the tube's operating characteristic, resulting in greater

Continued on page 72

A short survey of the British microwave industry

... an outline is given of the British microwave industry and shows that eight principal firms cover the broad field... very advanced techniques are evident in British microwave technology...

by R. C. Glass*

Although some of the first radio experiments ever carried out employed microwaves, it was not until 50 years later that microwaves were employed on any large scale. Isolated experiments had also been carried out in various parts of the world during the 1920s and 1930s but no microwave industry existed until much later. In 1940 the invention of the cavity magnetron, which provided for the first time a high-power microwave oscillator, led to extensive development in England of microwave components for radar purposes. In that year the first large contract for the production of ten centimeter microwave equipment was placed to be followed later by the large-scale manufacture of three centimeter components.

All microwave equipment used at that time was exclusively for radar systems, ground-based, marine and airborne. Since then microwave techniques have been applied in many other branches of scientific and engineering work in such diverse fields as wide-band communications, radio-astronomy, radio-therapy, air-field-control radar, spectroscopy, plasma physics, telemetry and others. This large increase in the use of microwaves has led to the establishment of an extensive industry devoted exclusively to the manufacture of microwave components. At the same time many ancillary industries have grown up devoted to the development and production of microwave tubes, communication and radar systems, antennas, radio-therapy, equipment and such like, all using microwave components of one kind or another.

It is impossible in such a short article to review all the many industries which now exist devoted to the manufacture of microwave components, instruments and ancillary equipment. The microwave tube industry alone, which has grown extensively during the past ten years due to the development of travelling-wave tubes, backward-wave oscillators and parametric amplifiers, would require a full-scale article on its own. The situation is further complicated by the fact that many of the more important and interesting developments are covered by security restrictions.

This article, therefore, is confined exclusively to the British microwave components industry and no attempt has been made to include details of allied industries such as tubes, receivers, radar systems and the like.

Figure 1.—Some 8 mm and 4 mm components manufactured by Hilger and Watts Ltd. Samples of 2 mm waveguide are also shown.

Readers interested in developments in microwave tubes are referred to a review article by Harvey¹. A review of published research in microwaves carried out in Britain during 1960 has been written by Karbowiak². Harvey³ has also written a paper on the mechanical design and methods of manufacture of microwave components, to which readers are referred.

Microwave component manufacturers

During the past ten years the microwave industry in Britain has expanded enormously both by the formation of new companies and the expansion of existing ones. Production of components during this period has increased more than tenfold. The table at the end of this article lists the principal British manufacturers of microwave equipment. There are also a number of smaller manufacturers who have facilities for producing microwave equipment but do not market components and only manufacture specific items on request. Since these companies are not primarily microwave

*See page 70

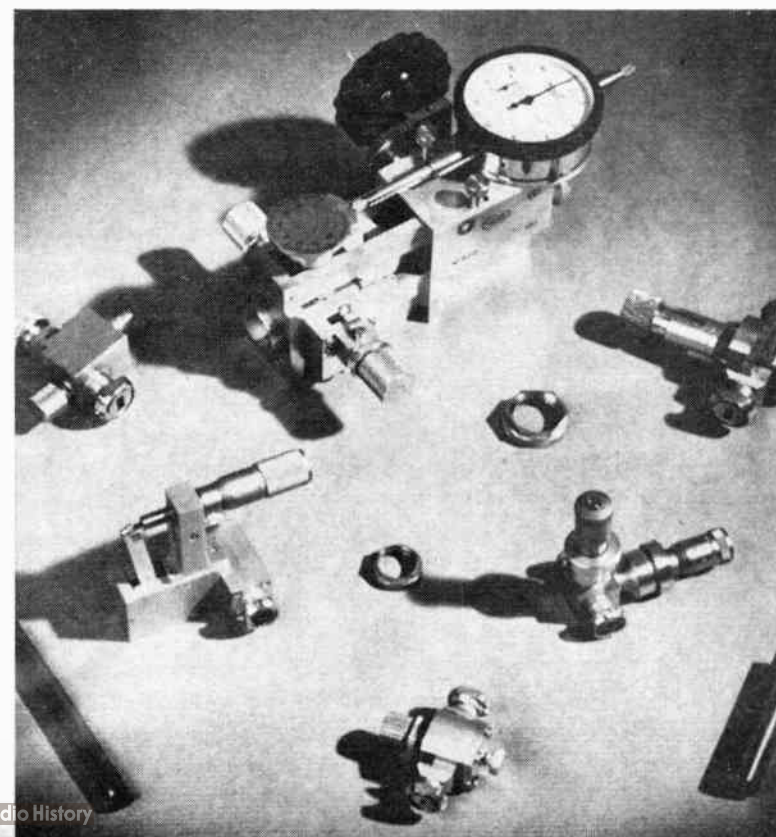



Figure 2. The Hilger and Watts 8 mm electron spin resonance spectrometer.

manufacturers they have been omitted from the table.

The three largest British manufacturers are Hilger and Watts Ltd., Elliott Brothers (London) Ltd., and W. H. Sanders (Electronics) Ltd. Hilger and Watts, originally a company of long standing in the manufacture of precision optical instruments, entered the microwave field with the manufacture of eight millimeter band components. The company has since extended its production to four millimeter and two millimeter components. By its amalgamation recently with the firm of Microwave Instruments Ltd., a company which manufactures centimetric components, Hilger and Watts now cover most of the centimeter and millimeter bands. The company also markets electron spin resonance spectrometers for the three centimeter and eight millimeter band.

The Microwave and Electronic Instruments Division of Elliott Brothers is part of the larger Elliott Brothers electrical engineering organization. The group specializes in the production of high-quality precision instruments and components covering all microwave bands. The company has also in the past manufactured a number of more sophisticated and advanced instruments, such as automatic radiation and impedance diagram plotters, and has pioneered the production of precision rotary attenuators and rotary standing wave indicators.

Sanders (Electronics) Ltd. has probably the largest output of microwave components in Britain and produces a large range of precision instruments covering all bands from waveguide 8 to waveguide 22. The remaining companies, though somewhat smaller, are

Figure 3. Hybrid tee junctions milled from solid aluminum by Elliott Brothers (London) Ltd. The junctions shown cover O-band, Q-band and X band respectively.

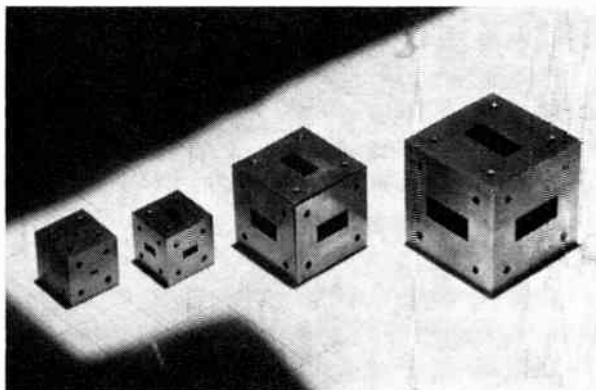

nevertheless important manufacturers. This applies particularly to Decca Radar Ltd., which not only produces high-quality precision components covering waveguide 8 to 22, but also supplies glass vanes for attenuators to much of the microwave industry. The company also has excellent electro-forming facilities for the manufacture of a wide range of microwave components.



The Author

R. C. GLASS

R. C. Glass was born in Manchester, England, and studied at the Dublin University, graduating in 1950 with first class honors in experimental physics. From 1950 to 1956 he was engaged in research on magnetrons at the Research Laboratories of the General Electric Co., Wembley, England, and on travelling-wave tubes at Decca Radar Research Laboratories. Mr. Glass is at present a lecturer in applied physics at Northampton College of Advanced Technology, London, England, where he is developing microwave optical techniques. He is an Associate Member of the Institution of Electrical Engineers and a Fellow of the Royal Astronomical Society.

Microwave Instruments Ltd., now a subsidiary of Hilger and Watts, produces components for the three centimeter and ten centimeter band as well as microwave benches particularly suited for student laboratories.

Midcentury Microwavegear Ltd. produces a large range of cheap yet robust components covering the range from waveguide 4 to waveguide 22, while Flann Microwave Instruments Ltd. specializes in high-quality precision instruments covering waveguide 10 to waveguide 21. Wayne Kerr Laboratories produces a number of special components, namely, resistive film bolometer wattmeters, cavity wavemeters and Q meters. Most of the companies also manufacture power supplies, noise sources, signal generators and allied equipment. New components are constantly being added and developed. Recently a number of ferrite devices

have become available, and many new millimeter and sub-millimeter components are being designed.

Present and future developments

In September 1961 a conference on microwave measurement techniques was held in London at which the present state of microwave research and development and future prospects were reviewed. A summary of the more important papers read at the conference has been written by Glass⁴ in which brief details of some of the latest techniques are given.

The present and future trends in the industry can be divided into two groups — (a) development of improved methods of design and production and (b) development of new instruments and components. In the former group the largest amount of attention is being given to the problems of producing sub-millimeter wave components. The difficulties of manufacturing precision instruments in these bands has led to much experiment with new transmission systems — strip-line and dielectric-filled and ridged waveguides. Experiments have been conducted on methods of producing integrated assemblies of components milled from a single piece of metal. Electro-forming methods



Figure 5. Standing wave indicator for covering the complete 8 mm band. Outer scale sets frequency, inner scale measures phase. Performance matches that of best slotted sections but simplicity makes unit much cheaper.

are also being widely developed. The elaborate precision machining required in the manufacture of many components could well be carried out more easily by the use of automatic and electronic machine control in which operations such as milling, drilling and so on are controlled by numerical information on punched and magnetic tape. Research on the development of such machinery is being carried out in the automation industry. The widely-used conventional methods of manufacture (hobbing, pressing and the like) are constantly being improved and streamlined.

New components

The chief developments in the field of new components have been the wide use of ferrite devices, the production of precision two millimeter components and the development of new methods of accurate power measurement using resistive films, the Hall effect and torque-operated waveguide devices. Many systems of measurement have now been adapted to automatic and semi-automatic operation — methods of measuring dielectric constant and of plotting reflection co-efficient



Figure 4. An X-band rotary attenuator by Elliot Brothers (London) Ltd. Unit may be used with either rectangular or circular waveguides . . . employs a rotating glass absorptive vane . . . can be used as a rotary phase-shifter.

and admittance automatically have and are being developed.

The progress in manufacturing techniques and instrument design has had important effects on measurement techniques. Accuracies never before possible are now attainable; for example, attenuation can now be measured to within plus or minus 0.01db. Wider applications have also been found for microwave radiation involving the design of new components and systems, for example, for medical and biological work, industrial dielectric heating systems, for the examination of free radicals, electron resonance methods and for cooking. There seems little doubt that the next ten years will see further extension of the uses of microwave radiation and increasing production of standard and new microwave components and instruments to meet these requirements.

REFERENCES

- (1) Harvey, A. F.: Microwave tubes — an introductory review with bibliography. Proc. I.E.E., C, Vol. 107, 29-59, March 1960.
- (2) Karbowski, A. E.: Microwaves — a review of progress in Great Britain during 1960. I.R.E. Trans. Vol. MTT-9, No. 5, 374-384, September 1961.
- (3) Harvey, A. F.: Mechanical design and manufacture of microwave structures. I.R.E. Trans. Vol. MTT-7, No. 4, 402-22, October 1959.
- (4) Glass, R. C.: The I.R.E. Conference on microwave measurement techniques. British Communication and Electronics, Vol. 8, No. 11, 833, November 1961.

Principal British Manufacturers of Microwave Components

- Hilger and Watts Ltd., 98 St. Pancras Way, London, N.W.1.
- Elliot Brothers (London) Ltd., Elstree Way, Borehamwood, Hertfordshire, England.
- W. H. Sanders (Electronics) Ltd., Gunnels Wood Road, Stevenage, Hertfordshire, England.
- Decca Radar Ltd., Decca House, 9 Albert Embankment, London, S.E.11.
- Microwave Instruments Ltd., North Shields, Northumberland, England.
- Midcentury Microwavegear Ltd., 19 Parsons Mead, West Croydon, Surrey, England.
- Flann Microwave Instruments Ltd., 9 Old Bridge Street, Kingston on Thames, Surrey, England.
- Wayne Kerr Laboratories Ltd., 44 Coombe Road, New Malden, Surrey, England.

Light route radio

Continued from page 60

staples to obtain high reliability under all conditions. All components mount on one side of the card, with their terminals or pigtailed passing through to the other side, where all the internal wiring is carried out. Only $\frac{5}{16}$ of an inch is required for the protective cover over the wiring and staple legs. The wiring visible on the component side of the card connects internal points to the plug-in connector or to components on the face panel. The finger hole in the front of the card permits easy extraction of the card from its shelf.

Three channels comprising twelve cards may be mounted in one shelf and occupy only $5\frac{1}{4}$ inches of rack space. Power supply units, also plug-ins, mount on the same size shelf and occupy one-third of the width. Thus an entire twenty-four channel terminal complete with power supplies requires less than six feet of vertical rack space.

Line levels and applications

The line levels of -10 dbm transmitting and -25 dbm receiving, obtained when eight channels are operated without group equipment, have been designed to co-ordinate with accessory equipment such as the four-way four-wire resistance network used in party line applica-

tions. The line levels obtained from the group equipment differ by 15 db from the line levels of the basic eight channels, and are designed to co-ordinate with typical radio equipment, such as the Type 71 Light Route Radio. Systems utilizing this radio equipment and the 34A Carrier provide a flexible and economic service to remote areas, facilities for voice and telemetering for pipe lines and power utilities as well as toll service to community dial offices. It may also be used in the frequency spectrum below heavy cross section systems to provide express order wire, supervisory and similar services. The party-line feature and absolute synchronization make it eminently suited for applications where it is necessary to drop a few channels at a number of locations.

The 34A is the successful achievement of a development objective to provide a simple, flexible transistorized system in which channels may be arranged for voice communication, data or facsimile transmission, speech plus telegraph or to carry up to 18 telegraph circuits.

Acknowledgments

Acknowledgments are due to the writers' colleagues at Lenkurt Electric Co. of Canada, Ltd., for their assistance, and to the Lenkurt Electric Co. of Canada, Ltd., for giving permission to publish this article.

Stereophonic receiver *Continued from page 68*

amplification. As a result, the 6EA8 is normally muted during monaural operation and only becomes fully operative with an adequate 19 KC signal.

In addition, the switching action turns on a light at the front of the receiver thereby indicating when the set is tuned to a Stereo FM transmission, and turns it off when the 19 KC pilot signal is no longer present.

The high selectivity of the stereo multiplex circuits, plus the highly stable characteristics of their cup core coils are factors contributing to the success of this novel circuit that acts as both an amplifier and an ON-OFF switch for the multiplex circuit.

Sub-carrier generation

The 38 KC DC pulses from the frequency doubler are fed to the grid of the 6EA8 triode where their peaks are clipped in order to remove any amplitude variations which could appear as noise. Since the pulses and the resonant circuit are of the same frequency, ringing occurs in the plate tuned circuit and a 38 KC sine wave or carrier is created. This carrier is now ready for reinsertion with the two L — R 38 KC side bands that were obtained from the output of the ratio detector.

The L + R audio voltage and the two 38 KC side bands, which came through the 67 KC trap from the ratio detector, are of low amplitude and must be amplified. They are fed, therefore, to the grid of the 6BN8 triode amplifier where their level is raised. Output from the plate of the 6BN8 is coupled through a .47 mfd. capacitor to the center tap of the 38 KC carrier reinsertion transformer. At the primary of this transformer, a 38 KC sine wave is present, and by transformer action, also appears at the secondary. As a result, the two L — R 38 KC side bands now have their 38 KC carrier reinserted, resulting in the amplitude modulated envelope appearing at the diode plates of the 6BN8.

Since the 6BN8 diodes are connected for full wave

demodulation (detection) with grounded center tap, the output will appear as L — R audio on one side and — (L — R) on the other. The sum signal (L + R) is at the same time fed through the diodes in parallel and appears at their outputs as L + R and L + R. One output has (L + R) plus (L — R) or 2L. The other output has (L + R) — (L — R) or 2R. In this manner, the signals are added to obtain separate L and R information which is now fed to the appropriate audio channel of the receiver. In the monaural mode of operation, there is no 38 KC carrier or any L — R sidebands. L + R audio feeds through the 6NB8 diodes to put monaural L + R sound into both LEFT and RIGHT channels.

General layout of the receiver

Figure 4 shows the main chassis layout and Figure 5 illustrates the complete receiver set-up.

There are four high quality speakers — an 8" woofer and a 3½" tweeter in both the main unit and its companion remote speaker cabinet. There is also a built-in cord antenna for Stereo and regular FM, and a ferrite plate loop antenna for AM, plus provision for an external antenna.

Listener-operated controls are all on the main unit of the receiver. They include a band selector switch, tuning control, combination volume or loudness and stereo balance control, and a broad range tone control. In addition, a manual Stereo Cut-Off switch, located on the back of the receiver, permits changing from Stereo FM to monophonic FM in fringe areas when and if noisy reception is encountered.

Tune-lite station indicators — blue for AM and amber for FM — tell the set owner whether the receiver is operating on the FM or AM band and also on which station.

Main unit of the receiver measures 10½" high; 17½" wide and 10 7/16" deep. The companion cabinet is 11½" wide. A 15-foot speaker cord connects the two.

Nomogram relates vacuum-tube parameters

by A. E. Maine, P.Eng.

The three main vacuum tube parameters are defined as follows:

$$G_t = \frac{\delta I_p}{\delta V_g}, \mu = \frac{\delta V_p}{\delta V_g}, Z_p = \frac{\delta V_p}{\delta I_p}$$

where: G_t = transconductance
 μ = amplification factor
 Z_p = plate impedance

whence: $\mu = G_t \cdot Z_p$

This is the basis of the accompanying nomogram.

PROBLEM

Find the stage gain for a vacuum tube where $G_t = 5,000 \mu\text{mhos}$, $Z_p = 20\text{K}\Omega$ and R_L (load resistance) = $10\text{K}\Omega$.

SOLUTION

Set a rule between the values 5,000 μmhos and $20\text{K}\Omega$ on scales B and D respectively. Read off $\mu = 100$ on scale C from the intersection with the rule.

Substitute into the formula:

$$\text{Gain (G)} = \frac{R_L}{Z_p + R_L} \cdot \mu$$

$$G = \frac{10\text{K}}{20\text{K} + 10\text{K}} \cdot 100$$

Therefore gain = 33.3

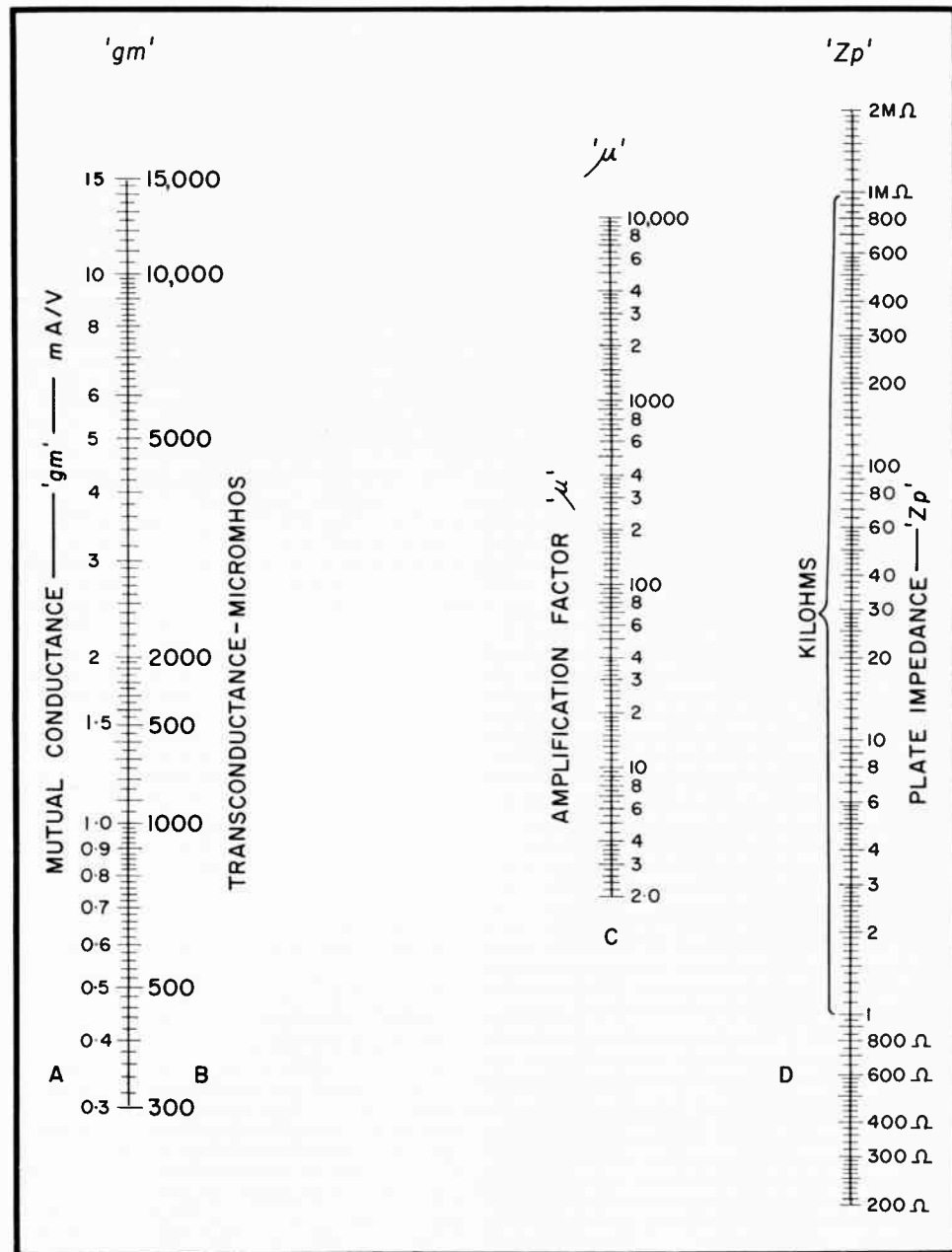

For a reprint of this page, circle 380 on the Reader Service Card or write to The Editor, Electronics & Communications 450 Alliance Ave., Toronto 9, Ontario

ADVANCED FLASH TECHNOLOGY

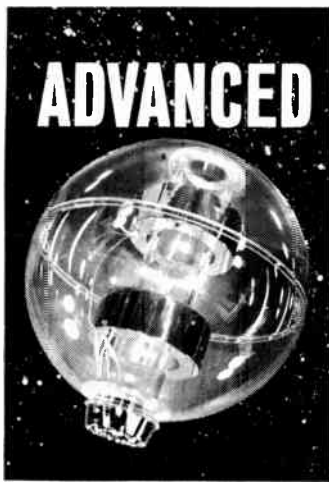

- for • Flash-induced chemical catalysis.
- High-speed photography of chemical and process reactions.
 - Motion studies, shock-wave photography.
 - Cloud chamber Physics.
 - Deep-sea photography.
 - U.V. printing and time-marking.
 - Satellite beacon systems.
 - Optical Maser (Laser) light pumps.

EG&G's leadership in flash technology is solidly based on original contributions to the state of the art which have produced more than 40 patents for tubes, circuits and stroboscopic systems.

XENON FLASH TUBES

Model 100 Designed for Laser and other special applications. Tube configuration ensures maximum light intensity per unit of rod area. Output: 250 HCPS/flash. Input: 100 ws. Price: \$50.

FX-31 Internally triggered. Non wandering arc. Single flash or strobe. Flat-topped for optimum optical characteristics. Output: 2.5 HCPS/flash. Input: 5 ws. Price: \$30. Standard **FX-6A** type: \$15.

FX-41 Paper-clip size tube now under development. Inquiries invited.

FX-38 3" arc. Output: 400 HCPS/flash. Input: 200 ws. Also available: **FX-1** Output: 2000 HCPS/flash. Input: 400 ws. Price: \$50. **FX-42** Output: 2500 HCPS/flash. Input: 600 ws.

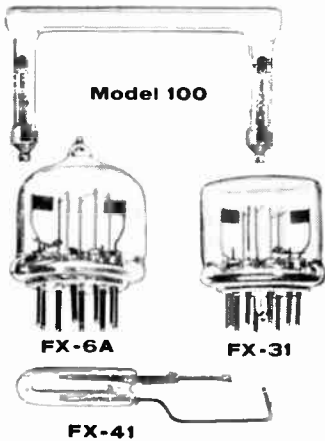

PULSED POWER SYSTEMS

- FOR LASER STIMULATION FLASH CATALYSIS, ETC.

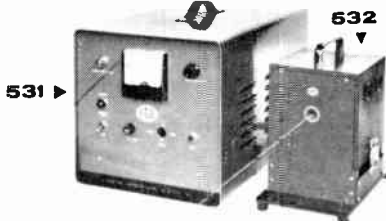

Model 531 Output: 400 ws. (1050 mfd at 900 v.) Input: 115 v. 60 cycle a.c. Price: \$795.00. **Model 532** Flash Head with 2 Model 100 tubes: \$395.00. System will drive polished and multicoated ruby rods with low threshold. System Price: \$1190.00.

Model 522 Two unit 1280 ws. system provides up to 4 kv. into 80 mfd. or 160 mfd. Triggered externally or from front panel. Drives Model 511, 512, 513 Flash Heads with 4 to 10 Model 100 tubes. Accommodates crystals 2" long up to 1/2" dia. Input: 110 v. or 220 v. 60 cycle a.c. Price: \$3345.00 (complete system with 4 tubes).

- FOR MOTION STUDIES, CLOUD CHAMBER PHYSICS, ETC.

Model 530 Output: 100 ws. (260 mfd. at 900 v.) Input: 115 v. 60 cycle a.c. Price: \$395.00. EG&G TR-36 external trigger transformer: \$13.95. System drives most EG&G flash tubes.

ELECTRONIC FLASH EQUIPMENT

Microflash (.5μsec duration) for ballistic photography... **High-Speed Stroboscope** (6 kc. rate) for photographing shock waves, projectiles, etc. . . . **Flash Illuminator** for macrophotography and photomicrography . . . **Double Flash** for silhouette photography . . . **Multiple Microflash** for superimposition of up to 20 photographs on single negative at up to 100 kc. rate . . . **Mark VI and VII Sensitometers** for rating film sensitivities, etc.



Further information on request on above products and on: Millimike® Oscilloscopes and accessories, Hydrogen Thyratrons and Diodes, Triggered Spark Gaps, Transformers, Oceanographic Instruments, Radiation Detection Devices.

TEL. COPLEY 7-9700 • CABLE: EGGINC, BOSTON; TWX: BS 1099

Edgerton, Germeshausen & Grier, Inc.

169 BROOKLINE AVENUE, BOSTON 15, MASSACHUSETTS

WESTERN OPERATIONS: P. O. Box 1912, Las Vegas, Nev. — Santa Barbara Airport, P. O. Box 98, Goleta, Calif.

Represented in Canada by

ALLAN CRAWFORD ASSOCIATES LTD., 4 Finch Ave. W., Willowdale, Ont., 225-7771 or HU 9-9009 — IN MONTREAL: RE: 9-6776



ELECTRONIC FLASH EQUIPMENT

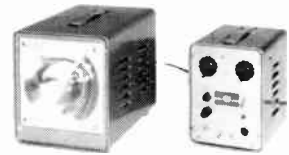

Microflash Flash Duration: 0.5 micro-second. Peak Light: 50 x 10⁶ beam candle power. Energy Input: 8 ws (.05 mfd at 18 kv). Recycle Time: 5 seconds. Time Delay: Adjustable from 3 to 1000 microseconds. Price: \$975.00. Point Light Source Attachment: \$35.00.

MARK VI SENSITOMETER

Compact, easy to use, laboratory device. Will accommodate glass plates, 16 mm. or 35 mm. films. Exposure Times: 1/100, 1/1000, 1/10,000 second. Built-in voltage regulator. Color correction filters unnecessary. Price \$600.00. Mark VII Sensitometer, which has the additional ranges of 1/100,000 and 1/1,000,000, is available at \$1200.00.

High-Speed STROBOSCOPE

Light source specially developed for use with high-speed cameras for studies of fast-moving objects such as shock waves and projectiles. Flashing Rate: Up to 6000 flashes per second. Flash Duration: As low as 1.2 microsecond. Triggering: From camera, oscillator or contactor. Price: \$3500.00.

MODEL 516



Microscope Flash Illuminator Model 516 lamp and 515 power supply provides high intensity flashes (150 microseconds at 100 ws) for extreme close-up photography of delicate subjects without heat damage... e.g. human eye, insects, botanical specimens, etc. Model 517, separate lamp assembly permits close-ups of underwater subjects in fish tanks, etc.

FOR FURTHER INFORMATION, CALL:

STATE	CITY	TELEPHONE
Alabama	Huntsville	536-0631
California	San Gabriel	ATLantic 7-9633
	San Carlos	LYtell 3-7693
	San Diego	ACademy 3-7133
Colorado	Oenver	MAIn 3-1458
	Willowdale, Ontario	BALdwin 5-7391
Canada	Orlando	CHerry 1-4445
Florida	Chicago	NAtional 2-8650
Illinois	Towson	VAlley 3-3434
	Wheaton	LOckwood 5-3066
Massachusetts	Boston	COpley 7-9700
Michigan	Livonia	453-8414
Minnesota	St. Paul	MIdway 8-5531
New Jersey	Ridgewood	GILbert 4-1400
New Mexico	Albuquerque	AMherst 8-2478
New York	Syracuse	GIBson 6-1771
North Carolina	Winston-Salem	STate 8-0431
Ohio	Dayton	BALdwin 3-9621
	Cleveland	JAckson 6-3990
Texas	Fort Worth	PErshing 8-2394
Utah	Salt Lake City	EMpire 4-3057
Washington	Seattle	PARkway 3-3320
Wisconsin	Milwaukee	FL 2-2657

RELIABILITY!...ON THE CIRCUIT LEVEL

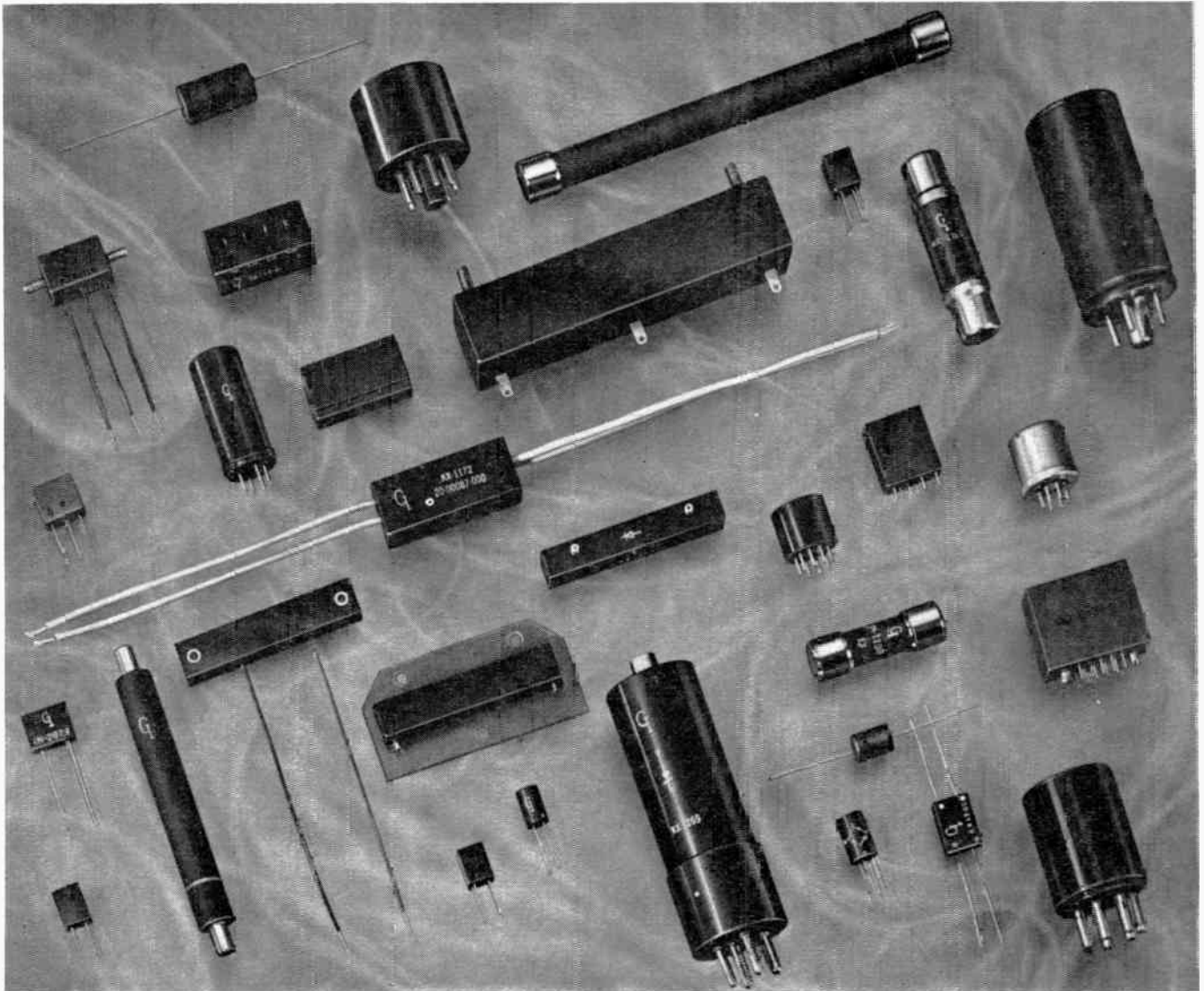

GENERAL INSTRUMENT **CIRCUIT CAPS** DESIGNED TO YOUR SPECIFICATIONS

...SAVE COST OF • *Engineering* • *Production* • *Quality Control*

General Instrument offers circuit modules with exact parameters needed for your specialized applications . . . regardless of configuration, electrical or environmental requirements. Typical applications include: high voltage rectifier assemblies; bridge rectifiers, packaged and finned types; comparators; limiters; blocking and flip-flops.

ENGINEERING: Experienced General Instrument engineers study your specifications, draw on research, development and production facilities in making an assembly to exceed your most stringent requirements.

PRODUCTION: General Instrument experience in volume semiconductor manufacture is applied to the production of "**CIRCUIT CAPS**". Maximum use of welded connections assure excellent resistance to vibration and shock.

QUALITY CONTROL: Components, as well as completed "**CIRCUIT CAPS**" are subjected to 100% electrical and environmental testing . . . exceeding the most stringent industrial and military specifications. Finished units are *guaranteed* to surpass your most rigid requirements.



MADE IN CANADA by:

GENERAL INSTRUMENT SEMICONDUCTOR

DIVISION OF GENERAL INSTRUMENT

F. W. SICKLES OF CANADA LIMITED

151 Weber Street South, Waterloo, Ontario

For complete details check No. 29 on handy card, page 83

ELECTRONICS AND COMMUNICATIONS, June, 1962



IN3464 HIGH VOLTAGE SILICON RECTIFIER

Designed in CANADA for military applications where high reliability and parameter stability over an operating period of 10,000 hours is mandatory.

IN3464 Specifications:

Temperature range: -65°C to $+125^{\circ}\text{C}$.
P.I.V. = 14Kv dc., min.

Maximum I_R at $V_R = 12\text{Kv dc.}$

Room temp. 0.0002 ma.dc.

70°C 0.005 ma.dc.

125°C 0.025 ma.dc.

V_F at $I_x = 100$ ma.dc., at room temp. = 24.0V max.

Predicted operating life: 10,000 hrs.

This rectifier meets the requirements of MIL-S-19500 B, for temperature cycling, moisture resistance, shock, constant acceleration, vibration and operates to altitudes up to 15,000 ft.

Distributed by:

Wholesale Radio & Electronics Ltd., Toronto

Alpha Aracon Radio Co. Ltd. Toronto

Payette Radio Limited, Montreal

Progress Electronics Co. Ltd. Montreal

product panorama

For further information on Products use Readers' Service Cards on pages 83 and 84.

Microwave radiometer head

Item 381

Somerset Radiation Laboratory, Inc. has expanded its line of solid-state microwave switching devices to include the new SRL Model X470 microwave radiometer head. It is a completely integrated unit permitting sampling of external radiation at

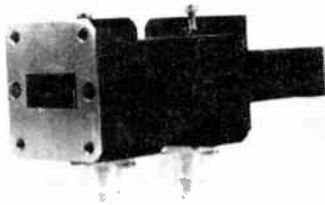

switching rates up to 200 mc and comparing the input energy with an internal reference standard. At 10 Gc/s the VSWR from receiver port to antenna port is less than 1.03 : 1.

The Glendon Instrument Co., Ltd., 46 Crockford Blvd., Scarborough, Ont.

Flush-wall intercom system

Item 384

Model 5500 AM/FM radio-intercom system consists of a master and up to nine remotes; it makes available a truly high performance system for those with an eye towards budget. Styled for flush-wall installation, this unit features sensitive AM/

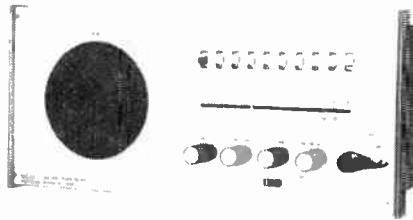

FM radio and wide-band, noise-free amplifier rated at 2 W. It's equipped with an automatic frequency control which prevents drift. Both master intercom unit and any remote may call one another.

Fanon Electronics of Canada Ltd., 431 King Street W., Toronto 2-B, Ontario.

Micromatch unit

Item 387

An inexpensive accessory instrument for use with the GRS radiotelephone equipment is Model 290 Micromatch unit which provides a visual means of observing RF power output and VSWR of any GRS transmitter. Measuring only 4½" x 2" x 2¼" this

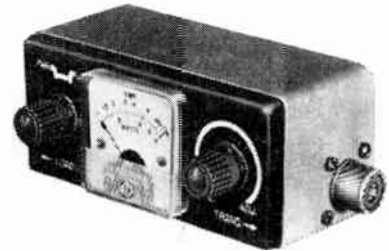

unit can be conveniently dashboard mounted for vehicular use or utilized as a test tool for radio service shop usage. Its meter is calibrated from 0-4 watts full scale with an additional VSWR scale.

Aviation Electric Ltd., 200 Laurentian Blvd., Montreal 9, P.Q.

Glass enclosed crystals

Item 382

Philips Electronic Equipment Ltd. have announced a further refinement in their manufacturing program for glass enclosed crystals. They can now supply 2 to 20 Mc/s quartz crystals with normal stabilities of 2 parts in 10⁶ per week. A significant reduction in series resistance for their entire line of glass enclosed crystals, in the order of 30% minimum, has been claimed.

A method of strain relief has eliminated crystal base breakage.

Philips Electronic Equipment Ltd., 116 Vanderhoof Ave., Toronto 17, Ont.

Bogart 5050 calorimeter

Item 385

This high power instrument was designed to measure RF power from 200 W to 14 KW. It utilizes plant water as the transfer medium, a flowmeter, a pair of precision thermometers and a pressure gage for instrumentation. Average powers can be measured to accuracies approaching 2% under controlled conditions. The unit has all stainless steel tubing and fittings, and comes with two 3' lengths of hose. Unit is independent of frequency.

Bogart Manufacturing Corp., 315 Seigel Street, Brooklyn 6, N.Y.

Pulsed beacon magnetron

Item 388

This unit, MCM-18, is a 1 KW pulsed beacon magnetron operating over the C-band frequency range of 5.4 to 5.9 KMc/s. It's available with coaxial output and differential tuning. The MCM-18 is extremely rugged missile type environment capable of 60 g up to 2000 ε/s vibration, close temperature compensation and long life and reliability operation. This magnetron is available within 45 days after receipt of order at small quantity price of \$1425. (U.S.)

Metcom, Inc., 76 Lafayette Street, Salem, Mass.

Mobile 2-way radio

Item 383

"Transicom 325" FM mobile 2-way radio has a new concept in design and a materially reduced price level. It features a small size, being only 4¼" high, 8" wide, and 12" deep. It has a power output of 25

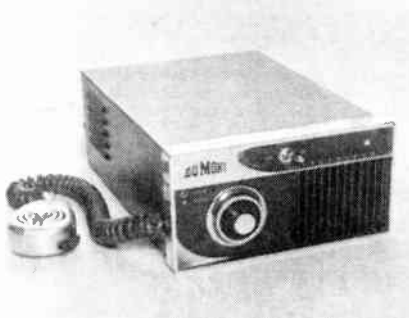

watts within the 144-174 Mc/s band, dual frequency receive and transmit operation, and extremely low current drain. It has modern, functional styling with brushed chrome trim used in a rugged die cast front.

Electronic Research & Development Co., Div. of Mandrel Industries Ltd., 303 Forge Rd. S.E., P.O. Box 1087, Calgary, Alta.

Antenna splitter

Item 386

With addition of a small piece of filtering equipment, a TV antenna can provide simultaneous reception for an FM receiver. This new antenna splitter, model TX-FM, permits reception from a common antenna

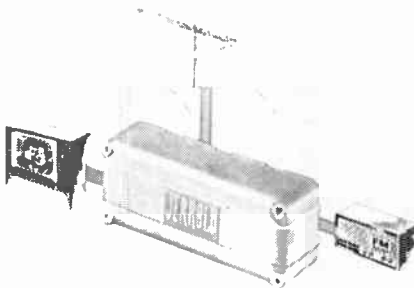

for both TV and FM sets, without interference or loss of signal to either set. A compact band pass filter separates FM from TV frequencies and filters FM frequencies (88 to 108 Mc/s) through to the FM set.

Jerrold Electronics (Canada) Ltd., 60 Wingold Avenue, Toronto, Ont.

Flexible coaxial cable

Item 389

Type H8 is the latest addition to the HELIAX series of flexible air dielectric coaxial cables. This nominal 3" high power low loss cable is suited for short or long runs in HF, FM, TV and UHF installations.

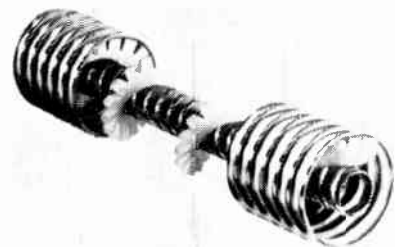

Produced in continuous splice free lengths of high conductivity copper, it offers low VSWR performance. Corrugated construction of both inner and outer conductors permits easy bending around obstructions.

Andrew Corporation, 606 Beech Street, Whitby, Ontario.

Microwave signal generators

Item 390

A series of four microwave signal generators covering the frequency range of 900 Mc/s to 11,000 Mc/s is available from Empire Devices, Inc. Designated models SG-11 (900-2200 MC), SG-12 (1800-4400 MC), SG-13 (3800-7600 MC) and SG-14 (7000-11,000 MC), are designed with complete uniformity of meter and control layout in order to



simplify operator training and reduce human errors. Construction is ruggedized for field use.

Instronics Ltd., P.O. Box 100, 11 Spruce St., Stittsville, Ont.

Broad band klystron amplifier

Item 391

This unit, Model SAX-191, has a peak power output of 1.25 MW at X-band. It delivers a minimum 1 MW of power output over a 370 Mc/s bandwidth. Although it operates in the 8.83 to 9.2 Gc/s range, the inherent flexibility of its 7-cavity design makes it easily adaptable for use in any area of X-band. With its 50 db gain figure, the tube delivers full output power from an input of only 12.5 W. This results in a simplified chain with only one driver required between oscillator and SAX-191.

Sperry Rand Corporation, Great Neck, L.I., New York, U.S.A.

RF antenna couplers

Item 392

Complete line of antenna couplers for the 1.6-16 Mc/s range has been produced by RF Communications Associates, Inc. Model SB-6C uses separate roller coils for each of six channels selected by a motor driven switch; a long wire or 15' whip can be loaded. Other models include: SB-6CA with a conventional tapped inductor to

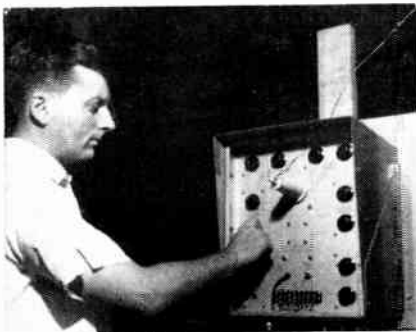

match a 75' wire antenna; SB-6MC is for mobile installations; SB-CMA is a manual coupler; and the SB-6SF remote antenna switch permits selection of more than one antenna.

Tele-Radio Systems Ltd., 3633 Oundas St. W., Toronto 9, Ont.

Telemetry signal generator

Item 393

Type 202-J which is specifically designed for the testing calibration of telemetry receivers operating in the 215-260 Mc/s band. It features less than 1½% FM non-

linearity at 150 Kc/s deviation, a peak-to-peak deviation meter, 1 Mc/s FM modulation bandwidth, automatic RF level set which eliminates the need to readjust the carrier monitor meter as frequency is varied over the band. It is housed in a single modular cabinet convertible to standard rack mounting.

Boonton Radio Corp., P.O. Box 390, Boonton, New Jersey.

Millimeter calorimeter

Item 394

This line is for use at 26 to 140 KMc/s, and they are useful over the entire waveguide band for which they were designated, have a power range of 10^{-1} to 0.5 W, and a VSWR of 1.3 max. The stabilization time is 10 sec., the accuracy is 5% (5 to 500 mw), the water flow rate is approximately 2 cc per min., and the power is supplied by internal batteries. They provide rapid, accurate and relatively inex-

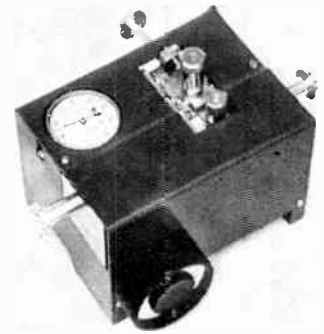

pensive measurement of millimeter power.

Technical Research Group, Inc., 400 Border Street, East Boston, Mass.

Continued on page 78

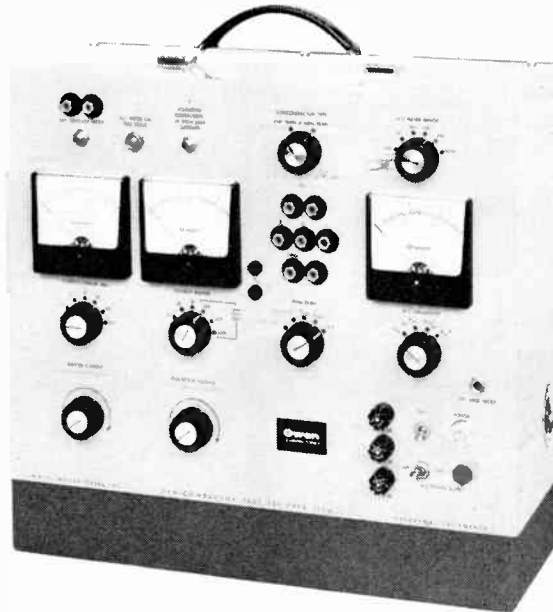

Owen
LABORATORIES

TYPE 310 SEMICONDUCTOR TEST SET

DESCRIPTION

The Type 310 is a sophisticated self-contained portable Semiconductor Test Set for accurately measuring operational parameters of small and medium transistors, rectifier diodes and zener diodes under constant current and constant voltage conditions to 100 ma and 30 volts. Leakage and reverse current test potentials range to 600 volts. Test results are clearly displayed on easy-to-read meters. Currents to one ampere with external supply.

SPECIFICATIONS

Terminals provided for external high-sensitivity meter. Internal wiring is designed to allow accurate measurement of extremely low leakage currents.

RECTIFIER DIODES

- Forward voltage drop at given currents
- Reverse leakage current at given voltages

ZENER DIODES

- Reverse current before breakdown
- Zener voltage at given currents
- AC impedance at given current

POWER REQUIREMENTS: 115 volts, 50-60 cycles, 75 watts.

CABINET: 17 x 15½ x 7. Gray, semi-gloss finish.

Base is gray wrinkle enamel. Leather carrying grip.

Write For Product Bulletin Type 310



MEL SALES LTD.
71 CROCKFORD BLVD., SCARBOROUGH, ONTARIO

For complete details check No. 46 on handy card, page 83

product panorama

For further information on Products use Readers' Service Cards on pages 83 and 84.

Continued from page 77

Bandpass gas duplexer

Item 395

The first millimeter bandpass gas duplexer designed for 4.3 mm operation is the BLP-017D. It operates from 68.75 to 70.75 Gc/s with a typical duplexer loss of less than 1 db. This short-slot hybrid duplexer designed for rugged service is operable at temperatures ranging from -40 to +85°C in excess of 500 hours. It weighs less than

4 oz. and occupies a volume of only 1.4 cu. in. It switches 15 KW peak power at 0.0006 duty cycle.

Varian Associates, 611 Hansen Way, Palo Alto, Calif.



RF pulsed generator

Item 396

Manson Laboratories has introduced a 2 MW pulsed RF generator, using a 5657 magnetron. Manson Model 475 is made in four sections; controls, power supply, pulse modulator which includes trigger generator, and RF source. It provides pulse width variations between .3 and 5 usecs. Occurrence of a fault in the unit shuts down the high voltage supply and is indicated by a panel light. A reset button is provided.

Atlas Instrument Corp. Ltd., 50 Wingold Ave., Toronto 19, Ont.

Compact waveguide termination

Item 397

High power compact waveguide termination, Model X913A, dissipates 500 watts average power without forced air or liquid cooling, and is only 9½" long and 4" in diameter. If desired the termination can be force cooled for greater dissipation. It is not damaged by severe overload, and can handle 100 KW peak power using only con-

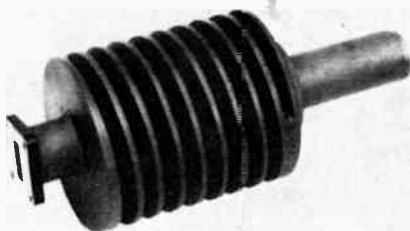

vection cooling. Excellent power handling capability is accomplished by bonding a layer of material to the walls of its interior.

Hewlett Packard Co., 1501 Page Mill Road, Palo Alto, Calif.

K-band square law detectors

Item 398

The Bolomister TM is available in IN26 and IN53 packages for use in the K_u and K_a band regions. These types come in 40 db dynamic square law range versions with sensitivities in excess of -40 DBM. The C-120 and E-120 detectors go from .01 mW up to 100 mW. These offer a great latitude in measurement of VSWR, attenuation and insertion loss. When properly calibrated they may be used for absolute power measurement in K-band regions.

mSi Electronics Inc., 116-06 Myrtle Ave., Richmond Hill 18, New York.

Waveguide directional coupler

Item 399

Technicraft Division of Electronic Specialty Co. developed a new double-ridge DR-19 waveguide directional coupler, with a Type C-UG571/U secondary line output connector. It has a frequency range of 8.50-10.75 Gc/s.; VSWR-primary arm; 1.10

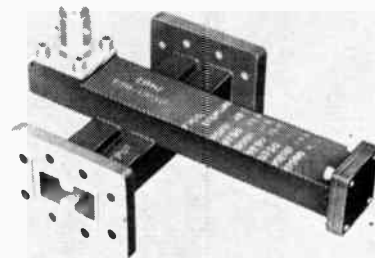

max.; coupling: 40±2 db; directivity: 15 db. min.; and power capability: 250 watts ave., 250 KW peak. The coupler is made of aluminum, is pressure tight, is not affected by temperature or humidity.

Electronic Specialty Co., Technicraft Division, 116 Waterbury Road, Thomaston, Conn.

Continued on page 91

PAYETTE stocks

SONAR G.R.S.

(CITIZENS BAND RADIO-PHONE)



5 WATT GENERAL PURPOSE RADIO

- 8 Crystal controlled channels for receiver and transmitter.
- Switch allows Receiver to tune 23 channels.
- Front panel R.F. indicator aids tuning.
- High level class "B" push-pull modulation.
- Heavy duty two-way power supply.
- Adjustable squelch.
- Rugged aluminum construction.
- Universal mounting bracket.
- Ideal for industry, sports, hospitals, government and marine.

PAYETTE RADIO LTD.
730 St. James St. W. Montreal 3

For complete details check No. 49 on handy card, page 83

APEO pushes post-grad courses

A technical education program launched by the APEO in co-operation with Ontario universities is aimed at keeping P.Eng.s up to date with rapidly changing technology. Post-graduate technical training is encouraged at the University of Toronto Extension Division with an advanced course in engineering maths. APEO hopes other Ontario universities will follow this lead.

Canadian communications network construction underway

Construction of \$36 million general communications microwave network between Montreal and Vancouver was announced jointly by Donald Gordon, president, Canadian National and N.R. Crump, president, Canadian Pacific.

The technical planning of the 3000-mile network has already been completed and actual construction will begin this summer. It is scheduled to be ready for service by the end of 1963. The line will be owned and operated jointly, with Canadian Pacific Telecommunications responsible for

administration and operating between Montreal and Melville, Sask., and Canadian National Telecommunications taking similar responsibility between Melville and Vancouver.

The new system is being built to provide high-quality, high-capacity circuits for use by Canadian business and to meet national defense requirements. For strategic defense reasons, the route of the new line will be generally well away from existing communications facilities spanning the country. Spur lines or "drop outs" from the main system will feed major centres across Canada.

Primary use of the network will be for commercial and business communications — telex, teletype circuits, data processing, facsimile transmission, tele-metering, cable and message traffic and allied fields.

RCA Victor Company of Canada Limited, Montreal, has been awarded a \$12 million contract for manufacture and installation of electronic equipment. Specifications call for microwave gear of an advanced design to give high-speed, high-quality transmission necessary for newer commercial telecommunications equipment and business data processing systems planned by manufacturers for the future.

Some 136 microwave relay towers
Continued on page 94

500kc to 100mc
new

rf **JERROLD**[®]
Logarithmic Amplifier
Model LA-5100



**ACCURATE TO WITHIN
±1 DB OVER 80-DB
DYNAMIC RANGE**



This extremely accurate log amplifier enables exact measurements of attenuation in networks, filters, amplifiers, and other devices exhibiting dynamic operating ranges down to 90 db. Write for complete technical data.

- Frequency range 500kc-100mc, with flatness better than ± 1/2 db.
- Four calibrated ranges: Logarithmic 0-40, 0-60, 0-80 db (readable to 90 db) and one linear range 0-20 db (variable gain).
- Continuously variable log-expand control permits uncompressed presentation of first 5 db of each range.
- Direct-reading meter for point-by-point measurements.
- Oscilloscope output jack for sweep display measurements.
- Designed for rack mounting: 7" x 14 1/2" x 19". \$795.00

JERROLD ELECTRONICS (CANADA) LTD.
50 Wingold Avenue, Toronto 19
Jerrold Electronics Corporation, Industrial Products Division, Dept. ITE-128, The Jerrold Bldg., Phila. 32, Pa.
Prices F.O.B. Philadelphia

*Prices and specifications subject to change without notice.

For complete details check No. 38

**THE FASTEST GROWING NAME IN
MOBILE COMMUNICATIONS**



**ERD
DUMONT**

DUMONT, a symbol of top dependability for more than 25 years . . . servicing and supplying government, industrial and private concerns with electronic communication equipment, now announces its

newest development . . . the new TRANSICOM "director" 2-way Citizens' Band Radio. Compact, diversified and lightweight, five-frequency, AC or DC transicom model, offers streamlined "tough duty" operation, designed for fast, efficient use to satisfy all personal or business radio requirements. ERD DUMONT also supplies a complete range of sophisticated 2-way radios in the 25-54 mc and the 144-174 mc band models.

MOBILE COMMUNICATIONS DIVISION

MANDREL INDUSTRIES

303 FORGE ROAD
CALGARY, ALBERTA



For complete details check No. 44 on handy card, page 83
ELECTRONICS AND COMMUNICATIONS, June, 1962



MINIATURE UNISELECTORS

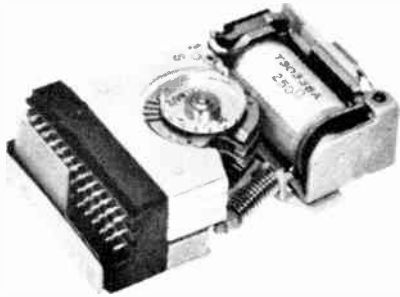

- 3 Level, 12 Outlet available now.
- 3 Level, 10 Outlet and 6 Level, 10 or 12 Outlet available soon.

Circle Reader Card No. 59

RELAYS

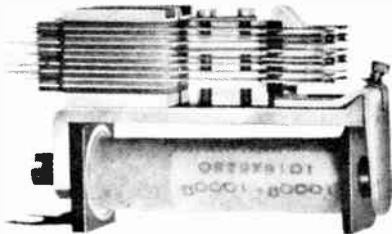

- Telephone Type
- High Speed
- Slow Acting
- Fast Service for Prototypes

Circle Reader Card No. 72

SIEMENS EDISON SWAN (CANADA) LTD.

419 NOTRE DAME AVE.
WINNIPEG 2, MAN.

Other Offices in
Halifax — Toronto — Edmonton

AEI Offices in
Montreal & Vancouver

AN AEI COMPANY

For complete details check No. 59

International Scene

Lake Engineering distributes French firm's products

Marketing of Lignes Telegraphiques et Telephoniques (LTT) France, millimeter wave magnetrons will be handled in Canada by Litton Industries' technical representative, Lake Engineering Company Limited, Scarborough, Ontario.

The new agreement complements Litton's activities in the microwave and millimeter wave field. Litton has the marketing and manufacturing rights to Elliott-Litton, Ltd., England, products, including millimeter wave floating drift tube and reflex klystrons.



Factory tests are carried out on transmission equipment for the round-the-world Commonwealth telephone cable. The engineers are working at the Woolwich, England, works of Associated Electrical Industries Ltd., and the equipment is destined to be installed at Sydney, Australia.

Argus computer contract confirmed at \$75 million

The recently announced confirmation of the \$75 million contract from the Swiss government for the Bristol/Ferranti Bloodhound guided weapon system has attracted widespread attention to the largest order of its kind ever placed in Britain by a foreign government.

Part of the Bloodhound system is the Ferranti Argus computer, already well known outside the military sphere for its applications in the direct control of industrial processes.

Argus is a digital computer designed especially for control applications. Built for maximum reliability in operation, its electronic circuits are fully transistorized. Calculations are per-

MIDGET TAP SWITCH has giant range

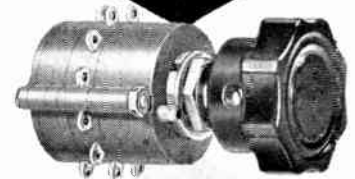

\$3.00 List

TYPE 3A

MOLDED FROM DIALLYL PHTHALATE

Only 1" in diameter . . . weighs 30 grams . . . as many as 8 decks and up to 12 positions per deck. These are among the features of Tech Labs' new all-molded miniature Type 3A tap switch.

Designed for a wide range of military and commercial applications, this single-hole mounted switch has adjustable stops if fewer than 12 positions, single pole, or 6 positions, double pole, are required.

"Shorting" and "non-shorting" types are available and the switch can be furnished solenoid-operated and hermetically sealed.

SPECIFICATIONS

Size: 1" diameter, 1 1/4" with terminals. First deck, 1-1/16" long. Each additional deck, 1/2" long.

Weight: First deck, 30 grams. 10 grams for each additional deck.

Rating: 1200 volts rms, 2000 VDC, 5 amps (carrying) 115V.

Insulating resistance: 100 megohms minimum at 500 volts DC.

Life: 1.5 — 2 million revolutions.

Contact resistance:
(standard) 6-10 milliohms.
(silver) 3-5 milliohms.

Temperature range: -65°C to 100°C.

Mounting: Single-hole.

Meets MIL-S-3786A

Tech Lab switches are on Qualified Products List.



Write for details and prices.

PALISADES PARK, NEW JERSEY

For complete details check No. 65

formed at a speed equivalent to 50,000 additions per second, or 10,000 multiplications per second.

Western Germany orders British TV equipment

Riva Film and Television Studios, Munich, Germany's largest independent TV studios have placed an order with EMI Electronics Ltd. for four complete 4½" image orthicon camera channels and ancillary equipment.

This is believed to be the first time that a West German studio has bought camera channels of this latest type, and it represents the first sales of British TV studio cameras to Western Germany for six years.

U.K. exports increased in 1961

United Kingdom electrical goods exported in 1961 were a record \$891,800,000, an 8.5 per cent increase over the previous year's figures. This was announced by the British Electrical and Allied Manufacturers' Association in their annual report issued recently.

Shipments to Canada and the United States last year dropped slightly to \$83,440,000. But to South Africa and the rest of the Commonwealth they remained steady at \$395,920,000.

Kollsman control systems chosen for DH-125 jet

Kollsman Instrument Corporation's London, England, subsidiary, Kollsman Instrument Limited, was awarded a contract by the de Havilland Aircraft Corporation for KS-54 Cabin Pressure Control Systems for use on de Havilland's DH-125 light executive jet aircraft.

Initial production of the systems, which are made up of cabin rate controllers, amplifiers, discharge valves and cabin pressure controllers, is taking place at Kollsman's New York facility. Further production is planned in England in 1963.

Philips adds Sivers Lab microwave equipment to line

Under the terms of an agreement with Sivers Lab, Stockholm, Sweden, Philips Electronic Equipment Ltd., Toronto, has taken over sales and service in Canada of Sivers Lab microwave equipment. The integrated Philips-Sivers line now includes direct reading frequency meters, manual and motor drive waveguide switches, standing wave indicators, sliding screw tuners, and many accessories. All frequency bands between 1120 and 170,000 Mc/s are accommodated in the new expanded line.



RAISED LETTER LABELS

MADE ON THE SPOT

If it can be mistaken, mislaid, misfiled, misused, misanything—label it with Dymo. See for yourself how easily you can make handsome, raised-letter labels for 1001 applications.

Embossed labels take seconds to make, cost pennies, stick permanently to almost any surface. Vinyl tape in 10 colors, five

striped tapes, six metal tapes. Five Dymo Tapewriter models, from \$29.95. Send the coupon for a free booklet "1001 Applications" for manufacturing, administrative, inventory, personalizing, professional, electrical, municipal, schools, electronics, and many more—along with a name badge personalized with your name.

Embossed letters provide maximum permanent legibility, quality appearance.



DYMO
OF CANADA, LTD.

192 Bay Street, Toronto, Ontario

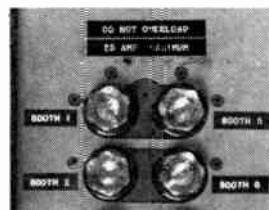

ELECTRICAL



INVENTORY



PERSONALIZING

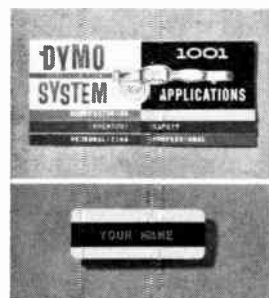

WRITE FOR FREE BOOKLET "1001 APPLICATIONS" AND YOUR SAMPLE NAME BADGE

Dymo of Canada, Ltd. Department EC-6
192 Bay Street, Toronto, Ontario

Please send me free booklet "1001 Applications" and my name badge as follows.

Name _____
 Title _____ Firm _____
 Product or Service _____ Tel. _____
 Address _____
 City _____ Zone _____ Prov. _____

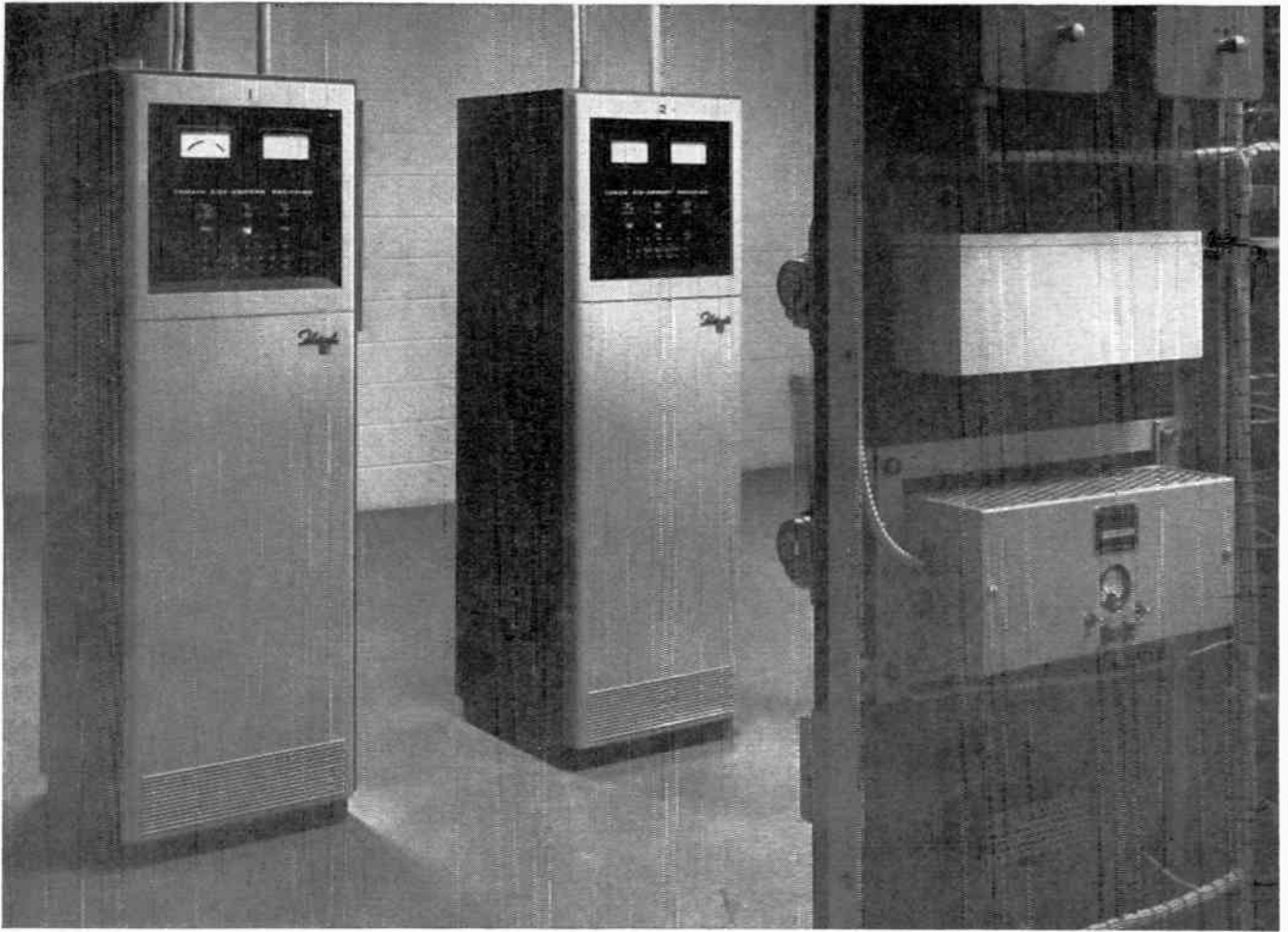

The Model F200D50 Flotrol rectifier-chargers were the logical choice for this new installation.

Small—Quiet—The Ultimate in Accessibility and Regulation

Why Automatic Electric selected Lorain power for the City of Edmonton Hemlock Exchange

The Lorain line of silicon Flotrol rectifier-chargers offers a 50% reduction in space requirements.

Accessibility is an important feature of the new Flotrol Chargers. All terminations are safe and available for ready installation. All adjustments, controls, alarms and meters are located on a convenient, single panel on the front of the compact unit.

The d-c output voltage of Lorain Silicon Flotrol rectifier units is precisely regulated by carefully designed, transistorized reference circuits.

Component circuits are hinged or card mounted for plug-in connection and may be individually serviced or removed with a minimum of handling.

Lorain Products (Canada) Limited, St. Thomas, Ontario.

POWER EQUIPMENT FOR COMMUNICATIONS AND INDUSTRY



LORAIN *Products (Canada) Limited*

ST. THOMAS, ONTARIO

DISTRIBUTED BY AUTOMATIC ELECTRIC SALES (CANADA) LTD., TORONTO, ONT.

For complete details check No. 43 on handy card, page 83

6202

FLOTROL
PARTNER IN DEPENDABILITY
SUB-CYCLE

APPLICATION FOR FREE SUBSCRIPTION

TECHNICAL LITERATURE BRIEFS

Digital servo applications are shown in a 12-page brochure which explains digital techniques applied to a 400 cycle carrier analog servo system. Topics include operation, stability, analysis, and error considerations. **Digital Servo Corp., 13425 Wyandotte Ave., North Hollywood, Calif.**

Item 404

Stock catalog 100C includes mercury-wetted contact relays — 10 pages of description, specifications and prices of all types of relays. **Technical Information Section, Potter & Brumfield, 135 Oxford Street, Guelph, Ont.**

Item 405

Dial and read 1 to 999,999 ohms is a new brochure on Power Resistor Decades from Clarostat Mfg. Co. Inc. Virtually an instruction manual as well as a descriptive item, it provides theory, circuit diagrams, general application and operation information, etc. **Tri-Tel Associates Ltd., 81 Sheppard Ave. West, Willowdale, Ont.**

Item 406

Service components catalog from Clarostat lists in detail various carbon element and wire wound controls for radio, TV and sound systems, as well as upgraded C-Line controls for more critical applications, and fixed wire-wound resistors. **Tri-Tel Associates Ltd., 81 Sheppard Ave. West, Willowdale, Ont.**

Item 407

Miniature transistorized Servoamplifiers are covered in data sheet 62457. They may be used to drive 33-40 volt, 400 cycle servomotors, size II or smaller. Photos and dimensional drawings are included with summaries of electrical and mechanical specs. **Helipot Technical Information Service, 901 Oxford Street, Toronto 18, Ont.**

Item 408

Silicone rubber — two new brochures describe how to use and how to make flexible molds with silicone rubber. Silastic RTV may be used to reproduce parts from a single master. **Dow Corning Silicones Ltd., 1 Tippet Road, Downsview, Ont.**

Item 409

Empire Devices microwave bulletin is an 8-page, two-color bulletin, Catalog 614, Supplement A, illustrating several new additions to the microwave line. Five categories of equipment are discussed: microwave signal generators, microwave impulse generators, broad-band crystal mixers, microwave pre-selectors and a tuning unit. **Instronics Ltd., P.O. Box 100, 11 Spruce St., Stittsville, Ont.**

Item 410

Designers handbook details characteristics and circuit applications of 12 Raytheon PNP fusion alloy sileion transistors. Fifty graphs and curves describe breakdown voltages, large signal characteristics, transconductance values, collector and emitter voltages, noise figures, collector capacitance and switching times. For free copy write to James Turpie on business letterhead: **Raytheon Canada, Ltd., 61 Laurel St., Waterloo, Ont.**

Item 411

Design engineering literature catalog is being offered by Spaulding Fibre Co. It includes descriptions of Spaulding brochures on the characteristics and applications of vulcanized fibre, laminates, glass filament wound epoxy tubing, gasket material, etc. All literature listed in this catalog is free on request. **Spaulding Fibre of Canada, Ltd., 70 Coronet Road, Toronto 18, Ontario.**

Item 412

Please ADD my name to receive **ELECTRONICS & COMMUNICATIONS**
 Please CHANGE my address for mailings.
Note — Card must be completed in full to be valid.

My Name (Please Print)

Mail copies to my home, or business address as noted below.

Street

City Zone Province

If you have recently CHANGED your address please note former address here:

Company Nature of Business
 (State, when applicable, whether electronic equipment or components are manufactured, sold, or used in manufacturing, etc.)

ARE YOU AN ENGINEER? Yes No

Signature Position

6-62

BUSINESS REPLY CARD
 No Postage Stamp Necessary if Mailed in Canada

5c POSTAGE WILL BE PAID BY



ELECTRONICS AND COMMUNICATIONS

450 Alliance Avenue

Toronto 9, Ontario

PLEASE SEND FURTHER INFORMATION ON FOLLOWING ITEMS AS NUMBERED BELOW. (All Literature & Product items Numbered)

- | | | | | | | | | | | | |
|------------------------------|------------------------------|------------------------------|------------------------------|------------------------------|------------------------------|------------------------------|------------------------------|------------------------------|------------------------------|------------------------------|------------------------------|
| <input type="checkbox"/> 380 | <input type="checkbox"/> 381 | <input type="checkbox"/> 382 | <input type="checkbox"/> 383 | <input type="checkbox"/> 384 | <input type="checkbox"/> 385 | <input type="checkbox"/> 386 | <input type="checkbox"/> 387 | <input type="checkbox"/> 388 | <input type="checkbox"/> 389 | <input type="checkbox"/> 390 | <input type="checkbox"/> 391 |
| <input type="checkbox"/> 392 | <input type="checkbox"/> 393 | <input type="checkbox"/> 394 | <input type="checkbox"/> 395 | <input type="checkbox"/> 396 | <input type="checkbox"/> 397 | <input type="checkbox"/> 398 | <input type="checkbox"/> 399 | <input type="checkbox"/> 400 | <input type="checkbox"/> 401 | <input type="checkbox"/> 402 | <input type="checkbox"/> 403 |
| <input type="checkbox"/> 404 | <input type="checkbox"/> 405 | <input type="checkbox"/> 406 | <input type="checkbox"/> 407 | <input type="checkbox"/> 408 | <input type="checkbox"/> 409 | <input type="checkbox"/> 410 | <input type="checkbox"/> 411 | <input type="checkbox"/> 412 | | | |

PLEASE SEND FURTHER INFORMATION ON THE FOLLOWING ADVERTISEMENTS AS NUMBERED BELOW. (Key numbers in column overleaf)

- | | | | | | | | | | | | |
|-----------------------------|-----------------------------|-----------------------------|-----------------------------|-----------------------------|-----------------------------|-----------------------------|-----------------------------|-----------------------------|-----------------------------|-----------------------------|-----------------------------|
| <input type="checkbox"/> 1 | <input type="checkbox"/> 2 | <input type="checkbox"/> 3 | <input type="checkbox"/> 4 | <input type="checkbox"/> 5 | <input type="checkbox"/> 6 | <input type="checkbox"/> 7 | <input type="checkbox"/> 8 | <input type="checkbox"/> 9 | <input type="checkbox"/> 10 | <input type="checkbox"/> 11 | <input type="checkbox"/> 12 |
| <input type="checkbox"/> 13 | <input type="checkbox"/> 14 | <input type="checkbox"/> 15 | <input type="checkbox"/> 16 | <input type="checkbox"/> 17 | <input type="checkbox"/> 18 | <input type="checkbox"/> 19 | <input type="checkbox"/> 20 | <input type="checkbox"/> 21 | <input type="checkbox"/> 22 | <input type="checkbox"/> 23 | <input type="checkbox"/> 24 |
| <input type="checkbox"/> 25 | <input type="checkbox"/> 26 | <input type="checkbox"/> 27 | <input type="checkbox"/> 28 | <input type="checkbox"/> 29 | <input type="checkbox"/> 30 | <input type="checkbox"/> 31 | <input type="checkbox"/> 32 | <input type="checkbox"/> 33 | <input type="checkbox"/> 34 | <input type="checkbox"/> 35 | <input type="checkbox"/> 36 |
| <input type="checkbox"/> 37 | <input type="checkbox"/> 38 | <input type="checkbox"/> 39 | <input type="checkbox"/> 40 | <input type="checkbox"/> 41 | <input type="checkbox"/> 42 | <input type="checkbox"/> 43 | <input type="checkbox"/> 44 | <input type="checkbox"/> 45 | <input type="checkbox"/> 46 | <input type="checkbox"/> 47 | <input type="checkbox"/> 48 |
| <input type="checkbox"/> 49 | <input type="checkbox"/> 50 | <input type="checkbox"/> 51 | <input type="checkbox"/> 52 | <input type="checkbox"/> 53 | <input type="checkbox"/> 54 | <input type="checkbox"/> 55 | <input type="checkbox"/> 56 | <input type="checkbox"/> 57 | <input type="checkbox"/> 58 | <input type="checkbox"/> 59 | <input type="checkbox"/> 60 |
| <input type="checkbox"/> 61 | <input type="checkbox"/> 62 | <input type="checkbox"/> 63 | <input type="checkbox"/> 64 | <input type="checkbox"/> 65 | <input type="checkbox"/> 66 | <input type="checkbox"/> 67 | <input type="checkbox"/> 68 | <input type="checkbox"/> 69 | <input type="checkbox"/> 70 | <input type="checkbox"/> 71 | <input type="checkbox"/> 72 |
| <input type="checkbox"/> 73 | | | | | | | | | | | |

Name Position

Company

Street City Prov.

6-62

BUSINESS REPLY CARD
No Postage Stamp Necessary if Mailed in Canada

5c POSTAGE WILL BE PAID BY

ELECTRONICS AND COMMUNICATIONS

450 Alliance Avenue

Toronto 9, Ontario

PLEASE SEND FURTHER INFORMATION ON FOLLOWING ITEMS AS NUMBERED BELOW. (All Literature & Product items Numbered)

- 380 381 382 383 384 385 386 387 388 389 390 391
- 392 393 394 395 396 397 398 399 400 401 402 403
- 404 405 406 407 408 409 410 411 412

PLEASE SEND FURTHER INFORMATION ON THE FOLLOWING ADVERTISEMENTS AS NUMBERED BELOW.

- 1 2 3 4 5 6 7 8 9 10 11 12
- 13 14 15 16 17 18 19 20 21 22 23 24
- 25 26 27 28 29 30 31 32 33 34 35 36
- 37 38 39 40 41 42 43 44 45 46 47 48
- 49 50 51 52 53 54 55 56 57 58 59 60
- 61 62 63 64 65 66 67 68 69 70 71 72
- 73

Name Position
(Please Print)

Company

Street City Prov.
5-62

BUSINESS REPLY CARD
No Postage Stamp Necessary if Mailed in Canada

5c POSTAGE WILL BE PAID BY

ELECTRONICS AND COMMUNICATIONS

450 Alliance Avenue

Toronto 9, Ontario

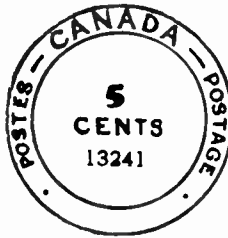

INDEX TO ADVERTISERS

Page number is on the right. Key number for use with READER SERVICE CARD is on the left.

Key No.	Page No.
1. Adcola Products Ltd.	92
2. Alpha Aracon Radio Co. Ltd.	90
3. Alpha Aracon Radio Co. Ltd.	90
73. Alpha Aracon Radio Co. Ltd.	90
4. Amphenol Canada Ltd.	95
5. Andrew Antenna Corp. Ltd.	25
6. Atlas Instrument Corp. Ltd.	IBC
7. Automatic Electric Sales (Canada) Ltd.	10-11
8. Automatic Electric Sales (Canada) Ltd.	18
9. Bach-Simpson Ltd.	27
10. Barnard Stamp & Stencil Ltd.	92
11. Benco T.V. Associates Ltd.	91
12. Canadian Marconi Co. (Electronic Tubes)	3
13. Canadian Marconi Co. (Marine and Land Comms.)	22-23
14. Canadian Pratt & Whitney Aircraft Co.	38
15. Canadian Westinghouse Co. (Electronics)	24
16. Cannon Electric Canada Ltd.	37
17. Centralab Canada Ltd.	8
18. Clark Ltd., Alex. L.	96
19. Collins Radio Co.	12
20. Crawford Associates Ltd., Allan	74
21. Croven Ltd.	91
22. Daystrom Ltd. (Heath Div.)	97
23. Delhi Metal Products Ltd.	97
24. Dymo of Canada Ltd.	81
20. Edgerton, Germeshaue & Grier Inc.	74
25. Edo (Canada) Ltd.	4
26. English Electric Valve Co. (Canada) Ltd.	34
27. Erie Resistor of Canada Ltd.	87
28. Ferranti-Packard Electric Ltd.	88
29. General Instrument Ltd.	75
30. Gerhill Inc.	92
31. Hammond Mfg. Co. Ltd.	20
32. Hewlett-Packard Co.	13
33. Hewlett-Packard Co.	OBC
34. Honeywell Controls Ltd.	21
35. Hunt Co., Philip A.	36
36. I.R.C. Resistors Div., Renfrew Electric Co. Ltd.	88
37. ITT (Canada) Ltd.	14-15
38. Jerrold Electronics (Canada) Ltd.	79
39. Jerrold Electronics (Canada) Ltd.	94
40. Kelk Ltd., George	92
41. Lenkurt Electric Co., Subsidiary of Gen'l Telephone & Electronics	9
42. Litton Systems (Canada) Ltd.	IFC
43. Lorain Products (Canada) Ltd.	82
44. Mandrel Industries Co. Ltd.	79
45. Marsland Engineering Ltd.	28
46. Mel Sales Ltd.	77
47. National Vulcanized Fibre Co.	6
48. Northern Electric Co. Ltd.	16-17
49. Payette Radio Ltd.	78
50. Philco Corp. of Canada Ltd.	7
51. Phillips Electrical Co. Ltd.	19
52. Potter & Brumfield Div. of AMF Canada Ltd.	35
53. Premier Metal Housings Ltd.	96
55. Pylon Electronic Development Co. Ltd.	86
56. R.C.A. Victor Co. Ltd.	85
57. Ryco Electronics Co.	93
58. Sarkes Tarzian Co. Inc.	99
59. Siemens Edison Swan (Canada) Ltd.	80
72. Siemens Edison Swan (Canada) Ltd.	80
60. Sigma Technical Associates	90
71. Snelgrove & Co. Ltd., C. R.	86
61. Stark Electronic Industries Ltd.	97
62. Struthers-Dunn Relays Div., Renfrew Electric Co. Ltd.	88
63. Sylvania Electric (Canada) Ltd.	29
64. Syntron (Canada) Ltd.	26
65. Tech Laboratories Ltd.	80
66. Tektronix Inc.	31
67. Telephone Mfg. Co. Ltd.	36
68. Transwave Electronics Co.	94
69. Welwyn Canada Ltd.	89
70. Wind Turbine Canada Ltd.	95



NEW COMMUNICATIONS TEST EQUIPMENT

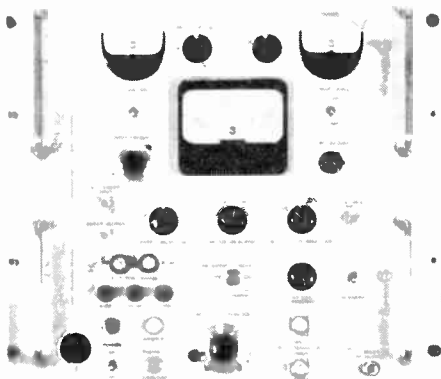

Developed by RCA for precise measurement of performance on high capacity multi-channel telephone microwave relay systems designed to comply with CCIR/CCITT recommendations. Simple to operate. Ideal for field installation and maintenance use.

← **RF SWEEP GENERATOR TYPE CG-75.** Center frequency in range 1.6-2.6 kmc; sweep range 0-1 kmc; rate 60 cps (int.) or 0.1-2 kc (ext.); amplitude flatness ± 0.1 db/50 mc or ± 1 db/1 kmc; output 0-200 mw; modulation 1 kc square wave (int.); 0-25 kc (ext.). Size 19" x 17.5" x 18".

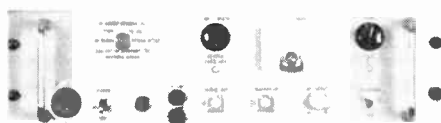

← **IF SWEEP GENERATOR TYPE CG-95.** Center frequency 70 mc; sweep range 0-28 mc; rate 75 cps; amplitude flatness ± 0.05 db 28 mc; output 0-1.0 volts rms. Size 19" x 5.25" x 10".

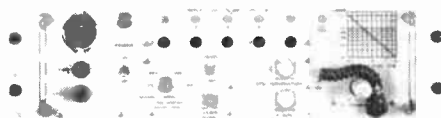

← **IF REFLECTOMETER TYPE CZ-88.** Frequency range 55-85 mc; direct reading VSWR range 1.20-1.02 (reflection coefficient 20-40 db); accuracy better than ± 1 db. Size 19" x 5.25" x 13.75".

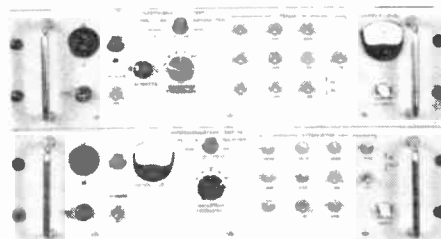

← **INTERMODULATION TEST SET. TRANSMITTER TYPE CI-86 RECEIVER TYPE CI-87.** White noise loading in accordance CCIR/CCITT recommendations. Voice channel capacities 24 to 960 by plug-in filters. Transmitter output -10 dbm; receiver input +20 dbm max; impedances 75 ohms unbalanced. Back-to-back NPR 75 db. Self-contained noise generator and level meters. Size, each unit 19" x 5.25" x 15".

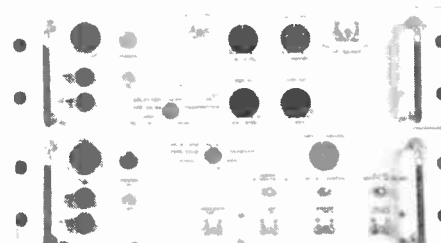

← **DELAY AND LINEARITY TEST SET. TRANSMITTER TYPE CS-80 RECEIVER TYPE CS-81.** Simultaneous direct reading group delay and mod/demod transfer linearity. Self-contained references 10 millimicroseconds group delay; 2% linearity. Derived carrier in receiver (no auxiliary path needed from transmitter). Resolution 0.5 millimicrosecond delay distortion and 0.25% linearity over wide bandwidth. Size, each unit 19" x 5.25" x 12.5".

ACCESSORIES: Complete range available for use with above equipment. Typical items are 2 kmc waveguide directional couplers, terminations and waveguide-to-coaxial transitions; 70 mc IF detectors, fixed and variable attenuators; baseband attenuators, etc. as well as standard cable assemblies for a variety of test applications.

For further information write:
RCA Victor Company, Ltd.,
Communications Systems Sales,
1001 Lenoir St., Montreal, P.Q.



Manufactured in Canada by
TECHNICAL PRODUCTS DIVISION
RCA VICTOR COMPANY, LTD.
The Most Trusted Name in Electronics

For complete details check No. 56 on handy card, page 83

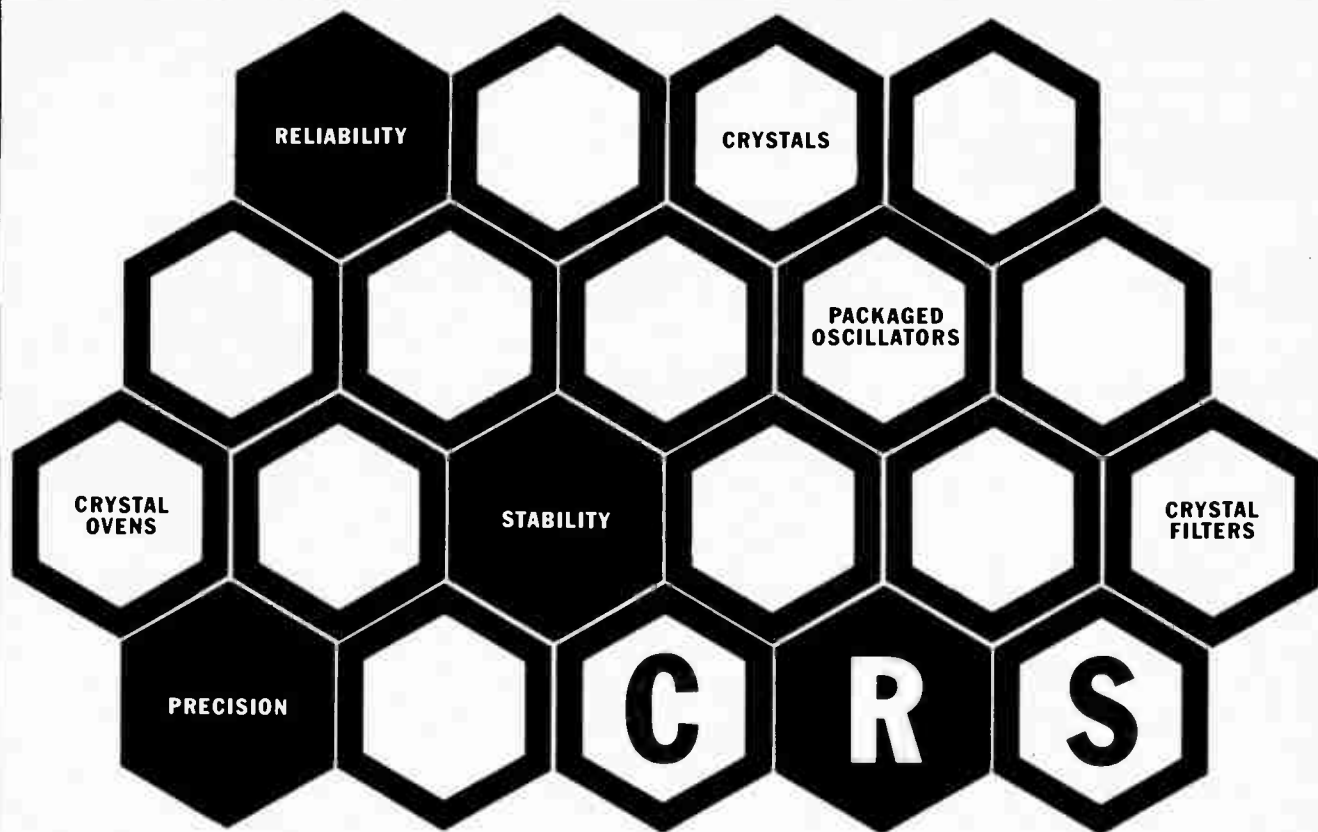

C. R. Snelgrove Co. Limited

141 BOND AVENUE DON MILLS
ONTARIO, CANADA 447-8531

For complete details check No. 71 on handy card, page 83

PYLONS SLASH POWER PLANT COSTS!



- RELIABLE STATIC DESIGN
- MINIMUM SPACE
- LARGE PRACTICAL CAPACITIES
- COMPLETE ENGINEERING DATA
- THOUSANDS NOW IN USE

PYLON MODEL	INPUT	OUTPUT
IN STOCK:		
CU-24	24V D.C.	48V D.C. @ 7.5A
CX-48P*	24/48V D.C.	{ 24V D.C. @ 10A 130V D.C. @ 2.5A
CX-130/152A	130/152V D.C.	130/152V D.C. @ 6.0A
I-48A	{ 115V A.C. } { 24/48V D.C. }	115V A.C. @ 350VA
RG-1	24/48V D.C.	20C/S A.C. @ 20W
RTS-1	115V A.C.	20C/S A.C. @ 6W 24/48V D.C. @ 2A
IN PRODUCTION:		
CX-130/152F	130/152V D.C.	48V D.C. @ 15A
CX-130/152L	130/152V D.C.	24V D.C. @ 20A
I-48E	24/48V D.C.	115V A.C. @ 420VA

*With built-in circuitry for parallel operation. Exact replacement for former CX-48-A-1 and CX-48-B-1.

Write for further details to:



PYLON ELECTRONIC DEVELOPMENT company, Ltd.

Communications Systems and Equipment

161 CLEMENT ST., LASALLE, MONTREAL 32, QUE.

Engineer's bookcase

"Masers and Lasers: A New Market with Enormous Growth Potential" by E. B. Rechsteiner and R. L. Saxe, published by Technology Markets, Inc., 509 Fifth Avenue, New York City. Price \$200.00 (U.S.)

Prepared by Emil B. Rechsteiner and Robert L. Saxe, Chairman of the Board and President, respectively, of Technology Markets, Inc., the report represents a year of combined effort on the part of both principals in the accumulation and presentation of facts on this promising area of electromagnetic radiation. (It is predicted that masers and lasers will be the fastest growing area of science in the next decade.)

According to Mr. Saxe, interviews with more than 80 scientists and businessmen revealed intensive research on applications for the highly intense, coherent radiation produced by masers and lasers.

The Rechsteiner-Saxe report describes 30 potential applications and shows that U.S. efforts in the field amount to the equivalent of 1,200 full-time specialists (three years ago technical activity amounted to the equivalent of 100 full-time scientists); and that 1962 revenues will be \$10-\$15 million with a growth future of more than \$260 million in 1970. It is also estimated that stepped-up government support of laser weapons systems could drive revenues to \$1¼ billion or more by 1970.

Although this comprehensive study is primarily concerned with commercial opportunities, it also presents detailed descriptions with diagrams of the technological aspects of masers and lasers.

"Forty Years of Radio Research" by George C. Southworth, published by Gordon and Breach Science Publishers, Inc., 150 Fifth Avenue, New York 11, N.Y. Price \$6.50 (U.S.).

A warm and informative autobiography provides the framework of this unique history of the development of modern radio. George C. Southworth, for over 40 years a pioneer at the frontiers of radio research, interweaves events, ideas and observations from his long and distinguished career with an authoritative first-hand account of radio's dramatic growth — from crystal detection and spark telegraphy to micro-waves and radio astronomy.

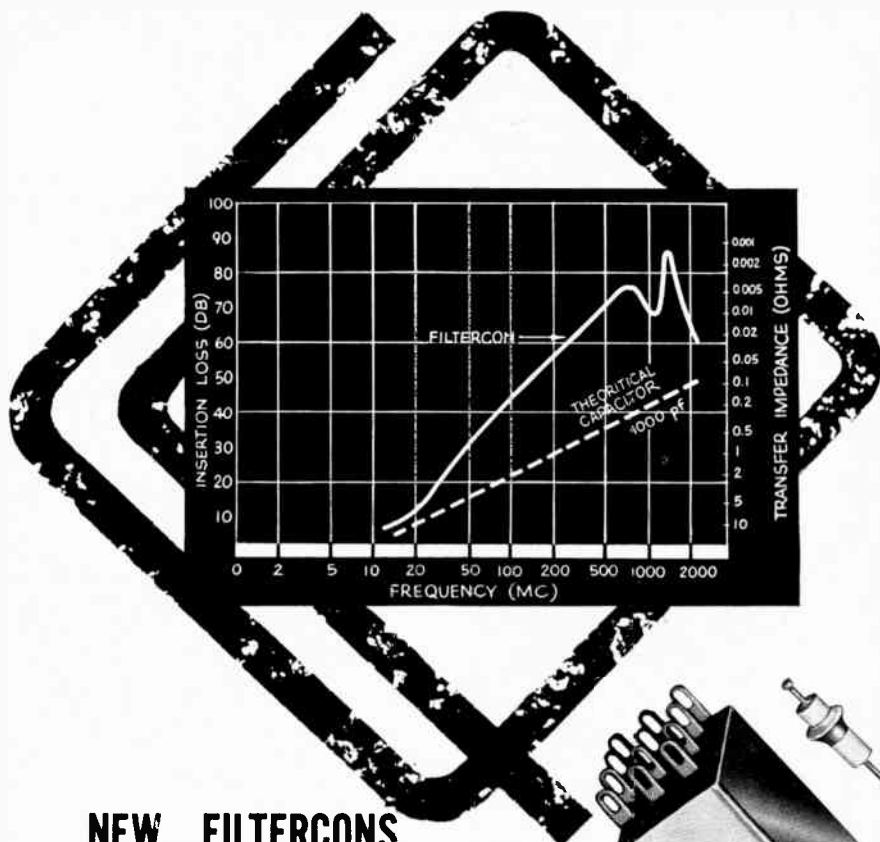

NEW...FILTERCONS by ERIE for highest attenuation in the 100 MC to 2000 MC range

Erie's new line of three-terminal, high-frequency, low-pass filters is ideal for the UHF range from 100 MC to 2000 MC.

The graph above shows the superiority in transfer impedance of Erie FILTERCONS compared with a theoretical 1000pf capacitor when measured in accordance with MIL-STD-220A. Note that at 500 MC, the transfer impedance of a FILTERCON is below 0.01 ohm as compared to the theoretical impedance of 0.35 ohm. Effective filtering continues well above 1000 MC.

FILTERCONS by Erie are designed around Erie-developed flat-temperature characteristic Hi-K ceramic dielectrics and temperature-stable ferrites which produce minimum change in filtering effect due to temperature.

FILTERCONS are available in the following models in temperature ranges up to 125°C:

ERIE STYLE	DESCRIPTION	MINIMUM ATTENUATION	WORKING VOLTAGE	LOW FREQUENCY CAPACITANCE
1201 1203	Small bushing mount Small eyelet mount	45 db from 200 MC to 2000 MC	200VDC	1000pf
1202 1204	Large bushing mount Large eyelet mount	50 db from 100 MC to 2000 MC	500VDC	2000pf
1206 1212	Six section Twelve section	50 db from 100 MC to 2000 MC	350VDC	5000pf

Write for Bulletin 512 for complete information.
Prototype and evaluation samples available.
Special designs in same R.F.I. suppression area also available.

ERIE RESISTOR of CANADA, LTD.

Division of Erie Resistor Corporation
Trenton, Ontario, Canada





ALARM RELAYS

"DUNCO" RSX 1440 SERIES

The RSX 1440 series of Alarm Relays represent another advance in our continued research into the design and manufacture of compact "Plug-in" type relays for to-day's requirements. These relays plug into the "DUNCO" 27390 socket.

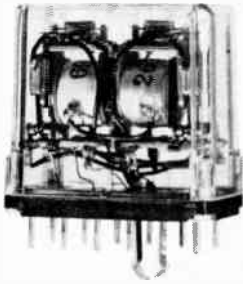

RSX 1440

This relay will operate a visual and audible alarm system through "locked in" remote trouble contacts and is designed to facilitate a silence switch to "cut off" the audible alarm leaving the visual alarm "on" until the relay is reset.

RSX 1440B

This relay will operate a visual and audible alarm system through the intermittent closing of remote trouble contacts and is also designed to facilitate a silence switch to "cut off" the audible alarm and leave the visual alarm on until the relay is reset.

RSX 1440C

To operate from the intermittent closing of a remote trouble contact and facilitate a flashing warning lamp and audible signal and a steady warning lamp after audible signal has been silenced.

Data Bulletins (complete with wiring diagrams) are available on all three types.

STRUTHERS-DUNN RELAYS

division of Renfrew Electric Co. Limited

TORONTO • OTTAWA • MONTREAL • CALGARY

For complete details check No. 62 on handy card, page 83



CASE HISTORY #1

PROBLEM: Matched temperature coefficient, high stability resistors required for multivibrator circuits in ground support equipment for well-known military electronics manufacturer.

Resistors to meet the following specs. -

1. Dissipate 1/8w. @ 125°C
2. Resistance of 649,200 Ω ± 0.1% on individual resistors, matched in pairs to within 0.05%
3. Temp. coeff. on individual resistors ± 25 PPM/°C from -55°C to + 165°C. Pairs to be matched within ± 3 PPM/°C
4. Dimensions - length: 0.43" max; diam. 0.14" max.

SOLUTION:

Molded Metal Film MEA-T9, 649,200 Ω, 0.1%

WHEREVER THE CIRCUIT SAYS 



RESISTORS

division of Renfrew Electric Co. Ltd.

TORONTO • OTTAWA • MONTREAL • CALGARY

For complete details check No. 36 on handy card, page 83



electronics



PUNCHED TAPE HANDLING EQUIPMENT

This high speed paper tape reader was developed, designed and manufactured to read information into an airborne computer at 200 characters per second - one more of the many digital components and systems originating at Ferranti-Packard.

LET FERRANTI-PACKARD PUT ELECTRONICS TO WORK FOR YOUR PROFIT

- Magnetic storage drums
- High speed paper tape readers
- Remote control and telemetering systems
- Reservations systems
- Document sortation systems
- Data display systems
- Data processing systems
- Engineering computation facilities

We continually seek competent engineers and scientists for development, design and production work. Contact our Personnel Manager.

FERRANTI-PACKARD ELECTRIC LIMITED



ELECTRONICS DIVISION
TORONTO 15,
ONTARIO

For complete details check No. 28

Letters to the Editor

Engineer's file book is growing

Dear Sir:

On checking through my Engineer's file page folder, I find that the number 6, February 1962 file page is missing. Would it be possible to obtain this page so that I may have the complete set. The Engineer's file page scheme was an excellent idea as the information is very useful.

J. F. Betemps, P.Eng.,
Hamilton, Ontario.

Dear Sir:

I have only been getting your *Electronics & Communications* magazine since January of this year. I therefore only have the Engineer's file pages numbers 5 and 6.

Would you please send me a reprint of each of the other previous ones, numbers 1, 2, 3, and 4?

I would appreciate this very much. I enjoy receiving this magazine, as it is extremely beneficial.

Thank you for your service.

Paul Zweifel,
Radio Dept.,
Prairie Bible Inst.,
Three Hills, Alberta.

An academy of science for Canada?

Dear Sir:

I would like to compliment you on your Canadian Space Electronics Issue of March 1962. It was indeed impressive to see such a diversity of scientific activity in astronautics, attributable to Canada and Canadians, as exemplified by the 10 fine articles in this issue. This collection of papers, representing activities within the government, industry and the universities, shows clearly that there exists, within Canada, a nucleus of top notch scientific resources in the space sciences.

I would agree wholeheartedly with your editorial that this nucleus should be nurtured and encouraged to expand. Aside from the obvious military overtones, which implicates the Defense Research Board, the large amount of money being spent on space by our American neighbors makes it an attractive export market for the Canadian electronics industry. Any governmental action that would foster this market would be most welcome. As you suggest, the current

Continued on page 90

METOX

TYPE
F-20

MINIATURE MOLDED OXIDE RESISTORS

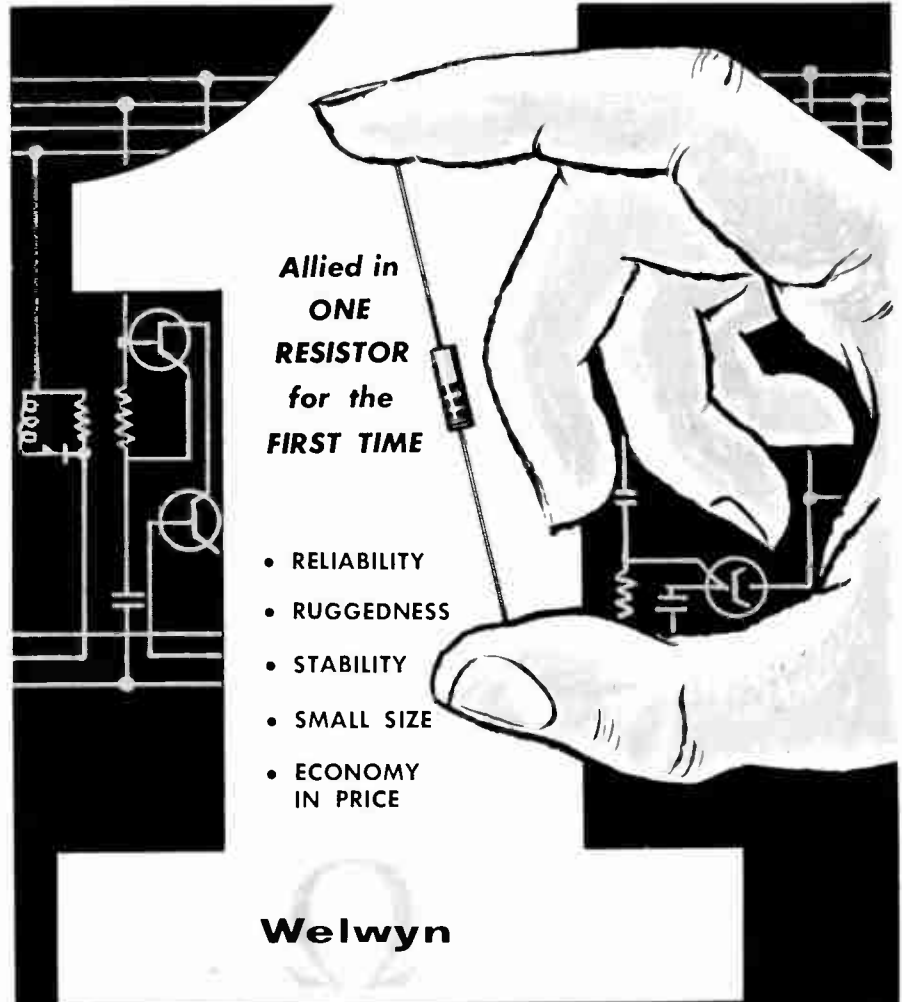

Allied in
**ONE
RESISTOR**
for the
FIRST TIME

- RELIABILITY
- RUGGEDNESS
- STABILITY
- SMALL SIZE
- ECONOMY
IN PRICE

Welwyn

RELIABILITY — Failure rate is better than one per ten million hours.

STABILITY — Under full load, the stability is better than 2% after 10,000 hours. Subsequent rate of change will not exceed 0.1% per thousand hours.

TEMP. COEF. — Will not exceed $\pm 0.05\%$ per $^{\circ}\text{C}$.

NOISE — Less than 0.5 $\mu\text{V}/\text{V}$ applied.

TOLERANCE — All MIL-R-22684 and MIL-R-11C values at $\pm 2\%$ and $\pm 5\%$.

SIZE — Same as MIL Types RL20 and RC20.

SPECIFICATION — Complies with MIL-R-22684 and exceeds materially MIL-R-11C.

Type	Rating @ 70° C Ambient	MIL Type	Rated Voltage	Minimum Resistance	Maximum Resistance	Dielectric Strength
F20	1/2 Watt	RL20 and RC20	350V	47 Ohms	270 K	1000 Volts



For complete data and specifications write to

Welwyn Canada Limited

1255 BRYDGES STREET, LONDON, ONTARIO

For complete details check No. 69 on handy card, page 83



SOLDERLESS CONNECTORS



ELECTRIC TERMINALS AND CONNECTORS

The ETC basic design incorporates every real advance ever made in the engineering of a solderless electric terminal. Five barrel styles, all CSA approved, have butted or brazed seams; tin plated brass, plastic or nylon sleeves optional, with a tongue type for every wiring need. Catalogue listing hundreds of types and sizes free on request. Circle reader enquiry card No. 73.



ONE STOP SHOPPING — LOWER COSTS

How much does it cost your company to issue a purchase order?

The "average" is \$5.72. But, average or not, this much is certain: getting the job done with fewer purchase orders will save you plenty of time, money and paper.

The easiest way to use fewer purchase orders is to do business with someone who has the stock to take care of most of your electronic component needs in one stop.

Alpha Aracon Radio Electronics for instance . . . where your one purchase order buys all your electronic needs.

- ★ MATHIAS
- ★ KLEIN
- ★ & SON

★ SPECIALTY ★ PLIERS ★ FOR ★ THE ★ ELECTRONIC ★ INDUSTRY

The electronic industry needs specially designed pliers . . . Klein engineers have developed many models unique in our industry. The type names suggest a tool for every production operation . . . "Wire-gripping oblique cutter" . . . "Oblique cutter for printed circuits" . . . "Transverse end-cutting plier" . . . "Needle-nose electronic pliers" . . . "End-cutting trimmer plier" . . . and more.

Available from stock. For complete Klein catalogue #105A, circle reader enquiry No. 3.

★★★★ BUD ★★★★★

SHEET METAL PRODUCTS

preferred by most engineers

- ★ SERIES ★
- ★ SIXTY ★
- ★ CABINET ★
- ★ RACKS ★

These enclosures are shipped completely assembled and ready for use the minute you get them. Complete Bud catalogue available, circle reader enquiry No. 2.



Alpha Aracon

radio company limited

Industrial Sales Division

555 Wilson Ave., Toronto

ME 5-6181 Direct Order RU 9-4353

Telex subscribers call 02-2647

Letters to the Editor

Continued from page 89

development - production sharing arrangements with the U.S. should be extended to cover non-military aspects of space. Furthermore, governmental spending at home in support of such activities as communications, meteorological and navigation satellite programs not only puts Canada on the ground floor for reaping the economic benefits from such projects, but also primes the pump for Canadian industry to exploit its own skills. An example of the latter is the STEM device described on page 46 which arose directly from the Canadian satellite program. The amount of business on developments of the STEM device that de Havilland has received from the U.S. is already more than three times the magnitude of its contribution to the Canadian satellite.

Finally, your appeal to keep the scientific brains and resources that we now have in Canada intact has led to an interesting thought. Why not create a Canadian National Academy of Sciences? Such an organization could form an active bond amongst scientists in the government, in industry and in the universities. Communications between these groups in a country as widespread as Canada, becomes vital if we are to coordinate activities so as to progress with maximum efficiency, and maintain high international prestige with our scientific achievements.

Such a group could also serve admirably well in a scientific advisory role to the cabinet, since it represents the three major functions of the scientific community without partiality.

Again, congratulations for a job well done — the Canadian Space Electronics Issue will undoubtedly surprise many both at home and abroad — few persons hitherto have been aware of the breadth, and depth, of Canadian space activities.

Philip A. Lapp,
Chief Engineer,
Special Products Div.,
The de Havilland
Aircraft of Canada,
Ltd.,
Toronto, Ontario.

Kind words from DDP

Dear Sir:

I recently had occasion to request additional copies of your March issue of *Electronics & Communications* (Canadian Space Issue) for distribu-

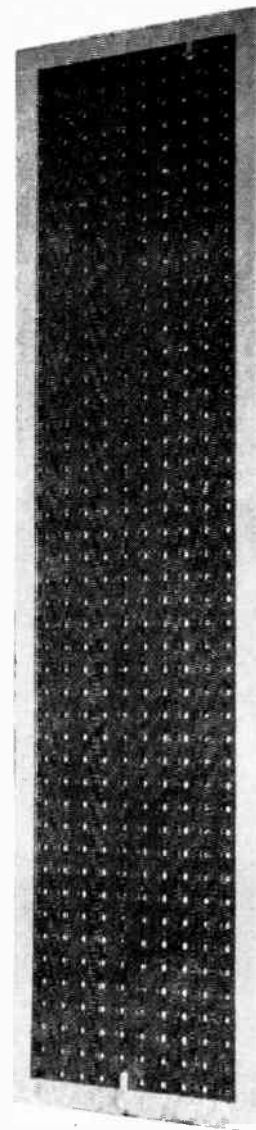

TRANSCENDENT BROAD BAND "ELECTROSTATIC" SPEAKERS

Superior to even the most elaborate cone type speaker systems, Transcendent electrostatic speakers are the inexpensive answer to perfection in high fidelity.

Absence of vibration and convenient size of modular panels (24" x 6" x 1/4") allow almost unlimited mounting configurations.

Amazingly clean transient response even at very low frequencies, combined with absence of resonance peaks, provides a depth and texture of sound never before realized.

For Prices and Technical Data Contact:



For complete details check No. 60

THIS SPACE



was reserved for an illustration of one of our crystal devices, but we asked ourselves "What's the point? Anyone reading this knows what a crystal 'can' looks like." You want to be sure of such things as quality and dependability so

THIS SPACE



was reserved for an example of the thousands of dollars worth of equipment we use to assure you of such quality. But still it seemed that we were "missing the boat" so we went a step further and reserved . . .

THIS SPACE



for a photograph of our new 12,000 sq. ft. plant that houses all the brains, capability and equipment that has made us one of the world's leaders in the manufacture of crystals, crystal and component ovens.

At this point we realized that we would have to use the space remaining to say merely that our products, used by major communication companies in Canada, the U.S.A. and Overseas speak for themselves. If you have crystal device requirements contact:



CROVEN
LIMITED

500 Beech Street,
Whitby, Ontario,
Canada.

In U.S.A.: Ovenaie Inc., 706 Forrest Street,
Charlottesville, Va.

Export: A.E.P. International, 147 Hymus
Blvd., Pointe Claire, Quebec.

For complete details check No. 21
ELECTRONICS AND COMMUNICATIONS, June, 1962

tion to interested personnel at Hq Electronics Systems Division, USAF, L. G. Hanscom Field

The March issue of *Electronics & Communications* is a commendable publication and I have received many complimentary remarks from personnel who have had the opportunity to see it. I appreciate the help such publications have given in furthering the efforts of Department of Defense Production at this location.

J. S. Vincent,
DDP Liaison Officer,
L. G. Hanscom Field,
Bedford, Mass.

. . . also from DRB
Dear Sir:

This will acknowledge with thanks the receipt of your letter of March 30, enclosing a copy of your special Canadian Space Electronics Issue.

I would like to take this opportunity of congratulating you on the manner in which you have presented the material made available to you. You have certainly made this an outstanding issue of your magazine. I am most pleased that we were able to let you have two papers dealing with some of our programs at CARDE.

J. J. Green,
Chief Superintendent,
Dept. of National
Defense,
Defense Research Board,
Quebec, P.Q.

product panorama

For further information on Products use Readers' Service Cards on pages 83 and 84.

Continued from page 78

High-frequency hybrid

Item 400
Contained in a rigid but light-weight aluminum housing only 5 27/32" x 4 1/8" x 1 1/4" including the four Type N connectors, the AMCT Type 2210-750 Hybrid has a rated

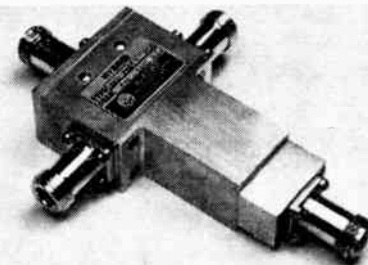

minimum isolation of 40 db over the frequency range of 750 to 1050 Mc/s. Maximum VSWR at the parallel end is 1.3 and at the series end is 1.45. CW-power rating is 100 W at the parallel end, and 10 W at the series end. Applications: diplexing, phase comparison, balanced detection, etc.
Alford Manufacturing Co., 299 Atlantic Avenue, Boston, Mass.

Continued on page 96



Wishing
for a
field strength
and wattmeter'

sufficiently small to
be portable, accurate
enough to use in lab,
ruggedly built for
field use and on
top of all that,
inexpensive?

Your wish is granted!

It's the
model FSP-3



- FREQUENCY RANGE**
52 to 220 Mc/s in 1 range.
- SELECTIVITY**
All spurious responses including image more than 80 db down, 4.5 Mc/s or more away from selected frequency.
- SENSITIVITY**
5 microvolts minimum readable signal or 60 μ V. Full scale with sensitivity control at maximum.
- BATTERY LIFE**
180 hours continuous or better than 3 hours per week for one year.
- DIMENSIONS**
Small — 5 1/4" x 11 1/4" x 7 3/4".
- WEIGHT**
Light weight — 10 lbs.



Television Associates Ltd.
27 Taber Road, Rexdale, Toronto, Ont.
Canada

Well known for quality equipment such as . . .

Low power VHF and UHF rebroadcasting transmitters (translators). A complete line of equipment for cable T.V. distribution, closed circuit installations and allied products.

For complete details check No. 11

1/8" Bit
Shield L. No. 70
L. No. 68



L. No. 64
3/16" Bit

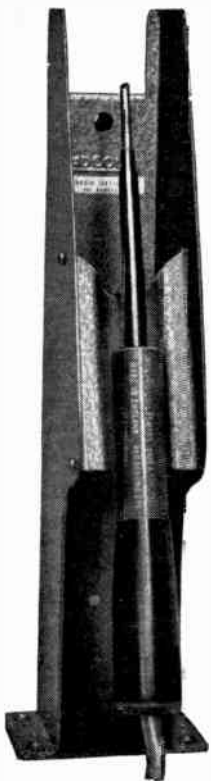

C.S.A. APPROVED
SOLDERING
INSTRUMENTS

Designed in Three Sizes
1/8" 3/16" & 1/4" Bits.

Manufactured for
All Supply Voltages
6/7 to 230/50 v.

Instruments maintain
soldering temperatures
and thorough jointing
is achieved in all the
fields of soldering, from
pin point to general
work in all sound
equipment.

Insulation standards are
approved in all leading
countries.

All Designs Cover the
Demands for Continual
Bench Production
Assembly.

Canadian, British and
Foreign Pats.
Reg. designs, etc.



ADCOLA PRODUCTS LTD.

BOX 103, WESTON, ONT.

For complete details check No. 1 on handy card, page 83

NOW-

... for those crowded circuits. They are shown actual size. They incorporate all the features of quick, positive, connect and disconnect of their larger, standard "cousins". Spring tension is adjustable. Springs are heat treated, nickel plated, beryllium copper—main stud and hex nuts are nickel plated brass. Tops in quality and equal to hard usage.

ULTRA-MINIATURE Grayhill Test Clips

Model 2-41 Single Spring Model 2-42 Double Spring

CURRENT CATALOGUE ON REQUEST

—for complete details on these and other miniature and sub-miniature components. "N. Gineer"

Represented in Canada by:
LAKE ENGINEERING CO. LTD.
123 Manville Road, Scarborough, Ontario
Phone: PLymouth 7-3253

"PIONEERS IN MINIATURIZATION"

For complete details check No. 30 on handy card, page 83

defense industry barometer

Given below is a list of unclassified contracts for \$10,000 or more awarded to Canadian electronics companies by the Department of Defense Production during the month of March. Figures represent total dollar value of one or more contracts in each case. Rental of Communications services is not included.

Firm	Item	Dollar Value
Abbey Electronics Ltd., Downsview, Ont.	electronic tubes	\$ 68,023
Alpha Aracon Radio Co. Ltd., Downsview, Ont.	cable assemblies	\$ 12,000
Atlas Instrument Corporation Ltd., Toronto, Ont.	oscilloscopes, frequency meters	\$ 86,445
Atlas Radio Corp., Ltd., Toronto, Ont.	electronic tubes	\$ 23,727
Aviation Electric Ltd., Montreal, Que.	ultrasonic cleaning equipment	\$ 10,767
Beaconing Optical and Precision Materials Co. Ltd., Montreal, Que.	pre-production models and production units of radio sets	\$223,703
Boeing of Canada Ltd., Arnprior, Ont.	revisions of technical publications	\$ 56,006
British Columbia Telephone Co., Vancouver, B.C.	maintenance of telephone plants during period ending March 31, '63	\$ 15,937
Canadair Ltd., Montreal, Que.	aircraft systems trainer, technical publications	\$772,721
Canadian Aviation Electronics Ltd., Winnipeg, Man.	maintenance of radar equipment, radar test sets	\$ 68,833
Canadian General Electric Co. Ltd., Toronto, Ont.	transmitting-receiving mobile equipment, harness assemblies, radar equipment	\$ 40,687
Canadian Marconi Co., Montreal, Que.	computer spares	\$ 62,535

ANNOUNCEMENT

The widespread use of Stedivolt A.C. Line Regulators in industry, communications, research and other areas has prompted the extension of the established line with a number of new models. This means that many formerly "special" requirements can now be met by standard units. Improvements have been incorporated in the new units such as clamp-type power connectors and hinged panels for ease of maintenance. Either tube type or fully-transistorized continuous control systems are available. If desired Stedivolts can be supplied to match any color scheme. A specification and price list presenting detailed information on the most complete range of electro-mechanical A.C. line regulators in the industry will be sent to you on request. Just phone, write or wire George Kelk Limited, 5 Lesmill Road, Don Mills, Ont., Canada. Phone No. 444-8464 (Area Code 416).

For complete details check No. 40 on handy card, page 83

IS MARKING - -
- - A PROBLEM?

INDUSTRIAL, DIRECT AND TRANSFER PRINTING EQUIPMENT A SPECIALTY

LET CANADA'S FOREMOST MANUFACTURER OF MARKING EQUIPMENT ASSIST YOU.

BARNARD STAMP & STENCIL LIMITED
8 GEORGE ST. HAMILTON, ONTARIO

For complete details check No. 10 on handy card, page 83

Canadian Westinghouse Co. Ltd., Ottawa, Ont.	electronic tubes, maintenance of electronic equipments contained in mobile tropospheric scatter equipments	\$ 46,662
Computing Devices of Canada Ltd., Ottawa, Ont.	technical representatives, rental of navigators and navigator track plotters, electronic equipment, data reduction equipment, photographic equipment	\$539,662
Garrett Manufacturing Ltd., Rexdale, Ont.	technical publications	\$ 28,493
Gould National Batteries of Canada Ltd., Toronto, Ont.	batteries	\$ 10,499
ITT Canada Ltd., Montreal, Que.	transmitter equipments and antenna tuning units and installation, technical representative	\$279,692
Instronics Ltd., Stittsville, Ont.	meter assemblies, computer and attachments	\$112,508
International Business Machines Co. Ltd., Ottawa, Ont.	procurement and maintenance of electronic data processing equipment	\$ 97,723
International Business Machines Co. Ltd., Toronto, Ont.	technical representative	\$ 21,960
McGraw-Edison (Canada) Ltd., Ottawa, Ont.	battery chargers	\$ 76,912
Muirhead Instruments Ltd., Stratford, Ont.	facsimile chart recorders, picture receiver and spare parts	\$128,586
National Telecommunication Supply Ltd., Ottawa, Ont.	supply and installation of remote control and video cables	\$ 29,505
Phillips Electrical Supply Co. Ltd., Ottawa, Ont.	telephone cable	\$ 94,918
Pirelli Cables, Conduit Ltd., Montreal, Que.	power cable	\$ 13,698
Presenty Engineering Products Ltd., Ottawa, Ont.	preproduction and production models of tape recorders	\$ 73,260
RCA Victor Co. Ltd., Montreal, Que.	electronic tubes	\$ 60,745
R-O-R Associates Ltd., Don Mills, Ont.	electronic tubes	\$110,751
Radionics Ltd., Montreal, Que.	radiacmeter spares	\$ 11,615
Railway & Power Engineering Corp. Ltd., Montreal, Que.	aircraft instruments	\$ 97,447
Rand Auto Electric, Halifax, N.S.	repair of marine electrical starters and ignition system parts during year ending March 31, '63	\$ 10,000
Renfrew Electric Co. Ltd., Renfrew, Ont.	spares for wireless sets	\$ 10,553
Servel (Canada) Ltd., Niagara Falls, Ont.	batteries	\$ 42,755
Sperry Gyroscope Co. of Canada Ltd., Montreal, Que.	aircraft instruments	\$ 77,511
Sylvania Electric (Canada) Ltd., Montreal, Que.	electronic tubes	\$ 46,865
Varian Associates of Canada Ltd., Georgetown, Ont.	electronic tubes	\$ 49,983

**NOTICE to all
Canadian members of
IRE and AIEE**

Ballot forms for the IRE-AIEE merger are presently being distributed. **Make sure that you cast your ballot — this is very important . . .** executive action regarding the merger can only be taken if there is a substantial ballot return.



at your service!

Hi! I'm Bob Ryan . . .

After 17 years of serving you through other electronic equipment suppliers, I've decided to strike out on my own in order to (a) serve you better, and (b) make more money . . . And Boy! have I got some beautiful exclusive lines to back me up! Just cast your eyes down the list below and you'll see what I mean . . .

ADVOC: Audio Visual Documentation div. of CONDUCTORLAB INC.

EMC: Electronic Modules Corp.

GERWIN ELECTRONICS: Ultrasonic equipment.

ANDERSON ELECTRONICS INC.: Quartz crystals.

GENERAL DATA CORP.: Analog to Digital converters.

VENCO: Vacuum Engineering Co., Vacuum ovens and furnaces, bell jar units and environmental chambers, etc.

RFI: RF Interasonics Inc. Dielectric capacitors, feed through capacitors, filters.

AERIALECTRONICS INC.: Microwave and telemetering refractometers.

CONDUCTORLAB INC.: Foremost in printed circuit reliability.

For more information or service drop me a line, or better still, phone me and I'll be there Johnny-on-the-spot.

RYCO ELECTRONICS CO.

26 Sunnyside Ave., Phone OX. 5-6236
Pointe Claire, Quebec

JERROLD®

SWEEP GENERATORS

NEW!



Model 900B

Very narrow to very wide sweep widths in one sweep SIGNAL generator

\$1980.00

Unusual stability in sweep widths from 10 kc to 400 mc. Frequency range 500 kc to 1200 mc. Built-in crystal-controlled harmonic markers, direct coupled scope pre-amplifier, and attenuators. The ultimate instrument for your IF-VHF-UHF requirements.



Model 900A

Wide-band sweep generator

\$1260.00

Center frequency: VHF, 0.5 to 400 mc; UHF, 275 to 1000 mc. Sweep widths from 100 kc up to 400 mc. Flatness: ± 0.5 db over widest sweep.



Model 707

Ultra-flat sweep generator

\$875.00

Featuring $\pm 5/100$ db flatness; plug-in oscillator heads*; variable sweep rates from 1/min. to 60/sec.; all electronic sweep fundamental frequencies; sweep width min. of 1% to 120% of C.F. *Heads available within the spectrum 2 to 265 mc. Narrow-band heads on request.

For applications bulletin and complete catalog (including wide-band comparators, precision attenuators and accessories), write:

JERROLD ELECTRONICS (CANADA) LTD.

50 Wingold Avenue, Toronto 19
Jerrold Electronics Corporation, Industrial Products Division, Dept. ITE-128, The Jerrold Bldg., Phila. 32, Pa.
Prices F.O.B. Philadelphia

*Prices and specifications subject to change without notice.

For complete details check No. 39

industry's business

continued from page 79

will be built to complete the system. Initial survey of the planned route has been completed.

Initially, the microwave network will consist of two channels, each capable of providing 600 voice circuits. Provision has been made in the design and engineering, however, for additional channels to be superimposed on the system as needed.

APEO announces scholarship awards available

A total of \$6,925 in scholarships will be awarded to students during 1962 by the Association of Professional Engineers of Ontario, it was announced in April by J. W. Holmes, P.Eng., of Niagara Falls, Ontario, Association president.

There will be two classes of scholarships: entrance and under-graduate. The former will be awarded to students entering engineering courses at eight Ontario universities who have achieved high standings in Grade 13; and the latter will be presented to students at the universities who have obtained the highest standings in their academic year.

In addition, the 20,000-member

APEO awards an annual gold medal for academic achievement to the engineering students who graduate with the highest standing from Ontario universities. Also announced was the Association's special award to an outstanding secondary school mathematics teacher to be given to two teachers this year — one located in the Metro Toronto area and the other from outside the region.

CBC-DOT plan emergency service

Almost all radio and TV stations in Canada will be included in the Emergency Broadcasting Network expansion announced by DOT. In the event of a national emergency, official warnings and instructions from federal and regional control studios linked with the Army warning centers would be carried. The network, including private and CBC stations, is coordinated by the CBC under the control of the Minister of Transport.

Canadian rep named by Magnetic Shield Division

Magnetic Shield Division Perfection Mica Company, Chicago, Illinois, has appointed Nuclear Enterprises, Ltd.,

Continued on page 95

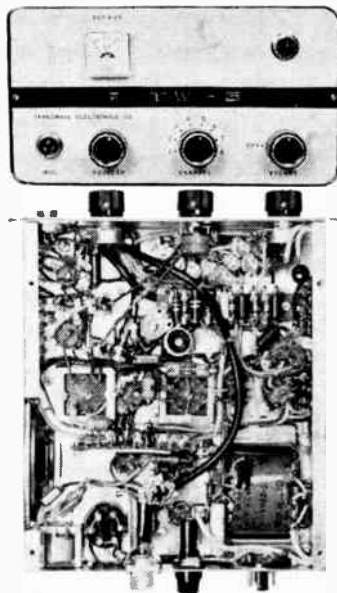

GENERAL RADIO SERVICE EQUIPMENT

built economically to Professional Standards

TW-5 Ruggedized for mobile use

8-channel crystal controlled on transmit and receive with netting facilities on all channels. Maximum allowable metered R.F. output, 115 VAC and 12 VDC power supply. Size 9" x 5" x 10½" — 13 lbs. D.O.T. Approved.

Suggested List \$199.50 complete with mike and one set of crystals.

TRANSIPHONE (TW200)

Operates like a telephone hand-set. Separate microphone and speaker improves signal/noise ratio. Two channels crystal controlled on transmit and receive, automatic noise limiter and auto-squelch circuit — 10 transistors and 4 diodes. Operates from built-in 9V. dry battery. (A.C. adaptor available).

2 R.F. stages, 200 milliwatts input power and centre loaded built-in whip antenna guarantees that the Transiphone will out-range any comparable unit. Aluminum splash proof case. Weighs only 1 lb. Size 9" x 2½" x 1¾". D.O.T. approval pending.

Suggested List \$99.50 complete with one set of crystals and leather carrying case.

DISTRIBUTOR, O.E.M. ENQUIRIES INVITED

TRANSWAVE ELECTRONICS CO. LTD.

17 Colville Road, Toronto 15, Ont. Telephone 241-4643

For complete details check No. 68 on handy card, page 83



550 Berry St., Winnipeg, Manitoba, to handle the Division's Netic and Co-Netic magnetic shielding in the provinces of Manitoba, Saskatchewan and Alberta.



Arthur Kingsnorth (right) manager of General Radio Company, Toronto, demonstrates a precision capacitance measuring system to Ron Rogers of IBM, at an exhibition of General Radio's newest instruments held at the Skyline Hotel, Toronto, on May 24.



Demonstrating a solid state counter at the exhibition is Ron Mossman who recently joined the company as a sales engineer.

Toronto firm delivers display board to Los Angeles Air Terminal

Ferranti-Packard Electric Limited, Toronto, has announced the delivery of a flight-information display board to Western Airlines for installation in the new Los Angeles Air Terminal. This remote-controlled display will disseminate flight arrival/departure information to the public and to airlines personnel. Information is electronically posted to the board according to switch settings on a remote input unit. The character-forming modules, which make-up the display, are a unique Ferranti-Packard development; the result of two years of research and engineering.

REFLECTORS

PASSIVE

by



- Designed for Canadian Climates ● Conforms to CSA & RETMA Specifications ● Maximum Reflectability ● Lightweight ● Rugged
- Maximum Rigidity ● Simple to install
- Lifetime Corrosion Resistant ● Universal Mountings ● Canadian Made by Canadian Craftsmen

For more information write

The WIND TURBINE CO. of CANADA LTD.

145 Lucan St., Waterloo, Ont., Canada

For complete details check No. 70 on handy card, page 83



COAXIAL CABLE & WIRE



Wide selection for radio frequency applications including such types as RG-/U, Metal Jacketed, High Power, High Voltage, Polyfoam®, Subminax®, Triaxial, Twin-Lead, and many others.

Typifying the creative engineering that has made AMPHENOL a leader in advanced coaxial cable design is the newly developed general purpose RG-281/U. This unique coaxial cable combines the virtues of an air dielectric with environmental immunity, mechanical stability and optimum electrical characteristics.

Write for Catalog W61 which details the largest selection of RG-type cables in the world — deliverable from stock.



MADE IN CANADA BY

AMPHENOL CANADA LIMITED
TORONTO ● OTTAWA ● MONTREAL ● CALGARY

HERE'S THE
**COMPLETELY
AUTOMATIC
LONG TERM
STORAGE RECORDER**

Designed to operate continuously for at least 8 hours (14 inch reels—4800-foot tape), the Magnecord 817-DL long-term storage recorder is completely automatic. Its recording time may be extended up to several weeks by the use of a voice operated relay.

Ideal for use by Police and Fire Departments, Hospitals, Business (conferences), Court Room Sessions and many others.

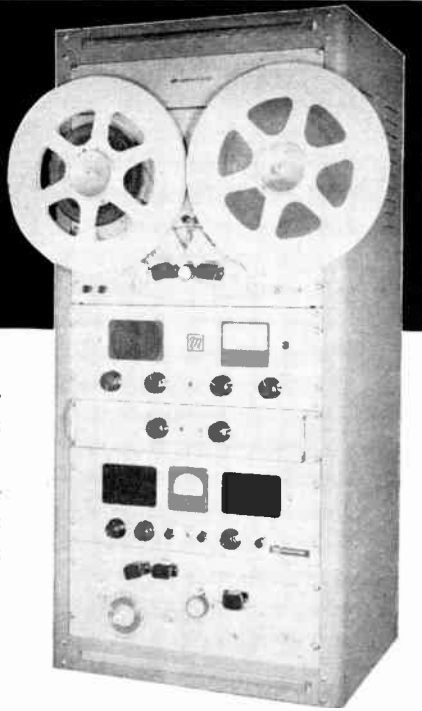

ASK FOR COMPLETE DETAILS



magnecord
CANADA LTD.

3751 Bloor St. W., Toronto, Ontario

For complete details check No. 18 on handy card, page 83

**PACKAGE
WITH
PREMIER
Standard
CONSOLES • RACKS • CHASSIS
PANELS • CABINETS • CASES**

NEW PRODUCTS:
Chassis Slides • Ventilating Fans
Manufactured in Canada

**PREMIER
METAL HOUSINGS, Ltd.**
5810 Smart Ave.,
Montreal

For complete details check No. 53 on handy card, page 83

product panorama

For further information on Products use Readers' Service Cards on pages 83 and 84.

Continued from page 91

Universal waveguide stand

Item 401

Waveline's new universal waveguide stand provides a convenient means of bench-mounting waveguide instruments and assemblies. This versatile device can accommodate all sizes of waveguides from S-band (3" x 1½" O.D.) to K_a band (.360 x .220 O.D.). In addition, one facet of the holding jaws has been grooved to enable

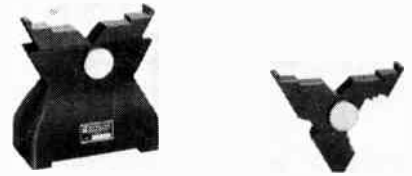

it to support coaxial instruments as well. It has provisions for variable height adjustments to simplify the set-up and leveling of lab. instruments.

Waveline, Inc., P.O. Box 718, Caldwell, New Jersey.

Transistorized frequency standard

Item 402

Model 1555 featuring better than 10,000 hours mean time between failure, has been produced by Borg Equipment Division, Amphenol Borg Electronics Corp. Short-term stability is better than 5 parts in 10¹¹; long-term stability better than 5 parts in 10¹⁰ per day. Stability is assured by the 5 Mc/s overtone crystal, which is held at a constant temperature to within ±0.003°C by dual ovens. It also has an emergency power supply.

Atlas Radio Corp. Ltd., 50 Wingold Ave., Toronto 19, Ont.

Airborne spectrum analyzer

Item 403

A swept filter spectrum analyzer for pre-telemetering analysis of random acoustic and vibration signals generated in airborne vehicles has been designed. Com-

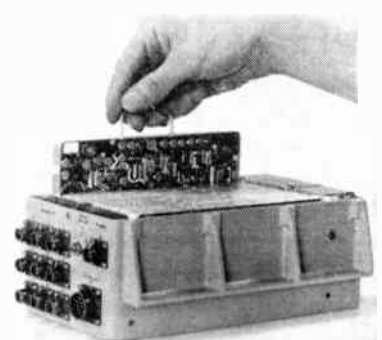

patible with IRIG telemetry standards, the 9-channel Ortholog Spectrum Analyzer Model OR/SY-OS2/9-1, reduces bandwidth requirements by factors as high as 1000:1 for telemetering over narrow band PAM, PCM or PDM channels. Data frequency range is 200 c/s to 2Kc/s.

Gulton Industries, Inc., 212 Durham Ave., Metuchen, N.J.

**IT'S
NEW!**

VMK-2

A V.T.V.M. of smart styling, proven printed circuit with 1% deposited carbon resistors plus a 6" full view meter. High input impedance (10.5 megs) and a frequency response up to approximately 3 m.c. R.M.S. Quality is built into the Kit or Factory wired unit. French/English manuals. Write for new Starkit Catalogue.



KIT \$44.95
WIRED \$59.70

**ELECTRONIC
MULTIMETERS
VMK-1**

The Starkit Model VMK-1 vacuum tube voltmeter is an indispensable in TV, FM receiver servicing. It is particularly a must when circuit loading cannot be tolerated, and can be used as DC, AC RMS, AC Peak to Peak Meter and as an electronic ohm meter, the VMK-1 permits unusual accuracy. Housed in attractive case.



KIT \$39.20 **WIRED \$53.95**



STARK ELECTRONIC INSTRUMENTS LTD.
AJAX, ONTARIO

For complete details check No. 61 on handy card, page 83

**THE PERMANENT TOWER
THAT'S BETTER EVERY WAY**

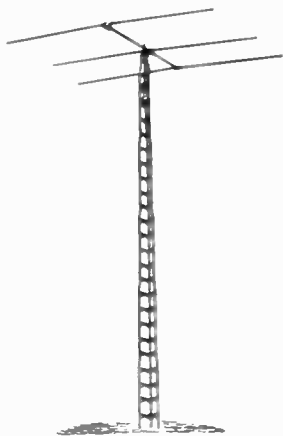

DELHI

**SPAULDING
STRATO-TOWER**

- Completely self-supporting
- Heavily galvanized all-steel construction
- "X"-brace design for greater strength
- Smartly styled, easily erected

CHOOSE FROM 4 BASES

- | | |
|------------------------------|---|
| 1. For anchoring in concrete | 3. Cylinder base |
| 2. Screw Anchor | 4. For the side of a building, ground rods driven through holes in base |

ASK YOUR DELHI DEALER about this and other DELHI towers:
Guyed towers up to 150' and "Erect-Tower" with crank-up . . . to 100'.

DELHI METAL PRODUCTS LIMITED
DELHI, ONTARIO — PHONE: 211

Towers for all TV requirements

For complete details check No. 23 on handy card, page 83
ELECTRONICS AND COMMUNICATIONS. June, 1962

**Quality HEATHKIT
test equipment at low,
low Heathkit prices**

**GENERAL PURPOSE
3" OSCILLOSCOPE**



Low cost and versatile, this 'scope has scores of uses. Circuit design features identical vertical and horizontal amplifiers, with a frequency response of ± 2 db from 2 cps to 200 kc. Sensitivity is .25 volts RMS/inch peak-to-peak deflection at 1 kc. There's provision for direct connection to the vertical deflection plates of the cathode ray tube—ideal for high level monitoring.

And the twin-triode sweep generator functions reliably from 20 to 100,000 cps in four switch-selected ranges.

Other features include automatic sync and retrace blanking . . . provision for internal line sweep and external horizontal input . . . and a 3RP1 CR tube with special alloy neck shield to minimize trace distortion from external fields. Focus and astigmatism controls assure a sharp, fine trace, and power supply is fused for protection. Altogether this is unbeatable 'scope value.

KIT 10-21 . . . \$65.95

**LABORATORY AC
VACUUM TUBE
VOLTMETER**



This latest unit contains all the proven features of its predecessor, the Heathkit AV-3. Many important new features include: extended frequency response ± 1 db from 10 cps to 500 kc . . . 10 megohm input impedance for high accuracy . . . up-to-the-minute styling . . . a cathode follower stage on all ranges for increased input impedance . . . and a 2-stage amplifier for high output stability and linearity. Meter has VU type ballistic damping, ideal for monitoring audio signals.

KIT IM-21 . . . \$51.95

For a free HEATHKIT catalogue listing more than 200 kits, write



1480 DUNDAS HWY. EAST, COOKSVILLE, ONT.

6216

For complete details check No. 22 on handy card, page 83

opportunities

Charges are 25c per word or figure, not including heading or box number. Minimum charge is \$5.00 payable on submission. NO CHARGE for "positions desired" advts.

Send all material to the attention of the Classified Editor of **ELECTRONICS AND COMMUNICATIONS**, 450 Alliance Ave., Toronto 9, Ontario.

POSITIONS VACANT

ELECTRICAL ENGINEERING OPPORTUNITIES

Our Switchgear and Control Division has two attractive openings for Electrical Design Engineers.

A position is available to a Graduate Engineer with 3-7 years' applicable experience in applications of silicon diodes and silicon controlled rectifiers.

Duties will include product design, project co-ordination, and field commissioning of large projects.

A position is available to a Graduate Engineer with 3-5 years' electronic and instrumentation control design experience. Duties will include selection and specification of process instruments, design of process control systems, and preparation of instruction data.

Progressive salary plan, a liberal program of fringe benefits and an excellent pension plan.

Send resume in confidence to:

Canadian Westinghouse Company Limited
Salaried Employment & Placement
Department
P.O. Box 510, Hamilton, Ontario

INDUSTRIAL ELECTRONICS SPECIALISTS

Required immediately as representatives in Toronto and Ottawa on commission basis; also full time salesman in Montreal. Write giving full particulars to:

Progress Electronics Company Ltd.
480 Port Royal Street West
Montreal, P.Q.

ENGINEERS

— COMMUNICATIONS AND ELECTRONICS —

Federal Government
Departments
OTTAWA

in one or more of the following areas;

Design and Development
Systems Analysis
and Application
Installation Engineering
Maintenance
Analysis and Regulation

BENEFITS

- 3 weeks' annual vacation leave.
- Accumulative sick leave.
- Excellent superannuation plan.
- Low cost term insurance.
- Promotion on merit.

Complete details and application forms available on request. Write to the **CIVIL SERVICE COMMISSION OF CANADA**, OTTAWA requesting Information, Circular 62-1151.

POSITIONS VACANT

PROJECT ENGINEER

To do electronic design and development work in either television or car radio circuitry. Provincial Technology Institute training or equivalent required, together with several years related experience.

This position offers challenge and opportunity. Full range of benefits including a Profit Sharing plan.

Apply in writing, giving full particulars to:

Employment Manager
Dominion Electrohome Industries Limited
Kitchener, Ontario

SPECIFICATION WRITER

Leading TV manufacturer has immediate permanent position for qualified man to do copy layout requiring the use of photo reproduction, varityper and blueprinting procedures. Also to prepare paste-up material for instruction booklets, labels, etc.

Preference given to applicant with draughting knowledge.
Good employee benefits and working conditions.

Letter of resume should include age, work experience, salary requirements, and personal data.

Box 5111
Electronics and Communications
450 Alliance Avenue, Toronto 9, Ontario

TECHNICAL SUPERVISOR

Required for Corner Brook, Newfoundland. Only applicants with experience in Radio and Television Broadcasting need apply.

Please send complete resume to:

Canadian Broadcasting Corporation
P.O. Box 5490
St. John's, Newfoundland

ELECTRONIC DESIGN

Engineer required for electronic circuitry and antenna design. Also some development work in radio transceiver design. Apply in writing giving full details of past experience, education, age, and personal data.

Box 5116
Electronics and Communications
450 Alliance Avenue, Toronto 9, Ontario

GYRO & ACCELEROMETER ASSEMBLY TECHNICIANS

Vacancies available for technicians with experience in the following fields: gyros, accelerometers, precision mechanical equipment, inertial platforms.

Excellent working conditions and fringe benefits with a progressive company in west end of Toronto.

Phone, write or drop in for a visit.
Litton Systems (Canada) Ltd.
Highway 27 and Dixon Road, Toronto, Ont.

FOR SALE

RECEIVER

SX62A receiver, world's finest, excellent condition, 1957; 500 KC — 109 MC; AM/FM/BFO; 3 microvolts; 250c/500c/1k/-2k/4/10k selectivities. All functions checked. Cost \$525 Canadian new; will accept \$220.

Box 5112
Electronics and Communications
450 Alliance Avenue, Toronto 9, Ontario

POSITIONS WANTED

DATA PROCESSING

Supervisory position wanted in data processing. Thirteen years experience in punch cards and computer programming fields. Ten years at data processing in Toronto area at supervisory level.

Box 5113
Electronics and Communications
450 Alliance Avenue, Toronto 9, Ontario

POSITION DESIRED

B.Sc. (London), AMIEE, A. Inst. P., MBIM, Mem. IRE. Wide experience in electronic techniques, components and systems.

Available to act for Canadian manufacturers in Europe, market surveys, contract negotiations, etc. Would consider a permanent position in Canada.

Box 5110
Electronics and Communications
450 Alliance Avenue, Toronto 9, Ontario

ELECTRONIC SALES ENGINEERS

with proven sales records are not plentiful. If your company lacks effective SALES coverage in Western Canada or British Columbia only, I solicit your inquiries. I offer 25 years of successful participation in the technical, sales and administrative phases of the electronic industry. My primary interest lies in straight commission propositions — components, engineered products or systems. Maturity, reputation and wide contacts assure results at the distributor, dealer or industrial user levels. Please write for history and proof-of-performance brochure.

Box 5114
Electronics and Communications
450 Alliance Avenue, Toronto 9, Ontario

RADIO COMMUNICATIONS EXECUTIVE

Over 15 years experience in technical, sales and administrative positions. Presently employed as district manager for manufacturer. Desire position offering more scope. Age 36, married, will re-locate, or provide western representation.

Box 5115
Electronics and Communications
450 Alliance Avenue, Toronto 9, Ontario

Technical Representative

required for equipment-component sales and also field installation supervision and testing.

Location Ottawa and/or Toronto.

Box 5109

Electronics and Communications

450 Alliance Avenue, Toronto 9, Ontario



RS = Economical Power Conversion

Sarkes Tarzian hermetically sealed medium and heavy current rectifiers combine efficient operation with low cost. A wide choice of ratings and circuitry fit power supply applications from air space to electrochemistry. Tarzian literature is available to show you the products—Tarzian engineering assistance is ready to apply them to economical solutions to your power conversion problems—at no cost. Write or call us now.

FOR HEAVY CURRENT APPLICATIONS...

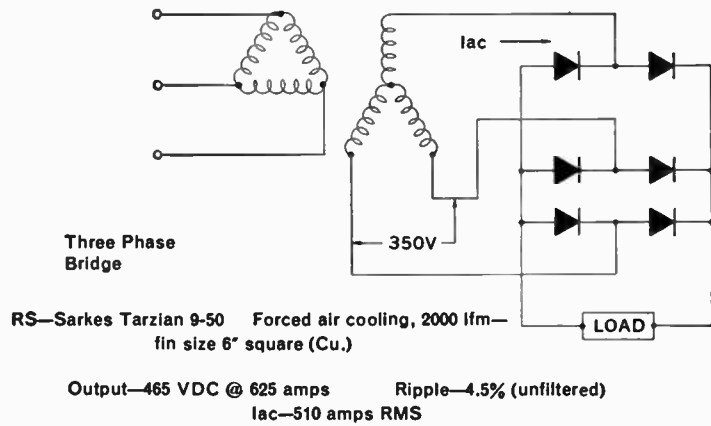
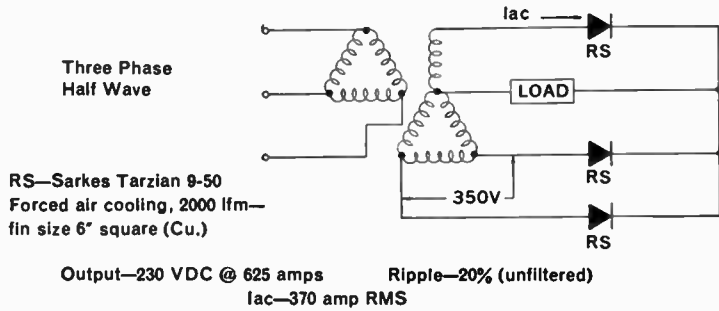

FOR VERY HEAVY CURRENT APPLICATIONS...

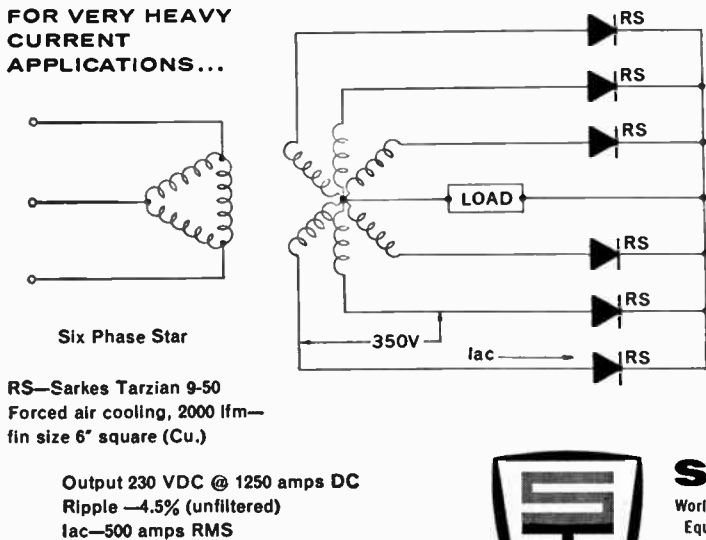

FOR MEDIUM CURRENT APPLICATIONS...

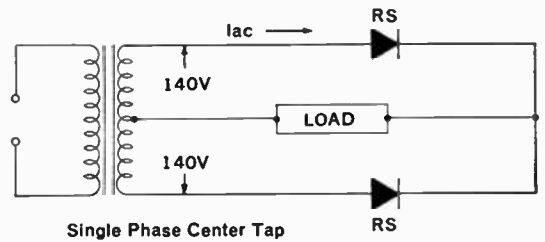

RS—Sarkes Tarzian 40H3
Convection cooling—fin size 3" square (Al.)

Output—125 VDC @ 12 amp DC
Ripple—52% (unfiltered)
Iac—9.5 amp RMS

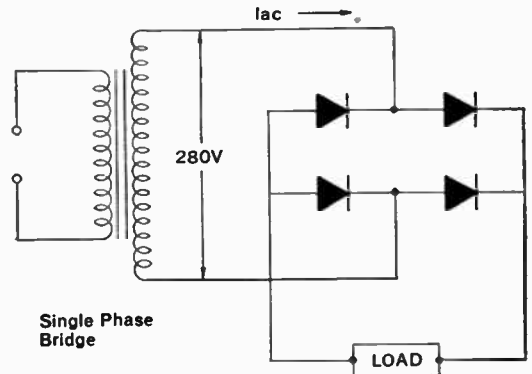

RS—Sarkes Tarzian 2-40
Convection cooling—fin size 4" square (Al. or Cu.)

Output—250 VDC @ 25 amp DC
Ripple—52% (unfiltered)
Iac—28 amp RMS

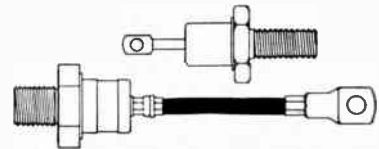

Some Typical Sarkes Tarzian Hermetically Sealed Rectifiers

Type	Max. Peak Volts	Max. DC Amps*
Type H3 - 6 Amp Series		
20H3	200	6
40H3	400	6
60H3	600	6
Type 2 - 12 Amp Series		
2 - 20	200	12
2 - 40	400	12
2 - 60	600	12
Type 9 - 250 Amp Series		
9 - 20	200	250
9 - 40	400	250
9 - 60	600	250

Positive or negative base polarity available in all types
*with adequate cooling fins



SARKES TARZIAN, INC.

World's Leading Manufacturers of TV and FM Tuners • Closed Circuit TV Systems • Broadcast Equipment • Air Trimmers • FM Radios • Magnetic Recording Tape • Semiconductor Devices

SEMICONDUCTOR DIVISION • BLOOMINGTON, INDIANA

For complete details check No. 58 on handy card, page 83



editorial

New foreign trade opportunities

Canada's trade imbalance with the United States was brought clearly into focus recently by Trade and Commerce Minister George Hees in his address to buyers from the United States at a dinner function in Toronto. Imports from the United States last year, he explained, amounted to \$3,874 million as against our exports to the United States of \$3,198 million, or, on a per capita basis, an import of \$212 compared with a per capita export of \$17. One doesn't have to be an economics expert to realize that this situation has sombre overtones for the Canadian economy in general and for business interests in particular. No small wonder that DOT&C are pushing hard to increase Canadian exports, especially to the United States.

In this general direction two new factors have recently entered the international trading picture, one is of course the 92 cent dollar and the other, a DOT&C experiment in bringing United States buyers and Canadian manufacturers more closely together.

Turning to the latter, DOT&C has assembled teams of United States buyers and, largely at government expense, has brought these to Canada to meet with representatives of Canadian manufacturers. Though this scheme was announced some considerable time ago, it is noteworthy that it has in fact been implemented. The first major meeting of this kind was held in Toronto late in May and ELECTRONICS AND COMMUNICATIONS has learned from the Trade Minister's office that already sizeable business has resulted, it being claimed that the "high-density" buyer-seller environment created by the meeting coupled with the softer Canadian dollar has presented the Canadian manufacturer with one of the most favorable selling pitches he's ever had.

To further the Buying Mission concept, several more of these gatherings are to be convened. The next will be held in Montreal at the Showmart in Berry Street on June 19-20, with others to follow in Winnipeg in September and Vancouver in October. A Common Market Buying Mission is planned by DOT&C for early 1963, probably in Paris or Dusseldorf, in this case the mission technique is reversed, the government financially assisting Canadian businessmen to attend the European meeting.

Although the measures described apply to Canadian industry in its broadest sense, there are doubtless opportunities awaiting manufacturers in the electronics field . . . all those companies in our industry with an eye to the export market would do well to follow up on the new Buying Mission technique.

A. E. Marino

ULTRA-STABLE...



FREQUENCY STANDARD STABILITY 1 TO 2 PARTS 10^{10} PER DAY! AT LOW COST

Serves as the Frequency Standard for the Pacific Missile range and has found extensive use in satellite tracking throughout the world.

Manson ultra-stable oscillators and frequency standards employ crystal references having extraordinary low drift rate due to crystal aging.

MODEL RD-180A

Is completely a solid-state unit, has a self-contained regulated power supply with stand-by battery pack. It provides frequency output of 1 Mc, and 100 Kc, with a 5 Mc output available at extra cost. All with a stability of 1 to 2 parts in 10^{10} /day. Size is 19" x 19 9/16" x 3 15/32".

PRICE — \$2,640.00 STE-FOB TORONTO
(plus U.S. exchange)

To increase greatly the flexibility of the RD-180A the following optional accessories are available:

1. **RD-181 Phase Detector** — to lock the RD-180A to the same frequency of a primary standard (Atomicon) or VLF operation.
2. **Special Adapter** — to provide a 5 Mc output with outstanding high spectral purity.
3. **Slides** for rack mounting.
4. **Shock Mount** for airborne operation or bench mounting in laboratory.
5. **RD-128 Divider** — to divide the 100 kc output of RD-180A to outputs of 1000, 100 and 1 pulse per second, these outputs have same stability as the RD-180A.

Other outputs are available upon special request

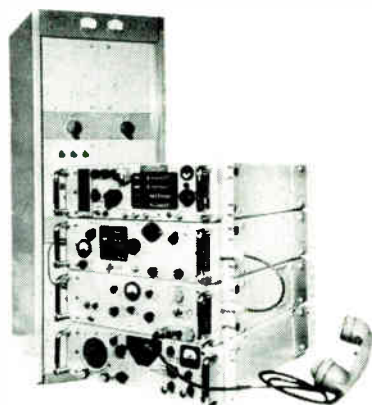

Manson SSB HF Communication System

This HF system is the finest obtainable and provides unexcelled stability and reliability under the most exacting operating conditions.

Model SSB 1000, 2.5 kw Transmitter & Receiver

This system utilizes an extremely stable and accurate frequency synthesizer. It is available in a variety of power levels including 1 KW, 2.5 KW and 10 KW configurations.

The following partial specifications indicate the extraordinary capability of this system:

Stability — 1 part in 10^8 /day. Frequency range — 2-32 Mc

Tuning — Options of 100 cycle steps or continuously variable throughout the entire range.

Spurious signal suppression (synthesizer) — 120 db

Capacity — up to four sidebands for simultaneous, independent transmitting and receiving.

*Write for detailed bulletins
on either of above equipments*



ATLAS INSTRUMENT CORPORATION LTD.

50 Wingold Avenue, Toronto 19, Canada

BRANCHES IN: MONTREAL · OTTAWA · VANCOUVER

For complete details check No. 6 on handy card, page 83

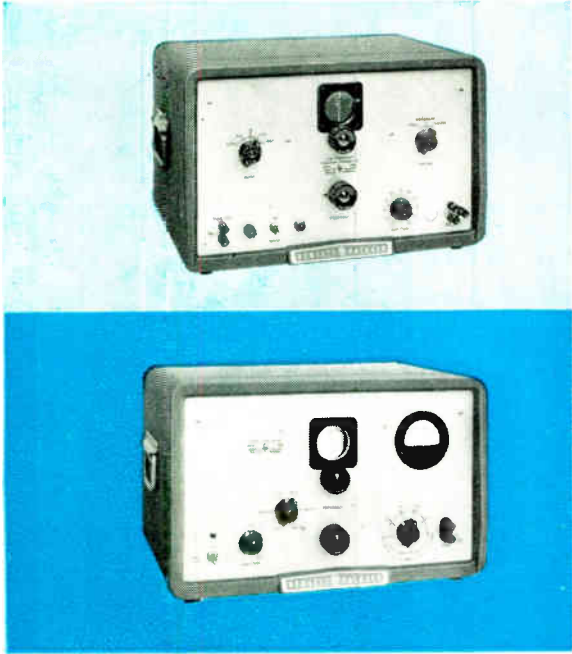

**Easy to operate,
highly stable,
wide range**



PRECISION OSCILLATORS

hp precision oscillators perform a wide variety of audio, video, and low frequency tests. They offer the outstanding advantages of flexibility and broad usefulness at moderate cost. Employing the hp pioneered RC resistance capacity circuit, the units combine accuracy and reliability with ease of operation and minimum adjustment.

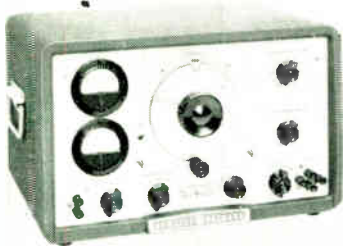

hp 205AG AUDIO SIGNAL GENERATOR—Six instruments in one; 20 cps to 20 KC!

Uses: Measure amplifier gain and network frequency response, measure broadcast transmitter audio and loudspeaker response, drive bridges, use in production testing or as precision source for voltages. Monitors oscillator output, measures output of device under test.

Advantages: Self-contained instrument, no auxiliary equipment needed. 5 watts output, ± 1 db response, less than 1% distortion, hum more than 60 db down, no zero setting, output and input meters read v and dbm; four output impedances.

Price: \$600.00 (cabinet model), \$585.00 (rack mount).



hp 206A AUDIO SIGNAL GENERATOR—Less than 0.1% distortion; 20 cps to 20 KC!

Uses: Convenient, precision audio voltage source; checks FM transmitter response, makes high quality, high fidelity amplifier tests, transmission measurements.

Advantages: Continuously variable audio frequency voltage, (output 15 dbm) 0.2 db response, hum 75 db down, 2% frequency accuracy, less than 0.1% distortion. 111 db attenuator with 0.1 db steps.

Price: \$900.00 (cabinet model), \$885.00 (rack mount).

Data subject to change without notice. Prices f.o.b. factory.

 pioneered the world-famous
resistance-capacity
oscillator circuit

HEWLETT-PACKARD (CANADA) LTD.

8270 MAYRAND ST., MONTREAL • 735-2273

Branches:

1762 Carling Ave., Ottawa • Parkway 2-8162

1415 Lawrence Ave., W., Toronto • 249-9196

6428

For complete details check No. 33 on handy card, page 83