

No.

#1

NAME
NOMI

CIRCUITS FILE

FROM ELECTRONICS TODAY

**Electronics
Today**
INTERNATIONAL

3.95
MM 70982

Circuits File

SUMMER SPECIAL 1982

**Projects, Designer Circuits & Tech Tips
for the Electronics Hobbyist**



ETI SPECIALS



Electronic Circuit Design
92 pages
 A collection of major articles on various aspects of circuit design including CMOS, Audio Amps, Op-Amps, Using the 3080 and Temperature Control. A large number of useful circuits are given but the emphasis is on guidance and how to tackle the design for yourself.

\$3.95

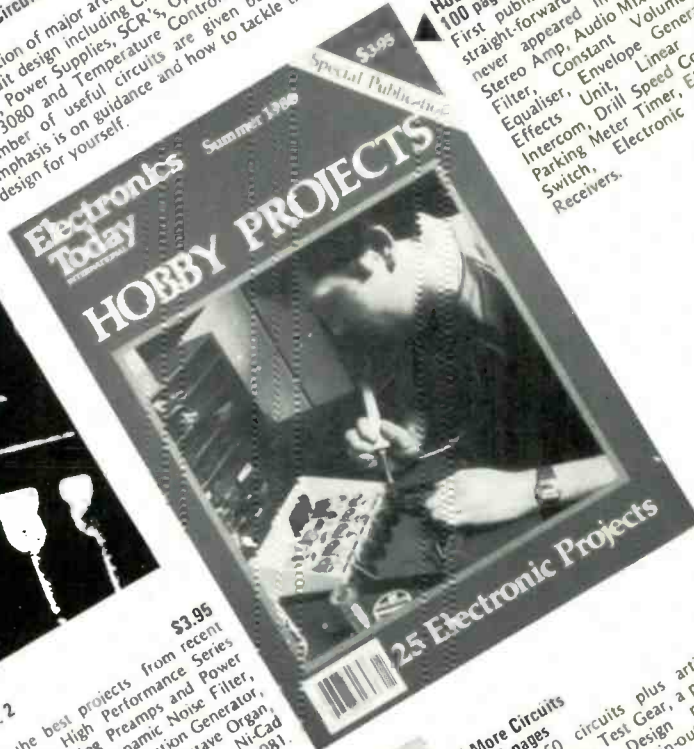

Hobby Projects
100 pages
 First published Summer 1980. Contains 25 straight-forward projects most of which have never appeared in the magazine including: Stereo Amp, Audio Mixer, Scratch and Rumble Filter, Constant Volume Amp, Graphic Equaliser, Envelope Generator, White Noise Effects Unit, Linear Scale Ohmmeter, Intercom, Drill Speed Controller, LED Tacho, Parking Meter Timer, Electronic Organ, Touch Switch, Electronic Dice, Siren, Simple Receivers.

\$3.95

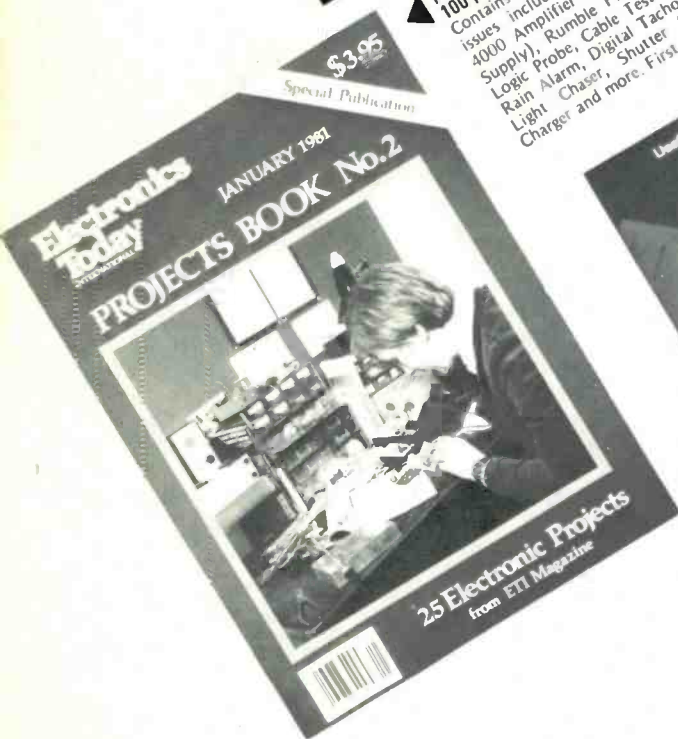

Projects Book No. 2
100 pages
 Contains 25 of the best projects from recent issues including the High Performance Series 4000 Amplifier (including Preamps and Power Supply), Rumble Filter, Dynamic Noise Filter, Logic Probe, Cable Tester, Function Generator, Rain Alarm, Digital Tacho, Two Octave Organ, Light Chaser, Shutter Speed Timer, Ni-Cad Charger and more. First published January 1981.

\$3.95

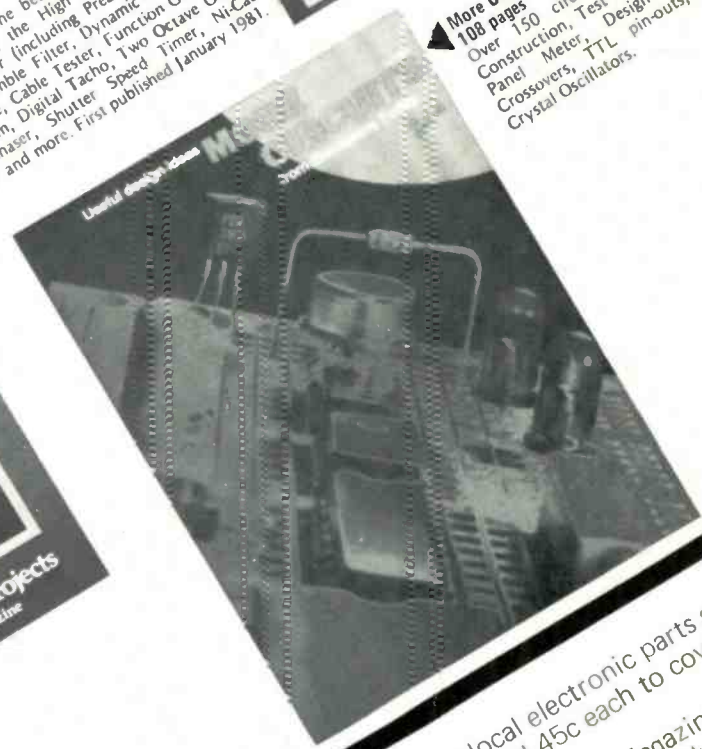

More Circuits
108 pages
 Over 150 circuits plus articles on Construction, Test Gear, a project on a Digital Panel Meter, Design notes on a Speaker Crossovers, TTL pin-outs, Design notes on Crystal Oscillators.

\$4.50

Available from your local electronic parts store or direct from ETI please add 45c each to cover postage.
 Send money to:
 Electronics Today Magazine,
 Unit 6, 25 Overlea Blvd.,
 Toronto, Ont.,
 M4H 1B1

CIRCUITS FILE

Projects

TEST	DUAL BEAM ADAPTER	4
PHOTO	FLASH TRIGGER	6
AUTO	COURTESY LIGHT EXTENDER	7
MUSIC	BASS BOOSTER	8
AUDIO	GENERAL PURPOSE PREAMP	10
AUDIO	STEREO SIMULATOR	11
AUTO	ANTI THEFT AUTO ALARM	12
MUSIC	ELECTRONIC BONGOS	13
HOME	PUSH BUTTON DIMMER	14
HOME	INTRUDER ALARM	16
HOME	GARDEN WATERING	18
AUDIO	GRAPHIC EQUALIZER	20
HOME	TOUCH SWITCH	23
AUDIO	SIMPLE STEREO AMPLIFIER	24
HOME	DRILL SPEED CONTROLLER	25
TEST	BASIC POWER SUPPLY	27
TEST	AUDIO FREQUENCY METER	26
MUSIC	WAA WAA UNIT	28
AUTO	HEADPHONE ADAPTOR	29
AUTO	HEADLIGHT REMINDER	30
HOME	AUTO LUME	31
TEST	MARKER GENERATOR	32
HOME	LIGHT DIMMER	34
TEST	RF ATTENUATOR	35

Designer Circuits

TEST	UNREGULATED POWER SUPPLY	39
TEST	REGULATED POWER SUPPLY	39
TEST	TRANSISTOR TESTER	40
AUDIO	TREBLE BOOSTER	40
MUSIC	METRONOME	41
TEST	MEASURING UNKNOWN CAPACITORS	41
AUDIO	STEREO SYNTHESIZER	42
MISC.	LOW FREQUENCY OSCILLATOR	42
TEST	CMOS LOGIC PROBE	43
HOME	INSECT REPELLENT	43
HOME	FLASH SLAVE UNIT	44
HOME	HOME INTERCOM	44
AUDIO	STEREO PREAMP	45
MISC.	PHASE SHIFT OSCILLATOR	45
TEST	QUICK TRANSISTOR CHECKER	46
TEST	SINGLE IC POWER SUPPLY	46
AUDIO	TRANSISTOR POWER AMPLIFIER	47
TEST	LOW BATTERY VOLTAGE INDICATOR	47
HOME	TWO TONE ALARM	48
TEST	ZENER DIODE TESTER	48
HOME	DOORBZZER	49
HOME	LIE DETECTOR	49
MISC.	TOUCH SWITCH	50
MISC.	555 IC MONOSTABLE TIMER	50
AUDIO	SCRATCH AND RUMBLE FILTER	51
MUSIC	VCF USING A CA3080	51
AUDIO	SIMPLE AMPLIFIER	52
TEST	FET VOLTMETER	53
AUDIO	AUDIO LIMITER	53
TEST	AF MILLIVOLTMETER	54
HOME	BASIC BURGULAR ALARM	54
MISC.	SOUND OPERATED SWITCH	55

Tech Tips

AUDIO	BATTERY OPERATED VCO	63
AUDIO	VLF SINE GENERATOR	63
AUDIO	5 WATT AUDIO AMP	64
AUDIO	ALTERNATIVE 5 WATT AMP	64
AUDIO	MOVING COIL PREAMP	65
AUDIO	ONE CHIP PRE-AMP	65
MISC.	BCD TONE GENERATOR	66
HOME	GENTLE ALARM CLOCK	66
MISC.	7400 SIREN	67
AUDIO	FIBRE OPTIC BASS GUITAR	67
AUDIO	AUDIO DOUBLER	68
AUDIO	SIMPLE COMPRESSOR	68
AUDIO	4 CHANNEL SYNTHESIZER	68
MISC.	RECTIFYING WITH THE LM3900	69
COMPUTER	BCB TO ANALOGUE CONVERTER	69
AUDIO	HIGH QUALITY TONE CONTROL	70
AUDIO	VARIABLE NOTCH FILTER	70
TEST	BATTERY INDICATOR	71
TEST	SUPPLY TELLTALE	71
AUDIO	STEREO BALANCE METER	72
AUDIO	SPEAKER POWER INDICATOR	72
MISC.	SLIDE SWITCH	73
MISC.	ELECTRONIC SWITCH	73
HOME	TRAIN CONTROLLER	74
HOME	TRAIN CONTROLLER WITH INERTIA	74
TEST	ANTI-SURGE REGULATOR	75
TEST	SIMPLE DUAL POWER SUPPLY	75
MISC.	MULTI-POWER INVERTER	75
COMPUTER	EXTERNAL INPUT FOR MICROS	76
COMPUTER	SEVEN SEGMENT DECODER	76
COMPUTER	KEYBOARD/DISPLAY CONVERTER	76
HOME	TELEPHONE AMPLIFIER	77
AUDIO	NOVEL SPEAKER CIRCUIT	77
TEST	NPN - PNP INDICATOR	78
TEST	MEASURING METER RESISTANCE	78
TEST	MORE OHMS PER VOLT	78

TEST	METER PROTECTION	78
MISC.	LOW CURRENT TOUCH SWITCH	79
MISC.	SPST SWITCH FLIP-FLOP	79
MISC.	SEQUENCE SWITCH	79
AUDIO	TAPE RECORDER CONTROLLER	80
HOME	DOOR BELL EXTENDER	80
MISC.	MULTI-ZENER	81
MISC.	INCREASING ZENER POWER	81
TEST	OVERVOLTAGE PROTECTION	81
COMPUTER	PROGRAMMABLE GATE	82
COMPUTER	CHEAP DOWN COUNTER	82
HOME	GEIGER COUNTER	83
TEST	CAPACITY CHECKER	83
HOME	TV GAME RESURRECTION	84
HOME	AUTO SELECT FOR AY-3-8760	84
HOME	PORCH LIGHT CONTROLLER	85
AUDIO	GUITAL SUSTAIN UNIT	85
HOME	DIGITAL BIKE SPEED	86
AUTO	CAR VOLTAGE REGULATOR	86
AUTO	CAR LAMP FAILURE WARNING	87
AUDIO	ICE WARNING	87
AUDIO	CAR LIGHTS REMINDER	87
COMPUTER	SEVEN TO BINARY	88
COMPUTER	555 MICRO RESET	88
HOME	2 CHIP DICE	89
HOME	DIGITAL DIE	89
HOME	PASSION METER	90
HOME	HEADS OR TAILS	90
COMPUTER	EXOR AND EXNOR	91
COMPUTER	MEMORY CONNECTIONS	91
TEST	LOGIC PROBE	92
TEST	POCKET DFM	92
TEST	CMOS GATE IDENTIFIER	93
TEST	CMOS TEST BED	93
TEST	BATTERY TESTER	93
COMPUTER	DIGITAL PULSE COMPRESSOR	94
AUDIO	SAMPLE AND HOLD	94
HOME	ELECTRONIC "SPIROGRAPH"	95
AUDIO	ANTI FEEDBACK	96
TEST	LED SPOTTING	96
HOME	TV ISOLATOR	96

HAMEG

OSCILLOSCOPE HM 203-3

The new HM203 is a 20MHz bandwidth general-purpose Dual Trace Oscilloscope. The **stable sweep triggering** (to 30MHz) and the relatively **high measuring accuracy** ($\pm 3\%$) are particularly impressive. The useful display area is approximately 8 x 10cm. With the aid of the **electronic stabilization** of all operating voltages and the thermally favorable arrangement of the drift-sensitive components, an **outstanding display stability** is obtained. The brightness and display definition of the cathode-ray tube are excellent.

Price includes two dual x1—x10 Probes
For further information on Scopes or Probes, call or write:



We service all makes of Oscilloscopes:
TEKTRONIX • HEWLETT-PACKARD •
GOULD • ETC.
From coast to coast. Call us next time.

980 Alness St., Unit 35, Downsview,
Ontario (416) 661-5585 M3J 2S2

NOW IMPROVED



LIST
\$790

- Rectangular CRT
- Bandwidth DC-20 MHz
- 8 cm x 10 cm Display
- Internal Graticule
- Dual Trace Oscilloscope
- Triggering up to 30 MHz

CIRCUITS FILE is Published by:

Electronics Today International
Editorial and Advertising Offices
Unit 6, 25 Overlea Boulevard,
Toronto, Ontario, M4H 1B1
Telephone (416) 423-3262

Publisher and Editor:
Assistant Editor:
Art Director:
Production:

Halvor W. Moorshead
Steve Rimmer
Terry Fletcher
Cindy Baker
Ann Rodrigues
Sarah Newman
Bebe Lall
Nadia Marar
Pirjo Dunphy
Senga Harrison
Omar Vogt
Carolyn Wyatt

Subscription Department:

Accounts Department:
Advertising Manager:
Advertising Representative:
Advertising Services:

NEWSSTAND DISTRIBUTION:
Master Media, Oakville, Ontario

PRINTED BY:
RBW, Owen Sound, Ontario

SUBSCRIPTIONS TO ETI MAGAZINE

\$16.95 (one year), \$29.95 (two years). For US add \$3/yr., other countries add \$5/yr. Please specify if subscription is new or a renewal.

BACK ISSUES AND PHOTOCOPIES

Previous issues of ETI Canada are available direct from our offices for \$3.00 each; please specify by month, not by feature you require.

We can supply photocopies of any article published in ETI Canada; the charge is \$2.00 per article, regardless of length. Please specify both issue and article.

COPYRIGHT

All material is subject to worldwide copyright protection.

LIABILITY

While every effort has been made to ensure that all constructional projects referred to in this publication will operate as indicated efficiently and properly and that all necessary components are available, no responsibility whatsoever is accepted in respect of the failure for any reason at all of the project to operate efficiently or at all whether due to any fault in the design or otherwise and no responsibility is accepted for the failure to obtain component parts in respect of any such project. Further no responsibility is accepted in respect of any injury or damage caused by any fault in design of any such project as aforesaid.

Projects

TEST	DUAL BEAM ADAPTER	4
PHOTO	FLASH TRIGGER	6
AUTO	COURTESY LIGHT EXTENDER	7
MUSIC	BASS BOOSTER	8
AUDIO	GENERAL PURPOSE PREAMP	10
AUDIO	STEREO SIMULATOR	11
AUTO	ANTI THEFT AUTO ALARM	12
MUSIC	ELECTRONIC BONGOS	13
HOME	PUSH BUTTON DIMMER	14
HOME	INTRUDER ALARM	16
HOME	GARDEN WATERING	18
AUDIO	GRAPHIC EQUALIZER	20
HOME	TOUCH SWITCH	23
AUDIO	SIMPLE STEREO AMPLIFIER	24
HOME	DRILL SPEED CONTROLLER	25
TEST	BASIC POWER SUPPLY	27
TEST	AUDIO FREQUENCY METER	26
MUSIC	WAA WAA UNIT	28
AUTO	HEADPHONE ADAPTOR	29
AUTO	HEADLIGHT REMINDER	30
HOME	AUTO LUME	31
TEST	MARKER GENERATOR	32
HOME	LIGHT DIMMER	34
TEST	RF ATTENUATOR	35

Component Notation and Units

We normally specify components using an international standard. Decimal points are dropped and sub-treated with the multiplier, thus 4.7uF is written 4u7. Capacitors also use the multiplier nano (one nanofarad is 1000pF). Thus 0.1uF is 100n, 5500pF is 5n6. Other examples are 3.6pF = 3p6 and 0.5pF = 0p5. Resistors are treated similarly. 1.8Mohms is 1M8, 56kohms is the same, 4.7kohms is 4k7, 10Mohms is 10M and 2.6Mohms is 2M6.

Dual Beam Adaptor

Simple unit converts single beam CRO to dual beam operation.

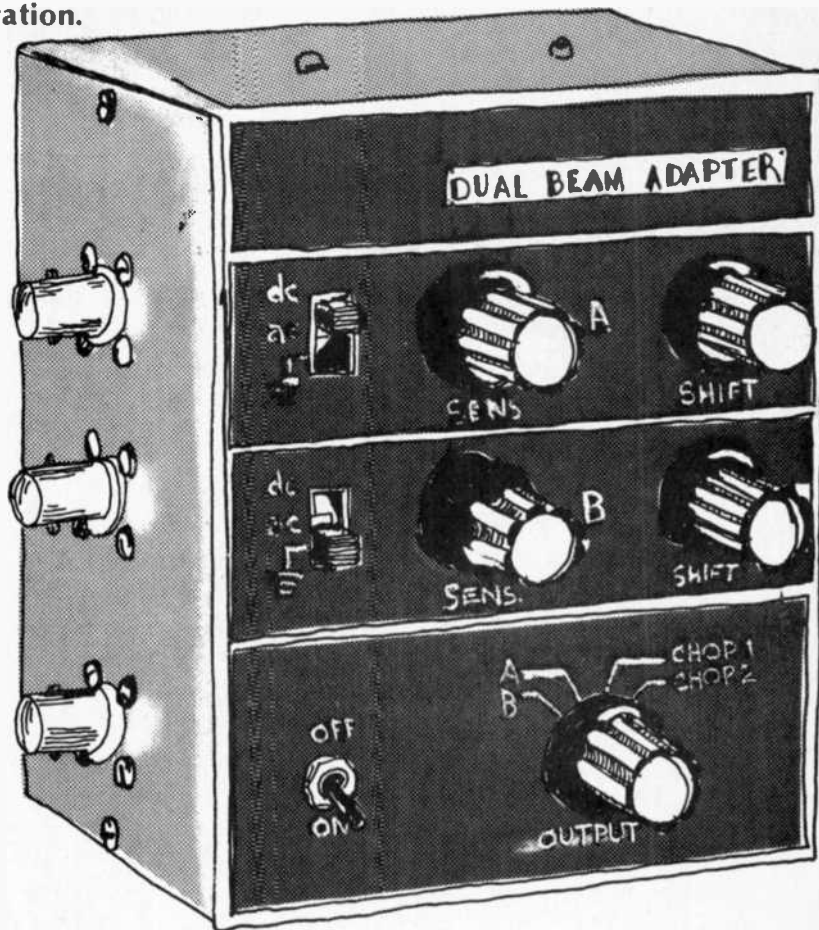

THE oscilloscope, next to the multimeter, is perhaps the most useful test instrument. Indeed, for any serious experimental work an oscilloscope is indispensable. Unfortunately they are expensive beasts, and whilst an experimenter may well afford a simple, low-frequency single-beam type, a dual-beam version (4900 or more) is usually beyond his means.

Nevertheless a dual-beam facility is most convenient, for it allows comparison of two different signals, for wave-shape or timing, and makes obvious differences which other wise would not be discernable.

The simple dual-beam adaptor described here, whilst not providing all the capabilities of an expensive dual-beam 'scopes, will however, cover most experimenter's requirements.

It is a low cost unit which allows two inputs of similar amplitude to be displayed simultaneously on separate traces. Frequency response of the unit is sufficient to allow observation of signals up to about 1 MHz.

SPECIFICATION

Input Level

dc	± 4 volts max
ac	2 volts RMS max
dc insula- tion on ac	± 400 volts max
dc level shift	± 1.5 volts

Frequency Response

– 3dB point > 1 MHz

Chopping Frequencies

A	60 Hz
B	35 kHz

Input Impedance

100 kΩ

HOW IT WORKS

Switches SW2 and SW3 select dc or ac coupling, or input shorted, for channel A and channel B inputs respectively. The signals are applied to the sensitivity potentiometers RV1 and RV2 and then passed to IC2/1 and IC2/2 which select one of the signals as an input to source follower Q1.

Transistor Q1 is supplied with a constant current (approximately 2.7 mA) by transistors Q2 and Q3. Hence, there is about 3 volts across RV3 and RV4, and this is unaffected by changes in input signal level. These potentiometers therefore provide a level-shift facility. When channel A is selected by IC2/1, IC2/3 selects RV3, and when channel B is selected by IC2/2, IC2/4 selects RV4. Thus as each signal has an independant level shift the two traces may be separated when chopped.

The CMOS gates of IC2 are driven by the outputs, A and B, the circuitry associated with IC1. The drive circuit mode of operation is selected by SW1, a four position switch, such that channel A only, channel B only, A and B chopped at 60 Hz or, A and B chopped at 35

kHz may be selected. The operation is as follows.

Integrated circuit IC1 forms a multivibrator which can run at 60 Hz or 35 kHz, or be locked in A-high B-low, or A-low B-high output states. For example, if SW1 selects –7 volts, IC1 pin 10 will be at +7, IC1 pin 11 will be at –7, IC1 pin 3 will be at +7 and IC1 pin 4 will be at –7 volts. The CMOS switches of IC2 will be "on" if the control voltage is at +7 volts and "off" if the control voltage is at –7 volts. Thus when –7 volts is selected by SW1, "A" will be at +7 volts, and IC2/1 and IC2/3 will select channel A. Similarly if +7 volts is selected by SW1, IC2/2 and IC2/4 will select channel B.

If C2 and R2 are selected by SW1 the multivibrator will be free to run at 60 Hz and channels A and B will be alternately selected at this frequency. Similarly if C1 and R1 are selected, channels A and B will be alternately selected at 35 kHz.

The power supply is a simple full-wave bridge type which uses two Zeners to provide the +7 and –7 volt supplies required.

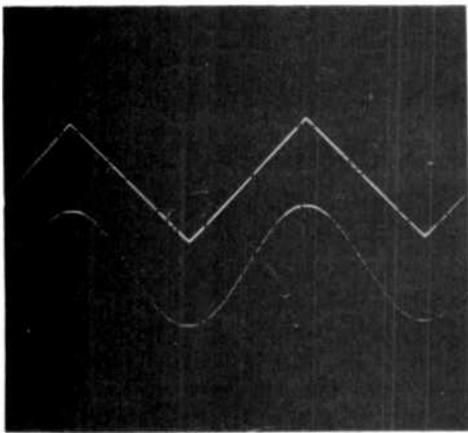

Fig. 2a Two signals, correctly displayed using the dual beam adaptor.

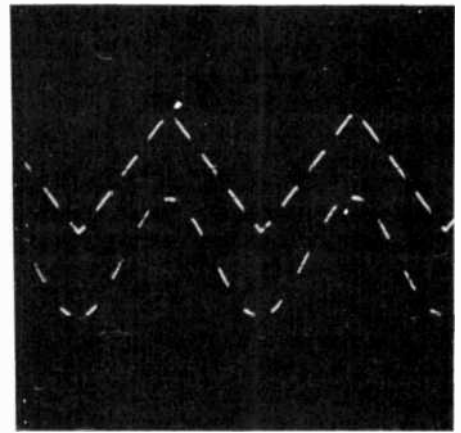
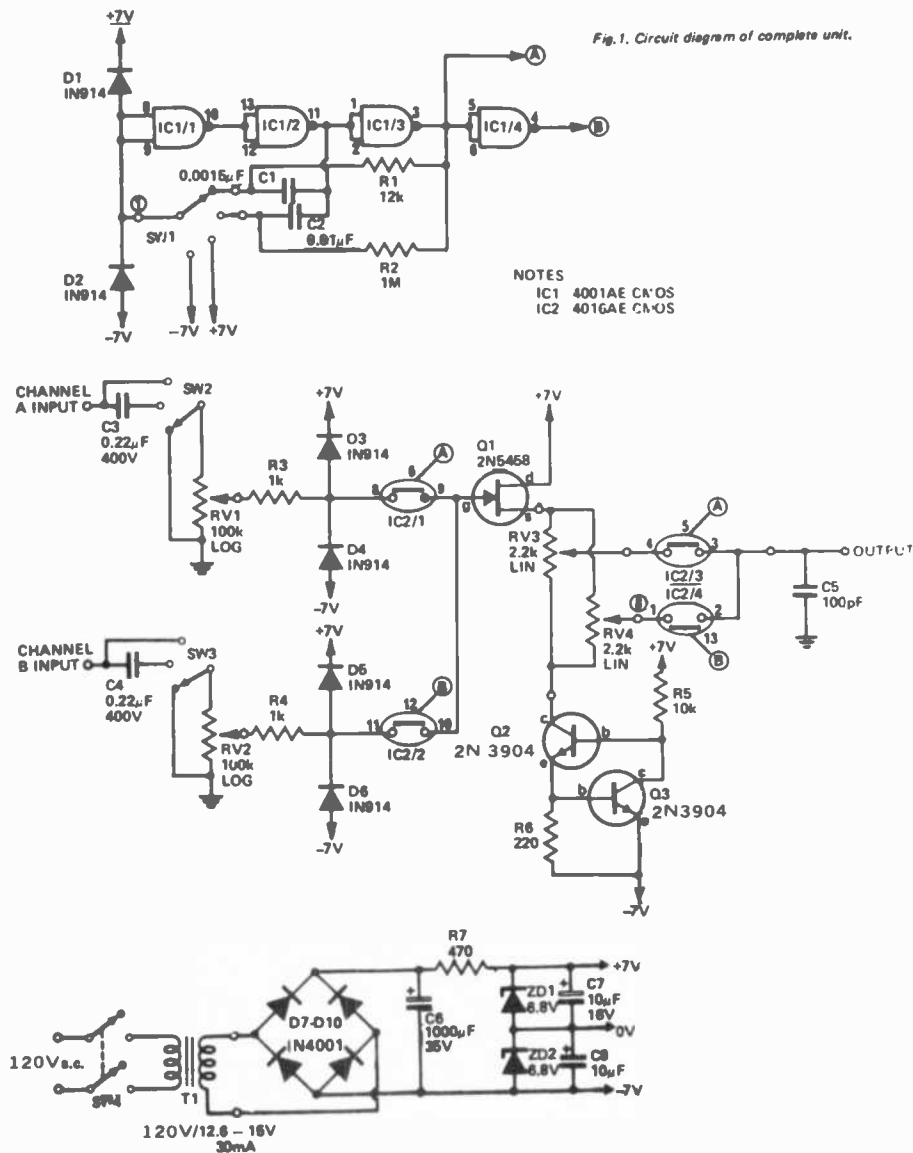

Fig. 2b Use of incorrect chopping frequency for particular input signal (chop frequency a harmonic of signal) results in the effect, shown right. To cure use other chop frequency.



USING THE ADAPTOR

Connect the output of the adaptor to the input of the 'scope. The two adaptor inputs now become A and B trace inputs to the 'scope. A triggering signal should be applied direct to the trigger input of the 'scope as otherwise the 'scope will tend to synchronize to the chop frequency and not to either input signal.

It is preferable that the two input signals have approximately the same amplitude as there is no input amplifier or range selection provided on the adaptor. However there is an attenuator provided on each input so that some adjustment may be made.

If only one input is to be applied it is best to switch to that input only thus eliminating the second trace and any cross talk which may occur due to the high input impedances.

Two chopping frequencies are used, having widely different frequencies, so that if the input signal is a harmonic of the chopping frequency, choosing the other chop mode will prevent the chop frequency being visible.

Normally CHOP 1 would be used for high frequency inputs, and CHOP 2 for low frequency inputs. An ALTERNATE mode has not been included (entails obtaining an output from the 'scope of unknown level and availability) as the CHOP 1 mode is similar and almost as effective.

By means of the two shift controls traces A and B may be separated by up to ± 1.5 volts. \odot

Flash Trigger

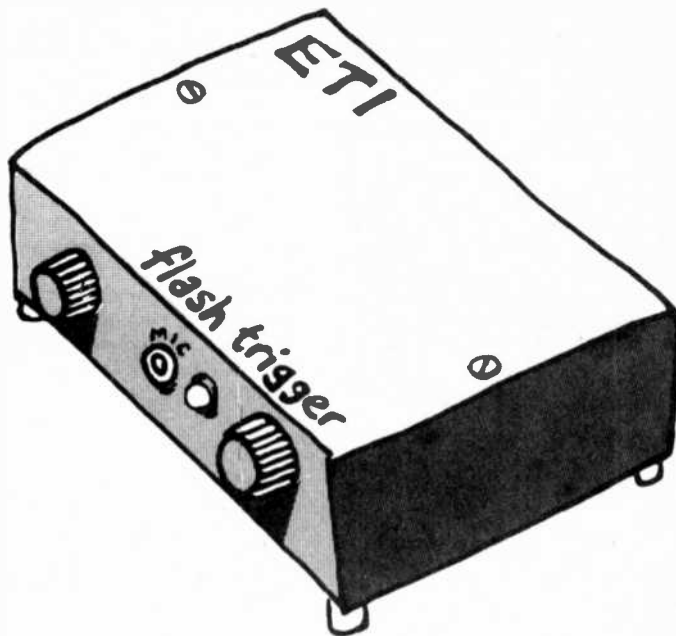

THIS device will set off any standard electronic flash unit a pre-determined time (adjustable between five milli-seconds and 200 milli-seconds) after a sudden change in ambient light or sound. The magnitude of the change required to trigger the unit is also adjustable.

The light triggering facility enables the trigger unit to be used as a slave flash.

To use the unit in the sound operated mode simply plug the microphone into the socket provided and connect the unit's flash lead to the camera.

Switch on SW1 and adjust RV1 so that the flash is not triggered by ambient noise, but will be triggered by the event to be recorded — ie gun firing, hands clapping, glass breaking, etc.

In most circumstances the stop action photography must be done in a dark room with the camera shutter open.

Working from either a sound or light stimulus this easily constructed project should prove versatile enough to be of use to most photographers.

Assume for example that you wanted to photograph a bottle at the instant it is broken by a stone from a catapult. The equipment, catapult and bottle are set up initially in the light and tested to confirm correct function and sequence.

A test film is then shot using an arbitrary setting of the delay in the now darkened room. This is done by opening the shutter, firing the catapult and then closing the shutter before turning on the lights. (Although shooting a bottle in the dark may seem difficult — with a

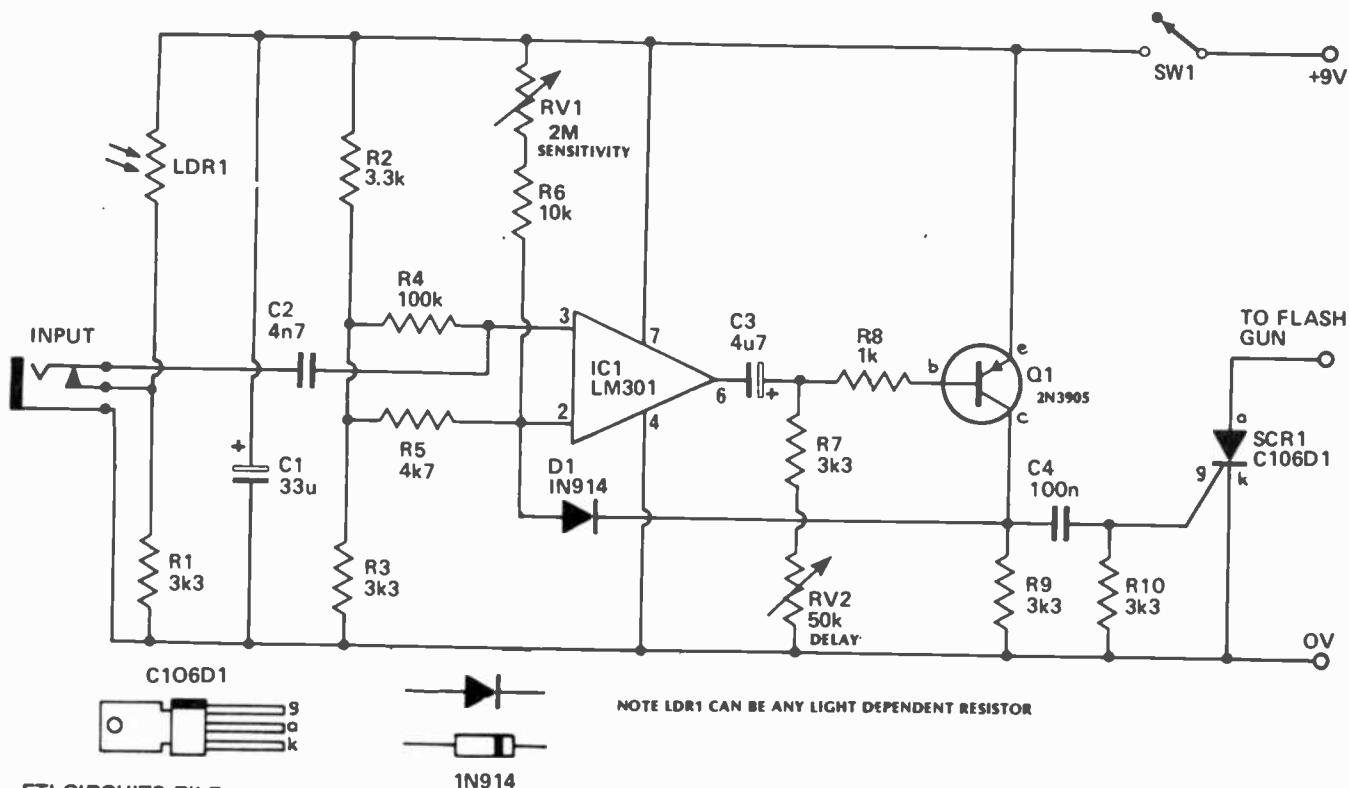

HOW IT WORKS

Basically the microphone triggers the IC monostable circuit which subsequently triggers an SCR, and hence the flash, after a time delay. This delay is adjustable — by varying a monostable on-time — from 5 milliseconds to 200 milliseconds.

Integrated circuit IC1 is an LM301A. This is a DC differential amplifier with a high gain — typically 25,000. The output swing of the IC with a 9 volt DC supply is of the order of 6 volts, and this is obtained with an input swing of only 24 microvolts. This makes the IC ideally suited for use as a comparator and is the mode of operation utilised in our circuit.

Due to the very high gain and the relatively large output signals normally encountered, the IC is almost always either fully cut off or fully saturated. The linear region is very narrow and is not utilized in this circuit.

The two inputs of the IC (pins 2 and 3) would be at the same potential were it not for the bias current supplied through RV1. This raises the voltage at pin 2 of the IC by 10 mV or more above pin 3 depending on the setting of RV1. The IC will therefore normally be fully saturated and the output voltage will be low.

Transistor Q1 is normally held on by the current through RV2, and its collector is high.

When an audio signal from the microphone produces at pin 3 a level exceeding that set on pin 2 by RV1, the IC will rapidly change state and its output will go high.

The front edge of this transition turns off Q1 via C3. The collector of Q1 will fall, D1 becomes forward biased and pulls down pin 2 to about one volt — the IC output is maintained in its high state.

After a time — determined by the time constant of C3 and RV2 — Q1 turns on again allowing the IC to revert to its normal low output.

The output signal from Q1 is differentiated by C4 and R10. The positive pulse which occurs at the end of the delay period, triggers the SCR and fires the flash.

When the microphone is pulled out LDR1 and R1 are placed in circuit. When the light falling on the LDR suddenly increases, the resistance of the LDR falls and the voltage across R1 increases. This increase is passed via C2 to pin 3 of the IC triggering it if it is above the voltage on pin 2.

little practice it is surprisingly easy. But do wear eye protection).

A run through the test film will show whether the chosen delay was correct. If too short, the bulb or bottle will be photographed before actually breaking up — if too late the action will have progressed

To use the unit as a slave flash simply unplug the microphone. This automatically places the built-in light sensor in circuit — adjust the sensitivity so that the unit is triggered out by the master flash when it is operated. In this particular application the delay should be set to minimum for use as a slave flash.

Or some delay may be used to obtain a time sequence exposure. Note that the minimum delay is 5ms and hence the unit cannot be used as a slave flash for extremely fast action without a double exposure-occurring ○

Courtesy Light Extender

Car interior light stays on briefly after the door is closed.

HOW IT WORKS

In a car where the negative terminal of the battery is connected to the chassis the negative wire of the unit (emitter of Q2) is connected to chassis and the positive wire (case of 2N3055) is connected to the wire going to the switch. In a car having a positive earth system this connection sequence is reversed.

When the switch closes (door open) C1 is discharged via D1 to zero volts and when the switch opens C1 charges up via R1 and R2. Transistors Q1 and Q2 are connected as an emitter follower (Q2 just buffers Q1) therefore the voltage across Q2 increases slowly as C1 charges. Hence Q2 acts like a low resistance in parallel with the switch — keeping the lights on.

The value of C1 is chosen such that a useful light level is obtained for about four seconds, thereafter the light decreases until in about 10 seconds it is out completely with different transistor gains and with variation in current drain due to a particular type of car the timing may vary, but may be simply adjusted by selecting C1.

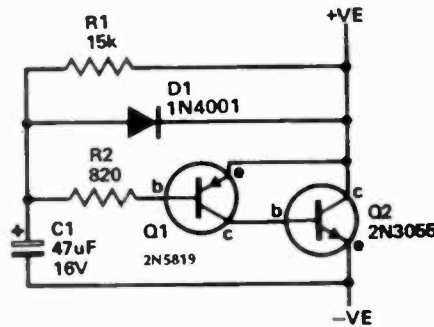

ALL MODERN CARS are fitted with door-switch operated courtesy lights. Useful devices, but not *quite* as useful as they might be because they are so arranged that the light is extinguished as soon as you close the door — just when you need light to find the ignition switch, do up your seat belt etc. How much better if the internal light stayed on for a few seconds *after* the door is closed.

This little project does just that. It provides a four-second delay (approx)

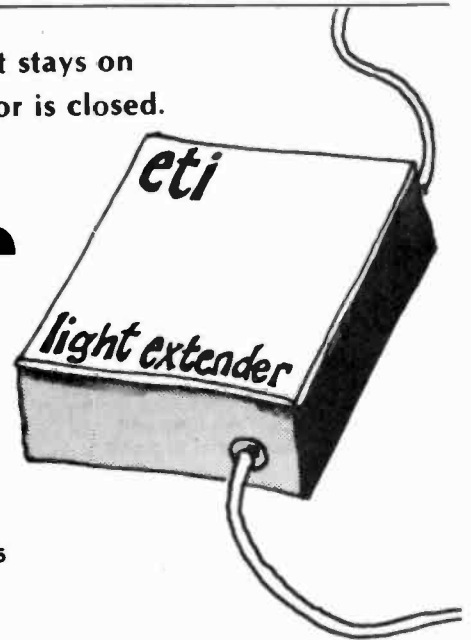

after which the interior light slowly dims — being finally extinguished after 10 or 12 seconds.

The unit is very simple to construct and once tested and properly insulated it may be wired across one of the car door switches. In operation, after a short delay the lights will gradually dim until they are completely extinguished. There is no battery drain in the off-state as the unit only operates during the delay period after the door is closed. ○

Bass Booster

Modify your hi-fi system to provide some real bass performance.

MANY ECONOMY hi-fi systems have adequate mid-range and treble response—but sound as if the bottom has fallen out of the amplifier when they come to some good solid bass.

And when you calculate the amplifier and speaker capacity required for realistic bass response you begin to appreciate why.

But all is not lost — for here is a modification that will reproduce the very deepest of bass, at levels practically guaranteed to infuriate your neighbours for life!

Unlike the higher audio frequencies, bass is largely non-directional, and because of this, the positioning of a bass speaker is not at all critical.

The bass booster described in this project exploits this principle. While in no way affecting the normal output or stereo separation of the existing system the booster effectively combines the bass signals from the left and right hand stereo channels and, following amplification, reproduces them through a common bass speaker.

The system may be used in several different ways.

Fig. 2. In this circuit the filter and amplifier are combined as one unit

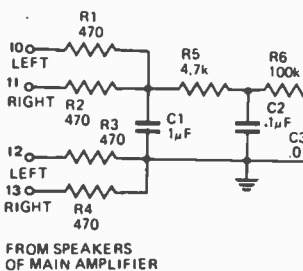

NOTES:
 D1-D3 ARE 1N4001
 D5-D6 ARE 100PIV, 1A6
 ZD1,ZD2 ARE 3V9, 400mW
 Q1,Q2 ARE 2N3904
 Q3 IS 2N3905
 Q4 IS 2N2905
 Q5 IS 2N2222A
 Q6,Q7 ARE 2N3055

Fig. 1. This filter circuit can be used with an external amplifier.

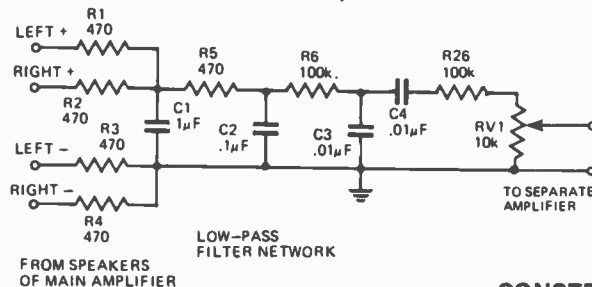

FROM SPEAKERS OF MAIN AMPLIFIER

LOW-PASS FILTER NETWORK

In its simplest form, the combining filter shown in Fig. 1 is connected to any spare mono or stereo amplifier (rated at 20 Watts or more) and played through a single speaker enclosure that has a good bass response.

In another form the same arrangement is used together with the speaker system specifically designed for bass reproduction.

But as few of us have spare high-powered amplifiers lying around waiting for a project like this—we have designed a very simple yet effective amplifier especially for this project. Note, that for this latter arrangement the design of the filter has been changed slightly.

CONSTRUCTION

If the booster is used in its simplest form — using a separate amplifier — the filter should be constructed on a small piece of perforated board or tag strips. The circuit is shown in Fig. 1. The layout is not at all critical.

In the form shown in Fig. 2, the amplifier and filter are constructed as one unit. This complete unit may be mounted within the new bass speaker enclosure (as we did with our prototype unit) or located in any readily accessible place.

When you are sure that all components have been wired correctly, set the wiper RV2 centre of its travel. Do not connect the speakers at this stage of the operation.

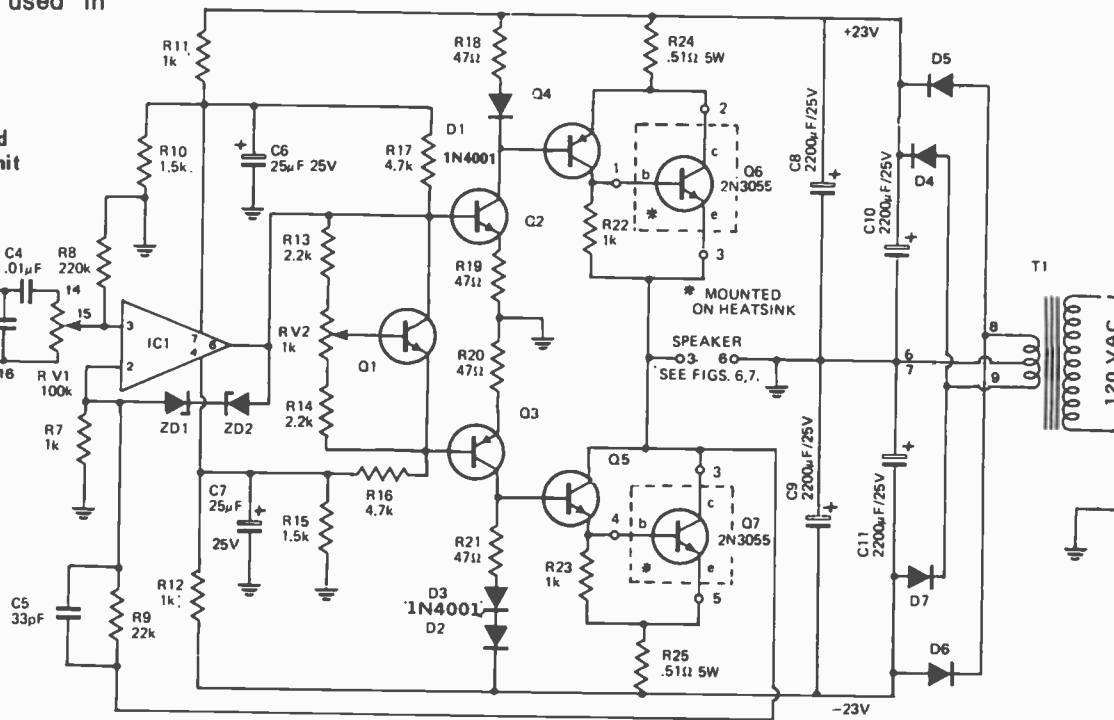

Switch on the main 120 Volt supply and check terminals. This should be less than 200 mV. If it is substantially higher than this, switch off and recheck all connections. (If a voltmeter is not available, connect one side of the speaker to one side of the amplifier and momentarily touch the second amplifier lead to the remaining side of the speaker. If all is well the speaker should remain practically silent or at most produce a slight 'click'. (If the speaker cone tries to fly across the room— then switch off at once and recheck all connections).

Next, if a milliammeter is available, disconnect the lead to pin 2 and measure the current in this lead. Adjust RV2 until the current approx. 40 mA. If no milliammeter is available, leave RV2 in mid-position.

Connect the leads from the existing speakers to the filter input and connect the bass speaker to the booster amplifier. The power may now be switched on and the complete system checked out. Remember that the sound from the bass booster will be grossly distorted if this unit is used alone — but when mixed with the sound from the existing two speakers in your stereo system it sounds just great.

BASS SPEAKER ENCLOSURE

The enclosure tested for use with this system is shown in Figs 4 and 5. The speakers used were two 8 ohm types connected in parallel, thus having an effective impedance of 4 ohms.

The inside of the speaker enclosure was lined on at least three non-facing surfaces (eg side, top and rear) with absorptive material such as felt. \odot

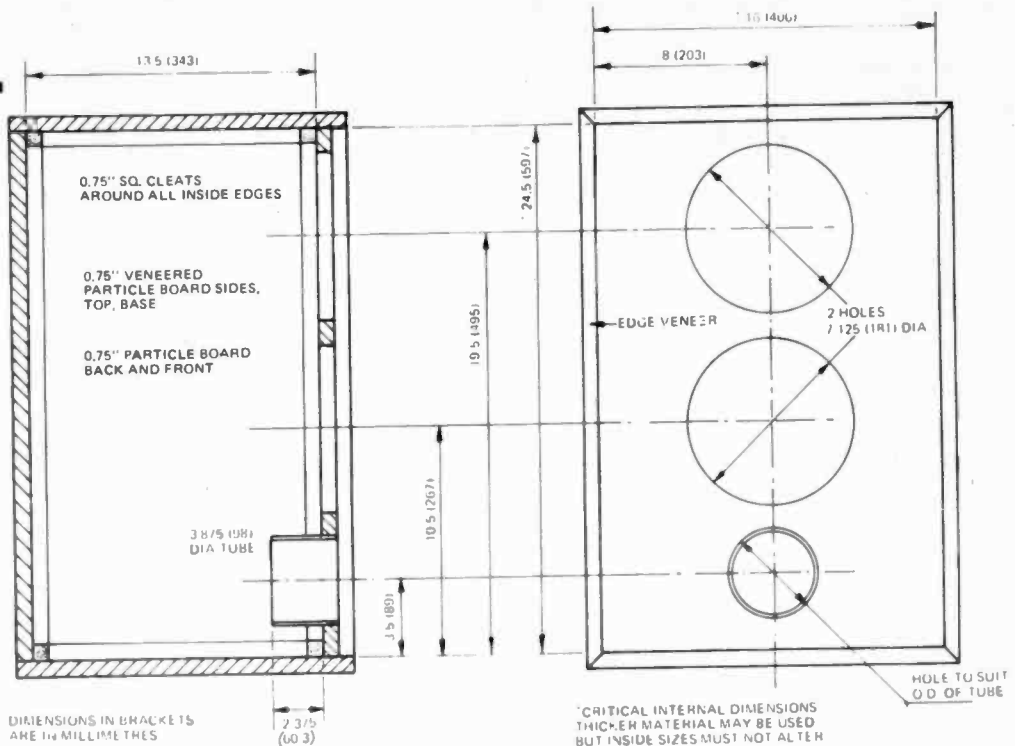

Fig. 4 Constructional details of recommended speaker enclosure.

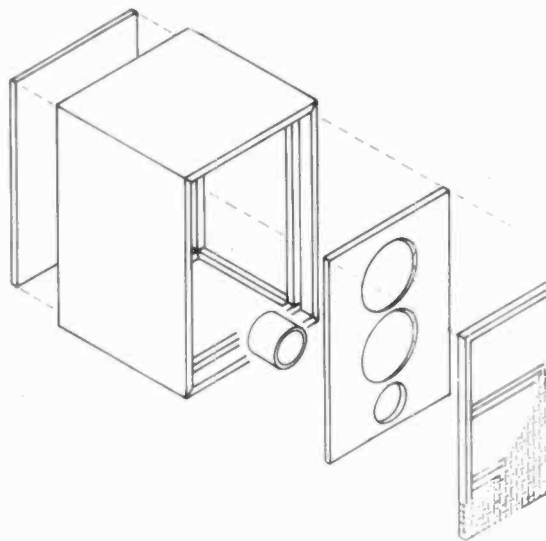

Fig. 5. Exploded view of speaker enclosure.

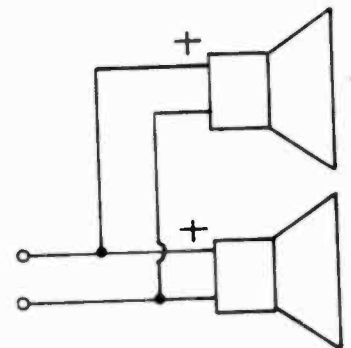

Fig. 6. How the speakers are interconnected.

HOW IT WORKS

The output from each channel of the existing stereo amplifier is combined by resistors R1-R4. Resistors R6, R6 and RV1, together with capacitors C1, C2 and C3 form a low pass filter that has a cut-off frequency around 200 Hz and a final 18 dB per octave slope.

Capacitor C4 provides a high pass filter of approximately 30 Hz to protect the speakers from large transients and de levels. (The filter shown in Fig. 1 — intended for use with separate amplifiers — has a 20 dB attenuator incorporated before the output potentiometer — this protects the following amplifier against overloads).

The amplifier shown in Fig. 2 has a voltage gain of $23 \times (R9 + R7)$, a power output of approx. 25 Watts into four ohms and a frequency response from 0Hz to approx.

50 kHz. However with the input filter incorporated, the frequency response of the amplifier is that of the filter—shown in Fig. 3.

The main voltage gain of the amplifier circuit is provided by IC1, Q2 and Q3. Q4 and Q5 provide the necessary current gain to drive the output transistors Q6 and Q7. Transistor Q1 compensates Q4. D2 and D3 compensate Q5 and Q7.

Zener diodes ZD1 and ZD2 protect Q2 and Q3 by limiting the output voltage swing of the IC.

The amplifier described in this project may also be used — without the filter — as a straightforward 25 Watt mono amplifier—in this case diode D2 or D3 (but not both) should be removed from its location on the printed circuit board and relocated on the heat sink.

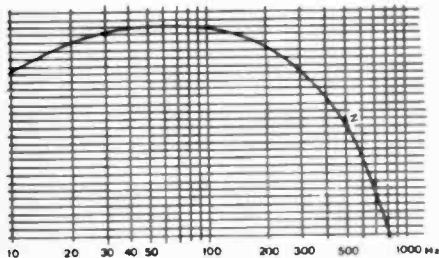

Fig. 3. This curve shows the frequency response of the filter.

General Purpose Preamplifier

A general purpose preamplifier using a simple LM382 IC which can be used with magnetic pickups, tape recorders or microphones by changing a few components.

THIS IS a simple preamplifier module suitable for fitting into an existing system. Many people require a module to amplify a magnetic pickup, whilst others may want a unit that can be used for a tape recorder or microphone.

While these requirements usually require different circuitry, a preamplifier based on the LM382 IC can be made to do any one of these jobs simply by changing a few components around the basic amplifier circuit.

As a straight preamplifier the frequency response extends to well beyond 20 kHz and gains of 40, 50 and 80 dB can be selected by means of simple components changes.

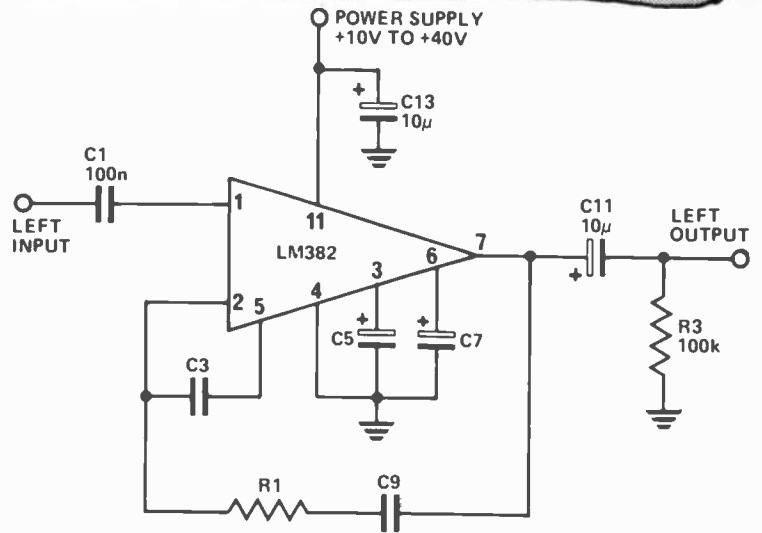
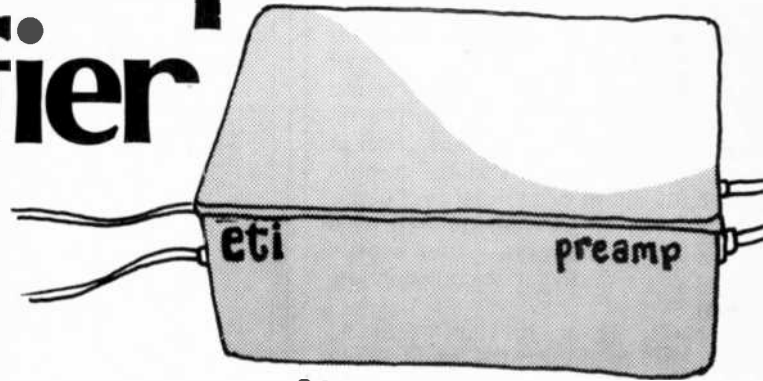

To use the preamplifier for your application, select the appropriate component values as detailed in Table One.

The input cables must be shielded as the signals at the input are at very low levels. If trouble with hum pickup is encountered it may be necessary to mount the whole preamplifier in a metal box to shield it. ○

FUNCTION	C3, 4	C5, 6	C7, 8	C9, 10	R1, 2
Phono preamp (RIAA)	330n	10u	10u	1n5	1k
Tape preamp (NAB)	68n	10u	10u	—	—
Flat 40dB gain	—	—	10u	—	—
Flat 55dB gain	—	10u	—	—	—
Flat 80dB gain	—	10u	10u	—	—

HOW IT WORKS

Not much can be said about how the LM382 works as most of the circuitry is contained within the IC. Most of the frequency-determining components are on the chip - only the capacitors are mounted externally.

The preamplifier may be powered by any dc voltage between 10 and 40 volts, the output automatically biased to about +6 volts. Due to this bias the output must be decoupled from the following stages and this is done by C11, 12 and R5, 4.

The LM382 has the convenient characteristic of rejecting ripple on the supply line by about 100 dB, thus greatly reducing the quality requirement for the power supply.

Thus the power rails of the main amplifier may be used.

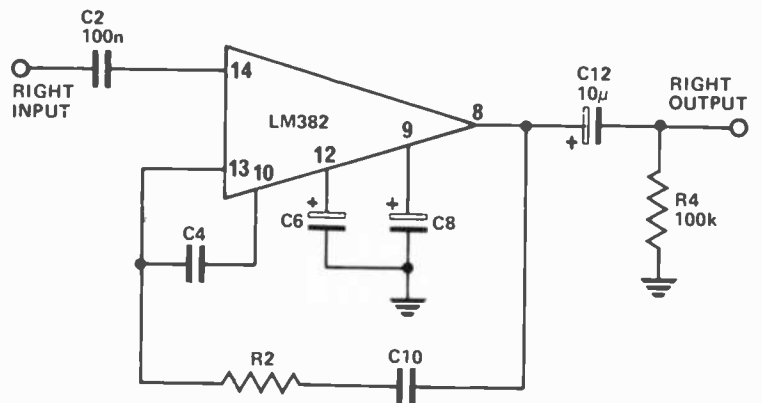

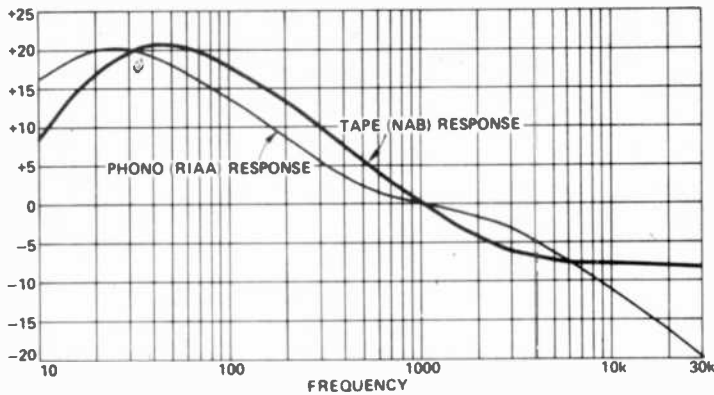

Get the habit.
Be a
Regular
RED CROSS
Blood
Donor!

Stereo Simulator

Make more of poor old-fashioned monophonic sound with this design to make use of both speakers in such a way you'd never know the difference!

IF YOU ARE a member of that illustrious band — the hi-fi enthusiast — read no further. The suggestions contained below are not for your eyes.

The stereo simulator is designed to take a mono signal, from a mono cassette recorder or, via an isolator please, your TV set, and turn it into a pseudo stereo signal.

It does this by splitting the input into two signal paths and then filtering each signal. The high frequencies are fed to the left input of your stereo amplifier and the low frequencies to the right hand channel.

Connect up the stereo simulator to your stereo amp and to a mono signal source. The effect of the circuit can be modified by use of the amplifiers' tone controls (giving a sort of width control) and the balance control. ○



HOW IT WORKS

The circuit is based on two second order filters built around IC1(b) and IC1(d).

IC1(b) is a low pass filter with component values chosen to give a break point of about 2kHz IC1(d) is a high pass filter with, again, a break point of 2kHz.

Thus the output at SK2 will consist of the low frequency portion of the input (bass) and SK3's output will consist of the high (treble) portion of the input signal.

The mono input from SK1 is fed via unity gain input buffers to each filter element. This is to avoid loading the filters which might degrade their performance.

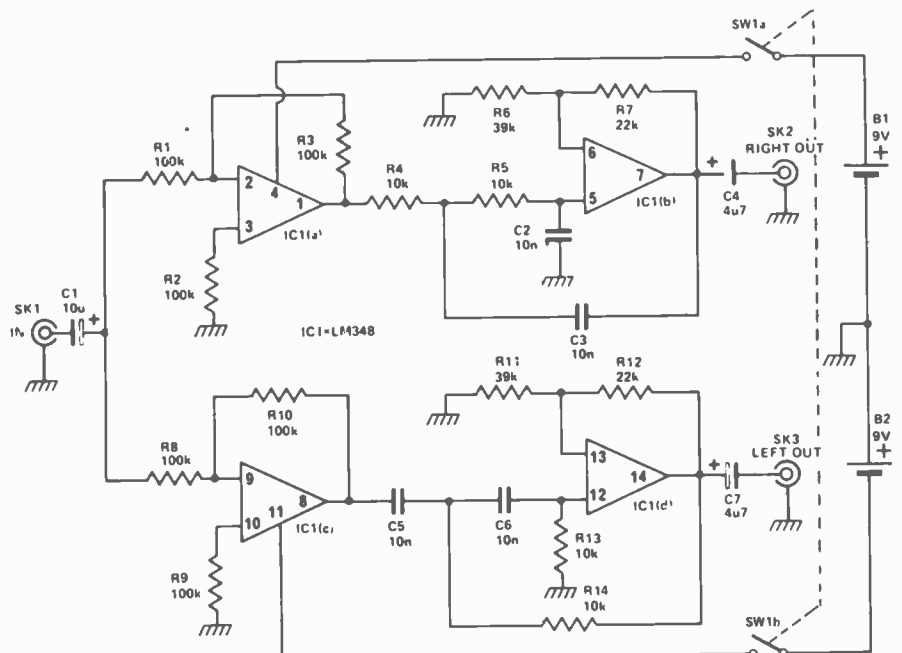

Anti-Theft Auto Alarm

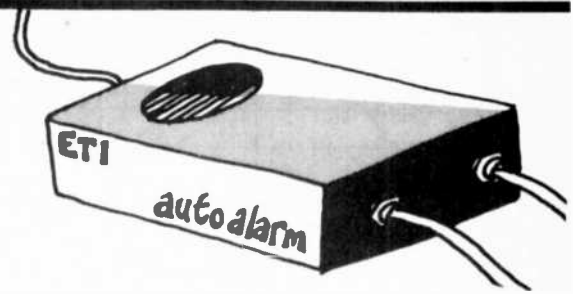

THIS UNIT OPERATES from the vehicle supply, and is a real deterrent to the unauthorised opening or taking away of the car to which it is fitted. This, in itself, can scare away an intruder as it is clear that some electronic means of protection is present. When this tone is heard, the owner has a few seconds in which to operate a master switch, the location of which is known only to himself. A pre-set control allows this "delay" to be adjusted. If the master switch is not operated, after this delay interval the vehicle horn is switched on -- and closing the door, with the would-be thief either in the car or outside, will not stop the horn.

The whole circuit is quite straightforward and for convenience can be divided into three sections. The *whole* circuit is shown in Fig. 1.

1. CAR WIRING

This is shown in thick lines in Fig. 1. The 12V battery supplies the interior light, which has its integral switch S1. The two door switches, S2 and S3, are in parallel, and operate automatically when a door is opened. None of this wiring has to be disturbed in any way.

2. TONE OSCILLATOR

Apart from its deterrent effect, this warns the legitimate user that the circuit is in operation. He can thus remember to operate the master switch S4 if he wishes to keep the door open, or to use the interior light during darkness. The tone also reminds him that the circuit is in use, when getting out of the car.

Q1 and Q2 form the tone oscillator, operating a small speaker contained in the case. When S2 or S3 are closed by a door being open, 12V appear across the interior light, and leads A (negative) and B (positive) make this available for the oscillator.

3. HORN SOUNDER

Q3 and Q4 operate in this part of the circuit. When the 12V supply is present across A and B, C2 commences to charge through R2 and RV1. When Q3 conducts, the base of Q4 is moved positive, causing Q4 to conduct, and

drawing on the relay. Relay contacts RC1 close. The relay is then energised from circuit B (positive) through R5 and circuit C (chassis and negative) so that the relay remains locked on even if the door is closed, opening S2 or S3. The second set of contacts RC2 completes the circuit to the horn.

If the door is closed before the relay locks on, the charging of C2 ceases, and the horn is not operated. This is necessary in order that the owner can get out of the car without starting the sequence.

When S4 is opened, this prevents the warning circuit working. The delay is adjustable, as mentioned, but RV1 can be set to give about 5 seconds or so. S4 is placed in an inconspicuous position, and it is unlikely that anyone could find this switch and operate it in the short time available.

The rectifier in the negative lead A is required because if the horn sounded when the owner entered the car, and the door were closed opening S2 or S3, and S4 were also opened, a path for positive supply would then exist through the interior light itself, holding on the relay. (Eg., with S1, S2 or S3

closed, circuit point A is negative. But with S1, S2 or S3 open, point A is positive via the lamp filament.)

EXTERNAL LEADS

These are most readily arranged by using three separate cords -- a twin for the horn switch circuit, a twin for the master switch S4, and a 3-core for the circuits A, B and C. The latter is best made from thin single bell wire, or line coloured wire, as this will result in a thin cord which can be inconspicuously run up to the interior light. Black is best for A (negative), with red for B (positive) and green or some other colour for chassis connection C. Chassis connection C could be taken to some other part of the vehicle chassis, but as it is available at S1, it is felt that the 3-core cord is more convenient.

RELAY

This is bolted to the end of the case. Numerous other contacts will be found on some relays, especially surplus types. Only two sets of "On" contacts are needed. These close when the relay is energised. It should pull on at a current of about 30-40mA or so. ◊

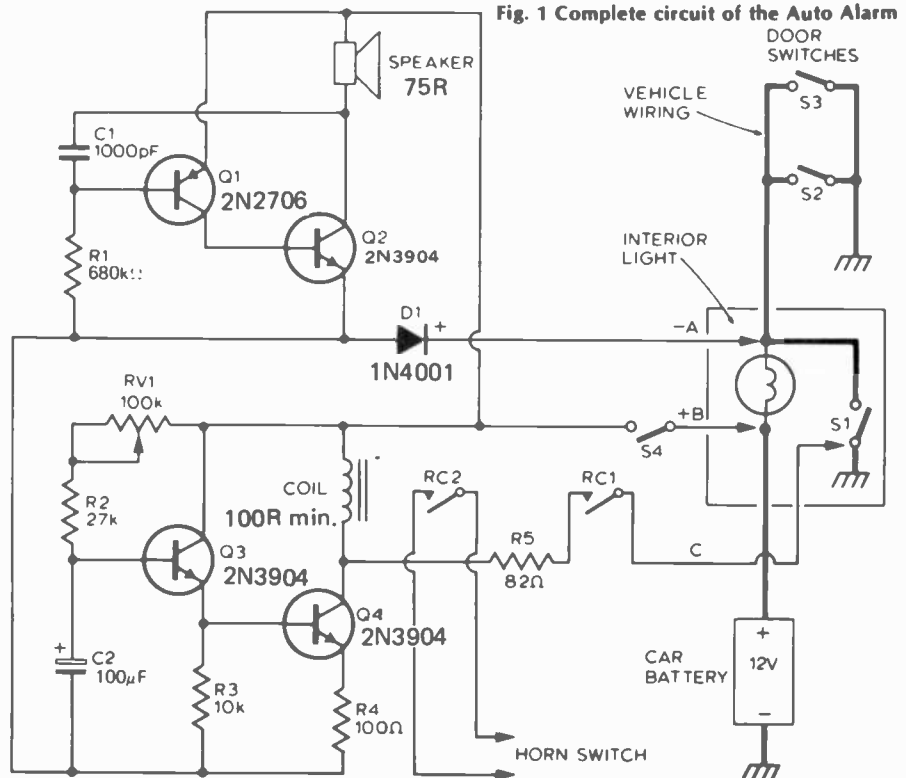
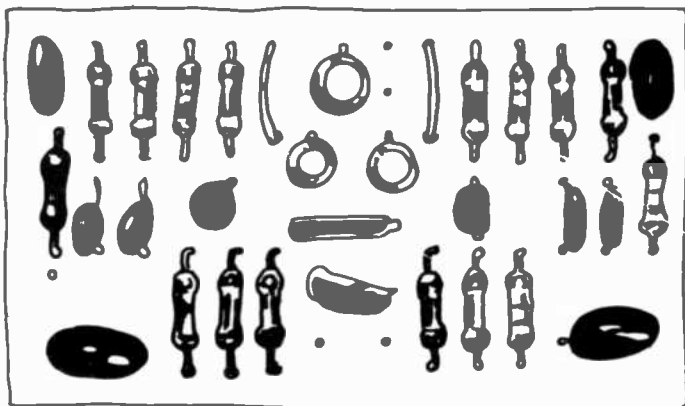

Fig. 1 Complete circuit of the Auto Alarm

Electronic Bongos



While full scale synthesisers are hideously expensive, one can cheaply create single sounds, in this case, bongos!

THE TOUCH plates may be made of any electrically conductive material — copper, brass, stainless steel, aluminum, etc. Size and shape is not critical — they need to be at least 50 mm across but they may be much larger than this is desired — and round, square, triangular or whatever you will!

The finished unit may be housed as you wish in a box — built into another instrument — or even made up as a full-size or miniature replica of a bongo drum. But if you use a metal case you must have the touch plates insulated from the case and spaced away from any metal surface by at least 25 mm.

Potentiometers RV1 and RV3 are used only in the initial setting up procedure — easy access is not essential. Potentiometer RV2 controls the level of sound output and is required if the unit is to drive an amplifier which has no built-in volume control. If desired this potentiometer may be omitted from the board and replaced by a larger rotary potentiometer located away from the circuit itself. If you do this you'll need a 50k half watt rotary device (logarithmic curve). Connect it as if you were using the original potentiometer — except that now you're doing it via three bits of wire

Setting up

Connect the unit to a suitable amplifier and loudspeaker. Connect the battery and then switch on the amplifier — keeping the volume control at a low setting.

Rotate RV1 to minimum setting and RV2 to about mid-way

Transistor Q1 should now be oscillating and you should hear a sound the loudspeaker. Now turn RV1 until

the oscillation just stops and touch the associated touch plate momentarily. This should cause the circuit to produce a 'bong' sound which then decays away. Continue to adjust RV1 until a realistic bongo sound is reproduced.

Now repeat the operation for the second oscillator by adjusting RV3. Turn the amplifier up loud and play away!

The components specified will result in frequencies of about 290 Hz and 400 Hz. These frequencies are determined by C1, C2 and C4

a whole series of oscillators of different frequencies. The circuit is totally symmetrical except for the capacitor values mentioned above, so all you do to build up 'half circuits' — all connected to the common battery — and with their outputs connected to the point on the circuit which is the junction of R8, R9 and R6.

It is also possible to build the circuit using a range of switched capacitors to provide the tonal range you require.⊙

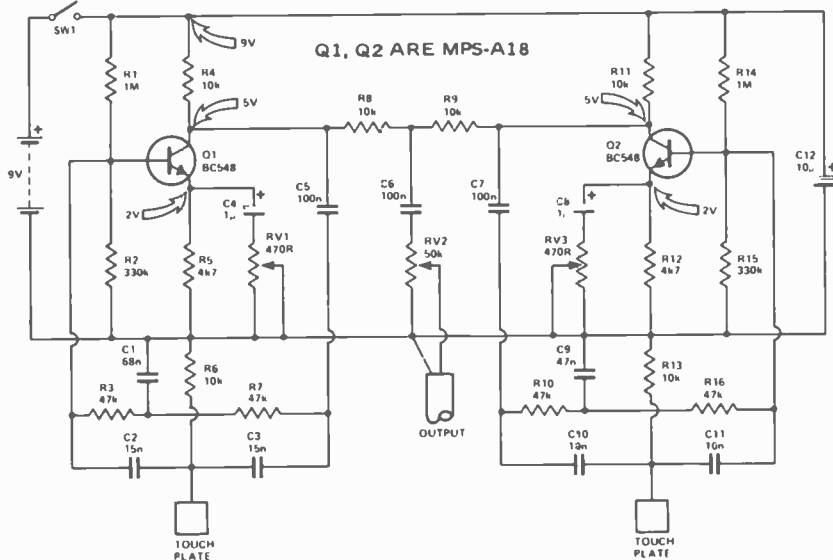

(for the left hand part of the circuit) and the corresponding C9, C10 and C11. The frequency produced is inversely proportional to the values of these capacitors. Thus doubling their value will halve the 'bong' frequency. If you change the frequency maintain the same approximate ratios between capacitor values.

If you are ingenious and/or have some knowledge of electronics it is quite possible to extend this circuit so that you have

HOW IT WORKS

The circuit consists of two twin-T type sine-wave oscillators. Each is virtually identical - there is one per touch plate.

Each oscillator has a filter in the feedback loop. If the loop gain is greater than unity the circuit will oscillate. In this application the gain is adjusted to be just less than unity. Touching 'touch plate' force starts the oscillator but the moment one's finger is removed from the touch plate oscillations will die away. The rate of decay is of course a function of circuit gain and this is controlled by RV1 (and RV3).

Push Button Dimmer



Simple circuit allows light control from a number of locations.

MANY CIRCUITS for light dimmers have been published over the years (including some by us) which are of very simple construction, and which use a rotary potentiometer. While such circuits are adequate in most respects — especially in terms of cost, there are some strong reasons for a more sophisticated dimming system.

The first objection to simple dimmers is that they usually have an unsightly knob by which light level is adjusted. A second objection is that the light level can only be adjusted from the position where the dimmer is mounted.

The dimmer described in this project can be operated from one or more remote positions — e.g. doors on opposite sides of a room, top and bottom of a long flight of stairs, bedside tables — or even from a control point beside your armchair.

The unit has an on/off switch and two (or more) sets of push buttons, one of which causes the light level to increase, smoothly from minimum to maximum in about three secs, and one which does the reverse. The adjustment may be stopped at any particular level, and that level will be maintained without change for periods up to 24 hours.

The dimmer will handle incandescent or fluorescent lamps up to 500 VA with the specified heat sink but, with a larger heat sink, may be used up to 1000 VA.

Wind the choke and transformer in accordance with the details provided in Tables 1 and 2. Be particularly careful to provide adequate insulation between the primary and secondary of the pulse transformers.

A small piece of aluminum (30 mm x 15 mm) bent at 90° in the centre of

HOW IT WORKS

As with most modern dimmers, we have used a phase-controlled triac for power control.

The triac, which may be regarded as a switch, is turned on by a pulse at a pre-determined point in each half cycle, and automatically turns off at the end of each half cycle.

Most conventional dimmers use a simple RC and diac system to generate the trigger pulse, but this dimmer is in effect voltage controlled. The 120 volt ac is rectified by D1-D4. This full-wave rectified waveform is clipped at 12 volts by R7 and ZD1. As no filtering is used, this voltage will fall to zero over the last half millisecond of each half cycle.

To provide the correct timing, and the energy required to fire the triac, a programmable unijunction transistor (P.U.T.) Q3 is used together with capacitor C3. A PUT also acts like a switch in the following manner. If the anode (a) voltage is higher than the anode-gate voltage (ag), the anode to cathode (k) path becomes effectively a short circuit.

The voltage on the anode-gate, is set by RV2 and, will be between 5 and 10 volts. Capacitor C3 is charged, via R6, and when the voltage across it exceeds that on terminal ag, the P.U.T. fires discharging C3 through the primary of pulse transformer T1. This induces a pulse in the secondary of T1 which gates on the triac.

As the voltage supply to R6 is unsmoothed the rise of voltage on capacitor C3 will follow what is called a cosine modified ramp. This gives a more linear change in light level versus control voltage.

Once C3 is discharged the P.U.T. may either stay on or turn off depending on the individual device. If it turns off it may well fire again if C3 charges quickly enough, but the operation of the dimmer is unaffected by either situation.

If C3 does not charge to the ag voltage before the end of the half cycle, the ag voltage will fall at the end of the cycle and the PUT will fire. This is an essential part of the operation as it ensures synchronization of the timing to the AC. It is for this very reason that the 12 volt supply is not filtered.

To control the charge rate of C3 (and hence the timing of the turn on of the triac within each half cycle) an auxiliary timing network of R5 and D6 is used. As the value of R5 is much less than that of R6, C3 would charge much quicker via this path. If we set the input of R5 at, say, 5 volts, the capacitor C3 would charge to about 4.5 volts quickly and then at the slower rate set by R6. This is called a ramp and pedestal type of charging.

As a result of the initial start given by R5, the PUT would fire earlier, and the triac will turn on earlier, delivering more power to the load. Hence by controlling the voltage at the input of R5 we may control the output power.

Capacitor C2 is used as a memory device. It can be discharged by R1 via PB1 (up) or charged by R2 via PB2 (down). The capacitor C2 is connected from the positive side of the 12 volt supply and hence when the capacitor is discharged the voltage actually goes up with respect to the zero volt line.

Diode D5 is used to prevent the voltage rising above that set by RV1. The capacitor C2 is connected to the input of Q2 by R3. Transistor Q2 is a field effect transistor FET which has a very high input impedance. Hence the input current is virtually zero and the source tracks the gate voltage but at several volts level. (The exact voltage difference depends on the individual FET).

Therefore if the gate voltage is changed, ie, the voltage on C2, the voltage applied to R5 will also vary. By pressing either PB1 or PB2 the capacitor voltage and hence the triac firing point and the power delivered to the load may be varied.

Upon releasing the push buttons the capacitor will 'hold' this voltage — EVEN WHEN THE POWER IS SWITCHED OFF — for extended periods of time. The memory time is dependent on a number of factors as listed below.

1. A capacitor with a leakage resistance in excess of 100,000 megohm is required. Use a good quality capacitor, preferably rated at 200 volts. If necessary try different brands.

2. The pushbutton switch should be rated for 120 Vac operation. These types have greater separation and hence insulation between the contacts. By physically disconnecting the pushbutton it is easy to determine whether this is a cause of low memory times.

3. The FET itself does have a finite input resistance. We tried many FETs without finding any that would not work. Nevertheless do not overlook this possibility.

The dimmer can be controlled from any number of stations simply by paralleling sets of pushbuttons. No damage will result from pressing both up and down buttons at the same time. However adding many stations increases the likelihood of leakage and consequent loss of memory time. The dimmer should be mounted in a dry dust-free position — as should the pushbutton. Do not try to use the dimmer or pushbuttons in a bathroom or kitchen as moisture will render the memory virtually useless.

Fig. 1. Circuit diagram of the dimmer.

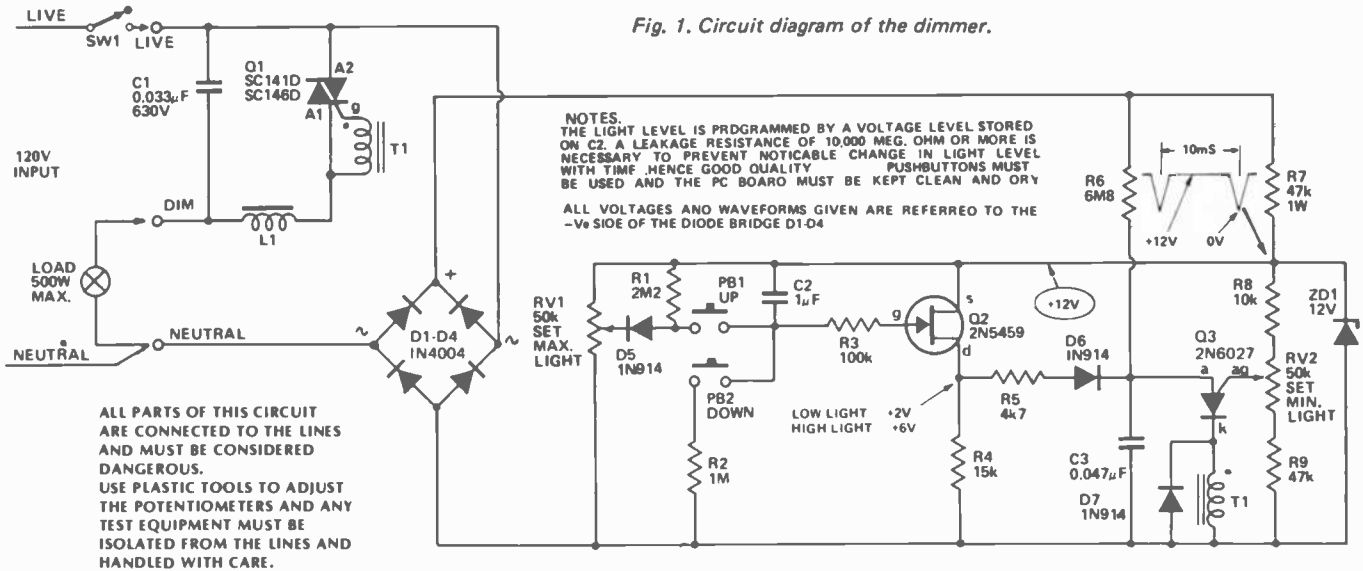

TABLE I
CHOKE WINDING DATA

CORE
30mm long piece of (3/8" dia.) ferrite aerial rod. (see main text).

WINDING
40 turns 0.63mm dia (26 swg) wound as two layers, each 20 turns, close wound using the centre 15 mm of the core only.

INSULATION
Use two layers plastic insulation tape over complete winding.

MOUNTING
Use a rubber grommet (3/8" I.D.) over each end and join to pc board using tinned copper wire in the holes provided.

TABLE II
PULSE TRANSFORMER WINDING DATA

T1
CORE
30mm long piece of (3/8" dia.) ferrite aerial rod.

PRIMARY
30 turns 0.4mm dia (30 swg) close wound on the centre 15 mm of the core.

INSULATION
Use two layers plastic insulation tape over primary winding.

SECONDARY
30 turns 0.4mm dia (30 swg) close wound on the centre 15 mm of the core. Bring wire out on the opposite side of the core to the primary.

INSULATION
Use two layers of plastic insulation tape over complete winding.

MOUNTING
Use a rubber grommet (3/8" dia.) over each end and join to pc board using tinned copper wire in the holes provided.

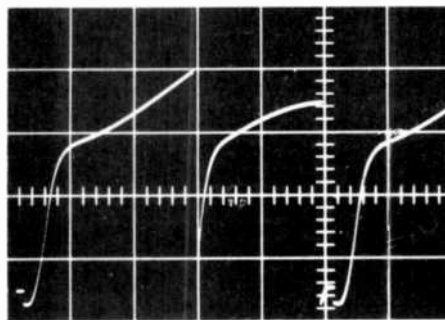

the long side, is used under the triac as a heatsink. The pulse transformer and the choke are mounted by means of rubber grommets and secured by tinned copper wire around the grommets and soldered into the holes provided.

All setting up, adjustments should be made using plastic, or well insulated tools. This circuit is live at line potential and therefore dangerous to handle. BE EXTREMELY CAREFUL.

Potentiometer RV2 should be adjusted to obtain the desired minimum light level setting, (with the down button held). Adjust potentiometer RV1 for maximum light level (with the up button held) to just past the point where maximum light level is obtained.

If the lamp load is fluorescent more care must be taken with these adjustments. Additionally the setting up must be redone if the fluorescent loading is changed.

When adjusting the maximum light point on a fluorescent load, slowly increase the light level until the lights just start to flicker. Then turn RV1 back until there is just a noticeable drop in light level. This increased setting difficulty is due to the inductive nature of fluorescent loads.

If the required minimum light level cannot be obtained within the range of RV2, increasing R6 will provide lower light level range, and decreasing R6 will provide a higher level range. ○

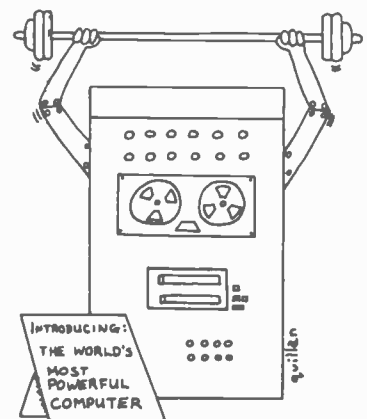
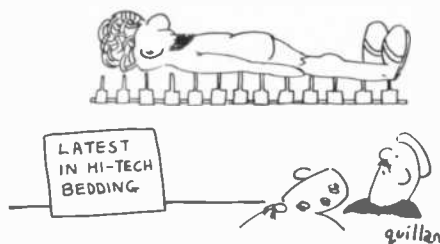

Intruder Alarm

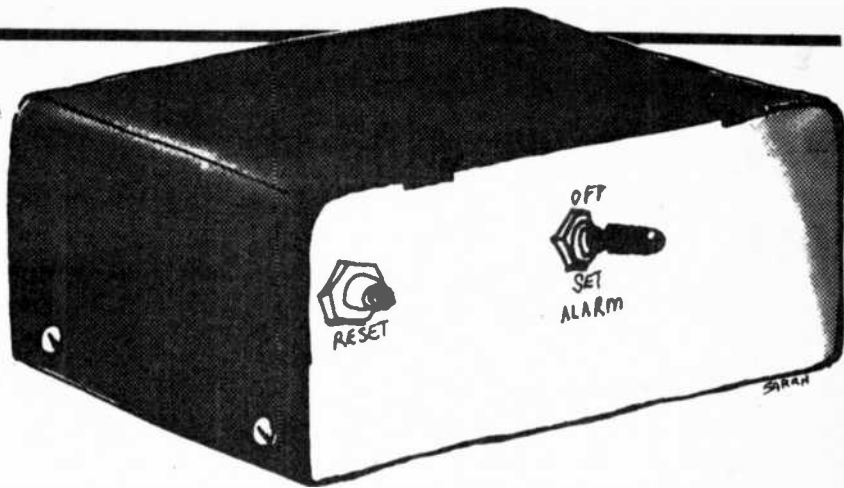

A simple burglar alarm with superior performance.

THE INCREASE in crime rate is common to the entire western world, and seems to be related to affluence rather than to poverty as was previously thought by many.

Hence, these days, the chances of your home being burgled are high indeed, and getting higher. Each householder should therefore give serious consideration to protecting his home by an effective alarm system.

In the ETI Alarm the CMOS IC has sufficiently low power drain (less than 1 mA) to make battery operation feasible. And by virtue of the high noise immunity of CMOS (half supply voltage) the unit is not susceptible to false alarms due to lightning flashes etc. Add to this the inherent reliability of integrated circuits and you have the basis of a very simple, but very effective, system.

Three modes of operation are built in to the unit which functions as follows:

ALARM MODE

Microswitches or reed relays fitted to

have closed contacts when the door, etc, is shut. All contacts are wired in a series loop such that if any door or window is opened, the loop will be broken activating the alarm. The series loop should be wired between points A and E on the circuit.

SILENT ENTRY

This mode of operation allows the owner, when leaving the premises, 30 seconds to open and close the front door before the alarm mode is activated. Additionally it allows the owner 30 seconds to disable the alarm after entering through the front door. Thus the front door microswitch is not included in the normal alarm loop but to its own 'silent entry' loop. The silent entry switch should be wired between point B and E on the circuit.

EMERGENCY

In this mode, any contact closure from a switch or sensor (eg fire, smoke

or gas detector) will immediately sound the alarm. Wire switch(s) across points F and D.

The completed alarm unit should be located in a reasonably well concealed position close to the 'silent entry' door.

The alarm bell is best located in a high, well concealed and not readily accessible position. As very high voltages are generated across the bell 'make and break' contacts it is preferable to use a separate bell battery of suitable voltage rather than to connect it across the main system battery. ○

SPECIFICATIONS

Power requirements	12 volts
Current consumption	1 mA
Silent entry delay	30 seconds approx.
Alarm circuits	Normally closed
Emergency circuits	Normally open
Alarm output	Relay change over contacts

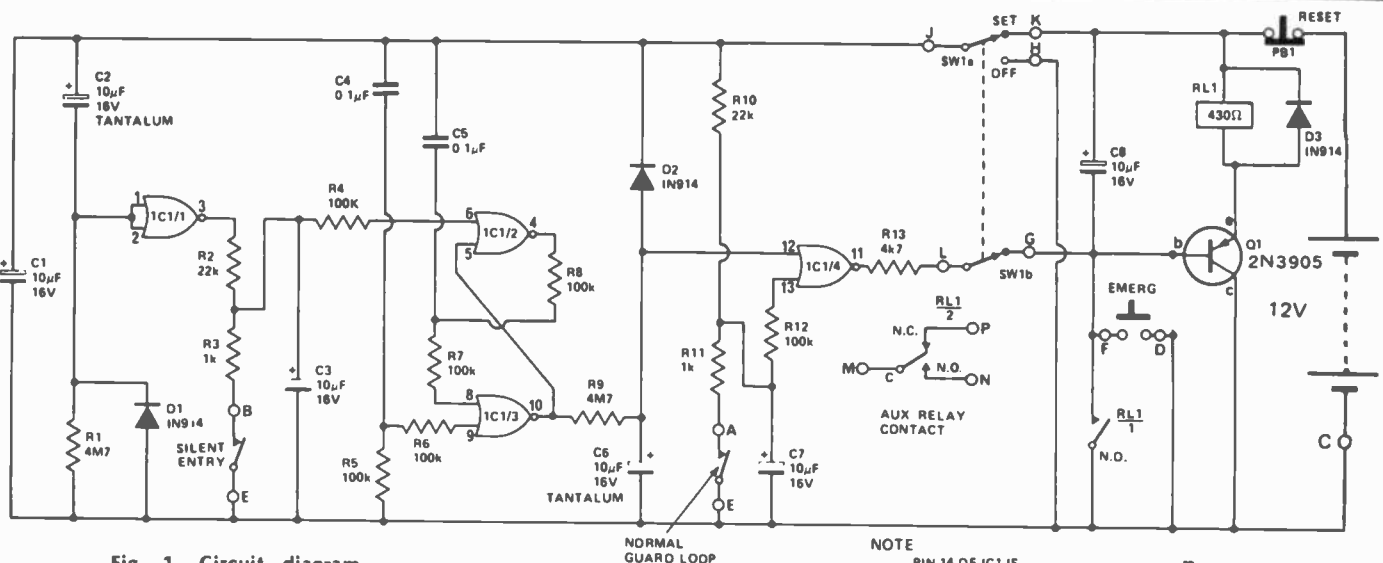

Fig. 1. Circuit diagram

NOTE

PIN 14 OF IC1 IS CONNECTED TO +12V
PIN 7 OF IC1 IS CONNECTED TO 0V



HOW IT WORKS

The alarm has three different modes of operation as described in the text.

When power is first applied, i.e. normal alarm mode enabled, capacitor C2 initially has no charge. This momentarily lifts the inputs of IC1/1 to +12 volts. The capacitor then charges slowly via R1 and the voltage presented to IC1/1 falls exponentially to zero. The output of IC1/1 will be zero if the input is over 7 volts, and at +12 volts if the input is less than 5 volts. There is a small linear region, around 6 volts, in which the output changes from zero to +12 volts. With the values given to C2 and R1 a delay of 30 seconds is provided which may be altered, if required, by changing C2. During this delay opening or closing the silent entry door will not affect the level presented to pin 6 of IC1/2.

An RS flip-flop is formed by IC1/2 and IC1/3 in which the control inputs (pins 6 and 9) are normally low (zero volts). On first switch-on pin 9 is pulled up momentarily to +12 volts by C4 before returning to zero. This presents a "1" to the input of IC1/3 and therefore its output will be low (see Table 1). Since pin 7 is at zero, and pin 5 is also at zero, (connected to pin 10) the output of IC1/2 will be high. Since this is coupled to the input of IC1/3 the flip-flop will be locked into the state

where IC1/3 output is low.

The only way the flip-flop can be reversed is for the input to pin 6 to go high. However during the first 30 seconds, as explained above, the output of IC1/1 is low. Hence, opening or closing the silent entry door during this time will not set the flip-flop and activate the alarm.

After this 30 second period, opening the silent entry door will present a "1" to pin 6 which will cause the flip-flop to change state. Closing the silent entry door will now have no effect and the flip-flop will remain set.

The high output of IC1/3 will allow C6 to charge slowly to +12 volts via R9. When this voltage reaches 6 volts (about 30 seconds) it will cause the output of IC1/4 to go low (assuming the normal alarm loop is closed). The low output of IC1/4, via emitter follower Q1, pulls in relay RL1

activating the alarm. When the relay closes contacts RL1/1 cause it to latch on, and only removing power by pressing PB1 will reset it.

If at any time the normal guard loop is broken, when the alarm is activated, a "1" is presented to pin 13 of the IC1/4 causing the output to go low and the relay to close.

When the emergency switch is closed the base of Q1 is taken to zero and the relay closes and latches. This action will take place regardless of whether the alarm is enabled or not.

Diodes D1 and D2 discharge capacitors C2 and C6 respectively via SW1 when it is in the "off" position, thus ensuring that the 30 second delay is always obtained. Resistors R6, 7 and 12 protect the CMOS IC against voltages in excess of the supply rails. Capacitors C3, 5, 7 and 8 add further protection against false triggering due to lightning etc.

INPUT		OUTPUT
A	B	
0	0	1
1	0	0
0	1	0
1	1	0

TRUTH TABLE FOR
2 INPUT NOR GATE
4001 (CMOS)

NOTES

INPUT

1 means > 55% supply voltage
0 means < 45% supply voltage

COMING UP IN ETI MAGAZINE

(Features mentioned here are planned for the August to December 1982 issues of Electronics Today International. Circumstances may well lead to changes in these plans).

30 Years of Canadian TV
Canadian Computer Store Directory
Light Memory
Hex Notation
TRS-80 Model III Review
High Performance Op Amps Circuits
Synthesizer Project
I-Ching Computer Project
Semiconductor Tester Project
Signal Tracer Project
Technical Aspects of the Scope
Telidon—Where are we now?
Crossover Networks
MX-80 Printer Review
XR2206 Function Generator Chip Circuits
150 Watt MOSFET Amp Project
Bodywork Checker Project
Sound Switch Project
Electronics In Cars
Particle Beam Fuslon
Supercooled Magnetic Sensors
History of Early Radio

DAC-ADC Circuits
Computer Terminal Project
Intelligent Ni-cad Charger Project
Into Digital IC's: Series
Game Playing Computers
Solar Energy In Canada
Flat Screen TV
What Is CP/M?
Dolby C
Voltage Controlled Pots Circuits
Solid State Reverb Project
RPM Meter Project
Heartbeat Monitor Project
Radio Astronomy
Satellite TV for Home Use
Microphones
Josephson Junctions
6500 CPUs
Junction FETs Circuits
Series 5000 Pre-amp Project
Hand Clap Synthesizer Project
Contrast Meter Project

Garden Watering

Some methods of keeping things blooming in your plots without really trying!

THIS ARTICLE is really intended for use by wives, to get their electronically-oriented men out of the workshop and into the garden!

The project provides an arrangement for checking comparative moisture levels in soil, and an arrangement responsive to a predetermined level of moisture. Further development allows for automatic watering or sounding of an alarm. A particularly attractive application takes the form of automatic watering of valuable indoor plants.

The circuits are almost ridiculously simple, and yet provide considerable interest in their preparation, construction and use.

OPERATING PRINCIPLE

Soil conductivity varies with moisture content, so that an absolute or a comparative measurement of conductivity can be translated into a corresponding measurement of moisture content. Elaborate instrumentation has been used for years in places like agricultural research stations to provide very accurate determination of soil moisture content and to control plant environments. However, intelligent use of a very simple arrangement providing only comparative indications can be very useful.

One arrangement to be described generates a tone, the frequency of which is dependent on soil conductivity, that is, on moisture content. Another arrangement triggers an external function when the soil conductivity falls below a predetermined level. The reader can gain useful experience to facilitate use of these arrangements by researching his own soil conditions.

SOIL CONDUCTIVITY

If an ohmmeter is connected to two wires pushed a few centimetres into

the ground, a resistance reading will be obtained. This resistance varies with the dampness of the soil. However, this is an over-simplification, as will be found if the ohmmeter connections are reversed almost inevitably a different reading will be obtained.

The situation becomes even more interesting if a high impedance voltmeter on a low range is connected to the wires, as a reading will usually be obtained. This potential may arise in various ways or in a combination of ways. Stray currents will usually be found, particularly near dwellings, arising from ground returns of power reticulation systems, galvanic action at buried waterpipes, and so on. Furthermore, because the soil almost certainly will not have a neutral pH balance, but will be either acidic or alkaline, two electrodes will themselves produce a battery action.

In addition to all this, soil characteristics vary a great deal. In the author's case, resistance (reciprocal of conductivity) readings which formed part of a preliminary exercise to get the "feel" of things varied considerably in apparently similar soils



measured at the same time. For example, comparatively thin wires, about 18 gauge tinned copper, showed readings varying between 15 k and 200 k for what appeared to be a reasonable range of dampness in good, "imported" garden soil. The use of thin wires was found less reliable and consistent than the use of flat electrodes or substantial rods.

Flat electrodes with effective surface areas of, say, 3-4 square centimetres in similar conditions produced a range of 10 k to 25 k. In an open yard with a heavy clay sub-soil and little dirt on top, two 8 gauge rods about 25 mm apart gave readings of 800-2000 ohms the day after a good rainstorm, and up to 15 k (on average) after a few dry days.

Indoor plants are a special case as they have only a finite amount of water available, that is, the soil being restricted to a pot, cannot call up sub-surface moisture as happens in the open garden. Potting soils can dry out to produce quite high resistance values, say several hundred thousand ohms even when substantial electrodes are used. Of course this represents a

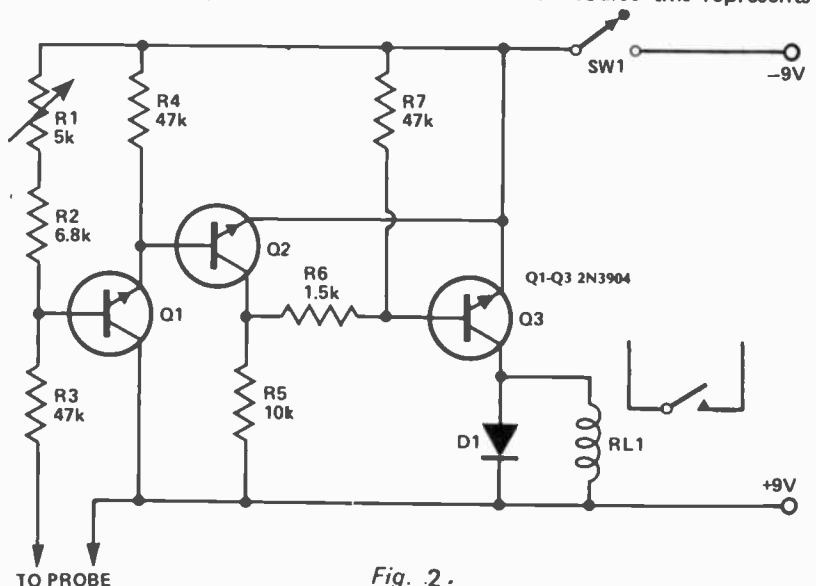

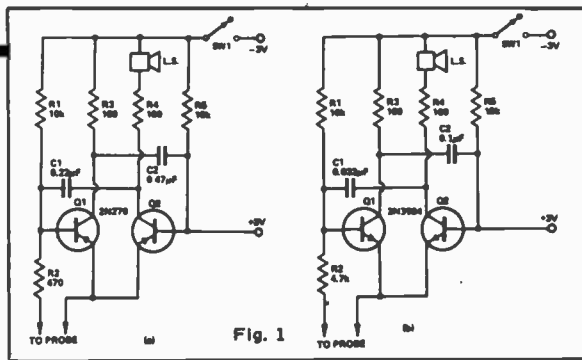

Fig. 1

condition in which a plant will already have permanently wilted.

THE PROBE

The probe can take a variety of forms, being basically two spaced electrodes inserted into the soil. However, the most successful form comprises at least two flat electrodes, rather than wires, although wires become more acceptable over 12 gauge and merging into rods. In either case a reasonably substantial exposed surface area of, say, 3-4 square centimetres produces acceptable operation in most soils.

For permanent insertion and for use with soft, friable soils, flat electrodes will probably be found most attractive, whilst for portable use with heavier soils, rod electrodes are probably best. Whilst the details are optional and dependent on the constructor's workshop resources,

The electrodes should be made of material which will not corrode. Monel metal or stainless steel are suitable. Short term experiments with tin plate are fine, but something better is needed for long-term use.

THE MOISTURE MOOD

In rather light-hearted vein the first arrangement to be described has been given a fancy name to make up for the fact that it really needs no description at all! One example using junk-box parts and two re-cycled 2N270 Ge pnp transistors is seen from Fig.1a to be a simple multivibrator, with the addition of a small speaker. Alternatively a low impedance ear plug could be used in lieu of the speaker.

With the probes in air, the circuit delivers a continuous low-pitched tone, which then increases in pitch as the probe is inserted in the soil. The higher the pitch the higher the moisture content. In cases of very high soil conductivity the note may rise above the level of hearing; in this case increase the 0.22 mfd capacitor until the highest audible pitch is obtained with a saturated area of soil.

THE WATER TRIGGER

The second device is shown in Fig.2. Its function is primarily the continuous monitoring of soil moisture content responding to a fall below a predetermined level to initiate an action. This circuit comprises a simple trigger, which operates the relay RL for values of soil conductivity below a level preset by the 5k variable resistor. The soil conductivity is sensed by a probe connected to the terminals shown. The circuit is very simple and reliable, and will operate anywhere between 6 and 12 volts or more, provided the supply voltage provides sufficient energisation for the relay. If a very low current relay is used, an appropriate limiting resistor can be inserted in the common emitter leads of Q2, Q3.

The only point really requiring attention in this circuit is the base circuit of Q1, here comprising the probe terminals, two fixed resistors (47k and 6.8k) and a 5k variable resistor. There are two possible approaches. One can insert a large value of variable resistor (say 250k - 500k) in place of the 6.8k fixed and 5k variable shown. This produces a circuit which will accept a wide range of values across the probe terminals, but will in general result in the adjustment of the variable resistor being far too wide, and all cramped at one end. The alternative is to decide the probable range of values across the probe terminals, based on tests of the kind described earlier, and then select values to suit. To see how this is done, the author's case will be worked through.

The triggering point of the circuit is with about 1.25 volts at Q1 base, but do not try to measure it with a low impedance voltmeter. This voltage corresponds to a supply voltage division at Q1 base of 1.25:7.75, so that the voltage between Q1 base and the positive supply rail is 6.2 (7.5 + 1.25) times the voltage between Q1 base and the negative rail. Therefore the resistances in the two parts of the

circuit need to have the same relationship. This ignores Q1 base current, which has fallen to a negligible value near the triggering point.

Initially a range of 500-25,000 ohms across the probe terminals was chosen as being correct for the application intended, based on test plus a margin. For the 500 ohm case, therefore, $47k + 50 = 6.2x$, where x is the resistance Q1 base to supply negative. This produces $x = 7661$ ohms. Similarly for the 25k case, $47k + 25k = 6.2x$, so that $x = 11613$ ohms. This shows a variation in x of $11613 - 7661 = 3952$ ohms. However, this is an awkward value, the nearest reasonable value being 5k. Then $11613 - 5k = 6613$, the obvious choice for the fixed resistor being 6.8k. Checking back then with these values, for $5k + 6.8k = 11.8k$, so that $+47k = 73.16k (11.8 \times 6.2)$, so that the probe resistance is $73.16k - 47k = 26.16k$. For 6.8k alone and the 5k variable all out of circuit, the probe + $47k = 42.16k (6.8 \times 6.2)$, giving a negative value for the probe resistance ($42.16 - 47 = 4.84$). Thus the chosen values provide for a probe variation of zero to 26.16k ohms, slightly wider than required. Similar simple calculations will provide values suitable for any other range of probe values.

WATER TRIGGER APPLICATIONS

One of the circuits of Fig. 1, less the probe connections, can be connected into the circuit of Fig. 2 in place of the relay and protective diode. A resistor of about 1k would also be needed in the common emitter lead of Q2, Q3 and Fig. 2. This combination draws about 8-10 mA in the alarm condition.

However the most important application of the trigger circuit is as an automatic waterer. Consider the case of an indoor planter box. The probe will indicate water content in the soil and trigger the circuit at a preset point. The relay is used to operate a low-voltage water pump, such as an aquarium pump, to pump water from an available supply into the plant container. If the water is well distributed over the surface, for example using a meandering tube with many small holes, the soil moisture content will be increased fairly evenly until the probe decides the minimum level has been left behind. At this stage the circuit resets and awaits further transpiration and evaporation. ○

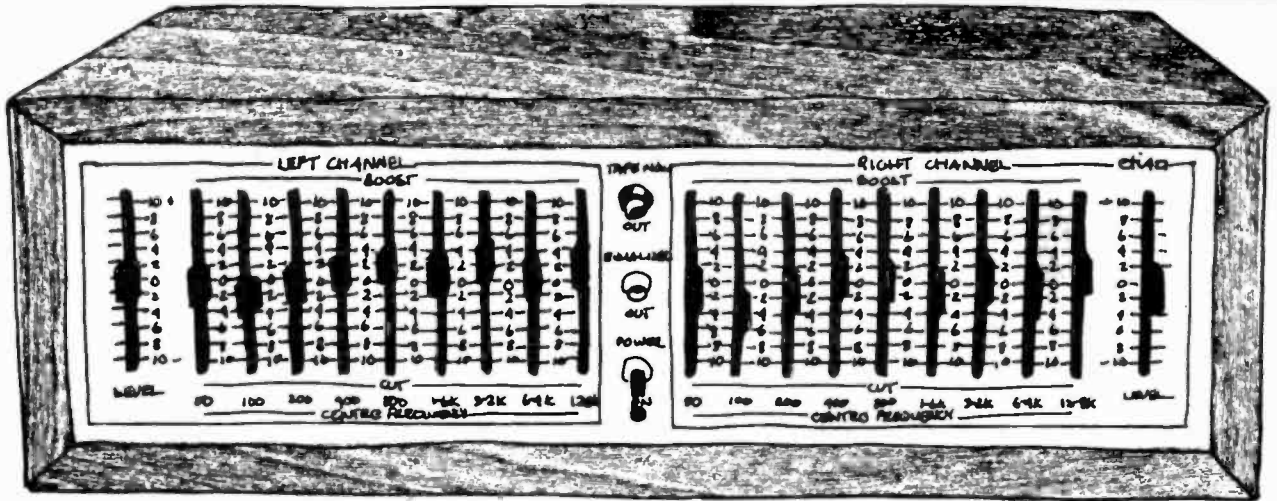

Graphic Equalizer

A unit that compensates for speaker and room deficiencies.

MANY audiophiles are discovering the advantages of graphic equalizers in domestic as well as professional sound systems. Unfortunately the costs of such units have prevented them becoming as popular as warranted by the many advantages they offer.

The advantages of an equalizer are not generally well known but are as follows.

Firstly an equalizer allows the listener to correct deficiencies in the linearity of either his speaker system alone, or the combination of his speaker system and his living room.

As we have pointed out many times in the past, even the best speakers available cannot give correct reproduction in an inadequate room. It is a sad fact that very few rooms are ideal, and most of us put up with resonances and dips, sadly convinced that this is something we have to live with.

Whilst the octave equalizer will not completely overcome such problems, it is possible to minimize some non-linearities of the combined speaker/room system.

In a concert hall it is also possible to use the unit to put a notch at the frequency where microphone feedback occurs, thus allowing higher power levels to be used.

Thirdly, for the serious audiophile, an equalizer is an exceedingly valuable tool in evaluating the deficiencies in a particular system. One adjusts the equalizer to provide a uniform response, the settings of the

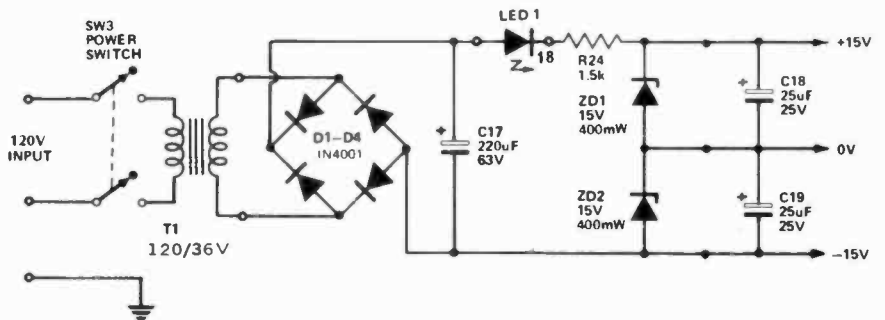
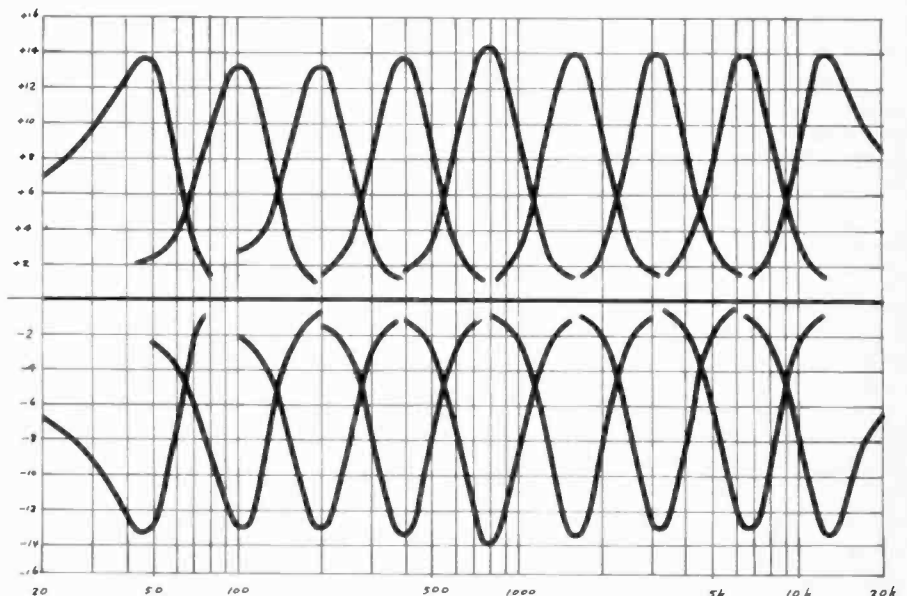

Fig. 1. Circuit diagram of the equalizer power supply.



Individual filter responses for the unit. Boost at top and cut at bottom.

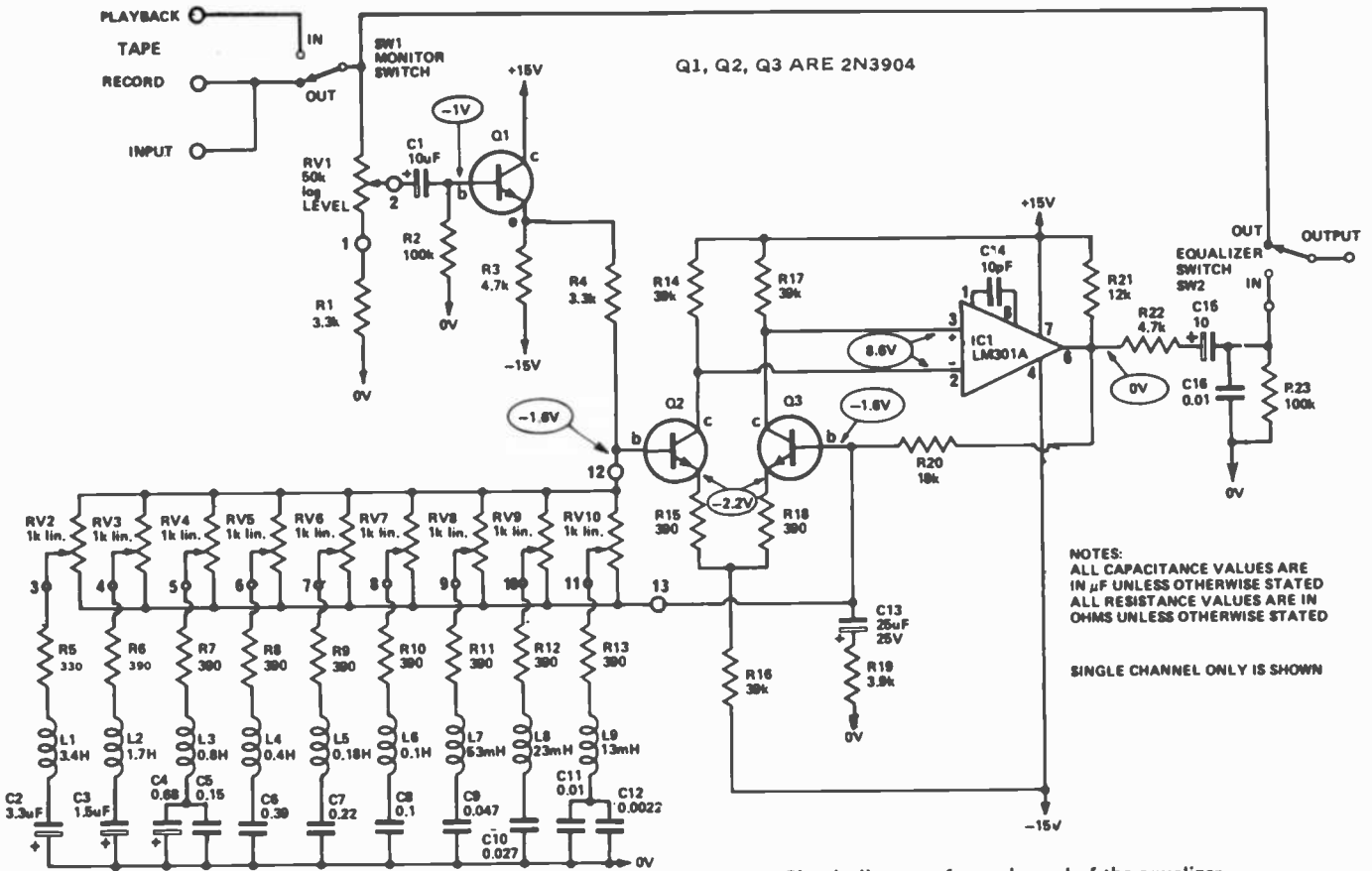

Fig. 2. Circuit diagram of one channel of the equalizer.

potentiometer knobs then graphically display the areas where the speaker etc is deficient.

There is a snag, however, one must have an educated ear in order to properly equalize a system to a flat response. It is not much use equalizing to your own preference of peaky bass etc in order to evaluate a speaker.

Ideally, a graphic equalizer should have filter at 1/3 octave intervals, but except for sound studios and wealthy pop groups, the expense and size of such units are too much for most people.

Due to tolerances of resistors variations in V_{be} of Q2 and Q3 etc, the steady-state output of IC11 may be anywhere within plus or minus one volt of zero.

Hence it is desirable to determine the polarity of the steady state voltage at pin 6 of IC1 in order to determine which way round C15 should be inserted. If the output is positive insert as shown in Fig. 1. Alternatively C15 should be a non-polarized type. ○

MEASURED PERFORMANCE (of Prototype)

Frequency Response		
Equalizer out		Flat
Equalizer in	10 Hz – 10 kHz	$\pm \frac{1}{2}$ dB
and all controls at zero	1.5 Hz – 30 kHz	$+\frac{1}{2}$ – 3 dB
Range Of Control		
Individual filters		± 13 dB
Level control		+ 14 – 9 dB
Maximum Output Signal		
at < 1% distortion		> 6 volts
Maximum Input Voltage		3 volts
Distortion		
at 2 volts out, controls flat	100 Hz	1 kHz
	< 0.1%	< 0.1%
	6.3 kHz	< 0.1%
Signal to Noise Ratio		
at 2 volts out (unweighted)		69 dB
Input Impedance		50 k
Output Impedance		4.7 k

GRAPHIC EQUALIZER

The equalizer stage is a little unusual in that the filter networks are arranged to vary the negative feedback path around the amplifier. If we consider one filter section alone, with all others disconnected, the impedance of the LCR network will be 390 ohms at the resonant frequency of the network. At either side of resonance the impedance will rise (with a slope dependant on the Q of the network which is 2.5) due to the uncancelled reactance. This will be inductive above resonance and capacitive below resonance. We can therefore represent the equalizer stage by the equivalent circuit below.

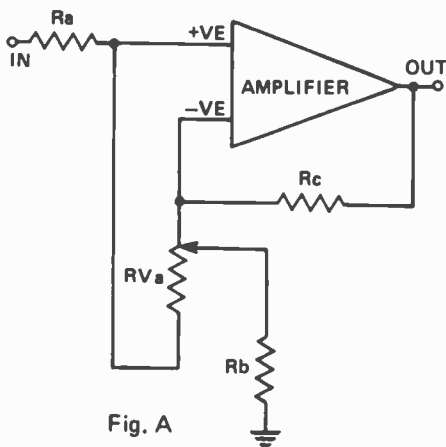

Fig. A

It must be emphasized that this equivalent circuit represents the condition with one filter only, at its resonant frequency. Additionally letters have been used to designate resistors to avoid confusion with components in the actual circuit.

With the slider of the potentiometer at the top end (Fig. A) we have 390 ohms to the OV line from the negative input of the

amplifier, and 1 k between the two inputs of the amplifier. The amplifier, due to the feedback applied, will keep the potential between the two inputs at zero. Thus there is no current through RVA. The voltage on the positive input to the amplifier is therefore the same as the input voltage since there is no current through, or voltage drop across resistor Ra.

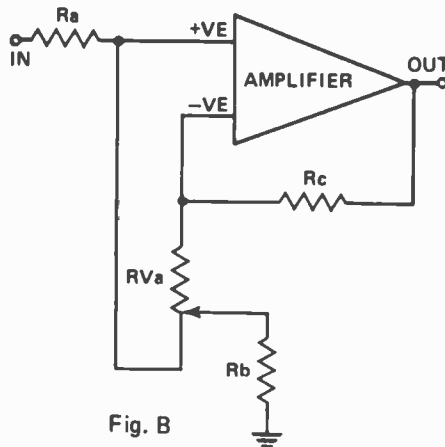

Fig. B

The output of the amplifier in this case is approximately the input signal times $(3300 + 390)/390$ giving a gain of 19 dB. If the slider is at the other end of the potentiometer, (Fig. B), the signal appearing at the positive input, and thus also the negative input, is about 0.11 $(390/(3300 + 390))$ of the input. There will still be no current in the potentiometer and in RC, thus the output will be 0.11 of the input. That is, the gain will be -19 dB.

If the wiper is midway, both the input signal and the feedback signal are attenuated equally, and the stage will have unity gain.

With all filter sections in circuit the maximum cut and boost available is reduced, but ± 14 dB is still available.

Reverting back now to the actual circuit,

the amplifier consists of IC1, Q2 and Q3. The transistors help to reduce the effect of the noise in the IC and add gain at the high-frequency end. This additional gain is required because the negative feedback, due to the potentiometer between the two inputs, causes high-frequency roll off. This does not affect operation of the unit provided the open-loop gain is above 60 dB over the entire audio range. An overall closed-loop gain of about 15 dB is

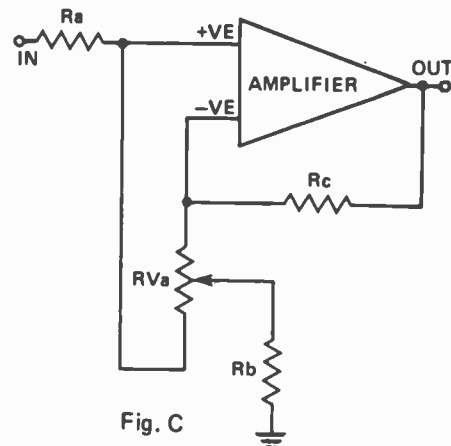

Fig. C

maintained by R20/R19 with the filter potentiometer at mid position.

The output of the amplifier is decoupled to the output of the unit via C15, and C16/R22 provide a cutoff above 30 kHz.

The input signal is buffered by Q1 because the equalizer stage requires a low impedance signal source for correct operation. Potentiometer RV1 provides level control with 0 to -23 dB range which, combined with the equalizer characteristic, results in an overall level range of +14 to -9 dB.

The power supply used is a simple, full-wave bridge filtered by C17. Plus and minus supplies are derived by means of two 15 volt zeners in series fed via R24. The front-panel power indicator is an LED connected in series with the dropping resistor R24.

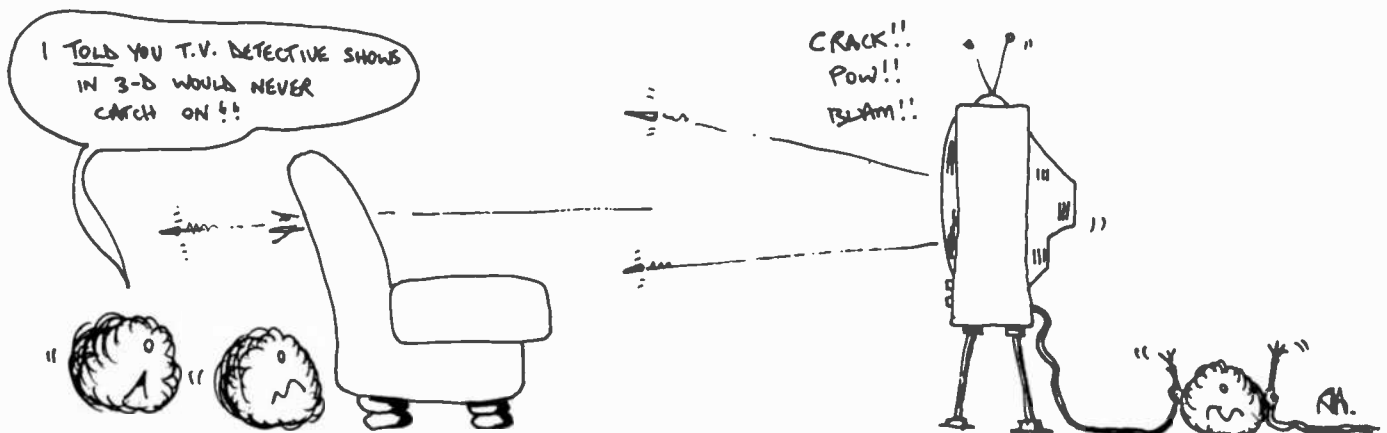

Touch Switch

New 120V design offers toggle action and complete safety.

IN THE TOUCH switch described in this project, it was specified that the action of the switch should be touch-on touch-off, and that no actual contact with the circuit be made (for safety reasons). These constraints led us to use a capacitive circuit. The touch plate is in effect a capacitor. When this plate is touched, the input of the first stage is capacitively referenced to ground, however as the supply falls to the control circuit are floating at rectified 120Vac the 60 Hz waveform effectively appears at the input of the control circuit and initiates the switch action. The actual contact plate is a piece of single-sided printed-circuit board arranged so the the non-copper



side is touched — the copper on the other side is connected to the control circuit.

CONSTRUCTION

A touch switch may be constructed (and used) in many different ways. It may be mounted within the base of a lamp; fitted onto a conventional switch-plate to control overhead lights; or mounted in a piece of electronic equipment. It is however unlikely that the switch would be used as a separate unit and for that reason housing details have not been provided.

As stated above the touch plate is constructed from a piece of printed-circuit board as detailed in the

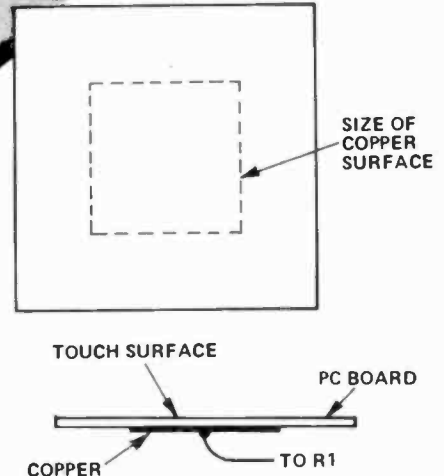

We constructed our touch plate from a 50 mm square piece of printed-circuit board. The board was etched to leave a 25 mm square section of copper in the centre. See text if different sized plate or long connecting lead is to be used.

HOW IT WORKS

POWER SUPPLY

The 120 Vac is rectified by diodes D4 to D7. The output of the diode bridge is then reduced, smoothed and regulated to 6 volts dc by R11, ZD1 and C5. The load is connected after the rectifier and has power switched to it via the silicon-controlled rectifier, SCR. Note particularly that the load is supplied with pulsating dc and therefore the type of load used with this circuit must be resistive, for example, an incandescent lamp. For inductive loads such as transformers etc, the load circuit must be modified as shown in the small diagram.

DETECTOR

The detector is formed by one section of a CMOS hex inverter, IC1a, in which the gain is set by the ratio of R2/R1. The touch plate is connected to the input of the detector and touching it effectively adds a capacitor to ground. However the '0' volt line (due to the diodes D4 to D7) when referenced to ground is effectively 60 Hz 120 volt rectified. The touch plate capacitance introduced therefore couples this waveform into the input of the

detector and over-drives the amplifier so that the output is a 60 Hz squarewave. If the plate is not touched the capacitance is very much lower and hence the output of the amplifier is very much lower in level. The sensitivity may be altered by changing the value of R2 (lower value gives less sensitivity).

LEVEL SHIFTER

The output of IC1a is centred about 3 volts, and C1, R3 and IC1b are used to provide level shift such that the output of IC1b is normally high at +6 volts until the plate is touched. When the plate is touched the output of IC1b oscillates between +6V and 0V at a 60 Hz rate. The hex-inverter IC has diodes internally which connect each input to ground. Thus these diodes prevent the inputs from being driven below -0.6 volts.

PULSE STRETCHER

The 60 Hz output from IC1b is not in a convenient form and must be converted into a signal which is only high and stays high whilst the plate is touched. This is performed by a pulse stretcher and inverter consisting of IC1c together with R4 and C2. The

output of IC1c is normally low and goes high and stays high whilst ever the plate is touched.

FLIP FLOP

To meet our mode of operation requirement the circuit needs to be held on after the finger is removed from the plate and only switched off when the plate is touched a second time. Thus a toggle action is required and this is obtained by incorporating a flip flop formed by IC1d and IC1e. Cross coupling of gates normally provides an RS flip flop which may take up any state if both inputs are taken high together. For this reason the capacitors, resistors and diodes at the inputs to the flip flop are used to provide steering logic to ensure that correct toggle action is obtained.

BUFFER

To prevent loading the flip flop, and because a spare section of the hex inverter is available, a buffer amplifier is inserted between the flip flop and the SCR. The SCR used is a C106D which is a sensitive gate type. This particular SCR will operate reliably with the 1 mA gate current provided. The SCR specified will be used — don't try substitutes.

Fig. 1 The complete circuit.

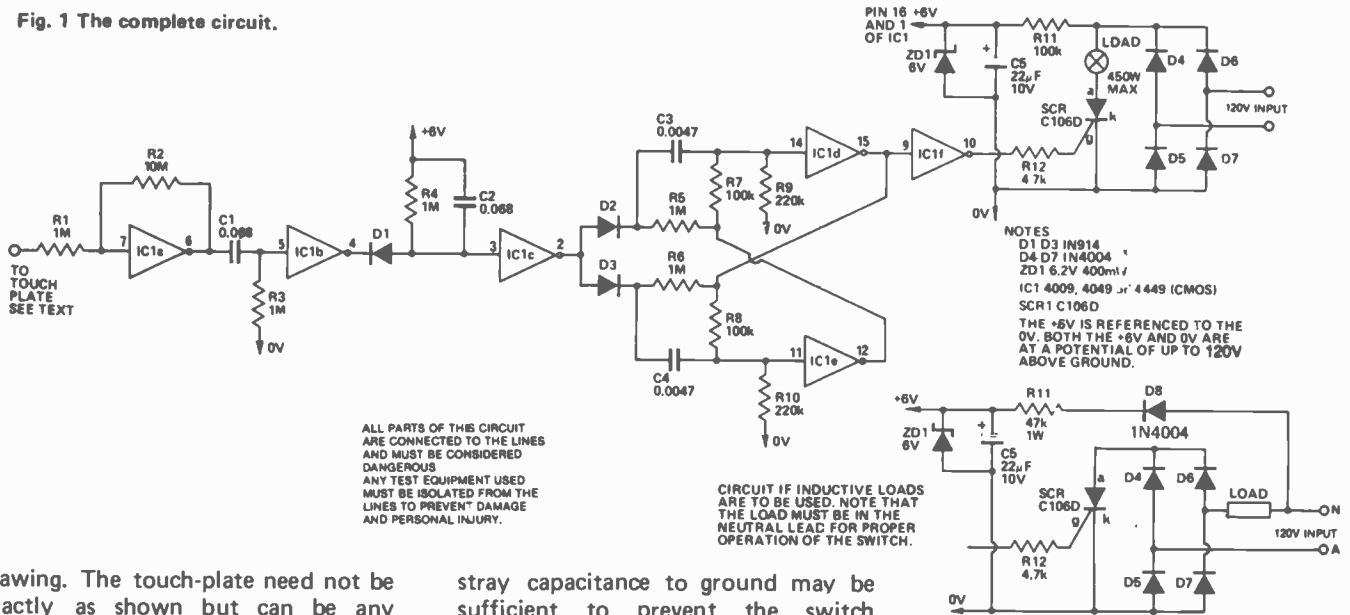

Drawing. The touch-plate need not be exactly as shown but can be any convenient shape or size. However make sure that the copper surface of the plate cannot touch any of the external metal surfaces and that it cannot be touched by the fingers. If the unit is to be built into a lamp that has a plastic base a piece of aluminium foil may be glued to the inner surface of the base to act as the pickup plate.

If the plate is too large or the lead connecting it to the circuit too long,

stray capacitance to ground may be sufficient to prevent the switch operating. If the lead is more than about 50 mm long shielded cable should be used (shield connected to '0' volts not to ground). If a large plate is used the gain of the first stage should be reduced by changing the value of R2. (Try 3.3 M first and if this is not effective try 1 M).

The circuit given in the main circuit diagram supplies the load with pulsating dc and is therefore suitable

to drive resistive loads (such as light bulbs) only. If an inductive load must be supplied the slightly more complex alternative circuit (shown in the insert) must be used. In this circuit the load must be inserted in the neutral lead if the switch is to operate correctly. Thus it is essential to ensure that the active and neutral are connected correctly. ○

Simple Stereo Amplifier

Ideal beginner's amplifier suits simple record players.

THIS SIMPLE stereo amplifier uses two LM380 IC's and a minimum of external components, it can easily be assembled in only one or two evenings. It is designed to match the *crystal* cartridges found on most simple record players and gives surprisingly good results. ○

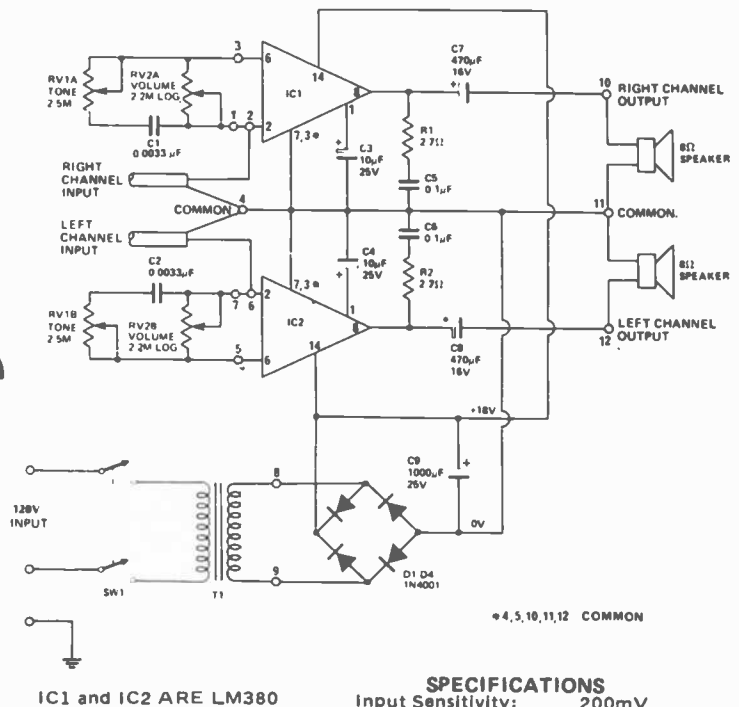

SPECIFICATIONS

Input Sensitivity:	200mV
Input Impedance:	150k
Output power:	2.5W RMS/channel
Distortion:	0.2%
Bandwidth:	100kHz (tone control flat)
Loudspeaker impedance:	8 ohm or 15 ohm

Drill Speed Controller

Variable speed control maintains constant (adjustable) speed regardless of load.

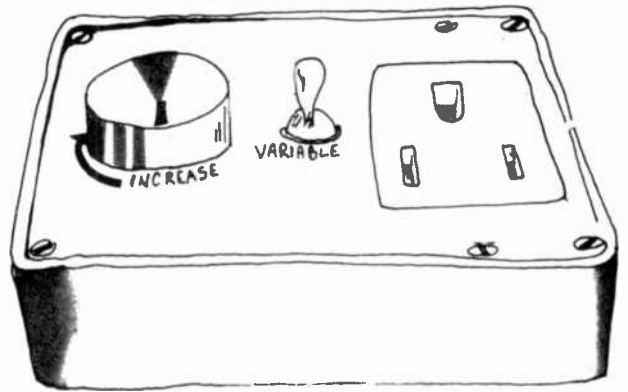

MOST HANDYMEN own a power drill.

There are tens of millions of them in use around the world — and they continue to be used for an ever greater variety of tasks.

Despite their popularity, many power drills have one major drawback and this is that their speed is often too high for many applications.

This is so even with dual-speed models where even the slow speed, typically 300-750 RPM, is too fast for such jobs as drilling masonry or using fly-cutters on sheet metal etc.

The speed controller described here allows infinite variation of speeds from zero to about 75% of full speed, and is provided with a switch to allow normal full-speed operation without disconnecting the drill from the controller. The controller has built in compensation to maintain substantially constant speed regardless of changes in load.

CONSTRUCTION

It must be emphasized that the controller is connected directly to the lines without the use of an isolating transformer. Care must therefore be taken with the construction to ensure that there is no likelihood of any dangerous conditions arising.

The SCR used is a stud mounting type and is mounted by using the solder lug, supplied with it, soldered onto the centre lug of the switch. For loads up to 3 amps no other heat-sinking is required. If a plastic-pack SCR is used a hole may be drilled through the switch lug and the SCR bolted directly to it. However in this case it is advisable to insert a piece of aluminum (about 25 mm x 15 mm) between the SCR and switch lug to act as a heatsink.

Remember that, since the unit operates at 120 Vac all external parts must be grounded. We used a plastic box with a metal lid. But we also used a

cable clamp with a metal screw through the side of the plastic box. This screw must be grounded, along with the lid and the ground terminal of the output socket. The ground wire should be continuous that is, it should go from one ground point through to the next and not be separate links. Two ground wires may be soldered to one ground lug. But under no account should two wires be secured under a single screw.

With some SCRs it may be found that the trigger current supplied by R1 and R2 is insufficient. If this is the case an additional 10 k resistor should be placed in parallel with each resistor.

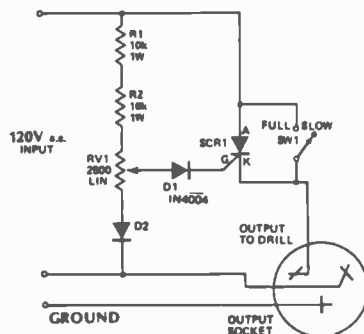

USING THE CONTROLLER

Plug the controller into the wall and the drill into the controller. Select either full speed or variable as required. Note that there is no ON/OFF switch provided on the unit and the normal switch on the drill is used for this purpose. When full speed is selected the drill will run normally and the speed control on the controller will have no effect.

At very low speeds it may be found that drill runs jerkily under no load.

When variable speed is selected, the control will adjust the speed anywhere between zero and about 75% of full speed. There may be a dead zone at both low speed and high speed ends of the control. This is entirely normal and is due to different drill characteristics and component tolerances within the controller.

However as load is applied the speed will smooth out.

When using the drill at less than full speed the cooling of the motor will be considerably reduced (as the cooling fan is on the armature shaft and also runs slower). Hence the drill will get hotter when used at low speeds, and extended periods of use in this mode should be avoided. ○

HOW IT WORKS

A universal motor, when running, produces a voltage which opposes the supply. This voltage, called the back EMF, is proportional to the speed of the motor. The SCR drill speed controller makes use of this effect to provide a certain amount of speed versus-load compensation.

This controller uses an SCR (silicon controlled rectifier) to gate half-wave power to the drill motor. The SCR will conduct only when a) anode (terminal A) is positive with respect to the cathode (terminal K), b) when the gate (terminal G) is at least 0.6 volts positive with respect to the cathode, and, c) when about 10 mA gate terminal. By controlling the level of the voltage waveform to the gate we effectively control the time at which the SCR turns on in each forward half cycle. By this means we effectively control the amount of power delivered to the drill.

Resistor R1, R2 and potentiometer RV1 form a voltage divider which provides a half wave voltage of adjustable amplitude to the gate of the SCR. If the motor is stationary the cathode of the SCR will be at zero volts and the SCR will turn on almost fully. As the drill speed increases, a voltage develops across the drill thus reducing the effective gate-cathode voltage. Thus as the motor speeds up, the power delivered decreases until the motor stabilizes at a speed determined by the setting of RV1.

Should a load be placed on the drill, the drill will tend to slow down, but as the voltage across the drill also drops, more power is delivered to the motor since the SCR firing-time is automatically advanced. Hence the speed, once set, is maintained relatively-constant regardless of load.

Diode D2 is used to halve the power dissipated in R1, R2 and RV1 by limiting the current through them to positive half-cycles only. Diode D1 protects the SCR gate against excessive reverse voltage.

In the full speed position the SCR is simply shorted out by SW1. Thus RV1 loses control and full power is applied to the drill.

Audio Frequency Meter

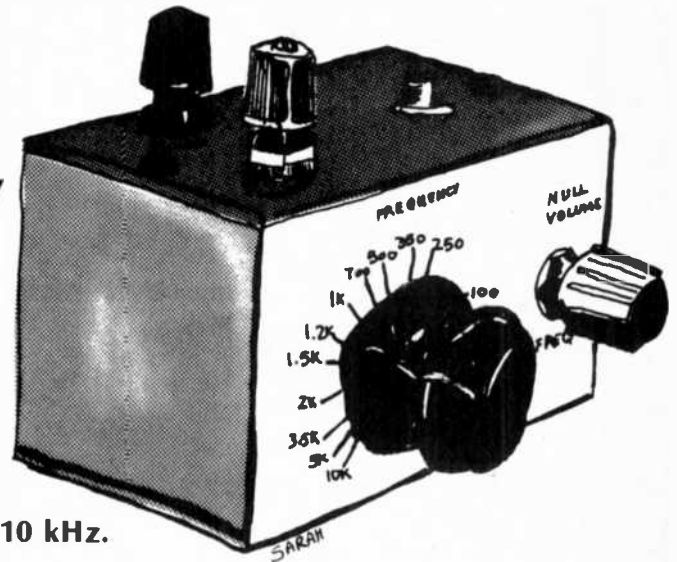

Simple unit measures frequencies from 50 Hz to 10 kHz.

ON MANY occasions it is useful to be able to determine the frequency of an audio signal. Often, the accuracy and expense of a commercial frequency meter is not justified.

This little circuit, using only a few components will provide an indication of frequencies from 50Hz to 10kHz with an accuracy primarily determined by the calibration of the instrument.

The audio signal — of which the frequency is to be established — is fed into the input terminals of the unit and the calibrated dial adjusted until a 'null' is obtained whilst listening to the signal through a pair of headphones, or even a single crystal earpiece.

We suggest that the components be mounted in one of the small aluminum miniboxes which are available readily at low cost. Our prototype unit had a 4" x 2½" front panel, but a larger box will enable a larger frequency scale to be used hence providing better resolution. Apart from this a larger box will allow input terminals and output socket to be mounted on the front panel together with the frequency-null controls.

Note that the dual potentiometer is a logarithmic type and is wired such that the frequency scale *increases* with anti-clockwise rotation. This results in a more linear scale (less cramped at the high end) than if wired conventionally.

Any type of earpiece or headphone may be used to detect the null but best efficiency will be obtained with those having an impedance of around one thousand ohms.

The best way to calibrate your meter is to compare it with a good quality oscillator and mark your scale to suit. Remember that most potentiometers have a manufacturing tolerance of

±20% and hence our front panel drawing may not be correct for your potentiometer.

If an oscillator is not available, but you do have an ohm-meter, then calibration may be carried out by measuring the settings of RV2 (disconnected from the circuit) and marking the scale as shown in Table I.

To use the meter, couple the audio signal into the input terminals and adjust RV2 to a point where the signal drops off. Adjust RV1 to increase the null and RV2 again for the final setting. The frequency of the incoming signal is then read from the front scale. What could be simpler? ○

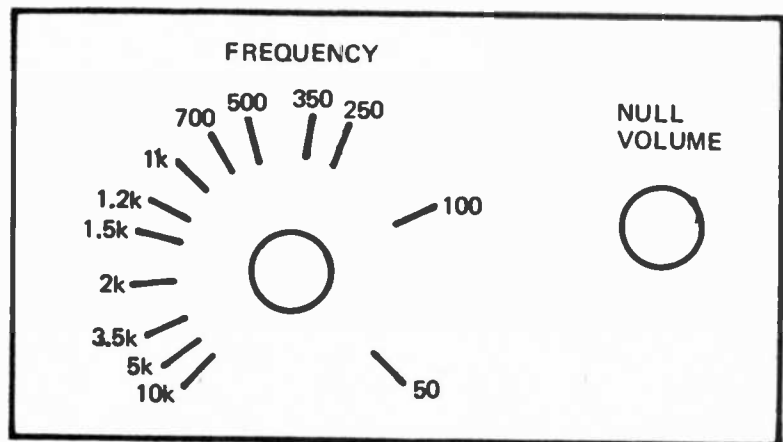
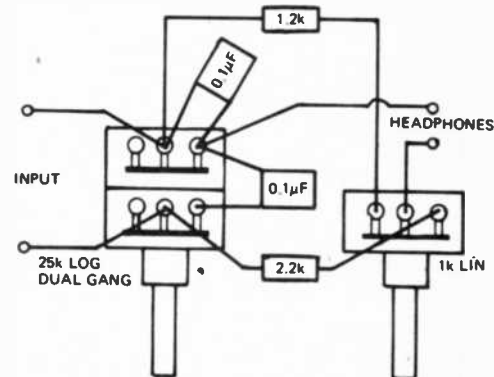
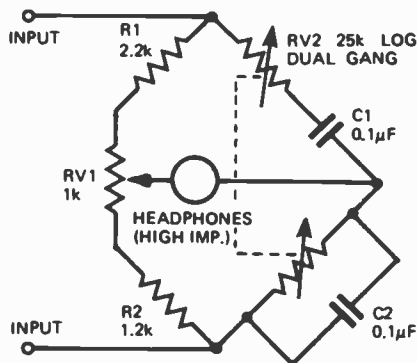

Fig. 3 Front panel of our meter shown for information only — calibration may not suit all potentiometers

HOW IT WORKS

The circuit is that of a Wien bridge which when used for frequency measurement has the form shown below:—

If $C_x = C_s$, $R_x = R_s$ and $R_a = R_b$, then $f = \frac{1}{2\pi C_s R_s}$ or, $R_x = R_s = 0.628 f$

where $C_x = C_s = 0.1\mu\text{f}$. Our calibration chart was calculated from this last formula.

At the frequency where the reactance of C_s equals R_s and also $C_x = R_x$, the series network has an impedance of $1.414R$ and phase angle of 45° . The parallel network has an impedance of $0.707R$ and the

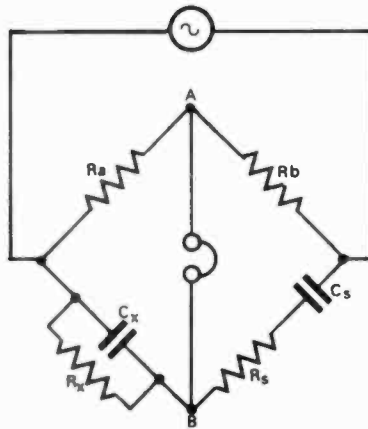

same phase angle. The signal at point B will therefore be in phase with the input level, but attenuated to $1/3$ of that level. If $R_b = 2R_a$ the signal at A will also be attenuated to $1/3$ of the input. Thus the bridge is balanced and the signals at A and B will be equal in amplitude and phase and a null will occur at that frequency.

At any other setting of the potentiometer the phase angle and amplitudes will be such that an increased output is obtained.

The respective sections of the dual ganged potentiometer never track each other perfectly and hence RV1 has been included to obtain best null at any point on the scale.

Basic Power Supply

Simple regulated supply provides 4.5-12 volts at 400 mA maximum.

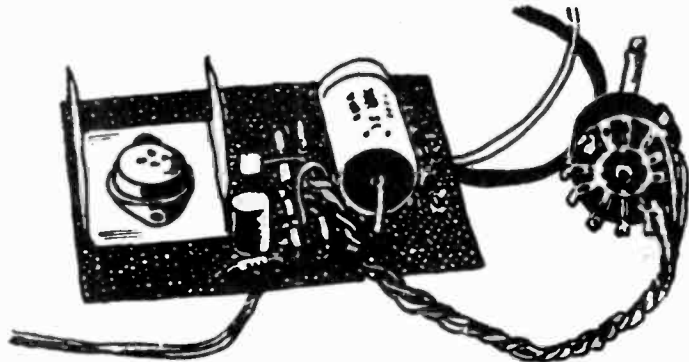

THIS little power supply provides a range of switch selectable output regulated voltages from 4.5 to 12 volts, selectable by a switch. The supply will provide up to 400 mA and the output can withstand a short circuit without damage. It is therefore ideal for the experimenter or for use with high drain appliances. ○

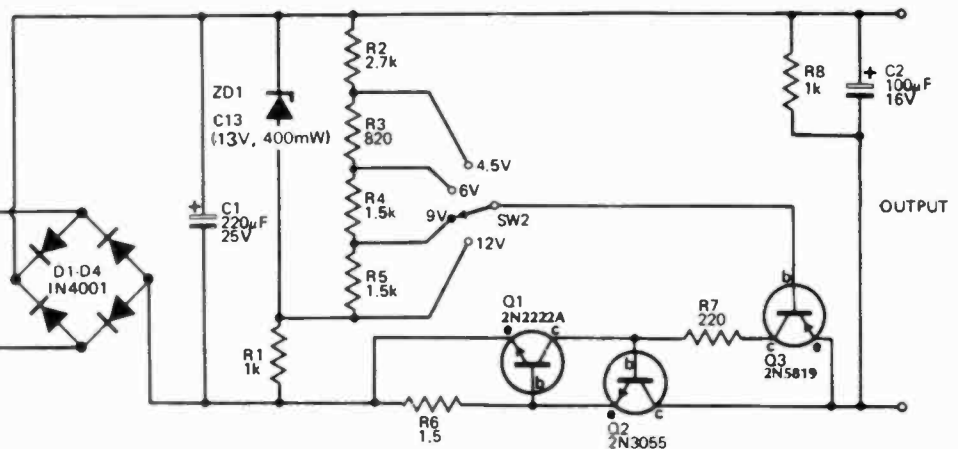
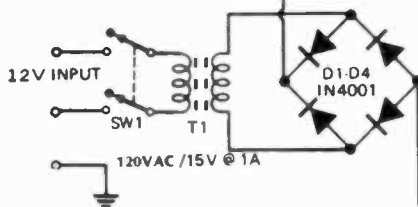

HOW IT WORKS

The 120V line voltage is reduced to 15 volts by transformer T1, and this secondary voltage is then fullwave rectified by rectifier bridge D1-D4.

The output of the bridge rectifier is filtered by C1 to provide approximately 20 volts dc.

The series combination, of Zener diode ZD1 fed by resistor R1, provides a stabilized voltage of around 13 volts which is applied across the voltage divider R2, R3, R4 and R5. Thus a series of reference voltages are generated for the regulator, where the positive rail is fixed and the

negative rail is the one that is varied.

Transistor Q3 is an emitter follower where the output (emitter) is about 0.6 V higher (more positive) than the base. The base voltage is selected by SW2 from one of the tapings on the reference-voltage divider. Since Q3 cannot handle the required output current, it drives Q2, a power transistor, which can handle the required load.

When the load exceeds 400 mA (approximately), the voltage drop across R6 forward biases Q1 which turns on and shunts current away from the base of Q2.

Thus the regulator loses control and the output voltage falls, limiting the current to 400 mA. As the power dissipated in Q2 under short-circuit conditions is around 10 watts, Q2 must be fitted to a heatsink. Additionally, resistor R7 limits the current supplied by Q3 to a safe value (for Q3) under short circuit conditions.

If a fully variable supply is required, a 10 k potentiometer should be used in place of the voltage divider. The wiper of the potentiometer is then fed directly to the base of Q3.

Waa Waa Unit

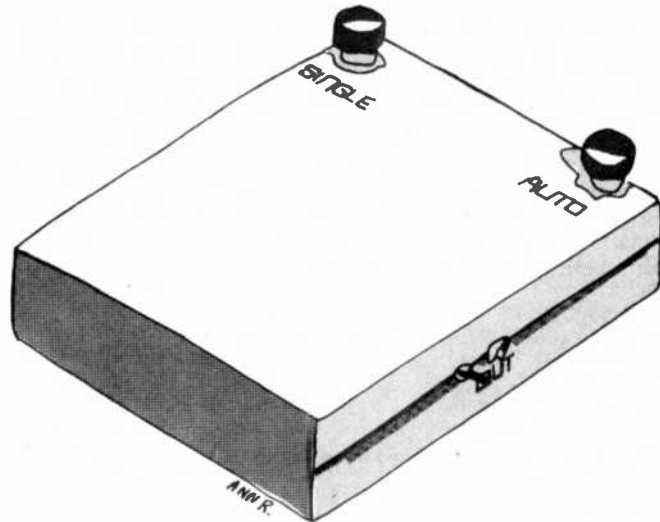

PERHAPS THE MOST used of all the various guitar effects is that of the 'Waa-Waa' unit. The sound of this circuit has been screaming from speaker stacks for many a decibel-ridden year now, and no doubt will continue to do so for a while yet.

Our unit described here will, we hope, contribute to this longevity!

Basically the characteristic sound of a Waa-Waa unit is produced by sweeping a band-pass filter across the audio spectrum of a guitar, a frequency range of approx. 70Hz–6kHz. This can be done in various ways, but is usually tailored to be operated by a foot pedal. However, these pieces of hardware are both expensive and hard to obtain other than full of electronics.

BACK PEDALLING

Since our design was to be for the home constructor, we decided against the use of a pedal, and instead we have substituted two foot switches. These are much cheaper and should be easy to get hold of.

By avoiding the pedal, we created a problems for ourselves, in that we could no longer operate the filter with a variable resistor. Instead it is made to sweep across the range by the switching into circuit of three capacitors, which alters the resonant frequency of the filter.

ON THE LEVELS

The input impedance of the unit is about 2k and the first stage gain such

that the device operates best with an input of around 10–20mV. Signals much higher will cause the stage to distort the incoming signal. If you wish to cause distortion of course, then go ahead (did someone mutter 'Fuzz to you too'?!) If not then a volume control of at least 2k is a good idea if the input exceeds 50mV. Output impedance is low and will match any amplifier.

USE AND ABUSE

Using the unit should pose no real problems, and there is no setting up to be done. Operating the single switch will result in a 'waa' on the next note played through the circuit. It is best not to hold the switch closed, but to

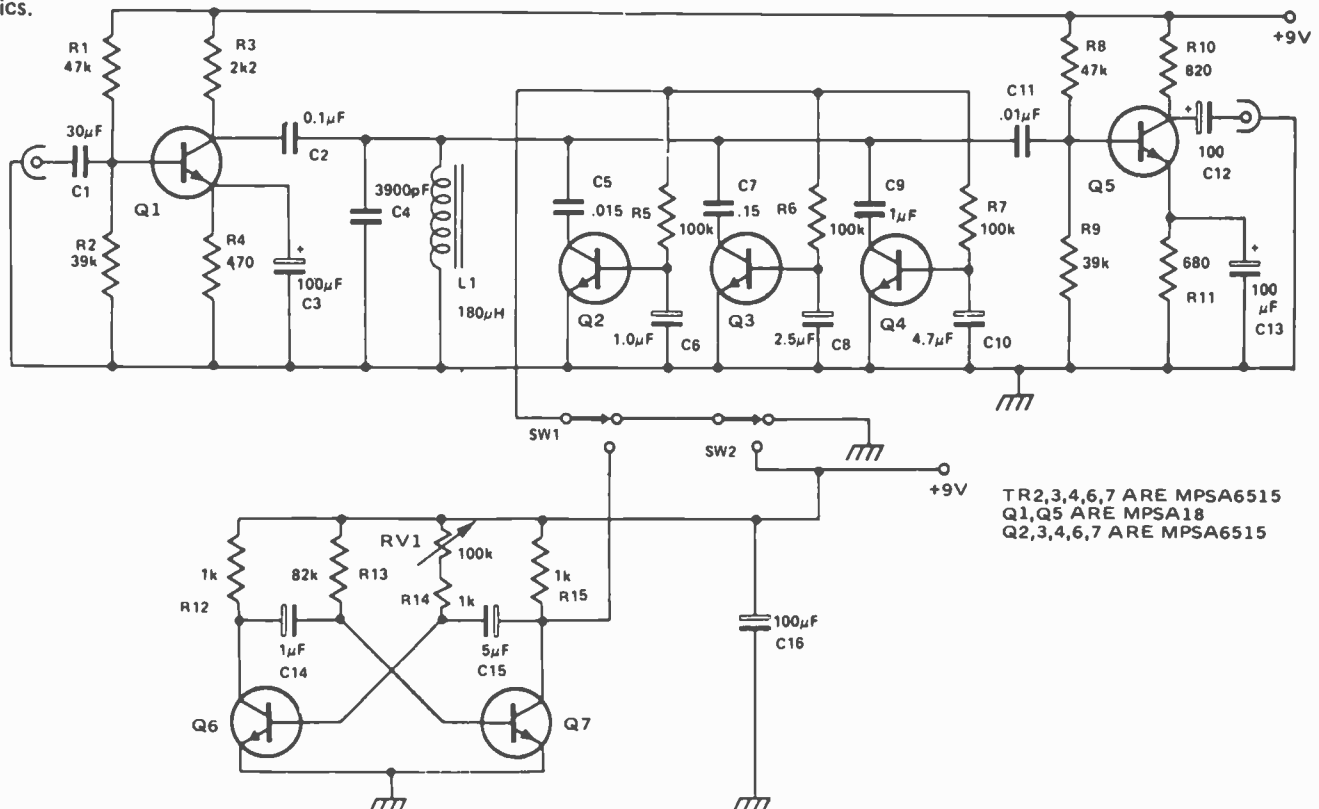

HOW IT WORKS

release it quickly. After a short while it becomes easy (relatively!) to add the effect to any required note or chord. Depressing the auto switch couples the filter to the oscillator, and thus produces a 'Waa-Waa' sound independent of the input, at a rate set by RV1, for as long as the switch is held down.

With no controls operated, the section of the filter which remains in circuit means that a 'treble boost' occurs on the signal. If you don't want this effect, then a third switch wired to take the signal away from the waa-waa is needed, and should not be difficult to add. ○

L and C4 form a band-pass filter with resonant frequency equal to

$$f = \frac{1}{2\pi\sqrt{L.C4}}$$

With the values shown here this value is about 6kHz. The R-C networks R5-C6 R6-C8 R7-C10 act as time delays to switch on Q2,3,4 respectively in sequence following the depression of SW2.

This switches C5, C7, C9 across the filter in turn, pulling the resonance point across the audio band. The time constants are such that the order of switch on is Q2, Q3 and Q4.

This resonance changes from 6kHz-2k7Hz-950Hz-to 400Hz

when Q4 switches on. Upon releasing the switch the electrolytics discharge through the 100k resistors to ground, switching off the transistors.

Automatic switching is provided by the multivibrator, the frequency of which is set by RV1. When the 'auto' switch, SW1, is depressed a slow square wave of about 8V is applied to the charging resistors. Thus the transistors are pulsed on and off. C13 is to decouple the supply to the oscillator to prevent problems with variations as the oscillator switches state.

Headphone Adaptor

Most headphone connectors take away damping from the phones by inserting resistors of around a few hundreds of ohms in value. By use of a ten ohm source this unit restores damping and improves sound quality.

HEADPHONES have impedances which range from 8 ohms to 2 k ohms or more and handle a typical maximum power of 500 mW. To limit the power that may be delivered into the 8 ohm types, commercial amplifiers generally supply the headphones from the amplifier output via series resistors of around 220 ohms.

Although this technique allows the use of practically any type of headphones without fear of damage the series resistor drastically reduces the amount of damping the amplifier can apply to the phones.

A further problem with headphone listening is that the stereo separation is unnatural in that there is little right channel information fed to the left ear and vice versa.

This simple little adaptor is inserted between the amplifier and the leads to the speakers. It restores damping, by supplying the phones from a 10 ohm source, and has a blend control by which the separation between channels can be varied to obtain a more natural sound. ○

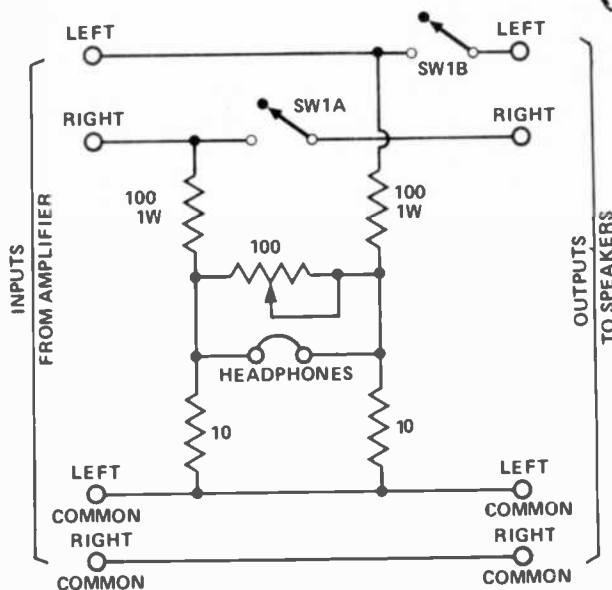
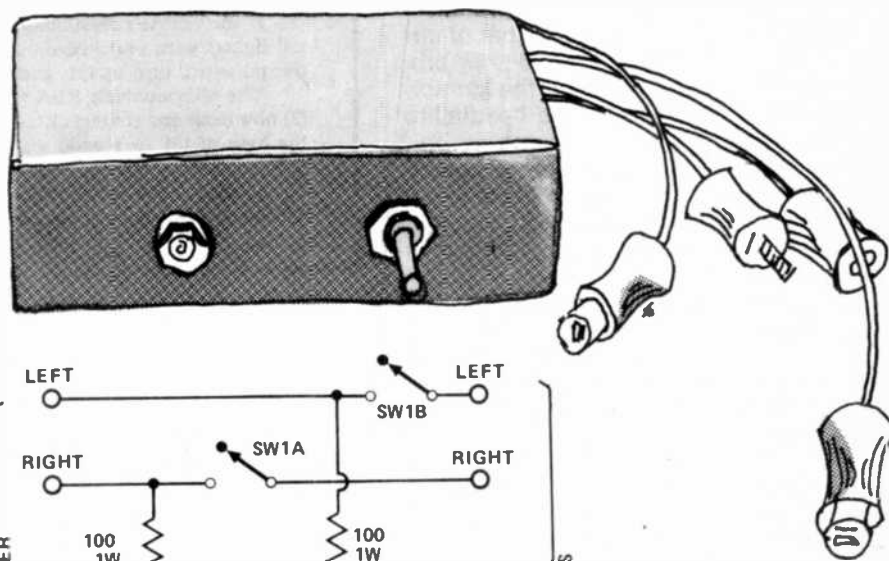

NOTE

SW1A AND SW1B ARE PART OF THE SOCKET USED FOR THE HEADPHONES

Fig. 1 The headphone adaptor circuit diagram. Note that the "live connections only are shown to headphones themselves. The ground comes from the amplifier earth connections.

Headlight Reminder

Electronic 'reminder' safeguards against flat batteries.

A CAR'S headlights cost very little to run while in use. Until you forget to turn them off.

Then you are up for recharging the battery, tow starting, apologising to the managing director who has just waited two hours to discuss your future with the company, placating uptight parents whose daughter you've returned just after they realised it was now daylight, or whatever combination of circumstances are least favourable to your immediate situation.

To avoid such predicaments is relatively simple and a number of circuits have been published that provide an audible warning if the ignition is switched off while the headlights or sidelights are still burning.

These circuits are simple and effective but invariably fail to cater to those occasions when one requires light to be on while the ignition is switched off.

Here then is a slightly more complex circuit that provides a 'headlight on — ignition off' warning as the driver opens a door to leave the vehicle. The alarm ceases as soon as the driver closes the door.

As shown in Fig. 1, the circuit is suitable for vehicles with a negative ground electrical system. To convert the circuit for use with positive ground vehicles replace the 2N3905 by a 2N3904 (the connections are the same) and reverse the diodes and the 25 uF capacitor.

Figure 2 shows how the basic circuit is wired into the car's electrical system. The alarm unit may be a buzzer, bell or even a flashing light. The existing door-operated interior light is used to extend a ground to the relay thus obviating the necessity to instal any additional switches.

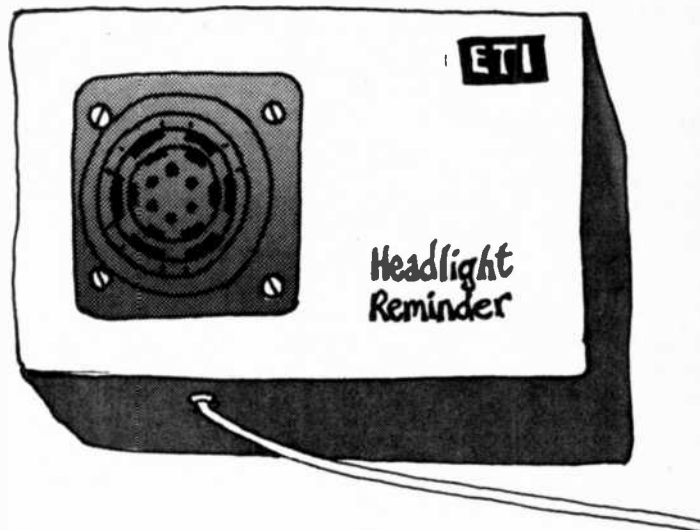

HOW IT WORKS

Normally capacitor C1 is discharged via R1 and the closed switch contacts of an accessory wired via the ignition switch. If the ignition is now switched off, C1 will charge rapidly via R2 thus producing a negative going pulse at the base of transistor Q1.

If the vehicle's headlights (or side and tail lights) were switched on at this time, this pulse will turn on Q1, and close RLA.

The relay contacts RLA (1) and RLA (2) now close and contacts RLA (1) connect the base of Q1 to ground via R2 and R3 thus causing the relay to 'latch on'.

If either front door of the vehicle is opened with the relay in the latched condi-

tion a ground will be extended to the audible alarm device via the now closed contacts of RLA (2) and the closed door light switch.

The audible warning will cease immediately the door is reclosed. Q1 will of course be cut off and the relay reset when the lights are turned off (thus removing the positive voltage from the emitter of Q1).

If at any time it is reqd to disable the alarm circuit all that is necessary is — having first switched off the ignition — to switch the lights off and then on again. The circuit will revert to the status quo next time the ignition is switched on.

Fig. 1 The basic circuit.

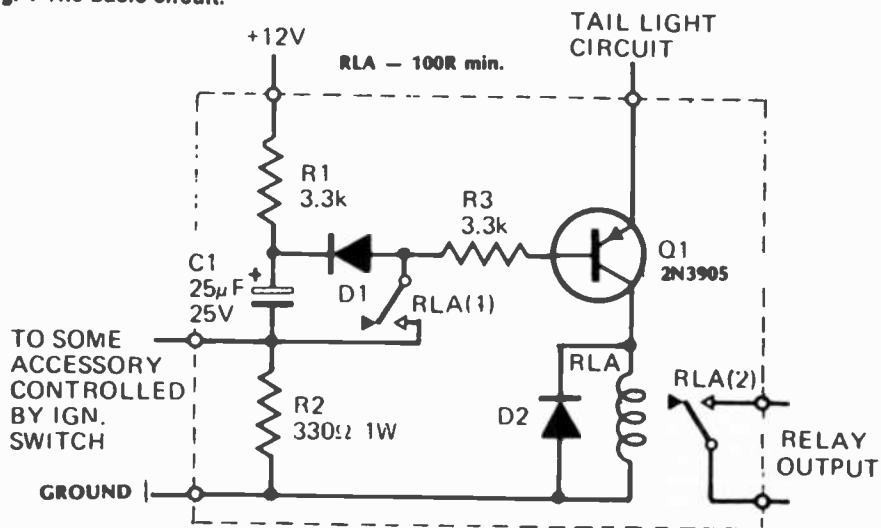
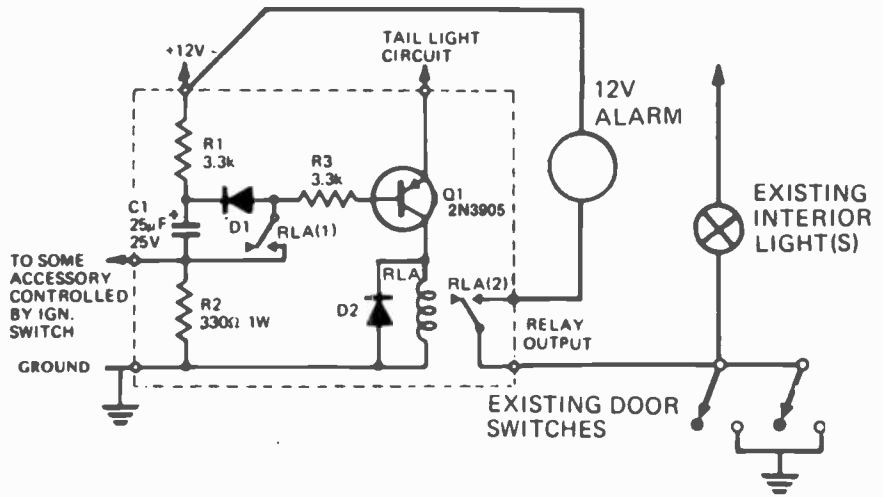
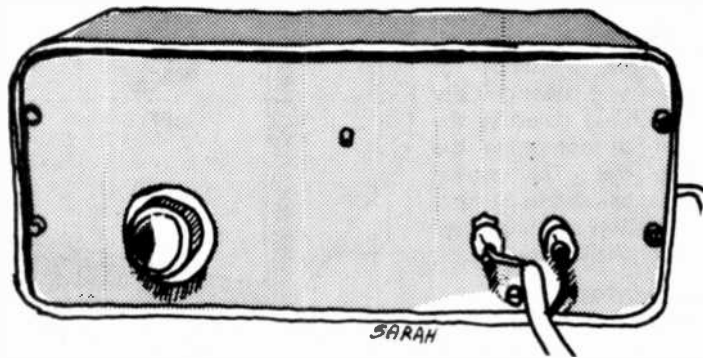

Fig. 2 The warning circuit is wired into the vehicle's electrical system.

The lead marked 'tail light circuit' should be connected to the live side of the tail light wiring. (If a headlight only warning is required, this lead should be connected to the live side of one of the headlights). Further leads connect the unit to ground, the 12V vehicle supply and to the live side of any accessory that is wired through the ignition switch.



Auto Lume



THIS UNIT is automatically operated by the level of general illumination, or the strength of light falling upon it. The most frequent uses of such a device include operating a child's night light, or switching on a light in a room, when darkness falls, as a deterrent to burglars, when leaving the house unoccupied.

The unit is operated from the a.c. lines and is adjustable to operate over a wide range of light intensities. It switches on an external circuit when light fades below a set level, as in the evening and switches off this circuit when light increases, as with the arrival of morning.

AUTO-LUME CIRCUIT

This is shown in Fig. 1. The resistance of the light-dependent resistor LDR rises as the illumination reaching it falls. This allows the base of Q1 to move positive so that it conducts. Q1 emitter and Q2 base also move positive, so that Q2 collector current rises. This current flows through the relay windings, closing the relay contacts.

RV1 is the sensitivity control, so that the device can be set to work at the desired light intensity. Spare con-

tacts on the relay close to bring R5 into circuit, providing additional current through the winding. This means that the relay release current through Q2 is lower than the pull-on current, and avoids vibration or flick-

Fig. 1. The circuit.

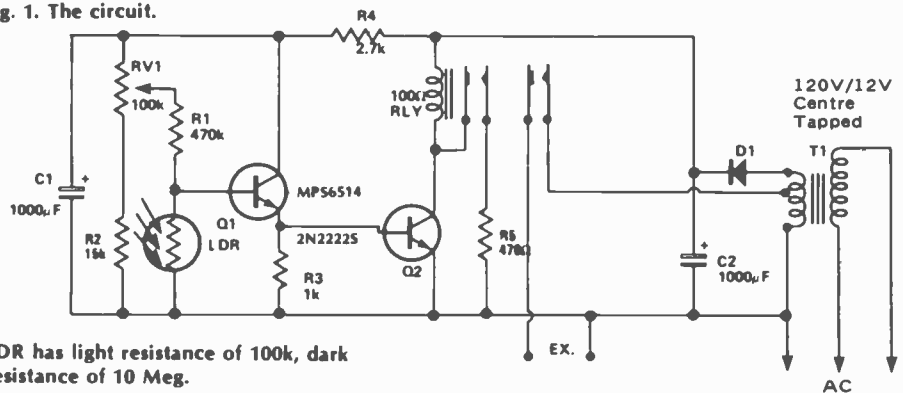

LDR has light resistance of 100k, dark resistance of 10 Meg.

ing on and off of the relay when darkness slowly comes and light has fallen to a level where the unit is about to operate.

A bell transformer or similar transformer T1 provides current, and the operating voltage is not very critical. The second set of relay contacts result in 5V a.c. being available at the extension sockets EX, which does well for a child's night

equipped with a 6V 3 watt or similar bulb. By changing the connections to T1 secondary, 3V or 8V may be obtained instead, if required.

To switch on a 110 Volt lamp, it is necessary either to use a line

voltage relay here, or to employ the extension circuit to control a relay which in turn switches on the AC powered equipment. Normally, however, a 3 watt or 6 watt low voltage lamp will provide enough light for the purposes for which the unit will be used. ○

Marker Generator

Employing an easily obtained 4 MHz crystal this unit forms an invaluable tool to those with calibration troubles.

A LIMITATION of most low priced communications receivers and conventional radios is that tuning accuracy cannot be guaranteed. This means that when waiting for a short-wave station to come on the air we may well miss the beginning of the transmission because we have been tuned to the wrong frequency. The traditional method of overcoming this problem has been to use a marker generator or crystal calibrator. Such instruments generate a series of accurately known and harmonically related signals which are tuned by the receiver in order to determine the accuracy of the dial. The marker generator may also be used to perform the periodic calibration and alignment required by most sensitive receivers.

Using the Generator

Say for example, that we wish to tune a signal that we know to be on 13 250 kHz. First select 4 MHz on the marker generator and connect its output to the aerial socket of the receiver. Tune the receiver to the marker which will be found at 12 MHz (third harmonic of 4 MHz). Once located confirm that it is indeed coming from the marker generator by switching it on and off. Now switch to the 1 MHz markers and tune the receiver upwards to locate the 13th harmonic at 13 MHz. Now select 100 kHz markers and tune upwards through two markers to locate 13.2 MHz. Finally select the 10 kHz markers and tune up through a further five markers to locate 13 250 kHz. Note that if this tuning procedure is carefully carried out it is quite simple to locate any position on the dial with great accuracy.

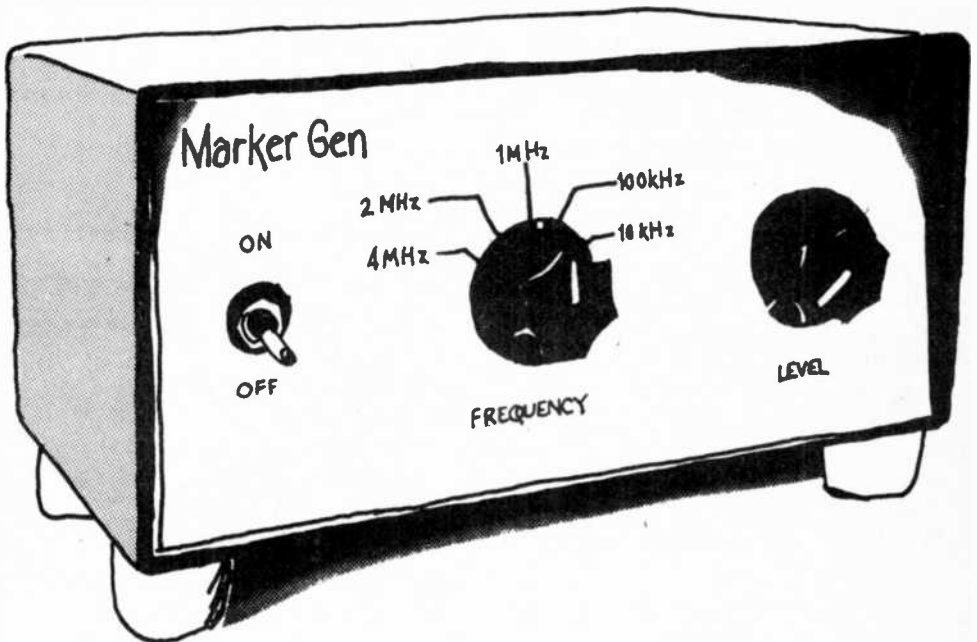

The Crystal

Crystals are supplied to work within specified tolerances. The tighter the tolerances the more expensive the crystal. However the crystal oscillator may be placed exactly on frequency (within small limits) by varying the amount of capacitance in parallel with it.

When purchasing a crystal you must tell the manufacturer what capacitance it will be working with and he will grind your crystal to be within the specified limits when it is used with that particular capacitance. This marker generator has been designed to work with crystals that are ground for 30 pF capacitance.

Calibration

The marker will be sufficiently accurate for most people with C2 set to half value. For those who want greater accuracy the generator must be calibrated against a signal of known accuracy.

The generator may be aligned against one of these frequencies by the zero-beating technique. First tune in the signal and then connect the generator. A whistle will now be heard and C2 should be tuned to the point where the beat frequency has dropped so low that it cannot be heard. The generator is now spot on frequency and it should be noted that this calibration is independent of the generator. ○

HOW IT WORKS

The marker generator is a constant-frequency oscillator driving into a CMOS divider chain. Switchable outputs from the divider chain are selected to drive a pulse generator.

The oscillator is IC1a in which R1 biases the IC into linear operation. The crystal determines the basic frequency of operation at 4 MHz in conjunction with C1, 2, 3 and 4 which appear to the crystal as one parallel capacitor. The capacitor C2

is used to tune the oscillator exactly to frequency as explained in the text. The resistor R2 adds extra phase shift but also reduces the gain. Thus if the oscillator is slow in starting reducing R2 may help. The output of the oscillator is buffered from the rest of the circuit by IC1/b.

IC2 is a CMOS dual type D flip flop that divides the 4 MHz by four to provide an output of 1 MHz, the 2 MHz also being brought out.

A further dual division by 10 is provided by IC3 which therefore provides outputs of 100 kHz and 10 kHz.

The required output is selected by SW1 and applied to C5 and R3 which differentiate the squarewave output of the divider. The waveform is then amplified and squared by IC1/c to provide an output train of narrow pulses, the amplitude of which may be varied by means of RV1.

Now NRI takes you inside the new TRS-80 Model III microcomputer to train you at home as the new breed of computer specialist!

NRI teams up with Radio Shack advanced technology to teach you how to use, program and service state-of-the-art microcomputers...

It's no longer enough to be just a programmer or a technician. With microcomputers moving into the fabric of our lives (over 250,000 of the TRS-80™ alone have been sold), interdisciplinary skills are demanded. And NRI can prepare you with the first course of its kind, covering the complete world of the microcomputer.

Learn At Home in Your Spare Time

With NRI training, the programmer gains practical knowledge of hardware, enabling him to design simpler,



Training includes new TRS-80 Model III microcomputer, 6-function LCD Beckman multi-meter, and the NRI Discovery Lab with hundreds of tests and experiments.

(TRS-80 is a trademark of the Radio Shack division of Tandy Corp.)

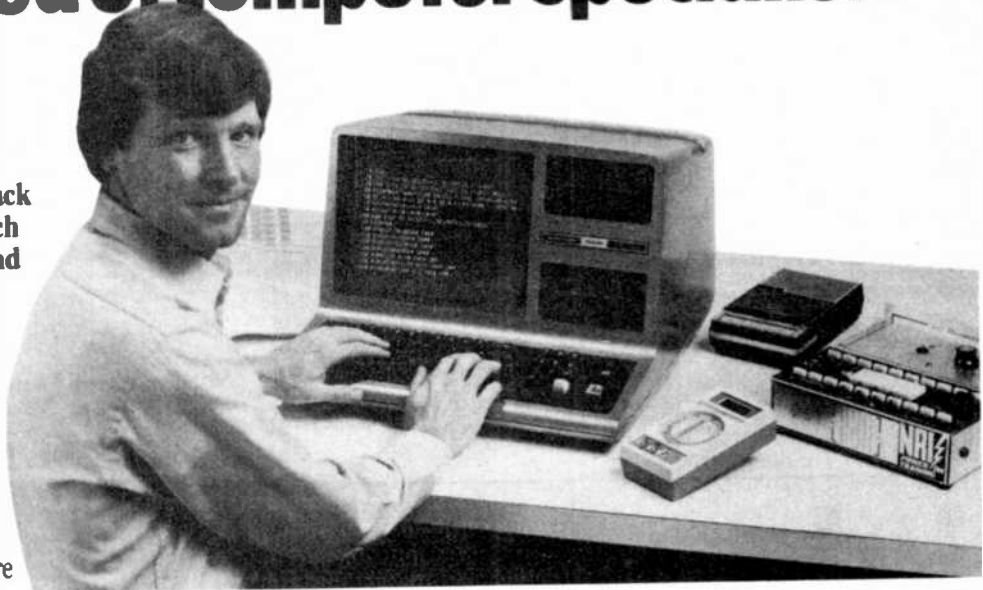

more effective programs. And, with advanced programming skills, the technician can test and debug systems quickly and easily.

Only NRI gives you both kinds of training with the convenience of home study. No classroom pressures, no night school, no gasoline wasted. You learn at your convenience, at your own pace. Yet you're always backed by the NRI staff and your instructor, answering questions, giving you guidance, and available for special help if you need it.

You Get Your Own Computer to Learn On and Keep

NRI training is hands-on training, with practical experiments and demonstrations as the very foundation of your knowledge. You don't just program your computer, you go inside it... watch how circuits interact... interface with other systems... gain a real insight into its nature.

You also work with an advanced liquid crystal display hand-held multi-meter and the NRI Discovery Lab, performing over 60 separate experiments. You learn troubleshooting procedures

and gain greater understanding of the information. Both microcomputer and equipment come as part of your training for you to use and keep.

Rush Card for Free Catalog

Get all the details on this exciting course in NRI's free, 100-page catalog. It shows all equipment, lesson outlines, and facts on other electronics courses such as Complete Communications with CB, TV/Audio and Video, Digital Electronics, and more. Keep up with the latest technology as you learn on the latest model of the world's most popular computer. If card has been used, write to:

NRI Schools
McGraw-Hill Continuing
Education Center
330 Progress Avenue
Scarborough, Ontario M1P 2Z5
or telephone 416-293-1911

We'll give you tomorrow.

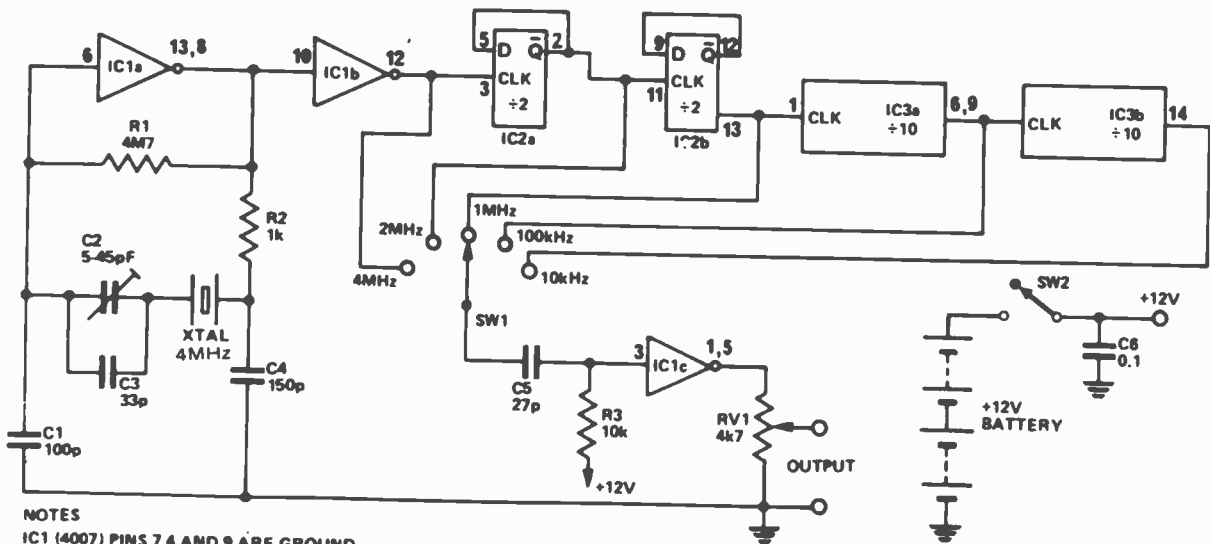

NOTES

IC1 (4007) PINS 7,4 AND 9 ARE GROUND
 IC2 (4013) PINS 6,4,8,10 AND 7 ARE GROUND
 IC3 (4518) PINS 8,7 AND 15 ARE GROUND

IC1 PINS 14, 2 AND 11 ARE +12V
 IC2 PIN 14, 15 +12V
 IC3 PINS 2,10 AND 16 ARE +12V

Circuit diagram for the marker generator.

Light Dimmer

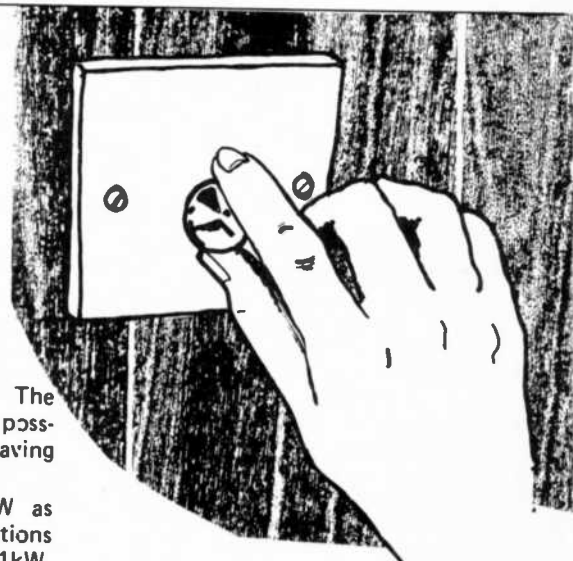

Fig. 1 The circuit of the dimmer.

The circuit for a light dimmer is not complex, as will be seen from Fig. 1, nor are the components all that expensive. The circuit overcomes a drawback in many of the commercial models: the Triac is protected against line transients. Many versions do not come on until the control is rotated over half way, yet current is still being drawn; in our circuit the light comes on almost at minimum setting.

An unusual facility is also incorporated in the design which some readers might wish to take advantage of. A light dimmer is perfect for use with a TV set as neither viewing in full light or complete darkness is very pleasant. The circuit is so arranged that the switch can also handle a load which is not controlled by the dimmer circuitry. Thus, the TV can be switched on using the unit, but only

the light will be controlled. The same arrangement also makes it possible to control only one light, leaving others unaffected.

The unit will handle 500W as shown, but with some modifications can easily be adapted to control 1kW. The choke L1 is made up from a

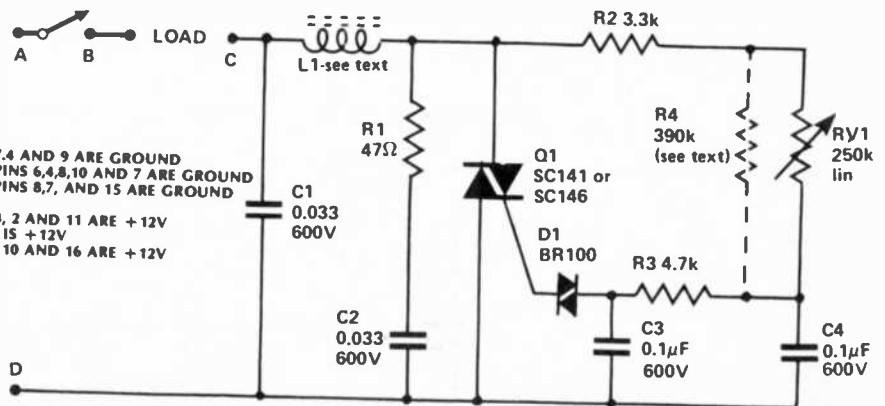

NOTES:

IC1 (4007) 7,4 AND 9 ARE GROUND
 IC2 (4013) PINS 6,4,8,10 AND 7 ARE GROUND
 IC3 (4518) PINS 8,7, AND 15 ARE GROUND

IC1 PINS 14, 2 AND 11 ARE +12V
 IC2 PIN 14, 15 +12V
 IC3 PINS 2, 10 AND 16 ARE +12V

piece of ferrite rod, 1/4" diameter and 1 1/4" long, wound with 55 turns of 28 s.w.g. enamelled copper wire, wound tightly and secured at each end by a strip of adhesive tape.

For those wishing to use the unit at 1kW it is necessary, for safety reasons, to use a separate switch from that in the pot. A suitable heatsink will also be necessary on the Triac and the wire gauge on L1 should be slightly heavier: 24 or 26 s.w.g. The greatest drawback when using the higher power is that RFI can be annoying. When used with a lower load, the radio interference is very low and could not be detected 12" from the prototype, even with the radio's ferrite rod in line with the choke.

Before fitting the unit, it is worth

testing on the bench, using a table lamp as a load. Connect this as follows. Terminal A: power live, Terminals B and C: load, Terminal D: power neutral.

If all is well, the unit can be fitted in place of a modern switch fitted in a box. In very shallow boxes, there may not be room for the unit but extension mouldings are available from the same people who supply the switch plate itself.

If the facility for switching an uncontrolled load is not required (i.e. using it conventionally), a jumper wire should be fitted between Terminals B and C and the two wires which normally connect to the switch that the dimmer replaces can be connected to A and D. ○

HOW IT WORKS

As with practically all modern dimmer circuits, this one makes use of a Triac for the power control.

A Triac can be regarded as an electronic switch that is turned on by a pulse at a predetermined time in each half cycle and turns off automatically at the end of the half cycle.

Control of the Triac is of the simple resistor/capacitor and diac system. By varying the resistance of potentiometer RV1, the time constant of RV1/C4 change the phase.

The pulse at the junction RV1/C4 is passed to the Diac through limiting resistor R3. The Diac is connected to the gate of the Triac and as the Diac is in fact a bi-directional diode, both the positive and negative pulses are applied to the gate.

Capacitor C1 and choke L1 are for suppressing RFI while R1 and C2 are used for transient suppression.

Resistor R4 is fitted so as to allow full control of light while using RV1. The ideal value for RV1 is 150k ohms but as this value is virtually impossible to obtain, it is paralleled by R4 to give effectively this value.

RF Attenuator

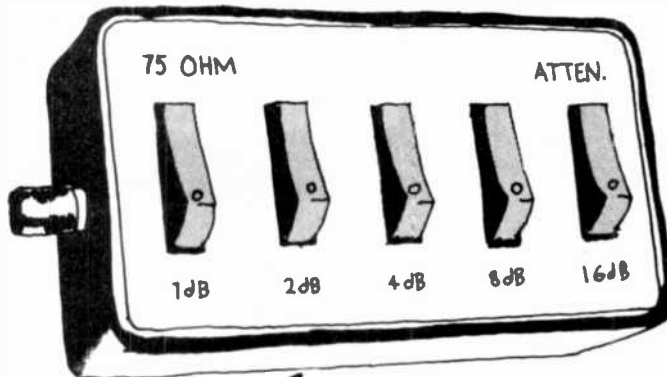

Table

ATTENUATION	R*	ACCURATE VALUES 75 OHM	ACCURATE VALUES 50 OHM	CLOSEST PREFERRED VALUE 50 OHM
1 dB	R1	1304	869.5	820
	R2	8.6	5.8	5.6
	R3	1304	869.5	820
2 dB	R4	654	436	470
	R5	17.4	11.6	12
	R6	654	436	470
4 dB	R7	331.5	221	220
	R8	36.8	23.9	12 + 12
	R9	0	0	0
	R10	331.5	221	220
8 dB	R11	174.2	116	120
	R12	79.3	52.8	27 + 27
	R13	174.2	116	120
16 dB	R14	103.2	68.8	68
	R15	230.7	154	150
	R16	103.2	68.8	68

* All values in ohms.

HOW IT WORKS

This RF attenuator works by switching into the signal path a selected network or group of networks that reduces the signal strength by known amounts. The networks are specially designed so that they do not disturb the characteristic impedance of the line. That is, they appear to both the source and the load as a signal parallel resistor equal in value to the respective source or load impedance. In our case networks have been calculated to provide matching to 75 ohm impedance.

characteristic shape that has led to the use of the name 'pi network' for this attenuator section.

The steps of attenuation are expressed in decibels. The voltage attenuation in decibels is equal to $20 \log \frac{V_1}{V_2}$. Where V_1

$$\frac{V_1}{V_2}$$

equals the input voltage and V_2 equals

the output voltage. Thus if the output is half the input voltage then $\frac{V_2}{V_1}$ equals 0.5

$$\frac{V_2}{V_1}$$

and $20 \log 0.5$ equals -6.02 dB. (the minus sign indicating attenuation).

The use of decibels is very convenient as it allows the combined value of two or more attenuators to be found by simply adding their separate values rather than by multiplying the separate attenuation ratios.

Each succeeding attenuator is chosen to be twice that of the one previous. This binary form allows us to obtain a range of 0 to 31 dB in 32, steps with only five switches. Thus for example if we require 5 dB we depress SW1 and SW3 to give us $1+4=5$ dB.

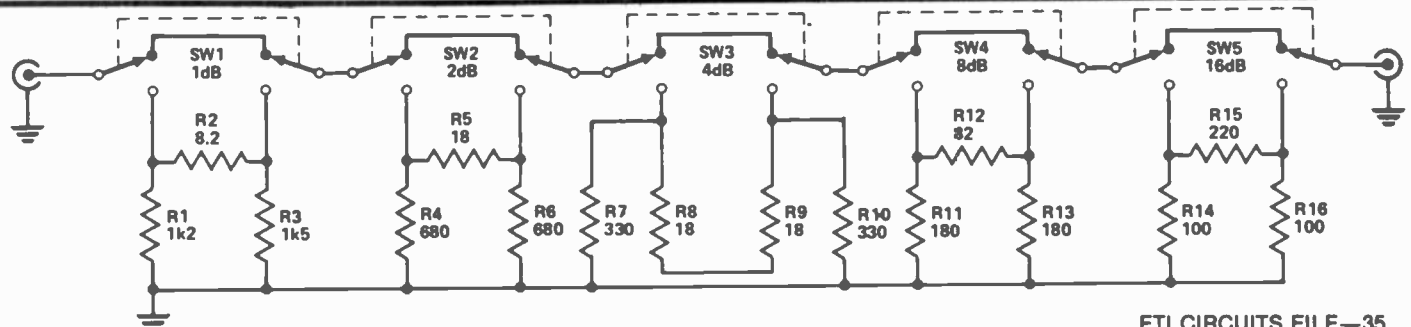

Designer Circuits

TEST	UNREGULATED POWER SUPPLY	39
TEST	REGULATED POWER SUPPLY	39
TEST	TRANSISTOR TESTER	40
AUDIO	TREBLE BOOSTER	40
MUSIC	METRONOME	41
TEST	MEASURING UNKNOWN CAPACITORS	41
AUDIO	STEREO SYNTHESIZER	42
MISC.	LOW FREQUENCY OSCILLATOR	42
TEST	CMOS LOGIC PROBE	43
HOME	INSECT REPELLENT	43
HOME	FLASH SLAVE UNIT	44
HOME	HOME INTERCOM	44
AUDIO	STEREO PREAMP	45
MISC.	PHASE SHIFT OSCILLATOR	45
TEST	QUICK TRANSISTOR CHECKER	46
TEST	SINGLE IC POWER SUPPLY	46
AUDIO	TRANSISTOR POWER AMPLIFIER	47
TEST	LOW BATTERY VOLTAGE INDICATOR	47
HOME	TWO TONE ALARM	48
TEST	ZENER DIODE TESTER	48
HOME	DOORBuzzer	49
HOME	LIE DETECTOR	49
MISC.	TOUCH SWITCH	50
MISC.	555 IC MONOSTABLE TIMER	50
AUDIO	SCRATCH AND RUMBLE FILTER	51
MUSIC	VCF USING A CA3080	51
AUDIO	SIMPLE AMPLIFIER	52
TEST	FET VOLTMETER	53
AUDIO	AUDIO LIMITER	53
TEST	AF MILLIVOLTMETER	54
HOME	BASIC BURGULAR ALARM	54
MISC.	SOUND OPERATED SWITCH	55

ORION

Electronic Supplies Inc.

ELECTRONIC DISTRIBUTOR

INDUSTRIAL — EDUCATIONAL — COMMERCIAL — HOBBYIST

RCA

COSMAC

VIP

Authorized distributor for RCA, COSMAC VIP

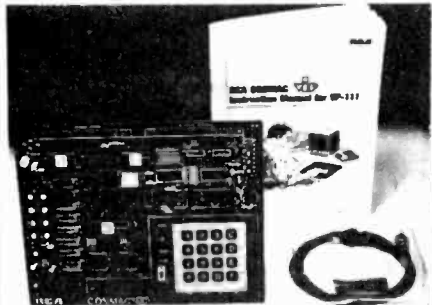

New! VP 111 Microcomputer... \$139.50

Assembled* and tested.

- Features
- RCA 1802 Microprocessor
- 1K Bytes static RAM
- Expandable on-board to 4K
- Expandable to 32K Bytes total
- 512 Byte ROM operating system
- CHIP 8 interpretive language or machine language programmable
- Hexadecimal keypad
- Audio tone generator
- Single 5-volt operation
- Video output to monitor or modulator
- Cassette interface — 100 Bytes/sec
- Instruction Manual with 5 video game listings, schematics, CHIP 8, much more
- Ideal for low-cost control applications
- Expandable to full VIP capability with VP-114 Kit
- *User need only connect cables included, a 5-volt power supply, and speaker

START WITH ORION FOR A NEW ERA IN THE WORLD OF ELECTRONICS

We have the most complete selection of electronic components.

Full line of TTL, CMOS, Linear, ICs, Computer Interface, Support Chips and CPUs.

What can you honestly expect from an interactive data terminal that costs only \$475.95

Well, to begin with, color graphics. RCA's VP-3301 has unique color-locking circuitry that gives you sharp, jitter-free color graphics and rainbow-free characters.

Plus much more: Microprocessor control. Resident and programmable character set. Reverse video. State-of-the-art LSI video control. 20 and 40 character formats. RS232C and 20 mA current loop. Six baud rates. Eight data formats. ASCII encoding. Light-touch flexible-membrane key switches for reliability and long life. CMOS circuitry and a spill-proof, dust-proof keyboard for hostile environments.

The VP-3301 can be used with a 525-line color or monochrome monitor or a standard TV set through an RF modulator. It serves a wide variety of industrial, educational, business and individual applications including communication with time sharing and data base networks such as those provided by Dow Jones News/Retrieval Service, CompuServe and Source.

All this—for the low price of \$475.95. And it's made by RCA.

VP-3501 Videotex Data Terminal

For time sharing applications via telephone. Connects to standard TV set for display. Built-in 300 baud direct connect modem, includes: numeric keypad, color graphics, tone and noise generator, RF and video/audio outputs, expansion interface, resident and user-definable character sets, cursor control, reverse video, plus many other features. (Includes connecting cables.)

VP-3303 Interactive Data Terminal (RF & Video/Audio)

General purpose terminal. Similar to the VP-3501. Does not include modem or numeric keypad. Six switch selectable baud rates to 19.2k. RS-232C and 20 mA current loop interfaces.

INTERACT COMPUTER

16K LEVEL II

Just \$595.



Write for our Flyer on Interact Computer

A powerful microcomputer with a full standard 53 key typewriter style keyboard and built-in cassette recorder for use in entering and storing programs. Utilizing the versatile Intel 8080 microprocessor, the Interact computer has 16K of RAM and 2K of ROM at its disposal. Output in color on your own TV screen. Sound is also generated through your TV set and can consist of exhilarating computer beeps or two full octaves of music. This is truly a powerful computer capable of developing and handling a variety of programs, and with available software provides true educational stimulus (examples: Star Trek, Chess, Concentration, etc.). The Interact computer offers the ideal opportunity to learn BASIC, the most popular computer language for small business and hobbyists, and with the use of the 84 page manual, you learn at your own pace.

INSTALLATION: Attach to antenna terminals of your color TV set and plug into 120 VAC wall outlet. Computer includes built-in RF modulator, FCC approved and UL and CSA listed.

PROGRAMING: Most Microcomputers start you off with an abbreviated 4K BASIC, and then later you have to relearn the more powerful language. Since this computer has 16K of RAM, we start you with Level II Microsoft 4.7 BASIC. BASIC is the most popular Micro-computer language using commands that are words we are ordinarily used to, such as, PRINT, NEW, GOTO (for go to), END, COLOR, JOY, INPUT, etc. To help you learn programming we have included an 84 page instruction manual, plus a 20 page book of program examples.

Educational and Entertaining

ASCII Keyboard Fully encoded, 128-character ASCII alphanumeric keyboard, 58 light touch keys (2 user defined). Selectable "Upper-Case-Only"

VP-601 \$109.75

ASCII/Numeric Keyboard ASCII Keyboard identical to VP-601, plus 16 key numeric entry keyboard for easier entry of numbers

VP-611 \$149.75



Cable: ASCII Keyboards to VP-711 Flat ribbon cable, 24 in. length, for connecting VP-601 or VP-611 and VP-711. Includes matching connector on both ends

VP-520 \$27.50

Cable: ASCII Keyboards Flat ribbon cable, 36 in. length with mating connector for VP-601 or VP-611 Keyboards. Other end is unterminated.

VP-623 \$27.50

RCA PRICE LIST

58-Key Typewriter Format for Alphanumeric Entry
VP-601 - 8-bit parallel output \$109.75
VP-606 - Asynchronous serial output 139.75

58-Key Typewriter Format Plus Separate 16-Key Calculator-Type Keypad for Fast Numeric Entry
VP-611 - 8-bit parallel output \$149.75
VP-616 - Asynchronous serial output 159.87
VP-3301 - Video output & built in audio 475.95
VP-3303 - Connects directly to TV set 498.95
VP-3501 - With built in modem & RF modulator 549.95

Sinclair ZX81 Computer

ASSEMBLED \$159.95

Kit \$109.95

The ZX81's advanced capability.

The ZX81 uses the same fast microprocessor (Z80A), but incorporates a new, more powerful 8K BASIC ROM — the "trained intelligence" of the computer. This chip works in decimals, handles logs and trig, allows you to plot graphs, and builds up animated displays. And the ZX81 incorporates other operation refinements — the facility to load and save named programs on cassette, or to select a program off a cassette through the keyboard.

New, improved specification.

"Unique 'one-touch' key word entry: eliminates a great deal of tiresome typing. Key words (PRINT, LIST, RUN, etc.) have their own single-key entry. "Unique syntax-check and report codes identify programming errors immediately. "Full range of mathematical and scientific functions accurate

to eight decimal places. "Graph-drawing and animated-display facilities. "Multi-dimensional string and numeric arrays. "Up to 26 FOR/NEXT loops. "Randomize function. "Programmable in machine code. "Cassette LOAD and SAVE with named programs. "1K-byte RAM expandable to 16K. "Full editing facilities. "Able to drive the new Sinclair ZX Printer (to be available shortly).

If you own a ZX80...

The new 8K BASIC ROM as used in the ZX81 is available as a drop-in replacement chip. (Complete with new keyboard template and operating manual). With the exception of animated graphics, all the advanced features of the ZX81 are now available on your ZX80 — including the ability to drive the Sinclair ZX Printer.

16K Memory Expansion Kit (No P.C. Board) \$89.95

Sinclair's new 8K Extended Basic offers features found only on computers costing three or four times as much. "Continuous display, including moving graphics. "Multi-dimensional string and numerical arrays. "Math and scientific functions accurate to 8 decimals. "Unique one touch entry of "key words" (i.e. basic and system commands). "Automatic syntax error detection. "Randomize function. "Built-in interface for ZX Printer. "Connects to standard TV and cassette recorder. "164 page manual included. "Power supply (9V at 650 mA) optional for \$14.95. "1K of memory is included. "Easy-to-build.

ZX81 Printer \$169.95

Designed exclusively for use with the ZX81 (and ZX80 with 8K basic ROM), the printer offers full alphanumerics and highly sophisticated graphics. COPY command prints out exactly what is on screen. At last you can have a hard copy of your program listing and results. Printing speed is 50 characters per second, with 32 characters per line and 9 lines per vertical inch. Connects to rear of ZX81 — using a stackable connector so you can use a RAM pack as well. A 65 ft paper roll, instructions included. Requires 9 volts, 1.2 amp power supply (option extra).

64K \$249.95

MEMOTECH 64K MEMOPAK

The Memopak is a 64K RAM pack which extends the memory of the ZX81 by a further 56K. Designed to be in the price range expected by Sinclair owners. Plugs directly into the back of the ZX81 and does not inhibit the use of the printer or other add-on boards. There is no need for additional power supply or cables. The Memopak together with the ZX81 gives a full 64K, which is neither switched nor paged, and is directly addressable. The unit is user transparent, and accepts such basic commands such as 10DIM A(9000). With the Memopak extension the ZX81 is transformed into a powerful computer, suitable for business, leisure and educational use, at a fraction of the cost of comparable systems.

Machine Language Software

ZXAS Machine Code Assembler. A full specification Z80 assembler. Standard mnemonics are written directly into your BASIC program. \$13.95
ZXDB Disassembler/Debugger. Perfect complement to ZXAS, also provides single step, string search, block transfer, hex loader. \$13.95



Hardware

ZX81 Assembled \$185.95
ZX81 Kit 149.95
ZX Printer 169.95
64 K-RAM 249.95
16K RAM 169.95
16K RAM Kit 89.95
Power Supply (for ZX81 + 16k memory) 14.95

Software

Multifile Data Storage System \$39.95
Dictator 19.95
Constellation 19.95
ZX Chess 29.95
Star Trek 13.95
Vu-Calc 29.95
Viewtext 19.95

Books

Not only 30 programs for the ZX81 — \$16.95
Understanding your ZX81 ROM — 23.95
Getting acquainted with your ZX81 — 16.95
The explorers guide to the ZX81 — 16.95
The gateway guide for the ZX81 & ZX80 — 16.95
Mastering machine code on your ZX81 — 24.95
The ZX81 pocketbook — 16.95

Orion Electronic Supplies Inc.

40 Lancaster Street West
Kitchener, Ontario N2H 4S9
(519) 576-9902

Master Charge & Visa, COD, Cheque, Money Orders accepted. COD's, shipping & insurance extra. Write for our FREE FLYER.

Prices subject to change without notice.

UNREGULATED POWER SUPPLY

A single rail power supply is shown in the diagram above. It has three separate sections, the power transformer, the full wave bridge rectifier and the smoothing capacitor. For safety, the fuse should be put in the live wire path to the transformer. The voltages quoted are AC voltages measured in Volts RMS. This is the equivalent "DC heating" voltage and is equal to 0.707Vp.

The output of the transformer is 6V RMS and this is the voltage level "on load". When the transformer is not loaded this voltage may increase by about 25%.

The difference between the loaded and unloaded output voltage is known as the "regulation" of the transformer. Transformers have power ratings expressed in terms of VA. A 10VA transformer will be able to supply 10 watts of power from its secondary output. The AC voltage from the transformer secondary is full wave rectified by the diode bridge D1 to 4 and then smoothed by capacitor C1. With no load on the power supply the output (DC) voltage will be approximately 11V. But when a resistive load is presented to it, the voltage drops and a ripple voltage appears, this being caused by the load discharging the capacitor. ●

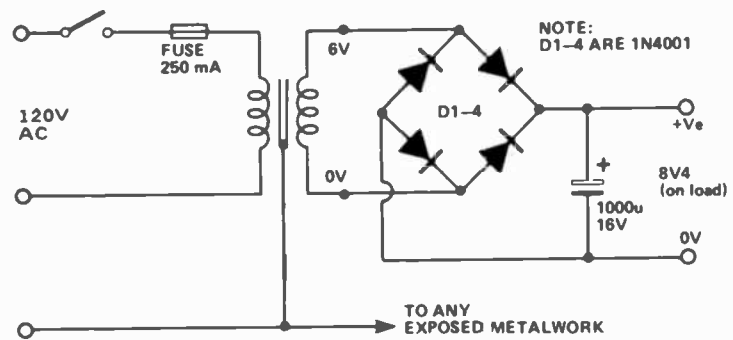

Typical Line Voltages

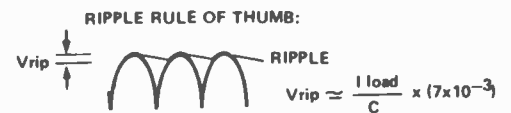
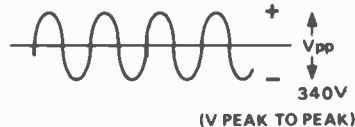
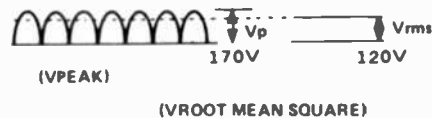

SO IF THE LOAD CURRENT (I_{load}) IS 100mA,

$$\text{THEN } V_{rip} \text{ IS } \frac{0.1 \times 7 \times 10^{-3}}{10^{-3}} = 700\text{mV}$$

REGULATED POWER SUPPLY

Two transistors and a voltage reference can be used to make a regulated power supply. Transistor Q1 is used as the power control element and so must be mounted on a heat sink. Q2 provides negative feedback and so helps to iron out any changes at the output due to fluctuating load conditions or variations in the unregulated rail. The circuit operation is as follows. A current flows through Q2 and D5 and so sets up a voltage of 5V1 across D5. The base of Q2 is connected to the output by a set of resistors, R2, 3, 4 and RV1. If the output voltage rises, then more current will flow through Q2. This causes the voltage at the base of Q1 to fall, which in turn reduces the voltage at the output. Thus the output voltage is regulated. RV1 is used to set up the output voltage to +9V. If the wiper of RV1 should accidentally lift off, then the output

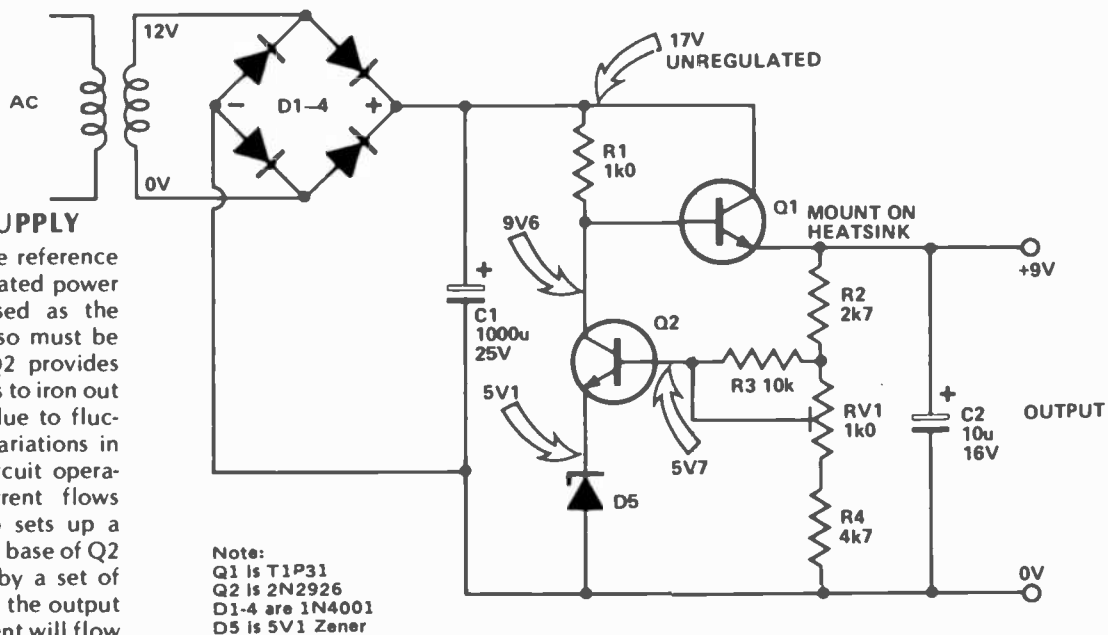

Note:
Q1 is T1P31
Q2 is 2N2926
D1-4 are 1N4001
D5 is 5V1 Zener

voltage would instantly rise to that of the unregulated rail. To prevent this R3 provides a permanent DC path to the base of Q2. Capacitor C2 helps to improve the regulation when the load conditions change rapidly. ●

TRANSISTOR TESTER

This very simple transistor tester measures DC current gain in three ranges, with full scale values of 10, 100 and 1 000. It will also show whether or not the device under test has a high leakage current.

The basic tests for a transistor are very simple and in order to test for high leakage, it is merely necessary to connect a voltage across the emitter and collector terminals of the test device, and then measure the current flow. In this circuit 9V is the voltage source, and ME1 registers the current flow. R4 is a current limiting resistor which protects ME1 and the test device from passing an excessive current.

Silicon devices have extremely low leakage currents, and if there is any deflection of ME1 when testing a silicon transistor, it certainly means that device is not functional (or is connected incorrectly). Germanium devices have somewhat higher leakage currents, and a very small deflection of ME1 is acceptable when testing this type of transistor.

The test for DC current gain (H_{fe}) is basically the same as for leakage testing, except that a current is fed into the base terminal of the test device. This causes a larger current to flow in the collector circuit of the transistor, and the current

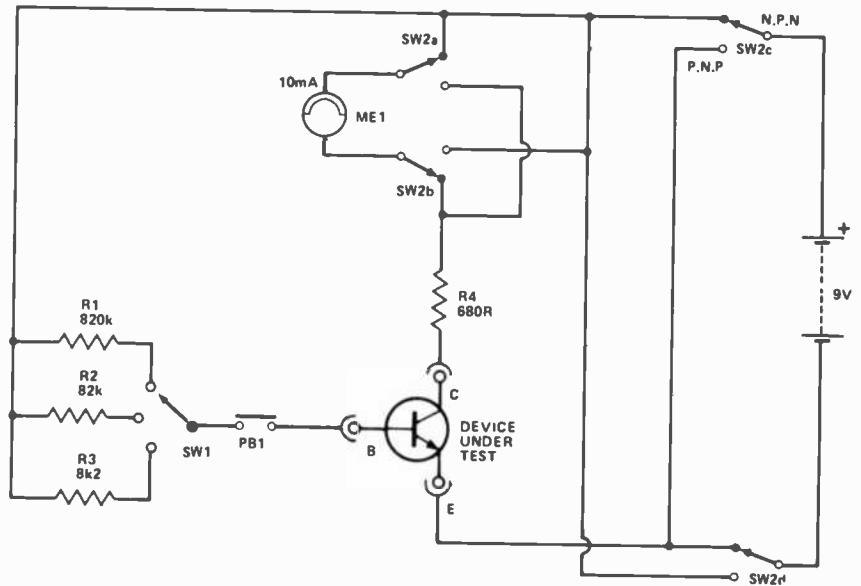

gain is equal to the collector current divided by the base current. If SW2 is depressed, a base current will be provided to the test device by whichever resistor (R1 to R3) is selected by SW1. With SW1 in the "10" position, a nominal base current of 1 mA is fed to the test device, and it must have a current gain of 10 in order to produce a collector current of 10 mA and give full scale deflection of ME1. Lower levels of

current gain give a proportionately lower meter reading. With SW1 in the "100" and "1 000" positions, the base current is reduced to 100 μ A and 10 μ A respectively, giving the correspondingly high full scale gain values.

PNP and NPN transistors require opposite supply polarities, and SW3 is used to switch the supply polarity to suit the type being tested and to connect ME1 with the correct polarity. ●

TREBLE BOOSTER

A treble booster circuit can be used with an electric guitar (and also electronic instruments) to boost the higher order harmonics and give a more "brilliant" sound. A circuit of this type gives a fairly flat response at bass and most middle audio frequencies, with the upper-middle and lower treble frequencies being given a substantial amount of boost. It is normal to give only a modest amount of emphasis to the upper-treble in order to give good stability and a low noise level, and this also prevents the output from sounding too harsh. The frequency response of this treble booster is shown in the accompanying graph.

The circuit is basically just an op

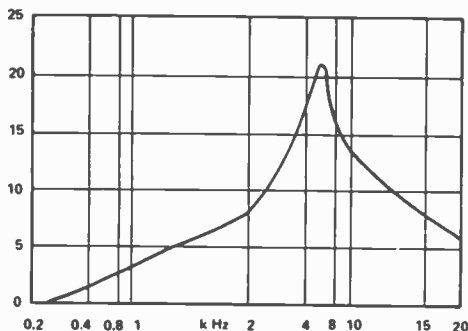

amp (IC1) used in the non-inverting amplifier mode. The non-inverting input is biased by R4 and R5 via a decoupling network which is comprised of R3 and C3. C4 and C5 give DC blocking at the input and output respectively. With SW1 open there is virtually 100% negative feedback through R1, R2 and C1, giving the circuit unity gain and a flat response. Closing SW1 brings C2 into circuit, and this decouples some of the feedback through R1 and R2 at frequencies of more than a few hundred Hz giving the

required rising response. Feedback through C1 at high treble frequencies causes the response to fall away above about 5.5kHz, and prevents the very high frequency harmonics from being excessively emphasised.

As the unit has unity gain at frequencies where boost is not applied it can simply be connected between the instrument and the amplifier. ●

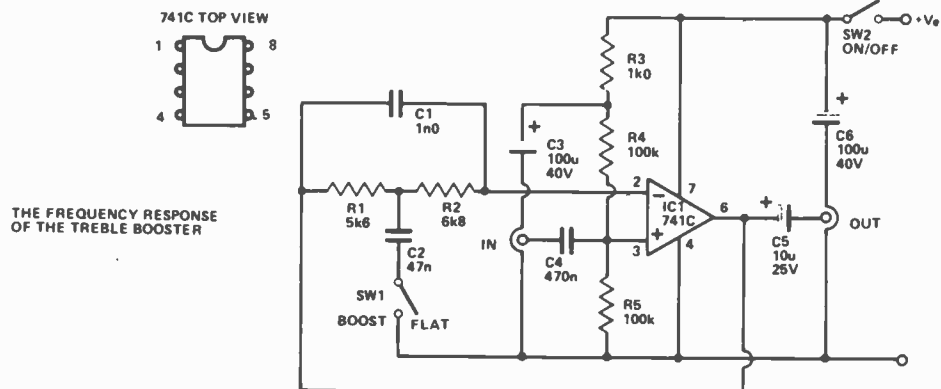

THE FREQUENCY RESPONSE OF THE TREBLE BOOSTER

ELECTRONIC METRONOME WITH SYNTHESISED TICK TOCK

An electronic metronome needs three sections, a variable rate beat generator, a sound synthesiser to produce the tick tock noises and a small audio amplifier. First the beat generator, IC1. This circuit is a schmitt trigger and an "integrator" all in one. The positive feedback via R1, 2 produces the schmitt action and the 'integrator' is made up of RV1, R5, C1. Imagine the output of IC1 is low at about +2V. The non-inverting terminal of IC1 will then be at +4V75. The positive end of C1 will be discharged via RV1 plus R5 towards +2V, until it reaches +4V75. When this happens the schmitt trigger makes the output of IC1 snap into its 'high state'. Now the voltage on the non-inverting terminal is +10V25 and C1 is charged up towards this voltage. When this voltage is reached by C1 the schmitt trigger snaps back into its low state.

Thus square wave oscillations are produced, the frequency of which is determined by RV1, R5, C1. The squarewave is fed into IC2 (via C4), which is a bandpass filter with a relatively high Q. The edges of the squarewave 'excite' the filter which rings producing a percussive, waveform. The pitch of the percussive waveforms is controlled by R7, 8 but R8 is only turned on by Q1 when the output of IC1 is high. Therefore two percussive notes are produced, a low note when IC1 output is low and a higher note when IC1 output is high. This double pitch percussive waveform sounds just like a 'tick tock' sound. If you want some really crazy sounds, try

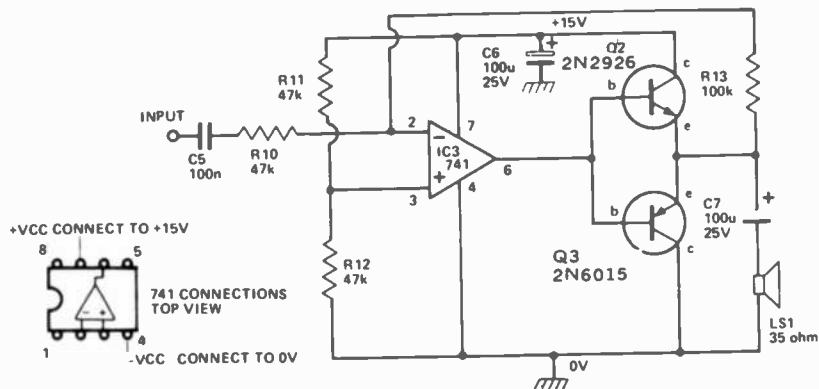
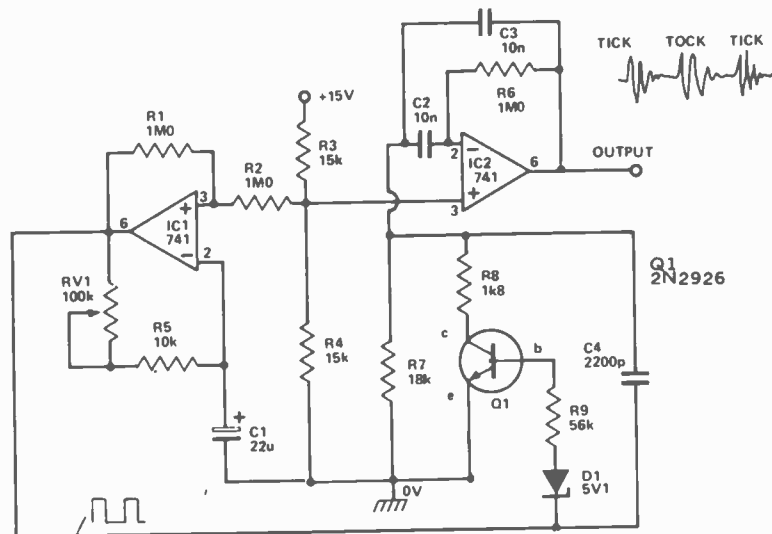

shorting out C4 or connecting a 5k pot across it!

The tick-tock waveform can then be fed into a small audio amplifier. IC3 is

just such an amplifier. The gain is set by R13, R10. If more gain is required, then increase R13, if less, then decrease it. ●

MEASURING UNKNOWN CAPACITORS

This simple circuit will enable you to find out the value of an unknown capacitor, it makes use of the 'Bridge' principle. The interesting part of the operation is to the right of T1, the rest of the circuit, including Q1 is simply an audio oscillator. T1 is a small transistor output transformer approx. 500R CT to 8R. Connected as shown, the circuit is known as a Hartley oscillator C2 converts the primary of the transformer into a tuned circuit operating in the audio range while C1 feeds back part of the signal to keep oscillation going. The effect of all this is to generate an audio signal into the secondary of T1.

Let us take a case where the two capacitors are the same value and the resistance in RV1 between x-y and y-z is the same; in that case the voltage at y and at the junction of the two capacitors

will be the same and nothing will be heard in the earpiece.

Assume now that our unknown capacitor is half that of our known. A larger amount of the signal will pass through our known component, the bridge is upset and a signal will be heard in our earpiece. However, if x-y is twice y-z, balance will once again be achieved and nothing will be heard. It follows that if a pointer knob of RV1 is marked in ratios, we will be able to calculate the value of almost any capacitor as long as we use our reference component one that is between ten times and one-tenth of the unknown, this is because it is only practical to mark out ratios of 10 to 1. This is not as much of a problem as may first be imagined as values between 1p and 100uF can be checked using four standards — these are 10p, 1n (100pF),

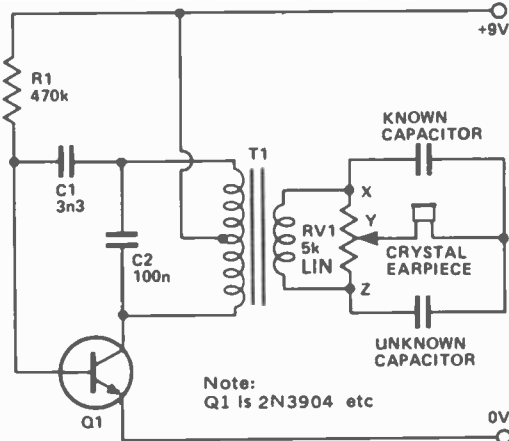

Note: Q1 is 2N3904 etc

100n (0.1uF) and 10uF. However, measuring low capacitance is likely to be inaccurate due to strays in the circuit and note that electrolytic capacitors are not normally close tolerance components. ●

Stereo Synthesiser

There are two common methods of producing a pseudo stereo effect from a mono signal; playing the mono signal from the two speakers in antiphase and the use of frequency selective techniques. The latter normally consists of directing lower frequency signals into one channel and higher frequency signals into the other. This circuit uses the second technique, but can additionally give antiphase signals which can give a better effect, especially when using headphones.

The two filters are formed by R4 and C3 (low pass), and C6 plus R8 (high pass). A high roll-off rate is by no means essential in this application and the 6 dB per octave attenuation rate of simple RC filters such as these is perfectly adequate. The -3 dB point of each filter is at approximately 800 Hz and the combined output of the filter, therefore, gives a virtually flat response with no significant peaks or troughs.

Q2 is connected as an emitter follower buffer stage and this ensures

emitter stage with 100% negative feedback (and unity voltage gain) due to R11. It also provides a 180° phase shift so that the two output signals are in anti-phase. An in-phase relationship is needed to give a good central stereo image and the use of anti-phase signals tends to give an impression of increased channel separation.

In a stereo orchestral recording it is normal for the violins to come from the left hand channel, with the cellos and basses from the right hand channel.

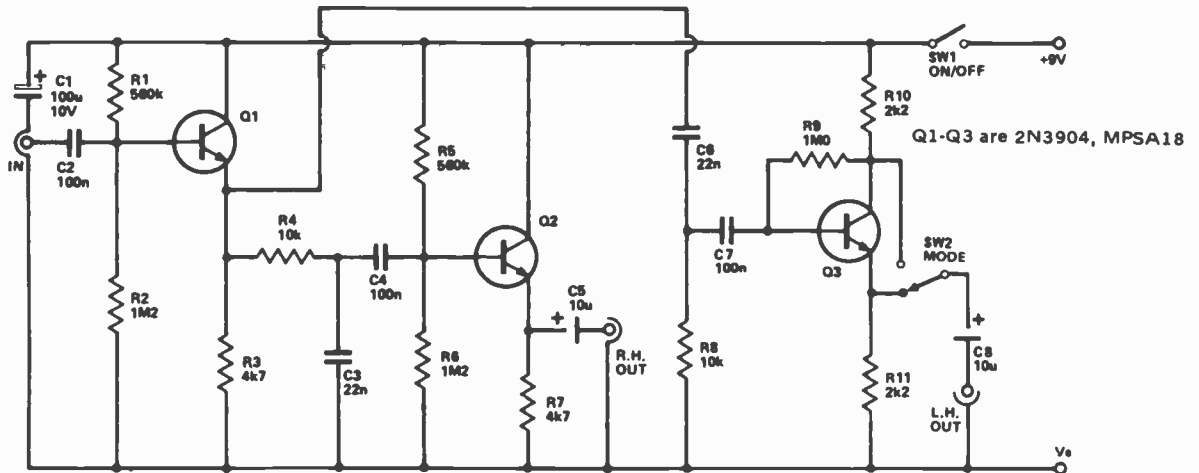

Q1 is used as an emitter follower buffer stage which ensures that the two filter networks fed from its output are driven from a low impedance source. If these were driven direct from the input, it is quite possible that they would be fed from a source impedance of a few kilohms or more, which would be quite sufficient to alter their effective characteristics.

that there is minimal loading on the low pass filter. Q3 similarly ensures that there is minimal loading on the high pass filter, but this device is used as a phase splitter. With SW2 switched to take the output from Q3's emitter, Q3 effectively operates as an emitter follower and gives no phase inversion. With SW2 switched to take the output from Q3's collector, Q3 then effectively acts as a common

emitter stage with 100% negative feedback (and unity voltage gain) due to R11. It also provides a 180° phase shift so that the two output signals are in anti-phase. An in-phase relationship is needed to give a good central stereo image and the use of anti-phase signals tends to give an impression of increased channel separation.

The current consumption of the circuit is about 3 mA. ●

A LOW FREQUENCY OSCILLATOR

IC1 is a MOSFET op-amp. Thus its input bias current is very low, typically 10 pA as compared with 100 nA for a 741 (10 000 times larger!). This allows very low current designs to be produced. The circuit above shows an integrator (IC1) and a Schmitt trigger (IC2). Imagine that the output of the Schmitt is high (+10 V). The voltage at the junction of R4, R5 is approximately +1 V. This pushes a current of 1 μ A through R1 which then charges C1. Thus C1 (the output of IC1) ramps down at a rate of $1/C$ which is in this case 1 V/Sec. When this voltage reaches -5 V, the Schmitt trigger flips over into its low state (-10 V). Now the current through R1 flows the other way, and so the output of IC1 ramps up at 1 V/Sec. this continues until it reaches +5

V (the upper hysteresis level of the Schmitt). The Schmitt trigger then jumps to its high output and so the process repeats itself. The circuit produces a square wave (± 10 V) and a triangle (± 5

V) output. Using the components shown the period is 20 seconds. To get 200 seconds make $R1 = 10M$. To get 2,000 seconds make $R1 = 10M$, $R5 = 1R$. ●

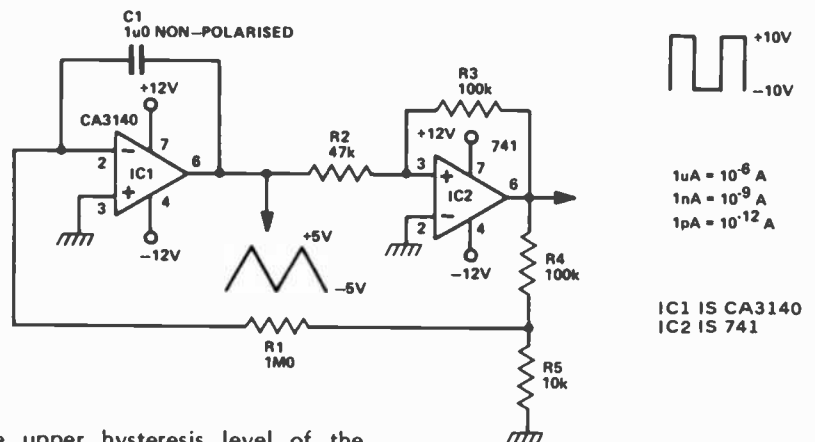

IC1 IS CA3140
IC2 IS 741

$1\mu A = 10^{-6} A$
 $1nA = 10^{-9} A$
 $1pA = 10^{-12} A$

CMOS LOGIC PROBE

A logic probe is a device which is used when testing digital circuits, and it shows the logic state at the selected test point. In common with most designs this one can indicate four input states, as follows:

1. Input high (logic 1).
2. Input low (logic 0).
3. Input pulsing.
4. Input floating.

The circuit uses the four 2 input NOR gates contained within the 4001 CMOS device, and is primarily intended for testing CMOS circuits. The probe derives its power from the supply of the circuit being tested. The first gate has its inputs tied together so that it operates as an inverter, and it is biased by R1 so that roughly half the supply potential appears at its output. A similar voltage appears at the junction of R4 and R5, and so no significant voltage will be developed across D1 and D2 which are connected between this junction and gate 1's output. Thus under quiescent conditions, or if the probe is connected to a floating test point, neither D1 or D2 will light up. If the input is taken to a high logic point, gate 1 output will go low and switch on D1, giving a "high" indication. If the input is taken to a low test point, gate 1 output will go high and D2 will be switched onto indicate the "low" input state.

A pulsed input will contain both logic states, causing both D1 and D2 to switch on alternately. However, if the

duty cycle of the input signal is very high this may result in one indicator lighting up very brightly while the other does not visibly glow at all. In order to give a more reliable indication of a pulsed input gates 2 to 4 are connected as buffered output monostable multivibrator. The purpose of this circuit is to produce an output pulse of predetermined length (about half a second in this case) whenever it receives a positive going input pulse.

The length of the input pulse has no significant effect on the output pulse. D3 is connected at the output of the monostable, and is switched on for

about half a second whenever the monostable is triggered, regardless of how brief the triggering input pulse happens to be. Therefore a pulsing input will be clearly indicated by D3 switching on.

The various outputs will be:
Floating input — all L.E.D.s off. Logic 0 input — D2 switched on (D3 will briefly flash on).

Logic 1 input — D1 switched on.
Pulsing input — D3 switched on, or pulsing in the case of a low frequency input signal (one or both of the other indicators will switch on, showing if one input state predominates). ●

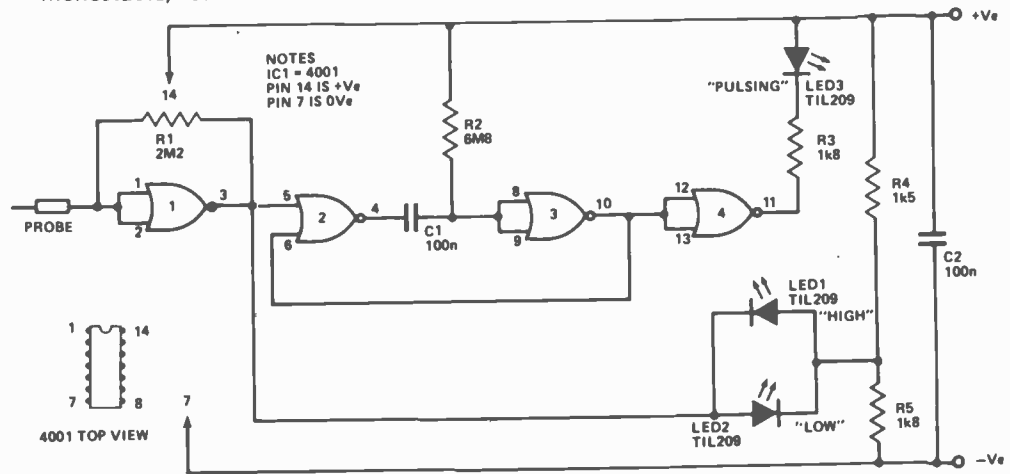

INSECT REPELLENT

The title of this circuit may at first appear to belong more in the pages of a biology or a chemistry book, but we are not joking. It is possible to make life uncomfortable for certain types of bugs using electronics. The theory is quite complex though it is possible to give a rough outline of what happens.

It seems that mosquitoes only mate at certain times and except for these times the two sexes are most unfriendly, in fact they stay well away from each other. It has also been reliably established that it is only the female of the species that actually bites. The third fact that we need to know is that the male mosquito (and this applies to other bugs as well) beats its wings at a slightly different rate than the female — this is one way that they identify each other. From these gems of information it will be seen that if one electronically simulates the sound of a male mosquito, the females will steer well clear. We are mentioning mosquitoes here but the same factors also apply to other bugs.

The circuit shown is a simple audio

oscillator whose frequency of operation can be varied over a wide range, in fact from about 500Hz to 10kHz and this will take in the range of all the common bugs. The circuit is a straightforward multivibrator with RV1 altering the audio frequency. This produces a square wave which is applied across the small crystal earpiece connected between the collector of Q2 and the negative line. Crystal earpieces have a very high impedance and it will in no way affect the operation of the circuit. Pretty well any transistors can be used in this simple circuit but if PNP types are used the battery supply should be reversed. The values of the capacitors are not too critical either and if others are used and it is found that the frequency range is not adequate, R1 can be altered to bring it back to the right sort of range. The current consumption is low at 2-3mA. This varies slightly with the frequency, but a 9V transistor battery will last quite a while; after all the unit will have to be left on for long periods. None of the components need

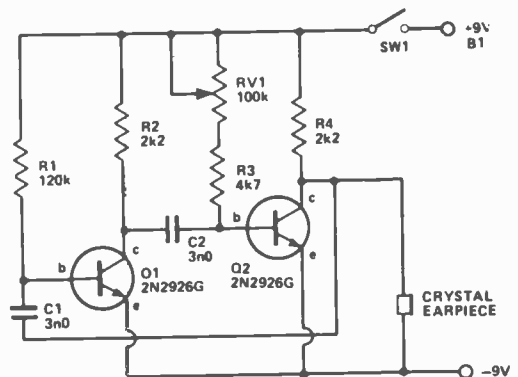

be large and the unit can be built in a small box to fit into a jacket pocket with the components arranged so that the earpiece is external. The preset RV1 should be a small skeleton preset with a facility for adjusting from outside.

As to adjusting for the right frequency this is a matter of trial and error. ●

Flash Slave Unit

The photocell used in this circuit is a photo-Darlington transistor. This gives a fairly fast operating speed and high sensitivity. In fact the sensitivity is rather too high, making it likely that the cell would saturate in only moderately light conditions. Its base terminal is, therefore, connected to the negative supply rail to give a suitable reduction in sensitivity. R1 and RV1 form the collector load resistance for photocell Q1 and RV1 acts as a sensitivity control. With RV1 at a low resistance, the increase in the current passed by Q1 when it picks up the pulse of light from the primary flashgun will produce a fairly small voltage spike across the load resistance. With RV1 set at a high resistance, a similar current pulse would produce a much larger voltage spike across the load and high sensitivity is obtained.

One problem with equipment of this type is that under bright conditions the photocell can saturate, preventing the circuit from functioning. When used indoors, saturation is unlikely to occur even with RV1 set for maximum sensitivity.

ty. The sensitivity of the unit should be so high that it will trigger reliably even if the primary flashgun and Q1 are aimed in opposite directions. When used outside in bright conditions it would be advisable to back off RV1 and the aim of Q1 and the flashgun will inevitably be more critical (there will probably be less reflected light to trigger the unit in addition to the reduction in sensitivity).

C2 couples the output from Q1's collector to the input of a common emitter amplifier using Q2. This is biased by R2 so that there is a quiescent collector voltage of only about 1V. Q3 is an emit-

ter follower buffer stage which is used to drive the gate of SCR1 from Q2's collector. The quiescent voltage at Q3's emitter is insufficient to activate the thyristor, but when Q2 receives the negative voltage spike from Q1 it switches off and the emitter potential of Q3 rises to a high enough level to trigger SCR1 and fire the second flashgun. R4 is a current limiting resistor which prevents Q3 from passing an excessive current.

The current consumption of the circuit is about 2 mA. Note that the flash lead must be connected to SCR1 with the correct polarity or the unit will not operate. ●

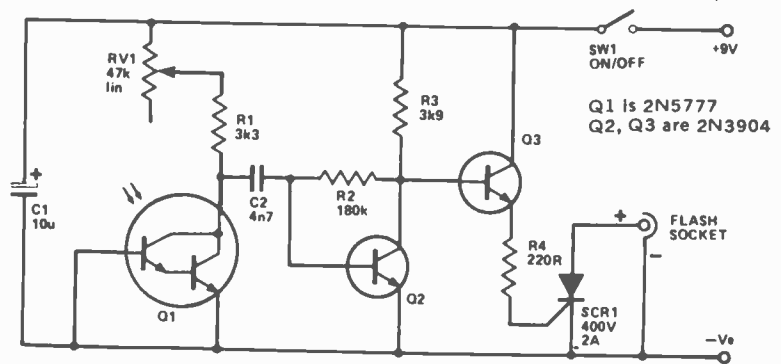

HOME INTERCOM

This intercom uses a straightforward three transistor amplifier which gives quite a good quality output (by intercom standards) and an adequate output power of a few tens of milliwatts.

As is normal practice with intercom designs, the loudspeaker in each station also doubles as a sort of moving coil microphone when 'sending'. The position of SW2 determines whether the slave unit is 'sending' and the master station is receiving, or vice versa. Ideally this should be a spring loaded switch which automatically returns to the 'receive' position when released. This enables the remote unit to call the master one if the operator closes SW1 so as to connect power from B1 to the amplifier, and then talks into the microphone in order to attract the attention of the person at the master station. If SW1 is not a spring loaded switch, it could be left in the 'send' mode, preventing the remote station from calling the master one. SW3 is the ordinary on/off switch at the master station.

The amplifier is a three stage unit capacitive coupling between stages. A common base input stage (Q1) is used as

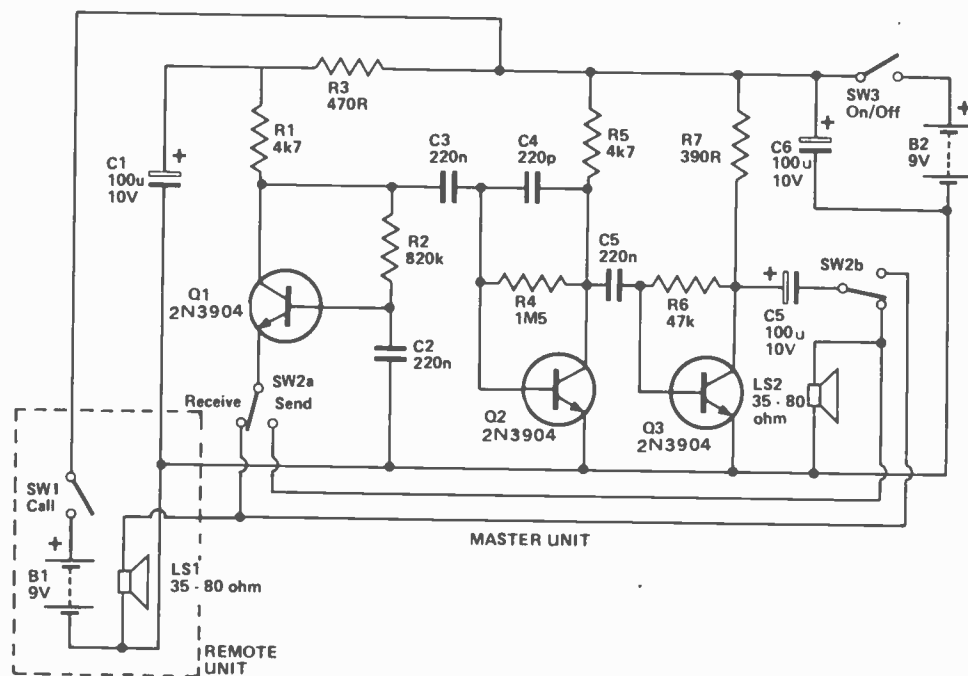

this gives a low input impedance. This is desirable as it minimises stray pick-up of line hum and radio interference in the connecting cable, and it also gives a good match to the microphones. The following two stages are both straightforward common emitter amplifiers. C4 rolls off the high frequency response of

the circuit and this aids stability. It can also help to prevent RF breakthrough.

The prototype was tried with connecting cables up to about 10 metres or so long, and gave perfectly good results. It should work with considerably longer connecting cables if necessary. A three conductor connecting cable is required ●

RIAA STEREO PREAMPLIFIER

There are two types of record player pickups, ceramic and magnetic. The first type is the cheapest and generally gives a large output voltage (0.5V). This type of pickup does not usually require any frequency response correction, but the sound quality produced is not as good as that which can be achieved with a magnetic pickup. Records are cut with a frequency response such that when they are replayed with a magnetic pickup and a preamplifier with a RIAA equalisation (Recording Industry Association of America) the reproduced sound will be as similar to the original as possible.

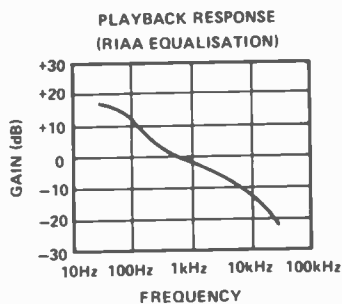

The disc is cut at constant amplitude, except from 500 Hz to 2120 Hz where it is cut at constant velocity. When this disc is replayed with a magnetic pickup, the relative output voltage rises with frequency, this being due to the fact that the magnetically generated voltage is proportional to the velocity of the stylus as it moves sideways in the groove. To restore the original sound quality, a preamplifier with a frequency response that gives decreasing output with increasing frequency is required. This response curve is known as the RIAA equalisation and it

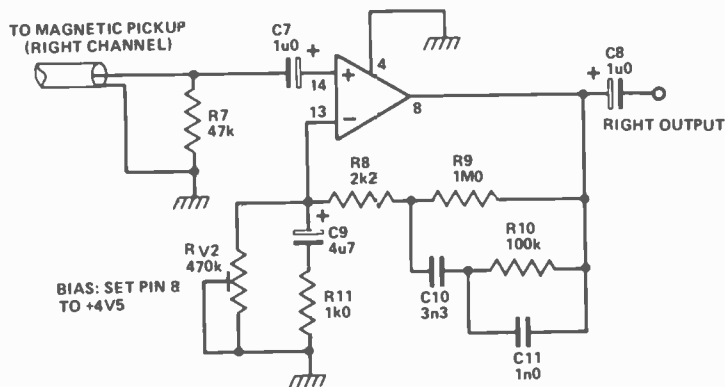
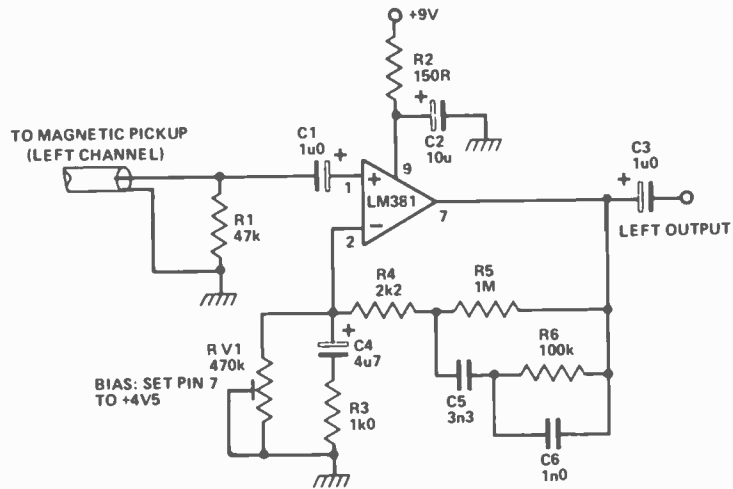

is tailored accurately to fit the cutting and replay processes. The signal level from a magnetic pickup is low, generally 20mV pp and so a low noise preamplifier is needed.

The circuit shows a realisation of this requirement. The low noise amplifier is the LM381 made by National Semicon-

ductor. A DC bias control is included (RV1, 2), and the feedback components generate the RIAA curve. Use screened cable for the wiring to the pickup, keep the circuit away from transformers (and the pickup and its wiring) and connect all the grounds shown in the circuit diagram together, near the IC. ●

PHASE SHIFT OSCILLATOR

A single transistor can be used to make a simple phase shift oscillator. The output is a sine wave with a 'lump' in it, which means that the distortion content is rather high, about 10%. This is not always a problem, quite often when generating audio tones a high harmonic content will make a more interesting sound. The sine wave purity can be increased by putting a variable resistor (25 ohms) in the emitter lead of Q1 (x). The resistor is adjusted so that the circuit is only just oscillating, then the sinewave is relatively pure. However, if the power supply level varies, the oscillation may cease altogether. The operating frequency may be varied by putting a 10k variable resistor in series with R3, or by changing C1,

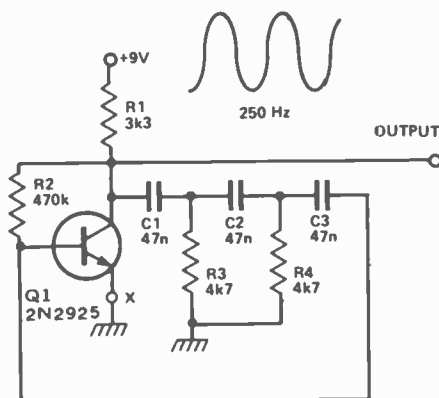

2, 3. Making C1,2,3 equal to 100nF will halve the operating frequency. Also Also, the operating frequency can be voltage controlled by a FET in series with R3, or optically controlled by an LDR in series with R3. ●



QUICK TRANSISTOR CHECKER

This very simple and inexpensive circuit is not designed to measure any transistor performance figures, but is intended for quick testing to show whether or not the test device is functional. The basic method of testing a transistor is to first connect a supply to its emitter and collector terminals and check that no significant current flows. If the base terminal is then given a small forward bias, this will be amplified in the form of a large collector-emitter current.

This circuit is based on a CMOS quad 2 input NAND or NOR gate IC. Either type is suitable as each gate has its two inputs connected together so that it acts as an inverter. The first two inverters are used in conjunction with R1 and C1 as a conventional CMOS oscillator operating at a frequency of a few hundred Hz. The other two inverters are connected in parallel, and fed from the output of the oscillator so that they provide a complementary output. In other words, one output will be positive and the other will be negative except during the brief periods when the outputs change state.

The collector and emitter of the transistor are fed from the outputs via D1 and D2, and the base is fed from one

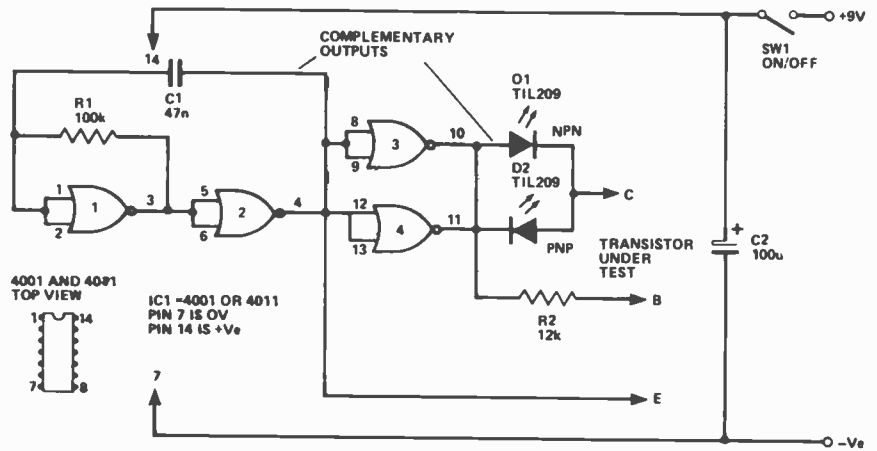

output via R2. If we assume that an NPN device is being tested, when gate 2 output is positive and the other output is negative, the transistor will not be forward biased by R2 (it will be reverse biased in fact) and it should pass no significant collector current. If it is a short circuit device and does pass such a current, this will pass through D2 which will light up and indicate the fault. When the outputs are in the opposite states, the transistor will be forward biased by R2 and should conduct heavily, causing D1 to pass a current and light up. Failure of D1 to come on indicates an open circuit or very low gain device. PNP devices operate with the opposite polarity, and

so when testing one of these it is D2 that should switch on, and D1 which should remain off.

summary

One LED on = functional device, type (ie PNP/NPN) as indicated.
Both LEDs on = short circuited device.
No LEDs on = open circuit or very low gain device.
Diode or rectifier testing (anode to collector, cathode to emitter).
D1 on = functional device.
D2 on = connected with wrong polarity.
Both LEDs on = short circuited device.
No LEDs on = open circuit device. ●

SINGLE IC POWER SUPPLY

Although variable voltage power supplies having good regulation and electronic overload protection used to be fairly complex pieces of equipment, using modern circuitry it is possible to build such a unit using just one IC and a few passive components. The unit described here has an output voltage which is variable from 5 to 15 volts, and a maximum output current of 500mA, can be provided. The output is extremely well stabilised and the output noise is well below 1mV.

The line supply is connected to the primary winding of isolation and step-down transformer T1 through on/off switch SW1. The centre tapped secondary of T1 feeds a standing fullwave rectifier and smoothing circuit which uses D1, D2 and C1.

IC1 is the voltage regulator chip, and this has four terminals. The unregulated input voltage is applied to the "IN" and "COM" terminals, while the stabilised output is taken from the "OUT" and "COM" terminals. The fourth terminal is the "CONT" one, and if this is fed from the output via a potential divider, a negative feedback action will stabilise the voltage at this terminal at a nominal level of 5 volts. In this case the potential divider is formed by RV1 and R1. If RV1 slider is at the top of its

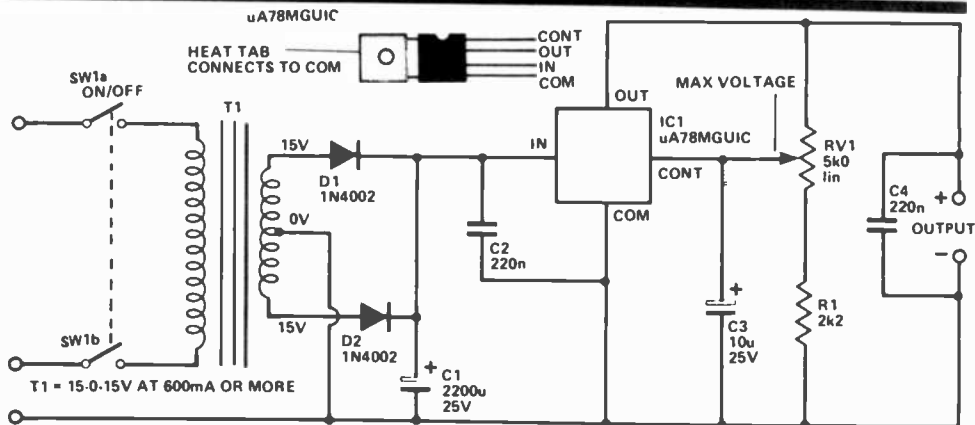

track the output will be stabilised at 5 volts. A higher voltage would take the "CONT" terminal (which is directly connected to the output) above 5 volts, causing the error to be sensed and corrected. Similarly, a lower voltage would take the "CONT" terminal below 5 volts, causing the output to swing more positive and correct the error.

If RV1 slider is moved down its track, the voltage fed to the "CONT" terminal will decrease, sending the output higher in order to return this potential to 5 volts. Thus RV1 can be used to vary the output voltage, with a maximum potential of about 16 volts or so appearing at the output when RV1 slider is at the bottom of its track. The feedback action accurately stabilises the output at the

potential set using RV1, but only at output levels up to about 15 volts. Above this level, at high output currents, there will be insufficient input voltage from the rectifier and smoothing circuit to properly maintain the output voltage.

The regulator device has built-in foldback current limiting which prevents the output from much exceeding 500 mA in the event of a minor overload. Stronger overloads result in decreased output current, the short circuit current being only about 200 mA!

Decoupling capacitors C2 and C3 should be mounted physically close to IC1. IC1 must be mounted on a substantial heatsink which can be the metal case of the unit. ●

TRANSISTOR POWER AMPLIFIER

Most of the Hi Fi amplifiers in use are based on circuitry similar to this design, although they are much more sophisticated. The circuit uses a 'complementary' output stage, with one NPN and one PNP power transistor, which eliminates the need for an output transformer found in old amplifier designs.

Output power is close to 1W, with reasonably low distortion. The input signal is passed through the volume control RV1 and then via C1 to the base of Q1. The collector load for Q1 is composed of R1, R5 and the loudspeaker and the voltage at the collector will be about half the supply voltage, i.e. 4V5. The bases of Q2 and Q3 are also at the same voltage (very nearly) as the collector of Q1 because the value of R1 is so low (68R).

At the junction of the emitters of Q2 and Q3 the voltage will also be very nearly 4V5, R3 and R4 and very low value resistors to limit the current through Q2 and Q3. When the amplified input signal is less than 4V5, Q2 is turned off (as the base will be at a lower voltage than its emitter), but Q3 will conduct the signal. When Q1 amplifies the signal to above 4V5 the reverse happens, Q2 conducts and Q3 is turned off.

The signals are combined at the the common emitter junction of Q2 and Q3,

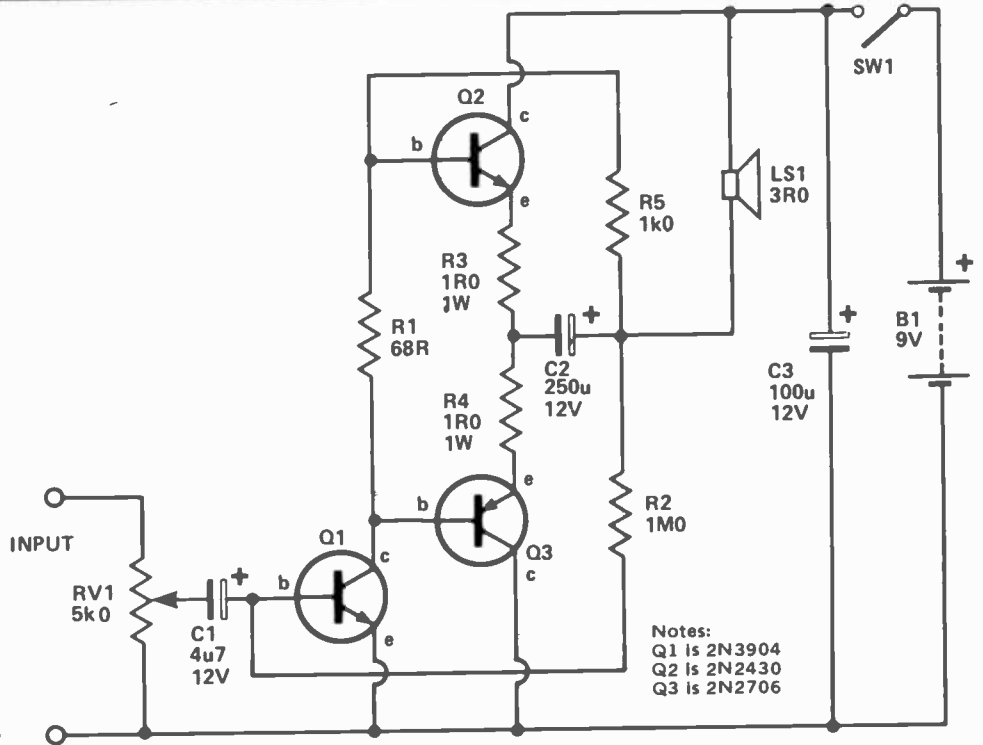

Notes:
Q1 is 2N3904
Q2 is 2N2430
Q3 is 2N2706

and passed to the loudspeaker through the large electrolytic capacitor C2. Small values of C2 result in a poor low frequency response. Negative feedback is provided by R5 and R2, these ensure stability by reducing the gain slightly. R1 is included to provide a small amount of base bias for Q2 and Q3; more sophisticated designs use thermistors or

diodes to prevent thermal runaway which can destroy the output pair.

A disadvantage is the DC coupling of the transistors, if one transistor alters its characteristics the result can be catastrophic! For this reason, the output pair should be a 'matched pair', other types can be tried as long as they are also "matched pairs". ●

LOW BATTERY VOLTAGE INDICATOR

This circuit can be used to monitor a supply voltage of between about 5 and 25 volts (30 V absolute maximum) and will switch on a warning light if the supply falls below some predetermined threshold level.

Although only five components are used, the circuit is actually quite sophisticated, giving good reliability and precision. This is due to the use of an Intersil 8211 voltage detector IC. A comparator forms the heart of the device, and a highly stable internally generated reference voltage is fed to the inverting (-) input of the comparator. Its non-inverting (+) input is available at pin 3, and in this circuit it is fed from the supply lines via the potential divider circuit which consists of R1 and RV1. The output of the comparator is available at pin 4, but is obtained by way of a constant current generator which limits the output current to a nominal figure of 7 mA.

If the voltage at the non-inverting input exceeds the reference voltage, the output assumes the high state and LED indicator D1 is not switched on. If the

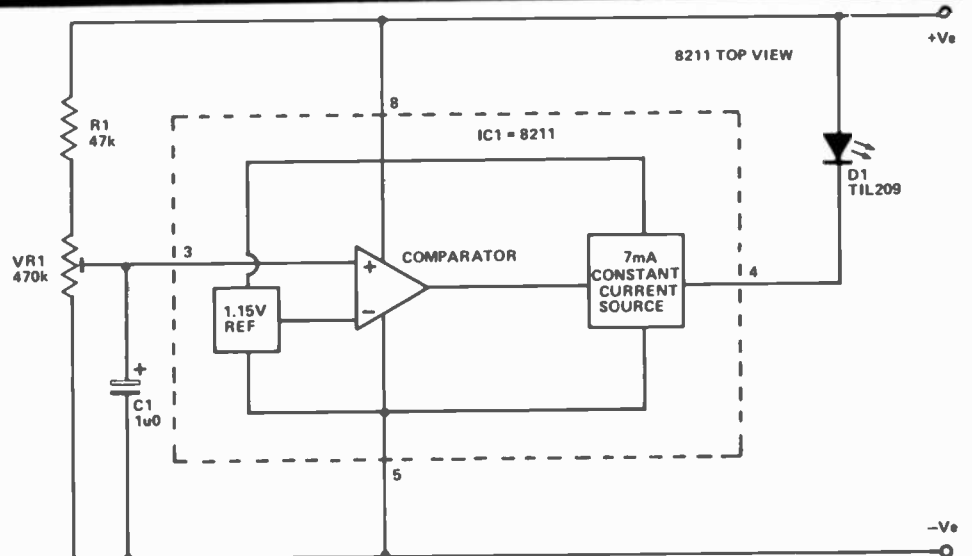

reference level, the output then goes low and power is applied to D1. The constant current source limits the LED current to a suitable level. In practice RV1 is adjusted so that with the supply voltage at its minimum acceptable level the non-inverting input is at a potential just marginally higher than the reference voltage. In other words it is adjusted for

D1 to be switched on. A fall in supply voltage below the threshold level then takes the non-inverting input below the reference voltage and switches on the warning light. C1 decouples any stray pick-up which could otherwise cause spurious triggering of the circuit. The quiescent current consumption is typically only about 50 uA. ●

TWO TONE ALARM

Audio alarm generators are needed in a number of applications, such as fire and burglar alarm systems. This circuit generates a penetrating two tone alarm signal having an output power of between about 250 mW and 4 W RMS depending on the speaker impedance and supply voltage used. For low power applications a 9 volt supply and a speaker impedance of about 64 to 80 ohms will give a nominal output power of 250 to 300 mW for a current consumption of around 55 to 70 mA. Where high volume is needed, a 12 volt supply and 8 ohm speaker will give an output power of about 4 W RMS at a mean current consumption of about 700 mA.

The circuit is based on two of the four Norton amplifiers contained in the LM3900N IC. A Norton amplifier is in many ways similar to an ordinary operational amplifier, but it is the comparative input currents rather than the input voltages that determine the output voltage. IC1b is used in a type of relaxation oscillator which generates the audio tone. Initially the bias current flowing into the non-inverting input takes the output high, and C2 begins to charge via R9. This causes the current flowing into the inverting input through R6 to gradually increase as the voltage on C2 builds up, until it exceeds the non-inverting input bias current. The output of IC1b then

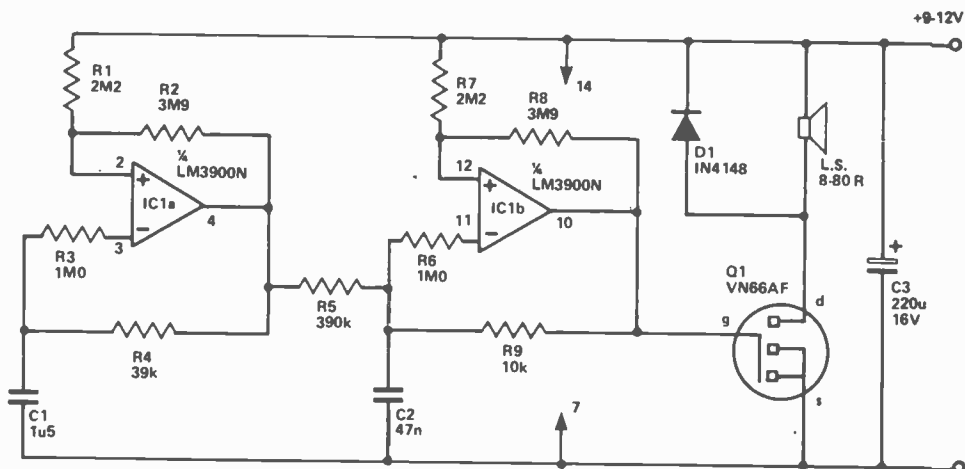

goes low, causing C2 to discharge through R9 until the inverting input current becomes less than that flowing into the non-inverting input. IC1b output then goes high, and the procedure starts again from the beginning, giving continuous oscillation. Note that when IC1b output went from the high to the low state this resulted in R8 draining off some of the non-inverting input bias current where it had previously added to it. This makes it necessary for C2 to considerably discharge before the current into the inverting input drops below that applied to the non-inverting input. This effect is a form of "hysteresis", and is essential to the operation of the circuit. R8 also provides positive feedback

which ensures that once IC1b output starts to change polarity it rapidly and reliably switches from one state to the other.

The squarewave output of IC1b is at quite a high impedance, and so the loudspeaker is driven by way of a common source amplifier using VMOS transistor Q1. IC1a is used in a second oscillator circuit, but this has component values which give oscillation at a frequency of only a few Hertz. Its output is loosely coupled to C2 by R5, and it frequency modulates the tone generator to produce a sort of warbling effect. This gives a much more noticeable and less easily masked signal than a straight forward audio tone. ●

ZENER DIODE TESTER

This circuit is an add-on unit for a multimeter having a sensitivity of 20k/V or better, and it enables a rough check to be made on zener diodes having operating voltages of up to about 33 volts. The unit operates from a standard 9 volt battery or special high voltage battery being required.

In order to obtain a suitably high voltage for this application from an ordinary 9 volt DC supply it is necessary to have a voltage step-up circuit of some kind. In this case, an audio oscillator using IC1 is used to drive the primary winding of step-up transformer T1, giving about 50 V AC from the secondary winding. T1 is actually intended for use as a step-down transformer in transistor amplifier output stages, but it provides satisfactory results when employed in reverse to give a voltage step-up. The output from T1 is halfwave rectified and smoothed by D1 and D3 to give an unloaded DC supply of about 75 to 80 volts (about 40 to 50 when loaded).

With SW1 at the 'low' position, a current of about 1 to 2 mA (depending

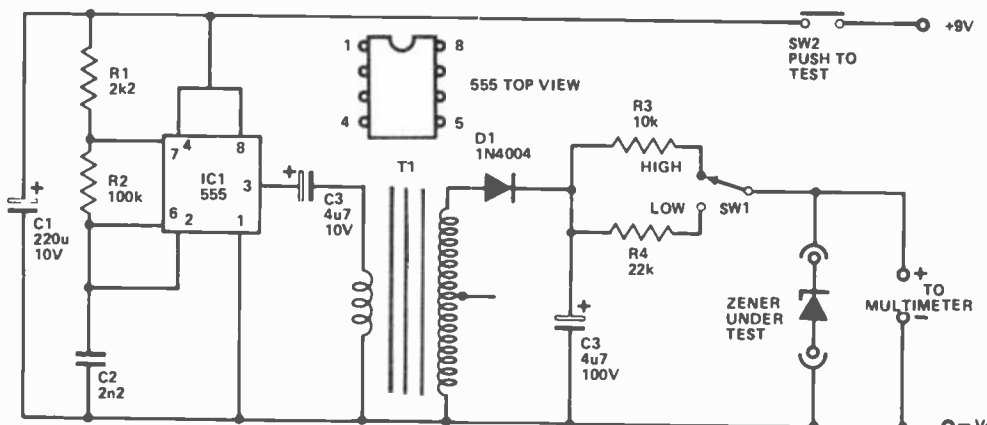

upon the voltage of the zener under test) is fed to the test device through current limiting resistor R4, when SW2 is operated and power is applied to the circuit. The multimeter, which is switched to an appropriate DC voltage range, is connected in parallel with the test device and registers its zener voltage. Switching SW1 to the 'high' position causes about double the previous current to flow through the zener under test,

as a lower value current limiting resistor (R3) is then switched into circuit. If the test device is fully functional this should cause only a very small increase in the meter reading and there may well be no noticeable change in the meter reading at all.

T1 can be virtually any type of small transistor output transformer. A 500R CT to 8R type will work fine. ●

DOORBuzzer

This unit is a two-tone doorbuzzer of the type that produces an initial tone for about one second, followed by a tone of lower pitch. The effect is similar to a conventional two-tone doorbell.

The audio tone is generated by IC2 which is an LM380N audio power amplifier. It is made to oscillate by applying positive feedback between its output and non-inverting input; and the frequency of oscillation is governed by the values of R6, R8, and C3. The specified values give an operating frequency of about 500Hz. The output from IC2 is fed to a loudspeaker via DC blocking capacitor C4, and an output power of nearly 1 watt RMS is obtained using an 8 ohm speaker. This falls to only about 200 mW RMS with a 40 ohm speaker, although this should still provide adequate volume for most situations.

The two-tone effect is obtained by the inclusion of IC1 and its associated components. This is a 555 IC connected in the monostable mode, and it produces a positive output pulse of just under one second in duration (set by R3 and C1)

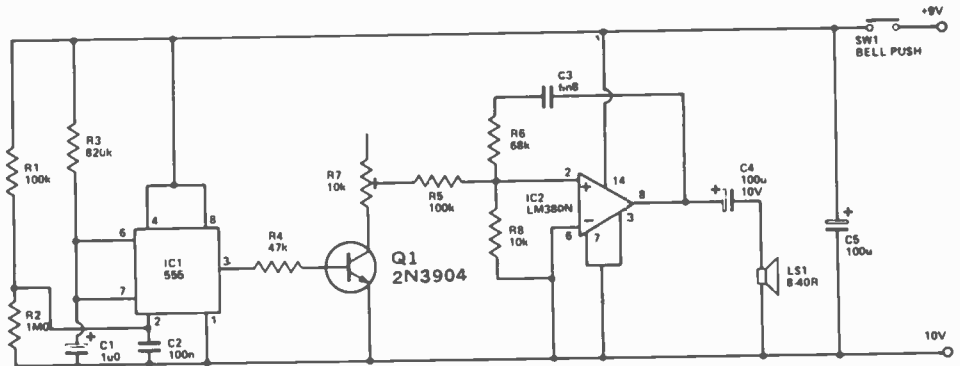

when a negative trigger pulse is applied to its pin 2. Such a pulse is produced at switch on, since C2 will initially be uncharged and will take pin 2 of IC1 to the negative supply potential. C2 rapidly charges by way of R1 though, so that the trigger input is quickly taken positive, and does not remain negative at the end of the output pulse (this would have the effect of lengthening the output pulse). When power is removed from the circuit, R2 rapidly discharges C2 so that the monostable is triggered when the device is operated again.

Q1 is biased hard into conduction

by the output pulse from IC1, and it therefore effectively connects the series resistance of R5 and R7 in parallel with R8. This increases the operating frequency of the oscillator by an amount that is controlled by R5. At the end of the pulse from IC1, the oscillator operates at its normal, lower frequency, giving the required two-tone effect. R5 is adjusted to give two tones that give a pleasant effect.

The current consumption of the circuit varies from just over 100mA with an 8 ohm speaker down to about 40mA with a 40 ohm type. ●

LIE DETECTOR

It is well known that a person perspires under tension; what is less well known is that this effect is a gradual one and that a small amount of perspiration takes place, especially in the palms of the hands, even under slight pressure. In the normal course of events this is rarely noticed but this effect can be shown electronically.

When a person is embarrassed or tells a lie there is a very small, but noticeable, increase in the sweat on the palms of the hands. Perspiration is reasonably conductive; holding the probes of a testmeter in the hands will show a resistance reading, albeit at a high level. It will therefore be seen that by measuring the resistance across a person's hands that we should be able to see an indication of whether they are telling the truth or not. Let us say straight away that this test is far from perfect and it has little serious use but it does illustrate an interesting phenomenon and makes for a little experimenting.

The change in the body resistance is quite small when shown as a percentage — about 5 or 10 percent and showing this change directly on a meter leaves something to be desired. For this reason we make use first of a transistor to

“amplify” the resistance and secondly we place this in a bridge circuit. When this is in balance the meter will only read changes in the resistance.

When the probes are held, one in each hand, the body resistance, in conjunction with R2, provides the bias for the transistor. The body resistance varies enormously from person to person as well as with their emotional state but a typical value could be taken as 100k ohms. R2 is included solely as a safety resistor and will prevent damage to the device if the probes are touched directly together. The current passing through this transistor through R1 will depend upon the value of the resistance between the collector and emitter. As the current varies, so will the voltage at the collector.

For setting up the circuit the probes should be held in the hands. This will give a particular voltage and RV1 is adjusted so that the voltage at the slider is the same as that at the collector of the transistor. As the voltages are the same, no current will be flowing through the meter coil and no reading will be registered.

If the body resistance now falls, Q1 will conduct more and the voltage at the collector will also fall and a reading will be

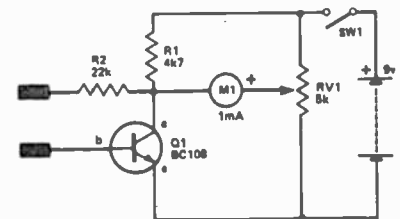

shown on the meter. The size of the deflection will indicate by how much the body resistance has fallen.

Although the probes are held in the hand, there is no danger as only a 9V battery is being used. RV1 will have to be adjusted for each individual and even for each set of readings with the same person

The effect is quite remarkable and also surprisingly rapid; within a very short while (one or two seconds) the meter will show a deflection. There may be a small amount of wandering of the needle but this will be small compared to normal readings.

As we have said, the results should not be taken too seriously but very definite readings are given when the person being tested is under stress. ●

TOUCH SWITCH

This touch switch is designed to provide on/off switching for 9 volt battery operated equipment having a current consumption of up to 100mA. It has a single touch contact which is briefly touched in order to change from on to off or vice versa. The circuit is operated by stray pick-up of line hum which is coupled to the input of gate 1 (which like the other three gates employed in the unit is connected to act as an inverter) via R1 when the input contact is touched. As IC1 is a CMOS device it has a very high input impedance, and the input signal will be capable of switching gate 1 input from one logic state to the other. The input impedance of the circuit is so high that the reverse resistance of D1 is used to tie the input to ground under quiescent conditions, so as to prevent spurious operation. R1 acts as a low pass

filter in conjunction with the input capacitance of the circuit, and this attenuates high frequency noise which may be present on the 60Hz line signal.

The output from gate 1 still contains significant noise products, and also has a rise time which is inadequate to drive the final stage of the circuit. This is overcome by using the trigger circuit based on gates 2 and 3. R3 tends to hold gate 2 input in the same state as gate 3 output, resisting any change in logic state caused by gate 1 output due to the coupling through R2. This resistance to change is termed 'hysteresis'. R2 has a lower value than R3, and so gate 1 can operate the trigger circuit if its output signal is of adequate amplitude. The 60Hz signal will be strong enough, but the noise spikes will not, and are thus eliminated from the output of the trigger. Once the output of the trigger does start to change

state, the coupling through R3 provides a triggering action which ensures a rapid change.

IC2 is a 14 stage binary (divide by 2) counter, and Q1 is driven from the output of the seventh stage via current limit resistor R5. C2 and R4 provide a positive reset pulse to the counter at switch on so that the outputs are all low, and Q1 is switched off. The controlled equipment forms the load for Q1, and obviously receives no significant power. If the touch contact is operated, a 60 Hz signal is fed to IC2 and the 7th stage output changes state every 64 pulses. As this output goes high and low the load is switched on and off. In practice the contact is touched just until the unit switches to the desired state (which one tends to do automatically).

The unit consumes only about 1uA in the "off" mode and approximately 3mA in the "on" state. ●

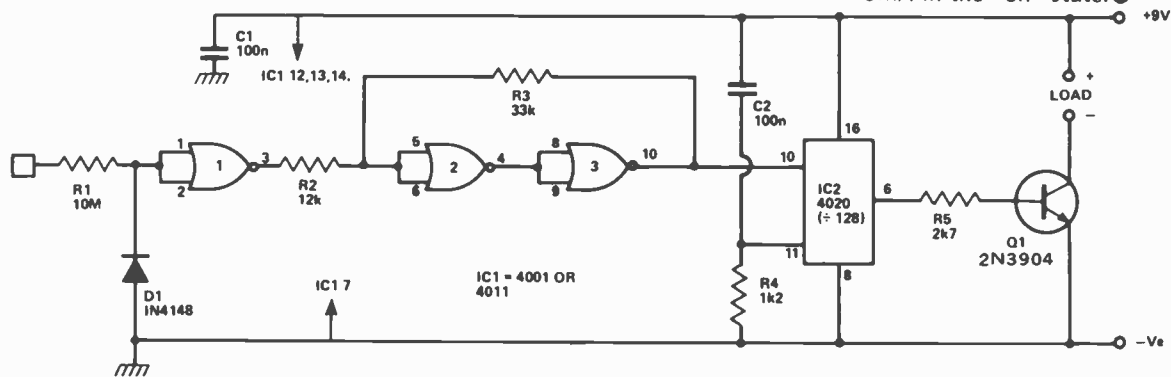

555 IC MONOSTABLE TIMER

In the monostable multivibrator mode the 555 IC requires a trigger pulse which takes the trigger input below $\frac{1}{3}$ of the supply voltage. The normally low output then goes high for a period determined by a C-R network, the pulse length being approximately 1.1 CR seconds. The device is a retriggerable type, and the output therefore stays high until the trigger pulse ceases, if the latter is longer than the pulse given by the C-R timing circuit.

The circuit is a timer having a 1 to 100 second range, and suitable for use as an enlarger timer, for example. It is triggered by depressing SW1 so as to generate a brief negative pulse as C3 charges via R2. This makes it impossible to prolong the output pulse and produce a false output period by keeping SW1 depressed. C3 is quickly discharged by R3 when SW1 is released, rendering the trigger circuit ready for the next operation.

The tolerance of timing components RV1, R1, and C2 make it impossible to obtain a highly predictable time range, and this is overcome by the

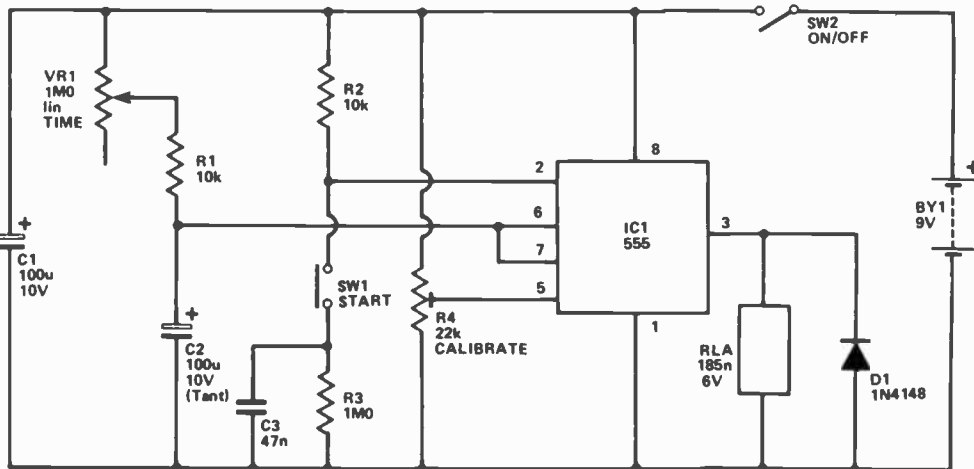

inclusion of R4. Normally the output pulse ends when the charge on the timing capacitor reaches $\frac{1}{3}$ V+ (it is held uncharged until the circuit is triggered and is discharged when the $\frac{1}{3}$ charge level is reached). R4 can be used to raise or lower the threshold voltage so as to

extend or shorten (respectively) the output pulse, as necessary to obtain the appropriate timing range. The output pulse at pin 3 is used to operate the controlled equipment by way of a relay, and D1 is simply a protective diode. ●

SCRATCH AND RUMBLE FILTER

Scratch and rumble filtering is a valuable feature in a hi fi amplifier, but is one which is absent from many designs, or if this filtering is present it may well be in the form of a relatively ineffective 6dB per octave type filter. This circuit is a 12dB per octave add-on scratch and rumble filter which can be connected into the tape monitor or some similar facility of the amplifier.

This is a conventional second order filter circuit having passive high pass filter formed by the series capacitance C3 and C4, plus the parallel resistance of R2 and R3 (the latter also being used to bias emitter follower transistor Q1). A passive filter of this type gives only a very slow initial roll off, and an ultimate attenuation rate of only 6dB per octave. A bootstrapping resistor is therefore used to improve performance. Above the cut-off frequency where the gain of the circuit would otherwise fall off somewhat, R1 has the effect of reinforcing the input signal from the output of the buffer amplifier based on Q1. Well below the cut off frequency, losses through C4 result in the signal level at Q1 emitter being well below that at the junction of C3 and C4. This results in some of the signal at the junction of C3 and C4 being tapped off through R1, with C3 and R1 ef-

fectively forming a second high pass filter network. This eliminates the slow initial roll off rate (in fact there is a small and insignificant peak of about 0.5dB above the cut off frequency) and speeds up the attenuation rate to a nominal 12dB per octave.

The low pass filter works in much the same way as the high pass one, except of course, the R and C filter elements have been transposed so as to give the correct filter action.

the high pass filter components. C2 then maintains DC blocking at the input. SW2 can be used to bypass the low pass filter components when only high pass filtering is required.

With the specified component values the rumble filter response falls below unity at approximately 45Hz, reaches the -6 dB point just above 30Hz, and then falls away at a nominal 12dB per octave. The scratch filter response crosses the unity gain point at about

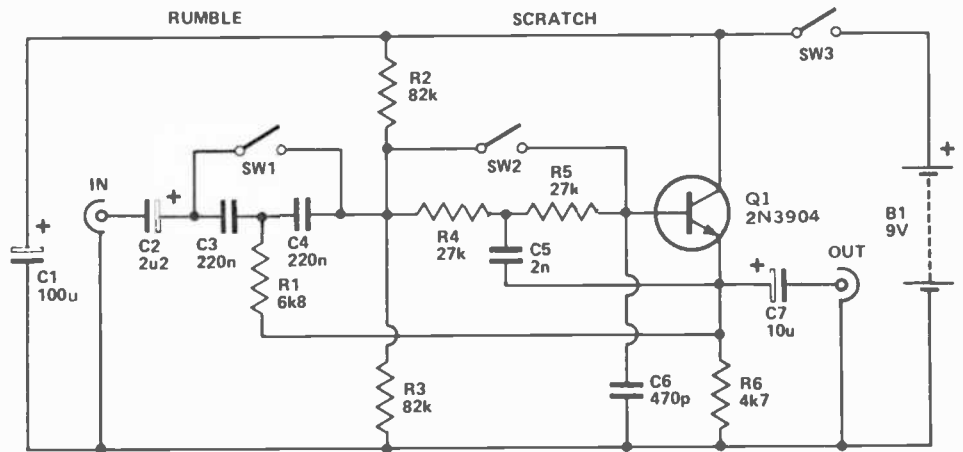

If only low pass filtering is required, SW1 can be used effectively to bypass

6.5kHz, reaches the -6dB point at approximately 10kHz, and then falls away at a nominal 12dB per octave. ●

VOLTAGE CONTROLLED FILTER USING A CA3080

The CA3080 is an Operational Transconductance Amplifier. What this means is that it is an amplifier whose gain can be controlled. Thus the CA3080 finds lots of uses in circuits where something has to be varied electronically, one such example being a voltage controlled filter.

A bandpass filter is constructed using IC2, R4, C1, C2. This is known as a multiple feedback bandpass filter and normally there is another resistor which is connected from ground to the junction of the two capacitors. By varying this 'other' resistor, the resonant frequency of the filter can be changed. The CA3080 and R1, R2 is this 'other' resistor. By varying the current into pin 5 of IC1 it is possible to control the gain of the device. R1, R2 provides negative feed-

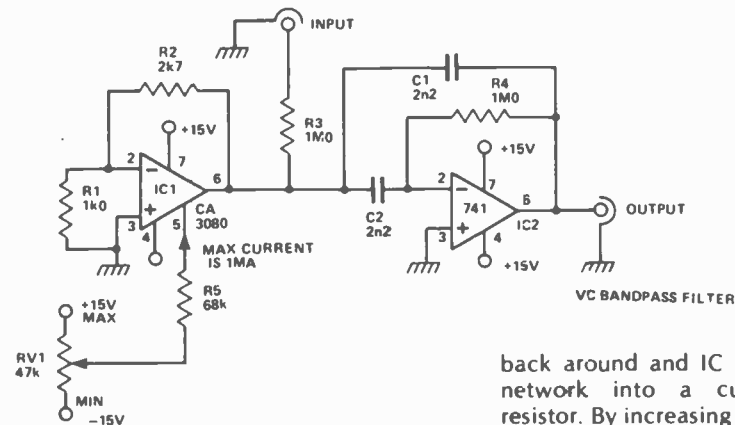

back around and IC and this turns the network into a current controlled resistor. By increasing the current, the effective resistance is reduced, which in turn alters the resonant frequency of the filter.

It is possible to provide a varying control current using the circuit involving IC3. This is a low frequency squarewave oscillator. The oscillation frequency is determined by C11, R5. The squarewave is heavily filtered by R6, R7, R8 and C3, C4, to produce a smoothly modulating current drive to IC1. This causes the centre frequency of the filter to be swept up and down. The autosweep can be used as an effect for electric guitar or for electronic music processing. ●

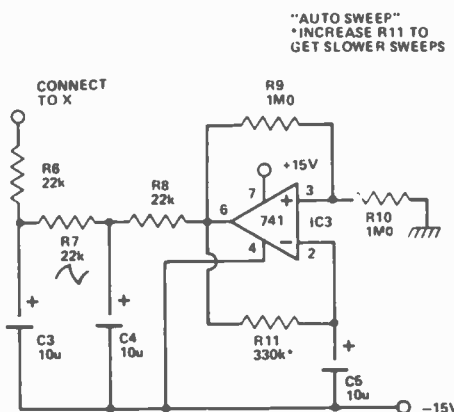
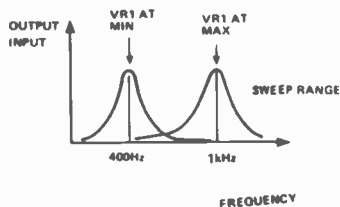

SIMPLE AMPLIFIER

The term amplifier covers a very wide range from a one transistor preamp to an ultra sophisticated high power Hi-Fi system. There is no doubt that the latter is much more pleasant to listen to but for many applications high quality is of little importance and simplicity is required. There is little doubt that the circuit shown here is very simple. The output is in the order 250 mW — which is quite sufficient for most purposes and is comparable to that of the average transistor radio. The distortion level is rather high, being about 5%.

The amplifier is also reasonably sensitive and will give full output with an input of about 50 mV. Input impedance is about 50k. A simple tone control is included though as since this is an active control, rather than a passive one, the range is quite sufficient.

The slider from the volume control is connected to the base of Q1 via a DC blocking capacitor. Q1 is connected as a pretty conventional common emitter amplifier with R2 providing the base bias and R3 acting as the collector load. This stage is directly connected to the second transistor which is a PNP type. In this way the current passing through Q1 provides the bias for the second transistor. Because of the values used, the output of the second transistor is connected directly to the speech coil of the loudspeaker. This is not normally good practice since the standing current in the output transistor continually biases the coil either slightly in or out from its usual operating point. However if a large speaker is used, as it should be, this has very little effect and since we are not aiming at Hi-Fi, it does not matter.

The tone control comprises C2 and RV2 which are connected between the collector and base of Q1. At high resistance settings of RV2 this has little effect but on minimum settings the 100n feeds back the high frequencies out of phase, thus cancelling them.

For this circuit to work properly R3 must be selected with great care. The value shown here of 39 ohms is only a typical one and although it may be used for initial setting up to ensure the circuit is operating, the value should be found

should be selected as being the lowest which is compatible with good quality. If a multimeter is available this should be wired in series with the supply voltage and R3 should be selected so that the quiescent current, this is the current flowing with no input signal, is reading 20 mA.

It is very important that Q2 is fitted with a heatsink as it will get very hot and will probably go into thermal runaway without it.

The speaker impedance is not all

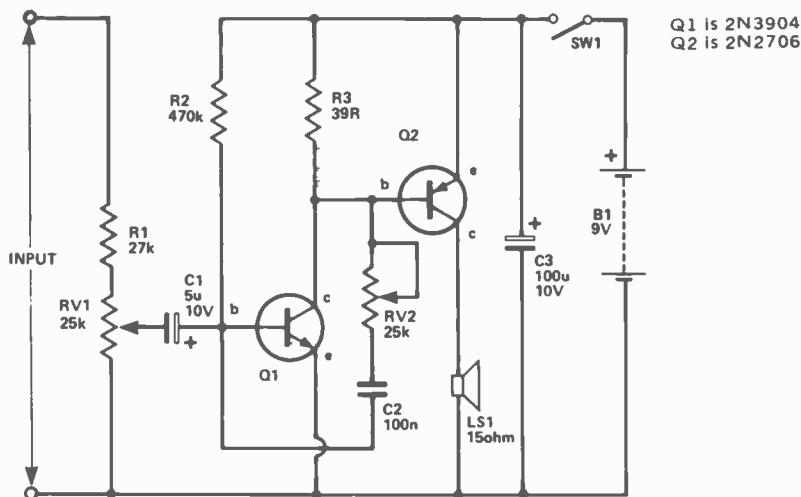

by experiment. If it is too low there will be severe distortion at the higher volume settings. If it is too high the current drain will be excessive even though the quality of reproduction will be good.

There are two ways of finding the value. Without a multimeter the value

that critical and in the prototype speakers with an impedance as low as 8 ohms and as high as 80 ohms all worked well although changing the speaker impedance will also necessitate a change in the value of R3. ●

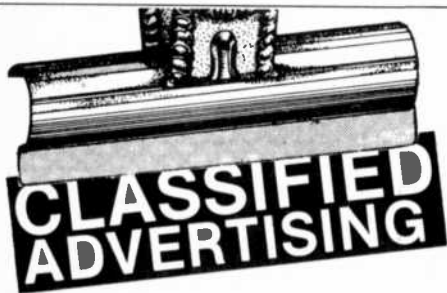

AVAILABLE Now LNA's Microwave associates 120° 50 db noise 4 GHZ amplifiers for satellite TV \$825.00. DRYDEN COMMUNITY T.V. LTD., 61A King St., Dryden, Ont. P8N 1B7. Phone (807) 223-5525.

J&J ELECTRONICS LTD., P.O. Box 1437E, Winnipeg, Manitoba R3C 2Z4. Surplus and Semiconductor Specialists. Do you get our bargain flyer? Send \$1.00 to receive the current literature and specials and to be placed on the mailing list for future publications.

IMAGINATION is all you need. Our growing inventory includes anything we can fit into the store. Bargain prices on all kinds of manufacturers surplus just waiting for your ideas! FOREST CITY SURPLUS, London, Ontario. 519-438-0233, open Tues.-Sat.

DIGITAL Multimeter, hand held, 3.5 digits, LCD, autoranging, autozero, autopolarity, 10 megohm input impedance, vinyl case, 20 amp current shunt, model DM-2350 @\$149.00 plus \$3.00 shipping plus 7% PST in Ontario WSI RADIO, 18 Sheldon Avenue, Kitchener, Ontario N2H 3M2.

SPECIAL! 1000 pieces for \$10 + \$2 handling. Choke - capacitor - transformer - diode - hardware - insulator - rectifier - relay - resistor - transistor - speaker - switch - zener - etc. All new material. Money-back guarantee. Free flyer. SURPLUS ELECTRO QUEBEC 2264 Montee Gagnon, Blainville, P.Q. J7E 4H5.

CLASS-A Amplifiers, S.E.A. Equalizer Preamp with cabinet, Parametric Equalizer, Electronic Speaker Protector, Colourful LED Meters, Power Supplies, FM Mic, Digital Clocks, Electronic Shock, Mosquito Repeller, Battery Fluorescent Light, Electronic Roulette with Sound and Much More. Send \$2.00 for your Catalog and Future Special Flyers. CLASS-A ENTERPRISES, INC. P.O. Box 2424, New Westminister, B.C. V3L 5B6.



FET VOLTMETER

Although an ordinary multimeter is suitable for most DC voltage measurement it can occasionally prove to be inadequate. This is the case when making measurements on high impedance circuits which cannot supply the current required to operate even a sensitive moving coil meter of the type normally employed in a multimeter. The loading effect of the meter then causes the voltage at the test point to substantially fall, giving a misleading reading.

The problem is overcome by this FET voltmeter circuit which has six ranges from 0.5V to 100V FSD with an input impedance of a little over 11 meg on all ranges. This gives a sensitivity of over 22 meg/V on the 0.5V range dropping to a little over 110k/V on the 100V range (most multimeters have a sensitivity of 20k/V).

A FET unity voltage gain buffer amplifier based on Q1 is used to give the necessary high input impedance, which is an inherent feature of a FET. A simple voltmeter circuit is fed from its output, and this has a FSD value of 0.5V in the

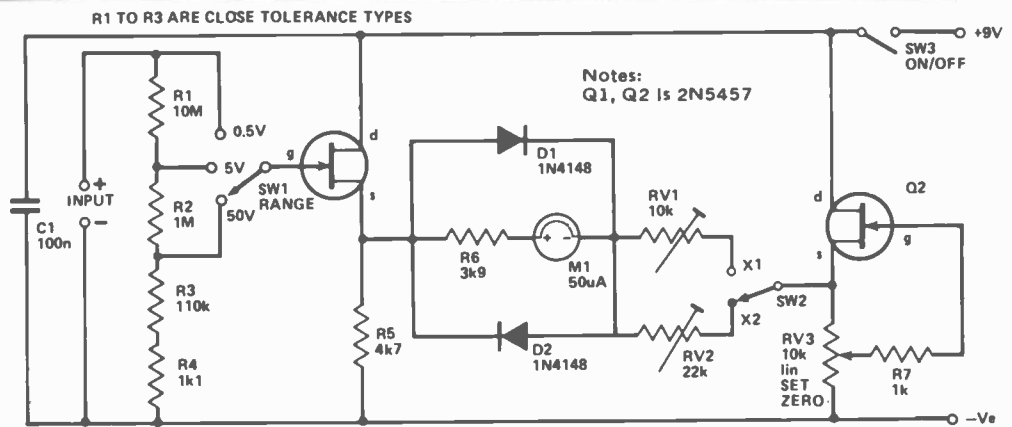

'X1' position of SW2, or 1V in its 'X2' position. R1 and R8 respectively are adjusted to give the circuit the correct FSD values. There is a small quiescent output voltage from the buffer stage and so a bridge circuit is used to give zero quiescent voltage across the meter circuitry. To give good stability another source follower is used to form the other section of the bridge and this results in no noticeable meter drift. RV1 is used to electrically zero the meter. D1 and D2 simply protect the meter movement

against serious overloading.

An input attenuator can be used to reduce the basic sensitivity by a factor of 10 or 100, giving FSD values of 0V5, 5V and 50V with SW2 in the 'X1' position, or 1V, 10V and 100V if it is set to the 'X2' position.

The circuit does not have to be built as a complete instrument in its own right, and it makes an excellent add-on unit for any multimeter which has a 50uA range.

AUDIO LIMITER

When making tape recordings, especially of "live" performances, it can be very difficult to set the correct recording level. This can easily lead to an excessive recording level and consequent distortion occurring unless the recording level control is kept well backed off. The price one then has to pay is a low recording level and subsequent low signal to noise ratio. The normal way of overcoming this problem is to use an audio limiter circuit ahead of the tape deck. This device normally passes the signal straight through to the recorder, but if the input exceeds a preset threshold level it attenuates the signal so that the output level is not sufficient to overload the recorder.

In this circuit the input signal is applied to an attenuator which is formed by R1 and PCC1. Normally PCC1 is in total darkness and exhibits a very high resistance (typically a few megohms) causing minimal losses through the attenuator. This stage feeds into the high input impedance of the emitter follower buffer stage formed by Q1 and its associated components, and this ensures little loss of signal level. Thus the input signal is normally fed straight through to the output socket with only a marginal loss of amplitude.

Some of the output signal is fed from the slider of R4 to a rectifier and smoothing circuit which is comprised of D2, D3, and C4. If the input signal is suf-

ficiently strong, the positive bias produced by the circuit will be adequate to switch on Q2 and light emitting diode D1 which is connected in its collector circuit. The light output from D1 is aimed at the sensitive surface of PCC1 (the surface to which the leadout wires do not connect) and this causes a large reduction in the resistance of PCC1. This gives the required attenuation of the signal. The larger the input signal is made, the more strongly D1 glows, and the greater the reduction in circuit gain. This process has the effect of preventing the output level from rising far above the level at which D1 begins to initially switch on. On the prototype this threshold level is at about 230 mV (with R4's slider at the

top of its track) and increasing the input level to 4 volts RMS causes the output to rise to only about 320 mV. Higher threshold levels can be obtained with R4's slider adjusted down its track to the appropriate point. The attack and decay times of the circuit are both quite short so that the unit quickly responds to changes in signal level and is not normally conspicuous in operation.

Construction of the unit should be quite straightforward, but the unit must of course be housed in a light proof box so that PCC1 is shielded from the ambient lighting. D1 and PCC1 are mounted as close together as possible. The current consumption of the circuit is only about 1 to 5 mA depending on the input level.

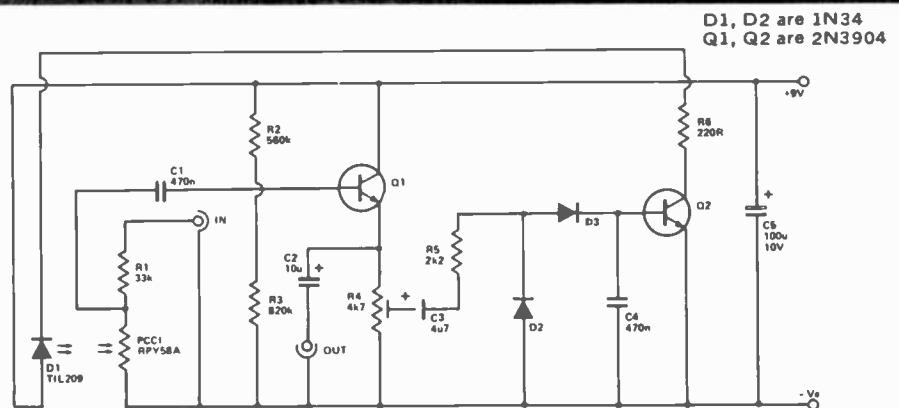

A. F. MILLIVOLT METER

This simple and inexpensive millivolt meter has three measuring ranges of 10mV, 100mV, and 1V. RMS full scale sensitivity has -1 dB points at about 20 Hz and 75kHz. The instrument is suitable for making audio noise, frequency response, and gain measurements, and would be useful to any beginner interested in the field of audio.

The unit uses a conventional arrangement with a non-inverting op-amp circuit feeding a meter via a bridge rectifier. The negative feedback loop is taken to the inverting input by way of the rectifier and meter circuit rather than direct from IC1 output. With low voltages applied to the rectifiers they have a high forward resistance, but this results in little feedback and the amplifier having a high level of gain. Thus small input signal amplitudes which would otherwise produce no meter deflection due to the high rectifier resistance are boosted to the point where they give the appropriate meter reading. Therefore, although the rectifier is inherently non-linear, it produces opposing non-linear feedback which compensates for this and gives the unit linear scaling. RV1 is used to adjust the circuit

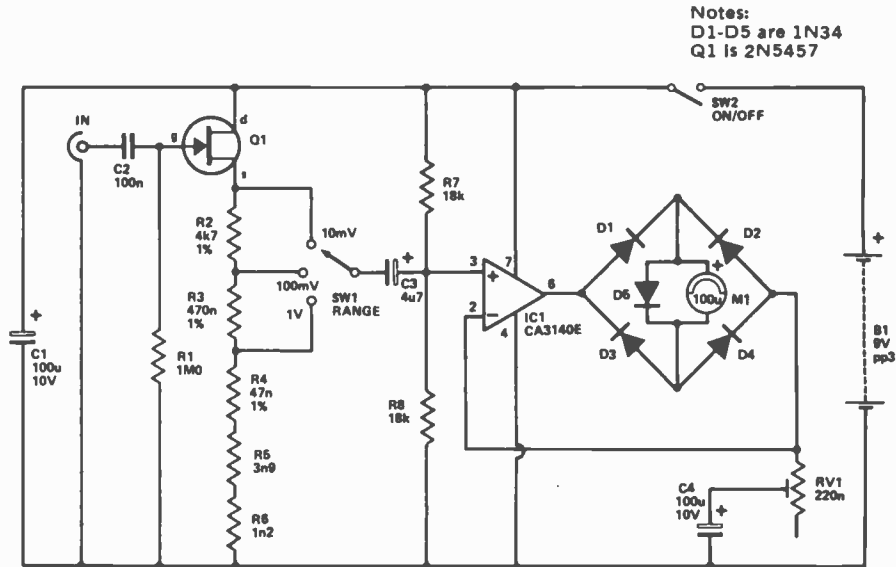

Notes:
D1-D5 are 1N34
Q1 is 2N5457

of the correct sensitivity and D5 protects the meter against severe overloads.

Q1 is used as a low noise source follower buffer amplifier which gives the circuit a high input impedance of about 1 Meg. This ensures that the instrument imposes little loading on the equipment under test. An attenuator is incorporated at the output of the buffer stage, and this can be used to reduce the basic 10 mV sensitivity to 100mV or 1V FSD. The attenuator does not need any frequency

compensation as it is in a low impedance part of the circuit.

To calibrate the unit it is switched to the 1V range, RV1 is set at maximum resistance, and with a 1V RMS audio source connected to the input, RV1 is adjusted for full scale deflection of the meter. The 1V audio source can be provided by an AF signal generator set to the correct output level with the aid of a multimeter switched to a low AC volts range. ●

BASIC BURGLAR ALARM

A burglar alarm circuit can be very simple if non-essential facilities such as entry and exit delays are omitted, and such a circuit is shown here. It can be used in conjunction with normally open (NO) or normally closed (NC) contacts which can be the usual door and window switches, trigger mats, etc.

SCR 1 is a silicon controlled switch (SCS) which is an NPN/PNP integrated pair of transistors connected to form a highly sensitive thyristor. As the circuit stands, R1 ties the CK terminal to the negative supply and prevents SCR 1 from triggering. The relay will not be energised and the alarm will not sound. If one or more of the NC contacts should open, SCR 1 will be switched on by the gate current it receives through R2, since R1 is then switched out of circuit. Even if the contacts should close again, SCR 1 will remain in the on state because it has a built-in latching action. Thus the relay will be activated and its contacts connect power to the alarm generator. The circuit can also be triggered by one or more of the NO contacts closing, as R3 then provides an adequate gate bias to switch on SCR 1. Once triggered the circuit can only be reset by switching off using SW1. The current through SCR 1 then falls to zero and the latching action is defeated so that the circuit is ready to commence operation once again when SW1 is closed.

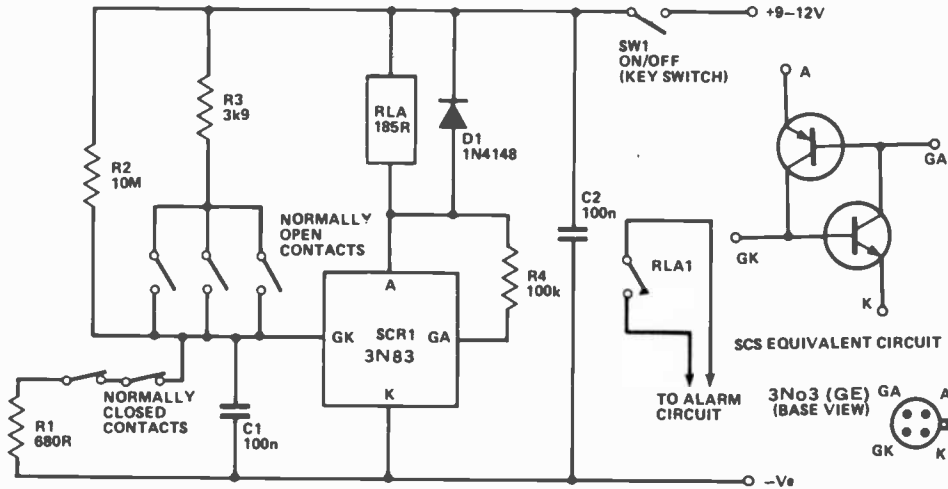

Although only two sets of NC contacts are shown, any number of contacts connected in series can be used. Similarly, any number of NO contacts connected in parallel can be utilized. If no NC contacts are used, R1 should still be included between the GK terminal of

SCR 1 and the negative supply rail. C1, C2, and R4 are needed to prevent spurious operation due to stray pick-up of noise spikes or noise pulses on the supply lines. D1 is a protective diode which suppresses the high back EMF developed across the relay coil as it de-energises.

The standby current consumption of the unit is only about 1μA and so the unit can be economically run from ordinary dry cell batteries if desired. ●

SOUND OPERATED SWITCH

Sound activated switches are used in many applications, some typical examples being voice operated tape recorders, baby alarms, burglar alarm systems, and VOX (voice operated switching) systems of radio transmitting/receiving installations. The simple circuit shown here will operate at a distance of up to about 2 or 3 metres from a voice of average volume (slightly

at low collector currents in order to give a low noise level and quiescent current consumption. C3 rolls off the high frequency response of the circuit and aids good stability.

The output from Q2 is coupled to a third common emitter stage by C5. This third stage is based on Q3, and is biased by R6 and R7 to a point where Q3 is virtually cut off. There is thus very little

ing up this component to an adequate level to switch on Q4 and the relay. A pair of relay contacts are used to control the supply to the slave equipment.

C4 charges via the fairly low impedance of Q3 and R9, giving the circuit a fairly fast attack time. C4's discharge path is through the relatively high impedance of Q4's base emitter junction giving a decay time of a second or two.

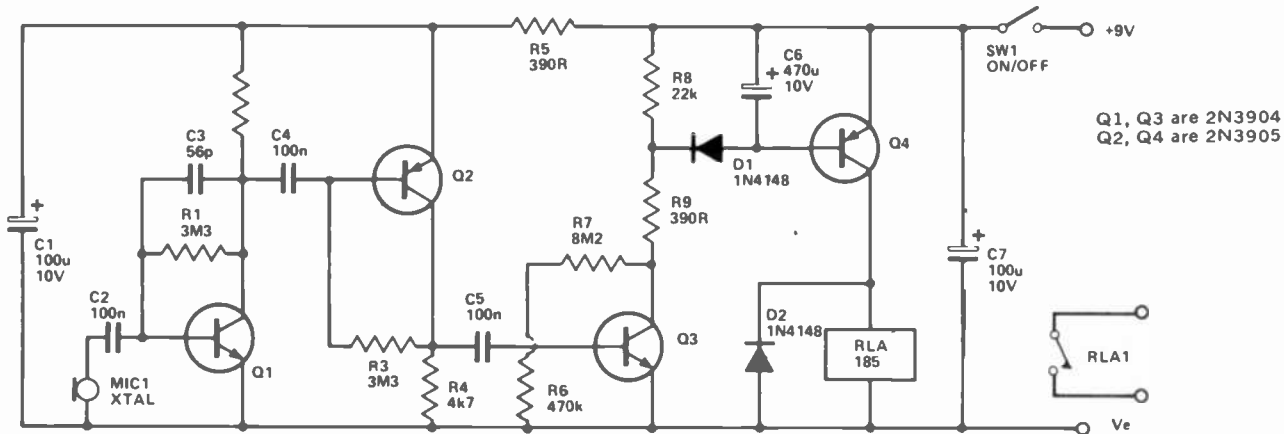

less if the xtal microphone insert is replaced by a medium or high impedance dynamic type).

Signals produced by the microphone are amplified by a high gain amplifier which uses two stages of common emitter amplification. These two stages are based on Q1 and Q2 and use a straight forward capacitively coupled arrangement. Both transistors are operated

voltage developed across load resistor R8, and the input voltage fed to Q4 via D1 is insufficient to switch on this device and activate the relay which forms its collector load. However, when sounds are received by the microphone, a strong signal is received at Q3's base, causing it to conduct heavily on positive going input half cycles. This produces a series of strong negative pulses across C4, charg-

Thus the circuit responds rapidly when a signal is initially received, but the relay does not cut out during the brief pauses that occur during normal speech.

The quiescent current consumption of the circuit is only about 250 uA, but this rises to about 35mA when the relay is activated.●

QUICK TRANSISTOR CHECK

These diagrams illustrate a handy method of checking any transistor with a multimeter switched to a low Ohms range

NOTE Battery (+) positive on most multimeters is the BLACK lead — NOT the RED lead

NPN TRANSISTORS

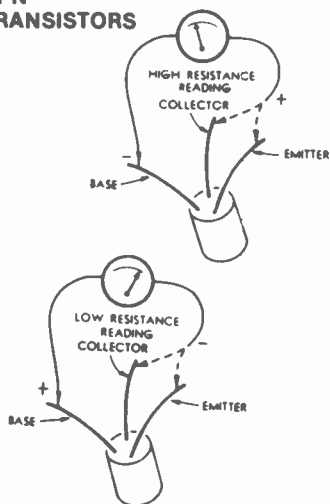

LEAKAGE TEST

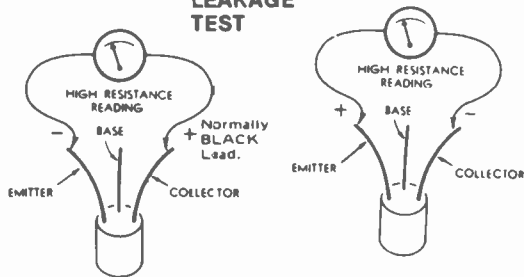

PNP TRANSISTORS

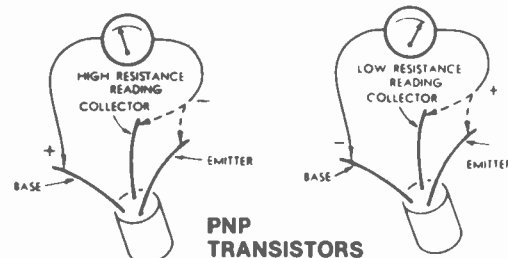

**Hear Ye!
Hear Ye!**

**We need volunteers
Give your local
RED CROSS
a call.**

COMPUTERS (HARDWARE)

THE ESSENTIAL COMPUTER DICTIONARY AND SPELLER AB011 \$9.45

A must for anyone just starting out in the field of computing, be they a businessman, hobbyist or budding computerist. The book presents and defines over 15,000 computer terms and acronyms and makes for great browsing.

A BEGINNER'S GUIDE TO COMPUTERS AND MICROPROCESSORS — WITH PROJECTS. TAB No.1015 \$13.45

Here's a plain English introduction to the world of microcomputers — it's capabilities, parts and functions — and how you can use one. Numerous projects demonstrate operating principles and lead to the construction of an actual working computer capable of performing many useful functions.

BP66: BEGINNERS GUIDE TO MICROPROCESSORS AND COMPUTING E.F. SCOTT, M.Sc., C.Eng. \$7.55

As indicated by the title, this book is intended as an introduction to the basic theory and concepts of binary arithmetic, microprocessor operation and machine language programming.

There are occasions in the text where some background information might be helpful and a Glossary is included at the end of the book.

BP72: A MICROPROCESSOR PRIMER T.A. PARR, B.Sc., C.Eng., M.I.E.E. \$7.70

A newcomer to electronics tends to be overwhelmed when first confronted with articles or books on microprocessors. In an attempt to give a painless approach to computing, this small book will start by designing a simple computer and because of its simplicity and logical structure, the language is hopefully easy to learn and understand. In this way, such ideas as Relative Addressing, Index Registers etc. will be developed and it is hoped that these will be seen as logical progressions rather than arbitrary things to be accepted but not understood.

BEGINNERS GUIDE TO MICROPROCESSORS TAB No.995 \$10.45

If you aren't sure exactly what a microprocessor is, then this is the book for you. The book takes the beginner from the basic theories and history of these essential devices, right up to some real world hardware applications.

HOW TO BUILD YOUR OWN WORKING MICROCOMPUTER TAB No.1200 \$16.45

An excellent reference or how-to manual on building your own microcomputer. All aspects of hardware and software are developed as well as many practical circuits.

BP78: PRACTICAL COMPUTER EXPERIMENTS E.A. PARR, B.Sc., C.Eng., M.I.E.E. \$7.30

Curiously most published material on the microprocessor tends to be of two sorts, the first treats the microprocessor as a black box and deals at length with programming and using the "beast". The second type of book deals with the social impact. None of these books deal with the background to the chip, and this is a shame as the basic ideas are both interesting and simple.

This book aims to fill in the background to the microprocessor by constructing typical computer circuits in discrete logic and it is hoped that this will form a useful introduction to devices such as adders, memories, etc. as well as a general source book of logic circuits.

HANDBOOK OF MICROPROCESSOR APPLICATIONS TAB No.1203 \$14.45

Highly recommended reading for those who are interested in microprocessors as a means of accomplishing a specific task. The author discusses two individual microprocessors, the 1802 and the 6800, and how they can be put to use in real world applications.

MICROPROCESSOR/MICROPROGRAMMING HANDBOOK TAB No.785 \$14.45

A comprehensive guide to microprocessor hardware and programming. Techniques discussed include subroutines, handling interrupts and program loops.

BP102: THE 6809 COMPANION M. JAMES \$8.10

The 6809 microprocessor's history, architecture, addressing modes and the instruction set (fully commented) are covered. In addition there are chapters on converting programs from the 6800, programming style, interrupt handling and about the 6809 hardware and software available.

AN INTRODUCTION TO MICROPROCESSORS EXPERIMENTS IN DIGITAL TECHNOLOGY HB07: SMITH \$15.85

A "learn by doing" guide to the use of integrated circuits provides a foundation for the underlying hardware actions of programming statements. Emphasis is placed on how digital circuitry compares with analog circuitry. Begins with the simplest gates and timers, then introduces the fundamental parts of ICs, detailing the benefits and pitfalls of major IC families, and continues with coverage of the ultimate in integrated complexity — the microprocessor.

DESIGNING MICROCOMPUTER SYSTEMS HB18: POOCH AND CHATTERY \$15.85

This book provides both hobbyists and electronic engineers with the background information necessary to build microcomputer systems. It discusses the hardware aspects of microcomputer systems. Timing devices are provided to explain sequences of operations in detail. Then, the book goes on to describe three of the most popular microcomputer families: the Intel 8080, Zilog Z-80, and Motorola 6800. Also covered are designs of interfaces for peripheral devices, and information on building microcomputer systems from kits.

S-100 BUS HANDBOOK HB19: BURSKEY \$22.75

Here is a comprehensive book that exclusively discusses S-100 bus computer systems and how they are organized. The book covers computer fundamentals, basic electronics, and the parts of the computer. Individual chapters discuss the CPU, memory, input/output, bulk-memory devices, and specialized peripheral controllers. It explains all the operating details of commonly available S-100 systems. Schematic drawings.

BASIC MICROPROCESSORS AND THE 6800 HB06: \$21.45

Provides two books in one: a basic guide to microprocessors for the beginner, and a complete description of the M6800 system for the engineer.

Each chapter is followed by a problem section.

DIGITAL INTERFACING WITH AN ANALOG WORLD TAB No.1070 \$14.45

You've bought a computer, but now you can't make it do anything useful. This book will tell you how to convert real world quantities such as temperature, pressure, force and so on into binary representation.

MICROPROCESSOR INTERFACING HANDBOOK: A/D & D/A TAB No.1271 \$14.45

A useful handbook for computerists interested in using their machines in linear applications. Topics discussed include voltage references, op-amps for data conversion, analogue switching and multiplexing and more.

COMPUTER TECHNICIAN'S HANDBOOK TAB No.554 \$17.45

Whether you're looking for a career, or you are a service technician, computer repair is an opportunity you should be looking at. The author covers all aspects of digital and computer electronics as well as the mathematical and logical concepts involved.

HOW TO TROUBLESHOOT AND REPAIR MICROCOMPUTERS AB013 \$10.45

Learn how to find the cause of a problem or malfunction in the central or peripheral unit of any microcomputer and then repair it. The tips and techniques in this guide can be applied to any equipment that uses the microprocessor as the primary control element.

TROUBLESHOOTING MICROPROCESSORS AND DIGITAL LOGIC TAB No.1183 \$13.45

The influence of digital techniques on commercial and home equipment is enormous and increasing yearly. This book discusses digital theory and looks at how to service Video Cassette Recorders, microprocessors and more.

HOW TO DEBUG YOUR PERSONAL COMPUTER AB012 \$10.45

When you feel like reaching for a sledge hammer to reduce your computer to fiberglass and epoxy dust, don't. Reach for this book instead and learn all about program bug tracking, recognition and elimination techniques.

COMPUTERS (SOFTWARE)

HOW TO PROFIT FROM YOUR PERSONAL COMPUTER: PROFESSIONAL, BUSINESS, AND HOME APPLICATIONS LEWIS HB01 \$17.00

Describes the uses of personal computers in common business applications, such as accounting, managing inventory, sorting mailing lists, and many others. The discussion includes terms, notations, and techniques commonly used by programmers. A full glossary of terms.

PROGRAMS FOR BEGINNERS ON THE TRS-80 BLECHMAN HB02 \$13.05

A valuable book of practical and interesting programs for home use that can be understood and used immediately by the beginner in personal computer programming. You'll learn step-by-step how 21 simple TRS-80 programs work. Program techniques are described line-by-line within the programs, and a unique Martri-Dex™ matrix index will enable you to locate other programs using the same BASIC commands and statements.

THE JOY OF MINIS AND MICROS: DATA PROCESSING WITH SMALL COMPUTERS STEIN AND SHAPIRO HB03 \$15.85

A collection of pieces covering technical and management aspects of the use of small computers for business or science. It emphasizes the use of common sense and good systems design for every computer project. Because a strong technical background is not necessary, the book is easy to read and understand. Considerable material is devoted to the question of what size computer should be used for a particular job, and how to choose the right machine for you.

BEGINNER'S GUIDE TO COMPUTER PROGRAMMING TAB No.574 \$16.45

Computer programming is an increasingly attractive field to the individual, however many people seem to overlook it as a career. The material in this book has been developed in a logical sequence, from the basic steps to machine language.

USING MICROCOMPUTERS IN BUSINESS VEIT HB04 \$14.45

An essential background briefing for any purchaser of microcomputer systems or software. In a fast-moving style, without the usual buzz words and technical jargon, Veit answers the most often asked questions.

BASIC FROM THE GROUND UP SIMON HB15 \$17.00

Here's a BASIC text for high school students and hobbyists that explores computers and the BASIC language in a simple direct way, without relying on a heavy mathematical background on the reader's part. All the features of BASIC are included as well as some of the inside workings of a computer. The book covers one version of each of the BASIC statements and points out some of the variations, leaving readers well prepared to write programs in any version they encounter. A selection of exercises and six worked out problems round out the reader's experience. A glossary and a summary of BASIC statements are included at the end of the book for quick reference.

BASIC COMPUTER PROGRAMS FOR BUSINESS: STERNBERG (Vol. 1) HB13 \$15.85

A must for small businesses utilizing micros as well as for entrepreneurs, volume provides a wealth of practical business applications. Each program is documented with a description of its functions and operation, a listing in BASIC, a symbol table, sample data, and one or more samples.

BP86: AN INTRODUCTION TO BASIC PROGRAMMING TECHNIQUES S. DALY \$8.25

This book is based on the author's own experience in learning BASIC and in helping others, mostly beginners, to program and understand the language. Also included are a program library containing various programs, that the author has actually written and run. These are for biorhythms, plotting a graph of Y against X, standard deviation, regression, generating a musical note sequence and a card game. The book is complemented by a number of appendices which include test questions and answers on each chapter and a glossary.

THE BASIC COOKBOOK. TAB No.1055 \$9.45

BASIC is a surprisingly powerful language. If you understand it completely. This book, picks up where most manufacturers' documentation gives up. With it, any computer owner can develop programs to make the most out of his or her machine.

PET BASIC — TRAINING YOUR PET COMPUTER AB014 \$16.45

Officially approved by Commodore, this is the ideal reference book for long time PET owners or novices. In an easy to read and humorous style, this book describes techniques and experiments, all designed to provide a strong understanding of this versatile machine.

PROGRAMMING IN BASIC FOR PERSONAL COMPUTERS AB015 \$10.45

This book emphasizes the sort of analytical thinking that lets you use a specific tool — the BASIC language — to transform your own ideas into workable programs. The text is designed to help you to intelligently analyse and design a wide diversity of useful and interesting programs.

COMPUTER PROGRAMS IN BASIC AB001 \$14.45

A catalogue of over 1,600 fully indexed BASIC computer programs with applications in Business, Math, Games and more. This book lists available software, what it does, where to get it, and how to adapt it to your machine.

PET GAMES AND RECREATION AB002 \$12.45

A variety of interesting games designed to amuse and educate. Games include such names as Capture, Tic Tac Toe, Watchperson, Motie, Sinners, Martian Hunt and more.

BRAIN TICKLERS AB005 \$8.00

If the usual games such as Bug Stomp and Invaders From the Time Warp are starting to pale, then this is the book for you. The authors have put together dozens of stimulating puzzles to show you just how challenging computing can be.

PASCAL TAB No.1205 \$16.45

Aimed specifically at TRS-80 users, this book discusses how to load, use and write PASCAL programs. Graphic techniques are discussed and numerous programs are presented.

PASCAL PROGRAMMING FOR THE APPLE AB008 \$16.45

A great book to upgrade your programming skills to the UCSD Pascal as implemented on the Apple II. Statements and techniques are discussed and there are many practical and ready to run programs.

APPLE MACHINE LANGUAGE PROGRAMMING AB009 \$16.45

The best way to learn machine language programming the Apple II in no time at all. The book combines colour, graphics, and sound generation together with clear cut demonstrations to help the user learn quickly and effectively.

Z80 USERS MANUAL

AB010 \$14.45
The Z80 MPU can be found in many machines and is generally acknowledged to be one of the most powerful 8 bit chips around. This book provides an excellent 'right hand' for anyone involved in the application of this popular processor.

HOW TO PROGRAM YOUR PROGRAMMABLE CALCULATOR

AB006 \$10.45
Calculator programming, by its very nature, often is an obstacle to effective use. This book endeavours to show how to use a programmable calculator to its full capabilities. The TI 57 and the HP 33E calculators are discussed although the principles extend to similar models.

Z-80 AND 8080 ASSEMBLY LANGUAGE PROGRAMMING SPRACKLEN

HB05 \$14.25
Provides just about everything the applications programmer needs to know for Z-80 and 8080 processors. Programming techniques are presented along with the instructions. Exercises and answers included with each chapter.

BASIC COMPUTER PROGRAMS IN SCIENCE AND ENGINEERING

GILDER \$15.85
Save time and money with this collection of 114 ready-to-run BASIC programs for the hobbyist and engineer. There are programs to do such statistical operations as means, standard deviation averages, curve-fitting, and interpolation. There are programs that design antennas, filters, attenuators, matching networks, plotting, and histogram programs.

GAME PLAYING WITH COMPUTERS SECOND EDITION SPENCER

HB11 \$31.25
Now you can sharpen programming skills through a relaxed approach. Completely devoted to computerized game playing, this volume presents over 70 games, puzzles, and mathematical recreations for a digital computer. It's fully illustrated and includes more than 25 game-playing programs in FORTRAN or BASIC complete with descriptions, flowcharts, and output.

MICROCOMPUTERS AND THE 3 R'S DOERR

HB09 \$14.25
This book educates educators on the various ways computers, especially microcomputers, can be used in the classroom. It describes microcomputers, how to organize a computer-based program, the five instructional application types (with examples from subjects such as the hard sciences, life sciences, English, history, and government) and resources listings of today's products. The book includes preprogrammed examples to start up a microcomputer program, while chapters on resources and products direct the reader to useful additional information. All programs are written in the BASIC language.

GAME PLAYING WITH BASIC SPENCER

HB10 \$15.25
The writing is nontechnical, allowing almost anyone to understand computerized game playing. The book includes the rules of each game, how each game works, illustrative flowcharts, diagrams, and the output produced by each program. The last chapter contains 26 games for reader solution.

SARGON: A COMPUTER CHESS PROGRAM SPRACKLEN

HB12 \$25.00
"I must rate this chess program an excellent buy for anyone who loves the game." Kilobaud.

Here is the computer chess program that won first place in the first chess tournament at the 1978 West Coast Computer Faire. It is written in Z-80 assembly language, using the TDL macro assembler. It comes complete with block diagram and sample printouts.

A CONSUMER'S GUIDE TO PERSONAL COMPUTING AND MICROCOMPUTERS, SECOND EDITION FREIBERGER AND CHEW

HB14 \$14.45
The first edition was chosen by Library Journal as one of the 100 outstanding sci-tech books of 1978. Now, there's an updated second edition!

Besides offering an introduction to the principles of microcomputers that assumes no previous knowledge on the reader's part, this second edition updates prices, the latest developments in microcomputer technology, and a review of over 100 microcomputer products from over 60 manufacturers.

THE BASIC CONVERSIONS HANDBOOK FOR APPLE, TRS-80, AND PET USERS BRAIN BANK

HB17 \$11.75
Convert a BASIC program for the TRS-80, Apple II, or PET to the form of BASIC used by any other one of those machines. This is a complete guide to converting Apple II and PET programs to TRS-80, TRS-80 and PET programs to Apple II, TRS-80 and Apple II programs to PET. Equivalent commands are listed for TRS-80 BASIC (Model I, Level II), Applesoft BASIC and PET BASIC, as well as variations for the TRS-80 Model III and Apple Integer BASIC.

SPEAKING PASCAL BOWEN

HB16 \$17.25
An excellent introduction to programming in the Pascal language! Written in clear, concise, non-mathematical language, the text requires no technical background or previous programming experience on the reader's behalf. Top-down structured analysis and key examples illustrate each new idea and the reader is encouraged to construct programs in an organized manner.

BP33: ELECTRONIC CALCULATOR USERS

HANDBOOK \$4.25
M.H. BABANI, B.Sc.(Eng.)

An invaluable book for all calculator users whatever their age or occupation, or whether they have the simplest or most sophisticated of calculators. Presents formulae, data, methods of calculation, conversion factors, etc., with the calculator user especially in mind, often illustrated with simple examples. Includes the way to calculate using only a simple four function calculator. Trigonometric Functions (Sin, Cos, Tan); Hyperbolic Functions (Sinh, Cosh, Tanh) Logarithms, Square Roots and Powers.

THE MOST POPULAR SUBROUTINES IN BASIC

TAB No. 1050 \$10.45
An understandable guide to BASIC subroutines which enables the reader to avoid tedium, economise on computer time and makes programs run faster. It is a practical rather than a theoretical manual.

PROJECTS

BP48: ELECTRONIC PROJECTS FOR BEGINNERS

F.G. RAYER, T.Eng.(CEI), Assoc.IERE \$5.90
Another book written by the very experienced author — Mr. F.G. Rayer — and in it the newcomer to electronics, will find a wide range of easily made projects. Also, there are a considerable number of actual component and wiring layouts, to aid the beginner.

Furthermore, a number of projects have been arranged so that they can be constructed without any need for soldering and, thus, avoid the need for a soldering iron.

Also, many of the later projects can be built along the lines as those in the 'No Soldering' section so this may considerably increase the scope of projects which the newcomer can build and use.

221: 28 TESTED TRANSISTOR PROJECTS

R.TORRENS \$5.50
Mr. Richard Torrens is a well experienced electronics development engineer and has designed, developed, built and tested the many useful and interesting circuits included in this book. The projects themselves can be split down into simpler building blocks, which are shown separated by boxes in the circuits for ease of description, and also to enable any reader who wishes to combine boxes from different projects to realise ideas of his own.

BP49: POPULAR ELECTRONIC PROJECTS

R.A. PENFOLD \$6.25
Includes a collection of the most popular types of circuits and projects which, we feel sure, will provide a number of designs to interest most electronics constructors. The projects selected cover a very wide range and are divided into four basic types: Radio Projects, Audio Projects, Household Projects and Test Equipment.

EXPERIMENTER'S GUIDE TO SOLID STATE ELECTRONIC PROJECTS

AB007 \$9.45
An ideal sourcebook of Solid State circuits and techniques with many practical circuits. Also included are many useful types of experimenter gear.

BP71: ELECTRONIC HOUSEHOLD PROJECTS

R.A. PENFOLD \$7.70
Some of the most useful and popular electronic construction projects are those that can be used in or around the home. The circuits range from such things as '2 Tone Door Buzzer', Intercom, through Smoke or Gas Detectors to Baby and Freezer Alarms.

BP94: ELECTRONIC PROJECTS FOR CARS AND BOATS

R.A. PENFOLD \$8.10
Projects, fifteen in all, which use a 12V supply are the basis of this book. Included are projects on Windscreen Wiper Control, Courtesy Light Delay, Battery Monitor, Cassette Power Supply, Lights Timer, Vehicle Immobiliser, Gas and Smoke Alarm, Depth Warning and Shaver Inverter.

BP69: ELECTRONIC GAMES

R.A. PENFOLD \$7.55
In this book Mr. R. A. Penfold has designed and developed a number of interesting electronic game projects using modern integrated circuits. The text is divided into two sections, the first dealing with simple games and the latter dealing with more complex circuits.

BP95: MODEL RAILWAY PROJECTS

R.A. PENFOLD \$8.10
Electronic projects for model railways are fairly recent and have made possible an amazing degree of realism. The projects covered include controllers, signals and sound effects: striboard layouts are provided for each project.

BP93: ELECTRONIC TIMER PROJECTS

F.G. RAYER \$8.10
Windscreen wiper delay, darkroom timer and metronome projects are included. Some of the more complex circuits are made up from simpler sub-circuits which are dealt with individually.

110 OP-AMP PROJECTS

MARSTON \$11.75
HB24
This handbook outlines the characteristics of the op-amp and present 110 highly useful projects—ranging from simple amplifiers to sophisticated instrumentation circuits.

110 IC TIMER PROJECTS

GILDER \$10.25
HB25
This sourcebook maps out applications for the 555 timer IC. It covers the operation of the IC itself to aid you in learning how to design your own circuits with the IC. There are application chapters for timer-based instruments, automotive applications, alarm and control circuits, and power supply and converter applications.

110 THYRISTOR PROJECTS USING SCRs AND TRIACS MARSTON

HB22 \$12.05
A grab bag of challenging and useful semiconductor projects for the hobbyist, experimenter, and student. The projects range from simple burglar, fire, and water level alarms to sophisticated power control devices for electric tools and trains. Integrated circuits are incorporated wherever their use reduces project costs.

110 CMOS DIGITAL IC PROJECTS

MARSTON \$11.75
HB23
Outlines the operating characteristics of CMOS digital ICs and then presents and discusses 110 CMOS digital IC circuits ranging from Inverter gate and logic circuits to electronic alarm circuits. Ideal for amateurs, students and professional engineers.

BP76: POWER SUPPLY PROJECTS

R.A. PENFOLD \$7.30
Line power supplies are an essential part of many electronics projects. The purpose of this book is to give a number of power supply designs, including simple unregulated types, fixed voltage regulated types, and variable voltage stabilised designs, the latter being primarily intended for use as bench supplies for the electronics workshop. The designs provided are all low voltage types for semiconductor circuits.

There are other types of power supply and a number of these are dealt with in the final chapter, including a cassette power supply, Ni-Cad battery charger, voltage step up circuit and a simple inverter.

BP84: DIGITAL IC PROJECTS

F.G. RAYER, T.Eng.(CEI), Assoc.IERE \$8.10
This book contains both simple and more advanced projects and it is hoped that these will be found of help to the reader developing a knowledge of the workings of digital circuits. To help the newcomer to the hobby the author has included a number of board layouts and wiring diagrams. Also the more ambitious projects can be built and tested section by section and this should help avoid or correct faults that could otherwise be troublesome. An ideal book for both beginner and more advanced enthusiast alike.

BP67: COUNTER DRIVER AND NUMERAL DISPLAY PROJECTS

F.G. RAYER, T.Eng.(CEI), Assoc. IERE \$7.55
Numerical indicating devices have come very much to the forefront in recent years and will, undoubtedly, find increasing applications in all sorts of equipment. With present day integrated circuits, it is easy to count, divide and display numerically the electrical pulses obtained from a great range of driver circuits.

In this book many applications and projects using various types of numeral displays, popular counter and driver IC's etc. are considered.

213: ELECTRONIC CIRCUITS FOR MODEL RAILWAYS

M.H. BABANI, B.Sc.(Eng.) \$4.50
The reader is given constructional details of how to build a simple model train controller; controller with simulated inertia and a high power controller. A signal system and lighting for model trains is discussed as is the suppression of RF interference from model railways. The construction of an electronic steam whistle and a model train chuffer is also covered.

BP73: REMOTE CONTROL PROJECTS

OWEN BISHOP \$8.60
This book is aimed primarily at the electronics enthusiast who wishes to experiment with remote control. Full explanations have been given so that the reader can fully understand how the circuits work and can more easily see how to modify them for other purposes, depending on personal requirements. Not only are radio control systems considered but also infra-red, visible light and ultrasonic systems as are the use of Logic ICs and Pulse position modulation etc.

BP99: MINI — MATRIX BOARD PROJECTS

R.A. PENFOLD \$8.10
Twenty useful projects which can all be built on a 24 x 10 hole matrix board with copper strips. Includes Doorbuzzer, Low-voltage Alarm, AM Radio, Signal Generator, Projector Timer, Guitar Headphone Amp, Transistor Checker and more.

CIRCUITS

BP98: POPULAR ELECTRONIC CIRCUITS, BOOK 2

R.A. PENFOLD \$9.35
70 plus circuits based on modern components aimed at those with some experience.

BP80: POPULAR ELECTRONIC CIRCUITS — BOOK 1

R.A. PENFOLD \$8.25
Another book by the very popular author, Mr. R.A. Penfold, who has designed and developed a large number of various circuits. These are grouped under the following general headings: Audio Circuits, Radio Circuits, Test Gear Circuits, Music Project Circuits, Household Project Circuits and Miscellaneous Circuits.

ETI book shelf

The GIANT HANDBOOK OF ELECTRONIC CIRCUITS

TAB No.1300 \$24.45
About as twice as thick as the Webster's dictionary, and having many more circuit diagrams, this book is ideal for any experimenter who wants to keep amused for several centuries. If there isn't a circuit for it in here, you should have no difficulty convincing yourself you don't really want to build it.

BP39: 50 (FET) FIELD EFFECT TRANSISTOR PROJECTS \$5.50

F.G. RAYER, T.Eng.(CEI), Assoc. IERE
Field effect transistors (FETs) find application in a wide variety of circuits. The projects described here include radio frequency amplifiers and converters, test equipment and receiver aids, tuners, receivers, mixers and tone controls, as well as various miscellaneous devices which are useful in the home.

This book contains something of particular interest for every class of enthusiast — short wave listener, radio amateur, experimenter or audio devotee.

BP87: SIMPLE L.E.D. CIRCUITS \$5.90

R.N. SOAR
Since it first appeared in 1977, Mr. R.N. Soar's book has proved very popular. The author has developed a further range of circuits and these are included in Book 2. Projects include a Transistor Tester, Various Voltage Regulators, Testers and so on.

BP42: 50 SIMPLE L.E.D. CIRCUITS \$3.55

R.N. SOAR
The author of this book, Mr. R.N. Soar, has compiled 50 interesting and useful circuits and applications, covering many different branches of electronics, using one of the most inexpensive and freely available components — the Light Emitting Diode (L.E.D.). A useful book for the library of both beginner and more advanced enthusiast alike.

BP82: ELECTRONIC PROJECTS USING SOLAR CELLS \$8.10

OWEN BISHOP
The book contains simple circuits, almost all of which operate at low voltage and low currents, making them suitable for being powered by a small array of silicon cells. The projects cover a wide range from a bicycle speedometer to a novelty 'Duck Shoot', a number of power supply circuits are included.

BP37: 50 PROJECTS USING RELAYS, SCR'S & TRIACS \$5.50

F.G. RAYER, T.Eng.(CEI), Assoc. IERE
Relays, silicon controlled rectifiers (SCR's) and bi-directional triodes (TRIACS) have a wide range of applications in electronics today. This book gives tried and practical working circuits which should present the minimum of difficulty for the enthusiast to construct. In most of the circuits there is a wide latitude in component values and types, allowing easy modification of circuits or ready adaptation of them to individual needs.

BP44: IC 555 PROJECTS \$7.55

E.A. PARR, B.Sc., C.Eng., M.I.E.E.
Every so often a device appears that is so useful that one wonders how life went on before without it. The 555 timer is such a device. Included in this book are Basic and General Circuits, Motor Car and Model Railway Circuits, Alarms and Noise Makers as well as a section on the 556, 558 and 559 timers.

BP24: 50 PROJECTS USING IC741 \$4.25

RUDI & UWE REDMER
This book, originally published in Germany by TOPP, has achieved phenomenal sales on the Continent and Babani decided, in view of the fact that the integrated circuit used in this book is inexpensive to buy, to make this unique book available to the English speaking reader. Translated from the original German with copious notes, data and circuitry, a "must" for everyone whatever their interest in electronics.

BP83: VMOS PROJECTS \$8.20

R.A. PENFOLD
Although modern bipolar power transistors give excellent results in a wide range of applications, they are not without their drawbacks or limitations. This book will primarily be concerned with VMOS power FETs although power MOSFETs will be dealt with in the chapter on audio circuits. A number of varied and interesting projects are covered under the main headings of: Audio Circuits, Sound Generator Circuits, DC Control Circuits and Signal Control Circuits.

BP65: SINGLE IC PROJECTS \$6.55

R.A. PENFOLD
There is now a vast range of ICs available to the amateur market, the majority of which are not necessarily designed for use in a single application and can offer unlimited possibilities. All the projects contained in this book are simple to construct and are based on a single IC. A few projects employ one or two transistors in addition to an IC but in most cases the IC is the only active device used.

BP97: IC PROJECTS FOR BEGINNERS \$8.10

F.G. RAYER
Covers power supplies, radio, audio, oscillators, timers and switches. Aimed at the less experienced reader, the components used are popular and inexpensive.

BP88: HOW TO USE OP AMPS \$9.35

E.A. PARR
A designer's guide covering several op amps, serving as a source book of circuits and a reference book for design calculations. The approach has been made as non-mathematical as possible.

IC ARRAY COOKBOOK

JUNG \$14.25
HB26

A practical handbook aimed at solving electronic circuit application problems by using IC arrays. An IC array, unlike specific-purpose ICs, is made up of uncommitted IC active devices, such as transistors, resistors, etc. This book covers the basic types of such ICs and illustrates with examples how to design with them. Circuit examples are included, as well as general design information useful in applying arrays.

BP50: IC LM3900 PROJECTS \$5.90

H. KYBETT, B.Sc., C.Eng.
The purpose of this book is to introduce the LM3900 to the Technician, Experimenter and the Hobbyist. It provides the groundwork for both simple and more advanced uses, and is more than just a collection of simple circuits or projects.

Simple basic working circuits are used to introduce this IC. The LM3900 can do much more than is shown here, this is just an introduction. Imagination is the only limitation with this useful and versatile device. But first the reader must know the basics and that is what this book is all about.

223: 50 PROJECTS USING IC CA3130 \$5.50

R.A. PENFOLD
In this book, the author has designed and developed a number of interesting and useful projects which are divided into five general categories: I — Audio Projects II — RF Projects III — Test Equipment IV — Household Projects V — Miscellaneous Projects.

224: 50 CMOS IC PROJECTS \$4.25

R.A. PENFOLD
CMOS IC's are probably the most versatile range of digital devices for use by the amateur enthusiast. They are suitable for an extraordinary wide range of applications and are also some of the most inexpensive and easily available types of IC.

Mr. R.A. Penfold has designed and developed a number of interesting and useful projects which are divided into four general categories: I — Multivibrators II — Amplifiers and Oscillators III — Trigger Devices IV — Special Devices.

THE ACTIVE FILTER HANDBOOK \$11.45

TAB No.1133
Whatever your field — computing, communications, audio, electronic music or whatever — you will find this book the ideal reference for active filter design.

The book introduces filters and their uses. The basic math is discussed so that the reader can tell where all design equations come from. The book also presents many practical circuits including a graphic equalizer, computer tape interface and more.

DIGITAL IC'S — HOW THEY WORK AND HOW TO USE THEM \$10.45

AB004
An excellent primer on the fundamentals of digital electronics. This book discusses the nature of gates and related concepts and also deals with the problems inherent to practical digital circuits.

MASTER HANDBOOK OF 1001 PRACTICAL CIRCUITS \$20.45

TAB No.800
MASTER HANDBOOK OF 1001 MORE PRACTICAL CIRCUITS \$19.45

TAB No.804
Here are transistor and IC circuits for just about any application you might have. An ideal source book for the engineer, technician or hobbyist. Circuits are classified according to function, and all sections appear in alphabetical order.

THE MASTER IC COOKBOOK \$16.45

TAB No.1199
If you've ever tried to find specs for a so called 'standard' chip, then you'll appreciate this book. C.L. Hallmark has compiled specs and pinout for most types of ICs that you'd ever want to use.

ELECTRONIC DESIGN WITH OFF THE SHELF INTEGRATED CIRCUITS \$10.45

AB016
This practical handbook enables you to take advantage of the vast range of applications made possible by integrated circuits. The book tells how, in step by step fashion, to select components and how to combine them into functional electronic systems. If you want to stop being a "cookbook hobbyist", then this is the book for you.

AUDIO

BP90: AUDIO PROJECTS \$8.10

F.G. RAYER
Covers in detail the construction of a wide range of audio projects. The text has been divided into preamplifiers and mixers, power amplifiers, tone controls and matching and miscellaneous projects.

HOW TO DESIGN, BUILD, AND TEST COMPLETE SPEAKER SYSTEMS \$13.45

TAB No.1064
By far the greatest savings in assembling an audio system can be realized from the construction of speakers. This book contains information to build a variety of speakers as well as instructions on how to design your own.

205: FIRST BOOK OF HI-FI LOUDSPEAKER ENCLOSURES \$3.55

B.B. BABANI
This book gives data for building most types of loudspeaker enclosure. Includes corner reflex, bass reflex, exponential horn, folded horn, tuned port, klipschorn labyrinth, tuned column, loaded port and multi speaker panoramic. Many clear diagrams for every construction showing the dimensions necessary.

BP35: HANDBOOK OF IC AUDIO PRE-AMPLIFIER AND POWER AMPLIFIER CONSTRUCTION \$5.50

F.G. RAYER, T.Eng.(CEI), Assoc. IERE
This book is divided into three parts: Part I, understanding audio IC's; Part II, Pre-amplifiers, Mixers and Tone Controls; Part III Power Amplifiers and Supplies. Includes practical constructional details of pure IC and Hybrid IC and Transistor designs from about 250mW to 100W output.

BP47: MOBILE DISCOTHEQUE HANDBOOK \$5.90

COLIN CARSON
The vast majority of people who start up "Mobile Discos" know very little about their equipment or even what to buy. Many people have wasted a "small fortune" on poor, unnecessary or badly matched apparatus.

The aim of this book is to give you enough information to enable you to have a better understanding of many aspects of "disco" gear.

HOW TO BUILD A SMALL BUDGET RECORDING STUDIO FROM SCRATCH \$16.45

TAB No.1166
The author, F. Alton Everest, has gotten studios together several times, and presents twelve complete, tested designs for a wide variety of applications. If all you own is a mono cassette recorder, you don't need this book. If you don't want your new four track to wind up sounding like one, though you shouldn't be without it.

BP51: ELECTRONIC MUSIC AND CREATIVE TAPE RECORDING \$5.50

M.K. BERRY
Electronic music is the new music of the Twentieth Century. It plays a large part in "pop" and "rock" music and, in fact, there is scarcely a group without some sort of synthesiser or other effects generator.

This book sets out to show how electronic music can be made at home with the simplest and most inexpensive of equipment. It then describes how the sounds are generated and how these may be recorded to build up the final composition.

BP74: ELECTRONIC MUSIC PROJECTS \$7.70

R.A. PENFOLD
Although one of the more recent branches of amateur electronics, electronic music has now become extremely popular and there are many projects which fall into this category. The purpose of this book is to provide the constructor with a number of practical circuits for the less complex items of electronic music equipment, including such things as a Fuzz Box, Waa-Waa Pedal, Sustain Unit, Reverberation and Phaser-Units, Tremolo Generator etc.

BP81: ELECTRONIC SYNTHESISER PROJECTS \$7.30

M.K. BERRY
One of the most fascinating and rewarding applications of electronics is in electronic music and there is hardly a group today without some sort of synthesiser or effects generator. Although an electronic synthesiser is quite a complex piece of electronic equipment, it can be broken down into much simpler units which may be built individually and these can then be used or assembled together to make a complete instrument.

ELECTRONIC MUSIC SYNTHESIZERS \$10.45

TAB No.1167
If you're fascinated by the potential of electronics in the field of music, then this is the book for you. Included is data on synthesizers in general as well as particular models. There is also a chapter on the various accessories that are available.

TEST EQUIPMENT

BP75: ELECTRONIC TEST EQUIPMENT CONSTRUCTION \$7.30

F.G. RAYER, T.Eng. (CEI), Assoc. IERE
This book covers in detail the construction of a wide range of test equipment for both the Electronics Hobbyists and Radio Amateur. Included are projects ranging from an FET Amplified Voltmeter and Resistance Bridge to a Field Strength Indicator and Heterodyne Frequency Meter. Not only can the home constructor enjoy building the equipment but the finished projects can also be usefully utilised in the furtherance of his hobby.

99 TEST EQUIPMENT PROJECTS YOU CAN BUILD \$14.45

TAB No.805
An excellent source book for the hobbyist who wants to build up his work bench inexpensively. Projects range from a simple signal tracer to a 50MHz frequency counter. There are circuits to measure just about any electrical quantity: voltage, current, capacitance, impedance and more. The variety is endless and includes just about anything you could wish for!

HOW TO GET THE MOST OUT OF LOW COST TEST EQUIPMENT \$9.45

AB017
Whether you want to get your vintage 1960 'TestRite' signal generator working, or you've got something to measure with nothing to measure it with, this is the book for you. The author discusses how to maximize the usefulness of cheap test gear, how to upgrade old equipment, and effective test set ups.

THE POWER SUPPLY HANDBOOK \$16.45

TAB No.806
A complete one stop reference for hobbyists and engineers. Contains high and low voltage power supplies of every conceivable type as well mobile and portable units.

BP70: TRANSISTOR RADIO FAULT-FINDING CHART \$2.40**CHAS. E. MILLER**

Across the top of the chart will be found four rectangles containing brief descriptions of various faults, viz. — sound weak but undistorted; set dead; sound low or distorted and background noises. One then selects the most appropriate of these and following the arrows, carries out the suggested checks in sequence until the fault is cleared.

ELECTRONIC TROUBLESHOOTING HANDBOOK**AB019 \$9.45**

This workbench guide can show you how to pinpoint circuit troubles in minutes, how to test anything electronic, and how to get the most out of low cost test equipment. You can use any and all of the time-saving shortcuts to rapidly locate and repair all types of electronic equipment malfunctions.

COMPLETE GUIDE TO READING SCHEMATIC DIAGRAMS**AB018 \$9.45**

A complete guide on how to read and understand schematic diagrams. The book teaches how to recognize basic circuits and identify component functions. Useful for technicians and hobbyists who want to avoid a lot of headscratching.

RADIO AND COMMUNICATIONS

BP79: RADIO CONTROL FOR BEGINNERS**F.G. RAYER, T.Eng.(CEI), Assoc.IERE. \$7.30**

The aim of this book is to act as an introduction to Radio Control for beginners to the hobby. The book will commence by dealing with the conditions that are allowable for such things as frequency and power of transmission. This is followed by a "block" explanation of how control-device and transmitter operate and receiver and actuator(s) produce motion in a model.

Details are then given of actual solid state transmitting equipment which the reader can build. Plain and loaded aerials are then discussed and so is the field-strength meter to help with proper setting up.

The radio receiving equipment is then dealt with which includes a simple receiver and also a crystal controlled superhet. The book ends with the electro-mechanical means of obtaining movement of the controls of the model.

BP96: CB PROJECTS**R.A. PENFOLD \$8.10**

Projects include speech processor, aerial booster, cordless mike, aerial and harmonic filters, field strength meter, power supply, CB receiver and more.

BP91: AN INTRODUCTION TO RADIO DXing**\$8.10**

This book is introduced to two main sections one to amateur band reception, the other to broadcast bands. Advice is given to suitable equipment and techniques. A number of related constructional projects are described.

SHORTWAVE CIRCUITS & GEAR FOR EXPERIMENTERS & RADIO HAMs**No. 215 \$3.70**

Covers constructional details of a number of projects for the shortwave enthusiast and radio "Ham". Included are: an add-in crystal filter, adding an "S" meter in your receiver; crystal locked H.F. Receiver; AM tuner using phase locked loop; converter for 2MHz, 40 to 800 MHz RF amplifier. Aerials for the 52, 144MHz bands, Solid State Crystal Frequency Calibrator, etc.

BP92: ELECTRONICS SIMPLIFIED—CRYSTAL SET CONSTRUCTION**F.A. WILSON \$7.30**

Aimed at those who want to get into construction without much theoretical study. Homewound coils are used and all projects are very inexpensive to build.

AUDIO AND VIDEO INTERFERENCE CURES**KAHANER \$9.05**

A practical work about interference causes and cures that affect TV, radio, hi-fi, CB, and other devices. Provides all the information needed to stop interference. Schematic wiring diagrams of filters for all types of receivers and transmitters are included. Also, it supplies simple filter diagrams to eliminate radio and TV interference caused by noisy home appliances, neon lights, motors, etc.

Book Of The Month

Crystal Set ConstructionBP92\$7.30

How often have you leaned back from your twelve giga-dollar microcomputer, switched off your 10,000 watt national debt stereo, told the robot to go kill compact cars and thought how long it's been since you've built a crystal radio? Not very often, right? You need this book. It's therapeutic, practical and, at the very least, it will help you build something you can actually understand.

This book is ideal for both the beginner just getting into electronics and the experienced soldering iron cavalier who just wants to stop slaying IC's for a while. All the aspects of crystal sets are covered, from simple circuits to multiband sets, plus their history and some radio theory. Simple, easy to get parts are specified throughout.

BP46: RADIO CIRCUITS USING IC's**\$5.90****J.B. DANCE, M.Sc.**

This book describes integrated circuits and how they can be employed in receivers for the reception of either amplitude or frequency modulated signals. The chapter on amplitude modulated (a.m.) receivers will be of most interest to those who wish to receive distant stations at only moderate audio quality, while the chapter on frequency modulation (f.m.) receivers will appeal to those who desire high fidelity reception.

REFERENCE

THE BEGINNER'S HANDBOOK OF ELECTRONICS**AB003 \$9.45**

An excellent textbook for those interested in the fundamentals of Electronics. This book covers all major aspects of power supplies, amplifiers, oscillators, radio, television and more.

ELEMENTS OF ELECTRONICS — AN ON-GOING SERIES**F.A. WILSON, C.G.I.A., C.Eng.****BP62: BOOK 1. The Simple Electronic Circuit and Components \$8.95****BP63: BOOK 2. Alternating Current Theory \$8.95****BP64: BOOK 3. Semiconductor Technology \$8.95****BP77: BOOK 4. Microprocessing Systems and Circuits \$12.30****BP89: BOOK 5. Communication \$12.30**

The aim of this series of books can be stated quite simply — it is to provide an inexpensive introduction to modern electronics so that the reader will start on the right road by thoroughly understanding the fundamental principles involved.

Although written especially for readers with no more than ordinary arithmetical skills, the use of mathematics is not avoided, and all the mathematics required is taught as the reader progresses.

Each book is a complete treatise of a particular branch of the subject and, therefore, can be used on its own with one proviso, that the later books do not duplicate material from their predecessors, thus a working knowledge of the subjects covered by the earlier books is assumed.

BOOK 1: This book contains all the fundamental theory necessary to lead to a full understanding of the simple electronic circuit and its main components.

BOOK 2: This book continues with alternating current theory without which there can be no comprehension of speech, music, radio, television or even the electricity utilities.

BOOK 3: Follows on semiconductor technology, leading up to transistors and integrated circuits.

BOOK 4: A complete description of the internal workings of microprocessor.

BOOK 5: A book covering the whole communication scene.

BP85: INTERNATIONAL TRANSISTOR EQUIVALENTS GUIDE**ADRIAN MICHAELS \$12.25**

This book will help the reader to find possible substitutes for a popular user-orientated selection of modern transistors. Also shown are the material type, polarity, manufacturer selection of modern transistors. Also shown are the material type, polarity, manufacturer and use. The Equivalents are subdivided into European, American and Japanese. The products of over 100 manufacturers are included. An essential addition to the library of all those interested in electronics, be they technicians, designers, engineers or hobbyists. Fantastic value for the amount of information it contains.

BP1: FIRST BOOK OF TRANSISTOR EQUIVALENTS AND SUBSTITUTES**B.B. BABANI \$2.80**

This guide covers many thousands of transistors showing possible alternatives and equivalents. Covers transistors made in Great Britain, USA, Japan, Germany, France, Europe, Hong Kong, and includes types produced by more than 120 different manufacturers.

BP14: SECOND BOOK OF TRANSISTOR EQUIVALENTS AND SUBSTITUTES**B.B. BABANI \$4.80**

The "First Book of Transistor Equivalents" has had to be reprinted 15 times. The "Second Book" produced in the same style as the first book, in no way duplicates any of the data presented in it. The "Second Book" contains only additional material and the two books complement each other and make available some of the most complete and extensive information in this field. The interchangeability data covers semiconductors manufactured in Great Britain, USA, Germany, France, Poland, Italy, East Germany, Belgium, Austria, Netherlands and many other countries.

TOWER'S INTERNATIONAL OP-AMP LINEAR IC SELECTOR**TAB No.1216 \$13.45**

This book contains a wealth of useful data on over 5,000 Op-amps and linear ICs — both pinouts and essential characteristics. A comprehensive series of appendices contain information on specs, manufacturers, case outlines and so on.

CMOS DATABOOK**TAB No.984 \$14.45**

There are several books around with this title, but most are just collections of manufacturers' data sheets. This one, by Bill Hunter, explains all the intricacies of this useful family of logic devices — the missing link in getting your own designs working properly. Highly recommended to anyone working with digital circuits.

MISCELLANEOUS

BP68: CHOOSING AND USING YOUR HI-FI**MAURICE L. JAY \$7.25**

The main aim of this book is to provide the reader with the fundamental information necessary to enable him to make a satisfactory choice from the extensive range of hi-fi equipment now on the market.

Help is given to the reader in understanding the equipment he is interested in buying and the author also gives his own opinion of the minimum standards and specifications one should look for. The book also offers helpful advice on how to use your hi-fi properly so as to realise its potential. A Glossary of terms is also included.

BP101: HOW TO IDENTIFY UNMARKED IC'S**K.H. RECORD \$2.70**

Originally published as a feature in 'Radio Electronics', this chart shows how to record the particular signature of an unmarked IC using a test meter, this information can then be used with manufacturer's data to establish the application.

SIMPLIFIED TRANSISTOR THEORY**TRAINING SYSTEMS, INC. AND LEVINE \$10.25**

This book is designed to provide thorough comprehension of the physical theory and basic operating principles of transistors and transistor circuits. The book assumes no previous knowledge of the subject other than an understanding of basic electricity.

The information is presented in a series of brief, logically-developed steps, or frames — over 400 in all. A concluding summary section provides both a concise review and a convenient reference source for future use.

BASIC TELEPHONE SWITCHING SYSTEMS**TALLEY \$15.25**

The Revised Second Edition of this book, for trainee and engineer alike, includes updated statistical data on telephone stations, and new and improved signaling methods and switching techniques. It also includes E & M signaling interface for electronic central offices and automatic number identification methods used in step-by-step, panel and crossbar central offices.

INTERRELATED INTEGRATED ELECTRONICS CIRCUITS FOR THE RADIO AMATEUR, TECHNICIAN, HOBBYIST AND CB'ER**MEDELSON \$11.35**

This book provides a variety of appealing projects that can be constructed by anyone from the hobbyist to the engineer. Construction details, layouts, and photographs are provided to simplify duplication. While most of the circuits are shown on printed circuit boards, every one can be duplicated on hand-wired, perforated boards. Each project is related to another projects so that several may be combined into a single package. The projects, divided into five major groups, include CMOS audio modules, passive devices to help in benchwork, test instruments, and games.

BASIC CARRIER TELEPHONY, THIRD EDITION**TALLEY \$14.45**

A basic course in the principles and applications of carrier telephony and its place in the overall communications picture. It is abundantly illustrated, with questions and problems throughout, and requires a minimum of mathematics.

ROBOTICS

THE COMPLETE HANDBOOK OF ROBOTICS**TAB No.1071 \$13.45**

All the information you need to build a walking, talking mechanical friend appears in this book. Your robot can take many forms and various options — light, sound, and proximity sensors — are covered in depth.

HOW TO BUILD YOUR OWN SELF PROGRAMMING ROBOT**TAB No.1241 \$13.45**

A practical guide on how to build a robot capable of learning how to adapt to a changing environment. The creature developed in the book, Rodney, is fully self programming, can develop theories to deal with situations and apply those theories in future circumstances.

BUILD YOUR OWN WORKING ROBOT**TAB No.841 \$11.45**

Contains complete plans — mechanical, schematics, logic diagrams and wiring diagrams — for building Buster. Buster is a sophisticated experiment in cybernetics you can build in stages. There are two phases involved: first Buster is leashed, dependent on his creator for guidance; the second phase makes Buster more independent and able to get out of tough situations.

ALL PRICES INCLUDE SHIPPING

ETI book shelf

February 1977

Features: CN Tower, Biorythm Calculator, VCT, 555 Timer Applications, Yamaha B1 Review, Scope Test Your Car.
Projects: 5W Stereo Amp, Philips Speaker System, Reaction Tester, Patch Detector, Heads or Tail, SCR Tester.

December 1978

Features: Designing Oscillators, Ham Spectrum Chart, Principles of Video, Getting into Video.
Projects: Digital Anemometer, Tape Noise Eliminator, EPROM Programmer.

February 1979

Features: Quarks, Op-Amps, Binary to Decimal and Back.
Projects: SW Radio, Phasemeter, Light Chaser.

April 1979

Features: Designing Audio Amps, Solar Power, RF Chokes, What Quad terms mean.
Projects: Differential Temperature Controller, Audio Compressor, Wheel of Fortune Game.

May 1979

Features: Space Shuttle Communications, Transducers in Measurement & Control, Research in Canada.
Projects: Light Show Controller, AM Tuner, VHF Antenna (pt.1), PCB Drill.

June 1979

Features: Op-Amps, Ultrasonic Sound, ETI Computer Catalogue.
Projects: Easy Colour Organ, LCD Thermometer, Light Show Colour Sequencer, VHF Antenna (pt.2), Bip Beacon.

August 1979

Features: Casing Survey, Smoke Detectors, TV Antennas, Reed Switches, Magnetic Field Audio Amp, Industrial Electronics.
Projects: Audio Power Meter, Shoot out, ETI-Wet Plant Waterer.

September 1979

Features: OSI Superboard Review, Solar Power from Satellites, Reed Switches.
Projects: Field Strength Meter, Digital Wind Meter, Up/Down Counter.

October 1979

Features: SW Receiver Survey, Ultra Fidelity, Computer Speech.
Projects: Simple Graphic Equaliser, Digital Dial, Variable Windscreen Wiper, Cable Tester.

November 1979

Features: Kit Survey, Ultra Fidelity (pt.2), Using UARTS.
Projects: 60W Amplifier, Model Train Controller, Scope Curve Tracer.

December 1979

Features: LM10—the Basics, Police Radar Speed Meters, Guide to TRIACS, Fluorescent Displays.
Projects: High Performance Stereo Preamp, Development Timer, Logic Trigger.

May 1980

Features: Delay Lines, Standing Waves, Microwave Cooking, Artificial Intelligence.
Projects: Click Eliminator, Soil Moisture Indicator, Fuel Level Monitor, 16k RAM Card.

June 1980

Features: Electronic Warfare, PLL Synthesis, CA3130 Circuits, Canadian Sound Archives, Magnetic Power Control, CLIP.
Projects: Function Generator, Dynamic Noise Filter, Overspeed Alarm.

July 1980

Features: CMOS 555 Circuits, Capacitors, Electronics in the Studio, Tesla Controversy.
Projects: Hebot Robot (pt.1), Photographic Timer, Analogue Frequency Meter, Accentuated Beat Metronome.

August 1980

Features: S100 Bus System, Introduction to Test Gear, Designer Circuits, FET Special, Life Out There?
Projects: 300W Amp, Hebot (pt.2), Transistor Tester, Passionmeter.

November 1980

Features: Designer Circuits Special, Cassette Decks and Tapes, Attenuators, Project Daedalus, Thermistors.
Projects: Guitar Practice Amplifier, 6W Siren, Infra-Red Remote Control.

December 1980

Features: Transducers in Audio, Floppy Disks, 10 Simple Transistor Circuits, Electric Cars, SI Units.
Projects: Digital Test Meter, RIAA Preamp, Survival Game.

**January 1981**

Features: Studio Techniques, Premium Batteries, Edison Effect, Alarm Circuits.
Projects: Electronic Ignition, Digital Frequency Meter, EPROM Eraser, Coin Toss.

February 1981

Features: Electronics in Photography, Audio Filter Design, Piezo Electricity, Modems, Choosing a Printer, Selecting a Floppy Disk.
Projects: Ultrasonic Burglar Alarm, Fuzz Sustain Unit, Process Timer.

March 1981

Features: The Ubiquitous Oscilloscope, VFET Applications, Photocells, Test Gear.
Projects: Hum Filter, Drum Synthesiser, Shark Game.

June 1981

Features: Project Galileo, Story Behind Stereo, Solder, Computerese.
Projects: 1573A VCA, High Speed Cassette Interface, Double Dice, Bicycle Speedometer.

July 1981

Features: LM3914 Circuits, How to Solder, Faraday, Auto Sound Survey, Project Fault-Finding.
Projects: Universal Timer, Bargraph Car Voltmeter, Engineer's Stethoscope, Computer Motherboard.

August 1981

Features: Recording Tape and Tape Recording, Anatomy of a Micro, Holograms, Wein Bridge Oscillators, 55 Circuits.
Projects: Infra-Red Alarm, Bench PSU, Wired Sound.

September 1981

Features: Thick Film Circuits, A look at CP/M, Gm Revisited, Hum Loops, Ex-OR Gates.
Projects: LED Vu Meter, Russian Roulette, LED Tacho, Emergency Light Unit.

October 1981

Features: Scope Survey, Graphic Equalizer Design, I/O Devices, Dolby C, Black Hole Theory.
Projects: Tape Optimizer, Antenna Extender, Win Indicator, Pulse Generator.

November 1981

Features: Canada in Space, Digital Design Handbook, Maxwell, POKing the ZX80, VIC-20 Review, PWM Explained.
Projects: Aljen Attack, Headlight Delay, Drum Machine, Computer Jovsticks.

December 1981

Features: Bandpass Circuits, Tubes, Early Radio in Canada, Speaker Design (pt.1).
Projects: Universal Counter, Musical Doorbell, 4-Input Mixer.

January 1982

Features: Speaker Design (pt.2), Big Bang Theory, Acorn ATOM Review, SLR Cameras, Micropower Circuits.
Projects: 4-Way Loudspeaker, Movement Alarm, Temperature Controlled Iron.

February 1982

Features: 50 Circuits, ATOM Review, Electronic Signs, Industrial Robots, Amplifier Class, dBx, SW Aerials.
Projects: Flash Sequencer, Enlarger Timer, Sound Bender.

March 1982

Features: Printers, Ni-Cads, ZX81 Review, Perfect Sound, Gluons, CMOS Circuits.
Projects: Music Processor, Crystal Marker, Ni-Cad Charger, Reaction Tester.

April 1982

Features: Satellite Applications, 4066B Circuits, TRS-80 Model II Review, Fessenden, Electric Pencil.
Projects: Ten Simple Projects Special.

May 1982

Features: Shroud of Turin, Faster than Light Travel, CMOS Circuits, Modems, Drone Speaker, 6809 Computer Review, Optical Disk Recorders.
Projects: AF Signal Generator, Super Dice, LED Level Meter.

June 1982

Features: Fibre Optics, Lasers in Hi-Fi, Lepions, Xerox Computer Review, Hertz, 50 More Circuits.
Projects: Phono Preamp, Roulette Game, Light Wand, Stylus Organ.

The Back Issues listed here are still available. A few others (listed on the order form) are also available but in very limited quantities. Our Back Issues are not unsold copies: each month about 500 are held in reserve for this service.

\$3.00 each or any FIVE for \$10
 (Price includes shipping)

**ETI Back Issues,
 Unit 6, 25 Overlea Blvd,
 Toronto, Ontario,
 M4H 1B1**

Tech Tips

AUDIO	BATTERY OPERATED VCO	63	MISC.	SEQUENCE SWITCH	79
AUDIO	VLF SINE GENERATOR	63	AUDIO	TAPE RECORDER CONTROLLER	80
AUDIO	5 WATT AUDIO AMP	64	HOME	DOOR BELL EXTENDER	80
AUDIO	ALTERNATIVE 5 WATT AMP	64	MISC.	MULTI-ZENER	81
AUDIO	MOVING COIL PREAMP	65	MISC.	INCREASING ZENER POWER	81
AUDIO	ONE CHIP PRE-AMP	65	TEST	OVERVOLTAGE PROTECTION	81
MISC.	BCD TONE GENERATOR	66	COMPUTER	PROGRAMMABLE GATE	82
HOME	GENTLE ALARM CLOCK	66	COMPUTER	CHEAP DOWN COUNTER	82
MISC.	7400 SIREN	67	HOME	GEIGER COUNTER	83
AUDIO	FIBRE OPTIC BASS GUITAR	67	TEST	CAPACITY CHECKER	83
AUDIO	AUDIO DOUBLER	68	HOME	TV GAME RESURRECTION	84
AUDIO	SIMPLE COMPRESSOR	68	HOME	AUTO SELECT FOR AY-3-8760	84
AUDIO	4 CHANNEL SYNTHESIZER	68	HOME	PORCH LIGHT CONTROLLER	85
MISC.	RECTIFYING WITH THE LM3900	69	AUDIO	GUITAL SUSTAIN UNIT	85
COMPUTER	BCB TO ANALOGUE CONVERTER	69	HOME	DIGITAL BIKE SPEED	86
AUDIO	HIGH QUALITY TONE CONTROL	70	AUTO	CAR VOLTAGE REGULATOR	86
AUDIO	VARIABLE NOTCH FILTER	70	AUTO	CAR LAMP FAILURE WARNING	87
TEST	BATTERY INDICATOR	71	AUDIO	ICE WARNING	87
TEST	SUPPLY TELLTALE	71	AUDIO	CAR LIGHTS REMINDER	87
AUDIO	STEREO BALANCE METER	72	COMPUTER	SEVEN TO BINARY	88
AUDIO	SPEAKER POWER INDICATOR	72	COMPUTER	555 MICRO RESET	88
MISC.	SEIDE SWITCH	73	HOME	2 CHIP DICE	89
MISC.	ELECTRONIC SWITCH	73	HOME	DIGITAL DIE	89
HOME	TRAIN CONTROLLER	74	HOME	PASSION METER	90
HOME	TRAIN CONTROLLER WITH INERTIA	74	HOME	HEADS OR TAILS	90
TEST	ANTI-SURGE REGULATOR	75	COMPUTER	EXOR AND EXNOR	91
TEST	SIMPLE DUAL POWER SUPPLY	75	COMPUTER	MEMORY CONNECTIONS	91
MISC.	MULTI-POWER INVERTER	75	TEST	LOGIC PROBE	92
COMPUTER	EXTERNAL INPUT FOR MICROS	76	TEST	POCKET DFM	92
COMPUTER	SEVEN SEGMENT DECODER	76	TEST	CMOS GATE IDENTIFIER	93
COMPUTER	KEYBOARD/DISPLAY CONVERTER	76	TEST	CMOS TEST BED	93
HOME	TELEPHONE AMPLIFIER	77	TEST	BATTERY TESTER	93
AUDIO	NOVEL SPEAKER CIRCUIT	77	COMPUTER	DIGITAL PULSE COMPRESSOR	94
TEST	NPN-PNP INDICATOR	78	AUDIO	SAMPLE AND HOLD	94
TEST	MEASURING METER RESISTANCE	78	HOME	ELECTRONIC "SPIROGRAPH"	95
TEST	MORE OHMS PER VOLT	78	AUDIO	ANTI FEEDBACK	96
TEST	METER PROTECTION	78	TEST	LED SPOTTING	96
MISC.	LOW CURRENT TOUCH SWITCH	79	HOME	TV ISOLATOR	96
MISC.	SPST SWITCH FLIP-FLOP	79			

Battery Operated VCO

R. Zaman.

By using the LM 3900N quad-op-amp, a simple portable battery operated VCO can be made very cheaply. A1 forms an integrator, the ramp rate depending on the voltage V_i and capacitor C. This ramp is fed to a Schmidt trigger which switches at about $5V_8$, making A1 ramp down, generating a triangular wave of about $0V_85$.

The Schmidt trigger feeds a transistor switch and an emitter follower.

The triangular wave is then fed to A3 which acts as an inverting amplifier, and the output is fed to A4 which is an exponential integrator set at a pseudo-ground of $4V_5$. The bias and gain pots must be adjusted to give the best sine waveform.

V_i can be any positive voltage from $+0.5 \leftrightarrow +15.0$ V, giving a frequency

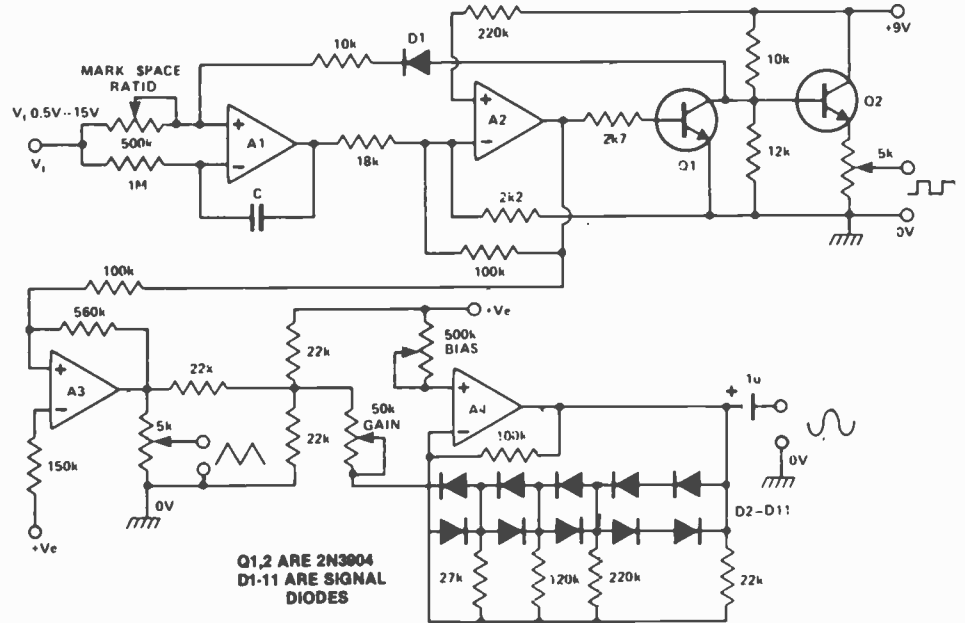

range of about 1:100. Capacitor C can be any value from 10n to 47n

and the outputs have a low distortion up to about 20 kHz. ●

VLF Sine Generator

G. Loveday

Generating very low frequency sine waves (i.e. less than 0.1 Hz) presents several problems. Timing capacitors usually have to be large value electrolytics, any amplifier used must be D.C. coupled, and the amplifier's input impedance must be very high. One standard method is to first generate low frequency square waves, and then to shape these into an approximation of a sine wave by the use of several non linear devices, such as diodes. The circuit shown in Fig. 1 is a relatively simple approach based on the familiar Wien bridge. An n-channel FET and a PNP transistor are arranged in a DC coupled circuit and the voltage gain is determined by the negative feedback R3 and R4. The gain need only be about three, thus if the bias required by the FET is 3V the output level will be approximately half the supply voltage to give

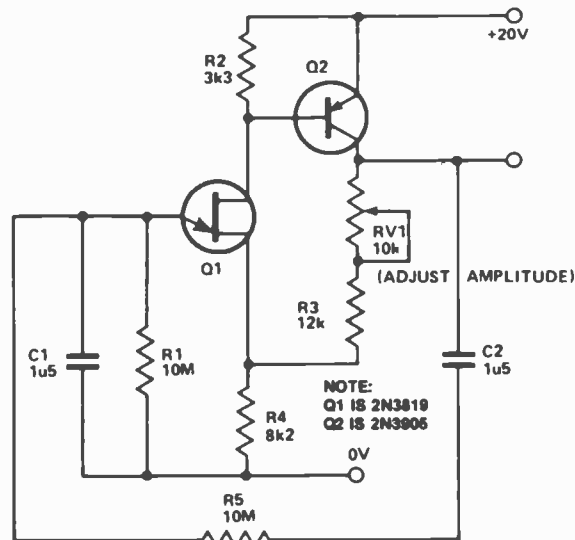

Since R1 can be a high value resistor the value of the capacitor is only 1u5 for sine wave outputs of 0.01 Hz. This capacitor is available in polycarbonate. The amplitude of the output can be adjusted by RV1 to give

low harmonic distortion and to be about 10V peak to peak. As expected, with this Wien bridge circuit, frequency stability is good with changes in both supply voltage and temperature. ●

5 Watt Audio Amplifier

A circuit for the TBA800 IC audio amplifier which requires a minimum number of external components is shown here. The mean output voltage at pin 12 of the device is about half of the positive supply potential and therefore a capacitor C4 must be employed in series with the speaker to prevent a steady current from flowing through the latter. If the value of this capacitor is reduced, the bass response will be reduced.

The bootstrap connection to pin 4 of the device is obtained from the junction of C4 and the loudspeaker.

The high frequency response of the circuit is affected by the value of C5. When the value of this capacitor is 270p, the response is level to ± 3 dB from about 40Hz to 20kHz. If, however, C5 is increased to 470p, the upper 3dB point is about 10kHz.

Feedback is taken from the output via a 7k Ω internal resistor to a point which is connected to pin 6. The feedback voltage is developed across R1; if the value of this resistor is increased, the gain will fall owing to the increased amount of feedback. However, the value of R1 also affects the frequency response.

The input is shown as being fed

directly to the volume control RV1. If, however, the input does not have a mean potential equal to the ground potential, a capacitor of about 220n should be placed in series with the input. The input impedance of the TBA800 is typically 5M Ω (minimum value 1M Ω for any TBA800); however, a resistor not exceeding about 100k must always be present between pin 8 and the negative line.

C1 should be soldered close to pin 1. It provides good decoupling of the power supply lines at high frequencies, whilst C2 provides good low frequency decoupling. Capacitor C7 and resistor R2 help to prevent instability.

A method of connecting a heatsink is shown below. The tabs and the external heatsink are soldered together into a common hole and are earthed. The maximum output without a heatsink is limited to about 2.3W. ●

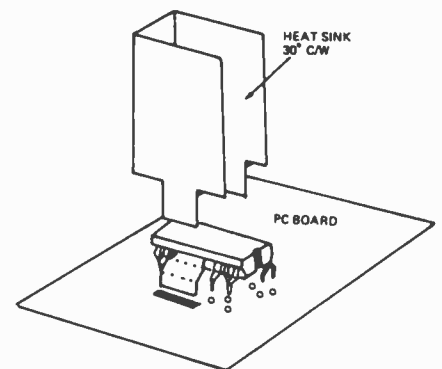
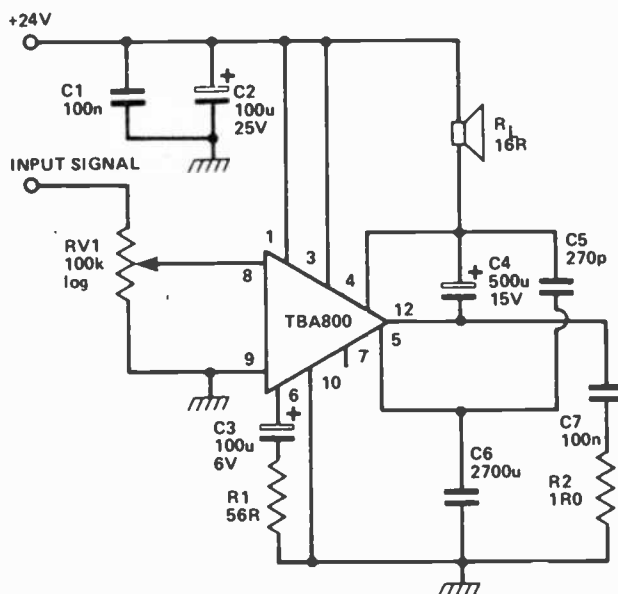

Alternative Circuit

In this circuit, the capacitor C9 provides a bootstrap between the output of the device and pin 4. This enables a performance similar to that of the circuit above to be obtained when one side of the loudspeaker is grounded.

If the supply voltage is low (up to 14V), a 150R resistor should be connected between pin 4 and the positive supply line. A capacitor C8 may be connected between pin 7 and ground to prevent hum from the power supply line being present at an appreciable amplitude at the output of the device. The value of C8 may be 10u to 100u, 25V.

The distortion rises rapidly with power output at high power levels. When a 24V supply is employed with a 16R load, the distortion introduced by the circuit shown here at 1kHz is

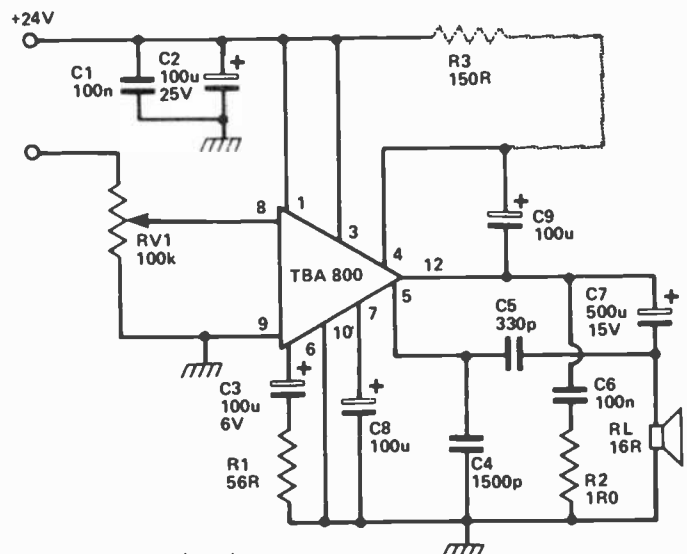

about 0.5 per cent at output levels up to 3W. At 4W it rises to about 2-4 per cent and at 5W to 10 per cent. ●

Moving Coil Cartridge Preamp.

J. Macauley

Although moving coil cartridges undoubtedly give better reproduction from disc they usually require an expensive step up transformer to enable them to be used with conventional RIAA equalisation.

The reason for this is that most cartridges of this type have outputs of 60-150uV and like to 'see' an input impedance between 60-330R.

The circuit shown was developed to cater for a particular cartridge of this type although by modifying the value of one component, R1, it is possible to cater for the complete range of inputs detailed above.

Input signals are coupled to the base of Q1 via the isolating capacitor C1. R1 damps the input impedance to the correct value to match the particular cartridge in use. R2 and R3 bias Q1 which is employed in the common

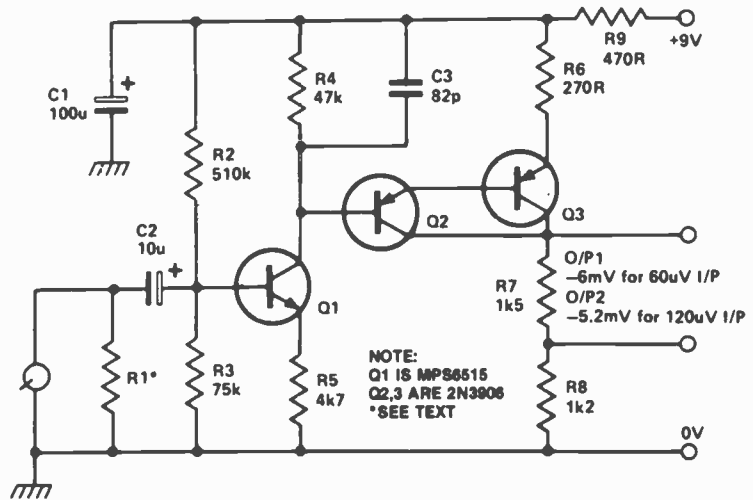

emitter mode. Heavy local AC and DC feedback is introduced by R5 and this defines the gain of the stage at 20dB. To minimise noise an MPS6515 is used here operated with a low collector current, 50uA. The output stage of this amplifier is the darlington pair Q2

and Q3, output signals being taken from across R7, R8.

R1 should be determined by experiment but can be initially found by using a 470R preset in the R1 position and adjusting this for optimum sound quality by ear. ●

One Chip Preamplifier

J. P. Macaulay

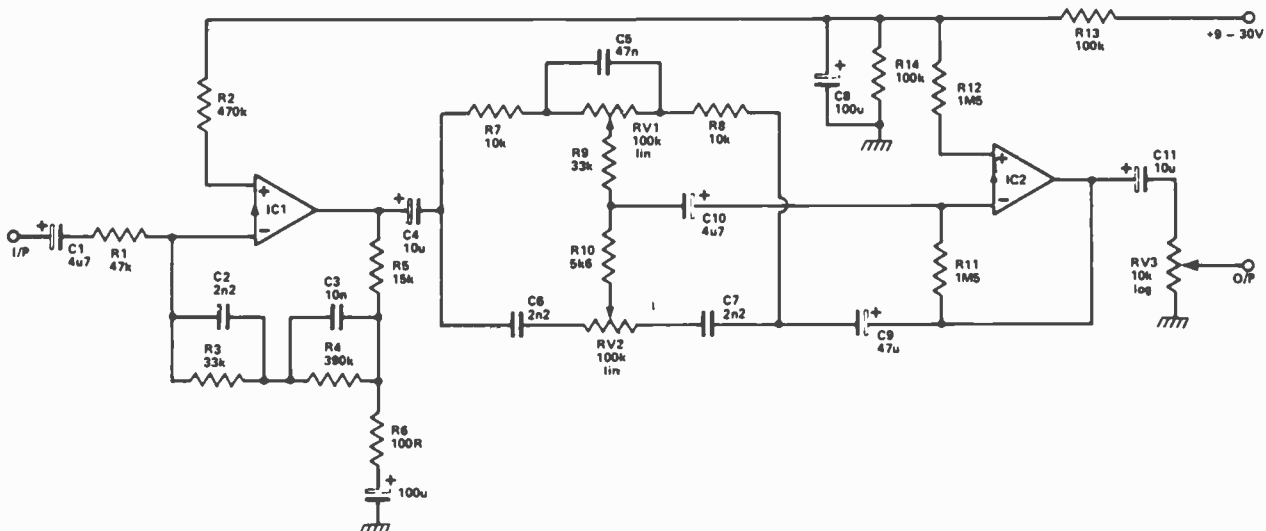

The circuit shown utilises the four Norton op amps contained within an LM3900 to produce a high quality stereo preamp, catering for magnetic cartridges.

IC1 is used in the inverting mode. Signals from the cartridge are fed via the blocking capacitor and R1 to the inverting input. R1 defines the input impedance and provides the right

damping for the cartridge.

R5 and R6 define the midband gain of the stage whilst the network R3, R4, C2 and C3 provide the required RIAA equalisation. From here the equalised signal is fed to a standard Baxendall tone control network built around IC2. This requires little comment although it should be noted that individual volume controls

are employed for each channel. This not only reduces crosstalk between channels but also works out cheaper in that only two single gang potentiometers are used.

Performance is good with overall distortion below 0.1% and a S/N ratio of -67db unweighted, ref 500 mV out. ●

BCD Tone Generator

P. Bailey

When one of the binary codes in the table is set up on the data inputs, a corresponding preset connected to IC1 and 2 will be grounded, and the unijunction will start to oscillate, the frequency of oscillation depending on which output of the ICs is grounded.

If the 18 presets are tuned to form a chromatic scale and the inputs interfaced to your MPU data bus — hey presto you have a simple MPU controlled organ! ●

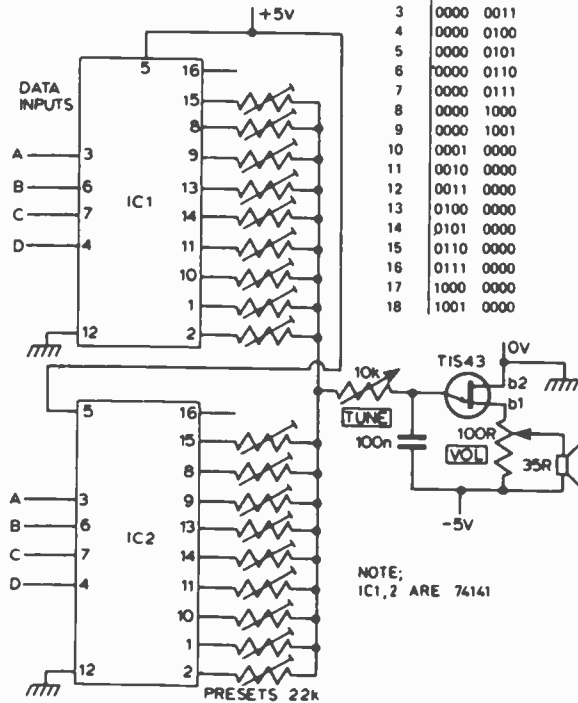

Gentle Clock Alarm

I. Hill-Smith

RING! RING! BUZZ! This is DLT
CLANG! PIP PIP PIP!

There are gentler ways to wake up. This circuit provides an alarm which builds up from being inaudible to loud over about one minute. As a result you are always woken by the minimum volume required to wake you; a far more comfortable experience than the

usual trauma. The three multivibrators in cascade provide a signal like the sound of a warbler telephone. As C slowly charges through R a larger fraction of the signal is amplified by the op amp producing a louder output. ●

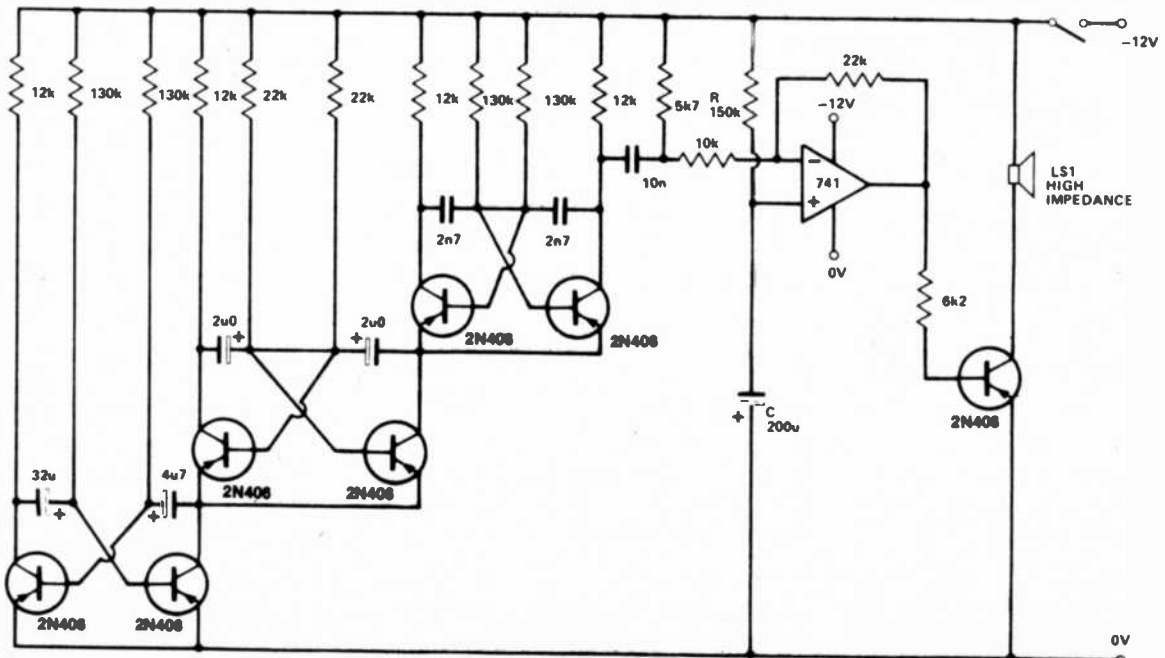

7400 Siren

The siren consists of two oscillators which generate the tones. A third oscillator is used to switch the others on and off alternately, giving the two tone effect

By changing the capacitor values different tones can be produced. ●

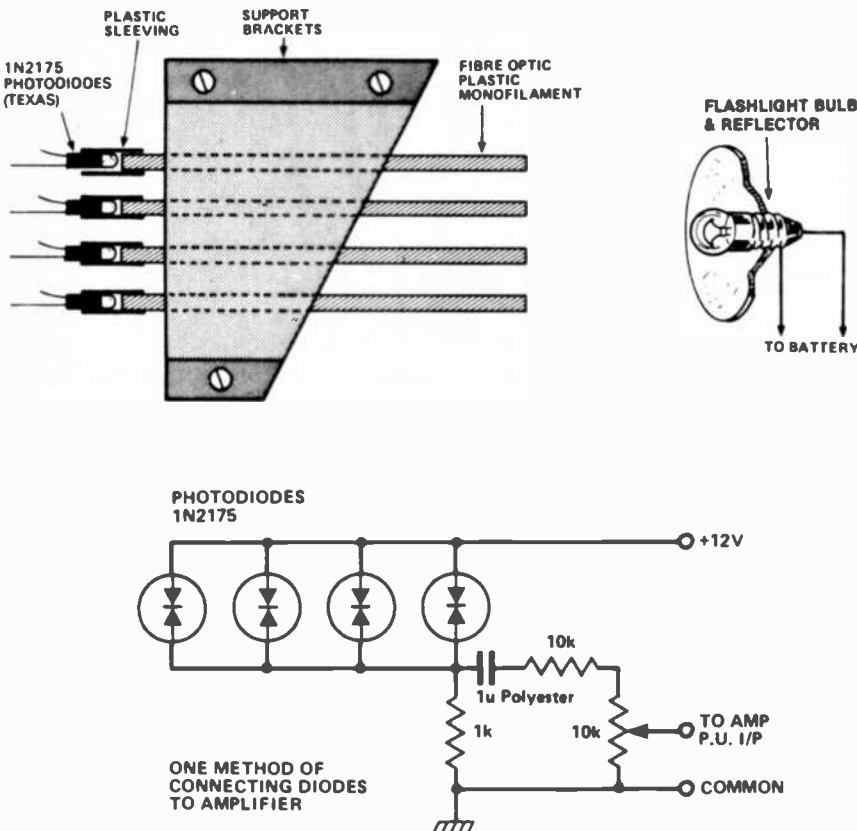
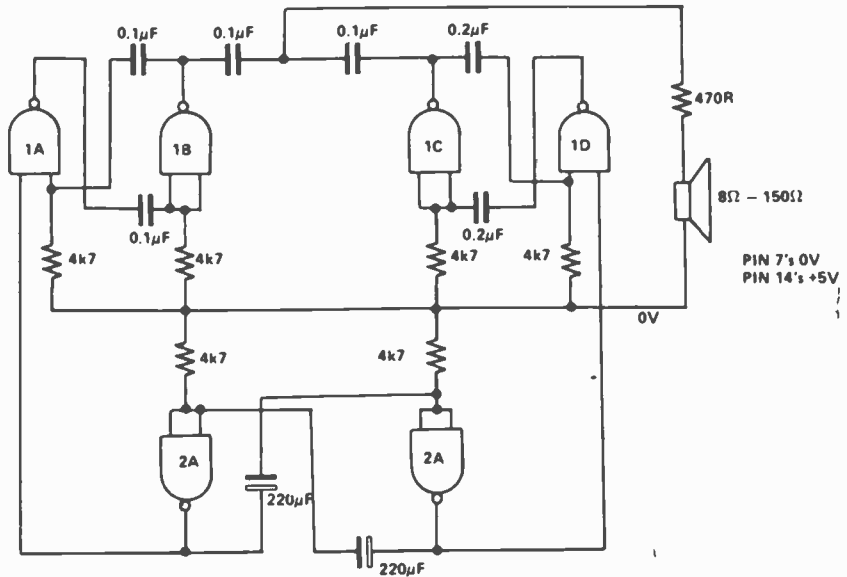
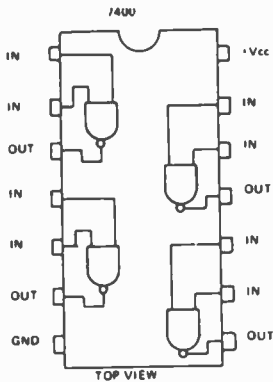

Fibre Optic Bass Guitar

J. Smith.

This item is in effect a simple musical instrument. It consists of a number of short lengths of plastic monofilament fibre optic material arranged in such a way that when a fibre is touched then released it vibrates at its own natural resonant frequency (like a ruler twanged on the edge of a desk). When in a light beam supplied from a flashlight battery the vibrating end sends sine wave impulses along the fibre. At the fixed end there is a photodiode which with suitable circuitry feeds a signal to a normal audio amplifier. The sound produced is similar to that obtained using a tea chest, piece of string and broom handle; remember those days? Thickness of the fibres and length are not critical and it is best to experiment to obtain the sound that pleases the constructor. The fibres need be no longer than about 60 mm. Remember the shorter they are the higher the note produced. ●

Audio Doubler

Audio frequencies may be doubled by this circuit which relies on the non-linear characteristic of a transistor to provide half-wave rectification. R1 is a feedback control and is adjusted to obtain a pure output waveform. ●

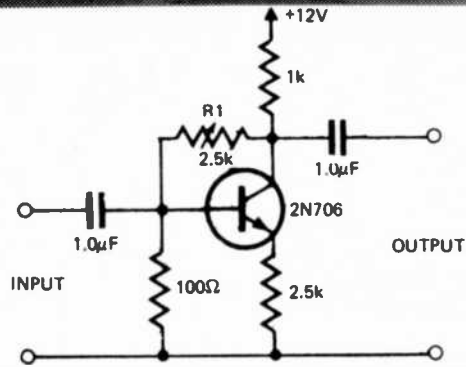

Simple Compressor

This simple compressor is very effective when tape recording from the speaker terminals of a receiver.

Input can vary anywhere from 200mV to six volts and the output will remain very close to five millivolts. Attack time is approximately three milliseconds and release time is approximately one hundred milliseconds. The diodes should be high back resistance types; 1N914s should be suitable. ●

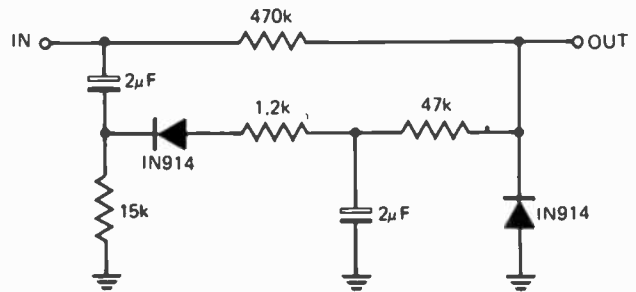

4 Channel Synthesizer

T. Huffinley

This circuit will synthesize two rear channels for 'quadraphonic' sound when fed with a stereo signal. The rear output for the left channel, is a combination of the left channel input

180° out of phase, added to a proportion of the right hand channel (also out of phase). The right hand rear output is obtained in a similar way. ●

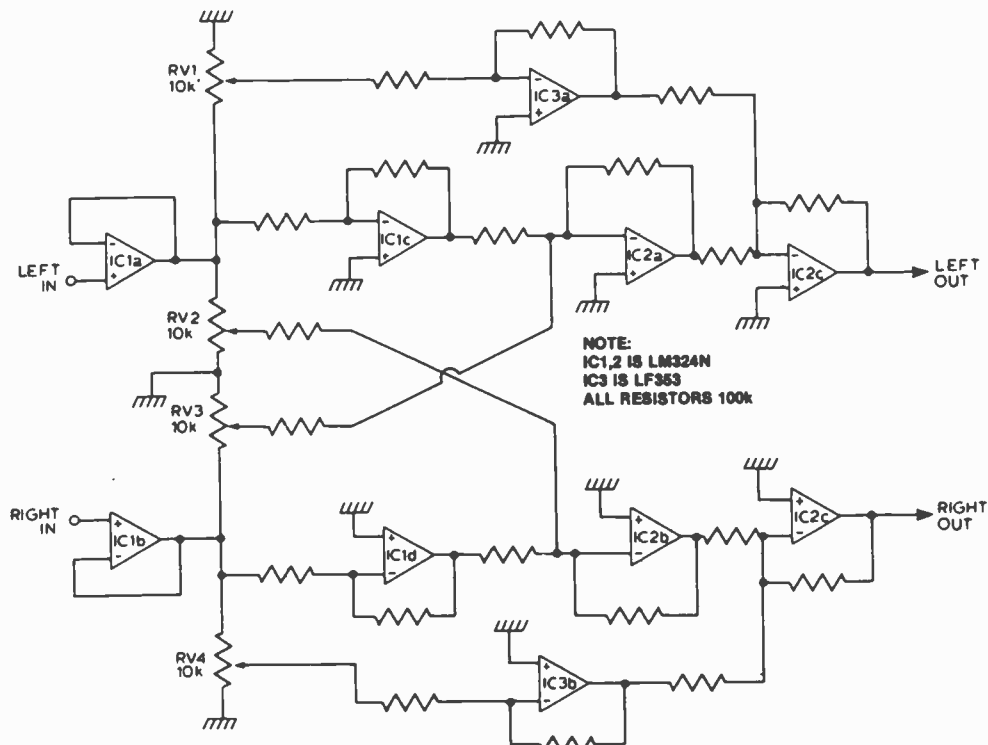

Precision Rectifying with the LM3900

A. Winsor

The LM3900 is different from most op-amps in that it is current differencing and operates from a single supply rail, which means that the inputs bias at one base-emitter voltage above ground. Hence standard techniques are not applicable as the diode would always be forward-biased. Two feedback paths are therefore provided:— R3 for DC stability, and R4 for the AC signal after C2 and R5 have filtered out the DC bias. When $R2 = 2 \times R3$ point A will be at $V_{cc}/2$, allowing the diode to be reversed at will. For large positive input returned to ground, input impedance equals R1, and voltage gain equals $-R4/R1$ since R4 is

made very much smaller than R3. C1 and C3 are DC blocking capacitors and determine the low frequency roll-off. Component values quoted are those used on the prototype and may be altered to suit individual require-

ments.

This circuit has obvious potential, especially in portable equipment where the 4 amps. in one package and single supply rail yield a more compact, more convenient unit. ●

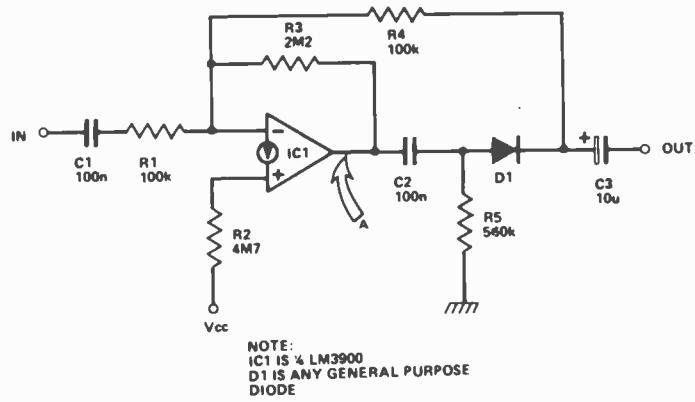

BCD to Analogue Converter

C. R. Poole

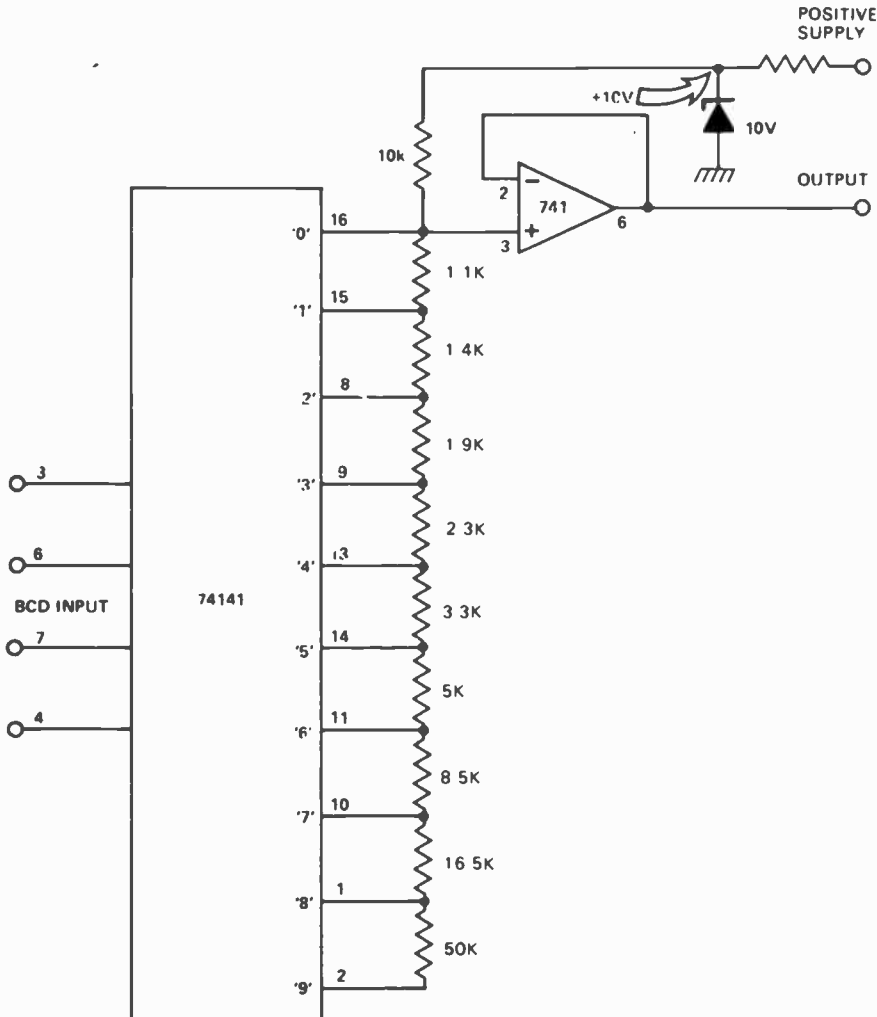

This circuit will convert four-bit BCD into a variable voltage from 0-9V in 1 volt steps. Only two ICs are used, both are readily available.

The SN74141 is a 'Nixie' driver, and has ten open-collector outputs. These are used to ground a selected point in the divider chain, determined by the BCD code at the input, and so produce a corresponding voltage at the output.

The accuracy of the circuit depends on the tolerance of the resistors and also the accuracy of the reference voltage. However, presets can be used in the divider chain, with correct calibration. The 741 is used as a buffer. ●

High Quality Tone Control

P. Mills

When designing a high quality pre-amp, the author was faced with the problem of designing a suitable tone control stage. Op amps such as the 741 are commonly used, but in

general have a poor slew rate, fairly high distortion and high noise when used in this application.

The circuit shown is based on an inverting op amp using discrete transistors to overcome the above problems. The output stage is driven by a constant current source, biased by a green LED to provide temperature compensation.

With the controls flat the unit provides unity gain, so the stage can be switched in or out.

The design is suitable for inputs between 100 mV and 1V0, and provides a good overload margin at low distortion for the accurate reproduction of transients. The usual screening precautions against hum should be carried out. ●

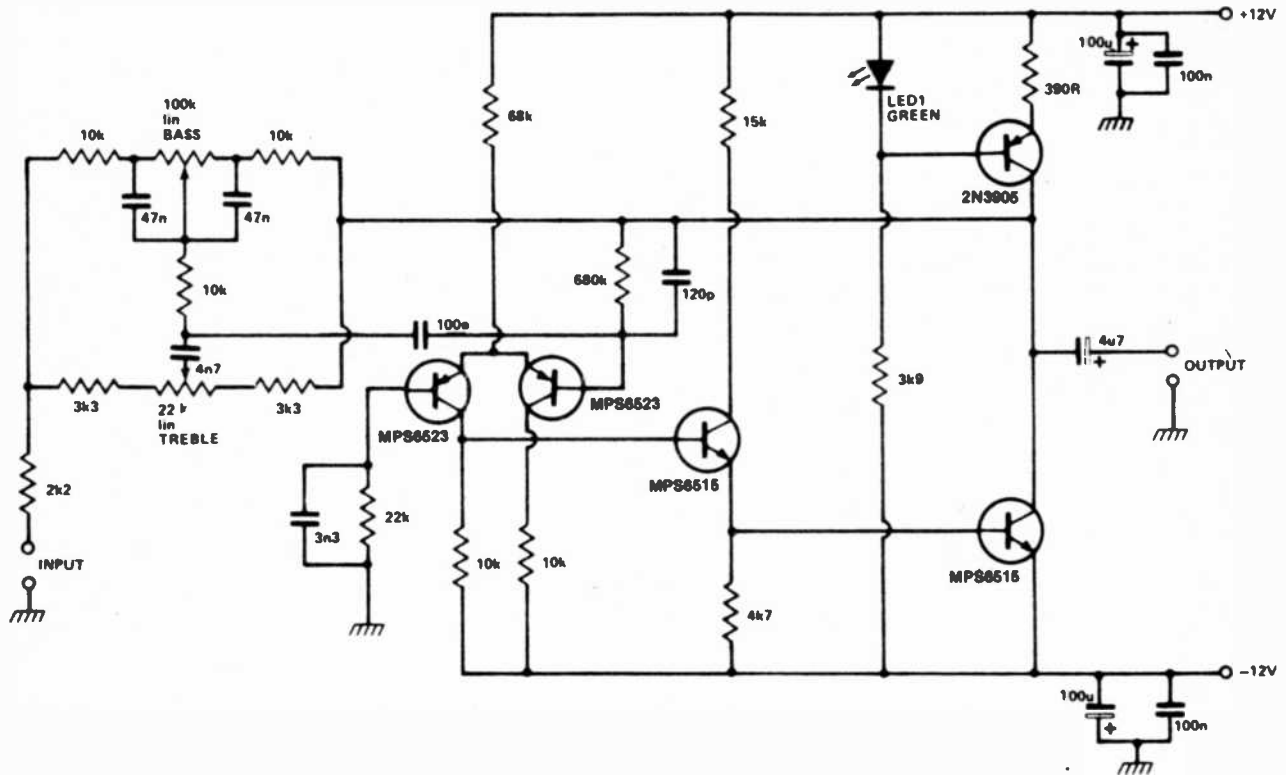

Variable Notch Filter

P. McChesney

In electronic music circuits there is need for an all-pass notch filter possessing a movable notch frequency. The circuit shown is capable of moving the reject frequency over a 10 kHz range throughout the full range of audio frequencies, the position of the notch being dependent on the voltage applied to the control input.

IC1 and IC2 are both all-pass filters possessing a flat frequency response well beyond the audio range, but having a phase difference between input and output signals of $0.5/CR$. This phase difference becomes 180 degrees, so that if the output and input are mixed, signal cancellation occurs i.e. the circuit is now working

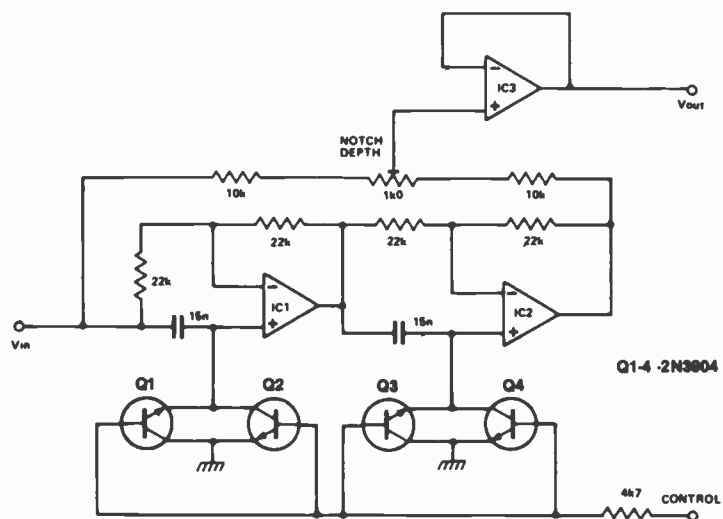

as an all-pass notch filter, letting through all frequencies except at $0.5/CR$.

The two transistor networks Q1, 2

and Q3, 4 act as voltage controlled resistors which allow the notch frequency to be moved when the control voltage is changed. ●

Battery Charge/Discharge Indicator

A. A. C. McInnes

This circuit is intended to monitor car battery voltage. It differs from other circuits in that it provides indication of the nominal supply voltage as well as low or high voltage. This makes it particularly useful for indicating deviation of the supply voltage from the nominal.

Three LEDs are used — red, yellow and green. Yellow indicates the nominal voltage and red and green indicate low and high values respectively. RV1 and RV2 adjust the point at which the red/yellow and yellow/green LEDs are on or off. Therefore, a wide supply voltage may be monitored.

The prototype has been installed in a car and set so that the red LED comes on at 11V7 and the green LED at 12V8. The yellow LED is on between these values. ●

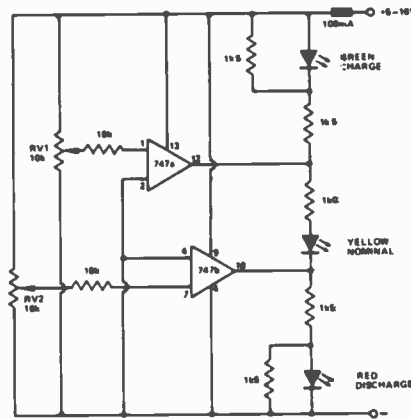
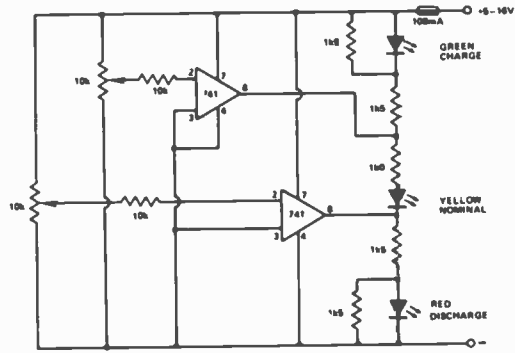

Supply Teltale

D. Shorthouse

Here is an idea for supply voltage monitoring, in the form of a voltage monitor for 12V supplies, indicating both over or under tolerance voltages. Using three LED's the user can see at a glance whether power is on, over-voltage or under-voltage.

This is achieved by means of a balanced bridge that uses zener diodes ZD1 and ZD2 in the bridge's opposite arms and back-to-back LEDs between the mid-points of the bridge arms, if the input voltage does not exceed the two zener breakdown voltages ($2 \times 6V8 = 13V6$) LED1 lights but above 13V6 LED1 becomes reverse biased and remains off. When

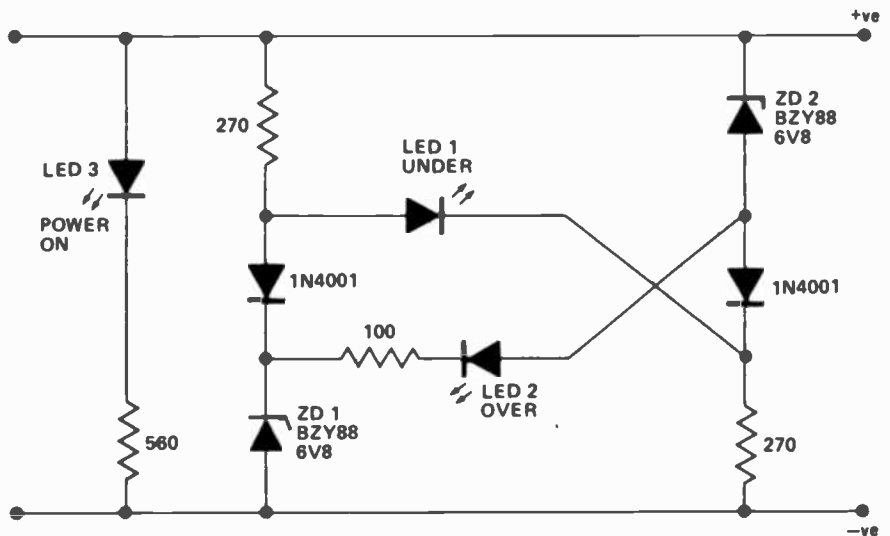

the input voltage increases to the extent that at the junction of ZD2, it exceeds the zener voltage of ZD1, plus the LED voltage of 1.6V, then

LED2 is turned on, with resistor 100R limiting the current through the LED. Note total drain of unit is about 50 mA. ●

Stereo Balance Meter

JP Macaulay

One of the more irritating aspects of owning a stereo system is the need to keep both channels in balance. What often sounds right when adjusting the controls turns out wrong when resuming one's normal listening position.

This circuit offers a solution to this problem provided that one's equipment is fitted with a stereo/mono mode switch.

IC1, a 741 op amp, is used as a differential amplifier. L and R signals are taken from across the speaker terminals. D1 and D2 rectify these and the resulting dc voltages are applied to the inputs of the IC.

The output voltage from the IC1 is applied to the LEDs D3 and D6 via the current limiting resistors R7 and R8, and the diodes D4 and D5.

These latter components allow the

LEDs to extinguish at extremes of the IC's voltage swings.

To use the indicator, switch the amplifier into the mono mode and adjust the the balance control until

both LED's are equally illuminated. The amplifier can now be switched back into stereo mode and will be found to be in perfect balance. ●

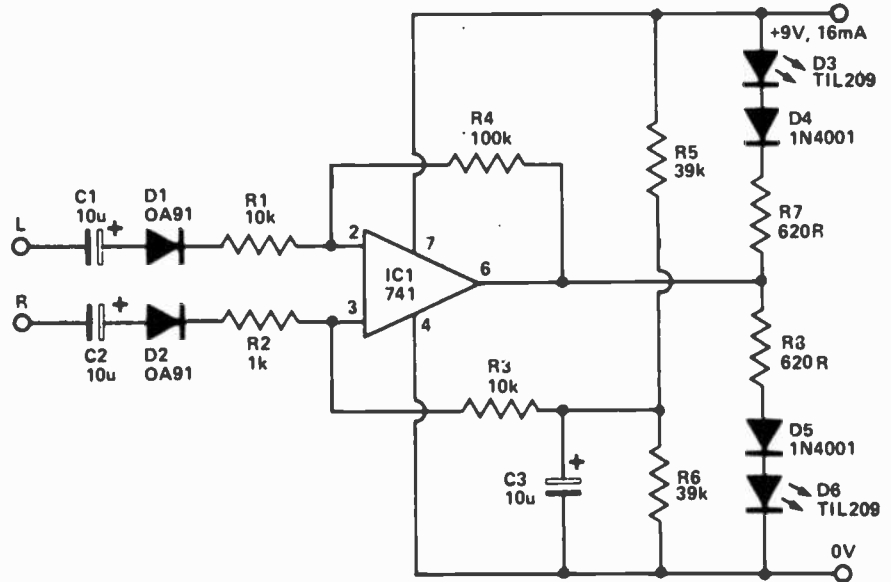

Speaker Power Indicator

J. Macauley

This circuit will indicate the peak level of an input signal applied to a speaker. It is primarily intended as a fail safe device when connected to an amplifier of higher power rating than the speaker.

The circuit is unique in that no separate DC power supply is required since the circuitry operates from the input voltage to the speaker.

R5 isolates the amplifier's output stage from possible fault conditions in the circuit. D1 to D4 full wave rectify the input signal and the resulting DC is used to supply the op amp.

The 741 is used as a comparator a reference voltage being obtained from across ZD3 and fed into the inverting input of the op-amp. The non inverting input samples the rectified input signal. When a peak is fed into the circuit the IC's output goes high and the led flashes. ZD1 prevents the LED turning on when the output of IC1 is

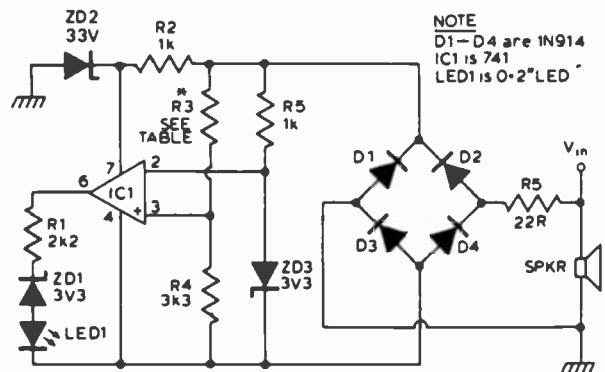

WATT/8Ω	5	10	15	20	25	30	35
R3 kΩ	5-6k	9-1k	12k	15k	16k	18k	22k

low due to the output being unable to go less than 1.5V above ground under these circumstances. ZD2 defines the upper limit of the op amp's supply voltage in the presence of large transients whilst R2 is the current limit resistor. It should be obvious that the level at which the led lights is dependent upon the value of R3. The accompanying table shows the value

required for this component for different input powers across an 8 ohm load. If different load values are to be used for the speaker the value of R3 can be determined from the equation,

$$R3 = \sqrt[1.4]{PR} - 3.3 \text{ k}\Omega$$

P = Pout

R = load in Ω ●

Slide Switch

C. Jordan

One of the disadvantages of slide pots is the unavailability of matching slide switches, as with rotary switches and pots, but slide pots can be given switching action by the use of this circuit.

Each analogue switch is only turned on when the comparators driving the respective EX-OR gate are in opposite states, i.e. when the voltage on the slider wiper is between the appropriate two preset voltages.

The example is a 4-way, 1-pole switch with off but anyway, any-pole switches can be made, using 741s as comparators if economic. A little mechanical ingenuity can provide click stops, if required.

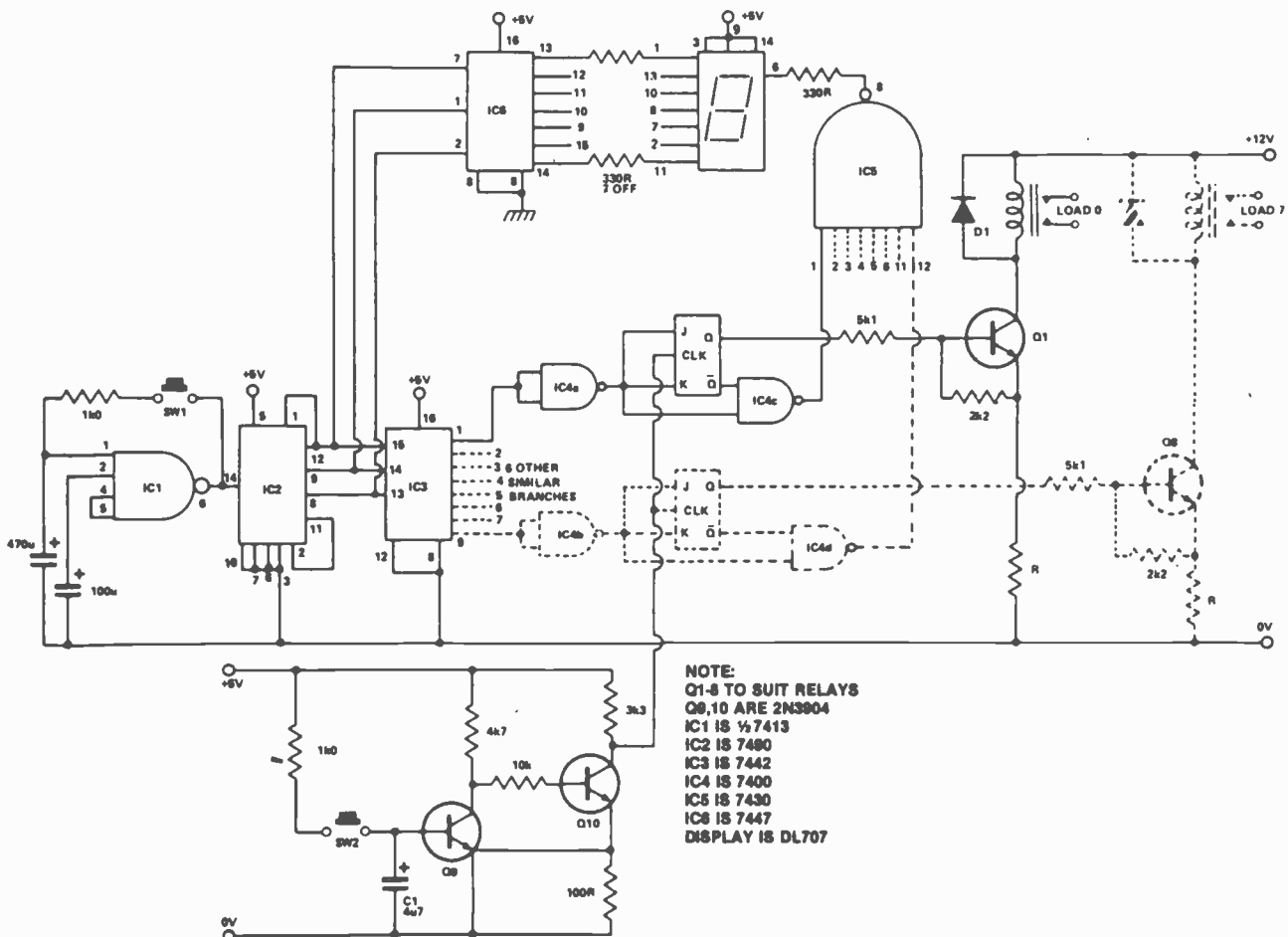
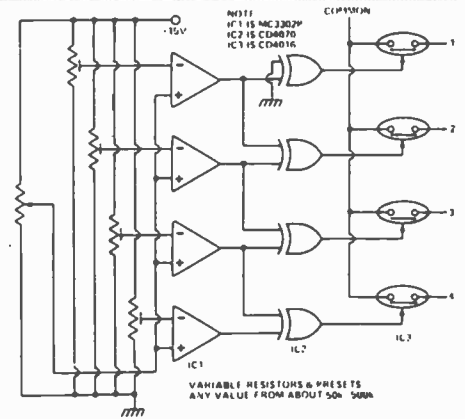

Electronic Switch

S. Yacu

This circuit provides remote switching of up to eight loads, and uses only two switches for selection. One switch is used to select the load to be controlled, the second controls whether the load is energised or not. If the state of one of the loads needs to be changed,

SW1 is depressed until the number of the load appears on the 7-segment display. The decimal point then indicates whether or not the load is energised. To change the state of the load, SW2 is depressed (pressing SW2 again will change the load's state again).

The circuit is based on a 7442, BCD-to-decimal decoder and a 7490 binary counter. When SW1 is closed,

the Schmitt trigger IC1 will oscillate and clock the 4-bit counter. This drives the 7-segment decoder/driver and the BCD decoder. The outputs from the BCD decoder are inverted and fed to the J-K flip-flops. When SW2 is pressed and released, a pulse will occur at the collector of Q10. The pulse will clock the selected flip-flop and activate or deactivate the relevant relay driver transistor (Q1-8).

Controller For Model Trains

E. Parr

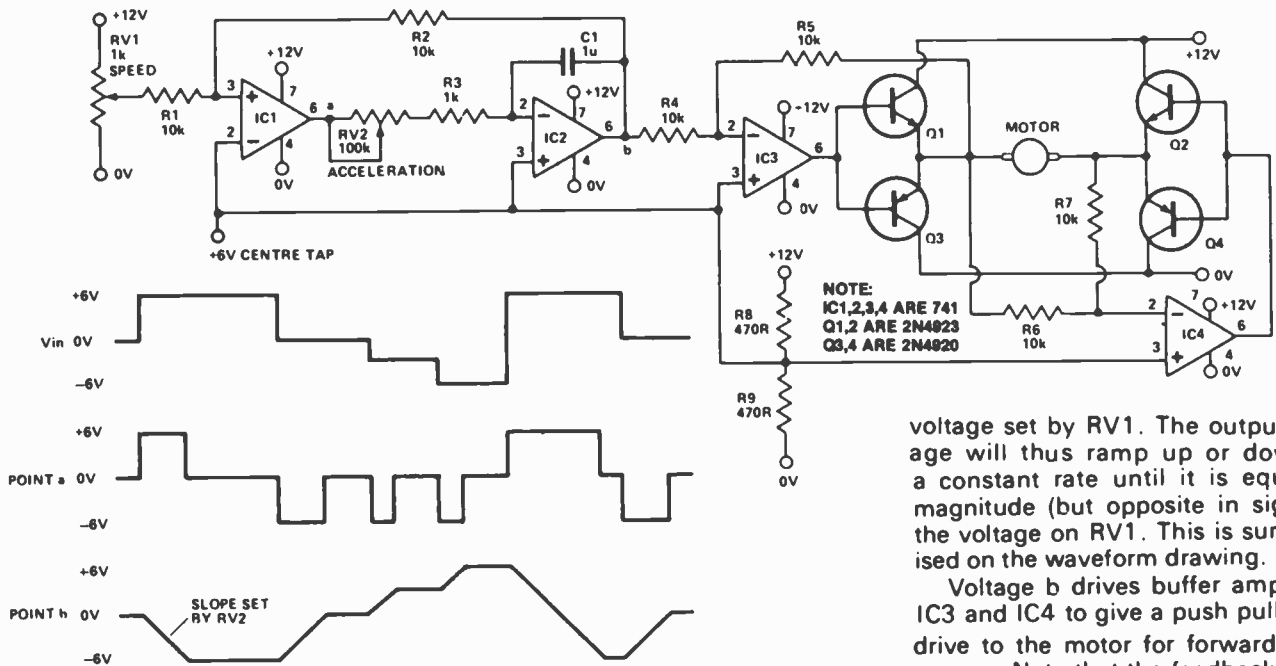

voltage set by RV1. The output voltage will thus ramp up or down at a constant rate until it is equal in magnitude (but opposite in sign) to the voltage on RV1. This is summarised on the waveform drawing.

Voltage b drives buffer amplifiers IC3 and IC4 to give a push pull 12 V drive to the motor for forwards and reverse. Note that the feedback resistors R5 and R7 are taken from the transistor emitters to compensate for the transistor V_{be} drops. The motor should have some current cut-out or limit connected in series with it to protect the transistors.

In use RV1 sets the speed, and RV2 the acceleration. It gives a very realistic train control, although much more skill is needed to stop a train accurately at a station platform. In this respect it is very close to driving a real train. ●

Most model railway controllers have the unfortunate characteristics of giving instant starts and stops to the train which would be very unnerving for the model passengers. The circuit described gives a steady acceleration or deceleration on speed changes, and the speed and acceleration controls do not interact.

The power supply is 12V split by R8 and R9 so it appears to the op amps as a ± 6 V supply. Voltages

in this description are referenced to the 6V centre tap. IC1 and IC2 together form a unity gain inverting amplifier, with the gain determined by R1 and R2. The slope of IC2's output, is determined by C1 and R3/RV2. The output of IC1 will thus take up one of three states: +6 V (hard positive), 0 V (balanced), -6 V (hard negative) dependent on the output voltage being more positive than equal to, or more negative than the

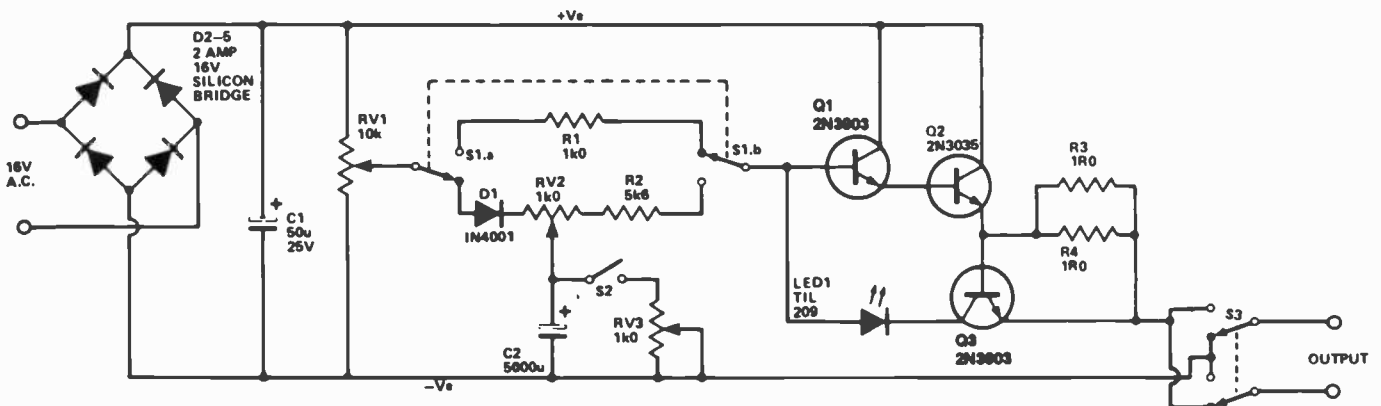

Train Controller with Inertia and Brake

M. Bright

D2-5 full wave rectifies the AC and C1 smooths the output. RV1 acts as a regulator controlling train speed.

Switch S1 switches in the inertia simulator (comprising D1, RV1, R2 and C2). S2 switches in the brake, the action of which is altered by RV3. RV2 controls the amount of inertia, so that the train can take as long as ten seconds before even moving. Q1,2 act as a Darlington pair, supplying current to the output. Q3 monitors the

output and provides short-circuit protection. When a short occurs, LED 1 lights up and the current into Q1 is reduced. Hence, the output is reduced. Two 1W resistors are used for R3,4 rather than a wirewound ½W resistor, which would cost more. S3 simply reverses the polarity and hence the train. ●

Anti-surge Voltage Regulator

A. Wey

This high gain voltage regulator with only two transistors has characteristics superior to those of the commonly used compound emitter-follower type.

The circuit was used in a 30 watt stereo amplifier which not only required a well regulated supply but also an output voltage that would rise slowly from zero volts when the system was first turned on. This slow application (about 2 seconds) to the power amplifiers allowed the 2000 μ F output capacitors

to charge without causing excessive collector current in the output transistors.

Typical regulator output impedance is 0.1 ohm.

Output voltage is expressed by:

$$V_O = V_Z - V_{BE1}$$

Output voltage rise time is expressed by:

$$T = R_B C_1 \ln(1 - V_Z/V_I)$$

Some digital systems require a preset turn on sequence for their power supplies. By setting appropriate R_B/C_1 values, the circuit's output rise time can be set to provide this sequence or delay. ●

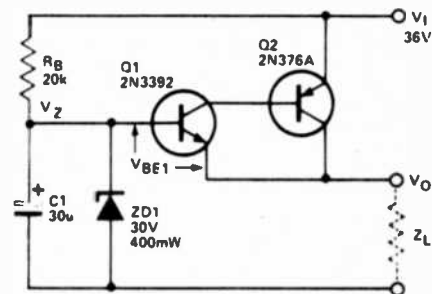

Simple Dual Power Supply

L Swann

This circuit offers a cheap and simple way of obtaining a split power supply (for op-amps etc.), utilising the quasi-complementary output stage of the popular LM380 audio power IC.

The device is internally biased so that with no input the output is held mid-way between the supply rails.

R_1 , which should be initially set to mid-travel, is used to nullify any imbalance in the output. Regulation of V_{OUT} depends upon the circuit feeding the LM380, but the positive and negative outputs will track accurately irrespective of input regulation and unbalanced loads.

The free-air dissipation is a little

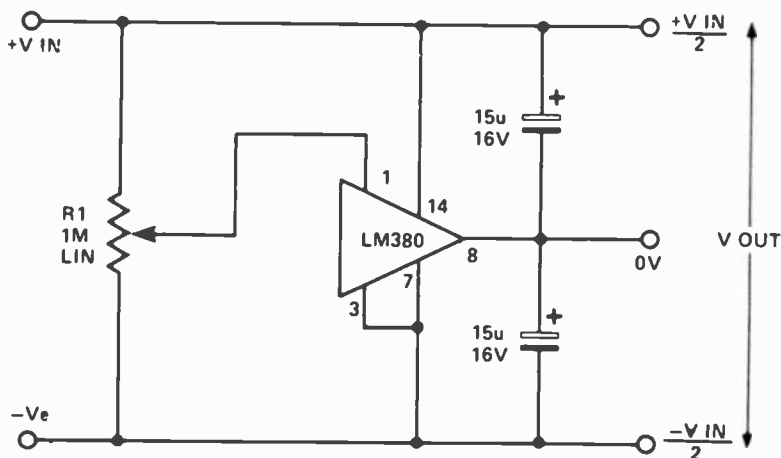

over 1 watt, and so extra cooling may be required. The device is fully protected and will go into thermal shut-down if its rated dissipation is exceeded, current limiting occurs if the output current exceeds 1A3.

The input voltage should not exceed 20 V. ●

Mini-power Inverter

J. S. B. Dick

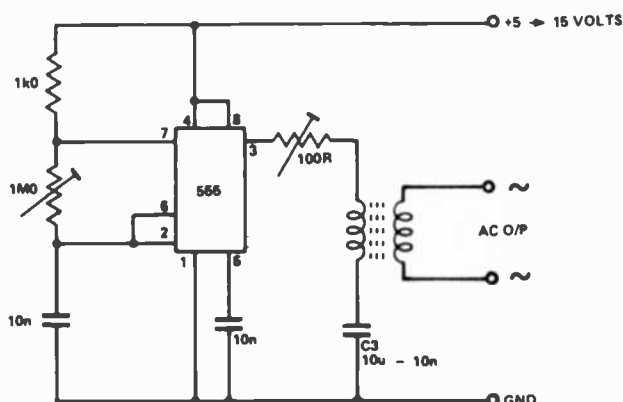

Many home-grown projects require a high voltage, low current source. The simplest and safest means of providing this is by an inverter. The circuit described here is versatile, efficient and easily capable of providing power for portable Geiger counters, dosimeter chargers, high resistance meters, etc.

The 555 timer IC is used in its multivibrator mode, the frequency being adjusted to optimise the transformer characteristics. When the output of the IC is high, current flows through the limiting resistor and the primary coil to charge C_3 . When the output goes low, the current is reversed. With a suitable choice of frequency and C_3 a good symmetrical output is obtained. ●

External Input For Micros

P. F. Tilsley

This simple circuit provides a micro with an 8 bit switch/external signal input port. The state of the switches controls the byte read by the micro, but any totem pole TTL signal applied to the external input socket over-rides the signal from the corresponding switch. The value of the resistor is not as critical. The circuit is shown for only one bit. ●

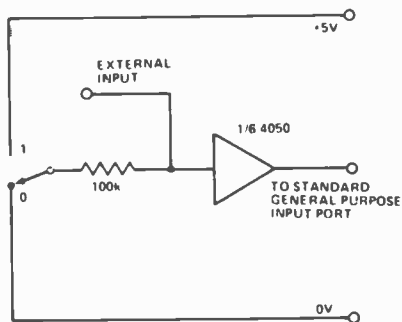

Seven Segment Decoder

Yap Sue-Ken

As not all of the possible seven segment codes are used, only 5 lines are required to define the ten numerals without ambiguity. The logic circuitry required to recover the other two segments is as shown in the figure.

In the case of microprocessor controlled displays this can save two valuable I/O pins. ●

DECIMAL DIGIT	INPUT SEGMENTS					OUTPUT SEGMENTS	
	a	b	e	f	g	c	d
0	1	1	1	1	0	1	1
1	0	1	0	0	0	1	0
2	1	1	1	0	1	0	1
3	1	1	0	0	1	1	1
4	0	1	0	1	1	1	0
5	1	0	0	1	1	1	1
6	1	0	1	1	1	1	1
7	1	1	0	0	0	1	0
8	1	1	1	1	1	1	1
9	1	1	0	1	1	1	1

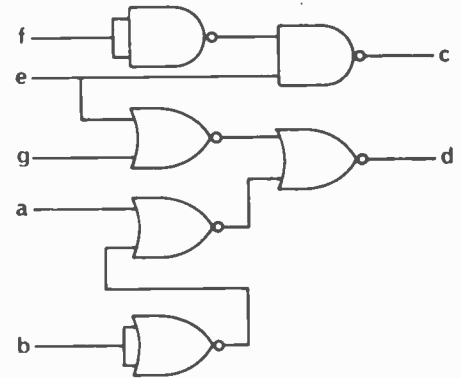

NOR GATE = CD4001 OR SN7402
NAND GATE = CD4011 OR SN7400
POSITIVE LOGIC: '1' = ON

$$c = e.f.$$

$$d = (g+e) + (a+b)$$

Keyboard/display sound converter

K G Reid

This circuit can be used in several modes: It can provide quantized feedback (a distinct improvement over the normal single 'bleep') from the key actions made on a calculator-type keyboard. It can be used to give a sound translation of a digital display, or completely replace the display when sound would be a better communication medium.

The keyboard or display information (a maximum of 16 bits with one 16-line 74150 multiplexer) is translated into a series of 16 high or low frequency tone pulses, corresponding to the 'high' or 'low' logic state of the 16 bits.

The circuit illustrated was used in conjunction with a digital multimeter, requiring three 4-bit words for the digits and three additional bits for over-range, negative and decimal point. Thus, 15 lines only were required, the 16th being used for resetting.

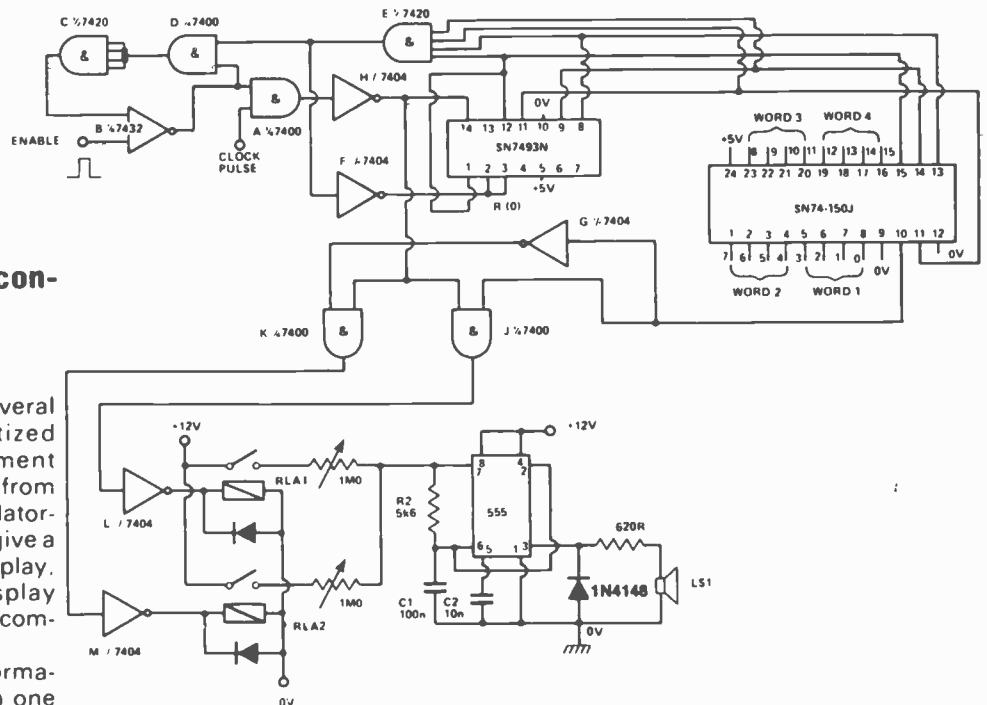

The 15 bits are latched on to the inputs of the 74150 multiplexer. Presentation of the enable pulse results in a logic '1' appearing at the output of gate B, allowing clock pulses to pass via gates A and H to the 7493 counter. Gates B, E, D and C form a latch which remains 'set' until all 15 bits have been sampled. As each bit is sampled, the inverse state appears at the multiplexer output, opening gate

J or K and thus operating one of the two reed relays. As a count of 1111 appears from the counter, the output of F drops low, resetting the latch and counter. The operation of either relay results in a tone appearing at the loudspeaker (or earpiece), the tone frequencies being set (1.2 kHz maximum) by the 1 megohm pots. The tone pulse length is governed by the clock rate. ●

Telephone Amplifier

J. P. Macaulay

One of the most frustrating things in life must be to wait in line whilst one's wife converses (nags?) on the phone. What makes the matter worse is that only one side of the conversation is heard. The circuit here will at least enable you to hear what's going on at the other end of the line.

The signals are picked up by the coil L1, a 5 mH RF choke taped to the side of the set. Q1 operates in the common base mode with the output signal appearing across the collector resistor, R4. The output stage consists of two complementary transistors fed from the output of IC1 and included in its feedback loop.

The gain provided by the IC is made variable by the inclusion of R6 and this should be adjusted for a comfortable output level. D1, D2 in conjunction with R7 provides the small but necessary bias required by the output pair.

The interstage capacitor provides a 13db point in the bass end at 300Hz.

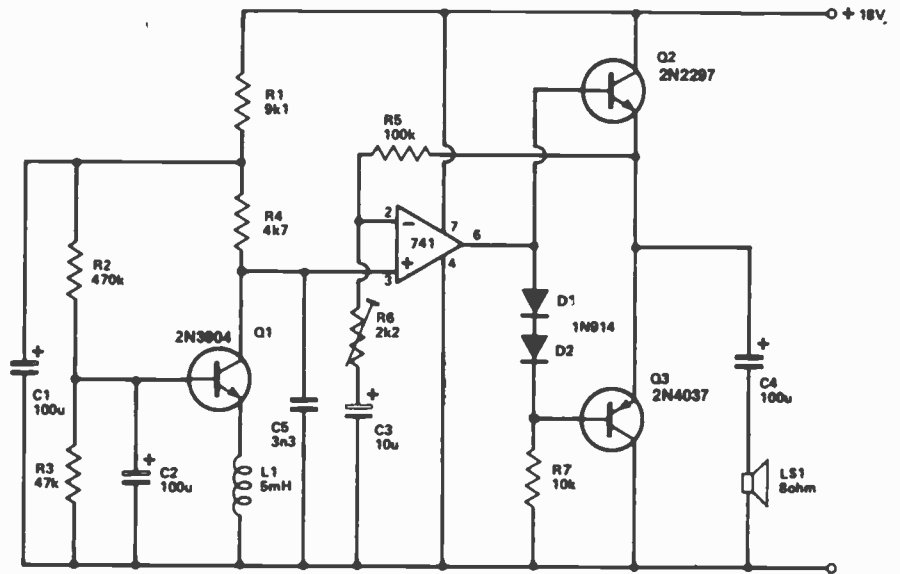

C5 defines the upper frequency limit of the circuit at 3 kHz, the best bandwidth for maximum intelligibility.

Quiescent current consumption is less than 5 mA so the circuit can be easily run from a pair of 9V batteries in series. ●

Novel Loudspeaker Coupling Circuit

P. Mills

In most amplifier designs the speaker is fed by a high value capacitor to provide DC blocking, but this may

result in a heavy switch-on surge, as the capacitor charges up.

An alternative approach, which is worthy of experiment, is shown in the diagram here. The ground side of the speaker is connected to the junction of two equal high value capacitors (1000u is typical) across the supply.

The amplifier output voltage will be at $V+/2$, and so will the voltage

across C1 (if C1 and C2 are equal); so as the supply voltage builds up, the DC voltage across the speaker will remain zero, eliminating the switch-on surge. C1 and C2 will also provide supply smoothing. The circuit is shown with the LM380, but could be applied to any amplifier circuit, providing that the DC voltage at the output is half the supply voltage. ●

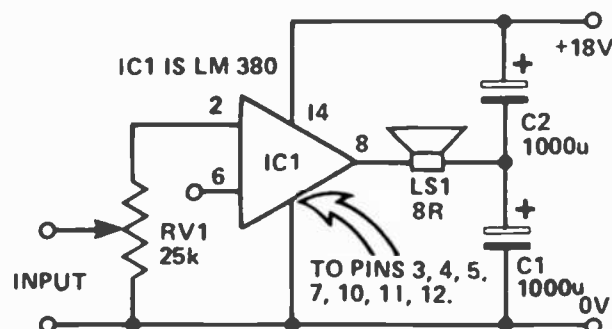

NPN-PNP Indicator

F Read

The first 2 inverters IC1a and IC1b form a multivibrator running at approximately 2 kHz. The next two inverters buffer the multivibrator outputs, which then go to the collector and emitter of

the transistor under test.

The signal applied to the base of the transistor is always in phase with the collector so the transistor, whether PNP or NPN, will always be turned fully on every half cycle.

When an NPN transistor is being tested the collector will always be near 0V and when a PNP transistor is being tested

the emitter will always be near 0V.

The last two inverters detect which terminal is held at 0V and drive the appropriate LED via the current limiting resistors R4 and R5.

The six inverters needed are all contained in a single IC package - the SN7404. ●

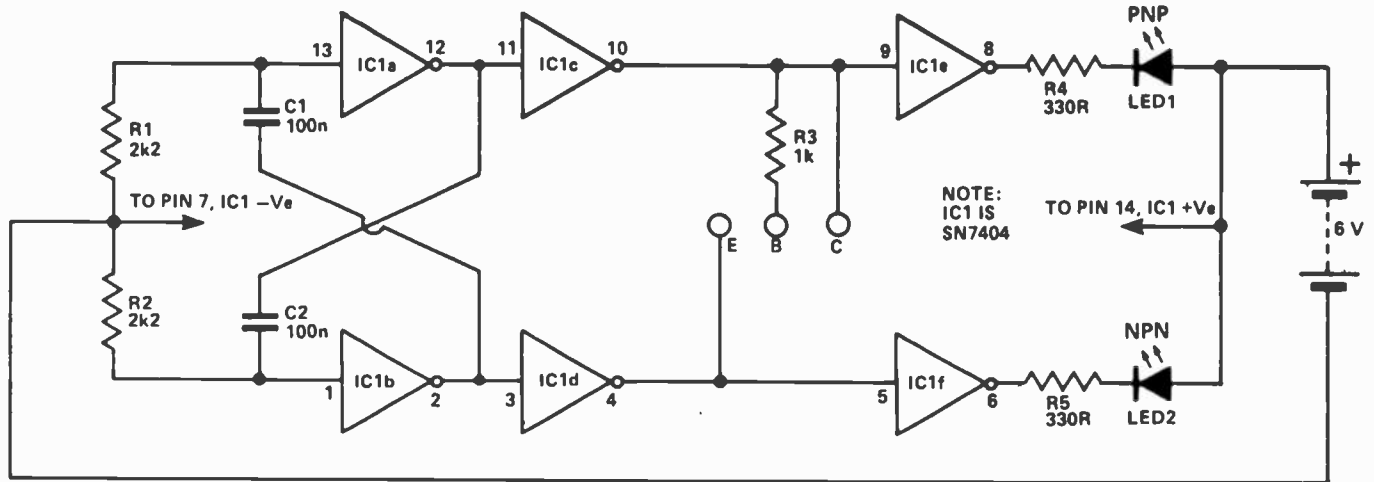

Measuring Micro-ammeter Resistance

When it is required to measure the unknown resistance of a micro-ammeter, then an ordinary multimeter on the necessary ohms range will send too much current through the meter coil, with the chance of causing damage. To avoid this, set up VR1 to give full scale deflection on the meter. Then shunt the meter with VR2 and adjust so that the meter reads exactly half scale. Remove the measure VR2, which, to a good degree of accuracy, will be equal to the meter resistance. ●

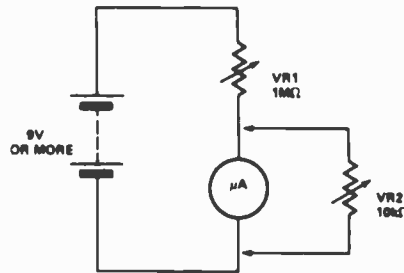

More Ohms Per Volt

R. Soar

This circuit is designed to improve the performance of a low cost 1k/volt multimeter on the 0.5V DC range.

The 2N3904 emitter follower provides an impedance transformation with a gain of 250 or more, so that the effective input impedance of the multimeter is now 250k/volt. The LED provides a fixed reference voltage for the set zero control, which compensates for the voltage drop across the transistor. ●

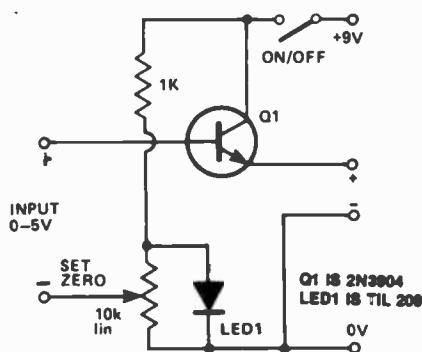

Meter Protection With Zener

A zener diode may be used to protect a meter from overloads without greatly reducing its accuracy. The zener is connected in parallel with the meter and under normal circumstances has such a high impedance that the accuracy of the meter is not affected. If the meter is overloaded, the diode breaks down and the meter is shunted by about 10 ohms, preventing damage to the bearings and pointer of the movement.

Breakdown voltage of the zener should be about 1.5 to three times the full scale deflection voltage of the meter.

The zener also prevents the meter from reading on reversed voltages and thus gives dual protection. ●

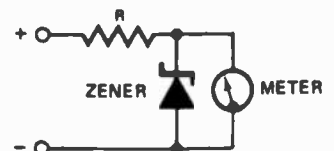

Low Current Touch Switch

D. Ian

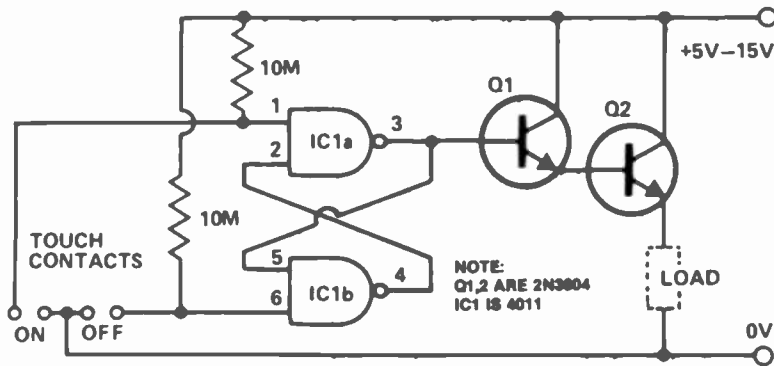

The cost of many CMOS ICs is now lower than a mechanical on/off switch. Using only one half of a 4011, plus a couple of general purpose transistors, a touch operated switch can be constructed which is ideal for many battery powered projects.

Assuming that the inputs to the remaining half of the 4011 are tied low, the current drawn in the off state

is almost negligible and battery life is hardly affected.

Touching the 'on' contacts with a finger brings pin 3 high, turning on the darlington pair and supplying power to the load (transistor radio etc). Q1 must be a high gain transistor, and Q2 chosen for the current required by the load circuit. ●

Improved SPST Switch Flip-Flop

D. J. Manford

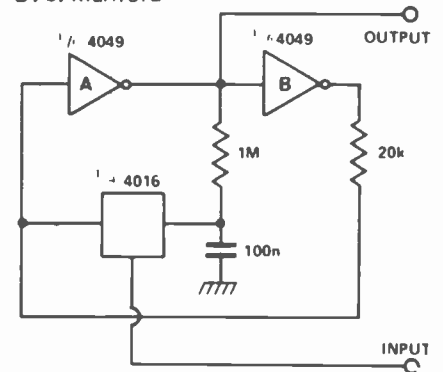

This circuit has the advantage it can be driven by an input referred to earth — logic outputs or pushbuttons.

When the input to the 4016 goes high it connects together the input to A, and C. This 'flips' the latch.

The 20k resistor between the output of inverter B and the input of A is needed as the 4016 cannot pull the output of inverter B down directly. ●

Sequence Switch

B. Willis.

The circuit right was designed to enable three relays to be individually switched by their appropriate buttons but such that only one relay can be energised at any one time. When any one relay has been energised the corresponding collector falls to near zero volts, which is connected to the base of the remaining two transistors; now if another relay is attempted to be energised the base of its transistor will remain bottomed and keep the relay off. The reset button must be pressed before another relay can be energised. The diodes ensure that each transistor is kept off until the voltage applied to the base exceeds 0.6 V.

The flip-flops and push buttons can of course be replaced with standard switches if momentary action is not required.

The circuit was used to control three radio transmitters where it was important that two should not be

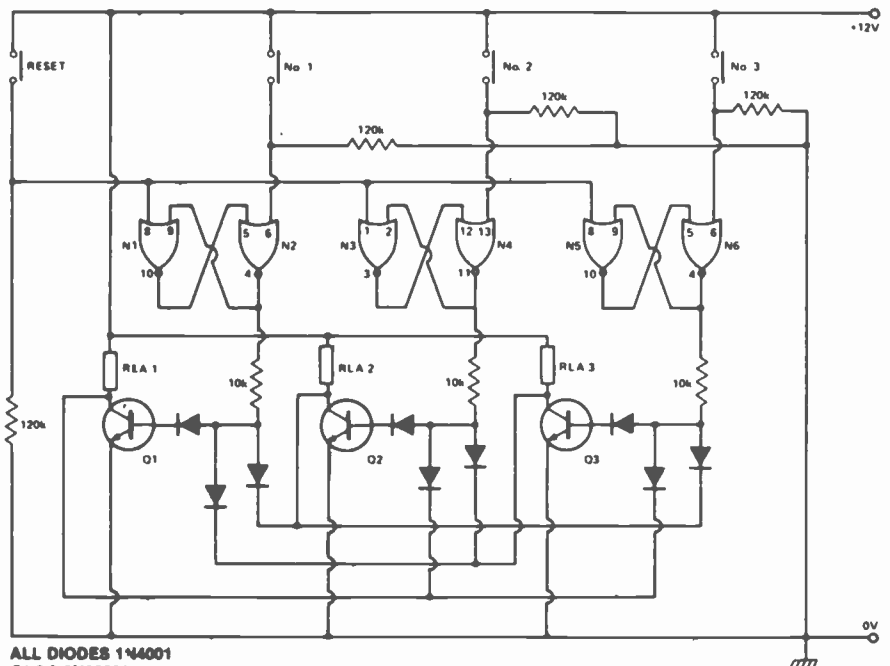

ALL DIODES 1N4001
Q1,2,3 2N2222A
N1—N4 CD4001
N5,6 1/2 CD4001
RELAYS 120R OR ABOVE

switched on at the same time. The circuit lends itself to further applications; for example, switching various

inputs into an amplifier where it can replace the self-cancelling selector buttons. ●

Tape Recorder Controller

P. B. Cordes

The circuit shown enables a solenoid operated tape recorder to be left to record a programme unattended. It was originally designed to be used on a Revox A77, in conjunction with a digital clock based on the CT7001, but could be adapted for other recorders, clocks, or mechanical time switches. The clock is set to switch on one minute before the programme starts, and switch off as it finishes.

When the clock contacts close, RLA is operated via Q2 and Q3, applying power to the receiver and recorder. At the same time C1 is discharged, and C2 applies a negative pulse to pin 2 of the timer, which triggers, discharging C4. The output of the timer goes high for one minute, allowing time for the recorder and receiver to warm up. As the timer output goes low, C4 charges through Q4 momentarily, operating RLC which starts the recorder.

At the end of the preset time the clock contacts open, discharging C2 through Q2 and Q3 which delays RLA from dropping out by approx-

imately 5 seconds. As the clock contacts re-open C1 charges through Q1, operating RLB opening the normally closed stop contacts for a short period, stopping the recorder. After the 5 second delay has elapsed, RLA opens, removing power from the equipment.

RLB and RLC may have light contacts, but RLA must be a heavy duty AC rated type. Ideally the digital clock should be crystal controlled, to eliminate short term AC frequency fluctuations. The numbers shown in brackets are the appropriate pin connections on the 10 way remote control plug of a Revox A77. ●

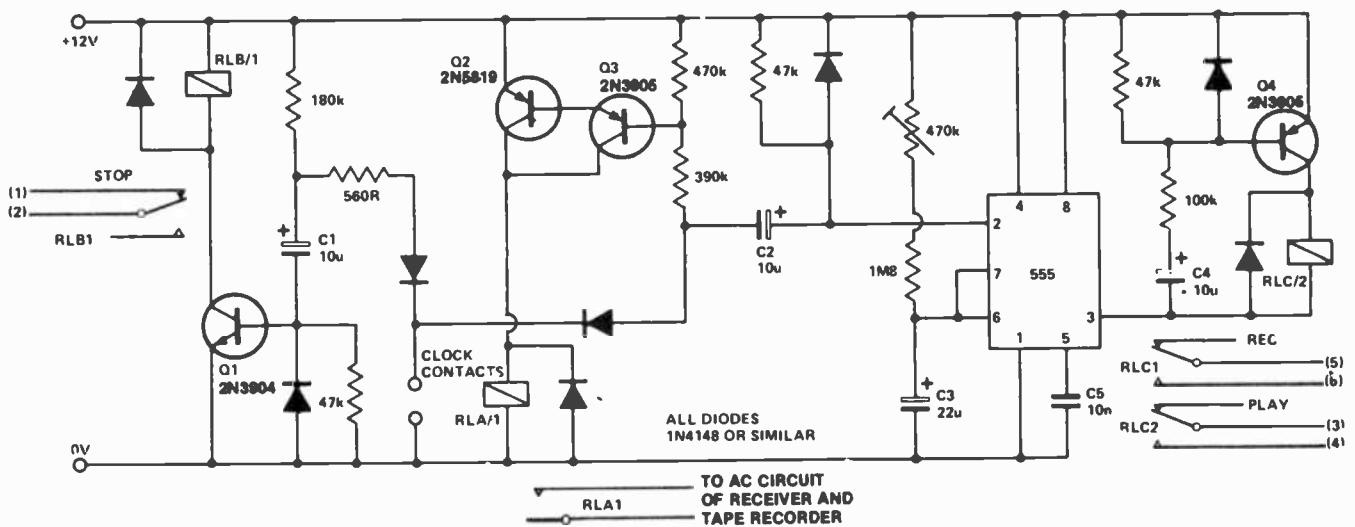

Unijunction Pulse Stretcher — Door Bell Extender

D. Wedlake

The circuit presented is a practical monostable timer which was designed to extend the ringing time of a door bell. It can be useful in cases when the bell push button might not be engaged long enough to attract attention, though it could be used in many other applications.

When the push button is closed the thyristor will switch on delivering power to the unijunction transistor timing circuit and energising the relay, the contacts of which are used to control the bell circuit. At the same time, capacitor C2 quickly charges to the load voltage potential via R3. After a time interval given approximately by $0.8 C1 R1$ (about 6 seconds in this case) the unijunction transistor will fire and the corresponding output pulse which is coupled to

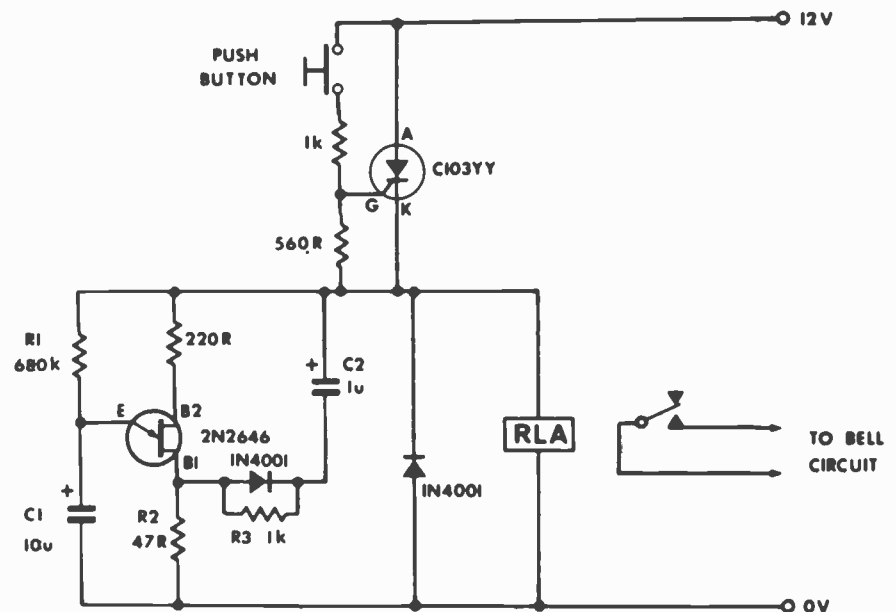

the cathode of the thyristor via C2 will put the thyristor in reverse bias switching it off. With these values the relay will become energised for at least 6 seconds. ●

The Multi-zener

R. N. Soar

This is an application of zener diodes based on the binary system. In the example shown three zener diodes are used 3 V, 6 V and 12 V (ie. 3.0 V, 6.2 V and 12 V) plus three S.P.S.T. switches. In the "on" position of a switch the diode is short circuit. In the 'off' position the diode is in circuit. Thus the effective diode by suitable

operation of the switches is 3, 3+6, 3+12 etc. ie. 3,6,9,12,15,18,21 volts. By the addition of the next in the

series 24 V and another S.P.S.T. switch the range is 3,6,9,12,15,18,21,24,27, 30,33,36,39,42,45 volts. ●

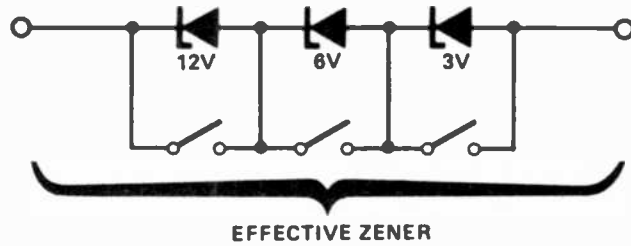

Increasing Power Rating of Zener Diodes

There are occasions when a higher power Zener diode is required and one is not readily available. Here is a circuit which with the aid of a power transistor can increase the power rating of any Zener diode.

By simply shunting the base-collector junction of the transistor by a low power Zener and if the gain of the transistor at the operating current

exceeds 30, then across the collector-emitter terminals the device will behave as a Zener diode.

If the original diode is a 250 mW device then the power dissipation of the system will be $30 \times 250 \text{ mW} = 7.5 \text{ watts}$. It should be noted that the Zener voltage thus obtained will be 0.7 V higher than the diode rating.

Thus if originally a 6.8 V diode was used then the new voltage will be $6.8 \text{ V} + 0.7 \text{ V} = 7.5 \text{ V}$. Thus for a power of 7.5 W, the maximum permissible current will be $7.5 \text{ W} / 7.5 \text{ V} = 1 \text{ A}$. ●

ZENER DIODE POWER BOOSTER

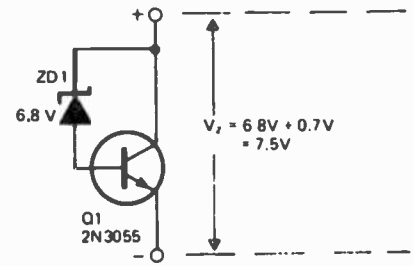

Overvoltage Protection for Logic

E. Parr

With the introduction of integrated circuit voltage regulators it is very easy to make power supplies for logic circuits. Unfortunately it is only too easy to blast a board of TTL by letting the voltage rise above 7V as could happen if the common line came off a regulator IC or the sense lines came off a commercial power supply.

The described circuit was designed by the author as a "last ditch" defence after a disconnected sense line allowed a commercial 5V supply to rise to 9V and blast 50 TTL chips. The circuit is simple to add onto any power supply, and it is the author's intention to build it "on board" with any future system containing more than about

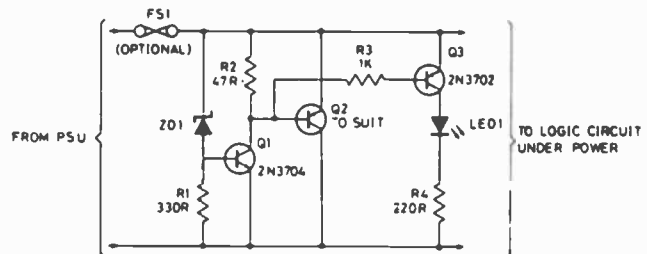

10 TTL chips

Zener diode ZD1 senses the supply, and should the supply rise above 6V Q1 will turn on. In turn Q2 conducts clamping the rail.

Subsequent events depend on the source supply. It will either shut down, go into current limit or blow its supply fuse. None of these will damage the TTL chips.

The rating Q2 depends on the source supply, and whether it will be

required to operate continuously in the event of failure. Its current rating obviously has to be in excess of the source supply. If the source supply is likely to shut down, LED1 should be added to indicate the circuit has operated.

The circuit will operate in approximately 500 nS space, so it will also protect the logic from transient spikes which a normal regulator would not block. ●

Programmable Gate

P. Mead

The Programmable Gate is a gate which converts an AND gate to an OR gate by applying a logic '1' on the function input.

The logic design uses 8 x 2 input NAND gates. The number of gates may be reduced by replacing the 5 NAND gates enclosed by the dotted line, with a 2 input exclusive OR, such as the TTL 7486. ●

FUNCTION INPUT	INPUTS		OUTPUT
	A	B	
0	0	0	0
0	0	1	0
0	1	0	0
0	1	1	1
1	0	0	0
1	0	1	1
1	1	0	1
1	1	1	1

AND FUNCTION

OR FUNCTION

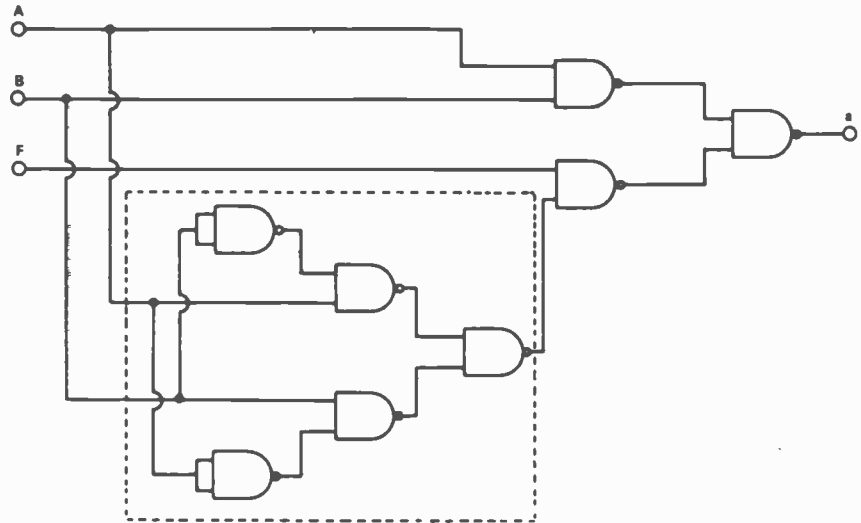

Cheap Down Counter

AF Bush

This circuit, when presented with a 4 bit binary number in the range 0000–1001 will present the nines complement of that number at the output.

Connecting the circuit between a 7490 and a 7447, will, instead of the usual up count, provide a display which counts down from nine.

This provides a useful alternative to the expensive 74192 when only a down count is required. ●

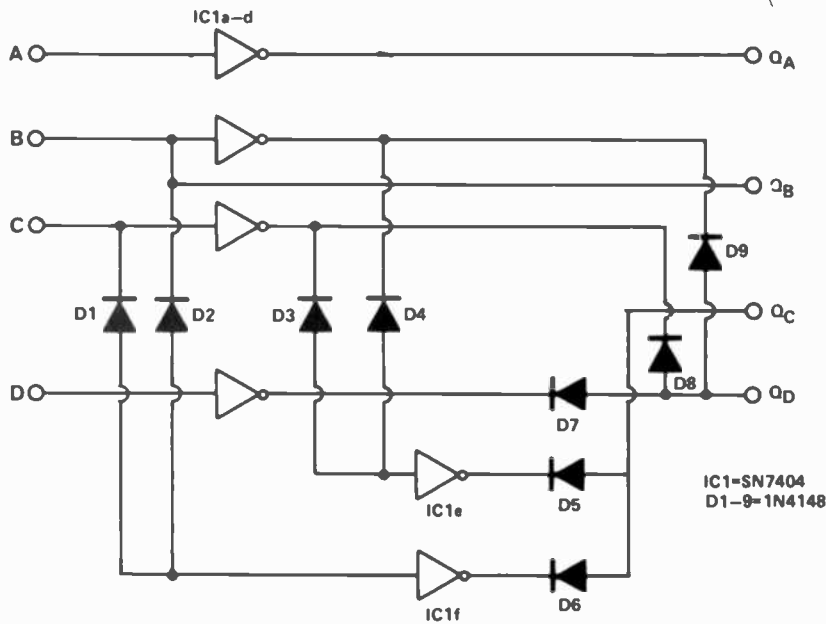

BCD COUNT	INPUTS				OUTPUTS				COMPL- EMENT
	D	C	B	A	q _D	q _C	q _B	q _A	
0	0	0	0	0	1	0	0	1	9
1	0	0	0	1	1	0	0	0	8
2	0	0	1	0	0	1	1	1	7
3	0	0	1	1	0	1	1	0	6
4	0	1	0	0	0	1	0	1	5
5	0	1	0	1	0	1	0	0	4
6	0	1	1	0	0	0	1	1	3
7	0	1	1	1	0	0	1	0	2
8	1	0	0	0	0	0	0	1	1
9	1	0	0	1	0	0	0	0	0

$$Q_A = \bar{A}$$

$$Q_B = B$$

$$Q_C = (B \cdot C) \cdot (\bar{B} \cdot \bar{C})$$

$$Q_D = \bar{B} \cdot \bar{C} \cdot \bar{D}$$

reaching
the unreachable



1981
International
Year
of Disabled
Persons

Unicef Canada



Give...
THE HEART FUND

Geiger Counter

A Wheatley

Although the circuit is inexpensive and simple it is just as sensitive as many commercial devices. The important part is the geiger tube and this will probably cost about \$15. It needs a high voltage supply which, in this case consists of Q1 and its

associated components. The transformer is a low current 120V 505 and is connected in reverse. The secondary is connected into a Hartley oscillator, the base bias being provided by R1. RV1 is connected to control the voltage to the Geiger tube. A device to double the voltage is included because otherwise the voltage would still be insufficient to drive the tube. This comprises D1, D2, C4

and C5. This also rectifies it and smooths it. It is very important that C4 and especially C5 are of good quality and have low leakage. RV1 should be set so that each click heard is a nice clean one because over a certain voltage all that will be heard is a continuous buzz. The high voltage section is perfectly safe although if touched it will give a slight shock. This is unpleasant but quite harmless ●

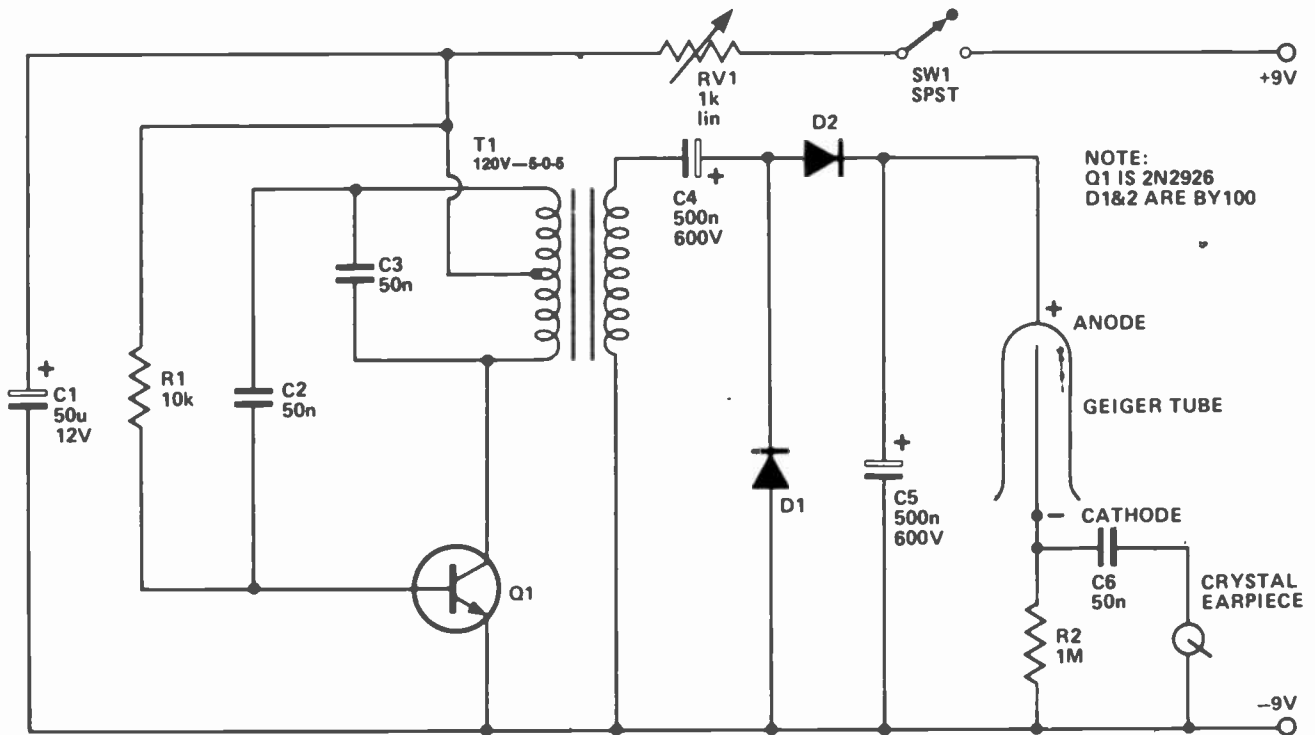

Capacity checker

D. Chivers.

This bridge was originally designed to find values for odd, unmarked or undecipherable capacitors. While not being of great accuracy, it does give a very good indication as to the value of the capacitor.

A known value component is placed across terminals A-A, polarity is not important, but polarised capacitors must not be used, and cannot be tested. The capacitor under test is inserted in B-B, the unit is switched on and VR1 rotated until a maximum value reading is obtained on meter M1. At this point, a reading is taken from the calibration scale on the pot which initially must be calibrated in ratios, ie:

1000:1, 100:1, 10:1, 1:1, 1:10, 1:100 etc. The unknown value is then calculated from this reading. Original calibration is from known values.

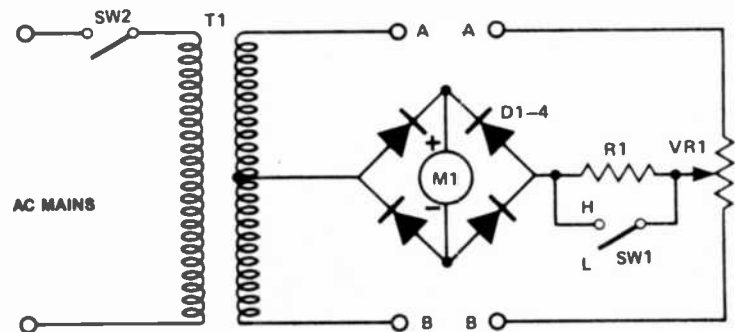

	H	L
10n	X	
100n	X	X
1u		X

To increase the range of the circuit switch SW1 has been included to bypass R1. Since the frequency used is 60 Hz from the AC line, ranges are limited; if

another source were used, driving an audio output transformer, the versatility of the unit would then be further increased. ●

TV Game Resurrection

S. Rice

Now that the novelty of TV games has worn thin and most of the units are gathering dust in the corner reserved for other five-minute wonders, here's a chance to add new spice to leisure

time. The circuit is an oscillator clocking at about one cycle per 4 seconds. This switches the ball angle "randomly" making the game unpredictable and difficult. Also this prevents the ball from getting stuck and bouncing back and forth from the bats and boundaries. Do not use B suffix CMOS except for Schmidt trigger and gates. ●

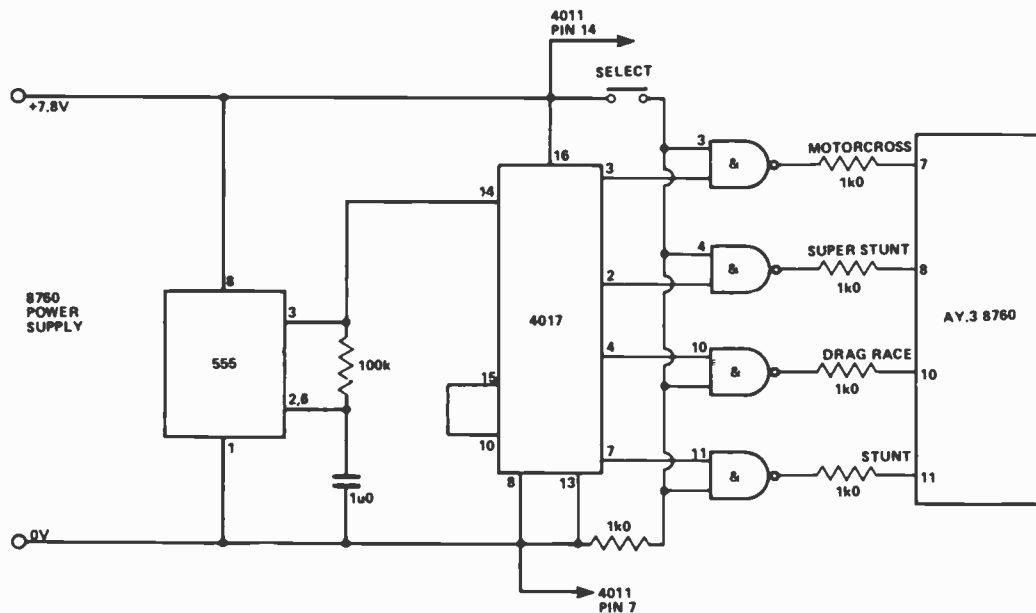
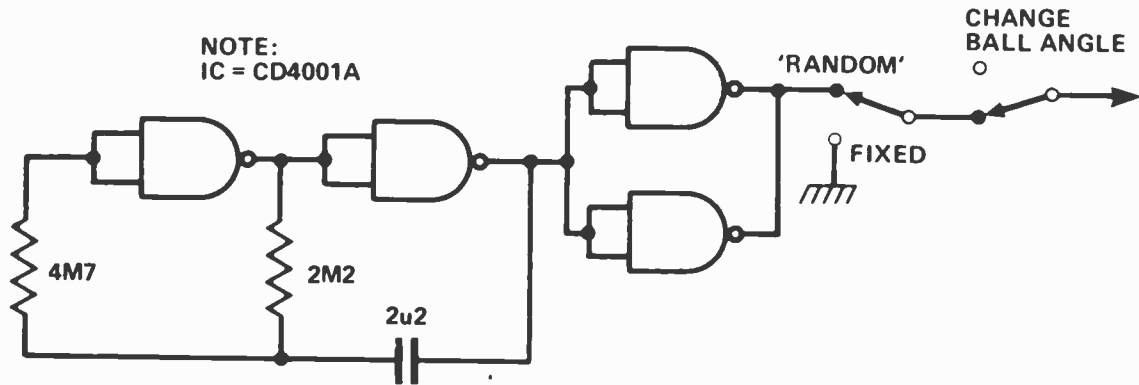

Auto Select for AY 3-8760 Stunt Cycle

S. D. Lang

Constructors of the Stunt Cycle TV game may wish to economise on switches and panel space by trying this circuit for game selection. Originally, game selection was by grounding the relevant game select pins. This requires four push switches; extravagant on switches

and panel space. In this circuit, three of those switches are made redundant in a novel game selection method. The only switch required is a push switch now entitled 'game select'. Upon depression of this switch, all four games are displayed upon the screen, one a time. When the playfield of the required game is displayed, the game select switch is released and play continues.

The circuit works from the power supply of the AY 3-8760. Circuit operation is straightforward, as follows: the 555 and associated com-

ponents form a pulse generator of period approx. 1 second. This pulse is applied to the input of the 4017 decade counter. Every pulse received advances the high output by one, so the high pin is 3,2,4,7 in that order. When pin 10 becomes high, the reset circuitry is operated. If the select switch is open, the output of all the NAND gates is high, so the game is played. When the select switch is closed, the selection circuitry may now operate, and the outputs of the NAND gates go low in turn, selecting the appropriate game. ●

Porch Light Controller

R. Johnson

This circuit controls a light bulb, so that its brightness is approximately inversely proportional to the surrounding lighting conditions. This may be useful for a porch light, which would begin to switch on at dusk, reaching full brightness late in the evening. In

the morning it would switch off again.

The dimmer consists of Q1, TH1 and their associated components. Q2 provides synchronisation pulses. RV1 effectively alters the time of day at which the light switches on and RV2 alters the maximum brightness of the bulb.

The LDR is connected to a differential amplifier whose output voltage rises when the resistance of the LDR is above about 600 kilohms (corresponding to dusk) and reaches a maximum when the resistance is about six megohms (corresponding to complete darkness). ●

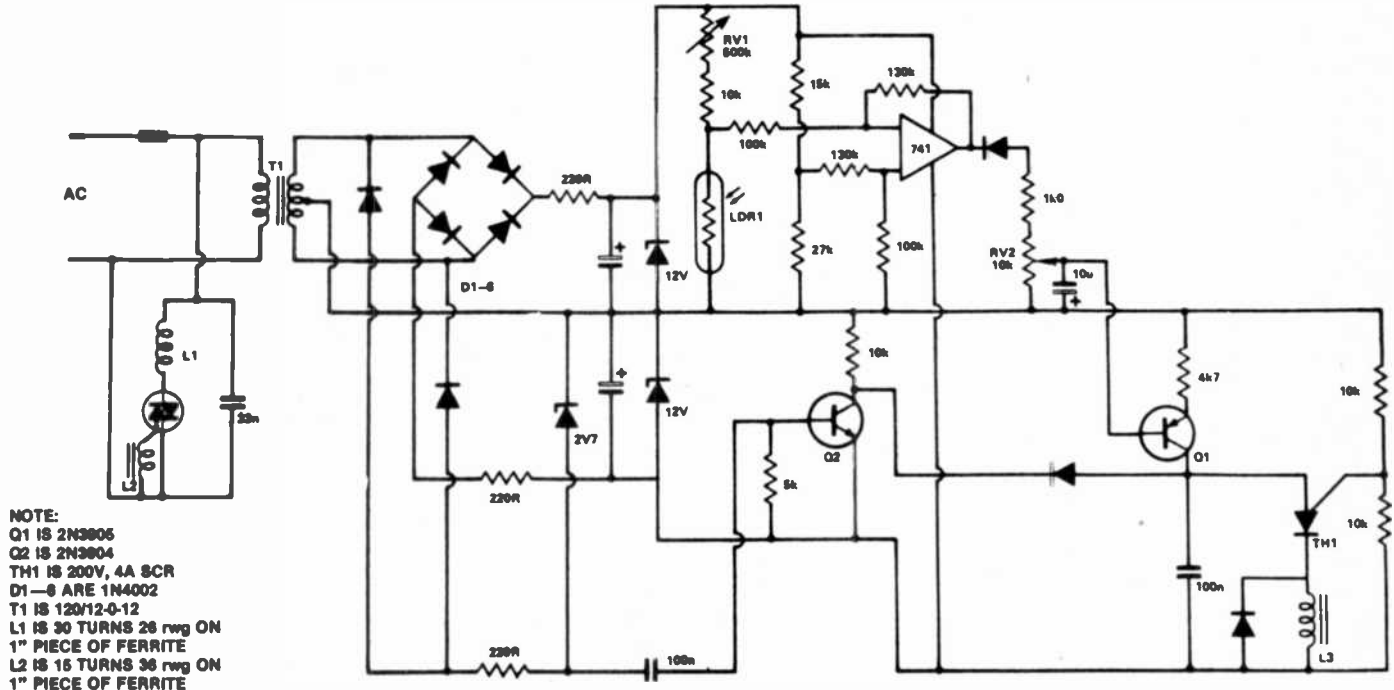

Guitar Sustain Unit

S. D. Maistre

The sustain to be described here holds the output at a constant level over a wide range of input levels. It was designed for use with electric

guitars and has a maximum effect with the guitar pick-up volume full up.

The principle employed is that of an AGC, whereby the circuit output is monitored by a DC voltage follower which controls the gain of the VCA through which the signal passes. The advantages of this

circuit are that, unlike many such devices, it does not use opto-coupling which draws too much current for battery powered equipment; it produces no audible distortion; components are easily obtained — and cost is low.

Construction method is not critical. ●

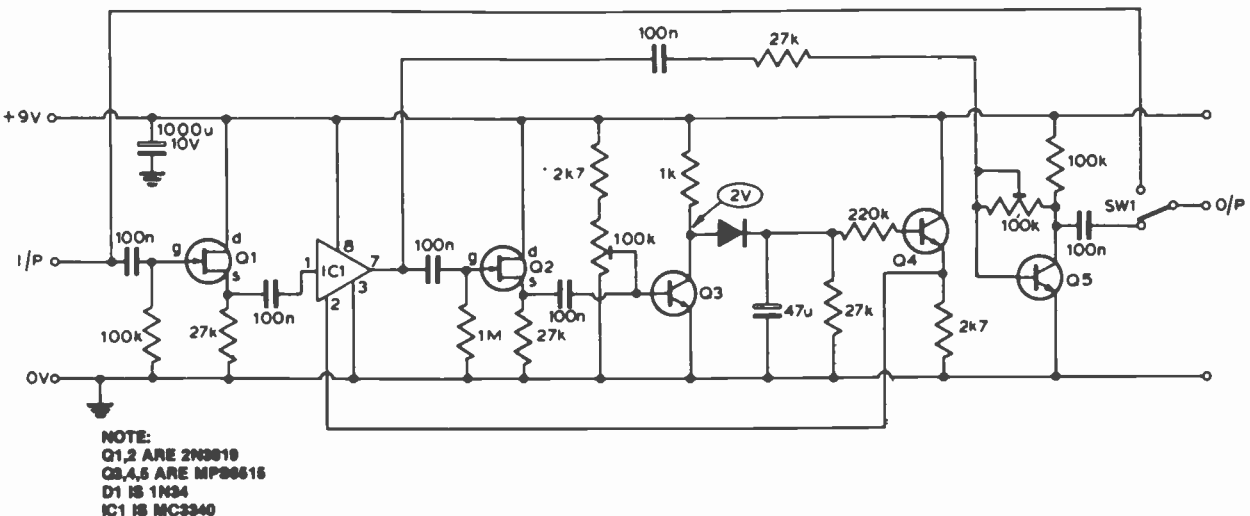

Digital Bike Speed

B. Lemming

This unit provides push-bike speed measurement between zero and 100 km/hr or 100 mph! The circuit is based on the Sintel MOS counter block, which counts the pulses from the photo transistor Q1.

These pulses are provided by fixing 18 aluminium 'barriers' to the wheels. Q1 was an unmarked type in the prototype, in a TO 18 package. This mounts in an old felt-tip pen case opposite the lamp so that the barriers interrupt the beam in operation. The counter operates whilst PB1 is pressed, but latches after a time determined by RV1 or RV2. IC1 and associated components. IC1 forms a square-wave oscillator with variable mark-space ratio. The time for which pin 3 is taken low is determined by RV1/RV2 — this enables the counter.

The speedo accuracy is determined by the accuracy of setting of controls RV1 and/or RV2. ●

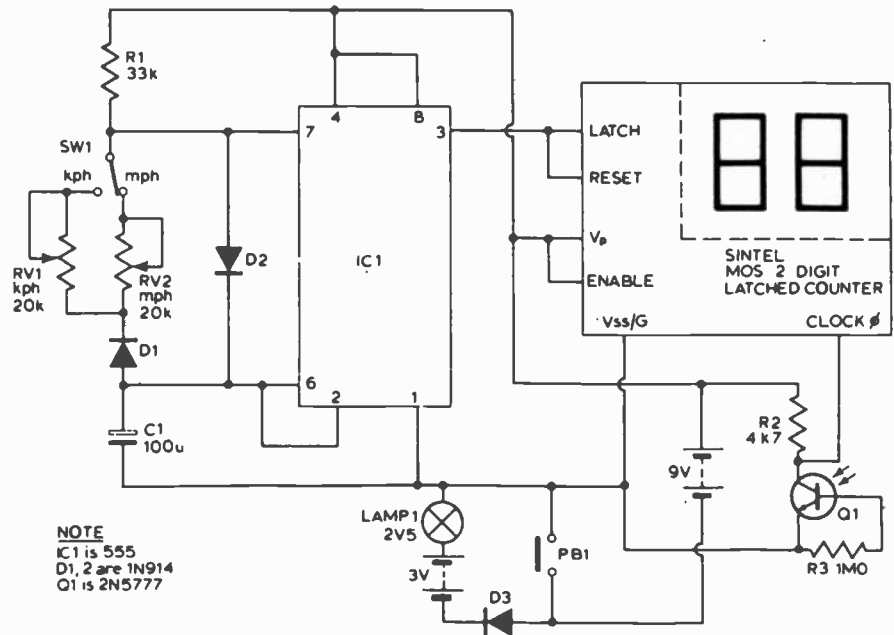

Car Voltage Regulator

C. Gibbons

This circuit provides solid state control of battery charging. The field winding of the dynamo is initially energized via the ignition light as in a conventional system. Current flowing down the WL lead passes through Q1 to the F lead then to the field coil. Once the engine has started, current from the dynamo passes through D2 to Q1. The ignition light goes out because the WL lead rises in voltage to that of the battery. Current also passes through D5 to the battery. The battery voltage is sensed by IC1, which is wired as a comparator, once the voltage of the non inverting input, rises above that of the inverting input (Held at 4.6 volts by D4) the output goes high. Current then flows through D3 and R2 to the base of Q2 turning it on. This then pulls down the base of Q1 turning it off and cutting off the current to the field winding. The output from the dynamo then drops bringing down the battery voltage. This holds the battery voltage con-

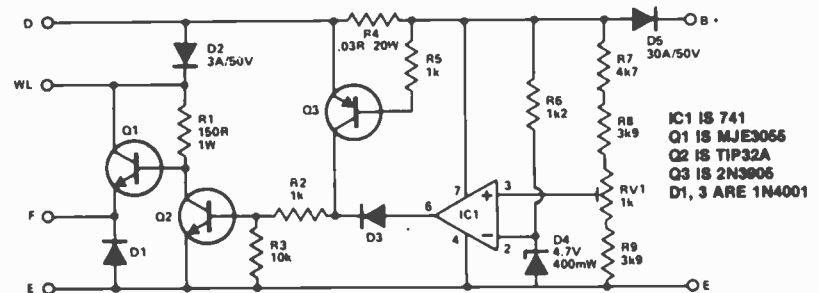

stant. The battery voltage is adjusted by RV1 to approximately 13.5 volts.

Under cold weather starting the battery voltage drops very low. Once the engine has started the internal resistance of the battery is also very low, which would draw excessive current from the dynamo causing possible damage. To limit the current R4 is inserted in the main power lead from the dynamo, the resistance of R4 is chosen so that at maximum current

(Typically 20 amps) 0.6 volts is developed across it, this then turns on Q3. When Q3 turns on current flows from the power rail through R2 to the base of Q2 turning it on, which in turn, turns off Q1 and cuts off current to the field winding. The output from the dynamo then drops.

No changes have to be made to the existing wiring. The circuit can be housed in an old regulator box, Q1, Q2 and D5 should be mounted on a heat sink. ●

Car Lamp Failure Warning

A. Taylor

Many lamp failure warning circuits indicate only when both bulbs are working or only when the lamps are on. The circuit shown solves this and has the added effect of not dimming the lamps as some failure circuits do.

A suitable gauge enamelled copper wire is wound around an SPDT reed switch until a certain number of turns are found that will only open the contacts when both lamps are working. If either or both of the lamps should fail, the contacts remain closed and the thyristor is triggered, illuminating the lamp failure indicator until the ignition switch is turned off or the circuit is reset. ●

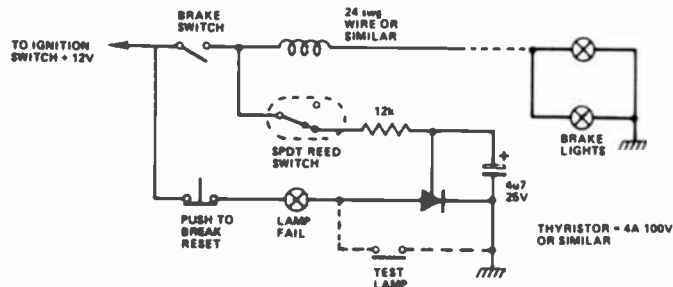

Ice Warning and Lights Reminder

D. Chivers

This simple device will tell a driver if his lights should be on and will warn him if the outside temperature is nearing zero, by lighting a LED and sounding a buzzer.

The unit's action is self explanatory; VR1 adjusts sensitivity for temperature, VR2 for light. Both thermistor and LDR should be well protected. Most high gain NPN transistors will work and the experimenter's junk box will almost certainly hold some. ●

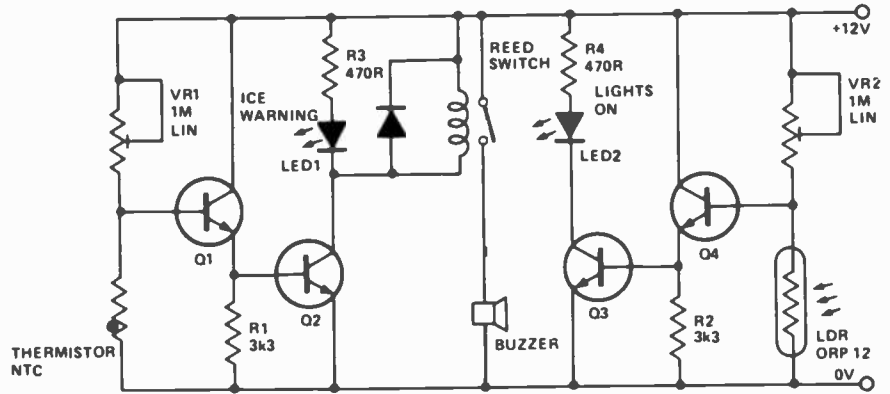

Car Lights Reminder D. J. Rayner.

Many circuits to warn motorists that they have left their headlights on after switching the engine off have appeared in the past. I feel this circuit is an improvement over many of these in that it requires no switches, and it is only necessary to make three connections to the car's electrical system.

If the ignition is switched off while the lights are on, an audible warning is sounded for about ten seconds. This tone is produced by NAND gates IC1/2, IC1/3 and IC1/4. Operation of this oscillator is inhibited by an '0' on the gating input of IC1/2. This in turn corresponds to a logic '1' present at the input to IC1/1 while the ignition switch is on, supplying a high logic level to IC1/1, the oscillator is thus disabled.

When the ignition is switched off, the output of IC1/1 goes high, enabling the oscillator. At this stage C2, which has until now been charged up via D1, begins to discharge via R4. While the voltage on C2 is high, the gating input of IC1/4 allows oscillator operation,

however as C2 discharges, this action is inhibited. This occurs after about ten seconds.

Power for the circuit is provided by R3 and ZD1 from the vehicle's 12 V rail. ●

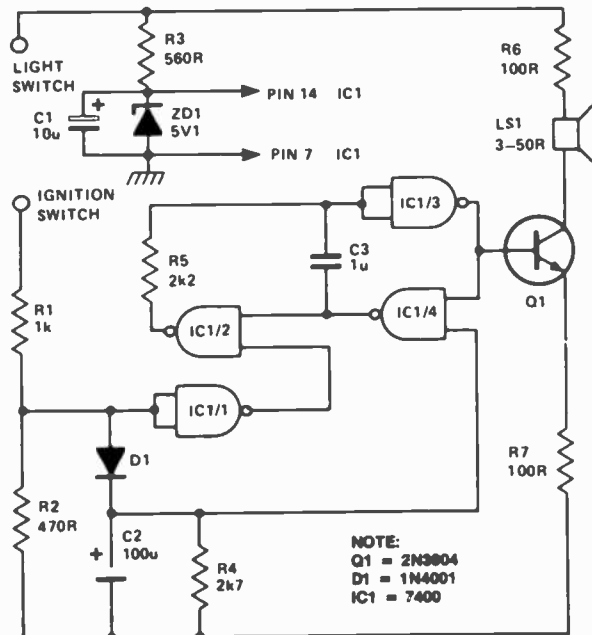

NOTE:
Q1 = 2N3904
D1 = 1N4001
IC1 = 7400

Seven to binary with a special bit!

T. Nash.

This circuit, which uses only four TTL or CMOS ICs, converts a seven segment digit to binary, with indication of the 'special' characters: minus, E (exponent or overflow), and optionally blank. Both types of 6, 7 & 9 can be handled, and for ease of manipulation blank is encoded as binary zero.

For a calculator — microprocessor interface the 'X' output should be fed to the sign position for ease of testing: this method is more economical in time and memory space than testing for a specific binary value. The extra bits needed for the equivalent ASCII character could also be added at the interface.

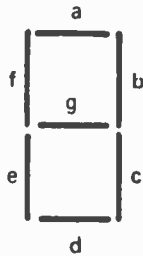

The segment identification shown above is the standard seven segment lettering system and so should be familiar to most constructors.

The letters also refer in this case to the circuit diagram and the truth table given below on the right hand side of the page.

No power supply connections are shown for the circuit as this depends on which version, TTL or CMOS is constructed.●

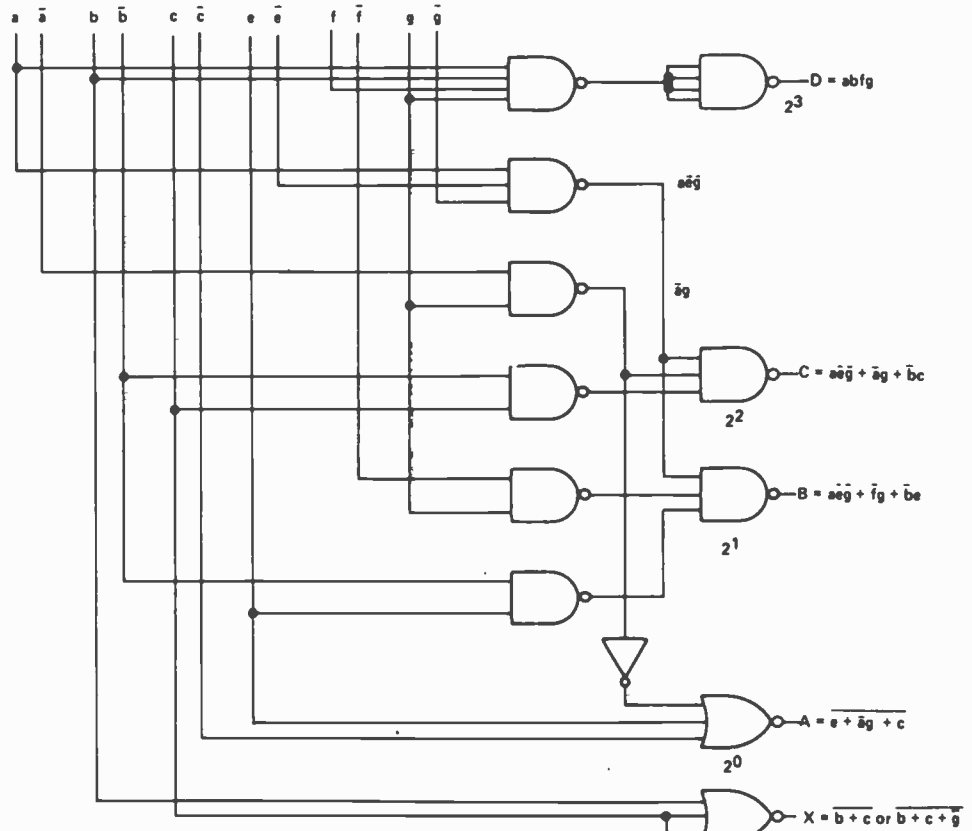

COMPONENTS:

- 1 x 7400/4011
- 1 x 7410/4023
- 1 x 7420/4012
- 1 x 7427/4025/4000 (4000 SHOWN)

FIRST VARIATION SETS X FOR BLANK, SECOND DOES NOT.

• FOR TTL AND 4025 VERSIONS, use 3 input nor.

555 Micro Input Reset

P. Davidson

When dealing with a microprocessor system, there are several features which place requirements on the duration of their input leg reset. These signals are usually negative (in the author's experience) and so, with the use of a 555, these requirements can be filled reliably (as opposed to the normal flip-flop debounce circuit). The circuit saves on logic used to invert the normal 555 monostable action.●

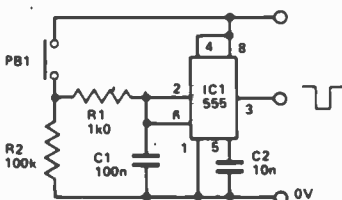

SEE DIAGRAM

TRUTH TABLE

7-SEG	a	b	c	d	e	f	g	D	C	B	A	X
BLANK	0	0	0	0	0	0	0	0	0	0	0	*
0	1	1	1	1	1	1	0	0	0	0	0	0
1	0	1	1	0	0	0	0	0	0	0	1	0
2	1	1	0	1	1	0	1	0	0	1	0	0
3	1	1	1	1	0	0	1	0	0	1	1	0
4	0	1	1	0	0	1	1	0	1	0	0	0
5	1	0	1	1	0	1	1	0	1	0	1	0
6	0	0	1	1	1	1	1	0	1	1	0	0
7	1	0	1	1	1	1	1	0	1	1	0	0
8	1	1	1	0	0	0	0	0	1	1	1	0
9	1	1	1	1	0	1	1	1	0	0	1	0
E	0	0	0	0	0	0	1	0	1	1	1	1
	1	0	0	1	1	1	1	0	0	1	1	1

2 Chip Electronic Dice

P. Adams

This electronic dice produces a true dice display using only two ICs — a 74132 and a 7495. The 7495 is a 4-bit parallel-access shift register. It can either operate as a shift-register or be parallel (broadside) loaded at inputs A-D. Control over these two functions is by a mode control input. When the mode is high data is loaded into Qa — Qd from inputs A - D on the next negative-going clock edge. When the mode is low data is shifted on Qa — Qd on the next negative-going clock edge.

By connecting the mode control to Qa so that the register alternates between load and shift and making the input word a function of the existing output word, with some simple logic, the register can be made to execute a count that will drive LEDs in a dice display. Note LEDs are lit when outputs are low. IC1a is connected as a conventional Schmitt oscillator providing clock pulses to the register. SW1 stops the oscillator and halts the count. On switch-on the register may start on an invalid count, but in a couple of clock cycles it will produce a valid count and then remain in that sequence. ●

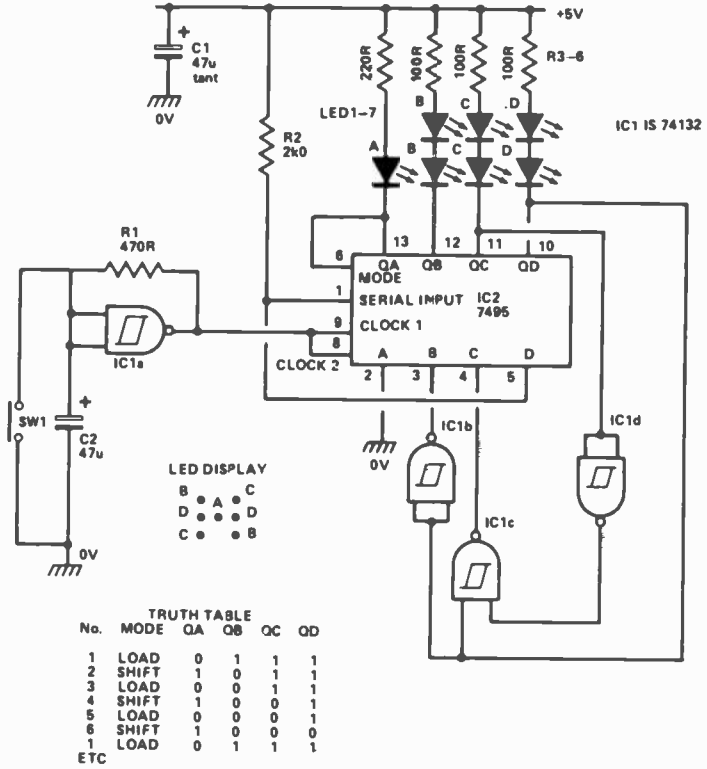

Digital Die

A. Slimming

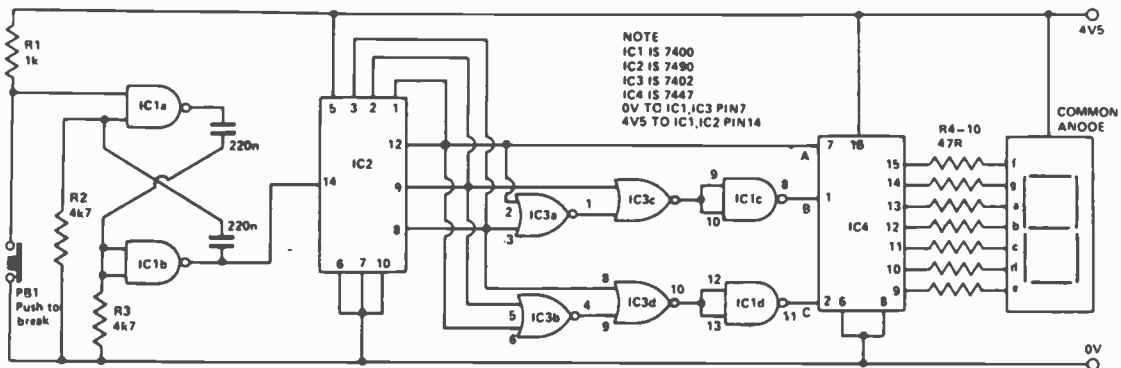

IC1a and IC1b form an oscillator running at a few kilohertz. The output is fed to a 7490 binary counter which is wired to produce an output of 0 to 5 in BCD. So that the display is the same

as a dice the display must read 1-6 and not 0-5, when the output of the 7490 is all '0's, the display must be made to show 6. IC1c, d and IC3 perform this task, and convert an

output of 000 from IC2 to 110 (b). IC4 is a BCD to 7-segment decoder which drives the display through the current limit resistors R4-R10. ●

Passionometer

D. Geary

This device is, to say the least, fun at parties!!!

The unit relies on skin resistance, picked up by 1 and 2, which form a Darlington Pair. The output of the amplifier is fed to a bloc buffer via a resistor network.

At each stage if the threshold voltage is reached, the associated LED will light. Previous stages will also light.

It may be found useful to fit a 25k pot in series with the base of Q1. The higher the ratings the better!!! ●

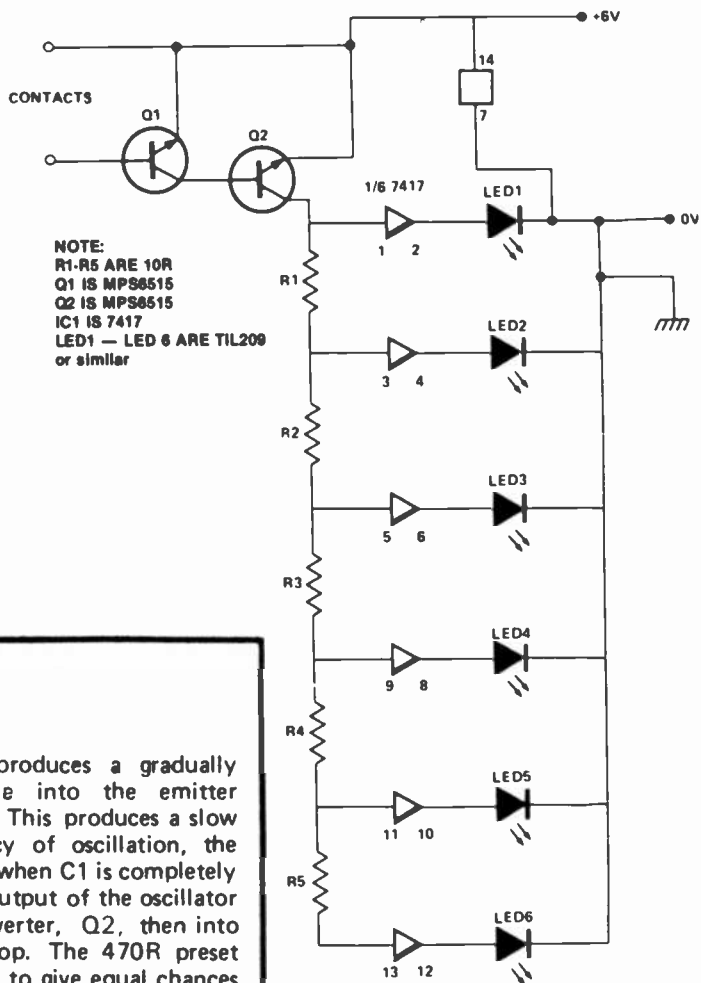

Heads Or Tails

Steven Snook

This circuit differs from previous Heads or Tails circuits in that when the switch is released the LEDs will continue to flash at a continually decreasing speed, until eventually they stop and one or the other will remain on. When SW1 is depressed C1 charges via the 2k resistor, when SW1

is released C1 produces a gradually decreasing voltage into the emitter junction of Q1. This produces a slow drop in frequency of oscillation, the oscillation ceases when C1 is completely discharged. The output of the oscillator is fed into an inverter, Q2, then into the 7472 flip flop. The 470R preset must be adjusted to give equal chances of each LED. A novel, untested, modification would be to omit the red LED and drive another 7472, this would give four combinations instead of two. ●

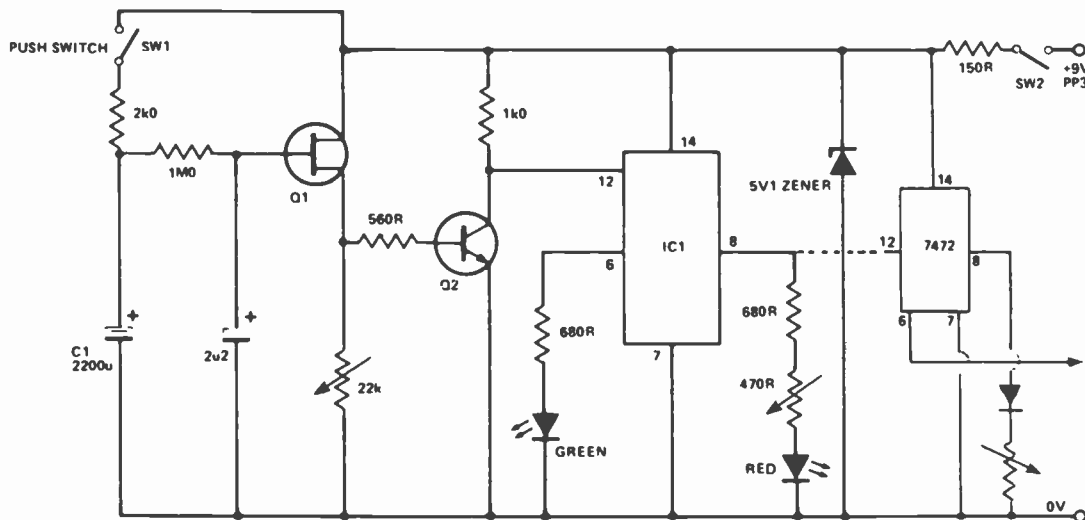

NOTES:
IC1 IS 7472 FLIP FLOP
Q1 ANY GP UNIJUNCTION
EQ T1843
Q2 2N3804 OR SIMILAR

Exclusive OR and NOR gates

D. S. Smith

When constructing logic circuits which need either an exclusive OR or exclusive NOR gate, and one is not available, the following arrangement

of NAND or NOR gates can produce the required results. The circuits can be constructed using standard TTL or CMOS gates. ●

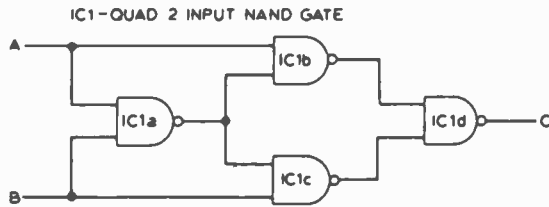

TRUTH TABLE

A	B	C
0	0	0
0	1	1
1	0	1
1	1	0

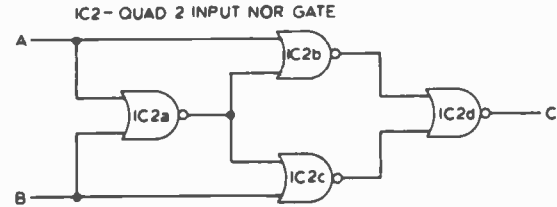

TRUTH TABLE

A	B	C
0	0	1
0	1	0
1	0	0
1	1	1

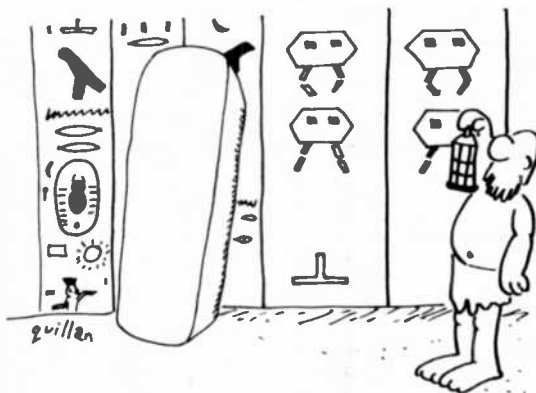
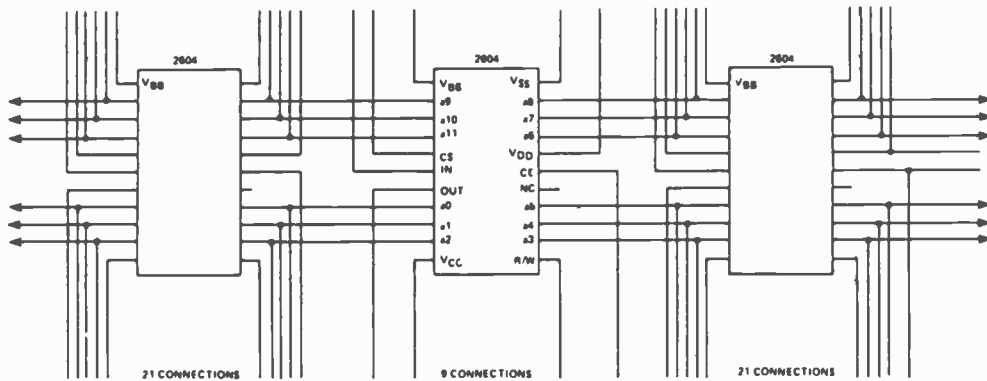

Minimising Memory Connections

M. T. Clarke

Anyone who has connected together memory ICs may well be appalled at the number of connections, especially those which simply parallel the IC pins.

Realizing that the address pin designations are purely notional means that address lines can be rearranged before they reach an IC, as convenient. This eases considerably PCB design.

An example is shown where connection of 4K dynamic RAMs (2604) was undertaken on Vero-board. The copper tracks provide all address connections for every alternate IC without any wiring from the surrounding ICs (this saved almost 100 connections on a 4K x 16 board).

Dynamic RAMs require segregating the row and column addresses, but within each they can be freely mixed. ●

Simple Logic Probe

David Boreham

This simple piece of test equipment can be built using widely available components for little more than £1.

If the probe is connected to an IC pin which is at logic 0, Q1 will be turned on, lighting D1. If, however, the pin is at logic 1, Q2 will be turned on, lighting D2. In the case of a damaged IC there may be no connection to the pin. If this is so, both D1 and D2 will light together.

The author used a 2N3905 and 2N3904 for Q1 and Q2 respectively, but any NPN or PNP transistors will do. Similarly, D1, 2 can be any LEDs.

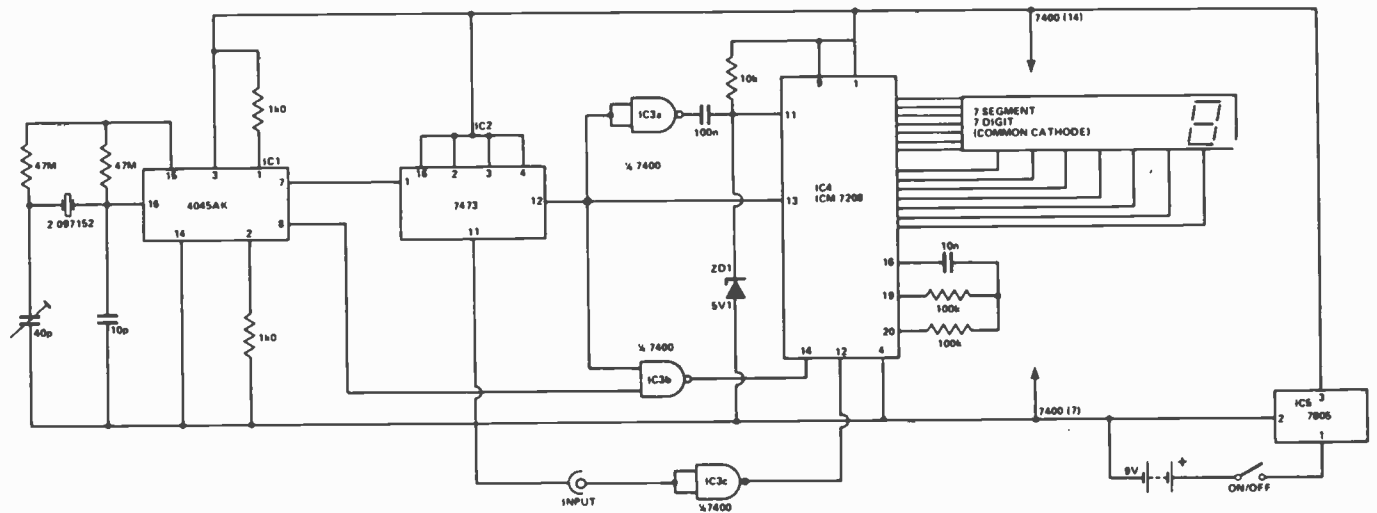
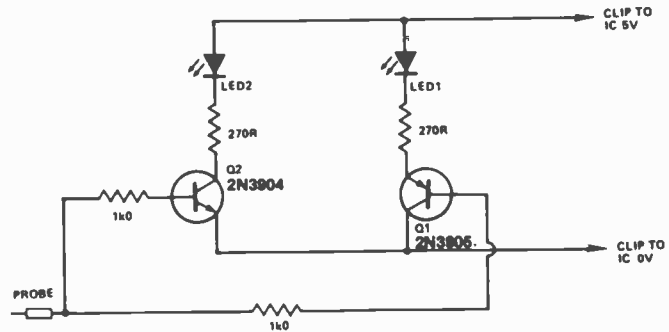

A Pocket Digital Frequency Meter

S. J. Barlow

The circuit uses only five ICs and 13 passive components. It is designed to fit into the casing of a pocket calculator and makes use of the calculator's seven segment display.

It has a single range measuring up to 10 MHz. The display is updated with a reading every two seconds. The preceding frequency count is held in the display during this period, thus avoiding a flashing display during the sampling interval.

The 7805 provides the 5V supply for the logic. The 4045 and the crystal form an oscillator and 21 stage binary counter producing 1/32 second pulses at 1 sec intervals as shown in waveforms 1 and 2. The 7473 flip-flop produces the one second gating pulse (waveform 3). Waveforms 2 and 3 are NANDed into pin 14 of the ICM 7208s counter chip to produce the RESET signal. Waveform 3 is also inverted before driving a differentiator

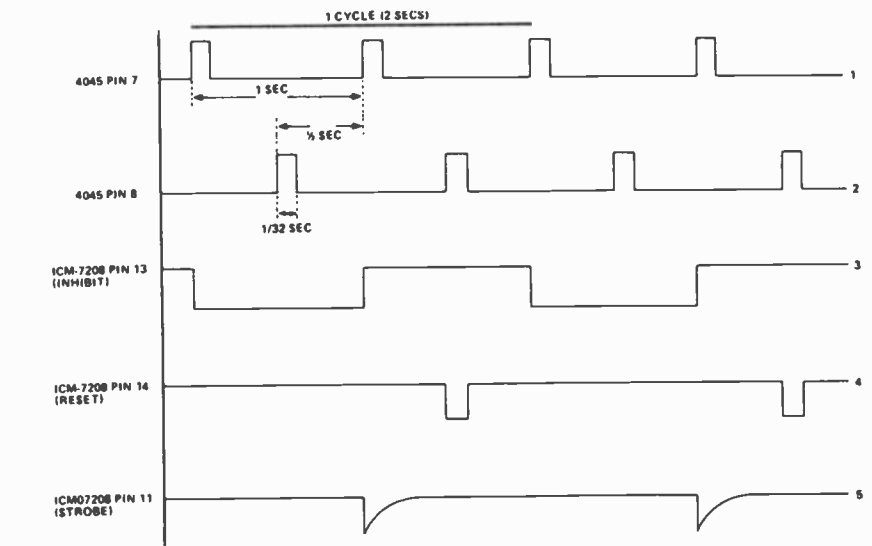

pulse (waveform 3). Waveforms 2 and 3 are NANDed into pin 14 of the ICM 7208s counter chip to produce the RESET signal. Waveform 3 is also inverted before driving a differentiator

with a 5V1 zener diode providing a clamp and discharge path. The differentiated waveform (5) gates the new frequency reading into the display.

CMOS Gate Identifier

C. Ching

This circuit can be used to distinguish four types of dual input gates — AND, OR, NAND, NOR — it is also a quick method of checking IC function. If an AND gate is inserted into the socket, an A appears on the LED. An O denotes an OR gate. The decimal point is used to denote inverted function, i.e. .A is an NAND gate. ●

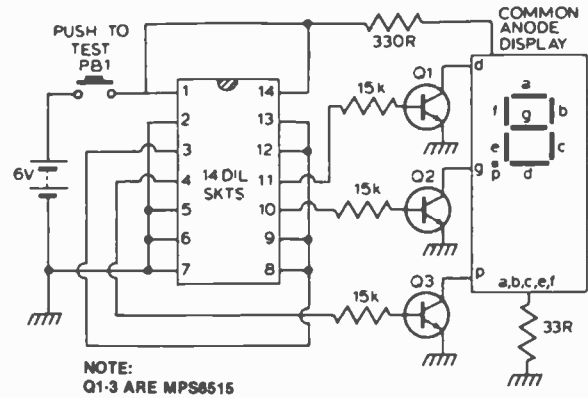

Versatile CMOS Test bed

J. Anderson

It is a cheap and easily constructed transistor tester utilising inexpensive and readily available CMOS ICs.

It not only carries out the normal GO/NO-GO test but will differentiate between PNP & NPN type as well as identifying their base leads.

Use of the tester is simple and is as follows:

- 1) GO/NO-GO:—If the transistor is "a dud", either all the LEDs will come on or they will all go out.
- 2) PNP/NPN differentiation —
 - a) PNP only one of the LEDs will come on.
 - b) NPN one of the LEDs will go out.
- 3) base lead identification:—the

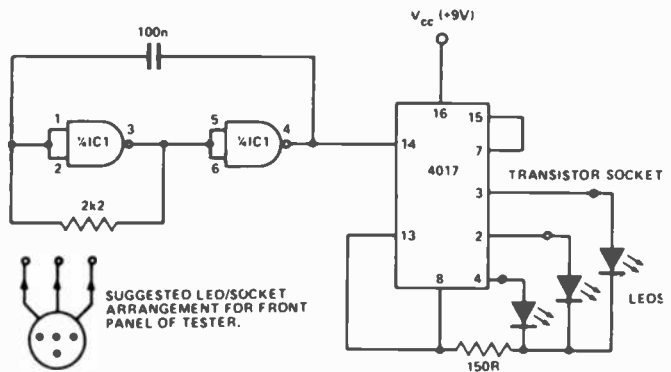

base lead is identified by the "odd LED out" (ie the one LED that is on with the other two out or the one that is out with the other two on).

The unit will also test diodes by the use of only two of the sockets of

the transistor socket in this case the anode of the diode is identified by the LED associated with its lead going out. The device also tests and identifies the gates of JUGFETs, SCRs & TRIACS. ●

Improved CMOS Test Bed

G. Scott

Having made Mr Anderson's CMOS test bed I found that the LEDs were barely bright enough to be seen. In

this circuit, with the addition of three, one transistor amplifiers, the LEDs are easily viewed and the current drain is only 13 mA. ●

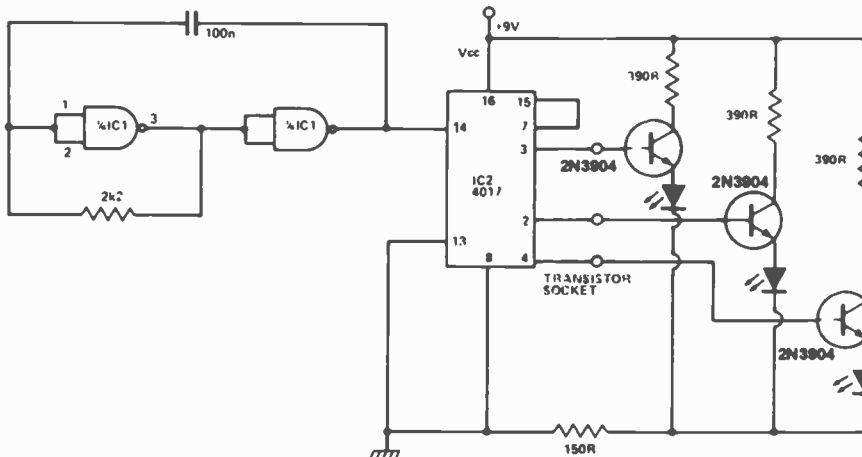

Battery Tester

R. N. Soar.

This circuit was designed as a simple tester for 1.5 and 9 volt batteries.

It uses a cheap 500μA recording level meter of the kind used in cassette recorders, costing around 80p.

The scale is as indicated in the diagram and can be interpreted as follows—

- BLACK—Replace battery
- RED—Weak battery
- GREEN—Good battery

A new battery should give a full scale deflection. ●

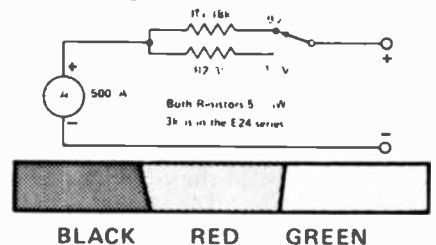

Digital Pulse Compressor

N. C. Hall

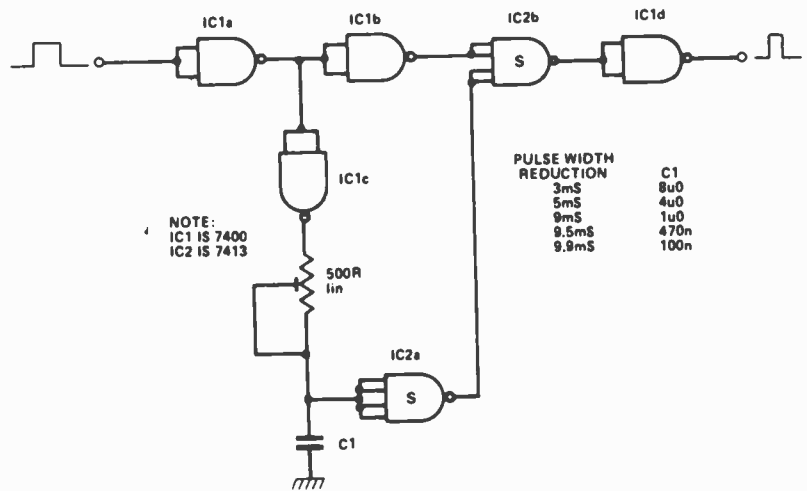

Whilst constructing a digital frequency meter the author found it necessary to be able to accurately trim the width of a gate pulse. The circuit shown uses only two ICs and can reduce the width of a pulse applied at its input by up to a few milliseconds. The table shows the reduction achieved by using different values of C1. ●

Sample And Hold For Music Synthesizers

L. Robinson

Sample and hold is a useful effect for use with music synthesizers and consists of 'sampling' an input voltage function such as a waveform for a very short time and then 'holding' it at this selected voltage level for the duration of the clock period. This voltage is then used to control the frequency of a voltage controlled oscillator, filter etc.

It is therefore possible to produce random or repeating sound patterns by varying the input waveform and frequency, pink noise can be used as a sample source to create authentic random voltages.

The circuit shown is much simpler than previously designed sample and hold circuits, this is possible by the use of CMOS technology. The clock oscillator is a standard CMOS square wave oscillator as found in RCA application notes, and this is used to provide a variable frequency rate from 0.2 Hz to 45 Hz. The output then goes to the synthesizer envelope shaper which should be of the ADSR type for maximum effect. The clock output also goes into a monostable which produces an output pulse of approximately 20 mS which opens the 4016 analogue gate for this period. The

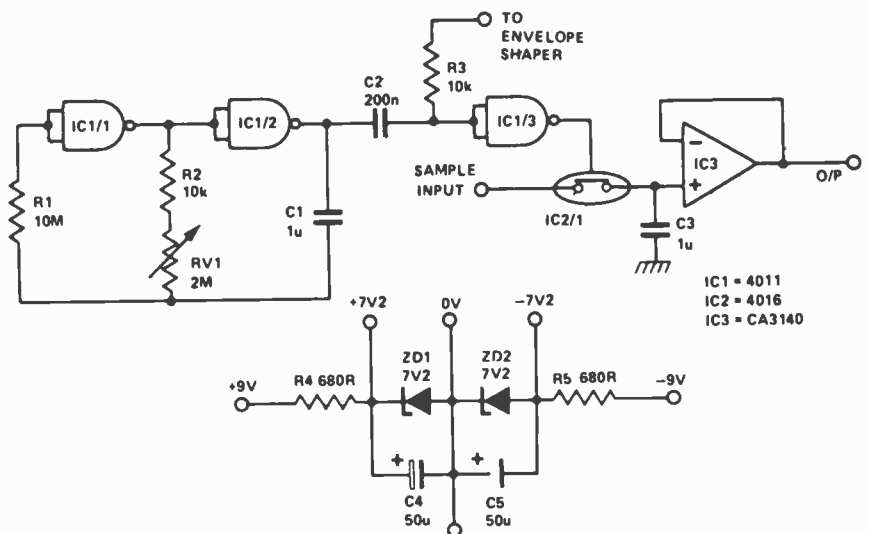

voltage input is therefore sampled and the value of the amplitude at this point of the waveform is remembered by the high input impedance (10^{12} Ohms) CA3140 voltage follower. This output is then used to control the VCO etc. The oscillator and monostable can be constructed from either a CMOS 4001 or 4069, ensuring that unused pins are connected to the high or low power supply line via a 1k resistor. The input waveform to the analogue switch can have an amplitude of ± 7 V maximum.

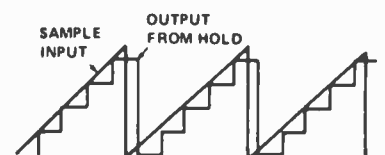

If a FET was used as the gate, it would only respond to negative voltages, so the more expensive analogue switch is used for this reason. The total cost of the circuit, including the ± 7 V rail, is less than \$3. ●

Electronic 'Spirograph'

A. Sharp.

The circuit will generate 'Spirograph' patterns on a conventional oscilloscope. The circuit consists of two sine wave generators followed by allpass filters which we use to phase shift the input signals by 90° . Applying a sinewave to the y input gives a circular trace. If a second set of sin and cos signals are mixed in, a 'Spirograph' pattern is obtained. A block diagram of the system is shown in Fig 1.

RV1 is a balance control which varies the contribution of each oscillator to the pattern without affecting the size, so that once set up there is no need to readjust the gain controls on the oscilloscope. This type of control can only be used if the oscillators have a low impedance output.

SW1 is a reversing switch which has the effect of turning the pattern inside out.

An existing sinewave oscillator can of course be used and the 60 Hz line could be employed (attenuated to about 2 V RMS from a low voltage transformer secondary) as the fixed oscillator. However flickering is a problem with lower frequencies (complex patterns requiring four or more cycles to complete will flicker at about 10 Hz using the mains frequency as an oscillator). I found 150 Hz to be a good compromise (higher frequencies require more critical tuning).

The allpass filter is recommended for phase splitting as it has a unity gain for all frequencies and settings of RV5.

First connect the y input of the scope to the output of an oscillator and adjust RV2 until a two volt RMS sinewave is obtained, repeat for second oscillator. Then connect up the x and y inputs as shown in Fig 1, turn the balance control to one end so as to look at the output of the fixed oscillator then adjust the 100 k pot until a circle is obtained (with suitable x and y gains). Now put the balance control in the middle and adjust the frequency controls until a stable pattern is produced. SW1 and RV1 the balance control can be used to alter the nature of the pattern without affecting its overall size, stability or symmetry. Adjust RV5, the phase control (following the variable oscillator) for symmetry.

— Have fun! ●

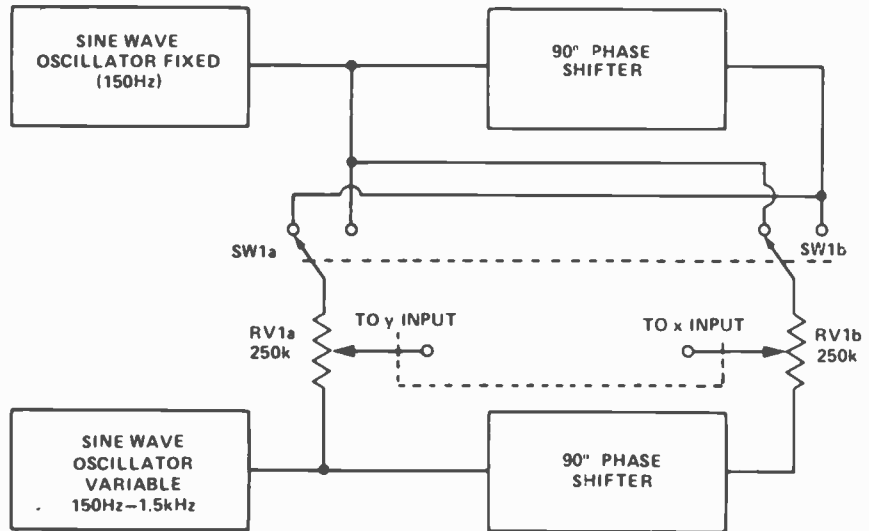

Fig. 1. Block diagram of the 'Spirograph'

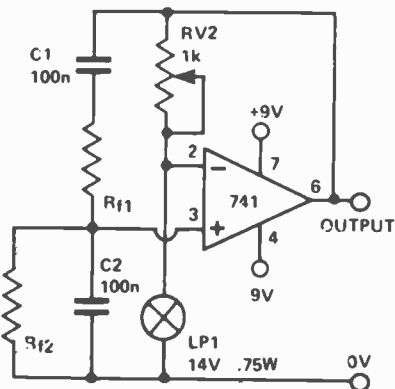

Fig. 2 (a) suitable oscillator for the 'Spirograph'

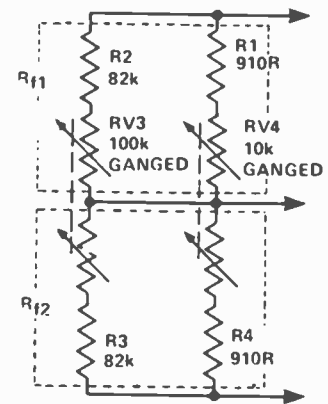

Fig. 2 (b) Arrangement to give fine control of the frequency of the oscillator shown in Fig. 2 (a). For 150 Hz fixed frequency use $Rf1 = Rf2 = 10k$

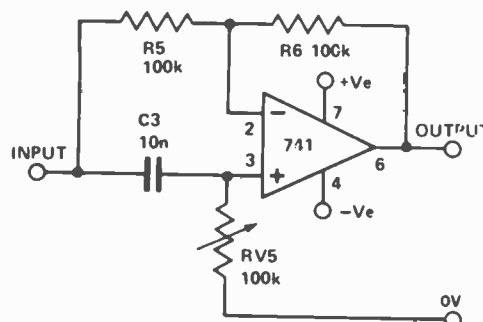

Fig. 3. Phase shifter circuit for use in 'Spirograph' circuit.

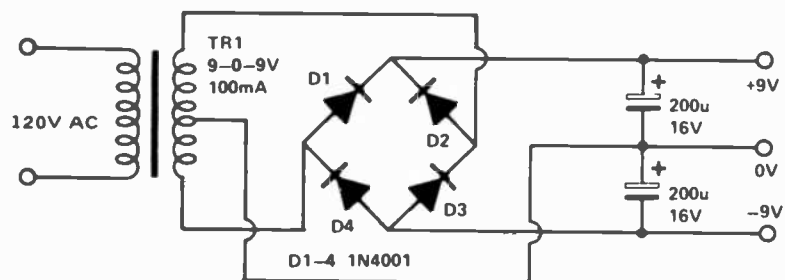

Fig. 4. PSU for 'Spirograph'

Anti — Acoustic Feedback System For Group Or Disco

G.T. Edwards

The directional properties of Line-Source Loudspeakers are best for minimising acoustic feedback ("Howl-Round"); unfortunately their bass response is usually inadequate for the full musical range. The ideal system would consist of a completely separated amplifier system for microphone inputs terminating in line-source loudspeakers, the "music" being amplified independently and fed at suitable power levels to less-directional full-range loudspeakers. However, as this is costly and increases transportation problems, a system was evolved in which a full-range non-directional loudspeaker would respond to "music" inputs only, a line-source being used at the same time responding to both "music" and "mic." inputs.

The principle has been proved in practice using the passive network shown in the diagram. As the microphone input is attenuated successively by three potential dividers before reaching the full-range loudspeaker system,

the risk of feedback from this speaker is negligible. Typically there is at least 26 dB reduction in microphone signal voltage between the input to amplifier 'A' and the input to amplifier 'B'.

The circuit is easily adapted to other signal levels and impedances by modifying component values on a proportional basis; a more elaborate "active" system is possible using virtual-earth summing amplifier stages.

Simulated stereo is possible from monophonic programme material by connecting a capacitor (about 2n2) between point 'Z' and ground; another capacitor (about 1n0) being connected in series at 'W'.

An inherent advantage of the system is that a "music" output is obtained even if one of the power amplifiers, or one of the loudspeakers, should go faulty during a performance. ●

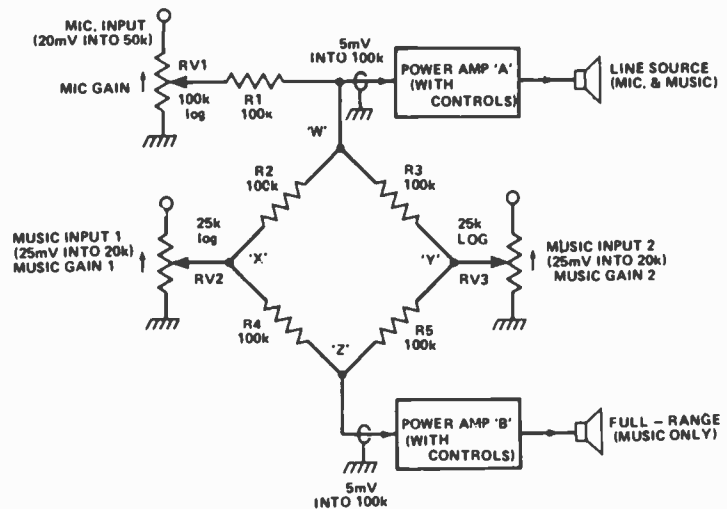

LED Spotting

A. Kenny

Since the leadout on LEDs varies according to the manufacturers preference, leadout diagrams are not always worthy of the trust placed in them. In some cases a reverse connection will destroy the device being used.

A simple way to avoid this is to use the following technique

If the LED is held up to the light, the structure can be clearly seen. There is a "cup" and an "arm" carrying a fine wire to the LED itself, which is in the "basin" of the cup (see drawing).

The lead with the cup is the cathode, and the other is the anode (of course). ●

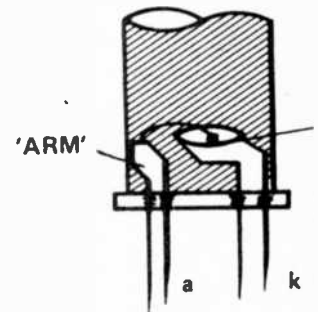

Television Optoisolator

A. P. Hiley

The problem of how to connect a tape recorder, or amplifier, to a television set is not an easy one to solve, because most televisions, having no mains transformer, have the chassis connected directly to the mains. The easiest, and simplest solution is to incorporate some form of optoisolation between the television and the external equipment. This particular design is simple, has a very low noise level, and introduces negligible distortion.

The LED or neon is brightness modulated by the output of the television sound channel. The light is picked up by a small, cheap silicon

photocell, placed a fraction of an inch away. A small current is produced, proportional to light intensity, which produces a PD across the load resistor, which is a replica of the original signal. ●

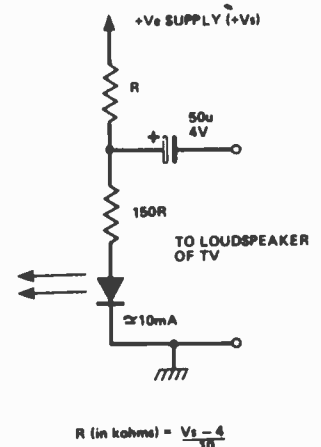
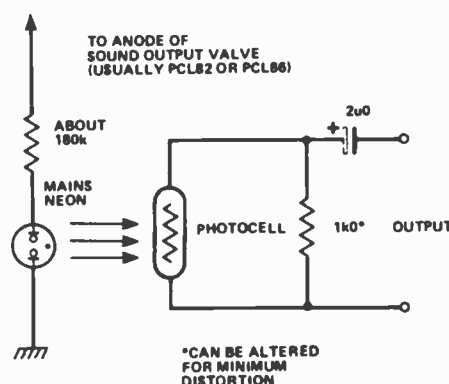

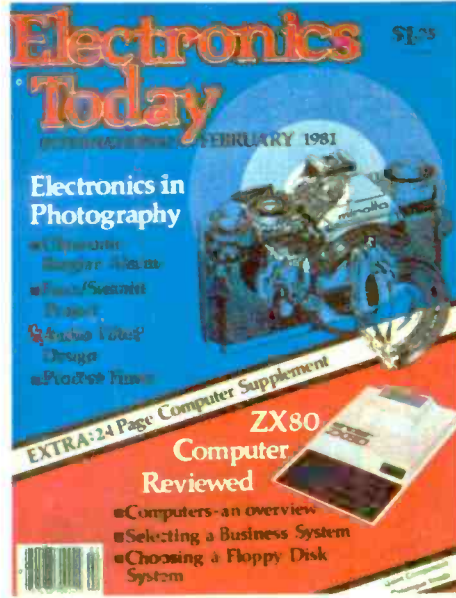
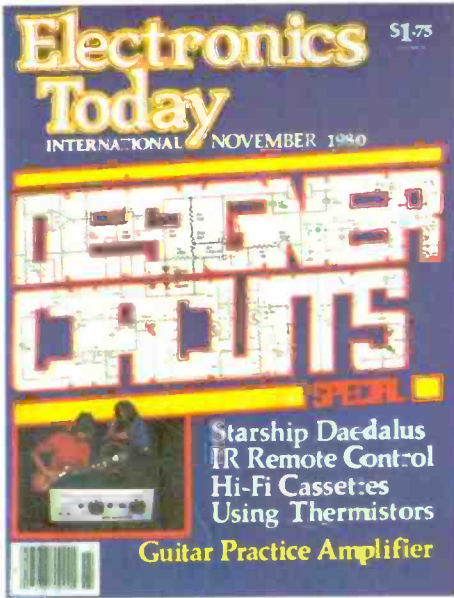

Subscribe to
ETI
Magazine,
Canada's largest
selling Electronics
publication and
**Save up to
36% on the
newsstand
price**

SEE ORDER CARD INSIDE

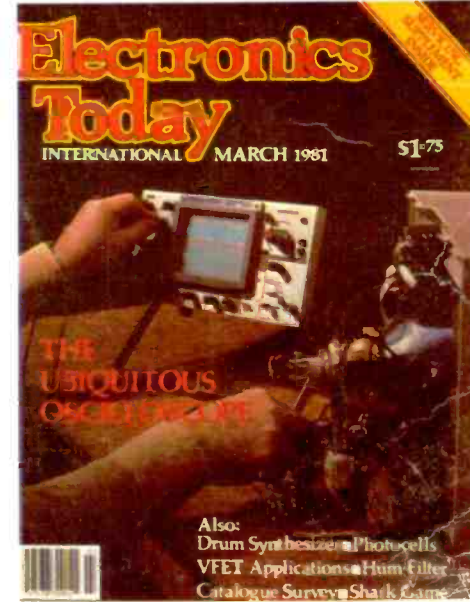
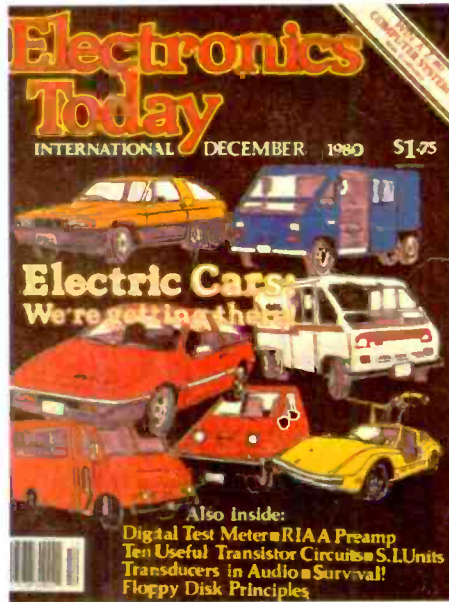

TTL DIGITAL IC's

7400

QUADRUPLE 2-INPUT POSITIVE-NAND GATES

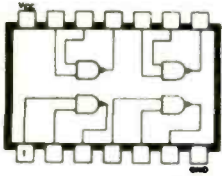

7401

QUADRUPLE 2-INPUT POSITIVE-NAND GATES WITH OPEN-COLLECTOR OUTPUTS

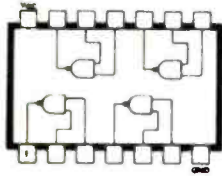

7402

QUADRUPLE 2-INPUT POSITIVE-NOR GATES

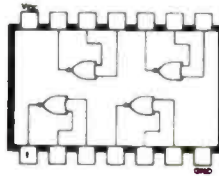

7404

HEX INVERTERS

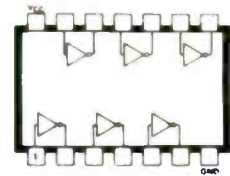

7405

HEX INVERTERS WITH OPEN-COLLECTOR OUTPUTS

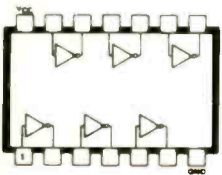

7408

QUADRUPLE 2-INPUT POSITIVE-AND GATES

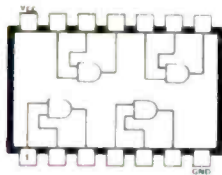

7410

TRIPLE 3-INPUT POSITIVE-NAND GATES

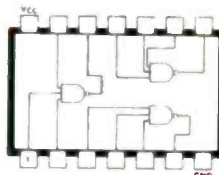

7413

DUAL 4-INPUT POSITIVE-NAND SCHMITT TRIGGERS

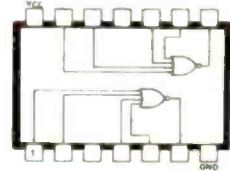

7414

HEX SCHMITT-TRIGGER INVERTERS

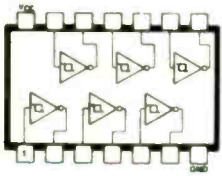

7420

DUAL 4-INPUT POSITIVE-NAND GATES

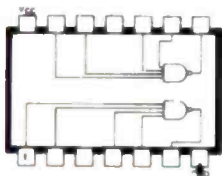

7430

8-INPUT POSITIVE-NAND GATES

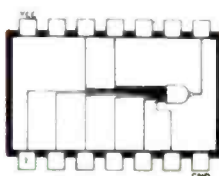

7437

QUADRUPLE 2-INPUT POSITIVE-NAND BUFFERS

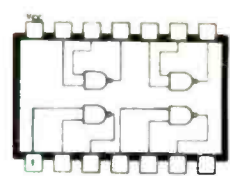

7447

BCD-TO-SEVEN SEGMENT DECODER/DRIVER

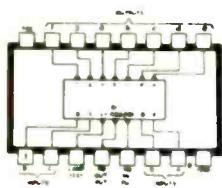

7453

EXPANDABLE 4-WIDE AND-OR-INVERT GATES

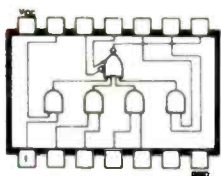

7454

4-WIDE AND-OR-INVERT GATES

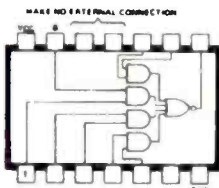

7474

DUAL D-TYPE POSITIVE-EDGE TRIGGERED FLIP-FLOPS WITH PRESET AND CLEAR

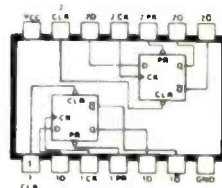

7475

4-BIT BISTABLE LATCHES

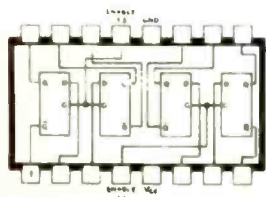

7486

QUADRUPLE 2-INPUT EXCLUSIVE-OR GATES

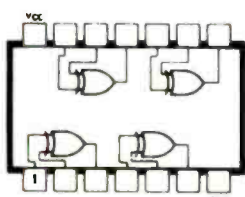

7490

DECADE COUNTER

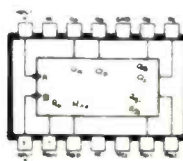

7491

8-BIT SHIFT REGISTERS

