

Electronics
Today
INTERNATIONAL

Summer 1980

Special Publication
\$3.95

HOBBY PROJECTS



25 Electronic Projects

Announcing

KITS • KITS •

NEW . . . PRE-DRILLED PCB'S FOR ALL KITS

STEREO AUDIO MIXER Kit

\$49.95

- 2-PHONO
- 1-AUX.
- 1-MASTER
- EXPANDABLE
- RESP. 20Hz - 20KHz
- 5V OUTPUT
- .01% DIST.

MODEL EK80AM001

ALL PRICES AND SPECIFICATIONS
SUBJECT TO CHANGES
WITHOUT NOTICE

EXPANSION
BOARDS
AVAILABLE
SOON

LED Chasers

\$22.95

- 3 MODES
- UP-DOWN
- ALTERNATE
- MODEL - EK80LC016

Muti Mode Chaser

\$32.95

- 120V
- ADAPTABLE
- 60 MODES
- MODEL - EK80LCM16

Audio Delay Line Kit

\$69.95

BBD

ECHO REVERB.

STEREO PRE-AMP

\$11.25

MODEL
EK805P001

5 Watt IC AMP

\$19.95

MODEL -
EK80A005

15 Watt AMP

"CAR STEREO"
MODEL - EK80A015

\$26.95

Three Channel Color Organ

500W
EK80C500

\$21.95

1500W
EK80C1500

\$32.95

STOBE Lite

\$21.95

MODEL
EK80SL001

Morse Code OSC

\$9.95

MODEL
EK80CP001

Variable Power Supply 0-30 volts

1 AMP
CONTINUOUS
\$39.95

MODEL - EK80PS028

•ALL KITS COMPLETE WITH DETAILED INSTRUCTIONS & PCB.
•DEALER & EDUCATIONAL INQUIRIES INVITED.

DOMINION RADIO & ELECTRONICS CO.
535 Yonge St., Tor., Ont. M4Y 1Y5 Phone: 922-1818

NOTES ON COMPONENTS

DIODE CHARACTERISTICS

	Material	I _{max}	V _{Rmax}	Application
1N34A	G	50mA	60V	Signal Diode
1N914	S	100mA	100V	Signal Diode
1N4001	S	1A	50V	Power Rectifier
1N4004	S	1A	400V	Power Rectifier
1N4148	S	100ma		Signal Diode

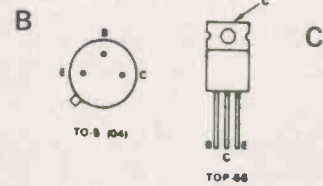
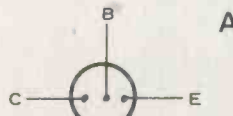

TRANSISTOR CHARACTERISTICS

Type	Leads	Polarity	H _{FE}	I _{Cmax}	V _{CEmax}	F _T	P _T	Use
2N3904	A	NPN	100+	200mA	40	250M	310mW	Signal
2N3905	A	PNP	50-150	200mA	40	200M	310mW	Signal
2N2222A	B	NPN	100+	800mA	30	250M	500mW	Switching
MPS6515	A	NPN	250+	100mA	25	200M	310mW	High Gain
2N3564	B	NPN	20-500	100mA	15	400M	200mW	RF
2N3055	D	NPN	20-70	15A	60	200k	115W	Audio Power
TIP29A	C	NPN	40-200	1A	60	3M	30W	Power
TIP30A	C	PNP	40-200	1A	60	3M	30W	Power

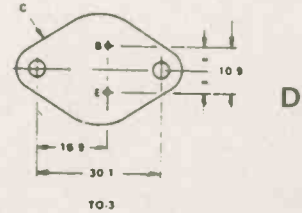

All cases shown with leads pointing at you.

Also notes on Components Notations in Table of Contents.

RESISTOR AND CAPACITOR LETTER AND DIGIT CODE

Resistor values are indicated as follows:

0.47 Ω marked	R47	100 Ω marked	100R
1 Ω	1R0	1 kΩ	1K0
4.7 Ω	4R7	10 kΩ	10K
47 Ω	47R	10 MΩ	10M

A letter following the value shows the tolerance.

F = ±1%; G = ±2%; J = ±5%; K = ±10%;
M = ±20%;
R33M = 0.33Ω ±20%;
6K8F = 6.8 kΩ ±1%.

Capacitor values are indicated as:

0.68 pF marked	p68	6.8 nF marked	6n8
6.8 pF	6p8	1000 nF	1u0
1000 pF	1n0	6.8 uF	6u8

Tolerance is indicated by letters as for resistors. Values up to 999 pF are marked in pF, from 1000 pF to 999 000 pF (= 999 nF) as nF (1000 pF = 1 nF) and from 1000 nF (= 1 uF) upwards as uF.

Some capacitors are marked with a code denoting the value in pF (first two figures) followed by a multiplier as a power of ten (3 = 10³). Letters denote tolerance as for resistors but C = ±0.25 pF. E.g. 123 J = 12 pF × 10³ ±5% = 12 000 pF (or 12nF).

Tantalum Capacitors

	1	2	3	4
Black	—	0	×1	10V
Brown	1	1	×10	
Red	2	2	×100	
Orange	3	3	—	
Yellow	4	4	—	6.3V
Green	5	5	—	16V
Blue	6	6	—	20V
Violet	7	7	—	
Grey	8	8	×0.01	25V
White	9	9	×0.1	3V

(Pink 35V)



RESISTOR AND CAPACITOR COLOUR CODING

Colour	Band A	Band B	Band C (Multiplier)		Band D (Tolerance)		Band e	Polyester Capacitors
			Resistors	Capacitors	Resistors	Capacitors		
Black	—	0	—	1	—	2 p0	—	—
Brown	1	1	—	10	±1%	0 p1	±20%	—
Red	2	2	—	100	±2%	—	±1%	—
Orange	3	3	1 000	1 000	—	—	±2%	250 v.w.
Yellow	4	4	10 000	10 000	—	—	±2.5%	—
Green	5	5	100 000	—	—	0 p5	±5%	—
Blue	6	6	1 000 000	—	—	—	—	—
Violet	7	7	10 000 000	—	—	—	—	—
Grey	8	8	10 ⁸	10 n	—	p25	—	—
White	9	9	10 ⁹	100 n	—	1 p0	±10%	—
Silver	—	—	0.01	—	±10%	—	—	—
Gold	—	—	0.1	—	±5%	—	—	—
Pink	—	—	—	—	—	—	—	Hi-Stab.

Note that adjacent bands may be of the same colour unseparated.

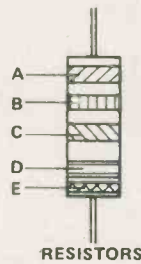

RESISTORS

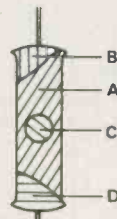

RESISTORS (OLD TYPE)

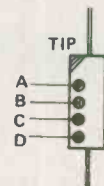

TUBULAR CAPACITORS

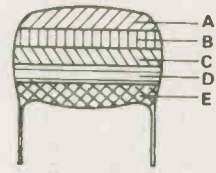

'CANDY STRIPE' CAPACITORS

Preferred Values

E12 Series (10%)					E24 Series (5%)									
1.0	1.2	1.5	1.8	2.2	2.7	1.0	1.1	1.2	1.3	1.5	1.6	1.8	2.0	2.2
3.3	3.9	4.7	5.6	6.8	8.2	2.4	2.7	3.0	3.3	3.6	3.9	4.3	4.7	5.1
and their decades					and their decades									

Electronics Today

Getting Started6

A few guidelines for the inexperienced project builder.



Tantrum8

A first rate amplifier for use with any of the amp modules now available.

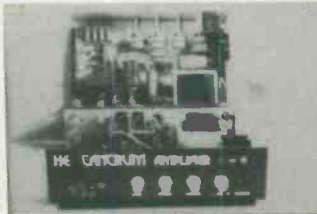

Audio Mixer14

A five-channel mixer with tone controls.



Scratch & Rumble Filter . . 18

Improve the quality of those old discs with this simple but versatile project.

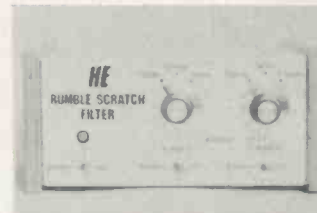

Constant Volume Amp. . . 23

Probably better known as a compressor and invaluable in high quality tape recording.



Graphic Equaliser27

A four frequency design making a fine companion for the mixer mentioned above.

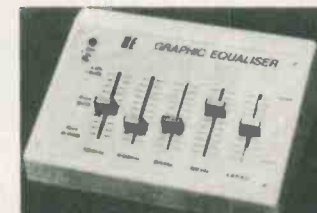

Envelope Generator33

Simulate the sound of almost any musical instrument or use it with our White Noise Generator.



White Noise Effects Unit. . 39

Simulate the sounds of wind, waves, surf, steam trains or jet aircraft with this unit.



Linear Scale Ohmmeter . . 44

Get rapid and accurate readings from a few tens of ohms to a megohm on an uncramped scale.



Simple Intercom.47

Three basic intercom circuits using a handful of components.

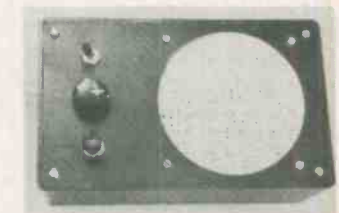

Drill Speed Controller . . . 50

Allows you to control the r.p.m. of your electric drill or any other universal electric motor.



Digibell53

A touch switch controlled doorbell. It's just touch and go, the 'chime' will never be ignored.

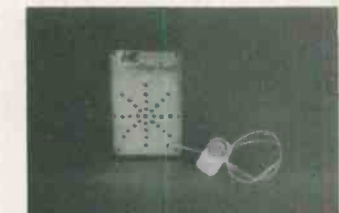

This is a Special Publication from:
Electronics Today International
(Canada) Limited
Unit 6, 25 Overlea Boulevard
Toronto, Ontario M4H 1B1
Telephone (416) 423-3262
Printed by: RBW Inc., Owen Sound, Ont.

Newsstand Distribution: Master Media

Publisher and Editor
HALVOR W. MOORSHEAD
Assistant Editor
JOHN VAN LIERDE
Production
SARAH-JANE NEWMAN
CHERYL MAY
Subscription Department
BEBE LALL

Accounts Department
SENGA HARRISON
Advertising Manager
MARK CZERWINSKI
Advertising Representatives
JIM O'BRIEN

Eastern Canada JEAN SEGUIN AND
ASSOCIATES INC. 601 Cote Vertu
St. Laurent, Quebec H4L 1X8
Telephone (514) 748-6561.

Hobby Projects

Summer
1980

Casanova's Candle 56
Lower the lights automatically to create the right atmosphere.



LED Tacho 61
A circle of LEDs give a solid state analogue display.

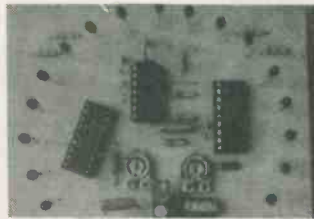

Parking Meter Timer 64
Avoid expensive parking fines with our pocket sized bleeper.



Hobbytune 67
An inexpensive electronic organ using a PCB keyboard.



Touch Switch 71
Using a relay you can switch on, or off, any electrical equipment.

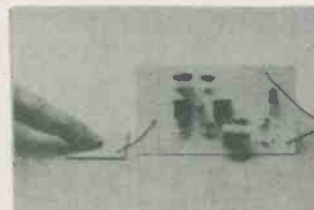

Push-Button Dice 73
The electronic substitute for an ancient random number selector.

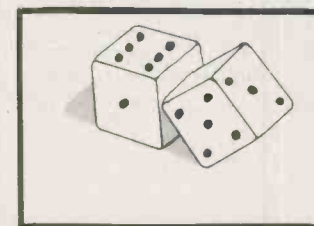

Photon Phone 76
Not a laser but you too can communicate down a light beam.



Starburst 81
A sound-to-light unit to hook up to your audio system.



Shark 85
An original competitive electronic game.

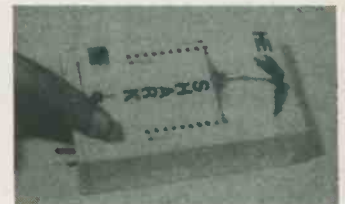

Multi-Option Siren 88
Produce practically any siren sound with this unit.



Code Practice Oscillator . . 92
Learn your dots and dashes with this simple circuit.

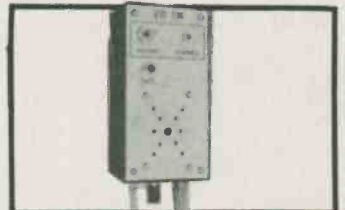

Four Simple Receivers. . . . 95
Four different versions of the crystal radio receiver.

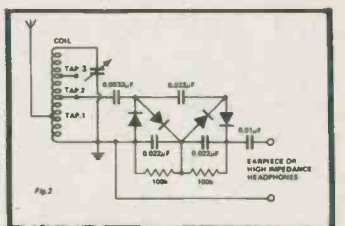

COPYRIGHT
All material is subject to worldwide copyright protection. All PCB patterns are copyright and no company can sell boards to our design without our permission.

LIABILITY
Whilst every effort has been made to ensure that all constructional projects referred to in this magazine will operate as indicated efficiently and properly and that all necessary components to manufacture the same are available, no responsibility whatsoever is accepted in respect of the failure, for any reason at all of the project to operate efficiently or at all whether due to any fault in design or otherwise and no responsibility is accepted for the failure to obtain component parts in respect of any such project. Further no responsibility is accepted in respect of any injury or damage caused by any fault in the design of any such project as aforesaid.

COMPONENT NOTATION AND UNITS
We normally specify components using an international standard. Many readers will be unfamiliar with this but it's simple, less likely to lead to error and will be widely used everywhere sooner or later. ETI has opted for sooner! Firstly decimal points are dropped and substituted with the multiplier, thus 4.7uF is written 4u7. Capacitors also use the multiplier nano (one nanofarad is 1000pF). Thus 0.1uF is 100n, 5600pF is 5n6. Other examples are 5.6pF=5p6, 0.5pF=0p5.
Resistors are treated similarly: 1.8M ohms is 1M8, 56k ohms is the same, 4.7k ohms is 4k7, 100 ohms is 100R and 5.6 ohms is 5R6.

PCB SUPPLIERS
The magazine does not supply PCBs but these are available from the following companies. Not all companies supply all boards. Contact these companies direct for ordering information.
B&R Electronics, P.O. Box 6326F, Hamilton, Ontario, L9C 6L9
Spectrum Electronics, Box 4166, Stn 'D', Hamilton, Ontario, L8V 4L5
Wentworth Electronics, R.R. No.1, Waterdown, Ontario L0R 2H0
Danoclntns Inc. P.O. Box 261, Westland, MI 48185, USA.
Exceltronix Inc., 319 College St., Toronto, Ontario, M5T 1S2
Arkon Electronics Ltd., 409 Queen St. W., Toronto, Ontario, M5V 2A5.

GETTING STARTED

Before you jump in at the deep end Rick Maybury has a few words of advice for beginners

MAYBE THIS IS THE FIRST TIME you've ever thought of building an electronics project? If this is so, then there are a few basic ground rules you should know about.

You will be dealing with a rather strange substance called electricity. You should never be afraid of electricity, just treat it with a very healthy respect. (Most of the projects in this book are battery powered. Voltages of up to around 50V are relatively safe.) If you should happen to let them run up your arm, chances are you will not even know it. Above 50 volts things change. Allow high voltages (and we are talking about line voltages now) to run around inside your body and you *will* notice it. But before you start worrying just consider this. Most, if not everyone in this country will have come into contact with line electricity at least once in their lives. 99.99% live to tell

the tale. Doubtless this experience encourages them not to do it again. So, take heed. Do not build any of the line powered projects in this book unless you are completely happy with your building abilities. If you have any doubts, leave it alone! Serve you apprenticeship on the battery powered projects first.

That said the rest is really common sense. You will find out fairly quickly which end of the soldering iron to pick up. How painful hot solder is when it has been carelessly flicked onto nylon socks and how pathetic a 'dead' project is. Let's take a quick look at a few tips that should enable you to avoid such traumas and build projects just like us. (Well, they can't be too bad or you wouldn't have bought this book!)

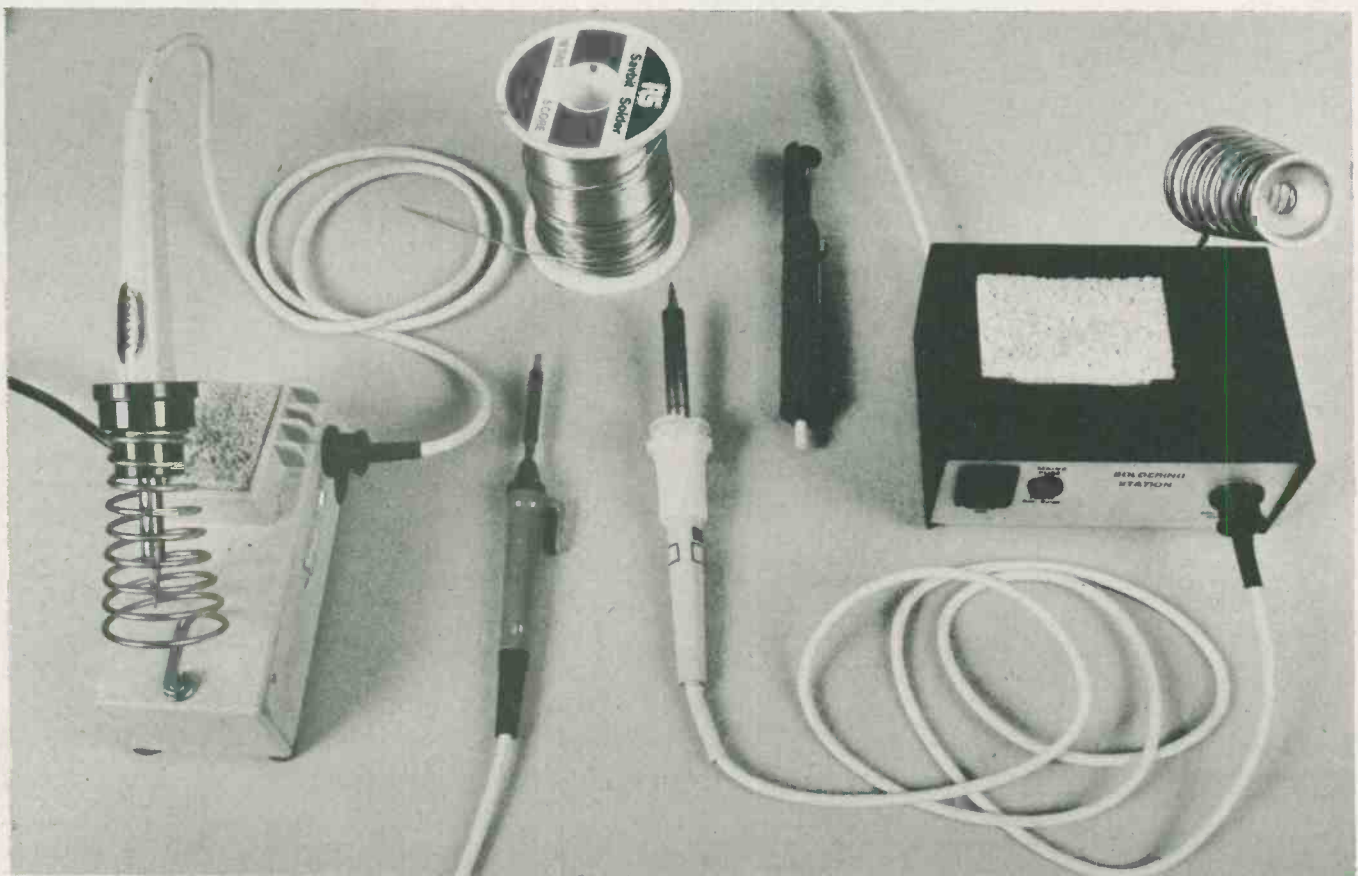

A selection of 'standard' soldering equipment. The irons on the extreme left and right have useful stands. Experience will show how valuable these can be. The inexperienced solderer is soon spotted by all the burn marks on the hands. In the centre, a hand-sized solder pump.

Soldering

There is no doubt about it, soldering is an art. Thankfully though, it is an art that is easily acquired and rarely forgotten.

The first time you attempt to make a soldered joint you will do it wrong! A bold claim? Not at all, the first rule of soldering is:—

Items to be soldered must be hot enough to melt solder.

Put another way, you do not use the soldering iron to melt the solder, the workpiece is heated up instead. If they are not hot enough the solder will not flow. Result, one dry joint. There are, of course, certain exceptions and precautions to go with this rule but more of them later. Now we have rule two;

Happy is the man with a clean bit.

No big explanation needed here. Always keep the bit of your soldering iron clean, a quick wipe on a damp sponge is all you need to do. Fail to observe this simple rule and you will be rewarded with duff projects.

Dirty bits = bad joint.

Lastly we have rule three;

Electronic Bits and Pieces Don't Like Being Too Hot.

At first glance that seems to contradict rule one. Surely if you heat something up, hot enough to melt solder it will be damaged?

This is true, but being metal, heat will be conducted quickly from the workpiece. Modern components are very tolerant. The early transistors needed heatsinks on the leads to prevent the heat being conducted inside the transistor body. Happily today, most electronic bits and pieces are very strong. But this is no excuse to leave the soldering iron on the joint for five minutes. Own up now, haven't you ever tried to make a joint with the soldering iron and added vast quantities of solder in an attempt to get it to stick?

Tools for cutting, stripping and pinching. Make sure it's not your fingers that stray!



Summary

So, a quick guide on how to make the perfect joint. Your iron must be hot. (A 25 watt model is quite sufficient for all of the projects in this book). The surfaces to be soldered must be clean (That includes wires, PCB pads and of course the iron itself). The parts to be soldered must be heated up by the iron, rather than by a blob of dirty solder quivering on the tip of your iron. The solder is applied to the workpieces, not the soldering iron bit. The whole process should be done quickly, if the first attempt looks dodgy, let it cool then try again later, but remember to remove any surplus solder before you start.

Tools Of The Trade

Like any half decent hobby, electronics is, or can be, expensive. Luckily most of your initial expense will be on tools. The type of tools you'll need are the sort that will last a lifetime, and will come in useful for lots of other jobs. You may well have a few of them already. Best advice when buying tools is to get the best you can afford and look for well known names.

What To Buy

To start you off here are a few suggestions for a basic toolkit. The soldering iron is top of the list. Choose a good quality 25 watt model, make sure the bits are easily changed, ensure it will be comfortable to hold. A solder pump, not too many to choose from, expect to pay a minimum of \$10. Sidecutters, you cannot scrimp on these, buy the best. Pliers, again look for quality. Screwdrivers, chances are you have some already, equally certain will be their condition. Isn't it about time you treated yourself to a new set? Try to get some miniature ones as well. If you intend to make your own boxes, PCBs and metalwork then equip yourself with a good quality drill, or three. A good DIY type electric drill, a small hand drill and if you still have money, an electric PCB drill. Try to get as many sizes of drill bits as possible, a 1mm for the PCB work to a 10mm for switches and pots. Well, what are you waiting for, get building and good luck. ●

Screwdrivers. Why not treat yourself to a decent set. They are friends for life.

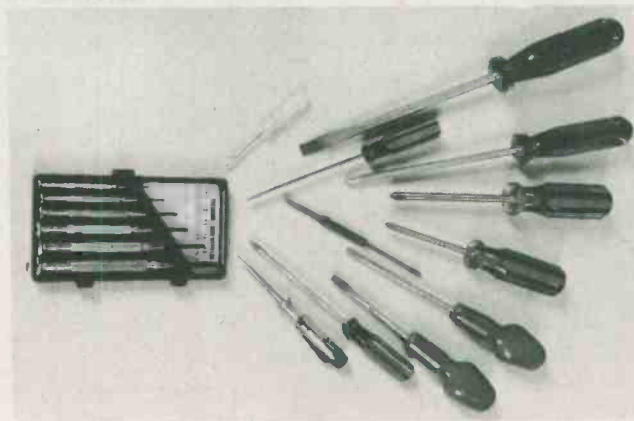

TANTRUM

Want a first rate 25 watt stereo amplifier? Look no further — build this project, turn up the volume and watch the neighbours live it up to its name.

AMPLIFIER CONSTRUCTION is full of such heart-breaking terms as: — 60Hz hum, ground loops, harmonic distortion, low signal to noise ratio etc., etc. ad nauseam. Mention any of these terms to a professional (let alone an amateur) audio engineer and you will see him turn a deep yellow colour and cower into a corner whimpering to himself or take a long, long holiday. Incidentally, this is the sort of thing which happens in our projects lab 3 or 4 times a week, hence the name of this project — TANTRUM.

Amplifier design has been known to push many a good audio engineer over the top and turn to digital circuits (the easy way out). However, we at HE have faced up to the subject with a great deal of trepidation, hard work and dutch courage and finally have the solution.

The HE TANTRUM is a stereo amplifier using good

design and construction techniques which upon completion will reward the builder with a 25 watt stereo amplifier with a signal/noise ratio of over 70 dB, negligible mains hum (due to the special construction techniques) and distortion of less than 0.1% (the human ear can't even pick that up).

Now, we don't often boast but though we say it ourselves, we have produced a printed circuit board layout for the pre-amplifier which is nothing short of superb. The distortion and noise figures for the pre-amp are remarkably low. On first sight the board might appear large but the quality obtainable using this layout far outweighs the minor disadvantages of size. Besides the use of on-board switches and pots enables an enormous reduction in interwiring (and therefore noise levels) to be achieved. It also eases cabinet construction problems.



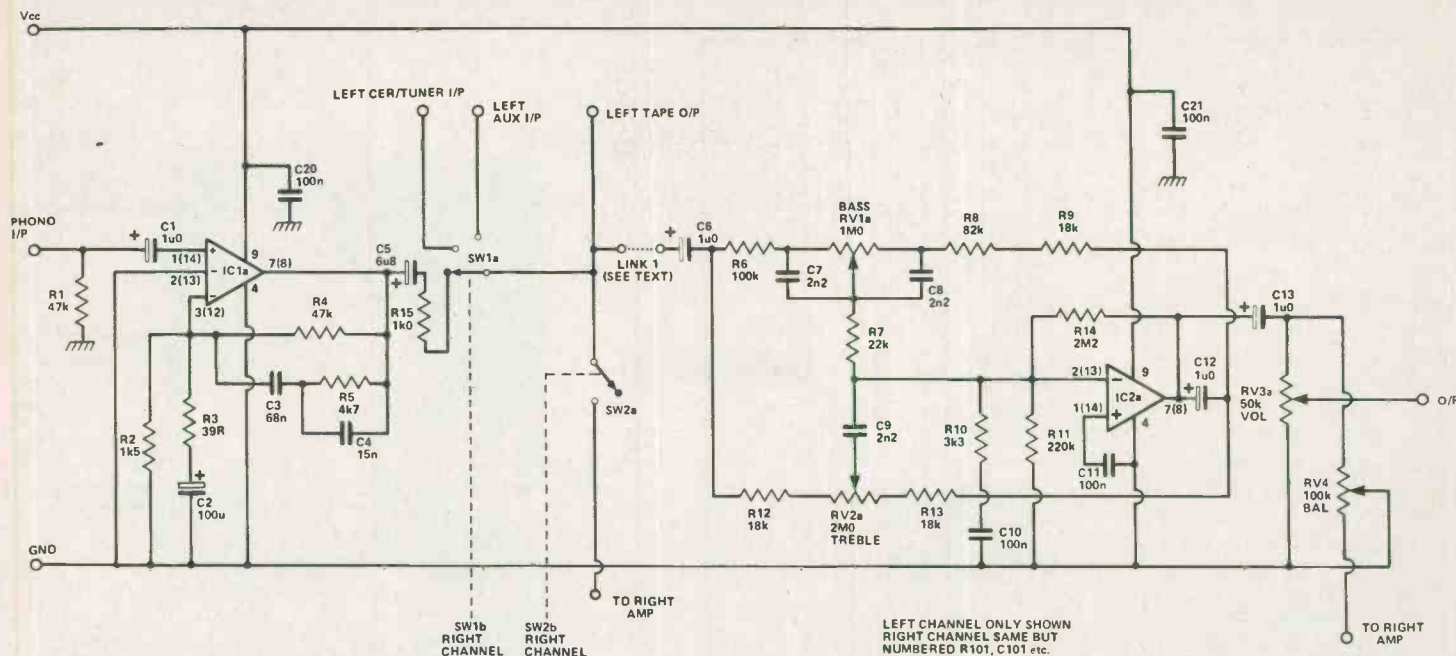

Fig.1. Main circuit diagram for the Tantrum, only the left channel is shown.

HOW IT WORKS

Any audio amplifier has two basic parts to it:—the pre-amplifier and the power amplifier (three parts if the power supply is taken into account).

The pre-amplifier is a voltage amplifier dealing with low voltage inputs, for example from a magnetic phono cartridge (which produces a signal of about 5 mV). The output from the pre-amp is normally set at a few hundred millivolts, enough to drive the power amp. Tone controls and volume are normally provided in this section.

The power amp is a current and voltage amplifier, to provide the power to drive the speaker. Because the power amps in TANTRUM are modular and are bought complete and tested there is little need for circuit explanation.

The design of the pre-amp is centred around two LM 381 dual, high quality op amps. IC 1 is used as a RIAA equalisation amplifier. This is necessary

when using a magnetic phono cartridge, as certain frequencies are emphasized on the recording of a record and consequently need to be de-emphasized on playback, hence the term equalise.

The second LM 381 is used for tone control, the controls being in the standard Baxendall type circuit.

The RIAA equalization is provided for in the feed-back loop of IC1, likewise the bass and treble controls are in the feedback Loop of IC2. Equalization and tone control can be obtained using passive resistors and capacitors, but significant noise is introduced, due to voltages across these components. Theoretically, an op amp produces no current flow through the components in its feedback loop. These 'active' components produce much less noise than any type of corresponding passive circuit.

We looked around and sampled power amplifiers which might fulfill 3 criteria:—

- 1) ease of use
- 2) adequate power levels
- 3) low noise and distortion figures

Integrated circuit amplifiers tend to have high distortion figures, while discrete components (transistors, etc.) amps can get very involved and are more often than not troublesome to build — and so, for these reasons we decided on the use of purpose built amplifier modules

which are obtainable ready built to high specifications. We used a commonly available 25W power amplifier module. There are many available, so shop around.

As an added extra to TANTRUM we have included links 1 and 2 in the PCB so that a remote mute control along ultrasonic principles can be used. (See the Ultrasonic switch on page 47, using one pair of relay contacts for each channel). Otherwise, simply insert links 1 and 2.

Construction

The pre-amplifier should be constructed first. Do this very carefully. Make sure you have the correct sized

PARTS LIST

RESISTORS (All 1/4W, 5%)

R1, 4, 101, 104	47K
R2, 102	1K5
R3, 103	39R
R5, 105	4K7
R6, 106, 108	100K
R7, 107	22K
R8	82K
R9, 12, 13, 112, 113	18K
R10, 110	3K3
R11, 111	220K
R14, 114	2M2
R201	6K8
R301, 302	270R

POTENTIOMETERS

RV1	1Meg Dual Lin
RV2	2Meg Dual Lin
RV3	50K Dual Log
RV4	100K Single Lin

CAPACITORS

C1, 12, 13, 101	1u0 Tant 25 V
C6, 106, 112, 113	1u0 Elect 63 V
C2, 102	100u Tant 25V(or PCB Elect)
C3, 103	68n Polyester
C4, 104	15n Polyester
C5, 105	6u8 Tant 25 V
C7, 8, 9, 107, 108, 109	2n2 Polystyrene
C10, 11, 20, 21, 110, 111	100n Polyester
C201	4700u Elect 63 V
C202	10u Elect 40 V
C203	22u Elect 40 V
C301, 302	To suit speakers used (See text)

SEMICONDUCTORS

IC1, 2	LM 381
BR 201	2 Amp 100 V Bridge Rectifier
Q201	2N4923
D201	33 V Zener Diode

MISCELLANEOUS

SW1, 2	Push Button Signal Switches (DPDT) with mounting bracket
SW3	DPST Line Toggle
Neon	
FS201	1.5A Fuse + Chassis Holder
FS202, 203	750 mA Fuse + PCB mounting holder
T201	Line/30 V 50 VA Transformer
2 x Power Amp Modules	
Case to suit	

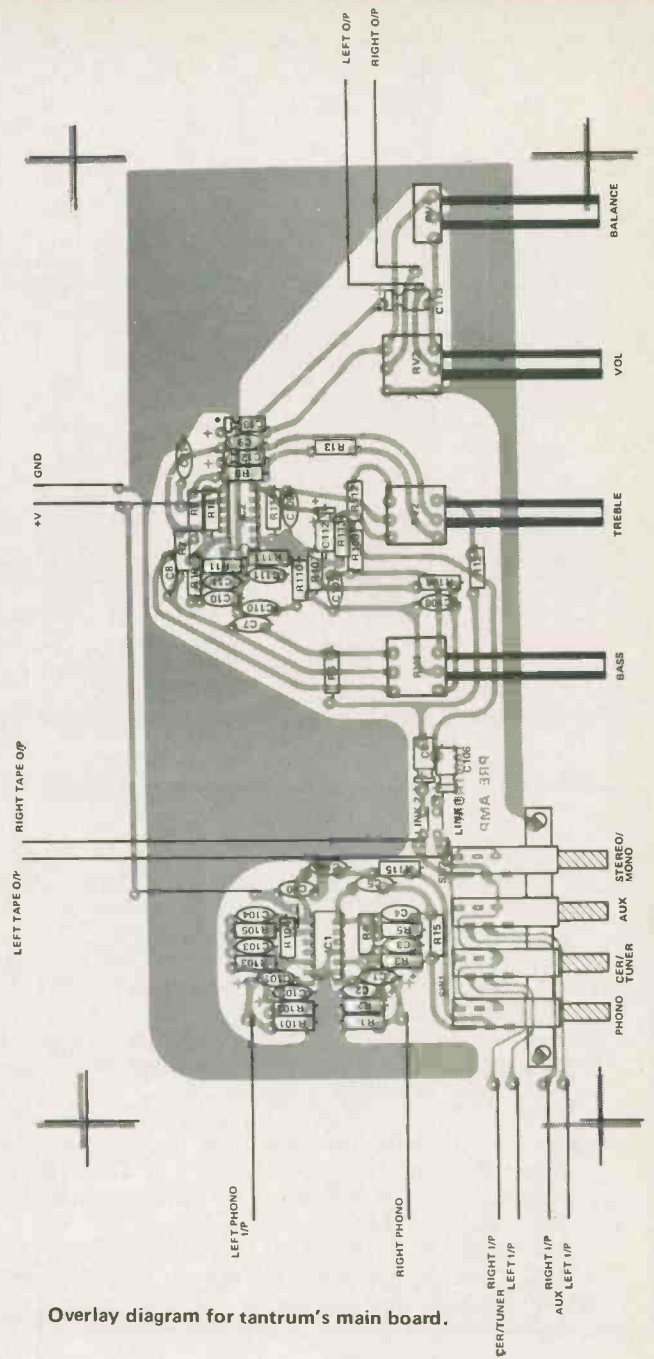

Overlay diagram for tantrum's main board.

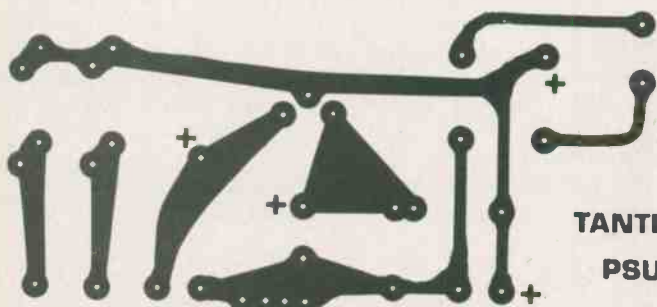

PCB foil the PSU module.

TANTRUM PSU

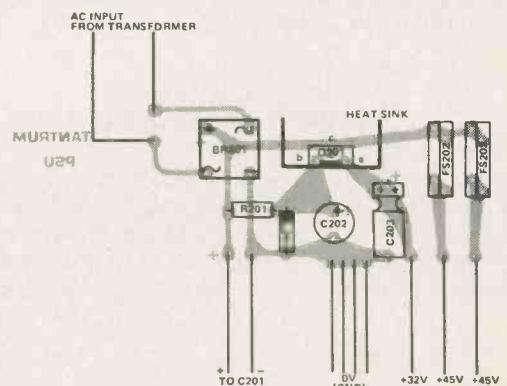

Overlay diagram for Tantrums PSU.

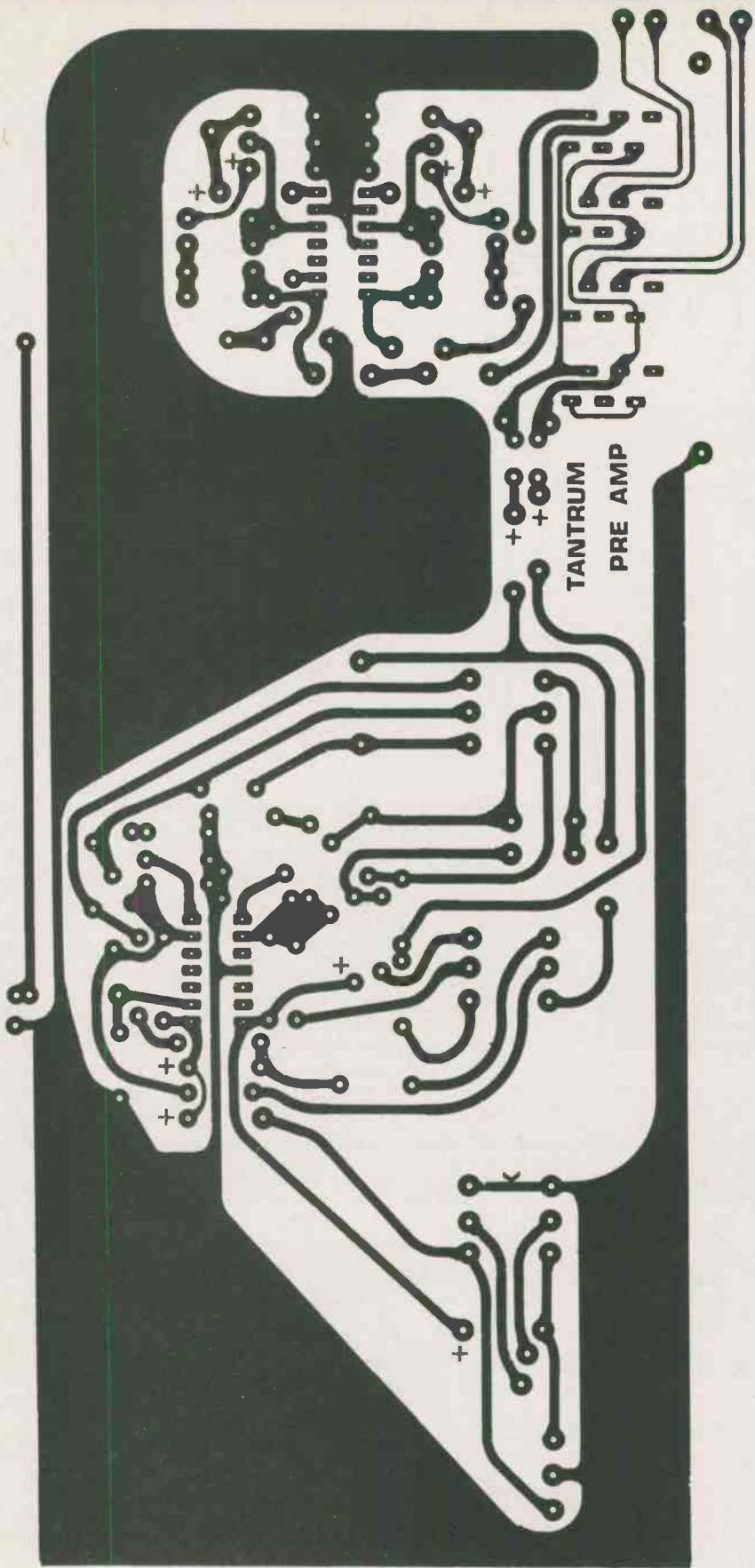

PCB foil pattern for the main board.

ETI Book Service

Single IC Projects

R. A. Pentold

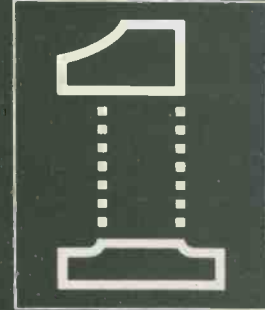

There are now a vast range of IC's available on the amateur market, the majority of which are not necessarily designed for use in a single application and can offer unlimited possibilities.

All the projects contained in this book are simple to construct and are based on a single IC. A few projects employ one or two transistors in addition to an IC but in most cases the IC is the only active device used.

BP65 \$5.80

Electronic Circuits for Model Railways

M. H. BABANI, B.Sc. (Eng)



In this book a number of constructional projects and ideas are discussed. Details are given on how to build three types of model train controller and ideas on signalling are considered in detail.

BP213 \$2.90

Shortwave Circuits & Gear for Experimenters and Radio Hams.

13 Projects covering many aspects of this hobby.

BP215 \$2.90

Prices include postage. Send to:

ETI Magazine
Unit 6, 25 Overlea Blvd.
Toronto, Ontario. M4H 1B1

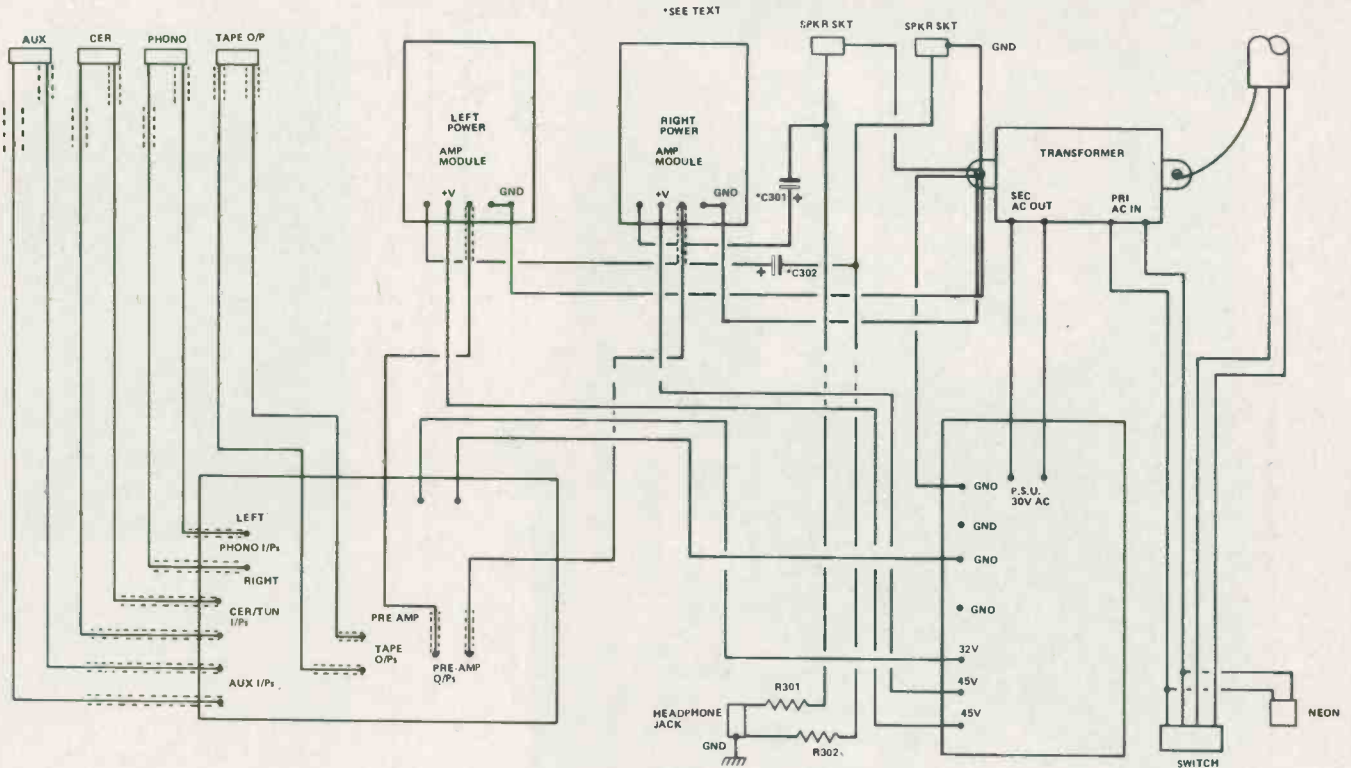

Interwiring diagram for the pre-amp, PSU and power amplifier modules.

push button switches for SW1 and SW2 as sizes vary slightly from manufacturer to manufacturer. The on-board pots can be of the PCB type, or you can simply drill larger than average holes (1.5mm) and insert ordinary potentiometers (as we did with our prototype). To do this the tags have to be bent carefully through 90 degrees and then shaped using pliers to fit through the PCB holes. This is a simple job and provides a suitable alternative to obtaining the more expensive, difficult to obtain PCB pots. The bodies of the pots should be all connected to ground via a length of single strand wire to provide screening.

Construct the power supply next — being careful that the bridge rectifier and the transistor are inserted correctly. Note the polarity of the zener diode. The heatsink should be attached to the transistor with a nut and bolt, smearing the connecting surfaces with heat-sink compound (this helps to dissipate heat) before fastening together. Make sure the metal heatsink is not touching anything else metallic as a short circuit could result.

FS2 and FS3, clipped into PCB fasteners which make a nice neat job, are necessary to protect the amplifiers in the case of overload.

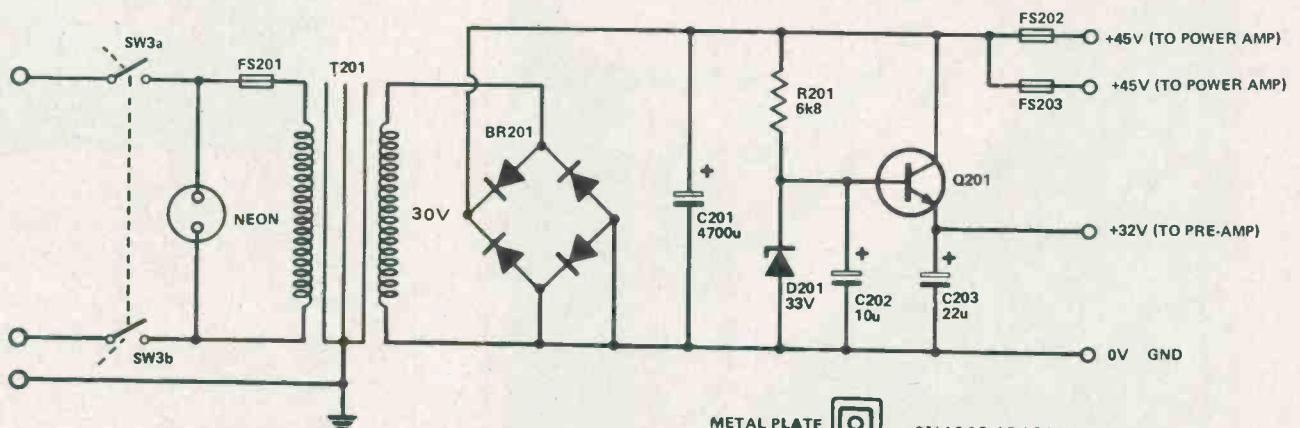

Notes:
 Q201 is 2N4923
 D201 is Zener 33V.
 BR201 is AMP 100V BRIDGE RECTIFIER



2N4923 (Q201)

Circuit diagram for the PSU for Tantrum.

C201 is mounted separate to the power supply board and hard-wired into circuit. This is best left until final assembly.

Note in the interwiring diagram the use of a single point earth for the power amplifiers, taken to a convenient point on the chassis (we used a transformer mounting bolt) close to the power amps. The earth return from the speakers also goes to this point. This single point earth system is used in audio equipment to minimise the effects of the high currents flowing through the leads, on the pre-amplifier.

Follow the inter-wiring diagram when connecting the modules. Use if possible a length of ribbon cable, colour coding each strand. This can only be used for power supply connections, power amp outputs and the leads

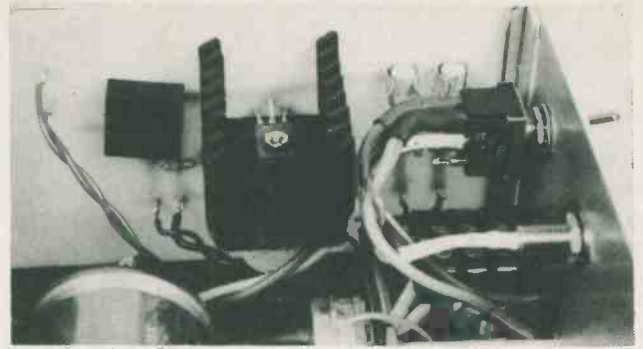

Close-up of the PSU module, note the heat-sink on the regulator

from the speaker terminals to the headphone jack. Any low level signal leads ie pre-amp I/P and O/P leads need to be screened low loss cable.

Finally, R301 and 302 are hard-wired in series with the left and right headphone outputs (taken from the speaker DIN sockets). These cut the power down to a reasonable level for headphones.●

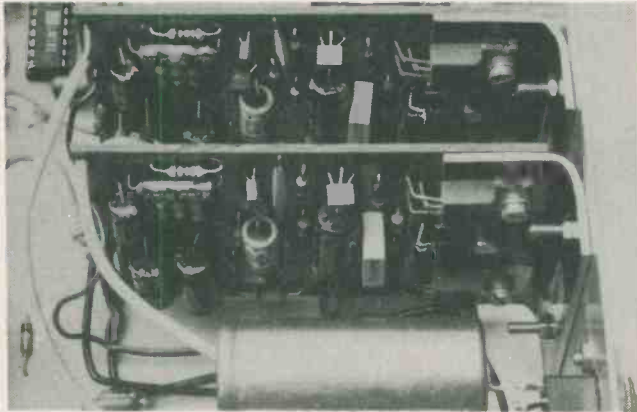

Close-up of the power amp mounting.

Some modules require that you use a coupling capacitor to the speaker. These are C301, C302 in the schematic.

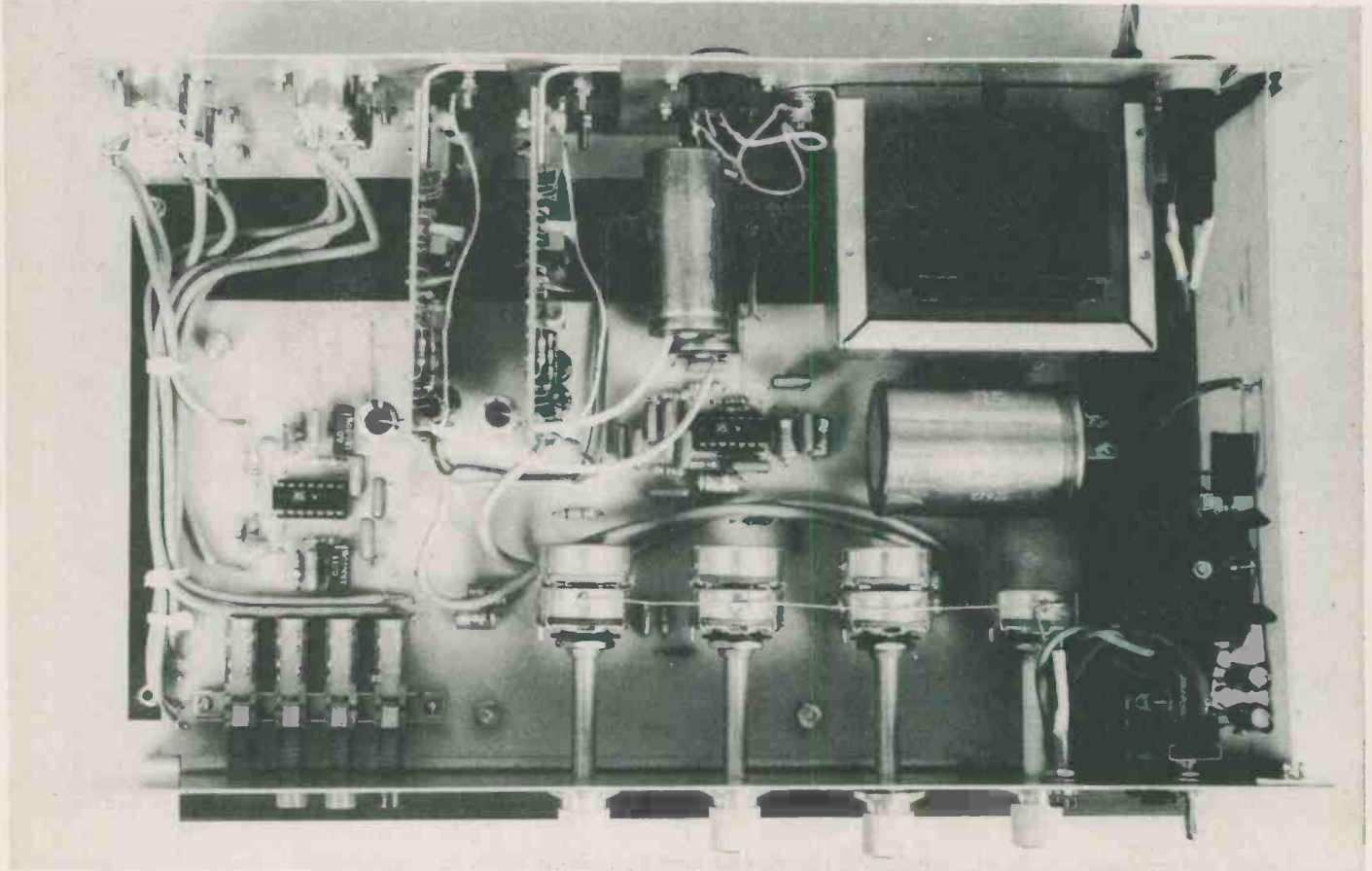

AUDIO MIXER

This project should prove invaluable to anyone who is into live music. That is, unless they've just spent five times as much on a commercial one!

AT FIRST GLANCE this may not seem all that useful an addition to a small band's equipment. It consists basically of input circuitry for handling up to five microphones, guitars or whatever. All it does to these is to mix them together, provide some tone control and send them back out of a single output.

Most small bands which do not own a mixer handle the problem of sound mix by using a PA amplifier with several inputs. This means that the bass guitarist controls the level of the bass guitar, et cetera. This can lead to problems when members of the band decide that they're not being heard above the rest of the instruments! Using a mixer, however, the overall sound balance can be monitored and controlled by someone sitting in the audience.

This mixer also gives control over the total output level. This means that the band can be faded in or out at the start and finish of a number.

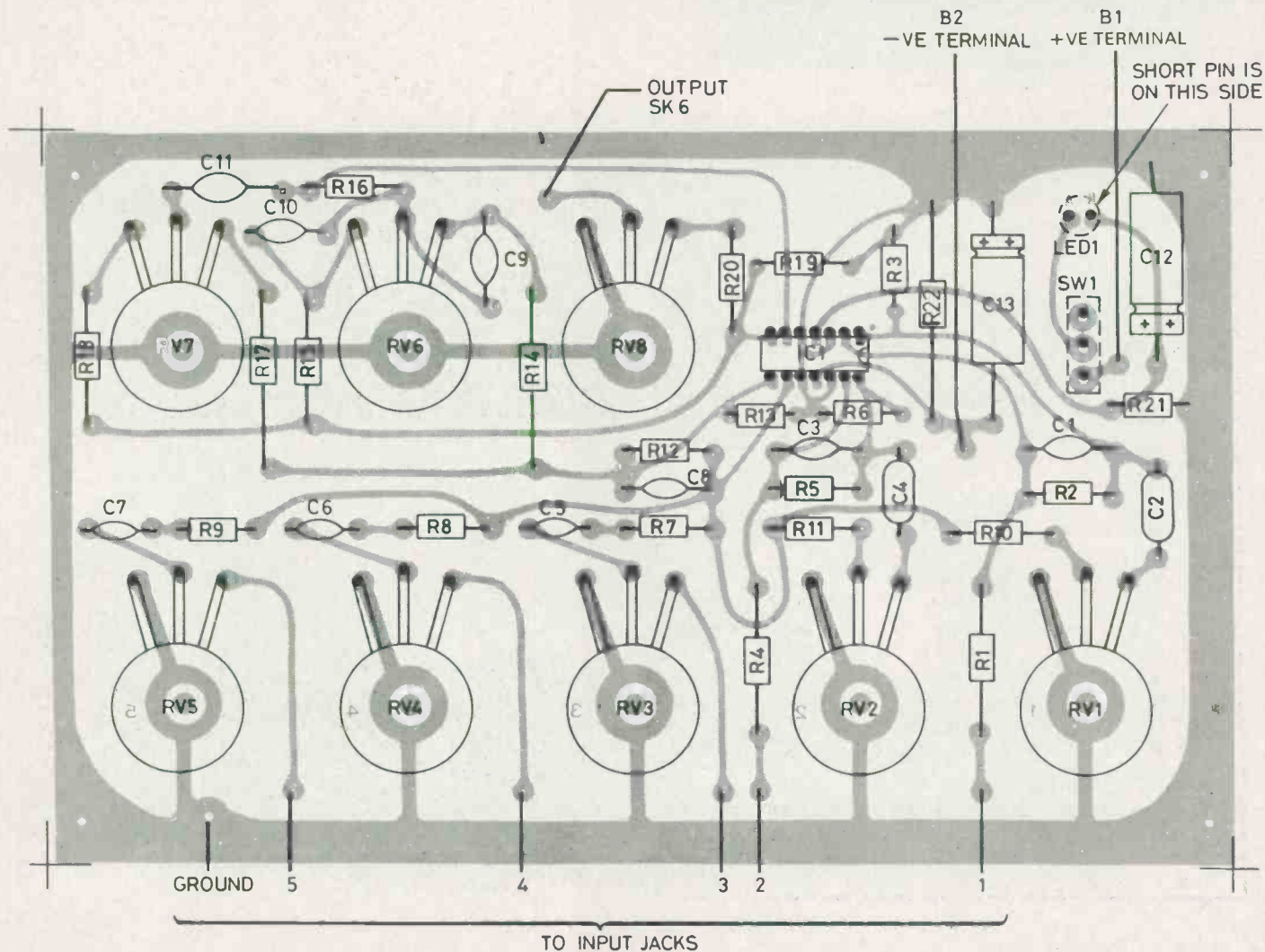

Apart from the facilities offered, what differentiates a good mixer from a mediocre one is the level of 'noise'. This is the amount of 'hiss' you hear with everything turned to full volume and no input. The noise level in this design compares very favourably with commercial mixers in a much higher price range.

Being battery-driven, this unit is particularly suited to 'on the road' applications, but other possible uses include stage sound effects cueing, tape recording, electronic music synthesis, et cetera.

Construction — The board

The important thing to watch is the orientation of C12, C13 and IC1. If you follow the 'overlay' carefully you shouldn't have any trouble. Another thing to be wary of if you are using an IC socket for IC1 (an IC socket is

usually soldered onto the board — the IC then plugs into it to save the risk of heat damage during soldering), then be careful that none of the IC pins are bent under the body of the IC.

The LED will only work one way round — one lead will be longer than the other. See the overlay to find out which one.

SW1 is not designed for printed circuit board (PCB) mounting, so use stiff wire for mounting. The potentiometer spindles will have to cut to length — the final length depending on what type of knobs you buy. Don't cut them until you've constructed the rest of the project. The potentiometer leads will have to be 'lengthened' by soldering stiff wires onto them so that they will reach the board.

PARTS LIST

RESISTORS (all 1/4W, 5% tolerance)

R1, 4	10k
R2, 5	100k
R3, 6, 13, 19	4k7
R7, 8, 9, 10, 11	56k
R12	100k
R14, 15, 16	10k
R17, 18	3k9
R20	1k0
R21, 22	4k7

CAPACITORS

C1, 3	56p	polyester
C2, 4	220n	polyester
C5, 6, 7	100n	polyester
C8	56p	polyester
C9, 10	47n	polyester
C11	4n7	polyester
C12, 13	220u	16V electrolytic

POTENTIOMETERS

RV1, 2, 3, 4, 5	25k	logarithmic
RV6	100k	linear
RV7	500k	linear
RV8	5k	logarithmic

SEMICONDUCTORS

IC1	LM324
LED1	any red LED

MISCELLANEOUS

Printed circuit board, single-pole double-throw switch, 2 9V batteries, battery clips to suit, 14-pin integrated circuit socket, knobs, 6 mono shorting jack sockets.

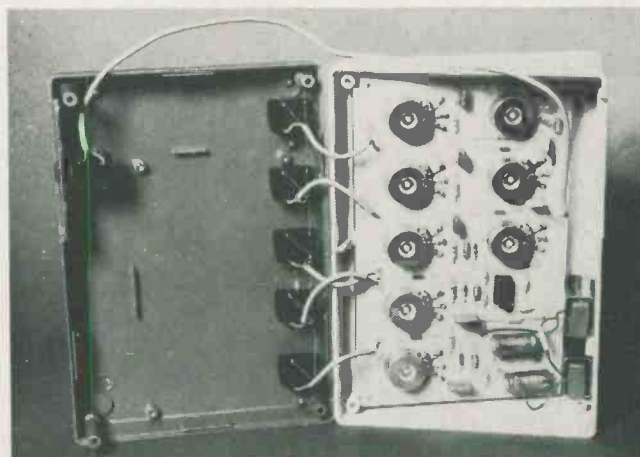

An internal view. Note the wiring layout.

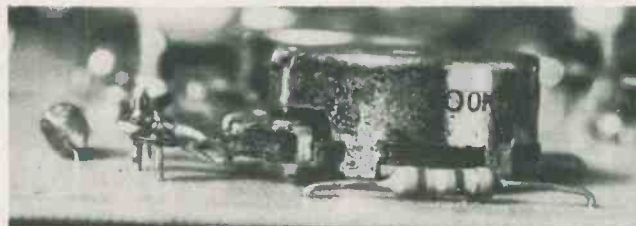

Do not solder the pots until you have bolted them in or you will risk straining the soldered joints.

Below: The circuit diagram. The power supply section is shown separately.

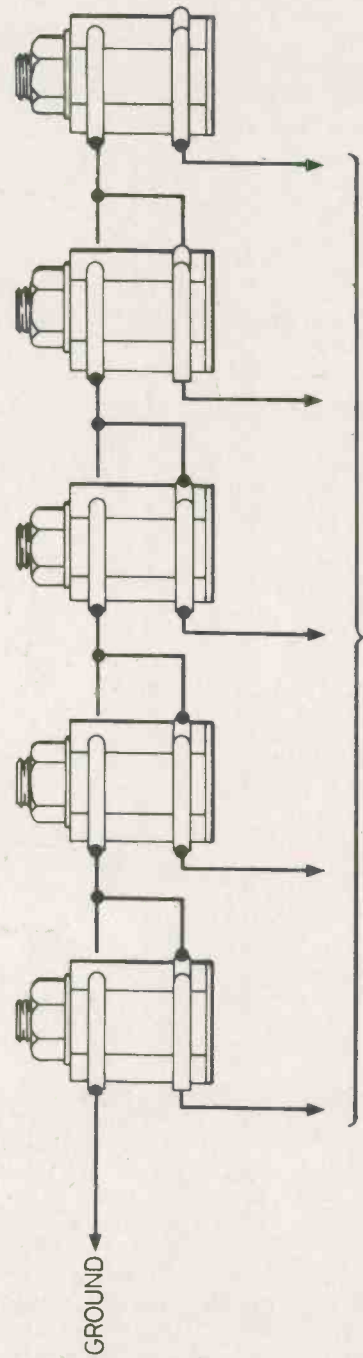
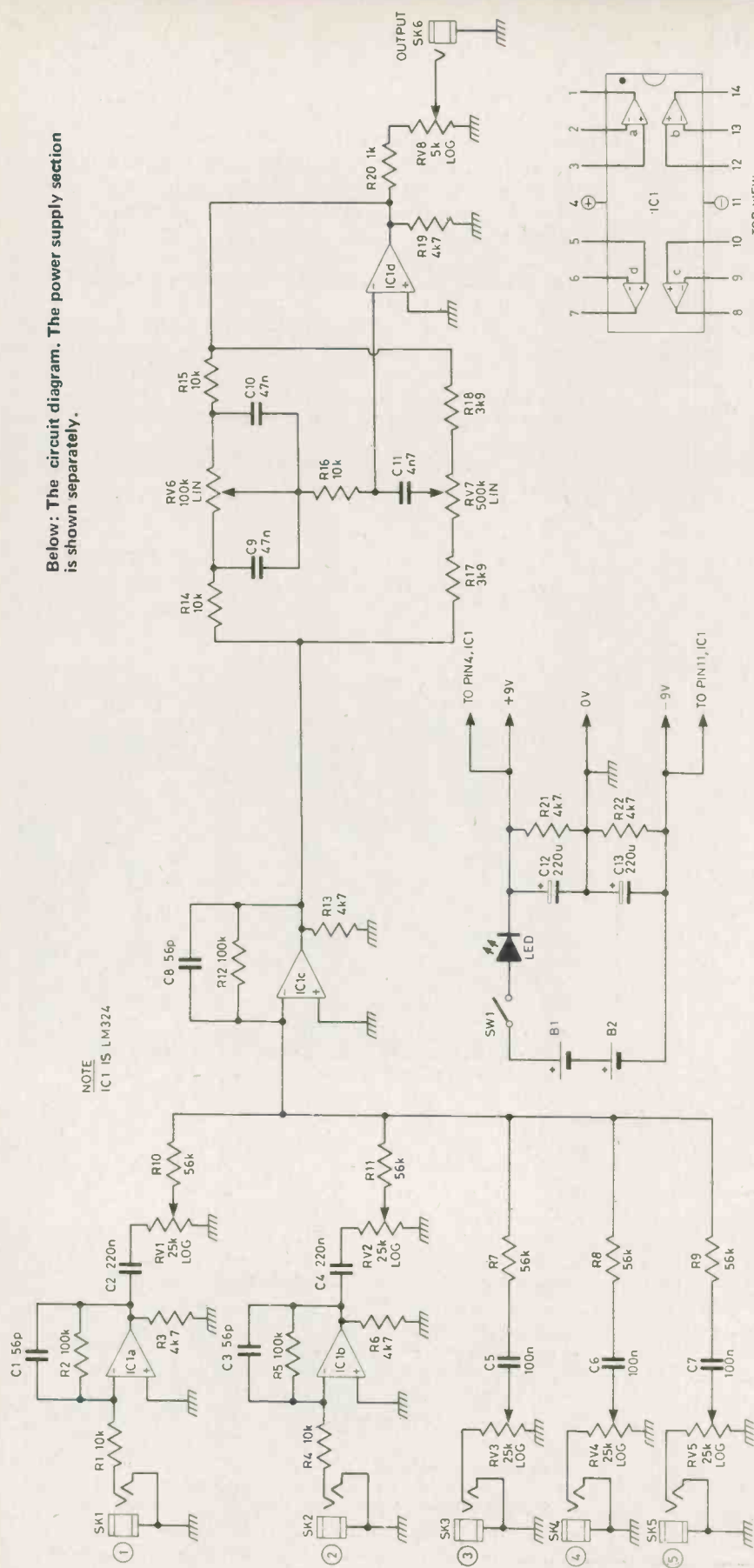

Above: Pinout diagram for IC1. The LM324 IC contains four operational amplifiers with common power supply inputs.
 Left: This diagram shows how to wire up the input sockets. Use screened cable to avoid 'hum' pickup.

HOW IT WORKS

An operational amplifier is shown like this:

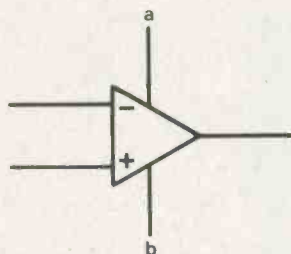

Connections a and b are the power supply leads. These are sometimes (as here) omitted for clarity. This leaves:



The leads at the left are inputs and the one at the right is the output. The “-” input is called the inverting input and the “+” input is called — in a burst of ingenuity, no doubt — the non-inverting input.

The operational amplifier is a very simple device in its operation, although each may contain (in a sub-miniature form) dozens of transistors, capacitors, etc.

All it does is to subtract the “-” input voltage from the “+” input voltage, multiply the result by a very large number (called the ‘open-loop gain’ for reasons which we won’t go into at this stage) and output the result. That’s all it does, and yet it’s one of the most flexible active components in use.

Suppose we connect it like this:

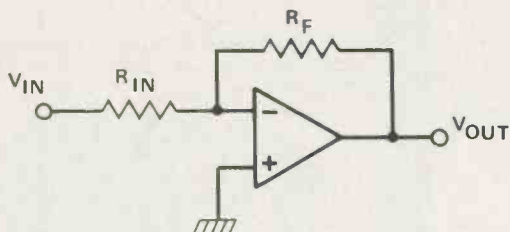

Since the non-inverting input is ‘grounded’, the voltage on it must be zero. Let’s suppose for the moment that the inverting input is above zero — the output will go below zero. In fact, it will go a lot below zero (remember, the open loop gain is a very large number, typically 20 000). This will cause the inverting input to be ‘dragged’ down (due to the current through R_F —the ‘feedback’ resistor). Eventually, the whole thing will settle down with the inverting input at zero volts.

Now, if we put current into the inverting input through the input resistor, the op-amp (operational amplifier) will change the output voltage until the whole thing balances again. The current through the feedback resistor will always be the same as the current through the input resistor and the inverting input will stay at zero volts.

The output voltage will always be a negative number times the input voltage:

$$V_{OUT} = -G \times V_{IN}$$

The value of G will be R_F/R_{IN} .
If we then add a second input:

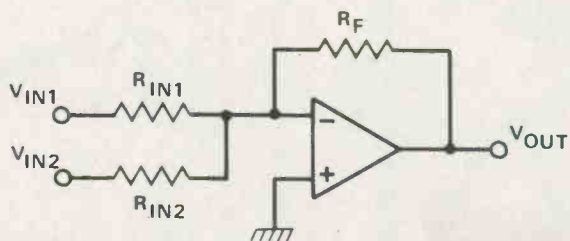

The voltage at the inverting input will stay at zero — the circuit will operate exactly as before, except that the output will be $V_{OUT} = (G_1 \times V_{IN1}) + (G_2 \times V_{IN2})$. In other words, the output voltage will be the sum of the amplified input voltages. Using this circuit, we can ‘mix’ signals together to form a composite output.

This form of circuit is called a ‘virtual ground mixer’ because the inverting input remains at zero volts (ie earth voltage). Any number of inputs may be mixed in this way by adding more input resistors.

Looking at the circuit diagram, it’s pretty obvious what’s happening (although there are some ‘fiddly bits’ which will require explanation).

IC1a and IC1b are used to boost the low-level inputs from SK1 and SK2. The gain, G , of each will be $100k/10k = 10$ times. C1 and C3 are required for the stability of the operational amplifier and R3 and R6 are ‘pull-down’ resistors. These are required because this particular device is good at supplying current but useless at shorting it to ground. These resistors help.

The outputs are AC coupled (to remove any DC bias which may be present) by C2 and C’s 4 thru 7. The inputs to SK3, 4 and 5 should be of a high enough level that they don’t require any extra amplification. Resistors 7 thru 12 and IC1c form the virtual earth mixer itself. Again, C8 and R13 are there to help the device along. IC1d and associated components form a standard ‘Baxendall’ tone control circuit which we won’t go into here.

The power supply to the IC is through LED1. This means that the effective supply voltage is $9+9-2 = 16$ volts (the voltage drop across a LED is about two volts), but this is sufficient.

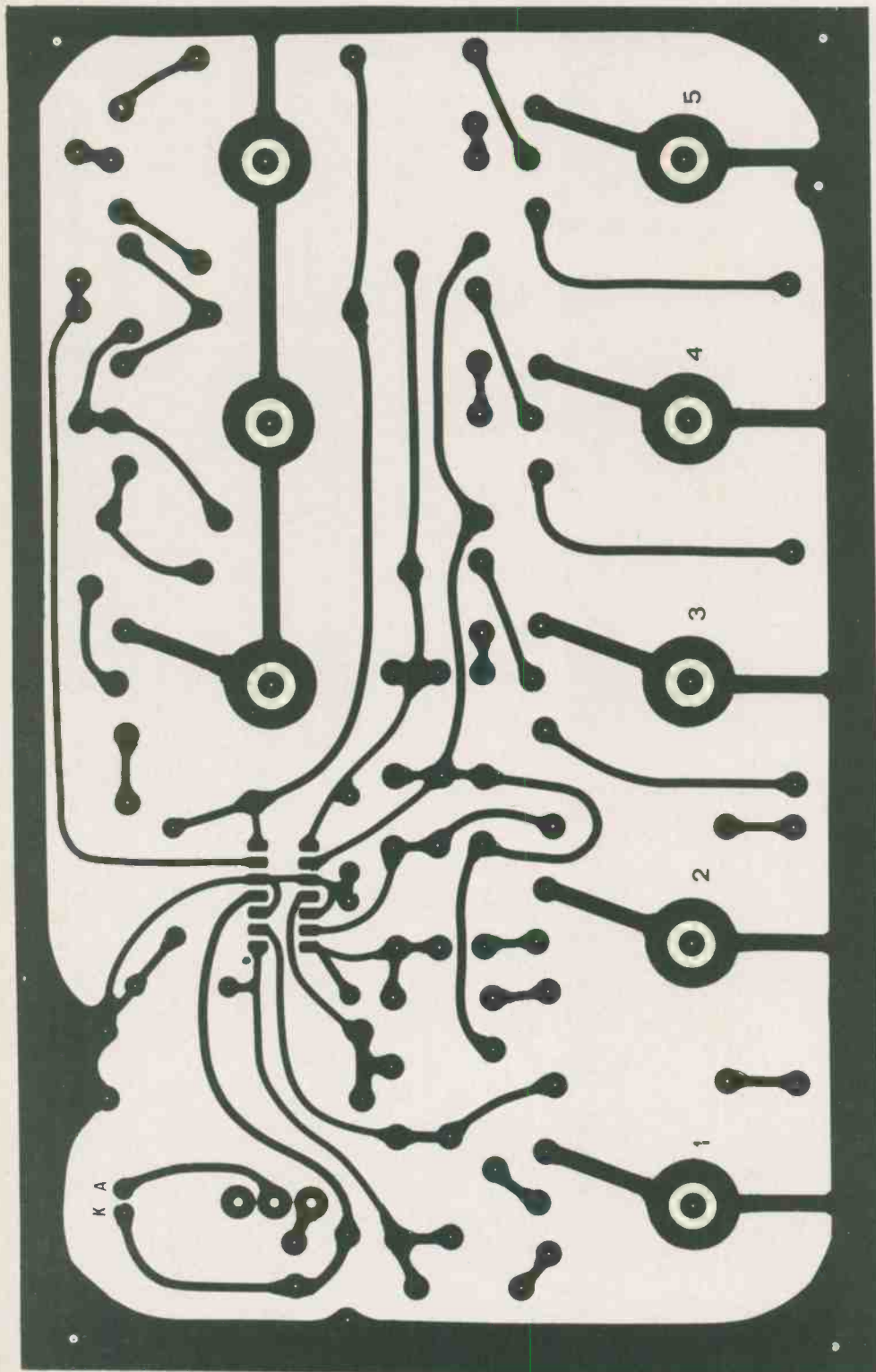

Construction – The Rest

The PCB should have holes which match threads on the case but don't screw it down until you've soldered the wires on!

Follow the diagram when it comes to wiring up the sockets and you should have no trouble – but use screened cable or you will run into problems due to hum pickup.

The batteries are connected in series—the negative terminal of one connected to the positive terminal of the other. The other two terminals are connected to the board. Use battery clips—they're useful when changing batteries!

Using It

Inputs 1 and 2 are 'low-level', suitable for microphones, guitars, etc. The other three inputs are for electric piano, synthesiser and the like. A good rule of thumb is that if what you're plugging it has either a) a line plug or b) a battery, then it can go into one of the high level inputs (3 to 5).

Don't leave leads plugged into the unit when there's on input from them – such as guitar leads with no input to ground if there's no plug inserted as this reduced the amount of hum present.

The tone controls both have a neutral position with the spindle rotated to half way between the end stops.

It is usual to leave the master volume control at full except when fading in or out. This means that the full travel of the control can be utilised, giving a smooth fade.●

The foil pattern. Printed circuit boards can either be made at home or bought from advertisers.

**Learn
the
Seven
Steps
to
Health**



CANADIAN CANCER SOCIETY

SCRATCH AND RUMBLE FILTER

Improve the quality of those old discs — and other things — with this simple but versatile Rumble and Scratch filter.

MANY OLD and not-so-old discs produce noises that they're not supposed to. They produce high-frequency 'clicks' from scratches on the faces of the actual discs, and low-frequency 'rumbles' from the record player turntable mechanism. Our Rumble-Scratch filter helps eliminate these nasty noises from an amplifier system.

The Rumble-Scratch filter incorporates two good quality filter systems, which process the record player pick-up signal as it passes on to the system's power amplifier stage. The first of these filters is a 'high pass type', which chops off the unwanted low-frequency rumble signals, and the second filter is a 'low-pass' type, which gets rid of the unwanted high-frequency scratch signals.

The Rumble-Scratch unit is battery powered, and quite versatile. Its low-frequency and high-frequency cut-off points can each be switch-selected to any one of three cut-off settings and each filter has a switched 'bypass' facility. The unit can easily be built in mono or stereo versions, with or without the switched cut-off frequency facility, to satisfy individual reader tastes.

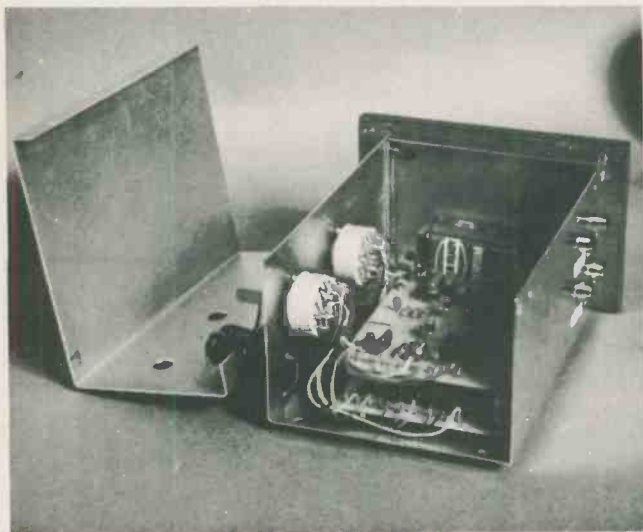

Inside the stereo version of the filter — two identical PCB's are used, by only a single battery and power switch are needed.



The finished filter. Note the two range switches, for the rumble and scratch sections, and the frequencies which they select.

Construction — The Board

Construction of the board should present few problems. Decide at the outset if you want a mono or stereo version of the unit, and if you want the cut-off frequency switching facility. Mono versions need only a single PC board. Stereo versions need two PC boards, and must have all compatible switches except S5 ganged together, e.g., S1 and S3 must be 2-gang 3-way types for mono and 4-gang 3-way types for stereo. Note that a single battery can be used to power the pair of boards used in a stereo set-up, since each board draws less than 2mA of current.

Using The Unit

The unit provides unity voltage gain at mid-band frequencies, and can readily handle signals from a few millivolts up to a couple of volts RMS. The design uses low-noise 2N3904 transistors, and can be used to interface directly between low- to medium-impedance pick-ups or pre-amplifiers and a main power amplifier.

The unit has uses other than as a mere Rumble-Scratch filter, and can be used to improve or modify the quality of any audio signal. It is, for example, useful for improving the sound quality on poor quality radio reception, or reducing the 'hum' from an audio system. ●

PARTS LIST

RESISTORS:—

- R1 27k
- R2 12k
- R3 2k7
- R4 15k
- R6 220k
- R7 4k7
- R9 10k
- R10 820R

CAPACITORS:—

- C1, C4: 68n
- C2, C5: 100n
- C3, C6, C9, 220n
- C7, C8: C16 1 μ TANT
- C10, C13, 10n
- C11, 22n
- C12, C15, 4n7
- C14, 2n2

MISCELLANEOUS

- SW1, SW3, 4 pole, 12 way wafer switch
- SW2, SW4, D.P.D.T. Toggle
- Case
- 4 phono sockets
- Knobs to suit, 9V battery

SEMICONDUCTORS:—

- Q1, Q2 2N3904
- LED 1 TIL209

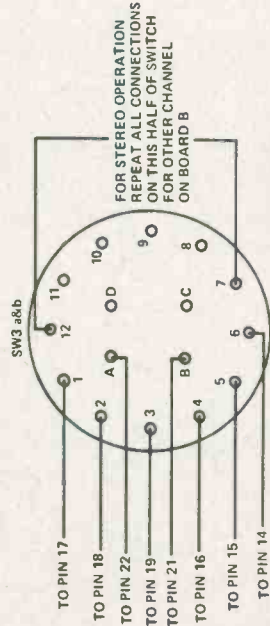
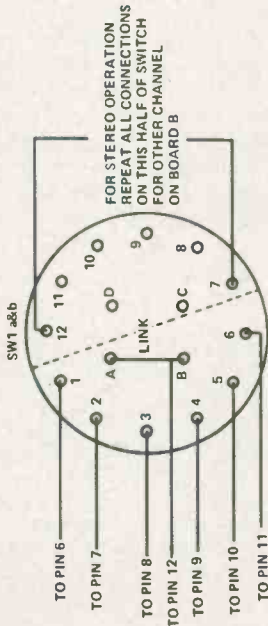

Note: Q1 & Q2 are 2N3904

SW1 Ranges
1=150Hz
2=100Hz
3=50Hz

SW3 Ranges
1=10kHz
2=5kHz
3=2k5Hz

Below: The circuit diagram.

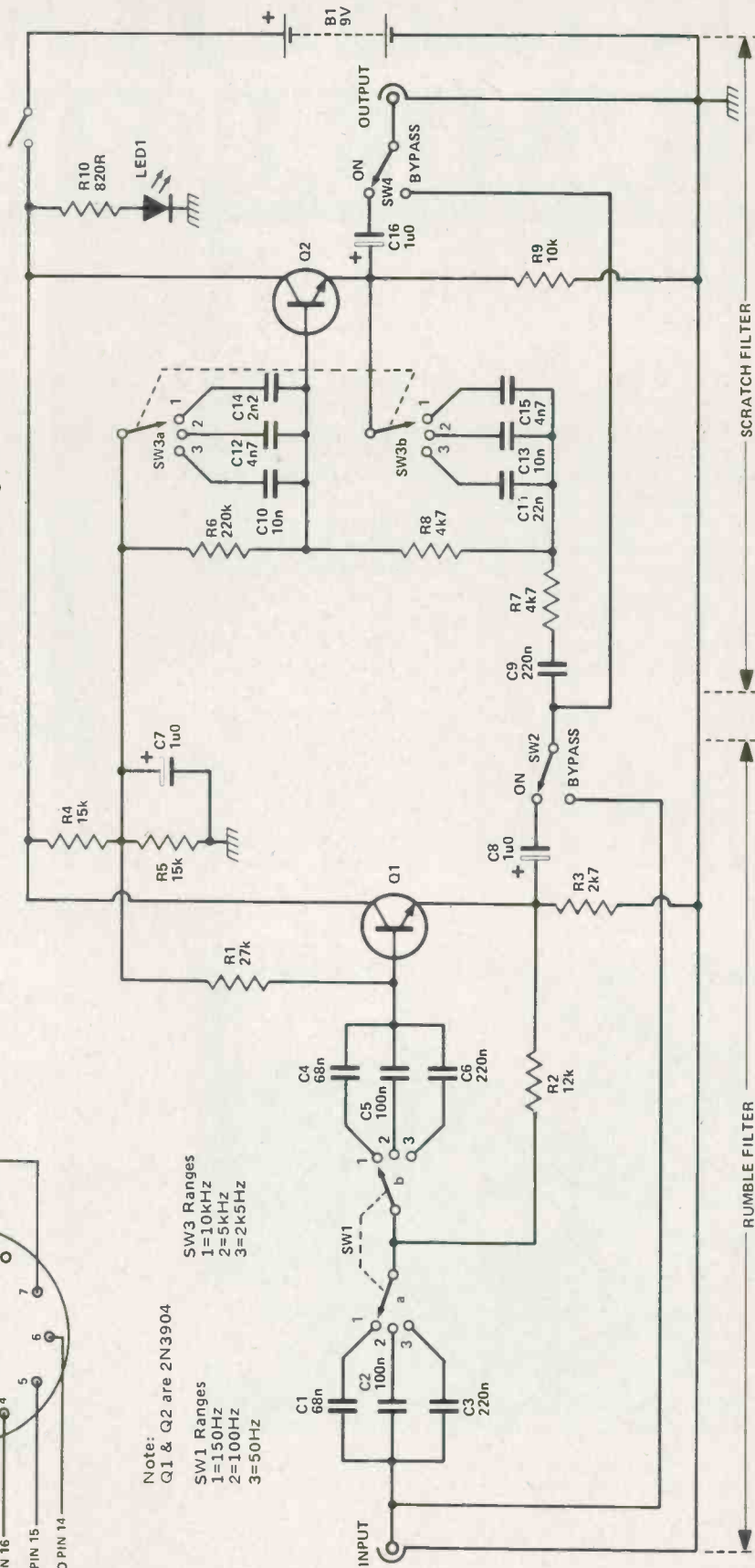

HOW IT WORKS

Figure 1 shows the block diagram of the mono version of the Rumble-Scratch filter. The input signal (derived from the turntable pick-up) is first fed through a high-pass filter (which rejects unwanted low-frequency RUMBLE signals) and is then fed through a low-pass filter (which rejects unwanted high-frequency SCRATCH signals). Each filter can be by-passed via a simple switch if required, so the input signal can be passed through either one, both, or neither of the filters.

Figure 2 shows the circuit (a) and performance graph (b) of a simple single-stage passive high-pass filter. At low frequencies capacitor C1 presents an impedance that is high relative to R1, so a lot of signal attenuation occurs between the input and output terminals. At high frequencies C1 presents an impedance that is low relative to R1, so negligible signal attenuation occurs between input and output.

The frequency at which the output signal is 3 dB down on the input signal of a pass filter is conventionally known as the BREAK frequency.

Note in Fig 2(B) that the graph shows a smooth ROLL OFF or SLOPE up to the break frequency point. A single stage filter has a slope or roll off of 6dB/octave, i.e., the signal output level doubles if the input frequency is doubled.

A number of filter stages can be cascaded to give a roll off of greater than the basic 6 dB/octave. Usually, some kind of electronic buffering or feedback is used between the individual sections of a multi-stage pass filter system.

Figure 3 shows the circuit (a) and performance graph (b) of a two-stage high-pass filter. This design is known as a Butterworth filter, and is the type used as the RUMBLE section of our project. It has a sharp break frequency, and gives a SLOPE or ROLL OFF of 12dB/octave.

The basic high-pass filter of Fig. 2 can be made to act as a low-pass type by simply transposing the positions of C1 and R1, as shown in Fig. 4. Figure 5 shows the two-stage (second order) Butterworth version of the low-pass filter. This is the design that is used as the SCRATCH filter in our project.

In the complete project (see main diagram) the high-pass or rumble filter is designed around Q1 and R1-R2-C1-C4 and the low-pass or scratch filter designed around Q2 and R7-R8-C14-C15. Resistors R4-R5 and by-pass capacitor C7 provide the low-impedance bias point for the two transistor stages. The low-frequency break point of the RUMBLE

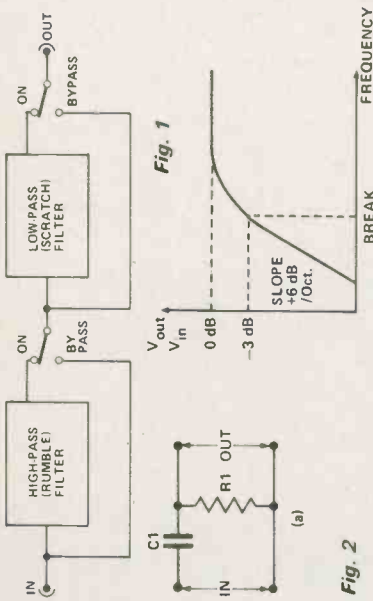

Fig. 1

Fig. 2

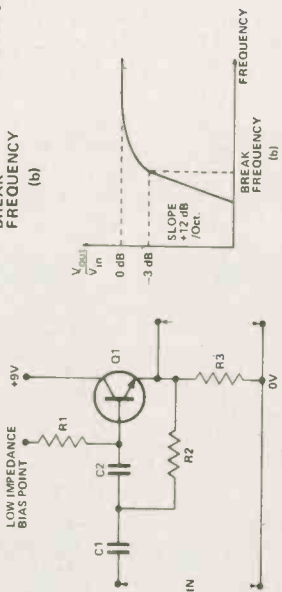

Fig. 3

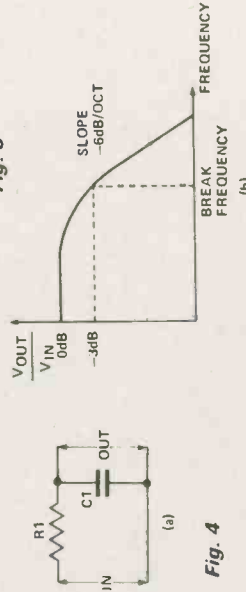

Fig. 4

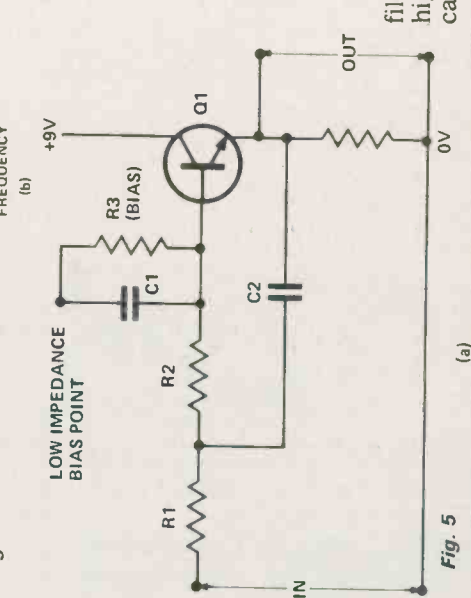
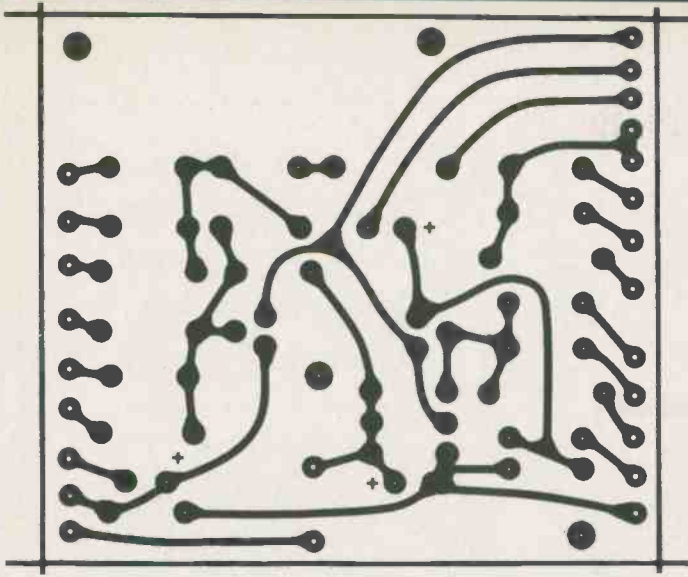
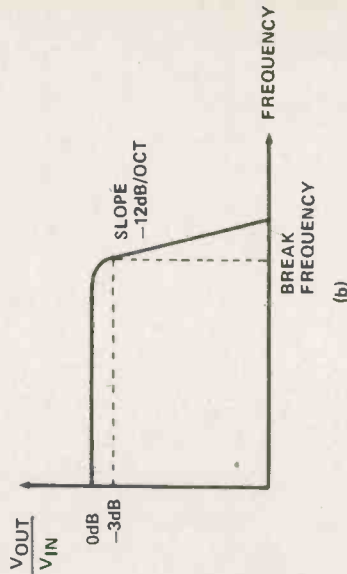

Fig. 5



The PCB foil pattern.



filter can be varied via 3-way switch S1, and the high-frequency break point of the SCRATCH filter can be varied via S3.

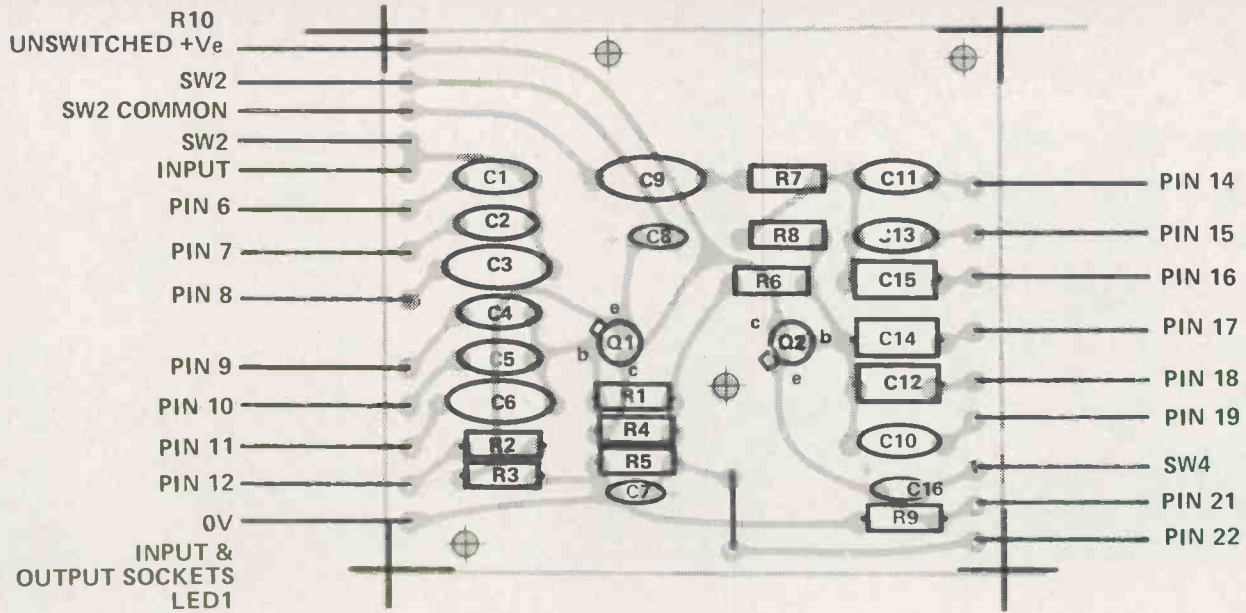

How to position the components on the PCB.

TABS AT ETI!

Prices shown include postage and packing. Send to Book Service, ETI Magazine, Unit 6, 25 Overlea Blvd, Toronto, Ontario, M4H 1B1

<p>1076 \$11.55</p> <p>Artificial Intelligence Making machines "think"</p>	<p>1071 \$10.90</p> <p>The Complete Handbook of Robotics</p>	<p>1010 \$9.85</p> <p>INTERNATIONAL TRANSISTOR SELECTOR</p>	<p>1064 \$11.85</p> <p>HOW TO DESIGN, BUILD & TEST COMPLETE SPEAKER SYSTEMS</p>	<p>1088 \$11.85</p> <p>ILLUSTRATED DICTIONARY OF MICROCOMPUTER TERMINOLOGY</p>	
<p>841 \$6.55</p> <p>BUILD YOUR OWN WORKING</p> <p>BY DAVID L. BEISERMAN</p>	<p>800 \$18.30</p> <p>Master Handbook of 1001 Practical Electronic Circuits</p> <p>Edited by Kendall Webster Sessions</p>	<p>TAB BOOKS NO. 804 \$18.35</p> <p>Master Handbook of 1001 MORE Practical Electronic Circuits</p> <p>Edited by Michael L. Fair</p>	<p>1015 \$9.70</p> <p>A BEGINNER'S GUIDE TO COMPUTERS & MICROPROCESSORS</p> <p>with projects</p> <p>BY CHARLES A. ADAMS</p>	<p>1000 \$11.55</p> <p>57 PRACTICAL PROGRAMS & GAMES IN BASIC</p> <p>Programs for everything from space war games to blackjack, from craps to 11 Change!</p> <p>BY BEN TRACCO</p>	<p>1070 \$12.35</p> <p>Digital Interfacing With An Analog World</p> <p>How to design circuits to interface microcomputers, computers, and other analog devices with the digital world</p>

CONSTANT VOLUME AMPLIFIER

The uses of a Constant Volume Amplifier may at first seem somewhat limited, but any audio enthusiasts will immediately recognise it as a compressor, invaluable in high quality tape recording etc.

ANY ENTHUSIASTIC USER of a tape recorder, cassette or reel to reel, will appreciate that the recording of rapidly fluctuating sound levels such as the human voice or an orchestra for example, can often pose certain difficulties. If the level control is set on the recorder during a loud passage then when a quiet passage comes along, it can be almost inaudible. Likewise if the level is set on a quiet passage then the louder ones will be distorted.

What is needed is a piece of equipment which can strengthen the weak signals and lower the louder. Such a device is the HE Constant Volume Amplifier which attempts to give a relatively unchanging output level for a multitude of inputs.

The key word here, of course, is 'relatively' — we don't really want a *constant* volume level because we might not be able to tell if the orchestra was playing a

crescendo or a quiet passage. The ideal device would simply reduce the volume range. In other words it compresses the volume, in fact equipment of this sort is

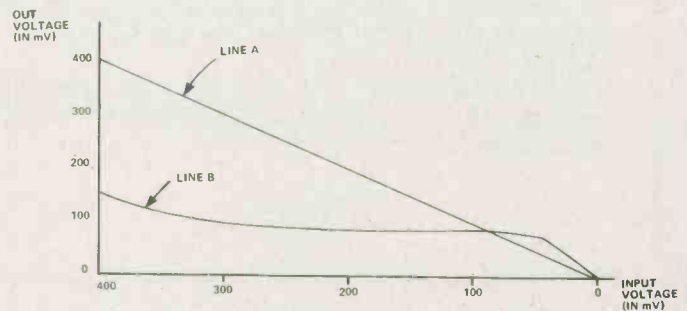

Fig.1. Graph of output vs. input voltage.



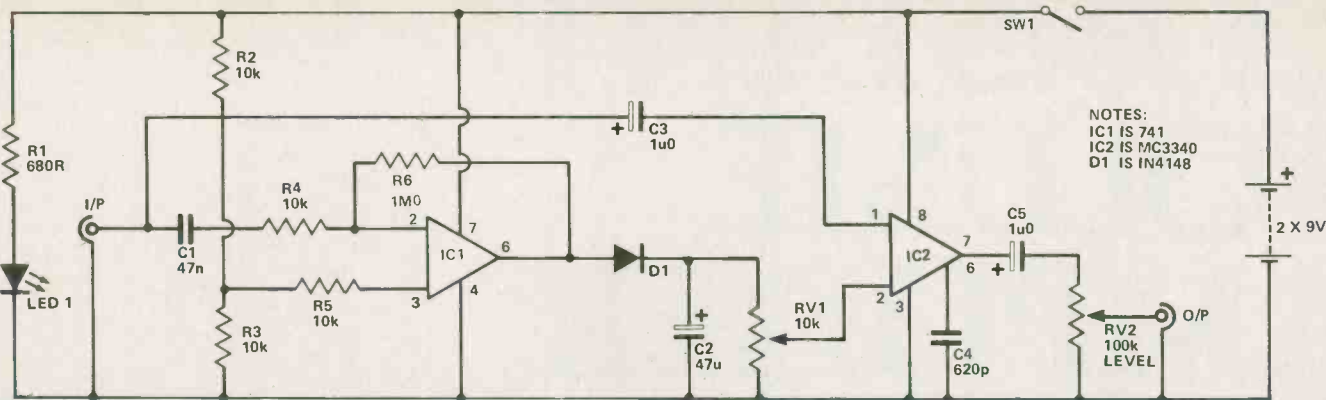

Fig.2. Circuit diagram of the Constant Volume Amplifier.

HOW IT WORKS

IC 2 is a voltage controlled amplifier. That is, an amplifier whose gain is directly proportional to a DC control voltage present at pin 2. Following the circuit diagram, the signal can be seen to pass through coupling capacitor C3, to pin 1 of IC2, the input. The output from pin 7 is coupled via C5 to the preset RV2 which is set to give the required output amplitude. As the voltage on pin 2 alters, so does the gain of the amplifier. At 3.5 V the gain is at maximum, but at 6 V the output of the amp is virtually zero. At control voltages in between these two limits the o/p amplitude is between maximum and zero. (See figure 5)

The circuit around IC 1 derives the control voltage. IC 1 is used as an inverting amplifier whose gain is given by the formula

$$\frac{\text{R feedback}}{\text{R input}}$$

according to figure 6. These two resistors correspond to R6 and R4 in the final circuit, giving a gain of $1\text{M}/10\text{K} = 100$.

D1 half wave rectifies this amplified AC waveform which is then stored as a DC voltage on C2. The voltage should vary between about 8-14 volts, depending on the amplitude of the input signal. RV1 is used as a variable potential divider to drop this voltage to 3.5 to 6 V DC – used now for the necessary control voltage to pin 2 of IC2.

A compressor should ideally have a fast attack time, in the order of just a few milliseconds, so that any sharp loud note is acted upon quickly, but a relatively slow decay time of say 100 milliseconds – otherwise the effect described previously of a constant CVA would occur. These two times are inherent in the circuit as capacitor C2 charges quickly through D1, when a loud sound is present at the input, but it discharges at a much slower rate through RV1.

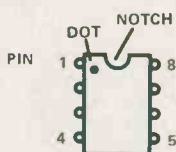

Fig.3. Showing an integrated circuit viewed from above (with pins pointing away).

locating notch or dot is on the top of the chip (see figure 3).

Some ICs have a dot used as a locator, some a notch and some have both. The printed circuit board has a dot

quite often referred to by people in the know as a compressor.

The graph in figure 1 displays the characteristics of the HE Constant Volume Amplifier showing output voltage vs input voltage. Line A is the graph obtained if the CVA is not used i.e. the output voltage is the same as that of the input (because there is nothing there to alter the input). However, with the CVA in use (line B) the output varies a greatly reduced amount as the input changes.

These results were obtained using the prototype constant volume amplifier and show how effectively it functions as an audio compressor.

Construction

Make sure that IC1 and 2 are inserted correctly – note that pin 1 of both ICs is the top left hand pin when the

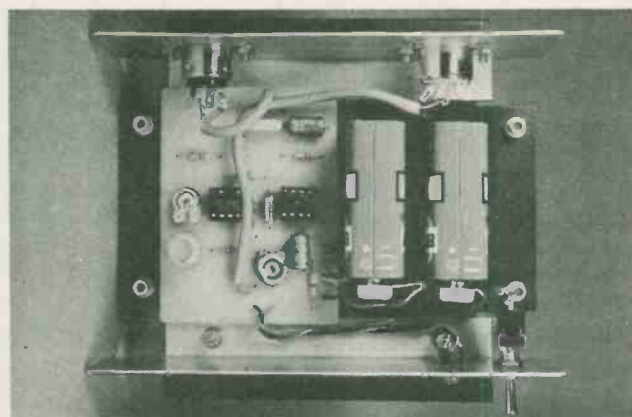

Note the position of the two nine volt batteries, make sure the metal cases of the batteries don't short against the switch or socket connections.

etched on it which corresponds to the correct placing of pin 1 for both ICs (see PCB pattern).

Looking at the inside photograph of the case shows the layout of wiring up, which is quite easy. Remember to use screened cable for input and output leads. The case ideally should be metal and grounded, to screen the circuit against lines hum. The grounding can take place at either input or output socket by connecting a short lead from tag 2 of the socket to the tag which is connected to the metal shield. The signal should come from tag 1 of the input socket and go to tag 3 of the output socket. (See figure 4).

The rest of the components should present no difficulties, the circuit being fairly straightforward.

Setting Up

The procedure for setting up requires the use of the CVA in situ. Feed an input to the device and the output to an amplifier with the amplifier volume turned down. Set RV2 to mid-position and RV1 fully anti-clockwise then switch everything on. Turn the amplifier volume up till you hear the signal. Now turn RV1 clockwise until distinct distortion of the signal occurs, then turn it back until the distortion just disappears. Finally, adjust RV2 to give the required volume level.

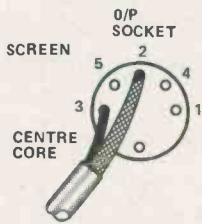

Fig.4. Phone sockets can be used or alternatively, D1N sockets could be incorporated, we have shown standard connections.

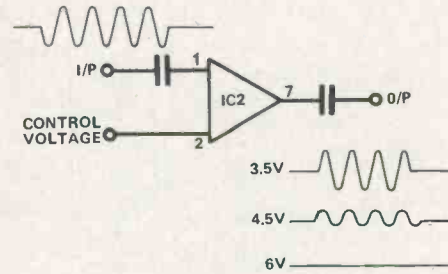

Fig.5. Showing the outputs obtained with control voltages.

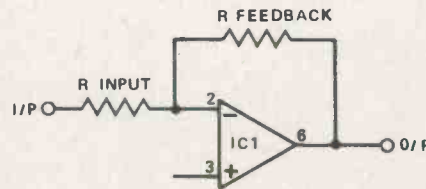
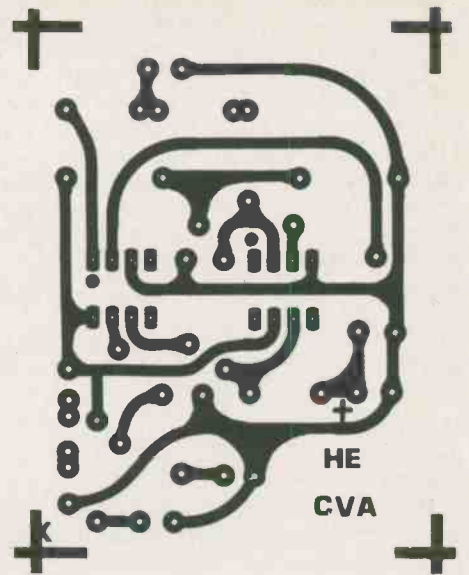
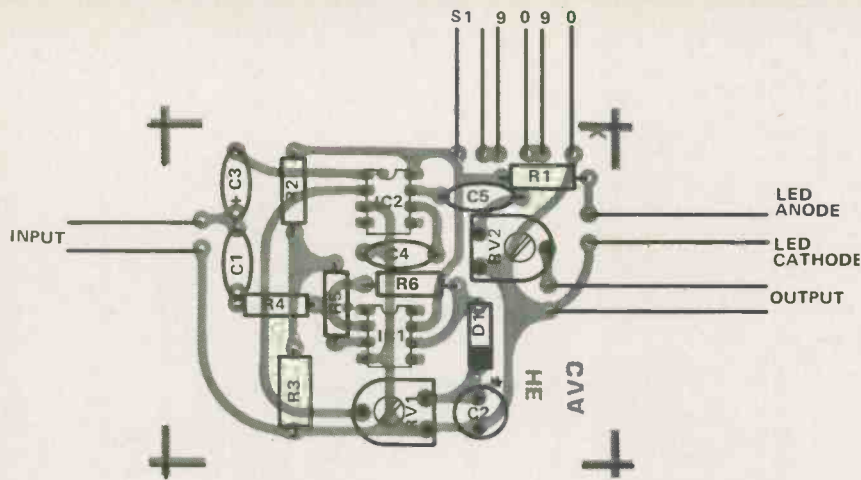

Fig.6. A straightforward operational amplifier circuit.



The on-off switch and LED keep the front panel neat and uncluttered.



PARTS LIST

RESISTORS (All 1/4W, 5%)

R1 680R
R2,3,4,5 10K
R6 1M

POTENTIOMETERS

RV1 10K Preset
RV2 100K Preset

CAPACITORS

C1 47nF Polyester
C2 47uF Elect.

C3,5 1uF Elect
C4 620pF Polystyrene

SEMICONDUCTORS

IC1 741
IC2 MC3340
D1 1N4148
LED 1 TIL 220 0.1" LED

MISCELLANEOUS

Switch
2x9 Volt batteries & clips
Case to suit
2 x 3-pin Din Sockets

Above Left: the overlay for the Constant Volume Amplifier.

Above: The PCB.

Below Left: The complete Amp Unit.

Below: The overhead view of the completed PCB.

The PCB foil pattern for the main board.

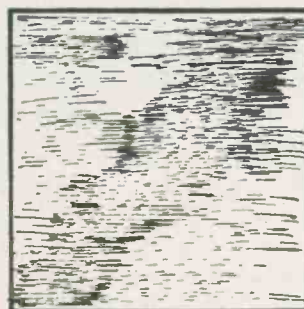
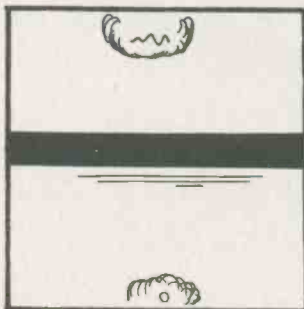
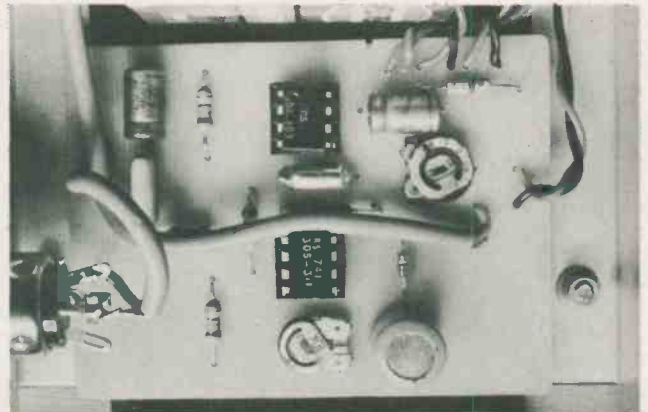

THERE IS A
FAULT IN THIS
CARTOON
PLEASE DO NOT ADJUST
YOUR MAGAZINE

GRAPHIC EQUALISER

Another project for those interested in audio work.

A GRAPHIC WHAT, you ask? A graphic equaliser is a complex form of tone control. It can be used to smooth out the frequency response of a Hi-Fi, or as a guitar effects unit. In fact, it will prove useful in any audio application.

Frequency Response

In order to explain how the equaliser works, first a quick explanation of the term 'frequency response'.

Say we take a circuit (any circuit) and set it up like this:

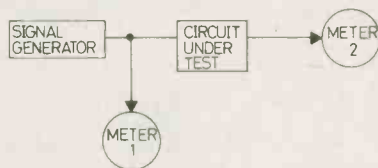

The ratio of the reading of meter 1 to the reading of meter 2 is called the response of the circuit. If the frequency of the signal used is varied, the response varies — because the circuit behaves differently when fed with different frequencies. A graph of response against frequency is called — you guessed it — the frequency response.

The frequency response of a typical amplifier looks something like this:

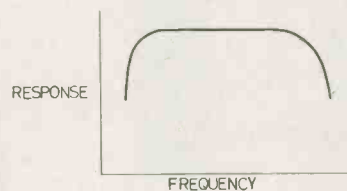

The central section is fairly 'flat' but when it comes to the very high or very low frequencies it loses power — the

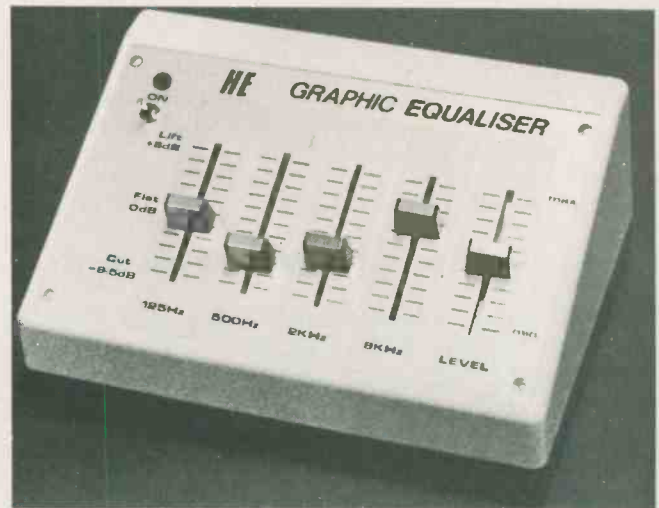

reading on meter 2 drops and so the response becomes less.

Once the signal from the amplifier has been passed to the speaker (which has its own frequency response as well), the response of the system overall may look like this:

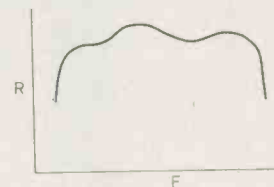

This will be further modified by the response of the room that the Hi-Fi is in — even your curtains have a response curve! By the time the signal finally reaches your ears the overall response will be fairly well mangled.

An equaliser is a device for correcting (equalising) the frequency response of a system.

Ironing Out the Bumps

Say, for instance, that the frequency response looked like this when it reached you (rather exaggerated, perhaps!):

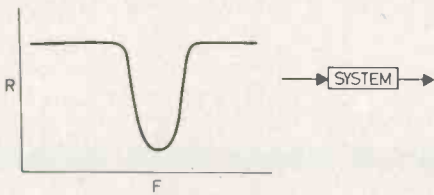

and we would of course like it to look like this:

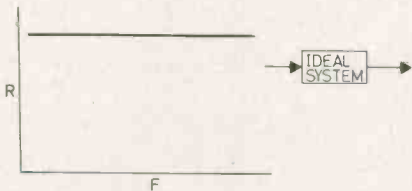

If we have a device (called an equaliser) which has a response like this (the opposite to the one we wish to correct):

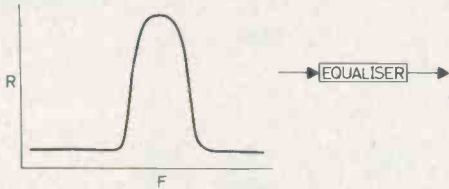

The board. Note the IC sockets and the electrolytic capacitor orientation

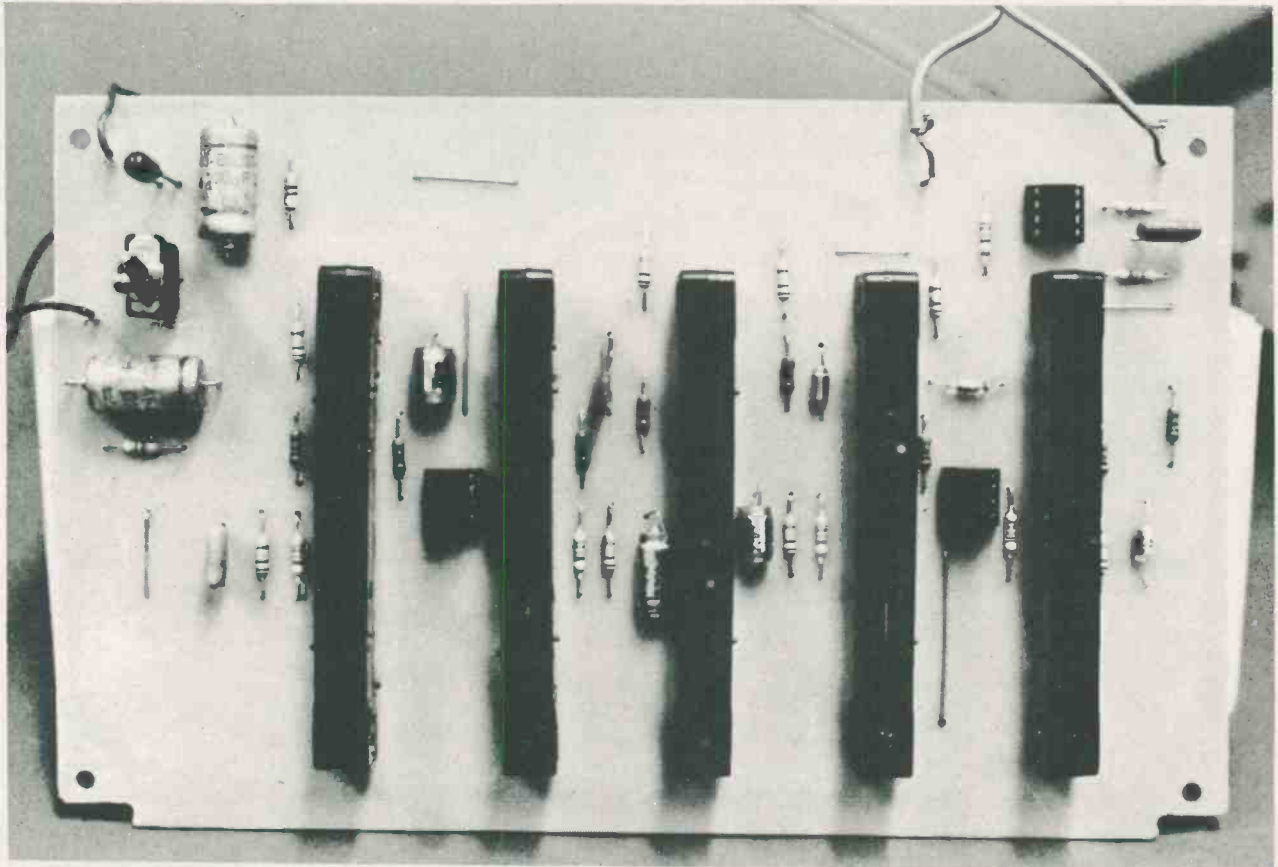

and we put it in series with the system, the overall response would be the sum of the two responses:

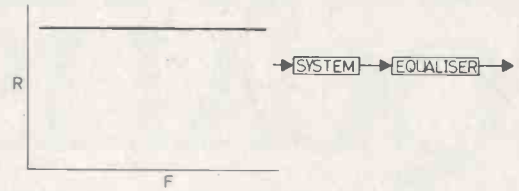

In this way we can take any system, be it a microphone, a telephone line or a Hi-Fi system, and 'iron out' the variations in its response.

There are two ways of finding the right equaliser response — directly or indirectly. The indirect method involves measuring the system curve and then designing an equaliser to fit it. This is fine if you are prepared to do all the sums and build a complete new unit for every application you run across.

The direct method is to build a device which has a variable response, connect it to the system and then vary the equaliser curve to give the desired effect.

The way this is usually done is to build a unit which will split the incoming signal into a number of frequency bands and then remix these in the desired ratios. This will give the device a number of plateaux on its response curve, all of which can be moved up or down independently of each other to give an approximation to the desired shape.

An equaliser of this type is called a graphic equaliser if the controls which determine the positions of the plateaux are of the 'slider' type. The positions of the

control knobs will then look like the frequency response graph of the equaliser.

The amount by which the HE Equaliser can vary the level of a particular frequency band is about 8 dB boost or cut.

The dB is a measure of voltage ratio — it measures the response in terms of the output divided by the input.

8 dB should prove sufficient for most applications.

Construction

The equaliser should be fairly easy to build — the only difficult part being the front panel.

Take care to mount all the electrolytic capacitors, the ICs and the LED the right way round and you should be okay. We suggest you use IC sockets to be on the safe side — these solder directly onto the board and the ICs

plug into them.

Don't forget the wire links on the PCB, by the way!

We stuck the batteries on with double-sided adhesive pads (useful things!).

After constructing the board, use the positions of the potentiometers, the LED and the switch to mark out the front panel.

The holes for the LED and switch can be drilled simply enough. The holes for the potentiometers can be fairly sloppy as we used stick-on bezels which go onto the front panel and have cut-outs the right shape for the shafts to run in. Make sure there are no burrs sticking out of the front panel.

PARTS LIST

RESISTORS (all 1/4W, 5% tolerance)

R1, 2	47k
R3, 4, 8, 9, 13, 14, 18, 19	18k
R5, 6, 10, 11, 15, 16, 20, 21	1M
R7, 12, 17, 22, 23	47k
R24, 25	4k7

CAPACITORS (all polyester unless otherwise specified)

C1	0u1
C2	33n
C3	3n3
C4	8n2
C5	820p
C6	2n2
C7	220p

C8	470p
C9	47p
C10, 11	220u 16V electrolytic

SEMICONDUCTORS

IC1, 2, 3	LM1458N
LED1	any red LED

POTENTIOMETERS

RV1	10k logarithmic slider
RV2, 3, 4, 5	100k linear slider

MISCELLANEOUS

One panel-mounting switch (single pole, double throw); Two sockets (see text); Three 8-pin IC sockets;

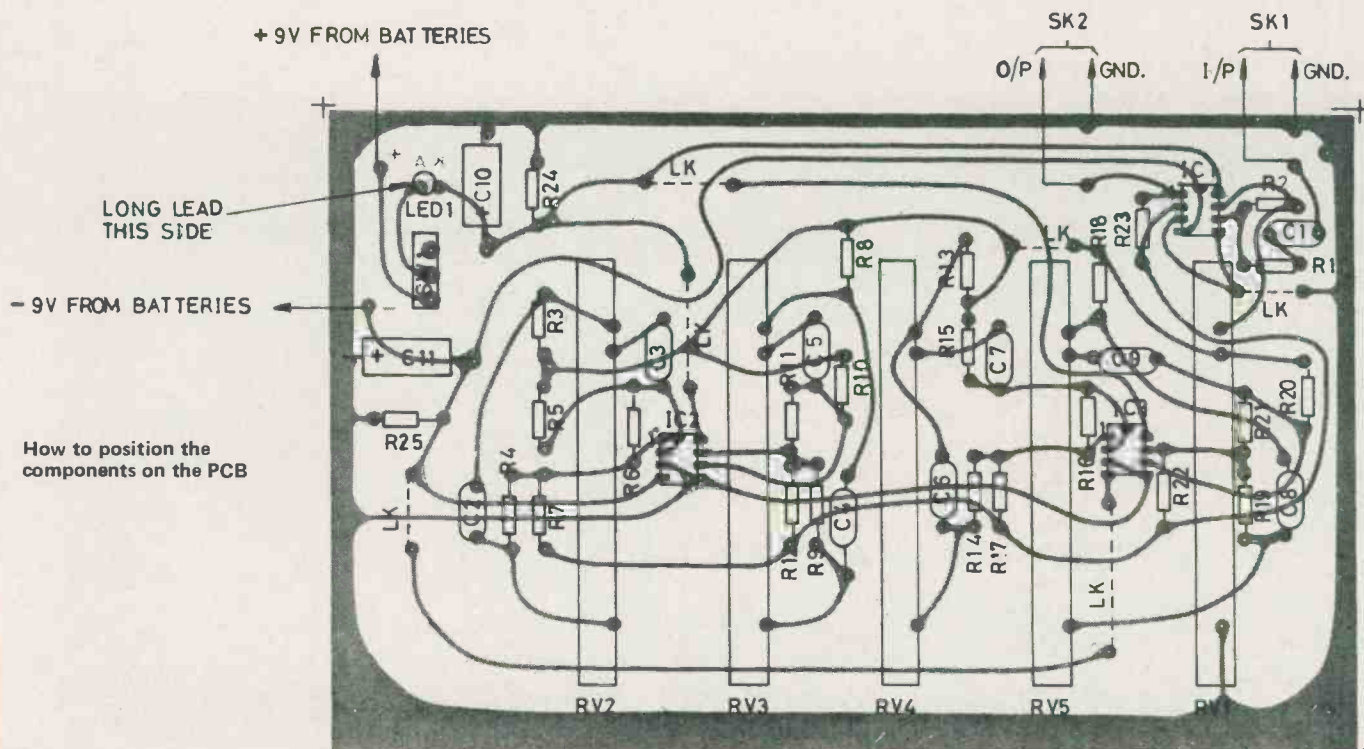

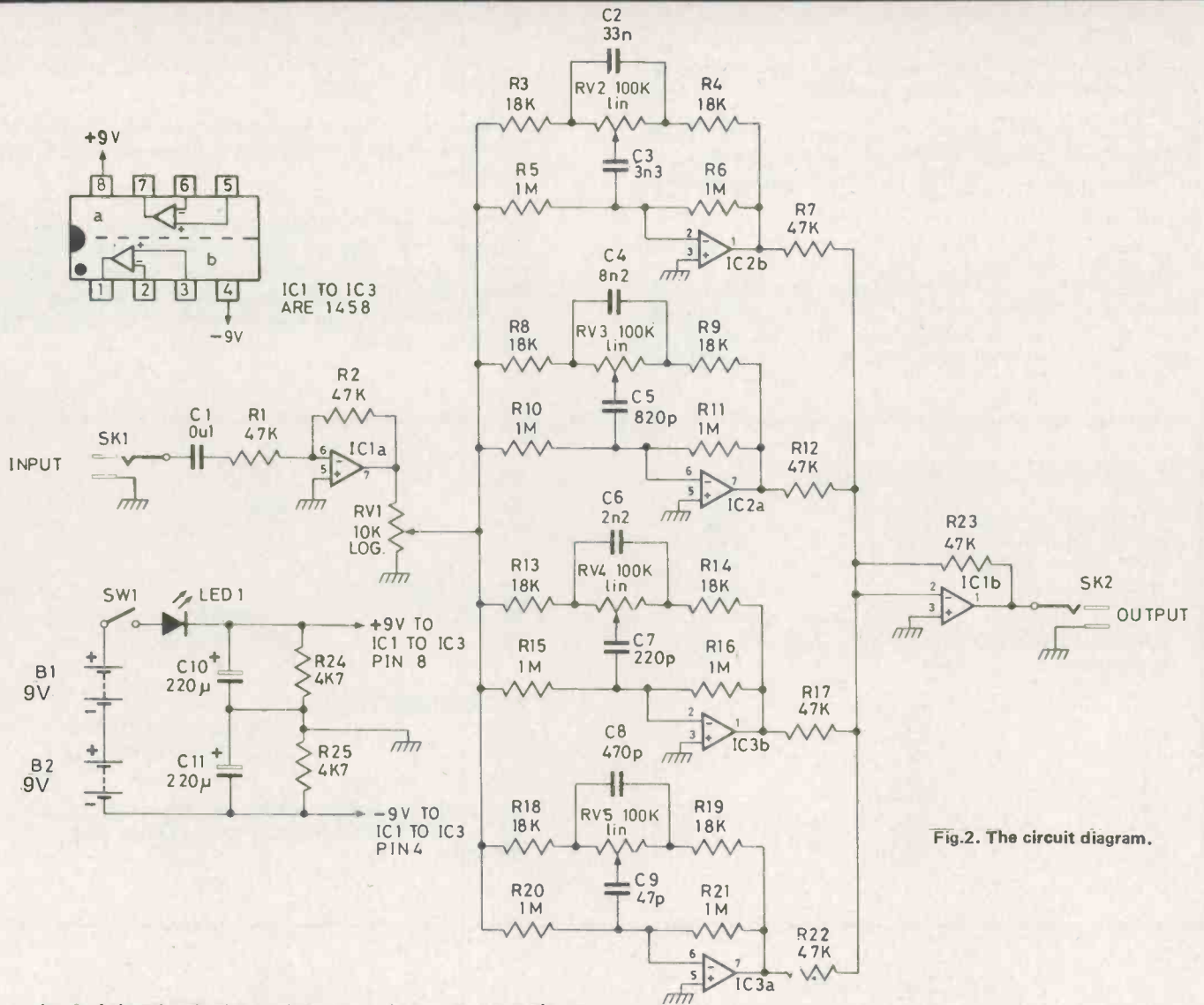
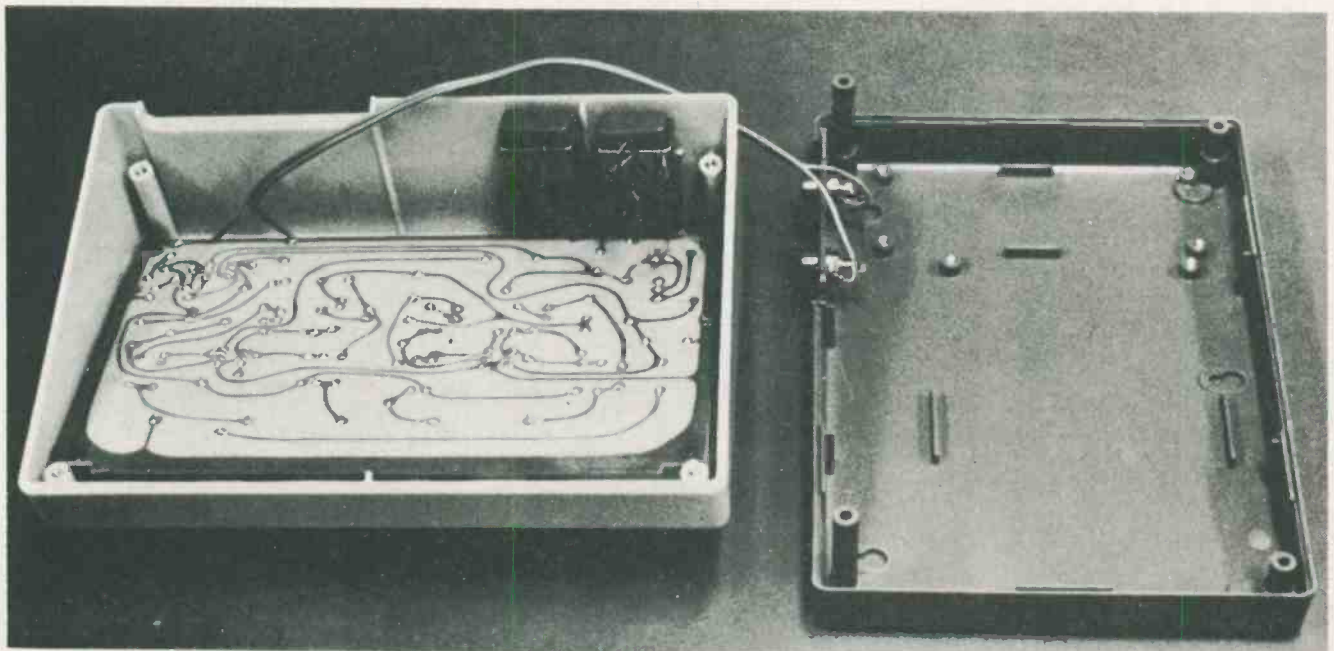

Fig.2. The circuit diagram.

An internal view showing how all the main components go together.



HOW IT WORKS

The input to the unit is decoupled (to remove DC) by C1 and fed into IC1a, which acts as a 'buffer' — it can be driven from a source with a very small current capability, which would be incapable of providing enough input otherwise. The output of IC1a is sufficiently powerful, however, to drive the rest of the circuit.

The output from IC1a is fed (via RV1, which controls the overall volume) to the four filter stages (ICs 2b, 2a, 3b, and 3a). These each respond to a particular frequency band and their output levels are adjustable by means of RVs, 2, 3, 4 and 5. The outputs from these filters are summed by IC1b, which acts as a virtual ground mixer — the "—" input is held at zero volts by virtue of the feedback through R23 and so the output of the unit is the inverted sum of the voltages at the outputs of the filter ICs.

The individual filters work as follows: the feedback effects will cause the output to be equal to the input times $(-Z_f/Z_{in})$, where Z_f is the impedance from the output to the "—" input and Z_{in} is the impedance from the input to the "—" input.

This is the same situation as in the buffer — IC1a. In its case, $Z_{in} = 47k$ and $Z_f = 47k$. Thus the

output is -1 times the input (i.e. the signal will be 'inverted' — it will sound the same, though).

In the filters, if the variable resistor is at mid-position, with an equal resistance between the wiper and either end, then $Z_{in} = Z_f$. Thus each filter will pass all frequencies with output $= -1 \times$ input when the slider is in mid-position.

When the slider is at the left-hand end on the circuit diagram, however, the impedances of the capacitors will cause the gain of the filter (gain = output/input) to vary with frequency in such a way as to increase the gain in a particular frequency band.

Similarly, moving the slider to the other end of the potentiometer will cause the same band of frequencies to be attenuated.

Thus, by moving the slider from one end to the other, the response of the filter to its particular frequency band can be changed. As the output is the sum of all the filters' outputs, the overall frequency response of the unit will follow the shape the sliders make on the front panel — pushing one of them up will boost that particular frequency band.

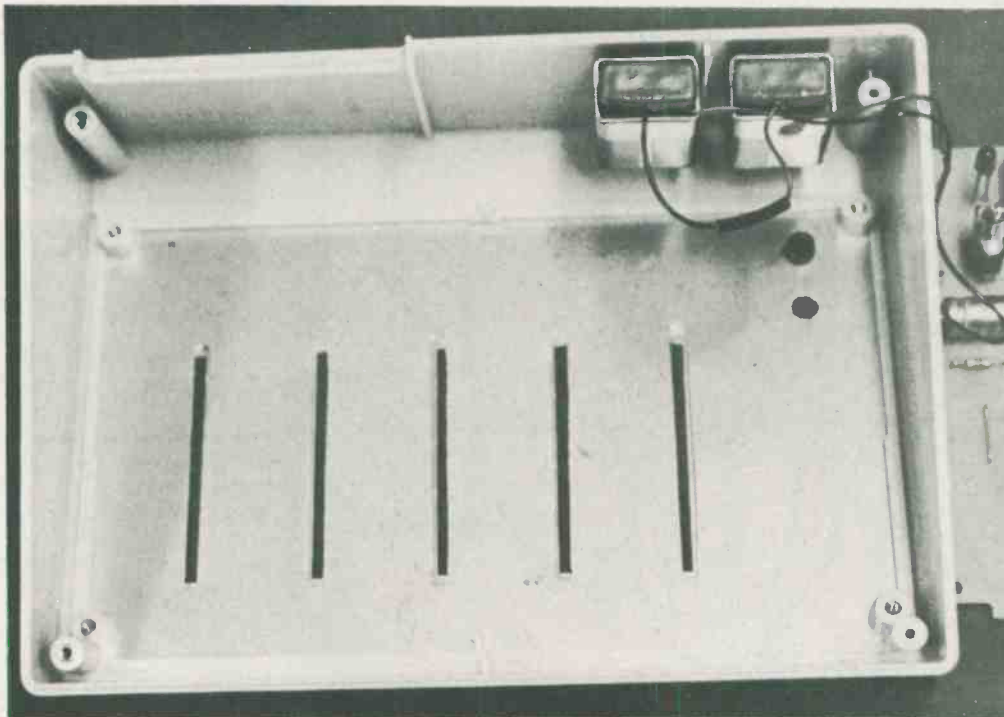

We used phono sockets for the input and output but there's no reason why any sockets suitable for audio signals shouldn't be used if there's room.

Having built the unit, you're now ready to use it — but how?

The back of the front panel, showing the method of connecting the batteries — with the positive terminal of one connected to the negative terminal of the other. The slightly oversized potentiometer holes can also be seen.

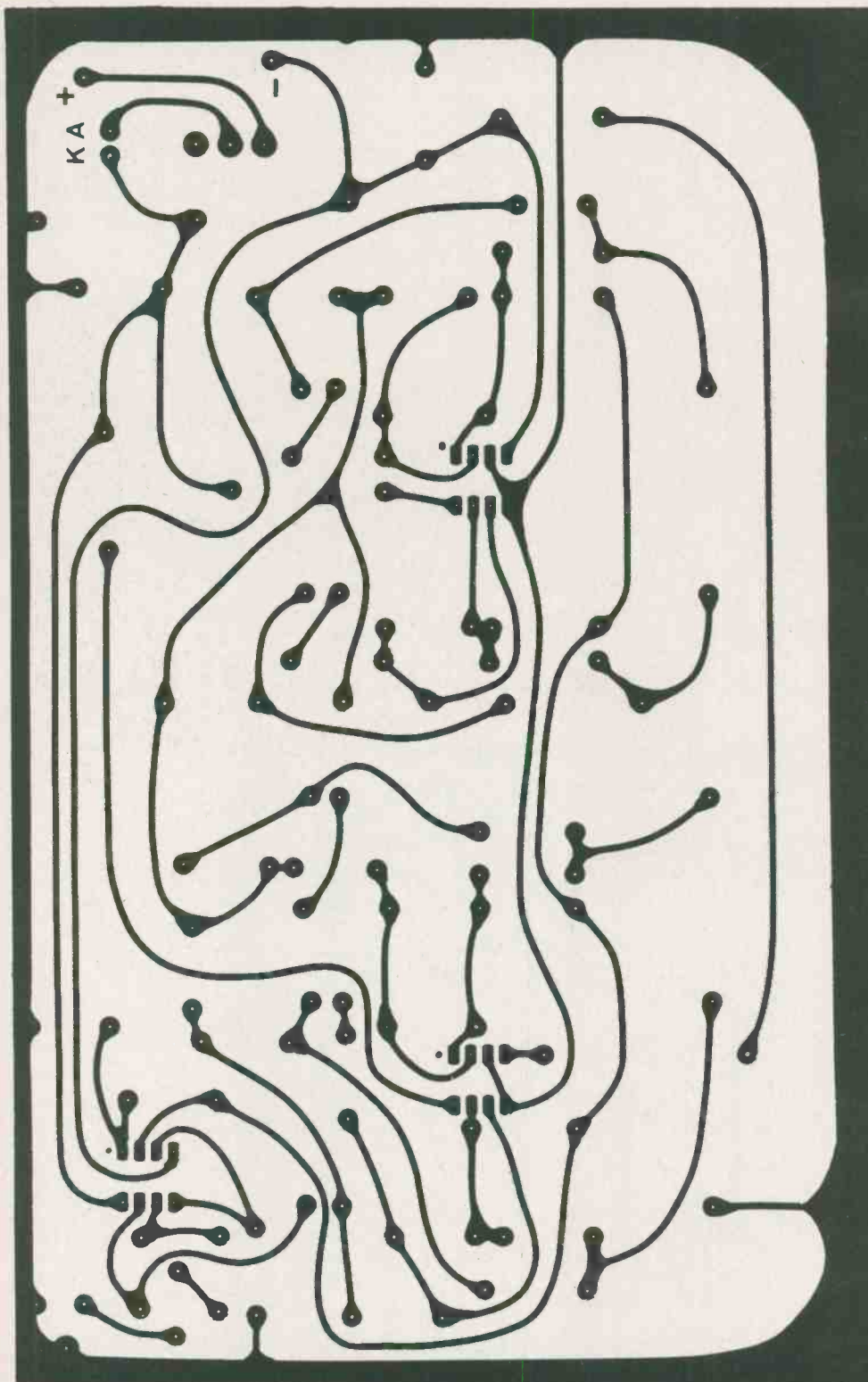

Effects Unit

The input to the equaliser should be of a fairly high level — a microphone or guitar will not do.

Any audio output from a device which either a) requires batteries or b) plugs into the lines should be of a high enough level.

The output from the unit should go wherever the input was going before you built the unit! This could be a PA amplifier or your Hi-Fi or tape recorder.

The sort of effects you can get from this unit are: a telephone line (with the 500Hz slider up and the rest down), a shout from a long way off (with the 8kHz sliders forming a diagonal up at the left).

Of course, by trying the unit yourself you can adapt it to new applications or use it in conjunction with other effects units to provide a versatile addition to your effects equipment.

Hi-Fi Smoother

Naturally, if your Hi-Fi is stereo, you'll need two of these units, but that shouldn't prove too much of a stumbling block to a hardened Hi-Fi perfectionist!

The unit should go between your pre-amplifier and power amplifier. The simplest way to adjust it is by ear, although it's not the most accurate method. You can reduce that annoying 'boominess' your speakers have always had, or boost the bass and treble and cut the middle from the signal from your tape recorder.

If you want to do it properly, however, you will need a signal generator, a good microphone and an oscilloscope, with the equaliser connected as described above. Assuming the microphone's response is absolutely 'flat' (i.e. the same at all frequencies), you should be able to measure the output of your Hi-Fi at a particular frequency by measuring the signal level with the oscilloscope. Merely adjust the equaliser until the system's response to all frequencies is the same. Make sure the amplifier's tone controls are in mid-position.

This sounds simple enough — but remember that the room's response will change if you move the chesterfield or open the curtains — so first adjust these to their normal position. Also remember the neighbours!

ENVELOPE GENERATOR



Here's a project that you can use to simulate the sound of any musical instrument, or use with the White Noise Generator to produce various sci-fi effects.

SO WHAT, YOU MAY ASK, is an ADSR (Attack, Decay, Sustain, Release) envelope generator, and what is it used for? It is a device that is used in electronic sound and music synthesis to mould the output sound envelope of a standard input signal (a tone or white noise signal) to the precise shape desired by the operator. By modifying the envelope, the operator can simulate the sounds of all types of musical instruments, or can simulate man-made sounds such as gun shots, explosions, steam engine 'chuffs', etc., or can create completely new 'science fiction' types of effects at will.

The action of the ADSR generator can be understood more clearly with the aid of the explanatory diagram of Figure 1. The top part of this shows what happens if you pass a steady tone signal through a linear transmission gate (an electronic switch) that is activated by an external control switch. The input signal appears at the output, with virtually zero 'Attack' time, as soon as the control switch is closed, it has a 'Sustain' amplitude identical to that of the input signal for the duration of the switch closure, and disappears with virtually zero 'Release' time as soon as the switch is opened again. The resulting output signal sounds completely artificial and uninteresting.

Attack and Decay

The lower part of the diagram shows what happens if the same input signal is passed through the ADSR envelope

Fig. 1. The diagram at the top shows the totally artificial waveform that is generated when a simple signal is passed through a transmission gate. The lower diagram shows the more realistic waveform that is produced when the same signal is passed through the ADSR envelope generator.

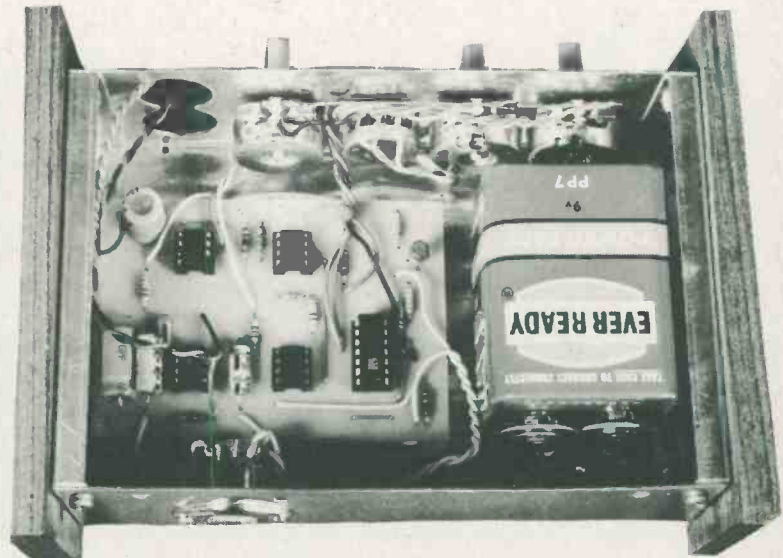
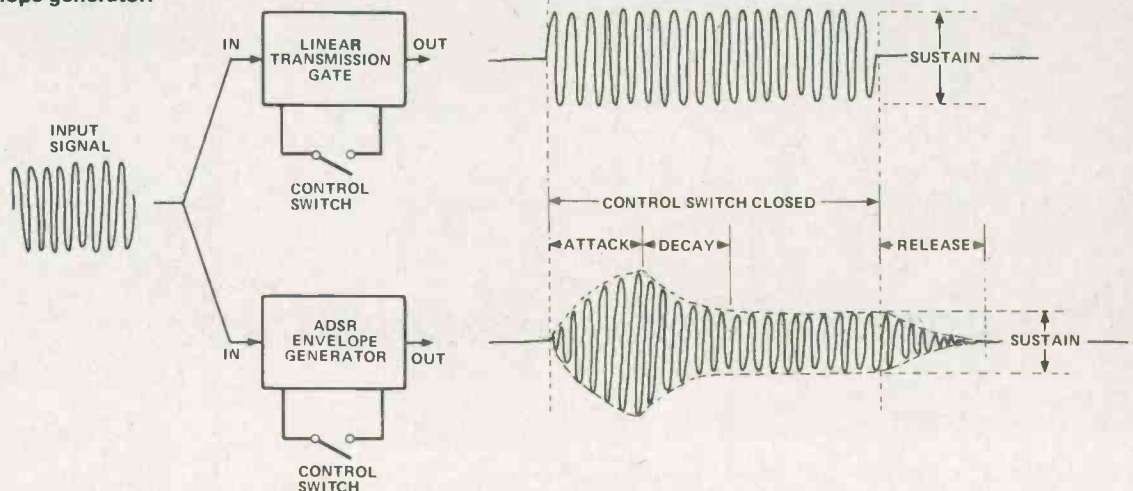

ADSR generator shown with the top removed.

generator. When the control switch is closed, the amplitude of the output signal first rises from zero at a controlled 'Attack' rate to a peak value, at which point it 'Decays' at a controlled rate until it reaches a controlled 'Sustain' amplitude, which it then maintains for the

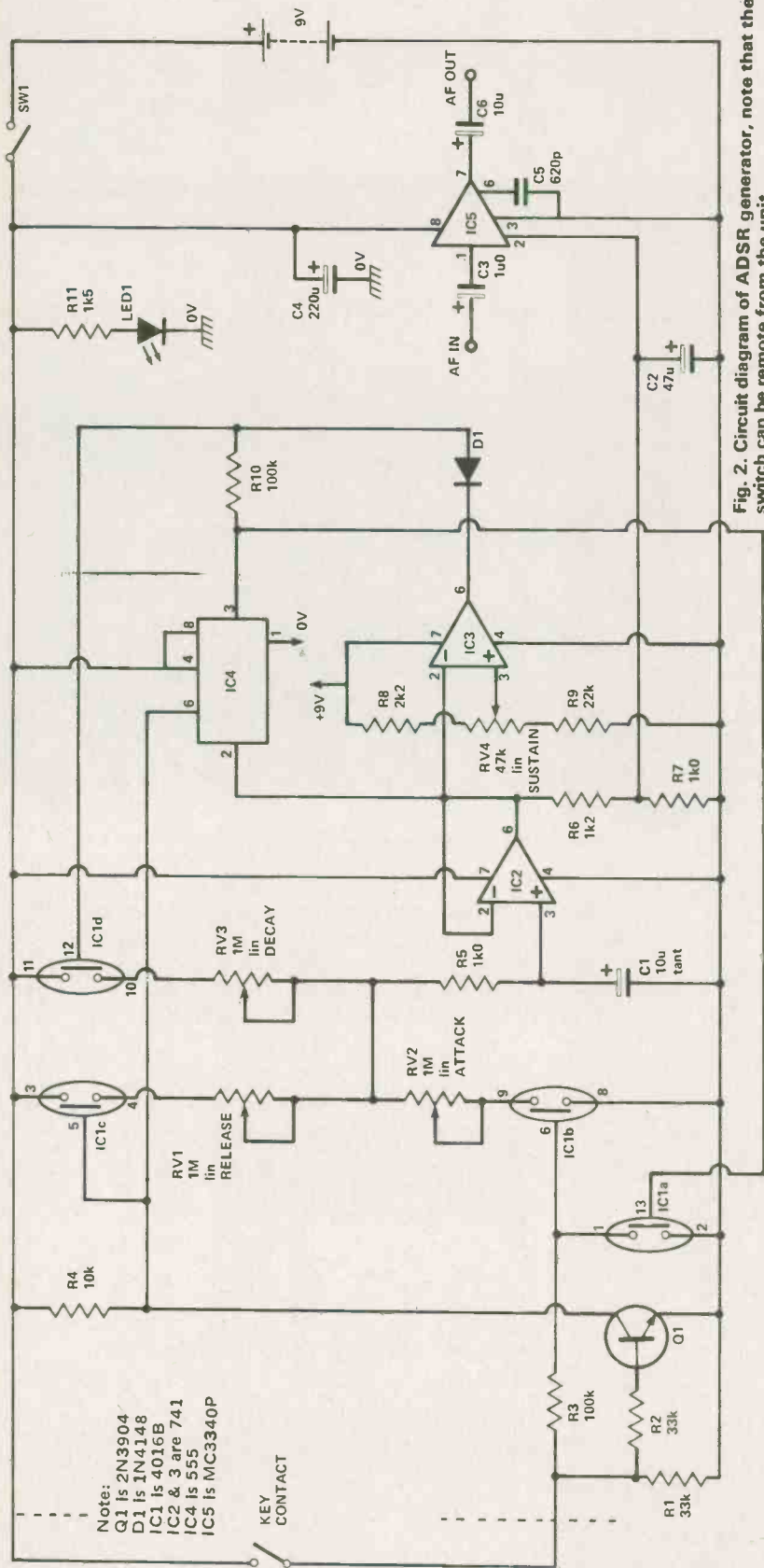

Fig. 2. Circuit diagram of ADSR generator, note that the contact switch can be remote from the unit.

HOW IT WORKS

The audio signal to be controlled passes through IC5 which attenuates it according to the control voltage on pin 2. This voltage is generated across C1 and fed via voltage follower IC2, potential divider R6 and R7 and capacitor C2 to the control pin where a voltage of about four volts causes a large attenuation so that no signal appears at the output and a lower voltage about one and a half volts lets the signal pass.

To produce a sound envelope, the control voltage must be somewhere between these two extreme levels and this is achieved by connecting discharging and charging resistors to C1. So that different sound envelopes can be produced, these are made variable and comprise RV1, 2, 3. R5 prevents excessive current flow through the transmission gates of IC1.

When the key contacts are open Q1 is off pro-

ducing a high voltage (about nine volts) at the control input of transmission gate IC1c. This turns on the gate and RV1 is connected to nine volts via the few hundred ohms resistance of IC1c providing a charging path for C1. IC1b is off and very high resistance of several millions of ohms exists between its input and output. IC1d is also off as the output of IC4 is at a low level.

As the key contacts are closed, IC1c will turn off and IC1b will turn on causing the charge on C1 to leak away via R5, RV2 and IC1b. When the voltage across C1 reaches one third of the supply voltage, the output of IC4 will go high turning on IC1a which turns off IC1b and removes the discharge path. Also, IC1d will turn on and C1 will charge via R5, RV3 and IC1d. The voltage across C1 will continue to rise until it reaches a level set by RV4. The output of IC3 will go low turning off IC1d

causing C1 to become disconnected from any charge or discharge path. The voltage will remain relatively constant thus sustaining whatever level of sound output has been achieved.

In practice the voltage across C1 will drop slightly owing to the leakage of C1 and the input current drawn by IC2. However, these effects are negligible so long as a tantalum capacitor is used for C1.

As the key contacts open, IC1c will turn on. The voltage across C1 will rise and the sound will fade to silence. The output of IC4 will go low again turning off IC1a, b, d, and preparing the system for the next key closure.

The key contact can either be a simple external push-to-make non-locking switch, or the gate switch of an external keyboard (e.g. synthesizer).

PARTS LIST

RESISTORS (All 1/4W, 5%)

R1,2	33k
R3,10	100k
R4	10k
R5,7	1k0
R6	1k2
R8	2k2
R9	22k
R11	1k5

POTENTIOMETERS

RV1,2,3	1M0 Lin
RV4	47k lin

CAPACITORS

C1	10u 16 V Tantalum
C2	47u 16 V Electrolytic
C3	1u 16 V Electrolytic
C4	220u 16 V Electrolytic
C5	620p Polystyrene
C6	10u 16 V Electrolytic

SEMICONDUCTORS

Q1	2N3904
D1	IN4148
IC1	4016B
IC2,3	741
IC4	555
IC5	MC3340P
LED 1	TIL220
SW1	Sub-min Toggle (on-off)

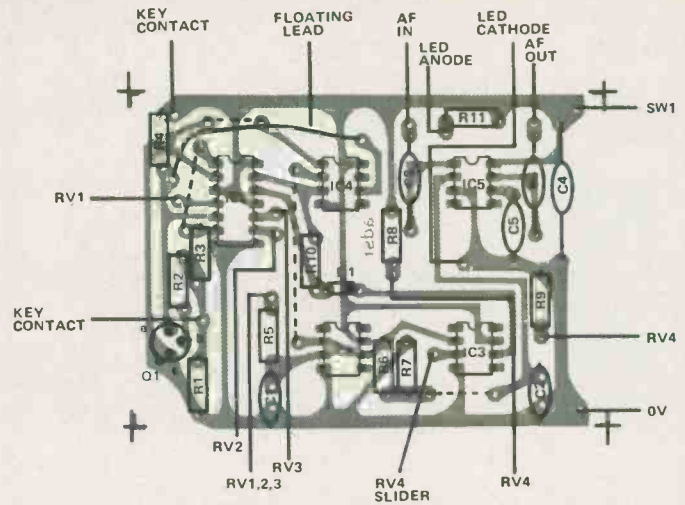

Fig. 3. PCB component overlay, note orientation of polarised components.

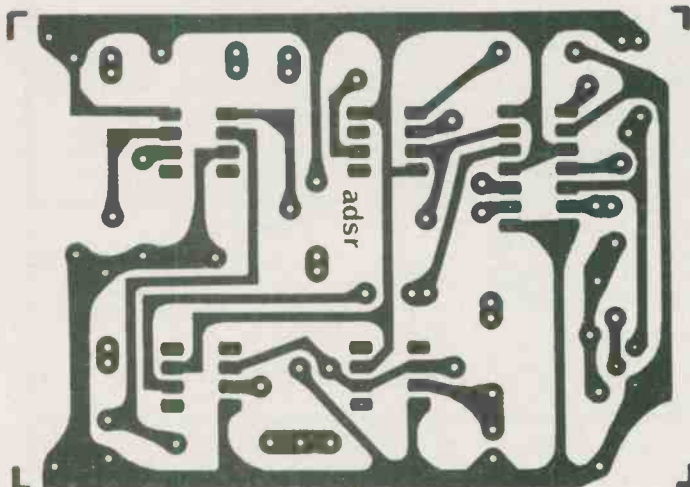
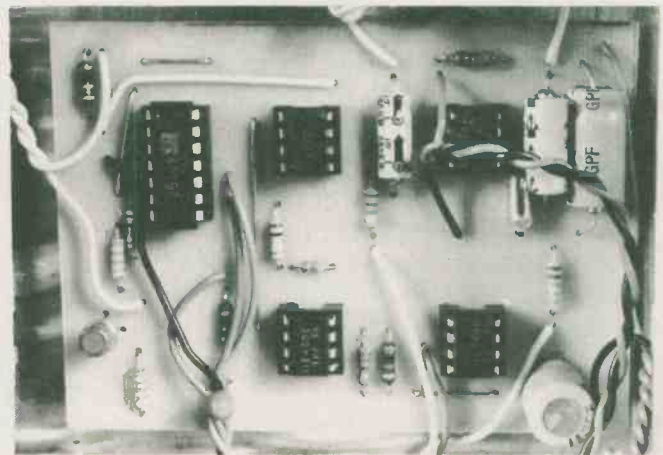

Fig. 4. PCB foil pattern for ADSR generator.

duration of the switch closure. When the switch is eventually opened again, the output signal amplitude falls to zero at a controlled 'Release' rate. The Attack, Decay, Sustain, and Release dimensions of the output sound envelope are all under the full control of the

operator, and the resulting output signals can readily be made to sound natural and interesting.

The complete ADSR instrument is intended for use in conjunction with an input signal source (the White Noise Unit, which can also act as an oscillator, is ideal), and an output power amplifier. The instrument can be activated via either a single switch, or via a bank of parallel-connected keyboard switches, which can also be used to control the frequency of the unit's input signal.

Construction

All of the ADSR circuit components other than the pots, switch, and LED, are mounted on a single PCB. Take care when wiring up the PCB to observe the polarities of all semiconductor devices and electrolytic capacitors. On our prototype unit we mounted the PCB and battery, etc., in a metal case measuring approximately 6 x 4 x 2 inches. Interwiring of the PCB and controls, etc., should present no problems. The input, output, and control switch are coupled to our prototype circuit via a 5 pin DIN socket, but alternative connection methods can be used if preferred. ●



PRB-1 DIGITAL LOGIC PROBE

- DC to > 50 MHz
- 10 Nsec. pulse response
- 120 K Ω impedance
- Automatic pulse stretching to 50 Msec.
- Automatic resetting memory
- Open circuit detection
- Automatic threshold resetting
- Compatible with all logic families 4-15 VDC
- Range extended to 15-25 VDC with optional PA-1 adapter
- Supply O.V.P. to ± 70 VDC
- No switches/no calibration

PRB-1 DIGITAL LOGIC PROBE \$61.95



PC BOARD

4 x 4.5 x 1/4 in. board, glass coated EPOXY laminate, solder coated 1 oz. copper pads. The board has provision for a 22/44 two sided edge connector. .156 in. spacing. Edge contacts are non-dedicated for maximum flexibility.

The board contains a matrix of .040 in. diameter holes on .100 in. centers. Component side contains 76 two-hole pads.

Two independent bus systems are provided for voltage and ground on both sides of the board.

H-PCB-1 HOBBY BOARD \$9.00



PROTOTYPE BOARD CM-100

TERMINALS: 1,020 TEST POINTS. 188 separate 5 point terminals, plus 2 horizontal bus lines of 40 common test points each.

SIZE: 6 1/2" Wide, 5" Long.

CM-100 MODULAR PROTOTYPE BOARD \$43.45



PROTOTYPE BOARD CM-200

TERMINALS: 630 TEST POINTS. 94 separate 5 point terminals, plus 4 bus lines of 40 common test points each. SIZE: 6" Wide, 3 1/2" Long.

CM-200 MODULAR PROTOTYPE BOARD \$27.50



CM-400

PROTOTYPE BOARD CM-300, CM-400

CM-300 and CM-400 have two separated rows of five interconnected contacts each. Each pin of a DIP inserted in the strip will have four additional tie-points per pin to insert connecting wires. They accept leads and components up to .032 in. diameter. Interconnections are readily made with RW-50 Jumper Wire. All contact sockets are on a .100 in. square grid (1/4 in. wide).

CM-300 MODULAR PROTOTYPE BOARD \$16.65

CM-400 MODULAR PROTOTYPE BOARD \$4.15



CM-300

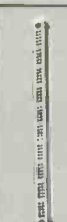

CM-500

MODULAR BUS STRIP

CM-500 is a bus strip to be used in conjunction with CM-300 and CM-400 for distribution of power and common signed lines. Two separate rows of common terminals, grouped into clusters of five. All contact sockets are on a .100 in. square grid.

CM-500 MODULAR BUS STRIP \$3.29

JUMPER WIRES

50 Preformed wires, from 1 1/2 to 4 inches, 20 AWG solid wire, white insulation.

RW-50 JUMPER WIRES \$4.98



"CLIP AND STRIP" TOOL

For cutting and stripping 1 in. insulation from 30 AWG wire.

CAS-130 CLIP AND STRIP \$3.55

THE ABOVE CUT AND STRIP TOOL IS NOT APPLICABLE FOR MYLENE OR TEFLON INSULATION



MINI SHEAR

MS-10 MINI-SHEAR \$8.95

MINI SHEAR WITH SAFETY CLIP

MS-20 MINI-SHEAR WITH CLIP \$10.75



VACUUM VISE

ABS construction, 1 1/2 in. wide jaws.

VV-1 VACUUM VISE \$5.85



WIRE WRAPPING KITS

WK-2, WK-3, WK-4

WK-2-B WIRE-WRAPPING KIT (BLUE) \$20.95

WK-2-Y WIRE-WRAPPING KIT (YELLOW) \$20.95

WK-2-W WIRE-WRAPPING KIT (WHITE) \$20.95

WK-2-R WIRE-WRAPPING KIT (RED) \$20.95

WK-3B (BLUE) WIRE-WRAPPING KIT \$27.35

WK-4B (BLUE) WIRE-WRAPPING KIT \$41.90



WIRE WRAPPING KIT WK-5

BW-630, WSU-30M, CON-1, EX-1, INS-1416, TRS-2, MS-20, 14, 16, 24 and 40 DIP sockets, WWT-1, WD-30-TR1, H-PCB-1.

WK-5 WIRE-WRAPPING KIT \$120.85



TERMINAL BOARD

.062 thick glass coated epoxy laminate. Outside dimensions 6.3 in. x 3.94 in. Not plated.

A-PC-01 TERMINAL BOARD \$5.79



PC BOARD

Same specifications as A-PC-01 except matrix pattern is copper plated and solder coated on one side.

A-PC-02 PRINTED CIRCUIT BOARD \$9.95



PC BOARD

Same specifications as A-PC-01. Each line of holes is connected with copper plated and solder coated parallel strips on one side.

A-PC-03 PRINTED CIRCUIT BOARD \$9.95



PC BOARD

Same specifications as A-PC-01. One side has horizontal copper strips, solder coated. Second side has vertical parallel bars.

A-PC-04 PRINTED CIRCUIT BOARD \$13.30

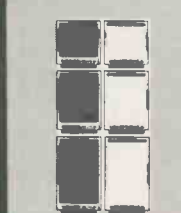

PC BOARD

The A-PC-05 features numbered contacts for easy reference along with a numbered matrix for easy hole locations. Made of .062 in. thick epoxy laminate. 4.5 in. x 5 in. Edge Connector Board.

A-PC-05 PRINTED CIRCUIT BOARD \$9.15

Same as A-PC-05 except outside dimensions are 4.5 in. x 6.5 in. Edge Connector Board.

A-PC-06 PRINTED CIRCUIT BOARD \$11.65

Same as A-PC-05 except outside dimensions are 4.5 in. x 7 in. Edge Connector Board.

A-PC-07 PRINTED CIRCUIT BOARD \$14.99

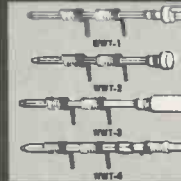

TERMINALS

WWT-1 SLOTTED TERMINAL \$5.39

WWT-2 SINGLE SIDED TERMINAL \$5.39

WWT-3 IC SOCKET TERMINAL \$7.20

WWT-4 DOUBLE SIDED TERMINAL \$3.59



TERMINAL INSERTING TOOL

For inserting WWT-1, -2, -3 and -4 terminals.

INS-1 INSERTING TOOL \$4.50



P.C.B. TERMINAL STRIPS

TS-4 4-POLE \$2.50

TS-8 8-POLE \$3.40

TS-12 12-POLE \$4.69



MODULAR TERMINAL STRIPS

TS-6MD 2-POLE \$3.00

(3 per Package)



PC CARD GUIDES

TR-1 CARD GUIDES \$3.40

QUANTITY — ONE PAIR (2 PCS.)



PC CARD GUIDES & BRACKETS

TRS-2 GUIDES & BRACKETS \$6.85

QUANTITY — ONE SET (4 PCS.)



PC EDGE CONNECTOR

44 pin, dual read-out, .156 in. spacing, wire-wrapping.

CON-1 P.C. EDGE CONNECTOR \$6.35

Available at your nearest Electronics Parts Distributor Write for complete OK Machine & Tool catalogue

len finkler limited

25 Toro Road, Downsview, Ontario M3J 2A6 Tel (416) 630-9103 Telex 065-24010

(Prices subject to change without notice)





JUST WRAP™ WIRE WRAPPING TOOL

WHY CUT? WHY STRIP? WHY SLIT?
WHY NOT JUST WRAP?

JW-1-B	BLUE WIRE	\$24.95
JW-1-W	WHITE WIRE	\$24.95
JW-1-Y	YELLOW WIRE	\$24.95
JW-1-R	RED WIRE	\$24.95

JUST WRAP REPLACEMENT ROLLS

R-JW-B	BLUE WIRE	50 ft. Roll	\$4.98
R-JW-W	WHITE WIRE	50 ft. Roll	\$4.98
R-JW-Y	YELLOW WIRE	50 ft. Roll	\$4.98
R-JW-R	RED WIRE	50 ft. Roll	\$4.98

UNWRAP TOOL FOR JUST WRAP

JUW-1	UNWRAPPING TOOL	\$5.85
-------	-----------------	--------

JUST WRAP KIT

JWK-6	JUST WRAP KIT	\$41.75
-------	---------------	---------

"HOBBY" WIRE WRAPPING TOOL BATTERY POWERED

BW-2630	FOR AWG 26-30	\$33.50
---------	---------------	---------

Use "C" size NICAD Batteries, not included. Bits not included.

BT-30	BIT FOR AWG 30	\$7.15
BT-2628	BIT FOR AWG 26-28	\$14.35

HOBBY WRAP TOOLS



WSU-30	REGULAR WRAP	\$12.55
WSU-30M	MODIFIED WRAP	\$14.35

30 B 50 010	30 AWG Blue Wire, 1" Long	\$2.00
30 Y 50 010	30 AWG Yellow Wire, 1" Long	\$2.00
30 W 50 010	30 AWG White Wire, 1" Long	\$2.00
30 R 50 010	30 AWG Red Wire, 1" Long	\$2.00
30 B 50 020	30 AWG Blue Wire, 2" Long	\$2.15
30 Y 50 020	30 AWG Yellow Wire, 2" Long	\$2.15
30 W 50 020	30 AWG White Wire, 2" Long	\$2.15
30 R 50 020	30 AWG Red Wire, 2" Long	\$2.15
30 B 50 030	30 AWG Blue Wire, 3" Long	\$2.35
30 Y 50 030	30 AWG Yellow Wire, 3" Long	\$2.35
30 W 50 030	30 AWG White Wire, 3" Long	\$2.35
30 R 50 030	30 AWG Red Wire, 3" Long	\$2.35
30 B 50 040	30 AWG Blue Wire, 4" Long	\$2.49
30 Y 50 040	30 AWG Yellow Wire, 4" Long	\$2.49
30 W 50 040	30 AWG White Wire, 4" Long	\$2.49
30 R 50 040	30 AWG Red Wire, 4" Long	\$2.49
30 B 50 050	30 AWG Blue Wire, 5" Long	\$2.60
30 Y 50 050	30 AWG Yellow Wire, 5" Long	\$2.60
30 W 50 050	30 AWG White Wire, 5" Long	\$2.60
30 R 50 050	30 AWG Red Wire, 5" Long	\$2.60
30 B 50 060	30 AWG Blue Wire, 6" Long	\$2.79
30 Y 50 060	30 AWG Yellow Wire, 6" Long	\$2.79
30 W 50 060	30 AWG White Wire, 6" Long	\$2.79
30 R 50 060	30 AWG Red Wire, 6" Long	\$2.79

PRE-STRIPPED WIRE WRAPPING WIRE

Wire for wire wrapping, AWG-30 (0.25mm) KYNAR™ wire, 50 wires per package stripped 1" both ends.

© KYNAR-PENNAWALT

TRI-COLOR DISPENSER

WD-30-TRI	TRI-COLOR DISPENSER	\$13.35
-----------	---------------------	---------

R-30-TRI	REPLACEMENT ROLLS	\$9.98
----------	-------------------	--------

WIRE DISPENSER

WD-30-B	BLUE WIRE	\$8.30
WD-30-Y	YELLOW WIRE	\$8.30
WD-30-W	WHITE WIRE	\$8.30
WD-30-R	RED WIRE	\$8.30

DISPENSER REPLACEMENT ROLLS

R-30B-0050	30-AWG BLUE 50 FT. ROLL	\$4.98
R-30Y-0050	30-AWG YELLOW 50 FT. ROLL	\$4.98
R-30W-0050	30-AWG WHITE 50 FT. ROLL	\$4.98
R-30R-0050	30-AWG RED 50 FT. ROLL	\$4.98

HOOK-UP WIRE

HK-18	18 AWG 25 FT.	SOLID CONDUCTOR	\$2.15
HK-20	20 AWG 25 FT.	SOLID CONDUCTOR	\$1.79
HK-22	22 AWG 50 FT.	SOLID CONDUCTOR	\$2.45
HK-24	24 AWG 50 FT.	SOLID CONDUCTOR	\$2.45
HK-26	26 AWG 50 FT.	SOLID CONDUCTOR	\$2.45
SHK-18	18 AWG 25 FT.	STRANDED CONDUCTOR	\$2.15
SHK-20	20 AWG 25 FT.	STRANDED CONDUCTOR	\$1.79
SHK-22	22 AWG 50 FT.	STRANDED CONDUCTOR	\$1.79
SHK-24	24 AWG 50 FT.	STRANDED CONDUCTOR	\$2.45
SHK-26	26 AWG 50 FT.	STRANDED CONDUCTOR	\$2.45

RIBBON CABLE ASSEMBLY SINGLE END

26 AWG Rainbow Coded flat cable.

SE 14-24	WITH 14 PIN DIP PLUG 24" LONG (609MM)	\$6.45
SE 14-48	WITH 14 PIN DIP PLUG 48" LONG (1218MM)	\$7.10
SE 16-24	WITH 16 PIN LONG DIP PLUG 24" LONG (609MM)	\$6.79
SE 16-48	WITH 16 PIN LONG DIP PLUG 48" LONG (1218MM)	\$7.40

DIP PLUG WITH COVER FOR USE WITH RIBBON CABLE

14-PLG	14 PIN PLUG & COVER	\$2.95
16-PLG	16 PIN PLUG & COVER	\$3.20

QUANTITY: 2 PLUGS, 2 COVERS

RIBBON CABLE ASSEMBLY DOUBLE END

DE 14-2	WITH 14 PIN DIP PLUG - 2"	\$6.79
DE 14-4	WITH 14 PIN DIP PLUG - 4"	\$6.95
DE 14-8	WITH 14 PIN DIP PLUG - 8"	\$7.15
DE 14-12	WITH 14 PIN DIP PLUG - 12"	\$6.79
DE 14-16	WITH 14 PIN DIP PLUG - 16"	\$6.85
DE 14-24	WITH 14 PIN DIP PLUG - 24"	\$7.50
DE 16-2	WITH 16 PIN DIP PLUG - 2"	\$7.50
DE 16-4	WITH 16 PIN DIP PLUG - 4"	\$7.69
DE 16-8	WITH 16 PIN DIP PLUG - 8"	\$7.85
DE 16-12	WITH 16 PIN DIP PLUG - 12"	\$7.40
DE 16-16	WITH 16 PIN DIP PLUG - 16"	\$7.55
DE 16-24	WITH 16 PIN DIP PLUG - 24"	\$8.25
DE 24-6	WITH 24 PIN DIP PLUG - 6"	\$10.00
DE 24-8	WITH 24 PIN DIP PLUG - 8"	\$10.85
DE 24-12	WITH 24 PIN DIP PLUG - 12"	\$11.50
DE 24-16	WITH 24 PIN DIP PLUG - 16"	\$11.85
DE 24-24	WITH 24 PIN DIP PLUG - 24"	\$12.79

DIP SOCKETS

14 DIP	14 PIN DIP SOCKET	\$1.40
16 DIP	16 PIN DIP SOCKET	\$1.65
24 DIP	24 PIN DIP SOCKET	\$2.49
36 DIP	36 PIN DIP SOCKET	\$4.15
40 DIP	40 PIN DIP SOCKET	\$4.98

DIP IC INSERTION TOOLS WITH PIN STRAIGHTENER

Narrow profile. Pin straightener built into tool. Automatic ejector.

INS-1416	14-16 PIN DIP/IC INSERTER	\$6.35
----------	---------------------------	--------

MOS, CMOS-SAFE

GROUND STRAP NOT INCLUDED

MOS-1416	14-16 PIN, MOS CMOS SAFE INSERTER	\$14.35
MOS-2428	24-28 PIN, MOS CMOS SAFE INSERTER	\$13.25

36-40 PIN (MOS-SAFE) IC INSERTION TOOL

Aligns bent out pins. Includes terminal lug for attachment of ground strap.

GROUND STRAP NOT INCLUDED

MOS-40	36-40 PIN CMOS SAFE INSERTION TOOL	\$14.35
--------	------------------------------------	---------

DIP IC EXTRACTOR TOOL

Extracts all LSI, MSI and SSI devices of from 8 to 24 pins.

EX-1	EXTRACTOR TOOL	\$2.70
------	----------------	--------

24-40 (MOS-SAFE) EXTRACTOR TOOL

Removes 24-40 pin IC's, .600" centers. CMOS safe. Includes terminal lug for attachment of ground strap.

GROUND STRAP NOT INCLUDED

EX-2	CMOS SAFE EXTRACTOR TOOL	\$13.30
------	--------------------------	---------

Available at your nearest Electronics Parts Distributor Write for complete OK Machine & Tool catalogue

len finkler limited

25 Toro Road, Downsview, Ontario M3J 2A6 Tel (416) 630-9103 Telex O65-24010

(Prices subject to change without notice)



CARTOONS

I DON'T LIKE THE LOOK OF THAT. IT'S TOO WISE AND TOO SHORT. IT'S NOT DEEP ENOUGH, EITHER. AND YOU'RE JUST ASKING FOR TROUBLE MAKING IT BE ALLOY ANYWAY. YOU'D BE A LOT BETTER.....



THAT'S OUR SUPER-CRITICAL WING DESIGNER!!

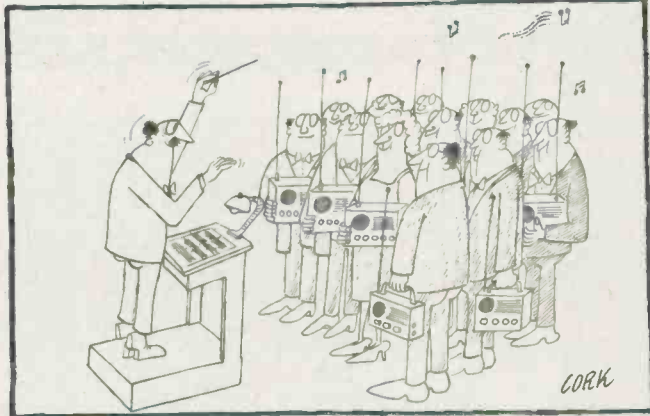

CORK

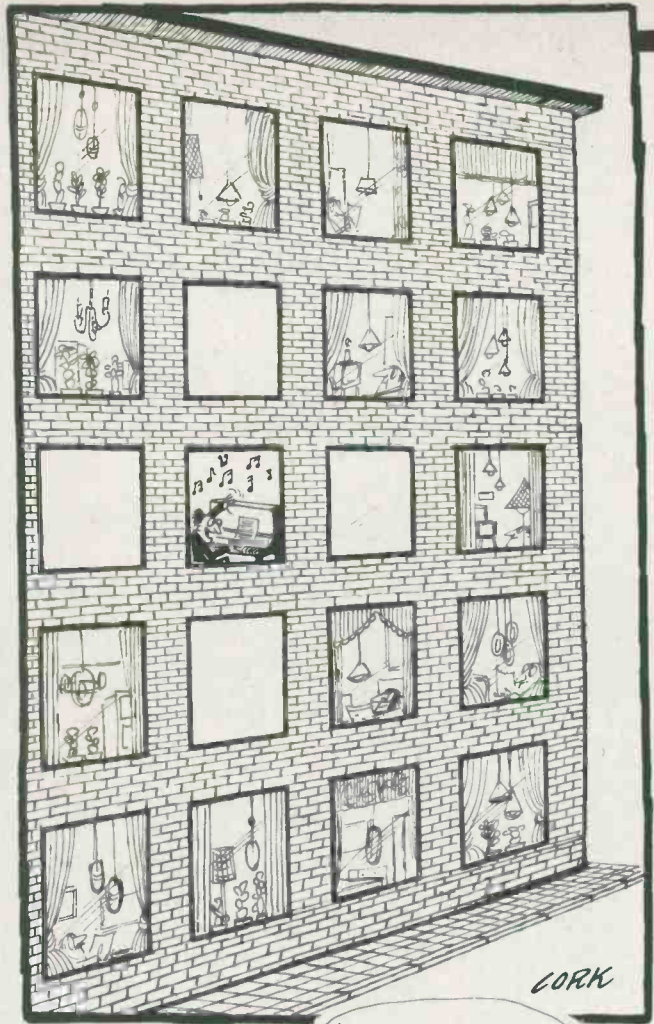

CORK

DID YOU REALISE THAT IF IT WASN'T FOR FARADAY'S DISCOVERIES, THE MAGAZINE WOULD BE FULL OF BLANK PAGES.....?

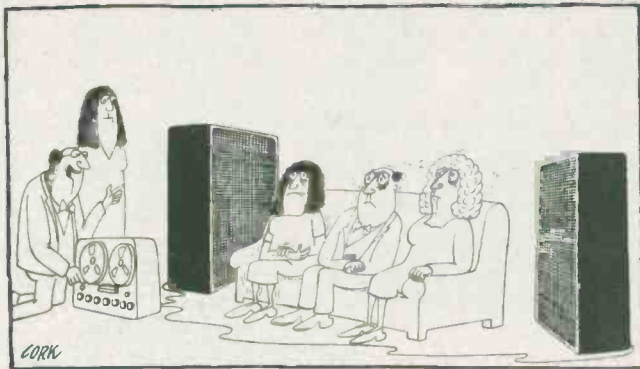

CORK

'And now a train crash, also in stereo.'

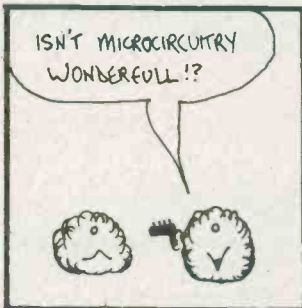

ISN'T MICROCIRCUITRY WONDERFULL!?

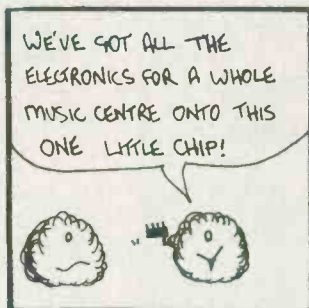

WE'VE GOT ALL THE ELECTRONICS FOR A WHOLE MUSIC CENTRE ONTO THIS ONE LITTLE CHIP!

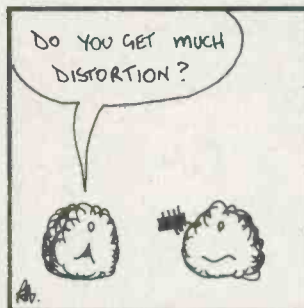

DO YOU GET MUCH DISTORTION?

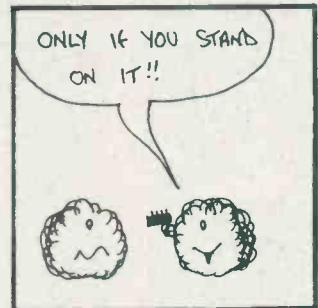

ONLY IF YOU STAND ON IT!!

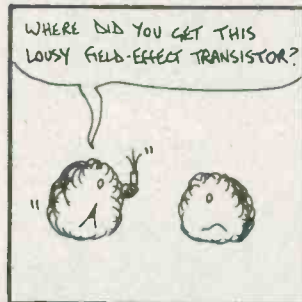

WHERE DID YOU GET THIS LOUSY FIELD-EFFECT TRANSISTOR?

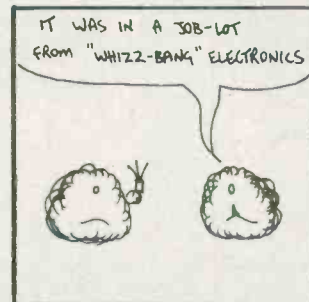

IT WAS IN A JOB-LOT FROM "WHIZZ-BANG" ELECTRONICS

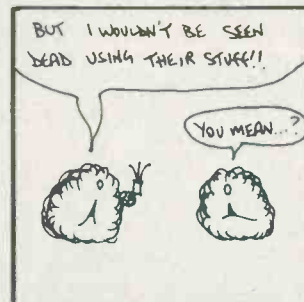

BUT I WOULDN'T BE SEEN DEAD USING THEIR STUFF!

YOU MEAN...?

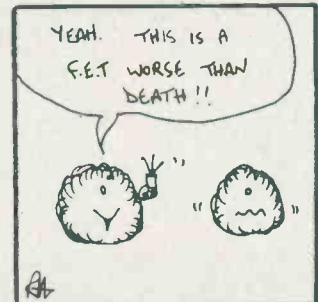

YEAH. THIS IS A F.E.T. WORSE THAN DEATH!!

RT

WHITE NOISE EFFECTS UNIT

Simulate the soothing sound of wind, waves and surf on the beach, or the roar of jet aircraft and steam trains, with this White Noise Effects Unit.

THIS COMPREHENSIVE little unit gives an excellent introduction to special sound effects. It contains a white noise generator, a variable-frequency low-pass filter and a variable-frequency tuned amplifier. This combination enables you to use the HE unit to generate a whole range of interesting sound effects, including those of wind, waves, surf, waterfalls, jumbo jets and 'steam' sounds, etc. As an added bonus, you can also use the unit as a variable-frequency 'tone' generator.

White noise can be simply described as a signal containing a full spectrum of quite randomly generated frequencies or 'tones', all with randomly determined amplitudes, but which have equal mean power when averaged over a reasonable unit of time. The basic sound

of white noise resembles that of hissing steam, but this sound can be greatly modified, to give very interesting effects, by passing it through the types of filters that we have used in the HE design.

The HE white noise effects unit is battery powered, and has a panel-mounted LED (light-emitting diode) to indicate the ON state. Variable front-panel controls are provided for the control of the low-pass FILTER frequency, the tuned-amplifier TUNE frequency, the tuned-amplifier SET Q or 'tuning sharpness' adjustment (which also gives the 'tone' generation facility), and for the control of volume or LEVEL.

The unit is provided with three output sockets. The main output is via a mode selector (FILTERED or



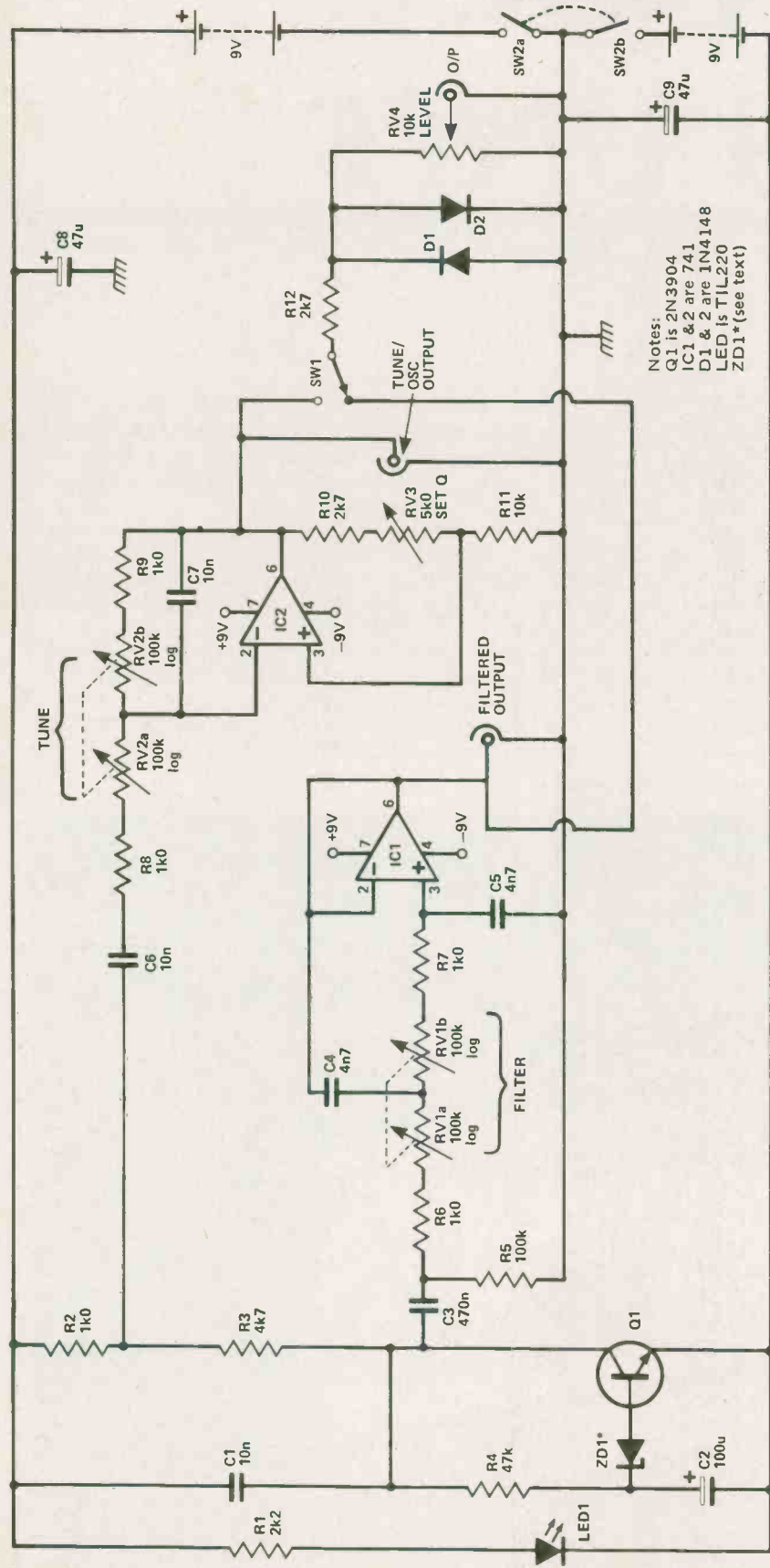

Notes:
 Q1 is 2N3904
 IC1 & 2 are 741
 D1 & 2 are 1N4148
 LED is TIL220
 ZD1* (see text)

HOW IT WORKS

The heart of the unit is the white noise generator, which is designed around transistor Q1 and zener diode ZD1. This zener diode can either be a specially selected 'noisy' type, with a zener voltage in the range 5V6 to 10V. The device is connected in series with the base of Q1 and is biased into its breakdown region at a low current from a low-impedance source via R4 and C2. Q1 is wired as a common emitter amplifier, with high-frequency roll-off provided by C1. When a reasonably noisy component is fitted in the ZD1 position, a noise signal of a few hundred

TUNE/OSCILLATE) switch and the LEVEL control and a pair of amplitude-limiting diodes. Direct outputs are also provided from the two filters for feeding into auxiliary circuits such as mixers, modulators, or envelope generators, to produce more elaborate special effects.

Construction

Most of the circuit is wired up on a single PCB. Follow the overlay carefully, taking special note of the polarities of all semiconductors and electrolytic capacitors. The most important component in the whole unit is the noise generator diode, ZD1. This can either be a selected 'noisy' 5V6 to 10V zener diode (ones from 'bargain'

junction of R2 and R3, and is fed on to the variable-frequency tuned amplifier formed by IC2 and its associated components. This amplifier makes use of a Wien tuning network (C6-R8-RV2a and C7-R9-RV2b), and can be tuned over the approximate range 150 Hz to 15 kHz via RV2. The Q or tuning sharpness of the circuit is variable via RV3, and can be varied from 'very low' to 'almost infinite'. When RV3 is set above the 'almost infinite' level IC2 acts as an unregulated tuned oscillator, and generates a rectangular output waveform that is variable from 150 Hz to 15 kHz via RV2: a certain degree

packs seem to have a particularly high yield of noisy types). When a suitably noisy component is used, the noise signal at the collector of Q1 will have a mean amplitude of a few hundred millivolts RMS.

When construction of the PCB is complete, fit it into a suitable box and complete all interwiring. Then connect the main output of the unit to an audio amplifier, switch on, and listen to the fascinating effects that the unit can generate.

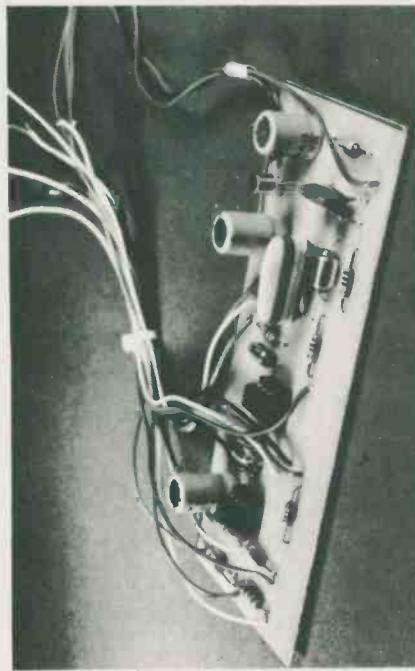

PCB with flying leads, ready for installation.

PARTS LIST

R1	2k2	C3	470n polyester
R2, 6, 7, 8, 9	1k0	C4, 5	4n7 polystyrene
R3	4k7	C6, C7	10n polystyrene
R4	47k	C8, C9	47u electrolytic
R5	100k		
R10, 12	2k7	SEMICONDUCTORS	
R11	10k	Q1	2N3904
POTENTIOMETERS		D1, D2	IN4148
RV1, 2	Dual Ganged	ZD1	see text
RV3	100k log Carbon.	IC1, IC2	741
RV4	5k0 Lin Carbon	LED	TIL 220
	10k Log Carbon	MISCELLANEOUS	
CAPACITORS		3 phone-sockets	
C1	10n polyester	2 9V batteries and clips	
C2	100u electrolytic	case to suit	

millivolts RMS appears at the collector of Q1.

The noise signal from Q1 collector is fed into the variable-frequency low-pass filter formed by IC1 and its associated components. This filter passes all signals below a certain turn-over frequency, but rejects signals above that frequency. The filter is a second-order type, and rejects signals at a rate of 12 dB/octave. The turn-over frequency is variable over the approximate range 220 Hz to 24 kHz via RV1. A second noise output is taken from Q1 at the

of interaction occurs between RV2 and RV3.

The outputs of the filter and the tuned amplifier/oscillator are taken directly to their own output sockets, and are taken to a master output socket via selector switch SW1 and LEVEL control RV4. Silicon diodes D1 and D2 are wired across RV4 to limit the peak-to-peak output signal level to about 600 mV, and ensure that cones will not suddenly be blown from their speakers if RV3 is inadvertently set to the 'oscillate' mode.

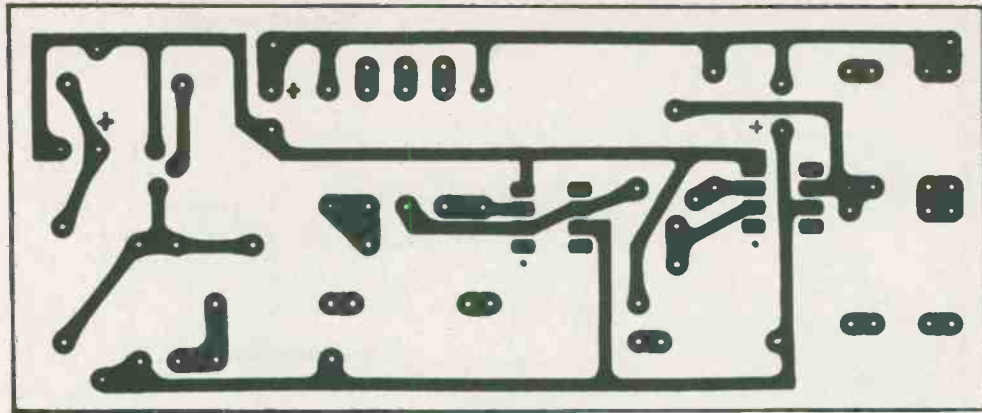
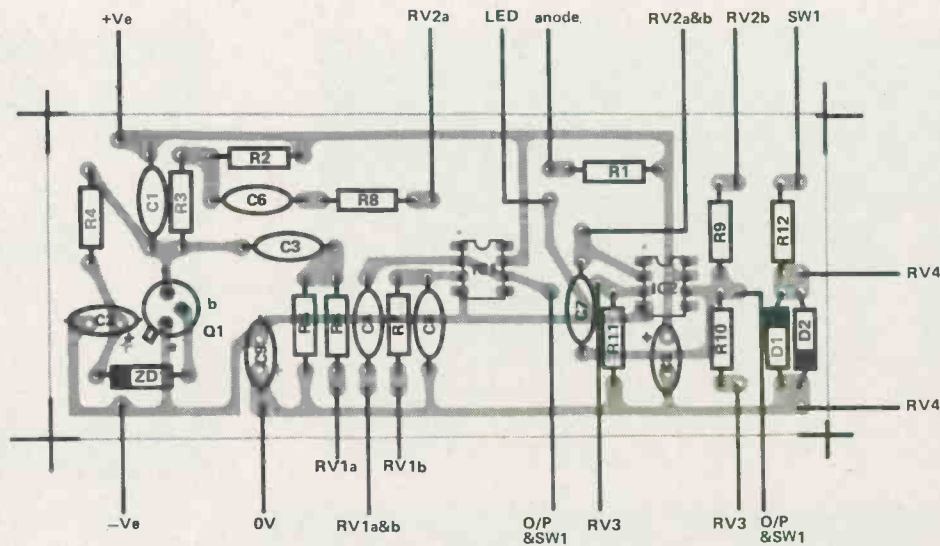

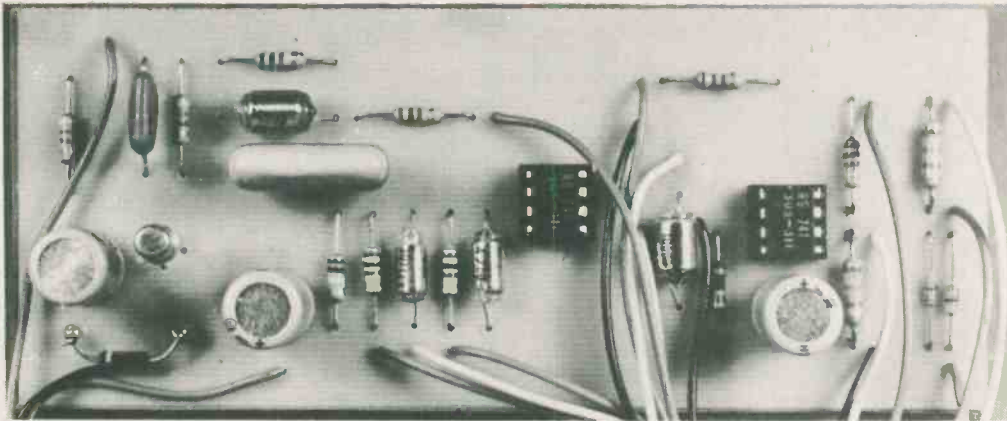

Top view of completed PCB.

Below Right: Internal view of the unit, ready to switch on.

Below Left: The front panel lay-out we use on our unit, transistor gain tester

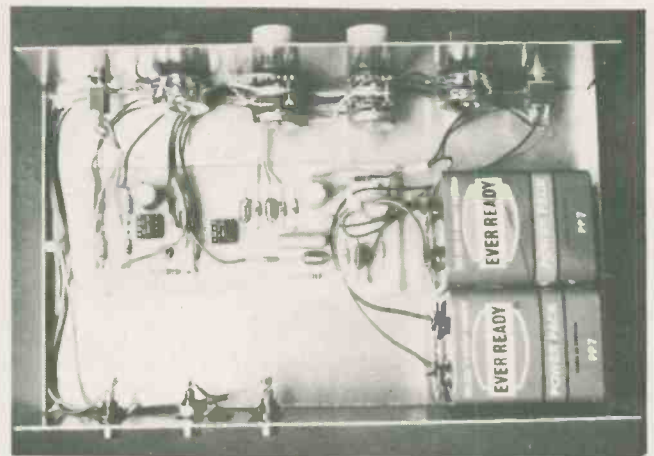

BRYAN ELECTRONICS

ARE YOU MISSING OUT!!

If you're not on our mailing list you are missing out on one of the largest mail order electronics selections in Canada to date.

First rate top quality semiconductors, capacitors, resistors, transformers, etc., from more than 400 famous makers like National, Texas, Hammond, Mallory and Philips.

SELECTION, AND SERVICE TOO!

- free price quotes
- no minimum order
- small parts shipped first class mail
- **\$2.00 flat rate shipping & handling**

and, of course, our flyers & catalogues -- bringing clear, precise, listings of the parts you've been looking for. Why place 3, 4, maybe 5 orders when one order from BRYAN ELECTRONICS will do it all.

Get on our mailing list today!

BRYAN ELECTRONICS
P.O. Box 2068
Bramalea, Ontario
L6T 3S3

YES I WANT TO BE ON YOUR MAILING LIST
PLEASE RUSH ME YOUR CATALOGUES & FLYERS
NAME
ADDRESS
CITY POSTAL CODE
DEALERS! We have dealer price schedules. Write our "Dealer
Distribution" Department at the above address.

SPECTRUM ELECTRONICS

Quality printed circuit boards at an affordable price. For only 40¢/sq.in., you'll receive a cut, etched, and drilled (single-sided glass-epoxy) pcb of YOUR design. All pcbs are given a conformal coating to prevent tarnishing of the copper and aid soldering.

Your parts are mailed to you within two weeks of receipt of your prepaid order.

Write for a free price-list of ETI pcbs and various parts that we stock. Quantity order discounts available on request.

Send cheque or money-order to: P.O. Box 4166
Stn. D. Hamilton, Ontario, Canada, L8V 4L5.

Ont. residents add 7% P.S.T.

Spectrum Electronics—a Canadian company
dedicated to serving the electronics
enthusiasts of today and tomorrow.



Number One ETI CIRCUITS

The first in a new series
of 'ideas books' for the experimenter

Contents

ALARMS

Basic Alarm
Photo Intruder Alarm
Intruder Alarm
Photo Electric Relay
Low Temperature/Lights out
Temperature Sensor
Coolant level
Water Level
Electronic Lock
Car Battery Watchdog
Simple Car Alarm
Simple Lock

AMPLIFIERS & PREAMPLIFIERS

High input impedance
High Impedance Buffer
Low Output Impedance
High Input Impedance
Low Frequency Extender
Virtual Earth Preamp
IC Tape Head Preamp
Simple Stereo Tape Player
2.5 Watt
20 Watt Slave
10 Watt
Loudspeaker Microphone
Voltage Controlled Amp
Wide Band Amplifier
Video Power Amp
Broadband Amp

SIGNAL PROCESSORS

Fuzz Box
Guitar Fuzz
Fuzz Box
Waa Waa
Disco Autofade
Simple Autofade
Information Transfer
Optical Pulse Conditioner
TV Sound Pickoff
Cracklefree Potentiometer
Voltage to Frequency
Sine to Square Wave
Precision AC to DC
Voltage Processor
Universal Meter
Double Precision
Fast Half Wave
Simple Chopper
Noise Rejecting SCR Trigger
Phase Shifter

SIGNAL GENERATORS

Simple
Variable Duty cycle
Fast Edge
FET
Improved Multivibrator
Variable Duty cycle
Stable R.C.
Cheap (CMOS)
Simple TTL XTAL
Uncritical XTAL
Pulse
Zero Crossing
Simple Pulse
Needle Pulse
Stable Linear Sawtooth
Zener
Noise
Pink

Simple Relaxation
Triangle with independent slope
Exponential
Widerange Multivibrator
Multiple Waveform
Linear Sweep
Step Frequency
Beeper
7400 Siren
Simple Siren
Ship Siren
Two Tone
Toy Siren
Kojak, Startrek, Z Cars
Sound Effects
Sound Effects

FILTERS

Bandpass
Low & High Pass
Rejection Notch
Bandpass
Cartridge EQ & Rumble
Hum Stopper
Tape Hiss Reduction
Simple Crossover

DIGITAL

Thermometer
Heads or Tails
Binary Calculator
Voltmeter
Seven Segment to Decimal
Die
Random Binary
CMOS Die
Multiplexer Hints
Learning Memory
CMOS Clock

POWER SUPPLIES

Constant
Temperature Stable
Constant
Voltage Controlled
Precision Voltage Divider
Dual Polarity
Simple Balanced
Voltage Divider
Low Regulated
Short Circuit Protected
Simple TTL Supply
ZN414 Supply
Stable Reference
Transformerless Inverter
DC to DC AC
Voltage Multiplier
Automobile Convertor
Shaver Adaptor
DC-DC
High Voltage From Battery
Variable +ve or -ve output
Simple
12V from Battery Charger
Bucket Regulator
Adjusting Zener Voltage
Variable Zener
Zener Boosting of Regulators
High Power
Electronic Fuse
Better Fuse
Regulator & Fuse
Fast Acting
SCR Crowbar
Voltage Polarity
Ni CAD Discharge
Current Limiting

TEST

Diode Checker
GO/NO GO Diode Tester
Zener Check
GO/NO GO Transistor Tester
Quick JFET Test
Current Gain Tester
Basic Transistor Tester
Simple Transistor/SCR
SCR Tester
Crystal Check
Crystal Checker
Good/Bad Battery Tester
Battery Tester
Op-Amp Tester
Op-Amp Checker
Cheap Logic Probe
Audible TTL Probe
Audible Slow Pulses
Logic Probe
Logic Analyser
I and O Display Probe
Simple High Impedance
Voltmeter
Audio/RF Tracer
Thermocouple Thermometer
Metering Stabilised supplies
Simple Frequency Meter

TIMERS & DELAYS

Low Standby Drain
741 Timer
Self Triggering Timer
Pulse Timer
Pulse Delay
Voltage Controlled Monostable
Sequential Relays
Door Chime Delay

SWITCHING

Touch Triggered Bistable
Touch Sensitive Switch
Electronic Switch
Sound Operated 2 Way
SPST Switch Flip Flop
Two Signals on one Wire

INDICATORS

Line-o-Light
3 Step Level
Light Level
Light Level
Bargraph Display
Fuse Failure
Blown Fuse
Back Up Lamp
DC Lamp Failure
FM Tuner Station
Current Flow
Disco Cue

FLASHERS

Dancing Lights
Low Frequency Strobe

Flasher
Ultra Simple

POWER CONTROL

LDR Mains Control
Floodlamp Control
Zero Crossing Sync
Train Controller
Low Differential Thermostat
Simple Temperature Control
Full Wave SCR Control

AUTOMOBILE

Brake Lamp Failure
Courtesy Light Delay
Simple Hazard Light
Light Extender & Reminder
Four Way Flasher
Headlamp Dipper
Wiper Delay
Suppressed Zero Voltmeter
Rev Counter/Tachometer
Auxiliary Battery

DETECTORS & COMPARATORS

Peak Detect & Hold
Window Detector
Peak Program
Positive Peak
Reaction Comparator

RADIO FREQUENCY

Crystal Marker
100 kHz Marker
RF Voltmeter
RF Detector
LED RF Indicator
RF Amplifier Protection
FET-Radio
Op-Amp Radio

MISCELLANEA

Phase Locked Loop
Touch Doorbell
Phase Lock Control
Audio Mixer
Virtual Earth Mixer
Pop Eliminator
Loudspeaker Protection
Digital Capacitance Probe
Digital Tape Recorder Adaptor
Breakdown Diode Substitution
Dual Function Charger
Dual Mode Amp

Capacitor Substitution
Electronic Capacitor
Speeding Up Darlington
Shutter Saver
Thyristor Sensitivity
Sound Operated Flash
Strength Tester
Logic Noise Immunity

TIPS

Identifying 74 Series
Supply Pins
Soldering IC's
Tinning With Solder Wick
PCB Stencils
Front Panel Finish
DIL Drilling
Fluorescent Starting
Avoiding Insulated Heat Sinks
TTL Mains Interface
Boost Your Mains
High Resistance on Low Meters
High Voltage Electrolytics
Transistor Identification
Template & Heat Sink for
Power Transistors
Transistor Socket
Solder Flow Problems
Odd Resistor Values
Resistors in parallel
CMOS DIL Handling
Identifying Surplus ICS
Extending Battery Life
Battery Snaps
Power Supply or Battery
Battery Checking
Muck Remover
Transformers in reverse
Loudspeaker Checking
Improving UJT Linearity
Signal Tracer
Crystal Earpieces
Cheap Varicaps
Zener Lifts Capacitor Rating

DATA

741 Op-Amp Data
BC 107-109 Data
BC 177-179 Data
CMOS & TTL Data
2N3055 Data
MJ2955 Data
Bipolar Data Tables
Bipolar FETs Rectifiers
Diodes Pinouts Zener Misc

SEND \$5.00 TODAY
To: ETI Circuits, ETI Magazine
Unit 6, 25 Overlea Boulevard
Toronto, Ont. M4H 1B1

LINEAR SCALE OHMMETER

Our latest piece of test gear. An inexpensive unit that gives rapid and accurate readings of resistance from a few tens of ohms to one megohm

THE HE LINEAR SCALE OHMMETER is a simple and inexpensive semi-precision instrument that can be used to give rapid and accurate readings of resistance values from a few tens of ohms up to one megohm. The unit has four decade ranges covering 1k Ω to 1M Ω full scale, and has a basic full-scale accuracy of 2%.

Conventional moving-coil ohmmeters have highly non-linear scales, which typically cover two to four decades of resistance value on a single scale. It is impossible to obtain accurate readings of resistance on

such values. The HE ohmmeter, by contrast, gives resistance value readings on a linearly-calibrated scale of a moving coil meter, and covers only a single decade of resistance on each switched range. The instrument thus inherently gives accurate readings of resistance.

Our linear scale ohmmeter can either be constructed as a completely self-contained unit, with its own built-in moving coil meter, as in the case of our prototype, or can be built as an add-on unit for use with an existing multimeter having a 1 mA DC current range.

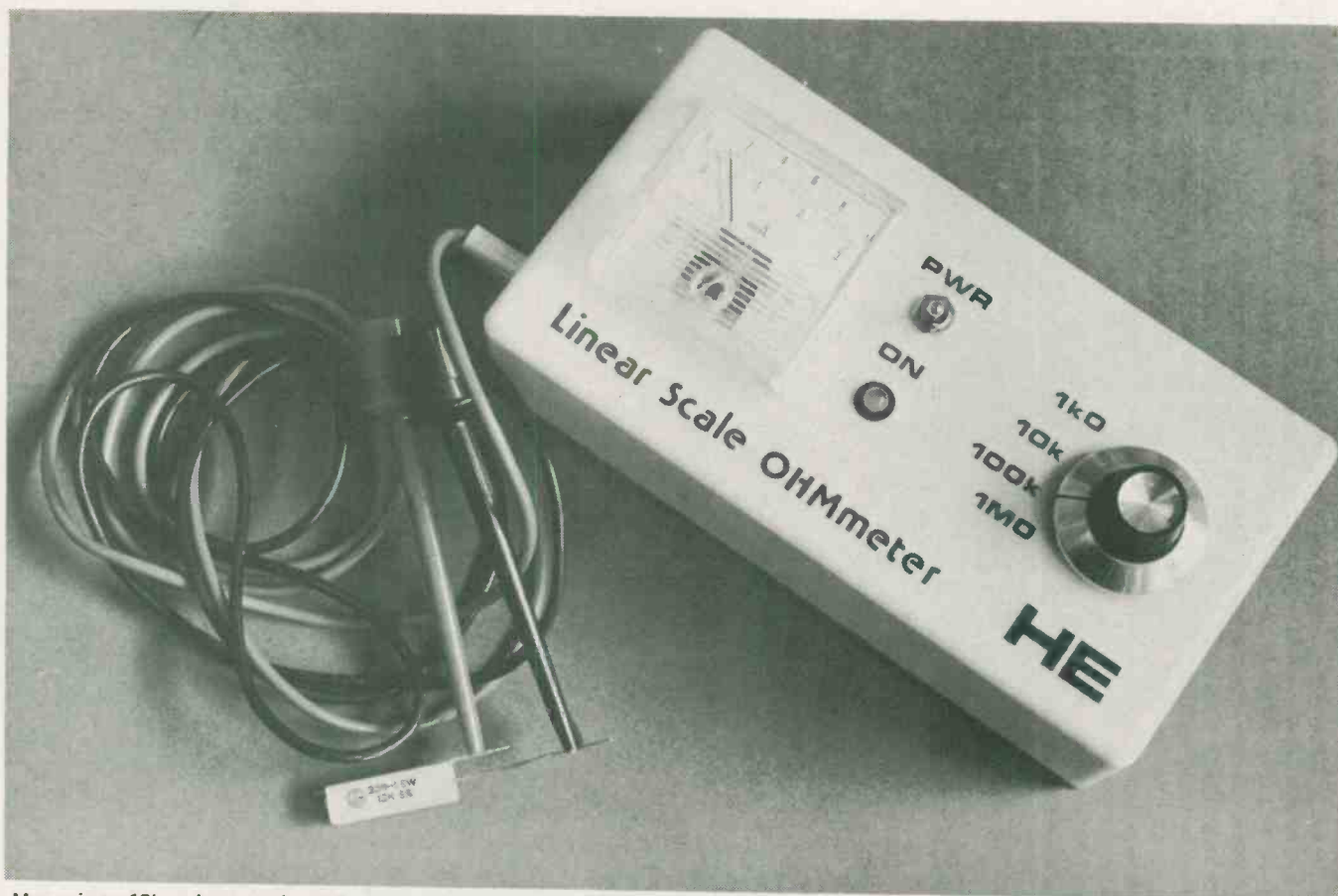

Measuring a 12k resistor on the 100k range. The scale is very easy to read.

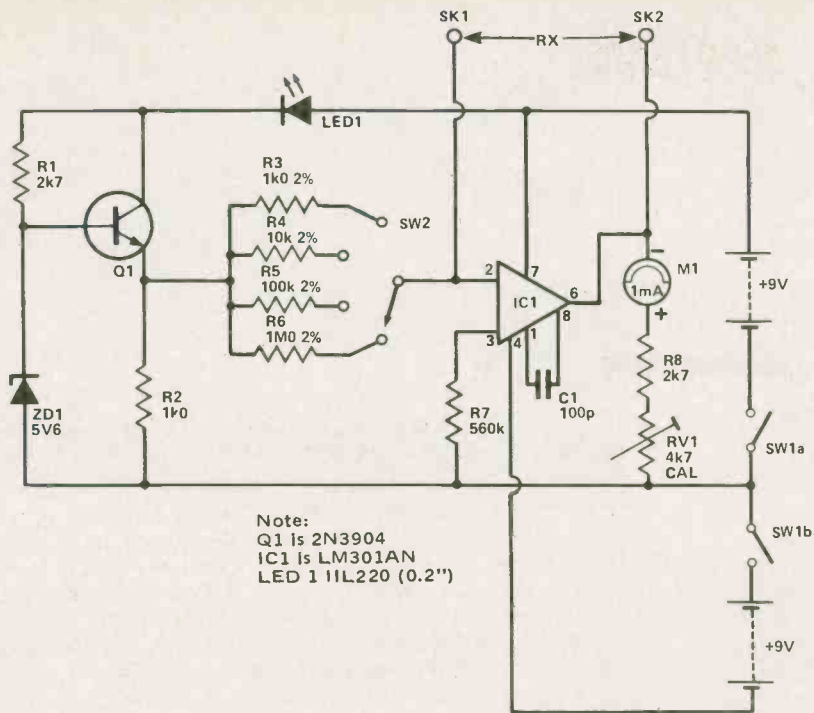

Note:
Q1 is 2N3904
IC1 is LM301AN
LED 1 11L220 (0.2")

PARTS LIST

RESISTORS

R1, 8	2k7
R2	1k0
R3	1k0 2%
R4	10k 2%
R5	100k 2%
R6	1M0 2%
R7	560k

POTENTIOMETER

RV1 4k7 preset

CAPACITORS

C1 100p polystyrene

SEMICONDUCTORS

Q1 2N3904
ZD1 5V6 zener
LED1 TIL220 (0.2in.)
IC1 LM301AN

MISCELLANEOUS

SW1 DPST
SW2 1 pole 4 way
M1 1mA meter
Sk1, 2 2mm sockets
2 9V batteries

Fig.1. Circuit diagram of the Linear Scale Ohmmeter.

HOW IT WORKS

The HE linear scale ohmmeter circuit is divided into two parts, and consists of a test voltage generator and a readout unit that indicates the value of the resistor under test. The test voltage generator section of the circuit comprises zener diode ZD1, transistor Q1, and resistors R1 and R2. The action of these components is such that a stable reference of about 5 volts is developed across R2, and this reference voltage is fed to the op-amp resistance-indicating circuit via range resistors R3 to R6.

The op-amp is wired as an inverting DC amplifier, with the 1 mA meter and R8-RV1 forming a voltmeter across its output, and with the op-amp gain determined by the relative values of ranging resistors R3 to R6 and by negative feedback resistor Rx. RV1 is adjusted so that the meter reads full scale when Rx has the same value as the selected range resistor, and under this condition the op-amp circuit has a voltage gain of precisely unity. Since the values of the reference voltage and the ranging resistors are fixed, the reading of the meter is directly proportional to the value of Rx, and the circuit thus functions as a linear-scale ohmmeter and has a full scale value equal to the value of the selected range resistor.

The op-amp in the IC1 position is a special device, the LM301 AN, used because its input bias currents are so small that they have negligible shunting effect on the range resistors, and the op-amp thus does not detract from the overall accuracy of the circuit.

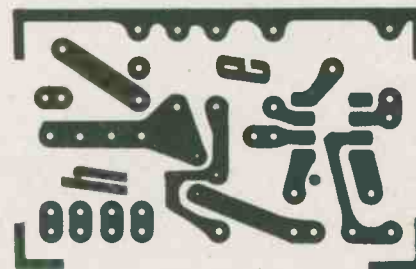

Fig.2. PCB foil pattern for the Linear Scale Ohmmeter.

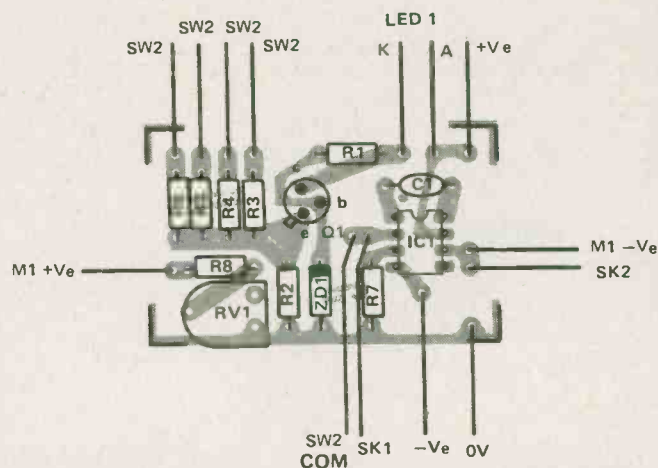

Fig.3. PCB overlay for the Ohmmeter, note the orientation of the IC, transistor and diode.

Construction and Use

Most of the circuit components are mounted on the PCB, and construction should present few problems. Note, however, that IC1 is not just the usual run-of-the-mill bipolar op-amp, so do NOT try using a 741 or similar device in this position. The overall accuracy of the completed instrument is determined by range resistors R3 to R6, so be sure to use high-accuracy (2% or better) components in these positions.

When the PCB assembly is finished, fit the board in a suitable case and complete the interwiring. Note that pin 2 of IC1 connects to the common terminal of SW2, and that resistors R3 to R6 connect to the four 'way' terminals of the switch. If you are making an add-on version of the circuit, fit a couple of 4mm panel terminals in place of meter M1, so that you can easily connect the unit to an external meter.

When construction is complete, switch the unit on and check that LED 1 lights up: if it doesn't, check that the LED is fitted in the correct polarity. When all is well, switch the unit to it's 10k range, connect an accurate 10k test resistor across the Rx terminals, and adjust RV1 to give a precise full-scale reading on the meter. The

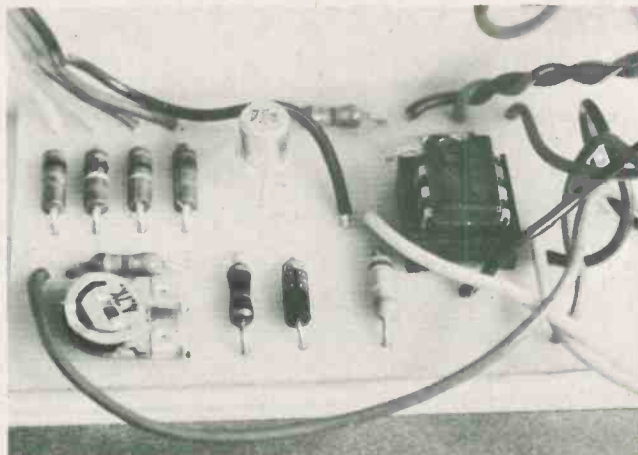

The PCB layout of the Ohmmeter, for accuracy over the entire range use only high stability resistors.

calibration is then complete, and the unit is ready for use.

If you are using the circuit as an add-on unit with an external meter or multi-meter, note that the external meter must have a full scale range of 1 mA DC.

BUILD YOUR OWN AND SAVE!

140W DC Class AB Stereo Amp	\$129.00
30W + 30W Stereo Amp	\$69.00
100W Class A Power Amp	\$89.00
DC Stereo Pre-Amp	\$79.00
60W DC Class A Power Amp	\$58.00
70W Class AB Power Amp	\$41.00
60W Low T.I.D. Power Amp	\$32.00
I.C. Stereo Pre-Amp	\$43.00
10 Band Graphic Equalizer	\$42.00
15 Steps Power Level Indicator	\$56.00
12 Steps Power Level Indicator	\$34.00
S.E.A. Level Display	\$69.00
Stereo Speaker Protector	\$19.00
Rack Mount Cabinets:	
16"(W)x4"(H)x8"(D)	\$39.00
19"(W)x4"(H)x12"(D)	\$54.00
19"(W)x7"(H)x12"(D)	\$74.00

Add 10% for postage and handling.
Ontario residents add 7% sales tax.
Send cheque or money order with order.
Master Charge and Visa accepted.
Prices subject to change without notice.

AUDIOVISION SERVICE
P.O. Box 955, Station B,
Willowdale, Ont.
M2K 2T6

Free Catalogue.

Retailers: Write for wholesale price list.

For the man who has everything else...

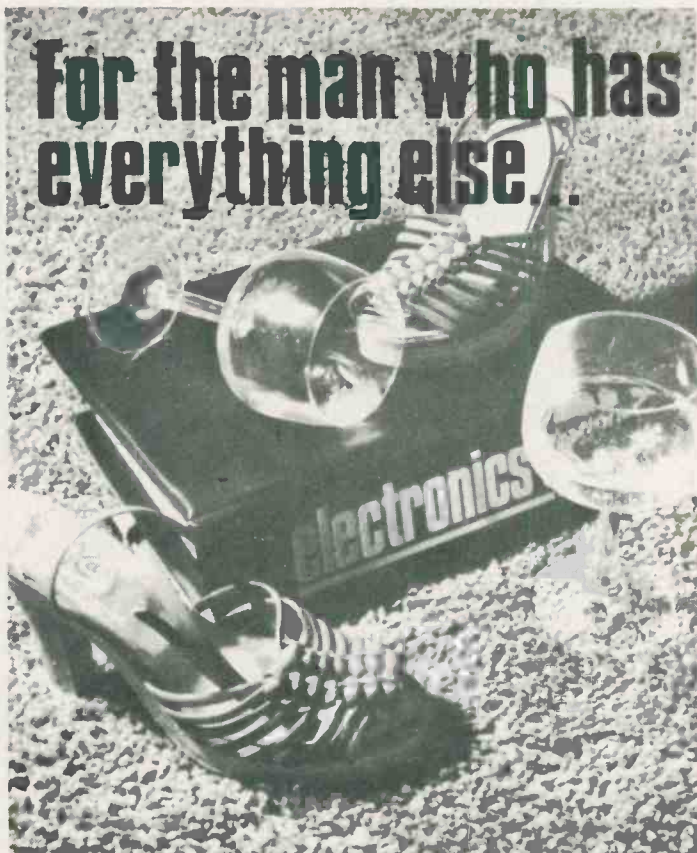

ETI Binders keep your issues in perfect shape. \$6.75 inc postage (Ontario residents add 7% PST. Send to: ETI Binders, Unit 6, 25 Overlea Blvd, Toronto, Ont. M4H 1B1

SIMPLE INTERCOMS

Three intercom systems using the LM380 audio IC.

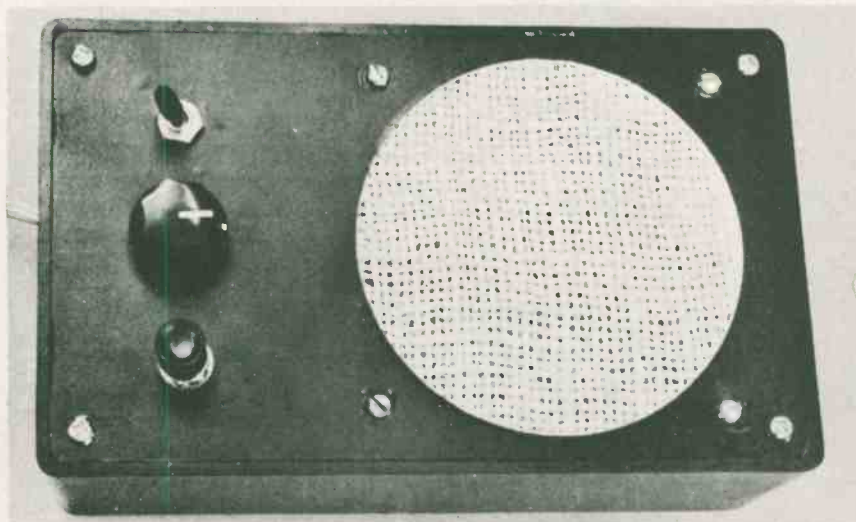

AN INTERCOM SYSTEM is not only one of the most useful projects that one can build, it is also one of the easiest.

Commercial intercoms are of course readily available — often at prices even lower than one could build the units for oneself. Nevertheless a project of this nature is still more than justifiable for not only does it provide valuable

experience but the system can also be built to suit one's exact needs.

In this unit, as with most simple intercoms, a speaker doubles as both microphone and loudspeaker, its role being changed from one to the other by a pushbutton 'talk/listen' switch.

As a loudspeaker is not particularly efficient when used as a microphone, we have used a step-up transformer

and LM 380 integrated circuit amplifier.

Whilst the circuit of a suitable power supply is shown (Fig. 4) current drain is low and battery operation may be used if the unit is not used very much.

Construction

Construction is very simple indeed and, as there are very few components, we suggest that the amplifier be built onto matrix board or similar. A heatsink is not required for the LM380, when working into a 15 ohm, be sure to obtain speakers having this impedance. Higher impedances will result in much lower power output, and lower impedance speakers (eg 8 ohms) will require the use of a heatsink.

The internal layout of the prototype unit is shown in Fig. 5. Note that we used the system connections shown in Fig. 2. This system requires (easily obtainable) single-pole push buttons but requires three interconnecting wires between station 1 and station 2. It also has the advantage that an

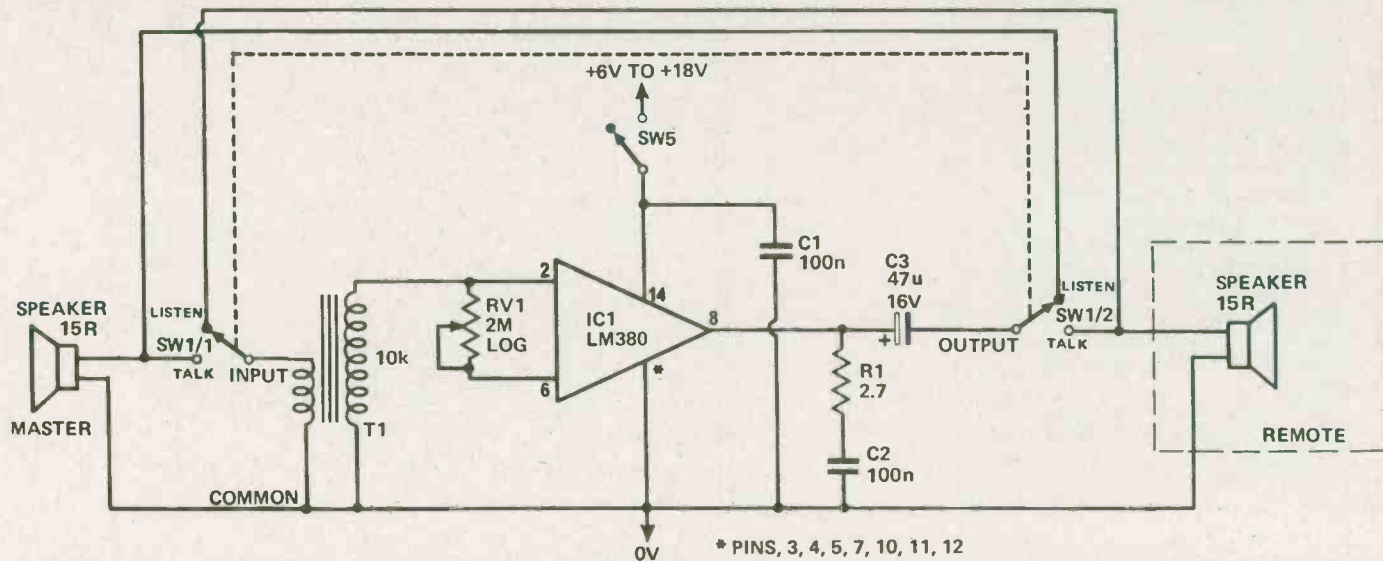

Fig. 1. About the simplest possible intercom, in this arrangement the master station listens to remote station at all times until TALK button is pressed.

output is heard only when the TALK button at either station is pressed.

The system shown in Fig. 1 only requires two wires to the remote station but has the disadvantage that station 1 is always listening to station 2 except when the talk button is pressed.

If two remote stations are required the system illustrated in Fig. 3 should be used. Again this requires three wires to each of the remote stations. Switch SW1 is the push-to-talk button and SW2 selects the required remote station.

We used a small 9 volt battery to power our unit but, if continuous use is expected, it would be wiser to use a larger battery. For example, the standby current is about 3 mA which would result in only about 150 hours operation from a small battery. The best battery system would probably be two 6 volt lantern batteries connected in series. Alternatively a simple power supply such as shown in Fig. 4 could be used. ●

HOW IT WORKS

The (approximately) 1 millivolt output from the speaker is stepped up by transformer T1. The transformer is a standard audio type used in reverse.

The output of T1 is connected directly to the non-inverting (+) input of the LM380 (pin 2) and also, via potentiometer RV1, to the (-) input. Since the input resistance of the IC is about 150 k, the signal level at the negative input is dependant upon the setting of RV1.

The IC, as with all differential amplifiers, amplifies the *difference* in signal level between its two inputs, pins 2 and 6. Thus RV1 effectively acts as a volume control.

With the connections shown on Fig. 1, the remote station speaker acts as a microphone, applying its output to T1. The output of T1 is amplified by the IC and applied to the MASTER speaker. Thus the master station is listening to the remote station at all times other than when SW1 is pressed.

When SW1 is pressed the master speaker becomes the microphone and the remote speaker receives the amplified signal from the IC.

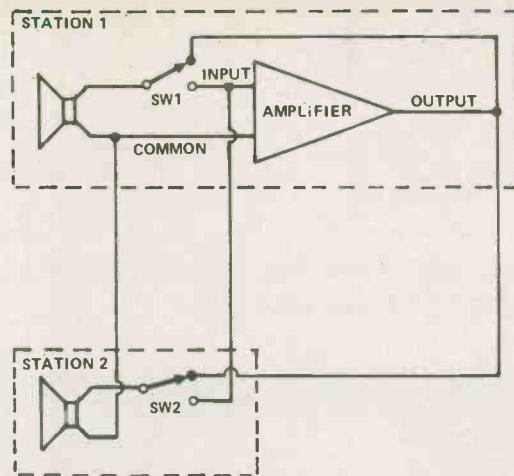

Fig. 2. This system gives privacy to station 2 but requires three wires between stations. The amplifier circuit is identical to that in Fig. 1.

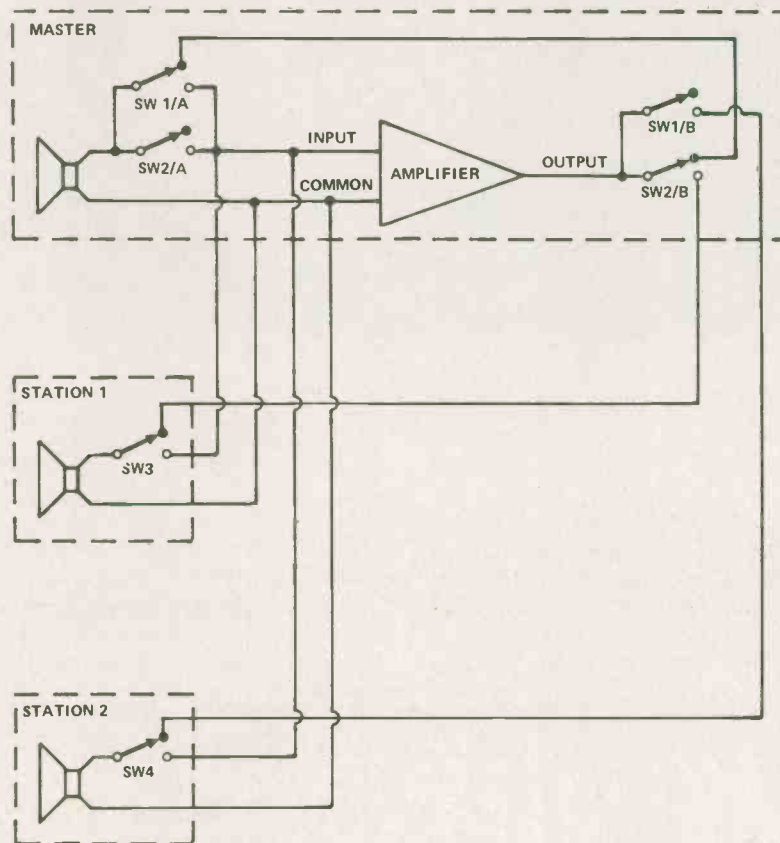

Fig. 3. An extension of the previous system to a master and two slaves requires three wires from the master to each slave, and a more complex switching arrangement.

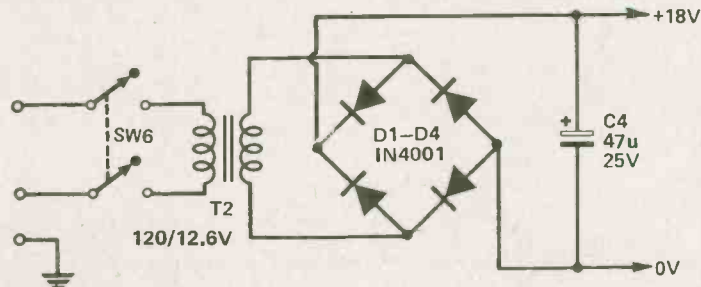

Fig. 4. A simple power supply for use with the intercom.

PARTS LIST

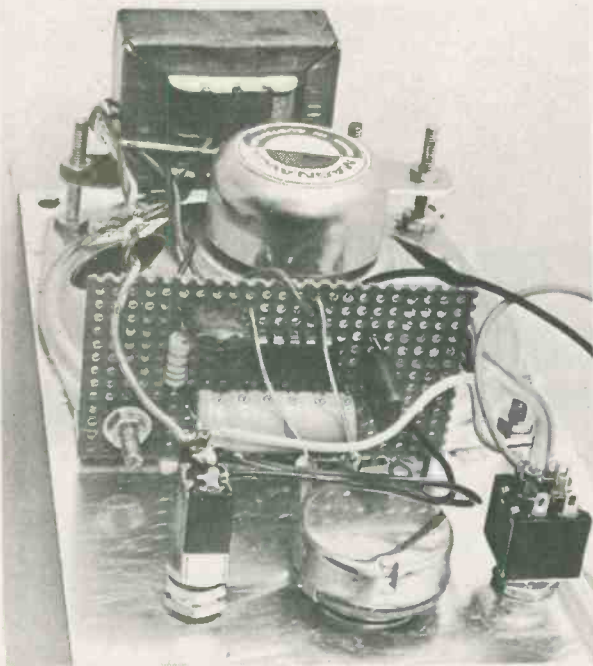

Fig. 5. The method of assembly may readily be seen from this internal view.

R1	2.7 ohm 1/2 watt 5%
C1, C2,	100n polyester
C3	47U 16 volt-electrolytic
IC1	LM380
T1	10k to 8R audio transformer
RV1	2M log rotary

	System 1	System 2	System 3
SW1	DPDT pushbutton	SPDT pushbutton	DPDT pushbutton
SW2	—	SPDT pushbutton	DPDT pushbutton
SW3	—	—	SPDT pushbutton
SW4	—	—	SPDT pushbutton
SW5*	SPDT toggle	SPST toggle	SPST toggle

Loudspeakers 15 ohm 3" diameter
Six to 12 volt battery. *
Plastic or metal box, piece of matrix board, bolts and nuts etc.
* required for battery versions only.

Power Supply

D1-D4	1N4001 or similar
C4	470u 25 volt electrolytic
C5	25u 25 volt electrolytic
T2	120/12.6 volt
SW6	DPST toggle

if you met these people, would you know they had Cystic Fibrosis?



Children and adults with CF often look as healthy as you. To stay that way they go through a rigorous program of medical treatment and therapy every day.

CF is inherited and incurable.

You know it's good to be alive... so do CF people.

With your help research will find a cure or control.

take action
MAKE CF PEOPLE
WINNERS

 Canadian Cystic Fibrosis Foundation

DRILL SPEED CONTROLLER

An easy-to-build gadget that lets you vary the speed of your power drill, or any other domestic appliance that is powered by a universal electric motor.

THIS PROJECT CAN BE USED to control the speed of virtually any domestic electric drill, power saw, grinder, sander, or other power tool that incorporates a universal electric motor. It enables the motor speed to be smoothly varied from zero to about 75% of maximum via a single control, and incorporates built-in compensation to maintain the motor speed virtually constant at any given speed setting, regardless of changes of load. This latter facility is of great value when tackling low speed jobs like drilling masonry or using fly-cutters on sheet metal, etc.

Construction

All components except C1, RV1, and SW1 are mounted on the single PCB, so construction should present few problems provided that care is taken to fit all semicon-

ductors in the correct polarity. It must be emphasised, however, that the controller is connected directly to the mains without the use of an isolating transformer, so care must be taken to ensure that there is no likelihood of any dangerous conditions arising. Under no circumstances touch the wiring when the unit is connected to the live mains.

The SCR used on the prototype circuit is a C106D type, but the design can in fact be used with virtually any 400 volt SCR with a current rating greater than 3 Amps. We didn't bother to fit a heat sink to the SCR on the prototype, but it is probably a good idea to do so in practice. If you do fit a heat sink, make sure it can't come into contact with any other components or wires.

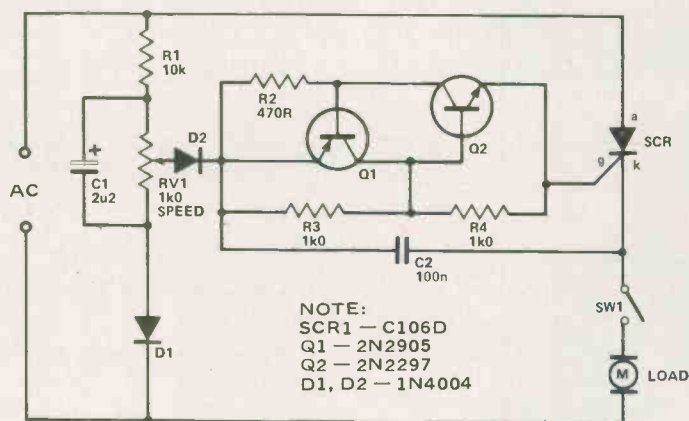
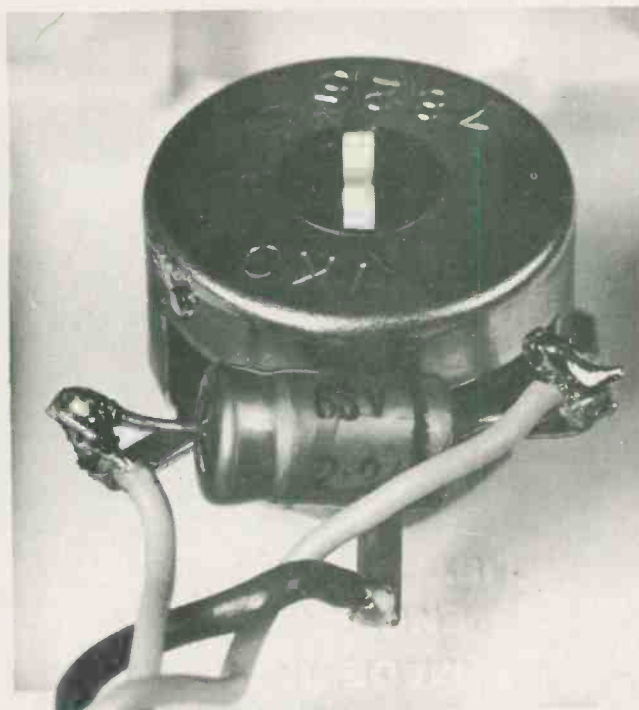

Fig. 1. Circuit diagram of the HE Drill Speed Controller.



Mounting capacitor C1 on the control potentiometer RV1.

PARTS LIST

RESISTORS (All 1/4W 5% unless stated)

R1 10k 5W
R2 470R
R3,R4 1k0

POTENTIOMETER
RV1 1k0 2W

CAPACITORS
C1 2 μ 2 63V
C2 100n polyester

SEMICONDUCTORS
SCR1 C106D
Q1 2N2905
Q2 2N2297
D1,D2 IN4004

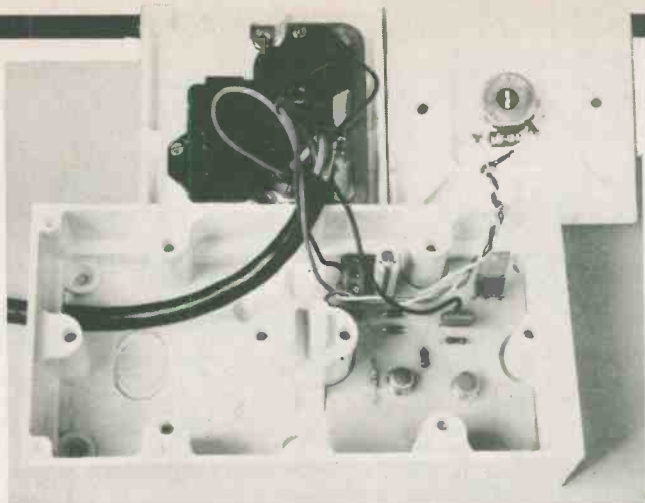

Inside the HE Drill Speed Controller, use of a PCB is strongly recommended, especially when using a line powered project.



Leadout for SCR1. Note the position of the heat-sink mounting hole.

HOW IT WORKS

A universal motor, when running, generates a voltage that opposes that of the supply. This voltage is called the back EMF, and is proportional to the motor speed. The HE drill speed controller uses this back EMF to sense motor speed, and automatically adjusts the power fed to the motor so that its speed remains reasonably constant under varying load conditions. The speed setting is variable via RV1.

Because of its back EMF characteristics, a universal motor runs at about 75% of its normal maximum speed when it is fed from a half wave rectified power line.

The HE controller uses an SCR (silicon controlled rectifier) to gate half-wave power to the drill motor. The SCR acts like a very fast self-latching power switch. The point at which it turns on during a half cycle depends on the setting of RV1, and on the back EMF of the motor. If the SCR is turned on near the end of each positive half cycle, very little power is fed to the motor; if the SCR is turned on at the start of each positive half cycle, high power is fed to the motor. The SCR turns off automatically at the end of each positive half cycle.

In the initial description of circuit operation, let's assume that SW1 is closed, and let's also ignore the presence of Q1-Q2 and their associated resistors and C2, and assume that D2 is connected directly to the gate of the SCR. In this case R1-RV1 and D1 form a half-wave voltage divider that feeds an adjustable voltage to the gate of the SCR via D2. The SCR turns on when its gate becomes slightly positive to its cathode, and the point at which this occurs depends on the setting of RV1 and on the back EMF, and hence speed, of the motor.

Suppose, for example, that the motor is lightly loaded, and RV1 is set so that the motor runs at

half-speed under this condition. If the load is now removed the motor speed will tend to increase, thus increasing the back EMF and countering the voltage set by RV1, so that the SCR will tend to fire later in each cycle and thus reduce the speed of the motor. The reverse action occurs if the motor load is increased. In either case, a negative feedback effect occurs which tends to cause the motor to operate at a constant speed in spite of load variations.

In extreme cases, when the controller is set for very low speed operation, this negative feedback causes power to be fed to the motor in 'bursts' or 'skip cycles' of half-wave power when the motor is lightly loaded, so that the motor seems to give an erratic form of operation. Capacitor C1 is fitted to reduce this skip cycling effect and give smoother operation.

The action of the Q1-Q2-C2 network, when it is triggered, is such that the SCR has to be supplied with gate current that is derived from RV1 slider. If the SCR is a sensitive type, like the C106D, RV1 can provide this gate current without trouble, but if the SCR is a low sensitivity device, RV1 may not be able to supply adequate gate current. Q1-Q2 and C2 are used to overcome this problem.

Q1-Q2 and their associated resistors act as a voltage-sensitive switch. In each half-cycle, C2 is able to charge up via RV1 slider. As soon as the C2 voltage rises to a suitable value, Q1 and Q2 both switch on and partially discharge C2 into the gate of the SCR, thus delivering a pulse of high current to the SCR gate, quite independently of any current-drive limitations of RV1 slider. The Q1-Q2 and C2 network thus enables virtually any SCR to be used in the SCR1 position, almost irrespective of its gate sensitivity characteristics.

Note when using the drill (or any other appliance) at low speeds that its motor will run rather hotter than usual, since the motor's cooling fan efficiency is greatly reduced at low speeds. It is wise to occasionally pause and allow the motor to cool down when using it for long periods at low speeds.

Using The Controller

Plug the controller into the lines, plug the drill into the controller, and switch both units on. The drill speed can be varied from zero to about 75% of full speed via RV1. Note that there may be a 'dead' zone at both the low speed and high speed ends of the control, due to different drill motor characteristics and component tolerances within the controller. This is quite normal.

At very low speeds the drill runs rather jerkily under low load conditions, due to the 'skip cycling' method of speed regulation that is used in the design. This jerkiness decreases or disappears when the drill is loaded up. ●

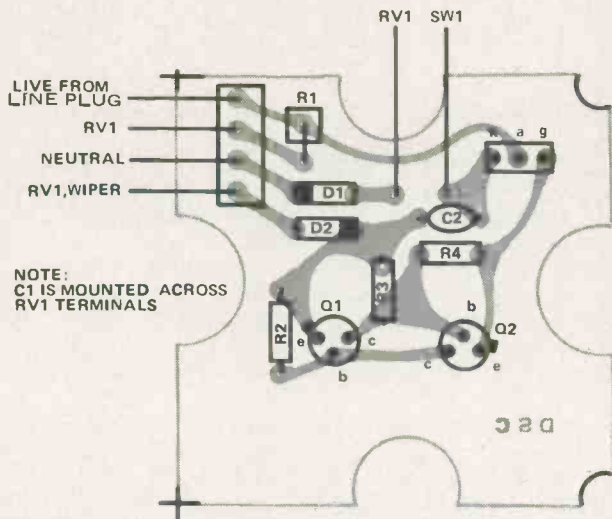

Fig. 2. PCB overlay, note position of the thyristor.

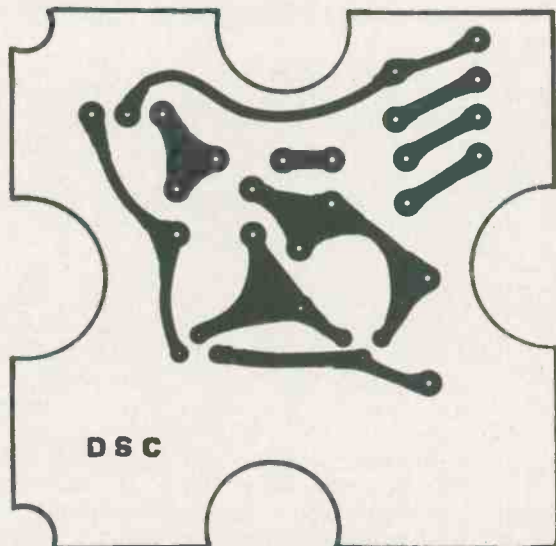

Fig. 3. PCB pattern for the HE Drill Speed Controller.

ETI online?



The 'wired-city' concept has a great future in Canada. One day you'll be able to have your own copy of ETI transmitted to you in your home via facsimile reproduction.

We're still waiting.

In the meantime, you're left with the regular time-honoured methods of getting ETI.

An ETI subscription assures you of a brand new copy of ETI every month. Never again will you be arrested for loitering at newsstands. You can't miss . . .

SUBSCRIBE NOW!

One year subscriptions are \$14.00, two years are only \$26.00. You save at least 1/3 of the regular newsstand rates!

Electronics Today
25 Overlea Blvd, Unit 6
Toronto, Ontario M4H 1B1

DIGIBELL PROJECT

No more pressing door bells with the HE Digi-Bell, it's just touch and go, the 'chime' will never be ignored.

UNTIL RECENTLY doorbells have all relied upon a mechanical action to strike a bell or chime. With the advent of reliable ICs the electronics industry has been attempting to inundate us with microprocessor based song-boxes. Any type of doorbell must fulfill one basic function, however, that is to attract the householder's attention to the fact that someone is at the door. It doesn't matter how many tunes it may play, if it can't be heard or even worse, is ignored altogether it's use as a doorbell is somewhat suspect.

There are two distinct methods of attracting someone's attention (audibly that is) the most obvious is volume, nothing wrong with the theory but it does rather lack elegance. Hopefully we will never be accused of that. The second method involves the peculiarities of the human ear. We are more sensitive to certain frequencies or combinations of frequencies than others.

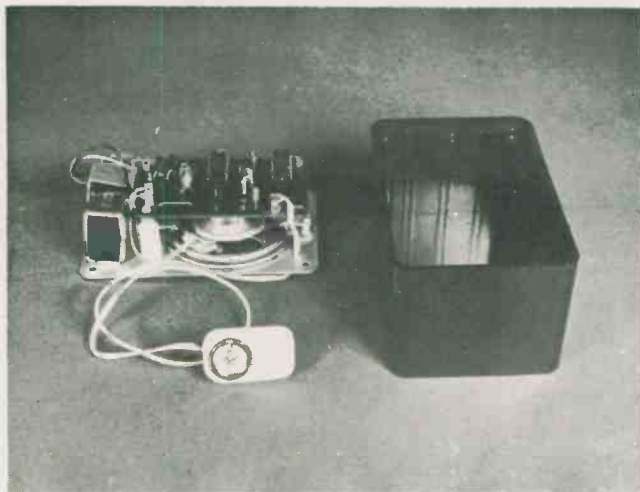

The compact design of the HE DigiBell.

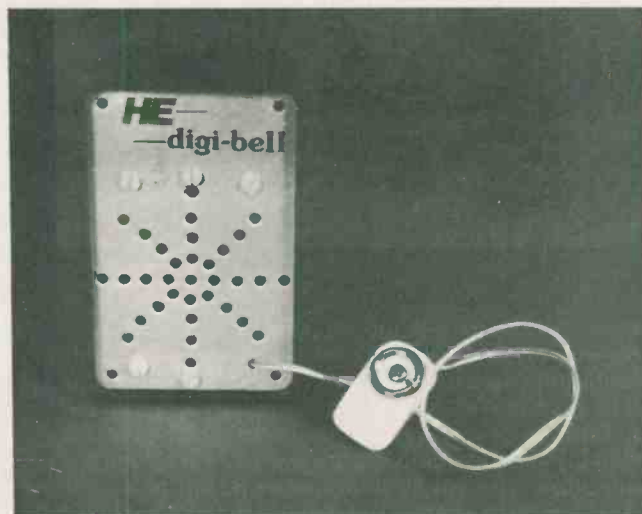

inclusion of a touch-switch as opposed to the normal mechanical push-button. The sensor uses the resistance of the skin to activate a short time delay which sounds the 'Bell' for a short time after the finger is removed.

Construction

All the electronics are mounted on a single PCB. The usual precautions must be taken when handling CMOS devices. Ensure all the polarised components are fitted the right way round. In the prototype the PCB was mounted above the speaker on pillars. The touch-plate was made from a small piece of plastic. The outer contact was an old knurled nut from a standard toggle switch, (use a plated type to avoid corrosion). The centre contact was made from a plated dome-headed 6-32 screw. Both contacts were filed and the connecting wires soldered directly. The knurled nut can then be fixed to the plastic plate by an epoxy adhesive.

Operation

Because the Digi-Bell uses CMOS IC's, the stand-by current is extremely low, around 2-5 uA, so an on-off switch is unnecessary. It's a good idea to use a mercury or alkaline battery, so the unit will function for several months.●

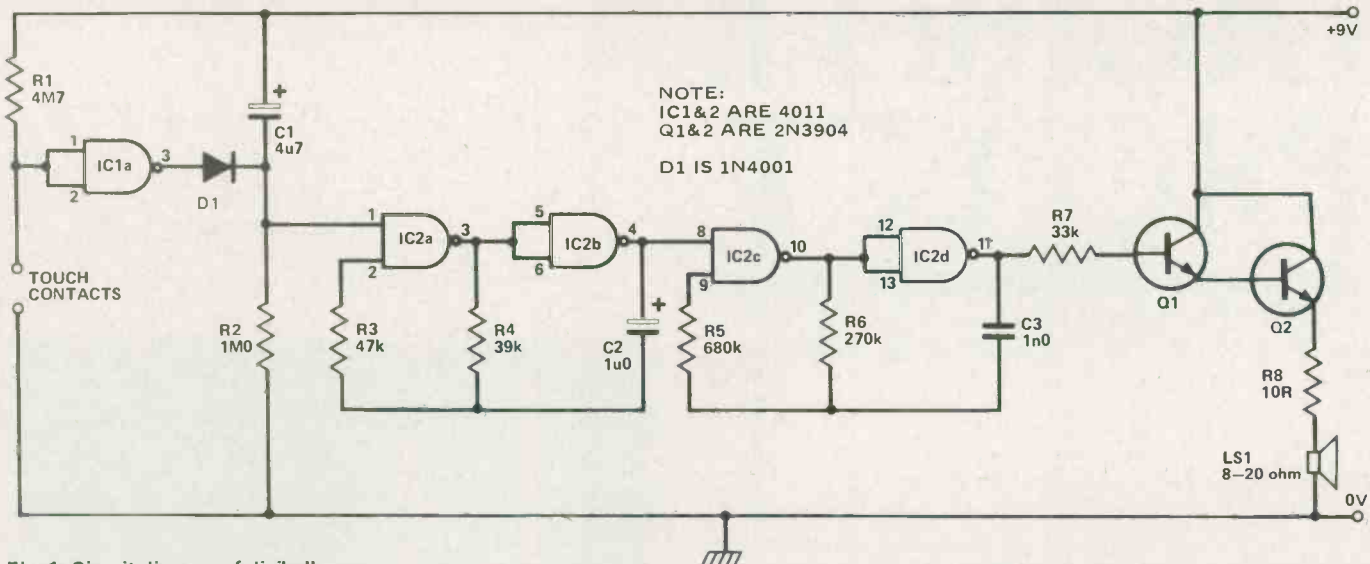

Fig. 1. Circuit diagram of digibell.

HOW IT WORKS

The circuit of the Digi-Bell can be broken down into three distinct sections.

Touch Switch

The touch switch uses skin-resistance to trigger the 'bell'. IC1 (quad, dual input NAND gate) has both inputs of gate (a) tied together. This now becomes a NOT gate. (If logic 1 (+9V) is present at the input, logic 0 (0V) will appear at the output and vice-versa, therefore it is an inverter). The input pins 1 and 2 are connected to the +9V line (logic 1) via R1, so there will be logic 0 on the output (pin 3). If a resistance less than R1 (eg a finger, typically 10-50 k ohms) is connected between the input pins and the 0 V line, the logic stage will change and the output will rise to +9V. A CR network C1, R2 holds the output high for a short period (about 1 second per microfarad of C1). The output from the CR network is taken to the first in a pair of astables.

The Oscillators

The output from the touch switch 'enables' the first astable (free running square-wave generator) which has a frequency of around 10 Hz. This in turn enables the second astable, with a frequency of 5 kHz, so the resulting output will be a 5 kHz squarewave, gated at 10 Hz.

Audio Output

The output from IC2 (c+d) pin 11 is fed to a Darlington Pair (current amplifier) comprising Q1, Q2, they drive a low impedance loudspeaker LSI. A 20 ohm speaker was found to give the greatest volume, although a lower impedance speaker will work but below 8 ohms damage to the output stage might occur.

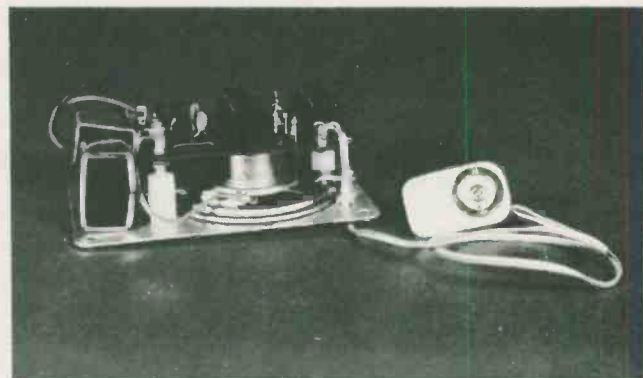

A loudspeaker sandwich. The PCB is bolted to the front panel, with the loudspeaker between the two.

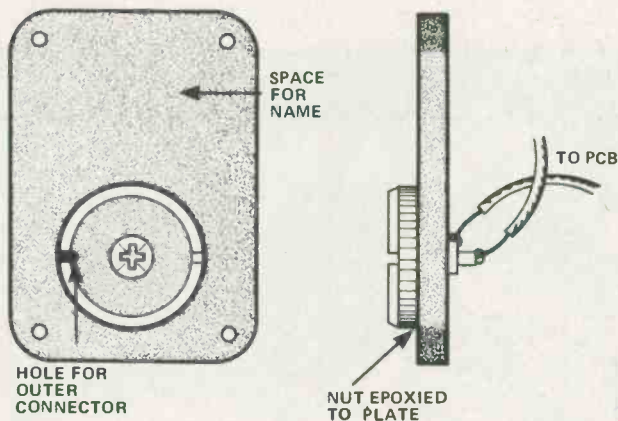

THROUGH CONNECTION

Fig. 2. Constructional details of the touch plate.



KNURLED SWITCH NUT

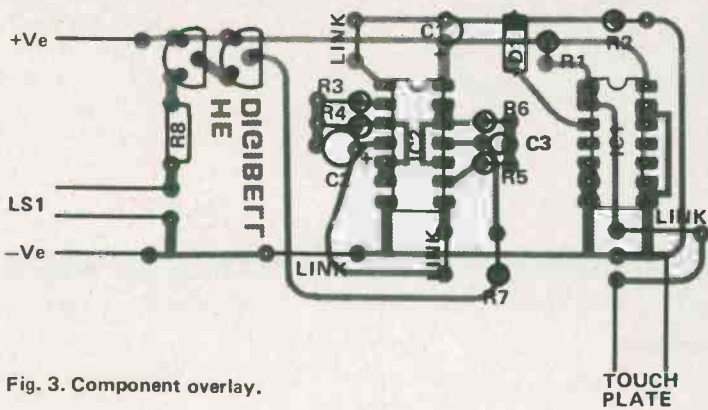
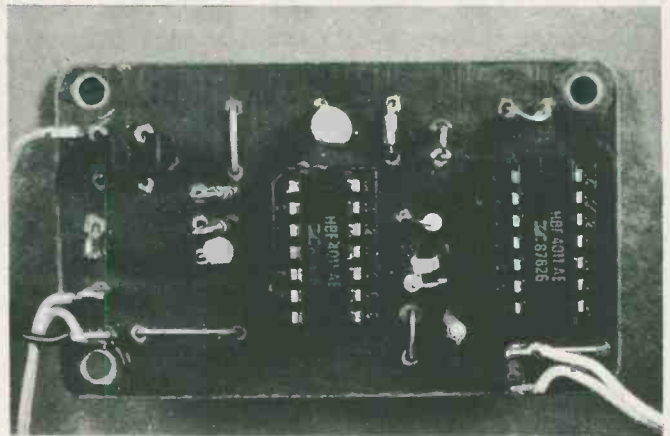

Fig. 3. Component overlay.



Top view of the PCB. Note that resistors are mounted vertically to save space.

PARTS LIST

RESISTORS (All 1/4W, 5%)

R1	4M7
R2	1M0
R3	47k
R4	39k
R5	680k
R6	270k
R7	33k
R8	10R

CAPACITORS

C1	4u7 Tant (See How It Works)
C2	1u0 Tant.
C3	1n0 Ceramic.

SEMICONDUCTORS

IC1, 2	CD4011
Q1, Q2	2N3904
D1	IN4001

MISCELLANEOUS

PCB to suit, small piece of plastic, knurled nut, 6.32 screw, battery, 9V (Mallory etc.), loudspeaker.

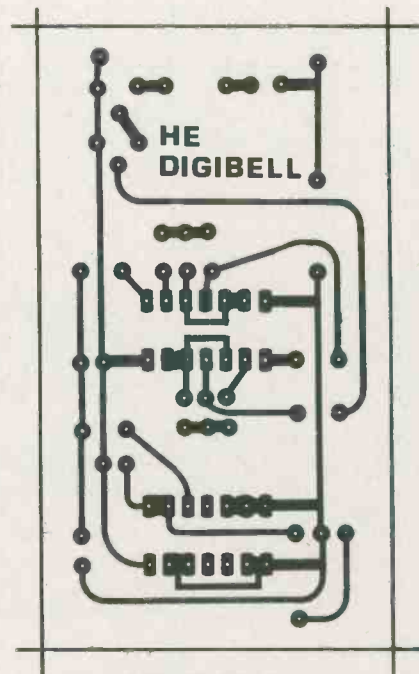
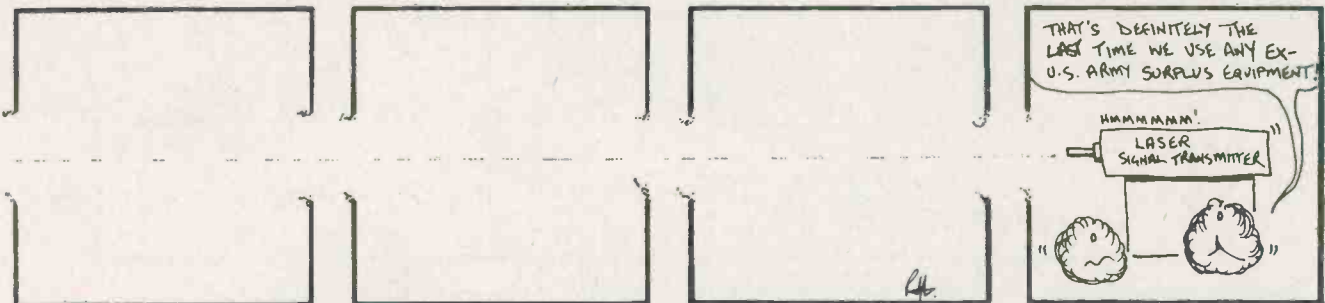

Fig. 4. PCB foil pattern.



CASANOVA'S CANDLE

If Casanova were alive today he would have certainly approved of this project, history however does not record whether or not he could solder

IT WOULD SEEM that almost every electronics manufacturer has at one time or another produced some kind of light dimmer. In general they all fulfill the same need, that is to vary the intensity of an incandescent lamp (a normal light bulb to you and me) over the whole range of brightness. Our dimmer has the added capability of being able to reduce the brightness of a lamp over the greater part of its range, over a period that can be from just one or two minutes to nearly one hour. At this point it's probably unnecessary to explain the title, however the unit could just as easily be used as a child's bedroom lamp, or indeed a reading lamp for any bedroom.

The Light Fantastic

Because only two wires protrude from the average light switch, certain constraints are placed upon the design, it is almost impossible to get the light to dim from full intensity for reasons that will become apparent later (see How It Works).

The final design managed to achieve a gradual reduction in brightness from about half-brightness to almost zero: using the components specified this will take about forty minutes.



The type of switch used is unimportant, it must, however be of the double pole changeover type.

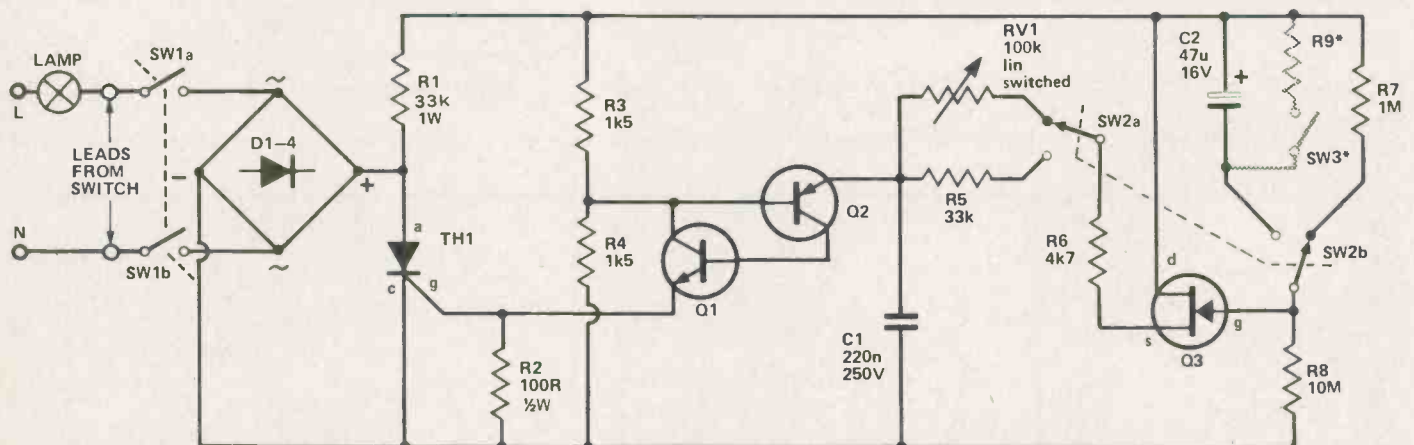

Fig. 1. Circuit of Casanova's Candle See text for notes on discharge switch SW3.

NOTE:
 Q1 IS 2N3904
 Q2 IS MPS6523
 Q3 IS 2N5458
 D1-4 ARE IN4004 diodes
 TH1 IS C106D
 *SEE TEXT

Construction

For ease of construction the unit is mounted on a shaped one-piece PCB. It is suggested that the board be cut to size and the central hole and cut-outs be completed before any etching is done.

The whole assembly relies upon the pot to mount the unit so care should be taken when soldering the pot to ensure a rigid joint between the pot and the board. Mounting the rest of the components should present no problems.

The Thyristor should be left slightly clear of the board to prevent any heat build-up.

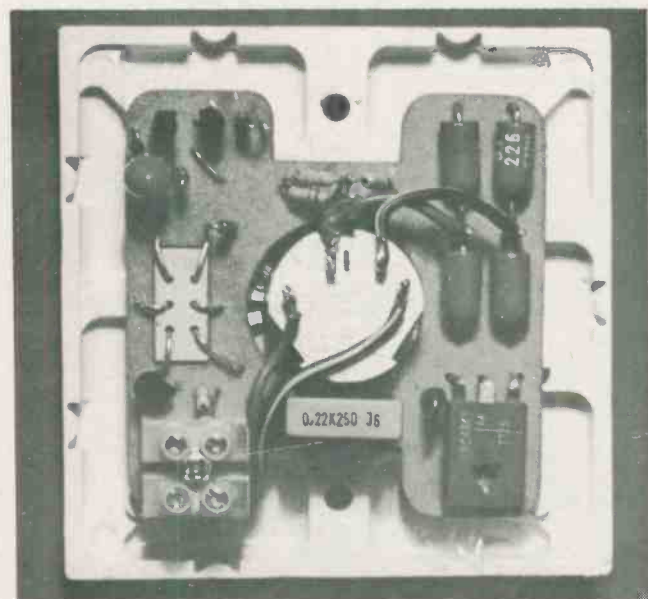

Note the cut-outs on the PCB, these are to clear the lugs on the mounting box.



The dimmer assembly is mounted on a blank switch plate. The hole for the pot and the slot for the switch should be drilled and filed with great care as the switch plate is made from an extremely brittle type of plastic and does not take too kindly to abuse.

How Fast Do You Work?

You may find that a discharge switch across C2 via R9 might be needed as the discharge time of C2 is somewhat prolonged. This however was not found to be necessary on the prototype.

HOW IT WORKS

This dimmer works in a rather unconventional way, most dimmers on the market use a TRIAC to switch both half-cycles of the cycles, this however was not practical for this application as the circuit requires a low voltage DC rail. To this end it was decided to use a fullwave bridge rectifier circuit with a thyristor across it's "DC" output to switch both half-cycles. The low voltage rail is provided by dropper resistor R1.

In each half-cycle, the thyristor will not conduct until it receives a trigger pulse from Q1. When this occurs, the thyristor will put a virtual short circuit across the bridge, causing maximum current to flow in the lamp. Hence the shorter the period between the start of the half-cycle and the firing of the thyristor, the brighter the bulb will burn.

The firing point of the thyristor is controlled by the comparator circuitry built around Q1, Q2. The DC rail carries an unsmoothed voltage with an amplitude of about 10 volts, which is applied to the base and emitter of Q2 by potential divider R3, R4 and CR network C1, RV1 and R6 respectively (assume for the moment that the FET Q3 is a short circuit). The CR network produces an out-of-phase signal at the Q2 emitter and whenever the voltage at this point rises above 0.6 V relative to the base, the transistor will conduct, thus Q1 will also be turned on, firing the thyristor.

The resistance of RV1 varies the amount of phase lag, and consequently the firing point of the thyristor, providing control of the lamp brightness. So far so good.

The delay circuitry comprises Q3 and the network C2, R8, and is switched in and out of circuit by switch SW2. The FET should be regarded as a purely resistive device, the degree of resistance being determined by the voltage on the Q3 gate. SW2 removes the pot RV1 from circuit and replaces it with R5 which gives approximately half-brightness until C2 begins to charge up.

The resistor R7 is used to keep the FET conducting during its normal operation so it becomes a virtual short circuit.

If for any reason the time taken to dim the lamp is either too long (or too short) the value of R8 can be changed to suit (C2 can be altered, but its physical size may prove to be a limitation).

Babani Books From ETI

These books are specially imported from England by us. If someone has already used the card, write to ETI Magazine, Unit 6, 25 Overlea Blvd. Toronto, Ontario M4H 1B1.

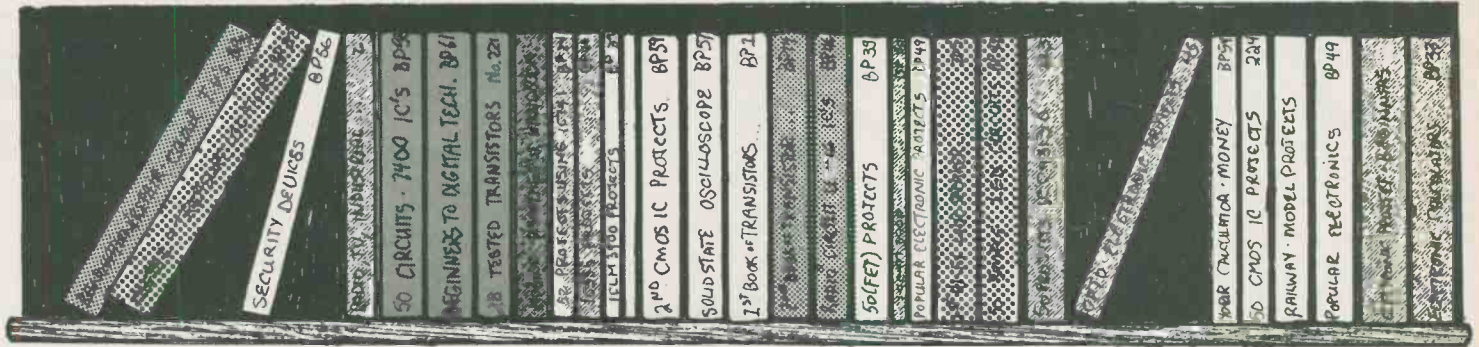

IC 555 Projects

■ Every so often a device appears that is so useful that one wonders how it went on before without it. The 555 timer is such a device.
 ■ It was first manufactured by Signetics, but is now manufactured by almost every semiconductor manufacturer and is inexpensive and very easily obtainable.
 ■ Included in this book are Basic and General Circuits, Motor Car and Model Railway Circuits, Alarms and Noise Makers as well as a section on the 556, 558 and 559 timers.
 ■ An invaluable addition to the library of all those interested in Electronics.
\$7.25 plus 30c postage and handling.

BP44

52 Projects Using IC741

■ IC741 is one of the most popular, inexpensive and easily obtainable devices available to the home constructor. It is also extremely versatile and can be used in a great number of various applications.
 ■ This unique book, originally published in Germany, shows fifty-two different projects that can be simply constructed using only the IC741 and a few discrete components.
 ■ An invaluable addition to the library of all those interested in electronics.
\$3.95 plus 30c postage and handling.

BP24

Mobile Discotheque Handbook

■ The vast majority of people who start up "Mobile Discos" know very little about their equipment or even what to buy. Many people have wasted a "small fortune" on poor, unnecessary or badly matched apparatus.
 ■ The aim of this book is to give you enough information to enable you to have a better understanding of many aspects of "disc" gear.
 ■ The approach adopted is to assume the reader has no knowledge and starts with the fundamentals, hopefully the explanations given are simplified enough for almost anyone to understand but please note that this is by no means the full story.
 ■ The book is divided into six parts: — Basic Electricity, Audio, Ancillary Equipment, Cables and Plugs, Loudspeakers, Lighting Equipment and the Information has been considerably sub-divided for quick and easy reference.
\$5.60 plus 30c postage and handling.

BP47

28 Tested Transistor Projects

■ Mr. Richard Torrins is a well experienced electronics development engineer and has designed, developed, built and tested the many useful and interesting circuits included in this book.
 ■ Some of the circuits are completely new and, to the best knowledge of the author, unlike anything previously published while others many bear similarity to more familiar designs.
 ■ The projects themselves can be split down into simpler building blocks, which are shown separately by boxes in the circuits for ease of description, and also to enable any reader who wishes to combine boxes from different projects to realise ideas of his own.
 ■ Most of the circuits are very economical on the use of components and in many cases the semiconductors employed are non-critical, commonly available and inexpensive types.
\$5.20 plus 30c postage and handling.

No.221

First Book of Transistor Equivalents and Substitutes

■ Shows alternatives and equivalents to many popular transistors made in Great Britain, U.S.A., Europe, Japan and Hong Kong etc.
 ■ Companion Volume to BP14 — SECOND BOOK OF TRANSISTOR EQUIVALENTS AND SUBSTITUTES
 ■ An invaluable addition to the library of all those interested in Electronics be they amateur or professional.
\$2.50 plus 30c postage and handling.

BP1

Second Book of Transistor Equivalents and Substitutes

■ Shows alternatives and equivalents to many popular transistors made in Gt. Britain, U.S.A., Europe, Japan and Hong Kong etc.
 ■ Companion Volume to BP1 — FIRST BOOK OF TRANSISTOR EQUIVALENTS AND SUBSTITUTES
 ■ An invaluable addition to the library of all those interested in Electronics be they amateur or professional.
\$4.50 plus 30c postage and handling.

BP14

Radio Circuits Using IC's

■ This book describes integrated circuits and how they can be employed in receivers for the reception of either amplitude or frequency modulated signals. The chapter on amplitude modulated (a.m.) receivers will be of most interest to those who wish to receive distant stations at only moderate audio quality, whilst the chapter on frequency modulation (f.m.) receivers will appeal to those who desire high fidelity reception of local v.h.f. stations possibly with stereo (and even quadrophony at some future date). Stereo decoder circuits and the devices available at present for quadrophonic circuits are discussed. Voltage regulator devices are also covered because they are so convenient in all vancap tuned receivers and because they have so many applications in all types of circuit.
 ■ Brian Dence is a highly experienced author who regularly contributes to many of the popular electronic magazines that are available both in the U.K. and overseas.
 ■ An extremely valuable addition to the library of all Electronics enthusiasts.
\$5.60 plus 30c postage and handling.

BP46

50 (FET) Field Effect Transistor Projects

■ Field effect transistors (F.E.T.'s) find application in a wide variety of circuits. The projects described here include radio frequency amplifiers and converters, test equipment and receiver aids, tuners, receivers, mixers and tone controls, as well as various miscellaneous devices which are useful in the home.
 ■ It will be found that in general the actual F.E.T. used is not critical and many suitable types will perform satisfactorily. The F.E.T. is a low-noise, high gain device with many uses, and the dual gate F.E.T. is of particular use for mixer and other applications.
 ■ This book contains something of particular interest for every class of enthusiast — shortwave listener, radio amateur, experimenter or audio devotee.
 ■ A valuable addition to the library of all electronic enthusiasts.
\$5.20 plus 30c postage and handling.

BP39

Popular Electronic Projects

■ Included in this book are a collection of the most popular types of projects which, we feel sure, will provide many designs to interest all electronics enthusiasts.
 ■ All the circuits utilize modern, inexpensive and freely available components.
 ■ The 27 projects selected cover a very wide range and are divided into four basic areas: Radio Projects, Audio Projects, Household Projects and Test Instruments.
 ■ An interesting addition to the library of both the beginner and more advanced constructor.
\$5.95 plus 30c postage and handling.

BP49

Electronic Music and Creative Tape Recording

■ Electronic Music is the new music of the 20th Century. It plays a large part in "Pop" and "Rock" music and, in fact, there is scarcely a group without some sort of electronic synthesiser or other effects generator.
 ■ It is possible with relatively simple apparatus to create complete compositions using electronic and sometimes non-electronic musical sources.
 ■ This book sets out to show how Electronic Music can be made at home with the simplest and most inexpensive equipment. It describes how the sounds are generated and how these may be recorded to build up the final composition.
 ■ With the constructor in mind, several ideas are given to enable a small studio to be built including a mixer and various sound effect units.
 ■ Circuits are included for VCOs, VCA's, Envelope Shapers, VCF's, Active and Passive Mixers, Fuzz, Noise Generators, Metronomes and a 10-Note Programmable Sequencer etc.
 ■ All the units shown have been successfully built and used by the author and most of the projects can be built by the beginner.
 ■ An unusual, fascinating and highly rewarding application of electronics.
\$5.20 plus 30c postage and handling.

BP51

IC LM3900 Projects

■ The purpose of this book is to introduce the LM3900 to the Technician, Experimenter and Hobbyist. It provides the groundwork for both simple and more advanced uses and is considerably more than just a collection of simple circuits or projects.
 ■ The LM3900 is different from conventional 'Op-Amps'; it can be used for many of the usual applications as well as many new ones. It is one of the most versatile, inexpensive and freely available devices on the market today.
 ■ The book is divided into six basic sections —
 Introduction
 Audio Applications
 Simple Linear Applications
 Simple Digital Applications
 Signal Generator Circuits
 Special Applications

BP50

■ The LM3900 can do much more than is shown here — this is just an Introduction. Imagination is the only limitation with this useful device, but first the reader must know the basics and that is what this book is all about.
\$5.60 plus 30c postage and handling.

1st Book of Hi-Fi Loudspeaker Enclosures

■ Contains 26 practical designs and over 40 drawings to enable the enthusiast to construct his own Hi-Fi Loudspeaker enclosures.
 ■ Includes the following types of enclosures: —
 Corner Reflex, Bass Reflex, Exponential Horn, Folded Horn, Tuned Port, Klipschorn, Labyrinth, Tuned Column, Loaded Port, Multispeaker Panoramic etc.
 ■ Also covers general construction hints and embellishing of cabinets as well as a considerable amount of other useful information.
 ■ A must for the library of all audio enthusiasts.
\$3.25 plus 30c postage and handling.

No.205

50 Simple L.E.D. Circuits

■ The author of this book, Mr. R.N. Soar, has compiled 50 interesting and useful circuits and applications, covering many different branches of electronics, using one of the most inexpensive and freely available components — the Light Emitting Diode (L.E.D.).
 ■ Also includes circuits for the 707 Common Anode Display.
 ■ A useful book for the library of both beginner and more advanced enthusiast alike.
 ■ Companion volume to book No. BP36 — 50 CIRCUITS USING GERMANIUM, SILICON & ZENER DIODES by the same author.
\$3.25 plus 30c postage and handling.

BP42

Handbook of IC Audio Preamp and Power Amplifier Construction

■ Shows what audio IC's are, as well as how to use them.
 ■ Includes practical constructional details of various IC and Hybrid IC/Transistor designs of about 250mW to 100W output.
 ■ This book is written by the very experienced and popular author Mr. F.G. Rayer who deals with the subject in four parts:
 Part I Understanding Audio IC's
 Part II Preampifiers, Mixers and Tone Controls
 Part III Power Amplifiers and Supplies
 Part IV Hybrid Circuits
 ■ An ideal book for both beginner and advanced enthusiast alike.
\$5.20 plus 30c postage and handling.

BP35

50 Projects Using Relays SCR's & Triacs

■ Relays, silicon controlled rectifiers (SCR's) and bi-directional triodes (TRIAC's) have a wide range of applications in electronics today. These may extend over the whole field of motor control, dimming and heat control, delayed, timing and light sensitive circuits and include warning devices, various novelties, light modulators, priority indicators, excess voltage breakers etc.
 ■ In this book, the very experienced and popular author — Mr. F.G. Rayer — has given tried and practical working circuits which should present the minimum of difficulty for the enthusiast to construct.
 ■ In most circuits there is a wide latitude in component values and types, allowing easy modification of circuits or ready adaptation of them to individual needs.
 ■ An ideal book for both beginner and advanced enthusiast alike.
\$5.20 plus 30c postage and handling.

BP37

50 Projects Using IC CA3130

■ The CA3130 is currently one of the more advanced operational amplifiers that is available to the home constructor. This means that it is often capable of a higher level of performance than many other devices and that it often needs fewer ancillary components.
 ■ In this book Mr. R.A. Penfold has designed and developed a number of interesting and useful projects which are divided into five general categories:
 I Audio Projects
 II R.F. Projects
 III Test Equipment
 IV Household Projects
 V Miscellaneous Projects
 ■ An ideal book for both the beginner and more advanced enthusiast alike.
\$5.20 plus 30c postage and handling.

No.223

Electronic Projects for Beginners

■ In this book the newcomer to electronics will find a wide range of easily made projects, many complete with actual component and wiring layouts. Furthermore, a number of projects have been arranged so that they can be constructed without any need for soldering and, thus, avoid the need for a soldering iron.
 ■ This book which is written by the very experienced author Mr. F.G. Rayer is divided into four sections:
 1. "No Soldering" Projects
 2. Miscellaneous Devices
 3. Radio and Audio Frequency
 4. Power Supplies
 ■ An absolute "must" for all beginners in electronics.
\$5.60 plus 30c postage and handling.

BP48

50 CMOS IC Projects

■ CMOS IC's are probably the most versatile range of digital devices for use by the amateur enthusiast. They are suitable for an extraordinarily wide range of applications and are now also some of the most inexpensive and easily available types of IC.
 ■ In this book Mr. R.A. Penfold has designed and developed a number of interesting and useful projects which are divided into four general categories:
 I Multivibrators
 II Amplifiers and Oscillators
 III Trigger Devices
 IV Special Devices
 ■ An ideal book for both the beginner and more advanced enthusiasts alike.
\$3.95 plus 30c postage and handling.

No.224

Electronic Calculator Users Handbook

■ An invaluable book for all calculator users whatever their age or occupation, or whether they have the simplest or most sophisticated of calculators.
 ■ Presents formulae, data, methods of calculation, conversion factors etc. with the calculator user especially in mind, often illustrated with simple examples.
 ■ Includes:
 The way to calculate, using only a simple four function calculator.
 Trigonometric functions (sin, cos, tan)
 Hyperbolic functions (sinh, cosh, tanh)
 Logarithms, square roots and powers.
 ■ A comprehensive section of conversion factors covering such common conversions as length, area, volume and weight etc. through to more specialised conversions such as viscosity, illumination, and cargo shipping measures etc.
 ■ Formulae and data for VAT, discounts and mark up, currency conversion, interest, solutions of equations, binary and octal numbers, areas and volumes, statistics and mathematics etc.
\$3.95 plus 30c postage and handling.

BP33

CANADA'S ELECTRONICS MAGAZINE

YOU DIDN'T KNOW that Canada had its own Electronics enthusiasts? Well every month ETI brings you features, and news, in a publication produced, published and printed in Canada.

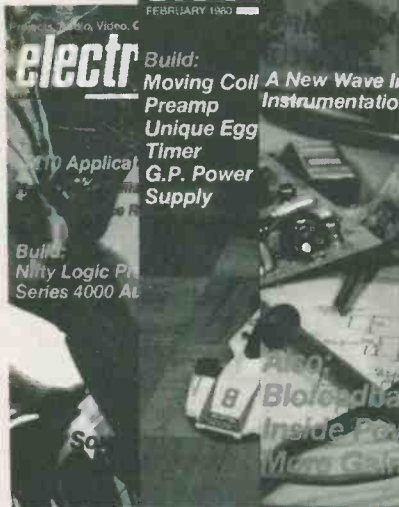

Audio, Video
elect
APRIL 1980
Build Wire Tr
elect
MARCH 1980
Deep Spa
Communi
We look at
That LONG
distance feel
Build:
Our very
— Minisys
— Electro
Also:
Surface A

Electronics Today \$1.75
INTERNATIONAL JUNE 1980

**CLIP: Computer Image Recognition
Dynamic Noise Reduction Project
Canadian Sound Archives
Function Generator**

Three Motorola Fiber Optics Kits Must Be Won! See page 43

FOR OFFICE USE _____

Code _____

Electronics Today Magazine, Unit 6, 25 Overlea Blvd., Toronto, Ontario M4H 1B1.

SUBSCRIPTIONS: NEW SUBSCRIPTION? OR... RENEWAL? Please check one.
 One year subscription (12 issues) \$14 Two year subscription (24 issues) \$26
 Postage and handling to Canada is included, for U.S. please add \$3, other countries add \$5/yr.

PLEASE PRINT CLEARLY

NAME _____

ADDRESS _____

TOWN/CITY _____ PROVINCE/STATE _____

CODE _____ DATE _____

Cheque enclosed DO NOT send cash

Bill Mastercharge. A/C No. _____ } Signature _____

Bill ChargeX. A/C No. _____ } Expiry Date _____

PLEASE ALLOW 6-8 WEEKS FOR YOUR FIRST MAGAZINE TO ARRIVE

**Act
Now!
Use
This
Coupon**

LED TACHOMETER

The HE Tacho uses 21 LEDs to give a solid-state analogue RPM display. It's an ideal project for the motoring or motor-cycling enthusiast.

THE HE LED TACHO or 'Rev Counter' is an all solid-state project. It displays engine speed in analogue form (like a conventional tacho) as an illuminated section of a semicircle of 21 LEDs (light-emitting diodes). The length of the illuminated section is proportional to the engine speed, so that half of the semicircle is illuminated at half of full-scale speed, and the full semicircle is illuminated at full speed. In other words, the display is in 'bar' rather than 'dot' form.

The HE Tacho can be used with virtually any type of multi-cylinder gas engine. It has two speed ranges, each of which can be calibrated via a pre-set pot to give any full-scale speed range required by the individual owner. Our prototype is calibrated to give full scale readings of 10000 RPM and 1000 RPM on a 4-cylinder 4-stroke engine. The lower range is of great value when adjusting the engine's ignition and carburation for recommended tick-over speeds.

The unit is designed for use only on vehicles fitted with 12 volt electrical systems. It can be used with conventional or CD (capacitor-discharge) ignition systems, and is wired into the vehicle via three connecting leads. It can be used on vehicles fitted with either negative or positive ground electrical systems.

Construction

The complete unit, including the 21-LED display, is wired up on a single PCB. Take extra care over the construction, paying special attention to the following points.

- (1). Confirm the polarity of each of the 21 LEDs, by connecting in series with a 1k Ω resistor and testing across a 12 volt supply, before wiring into place on the PCB. Note that LED colours can be mixed, if required.
- (2). Take care to connect all semiconductor devices and electrolytic capacitors into circuit as shown on the overlay. Note the orientation of the three ICs.
- (3). Note that four LINK connections (using insulated wire) are used on the underside of the PCB: if in doubt about these connections, cross-check with the circuit diagram. Also note that the external connections to the unit (0 V, + ve, and CB) are made via solder terminals (Veropins).
- (4). Note that the values of C2 and C3 must be chosen to suit the engine type and the full-scale RPM ranges required (see the conversion graph). Our prototype is calibrated to read 10 000 RPM and 1000 RPM on a 4-cylinder 4-stroke engine, and uses C2 and C3 values of 22n and 220n respectively.

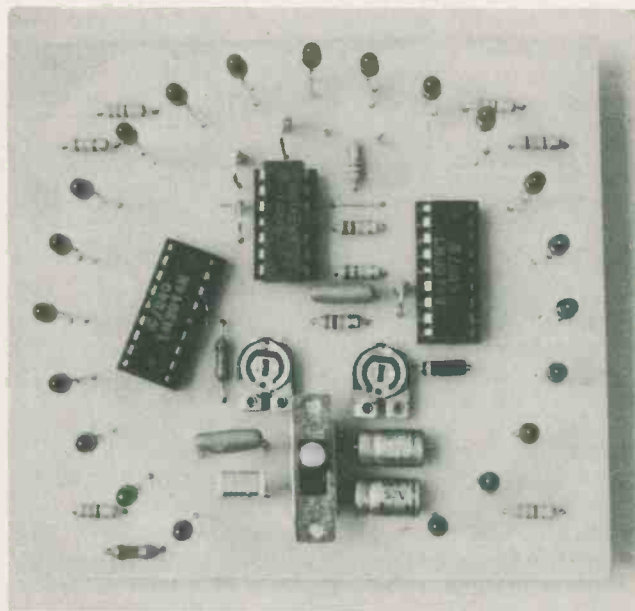

The HE tachometer, make sure all polarised components are inserted the correct way round.

When the construction is complete, connect the unit to a 12 volt supply and check that only LED 1 illuminates: if all LEDs illuminate, suspect a fault in the IC1 wiring.

Calibration

The unit can be calibrated against either a precision tachometer or against an accurate (2% or better) audio generator that gives a square wave output of at least 3 volts peak-to-peak. The method of calibration against an audio generator is as follows:

Connect the tacho to a 12 volt supply, and connect the square wave output of the audio generator between the 0V and CB terminals of the unit. Check against the conversion graph to find the frequency needed to give the required HIGH range full-scale RPM reading on the type of engine in question, and feed this frequency into the tacho input. Switch SW1 to its HIGH range (10 000 RPM on our prototypes) and adjust RV1 for full-scale reading.

Repeat the procedure on the LOW range of the tacho (1000 RPM on our prototype), adjusting RV2 for full-scale reading.

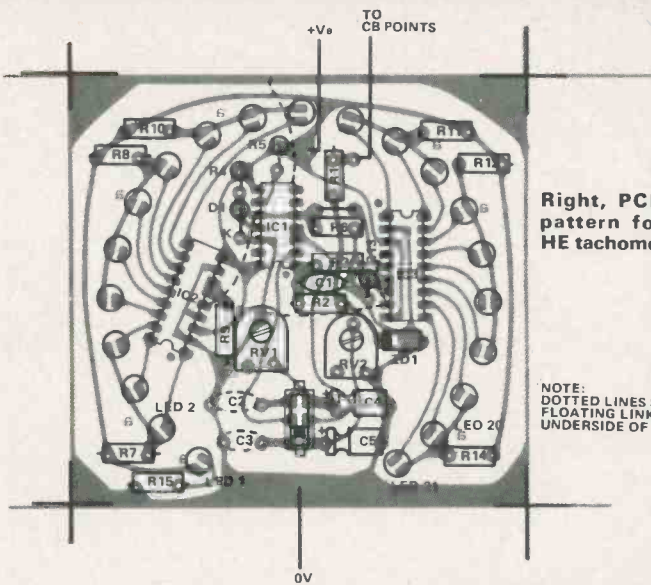

Component overlay for the Tacho.

Right, PCB foil pattern for the HE tachometer.

NOTE: DOTTED LINES SHOW FLOATING LINKS MADE UNDERSIDE OF PCB

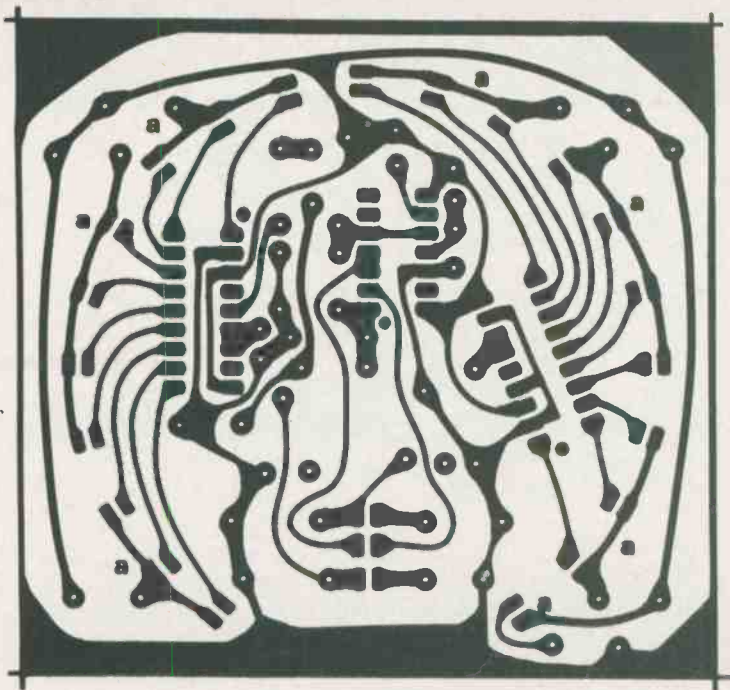

PARTS LIST

RESISTORS

R1, R2, R4	10k
R3, R6	22k
R5	470R
R7, R10, R11, R14	330R
R8, R12	270R
R9, R15	1k2
R13	2k2

POTENTIOMETERS

RV1, RV2	100k Sub. min. preset
----------	-----------------------

CAPACITORS

C1, C2*	22n polyester
C3*	220n polycarbonate
C4	1μ0 elect. 63V
C5	4μ7 elect. 63V

*=values used on prototype: see text

SEMICONDUCTORS

IC1	LM2917N
IC2, IC3	LM3914N
ZD1	12V @ 400mw
D1	IN4148

LEDS 1-21 are TIL209 0.2" dia.

MISCELLANEOUS

Miniature slide switch (two position double pole). PCB foil pattern.

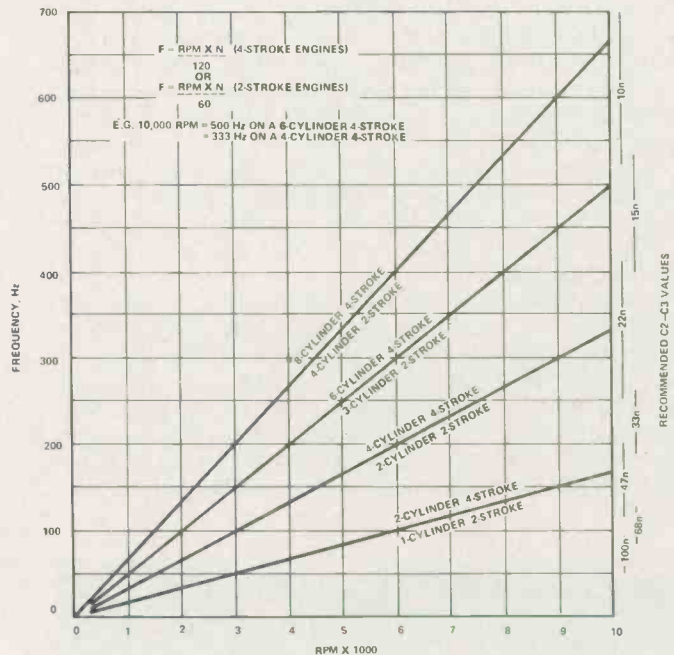

Conversion Graph for determining values of C2, C3.

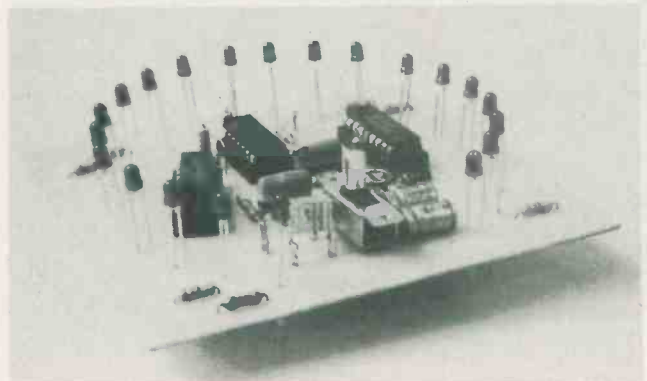

The Tacho prior to installation.

PARKING METER TIMER

Avoid expensive parking fines with our pocket-sized warning bleeper

HAVE YOU EVER returned to a parking meter just in time to see a green hornet slap a ticket on your jallopy windshield? If so, our parking meter timer will help ensure that that experience never happens again. It does so by sounding a loud 'beeping' alarm signal several minutes before your parking time is up, thus giving you time to sprint back to the parking zone and feed another coin into the meter just before your 'legal' time expires.

The timer uses just two CMOS integrated circuits and half a dozen discrete components and is small enough to fit comfortably into a shirt pocket. To use the unit, you simply select either a one hour or two hour parking period via a slide switch when you first feed the meter after initially parking the car: this automatically switches the timer on. Then slip the timer unit into your pocket and forget about it.

A few minutes before the expiry of your selected parking time, the timer automatically emits a loud 'times-nearly-up' beeping alarm sound. This sound is loud enough to be heard in a noisy room, even when the unit is pushed into an inside pocket. Once the alarm has sounded, you can turn the unit off via its slider switch. The parking meter timer costs only a few bucks to build, but could save you a lot of money from parking fines.

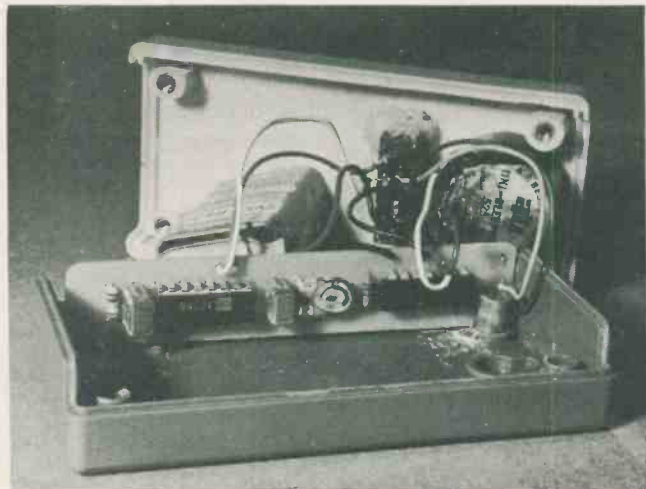

Internal view of timer showing how the PCB is fitted.

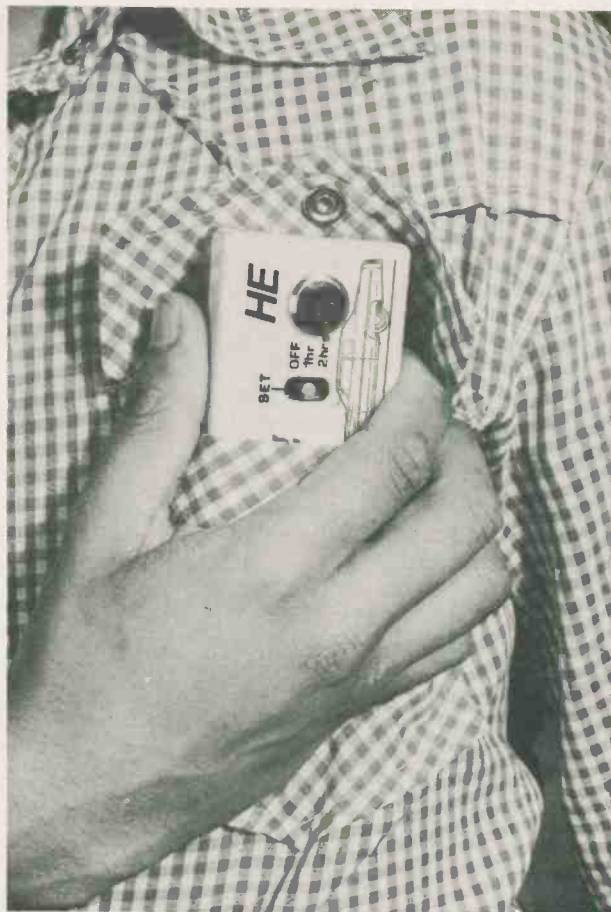

The Parking Meter Timer is small enough to fit in a shirt pocket.

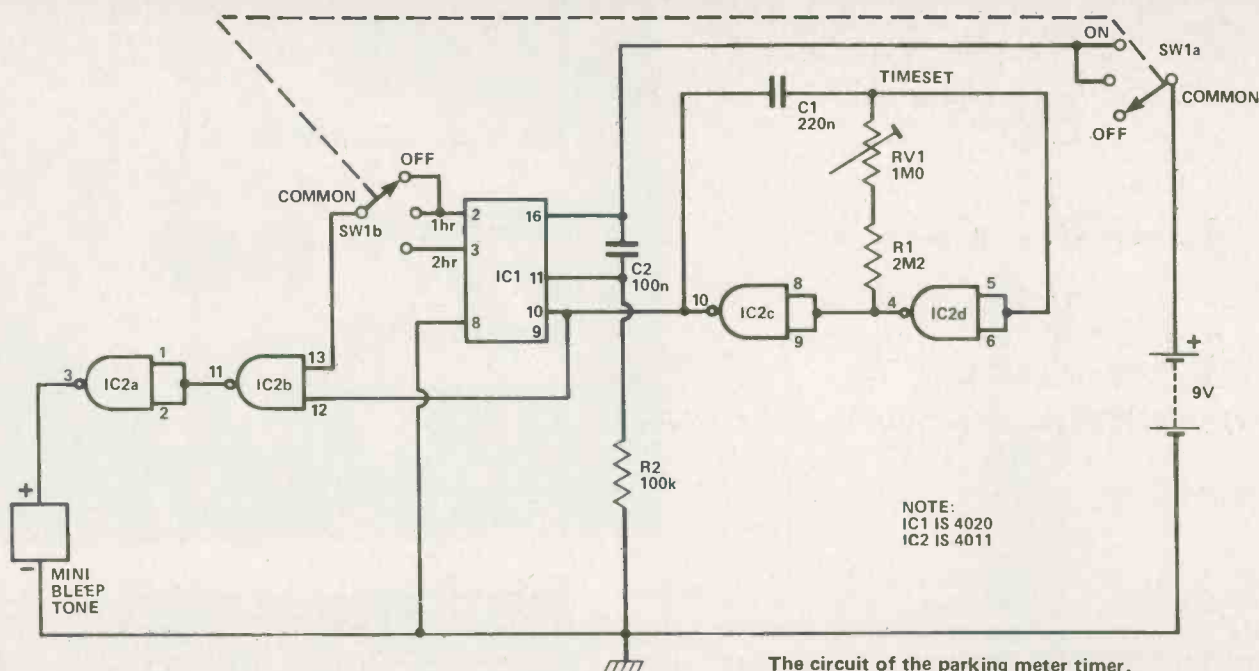

The circuit of the parking meter timer.

HOW IT WORKS

The two integrated circuits used in the design are CMOS devices. IC1 is a 4020 14-stage ripple carry binary counter, and IC2 is a 4011 quad 2-input NAND gate. Two of the NAND gates (IC2c and IC2d) are interconnected as a low-frequency astable multivibrator, with its output feeding to the CLOCK (pin 10) input terminal of the 4020 and to one of the input terminals of the IC2b NAND gate: the second terminal of the IC2b NAND gate is fed from either the 14th (pin 3) counter stage of the 4020, which is normally low but goes high on the 4096th count of the clock, in the '2 hour' position of SW1, or from the 13th (pin 2) stage of the 4020, which goes high on the 2048th count of the clock, in the '1 hour' position of SW1. The output of the IC2b NAND gate is fed to a miniature tone generator module via IC2a, which is connected as a simple inverter. The complete operating sequence of the circuit is as follows:

The unit is switched on by moving SW1 to either the 1 Hour or 2 Hour position. At switch-on a brief reset pulse is fed to pin 11 of the 4020 via the C2-R2 network, and all outputs of this IC go low. The astable 'clock' generator starts to operate as soon as the unit is switched on, but the tone generator is held off because one of the inputs to the IC2c NAND gate is low. At the end of the 2048th clock cycle in the '1 Hour' position or the 4096th clock cycle in the '2 Hour' position, one of the inputs of the IC2b NAND gate is set high by the respective output of the 4020. The tone generator module is then switched on whenever the output of the clock generator goes high, and thus produces a 'bleep' signal.

In use, the timer can be set to produce either precise 1 and 2 hour periods, or periods that are a few minutes short of these times, by adjustment of the RV1 'set time' control.

Construction

The most important thing to remember about this project is that, to be of real practical value, it must be small enough to fit comfortably in a shirt pocket, so that you can use it even in the warmest weather. With this in mind, we've taken a lot of trouble over miniaturisation.

The housing that we've chosen for the project is a Type 65-2514F Verocase, which is just large enough to house all of the components. Even so, it is necessary to cut away part of the pillars along one side of the case, to accommodate the PCB and its components.

Slide switch SW1 should be recessed into the front of the case, so that it doesn't get accidentally switched off when the unit is in use. We achieved this by cutting a small slot in the front cover and fixing the switch into position from the rear by using layers of epoxy adhesive to set the switch at the correct height.

Take Precautions

Note when assembling the PCB that miniature polycarbonate capacitors are used for C1 and C2, and also that sensible precautions must be taken when soldering the two CMOS IC's into place. The wiring of SW1 to the PCB should be done with special care. When construction of the timer unit is complete, it can be calibrated as follows.

Calibration

Temporarily disconnect the lead to the 'common' tag of SW1b and connect the lead to the positive supply rail. Switch the unit on. The unit should now produce the 'bleeping' tone. If you want the unit to give precise one hour and two hour timing periods, adjust RV1 to give 68.3 bleeps per minute. If, on the other hand, you want periods of 1 hour 50 minutes (to give you the 'times-nearly-up' warning), set RV1 to give 74.5 bleeps per minute. That completes the calibration, and you can now reconnect the lead to the common tag of SW1b, and put the unit to practical use.

As a final point, you may care to note that you can get timing periods of 1/2 hour or 1/4 hour from the unit by connecting SW1b to pin 1 or pin 15 of IC1, if you so wish.

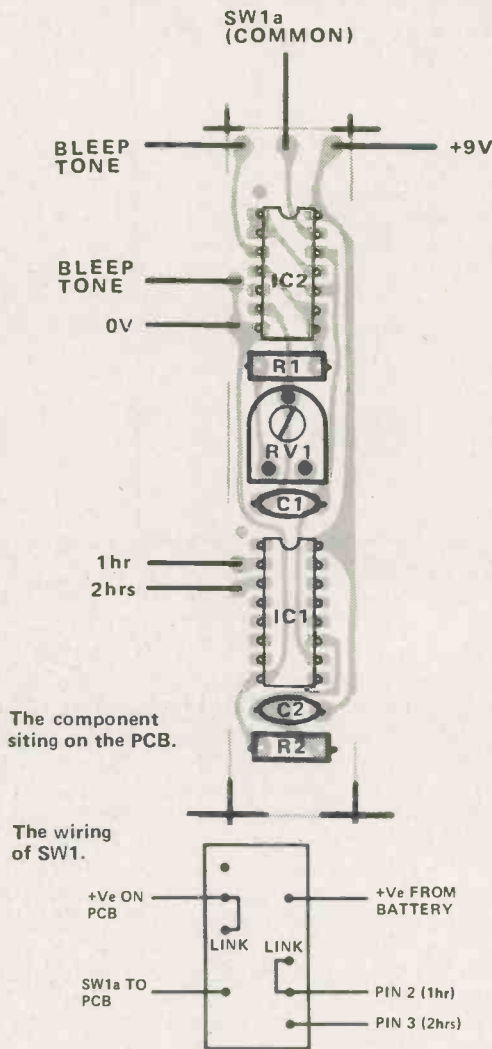

The component sitting on the PCB.

The wiring of SW1.

PARTS LIST

- | | |
|--|--------------------|
| RESISTORS. (all 1/4w 5%) | |
| R1 | 2M2 |
| R2 | 100k |
| CAPACITORS | |
| C1 | 220n polycarbonate |
| C2 | 100n polycarbonate |
| POTENTIOMETER | |
| RV1 | 1M0 preset |
| SEMICONDUCTORS | |
| IC1 | 4020 |
| IC2 | 4011 |
| MISCELLANEOUS | |
| Bleep tone (9V-15mA) | |
| SW1 min. slide three position double pole. | |
| Vero case to suit. PCB | |

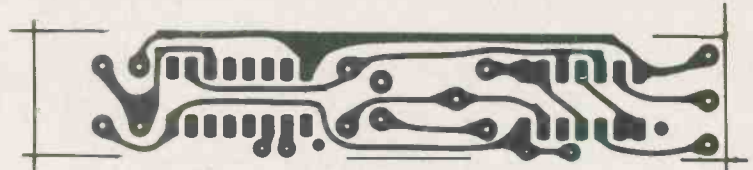
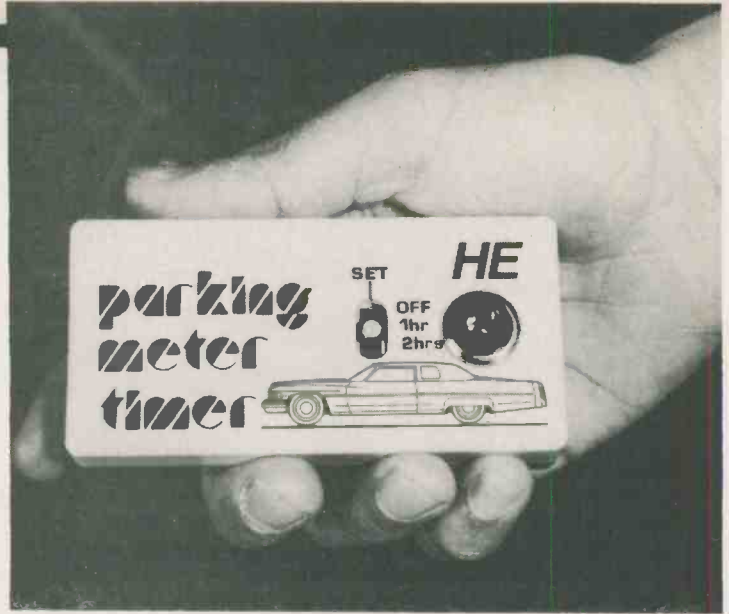

The PCB pattern shown full size.

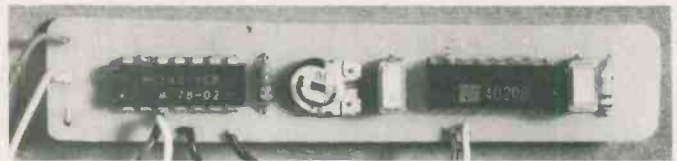

Completed PCB

FINGERS TO DONUTS



KIT 551 **NEW** Photo Reversing Kit for Lifting Off Circuits



This kit may be used to lift off any circuit diagram in a magazine and gives sharp resolution and professional quality negatives. Drafting aids are mounted on a clear layout film over the circuit. This becomes the positive used by the kit to produce a real sharp negative which is then used on boards previously coated with a negative acting resist. This method produces a sharper image than positive resists. The PHOTO REVERSING KIT has 3 sheets of contact film 5 x 8 in., developer, fixer and toner.

omnitronix Ltd.

2056 Trans Canada Highway
Dorval, Quebec H9P 2N4
Tel: (514) 683-6993

HOBBYTUNE

Build a full feature monophonic organ

HOBBYTUNE IS A SELF-CONTAINED, battery-powered stylus organ with a number of novel features. You can select between four independent voices, use them all at once or in combinations for a full chorus sound. Vibrato is available and the depth of modulation is fully adjustable enabling effects from a gentle 'harmonica' beat to a modern synthesizer sound to be produced.

A twenty note keyboard was chosen as the best compromise between economy and performance. This gives a scale in the key of 'C' ranging between 'G' and 'D' including sharps and flats; the 'black' notes. Though only an octave with a fourth below and a tone above, the range of the instrument can be extended by judicious use of the stops as square and triangle outputs are

available both at the fundamental pitch and an octave below.

The vibrato frequency is fixed, though it is very easy to change if required by selection of three capacitors. Though designed for use with its built-in amplifier and loudspeaker, Hobbytune can be easily modified to plug into your home stereo amp by taking an output from the slider of the volume control. Also the keyboard can be extended to any desired size by addition of further tuning resistor networks. As each note can be individually adjusted the instrument can be tuned very accurately avoiding the generation of unwanted 'blue' notes. The unmodified instrument, built as described here proved to be very popular in the office and the tone was very pleasant with more than adequate volume.

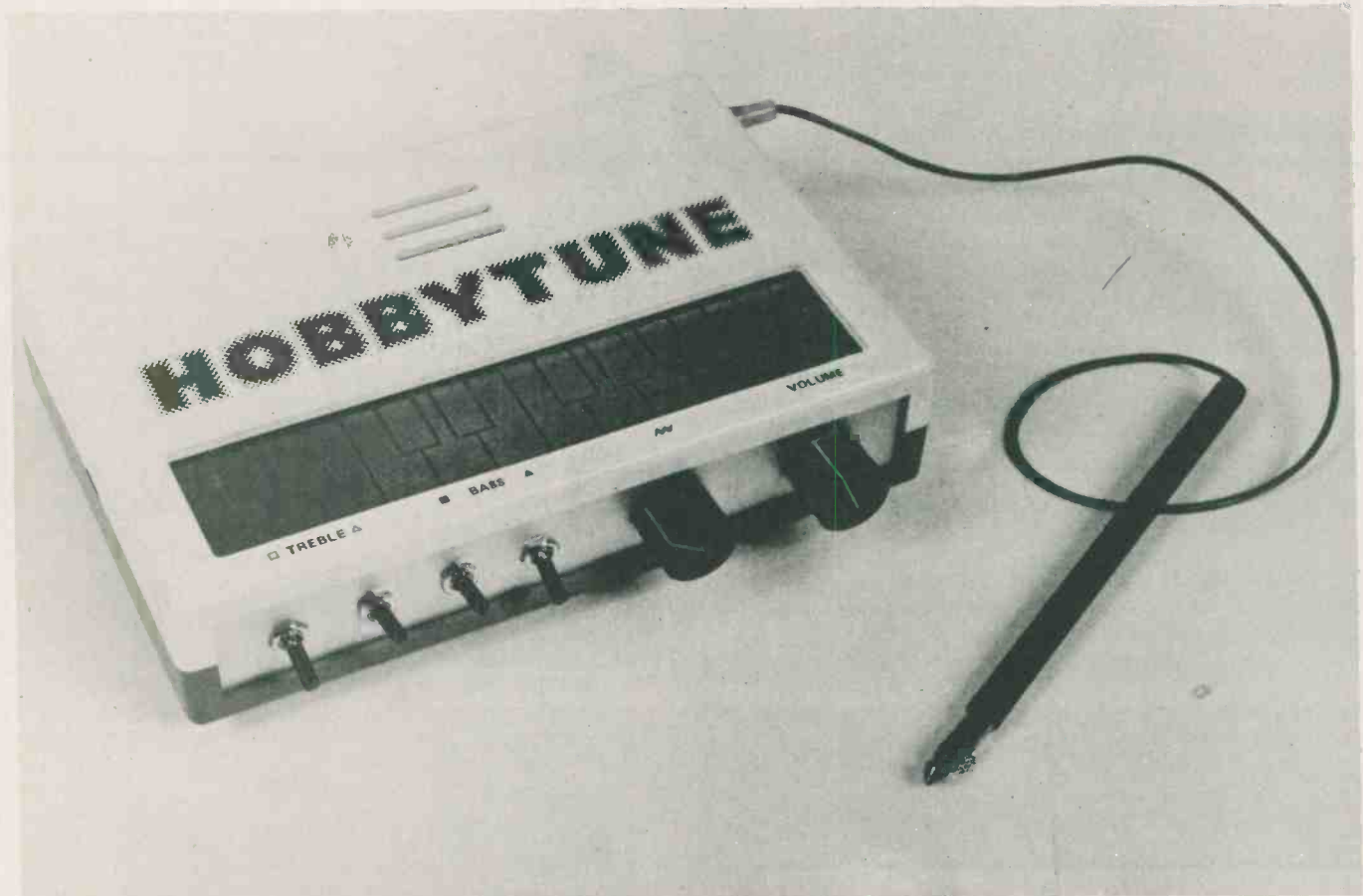

The Hobbytune awaiting a guiding hand, note the use of an old jack-plug for the stylus.

NOTES:
 IC1 IS 4027B
 IC2 IS LM389
 D1, D2 ARE 1N4148
 ZD1 IS 6V2 400mW

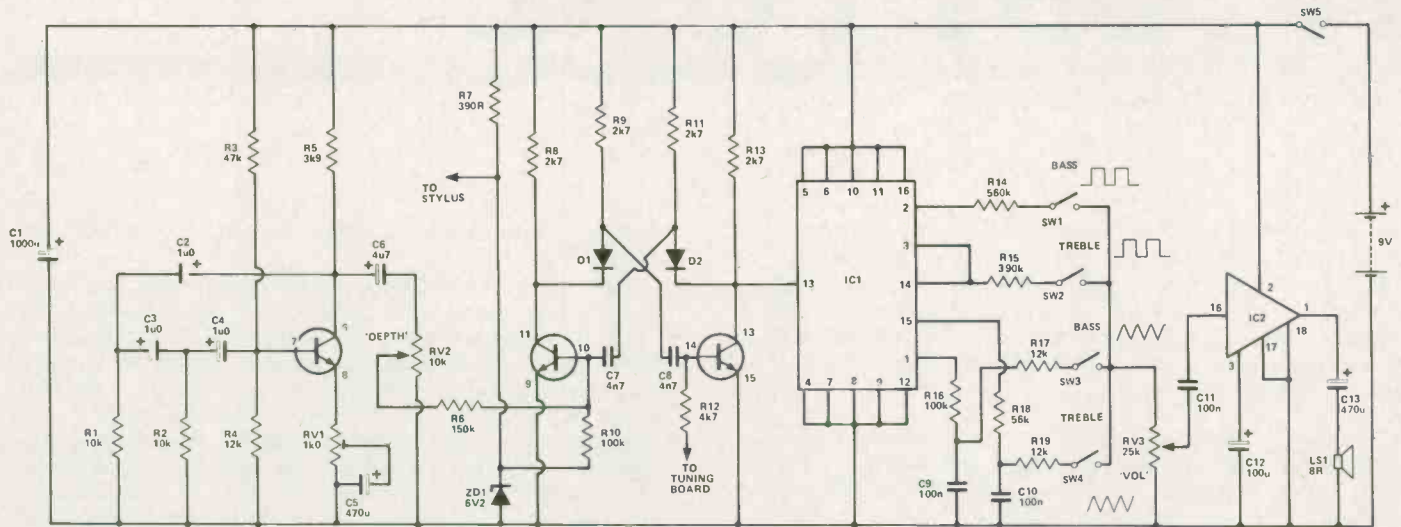

Fig. 1. Circuit diagram for the Hobbytune.

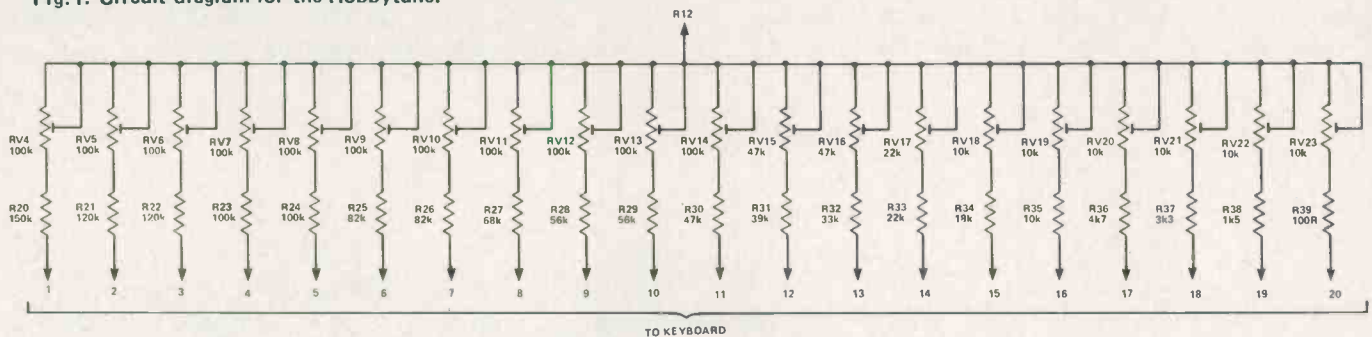

Fig. 2. Circuit diagram for the resistor tuning network

HOW IT WORKS

Circuit operation may be most easily understood by considering it as four separate sections. The master tone generator, vibrato oscillator, divider and waveshaping circuits and the audio amplifier. We will look at these in more detail.

The master tone generator is formed by two transistors (pins 9, 10, 11 and 13, 14, 15) connected as an astable multivibrator. The only unusual feature of this circuit is the inclusion of diodes D1, 2 and resistors R9, 11. These components steer current into the timing capacitors C7, 8 on the positive going edges of the waveform and enable clean fast squarewaves to be obtained at the transistor collectors. This ensures reliable triggering of the CMOS divider IC1. Frequency is altered by adjustment of resistance between R12 and the junction of R7 and ZD1. The zener diode is included to provide a measure of protection against falling battery voltage. The frequency may be altered by injecting a current into the base of either transistor. In this circuit, the modulation voltage is applied to R6. Modulation depth is controlled by adjustment of RV2.

The modulation signal, an approximation to a sinewave at between 5 to 10 hertz, is obtained from the phase-shift oscillator built around one transistor (pins 6, 7, 8) which runs continuously. C2, 3, 4

set the frequency of oscillation and should be adjusted equally if a change is required. RV1 sets the gain and should be adjusted so that the stage just oscillates. The easiest way to do this is with the master tone generator working and the modulation depth control set at maximum. Simply play a note by touching the stylus to the keyboard, adjust RV1 and listen to the result. The best sinewave and most attractive effect is obtained when the circuit is just oscillating.

There is little to say about IC1. It simply divides the master tone generator output by two and divides its own output by two again producing two squarewave signals of equal duty cycle an octave apart. As signals are available from both the Q and Q outputs, one of these is simply attenuated by a resistive divider (R14, RV3) whilst the other is shaped by a lowpass RC filter formed by R16, C9. Values of the waveshaping and attenuating components are not critical though those shown gave good results in the prototype.

IC2 contains an audio amplifier with a voltage gain fixed at about 20 and bias set internally. C12 is a decoupling component while C11 and C13 couple the signal input and output respectively. C1 is the overall supply decoupling capacitor.

Take Two

Only two integrated circuits are used in the unit. Do not be misled by the circuit diagram, the three transistors and the audio amp are all contained in a single package, the LM389 from National Semiconductor. The other device is an ordinary CMOS dual JK flip-flop configured as two divide by two counters. This ensures symmetrical

waveforms are available for waveshaping. Very simple RC filters are used to perform waveshaping and square and triangle waveforms are available. These approximate to string and woodwind sounds. More complex tone formation would have been prohibitively expensive and is really unnecessary as the tones produced by the simple techniques used sound very good.

PARTS LIST

RESISTORS (All 1/4W 5%)

R1, 2, 35	10k
R3, 30	47k
R4, 17, 19	12k
R5	3k9
R6, 20	150k
R7	390R
R8, 9, 11, 13	2k7
R10, 16, 23, 24	100k
R12, 36	4k7
R14	560k
R15	390k
R18, 28, 29	56k
R21, 22	120k
R25, 26	82k
R27	68k
R31	39k
R32	33k
R33	22k
R34	18k
R37	3k3
R38	1k5
R39	100R

POTENTIOMETERS

RV1	1k preset
RV2	10k lin
RV3	25k lin
RV4, 5, 6, 7, 8, 9, 10, 11, 12, 13, 14	100k preset
RV 15, 16	47k preset
RV17	22k preset
RV 18, 19, 20, 21, 22, 23	10k preset

CAPACITORS

C1	1,000 μ electrolytic
C2, 3, 4	1 μ tantalum
C5, 13	470 μ electrolytic
C6	4 μ 7 tantalum
C7, 8	4n7 polyester
C9, 10, 11	100n polyester
C12	100 μ electrolytic

SEMICONDUCTORS

IC1	4027B
IC2	LM389
D1, 2	1N4148
ZD1	6V2 400mW

MISCELLANEOUS

SW1, 2, 3, 4, 5	SPST
LS1	8 ohm 2 1/4"
Stylus (see text)	case to suit

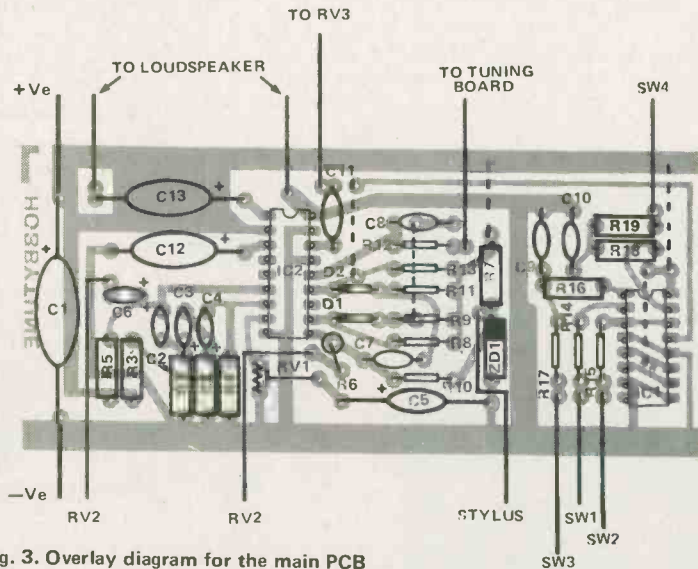
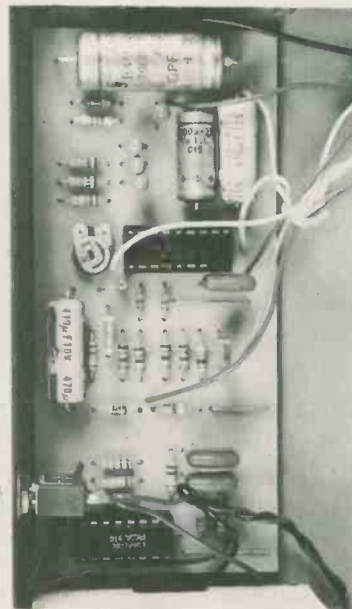

Fig. 3. Overlay diagram for the main PCB



Close-up of the main electronics

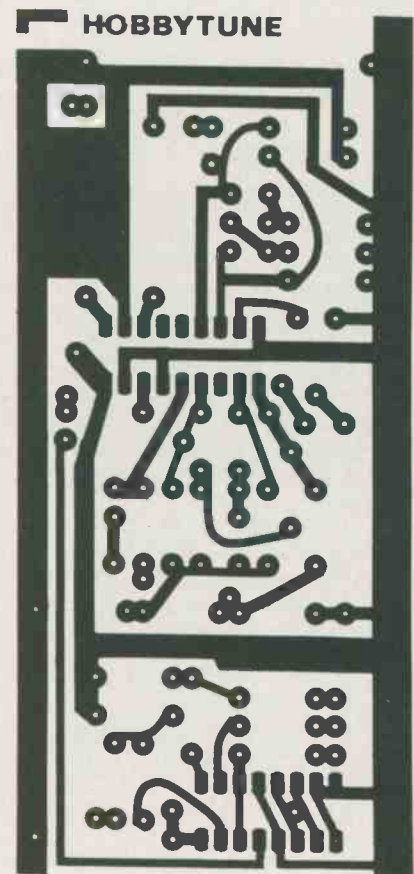

Fig. 4. PCB foil pattern for the Hobbytune main board.

Construction

The organ is assembled on three PCBs. Other methods may be used but use of our PCBs will greatly reduce the chance of errors creeping in and simplify construction. To enable flexibility of layout and design, the main circuitry is contained on one board while another carries the tuning resistors. The third board is used as the keyboard. Keyboard and tuning board may be mounted together, simplifying the interwiring and producing an efficient use of space as shown in our photos.

Construction should proceed in the usual order. Insert and solder the links first followed by the IC holders, resistors, capacitors and diodes. Make the connections

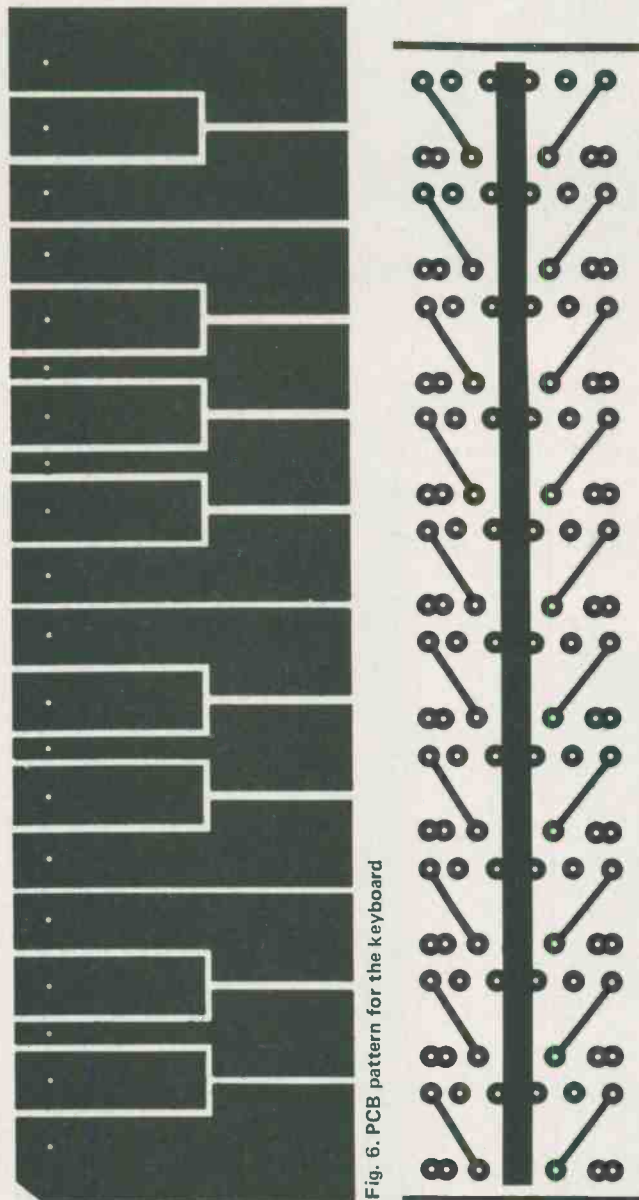

Fig. 6. PCB pattern for the keyboard

Fig. 7. PCB foil pattern for the resistor tuning board



Fig. 5. Overlay diagram for the tuning board

between the case mounted components and complete the interwiring between boards. A connector may be used for the stylus if required or a wire may be brought out directly from the board.

If all looks well, connect a battery (we used six AAs giving nine volts) and switch on. By selecting a voice and touching the stylus to the keyboard, a tone should be produced. You can now tune the instrument by adjustment of the trimmer resistors.

Anything from a disused test probe to a ball point pen may be used as a stylus. We used part of an old quarter-inch jack plug with good results.

Once the instrument is in tune, you can begin playing in earnest. Some sample tunes are included here . . . and you know what practice makes. ●

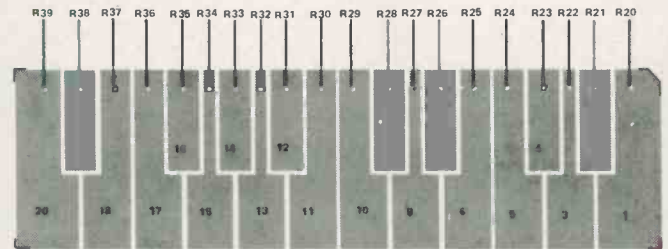
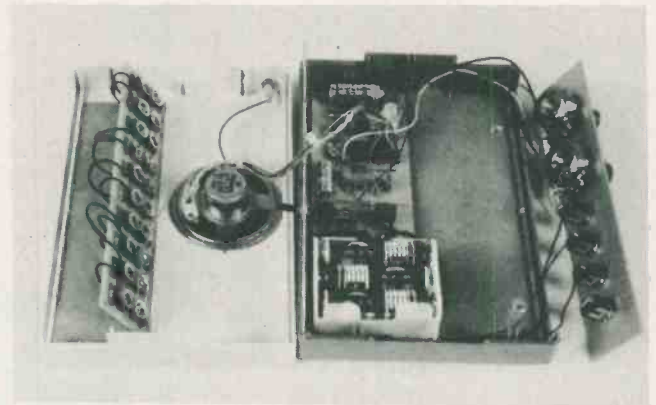

Fig. 8. Connections for the Hobby tune keyboard



Hobbytunes — naked to the world, we strongly advise any budding musicians to use our PCB design to ensure an easy and trouble-free project.

HOBBYTUNES

AMAZING GRACE

6, 8, 11, 15, 13, 11, 15, 15, 13, 11, 8, 6, 6, 8, 11, 15, 13, 11, 15, 18, 18.

TELSTAR

6, 1, 3, 6, 11, 10, 8, 6, 8, 1, 11, 10, 8, 6, 8, 1, 13, 15, 13, 6, 13, 11, 10, 3, 10, 8, 10, 10, 11, 10, 8, 6, 8, 8, 10.

LAND OF HOPE AND GLORY

6, 6, 5, 6, 8, 3, 1, 11, 11, 10, 11, 13, 8, 10, 10, 12, 13, 15, 20, 13, 18, 18, 17, 15, 13.

TOUCH SWITCH

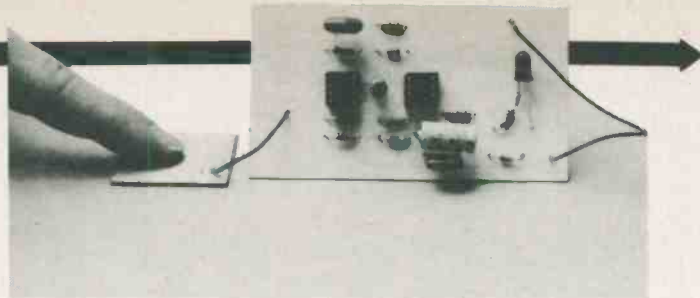

Above: the completed PCB. In this version we did not use a relay, connecting a resistor and the LED in series across the output.

For turning on equipment sensitive to vibration — photographic enlargers for example — or even just for a doorbell, this circuit is ideal.

IF YOU'VE EVER got involved in repairing a transistor radio, you will probably know the trick of dabbing your finger at the input to the audio stage to see if you can hear the hum and /or increase in noise level to prove that the audio stage is working.

It is also possible to make use of this effect to switch a circuit positively. Switching by touch has become quite common in the last two or three years since the IC manufacturers have introduced devices specifically to

perform this function. TV sets and elevators are amongst the common users (though some TV sets make use of your finger bridging two terminals and operate differently).

Touch switches may seem highly extravagant but industrially they are far more reliable than mechanical types. In TV sets, touch switches have the great advantage of enabling the preset pots which control the varicap diodes in the tuner to be put at the back of the set.

PARTS LIST

RESISTORS, All 1/4W, 5%

R1	56k
R2	100k
R3	10M
R4	15k
R5	15k
R6	3k3
R7	100k

CAPACITORS

C1	100n polyester
C2	100uF 25 V electrolytic
C3	2u2 25 V electrolytic
C4	100n polyester

SEMICONDUCTORS

IC1, IC2	741 Op Amp
D1, D2	1N4148 silicon diode

MISCELLANEOUS

PCB as pattern, Miniature relay (500 ohm or more coil and change-over contacts).

On the right is the component overlay for the PCB. Be sure to position the polarised components C2, C3, IC1, IC2, D1 and D2 the right way round. If you're buying a relay get one to fit the holes as shown, otherwise extra drilling and soldering may be needed.

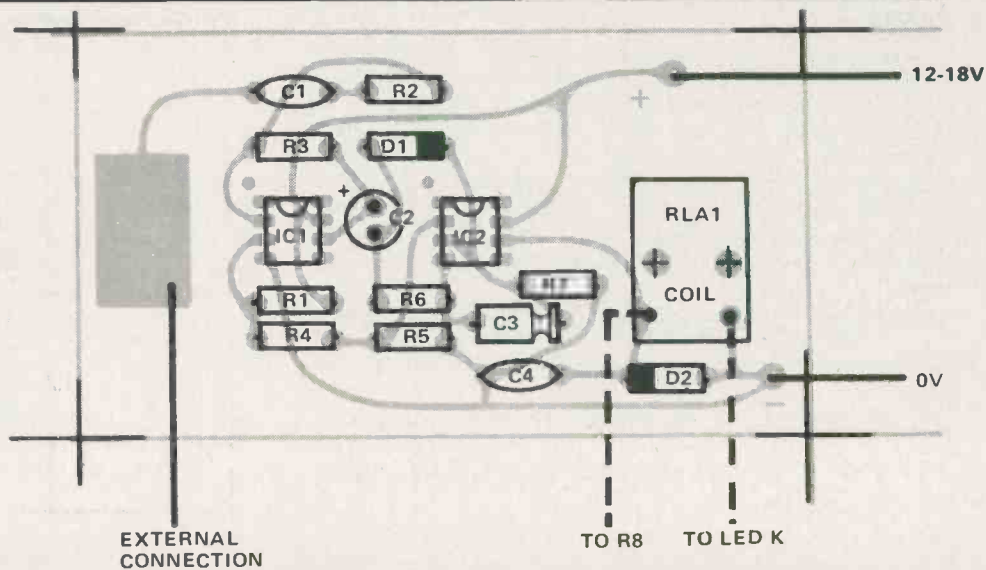

HOW IT WORKS

When a finger is placed on the touch contact, a low level of line hum is introduced to IC1 via the DC blocking capacitor C1 and R2. The gain of IC1 is arranged at a very high level and the hum is thus enormously amplified and switches the output of IC1 to about 7V peak-to-peak. The signal passes through C2 which blocks the DC to diode D1.

When the signal is swung positive, D1 conducts and charges up C3. When the voltage at the non-inverting terminal of IC2 (pin 3) exceeds the voltage at the inverting terminal (pin 2) the output of IC2 goes high and switches the relay.

IC2 acts as a voltage comparator. When the finger is removed, R7 discharges C3 and the output of IC2 goes low and the relay switches off.

D2 and C4 are included to protect IC2 from the very high voltages caused by abruptly turning RLA1 off.

If used to switch power equipment, great care should be taken to isolate the switched power from the rest of the circuit. R2 and C1 give only a margin of safety and are no substitute for taking care. The power for the circuit itself should only be derived from batteries.

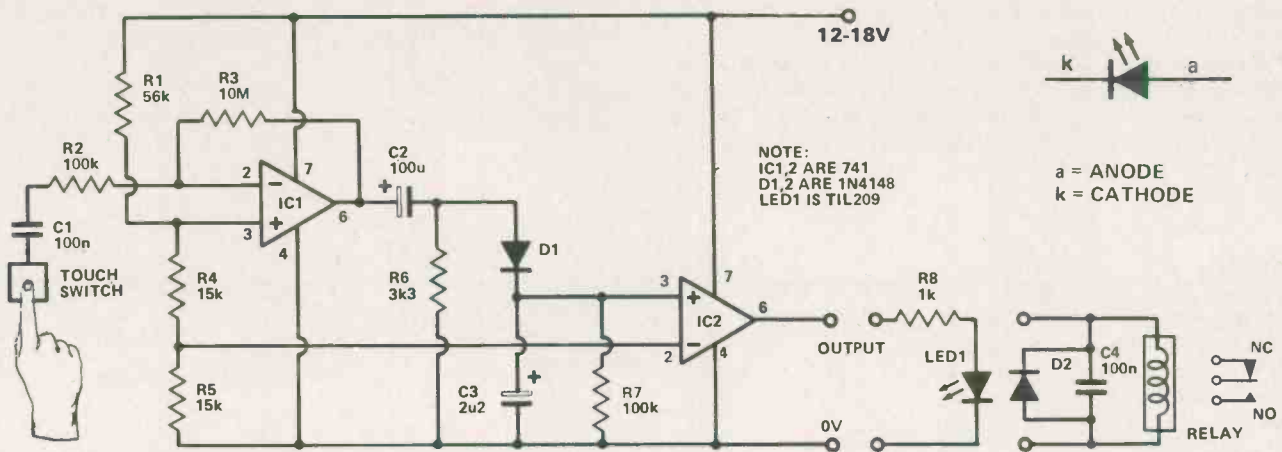

Above is the circuit diagram, showing, on the right, the connections for either an LED or a relay.

On the right is the copper foil pattern for the PCB we used, printed actual size.

Construction

We have designed our PCB so that the touch contact is on the board itself but have also allowed a terminal for taking the touch contact to somewhere more remote.

Small relays don't normally come in standard types and for that reason we have only left a general area showing the coil contacts, though these may have to be changed. We have not even attempted to show the switch contacts but there is plenty of room to run the contacts to terminals sited between the supply connections.

Apart from the obvious precautions to ensure that the ICs, diodes and the two electrolytic capacitors (C2, C3) are connected the right way around, construction is easy.

For safety reasons, we strongly recommend that the circuit is battery operated. If it is used to switch a relay, the contact of the relay can be used to switch a line supply on.

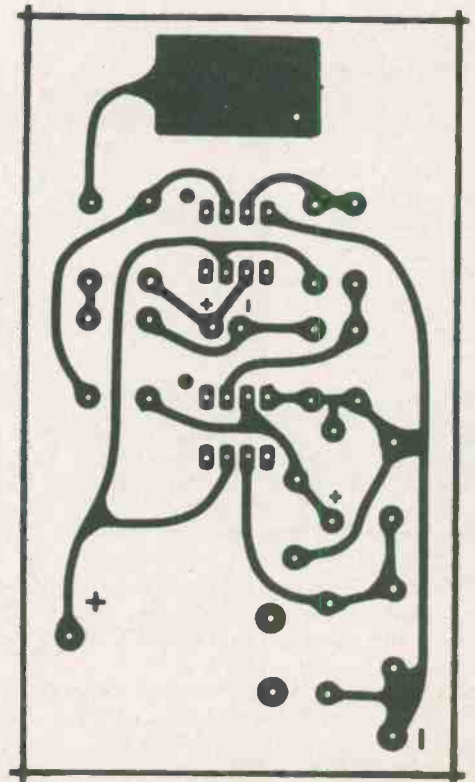

PUSH BUTTON DICE

We think this project will be a winner . . .

GENERATORS OF RANDOM NUMBERS in the range one to six (dice to most of us), are essential items in games ranging from Ludo to Backgammon. This is fortunate for those of us who count electronics amongst our hobbies. Why? you ask, well the answer's simple. When asked what your hobby is, if in reply you answer electronics, as often as not this will be greeted with a yawn, pictures of boring theory and mountains of test gear being conjured up by the questioner. Bring out an electronic game, however, and all this changes. Electronics can be fun.

Never Say Die

Unfortunately, most games, in order to be interesting, involve a lot of different factors that our electronics must keep track of. This, in terms of 'hardware' means lots of lamps, switches, and wire — complications. Happily, to build a dice, if our plans are followed, is an easy task, and will impress your friends as it is a distinct improvement over the traditional spotty blocks of wood.

Straight As A Die

Our photographs show that our die is built into a small box that has a line of Light Emitting Diodes (LEDs) to represent the six numbers plus a push button. Operating the button will activate the circuit and when the button is released one of the six LEDs will be lit, the particular one being impossible to predict. The LED will stay on for about five to ten seconds before going out. The dice is now ready to be "rolled" again.

The dice does not have an on/off switch, as with the LEDs off the circuit draws such a small amount of current from the battery that such a switch is not necessary.

Construction

As with any project, the exact method of construction is largely a matter of personal choice. The photographs clearly show how our dice went together, but there is no reason why you should not put your project in a different type of case. At any rate the first thing to do is to assemble the PCB according to our overlay.

The dice uses a type of IC known as CMOS and for this reason we suggest that you use IC sockets when building the project as CMOS ICs are more electrically 'fragile' than other types of IC.

When mounting the components, make sure that the ICs and the electrolytic and tantalum capacitors are fitted



PARTS LIST

RESISTORS (all 1/4w 5%)

R1, 3, 5	100k
R2	10k
R4	56k
R6	470R

CAPACITORS

C1	100n	polyester
C2	100u	16V electrolytic
C3, 5	10n	polyester
C4	100u	10V tantalum

SEMICONDUCTORS

IC1	CD4011B
IC2	CD4017B
LEDS 1-6	TIL209

SWITCH

PB1	Miniature push to make
-----	------------------------

MISCELLANEOUS

PCB as pattern, 9V battery plus clip, Vero box, wire, etc.
--

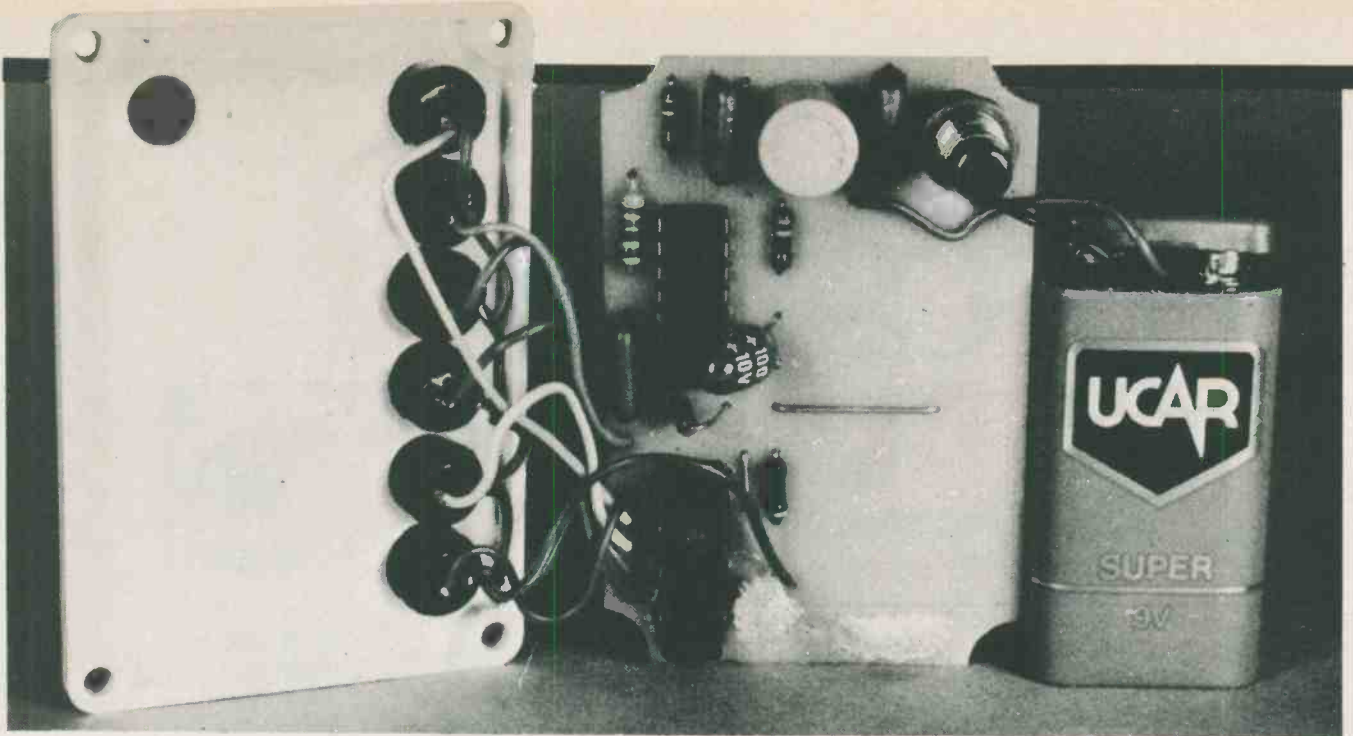

ABOVE: the case opened to show what makes the dice tick. LEFT: the 'component overlay' which links the circuit diagram with the above photo. BELOW: the pattern for the copper foil side of the printed circuit board.

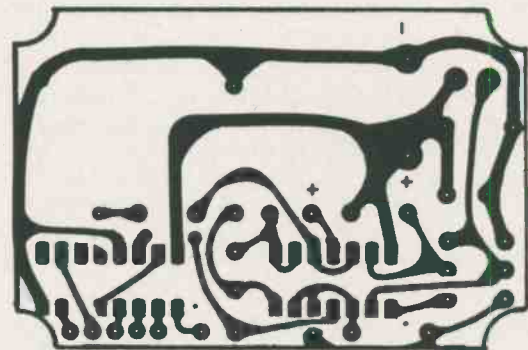
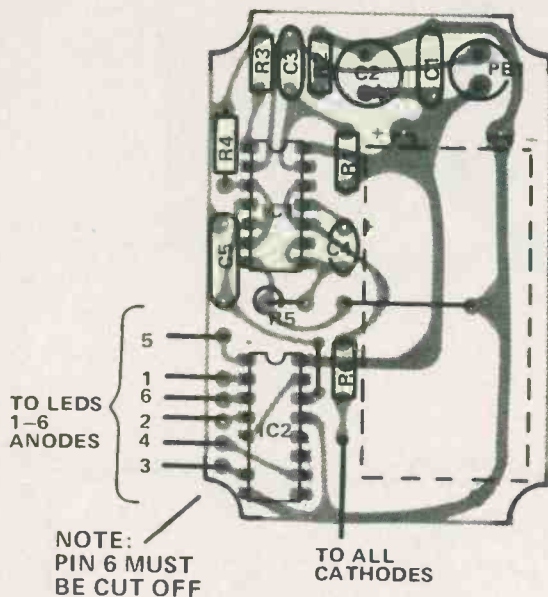

Below: Pin out data for IC1 and LEDs 1-6.

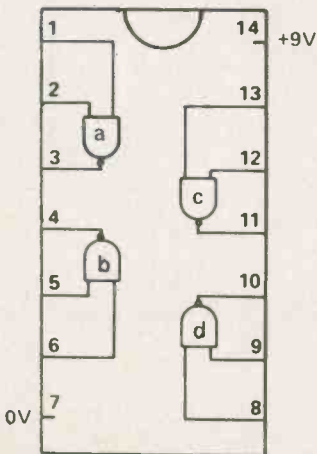

a = ANODE
k = CATHODE

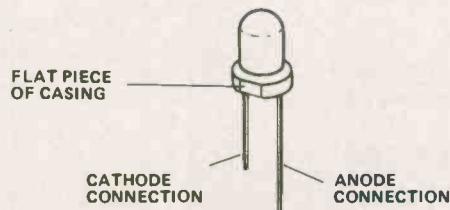

Note: for tantalum capacitors



ABOVE: some tantalum capacitors are not marked with a "+" as in the photo. They instead have a dot on one side only.

the right way round. Failure to do so will result in a dead LED dice.

When marking out the front panel take care that the LEDs are in a straight line. The LEDs are mounted with special mounting clips that should be available from the people who supply the LEDs themselves.

There is a fair bit of wiring to do so take care when doing this job. It's easy to make a mistake here, and any error can take a long time to find.

When all construction is complete, fit the battery and get ready to roll your first electronic die.●

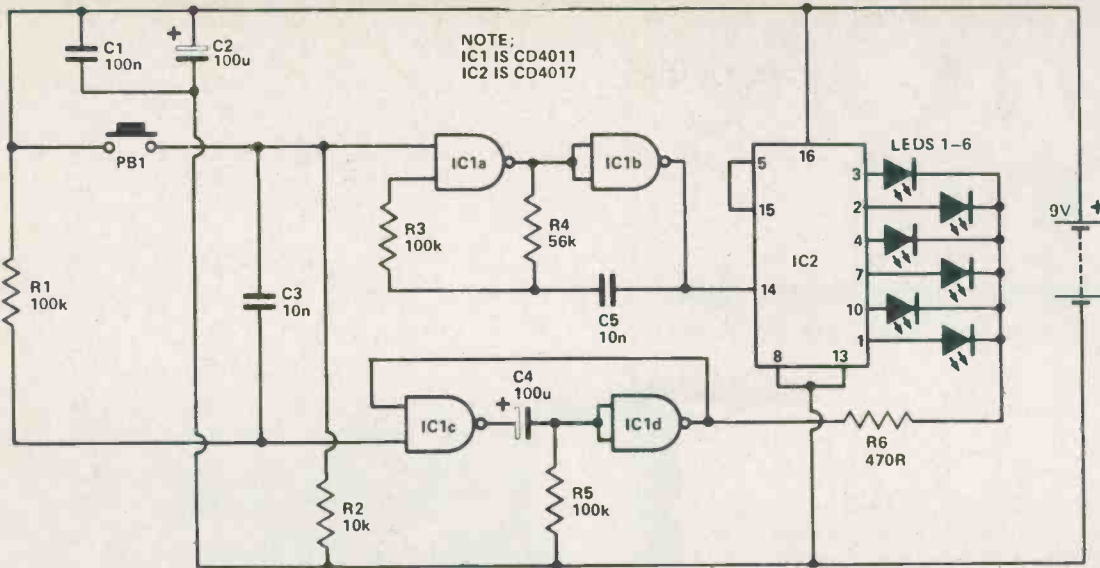
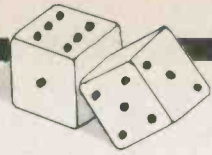

The circuit diagram

HOW IT WORKS

THE digital dice, in order to simulate the action of a real die, is required to "stop" with one of the circuit's six light-emitting diodes (LEDs) lit, each LED corresponding to one of the six numbers on the faces of the real die. To do this, it quickly turns each LED on in sequence when the start button is pressed, stopping with one LED on when the button is released. Because the circuit cycles through the sequence very quickly it is not possible to cheat by waiting for a particular LED to light and release the button at this point!

The circuit can be broken down into two sections, one dealing with the display and the other with timing and control signals. The latter are provided by two 'classic' circuit building blocks, namely the 'astable' formed by IC1a and IC1b and the 'monostable' configuration of IC1c and IC1d.

Each circuit is formed from two out of the four logic gates of IC1. The inputs of the logic gate can be in one of two conditions. They can either be 'low' (that is, near 0V), or 'high' (near to the supply voltage, 9V in this case). The output of the gate can also adopt only these two values, the choice being determined by the state of the inputs. In this case as the gates are 'NAND' gates the output will be high at all times except when both the inputs are high at which point the output will go low. 'NAND' stands for 'not-and', the output being low whenever both one input 'and' the other are high.

The astable will not function until the start button takes one of IC1a's inputs high. At this point the output of IC1b will oscillate between 0V and 9V. The circuit is referred to as an astable (meaning 'not stable') because the output can assume these two conditions but is stable in neither.

A detailed description of the circuit would take up too much room but briefly the oscillator works like this: Suppose the output of IC1a is low and that as one of this gates' inputs is 'tied' high the other, connected to R3, must also be high. The junction of R3, R4 and C5 is thus high,

but as R4 goes to the output of IC1a, which is low, the charge on C5 will leak away. At some point the voltage at this junction, having fallen to near the 0V rail, will cause the output of IC1a to go high and that of IC1b to go low. C5 will now charge up via R4 which will in turn cause the circuit to assume its original state.

The series of pulses generated by the astable is fed to IC2. This is a counter IC, having ten outputs. As the pulses are fed to its input, each of the ten outputs will be turned on in sequence. For this circuit, however, we only want the IC to count up to six. To achieve this we connect the seventh output of IC2 to another of the IC's inputs called the 'reset' pin. When this pin is taken high it resets the counter back to the start. We now have our count of six.

The outputs of IC2 are taken to LEDs 1-6. LEDs are like ordinary diodes in that they will only pass current in one direction, but in addition when they are passing current will emit light. When an output of IC2 is high the associated LED will emit light if the common point to which the LEDs are taken, R6, is low.

R6 is taken to the output of IC1d. This point is normally high and thus the LEDs are all off. When the start button is released, however, the input of IC1c, junction of C3 and R1, goes low for a brief period of time and causes the output of this gate to go high. C4 'couples' this change to the input of IC1d and causes the output this gate to go low, activating the display and, by virtue of the fact that the output is also connected to IC1c, maintaining the high on the output of this gate. The charge on C4 will leak away, however, via R5 - and cause the circuit to assume the previous state after several seconds. This circuit is termed a monostable because it has two possible states, only one of which is stable (mono = one). It is necessary to include R6 in the circuit because the current passed by the LEDs must be limited to a safe value.

C2 and C1 are included to 'decouple' the supply that is, remove any fluctuations in the supply voltage that might upset circuit action.

PHOTON PHONE

The PHOTON is a light-talker: a communications system which requires no licence.

THIS IS NOT a morse flasher. This is the equivalent of a two-way radio — but using light instead of radio waves!

All a radio transmitter is, is a source of radio-frequency signals and some means of impressing information onto it. This project uses light, and as a source of light we use — you guessed it — a light bulb!

This project should provide not only an introduction to photoelectronics but also a product which is fun to build and use.

Using It

The device is almost as easy to use as a radio — you point your set at the one you want to communicate with; you switch to 'transmit'; with the other set at 'receive', anything you say into the built-in microphone will be heard, via the light beam, at the other set. Reversing the switch positions allows full two-way communication.

The range of the device is limited to about 15 to 20 yards but for many applications (at sea, in a factory, between moving vehicles or just across the street!) this will be sufficient.

The electronics are easy to put together — the only difficult bit is the case.

Construction

The flashlight we used can be seen in the various pictures. Actually any unit should do, as long as you have lots of space.

The first thing to do is to open it and remove the battery connectors in the inside of the top cover. We need the room and we're using a different type of battery anyway. You will find that these come out with a small amount of force — try not to damage the plastic.

The next thing to do is to take the bulb out and replace it with one of the same size and shape but of a different voltage (see the parts list). You will probably be able to get this at the same place you got the torch body. Now solder the wires onto the phototransistor, as shown in the overlay (the diagram which shows you what goes where on the board). Clip the unused (middle) wire short. The diagram shows a view looking onto the end of the wires. Take care not to damage the transistor by excessive heating — it's a good idea to hold the wire you're soldering at a point between the joint and the transistor with a pair of long-nosed pliers while the joint is hot. This will prevent heat from getting into the transistor body. Insulate the wires in some way.



Having done that, fit the phototransistor (Q2) onto the bulb as shown in the photo. We used a quick-setting epoxy resin adhesive. You will have to make a small hole in the reflector for the wires to go through. Try to get the transistor as close to the focal point of the reflector as possible. This means mounting it at the very tip of the bulb.

Looking closely at the inside of the flashlight, you will find that the metal strips which form the normal circuit pass from the battery holders (or rather, where the battery holders were until we ripped them out!) up the hand to the switch and then back down to one side of the bulb assembly. Cut the connection between the switch and the bulb. This will probably mean a little minor metalwork with a pair of wire cutters. It should leave you (it is possible to trace the connection path fairly clearly with a little thought) with two connections to the bulb and two to the switch. Solder wires onto all four of these points. Leave the wires fairly long (6" to 8") for future connection to the board.

Start At The Bottom

The speaker fits into the base of the case (poetry, yet! — ED.) at the back. This means that you can either drill an artistic pattern of holes as we have done or just put a few large ones as you think fit. If you don't put any holes at all, the sound won't get in or out.

It's probably a good idea at this stage to solder a couple of wires onto the speaker and glue it into place.

The only thing left to do now is to fit the extension speaker socket (the method should be fairly self-evident from the socket mounting), as the other holes in the case should really be matched with the printed circuit board.

Board Meeting

Having acquired a printed circuit board fit it into the top of the case (making sure you get it the right way round) and mark out the rest of the holes to be made in the case:

- a) the four PCB mounting holes,
- b) the volume control (RV1) hole and
- c) The SW2 hole (make this big enough for the push-fitting knob).

The construction for the electronics should be fairly straightforward — just follow the diagrams. Watch out that you get C1, the transistors and IC1 the right way round, though. We suggest you use an integrated circuit socket for IC1 — solder it onto the board and then plug the IC into it, making sure all the 'legs' go in. Use a heatsink on Q3. This acts in exactly the same way as a car radiator — it carries the heat into the air, preventing the transistor from overheating.

At the points where wires from the bulb, speaker etc. are to connect it to the board, poke stiff wire through the board and solder it, leaving about 1/2 in sticking above the board. This will allow you to solder wires on the board *after* it has been bolted down. You will have to use similar bits of wire to connect RV1, as the leads on this will not poke through the holes.

If possible, use a 'lash-up' at this stage — a collection of bits of odd wire connecting the board to the various other bits of the circuit — to check that the board works before you bolt it in.



A view of the reflector modifications. The transistor should be placed with the small metal dot (just visible inside the protective gel of its case) towards the rear of the communicator. Some experimentation may be necessary to find the reflector's focal point exactly.

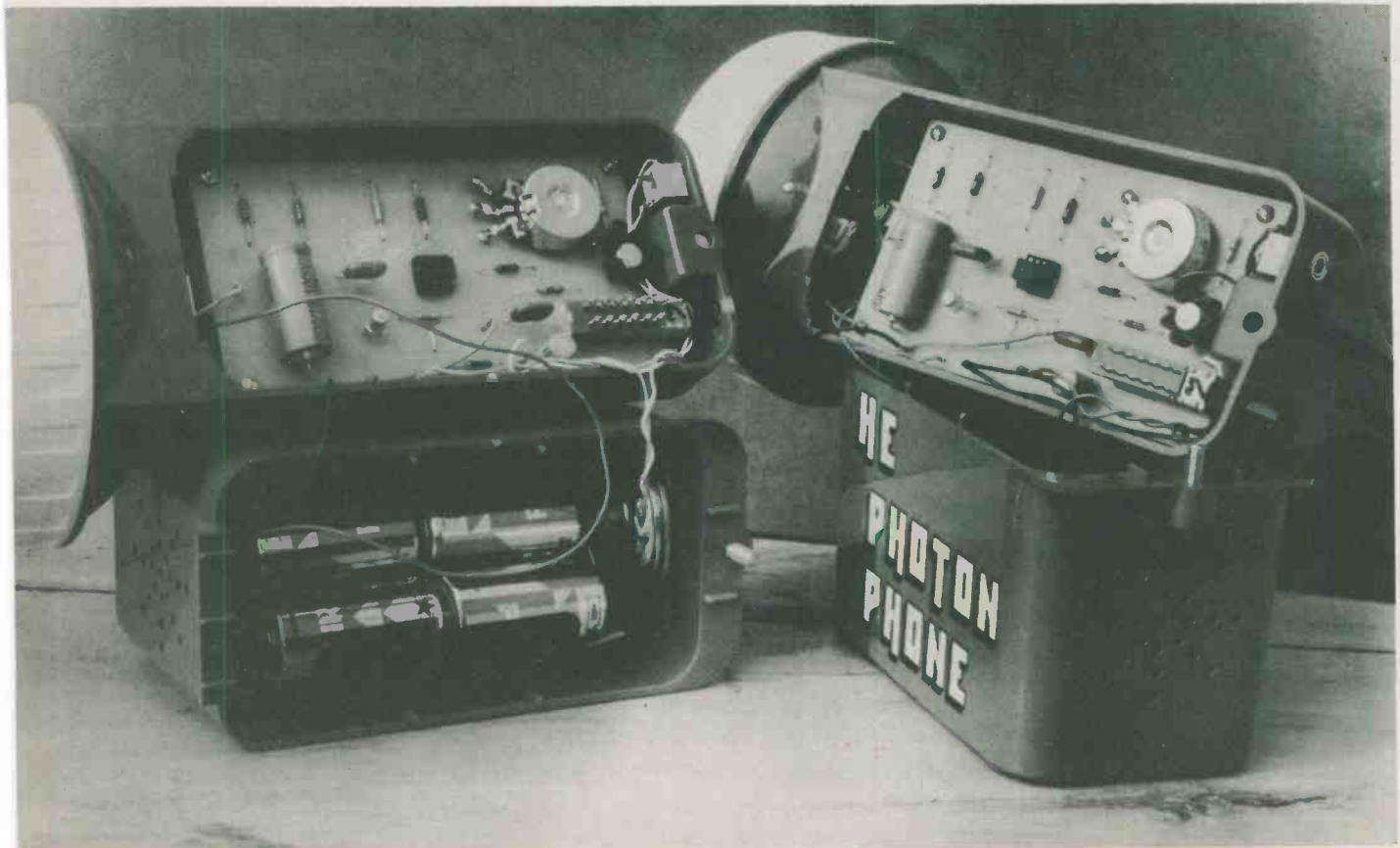

Bolt it Down

Use pillars on the four PCB mounting bolts. These are plastic or metal cylinders which slip over the first 1/4 in or so of the bolts and will hold the board away from the top of the case.

Actually getting the board in is a bit fiddley — but remember that you can always push SW2 in to get it out of the way. It might also be an idea to trim the spindle of RV1 a bit before you mount the board — not too much, though remember you don't know exactly what length it should be until *after* the board is fitted!

Having fitted the board and both of the knobs (SW2 and RV1), you can proceed with the wiring.

The only complicated bit is the wiring of the external speaker socket and the speaker. Connect the 'speaker' point on the board to one side of the speaker and also to the connection on the side of the socket. The 'socket' output of the board goes to the socket connection which is part of the sprung contact of the socket (put a plug into the socket — the bit of the socket that moves is the bit you want). The third socket connection goes to the other side of the speaker. Got all that?

If you're confused, just connect the speaker to the two board outputs mentioned to make sure it all works. You can connect the socket up later.

The battery holders should be connected in series: the '+' connection of one goes to the '-' connection of the other.

The remaining '+' connection goes to the handle switch (SW1 — remember those wires you connected earlier?) and the other side of the switch goes to the board.

Connect the rest up as per the diagram, and the whole thing should work! If it doesn't, check all the wiring carefully.

HOW IT WORKS

The circuit diagram shows SW2 in the 'transmit' position. The speaker (LS1) acts as a microphone in this mode. C1, R1, Q1 and R2 form a simple single-stage amplifier to boost the signal before it is fed, via C2, to IC1. R4, R6 and C2 set the average voltage at pin 3 of IC1 (the so-called 'bias' voltage).

Q2 is illuminated by LP1. Suppose LP1 is bright. This will cause more current to pass through Q2 and cause pin 2 of IC1 to go to a higher voltage. IC1 is connected as an inverting amplifier (in much the same way as the op-amps in the 'mixer' project on this issue) and so this will cause the output (pin 6) to fall in voltage. This in turn will turn Q3 down and the current through LP1 will reduce.

All in all, the effect will be to set LP1 at a brightness determined by the pin 3 input of IC1. As this is derived from LS1, speaking into it will cause a brightness fluctuation.

In the 'receive' mode, the light variations at Q2 will cause a voltage variation in the output of IC1. This is used to drive Q3 which is now connected to LS1.

Notice that the rest of the circuit is 'decoupled' from Q3 by R8 and C4. As this device is battery-driven, the current drawn by Q3 will cause major variations in supply voltage. So that these do not interfere with the rest of the circuit's operation, they are filtered out by R8/C4.

The circuit diagram. SW2 is shown in the 'transmit' position.

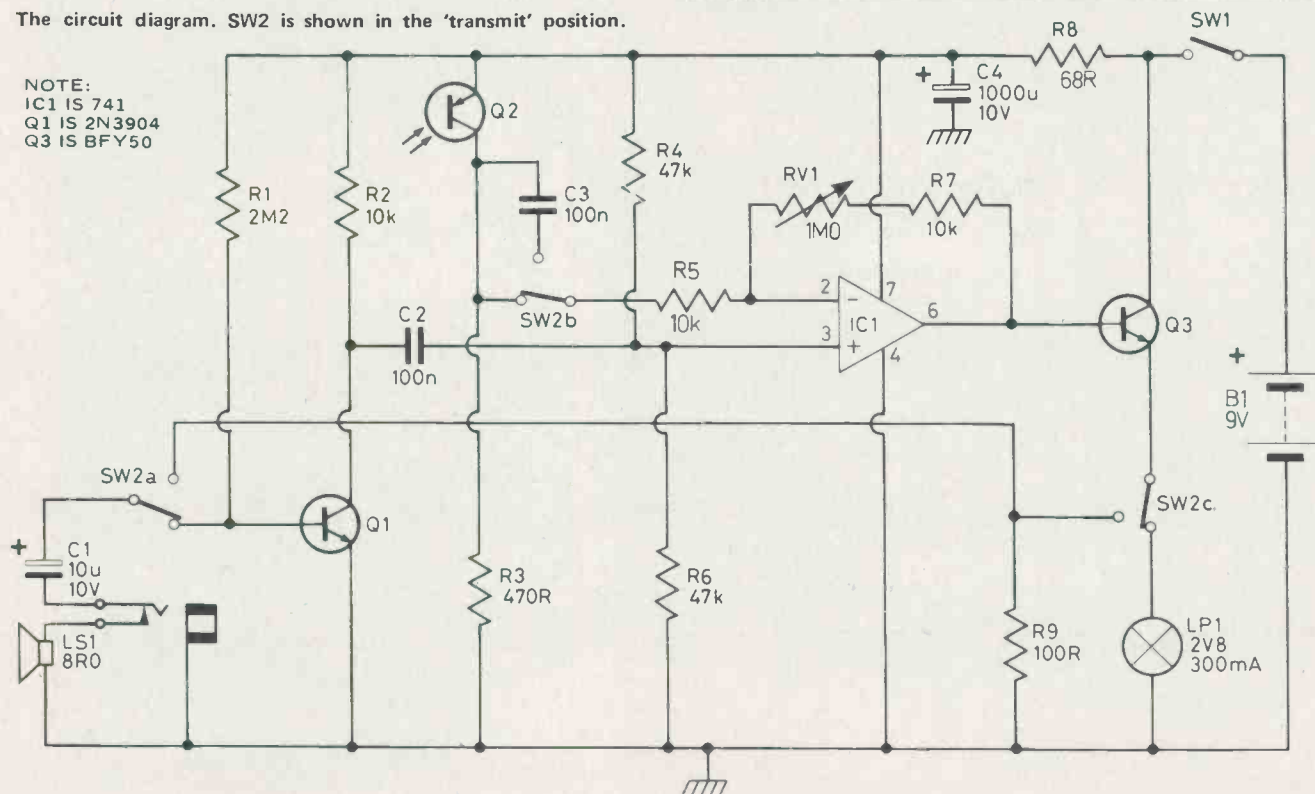

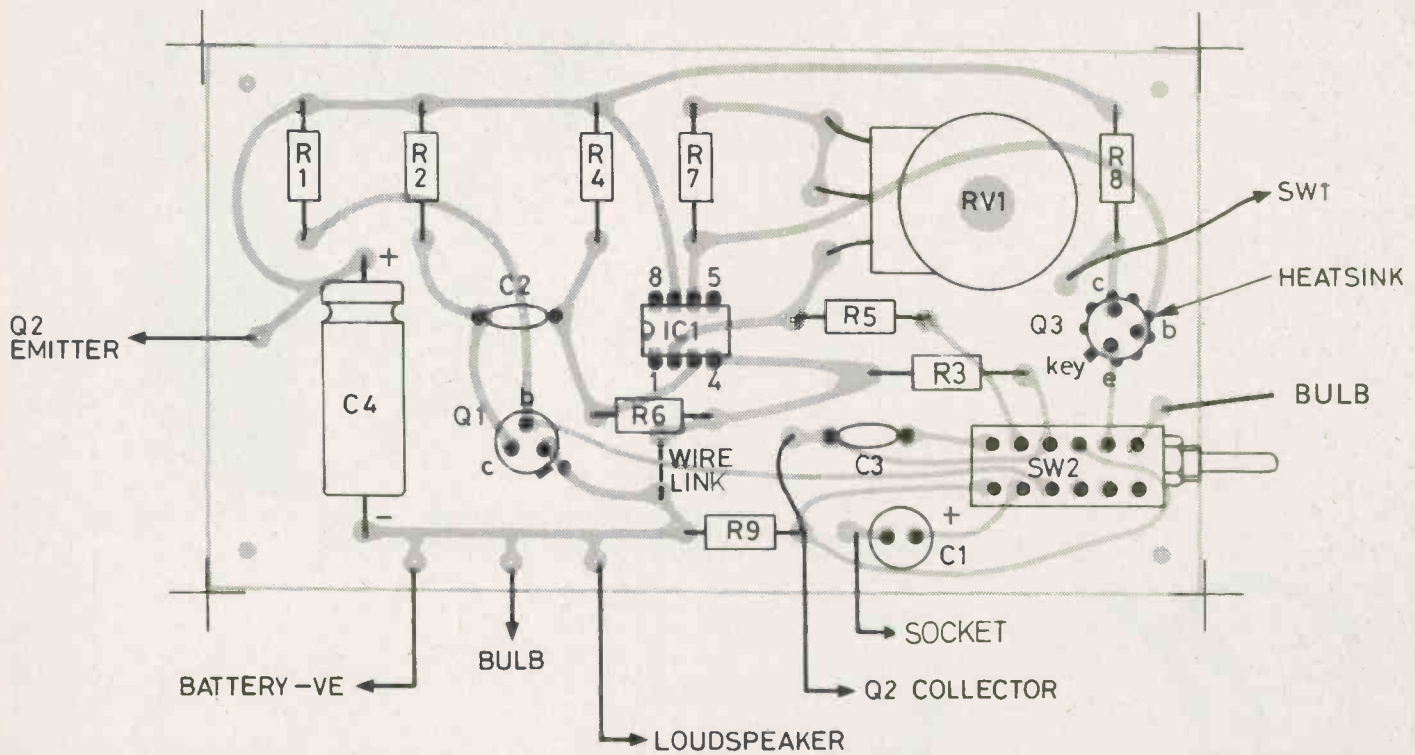

How to position the components on the PCB, make sure the transistors, integrated circuits, diode and electrolytic capacitors are the correct way round before soldering in place.

PARTS LIST

RESISTORS

R1	2M2
R2	10k
R3	470R
R4,6	47k
R5,7	10k
R8	68R
R9	100R

CAPACITORS

C1	10u 10V electrolytic
C2	100n polyester
C3	100n polyester
C4	1000u 10V electrolytic

SEMICONDUCTORS

Q1	2N3904
Q2	phototransistor
Q3	BFY50 + heatsink
IC1	741

MISCELLANEOUS

RV1	1M logarithmic
LS1	8R, 2 inch
SW2	4 pole 2 way, latching, PCB-mounting switch
LP1	2V8, 300mA

Spock To Enterprise . . .

With the sets switched on and the SW2s to the relevant positions (one in, one out) point the two devices at each other at a distance of a couple of yards. Speaking into the speaker of the one switched to transmit (SW2 out), you should be able to see the light intensity varying and a well-placed ear beside the receiving set should be able to hear your voice. (Needless to say, it will not be your ear if it's your voice two yards away!). The volume of the received sound can be adjusted by RV1 to give a pleasant level.

You may find that putting your ear to the speaker while pointing the device is a bit tiresome after a while. This is where SK1 comes in. A speaker similar to the one already used can be connected across a suitable plug and inserted into the socket. This has the same effect as plugging an earpiece into a radio. The internal speaker is 'disabled' (temporarily!) and the hand-held one is used

instead. Putting the external speaker in a small box is a good idea, as is using 'screened' cable for the connecting lead. The centre of the cable goes to the tip connection of the plug.

Summary

This project is difficult to build as a finished product and the fact that two (at least!) are required may seem daunting. However, it can also be built as a 'bread-board' type prototype, or into any type of box you can get your hands on. If you do build it as we suggest, though, you will have a very sturdy product indeed. ●

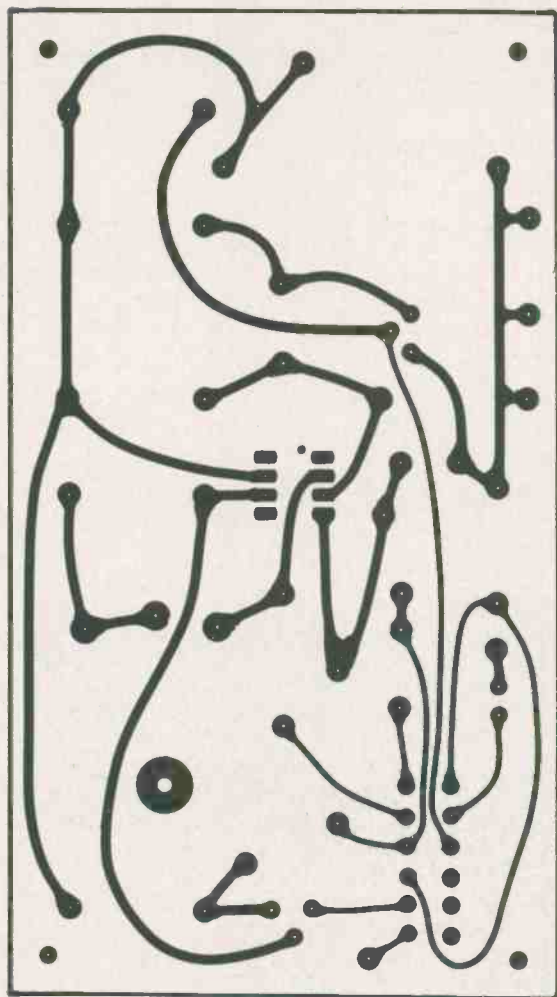

The printed circuit board pattern shown here is the correct size.



A rear view of the PHOTON, showing the artistic pattern of holes we drilled to form the speaker grille!

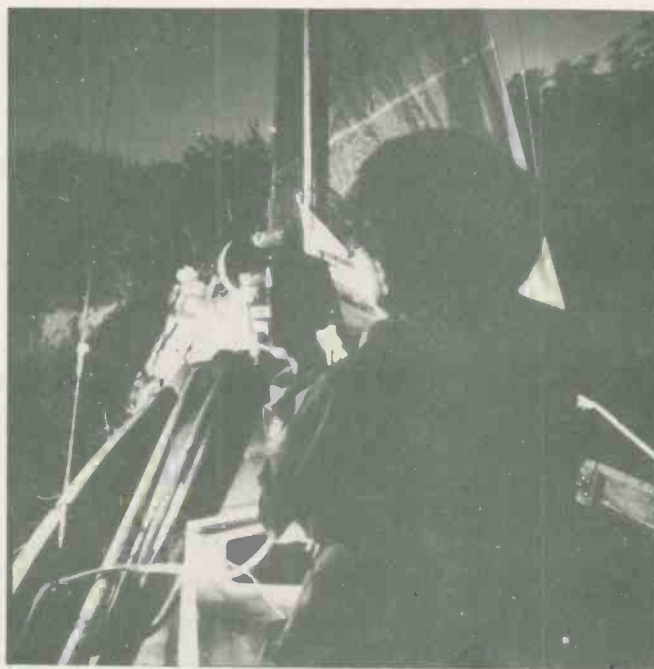

All at sea — but the PHOTON comes to the rescue.

STARBURST

Expand your universe with HE's pulsating phonoptic display. Ordinary LED chasers beware . . .

LOOKING FOR a novel, economical, yet versatile LED display? Here is the answer to your dreams. Featuring an attractive matrix design, audio control input and a choice of three operating modes, the HE Starburst adds a new dimension to conventional light-chasers.

Assembled on two printed circuit boards, the unit is designed around readily available CMOS chips and uses only a few other discrete components. The display is arranged as five semicircles of ten LEDs each of which are illuminated in bands sequentially producing the illusion of either an expanding line of light or a band of light that grows outward and collapses. A novel bonus of the circuit design is the automatic mode where dots and bars are displayed alternately.

The audio signal pre-conditioner, clock oscillator and counter-decoder-driver circuitry is mounted on one board, whilst the other board holds the display and main decoupling capacitor. The circuit is powered by a single nine volt battery. Choice of a larger battery ensures longer life as currents of up to one hundred milliamps may be drawn when all the LEDs are lit. No provision is made for the battery or power switch on-board enabling the unit to be neatly boxed and mounted in any suitable remote position.

Seeing The Light

After applying power to the circuit, the LEDs will illuminate from the centre of the display outwards appearing as a bar or dots of light; or alternately depending on the position of mode switch SW1.

Application of an audio signal will cause the frequency of movement to increase. By adjustment of the input level and control RV1, the display can be made to follow the dynamic range of the audio input; increasing in frequency as the audio input level increases in amplitude. Component values shown make the unit more sensitive to input frequencies above 1 kHz or so and more responsive to melody lines in music and to vocal input.

Lucky Number

At first glance, it would appear that the way to produce a display such as the one described above might be to use a ' bargraph ' chip driven from a ramp whose frequency would be controlled by the audio signal. However, the CMOS family contains some not so popular but nonetheless versatile chips which enable an economical

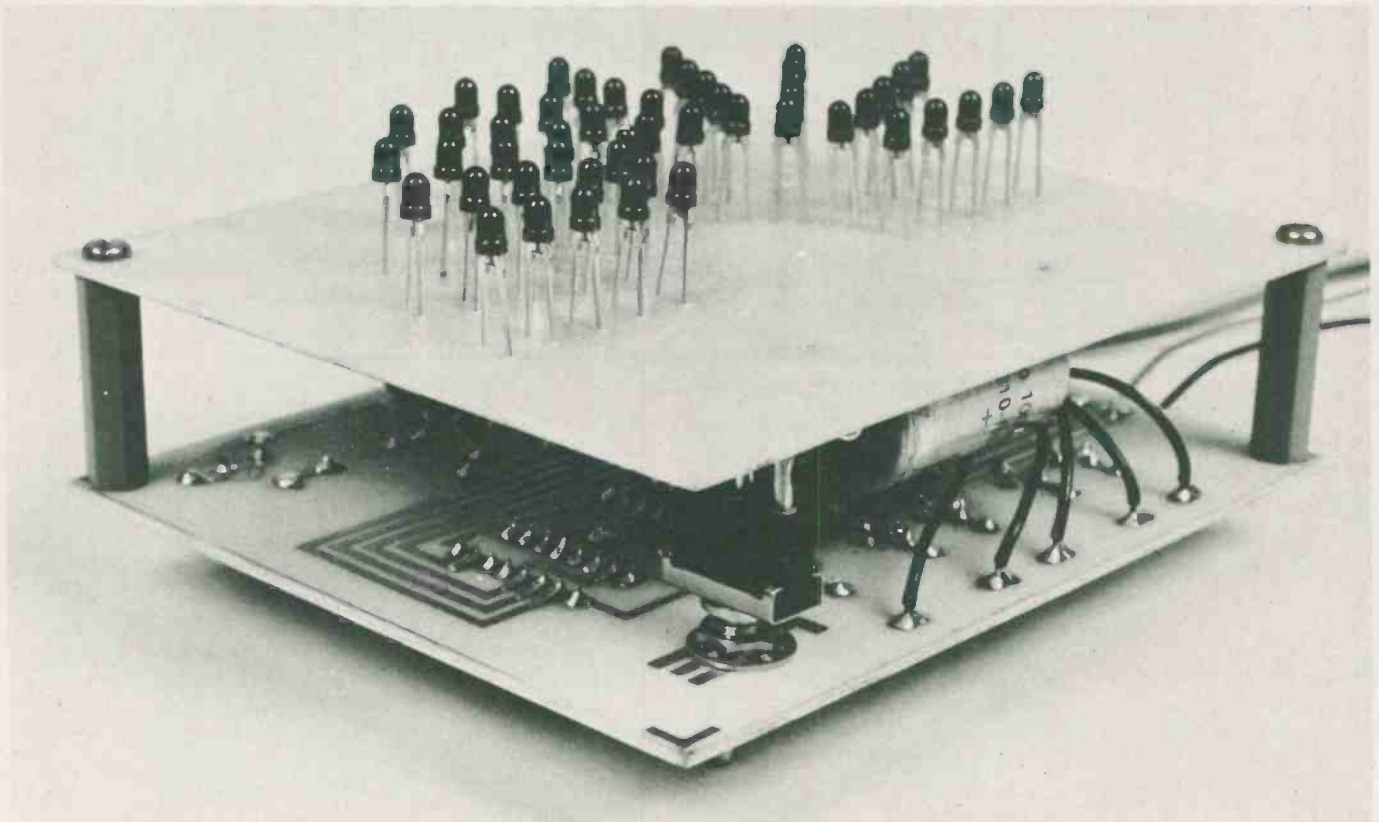

The two boards of the HE "Starburst", the switch in the foreground controls the three modes of display.

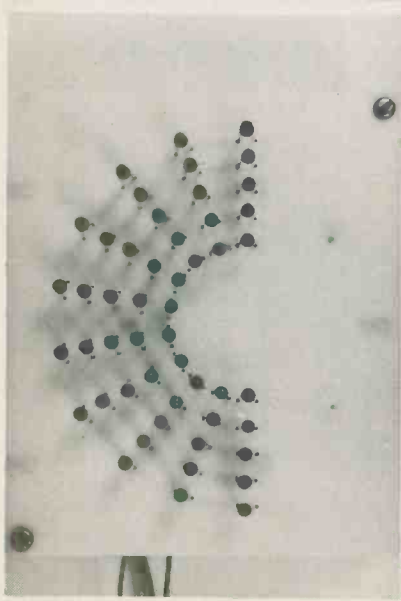

The display board viewed from above, the effects, especially when in the 'auto' mode are quite exciting, to say the least.

The control voltage for IC1 is derived from the audio signal input to Q1 via RV1, C1. The amplified signal appearing at the collector of Q1 is coupled via C2 to rectifiers D1, D2 which charge C3. R3 and R4 tap off a proportion of the voltage across C3 as

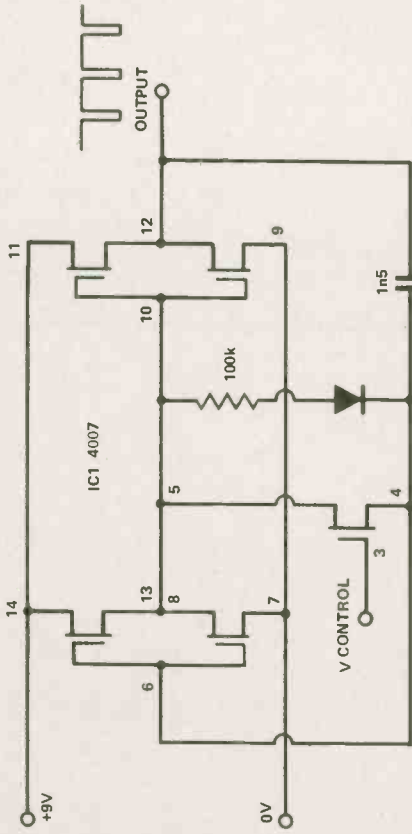

Fig. 2. Simplified view inside the 4007. (Note that the resistor, capacitor and diode are external components).

the K inputs are pulled up to a logic '1' by R6 giving a dot display.

The outputs from the J K flip-flops control transistors Q2-Q6 which drive the LED display. C5 and C6 are power supply decoupling capacitors.

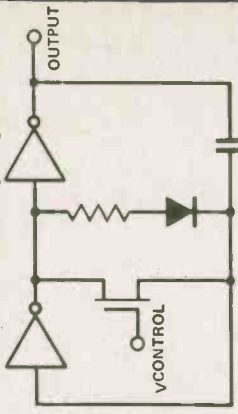

Fig. 3. MOSFET used as a variable resistor.

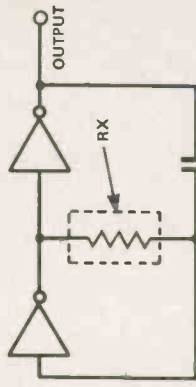

Fig. 4. Conventional CMOS oscillator.

yet sophisticated circuit to be produced. By coincidence, all the chips in this project contain the number seven in their device code. They are the 4007, 4017 and 4027.

The mainstay of the circuit is the ubiquitous 4017 decade counter-decoder whose outputs are processed by the 4027 chips to produce the logic control signals for the display driver transistors.

The 4007 is probably the least familiar device. It is not strictly speaking a logic chip as it contains only three pairs of complementary metal oxide silicon transistors which may be interconnected in a number of different ways. They are configured here as a novel voltage-controlled oscillator which provides the clock drive signals for the 4017 counter and 4027 JK flip-flops. Operation of this part of the circuit is described in more detail in 'how it works'.

Construction

The unit is assembled on two PCBs. Use of our PCBs will greatly simplify construction as well as enabling an attractive free-standing display to be produced.

Wire links should be inserted first and soldered into place followed by the IC sockets. Use of sockets is strongly recommended. Next, insert the resistors, capacitors and transistors and diodes. Do not insert the

he

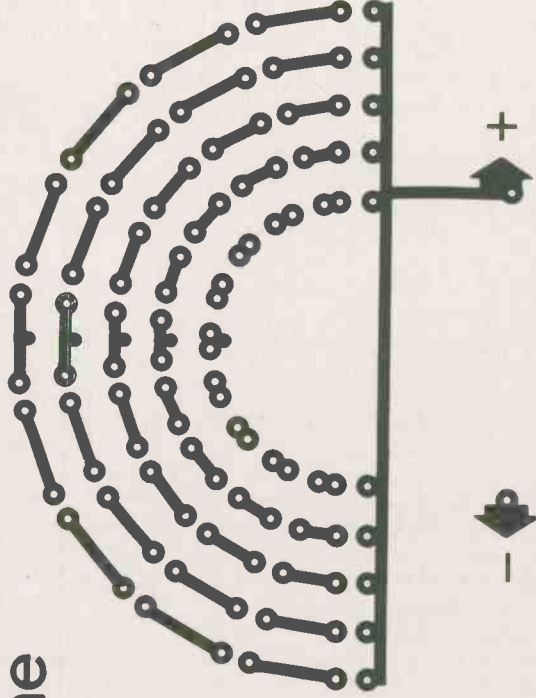

PCB foil pattern for the "Starburst" display board, no problems here, as always take care with your soldering.

CMOS chips at this stage. Note that some of the links pass under the IC sockets. If you do forget to put one in and discover later that it is inaccessible simply use a piece of insulated wire on the underside of the board to complete the connection.

The LEDs are wired in series-parallel and failure of one will cause the other four in an arm to extinguish. The display board can be tested as it is assembled by use of a separate nine volt supply. Insert and solder into place C6 ensuring correct orientation then connect the positive lead of the battery as shown on the overlay and make up a length of wire in series with a 330 ohm resistor. Connect the free end of the resistor to the negative terminal of the battery. Then as assembly of each arm of LEDs is completed, touch the free end of the wire from the resistor to the connector pads on the PCB (shown going to resistors R12 to R16 on the overlay). The LEDs should light. Failure to do so indicates an open circuit or reversed LED. Check for this condition by shorting each LED in turn until the display lights and replace any faulty ones ensuring correct orientation. A short lead, indent or flat on the plastic encapsulation usually indicates the cathode. We used red LEDs. In fact green or yellow LEDs will not work with a nine volt supply as they have a higher forward voltage drop.

Once satisfied that the display board is working correctly, make the remaining interconnections between the boards. We mounted SW1 on the main circuit board, there's plenty of room. Insert the ICs observing the usual CMOS handling precautions and connect a nine volt battery. The display should illuminate. If all is well, connect an audio signal to the input and adjust RV1 for satisfactory operation. Check that operation of SW1 causes the display mode to change.

We used the earphone socket of a transistor radio as an audio source though any signal of around 1 volt peak to peak will do. Finally, disconnect the battery and assemble the boards together using spacing pillars to separate them. That completes construction so switch on, plug in and flash out!●

PARTS LIST

RESISTORS		(all 1/4W, 5%)
R1		3M9
R2		10k
R3, 4		33k
R5		100k
R6		1M
R7,8,9,10,11		47k
R12,13,14,15,16		100R
CAPACITORS		
C1, 2		100n polyester
C3, 5		10µ tantalum
C4		1n5 polystyrene
C6		1,000µ electrolytic
SEMICONDUCTORS		
IC1		4007B
IC2		4017B
IC3,4,5		4027B
Q1,2,3,4,5,6		2N3904
D1,2,3		1N4148
LEDs		0.125" red (50 are needed if our display board is used)
MISCELLANEOUS		
SW1		SPDT centre off switch. PCB PP9 battery, connectors.

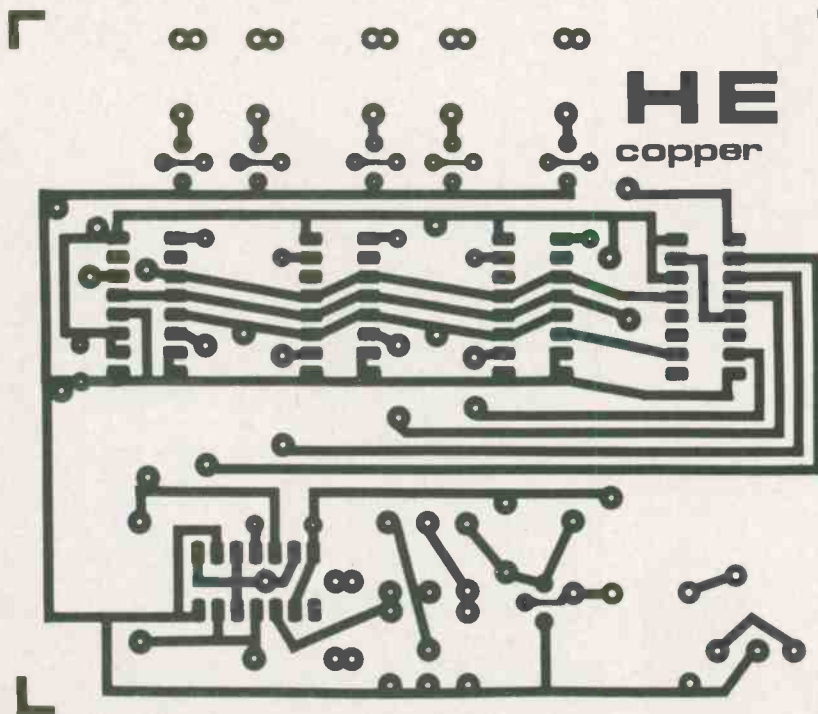

PCB foil pattern for the main control board, take particular care when soldering in the ICs to avoid any solder bridges.

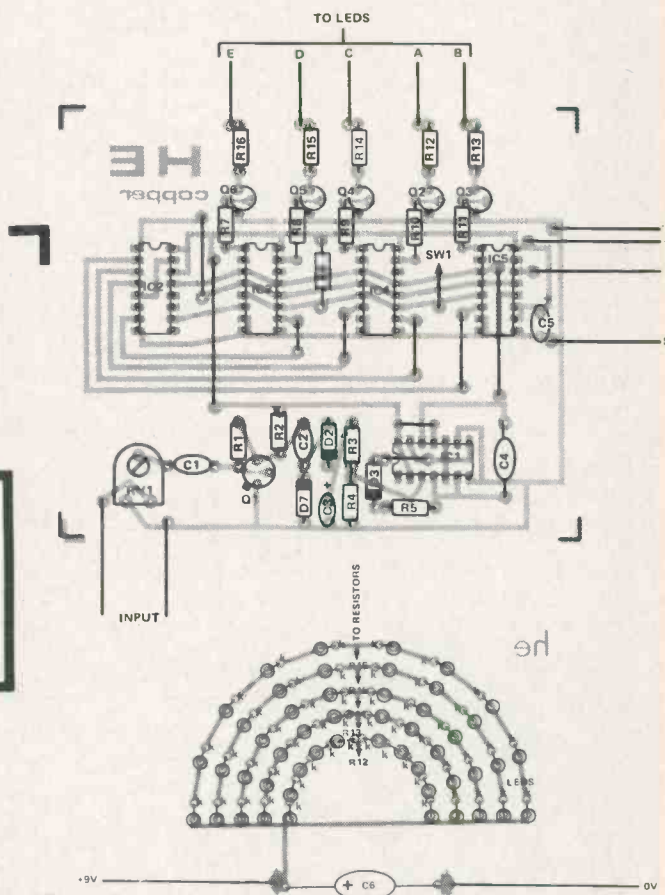

SHARK!!

Shark game brings you the sun, surf and sand. All electronic; add absolutely no water!

OVERTIRED, TENSE, NERVOUS HEADACHE? Then this is the game to really send you over the edge. Featuring fingertip control, it is the ideal toy for the squeamish, hydrophobics and non-swimmers. It takes the shark out of water and the mess out of being devoured.

The top panel has two columns of ten LEDs leading to a tropical island. One LED lights in each column to indicate the swimmers' progress towards the safety of the island. Two push buttons are mounted, one either side of a central LED which represents the shark's fin. The power switch, reset button and 'lose' alarm are mounted on the small front panel while a PCB accommodates most of the other components.

A Bigger Splash

To play, after pressing reset, each player must depress his pushbutton switch for as long as possible while the single 'shark's fin' LED remains lit. This causes his swimmer to appear and begin moving towards the island. Short depressions or failure to play at all will result in that swimmer moving only slowly or not at all. A depression while the LED is extinguished causes the swimmer to slip back towards the shark.

The winner of the game is the player whose swimmer first reaches the safety of the island when the 'lose' buzzer will sound for his opponent and both columns of LEDs will light, the highest indicating the winner.

What! No Chips?

It has often been remarked that most electronic games can be reduced to one; find the 4017. It is true that this chip has been overused and we are pleased to say that this game is an outstanding exception. Featuring a hybrid mixture of analogue and digital circuit techniques it is based on the LM3914. This little known chip from National is an LED dot/bar bargraph display driver and comes in an eighteen pin DIL package. It is very simple to set up and use. LED display current and full scale range are programmable by selection of a couple of resistors and individual constant current outputs remove the need for limiting resistors and tedious LED selection which was necessary with previous devices of this type. CMOS analogue transmission gates are used to multiplex the two signals to the bargraph chip input. This keeps the unit's cost down without sacrificing performance or increasing circuit complexity too much. Any size and colour of LEDs may be used. We used miniature green for one column and red for the other with a yellow standard 0.2" LED for the shark fin. The driver chip sinks about ten milliamps through each LED.



The case for Shark was made from a Vero box, the artwork on the case makes it look very attractive.

Construction

Construction of the game is greatly simplified if our PCB is used. As the components are closely packed on the board, the PCB tracks have to be made quite thin, so take care when soldering that no excessive heat is applied to any section of the board.

Begin construction by inserting all vero-pins and links followed by IC holders, resistors, capacitors and semiconductors paying attention to the orientation of all polarised components. To allow more space on the PCB, C7 has been mounted off board beside the battery and is held in place by a sticky pad as shown in the internal photograph of the game. The solid state buzzer was glued into position against the front panel of the case.

To complete construction, mount the switches in

Fig. 1 Circuit diagram of Shark, take care when inserting the LEDs to make sure they're all the right way round.

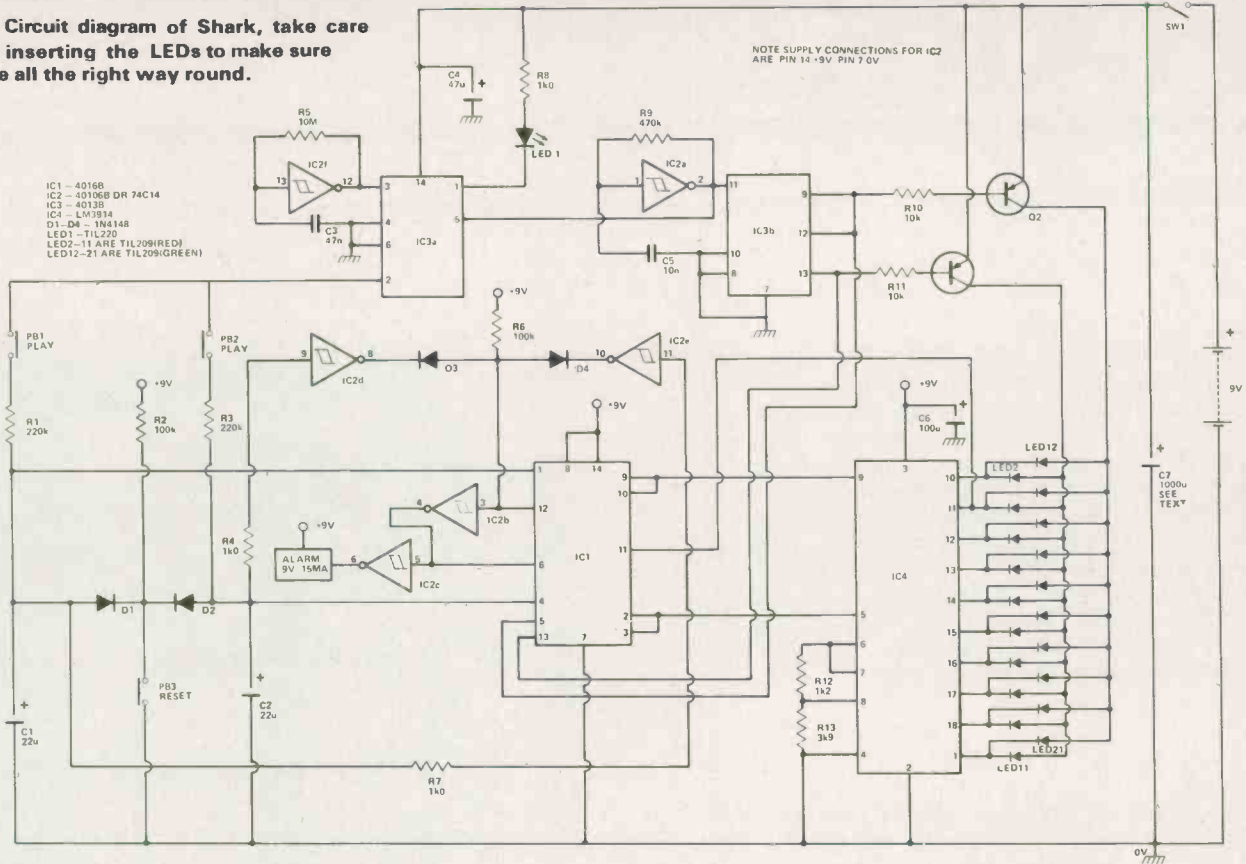

HOW IT WORKS

Each competitor's progress is represented by the charge on C1 or C2. These capacitors are initially discharged at the start of a game by depressing 'reset'. The 'shark's fin' LED is on when the Q output of IC3a is low. During this time the Q output (pin 2) is high and C1 or C2 can charge via R1 or R3 if the corresponding play button is depressed. If the switch remains closed when the output goes low then C1, C2 will discharge. To introduce a degree of chance into the game, the state of IC3a and the 'shark's fin' LED depends on the logic level from fast clock IC2a which is present at the data input (pin 5) during the rising edge of the slow clock signal from IC2f.

IC4 drives the LED displays in dot or bar format according to the state of two of the transmission gates in IC1. These are in turn controlled by the 'OR ed' outputs from IC2d and IC2e and the inverted signal from IC2b. When the voltage on C1 or C2 rises above the transition level of IC2d or IC2e, the display changes from dot to bar mode, one column of LEDs lights and the 'lose' alarm sounds indicating a completed game.

To conserve power and keep construction costs down, the input signals to IC4 from C1, C2 are multiplexed by transmission gates in IC1. These are controlled by the antiphase Q and Q signals from IC3b which also control the LED driver transistors Q1 and Q2. C6 helps to prevent possible oscillations at the output of IC4 while C7 smooths the whole supply and prevents false triggering of IC3.

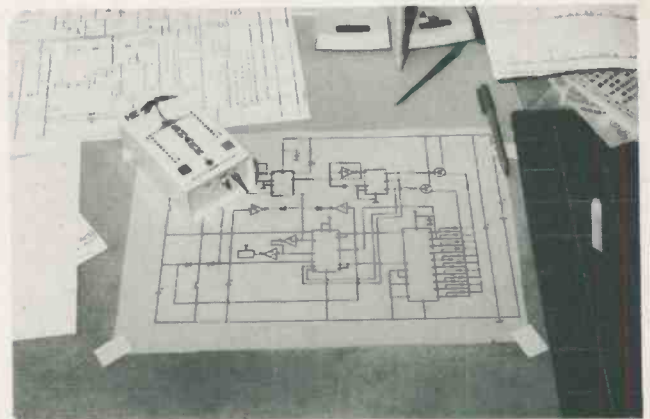

position and insert all LEDs. It is wise at this point to confirm their polarity. For the Texas TIL 209 series the flat on the body denotes the cathode. Most of the interwiring is concentrated between the LEDs and the PCB so extreme care and attention should be exercised. Flying leads should be taken from the PCB to the case mounted components and the battery fitted. There are no adjustments to make and the circuit should work first time so switch on and swim for your life! ●

PARTS LIST

RESISTORS:—

R1, R3	220k
R2, R6	100k
R4, R7, R8	1k Ω
R5	10m
R9,	470k
R10, R11	10k
R12	1k Ω
R13	3k Ω

CAPACITORS:—

C1, C2	22 μ 10V Tantalum
C3	47n polyester
C4	47 μ 10V Tantalum
C5	10n polycarbonate
C6	100 μ 10V Tantalum
C7	1000 μ 10V Electrolytic, (PCB mounting — see text)

SEMICONDUCTORS:—

(All CMOS ICs are 'B' series)

IC1	4016
IC2	40106 (74C14)
IC3	4013
IC4	LM3914
Q1, Q2	MPS6523
D1—D4	IN4148

LED 1 — Standard yellow (0.2" dia.)
LEDs 2-11 are TIL 209 red (0.125" dia.)
LEDs 12-21 are TIL 211 green (0.125" dia.)

MISCELLANEOUS:—

SW1 — SPST Min. Toggle.
PB1—PB3, push buttons momentary action
Audible alarm, 9V @ 15mA.
Vero case — Series 2 casebox No. 65-2066A.
PP7 Battery.

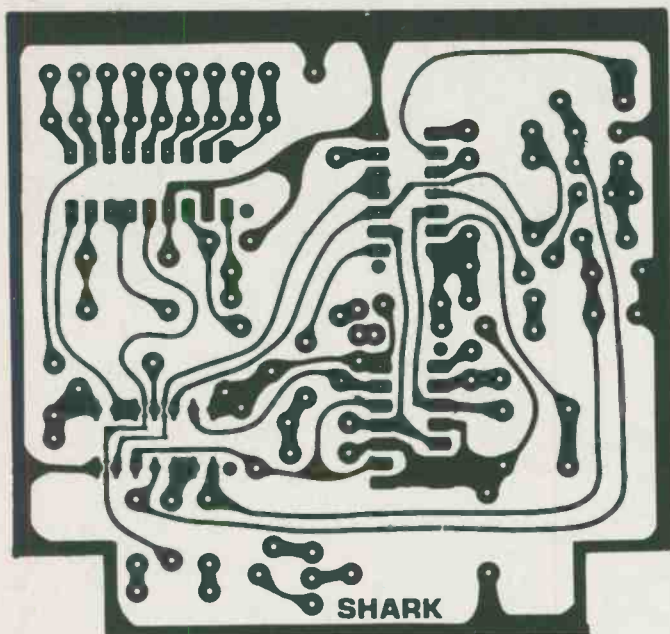

Fig. 3. PCB foil pattern for Shark, using a PCB will lessen the amount of interwiring that has to be made.

ETI Hobby Projects — 1980

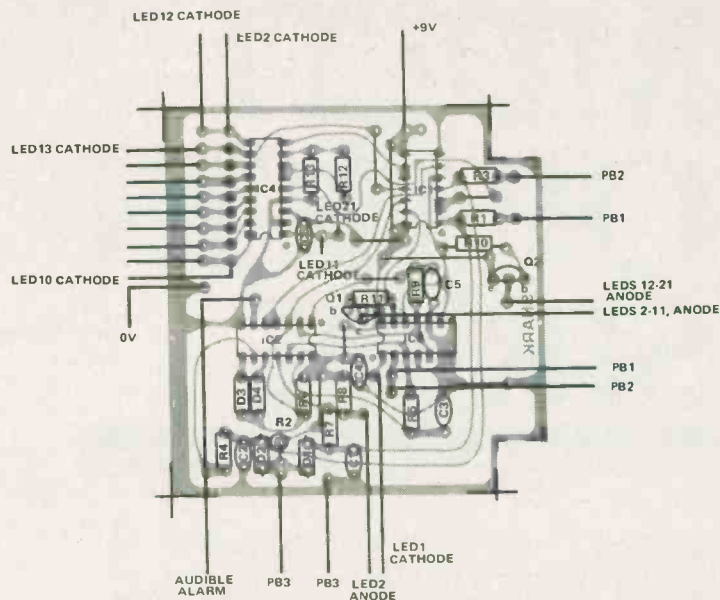
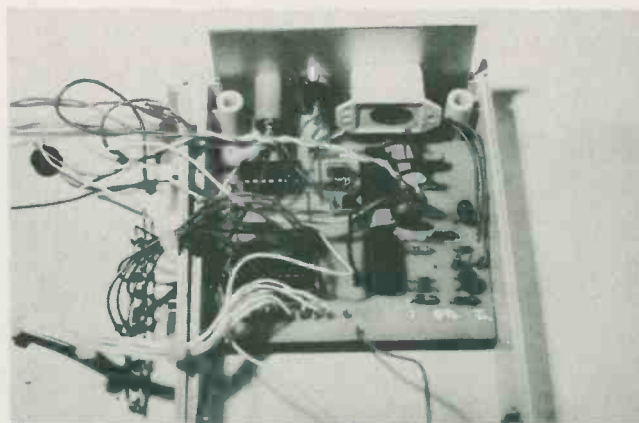
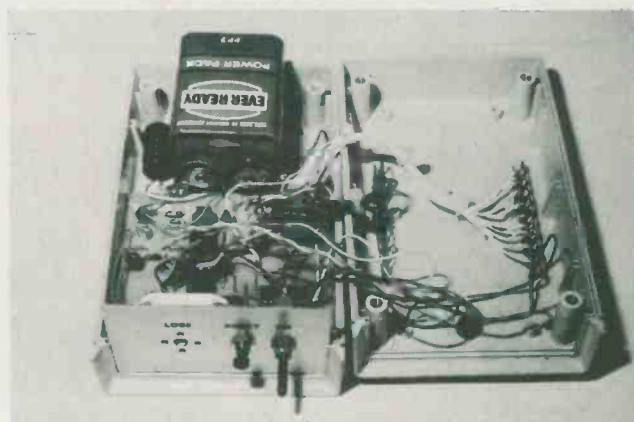

Fig. 2. PCB overlay for shark. It's a good idea to use IC sockets.



Inside Shark, you can see the buzzer that operates when the shark catches the luckless swimmer.



The case of Shark opened for inspection, using a large battery ensures the game will not suddenly die on you. Note C7 mounted next to the battery, using a PCB type makes the wiring easier.

MULTI OPTION SIREN

Subtle Susurrations from a Sensational Sonic Siren

ECONOMY AND VERSATILITY are the key features of this unit. We are not saying you can produce any siren sound, but there is enough variety available to keep anyone happy for hours if not days. Build two and saturate your senses in stereo. You can reproduce a great American police siren and a World War two air raid alert and a whole universe of effects as well.

Possible applications include burglar alarms, sound effects units, a 'button-box' to amuse the kids or just put it through your stereo and annoy the neighbours.

Complete Control

Four independently adjustable parameters give you fingertip control over the rise and fall times of the control voltage, the sensitivity of the voltage controlled oscillator and the basic centre frequency of the unit. You can switch between a square wave or triangle waveshape from the control oscillator and the control oscillator period may be varied between several seconds and several hertz.

The unit may find uses at home or in the family wheel-mobile. Although characterised for use at 9

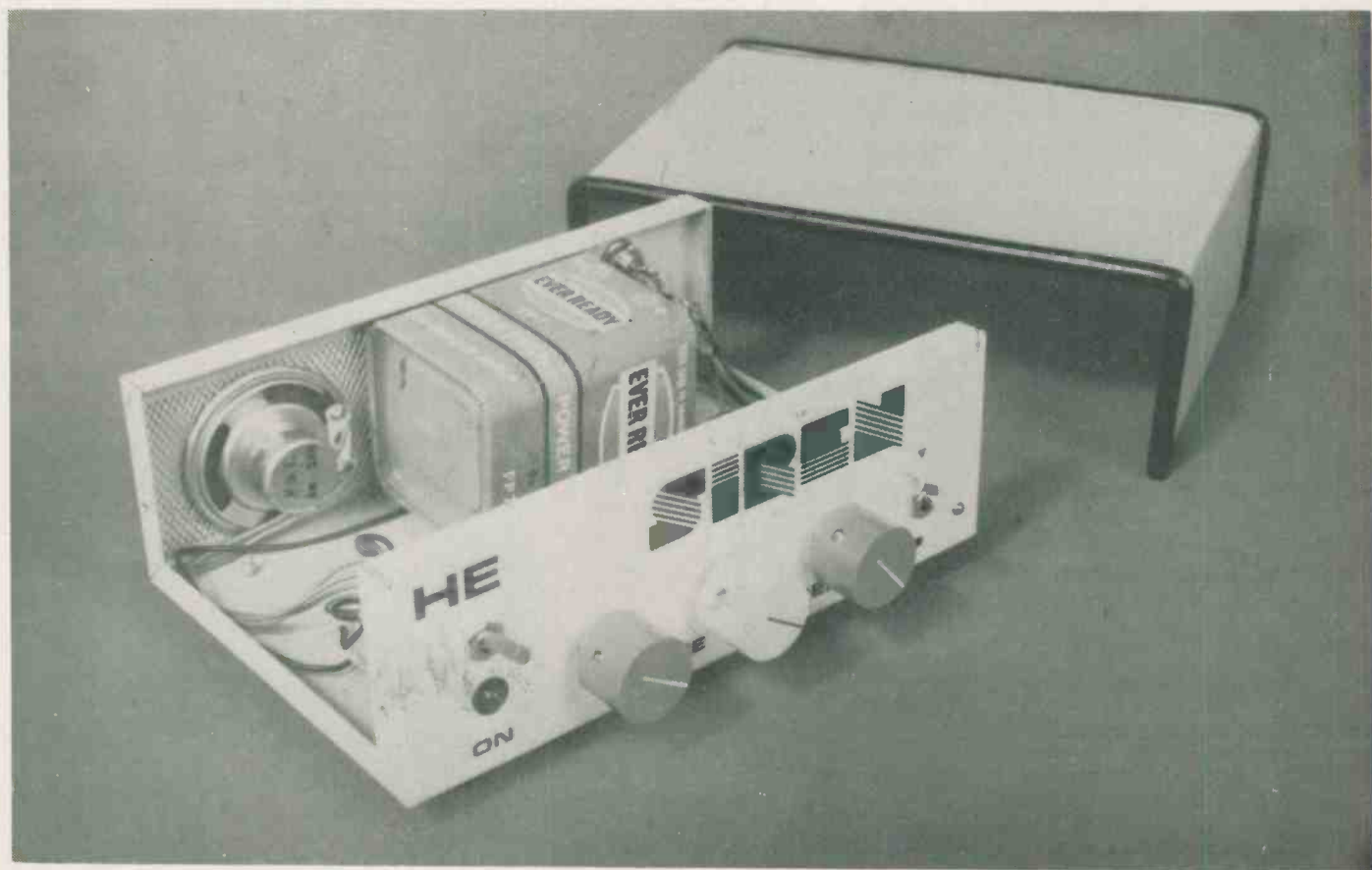

The Hobby Siren on view to the world. Note the miniature speaker which produces surprisingly loud volume and the use of a large battery for extra long life.

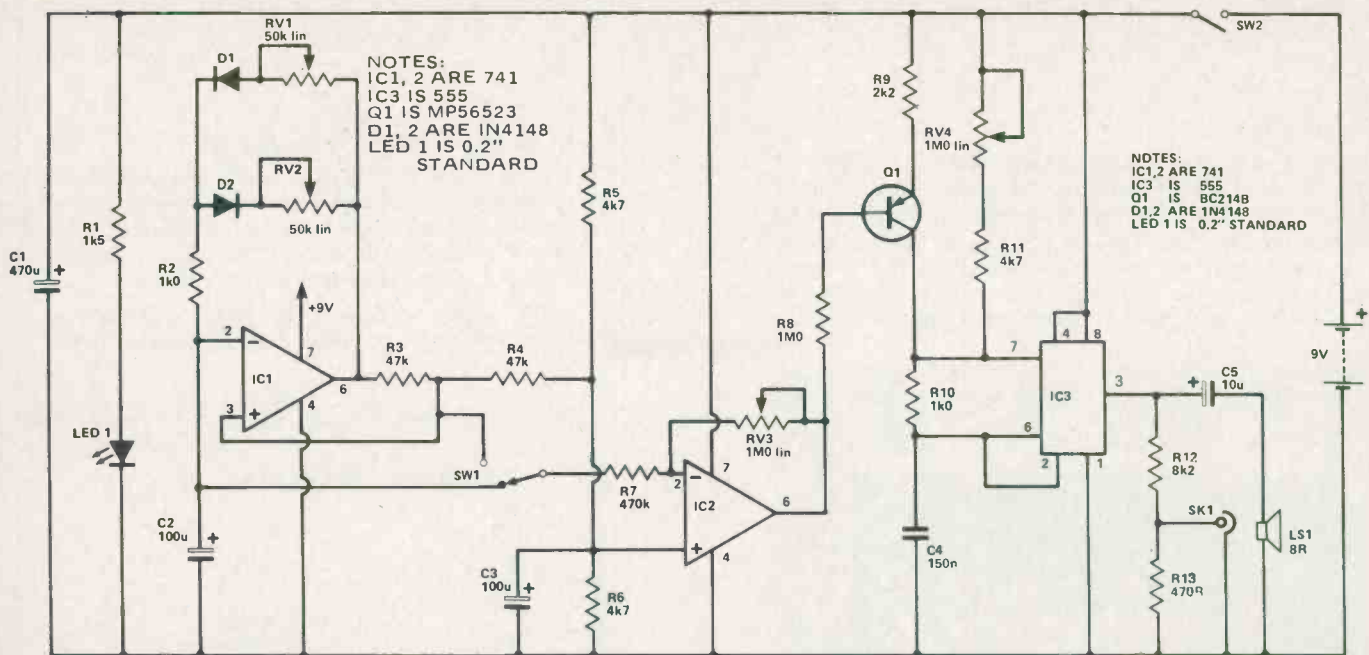

Fig. 1. Circuit diagram of Multi Siren.

HOW IT WORKS

Circuit operation is quite straightforward. IC3 is configured as a voltage controlled oscillator and produces the audio frequency tone. RV4 provides direct control over the frequency while Q1 provides an electronic control. Frequency is altered by changing the voltage applied to R8 and thus the current into Q1. C4 is the timing capacitor.

The control voltage is derived from the slow oscillator built around IC1. IC2 is used to amplify this signal and controls the depth of modulation

applied to the VCO by adjustment of feedback resistor RV3. IC1 is connected as a conventional op-amp astable multivibrator with the exception of diodes D1, 2 which are used to steer current through RV1 and RV2 on alternate half cycles. R2 limits the maximum current flow.

Power 'on' is indicated by LED 1 and current is limited to about 5 milliamps by R1. A mid-voltage point is provided by R5, 6 decoupled by C3 and overall supply decoupling is provided by C1.

volts, satisfactory operation will be obtained from a car battery (up to 14 volts) provided capacitors of suitable voltage rating are employed.

A miniature one and a half inch monitor loudspeaker was incorporated in the prototype and the sound output was surprisingly loud (we could hear it all over the office much to everyone's great delight?). If you want real pulverising power, a low level output is provided for an interface to your sound system. The output level is suitable for an amplifier line input; about 500 mV peak to peak, but can be easily changed by selection of two resistors.

The electronic 'works' of this sonic sensation are built around three readily available and inexpensive chips, two 741 op-amps and the ubiquitous 555 timer. The 555 is employed in a novel configuration as a voltage controlled oscillator with one of the

timing resistors replaced by a transistor current source. Only a few other inexpensive components are required.

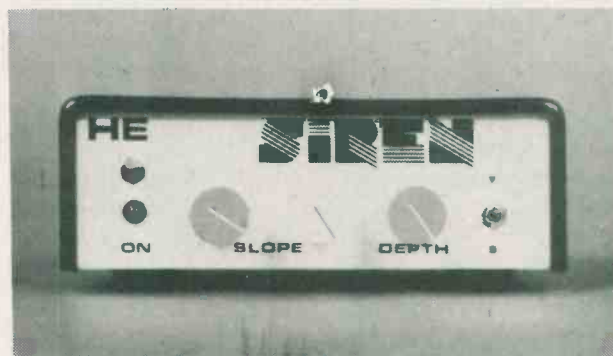

A few simple to operate controls enable the production of an amazing variety of effects.

Construction

Construction is uncritical and should be simplicity itself. Layout is unimportant and any scraps of veroboard, breadboard or cheeseboard (copper-clad only) may be pressed into service. Though if you are too haphazard you may have problems troubleshooting the monster you've created. For a trouble-free, no hassles, right first time project use of a PCB is recommended. Our design is

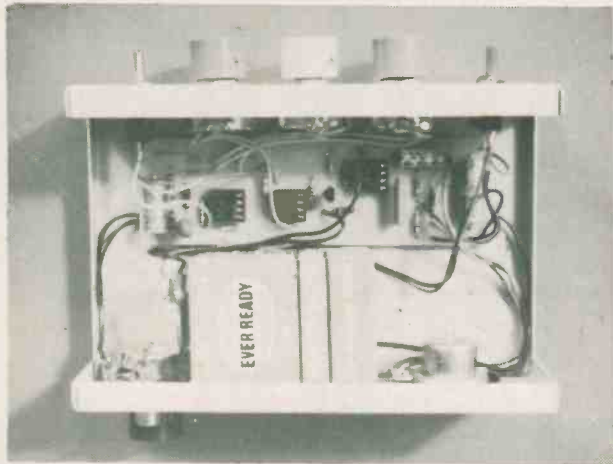

A bird's eye view of the Siren showing the component layout. Note the phono output socket and pot RV4 on the rear panel.

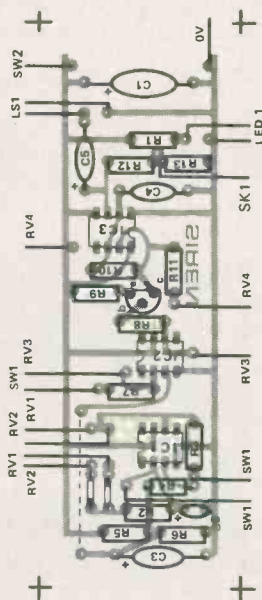
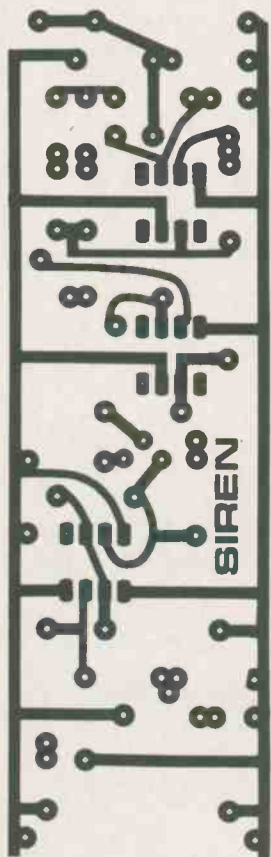

best (or so we keep telling ourselves).

None of the component values are critical and you can change almost anything to achieve that elusive sound you seek. However, polarity of diodes and capacitors is important and these should be checked first if you experience any problems.

The Hobby siren was designed and built in two days. It was easy, it was cheap. Go and do it! ●

PARTS LIST

RESISTORS (All 1/4W 5%)

R1	1k5
R2, 10	1k
R3, 4	47k
R5, 6, 11	4k7
R7	470k
R8	1M
R9	2k2
R12	8k2
R13	470R

POTENTIOMETERS

RV 1, 2	50k lin
RV 3, 4	1M lin

CAPACITORS

C1	470 μ electrolytic
C2	100 μ tantalum
C3	100 μ electrolytic
C4	150n polyester
C5	10 μ electrolytic

SEMICONDUCTORS

IC1, 2	741
IC3	555
Q1	MPS 6523
D1, 2	1N4148
LED 1	standard 0.2"

MISCELLANEOUS

SW1	SPDT
SW2	SPST
SK 1	phono socket
LS1	8 ohm loudspeaker
PCB	case to suit

You're young, bright, ambitious, active and you've just been hit by MS.

Welcome to the Club.

Unfortunately, the membership is not all that exclusive. The fact is, there are some 35,000 Canadians with MS. If you had MS you'd be paying your dues every day. You see, there is no known cause of MS, nor is there a known cure.

As it stands now, 35,000 Canadians are living with the prospect of impaired vision, losing their speech, or waking up one morning to find themselves partially paralysed.

If we hope to put an end to what is often referred to as the 'number onecrippler since polio', we're going to have to get involved. Now.

Contact your local chapter of the Multiple Sclerosis Society. And find out how you can help. Do it for thirty-five thousand Canadians. Do it because you're young, bright, ambitious and active.

A large, bold, black graphic of the letters 'MS'. The 'M' is composed of three thick vertical bars, and the 'S' is a thick, rounded shape with a white cutout in the middle.

MS What are we doing about it?

Contact your local Multiple Sclerosis Society of Canada Chapter

CODE PRACTICE OSCILLATOR

MANY YOUNG readers interested in radio eventually feel the urge to try for their radio license. Needless to say a knowledge of Morse Code is highly desirable.

Now that the Novice Licence has finally been introduced, many young readers will want to learn the Morse Code. This is so because one of the Novice Licence requirements is the ability to send and receive Morse at the rate of five words per minute.

The first step in learning Morse is to obtain a means of practicing the code and the ETI 236 Code-practice set is specifically designed for that purpose. It may be used for practicing alone or with a friend. Practice with a friend is strongly advised as it is not much use knowing the code but transmitting it in a way that no-one else can understand.

An important aid to learning is to memorise the way a code group sounds. For example the letter A is represented by the code group $\bullet\text{---}$, this should be learned as the rhythmic sound *didah* — not as dot dash, or even as dit dah!

Finally there is no substitute for practice. Try to do at least half an hour to an hour a day. Don't worry about speed, this will come naturally, concentrate mainly on accuracy.

CONSTRUCTION

The oscillator is built onto one section of the ETI experimenter board as shown in the component overlay diagram. Take particular care to correctly orientate the IC, the electrolytic capacitor and the diode. The whole unit was built into a 100 x 165 x 300 mm plastic box which had an aluminium lid. Almost any box will do of course, but make

sure that it is large enough to house the speaker you intend to use. We mounted our small 50 mm speaker to the back of the aluminium front panel.

Drill holes in the end of the box, for J1, 2 and 3, and fit them. Drill holes to mount the speaker, the phone and tape sockets and RV1 on the front panel. Note that we used two of the screws which secured the speaker to also secure the printed circuit board and that some holes must be provided for the sound from the speaker. Mount the components to the front panel and the printed circuit board and interconnect them as shown in Fig. 2. Note that the aluminium panel is connected to zero volts via the phone socket, the tape socket and the screw

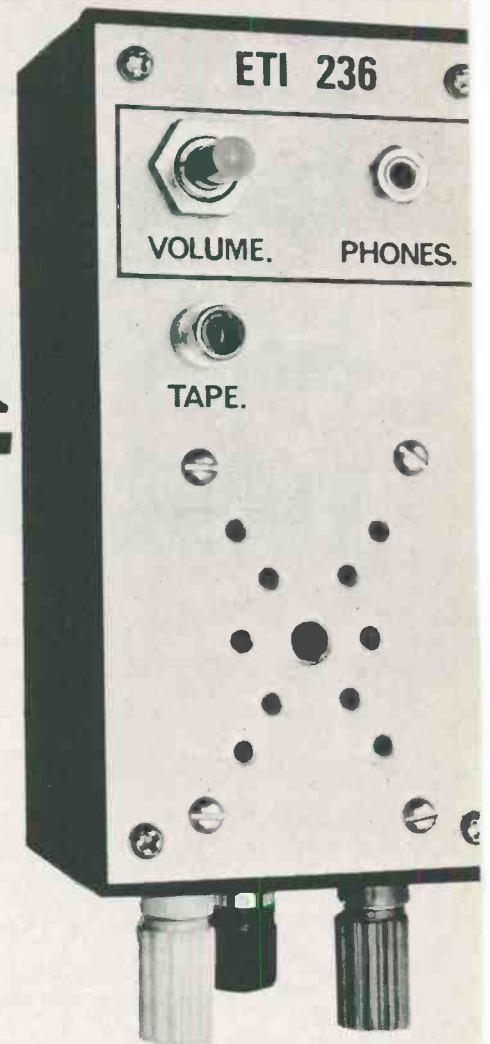

The International Morse Code.

A	•—	N	—•	1	•— — — —	=	—•••—
B	—•••	O	— — —	2	•• — — —	:	— — —•••
C	—••••	P	• — — •	3	••• — —	;	—••• — —
D	—•••	Q	—••• —	4	•••• —	()	—••• —••• —
E	•	R	••••	5	•••••	/	—••• —
F	•••••	S	•••	6	—••••	Error	••••••••
G	—••••	T	—	7	— —•••	Wait	• —••••
H	••••	U	•• —	8	—• —•••	End of message	—••• —
I	••	V	••• —	9	— — —••	Invitation to transmit	—••• —
J	• — — —	W	—• —	0	— — — — —	—••• —	
K	—•••	X	—••••	.	•••••••	End of work	•••••••
L	•••••	Y	—••• —	,	—••••• —		
M	— —	Z	— —••	?	••• —•••		

supporting the board, and that this screw is part of the connection between pin one of IC1 and zero volts. The battery is held into the bottom of the box by a piece of adhesive tape.

Practically any speaker may be used that fits your box. It is recommended, however, that 3 or 4 ohm speakers not be used unless the supply battery is changed to 6 volts instead of 9 thus not exceeding the output stage rating of the IC.●

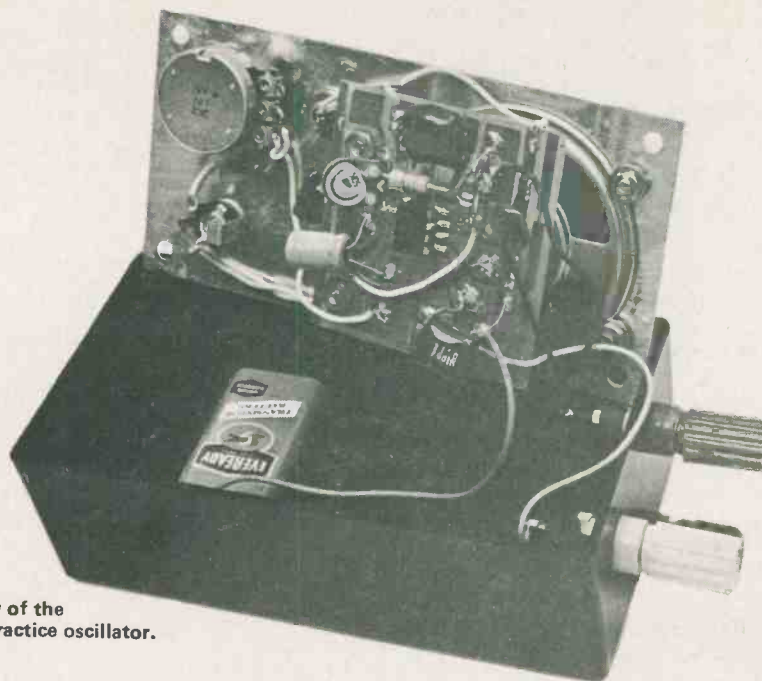

Internal view of the completed practice oscillator.

HOW IT WORKS

The oscillator is largely built around a 555 timer and not much can be said.

R2, R3, RV2 and C3 all determine the pitch with RV2 being the variable element.

Capacitor C2 provides filtering for the reference divider via pin 5 and output for a tape recorder is taken from pin 7 and filtered and attenuated by R4 and C5 to produce a sawtooth output. Diode D1 is used to protect the oscillator from re-

versed battery connections when the unit is connected to other units operating on different supply voltages over a two wire circuit. If you intend to use your oscillator by itself only D1 may be omitted.

The Morse key is a normally-off switch. When it is pressed the Vcc circuit is completed and the oscillator functions. An ON/OFF switch is not included as power is only drawn when the Morse key is depressed.

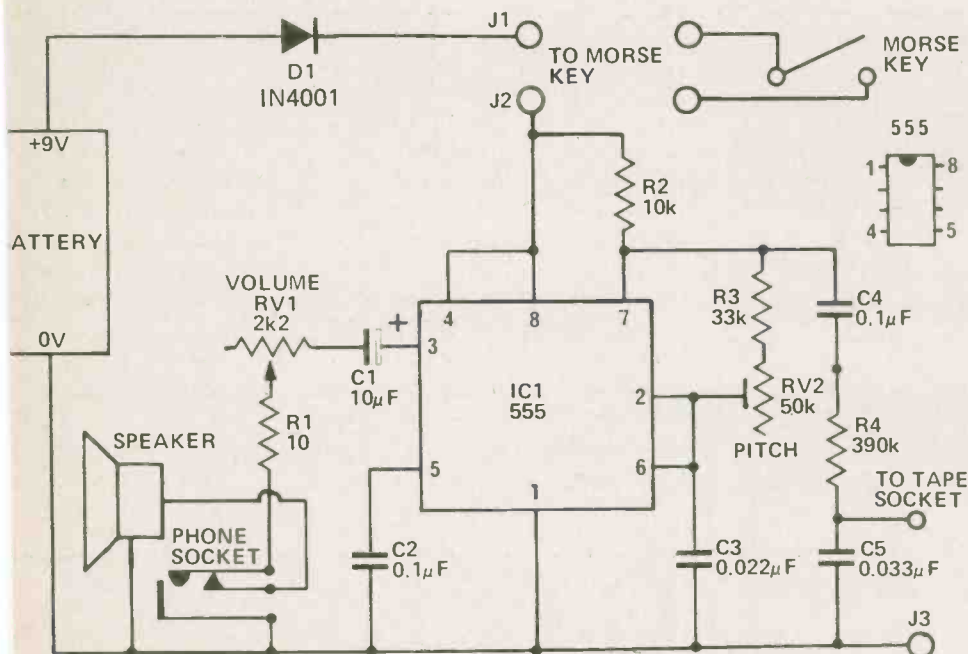

Fig. 1. Circuit diagram of the code practice oscillator.

PARTS LIST

R1	100hm	1/2W	5%
R2	10k		
R3	33k		
R4	390k		
RV1	2.2k		
RV2	50k trim type		
C1	10μF	16 volt electrolytic	
C2	0.1μF	polyester	
C3	0.022μF	polyester	
C4	0.1μF	"	
C5	0.033μF	"	

D1 Diode IN4001 or similar
IC1 Integrated Circuit NE555
Speaker 50 or 75 mm 8 ohm (to suit case).

J1,2,3 Binding posts 3 mm. RCA tape socket, 3mm jack socket, 9 volt battery, box to suit.

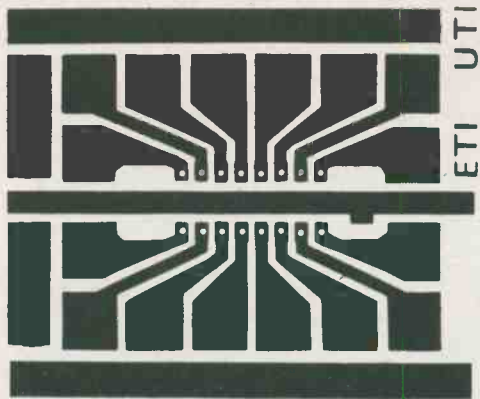

Printed circuit board, shown full-size.

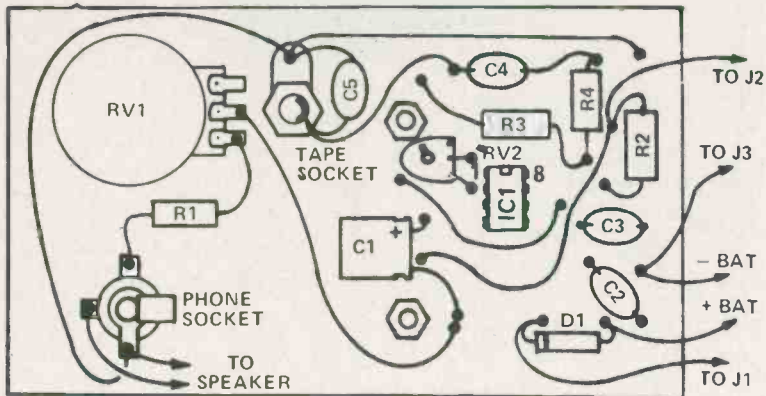

Fig. 3. Internal arrangement of the NE 555 timer IC.

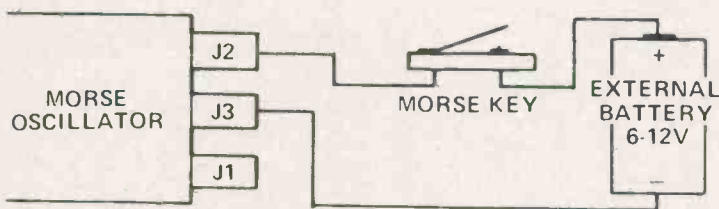

Fig. 4. Method of connecting an external battery to operate the oscillator.

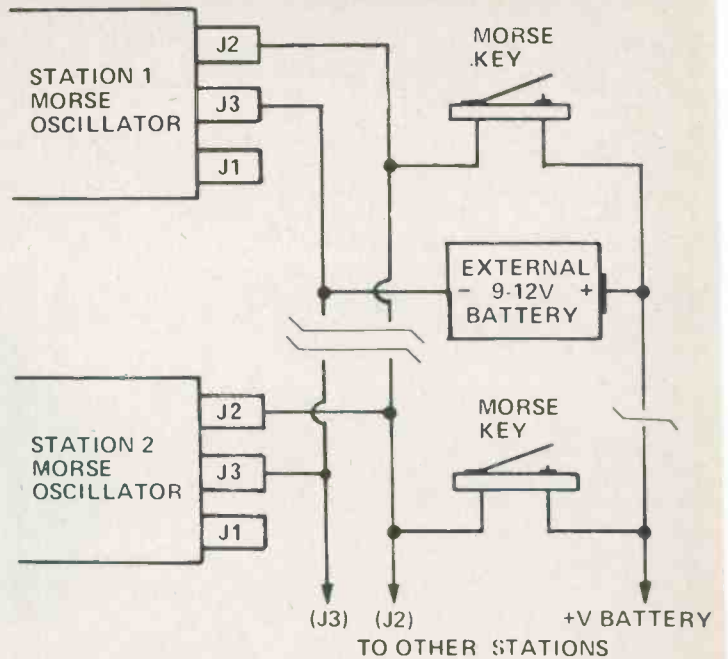

Fig. 6. Two way communication system using an external battery

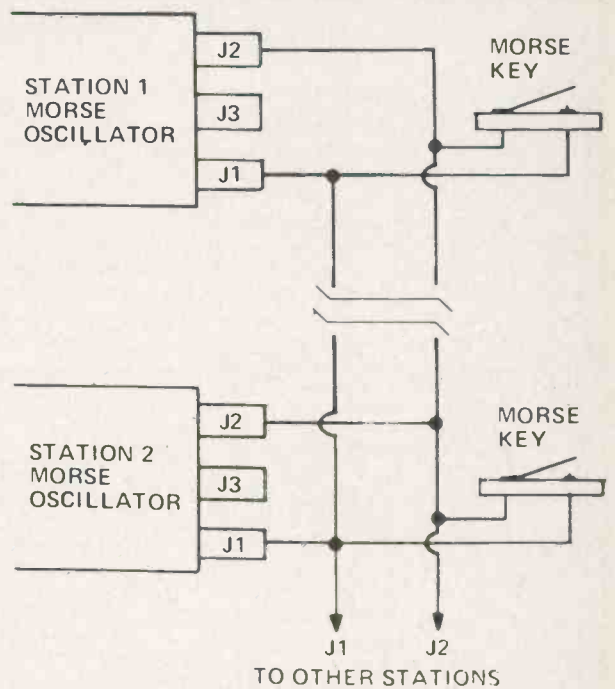
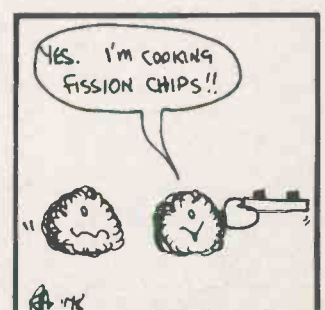
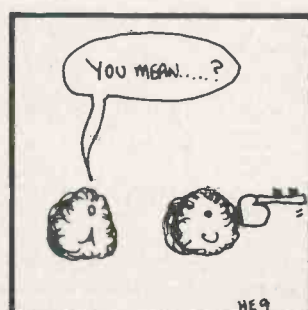
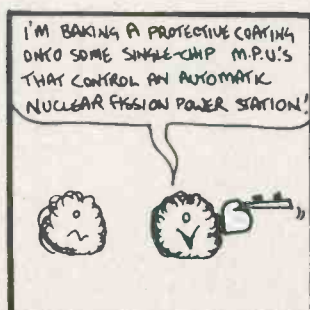
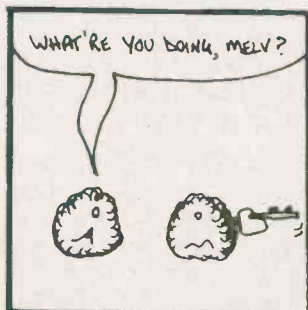

Fig. 5. For two way communication with a friend two oscillators are required connected as shown.



FOUR SIMPLE RECEIVERS

Biased diode; voltage multiplier; or solar powered — four simple but unusual receivers.

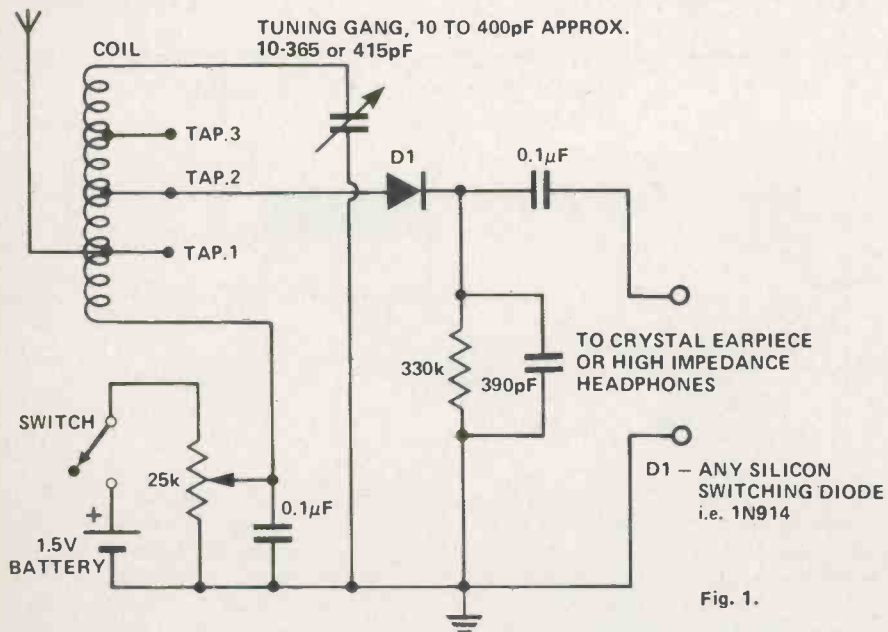

Fig. 1.

Biased Diode Crystal Set

THE CLASSIC "beginning beginner's" project is the crystal set — the workhorse of the pioneers and first popularised in the 1920's. For utter simplicity there is nothing to beat it. However, one can make various improvements and refinements on the basic circuit. One such refinement is shown in Fig. 1. In this version, a biasing voltage is impressed across the diode detector.

One failing of a basic crystal receiver (in which a diode is used as a detector) is that the diode will not commence conducting in the forward direction (from anode to cathode) until the anode-cathode voltage exceeds a certain (small) value. For germanium

Voltage Multiplier Crystal Set

THE DIODE detector, as in a crystal set, is basically a special use of a rectifier circuit. Borrowing from rectifier circuitry, a 'voltage-multiplier'

can be used to increase the output (the loudness in the headphones) of a crystal set. The circuit in Fig. 2 uses what is known as a 'Cockcroft-Walton'

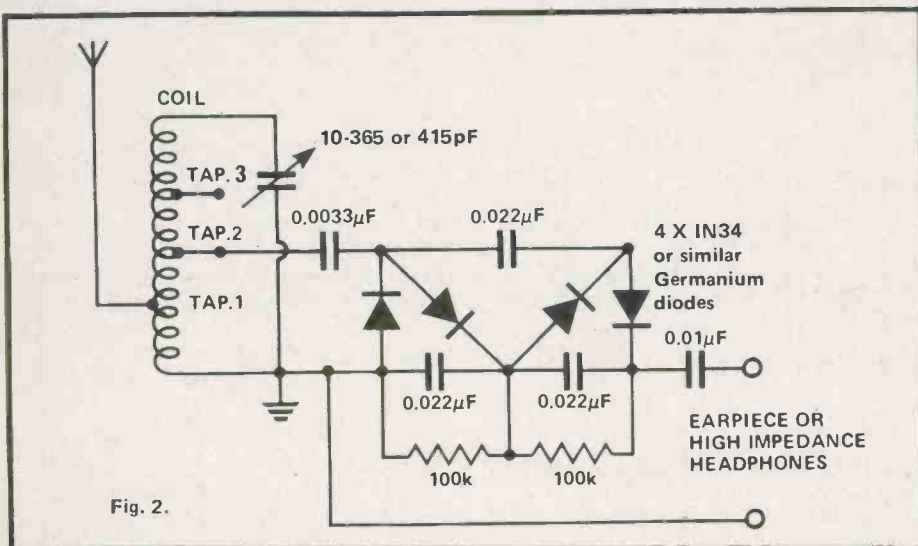

Fig. 2.

multiplier (after the original designers).

Here, a voltage multiplication of four is obtained. You may wonder 'why not use a higher multiplication?'. The answer is that one runs into the ubiquitous 'law of diminishing returns'. For this application, a multiplication of four is all that is practicable as any further increase results in excess load being placed on the tuned circuit, reducing sensitivity and the ability to separate stations (selectivity).

The coil details are the same as for Fig. 1 in the Biased Diode Receiver (see Tables 1 and 2 on page 13). See also the comments in the project concerning use of the taps on the coil.

Construction is also simple, matrix board and pins may be used here again. This tuning capacitor was salvaged from an old broadcast receiver (only one gang being used).

diodes, this is between 200 and 400 millivolts (0.2 to 0.4 V), for silicon diodes it is between 0.6 V and 1.0 V. However, if the diode detector has a voltage almost equal to its forward conditioning voltage impressed upon it (called 'bias') then it becomes a more sensitive and efficient detector. This arrangement also reduces distortion.

Construction is simple and not critical. The unit may be built up on a matrix board as in our prototype — or assembled on tag strips.

Coil details are given in Table 1. Find the best tap for the diode and the aerial by experiment. The aim is to find the combination which gives the clearest signals for the best rejection of unwanted stations.

For short length aerials, say three to six metres of wire, tap high up the coil or across the full turns. Make the diode tap about half-way to three-quarters of the way up the coil in this case. For a long aerial, use the lower taps and tap the diode between one-quarter and half-way up the coil.

The tuning capacitor used was salvaged from an old tube-type broadcast receiver (only one of the three gangs is used) but any unit having a range of about 10 to 400 pF may be used.

The best headphones to use for a crystal set are the high impedance type — having an impedance between 1000 ohms and 5000 ohms or more (if

COIL DIA.	22 SWG	24 SWG	26 SWG	28 SWG	TAPS
1¼"				110	at ¼, ½ and
1½"			96	90	¾ of the turns.
1¾"		88	80	70	You may tap
2"	82	72	68	60	every ten turns
2¼"	71	64	60	52	if you wish
2½"	61	56	54	47	for more range
2¾"	54	52			of adjustment.

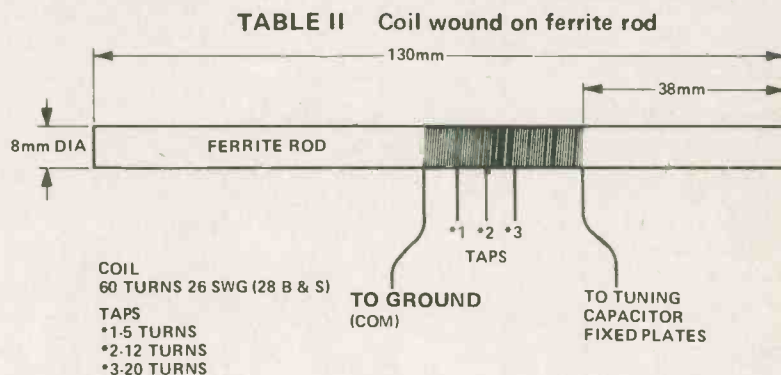

obtainable). Crystal earpieces may also be used but are not as sensitive as good headphones.

With the control potentiometer set at minimum, tune in a station that is not too strong but can be clearly heard.

Advance the potentiometer slowly and an increase in volume and a reduction in distortion will be noticed. The point at which this occurs will vary from station to station but is not critical, there being some range of adjustment.

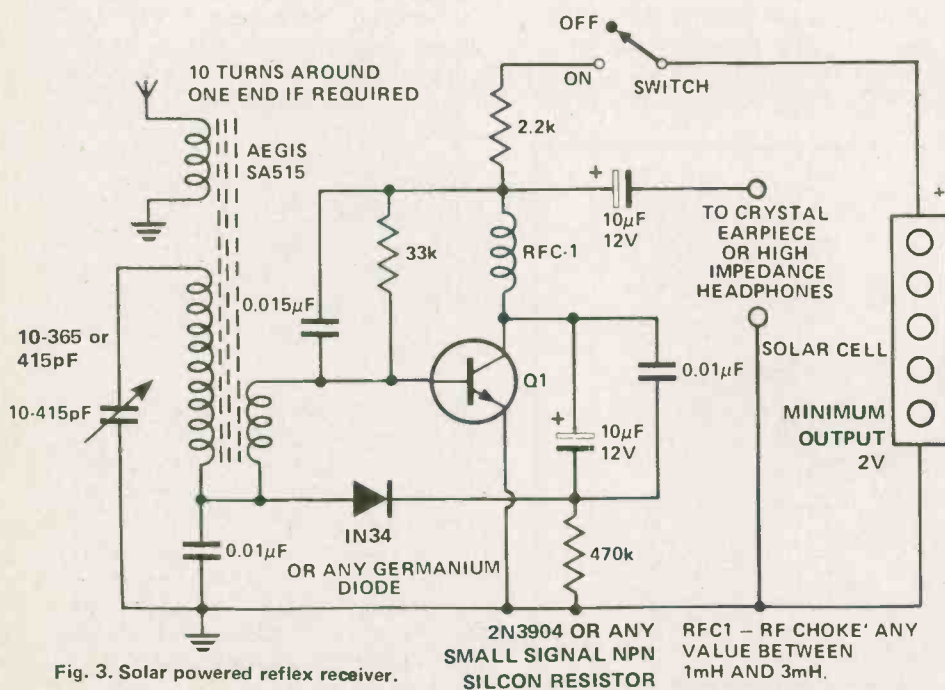

Fig. 3. Solar powered reflex receiver.

Solar-Powered Radio

SOLAR CELLS are dropping rapidly in price. They will continue to drop in price as they gain acceptance and use in more and more applications. Solar cells require no maintenance and the energy source (being the Sun) is free and presumably almost everlasting.

Modern solar cell arrays will deliver over one watt in bright sunlight from a single array, or about 200 milliwatts in cloudy conditions.

The solar array can be used to drive a low-voltage radio receiver or to trickle charge rechargeable batteries such as the small nickel cadmium (Nicad) cells that are commonly available. These cells can be used to run a low voltage radio. Mercury cells, such as used in cameras, also make good low voltage-power sources.

The circuit in Fig. 3 is a simple one transistor 'reflex' receiver that can be run from any of the above power

sources, or a combination of them. It has been especially designed for maximum sensitivity using a low voltage collector supply. This supply may be of any voltage from two to four volts — but no more — it oscillates above that.

The transistor, Q1, amplifies both the radio frequency signal picked up by the ferrite rod antenna coil and the audio signals recovered by the diode detector. Thus both RF amplification and audio amplification are achieved using the one transistor. Surprising sensitivity is obtained, no external antenna is necessary in metropolitan areas.

One Transistor Radio

Here is a simple one-transistor receiver that will bring in broadcast stations with surprising clarity and strength. It can be made from readily available, cheap components, requires no adjustments, and will work straight off!

The circuit of the complete unit is shown in Fig. 4. A single transistor is used to amplify both the radio frequency signal picked up by the ferrite rod and coil antenna, and the audio signals recovered by the detector

If you live in the country, an external antenna may be necessary. A length of wire 10 m or more long, mounted 5 m to 10 m high is usually adequate. An added winding, as shown in Fig. 3, provides coupling for the external antenna. An earth connection may improve reception also.

Construction

Construction is straightforward and non-critical. Matrix board and pins, or tag strips are used to support the small components. Two rubber grommets are slipped over the ends of the ferrite rod and the assembly tied down to the matrix board with short lengths of *insulated* hook up wire around the

(IN34 diode). This results in excellent sensitivity and selectivity ensuring that radio stations can be received at good strength and without interference.

Construction

The receiver can be constructed on a small piece of circuit board — as shown in Fig. 2. This can be mounted, together with the ferrite rod, tuning condenser, and battery and headphone connectors, on a piece of wooden board to which a panel has been screwed. This panel can be made from

grooves in the grommets.

As we said at the beginning of this article, solar cell arrays are still expensive. However, like so many other electronic components the price may realistically be expected to fall dramatically as soon as demand increases.

In the meantime, why not build it and run it from Nicad or mercury cells. These have terminal voltage of about 1.2 V to 1.3 V per individual cell, so two or three in series may be used to power this receiver. Current consumption from a two volt supply is about 0.5 mA. Alternatively, ordinary dry cells may, of course, be used. ●

plywood, fibre-board, bakelite etc.

Two rubber grommets should be fitted over the ends of the ferrite rod. These can then be fitted into the brackets (illustrated in Fig. 6) which are then screwed to the baseboard.

baseboard.

Take care when soldering the transistor into the circuit — leave this item until last.

Antennae

The ferrite rod acts as a built in antenna — and — if you live in the metropolitan area of a city, the local broadcasting stations will be heard at good strength with this antenna alone.

In fact an external antenna will probably be a disadvantage in city areas, because the received signal strength from nearby stations may be so powerful that distant stations will be swamped.

However if you live in a country area, then an external antenna may well be necessary.

Figure 7 shows the general idea. A length of wire, from 20 ft. to 100 ft. long should be erected, preferably in line with the nearest broadcasting stations, and as high as possible.

Insulators should be used at either end. The type of wire is not important as long as it is strong enough to withstand wind forces etc.

A ground connection may also improve reception of weak signals. Use a length of metal rod or pipe, about two or three feet long, hammered into the ground. The surrounding soil should be kept moist. If water mains are available the water pipe will make a good ground — but ensure that it is a metal pipe. Many water systems are now being constructed using plastic pipes, and plastic water pipe is a remarkably poor conductor! ●

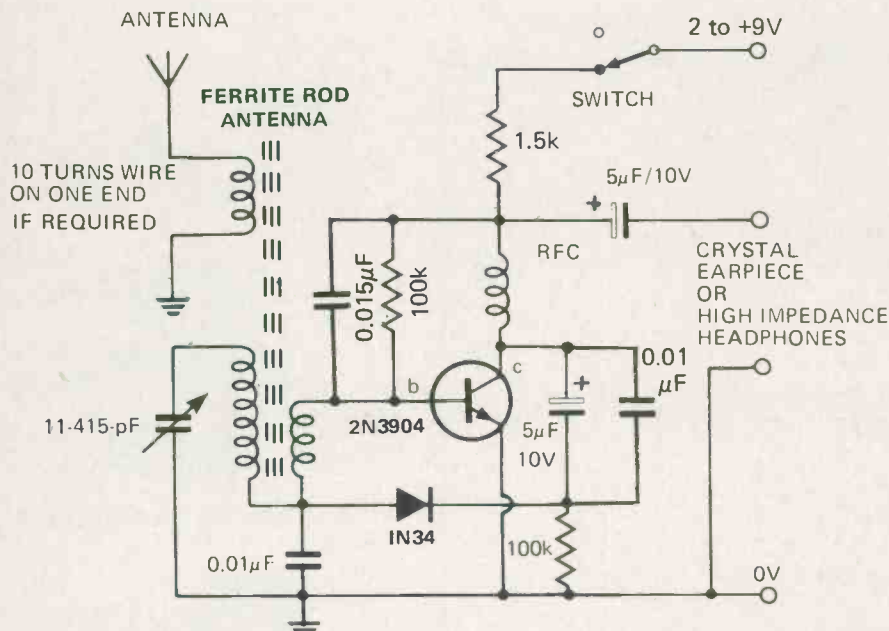

Fig. 4. Circuit diagram.

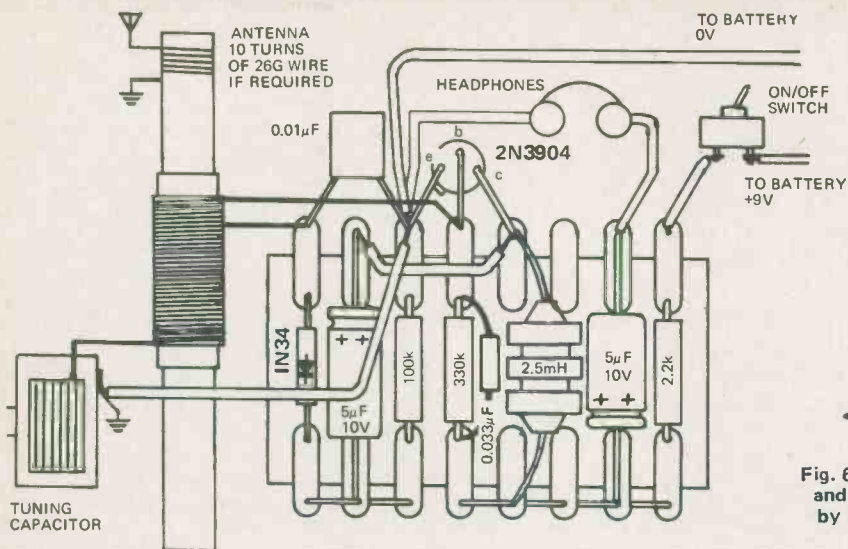

Fig. 5. The receiver may be built on tag strips of a piece of circuit board.

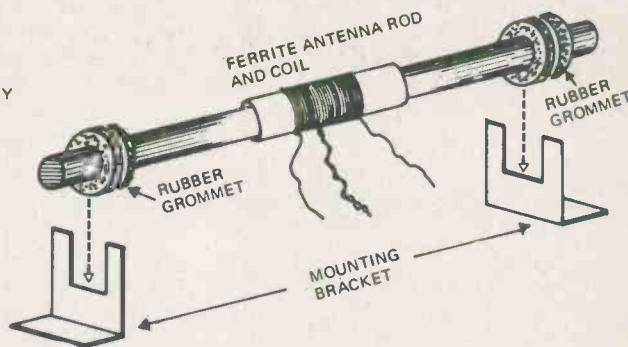

Fig. 6 The ferrite antenna rod and coil should be supported by two grommets and small metal brackets.

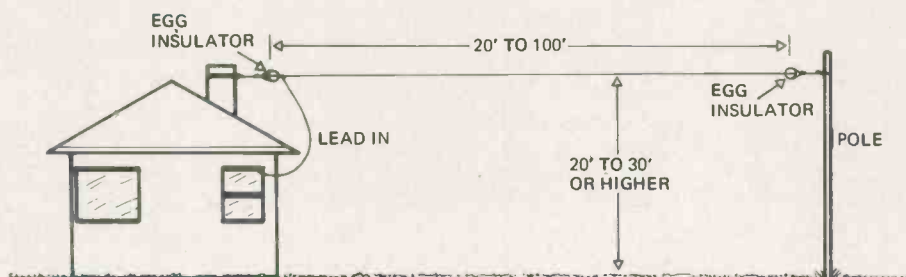
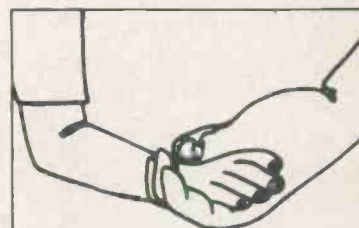

Fig. 7 How to make a simple antenna.

PARTS LIST

- 1 resistor 1.5k ½ watt, 10%
- 2 resistor 100k ½ watt, 10%
- 2 capacitors 5µF 10 volt electrolytic
- 2 capacitors 0.01µF
- 1 capacitor 0.015µF
- 1 transistor (Q1) 2N3904
2N3564, 2N3565, 2N5770.
- 1 diode (D1) 0A91, 0A95 or any germanium diode
- 1 ferrite rod and coil – broadcast type
- 1 tuning capacitor 11-415 pF,
- 1 nine volt battery and connectors
- 1 toggle switch – single pole single throw
- 1 RF choke, 1mH – 3mH
- 1 crystal earpiece or high impedance headphones
- 1 pointer control knob
- Rubber grommets, screws, plywood etc.



**LEND A
HELPING
HAND**

SUPPORT THE UNITED WAY.



Thanks to you
it works . . .
FOR ALL OF US

**United
Way**

Canadian Projects Book Number One gives you twenty-five projects from issues of ETI sold in Canada.

THE BEST OF ETI

For Only \$3.00!

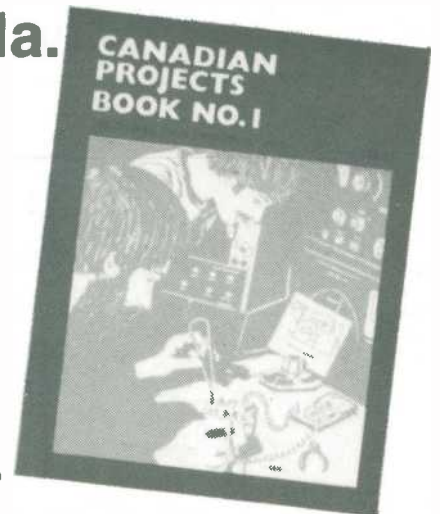

This book is a must for all Canadian electronics enthusiasts. We show you how to make your own digital voltmeter, and an injector-tracer for your test-bench.

Then you can set about building our induction balance metal locator — this is the Cadillac of metal locators, a big improvement on the usual BFO types. And when you are out searching for treasure you can relax in the assurance that our burglar alarm project is watching over your home (to make sure no-one steals your valuable Canadian Projects Book).

While you are building our electronic version of the Mastermind game you can keep your kids/parents/roommates occupied with your homebuilt reaction tester and double dice games. If the excitement gets too much you can relax with our biofeedback GSR (Galvanic Skin Response) meter (and if you want to do more experiments with biofeedback you can build our heart-rate monitor).

Another project for the experimenter is our sound-activated photographic flash trigger. With this device you can photograph a bullet leaving the barrel of a gun, or a balloon bursting, etc.

In addition to the projects mentioned above we have designs for fifteen audio projects. Eight of these can be connected together to make the mixer and power-amp sections of a discotheque sound system. For the musician we have plans for a fuzz box and for a phaser; for the beginner in electronic music we have our clever twenty-five note electronic organ which uses a touch-sensitive keyboard etched into half of the single PCB (and we include variable-depth tremolo, volume control, and two voices).

For the hi-fi enthusiast we have do-it-yourself instructions on how to build a simple LED indicator to tell you when you are overloading your amplifier. If you aren't getting the bass response you would like from your speakers you can build up a little gadget to put that right. If you are more adventurous with your sound system you will be interested in our audio limiter. This project can be used to protect your group's amplifiers from distorting when high-level signals are produced, it can be used to compress the dynamic range of a signal for recording or addressing public meetings, or it can be used as a voltage-controlled volume control for remote or automatic adjustment.

There's got to be something in this book for all ETI readers. All the projects have been reworked since they were first published to update them with any information we might have received about availability of components, improvements, etc.

All for the amazingly low price of three dollars.

To order Canadian Projects Book Number One send \$3.00 per copy (no extra to cover postage) to Canadian Projects Book, ETI Magazine, Unit Six, 25 Overlea Blvd, Toronto, Ontario, M4H 1B1.

Useful design ideas

MORE CIRCUITS

from Electronics Today.

\$4.50

Editor
STEVE BRADWOOD, BSc.
Assistant Editor
GRAHAM WOODWARD, BSc.
Advertising Manager
MARK CZECHOWSKI, BSc.
Advertising Services
COUNCIL W/CDMA
Advertising Representatives
JULIE O'BRIEN
Eastern Canada: JEAN SEGUIN &
ASSOCIATES INC., 501 Gore Way
S., Aurora, Ontario, M6L 1K1
Telephone (541) 748-6561
Subscription Department
JILL LALL
Accounts Department
SENICK HARRISON
Layout and Assembly
GAIL WINFIELD

MORE CIRCUITS

PUBLISHED
SUMMER
1979

FROM THE PUBLISHERS OF **electronics today**

CANADA'S OWN ELECTRONICS MAGAZINE

EDITORIAL AND ADVERTISING OFFICES: Unit 6, 25 Overlea Boulevard, Toronto, Ontario, M4H 1B1. Telephone: (416) 492-2882.
Post Office return to Unit 6, 25 Overlea Boulevard, Toronto, Ontario, M4H 1B1.
Published by The Society of Electronic Engineers, Limited, Ltd.
Printed by Compendium Printing Ltd., 1000 Sheppard Avenue East, Toronto, Ontario.
Copyright © 1979 by The Society of Electronic Engineers, Limited.

FEATURES & INFO

CIRCUIT CONSTRUCTION
THE IMPORTANCE OF INSTRUMENTS 6
EASY DIGITAL PANELMETER 16
ETI PUBLICATIONS AND T-SHIRTS CENTRE 93
ETI SUBSCRIPTIONS CENTRE 105
ETI CIRCUITS NO. 1 105
CRYSTAL OSCILLATORS 102
SPEAKER CROSSOVERS 100
NOTES ON COMPONENTS 100
CMOS FUNCTIONS 102
TTL FUNCTIONS 103
TRUTH TABLES 104
TTL PINOUTS 106
CMOS PINOUTS 106
ADVERTISERS' INDEX 106

CIRCUITS

ALARMS
Comprehensive Burglar Alarm 20
SCR Alarms 20, 21
Car Radio Protector 21
Fire Alarm, Simple 21
AMPLIFIERS & PREAMPLIFIERS
Non-Inverting Amplifier 22
AC Amplifier, Simple 22
Voltage Follower 22
Flexible Resonance 24
Hi-Z, Hi Gain Amplifier 26
Voltage Controlled Amplifier 26
Recording Pickup 26
High Impedance Bridge 28
Direct Coupled Power 28
CMOS Power Booster 28

Prostate Amplifiers 30
12 Volt PA System 30
Class A Amplifier 32
Copper Preamp 32
Heterodyne Amplifier 34
Op-Amp Circuits, Standard 34
SIGNAL PROCESSORS
Track and Hold Circuit 35
Sine Wave, Simple 35
ADSR Envelope Shaper 36
Frequency Doubler 36
Square Wave to Voltage Converter 36
Digital to Analogue Converter 37
Schmitt Trigger, Without Hysteresis 37
Pulse Lengthener, Optical 38
SIGNAL GENERATORS
Square Wave, Low Frequency 39
Square Wave Generator 39
Monostable Multivibrator 39
Triangle Waveform Generator 39
Marker Generator 40
Voltage Controlled Oscillator 40
Voltage and Frequency Calibrator 41
VCO, Simple 41
Tone Burst Generator 42
Sine Wave Oscillator 42, 43
Exponential Waveform Generator 43
Thermistor Oscillator 44
FILTERS
Voltage Controlled Filter 44
CMOS Filters 44
Loudness Control 45
Rumble Filter, Switchable 45
Tone Control, Active 46
Tone Control Circuit 46
SPECIAL EFFECTS
Guitar Fuzz 46
Warning Alarm 47

Guitar Synthesiser 47
Fetichaler, Transistorised 48
MIXERS
Audio Mixer 48
Basic Mixer 49
DETECTORS & COMPARATORS
Low Battery Warning 49
Recording Level Meter 50
Comparator Voltmeter 50
Voltage Comparator 50
True RMS Detector 50
Battery Voltage Monitor 51
Temperature Sensor, Differential 52
True RMS Converter 52
Schmitt, 555 57
Positive Peak Detector 57
INDICATORS
Warmth Indicator 57
Temperature Sensor/Remote 58
Neon Tube Flasher 58
Warning Flasher 59
Transistorised Flasher 59
Blown Fuse Indicator 59
SWITCHING
Stereo Input Selector 60
Stereo Switch, Simple 60
Logic Touch Switch 60
Stereo Only 61
Beam Splitter, Oscilloscope 61
Touch Switch, Automatic 62
Touch Switch, Thermo 62
4005 DROT Switch 62
AND Gate, SCR 63
OR Gate, SCR 63
LED Changer Circuit 63
SEQUENCE & TIMING
Flexible Timer 63
Time Delay Switch 64
Snootie Delay Unit 64
Timer, 1-12 Minutes 65
Code Switch 65
Timing Circuit 65
POWER & CONTROL
Impulse Power 66
Half Wave Control 66
Improved Half Wave 66
Zero Switching Temperature Control 67
Triac Lamp Flasher 68
Triac Slave Controller 68
Light Shown, Simple 68
DC Lamp Intensity 69
Car or Train Speed Control 69
Temperature Controller 69

POWER SUPPLIES
Current Source, Drift Free 70
Constant Current, High Voltage 70
Output Voltage, Adjustment 71
High Voltage, Variable Regulator 71
Switched Output 71
Dual PSU 72
Muffler Power Supply 72
Low Ripple PSU 72
Crewbar, Simple 73
Clean Low Voltage, Short Protection 73
Low Ripple at Low Current 74
30 Volt Regulators 74
Standard Configurations 74
Converting Single to Dual 75
Zener Assistance 75
TEST
Logic Indicator, Audible 75
PET Testing, Static 76
Diode Tester 76
Anemeter, Wide Range 76
Millivoltmeter, Audio 77
DC Probe, 100,000 Megohm 77
Transformer/Inductor Tester 76
Pulse Catcher, Probe 78
JFET Test, Quick 78
DIGITAL
Data Selector, Two Way 79
7 Segment Improvement 79
3 Chip Die 80
Hex to 7 Segment 80
Binary Calculator 80
TTL Keyer 81
ASCII Keyboard 82
Counter/Display Module 82
Multiphase Clock Generator 82
Wavelength 83
Salt Crystals 83
LED Counter 83
AUTOMOBILE
Fuel Gauge, Digital 84
Immobiliser/Alarm, Automobile 84
MISCELLANEA
Emergency Lights 85
Digital Thermometer 85
SCR One Shot 86
SCR Multi-Inverter 86
Meter Amplifier 86
Night Light, Automatic 87
Headphone Adaptor 87
Rising Edge Trigger 88
Position Transducer, Digital 88
Temperature Stabilised Relay 88

Obtain your copy of this new publication directly from us by using the order card in this issue. Or send a cheque, money order, or Visa/Mastercharge information for \$4.50 plus 45c postage and handling to: MORE CIRCUITS, Electronics Today Magazine, Unit 6, 25 Overlea Blvd., Toronto Ontario, M4H 1B1.

PS. The real book is orange.