

# Electronics Today

INTERNATIONAL

The Magazine for  
Electronics & Computing  
Enthusiasts

\$1.95  
MM70924

March 1982

## Printers

The intricacies  
of hard copy

## Ni-Cads

Unending  
power

## Reaction Tester

How fast  
are you?

## CMOS Circuits

Unusual new  
applications

## Music Processor



4 effects in 1



## Sinclair ZX 81

Toy or  
tool?







# EXCELTRONIX INC. COMPUTING DIVISION

**Exceltronix**  
Components & Computing Inc.

## COMPUTERS

APPLE II™ +  
W/48K RAM ..... \$1795.00  
DISK II W/DOS 3.3 ..... 795.00  
DISK II ..... 739.00  
PACKAGED SA 400 DISK  
DRIVE WITH MULTIFLEX  
CONTROLLER AND DOS  
3.3 UPGRADE KIT ..... 599.00  
PACKAGED SA 400 DRIVE  
USED AS A SECOND  
DRIVE ONLY ..... 499.00  
ATARI 400 ..... 539.00  
ATARI 410 PROGRAM  
RECORDER ..... 106.80  
ATARI 800 W/16K (WHILE  
SUPPLIES LAST!) ..... 1099.00  
ATARI 810 DISK DRIVE  
..... 735.00

## DISK DRIVES

SHUGART SA400  
(5 1/4", SS) ..... \$390.00  
SHUGART SA450  
(5 1/4", DS) ..... 549.00  
SHUGART SA801  
(8", SS) ..... 689.00  
SHUGART SA851  
(8", DS) ..... 950.00  
CDC 9406 8" DOUBLE  
DENSITY DD SPECIAL  
PRICE ..... 649.00

## BLANK DISKETTES

CONTROL DATA  
8" DSDD SOFT ..... \$7.95  
8" DSDD SOFT ..... 6.50  
8" SSDD SOFT ..... 6.45  
8" SSDD SOFT ..... 4.99  
MAXELL  
MD1 5 1/4" SSDD SOFT ..... \$5.75  
MD2 5 1/4" DSDD SOFT ..... 8.95  
MH1 5 1/4" SSDD HARD ..... 5.49  
FD2 8" DSDD SOFT ..... 8.95  
FH1 8" SSDD HARD ..... 11.75  
VERBATIM  
MD 525-01 5 1/4" SSDD SOFT ..... \$4.45  
MD 577-01 5 1/4" SSDD SOFT ..... 4.99  
FD 34-8000 8" SSDD SOFT ..... 5.85  
FD 34-4001 8" DSDD SOFT ..... 6.99

## THE MULTIFLEX Z80A COM- PUTER

The popular Multiflex Z80A Computer has the following stand-alone features which were selected for maximum usefulness:

— An S-100 CPU board and a separate motherboard which will accommodate up to 4 S-100 boards.

— The CPU card has space for 4K of RAM, jumper selectable in 2K blocks to any location in memory, and up to 16K of EPROM using combinations of 2708's or 2716's.

— A 3.8K monitor, in two 2716's, which facilitates machine-language programming, execution, and debugging and also controls the I/O hardware.

— A hex keyboard, fourteen monitor function keys and 2 user-definable keys.

— A six digit hex display.

— A 2000 bits per second cassette interface, with monitor routines to make calibration easy.

— An EPROM programmer for 2708, 2716, 2732, and 2532 chips. Any block of system memory may be used as the source for the EPROM, and programmed EPROM's may be read into RAM as well.

— A parallel interface with 24 I/O lines using the 8255 PPI chip.

— An optional RS232C for serial communication at rates from 110 to 9600 baud.

— A 40 chip wire-wrap area located on the motherboard with easy access to all bus signals and I/O hardware.

**\$375.00** Kit or  
**\$450.00** A & T

## MODEMS

NOVATION MODEMS  
CAT ACOUSTIC ..... \$259.00  
D-CAT DIRECT  
CONNECT ..... 269.00  
AUTO CAT D.C.  
AUTO-ANSWER ..... 329.00

## TERMINALS

ADM-3A ..... \$975.00  
ADM-5A ..... 1019.00  
HAZELTINE 1420  
..... 1479.00  
HAZELTINE 1500  
..... 1695.00  
HAZELTINE ESPRIT  
..... 1089.00

## MULTIFLEX S-100 MEMORY CARDS

Multiflex Technology, Inc. is proud to announce a new series of S-100 dynamic memory cards. The first is based on the 8202 Dynamic Memory Controller chip, which minimizes the introduction of wait states and allows on-board refresh.

Each board can hold a maximum of 64K bytes, 200nS 4116 chips. The boards have a software bank-selection feature, which allows up to eight full boards to be used in a single system. Using a slightly modified addressing scheme, any microprocessor can access 512K bytes (one half Megabyte) of RAM.

To maximize flexibility, hardware jumpers are used to select certain functions of the boards, allowing for refreshing in user applications. Firstly, the done automatically by the 8202 (this is to an external refresh signal such as that generated by the Z80 microprocessor. Second, the parts of the board which answer to addressing is used mainly with partially-populated boards, but also has limited applicability for write-protection.

The boards feature a buffered S-100 bus interface and have been designed for the Multiflex Z80A computer system, but they are fully compatible with most other S-100 microcomputers.

**\$350** KIT (WITH ALL  
MEMORY)  
**\$450** A & T



## ECONO RAM

The second board is of simple design and construction for those people who want extra memory, but don't want to spend extra money. This board, which is ideal for the Multiflex Z80A Computer, uses 8 4164 single supply chips. The refreshing is done via the refresh signal provided by the Z80A CPU chip. Two important features are the 28 chip prototype area for custom circuits, and the fact that this board needs only a +5V power supply, lowering the cost of your power supply.

**\$249** KIT (WITH ALL  
MEMORY)  
**\$345** A & T

## U of T 6809 BOARD

The University of Toronto 6809 board is designed to give the user access to a compact hardware unit for the purpose of learning about the use, programming and characteristics of microprocessors in general and the 6809 in particular.

### Basic Board Attributes

The 6809 is a third generation microprocessor which has a varied set of addressing modes and a large instruction set.

There are 16 to 48 kilobytes of RAM located on board. This is controlled by an 8202 dynamic RAM controller. This provides hidden refresh to the Ram located on board i.e. no wait states

There are two RS 232 compatible serial ports located on board: one is used to interface user programs with the required terminal; the other to interface to a printer or modem.

There are 16 I/O lines (plus 4 control lines) from a VIA, available at a cable connector for the user to interface with external hardware.

There are 8 I/O lines which can be used to connect a keyboard to the microprocessor. One is a control line (strobe), and 7 are from an I/O port.

There is a direct interface to a standard audio cassette unit so that programs may be stored and retrieved at a later date. The cassette interface runs at 300 baud for the basic monitor but the interface for the optional editor/ assembler saves at about twice the speed.

There is an optional 4 character ASCII display for programs requiring simple output facilities.

There is a completely buffered version of the main CPU bus available at a cable connector so the user may add any additional peripheral controllers (or memory) needed for a given application.

There is a built-in monitor and optional editor/assembler in ROM that can be used for program development.

The board requires +5, +12, -12 volts for operation.

**\$495** Kit **\$649** A&T  
THIS MONTH'S SPECIAL IN-  
CLUDES FULL 48K OF RAM.



If any items are out of stock  
we have a rapid order service  
to meet your needs.

QUANTITY  
DISCOUNTS  
AVAILABLE



319 COLLEGE STREET, TORONTO, ONTARIO, CANADA, M5T 1S2 (416) 921-5295  
ALL PRICES ARE IN CANADIAN FUNDS. 9% FEDERAL SALES TAX INCLUDED

# Exceltronix

Components & Computing Inc.

**YOU CAN'T BEAT THE BEST!**

**DON'T HESITATE TO CONTACT US ON OUR PRICE HOTLINE 921-4114 FOR THE MOST COMPETITIVE PRICES IN CANADA!**

**Rockwell Computer**  
AIM-65 \$635

Good stock of Aardvark software available at super prices

Ohio Scientific SUPERBOARD II with 8K of memory only \$439<sup>00</sup>  
RF Modulator kit only \$8.95 extra

## SPECIAL MEMORY SUPER SPECIALS

very good stock



- 4164-150ns \$11.95 (1 x 64K single (+5V) supply)
- 4116-150ns (1x16k) \$2.75
- 4116-200ns (1x16k) \$2.49
- 4116-300ns (1x16k) \$1.75
- 2114L-200ns low power \$2.89
- TMM 2016 (2k x 8 static RAM) \$13.50
- NOTE: 1 of these can do the job of 4 2114's but uses only one 24 pin socket
- 6116 (2k x8) \$14.55 (same as above but CMOS)
- 2102 CFPC \$1.57
- 5101 CMGS \$3.85
- 2708 EPROM (1k) \$3.95
- 2716 EPROM (2k) \$5.95
- 2732 EPROM (4k) \$11.50
- 2532 EPROM (4k) \$12.75
- 2764 EPROM \$53.00

**FOR QUANTITY PRICES CONTACT US FOR REALLY SUPER PRICES**

## EPSON PRINTERS

- 730-1 (PARALLEL) \$775.00
- 730-3 (SERIAL) 875.00
- 739-1 (PARALLEL) 895.00
- 739-3 (SERIAL) 939.00
- EPSON INTERFACE BOARDS
- TRS-80 \$ 69.00
- APPLE 89.00
- APPLE (MX-100/MX-82) 135.00
- SERIAL:RS-232-C 89.00
- SERIAL:2K BUFFER 185.00
- IEEE 79.00
- PET 95.00
- EPSON CABLES \$52.00
- TRS-80 43.00
- APPLE 39.00
- APPLE (MX-100/MX-82) 45.00
- SERIAL 39.00
- IEEE/PET 39.00

## SALE PRICE ON HAMEG

- HAMEG 307 SINGLE TRACE BANDWIDTH DC-15 MHZ (-6DB) IN 18 STEPS SENSITIVITY 5MV/CM-20V/CM IN 12 STEPS WITH BUILT IN COMPONENT TESTER \$495
- HAMEG 203 DUAL TRACE BANDWIDTH DC-30 MHZ(-6DB) IN 18 STEPS WITH X5 MAGNIFIER SENSITIVITY 5MV/CM-20V/CM IN 12 STEPS \$743
- HAMEG 412 DUAL TRACE BANDWIDTH DC-30 MHZ(-6DB) IN 18 STEPS WITH X5 MAGNIFIER STEPS WITH X5 MAGNIFIER SENSITIVITY 5MV/CM-20V/CM IN 12 STEPS WITH SWEEEP DELAY Z AXIS MODULATION AND MORE \$1149
- HAMEG 512 DUAL TRACE BANDWIDTH DC-65 MHZ(-6DB) IN 23 STEPS WITH X5 MAGNIFIER SENSITIVITY 5MV/CM-20V/CM IN 12 STEPS WITH VARIABLE DELAY LINE Z-AXIS MODULATION TRACE ROTATION AND MORE \$1795

**SD SYSTEMS**  
A LEADER IN THE MICRO-COMPUTER MARKET

**SALE CONTACT US FOR BEST PRICES ON SD SYSTEMS AND SSM PRODUCTS**

## SPECIAL

ZENITH MONITORS COMPLETE WITH HOUSING AND POWER SUPPLY READY-TO-USE WITH ANY COMPOSITE VIDEO SIGNAL 12" GREEN PHOSPHORUS SCREEN SWITCH SELECTABLE FOR 40 OR 80 CHARACTERS

**SALE PRICE \$179.00**

NEC 12" COLOUR MONITOR \$575

ASCII KEYBOARD With 105 KEYS (single 5V supply) \$99.00

ATTRACTIVE CASE \$15.95 EXTRA

**WE HAVE A SUPER STOCK OF TTL, LINEAR, CMOS & DISCRETE AT MOST COMPETITIVE PRICES.**

## CENTRONICS PRINTERS

- MX-80 — \$779
  - MX-80FT
  - MX-82
  - MX-82FT
  - MX-100
- PLEASE CALL PLEASE CALL FOR MOST COMPETITIVE PRICES

T.T.L.

74LS27	29	74LS95	51	74LS158	65	74LS242	99	74LS323	6.95
74LS30	21	74LS96	73	74LS160	85	74LS243	99	74LS324	3.95
74LS32	28	74LS107	49	74LS161	99	74LS244	99	74LS324	3.95
74LS37	34	74LS109	47	74LS162	130	74LS245	99	74LS348	3.29
74LS38	25	74LS112	45	74LS163	74	74LS247	1.49	74LS352	1.75
74LS42	51	74LS122	59	74LS164	89	74LS248	1.29	74LS353	2.09
74LS47	79	74LS123	95	74LS165	105	74LS249	1.35	74LS362	12.75
74LS48	115	74LS125	55	74LS166	255	74LS251	85	74LS365	85
74LS51	25	74LS126	55	74LS167	199	74LS253	85	74LS367	89
74LS51	25	74LS128	50	74LS170	199	74LS257	99	74LS368	88
74LS51	25	74LS132	175	74LS173	75	74LS258	59	74LS374	1.49
74LS51	25	74LS133	175	74LS174	75	74LS259	1.49	74LS374	1.79
74LS51	25	74LS136	84	74LS175	49	74LS260	1.39	74LS377	1.50
74LS51	25	74LS138	85	74LS181	255	74LS266	38	74LS378	1.25
74LS51	25	74LS139	85	74LS189	569	74LS273	38	74LS379	1.29
74LS51	25	74LS145	139	74LS190	89	74LS275	1.99	74LS390	1.25
74LS51	25	74LS148	237	74LS191	89	74LS279	59	74LS393	1.39
74LS51	25	74LS149	170	74LS192	80	74LS280	1.39	74LS395	1.49
74LS51	25	74LS151	54	74LS193	79	74LS283	1.39	74LS447	45
74LS51	25	74LS152	49	74LS194	82	74LS290	99	74LS447	45
74LS51	25	74LS156	225	74LS197	109	74LS293	49	74LS469	1.95
74LS51	25	74LS159	89	74LS221	109	74LS298	1.09	74LS470	1.95
74LS51	25	74LS161	119	74LS240	85	74LS299	3.35	74LS490	2.50
74LS51	25	74LS166	85	74LS241	85				

## MICROPROCESSORS

6500 FAMILY	6800 FAMILY	8080 FAMILY	Z80 FAMILY	
6502 CPU \$ 8.50	6800 CPU 6.50	8080A CPU 8.95	Z80A-CPU 4 MHz 9.50	
6504 CPU 8.69	6802 CPU 9.89	8085 CPU 8.95	Z80A-PIO 4 MHz 8.50	
6505 CPU 8.65	6808 CPU 9.75		Z80A-CTC 4 MHz 8.50	
6520 9.10	6809 CPU 20.95		Z80A-DMA 4 MHz 27.00	
6522 13.25	6810 3.15		Z80A-S10/1 4 MHz 33.50	
6532 13.95	6812 3.25		Z80A-S10/2 4 MHz 33.95	
6551 13.95	6816 19.00		Z80A-S10/9 4 MHz 18.75	
	6821 3.75		Z80A-DART 4 MHz 13.50	
	6845 6.89		Z80A-S10/1 4 MHz 9.50	
	6847 17.99		Z80A-S10/2 4 MHz 9.50	
	6850 18.22		Z80A-S10/9 4 MHz 2.50	
	6852 3.75		Z80A-DART 4 MHz 1.95	
	6855 6.89			

### PRICE POLICY

Remember that at Exceltronix, all prices are negotiable for quantity purchases. If you cannot afford large quantities on your own, how about starting a Co-op.

Send a certified cheque or money order (do not send cash). Minimum order is \$10 plus \$3 for shipping. Ontario residents must add 7% provincial sales tax. Visa and Mastercard accepted; send card No., signature, expiry date and name of bank.



319 COLLEGE STREET, TORONTO, ONTARIO, CANADA, M5T 1S2 (416) 921-5295  
ALL PRICES ARE IN CANADIAN FUNDS, 9% FEDERAL SALES TAX INCLUDED

**Electronics Today International**  
 Editorial and Advertising Offices  
 Unit 6, 25 Overlea Boulevard,  
 Toronto, Ontario, M4H 1B1  
 Telephone (416) 423-3262

**Publisher and Editor**  
 HALVOR W. MOORSHEAD

**Assistant Editor**  
 STEVE RIMMER

**Advertising Manager**  
 SENG HARRISON

**Advertising Services**  
 CAROLYN WYATT

**Subscription Department**  
 BEBE LALL  
 NADIA MARAR

**Accounts Department**  
 NANCY ALLEN

**Art Director**  
 TERRY FLETCHER

**Production**  
 CINDY BAKER  
 ANN RODRIGUES



**INTERNATIONAL EDITIONS**  
 Electronics Today International,  
 145 Charing Cross Road,  
 London WC2H 0EE, UK  
 Electronics Today International,  
 Ryrie House, 15 Boundary Street,  
 Rushcutters Bay, Sydney, Australia  
 Elrad  
 Kommanditgesellschaft, Bissendorfer  
 Strasse 8, 3000 Hannover 61, Germany  
 Electronica Top Internationaal  
 Postbus 93, Bilthoven, Holland

**ETI Magazine is Published by:**

Electronics Today International (Canada) Limited  
 Newsstand Distribution: Master Media, Oakville,  
 Ontario

**SUBSCRIPTIONS**  
 \$16.95 (one year), \$29.95 (two years). For US  
 add \$3/yr., other countries add \$5/yr. Please  
 specify if subscription is new or a renewal.

**BACK ISSUES AND PHOTOCOPIES**  
 Previous issues of ETI Canada are  
 available direct from our offices for  
 \$3.00 each; please specify by month, not by  
 feature you require. See order card  
 for issues available.

We can supply photocopies of any article  
 published in ETI Canada; the charge is  
 \$2.00 per article, regardless of length. Please  
 specify both issue and article.

**POSTAL INFORMATION**  
 Second Class Mail Registration No.3955.  
 Mailing address for subscription orders, undeliverable  
 copies and change  
 of address notice is:  
 Electronics Today International, Unit 6,  
 25 Overlea Blvd., Toronto,  
 Ontario, M4H 1B1.

**COPYRIGHT**  
 All material is subject to worldwide copyright protec-  
 tion. All PCB patterns are copyright and no company  
 can sell boards to our design without our permission.

**LIABILITY**  
 While every effort has been made to ensure that all  
 constructional projects referred to in this magazine  
 will operate as indicated efficiently and properly and  
 that all necessary components are available, no  
 responsibility whatsoever is accepted in respect of the  
 failure for any reason at all of the project to operate  
 efficiently or at all whether due to any fault in the  
 design or otherwise and no responsibility is accepted  
 for the failure to obtain component parts in respect of  
 any such project. Further no responsibility is accepted  
 in respect of any injury or damage caused by any fault  
 in design of any such project as aforesaid.

# Electronics Today

INTERNATIONAL

March 1982 Vol. 6, No.3

## Features

**Printers . . . . . 16**

Peripherals are the spice of computing, and a printer is usually the first peripheral one acquires. Robert Traub investigates what goes on beneath those calm high-impact plastic exteriors.

**Ni-Cads . . . . . 25**

Ever feel that civilization is rapidly coming to an end due to dead D cell inundation? You're not alone. Shane Dunne has often been concerned about this, and outlines a rechargeable salvation.

**ZX-81 Review . . . . . 35**

Hardly larger than a pocket calculator, the ZX-81 is a complete computer for under \$150.00. We have a peer at the tiny men that run around inside and make it work.

**Perfect Sound . . . . . 40**

Up in the rarefied atmosphere of ultra-sophisticated audio design, we find some fairly bizarre speaker designs. . . all in pursuit of the elusive perfect sound. (Like the Grateful Dead on a car radio.)

**Glouons . . . . . 41**

If, in fact, they exist, gluons are a very important aspect of atomic physics. Not quite so much if it turns out that they don't.

**CMOS Circuits . . . . . 45**

A trove of fabulous circuits to construct with this popular logic family. And that's a metric trove; larger than the old type.

**Into Linear IC's . . . . . 61**

The further adventures of Ian Sinclair as he prepares to do battle with the wicked 741 op amp, taming it into still more interesting circuits.



Printers, p.16



Ni-Cads, p.25

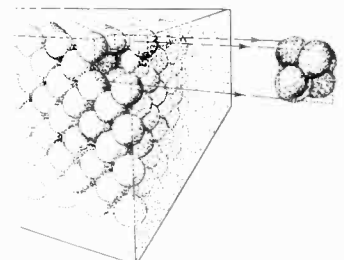

Glouons, p.41

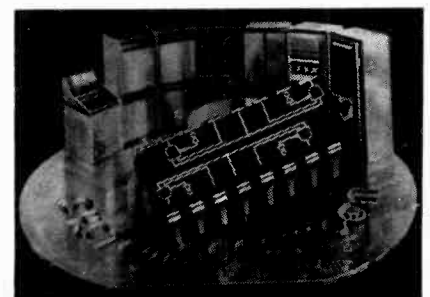

CMOS Circuits, p.45





Our Cover: If you put it next to an IBM 370 somebody would undoubtedly not notice it and step on it, but the ZX-81 is a powerful little computer in its own right. Just how powerful is explained on page 35.

ISSN 0703-8984

## Projects



### Music Processor . . . . . 10

The ultimate effect! It flanges, phases, double tracks, choruses and kills mice if you drop it on them.

### Crystal Marker . . . . . 19

If your short wave radio lacks absolute accuracy, or if a "compact" dial has situated Radio Moscow right beside TV channel 5, you need our simple marker to dig yourself out.

### Ni-Cad Charger . . . . . 31

No, charging your Ni-Cads on your Visa card will not keep them full of juice. You need our circuit for that. Build this simple project and, next time, there will be no batteries on your bill.

### Reaction Tester . . . . . 55

A novel way to test your reactions. Great for parties when it comes time to decide who's driving home (Not being able to find the button should result in immediate disqualification).

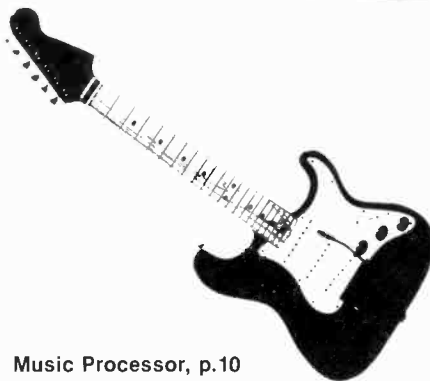

Music Processor, p.10

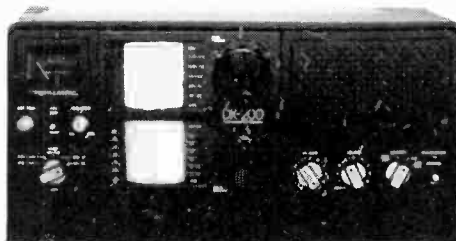

Crystal Marker, p.19

## Columns, News and Information

News . . . . .	6,9
ETI Books . . . . .	22
Next Month in ETI . . . . .	30
Reader Service Card . . . . .	44
Specials . . . . .	44
Back Issues . . . . .	51
Fun of Electronics . . . . .	52
Order Form . . . . .	53
Computing Today . . . . .	58
Classified . . . . .	68

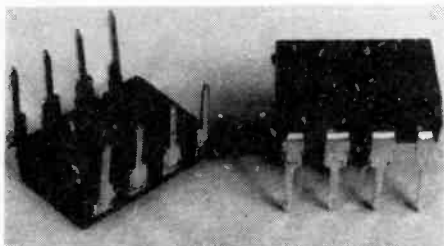

Into Linear IC's, p.61

## ADVERTISERS' INDEX

Aaron-Gavin . . . . .	42
Active Component Sales Corp . . . . .	43
Active Surplus Annex . . . . .	33
Arkon Electronics . . . . .	8
Atlas Electronics Limited . . . . .	67
Audiovision . . . . .	8
BCS Electronics . . . . .	39
Classified . . . . .	68
EduKit Ltd . . . . .	38
Electronic Packing Systems . . . . .	33
Epitek Electronics Ltd . . . . .	8
Exceltronix . . . . .	2,3
General Electronics . . . . .	8
Gladstone Electronics . . . . .	7
I Systems . . . . .	70
McGraw-Hill . . . . .	29
Metermaster . . . . .	65
Mode . . . . .	71
Nu West Video Systems Ltd . . . . .	33
Orion Electronic Supplies . . . . .	34
R-A-E Industrial Electronics Ltd . . . . .	33
H. Rogers Electronic Instruments . . . . .	34
Torch International Computers Ltd . . . . .	72

### Editorial Queries

Written queries can only be answered when accompanied by a self-addressed, stamped envelope. These must relate to recent articles and not involve the staff in any research. Mark such letters ETI-Query. We cannot answer telephone queries.

### Binders

Binders made especially for ETI are available for \$8.00 including postage and handling. Ontario residents please add provincial sales tax.

### Sell ETI and ETI Special Publications

ETI is available for resale by component stores. We can offer a good discount when the minimum order of 15 copies is placed. Readers having trouble in obtaining the magazine could ask their local electronics store to stock the magazine.

### Component Notation and Units

We normally specify components using an international standard. Many readers will be unfamiliar with this but it's simple, less likely to lead to error and will be widely used everywhere sooner or later. ETI has opted for sooner!

Firstly decimal points are dropped and substituted with the multiplier: thus 4.7uF is written 4u7. Capacitors also use the multiplier nano (one nanofarad is 100pF). Thus 0.1uF is 100nF, 5600pF is 5n6. Other examples are 5.6pF = 5p6 and 0.5pF = 0p5.

Resistors are treated similarly: 1.8Mohms is 1M8, 56kohms is the same, 4.7kohms is 4k7, 100ohms is 100R and 5.6ohms is 5R6.

### PCB Suppliers

ETI magazine does NOT supply PCBs or kits but we do issue manufacturing permits for companies to manufacture boards and kits to our designs. Contact the following companies when ordering boards.

Please note we do not keep track of what is available from who so please don't contact us for information on PCBs and kits. Similarly do not ask PCB suppliers for help with projects.

K.S.K. Associates, P.O. Box 54, Morriston, Ont. N0B 2C0.

B&R Electronics, P.O. Box 6326F, Hamilton, Ont., L9C 6L9.

Wentworth Electronics, R.R.No.1, Waterdown, Ont., L0R 2H0.

Danocinths Inc., P.O. Box 261, Westland MI 48185, USA.

Arkon Electronics Ltd., 409 Queen Street W., Toronto, Ont., M5V 2A5.

A-1 Electronics, 5062 Dundas Street W., Islington, Ont., M9A 1B9.

Beyer & Martin Electronic Ltd., 2 Jodi Ave., Unit C, Downsview, Ontario M3N 1H1.

Spectrum Electronics, Box 4166, Stn 'D', Hamilton, Ontario L8V 4L5.

Dacor Limited, P.O. Box 683, Station Q, Toronto, M4T 2N5.

# News

## Microsoft Announces Multiplan

An interactive computer program for use as a tool for any kind of numeric planning and modeling has been developed by Microsoft, Inc. of Bellevue, Washington.

Named Multiplan, it has applications in financial analysis, home budgeting, marketing evaluations, sales projections, record-keeping-any planning, modeling or numeric application. Multiplan is used interactively, presenting menus, "next action" messages, as well as a Help command. Programming or computer skills are not required.

"Anyone who has used a calculator can use Multiplan," Microsoft President Bill Gates says. "It is highly user-friendly. It is a solution-oriented, decision-support tool rather than a programming tool."

Multiplan provides a grid of cells, called a "worksheet," for holding the information that the user supplies. After figures and formulas are entered, they can be modified or rearranged. Multiplan preserves the relationships on the worksheet and recalculates totals and formulas on command, or automatically, as changes are made.

Multiplan is usable under a variety of hardware systems, and is effective in different environments for different applications. It also has extracapability features such as multiple windows (as many as eight open at a time), easy entry of commands and data, Help command, and cell formatting. Another unique feature is the ability to assign descriptive names to parts of a worksheet for use in formulas, commands, and linking of worksheets via off-sheet references.

Computer systems that run Multiplan will soon be available from major manufacturers. Microsoft has already licensed Multiplan to the following OEM customers: Zenith, Texas Instruments, Fortune Systems, Zerox, Dataview, The Santa Cruz Operation, and Interactive Data Corporation.

For more information about Multiplan, contact Microsoft, 10800 N.E. 8th St., Suite 819, Bellevue, WA 98004, telephone (206) 455-8080.

## Canadian Government Support for Microelectronics

Throughout the western world there is criticism of governments not understanding the true impact of the latest generation of microelectronics hardware. In the case of our own government this isn't really fair and the new Microelectronics Support Program (MSP) shows how serious Ottawa is being.

Grants are available to all manufacturers who have not previously incorporated microelectronic devices in their products or operation or to manufacturers with experience who are considering custom microelectronic devices. Grants up to \$10,000 are available towards the cost of retaining the services of a consultant to study the feasibility of incorporating microelectronic devices. Additionally up to 75% of eligible cost for approved projects to a maximum of \$100,000 are available.

Obviously there are conditions which companies have to meet but it does show that the Government is serious. For more information contact: Microelectronics and Instrumentation Division, Electrical and Electronics Branch (45), Dept of Industry, Trade and Commerce, 235 Queen Street, Ottawa, Ontario K1A 0H5. (613) 593-4481.

## Mic Pre-amp

The Marble Sound Company, a division of Epitek Electronics Ltd., Kanata, Ontario, reports the availability of its MIC-D15-D Stereo Microphone Preamplifier and MAG-D15-D Stereo Magnetic Cartridge Preamplifier for professional or home audio use. Both devices are low-noise, low-distortion audio preamplifiers featuring high quality and reliable thick-film hybrid construction. Delivery is stock to 4 weeks.

Other features of the MIC-D15-D and MAG-D15-D include a ground plane, power supply by-passing, an RF filter to reduce noise pick-up, complete short circuit protection and separate ground pins to help eliminate ground-loop difficulties. Standard pin spacing, simple connections, and compact size combine to make the preamplifiers suitable for professional or hobbyist use. As well, their modular construction makes them ideal for separate use or with other Marble Sound products.

For more information, contact Epitek Electronics LTD., 100 Schneider Road, Kanata, Ontario. K2K 1Y2.

WHADDY'A MEAN ~ "TIME FOR A COMMERCIAL BREAK?!"



WITH APOLOGIES TO CHESTER GOULD

## Wrist-Watch TV

The wrist-watch TV screen or information terminal is on the way. The London-based Standard Telephone and Cable company (STC) has revealed that it has already demonstrated that such a concept was possible with a display unit that is just 36 millimetres square and only a few millimetres thick.

STC says the tiny device, developed at the Standard Telephone Laboratories in Harlow near London, is a major step towards the on-the-wrist TV screen. It is expected to lead to what the company describes as "probably the ultimate in display compactness and miniaturisation."

The sub-miniature visual display unit or VDU was first shown at the recent New York international symposium of the Society for Information Display. STC's work in this field is backed by British Telecom and the UK Ministry of Defence because of its potential use in many types of pocket-sized equipment as well as telecommunications and aircraft instrumentation.

The unit has a liquid crystal display instead of the more conventional cathode ray tube. But unlike the liquid crystal display used on most digital watches, the normal seven segments used for each numeral in a watch are replaced by 1,600 picture elements.

Built in as the back of the display is a large area silicon chip which can provide all the electronic drive circuits needed for a display of such complexity.

Dyes are used to give the device a range of colours and it is the first liquid crystal display of its kind to have a large-area integrated circuit incorporated into its structure.

Now that the 1,600 picture elements version has shown that the concept works, scientists at the Standard Telephone Laboratories are working on a display that will have 57,600 picture elements on a screen 69 mm square to give good clarity.

STC says such displays need only very low electrical power but are able to display, for example, a full page of text together with diagrams and graphics.



# GLADSTONE-ELECTRONICS

## SINCLAIR ZX81 Personal Computer Kit



**\$149.95**

**SPECIAL COMBINATION OFFER**  
**ZX81 KIT + 16K RAM**  
**\$299.95**  
 (POWER SUPPLY OPTIONAL)

Sinclair's new 8K Extended Basic offers features found only on computers costing three or four times as much. \*Continuous display, including moving graphics. \*Multi-dimensional string and numerical arrays. \*Math and scientific functions accurate to 8 decimals. \*Unique one touch entry of "key words" (i.e. basic and system commands). \*Automatic syntax error detection. \*Randomize function. \*Built-in interface for ZX Printer. \*Connects to standard TV and cassette recorder. \*164 page manual included. \*Power supply (9V at 650 ma) optional for \$19.95. \*1K of memory is included. \*Easy-to-build.

16K Memory Expansion **\$169.95**  
 NEW! 64K Memory Expansion **COMING SOON**

## ACORN ATOM COMPUTER

Circle No. 15 on Reader Service Card.

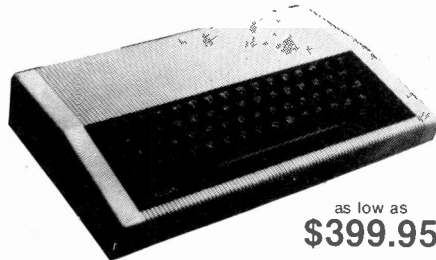

as low as **\$399.95**

A powerful 6502-based full-facility computer that will connect to standard TV or monitor. \*Full sized QWERTY keyboard with rugged injection molded case. \*High resolution graphics (256 x 192) \*Optional colour board \*Programmable in Basic and Assembler \*Built in cassette interface \*RAM expandable on board from 2K to 12K, up to 40K external memory. \*ROM expandable from 8K to 16K (two 4K additions). \*Comprehensive manual included \*32 bit arithmetic. \*Optional "Word Pack" plug-in ROM gives advanced word processing and text editing capabilities.

BASIC ATOM; 2K RAM & 8K ROM **\$399.95**  
 EXPANDED ATOM; 12K RAM & 12K ROM Colour **\$525.00**  
 Power Supply (nominal 8V/2A) **35.00**  
 Write for free ACORN/SINCLAIR Users Group Magazine.

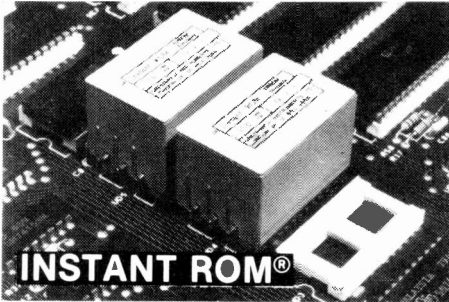

### INSTANT ROM®

(for PET and other microcomputers)

INSTANT ROM is 2K or 4K of CMOS memory with battery back-up. Just plug it into the socket provided on your PET. Then write your program into it as if it were RAM. Or load programs into INSTANT ROM from tape, disc, or some other part of memory. Then remove the Write Enable lead, and your program is there, permanently.

#### HOW YOU USE IT

You need access to the Write Enable signal in your microcomputer. This is easy in the PET — we provide the lead, adaptor, and instructions. There is no soldering or hardware modification. You only need to know how to lift the lid.

#### OTHER MICROCOMPUTERS

We're working on adaptors for other microcomputers, and we can probably advise you. But any microcomputer owner with sockets for 2516/2532 or 2716/2732 EPROMs can consider using INSTANT ROM. **3-year guarantee**

#### SPECIFICATION

All types are only suitable for +5V single-rail systems.  
**GR2516**—2kBytes, located in the lower half of the 4k slot. 2516 pin-out, suitable for PET/AIM. **\$109.00**  
**GR253**—4kBytes, occupies the entire 4k slot. 2532 pinout, suitable for PET/AIM. **\$157.00**  
**GR2716**—2kBytes, located in the lower half of the 4k slot. 2716 pin-out, in very wide use. **\$109.00**  
**GR2732**—4kBytes, occupies the entire 4k slot. 2732 pinout, in very wide use. **\$157.00**

Circle No. 14 on Reader Service Card.

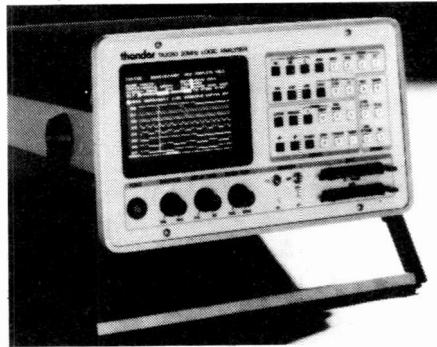

### THANDAR TA2080 20 MHz 8 channel Portable Logic Analyzer

Offers comprehensive triggering, recording, and display capabilities at an affordable price. The TA2080 is controlled by a Z80 microprocessor linked to an interactive keyboard. Full system status is shown at all times in the top lines of a 5-inch CRT and simplicity of operation is achieved by display prompting.

Recording memory depth is 252 bytes and a 252 byte reference memory is provided which can be loaded directly from the recording memory or from keyboard. Extensive triggering capabilities include 23 bit trigger recognition facility, powerful compound trigger delay by trigger event and/or clocks, a selectable trigger position, variable trigger filter, and an input arm.

Price: under **\$7000**. Please contact us for a brochure.

Circle No. 12 on Reader Service Card.

**CENTRONICS 739 PRINTER**. New low price, only **\$875.00!** (Was \$1195.00) Features 3 print formats, graphics, uses computer roll or standard paper. Printer interface & Cable for Atom ..... **\$59.95**

## thandar Electronic Test & Measurement

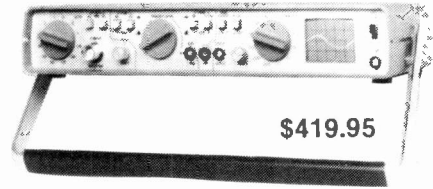

**\$419.95**

### SC110 SINGLE TRACE LOW POWER 2" OSCILLOSCOPE

Bandwidth	DC to 10MHz
Sensitivity	10mV/division to 50V/division
Sweep Speeds	0.1µsecs/division to 0.5 secs/division
Power Requirements	4 to 10V DC from 4' C' cells or AC adaptor
Size	255 x 150 x 40mm
Weight	800gms excluding batteries

Accessory probes for SC110 Oscilloscope  
 x1 Probe **\$27.95** x10 Probe **\$29.95**  
 Special Package SC110 Scope, x1 probe, x10 probe, AC adaptor, carrying case **Save \$15.00! Complete for \$512.00**

THANDAR's Amazing SC110 is less than 2 inches OSCILLOSCOPE thick and weighs under 2 pounds, yet has the performance of a standard bench scope. Has full trigger facilities including Bright Line and Auto with TV Line and Frame filtering. The SC110 can operate for very long periods of time on low cost disposable cells as well as on rechargeables (has built-in recharger).

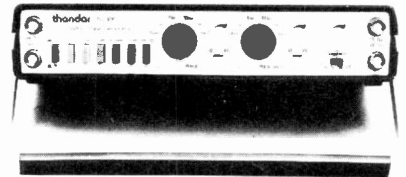

### PULSE GENERATOR

<b>TG105 5MHz PULSE GENERATOR \$249.95</b>	
Period:	200nsec to 200ms (5MHz to 5Hz)
Pulse Width:	100nsec to 100ms, independent of period
Operating Modes:	Run, Triggered, Gated, One Shot, Square Wave and Complement
Outputs:	0.1V to 10V variable 50Ω output; Separate TTL output; Sync. output
Power Requirements:	120V or 240V AC (nominal) 50/60Hz
Size:	255 x 150 x 50mm
Weight:	1200gms

### Thandar Brings Low Cost to Temperature Measurement!

The TH301 is a hand-held LCD digital thermometer designed to accept any standard type K (NiCr-NiAl) sensor and offering measurement range of -50 C to 750 C with 1 degree resolution. Accuracy better than 0.5%. 1000 hours battery life from 9V alkaline battery. Price: **\$199.00.**

### OTHER THANDAR INSTRUMENTS

<b>Digital Multimeters (3½ digit)</b>	
TM354 Hand held, 2Mohm, DC 2A	<b>\$109.00</b>
TM351 Bench, 20Mohm, DC 10A	<b>279.00</b>
TM353 Bench, 20Mohm, DC 2A	<b>239.00</b>
<b>Frequency Counters (8 digits)</b>	
PFM200 Hand held 200 MHz	<b>\$150.00</b>
TF040 Bench LCD, 40 MHz 40mV	<b>349.00</b>
TF200 Bench LCD, 200MHz 10-30mV	<b>449.00</b>
TP600 600 MHz Prescaler	<b>110.00</b>
<b>Generators</b>	
TG100 Function, 100 Hz - 100 KHz. Sine/SQ/Triangle/TTL	<b>255.00</b>

Circle No. 9 on Reader Service Card.

1736 Avenue Rd., Toronto, Ont., M5M 3Y7  
 Telephone (416) 787-1448 Telex 986782

# GLADSTONE-ELECTRONICS

Send \$1.00 for catalogue.

Personal orders with VISA, Mastercard, American Express welcomed. Prices shown are federal tax included, provincial extra if applicable.

# MARBLE SOUND

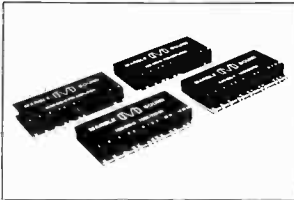

Professional quality audio modules are now available from Marble Sound, a division of Epitek Electronics. Reliable thick-film construction, modular design and computer-controlled testing assure you of an audio system to be proud of.

#### FEATURING MODELS:

- MAG-D15-D Stereo Phono Preamp
- MIC-D15-D Stereo Microphone Preamp
- TON-D15-S Tone Control/Filter Module
- XVR-D15-S Active Crossover
- MS-2 Interconnect Mother Board

#### COMING SOON:

- P20-D20-S 20 Watt Power Amplifier
- P40-D30-S 40 Watt Power Amplifier

"Distributor Inquiries Invited"

Write for data or telephone  
(613) 592-3270



## MARBLE SOUND

814 Proctor Avenue  
Ogdensburg, N.Y.  
13669-2293

In Canada  
100 Schneider Road,  
Kanata, Ont. K2K 1Y2

Circle No. 20 on Reader Service Card.

8—MARCH 1982—ETI

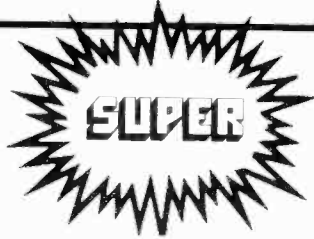

### 150W MOSFET POWER AMP

- 1% Matched Pair HITACHI MOSFET.
- 1% Metal Film Resistors.
- High Quality WIMA Capacitors.
- Gold Plated P.C. Board.
- THD at 150W into 8 Ohm Less Than 0.0015% at 1Khz.
- Freq. Response from 1Hz - 100Khz.
- Operates on  $\pm 45$  to 55 V D.C.

Kit \$119.50 each      \$199.50/2

HITACHI MOSFET 2SK134, 2SJ49  
\$14.95 each - 2 or more \$12.95 each

Send cheque, money order plus 5% for postage and handling. (no charge for orders over \$100.00). Ontario residents add 7% P.S.T. Visa and Master Card accepted. Send card No., expiry date and signature to:

**AUDIOVISION**  
578 Marlee Ave,  
(Just one block West of Glencairn Sub-  
way)  
Toronto, Ont. M6B 3J5  
Tel: (416) 781-3263

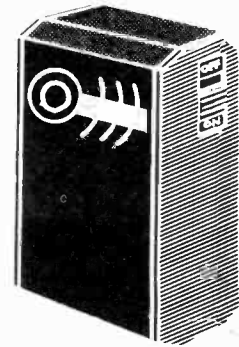

## MINI FM MIC

This compact (3/4" x 1" x 2") super FM wireless Mic kit outperforms many other expensive units available. Transmits a stable, exceptional quality audio signal up to 300 yards. Receive on any FM radio. Complete easy-to-build kit includes case, battery and all parts with illustrated instr. manual.

## KIT—\$26.95

Ontario residents add 7% P.S.T.  
Please add \$3.00 for postage & handling.

 **general  
electronics**

general electronics company • 5511 yonge street  
• willowdale • ontario • M2N 5S3

Circle No. 10 on Reader Service Card.

## Computer / TV Interface Unit's

### Sup'R' Mod II

Sup'R' Mod II is a wideband colour and black & white compatible interface system designed to allow your Apple II, TRS-80 (or other video source) to connect to your home television, eliminating the need for an expensive video monitor. It is pretuned to UHF channel 33 and comes complete with cable and antenna transformer. The unit ensures safe isolation with high performance.

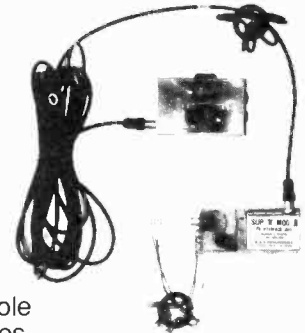

**\$44<sup>95</sup>**

Also available:

Sup'R' Mod III — Apple III compatible \$49.94

Arkon Colour Modulator — Colour Modulator kit (CH-2) \$19.95

Arkon B&W Modulator — Low cost B&W Modulator kit (CH-2,3) \$7.95

**DISCOVER OUR WORLD OF ELECTRONIC... 1**

To order send certified cheque, money order, VISA, MasterCard, American Express...include expiry date, card number and signature. We process prepaid orders only. Add \$2.50 for shipping and handling charges. Ontario residents add 7% sales tax.

409 Queen Street West, Toronto, Ontario, Canada  
M5V 2A5. Tel. (416) 868-1315.

**arkon  
electronics ltd**



## Spacephone

Low-cost voice and data telecommunications services to remote areas will become available when AEL Microtel Limited completes a satellite communications system now being developed.

Called *Spacephone*, the system will link subscriber equipment by using Telesat's Anik C-1 satellite which is scheduled to be launched next year.

"It is one of the biggest single research and development projects we have ever undertaken," said Ray Herron, president of the British Columbia-based telecommunications manufacturer. "We are developing a thin route 14/12 GHz Single Channel Per Carrier/Demand Assignment Multiple Access (SCPC/DAMA) satellite communications system integrated with the switched voice and data networks. Our parent company B.C. Tel, our research and development subsidiary Microtel Pacific Research, and four of our factories — those located in Burnaby, Brockville, Saskatoon and Winnipeg — are all involved."

"Our initial thrust is to provide improved telecommunications, voice and data, for the remote resource industries of Western Canada. The earth terminals developed in this program will be readily adaptable for providing communications into small remote villages, and also for providing roof-top terminals in urban areas for private business networks. The export opportunities for hardware developed in this project are considered to be excellent," he said. "In fact, indications are that the potential global market for thin route earth stations is at least ten times greater than that believed to exist in Canada."

"The merging technologies of switching and transmission are being applied on this project, including state-of-the-art technologies such as Very Large Scale Integrated circuitry being developed by Microtel Pacific Research, as well as Gallium Arsenide Monolithic Microwave Integrated circuits."

"We are developing a total system, not just individual terminals, so that all the benefits of modern telecommunications can be offered to the public in remote areas at the lowest possible cost. It will be a subscriber system which will provide a foreign exchange service. This means, for example, that a telecommunications subscriber, say in a remote logging camp of British Columbia, could have a Vancouver number, receive a Vancouver dial-tone when he or she picks

up the phone, and have all the services that are available in urban areas," Herron explained. "It will be fully automatic, not an operator-intercept system. TVRO's (television receive only terminals) could become a part of this; so could radio program distribution."

"There are no standards to follow — it hasn't been done on this scale before, the development of a system to provide remote areas with telecommunications as up-to-date as any found elsewhere at the lowest possible cost. That will mean service where none exists — it will be transportable and a station could be installed in one day — and improved services in areas currently served only by VHF radio, giving privacy and business security, for example, since encryption is part of the project."

"Our system concepts have been tied down. In First Quarter, next year, a prototype 'Spacephone' system will be tested using a 14/12 GHz transponder on Anik B. A terminal prototype system will be ready for field testing by early 1983, using Anik C-1."

The Microtel project was given an injection of enthusiasm as a result of the successful testing of the Canadian-developed "arm" during the test flight of space shuttle Columbia earlier this month. The "arm" is an \$80-million mechanical crane developed by the Canadian government's National Research Council together with Spar Aerospace Ltd. of Toronto. Called a Remote Manipulator Arm, or Canadarm, it will enable space shuttles to deploy and maintain satellites. Telesat's Anik C-1 is scheduled to be the first payload for space shuttle Columbia in September, 1982.

## High-Speed Buffer/Voltage Follower

Precision Monolithics, Inc. announces the BUF-02, one of the industry's first high-speed BIFET buffers specifying Maximum Output Error. The maximum output error includes offset voltage, input bias current, finite gain, common-mode-rejection and output-impedance induced errors.

With previously available voltage followers, users were left to perform a worst-case output error analysis. This task is unnecessary with the BUF-02 since each BUF-02 undergoes a 100% test that verifies the 1.5 mV maximum output-error specification.

The BUF-02 is pin compatible with the LM110 type voltage follower in unnullled applications. A worst-case output-error analysis indicates the LM110's output error may reach 17 mV. The BUF-02's 1.5 mV maximum error specification is a tenfold performance improvement.

The BUF-02 features a 0.03x typical output impedance; a 0.015% maximum voltage gain error; a 100dB typical power-supply-rejection ratio; a 1.5 mV maximum output error; a 0.2 nA maximum input bias current; a 12 V/usec minimum slew rate; and a 1.0mV maximum offset voltage specification.

The FET input BUF-02 design incorporates a patented bias-current cancellation circuit. With this circuit, the input bias current doubles with every 18° to 20°C increase in temperature, while input bias current would double every 10° without the cancellation circuit.

Four electrical grades are available. The BUF-02 A and B electrical grades have an operating temperature of -25°C to +125°C and are available with MIL-STD-883 Class B processing. The E and F grade parts have an operating temperature range of 0°C to +70°C.

For more information, contact PMI 1500 Space Park Drive, Santa Clara, CA 95050, telephone 408-727-9222.

## New Electronics Store for Kingston

Readers in the Kingston, Ontario area now have a new electronics store to serve their needs: Attair Electronics at 660 Progress Avenue (613) 384-3876. Dick Shaw the proprietor was until recently a manager with a very large Montreal-based electronics distributor and thus has considerable experience in the field. In addition to electronic parts, Altair will handling microcomputer boards and software specialising in Ohio Scientific; they are also carrying ETI Magazine and Specials.

## ATOM Owners . . . Hark!

If you purchased an Acorn ATOM computer, you may have noticed that the tape operating system has a few . . . er, hassles. It's actually not a bad system at all, it's just that it has peculiar taste in the cassette decks it likes to associate with. If you do the setting up test as specified in the manual, producing a tape of X's, and cannot get them to print on the screen completely error free, the problem is likely in the way the ATOM processes the played back signal. What it likes to see is a very rounded off string of square waves. This can usually be provided if your cassette deck has a tone control; just turn it almost all the way down. If it doesn't (you bought the \$17.95 special, didn't you), you can add a low pass filter in the lead of the cassette interface cable that goes to the earphone jack. Install a resistor of about 1K in series with the centre conductor (presumably at the mini phone plug), and hang a capacitor of about .22 uF from the side of the resistor pointing at the computer to ground. This simple addition can do wholly astounding things for the performance of the ATOM tape system.

## Stores Directory Additions.

### QUEBEC

Montreal  
CORONET ELECTRONICS  
649A Notre Dame W., Montreal, QUE., H3C 1H8.  
EC, CA, RTV, TG, EK, MO, CAT \$1.00  
We carry, Texas Instrument, Fairchild, R.C.A., Nat., Exar, Armaco, Daveco, and much more.

### ONTARIO

Toronto  
AUDIOVISION  
578 Marlee Ave., Toronto, Ont., Canada. M6B 3J6.  
Tel. (416) 781-3262  
EC, RTV, TG, EK, MO, CAT.  
Direct import and sale of audio/electronic kits, parts and cabinets. Serving: electronic hobbyists, technicians, engineers, schools, industries and disc jockies.  
Volume parts and kits can be supplied at competitive prices.

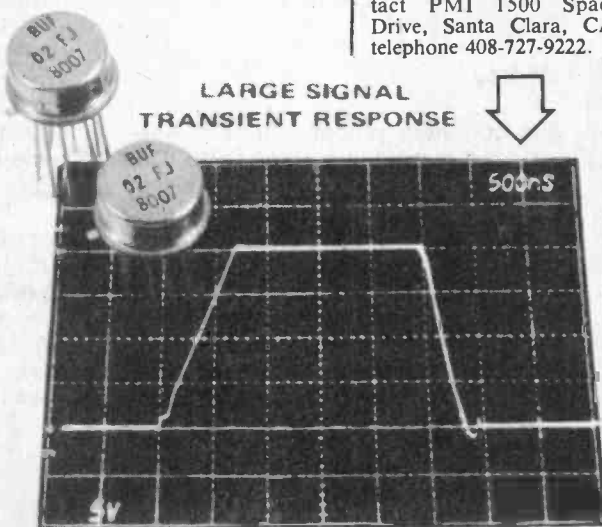

# MUSIC PROCESSOR

Tired of spending endless weeks out on the range trying to lasso all those effects pedals? Build the ETI music processor and corral them all into one box.

THE ETI Music Processor is designed to add any of four switch-selected effects to any musical or audio signal, these effects being double-tracking (mini-echo), auto-double-tracking or ADT (mini-chorus effect), phasing and flanging. None of these effects can be claimed as unique; it is, however, pretty rare to be able to get all four effects from a single unit. The unique feature of our processor, however, is the way in which its scanning circuit works.

In conventional ADT, phasing and flanging units a low-frequency oscillator is used to scan the selected effect up and down the audio band, and in all the commercial units that we've seen this oscillator simply free-runs so that, for example, a phaser unit phases continuously and thus eventually tends to produce a rather tedious musical effect. Our unit is different, because the scan oscillator can be operated in one of three basic modes — manual scan, one-shot scan, or free-run scan. In the first two of these modes the scanning can be initiated by either a push-button or a foot switch, and in each of the three modes a range of four different scan speeds is available.

## A Passing Phase

Because of the unusual scanning generator used in our unit the processor produces the kinds of operating effects that all musicians dream of. Suppose, for example, that you are using the unit as a phaser in the one-shot scanning mode; in this case your musical instrument will normally play straight through the unit with no special effects being added. As soon as you want to add the phasing effect to a musical passage you simply press the scan button or the foot switch once, at which point



If you liked this project, please circle Reader Service Card number 59. If you didn't, circle number 60.

the unit will noiselessly switch over (using built-in electronic switches) to the phasing mode until one complete phase-down/phase-up scan cycle is complete, and then revert to the straight-through mode.

A similar effect is obtained in the manual scan mode, except that the unit scans down only while the scan button or foot switch is held closed and scans back up again as soon as the button/foot switch is released. A red LED illuminates if the unit reaches a self-imposed limit in the scan-down mode, and a green LED illuminates when the scanner reaches its upper limit and returns to the straight-through or normal mode of operation.

Similar kinds of action occur when the processor is used in the ADT and flanging modes, with special effects being imposed on the music only when the scanning action is initiated by the press button or foot switch. When the scanner is used in the free-running mode, of course, the special effects are imposed continuously, as in a conventional unit, and when the unit is used in the simple double-tracking (echo) mode the scan generator is switched out of circuit and the echo is permanently present.

## MP Use

The complete processor unit is line-powered, contains a total of 10 ICs, and is easy to use: the music signal (with a nominal peak-to-peak amplitude of at least a few hundred millivolts) is simply connected to the unit's input, and the output of the unit is then taken to a suitable power amplifier. The desired musical effects and scan speed and mode are then selected by panel-mounted switches and the input level is adjusted by RV1

so that straight-through operation is obtained with minimal distortion. When the unit is used in the double-tracking and ADT modes, the echo depth can be varied with RV2: when the unit is used in the flanging mode, the flanging level or depth is varied with RV3.

The complete unit can, if desired, be used to add the specified effects to virtually any audio signal source. The unit does, however, generate a small amount of RFI, and if it is to be used with a radio or tuner-derived audio signal it may be necessary to fit the unit into a well screened metal case, to avoid interference; the unit is provided with a simple RF input filter (activated by a slide switch) that is intended for use with radio-derived input signals.

## Construction

There should be no problems in the construction of this project provided you follow the overlay carefully, paying particular attention to the orientation of the electrolytic capacitors and semiconductor devices. All components are mounted on a single PCB except for R24 and C7, which are hardwired between SK1 and SW3.

Start construction by assembling the power supply components. When this section is built, connect a voltmeter across the output and check you get a reading of 15V. The remainder of the circuit can now be built.

The Music Processor project is not particularly difficult to build: the circuit does, however, incorporate a couple of preset pots and access to scope and an audio generator is desirable when adjusting one of these components, so that optimum phasing effects can be obtained.

To adjust PR1, connect a DC



voltmeter between PR1 slider and the +15V rail and then adjust PR1 for a reading of precisely 5V. To adjust PR2, switch the unit to the double-tracking mode, set RV2 (echo depth) to mid value, and apply a 1 kHz (nominal) sine wave signal of about 1V peak-to-peak to the unit's input. Use a scope to monitor the two signals on the inputs of R46 and R47 and then adjust PR2 until the magnitudes are equal.

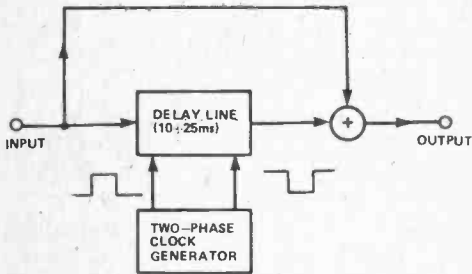

Fig. 1 Block diagram of the double-tracking or echo circuit.

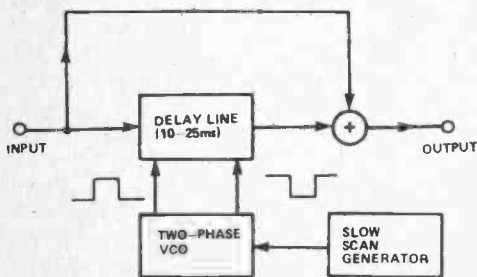

Fig. 2 block diagram of the auto-double-tracking or mini-chorus circuit.

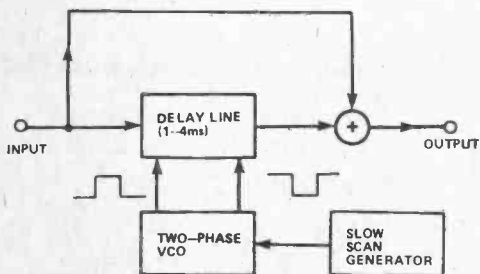

Fig. 3 With a shorter delay time the Fig. 2 circuit becomes a phaser.

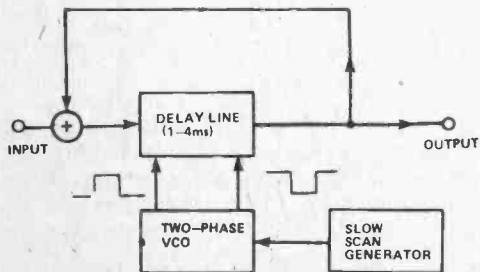
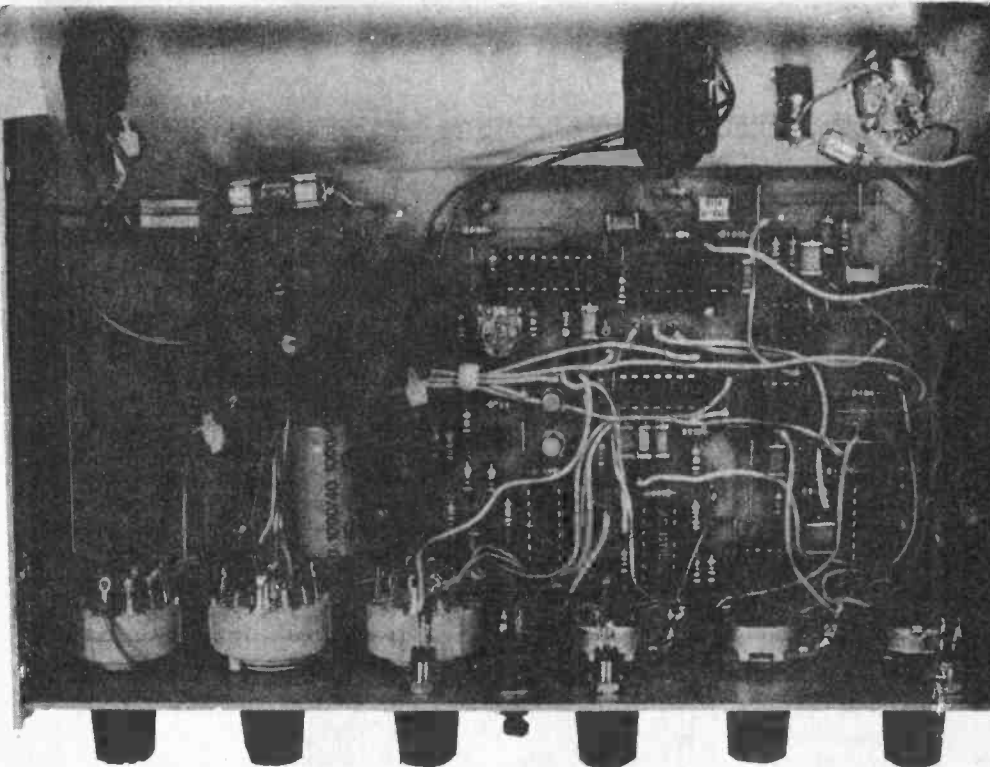

Fig. 4 This configuration of the circuit elements causes flanging.



Inside the Music Processor. It may look as if we had an accident with a plate of spaghetti, but you shouldn't have any pro-

blems if you follow the overlay methodically.

### HOW IT WORKS

The ETI Music Processor uses a number of basic circuit elements, such as a CCD delay line, a VCO, a couple of audio mixers and low pass filters and a special slow scan generator to implement the effects that are available from the unit. In each of the four basic operating modes of the unit (double-tracking, ADT, phasing and flanging), these elements are configured by electronic switches to give the desired mode of circuit operation. Figs. 1 to 4 show the four basic configurations of the unit.

Thus, in the basic double-tracking mode (Fig. 1) the delay line is clocked by a fixed-frequency two-phase generator to give an overall delay in the range 10-25 ms. The audio input signal splits two ways as it enters the unit, one path going directly to one input of an audio mixer and the other going to the remaining mixer input via the delay line. Consequently, the output of the mixer consists of two identical audio signals that are time-displaced by a fixed amount, thus giving a simple echo or double-tracking effect.

The ADT (automatic double-tracking) circuit of Fig. 2 differs from that of Fig. 1 in that the fixed-frequency two-phase clock generator is replaced by a two-phase VCO (voltage controlled oscillator) that can have its frequency (and thus the delay time of the line) varied using a slow scan generator. The ear perceives the audio output signals of this circuit as two distinct signals with a variable time-displacement, this being the so-called 'chorus' effect.

The phasing circuit of Fig. 3 differs from the ADT circuit only in that the VCO frequency is speeded up to give line time-delays in the range 1-4 ms. The effects of this time-delay reduction are quite dramatic; the ear no longer perceives the unit's output as two distinct signals. As the direct and delayed signals are added together in the audio mixer, those signal components that arrive in anti-phase tend to self-cancel, introducing a series of notches throughout the audio frequency band (i.e., a comb filter). With 1 ms delay the notches are spaced 1 kHz apart, and with 4 ms delay they are spaced 250 Hz apart. These phase-induced notches are relatively shallow (about 20 dB deep), but introduce a pleasing acoustic effect as they are swept up and down through music signals by the slow scan generator.

The flanging circuit of Fig. 4 differs from the phasing circuit in that the audio mixer is placed ahead of the delay line, and part of the delayed signal is fed directly back to one input of the mixer. The consequence of this configuration is that in-phase signal components arriving at the mixer tend to add together regeneratively, introducing a series of comb-like peaks in the audio frequency response. The amplitude of these peaks depends on the degree of feedback and can be made very steep. These phase-induced peaks introduce very powerful acoustic effects as they are swept up and down through a music signal via the slow scan generator.

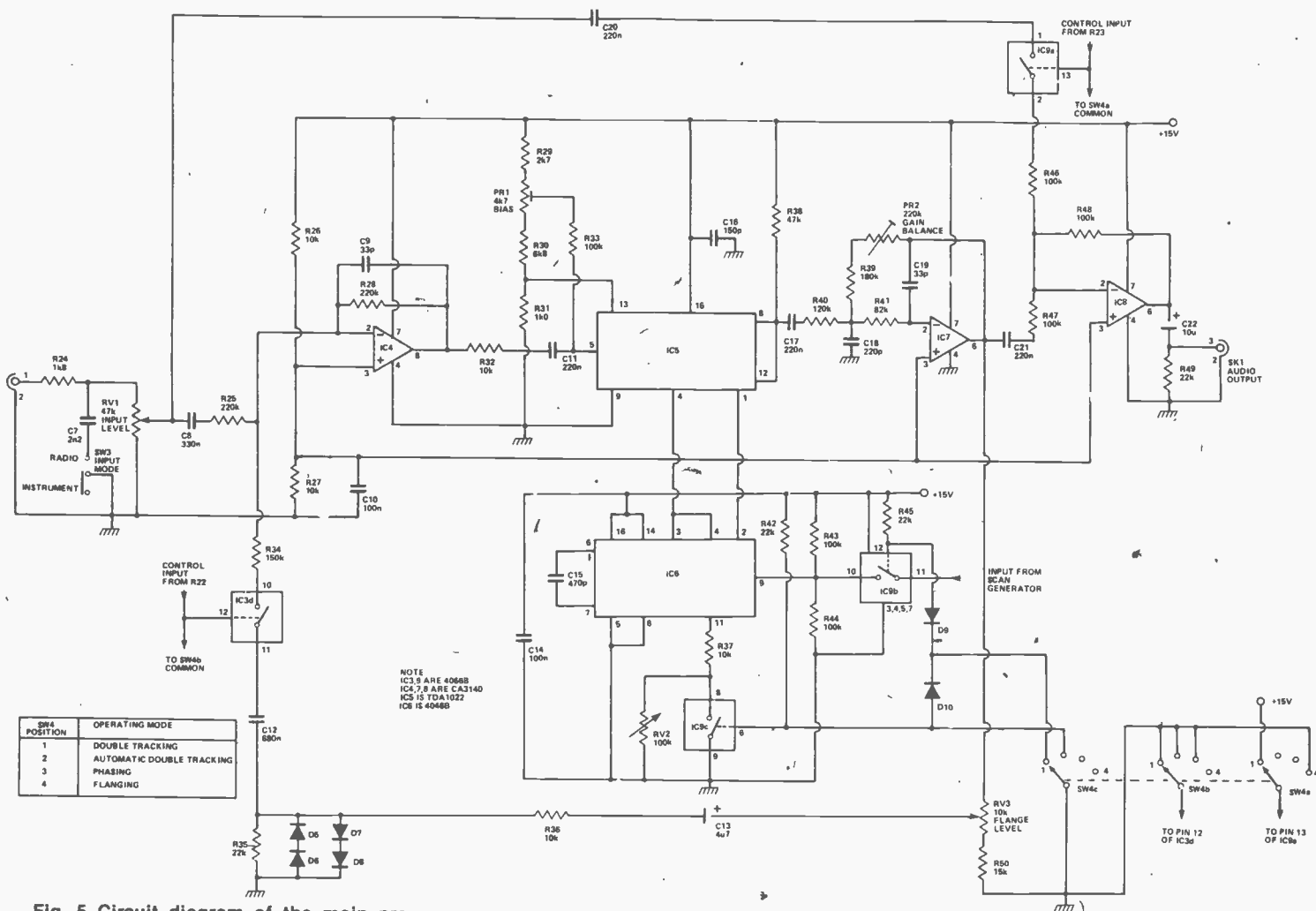

Fig. 5 Circuit diagram of the main processing circuit.

HOW IT WORKS

The main circuit of the unit contains all of the elements described above, except for the slow scan generator. Here, IC5 is the CCD delay line, IC6 is the VCO or clock generator, IC4 and IC8 are two-input audio mixers and IC7 is a low pass amplifier. Input signals are applied to the unit via level control RV1; the unit's clock generator produces a certain amount of RFI, and R24-C7 can be used to prevent this RFI feeding back to the input terminal when the unit is used with a radio music source. ICs 3 and 9 are used in the circuit as voltage-controlled electronic mode selector switches.

In the double-tracking mode, switches IC3d, IC9b and IC9c are open and IC9a is closed. In this case one half of the input signal is fed directly to the R46 side of audio mixer IC8 and the other half is fed to the R47 side of the IC8 mixer via low pass (22 kHz) mixer IC4, delay line IC5, and low pass amplifier IC7. The IC5 clock generator operates at a fairly low frequency,

its rate determined by C15 and the series values of R37 and RV2; the scan generator input is disabled by IC9b, and the second input of mixer IC4 is disabled by IC3d.

Table 1 shows the states of the IC3 and IC9 switches (which are DC-controlled by SW4) in the different operating modes of the circuit. Note here that IC3d and IC9a are activated automatically by the scan generator circuitry (provided they haven't been overridden by SW4), and that these switches are closed when scanning is in progress. Also note that, when the unit is used in the flanging mode and IC3d is closed, the R35-R36-D4-D6-D7-D8 network is used to automatically limit the magnitude of feedback signals from RV3 to R34, so that flanging does not attain uncontrolled levels.

From Table 1 and the above information, the reader should have little trouble in figuring out the precise methods of circuit operation in the other modes. Note that IC9c controls

the coarse speed range of the VCO, and IC9b enables or inhibits the input from the scan generator circuit.

The Scan Generator Circuit

The scan generator provides a ramp waveform to the input of the VCO and provides control signals to IC3d and IC9a of the main circuit. When the circuit is used in the manual and one-shot modes the scanning is initiated by closing either PB1 or an external foot switch; the circuit action is such that the IC3d and IC9a switches of the main circuit are normally opened and music signals are played straight through the unit (via the delay line) without any special effects being imposed, but as soon as a scan is initiated these two switches are activated by IC2b and special effects are imposed for the duration of the scan.

The operating theory of the scan generator circuit is fairly involved. IC1a is an op-amp integrator circuit and is

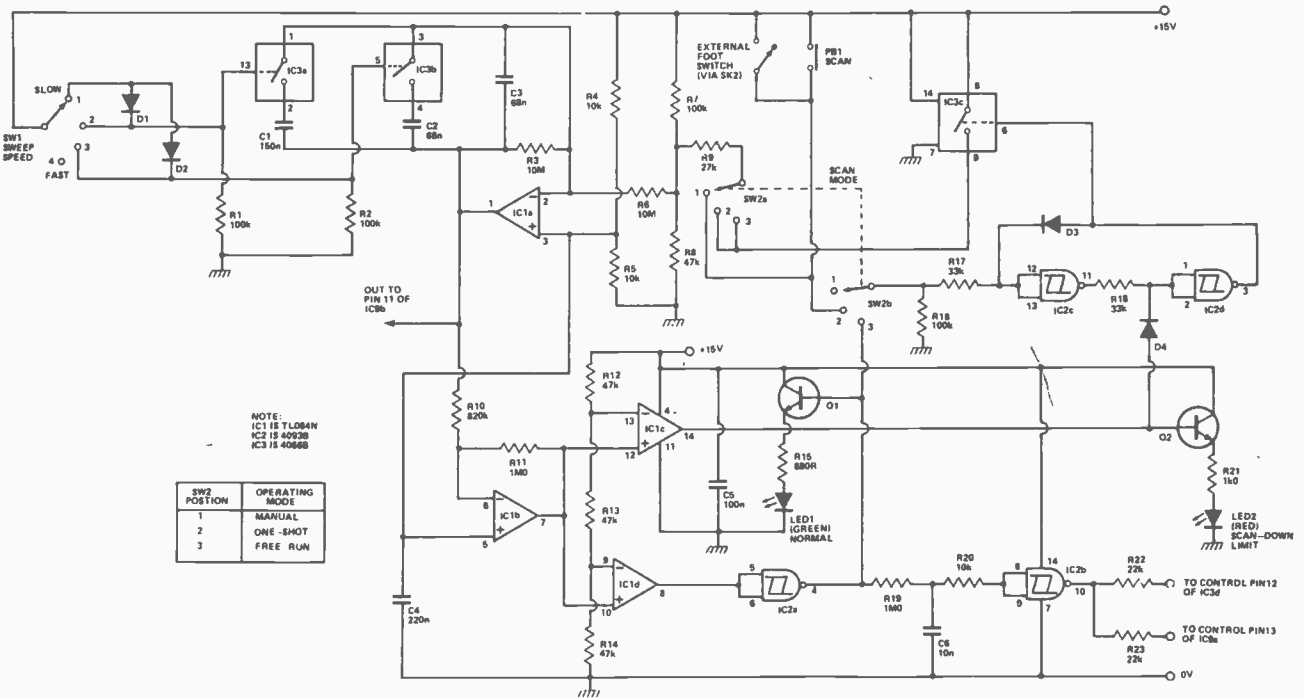

Fig. 6 Circuit diagram of the scan generator circuit.

TABLE 1

OPERATING MODE	SWITCH STATES			
	IC9a	IC9b	IC3d	IC9c
Double Tracking	Closed	Open	Open	Open
ADT	Closed	Closed	Open	Open
Phasing	Closed	Closed	Open	Closed
Flanging	Open	Closed	Closed	Closed

DC-biased at half-supply volts by R4-R5. In our application, the circuit is used as a ramp waveform generator and its timing action is controlled by R6, capacitors C1 to C3 and by the DC voltage on the R7-R8 junction; normally, this voltage has a value of 5V but switches to 10V when PB1 or IC3c are closed. Thus, the output of IC1a (which feeds the VCO input of the main circuit via IC9b) is normally at +10V, but starts to ramp down towards +5V as soon as the R7-R8 junction is pulled high by PB1 or IC3c. As soon as the R7-R8 junction is allowed to switch to +5V, the IC1a output starts to ramp back towards +10V again.

The ICa circuit has four ramp speeds available, which are controlled by switching in different total values of integrating capacitance using SW1. In the fastest ramping speed, only 68n of capacitance (C3) is used; in the next speed, 136n (C2 + C3); in the third speed 218n (C1 + C3) and in the slowest speed 286 (C1 + C2 + C3).

The output of IC1a is fed to inverting amplifier IC1b, which has a DC voltage gain slightly greater than unity, and the output of IC1b is fed to the inputs of non-inverting voltage comparators IC1c and IC1d. IC1c is referenced to +10V; IC1d is referenced to +5V and has its output inverted by IC2a. The circuit action is such that the output of IC1c switches high whenever the IC1a ramp generator reaches or exceeds the scan-down limit, and the output of IC2a switches high whenever IC1a is not ramping or whenever it reaches or exceeds the scan-up limit; these two states are indicated by LED2 and LED1 respectively.

IC2c-IC3d is a simply bistable circuit, which can be set by a positive pulse applied across R16 or reset by a positive pulse fed to D4; the output of the bistable is used to control switch IC3c. The reset signal of the bistable is derived from the output of IC1c; the set signal is derived from PB1 or from the output of IC2a, depending on the

operating mode (selected with SW2) of the scan generator. The output of IC2a is also used to control IC3d and IC9a (in the main circuit) via 10 ms delay/inverter network R19-C5-R20-IC2b and R22 and R23. The overall action of the generator in each of the three different operating modes is as follows.

**Manual Scan.** In this mode of operation the scanning is entirely controlled by PB1 (or the external foot switch) and the unit simply gives a scan-down action when PB1 is closed, or a scan-up action when PB1 is open. The scan limits are indicated by LEDs 1 and 2; switches IC3d and IC9a receive 'close' control signals when scanning is in progress and 'open' signals when scanning is not in progress, SW4a and SW4b determine whether or not these control signals are acted upon.



Fig. 7 Component overlay of the ETI Music Processor. There's a great deal that fits on the board, and a great deal that doesn't, so take time and care over construction. Note the large number of 'blob and arrow' symbols; some of these represent wiring to off-board components, some are point-to-point connections on the PCB.

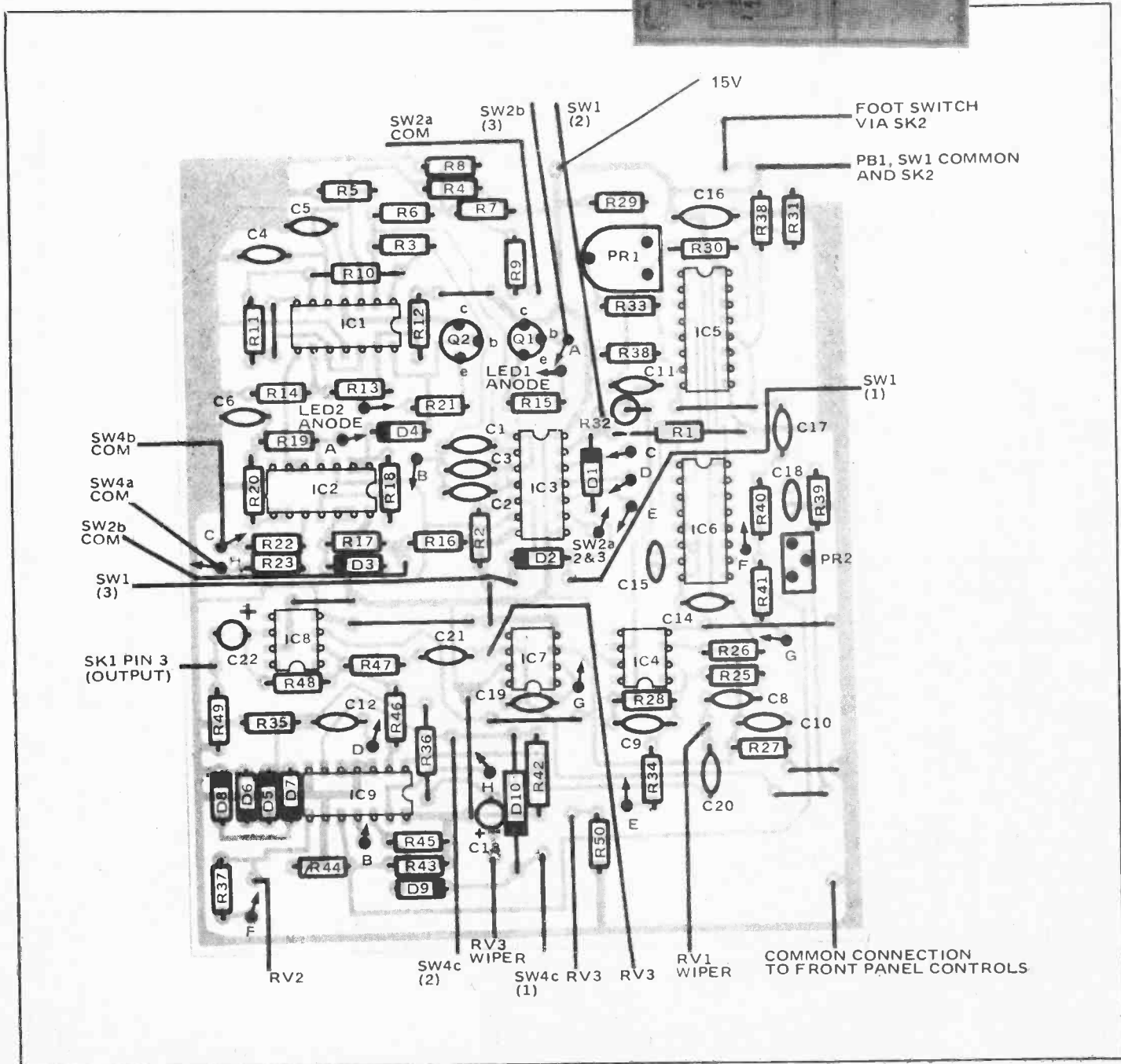
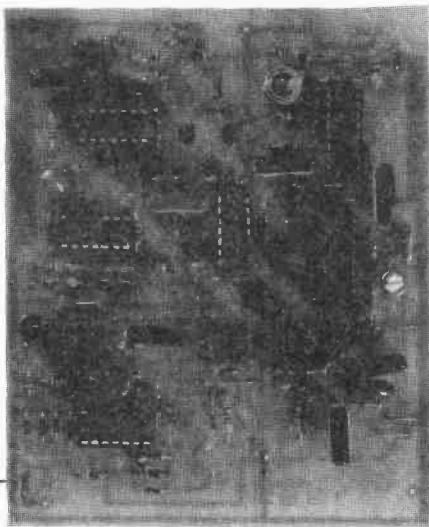
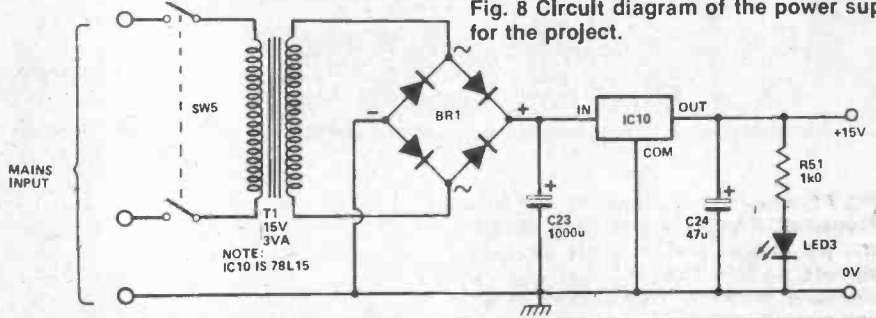

Fig. 8 Circuit diagram of the power supply for the project.



## PARTS LIST

### Resistors (all 1/4 W, 5%)

R1,2,7,16,33	
43,44,46,	100k
47,48	10M
R3,6	10M
R4,5,20,26,	
27,32,36,37	10k
R8,12,13,14,	
38	47k
R9	27k
R10	820k
R11,19	1M0
R15	680R
R17,18	33k
R21,31,51	1k0
R22,23,	
35,42,45,49	22k
R24	1k8
R25,28	220k
R29	2k7
R30	6k8
R34	150k
R39	180k
R40	120k
R41	82k
R50	15k

### Potentiometers

RV1	47k logarithmic
RV2	100k linear
RV3	10k linear
PR1	4k7 miniature horizontal
	preset
PR2	220k miniature vertical
	preset

### Capacitors

C1	150n polycarbonate
C2,3	68n polycarbonate
C4,11,17,20,	
21	220n polycarbonate
C5,10,14	100n polycarbonate
C6	10n polycarbonate
C7	2n2 polystyrene
C8	330n polycarbonate
C9,19	33p ceramic
C12	680n polycarbonate
C13	4u7 35 V tantalum
C15	470p ceramic
C16	150p ceramic
C18	220p ceramic
C22	10u 35 V tantalum
C23	1000u 40V axial elec-
	trolytic
C24	47u 16 V tantalum

### Semiconductors

IC1	TL084N
IC2	4093B
IC3,9	4066B

### IC4,7,8

CA3140	
IC5	TDA1022
IC6	4046B
IC10	78L15
Q1,2	MPS6515
BR1	50V, 1A bridge rectifier
D1-10	1N4148
LED1	0.125" green LED
LED2,3	0.124" red LED

### Miscellaneous

T1	15-0-15 3 VA
	transformer
SW1	1-pole 4-way rotary
	switch
SW2	2-pole 4-way rotary
	switch
SW3	SPDT miniature toggle
	switch
SW4	3-pole 4-way rotary
	switch
SK1	five pin DIN socket
SK2	1/4" mono jack socket

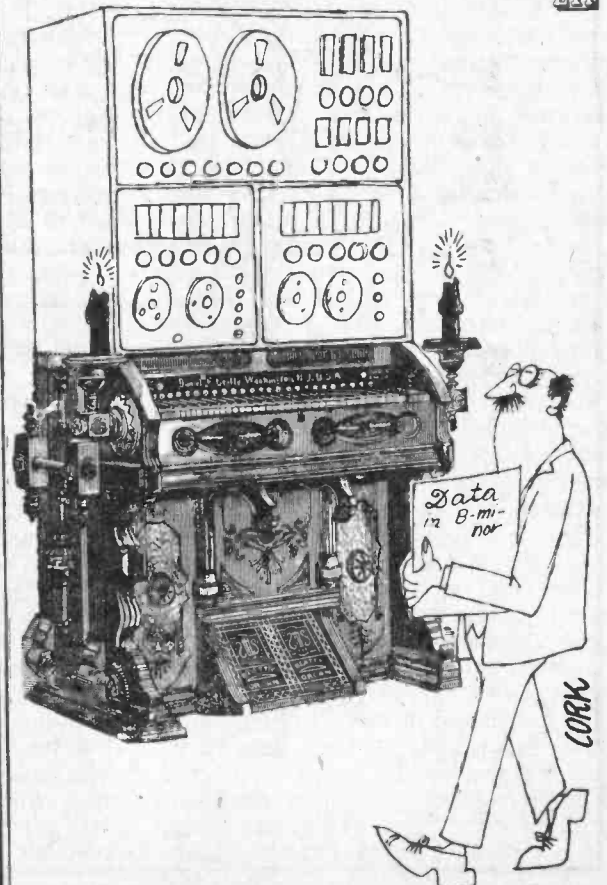
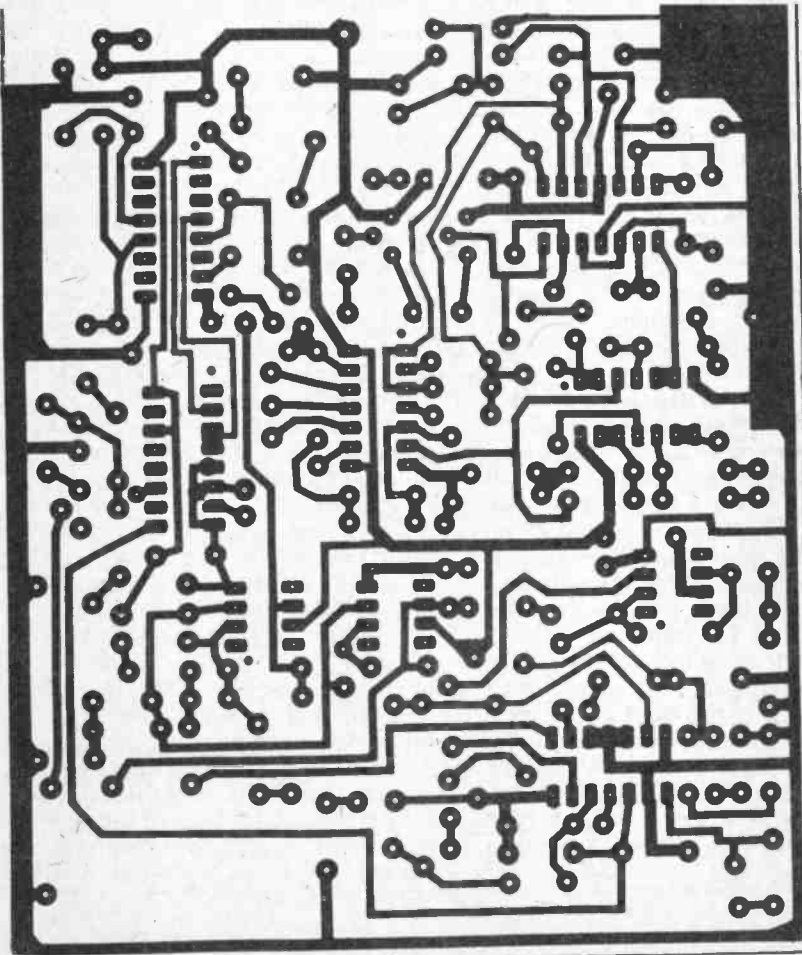

# Printers

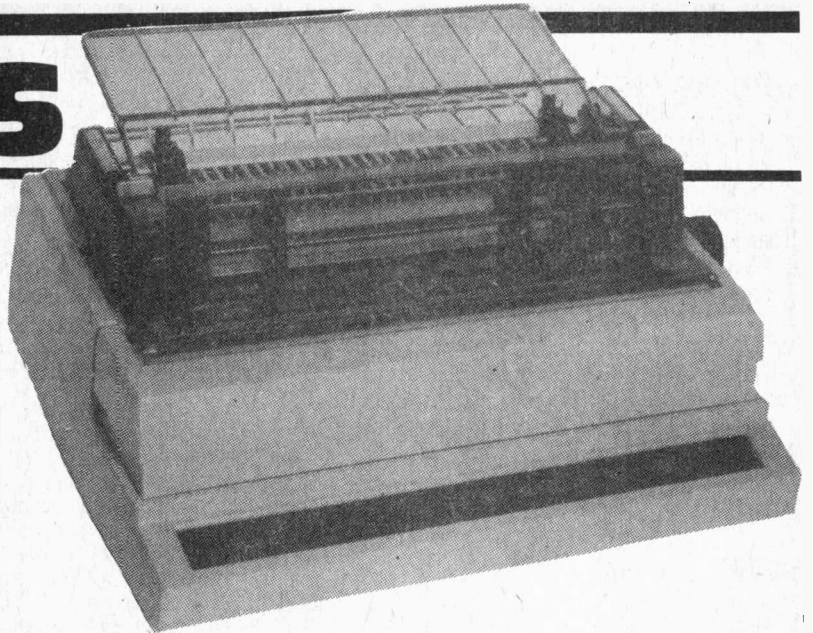

When you type LPRINT, does your computer just look at you funny? Robert Traub looks at printers to dispell this.

PRINTERS VARY GREATLY in their functions and features. There are a great number of types to choose from and the choice can be almost impossible. Some very basic points about printers may assist in the selection of a printer for personal use.

The first point to cover is columns. What is a column? Some printers will print 132 columns, some only 40 columns and some just about everything in between and more. A column is the space occupied by a single character. Consider first printers with fixed pitch. Fixed pitch means that each character occupies the same amount of space on the page. The common fixed pitch is 10 characters per inch. This standard pitch would allow 85 columns across an 8½ inch wide paper if no room were allowed for margins. That is 10 characters per inch times 8.5 inches equals 85 columns. If the page were allowed to have margins of approximately 5/8 inch on each side, that would leave 7.2 inches. At 10 characters per inch, that would give us 72 columns, and this is the standard print page for TTY type printers (and others). If the printer were to offer 132 columns, then the paper would have to be at least 10 characters per inch divided into 132 columns equals 13.2 inches wide. If margins were to be included that would bring the width of the paper to 15 7/8 inch. Therefore a common 132 column page would be 15 7/8 inches wide by 11 inches deep. Some fixed pitch printers offer the ability to select the pitch at which the characters will be fixed. Some common values are 12 characters per inch and 13.5 characters per inch. A bit of math would soon tell us that a printer with a fixed pitch of 13.5 characters per inch could print a standard page with margins with up to 96 characters or columns, while a printer with a fixed pitch of 12 characters per inch could print 87 columns in the same space. The 13.5 character per inch

printers compress the characters much closer together and may be a bit harder to read if they don't use a good quality print head. Some dot matrix printers offer a very compressed print of 132 columns in 8 inches or 16.5 characters to the inch.

Next we will look at printers that are not fixed pitch. A few printers offer the ability to allow a given amount of space on the line to each character. With this type of printer, less space would be allowed for the letter "i" than would be allowed for letters such as "m" or "w". Each letter is assigned a given amount of space on the line, as well as the distance between each letter. (With fixed pitch printers the amount of space allotted is the same for all characters.) This type of print is referred to as proportional spaced print. With this type of print you can develop excellent quality documents and avoid the common "river of white" that is found running through the body of text done with fixed pitch printers. Proportional spaced printers are the type required for professional word processing systems; the quality of print is excellent, and the overall appearance of the documents produced on the system is outstanding. These types of printers are very expensive, and very elaborate software is required for their operation in order to exploit their full potential.

Before leaving this subject, there are a couple of terms that you may run across and not be sure of their meaning, these being *pica* and *elite*. The term *pica* refers to typewriter type providing 10 characters to the inch, while *elite* is typewriter type that provides 12 characters to the inch.

## Type of type

The next thing to consider is the type of print. One common type is dot matrix print. This type of printer comes in many dot matrix forms; some may be 5 by 7, some 7 by 9, some 9 by 9, and some even greater. The dot matrix is comprised of a number of small wires or pins that are struck against a ribbon and the paper leaving a dot on the paper. The number of dots that the matrix has will determine the fullness of the character that it is reproducing. A 5X7 dot matrix is comprised of 35 small dot positions arranged in such a manner as to have a total of 5 dots across (horizontal) and 7 vertical rows of 5 dots each. This arrangement is the minimum number of dots required to produce a decent upper case letter set and numerals. The characters are not always well formed, as can be seen by the "s", not being curled around at the top and bottom, and by such characters as the slash(/). The slash will have a small vertical line on both ends rather than being a single straight line. A 7X9 dot matrix is arranged in such a manner as to have 7 dots across (horizontal) and 9 vertical rows of 7 dots each for a total of 63 dots. This type of matrix will produce much better letters, and give a more natural look to the overall print. As the number of dots in the matrix increases, the ability to reproduce characters increases and some very nice natural looking print can be found with such printers. Of course, if graphics are being considered, the greater the matrix dot count, the better the quality of graphic representation. Better quality print will be produced by matrixes with greater



numbers. The least expensive of the dot matrix printers will generally have a standard 5 by 7 matrix print head. This printer is satisfactory for general use, but is not intended for word processing, as it does not have descenders. A descender is the tail of lower case characters such as 'p', 'q', 'j', 'y' etc. Note that the tail of these characters will extend below the base line on a normal typewriter quality printer. On dot matrix printers this is not always available, and never on a 5 by 7 dot matrix. As the number of dots in the matrix increases, so does the price and overall general quality of the printer. The very

a few methods. The daisy wheel comes in different sizes with 88, 92, 96 characters per wheel and are cast in both plastic and metal. Some of the cheaper printers, whether dot matrix or full formed character type, do not offer lower case characters; again, this may or may not be important to the user, however lower case is a must if word processing is being considered. Each printer must be studied in order to determine if it offers lower case characters, descenders, and other features (graphics) that would be of interest to the user.

This brings us to the question of friction feed or tractor feed. In the

of printer option, paper can be advanced rapidly with assurance that the print will start at the same line on each page or form. One other type of paper feed system is the pin feed; this system is used on TTY printers to ensure that forms such as telgraphs will always line up properly. Another feature offered by the tractor feed and pin feed systems is the assurance that the printed line is horizontal with respect to the top and bottom edge of the paper. With friction feed systems, the page can slip slightly one way or the other.

As there are different systems that can be used to feed paper, the choice will depend on the type of work the printer will be required to do. If a lot of forms are going to be filled out, then of course a printer with the tractor feed option would be a good choice. If individual letters are the order of the day, then the standard friction feed type of paper advance will serve well.

#### BAUDy stories

Briefly we will take a look at the question of baud rates. The baud rate or just plain baud means *bits per second*. If the ASCII code were taken as a 10 unit code, then a baud rate of 1200 baud would transfer data at the rate of 1200 bits per second divided by 10 units per character for 120 characters per second. If the ASCII code were to be considered as an 8 unit code, then 1200 baud would represent a rate of 1200 bits per second divided by 8 units per character for total of 150 characters per second. Many printers will accept data at a rather high baud rate, say 9600 baud; this is the rate at which they accept data into their buffers and not the rate at which they print. The printer may only be able to produce 150 characters per second on paper; therefore, that printer's true baud rate is 1200 baud if an 8 unit ASCII code is assumed. The baud rate then is the speed at which the data or information can be printed. There are many reasons why a faster speed is needed in some cases and not at all needed in other cases. Typical baud rates range from a slow 110 baud to a fast 9600 baud, but be sure to check if the baud rate is the rate that the printer will print characters or if it is the rate at which the host computer can send characters to its internal storage area (buffer).

Some printers you hear about are called *line printers*; a line printer is a

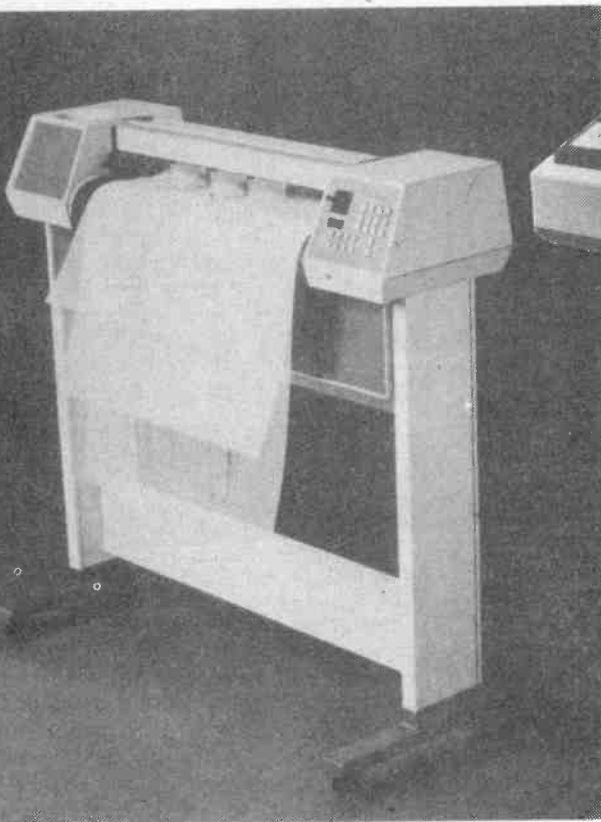

A fast page printer.

elaborate dot matrix printers that are now available can rival almost any type of print, but are very expensive and therefore not generally appropriate for hobby applications. Printers that offer fully formed characters such as found on typewriters are the best quality for word processing at a more reasonable cost. Fully formed characters are the type found in typewriters and are cast in metal or plastic. Some systems have the characters formed on a ball, some have them formed on a cylinder and others use a daisy wheel to name but

case of friction feed, the paper is held in place by some small pinch rollers that press against the printer's platen. The paper is inserted between these pinch rollers and the platen. This is fine in most cases where each line is advanced one at a time by a carriage return-line feed combination, but if the lines were to be advanced by the inch with a sudden command, as is the case with the form feed character, the paper could 'slip' as the platen first starts its fast advance. To overcome this problem, the tractor feed type of paper advance systems can be used. With this type



A smaller line printer.

special type of printer that will not print each character as it is received, but rather will wait for the complete line and then print the entire line at once, a character at a time. The length of the line that it prints is determined by the sending of the RETURN character, as a return signifies the end of that line in text. Line printers require special handling by the host computer and provisions must be made for *handshaking*. Line printers have buffers to store the data in before it is printed and handshaking is simply the printer's method of telling the computer when to send more data to the buffer and when to stop sending data as it can not handle any more at the moment. Printers are generally slower than the host computer, although there are some very fast printers not generally used by the hobbyist.

One other thing that you might run across is the term *bi-directional* printer. What this means is that the print head will print a line from left to right across the paper, advance the line (line feed) and then print the next line from the right side back to the left. The *bi-directional* printer requires fewer mechanical parts and movement than single direction types and this is one reason for increased printer speeds. With the conventional type of printers, a carriage return is required in order to bring the print head back to the start of the next line. This takes time and computers have to send the printer a *pad* or *fill* character in order to assure that the head has returned to the far left before it start printing again. After many, many line feeds and carriage returns the amount of time wasted can be considerable. Therefore, the bi-directional printer, which does not return the head every line, is capable of greater speeds (throughput). As well, because there are fewer mechanical parts to wear out, reliability is increased over the long run.

### Summary

At this point there are a few things to consider. If the printer is going to be used for listing BASIC or assembly programs, the dot matrix type of printer or the teletype printer may do the job very well. If a teletype printer such as the model 33 is used, you will have upper case only, a slower 110 baud rate and require a 20 mA loop interface. Printers of the dot matrix type vary by a great amount and will

require either a parallel or RS-232 serial interface. The lower priced 5X7 dot matrix printers have a great deal to offer those wishing listings. They can be found in a variety of speeds ranging from 110 baud to 9600 baud. They vary greatly as to the size of paper that they can accommodate. If you require listings at 10 characters per inch, on an 11 X 8.5 sheet of paper, that is, 11 inches horizontal and 8.5 inches vertical, you may find that the printer will not accommodate this size of paper and in fact the largest that it can handle is 9.5 inches horizontal. If the printer cannot handle wide paper, check out the print

one that will do those limited number of things. You can never be sure that you have covered all the bases, so be sure to explain to the dealer what use you wish to put the printer to, and he will be in a position to advise you as to what you might need that you have overlooked. Try to stay away from printer that will do everything; they require special features and will do all the different things if: if you buy a lot of extras, etc. Some printers offer tractor feed as a option; this may be a valuable option to have, as trying to stop the printer at the right time to change paper for the next page is not always desirable. Check your com-

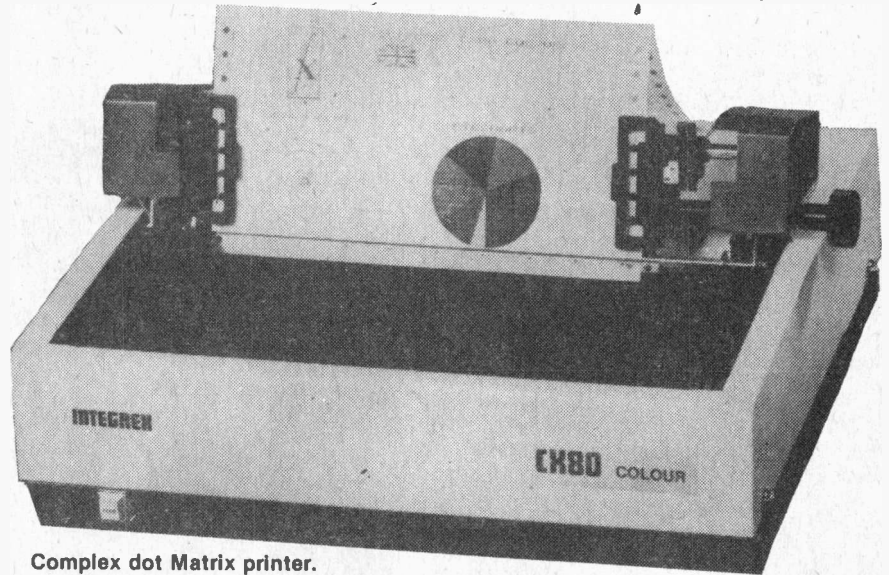

Complex dot Matrix printer.

quality of the printer at its most compressed setting, 16.5 characters per inch for instance, and use a very complex basic program line with as many characters and commands as possible. This will allow you to see first hand the type of print out you will be trying to work with. You may find it unsatisfactory for long listings, as the heavily compressed text makes it very hard to find semi-colons and other needed BASIC syntax characters. If you will be doing a lot of amortization charts, or charts of any type, then it is recommended that you look at a printer that falls into the line printer category, as the speed will be needed. You would soon go broke trying to produce amortization charts at 110 or even 300 baud. There are as many reasons for getting a printer as there are printers on the market, it is advised that the first thing you do when thinking about getting a printer is sit down in your computer room and try to determine exactly what service you want that printer for, and then proceed to find

computer program and see if you can stop the printer from the terminal keyboard at any given time, or if the software will do that automatically. If not, you will need tractor feed and continuous form paper for the job you are doing or roll paper if friction feed. If the printer is to be used for word processing, even on a small scale, it is recommended that you have lower case with decenders at the very least. Speed is not important in this type of printer and print rates of 30 to 55 characters per second are common. What is important is the quality of print and that is what you should look at first and last.

There are other things to consider in purchase of a printer, such as whether a warranty or service contract is available. Second hand equipment often does not come with service contracts. The application the printer will be used for will largely determine the quality of print required, but the cost could be the main consideration for the hobbyist.

# Crystal Marker

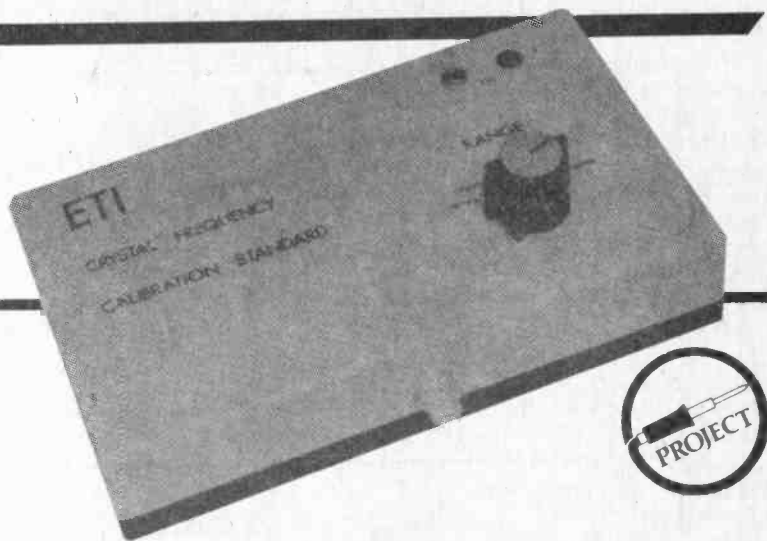

A simple but useful piece of test gear. Ideal for spot calibrating radio dials, 'scope timebases, etc.

THIS SIMPLE piece of test gear produces a square wave output with any one of six selected frequencies or periods. The outputs which range from 100 Hz (10 mS) to 1 MHz (1  $\mu$ S), are derived from a crystal oscillator via decade divider stages and thus have a high degree of frequency/period precision. The instrument is thus specifically intended to be used as a precision frequency/period standard, for calibrating items such as radio dials, 'scope timebases, etc.

To calibrate a radio dial, loosely couple the output of the instrument to the radio antenna (i.e., dangle a bit of wire near to the aerial), switch to the 1 MHz range and then tune the radio through its ranges, marking off the dial points at which the 1 MHz signal and its harmonics (up to about 30 MHz) are heard as a heterodyned 'zero beat' audio signal. Then repeat the procedure at lower standard frequencies (100 kHz, 10 kHz, etc) until the dial is adequately calibrated.

To calibrate a 'scope timebase, simply connect the output of the calibration standard to the Y amplifier of the 'scope and then run through the timebase ranges, checking that the indicated periods agree with those of the calibrator.

## Construction

This is a fairly simple project and construction should present few problems. Most components are mounted on a single PCB. Note here that five links are used on top of the PCB and that the crystal and the five ICs must all be mounted in suitable sockets.

When the PCB construction is complete, mount it in a suitable box and make the interconnections to SW1, SW2 SK1 LED1-R9 and B1. The unit is then ready for use.

The basic instrument has a typical accuracy of better than 0.01% with the C2 value shown. If you want better accuracy than this and have access to a precision frequency standard, replace C2 with a 100pF trimmer and adjust it to give a precise 1 MHz crystal oscillator frequency.

If you liked this project, please circle Reader Service Card number 57. If you didn't, circle number 58.

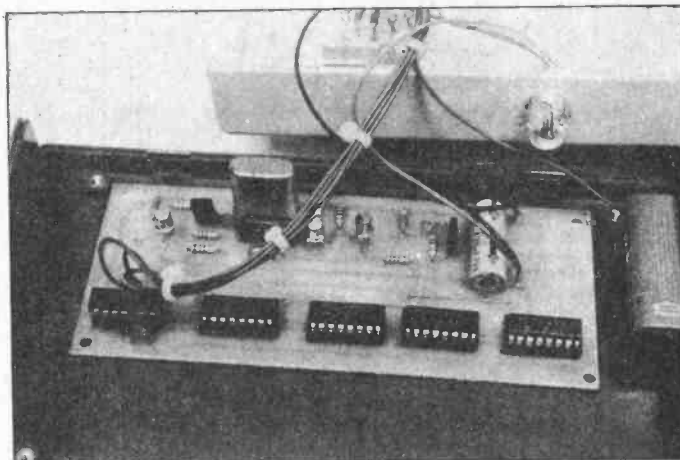

For those of you who have always wanted to know what the inside of a crystal calibrator looks like but were too bashful to ask, here it is. You could go mad with a power drill (or sharpened boy scout) drilling holes for PCB bolts and battery clips. We've found sticky pads to be perfectly adequate.

## HOW IT WORKS

The heart of the instrument is the crystal oscillator designed 'around Q2-Q3. Q3 is wired as a common base amplifier. Its collector signal is buffered by emitter follower Q2 and then coupled back to Q3 emitter via the series-resonant 1 MHz crystal, thereby causing Q2-Q3 to oscillate at the crystal frequency. The oscillator output signal is then amplified by Q1 and converted to a clean square wave by Schmitt trigger IC1a.

The 1 MHz square wave from IC1a is used to clock a chain of cascaded decade dividers to generate standard frequencies of 100 kHz, 10 kHz and 100 Hz. All of these signals are made available at output socket SK1 via SW2 and are individually buffered by Schmitt inverters (IC1b to IC1f).

The instrument is powered from a single 9V battery. LED 1 illuminates while SW1 is closed.



# CRYSTAL MARKER

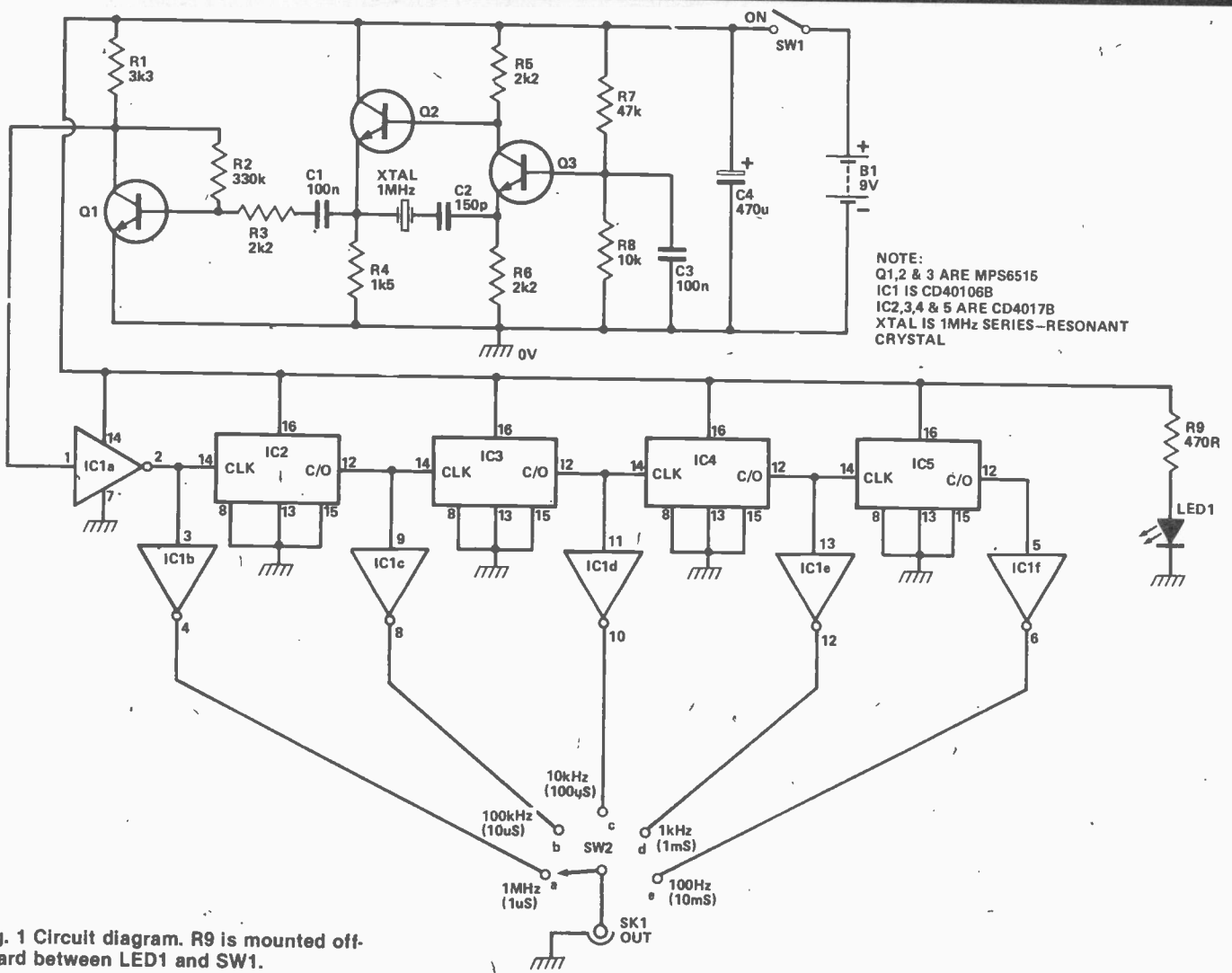
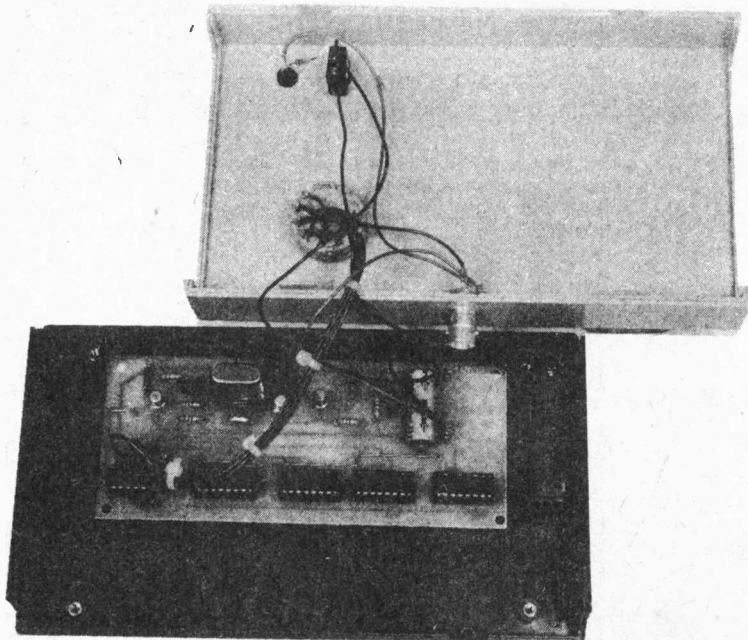

Fig. 1 Circuit diagram. R9 is mounted off-board between LED1 and SW1.



We can confidently predict that you won't have any trouble fitting the specified components into the case used!

## PARTS LIST

### Resistors all 1/4 W, 10%

R1	3k3
R2	330k
R3,5,6	2k2
R4	1k5
R7	47k
R8	10k

### Capacitors

C1,3	100n ceramic
C2	150p polystyrene
C4	470u 25V electrolytic

### Semiconductors

IC1	CD40106B
IC2,3,4,5	CD4017B
Q1,2,3	MPS6515
XTAL	1 MHz
LED1	TIL 220

### Miscellaneous

SW1	SPST miniature toggle
SW2	1 pole 5 way rotary switch

### Case

SK1	BNC (50R) Socket knob to suit
-----	-------------------------------

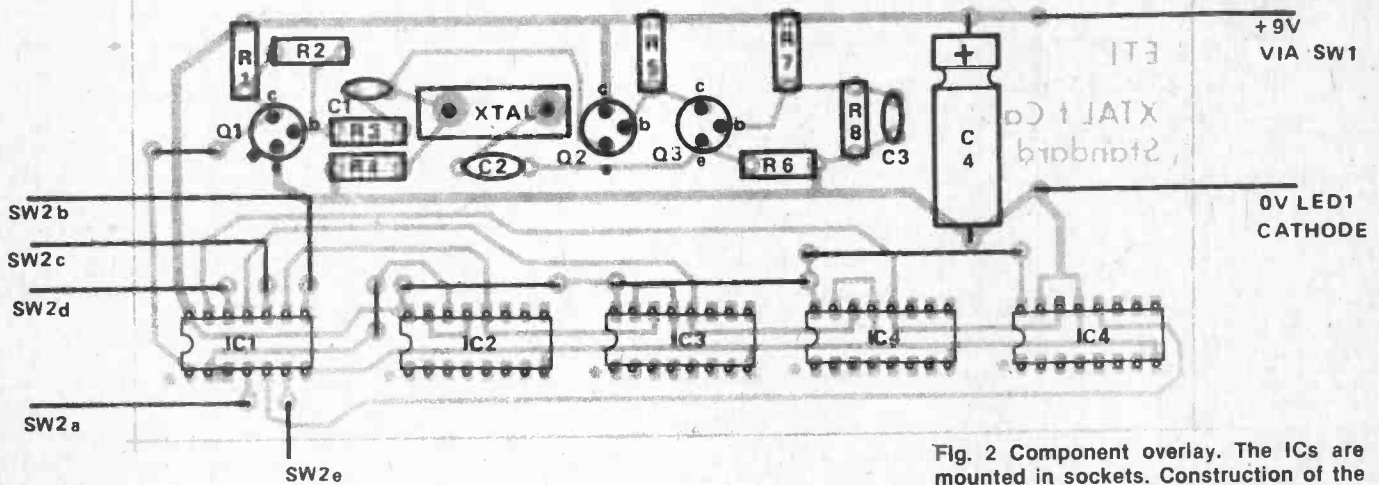
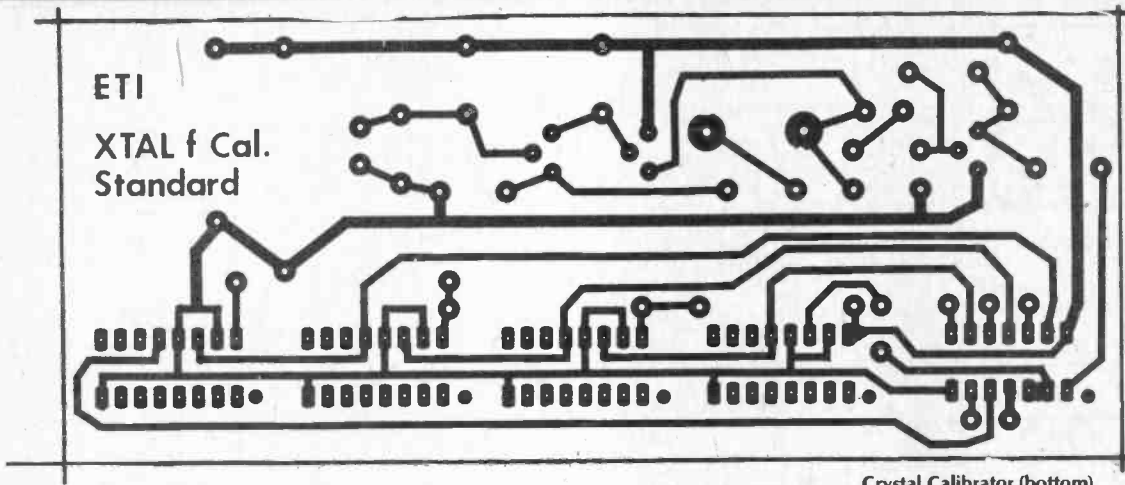

Fig. 2 Component overlay. The ICs are mounted in sockets. Construction of the board is fairly straightforward.

## Designer Circuits

### TREBLE BOOSTER

A treble booster circuit can be used with an electric guitar (and also electronic instruments) to boost the higher order harmonics and give a more "brilliant" sound. A circuit of this type gives a fairly flat response at bass and most middle audio frequencies, with the upper-middle

and lower treble frequencies being given a substantial amount of boost. It is normal to give only a modest amount of emphasis to the upper-treble in order to give good stability and a low noise level, and this also prevents the output from sounding too harsh. The frequency response of this treble booster is shown in the accompanying graph.

The circuit is basically just an op. amp. (IC1) used in the non-

inverting amplifier mode. The non-inverting input is biased by R4 and R5 via a decoupling network which is comprised of R3 and C3. C4 and C5 give DC blocking at the input and output respectively. With SW1 open there is virtually 100% negative feedback through R1, R2 and C1, giving the circuit unit gain and a flat response. Closing SW1 brings C2 into circuit, and this decouples some of the feedback through R1 and R2 at frequencies

of more than a few hundred Hz, giving the required rising response. Feedback through C1 at high treble frequencies causes the response to fall away above about 5.5kHz, and prevents the very high frequency harmonics from being excessively emphasised.

As the unit has unity gain at frequencies where boost is not applied it can simply be connected between the instrument and the amplifier.

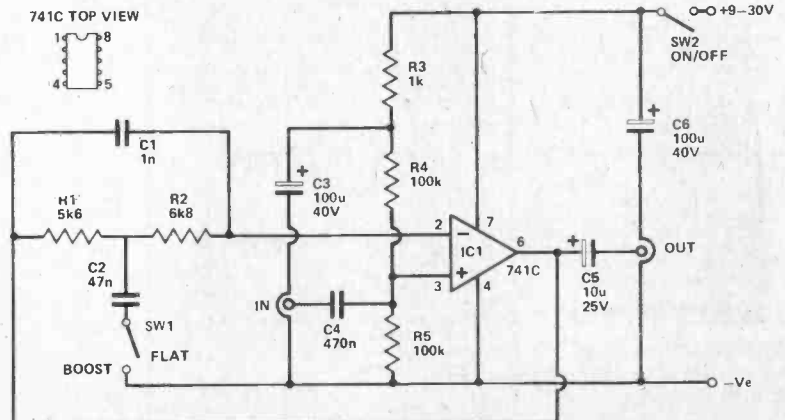
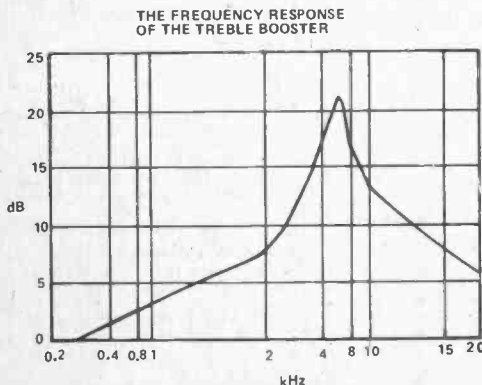

# ETI BOOKS

## COMPUTERS

(HARDWARE)

### A BEGINNER'S GUIDE TO COMPUTERS AND MICROPROCESSORS — WITH PROJECTS.

**TAB No.1015 \$13.45**  
Here's a plain English introduction to the world of microcomputers — its capabilities, parts and functions... and how you can use one. Numerous projects demonstrate operating principles and lead to the construction of an actual working computer capable of performing many useful functions.

### BP66: BEGINNERS GUIDE TO MICROPROCESSORS AND COMPUTING

**E.F. SCOTT, M.Sc., C.Eng. \$7.55**  
As indicated by the title, this book is intended as an introduction to the basic theory and concepts of binary arithmetic, microprocessor operation and machine language programming.

There are occasions in the text where some background information might be helpful and a Glossary is included at the end of the book.

### BP72: A MICROPROCESSOR PRIMER

**E.A. PARR, B.Sc., C.Eng., M.I.E.E. \$7.70**  
A newcomer to electronics tends to be overwhelmed when first confronted with articles or books on microprocessors. In an attempt to give a painless approach to computing, this small book will start by designing a simple computer and because of its simplicity and logical structure, the language is hopefully easy to learn and understand. In this way, such ideas as Relative Addressing, Index Registers etc. will be developed and it is hoped that these will be seen as logical progressions rather than arbitrary things to be accepted but not understood.

### BEGINNERS GUIDE TO MICROPROCESSORS

**TAB No.995 \$10.45**  
If you aren't sure exactly what a microprocessor is, then this is the book for you. The book takes the beginner from the basic theories and history of these essential devices, right up to some real world hardware applications.

### HOW TO BUILD YOUR OWN WORKING MICROCOMPUTER

**TAB No.1200 \$16.45**  
An excellent reference or how-to manual on building your own microcomputer. All aspects of hardware and software are developed as well as many practical circuits.

### BP78: PRACTICAL COMPUTER EXPERIMENTS

**E.A. PARR, B.Sc., C.Eng., M.I.E.E. \$7.30**  
Curiously most published material on the microprocessor tends to be of two sorts, the first treats the microprocessor as a black box and deals at length with programming and using the "beast". The second type of book deals with the social impact. None of these books deal with the background to the chip, and this is a shame as the basic ideas are both interesting and simple.

This book aims to fill in the background to the microprocessor by constructing typical computer circuits in discrete logic and it is hoped that this will form a useful introduction to devices such as adders, memories, etc. as well as a general source book of logic circuits.

### HANDBOOK OF MICROPROCESSOR APPLICATIONS

**TAB No.1203 \$14.45**  
Highly recommended reading for those who are interested in microprocessors as a means of accomplishing a specific task. The author discusses two individual microprocessors, the 1802 and the 6800, and how they can be put to use in real world applications.

### MICROPROCESSOR/MICROPROGRAMMING HANDBOOK

**TAB No.785 \$14.45**  
A comprehensive guide to microprocessor hardware and programming. Techniques discussed include subroutines, handling interrupts and program loops.

### DIGITAL INTERFACING WITH AN ANALOG WORLD

**TAB No.1070 \$14.45**  
You've bought a computer, but now you can't make it do anything useful. This book will tell you how to convert real world quantities such as temperature, pressure, force and so on into binary representation.

### MICROPROCESSOR INTERFACING HANDBOOK: A/D & D/A

**TAB No.1271 \$14.45**  
A useful handbook for computerists interested in using their machines in linear applications. Topics discussed include voltage references, op-amps for data conversion, analogue switching and multiplexing and more.

### COMPUTER TECHNICIAN'S HANDBOOK

**TAB No.554 \$17.45**  
Whether you're looking for a career, or you are a service technician, computer repair is an opportunity you should be looking at. The author covers all aspects of digital and computer electronics as well as the mathematical and logical concepts involved.

### THE ESSENTIAL COMPUTER DICTIONARY AND SPELLER

**AB011 \$9.45**  
A must for anyone just starting out in the field of computing, be they a businessman, hobbyist or budding computerist. The book presents and defines over 15 000 computer terms and acronyms and makes for great browsing.

### HOW TO TROUBLESHOOT AND REPAIR MICROCOMPUTERS

**AB013 \$10.45**  
Learn how to find the cause of a problem or malfunction in the central or peripheral unit of any microcomputer and then repair it. The tips and techniques in this guide can be applied to any equipment that uses the microprocessor as the primary control element.

### TROUBLESHOOTING MICROPROCESSORS AND DIGITAL LOGIC

**TAB No.1183 \$13.45**  
The influence of digital techniques on commercial and home equipment is enormous and increasing yearly. This book discusses digital theory and looks at how to service Video Cassette Recorders, microprocessors and more.

### HOW TO DEBUG YOUR PERSONAL COMPUTER

**AB012 \$10.45**  
When you feel like reaching for a sledge hammer to reduce your computer to fiberglass and epoxy dust, don't. Reach for this book instead and learn all about program bug tracking, recognition and elimination techniques.

### THE COMPLETE HANDBOOK OF ROBOTICS

**TAB No.1071 \$13.45**  
All the information you need to build a walking, talking mechanical friend appears in this book. Your robot can take many forms and various options — light, sound, and proximity sensors — are covered in depth.

### HOW TO BUILD YOUR OWN SELF PROGRAMMING ROBOT

**TAB No.1241 \$13.45**  
A practical guide on how to build a robot capable of learning how to adapt to a changing environment. The creature developed in the book, Rodney, is fully self programming, can develop theories to deal with situations and apply those theories in future circumstances.

### BUILD YOUR OWN WORKING ROBOT

**TAB No.841 \$14.45**  
Contains complete plans — mechanical, schematics, logic diagrams and wiring diagrams — for building Buster. There are two phases involved: first Buster is leashed, dependent on his creator for guidance, the second phase makes Buster more independent and able to get out of tough situations.

## COMPUTERS

(SOFTWARE)

### BEGINNER'S GUIDE TO COMPUTER PROGRAMMING

**TAB No.574 \$16.45**  
Computer programming is an increasingly attractive field to the individual, however many people still overlook it as a career. The material in this book has been developed in a logical sequence, from the basic steps to machine language.

### BP86: AN INTRODUCTION TO BASIC PROGRAMMING TECHNIQUES

**S. DALY \$8.25**  
This book is based on the author's own experience in learning BASIC and in helping others, mostly beginners, to program and understand the language. Also included are a program library containing various programs, that the author has actually written and run. These are for biorhythms, plotting a graph of Y against X, standard deviation, regression, generating a musical note sequence and a card game. The book is complemented by a number of appendices which include test questions and answers on each chapter and a glossary.

### THE BASIC COOKBOOK

**TAB No.1055 \$9.45**  
BASIC is a surprisingly powerful language... if you understand it completely. This book picks up where most manufacturers' documentation gives up. With it, any computer owner can develop programs to make the most out of his or her machine.

### PET BASIC — TRAINING YOUR PET COMPUTER

**AB014 \$16.45**  
Officially approved by Commodore, this is the ideal reference book for long time PET owners or novices. In an easy to read and humorous style, this book describes techniques and experiments, all designed to provide a strong understanding of this versatile machine.

### PROGRAMMING IN BASIC FOR PERSONAL COMPUTERS

**AB015 \$10.45**  
This book emphasizes the sort of analytical thinking that lets you use a specific tool — the BASIC language — to transform your own ideas into workable programs. The text is designed to help you to intelligently analyse and design a wide diversity of useful and interesting programs.

### COMPUTER PROGRAMS IN BASIC

**AB001 \$14.45**  
A catalogue of over 1 600 fully indexed BASIC computer programs with applications in Business, Math, Games and more. This book lists available software, what it does, where to get it, and how to adapt it to your machine.

### PET GAMES AND RECREATION

**AB002 \$12.45**  
A variety of interesting games designed to amuse and educate. Games include such names as Capture, Tic Tac Toe, Watchperson, Motie, Sinners, Martian Hunt and more.

### BRAIN TICKLERS

**AB005 \$8.00**  
If the usual games such as Bug Stomp and Invaders from the Time Warp are starting to pale, then this is the book for you. The authors have put together dozens of stimulating puzzles to show you just how challenging computing can be.

### PASCAL

**TAB No.1205 \$16.45**  
Aimed specifically at TRS-80 users, this book discusses how to load, use and write PASCAL programs. Graphic techniques are discussed and numerous programs are presented.

### PASCAL PROGRAMMING FOR THE APPLE

**AB008 \$16.45**  
A great book to upgrade your programming skills to the UCSD Pascal as implemented on the Apple II. Statements and techniques are discussed and there are many practical and ready to run programs.

### APPLE MACHINE LANGUAGE PROGRAMMING

**AB009 \$16.45**  
The best way to learn machine language programming the Apple II in no time at all. The book combines colour, graphics, and sound generation together with clear cut demonstrations to help the user learn quickly and effectively.

### Z80 USERS MANUAL

**AB010 \$14.45**  
The Z80 MPU can be found in many machines and is generally acknowledged to be one of the most powerful 8 bit chips around. This book provides an excellent 'right hand' for anyone involved in the application of this popular processor.

### HOW TO PROGRAM YOUR PROGRAMMABLE CALCULATOR

**AB006 \$10.45**  
Calculator programming, by its very nature, often is an obstacle to effective use. This book endeavours to show how to use a programmable calculator to its full capabilities. The TI 57 and the HP 33E calculators are discussed although the principles extend to similar models.

### BP33: ELECTRONIC CALCULATOR USERS HANDBOOK

**M.H. BABANI, B.Sc.(Eng.) \$4.25**  
An invaluable book for all calculator users whatever their age or occupation, or whether they have the simplest or most sophisticated of calculators. Presents formulae, data, methods of calculation, conversion factors, etc., with the calculator user especially in mind, often illustrated with simple examples. Includes the way to calculate using only a simple four function calculator: Trigonometric Functions (Sin, Cos, Tan); Hyperbolic Functions (Sinh, Cosh, Tanh) Logarithms, Square Roots and Powers.

## PROJECTS

### BP48: ELECTRONIC PROJECTS FOR BEGINNERS

**F.G. RAYER, T.Eng.(CEI), Assoc.IERE \$5.90**  
Another book written by the very experienced author — Mr. F.G. Rayer — and in it the newcomer to electronics, will find a wide range of easily made projects. Also, there are a considerable number of actual component and wiring layouts, to aid the beginner.

Furthermore, a number of projects have been arranged so that they can be constructed without any need for soldering and, thus, avoid the need for a soldering iron.

Also, many of the later projects can be built along the lines as those in the 'No Soldering' section so this may considerably increase the scope of projects which the newcomer can build and use.

### 221: 28 TESTED TRANSISTOR PROJECTS

**R.TORRENS \$5.50**  
Mr. Richard Torrens is a well experienced electronics development engineer and has designed, developed, built and tested the many useful and interesting circuits included in this book. The projects themselves can be split down into simple, building blocks, which are shown separated by boxes in the circuits for ease of description, and also to enable any reader who wishes to combine boxes from different projects to realise ideas of his own.

### BP49: POPULAR ELECTRONIC PROJECTS

**R.A. PENFOLD \$6.25**  
Includes a collection of the most popular types of circuits and projects which, we feel sure, will provide a number of designs to interest most electronics constructors. The projects selected cover a very wide range and are divided into four basic types: Radio Projects, Audio Projects, Household Projects and Test Equipment.

### EXPERIMENTER'S GUIDE TO SOLID STATE ELECTRONIC PROJECTS

**AB007 \$9.45**  
An ideal sourcebook of Solids State circuits and techniques with many practical circuits. Also included are many useful types of experimenter gear.

### BP71: ELECTRONIC HOUSEHOLD PROJECTS

**R. A. PENFOLD \$7.70**  
Some of the most useful and popular electronic construction projects are those that can be used in or around the home. The circuits range from such things as '2 Tone Door Buzzer', Intercom, through Smoke or Gas Detectors to Baby and Freezer Alarms.

### BP94: ELECTRONIC PROJECTS FOR CARS AND BOATS

**R.A. PENFOLD \$8.10**  
Projects, fifteen in all, which use a 12V supply are the basis of this book. Included are projects on Windscreen Wiper Control, Courtesy Light Delay, Battery Monitor, Cassette Power Supply, Lights Timer, Vehicle Immobiliser, Gas and Smoke Alarm, Depth Warning and Shaver Inverter.

### BP69: ELECTRONIC GAMES

**R.A. PENFOLD \$7.55**  
In this book Mr. R. A. Penfold has designed and developed a number of interesting electronic game projects using modern integrated circuits. The text is divided into two sections, the first dealing with simple games and the latter dealing with more complex circuits.

### BP95: MODEL RAILWAY PROJECTS

**\$8.10**  
Electronic projects for model railways are fairly recent and have made possible an amazing degree of realism. The projects covered include controllers, signals and sound effects; sriboard layouts are provided for each project.





## PROJECTS (CONTINUED)

### BP76: POWER SUPPLY PROJECTS \$7.30 R.A. PENFOLD

Line power supplies are an essential part of many electronics projects. The purpose of this book is to give a number of power supply designs, including simple unregulated types, fixed voltage regulated types, and variable voltage stabilised designs, the latter being primarily intended for use as bench supplies for the electronics workshop. The designs provided are all low voltage types for semiconductor circuits.

There are other types of power supply and a number of these are dealt with in the final chapter, including a cassette power supply, Ni-Cad battery charger, voltage step up circuit and a simple inverter.

### BP84: DIGITAL IC PROJECTS \$8.10 F.G. RAYER, T.Eng.(CEI),Assoc.IERE

This book contains both simple and more advanced projects and it is hoped that these will be found of help to the reader developing a knowledge of the workings of digital circuits. To help the newcomer to the hobby the author has included a number of board layouts and wiring diagrams. Also the more ambitious projects can be built and tested section by section and this should help avoid or correct faults that could otherwise be troublesome. An ideal book for both beginner and more advanced enthusiast alike.

### BP67: COUNTER DRIVER AND NUMERAL DISPLAY PROJECTS \$7.55 F.G. RAYER, T.Eng.(CEI), Assoc. IERE

Numeral indicating devices have come very much to the forefront in recent years and will, undoubtedly, find increasing applications in all sorts of equipment. With present day integrated circuits, it is easy to count, divide and display numerically the electrical pulses obtained from a great range of driver circuits.

In this book many applications and projects using various types of numeral displays, popular counter and driver IC's etc. are considered.

### 213: ELECTRONIC CIRCUITS FOR MODEL RAILWAYS \$4.50 M.H. BABANI, B.Sc.(Eng.)

The reader is given constructional details of how to build a simple model train controller; controller with simulated inertia and a high power controller. A signal system and lighting for model trains is discussed as is the suppression of RF interference from model railways. The construction of an electronic steam whistle and a model train chuffer is also covered.

### BP73: REMOTE CONTROL PROJECTS \$8.60 OWEN BISHOP

This book is aimed primarily at the electronics enthusiast who wishes to experiment with remote control. Full explanations have been given so that the reader can fully understand how the circuits work and can more easily see how to modify them for other purposes, depending on personal requirements. Not only are radio control systems considered but also infra-red, visible light and ultrasonic systems as are the use of Logic ICs and Pulse position modulation etc.

## CIRCUITS

### BP80: POPULAR ELECTRONIC CIRCUITS — BOOK 1 \$8.25 R.A. PENFOLD

Another book by the very popular author, Mr. R.A. Penfold, who has designed and developed a large number of various circuits. These are grouped under the following general headings: Audio Circuits, Radio Circuits, Test Gear Circuits, Music Project Circuits, Household Project Circuits and Miscellaneous Circuits.

### THE GIANT HANDBOOK OF ELECTRONIC CIRCUITS TAB No.1300 \$24.45

About as thick as thick as the Webster's dictionary, and having many more circuit diagrams, this book is ideal for any experimenter who wants to keep amused for several centuries. If there isn't a circuit for it in here, you should have no difficulty convincing yourself you don't really want to build it.

### BP39: 50 (FET) FIELD EFFECT TRANSISTOR PROJECTS \$5.50

F.G. RAYER, T.Eng.(CEI),Assoc.IERE  
Field effect transistors (FETs), find application in a wide variety of circuits. The projects described here include radio frequency amplifiers and converters, test equipment and receiver aids, tuners, receivers, mixers and tone controls, as well as various miscellaneous devices which are useful in the home.

This book contains something of particular interest for every class of enthusiast — short wave listener, radio amateur, experimenter or audio devotee.

### BP87: SIMPLE L.E.D. CIRCUITS \$5.90 R.N. SOAR

Since it first appeared in 1977, Mr. R.N. Soar's book has proved very popular. The author has developed a further range of circuits and these are included in Book 2. Projects include a Transistor Tester, Various Voltage Regulators, Testers and so on.

### BP42: 50 SIMPLE L.E.D. CIRCUITS \$3.55 R.N. SOAR

The author of this book, Mr. R.N. Soar, has compiled 50 interesting and useful circuits and applications, covering many different branches of electronics, using one of the most inexpensive and freely available components — the Light Emitting Diode (L.E.D.). A useful book for the library of both beginner and more advanced enthusiast alike.

### BP82: ELECTRONIC PROJECTS USING SOLAR CELLS \$8.10 OWEN BISHOP

The book contains simple circuits, almost all of which operate at low voltage and low currents, making them suitable for being powered by a small array of silicon cells. The projects cover a wide range from a bicycle speedometer to a novelty 'Duck Shoot'; a number of power supply circuits are included.

### BP37: 50 PROJECTS USING RELAYS, SCR'S & TRIACS \$5.50 F.G. RAYER, T.Eng.(CEI),Assoc.IERE

Relays, silicon controlled rectifiers (SCR's) and bi-directional triodes (TRIACS) have a wide range of applications in electronics today. This book gives tried and practical working circuits which should present the minimum of difficulty for the enthusiast to construct. In most of the circuits there is a wide latitude in component values and types, allowing easy modification of circuits or ready adaptation of them to individual needs.

### BP44: IC 555 PROJECTS \$7.55 E.A. PARR, B.Sc.,C.Eng., M.I.E.E.

Every so often a device appears that is so useful that one wonders how life went on before without it. The 555 timer is such a device. Included in this book are Basic and General Circuits, Motor Car and Model Railway Circuits, Alarms and Noise Makers as well as a section on the 556, 558 and 559 timers.

### BP24: 50 PROJECTS USING IC741 \$4.25 RUDI & UWE REDMER

This book, originally published in Germany by TOPP, has achieved phenomenal sales on the Continent and Babani decided, in view of the fact that the integrated circuit used in this book is inexpensive to buy, to make this unique book translated from the original German with copious notes, data and circuitry, a "must" for everyone whatever their interest in electronics.

### BP83: V MOS PROJECTS \$8.20 R.A. PENFOLD

Although modern bipolar power transistors give excellent results in a wide range of applications, they are not without their drawbacks or limitations. This book will primarily be concerned with V MOS power FETs although power MOSFETs will be dealt with in the chapter on audio circuits. A number of varied and interesting projects are covered under the main headings of: Audio Circuits, Sound Generator Circuits, DC Control Circuits and Signal Control Circuits.

### BP65: SINGLE IC PROJECTS \$6.55 R.A. PENFOLD

There is now a vast range of ICs available to the amateur market, the majority of which are not necessarily designed for use in a single application and can offer unlimited possibilities. All the projects contained in this book are simple to construct and are based on a single IC. A few projects employ one or two transistors in addition to an IC but in most cases the IC is the only active device used.

### BP 50: IC LM3900 PROJECTS \$5.90 H.KYBETT, B.Sc., C.Eng.

The purpose of this book is to introduce the LM3900 to the Technician, Experimenter and the Hobbyist. It provides the groundwork for both simple and more advanced uses, and is more than just a collection of simple circuits or projects.

Simple basic working circuits are used to introduce this IC. The LM3900 can do much more than is shown here, this is just an introduction. Imagination is the only limitation with this useful and versatile device. But first the reader must know the basics and that is what this book is all about.

### 223: 50 PROJECTS USING IC CA3130 \$5.50 R.A. PENFOLD

In this book, the author has designed and developed a number of interesting and useful projects which are divided into five general categories: I — Audio Projects II — R.F. Projects III — Test Equipment IV — Household Projects V — Miscellaneous Projects.

### 224: 50 CMOS IC PROJECTS \$4.25 R.A. PENFOLD

CMOS IC's are probably the most versatile range of digital devices for use by the amateur enthusiast. They are suitable for an extraordinary wide range of applications and are also some of the most inexpensive and easily available types of IC.

Mr R.A. Penfold has designed and developed a number of interesting and useful projects which are divided into four general categories: I — Multivibrators II — Amplifiers and Oscillators III — Trigger Devices IV — Special Devices.

### THE ACTIVE FILTER HANDBOOK TAB No.1133 \$11.45

Whatever your field — computing, communications, audio, electronic music or whatever — you will find this book the ideal reference for active filter design. The book introduces filters and their uses also presents many practical circuits including a graphic equalizer, computer tape interface and more.

### DIGITAL IC'S — HOW THEY WORK AND HOW TO USE THEM \$10.45 AB004

An excellent primer on the fundamentals of digital electronics. This book discusses the nature of gates and related concepts and also deals with the problems inherent to practical digital circuits.

### MASTER HANDBOOK OF 1001 PRACTICAL CIRCUITS \$20.45 TAB No.800

### MASTER HANDBOOK OF 1001 MORE PRACTICAL CIRCUITS \$19.45 TAB No.804

Here are transistor and IC circuits for just about any application you might have. An ideal source book for the engineer, technician or hobbyist. Circuits are classified according to function, and all sections appear in alphabetical order.

### THE MASTER IC COOKBOOK \$16.45 TAB No.1199

If you've ever tried to find specs for a so called 'standard' chip, then you'll appreciate this book. C.L. Hallmark has compiled specs and pinouts for most types of ICs that you'd ever want to use.

### ELECTRONIC DESIGN WITH OFF THE SHELF INTEGRATED CIRCUITS \$10.45 AB016

This practical handbook enables you to take advantage of the vast range of applications made possible by integrated circuits. The book tells how, in step by step fashion, to select components and how to combine them into functional electronic systems. If you want to stop being a "cookbook hobbyist", then this is the book for you.

## AUDIO

### BP90: AUDIO PROJECTS \$8.10 F.G. RAYER

Covers in detail the construction of a wide range of audio projects. The text has been divided into preamplifiers and mixers, power amplifiers, tone controls and matching and miscellaneous projects.

### HOW TO DESIGN, BUILD, AND TEST COMPLETE SPEAKER SYSTEMS. TAB No.1064 \$13.45

By far the greatest savings in assembling an audio system can be realized from the construction of speakers. This book contains information to build a variety of speakers as well as instructions on how to design your own.

### 205: FIRST BOOK OF HI-FI LOUDSPEAKER ENCLOSURES \$3.55 B.B. BABANI

This book gives data for building most types of loudspeaker enclosure. Includes corner reflex, bass reflex, exponential horn, folded horn, tuned port, klipschorn labyrinth, tuned, column, loaded port and multi speaker panoramic. Many clear diagrams for every construction showing the dimensions necessary.

### BP35: HANDBOOK OF IC AUDIO PREAMPLIFIER AND POWER AMPLIFIER CONSTRUCTION \$5.50 F.G. RAYER, T.Eng.(CEI),Assoc.IERE

This book is divided into three parts: Part I, understanding audio IC's, Part II, Preamplifiers, Mixers and Tone Controls, Part III Power Amplifiers and Supplies. Includes practical constructional details of pure IC and Hybrid IC and Transistor designs from about 250mW to 100W output.

### BP47: MOBILE DISCOTHEQUE HANDBOOK \$5.90 COLIN CARSON

The vast majority of people who start up "Mobile Discos" know very little about their equipment or even what to buy. Many people have wasted a "small fortune" on poor, unnecessary or badly matched apparatus.

The aim of this book is to give you enough information to enable you to have a better understanding of many aspects of "disco" gear.

### HOW TO BUILD A SMALL BUDGET RECORDING STUDIO FROM SCRATCH. . . \$16.45 TAB No.1166

The author, F. Alton Everest, has gotten studios together several times, and presents twelve complete, tested designs for a wide variety of applications. If all you own is a mono cassette recorder, you don't need this book. If you don't want your new four track to wind up sounding like one, though, you shouldn't be without it.

### BP51: ELECTRONIC MUSIC AND CREATIVE TAPE RECORDING \$5.50 M.K. BERRY

Electronic music is the new music of the Twentieth Century. It plays a large part in "pop" and "rock" music and, in fact, there is scarcely a group without some sort of synthesiser or other effects generator.

This book sets out to show how electronic music can be made at home with the simplest and most inexpensive of equipment. It then describes how the sounds are generated and how these may be recorded to build up the final composition.

### BP74: ELECTRONIC MUSIC PROJECTS \$7.70 R.A. PENFOLD

Although one of the more recent branches of amateur electronics, electronic music has now become extremely popular and there are many projects which fall into this category. The purpose of this book is to provide the constructor with a number of practical circuits for the less complex items of electronic music equipment, including such things as a Fuzz Box, Waa-Waa Pedal, Sustain Unit, Reverberation and Phaser-Units, Tremolo Generator etc.

### BP81: ELECTRONIC SYNTHESISER PROJECTS \$7.30 M.K. BERRY

One of the most fascinating and rewarding applications of electronics is in electronic music and there is hardly a group today without some sort of synthesiser or effects generator. Although an electronic synthesiser is quite a complex piece of electronic equipment, it can be broken down into much simpler units which may be built individually and these can then be used or assembled together to make a complete instrument.

### ELECTRONIC MUSIC SYNTHESIZERS \$10.45 TAB No.1167

If you're fascinated by the potential of electronics in the field of music, then this is the book for you. Included is data on synthesizers in general as well as particular models. There is also a chapter on the various accessories that are available.

See the order form on page 53

## TEST EQUIPMENT

### BP75: ELECTRONIC TEST EQUIPMENT CONSTRUCTION \$7.30

F.G. RAYER, T.Eng. (CEI), Assoc. IERE  
This book covers in detail the construction of a wide range of test equipment for both the Electronics Hobbyists and Radio Amateur. Included are projects ranging from a FET Amplified Voltmeter and Resistance Bridge to a Field Strength Indicator and Heterodyne Frequency Meter. Not only can the home constructor enjoy building the equipment but the finished projects can also be usefully utilised in the furtherance of his hobby.

### 99 TEST EQUIPMENT PROJECTS YOU CAN BUILD \$14.45

TAB No.805  
An excellent source book for the hobbyist who wants to build up his work bench inexpensively. There are circuits to measure just about any electrical quantity. The variety is endless and includes just about anything you could wish for!

### HOW TO GET THE MOST OUT OF LOW COST TEST EQUIPMENT \$9.45

AB017  
Whether you want to get your vintage 1960 TestRite signal generator working, or you've got something to measure with nothing to measure it with, this is the book for you. The author discusses how to maximize the usefulness of cheap test gear, how to upgrade old equipment, and effective test set ups.

### THE POWER SUPPLY HANDBOOK \$16.45

TAB No.806  
A complete one stop reference for hobbyists and engineers. Contains high and low voltage power supplies of every conceivable type as well as mobile and portable units.

### BP70: TRANSISTOR RADIO FAULT-FINDING CHART \$2.40

CHAS. E. MILLER  
Across the top of the chart will be found four rectangles containing brief descriptions of various faults; vis: — sound weak but undistorted; set dead; sound low or distorted and background noises. One then selects the most appropriate of these and following the arrows, carries out the suggested checks in sequence until the fault is cleared.

### ELECTRONIC TROUBLESHOOTING HANDBOOK \$9.45

AB019  
This workbench guide can show you how to pinpoint circuit troubles in minutes, how to test anything electronic, and how to get the most out of low cost test equipment. You can use any and all of the time-saving shortcuts to rapidly locate and repair all types of electronic equipment malfunctions.

### COMPLETE GUIDE TO READING SCHEMATIC DIAGRAMS \$9.45

AB018  
A complete guide on how to read and understand schematic diagrams. The book teaches how to recognize basic circuits and identify component functions. Useful for technicians and hobbyists who want to avoid a lot of headscratching.

## RADIO AND COMMUNICATIONS

BP79: RADIO CONTROL FOR BEGINNERS \$7.30  
F.G. RAYER, T.Eng. (CEI), Assoc. IERE.  
The aim of this book is to act as an introduction to Radio Control for beginners to the hobby. The book will commence by dealing with the conditions that are allowable for such things as frequency and power of transmission. This is followed by a "block" explanation of how control-device and transmitter operate and receiver and actuator(s) produce motion in a model.  
Details are then given of actual solid state transmitting equipment which the reader can build. Plain and loaded aerials are then discussed and so is the field-strength meter to help with proper setting up.  
The radio receiving equipment is then dealt with which includes a simple receiver and also a crystal controlled superhet. The book ends with the electro-mechanical means of obtaining movement of the controls of the model.

BP91: AN INTRODUCTION TO RADIO DXing \$8.10  
This book is divided into two main sections one to amateur band reception, the other to broadcast bands. Advice is given to suitable equipment and techniques. A number of related constructional projects are described.

No. 215: Shortwave Circuits & Gear For Experimenters & Radio Hams \$3.70  
Covers constructional details of a number of projects for the shortwave enthusiast and radio "Ham". Included are: an add-in crystal filter, adding an "S" meter in your receiver; crystal locked H.F. Receiver; AM tuner using phase locked loop; converter for 2MHz, 40 to 800 MHz RF amplifier; Aerials for the 52, 144MHz bands, Solid State Crystal Frequency Calibrator, etc.

BP46: RADIO CIRCUITS USING IC's \$5.90  
J.B. DANCE, M.Sc.  
This book describes integrated circuits and how they can be employed in receivers for the reception of either amplitude or frequency modulated signals. The chapter on amplitude modulated (a.m.) receivers will be of most interest to those who wish to receive distant stations at only moderate audio quality, while the chapter on frequency modulation (f.m.) receivers will appeal to those who desire high fidelity reception.

## REFERENCE

### THE BEGINNER'S HANDBOOK OF ELECTRONICS \$9.45

AB003  
An excellent textbook for those interested in the fundamentals of Electronics. This book covers all major aspects of power supplies, amplifiers, oscillators, radio, television and more.

### ELEMENTS OF ELECTRONICS — An on-going series

F.A. WILSON, C.G.I.A., C.Eng.,  
BP62: BOOK 1. The Simple Electronic Circuit and Components \$8.95

BP63: BOOK 2. Alternating Current Theory \$8.95

BP64: BOOK 3. Semiconductor Technology \$8.95

BP77: BOOK 4. Microprocessing Systems And Circuits \$12.30

BP89: BOOK 5. Communication \$12.30  
The aim of this series of books can be stated quite simply — it is to provide an inexpensive introduction to modern electronics so that the reader will start on the right road by thoroughly understanding the fundamental principles involved.

Although written especially for readers with no more than ordinary arithmetical skills, the use of mathematics is not avoided, and all the mathematics required is taught as the reader progresses.

Each book is a complete treatise of a particular branch of the subject and, therefore, can be used on its own with one proviso, that the later books do not duplicate material from their predecessors, thus a working knowledge of the subjects covered by the earlier books is assumed.

BOOK 1: This book contains all the fundamental theory necessary to lead to a full understanding of the simple electronic circuit and its main components.

BOOK 2: This book continues with alternating current theory without which there can be no comprehension of speech, music, radio, television or even the electricity utilities.

BOOK 3: Follows on semiconductor technology, leading up to transistors and integrated circuits.

BOOK 4: A complete description of the internal workings of microprocessor.

BOOK 5: A book covering the whole communication scene.

### BP85: INTERNATIONAL TRANSISTOR EQUIVALENTS GUIDE \$12.25

ADRIAN MICHAELS  
This book will help the reader to find possible substitutes for a popular user-oriented selection of modern transistors. Also shown are the material type, polarity, manufacturer selection of modern transistors. Also shown are the material type, polarity, manufacturer and use. The Equivalents are sub-divided into European, American and Japanese. The products of over 100 manufacturers are included. An essential addition to the library of all those interested in electronics, be they technicians, designers, engineers or hobbyists. Fantastic value for the amount of information it contains.

### BP1: FIRST BOOK OF TRANSISTOR EQUIVALENTS AND SUBSTITUTES \$2.80

B.B. BABANI  
This guide covers many thousands of transistors showing possible alternatives and equivalents. Covers transistors made in Great Britain, USA, Japan, Germany, France, Europe, Hong Kong, and includes types produced by more than 120 different manufacturers.

### BP14: SECOND BOOK OF TRANSISTOR EQUIVALENTS AND SUBSTITUTES \$4.80

B.B. BABANI  
The "First Book of Transistor Equivalents" has had to be reprinted 15 times. The "Second Book" produced in the same style as the first book, in no way duplicates any of the data presented in it. The "Second Book" contains only additional material and the two books complement each other and make available some of the most complete and extensive information in this field. The interchangeability data covers semiconductors manufactured in Great Britain, USA, Germany, France, Poland, Italy, East Germany, Belgium, Austria, Netherlands and many other countries.

### TOWER'S INTERNATIONAL OP-AMP LINEAR IC SELECTOR \$13.45

TAB No.1216  
This book contains a wealth of useful data on over 5 000 Op-amps and linear ICs — both pinouts and essential characteristics. A comprehensive series of appendices contain information on specs, manufacturers, case outlines and so on.

### CMOS DATABOOK \$14.45

TAB No.984  
There are several books around with this title, but most are just collections of manufacturers' data sheets. This one, by Bill Hunter, explains all the intricacies of this useful family of logic devices... the missing link in getting your own designs working properly. Highly recommended to anyone working with digital circuits.

### BP68: CHOOSING AND USING YOUR HI-FI \$7.25

MAURICE L. JAY  
The main aim of this book is to provide the reader with the fundamental information necessary to enable him to make a satisfactory choice from the extensive range of hi-fi equipment now on the market.

Help is given to the reader in understanding the equipment he is interested in buying and the author also gives his own opinion of the minimum standards and specifications one should look for. The book also offers helpful advice on how to use your hi-fi properly so as to realise its potential. A Glossary of terms is also included.

See the order form on page 53

## Single IC Projects

R. A. Penfold

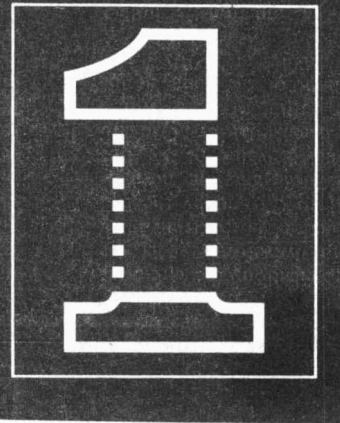

### Book Of The Month Single IC Projects.....BP65.....\$6.55

A book about the secret lives of unmarried chips, you say? Hardy. . . this is *exciting* stuff. While there is a certain satisfaction in having the truck from Texas Instruments off-load its entire contents in your garage, and thereafter to spend the next twenty seven years, four months and an afternoon building the world's most complex blender speed control, much of the real fun of electronics is experimenting with simple circuits. This is a book dedicated to this lofty purpose.

Covering diverse areas such as audio ICs, timers, op amps and even a simple radio receiver, *Single IC Projects* is ideal for the beginner who wants to learn by getting some hands on experience, or the seasoned hobbyist with soldering iron scars over three quarters of his body who just wants to leave the 32 bit missile launch controller aside for a few evenings. Easy to follow Vero board layouts are included for the circuits.

# Ni-Cads

**Rechargeable NiCad Batteries:**  
The perfect solution if your electric pile driver runs on D Cells. Shane Dunne explains.

ALL HOBBYISTS, at one time or another, consider using rechargeable batteries in their projects. Few actually do, however, because good information on nickel-cadmium and other types is too hard to come by. Most of the available information is either hopelessly general or too highly technical, and either type is useless.

This article is an attempt to provide a good working knowledge of nickel-cadmium power systems. The characteristics of nicad cells and batteries will be discussed, and it will be shown how these characteristics affect the design of chargers and power systems. As an example, the complete design procedure will be given for a blackout-proof computer power supply.

## Why Use Nicads?

Nickel-cadmium batteries or "nicads" have two major advantages over conventional types: They are rechargeable, and also capable of storing and delivering very high currents. Nicads are also lighter and more reliable than ordinary "dry cells". Their principal disadvantage is their initial cost, since the cells themselves are expensive and a charger must be purchased or built to make them useful. Of course, since one nicad can replace over a thousand dry cells, they are quite economical in the long run.

In contrast to other types of rechargeable batteries such as lead-acid or sealed-lead ("gel-cell") systems, nicads are superior in terms of weight, maintenance requirements (or more specifically, the lack of them), and general ruggedness. Lead-acid batteries are a better choice only when extremely high currents are required, and when weight and size are not important.

## How Nicads Work

Fig. 1 shows the construction of a typical sealed nicad cell. The elec-

trolyte, a liquid solution of a strong base such as potassium hydroxide, is more conductive than the paste electrolytes used in so-called "dry" cells. This results in a lower figure of internal resistance (see later) for these cells. Note that the electrodes or plates are rolled up to provide a large area of active chemicals in contact with the electrolyte and a very tight spacing between the plates. This design is used in the majority of sealed nicads because it allows the cells to work at maximum efficiency and further lowers the internal resistance. The plates themselves are porous and soak up the electrolyte, so that the actual surface area of contact between the plates and the electrolyte is considerably larger than the area of the plates themselves.

## Internal Resistance

The design techniques which lower the cell's internal resistance are

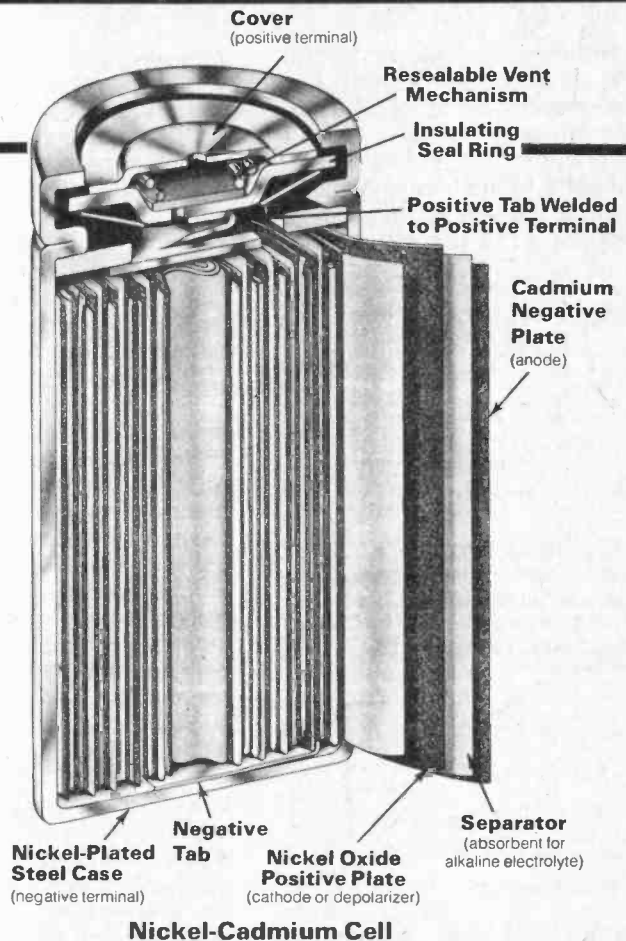

**Nickel-Cadmium Cell**

Fig. 1: reprint from "Packaged Power", page 33. Cutaway view of a typical nicad cell. Note how the electrodes or plates are rolled up to provide a large area of contact with the electrolyte, combined with tight spacing between cathode and anode. This design minimizes internal resistance. (Courtesy Duracell Products)

highly important, because this resistance determines the maximum current that the cell deliver to a load. Imagine a 1.5 Volt cell short-circuited by a heavy wire whose resistance is only 10 milliohms, as in fig. 2A. Ohm's law tells us that the current in this little circuit will be

$$I = \frac{V}{R} = \frac{1.5 \text{ V}}{0.01 \text{ R}} = 150 \text{ Amperes!}$$

In practice the current can never be this great. The material of which the cell is composed and its chemical efficiency combine to present an effective resistance to current flow within the cell. To an external circuit, the cell therefore "looks" like an ideal voltage source E (a quite imaginary beast capable of supplying infinite current) in series with this internal resistance. This is shown in fig. 2B. E is referred to as the open-circuit voltage of the cell, since it is the

voltage which would appear at the terminals if no load were connected.

Analyzing the circuit of fig. 2B by the rules of series circuits reveals some interesting things. The current in the circuit is limited not only by the resistance of the wire, but by the internal resistance of the cell as well.

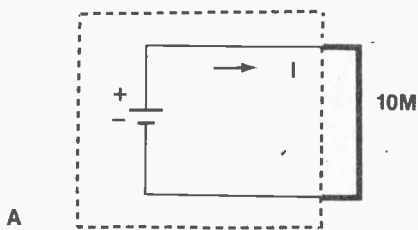

**Internal Resistance: Shorting a 1.5 Volt battery with a heavy wire, one would expect a massive current (A), but in practise the current is severely limited by the battery's own internal resistance (B).**

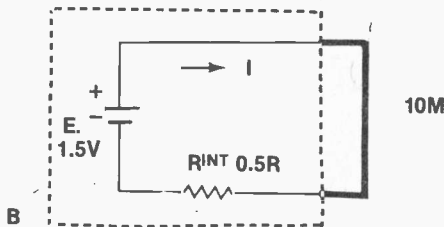

Furthermore, the two resistances form a voltage divider, so the voltage across the cell's terminals must be less than 1.5 volts. To see the extent of these two effects, a numeric value for the internal resistance is needed, which might be 0.5 Ohms for a typical dry cell. The current in the circuit of fig. 2B is therefore

$$\frac{1.5V}{0.5\Omega + 0.01R} = 2.9 \text{ Amperes}$$

which is considerably less than the previous estimate. Each of the resistances will produce a voltage drop which may be calculated by Ohm's law. The drop across the cell's internal resistance is

$$V_{RINT} = 2.99A \times 0.5\Omega = 1.47 \text{ Volts}$$

So all that is left to appear across the cell's terminals is

$$1.5 - 1.47 = 0.03 \text{ Volts}$$

Not much! This is why the internal resistance of any power source must be kept as low as possible for high-current applications. Nicads, with a typical internal resistance of about 28 milliohms when fully charged, are hence ideal for such applications.

### Charging and Discharging

Nicads are rechargeable because they are powered by easily reversible chemical reactions. These reactions occur between the electrolyte and the plate surfaces to provide electrical current during discharging, at the expense of chemical energy within the cell. Forcing current from an external (charging) source causes these reactions to occur in reverse, restoring chemical energy to the cell.

It is theoretically possible to recharge any type of cell in this way. Practically, however, some cells cannot be recharged because in discharging they undergo a physical change as well as a chemical one. A conventional carbon-zinc cell, for example, discharges when its electrolyte literally dissolves its zinc casing. Forcing current back through the cell would plate some of the dissolved zinc back onto the casing, but such an attempt at recharging would be inefficient and dreadfully slow. (Furthermore, the cell would have been structurally weakened and might explode from internal heat and pressure.) In nicads, the charging and discharging reactions merely change the chemical state of the electrode surfaces, and the electrolyte is unaffected. Hence the reactions are easily reversible without risk.

### Discharge Characteristics

The graph of Fig.3 shows how the output voltage of a nicad cell varies as it is discharged into a constant load such as a resistor. The voltage remains fairly constant over nearly the entire discharge time, a feature which makes nicads extremely useful with voltage-sensitive circuitry. The slow decrease in output voltage is due to a gradual lowering of the cell's efficiency, and hence a decrease in the open-circuit voltage (E in fig. 2B). When the

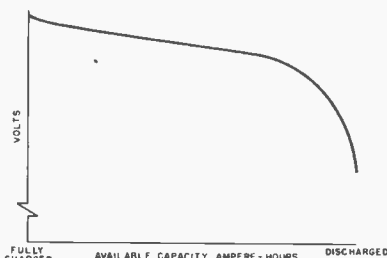

**Fig. 3: reprint from GE nicad handbook, page 6-1. The curve shows how the voltage of a typical nicad varies as it is discharged.**

cell is almost completely discharged, its internal resistance rises sharply, causing the sudden decrease in output voltage at the end of the curve. By contrast, ordinary carbon-zinc cells show changes in both internal resistance and open-circuit voltage as they discharge. Their discharge curve has a much more pronounced downward tendency, as shown by the dashed lines in Fig. 3.

The time that the nicad produces usable output current, multiplied by the amount of current delivered, yields an important figure of merit for the cell. This is called capacity and is given in Ampere-hours (A-h). A nicad rated for one Ampere-hour could deliver one ampere to a load for one hour, or one-half ampere for two hours, and so on. Another important figure for nicads is the C rate in amperes, numerically equal to the capacity. As will be shown, expressing charge and discharge currents in terms of the C rate is useful in cell selection and charger design.

### Charge Characteristics

The graph of Fig. 4 shows how the terminal voltage of a nicad varies as it is charged at the C/10 rate (for a 500 mA-h cell, C/10 would be 50 mA). Within minutes after the start of charging, the voltage rises to about 1.4 Volts and stays fairly constant as the cell draws energy from the charger. As the cell approaches full charge, the voltage rises slightly again.

During the actual charging time (under the level portion of the curve in Fig. 4) the cell undergoes chemical reactions which are the reverse of those which will provide power during discharging. Once the cell is fully charged, and its active materials have been restored to their original

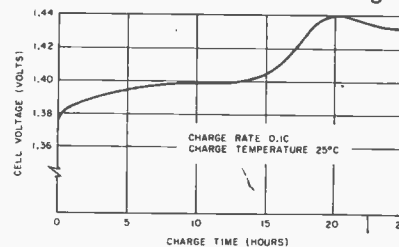

**Fig. 4: reprint from GE nicad handbook, page 4-10. During charging, the voltage across the terminals of a nicad rises quickly at the start of the cycle and remains nearly constant until the end, at which point it rises slightly again. This final voltage rise may be detected and used to switch off a charger. (Courtesy General Electric)**



chemical state, different reactions occur if the charging current is continued. This condition is called overcharging. The most important overcharging reaction is the electrolysis of the water in the cell's electrolyte, breaking up the water into its component gases. Sealed nicads are designed to re-absorb these gasses, but they can only do so at a fixed rate. The recharging current must therefore be limited during overcharging, so that gases are not generated faster than they can be absorbed. Most nicads can withstand an overcharge current of  $C/10$  indefinitely, although "quick-charge" types are available which can withstand up to  $C/3$ .

### Charging Methods

There are four basic categories of charging methods for nicads. Constant-potential, constant-current, "fast", and timed.

Constant-potential charging is used only for large "vented" nicads, typically in aircraft applications. These cells can withstand high overcharge currents because their design allows gases to escape through a low-pressure vent. In constant-potential charging, the cell or battery is connected through a resistor to a regulated power supply as in Fig. 5A. The output voltage of the supply is adjusted so that it will be cancelled out by the battery's voltage as it rises at the end of the charging cycle.

Constant-current charging is the most common method of charging sealed nicads, and is used in most consumer products, such as calculators. In some cases, a transistor constant-current source is used as in Fig. 5B, but usually a simple unregulated and unfiltered supply is connected through a resistor to the nicad to be charged, as in Fig. 5C. This last approach is called "modified constant-current" charging, because the charging current involved varies somewhat over the charging cycle.

Filtering and regulation are not really necessary because nicads themselves act as very good ripple filters. The current variations over the charging cycle are also unimportant, because only the overcharge current requires limiting. Modified constant-current charging is usually done at the "slow" rate of  $C/10$  so that the nicad can simply be connected to the charger and left alone for an indefinite period.

Full charging at the slow rate

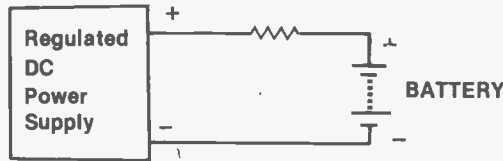

A

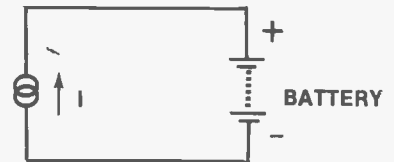

B

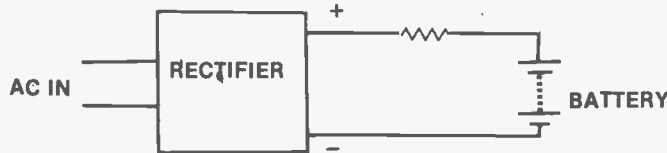

C

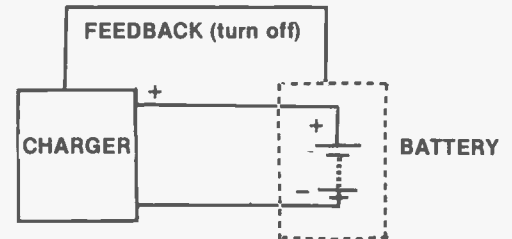

D

Four charging configurations: (A) constant potential; (B) constant-current; (C) modified constant current; (D) fast charging with automatic shut-off.

usually takes 12 to 14 hours. The so-called "quick-charge" cells can be completely charged at the "quick" rate of  $C/3$  in 3 to 5 hours. For standby power system, nicads are often kept charged at a "trickle" rate between  $C/10$  and  $C/100$ . Such a rate is too low to efficiently recharge a discharged cell, but very good for keeping a charged one at full capacity without risk of damage.

"Fast" charging implies that a rate of  $C$  or greater is used, and that some form of feedback device limits the current once overcharging begins. This is shown in block form in Fig. 5D. The feedback may be from a precisely-calibrated voltage com-

parator (activated by the small rise in cell voltage at the beginning of overcharging), or from a thermistor (activated by heat generated within the cell during overcharging), or from a pressure sensor within the cell.

Timed charging involves "dumping" a very high current into a nicad for a controlled time, and is the fastest way to partially recharge nicads. Calculation of the current and time interval require knowledge of all the characteristics of the cell or battery, and its initial state of discharge.

### Charger Design

Only the modified constant-current

approach will be discussed further, because it is the easiest and most economical. Serious experimenters should consult some of the references at the end of this article for information on the other techniques.

Fig. 6 is a circuit for a regulated,

Note that T2 is connected directly across the AC line, so the battery is always kept charging. Power switch S1 controls AC power to T1 (S1a) and also isolates the battery from the regulator (S1b) while the AC-powered supply is "off". S2 selects one of two charging rates: "trickle" charging for

The C size nicads used have a capacity of 1.5 A-h and hence a "C" rate of 1.5 A. The trickle rate of C/100 is therefore 15 millamps, which is the value used for  $I_{CH}$ .

$K_1$  is found in terms of

$$\frac{E_B + E_D}{E_S}$$

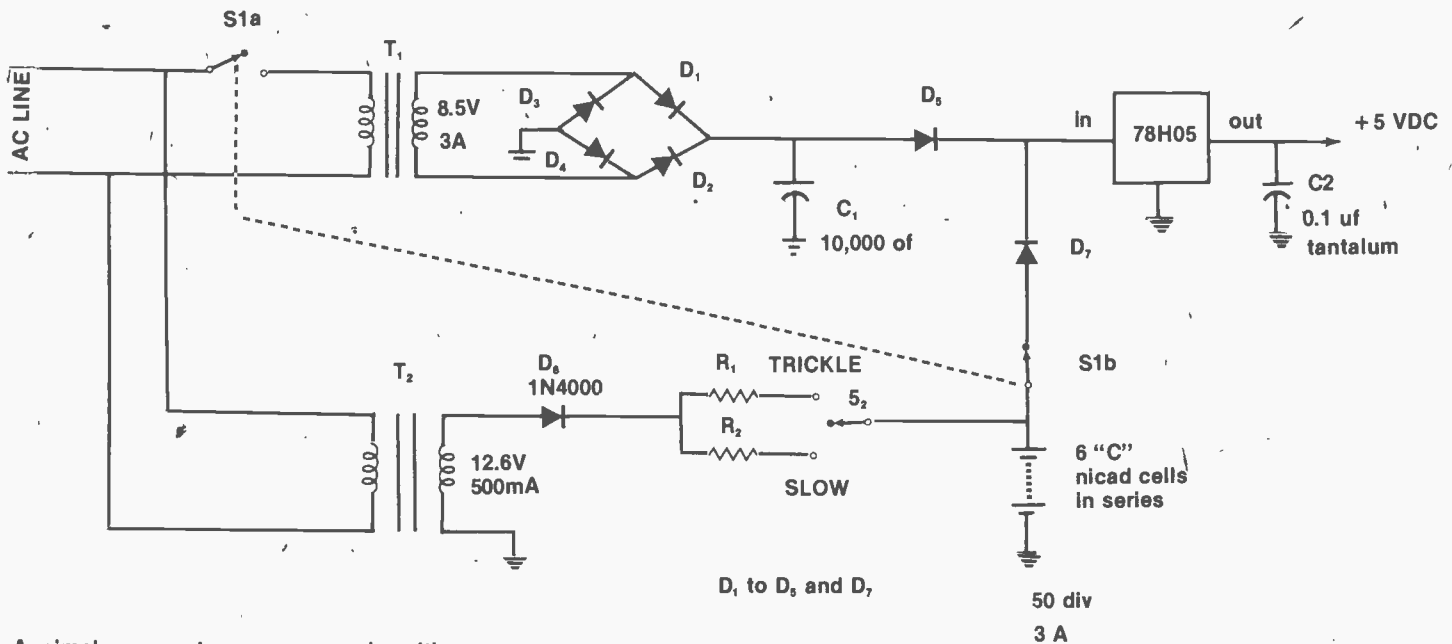

A simple computer power supply with nicad battery backup. Diodes D5 and D7 form a current-steering network to smoothly switch from AC to battery power.

blackout-proof 5-volt power supply, suitable for use with a small computer. Dissection of this circuit will reveal the most important aspects of nicad charger and power system design.

T1, D1 to D4, C1, C2 and VR1 form a simple regulated 5-volt power supply which can deliver up to 5 Amps, depending on the size of transformer used. T2, D6, R1 and R2 form a modified constant-current charger, similar to that in Fig. 5C, for the battery of six C cells in series. The simple current-steering circuit, consisting of D5 and D7, allows the supply to switch from AC to battery power without noise spikes occurring at the output. Normally, the AC-powered supply produces a higher voltage than the battery, keeping D7 reverse-biased and preventing current from being drawn from the battery. When the AC line fails, however, D7 conducts and battery power is delivered to the regulator.

normal operation and the "slow" rate for efficient recharging after a power failure.

General electric's Nickel Cadmium Battery Application Engineering Handbook supplies the following information for determining the values of R1 and R2. In order that these may be within the normal range of resistor values, the rather high value of 12.6 VAC was selected for transformer T2. For any half-wave, modified constant-current charger, the value of the charging resistor is given by

$$R = \frac{0.45 E_S K_1}{I_{CH}}$$

where  $E_S$  is the RMS voltage of the transformer (12.6 Volts),  $K_1$  is a constant from the graph of Fig. 7, and  $I_{CH}$  is the desired over-charge current. The formula is the same for both R1 and R2, so the full design procedure will be given for R1 (trickle rate) only.

Where  $E_D$  is the voltage drop of the diode D6 and  $E_B$  is the battery voltage during charging (recall Fig. 4). For

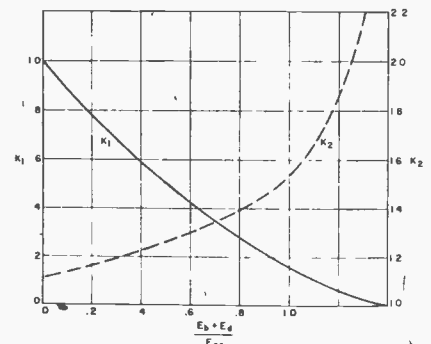

Fig. 7: reprint from GE nicad handbook, page 5-6. Graph provides constants to simplify design of nicad charger circuits. (Courtesy General Electric)

Continued on page 70

The future belongs to the creative electronics technician.

# NEW FROM NRI... ELECTRONIC DESIGN TECHNOLOGY TRAINING

**Be prepared to grow with the world's biggest growth industry. Enroll now in this exciting career program from the leader in electronics training.**

The best jobs in electronics go to the people who can think and work creatively. The people who can conceive and design circuits and equipment command up to \$18,000 as starting salaries, earn \$30,000 or more with experience and ability. And NRI can help you join their company.

## **The First Complete Program of Its Kind**

This new course starts with the fundamentals and builds from there to prepare you for an electronic career where the growth is. You're trained for exciting jobs in the creation of communications equipment, computers, consumer products, anything that needs electronic circuits.

And you learn at home in your spare time, without quitting your job or wasting time, travel, and gas going to night school. You learn with NRI-developed training methods that combine knowledge with practical experience.



**Your training includes all these laboratory and professional working instruments.**



## **NRI Circuit Designer Gives Hands-On Experience**

You actually design and build modern electronic circuits, run tests, and verify specs. You learn how various systems interact, design your own circuits to perform specific tasks, learn to look for better ways and new ideas.

The NRI Circuit Designer is a totally unique instrument with full breadboarding capability, built-in multiple power supplies and multi-function signal generator for circuit testing. Fast, simple connections let you build up prototype circuits, immediately check them out for function or faults. It handles both linear and digital integrated circuits as well as discrete components such as transistors and diodes. Six practical lab units carry you through both the theoretical and practical world of electronic circuit design.

## **Professional Working Instruments**

Your course also includes the choice of the professionals...the 6-function, 26-range Beckman digital multimeter for fast, accurate voltage, current, and resistance measurements. It features accurate LCD readout and full portability. You also get the famous Texas Instruments TI-30 scientific calculator to speed and simplify circuit analysis and design. It's a true engineering instrument that includes trigono-

metric functions as well as square root, logarithms, and memory.

## **NRI Fast-Track Training**

The unique NRI lesson concept simplifies and speeds learning. Especially written for individual instruction, each lesson covers its subjects fully and thoroughly. But extraneous material is eliminated, language is clear and to the point, organization is logical and effective.

You'll start with subjects like Fundamentals of Electronic Circuits, progress rapidly through Circuit Theory to Solid-State Electronics and on to Digital Electronics, Computers, and Microprocessors. Hand in hand with your theory will be practical Design Lab experiments, circuit demonstrations, and test/measurement procedures that make it all come to life.

## **No Experience Necessary**

You need absolutely no electronic experience to be successful with this modern course. If you're a high school graduate with some algebra you should handle it without any trouble. We even include, at no extra charge, the NRI Math Refresher Module, designed to help you brush up on your math and teach you any new concepts you may need.

## **Rush Card for Free Catalog**

Send the postage-paid card for our free, 100-page catalog with all the facts about this and other NRI electronics courses. We'll rush it right to you without obligation. Look it over and discover for yourself why only NRI can prepare you so well for your future. If card has been removed, please write to us.



**NRI Schools**  
McGraw-Hill Continuing  
Education Center  
330 Progress Avenue  
Scarborough, Ontario M1P 2Z5  
or telephone 416-293-1911

**We'll give you tomorrow.**

# next month

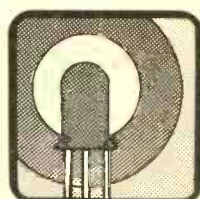
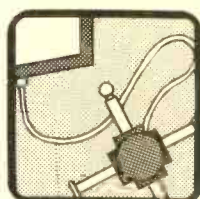
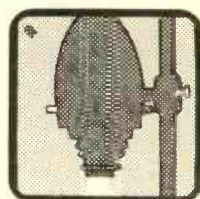
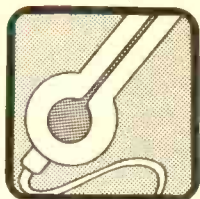
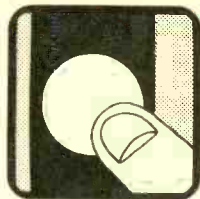
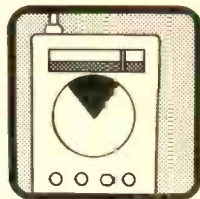

## 10 New projects for you to build

- (LEFT TO RIGHT) STEAM LOCO WHISTLE • AM RADIO •  
• TOUCH LAMP • ELECTRONIC DOORBZZER •  
• ELECTRONIC THERMOMETER •  
• uPOWER THERMAL ALARM • PHOTO TIMER •  
• BACKGROUND NOISE SIMULATOR POWER PACK •  
• LOW POWER PILOT LAMP •



*At the time of going to press, the articles mentioned are in an advanced stage of preparation. However, circumstances may result in changes to the final contents of the magazine.*

# COMING TO ETI



# Ni-Cad Charger

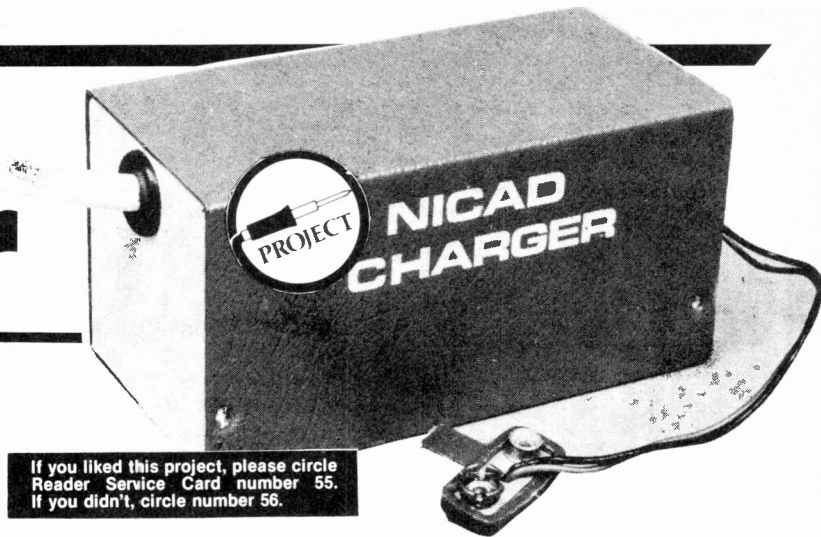

If you liked this project, please circle Reader Service Card number 55. If you didn't, circle number 56.

Return your Nicads to the glow of health without risking the glow of internal melting.

ISN'T IT SAD — just when you want to listen to your favourite radio programme on your little squawk-box, you inevitably find the batteries are defunct. And don't they cost a lot to replace? Well, here is the answer to all your problems — rush out and buy some nicad cells for your battery-powered calculator, transistor radio or cassette player etc. Although they are more expensive initially, you can recharge them again and again on the ETI Nicad Charger, thus saving \$\$\$\$\$\$ overall! With this project, whenever your batteries run down an overnight charge will revitalise them to their full vigour.

Nicad cells can be recharged many hundreds of times but they need a regulated charge current. Our charger provides this regulation and, in the mode shown in Fig. 2, it will handle up to six AA size cells. It can be easily modified to suit other sizes as described below.

Nicads need a constant current charge. For example AA cells need about a 65 mA charge, for a set period (normally 12 hours and so an overnight charge is ideal). For other sizes of cells, different charge currents are required. The table in Fig. 1 shows typical values of current required for various-sized cells. Altering our charger to suit other cells is a cinch, as the output current is set solely by R1.

Its value in ohms is equal to:

$$\frac{0.65}{\text{the required charge rate in amps.}}$$

the required charge rate in amps.

So, for any required charge current, choose the nearest preferred value of resistor to the calculated value.

Output currents of more than 80 mA will require a larger transformer because this should have a secondary current rating at least 20 mA more than the charge current. Higher charge currents might also make it

necessary to fit Q1 with a more substantial heatsink.

### Construction

The components are mostly assembled on one standard-size (24 holes by 10 strips) 0.1" pitch Veroboards as can be seen from the wiring diagram of Fig. 3. Transformer T1 is not mounted on the board, but is bolted to the inside of the case. For reasons of safety the case should be a type having a screw-on lid, and must not be a clip-on type. If a metal case is used it must be connected to the AC ground. It is likely that T1 will have

flying leads rather than tags, and a connector block will then be needed to facilitate the connections between the AC cord and T1. The ground lead to the component panel can also be taken via this block. Connector blocks are usually sold in twelve-way strips, and the required three-way block can be cut from one of these using a sharp knife.

The output of the unit can be taken to a 9V type battery connector, making quite sure that it is connected with the correct polarity. Plastic battery holders for AA size cells are readily available, and these have a 9V type connector. These holders connect the batteries in series (connected '+' to '-') — the batteries must never be connected in parallel ('-' to '-' and '+' to '+').

Q1 may become quite hot in use and should be fitted with a small heatsink.

SIZE OF CELL	CHARGE CURRENT (FOR 12hr CHARGE)
9V	100mA
AAA	20mA
AA	65mA
C	250mA
D	500mA

Fig. 1 Table of charge currents for various cells.

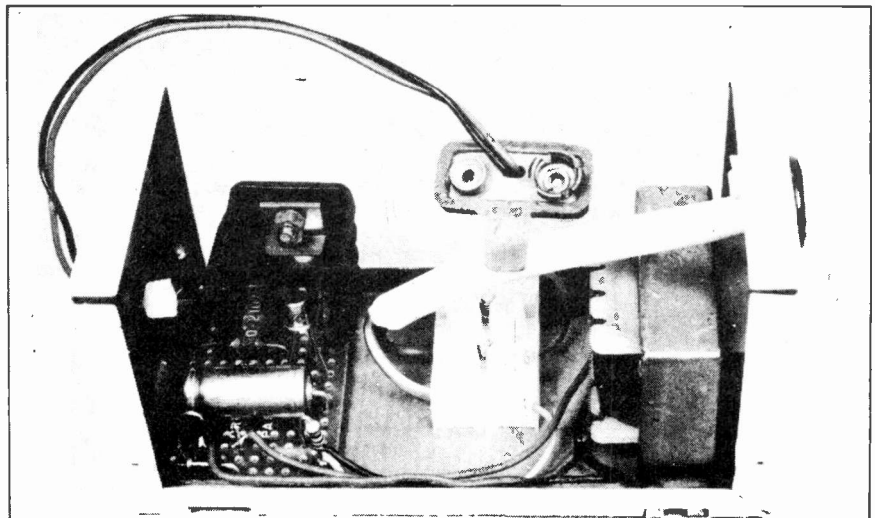

The interior of the charger

HOW IT WORKS

The line voltage is stepped down to a more suitable potential by transformer T1, with D1, D2, and C1 then full-wave rectifying and smoothing the output of T1 to give a low voltage (about 14V under load) DC supply. This supply cannot be connected directly across the nicad cells as these have an extremely low internal resistance, and would place virtually a short circuit across the supply. The supply in turn would damage the cells, which should not be charged at a higher current than that recommended by the manufacturer, and would also result in the destruction of the supply circuit!

A current regulator must be included to ensure that the cells are charged correctly, and this is the purpose of Q1, Q2, R1 and R2, which are used in a conventional constant-current generator configuration. Transistor Q1 is biased hard into conduction by R2, and current therefore flows through R1, Q1 and the cells being charged. The current is limited to a safe level by Q2 which becomes biased into conduction by the potential developed across R1. This results in Q2 tapping off some of the base current for Q1, so that the impedance of Q1 increases.

Therefore, even with a low impedance across the output, such as

that of the nicad cells, the output current passed by Q1 is stabilised by Q2 at a safe level, since Q2 can reduce the bias on Q1 to practically zero if necessary. As Q2 is a silicon device it requires a base bias voltage of about 0.65 V to bring it into normal conduction, and so the circuit stabilises with about this potential across R1. From Ohm's Law it can be seen that about 65 mA flows through R1, Q1, and the cells under charge (0.65 V divided by 10R gives 0.065 A, or 65 mA), which is about the correct charge for AA size cells.

PARTS LIST

RESISTORS (All 1/3 watt 5%)

- R1 10R
- R2 680R

CAPACITOR

- C1 100u 25V electrolytic

SEMICONDUCTORS

- Q1 TIP41A NPN power transistor
- Q2 MPS6515 NPN Transistor
- D1, D2 1N4002

MISCELLANEOUS

- T1 12-0-12V 100mA transformer
- 10 x 24 hole 0.1" Veroboard case, battery holder, battery clip, AC cord, connector block, fitted heatsink, etc.

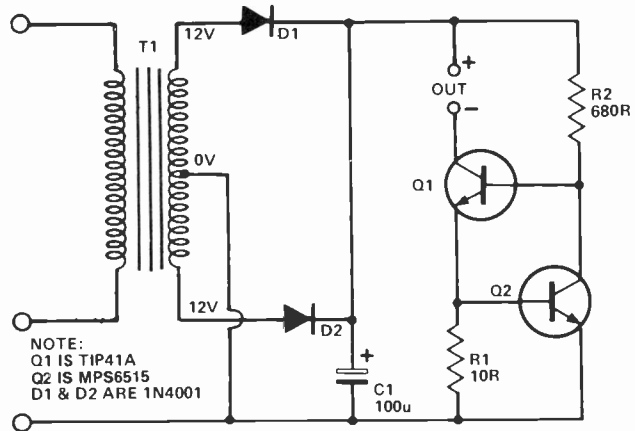

NOTE:  
Q1 IS TIP41A  
Q2 IS MPS6515  
D1 & D2 ARE 1N4001

Fig. 2 Circuit diagram.

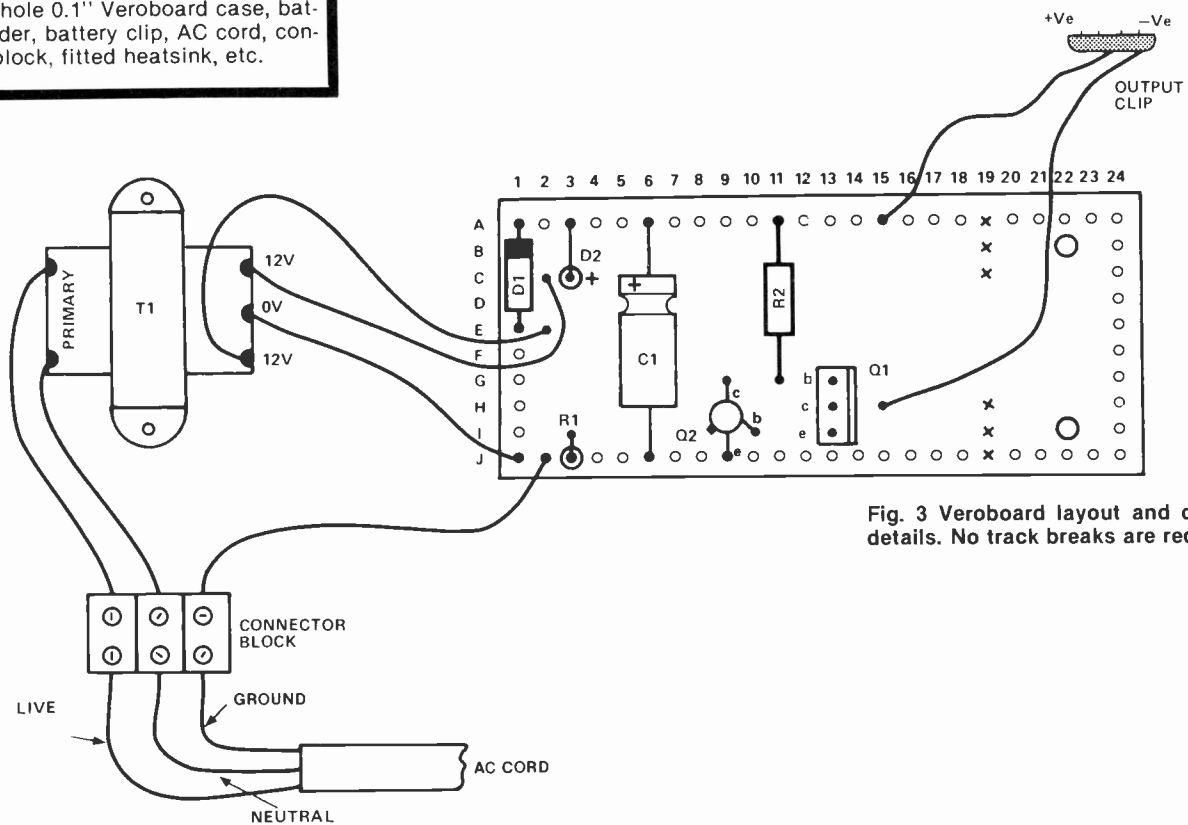

Fig. 3 Veroboard layout and connection details. No track breaks are required.

**PROFESSIONAL PRODUCTS** **VERO**

for your free catalogue  
circle No. 16 on readers service  
card

**VEROBOARD  
CIRCUIT  
BOARDS  
ACCESSORIES  
MODULE  
SYSTEMS  
CASES &  
BOXES**

Dealers reply on letterhead

**EPS** Electronic Packaging Systems Ltd.  
Retail Dept., P.O. Box 481,  
Kingston, Ontario K7L 4W5  
Telephone (613) 384-1142

Circle No. 16 on Reader Service Card.

**ACTIVE SURPLUS ANNEX**  
345 QUEEN ST. W.  
TORONTO, ONTARIO  
M5V 2A4  
368-7936

**THE LARGEST VARIETY OF  
ELECTRONICS RELATED ITEMS  
AT THE LOWEST PRICES IN  
TOWN!**

<p><b>SONY TVs</b></p> <ul style="list-style-type: none"> <li>— 5" — \$45.00, 7" — \$55.00</li> <li>— OPERATE ON 12 VOLT dc ONLY</li> <li>— VHF &amp; UHF TUNERS</li> <li>— BLACK AND WHITE PICTURE</li> <li>— MONITOR FOR COMPUTER</li> <li>— TV'S ARE USED AND DO REQUIRE SOME WORK</li> <li>— TEST FACILITIES ARE PROVIDED</li> <li>— SCHEMATICS INCLUDED</li> </ul>	<p><b>64K RAM BOARD</b></p> <p>PROVIDES A LOW COST MEANS FOR EXPANDING RAM CAPABILITY FOR COMPUTERS UTILIZING THE S-100 BUS SYSTEM COMPLETE DATA AVAILABLE. CAN BE INTERFACED TO</p> <ul style="list-style-type: none"> <li>— IMSAI</li> <li>— ALTAIR A</li> <li>— ALTAIR B</li> <li>— SOL-8</li> <li>— CROMEMCO</li> <li>— SBC-100</li> <li>— Z80 CPU-B</li> </ul>
<p><b>VIDEOTONE BOOKSHELF SPEAKERS</b> 30 WATT <b>\$65.00 PAIR</b></p>	<p><b>\$250.00</b></p>
<p align="center">• <b>ETI BOARDS</b> • <b>OVER 140 IN STOCK</b></p>	
<p>12" HITACHI MONITOR REQUIRES COMPOSITE VIDEO 12 MHz BANDWIDTH <b>\$85.00</b></p>	<p>CASSETTE TAPE \$1.00 TANTALUM CAPACITORS 5/s1.00 IN 4007 DIODES 10c each /100/\$6.50 MUFFIN FANS \$6 to \$20.00 ea. ZENER DIODES 20c to \$1.75 WE ALSO CARRY A WIDE AND ALWAYS CHANGING SUPPLY OF SEMICONDUCTORS, RESISTORS AND CAPACITORS</p>
<p>NI-CAD BATTERY PACKS 4 SUB-C BATTERIES 4.8 VOLT 1.2 AL <b>\$5.00</b></p>	
<p align="center"><b>FOR MAIL ORDER INFORMATION WRITE P.O. BOX 683, STATION Q, TORONTO, CANADA M4T 2N5</b> PRODUCTS AVAILABLE WHILE QUANTITIES LAST</p>	

Circle No. 18 on Reader Service Card.

# RAEKIT

Quality Electronic Kits For Over A Decade

## LED VU/Peak Meter Kit



- 12 LED's
- Red, green, yellow
- Horizontal or vertical mount
- Fast "attack" time
- Peak-Hold Switch
- Split ± 12 Volt Supply

#2100 Meter \$22.95  
#2101 Dual Supply \$19.95

### MAIL ORDER INFORMATION

Payment by VISA/Mastercard (Include signature, number and expiry date), cheque or money order. Add \$2.00 for shipping, B.C. residents add 6% Sales Tax. Visit our new Edmonton store

RA-E Industrial Electronics Ltd.  
3455 Gardner Court, Burnaby, B.C.  
V5G 4J7 Phone: (604) 291-8866



Circle No. 4 on Reader Service Card.

# SATELLITE TV

SATELLITE HANDBOOK — \$5.00



**DEXCEL DXP 1000 SATELLITE SYSTEM**

## \$2995

The DXP 1000 system is the latest in state-of-the-art satellite communication components from DEXCEL. The system consists of the DXR 1000 Receiver and the Dexcel low-noise amplifier/down-converter. It is designed for audio and video reception superior to standard earth facilities.

A six-channel audio selector allows the complete selection of six subcarriers, and the DXP 1000 is able to receive 24 distinct channels with amazing clarity. The 70-MHz input connector accepts standard coaxial termination from the antenna.

BRANCH OFFICES: MONTREAL (514) 286-4031 TORONTO (416) 281-3457 WINNIPEG (204) 895-2031 SEATTLE (206) 575-8367

SOME FRANCHISES STILL AVAILABLE



(604) 324-3303 **No. West Video Systems Ltd.**  
6590 VICTORIA DRIVE, VANCOUVER B.C. V5P 3X9

Circle No. 13 on Reader Service Card.

# ORION

Electronic Supplies Inc.

ELECTRONIC DISTRIBUTOR

INDUSTRIAL — EDUCATIONAL — COMMERCIAL — HOBBYIST

RCA

COSMAC  
VIP

Authorized distributor for RCA, COSMAC, VIP

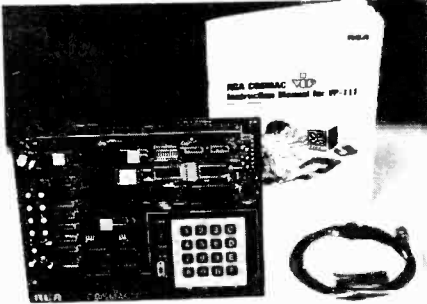

New! VP 111 Microcomputer \$139.50

- Assembled\* and tested.
- Features
- RCA 1802 Microprocessor
  - 1K Bytes static RAM
  - Expandable on-board to 4K
  - Expandable to 32K Bytes total
  - 512 Byte ROM operating system
  - CHIP? Interpretive language or machine language programmable
  - Hexadecimal keypad
  - Audio tone generator
  - Single 5-volt operation

- Video output to monitor or modulator
  - Cassette interface—100 Bytes/sec
  - Instruction Manual with 5 video game listings, schematics, CHIP-8 much more
- Ideal for low cost control applications
- Expandable to full VIP capability with VP-114 Kit
- \*User need only connect cables (included) a 5 volt power supply and speaker

START WITH ORION FOR A NEW ERA IN THE WORLD OF ELECTRONICS

We have the most complete selection of electronic components.

Full line of TTL, CMOS, Linear, ICs, Computer Interface, Support Chips and CPUs.

INTERACT COMPUTER 16K LEVEL II

Just \$595.

Write for our Flyer on Interact Computer



A powerful microcomputer with a full standard 53 key typewriter style keyboard and built-in cassette recorder for use in entering and storing programs. Utilizing the versatile Intel 8086 microprocessor, the Interact computer has 16K of RAM and 2K of ROM at its disposal. Output is in color on your own TV screen. Sound is also generated through your TV set and can consist of exhilarating computer beeps or two full octaves of music. This is truly a powerful computer capable of developing and handling a variety of programs, and with available software provides true educational stimulus (examples: Star Track, Chess, Concentration, etc.). The Interact Computer offers the ideal opportunity to learn BASIC, the most popular computer language for small business and hobbyists, and with the use of the 84 page manual, you learn at your own pace.

INSTALLATION: Attach to antenna terminals of your color TV set and plug into 120 VAC wall outlet. Computer includes built-in RF modulator, FCC approved and UL and CSA listed.

PROGRAMING: Most Micro-computers start you off with an abbreviated 4K BASIC, and then later you have to relearn the more powerful language. Since this computer has 16K of RAM, we start you with Level II Microsoft 4.7 BASIC. BASIC is the most popular Micro-computer language using commands that are words we are ordinarily used to, such as, PRINT, NEW, GOTO (For go to), END, COLOR, JOY, INPUT, etc. To help you learn programming we have included an 84 page instruction manual, plus a 20 page book of program examples.

## The ZX81 Personal Computer Kit \$149.95

NEW

The ZX81's advanced capability. The ZX81 uses the same fast microprocessor (Z80A), but incorporates a new, more powerful 8K BASIC ROM — the "trained intelligence" of the computer. This chip works in decimals, handles logs and trig, allows you to plot graphs, and builds up animated displays. And the ZX81 incorporates other operation refinements — the facility to load and save named programs on cassette, or to select a program off a cassette through the keyboard.

to eight decimal places. \*Graph-drawing and animated-display facilities. \*Multi-dimensional string and numeric arrays. \*Up to 26 FOR/NEXT loops. \*Randomize function. \*Programmable in machine code. \*Cassette LOAD and SAVE with named programs. \*1K-byte RAM expandable to 16K. \*Full editing facilities. \*Able to drive the new Sinclair ZX Printer (to be available shortly). If you own a ZX80...

New, improved specification. \*Unique "one-touch" key word entry: eliminates a great deal of tiresome typing. Key words (PRINT, LIST, RUN, etc.) have their own single-key entry. \*Unique syntax-check and report codes identify programming errors immediately. \*Full range of mathematical and scientific functions accurate

The new 8K BASIC ROM as used in the ZX81 is available as a drop-in replacement chip. (Complete with new keyboard template and operating manual). With the exception of animated graphics, all the advanced features of the ZX81 are now available on your ZX80 including the ability to drive the Sinclair ZX Printer.

16K Memory Expansion Kit (No P.C. Board) \$89.95

Educational and Entertaining

ASCII Keyboard Fully encoded, 128-character ASCII alphanumeric keyboard. 58 light touch keys (2 user-defined). Selectable. Upper-Case-Only. VP-601	\$109.75
ASCII/Numeric Keyboard ASCII Keyboard identical to VP-601 plus 16 key numeric entry keyboard for basic math numbers. VP-611	\$149.75
Cable: ASCII Keyboards to VP-711 Flat ribbon cable. 24 in. length for connecting VP-601 or VP-611 and VP-711. Includes matching connector on both ends. VP-620	\$27.50
Cable: ASCII Keyboards Flat ribbon cable. 36 in. length with mating connector for VP-601 or VP-611 Keyboards. Other end is unterminated. VP-623	\$27.50

Orion Electronic Supplies Inc.  
40 Lancaster Street West  
Kitchener, Ontario N2H 4S9  
(519) 576-9902

Master Charge & Visa, COD, Cheque, Money Orders accepted. CODs, SHIPPING & insurance extra. Write for our FREE catalogue!

# HICKOK MX SERIES DMM's

## World's Fastest Troubleshooters



MX333 \$325.00  
MX331 \$219.00

Compact size, unique shape and easy-to-read-from-almost-any-angle slanted display facilitates use as a hand held, bench top or belt mounted instrument.

VARI-PITCH, audible signal on MX333 provides instant indication of the resistance, voltage or current measured for quick and easy troubleshooting. The audible response is instantaneous and proportional to the reading.

- 0.1% Basic Accuracy
- LCD Display In Unique Wide View Case
- Uses Single 9V Battery
- Compact Size. Rugged Construction
- Superior Overload Protection
- Exclusive VARI-PITCH Audible Output (MX333)
- Fast LOGI-TRAK Logic Function (MX333)
- 20Ω Range (MX333)

LOGI-TRAK function on MX333 combines the features of a high performance logic probe and voltmeter in one convenient function. Use any 10:1 high frequency scope probe to measure all logic signals and DC voltages from 10mV to 20V. Audible tone output identifies logic Hi's, Lo's, pulses as narrow as 5 nsec as well as marginal and faulty logic states and pulse trains.

Duty and FST included. Charge (Visa) accepted. Ont. res. add 7% sales tax. Shipping Extra.

**ROGERS** electronic instruments ltd.

P.O. Box 310, 595 Mackenzie Avenue Units 1 & 2  
Ajax, Ontario L1S 3C5 Tel. (416) 683-4211

CONDENSED SPECIFICATIONS: MX331 and MX333

DC VOLTS (5 RANGES): 200mV to 1000V full scale. RESOLUTION: 0.1mV. ACCURACY: ±0.1%. ±1 digit. INPUT IMPEDANCE: 10MΩ. OVERLOAD PROTECTION: 1000V DC or peak AC + up to 6kV transients all ranges.

AC VOLTS (5 RANGES): 200mV to 1000V full scale. RESOLUTION: 0.1mV. ACCURACY: ±1% + 2 digits, 45 Hz to 1kHz. ±5% + 5 digits to 5 kHz. INPUT IMPEDANCE: 10mΩ. OVERLOAD PROTECTION: 1000V DC/750 RMS.

RESISTANCE (7 RANGES): 20Ω to 20MΩ full scale except no 20Ω range on MX331, RESOLUTION: 0.01Ω on MX333, 0.1Ω on MX331. ACCURACY: 0.1% + 1 digit except 0.2% on 200Ω. 1% on 20MΩ and 3% on 20Ω ranges. OVERLOAD PROTECTION: 500V DC on RMS all ranges plus 2A fuse on 20Ω range. TEST VOLTAGE: Low power, 0.25V max of full scale.

DIODE TEST (1 RANGE): Measures forward voltage drop across diode and transistor junctions at 2mA nominal current.

AC/DC CURRENT (5 RANGES): 2mA to 10A full scale. RESOLUTION: 1μA. ACCURACY: ±1.2% + 1 digit DC. ±2.5% + 1 digit AC. OVERLOAD PROTECTION: 250V @ 2A all ranges except 10A, max 15A on 10A range.

VARI-PITCH (MX333 ONLY): Variable pitch proportionate to reading, off at open circuit. Increasing frequency as resistance approaches "0" on ohms function. Increasing frequency as input increases on volts and current functions. RESPONSE: Instantaneous (less than 100 msec.).

LOGI-TRAK (MX333 ONLY): 0-20V range using Hickok SP-7 (not incl.) or other 10:1 scope probe. HI/LO INDICATION: High or low audible tone. PULSE INDICATION: Audible "chirp" plus lighted colon on display. MIN PULSE WIDTH: 5 nsec typical. MAX FREQUENCY: 80 MHz. ACCURACY: ±0.25% + 1 digit + probe accuracy. INPUT IMPEDANCE: 10MΩ. INPUT PROTECTION: 300V DC or RMS.

GENERAL: Dimensions: 2.2x6.7x6 in. (5.6x17x15.2 cm); Weight: 22 oz. (7kg). Power: 9V battery (incl.) or Hickok AC adapter. Battery Life: 200 Hrs typical. Temperature: 0-50°C operating, -35 to +60°C storage. INCLUDES: Deluxe safety test leads, battery, manual and belt clip.

ACCESSORIES

SP-7 10:1 Divider Probe for Logi-Trak Input	\$59.50
TP-20 (C or F) Temperature Probe	\$79.75
VP-14 RF Probe (0.25V to 40V rms)	\$61.25
VP-40 40KV DC Probe (0 to 40KVDC)	\$69.50
CC-4 Deluxe Vinyl Carrying Case	\$24.00
RC-3 AC Adapter	\$15.00

Circle No. 8 on Reader Service Card.



# Sinclair ZX81



Is there a Sinclair ZX81 in your future? Steve Rimmer gazes deeply into the 6.5 MHz crystal ball and sees. . .

## Toy or tool?

WE SEEM TO HAVE come upon a watershed of computer marketing. . . it's getting to the point where we reserve about three pages in each issue for "Computer of the Month". It's not all that unrealistic though; innovative small systems are springing up like magic mushrooms. Many cause hallucinations, too.

The Sinclair ZX81 is, first off, about the least expensive computer you can buy. \$149.95 gets you the whole works. . . in kit form, mind you, including a very well written user's manual on how to write programs in the, ahem, unusual BASIC that comes with it. An AC adapter is ten dollars extra. Other add ons include a memory expansion to take the 1K on board to 16K, for \$169.95 (requiring a juicier power pack for \$19.95), a colour card, a sound board, character generator, disk drive and a full size keyboard. There are several advanced programming books also available. (Incidentally Gladstone Electronics give a \$20.00 discount on the 16K expansion if it's ordered with the basic system.)

### Kats and KITtens

Obviously, before you can begin writing that fabulous program to solve the riddle of creation, it is necessary to get the bits and pieces soldered onto the board, and connect up the works. The kit is not at all difficult to complete, by virtue of the machine's being incredibly simple. There are four or five chips (depending upon which version you get) for the whole scene. Everything is socketed, of course. There is no interwiring, and the board is screened and masked. The directions are a bit dismal (only a bit), but they can be puzzled out, and reading them

through once *before* lighting yonder propane torch and commencing to solder is of great value.

We did the kit in about three hours, and only came up with one problem, a crack in one of the ribbon cables that connects the keyboard to the main PCB. Fortunately, these are quite long, and it was possible to cut the thing back beyond the broken area. We have decided that we probably caused this break ourselves during the initial period of fumbling, probing and holding the pieces up to the light. We've checked with a number of people who've built the kit and no one else has had this problem.

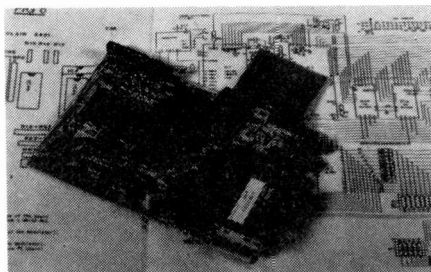

Figs 1 through 5 show the unkitting of the ZX81.

### Upon Plugging It In

There are several aspects of the ZX81 which are most unusual, at least in comparison to other computers we've had a peer at. First off, the keyboard.

The keyboard consists of two flexible membranes separated by a perforated spacer. Stuck to the inside surfaces of the membranes directly over yon perforations are conductive pads. Pushing down on the membrane over one of the perforations causes the two pads to come into contact, simulating a key closure. Cheap but effective.

The keyboard, while best appreciated if you are a munchkin, is not as difficult to use as you'd think once you get used to it (and your fingers flatten out). Don't plan on implimenting word processing with it, though.

The keys each do a variety of things. First of all, they are BASIC keyword tokens. If, for instance, you want to print something, you don't type "PRINT". You hit "P" and the machine types "PRINT" on the screen. This is analagous to using "?" as a PRINT command. If you actually type out a keyword, the machine gives you a syntax error to null over.

This wants some getting used to, but is ultimately quite an advantage on a system that doesn't lend itself to prolonged typing.

The arrangement of the tokens on the keyboard is fairly well thought out, such that all the ones that start with "R", REM, RUN, RAND and RETURN are nearby to the "R" key, all the ones that start with "L" are near the "L" key, and so forth.

The neat thing about the token mode is that the machine slips into it whenever it's appropriate for one to be entering BASIC keywords, and back out when it isn't, all without any prompting or stabbing of buttons.

Once the appropriate token has been entered, the keys produce letters, and the whole works is set up in largely the familiar QWERTY style. The SHIFT key does most of the symbol set, like "★", "=", "\$" and so on. It also takes care of a few of the lesser used BASIC keywords, like "THEN" and "OR". At first, one needs do some hunting, as the shifted symbols and words are not laid out in any particularly logical pattern.

There are two supershifted modes, FUNCTION and GRAPHICS. The FUNCTION mode allows the use of BASIC math and string functions, like TAN, RND and CHR\$. These, like the other BASIC keywords, are tokens, and hitting the designated key in the function mode produces the whole word on the screen. The function mode is such that if the machine is put in it, and a function is caused to function itself onto the screen, the thing will then drop back into normal entry mode of its own accord. This saves a keystroke, as there is no situation in BASIC calling for two consecutive functions to be entered without at least one normal character in between.

The GRAPHICS mode is like the FUNCTION mode in that it makes the keys produce yet another different character set. The computer does not drop out of GRAPHICS mode after a key is hit, though, and must be return-

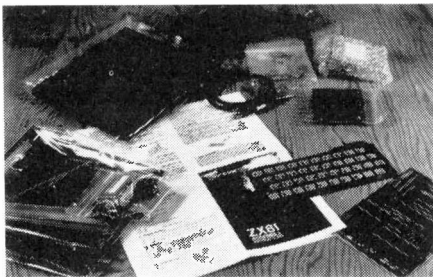

ed manually. Obviously, one may wish to enter more than one graphics character at a time.

The graphics characters aren't bad for a machine this size. They resemble some of the PET/VIC characters, and can be used to produce simple diagrams, graphs and so on.

### One For The Mode

There is one other mode involved in entering text into the machine, this being the all important EDIT mode. A bit unusual, this.

It should be clear, if you think about it, that whenever you add a line of text to the screen on a computer, move the cursor around, scroll, or make any changes to the appearance of the display, the machine is usually reprinting the whole screen. . . very fast. Well, such is true of the ZX81, except that its speed leaves something to be desired. Having LISTed the text we wish to EDIT, it is necessary to move the cursor down

from the top to the line we want to modify, utilizing shifted "6" and "7". However, every time the cursor moves, the screen blanks out and is reprinted, taking a second or two. This isn't a serious drag, but it does slow things up a bit.

Once the cursor is in place, the EDIT key is hit, and the line is copied on the bottom of the screen, where it can be cursoried through and changed (and bits INSERTed). This aspect of the EDIT mode is very quick and easy to use. It can be RUN. (Oh, gee, Billy. . . you mean it does that *too*?)

### See the Computer RUN

The first thing that needs be said about the running of the ZX81 is about its speed, or lack thereof. If you harken back to the kit building part, you'll remember the scarcity of chips. One aspect of the fallout of this is that there *ain't no CRT controller te speaks of*. The CPU drives the screen directly, meaning that it can only do other stuff. . . like running programs. . . during the retrace intervals, which are very short. This means that things don't execute terribly fast if there's much happening on the screen. There is a way around this: the FAST instruction throws the works into a mode whereby the CPU ignores the screen until further notice, but this means that the tube blanks out (shades of the ZX80).

One of the evaluatory programs we wrote for the ZX81 was a PONG ball bouncing about the tube. The maximum speed attainable was equivalent to about one step above beginner level on a home video game. In short, fast real time animation on the ZX81 requires some machine code programming. Perhaps recognizing this, there has emerged a book dedicated to this very subject.

Alright, now, question 1. . . what does this program do?

```
10 PRINT "TRUDEAU WILL SAVE US"
20 GOTO 10
```

On any other system, it would print an obvious lie over and over again until the BREAK key was actuated, or until the cat chewed through the power cord. On the ZX81, it would reproduce the lie until it filled the screen, and then it would stop, and print

```
5/10
```

and wait, mysteriously, for further

directives. What this means is that there is an error number 5 in line number 10. And error number 5 means "no more room on the screen".

Which is to say that the little fellow wants to be given a special SCROLL command if it's to keep on going.

The thing with the slash through it is called a "report code", and tells you what exactly your program did. The first character can be 0 to F, with 0 representing "everything ran cool, boss". The second number is the line at which trouble occurred if everything *didn't* run cool.

### Oddities

Every system's BASIC has a few little uniquenesses, and the ZX81 is no exception. In this case, none are unfathomable or unpleasant, and most are useful to some degree.

PLOT and UNPLOT are usually reserved for high level graphics commands. . . a feature the ZX81 certainly does not have. In this case, they are subsets of PRINT AT, in which the thing PRINTs a black box at the specified co-ordinates for PLOT, and erases it for UNPLOT.

PAUSE n waits for n frames of

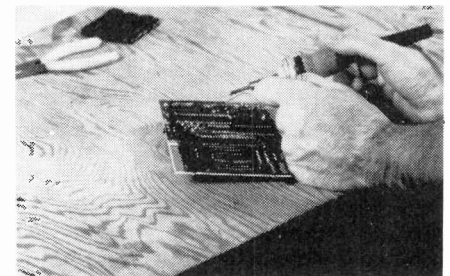

the TV scan, with n being any number up to 32768. PAUSE without a number after it waits 'til the cows come home. PAUSE 32768 would vegetate for some 11 minutes. The nice thing about PAUSE is that it can be interrupted by hitting any key.

String manipulation, while possible, is a mite unusual. Gone are the LEFT\$, MID\$ and RIGHT\$ functions, banished, never again to be entered. In their place lies TO. This TO will be recognized as being a component of the FOR NEXT loop syntax. Well, here it is again, tireless worker. To get the right 3 characters of the string "AARDVARK", you would say, for instance, A\$ = 1"AARDVARK"(TO 3). A\$ would then equal "AAR". If the brackets contained, say, 3 TO 5, it

would extract the third, fourth and fifth characters.

## Expansion

There several things that can be added to a ZX81 to make it more fabulous and a better servant of humanity. The first is a memory expansion. This increases the rather meagre 1K to 16K. The error code for memory being full is among the favourite of the machine's repertoire in its unexpanded form, and anyone seriously planning to get into ZX81 programming would be well to do this trip.

Next, there is the a ZX81 printer, which is expected to be available shortly. It does 32 characters per line, 9 lines to the inch, and prints at 50 characters per second. The printer is fully supported by the ZX81's existing BASIC, which has LLIST, LPRINT and COPY, the latter of which reproduces the screen on the printer. The printer dangles on the memory bus using a stackable connector, permitting it and a RAM expansion pack to be used simultaneously.

The printer will probably cost about the same as the computer.

## Toy or Tool

On one hand, it's a real live computer for \$150.00. On the other hand, every other computer going costs upwards of two and three times that much. You might be puzzling over whether or not you should be thinking about lathering up the Visa card and buying one. Is it a real, useable system, or just a wedding gift for a young couple in the data processing industry?

The biggest problem in answering this question is in deciding where you draw the line between a game and a serious machine. If you had in mind some moderately complex operation, such as driving a fusion plasma torus or searching for spelling errors in the sum of man's knowledge, even a fully equipped Apple II or an IBM with a six digit price tag could be considered a toy. The nature of a tool is defined by its uses.

The uses to which an unexpanded ZX81 can be put, first off, are fairly limited because the available BASIC storage space is very, very tiny. A lot more can be done in machine code with this, but machine code programming isn't really something you'd want to do for fun. A 1K machine can run simple demonstration and learn-

ing programs, do some interesting abstract graphics, and play a few games.

The capabilities of the ZX81 change radically, however, if you pop for the 16K RAM expansion. Programs to do very complex calculations, play quite absorbing games (chess, for example, is available for the expanded system) or do quite a bit in the way of visuals can be realized. The large block of memory can hold quite a lot of data, which can be manipulated. Attached to its printer, the ZX 81 is quite capable of handling

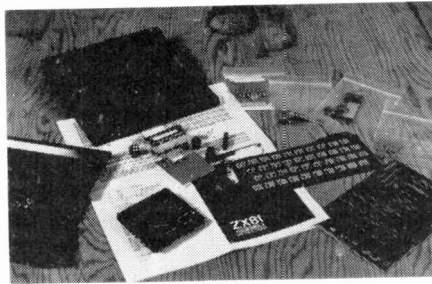

operations which entail producing reports, charts and similar hard copy things.

It may seem a bit silly at first to think of using a computer as a complex programmable calculator, but, in fact, this is a very practical application for the ZX 81. First off, it's inexpensive. It's much easier to program, and its programs easier to debug,

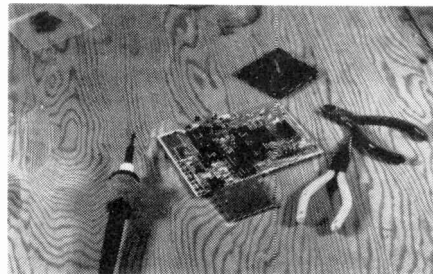

than is the case with most programmable calculators. The display is easier to read, and capable of displaying much more information. With 16K of RAM it can handle much more information, and storage of both programming and data is relatively easy.

One very practical application for the ZX 81 is in harsh environments, especially where it's likely to get things spilled on its keyboard, as, owing to its simple design, it is fairly impervious to liquid accostations.

Probably the greatest interest in the ZX 81, however, is from people who have never owned a computer, and are considering buying one of these because it's a cheap way to try one. Will learning BASIC on a ZX 81 make you a fuller human being and equip you to take a meaningful place in our technological society, you ask. . . Well you might.

No matter what machine you learn on, the principals of programming are the same, and the nature of BASIC, despite many syntactical variations, is also pretty well constant. If you are familiar, for instance, with ZX 81 BASIC, you should be able to fathom most of, say, PET BASIC in a couple of hours. Most BASIC's are about 90% identical.

The error messages and other diagnostics on screen for the Sinclair are not as easily understood as those of a VIC or a TRS-80, and not as easy to use. However, these things occupy a lot of operating system in those machines, and, obviously, economies must be made somewhere. On the other hand, there are some features of the ZX 81, such as its refusal to accept inaccurate syntax, and its one statement per line programming structure that actually makes debugging software easier. You can learn just as much of the fundamentals of programming on a ZX 81, but you are much more likely to become frustrated doing so.

Being an inherently simpler machine, the ZX 81 has both advantages and disadvantages. You will run out of the capabilities of the BASIC much sooner, but you will, as a result, be booted into learning about machine language and system architecture all the earlier on, and these are very useful things to know about.

## A Bouncing Baby Computer. . .

In short, the practical applications of the ZX 81 will be defined by exactly what you have in mind; it may be more than adequate, or just a toy. The learning potential of it, especially with the myriads of documentation and literature available for it, is good. At the very least, it can teach you about the fundamental considerations of computers; if you do outgrow it, you'll be in a much better position to choose a larger system intelligently. *(Just as we're going to press we've been told that a memory expansion system to 64K is going to be available shortly.)* Continued on page 39



# Edu Kit's

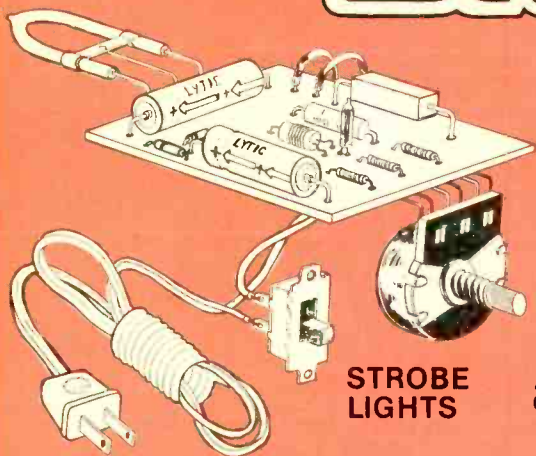

**STROBE LIGHTS**

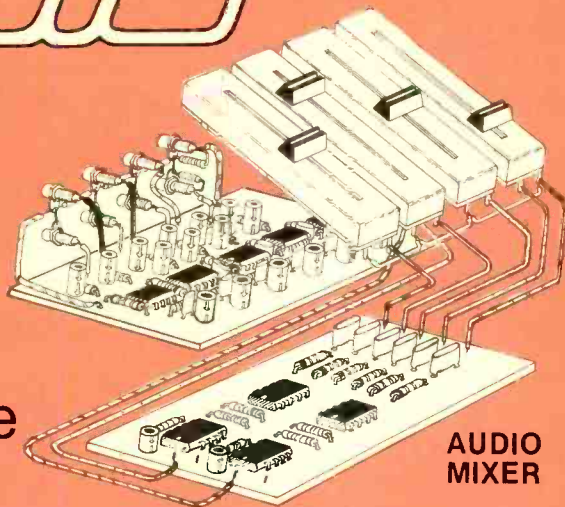

**AUDIO MIXER**

Other kits available are

Model	Description	Price
SP001	Stereo Pre Amp	13.95
A001	1 Watt Amplifier	12.95
A005	5 Watt Amplifier	16.95
AM001	Audio Mixer	68.95
LC016	LED Chaser	32.95
LCM16	Multi Mode Chaser	41.95
PLC120	Power Support	26.95
DLT01A	Logic Trainer with cabinet & Regulated Power Supply	159.95

Model	Description	Price
SL001	Strobe Light	26.95
C200	Single Ch. Colour Organ	9.95
C500	3 Ch. 500W Colour Organ	19.95
C1500	3 Ch. 1500W Colour Organ	29.95
CR001	X Tal Radio	7.95
PS024	0-24 V.D.C. Power Supply	29.95
PS028	0-28 V.D.C. Power Supply	39.95
DLT01	Logic Trainer	99.95

**Dealer and Educational Enquiries Invited.**

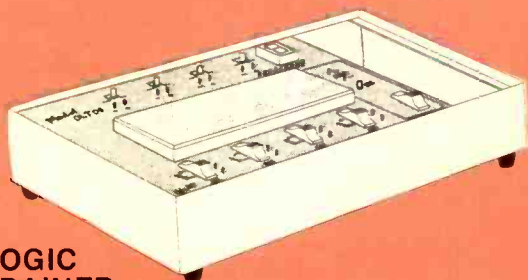

**LOGIC TRAINER**

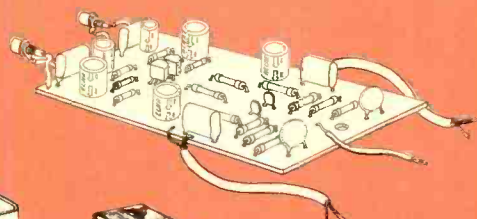

**STEREO PRE-AMP**

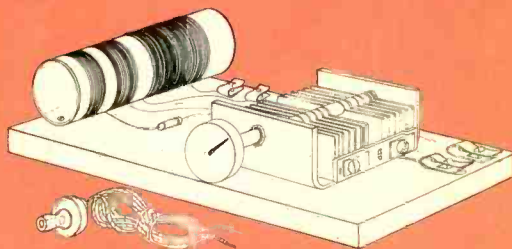

**CRYSTAL RADIO**

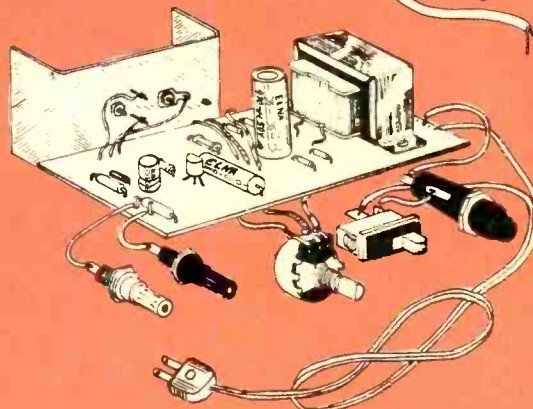

**POWER SUPPLY**

*Edu Kit* Ltd., 151 Amber St.,  
Unit 6, Markham, Ont.,  
L3R 3B3. Phone 495-2524.



Continued from page 37

**SOFTWARE**

The software and literature backup for the ZX81 is very impressive. Although the first systems were not available in North America until recently, it has been on sale in Britain since the spring of 1981. With production of the ZX81 running at a reported 50,000 units a month dozens of companies and individuals are latching on to the system.

The books we have seen are very good. They include *Machine Language Programming Made Simple*, *Understanding your ZX81 ROM*, *Get Acquainted with your ZX81*, *The ZX81 Pocket Book* and *Stretching your ZX81 or ZX80 to its Limits*.

We've also tried some of the software. Some falls into the demonstration type which is interesting but not engrossing to a chess program which is excellent with selectable skill levels. We can assure you its very humiliating to be thrashed by a kit you've built-yourself.

New books and software are being added literally every week.

"There's definitely something wrong! Every time I try to input some data it keeps printing 'Take this job and shove it!'"

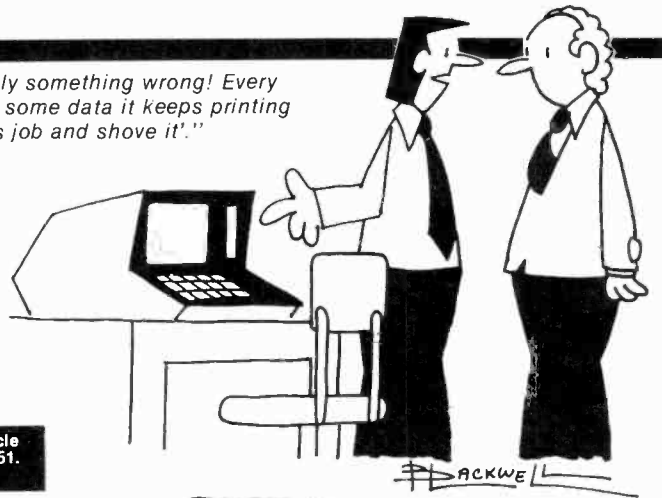

If you liked this article, please circle Reader Service Card number 51. If you didn't, circle number 52.



"When I told you the system needed debugging, Fenton, I never dreamed you'd call an exterminator!"

# HAMEG

## OSCILLOSCOPE HM 203

The new HM203 is a 20MHz bandwidth general-purpose Dual Trace Oscilloscope. The **stable sweep triggering** (to 30MHz) and the relatively **high measuring accuracy** ( $\pm 3\%$ ) are particularly impressive. The useful display area is approximately 8 x 10cm. With the aid of the **electronic stabilization** of all operating voltages and the thermally favorable arrangement of the drift-sensitive components, an **outstanding display stability** is obtained. The brightness and display definition of the cathode-ray tube are excellent.

Price includes two dual x1-x10 Probes  
For further information on Scopes or Probes, call or write:



We service all makes of Oscilloscopes:  
TEKTRONIX • HEWLETT-PACKARD • GOULD • ETC.  
From coast to coast. Call us next time.

980 Alness St., Unit 35, Downsview, Ontario (416) 661-5585 M3J 2S2



LIST  
\$760

- Bandwidth DC-20MHz
- Dual Trace Oscilloscope
- 8 cm x 10cm Display
- Triggering up to 30MHz

Circle No. 17 on Reader Service Card.

# Perfect Sound

These are *not* the speakers for you if you're currently using a twenty nine dollar turntable and two LM 380's for an amp. Ultra high fidelity, by Donald Aldous

(Courtesy London Press Service)

THE ATTACHMENT of a crude horn to a telephone earpiece to create the first loudspeaking telephone led eventually to the various forms of moving coil loudspeakers. Later, other drive principles -and notably the electrostatic - were developed in the never ending search for "perfect" sound reproduction.

British physicists and engineers -from Lord Rayleigh and Sir Oliver Lodge to Captain H.J. Round, P.K. Turner, Paul Voigt and Peter Walker - have been in the vanguard of developing transducer systems. Some have outlined the theory, while others have perfected working designs.

In the beginning of the hi-fi era, enthusiasts had to be do-it-yourself practitioners. A drive unit or two would be bought, and then suitable crossover networks and cabinets had to be obtained or constructed. These assemblies were often bulky, and with the coming of stereo, space and design problems were doubled.

So many factors are involved in the design of loudspeakers that compromises have to be accepted. To flatten the frequency response, efficiency has to be degraded, which is also a problem with the various new plastic materials used in drive units, and particularly in high frequency types. Smaller rooms in modern houses have spurred a move towards smaller physical size, and this means that problems of bass extension and sound output have to be tackled.

## Reduction In Distortion

Nevertheless, the latest technology, allied to improved measurement techniques, has reduced loudspeaker distortions significantly. Even so, listening checks still have their place, because loudspeaker/room interac-

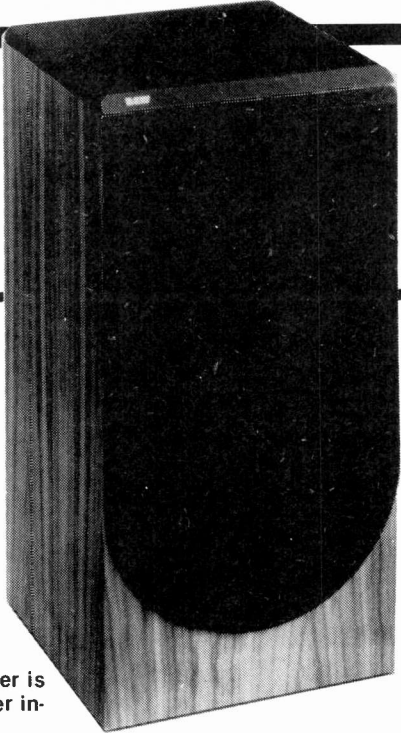

Fig. 1 The B and W DM22 loudspeaker is one of a number produced using laser interferometry techniques.

tions affect the total listening performance of a system.

Reputedly, Wharfedale was the first manufacturer to employ laser holography in the study of cone behaviour. By feeding a loudspeaker cone with a test signal and exposing it to laser light, a holographic image of its movement can be produced and photographed. This permits areas of cone breakup, which cause audible coloration, to be detected precisely and instantly, and then modified as necessary.

One aspect of distortion in loudspeakers is audibility, and Wharfedale has analysed all the major forms of distortion and documented their effects on audibility. One disturbing type of resonance is "delayed resonance", which is the tendency of a speaker cone to continue moving after the signal has subsided. As an additional complication, different sections of the cone continue to resonate in different modes during the few micro-seconds following a signal input.

Wharfedale employs delayed resonance testing as a loudspeaker development tool, and computers are also used to examine the relationship between efficiency, cabinet volume and bass response. This produces information on the optimum size and shape of drive units for any given combination.

## No Hit-And-Miss Element

Other British speaker manufacturers

employing laser interferometry techniques are B and W Loudspeakers, Celestion International and KEF Electronics. This approach to design and engineering production removes any hit-and-miss element in manufacturing loudspeakers, although subjective listening tests are not ignored.

Although the major British manufacturers market sophisticated equipment with elaborate electronics for the crossover networks which divide the amplifier output into different frequency bands to feed appropriate units, so-called "budget boxes" have recently been added to their ranges.

Among the smaller British manufacturers are Castle Acoustics, which produces the Clyde model, and Keesonic, with its Kolt and Kub systems. A feature of such companies is that they are no mere assemblers of drive units, but produce all the hardware in their own plants.

Keesonic's Peter Keeley tested many materials for possible use in loudspeaker cones. The ideal cone would combine lightness with strength, would have a very low storage time, and would give excellent transient response.

## Few Components

Numerous cone shapes were tried and speech coils wound to very high tolerances. During these experiments, it was found that complex

*Continued on page 50*

# Gluons

## Are gluons the fundamental particles that hold everything together?

IT'S A LONG TIME since Thomson discovered the electron (from which the name of our hobby is derived), but modern electronic equipment has been used to search for more and more particles, the latest being the 'gluon'. The name gluon obviously comes from the fact that this particle is postulated as acting as a glue which holds something together, but the story is a little more involved than this.

In the 1960s the hypothesis that all nuclear particles consist of still smaller particles known as 'quarks' was tentatively proposed and this idea has grown in importance with time so that it is now widely accepted. Evidence has been accumulated for the existence of five different quarks and physicists are now seeking a sixth type which is believed to exist for reasons of symmetry. According to the current theory, quarks combine in groups of three to form protons and neutrons which are held together by the 'strong' nuclear force. The latter is one of the four fundamental forces of nature, the others — in order of diminishing strength — being the electromagnetic force which controls all chemical change, the 'weak' force responsible for certain radioactive changes (beta radioactivity) and the gravitational force.

Each of these forces is associated with an intermediary particle, at least in theory. The best known of these intermediary particles is the photon, which gives rise to the electromagnetic forces which manifest themselves as electrostatic forces between electrical charges, the magnetic forces in electric motors, etc. The intermediary particle connected with the strong force is the gluon, which is said to travel very rapidly between the quarks which it is holding together.

Experimenters have thought there would be little hope of detecting the gluon to confirm the theoretical work, since it is associated with the strongest of the four forces known to

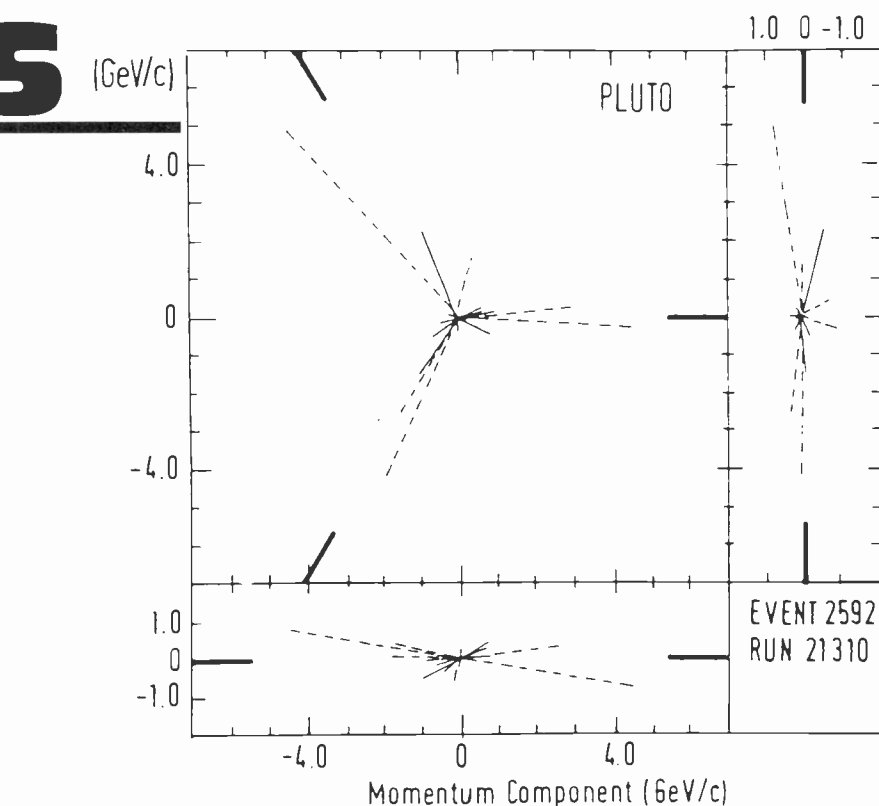

Fig. 1 Momenta of particles produced at 31.6 GeV at PETRA. Solid and dotted lines correspond to charged and neutral particles respectively. The thick bands show the directions of the jet axis. The three drawings cover the three dimensions. (CERN COURIER.)

If you liked this article, please circle Reader Service Card number 49. If you didn't, circle number 50.

exist in nature. However, recent work has provided quite strong evidence that this particle exists. Nobel prize winner Professor Abdus Salam predicted in his concluding talk at the Geneva high energy physics conference in 1979 that the gluon is likely to be discovered before the long-awaited intermediary particle of the weak interaction, the intermediate vector boson which has been sought in neutrino experiments, and it certainly appears that his forecast will be correct.

A team of people working with the PETRA accelerator (near Hamburg, West Germany) announced details of the evidence they had obtained for the existence of gluons at an international conference held at the Fermi National Accelerator Laboratory in Batavia, Illinois, USA, and astonished the particle physicists working in this field.

The PETRA work employed beams of high energy electrons and of positrons. (The positron is the antiparticle of the electron and is similar to it, except that it has a positive charge.) At moderate energies the

colliding beams of particles and their antiparticles result in the disintegration of the components into pairs of quarks and anti-quarks, which move off very rapidly in opposite directions before they are transformed into the types of particles with which we are much more familiar.

The PETRA workers employed particle energies of about 30 GeV (30,000 million electron volts). They found that, instead of two particles moving in opposite directions from the point of collision, three jets of particles were formed. Two of these jets were narrow, but the third was broad and it was this latter beam that contained the evidence for the existence of gluons.

Theoretical particle physicists have been gradually formulating a theory of quantum chromodynamics (QCD) to describe the forces that operate deep inside protons, neutrons and similar particles. Gluons are postulated as the carriers of the 'colour' force acting between quarks and are thus ultimately responsible for all of the strong force phenomena. Somewhat delicate ef-

fects found in neutrino experiments have given considerable support to the QCD theory, but these effects can easily be masked and are difficult to measure. The work at the PETRA accelerator has provided a new and very effective way of testing the QCD theory.

Under the high energy conditions, one particle of each quark-antiquark pair is believed to have produced a high speed gluon. This process, when continuously repeated, knocked the main beam of particles slightly to one side and thus created a stream of gluons which quickly transformed into quarks and then into other particles. The gluons and the quarks have such a short lifetime that their existence has to be inferred from their effects in the same way that the existence of an animal is often inferred from its foot-prints. The detection of the three beams by the PETRA workers provided very strong evidence of the existence of gluons. The hard gluon emission has been called 'Gluhstrahlung' (German for 'glue radiation') by some workers.

This new work at PETRA may well be of great importance for the future in our understanding of the relationship of the four forces of nature — which are of vital importance in modern physics. The director of the FermiLab, Leo Lederman, has said that physicists are absolutely delighted with the new results and that the discovery of the gluon is of vital importance for our understanding of the theory of the strong force. Physicists are already convinced that the electro-magnetic and weak forces are basically different views of the same thing and it seems likely that the QCD theory will bring the strong nuclear force into the same general system.

We have known about the photon since early this century. If the existence of the gluon is confirmed, it will be only the second intermediary particle to be found. These particles are vital to our understanding of the basic particle interactions and such a discovery should encourage work on further searches for the intermediate vector boson; if the latter has a relatively high mass, a more powerful and more expensive accelerator may be required before it can be produced. The fourth intermediary, the graviton, has also been proposed, but owing to the very weak nature of the gravitational force, it may be a very long time before it is discovered — assuming it can exist.

FORCE	APPROXIMATE RELATIVE STRENGTH
Nuclear or strong	1
Electro-magnetic	$10^{-2}$
Weak	$10^{-12}$
Gravitational	$10^{-39}$

Table 1. The forces of nature.



# Aaron-Gavin

Equalizers • LED Meters • Mixers **Kits**  
**DUE TO RESPONSE — OFFER BEING REPEATED**  
**\$\$\$\$ DUTY FREE \$\$\$\$**  
**INTRODUCTION OFFER**

**That's right! — We pick up the bill for both DUTY and FEDERAL TAX.**

We are making this fantastic offer to determine the potential of doing business directly in CANADA. So... take us up on this limited offer. A copy of this ad must be with your order.

Featuring this month — 31 Band Stereo EQ (1/3-octave)

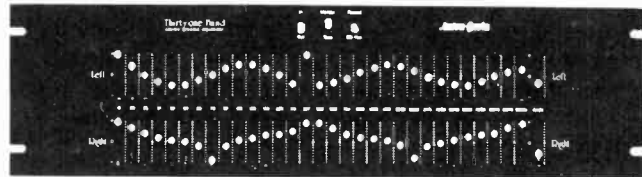

FEATURES: Linear Circuit, Follower Filter Circuit, Regulated Power, +15dB Boost and Cut on EVERY BAND, 13V usec Slew Rate.

BENEFITS: Distortion/Noise: -80dB, NO Snap-On, NO Rainbow Effect, NO Band to Band Phase Cancellation. Truly built to PROFESSIONAL STANDARDS — by you or us.

STYLE: Rack or Cabinet      FREQ. 16-16KHz or 20-20KHz      *Black or Silver Finish*

GRAPHIC EQUALIZERS			LED METERS		
Mfg.	Kit	Model	Mfg.	Kit	Model
\$690.	\$328.	31 BAND Stereo EQ	\$229.	\$ 84.	20/40S:
230.	119.	11 BAND Stereo EQ	40 LED Stereo Meter W/3 color range display, rectangle leds, -71dB to +26dB W/only 3dB separation.		
\$490.	\$235.	21 BAND Stereo EQ			
280.	149.	11 BAND Stereo EQ			
W/MIC, MIXER, LED PEAK INDICATORS, DUAL MASTER GAIN CONTROL AND MORE.			\$149.	\$ 69.	20/40R:
			40 LED Stereo Meter W/1 color range display, Round Leds, -71 to +26dB W/only 3dB Separation.		

SINGLE CHANNEL MONO VERSIONS AVAILABLE IN ALL OF THE ABOVE. (20% less)

Order with this ad or send for full product information and specifications to: **AaRON-GAVIN**, 123 South McClay Street, Unit F, Santa Ana, California 92701, phone 714/957-8710.

In addition to kits and finished goods, we also manufacture Rack Mount Front Panels and Rear Covers, Wood Cabinet Panels and rear covers, Printed Circuit Boards, Potentiometers (sliders), transformers, Mylar Capacitors (1% to 10% tolerance). We also distribute RAM, ROM, EPROM, LS and TTL components.

NEW KIT PRODUCTS AVAILABLE SOON! 40 LED per Band SPECTRUM ANALYZER with 1 1/2dB Separation from -77 to +26dB. POWER AMPS. 80 to 800 Watts Stereo. Modular Studio MIXER, in multiples of 2 to whatever number of channels desired.

**NOTE:** No company in this magazine can beat our prices on components even WITH Duty and Federal Taxes.

**WANTED! — FACTORY REPRESENTATIVE AND DISTRIBUTORS**

Circle No. 19 on Reader Service Card.





**Visit our NEW WAREHOUSE SHOWROOM - Over \$10,000,000 of devices in stock!**  
 5651 Ferrier St., Town of Mount Royal; Montreal, Quebec. (514) 731-7441

TTL STANDARD AND LOW POWER SCHOTTKY			
7400N	32	74165N	83
7401N	33	74170N	255
7402N	31	74173N	105
7403N	31	74172N	644
7404N	34	74174N	86
7405N	34	74175N	75
7406N	47	74176N	136
7407N	47	74178N	152
7408N	34	74179N	176
7409N	36	74182N	1.88
7410N	33	74180N	307
7412N	81	74184N	3.11
7413N	55	74185N	1.13
7414N	55	74190N	88
7415N	59	74191N	1.09
7417N	59	74192N	1.09
7420N	38	74193N	84
7422N	48	74195N	1.02
7423N	48	74196N	1.02
7425N	41	74197N	1.16
7426N	51	74198N	1.95
7427N	42	74199N	2.02
7428N	62	74200N	2.07
7430N	29	74201N	2.07
7432N	55	74202N	1.88
7433N	55	74203N	1.88
7437N	49	74204N	1.87
7438N	49	74205N	1.87
7440N	33	74206N	2.46
7442N	57	74207N	3.11
7445N	124	74208N	3.09
7446N	108	74209N	3.11
7447N	85	74210N	3.11
7448N	78	74211N	3.11
7451N	33	74212N	1.16
7453N	38	74213N	1.16
7454N	38	74214N	1.16
7472N	47	74365AN	90
7473N	49	74367AN	75
7474N	47	74368AN	90
7475N	55	74369AN	90
7476N	55	74370AN	90
7483AN	82	74371AN	1.68
7484AN	177	74372AN	1.68
7485N	86	74373AN	1.68
7486N	51	74374AN	1.68
7490AN	55	74375AN	1.68
7491AN	57	74376AN	1.68
7492AN	49	74377AN	1.68
7493AN	49	74378AN	1.68
7494AN	58	74379AN	1.68
7495AN	70	74380AN	1.68
7496N	77	74381AN	1.68
7497N	246	74382AN	1.68
74100N	203	74383AN	1.68
74104N	83	74384AN	1.68
74107AN	57	74385AN	1.68
74109N	57	74386AN	1.68
74110N	68	74387AN	1.68
74111N	94	74388AN	1.68
74116N	179	74389AN	1.68
74120N	179	74390AN	1.68
74121N	82	74391AN	1.68
74122N	70	74392AN	1.68
74123N	82	74393AN	1.68
74125N	90	74394AN	1.68
74126AN	62	74395AN	1.68
74128N	83	74396AN	1.68
74132N	59	74397AN	1.68
74136N	68	74398AN	1.68
74141N	109	74399AN	1.68
74142N	425	74400AN	1.68
74143N	493	74401AN	1.68
74144N	493	74402AN	1.68
74145N	87	74403AN	1.68
74148N	116	74404AN	1.68
74150N	187	74405AN	1.68
74151N	57	74406AN	1.68
74153N	49	74407AN	1.68
74154N	187	74408AN	1.68
74155N	62	74409AN	1.68
74157N	68	74410AN	1.68
74159N	198	74411AN	1.68
74160N	62	74412AN	1.68
74161AN	83	74413AN	1.68
74162N	83	74414AN	1.68
74163AN	83	74415AN	1.68
74164AN	83	74416AN	1.68

CMOS			
CD4001BE	29	CD4073BE	36
CD4002BE	23	CD4075BE	36
CD4006BE	77	CD4076BE	77
CD4008BE	31	CD4078BE	36
CD4009BE	51	CD4510BE	94
CD4010BE	51	CD4511BE	87
CD4011BE	29	CD4512BE	94
CD4012BE	51	CD4513BE	94
CD4013BE	29	CD4514BE	218
CD4014BE	77	CD4515BE	218
CD4015BE	77	CD4516BE	98
CD4016BE	42	CD4517BE	98
CD4017BE	70	CD4518BE	98
CD4018BE	68	CD4519BE	98
CD4019BE	62	CD4520BE	94
CD4020BE	88	CD4521BE	1.83
CD4021BE	74	CD4522BE	1.01
CD4022BE	103	CD4523BE	1.17
CD4023BE	25	CD4524BE	1.87
CD4024BE	57	CD4525BE	3.89
CD4025BE	26	CD4526BE	1.83
CD4026BE	1.89	CD4527BE	2.07
CD4027BE	55	CD4528BE	2.07
CD4028BE	70	CD4529BE	3.3
CD4029BE	98	CD4530BE	94
CD4030BE	49	CD4531BE	94
CD4031BE	104	CD4532BE	94
CD4032BE	217	CD4533BE	21.13
CD4033BE	317	CD4534BE	29
CD4034BE	74	CD4535BE	33
CD4035BE	83	CD4536BE	60
CD4036BE	1.16	CD4537BE	76
CD4037BE	1.16	CD4538BE	76
CD4038BE	77	CD4539BE	76
CD4039BE	77	CD4540BE	76
CD4040BE	77	CD4541BE	76
CD4041BE	1.16	CD4542BE	3.09
CD4042BE	1.16	CD4543BE	1.08
CD4043BE	1.16	CD4544BE	1.26
CD4044BE	1.16	CD4545BE	1.26
CD4045BE	1.16	CD4546BE	1.26
CD4046BE	1.16	CD4547BE	1.26
CD4047BE	1.16	CD4548BE	1.26
CD4048BE	1.16	CD4549BE	1.26
CD4049BE	1.16	CD4550BE	1.26
CD4050BE	1.16	CD4551BE	1.26
CD4051BE	1.16	CD4552BE	1.26
CD4052BE	1.16	CD4553BE	1.26
CD4053BE	1.16	CD4554BE	1.26
CD4054BE	1.16	CD4555BE	1.26
CD4055BE	1.16	CD4556BE	1.26
CD4056BE	1.16	CD4557BE	1.26
CD4057BE	1.16	CD4558BE	1.26
CD4058BE	1.16	CD4559BE	1.26
CD4059BE	1.16	CD4560BE	1.26

LINEAR IC'S			
LM309K	2.03	LM741CH	.75
LM323K	7.28	LM747CN	.73
LM324CN	.79	LM1488CN	.83
LM339CN	.68	LM1489CN	.83
LM348CN	1.25	LM2240CN	2.08
LM555N-8	.38	LM3403CN	1.55
LM556CN	.68	LM4136CN	1.25
LM567N-8	1.27	LM4558CN	.57
LM723CN	.57	ULN2003AN	1.09

BI-FET OP AMPS			
TL071CP	.68	TL071CP	1.16
TL072CP	2.41	TL072CP	1.01
TL081CP	2.41	TL081CP	1.01
TL082CP	2.41	TL082CP	1.01
TL084CN	2.13	TL084CN	1.01
TL430CLP	1.25	TL430CLP	1.25
TL431CLP	1.25	TL431CLP	1.25
TL497ACN	3.74	TL497ACN	3.74

1 AMP VOLTAGE REGULATORS			
78XXUC	Positive TO-220 Pkg.	.99	
Voltages 5, 6, 8, 12, 15, 18, 24.			
78XXKC	Positive TO-3 Pkg.	2.20	
Voltages 5, 8, 12, 15, 18, 24.			
79XXUC	Negative TO-220 Pkg.	1.16	
Voltages 5, 6, 8, 12, 15, 18, 24.			
79XXKC	Negative TO-3 Pkg.	2.20	
Voltages 5, 8, 12, 15, 18, 24.			

LINEAR INTERFACE CIRCUITS			
SN75107AN	1.63	SN75385N	1.81
SN75108AN	1.63	SN75428P	.49
SN75150P	1.92	SN75491N	1.56
SN75154N	1.92	SN75492N	1.56

DUAL-IN-LINE LOW PROFILE I.C. SOCKETS			
CONTACTS	PRICE	CONTACTS	PRICE
8 PIN	.10	22 PIN	.25
14 PIN	.16	24 PIN	.28
16 PIN	.18	28 PIN	.32
18 PIN	.21	40 PIN	.40
20 PIN	.23		

For every \$100 order we will send you at no extra charge - 4 data books valued at \$25.00 - MOS Memory Data book, Opto Selection Guide, Unifrote Data book, JFet Applications and Specs.

★ ★ ★ **COMPUTER SUPPORT CENTER** ★ ★ ★  
 Absolutely the lowest prices and highest quality  
 Only current date coded products

STATIC RAM'S			DYNAMIC RAM'S			
2101-35	1K (256 x 4)	350NS 22 PIN	4.45	P4060-30	4K (4K x 1) 300NS 22 PIN	3.45
2102-25	1K (1K x 1)	250NS 16 PIN	1.95	P4116-20	16K (16K x 1) 200NS 16 PIN	3.12
P2111-45	1K (256 x 4)	450NS 18 PIN	3.45	C4164-15	64K (64K x 1) 150NS 16 PIN	31.20
P2112-35	1K (256 x 4)	350NS 16 PIN	3.45	C4164-20	64K (64K x 1) 200NS 16 PIN	28.60
2114L-30	4K (1024 x 4)	300NS 18 PIN Low Power	2.25			
2147	4K (4K x 1)	55NS 18 PIN	11.25			
2147	4K (4K x 1)	70NS 18 PIN	9.69			
P2016-10	16K (2K x 8)	100NS 24 PIN	43.50			
P2016-15	16K (2K x 8)	150NS 24 PIN	25.94			
P2016-20	16K (2K x 8)	200NS 24 PIN	19.34			
26132-6PS	32K (4K x 8)	450NS 28 PIN	41.64			
C2708-45	8K (1K x 8)	450NS 24 PIN	5.90			
C2716/TMS2516	16K (2K x 8)	450NS 24 PIN	5.90			
Single 5 Volt Supply, Intel Pin Out			7.74			
TMS2716	16K (2K x 8)	450NS 24 PIN	19.95			
3 Power Supply, T1 Pin Out			16.84			
C2532	32K (2K x 8)	450NS 24 PIN	16.84			
T1 Pin Out			57.20			
C2732	32K (4K x 8)	450NS 24 PIN	16.84			
Intel Pin Out			57.20			
C2764	64K (8K x 8)	450NS 24 PIN	57.20			
Intel Pin Out			57.20			

**SHIFT REGISTERS**

1404A	TO-5 Single 1024 bit	3.87
3341APC	FIFO 1MHz	5.79
3342PC	64 bit	5.14
3347PC	80 bit	5.14

Any order over \$50 receive free - MOS Memory Data Book

**8080 FAMILY**

8800 CPU	7.35	8035 CPU	9.43	8224	4.47
8802 CPU	11.25	8039 CPU	10.34	8226	3.04
8808 CPU	10.99	8080A CPU	6.44	8228	6.46
8809 CPU	25.94	8085 CPU	10.34	8251	7.74
6810	3.45	6520	7.09	8155	11.70
6821	3.45	6522	10.21	8748	46.80
6845	35.69	6522	10.21	8755	41.60
6850	3.84	6532	14.11	8212	2.93
6852	7.48	6551	15.15	8214	5.53
				8216	2.57

**Microprocessor Chip Sets**

Z80-CPU	2.5 MHz	9.82
Z80A-CPU	4.0 MHz	12.29
Z80-PIO	2.5 MHz	8.65
Z80A-PIO	4.0 MHz	9.95
Z80-CTC	2.5 MHz	7.74
Z80A-CTC	4.0 MHz	9.95
Z80-DMA	2.5 MHz	23.39
Z80A-DMA	4.0 MHz	29.84
Z80-SID/0	2.5 MHz	29.19
Z80-SID/1	2.5 MHz	29.19
Z80-SID/2	2.5 MHz	29.19
Z80-SID/3	2.5 MHz	36.21
Z80-SID/4	2.5 MHz	21.91
Z80-SID/9	2.5 MHz	27.95
Z80A-SID/9	4.0 MHz	27.95
Z80-DART	4.0 MHz	15.54
Z80A-DART	4.0 MHz	19.31

Active supplies Z80B'S - 6 MHz device types. Prices available upon request.

**SCR'S and TRIAC'S**

TIC1060	SCR	5 amp	400V TO-202	.51
TIC47	SCR	0.6 amp	200V TO-92	.77
TIC1168	SCR	8 amp	200V TO-220	1.38
TIC1180	SCR	8 amp	400V TO-220	1.55
TIC1268	SCR	12 amp	200V TO-220	1.53
TIC1260	SCR	12 amp	400V TO-220	1.92
TIC2168	Triac	6 amp	200V TO-220	1.46
TIC2160	Triac	6 amp	400V TO-220	1.22
TIC2260	Triac	8 amp	400V TO-220	1.43
TIC2360	Triac	12 amp	400V TO-220	1.69
TIC2460	Triac	16 amp	400V TO-220	2.08
2N1595	SCR	1 amp	50V TO-220	.85
2N4442	SCR	8 amp	200V TO-127	1.29
2N6401	SCR	16 amp	100V TO-22C	1.46

**PLASTIC POWER TRANSISTORS**

TIP29B	.65	TIP41C	1.01	TIP125	.95
TIP29C	.65	TIP42B	1.00	TIP126	1.21
TIP30B	.64	TIP42C	1.09	TIP127	1.12
TIP30C	.69	TIP110	.86	TIP140	2.20
TIP31A	.64	TIP111	.91	TIP141	2.52
TIP31B	.66	TIP112	1.00	TIP142	3.00
TIP31C	.70	TIP115	.86	TIP145	2.70
TIP32A	.65	TIP116	.85	TIP146	2.8

## CANADIAN PROJECTS BOOK NO. 1

Canadian Projects Book No. 1

100 pages

\$3.00

25 of our most popular projects from our earlier issues including: Audio Limiter, 5W Stereo, Bass Enhancer, Modular Disco, 50W/100W Amp Modules, IB Metal Locator, Touch Organ, Electronic Mastermind, Double Dice, Reaction Tester, Sound Operated Flash, Burglar Alarm, Injector-Tracer, Digital Voltmeter.

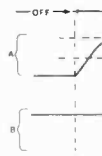

Electronics Today  
INTERNATIONAL

JANUARY 1981

## PROJECTS BOOK No. 2

Projects Book No. 2

100 pages

\$3.95

Contains 25 of the best projects from recent issues including the High Performance Series 4000 Amplifier (including Preamps and Power Supply), Rumble Filter, Dynamic Noise Filter, Logic Probe, Cable Tester, Function Generator, Rain Alarm, Digital Tacho, Two Octave Organ, Light Chaser, Shutter Speed Timer, Ni-Cad Charger and more. First published January 1981.

Electronics Today  
INTERNATIONAL

Summer 1982

## ELECTRONIC CIRCUIT DESIGN

Electronic Circuit Design

92 pages

\$3.95

A collection of major articles on various aspects of circuit design including CMOS, Audio Amplifiers, Power Supplies, SCR's, Op-Amps, Using the 3080 and Temperature Control. A large number of useful circuits are given but the emphasis is on guidance and how to tackle the design for yourself.

CD40...  
RCA

## MORE CIRCUITS

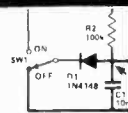

Electronics Today  
INTERNATIONAL

Summer 1980

## HOBBY PROJECTS



25 Electronic Projects

More Circuits  
108 pages

\$4.50

Over 150 circuits plus articles on Circuit Construction, Test Gear, a project on a Digital Panel Meter, Design notes on Speaker Crossovers, TTL pin-outs, Design notes on Crystal Oscillators.

Hobby Projects

100 pages

\$3.95

First published Summer 1980. Contains 25 straight-forward projects most of which have never appeared in the magazine including: Stereo Amp, Audio Mixer, Scratch and Rumble Filter, Constant Volume Amp, Graphic Equaliser, Envelope Generator, White Noise Effects Unit, Linear Scale Ohmmeter, Intercom, Drill Speed Controller, LED Tacho, Parking Meter Timer, Electronic Organ, Touch Switch, Electronic Dice, Siren, Simple Receivers.

# ETI SPECIALS

Available from your local electronic parts store or direct from ETI (please add 45c each to cover postage).

Send money to:

Electronics Today Magazine,  
Unit 6, 25 Overlea Blvd.,  
Toronto, Ont.,  
M4H 1B1

## NEED MORE INFORMATION?

If you would like more information on the products or services mentioned in the advertisements:

1. Fill in the attached card with your name, address, etc.
2. Circle the appropriate Reader Service number for further information about advertised products.
3. Mail the card and the advertiser will send you literature free of charge. If the card has been removed, or if you want the information in a hurry, phone or write direct to the advertiser and refer to the ETI issue and page number.

Your Company Classification (if applicable):

- A. Manufacturer
- B. Retailer
- C. Government
- D. R&D
- E. Servicer/Installer
- F. Distributor/Representative
- G. Educational Institution

In the field of:

1. Computer and Related Equipment
2. Communications Equipment & Systems
3. Navigation, guidance or Control Systems
4. Test & Measurement Equipment
5. Consumer Products
6. Industrial Controls & Equipment
7. Components & Subassemblies
8. Other (Please specify on the card)

Your major job function (if applicable):

- A. Buying
- B. Technologist
- C. Educator
- D. Not employed in an electronics-related field
- E. Engineering
- F. Technician
- G. Management
- H. Sales
- I. Other (Please specify on the card)

What interests you most about ETI?  
(your favourite five or less):

- A. Audio
- B. Video
- C. Ham Radio
- D. Shortwave Listening
- E. Servicing
- F. Components & Technology
- G. Reports on the Electronic Industry
- H. Microcomputers
- J. Projects
- K. News Digest
- L. Other (Please specify on the card)
- M. Tech Tips

# CMOS Circuits

If you liked this article, please circle Reader Service Card number 53. If you didn't, circle number 54.

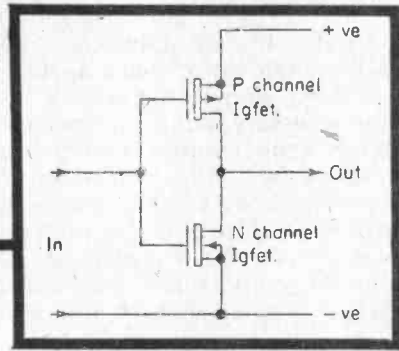

Fig. 1 Basic CMOS Inverter circuit.

CMOS circuits to tickle your imagination and clutter every flat space, by R.A. Penfold.

ALTHOUGH CMOS ICs are a range of digital devices they are suitable for a range of applications which is far more diverse than one might expect. In fact, there can be little doubt that these ICs are the most useful range of digital devices for the average amateur user, and are perhaps even the most useful range of ICs of any type.

When CMOS devices were first introduced in the early 1970s they were much more expensive than their alternatives in other logic families. This is not the case these days and they are now about the cheapest ICs available. The more simple of the devices in the CMOS range cost less than many ordinary transistors, and on a cost basis these ICs are just about unbeatable.

Earlier families of digital devices suffer from three main disadvantages which limit their usefulness to the amateur. They require relatively high supply currents (about 20 mA for a simple quad gate IC), supply voltages are rather critical ( $5\text{ V} \pm 10\%$  for TTL devices for instance), and input impedances are usually rather low, often being only in the region of a few hundred ohms.

CMOS devices do not have any of these disadvantages. They require only very modest supply currents, and even some quite complex devices, such as the 4046 low frequency phase locked loop will operate at supply currents of less than 1 mA. Simple gates, when they are in a static condition, use virtually no power at all.

The supply voltage range over which a CMOS device will operate depends upon the suffix given after the type number. The devices usually supplied to amateur users, and specified for the projects in this book, have an 'AE' suffix. The 'A' of the suffix denotes that the unit has an operating voltage range of 3 to 15 V and the 'E' indicates that it is contained in a standard DIL plastic encapsulation.

Input impedances of CMOS ICs are extremely high indeed, being something in the order of 1,000,000 Megohms. For all practical purposes they can be regarded as having an infinite input impedance, and are voltage rather than current operated devices.

## TOUCH SWITCH

Touch switches seem to have become quite popular these days and although this is probably mainly due to their novelty value rather than any practical advantage, they do have certain practical advantages over more conventional forms of switch. Probably the main one in most applications is that they can be designed to have no moving parts to wear out. This makes them as reliable and hard wearing as the main (electronic) part of the

equipment they are controlling.

The circuit diagram of a simple touch switch using a CMOS bistable circuit is shown in Fig. 3. This will provide on/off switching for any piece of 9 volt battery operated equipment which does not have a current consumption of more than 100 mA (the maximum operating current for the 2N3905 transistor).

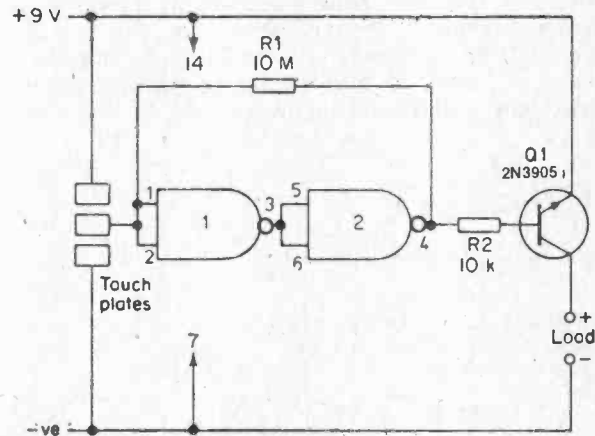

Fig. 2 The touch switch circuit.

CMOS ICs are ideal for use in this particular application since they can easily provide the necessary very high input impedances, and they also consume no significant current when they are not driving a load. The current consumption of this circuit in the off state is very low, being actually less than 1 micro-amp. There is subsequently no significant battery drain when the equipment is turned off, and the battery life should not be significantly less than if a mechanical switch were used.

The circuit operates in the following manner. When the power is initially connected to the device the output of the bistable will go into the high condition. Q1 is cut off and no power is applied to the load.

It is possible to alter the state of the bistable by touching the lower set of touch contacts. The resistance of the operator's skin then takes the input of the bistable low, and the output of the bistable will then also go low. A base current is then applied to Q1 which is biased into saturation and virtually the full supply rail potential is supplied to the load.

The unit can be switched off again by touching the upper set of touch contacts. The input of the bistable is then connected to the positive supply by way of the skin resistance of the operator's finger, and in consequence

both the input and output of the bistable take up the high condition. Q1 is therefore cut off once again, with no significant current being supplied to the load.

R1 provides the necessary latching action by holding the input in whatever state it was in when the finger of the user is removed from the touch contacts. If necessary, the sensitivity of the circuit can be boosted by raising the value of R1. Resistors having values of more than 10 Megohms are not readily available, and so an increased value for R1 can only be obtained by adding two or more resistors in series to make up the required value.

R2 is needed in order to prevent Q1 from passing an excessive base current. It also limits this current to an economical level. If the unit is being used to control a fairly high current level. If the unit is being used to control a fairly high current load, say 25 mA or more, it is necessary to reduce the value of R2 to 1 k.

**CRYSTAL OSCILLATOR**

Crystal oscillators have been used since the early days of entertainment broadcasting whenever a highly stable RF oscillator is required. They are probably used more now than at any time in the past, and apart from use in crystal calibration oscillators and similar radio applications they are often used in digital clocks and other digital equipment where they generate a stable timebase signal.

CMOS ICs can be used as the active devices in good quality crystal oscillators having operating frequencies up to about 10 MHz or so Fig. 3 shows the circuit diagram of a simple CMOS crystal oscillator which uses a couple of inverters.

The two inverters are used to provide an amplifier which has its input and output of the amplifier via TC1, and at the series resonant frequency of the crystal (where it has a very low impedance) positive feedback will be applied to the circuit and it will oscillate.

VC1 enables the oscillation frequency of the circuit to be finely trimmed to the nominal frequency of the crystal. If this feature is not required VC1 can be omitted, with the crystal then being connected in parallel with R1.

At first sight R1 may appear to perform no useful function, but it was found to be necessary to add this as otherwise the oscillator often failed to start when power was applied to the circuit. C1 is the output DC blocking capacitor and C2 is a supply decoupling capacitor.

This circuit seems to operate satisfactorily over a wide range of frequencies with the component values shown, and the prototype oscillated properly with any crystal having a frequency from a few tens of kHz to many MHz.

**CAPACITANCE METER**

Most multimeters are equipped to measure wide ranges of voltage, current, and resistance, but few, if any, are capable of capacitance measurements. As a result of this, most electronics enthusiasts are unable to undertake capacitance measurements, and this must lead to many useable capacitors being discarded simply because their identification markings have become erased. Some means of testing capacitors is also very useful when one is engaged on servicing faulty equipment.

A capacitance meter is therefore a very useful piece of equipment to have in the workshop. A simple capacitance meter can be based on an astable and a monostable multivibrator, and it is possible to make one using a single CMOS IC as the only active device. The circuit diagram of such a unit is shown in Fig. 4 and this uses a single 4001 IC.

Gates 1 and 2 are connected as the astable circuit and gates 3 and 4 form the monostable multivibrator. The astable operates at a frequency of about 100 Hz, and its output is fed to the trigger input of the monostable. Thus

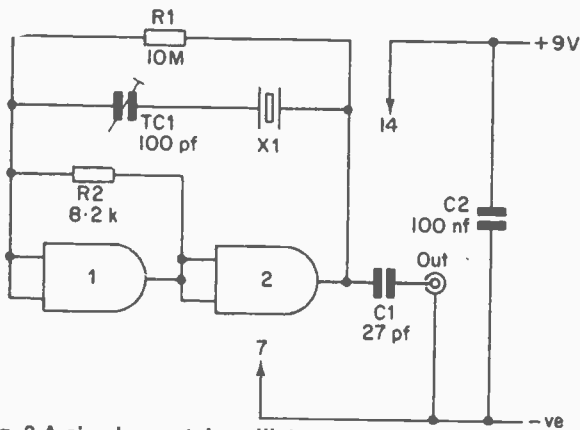

Fig. 3 A simple crystal oscillator.

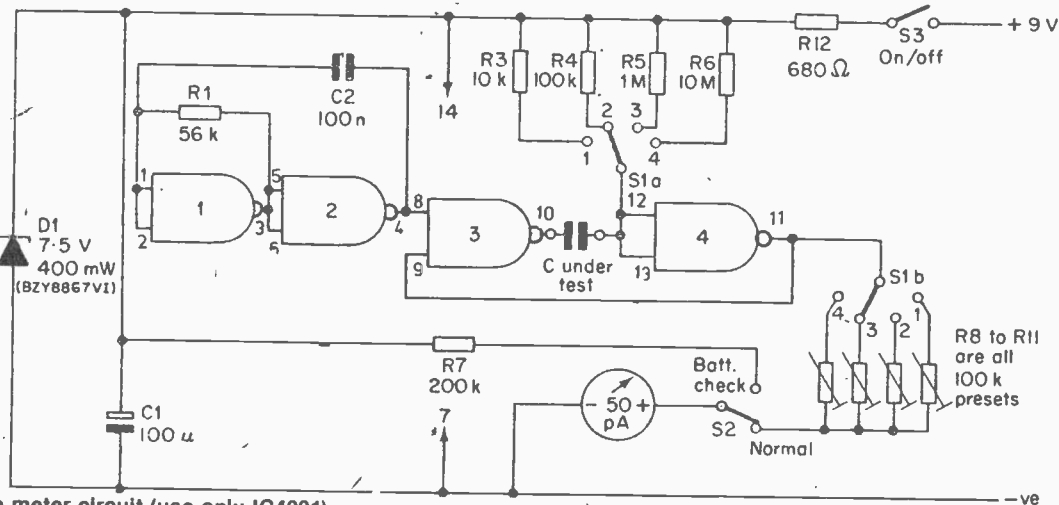

Fig. 4 Capacitance meter circuit (use only IC4001).



one hundred times per second the monostable will produce an output pulse. The length of this output pulse is determined by the values of the timing components, and the timing capacitor under test. The timing resistor is one of the four resistors, R3 to R6, and is whichever one is switched into circuit by S1.

By using four timing resistors the unit is able to provide four measuring ranges. These are as follows:

Range 1	0 to 500 nF
Range 2	0 to 50 nF
Range 3	0 to 5 nF
Range 4	0 to 500 pF

The unit thus covers most normal amateur requirements. The circuit values have been chosen so that the monostable acts as a pulse shortener. For instance, with the unit switched to Range 1 and a 500 nF test capacitor in circuit, the output pulse from the monostable will only be about half the length of the trigger pulse from the astable. Lower values of test capacitance will produce an even shorter monostable pulse length.

A voltmeter circuit consisting of M1 and one of the set of four preset resistors (R8 to R11) is connected at the output of the monostable. Each time the output of the monostable goes high, a pulse of current will be fed to the meter. A constant string of pulses are generated when a test capacitor is connected to the unit, and the meter will respond to the average output voltage.

On Range 2 the timing resistor is ten times the value of that used on Range 1. Only one-tenth of the previous test capacity is therefore needed to produce an identical meter reading. For example, 500 nF was needed to produce FSD of the meter on Range 1 whereas only 50 nF will be needed on Range 2. In practice this is not quite the case since the tolerances of the timing resistors will prevent such a precise relationship from being obtained. In order to ensure that good accuracy is obtained on all four ranges, a different preset resistor for each range is provided in the meter circuit. This enables each range to be calibrated against a close tolerance capacitor.

An alternative approach is to use 1% tolerance components for R3 to R6, and a single calibration preset. The unit would then only need to be calibrated on one range, with good accuracy being automatically obtained on the other three ranges.

A simple battery check facility is incorporated in the circuit, and this merely consists of S2 and R7. When S2 is in the position shown, the circuit functions normally. The meter is connected across the stabilised supply rail when S2 is in the other position. It is connected via R2 which converts the meter into a 0 to 10 V voltmeter. This can be used to monitor the supply potential and when it falls below its nominal level of 7.5 V, this indicates that a new battery is required.

Calibrating the unit is quite straightforward, and four

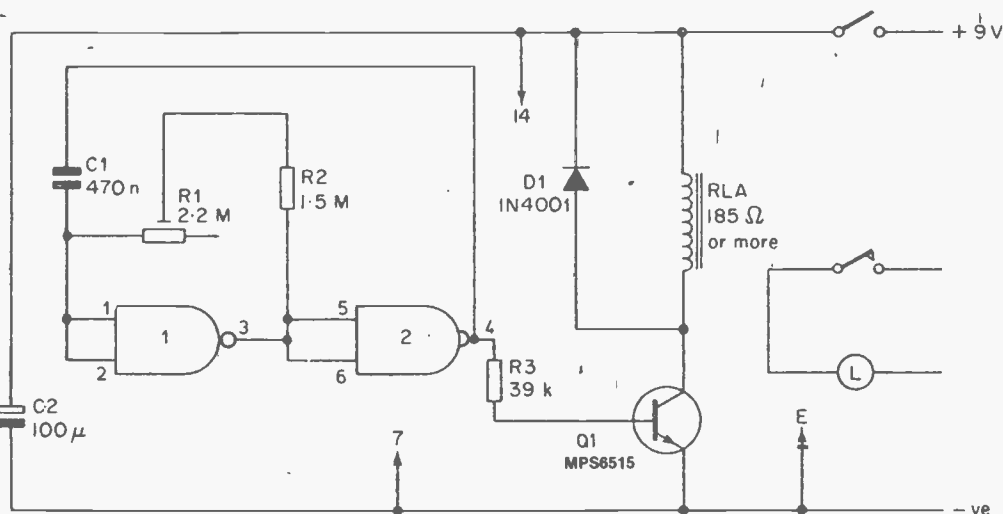

Fig. 5 Christmas tree lamps flasher.

With a 500 nF capacitor in circuit, R9 is adjusted to produce FSD of the meter. If, for instance, a 100 nF capacitor is connected in place of the 500 nF one, the length of the output pulses will only be one-fifth of the previous duration. The rate at which the monostable is triggered is the same, and so the pulses still occur at the same frequency. Therefore, the average voltage across the meter circuit will only be one-fifth of its original level and the meter will read one-fifth FSD.

It will be apparent from this that there is a linear relationship between the meter reading and the value of the test capacitor. The unit thus functions very effectively as a linear reading capacitance meter.

close tolerance capacitors are required for this. For example, a 470 nF 2% capacitor could be used to calibrate Range 1. With this connected across the test terminals and the unit set for normal operation on Range 1, R10 would be adjusted for a reading of 47 on the meter.

It is best not to use a calibration capacitor which has a value corresponding to less than half FSD of the range being calibrated, as this will result in inferior accuracy being obtained. It is advisable to initially adjust all the preset resistors for maximum resistance before commencing calibration of the unit.

## CMOS CIRCUITS FLASHER

Several useful gadgets can be made by using a multivibrator to drive a relay, and a popular example is a Christmas Tree Lights Flasher. This will provide a much more regular flashing rate than can be obtained by using a bi-metal flashing bulb, and the flashing rate can also be made variable. The circuit diagram of this device appears in Fig. 5.

The two inverters are connected as a low frequency astable circuit, and the operating frequency of this is variable over a range of about 0.5 to 1.5 Hz by means of R1. The output of inverter 2 drives common emitter amplifier Q1 via R3. R3 is a current limiting resistor.

Q1 has the relay coil as its collector load, and the relay will be energised when the output of inverter 2 is high. The relay will be off when the output of inverter 2 is low. A single set of relay contacts (either normally closed or normally open ones) are used to control the lights. These will therefore switch on and off at a rate determined by the setting of R1.

D1 is a protective diode, and this is needed to protect the circuit against the high reverse voltage which is developed across the relay coil as the power to the circuit is switched off. This voltage is generated by the magnetic lines of force quickly decaying and cutting through the relay coil. Because of the speed at which this magnetic force dies away, quite a high voltage can be produced, but it is at a high impedance. D1, in effect, shorts out this voltage and is protected against passing an excessive current by the high source resistance of the signal. D1 should not be omitted from the circuit as this voltage spike is quite capable of destroying both the IC and Q1.

Schmitt trigger. The trigger circuit then provides a base current to a high gain Darlington pair using Q1 and Q2. Q2 is a power transistor which is capable of handling the relatively high current drawn by a parking light. S1 enables the light to be turned on independently of the automatic circuitry.

In this circuit the current consumption of the device is of secondary importance since it will be powered from a high capacity car battery. However, it is obviously desirable to have the lamp switching cleanly from one state to the other. Perhaps less obviously it is necessary for the circuit to avoid intermediate output states in order to illuminate the possibility of damage to Q2 due to overheating.

This could occur if Q2 was partially switched on with about half the supply voltage being present at its collector, as it would then have to dissipate several watts of power. This could be overcome by using a large amount of heatsinking for Q2, but it is probably better to use a trigger circuit, as Q2 can then only rest in the hard on or fully off state. The dissipation in either case can only be low, as when it is turned hard on very little voltage is produced across it, and when it is turned hard off it passes no significant current. It will dissipate a significant amount of power when it is turned on, and if a high current lamp is being controlled a certain amount of heatsinking will be necessary, but this will only need to be minimal. In all the light switches just described it is possible to adjust the circuit by means of RV1 to produce a switching threshold at almost any required light intensity.

## ELECTRONIC EGG TIMER

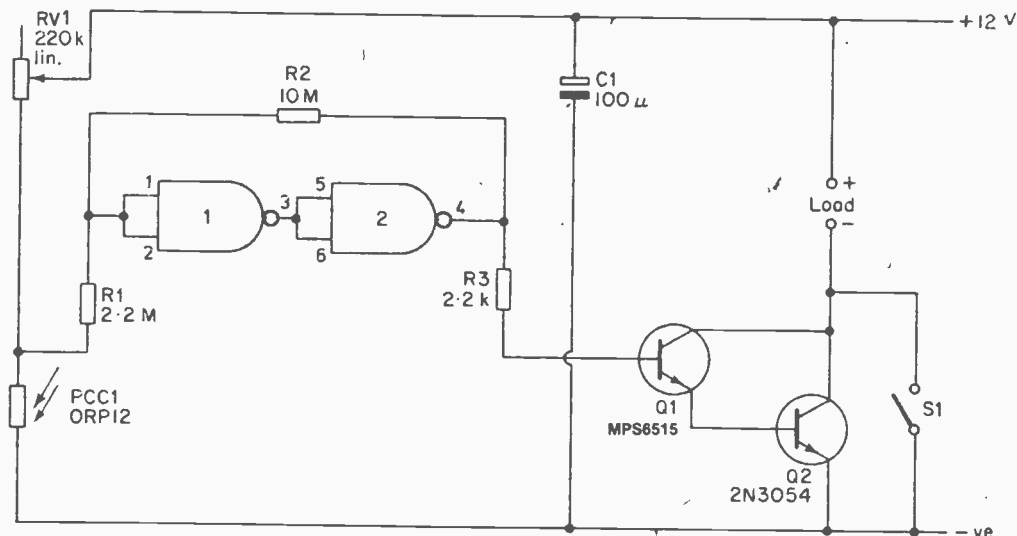

Fig. 6 An automatic parking light.

## AUTOMATIC PARKING LIGHT

In applications where a light switch is to be used to operate a low voltage DC load it is usually possible to use a relayless circuit. An automatic parking light for a car is one such example, and a suitable circuit is shown in Fig. 6.

Here the circuit is triggered when the light level falls below a level which causes the voltage at the junction of RV1 and PCC1 to exceed the trigger voltage of the

Simple timers which provide an audible output at the end of a variable timing period are always interesting. Such circuits are limited to a maximum timing interval of only about 10 seconds, because using a longer time constant would result in the tone generator being turned on only gradually, which would obviously not be satisfactory.

The timer circuit shown in Fig. 7 uses an R-C timing network and an astable multivibrator tone

generator. The multivibrator itself is controlled via a control voltage which is fed to one input of gate 4. This terminal is normally low and the astable circuit is muted. The output of gates is also normally low with Q1 being cut off and passing no current. This is very important, as if it were normally high, Q1 would be biased on and there would be a very high static current consumption.

Gates 2 and 3 are used as the Schmitt trigger, and this has its input fed from an inverter which in turn has its input fed from the R-C timing network. C1 is the capacitive part of the timing network and R1 — RV1 are the resistive part.

immediately go high. This turns on the multivibrator and the audible alarm tone is produced from the speaker.

When the unit is switched off, S1a discharges C1 and the unit is then ready to start another timing period when it is switched on once again. RV1 enables the length of the timing interval to be varied from less than 30 seconds to more than 6 minutes, and the unit is thus suitable for use as an egg timer, or indeed for a multitude of uses in the house. A timer of this type can be much more useful than one might imagine.

A dial calibrated in minutes should be marked around the control knob of RV1, and there is unfortunately no

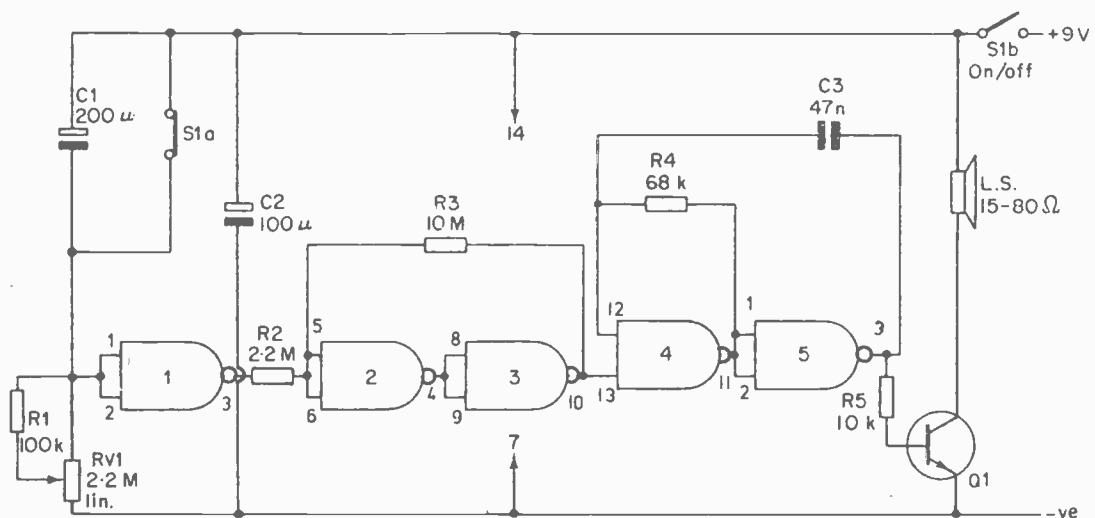

Fig. 7 Electronic egg timer circuit (use 4011 only).

## ELECTRONIC GAME

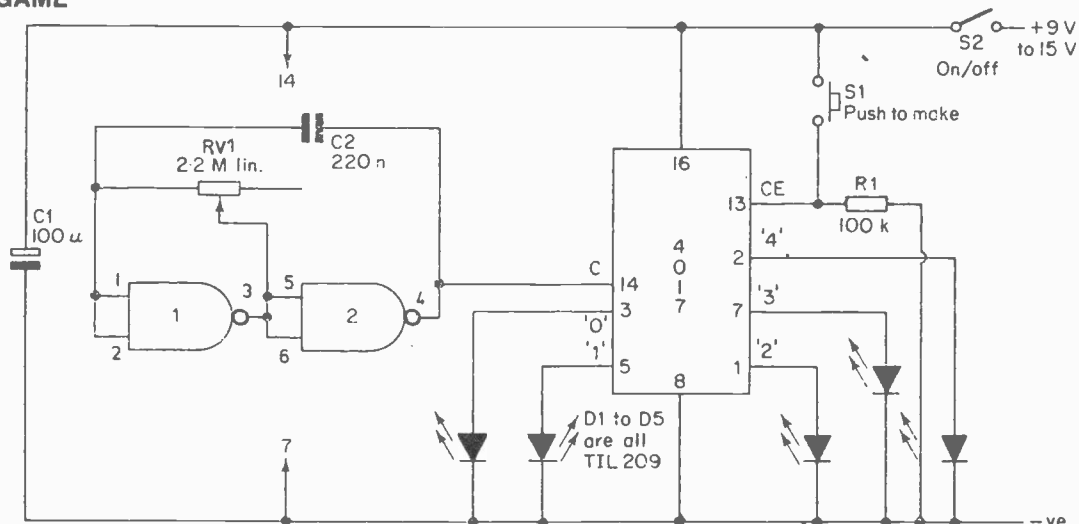

Fig. 8 Simple electronic game.

S1a opens when the on/off switch (S1b) is closed and this starts the timing interval. C1 begins to charge up through RV1 and R1 and eventually the voltage across R1 and RV1 will fall to the transfer voltage of gate 1. When this happens, the output voltage of gate 1 will gradually begin to rise. After a short while its output voltage will reach the trigger voltage of the Schmitt trigger circuit, and the output of inverter 3 will

quickly go high. This turns on the multivibrator and the audible alarm tone is produced from the speaker.

Note that this circuit can only be built using a 4011 IC, as gate 4 must be a NAND type. In actual fact it requires two ICs, since five gates are employed in the circuit and only four are contained in each 4011 IC.

The diagram above shows that the 4017 IC has ten outputs are utilised in the circuit of Fig. 9 which shows

how the device can be used as the basis of a simple electronic game. It also demonstrates the properties of the 4017 IC.

The two inverters are used in an astable multivibrator, and the operating frequency of this can be varied from less than 1 Hz to over 100 Hz by means of RV1. The output of the multivibrator is used to drive the clock input of the 4017.

The clock enable terminal of the 4017 is connected to ground through R1, and so when S2 is closed and power is applied to the circuit, the 4017 will start to operate. The first input cycle will cause pin 3 (the '0' output) to go high, and the first LED will light up. At the commencement of the next clock input cycle pin 3 will return to the low state and pin 5 (the '1' output) will go high for one complete input cycle. Then pin 5 goes low and pin 1 goes high, and so on until all the LEDs have turned on in sequence.

There is then a pause during which none of the LEDs come on, and this is the period during which the unconnected outputs go high. When all five of these outputs have gone high the cycle starts once again from the beginning, with the five LEDs turning on in sequence followed by a break.

In practice the LEDs are mounted in a row along the front panel of the unit, and the idea of the game is to stop the sequence when the middle LED (D3) is on. The

sequence is stopped simply by pressing S1 which is a push to make non-locking push button switch. When this is operated it takes the clock enable input high, and this blocks the clock signal and holds the 4017 in whatever state it was in when at the instant S1 was closed.

The circuit is reset ready for a new round by releasing S1. The sequence then continues from where it left off. The speed at which the circuit operates, and therefore the degree of difficulty, is controlled by the setting given to RV1. The circuit may appear to be one that tests the reaction speed of the competitor, but it is really more a test of co-ordination and anticipation.

It is possible to use the circuit from a 9 volt supply, but the LED display will not be very bright and it is better to use a supply voltage of about 12 to 15 volts.

ETI

This article has been reproduced from 50 CMOS circuits by R. A. Penfold, published by Babani Books available from the ETI Book Service for \$4.25.

*Continued from page 40*

multi-element crossovers were not necessary, and as a result only a few components are used in the Keesonic models. The overcomes the problems of low efficiency and loss of signal detail.

The Keesonic Kolt is engineered for restricted listening areas, and measures only 238 x 133 x 165 mm, weighs less than 4 kg, and will handle 60W.

The major British companies, of course, manufacture their own drivers and have formulated various synthetic materials. These range from Bextrene thermo-plastic cones to polyester weave domes for the high frequency drivers. B and W introduced in its Series 80 mid-range head assembly a special type of glass reinforced concrete, and the outer head casing is moulded in rigid polystyrene.

Designers have paid great attention to overloading, which can result in distortion and even damage to the speaker, and the world's first automatic overload protection system was incorporated in the B and W 801 Studio Reference Monitor. The company's DM12 model has an even more refined version in the form of APOC, which stands for audio powered overload circuit.

### Steady State And Transient

KEF has its S-Stop - steady state and

transient overload protection system, which is fitted to the KEF Reference Model 101.

For 25 years the QUAD, electrostatic has been regarded by many audiophiles as the standard by which other loudspeakers are judged. It thus is a major event when QUAD's designer, Peter Walker, and his colleagues introduce a new model based on the same principle.

The concept of a relatively large and light membrane acting directly upon the air, and driven over its entire surface in a controlled manner, is very attractive. In fact, work was done on the concept long before Rice and Kellogg invented the familiar moving coil loudspeaker in 1925-26.

QUAD's new ESL-63 stems from 18 years of development work. Given the acronym FRED - full range electrostatic doublet - this dipole source has benefits in terms of room position and stereo perception. The ratio of direct to reflected sound is much greater with a dipole source, which gives better localisation of the stereo image, and its sound dispersion pattern is substantially figure-of-eight.

### Concentric Rings

The centre diaphragm of the ESL-63 consists of about half a square metre of suspended thin plastic sheeting, with a special coating, and on each side of it a set of electrostatic plates.

The central "disc" is fed directly with high voltage audio, and concentric rings receive the audio signals through a system of electronic time delays, which lengthen according to each segment's distance from the centre. The two areas furthest from the centre are fed from a normal capacitive delay, so that they have only the frequency dependent characteristic necessary to improve response and phase linearity.

The base stand contains the electronics required to supply the 5 kV polarisation voltage, audio currents and complex protection circuitry.

From an auditory standpoint, the listener cannot ascribe the source of sound to the loudspeakers, and a stereo pair creates an illusion of depth as well as width in the sound picture.

Although the ESL-63 may not be able to produce sounds loud enough for the rock music enthusiast, this latest QUAD design offers a fidelity for the listener in the home that has to be heard to be believed. In fact, the sound quality is of such a standard that all source - broadcast, disc or tape - imperfections are very evident. (16D981/JS)

ETI



#### February 1977

**Features:** CN Tower, Biorythm Calculator, VCT, 555 Timer Applications, Yamaha B1 Review, Scope Test Your Car.  
**Projects:** 5W Stereo Amp, Philips Speaker System, Reaction Tester, Patch Detector, Heads or Tail, SCR Tester.

#### August 1978

**Features:** Getting into Shortwave, Using a 'Scope, Semiconductor Guide, Intro to Amateur Radio 2.  
**Projects:** Sound Level Meter, 2 Chip Siren, Induction Balance Metal Locator, Porch Light.

#### November 1978

**Features:** Bally Arcade, PCM Explained, Danger of Lightning, Easy PCB Making.  
**Projects:** Hi-Fi Amp with CMOS Switching, Capacitance Meter, Stars-n-Dots Game.

#### January 1979

**Features:** Robots: some Facts, Robots: Brain Power, Robots: Building Guide, VCT, Getting into Video.  
**Projects:** Digital Tachq, Log-Exponential Converter, FM Broadcaster.

#### February 1979

**Features:** Quarks, Op-Amps, Binary to Decimal and Back.  
**Projects:** SW Radio, Phasemeter, Light Chaser.

#### August 1979

**Features:** Casing Survey, Smoke Detectors, TV Antennas, Reed Switches, Magnetic Field Audio Amp, Industrial Electronics.  
**Projects:** Audio Power Meter, Shoot-out, ETI-Wet Plant Waterer.

#### September 1979

**Features:** OSI Superboard Review, Solar Power from Satellites, Reed Switches.  
**Projects:** Field Strength Meter, Digital Wind Meter, Up/Down Counter.

#### October 1979

**Features:** SW Receiver Survey, Ultra Fidelity, Computer Speech.  
**Projects:** Simple Graphic Equaliser, Digital Dial, Variable Windscreen Wiper, Cable Tester.

#### January 1980

**Features:** LM10 Applications, Guide to Triac's, History of Car Ignition.  
**Projects:** Guitar Effects Unit, Series 4000 Stereo Amplifier, Logic Probe.

#### February 1980

**Features:** Simple Radio Control, Gain Control, Guide to Triac's.  
**Projects:** Series 4000 Moving Coil Preamp, Egg Timer, Power Supply.



#### March 1980

**Features:** Biofeedback, Gain Control, Power Supplies, Self Resonant Capacitors.  
**Projects:** Electromyogram (pt.1), Battery Condition Indicator, Wire Tracer.

#### May 1980

**Features:** Delay Lines, Standing Waves, Microwave Cooking, Artificial Intelligence.  
**Projects:** Click Eliminator, Soil Moisture Indicator, Fuel Level Monitor, 16k RAM Card.

#### June 1980

**Features:** Electronic Warfare, PLL Synthesis, CA3130 Circuits, Canadian Sound Archives, Magnetic Power Control, CLIP.  
**Projects:** Function Generator, Dynamic Noise Filter, Overspeed Alarm.

#### July 1980

**Features:** CMOS 555 Circuits, Capacitors, Electronics in the Studio, Tesla Controversy.  
**Projects:** Hebot Robot (pt.1), Photographic Timer, Analogue Frequency Meter, Accentuated Beat Metronome.

# ETI BACK ISSUES

#### August 1980

**Features:** S100 Bus System, Introduction to Test Gear, Designer Circuits, FET Special, Life Out There?  
**Projects:** 300W Amp, Hebot (pt.2), Transistor Tester, Passionmeter.

#### November 1980

**Features:** Designer Circuits Special, Cassette Decks and Tapes, Attenuators, Project Daedalus, Thermistors.  
**Projects:** Guitar Practice Amplifier, 6W Siren, Infra-Red Remote Control.

#### March 1981

**Features:** The Ubiquitous Oscilloscope, VFET Applications, Photocells, Test Gear.  
**Projects:** Hum Filter, Drum Sythesiser, Shark Game.

#### April 1981

**Features:** Introduction to Lasers, Test Meter Circuits, Eddy Currents, Modern Turntable Technology, Honeycomb Speakers.  
**Projects:** Stereo Image Coordinator, Ultrasonic Switch, Autoprobe.

#### June 1981

**Features:** Project Galileo, Story Behind Stereo, Solder, Computerese.  
**Projects:** 1573A VCA, High Speed Cassette Interface, Double Dice, Bicycle Speedometer.

The Back Issues shown here are available from ETI. Back issues are not just unsold issues; each month about 500 copies are held in reserve for later interest. The order form in this issue gives a complete list of issues still available.

Price is \$3.00 each, any five for \$10

ETI Back Issues,  
Unit 6  
25 Overlea Blvd,  
Toronto, Ontario,  
M41 1B1

# The Fun of Electronics



Are you sure you want this 11th commandment about always providing a ground?

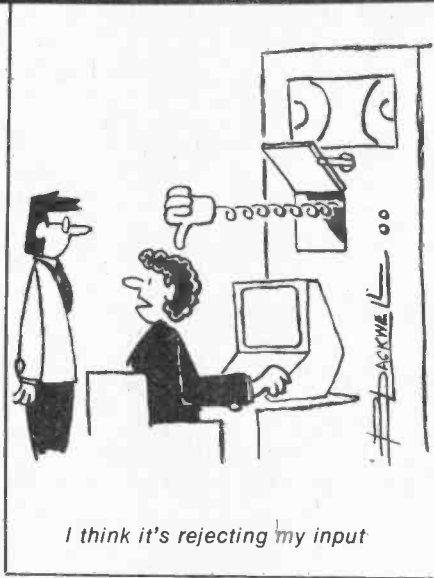

I think it's rejecting my input

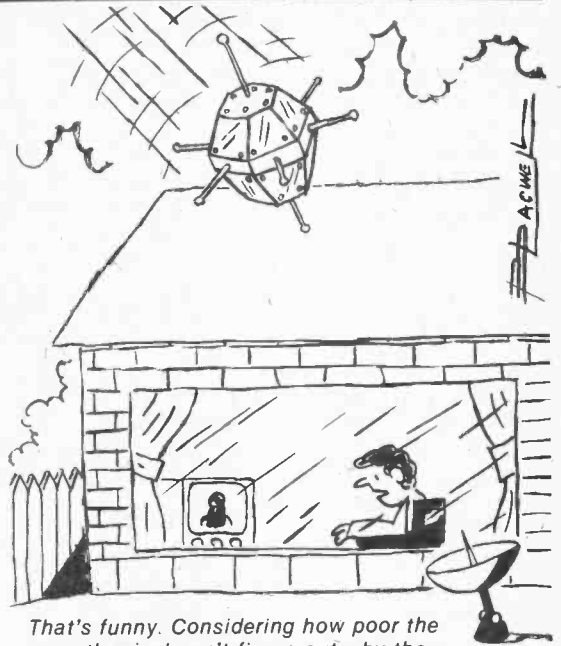

That's funny. Considering how poor the weather is, I can't figure out why the picture's so clear.

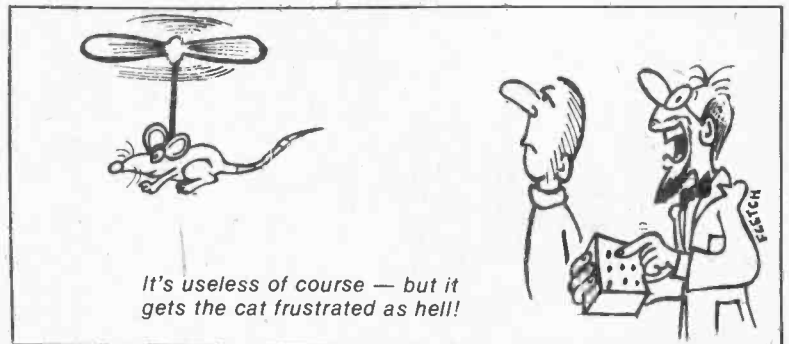

It's useless of course — but it gets the cat frustrated as hell!

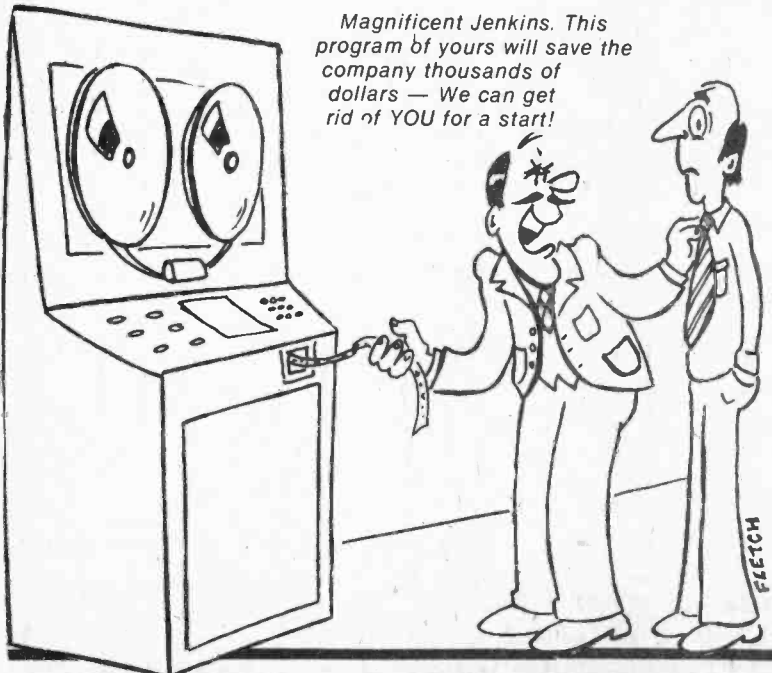

Magnificent Jenkins. This program of yours will save the company thousands of dollars — We can get rid of YOU for a start!



# PULLING THE PLUG

## ETI Mouse Masher

FOR THE PAST FEW WEEKS, we've been having no end of trouble here at ETI. . . with mice. Now, it depends on who exactly you talk to; the mice range from tiny little brown balls of fluff that scamper merrily in among the back issues to great gargantuan cat killers that thunder about the rafters and register 3.4 on the Richter scale every time they burp (after eating some of the cars in the parking lot). Anyway, we decided that something should be done about them, and, since no one could find them during the day to serve them with eviction notices, we figured it was time to employ everybody's all time fave form of social discourse; violence.

Well, we dusted off the project lab, got out the old *Rat Destroyer Cookbook, Volume II*, and set to work. The result of our efforts is presented here for any readers similarly plagued with either mice or imaginative co-workers. . . whichever the case may be.

To date, this thing has not failed to kill a single mouse that has set it off!

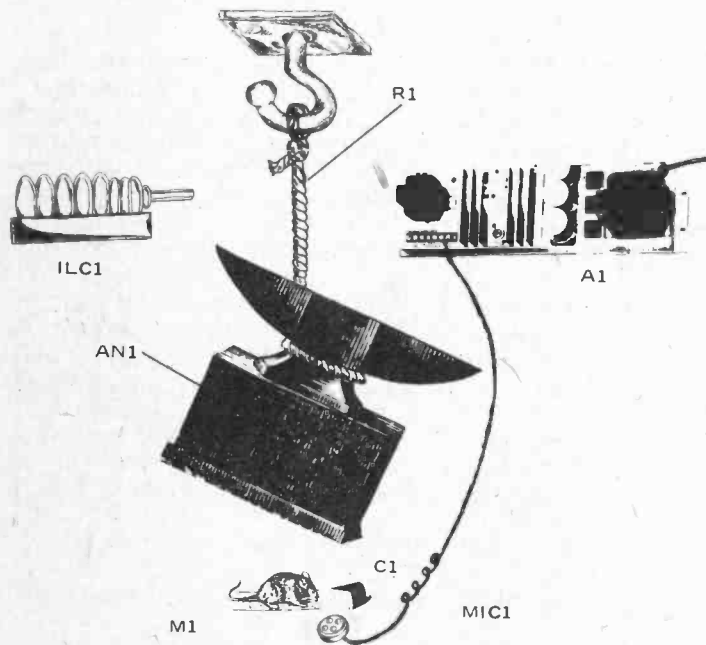

### How It Works

The operation of the ETI mouse masher is very simple, as can be seen from the accompanying diagram. The mouse, M1, steps under the five hundred pound anvil AN1, lured by the traditional wedge of cheese, C1. (Kraft singles, KS1, are also cool, but should be unwrapped first, as mice aren't terribly good at this. They also don't like Mayonnaise, as a rule.) The mouse, aware that something wierd is obviously afoot, eats the cheese very fast, which gives him hiccoughs, H1. The sound of the hiccoughs is picked up by microphone button MIC1, which is coupled to amplifier A1. Amplifier A1 is actually defective, and goes into oscillations whenever it gets any signal in, and, usually, will blow its fuse, F1. This blowing of its fuse shuts off the power to its auxillary power socket, which has the coil leads of a relay, K1, stuck into it. The normally closed contacts of the relay thus close, causing the 90 kW industrial Laser cannon ILC1 to start up, burning through the rope, R1, holding up the anvil, and thus flattening the mouse into a very thin stain on the floor, TSF1.

*Pulling the Plug* is a forum for the dissemination of sacred technical balderdash. Consisting entirely of lies, half truths, figments and fictions, it should not be taken too seriously if you can at all help it.

# ETI ORDER FORM

**BACK ISSUES:** Please circle Issues desired.

1977 February	July			
1978	June	July	August	September
	October	November	December	
1979 January	February	March	April	June
	August	September	October	November
1980 January	February	March	April	May
	August	October	November	December
1981 January	February	March	April	June
	August	September	October	November

QTY.	ITEM	AMOUNT
.....	Back issues @ \$3 (mark choice above)	\$.....
.....	More Circuits @ \$4.95	\$.....
.....	Hobby Projects @ \$3.95	\$.....
.....	Electronic Circuit Design @ \$3.95	\$.....
.....	Projects Book No. 2 @ \$3.95	\$.....
.....	Subscriptions @ \$16.95/\$29.95	\$.....
.....	ETI T-shirts @ \$5.50	\$.....
.....	Small ( ) Medium ( ) Large ( )	\$.....
.....	ETI Binders @ \$9.45	\$.....

Ontario residents add 7% PST on last two only.

BABANI			TAB		
QTY.			QTY.		
.....	BP1	\$2.80	.....	No.554	\$17.45
.....	BP14	\$4.80	.....	No.574	\$16.45
.....	BP24	\$4.25	.....	No.785	\$14.45
.....	BP33	\$4.25	.....	No.800	\$20.45
.....	BP35	\$5.50	.....	No.804	\$19.45
.....	BP37	\$5.50	.....	No.805	\$14.45
.....	BP39	\$5.50	.....	No.806	\$16.45
.....	BP42	\$3.55	.....	No.841	\$11.45
.....	BP44	\$7.55	.....	No.984	\$14.45
.....	BP46	\$5.90	.....	No.995	\$10.45
.....	BP47	\$5.90	.....	No.1015	\$13.45
.....	BP48	\$5.90	.....	No.1055	\$9.45
.....	BP49	\$6.25	.....	No.1064	\$13.45
.....	BP50	\$5.90	.....	No.1070	\$14.45
.....	BP51	\$5.50	.....	No.1071	\$13.45
.....	BP62	\$8.95	.....	No.1133	\$11.45
.....	BP63	\$8.95	.....	No.1166	\$16.45
.....	BP64	\$8.95	.....	No.1167	\$10.45
.....	BP65	\$6.55	.....	No.1183	\$13.45
.....	BP66	\$7.55	.....	No.1199	\$16.45
.....	BP67	\$7.55	.....	No.1200	\$16.45
.....	BP68	\$7.25	.....	No.1203	\$14.45
.....	BP69	\$7.55	.....	No.1205	\$16.45
.....	BP70	\$2.40	.....	No.1216	\$13.45
.....	BP71	\$7.70	.....	No.1241	\$13.45
.....	BP72	\$7.70	.....	No.1271	\$14.45
.....	BP73	\$8.58	.....	No.1300	\$24.45
.....	BP74	\$7.70	<b>PRENTICE-HALL</b>		
.....	BP75	\$7.30	.....	AB001	\$14.45
.....	BP76	\$7.30	.....	AB002	\$12.45
.....	BP77	\$12.30	.....	AB003	\$9.45
.....	BP78	\$7.30	.....	AB004	\$10.45
.....	BP79	\$7.30	.....	AB005	\$8.00
.....	BP80	\$8.25	.....	AB006	\$10.45
.....	BP81	\$7.30	.....	AB007	\$9.45
.....	BP82	\$8.10	.....	AB008	\$16.45
.....	BP83	\$8.20	.....	AB009	\$16.45
.....	BP84	\$8.11	.....	AB010	\$14.45
.....	BP85	\$12.25	.....	AB011	\$9.45
.....	BP86	\$8.25	.....	AB012	\$10.45
.....	BP87	\$5.90	.....	AB013	\$10.45
.....	BP89	\$12.30	.....	AB014	\$16.45
.....	BP90	\$8.10	.....	AB015	\$10.45
.....	BP94	\$8.10	.....	AB016	\$10.45
.....	No.224	\$4.25	.....	AB017	\$9.45
.....	No.205	\$3.55	.....	AB018	\$9.45
.....	No.213	\$4.50	.....	AB019	\$9.45
.....	No.215	\$3.70	<b>TOTAL</b>		
.....	No.221	\$5.50	<b>ENCLOSED</b>		
.....	No.223	\$5.50			

If we cannot complete your order would you like a refund or held for a backorder

**REMEMBER TO PUT YOUR NAME & ADDRESS ON REVERSE OF THIS FORM.**

**THE ONLY WAY TO BE SURE OF YOUR ISSUE EACH MONTH**



**SUBSCRIBE**

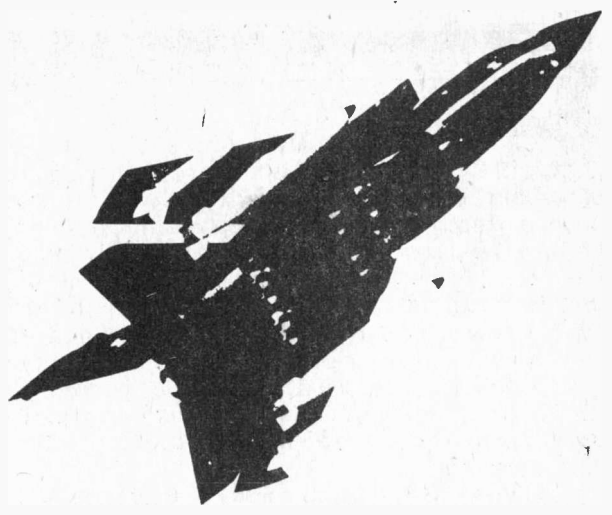

**Remember the Famous ETI Supersonic Fighter Plane Project?**

**BOOKS, BACK ISSUES BINDERS—SEE OVER**

What? No? Oh, well, you must have missed that issue. It was easily as neat as our home brew atomic sub. You don't remember the sub either? That was the same month we ran the full length interview with God on how he came up with the laws of nature. Great story about using Jupiter as a dart board. No, huh? Wow, you've been missing quite a bit. How about the three parter on how to set up your own computer data net with the intellegent earth movers on the planet Abysmalak IV which we recently discovered? Oh no. . . all three parts? That was a really hot one, too. . . afraid we're out of back issues for it. You see, that's the difficulty in dealing with news stands. You never know if you're going to get your copy or not. Now, if you had a subscription things would be different. If we were to run an article on a twelve cent 64K computer, a do-it-yourself time warp generator or even something simple like a nice, basic meta-galactic hand phaser, you'd be sure to get your copy.

ETI is *the* magazine for keeping up with the fast moving world of electronics. If you don't want to be stuck in the past with nothing but a three dimensional TV system and a fusion powered space scooter to amuse yourself with, you'd better be sure you get your copies. Just send \$16.95 for one year, or \$29.95 for two, in either Canadian funds or Saurian Interstellar Credits (if you have any), and we'll see that you don't miss any more issues.

Or, save the postage and use our instantaneous matter transportation project to send us the cash. . . oh no, not the matter transportation project too.

*ETI Subscriptions*  
25 Overlea Boulevard, Unit 6  
Toronto, Ontario  
M4H 1B1

**PLEASE ALLOW 6—8 WEEKS FOR YOUR FIRST MAGAZINE TO ARRIVE**

Code \_\_\_\_\_

Electronics Today Magazine, Unit 6, 25 Overlea Blvd., Toronto, Ontario M4H 1B1.

ORDER  Please fill out form overleaf  
**SUBSCRIPTIONS:**  NEW SUBSCRIPTION?  Or...  RENEWAL? Please check one.

One year subscription (12 issues) \$16.95  Two year subscription (24 issues) \$29.95 Postage and handling to Canada is included, for U.S. please add \$3  other countries add \$5/yr.

NAME \_\_\_\_\_

ADDRESS \_\_\_\_\_

TOWN/CITY \_\_\_\_\_ PROVINCE/STATE \_\_\_\_\_

CODE \_\_\_\_\_ DATE \_\_\_\_\_

Cheque enclose DO NOT send cash  
 Bill Mastercard A/C No. \_\_\_\_\_ Signature \_\_\_\_\_  
 Bill Visa/A/C No. \_\_\_\_\_ Expiry Date \_\_\_\_\_

**PLEASE PRINT CLEARLY**



# Reaction Tester

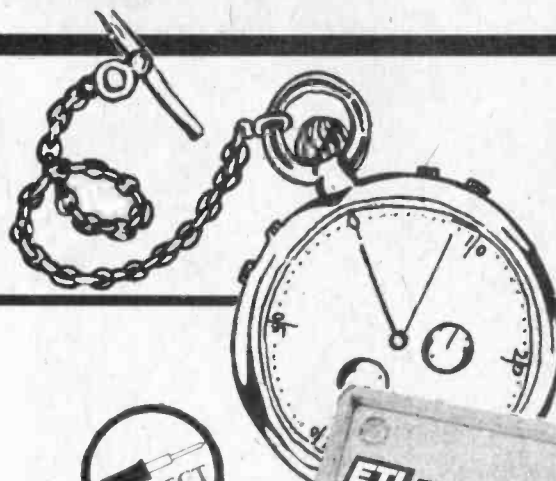

Here's a 'game' project, adapted from a design sent to us by a reader. It provides a novel way of testing your reactions — and it's fun, too!

THERE ARE ONLY a limited number of ways you can use a 4017 and a 555. Or so we thought.

We used to think that the stockpile of possible ways of combining the two ICs had been exhausted until we opened the mail one morning and saw this ingenious idea for an electronic game from A. Trafford (see Fig. 1).

The game has, as its main feature, a row of coloured LEDs. When you switch on; the bottom LED lights up, ready for play. When the 'GO' button is pressed the light moves up the row. The idea is to get the light as far up the row as possible — the higher up the row, the higher your score — but not past LED5. You see, LED5 gives maximum score (+20 points) and if the light goes further up than this you lose points.

Finally, if the light goes further than LED9 (-20 points) another LED (LED10—LOSE) lights up, and stays on until you reset the game.

Now, as far as we're concerned, this game must definitely be the very last way that these two ICs can possibly be used together — or do you know different?

## Construction

Following the printed circuit board (PCB) overlay details in Fig. 2, insert and solder all components into the board, starting with the low-level components (ie, resistors, IC sockets). Solder in PCB pins at all connection points.

Next, insert and solder the two capacitors making sure capacitor C1 is the right way round.

Push the two ICs into their sockets, and insert and solder the thyristor SCR1 into place making sure that the polarity of all semiconductors is correct.

Now, mark and drill the case for switch SW2 and fit it into position.

Using double-sided, self-adhesive pads, stick the 9V battery and the PCB to the bottom of the case.

Finally, wire up your project, following the connection details of Fig. 2. A tip to help prevent your project becoming a 'bird's nest' is to wire each switch or push-button separately, twisting the leads before soldering. Similarly the 11 wires connecting the PCB to the LEDs should be twisted together.



## PARTS LIST

### RESISTORS (All 1/4 W, 5%)

R1	2k2
R2,7	10k
R3	18k
R4	27k
R5	39k
R6	47k
R8	22k
R9	820R
R10	470R

### CAPACITORS

C1	1u, 10V electrolytic
C2	100n polyester

### SEMICONDUCTORS

IC1	555 timer
IC2	4017 counter
SCR1	C103 thyristor

LED1-4	0.2" green LEDs
LED5	0.2" orange LED
LED6-9	0.2" yellow LEDs
LED10	0.2" red LED

### MISCELLANEOUS

SW1	single-pole, six-way rotary switch
SW2	single-pole, double-throw biased toggle switch
SW3	single-pole, single-throw toggle switch
PB1	single-pole, push-to-make release-to-break switch
Case to suit	
Knob to suit	
Battery + clip	

# REACTION TESTER

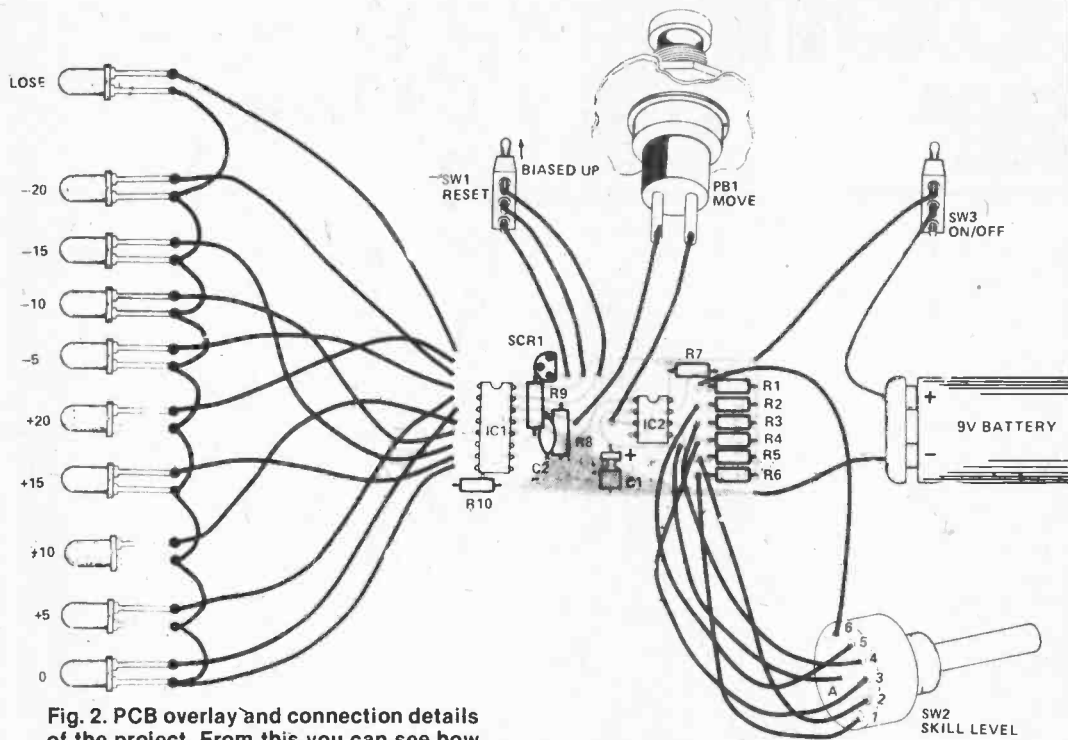
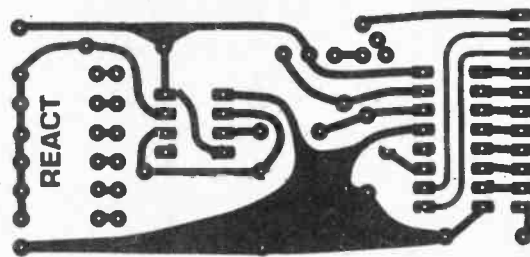
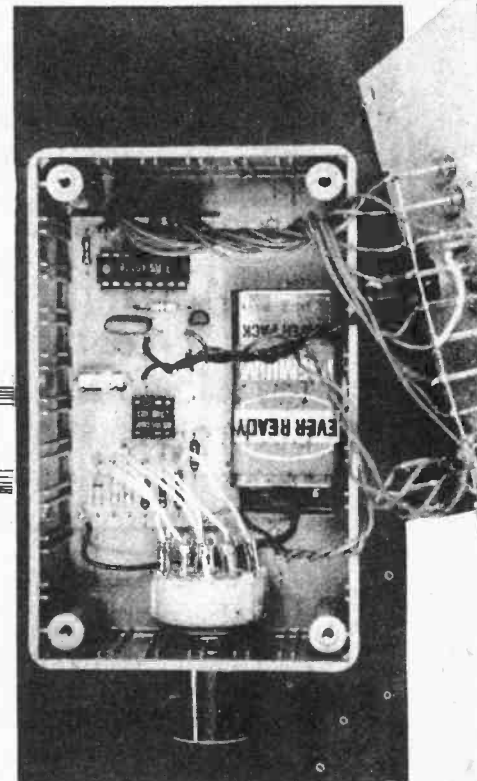

Fig. 2. PCB overlay and connection details of the project. From this you can see how one terminal of each LED (ie, their cathodes) are commoned and connected to resistor R10.



PCB pattern for Reaction Tester Game

## HOW IT WORKS

An oscillator formed by an astable multivibrator continually oscillates at a set frequency.

Pressing the push-button connects the output of the oscillator to the input of a counter, the outputs of which are connected to a row of LEDs. On every positive pulse from the oscillator the counter counts on and lights the next LED.

When the '10' output of the counter turns on it fires a thyristor, which holds LED 10 on, permanently, until power is disconnected.

The astable multivibrator oscillator is configured round a 555 timer. The frequency of oscillation is determined by one of the resistors

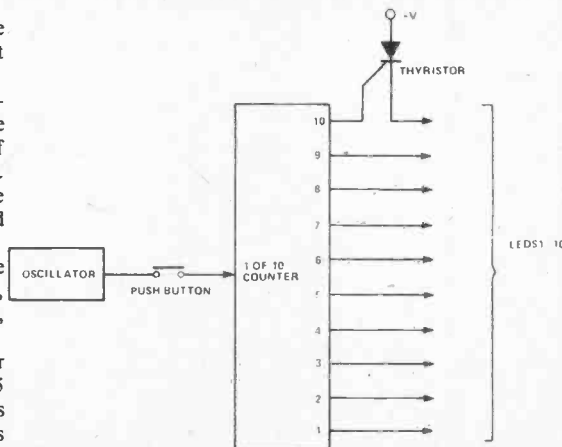

R1-6, and the chosen resistor is switched into circuit by a switch SW1.

A 4017 (IC2) is used as a '1 of 10 counter' and every time push-button PB1 is pressed, the 4017 counts the output pulses of the 555 oscillator. The first nine outputs of the counter directly drive LEDs which give an indication of the state of the count.

Output 10 is connected to the gate of thyristor SCR1 thereby turning on the thyristor on the count of 10. This thyristor drives LED 10, the LOSE indicator.

Switch SW2 disconnects power from the thyristor, thus turning off LED 10, and also resets the counter to a zero count.

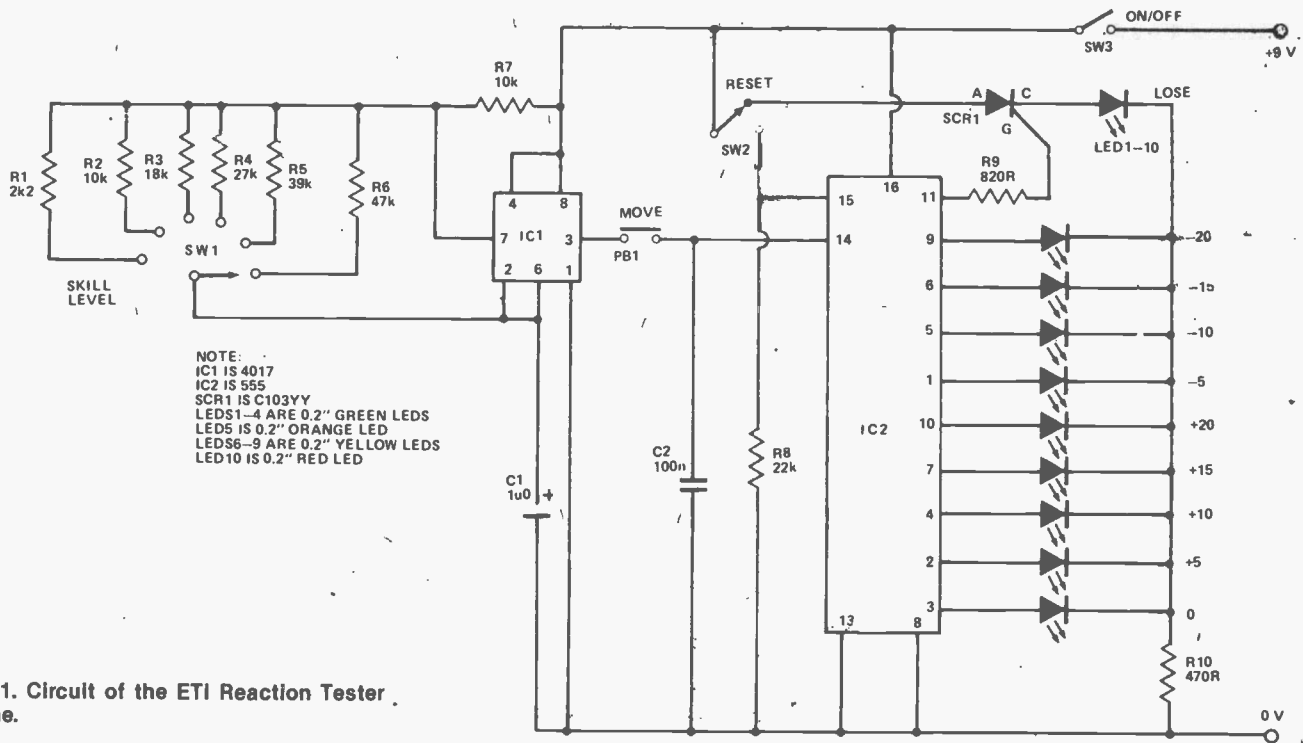

Fig. 1. Circuit of the ETI Reaction Tester Game.

# Designer Circuits

## QUICK TRANSISTOR CHECKER

This very simple and inexpensive circuit is not designed to measure any transistor performance figures, but is intended for quick testing to show whether or not the test device is functional. The basic method of testing a transistor is to first connect a supply to its emitter and collector terminals and check that no significant current flows. If the base terminal is then given a small forward bias, this will be amplified in the form of a large collector-emitter current.

This circuit is based on a CMOS quad 2 input NAND or NOR gate IC. Either type is suitable as each gate has its two inputs connected together so that it acts as an inverter. The first two inverters are used in conjunction with R1 and C1 as a conventional CMOS oscillator operating at a frequency of a few hundred Hz. The other two inverters are connected in parallel, and fed from the output of the oscillator so that they provide a

complementary output. In other words, one output will be positive and the other will be negative except during the brief periods when the outputs change state.

The collector and emitter of the transistor are fed from the outputs via D1 and D2, and the base is fed from one output via R2. If we assume that an NPN device is being tested, when gate 2 output is positive and the other output is negative, the transistor will not be forward biased by R2 (it will be reverse biased in fact) and it should pass no significant collector current.

If it is a short circuit, device and does pass such a current, this will pass through D2 which will light up and indicate the fault. When the outputs are in the opposite states, the transistor will be forward biased by R2 and should conduct heavily, causing D1 to pass a current and light up. Failure of D1 to come on indicates an open circuit or very low gain device. PNP devices operate with the opposite polarity, and so when testing one of these it is D2 that should switch on, and D1 which should remain off.

### Summary

One LED on = functional device, type (ie PNP/NPN) as indicated.  
 Both LEDs on = short circuited device.  
 No LEDs on = 'open circuit or very low gain device.  
 Diode or rectifier testing (anode to collector, cathode to emitter).  
 D1 on = functional device.  
 D2 on = connected with wrong polarity.  
 Both LEDs on = short circuited device.  
 No LEDs on = open circuit device.

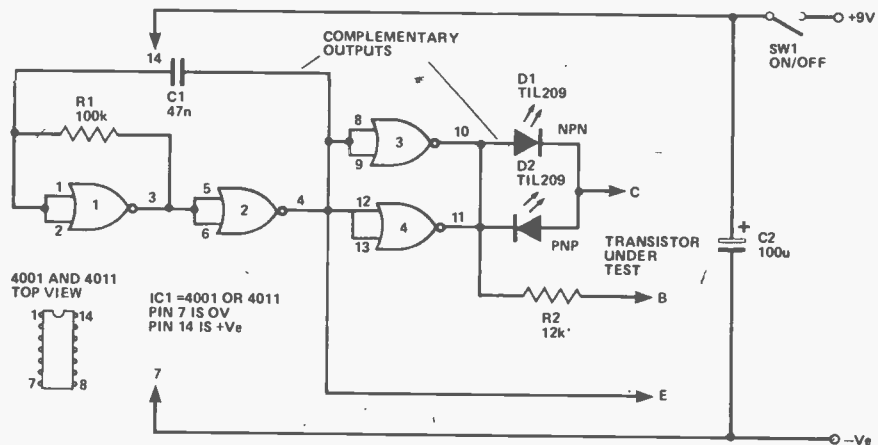

# COMPUTING TODAY



Edited by  
Steve Rimmer

THIS MONTH, some more machine code. However, this time we're going to look at a somewhat more useful ML code application, and one with a fairly high degree of sophistication.

Old 8K PETs are among my favourite funky operating systems. It's not only that they're weird and have unusual personalities; there has been so much written about them, and so many tricks discovered to coerce them into doing things that they are (with enough photocopies of magazine articles and scribbled notes) surprisingly powerful

machines. The biggest hassle with them is their munchkin sized keyboards. ... spit roasting is too good for whoever it was that decided to go for that calculator nouveau styling.

There are several ways to get rid of the little keyboards; some Commodore service places used to be willing to replace the cover and keyboard (for a lot of money), there are commercial clamp-on-the-front replacement deals, and, of course, you can always unplug the existing keyboard and run a hand wired ver-

sion in on a ribbon cable (gross!).

Or you can use the following program.

At the back of the PET there are three edge connector deals, of which the middle is the PET User's Port. It is I/O for idiots; no handshaking, funny signals or critical timing. It is memory mapped with a VIA, and can be implemented by doing little more than setting a data direction register and PEEKing or POKEing the data register.

Now, this port can be hooked to any eight bit digital thingy you want

Program 1: Machine Language Source Code Listing For Routine to Add Second Keyboard To Original ROM 8K PET through user port.

033A	78	XON	SEI	037C	20 6C 03	FINISH	JSR STAX
033B	A9 75		LDA 75	037F	EA		NOP
033D	8D 19 02		STA \$0219	0380	4C 7E E6		JMP \$E67E
0340	A9 03		LDA 03				
0342	8D 1A 02		STA \$021A	0383	AD 41 E8	KEYS	LDA \$E841
0345	A9 00		LDA 00	0386	29 7F		AND 7F
0347	8D 43 E8		STA \$E843	0388	C9 60		CMP 60
034A	8D C7 03		STA	038A	30 02		BMI +2
034D	AD 4C E8		LDA \$E843	038C	69 5F		ADC 5F
0350	09 01		ORA 01	038E	A2 00		LDX 00
0352	8D 4C E8		STA \$E84C	0391	DD B4 03	COMP	CMP TABLE 1
0355	AD 4B E8		LDA \$E84B	0394	D0 04		BNE +4
0358	09 01		ORA 01	0396	BC BE 03		LDY TABLE 2
035A	8D 4B E8		STA \$E84B	0399	98		TYA
035D	58		CLI				
035E	60		RTS				
				039A	E8		INX
035F	78	XOFF	SEI	039B	E0 0B		CPX 0B
0360	A9 85		LDA 85	039D	30 F2		BMI COMP
0362	8D 19 02		STA \$0219	039E	4C A1 03	(woops!)	JMP STASH
0365	A9 E6		LDA E6				
0367	8D 1A 02		STA \$021A	03A1	AE 0D 02	STASH	LDX \$020D
036A	58		CLI	03A4	9D 0F 02		STA \$020F
036B	60		RTS	03A7	E8		INX
				03A8	E0 0A		CPX 0A
036C	A9 00	STAX	LDA 00	03AA	D0 02		BNE +2
036E	48		PHA	03AC	A2 00		LDX 00
036F	48		PHA	03AE	8E 0D 02		STX \$020D
0370	48		PHA	03B1	4C 7C 03		JMP FINISH
0371	48		PHA				
0372	4C 85 E6		JMP \$E685				
				TABLE 1			
0375	AD 4D E8	PCODE	LDA \$E84D	03B4	00 DF 03 DE OF 0A 1C 1E 1F 1B		
0378	29 02		AND 02	TABLE 2			
037A	D0 07		BNE KEYS	03BE	00 14 93 13 92 11 1D 91 9D 94		



your computer to converse with. . . including an ASCII keyboard. If a big keyboard were to become hooked to the port, and the PET's internal character getting (CHARGET) routine were to be modified to look at it, along with its regular keyboard, characters could be entered via either keyboard, and you wouldn't have to put your fingers in the pencil sharpener anymore.

Now, obviously, this isn't the sort of thing to try to implement in BASIC, as its primary usefulness is in the direct mode, i.e., when BASIC isn't really running. No, what's needed here is an ML routine that lives somewhere else and kind of sidetracks the CHARGET.

Program 1, grizzly though it may seem, is just such a routine. Program 2 is a bit less grizzly: it POKEs the thing into RAM from BASIC, and thus makes it possible to load it without using a monitor.

This program has a rather long history. It is derived from a program

## The Routines

There are actually three programs in this thing. In order of appearance, they (a) set up the user port to take in characters and fool the CHARGET going through the port routine, (b) reverse the first routine, because the tape recorder won't work when the second keyboard is operative, and (c) do the actual character getting and processing. All three programs live in the second cassette buffer, which is hardly ever used to do anything but hold machine code programs. The first and second routines are called from BASIC by SYS(826) and SYS(863) respectively, and the third is called by the PET.

Now, as to what they do. . .

In the PET's page zero memory, there are two locations, 527 and 538, which hold the "Hardware interrupt vector", which is the address the PET jumps to to troll for characters. The first thing routine one does is to

when the tape recorder's trying to work.

Ignoring the STAX routine, the PCODE is the actual working part of the program, and is the bit that the hardware vector address points to. The first LDA loads the accumulator with the port's interrupt flag status. If it is set, indicating that the keyboard has delivered it a character, the thing branches to the KEYS routine to get the character. Otherwise it goes on to CHARGET at E67E.

KEYS pulls the character out of the VIA's data register at E841, masks off the parity bit by ANDing whatever it gets with 127 (7F). Then it decides if it's greater than 96 (60) and, if it isn't, adds 95 (5F). This is the difference between the PET's internal character code and true ASCII (at least, it is for the printable characters). At this point, we could jump to the FINISH routine, which sticks the character in the keyboard buffer, and be done with it. The only hassle is that a standard

```

1 REM ML ROUTINE FOR GETTING CHARACTERS          FROM KEYBOARD IN USER PORT
2 REM LIVES IN 2ND CASSETTE BUFFER SYS (826) ACTIVATES, SYS(863) DEACTIVATES
3 REM FROM ORIGINAL PROGRAM BY G. YOB,          MODIFIED BY S. RIMMER
5 DATA120,169,117,141,25,2,169,3,141,26,2,169,0,141,67,232,141,199,3,173,76,232
6 DATA9,1,141,76,232,173,75,232,9,1,141,75,232,88,96,120,169,133,141,25,2,169,2
30
7 DATA141,26,2,88,96,169,0,72,72,72,72,76,133,230,173,77,232,41,2,208,7,32,108
8 DATA3,234,76,126,230,173,65,232,41,127,201,96,48,2,105,95,162,0,221,180,3,208
9 DATA4,188,190,3,152,232,224,11,48,242,76,161,3,174,13,2,157,15,2,232,224,10,2
08
10 DATA2,162,0,142,13,2,76,124,3,0,223,3,222,15,10,28,30,31,27,0,20,147,19,146
11 DATA17,29,145,157,0,0,0,0,0
12 FORX=826TO970:READA:POKEX:A:NEXTX
13 POKES9468,14:SYS(826):NEW

```

### Program 2: SAVE before RUNNING.

by Greg Yob, which appeared in Kilobaud. Yob's program, however, was for a "Command" keyboard, i.e., one for entering BASIC text, and, as such, the alpha characters couldn't be shifted. This version is one I've begotten, in which the setup routines are the same as before, but the character handling is different.

This program will let a standard 55 key keyboard generate all the usual upper and lower case characters, in the usual (typewriter) style arrangement of shifts and what-not. It will also generate the PET's control characters except for the INSERT, which I forgot. You can add this if you want. . . as we'll see, formidable as it may look, the works aren't too hard to master once you check them out carefully.

change this address so that the PET will go to the PCODE routine in the second cassette buffer, which will, actually, send it along to the CHARGET routine when it's done. Next, beginning at 0345, it sets up the data direction register for input, loading location E843 with 00. It also adjusts some of the VIA's control registers.

The STA command at 034A is a hold over from the original program, and may cause trouble later on if you decide to incorporate more control characters. The three bytes of this command can be replaced with EA's (NOPs) to forestall future negativity.

The second routine, at 035F, loads the hardware interrupt vector with its proper address so the thing won't be swooping around the VIA

ASCII keyboard can't produce the PET's control characters, and we'd therefore have to use the small keys to backspace, move the cursor, and so on. Very messy, this.

The way to get these characters is to assign some of the ASCII characters the values of the PET's control characters. . . ideally, ones that aren't used for anything else. The keyboard has a supershift key, called CNTRL, which produces a raft of non-printable teletype control codes like ACK and BELL, all perfect for our purposes. Now, I've chosen control keys to my liking; you can modify the code table to suit yourself.

There are two tables at the end of the routine. The first holds the codes of the ASCII characters which will become PET control codes, and

second holds their replacement PET values. The COMP routine, beginning at 038E, takes each character that comes through the port and compares it with each of the values in table one, substituting the corresponding value in table 2 if it happens to match. It scans the table by a special form of addressing called absolute addresses. For example, the CMP instruction at 0391 will compare the contents of the accumulator to the memory location specified by the two bytes after it (03B4, the first value in table 1) plus the value of the X register, which gets incremented each time this instruction is passed.

When the whole table has been scanned, the PET jumps to FINISH. Obviously, this is a bit superfluous, as FINISH is the next routine, and it would get there anyway. FINISH used to be somewhere else, and I forgot to get rid of the JMP instruction. You can replace it with three EAs if you feel like it.

The last routine, STASH, at 03A1,

sticks the character in the keyboard buffer, and increments the keyboard buffer index by one so the PET will know it's there. Then it jumps to FINISH, and carries on its merry way.

**The Codes**

The external keyboard can be anything producing the usual ASCII code you are cool with. Try not to get anything from before the civil war. Excetronix had some fairly friendly microswitch ones at about thirty five dollars as of this writing. These are good (the one I used for this bit is one of these), but are inclined to drop into funny character modes if you type CNTRL with the shift key down.

The power for the keyboard should come from an external supply, as the PET really isn't capable of supplying more than about 20 mA above its own requirements without severe heating. Table 1 shows how to hook up the keyboard.

The control codes, as the

machine code routine tables are set up, are produced as follows:

DEL	Delete
CLR	CNTRL "C"
HOME	Up Arrow
Rev. On	CNTRL "R"
Rev. Off	CNTRL "O"
Cursor up	CNTRL Up Arrow
Cursor down	Line Feed
Cursor Left	CNTRL Delete
Cursor Right	CNTRL FS

**Table 1**

PET User Port Keyboard Pin

CA1	Strobe
PA7	Parity
PA3	Bit 4
PA2	Bit 3
PA0	Bit 1
PA6	Bit 7
PA1	Bit 2
PA5	Bit 6
PA4	Bit 5



**Send Us Stuff. . .**

Yes, even that simple program to calculate the number of hairs on a black Norway rat from its body weight and the number of times it squeaks when picked up by the tall may do. If you have a favourite bit, send it to *Computing Today*. If it doesn't leave us open to criminal proceedings we will consider it for publication. We pay handsomely for everything we use (assuming you believe that Quasimodo was handsome).

"Gee . . . It's just like the commercial says!  
The tape will break glass!"



# Into Linear ICs

## Part 4

If you liked this article, please circle Reader Service Card number 45. If you didn't, circle number 46.

More 741 circuits from Ian Sinclair. How about a simple AM Radio or a 'phone sound synthesizer, all with one IC.

Something different now, in the circuit of Fig. 1. This one is called the Ma Bell box because it can be inserted between two stages in an amplifier to make the output sound as if it had come from a telephone. It's a circuit which is very useful in radio and taped plays, and project ideas, and that's the next step.

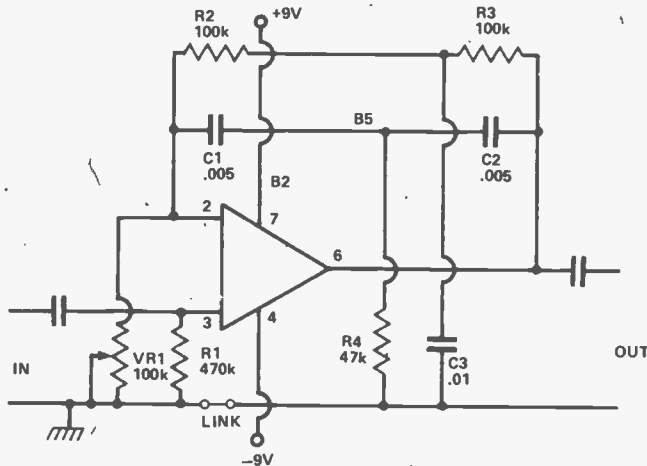

Fig. 1 The Ma Bell box, dual voltage supply version. Input and output capacitors are shown dotted; they will not be needed if the input is a microphone and the output is to an amplifier or tape recorder. RV1 controls the amount of phone in the sound.

decreasing the resistance of RV1 will increase the effect, even to the extent of letting the whole circuit oscillate, generating a tone.

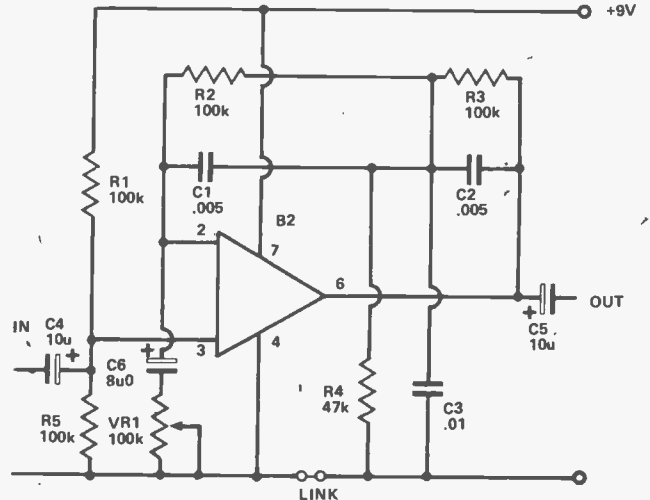

Fig. 2 Single-voltage supply version of the Ma Bell box.

Try this one out between a microphone and a tape recorder or between a tape recorder and an amplifier — but if you use a small cassette recorder, the sound may be pretty well phoned even without this circuit!

I sometimes wonder if it's not used in 'phone-in' programs. The circuit needs a lot more components than any of the circuits we've used up to now. As usual, the dual-supply version is simpler, but Fig. 2 shows an alternative single-supply circuit. The signal input in each case is to the + input of the 741, with feedback of DC bias and of signal through the resistors and capacitors which are connected between input and output — an arrangement which is called a 'network'.

These resistors and capacitors aren't just any old values, they've been chosen so that they control the feedback of signals. At one particular frequency, around 400 Hz, there's less feedback of signal than there is at other frequencies. The result is that we get more gain at that particular frequency range, around 400 Hz, than at other frequencies. It's this feature which makes the phone sound, because a telephone acts also to emphasise these same frequencies. The telephone does it unintentionally — it's the construction of the telephone microphone and earpiece which filters out all the other frequencies, but our circuit does this deliberately and with some control because of the use of the 100K potentiometer. With this control at its maximum resistance setting, the sound isn't terribly "phoned", but

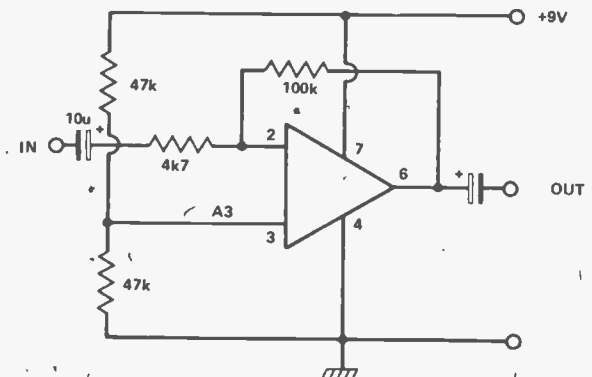
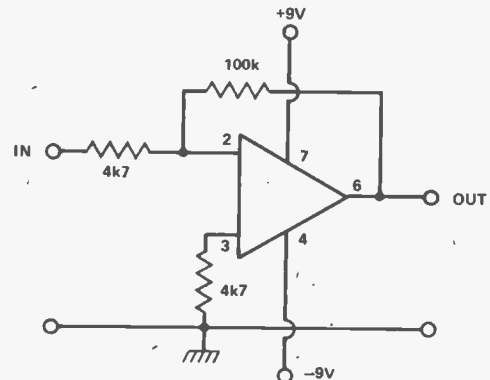

Fig. 3 Microphone booster circuits (a) dual supply, (b) single supply.

TALK ABOUT TAPE

Talking about recorders, is your cassette recorder sensitive enough when you use it with a microphone? If it isn't, then the circuit of Fig. 3 could prove useful. This is a booster preamp which uses the microphone as its input and delivers a boosted signal to the recorder. It can't be used with the built-in microphones which some cassette recorders have, of course, but most recorders have a separate microphone which is seldom very sensitive.

The circuit is straightforward, particularly when dual supplies can be used. The gain is fixed at about 25 times, because there's not much point in having a variable-gain pre-amplifier when the recorder itself has a gain control or has automatic gain-control circuits.

Connections can be a bit awkward when you're trying out the circuit. For testing the breadboarded circuit, I used crocodile clips to connect to the jack plug which was on the end of the microphone cable, with short lengths of wire plugging into the board. The recorder which I used also had a 5-pin socket input, and wires from the board could be inserted (once I found the correct holes) to make contact. A better method would be to solder wires to a jack socket for the input and connect a jack-plug to the board (Fig. 4) for the output. Remember that stranded wire must NEVER be plugged into a breadboard — not all the strands will come out again, and the lost strands will create short circuits inside the board until you peel the backing off and remove them.

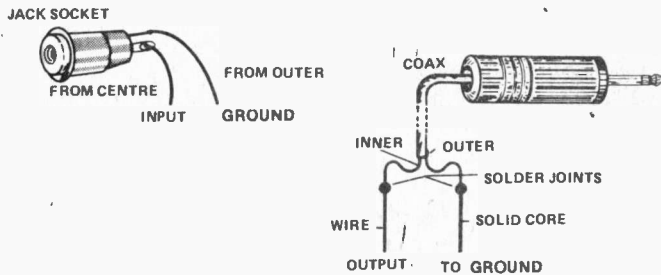

Fig. 4 Making connections to and from the booster.

Has that lot whetted your appetite for 741 circuits? If it has, the next one will also be of interest, because it allows you to get a fair amount of audio power to a loudspeaker by adding a couple of cheap transistors to the IC circuit. At the same time, it's not too hard on batteries because the current which the circuit takes is fairly low unless you turn the volume right up.

SOUNDING OFF

The 741 is a voltage amplifier, and its output resistance is not low enough to drive much current into a low-resistance speaker. In addition, to prevent overheating, the 741 is fitted with circuits which limit the amount of current which can be passed. The transistors which we've added in Fig. 5 can pass rather more current to the loudspeaker than a 741, and are completely controlled by the 741. One of these transistors, Q1 is a PNP type, and the other is NPN, but you can't tell them apart by looking at the cans, so be careful not to rub the labels off. An alternative is to use a waterproof marker pen, the kind that's used for marking PCB tracks is ideal, to mark P on top of the PNP can, and N on top of the NPN can. With a dual 9 V supply, this circuit can pass rather a lot

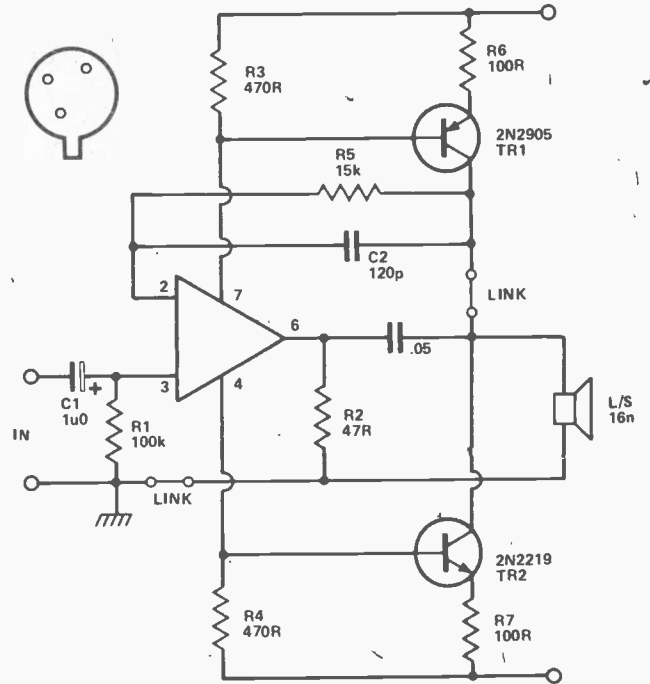

Fig. 5 A medium-power output stage using a 741 with two transistors.

of signal current into an 8R loudspeaker, so that emitter resistors R6 and R7 have been added for safety. These resistors also control the bias in the output pair of transistors, so don't be tempted to omit them!

The circuit is a bit unusual, because it doesn't use the output of the 741 directly. The output is simply connected to ground through a resistor, and the output transistors are driven from the power supply terminals! It certainly looks unusual, but it's quite a reasonable way if using the 741, because most of the current flowing in the power supply terminals goes to the output terminal.

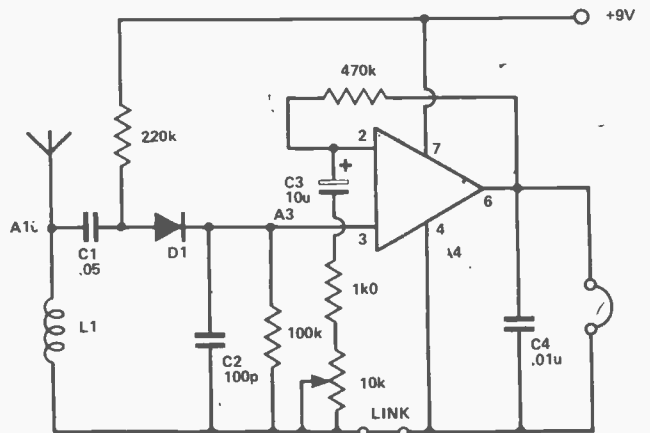

Fig. 6 A simple radio circuit using a single voltage supply.

On one half of the signal sinewave current flows mainly through R3 into the 741, and to ground through the output and R2. On the other half of the sinewave, current flows through R2, the output, and so through the 741 to the — supply terminal then through R4. On the positive half of the wave, the voltage across R3 biases Q1 on (it's PNP, remember, so that it turns on



when its base voltage is more negative than its emitter voltage. Q1 then passes current to the loudspeaker. On the other half of the cycle, Q1 is biased off, and the voltage across R4 turns Q2 on, so that current flows through the loudspeaker in the opposite direction and through Q2.

Because of the difference between this and the other circuits we've looked at so far, the constructional methods for this one should be rather different.

### DC COUPLING

Because the circuit is completely DC coupled, the bias/feedback connection is very important. Any fault in this line can cause one of the output transistors to pass a lot of DC through the loudspeaker, and this can happen also if the input line is biased above or below ground voltage. For safety, then, it's a good idea to use an old loudspeaker when the circuit is first tried out, and to couple to the input through a capacitor. Since this is a power amplifier, there isn't much voltage gain, and a preamplifier will be needed if very small signals are to produce an output which can be clearly heard.

The high gain which can be obtained from a 741 can be used for simple radio circuits. The circuit of Fig. 6 is just another up-to-date version of the old crystal set, but it's a useful way of using the gain of the 741 to display the principles of radio reception, and quite acceptable results can be obtained if a long-wire aerial is used.

In the circuit of Fig. 6 L1 is a tuning coil which consists of 50 turns of enamelled copper wire wound on to a ferrite core. This is connected in parallel to a 500 pF tuning capacitor, so forming a resonant circuit which can be tuned to various frequencies by altering the setting of the variable capacitor. The radio frequency which is selected by the tuned circuit is detected by diode D1, and the resulting audio frequencies are amplified by the 741.

The audio output can be heard if a pair of high-resistance (2K or more) headphones are connected to the output, alternatively a high resistance (80R) loudspeaker can be used.

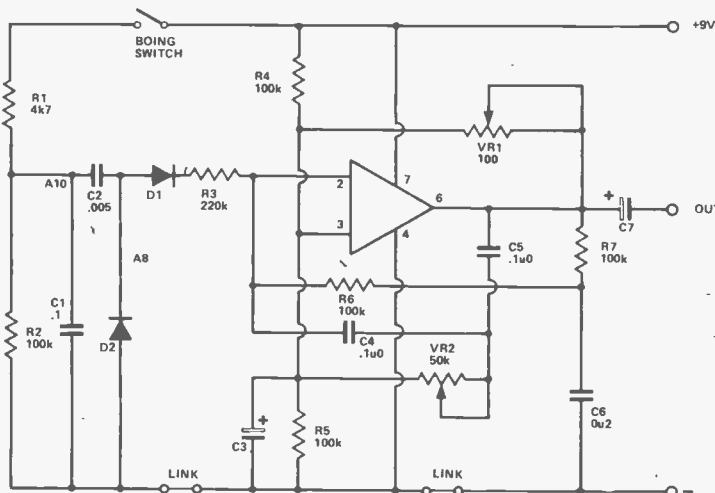

Fig. 7 The 'Boing' circuit.

### 'BOING' 'BOING'

How about something different? Fig. 7 is a 'boing' circuit — if the signal at its output is taken to an amplifier and loudspeaker, then a drum-like 'boing' sound will be produced each time the push-button is pressed. The pitch of the note can be varied by adjusting RV2, and the amount of 'boing' by adjusting RV1.

It works like this. The 741 has two feedback circuits. One of them uses capacitors and resistors, like the circuit of Fig. 1, to ensure that the gain of the 741 is greatest at one selected frequency. There's a variable resistor included in this bit of the circuit to control the pitch (frequency) of the note that we get when the 'boing' occurs. The other bit of the feedback circuit is just a variable resistor, RV1. This, along with resistor R3 decides what the gain of the 741 is for a signal which comes in through D1. When the push-button is pressed, C1 is quickly charged to +9V, and the rise of voltage is passed through C2 and D1 to the 741 input. This disturbance causes the 741 to give an output, and the feedback network of C4 to C6 and R6 to R7 turns this into a continuous signal. As the charge on C2 leaks away through R3, the — input is slowly biased off, so that the signal produced by the feedback network dies away — end of boing.

### MILLIVOLTMETER

Finally, Fig. 8 shows a circuit for an AC millivoltmeter, which allows you to measure the size of small AC signals which are at audio frequencies. The 741 is connected as an inverting amplifier so as to amplify the audio signals at the input. At the output of the 741, the signals are forced by diodes (it's the familiar bridge rectifier circuit) to pass through the meter M, a 1 mA meter, before being fed back through resistor R5 to the

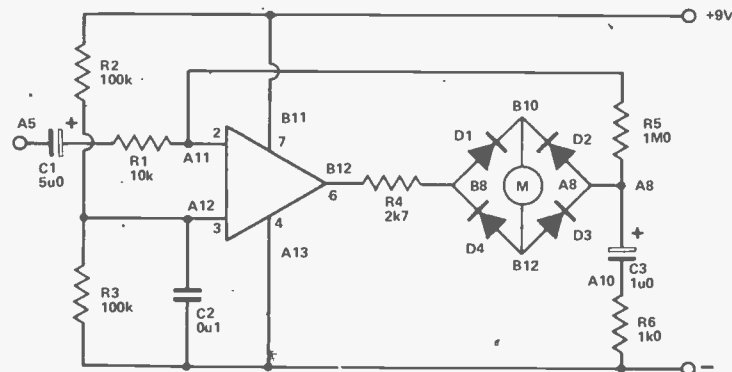

Fig. 8 The AC millivoltmeter circuit.

— input of the 741. Because of the way the diodes are connected, signal current always passes through the meter in one direction, so that the meter reads average current. The resistors in the circuit are there to ensure that the meter readings correspond to RMS values of a sine-wave input; their values must not be altered.

The sensitivity of the circuit is selected by the value that is chosen for R1. With the value shown, 10K, the meter reads full-scale for an input of an input of 10 mV RMS; other ranges can be selected by using switched values for R1. A value of 100 K gives a sensitivity of 100 mV, and a value of 1M gives a sensitivity of 1 V for full-scale meter deflection. For a lot of applications a cheap edge-type meter is adequate, so that the AC millivoltmeter needn't be an expensive project.

# TECH TIPS

## AF Signal Generator

Although the 8038CC is not capable of generating an extremely pure sine wave, it is capable of producing an output of high enough quality for general audio testing. The simple circuit shown here covers the audio frequency spectrum in three ranges — less than 20 Hz to more than 200 Hz; less than 200 Hz to more than 2 kHz; less than 2 kHz to more than 20 kHz. The output amplitude is continuously variable up to a maximum of about 550 mV RMS and is from a low impedance source.

The 8038CC oscillates by first charging a capacitor via a constant current source and then discharging it through another constant current generator. It thus generates a triangular waveform. This is then fed to a trigger circuit to generate a squarewave signal and to a non-linear amplifier which "rounds off" the signal to give a sine wave output of reasonable purity. C2 to C4 give the three ranges. R1, RV1 and R2 form a potential divider circuit, which is used to control the charge and discharge currents of the timing capacitor. RV1 thus acts as the fine

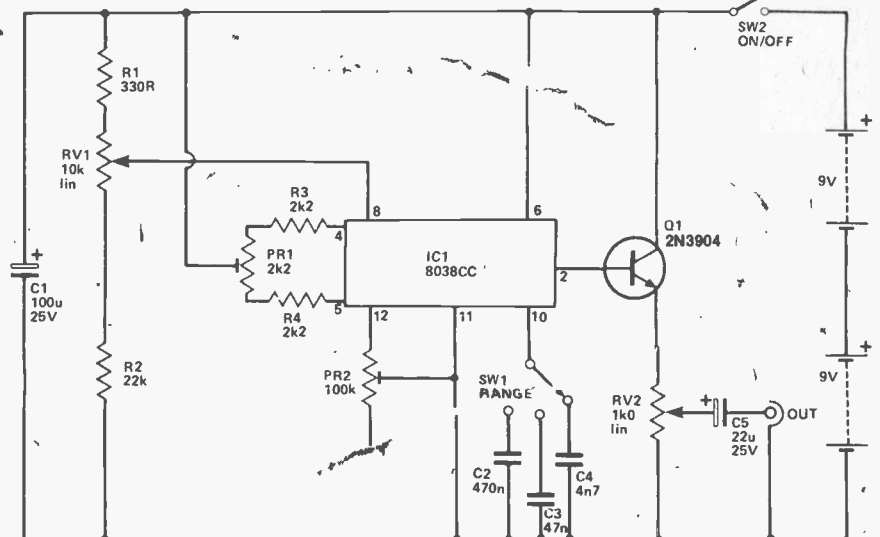

frequency control. PR1, R3, R4 balance the charge and discharge currents, so that a symmetrical output is obtained. PR2 is part of the sine wave shaping circuitry and is adjusted for maximum purity.

The sine wave output at pin 2 of IC1 is at a high impedance and is, therefore, coupled to the output via an emitter follower buffer stage using Q1. RV2 is the output level control, and C2 provides DC blocking at the

output. Current consumption is approximately 9 mA.

With the unit adjusted for a fairly low frequency output (about 50-200 Hz), it should be possible to hear the main fundamental frequency plus the higher frequency harmonic signals. The output can be monitored using a crystal earphone or amplifier/loudspeaker. PR1, 2 are adjusted to minimise the harmonics.

## Video Buffer for the ZX80

When J.L. Elkhorne became the proud possessor of a brand new ZX80, he didn't want to disturb the family's TV viewing by commandeering the TV set as the ZX80's VDU. Having a 230 mm (9") monochrome monitor on hand, the circuit here was developed to press it into service.

Nothing critical exists in the circuit; all values were determined empirically. Transistor type substitutions could probably be made without problems. The bias for the 2N3904 is provided by the dc coupling to the source of the 2N5245. In the prototype, the drop across the 4k7 resistor was about two volts.

The circuit was built on a tiny piece of Veroboard and put in a small plastic box on hand. The plugpack used with the ZX80 supplied the power. In keeping with a personal policy of minimal changes to commercial hardware, the only internal change to the ZX80 itself was tacking the

560 pF capacitor on the video lead into the on-board modulator. The free end was protected with sleeving and protrudes out the back slot by the card edge connector.

The centre conductor of a length of miniature coax clips onto the capacitor.

The flex of the plugpack was cut and the buffer board used to reconnect it, thus deriving power for nothing. A BNC connector mounted on the plastic box completed this small project.

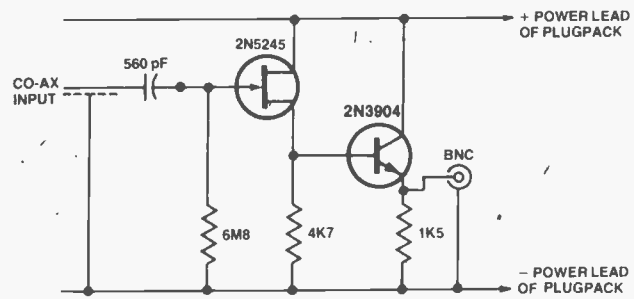

# OSCILLOSCOPES!

## The Best Buys Available

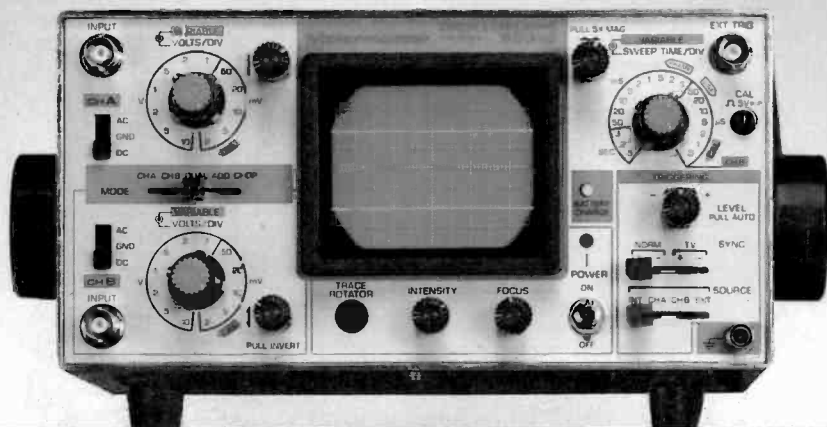

- Model 65310**  
**Dual Trace Portable**
- ▶ 15MHz (-3dB) Bandwidth
  - ▶ X5 Sweep Magnifier
  - ▶ Battery, 12VDC & AC Operation
  - ▶ 2mV Vertical Sensitivity
  - ▶ Trace Rotator
  - ▶ Price \$775.00 taxes not included

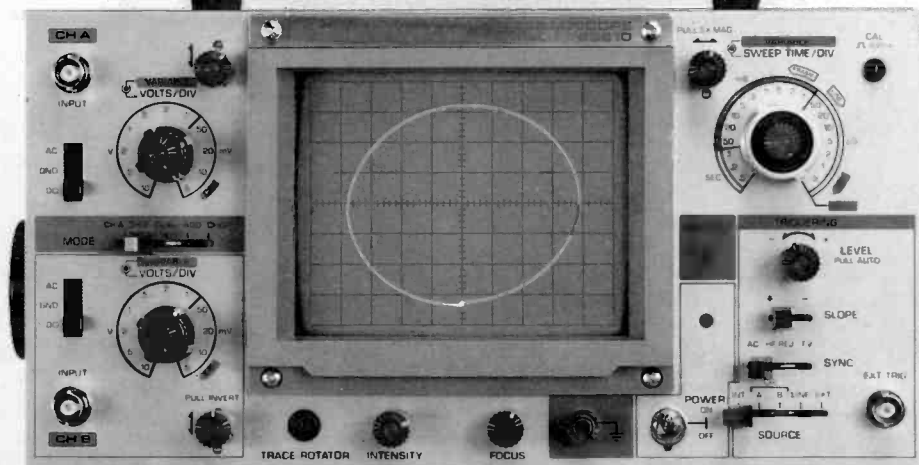

- Model 65610**  
**Dual Trace Bench**
- ▶ 15MHz (-3dB) Bandwidth
  - ▶ 5" CRT Display
  - ▶ 120VAC & 12VDC Operation
  - ▶ Fully Automatic Triggering
  - ▶ Trace Rotator
  - ▶ 5mV Vertical Sensitivity
  - ▶ HF Rejection
  - ▶ Price \$795.00 taxes not included

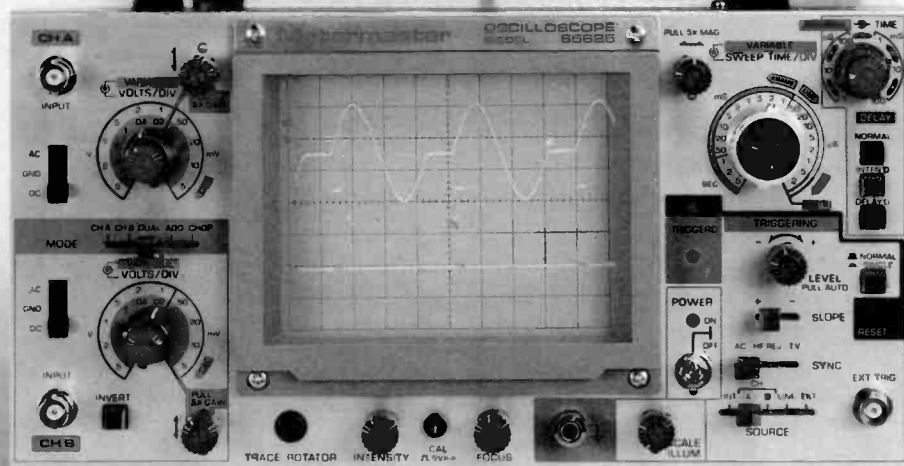

- Model 65625**  
**Dual Trace Bench**
- ▶ 45MHz (-3dB) Bandwidth
  - ▶ Delayed Sweep (selectable)
  - ▶ Single Sweep (selectable)
  - ▶ Extremely Bright 5" CRT
  - ▶ Illuminated Internal Graticule
  - ▶ Optimal Sensitivity of 1mV
  - ▶ X-Y or X-Y-Z Operation
  - ▶ 120VAC Line Operation
  - ▶ Price \$1295.00 taxes not included

**Metermaster**  
**R.H. NICHOLS**



All prices F.O.B.  
 Downsview, Ontario  
 subject to change with-  
 out notice. P.S.T. extra  
 where applicable.

Head Office: 214 Dolomite Drive, Downsview, Ontario M3J 2P8  
 TORONTO (416)661-3190 • MONTREAL (514)337-0425 • EDMONTON (403)432-7746 • OTTAWA (613)238-7007

Circle No. 11 on Reader Service Card.

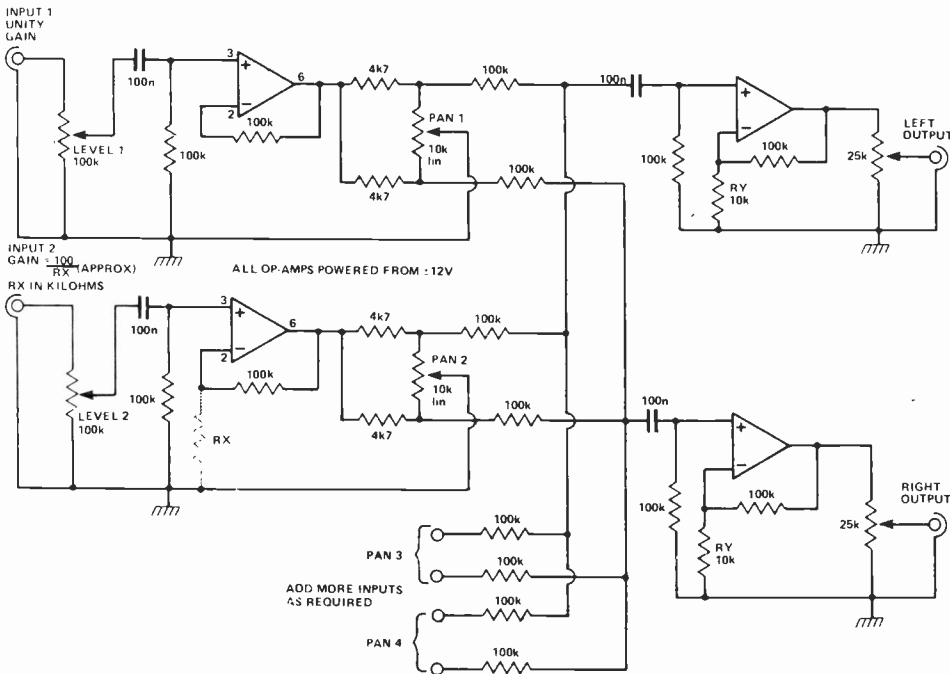

### Four Input Stereo Mixer

R.D. Person

The mixer circuit shown was designed to allow four or more inputs to be mixed down, producing a stereo output. Each input has stereo panning and a level control. The gain of the input stages can be boosted according to specific needs by adding RX, making it possible to use a direct input from guitars, microphones and so on. Note that to avoid poor frequency response, the gain of this stage should be kept below 50 (keep RX above 2k2). The input impedance is 100k and should be high enough for most applications.

The two output stages have sufficient gain to compensate for the attenuation of the panning controls. If more than four inputs are used it will be necessary to increase the gain of the output stages by decreasing the value of RY to 6k8 for six inputs or 4k7 for eight inputs.

741 op-amps should prove suitable for most purposes, but if lower noise is desired then a low noise op-amp such as the TL071 may be substituted. The simple zener regulated power supply shown should be suitable for general purpose applications.

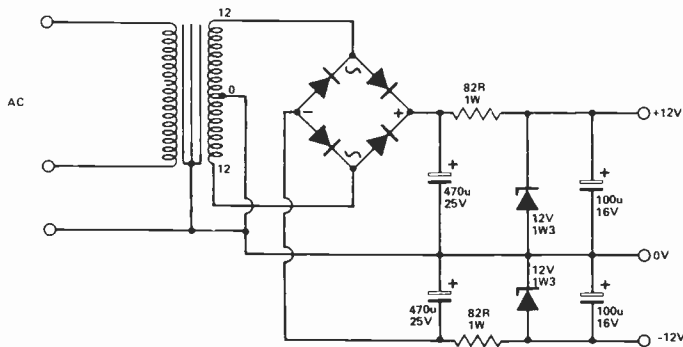

### Adjustable Sensitivity Continuity Tester

David Wolfe

Continuity testers operate by comparing the resistance between the test probes with a fixed reference resistance (if the probe resistance is less than the reference then the tester indicates this somehow). This is fine if the tester is to be used in only one type of application, but means that the tester is limited to this application. For example, when testing continuity on a circuit board one is generally testing for very low 'hookup' resistances; when testing long cable runs, however, such as in house wiring, one tests for resistances often up to several kilohms.

This design overcomes this problem by having an adjustable reference. The tested resistance is configured as half of the potentiometer which is adjusted to give the

required sensitivity. Obviously by changing the component values, especially that of R2, the range over which the tester can operate can be altered, but it should be remembered that for the tester to discriminate very low resistances the potentiometer must be able to output voltages very close to 0V.

Continuity can be indicated in several ways depending largely on user preference, but also on parameters such as current con-

sumption and parts availability eg a mechanical 'buzzer', an astable driving a loudspeaker or an LED. These would all need a suitable driving circuit as the op-amp could not do this directly. In the prototype a piezo buzzer was used for low current consumption. A CA3140 IC was chosen in this circuit for its ability to operate with inputs near to the negative supply rail.

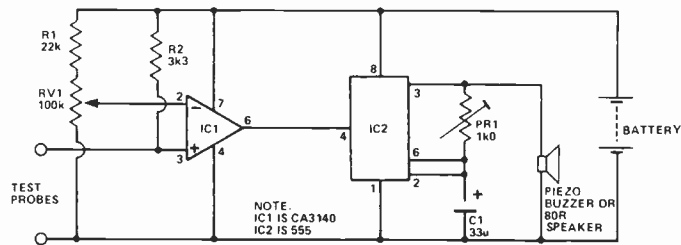



## TECH TIPS

### Solid State Audio Switch

G.B. Wolfe

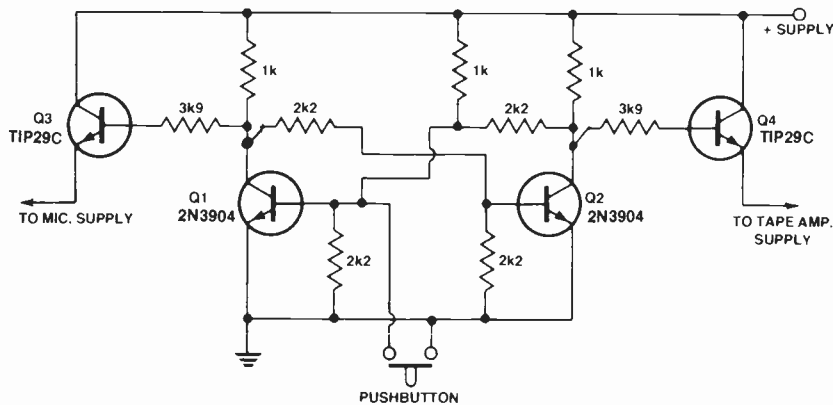

The purpose of this circuit is to switch off a music source (from a tape amp in this case) and turn on a microphone.

The pushbutton on the microphone stand is pressed into service to operate the solid-state switch. When operated (i.e. when you want to switch the music off and switch the mic in), the pushbutton shorts the base of Q1 to 0V. Q1 turns off and Q2 turns on. This turns Q4 off, and as it is in series with the positive supply

rail to the music source (tape amp), then the music source turns off. At the same time, Q3 turns on and provides positive supply to the mic preamp.

When the pushbutton is open, Q1 is biased on and Q2/Q3 biased off. Thus only Q4 will be biased on and the music source will be operating.

This way, there is no need to alter the signal circuits and the only change required is to the supply rails; control is by a single-pair lead.

### Simple Timer

David Hughes

This simple little timer features a minimum of components, most of which can be found in any well-stocked hobbyist's junkbox, and you can fudge a variety of delays by trial and error substitution of components.

It works as follows. When you press S1 (an ordinary pushbutton) the 100u electrolytic capacitor rapidly charges up. When it gets to about 0.7 V the transistor will be forward biased and collector current will flow, in turn operating the relay. When you release S1, the capacitor will begin to discharge via the 33k resistor and the base of the transistor. When the voltage across the capacitor gets down to half a volt or so the transistor base will no longer be forward biased, collector current will cease and the relay will drop out. The capacitor will continue to discharge via the 47k resistor.

With the values shown, the relay will remain operated for about eight seconds or so. It is advisable to use either a tantalum or a low leakage (RBLL) electrolytic capacitor.

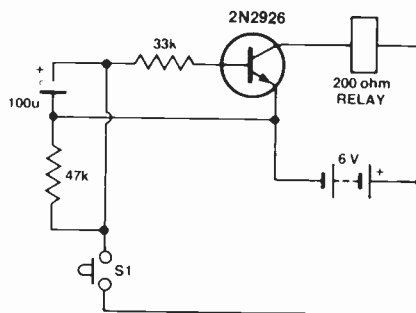

You can fudge things a little to obtain increased times by simply increasing the value of the electrolytic capacitor. Decreasing the value will shorten the period.

You can get quite long times with lower values of capacitance by substituting a Darlington pair for the 2N2926. In this case you can increase the two resistor values into the megohm range.

# Computer power in a DMM!

## An autoranging DMM breakthrough from B&K-PRECISION

- Microcomputer autoranging speeds operation and stabilizes readings
  - Auto-skip program for best resolution in least time
  - Easiest, fastest-to-use DMM available
  - 0.1% basic DC accuracy
  - 3½ digit, 0.5" LCD display
  - Continuity test "beeper"
  - Range-lock, holds selected range
  - Measurers AC/DC voltage; AC/DC current; resistance
  - Meets tough U.L. 1244 safety standards
- Model 2845  
\$273.85  
(Subject to change without notice)

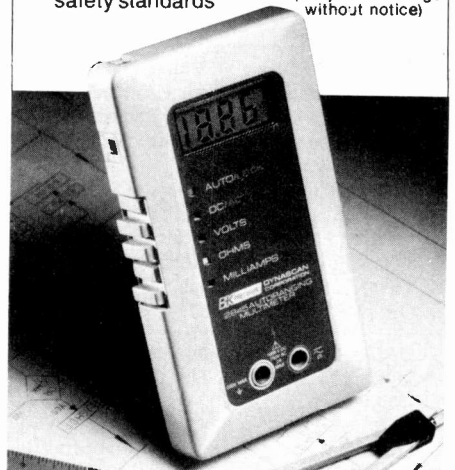

B&K-PRECISION's new 2845 is a major advance in digital multimeter technology. At a price comparable to ordinary manually operated units the 2845 brings micro-computer intelligence to a handheld portable DMM. When applied to a circuit, its computer selects the range providing maximum resolution without the slow "hunting" action characteristic of many bench-type autoranging DMMs.

The 2845 is certainly the most user oriented hand-held DMM available. No other DMM can match its speed and simplicity of operation. With tilt stand optional AC power adapter, it becomes a remarkably inexpensive bench DMM.

**BK PRECISION**

**DYNASCAN CORPORATION**

Represented and stocked in Canada by:  
Atlas Electronics Limited  
50 Wingold Avenue, Toronto, Ontario  
M6B 1P7 Tel: (416) 789-7761  
Telex: 065-24140

Electronique Atlas Ltée.  
970 Montee De Liesse, Ste 202  
St. Laurent, Quebec. H4T 1W7  
Tel: (514) 337-5260, Telex: 05-824695

Circle No. 3 on Reader Service Card.

# CLASSIFIED ADVERTISING

ETI's classified advertising section allows you to reach 30,000 Canadian readers nation-wide for 75¢ per word. For as little as \$15 per insertion (there's a 20 word minimum) you can promote your business from coast-to-coast.

## WHAT DO YOU DO?

Send us your typewritten or clearly printed words, your permanent address and telephone number, and your money (no cash please). Make your

cheque or money order payable to 'ETI Magazine'. We're at Unit 6, 25 Overlea Blvd., Toronto, Ontario. M4H 1B1.

## WHAT DO WE DO?

We typeset your words (and put the first word and your company name in **BOLD** capital letters). If we get your message by the 14th of the month, it will appear in ETI 1½ months later. For example if we receive it by October 14th you (and thousands more) will see it in the December issue.

**S.E.A.** Equalizer Preamp with cabinet, Class-A Amplifiers, Parametric Equalizer, Electronic Speaker Protector, Colourful LED Meters, Power Supply, DC Voltage Doubler/Tripler, FM Mic, Programmable Music Box, Digital Clocks, Electronic Roulette with Sound and Much More. Send \$2.00 for your Catalog and future special flyers. **CLASS-A ENTERPRISES, INC.**, #104-206 East 6th Avenue, Vancouver, B.C. V5T 1J8.

**GET** off, eh! . . . at Yonge & Finch and visit the General for your electronic needs, parts, kits, speakers, ETI Project Circuit Boards and advice. Do you want to sell some of your equipment . . . let's talk. Great (White North) prices. Custom circuits designed and built at low prices. Send for free Electronakit catalogue. Sabtronic Test Equipment. **GENERAL ELECTRONICS**, 5511 Yonge St., Willowdale, Ont. M2N 5S3. (416) 221-6174.

**DACOR** ETI PCB catalogue (Dec 81 ETI Magazine) update - Dec 81-# 151 Four Input Mixer \$1.23, # 152 Musical Doorbell \$2.04, Jan 82-# 153 Four Way Loudspeaker \$4.91, # 154 Temperature Controlled Soldering Iron \$2.04, Feb 82-# 155 Flash Sequencer \$3.27, # 156 Enlarger Timer \$1.84, # 157 Sound Bender \$1.43. **DACOR LIMITED**, ETI PCB Dept., P.O. Box 683, Station Q, Toronto, Canada, M4T 2N5.

**ELECTRO-MUSIC** Kits. Microprocessor controlled, user programmable orchestral generator provides backing trio of drums, bass and multi-voiced chord instrument. Stores up to 100 scores. Other kits include touch sensitive, multi-voiced pianos, programmable drums, string synthesizers etc. Details from **G & R ADVANCED ELECTRONIC DESIGNS INC.**, P.O. Box 38, Streetsville, Ontario L5M 2B7.

**AUTOMOBILE** Burglar alarms - inexpensive - install yourself. Send \$2.00 for information and brochure. **KAMTRONICS**, 1460 Montcalm Street, Laval, Quebec, Canada. H7W 1X1.

**CORONET ELECTRONICS**, 649A Notre Dame W., Montreal, Que. H3C 1H8, Catalogue IC's, Semi's, Parts, send \$1.00 to cover postage. Monthly specials at crazy prices.

**GROWING** continuously, our inventory includes anything we can fit into the store. Bargain prices on all kinds of manufacturers surplus. **FOREST CITY SURPLUS**, 781 Dundas (near fairgrounds), London, Ontario. 519-438-0233

**J&J ELECTRONICS LTD.**, P.O. Box 1437E, Winnipeg, Manitoba R3C 2Z4. Surplus and Semiconductor Specialists. Do you get our bargain flyer? Send \$1.00 to receive the current literature and specials and to be placed on the mailing list for future publications.

**HYDROGEN GAS GENERATOR** plans and starter kit, \$12.00. **PRAIRIE POWER RESEARCH AND DEVELOPMENT**, P.O. Box 8291, Edmonton, Alberta. T6H 0L0.

**SEMIS & KITS** MJ15003, 15004 \$10 per pair/ 250W class A amplifier kit \$239.95/ 160W \$149.00/ 140W \$84.95/ 60W \$60.00. Send \$1.00 for our catalogue. Add 5% for shipping **KITSTRONIC INTERNATIONAL**, Box 577, Station J, Toronto M4J 4Z2.

**LOW-PRICED**, high quality PCBs. Glass epoxy, drilled, tinned, guaranteed. Most E.T.I. boards available. Custom boards from your artwork. 8080/85/Z80 hardware and software design. Send 30¢ stamp for flyer. **KSK ASSOCIATES**, P.O. Box 54, Morriston, Ontario, N0B 2C0.

**AUDIO** exchange. Quality solid state and tube equipment bought & sold. Send self addressed/stamped request/offer to Royal View Electronics, 2327 Bloor St. W. Toronto (416) 762-8655.

**EXCESS** stock: Kim computers, color organs, chasers, new and used parts. Write for free catalog: **SYNCHROSON LTD.**, P.O. Box 130, Station Ahuntsic, Montreal, H3L 3N7.

**WSI RADIO** — SWL Radios — Ham radios 18 Sheldon Avenue North, Kit-chener, Ontario N2H 3M2. Tel. (519) 579-0536. Write for giant catalogue, \$2.00 (VE3EHC).

**ROBOTICS** - The World of Tomorrow Today - from **DACOR LIMITED**, ROBOTICS DIVISION. We start with an upgraded and expanded design of ETI HEBOT, July 1980 - write for details - **DACOR LIMITED**, ROBOTICS DIVISION, P.O. Box 683, Station Q, Toronto, Canada, M4T 2N5.

**\$150.00** Single Board Computer. 4k ROM Monitor, 3k RAM, RS232, auto baud rate. Ideal learner or developmental system. Send 30¢ stamp for specifications. **KSK ASSOCIATES**, P.O. Box 54, Morriston, Ontario, N0B 2C0.

**SPECIAL!** 1000 pieces for \$10 + \$2 handling. Choke - capacitor - transformer - diode - hardware - insulator - rectifier - relay - resistor - transistor - speaker - switch - zener - etc. All new material. Money-back guarantee. Free flyer. **SURPLUS ELECTRO QUEBEC** 2264 Montee Gagnon, Blainville, P.Q. J7E 4H5.

**PC** boards for all magazine projects. Etched and drilled 30¢ sq. in. Etched only 25¢ sq. in. Send photocopy of etch patterns and cheque or money order to **SAKURA ELECTRONICS**, P.O. Box 231 Richmond Hill, Ontario. L4C 4Y2.

**DAVIS SKILLGAMES** needs person with experience troubleshooting, repairing P.C. Boards. Part time position, flexible hours. Toronto area. Mr. Davis - 657-1782.

**MULTIFLEX Z80A** computer assembled, tested. Includes manuals, programming text book, transformer, capacitor. \$375. **RAY HILL** Box 535 MacGregor, Man. R0H 0R0, Ph. 685-2564.

**AVAILABLE** Now LNA's Microwave associates 120° 50 db low noise 4 GHz amplifiers for satellite TV \$885.00. **DRYDEN COMMUNITY T.V. LTD.**, 61A King St., Dryden, Ont. P8N 1B7. Phone (807) 223-5525.

**FREE EPROM 2716**, Programmed for only \$55.00. Your HEX. table. **AKHTRONIC LTD.** P.O. Box 3011 Stn. "D", Willowdale, Ontario, M2R 3G5.

**LOOK** what \$1 will buy! Your choice of 3-to-220 Heatsinks; 20 Nylon Cable Ties; 10-NE-2 Neon Lamps; 2-5K Pot with Switch; 5-16 Pin Sockets; 3 Photocells; 10 DTL IC's; To-3 Heatsink; 50 unmarked Diodes; 10 Thermistors; 10-to-92 Transistors; 5 Assorted LED's. Buy 12, receive one FREE! \$10 minimum order (Certified Cheque or Money Order) Add 5% (minimum \$2.00) for P&H. See January and February ETI for more bargains or send \$1 for flyer. **ELECTRONICS**, Box 68, Whitecourt, AB. T0E 2L0.

**FREE** THE GREAT ELECTRONIC THINGS & IDEAS BOOK! HUNDREDS OF UNUSUAL PARTS, GADGETS & IDEA ITEMS, UNAVAILABLE IN STORES OR CATALOGS ANYWHERE! Bargain prices on everything! New items in every issue! Rush postcard for your copy!

**ETCO** ELECTRONICS Dept. 306 Plattsburgh, N.Y. 12901

**TECH TIPS**  
**Anti-Theft Device**  
 G.J. Phillips B.Sc.

Many audio retailers employ anti-theft devices whereby a loop, made up of lengths of cable joined with plugs and sockets, is passed through the handles of radios and cassette players. If the loop is broken an alarm sounds.

The circuit diagram shows a design which has been built in the lab and functions very well. R1 sets the quiescent current in the loop. The loops could include vibration sensors or any other suitable normally closed contacts. When the loop is broken, the logic 0 at R1 causes the astable multivibrator formed by IC2a, b to be enabled via gate IC1d, which acts as an OR gate for 0s at its inputs. The astable frequency is set at approximately 1/4Hz causing the buzzer to sound intermittently.

The logic 0 at R1 also triggers the monostable formed by IC1a,b,c and the output of this monostable also enables the astable via pin 12 of IC1d. Thus, if a quick-witted thief

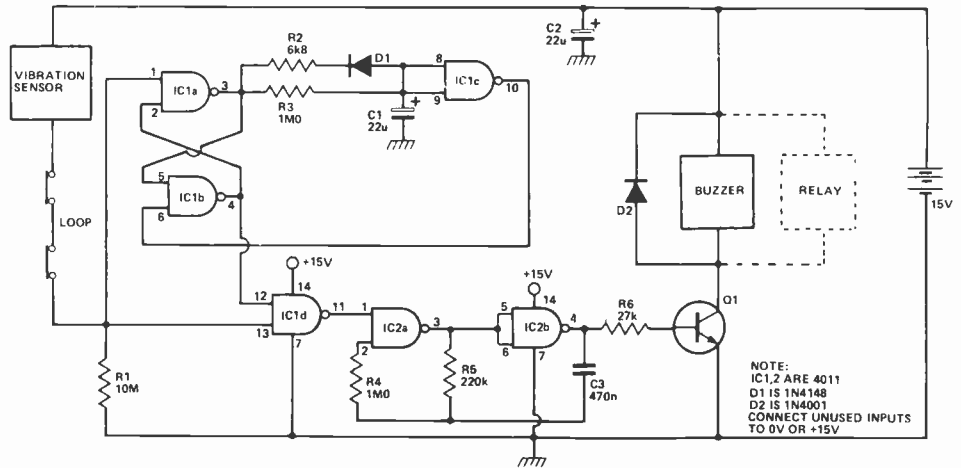

quickly remarques the broken loop or the vibration sensor quickly breaks the loop, the monostable ensures that the alarm continues to sound for approximately 20 seconds. If the loop is left open then the alarm will sound all the time. Unused inputs of the CMOS chips should be tied to  $V_{CC}$  or 0V whereupon the quiescent battery

drain will be less than a microamp.

R1 can be replaced with an LDR (ORP12) and a 10M resistor used to replace the loop. The alarm is then triggered by light. Place the device in your components drawer and you'll be able to nab the guy who's been pinching your ICs when no-one's looking.

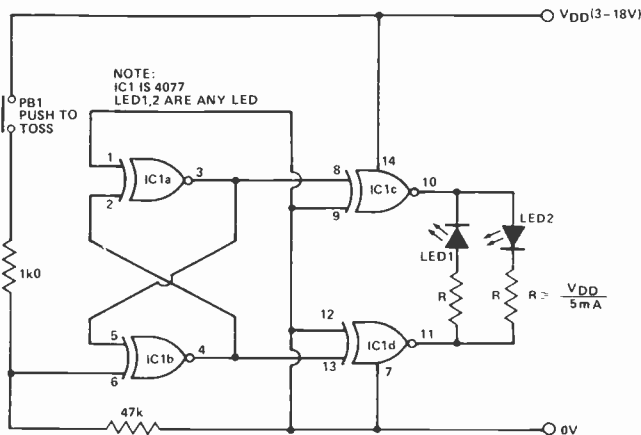

**Heads Or Tails**  
 D. Indyk

An ultra-simple heads or tails indicator can be built using a single 4077 EXNOR IC. The circuit is normally in a latched bistable mode; when the switch is closed the circuit will oscillate, ie toss the coin. The astable frequency is approximately 5-10 MHz. If desired a small push-to-make switch can be connected in series with the battery as an on/off switch, such that the battery will be disconnected from the circuit unless the device is being held. The LEDs can be any colour.

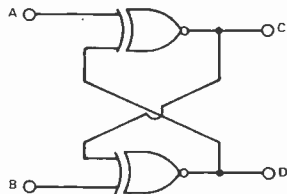

A	B	C	D	MODE
0	0	$\bar{D}$	$\bar{C}$	BISTABLE
0	1	$\bar{D}$	$\bar{C}$	ASTABLE
1	0	$\bar{D}$	$\bar{C}$	ASTABLE
1	1	D	C	BISTABLE

Tech Tips is an ideas forum and as such is not aimed at the beginner; we regret that we can not answer queries relating to these items. We do not build or test these circuits prior to publication.

ETI is happy to consider circuits or ideas submitted by readers; we will pay \$20.00 for each one we use. Drawings should be as clear as possible and the text preferably typed. Submissions should not be subject to copyright. Items for consideration should be sent to the editor.

## NI-CADS

Continued from page 28

design purposes this is usually taken to be 1.45 volts per cell. So

$$\frac{E_B + E_0}{E_S} = \frac{(6 \times 1.45) + 0.6}{12.6} = 0.74$$

and from fig. 7,  $K_1$  is about 0.32. Putting this into the formula for  $R_1$ ,

$$R_1 = \frac{0.45 E_S K_1}{I_{CM}} = \frac{0.45 \times 12.6 \times 0.32}{0.015} = 121 \text{ ohms}$$

so a standard 120R resistor may be used for  $R_1$ . The RMS current in the charger circuit is needed to find the power dissipated in  $R_1$ , and is given by

$$I_{RMS} = 2 K_2 I_{CM}$$

$K$  is found from Fig. 7 in the same way as  $K_1$ , and is about 1.35.  $I_{CM}$  is 15 mA, and  $I_{RMS}$  works out to be about 29 mA. Hence the power rating of  $R_1$  must exceed

$$P = (I_{RMS})^2 R = (0.029)^2 \times 120 = 0.1 \text{ watt}$$

so a 1/4 watt resistor will be adequate.

Using the same methods, the value of  $R_2$  for the slow recharge rate of  $C/10$  may be calculated. It works out to 12R at just under one watt, but a two-watt resistor should be used to provide a margin of safety.

The circuit of Fig. 6 will provide 3 amps to an OSI Superboard or similar computer for 15 to 20 minutes during a power failure. This should be sufficient time to save the precious RAM

contents on cassette tape, but the charger could be re-designed to work with larger cells, to keep the system running even longer.

### Summary

Nicad-based power systems are quite easy to design, knowing only the capacity of the batteries to be used. Nicads can be cost-effective replacements for conventional batteries, and can also be used in stand-by power applications where other types of batteries are unfeasible. With this article and a little imagination, readers should be able to design nicad power systems for just about any application.

### References:

1. *Nickel-Cadmium Battery Application Engineering Handbook*, copyright 1971 by the General Electric Co. (Publication No. GET-31481). This or a newer edition is available from General Electric Battery Products Division, P.O. Box 114, Gainesville, Florida 32601.
2. *Characteristics and uses of Nickel-Cadmium Batteries*, copyright 1966 by the International Nickel Company of Canada Ltd. Available from International Nickel

Co., Toronto-Dominion Centre, Toronto, Ontario.

3. *Packaged Power*, copyright 1979 by Duracell Products Co. Available from Duracell Batteries Ltd., 2333 North Sheridan Way, Clarkson, Ontario.

4. *Nicad Batteries*, copyright 1976 by Gould Inc. Available from Gould, Inc. Portable Battery Division, 931 North Vandalia Street, St. Paul, Minnesota 55114.

ETI

If you liked this article, please circle Reader Service Card number 47. If you didn't, circle number 48.

**Editorial inquiries will not be answered unless accompanied by a self stamped and addressed envelope!**

Please help us help you!

(If this wasn't getting to a problem, we could have had a cartoon in this space.)

## YES! FULLY ASSEMBLED MICROCOMPUTER ONLY \$99.95

- \* For Test Equipment, OEM product, Hobbyist, Education Trainer, Etc.
- \* Lowest price STD BUS Compatible board
- \* All addresses, data and control lines are brought to 56 pins edge connector

### Z80 MICROCOMPUTER

- \* Z80 CPU \* 2K Ram \* 24 I/O pins \* 4K Eprom 2732 \* USART
  - \* Top connector for I/O \* Bottom edge connector for STD BUS
  - \* EPROM & USART circuit comes with sockets only.
- 03-0800 Kit \$79.95  
03-0801 A & T \$99.95  
03-0810 Monitor \$39.95

### ALL PURPOSE I/O

- \* 8 bit A/D \* 8 Bit D/A \* 24 Bits I/O \* Three 16 Bits Timer
  - \* Top connector for I/O \* Bottom edge connector for STD BUS
  - \* Use with any 8 bit system
- 03-1800 Kit \$79.95  
03-1801 A & T \$99.95

### DISPLAY & KEYBOARD

- \* Hex keyboard with eight 1/2 inch displays
  - \* Connect to top connector of Z80 CPU Board or any I/O Board
  - \* Simple to use, no refreshing of digits in software
  - \* Use with Monitor & Z80 CPU Board for program development
  - \* Use this board in final product for display & entry
- 03-2800 Kit \$79.95  
03-2801 A & T \$99.95

### 6802, 6809 CPU Board & CRT Controller Board Coming Soon !!!

- \* 6 slot mother board (comes with 2 connectors)
- 03-3801 A & T \$35.00

### POWER SUPPLY \* +5V, ±12V

- 03-4800 Kit \$39.95
- 03-4801 A & T \$49.95

### PROJECT BOOK

- \* 10 projects using above system
  - \* Intelligent Eprom Programmer \* CRT Terminal \* Intelligent Voltage Meter and Counter \* Low cost Digital & Analog Computer Control Tester \* And many more
- 03-5800 \$1.95

To Order: Send your cheque, or money order plus \$5 for shipping (except Project Book). Ontario residents add 7% provincial sales tax. Visa & MasterCard accepted, send card no., signature, expiry date & name of bank. Quantities discount available

I system P.O. Box 447, Station T, Toronto, Ont. M6B 4A3

Circle No. 22 on Reader Service Card.

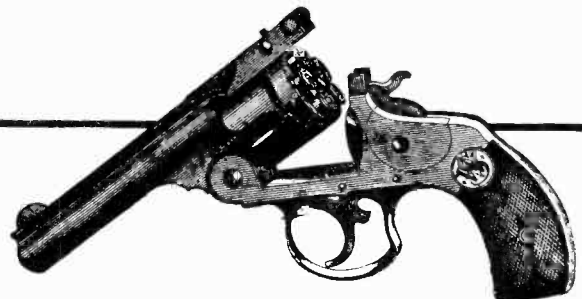

### New ETI Loose Leaf Binder Punch

We here at ETI realize that money is scarce, and that there are plenty of our readers who would rather not spring for binders to preserve their copies of this precious publication. Well, that's cool, and there is always the time worn solution of digging out those filthy loose leaf binders you used in high school, the ones with the smeared anatomical renderings etched into the vinyl in greasy ball point pen, and giving over to their tender embraces your clean, shiny issues of *Electronics Today*. The only hassle is getting the holes punched.

Well, that need not be a problem any more, not if you use the ETI loose leaf magazine punch illustrated above. Complete with enough supplies to punch two issues, the ETI punch is guaranteed to get through even the real fat issues with the catalogs in the middle. Try that with a regular hand punch!

In addition, the ETI punch can serve as a handy vermin killing device, fly swatter, attention getter at parties, robbery implement or murder weapon. What could be more useful?

The ETI magazine punch is available to all ETI readers for the amazing low price of just \$9.45. All orders must be postmarked before July 1, 1981. Supplies are limited, so order now.

(Note: if you'd prefer to use our regular ETI binders, they will, of course, still be available for \$8.00 each... postmarked anytime.)

ETI Binder Punch/Funny Old Gun  
25 Overlea Boulevard, Unit 6  
Toronto, Ontario  
M4H 1B1



# MODE ROAD RUNNER

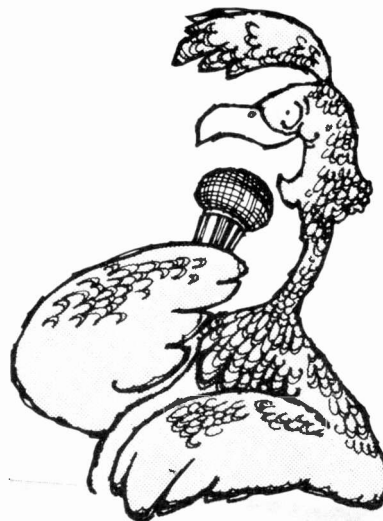

**You can master complex electronics and mimic the strange bird's erratic sound with this complete Mode kit!**

You can duplicate the cry of the Road Runner and create many other unusual audio effects with the Mode Road Runner kit.

All the necessary control parts for the Road Runner sound effects generator are in the Mode kit, including some that are not commonly available. Clear, step-by-step instructions help you become an expert electronics technician.

After building several Mode kits, you may become good enough to design your own devices. Even advanced students will have trouble duplicating the functions of the Road Runner and some other Mode projects without obtaining Mode's unique, very ingenious chips, diodes, and other tiny marvels.

Check out Mode's growing list of electronic projects that are entertaining, useful . . . and always instructive.

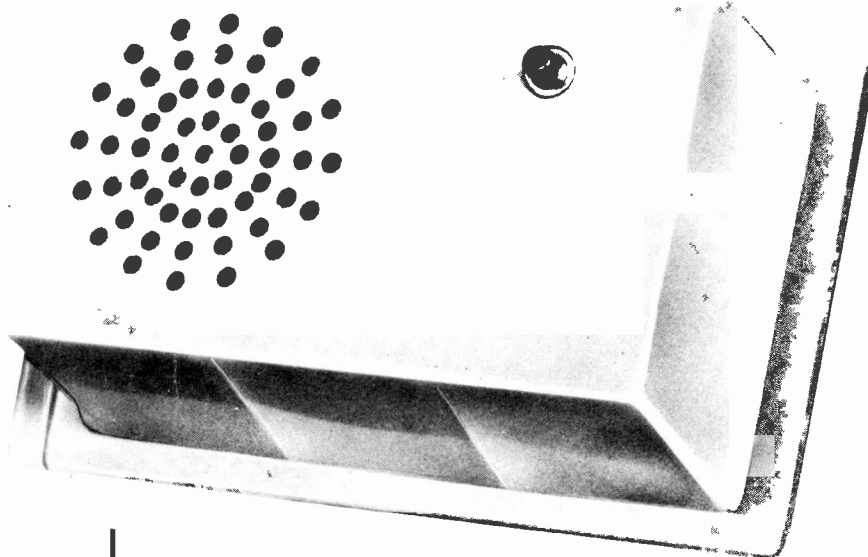

#### Mode kits for many useful and entertaining purposes.

- |                                       |                                   |
|---------------------------------------|-----------------------------------|
| 1. Automatic Headlight Reminder       | 19. Tone Generator                |
| 2. Battery Operated Fluorescent Light | 20. 5 Transistor 1 Watt Amplifier |
| 3. Bug Shoo                           | 22. Xenon Strobe                  |
| 4. Code Oscillator                    | 23. 3 Channel Color Organ         |
| 5. Crystal Radio                      | 24. Loudmouth Siren               |
| 7. Curiosity Box II                   | 25. Roulette Wheel                |
| 8. Dally Lighter                      | 26. Electronic Sheet Game         |
| 9. Decision Maker                     | 27. Electronic Dice               |
| 10. Fish Caller                       | 28. Super Roulette                |
| 11. Hi Power 12V DC Flasher           | 29. FM Mini Broadcaster           |
| 12. Photo Electric Night Light        | 31. Electronic Shoot Out          |
| 15. 0-20V Power Supply                | 32. Road Runner Sound Effects     |
| 16. Single Channel Color Organ        | 33. Love-O-Meter                  |
| 17. Electronic Siren                  | 34. Soldering Iron Kit            |
| 18. Shimmer Strobe Light              | 35. Audio Power Watt Meter        |
|                                       | 36. Steady Hand Game              |
|                                       | 37. Decision Maker D.C.           |

**MODE**  
ELECTRONICS

**HEAD OFFICE**  
1777 ELLICE AVE. WINNIPEG, MANITOBA  
R3H 0W5 PH: (204) 786-3133

**BRANCH LOCATION**  
88 HORNER AVE. TORONTO, ONTARIO  
M8Z 5Y3 PH: (416) 252-4838

Circle No. 21 on Reader Service Card.

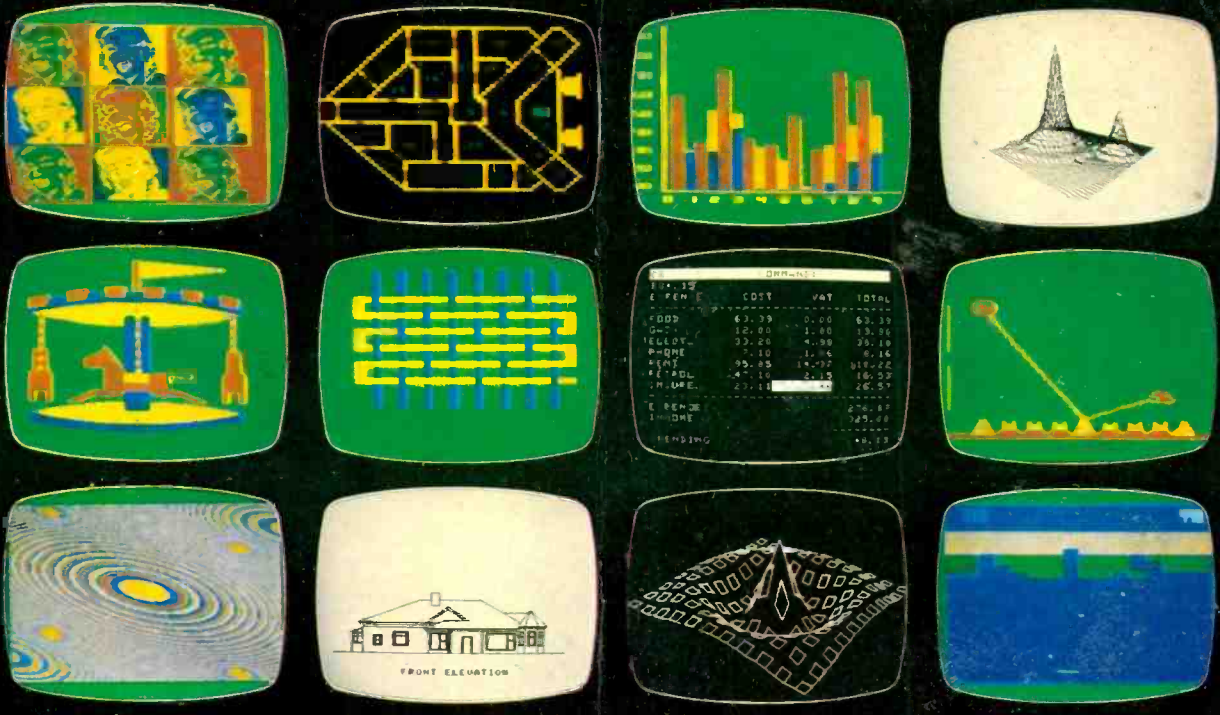

# CHOOSE ATOM POWER

At work or play—everything you need in a personal computer

The Atom is a machine to be used. Every day, day after day. It's a full function machine—check the specification against others. It's rugged, easy to operate built to last and features a full-size typewriter keyboard.

Just look at some of the features!

- More hardware support than any other microcomputer
- Superfast BASIC includes symbolic Macro Assembler
- High resolution and comprehensive graphics ideal for games programmers and players
- Designed in Britain
- Software available for games, education, math, graphs, business, word processing, etc.
- Other languages: Pascal, FORTH, LISP
- I/O port for control of external devices
- Built-in loudspeaker
- Cassette interface
- Full service/repair facility
- Users club

### Optional Extras

- Network facility with Econet
- Disk
- Printer connection
- Add-in cards include 32K memory, analogue to digital, viewdata VDU, disk controller, daisywheel printer, plus many, many more!
- Power supply

### FREE MANUAL

The Atom's highly acclaimed manual comes free with every Atom and leaves nothing out. In just a while you'll be completely at ease with your new machine! Within hours you'll be writing your own programs.



**ATOM SOFTWARE** is designed and produced by Acomsoft, a division of Acorn Computers, Trust the manufacturer to get the very best from its own product. Current software includes word processing, maths packs over 30 games, database, Forth and business packages.



Dealer Enquiries Welcome

ATOM 12k RAM, 12k ROM  
**\$525.00** (Black and White)  
**\$599.00** (Colour)



Order direct from the Canadian Distributors

Mail Order to:  
 Torch International Computers (Canada) Ltd., Suite 212,  
 7240 Woodbine Avenue, Markham, Ontario, L3R 1A4.  
 Or Call (416) 490-8622

Name .....

Address .....

Total amt encl. ( ) Cheque ( ) Money order

Charge to ( ) Visa ( ) Mastercard ( ) American Express

Card No. ....

Expiry .....

Ontario Residents add 7% P.S.T.

Qty.	Item	Price
	Atom 12k RAM, 12k ROM (Black and White)	\$525
	Atom 12k RAM, 12k ROM (Colour)	\$599
	Power Supply	\$35

Delivery will be made by courier service where possible