

# Electronics Today

\$3.25  
MM70924

April 1986

Canada's Magazine for Electronics & Computing Enthusiasts

## Professional Audio

Console techniques

Printed Circuit Layout

An artwork guide

Protoboard Project

Breadboard ideas

Autowiper Project

Controlled delay



# BEST Computers

Made in Canada, IBM PC, XT & AT Compatible

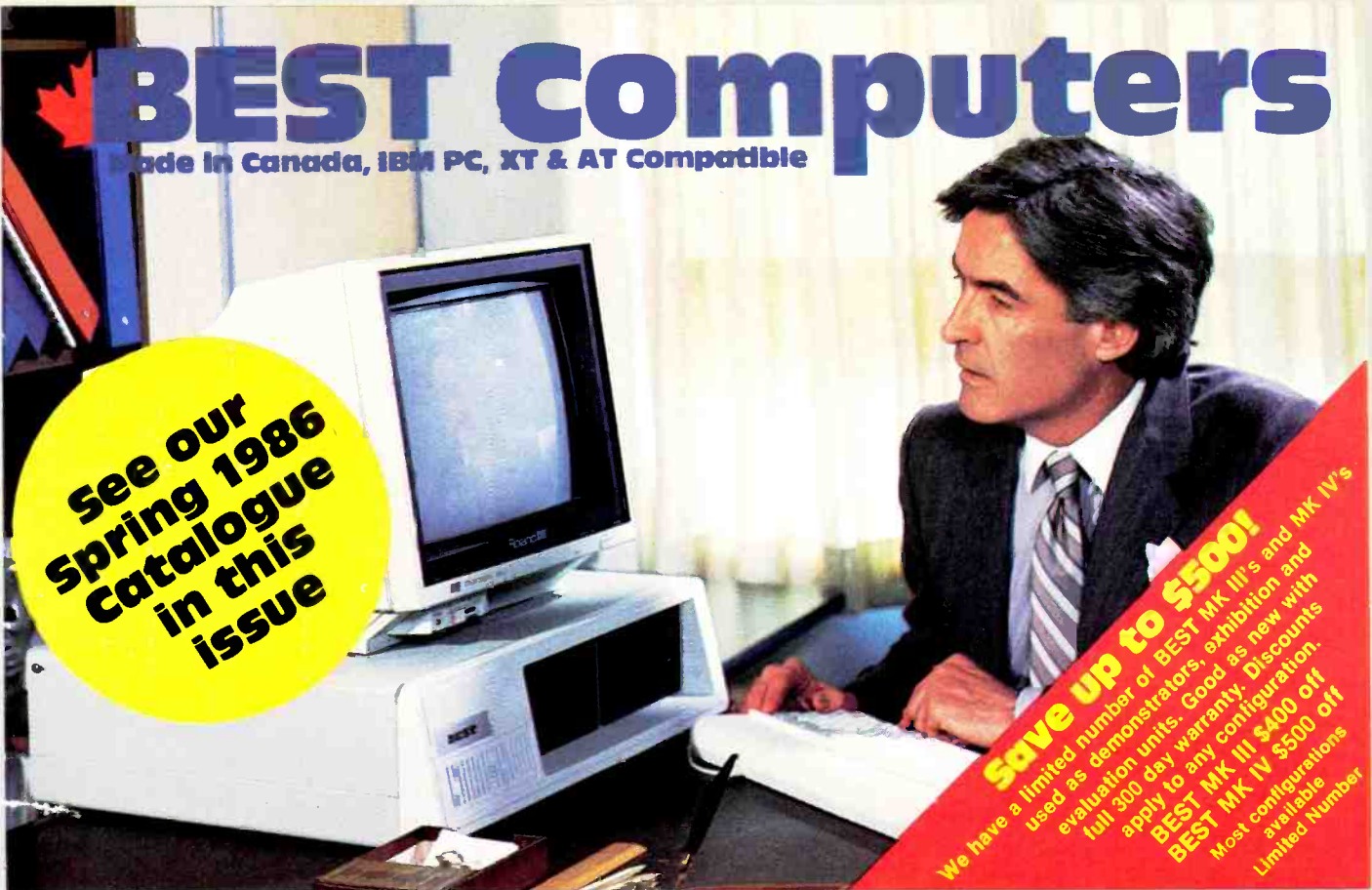

**See our Spring 1986 Catalogue in this issue**

**Save up to \$500!**  
We have a limited number of BEST MK III's and MK IV's used as demonstrators, exhibition and evaluation units. Good as new with full 300 day warranty. Discounts apply to any configuration. **BEST MK III \$400 off** **BEST MK IV \$500 off**  
Most configurations available  
Limited Number

Monitor not included. IBM registered trade mark of IBM Canada Ltd.

## Features common to BEST MK II, MK III & MK IV

- Superb IBM PC & XT Compatibility
- Canadian Made
- 256K RAM Standard minimum (uses 41256K RAM chips)
- Expandable on board to 640K RAM
- Parallel Port (for printer)
- Serial Port (for communications)
- Real Time Clock/Calendar (with Battery Backup)
- Presocketed for optional co-processor — such as 8087 Math Processor
- IBM Compatible Keyboard
- Reset Switch
- Phoenix BIOS as used in many major brand IBM compatible systems.
- 150 Watt Power Supply which will handle a Hard Drive without upgrade.
- 7 Slots
- Flip top case
- 2 Slimline DS,DD 5¼", 360K Disk Drives
- Colour Video (RGB & Composite) Board or Hi-Res Monochrome Card (customer choice)
- Disk Controller Board

## Warranty

We have such confidence in the time tested reliability of the BEST that we offer a 300-day warranty, way above the industry standard.

Please Note: Don't be put off by our spectacularly low price; this is due to the fact we do not deal with middlemen and our volume buying power of parts. All BEST's are manufactured in Canada to the highest quality standards using prime, guaranteed components by our sister company. All systems are pretested (burnt-in) for about 48 hours before shipping. Hundreds of happy customers report excellent reliability and compatibility.

### BEST MK II

Two 360K DS,DD disk drives, Serial and Parallel Ports, Real Time Clock, Phoenix BIOS, uses 8088 processor — full specifications given below.

**\$1595<sup>00</sup>**

#### Other Configurations:

|  |        |
|--|--------|
| With 640K RAM .....                        | \$1695 |
| With 10 Meg Hard Drive/1 Floppy/256K ..... | \$2495 |
| With 10 Meg Hard Drive/1 Floppy/640K ..... | \$2595 |
| With 20 Meg Hard Drive/1 Floppy/256K ..... | \$2795 |
| With 20 Meg Hard Drive/1 Floppy/640K ..... | \$2895 |

**NEW**

### The FAST BEST MK III

As BEST MK II plus speed selectable: 4.77 and 8MHz (most software will run on the higher speed), uses 8088-2 processor.

**\$1895<sup>00</sup>**

#### Other Configurations:

|  |        |
|--|--------|
| With 640K RAM .....                        | \$1995 |
| With 10 Meg Hard Drive/1 Floppy/256K ..... | \$2795 |
| With 10 Meg Hard Drive/1 Floppy/640K ..... | \$2895 |
| With 20 Meg Hard Drive/1 Floppy/256K ..... | \$3095 |
| With 20 Meg Hard Drive/1 Floppy/640K ..... | \$3195 |

**NEW**

### SUPER-FAST BEST MK IV

As BEST MK III plus TRUE 16-Bit machine, 8086-2 processor, IBM compatible 8-Bit I/O channel bus, even faster than MK III due to 16-Bit architecture.

**\$2500<sup>00</sup>**

#### Other Configurations:

|  |        |
|--|--------|
| With 10 Meg Hard Drive/1 Floppy/640K ..... | \$3395 |
| With 20 Meg Hard Drive/1 Floppy/640K ..... | \$3695 |

**NEW**

### AVT-286

Superb IBM AT compatibility, 640K RAM, Two 5.25 in disk drives (one high density 1.2 Megabyte, one standard 360K), serial and parallel ports high quality keyboard, keyboard lock and status monitor.

**\$3495<sup>00</sup>**

With 20 Megabyte fast stepping Hard Disk and Controller:

**\$4950<sup>00</sup>**

40 Megabyte systems also available at reasonable prices.

**EXCELTRONIX**

319 College Street, Toronto, Ont. M5T 1S2  
(416) 921-8941. Order line only 1-800-268-3798  
Ottawa, 217 Bank Street (613) 230-9000  
Visa, Mastercard and American Express accepted.

# Super Special on Printers

## New from Star Micronics SG-10 Printer

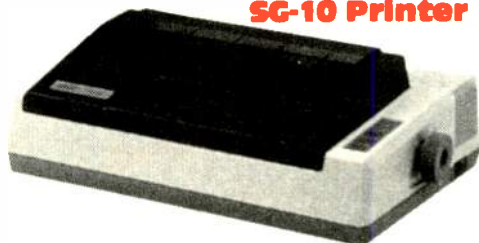

### Ideal for Text & Graphics

• Dual Mode - NLQ/draft standard (NLQ = near letter quality) • 120 CPS and 20% faster throughput • Bidirectional, logic/seeking • 2K buffer (expandable to 6K with optional buffer interface) • 100% IBM PC or Star standard control codes-switch selected • Friction and tractor standard • full 1 year warranty • 10" wide carriage • Standard parallel interface (serial optional) ..... **\$379.00**

### SG-10 C for Commodore Computers

All the same features as the SG-10 but includes built-in interface which plugs directly into Commodore computers.

**\$389.00**

## Star Micronics SG15

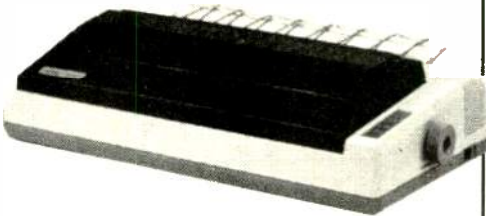

Same specifications as the SG-10 except with 15in. carriage and standard 16K buffer.

**\$599.00**

### SR-15

• 200 cps and 20% faster throughput • IBM PC or Star standard control codes switch selected • Dual Mode - NLQ/draft standard • Friction/tractor and automatic single sheet feed - standard • 15" carriage • 16K buffer • Bidirectional, logic seeking • Price/performance leader • Parallel port standard, serial optional • Full 1 year warranty. **\$995.00**

## Star Micronics — Power Type daisywheel printer Letter Quality



18 c.p.s., Bi-directional, Logic-seeking, 110, 132 or 165 columns. 100 Typefaces available, Proportional Spacing.

**\$535.00**

**Call or write for our  
1986 catalogue**

## Save Money — Time Limited Specials

Please note: These unbelievably good prices are due to a bulk purchase  
Prices good while stocks last.

### Star Micronics Gemini 10X Ideal for Text and Graphics

• 120 c.p.s., • 816 characters print buffer, option 4K or 8K • standard parallel optional RS232C • tractor & friction feed. **Super Special \$279.00**



### Star Micronics Gemini 10X PC

All the above features but IBM Compatible.

**\$279.00**

**Check out our catalogue for  
prices of Monitors, Disk  
Drives, Print Supplies and  
Printer Cables**

**We have excellent pricing  
on 10 and 20 Megabyte  
Hard Drives and Controllers**

### Star Micronics Gemini 15X PC IBM Compatible

Same as Gemini 10X PC but with 15in. carriage.

**\$399.00**

### Delta 15 PC IBM Compatible

160 c.p.s draft, 40 c.p.s Near Letter Quality, Friction and Tractor feed, 8K Buffer, Serial and Parallel Interfaces. 15in. carriage. Ultra-High Resolution.

**\$499.00**

### Delta 10 PC IBM Compatible

As above but 10in. carriage.

**\$399.00**

### Radix 15 PC IBM Compatible

200 c.p.s draft, 50 c.p.s. NLQ, Friction and Tractor Feed, Serial and Parallel Interfaces, 16K Buffer. 240 x 144 Ultra High Resolution.

**\$689.00**

### Radix 10 PC IBM Compatible

As above but with 10in. carriage.

**\$549.00**

### 5 1/4" 360K DS/DD Drives for your IBM or Compatible

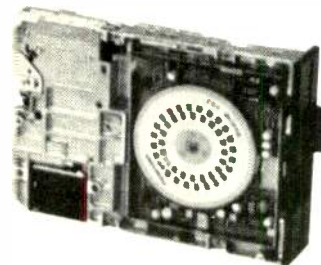

Toshiba ND-04D (Black) ... **\$159.00**

Toshiba ND-04DE-G (Grey) . **\$169.00**

**Shugart/Panasonic SA455  
\$144.00**

### Memory Special

41256 ..... **\$4.79**

4164 150nS ..... **\$2.49**

Large Quantity Discounts Available

**Check our catalogue for  
other spectacular  
memory pricing**

# EXCELTRONIX

319 College Street, Toronto, Ont. M5T 1S2

(416) 921-8941. Order line only 1-800-268-3798

Ottawa, 217 Bank Street (613) 230-9000

Visa, Mastercard and American Express accepted.

Circle No. 2 on Reader Service Card

# TOMORROW'S TECHNOLOGY TODAY

HOME AUDIO • CAR AUDIO • VIDEO • CELLULAR PHONES • PERSONAL COMPUTERS

SOUND & VISION MAGAZINE brings up-to-date information on our Electronic World to your doorstep. Find out not only what's available now, but what will be available in the future. Internationally recognized writers demystify the latest consumer electronics products through Equipment Features, Test Reports, and "How To" articles. Reviews of the latest L.P., CD and Videocassette releases help you get the most from your home entertainment centre. In addition, subscribers receive once a year, the Audio/Video Preview, Canada's most comprehensive consumer electronics catalogue containing pictures, specifications, and Canadian prices of the thousands of Audio and Video products available in Canada.

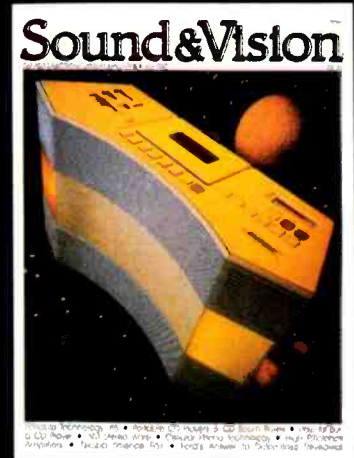
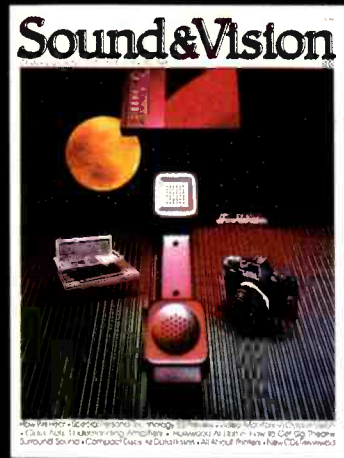
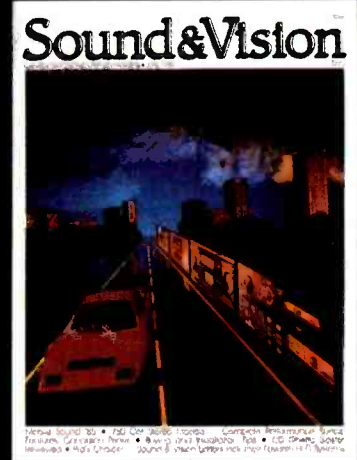
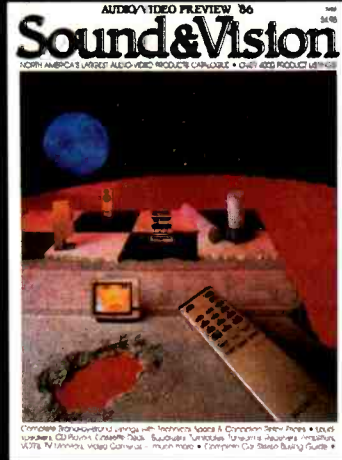
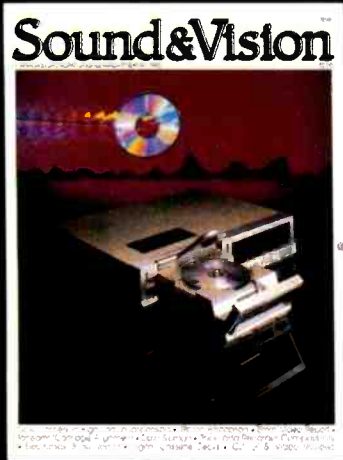

With it, you can check loudspeaker and tape deck frequency response, channel balance and speaker phasing; evaluate turntable rumble, cartridge tracking and stereo separation; and optimize speaker positioning and low-frequency performance. No special equipment is required; step-by-step instructions allow you to make the most of your hi-fi system's performance.



This unique record is yours, free, when you subscribe to *Sound & Vision* magazine.

## Sound & Vision

CANADA'S ELECTRONIC LIFESTYLE MAGAZINE

- Send me my one-year subscription and test record for \$11.97
- I prefer two years at \$19.97
- I prefer three years at \$29.97
- Payment enclosed. Send my test record now.
- Bill me and send the record when I pay.

Name \_\_\_\_\_

Address \_\_\_\_\_

City \_\_\_\_\_ Prov. \_\_\_\_\_ Code \_\_\_\_\_

Visa Number \_\_\_\_\_ Expiry Date \_\_\_\_\_



### Our Cover

Special thanks to the staff at The Master's Workshop, Rexdale Blvd., Toronto, for letting us invade; shown is the MCI console doing soundtracks. Photo by Bill Markwick.

Electronics Today is Published by:  
**Moorshead Publications Ltd.** (12 times a year)  
 1300 Don Mills Road,  
 Don Mills, Toronto, Ont. M3B 3M8  
 (416) 445-5600

Editor: **William Markwick**  
 Assistant Editor: **Edward Zapletal**  
 Director of Production: **Erik Blomkwist**  
 Production Manager: **Douglas Goddard**  
 Production: **Naznin Sunderji**  
**Dolph Loeb**  
 Circulation Manager: **Lisa Salvatori**  
 Advertising Account Manager: **Marlene Dempster**

Publisher: **H.W. Moorshead**; Executive Vice-President: **V.K. Marskell**; Vice-President - Sales: **A. Wheeler**; General Manager: **S. Harrison**; Controller: **B. Shankman**; Accounts: **P. Dunphy**; Reader Services: **M. Greenan, J. Fairbairn, R. Cree, L. Robson, N. Jones**; Advertising Services: **H. Brooks**; Advertising Telemarketing: **Rod Macdonald**.

Newsstand Distribution:  
 Master Media, Oakville, Ontario

Subscriptions:  
 \$22.95 (one year), \$37.95 (two years). Please specify if subscription is new or a renewal.

Outside Canada (US Dollars) U.S.A. add \$3.00 per year. Other countries add \$5.00 per year.

Postal Information:  
 Second Class Mail Registration No. 3955. Mailing address for subscription orders, undeliverable copies and change of address notice is:  
 Electronics Today, 1300 Don Mills Rd., Toronto, Ontario, M3B 3M8

Printed by Heritage Press Ltd., Mississauga  
 ISSN 07038984.

Moorshead Publications also publishes Computing Now!, Computers in Education, and Pets Magazine.

Circulation Independently Audited  
 by MURPHY and MURPHY  
 Chartered Accountants.

### Advertisers' Index

|                                     |                |
|-------------------------------------|----------------|
| Atlas Electronics Ltd.              | 63             |
| BCS Electronics Ltd.                | 28, 61, 62, 63 |
| Canada Remote Systems               | 8              |
| Computer Parts Galore               | 36, 37         |
| Copp Clark Pitman Ltd.              | 8              |
| Daetron                             | 60             |
| Electronic Control Systems          | 32             |
| Electronic Supplies Inc.            | 40             |
| Exceltronix                         | 2, 3           |
| Heath Company                       | 62             |
| Hobbitt Electronique                | 63             |
| Information Unlimited               | 6, 62          |
| Kaiental Electronics Merchants Ltd. | 32             |
| KB Electronics                      | 59             |
| Len Finkler & Co.                   | 62             |
| McGraw Hill                         | 25             |
| Mesurina                            | 63             |
| Metermaster                         | 58             |
| Raitronic's                         | 59             |
| Sound & Vision                      | 4              |
| Sunix Inc.                          | 40             |
| Surplustronics                      | 29             |
| The Software Link Inc.              | 64             |
| Universal Cross Assemblers          | 40             |
| Varah's Direct                      | 7              |

For Advertising Information  
 Call 445-5600

# Electronics Today

April 1986  
 Vol. 10 No. 4

Canada's Magazine for Electronics & Computing Enthusiasts



Professional Audio p. 30

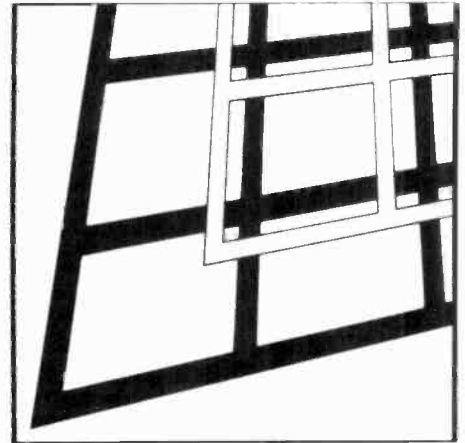

PCB Layout Guide p. 53

## Features

|                              |    |
|------------------------------|----|
| Automatic Test Equipment     | 9  |
| Designing Transistor Stages  | 18 |
| A Look At Professional Audio | 30 |
| PCB Layout Guide             | 53 |

## Projects

|                    |    |
|--------------------|----|
| Analog Thermometer | 26 |
| Protoboard         | 38 |
| Autowiper          | 49 |

## Series

|   |    |
|---|----|
| For Your Information                    | 5  |
| Electronics From The Start, Part 10     | 14 |
| Designer's Notebook: Custom Gate Arrays | 34 |

## Columns and Information

|                           |    |               |    |
|---------------------------|----|---------------|----|
| Next Month                | 10 | Order Form    | 47 |
| Computing Now! This Month | 11 | Subscriptions | 48 |
| Software                  | 12 | Binders       | 48 |
| Books                     | 22 | Product Mart  | 52 |

# For Your Information

## PCB Coating

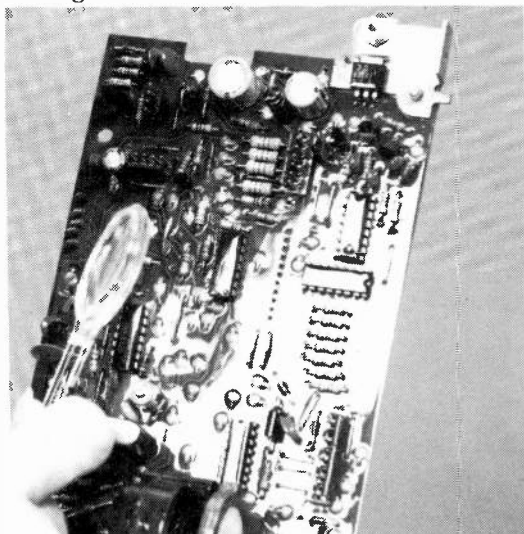

Loctite's new Shadowcure 361 is a PCB coating which can protect boards from environmental exposure. It's sprayable and cures in seconds under ultraviolet light.

The thin protective film resists solvents and moisture. Loctite Canada Ltd., 5115 Timberlea Blvd., Mississauga, Ontario L4W 2S3, (416)625-6511.

Circle No. 30 on Reader Service Card.

## Test Clip

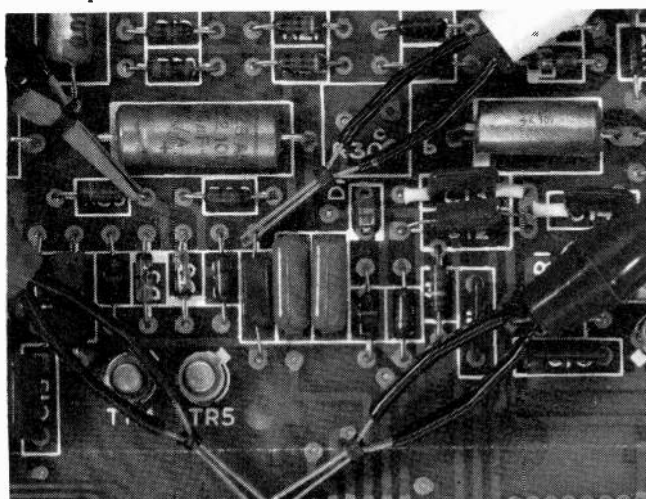

Miniclips from Maag Technic of Switzerland are called 'eagle' clips because of the beak-like tip. The metal spring tips open easily and close securely in the smallest of spaces; the spring clips are coated

with epoxy insulation right up to the tip. From I.J. Safety Distributors Inc., 3356 Henry St., Port Moody, BC V3H 3K4, (604) 461-3191.

Circle No. 31 on Reader Service Card.

## AMAZING

SCIENTIFIC and ELECTRONICS

## DEVICES

### LASER DEVICES

- LC5 BURNING CUTTING CO2 LASER ..... \$20.00
- RUB3 RUBY LASER RAY PISTOL ..... 20.00
- LRG3 IR LASER RIFLE/PISTOL ..... 10.00
- LGU3 VISIBLE RED LASER RIFLE ..... 10.00
- LBT1 - LIGHT BEAM COMMUNICATOR ..... 10.00
- LHC2 BEGINNER simulated VISIBLE LASER . 5.00

### SCIENTIFIC & ELECT

- TCL3 SOLID STATE TESLA COIL 35KV ..... 7.00
- BTC3 250 THOUSAND VOLT TESLA COIL ..... 10.00
- BTC5 1.5 MILLION VOLT TESLA COIL ..... 15.00
- GRA1 - GRAVITY GENERATOR ..... 10.00
- IOG3 ION RAY FORCE FIELD GUN ..... 10.00
- PTG1 - PLASMA TORNADO GENERATOR ..... 10.00

### ULTRASONIC ACCOUSTICAL

- PPF1 PHASOR PAIN FIELD GENERATOR ... 15.00
- PSP3 PHASOR SHOCK WAVE PISTOL ..... 8.00
- IPG5 POCKET PAIN FIELD GENERATOR ..... 8.00
- MDD1 MAGNETIC DIORIENTATION DEVICE . 10.00
- HT9 HIGH FREQ. LISTENING DEVICE ..... 8.00

### SECURITY & PROTECTION

- STG1 - STUN AND PARALYZING GUN ..... 7.00
- PPG1 PHASOR PROPERTY GUARD ..... 15.00
- MFT1 MINI VOICE XMTR 2-3 MILE ..... 7.00
- INF1 INFINITY TRANSMITTER ..... 15.00
- PSW3 PHASOR BURNING STUN WAND ..... 7.00
- ITMI INTIMIDATOR PLASMA GUN ..... 10.00

WE STOCK ALL PARTS NECESSARY FOR CONSTRUCTION OF THE ABOVE PROJECTS

• CATALOG CONTAINING HUNDREDS MORE OF ALL NEW AMAZING and FASCINATING PLANS. EASY TO BUILD KITS AND ASSEMBLED ITEMS \$1.00. CATALOG INCLUDED FREE WITH ANY OF THE ABOVE PROJECT PLANS. SEND CASH, CHECK, MO, VISA, MC IN US FUNDS.

### INFORMATION UNLIMITED

P.O. Box 718, DEPT. ET, AMHERST, NH 03031

## Digital Thermometer

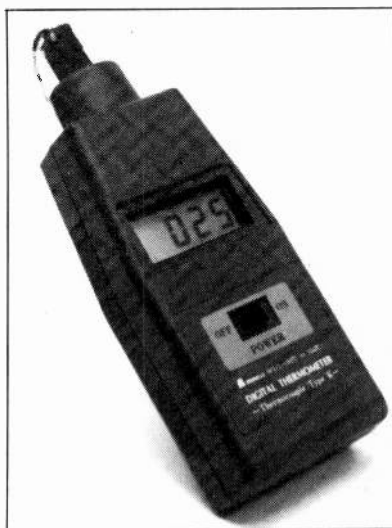

The model 901C hand-held digital thermometer from Brunelle Instruments operates with a Type K thermocouple with a five-foot length. The 3 1/2 digit display has a hold switch; temperature range is -50 to 750 degrees C with an accuracy of plus or minus 0.5 percent. For further information, request bulletin 901C from Brunelle Instruments, 73 6th Range S., St. Elie d'Orford, Quebec JOB 2S0,, (819) 569-1408.

Circle No. 32 on Reader Service Card.

## Low-Cost Overlay

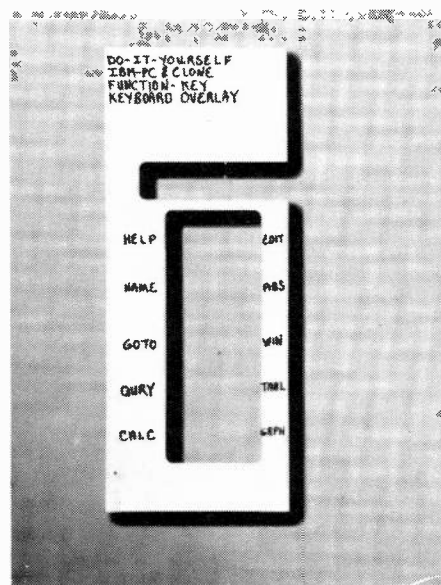

If you can never remember how you've set up the function keys on your IBM or compatible, these mini-templates are the simplest answer. They're six for \$9.95 (US) plus \$1 (US) for shipping. Made of plastic and stackable for use with different software, they have a surface that accepts pencil or pen. Micro Logic Corp., PO Box 174, 100 2nd St., Hackensack, New Jersey 07602, (201) 342-6518.

Circle No. 33 on Reader Service Card.

#### Copyright

All material is subject to worldwide copyright protection. All PCB patterns are copyright and no company can sell boards to our design without our permission.

#### Liability

While every effort has been made to ensure that all construction projects referred to in this magazine will operate as indicated efficiently and properly and that all necessary components are available, no responsibility whatsoever is accepted in respect of the failure for any reason at all of the project to operate efficiently or at all whether due to any fault in the design or otherwise and no responsibility is accepted for the failure to obtain component parts in respect of any such project. Further no responsibility is accepted in respect of any injury or damage caused by any fault in design of any such project as aforesaid.

#### Editorial Queries

Written queries can only be answered when accompanied by a self-addressed, stamped envelope. These must relate to recent articles and not involve the staff in any research. Mark such letter Electronics TodayQuery. We cannot answer telephone queries.

#### Binders

Binders made especially for Electronics Today (ETI) are available for \$9.75 including postage and handling. Ontario residents please add provincial sales tax.

#### Back Issues and Photocopies

Previous issues of Electronics Today Canada are available direct from our office for \$4.00 each; please specify by month, not by feature you require. See order card for issue available.

We can supply photocopies of any article published in Electronics Today Canada; the charge is \$2.00 per article, regardless of length. Please specify both issue and article.

#### Component Notation and Units

We normally specify components using an international standard. Many readers will be unfamiliar with this but it's simple, less likely to lead to error and will be widely used everywhere sooner or later. Electronics Today has opted for sooner!

Firstly decimal points are dropped and substituted with the multiplier; thus 4.7uF is written 4u7. Capacitors also use the multiplier nano (one nanofarad is 1000pF). Thus 0.1 uF is 100nF, 5600pF is 5n6. Other examples are 5.6pF = 5p6 and 0.5pF = 0p5.

Resistors are treated similarly: 1.8Mohms is 1M8, 56kohms is the same, 4.7kohms is 4k7, 100ohms is 100R and 5.6ohms is 5R6.

#### PCB Suppliers

ETI magazine does NOT supply PCBs or kits but we do issue manufacturing permits for companies to manufacture boards and kits to our designs. Contact the following companies when ordering boards.

Please note we do not keep track of what is available from who so please don't contact us for information PCBs and kits. Similarly do not ask PCB suppliers for help with projects.

K.S.K. Associates, P.O. Box 266, Milton, Ont. L9T 4N9.

B—C—D Electronics, P.O. Box 6326, Stn. F., Hamilton, Ont. L9C 6L9.

Wentworth Electronics, R.R. No. 1 Waterdown, Ont. L0R 2H0.

Danocinths Inc., P.O. Box 261, Westland MI 48185 USA.

Arkon Electronics Ltd., 409 Queen Street W., Toronto, Ont., M5V 2A5.

Spectrum Electronics, 14 Knightswood Crescent, Brantford, Ontario N3R 7E6.

# The Kits Keep on Coming from Varah's Direct!

Introducing the latest from Tandon, the **DISKARD 21 - the Kit on a Card!**

**INTRO PRICED: \$1199**

ORDER STK# 62622



Since Varah's Direct first introduced Tandon's terrific new Winchester drive kits, we've been fighting to keep up to the demand. No wonder they're so popular — never has so much capacity been made available so easily and inexpensively!

But how does the owner of an IBM® PC, XT or compatible expand his machine when it is already installed with two floppies?

The DISKARD 21 Megabyte card is the perfect solution!

The DISKARD 21 slides easily into a single expansion slot\* without any need for additional cables, accessory boards, or installation software. It's plug-in compatible with PC-DOS and MS-DOS versions 2.0 or higher. And because it only consumes 11 watts, no power upgrading is required. Simply format with "fdisk" from your DOS diskette and you'll be up and going in as little as 10 minutes!

The DISKARD 21 and the other drive kits offered here come with the full 90-day Varah's Direct warranty. They're in short supply, so act now! To order, write us or call (416) 842-8833 between 8:00 and 6:00 (EST), Monday to Friday.

\*PC and XT compatibles may require an additional expansion slot.

| IBM or Compatible           | 360KB Kit<br>½ Height<br>Floppy | 10MB Kit<br>½ Height<br>Winchester | 20MB Kit<br>½ Height<br>Winchester | 20MB Kit<br>Full Ht.<br>Winchester | DISKARD 21<br>21 MByte<br>Card | 40MB Kit<br>½ Height<br>Winchester | 40MB Kit<br>½ Height<br>Winchester |
|-----------------------------|---------------------------------|------------------------------------|------------------------------------|------------------------------------|--------------------------------|------------------------------------|------------------------------------|
| PC                          |                                 |                                    |                                    |                                    |                                |                                    |                                    |
| XT                          |                                 |                                    |                                    |                                    |                                |                                    |                                    |
| AT                          |                                 |                                    |                                    |                                    |                                |                                    |                                    |
| Access Time                 | 90 mS                           | 85 mS                              | 80 mS                              | 40 mS                              | 80mS                           | 35 mS                              | 35 mS                              |
| Varah's Direct Stock Number | 62601 *                         | 62611                              | 62621                              | 62625                              | 62622                          | 62640                              | 62645 *                            |
| Introductory Price          | <b>\$169</b>                    | <b>\$729</b>                       | <b>\$879</b>                       | <b>\$999</b>                       | <b>\$1199</b>                  | <b>\$1899</b>                      | <b>\$1499</b>                      |
| Indicates compatibility     |                                 |                                    |                                    |                                    |                                | *No controller card needed         |                                    |



For more information on the complete line of electronic components and supplies offered by Varah's Direct, write, circle, or call today for your free copy of the:

### 1986 Varah's Direct Reference Guide & Mail Order Catalogue

Not just a price listing, this is a fully referenced book supplying pin-outs, electrical specs, and dimensions on over 2500 items from our multi-million dollar industrial inventory. Contact us today for your free copy!



Member Canadian Direct Marketing Association

#### LOCATIONS:

Vancouver  
Edmonton  
Calgary  
Winnipeg  
Oakville  
Nepean

#### WRITE:

Varah's Direct  
504 Iroquois Shore Rd.  
Oakville, Ontario  
L6H 3K4  
(please include your return postal code)

#### CIRCLE:

The reader service number for this ad OR CALL: (416) 842-8833 Monday to Friday 8:00 - 6:00. E.S.T.

**SAMS COMPUTER BOOKS...**  
bringing technology down to earth!



**Cellular Mobile Telephone Guide**

Gives all the information you need to intelligently buy, lease, or rent the system best suited to your needs. Diagrams of systems layouts and operations are included. 224 pages, paper, \$15.50

**Mobile Communications Design Fundamentals**

This authoritative introduction to mobile communications design provides easy-to-understand methods of analysis for the communications engineer and engineering student. 352 pages, hard, \$77.95

**Gallium Arsenide Technology**

A comprehensive introduction to gallium arsenide — its properties and crystal structure, how to grow it, and how to apply it in a variety of digital and analog uses. 496 pages, hard, \$70.50

Available at better bookstores or



**Copp Clark Pitman**  
495 Wellington St. W.  
Toronto, ON M5V 1E9  
(416) 593-9911

Circle No. 5 on Reader Service Card

**CANADA REMOTE SYSTEMS**

**OFFERS YOU!**

**PUBLIC DOMAIN SOFTWARE**

**Canada's Largest Selection For CP/M, IBM, Macintosh Microcomputers**

By Telephone — 12 remote Telecommunications Systems available 24 hours per day. Annual Access charge only \$55.00. No charge for downloading. For CP/M and IBM type microcomputers. Data Pac available.

By Mail — for over 200 different Computers. Over 1000 disks representing all major user groups including SIG/M and PCSIG. From \$10.00 per user group disk. Our special collection disks contain the most popular software and are priced from \$15 per disk.

**COMMERCIAL SOFTWARE**

Specializing in CP/M and IBM commercial software, Low overhead, low prices, good service. We work with what we sell, and provide full assistance.

**COMMERCIAL HARDWARE**

Including coprocessor boards for CP/M computers and a full line of modems. The new 2400 Baud U.S. Robotics Courier Modem is now available for only \$825.00

Call us at (416) 239-2835 or Circle Reader Service Number 15 for a free mini-catalog.



Circle No. 6 on Reader Service Card

**For Your Information**

**RS232 Breakout Box**

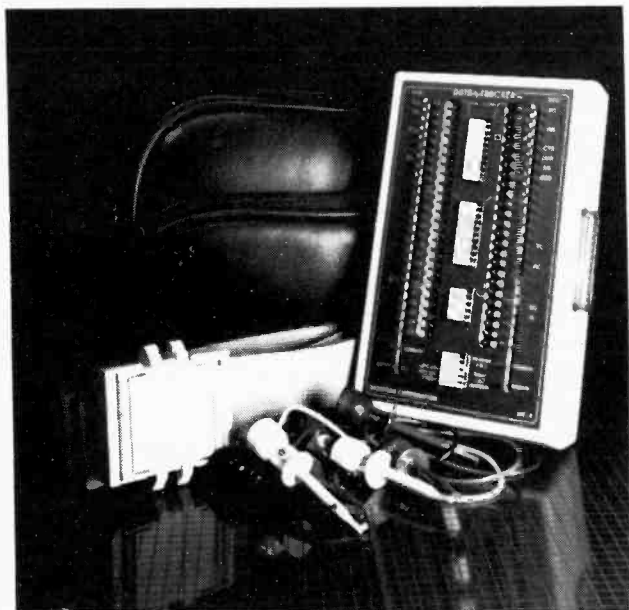

The Datalogger has turret-topped test points that permit easy multiple clip lead connections or accessibility to other test equipment. The indicator LEDs draw only

2mA each, a typical RS232 receiver load. Contact Home Base Inc., 60 Nably Court, Scarborough, Ontario M1B 2K9, (416) 293-4488.

Circle No. 34 on Reader Service Card.

**Controlled Iron**

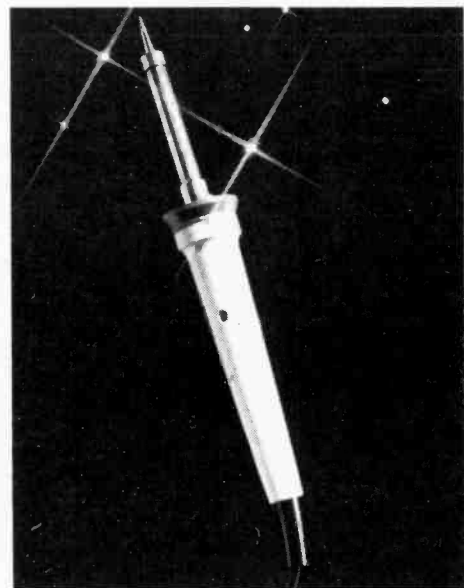

The Oryx Platinum 45 has a thick film cermet element and a platinum temperature sensor. The iron runs directly from 115VAC and is rated at 45 watts. The temperature is adjustable by the

user over the range 490 to 750 degrees F. The control circuit features zero-point switching to eliminate RFI. Oryx, 4 Columbus Avenue, Mt. Kisco, NY 10549, (914) 241-0237.

Circle No. 35 on Reader Service Card.



# Automatic Test Equipment

*Analog electronics is considered by many electronic engineers to be a black art, and the testing of analog circuits even darker.*

By W.P. Bond

BECAUSE OF the specialized nature of most analog circuits, the main limitation on their design is the ingenuity of the designer. It is difficult to lay down any single technique which would work for all possible analog circuits. The automatic test equipment used to test analog circuits must allow for a variety of different techniques and has to be capable of being modified to provide a range of input stimuli and response measurement configurations. Such ATE is usually described as modular.

Modular ATE will incorporate a standard instrument bus (most commonly, the IEEE 48 or General Purpose Interface Bus, GPIB) and all the test instruments required can be hung on the bus. The instruments are controlled by the ATE program and are routed to the unit under test (UUT) by a set of scanners, for example, a relay matrix. Each instrument can be considered a module of any given testing configuration. Each testing configuration would employ a particular set of modules, typically including programmable power supplies, programmable DC sources, an AAC source, a digital voltmeter, general purpose or reed relays, a phase angle voltmeter and logic units to perform drive and sense functions. Specialist modules would include spectrum analysers, synchro sources and pulse generators. For obvious reasons, such a modular system is often referred to as 'rack and stack', and a typical configuration is shown in Fig. 1.

## Having a Breakdown

The circuit to be tested is broken-down into functional blocks for which we have defined test procedures. Fig. 2 shows a basic block layout for a data acquisition subsystem, consisting of input buffering, input multiplexing, sample and hold, analog-to-digital conversion, output buffering and control/decode logic.

This last block should be tested first in any circuit in which it features.

Signature analysis or static truth-table testing could be used. Input buffering and multiplexing come next and are tested for insertion loss and crosstalk errors. All MUX inputs are grounded and the addresses are stepped through in sequence until all channels have been selected.

Insertion loss results from the inclusion of networks and functional blocks in a signal path. It can readily be measured by comparing output with input (voltage, current or power) and if the result is outside acceptable limits, the measurement can be interpreted as indicating a fault within the network or functional block. Similar comments apply where insertion gain might be expected from the inclusion of amplifying stages in a circuit.

In our example, the output of the multiplexer would be monitored assuming a fixed input. If the analog-to-digital converter in the circuit operates at a full-scale (FS) of 10V, insertion loss might be tested at + FS, -FS and 0V. The limit for accep-

table loss in this sort of circuit would usually be set at the voltage equivalent of one least-significant bit (1 LSB) - with a 12-bit bipolar ADC operating over a 20V range this would be  $20V/4096$  or 4.88mV.

As each channel is tested for insertion loss, the other inputs are grounded. Tests for input shorts and multiplexer selectivity (channel isolation or crosstalk) can be carried out at the same time since, if any channel is not isolated when another is selected, the output of the multiplexer will be loaded. Pin faults can also be detected during this procedure.

The sample and hold (S-H) circuitry is tested next. Its function is to hold the instantaneous (sampled) input voltage constant while the ADC is converting it. All tests after the MUX will usually be made with a signal routed through one particular channel so that known channel losses can be accounted for and kept constant. In testing the S-H block, it is desirable to have low offset in sample

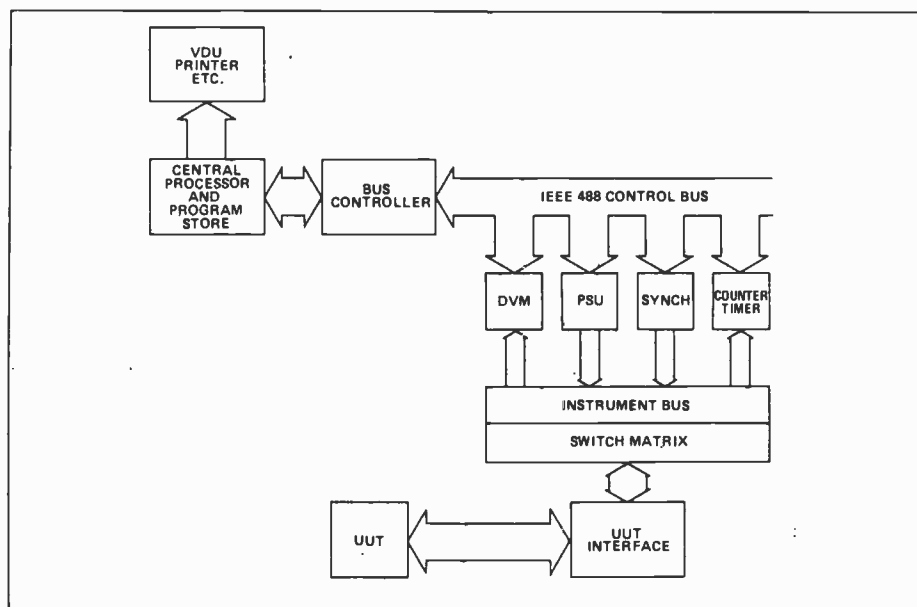

Fig. 1 Analog test-bed.

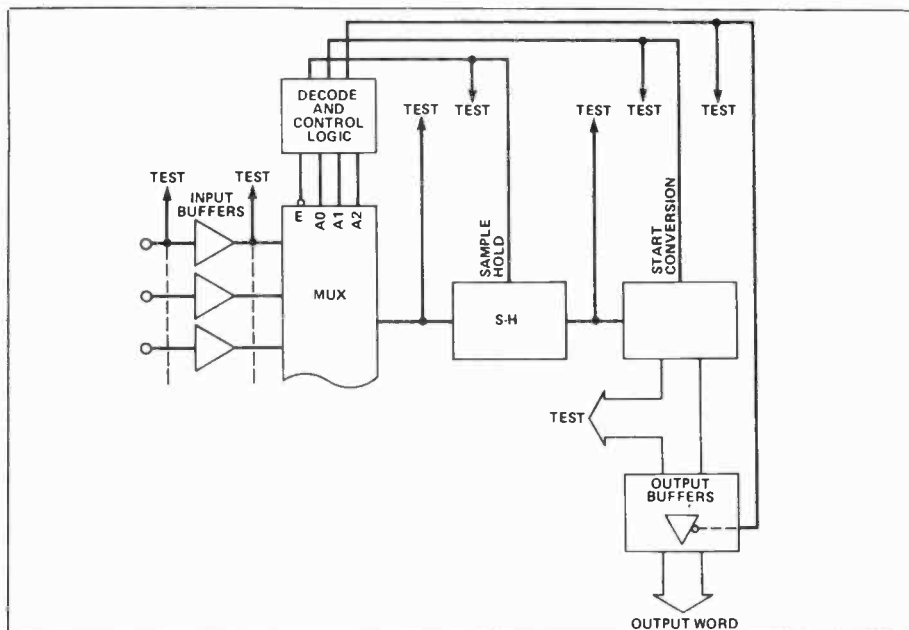

Fig. 2 Data-acquisition system.

mode with 0V and +/-FS as suitable input voltages. Acceptable errors are specified in manufacturers' data sheets. It is easier to check S-H hold performance by performing a conversion than by dynamically measuring the drift.

### Testing the Converter

A comprehensive test on an ADC block can be very complex. First, offset and gain adjustment should be set according to manufacturers' directions. After adjustment, the 0V offset should be tested to check that it is within 1 LSB. Offset (or

zero scale) error is a measure of the difference between theoretical and actual behaviour of an ADC at zero input voltage. As Fig. 3b shows, the effect is to shift the transfer characteristic of the ADC to the right or left. Offset is determined as the difference between the theoretical and actual input voltage at which the output of the ADC switches from zero to one bit and can be expressed as a percentage of the full-scale voltage. It is usually adjusted to 1/2 LSB, at which value quantization error is minimized.

Gain (or full scale) error is a measure of the difference between the theoretical and actual behaviour of an ADC at an input equal to full-scale (Fig. 3c). The effect is to rotate the ideal transfer characteristic about the origin. The error is determined as the difference between the theoretical and actual input voltage at which the output switches to full-scale and is expressed as a percentage of FS. Gain error is sometimes adjustable to zero in the circuit, but where it is greater than 1 LSB and is not adjustable, it will have to feature in later calculations.

The single most important error when it comes to determining the performance of an ADC is linearity error. It is a measure of the maximum deviation of actual performance from the theoretical

# This Month in



## Computer Music

Keyboards, drum pads, drum synths, all under the control of the MIDI system. Check out how it works and some of the equipment available.



## Fractals

Two more articles on fractals, those mathematical graphic displays for computers.

## A Review of Unix

We look at this popular operating system, how it works, and what you can do with it.

## The Hercules Card Meets C

Working with the high-resolution Hercules video card and the C language.

For Subscription or Advertising Information Call (416) 445-5600

straight-line (Fig. 3c). It is an intrinsic feature of the ADC and cannot be adjusted, and it should be measured after offset and gain have been calibrated. It is expressed as a fraction of LSB or as percentage of FS and it is tested for by checking actual ADC output against expected output for a range of definite input voltages. The number and value of the test voltages are fixed only by the degree of accuracy desired.

The final test for ADCs is for differential non-linearity (DNL) which will reveal missing codes. Differential non-linearity implies that the ADC will display non-monotonic behaviour and it is, if it exists, an intrinsic feature of the particular ADC. The ideal step size for any ADC is 1 LSB. A deviation from this ideal may result in some codes not appearing at the output at all (Fig. 3d). The important parameter is code-width, that is, the voltage range over which a given code will be output. It should be clear that a code width of 1 LSB gives a differential linearity error of zero, in other words, there will be missing codes.

Testing for code-width usually demands a programmable DC voltage source with a high resolution (at least 1mV). By gradually incrementing the voltage applied to an input in, say, 1 mV

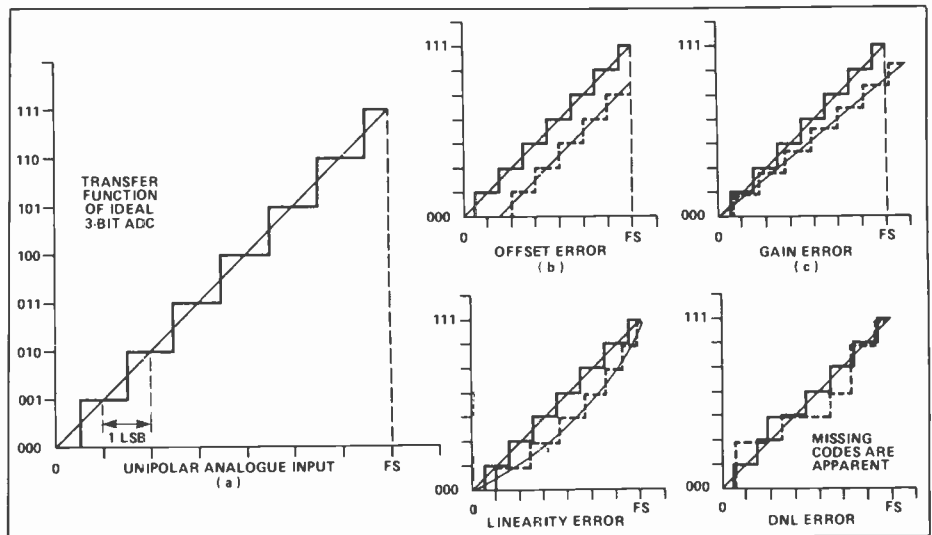

Fig. 3 ADC errors.

steps it is possible to count the number of steps between actual transition points and compare the count with the theoretical code-width representing 1 LSB in mVs. An error can then be used to generate a fault message. The accuracy is dependent on the precision with which the transition voltages can be determined. Differential non-linearity only relates to adjacent codes. In order to obtain a comprehensive

idea of the DNL of an ADC it is, of course, necessary to test at every transition point.

The final test in our example circuit would be on the output buffer. The required procedures have all been dealt with before, so I won't repeat them. The principles outlined above for testing analog units can be readily modified for the testing of practically any such module. ■

# NEXT MONTH IN Electronics Today

## A Guide To Troubleshooting

Techniques and tips on troubleshooting equipment and projects from simple to complex circuits.

## Speech Synth Project

Using the readily available SP0256 chip, we make your computer sit up and talk.

## Solid State Light Meter

Dropped your expensive Gossen? Here's a solid-state light meter with the accent on solid.

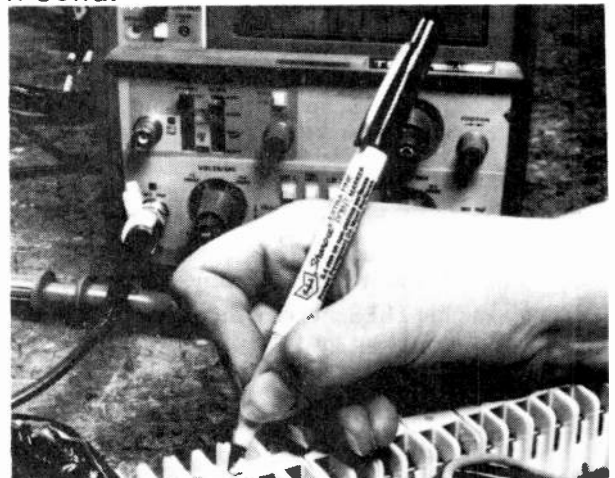

For Subscription or Advertising Information Call (416) 445-5600

# Almost Free PC Software

## Volume VII

Total sensory overload on a single floppy disk

There seems to be no end to the ingenuity one finds in public domain software for the IBM PC. Far from being simply programs and video games, there seems to be stuff for every application, ranging from end user applications to business packages. We've assembled another selection of some of its finest works.

This disk includes a host of remarkable code. Some, like PCBW, are tiny files that solve large problems. Others, like QUIKGRAF, a business graphics generator, are complete applications in many ways comparable to commercial software.

**BLACKJACK** is a BASIC implementation of this popular card game. It's both interesting to play and enlightening to dismantle. It can, of course, be easily listed so you can see how it works.

**EDSCR** is a screen editor which can be used with pretty well any programming language from assembler to dBASE III. It generates PC screens replete with block graphics and text, creating universally applicable source files for them. An example screen is included.

**FK** allows you to make the function keys of your PC do more useful things under DOS. You can program them for macros, store your most used commands in them and generally make them less mysterious.

**FXMASTER** is a printer program for the popular Epson FX series printers and all work alikes. It uses a full screen menu to give you easy access to the features of these powerful boxes.

**INDEX** allows you to generate indexes from WordStar documents... or text files from any other text editor, for that matter. It's an invaluable writer's tool.

**KEYCLICK** is a resident program which will make your keys click. It's very small, easily included in an AUTOEXEC file and solves a multitude of problems associated with clone keyboards.

**PCBW** is another tiny program... run it and it will convert colour screen displays from one's software to black and white video for a green screen monitor.

**PINBALL** is a pinball simulation that's easily worth the cost of the disk all by itself. It will waste more of your time for you than you knew you had.

**QUIKGRAF** is powerful business graphics package which renders complex bar, line and scatter charts in medium and high resolution. An Epson compatible printer with GrafTrax is required to produce hard copy with this package.

**SERPENT** is a variation on the classic snake game in BASIC. It's remarkably fast and moderately weird.

**SHOWCLK** is yet another clock program... it's the smallest one yet, and it beeps to chime the hour.

**VTREE** is a graphic TREE program that shows you how the subdirectories are set up on your disk... in a much more easily understood way than does the MS-DOS TREE utility.

**WORLD** is a remarkable program which incorporates a world map. It allows you to zoom in on bits of the globe, locate major cities and perform a number of useful calculations about the map. It also has a feature for tracking hurricanes... tracked any good hurricanes recently?

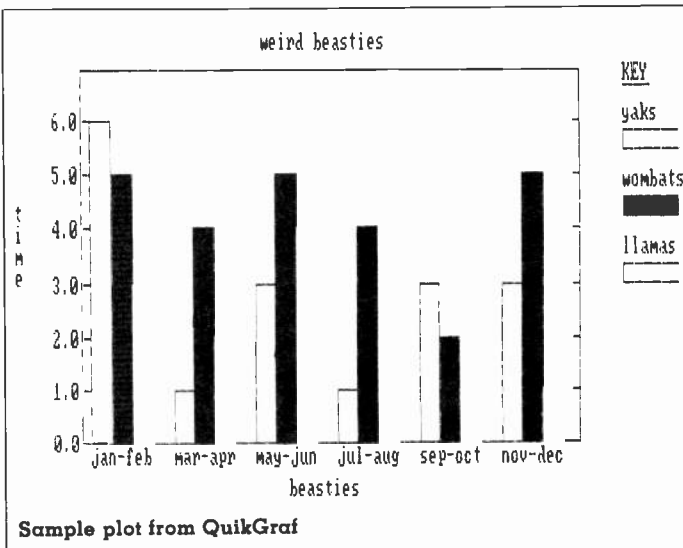

The disk is available for just

**\$19.95**

plus seven percent Ontario sales tax

**Almost Free PC Software**  
**Moorshead Publication**  
**1300 Don Mills Road**  
**Don Mills, Ontario**  
**M3B 3M8**

or you can order by phone at

**(416) 445-5600**

during business hours. Have your VISA, Mastercard or American Express card handy.

**Fine Print:** This software has all been collected from public access bulletin boards and is believed to be in the public domain. The fee charged is to defer our cost in collecting, testing and debugging it and for the cost of the media and postage.

While we endeavour to make sure that all this software works, we are unable to assist you in applying it to your specific applications. This software is intended for use on PCs and true compatibles... it may misbehave on partially compatible systems.

Moorshead Publications warrants that the disk you receive will be readable. The post office, on the other hand, warrants nothing. If you are unable to read any of the files on your disk please return it to us for a prompt replacement.

# Almost Free PC Software

## Volume VIII

This is another collection of fairly large applications. We've had to spread them over two disks. However, the extra three bucks is nothing compared to the power of some of this software. Whether you're interested in games, business applications or code hacking, you'll find something of interest in this larger than usual collection of programs. In addition to the programs themselves, the set includes all the support files needed to use them.

**Load-Us** allows users of the popular Lotus 1-2-3 and Symphony programs to run them on a hard drive. It isn't a cracking program, but, rather, a preboot to avoid the inconvenience of this copy protected software for legitimate users.

**DDCal** is a very clever perpetual calendar and desk diary. It keeps track of your appointments and performs several other functions that you probably thought could only be done on the backs of match books.

**PC Key Draw** is the remarkable public domain paintbox program which blows away so many commercial applications. It'll handle multiple screen images, business graphics and superb computer art...all in full colour. It's worth the cost of this package all by itself.

**CPU** is a tiny program to tell you the effective speed of your system.

**Xray** is a remarkable co-resident utility to monitor what a program is doing while it's busy doing it. It allows you to interrupt the execution of your code and have a look inside.

**Game**...well, there are no words for this program, or, at least, none that are printable. This game is a bit rude... depending on just how weird your mind is, it can get pretty bizarre. This program does use some suggestive language, and we recommend that young or sensitive users not boot it.

**Tune** is a very small music generator to make noises from within batch files. It's useful to see where things are in a complex process.

**Chasm**, or cheap assembler, is just the thing if you want to get into assembly language programming but don't want to spring for the Microsoft macro assembler package. It's reasonably fast, not too huge... it'll run in as little as sixty-four kilobytes... and, above all, cheap.

**Getdir** is a resident directory utility. It allows you to see what's happening on your disks even if you're in the middle of doing something else.

**CopyPC**, not to be confused with the commercial Copy II PC, is a quick disk backup utility for the IBM.

**Lookit** is a full screen browsing program to let you scroll forward and backwards through text files... a sort of a tiny word processor that can't edit anything.

**Syslock** is a security device for hard disk users. By implementing this package on your XT or compatible no one without a secret password will be able to have access to your computer.

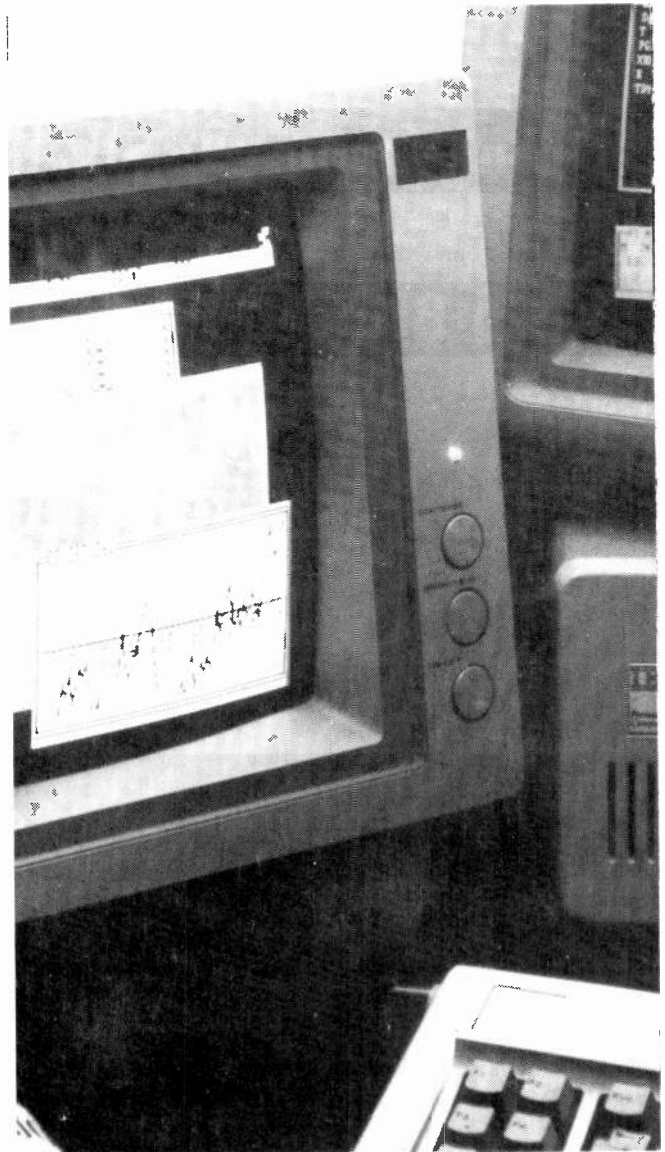

This two disk set is available for just

**\$22.95**

plus seven percent Ontario Sales tax

**Almost Free PC Software**  
**Moorshead Publications**  
1300 Don Mills Road  
Don Mills, Ontario  
M3B 3M8

or you can order it by phone at

**(416) 445-5600**

during business hours. Have your VISA, Mastercard or American Express card handy.

**Fine Print:** This software has all been collected from public access bulletin boards and is believed to be in the public domain. The fee charged is to defer our cost in collecting, testing and debugging it and for the cost of the media and postage.

While we endeavour to make sure that all the software works, we are unable to assist you in applying it to your specific uses. This software is intended for use on PCs and true compatibles... it may misbehave on partially compatible systems.

Moorshead Publications warrants that the disk you receive will be readable. The post office, on the other hand, warrants nothing. If you are unable to read any of the files on your disk please return it to us for a prompt replacement.

# Electronics from the Start

by Keith Brindley



— Part 10

## Transistors: how they work and how to use them correctly.

YOU DON'T need many components this month, just the following resistors:

1 x 100k  
1 x 220k  
1 x 47k miniature horizontal preset,  
and one 2N3053 transistor.

You'll see that the transistor has three terminals labelled, base, emitter, and collector (commonly shortened to B,C and E). When using transistors in electronic circuits it's essential that these three terminals are correctly oriented. The 2N3053 transistor terminals are identified by holding the transistor with its terminals pointing towards you from the body and comparing the transistor's underside with the diagram in Fig. 1. The terminal closest

to the tab on the body is the emitter, then in a clockwise direction are the base and the collector.

Other transistor varieties may have different body types so it's important to check with reference books or manufacturer's data regarding the transistor terminals before use. All 2N3053 transistors, however, are in the same body type, known as a TO-5 body, and follow the diagram in Fig. 1.

Recently we have looked closely at diodes, the simplest of the group of components known as semiconductors. The many different types of diodes are all formed by combining doped layers of semiconductor material at a junction. The PN junction (as one layer is N-type semiconductor material and the other layer is P-type) forms the basis of all other semiconductor-based electronic components. The transistor, the component we're going to look at now, is made of two PN junctions back to back. Fig. 2 shows how we may simply consider a transistor as being two back-to-back diodes, and we can verify this using our meter to check resistances between the three terminals of the transistor.

To do the experiment, put a transistor into your breadboard, as shown in Fig. 3, then use the meter to test the

resistance between transistor terminals. We know that if there are three terminals there must be six different ways the meter leads can be connected to the terminals. Table 1 lists all the combinations but the

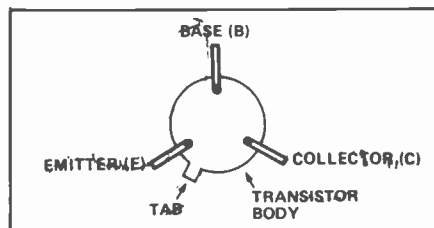

Fig. 1 How to recognize the location of the base, emitter and collector connections on a common transistor body.

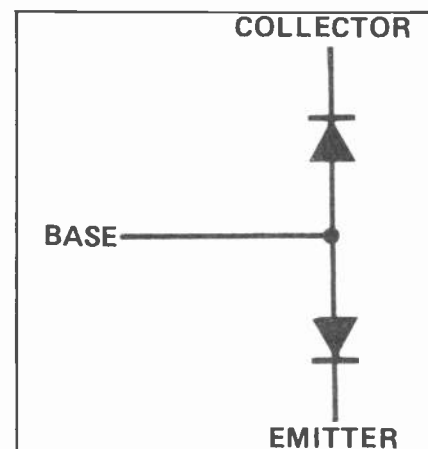

Fig. 2 A symbol for a transistor considered as two diodes, back-to-back.

results column is left blank for you to fill in as you perform the experiment. It's not necessary for you to measure the exact resistance obtained between terminals, it's sufficient just to find out if the resistance is high or low.

One final point before you start, the casing of the transistor body (sometimes called the 'can') is metal and therefore conducts. When connecting test leads to the transistor terminals, make sure that they don't contact the can; short circuits give an incorrect result! The can of a TO-5 bodied transistor such as the 2N3053 is also electrically connected to the transistor's collector, so take extra care.

Your results should show that low resistances occur in only two cases, indicating forward current flow between base and emitter, and base and collector. This corresponds as we should expect to the diagram of Fig. 2.

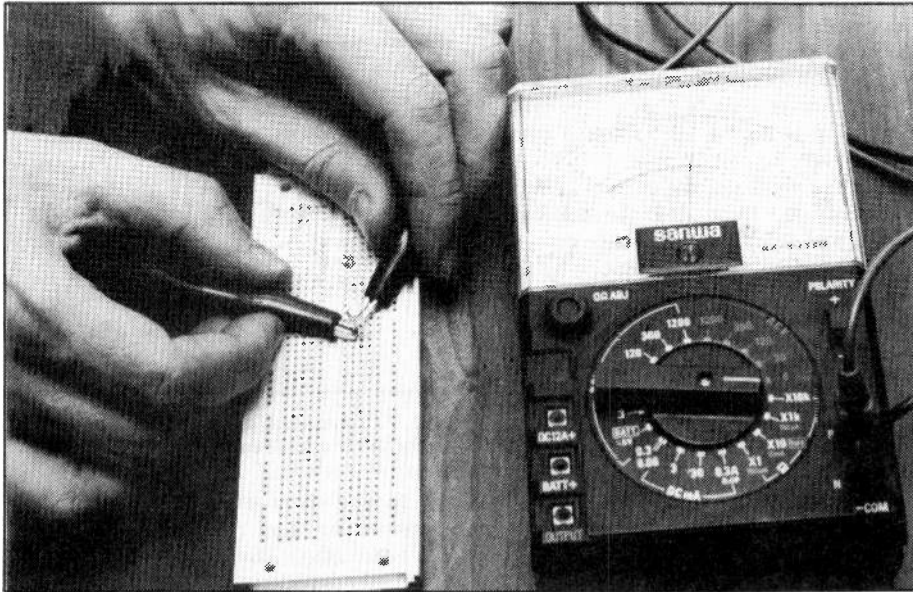

Fig. 3 An experiment to check resistances between the transistor terminals.

### Very Close

Unfortunately things aren't quite as simple as that in electronic circuits, where individual resistances are rarely considered alone. The real life transistor deals with currents in more than one direction and this confuses the issue. What is happening is that the two PN junctions are very close together. So close that, in fact, they affect one another.

Fig. 4 illustrates how a transistor can be built up, from two PN junctions situated very close together. It's really only a thin layer of P-type semiconductor material (only a few hundred or so atoms thick) between two thicker layers of N-type semiconductor material. Now let's connect this transistor arrangement between a voltage supply, so that collector is positive and emitter is zero, as in Fig. 5.

From what we know so far, nothing can happen and no current can flow from collector to emitter because two back-to-back PN junctions lie between these two terminals. One of these junctions is reverse biased and so, like a reverse biased diode, cannot conduct. So, what's the

point of it all?

Well, as mentioned earlier, what happens in one of the two PN junctions of the transistor affects the other. Let's say for example that we start the lower PN junction (between base and emitter) conducting by raising the base voltage so that the base-to-emitter voltage is above the transition voltage of the junction (say, 0V6 if the transistor is a silicon variety). Fig. 6 shows this situation. Now, the lower junction is flooded with charge carriers and because both junctions are very close together, these charge carriers allow current flow from collector to emitter also (Fig. 7).

To summarize, a current will flow from collector to emitter of the transistor when the lower junction is forward biased by a small base-to-emitter voltage. When the base-to-emitter voltage is removed the collector-to-emitter current will stop.

We can build a circuit to see if this is true, as shown in Fig. 8. Note the transistor circuit symbol. Fig. 9 shows the

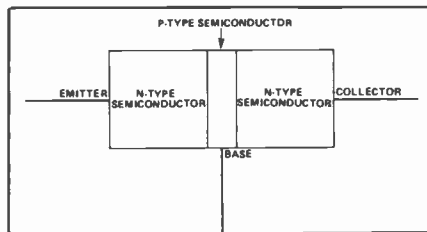

Fig. 4 A narrow P-area gives two PN junctions very close together.

breadboard layout. From the circuit you'll see that we're first measuring the transistor's collector-to-emitter current (collector current) when the base-to-emitter junction is first connected to zero

volts (reverse biased), then when the base is connected to positive and the base-emitter junction is forward biased.

Now do the experiment and see what happens. You should find that when the

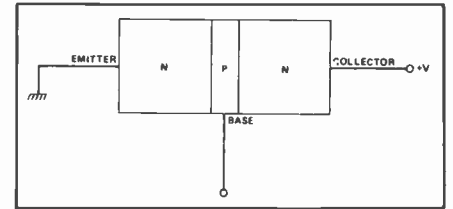

Fig. 5 Connected up, the emitter is at 0V and the collector is positive.

base is connected to zero via the 100k resistor nothing is measured by the meter. But when the base resistor is connected to positive, the meter shows a collector current flows. In our experiment a collector current of about 12mA was measured, yours may be a little different. Finally, when the base resistor is returned to zero

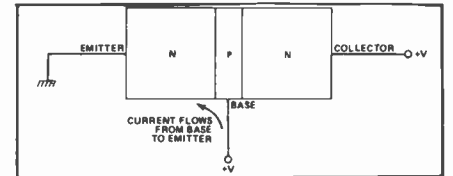

Fig. 6 If the voltage at the base is raised, current flows from base to emitter.

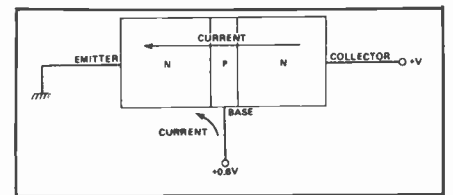

Fig. 7 Charge carriers accumulating around the lower junction allow current to flow from the collector to the emitter.

volts (or simply when it's disconnected!) the collector current again does not flow.

What use is this? Not a lot as it stands, but it becomes very important when we calculate the currents involved. We already know the collector current (about 12mA in our case) but what about the base-to-emitter current (base current)? The best way to find this is not by measurement (the meter itself would affect the transistor's operation) but by calculation. We know the transistor's base-to-emitter voltage (base voltage) and we know the supply voltage. From these we can calculate the voltage across the resistor, and from Ohm's law we can therefore calculate the current through the resistor. And the current through the resistor must be the base current.

So, the resistor voltage is:

$$9 - 0.7 = 8.3V$$

And from Ohm's law the current is:

$$I = V/R = 8.3/100,000 = 83\mu\text{A}$$

Now we can begin to see the importance of the transistor. A tiny base current can turn a large collector current on or off. This is illustrated in Fig. 10 and is of vital importance.

In effect, the transistor is a current amplifier. No matter how small the base

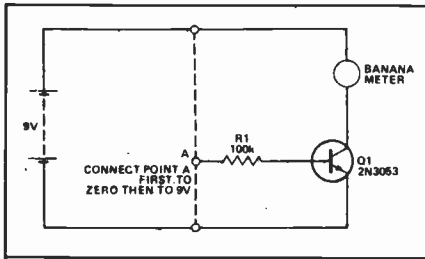

Fig. 8 An experimental circuit to test what we have described so far.

current is, the collector current will be much larger. The collector current is, in fact, directly proportional to the base current. Double the base current and you double the collector current. Halve the base current and the collector current is likewise halved. It's this fact that allows the transistor to be used as a controlling element (the base current controlling the collector current) which makes it the most

important component in electronics.

The ratio:

collector current/base current

gives a constant of proportionality for the transistor, which can have many names depending on which way you butter your bread. Officially it's called the forward current transfer ratio, common emitter, but as that's quite a mouthful it's often just called the transistor's current gain (seems sensible!). You can sometimes shorten this even further if you wish, to the symbols:  $h_{fe}$ , or  $B$ . In manufacturer's data sheets for transistors the current gain is normally just given the symbol  $h_{fe}$  (which if you're interested stands for Hybrid parameter, Forward, common Emitter. Are you any wiser?). However, we'll just stick to the term current gain, generally.

We can work out the current gain of a transistor by measuring the collector current, and calculating the base current as we did earlier, and dividing one by the other. For example the current gain of the transistor we used is:

$$(12 \times 10E-3)/(83 \times 10E-6) = 145$$

Yours may be a bit different. Manufacturers will quote typical values of current gain in their data sheets; individual tran-

sistors' current gains will be somewhere around this value, and may not be exact at all. It really doesn't matter, too much. The transistor we use here, the 2N3053, is a fairly common general purpose transistor. High power transistors may have current gains more in the region of about 10, while some modern transistors for use in high frequency circuits such as radio may have current gains around 1000 or so.

### NPN

The 2N3053 transistor is known as an NPN transistor because of the fact that a thin layer of P-type semiconductor material is sandwiched between two layers

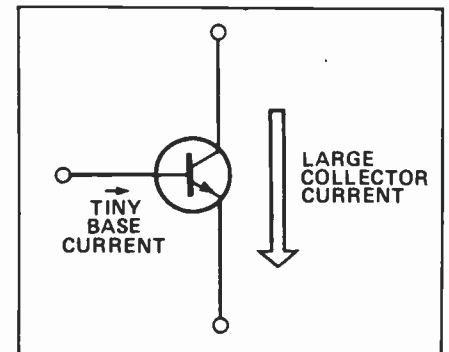

Fig. 10 Important: a very small base current can control a large collector current.

of N-type semiconductor material. The construction and circuit symbol of an NPN transistor are shown in Fig. 11a. You may have worked out that there is another way to sandwich one type of semiconductor material between two others, and if so you would also have worked out that such a transistor would be called a PNP transistor. Fig. 11b shows a PNP transistor construction and its circuit symbol. The only difference in the circuit symbols of both types is that the arrow on NPN transistor's emitter points out and the arrow on the PNP transistor's emitter points in.

The emitter arrow of either symbol indicates direction of base current and collector current flow. So from the circuit symbols we can work out that base current in the NPN transistor flows from base to emitter, while in the PNP transistor it flows from emitter to base. Likewise collector current flow in the NPN transistor is from collector to emitter and from emitter to collector in the PNP transistor.

Knowing this and comparing the PNP construction to that of the NPN transistor we can further work out that a tiny emitter-to-base current (still called the base current, incidentally) will cause a much larger emitter-to-collector current (collector current). This is illustrated in Fig. 12. The ratio of collector current to

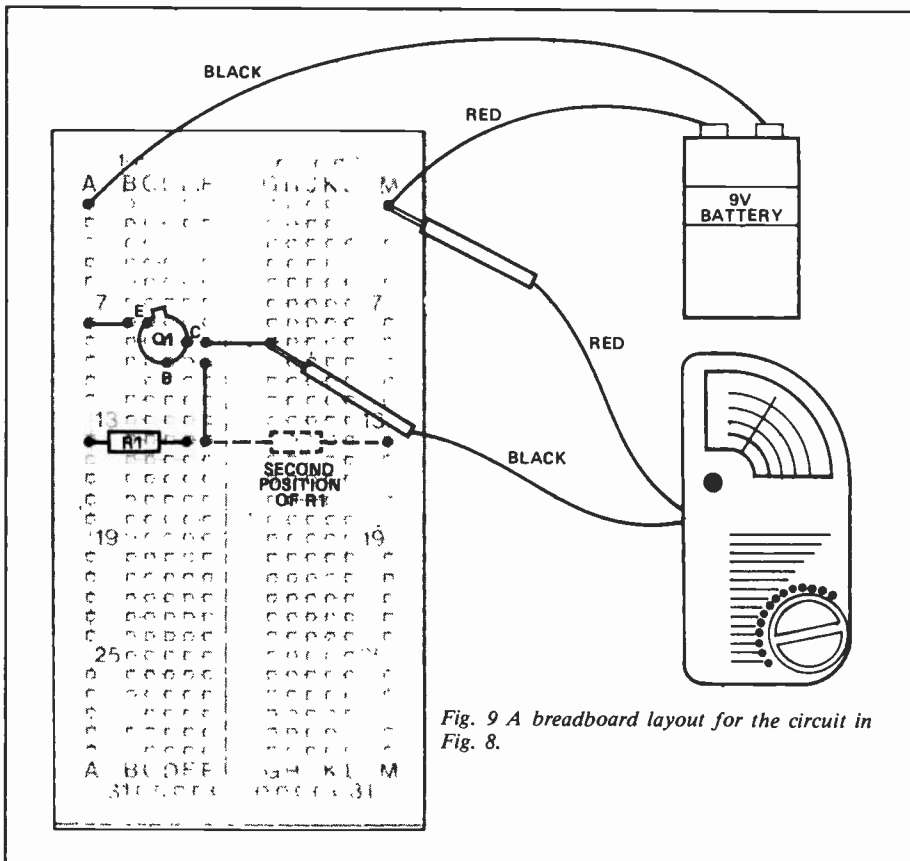

Fig. 9 A breadboard layout for the circuit in Fig. 8.



base current of a PNP transistor is still the current gain. In fact, apart from the different directions of currents, a PNP transistor functions identically to an NPN transistor. As we've started our look at transistors with the use of an NPN transistor, however, we'll finish it the same way.

to use a variable resistor to provide a variable base current for the transistor in the circuit. The breadboard layout of the circuit is in Fig. 14. Before you connect the battery, make sure the preset variable resistor is turned fully anticlockwise.

Now, connect the battery and slowly (with a small screwdriver) turn the preset

control the much larger collector current, which can be the driving the current of an LED, an ordinary lamp, a motor, a loudspeaker, in fact just about anything which is variable.

These two operational modes of transistors have been given names. The first, as it switches between two states, one where the collector current is on or high, the other where it is off or low, is called digital. Any circuit which uses transistors operating in digital mode is therefore called a digital circuit.

The other mode, where transistors control, is known as the analogue mode, because the collector current of the transistor is simply an analogue of the base current. Any circuit which uses transistors operating in the analogue mode is known as an analogue circuit. Sometimes analogue circuits are mistakenly called linear circuits. However, this is wrong, because although it might appear that a linear law is followed, this is not so. If transistors were linear they would follow Ohm's law, but (like diodes) they do not follow Ohm's law and are non-linear devices.

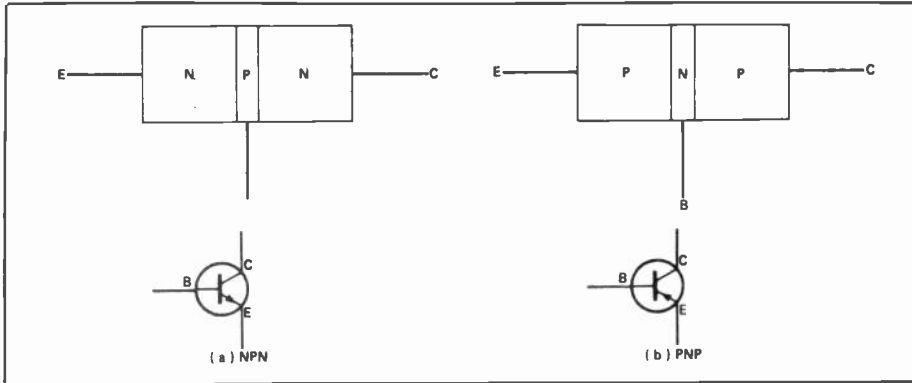

Fig. 11 The internal construction and circuit symbols for NPN and PNP transistors.

### Using Transistors

We've seen how transistors work but we don't yet know how they can be used. Only two basic uses of a transistor exist, and every transistorized circuit, every piece of electronic equipment, every television, every radio, every computer, etc, contains transistors in one form or another which do only one of two things. We've already seen the first of these two uses, an electronic switch, where a tiny base current turns on a comparatively large collector

clockwise. Gradually, as you turn the preset, the LED should light up: dim at first, then brighter, then fully bright. What you've built is a very simple lamp dimmer.

So, the other use of a transistor is as a

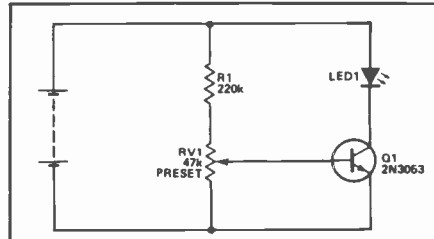

Fig. 13. The preset should be turned slowly with a small screwdriver.

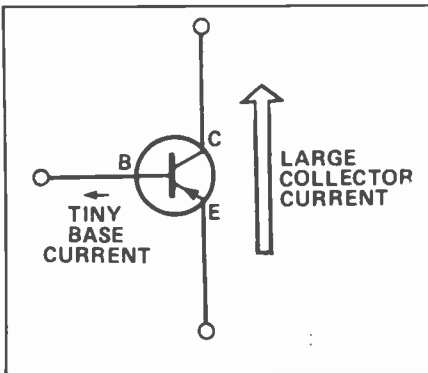

Fig. 12 An NPN has the same effect as a PNP transistor, but in the opposite direction.

current. This may appear insignificant in itself, but if you consider that the collector current of one transistor may be used as the base current of a following transistor or transistors, then you should be able to imagine an enormous number of transistors inside one appliance, all switching and hence controlling the appliance's operation.

We can see the second use of a transistor in the circuit of Fig. 13. From this you should be able to see that we're going

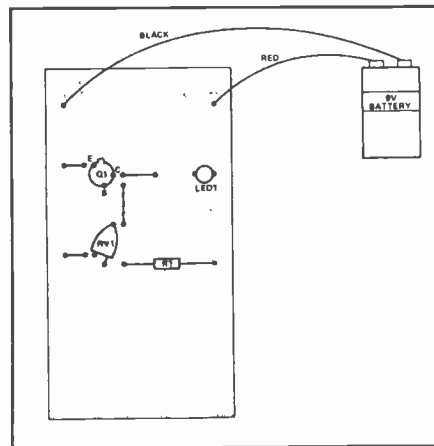

Fig. 14 A breadboard layout for the circuit in Fig. 13.

variable control element. By controlling the transistor's tiny base current we can

## 50 Top Projects

Fifty all-time best projects from ETI magazine packed into one giant 156 page special. There are projects for the beginner to the more advanced builder, including; Semiconductor Tester, Universal Counter, LED Level Meter, AM radio and much much more.

\$3.95 plus \$1.00 postage and handling. Ontario Residents add 7% PST. For a copy call or write:

**1300 Don Mills Road,  
Don Mills, Toronto, Ontario,  
M3B 3M8  
(416) 445-5600**

# Designing Transistor Stages

**Concluding the investigation of simple transistor stages with a roundup of some useful two-transistor configurations.**

**By Les Sage**

SO FAR all the circuits we've looked at have used only one transistor. A second transistor, however, can bring about a dramatic improvement in one aspect of circuit performance, if used judiciously.

Fig. 1 shows a simple and economical method of achieving higher gain, just by running two stages together in series. Since neither stage has any emitter degeneration, the total gain (the product of each individual stage gain) can be very high indeed, around 5000 in this case. With such a high gain, it is important to keep the power supply smooth. In most applications, the power rail should be decoupled with a small series resistor and a parallel capacitor. It should also be noted that the DC operating point of each transistor is dependent on its hFE figure, so that R1 and R3 may need to be changed for individual transistors. General purpose NPNs are suitable, but each transistor will demand attention to these resistor values, so no recommendation has been made.

In fact, the circuit can also suffer from high distortion and demands low level signals in and out. Its only virtue is simplicity, and that is not outstanding.

A few extra components can make all the difference, as in Fig. 2. This is a universal gain block which finds many applications in audio equipment, particularly as an input stage in high quality amplifiers and is the basis of equalization stages. It utilizes the very high gain of a two-transistor stage to provide negative feedback (via R6). The eventual gain is considerably reduced, but the circuit is much less prone to noise, distortion and the idiosyncrasies of transistors than that of Fig. 1.

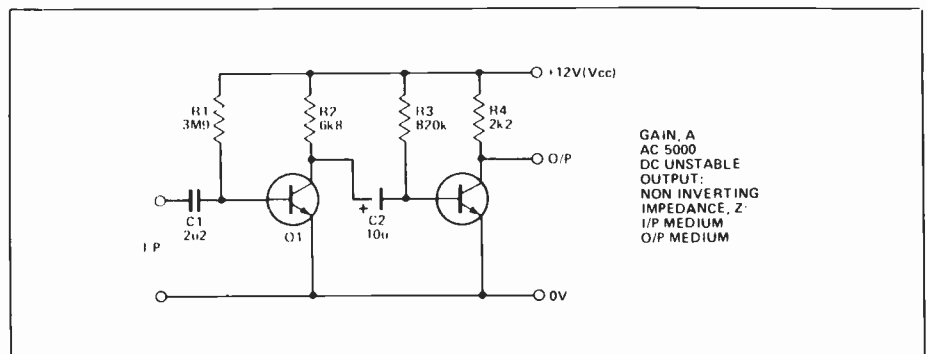

Fig. 1 Economic high gain amplifier. (Note: all circuits use general purpose silicon transistors operating at lower power AF or RF frequencies).

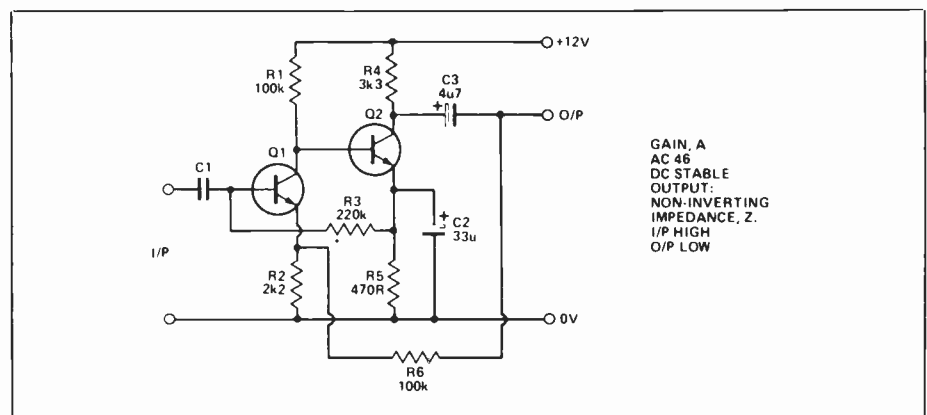
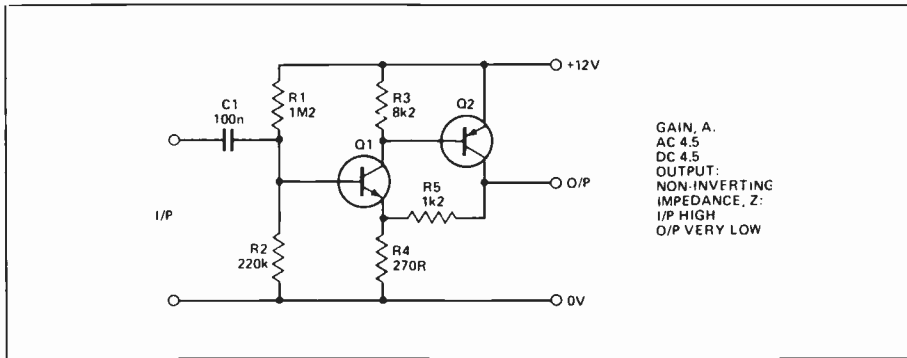

Fig. 2 Low noise, low distortion.

The operating point of Q2 is set by the emitter resistor, R5, while R4 determines the open-loop output impedance (that is, assuming no feedback). DC feedback is run separately from AC feedback via R3. This biases Q1 and gives the circuit very good DC stability. R1 has a relatively high value to give the circuit low noise

performance which is better than that of most op-amps. The feedback resistors, R6 and R2, set the overall gain at  $(R6 + R2)/R2$  (in theory, 46.45). The negative feedback through R6 also controls the input and output impedances. The lower R6 is, the more feedback there will be and the lower will be the output impedance.



GAIN, A.  
AC 4.5  
DC 4.5  
OUTPUT:  
NON-INVERTING  
IMPEDANCE, Z:  
I/P HIGH  
O/P VERY LOW

Fig. 3 Low gain, very low distortion.

Lowering the value of R6 also increases the circuit's input impedance and a high input impedance using one component is very desirable in audio circuits. It can also be exploited to design equalizing stages by replacing R6 with a suitable RC network, and such circuits are frequently found in RIAA equalizers.

**Really Negative**

Negative feedback is further exploited in the next two configurations. In the circuit shown in Fig. 3, the feedback is enormous, with the result that gain is very low and distortion is even lower. The circuit is popular in high quality pre-amps. With DC coupling as featured gain must be kept low in order to prevent DC operating point drift. The gain is actually determined by R5 and R4 and is given, approximately, by (R5 + R4)/R4. If gain is altered by changing these values, then R1 and R2 will also need to be altered to bring the output DC point to around half the supply voltage. Like the previous circuit, this one features high input impedance (thanks largely to the negative feedback in the Q1 circuit) and low output impedance. In this case, the output impedance is very low at a few tens of ohms. Once again general purpose transistors can be used, remembering that Q2 is PNP and both transistors should be low noise varieties for audio work.

The next circuit (Fig. 4) features significantly higher gain at the cost of worse performance from the noise and distortion point-of-view. The circuit is very similar to that of Fig. 3, but has separate DC and AC feedback paths. The DC gain is unity and the AC gain (determined by feedback resistors, R4 and R5) is around 20. AC gain is given by (R4 + R5)/R5 and can be adjusted over a wide range without significantly affecting the DC operating point.

Distortion tends to increase with gain, but can be kept down by the use of complementary transistors. As with the Fig. 2 circuit above, frequency response can be tailored to the user's requirements by including reactive networks in the feedback loop. If the gain is lowered too much at HF, circuit stability might suffer with spurious oscillations as the result.

Both of the last two circuits depend heavily on feedback and may tend to oscillate if they are required to drive a large capacitive load. It is a wise precaution to include a small series resistor of around 100R at the output, especially if driving a shielded cable.

**More Frequency**

Amplifying frequencies above, say, 100kHz demands different techniques, as touched upon in discussing the common base amplifier. Video frequencies go from

DC to around 10MHz, and we need to consider how to prevent deterioration of performance over such a considerable bandwidth.

The circuit shown in Fig. 5 has been designed with the main considerations for any bandwidth amplifier in mind. Firstly, it features optimum collector current for maximum current gain/bandwidth product. An increase in emitter current (and therefore collector current) produces a decrease in the dynamic resistance of the base-emitter junction of a transistor as viewed from the base. This parameter is known as hIE and is related to the dynamic resistance of the base-emitter junction as viewed from the emitter (or, rE) by the following equation:

$$h_{ie} = (h_{fe} + 1)r_e$$

The decrease in hIE with increasing emitter current follows from the approximate equation:

$$h_{ie} = (h_{fe} \cdot 25) / I_e$$

which itself follows from the relationship between rE and iE:

$$r_e = 25 / I_e$$

Unfortunately, as collector current increases the effective base-emitter capacitance also increases due to a phenomenon known as base-stretching. It is the base-emitter capacitance, Cbe, which determines the high-frequency current-gain of a transistor and the cut-off frequency (the point at which transistor current gain falls by 3dB). The cut-off frequency, in fact, is defined as the frequency at which Cbe and hIE are equal, while the transition frequency, fT, is defined as the frequency at which current gain, hIE, falls to unity. The transition frequency is roughly equal to the product of current gain and cut-off frequency.

Clearly, there will be an optimum collector current at which Cbe going up meets hIE coming down. In practice, this current is between 5mA and 50mA and is the value at which the transition frequency of the transistor is at its maximum.

Another consideration involved in the design of the Fig. 5 circuit is the inclusion of a low-level load resistor, R3. As well as helping to achieve optimum collector current in Q2, this serves to minimize the time constant of the output of the stage.

The circuit shown in Fig. 5 achieves a bandwidth of more than 40MHz although, like most video circuits, it is a heavy consumer of current. It also has a low input impedance. Transistor Q2 is configured as a common base amplifier giving a good voltage gain up to the transition frequency. It is fed by Q1 providing current gain alone and therefore not

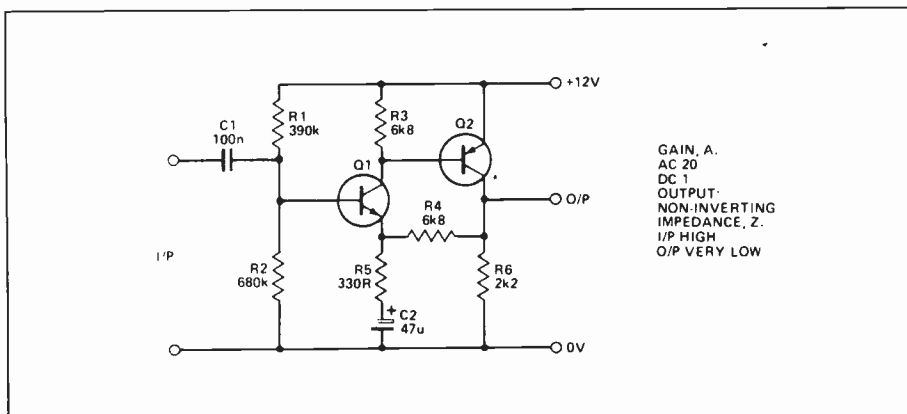

GAIN, A.  
AC 20  
DC 1  
OUTPUT:  
NON-INVERTING  
IMPEDANCE, Z:  
I/P HIGH  
O/P VERY LOW

Fig. 4 DC stable, low distortion (Note: Q2 is PNP).

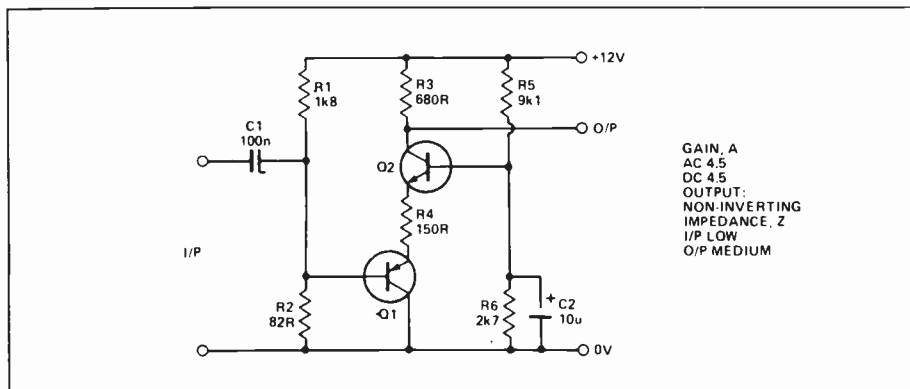

Fig. 5 Video amplifier (Note: both RF, Q1 is PNP).

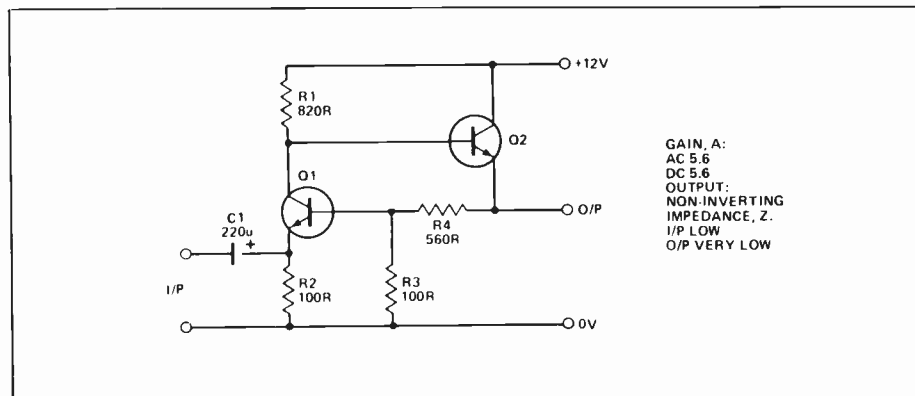

Fig. 6 Video amplifier.

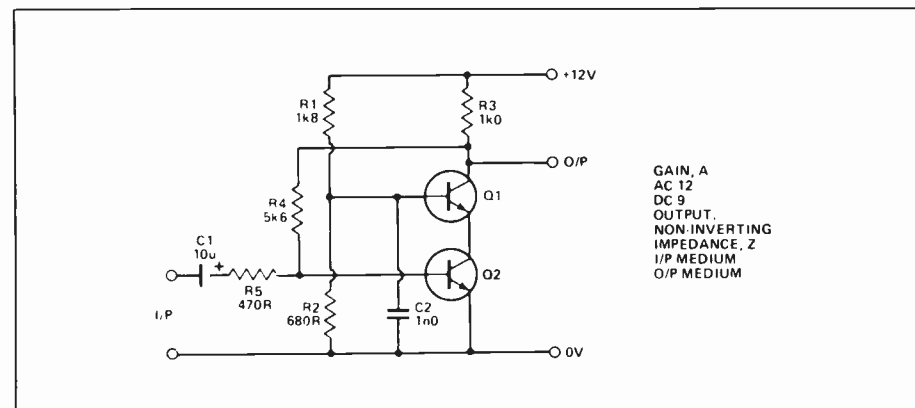

Fig. 7 Very linear cascode stage.

susceptible to bandwidth limitation. In fact, Q1 is configured as an emitter follower, giving a suitable low output impedance to match the subsequent stage. Resistor R3 provides a low load for Q2. The circuit resembles a standard cascode amplifier, but gives superior performance. It should be remembered that layout and supply decoupling are very important with any HF amplifier.

The main drawback with this cut at the cost of increasing output impedance. Fig. 6 shows a circuit using two NPN transistors configured as common base and emitter follower stages and employing

parallel feedback. Here, the feedback path is provided by R4 and R3. The circuit has a very low output impedance, although its high frequency response is weaker than that of the Fig. 5 circuit. The open loop gain of this circuit is given by  $R1/(R2//Rs)$ , where  $Rs$  is the source resistance. Closed loop gain is effectively  $(R4 + R3)/R3$ .

The next circuit (Fig. 7) is a more-or-less conventional cascode amplifier with Q1 in common base mode and Q2 connected as a common emitter. The common emitter provides current gain and feeds the common base which

provides voltage gain. The arrangement produces a high power gain. With the base of Q1 held at a constant voltage,  $V_{ce}$  for Q2 is also constant. This avoids the effects of Miller capacitance and so the normal deterioration of frequency response of a common emitter stage does not occur.

The configuration is widely accepted as a very high frequency amplifier displaying extremely good linearity. This feature is useful for quality audio, and the circuit can often be found in amplifier systems.

In this circuit, gain is controlled by parallel feedback via resistor R4, lowering the open-loop output impedance and successfully stabilizing the circuit. Improved frequency response can be obtained by omitting R4, short-circuiting R5 and placing resistor in the emitter of Q2 to provide series feedback. This will increase both the input and output impedance.

## Vive La Difference

The circuit shown in Fig. 8 is commonly called a differential (or operational) amplifier, although it was once universally referred to as a long-tailed pair in deference to the joint emitter resistor. In this configuration, the input signal is applied across the two input terminals and the output is taken from across the two output terminals. If there is no potential difference across the two inputs (both being positive for conduction to take place) and assuming the transistors and collector resistors are identical, then both halves of the circuit will conduct equally and there will be no difference across the output terminals. The input here is described as common mode. Referred to ground, each output terminal produces an inverted version of the input at a gain given by the ratio of one collector resistor to twice the tail resistor (in the example, about unity).

Now, imagine that input 1 is made slightly more positive than input 2, either by increasing the applied DC voltage or through the application of an instantaneous AC voltage. More current will flow in the collector-emitter circuit of Q1 and the voltage across R1 will increase. Referred to ground, the voltage on output 1 will fall and a potential difference will appear between outputs 1 and 2. This potential will be proportional to the potential across the inputs and will be inverted (output 1 voltage decreasing as input 1 voltage increases). The same reasoning applies if input 2 voltage is changed, with the net result that the output of the circuit will be proportional to the potential difference across the input terminals.

Assuming that the tail resistor is large enough (much greater than the dynamic emitter resistance of the transistors,  $r_E$ ), then the potential drop across the inputs can be expressed in terms of emitter current and  $2r_E$ . In this way, it becomes clear that the output can be taken from only one collector with reference to ground and

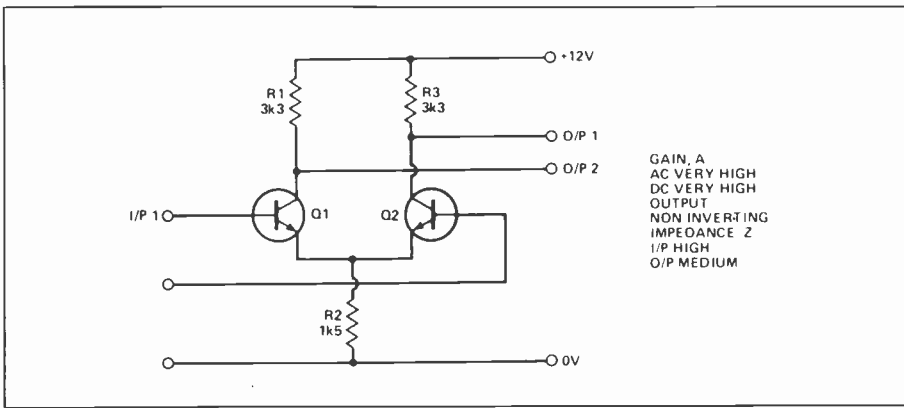

Fig. 8 Basic differential amplifier.

still be proportional to the potential difference across the two inputs.

In fact, this depends on the tail resistor acting as a constant current source, which it will do if it is large enough. Looked at in this way, the voltage drop across the resistor remains constant and the current flowing through it remains constant - which actually applies only when small voltage changes take place. As long as R3 can be considered a constant current source, any change in collector and emitter current in one transistor will be exactly matched by an opposite change in the other. Current is diverted to whichever transistor is more heavily biased into conduction and, using a single-ended output, one input becomes an inverting input and the other non-inverting. In effect, R3 is decoupled to difference signals across the input terminals while common mode signals produce a voltage across it thereby providing negative, gain-reducing, feedback.

For difference signals, the differential amplifier has a very high gain, given approximately by the formula  $10I_tR_1$ , where  $I_t$  is tail current and  $R_1$  is one of the collector resistance values. The compromise involved here is due to the fact that, in our circuit, a high tail current is incompatible with a high tail resistance value. In practice, differential amplifiers tend to be designed with genuine current sources in the tail (usually a fully stabilized transistor circuit producing a quiescent collector current).

The most important feature of differential amplifiers is their common mode rejection, which ensures that thermal noise, drift and any similar voltage disturbances common to both transistors are ignored during amplification. The measure of a differential amplifier's quality is its common mode rejection ratio (CMRR), given by the ratio of difference signal gain to common mode gain and usually expressed in dB. In the Fig. 8 circuit, the CMRR would be between about 20 and 40 dB, an unimpressive figure, given contemporary op amp CMRRs in excess of

100dB. The simplest way to improve the CMRR would be to increase the value of R3, but this would require higher supply voltages (or even a split rail supply) to maintain tail current.

### Conclusion

The few circuit blocks described in this series should show the wealth of design opportunities for those willing to work with discrete components. The important thing to remember is that a circuit can be readily designed for practically any given purpose, if first you are clear as to the requirements that will be made of it. Once the general outlines have been understood and a configuration decided on, the calculation of component values can proceed with recourse to little more than Ohm's Law. Rather than tie yourself up with complex mathematics (unless, of course, that is what you enjoy) a circuit sense, a few rules of thumb, a few sums and a clear idea of what you want. The final stage in the process, of course, is to build your design and test it. You will, undoubtedly, find that minor adjustments need to be made to your component values, but if you pay heed to the advice that a little observation and measurement is worth a ton of theory you will almost certainly produce circuits which work and work well. The theory may produce working circuits, but only the practice will make them perfect. ■

PRODUCT MART  
CLASSIFIED  
CALL (416) 445-5600

## Subscribe now to Computing Now!

Computing Now! is from the publishers of Computers in Education and Electronics Today and offers full coverage of what's happening in Canadian microcomputing. Get the most out of your micro with:



### Listings!

From the ZX81 to CP/M to MS-DOS; programs for business use or just for fun.

### Reviews!

The newest computers, the latest peripherals. Software, book reviews, and interesting gadgetry.

### Programming!

Articles and discussions on how to solve those programming bottlenecks.

### Systems!

If you're looking for a business system, you'll find information that lets you find the most efficient, most economical equipment for your needs.

### Subscribe now:

\$22.95 for one year (12 issues) or  
\$37.95 for two years (24 issues).

**Computing Now!**

1300 Don Mills Road,  
Don Mills,  
Toronto, Ontario  
M3B 3M8  
Telephone (416) 445-5600

# BABANI BOOKS

Imported from England and exclusively available in Canada from Moorshead Publications.

**BP53: PRACTICAL ELECTRONICS CALCULATIONS AND FORMULAE** \$11.75  
A book that bridges the gap between complicated technical theory and the 'cut and try' method. A good reference book.

**BP136: 25 SIMPLE INDOOR AND WINDOW AERIALS** \$6.65  
People living in apartments who would like to improve short-wave listening can benefit from these instructions on optimising the indoor aerial.

**BP147: AN INTRODUCTION TO 6502 MACHINE CODE** \$7.75  
The popular 6502 microprocessor is used in many home computers; this is a guide to beginning assembly language.

**BP150: AN INTRO. TO PROGRAMMING THE SINCLAIR QL** \$7.75  
Helps the reader make the best use of the Sinclair QL's almost unlimited range of features. Complements the manufacturer's handbook.

**BP225: A PRACTICAL INTRODUCTION TO DIGITAL ICs** \$6.65  
This book deals mainly with TTL type chips such as the 7400 series. Simple projects and a complete practical construction of a Logic Test Circuit Set are included as well as details for a more complicated Digital Counter Timer project.

**BP130: MICRO INTERFACING CIRCUITS - BOOK 1** \$8.55  
Aimed at those who have some previous knowledge of electronics, but not necessarily an extensive one, the basis of the book is to help the individual understand the principles of interfacing circuits to microprocessor equipment.

**BP131: MICRO INTERFACING CIRCUITS - BOOK 2** \$8.55  
Intended to carry on from Book 1, this book deals with practical applications beyond the parallel and serial interface "Real world" interfacing such as sound and speech generators, temperature and optical sensors, and motor controls are discussed using practical circuit descriptions.

**BP111: AUDIO** \$13.25  
This one is ideal for readers who want to really get into sound. A wide range of material is covered from analysis of the sound wave, mechanisms of hearing, room acoustics, microphones and loudspeakers, amplifiers, and magnetic disc recording.

**BP141: LINEAR IC EQUIVALENTS AND PIN CONNECTIONS** \$21.95  
Find equivalents and cross-references for both popular and unusual integrated circuits. Shows details of functions, manufacturer, country of origin, pinouts, etc.; includes National, Motorola, Fairchild, Harris, Motorola, Intersil, Philips, ADC, AMD, SGS, Teledyne, and many other European, American, and Japanese brands.

**BP156: AN INTRODUCTION TO QL MACHINE CODE** \$7.75  
The powerful Sinclair QL microcomputer has some outstanding capabilities in terms of its internal structure. With a 32-bit architecture, the QL has a large address range, advanced instructions which include multiplication and division. These features give the budding machine code programmer a good start at advanced programming methods. This book assumes no previous knowledge of either the 68008 or machine code programming.

**BP47: MOBILE DISCOTHEQUE HANDBOOK** \$5.25  
Divided into six parts, this book covers such areas of mobile "disco" as: Basic Electricity, Audio, Ancillary Equipment, Cables and Plugs, Loudspeakers, and Lighting. All the information has been considerably sub-divided for quick and easy reference.

**BP59: SECOND BOOK OF CMOS IC PROJECTS** \$7.75  
This book carries on from its predecessor and provides a further selection of useful circuits, mainly of a simple nature, the book will be well within the capabilities of the beginner and more advanced constructor.

**BP32: HOW TO BUILD YOUR OWN METAL & TREASURE LOCATORS** \$7.75  
Several fascinating applications with complete electronic and practical details on the simple, and inexpensive construction of Heterodyne Metal Locators.

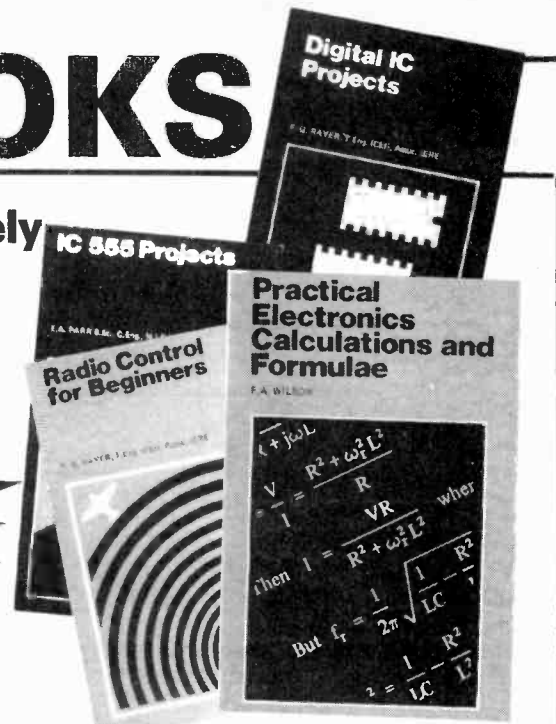

## ELECTRONIC THEORY

### ELEMENTS OF ELECTRONICS - AN ON-GOING SERIES

F.A. WILSON, C.G.I.A., C.Eng.

**BP62: BOOK 1. The Simple Electronic Circuit and Components** \$11.70

**BP63: BOOK 2. Alternating Current Theory** \$ 8.55

**BP64: BOOK 3. Semiconductor Technology** \$18.55

**BP77: BOOK 4. Microprocessing Systems and Circuits** \$11.70

**BP89: BOOK 5. Communication** \$11.70

The aim of this series of books can be stated quite simply — it is to provide an inexpensive introduction to modern electronics so that the reader will start on the right road by thoroughly understanding the fundamental principles involved.

Although written especially for readers with no more than ordinary arithmetical skills, the use of mathematics is not avoided, and all the mathematics required is taught as the reader progresses.

Each book is a complete treatise of a particular branch of the subject and, therefore, can be used on its own with one proviso, that the later books do not duplicate material from their predecessors, thus a working knowledge of the subjects covered by the earlier books is assumed.

**BOOK 1.** This book contains all the fundamental theory necessary to lead to a full understanding of the simple electronic circuit and its main components.

**BOOK 2.** This book continues with alternating current theory without which there can be no comprehension of speech, music, radio, television or even the electricity utilities.

**BOOK 3.** Follows on semiconductor technology, leading up to transistors and integrated circuits.

**BOOK 4.** A complete description of the internal workings of microprocessor.

**BOOK 5.** A book covering the whole communication scene.

## PROJECTS

**BP48: ELECTRONIC PROJECTS FOR BEGINNERS** \$ 7.75  
F.G. RAYER, T.Eng.(CEI), Assoc.IERE

Another book written by the very experienced author — Mr F.G. Rayer — and in it the newcomer to electronics, will find a wide range of easily made projects. Also, there are a considerable number of actual component and wiring layouts, to aid the beginner.

Furthermore, a number of projects have been arranged so that they can be constructed without any need for soldering and, thus, avoid the need for a soldering iron.

Also, many of the later projects can be built along the lines as those in the 'No Soldering' section so this may considerably increase the scope of projects which the newcomer can build and use.

**BP37: 50 PROJECTS USING RELAYS, SCR'S & TRIACS** \$ 7.75  
F.G. RAYER, T.Eng.(CEI), Assoc.IERE

Relays, silicon controlled rectifiers (SCR's) and bi-directional triodes (TRIACS) have a wide range of applications in electronics today. This book gives tried and practical working circuits which should present the minimum of difficulty for the enthusiast to construct. In most of the circuits there is a wide latitude in component values and types, allowing easy modification of circuits or ready adaptation of them to individual needs.

**BP221: 28 TESTED TRANSISTOR PROJECTS** \$5.00  
R. TORREN'S

Mr Richard Torrens is a well experienced electronics development engineer and has designed, developed, built and tested the many useful and interesting circuits included in this book. The projects themselves can be split down into simpler building blocks, which are shown separated by boxes in the circuits for ease of description, and also to enable any reader who wishes to combine boxes from different projects to realise ideas of his own.

**BP71: ELECTRONIC HOUSEHOLD PROJECTS** \$ 7.20  
R. A. PENFOLD

Some of the most useful and popular electronic construction projects are those that can be used in or around the home. The circuits range from such things as '2 Tone Door Buzzer', Intercom, through Smoke or Gas Detectors to Baby and Freezer Alarms.

**BP73: REMOTE CONTROL PROJECTS** \$ 8.10  
OWEN BISHOP

This book is aimed primarily at the electronics enthusiast who wishes to experiment with remote control. Full explanations have been given so that the reader can fully understand how the circuits work and can more easily see how to modify them for other purposes, depending on personal requirements. Not only are radio control systems considered but also infra-red, visible light and ultrasonic systems as are the use of Logic ICs and Pulse position modulation etc.

**BP90: AUDIO PROJECTS** \$ 7.60  
F.G. RAYER

Covers in detail the construction of a wide range of audio projects. The text has been divided into pre-amplifiers and mixers, power amplifiers, tone controls and matching and miscellaneous projects.

**BP74: ELECTRONIC MUSIC PROJECTS** \$ 7.20  
R. A. PENFOLD

Although one of the more recent branches of amateur electronics, electronic music has now become extremely popular and there are many projects which fall into this category. The purpose of this book is to provide the constructor with a number of practical circuits for the less complex items of electronic music equipment, including such things as a Fuzz Box, Waa-Waa Pedal, Sustain Unit, Reverberation and Phaser-Units, Tremelo Generator etc.

**BP44: IC 555 PROJECTS** \$ 7.75  
E.A. PARR, B.Sc., C.Eng., M.I.E.E.

Every so often a device appears that is so useful that one wonders how life went on before without it. The 555 timer is such a device. Included in this book are Basic and General Circuits, Motor Car and Model Railway Circuits, Alarms and Noise Makers as well as a section on the 556, 558 and 559 timers.

**BP82: ELECTRONIC PROJECTS USING SOLAR CELLS** \$ 7.75

A collection of simple circuits which have applications in and around the home using the energy of the sun to power them. The book deals with practical solar power supplies including voltage doubler and tripler circuits, as well as a number of projects.

# BABANI BOOKS

## BP49: POPULAR ELECTRONIC PROJECTS \$7.75

R.A. PENFOLD

Includes a collection of the most popular types of circuits and projects which, we feel sure, will provide a number of designs to interest most electronics constructors. The projects selected cover a very wide range and are divided into four basic types: Radio Projects, Audio Projects, Household Projects and Test Equipment

## BP94: ELECTRONIC PROJECTS FOR CARS AND BOATS \$7.60

R.A. PENFOLD

Projects, fifteen in all, which use a 12V supply are the basis of this book. Included are projects on Windscreen Wiper Control, Courtesy Light Delay, Battery Monitor, Cassette Power Supply, Lights Timer, Vehicle Immobiliser, Gas and Smoke Alarm, Depth Warning and Shaver Inverter

## BP95: MODEL RAILWAY PROJECTS \$7.60

Electronic projects for model railways are fairly recent and have made possible an amazing degree of realism. The projects covered include controllers, signals and sound effects: striboard layouts are provided for each project.

## BP93: ELECTRONIC TIMER PROJECTS \$7.60

F.G. RAYER

Windscreen wiper delay, darkroom timer and metronome projects are included. Some of the more complex circuits are made up from simpler sub-circuits which are dealt with individually.

## BP113: 30 Solderless Breadboard Projects-Book 2 \$8.85

R.A. Penfold

A companion to BP107. Describes a variety of projects that can be built on plug-in breadboards using CMOS logic IC's. Each project contains a schematic, parts list and operational notes.

## BP104: Electronic Science Projects \$8.85

Owen Bishop

Contains 12 electronic projects with a strong scientific flavour. Includes Simple Colour Temperature Meter, Infra-Red Laser, Electronic clock regulated by a resonating spring, a Scope with a solid state display, pH meter and electrocardiograph.

## BP110: HOW TO GET YOUR ELECTRONIC PROJECTS WORKING \$7.60

R.A. PENFOLD

We have all built circuits from magazines and books only to find that they did not work correctly, or at all, when first switched on. The aim of this book is to help the reader overcome just these problems by indicating how and where to start looking for many of the common faults that can occur when building up projects.

## BP84: DIGITAL IC PROJECTS \$7.60

F.G. RAYER, T.Eng.(CEI), Assoc.IERE

This book contains both simple and more advanced projects and it is hoped that these will be found of help to the reader developing a knowledge of the workings of digital circuits. To help the newcomer to the hobby the author has included a number of board layouts and wiring diagrams. Also the more ambitious projects can be built and tested section by section and this should help avoid or correct faults that could otherwise be troublesome. An ideal book for both beginner and more advanced enthusiasts alike.

## BP67: COUNTER DRIVER AND NUMERAL DISPLAY PROJECTS \$7.05

F.G. RAYER, T.Eng.(CEI), Assoc. IERE

Numeral indicating devices have come very much to the forefront in recent years and will, undoubtedly, find increasing applications in all sorts of equipment. With present day integrated circuits, it is easy to count, divide and display numerically the electrical pulses obtained from a great range of driver circuits.

In this book many applications and projects using various types of numeral displays, popular counter and driver IC's etc. are considered.

## BP99: MINI-MATRIX BOARD PROJECTS \$7.60

R.A. PENFOLD

Twenty useful projects which can all be built on a 24 x 10 hole matrix board with copper strips. Includes Doorbuzzer, Low-voltage Alarm, AM Radio, Signal Generator, Projector Timer, Guitar Headphone Amp, Transistor Checker and more.

## BP103: MULTI-CIRCUIT BOARD PROJECTS \$7.60

R.A. PENFOLD

This book allows the reader to build 21 fairly simple electronic projects, all of which may be constructed on the same printed circuit board. Wherever possible, the same components have been used in each design so that with a relatively small number of components and hence low cost, it is possible to make any one of the projects or by re-using the components and P.C.B. all of the projects

## BP107: 30 SOLDERLESS BREADBOARD PROJECTS - BOOK 1 \$8.85

R.A. PENFOLD

A "Solderless Breadboard" is simply a special board on which electronic circuits can be built and tested. The components used are just plugged in and unplugged as desired. The 30 projects featured in this book have been specially designed to be built on a "Verobloc" breadboard. Wherever possible the components used are common to several projects, hence with only a modest number of reasonably inexpensive components it is possible to build, in turn, every project shown.

## BP106: MODERN OP-AMP PROJECTS \$7.60

R.A. PENFOLD

Features a wide range of constructional projects which make use of op-amps including low-noise, low distortion, ultra-high input impedance, high slew-rate and high output current types.

## CIRCUITS

### How to Design Electronic Projects

#### BP127 \$8.95

Although information on standard circuit blocks is available, there is less information on combing these circuit parts together. This title does just that. Practical examples are used and each is analysed to show what each does and how to apply this to other designs.

### Audio Amplifier Construction

#### BP122 \$8.95

A wide circuits is given, from low noise microphone and tape head preamps to a 100W MOSFET type. There is also the circuit for 12V bridge amp giving 18W. Circuit board or strip-board layout are included. Most of the circuits are well within the capabilities for even those with limited experience.

## BP80: POPULAR ELECTRONIC CIRCUITS - BOOK 1 \$7.75

R.A. PENFOLD

Another book by the very popular author, Mr. R.A. Penfold, who has designed and developed a large number of various circuits. These are grouped under the following general headings: Audio Circuits, Radio Circuits, Test Gear Circuits, Music Project Circuits, Household Project Circuits and Miscellaneous Circuits.

## BP98: POPULAR ELECTRONIC CIRCUITS, BOOK 2 \$8.85

R.A. PENFOLD

70 plus circuits based on modern components aimed at those with some experience

## BP39: 50 (FET) FIELD EFFECT TRANSISTOR PROJECTS \$6.75

F.G. RAYER, T.Eng.(CEI), Assoc.IERE

Field effect transistors (FETs), find application in a wide variety of circuits. The projects described here include radio frequency amplifiers and converters, test equipment and receiver aids, tuners, receivers, mixers and tone controls, as well as various miscellaneous devices which are useful in the home.

This book contains something of particular interest for every class of enthusiast - short wave listener, radio amateur, experimenter or audio devotee.

## BP87: SIMPLE L.E.D. CIRCUITS \$5.40

R.N. SOAR

Since it first appeared in 1977, Mr. R.N. Soar's book has proved very popular. The author has developed a further range of circuits and these are included in Book 2. Projects include a Transistor Tester, Various Voltage Regulators, Testers and so on.

## BP24: 50 PROJECTS USING IC 741 \$6.75

A unique book containing 50 projects that can be simply constructed using a 741 op amp and a few components. Originally published in Germany, this book will be an valuable asset to any hobbyist.

## BP88: HOW TO USE OP AMPS \$8.85

E.A. PARR

A designer's guide covering several op amps, serving as a source book of circuits and a reference book for design calculations. The approach has been made as non-mathematical as possible.

## BP65: SINGLE IC PROJECTS \$6.05

R.A. PENFOLD

There is now a vast range of ICs available to the amateur market, the majority of which are not necessarily designed for use in a single application and can offer unlimited possibilities. All the projects contained in this book are simple to construct and are based on a single IC. A few projects employ one or two transistors in addition to an IC but in most cases the IC is the only active device used.

## 223: 50 PROJECTS USING IC CA3130 \$5.00

R.A. PENFOLD

In this book, the author has designed and developed a number of interesting and useful projects which are divided into five general categories: I - Audio Projects II - R.F. Projects III - Test Equipment IV - Household Projects V - Miscellaneous Projects.

## BP117: PRACTICAL ELECTRONIC BUILDING BLOCKS BOOK 1 \$7.60

Virtually any electronic circuit will be found to consist of a number of distinct stages when analysed. Some circuits inevitably have unusual stages using specialised circuitry, but in most cases circuits are built up from building blocks of standard types.

This book is designed to aid electronics enthusiasts who like to experiment with circuits and produce their own projects rather than simply follow published project designs.

The circuits for a number of useful building blocks are included in this book. Where relevant, details of how to change the parameters of each circuit are given so that they can easily be modified to suit individual requirements.

## BP102: THE 6809 COMPANION \$7.60

Written for machine language programmers who want to expand their knowledge of microprocessors. Outlines history, architecture, addressing modes, and the instruction set of the 6809 microprocessor. The book also covers such topics as converting programs from the 6800, program style, and specifics of 6809 hardware and software availability.

## BP118: PRACTICAL ELECTRONIC BUILDING BLOCKS - Book 2 \$7.60

R.A. PENFOLD

This sequel to BP117 is written to help the reader create and experiment with his own circuits by combining standard type circuit building blocks. Circuits concerned with generating signals were covered in Book 1, this one deals with processing signals. Amplifiers and filters account for most of the book but comparators, Schmitt triggers and other circuits are covered.

## BP24 50 PROJECTS USING IC741 \$6.75

RUD & UWE REDMER

This book, originally published in Germany by TOPP, has achieved phenomenal sales on the Continent and Babani decided, in view of the fact that the integrated circuit used in this book is inexpensive to buy, to make this unique book available to the English speaking reader. Translated from the original German with copious notes, data and circuitry, a "must" for everyone whatever their interest in electronics

## BP83: VMOS PROJECTS \$7.70

R.A. PENFOLD

Although modern bipolar power transistors give excellent results in a wide range of applications, they are not without their drawbacks or limitations. This book will primarily be concerned with VMOS power FETs although power MOSFETs will be dealt with in the chapter on audio circuits. A number of varied and interesting projects are covered under the main headings of: Audio Circuits, Sound Generator Circuits, DC Control Circuits and Signal Control Circuits.

## RADIO AND COMMUNICATIONS

## BP96: CB PROJECTS \$7.60

R.A. PENFOLD

Projects include speech processor, aerial booster, cordless mike, aerial and harmonic filters, field strength meter, power supply, CB receiver and more.

## BP22: SOLID STATE SHORT WAVE RECEIVER FOR BEGINNERS \$47.60

R.A. PENFOLD

In this book, R.A. Penfold has designed and developed several modern solid state short wave receiver circuits that will give a fairly high level of performance, despite the fact that they use only relatively few and inexpensive components

## BP91: AN INTRODUCTION TO RADIO DXing \$7.60

This book is divided into two main sections one to amateur band reception, the other to broadcast bands. Advice is given to suitable equipment and techniques. A number of related constructional projects are described.

## BP105: AERIAL PROJECTS \$7.60

R.A. PENFOLD

The subject of aeriels is vast but in this book the author has considered practical designs including active, loop and ferrite aeriels, which give good performances and are reasonably simple and inexpensive to build. The complex theory and math of aerial design are avoided.

# OTHER PUBLISHERS

**PH121: HARDWARE INTERFACING WITH THE TRS-80**  
**J. UFFENBECK (1983) \$19.45**  
 TRS-80 Model I and Model III users now have a book to help them understand their personal computers to monitor and control the interfaces between the computer and the industrial environment. Contains 14 hands-on experiments using BASIC.

**SB22026 POLISHING YOUR APPLE®**  
**\$7.45**  
 Clearly written, highly practical, concise assembly of all procedures needed for writing, disk-filing, and printing programs with an Apple II. Positively ends your searches through endless manuals to find the routine you need! Should be in the hands of every new Apple user, regardless of experience level. Ideal for Apple classrooms too!

**A BEGINNER'S GUIDE TO COMPUTERS AND MICROPROCESSORS — WITH PROJECTS.**  
**TAB No. 1015: \$14.45**  
 Here's plain English introduction to the world of microcomputers — its capabilities, parts and functions — and how you can use one. Numerous projects demonstrate operating principles and lead to the construction of an actual working computer capable of performing many useful functions.

**TAB1370: A MASTER HANDBOOK OF IC CIRCUITS**  
**\$21.95**  
 A circuit for every occasion. You'll find all the circuits you're looking for in this 512-page book. The 932 circuits are broken down by function and in six categories. It's a cornucopia of ideas, projects, and designs that you can build now.

**TAB1544: ELECTRONIC PROJECTS FOR PHOTOGRAPHERS**  
**\$21.95**  
 This book gives you needed tips on the principles of electronics and building techniques. How to set up a work area, and mix and match kinds of practical accessories for your studio, or darkroom with this helpful guide.

**SB22361: INTRODUCING THE APPLE MACINTOSH**  
**\$20.95**  
 A wealth of information on hardware, software etc for the Mac. Included are such topics as making your desktop more efficient, improving your productivity with the Mac, getting the most from your mouse, how the 68000 microprocessor works and much, much more.

**PH131: ZAP! POW! BOOM! ARCADE GAMES FOR THE VIC 20**  
**T. HARTNELL & M. RAMSHAW (1983) \$17.45**  
 Move through the maze eating dots with MAZEMAN. Sail through space zapping the ASTEROIDS. Outshoot the fastest draw in town GUNFIGHT. Owners of the VIC 20 can now play these games — and more — simply by following the programs outlined in this handy guide.

**THE BASIC COOKBOOK.**  
**TAB No. 1055: \$10.45**  
 BASIC is a surprisingly powerful language... if you understand it completely. This book, picks up where most manufacturers' documentation gives up. With it, any computer owner can develop programs to make the most out of his or her machine.

**HANDBOOK OF MICROPROCESSOR APPLICATIONS**  
**TAB No. 1203 \$16.45**  
 Highly recommended reading for anyone who are interested in microprocessors as a means of accomplishing a specific task. The author discusses individual microprocessors, the 1802 and how they can be put to use in real world applications.

**MICROPROCESSOR INTERFACING HANDBOOK: A/D & D/A**  
**TAB No. 1271 \$16.45**  
 A useful handbook for computer users interested in using their machine in linear applications. Discussed include voltage reference, data conversion, analogue switching and much more.

**HOW TO BUILD YOUR OWN WORKING MICROCOMPUTER**  
**TAB No. 1200 \$16.45**  
 An excellent reference or building your own microcomputer hardware and software are developed as well as many practical circuits.

**PH180: 1984 CANADIAN BUSINESS GUIDE TO MICROCOMPUTERS**  
**K. DORRICO \$11.95**

Written by the managing director of Deloitte, Haskins & Sells, a Canadian partnership of public accountants and other professional advisors to management, this book is one of the most complete comprehensive guides to microcomputers available. Starting with a general overview of microcomputers and their business applications, the author helps you assess your computer needs, compares and evaluates computer systems and application packages, and gives you tips on "doing it right". A must for anyone thinking of purchasing a microcomputer for business.

**COMPUTER PROGRAMS IN BASIC**  
**AB01 \$15.45**  
 A catalogue of over 1,600 fully indexed BASIC computer programs with applications in Business, Math, Games and more. This book lists available software, what it does, where to get it, and how to adapt it to your machine.

**PH217: BASIC COMPUTER PROGRAMMING FOR KIDS**  
**P. CASSIDY & J. CLOSE \$16.45**  
 Fully illustrated with photos and drawings, this book teaches the reader how to use computers and computing and gently introduces mathematics and the basic theory of work. Written in an easy, conversational tone.

**PH51: PASCAL FOR THE APPLE**  
**IAIN MacCALLUM \$34.20**  
 A step-by-step introduction to Pascal for Apple II and Apple II Plus users. The package of text and software diskette provides readers with worthwhile and interesting programs which can be run immediately and the results studied. Includes over 200 exercises with full solutions. Book/Disk Package.

**PH52: APPLE GRAPHICS GAMES**  
**PAUL COLLETTA \$40.95**  
 Contains 10 arcade-style games written especially for Apple II, including Spider, Piano, Pairs and Poker, as well as education, math, and designing games. Book/Disk Package.

**PH57: START WITH BASIC FOR THE COMMODORE VIC 20**  
**D. MONRO \$33.45**  
 This book/cassette package shows the reader, how easy it really is to create programs using the full capacity of the machine. Includes helpful exercises and step-by-step instructions to put the full power of the VIC 20 at the user's fingertips. Book/Cassette Package.

**SB21822: ENHANCING YOUR APPLE® II — VOLUME 1**  
**D. LANCASTER \$25.50**  
 Who but Mother Nature or Don Lancaster could successfully enhance an Apple? YOU can, with help from Volume 1 in Don's newest series for Sams. Among other things, you'll learn (1) to mix text, LORES, and HRES together anywhere on the screen in any combination, (2) how to make a new-wire modification that will open up whole new worlds of 3-D graphics and other special effects, plus (3) a fast and easy way to tear apart and understand somebody else's machine-language program. Other goodies abound!

**PH106: PROGRAMMING TIPS AND TECHNIQUES FOR THE APPLE II**  
**J. CAMPBELL (1983) \$23.45**  
 An advanced exploration of the intricacies of structures programming. Further develops the skills necessary to solve programming problems. Special chapter on sound and graphics which discusses both high and low resolution graphics for the Apple II.

**HB131: THE BEGINNER'S GUIDE TO BUYING A PERSONAL COMPUTER**  
**\$6.45**  
 Written for the potentially interested computer buyer, in non-technical language, this affordable book explains the terminology of personal computers, the problems and variables to be discussed and discovered while making that initial buying decision. The book does not make recommendations, but does present a great deal of information about the range of hardware available from the largest personal computing manufacturers. Readers discover the meaning and impact of screen displays, tape cassette storage and disk storage, graphics and resolution, and much more. Comparison charts clearly define standard and optional features of all the current mass market personal computers.

**DESIGNING MICROCOMPUTER SYSTEMS**  
**HB18: \$18.95**  
**POOCH AND CHATTERGY**

This book provides both hobbyists and electronic engineers with the background information necessary to build microcomputer systems. It discusses the hardware aspects of microcomputer systems. Timing devices are provided to explain sequences of operations in detail. Then, the book goes on to describe three of the most popular microcomputer families, the Intel 8080 Zilog Z-80, and Motorola 6800. Also covered are designs of interfaces for peripheral devices, and information of building microcomputer systems from kits.

**S100 BUS HANDBOOK**  
**HB19: \$26.00**  
**BURSKY**

Here is a comprehensive book that exclusively discusses S-100 bus computer systems and how they are organized. The book covers computer fundamentals, basic electronics, and the parts of the computer. Individual chapters discuss the CPU, memory, input/output, bulk-memory devices, and specialized peripheral controllers. It explains all the operating details of commonly available S-100 systems. Schematic drawings.

**110 THYRISTOR PROJECTS USING SCRs AND TRIACS**  
**MARSTON \$13.45**  
**HB22**

A grab bag of challenging and useful semiconductor projects for the hobbyist, experimenter, and student. The project range from simple burglar, fire, and water level alarms to sophisticated power control devices for electric tools and trains. Integrated circuits are incorporated wherever their use reduces project costs.

**PH104: ACCOUNTANT'S BASIC PROGRAMMING FOR THE APPLE II**  
**A PARKER & J. STEWART (1983) \$20.45**

Shows the reader how to program the Apple II to perform a variety of accounting functions, such as payroll, accounts payable, accounts receivable, tax, inventory, customer statements, and more.

**HOW TO PROFIT FROM YOUR PERSONAL COMPUTER: PROFESSIONAL, BUSINESS, AND HOME APPLICATIONS**  
**LEWIS \$18.95**

**HB01**  
 Describes the uses of personal computers in common business applications, such as accounting managing, inventory, sorting mailing lists, and many others. The discussion includes terms, notations, and techniques commonly used by programmer's. A full glossary of terms.

**AN INTRODUCTION TO MICROPROCESSORS EXPERIMENTS IN DIGITAL TECHNOLOGY**  
**HB07 \$18.95**  
**SMITH**

A "learn by doing" guide to the use of integrated circuits provides a foundation for the underlying hardware actions of programming statements. Emphasis is placed on how digital circuitry compares with analog circuitry. Begins with the simplest gates and timers, then introduces the fundamental parts of ICs, detailing the benefits and pitfalls of major IC families, and continues with coverage of the ultimate in integrated complexity — the microprocessor.

**MICROCOMPUTERS AND THE 3 R'S**  
**DOERR \$16.45**  
**HB09**

This book educates educators, on the various ways computers, especially microcomputers, can be used in the classroom. It describes microcomputers, how to organize a computer-based program, the five instructional application types (with examples from subjects such as the hard sciences, life sciences, English, history, and government), and resources listings of today's products. The book includes preprogrammed examples to start up a microcomputer program, while chapters on resources and products direct the reader to useful additional information. All programs are written in the BASIC language.

**HB107: GRAPHICS COOKBOOK FOR THE APPLE WADSWORTH**  
**HB107 \$15.95**

Learn how to use your Apple II to "paint" shapes, objects, and letters in low-resolution graphics. The author provides a library of microcomputer graphics including such multicolored illustrations as robots and flying saucers, trees, sailboats, and colourful picture backgrounds. Contains complete annotated Applesoft BASIC programs to draw all the pictures described in the book as well as suggestions for improving programming techniques.

**HB116: THE BASIC CONVERSIONS HANDBOOK FOR APPLE™, TRS-80™, and PET™ USERS**  
**BRAIN BANK \$14.50**

A complete guide to converting Apple II and PET programs to TRS-80, TRS-80 and PET programs to Apple II, and TRS-80 and Apple II programs to PET. Equivalent commands are listed for TRS-80 BASIC (Model I, Level II), Applesoft BASIC and PET BASIC, as well as variations for TRS-80 Model III and Apple Integer BASIC. Also describes variations in graphics capabilities.

**SARGON: A COMPUTER CHESS PROGRAM**  
**SPRACKLEN \$27.50**  
**HB12**

"I must rate this chess program an excellent buy for anyone who loves the game." Kilobaud

Here is the computer chess program that won first place in the first chess tournament at the 1978 West Coast Computer Faire. It is written in Z-80 assembly language, using the TDL macro assembler. It comes complete with block diagram and sample printouts.

**BASIC COMPUTER PROGRAMS FOR BUSINESS: STERNBERG (Vol. 1)**  
**HB13 \$21.50**

A must for small businesses utilizing micros as well as for entrepreneurs, volume provides a wealth of practical business applications. Each program is documented with a description of its functions and operation, a listing in BASIC, a symbol table, sample data, and one or more samples.

**AUDIO AND VIDEO INTERFERENCE CURES**  
**KAHANE \$8.95**  
**HB21**

A practical work about interference causes and cures that affect TV, radio, hi-fi, CB, and other devices. Provides all the information needed to eliminate interference. Schematic wiring diagrams of filter types of receivers and transmitters are included. Also supplies simple filter diagrams to eliminate TV interference caused by noisy home appliances, neon lights, motors, etc.

**PH107: APPLE LOGO PRIMER**  
**G. BITTER & N. WATSON (1983) \$19.95**

A pictorial starter book that will make LOGO easy for anyone. Includes easy to follow examples and reference tables. Also included is a workshop outline for teachers and leaders who want to train others.

**SB22047: 26 BASIC PROGRAMS FOR YOUR MICRO**  
**\$17.45**

Features 26 previously unpublished, simple-to-complex games you can run on almost any brand of microcomputer as long as you have enough RAM on board. Most take between 500 and 5000 bytes, with the highest taking 13K. Conversion charts that let you key them into your Radio Shack, TRS-80, Apple II, Times/Sinclair 1000 (ZX81), Spectrum, Atari, or PET are included. Also features notes on program techniques and structures.



# Learn robotics and industrial control as you build this robot

New NRI home training prepares you for a rewarding career in Canada's newest high-technology field.

The wave of the future is here. Already, advanced robotic systems are producing everything from precision electronic circuits to automobiles and giant locomotives. By 1990, over 100,000 "smart" robots will be in use.

## Over 30,000 New Jobs in North America

Keeping this robot army running calls for well-trained technicians... people who understand advanced systems and controls. By the end of the decade, conservative estimates call for more than 30,000 new technical jobs. These are the kind of careers that pay \$25,000 to \$35,000 a year right now. And as demand continues to grow, salaries have no place to go but up!

## Build Your Own Robot As You Train at Home

Now, you can train for an exciting, rewarding career in robotics and industrial control right at home in your spare time. NRI, with 70 years of experience in technology training, offers a new world of opportunity in one of the most fascinating growth fields since the computer.

You need no experience, no special education. NRI starts you at the beginning, takes you in easy-to-follow, bite-size lessons from basic electronics right on through key subjects like instrumentation, digital and computer controls, servomotors and feedback systems, fluidics, lasers, and optoelectronics. And it's all reinforced with practical, hands-on experience to give you a priceless confidence as you build a programmable, mobile robot.

## Program Arm and Body Movement, Even Speech

Designed especially for training, your robot duplicates all the key elements of industrial robotics. You learn to operate, program, service, and troubleshoot using the same techniques you'll use in the field. It's on-the-job training at home!

Building this exciting robot will take you beyond the state of the art into the next generation of industrial robotics.

You'll learn how your completely self-powered robot interacts



You get and keep Hero 1 robot with gripper arm and speech synthesizer, NRI Discovery Lab for electronic experimentation, professional multimeter with 3 1/2-digit LCD readout, 51 fast-track training lessons.



with its environment to sense light, sound, and motion.

You program it to travel over a set course, avoid obstacles using its sonar ranging capability. Program in complex arm and body movements using its special teaching pendant. Build a wireless remote control device demonstrating independent robot control in hazardous environments. You'll even learn to synthesize speech using the top-mounted hexadecimal keyboard.

## Training to Build a Career On

NRI training uniquely incorporates hands-on building experience to reinforce your learning on a real-world basis. You get professional instruments, including a digital multimeter you'll use in experiments and demonstrations, use later in your work. And you get the exclusive NRI Discovery Lab®, where you examine and prove out theory from basic electrical concepts to the most advanced solid-state digital electronics and microprocessor technology. Devised by an experienced team of engineers and educators, your experiments, demonstrations, and equipment are carefully integrated with 51 clear and concise lessons to give you complete confidence as you progress. Step-by-step, NRI takes you from the beginning, through today, and into an amazing tomorrow.

## Send for Free Catalog Now

Send for NRI's big free catalog describing Robotics and Industrial Control plus over a dozen other high-technology courses. You'll see all the equipment you get in detail, get complete descriptions of every lesson, find out more about career opportunities for trained technicians. There's no cost or obligation, so send today. Your action today could mean your future tomorrow.

## NRI SCHOOLS

McGraw-Hill Continuing Education Center  
330 Progress Avenue  
Scarborough, Ontario M1P 2Z5  
or telephone 416-293-8787  
We'll give you tomorrow.

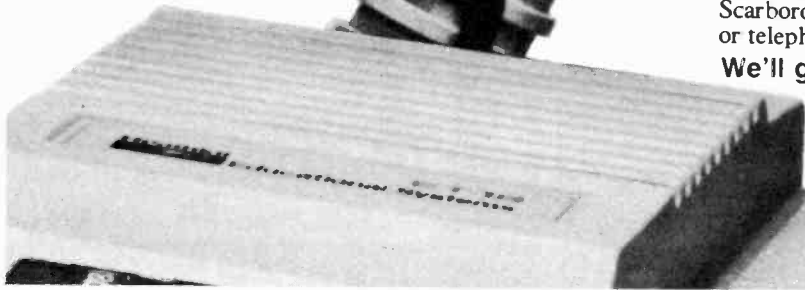

trolled by a discrete resistor (R2). Output currents of 1 microamp to 10 milliamps can be accommodated, and the output current is approximately equal to 0.0677 divided by the value of R2 in ohms. Using the specified value of R2 gives a nominal



For Your Information

Continued from page 8

Function Generator

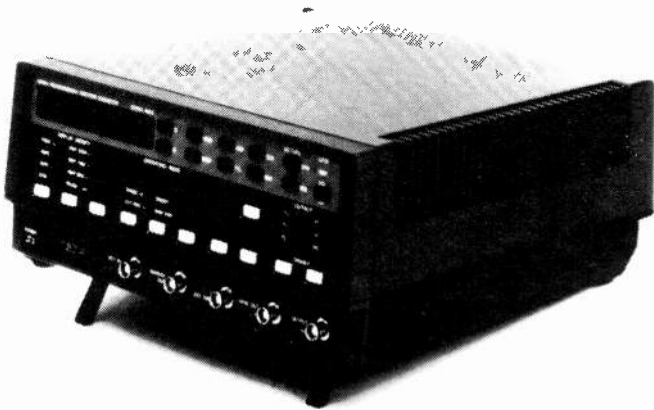

The Series 8200 programmable function/sweep generator has a range of 2 milliHertz to 20MHz, waveforms of sine, square, triangle, ramp and pulse, TTL and DC. A standard IEEE interface programs all front panel controls. Variable duty cycle, DC offset and

symmetry controls are provided, together with a sweep mode which covers 10 decades maximum width. Duncan Instruments, 121 Milvan Drive, Toronto, Ontario M9L 1Z8, (416) 742-4448.

Circle No. 36 on Reader Service Card.

Owners of Texas Instruments 99/4A computers may be interested in the TI 99/4A National Users Group with chapters all across Canada. Software, hardware and full assistance can be yours for \$10 per year. Call or write the headquarters for further information: 759 - 6th St., Brandon, Manitoba R7A 3P3, (204) 727-7715.

Circle No. 37 on Reader Service Card.

Zilog has introduced a 28-pin 8-bit microcontroller, the Z8, designed for low-cost control of appliances and electronic products. The component has been specifically designed for applications with low input/output requirements that require inexpensive silicon replacements for mechanical devices.

Versatile Tester

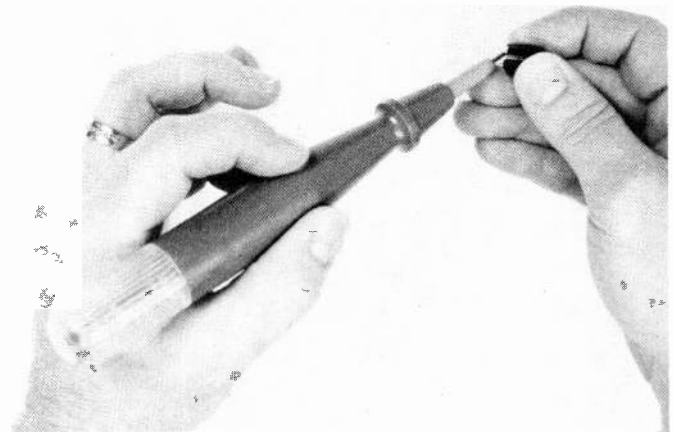

The UTM tester checks circuits not under power for continuity, and also checks live circuits from 5 to 380 volts, AC or DC. When DC is checked, the tester reacts only to positive voltages. It's said to be ideal for cable testing, checking wiring and computer circuits, checking car circuits and various components. \$29.95 including postage and handling. From Rolek Enterprises, PO Box 22186, Barrie, Ontario L4M 5R3, (705) 737-3334.

Circle No. 38 on Reader Service Card.

PROBES & TEST/LEAD CLEARANCE

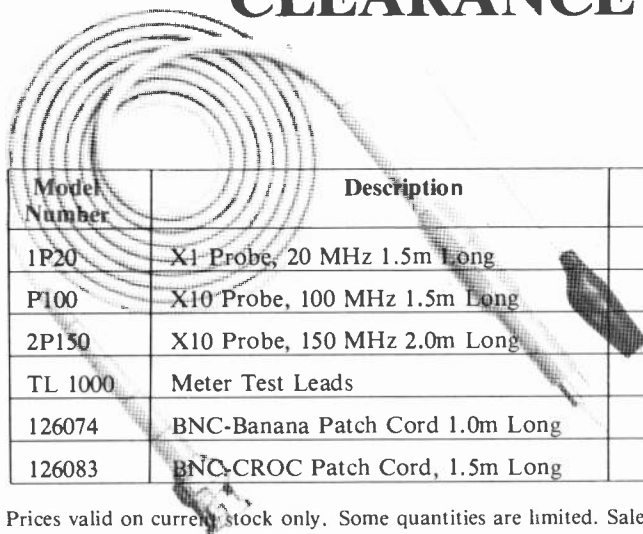

| Model Number | Description                     | Regular Price | Sale* Price |
|--------------|---------------------------------|---------------|-------------|
| 1P20         | X1 Probe, 20 MHz 1.5m Long      | \$21.05       | \$17.95     |
| P100         | X10 Probe, 100 MHz 1.5m Long    | \$24.95       | \$19.95     |
| 2P150        | X10 Probe, 150 MHz 2.0m Long    | \$26.82       | \$18.95     |
| TL 1000      | Meter Test Leads                | \$13.13       | \$10.95     |
| 126074       | BNC-Banana Patch Cord 1.0m Long | \$12.17       | \$ 9.95     |
| 126083       | BNC-CROC Patch Cord, 1.5m Long  | \$10.74       | \$ 8.95     |

Prices valid on current stock only. Some quantities are limited. Sale ends June 30th 1986.

Your Canadian Coline Sales and Stocking Source.

Please add \$2 for shipping and handling. Ontario residents please add 7% P.S.T.



980 Alness St. Unit 7, Downsview, Ontario, M3J 2S2 (416) 661-5585 TELEX 065-28169

Store Hours:  
Monday to Friday 8:00 am to 5:00 pm.  
Saturday: 10:00 am to 1:00 pm.

Power Supply

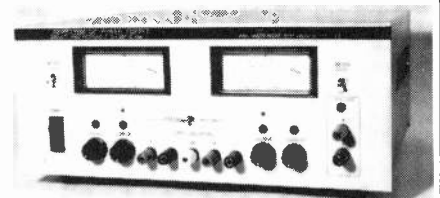

The King KI-1353B is a general-purpose constant voltage/current supply. It provides three types of output: two 0 to 30V variables and a 5V 3A fixed. It features low noise, excellent regulation and fast recovery time. Contact RCC Electronics, 310 Judson St., Unit 6, Toronto, Ontario M8Z 5T6, (416) 252-5094.

Circle No. 39 on Reader Service Card.

# Toronto Computing Centre Inc.

Formerly Surplustronics

8088 Computer Systems  
with 90 day Warranty

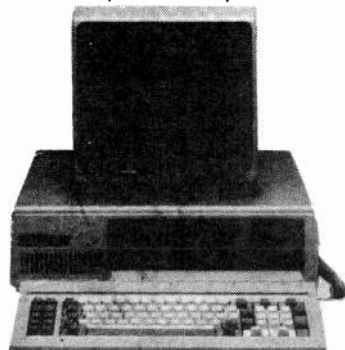

From \$995

- Includes:
- 8088 motherboard
  - High quality legal Bios
  - One DS, DS 360K Drive
  - Power Supply with Fan
  - Keyboard
  - Flip-Top case
  - Disk Controller
  - With plenty of spare slots
  - All you need for complete System is Video Board
  - Colours: \$159.00
  - Mono \$159.00

**\$339** 8088 motherboard with 256K (expandable on board to 640K) Fully assembled and tested with legal Bios, Flow soldered provision for 8087.

### 256K Memory

41256 (150nS) ..... \$ 4.35  
Set of 9 ..... \$38.95

### 64K Memory

4164 (150nS) ..... \$2.45

### IBM Compatible Keyboards

Maxiswitch ..... \$135.00  
Keytronics 5151 ..... \$195.00  
IBM &  
Apple Compatible ... \$149.00

### IBM Style Case

Flip-Top 8 slot ..... \$75.00

Set of 8088, 8255A-5, 8237A-5, 8288, 8284, 8253A-5, 8259A ..... \$45.00

### IBM Peripheral Cards

Colour Video Board ..... \$159.00  
Floppy Controller with RS232 ..... \$139.00  
Modem 300 Baud ..... \$179.00  
Multifunction Floppy Board ..... \$199.00  
Parallel and Game Port Card ..... \$ 59.00  
Cable and connector extra.  
Peripheral Interface Card ..... \$159.00  
Includes two serial ports, parallel port, game port and provision for (but not including) real time clock.  
Clock/Calendar Option ..... \$ 29.00  
With battery backup.

## Hard Drives Half-height, with Controller and Cables

10 Meg ..... \$639.00  
20 Meg ..... \$975.00

### Disk Drives for IBM Computers

Shugart/Panasonic, 5¼" slimline, DD, DS 360K, 40 track ..... \$169.95

### Monitors

Zenith ZVM1230 Green and ZVM1220 Amber ..... \$135.00  
Tatung, TTL, Hi-Res, 22MHz ..... \$219.00

### Complete 6502 System

- Assembled and fully tested (flow soldered)
- 64K, 80 x 24 video with soft-switch, floppy controller.
- System comes with blank EPROM's on board, does not come with any proprietary software or Basic ..... \$199.00

### Complete System

- Using 6502 board above in IBM style flip-top case, using powerful 75 watt power supply with fan, programmable serial keyboard adaptor, IBM style keyboard

As above with one built in disk drive ..... \$699.00  
As above with two drives ..... \$859.00

### 6502 Power Supply

For 6502 Case. CSA Approved 5V, 5A, +12V 2.5A, -5V 0.5A, -12V 0.5A. .... \$69.00

### Kepeco Power Supply

5V 5A, +12V 2.8A, +12V 2A, -12V 0.5A, Open Frame

..... \$38.95

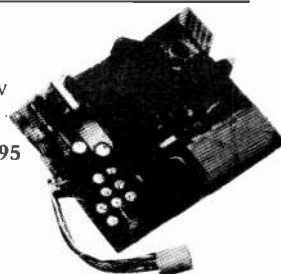

### Panasonic Printers — Sale

Open Frame ..... \$29.95  
Ideal for experimenters. No warranty.

### 256K & Multifunction Board.

Includes: Serial port, parallel port, game port, provision for optional real time clock/calendar and socketed for up to 256K RAM.  
With 64K RAM ..... \$149.00  
With 256K RAM ..... \$299.00  
512K Board. Socketed for 512K including:

64K RAM ..... \$149.00

IBM Compatible Disk Drives ..... \$169.95

Brand New, fresh from factory. Shurgart SA455 40 track, double sided, double density Slimline. We have ordered 10,000 from Shugart - that is why we can pass the savings on to you.

### IBM Compatible Keyboards

Maxiswitch ..... \$135.00

### Keyboard

IBM and Apple compatible with adapter ..... \$149.00

We have changed our name. We felt our previous name of **Surplustronics** did not properly describe our line of quality products. Service and prices are still the best available to which we now add warranties on most products.

### IBM Style Power Supply

130W, +5V 13A, -5V 0.5V, +12V 4.5A, -12V 0.5A ..... \$145.00  
150W ..... \$155.00  
220W ..... \$259.00

### Power Bars with

Surge Protectors ..... \$49.95

### Apple Cards

Assembled, flow-soldered/cleaned and 100% tested  
16K RAM Card ..... \$ 49.00  
80 x 24 video card ..... \$ 69.95  
Z80A Card ..... \$ 59.00  
Parallel Printer Card (cables extra) ..... \$ 49.00  
Parallel Printer Card with cable ..... \$69.00  
128K RAM Card with 128K ..... \$105.00  
EPROM Programmer with Software ..... \$ 79.00  
(programs 2716, 2732, 2732A, 2764)  
Z80/64K Card ..... \$119.00  
Serial Card (cable extra) ..... \$ 69.00  
Floppy Controller ..... \$ 44.00  
Prototyping Board ..... \$ 14.95

### Modem Bargain!

Apple Compatible plug-in Autoanswer, Autodial, Touch Tone or Pulse Dial. Excellent for use with most Bulletin Boards. 300 Baud. Final Sale as is ..... \$39.95

### Apple Compatible Slimline

Disk Drives 5-1/4" ..... \$179.00

### Apple Compatible Modem \$159.00



Plugs into your Apple or compatible computer, Direct connect, 300 Baud, Autodial, Autoanswer, Touch Tone/Pulse Dial, complete with documentation.

### IBM Style Case Suitable for 8088 or Apple Boards \$75.00

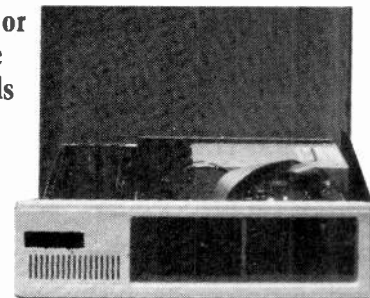

Mail Orders add \$5.00 minimum for shipping & handling. Ontario residents add 7% P.S.T. Visa, Mastercard and American Express cards accepted: send card number, expiry date, name of bank and signature. Send certified cheque or money order, do not send cash.

More lines to serve you better **(416) 960-1350**

Toronto Computing Centre Inc. 310 College Street, Toronto, Ontario M5T 1S3



# A Look At Professional Audio

*One step beyond the highest of hi-fi a look at studio techniques.*

*By Bill Markwick*

WHEN you play a compact disk or a quality regular disk and you revel in the clarity and power of really good sound, you might assume that studios have some sort of other-worldly high-tech electronics available to them, something that isn't accessible to the regular herd.

Your suspicions will be confirmed if you try to make a recording in your living room, even under the best of conditions with really good equipment. 'Well, that clinches it,' you think, after you hear your efforts. 'They're onto something cosmic, I guess.'

Yet it isn't true, at least not in the sense of the existence of some sort of special high-performance circuitry that's light-years above home hifi. Most of the electronics in recording studios or professional sound reinforcement is pretty much a cousin to the circuit cards in your home system. In fact, there are studios whose technical performance is the same or falls behind the quality audio gear available at reasonable prices today. A lot of professionals in sound or photography or similar crafts envy the amateurs with the time and money to tinker with really good gear.

Mind you, I'm oversimplifying a bit here, but in general, the splendid results obtained by the pros result more from techniques of design and application than from dark secrets of the inner sanctum.

Of course, when you see the dazzling array of controls in a large studio, or get your ears flapped by a huge tower of speakers at a concert, it's hard to keep in mind that it's all related to the stereo on your bookcase.

## Overview

The basic idea is straightforward; each of up to 32 or more microphones has its own amplifier and equalizer (tone controls); the output of these amplifiers can be switched into any of the tracks on the tape machine. Each microphone can then be recorded onto any number of the tape tracks.

There may be only one track, for mono recordings, or up to 24 or more. Some gigantic setups use two 24-track machines synchronized together with digital techniques, giving a total of 44 tracks after you subtract the four control tracks for sync and level controls. What they do with 44 tracks remains a mystery to those of us who think of stereo as two mikes, but it's sort of like computer memory space: the more you have, the more uses you find for it, and you soon fill up 640K, or what used to be a staggering amount of RAM.

On multi-track recordings, the input channels on the console are switched from mike to line; the channels now get their in-

put from the tape machine's playback. The console's mixing facility is now used to mix the recorded tracks down to stereo. Or quad, back in the days when they wanted to sell more speakers and amps.

That's really all there is to the basic layout; everything else is icing on the cake, providing a myriad of functions to manipulate the sounds into their final form.

## An Input Strip

The input channel, or strip, is responsible for setting up the initial corrections to the tone, and routing its output to the final mixing stage, which is usually just a fader (volume control) which accepts any number of input channels and sends them to one tape track.

The first control that you usually meet will be the gain control. This is a control missing from most microphone inputs on home or amateur equipment; it's usually just a feedback resistor in an op amp circuit that can vary the gain up or down. On some mixing boards a switch is included to insert a resistive attenuator ahead of the first stage of amplification for handling really large outputs from microphones.

It's interesting to consider the output of microphones. The best way to do it is to watch the microphone's output using

an oscilloscope, because what we're interested in is the peak voltage that the microphone can achieve under operating conditions. Studio mikes are always low impedance, usually 50 to 600 ohms, and will usually be either dynamic (moving coil) or electronic types (condenser, electret, etc.). A 250-ohm dynamic mike may only produce 50 to 100mVAC if you sing directly into it, but on certain sounds, particularly sustained ones, it's not unusual to see peaks of up to 2V. High-impedance mikes were once very popular for home use because the internal transformer gave a voltage gain of about 20dB (ten times), and this allowed manufacturers to scrimp on expensive gain stages. These can hit a remarkable 20V of output.

The input stage, then, must be designed to handle high input voltages as well as supplying up to 80dB of gain for very soft signals, and this can only be done by using a variable gain control. The maximum input can be found by dividing the amplifier's output by the gain. For instance, an op amp running from plus-and-minus 15VDC can usually swing about 9 volts RMS. If the gain is 40dB (a good general-purpose gain figure), then the maximum output is  $9/100$ , or 90mV (we'll get further into the decibel as we go). This is  $90 \times 1.414 = 127\text{mV}$  peak.

At one time, most consoles ran with plus-and-minus 15V supplies to accommodate the limitations on the op amps of the time, but now that higher-voltage amplifiers are available, bipolar supplies of 20V or higher are becoming popular.

While the professional input preamp is fitted with gadgetry for optimizing the signal, it probably isn't a great deal different in noise or distortion than a good home stereo. For instance, a zillion radio stations and studios use Shure mike mixers for auxiliary mixing, and the older models of these had signal-to-noise about 10dB worse than an average stereo system. I recall them being plagued with hum and hiss, but everybody went on using them anyway.

The next function in the strip is the equalization, or EQ. The EQ on even a basic board should consist of bass and treble control similar to a home stereo and a midrange control which can boost or cut (by 15 or 20dB) a band of frequencies tunable from about 500Hz to 5kHz. The mid control is essential; because it affects the frequencies to which the ear is most sensitive, it's the best control for brightening or diminishing the tone of almost any sound. In fact, it's such a useful control that the more expensive boards have up to four of them, tunable to overlapping bands covering the audio range. In effect, each input strip then has a graphic equalizer, except that rotary controls are used.

Next comes the auxiliary outputs.

These vary tremendously in number with the make and price of the console, but in general, the two most-often used outputs are the effects send and the cue (or foldback) send. Both of these are generally switchable from pre- to post-fader; that is, they can work independently of the main fader (pre) or they can fade along with it (post). The effects send is used to send the mike output to a reverberation unit, or an echo unit, or similar. Generally, the master tapes are made without an special effects added; it's easy to add them later, but very difficult to take them out afterwards. The separate output allows the effects (if used) to be stored on a separate tape track or just sent back to performers.

The cue or foldback outputs are used to send the mike output to one or more headphone amplifiers so the performers can hear each other via headsets. On most boards the cue feeds can be 'wet or dry'; that is, the sound heard by the performer can be straight from the mike without effects added, or it can be jazzed up with reverb or echo. It's a bit easier to hear your own voice in a headset if there's some reverb added.

The fader comes in now. Most are conductive-plastic for low operating noise, and the taper is logarithmic. The usual operating level is marked near the top as 0dB, and there's another 10dB or more remaining in the travel. Large consoles have insertion points before and after the fader; this lets the operator add in (patch) special effects boxes in the pre- or post-fader mode.

Lastly comes the assignment buss (or bus) strip. It consists of two banks of pushbuttons, one for each track, usually with the odd numbers on one side and the evens on the other. A pan pot is used to adjust the level between any two opposite

buttons, allowing positioning of a track or mike in a stereo mix.

It's like the balance pot on a stereo, but with only one input.

## Outputs and Monitoring

The various inputs are mixed; each mixing buss will consist of a resistor from each input strip wired to a common rail that runs the length of the mixer. Most consoles use feedback mixing; the common rail is fed into an inverting output and a resistor wired from the output to the input. This resistor is usually the same as the mixing resistors (typically 10k); the feedback method has the advantage of lowering the buss impedance to a few ohms, and this means that you can add or subtract input channels without disturbing the buss level through impedance changes. The voltage level out of the mixing amp is usually 30 or 35dB below maximum, giving lots of headroom when multiple signals are added together.

Each mixing amplifier goes to a fader and then to the final line amplifier which feeds a track of the tape machine. A typical line amplifier is an op amp with a current booster on the output, capable of swinging about 12 volts RMS into 600 ohms. This is about 20dB higher than line level, allowing lots of room for transient peaks.

Monitoring is an exceptionally important part of any mixer. It's the gadgetry that lets the operator hear what's going on in the studio and what's been put on tape. Several pairs of speakers are switch-selected so the operator can hear the sound through super speakers, through car-radio types, and so forth. The top-of-the-line studio monitor speakers are extremely impressive. Not that you can't get them for home use, but most people just can't afford them.

*The monitor controls and patchbay of an MCI console. The patching jacks allow direct outputs and equipment insertions.*



The monitor speakers are fed in one of two ways, at least in general. The first way is the separate monitor panel. This consists of a separate mixer all on its own, but mounted on one side of the console. This little mixer has two main sets of inputs: the first one listens to the outputs of the console (the audio going to the tape) and lets the operator doodle with levels and effects and panning without actually affecting the tape. The second set of inputs is connected to the playback outputs of the tape machine; this set can be switched in place of the console outputs all at once, either by a massive mechanical switch or by electronic switching (FETs, 4066 ICs, etc.). If the operator wants to hear a single microphone or tape channel, there's a switch called the Solo; it activates a relay to change the monitor feeds from multi-track to the output of the desired channel. Most operators spend a lot of time punching the solo buttons frantically, yelling 'where's that buzz coming from???'

The second method of monitoring is to have a volume control and pan pot on each input channel. This greatly simplifies the console monitor panel, but lots of switching is still needed to go from console output to tape machine output. The choice is a matter of operator preference.

**Patching**

Consoles have inputs and outputs routed to 1/4' telephone-type jacks in a large panel; how many you have depends on how much money you have. Operators would like thousands of patch point for inserting special effects wherever they want, but the high cost of the hardware usually limits the choice to pre- and post-fader. In addition to insertion points (in which the connection is normally made by spring contacts in the jacks and broken by the plug for adding other equipment in series), there are also channel outputs and tape machine inputs. This is a great moneysaver, because it minimizes the number of mixing busses required. The operator only needs so many mixes, and some input channels can bypass the mixing process completely and go straight to the tape machine via the patching jacks (the monitoring facilities still listen to these direct channels). This is how a console with only eight output faders can be called a 16-track board. The other eight tracks are fed directly through the patchbay; the line returns (playbacks) from the tape machine are listened to via a 16-input monitoring system.

**Balancing**

Studios consist of enough wire to lash up

a trawler net if you needed one. This incredible tangle of mike, console and tape lines makes an ideal setting for interference, crosstalk, RFI and what have you. To minimize the problems, all lines are balanced in professional studios, though on smaller setups you often see unbalanced lines which do the job using very low impedances and lots of filters. The subject of balance/unbalance or transformer versus electronic balancing will provoke a hot debate among operators any time. The choice of monitor speakers, for instance, is seen as a personal thing, like your choice of religion, but wiring fans see unbalanced studios as some sort of ignorant recklessness, or balancing as intolerably old-fashioned. In fact, it doesn't matter an awful lot. Both systems work excellently if properly installed.

The balanced line consists of two wires plus a shield; the output amplifiers are either transformers or two amps in antiphase. The inputs are either transformers or differential amplifiers. Since only the potential difference across the line pair is amplified, interference signals common to both sides of the line are subtracted by an amount dependent on the quality of the unit.

Unbalanced lines are much more eco-

**K.E.M.**

**NOW JUST ARRIVED!**

**More Powerful More friendly**

**High Speed EPROM Toaster For Apple and IBM**

From 2716 to 27256 all-round player. Function programming voltage (12.5V, 21V, 25V), and ROM selection totally software control. Just change I/F card, Can switch to IBM or Apple.

- For Apple .....\$185.00
- For IBM .....\$195.00
- Extra I/F card Apple or IBM ... \$ 79.00

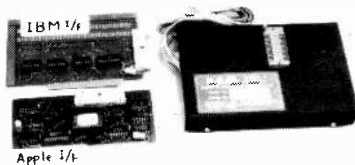

Also KEM High Speed Rom UV Eraser. Erasing time only within 5 to 10 minutes.

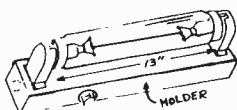

- 1 set .....\$29.98
- Timer .....\$ 4.98

\$5.00 for shipping. Plus Provincial Tax for B.C. residents. Plus C.O.D. fee if required. Price and specification are subject to change without notice.

**K.E.M. Electronics Ltd**

Mail to Box 69126 Station (K), Vancouver, B.C. V5K 4W4  
Office 879 E. Hastings St. Vancouver Tel (604) 251-1514

**PC/XT Compatible ECS1-PC/XT**

*Special*  
**\$899.00**

- 8088 processor
- optional Intel 8087
- numeric coprocessor
- 256K memory
- double sided double density disk drive
- detachable keyboard
- colour graphic board
- 130 watt power supply
- support PC software
- 90 day warranty
- 8 slot Mother board



**TTL Flat Screen Monitor**

**\$199.00**



**Mouse —**  
**\$149.00**



**AT Compatible**  
**\$2995.00**

- 512K memory
- 1 1.2M drive
- Colour card
- Keyboard
- 200 watt power supply

**XT/PC MAIN PERIPHERAL**

|                        |               |
|------------------------|---------------|
| Enhance Graphic Card   | .....\$695.00 |
| Mother Board 8 Slot    | .....\$249.00 |
| Color Graphic Card     | .....\$139.00 |
| Multifunction          | .....\$149.00 |
| Monochrome Card        | .....\$139.00 |
| Monochrome Graphic     | .....\$175.00 |
| Game Port              | .....\$ 49.00 |
| RS232 Card             | .....\$ 59.00 |
| Parallel Interface     | .....\$ 59.00 |
| Disc Controller Card   | .....\$ 89.00 |
| Case                   | .....\$ 69.00 |
| Keyboard (Cherry)      | .....\$ 99.00 |
| Power Supply 130 Watts | .....\$139.00 |
| Printer Cable          | .....\$ 25.00 |
| RS232 Cable            | .....\$ 25.00 |
| Disk Drive Cable       | .....\$ 15.00 |
| Moving Message Board   | .....\$495.00 |
| TTL and CMOF test Card | .....\$ 99.00 |
| 150 Watt Power Supply  | .....\$149.00 |
| Modem 1200 B           | .....\$349.00 |
| Network Card           | .....\$595.00 |



**ELECTRONIC CONTROL SYSTEMS**

1590 Matheson Boulevard, Suite 1 & 2 Mississauga, Ontario L4W 1J1  
(416) 625-8036 Hours — Mon. to Fri. 10-6. Sat. 10-2

# Exceltronix

Computers and Components

Spring 1986  
Catalogue

Toronto Store and Mail Orders  
319 College Street,  
Toronto, Ontario M5T 1S2  
(416) 921-8941

Ottawa Store  
217 Bank Street, Ottawa  
(613) 230-9000



**Long Distance Ordering**  
**1-800-268-3798**

(Operators on 800 number cannot handle enquiries other than orders)

**Local Orders (416) 921-8941**

Opening soon near Toronto  
Airport, our new facility.  
regular advertisements for  
address and phone  
numbers

# Exceltronix



Our original store in Toronto is still at the same location (319 College Street — College and Spadina) but has greatly expanded to incorporate adjacent stores.



Multiflex and Versa-Digital developed and manufactured the digital display signs used on the Toronto Subway System and the Vancouver LRT Transit System — and they are now controlled and updated using several BEST computers!



Our newly purchased 25,000 square foot facility, near Toronto airport, will allow us to expand research and development in the computer field. It will also take us into a new field of development: advanced underwater intelligent robotics.

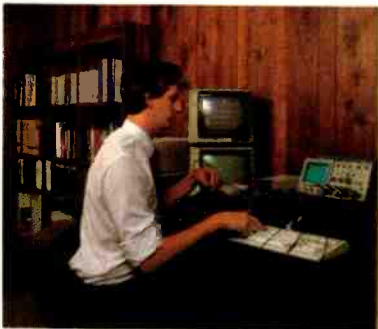

In excess of \$1 million was devoted by Multiflex to development of new high tech products in 1985.

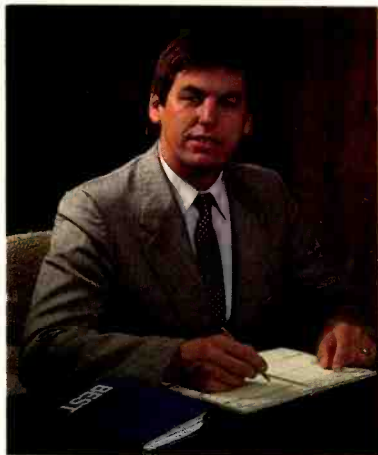

Eugen F. Hutka, the founder and President of Exceltronix, Multiflex and all the associated companies.

All prices and specifications in this catalogue are subject to change without notice.

Our cover shows our AVT-286, IBM AT compatible computer with a graph showing our rapid and sustained growth.

## The History and Development

of our successful and rapidly expanding All-Canadian company committed to high technology.

Now in its seventh year, Exceltronix and its associated companies, has grown from a single store, to three retail outlets, a large mail order division, and an ever expanding engineering and manufacturing facility with revenues for 1986 expected to exceed \$15 million.

Many of the products sold at our own retail outlets are manufactured by our associated company, **Multiflex Inventions and Technology** in Toronto. This direct link between manufacturing and retailing benefits our customers in several ways. Our competitive prices result from not having to deal with middlemen (with their markups) and enables us to respond rapidly to the changing needs of customers. We are proud of both the high quality of our products and their excellent reliability and consequently we are able to offer warranties far better than the industry standard. Exceltronix is probably most widely known for its highly successful line of IBM compatible **BEST** personal computers and peripherals, but when an off-the-shelf product will not satisfy your needs, the engineering division at **Multiflex** is able to analyze your problem and develop a cost effective solution. Proof of this is the Advanced Message Display System in the Toronto Subway System and the Vancouver LRT, manufactured by **Versa-Digital**, another associated company. These examples are just some of the many solutions that we have provided for Canadian industry and commerce and we will be happy to discuss your particular requirements.

Even though we have grown enormously, we have not lost the personal touch that contributed to that growth. Although we are now one of the largest manufacturers of computers in Canada, our dedicated and knowledgeable staff are happy to discuss your needs, be it for a computer to solve a problem or a single electronic component.

In the recent past, the microcomputer business has seen huge booms and some massive recessions. Despite this, Exceltronix and its associated companies have grown consistently and we continue to increase our market share. Being diversified, we have the resources to research and develop our products properly. Not being dependent on a single line, we have avoided the mistake of many computer companies of bringing out products before they are properly developed.

Our company is proud of the fast and excellent service in our stores and we now have available a team of specialists who can provide on-site analysis of your hardware, software and interfacing needs.

We have yet to see what tomorrow has to offer, but you can be assured that the Exceltronix group of companies will be accepting the challenge.

**Associated Companies:**  
**Exceltronix Inc.**  
**Multiflex Inventions and Technologies Inc.**  
**BEST Computers Inc.**  
**Toronto Computing Centre Inc.**  
**Versa-Digital Technology Inc.**  
**Digi-Media Inc.**  
**XL Electronix Computer Music Centre Inc.**



All our own products are manufactured in Canada to the highest quality, including being flow-soldered and ultrasonically cleaned.



# BEST AVT-286: the IBM AT Compatible

Designed and made in Canada with pride.

Proving once again that Multiflex is an industry leader, by producing more than just affordable alternatives in personal computer design, we are pleased to announce the **BEST AVT-286 Microcomputer**, our new, fast IBM AT compatible. The AVT-286 is based on the 80286 microprocessor. The AVT-286 is supported by the *Phoenix AT compatible Bios*, the same software house that supplies the Bios for all other BEST computers as well as many of the well known IBM compatibles currently manufactured.

Check the long list of standard features that are included on the new **BEST AVT-286**:

- The AVT-286 runs faster than the (12MHz) IBM AT but retains superb software compatibility.
- The main board features a standard 640K RAM using state-of-the-art memory chips for fast, reliable data processing.
- Seven expansion slots of which five support IBM AT signals. The two remaining slots are compatible with IBM PC or XT peripheral boards.
- Presocketed for the optional 80287 math co-processor
- Two floppy diskette drives, one formatted for a capacity of 1.2 Megabytes, the other for 360K to read and write normal diskettes.
- The BEST Colour Video board which offers the user four modes of operation, composite and RGB output.
- An AT compatible keyboard.
- On board Real Time Clock/Calendar with battery backup.
- Parallel Port (for printers etc.)
- Serial Port (for communications).



- Heavy duty Power Supply as standard allows for adding extra cards as well as a Hard Disk without requiring an upgrade.
- Attractive flip-top case.
- A keyboard lock with unique security key which prevents any unauthorised use of the system.

- A front control status panel provides information on the keyboard lock status, reset, power-on, disk activity and parity errors.
- A hardware reset button so the system can restart without having to power down.

## The BEST AVT-286

Canadian designed and made, Super IBM AT compatibility, 640K RAM, Two 5.25in. Disk Drives (one high density 1.2Mb, one 360K), Serial and Parallel Ports, High quality keyboard, Keyboard lock and Status Panel. See detailed description above.

Simpler or more complex configurations available at most competitive prices.

# \$3495<sup>00</sup>

As standard configuration with fast-stepping Hard Drives:

- 20 Meg Hard Drives ..... \$4950
- 30 Meg Hard Drives ..... \$5475
- 40 Meg Hard Drives ..... \$5795

## Warranty

We have such confidence in the time tested reliability of the BEST that we offer a 300 day warranty which is way above the industry standard. On-site service plan available at extra cost Nation-wide through 3M of Canada Ltd.

## The BEST IBM AT Compatible 4 Meg Memory Card

In order to take advantage of the memory addressing capabilities of the IBM AT or the BEST AVT-286 business computer, we developed a memory card to give the user up to 4 Megabytes of dynamic RAM. The memory card will run at speeds up to 16MHz, which is fast enough to meet the needs of any 80286 microprocessor on the market today. The design uses state-of-the-art (256K x 9) memory arrays, to allow for maximum memory in the smallest physical space. The ninth bit is used as a parity bit to insure the validity of the data. The card is available in memory sizes from

512K to 4 Megabytes in steps of 512K. Boundaries are switch selectable above 1 Meg in blocks of 512K.

- With 512K ..... \$ 695
- With 1 Meg ..... \$ 895
- With 4 Meg ..... \$1995

### Attention IBM Owners!

#### BEST AT Compatible Enhancement Card

This card includes the following features: Two Serial Communications Ports, One Parallel Printer Port and Memory starting from 128K to 512K in selectable boundaries. This card will allow IBM AT user with 256K or 512K of on-board memory to



expand that AT machine to full 640K capability as well as provide them with two serial ports and one parallel port.

..... \$299.00

# Exceltronix

319 College Street, Toronto, Ont. M5T 1S2

(416) 921-8941. Order line only 1-800-268-3798

Ottawa 217 Bank Street (613) 230-9000

Visa, Mastercard and American Express accepted.

# SUPER-FAST BEST Mark IV

In today's industry, more than ever, time is money. It is for that reason we developed the **Mark IV** personal computer.

Still retaining IBM PC and XT software and hardware compatibility, the **Mark IV** uses the true 16-bit 8086-2 microprocessor. Although the system runs at the same clock speed as the Mark III, the 8086-2 has a 16-bit external data bus compared to the 8088 and 8088-2's 8-bit data bus. This allows memory access to occur **much faster** than with most other IBM PC/XT and compatible computers.

The bus structure of the **Mk IV** remains compatible with the standard IBM 8-bit I/O channel but still has the benefits of the 16-bit architecture.

Couple the 8086-2 microprocessor with the 8087 math co-processor and you have **one of the fastest, most reliable business or engineering aids** available in this price range.

Since the **BEST Mark IV** is geared towards the serious microcomputer user, a **standard complement of 640K RAM** is installed on the main board, along with a long list of standard features.

**Made in Canada with pride.  
Superb IBM PC/XT Compatibility**



## Standard Features of the BEST Mk IV

- Superb IBM Compatibility.
- Canadian made
- **Phoenix BIOS**, as used in many major brand IBM compatible systems.
- **640K of RAM** Memory.
- **Seven Expansion slots**, so that you have lots of room to tailor the system to your needs, with the wide range of peripheral cards available.
- **Real Time Clock/Calendar**, with software and battery backup.
- **Parallel Printer port**, to interface dot matrix, letter quality printers and digital plotters.

- **Serial Communications Port** that supports all RS232-C signals (a second serial port can be added).
- **Two double sided, double density 360k 5.25 inch floppy disk drives**, with the option of adding an additional two drives.
- **Colour graphics video board**, with both RGB and composite video outputs. Four modes of operation are available with this board.
- **Pre-socketed** for the optional Intel 8087 math co-processor.
- A reset switch, which can be a life

saver, in the event of a program hanging your system.

- A **150 watt** power supply, with more than enough power to supply expansion boards, disk drives, and hard disk drives.
- IBM compatible, **high quality** keyboard.

## Warranty

We have such confidence in the time tested reliability of the BEST that we offer a **300 day warranty** which is way above the industry standard. **Nation-wide on-site service plan** available at extra cost through 3M of Canada Ltd.

## SUPER-FAST BEST MK IV

As BEST MK III plus TRUE 16-Bit machine, 8086-2 processor, IBM compatible 8-Bit I/O channel bus, even faster than MK III due to 16-Bit architecture. With 640K RAM.

# \$2500<sup>00</sup>

### Other Configurations:

With 10 Meg Hard Drive/1 Floppy/640K ..... \$3395  
With 20 Meg Hard Drive/1 Floppy/640K ..... \$3495

### Options:

Tape Drive ..... from \$1295  
Second Floppy on H.D. systems ..... \$180  
300/1200 Baud Modem Board ..... \$379  
BEST Monochrome Card ..... \$179

## The BEST line

ALL of the **BEST** personal computers come with standard features that other manufacturers consider expensive options. The excellent reliability proved since we started manufacturing this range enables us to offer warranties far, far better the industry standard.

A complete description of the personal computers manufactured is included in this catalogue. Before you buy your system our computer fluent sales staff can provide you with advice on the hardware and software required to solve your problem. And remember that after you purchase the **BEST** computer that suits your needs, **Exceltronix** and its sister companies will be around long after some other retailers have come and gone, to offer you unparalleled service and selection, as we have been for the last six years.

**Special Requirements?** We have the in-house experts in both hardware and software to interface a lot of complex equipment to IBM, **BEST** or compatible computers. We can recommend or customise existing software packages for your business or industrial needs. We have excellent in-store and on-the-road sales staff with computer expertise and a superb team of in-house hardware and software engineers.

We can probably help you with every aspect of your computer needs at reasonable, honest prices. Call us.

## APPROXIMATED SPEED COMAPRISONS

For the speed comparison test a PL1 programmer was compiled on a 360K RAM disk, namely VDisk supplied on Dos 3.0. The reasons for this instead of a diskette are twofold: 1. The drive characteristics between an AT and a PC are radically different. We wouldn't know if we were comparing speed of the drives or speed of the machines. 2. The 16-bit machines such as the Mark IV and AT cannot utilize their full power while talking to 8-bit devices.

The base was an IBM PC/XT with 640K running at 4.77MHz. The compile was of moderate length: 170 seconds. The table here gives the results of the speed test:

| Machine Type   | IBM PC/XT<br>4.77 MHz | Mark III<br>8.00 MHz | Mark IV<br>8.00 MHz | IBM PC/AT<br>(12 MHz)<br>(6 MHz CPU) | AVT-286<br>(16 MHz)<br>(8 MHz CPU) |
|----------------|-----------------------|----------------------|---------------------|--------------------------------------|------------------------------------|
| Seconds        | 170                   | 105                  | 80                  | 67                                   | 53                                 |
| Relative Speed | 1.00                  | 1.62                 | 2.13                | 2.53                                 | 3.2                                |

Looking at the table we see a number of remarkable things. The first is the speed of the AVT-286 over the IBM PC/AT. The AVT-286 is about 25% faster than the IBM AT. The other remarkable thing is that the Mark IV is only 16% slower than the IBM AT! (This is even more remarkable considering the price differential). We also see, as expected, that the 16 bit data path of the 8086 in the Mark IV gives 31% improvement over the Mark III at equivalent processor clock speeds.

**If you want the Best, buy the BEST**

# We are proud to introduce the New FAST BEST Mark III

Made in Canada with pride.

To meet the demanding needs of industry for faster information processing, Exceltronix is pleased and proud to introduce the Mark III personal computer. Based on the success of the BEST Mark II, the Mark III goes a step beyond. The system is based on the 8088-2 microprocessor, which is capable of running almost twice as fast as any 8088 based system.

● Superb IBM PC/XT software and hardware compatibility has been retained.

● A hardware switch allows you to go from 4.77MHz to 8MHz operation. Any software that implements a lot of memory manipulation will run visibly faster. Compilers work much faster, spreadsheets will speed through calculations, and even video intensive games run quicker.

● All the same cost effective package that made the Mark II a success, has been continued in the Mark III. We consider features such as a Real Time Clock, Parallel Printer Port, Serial Communications Port and a minimum of 256K RAM memory, necessities in today's personal computer. These have been included in the base price along with a colour video board, so even if you don't need the options today, tomorrow you will not have to pay to have them installed.

Superb  
**IBM PC/XT**  
Compatibility



Monitor and printer not included. IBM is a registered trade mark of IBM Canada Limited.

## The FAST BEST MK III

As BEST MK II plus speed selectable: 4.77 and 8MHz (most software will run on the higher speed), uses 8088-2 processor.

# \$1895<sup>00</sup>

### Other Configurations:

|  |        |
|--|--------|
| With 640K RAM .....                        | \$1995 |
| With 10 Meg Hard Drive/1 Floppy/256K ..... | \$2795 |
| With 10 Meg Hard Drive/1 Floppy/640K ..... | \$2895 |
| With 20 Meg Hard Drive/1 Floppy/256K ..... | \$2895 |
| With 20 Meg Hard Drive/1 Floppy/640K ..... | \$2995 |

## Standard Features Common to the BEST MK II and MK III

- Superb IBM Compatibility.
- Phoenix BIOS, as used in many major brand IBM compatible systems.
- Minimum of 256K RAM (Random Access Memory) using 41256K RAM chips, expandable to 640K or higher on the main board.
- Seven Expansion slots
- Real Time Clock/Calendar, with software with battery backup.
- Parallel Printer port
- Serial Communications Port that supports all RS232-C signals (a second serial port can be added for only \$39.00 extra).
- Two double sided, double density 360K 5.25 inch floppy disk drives
- Colour graphics video board, with both RGB and composite video outputs.
- Pre-socketed for the optional Intel 8087 math co-processor
- A reset switch
- A 150 watt power supply, with more than enough power to supply expansion boards, disk drives, and hard disk drives.
- IBM compatible, high quality keyboard.

## Warranty

We have such confidence in the time tested reliability of the BEST that we offer a 300 day warranty which is way above the industry standard. Nation-wide on-site service plan available at extra cost through 3M of Canada Ltd.

### Options:

|                                     |             |
|-------------------------------------|-------------|
| Tape Drive .....                    | from \$1295 |
| Second Floppy on H.D. systems ..... | \$180       |
| Second Serial Port .....            | \$39        |

## The BEST Mark II

Made in Canada

## Superb IBM PC/XT Compatibility

In the past two years, thousands of BEST personal computers have been working their way into the Canadian business, educational and home environment. Based on the 8088 microprocessor, the BEST Mark II is an inexpensive entry into the personal computer field.

As with all the BEST product range, it is made in Canada to the highest standard of quality.

It is the success of the original BEST and the Mk II that prompted us to develop the newer and faster Mk III and Mk IV.



Monitor and printer not included. IBM is a registered trade mark of IBM Canada Limited.

## BEST MARK II

Standard Mark II with 256K RAM and two 360K DD/DS diskette drives, Serial and Parallel Ports, Real Time Clock, Phoenix BIOS. Uses 8088 processor.

# \$1695

### Other Configurations:

|  |        |
|--|--------|
| With 640K RAM .....                        | \$1795 |
| With 10 Meg Hard Drive/1 Floppy/256K ..... | \$2595 |
| With 10 Meg Hard Drive/1 Floppy/640K ..... | \$2695 |
| With 20 Meg Hard Drive/1 Floppy/256K ..... | \$2695 |
| With 20 Meg Hard Drive/1 Floppy/640K ..... | \$2795 |

**If you want the Best, buy the BEST**

## Upgrade your IBM

### **BEST External Hard Disk Drive and Tape Back-up Unit**

**Easily Convert your IBM PC or Compatible into a Hard Drive System with Tape Backup.**

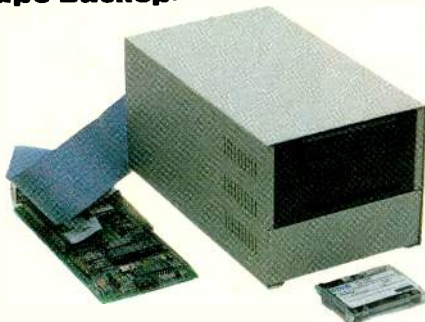

As more people become educated in the use of personal computers, the office computer becomes victim to late night hackers and curiosity seekers. The data upon which your business decisions are made every day is in danger of being wiped away by a wrong sequence of key presses or the data may be seen by those without proper authorization. Protect your data and yourself by removing the hard disk drive from the system.

Multiflex has designed a unit which allows you to physically remove the mass data storage device and lock it in another room without disassembling your entire system. The external hard disk drive and tape backup unit is self contained with its own power supply and connects to back of your system through a ribbon cable. Simply follow normal shut down procedures then unplug the unit and carry it to a safe location.

**With Seagate 20 Megabyte Hard drive and Scorpion Tape Backup unit  
\$2795.00**

**With 10 Megabyte Hard Drive and Irwin Tape Backup unit  
\$2395.00**

### **Convert your IBM PC or XT into a Hard Drive System within Minutes**

**Do it yourself with no mechanical alterations.**

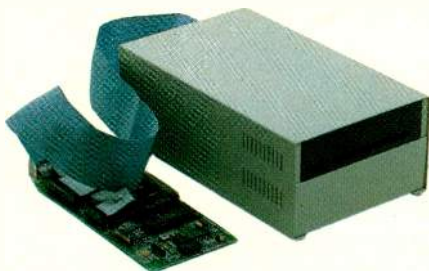

This unit rapidly converts your system into a Hard Drive unit, and it is compact enough to fit in a brief case. The unit contains its own power supply, fan, a reliable Seagate 20 Megabyte hard drive and a controller card which plugs into your existing system.

**With Seagate 20 Megabyte Hard Drive  
\$1295.00**

**With 10 Megabyte Hard Drive  
\$1195.00**

### **BEST EXPANSION System for your IBM PC**

If you are one of the many who invested thousands of dollars in an IBM PC, you may be realizing the limitations of the hardware you own. The power supply may not be able to handle the addition of a hard disk drive or the five expansion slots may already be filled with necessities, leaving no room for the luxuries of more memory or communications hardware.

The BEST Expansion System was designed to function in a transparent fashion to the IBM operating system. The host system (IBM PC or XT) will look at a peripheral card in any of the eight slots of the expansion system as if it were installed in the slots on its own main board.



The Expansion System is packaged in an attractive flip-top case with its own power supply and ventilation fan. Two 3 foot long ribbon cables connect the host computer to the expansion system, which allows the expansion system to be placed on top, beside or underneath of your existing IBM PC or XT system.

The expansion chassis is powered by a 150 watt power supply with power connectors for two disk drives included as a standard feature. This power supply has enough power to run four diskette drives, expansion cards, or hard disk drives.

Although the system provides you with more slots and the capacity for a hard drive, your existing system will run with less load and therefore cooler.

Complete BEST Expansion System including the peripheral adapter to plug into your existing IBM PC or XT system, 8-slot expansion bus, with flip-top case and 150W power supply and cooling fan.

**Price \$795.00**

### **Add a Tape Drive to your Existing System**

Those who have used computers for any length of time can explain the absolute necessity for an external backup of the data held in a Hard Disk. Our self-contained unit, including power supply, (which looks similar to the Hard Drive Unit illustrated left) has a cable and peripheral card which simply plugs into your IBM or compatible system.

Tapes for these systems are readily available.

**With Irwin Tape Drive and BEST Controller  
\$1195**

**With Scorpion Tape Drive and Controller  
\$1395**

### **Add Extra 360K Disk Drives to your System**

If you need more than the two existing drives for your system, our self-contained external unit with two 5.25in. 360K disk drives with its own power supply, fan and controller will be of interest.

**Price \$595.00**

## The BEST Colour Graphics Video Board

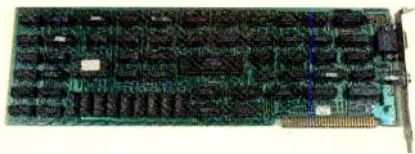

The BEST Colour Graphics Video Board was designed for those personal computer users who require an inexpensive, but versatile video display. The user has a choice of three types of monitors that can be connected to the card, a composite monochrome monitor, composite colour monitor or direct drive RGB colour monitor. Software utilizing a light pen can be run since the BEST-Colour Video board supports the necessary hardware.

The video board is capable of operating in four modes, two text and two modes of graphics display

### Text display

The BEST Video Card can display either 80 or 40 characters on one line. The character generator contains all the standard ASCII characters plus block graphic characters and a set of international characters such as the English pound and Japanese Yen. Depending on your choice of monitor, the application text can be displayed with a variety of foreground and background colours. In addition, black and white mode allows for the following attributes: reverse video, blinking and highlighting.

The operator can switch between 40 and 80 column display by using the DOS MODE command. The 80 column mode gives crisp characters on either colour or monochrome monitors. The 40 column text mode is suitable to use if you were to use a common television set in conjunction with a RF modulator that can be directly attached to the video board.

### Graphics Display

The BEST video board is capable of displaying three styles of graphics.

### Low resolution — Monochrome or Colour

In the low resolution mode either colour or monochrome graphics can be displayed. The screen is capable of displaying 200 rows of 320 pixels (a pixel is one dot on the screen). In the colour graphics mode each pixel can be one of four colours, and the background can be one of 16 colours. Many software packages are written with colour graphics capabilities. LOTUS 123, and Symphony for example become more powerful and easier to use with the addition of crisp and vivid colour graphics.

### High resolution — monochrome

For applications such as computerized drafting or intricate business charts, colour may not be desired, but high resolution is required. The BEST card is able to double the resolution of the display to 200 rows of 640 pixels, by selecting the monochrome instead of colour graphics. In the high resolution mode an inexpensive composite monitor can still be used.

**\$179.00 with Warranty**

## The BEST Monochrome Card



In the office environment where a great deal of word processing, or data entry takes place, eye fatigue may be a problem. A solution to this problem is an upgraded text display card for your BEST, IBM PC or compatible. The monochrome card displays a character that is made up of 7 x 9 matrix of dots in comparison to the 5 x 7 matrix used on the standard colour graphics video board. The finer dot pattern makes text appear much cleaner and easier to read. The monochrome card will display characters in four modes; normal, intensified, reverse video and blinking. The display is 80 x 25 characters.

Note: This is a half size board which will fit even those computers with restricted space.

**\$179.00 with Warranty**

## Phoenix Video Board

The choice of a video display card can be a difficult one. There are many different capabilities for each style of video card available. If your display needs are as diverse as the number of cards available, you may have to install two or three video cards in your system. Not only is this expensive, but it also steals precious expansion slots from your system. Phoenix Computer corp. has a designed an expansion card to satisfy all of your display needs. The Phoenix video card can emulate the following styles of display cards.

IBM colour graphics card — 40 or 80 column character display

320 x 200 colour graphics

640 x 200 monochrome graphics

IBM monochrome text display — 80 column high resolution text display

Techmar

Hercules high resolution monochrome graphics display 120 x132 column colour text display mode

Depending on which display mode you choose any monitor up to 25kHz colour monitors can be interfaced to the Phoenix video card. The setup software is menu driven, and allows the user to program its own character set, as well as selecting from a 64 colour pallet.

**\$395.00 with Warranty**

## Hercules

Colour Graphics Board . . . . . **\$312.00**

4 colour graphics and printer board that fits into standard PC/XT or compatible slot. Also included is a parallel interface.

Monochrome Board . . . . . **\$600.00**

A high resolution monochrome display of graphics. Supports word processor, and business graphics software.

## Tecmar

Graphics Master Board/Paint . . . . **\$799.00**

Displays alphanumeric text and graphics on any monochrome display or other standard composite or RGB monitors. Comes complete with a light pen and PC paint brush.

## EPROM PROGRAMMER

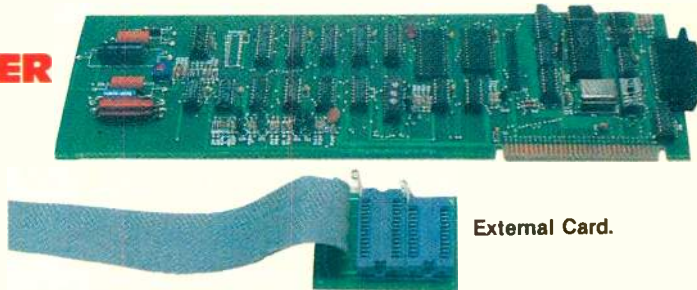

This card can program any one of the following EPROMs: 2716, 2732, 2732A, 2764 and 27128s. Two sockets are available on the adaptor board, one for the 28-pin EPROMs, the other for 24-pin types. These sockets are standard sockets, however as an option ZIF sockets can be used (we recommend ZIF sockets if large numbers of EPROMs will be programmed). Also as an option an extension board is available. This board attaches to the adaptor via a ribbon cable and extends out the back panel. This is to allow EPROMs to be programmed without removing the cabinet cover every time programming is to be performed. Also as a standard feature, the source software is supplied to allow users to modify the program to suit their needs.

As an option a serial port can be included on the card; this serial port has the same features as the port described with the floppy disk controller (see the floppy disk description for documentation of the serial port).

### MAIN EPROM PROGRAMMER CARD (WITH SOFTWARE)

With 2 standard EPROM sockets . . . . . **\$99.00**

### EPROM PROGRAMMER WITH ZIF SOCKETS (WITH SOFTWARE)

With one 24-pin ZIF socket and one 28-pin ZIF socket with provision for serial port . . . . . **\$139.00**

### EXTERNAL CARD

Ready to plug into the main EPROM Card (includes one 24-pin and 28-pin ZIF socket and cable). Saves you from opening the computer each time you want to program your EPROMs. . . . . **\$69.00**

### SERIAL OPTION

For your main EPROM programmer. Provides you with a second RS232 serial port . . . . . **\$49.00**

## BEST MODEM

The BEST modem is a smart 1200/300 direct connect modem. It can either be a stand-alone unit in which case it requires a small wall adaptor, or it plugs in one of the IBM slots. When used as a stand-alone unit, the modem looks like a Hayes 1200 Smart Modem, that is, it emulates the same instruction set. When it is used in the IBM, it looks like an intelligent serial communications port which also supports a super-set of the Hayes instruction set.

The modem supports auto-dial, auto-answer, and auto-speed select directly from software control. The modem also has a speaker so that aural monitoring of the call is possible. There are also LED monitors so that the state of the modem can always be known. These LEDs are: Modem Ready, Auto-Answer enabled, Carrier Detected, Transmitting,

Receiving, Data Set ready.

Software packages such as Crosstalk, PC-talk, and Hayes' Smart-com II also will run with this modem.



300 Baud **\$179.00** 300/1200 Baud **\$249.00**  
300/1200 Baud, Stand-Alone Unit,  
Attractively Packaged . . . . . **\$299.00**

## The BEST Quanta Board



Do you find that your PC is not able to communicate with the outside world and you are constantly having to tell it the correct time and date? A simple solution for a system's short coming would be the BEST Quanta Board. Another of the multi-function boards designed with the personal computer user in mind, its features include the following:

### Serial Ports

- Two serial communication ports that are configured under PC or MS-DOS as COM1 or COM2. Both communications ports support RS232-C signals (TxD, RxD, DTR, DSR, RTS, CTS, CD, and RI) at communication rates of up to 9600 Baud. One or both the serial ports can be disabled, to alleviate contention between any other serial port your system may already contain. The serial ports can also be configured to support the IBM PC mA current loop. The current loop allows the system to communicate with some types of teletype printers.

### Parallel Printer Port

- A parallel printer port which supports many of the popular dot matrix and letter quality printers, as well as digital plotters that are commercially available. The parallel port can be selected as the primary or secondary printer port (LPT2 or LPT3 using DIP switches).

### Games Port

- A game port which allows up to four game paddles, or two joy sticks to be connected to the system. The port is not limited to entertainment software. The port actually gives a value proportional to the resistance on the input, which allows your system to control industrial applications and CAD (computer aided design) software.

### Real Time Clock/Calendar

- A real time clock/calendar with software to interface the clock hardware with the TIME and DATE functions of MS-DOS and PC-DOS. The clock continues to keep the correct time when the system is powered down by utilizing a replaceable lithium battery. The clock is based on the MM58274 CMOS chip and it is accurate to within seconds every year.

**\$159.00 Cables Extra.**

## BEST Multi-Function Disk Drive Controller



The BEST Multi-Function disk drive controller is much more than its name implies. This card makes the most use of an expansion slot in your system by including many needed options on one card. This board may be the last you will have to install in your IBM PC or compatible system because of the extra features we have included.

### Floppy Controller

- Floppy disk drive controller, which can handle up to four double sided, double density 5.25in. 360K disk drives.

The controller circuitry will also control some Tape Back Up units such as those manufactured by Irwin Magnetics in place of one of the four disk drives.

### Serial Ports

- Two serial communications ports that support RS232-C standard signals (TxD, RxD, CTS, RTS, DSR, DTR, and RI).

### Parallel Printer Port

- Parallel Printer Port that can be configured as either your primary or secondary printer port.

### Real Time Clock/Calendar

- Real Time Clock with software, to integrate the clock with your version of PC-DOS or MS-DOS. The clock is designed around an ICL clock chip and is accurate to within seconds a year. A battery back up continues to keep the time during power down.

This is the same floppy controller used in all versions of the BEST personal computer, with excellent reliability and compatibility. Using PC-DOS 2.0 or later, each diskette has a formatted capacity of 360 Kilobytes.

**\$199.00**

## The BEST Economy Floppy Controller

If all you need is an IBM Floppy Controller for your IBM or compatible 360K DS/DD disk drives, we have an economy BEST Floppy Controller which does not have provision for the extra features described in the Multi-Function Disk Drive Controller.

**\$99.00**

## The BEST 256K/512K PentaRAM Board

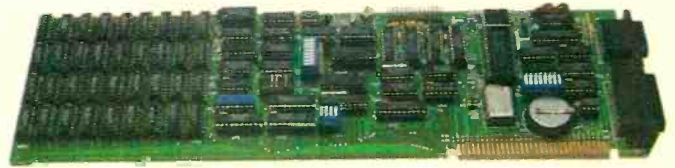

Almost every option your system is lacking can be supplied by the BEST PentaRAM board. This combination of options is one of the most economical ways (from the point of view of both your pocketbook and the expansion slots on your system) to expand your system. All communication ports follow the Industry standards. The additional memory continues on from where your main board's memory stopped, in a completely transparent fashion. In detail the features of the BEST PentaRAM board are as follows:

### Memory

- Up to 256K RAM using 4164's or 512K RAM using state-of-the-art 41256's can be added to your system. The starting memory boundary can be set to 256K, 384K, 512K, or 640K by configuring a bank of dip switches. The added memory is necessary for anyone wishing to operate a RAMdisk, and much of today's software requires a minimum of 384K RAM (Symphony, Framework, etc.) which many of the older PC's are not capable of holding on the main board. Each bank of memory contains an extra chip to support a parity bit for reliable data handling. (If the above boundaries do not match your system's configuration, they can be modified at the factory).

### Serial Port

- A serial communication port that is configured under PC-DOS or MS-DOS as COM1 or COM2. The communications port supports RS232-C signals (TxD, RxD, DTR, DSR, RTS, CTS, CD, and RI) at communication rates of up to 9600 Baud. The serial port can be disabled, to alleviate contention between any other serial port your system may already contain. The serial port can also be configured to support the IBM PC mA current loop. The current loop allows the system to communicate with some types of teletype printers.

### Parallel Printer Port

- A parallel printer port which supports many of the popular dot matrix and letter quality printers, as well as digital plotters that are commercially available. The parallel port can be selected as the primary or secondary printer port (LPT2 or LPT3 using DIP switches).

### Games Port

- A game port which allows up to four game paddles, or two joy sticks to be connected to the system. The port is not limited to entertainment software. The port actually gives a value proportional to the resistance on the input, which allows your system to control industrial applications and CAD (computer aided design) software.

### Real Time Clock/Calendar

- A real time clock/calendar with software to interface the clock hardware with the TIME and DATE functions of MS-DOS and PC-DOS. The clock continues to keep the correct time when the system is powered down by utilizing a replaceable lithium battery. The clock is based on the MM58274 CMOS chip and it is accurate to within seconds every year.

**PentaRAM Board with 256K and all options  
\$299.00**

**PentaRAM Board with 512K and all options  
\$379.00**

## The BEST Parallel/ Game Card

**\$69.00 (Cables Extra)**

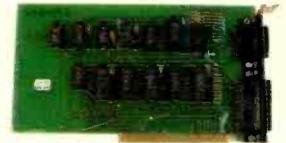

The BEST parallel/game card is an inexpensive addition to any BEST, IBM PC or compatible, which gives you the ability to connect almost any parallel printer or plotter to you system. The Parallel port is accessible through a DB25 connector located on the back of the card, which eliminates the need to disassemble the system case to connect the interface cable to the card. Printers such as the Epson family and Star Micronics, Toshiba and others work with the BEST printer card with no special hardware except the connecting cable.

The game port is compatible with game paddles. Up to four game paddles or two joysticks can be connected via a 15-pin connector on the back of the card.

## BEST 512K RAM Board

Switch selectable boundaries

**Complete with 512K-\$299.00  
With 64K-\$169.00**

**BEST PROTOTYPING BOARD**

**\$28.95**

Mail Orders: 319 College Street, Toronto, Ontario, M5T 1S2

## MICROPROCESSOR CHIPS

|                    |                                    |       |
|--------------------|------------------------------------|-------|
| <b>6500 Series</b> |                                    |       |
| 6502               | 8-bit CPU (1 MHz)                  | 4.95  |
| 6502A              | 8-bit CPU (2 MHz)                  | 8.90  |
| 6522               | VIA Versatile Interface Adaptor    | 6.95  |
| 6522A              | VIA Versatile interface Adaptor    | 8.95  |
| 6532               | RIOT (128x8 RAM, I/O, Timer)       | 7.45  |
| 6545               | CRT Controller                     | 12.95 |
| 6551               | ACIA Async Comm. Interface Adaptor | 8.75  |

|                    |                                  |       |
|--------------------|----------------------------------|-------|
| <b>6800 Series</b> |                                  |       |
| 6800               | 8-bit CPU (1 MHz)                | 4.30  |
| 6802               | On-Chip 128x8 1MHz CPU           | 5.99  |
| 68050              | 8-bit CPU (2 MHz)                | 7.39  |
| 6809               | 8-bit CPU (1 MHz)                | 9.95  |
| 6809D              | 8-bit CPU (2 MHz)                | 23.00 |
| 6810               | 128x8 static RAM                 | 4.15  |
| 6821               | PIA Peripheral Interface Adaptor | 3.59  |
| 6840               | Programmable Timer               | 8.10  |
| 6844               | DMA Controller                   | 14.00 |
| 6845               | CRT controller                   | 8.95  |
| 6845A              | CRT controller                   | 9.95  |
| 6847               | Video Display Generator          | 9.95  |
| 6850               | ACIA                             | 3.45  |
| 6852               | Synchronous Serial Data Adaptor  | 5.80  |
| 6860               | 0.600 Baud Modem                 | 11.95 |

|                     |                              |        |
|---------------------|------------------------------|--------|
| <b>68000 Series</b> |                              |        |
| 68000L8             | 16-bit CPU (8 MHz)           | 50.00  |
| 68000L10            | 16-bit CPU (10 MHz)          | 59.00  |
| 68008               | 16-bit CPU (8-bit data path) | 52.00  |
| 68230               | Parallel Interface Adaptor   | 25.95  |
| 68450               | 6MHz 16-bit DMA Controller   | 110.00 |
| 68451               | Memory Management Controller | 189.00 |
| 68561               | MFPC (68000 Compatible)      | 96.00  |
| 68681               | Duante                       | 19.50  |

|                    |  |        |
|--------------------|--|--------|
| <b>8080 Series</b> |  |        |
| 8080               | 8-bit CPU  | 9.90   |
| 8085               | 8-bit CPU  | 9.45   |
| 8087               | Math Processor (Intel)   | 219.00 |
| 8087-2             | Math Processor Fast 8MHz (Intel)                                 | 279.00 |
| 8088               | 16-bit CPU 8-bit Databus (AMD)                                   | 10.99  |
| 8088               | 16-bit CPU 8-bit Databus (Intel)                                 | 10.99  |
| 8088-2             | 16-bit CPU 8-bit Databus 8MHz (Intel)                            | 14.95  |
| 8212               | 3-bit I/O Port   | 4.99   |
| 8214               | Priority Interrupt Controller                                    | 13.99  |
| 8216               | 4-bit Bidirectional Bus Driver                                   | 4.99   |
| 8224               | Clock generator for 8080/8085                                    | 12.99  |
| 8226               | Inverting Bus Driver   | 5.36   |
| 8228               | System controller for 8080/8085                                  | 9.75   |
| 8237A-5            | High Speed DMA Controller (AMD)                                  | 8.90   |
| 8237A-5            | High Speed DMA Controller (Intel)                                | 12.99  |
| 8250               | Serial Port  | 12.95  |
| 8251A              | Programmable Communications Interface                            | 8.32   |
| 8253A-5            | Programmable Interval Timer (AMD)                                | 5.95   |
| 8253A-5            | Programmable Interval Timer (Intel)                              | 8.95   |
| 8254A-5            | Latest Programmable Interval Timer (improved version of 8253A-5) | 7.95   |
| 8255               | Programmable Interface Adaptor                                   | 4.89   |
| 8255A-5            | Programmable Interface Adaptor                                   | 4.89   |
| 8257-5             | Programmable DMA Controller                                      | 9.95   |
| 8259A              | Programmable Interrupt Controller                                | 4.95   |
| 8275               | Programmable CRT Controller                                      | 24.00  |
| 8279-5PC           | Programmable Keyboard Display Interface                          | 7.50   |
| 8282PC             | Octal latch, non-inverting                                       | 8.55   |
| 8283PC             | Octal latch, inverting   | 20.95  |
| 8284A              | Clock gen and driver   | 5.95   |
| 8286               | 8-bit Bus trans. non-inverting                                   | 8.50   |
| 8287PC             | 8-bit Bus trans. inverting                                       | 10.50  |
| 8288               | Bus Controller   | 8.95   |
| 8289               | Bus Arbiter  | 40.95  |
| 8272               | Floppy Disk Controller (Eqv. to NEC 765)                         | 8.95   |
| 8714ADC            | Univ. Programmable Interface                                     | 34.95  |
| 8748DC             | GPU, 4K EPROM, I/O   | 28.00  |
| 8749DC             | GPU, EPROM, RAM, I/O   | 35.00  |
| 8755ADC            | 2048x8 EPROM, I/O  | 37.95  |

|                    |            |       |
|--------------------|------------|-------|
| <b>8086 Series</b> |            |       |
| 8086               | 16-bit CPU | 13.50 |

|                     |       |        |
|---------------------|-------|--------|
| <b>80286 Series</b> |       |        |
| 80286               | 6 MHz | 139.00 |
| 80286               | 8 MHz | 149.00 |
| 80286               | 10MHz | 190.00 |
| 82288               |       | 23.99  |
| 82284               |       | 18.95  |

|                   |  |       |
|-------------------|--|-------|
| <b>Z80 Series</b> |  |       |
| Z80A-CPU          | 8-bit CPU (4 MHz)                      | 4.50  |
| Z80B-CPU          | 8-bit CPU (6 MHz)                      | 14.95 |
| Z80A-PIO          | Parallel I/O                           | 5.95  |
| Z80A-CTC          | Counter Timer                          | 7.79  |
| Z80A-DART         | Dual Asynchronous Receiver Transmitter | 13.95 |
| Z80A-DMA          | Direct Memory Access                   | 16.50 |
| Z80A-SIO-0        | Serial I/O ver. 0                      | 18.95 |

## Communications & Timers

|          |   |       |
|----------|---|-------|
| AY3-1015 | UART (Single 5V Supply)                   | 7.95  |
| AY5-1013 | UART                                      | 5.90  |
| S1602    | UART                                      | 4.49  |
| TMS9918  | Sprite Graphics Generator                 | 18.95 |
| TMS99632 | Realtime Clock                            | 13.95 |
| COM5016  | Dual Baud Rate Generator                  | 18.10 |
| COM8116  | Quad Baud Rate Generator (5V supply only) | 16.75 |
| AY53600  | Keyboard Encoder                          | 10.95 |
| KR3600   | Keyboard Encoder                          | 8.95  |
| MSM5632  | Realtime Clock                            | 18.10 |
| MSM58321 | Realtime Clock                            | 18.10 |
| SND5037  | CRT Video Timer Controller                | 32.25 |

## Floppy Controllers

|               |   |       |
|---------------|---|-------|
| WD2143        | 4-phase Clock Generator for Floppy        | 14.50 |
| FDC1771       | Single Density Disk Controller            | 19.00 |
| FDC1793       | Double Density Disk Controller            | 47.00 |
| FDC1795       | Double Density/Sided Disk Controller      | 69.00 |
| FDC2793       | Dbl. Density Disk Controller c/w precomp. | 45.00 |
| FDC2795       | ODDS Disk Controller c/w precomp.         | 59.95 |
| FDC9216       | Floppy Disk Data Separator                | 10.50 |
| NEC765 (8272) | Floppy Disk cont.                         | 8.95  |

## 74LS00 SERIES

|         |   |      |
|---------|---|------|
| 74LS00  | Quad 2 input NAND gate                      | 29   |
| 74LS01  | Quad 2 input NAND gate O/C                  | 45   |
| 74LS02  | Quad 2 input NOR gate                       | 29   |
| 74LS03  | Quad 2 input NOR gate O/C                   | 45   |
| 74LS04  | Hex inverter                                | 32   |
| 74LS05  | Hex inverter O/C                            | 45   |
| 74LS08  | Quad 2 input AND gate                       | 29   |
| 74LS09  | Quad 2 input AND gate O/C                   | 45   |
| 74LS10  | Triple 3 input NAND gate                    | 40   |
| 74LS11  | Triple 3 input AND gate O/C                 | 45   |
| 74LS12  | NAND gate inverter                          | 50   |
| 74LS13  | Dual Schmidt trigger                        | 50   |
| 74LS14  | Hex Schmidt trigger inverter                | 59   |
| 74LS15  | Triple 3 input AND gate                     | 75   |
| 74LS20  | Dual 4 input NAND gate                      | 45   |
| 74LS21  | Dual 4 input AND gate                       | 45   |
| 74LS22  | Quad 2 input NAND gate                      | 45   |
| 74LS24  | Quad 2 input NAND Schmidt trigger           | 75   |
| 74LS26  | Quad 2 input positive NAND gate             | 45   |
| 74LS27  | Triple 3 input NOR gate                     | 45   |
| 74LS28  | Quad 2 input NOR buffer                     | 45   |
| 74LS30  | 8 input NAND gate                           | 45   |
| 74LS32  | Quad 2 input NOR gate                       | 45   |
| 74LS33  | Quad 2 input NOR gate O/C                   | 55   |
| 74LS37  | Quad 2 input AND gate                       | 45   |
| 74LS38  | Quad 2 input AND gate O/C                   | 60   |
| 74LS42  | BCD to decimal decoder                      | 90   |
| 74LS47  | BCD to 7 segment decoder/driver             | 90   |
| 74LS48  | BCD to 7 segment decoder/driver             | 99   |
| 74LS49  | BCD to 7 segment decoder/driver             | 79   |
| 74LS51  | And/or Invert gate                          | 45   |
| 74LS54  | 4 wide and/or invert gate                   | 45   |
| 74LS55  | 2 wide 4 input and/or invert gate           | 45   |
| 74LS63  | Hex current sensing switch                  | 1.70 |
| 74LS73  | Dual JK flip flop with clear                | 55   |
| 74LS74  | Dual D flip flop                            | 55   |
| 74LS75  | 4 bit bistable latch                        | 50   |
| 74LS76  | Dual JK master/slave flip flop              | 90   |
| 74LS77  | 4 bit bistable latch                        | 1.00 |
| 74LS78  | Dual JK flip flop preset, common clear      | 80   |
| 74LS83  | 4 bit binary full adder                     | 55   |
| 74LS85  | 4 bit magnitude comparator                  | 94   |
| 74LS86  | Quad input XOR gate                         | 55   |
| 74LS90  | Decade counter                              | 75   |
| 74LS91  | 8 bit shift register                        | 65   |
| 74LS92  | Divide by 12 counter                        | 66   |
| 74LS93  | 4 bit binary counter                        | 66   |
| 74LS95  | 4 bit right/left shift register             | 80   |
| 74LS96  | 5 bit shift register asynch. preset         | 80   |
| 74LS97  | Dual JK flip flop with clear                | 55   |
| 74LS109 | Dual JK pos. edge triggered flip flop       | 60   |
| 74LS112 | Dual JK edge triggered flip flop            | 60   |
| 74LS113 | Dual JK edge triggered flip flop            | 55   |
| 74LS114 | Dual JK edge triggered flip flop            | 55   |
| 74LS122 | Retriggerable monostable multivibrator      | 90   |
| 74LS123 | Dual retriggerable monostable multivibrator | 53   |
| 74LS125 | Tri state quad bus buffer                   | 50   |
| 74LS126 | Quad 3 state buffer                         | 60   |
| 74LS132 | Quad 2 input NAND Gate                      | 89   |
| 74LS133 | 13 input NAND gate                          | 70   |
| 74LS136 | Quad XOR gate                               | 55   |
| 74LS137 | 3 bit 8 decoder/demultiplexer               | 99   |
| 74LS138 | 3 to 8 decoder/multiplexer                  | 68   |
| 74LS139 | Quad 1 of 4 decoder/demultiplexer           | 58   |
| 74LS145 | BCD to decimal decoder/driver               | 1.25 |
| 74LS147 | 10/4 priority encoder                       | 2.00 |
| 74LS148 | 8 to 3 line priority encoder                | 2.15 |
| 74LS151 | 8 channel digital multiplexer               | 75   |
| 74LS153 | Dual 4:1 multiplexer                        | 75   |
| 74LS154 | 4 to 16 decoder multiplexer                 | 1.05 |
| 74LS155 | Decoder/demultiplexer                       | 99   |
| 74LS156 | Decoder/demultiplexer                       | 85   |
| 74LS157 | Quad selector/multiplexer                   | 70   |
| 74LS158 | Quad 2 input multiplexer (inverting)        | 75   |
| 74LS160 | Decade counter with asynch. clear           | 96   |
| 74LS161 | Sync. 4 bit counter                         | 95   |
| 74LS162 | Sync. 4 bit counter                         | 95   |
| 74LS163 | Sync. 4 bit counter                         | 95   |
| 74LS164 | 8 bit serial shift register                 | 89   |
| 74LS165 | Parallel load 8 bit shift register          | 1.08 |
| 74LS166 | 8 bit PISO shift register                   | 1.95 |
| 74LS168 | Up/down decade counter                      | 2.25 |
| 74LS169 | 4 bit synch. binary counter                 | 1.38 |
| 74LS170 | 4x 4 register file                          | 1.95 |
| 74LS173 | 4 bit tri-state register                    | .78  |
| 74LS174 | Hex D flip flop with clear                  | .80  |
| 74LS175 | Quad D flip flop with clear                 | .80  |
| 74LS181 | 4 bit ALU                                   | 2.75 |
| 74LS182 | Look ahead carry                            | 2.75 |
| 74LS190 | Sync. up/down counter BCD                   | .93  |
| 74LS191 | Sync. up/down counter binary                | .93  |
| 74LS192 | Binary up/down counter                      | .93  |
| 74LS193 | Binary up/down counter                      | .93  |
| 74LS194 | 4 bit bi-directional shift register         | .93  |
| 74LS195 | 4 bit shift register                        | .75  |
| 74LS196 | Decade counter                              | 1.50 |
| 74LS197 | Presetable binary counter                   | 1.05 |
| 74LS221 | Dual monostable multivibrator               | 1.25 |
| 74LS240 | Octal inverter bus driver                   | 1.25 |
| 74LS241 | Octal bus driver                            | 1.25 |
| 74LS242 | Quad Inverting transceiver                  | 1.20 |
| 74LS243 | Quad transceiver                            | 1.17 |
| 74LS244 | Tri state octal driver                      | 1.20 |
| 74LS245 | Octal bus transceiver                       | 1.39 |
| 74LS247 | BCD to 7 segment decoder driver             | 1.05 |
| 74LS248 | BCD to 7 segment decoder driver             | 1.35 |
| 74LS249 | BCD to 7 segment decoder driver             | 1.35 |
| 74LS251 | Tristate data selector multiplexer          | .78  |
| 74LS253 | Dual 4 bit multiplexer                      | .75  |
| 74LS257 | Quad 2 input multiplexer                    | .80  |
| 74LS258 | Quad 2 input multiplexer                    | .80  |
| 74LS259 | 8 bit addressable latch                     | 1.30 |
| 74LS260 | Dual 5 input NOR gate                       | .79  |
| 74LS266 | Quad 2 input NOR O/C                        | .50  |
| 74LS273 | Octal D flip flop                           | 1.18 |
| 74LS275 | 7 bit slice Wallace tree                    | 5.55 |
| 74LS279 | Quad S-P latches                            | .59  |
| 74LS280 | 9 bit odd/even parity checker/generator     | 3.25 |
| 74LS283 | 4 bit binary full adder                     | .79  |
| 74LS290 | 64 bit RAM                                  | 6.25 |
| 74LS291 | Decade counter                              | .90  |
| 74LS293 | 4 bit binary counter                        | .95  |
| 74LS295 | 4 bit shift register                        | 1.50 |

|           |   |       |
|-----------|---|-------|
| 74LS298   | Quad 2 input multiplexer                  | 1.12  |
| 74LS299   | 8 bit storage register                    | 2.75  |
| 74LS320   | Crystal oscillator                        | 4.00  |
| 74LS321   | Crystal oscillator                        | 3.90  |
| 74LS322A  | 8 bit shift register                      | 5.49  |
| 74LS323   | 8 bit bidirectional universal shift       | 4.25  |
| 74LS348   | 8 to 3 priority encoder                   | 2.75  |
| 74LS352   | Dual 4 bit multiplexer                    | 1.05  |
| 74LS353   | Dual 4 bit multiplexer                    | 1.05  |
| 74LS354   | Data selector multiplexer                 | 4.75  |
| 74LS355   | Data selector multiplexer                 | 4.75  |
| 74LS356   | Data selector multiplexer                 | 4.75  |
| 74LS357   | Data selector multiplexer                 | 4.99  |
| 74LS365   | Hex bus driver (tri state)                | .62   |
| 74LS366   | Hex bus driver (inverted output)          | .62   |
| 74LS367   | Hex bus driver (inverted output)          | .62   |
| 74LS368   | Hex bus driver (inverted output)          | .62   |
| 74LS373   | Octal transparent latch                   | 1.20  |
| 74LS374   | Octal D flip flop                         | 1.20  |
| 74LS375   | 4 bit bistable latch                      | .65   |
| 74LS377   | Octal D register                          | 1.23  |
| 74LS378   | Hex D register                            | 1.85  |
| 74LS379   | 4 bit register                            | 1.85  |
| 74LS380   | Multifunction octal generator             | 9.00  |
| 74LS384   | 8 bit multiplexer                         | 7.95  |
| 74LS386   | Quad 2 input XOR gate                     | 50    |
| 74LS390   | Dual decade counter                       | 1.28  |
| 74LS393   | Dual 4 bit binary counter                 | 1.12  |
| 74LS395   | Tri state shift register                  | 1.89  |
| 74LS396   | Octal storage register                    | 2.75  |
| 74LS398   | Quad 0 flip flop                          | 2.75  |
| 74LS399   | Quad 2 input multiplexer with storage     | 1.45  |
| 74LS629   | Voltage controlled oscillator             | 3.30  |
| 74LS612   | Current controlled oscillator             | 28.00 |
| 74LS610   | Octal bus transceiver                     | 2.20  |
| 74LS641   | Octal bus transceivers AND registers      | 3.20  |
| 74LS642NT | Octal bus transceivers AND registers      | 10.95 |
| 74LS643NT | Octal bus transceivers AND registers      | 10.95 |
| 74LS644NT | Octal bus transceivers AND registers      | 10.95 |
| 74LS645NT | Octal bus transceivers AND registers      | 10.95 |
| 74LS670   | 4x 4 register file 3-state                | 1.85  |
| 74LS673   | 16 bit SISO shift reg.                    | 19.95 |
| 74LS682   | 8 bit magnitude comparator                | 3.99  |
| 74LS683   | 8 bit magnitude comparator-open collector | 3.99  |
| 74LS684   | 8 bit magnitude comparator, 3-state       | 3.99  |
| 74LS688   | 8 bit magnitude comparator, 3-state       | 3.99  |
| 74LS689   | 8 bit magnitude comparator open collector | 5.35  |
| 74LS795   | Octal buffer (81LS95), 3-State            | 1.29  |
| 74LS796   | Octal buffer (81LS96), 3-State            | 1.29  |
| 74LS797   | Octal buffer (81LS97), 3-State            | 1.29  |
| 74LS798   | Octal buffer (81LS98), 3-State            | 1.29  |

**Commonly used parts for your IBM compatible (8088) systems and peripherals**  
**Only prime quality parts sold.**  
**Quantity Discounts Available**  
 8088 CPU \$10.99  
 8087 Math Processor \$219.00  
 8237A-5 Prog. DMA Cntrl. \$ 8.90  
 8250 Serial Port \$12.99  
 8253A-5 Prog. Interval timer \$5.99  
 8255A-5 P.I.A. \$4.89  
 8259A Prog. Interrupt Cntrl. \$4.95  
 8284A ADC clock gen & driver \$5.95  
 8288 Bus Controller \$8.95  
 8272 Floppy Disk Controller \$ 8.95  
 NEC 765 Floppy Disk Controller (equivalent to 8272) \$ 8.95  
 8086 CPU \$13.50  
 Set of 8088, 8255A-5, 8237A-5, 8288, 8284, 8253A-5 and 8259A \$43.95

100ns delay llne \$4.95  
 7ns delay llne \$12.45  
 62 pin edge con (high quality) \$1.79  
 5 pin Din conn \$ .99  
 Power conn \$1.25  
 Dip switch 8 pos \$1.75  
 4.7k x 6 sfp \$ .39  
 4.7k x 8 pin sfp \$ .44  
 8.2k or 10k 16 pin Resistor or network \$ .99  
 30ohm x 8 network \$ .99  
 Small speaker \$1.99  
 .1 uf 50V high quality bypass capacitors \$ .10  
 Trimcap \$ .99

| CMOS |   |       |  |
|------|---|-------|--|
| 4000 | Dual 3 input NOR gate                         | 33    |  |
| 4001 | Quad 2 input NOR gate                         | 33    |  |
| 4002 | Dual 4 input NOR gate                         | 33    |  |
| 4006 | 18 static shift register                      | 36    |  |
| 4007 | Dual complementary pairs/inverters            | 35    |  |
| 4008 | 4 bit full adders                             | 84    |  |
| 4009 | Hex buffer/converter (inverting)              | 89    |  |
| 4010 | Hex buffer/converter                          | 89    |  |
| 4011 | Quad 2 input NAND gate                        | 33    |  |
| 4012 | Dual 4 input NAND gate                        | 33    |  |
| 4013 | Quad D edge triggered flip flop               | 43    |  |
| 4014 | 8 bit static shift register                   | 89    |  |
| 4015 | Dual 4 bit static shift register              | 79    |  |
| 4016 | Quad bilateral switch                         | 46    |  |
| 4017 | Decade counter/divider                        | 75    |  |
| 4018 | Presetable BCD decade counter                 | 82    |  |
| 4019 | Quad and/or select gate                       | 52    |  |
| 4020 | 14 stage binary ripple counter                | 85    |  |
| 4021 | 8 bit static shift register                   | 85    |  |
| 4022 | Divide by 8 counter/divider                   | 85    |  |
| 4023 | Triple 3 input NAND gate                      | 34    |  |
| 4024 | 7 stage binary counter                        | 55    |  |
| 4025 | Triple 3 input NOR gate                       | 34    |  |
| 4026 | Decade counter/divider                        | 1.30  |  |
| 4027 | Dual JK flip flop                             | 50    |  |
| 4028 | BCD to decimal decoder                        | 65    |  |
| 4029 | Presetable up/down binary/decade counter      | 90    |  |
| 4030 | Quad XOR gate                                 | 42    |  |
| 4033 | 7 segment decade counter                      | 1.00  |  |
| 4034 | 8 state universal bus register                | 1.95  |  |
| 4035 | 4 state 4 input register                      | 1.32  |  |
| 4038 | Triple serial register                        | 2.00  |  |
| 4040 | 12 stage binary ripple counter                | 78    |  |
| 4041 | Quad true complement buffer                   | 79    |  |
| 4042 | Quad clock D latch                            | 59    |  |
| 4043 | Quad RS NAND latch                            | 64    |  |
| 4044 | Quad tri state NAND RA latch                  | 80    |  |
| 4046 | Microprocessor phase locked loop              | 95    |  |
| 4047 | Low power monostable/astable multivibrator    | 75    |  |
| 4049 | Inverting hex buffer                          | 45    |  |
| 4050 | Hex buffer                                    | 45    |  |
| 4051 | Single 8 channel multiplexer/demultiplexer    | 80    |  |
| 4052 | Dual 4 channel multiplexer                    | 90    |  |
| 4053 | Triplet 2 channel multiplexer/demultiplexer   | 90    |  |
| 4054 | 4 segment display driver                      | 99    |  |
| 4055 | BCD to 7 segment recorder/LCD driver          | 1.75  |  |
| 4056 | BCD to 7 segment recorder/LCD driver          | 1.75  |  |
| 4060 | 14 stage binary counter/oscillator            | 83    |  |
| 4066 | Quad bilateral switch                         | 46    |  |
| 4068 | 8 input NAND gate                             | 44    |  |
| 4069 | Hex inverter                                  | 34    |  |
| 4070 | Quad 2 input XOR gate                         | 34    |  |
| 4071 | Quad 2 input OR gate                          | 36    |  |
| 4072 | Dual 4 input OR gate                          | 34    |  |
| 4073 | Triple 3 input gate                           | 34    |  |
| 4075 | Triple 3 input OR gate                        | 34    |  |
| 4076 | 4 bit D register                              | 90    |  |
| 4078 | 8 input NOR gate                              | 34    |  |
| 4081 | Quad 2 input AND gate                         | 32    |  |
| 4082 | Dual 4 input AND gate                         | 32    |  |
| 4086 | Expandable 4 by 2 AND/OR invert gate          | 52    |  |
| 4093 | Quad 2 input NAND Schmitt trigger             | 59    |  |
| 4094 | 8 state shift register                        | 99    |  |
| 4097 | Diff 8 channel analog mux/demux               | 1.90  |  |
| 4099 | 8 bit addressable latch                       | 99    |  |
| 4501 | Industrial control unit                       | 2.99  |  |
| 4502 | Strobus Hex inverter/buffer                   | 1.25  |  |
| 4503 | Hex in state buffer                           | 89    |  |
| 4504 | Hex level shifter                             | 1.49  |  |
| 4506 | Dual Expandable AOI gate                      | 2.54  |  |
| 4508 | Dual 4 bit latch tri-state                    | 1.75  |  |
| 4510 | BCD up/down counter                           | 95    |  |
| 4511 | BCD to 7 segment latch/decoder/divider        | 95    |  |
| 4512 | 8 channel data separator                      | 89    |  |
| 4514 | 1 of 16 decoder/demultiplexer                 | 1.85  |  |
| 4515 | 1 of 16 decoder/demultiplexer                 | 1.85  |  |
| 4516 | Binary up/down counter                        | 95    |  |
| 4518 | Dual BCD up counter                           | 89    |  |
| 4519 | 4 bit AND/OR select gate                      | 85    |  |
| 4520 | Dual binary up counter                        | 79    |  |
| 4521 | 24 state frequency divider                    | 1.99  |  |
| 4522 | BCD divide by N counter                       | 1.25  |  |
| 4526 | 4 bit binary divide by N counter              | 1.10  |  |
| 4527 | BCD rate multiplier                           | 1.10  |  |
| 4528 | Dual reprogrammable/resettable monostable     | 1.10  |  |
| 4529 | Dual 4 channel mux                            | 1.30  |  |
| 4530 | Dual 5 input majority logic gate              | 1.05  |  |
| 4531 | 12 bit parity generator/checker               | 1.35  |  |
| 4532 | 8 bit priority encoder                        | 1.35  |  |
| 4534 | Real time 5 decade counter                    | 7.50  |  |
| 4536 | Programmable timer                            | 2.37  |  |
| 4538 | Dual precision monostable multivibrator       | 1.30  |  |
| 4539 | Dual 4 channel digital multiplexer            | 1.25  |  |
| 4541 | Quad 2 input NAND gate                        | 33    |  |
| 4543 | BCD to 7 segment latch/decoder/divider        | 1.05  |  |
| 4553 | 3 digit BCD counter                           | 2.89  |  |
| 4555 | Dual binary 1 of 4 decoder                    | .63   |  |
| 4556 | Dual binary 1 of 4 decoder                    | .75   |  |
| 4557 | 4 bit shift register                          | 45    |  |
| 4558 | BCD to 7 segment decoder                      | 1.55  |  |
| 4560 | NBCD adder                                    | 1.59  |  |
| 4561 | 9's complementor                              | 1.05  |  |
| 4562 | 128 bit static shift register                 | 7.95  |  |
| 4566 | Real time base generator                      | 1.89  |  |
| 4568 | Phase comparator/programmable counter         | 2.50  |  |
| 4572 | Hex gate                                      | .85   |  |
| 4573 | Quad programmable comp. amp.                  | 3.43  |  |
| 4575 | Quad programmable comp. amp.                  | 3.43  |  |
| 4580 | 4 x 4 multiport register                      | 6.49  |  |
| 4581 | 4 bit AUI                                     | 2.25  |  |
| 4582 | Carry look ahead generator                    | 1.75  |  |
| 4583 | Dual Schmitt trigger                          | .95   |  |
| 4584 | Hex Schmitt trigger                           | .99   |  |
| 4585 | 8 bit magnitude comparator                    | .99   |  |
| 4702 | Programmable bit rate generator               | 11.99 |  |
|      | 1A - 5V regulator                             | 8.38  |  |
| 129  | Quad op amp                                   | 3.95  |  |
| 134  | Quad comparator                               | 3.95  |  |
| 148  | Quad op amp                                   | 5.50  |  |
| 300  | General purpose op amp                        | 4.10  |  |
| 301A | General purpose op amp                        | 7.86  |  |
| 305  | Voltage regulator                             | 1.15  |  |
| 306  | Improved voltage comparator                   | 1.50  |  |
| 307  | Op amp  | .60   |  |
| 308  | Super beta op amp                             | .75   |  |
| 309  | Op amp  | .63   |  |
| 310  | Voltage follower                              | 3.38  |  |
| 311  | Voltage comparator                            | 1.50  |  |
| 317  | 3 terminal adjustable regulator               | 1.29  |  |
| 318  | Precision high speed op amp                   | 1.45  |  |
| 319  | High speed dual comparator                    | 74.09 |  |
| 323  | 3A - 5V regulator                             | 5.19  |  |
| 324  | Quad op amp                                   | .58   |  |
| 337  | 3 terminal negative regulator                 | 1.75  |  |
| 339  | Quad comparator                               | .55   |  |
| 348  | Quad low-power 741                            | .88   |  |
| 350  | 3A 3 term. positive adjust. regulator         | 7.25  |  |
| 355  | FET input op amp                              | .89   |  |
| 356  | Monolithic J-FET input op amp                 | 1.95  |  |
| 357  | Monolithic J-FET input op amp (uncompensated) | 1.95  |  |
| 358  | Dual version of 324                           | .55   |  |
| 380  | 2W audio amp                                  | 1.10  |  |
| 393  | Dual version of 339                           | .60   |  |
| 398  | Sample and hold amplifier                     | 5.94  |  |
| 413  | Timer   | .55   |  |
| 415  | Dual timer                                    | .82   |  |
| 417  | Quad timer                                    | 1.90  |  |
| 418  | Tone decoder                                  | .95   |  |
| 419  | Op amp  | .78   |  |
| 420  | Differential comparator                       | 1.32  |  |
| 421  | Dual channel differential comparator          | .99   |  |
| 422  | Precision op amp                              | 4.45  |  |
| 423  | High speed op amp                             | 5.25  |  |
| 424  | Voltage regulator                             | .59   |  |
| 425  | Instrumentation op amp                        | 2.99  |  |
| 426  | Differential video amp                        | 2.99  |  |
| 427  | Dual high performance op amp                  | 2.05  |  |
| 428  | Operational amplifier                         | .59   |  |
| 429  | Dual op amp                                   | .75   |  |
| 430  | Op amp  | .65   |  |
| 431  | Dual audio preamplifier                       | 2.99  |  |
| 432  | Power op amp                                  | 2.89  |  |
| 433  | High speed differential comparator            | 11.95 |  |
| 434  | Multi-purpose programmable op amp             | 1.10  |  |
| 435  | Modulator/demodulator                         | 3.25  |  |
| 436  | RF modulator                                  | 4.32  |  |
| 437  | High voltage op amp                           | 1.72  |  |
| 438  | Quad op amp                                   | .54   |  |
| 439  | Quad line driver                              | .59   |  |
| 440  | Quad RS232 line receiver                      | .59   |  |
| 441  | Multiplier                                    | 5.25  |  |
| 442  | Modulator/demodulator                         | 1.98  |  |
| 443  | Dual op amp                                   | 1.98  |  |
| 444  | Four quad multiplier                          | 7.77  |  |
| 445  | Modulator/demodulator                         | 6.25  |  |
| 446  | Demodulator                                   | 5.49  |  |
| 447  | Video modulator                               | 6.25  |  |
| 448  | Quad op amp                                   | 0.95  |  |
| 449  | Quad RS423 line driver                        | 5.49  |  |
| 450  | Quad RS422/423 line driver                    | 3.95  |  |
| 451  | Quad differential line driver RS422           | 2.30  |  |
| 452  | Quad differential line driver RS422           | 2.30  |  |
| 453  | Quad differential line driver RS422           | 2.45  |  |
| 454  | Floppy disk read amplifier                    | 5.99  |  |
| 455  | Quad RS422/423 line receiver                  | 2.25  |  |
| 456  | Quad line driver RS422                        | 2.35  |  |
| 457  | Analog complex sound generator                | 5.00  |  |
| 458  | Analog complex sound generator c/w amp        | 6.90  |  |
| 459  | Microprocessor cont. complex sound generator  | 8.30  |  |
| 460  | Quad tri-state bus transceiver                | 1.75  |  |
| 461  | Quad tri-state bus transceiver                | 1.50  |  |
| 462  | Low noise bifet op amp                        | .86   |  |
| 463  | Low noise bifet op amp                        | .78   |  |
| 464  | Low noise bifet op amp                        | 1.90  |  |
| 465  | Low noise bifet op amp                        | 2.99  |  |
| 466  | Low noise bifet op amp                        | .69   |  |
| 467  | General purpose bifet op amp                  | .75   |  |
| 468  | General purpose bifet op amp                  | .99   |  |
| 469  | General purpose bifet op amp                  | 2.50  |  |
| 470  | General purpose bifet op amp                  | 1.85  |  |
| 471  | Switching voltage regulator                   | 2.35  |  |
| 472  | 7 segment transistor array                    | 1.00  |  |
| 473  | 7 segment transistor array                    | 1.00  |  |
| 474  | 7 segment transistor array                    | 1.00  |  |
| 475  | Multifunction IC                              | 67.95 |  |
| 476  | Monolithic wavform generator                  | 8.10  |  |
| 477  | FSK modulator/demodulator                     | 4.99  |  |
| 478  | Phase lock loop                               | 4.99  |  |
| 479  | RF repeater                                   | 11.95 |  |
| 480  | Monolithic timing circuit                     | 1.64  |  |
| 481  | Stereo demodulator                            | 1.25  |  |
| 482  | Monolithic function generator                 | 2.75  |  |
| 483  | Voltage controlled oscillator                 | 4.95  |  |
| 484  | Operation multiplier                          | 2.99  |  |
| 485  | Precision oscillator                          | 3.25  |  |
| 486  | FSK demodulator/tone decoder                  | 6.99  |  |
| 487  | Precision phase locked loop                   | 8.99  |  |
| 488  | Long range timer                              | 2.25  |  |
| 489  | Dual monolithic tone decoder                  | 2.40  |  |
| 490  | Dual low noise op amp                         | 1.55  |  |
| 491  | FSK modem system                              | 8.75  |  |

**74SXX Series TTL**

|        |   |      |
|--------|---|------|
| 74S00  | Quad 2 input NAND gate                    | .62  |
| 74S02  | Quad 2 input NOR gate                     | .62  |
| 74S03  | Quad 2 input NOR gate O/C                 | .75  |
| 74S04  | Hex inverter                              | .62  |
| 74S05  | Hex inverter O/C                          | .75  |
| 74S06  | Quad 2 input AND gate                     | .79  |
| 74S09  | Quad 2 input AND gate O/C                 | .79  |
| 74S10  | Triple 3 input NAND gate                  | .79  |
| 74S11  | Triple 3 input AND gate O/C               | .79  |
| 74S15  | Triple 3 input AND gate O/C               | .79  |
| 74S20  | Dual 4 input NAND gate                    | .62  |
| 74S22  | Dual 4 input NAND gate O/C                | .62  |
| 74S30  | 8 input NAND gate                         | .72  |
| 74S32  | Quad 2 input NOR buffer                   | .62  |
| 74S37  | Quad 2 input NAND buffer                  | 2.49 |
| 74S38  | Quad 2 input NAND buffer O/C              | 2.49 |
| 74S40  | Dual 4 input NAND buffer                  | .99  |
| 74S74  | Dual D flip flop                          | 2.99 |
| 74S85  | 4 bit magnitude comparator                | .50  |
| 74S86  | Quad 2 input XOR gate                     | 1.00 |
| 74S109 | Dual JK positive edge triggered flip flop | 1.60 |
| 74S112 | Dual JK flip flop                         | 2.50 |
| 74S113 | Dual JK negative edge triggered flip flop | 1.25 |
| 74S114 | Dual JK negative edge triggered flip flop | 1.25 |
| 74S115 | Dual JK negative edge triggered flip flop | 1.45 |
| 74S124 | Dual VCO                                  | 3.95 |
| 74S132 | Quad 2 input Schmitt trigger              | 2.20 |
| 74S138 | 3 decoder/multiplexer                     | 1.99 |
| 74S139 | Dual 2 decoder/multiplexer                | 1.99 |
| 74S140 | Quad line driver                          | 1.05 |
| 74S151 | 8 channel digital multiplexer             | 1.99 |
| 74S152 | Dual 4 input multiplexer                  | 1.50 |
| 74S157 | Quad 2 input multiplexer                  | 1.59 |
| 74S158 | Quad 2 input multiplexer                  | 1.59 |
| 74S160 | Decade counter with async clear           | 4.95 |
| 74S161 | Quad 2 input multiplexer                  | 4.95 |
| 74S162 | Quad 4 bit counter                        | 3.69 |
| 74S163 | Quad 4 bit counter                        | 2.75 |
| 74S166 | 4 bit down/up sync counter                | 7.44 |
| 74S169 | 4 bit sync counter                        | 6.95 |
| 74S174 | Quad D flip flop with clear               | 1.70 |
| 74S175 | Quad D flip flop with clear               | 1.80 |
| 74S182 | Look ahead carry generator                | 3.75 |
| 74S189 | 16 x 4 RAM                                | 4.50 |
| 74S195 | 4 bit parallel access shift register      | 2.99 |
| 74S196 | Hex bus drivers/inverters                 | 4.95 |
| 74S197 | Hex bus drivers/inverters                 | 4.95 |
| 74S201 | 256 bit RAM                               | 8.95 |
| 74S241 | Octal line driver                         | 3.95 |
| 74S242 | Octal line driver                         | 2.99 |
| 74S251 | Tri-state data selector/multiplexer       | 1.65 |
| 74S260 | Dual 5 input NOR gate                     | 2.18 |
| 74S280 | 8 bit universal shift storage register    | 3.10 |
| 74S289 | Octal D latch                             | 2.50 |
| 74S374 | Octal D latch                             | 3.90 |

**74F00 Series**

|        |  |      |
|--------|--|------|
| 74F00  | Quad 2 input NAND gate                   | .73  |
| 74F02  | Quad 2 input NOR gate                    | .73  |
| 74F04  | Hex inverter                             | .73  |
| 74F06  | Quad 2 input AND gate                    | .73  |
| 74F10  | Triple 3 input NAND gate                 | .73  |
| 74F11  | Triple 3 input AND gate                  | .73  |
| 74F12  | Triple 3 input NOR gate                  | .73  |
| 74F20  | Dual 4 input NAND gate                   | .73  |
| 74F32  | Quad 2 input NOR gate                    | .88  |
| 74F74  | Dual D type flip flop                    | 65   |
| 74F86  | Quad exclusive OR gate                   | 1.75 |
| 74F109 | Dual JK POS edge triggered flip flop     | 1.99 |
| 74F112 | Dual JK NEG edge triggered flip flop     | 1.79 |
| 74F113 | Dual JK edge triggered flip flop         | 1.79 |
| 74F114 | Dual JK NEG edge triggered flip flop     | 1.75 |
| 74F138 | 3 to 8 line decoder/multiplexer          | 1.79 |
| 74F139 | Dual 1-4 decoder/demultiplexer           | 1.79 |
| 74F148 | 8 to 3 line priority encoder             | 1.75 |
| 74F151 | 8 input multiplexer                      | 1.95 |
| 74F153 | Dual 4 input multiplexer                 | 1.75 |
| 74F157 | Quad 2 to 1 line data selector           | 1.75 |
| 74F158 | Quad 2 input multiplexer                 | 1.75 |
| 74F160 | Quad 2 input multiplexer with BCD decade | 4.35 |
| 74F164 | Serial in, parallel out shift register   | 2.95 |
| 74F174 | Hex D flip flop                          | 3.95 |
| 74F175 | Quad D flip flop                         | 2.79 |
| 74F181 | 4 bit ALU                                | 6.75 |
| 74F182 | Carry, look ahead generator              | 2.99 |
| 74F190 | Up/down decade counter                   | 4.25 |
| 74F192 | Up/down decade counter                   | 4.35 |
| 74F193 | 8 bit binary counter                     | 5.45 |
| 74F240 | Octal bufferline driver                  | 3.19 |
| 74F241 | Octal bufferline driver                  | 3.19 |
| 74F242 | Quad bus transceiver 3S                  | 6.49 |
| 74F244 | Octal bufferline driverline receiver     | 3.19 |
| 74F245 | Octal bidirectional transceiver          | 6.95 |
| 74F251 | 8 input multiplexer                      | 1.75 |
| 74F253 | Dual 4 input multiplexer                 | 1.75 |
| 74F254 | Quad 2 input multiplexer                 | 1.75 |
| 74F280 | 8 bit parity generator/checker           | 2.19 |
| 74F283 | 4 bit binary full adder                  | 1.75 |
| 74F290 | Shift/store reg./3S                      | 3.99 |
| 74F350 | 4 bit shifter                            | 1.39 |
| 74F352 | Dual 4 input multiplexer                 | 1.75 |
| 74F353 | Dual 4 input multiplexer                 | 1.75 |
| 74F373 | Octal transparent latch                  | 4.35 |
| 74F374 | Octal dual flip flop                     | 2.45 |
| 74F378 | Parallel D register                      | 4.65 |
| 74F379 | Quad parallel register                   | 3.99 |
| 74F381 | 4 bit ALU                                | 2.99 |
| 74F382 | 4 bit ALU                                | 6.19 |

Prices and Specifications subject to change without notice.



## Designers Dreambox

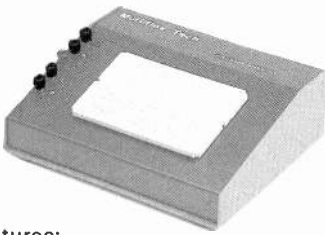

### Features:

- Fully enclosed power supply
- On/off switch with indicator light
- Voltage plus 5V at 5A, plus 12V at 2A, minus 12V at 0.5A and 0 to 12V at 2A.
- With Prototyping Breadboard mounted right on the power supply box.

**All this for only \$149.00**

Other combination of set voltages and variable voltages available to order at slightly higher cost.

## IBM Style Case

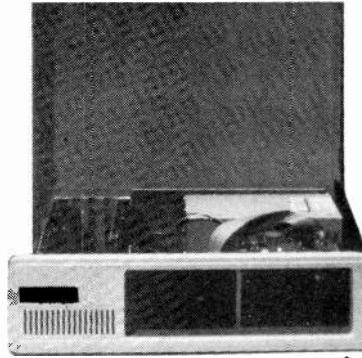

Flip-Top, 8 Slot ..... **\$ 75.00**  
With 150W Power Supply ..... **\$219.00**

## IBM Compatible Keyboards

Maxiswitch ..... **\$135.00**  
Keytronics 5150 ..... **\$135.00**  
Keytronics 5151 (Enhanced) ..... **\$249.00**

## KEPCO POWER SUPPLIES

Rated 90W Max  
RFI filter and  
fuse on board  
115/230V

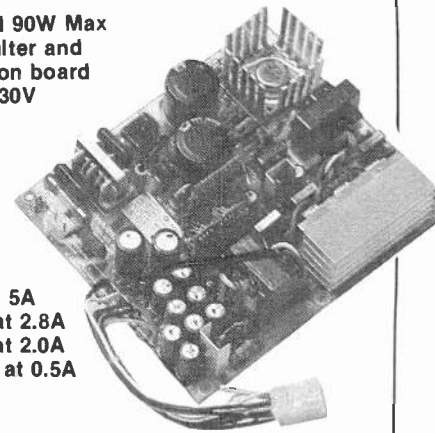

5V at 5A  
12V at 2.8A  
12V at 2.0A  
-12V at 0.5A

Open Frame ..... **\$ 49.00**

## MISCELLANEOUS PARTS

### DB Connector Series

|   |        |   |         |
|---|--------|---|---------|
| DB9P Solder Tail Male                   | \$.175 | DB25P Flat Ribbon IDC Crimp Type Male       | \$8.99  |
| DB9S Solder Tail Female                 | \$1.89 | DB25S Flat Ribbon IDC Crimp Type Female     | \$9.99  |
| DB9P Right Angle PCB Mount Male         | \$2.49 | DB25S Flat Ribbon IDC Crimp, Economy M or F | \$5.95  |
| DB9S Right Angle PCB Mount Female       | \$2.49 | DB25 Shell (Economy Type)                   | \$0.95  |
| DB9S Flat Ribbon IDC Crimp Type Male    | \$5.75 | DB25 Shell, High Quality                    | \$1.99  |
| DB9S Shell (Economy Type)               | \$6.25 | DB37S Solder Tail Male                      | \$4.25  |
| DB9S Shell, High Quality                | \$1.99 | DB37S Right Angle PCB Mount Male            | \$7.75  |
| DB15 Solder Tail Male                   | \$1.95 | DB37S Right Angle PCB Mount Female          | \$8.95  |
| DB15S Solder Tail Female                | \$1.95 | DB37S Flat Ribbon IDC Crimp Type Male       | \$14.00 |
| DB15S Right Angle PCB Mount Male        | \$1.95 | DB37S Flat Ribbon IDC Crimp Type Female     | \$14.95 |
| DB15S Right Angle PCB Mount Female      | \$2.95 | DB37 Shell, High Quality                    | \$2.95  |
| DB15S Flat Ribbon IDC Crimp Type Male   | \$7.95 |   |         |
| DB15S Flat Ribbon IDC Crimp Type Female | \$8.50 |   |         |
| DB15 Shell (Economy Type)               | \$0.95 |   |         |
| DB15 Shell, High Quality                | \$1.95 |   |         |
| DB25S Solder Tail Female                | \$1.95 |   |         |
| DB25S Solder Tail Male                  | \$1.95 |   |         |
| DB25S Right Angle PCB Mount Male        | \$4.95 |   |         |
| DB25S Right Angle PCB Mount Female      | \$4.95 |   |         |

### Delta Ribbon Connectors

(Centronics Parallel Printer Connector)

36 Contacts Plug (IDC) Flat Ribbon Crimp Type Male ..... **\$8.95**  
36 Contacts Socket (IDC) Flat Ribbon Crimp Type Female ..... **\$9.95**  
36 Contacts Chassis Mount Female ..... **\$8.95**  
36 Contacts Solder Cable Male ..... **\$8.85**  
36 Metal Shell (for solder male) ..... **\$2.95**

**Flat Cable Card Edge Connectors**  
(Disk Drive Connectors)

50 Pin Edge Connector (8" Drive) ..... **\$5.95**  
40 Pin Edge Connector ..... **\$4.95**  
34 Pin Edge Connector (5 1/4") ..... **\$5.85**  
20 Pin Edge Connector (Hard Drive) ..... **\$4.79**

### Card Edge PC Mount Connectors

50 Pin Connector (used on Apple Comps) ..... **\$2.45**  
62 Pin Connector (used on IBM Comps) ..... **\$2.45**  
32 Pin High Quality Economy ..... **\$1.85**  
S-100 Connector (S-100, Z-80 Systems) ..... **\$4.95**

### DIP Switches

4-position ..... **\$1.30**  
6-position ..... **\$1.55**  
8-position ..... **\$1.75**  
10-position ..... **\$1.85**

### Two Row Right Angle Header Strips (Male)

40 Pin 20x2 ..... **\$3.45**  
34 Pin 17x2 ..... **\$2.80**  
26 Pin 13x2 ..... **\$1.95**  
16 Pin 8x2 ..... **\$1.40**  
10 Pin 5x2 ..... **\$0.95**

### Two Row Straight Header Strips (Male)

50 Pin 25x2 ..... **\$3.90**  
40 Pin 20 Pin 10x2 ..... **\$1.85**  
16 Pin 8x2 ..... **\$1.40**  
10 Pin 5x2 ..... **\$0.95**

### Female Header Strips

(Flat Ribbon Crimp Type Socket Connector)

50 Pin Female Header 25x2 ..... **\$4.99**  
40 Pin Female Header 20x2 ..... **\$4.35**  
34 Pin Female Header 17x2 ..... **\$3.20**  
26 Pin Female Header 13x2 ..... **\$2.95**  
20 Pin Female Header 10x2 ..... **\$1.89**  
16 Pin Female Header 8x2 ..... **\$1.95**

Two Position Female Jumpers  
(Shunt) 20 cents each

### DEVICE

|         |        |         |        |        |        |        |        |         |        |         |        |         |        |
|---------|--------|---------|--------|--------|--------|--------|--------|---------|--------|---------|--------|---------|--------|
| 2N697   | \$.50  | 2N3391A | \$.45  | 2N3773 | \$2.99 | 2N4339 | \$.45  | 2N5771  | \$.75  | MPSA20  | \$.30  | TIP49   | \$1.20 |
| 2N2219A | \$.90  | 2N3394  | \$.80  | 2N3819 | \$.85  | 2N4400 | \$.25  | 2N5772  | \$.37  | MPSA55  | \$.46  | TIP115  | \$.98  |
| 2N221A  | \$.40  | 2N3415  | \$.28  | 2N3820 | \$.85  | 2N4401 | \$.25  | 2N6028  | \$.45  | MPSU51  | \$.78  | TIP122  | \$1.80 |
| 2N2222A | \$.50  | 2N3440  | \$.10  | 2N3904 | \$.19  | 2N4402 | \$.25  | MJ802   | \$4.50 | MPSU56  | \$.99  | TIP125  | \$1.00 |
| 2N2270  | \$.50  | 2N3442  | \$2.25 | 2N3905 | \$.25  | 2N4403 | \$.25  | MJ2955  | \$1.83 | PN2222A | \$.39  | TIP142  | \$2.95 |
| 2N2369A | \$.50  | 2N3566  | \$.78  | 2N3906 | \$.28  | 2N4416 | \$.14  | MJ4502  | \$5.50 | TIP29C  | \$.70  | TIP146  | \$2.98 |
| 2N2646  | \$1.42 | 2N3568  | \$.78  | 2N4042 | \$.88  | 2N4353 | \$4.22 | MJE340  | \$2.50 | TIP30C  | \$.70  | TIP2955 | \$1.85 |
| 2N2909  | \$.48  | 2N3638A | \$.78  | 2N4112 | \$.28  | 2N4856 | \$1.39 | MJ8502  | \$4.95 | TIP31C  | \$.70  | TIP3055 | \$1.50 |
| 2N2970A | \$.52  | 2N3642  | \$.78  | 2N4123 | \$.20  | 2N4891 | \$.85  | MPF 102 | \$.85  | TIP32C  | \$.10  |         |        |
| 2N3053  | \$.70  | 2N3643  | \$.78  | 2N4124 | \$.50  | 2N5245 | \$.75  | MPS6515 | \$.42  | TIP33C  | \$1.80 |         |        |
| 2N3055  | \$1.88 | 2N3645  | \$.78  | 2N4288 | \$.87  | 2N5400 | \$.27  | MPSA05  | \$.35  | TIP34C  | \$1.85 |         |        |
| 2N3117  | \$1.50 | 2N3703  | \$.28  | 2N4222 | \$1.99 | 2N5457 | \$.57  | MPSA13  | \$.35  | TIP35C  | \$3.10 |         |        |
| 2N3227  | \$4.18 | 2N3704  | \$.31  | 2N4248 | \$.85  | 2N5485 | \$.57  | MPSA14  | \$.35  | TIP41C  | \$1.15 |         |        |
| 2N3250  | \$.70  | 2N3705  | \$.28  | 2N4250 | \$.78  | 2N5770 | \$.48  | MPSA18  | \$.38  | TIP42C  | \$1.90 |         |        |

### TRANSISTORS

### Heat Sinks

T0220 ..... **\$0.38**  
T03 ..... **\$2.98**

### LEDS

Large LE DS  
T-1 3/4 (Normal Size)  
Red (General purpose) ..... **\$ 0.25**  
Green (General purpose) ..... **\$ 0.39**  
Yellow (General Purpose) ..... **\$ 0.39**  
Red (Extra Bright) ..... **\$ 0.58**  
Green (Extra Bright) ..... **\$ 0.85**  
Yellow (Extra Bright) ..... **\$ 0.85**

### Small LE DS (T-3/4)

Red ..... **\$ 0.30**  
Green ..... **\$ 0.35**  
Yellow ..... **\$ 0.35**

### Rectangular LE DS 75 cents each

### Bar Graph Display

8-Segment, (Red, Green or Yellow) ..... **\$4.85**  
35 LED Matrix 2" or 3" ..... **\$8.85**  
(Great for Digital Signs)

### Rectifier Diodes

1N4001 50V 1A ..... **\$.07**  
1N4004 400V 1A ..... **\$.09**  
1N4007 1000V 1A ..... **\$.11**  
1N5403 300V 3A ..... **\$.40**  
1N5404 400V 3A ..... **\$.40**  
1N5406 600V 3A ..... **\$.90**

### Switching and Signal Diodes

1N34A ..... **\$.19**  
1N914 ..... **\$.05**  
1N4148 ..... **\$.05**  
1N4448 ..... **\$.05**

### Zener Diodes

1 Watt, All Values 25 cents each.  
Voltages Available  
3.9, 4.3, 4.7, 5.1, 5.6, 6.2, 7.5, 8.2, 9.1, 10, 12, 13, 15, 16, 18, 20, 22, 24, 27, 30, 33, 36

### Switches

Momentary push-button switches ..... **\$.09**  
Momentary push-button switches SPDT ..... **\$.95**  
On-Off Switch SPDT ..... **\$.95**

### Parts for your Modem

Small Speakers ..... **\$1.84**  
600 ohm to 600 ohm (1, 1) Isolation Transformers ..... **\$9.95**  
Relay for your modem (HE721A0500) 5V ..... **\$4.99**  
DAA 1812 for Modem (Contains Built-in Transformer, relay and surge protector) ..... **\$39.00**

### SCR'S

2N5064 ..... **\$.75**  
2N6337 ..... **\$.55**  
TIC106D ..... **\$1.25**  
TIC116D ..... **\$1.99**  
TIC126D ..... **\$1.99**

### TRIACS

TIC208D ..... **\$1.55**  
TIC218D ..... **\$1.99**  
TIC228D ..... **\$1.87**  
TIC263D ..... **\$4.25**

### Voltage Regulators

POSITIVE  
7805 + 5V 1A ..... **.99**  
78L05 + 5V 1A ..... **.75**  
78H05 + 5V 5A ..... **9.44**  
78P05 + 5V 10A ..... **14.87**  
7808 + 8V 1A ..... **.99**  
78L08 + 8V 1A ..... **.75**  
7812 + 12V 1A ..... **.99**  
78H12 + 12V 5A ..... **10.99**  
7815 + 15V 1A ..... **.99**  
7824 + 24V 1A ..... **.99**  
78GUIC Adjust. 1A ..... **1.80**  
78GUIC Adjust. 5A ..... **1.80**

78HGASC Adjust 5A ..... **11.47**  
78S40 Switching regulator ..... **3.84**

NEGATIVE:  
7905 5V 1A ..... **.99**  
79L05V 1A ..... **.75**  
79L05V 1A ..... **.99**  
7906 6V 1A ..... **.85**  
7912 12V 1A ..... **.85**  
79L12 12V 1A ..... **.99**  
7915 15V 1A ..... **.99**  
79GUIC Adjust. 1A ..... **1.65**  
79HGASC Adjust 5A ..... **17.99**

### CRYSTALS

32.768KHZ ..... **\$1.15**  
1.00MHZ ..... **\$6.95**  
1.8432MHZ ..... **\$3.99**  
2.00MHZ ..... **\$2.50**  
2.457MHZ ..... **\$3.75**  
3.57MHZ ..... **\$1.55**  
4.00MHZ ..... **\$1.99**  
5.00MHZ ..... **\$1.95**  
5.017MHZ ..... **\$3.50**  
5.068MHZ ..... **\$1.95**  
8.00MHZ ..... **\$1.95**  
10.00MHZ ..... **\$1.95**

10.24MHZ ..... **\$2.99**  
12.00MHZ ..... **\$2.25**  
14.00MHZ ..... **\$2.99**  
14.318MHZ ..... **\$2.19**  
16.00MHZ ..... **\$1.99**  
18.00MHZ ..... **\$2.29**  
18.432MHZ ..... **\$1.99**  
20.00MHZ ..... **\$2.15**  
21.43MHZ ..... **\$2.99**  
22.118MHZ ..... **\$2.99**  
48.00MHZ ..... **\$3.99**

### Wire Wrap Wire. All Colours (30 gauge)

25 ft ..... **\$5.00**  
50 ft ..... **\$9.95**  
100 ft ..... **\$16.25**  
Wire Wrap /Unwrap Tool/Strip Tool ..... **\$63.00**  
Wire Wrap Gun and Bit ..... **\$18.95**  
IC Extractor ..... **\$3.99**  
IC Insertion Tool ..... **\$18.95**  
High Quality 24-40 Pin Extractor ..... **\$23.50**

### SIP Resistor Networks

| Part #   | Pins | Common Pin # | Value |
|----------|------|--------------|-------|
| 6-1-XXX  | 6    | 1            | 0.39  |
| 8-1-XXX  | 8    | 1            | 0.44  |
| 10-1-XXX | 10   | 1            | 0.59  |

XXX = Value

### Trim Pots

P.C. MOUNT MULTITURN TRIMPOTS

| RESISTANCE | 1K  | 10K  | 200K |
|------------|-----|------|------|
| 10         | 20K | 500K |      |
| 50         | 2K  | 50K  | 1M   |
| 100        | 5K  | 100K | 2M   |

**\$1.65 ea.**

TRIMPOTS

| RESISTANCE | 10K  | 100K | 1M   |
|------------|------|------|------|
| 100        | 1000 | 25K  | 250K |
| 250        | 2500 | 50K  | 500K |
| 500        | 5000 | 50K  | 500K |

OPEN CASE 35¢ ENCLOSED CASE 85¢

### Resistors

We carry a full range of 1/4 Watt, 5% resistors...5 cents each.

# Europe's best selling oscilloscopes, made in West Germany

## HAMEG

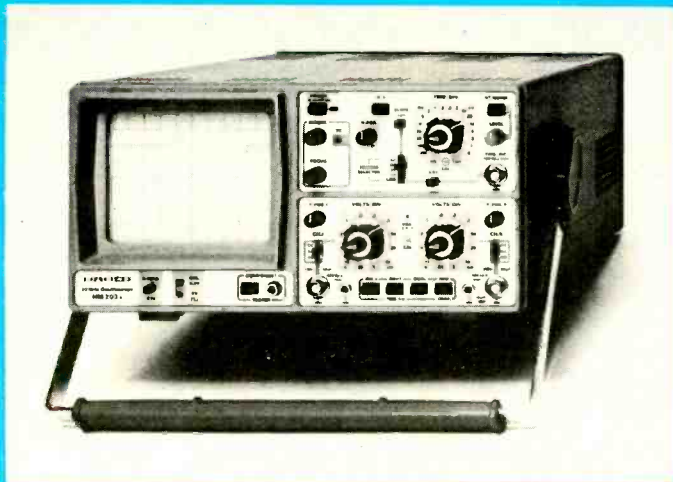

**OSCILLOSCOPE HM 203-5**

### 20 MHz Standard Oscilloscope

Y: 2 channels, DC-20 MHz, max. sensitivity 2mV/cm;  
X: 0.2s/cm-20ns/cm incl. x 10 magnification;  
triggering up to 40 MHz; Component Tester

**\$695.00**

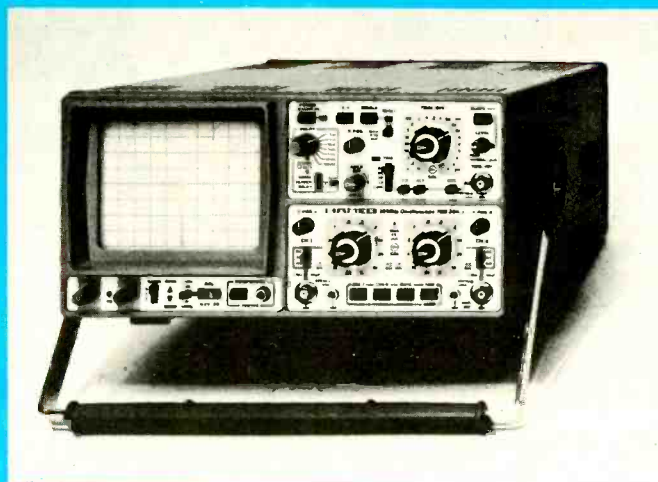

**OSCILLOSCOPE HM 204-2**

### 20 MHz Multifunction Oscilloscope

Y: 2 channels, DC-20 MHz, max. 1mV/cm, delay line;  
X: 1.25s/cm-10 ns/cm incl. x 10 magnification, delayed sweep;  
triggering up to 50 MHz; var. hold-off time; Component Tester.

**\$1140.00**

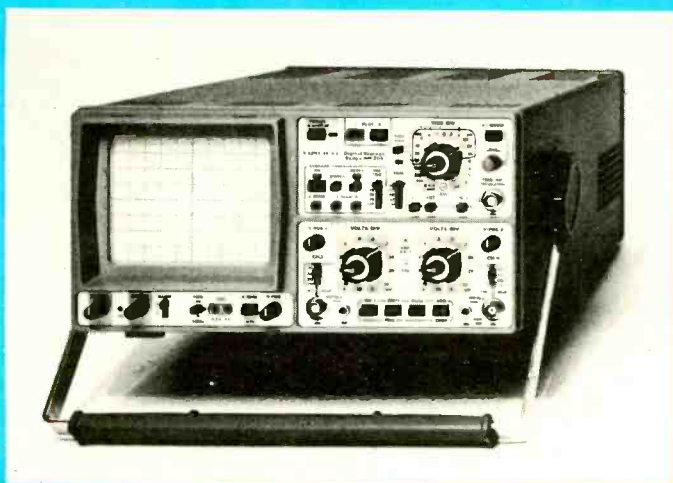

**OSCILLOSCOPE HM208**

### 20 MHz Digital Storage Oscilloscope

Y: 2 channels, DC-20 MHz, max. sensitivity 1mV/cm;  
X: 0.25 s/cm-20ns/cm incl. x 10 magnification, trig. to 40 MHz.  
Storage: max. clock rate 20 MHz; Single and X-Y operation.

**\$2885.00**

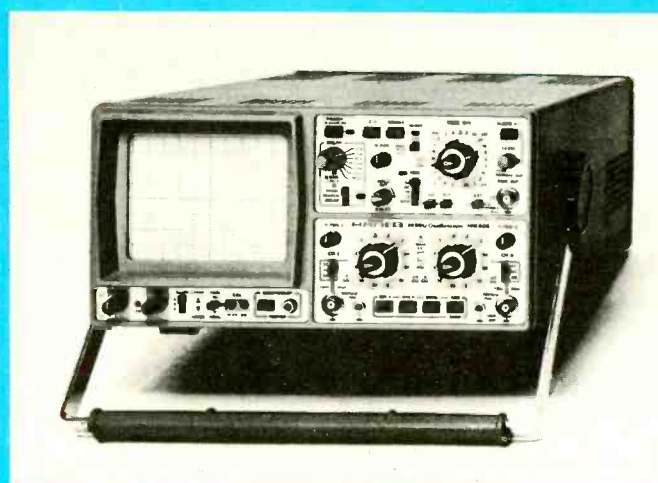

**OSCILLOSCOPE HM 605**

### 60 MHz Multifunction Oscilloscope

Y: 2 channels, DC-60 MHz, max. 1mV/cm, delay line;  
X: 2.5s/cm-5ns/cm incl. x 10 magnification, delayed sweep;  
triggering up to 80 MHz; var. hold-off time; Component Tester.

**\$1475.00**

**HAMEG GmbH**

West Germany is represented,  
distributed and serviced in Canada by:



990 Alness St. Unit 7,  
Downsview, Ontario,  
M3J 2S2  
(416) 881-5585  
TELEX 085-28189

**Now Available from Stock**  
for the complete line of HAMEG instruments write or phone

**Exceltronix**

319 College Street, Toronto, Ont. M5T 1S2  
(416) 921-8941 1-800-268-3798

## The 8088 Controller and Trainer System

Based on the success of our Multiflex starter systems, we are proud to announce the arrival of the 8088 Controller and educational Trainer System. With the option to upgrade to a full IBM PC compatible, the starter system is the perfect education tool to learn 8088 based hardware and assembler code. It is also ideal for use as a complex, high speed industrial controller at an affordable price. This 8088 System consists of two boards. The first board (as seen in the picture) is the motherboard which can be used as a general purpose controller and contains the following:

- Socketed for 64K static RAM
- Socketed for 64K of EPROM
- RS232-C serial communications port
- Controller Port
- 300 baud modem
- 3 IBM PC compatible expansion slots (when the multifunction board is used)
- Wire Wrap area

The motherboard is a very versatile controller for which it is very easy to write software on the IBM PC/XT.

The second component is a console which connects to the motherboard via a ribbon cable. The console contains a display, hex keypad and another keypad containing function keys to perform memory block moves, register examination, the examination of I/O ports and a myriad of other functions. This board also contains an EPROM programmer.

A further multi-function board which has been designed specifically for the system to make it IBM PC compatible is available. This multi-function card contains a floppy diskette controller, DMA controller and up to 512K dynamic RAM.



**Controller Board with 16K RAM  
(optionally expandable to 64K)  
\$250.00**

**Keyboard and Display Board with EPROM  
programmer and monitor software  
\$159.00**

**Multi-function Board with 64K RAM  
(expandable to 512K)  
\$250.00**

## S100 Starter System

**Complete, Assembled and Tested**

**\$299**

**Options:  
64K Dynamic RAM and  
Multiplexers**

**\$19.95**

**Big Piggyback Board with RS232  
and Real Time Clock**

**\$179**

**RS232 Option for Motherboard**

**\$38.00**

**DC to DC Converter Option**

**\$29**

**Extra S100 Connectors**

**\$5.95**

**S100 Video Board**

**\$149**

**S100 Floppy Disk Controller**

**\$199**

**S100 256K RAM Card (with 256K)**

**\$250**

**S100 CPU Board with 64K**

**\$149**

MULTIFLEX's Z80 computer is a versatile and expandable stand-alone computer system designed and built right here in Canada. It uses the newest technology to provide the user with the most capabilities for the smallest price-tag. Its adaptability to any situation and extremely low cost allow it to be used in many applications ranging from a trainer to a complete CP/M-based computer comparable to the best on the market, at a fraction of the price.

The actual layout of the system is a two board design. One board (the "motherboard") contains a 24-line parallel I/O chip for interfacing to the external world, an RS232C serial port with baud rates selectable from 110 to 9600 baud, a hex address and data display, a

hex keypad, 14 monitor function keys, 2 user definable keys, a 40-chip wire wrap area with full access to all the bus signals, on-board provision for regulators so that the board can be supplied with standard S-100 voltages, an EPROM programmer which will handle 2708 (1Kx8), 2716 (2Kx8), 2732 (4Kx8) 2532 (4Kx8), 2764 (8Kx8) and the brand new 27128 (16Kx8) EPROMs, a DC-to-DC converter to supply the programming voltage to the EPROM programmer and four (4) slots for IEEE S-100 compatible boards for further expansion. This is an extremely useful and important feature as it allows expansion of the system with all boards using this industry-standard bus structure, which are available from MULTIFLEX, as well as from hundreds of manufacturers worldwide.

The other board is the CPU card. This card plugs into one of the S-100 slots on the motherboard and is IEEE 696/S-100 compatible with the full 24-bit address path to allow up to 16 megabytes of memory to be addressed. The processor used is the Z80 (running up to 6 MHz) and there is provision on-board for 64K of dynamic memory (using 4164 chips) which will operate without wait states. Provided for as well is a 2K to 32K (selectable in 2K blocks) common resident area in memory for use with multiple memory banks. There are also 4 sockets on board which will handle 2732 (4Kx8) or 2764 (8Kx8) EPROMs or the new 6116/2016 (2Kx8) static RAMs (all of which can be software deselected if desired) to allow the user complete versatility in setting up the board to meet his own specifications. Also on board is 1 parallel port with 24 lines of I/O and 3 16-bit counter/timers for applications which require the unit to keep track of real time. Another feature of the CPU board is that it was designed by our engineers to run the CP/M 2.2 disk operating system so that if a floppy disk controller board is added to the system a fully configured CP/M machine can be set up for a very low cost.

The monitor software that comes with the kit is a well-written extensive package which allows the user to have complete versatility in machine language programming and execution as well as control of all the features on the board. The monitor functions include: examine/modify memory locations, memory block moves, compare 2 blocks of memory, examine CPU register, ex-

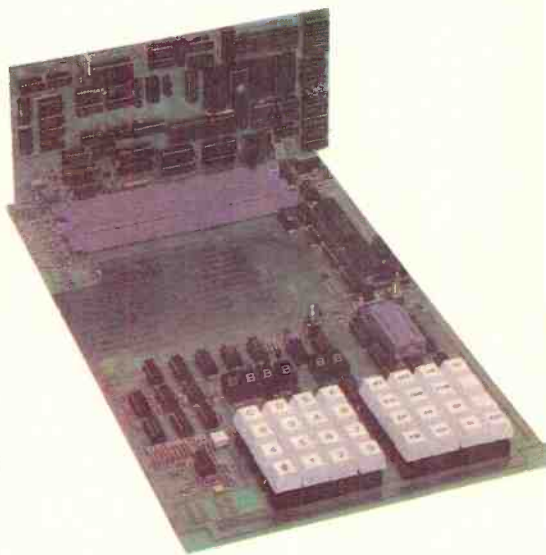

amine I/O ports, load and save from cassette calculate relative branch offsets, set breakpoints single step programs, execute programs, and program EPROMs. Each of these process is invoked by a single keypress. Also available to the user are 2 spare keys definable for special functions a required by specific applications and applicator programs.

The standard kit includes the CPU board with a Z80A (4MHz) processor, 2K of RAM (a 6116), and 4K of EPROM (a 2732) as well as the motherboard with all the features mentioned above except the RS232C port and the DC-to-DC converter. Also supplied are sockets for all IC's and 1 S-100 connector.

# 8088 Board with Built-in Modem: \$49.95!

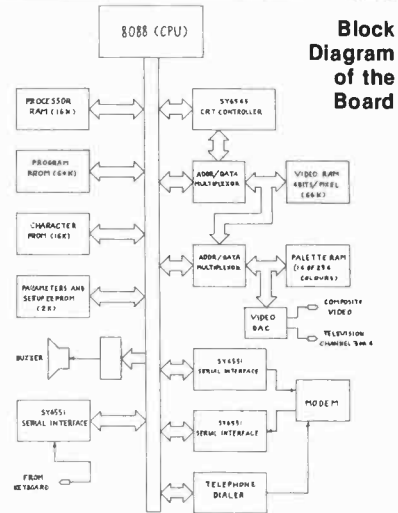
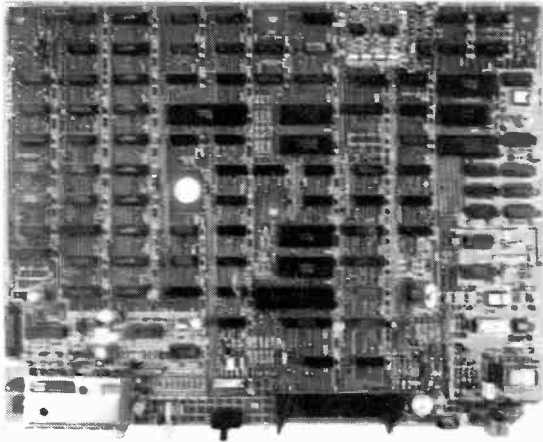

## This could be the biggest bargain of all times.

The main board shown can be used in many different ways. Made recently by one of Canada's leading electronics companies, this board utilizes some of the most current technology and parts.

Use your imagination, software and hardware to make this board into many interesting projects. The board is capable of colour graphics and was originally designed as a terminal for home-ordering system many of the facilities similar to the Telidon terminals in use in shopping malls, hotels etc.

This magnificent board features an 8088 CPU, 6545 CRT Controller, 150/1200 Baud auto-dial, direct-connect modem, serial ports, RF Modulator (Ch.3) for 40 characters, EEPROMs, 64K Video RAM, 16K RAM and 64K of EPROM for the processor.

All you need is a power supply with 5V at 2A, plus/minus 12V at 0.05A

The current value of the parts alone on this board is in excess of \$300!

- A. The Board** itself with the original software, schematics, memory map and block diagram: ..... **\$49.95**
- B. Membrane Keyboard Kit** ..... **\$19.95**
- C. Plastic Case** to house the main board ..... **\$ 9.95**
- Items A, B and C** as a package ..... **\$74.95**

## Digital Modem

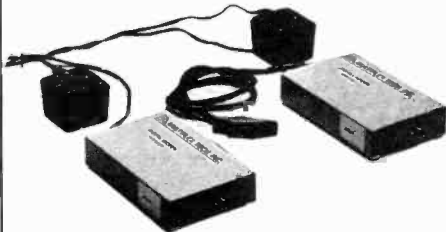

**DO YOU HAVE A PROBLEM?** Lack of wires for two-way communications? Do you have a single coax cable between four floors of a building?

If the above holds true for you, as it may well do, if you wish to put equipment in some older Government buildings which were wired years ago, using a single coax to communicate between main frames and which may now be obsolete, you need our solution. If you want to communicate using RS232 between your computers and all you have is a single coax between rooms or floors or buildings, now you can

do it without rewiring using our economical solution.

About a year ago we were approached by a Government agency asking if we could solve the problem described above. Well, we solved their problem economically, in fact it worked so well that they bought hundreds of units from us.

The Digital Modem consists of two boxes (approx. 6" x 4") and two wall adaptors. Now you can simply have the RS232 of your computer terminal or other devices plugged directly into one of our Digital Modem boxes (which has a wall plug adaptor to get its power) and you can run up to 800 feet over a single wire to another of our Digital Modem boxes (which again has its own CSA approved power supply) and you again plug in the RS232 DB25 connector to your equipment. Now you can communicate at 9600 Baud or faster (or slower) simultaneously in both directions using your existing single coax cable wiring.

**Digital Modem Pair . . . . \$350.00**

**(Two Boxes and two adaptors) Quantity Discounts.**

## Keyboard \$19.95

## Suitable Serial Adapter \$19.95



All prices and specifications in this catalogue are subject to change without notice. Please follow our ads monthly in Electronics Today and Computing Now!. Whatever market conditions exist, you will find our prices the most competitive in Canada.

# Exceltronix

319 College Street, Toronto, Ont. M5T 1S2

(416) 921-8941. Order line only 1-800-268-3798

Ottawa, 217 Bank Street (613) 230-9000

Visa, Mastercard and American Express accepted.

These collections are comprised of 'Public Domain', 'Freeware' and other software represent one of the last remaining bargains. The software itself is free charge, the charge is for the patching, debugging, selecting and the cost of disks, copying and distribution. All disks are 5 1/4", DS, DD for the BEST, IBM a compatible computers. Two of the collections are Double Disk sets.

**Volume 1**

PC-WRITE While not quite WordStar for nothing, this package comes extremely close to equaling the power of commercial word processors costing several hundred dollars. With full screen editing, sophisticated cursor movement, PC-Write also boasts features such as user-definable help screens and a 'printer ruler file' which can be customized to work with virtually any printer.

SOLFE is a small BASIC program that plays baroque music. While it has little practical use, it's a lot of fun. It's also a fabulous tutorial on how to use BASIC's sound statements.

PC-TALK Telecommunications packages for the IBM PC are typically intricate, powerful and huge. This one is no exception. It has menus for everything and allows full control of all parameters, even the really silly ones. It does file transfers in both ASCII dump and MODEM/XT-MODEM protocols. And, it comes with a comprehensive documentation file which uses 11942 bytes of disk space.

SD This sorted directory produces displays which are a lot more readable than those spewed out by typing DIR.

FORTH This is a small FORTH, written in Microsoft BASIC. It's good if you want to get used to the ideas and concepts of FORTH. You can build on the primitives in FORTH with the language.

LIFE This is an implementation of the classic ecology game written in 8088 assembler code. While you may grow tired of watching the cells chewing on each other, the source code provides a good example of how to write assembler applications.

MAQDALEN This is another BASIC music program. We couldn't decide which of the two we liked better, so we wound up putting both of them on one disk.

CASHACC is a fairly sophisticated cash acquisition and limited accounting package written in BASIC. It isn't exactly BPL, but it's a lot less expensive and suitable for use in your small business applications.

DATABASE is a simple data base manager, written in Microsoft BASIC.

UNWYS WordStar has an unusual propensity for filling the high order bits on some of the characters in the files it creates. Here's a utility to strip the bits and 'unWordStar' the text. The assembler source code is also provided.

HOST2 This program includes BASIC source and documentation files to allow users with SmartModems to access their PC's remotely.

**Volume 2**

SWEEP is a disk utility which virtually replaces the DOS COPY command. It allows one to mass copy, delete, rename and other disk operations in menu-driven format.

Wordmap is a sophisticated graphics program which draws a very detailed map of the world. It can display its wares on the tube, or send them out to dot-matrix printer.

ANITRA plays Anita's Dance by Edward Grieg. A useful addition to your computer music collection.

RAMBISK is one of the most useful utilities you'll ever plug into your PC. Once installed, it creates a virtual drive in memory on your PC. Files can be copied to the RAM-disk and accessed in less time than real drives take to turn on their LEDs.

Allen plays a bizarre adventure game and will lead you into some of the most exotic spots in the universe. It comes with a massive data file for an adventure that you won't get tired of 'til the dragons come home for the evening.

FOS is a well designed personal finance manager which will do much to help you tame your cheque books.

Jukebox represents yet another PC music system. This one comes with a host of songs to play and some really exotic graphics.

ASMOEN is one of the best text disassemblers we've come across. It takes any executable COM or EXE file and produces an assembler listing it's surprisingly good at distinguishing between code and embedded data or text.

STRUCT will appeal to the rabid programmer in everyone. It enables MASM to be used to assemble a higher level language. Included also is a test file to illustrate the syntax.

PRTSVC replaces the internal PC screen dump code with something more suited to reality. It allows one to hit the PrtSc key and then select the print quality from a menu. It supports a number of popular printers.

BREAKOUT plays a PC version of the popular game. It will accept input from either a joystick or the keyboard. The graphics are good and the action is adjustable from a beginner's level right up to 'fast and nasty'.

UTIL is a collection system utilities which can be accessed from a single menu. Among its many talents are a sorted directory, keyboard redefinition and the facility for scrolling up and down through a text file.

PRTSVC replaces the internal PC screen dump code with something more suited to reality. It allows one to hit the PrtSc key and then select the print quality from a menu. It supports a number of popular printers.

BREAKOUT plays a PC version of the popular game. It will accept input from either a joystick or the keyboard. The graphics are good and the action is adjustable from a beginner's level right up to 'fast and nasty'.

UTIL is a collection system utilities which can be accessed from a single menu. Among its many talents are a sorted directory, keyboard redefinition and the facility for scrolling up and down through a text file.

3-DEMION is one of the most interesting variations of Pac-Man in the known universe. Instead of simply looking at a map of a maze, this program shows you a three dimensional view of it. You wander through endless corridors, munching food pellets or granite bars... your choice - and avoiding the deadly ghosts.

DU was one of the most powerful CP/M-based disk utilities ever created. This version for the PC captures much of its power and flexibility. It allows you to see what the tracks and sectors on your disks look like, recover erased or damaged files, and muddle with the system tracks.

General Ledger This is a complete general ledger accounting program. Written in BASIC, the program possesses most of the features found in commercial packages. An enormous documentation file is also included.

PC-CHESS is a slick chess program which makes good use of the PC's colour graphics abilities and boasts a running chess clock.

RAMBISK is the assembler source code for a memory disk program. If you've always wanted to know how these things work, or have a secret desire to write your own variation of this useful utility, here's your chance.

VFLER is a file management utility which lets you view files in a directory and allows you to COPY, TYPE and even run programs... in short, it does almost everything DOS does but it's user-friendly.

OMODEM is unquestionably the best telecommunication package. Written in BASIC, the program is rife with windowing, multiple protocols, definable function keys. And the code is unspeakably well debugged.

ARC is a sophisticated file archiving program which stores several files in single library files. As an added bonus, ARC applies one of our data compression techniques to each file in order to optimize disk space.

ZAPLOAD is a utility for programmers to handle Intel standard HEX files. Very fast and well documented.

SOPWITH Using superb graphics, SOPWITH lets you pilot a World War I biplane on dangerous bombing missions.

JSB Another BASIC music program for your collection. This one plays a soothing sonata.

STAR is one of a growing breed of small, somewhat silly novelty programs. This one, as you might guess, draws stars.

SURFACE demonstrates the complexity of the 'hat' function by graphing it on a monitor screen.

OP is the operator program from the November '85 issue of Computing Now!

**\$19.95**  
**\$24.95**  
**(Two Disk Set)**

**Volume 3**

FIXWS is a simple utility which modifies WordStar files so that they can be used by programs which work with ordinary ASCII files.

WRT DOS 2.0 allows for each file to have a 'read only' flag, but it lacks a way of manipulating them. This pair of utilities allows you to set and unset this flag, protecting important files from accidental erasure.

BROWSE is a timesaving program which provides a useful alternative to the DOS TYPE command. BROWSE allows you to easily scroll up and down through text files, saving you the effort of running your word processor just to get a quick look at a text file.

CAT if the DIR display is too dull for your tastes, CAT may be just what you need. It will tell you everything you could possibly want to know about the files in your disks.

CGCLOCK is a simple little program which displays the running time in the upper right hand corner of your screen. In addition, the program has lots of display options and works with the colour graphics card.

CURSOR A tiny twenty-four byte program which displays a large cursor on your monitor.

CMP This program does a very elaborate comparison of two files and reports their differences. It can, for example, spot corrupted files and may prove useful when dealing with files created by redirection.

JUMPJOE A bit like "Miner 2049'er", this game is certain to damage your mind. You get to be the janitor of a space station and must deal with berserk robots and other weirdness. It's a hoot!

CASTLE Wander through a deserted castle collecting treasures... but mind you don't get killed by the nasties. A solution is included should frustration set in.

78INT This is a small BASIC program to calculate interest using the rule of seventy-eight.

MOON is one of the nicest lunar ladder games we've come across. This version uses high resolution graphics and starting sound effects to hurt you to your doom in style.

PERTCHT is a BASIC program which prints PERT charts. It should interest anyone involved in project management and scheduling.

DATNOIDS is one of the strangest games ever put on a disk. In fact, more words can't describe it, you'll have to try it for yourself!

NUP-NY This is one of the nastiest bits of software we've ever seen. It produces a full color high resolution simulation of a nuclear attack on New York City.

BLACKJACK is a BASIC implementation of this popular card game. It's both interesting to play and enlightening to dismantle. It can, of course, be easily listed so you can see how it works.

EDSCR is a screen editor which can be used with virtually any programming language from assembler to dBase III. The program lets you 'paint' PC screens with block graphics and saves them as DAT files which can be easily adapted to work in most languages. An example screen is included.

FK allows you to make the function keys of your PC do more useful things under DOS. They can be realigned to execute commonly used commands and command sequences.

FMASTER is a printer program for the popular Epson FX Series and compatible printers. It uses a full screen menu to enable you to easily change printer settings and modes.

INDEX allows you to generate indexes from WordStar documents... or text files from any other text editor. It's an invaluable writer's tool!

KEYCLICK is a memory co-resident program which will make your keys click. Small and easily included in an AUTOEXEC file, KEYCLICK solves many problems associated with clone keyboards.

PCBW is a small utility which makes colour screen displays show up in monochrome mode. Great for users with colour graphics cards and monochrome monitors.

PINBALL is a pinball simulation that is easily worth the cost of this disk all by itself. The games play much like a 'real' pinball machine... but its hard to tilt.

QUICKGRAF is a powerful business graphics package which generates complex bar, line and scatter charts in medium and high resolution. An Epson with GrafTrax compatible printer is necessary to produce hardcopy.

SERPENT is a variation on the classic snake game. Written in BASIC, this one is weird, but very fast!

SHOWCLK is yet another clock program. It's the smallest one yet, and it keeps to chime the hour.

VTREE is a graphic TREE program that allows you how the subdirectories are set up on your disk... in a fashion more easily understood than the MS-DOS TREE utility.

WORLD is a remarkable program which incorporates a world map. It allows you to zoom in on specific areas of the globe, locate major cities and perform a number of useful calculations. It also has a feature for tracking hurricanes... tracked any good hurricanes lately?

**\$19.95**

**Volume 4**

BACKSCROLL Perhaps one of the cleverest DOS utilities, BACKSCROLL hooks into the PC and buffers whatever scrolls by. Using a well thought out command structure, it allows one to scroll back and forth through text which would normally have scrolled off the screen into oblivion.

BIGCAL is a BASIC program which performs calculations on extremely large numbers. Using floating point math instead of scientific notation, very accurate calculations can be made.

BUGS is an off the wall JESCL game in which a player uses the cursor pad keys to move a 'nuclear fly swatter' around the screen blowing up a long crawling bug.

CLOCK is a useful utility in writing character oriented device drivers for the PC. In addition the program is an improved replacement CLOCKSYS file which works with many real time clocks. The ASM file is included.

CRYPTO is a BASIC program which unscrambles cryptograms. It's an interesting study for puzzle enthusiasts.

DEFRAG is a utility that lets you "de-fragment" your disks to make your applications run faster. The utility reorganizes a disk, combining up the fragments of files created by DOS.

DOSEDT is one of the most useful DOS utilities available. It enhances the command line facility of MS-DOS by creating a command stack. Instead of merely being able to recall a command with the F3 key, DOSEDT lets you use the cursor arrow keys to scroll through a whole stack of recently entered commands, re-executing the ones you need.

Dump is a utility program designed to produce Hex dumps of object files. Useful in its own right, the program also serves as a good example of how to use DOS disk service calls. The ASM file is also included.

FREE is a tiny file which tells you how much space is left on your disk, without having to view an entire directory listing. It's especially handy for hard disk systems.

KBDF displays the status of the keyboard lock keys on the screen and expands the size of the keyboard character buffer to avoid losing bytes.

LABEL changes the labels on disk drive volumes. It's a simple utility, but useful if you use volume labels to keep track of your disks.

LIST is an improved version of the DOS TYPE command which shows you the contents of a file page by page.

MEMBRAIN is the most sophisticated RAM disk program we've seen yet. It lets users install various sized disks and provides control over several other parameters.

**\$19.95**

**Volume 5**

AREACODE is a useful tool if you use the telephone area code in an area code and it will match it with the city in which the code is used.

D in another sorted directory program. This one emulates the CPM file D, which arguably is more useful for most applications.

FRACTALS An amazing implementation of the Mandelbrot Microscope, which generates unearthly images on your screen.

HIDE is a set of utilities which let you create, enter and manage invisible DOS directories. This allows you to set up a hard drive system with secure areas which can only be used by people who know about them.

LAR is a library utility that allows you to concatenate several small files into a library to save on disk overhead. Individual files can be extracted as they are needed.

MAIL is a mailing label utility written in BASIC.

MORERAM This is an assembler program. You need MASM and LINK to make it work. It lets you alter the memory setting on the PC's motherboard to enable it to use more than 640K RAM. It will even let you set the switch settings to GAK to speed up disk boots and then change the RAM setting after bootup.

MORTGAGE generates amortization charts.

MXSET lets you control the parameters of Epson printers from the DOS command line. It's a lot easier than LPRINTing characters from BASIC every time you want to change print modes.

NUSO unscrambles files that have been previously compressed to save space. Should be of primary interest to bulletin board users.

PARCHK is an assembler program which requires MASM and LINK to work. It installs a trap for parity errors in your computer. A vital aid to help locate suspect RAM chips.

PCBOSS is a handy "DOS shell" program which creates a user-friendly working environment. It lets you create DOS file handling commands such as COPY, OEL and DIR from the comfort of a menu.

VDEL is a Delete with Verily program. You could type VDEL \*BAK and it would show them name of every BAK file in the current directory and ask you if you want it deleted.

WHEREIS finds files in a complex hard disk system.

ZAXXONPC This is an incredible implementation of one of the most popular micro games ever created.

**\$19.95**

**Volume 6**

3-DEMION is one of the most interesting variations of Pac-Man in the known universe. Instead of simply looking at a map of a maze, this program shows you a three dimensional view of it. You wander through endless corridors, munching food pellets or granite bars... your choice - and avoiding the deadly ghosts.

DU was one of the most powerful CP/M-based disk utilities ever created. This version for the PC captures much of its power and flexibility. It allows you to see what the tracks and sectors on your disks look like, recover erased or damaged files, and muddle with the system tracks.

General Ledger This is a complete general ledger accounting program. Written in BASIC, the program possesses most of the features found in commercial packages. An enormous documentation file is also included.

PC-CHESS is a slick chess program which makes good use of the PC's colour graphics abilities and boasts a running chess clock.

RAMBISK is the assembler source code for a memory disk program. If you've always wanted to know how these things work, or have a secret desire to write your own variation of this useful utility, here's your chance.

VFLER is a file management utility which lets you view files in a directory and allows you to COPY, TYPE and even run programs... in short, it does almost everything DOS does but it's user-friendly.

OMODEM is unquestionably the best telecommunication package. Written in BASIC, the program is rife with windowing, multiple protocols, definable function keys. And the code is unspeakably well debugged.

ARC is a sophisticated file archiving program which stores several files in single library files. As an added bonus, ARC applies one of our data compression techniques to each file in order to optimize disk space.

ZAPLOAD is a utility for programmers to handle Intel standard HEX files. Very fast and well documented.

SOPWITH Using superb graphics, SOPWITH lets you pilot a World War I biplane on dangerous bombing missions.

JSB Another BASIC music program for your collection. This one plays a soothing sonata.

STAR is one of a growing breed of small, somewhat silly novelty programs. This one, as you might guess, draws stars.

SURFACE demonstrates the complexity of the 'hat' function by graphing it on a monitor screen.

OP is the operator program from the November '85 issue of Computing Now!

**\$19.95**  
**\$24.95**  
**(Two Disk Set)**

**Volume 7**

BLACKJACK is a BASIC implementation of this popular card game. It's both interesting to play and enlightening to dismantle. It can, of course, be easily listed so you can see how it works.

EDSCR is a screen editor which can be used with virtually any programming language from assembler to dBase III. The program lets you 'paint' PC screens with block graphics and saves them as DAT files which can be easily adapted to work in most languages. An example screen is included.

FK allows you to make the function keys of your PC do more useful things under DOS. They can be realigned to execute commonly used commands and command sequences.

FMASTER is a printer program for the popular Epson FX Series and compatible printers. It uses a full screen menu to enable you to easily change printer settings and modes.

INDEX allows you to generate indexes from WordStar documents... or text files from any other text editor. It's an invaluable writer's tool!

KEYCLICK is a memory co-resident program which will make your keys click. Small and easily included in an AUTOEXEC file, KEYCLICK solves many problems associated with clone keyboards.

PCBW is a small utility which makes colour screen displays show up in monochrome mode. Great for users with colour graphics cards and monochrome monitors.

PINBALL is a pinball simulation that is easily worth the cost of this disk all by itself. The games play much like a 'real' pinball machine... but its hard to tilt.

QUICKGRAF is a powerful business graphics package which generates complex bar, line and scatter charts in medium and high resolution. An Epson with GrafTrax compatible printer is necessary to produce hardcopy.

SERPENT is a variation on the classic snake game. Written in BASIC, this one is weird, but very fast!

SHOWCLK is yet another clock program. It's the smallest one yet, and it keeps to chime the hour.

VTREE is a graphic TREE program that allows you how the subdirectories are set up on your disk... in a fashion more easily understood than the MS-DOS TREE utility.

WORLD is a remarkable program which incorporates a world map. It allows you to zoom in on specific areas of the globe, locate major cities and perform a number of useful calculations. It also has a feature for tracking hurricanes... tracked any good hurricanes lately?

**\$19.95**

**Volume 8**

This is another collection of fairly large applications. We've had to spread them over two disks. However, the extra three bucks is nothing compared to the power of some of this software. Whether you're interested in games, business applications or code hacking, you'll find something of interest in this larger than usual collection of programs. In addition to the programs themselves, the set includes all the support files needed to use them.

Load-It allows users of the popular Lotus 1-2-3 and Symphony programs to run them on a hard drive. It isn't a cranking program, but, rather, a preboot to avoid the inconvenience of this copy protected software for legitimate users.

DDECal is a very clever perpetual calendar and desk diary. It keeps track of your appointments and performs several other functions that you probably thought could only be done on the backs of match books.

PC Key Draw is the remarkable public domain paintbox program which blows away so many commercial applications. It handles multiple screen images, business graphics and superb computer art... all in full colour. It's worth the cost of this package all by itself!

CPU is a tiny program to tell you the effective speed of your system.

Xray is a remarkable co-resident utility to monitor what a program is doing while it's busy doing it. It allows you to interrupt the execution of your code and have a look inside.

Game...well, there are no words for this program, or at least, none that are printable. This game is a bit rude, depending on just how weird your mind is, it can get pretty bizarre. This program does use some suggestive language and we recommend that young or sensitive users not boot it.

Tune is a very small music generator to make notes from within batch files. It's useful to see where things are in a complex process.

Chasm, or cheap assembler, is just the thing if you want to get into assembly language programming but don't want to spring for the Microsoft Macro assembler package. It's reasonably fast but not too huge... it'll run as little as sixty four kilobytes, and, above all cheap!

Getdir is a resident directory utility. It allows you to see what's happening on your disks even if you're in the middle of doing something else.

CopyPC, not to be confused with the commercial Copy II PC, is a quick disk backup utility for the IBM.

LookIt is a full screen browsing program to let you scroll forward and backward through text files. A sort of a tiny word processor that can't edit anything.

Secure, a security device for hard disk users. By implementing this package on your XT or compatible no one without a secret password will be able to get access to your computer.

This two disk set is available for just  
**\$24.95**  
**(Two Disk Set)**

**Business Software**

MA.BAS The Micro Accountant is a complete, working accounting and check register program, with a 25K documentation file.

PCWINDOW2 A "Sidekick"-like co-resident window utility that handles multiple windows. It can take, store, watch, alarm, remind, print utility and notepad. The entire program takes up less than 30K of space on your disk.

PSHIFT A time saving and convenient memory partitioning utility. Lets you define up to nine memory areas. Load programs such as dBase III and WordStar into separate partitions and "flip" between them instantly with simple keystrokes.

PC-TOUCH-BAZ Increase typing speed and accuracy with this easy-to-use typing tutor. Also provides accuracy and speed statistics.

PCEYARBKEEEOE Appointments and reminder program to help you keep track of your time.

TASKPLAN.BAS Project management software which lets you track up to 50 tasks during 30 time periods (days, weeks or months).

NOCOLOR A handy little utility for users with monochrome monitors and colour software.

MAKIT A simple but subtle game for two human opponents, or one player and the computer. Hours of fun!

PERTCHT A sophisticated project management utility using the Program Evaluation Review Technique.

PLUS More utilities to help organize, maintain and copy your files, including a "monitor saving" program which blanks out your screen when it is not in use.

**\$19.95**

**StockBoy**

StockBoy is a good, powerful, flexible bargain-priced inventory package which will handle inventory for most small businesses. Use it to use StockBoy for our own inventory control and it has stood the test of time.

StockBoy can:  
• Maintain an inventory database with current, maximum and minimum stock reporting when an item needs re-ordering.  
• Be a point of sale! Generate a customer list to be used in mass mailings.

• Run on any CPM or MS DOS based computer, including Apple II systems with a Softcard.  
StockBoy is written in Microsoft BASIC and is designed to be easily altered to suit your needs. It can be compiled using BASCOM if desired and is designed to be used by nontechnical operators. Available for MS DOS/PC DOS and many CPM systems. See order form for a list of available formats.

**\$29.95**

# state-of-the-art MIDI systems

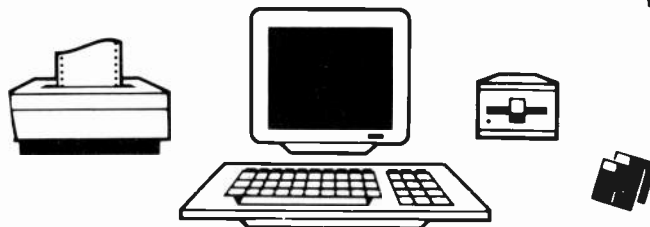

## from canada's MIDI specialists

### System 1 (under \$650)

Yamaha CX5M Music Computer, FM Music Composer and FM Voicing software, and YK-01 Music Keyboard. Complete orchestration with 8 independent timbres over 8 MIDI channels and up to 96 voices onboard. Add monitor (\$135), optional MSX Mouse/disk drive/printer.

### System 3 (under \$550)

PERFORMER software/MIDI Conductor interface. Real-time sequencing for the Macintosh. Unlimited tracks, full editing. Mouse driven. Add 512K Macintosh, any MIDI keyboard.

### System 5 (under \$1050)

PERSONAL COMPOSER software/MPU 401 MIDI Processing Unit for IBM and compatibles. Real-time 32 track recording with conversion to score for editing/printing. DX7 voice librarian. Free updates. Add IBM or compatible (our BEST MK III w/640K/2 DD/8 MHz @ \$1845), Hercules or compatible graphics card (ours only \$380), TTL monitor, optional MIDI keyboard/printer.

### System 2 (under \$410)

CX5M Music Computer and MIDI Recorder software. Real-time sequencing, punch-in/out recording, auto-record, chaining, auto-correct, full step editing. Like a multi-track tape recorder in software! Add monitor, any MIDI keyboard or CX5M slave, optional MSX Mouse/disk drive/printer.

### System 4 (under \$650)

TOTAL MUSIC software/interface. Real-time sequencer and scoring program for the Macintosh. 99 tracks, 50,000 notes. Mouse driven, free software updates. Add 512K Macintosh, any MIDI keyboard.

### System 6 (under \$700)

TEXTURE software/MPU 401 MIDI Processor for IBM or Apple II+ /Ile. 8 track real-time sequencing with flexible sequence chaining/editing. Add Apple or IBM, any MIDI keyboard.

**other software...call or write us  
WE'VE GOT IT!!!**

## MIDI keyboards, modules, drums, controllers, processors

### Yamaha

DX7, DX9, DX21, DX27, DX100 programmable keyboards and editing software.  
RX21, RX15, RX11, rhythm programmers and editing software.  
TX816, TX216, TX7 voice modules and editing software.

### Roland

MKS 7 (4 timbre module)  
SDE2500 MIDI Digital Delay  
SRV2000 MIDI Digital Reverb  
MIDI Thru boxes, MIDI Filters, etc.  
Micro Rack Digital Delay/EQ

### IVL

Pitchrider 4000 Pitch to MIDI controller  
Pitchrider 7000 MIDI Guitar controller

**XI** **electronix**



**COMPUTER MUSIC CENTRE INC.**

317 College Street, Toronto, Ontario M5T 1S2

**CALL THE MIDI HOTLINE**



**(416) 921-8941**

VISA, MasterCard, American Express accepted

# Apple Compatible Products

## MULTIFLEX 128K MEMORY CARD . . \$99.00 (with 128K of RAM on board)

128K Card can be used to function as RAM disk with your Apple.



128K RAM Card



Parallel Printer Card



Z80/64K Card

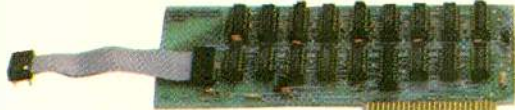

16K RAM Card



80 x 24 Card



Serial Card



EPROM Programmer

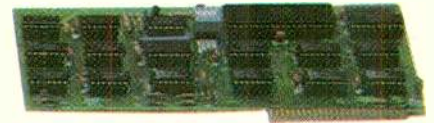

Z80 Card

## MULTIFLEX SUPER SERIAL CARD . . . \$89.00

This card allows you to: • select desired baud rate • connect to a serial RS-232 modem, terminal, or a serial printer port • for example, connect two Apple computers (using this card) to communicate with each other, through the RS-232 link over hundreds of feet.

## MULTIFLEX NEW SUPER 80 X 24 VIDEO CARD WITH SOFTSWITCH \$89.00

This new Multiflex card features: • superb 80 columns by 24 lines display, with upper and lower case, reverse video • includes built-in soft switch, allowing you to switch between the Apple's 40 column and the video cards 80 column from the keyboard. • superb compatibility.

## WIZARD IPI INTERFACE \$69.00

## MULTIFLEX EPROM PROGRAMMER . . . . \$89.00

Features:

- Eprom programmer for Apple computers • Programs 2716, 2732, 2732A, 2764 • ZIF socket for the EPROM
- Complete with software • Comes with a built-in programming voltage supply.

Included with the card is a disk full of software, which using menus allows the user to program or verify EPROMS, check if they are blank, set pointers anywhere in memory, and save or load memory ranges to/from the disk drive, making this unit a very versatile piece of hardware for the hardware developer or hobbyist.

## MULTIFLEX 16K RAM CARD . . . . . \$59.00

Expand your 48K Apple II+ to 64K. The Multiflex 16K Ram Card allows other languages to be loaded into your Apple from disk or tape.

## MICROTEK SERIAL CARD FOR THE APPLE . . \$139.00

Similar functions to MULTIFLEX super serial card.

## MULTIFLEX Z80-64K CARD

This spectacular card provides you with the functions of a Z80 card along with giving you extra 64K of self contained memory, on top of the existing memory in your Apple computer. (Software not included)

**\$179.00**

## MULTIFLEX UPGRADED Z80 CARD . . . . . \$59.00

This card allows the user to run Z80/8080 programs on his Apple II+ or IIe computer. Specifically, it allows him to run the CP/M operating system with all its attendant software such as word processors, accounting packages, etc. (CP/M software not included).

## MULTIFLEX APPLE COMPATIBLE MODEM



Plugs into your Apple or compatible computer, Direct connect, 300 Baud, Autodial, Autoanswer, Touch Tone/Pulse Dial, complete with documentation.

**\$169.00**

Apple is a registered trade mark of Apple Canada Inc.

## 6502 Style Case

## 6502 Power Supply

CSA Approved, 5V 5A, 12V 2.5A, -5V 0.5A -12V 0.5A  
**\$69.00**



With Numeric Keypad  
**\$129.00**

## APPLE COMPATIBLE DISK DRIVES

**\$199.00**

for Apple II+ and IIe

Now available for Apple IIc

**\$229.00**



Features:

- Apple compatible • Attractively packaged • Professionally built and tested
- Canadian Made • We believe that Multiflex put out more drives in the last year than all other Canadian manufacturers combined.

## SLIMLINE DISK DRIVE \$179.00

Attractively packaged, Apple compatible, ultra reliable (90 day warranty).

# Exceltronix

Toronto Store: (416) 921-8941; Ottawa Store: (613) 230-9000

## IBM Compatible Software and Books



### ACCOUNTING

|                         |          |
|-------------------------|----------|
| BPI                     |          |
| Accounts Payable        | \$654.72 |
| Accounts Receivable     | \$654.72 |
| Information Management  | \$467.67 |
| Inventory Con/Gen Acct. | \$874.80 |
| Job Cost                | \$874.80 |
| Payroll                 | \$654.72 |

### DATABASES INTEGRATED

|                    |          |
|--------------------|----------|
| ASHTON TATE        |          |
| DBase III IV-1     | \$688.31 |
| Framework overhead |          |
| exp. bnd.          | \$668.25 |
| Friday             | \$291.33 |
| Dbase Upgrade      | \$CALL   |

|                       |            |
|-----------------------|------------|
| MICROPRO              |            |
| Wordstar 2000 +       | \$1,099.60 |
| Wordstar Professional | \$638.23   |

|                   |          |
|-------------------|----------|
| STONEWARE         |          |
| Advance DB Master | \$654.72 |

### DATABASE - NON INTEGRATED

|            |          |
|------------|----------|
| SORCIM     |          |
| Easy Filer | \$440.15 |

|                 |          |
|-----------------|----------|
| THORN EMI       |          |
| Perfect Library | \$546.89 |

|                |         |
|----------------|---------|
| TIMEWORK       |         |
| Data Manager 3 | \$98.96 |

|                     |          |
|---------------------|----------|
| FILING              |          |
| SOFTWARE PUBLISHING |          |
| PSF File            | \$154.09 |
| PSF Report          | \$137.55 |
| PFS Write           | \$154.05 |
| PSF Proof           | \$104.54 |

|              |        |
|--------------|--------|
| SPREADSHEETS |        |
| LOTUS        |        |
| Lotus 123    | \$CALL |
| Symphony     | \$CALL |

|                    |         |
|--------------------|---------|
| WORD PROCESSORS    |         |
| BRODERBUND         |         |
| Bank Street Writer | \$87.98 |

|                            |         |
|----------------------------|---------|
| HAYDEN                     |         |
| Business Program Portfolio | \$43.96 |

|                        |          |
|------------------------|----------|
| LIFETREE               |          |
| Volkswriter Delux      | \$282.15 |
| Volkswriter Scientific | \$489.54 |

|                           |          |
|---------------------------|----------|
| MICROPRO                  |          |
| Wordstar                  | \$324.47 |
| Wordstar 2000             | \$455.68 |
| Wordstar 2000 Upgrade Kit | \$456.38 |

|           |          |
|-----------|----------|
| MULTIMATE |          |
| Multimate | \$391.77 |

|                     |          |
|---------------------|----------|
| SATELLITE           |          |
| Word Perfect        | \$420.00 |
| Word Perfect Sorter | \$87.18  |

|           |          |
|-----------|----------|
| MICROSOFT |          |
| Word      | \$214.57 |

|                       |          |
|-----------------------|----------|
| GRAPHICS APPLICATIONS |          |
| FOX & GELLER          |          |
| Dgraph III            | \$272.28 |

|                     |          |
|---------------------|----------|
| SOFTWARE PUBLISHING |          |
| PFS Graph           | \$154.05 |

|                          |         |
|--------------------------|---------|
| UNISON ADVANCED PRODUCTS |         |
| Print Master             | \$65.96 |

|                  |          |
|------------------|----------|
| COMMUNICATIONS   |          |
| TERMINAL PACKAGE |          |
| MICROSOFT        |          |
| Microsoft Access | \$275.10 |

|               |          |
|---------------|----------|
| MICROSTUFF    |          |
| Crosstalk XVI | \$177.05 |

|                     |          |
|---------------------|----------|
| SOFTWARE PUBLISHING |          |
| PFS Access          | \$104.54 |

|              |          |
|--------------|----------|
| THORN EMI    |          |
| Perfect Link | \$141.95 |

|                     |          |
|---------------------|----------|
| PROGRAMMING AIDS    |          |
| BORLAND             |          |
| Turbo Pascal        | \$76.98  |
| Turbo Pascal MS DOS |          |
| Generic             | \$76.98  |
| Turbo Pascal W/8087 | \$120.93 |
| Turbo Tutor         | \$38.46  |

|                       |          |
|-----------------------|----------|
| DIGITAL RESEARCH      |          |
| CBasic 86             | \$220.08 |
| CIS COBOL for CP/M 86 | \$935.33 |
| DR LOGO               | \$165.00 |
| Personal Basic        | \$165.06 |
| PL/I                  | \$825.28 |

|                          |         |
|--------------------------|---------|
| HOLT RHINEHART WINSTON   |         |
| Programming IBM PC BASIC | \$43.96 |

|                       |          |
|-----------------------|----------|
| PROGRAMMING LANGUAGES |          |
| DIGITAL RESEARCH      |          |
| Concurrent PC DOS     | \$324.61 |
| CP/M 86               | \$66.03  |

|                        |         |
|------------------------|---------|
| R BRANDY/PRENTICE HALL |         |
| Pascal programming     | \$71.44 |

|              |          |
|--------------|----------|
| UTILITIES    |          |
| ASHTON TATE  |          |
| Framework II | \$688.31 |

|                          |          |
|--------------------------|----------|
| BORLAND                  |          |
| Sidekick Unprotected     | \$93.47  |
| Super Key                | \$76.98  |
| Turbo Graphics Toolbox   | \$60.47  |
| Turbo Game Words         | \$76.96  |
| Reflex                   | \$101.97 |
| Super Key/Sidekick Promo | \$852.09 |
| Turbo Holiday Pack #1    | \$137.55 |
| Turbo Toolbox            | \$60.47  |

|                      |          |
|----------------------|----------|
| DIGITAL RESEARCH     |          |
| Access Manager       | \$440.15 |
| Animator (3103-AA)   | \$880.31 |
| C Compiler           | \$385.43 |
| CBASIC COMPLIER C86  | \$660.23 |
| Display Manager 86   | \$550.19 |
| DR Graph (5017-AA)   | \$214.57 |
| Forms 2 (3104-AA)    | \$220.08 |
| Dr Assembler + tools |          |
| cpm/86               | \$222.75 |

|                          |          |
|--------------------------|----------|
| MICROSOFT                |          |
| Macro Assembler          | \$165.06 |
| Microsoft Mouse (bus)    | \$220.87 |
| Microsoft Mouse (serial) | \$247.01 |
| Windows                  | \$107.65 |

|            |        |
|------------|--------|
| ROSESOFT   |        |
| Prokey 3.0 | \$CALL |

|                          |          |
|--------------------------|----------|
| SOFTWARE RESEACH TECH    |          |
| Smart Key II Plus MS DOS | \$109.96 |

|                            |           |
|----------------------------|-----------|
| AUTOCAD SOFTWARE           |           |
| Autocad 2 w/ext's 1 & 2    | \$2750.00 |
| Autocad 2 w/ext's 1, 2 & 3 | \$3425.00 |
| Autocad 2 (main module)    | \$1375.00 |
| Extension 3                | \$695.00  |
| Acad 2 arch. & engineer    | \$1375.00 |

|               |         |
|---------------|---------|
| ENTERTAINMENT |         |
| INFOCOM       |         |
| Zork I        | \$43.96 |
| Zork II       | \$49.46 |
| Zork III      | \$49.46 |

|                  |         |
|------------------|---------|
| SIMON & SCHUSTER |         |
| Frogger II       | \$38.45 |
| Super ZAXXON     | \$38.45 |

|                  |         |
|------------------|---------|
| MICROSOFT        |         |
| Flight Simulator | \$54.96 |

|                    |         |
|--------------------|---------|
| SUBLOGIC           |         |
| Jet                | \$54.88 |
| MUSE               |         |
| Castle Wolfenstein | \$32.95 |

|             |         |
|-------------|---------|
| BLUE CHIPS  |         |
| Tycoon      | \$54.96 |
| Millionaire | \$54.96 |

|          |         |
|----------|---------|
| DATASOFT |         |
| PAC Man  | \$29.11 |

|            |         |
|------------|---------|
| HAYDEN     |         |
| Holy Grail | \$56.70 |

|               |          |
|---------------|----------|
| MISCELLANEOUS |          |
| MS DOS        | \$178.20 |
| PC DOS        | \$99.00  |
| GW BASIC      | \$109.69 |

|                                |         |
|--------------------------------|---------|
| IBM Computer Books             |         |
| dBase III Handbook             | \$25.95 |
| C Programming Guide            | \$28.95 |
| IBM PC Expan. & Software Guide | \$31.00 |
| Turbo Pascal For Adv. Prog.    | \$21.95 |
| Symphony tips & traps          | \$28.95 |
| Using Netware                  | \$36.00 |
| Using 123                      | \$24.95 |
| Using 123 workbook & disk      | \$39.95 |
| Using Symphony                 | \$27.95 |
| Using the PFS Family           | \$21.00 |
| Using Wordstar 2000            | \$27.95 |
| Using Wordperfect              | \$25.95 |
| PC DOS User's Guide            | \$24.95 |
| PC DOS Wordbook                | \$21.00 |
| MS-DOS User's Guide            | \$24.95 |
| Understanding XENIX            | \$27.95 |
| Understanding UNIX             | \$27.95 |
| CP/M Programmers Encyclopedia  | \$25.95 |
| Using Microsoft Word           | \$55.00 |
| IBM PC AT User Ref. Manual     | \$42.00 |

|   |         |
|---|---------|
| <b>Data Books</b>   |         |
| <b>Motorola</b>   |         |
| DL128 Linear Data Book  | \$14.95 |
| DL129 High Speed CMOS   | \$ 9.95 |
| DL118 Opto Device Data  | \$ 8.75 |
| DL130 Cmos Integrated CCTS  | \$ 9.95 |
| DL110 RF Data Manual  | \$14.95 |
| DL111 Power Data Book   | \$14.95 |
| DL113 Memory Data Book  | \$ 9.95 |
| DL121 TTL Data Book   | \$12.95 |
| DL122 Mecl Data Book  | \$ 9.95 |
| DL126 Small Signal Trans.   | \$15.00 |
| DL105 Cmos Data   | \$14.95 |
| HB206 Voltage Regulator Handbook  | \$ 9.95 |
| SG73 Master Selection Guide   | \$ 5.55 |
| TB301 Basic Micro. & The 6800   | \$35.00 |
| TB303 The 6800 Family using Micropro & Microcom                         | \$34.00 |
| MC68000um AD4 68000 Users Guide   | \$12.50 |
| Single Chip Microcomputer Data (Includes 6800 Series and Support Chips) | \$19.95 |

|   |         |
|---|---------|
| <b>Other Data Books</b>   |         |
| Intel Micro System Components Handbook Vol. 1 and 2 (Includes 8088 and support chips) | \$26.00 |
| National Linear   | \$19.95 |
| National TTL  | \$14.95 |
| National CMOS   | \$14.95 |

## Keyboards



|                                    |          |
|------------------------------------|----------|
| Keytronics 5151 (PC/XT compatible) | \$195.00 |
| Keytronics 5150 (PC/XT compatible) | \$135.00 |
| Keytronics 5151A (AT compatible)   | \$279.00 |
| Maxiswitch                         | \$135.00 |

## Printer Ribbon's

|                       |         |                       |         |
|-----------------------|---------|-----------------------|---------|
| <b>Star Micronics</b> |         | <b>Epson</b>          |         |
| SG10                  | \$ 4.50 | FX80                  | \$10.95 |
| SG15                  | \$ 4.50 | FX100                 | \$15.95 |
| SR10                  | \$ 4.50 | LQ1500                | \$24.00 |
| SR15                  | \$4.50  |                       |         |
| PowerType             | CALL    | <b>Copal</b>          |         |
| Radix 10              | \$16.00 | SC-1200               | CALL    |
| Radix 15              | \$19.00 | SC-55001              | CALL    |
| <b>Toshiba</b>        |         | <b>Oki Data</b>       |         |
| P-1351                | \$15.50 | ML80, 82A, 83, 92, 93 | \$ 3.50 |
| P-1340                | \$15.50 | ML182                 | CALL    |
| P-351                 | \$15.50 | ML183                 | CALL    |
|                       |         | ML184                 | CALL    |



## New from Star Micronics



### SG-10 Printer

#### Ideal for Text & Graphics

- Dual Mode - NLQ/draft standard (NLQ = near letter quality) • 120 CPS and 20% faster throughput • Bidirectional, logic/seeking • 2K buffer (expandable to 6K with optional buffer interface) • 100% IBM PC or Star standard control codes-switch selected • Friction and tractor standard • full 1 year warranty • 10" wide carriage • Standard parallel interface (serial optional) ..... **\$379.00**
- SG-10C for Commodore ..... **\$399.00** (No interface required)

### SG-10 C for Commodore Computers

All the same features as the SG-10 but includes built-in interface which plugs directly into Commodore computers.

**\$389.00**

### SR-15

- 200 cps and 20% faster throughput • IBM PC or Star standard control codes switch selected • Dual Mode - NLQ/draft standard • Friction/tractor and automatic single sheet feed - standard • 15" carriage • 16K buffer • Bidirectional, logic seeking • Price/performance leader • Parallel port standard, serial optional • Full 1 year warranty. **\$995.00**

## Toshiba Printers

### P321

Impact Wire Dot Matrix, 24-pin overlapping. Letter quality 72 c.p.s.; Draft quality 216 c.p.s. (12 cpi), 180 c.p.s. (10 cpi). Accepts Font Cartridges and downloadable font disks, Qume Sprint 11 emulation, 4" to 11" paper widths, PC compatible and more.

**\$1079.00**

### P351



Impact wire dot matrix, 24-pin overlapping. 4" to 15" paper width. Accepts font cartridges and downloadable font disks, Qume Sprint 11 emulation, IBM PC compatibility, and more.

- Letter quality at 100 cps
- High-speed drafts at 288 cps
- Superb graphics at 360 x 180 and 180 x 180 dots per inch.

**\$1995.00**

## Epson

FX 85 ..... **\$649.00**  
 FX 286 ..... **\$1129.00**  
 LQ1000 ..... **\$1495.00**  
 CR 420 ..... **\$5499.00**  
 SQ 2000 ..... **\$3099.00**

## Star Micronics

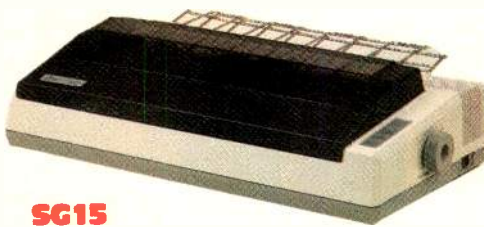

### SG15

Same as SG10 except with 15" carriage and standard 16K buffer ..... **\$599.00**

### Radix

15" 200 cps, 100% duty cycle • 16k buffer • serial & parallel standard • proportional & downloadable characters • 240 x 144 Ultra High Res. • tractor & friction...

Radix 15 PC (for IBM PC) ..... **\$995.00**

### Star Printer Accessories

Printhead ..... **\$80.00**  
 Printwheel ..... **\$18.00**  
 Ribbons ..... **\$4.50**  
 Paper (500 sheets) (8½x11) ..... **\$9.95**  
 Paper (2,000 sheets) (8½x11) ..... **\$32.00**  
 Dust covers ..... **\$8.50**  
 Printer Stand (plastic) 10" ..... **\$34.00**  
 Printer Stand (plastic) 15" ..... **\$38.00**

## NEW NB-15 ..... \$CALL

Impeccable letter quality at 100 c.p.s.!

- 24 pin Dot Matrix • Letter Quality 100 c.p.s. (12 c.p.i) • Draft quality 300 c.p.s. • Optional Character Font cartridges • Optional sheet feeder • 4"-15" paper widths • IBM compatible.

## Star Micronics — Power Type daisywheel printer

Letter Quality

**\$535.00**



Print Speed: 18 c.p.s. bi-directional, logic seeking

Interface standard parallel (Centronics compatible) and serial RS232C-20mA current loop

Paper Slow Speed: 12 l.p.s. @ 1/8" spacing

Print Buffer: One line

Print Size: 10, 12, 15 c.p.i and proportional spacing

Number of Columns: 110, 132, 165

Character Sets: over 100 Type fonts available.

Special Features: proportional spacing; dual interface; standard printer mode and word processing mode; 32 easy access format switches

reverse paper feed; short form tear-off;

Line Spacing: 3,4,6,8 lines/inch; switch and software selectable

Paper Handling: single sheet: 5.5" to 8.5" wide; sprocket 4" to 13" wide; copies 3 carbonless sheets

Ribbon standard cassette



## Copial

SC5500I 180cps, 132 column **\$699.00**



Copial SC1500T ..... **\$499.00**  
 180 cps, 80 column

Copial SC1200L ..... **\$329.00**  
 120 cps, 80 column

Okidata ML192 ..... **\$699.00**

(Apple Imagewriter or compatible, Ile, Iic, Mac)  
 • 120 cps • 2K Buffer, Serial int., upgradeable to 10K  
 • Tractor and friction • 10" • 19.2K Baud max. • Cable extra.

Okidata ML192 (IBM) ..... **\$679.00**  
 • 160 cps • Parallel (optional Serial) • Correspondance quality • 10".

Okidata ML193 ..... **\$1089.00**  
 (Apple imagewriter compatible Ile, Iic, Mac)  
 • 120 cps • 2K Buffer, Serial int., upgradeable to 10K  
 • Tractor and friction • 15" • 19.2K Baud max. • Cable extra.

Okidata ML193 (IBM) ..... **\$1069.00**  
 • 160 cps • Parallel (optional Serial) • Correspondance quality • 15".

## Cable Assemblies



DB25 Male to DB25 Female ..... **\$35.00**

RS232 Cable (6ft of round conductor) ..... **\$39.00**  
 RS232 other lengths and connector configurations available on request.

Parallel cable 36 pin Centronics type connectors, male joined by 6ft of ribbon cable to female ..... **\$35.00**

Parallel Cable for IBM interface DB25 through 6ft of ribbon to 36 pin centronics with appropriate connections ..... **\$35.00**

Cable Assemblies for two 5-1/4in drives and controller (e.g. IBM) using three 34 pin connectors and appropriate length of 34 conductor cable ..... **\$35.00**

20 pin Female header 24in. to 20 pin for Apple drives ..... **\$6.95**

## Serial Switch Box .. \$59.00



Contains 3 RS232 connectors and a switch which switches all lines between input and one of two outputs.

# Monitors and Disk Drives

## Zenith Data Systems



**NEW**

### ZVM1220A

12in. diagonal screen • non-glare amber display  
• composite input • 25 lines x 40/80 characters

**\$135.00**

**NEW**

### ZVM1230A

12in. diagonal screen • non-glare green display  
• composite input • 25 lines x 40/80 characters

**\$135.00**

**NEW ZVM 1240** • 12" diagonal screen •  
glare amber display • PC monochrome input  
(TTL) • 25 lines x 80 characters • 720 x 350  
pixels • IBM PC & compatibles

**\$229.00**

## NEW ZENITH COLOUR MONITORS

**NEW ZVM 1330** • 13" diagonal screen •  
input • 25 lines x 80 characters • 640 x 240  
pixels • green screen only switch • 16 colours  
including PC brown •

**\$799.00**

**NEW ZVM 1350** • 13" diagonal screen •  
RGB/composite inputs • 25 lines x 80  
characters • 640 x 240 pixels • sound capabili-  
ty • green screen only switch • video "loop  
thru" feature •

**\$839.00**

**CV-2560** • 25" diagonal screen • RGB/com-  
posite input • 25 lines x 80 characters • sound  
capability • green screen only switch • video  
"loop thru" feature

**\$1049.00**

**ZVM 136** • 13" diagonal screen • RGB input •  
25 lines x 80 characters • 640 x 480 pixels •  
long persistence phosphors for interlaced ap-  
plications •

**\$1195.00**

## Amdtek Monitors

**300A** • 12in amber composite • 40-132 character  
display ..... **\$218.00**

**310A** • 12in amber TTL • 40-132 character  
display ..... **\$229.00**

**700** Ultra high resolution ..... **\$Call**

## Princeton Graphics Monitors

**HX-12** 12in 15MHz RGB high resolution, horizon-  
tal resolution 690 dots, vertical 240 lines (non-  
interlaced) 480 lines (interlaced) .... **\$1199.00**

**SR-12** 12in, 30MHz RGB ultra high resolution,  
horizontal resolution 690 dots, vertical 400-480  
lines (non-interlaced) ..... **\$1249.00**

**NEC Monitors now available — Call  
for price**

12 — Exceltronix Spring 1986 Catalogue

## Irwin 10 Meg Tape Drive Backup \$1199.00



Hooks up to your  
existing floppy  
controller.

## Scorpion 20 Meg Tape Drive Backup and Controller. \$1495.00

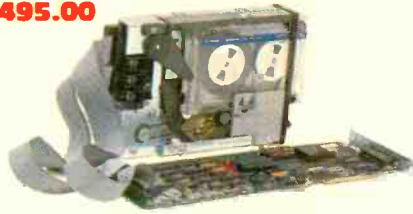

## 5.25in. Disk Drives

### SA455 ..... \$169.00

• Shugart/Panasonic 5.25in. slimline, double sid-  
ed, double density disk drive with 360K storage  
capacity. IDEAL FOR IBM COMPUTERS.

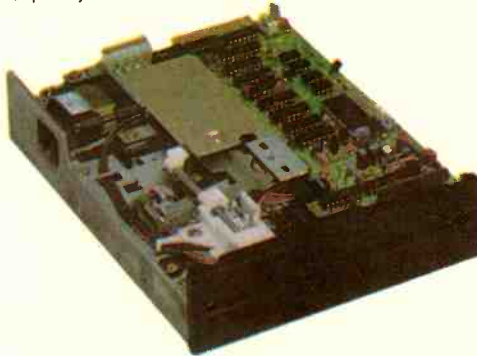

## Toshiba Disk Drives

**ND-04D 360K DS/DD**  
(black or grey) ..... **\$169.00**

**ND-08DE-G 1.2Mbyte AT Compatible,  
Grey** ..... **\$269.00**

Prices and specifications subject to change without  
notice.

## Diskettes

### Prices per box of 10

10% discount on 3 or more boxes.

|                        |            |
|------------------------|------------|
| Dysan DS/DD .....      | \$35.95/10 |
| Dysan SS/DD .....      | \$27.50/10 |
| Maxell DS/DD .....     | \$35.95/10 |
| Maxell SS/DD .....     | \$28.95/10 |
| Exeltronix DS/DD ..... | \$24.95/10 |
| BASF DS/DD .....       | \$29.95/10 |
| BASF SS/DD .....       | \$22.95/10 |
| Pinnacle DS/DD .....   | \$21.95/10 |
| Pinnacle SS/DD .....   | \$16.50/10 |
| Elephant DS/DD .....   | \$24.95/10 |

## Modems

### Anchor Automation

Singleman 1200

300/1200 baud smart modem ..... \$469.00

Volks Modem (300-1200) ..... \$399.00

### Hayes

1200B Modem (stand alone) ..... \$605.00

1200 Modem ..... \$620.00

300 Modem ..... \$365.00

Smartcom II ..... \$188.00

## Joysticks & Input Pads

### CH Products

Mach II ..... \$ 67.00

Mach III ..... \$ 67.50

### Koala Technologies

Koala Pad W/PC Design ..... \$199.00

The Speed Key System ..... \$259.95

### Kraft

Kraft Joysticks ..... \$ 65.00

## Mice

### Microsoft

Microsoft Mouse ..... \$227.50

### Mouse Systems

PC Mouse ..... \$239.20

PC Mouse/PC Paint ..... \$277.20

## Bill Boards

Compuserves Starter Kit ..... \$ 59.00

## Toshiba Hard Drives

**MK 53FA, 43.5 Meg** .... **\$2579**

**MK 54FA, 60.5 Meg** .... **\$2725**

**MK 56FA, 86.5 Meg** .... **\$2898**

Controllers available.

## Hard Disk Drives

10 MEG Seagate, slimline drive and  
hard disk controller. This controller  
can handle up to two 10 MEG hard  
drives. **\$895.00**

Seagate 20 MEG. with  
controller ..... **\$995.00**

Cables (for 10 or 20 MEG) **\$18.00**

Quantity discounts  
available on two or more

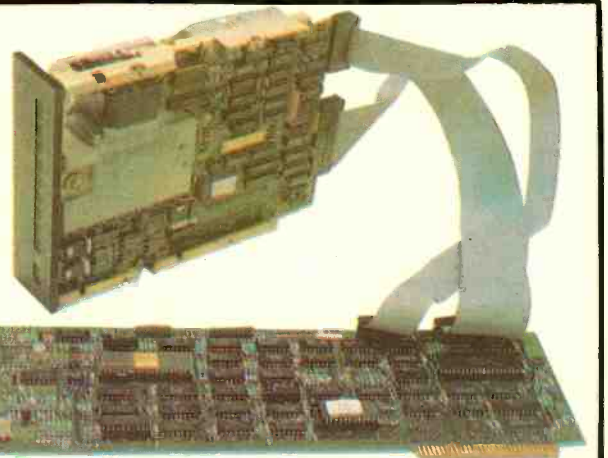

11/11/86

## Multiflex Products

### Multiflex Economy Video Display Terminal

Now available from MULTIFLEX is an economy video display terminal. Originally designed as a low cost access unit for our mail-ordering and bulletin board system, this terminal is a semi-intelligent system which is controlled by a Z80A microprocessor and a 6845 CRT controller chip. The keyboard is fully ASCII encoded and the character generator contains the full 128-character set as well as a 128-character alternate set both of which are in the 5x7 dot matrix format. The screen display is 80 characters by 24 lines if the unit is hooked to an external monitor. (Monitor not included). There are 3 software selectable attributes (dim, reverse video, and alternate character set) which can be chosen one at a time for the whole screen. The attribute can then be switched on and off for each individual character. A 2K buffer is provided for normal operation. However when the optional 6K memory upgrade is purchased, 4 screen pages can be loaded from the host machine, edited, locally, and then downloaded back to the host again saving on connect time and phone line bills. Also included are 2 RS232 ports: one for a modem and one so that a printer can be attached to the terminal. The baud rates on these ports are software programmable and can range from 110 to 9600 baud. With all these features, you would expect to pay a lot for this system, but all this is available to you, complete with an attractive case, for an extremely low price.

**A&T board with keyboard (as picture top right) with one RS232 and 2K buffer \$169.00**



**Terminal Complete: Tested and 90 days warranty with 2 RS232 ports, 2K buffer case and power supply (Hydro approved)**

**\$299.00**

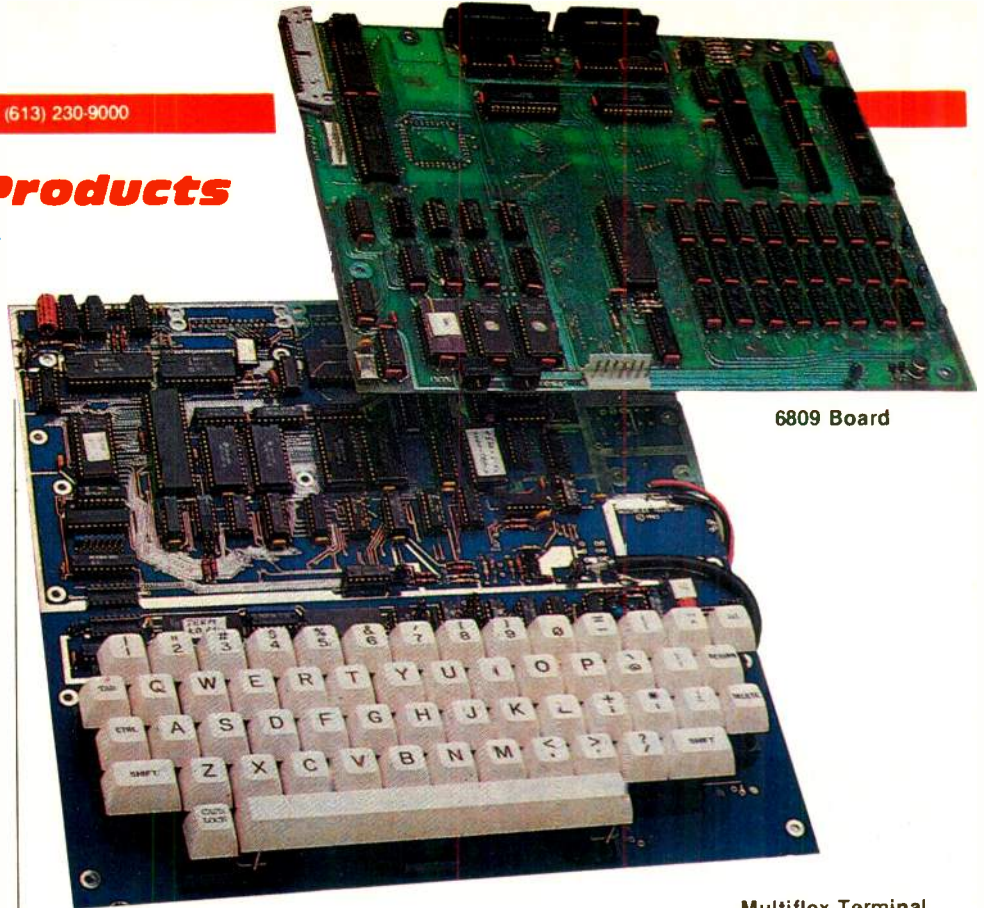

6809 Board

### U of T 6809 Single Board Computer

The 6809 Single Board Computer, designed at the University of Toronto and distributed exclusively by EXCELTRONIX, is a compact hardware unit which was designed originally as a lab board for teaching students about microprocessor systems. Its many features, however, make it an ideal unit for stand-alone control applications or software development systems as well.

The system is designed around the Motorola MC6809 microprocessor. This is an 8-bit processor with full 16-bit internal architecture, 2 index registers, 2 stack pointers, 28-bit or 1 16-bit accumulators, a direct page register and a wide range of addressing modes, including a program-counter-relative mode. This mode allows the user to write completely position independent software, important in systems software development.

There is provision for up to 48K bytes of dynamic RAM on-board. The refreshing of this RAM is controlled by an 8202 Dynamic RAM Controller. This chip allows for completely transparent refreshing of the RAM (ie. no wait states to slow the system down). There is also provision for up to 12K of EPROM using 2532 chips.

There are 4 complete I/O circuits built onto the board. 2 of them are serial (RS232); one is used for a terminal (which is required for use of the board with the supplied monitor software), and the other one is user defineable, but it is set up to

#### Multiflex Terminal

communicate with either a modem or a printer. Also on-board are 2 6522 VIA chips. These provide 2 parallel ports per chip along with 2 16-bit timer/counters. One of the parallel ports and one of the timers are used by the monitor software to provide a cassette interface (which operates at 300 baud). The second parallel port on that chip is wired into a connector which is ideal for interfacing a parallel printer or keyboard. The 2nd VIA is not used at all and is completely free for the user. For further expansion of the system, a fully buffered version of the CPU signals (data, address, control lines and a signal indicating whether or not the current address is located on the board) is available at a cable connector.

The software provided with the system is in a 2532 EPROM and allows the user to: test the memory; dump blocks of memory; examine and modify single memory locations; read or write from the cassette port; set and examine breakpoints; single step and/or execute machine language programs and set and examine the processor registers. All this is accomplished through a 9600-baud terminal interface (one of the serial ports) Included is a full screen editor/assembler which allows the user to work in 6809 assembly language rather than machine language. All this makes this board an ideal trainer, control unit or software development unit for just about anyone.

Includes U of T course documentation

**A&T with 48K \$299**

Special Pricing is available when both items on this page are purchased together

# Multiflex Low-Cost Logic State Analyzer

## Ideal for educational institutions and hobbyists.

You've just completed a microprocessor system, and it doesn't work. What next? You can use an oscilloscope to check for clock signals and the like, but if everything appears to be in order you can't go much further without sophisticated equipment. In these situations, professionals turn to their logic state analyzers, each of which cost thousands of dollars. MULTIFLEX has the answer for all those people who don't want to take a mortgage on their house just to get a computer working. The MULTIFLEX Logic State Analyzer has all the essential features of those more expensive units at a fraction of the cost. This is a high-quality piece of test equipment, suitable for industrial or scientific use, but its price is well within the price range of a hobbyist.

Easy to understand and operate, the Logic State Analyzer allows you to monitor 16 points in a digital system (ie. data and/or address bus, or control lines) which carry continually changing signals. You can select a bit pattern you expect will appear at these points. Once the pattern appears the Analyzer will trigger and record ("freeze") the next 1023 bit patterns so that they can be examined step by step even though data is no longer available in the unit being examined. For software development the Analyzer is invaluable, especially in dedicated systems. If you design a microprocessor system for a specific function, and you have no monitor, assembler or other such software, the best and often only way to debug the system is to use a logic analyzer. It will let you look closely at the data flow as a program is executing, or monitor the address lines to make sure that the instructions are being executed in the proper sequence. The various control lines such as memory read and write, DMA, interrupts, or enable and disable signals can also be examined. You can, of course, monitor any combination of these signals, such as the data bus and half of the address bus, or half of each plus 4 control lines. The combinations are endless.

**Complete, assembled  
and tested  
\$369**

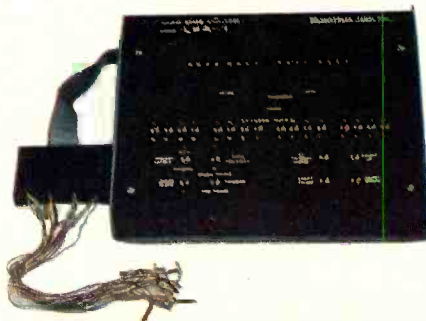

### Note from Industry to Educational Institutions:

At Multiflex we interview many technicians each year, from a variety of Colleges. Only a few applicants know what a Logic State analyzer is and even fewer know how to use one.

Yet in our industry, it is almost as important to know how to operate logic analyzers as it is to use an oscilloscope since the technician will need to use a logic or timing analyzer to trouble-shoot complex equipment.

We have spoken to many other companies and found that they are experiencing the same problems with technicians coming fresh from college. So, we asked educational institutions why they don't teach this aspect of electronic engineering. The teachers are fully aware of the problem but explained that they cannot afford the high cost of logic analyzers; even those institutions which have them can afford only one or two which gives the students little chance to learn them.

Our LSA is a time-proven product which is considerably less expensive than the alternatives.

**Here is your chance to prepare technicians for the real world!**

## EPROM Emulator

If you are a computer designer who values your time, you can't afford to be without this!

Did you ever write a piece of code, burn it into an EPROM, plugged it in and it didn't work?

Did you then go through the code (using an analyzer or your brain power) and then discover you left out some crucial Byte which caused the processor go the point of no return?

If the above holds true, how many EPROMs have you reprogrammed, erased and damaged? More important how many hours have you wasted?

Put an end to all the above problems and save time, money and frustration: Buy an EPROM Emulator.

It allows you to download over RS232 (at 300 to 9600 Baud) a program from your computer into the Emulator's memory (16Kx8) and then simply plug a 24 or 28 Pin header connected via ribbon cable to the Emulator in place of your EPROM and you have successfully emulated an EPROM.

If you need to change your code, simply change it on your computer, download to the Emulator's memory and you are back in business in seconds.

This stand-alone product emulates the following EPROMs: 2716, 2732, 2764 and 27128. Can be used with any computer with an RS232 interface.

This product is a must for any hardware development since it allows the user to test and modify EPROM data roughly 20 times faster than conventional methods.

The Emulator normally comes attractively packaged and contains its own power supply. However, to make it more affordable for beginners, we have separated the price into several categories:

1. Complete Emulator with 16Kx8 memory, attractively packaged with power supply. Fully assembled and tested with warranty. **\$189.00**
2. As above but with 8Kx8 memory **\$159.00**
3. Emulator with 4K RAM, no housing or power supply (requires +5V at 1.5A Max, +/- 12V at 0.03A. Fully assembled and tested. **\$99.00**



# SPECTACULAR GANG EPROM PROGRAMMER AND EMULATOR

Totally self-contained (has its own display, entry keypad and power supply).

Based on the Z-8 microprocessor.

Can program up to 8 EPROMs simultaneously (anywhere from one to 8 EPROMs at the same time with the information in its own memory or master EPROM).

Each of the 8 EPROM programming sockets is individually buffered and isolated from one another providing protection in situations when there is a bad EPROM among the eight being programmed. Clearly indicates and singles out any defective or marginal EPROMs prior to or after programming.

After programming the unit does a full VERIFY routine of the EPROM (at a Max Vcc of 5.4V and at a Min Vcc of 4.5V) to ensure high reliability of your EPROMs. Very simple to use.

A standard unit contains 8x16K of on-board memory which is sufficient in most cases, but can easily optionally be upgraded to 8x64K of on-board memory.

The Gang Programmer can handle a wide selection of EPROMs: 2716, 2732, 2732A, P2732A, 2532, 2564, 2764, 27128, 27128A and optionally upgradeable to handle 27256, 27512, 2758 and 2724.

Gives you option of entering the data which you want to be programmed on the EPROM through a built-in keypad and display into the EPROM programmer's built-in RAM or by downloading the data to be programmed by

RS232 interface (110 to 9600 Baud). The RS232 is standard — not optional!

Data can be checked or modified, since you can examine any memory location of the programmers built-in RAM, this holds true even after you have down-loaded through the RS232 from your computer; you can check or modify the memory before finally programming it on your EPROMs.

Read Master EPROMs; you can plug in a programmed EPROM, dump it into the programmers RAM, check the contents on display by stepping through the memory and, if you wish, you can alter any location before copying to other EPROMs.

EPROM Programmer can also be (optionally) used as an EPROM emulator, saving hours of frustration, reprogramming and waiting.

Using the Emulator option, you can enter via the keyboard or down-load through the RS232 from your computer or development system, the information which you think is right for whatever project you are building. This is the same information which you would normally burn into an EPROM, plug into your new undebugged processor and moments later you realize that you forgot to enter a code or that you must add or delete some codes. This normally would mean waiting 20 minutes for erasing of the EPROM and reprogramming and wasting time.

Using the Emulator option, you simply plug in a 24 or 28 Pin buffered pod into the socket on your board where you would normally fit the



EPROM, the difference being now that you can have all the information in the programmers RAM, connected to the pod by a ribbon cable and you can start your testing. If you wish to change, add, delete any codes, you can modify the contents of the programmers RAM using the keypad and display and continue testing moments later. Keep in mind that the RAM is protected from being accidentally altered.

Complete package with EPROM Emulator, 8 ZIF sockets, Gang Programmer with 16Kx8 of RAM and RS232 **\$995.00**

Gang EPROM Programmer with 8 ZIF sockets, 16Kx8 RAM and RS232, without Emulator **\$695.00**

EPROM Programmer with only one ZIF socket, 16Kx8 RAM and RS232, without Emulator. Able to do all the functions describe but can handle only one EPROM at a time **\$499.00**

## UV EPROM Erasers

Industrial quality EPROM erasers.

Erase time about 15-20 minutes

**Starting at \$129.00**



# Exceltronix Digital Signs

## FEATURES

- Up to 128 labelled messages can be stored within the unit's memory for display at any preselected time and date and in any order.
- 12,288 character memory is standard, this can be expanded if needed to 36,864.
- With the internal clock, you can program specials to appear at selected times throughout the day and then just leave it alone. (Programming up to one [1] year in advance.)
- The display's optional voice capability ensures that your messages will be noticed as they come up.
- Graphics — Use your imagination.

### INCREASE SALES

- Generate new markets
- Stimulate more walk-in-traffic
- Increase your sales from in house and window displays.

### INFORM CUSTOMERS:

- Price Discounts
- Change prices instantly
- Promote up-coming specials - dates
- Special service announcements
- Community service announcements

### PROMOTE:

- Discounted Items
- Seasonal Sales & Special Services
- Slow moving merchandise and discounted lines
- New product lines

### COMMUNICATE:

- Sport scores and highlights
- Public Service information
- Seasonal messages
- Up incoming events

In a competitive world, you need the advantage to create new customers and retain the current ones. That advantage is the VERSADIGITAL DISPLAY — the state of the art advertising vehicle.

The VERSADIGITAL DISPLAY provides you with advertising flexibility because it instantaneously communicates your products, your identity, your personality and your desire to provide quality service. It stimulates positive reaction from the people you want to reach at the lowest possible cost! It works for you around the clock, day in, day out to increase client awareness and identification. Your sign is fully computerized and will allow you to slot your sales messages to the audience you wish to reach, including morning, evening, and weekend viewers. You can program messages an entire year in advance at one time, and schedule them for display when you want them to promote special sales, featured products, and services.

In this modern market place, you cannot afford to let a superb, competitive advantage such as this to pass you by. The VERSADIGITAL DISPLAY gets results — in increased market awareness, improved market share and most importantly, increased sales.

**Manufactured by our sister companies: Multiflex and Versadigital and distributed by Exceltronix.**

1-(800) 268-3798 for orders only. Local orders and information 921-8941 or send for our free brochure.



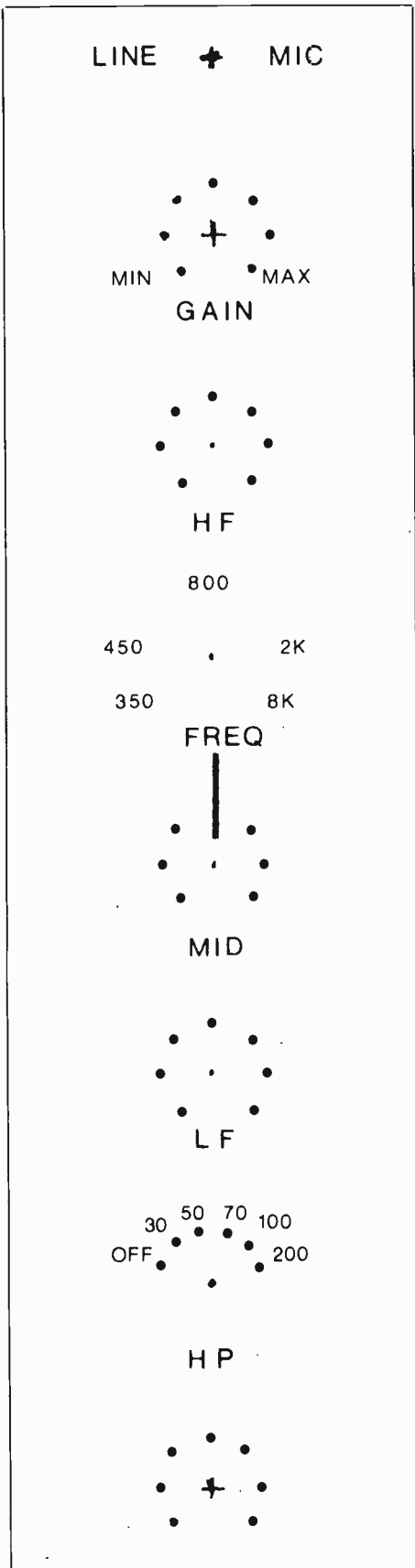

The artwork for a typical console, showing the gain and tone controls. The HP is a highpass filter.

nomical, but they do suffer from hum loops and hum pickup unless a lot of care is taken to ensure proper grounding (an article, nay, a book unto itself). Once it works, it's just fine. The drawback is that adding new equipment may upset the apple cart. This is one big advantage to balancing: it's very tolerant of changing or unusual circumstances, something that's important if you're pressed for time.

### Standard Level

More arguments arise as people try to explain the decibel and the concept of 'operating level', which gets confused some more by the VU and the VU meter.

Here we go, but I guarantee that as you read this, you'll hear distant shouts of 'no, no! Here's what it really is!'

The unit of level in pro audio is the dBm. Properly speaking, this is a measure of power levels, with the 'm' meaning that 0dB is 1mW or 775mV across 600 ohms. This is borrowed from the engineering art of telephony.

However, solid-state has nixed the old 600-ohm concept, which was fussy about source and load impedances being exact. Now we have buffered op amp outputs with an output impedance close to zero, and input amps that bridge the line with impedances of 10k or more.

Still, the dBm hangs in, and is popularly used to mean plus-or-minus so many dB above or below .775V, regardless of the actual line impedance. There have been attempts to correct things, what with one-volt standards and 775mV standards and so forth, but the dBm as a voltage level refuses to go away, even if it makes engineering teachers grind their teeth.

And the VU? Many moons ago, someone in Bell Labs set the standard for the mechanical VU meter, and it just happened that if you put it across a 600-ohm line, it loaded it down by 4dB. The level had to be cranked up by 4dB to get the needle to register 0 VU, and line level was born. That's where the +4dBm standard audio line level comes from.

There's been some attempt to get home stereo levels standardized, with 0 VU indicating about .775 or .75V RMS. It isn't always followed, but having patch points such as tape-monitor jacks at a standard level simplifies changing equipment.

### Fadeout

Now that we've covered the basics of routing the signals around the studio, there are the gadgets and widgets that are used to simulate natural acoustics or create a completely new sound, but there isn't room to even begin to cover them all (another article idea!).

Is it true that given enough toys, you can make a bad singer sound good? You

bet. It happens all the time. Some studios turn out music like Campbell's makes soup. The performer is almost an irrelevant part of things, like an effects box.

On the other hand, there are lots of studios doing a great job of capturing the musician's sound. Aside from lots of money, the secret lies in lots of overload protection (headroom), standard levels at all input and output points, and properly installed audio lines. And, of course, the most important part: the skills of the people who operate the equipment. ■

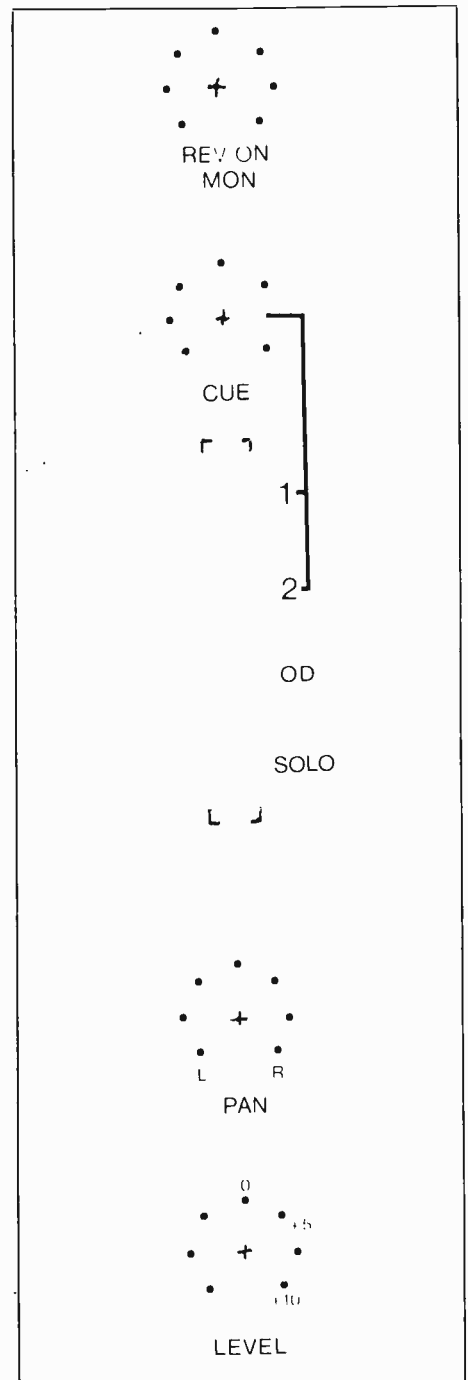

One of eight monitor channels from a console designed by the author. It can listen to either the console or the tape with or without reverb, and features an overdub button for mixing live and taped sound.

THE PREDOMINANCE of VLSI chips in modern computer boards does not mean that small logic devices are becoming a thing of the past. A microprocessor chip does not usually 'bolt' directly into RAMs, EPROMs or PIAs but instead requires a considerable amount of interface logic, using ICs often referred to as 'glue chips' and most frequently being 74LSTTL devices. A look at the inside of many personal computers will confirm that the glue chips often account for a significant proportion of board space. Clearly it would be of considerable advantage if these TTL devices could be combined together into a single integrated circuit. Since each different application has slightly different interfacing requirements the computer manufacturer, rather than the semiconductor manufacturer, would have to specify the device and have it made.

Custom chips dedicated to one narrow function within one circuit design are prohibitively expensive to develop for all but highest volume production runs (in excess of 100,000). The one-chip, one-product notion is attractive, but for moderate volumes or circuit development a compromise is necessary.

### The Semi-Customer is Always Right

The first alternative is the semi-custom chip. These chips fall into two categories: standard cell and gate arrays. The closest in concept to full custom is the standard cell integrated circuit. Various semiconductor manufacturers provide a service for customers to specify such a semi-customized device.

Rather than have to build up a custom circuit from scratch, in the standard cell approach the chip is built up from a library of standard elements. The building blocks include quite complex functions such as RAM, EPROM and CPUs as well as simpler ones such as gates, flip-flops, decoders and multiplexers. Using the semiconductor manufacturer's data on the available circuit elements and computer aided design (CAD) workstations, the customer generates data describing the requirements from which the supplier manufactures the chip.

As in the case of the full custom design, a complete set of masks must be

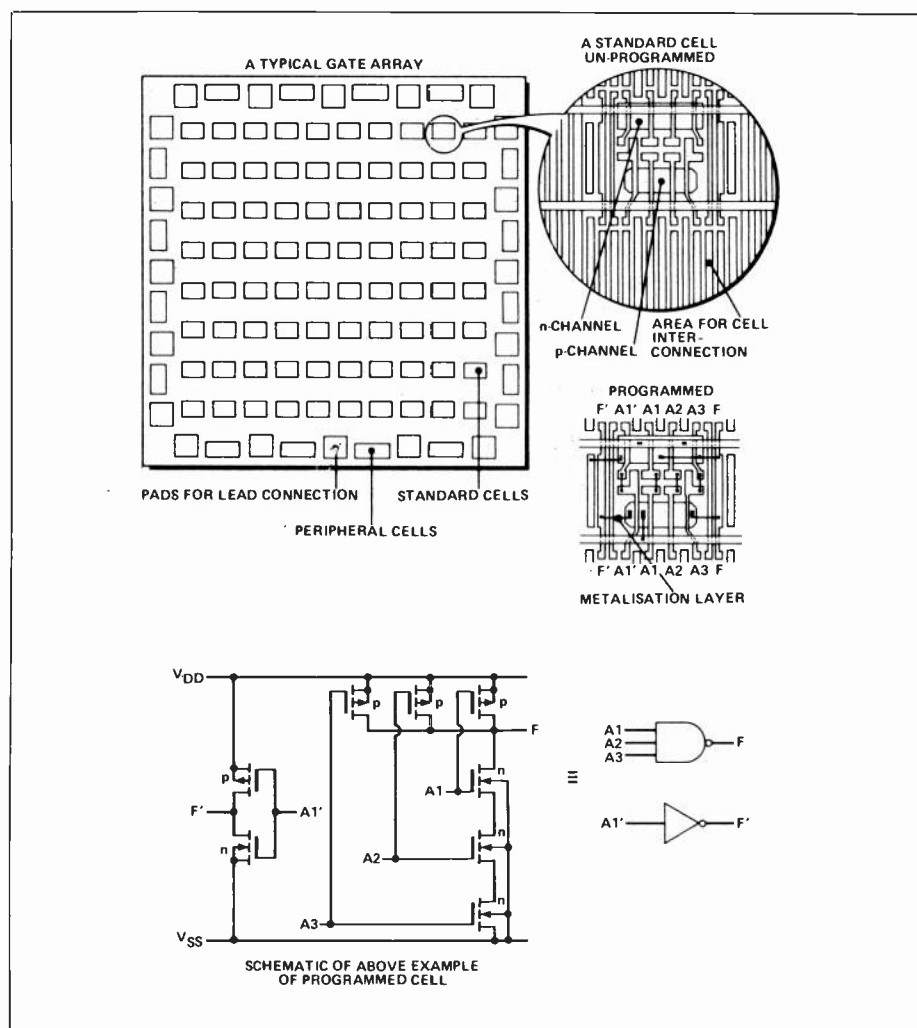

Fig. 1 A typical gate array.

produced for the manufacture of a standard cell device and although design time is shorter, the initial cost is still very high. Accordingly, volume production would once again be required to justify the approach - although the point at which it becomes viable is not quite as high as for the full custom design.

The gate array, or uncommitted logic array (ULA), offers a quite different approach to semi-custom chip design. The basic building block here is nothing more complicated than cells of n-channel and p-channel transistors which can be configured as simple logic gates. Unlike the standard cell, the elements are already etched onto the chip and the customer need only provide interconnection data. Only

the mask needs to be produced, for the final, metallization layer.

Fig. 1 shows a typical gate array. It will be noticed that there are two distinct areas on the chip. Around the edges are pads for lead connection and a number of special peripheral cells. These cells, being close to the outside world, are especially suited to providing I/O interfacing to a variety of other devices.

The centre of the chip, on the other hand, is composed of a matrix of standard cells, sometimes thousands in numbers. Figure 1b shows a typical standard cell. The cell has been masked to provide an inverter and a 3-input NAND gate. Conducting strips between the cells are used in conjunction with the mask programming

# Designer's Notebook



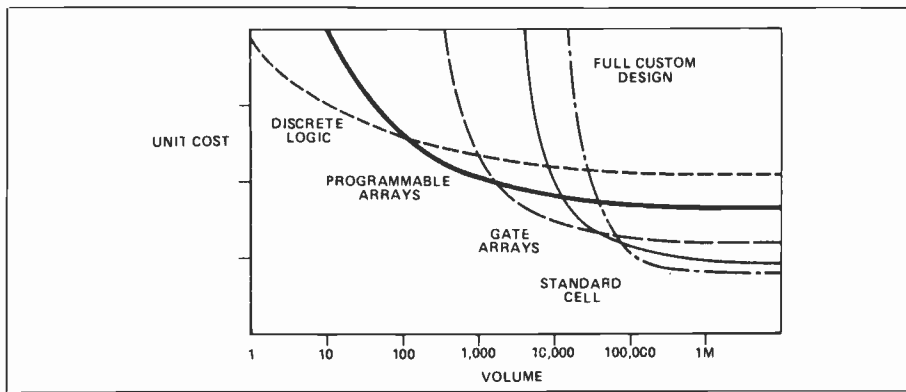

Fig. 2 Price comparison of logic technologies.

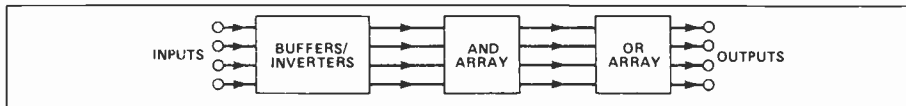

Fig. 3 Generalized AND/OR array.

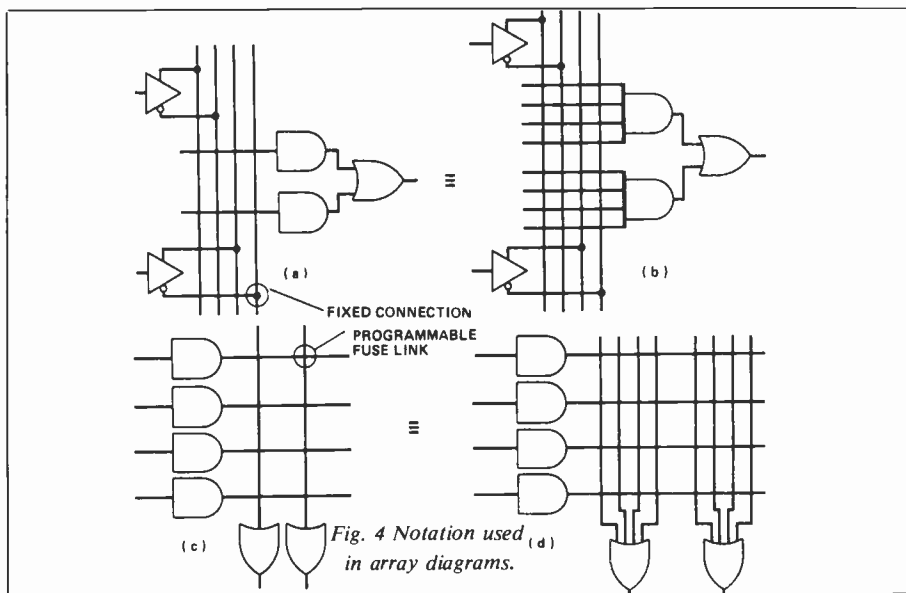

Fig. 4 Notation used in array diagrams.

within the cells to provide the required interconnections. Designing interconnections is more involved than in the case of standard cell chips but the initial manufacturing set-up cost of gate arrays is much less and they are, therefore, suited to smaller volumes. Even so, they would not be used for runs of less than a few thousand.

### Array of Hope

Programmable arrays constitute a class of devices which are much less versatile than

either custom or semi-custom chips but still provide a high degree of flexibility. Their major advantage is that the semiconductor manufacturer is not involved in the customization process. Instead, standard devices are obtained and programmed by the customer using equipment similar to a PROM programmer. Initial costs are nowhere near as high as with custom and semi-custom ICs and the devices can be used for relatively small volume production runs. In high volume, the lower initial cost would be more than

offset by a higher unit cost. Fig. 2 illustrates the varying costs of custom, standard cell, gate array, programmable devices and discrete logic against the volume used.

Programmable arrays are of three types: PROMs, PALs and FPLAs. The first will be well known to home computer enthusiasts as non-volatile data or program memory chips. The PROM is actually a special case of the programmable AND/OR array. Fig. 3 illustrates such an array. The configuration can be used to implement any logic function expressed as a sum of products by selecting appropriate connections into the AND array and out of the OR array. In fact, any Boolean transfer function can be translated to this logic form, given the use of inverters, the only limitations being the number of inputs and outputs.

In order to understand the differences between the various programmable arrays, it is necessary to clarify the notation used in diagrammatic representations of these arrays. Since the gates in any array may well have tens of inputs, for convenience single input lines are used to represent actual multiple inputs (Fig. 4). This also shows that two lines crossing in a programmable section of an array represent a fuse programmable link. Fixed sections of an array use the convention of a solid dot to show a connection and crossing lines without a dot to indicate no connection.

### PROMs

the characteristic feature of a programmable read-only memory is that the AND array is fixed while the OR array is programmable (Fig. 5). This will be a novel way of looking at a PROM to those who are used to its application as a microprocessor memory. The Fig. 5 circuit should convince you that this truly is a 4-bit wide, 8-location PROM. In the general case, there will be one AND gate for each combination of inputs (that is, for each location or address) and one OR gate for each output bit.

PROMs have the advantage of low cost and are relatively easy to program. However, since the AND array is fixed, with one gate for each combination of inputs the chip size increases rapidly with the number of inputs. In fact, the total number of AND gates will be equal to 2

Continued on page 43

## Digital Superglue -

**The superchips of today are beginning to use programmable logic for all the small but vital tasks that hold a complex piece of equipment together.**

**By Mike Bedford**

# ook

**Toll Free Orders Only**  
**1-800-387-1385**  
**(416) 928-2161**

MAIL ORDERS: We accept VISA, MC, AMEX, credit cards. Money orders, cheques (2 week wait) are also OK. Minimum packing and handling fee \$5.00 or 5%, whichever is larger. The only COD we use is via CANPAR (Add \$4.00 COD fee) or at all. All Ont. res. add 7%. All prices are subject to change without notice. Returns are subject to a 20% restocking charge.

**IBM CASE**

We have the nicest case of all the various competing cases, ask any friend who has bought someone else's case and then has seen ours. The lid is hinged with pushbutton access. The back is cut for 8 XT slots and it comes with all the case back inserts for cards, card guides, blind disc filer plates, standoffs, feet, crews, all for **\$69.95**. Please specify back or side cutout for power supply.

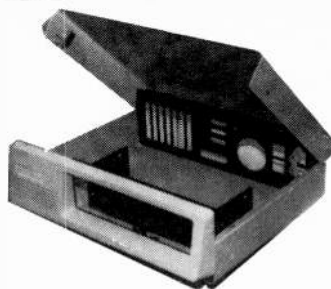

We also have an IBM 8 Slot/6502 Board dual duty case for making IBM look-a-like 6502 systems ..... **\$79.95**

**NICADS 8.4V 7 "D" 4A.H CELLS**



A great buy, a pack of 7 brand new GE NICADS giving 8.4v at 4 Amp hours. Each cell is 12v and separates easy. Used as 5V backup through a 7805. Gives 5v 1 Amp for 4 hours. .... **\$.14.95**

**WIRED CARDS FOR IBM**

- (A) 384K RAM CARD. A 1/4 sized card that has 384K of 64K DRAM on board. With OK ..... **\$79.95**
- (B) 512K RAM CARD. A full sized card with 512K of 64K DRAM on board. With 64K ..... **\$119.00**
- (C) 576K RAM CARD. A very popular card with 576K of 64K and 256K DRAM on board. This is a 1/4 sized card for portable use. With OK ..... **\$ 79.95**
- (D) KRAM RAM CARD. A clone of the JRAM with up to 2 MBYTE on board using 256K DRAM. 100% compatible, complete with software for using as RAMDISC and RAMSPOLL. With OK ..... **\$139.00**
- (E) COLOR GRAPHICS. A clone of the popular PERSYST color card. Has three outputs and one input. A. RGB for IBM color monitor. B. Video 1v P to P composite color video. C. Video gray scale 1v P to P for seeing color on green or amber monitor ..... **\$129.95**
- (F) MONOCHROME GRAPHICS/PRINTER. A workalike clone 100% IBM compatible for the HERCULES card. Has par printer port and hi-res text and graphics mono output ..... **\$159.95**
- (G) 384K HEXPACK. A copy of the AST 6-PACK, 100% compatible with software. Has Clock/calendar/alarm and 384K DRAM and serial and parallel ports and game I/O. With OK ..... **\$189.00**
- (H) 640K HEXPACK. Similar to above but with 840K on board using 256K and 64K DRAM. All other features the same. With OK ..... **\$279.00**
- (I) DISC CONTROLLER. For 1-4 DS-DD drives. Full IBM standard with cable and instructions. .... **\$ 79.95**
- (J) DISK CONTROLLER + I/O CARD. A very good card that has a clock/calendar/alarm and game I/O and serial and parallel ports and a standard 1-2 drive controller card on a full sized card. Very efficient card ..... **\$189.95**
- (K) I/O + 2. A clone of the very popular USA card of the same name. Has clock/calendar/alarm, with game I/O, serial and parallel ports ..... **\$129.95**
- (L) PRINTER CARD. A standard centronics printer port for all parallel printers ..... **\$ 59.95**
- (M) SERIAL CARD. A standard ASYNC serial card for modem use etc. .... **\$ 49.95**
- (N) MODEM CARD. A 300/1200 Baud modem using the 8910 WORLD chip. Compatible with many popular software packages. .... **\$189.00**
- (O) 8255 I/O CARD. Uses 2 8255's to give 16 lines of I/O for various uses. Fully locatable ..... **\$129.95**
- (P) CLOCK CALENDAR CARD. A small card to add the clock/calendar/alarm battery to system ..... **\$ 49.94**
- (Q) GAME PORT CARD. Adds two std game I/O ports to the system ..... **\$ 39.95**

**IBM COMPATIBLE SYSTEMS**

- All SME-XT systems share these attributes.
- High order compatibility due to the DTC bios which is recognized superior to others.
  - 8 Slots for plug in cards, just like IBM
  - Made right here in Canada
  - Socketed for the 8087 Co-processor
  - IBM compatible serial keyboard
  - Disc controller using 9216 IC, the most advanced, for error free operation.
  - Properly made 135W power supply with accessory plugs.
- (A) Basic system 256K, 1 DSSD drive, & controller monochrome card, 135W PS and keyboard **\$949.00**
- OPTIONS, Add the amount indicated for the option.
- (1) 640K Motherboard with 640K ..... **\$110.00**
  - (2) Color graphics card with gray scale ..... **\$ 80.00**
  - (3) Parallel printer port card ..... **59.00**
  - (4) Clock, calendar, alarm, serial, parallel, and game card ..... **\$110.00**
  - (5) Extra drive, installed and tested ..... **\$160.00**
  - (6) 10 Meg hard drive, w/controller ..... **\$649.00**
  - 20 Meg hard drive, w/controller ..... **\$899.00**
  - (7) IRWIN 10 meg tape B/U ..... **\$649.00**
  - IRWIN 20 meg tape B/U ..... **\$799.00**
  - Tape cartridges for above ..... **\$ 34.95**
  - (8) External hard drive box w/power supply for hard drive or tape B/U option, w/cables and ready to go ..... **\$249.00**

**NEW SME-XT 640K TO 1M BYTE**

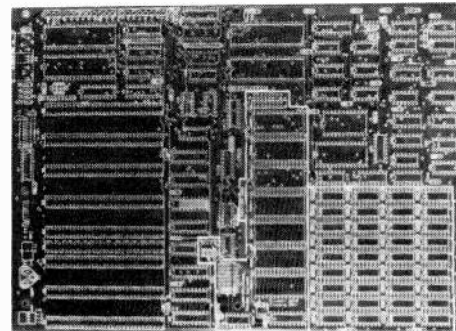

In response to popular demand we have developed an upgrade of the famous MBE-XT board. The new board is called the SME-XT and has space for up to 1 Mbyte on board. The most popular configuration is 640K which is the IBM max addressable memory. The extra RAM above 640K is normally used for system purposes such as video lookup, ROM sitting, and other uses. However, we can supply proms to allow full use of this overhead space on demand. The 256K RAMs are more highly evolved than 64K RAMs and board using them have far fewer problems with parity errors. We have decided to maintain the low price we pioneered with the MBE-XT and sell the new PCB at \$39.95 as well. All other attributes stay the same as the original IBM and the MBE-XT.

- SME-XT Baseboard 1 Parts List ..... **\$39.95**
- SME-XT Wired and Tested with OK RAM with BIOS ..... **\$199.00**
- Manual and Schematic ..... **\$ 4.95**

**HARD DRIVE BOX**

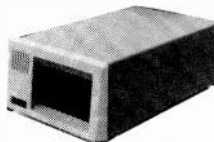

This nicely made box is ideal for externally mounted hard or floppy drives. It has space for one full height or two half height drives and power supply space at rear. This is a well made and rugged units for only **\$59.95**

**LAZY BOARD**

LAZYBOARD. No we are not lazy, it's for YOU!!! We had a bunch of 640K motherboards expertly wave soldered with all solder-in parts with AMP style IC sockets but no IC's at all. You buy the IC's or use your own stock and you can get a system going really cheaply. We are selling this "LAZY BOARD" for only ..... **\$119.00**

**QUME**

Yes we have the same QUME drives that IBM uses in their IBM-XT® system, 40 track, 1/2 height, double sided, double density. The exact ones you need to upgrade your old system or build your clone system up to the max. These are brand new drives that are from QUME's own inventory. They are absolutely perfect, at a perfect price of only ..... **\$149.00**

**MEMORY FLASH**

- 64K-200Ns DRAM ..... **\$2.00**
- 64K-150Ns DRAM ..... **\$2.00**
- 256K-150Ns DRAM ..... **\$5.75**
- Set of 941256 ..... **\$44.00**

**CABLES**

- Disc Drive cable (3 Con & twist) ..... **\$12.95**
- IBM Parallel printer cable ..... **\$14.95**
- IBM serial printer cable ..... **\$14.95**
- IBM 6' Keyboard extension (curly) ..... **\$ 9.95**

**KEYTRONICS 5150**



Yes the famous KEYTRONICS 5150 IBM® compatible keyboard. MADE IN USA. We bought a bunch and can sell them for only ..... **\$129.00**

We also have some Taiwan copies that are quite good and all are checked for only ..... **\$109.00**

And lastly we have some Taiwan copies of the famous KEYTRONICS 5151 keyboard with all the same enhanced features for only ..... **\$139.00**

**SWITCHING POWER SUPPLY**

**110V, 60Hz with Fan and two rear switched outlets**

- These power supplies fit our cases
- 130 WATT +5V - 14A, +12v - 4.2A, ±12V - 1/2A
  - Back Switch ..... **\$135.00**
  - Side Switch ..... **\$139.00**
  - CSA Approved 150W Side Switch P/S ..... **\$159.95**



**COMPUTER PARTS GALORE INC.**  
316 College St.  
Toronto, Ontario M5T 1S3

**DISC DOUBLER**

Just that, it doubles your discs by cutting another write protect notch on the other side of the Apple SSD diskette so the other side can be used, doubling your storage space. Note, almost all diskettes are good on both sides and the diskette packagers just label them SS or DS and sell the DS for 25% more. So spend \$8.95 and save hundreds later on.

**MODULATOR**

This modulator was made for the TI 99-44 that is now dead as a doornail. We bought a bunch and are selling em for \$14.95. They are a very good quality modulator for use on 12 Volts DC and have both sound and video inputs and are for color use on channel 3 or 4. They also have a built in antenna switch. They are a very good unit professionally built.  
Video cable, RCA/RCA 6 feet

**CONNECTORS**

|                         |           |        |
|-------------------------|-----------|--------|
| DB-25 M solder          | DB SERIES | \$1.95 |
| DB-25 F solder          |           | \$1.95 |
| DB-25 M IDC, Flat cable |           | \$3.49 |
| DB-25 F IDC, Flat cable |           | \$3.49 |
| DB-25 M Right angle PCB |           | \$2.99 |
| DB-25 F Right angle PCB |           | \$2.99 |
| DB-25 Shell             |           | \$ .99 |
| DB-15 M solder          |           | \$1.35 |
| DB-15 F solder          |           | \$1.35 |
| DB-15 F IDC, flat cable |           | \$2.49 |
| DB-15 M right angle PCB |           | \$1.49 |
| DB-15 F right angle PCB |           | \$1.49 |
| DB-15 Shell             |           | \$ .99 |
| DB-9 M solder           |           | \$1.35 |
| DB-9 F solder           |           | \$1.35 |
| DB-9 M right angle PCB  |           | \$2.50 |
| DB-9 F right angle PCB  |           | \$2.50 |
| DB-9 Shell              |           | \$0.75 |

**MOTHER BOARD**

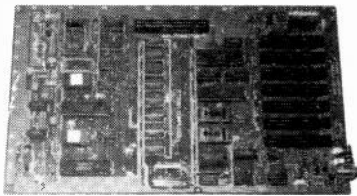

100% Iie\* Compatible, for those of you who wish to build a clone of the very popular APPLE Iie\*. This board is a reverse engineered copy of the Iie\* and is 100% compatible. We have the motherboard and the custom ICs only. All other parts are widely sold. The custom ICs are workalike chips that do not infringe any copyrights. The software for operating the board must be obtained elsewhere as we do not have it for sale. When we say 100% we mean it.  
A very good buy at \$49.95  
Custom IC set(2) \$49.95  
Keyboard encoder (AY3-3600) \$14.95  
Character generator, U/LC \$14.95  
48K 6502 Motherboard, same old 100% compatible 2 + clone \$29.95

**APPLE Iie® DETACHED NUMERIC KEYBOARD \$99.00**

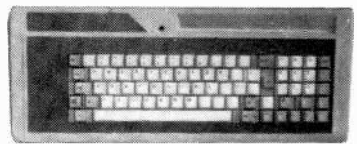

For those of you who would like to put your Iie in another case we have a high quality 100% plug in compatible Matrix keyboard with all Iie keys plus the highly desirable numeric keypad for quick entry of numeric data

**SWITCHING POWER SUPPLY**



Another great bargain from PARTS GALORE, A small power supply switching style that give +5v -4A; ±12v 1A and -5v (adjustable) on a compact 4x8" open frame PCB. Cost Northern Telecom \$50.00 when they bought 5000 pieces. We got em when a subcontractor went belly up for 10% of that price and we are selling em for

**\$18.95 NEW IN BOX TESTED**

AC power cable (3 Wire) for above \$2.50

**Toll Free Orders Only 1-800-387-1385 (416) 928-2161**

**STEP UP/DOWN TRANSFORMERS**

- (A) 1400 WATT AUTOTRANSFORMER. Has taps for 120-220-230-240 Volt operation and is 100% new in the box. Cool Xerox over \$150.00 In large lots, your cost only ..... \$49.95
- (B) 240 WATT 120/240. This beauty has two 120 Volt primaries and two 120 Volt secondaries and can step up/step down with isolation. Each side is good for 2 Amp at 120 or 1 Amp at 240 Volts. Your Cost ..... \$24.95

NOTE, due to the weight freight is extra, ask for \$.

**FLAT CABLE DRIVE CONNECTORS**

|                             |        |
|-----------------------------|--------|
| 50 Pin Edge C, 8" drive     | \$5.95 |
| 40 Pin Edge C,              | \$4.95 |
| 34 Pin Edge C, 5-1/4" drive | \$2.95 |
| 20 Pin Edge C, Hard drive   | \$1.95 |
| 34 Pin Fem header 17 x 2    | \$1.95 |
| 26 Pin Fem header 13 x 2    | \$1.49 |
| 20 Pin Fem header 10 x 2    | \$ .99 |
| 16 Pin Fem header 8 x 2     | \$ .99 |
| 16 Pin DIP header           | \$ .99 |
| 10 Pin Fem header 5 x 2     | \$ .99 |

**CENTRONICS CONNECTORS**

|                            |        |
|----------------------------|--------|
| 36 Pin solder cable male   | \$4.95 |
| 36 Pin Flat cable male IDC | \$4.95 |
| 36 Pin Flat cable female   | \$4.95 |
| S-100 Edge Connectors      | \$ .99 |

**Iie® ABS PLASTIC CASE \$59.95**

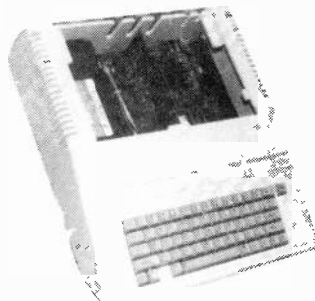

This case is made to fit the Mother Board listed here for making Iie\* clones and it makes a very nice looking copy. There is just enough difference to avoid design infringement. The case also has no brand names or other marks on it  
A good buy at \$59.95  
ABS numeric case for 48K motherboard Exact fit \$49.95

**Iie® MATRIX KEYBOARD**

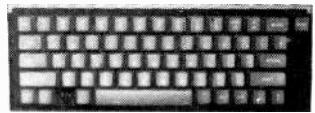

This keyboard fits the above case and has 100% clone compatibility, it will allow operation of all Iie\* commands. Another bargain at \$79.95  
2 + numeric keyboard for 48K mother boards, 100% comp. 88 basic functions for on y \$69.95  
Standard same as above \$69.95

**ASCII KEYBOARD**

This is a high quality Hall Effect keyboard made by Microswitch of Canada for AES data and now bought by us for 10% of the \$169.00 that AES paid for them in 10,000 lots. They are a very good word processing keyboard with both serial and parallel data outputs for use with APPLE and IBM type systems and come complete with a ribbon cable connector and complete pinout. .... \$24.95

**IBM POWER SUPPLY**

One of the nicest open frame IBM type switching power supplies we have ever seen. Came from the defunct NCR IBM compatible, runs the whole thing, has -5V-7A, +12V-3A, -5, -12-1/4A. A very good unit for starter system. Will not run hard disc system. A real Steal at ..... \$49.95

**TEACHERS**

We accept all SCHOOL BOARD purchase orders. We will provide a written quote if needed. We have access to all monitors, printers, disc drives, software etc. now sold in Canada and can quote very competitively on these items. Pls include any duty or sales tax data on any RFQ.

**INSTRUCTIONAL USE BONUS**

Any order for 12 units at regular price will be given an extra unit for instructional use. Larger orders will be pro-rated accordingly. Instructor may specify alternate goods for equal value. Pls invoke this bonus in writing at time of order referencing PO # in letter.

**PARTS,**

|  |         |
|--|---------|
| 100ns delay line                             | \$5.00  |
| 7ns delay line                               | \$13.95 |
| 62 pin edge con (high quality)               | \$1.89  |
| 5 pin Din conn                               | \$1.25  |
| Power conn                                   | \$1.25  |
| Dip switch 8 pos                             | \$2.49  |
| 4.7k x 8 sip                                 | \$ .69  |
| 4.7k x 8 pin sip                             | \$ .69  |
| 8.2k or 10k 16 pin Resistor or net           | \$ .99  |
| 33ohm x 8 network                            | \$1.10  |
| Small speaker                                | \$1.99  |
| 1 ul 50V high quality bypass capacitors x 10 | \$ .10  |
| Trimcap                                      | \$ .99  |
| 34 pin card edge con                         | \$5.95  |
| 2716   | \$3.49  |
| 2732   | \$3.95  |
| 2764   | \$4.95  |

**GRAY SCALE ADAPTER**

As you know the IBM color graphics card does not look very good on a monochrome monitor. This is because often two colors look the same on monochrome so you cannot read red print on a blue background or some such. This little gray scale proportionately scales each color into a different intensity allowing easy viewing on amber green or white monitors. We sell it as a kit for only (with cable) or wired and tested (with cable) ..... \$24.95

**V-20 CHIP**

You may have heard of the NEC V-20 chip. It is an upgraded 8088 that can run programs up to 50% faster (depending on code). It also can run Z-80 code, allowing it to be used for Z-8C development. Especially good for Video when using code using it's features. A hot and hard to get CHIP at (E MHz) ..... \$24.95  
Faster version runs at 8 MHz ..... \$44.95  
Note: this chip is also rebranded and sold as the 88000 by others be warned

**DUAL TRACE BENCH/PORTABLE SCOPE**

Featuring at no extra cost The Component Tester  
+ 20 MHz (—30B) + Trace Rotator  
Bandwidth +5 mV Vertical  
+ CRT Display Sensitivity  
+ Fully Automatic + HF Rejection  
Triggering  
We have a lot of these 20 MHz scopes that are sold elsewhere for up to \$699.00! Well we'll em a lot cheaper only \$475.00  
Dual probe set per probe \$134.95

**IBM BARE PCB**

|                                    |         |
|------------------------------------|---------|
| (A) Color Graphics (Pcryst)        | \$27.95 |
| (B) Monochrome graphics            | \$24.95 |
| (C) Disc controller                | \$17.95 |
| (D) Disc controller + Printer      | \$24.95 |
| (E) Disc controller + Game         | \$24.95 |
| (F) IO + 2 I/O clock etc.          | \$24.95 |
| (G) Multifunction card 11 function | \$24.95 |
| (H) AT SIXPACK COPY                | \$34.95 |
| (I) Parallel printer               | \$17.95 |
| (J) RS-232 card                    | \$17.95 |
| (K) Simple modem card              | \$17.95 |
| (L) Disc for above                 | \$ 8.00 |
| (M) 512K card                      | \$24.95 |

**SPECIAL 10 MEG HALF HEIGHT HARD DRIVE W/CONTROLLER AND CABLES \$649.00**

**20-MEG HALF HEIGHT HARD DRIVE W/CONTROLLER AND CABLES \$899.00**

**PARTS,**

|   |            |
|---|------------|
| 8088 CPU  | \$12.95    |
| 8087 Math Processor                                 | \$219.00   |
| 8237A-5 Prog. DMA Cntrl                             | \$8.95     |
| 8250 Serial Port                                    | \$9.95     |
| 8253A-5 Prog. Interval timer                        | \$5.95     |
| 8255A-5 P.I.A.                                      | \$4.95     |
| 8259A Prog. Interrupt Cntrl                         | \$4.95     |
| 8284A ADC clock gen & driver                        | \$5.95     |
| 8288 Bus Controller                                 | \$9.95     |
| 8272 Floppy Disk Controller                         | \$9.95     |
| NEC 765 Floppy Disk Controller (equivalent to 8272) | \$9.95     |
| Set of 8088, 8255A-5, 8237A-5, 8288                 | \$284      |
| 8253A-5 and 8259A                                   | \$44.00    |
| 6502 CPU  | \$ 5.50    |
| 6845 CRT controller                                 | \$ 9.50    |
| 6845 CRT controller                                 | \$ 9.95    |
| Z80A CPU (4 MHz)                                    | \$ 4.99    |
| MC3242  | \$11.95    |
| 74LS367   | \$ .62     |
| 74LS259   | \$ 1.38    |
| 74LS161   | \$ .82     |
| 74S74   | \$ .99     |
| 74S174  | \$ 1.70    |
| 74LS323   | \$ 4.55    |
| Card edge connector (50 pin)                        | \$ 2.49    |
| RCA jack PC mount                                   | \$ .89     |
| 6 pin power square connector                        | \$ .99     |
| Phono jack (small)                                  | \$ .99     |
| MPSA 13 trans                                       | \$ .55     |
| 2N3904 trans  | \$ .19     |
| 2N3906 trans  | \$ .27     |
| MPSU1 trans   | \$ .79     |
| 2N4258 transistor or equiv                          | \$ .69     |
| 1K SIP 10 pin                                       | \$ .60     |
| 1K SIP 8 pin  | \$ .69     |
| 10K SIP 10 pin                                      | \$ .75     |
| 4 pos dip sw  | \$ 1.99    |
| 20 pin female header for disk drive                 | \$ .95     |
| 20 pin male   | \$ 1.79    |
| 50 pf trim cap                                      | \$ .89     |
| 220 ohm trimpot                                     | \$ .59     |
| 20 conductor ribbon cable                           | \$ .89/ft. |

**SOCKETS AMP IC SOCKETS**

As you know AMP makes the best IC sockets. With a double wipe action and a very wide open target for easy insertion, the best.  
6, 8, 14, 16, 18, 20, 24, 28, 40  
Pin in stock at only  
1.5¢ PER PIN

**FEEWARE**

Feeware?? It is public domain software that we have collected into volumes and are offering out at a fair price considering the gathering effort. You can do what you like with it, set up your own resale operation in your area etc. What we offer is two sets of 4 diskettes with each set covering a general area of interest  
SET A — Communication oriented  
Full Modem package 1200/300 Baud + Word processor + Keyboard Macros + Desktop environment + Help + DOS utilities + Copy programs + Many other small routines too detailed to list here  
SET B — Data Base package  
Spreadsheet + Printer utilities + File utilities + Help + Games + Data Base + "C" Compiler + Language utilities + Many other small routines too detailed to list here  
Price \$24.95 for each set  
Please specify package A or B Catalog (refundable on purchase) ..... \$2.00

# The Protoboard

**Make these simple, inexpensive accessories for your solderless, plug-in experimenter's breadboard.**

**By Harold Wright**

THE accessories described here will save a lot of time and reduce the frustration index when a circuit is being set up on a plug-in board. Every time you set up a long string of LEDs, driven by a 74154 or similar IC, all 16 anodes, (or in some cases cathodes), must be tied together and run to V+ or ground through a common, current limiting resistor. Whether you jumper all the LEDs together with hairpin bend copper wire conductors, or use a common bus strip, it will still require the preparation and insertion of sixteen small jumpers, a tedious task. If you use the common bus strip, that strip will be tied up and cannot be used for voltage distribution purposes.

## Extra Strips

Fig. 1 shows a cheap and simple solution. Made mostly from the junk box, it consists of a scrap of leftover 0.1 inch hole spacing perforated board, a length of self-adhering copper tape (Bishop Graphics), a small amount of five-minute epoxy cement, some 22 gauge solid, tinned, insulated hook-up wire and some solder. The cut-off ends from resistors and capacitors, after they have been installed in a circuit board are good because they are a bit stiffer than ordinary hook-up wire. Do not use wire larger than 22 gauge because the pins may damage your plug-in board sockets and the accessory will be very difficult to insert. The copper tape is applied along the center row of holes on the perf-board strip and is punctured at every other hole using a large darning needle. This spacing allows room for the body of the LED on the plug-in board. Short lengths of bare wire are given a right-angle bend, soldered to the copper tape and held rigidly to the perf-board with a long bead of epoxy cement. After the epoxy has cured, the protruding wires are trimmed evenly to a

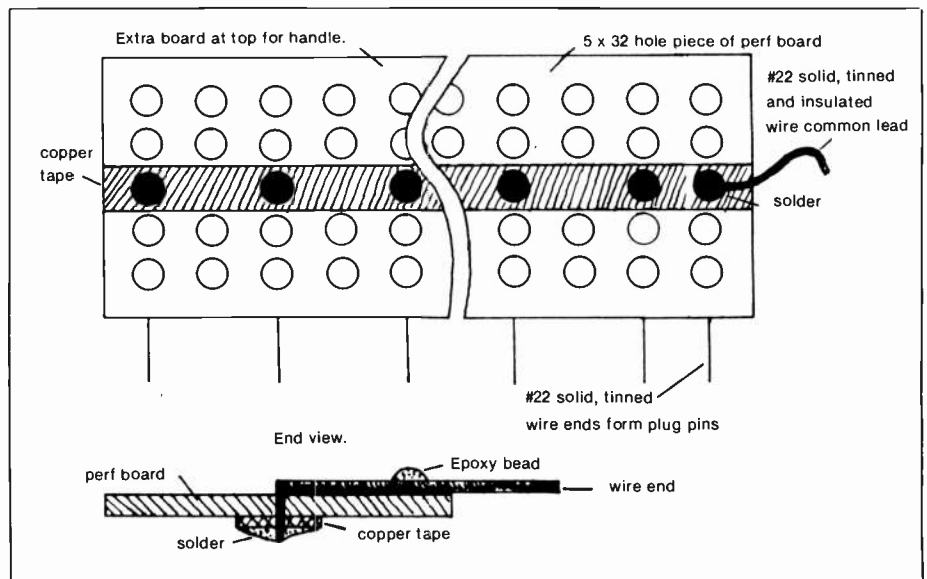

Fig. 1 Simple plug-in protoboard common bus for connecting the cathodes or anodes of a long string of LEDs.

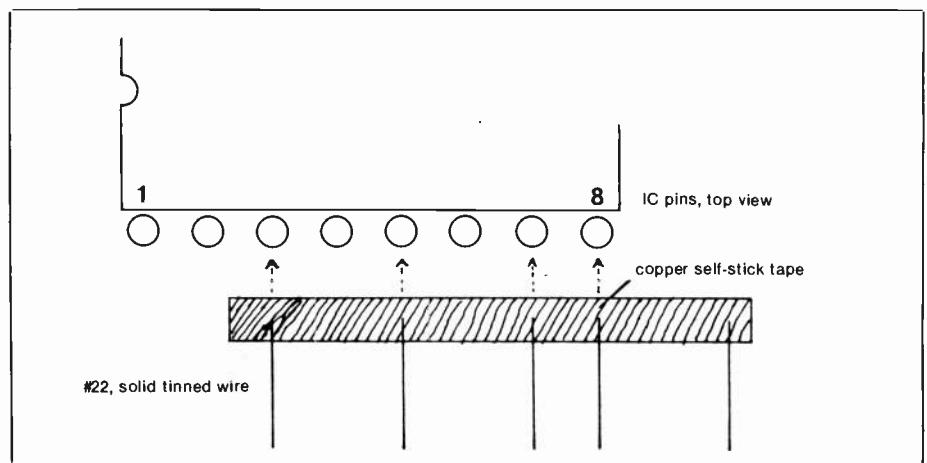

Fig. 2 Pin pattern for 4049, 4010, 4050 ICs; the construction is the same as in Fig. 1. The extra pin at the right provides a connection to a separate row of holes on the protoboard via a simple loop to the ground strip.

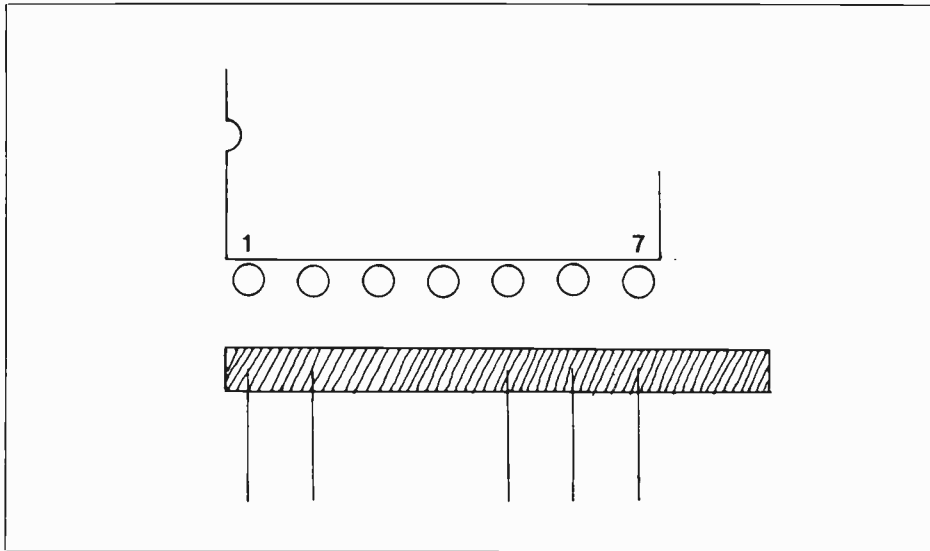

Fig. 3 Grounding strip for 4011, 4001, 4070, 4071, 4077, 4081, and 4093.

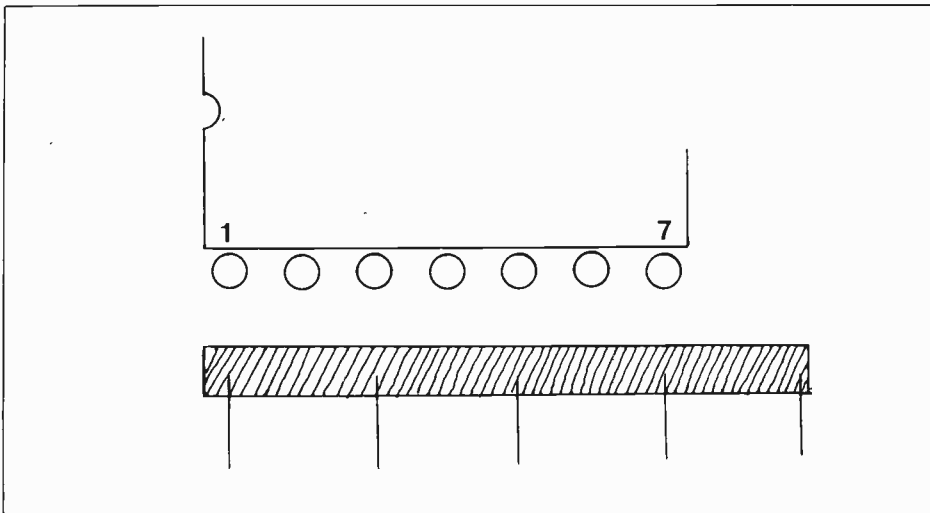

Fig. 4 Grounding strip for 4584 hex Schmitt trigger.

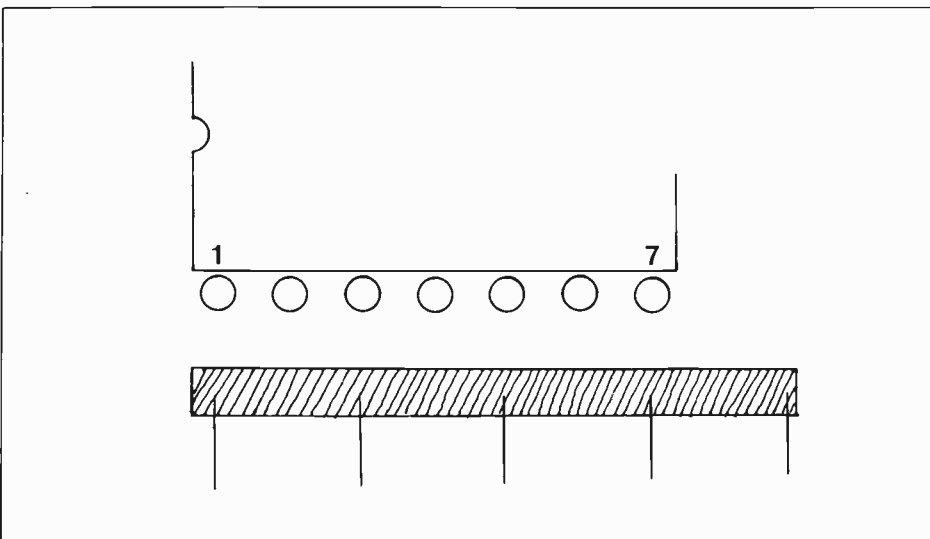

Fig. 5 Grounding strip for 7404 — 7407, 7414, 7416, and 7417.

length of about one-quarter inch. This accessory can be made in about half an hour and will save much time on future circuit development projects. A ten pin strip can be made for ICs such as the 4017.

### IC Grounds

There are many times when a circuit is under development that only one inverter from a hex such as the 4049 or one gate from a 4001 is required. On these devices all unused inputs must be grounded or strange effects may occur. Fig. 2 shows another, even simpler strip that will ground half the inputs on a 4049, 4010 or 4050 IC. This one has only five pins and can be made in ten or fifteen minutes. Once built as in the first one, it can be used over and over again. Construction is the same as Figure 1 except for the pin spacing.

These grounding strips will serve a large number of different IC types because there is a large degree of pin-out standardization between ICs with similar functions. Figures 3,4,5 and 6 show the pin arrangements for shorting unused inputs to ground on a large number of CMOS-4000 series and TTL-7400 series devices. In these figures only the pins and tape are shown related to the IC socket. A top view of the socket is shown in each case because this is the way ICs are seen on a protoboard.

### Interfacing

Have you ever tried to interconnect a completed circuit on a plug-in card with a developing circuit on the plug-in board? A tangle of 22 or more midjet alligator clips with flex wires perhaps? What a great way to get lost in the resulting rat's nest, not to mention the damage the clips might do to the card contacts! It can be very simple if you build an adapter plug interface similar to the one shown in Fig. 7. A surplus double 22-position socket that had been chopped from a cable was used in the prototype. Enough flex wire had been left on the socket to allow spreading and permit connection to a 44 pin edge set of male pins made the same way as in Figure 1. Many of these surplus card edge sockets have gold plated contacts and are of very high quality. The interconnection between the socket flex wires and the solid wires required for the edge pins was made by using a 22 hole length of Bishop Graphics self-stick DIP pattern. If you can find a card socket with solder eyelets, the copper DIP pattern can be eliminated. One row of contacters was wired to alternate pins and the other row filled in the gaps. Different insulation colours were used to allow easy identification between front and back row contacts. If you are only involved in single sided boards, the construction would be simpler and the adapter length reduced.

# XT \$750

**COMPATIBLE** (Major Boards made in Japan)

- 256K Memory • One DSDD Disk Drive
- Controller Card
- Flip-Top Case and Keyboard
- Heavy Duty Power Supply • 180 Day Warranty

(All you need for complete system is Video Card and Monitor)



## COMPLETE 640K SYSTEM \$1,285

- Two DSDD Disk Drive • Controller Card
- Colour Graphic Card or Monochrome Display Card
- Real Time Clock • Serial, Parallel and Game Ports
- Flip-Top Case and Keyboard • Heavy Duty Power Supply • 180 Day Warranty

(All you need to get the system ready to use is a Monitor)

**MAIL ORDER:** Cheque, Money Order, Certified Cheque plus \$20.00 for shipping and handling. Ontario residents add 7% P.S.T. (Prices subject to change without notice).

**SUNIX INC.** 578 MARLEE AVE. Tel: 06-217736 SUNIX TOR.  
(At Glencairn Subway) Toronto, Ontario Tel: (416) 781-3263  
M6B 3J5 In Dallas, USA: (214) 985-1842

Circle No. 13 on Reader Service Card



# CROSS - 8

**MAYBE THE ONLY DEVELOPMENT SOFTWARE YOU'LL EVER NEED**

- Table based 8 bit cross-assembler
- Tables/Source files included for:
 

|      |      |      |        |
|------|------|------|--------|
| 1802 | 6502 | 8048 | COP400 |
| 3870 | 6801 | 8051 | Z8     |
|      | 6805 | 8085 | Z80    |
- Modify/Create tables for most 8 bit micros  
Create your own instruction sets
- INTEL, MOTOROLA, TEKTRONIX output formats
- Use with any EPROM programmer
- 36 page manual, full instructions
- Available in the following disk formats:
  - 5" IBM-PC PC/MS-DOS 2.0 or greater, compatibles
  - 5" APPLE II+/IIe CP/M-80 (Softcard), compatibles
  - 8" SSSD CP/M-80 (Z80 only)

**\$99<sup>95</sup> US**      **\$129<sup>95</sup> CDN**

Credit card orders: Include card no., name on card, expiry date, signature. Nova Scotia residents add 10% sales tax.



## UNIVERSAL CROSS-ASSEMBLERS

P.O. BOX 384 BEDFORD NOVA SCOTIA  
B4A 2X3 CANADA

Circle No. 14 on Reader Service Card

## FAST SERVICE

100-MHz 3-Channel Oscilloscope

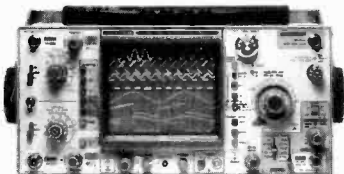

The LBO-516 is an economical 100-MHz Dual Time Base Oscilloscope. In addition to its 8 trace capability and bright 20 kV PDA, CRT, this scope offers excellent triggering sensitivity, alternate triggering and alternate time base capability, making it possible to observe a stable display of asynchronous signals, in both the main and delayed time base modes.

For professionals who know the difference.



• Mail Order:  
Certified Cheque, Money Order, COD'S FOB  
Rexdale. Ontario Residents add 7% P.S.T.

**THE WHOLESALE SOURCE**

**YOU'VE BEEN SEARCHING FOR!...**

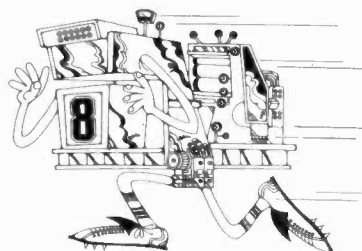

**TRY US FOR:**

- NEEDLES AND C
- AUDIO ND VIDEO ACCESSORIES
- SEMICONDUCTORS
- WIRE AND CONVERTERS AND MUCH MORE

## BEST PRICES

**DIGITAL MULTITESTERS**



YF-1100 3 1/2 dgt LCD

**\$69.00**

**Features**

- Large display 3-1/2 dgt 0.5" height LCD with a maximum read of 1999
- Automatic polarity, "-" display for negative input
- High over-load protection for all ranges
- Over load display, highest figure "1" or "-1" alone glows
- Service temperature and humidity 0-50°C and 0-80% RH
- Power consumption 20mW approx.

**DEALERS:**  
PHONE FOR WHOLESALE QUANTITY PRICES

**ELECTRONIC SUPPLIES INCORPORATED**



306 Rexdale Blvd., REXDALE, Ontario  
M9W 1R6 (416) 741-4000  
INDUSTRIAL ORDER DESK  
(416) 741-6000

**BRANCHES:**

32 Massey Lane at Beattie, CHATHAM, Ont., N7M 5W6, (519) 352-4000  
269 Colborne St., LONDON, Ont. N6B 2S7, (519) 433-0101

1173 Michener St., Unit 4, SARNIA, Ont. N7S 5G5, (519) 344-2449  
600 Wyandotte St., E., WINDSOR, Ont. N9A 3J2, (519) 258-2240

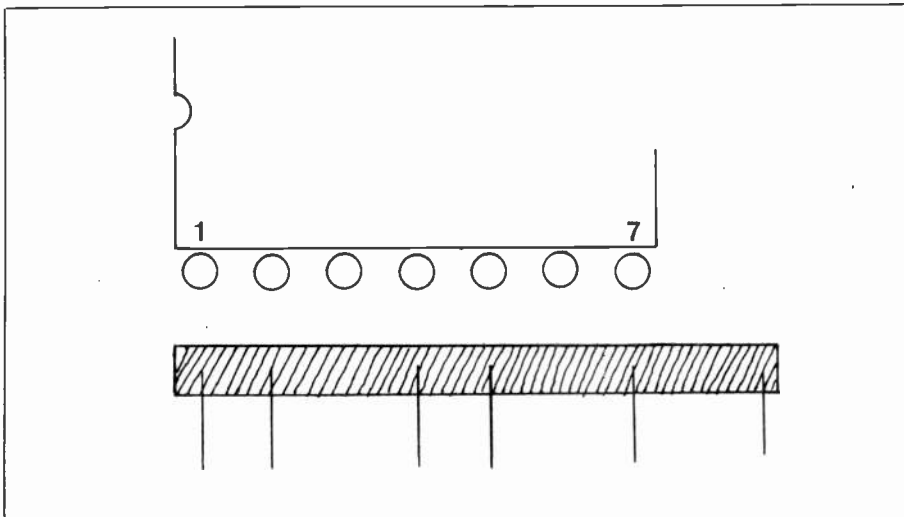

Fig. 6 Grounding strip for 7401, 7403, 7408, 7432, 7437, and 7486.

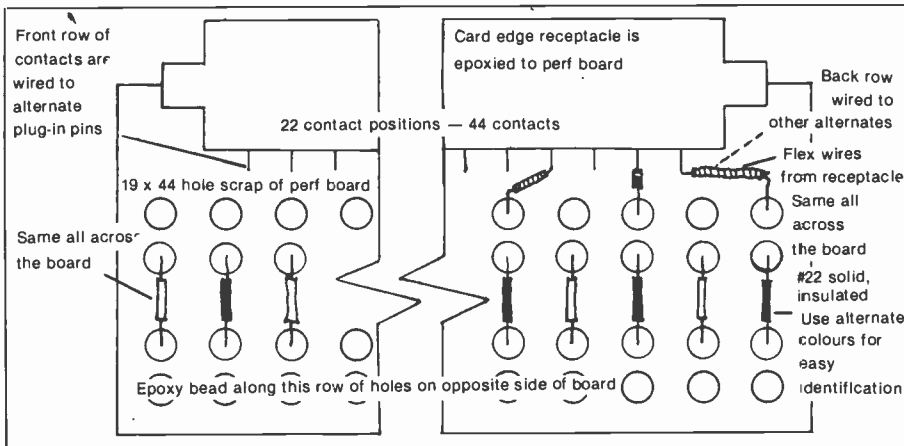

Fig. 7 Construction layout for 44 contact adapter for plug-in cards. Output pins match the spacing for protoboards.

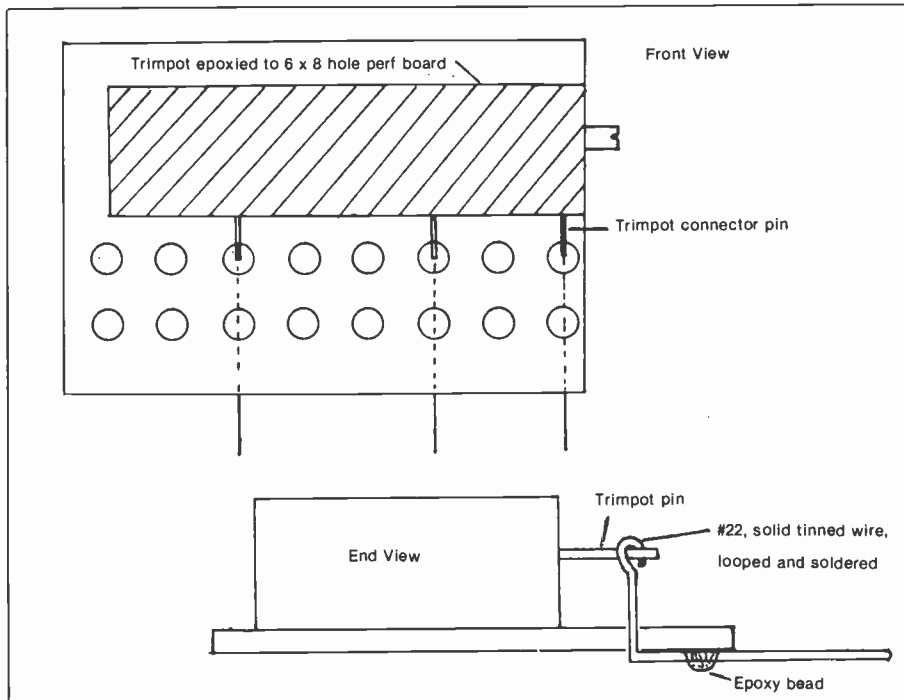

Fig. 8 Trimpot adapter for protoboard.

Another useful addition to these time savers is shown in Fig. 8. Here, similar techniques are used to mount multi-turn trimmings on scraps of perf board. The same technique can be used on one-turn rotary resistive trimmers or for screwdriver operated trimmer capacitors. Some trimmers have pins that will not enter the plug-in board. Figure 8 provides a solution for this and at the same time lifts the trimmer a bit higher than the DIP ICs and other components allowing easier access to the adjusting screws.

It is also possible to make an interface between decoders and distributors using similar techniques to those described above. A string of NPN or PNP transistors would be needed with base input limiting resistors and where necessary, output load resistors. Some devices cannot drive LEDs directly except at very low currents and low visibility. Such an interface could also be used to drive outside world devices such as relays or lamps.

Care should be used when inserting these devices. They enter the sockets more easily, for the long ones, if they are started at one end and worked along the strip using a tiny screwdriver to push a pin that may be slightly out of line. These pins will withstand straightening and if broken are easily replaced. If you build a few of them you will wonder why you didn't have them sooner!

## Electronics Today

Each year Electronics Today delivers thousands of sales leads processed through our Reader Service Card Program. These sales leads are qualified with name, address and title of respondent.

For advertising information call  
**(416) 445-5600**

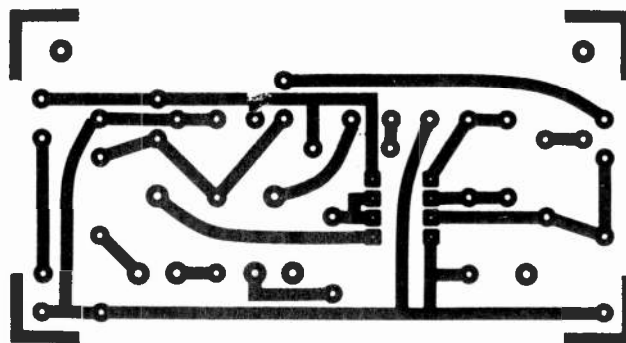

Fig. 4B The PCB

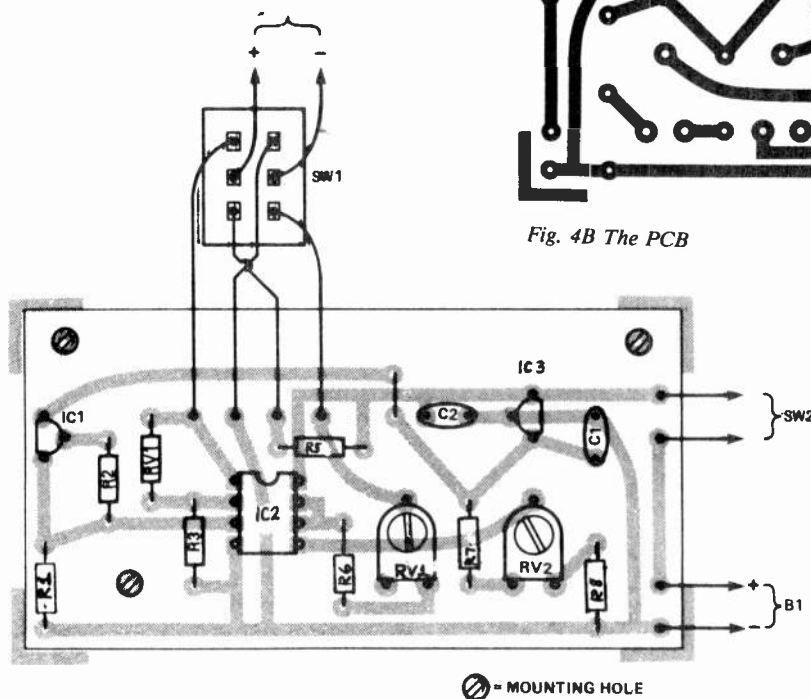

Fig. 4 The PCB layout.

way cable should be suitable.

## Adjustment

Start with RV1 adjusted for maximum resistance (fully anticlockwise), and RV2 at roughly the midway setting. Set SW1 to the *normal* mode, switch the unit on, and immediately adjust RV2 to give a reading of about half full scale deflection from the meter.

In order to calibrate the unit it is necessary to have two glasses of water; one at or close to 0 degrees Centigrade (throw in some ice) and the other in the region of 30 to 50 degrees Centigrade. A thermometer placed in each glass will allow the monitoring of the temperature during the calibration process.

The basic procedure for calibration is to first place the temperature sensor in the cold water, and then to adjust RV2 to zero the meter. Next, the sensor is placed in the hot water and RV1 is adjusted to give the correct reading on the meter. This procedure is repeated a few times until no further adjustment is needed. RV2 is then adjusted to obtain the approximate temperature reading from the meter, rather than to zero the meter. However, calibration is likely to be much quicker and easier using water at 0 degrees Centigrade.

The meter has been designed to use a 50 microamp meter so that a 0 to 50 scale is obtained, and no re-marking of the scale is needed. ■

### Parts List

| Resistors (1/4W 5% except where noted) |              |
|--|--------------|
| R1,3,4                                 | .....10K     |
| R2                                     | .....680R    |
| R5                                     | .....200k 1% |
| R6                                     | .....1k      |
| R7                                     | .....33k     |
| R8                                     | .....22k     |

### Capacitors

|      |                    |
|------|--------------------|
| C1,2 | .....100nF ceramic |
|------|--------------------|

### Potentiometers

|     |                                      |
|-----|--------------------------------------|
| RV1 | .....4k7 0.1W horiz. preset          |
| RV2 | .....22k 0.1W horiz. preset sub-min. |

|     |                                  |
|-----|----------------------------------|
| IC1 | .....LM334 current regulator     |
| IC2 | .....LM358 dual op amp           |
| IC3 | .....78L05 5V 100ma voltage reg. |

### Miscellaneous

|     |                                   |
|-----|-----------------------------------|
| ME1 | .....50uA moving coil panel meter |
| SW1 | .....DPDT min. toggle switch      |
| SW2 | .....SPST min. toggle switch      |
| B1  | .....9V battery                   |

Battery connector; plastic case approx. 150 x 80 x 50mm; PCB; 5-way DIN plug; 5-way DIN socket; three-way lead wire (screened); Veropins etc.

## Product Mart Classified

### Turn unneeded goods into cash

Sound like a real challenge? It doesn't have to be. Not when you employ low-cost Product Mart advertising to sell the things you no longer need. Classified works for you by putting your selling information in the hands of people who are ready to buy. Call today for assistance in wording and placing your advertisement for maximum response.

Call (416) 445-5600



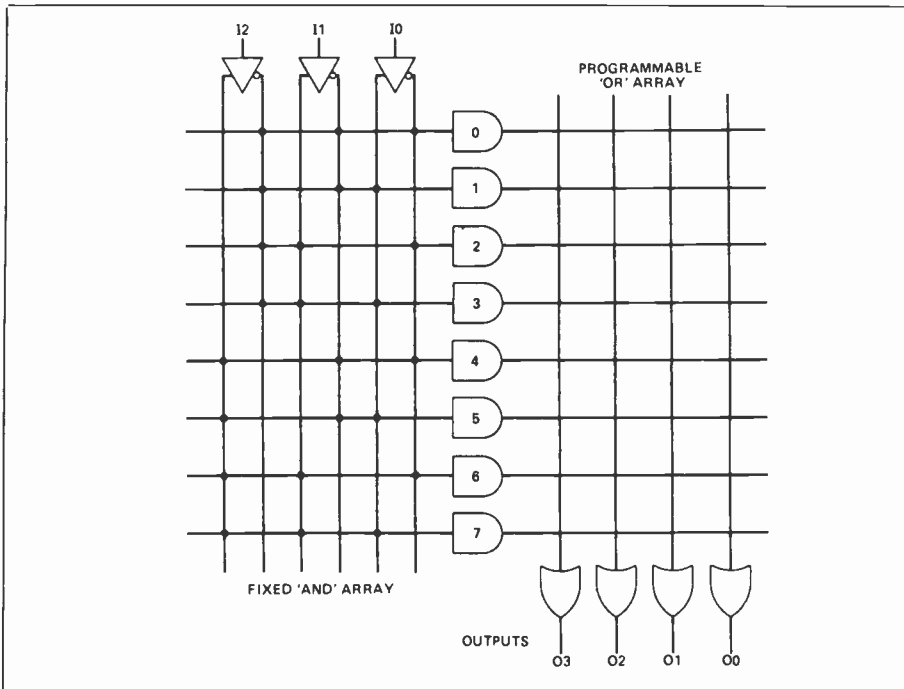

Fig. 5 Typical PROM arrangement (8 x 4 bits).

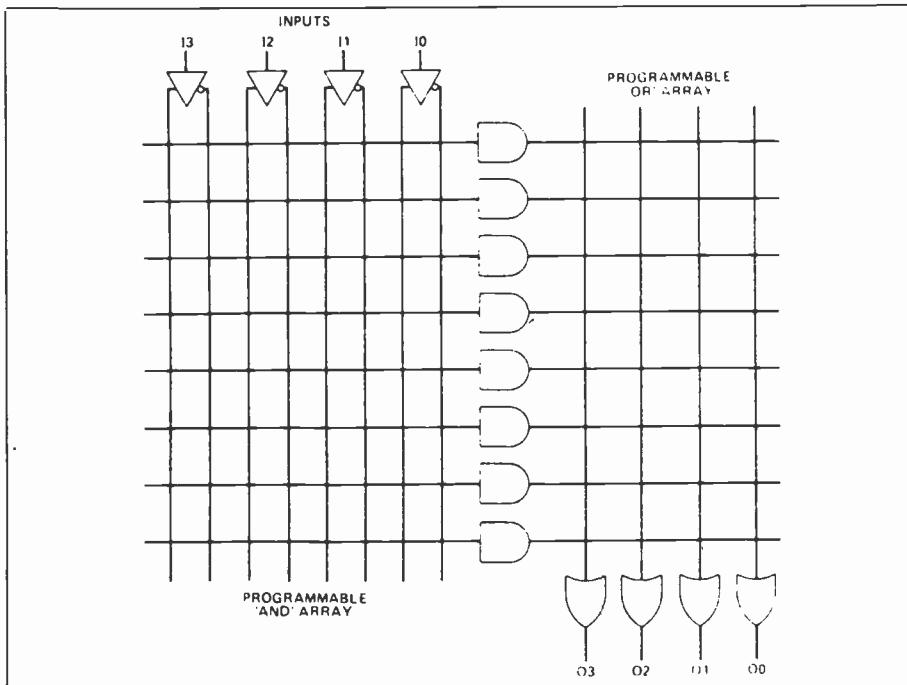

Fig. 6 Typical FPLA arrangement.

raised to the power of the number of inputs. For example, a 16-input PROM will have 64,000 locations. In the vast majority of applications such a PROM would be heavily under utilized.

A further limitation shows itself in the implementation of state machines. A feedback path is required for each state and, since there is no provision within the PROM for feedback, the loop has to be wired externally - using up valuable inputs and output. Despite these drawbacks, the PROM does find application as a programmable array.

Electronics Today April 1986

### FPLAs

The field-programmable logic array (sometimes known by the acronym PLA or IFL, for integrated fuse logic) is illustrated in Fig. 6. It differs from PROMs in that the AND array is programmable as well as the OR array, giving a much greater degree of flexibility. The FPLA does not need a very large array to accommodate a reasonable number of inputs. Further advantages in the form of registered outputs, internal feedback and output polarity are sometimes offered in FPLAs, but since these features are com-

mon to PALs, they will be fully covered under that heading.

Despite these advantages, FPLAs have attracted less interest than PALs, possibly because they are too flexible. The increased flexibility results in longer propagation delays, making FPLAs unsuitable for very high performance designs. All programmable arrays are costly in silicon area, so that if everything is programmable, as with FPLAs, the number of gates is more of a limiting factor. The pros and cons of FPLAs and PALs are hotly debated, the manufacturers of each pushing the advantages of those they supply.

### PALs

The PAL configuration (Fig. 7) is the third option for a logic array: a programmable AND array with a fixed OR array. Like FPLAs, PALs provide a number of additional features beyond the basic AND/OR structure. The previously mentioned limitation of PROM architecture due to the fixed number of inputs is overcome in many PALs by use of bi-directional outputs (Fig. 8).

The output shown in Fig. 8 is fed through a tri-state buffer controlled from the AND array, and so can be disabled. Since a line from this output is fed back to the AND array, the same pin could be used as a further input. It is also possible to provide feedback to the AND array even if the pin in question is being used as an output.

A further facility sometimes offered is the use of D-type latches on the outputs to provide a registered output (Fig. 9). Implementations of state machines use internal feedback from this registered output. An output enable may also be provided, controlled from a line common to all outputs on the device.

Programming PALs is not as straightforward as programming PROMs. The procedure is complicated by the fact that it is impossible to address the large number of fusible links inside a typical PAL without multiplexing the functions on the limited number of pins. It would not be outside the realms of possibility for an ambitious home constructor to design and build a PAL programmer. Commercial programmers usually have a reasonable degree of intelligence and only require Boolean equations to be entered in order for a fuse map to be worked out automatically. It is outside the scope of an introductory article to go into programming in great depth but the information is of course available from manufacturers' data books.

### Applying Some Logic

The application of programmable logic using a PAL can be demonstrated in the simple microcomputer interfacing circuit

of a typical low complexity 6809 board (Fig. 10). Discrete TTL logic is used to generate chip select signals for the EPROMs, RAMs, VIA, ACIA and CRTc. Also generated are the OE and WE signals for the memories and a signal to other boards in the system to indicate that on-board memory is being accessed, which is also used to enable or disable the address and data buffers.

The resultant memory map of this circuit has EPROM 1 at E000 - FFFF, EPROM 2 at C000 - DFFF, RAM 1 at A000 - BFFF, RAM 2 at 8000 - 9FFF and I/O at 6000 - 7FFF. The I/O area is partially decoded to provide addressing for the VIA, ACIA and CRTc. This implementation uses 5 TTL packages, the functions of which may be expressed by the following Boolean equations:

$$\begin{aligned} \overline{\text{EPROM1}} &= \overline{A15.A14.A13} \\ \overline{\text{EPROM2}} &= \overline{A15.A14.\overline{A13}} \\ \overline{\text{RAM1}} &= \overline{A15.\overline{A14}.A13} \\ \overline{\text{RAM2}} &= \overline{A15.A14.\overline{A13}} \\ \overline{\text{VIA}} &= \overline{A15.A14.A13.A5.A4} \\ \overline{\text{ACIA}} &= \overline{A15.A14.A13.A5.A4} \\ \overline{\text{CRTc}} &= \overline{A15.A14.A13.A5.A4} \\ \overline{\text{OE}} &= \overline{E.RW} \\ \overline{\text{WE}} &= \overline{E.RW} \\ \overline{\text{MEMACC}} &= \overline{\text{EPROM1.EPROM2.} \\ &\quad \overline{\text{RAM1.RAM2.VIA.} \\ &\quad \overline{\text{ACIA.CRTc}}} \end{aligned}$$

These functions may be implemented by a PAL device, reducing the chip count from 5 to 1.

Ten active low non-registered outputs and at least seven inputs are necessary and are available on the 20L10 PAL. Fig. 11 is a schematic diagram of this device programmed for the example application. The program was worked out by hand but it should be quite clear that it will implement the above equations and replace the discrete TTL of the original circuit. This is a simple case, the equations only consisting of ANDed terms so that only one of the inputs of each OR gate is used, the tri-state buffers are always enabled and five of the chip inputs are not used at all.

Programming would not usually be done manually. Instead, a software package would translate the Boolean equations into a fuse map, generating a master tape from which further PALs may be programmed. (Please note that this design is only presented as an example and has not been prototyped and checked in practice.)

### Recent Developments

Fig. 12 sums up the relationships between the various existing logic technologies. Recently, the clear divisions between the various families shown have become much less definite. In particular, the two ap-

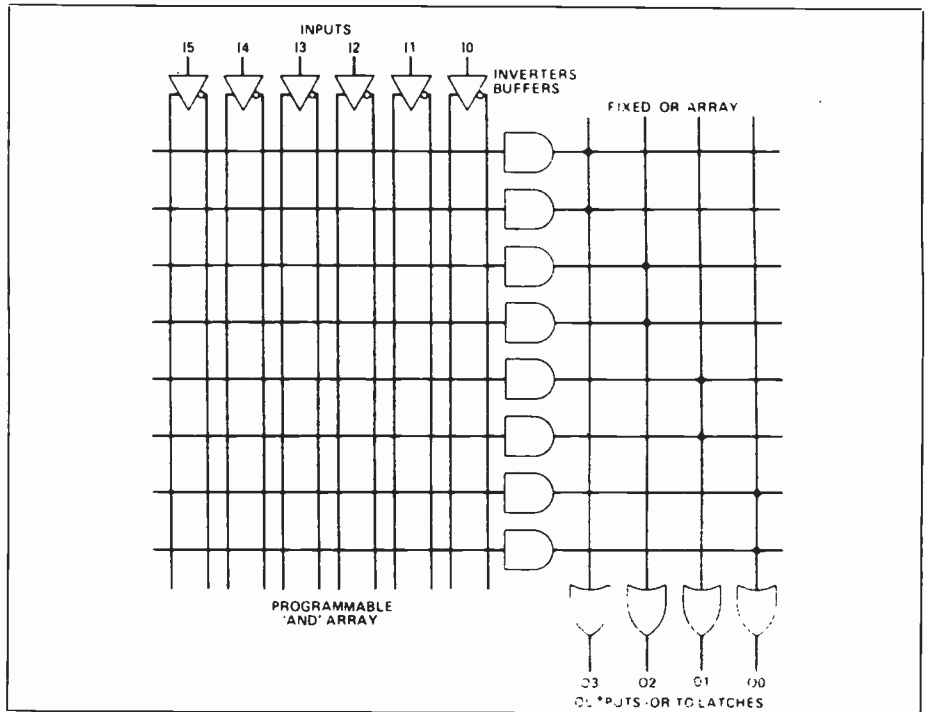

Fig. 7 Typical PAL arrangement.

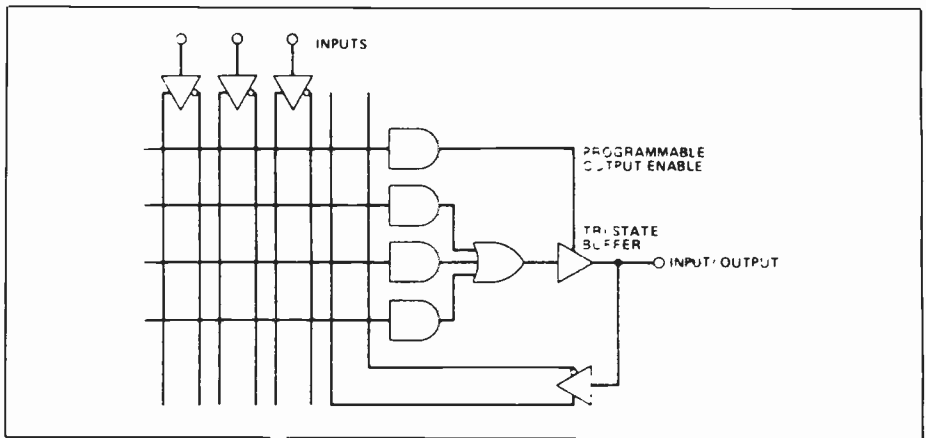

Fig. 8 Bi-directional I/O on PAL.

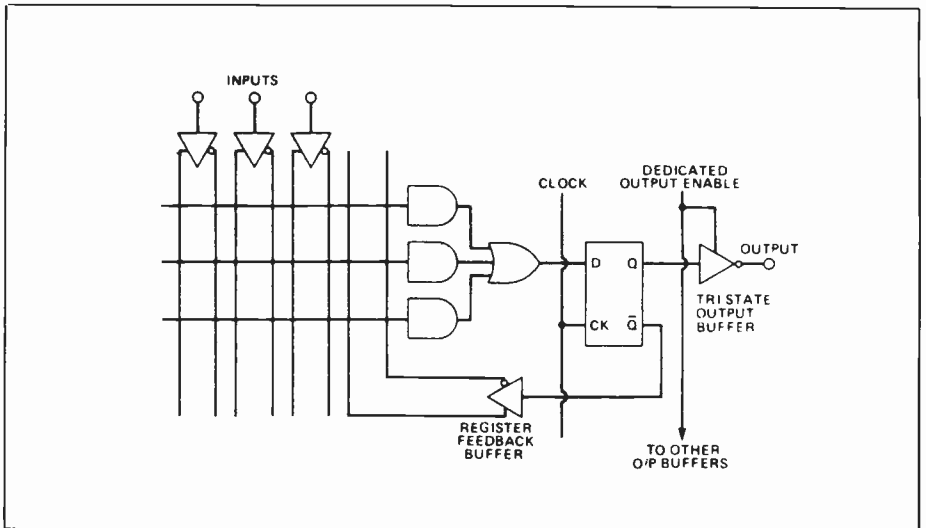

Fig. 9 Registered output on a PAL.

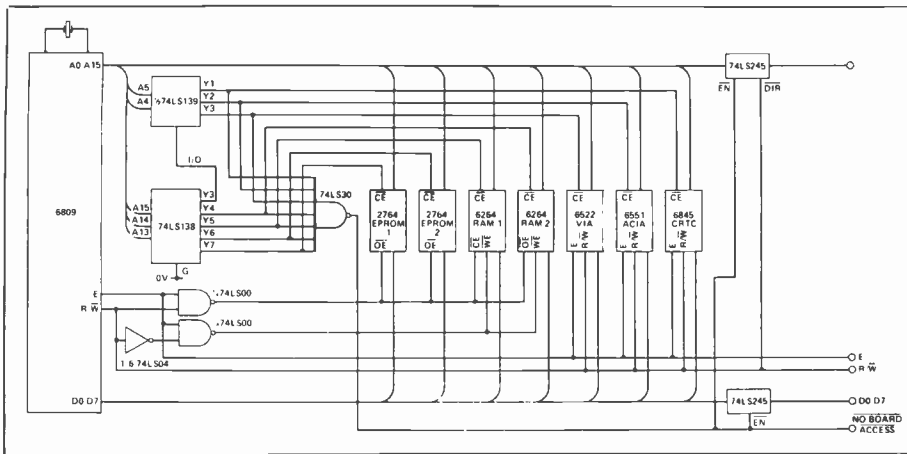

Fig. 10 Simple 6809 board with discrete TTL.

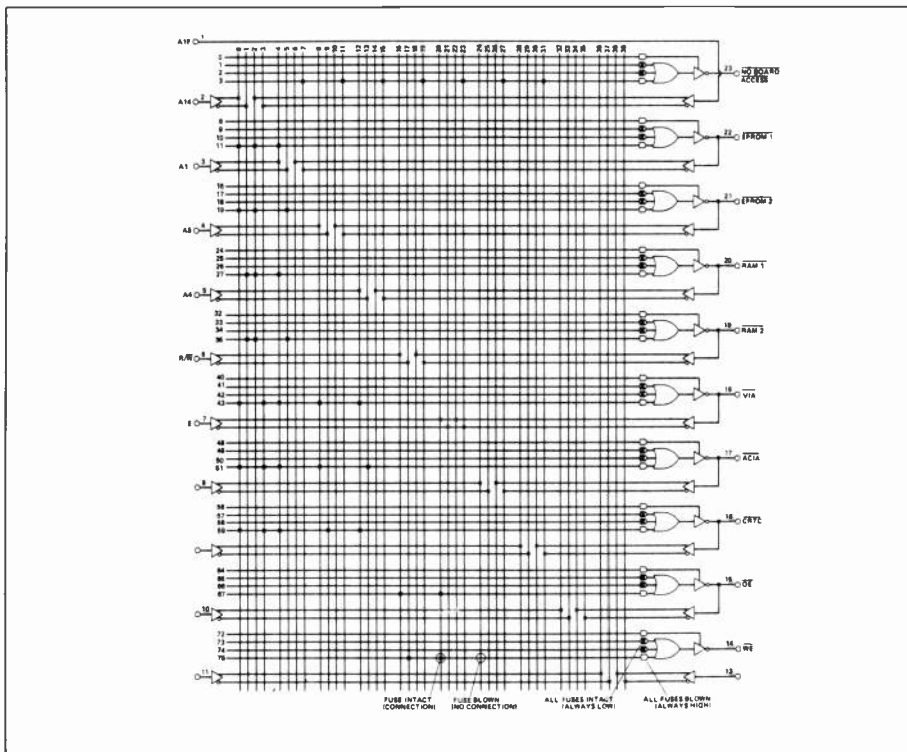

Fig. 11 PAL implementation of 6809 board logic (20L10 PAL).

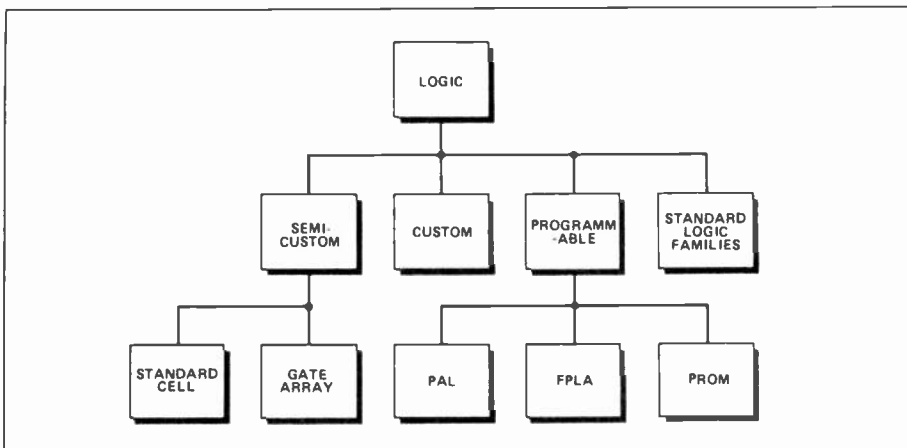

Fig. 12 The families of logic technologies.

proaches to semi-customizing, standard cell and gate arrays, are beginning to merge. This breakdown of the distinction becomes particularly noticeable to the customer as use is made of increasingly more sophisticated CAD software.

The designer of both standard cell or gate array devices is faced with almost indistinguishable development tools, the differences which are transparent being of relevance only at the manufacturing stage. From a customer point of view the only difference is in the price-volume relationship. Performance and interfacing requirements are very similar.

The facilities offered on many recent standard cell libraries and gate arrays are also becoming less distinctive. Gate arrays are now available with much more complex elements than the usual cells of p-channel and n-channel transistors. It is possible to find gate arrays with CPU and memory cells performing functions previously available only in standard cells. From the other side, standard cell libraries may now include blocks of gate arrays to allow last minute customization and even blocks of PAL to allow modifications after manufacture. Clearly, these enhancements to gate arrays and standard cells will eventually result in very similar types of semi-custom device.

A further area of recent advance is the development of erasable programmable logic devices. These have the same relationship to standard PALs and FPLAs as EPROMs have to bipolar PROMs. In full production runs, these devices do not yet provide an economically viable solution to logic design but, in the initial stages of design, they greatly reduce the speed and cost of turning a series of development versions of a circuit.

## Electronics Today

Offers advertisers the opportunity to increase their sales and profits in the electronic field. Over \$200 million is spent annually for both electronics and micro-computer products by Electronics Today readers.

For advertising information

Call (416) 445-5600

# The Book of Computer Music

approaches

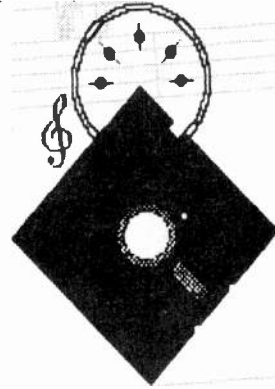

**T**his June will mark the publication of The Book of Computer Music, a special guide to MIDI based instruments, software and paraphernalia. Included in it will be incisive equipment reviews, tutorials on the use of MIDI, a comprehensive survey of what's available and news of the latest releases.

Most of what has been written about MIDI has been comprehensible only to technically advanced computer users. The Book of Computer Music is being created for musicians, performers and composers whose interests are in music, not technology. It will be easily understandable, complete and, above all, useful.

If the symphonies you listen to don't involve Lotus you'll want to audition The Book of Computer Music. You can order a copy now for shipment as soon as it rolls off the press. Send \$4.95 plus \$1.00 for shipping and orchestration to:

**Moorshead Publications  
1300 Don Mills Road,  
Toronto, Ontario  
M3B 3M8**

or call (416) 445-5600 to order with Visa, Mastercard or American Express.

For advertising information on The Book of Computer Music please call  
Denis Kelly at (416) 445-5600.

# For Your Information

## Surface Mount Switches

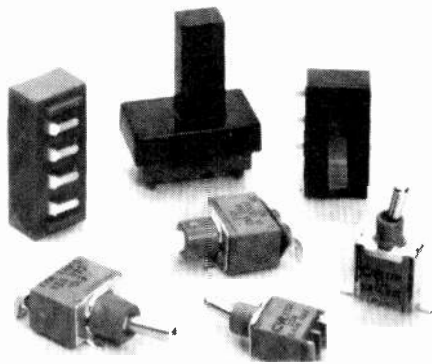

C&K Components announces the availability of surface mounted slide, toggle and pushbutton switches. The E series toggles, E010 and E020 Pushbuttons, ET Tiny toggles are sealed to withstand soldering and cleaning processes without special attention. They're available in various current ratings up to 7.5A and various actuators and mounting styles. C&K is represented in Canada by Avotronics Ltd., 230 Don Parker Rd, Unit 2, Markham, Ontario L3R 2P7, (416) 475-2024, and by Line Electronics, 1503 Dover Court Road, N. Vancouver, BC V7K 1K6, (604) 922-5315.

Circle No. 40 on Reader Service Card.

## Signal Conditioner

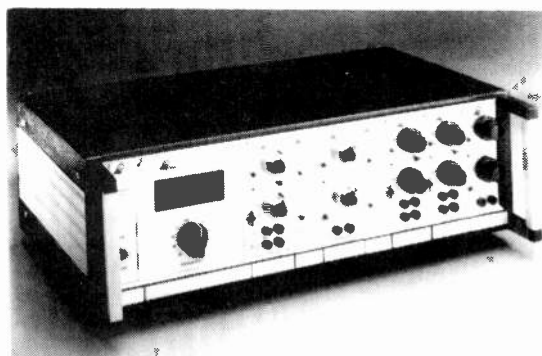

The new Aries AI 1000 Analog Signal Conditioning System consists of a series of amplifier modules for stress analysis and strain gauge transducers. Gain is variable up to 11,000 and frequency response to 10Khz. Other types of modules are available, as are digital displays, channel selectors, peak hold, filters, etc. From Durham Instruments, PO Box 426, Pickering, Ontario L1V 2R7, (416) 839-9960.

Circle No. 41 on Reader Service Card.

## Standby Power

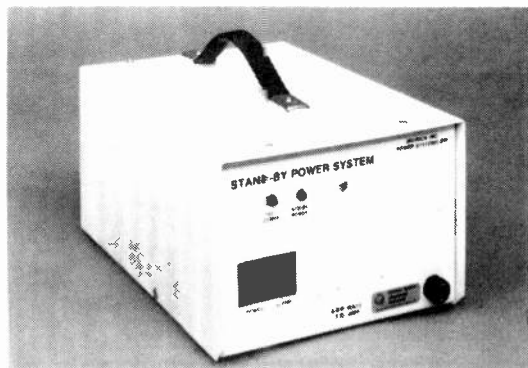

The Merrick Systems Emergency Power Supply systems feature RFI suppression, surge suppression and a long-life sealed battery for maintenance-free service. Battery charging is automatic after a power failure. Ideal for all popular computers and available in 250, 400 and 800 watts from \$750 to \$1600. Power Control Inc., 12-175 Toryork Drive, Weston, Ontario M9L 2Y7, (416) 747-6643.

Circle No. 42 on Reader Service Card.

Electronics Today April 1986

# Moorshead Publications Order Form

## Subscriptions:

Please complete reverse side of order form to start or renew a subscription.

**Back Issues:** \$4.00 each; Ontario residents add 7% sales tax. Please circle issues desired.

|      |          |           |           |          |          |          |
|------|----------|-----------|-----------|----------|----------|----------|
| 1977 | February |           |           |          |          | July     |
| 1978 | April    | May       | September | November | December |          |
| 1979 | February |           | March     | April    | May      | July     |
|      | August   |           | September | October  | November |          |
| 1980 | January  | February  | May       | June     | November | December |
| 1981 | January  | February  | March     | April    | June     | July     |
|      | August   | September | October   | November | December |          |
| 1982 | January  | March     |           | April    | May      | June     |
|      | July     | August    | September | October  | November | December |
| 1983 | January  | February  | March     | April    | May      | June     |
|      | August   | September | October   | November | December |          |
| 1984 | January  | February  | March     | April    | May      | June     |
|      | July     | August    | October   | November | December |          |
| 1985 | January  | February  | March     | April    | May      | June     |
|      | July     | August    | September | October  | November | December |

On the following items please add \$1.00 for postage and handling plus 7% Ontario provincial sales tax.

## Special Publications:

| ITEM                        | QTY    | AMOUNT   |
|-----------------------------|--------|----------|
| Electronic Circuit Design   | \$3.95 | \$ ..... |
| Projects Book No. 2         | \$3.95 | \$ ..... |
| Personal Computer Guide     | \$3.95 | \$ ..... |
| 50 Top Projects             | \$4.95 | \$ ..... |
| Your First Computer         | \$3.95 | \$ ..... |
| Computers in Small Business | \$3.95 | \$ ..... |

**Binders:**  Electronics Today;  Computing Now!  
 Moorshead Publications  
 \$9.75 each plus 7% P.S.T.

## BOOKSHELF ORDER FORM

| Code<br>(e.g. BP12) | Title<br>(Short-form is O.K.) | Price    |
|---------------------|-------------------------------|----------|
| .....               | .....                         | \$ ..... |
| .....               | .....                         | \$ ..... |
| .....               | .....                         | \$ ..... |
| .....               | .....                         | \$ ..... |
| .....               | .....                         | \$ ..... |

## SOFTWARE ORDER FORM

|   |          |
|---|----------|
| .....                                   | \$ ..... |
| .....                                   | \$ ..... |
| .....                                   | \$ ..... |
| <b>Sub Total</b> \$ .....               |          |
| <b>Tax (Ontario Residents)</b> \$ ..... |          |
| <b>Postage</b> \$ .....                 |          |
| <b>Total Enclosed</b> \$ .....          |          |

Orders from the Bookshelf are tax exempt. Please add \$1.00 for postage. Remember to put your name and address on reverse side. See over for mailing details.

Do you currently subscribe to Electronics Today Yes  No  Computing Now! Yes  No  Computers in Education Yes  No  Software Now Yes  No

**BE SURE OF YOUR ISSUE EACH MONTH. SUBSCRIBE TODAY.**

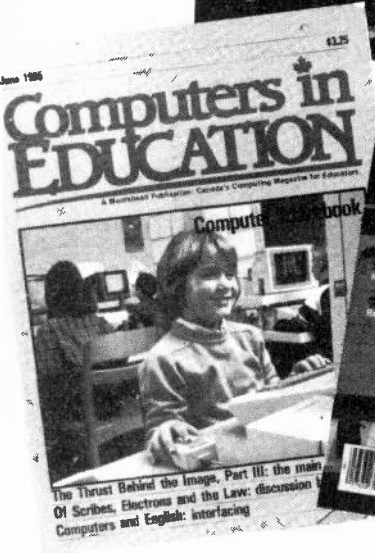
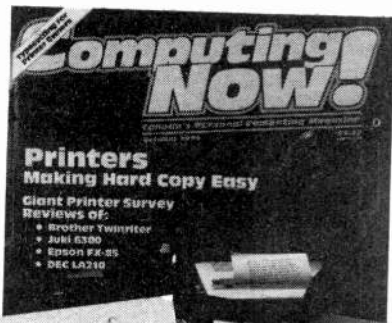

**BOOKS, BACK ISSUES, SPECIAL PUBLICATIONS, BINDERS — SEE OVER**

**Moorshead Publications**

1300 Don Mills Rd., Don Mills, Toronto, Ont. M3B 3M8

**MERCHANDISE ORDER**  Please fill out form overleaf  
**SUBSCRIPTIONS:**  NEW SUBSCRIPTION  RENEWAL

- Electronics Today**  
 One year (12 issues) \$22.95  Two years (24 issues) \$37.95.
- Computing Now!**  
 One year (12 issues) \$22.95  Two years (24 issues) \$37.95
- Computers in Education**  
 One year (10 issues) \$25.00  Two years (20 issues) \$45.00

**Outside Canada (US Dollars)**  
 For U.S. please add \$3.00 per year  other countries add \$5 per year

NAME \_\_\_\_\_  
 ADDRESS \_\_\_\_\_  
 TOWN/CITY \_\_\_\_\_ PROVINCE/STATE \_\_\_\_\_  
 CODE \_\_\_\_\_ DATE \_\_\_\_\_  
 POSTAL CODE \_\_\_\_\_

Cheque enclosed DO NOT send cash  
 Mastercard Account No. \_\_\_\_\_  
 Visa Account No. \_\_\_\_\_  
 American Express Account No. \_\_\_\_\_

Expiry Date \_\_\_\_\_  
 Signature \_\_\_\_\_

**Electronics Today Presents  
 The World's First 3-D Binder Ad!**

The two photos below, which had to be printed sideways to fit the format, were photographed separately with the camera moved about two inches and can be blended into a three-dimensional image in a number of ways.

Try staring at one of them and move the page back and forth in front of your eyes until they blend. This method is extremely frustrating, though it works eventually.

Place a piece of cardboard about 3 inches square between your eyes and move the images up to the cardboard. This works, but they'll be out of focus, unless you have weird eyes.

Put a small slide magnifier or magnifying glass above each photo and look through them. This works really well except for the cost of the magnifiers.

Listen. If you've spent an evening trying unsuccessfully to get the two images to blend, we apologize for wasting your time with this foolery.

What won't waste your time, however, are the new Electronics Today binders, also available with Moorshead Publications on the spine for keeping Computing Now!, Computers In Education, or our special issues.

They hold twelve issues without cutting or punching, and they're spacious enough that the magazines are held fair and square without bunching or creasing.

To order yours, specify which imprint and send \$9.75 (Ontario residents add 7% sales tax) to:

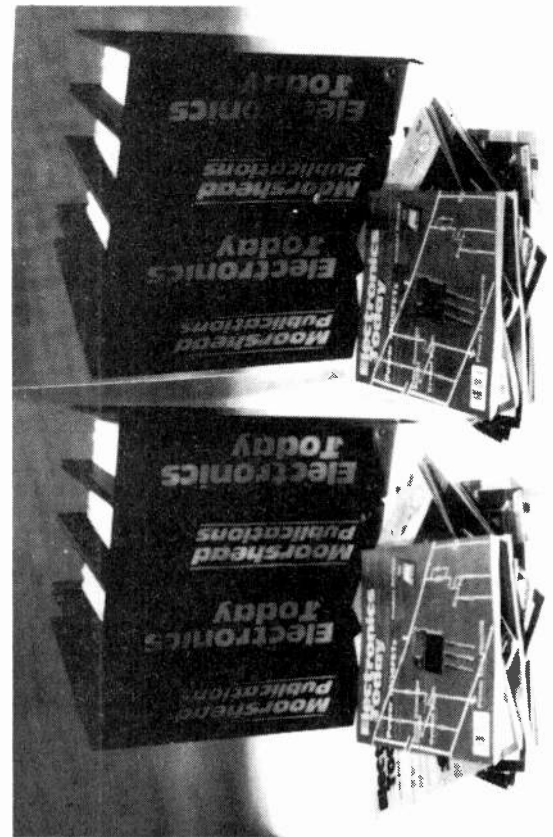

**Binders**

Moorshead Publications  
 1300 Don Mills Rd.,  
 Don Mills, Ontario M3B 3M8

# Autowiper

**Set the pace with a digitally-controlled variable delay for windshield wipers.**

**By A. Armstrong**

THE AUTOWIPER is quick and simple to install and it requires just four connections to the motor wiring with no unsightly holes in the dashboard. It's also especially useful on the rear wiper of hatchbacks. The connections are 0V, the +12V motor supply, and the normal speed motor wire, cut in two with both ends joined to the unit.

The time period is set by triggering a single wipe of the windshield and another after the desired interval has elapsed. The unit remembers the interval and keeps on working at this rhythm (give or take 10%) until cancelled or reset.

## Principles

A timer starts when the switch is turned on briefly for the first time, and its state is stored on the second switch operation. The timer is then cycled repeatedly; the windshield wipers being operated once in each cycle. A third switch operation, if it occurs when the wipers are stationary, resets and restarts the timer. A fourth operation of the wiper switch stores the new time period (between third and fourth switch operations). If no fourth operation is received, the unit times out after about 30 seconds.

The timing is digital in nature, and uses a four bit binary counter. This provides 14 usable time periods, since both zero and terminal count are not valid time settings. In order that this quantization of available timings is not a nuisance, the speed of the clock oscillator is controlled by the state of the counter. The clock starts off fast when the time period is being set and slows as the period lengthens. In this way, the accuracy of the timer (expressed as a percentage of the required time period) remains constant. A limit is placed on the oscillator speed so that it does not use up too many possible states while the wipers are crossing the windshield the first time the switch is operated.

Earlier designs used an analogue timer, but in damp weather leakage currents caused a significant timing drift over a period of five minutes. The digital design is much less susceptible to this, though condensation on bare tracks can cause problems.

Electronics Today April 1986

## Construction

The first job is to link the top and bottom sets of tracks on the PCB. The board is laid out so that none of the pads on the top of the board connect to components, they are all simply links to the bottom. This simplifies both assembly and repair. The preferred method of joining the two sides is to use track pins. If these are unavailable, wire links may be used.

It's a good idea to spray the component side of the PCB with lacquer once the track pins are soldered on both sides. This will ensure that even the tracks which run underneath components are coated. This can prove to be important if the PCB is to be mounted in the engine compartment of a car, because condensation can sometimes occur under these circumstances.

The components may then be mounted on the PCB, starting with the passive components. The only one likely to be difficult is the relay, as some samples of these have pins which are very resistant to soldering. The most effective method of persuading them to solder is to clean them up with a glass fibre brush. Another solution which has worked is to pre-tin the pins with the aid of a corrosive flux. The flux must then be cleaned off the pins very thoroughly, or else the board will fail due to the tracks being eaten through every few months.

When all the components are correctly fitted, a bench test is in order. The best way to do this is with a test harness (Fig.3). Switch on the supply, and wait ten seconds for C4 to charge up. With the aid of a digital watch operate the switch twice, at a ten second interval. Time the flashing of the LED, and check that its period is between nine and eleven seconds.

If it is far out, then check that R5 to R8 and D2 to D5 are properly oriented. If nothing happens, or if the relay just switched on, check that both parts of the flip-flop switch over properly. Check that the clock oscillator works, and that a pulse appears on IC5 pin 10 when the switch is turned on. It might also be worth checking whether Q1 is switching but failing to operate the relay, this is always a possibility.

Once the board is shown to be in good working order, a liberal coat of lac-

quer should be applied to the underside, and allowed to dry thoroughly.

## Installation

There are two points requiring careful consideration. The first is to find a place to mount the PCB, within reach of the wiring of the windshield wiper motor. The second is to discover which of the wires going to the motor is which. If you've ever tried to decipher car wiring harnesses you probably already know that they are like an overnight bag full of snakes.

The first of these depends on the individual car, so only general advice can be given. Any flat surface, at whatever angle, near to the motor, may be suitable. It should not be in direct line with any spray which may come in through the radiator grill, nor should it be somewhere where corrosion is obviously occurring. Hammond makes a series of small moisture-proof cases which are ideal for this (see *Cabinetry For Electronics* - March '86). If there is convenient access to the wiring inside the car (and there rarely is), then this is a preferable mounting place, especially if there is also a convenient plastic panel to attach the PCB to.

The only way to identify the wires non-destructively is to find a connector somewhere in the windshield wiper motor wiring. The positive connection can be found with the aid of a meter first of all, and then it should be possible to identify the standard speed connection to the motor by finding which one receives a continuous supply only when the wiper switch is in the standard speed position. This wire should be cut and connected to the unit (Fig.4).

The positive supply may be obtained via a tap-in connector, and the 0V connection may be taken to any convenient bolt which passes through the metallic structure of the car. A quick final test is now all that is needed before the unit is ready for use.

Should the unit be used on any car in which the switch wire is not grounded by the park switch in the motor, then an external pulldown resistor may have to be connected to the terminals, as shown in the test circuit (Fig.3).

The operation sequence is: operate wiper switch to wipe windshield once.

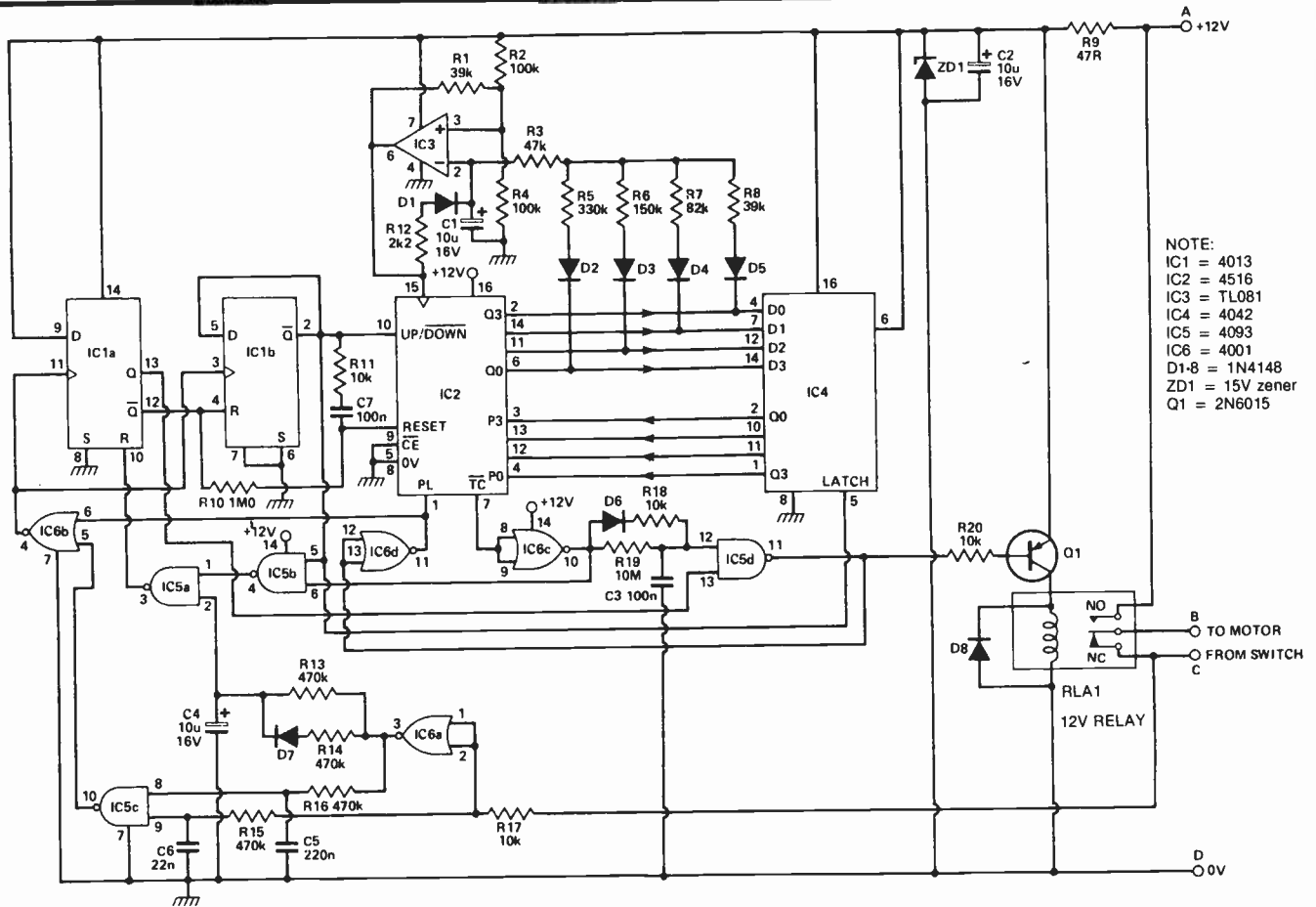

NOTE:  
 IC1 = 4013  
 IC2 = 4516  
 IC3 = TL081  
 IC4 = 4042  
 IC5 = 4093  
 IC6 = 4001  
 D1-8 = 1N4148  
 ZD1 = 15V zener  
 Q1 = 2N6015

Fig. 1 Circuit diagram of the Autowiper.

When the wiper switch is switched on, a logic 1 is applied to the input of IC6a via R17 to protect the input. Because of the inequality of the time constants of R15/C6 and R16/C5, there is a brief period when both of the inputs of IC5c are at logic 1. This results in a brief negative going output pulse, which is inverted by IC6b which then clocks the flip-flop, IC1a. The inequality of the time constants ensures that a transition from logic 1 to logic 0 on R17 will not cause a clock pulse.

The fact that both inputs to IC5c have RC time constants means that electrical noise is rejected to a large extent. Should electrical noise or switch bounce prove to be a problem in use, then both time constants may be increased in proportion.

The first clock pulse switches IC1a so that its Q output goes to logic 1. This enables the relay drive, via IC5d. The Q output goes to the reset inputs of IC1b, and the counter, IC2, via R10. The counter is therefore allowed to start counting up as soon as C7 has discharged to logic 0 via R10. We get to the purpose of C7 later.

The oscillator which clocks the binary counter is derived from a standard configuration, but it has been designed so that the discharge path of C1 is separate from the charge path, and is connected externally to the oscillator part of the circuit. This means that the cycle time of the oscillator can be controlled by the voltages applied to

the discharge resistors. These resistors, R5 to R8, are approximately binary weighted, and connected to the outputs of the binary counter. To limit the maximum oscillator speed to something useful, while leaving the slower speeds almost the same, an extra fixed discharge resistor, R3, is placed in series with the discharged path.

Clearly, if the counter is allowed to reach state 15 (1111) then there will be no discharge path for C1, and the oscillator will stop. This does not matter because when the counter reaches this state, the terminal (or carry) output, IC2, pin 17, switches to logic 0. This resets the first flip-flop, IC1a, via IC6c, IC5b, and IC5a, which means that the unit has timed out.

There is only one further point to make about the oscillator and counter. IC3 must have a sufficient slow rate to clock the CMOS counter used. A 741, for example, will not work because the counter will count up for a while, but normally stops when it is time for the third most significant bit to switch. TL081s and LF351s with a 13V/microsecond slew rate are perfectly adequate.

Back to the main sequence of operation. If a second clock pulse is applied (the wiper switch is operated again) before the counter reaches terminal count, then IC1b is clocked. This has the effect of latching the counter output in the transparent latch, IC4. The counter up/down input is switch-

ed to down, and the counter now counts down from whatever number it has reached until the terminal count bar output switches over. This now occurs at zero, because the counter is in the down mode. The down count takes the same period of real time as the up count took, since the oscillator is progressively speeding up rather than slowing down. When terminal count is reached, the relay is energized for a period set by the time constant of R19 and C3. This starts a wipe of the windshield, which is then completed by the park switch in the motor.

While the relay is energized, the counter is parallel loaded with the latched count data, so that a new down count can be started from the same number. Any clock pulse generated on the output of IC5c as a result of the wipe, is prevented from reaching IC1a by IC6b during this period.

The terminal count output is prevented from resetting the flip flops by IC5b as long as IC1b is set.

If the wiper switch is operated when the wipers are stationary, the resulting clock pulse from IC5c is allowed through to the flip-flops, and it switches over IC1b. A reset pulse is applied to IC2 via C7, with R11 in series to limit the peak current in the input protection diodes when it switches back the other way. IC2 is now allowed to count up, and the circuit is in the state it was in after the first operation of the wiper switch. It is waiting for a new time setting.



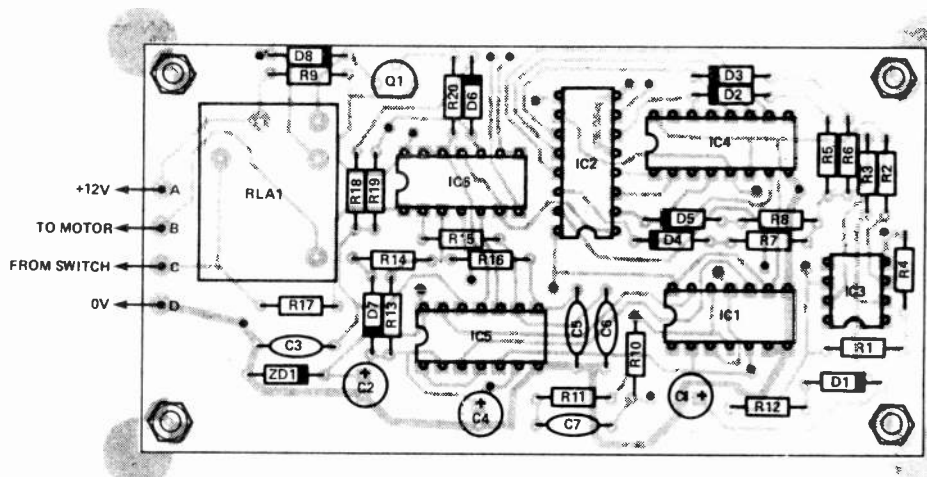

Fig. 2 Component overlay for the Autowiper PCB

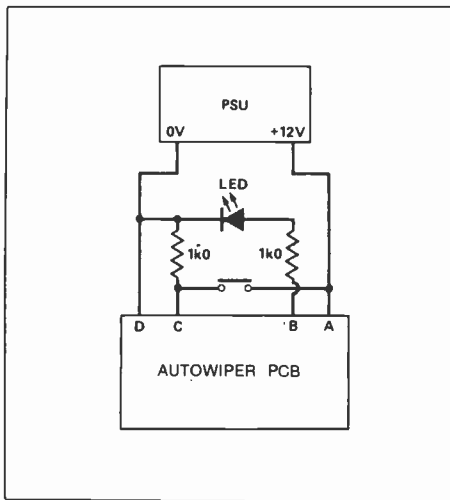

Fig. 3 Test harness circuit.

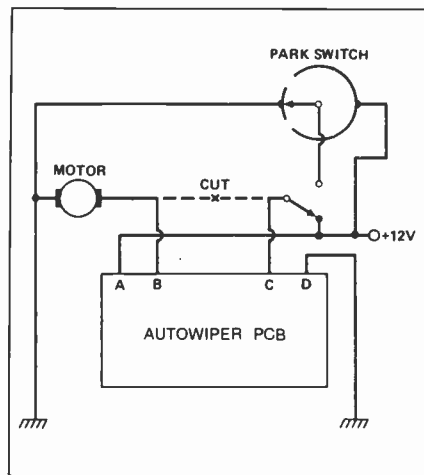

Fig. 4 Simplified wiring diagram.

**Parts List**

Resistors (all 1/4W, 5%)

|              |       |       |
|--------------|-------|-------|
| R1,8         | ..... | .39k  |
| R2,4         | ..... | 100k  |
| R3           | ..... | .47k  |
| R5           | ..... | 330k  |
| R6           | ..... | 150k  |
| R7           | ..... | .82k  |
| R9           | ..... | .47R  |
| R10          | ..... | 1M0   |
| R11,17,18,20 | ..... | 10k   |
| R12          | ..... | .2k2  |
| R13,14,15,16 | ..... | .470k |
| R19          | ..... | 10M   |

**Capacitors**

|        |       |          |
|--------|-------|----------|
| C1,2,4 | ..... | 10u, 16V |
| C3,7   | ..... | 100n     |
| C5     | ..... | 220n     |
| C6     | ..... | .22n     |

**Semiconductors**

|      |       |        |
|------|-------|--------|
| IC1  | ..... | .4013  |
| IC2  | ..... | .4516  |
| IC3  | ..... | TL081  |
| IC4  | ..... | .4042  |
| IC5  | ..... | .4093  |
| IC6  | ..... | .4001  |
| D1-8 | ..... | 1N4148 |
| ZD1  | ..... | 15V    |
| Q1   | ..... | 2N6015 |

**Miscellaneous**

RLA1 ..... 12V relay  
 4-way, 0.2in pitch screw connector block; track pins for through-board connections.

Repeat after a delay of x. The intermittent switch will now operate at a period of x (+-10%), with the switch in the off position, until a third manual wipe is carried out, or the switch is turned on for several seconds continuously, or the ignition is turned off. It is always possible to switch the wipers on continuously (even if the accessory should malfunction), so there is no safety hazard.

In the event of a fault which causes the wipers to operate continuously (for example, the relay remaining on all the time), it is possible to return to normal

wiper operation by disconnecting just the positive supply to the unit, pending a proper repair.

**Quirks**

There is one more important detail to mention. It is possible that, by mistake, a time period may be set which leaves the wiper stationary for only a small fraction of a second. If this happens, it is very difficult to flick the wiper switch during the stationary period to reset the circuit. If the circuit is allowed to run for a few seconds

C4 will, on average, discharge rather than charge, and after a while IC1a will be reset via IC5a. (This part of the device has been nicknamed the 'anti-knickers-in-a-twist' circuit.)

To improve reliability, the power supply connections to the ICs are protected from spikes and reverse polarity connection by R9, ZD1, and C2. If the circuit should accidentally be connected to the power the wrong way round, the only damage likely is that R9 may smoke mightily.

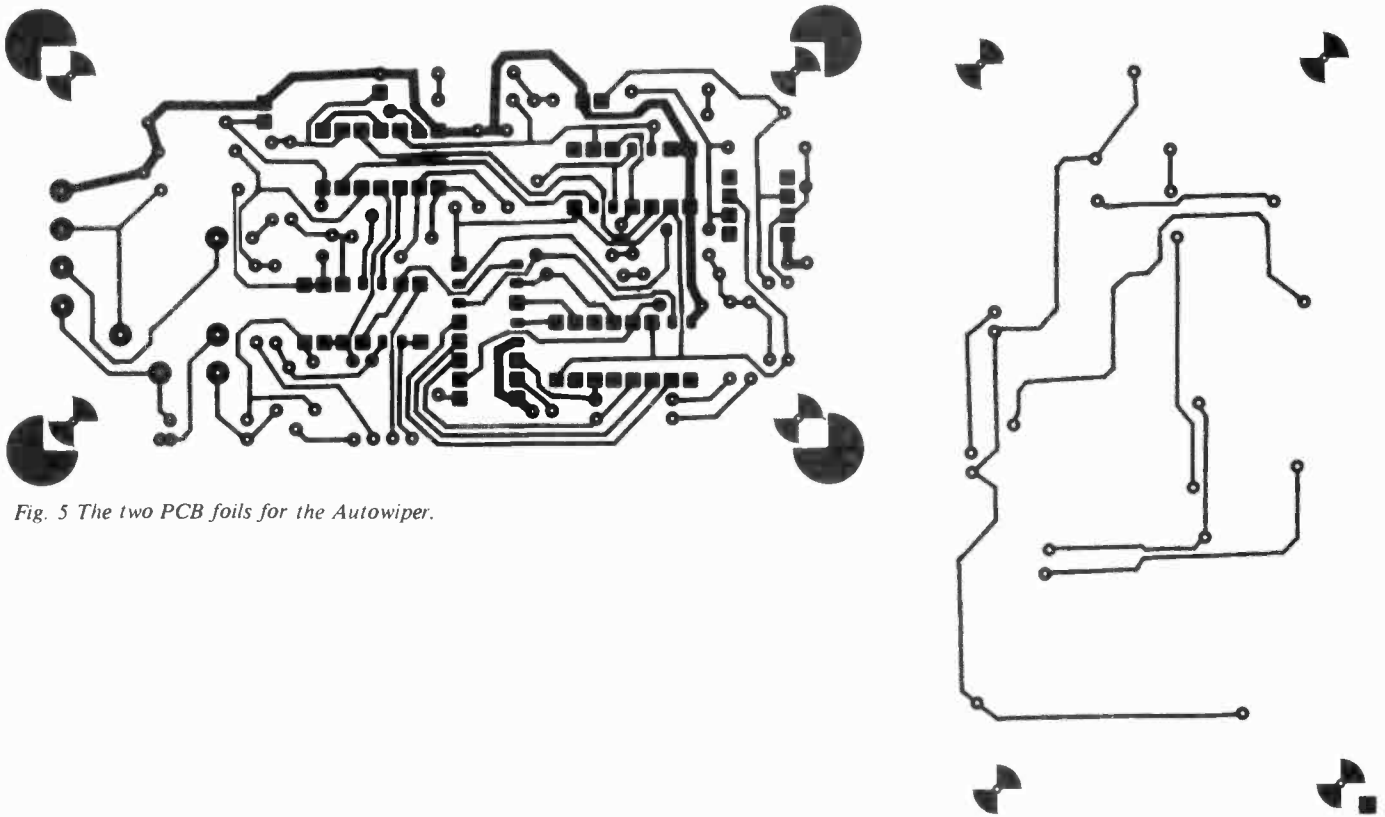

Fig. 5 The two PCB foils for the Autowiper.

# Product Mart *Where Buyers Find Sellers*

## HOBBIT ÉLECTRONIQUE

WE DON'T SELL COMPUTERS.  
WE JUST SELL THE PARTS!

Send your name and address along with \$1.50 to: 7454 Langelier, St. Leonard Montreal, Que. H1S 3A7 Tel: (514) 259-5581.

**DESCRAMBLER-Jerrold** System Compatible, \$275.00 (Postal Money Orders only). \$5.00 for information.  
**G.C. INDUSTRIES**, P.O. Box 4958, St. Laurent Station, Montreal, Quebec, H4L 4Z6 (Quebec residents add 9% sales tax).

**J&J ELECTRONICS LTD.**, Box 1437E, Winnipeg Manitoba R3C 2Z4. Surplus and Semiconductor Specialists. Do you get our bargain flyer? Send \$1.00 to receive the current literature and specials and to be placed on the mailing list for future publications.

**MEMORIES, RAMS and CPU's**, Hitachi, AMD, Intel, Fujitsu. Guaranteed name brand devices. Check our prices! Call Terry, Sask. **MICRO DEVICES**, (306) 652-2123.

**ELECTRONIC SURPLUS INDUSTRIES LIMITED**, we sell used industrial/military test instruments, including oscilloscopes by HP Tektronix, Philips; Signal generators, meters, components, tubes, etc. 1191 Lawrence Avenue West, Toronto, Ontario M6A 1E2 416-787-1837.

### KIT-KING

75 fun projects that you can build. Start today by writing for our catalogue. It is free! Catalogues, **KIT-KING**, 21 Mill St., Orangeville, Ontario, L9W 2M2.

**COMPUTER and Electronics parts**. Priced to sell. Send for free catalogue and get on mailing list for frequent. "Sale Flyers." **M.O. ENTERPRISES**, Box 2066, Bramalea, Ontario, L6T 3S3.

**LED..LED...LED....** Always in stock for immediate delivery by return mail. (5mm diffused) Red. 10, Green.12, Yellow.12, Amber.14, Orange.14, 2 Pcs holder. 04, Minimum order 100 each. Add \$2. for postage. Free sample and selection guide on your letterhead. To **SURPLUS ELECTRO QUEBEC**, 2264 Montee Gagnon, Blainville, P.Q. J7E 4H5.

**"NEED A PCB?"** We've got it. Single, Double and Feed Through, Best Prices. **PRO PC**, 279 Beauchemin, Sorel, Quebec, J3P 2N8 Tel: (514) 742-3562.

**SARNIA** now has surplus! Resistors, capacitors, I.C.'s, switches, LED's, and more! Thousands of electronic parts plus other interesting hobby gadgets (new deals arrive every week)! Almost every kind of manufacturers surplus you can imagine! Visit **SARNIA SURPLUS LIMITED**, 174 Christina St. N., Sarnia, Ontario, N7T 5T9 (519) 344-3044.

**For Advertising Information Call:**  
(416) 445-5600

---

# PCB Layout Guide

---

*It's not that difficult to get from a schematic to a printed circuit layout.*

---

*By Barry Porter*

IN basic terms, a printed circuit board is nothing more than a support for the components of a circuit which happens to have builtin interconnections that enable the circuit to operate. In reality, it is something more than that. A well-designed circuit board can have considerable aesthetic appeal. It also assists in keeping the blood pressure of anyone called upon to carry out repairs within tolerable limits, and provides additional boozing time by accelerating the construction of your latest masterpiece.

The only difference between bad and good circuit board layouts is care. There is no excuse for boards in manufactured products being second rate, but there is even less reason for one-offs produced by home constructors to resemble a windy night at a spaghetti factory. Time is money to the manufacturer, but the electronics enthusiast should not suffer from this constraint.

## The Birth Of The Board

The object of the exercise is to guide you through the design and preparation of the

necessary artwork to send to a PCB manufacturer. Although it is possible to make your own boards, the expenditure of time and the amount of mess generated are unlikely to be justified by the end result, so unless you are prepared to invest a considerable amount of the folding stuff in specialized equipment, it is best to leave the difficult bit to a professional.

Circuit boards usually start their careers as circuit diagrams, and the stages necessary to translate a familiar schematic into a finished board begin as a number of very rough layouts, followed by one or more attempts to transfer these to graph paper at a defined scale. The successful graph paper layout is used as a master from which the various artwork layouts are generated. These consist of plastic drafting film masters for the copper tracks, a solder resist mask and the component identification screen. If the board is to be double sided, a separate artwork is normally provided for each side. The artwork will normally be produced at 2:1 scale with linear dimensions which are twice those of the final board, although for very large boards, it may be necessary to work same-size, and for very small layouts, a 4:1 scale is sometimes preferable.

To illustrate the various steps in the production of a set of artworks, we will start with a circuit for a high quality tape record amplifier (Fig. 1), and attempt to design a layout which fits a circuit board with the dimensions shown in Fig. 2. Any layout is made easier if you are free to choose the overall board size and the points at which connections to the outside world are made. The most difficult tasks involve fixed board dimensions, such as the design of a replacement board for an existing piece of equipment. Life is further complicated if the external connections are made via an edge connector with predetermined locations. Just to ensure that life retains some enjoyment, this is

the situation that will be tackled during the course of this article.

Before getting too involved with the design of a specific board, a few basic rules may not go amiss. Circuit diagrams are usually drawn in a way that can almost be taken as a worldwide standard. Signal normally progresses from an input at the left hand side, through various transistor or opamp stages, to emerge at the right hand side. It is usually good practice to lay out a circuit board so that it bears a close resemblance to the original schematic.

Inexperienced PCB designers usually fall into one of two main traps: running low level inputs and high level outputs too close together, so that a circuit that worked in breadboard form becomes unstable, and getting the grounding arrangements wrong, causing hum loops.

Where possible, input and output signal paths should be well separated, particularly when there is more than about 15dB difference in their levels. Providing the operating impedances are low, it is normally quite safe to allow the inputs and outputs of low level circuitry to be within 0.5 of each other. If an area of track at ground potential can be placed between them, it is quite possible to reduce the spacing to 0.25. Power amplifiers are a different ball game, and a minimum input to output spacing of 3.0 should be allowed, but 6.0 or even more is to be preferred.

Bad grounding practice can cause problems beyond your wildest imagination, yet perfectly good grounding can be achieved very easily by ensuring that the input to output ground path of any circuit simply follows the signal through the various stages. The impedance of all ground connections must be kept as low as possible, which means using large areas of copper track wherever space allows.

One very popular way of introducing instability is to place a continuous strip of copper track at ground potential around the outer edge of a board. This is often the most convenient place for the ground track to be positioned, but it is essential that the circle is broken at one point so that as far as possible, the ground path

follows that of the signal.

In designing a printed circuit board, the aim should be to arrive at a layout where the components are neatly positioned without compromising the performance of the circuit. As far as possible,

is wise to make sure that certain items are at hand:

1. One each of the various circuit components, or accurate details of their dimensions.
2. Lots of scrap paper for the initial

budget.

The first step is to produce a very rough sketch of where the different parts of the circuit will fit onto the circuit board. If there are no constraints brought about by board dimensions or edge con-

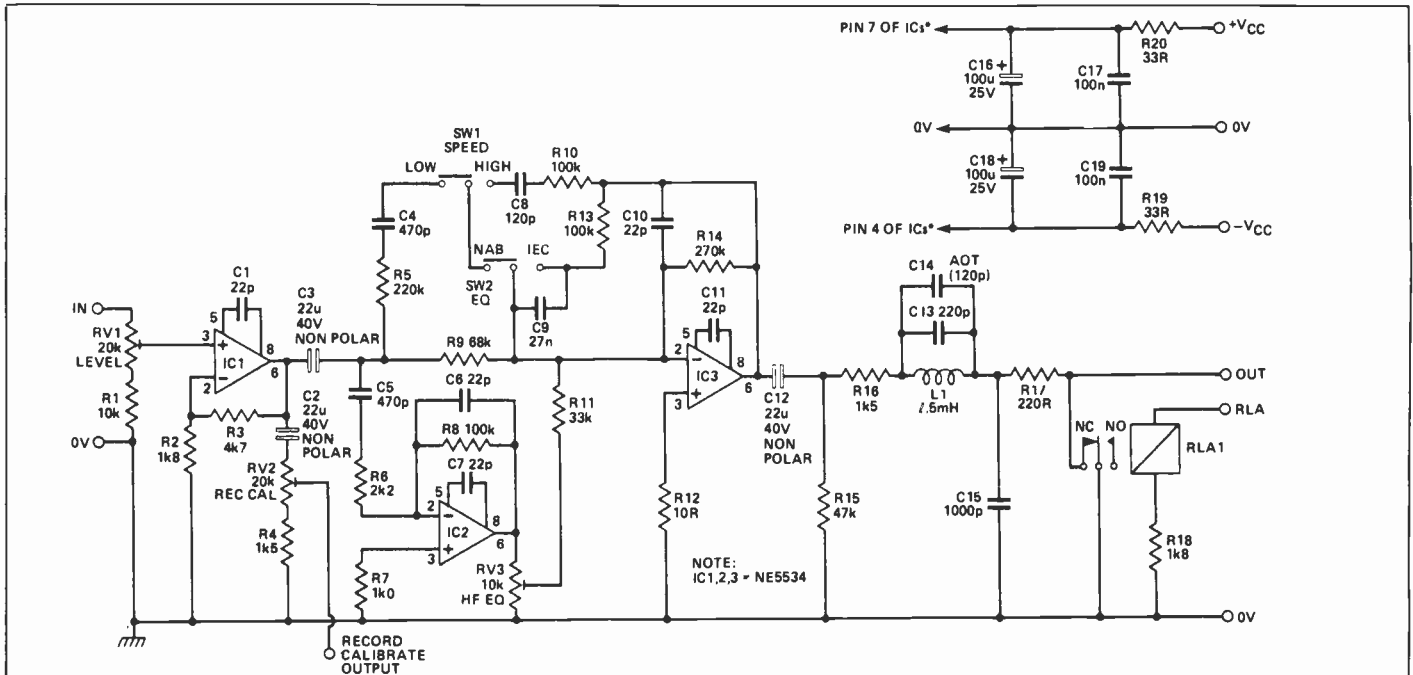

Fig. 1 Circuit used for layout exercise.

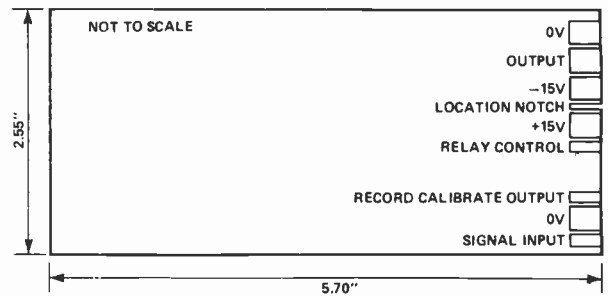

Fig. 2 Circuit board dimensions and edge connections.

the components should be placed in rows with correct spacing between the mounting holes. Before laying out any board, it is essential to have some examples of the components which will be used or obtain accurate dimensions from a data sheet. The appearance of many a board has been ruined because of an incorrect guess at the length of a capacitor, so pay special attention to your component sizes, as plenty of eager gremlins lie in wait for the unwary.

Some complicated circuits can only be laid out by using double-sided boards, but the additional cost of these is usually a sufficient incentive to extract the necessary effort to achieve a single sided layout. Whenever possible, the use of wire links should be avoided, more as a matter of designers' pride than because of their effect on circuit operation.

## Getting Down to It

Let's look at the layout of the circuit in Fig. 1. Before starting any design work, it

rough design,

3. A supply of graph paper, slightly larger than the finished artwork, with scale markings at 1.00 and 0.1 inch. (None of yer metric stuff here; components invariably fit a 0.1 inch grid).
4. Matte surfaced plastic drafting film, same size as graph paper.
5. Drawing instruments: pencils, pens, stencils, compasses, rule scaled in tenths of an inch.
6. Talcum powder.
7. Supply of circuit layout materials (details later).
8. Roll of red transparent adhesive tape.
9. Scalpel with selection of blades.
10. Pair of good quality 6 inch tweezers with undamaged points.

Having collected together these tools of the trade, the time has arrived to leave the world for a few hours. Find somewhere where your concentration will not be disturbed, even if you have to send the family to Disneyland and gag the

nectors, it is quite easy to arrange the circuit parts in a reasonably compact and symmetrical manner. Working to predetermined dimensions, it is necessary to decide where various circuit elements should be placed to fit within the confines of the board, and if the external connections have been specified, these should be taken into consideration.

Fig. 3 shows the first attempt to fit the Fig.1 circuit on to the designated board. At this stage, the main consideration has been given to establishing a route for the signal input and output tracks, the placing of the three integrated circuits and connections to the multiterminal potentiometers.

At first sight, getting a direct connection from the edge connector to the wiper of RV2 is likely to be a problem, but one that can be noted and dealt with as the design progresses.

The next task is to produce some rough layouts of separate parts of the cir-

cuit, this time putting in all components and the interconnecting tracks. At this point, it should be mentioned that most PCB designers produce their layouts and art work as it is viewed from the component side of the board. Some people

straight rows, and not staggered as shown in Fig. 4b, the spacing between normal 0.25 or 0.5W resistors is likely to be 0.15, and this does not leave sufficient space between the solder pads for the passage of a piece of track without the track without

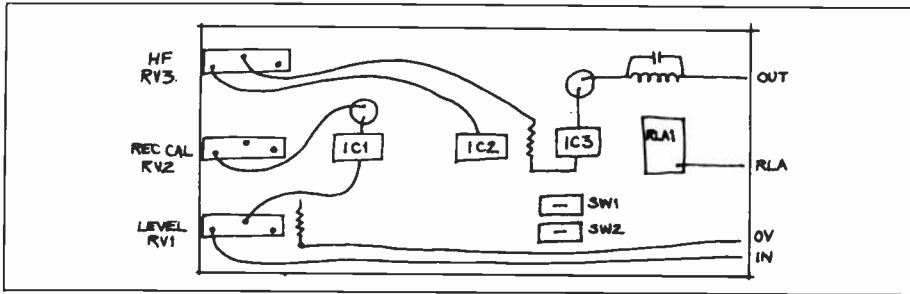

Fig. 3 First rough layout.

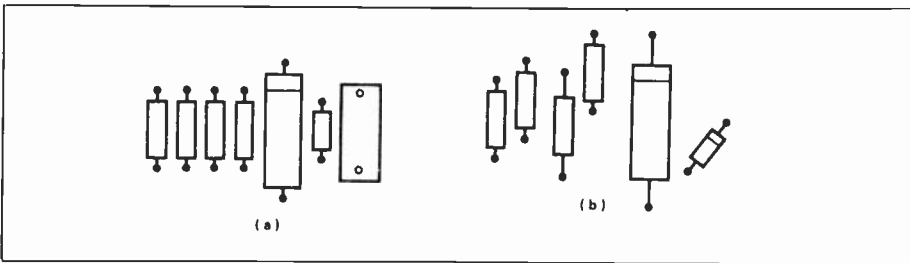

Fig. 4 Component spacing and layout. The right way (a), and the wrong (b).

prefer to work as though they are looking at the copper side, but this method can lead to problems, the most popular being ICs with reversed connections, easily identified by the emission of grey smoke if not discovered before the board is built and tested. Throughout this article it will be assumed that all views are from the component side.

As the next layout rough is prepared, account should be taken of the component sizes and spacing, especially with regard to resistors and capacitors. In order that the final result is as neat as possible, one aim should be to keep the ICs and their associated components in

the track becoming too narrow for comfort or the pads requiring modification with a scalpel.

Without getting too involved in pad and track sizes at this stage, while doing the rough layouts, keep in mind that tracks passing between 0.15 spaced pads may cause problems at a later stage, so avoid the practice if possible without damaging the appearance of the layout.

The first rough layout of the record amplifier board is shown in Fig. 5. Although this has several areas which need correcting, for example the input and OV tracks will have to be reversed, and the output of RV2 is in danger of be-

ing trapped by the track going to R11, it is at least a starting point, and as such it forms a foundation of sorts on which to build.

The remaining circuitry is shown in Fig. 6. Again, it contains a few problem areas, such as the nonappearance of the Record Cal track and the rather tortuous path from the bottom of C9 to pin 2 of IC3, but these can be sorted out at the next stage.

### Slow on the Draw

Having produced a satisfactory rough layout with sufficient accuracy to establish that it is not necessary to use a double sided board, and that wire links will probably not be needed, it is possible to attempt a correctly scaled layout on graph paper.

From now on, everything must be related to the scale of the artwork, in our case, 2:1, so care must be taken to double every dimension. Experience has shown that this is not always as easy as it sounds. It is quite easy to draw small components with correct dimensions, simply by counting squares on the graph paper, but with larger items such as electrolytic capacitors, it is very easy to make a mistake, and the distance between mounting holes should always be checked by measuring them with a rule calibrated in tenths of an inch. The time spent doing this should not be considered as wasted, especially if you have ever suffered the sinking feeling when you realize that a component will not fit a board because of your own lack of care.

If your board dimensions are not fixed, you should be able to estimate an approximate size, which will give you an idea of the size of graph paper you need. With an established board size, an outline of the board should be drawn in ink to the correct scale and any fixed components, mounting holes or edge connector details added using a fine felt tipped pen or similar.

In our example, the only restraint apart from the overall board size and edge connector positions is the placing of the three preset potentiometers which are required to line up with similar controls on other boards in the recorder. The outlines and mounting holes of these are therefore drawn in ink, and then using a soft pencil, an attempt is made to transfer the rough layouts of Figs. 5 and 6 on to the double sized graph paper grid.

Although this may be done freehand, keep everything as neat as possible. This is the best way to ensure accuracy. It's worth repeating that, unless absolutely necessary, all components should be in neat rows and not scattered haphazardly round the board. If your circuit uses ICs, these should lie along the same line, and should be placed in the same direction,

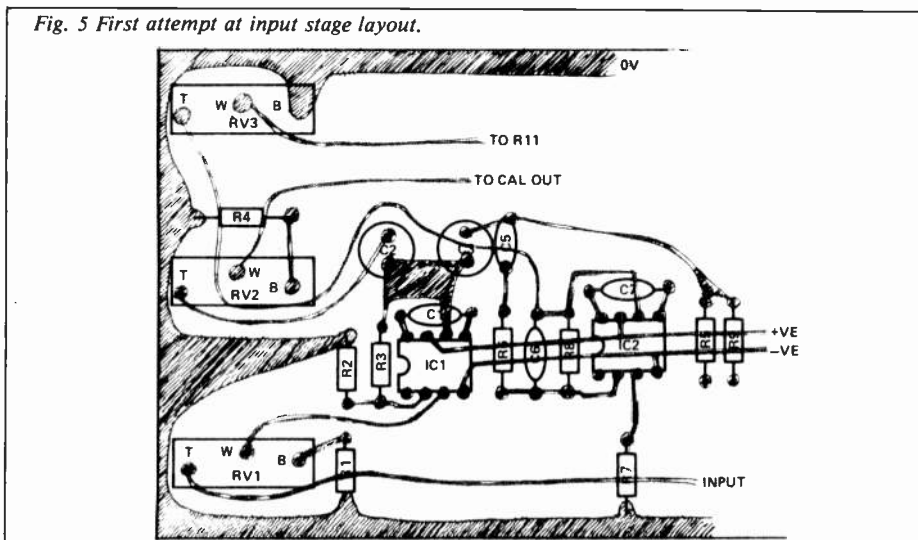

Fig. 5 First attempt at input stage layout.

which normally happens automatically if the power rails are run between the rows of IC mounting pads, and don't approach each device from a different direction. The sign of ultimate neatness is when groups of polarized components, such as

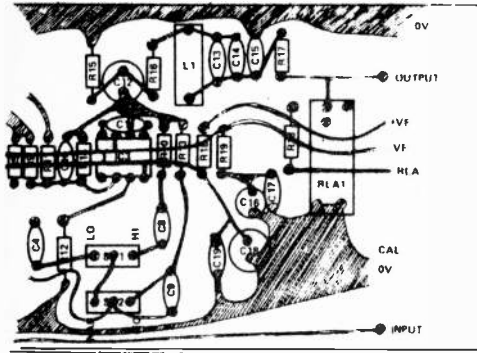

Fig. 6 First attempt at output stage layout.

diodes or electrolytic capacitors, all have their positive ends facing the same direction. Figure 7 shows some examples of how electrolytics and diode bridges may be laid out, (d) and (f) illustrating how they should be positioned for the best appearance.

If you are having a good day, you will achieve a satisfactory layout before your local graph paper factory has to start working overtime. do not be surprised if it takes three or four attempts before you are happy. It can often be beneficial to get an electronically inclined colleague to give your layout the onceover, as this can often result in the discovery of glaring mistakes which would prove expensive if not corrected.

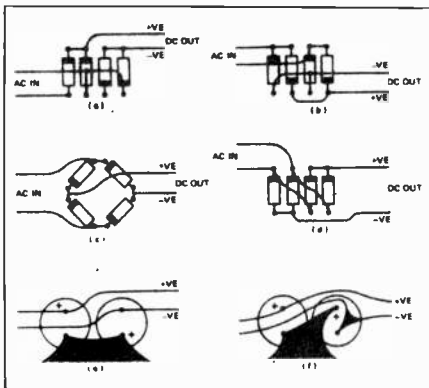

Fig. 7 Examples of diode bridge and electrolytic capacitor layout.

## Getting the Bugs Out

Having arrived at an acceptable layout, you should now start again. Take another sheet of graph paper and draw the board outline and fixed component outlines in ink. Then, being careful to follow your previous pencil layout, draw just the component outlines in ink. By separating the components from the confusion of tracks, it is possible to get a good idea of how the

final board will look. At this stage you should be quite objective: are the components evenly spread out over the PCB area, or are they in overcrowded clumps, leaving large areas of unused board? Is everything as neat as it could be, or are there staggered rows of components and wire links all over the place? Are all the component dimensions accurate, so that

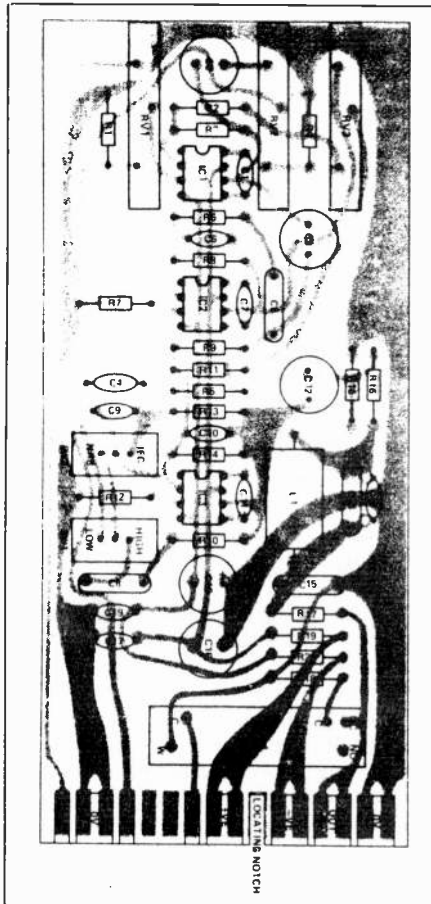

Fig. 8 The final layout from the component side.

everything can be correctly mounted? If you are not totally satisfied, now is the time to carry out any final corrections, so make any changes by drawing a new board outline, with the modified component placings, making sure that the movement of any component does not upset your carefully planned track layout. Once the final component positions have been established, the track layout should be added, using pencil or coloured ink, so that you arrive at a final layout master similar to the example shown in Fig. 8.

After a final check to ensure that the layout agrees with the circuit diagram, the first artwork master may be produced. Often referred to as the 'tape or dot' stage, this is simply a double-sided replica of the copper areas which will be on the finished circuit board, and is produced by sticking self adhesive opaque tape and other symbols onto a sheet of plastic drafting film, using the graph paper layout as

a guide.

The first step is to lay claim to at least half the kitchen table to which you firmly attach the graph-paper master with masking tape. Take a sheet of drafting film which is at least an inch larger all round than the circuit board outline and firmly tape this along its top edge so that it covers the graph paper layout. If possible, use drafting film which is matt on both sides. If yours has one shiny side, this should be kept as the underside.

Those who have only been reading this to find out why you were told to purloin some talcum powder, take heart, your moment has come. If your drafting film is typical of just about every other sheet of drafting film in the universe, it will be covered with enough greasy fingerprints to keep the cops amused for years. This being the case, take your precious powder and give the sheet of film a light dusting and a quick rub with a piece of clean tissue before blowing any surplus away.

## The Last Stage

You are now ready to begin the layout proper, for which you will require a supply of opaque adhesive pads, tapes and other shapes in an assortment of sizes. For working at a 2:1 scale, the following should be a minimum set:

- PADS: 0.2' diameter and 0.15' diameter (the smaller ones for ICs).
- TAPE: self-adhesive black crepe tape in widths of 0.06', 0.08' and 0.01'.
- SHAPES: right angle elbows and T-pieces in the same three widths.

These materials should be available from any artist's supply shop.

The first stage is to place the pads in position on the film, and this is where a good pair of tweezers will prove invaluable. Make sure that each pad is placed accurately so that its central hole is aligned with the crossing point of the relevant graph paper lines. For maximum accuracy, the layout should be carried out over a precision grid placed on a light box. This can lead to mistakes, and the finished artwork should always be checked by placing it over the graph paper master. For most purposes, graph paper is sufficiently accurate to use as the guide for pad placement.

When all the pads are in position, place a second sheet of drafting film over the first, and place a further set of pads on this. Stick small pieces of 0.1' wide tape on each pad, covering the central hole. Draw in the corners of the circuit board, and you have created a solder resist mask. Return to the first 'dotted' sheet of film and add the interconnecting tracks, using

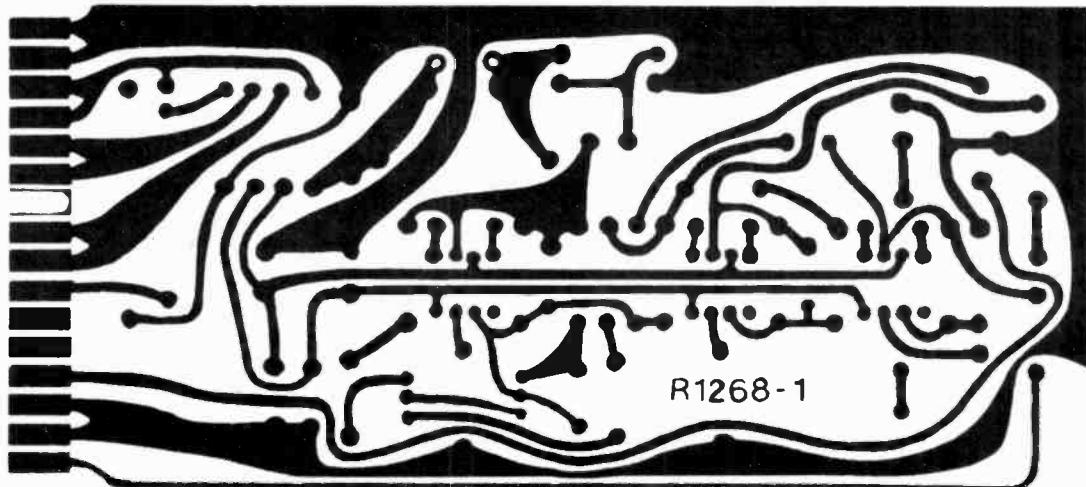

Fig. 9 The actual foil pattern — copper side.

suitable width tape. Where track density is fairly low, use at least 0.1" wide tape. For low impedance connections, such as ground or power supply rails, outline the copper area with tape and fill in with red transparent tape, which is considerably cheaper than track tape.

Don't forget to accurately mark the board edges; the accepted way of doing this is to mark each corner with a right angle using tape. Obviously, this is not necessary if copper is taken to the edge of the board. Be sure to show the scale of the artwork and finished board dimensions in an unambiguous way. Always put a board name or number on the copper layout, as this ensures that you don't end up with back to front boards. If, as suggested, your layout has been carried out as viewed from the component side of the board, the annotation must be on the reverse side of the track artwork. Letraset or similar lettering should be used, and covered with a strip of matt adhesive tape for protection. Double-sided boards require a separate artwork for the top tracks, and this is easily prepared if the bottom artwork is used as a guide for positioning both pads and tape.

The component identification artwork requires a further sheet of film which should be placed over the graph paper master. Using a 1.0mm drawing pen, draw in the component outlines, using a stencil for small circles and a raised edge rule for straight lines. Unless your handwriting is up to survey standards, component identification numbers should be added by using a 3.0mm stencil and appropriate sized pen.

Once your artwork layers are complete, obtain a photocopy of the copper tracks on which to indicate the various hole sizes you require. As a guide to this, most resistor and capacitor mounting holes will be 1.0mm, and IC pads will require 0.6mm holes.

Now take your completed set of artwork and check everything at least twice before despatching them to your chosen PCB manufacturer.

Having just a few circuit boards made is not cheap, and a large proportion of the cost is in the photographic reduction work. This part of the process can often be carried out, at a considerable saving, by a friendly litho printing company who have their equipment in constant use and are usually less inclined to charge silly prices for what is, after all, a relatively simple operation.

Before placing your order with a circuit board manufacturer, establish what their total charge is likely to be, and don't be afraid to admit to your lack of experience and/or money. They are the best people to advise you about board thickness and copper weight, and to point out any shortcomings with your artwork — but don't blame them if, after all your efforts, your first circuit board explodes with a cloud of smoke. When that happens, it really is 'back to the drawing board...'. But it is still well worth the additional effort. It is a rewarding experience to turn out a good, well-planned circuit board. It's worth bearing in mind that there is no such thing as a professional circuit board designer who has not, at one time or another, made an error — so don't be too hard on yourself. If you really want to get it right, you may have to start from scratch and do it again until it's right. If you've been careful, and thought it all through, you'll get there. ■

## Computers in Small Business

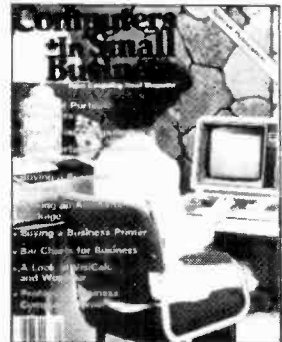

A Moorshead Special published especially for owners of small business who would like to learn how a microcomputer could improve the operation of their occupation. Included in this issue are such articles as: A Survey of Portable Computers, Should You Computerize?! Using a Portable Computer in Sales, Profiles of business computer users and much much more!

\$3.95 plus \$1.00 postage and handling. Ontario Residents add 7% PST. For a copy call or write:

1300 Don Mills Road,  
Don Mills, Toronto, Ontario,  
M3B 3M8  
(416) 445-5600

**PRODUCT MART  
CLASSIFIED  
CALL (416) 445-5600**

# ESCORT TEST INSTRUMENTATION

## QUALITY AT THE RIGHT PRICE!

WE DARE YOU TO COMPARE

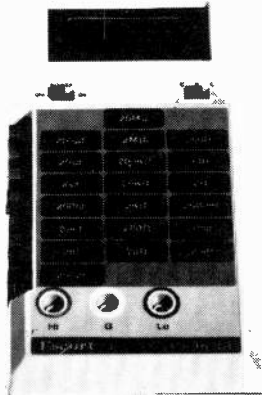

- MODEL ELC 120**  
**3 1/2 DIGIT LCR METER**  
**Feature Packed Priced Right**
- 3 1/2 Digit LCD Display
  - Capacitance, Resistance, and Inductance Measurements
  - Basic Accuracy 1.0%
  - 200 HR Operation
  - Test Frequency of 1KHZ

**\$267.00 Price**

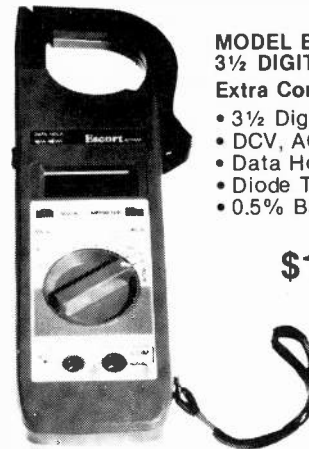

- MODEL ECT 620**  
**3 1/2 DIGIT CLAMP-ON**  
**Extra Convenience**
- 3 1/2 Digit LCD Display
  - DCV, ACV, ACA, RES.
  - Data Hold, Audible Continuity Test
  - Diode Test, Peak Hold
  - 0.5% Basic DC Accuracy

**\$159.00 Price**

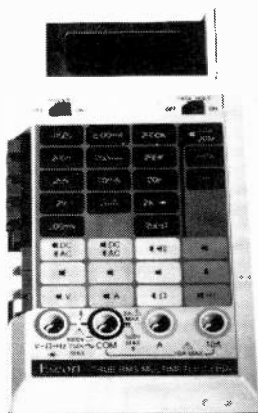

- MODEL EDM 1346A**  
**4 1/2 DIGIT MULTIMETER**  
**Feature Packed Handheld**
- 4 1/2 Digit LCD Display
  - 0.5% Basic DC Accuracy
  - True RMS Measurement (ACA/ACV)
  - Frequency Measurement to 200KHZ
  - Audible/Visual Continuity Test
  - Data Hold Function
  - Diode Test Function
  - 10A AC/DC Current Measurement
  - Up to 1000 Volt DC Measurement

**\$299.00 Price**

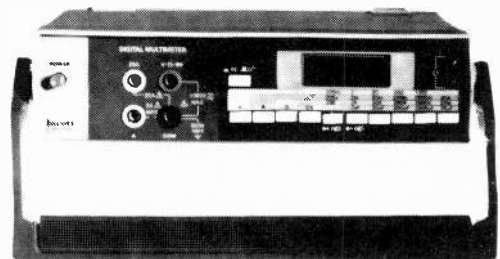

- MODEL EDM 2347**  
**4 1/2 DIGIT MULTIMETER**  
**Feature Packed Bench Model**
- 4 1/2 Digit LCD Display
  - 0.03% Basic DC Accuracy
  - True RMS ACA/ACV Measurement
  - Frequency Measurement to 200KHZ
  - Audible/Visual Continuity
  - Conductance Measurement
  - dB Measurement
  - Battery or AC Operation
  - Diode Test Function
  - Data Hold Function
  - 20A AC/DC Current Measurement

**\$423.00 Price**

**ESCORT:** A line of quality Electronic Test Instruments is the latest addition to Metermaster, backed by a full one year warranty... at an unbeatable price!

**Metermaster**

A Div. of R.H. NICHOLS CO. LTD.

Head Office: 80 Vinyl Court  
 Woodbridge, Ontario L4L 4A3



5% Discount for Cash  
 plus Student Discount 5% on all products  
 Certified Cheque, or Money Order  
 DEALER INQUIRIES INVITED

All prices F.O.B.  
 Woodbridge Ontario  
 subject to change without  
 notice P.S.T. extra  
 where applicable

TORONTO (416) 741-9381 • MONTREAL (514) 337-0425 • EDMONTON (403) 432-7746 • OTTAWA (613) 727-3974  
 • VANCOUVER (604) 937-3622



# AFFORDABLE

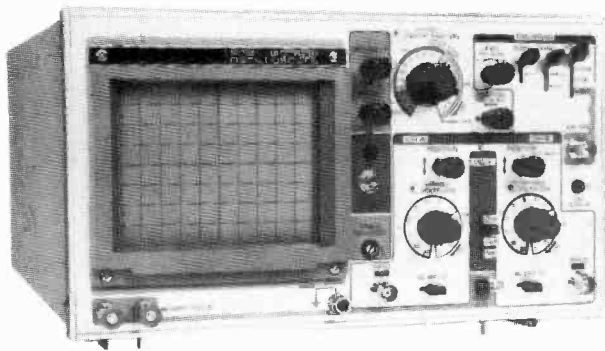

## DUAL TRACE OSCILLOSCOPE

Here's exceptional value at a budget price! This 20 mHz dual trace scope has a built-in component tester ideal for troubleshooting solid state circuits and components with no circuit power, and features 6" high luminence CRT, TV sync measurement for vertical & horizontal circuitry, sensitivity 1 mV/div.

Model 33330 dimensions:

6.4" x 11.5" x 14"

All for an incredible price of

# \$525.

Set of 1:1/10:1 switchable probes \$59.

35 and 45 mHz scopes also available.

Order by phone or mail. Visa, money order, certified cheque or C.O.D. accepted. Add \$15. for shipping and handling. Ontario residents add 7% PST.

Circle No. 18 on Reader Service Card

## KB ELECTRONICS

355 Iroquois Shore Road, Oakville, Ont. L6H 1M3  
(416) 842-6888 Telex: 06-982396 (KBEL OKVL)

# WHY PAY MORE

## PC/XT TURBO PLUS

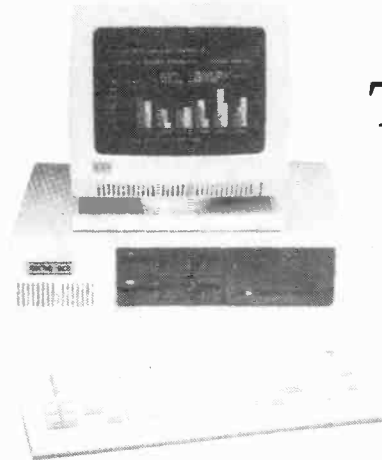

NEC V-20 Proc.  
4.77 & 8 Mhz  
256 K Memory  
2 Drives  
Color Graphics  
155 W. Power  
Supply (CSA)

**\$1395.00**  
**Complete**

ONE YEAR WARRANTY

|                                 |          |
|---------------------------------|----------|
| XT Turbo M/B OK .....           | \$399.00 |
| Modem 300/1200 Baud .....       | \$279.00 |
| Apple IIe Compatible 128K ..... | \$479.00 |
| Disk Drive 143/160 K .....      | \$179.00 |

### Raitronic's Ltd

207 W. 6th Ave.,  
Vancouver, B.C. V5Y 1K3  
(604) 875-0207

Terms: COD, VISA,  
Master Card

Circle No. 17 on Reader Service Card

## WHY YOU SHOULD SUBSCRIBE TO ELECTRONICS TODAY!

What's new in electronics. From our information columns to feature articles on new devices and methods, we bring you up-to-date on what's happening in the constantly changing world of technology.

How it works. We take the practical approach to circuits, computers, gadgets, components, and techniques, giving you an explanation of how it works and how you can make it work for you.

Your favourite projects. From doorbells to complex computer additions, our projects include everything you need to build projects for fun, for practical use, for learning.

Whether you're a beginner or an old hand, Electronics Today has what you want. There are series for beginners who want to learn basic theory as well as practical techniques, series for the advanced designer who'd like to share the ideas of other technicians, circuit ideas, reviews of new products of technical interest, and more.

And, it's Canadian, giving you Canadian sources for your needs.

A subscription to Electronics Today also makes a great gift both for someone just getting started in technology and for the advanced technician.

### Electronics Today: the book of ideas.

See the subscription form in this issue, or contact:

**Moorshead Publications**  
Subscription Department,  
1300 Don Mills Road, Don Mills, Ontario  
M3B 3M8 (416) 445-5600



## Resistor Kits

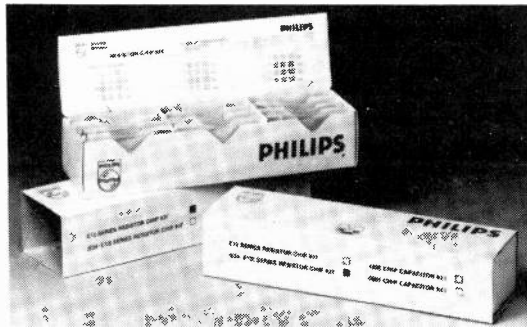

Surface Mount resistors are available from Philips in kit packages of various sizes. The RCO1 KIT/E12 contains all values in the Philips E12 series, for instance. Each kit contains 100 pieces of each resistance value;

resistors are 5 percent, 1/4 watt types with 60/40 surface mount contacts. From Elcoma Division, Philips Electronics Ltd., 601 Milner Avenue, Scarborough, Ontario M1B 1M8.

Circle No. 43 on Reader Service Card.

Those who design transformers and inductors can have a lot of the work done for them by computer, using *Transformer and Inductor Design Software For The IBM PC Or Macintosh*. This menu-driven software does new designs or evaluates existing designs for effi-

ciency, regulation, losses, inductions, temperature rises, etc. The software and manual costs \$89 in US funds and can be obtained from the publisher, Marcel Dekker Inc., 270 Madison Avenue, New York, NY 10016, (212) 696-9000.

Circle No. 44 on Reader Service Card.

Software for engineering and manufacturing will be the topic of E&M Software 86, a conference/exhibition to be held in the Chicago Hilton, September 23-25. Besides exhibitions of all types of technical software for CAE, CAD, CIM, CAM, production control,

process control and distribution, there'll be 18 technical sessions and six workshops. For more information, contact the organizers, Tower Conference Management Co., 331 W. Wesley St., Wheaton, IL 60187. (312) 668-8100.

Circle No. 45 on Reader Service Card.

According to the Technical Service Council of Toronto, the increasing complexity of technology means that employers are looking for technicians and engineers with

specific job experience rather than just a general technical training. Communications skills and supervisory potential also enhance job chances.

Circle No. 46 on Reader Service Card.

## DOES YOUR DIGITAL CAPACITANCE METER DO THIS?

FULL 4 DIGIT 0.5 INCH LCD DISPLAY COMPLETELY AUTORANGING WITH 10 RANGE MANUAL CAPABILITY

### AND THIS

RANGE OF 0.0 pF to 1 FARAD (999.9 mF)  
0.5% BASIC ACCURACY UP TO 100 uF

### AND THIS

READS DIELECTRIC ABSORPTION

### AND THIS

EXTENDED PSEUDO 5 DIGIT  
RESOLUTION ON SOME RANGES ONLY

### AND THIS

ABILITY TO ZERO LARGE CAPACITANCE  
VALUES UP TO 99.99 uF

### AND THIS

CALCULATES TRUE CAPACITANCE  
IF CAPACITOR IS LEAKY

### AND THIS

DIODE CLAMP AND FUSED  
PROTECTED INPUT.

DISCHARGE RESISTOR IN OFF  
POSITION AT TERMINAL INPUTS.

POWERED BY 9V BATTERY

**ONE YEAR PARTS &  
LABOUR WARRANTY**

**FOR ONLY THIS**

**\$149.95**

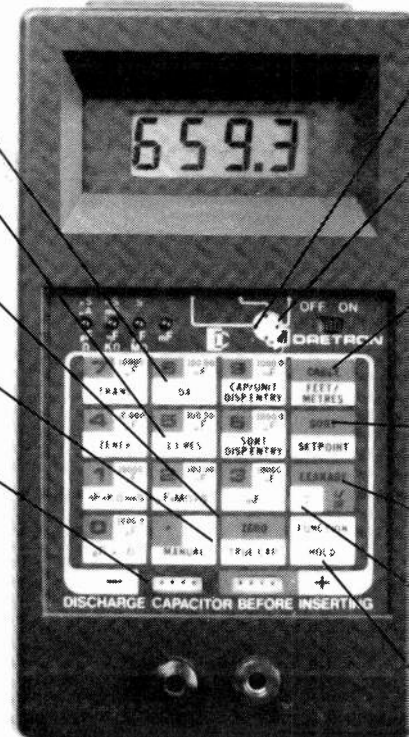

### AND THIS

IDENTIFIES TRANSISTORS (NPN, PNP)  
AND THEIR LEADS (E, B, C, ETC.)

### AND THIS

TESTS ZENER DIODES AND RECTIFIERS.  
UP TO 20V ZENER WITH AC ADAPTOR,  
ZENER VOLTAGE WITH 9V BATTERY  
DEPENDS ON ITS CONDITION

### AND THIS

AUTOMATICALLY CALCULATES LENGTHS  
OF CABLES IN FEET, METRES, MILES,  
KILOMETRES (THEORETICAL RANGE  
OF 9,999 MILES)

### AND THIS

ABILITY TO SORT CAPACITORS IN  
MANY DIFFERENT MODES

### AND THIS

ABILITY TO READ LEAKY CAPACITANCE  
(INSULATION RESISTANCE OR CURRENT)

### AND THIS

CALCULATES TIME CONSTANTS WITH  
USER DEFINED RESISTANCE VALUES

### AND THIS

HOLD FUNCTION FREEZES DISPLAY

MADE IN CANADA

MODEL  
**MC300**

Approx. Size  
7" x 4" x 1 1/4"

**DAETRON**  
A DIVISION OF BERGERON  
TECHNOLOGIES INC.

935 THE QUEENSWAY  
BOX 641  
TORONTO ONTARIO M8Z 5Y9  
(416) 255-9701

DEALER ENQUIRIES INVITED

PLEASE SEND ME

---(QUANTITY) MC300(s) @ \$149.95 \$ \_\_\_\_\_

CARRYING CASE \$19.95 \$ \_\_\_\_\_

AC ADAPTOR \$11.00 \$ \_\_\_\_\_

ONTARIO RESIDENTS ADD 7% PST \$ \_\_\_\_\_

SHIPPING AND HANDLING @ 4.45 per instrument \$ \_\_\_\_\_

I ENCLOSE CHEQUE  MONEY ORDER  BILL MY VISA

VISA CARD NO. \_\_\_\_\_

EXPIRY DATE \_\_\_\_\_ SIGNATURE \_\_\_\_\_

NAME \_\_\_\_\_

ADDRESS \_\_\_\_\_

CITY \_\_\_\_\_ PROV. \_\_\_\_\_ POSTAL CODE \_\_\_\_\_

## PCB Software

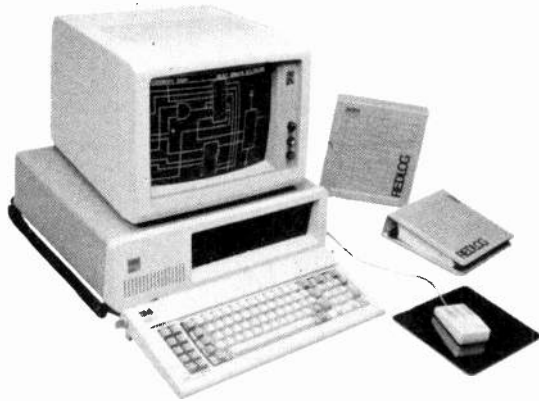

Redcad software for the IBM PC will design both schematics and PCBs. Input for the PCB design can come from the schematic files or can be input by the user via keyboard or mouse; 512 electrical symbols can be used per drawing and 511 components per PCB. Up

to 16 layers can be used per PCB. The system requires a PC, XT, AT or compatible with 512K RAM, one floppy drive and one fixed drive. Contact CAD/CAM Graphics (1984) Limited, 700 Industrial Avenue, Ottawa, Ontario K1G 0Y9, (613) 526-0620.

Circle No. 47 on Reader Service Card.

A reminder that Mastertech Laboratories Inc., makers of the Microlab digital logic trainer (to be reviewed in the next issue) have

moved, and their address is 302 Royal Trust Building, 612 View St, Victoria, BC V8W 1T5, (604) 388-6631.

Circle No. 48 on Reader Service Card.

Thanks to all those who responded to our request for project manuscripts in the December issue. Just about everyone who sent in an idea was accepted; we had to turn down a few who submitted previously-published projects, but we asked them to submit something else. Again, if you have

an article, circuit idea or project that you think might interest readers, write to The Editor, Electronics Today. Don't worry about literary polish; we're looking for ideas. If you're not sure about acceptance, it will save you effort if you send a brief outline instead of a completed manuscript.

Amprobe announces the DigiMatic DM-1, a three-phase microcomputer based chartless recorder. It can read 44 separate functions, including peak, minimum, times, sweep, etc. The readings can be read out up to 41 days later. The

autorange covers 0-750V and 0-1000A. For complete information on Amprobe recorders, ask for catalogue AAD76 from Atlas Electronics Ltd., 50 Wingold Ave., Toronto, Ontario M6B 1P7, (416) 789-7761.

Circle No. 49 on Reader Service Card.

Last month we reported on gallium arsenide devices and how they work. A press release from Bell-Northern Research arrived shortly after, detailing the new \$3.5 million gallium arsenide laboratory in Ottawa. Prototypes

are fabricated in a vacuum chamber with the operator observing through a built-in electron microscope. The new technology should allow operating speeds of several times that of conventional silicon.

According to StatsCan, we still import about twice the value of electrical and electronic goods as we export: in October of last year, for instance, we imported \$1120

million and exported \$610 million. Still, the shift over the last year favoured exports, which were up 15 percent. Imports were down about 5 percent.

## Multimeter



Fluke has introduced the 8842 5 1/2 digit bench or rackmount multimeter, offering 0.003 percent DC accuracy and 0.08 percent AC accuracy. It also features 100nV resolution for DC voltage, 1uA resolution for DC current and 100 micro ohm resolution for resistance. The IEEE-488 interface and true-RMS option allow configuration to suit the user. From Allan Crawford and Associates, Test and Measurement Division, 5835 Coopers Ave., Mississauga, Ontario L4Z 1Y2, (416) 890-2010.

Circle No. 50 on Reader Service Card.

# PROBES FOR SALE

FROM THE BEST SOURCE FOR OSCILLOSCOPE PROBES AND DMM/VOM TEST LEAD SETS.



- Low cost
- High Quality
- Excellent Performance
- Slender, Flexible Cable

- Wide Range of Choice
- Switchable X1 and X10 Attenuation Factor
- 100 MHz Bandwidth

MODEL SP100

**\$25.00**

Please add \$2.00 for shipping

Your Probe Specialists



Coline Canadian Sales & Stocking Source

Store Hours: Monday to Friday 8:00 am to 5:00 pm.  
Saturday: 10:00 am to 1:00 pm.

900 Alness St. Unit 7,  
Downsview, Ontario,  
M3J 2S2  
(416) 661-5585  
TELEX 065-28169

# HAMEG model HM203-5

Ideal for schools • industry • students • service

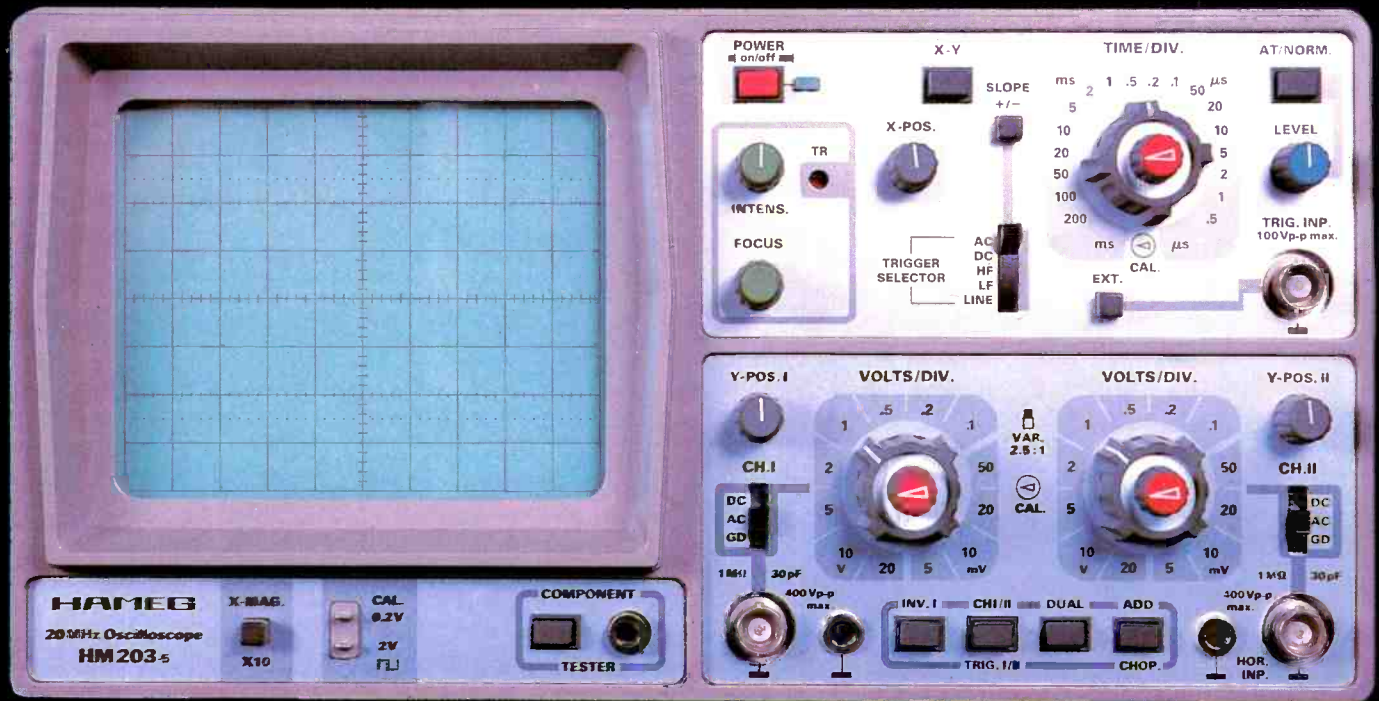

for the complete line of HAMEG instruments write or phone BCS

# Electronics Today

## LITERATURE REVIEWS

### HOBBILT ELECTRONICS

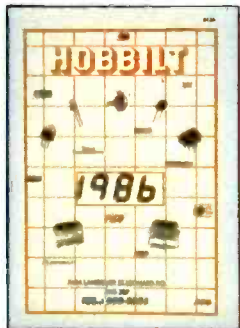

For industry, technicians or students, Hobbilt Electronics offers a complete selection of electronic supplies. Ranging from solderless breadboards, TTL components, to miscellaneous hardware and cabinetry, Hobbilt has what you need. Special prices on Kyoritsu digital multimeters. Student discounts on orders of \$5 or more, layaway available on items over \$50. Send for illustrated catalog, order by mail or phone.

Circle No. 75 on Reader Service Card.

### THE COMPLETE CATALOG OF AMAZING and FASCINATING devices



### INFORMATION UNLIMITED SCIENCE CATALOG

INFORMATION UNLIMITED INC. is a New Hampshire Corporation formed solely for the development of scientific and electronic products and devices. These are made available as do-it-yourself projects, as plans and kits, or fully assembled and tested. Complete catalog of 'Amazing and Fascinating Devices' covers lasers, ultrasonic and high sound pressure acoustical devices, geiger counters, infrared see-in-the-dark viewers... and much more.

Circle No. 76 on Reader Service Card.

# COMPARE..... then make your selection

*Take home the European Champion at a special HAMEG-BCS purchase price but only while the supply lasts.*

The 20MHz Oscilloscope that outsells all others in Western Europe. The model HM203-5 is available complete with two (X1-X10) probes. This CSA approved Oscilloscope is covered by a two year parts and labour warranty.

All major credit cards accepted.

Immediate delivery from Stock

**\$695.<sup>00</sup>**

F.O.B. Downsview, Ont.  
FST Incl'd  
Shipping Extra

**HAMEG GmbH**

West Germany is represented  
and distributed in Canada by



980 Alness St. Unit 7,  
Downsview, Ontario  
M3J 2S2  
(416) 661-5585  
TELEX 065-28169

Mon-Fri 8-5 pm, Sat 10-1 pm

Circle No. 21 on Reader Service Card

## NORMA POLYPHASE AC ANALYZER



The Norma D5155 Polyphase AC Analyzer displays voltage with averaging period selectable in increments of 400 ms, gives lead and lag display with power factor, and more. Special Transformer Testing Version displays rectified average voltage and form factor, and increases precision at low power factors. Motor Testing Version provides 3 DC input channels for torque, speed and frequency, and calculates mechanical power output, efficiency and slippage. Available in Canada from MESJRINA LTD.

Circle No. 79 on Reader Service Card.

## HEATHKIT'S CATALOGUE



Spring '86 Catalogue is available now. Packed with over 400 Do-It-Yourself kits, the Heathkit Catalogue also has a full line of assembled products. See our new line of assembled oscilloscopes. Eprom Programmers and Erasers are also available. There are numerous PC-Compatible Computers in both assembled and kit form from under \$1600. New courses in Fibre Optics, Lasers and Computer Servicing, round out the field.

Circle No. 80 on Reader Service Card.

## B + K - PRECISION IC COMPARATOR TESTER



From Dynascan Corporation comes the B + K-Precision series of IC Comparator Tester/Logic Monitors. Features include in-circuit dynamic testing using external reference IC mounted in the tester; 20-channel logic monitor; one-button test selection; reverse polarity and overvoltage protection. Model 550 tests most 54 and 74 series TTL. Model 552 tests most 4000 and 74 series CMOS devices. Both operate entirely on power from equipment under test. Available in Canada from ATLAS ELECTRONICS LTD.

Circle No. 77 on Reader Service Card.

## LEN FINKLER & CO.



92 page Len Finkler & Co. syndicated catalog is now available. Featuring industrial electronic products, hand tools, tool cases, chemicals, optoelectronics, assembly devices, communication antennas and accessories, etc.

Name brand products from nationally recognized manufacturers such as Edsyn, Industrial Devices, K40, Kurz Kasch, Lenline, Lindstrom, Liton, Miyama, OK Industries, PanaVise, Shakespeare, Workman and more.

Write today — Len Finkler & Co., 80 Alexdon Road, Downsview, Ontario, M3J 2B4.

Circle No. 78 on Reader Service Card.

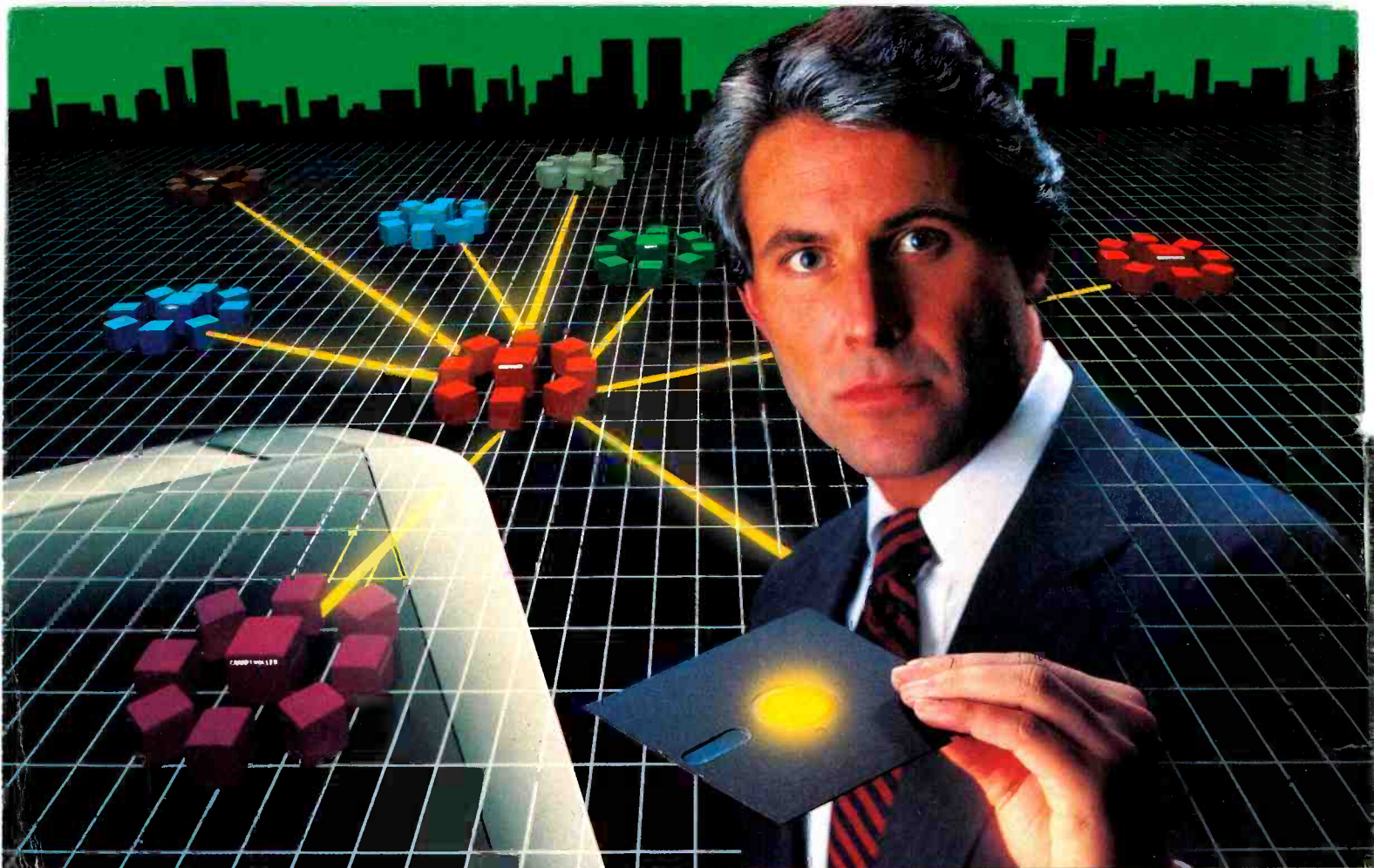

## The Most Powerful LAN Fits on a Disk.

Network Power. You knew that someday there would be a powerful LAN that didn't need old-technology network boards. It would be fast, easy to install, and run 99% of PC-DOS software. It would be expandable, provide remote access, password-protection, and enable you to use inexpensive terminals as workstations in a PC-DOS environment.

Dream no more, because the power is here. Its name is LANLink™.

**A Software-Driven LAN Powerful Enough To Use RS-232 Ports for Network Communications.** In development for over three years, LANLink™ represents the next generation of local area networks. All of the logic which has traditionally resided on network boards is on LANLink's Satellite and Server Diskettes.

No additional hardware is required. Inexpensive serial ports replace "Kilobuck" Network Interface Boards making installation costs one-third that of a board-driven network.

**How To Configure a Smart Network...With Dumb Terminals, But Without Dedicated Servers.** Boasting a wide variety of configurations, LANLink™ is most often set up as a "Star" having up to eight satellites connected to a central, nondedicated server. Larger networks can have multiple servers, supporting a total of 73 or more network users.

R-LAN™ (Remote-LAN) gives users the ability to interact with a LANLink™ network in real time via modem. Plus, if MultiLink Advanced™ is run on a Satellite, inexpensive dumb terminals can be used to access network disks, files, and programs.

**99% of PC-DOS Applications Run in a Totally-Transparent Network Environment.** If you know DOS, you already know how to use LANLink™ COPY transfers files among users, and a 2-drive PC Satellite boots 1-2-3 from the Server's hard disk with the entry c:\lotus. Each satellite's access can be limited to specific disks, printers, and sub-directories. A wide variety of software including Lotus 1-2-3, dBASE III, and WordStar 2000 is fully compatible. LANLink™ has a collision-free data transfer rate which exceeds 115,000 BPS.

**Power Up Your PCs Today.** For complete details and the authorized dealer nearest you, call The Software Link TODAY. The LANLink™ Starter Kit is \$745 and includes modules for both a Server and a Satellite. For a limited time, 50 feet of shielded RS-232 cable will be included free of charge. Additional Satellite Modules are only \$320, each.

LANLink™ is immediately available and comes with a money-back guarantee. VISA, MC, AMEX accepted.

**LANLink™**  
 **THE SOFTWARE LINK, INC.**  
 Developers of LANLink™ and MultiLink Advanced™

400 Esna Park Drive, Suite 18 Toronto (Markham), Ontario L3R 3K2

CALL: 416/477-5480

Dealer Inquiries Invited

LANLink™ MultiLink Advanced™ & R-LAN™ are trademarks of The Software Link, Inc.  
 IBM, PC, & PC-DOS are trademarks of IBM Corp. WordStar 2000, dBASE III, and Lotus 1-2-3 are trademarks of MicroPro, Ashton-Tate, and Lotus Development Corp., respectively.

Circle No. 22 on Reader Service Card