

Electronics Today

\$1.75

MM70924

INTERNATIONAL JUNE 1980



Electronics in Warfare

CLIP: Computer Image Recognition

Dynamic Noise Reduction Project

Canadian Sound Archives

Function Generator

Three Motorola Fiber Optics
Kits Must Be Won!
See page 43

arkon electronics ltd

409 Queen St. W. Toronto Ont. M5V 2A5 868-1315

spring into summer values!

All orders processed promptly. Send *only* certified cheque, money order or ChargeX, M/C. Include expiry date, card number and signature on all card orders. We process COD's for Canpar or post office. *Minimum order \$10.00.* Add 5% for shipping and handling (*minimum \$2.00*) excess refunded. Ontario residents add 7% sales tax. *All prices subject to change.*

CP•IO•1 \$100 SYSTEM CARD WIRED AND TESTED

Do you need an S-100 system that will out-perform the mass marketed systems in versatility, price, and speed? Perhaps the CP-10-1 system card will fill that need. The CP-10-1 has all the CPU (8080) Disc Control (1771) and IO (8255) needed for a disc based CPM system. Interfacing to all common 8" and 5 1/4" drives. (Shugart, Memorex, BASF, Siemens, Wang). A system consisting of a 32K memory card, the CP-10-1, an S-100 back plane, a terminal (stand alone or S-100), an 8" disc drive, keyboard and power supply can be built for about \$2,000.

FEATURES:

- 2 Mhz 8080-A
- EIA RS-232 port, 110 to 9600 baud
- Fully vectored interrupt (TMS5501)
- On board digital data separator
- 2K bytes EPROM
- 24 Fully handshaked IO lines
- Dual mapped IO
- Cassette interface on board
- S-100
- Fully buffered

\$495

ASCII KEYBOARD KIT

- 60 Key complete ASCII character set
 - Fully buffered output for TTL/DTL/MOS logic
 - Caps lock for upper case alpha characters
 - Uses a KR 2376 ST encoder IC
 - Uses 100 ma at +5 to 30 volts
 - Parity invertable • Data invertable
 - Repeat key
- Complete kit of all parts \$99.95
Power supply kit \$ 7.95
Enclosure and template \$17.00

RE6416 VIDEO TERMINAL

DISPLAY: 16 lines of 64 characters
FORMAT: 5x7 Dot matrix
VERT SYNC: 60 Hz Xtal controlled
HOR SYNC: 15,840 Hz Xtal controlled
VIDEO O/P: 1v Peak to peak
IO: Parallel, 20 MA, RS232
DATA RATE: 110 to 9600 baud
POWER: 5V DC 1A, +12V DC .1A

RE6416: Kit of all parts \$169.95
RE6416: Lower case option \$ 16.95
RE6416: 5 V pow. sup. option \$ 16.95
RE6416: ± 12V pow. supply \$ 16.95

S-100 MOTHER BOARD.

The ARKON A6S100 6 slot mother board was designed for the system builder using modern boards where few slots are required. Provision for semi-active termination.
A6S100 \$19.95
S-100 EDGE CONNECTORS \$5.95 ea

MULLEN EXTENDER BOARD TB-4

The best extender board made, complete with a digital probe for in circuit checkout and tracing, for S-100 buss \$69.00

BIOTECH

S-100 INTELLIGENT COLOUR GRAPHICS BOARD CGS-808

FEATURES:

- Eight colors—green, yellow, blue, red, buff, cyan, magenta, orange.
 - 11 programmable modes ranging from 64x64 to 256x192 in 4 and 1 colors.
 - 1/0 mapped for true S-100 compatibility.
- CGS 808B (Bare "Kit") includes PC board, documentation, MC6847, MC1372, 8085, and firmware pack I with clear, plot, draw, alpha-num/semigraphic capability \$169.00

SD SYSTEMS

A fully compatible line of S-100 system cards. Full data and specs on all kits sent free on request.

Expandom I	S-100 Board Kits	
0K	SBC-100	\$375
16K	SBC-200	\$435
32K	Z-80 Starter Kit	\$450
48K	MPB-100	\$325
64K	ExpandoPr n	\$225
Expandom II	VDB 8024	\$475
0K	Versafloppy I	\$325
16K	Versafloppy II	\$450
32K		
48K		
64K		

SOFTWARE

For 8080 8" disc

• CPM 1.4	\$130.00
• CPM 2.0	\$190.00
• SID debugger	\$ 95.00
• MAC assembler	\$115.00
• TEX text editor	\$ 95.00
• DES despooler	\$ 65.00
• CPM manual set	\$ 30.00

©1981 Digital Research

• FORT / 80 fortran for 8080, Z80, 8085 \$ 99.00
• FORT / 80 manuals \$ 20.00

©1981 Arkon Electronics

C-BASIC II \$175.00

For OSI, CI, on cassette

Starfighter	\$ 8.95
Alien invaders	\$ 8.95
Seawolf	\$ 8.95
Tank for two	\$ 7.95
Bomber	\$ 8.95
Barrierball	\$ 7.95
Breakthru	\$ 7.95
Fighter pilot	\$ 5.95
Killerbot	\$ 5.95
Lunar Lander	\$ 4.95
Concentration	\$ 5.95
Joystick, data	\$ 3.95
CI-P Cursor ctrl	\$ 12.95
Renumberer	\$ 7.95
Autoloader	\$ 7.95

Ask for our giant list of software available for Apple™, Pet™, TRS-80™ by Programma Int'l, Instant Software, Creative Computing, Hayden and Softape.

JANA KITS

PCB'S ARE AVAILABLE AT EXTRA COST.

Auto headlight reminder	\$ 3.95
12 volt high power flasher	\$ 5.95
0-20 volt 1 ampere power supply	\$18.95
Single channel colour organ, 300W	\$ 6.25
Electronic siren	\$ 5.95
Shimmer light kit	\$ 7.25
Xenon strobe kit	\$15.95
3 CH. colour organ, 300W, PCB incl.	\$18.95
30 watt soldering iron kit	\$ 7.95

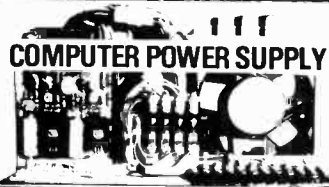

An exceptional Milwaukee power supply. Fully regulated and crowbarred with heat sink and fan. Gives 5V at 10A plus -5V at 2A plus 12V at 5A plus -12V at 2A. Each voltage separate and floating. Very compact cubic design, standard parts 16" x 10" x 7" 110/220 VAC 60/50 Hz. \$45.00 plus \$10.00 freight.

ARKON GRAB BAGS

GB-100 100 disc ceramic	\$2.00
GB-101 60 Mylars	\$4.00
GB-102 60 Electrolytics	\$4.00
GB-103 40 Tantalums	\$5.00
GB-104 20 Ceramic trimmers	\$7.00
GB-113 50 Miniature trimpots	\$5.00
GB-116 200 Asstd 1/4 w.res.	\$3.00
GB-117 200 Asstd 1/2 w.res.	\$3.00
GB-118 100 Asstd 1-2w.res.	\$3.00
GB-120 25 Asstd switches	\$5.00
GB-139 5 Lbs hardware	\$4.95
GB-160 5 Lbs circuit boards	\$4.95
GB-146 100 Grommets	\$3.95
GB-147 100 Inductors, coils	\$3.95
GB-150 2 Lbs. potentiometers	\$1.00

The ARKON grab bags are assorted good parts and are ideal for getting a startup stock for the bench, service area at a bargain price. We save on individual sales effort, you get bulk prices

ARKON KITS

All ARKON kits are complete with PCB

Decision Maker Kit	\$ 4.95
Transistor IW Amp Kit	\$ 8.95
555 IC Timer Kit	\$ 3.95
555 Code Oscillator Kit	\$ 3.95
Code Key Brass WWII	\$ 3.95
RS 232 to TTL Converter Kit	\$ 9.95
LM 380 Audio Amp Kit	\$ 5.95
Crystal Radio Kit	\$ 4.95
He-Ne Laser Kit	\$149.00
TRS-80, Apple II 16K	
Upgrade Kit	\$ 89.95
VD-1 Video Modulator Kit	\$ 8.95
TD-1 567 Tone Decoder Kit	\$ 6.95
FM-Wireless Mike Kit	\$ 3.95
FM-2 Wireless Mike	
w/Preamp Kit	\$ 5.95
Whisper Light Kit	\$ 12.95
Music Light Kit	\$ 12.95
LED Blinky Kit	\$ 2.95
Siren Kit	\$ 3.95
Mad Blaster Noise Generator	\$ 4.95
UT-1 Universal Timer Board	\$ 3.95
MA 1003 Car Clock Module	\$ 19.95
MA 1023 Car Clock Module	\$ 19.95
LCD Alarm Clock Module	\$ 29.95
ETI Sound Generator Kit	\$ 44.95

DISKETTES

8" Control Data or Wabash	\$7.95
8" Dysan	\$8.95
5 1/4" Control Data or Dysan	\$7.50

Order 10, save 10% get a nice box

OHIO SCIENTIFIC

SUPERBOARD II-4K Computer-on-a-board	\$415.00
CHALLENGER IP - Superboard 8K in box & P.S.	\$595.00
SUPERBOARD 8K Memory expansion (8) chips	\$60.00
SUPERBOARD memory expansion PCB (24K), data	\$50.00
CHALLENGER 4P - 8K with sound, colour, IO	\$1,045.00
CHALLENGER 4PMF - 4P with minifloppy + IO	\$2,559.00

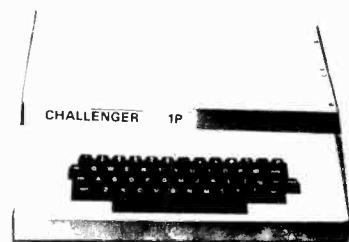

WE MAIL ORDER APPLE™ COMPUTER PRODUCTS. ASK FOR OUR COMPLETE PRICE LIST.

TX-80 DOT MATRIX PRINTER

Description: The TX-83 is a self-contained unit, complete with electronic components and housing. It is a tractor feed dot printer featuring 160 million character dot head life and printing speed of 150 characters per second using 95 ASCII characters. The printing wires are supported with expensive watch type rubys, jewels insuring minimum friction and wear. The plug used fits any CENTRONICS type interface making this dot Matrix Printer compatible with all types of mini and micro computers thus giving it a wide range of operations. The printing paper used is readily available at all office supply houses. Various interfaces provided as options, including EIA RS-232C, makes the EPSON Model TX-80 Dot Matrix Printer an outstanding equipment designed and mass produced to provide the business and home computer markets with an exceptionally inexpensive, sturdily built and highly reliable dot printer.

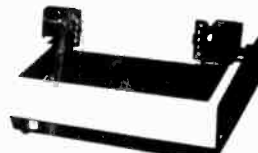

TX-80 with parallel interface\$995.00

8210 PET cable	\$ 40.00	8110 PET 2001 interface board	\$ 83.00
8220 TRS-80 cable expansion	\$ 57.00	8120 TRS-80 interface board	\$ 70.00
8221 TRS-80 cable bus	\$ 40.00	8130 APPLE II interface board	\$105.00
8230 APPLE II cable	\$ 40.00	8140 RS232 interface board	\$ 95.00
Above items sold with printers only.			8160 IEEE interface board	\$150.00

COMPUTER FANFOLD PAPER CD

	Single	Double	Triple	Quad	Labels — one up
8 1/2 x 11	\$10.00	\$30.00	\$44.00	\$60.00	3 1/2" x 15/16" \$ 7.00
9 1/2 x 11	\$17.00				4" x 2-7/16"\$20.00
15 x 11	\$17.00		\$55.00	\$80.00	

Price per thousand. Add 5% for shipping.

RCA ASCII encoded keyboard \$99.00



The RCA VP-601 keyboard has a 58 key typewriter format for alphanumeric entry. The VP-611 (also available) offers the same typewriter format plus an additional 16 key calculator type keypad.

Both keyboards feature modern flexible membrane key switches with contact life rated at greater than 5 million operations, plus two key rollover circuitry.

A finger positioning overlay combined with light positive activation key pressure gives good operator "feel" and an on-board tone generator gives aural key press feedback.

The unitized keyboard surface is spillproof and dustproof. This plus the high noise immunity of CMOS circuitry makes the VP-601 and VP-611 particularly suited for use in hostile environments.

The keyboards operate from a single 5-volt DC power supply and the buffered output is TTL compatible.

How the intrepid electronics hobbyist can survive in the wildest outdoors despite black flies, hunger, nightmares... and just ordinary getting lost.

If you think Jana is concerned only with fun—or with learning all about what resistors and diodes can do—then you know only half of it.

Jana is also concerned that electronics people live better and safer than everybody else. For example, nobody who likes electronics must ever be left to perish in a wilderness. A Jana Survival Pack will save the day!

This Jana Survival Pack consists of four easy-to-build electronic hobby kits which are just about essential if you plan to step far off a main road.

Jana Bug Shoo Kit: It produces a tiny sound through an ear phone. The ear phone is not usually placed in the bug's ear. Bugs can hear it at a fair distance.

Present research does not indicate whether bugs dislike the sound and avoid its source, or whether it cleverly jams their radar and causes them to miss their target.

If you are going into mosquito or black fly country (like out the back door of your home), pin a Jana Bug Shoo to your belt loop and turn it ON!

Jana Fish Caller. Only helpless people starve in the wilds. Those in the know about electronics take along a Jana Fish Caller and summon their dinner while starting a fire. Nothing better than fresh fish arriving right on time.

So far, research does not clearly establish whether the Jana Fish Caller lures fish with a siren sound they love, or so maddens them with rage that

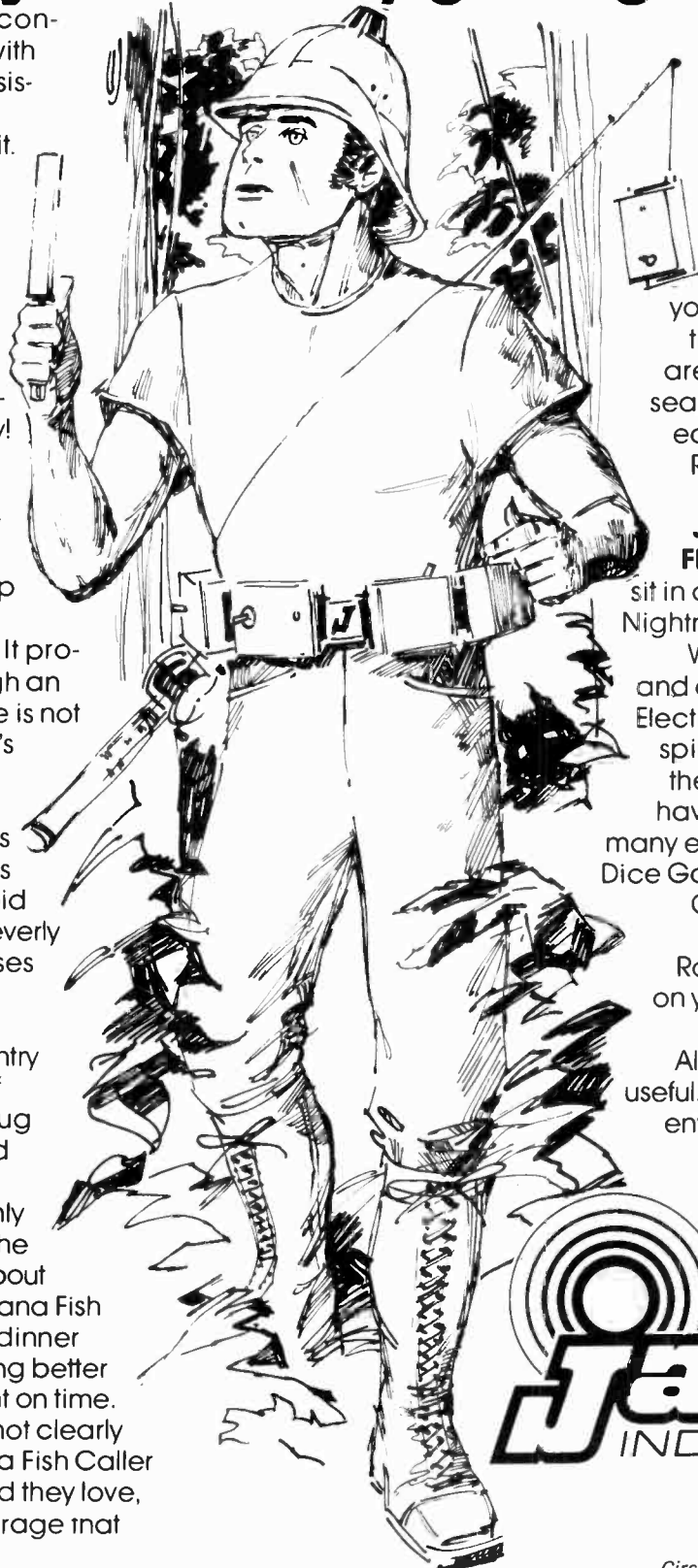

they suicide on the nearest hook.

Make one and try it: there is extra fun in figuring out why it works.

Jana Flasher. This is a high powered job that is a good trouble light when you are changing tires on the road side. When you are lost in a vast Nowhere, search planes can find you easily. Especially at night. Runs on 12-volt batteries found in most vehicles.

Jana Battery Operated Fluorescent Light. Never sit in a tent afraid of the dark. Nightmares are not pleasant!

With this Jana kit, a bulb, and a battery, you can read Electronics Today or other inspiring literature to fight off the gloomies. Or, you can have fun with one of Jana's many exciting game kits: Jana Dice Game...Jana Skeet Shoot Game...Jana Shoot Out Game...Jana Super Roulette...or (depending on your companions) Jana Love-O-Meter.

All fun. All easy to build. All useful. All likely to make friends envious of your ability and your clever style.

Jana makes kits that make life and learning better for people who like electronics.

Jana
INDUSTRIAL

1777 Ellice Ave.,
Winnipeg, Man. R3H 0W5

Circle No. 3 on Reader Service Card.

Editorial and Advertising Offices
 Unit 6, 25 Overlea Boulevard,
 Toronto, Ontario, M4H 1B1
 Telephone (416) 423-3262

Publisher and Editor
 HALVOR W. MOORSHEAD
 Assistant Editor
 JOHN VAN LIERDE

Advertising Manager
 MARK CZERWINSKI
 Advertising Services
 NANCY ALLEN
 Advertising Representatives
 JIM O'BRIEN

Eastern Canada JEAN SEGUIN &
 ASSOCIATES INC. 601 Cote Vertu,
 St. Laurent, Quebec H4L 1X8.
 Telephone (514) 748-6561.

Subscription Department
 BEBE LALL
 Accounts Department
 SENG HARRISON
 Layout and Assembly
 SARAH-JANE NEWMAN

Contributing Editors
 WALLACE PARSONS (Audio)
 BILL JOHNSON (Amateur Radio)
 JOHN GARNER (Shortwave Listening)
 STEVE RIMMER (Video)
 DICK CARTWRIGHT (Servicing)
 DAVID VAN IHINGER (Servicing)

INTERNATIONAL EDITIONS
Electronics Today International,
 145 Charing Cross Road,
 London WC2H 0EE, UK
Electronics Today International,
 Ryrie House, 15 Boundary St.,
 Rushcutters Bay, Sydney, Australia.

EIrad
 Kommanditgesellschaft, Bissendorfer
 Strasse 8, 3000 Hannover 61 Germany.

Electronica Top International
 Post Bus 93 Bilthoven, Holland.

Published by:
 Electronics Today International (Canada) Ltd
 Printed by:
 RBW Inc., Owen Sound, Ontario
 Newsstand Distribution:
 Master Media, Oakville, Ontario

SUBSCRIPTIONS
 \$14 (one year), \$26 (two years). For US add
 \$3/yr., other countries \$5/yr. Please
 specify if subscription is new or renewal.

BACK ISSUES AND PHOTOCOPIES
 Previous issues of ETI-Canada are available
 direct from our offices for \$3 each; please
 specify issue by month, not by feature
 you require. 1977 issues available: Feb,
 May, July. 1978 issues not available: Jan
 and April.
 We can supply photocopies of any article
 published in ETI-Canada for which the charge
 is \$2 per article, regardless of length. Please
 specify both issue and article.

Postal Information:
 Second Class Mail Registration No. 3955.
 Return postage guaranteed. Post Office
 returns to: Unit 6, 25 Overlea Blvd., Toronto,
 Ontario, M4H 1B1.

Electronics Today

INTERNATIONAL

JUNE 1980 Vol. 4 No. 6

FEATURES

Electronic Warfare 12
 Hardware is what fascinates us about modern weapons but it is more likely that electronics and software will settle the outcome of any future major conflict.

PLL Synthesis 18
 A. Jaremko outlines the principles of phase locked loop synthesis and how it relates to the hobby field.

CA3130 Circuits 27
 Ten practical circuits for the home using this inexpensive I.C. This feature is abstracted from the Babani book '50 CA3130 Projects'.

Canadian Sound Archives 33
 A written record of a nation's history is no longer sufficient — there are radio and other recordings to keep for posterity.

Magnetic Power Control 41
 There are other ways to amplify other than tubes and transistors. K.T. Wilson explores this frequently ignored area.

Beryllium—How Dangerous? 35
 A really common substance used in electronics but, unless handled properly, it can be far from safe — and there's no warning label!

Getting 'round HEX 48
 Working in HEX doesn't come naturally but make our circular slide rule and your problems will evaporate.

C.L.I.P. 51
 Cellular Logic Image Processing could prove to be the link between the human eye and the computer.

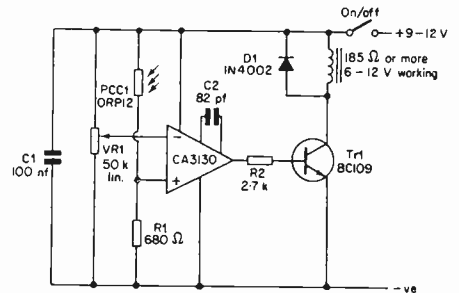

CA3130, p.27



Electronic Warfare, p.12



Canadian Sound Archives, p.33

Active Component Sales Corp80
 Active Surplus74
 A.P. Products77
 Arkon Electronics2
 Atlas Electronics65,67,69,71
 Audiex71,73
 Audiovision67
 B.C.S50
 Classified78
 Cyprus79
 D.C.B71
 Dominion Radio and Electronics . . 10
 Exceltronix74
 Len Finkler65,67
 Gladstone75
 GTE Sylvania69
 Heath Company8
 Jana3
 Melco Sales Canada11
 McGraw Hill37
 Motorola6
 Orion67
 Radionics74
 Royal View71
 Weber77
 Weston9



Cover Photo:
 HMCS Margaree
 takes part in anti-
 submarine exercises
 in the Atlantic;
 Canadian Forces Photo.

ISSN 0703-8984

PROJECTS

Function Generator21
 A 1Hz to 100kHz sine/triangle/square wave generator with a built-in analogue frequency meter.

Dynamic Noise Filter38
 Last month we showed you how to get rid of 'clicks'; this month we describe a project which will reduce tape hiss.

Overspeed Alarm63
 A simple circuit that gives you a warning if the RPM of your engine exceeds a predetermined level.

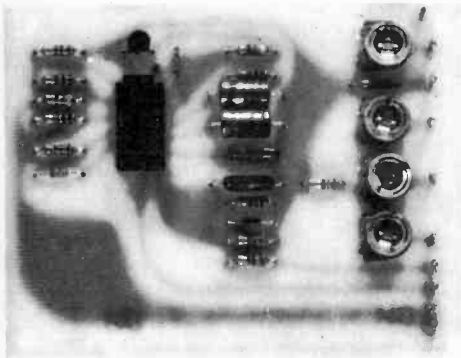

Overspeed Alarm, p.63

COLUMNS

Service News26
 David Van Ihinger
Audio News45
 Wally Parsons
What's On?54
 Steve Rimmer
Fun of Electronics57
 Paul Geiger
Teacher's Topics58
 Ian Sinclair
QRM62
 Bill Johnson
Short Wave World66
 John Garner
Tech-Tips72

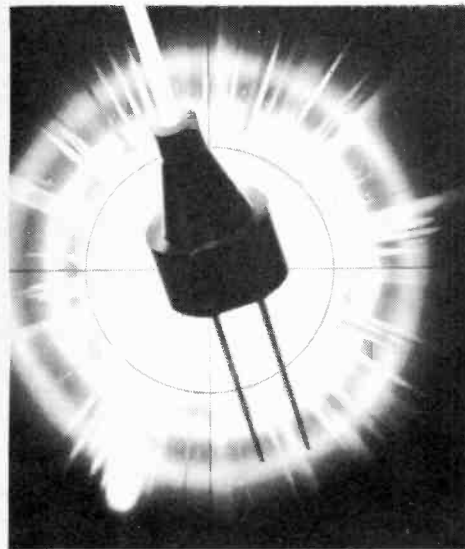

Win a Motorola Fiber Optics Kit, p.35

NEWS / INFO

News7
Next Month's ETI20
Specials34
Babani Books25,34,35,62
Reader Service Card44
Subscriptions46
Binders69

SPECIAL FEATURE43
Win a Fiber Optics Kit from Motorola!



Dynamic Noise Filter, p.38

COPYRIGHT
 All material is subject to worldwide copyright protection. All PCB patterns are copyright and no company can sell boards to our design without our permission.

LIABILITY
 Whilst every effort has been made to ensure that all constructional projects referred to in this magazine will operate as indicated efficiently and properly and that all necessary components to manufacture the same are available, no responsibility whatsoever is accepted in respect of the failure for any reason at all of the project to operate efficiently or at all whether due to any fault in design or otherwise and no responsibility is accepted for the failure to obtain component parts in respect of any such project. Further no responsibility is accepted in respect of any injury or damage caused by any fault in the design of any such project as aforesaid.

EDITORIAL QUERIES
 Written queries can only be answered when accompanied by a self-addressed, stamped envelope. These must relate to recent articles and not involve the staff in any research. Mark such letters ETI-Query. We cannot answer telephone queries.

BINDERS
 For ETI are available for \$6.75 including postage and handling. Ontario residents add 7% PST.

SELL ETI
 ETI is available for resale by component stores. We can offer a good discount and quite a big bonus, the chances are customers buying the magazine will come back to you to buy their components. Readers having trouble in buying ETI could ask their component store manager to stock the magazine.

COMPONENT NOTATION AND UNITS
 We normally specify components using an International standard. Many readers will be unfamiliar with this but it's simple, less likely to lead to error and will be widely used everywhere sooner or later. ETI has opted for sooner!
 Firstly decimal points are dropped and substituted with the multiplier, thus 4.7uF is written 4u7. Capacitors also use the multiplier nano (one nanofarad is 1000pF). Thus 0.1uF is 100n, 5600pF is 5n6. Other examples are 5.6pF=5p6, 0.5pF=0p5.
 Resistors are treated similarly: 1.8M ohms is 1M8, 56k ohms is the same, 4.7k ohms is 4k7, 100 ohms is 100R and 5.6 ohms is 5R6.

PCB SUPPLIERS
 The magazine does not supply PCBs but these are available from the following companies. Not all companies supply all boards. Contact these companies direct for ordering information.
 B&R Electronics, P.O. Box 6326F, Hamilton, Ontario, L9C 6L9
 Spectrum Electronics, Box 4166, Stn 'D', Hamilton, Ontario, L8V 4L5
 Wentworth Electronics, R.R. No.1, Waterdown, Ontario L0R 2H0
 DanocInhs Inc. P.O. Box 261, Westland, MI 48185, USA.
 Exceltronix Inc., 319 College St., Toronto, Ontario, M5T 1S2
 Arkon Electronics Ltd., 409 Queen St. W., Toronto, Ontario, M5V 2A5.

MOTOROLA

KITS

HAVE ARRIVED

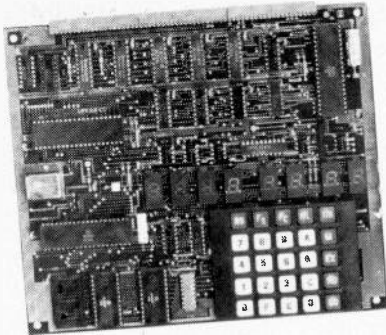
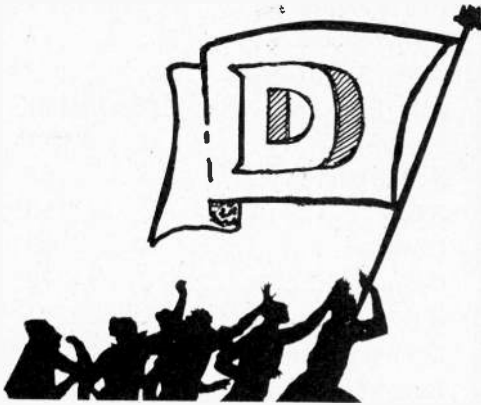

MEK6802D3

The MEK6802D3 is a self-contained system, MC6802 microprocessor and the MC6846 ROM/RAM/I/O/Timer combination, utilizing an on-board hexadecimal keypad and LED display user interface.

- 2K Monitor Contained in MC6846 Eases Programming Steps
- All Bus and I/O Lines are Buffered
- 256 Bytes of User RAM and 128 Bytes of Stack included

MEK6809D4A

The MEK6809D4A Advanced Microcomputer Evaluation Board provides the necessary hardware and firmware for a computer system based on the Motorola MC6809 High Performance Microprocessor. The MEK6809D4A is used with an MEK68KPD (Key pad/display board) and power supply, as shown. The MEK6809D4B requires an external power supply and is used with RS-232 terminal or an MEK68R2D.

- D4BUG Monitor Firmware (4K) Expandable to 6K
- Direct Memory Access
- User RAM, 512 Bytes Expandable to 4K
- Audio Cassette Interface, 300 or 1200 Baud.

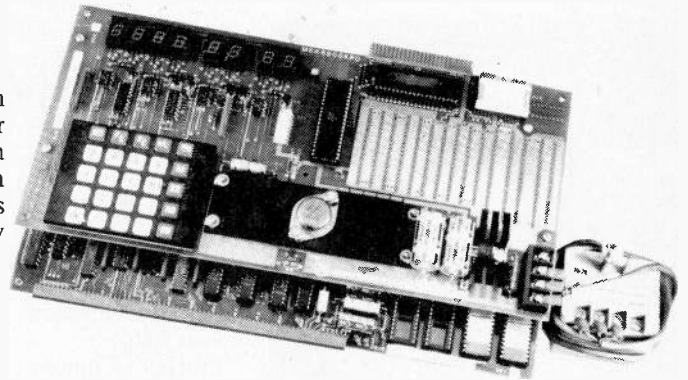

MEK6802D5

The MEK6802D5 is a low-cost single board computer. It is supplied with a 115 VAC plug-in transformer and integral power supply. The system is based on an MC6802 microprocessor and utilizes a 25 key scanned keypad and six 7-segment LED readouts for program entry.

- Integral 300 Baud Modified Kansas City Standard Audio Cassette Interface.
- 128 Bytes of RAM in MC6802 Available as User RAM Space.
- Provisions for Adding Two MCM2114 RAMs for Total of 1152 Bytes.
- Provisions for 24-pin User ROM or EPROM.
- MC6821 Peripheral Interface Adaptor for user I/O

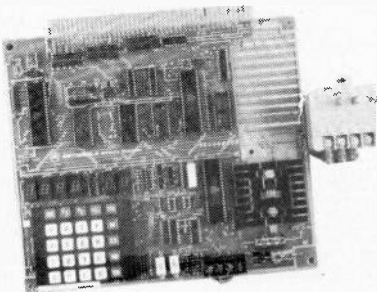

All boards are assembled and tested. Available through local franchised distributors across the country.



MOTOROLA
Semiconductor Products

490 Norfinch Drive
Downsview, Ontario
M3N 1Y4
(416) 661-6400

2383 Ness Ave.
Winnipeg, Manitoba
R3J 1A5
(204) 837-9242

1007 Merivale Road, Rm. 108
Ottawa, Ontario
K1Z 6A6
(613) 729-4361

7800 Cote de Liesse Road
Montreal, Quebec
H4T 1G1
(514) 731-6881

NEWS

Be It Ever So Humble . . . It's Computerized.

A newly opened "House of the Future" at Atwatukee features a unique home management computer system that was designed and built by Motorola's Semiconductor Group in Phoenix.

The philosophy on which the system is based is that a home microcomputer system should make life simpler, more comfortable, add new capabilities to the home, and be as responsive to the particular needs of the homeowner as possible.

The system features five Motorola produced microcomputers, linked together to perform a number of important home management functions, including electrical load switching, energy conservation, environmental control, security, and information storage and retrieval. The homeowner can communicate with the microcomputer system, and program it to perform desired management functions, through an easy-to-use input keyboard device. The system also includes a number of TV monitors, closed circuit television cameras, temperature and humidity sensors and motion detectors.

The electrical load switching capability allows the microcomputer system to control lights, wall outlets and other electrical equipment in the home, in order to conserve energy and "even-out" the usage of electricity the home.

The environmental control function of the system will also serve to reduce energy consumption, while at the same time maximizing the home's comfortability. The Motorola system will not only decide when to heat or cool different areas in the home, but it will also decide how to do it. It will always accomplish the task by selecting the least expensive means.

Another important function is security. By monitoring smoke and motion detectors located throughout the home, the microcomputer can alert the homeowner to fires or intruders by sounding alarms or turning on the lights.

The same microcomputer system can provide informational storage and retrieval system for the homeowner. It can store income tax information, cheque book or savings account data, educational or instructional material, or even the weekly grocery list, to be retrieved and displayed on the TV monitor whenever the homeowner wishes. The microcomputer can also be used to keep track of appointments or meetings, displaying them on the TV monitor on the appropriate day.

Educational Catalogue

Teachers and students of electronics alike will be interested in Graymark's 1980 catalogue of educational kits.

Kits include strobe lights, colour organs, a binary clocks and more. Ask for catalogue no. 115-1980 from Graymark International Inc., 5370 13th Avenue, Rosemount, Que. H1X 2X8.



Switching Supply Saviour

Silicon General has announced the availability of the SG1549 Current Sense Latch — a linear chip that uses pulse-by-pulse sensing to cut current limit reaction time to less than 200 nanoseconds.

Intended primarily for use in current limiting for switch-mode power supplies, the SG1549 monitors current build-up each time the power supply's switching transistor conducts. Each ON cycle is treated as a separate problem. Upon sensing an overcurrent condition, the SG1549 immediately turns the transistor off and holds it off for the duration of the normally ON period.

The price? SG3549M (100 pieces, plastic dip) \$1.45 US each. Silicon General, Inc., 11651 Monarch St., Garden Grove, CA 92641.

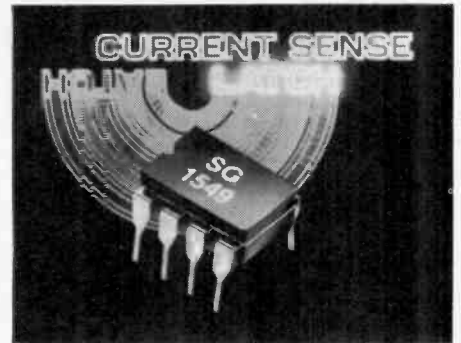

Flat Connection

Amphenol announces its entry into the flat cable connector market with a new standard line that is intermateable, interchangeable and cost competitive with most current products.

The Amphenol flat cable connector line offers sockets and headers in 20, 26, 34, 40, 50 and 60 contact sizes. Headers are offered in both straight and right angle dip solder and wire wrap configurations. All of these are available in two different contact tail lengths. A single standard socket style is offered in various sizes to mate with all corresponding headers.

Key features of the line include; physical and visual polarization, header positive locking device, simplified, one motion mating and unmating.

For more information about the new Amphenol flat cable connector line, contact Amphenol North America Division, Bunker Ramo Canada, Inc., 44 Metropolitan Road, Scarborough, Ontario, M1R 2T9.



FREE

You'll save money, have fun, and learn by building it yourself — with easy-to-assemble Heathkit Computers. See all the newest in home computers, video terminals, floppy disk systems, printers and innovative software.

Send today for your **FREE Heathkit® Catalogue**



If coupon is missing, write Heath Company, 1480 Dundas Highway East, Mississauga, Ontario L4X 2R7

Send to: Heath Company, EV0680 1480 Dundas Highway East, Mississauga, Ontario L4X 2R7

Send my free Heathkit Catalogue now. I am not currently receiving your catalogue.

Name _____

Address _____

City _____ Province _____

GF0380 Post.Code _____

A Big Little Beeper

Series YMB miniature, solid state electronic buzzers, developed by Star Micronics, Inc., New York, pin-type buzzers are designed to provide minimum audible signal of 75 dB at a distance of more than three feet. They are intended for use in automobiles, aircraft, microwave ovens, computer peripherals and other applications requiring a pleasant but penetrating signal for warning, monitoring or timing controls. Buzzers can be soldered directly to PC boards, either manually or by wave soldering. Available from local stocks.

For further information, contact Lenbrook Industries Ltd., 1145 Bellamy Road, Scarborough, Ontario, M1H 1H5.

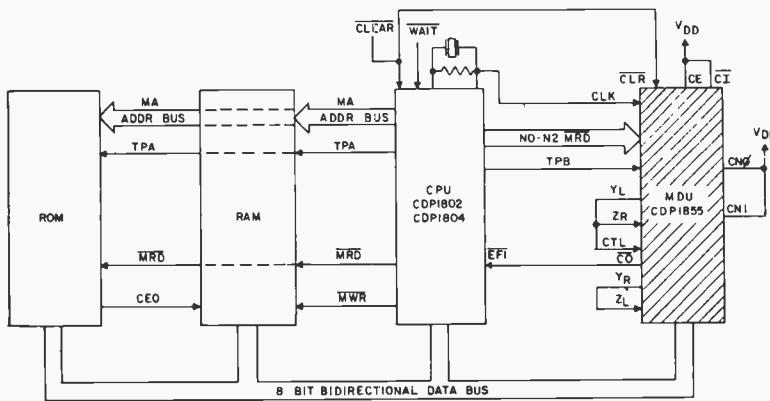
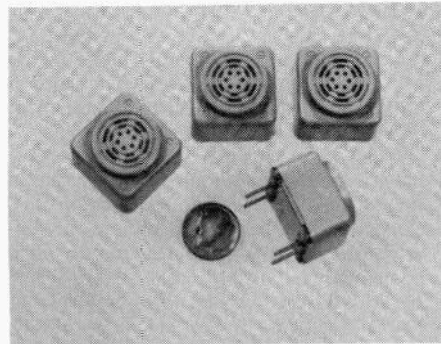

Typical 1800 system with CDP1855.

COSMAC Math

RCA Solid State Division has introduced the CDP1855 and CDP1855-C 8-bit multiply/divide units designed to be compatible with CDP1800 series microprocessor systems and to interface with most 8-bit microprocessors, increasing their capabilities.

The two MDU's perform multiply and divide operations on unsigned, binary operators. These units feature 8-bit by 8-bit multiply or 16 - 8 bit divide in 5 microseconds at 5 volts. In general, microprocessors do not contain multiply or divide instructions and even efficiently coded multiply or divide subroutines require considerable memory and execution time. The units are structured to permit cascading identical units to handle operands up to 32 bits. Each unit can do a 16N-bit by 8N-bit divide yielding an 8-bit result plus an 8N-bit remainder. The multiply is an 8N-bit by 8N-bit operation with a 16N-bit result. The "N" represents the number of cascaded CDP1855's and can be 1, 2, 3, or 4.

The multiply/divide is based on the method of multiplying by add and shift right operations and dividing by subtract and shift left operations.

Copies of the data sheet, File No. 1053, may be obtained from RCA solid state Division, Box 3200, Somerville, NJ 08876, or by contacting an RCA distributor.

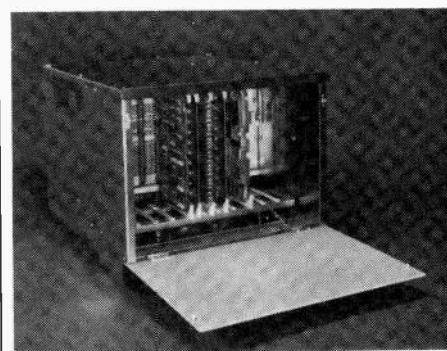

Front Load Chassis

A new Motorola microcomputer chassis that permits the insertion of micromodule cards from the front, rather than the top, has been introduced.

The new chassis incorporates a built-in power supply (for either 110 Vac or 220 Vac operation), a card cage with a 14-slot mother board (for up to 2 MHz operation) and two cooling fans. The chassis complements Motorola's Micromodule line by providing the power source and bus system that permits microcomputer implementation through the selection and installation of the required number of predesigned board functions.

These new Front Load Chassis are now available from both OEM sales offices and authorized Motorola distributors.

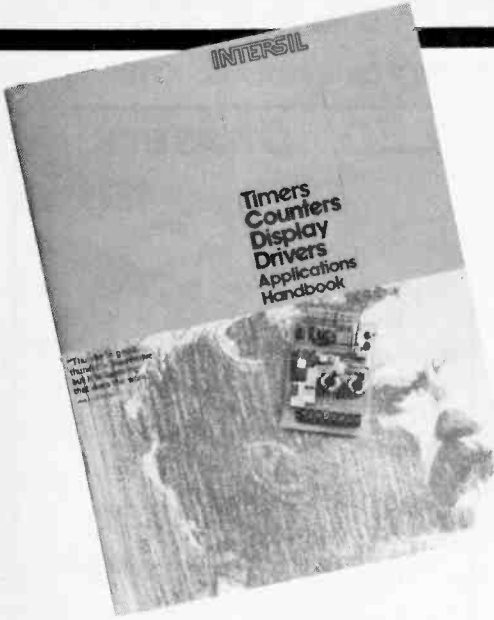

New Timer/Counter/Display Applications Handbook

A new 30 page handbook detailing many applications for the company's broad line of integrated circuits for timers, counters, and display drivers has been published by Intersil, Inc.

The brochure deals with recommended application circuits for up-counters; multi-function universal counters; LED, LCD and vacuum fluorescent counter display drivers; clock, watch, and stopwatch ICs; and general purpose timers. The majority of the devices cited are executed in low power CMOS technology.

Also offered is availability information on Intersil's line of panel meter, stopwatch, touch-tone encoder and oscillator controller evaluation kits.

For further information, contact Lenbrook Industries Limited, 1145 Bellamy Road, Scarborough, Ontario, M1H 1H5.

Calling ACA

A new toll free number has been installed by Allan Crawford Associates Ltd., providing Atlantic region customers with easier and more convenient access to product specialists, the order processing department, and other ACA technical support personnel.

Customers located in area codes 902 and 506 can now call ACA without charge by dialing 1-800-267-6131.

Customers in Newfoundland can also phone ACA without charge by dialing the operator and asking for ZENITH 01720.

For more information please contact Mr. Steve Dineen, Allan Crawford Assoc., Ltd., 6503 Northam Drive, Mississauga, Ontario, L4V 1J2.

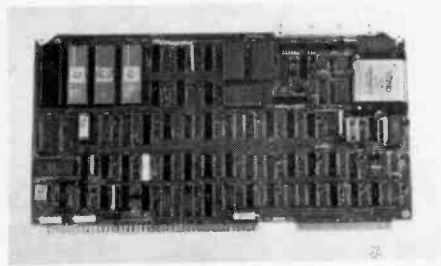

More Education

A colour videotape now available from Intel Magnetics, Inc., shows microscopic views of a million-bit magnetic bubble memory device's internal operation. It also shows how the device is constructed and how it is used with other components in a microcomputer memory system.

The videotape is available on ¾ inch U-Matic and VHS format cassettes, and on fast and slow Betamax cassettes. Send \$25. for each cassette to Intel Corporation, Literature Dept., 3065 Bowers Road, Santa Clara CA 95051.

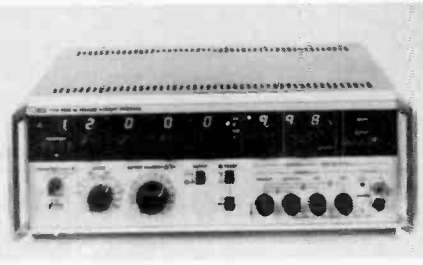

AC Voltage/Current Standard

The Yew Model 2558 is an AC voltage/current standard-calibrator. It features 0.08% accuracy and is fully programmable, when ordered with the optional IEEE-488 (GP-IB) Interface. The 2558 is designed to fully interface with automated testing systems or other types of instrumentation systems that have this interfacing capability.

The 2558 features an extremely high output burden capability (30 volt-amperes), allowing it to handle heavy or multiple loads that can speed up many measurement functions.

For more information contact Metermaster, 214 Dolomite Drive, Downsview, Ont. M3J 2P8.

Right Angle Phone Jacks

Compact new, two or three conductor jacks with built-in right angle mountings have been introduced by Switchcraft, Inc., Chicago, a Raytheon company. Called right angle Hi-D Jax jacks, the new phone jacks are designed so the plug axis will be parallel to the circuit boards to which they are mounted.

Available with or without shunt circuits, right angle Hi-D Jax jacks may be used with military or commercial phone plugs with a .25-inch dia. finger.

Switchcraft Inc. is represented in Canada by Atlas Electronics Ltd., 50 Wingold Ave., Toronto, Ontario, M6B 1P7.

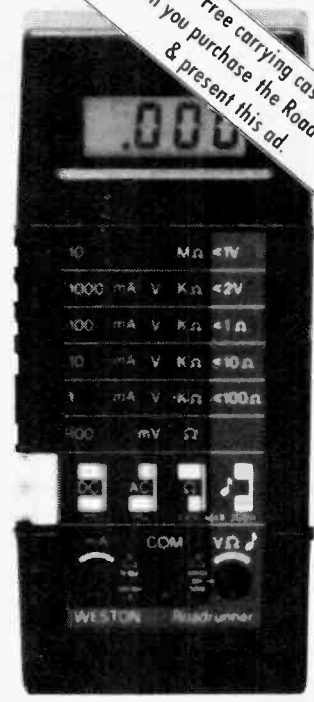

Free carrying case
& present this ad
when you purchase the Road Runner

AUDIO RESPONSE PLUS DIGITAL DISPLAY

THE ROAD RUNNER ADMM™

The industry's first hand held Audio Response service multimeter

- 5 range audible signaling function
- 6 functions
- 29 ranges
- 0.5% accuracy
- Self check on DC volts
- 0.5" LCD display
- Rugged field service design

FOR ONLY \$195.

- DISTRIBUTORS:**
- | | |
|---|--|
| WESTBURNE - NEDCO - CANADA WIDE | |
| ARMATEK
TORONTO | L.A. VARAH
VANCOUVER
CALGARY
WINNIPEG |
| PRELCO
MONTREAL
OTTAWA
TORONTO | MODERN
VANCOUVER |
| L.D. INDUSTRIES
CHICOUTIMI | ATLANTIC INSTRUMENT
DARTMOUTH |
| CARDINAL
EDMONTON | BRUNELLE
SHERBROOKE
QUEBEC |



1200 Aerowood Dr., Unit 8, Mississauga, Ontario L4W 2S7 (416) 624-6660
Telex 06-960302

THE MEASUREMENT PEOPLE

Circle No.20 on Reader Service Card.

Announcing

KITS • KITS •

NEW . . . PRE-DRILLED PCB'S FOR ALL KITS

STEREO AUDIO MIXER Kit

\$49.95

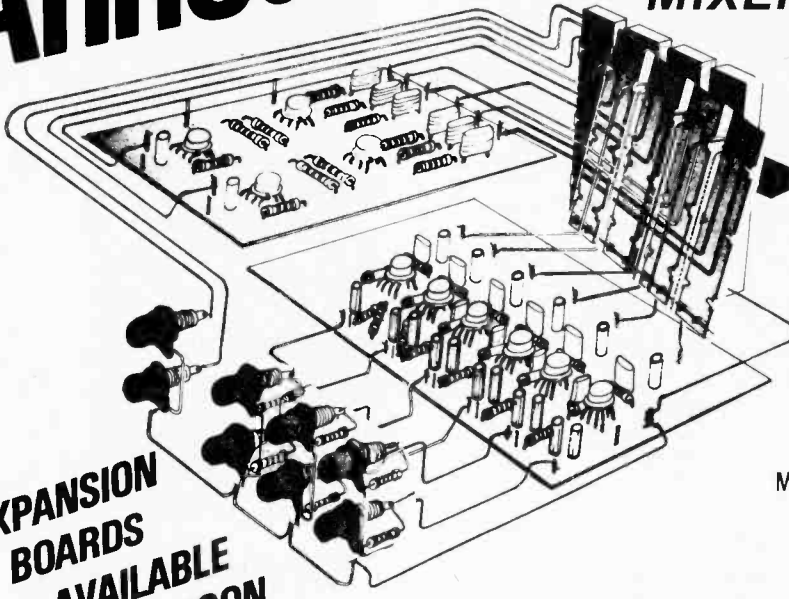

- 2-PHONO
- 1-AUX.
- 1-MASTER
- EXPANDABLE
- RESP. 20Hz - 20KHz
- 5V OUTPUT
- .01% DIST.

MODEL EK80AM001

EXPANSION
BOARDS
AVAILABLE
SOON

LED Chasers

\$22.95

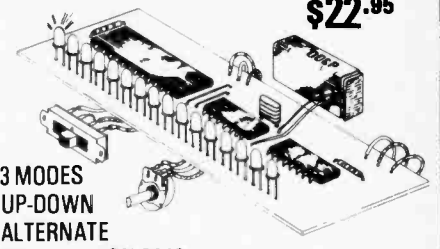

- 3 MODES
- UP-DOWN
- ALTERNATE
- MODEL - EK80LC016

Muti Mode Chaser

\$32.95



- 120V
- ADAPTABLE
- 60 MODES
- MODEL - EK80LCM16

Audio Delay Line Kit

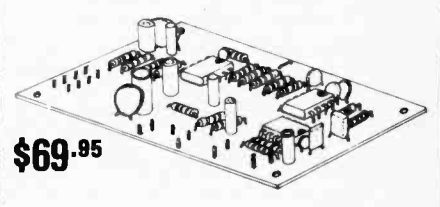

\$69.95

BBD

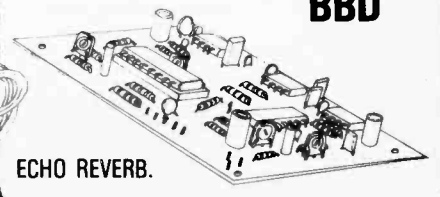

ECHO REVERB.

STEREO PRE-AMP

\$11.25



MODEL
EK805P001

Three Channel Color Organ

\$21.95

500W
EK80C500

\$32.95

1500W
EK80C1500

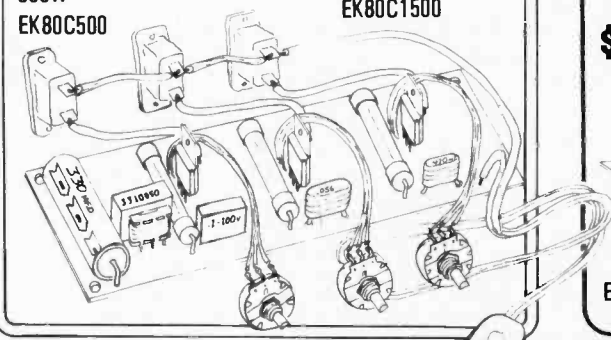

5 Watt IC AMP

\$19.95

MODEL -
EK80A005

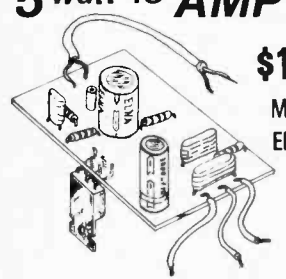

15 Watt AMP

"CAR STEREO"
MODEL - EK80A015

\$26.95

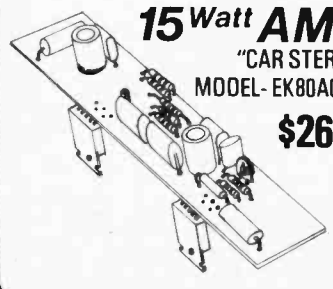

STOBE Lite

\$21.95

MODEL
EK80SL001



Morse Code Osc

\$9.95

MODEL
EK80CP001

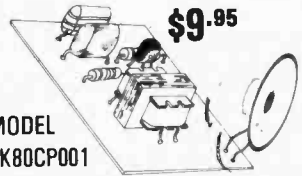

Variable Power Supply 0-30 volts

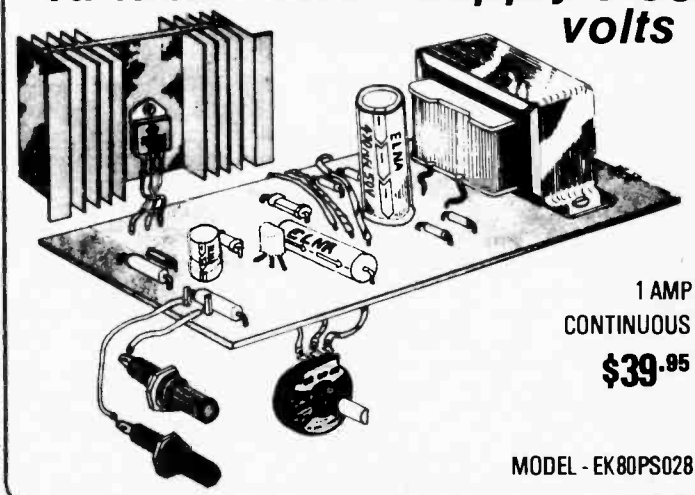

1 AMP
CONTINUOUS

\$39.95

MODEL - EK80PS028

•ALL KITS COMPLETE WITH DETAILED INSTRUCTIONS & PCB.
•DEALER & EDUCATIONAL INQUIRIES INVITED.

DOMINION RADIO & ELECTRONICS CO.
535 Yonge St., Tor., Ont. M4Y 1Y5 Phone: 922-1818

Kit DMM

Heath Company has introduced a hand-held portable digital multimeter kit, designated IM2215.

Designed primarily for use in the field, this unit features special alternating high-to-low resistance test voltage for measuring semi-conductors and in-circuit resistance, built-in references for in-the-field calibration and a large 3½ digit liquid crystal display.

Five ranges allow AC voltage measurement to 750 V rms and DC voltage measurement to 1000 volts, while the six-range resistance function spans impedance measurement up to 20 megohms. AC and DC current flow is measurable to 2000 mA.

It is available from Heath Electronic Centres in Vancouver, Edmonton, Winnipeg, Mississauga, Montreal and Ottawa priced at \$159.95. Write to Heath Company, 1480 Dundas Street East, Mississauga, Ontario, L4X 2R7.

**Expose Yourself**

News Digest is a regular feature of ETI Magazine. Manufacturers, dealers and clubs are invited to submit news releases to News Digest, c/o ETI Magazine. Sorry, submissions cannot be returned.

Sabtronics Line Available

Kumar & Company have recently been named for the Sabtronics line in Canada. They now carry the complete line of kit and assembled instruments: frequency counters, benchtop/portable DMMs, and hand-held DMMs. A brochure describing the line is available by writing: Kumar & Company, 3344 Mainsail Crescent, Mississauga, Ontario L5L 1H2 — or phone (416) 828-0583.

**LOOKING BACK
Minisynth, April 1980**

Minor error in the pcb here. The trace between the cathode of D1 and positive terminal of C14 is missing. This is Vcc for the SN76477. Solder in a short jumper.

STAC Timer, July 1979

We have been advised by Northern Bear Electronics that the National Semiconductor MM57160 IC has been discontinued.

We strongly advise that readers building this project make sure they have the IC in hand. ●

Dr. What??!

EnerCon Inc introduces Dr. Watt, an energy conserving device utilizing patented NASA technology. Dr. Watt cuts the power required for induction motors by 10 to 60%.

Products with continuous running induction motors include: washers, gas dryers, refrigerators, air conditioners and furnaces. By plugging Dr. Watt into a wall socket and then the appliance into Dr. Watt, the unit measures the power needed to do the job and delivers only that amount to the motor. The motor continues operating, but when it doesn't require full power, the unit estimates and delivers the minimum power required thus conserving the unrequired extra power.

NASA developed the patented device used in Dr. Watt to achieve the greatest possible

efficiency from motors which would operate on solar energy. EnerCon, under licence from NASA, modified this innovation for use with home appliances which have induction motors of ½ horsepower or less. Depending on the function of the motor, the consumer can conserve 10 to 60% motor power.

Dr. Watt is available for \$29.95 (US) plus \$2.95 postage and handling from EnerCon, Inc.; 30044 Lakeland Avenue, Wickliffe, Ohio 44092.



ETI — JUNE 1980

**SOUND SHAPER**

The CV-23 Control Amplifier/Graphic Equalizer gives you sound as you want it. Six position graphic equalizer, variable plus or minus 12 dB's, lets you adjust highs and lows the way you like it. You shape the sound for your van or car. And a true 30 watts of RMS power per channel pumps out the sound at the level you want. And there's more. Fader and balance controls for further sound control — two channel LED power indicator — source selector switch — and more. Low and high level inputs to match your music source. Great technical specifications and a price that is so low you won't believe it... but you can expect more from Mitsubishi. CV-23 — one of thirty-one superb automotive audio products.

Expect more from Mitsubishi.

Sugg. List \$249.95

Melco Sales Canada Inc.
900C Denison Street
Markham, Ontario L3R 3K5
(416) 495-7728

MITSUBISHI
CAR AUDIO

Circle No. 10 on Reader Service Card.

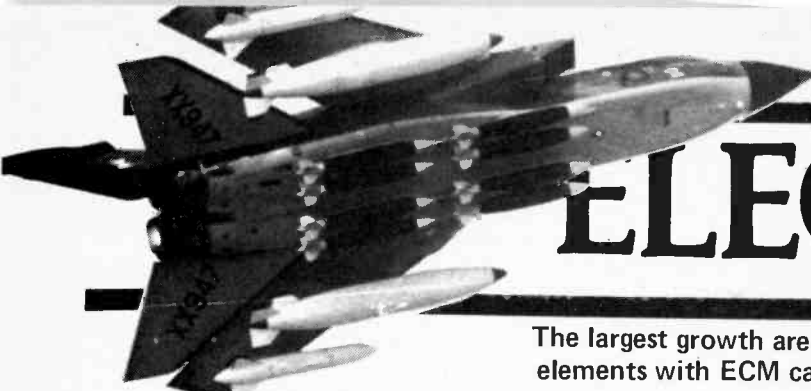

ELECTRONIC

The largest growth area in electronics is military hardware. Modern warfare is elements with ECM capability, as David Chivers explains.

ELECTRONIC WARFARE had its beginnings in the Second World War, with the development of radar, electronic navigation aids and early means of disrupting the enemy.

However, after the war, interest waned as Chiefs of Staff were more interested in hard weapons such as aircraft and tanks rather than somewhat 'ethereal' electronic weapons. In fact the importance of radar was not forgotten, and radar development continued apace, but the capability to deceive or deny the use of that radar was, in the West at least, given low priority.

This mode of thinking has been radically altered in the last 15 years and development of the military aspects of electronics is rapidly increasing, taking up a larger and larger proportion of military budgets each year.

The reason for this sudden surge in interest stems from experience; in peace time electronic aids and counter measures may seem a luxury, in any military action they have been shown to prove their worth. Three areas of conflict produced developments which finally shocked the West's military planners into action. The first was the U.S. experience in Vietnam, particularly with the B-52 raids on North Vietnam known as the 'Linebacker' raids. In the second series of raids, highly trained and experienced defensive forces fired over 800 surface-to-air missiles at 714 strike sorties, yet only 15 planes were lost, indicating that the electronic counter measures (ECM) were highly successful.

The next indication of the importance of an electronic capability was the Soviet invasion of Czechoslovakia, when NATO early warning devices were totally blinded by Soviet ECM. Czechoslovakia was already occupied by the time the West knew of the invasion.

ECM For Desert?

The Middle East War of 1973 provided more evidence. Before this it had been assumed that when it come to electronics the USSR would always be one step behind, but in fact the Arabs were armed with weapons to which Israel had no immediate answer: Surface-to-Air missiles and anti-aircraft guns guided by radar.

The type of radar employed 'Continuous Wave' or CW radar. This is a radar which instead of sending a series of pulses to be reflected from the target, illuminates constantly with a transmitted signal. The protection equipment carried by Israeli — and indeed all Western aircraft — was orientated to a Pulse-radar threat and was incapable of detecting — let alone jamming the CW radar.

However, despite an initial high loss rate, Israeli losses fell rapidly with the introduction of new tactics and extensive use of ECM both in aircraft and 'dedicated' ECM helicopters.

EW is concerned with measures taken by either side to give them a combat effectiveness over their enemy by competitive use of the electromagnetic spectrum. There are three categories: Electronic Counter Measures (ECM); Electronic Warfare Support Measures (ESM); and Electronic Counter Counter Measures (ECCM); and we shall consider each in turn.

A Word About Air

To defend its airspace, a country must use radar first to detect an intruder and secondly to determine its position and course, guiding either an aircraft or missile to intercept. In either case at long range the only way to home in on an intruder is by radar.

Need an accurate way to take out a tank? TOW is a Tube launched, optically tracked and Wire guided heavy anti-atmour weapon. It is suitable for use against tanks or other land targets from 65 to 35000 meters. Possible mountings include; armoured personell carriers, wheeled vehicles and helicopters. Alternatively, it can be carried by a four man crew over short distances and fired from ground positions.



WARFARE

increasingly becoming a battle of software rather than armour. Any future combat force will have to include

At close range low light television (LLTV) or heat seeking equipment (infra-red) guidance is used.

This 'radar threat' to an attacking aircraft is very real and tactics have naturally been devised to escape detection.

Due to the inability of land based radar to cover low altitudes at anything other than very short range, the accepted way for strike aircraft to penetrate enemy air space is by flying in at very low altitude.

However, the introduction of airborne radars in AWACS (Airborne Warning And Control Systems) aircraft challenges aircraft to intrude unnoticed, since their 'Lookdown' capability enables them to spot low flying aircraft and direct an attack on the intruder concerned. With the opportunity to make an undetected attack strongly diminished, it is increasingly important to be able to counter the enemy's radar.

Once a missile has been fired at an intruder, it must evade an enemy which is faster and at best only *slightly* less agile than itself; if the missile is heat-seeking or LLTV guided, then flares and manoeuvres may be effective.

Electronic Counter Measures

These seek to deny the enemy the use of the electromagnetic spectrum. This may take the form of 'jamming' enemy radar or communications by selective use of radiated energy, or by deceiving the radar operator — or computer — into believing that a number of targets are present when in fact only one exists, or that the target is in a different position.

ECM may be divided into two techniques: denial, where the enemy's electronic equipment is made ineffective by jamming communications or radar — and deception as described above. Both denial and deception may be either 'active' or 'passive'; that is, involve the use of radiated energy — or not. The simplest and most common form of active denial is that of noise-jamming.

Various techniques are used, but white noise, if transmitted at a high enough power, into the enemy's receiver will usually be effective in rendering it inoperative. If the jammer's noise energy is concentrated on a small bandwidth covering only the input frequency range of the enemy receiver then it is known as a 'spot jammer' while a jammer radiating noise over a much broader part of the frequency spectrum is a 'barrage jammer'. The former has the advantage of design simplicity, and greater effectiveness, while the latter can counter a number of receivers operating on different frequencies at the same time.

Active deception of radar can be accomplished by repeater jamming, i.e. creating a false echo of the radar signal by re-transmitting a noise signal at a set time after a receiver picks up an enemy radar pulse. An additional refinement is to use either a pre-recorded replica of the incoming signal or a transponded pulse to confuse the radar operator into believing that one or more false targets exist.

Tracking radar can be forced to 'lose track' by electronic means, and this is done by shifting the image of the target from its true position, so that the system follows the image.

In radars which have two modes — scan and track, once the tracking system has lost the target, the repeater may be silenced leaving the radar to return to its scan mode against which other jamming forms may now be used. However, new radars now employ 'track while scan' mode which is



Above: The ZB298 is a mobile ground surveillance radar for the detection and location of moving targets.

slightly more resistant to this kind of deception. Even so modern ECM equipment may deceive the radar in terms of range, altitude, position or speed and as such provides a very useful means of increasing the survivability of an aircraft in a hostile radar environment.

Passive Resistance

Passive ECM is concerned with chaff, decoys and the radar cross section' of a potential target.

Chaff was the earliest countermeasure against radar and is still effective today, it consists of thin strips of aluminium foil, released in a cloud which is highly reflective to radar. Spot chaff dropped as an individual bundle may appear as another aircraft on a radar screen or its larger reflected signal may steal a tracking radar from the faster moving true target. Corridor chaff, released in a long cloud is a confusion measure which enables a series of aircraft to fly undetected behind a 'smoke screen.'

Chaff has proved particularly useful as a defence against radar-homing surface-to-air missiles, which, with their small radar window can be totally blinded at close range.

Plane To See

The cross section of a plane as it appears to radar may be reduced by careful design and the avoidance of sharp corners for example will help to keep the radar reflectivity low, as will the use of 'doubly' curved surfaces.

Flat, cylindrical, or conical surfaces not possessing double curvature are highly reflective if caught at right-angles to the incident wave. The US mothballed super-bomber the B1 is a good example of careful design, and despite its large size, it exhibits a far smaller radar cross section than many much smaller aircraft with the consequent result of increased survivability.

Radar absorbent materials may be used to reduce the reflectivity of the target, again reducing the ability of radar to detect the target, particularly at long range.

FEATURE

A decoy is a small aircraft-like device which can, by means of electronic and structural design, appear as a real aircraft to a radar set. Thus a number of attack aircraft, each carrying perhaps two decoys, could by tripling the number of targets present saturate the enemy defences. To add to the illusion of a full scale aircraft, the decoy may even carry a small jammer, to duplicate as accurately as possible the image of its mother aircraft.

Support Measures

Warfare support concerns the collection of data from the reception of enemy radar, communications or counter measures. This data is then processed and may be used either immediately to warn of the nature of an impending threat or as ELINT (Electronically gathered INTelligence) from which a picture of enemy operations in the electromagnetic spectrum may be built up and equipment or tactics altered accordingly.

Whereas electronic warfare is for the most part actively deployed during time of war, ESM is at its height during peacetime. Indeed once hostilities have broken out, if enemy electronic capability has been underestimated or is not known, then the enemy has won the first round of the electron war.

Both the Warsaw Pact and NATO indulge in ESM during detente especially during the other side's manoeuvres and

Below: EMI Searchwater. Probably the best airborne surveillance radar there is. Used from Nimrod aircraft it can identify ships and subs by their radar profiles



Above: Troops rappel from a helicopter during a training exercise.

Below: Representation of modular ESM equipment (shipboard). Such a system can be reduced according to vessel size down to simply a console and bearing array.

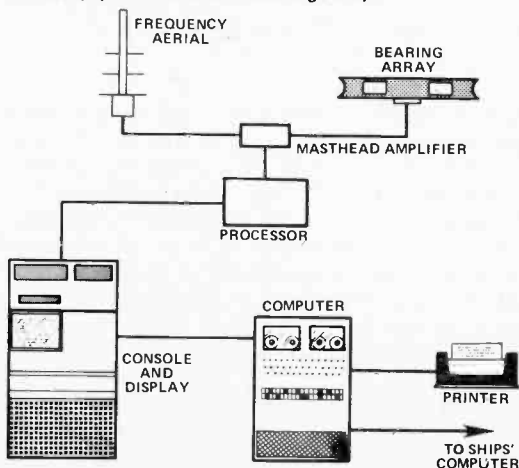

exercises trying to gain information on the effectiveness of each other's EW capability. Soviet Spy trawlers have caught the news as they shadow NATO fleets, and Soviet Bear aircraft, studded with ELINT gathering devices, are regularly turned away from airspace as they probe the capabilities of the West's air defence. No doubt NATO aircraft are involved in similar activities in the opposite direction.

Staged System

The first stage of an ESM system is the receiver and processing stage and on its own this makes a useful instrument. This is known as a Radar Warning Receiver (RWR) and is a cheap but effective preliminary protection against radar threat. (Similar warning devices are available for other threats; including sonar warning on submarines, and new Laser warning receivers for protection against guided weapons).

For helicopters and smaller aircraft where space is at a premium and additional weight results in lower performance, simple devices may be used such as the US army's new series of RWRs. These weigh only 3.5kg yet indicate on a CRT the bearing and nature of any radar, while identifying any particular threats associated with known anti-aircraft weapons systems.

Identification of a radar is of particular importance especially in an environment where both sides are actively involved in EW and where there is such a diversity of radar types and threats. Friendly radar cannot be treated in the same way as hostile radar and must therefore be positively identified. Shipborne ESM systems are far more useful in this respect and can employ sizeable computers to aid identification and response. Such a system is made by Decca, whose Cutlass ESM system can hold a library of up to 2,000 radar signatures. The device can give radar type, frequency and bearing as well as all the relevant information available on that radar. MEL have a similar modular system — Susie — which can be tailored to suit the type of vessel it is to be employed upon from small Patrol Boats up to large Cruisers.

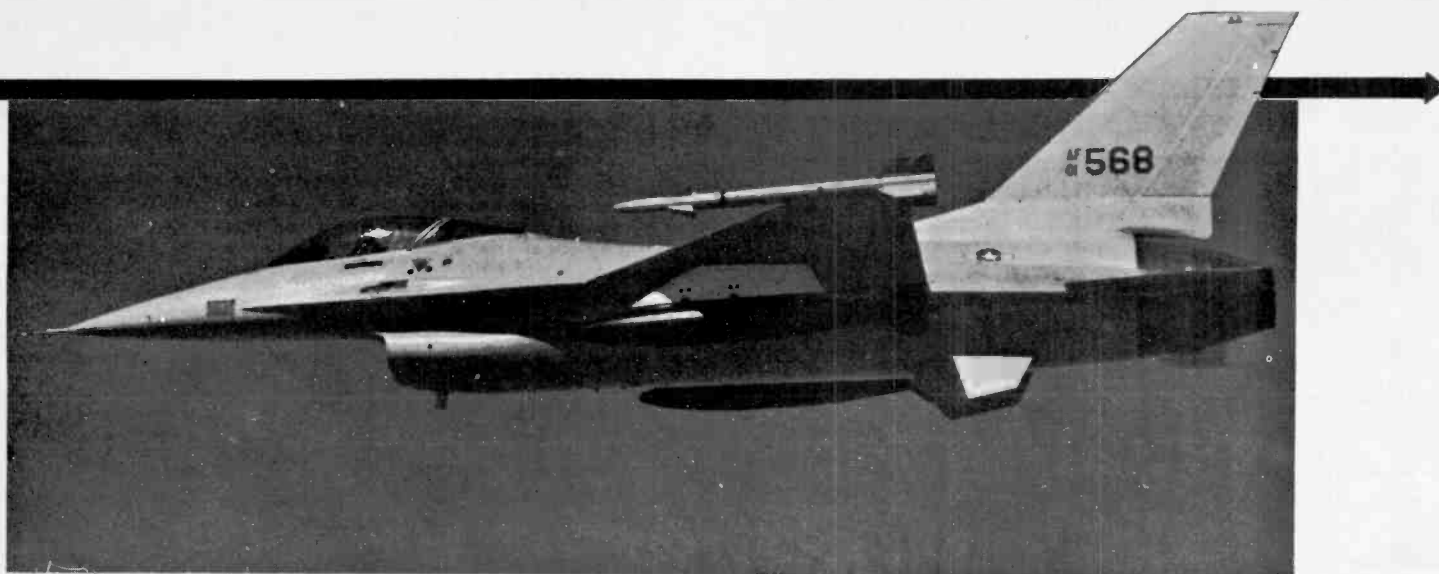

Above: The F-16 fighter. The craft uses a computer stabilisation system to provide a stable weapons platform without the pilot having to worry about it. As a ground strike craft an external ECM pod can be fitted, as can 'chaff' missiles to help shield the craft from interrogating radar.

Such systems can be used in conjunction with jamming equipment to provide a very potent ECM capability. All the operator has to do is to decide whether or not to jam a particular threat radar. If he decides 'yes' the computer will decide on the most appropriate counter measures to take and then apply them.

Information Received

In any case ESM carried out by a Radar Warning System is only secondary; the most important ESM being the incorporation of the 'potential threat' into the computer library, or in a RWR. This depends on good intelligence, anticipation of possible developments and the speed with which the system can be altered to meet any new threat.

Thus the effectiveness of any counter measure or counter counter measure depends on the accuracy of information received, the speed with which it is processed and the flexibility of the response. Current RWR trends are the use of broadband receivers — often with a crystal video front end — and detection circuits enabling a computer or microprocessor-based comparison with known parameters to be made. Also important is the incorporation of a simple display, which enables the user to assess any threat at a glance essential to the pilot or helicopter crew in a combat situation where a few seconds may be the difference between survival or destruction. Hence the use of automatic response systems, which may for example dispense chaff as soon as a threat is identified.

Naturally the task of the RWR designer is made more difficult the more diverse the types and frequencies of radar

employed. However, if designated for a particular use, the number of threats it is likely to encounter may be reduced. An air superiority fighter such as the USAF Eagle need only provide light ECM and ESM defence against ground based threats — its adversaries will be airborne weapons systems of which there are fewer types. The RAF's Tornado on the other hand is required to penetrate deep into enemy air space where the threat will be from both ground and air, hence its much more complex ECM and ESM equipment. The difficulty of designing equipment to face a varied assortment of threats must surely be seen as a very effective argument against too much standardisation of military electronics.

Counter Counter Measures

This will be more difficult from an aircraft or missile in which case the radar set as well as a target will be moving in relation to both the target and the chaff, where the chaff is very likely to have the higher relative speed.

To counter repeater tactics employed by the enemy as ECM, the waveforms of the transmitted pulses may become more complex, with subsequent recognition circuitry in the radar receiver. In addition, as a counter to various types of jamming and other ECM, radar should possess a good frequency range and if possible frequency agility — the ability to change frequencies from one pulse to the next.

Below: The F-14 combat aircraft. It has a fire control system which can attack six targets simultaneously at 200km range, while tracking 18 others, deciding for itself which pose the greatest threats and facing them in that order! In addition the wings are automatically swept back to the optimum position by MPU control.

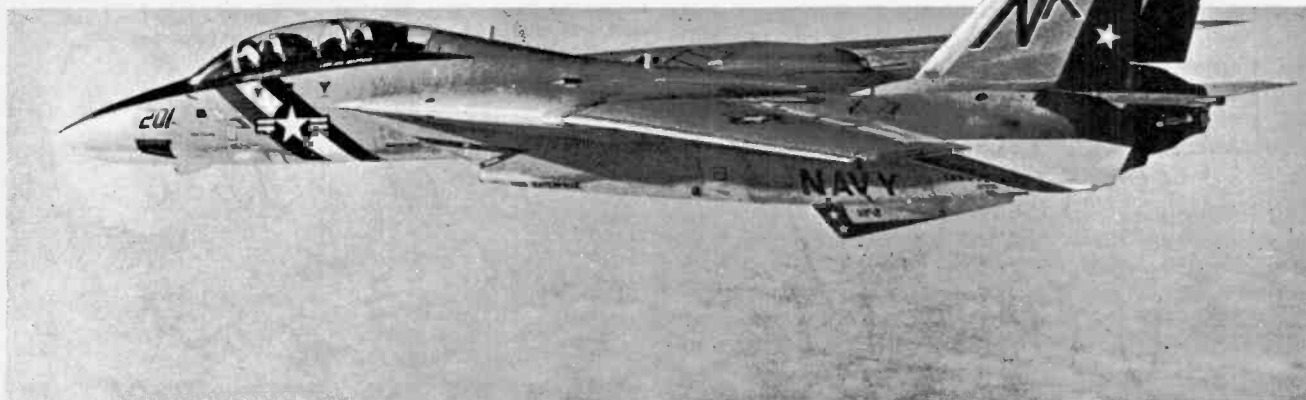

FEATURE

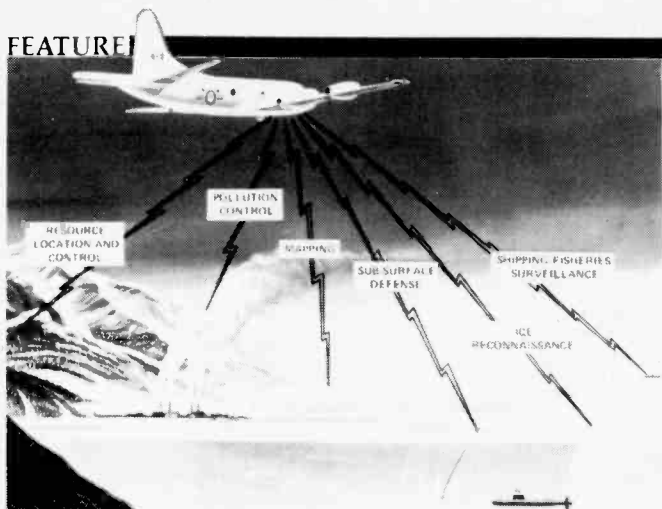

Above: Electronic systems often require mobility. Enter the CF Aurora, primarily a long range aircraft intended for coastal work. With its 'plug in' capability it can accommodate a variety of equipment items to perform a wide range of tasks, both civilian and military.

A useful ECCM is that of a Constant False Alarm Receiver (CFAR). This works by setting the receiver to 'expect' a certain number of false alarms, or rather spurious signals above a level which trips the receiver's processing circuitry and causes the radar to treat it as a target, giving a false signal on the radar screen. Assuming that such signals are caused by random noise in the atmosphere and receiver circuitry, then false alarms may be expected to occur in a poisson distribution from which a mean rate can be calculated and the receiver set accordingly. Noise jamming will therefore appear as noise above the expected rate, and the receiver will reduce its gain accordingly, though if the jamming is effective and persistent this may amount to shutting down the receiver.

Nevertheless CFAR technique is a valuable counter to noise jamming and is even more effective when used in conjunction with other ECCM.

Radiate Confidence

It should not discourage the aspiring ECCM designer to realise that all radiating electronics can be jammed. While the enemy might find this possible, there are two restrictions on his ECM activity, in particular on active ECM. The first is the cost of any jamming measures and especially the cost of providing comprehensive protection in a confined space and at limited weight. The second is the fact that the enemy needs to use the electromagnetic spectrum as well, and must ensure that at least his sections of the frequency spectrum are as clear as possible for his own use.

To ensure that one's own transmissions are not likely to be adversely affected by friendly jamming activity, Electro-Magnetic Compatability (EMC) is necessary. This may be particularly difficult in a large defence force such as NATO where most member countries have their own electronics industries and where a subsequent diversity of standards and techniques are found in electronic equipment of all kinds. Thus compatability of equipment is a very important ECCM, though the versatility achieved through diversification is an obvious and useful ECCM in itself and should not be forgotten in the current race for standardisation.

Keep On Trackin'

Another major application is in missile guidance and fire control. This can range from navigation systems for intercontinental missiles to small guidance systems for anti-tank weapons. A classic example is the TOW heavy anti-armour weapon. It is intended for use against armoured targets for distance of up to 3km. The rocket is optically tracked by the weapon and course

correction are sent over wires trailing behind the missile. The name? Tube launched, Optically tracked and Wire guided.

Train Thoughts

An additional advantage of the increasing use of electronics in warfare is that it is increasingly simple and much cheaper to train personnel and simulate 'live' action. For example the British Army's 'Striker' anti-tank vehicle comes complete with a computer based simulation system as standard, for training soldiers in the use of its missiles. Since each anti-tank missile costs upwards of \$12000 it is extremely expensive to use live rounds for practice firings. However because the control systems for the missile firing are contained in digital logic, it is a simple matter to provide a simulation facility in which the operator experiences exactly the same situation as under real action.

In conjunction with laser gun sights and computer references, this makes the expensive business of 'war gaming' cheap yet more realistic since combatants can actually 'fire' at each other much as in a TV 'tank battle' game. The use of simulators is also of great importance in training pilots, and though a simulator may cost more than a real aircraft, the fact that it requires no fuel, no expensive maintenance and cannot be grounded due to poor weather makes such equipment very worthwhile.



Ferranti PADS (Position and Azimuth Determining System). A digital inertial navigation system for accurate artillery survey purposes.



Above: Operators in the Sonar control room of the HMCS Kootenay.

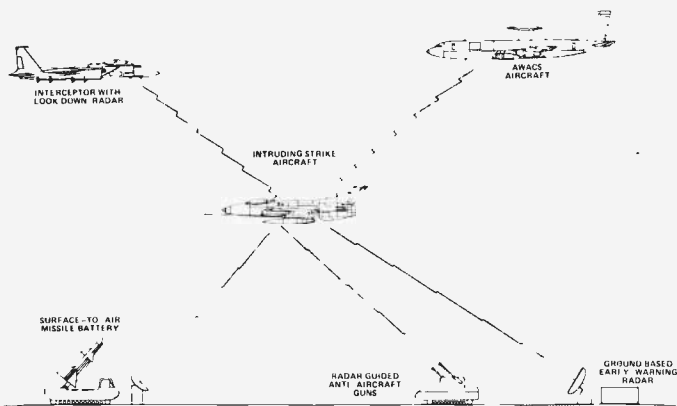

Above, intruding strike aircraft have to face a multitude of threats. Low flying is the usual way of avoiding being spotted. However 'look-down' capability is now fitted to most interceptors, and the AWACS system protects NATO airspace to some extent.



Above: One of the early warning radars of the 16th Light Air Defence Regiment. Such units alert interceptor forces to tackle intruding strike aircraft.

Summary

Whatever happens in the future, one thing is certain — without EW capability any armed force engaging in combat will be at a severe disability when faced by an EW equipped enemy. Its communications will be blinded, its radar jammed its planes downed and its hardware detected and neutralised. Not a comforting picture.

Let us hope it doesn't happen to us. ●

Above Right: A polaris missile fired from HMS Resolution. The range of Polaris is about 2,500 nautical miles, and being fired from an undersea platform it makes them difficult to stop. Satellite mounted weapons will undoubtedly be a front line defence for both powers against ICBMs within a few years.

Right: EMI's Cymbaline mortar location system. It uses radar beams to reference a projectile's flightpath to a map to give accurate prediction of launch and impact points.

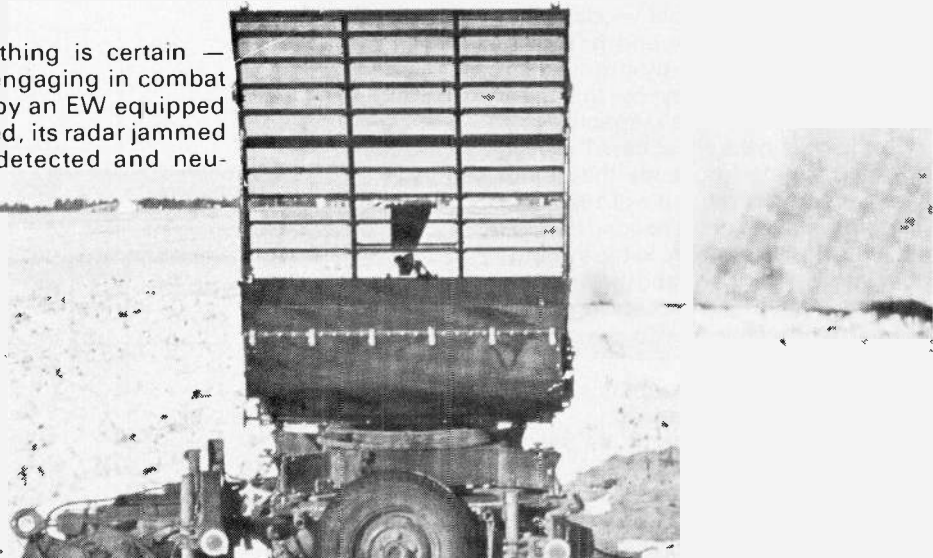

PLL SYNTHESIS

Need to derive an unusual frequency from a fixed source? A. Jaremko outlines the principles of phase locked loop synthesis and how it applies to his hobby.

A PROBLEM that often comes up in electronics is the generation of frequencies that are related. Some relationships are simpler to obtain than others — for instance, a 2:1 ratio can be obtained using very simple logic circuits. But often, the ratios need to be more complex. One instance is in filmmaking, where it is often necessary to provide a reference frequency at the frame rate of a projector, but synchronized to the power line frequency. The two standard frame rates are 18 and 24 frames per second, and power lines run at either 50 or 60 Hz., depending on where you live.

A popular scheme for frequency synthesis is shown in Fig. 1a. The reference frequency is first multiplied by the factor N1 to obtain an intermediate frequency. Then a second division by N2 gets the output frequency. Fig. 1b shows one set of N factors that will get 18 and 24 Hz out of the power line frequencies.

For other frequency combinations, other values of N1 and N2 are used. To find these factors, first find the least common multiple of the input and output frequencies. This becomes the intermediate frequency, and the factors N1 and N2 are found by dividing the intermediate frequency by the input and output frequencies respectively.

Notice that in the 60 Hz case I've used an intermediate frequency that is not the least common multiple of 18, 24 and 60 Hz. This is because I needed a signal at about 1kHz elsewhere in the system I built using this idea, and having this frequency as a line-locked reference seemed worthwhile. It also doesn't add to the complexity or cost of the circuit to use this intermediate frequency, rather than the "proper" 360 Hz.

Two implementations of the design are shown in Figs. 2 and 3. The same basic circuit is used in each, with a few connections changed to effect the switch from 50 to 60 Hz. The circuit can

be built by your favourite method, since it is low-frequency, there is nothing particularly critical about layout. The values of resistors R2 and R3 depend a bit on the supply voltage. I have selected them for 9 to 15 volt operation. Since the circuit is built with CMOS, it should draw very little power. Connections for obtaining the power line frequency input with various types of power supplies are shown in Fig. 4, along with the D.C. referenced waveforms that you get with each type of connection. These are all suitable inputs for the circuit.

The output from the circuit is an asymmetrical square wave, with a duty cycle that depends on the configuration. Normally in film applications this

doesn't matter much; either the leading or trailing edge of the square wave will be used. If your application requires symmetry, or a sine or triangle output, other methods will have to be used to generate them.

How it Works.

IC1 is a CMOS phase locked loop (PLL); and in conjunction with IC2 it multiplies the input frequency by a factor determined by IC2, which is a seven-stage binary counter. IC1 compares the frequencies at its pins nos. 3 and 14, and puts out a signal at pin 13 that indicates whether they are the same. This raw signal is filtered by R4, R5 and C2 and applied to the Voltage

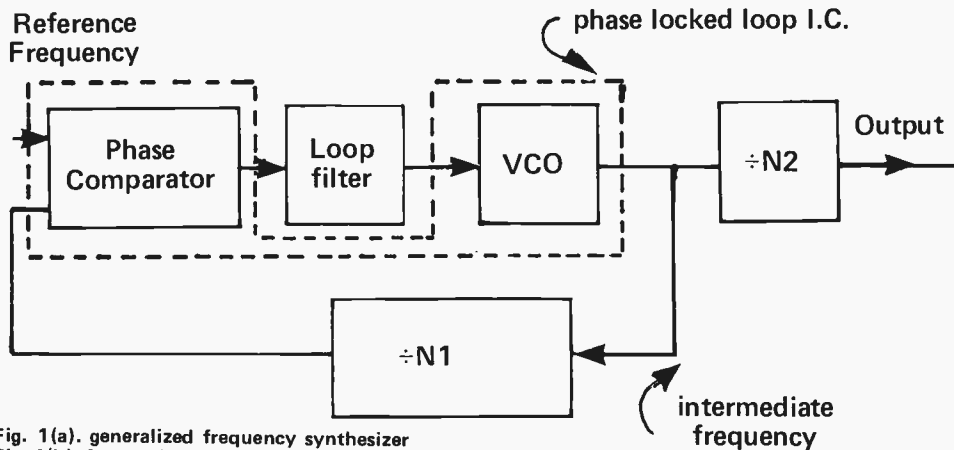

Fig. 1(a). generalized frequency synthesizer
Fig. 1(b). factors for filmmakers

$$f_{out} = \frac{f_{ref} N1}{N2}$$

Input, Hz	Output, Hz	N1	N2	Intermediate frequency, Hz
50	24	36	75	1800
50	18	36	100	1800
60	24	18	45	1080
60	18	18	60	1080

Controlled Oscillator (VCO) that is built into the IC. The voltage at pin 9 varies up or down until the loop locks and the two input frequencies are equal. Resistors R2 and R3 program the range and offset of the VCO, to match it up with the frequencies that need to be generated.

Binary counters IC2 and IC3 have a maximum count length of 128 counts. The count sequence is shortened by decoding an appropriate count and resetting the counter to zero. In the case of IC2, this is done by the two-input AND gate. This gate provides a high output whenever both its inputs go high. For the 60 Hz version of the circuit, this happens on count 10010₂, or 18₁₀. As soon as the output of this gate goes high, capacitor C3 charges through D1 and the counter is reset to zero. R6 ensures that C3 will discharge before the next input pulse occurs.

Are D1, C3 and R6 really necessary? Yes, they are. If they are omitted, strange things can happen. Assume that count 10010 is reached without these components in the circuit. A positive voltage appears at the output of the AND gate and starts to reset the counter. If one of the flip-flops in the counter resets before the others, the output from the gate can go back to zero before the counter has finished resetting, leaving some unknown count. The resistor-capacitor-diode network stretch out the high output and ensure that the counter will be fully reset.

The output division is performed by IC3 in conjunction with IC5. A switch is provided to allow selection of 18 or 24 Hz outputs, with the duty cycles shown. Other frequency combinations are

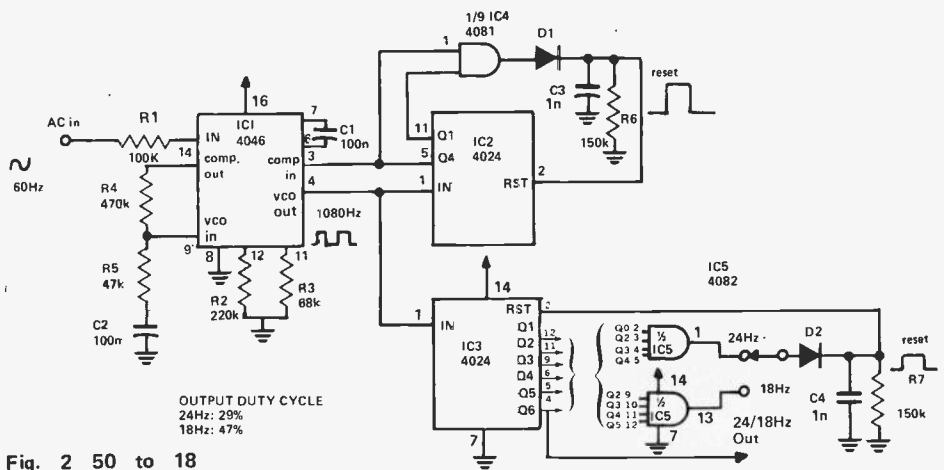

Fig. 2 50 to 18 or 24Hz converter.

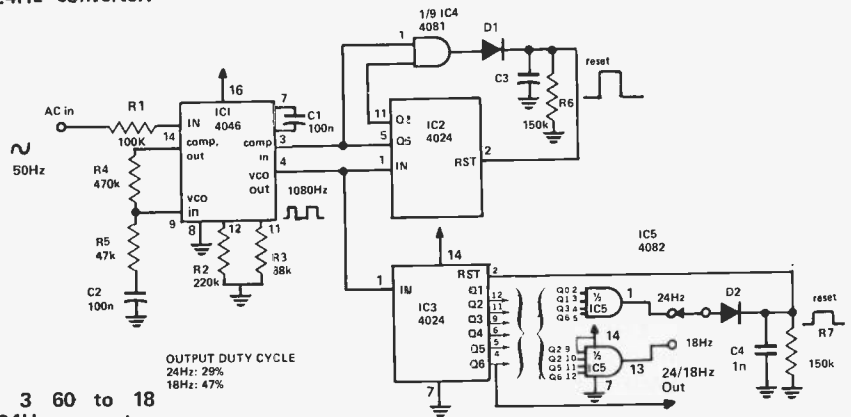

Fig. 3 60 to 18 or 24Hz converter.

possible with this circuit, by reprogramming IC2 and IC3. One limitation is the intermediate frequency, which can only vary from 900Hz to 2100Hz with the components shown. The maximum frequency is set by R2, R3 and C1, while the minimum frequency

is set by R2 and C1. You can scale the frequency by changing C1 as necessary. For very much lower frequencies, the values in the loop filter, R4, R5 and C2 may also need changing. For details, consult RCA's CMOS Data Book, or Don Lancaster's CMOS Cookbook. ●

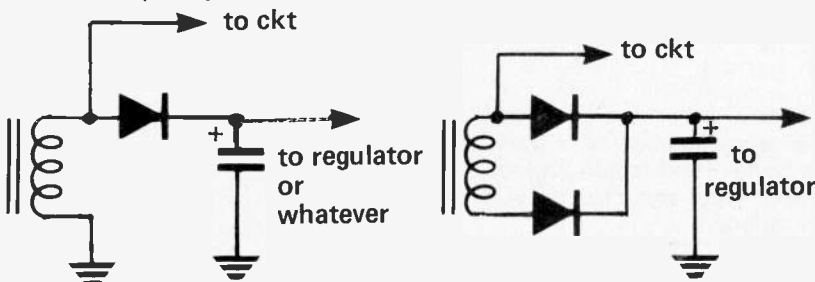
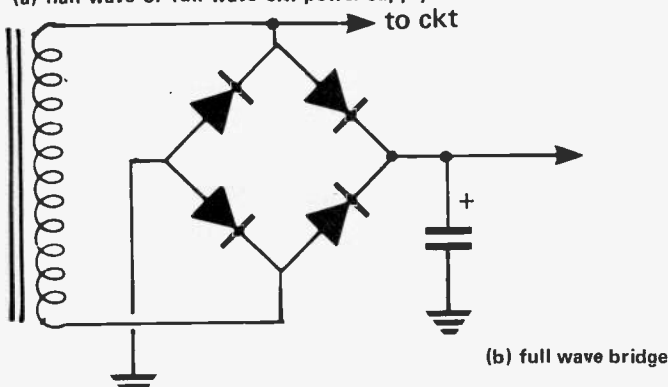
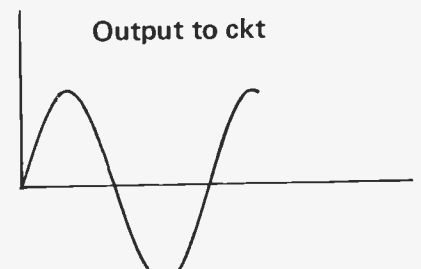

Fig. 4. How to get 60Hz power line signal (a) half-wave or full wave c.t. power supply



(b) full wave bridge



How to get 60Hz power line signal



clamped at -0.6v by the bridge

Electronics Today

INTERNATIONAL

JULY 1980

NEXT MONTH

A Robot??!

The amount of fiction and speculation devoted to the subject of robots seems endless. Next month ETI gets on the bandwagon and we'll present constructional details on how to build your own working (though not necessarily useful) robot.

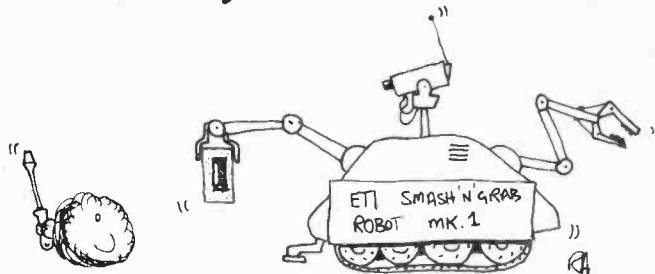

Decibels

Decibels are a never ending bother for the student of electronics. Next month we try to clear up some confusion.

Great little amp this, 25 pb power output & weighs 45 watts

Analogue Frequency Meter

Everyone wants to own a digital frequency counter, but honestly now, do you really need four digits of accuracy?

If you said 'no' then our AFM is just what you need.

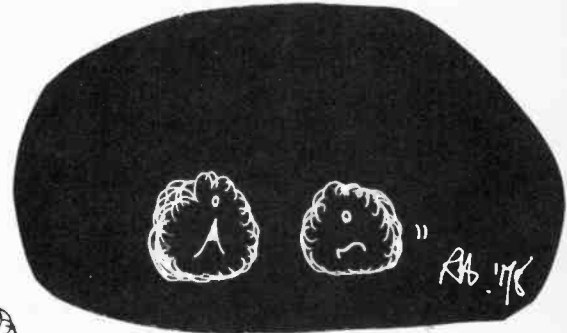
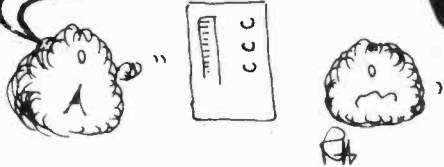

Phototimer

Nothing can be more tedious than to count 'steamboats' or 'Mississippi' while you've got the enlarger turned on. Check out our July issue for a really simple phototimer project.

Electronics in the Studio

Ever wonder why records cost as much as they do? We can't explain \$8.00 disks, but there's more to recording than a few mics.

Capacitors

There a large number of capacitors available today. Next month we look at some major types and their properties and applications.

CMOS RULES!!

(Bipolar is dead)

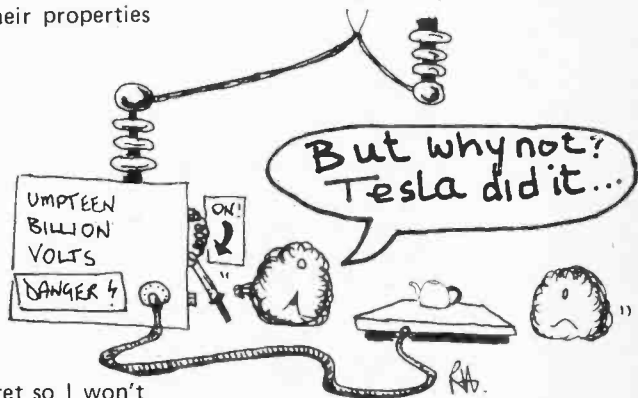

CMOS 555

Mention the words 'timing applications' and the 555 timer comes to mind. Did you know there's something better? No, it's not blasphemy. Intersil built a better one. Next month we look at some applications.

Another Contest!!!!

It's supposed to be a secret so I won't tell you the prize is a Leader Instruments product from Omnitronix that would give the average reader lots of scope. Oops! . . . Don't tell the editor I told you, he'd fire me for this.

The articles listed here are in advanced stage of preparation. Circumstances, however, may alter the final contents.

FUNCTION GENERATOR

A wide range (1Hz–100Hz) sine/triangle and square wave generator with built-in analogue frequency meter. A really nice piece of test gear from ETI.



The main characteristic of a function generator is that it produces a basic fixed-amplitude waveform other than a sine wave, from which a fixed-amplitude sine wave is then synthesized. The main advantage of this technique is that the resulting output waveforms of the generator are immune to amplitude 'bounce' when they are swept through their frequency ranges, thus enabling amplifier or filter gain/frequency tests, etc. to be carried out very rapidly. The only disadvantage of the technique is that the resulting sine wave has an inherently higher degree of distortion than is obtainable from good 'Wien bridge' and similar 'tuned' oscillator circuits.

The ETI function generator produces three output waveforms (sine, triangle and square) and covers the frequency range 1 Hz to 100 kHz in five decade ranges. The sine wave output typically produces a THD (total

harmonic distortion) value of only 0.5%, has a maximum amplitude of 2 volts rms, and is ideal for general purpose testing. The triangle output has a typical linearity of 1%, a maximum peak-to-peak amplitude of 5V6 and is ideal for cross-over distortion testing of class-AB amplifiers, etc. The square wave output is positive-going, has a maximum peak amplitude of 8 volts, has typical rise and fall times of less than 200 nS and is ideal for testing digital circuits. All output waveforms of the generator are DC coupled, with the sine and triangle waveforms swinging symmetrically about the zero volts line.

Our function generator incorporates a number of additional, very attractive features. It has a built-in analogue frequency meter, for ease of calibration. It has two output terminals, each with its own attenuator network. A sine or triangle waveform is available from one output and a

PARTS LIST

RESISTORS ALL ¼W, 5%

R1,2,14	10k
R3,17	1k0
R4,5,10	2k2
R6,7,9	22k
R8	470R
R11,18	100R
R12,13, 15 & 16	47R
R19	11R

POTENTIOMETERS

RV1,2	47k cermet multiturn (3/4")
RV3	22k cermet multiturn (3/4")
RV4	470R cermet multiturn (3/4")
RV5	4k7 cermet multiturn (3/4")
RV6	100k lin dual gang
RV7-10	10k
RV11	100k cermet multiturn (3/4")
RV12,13	1k0 lin

CAPACITORS

C1,2	100u 25V electrolytic
C3,9	150p polystyrene
C4,13	10n polyester
C5,10,14,11	100n polyester
C6,15	1u0 polycarbonate
C7,8	10u 25V electrolytic
C12	1n0 polystyrene

SEMICONDUCTORS

IC1	XR2206CP
IC2	NE555
Q1,3	2N5209
Q2,4	2N5086
D1-3	1N4148
ZD1	5V6 ZENER

MISCELLANEOUS

SW1	DPDT toggle
SW2	4 pole 5 way wafer switch assembly and 2 PCB wafers (2 pole 6 way)
SW3	DPDT toggle
SW4	1 pole 3 way rotary switch

2 BNC connectors, 2 9V batteries, case to suit, PCB.

square wave is available from the other. The square wave output is available at all times, is synchronous with the sine/triangle waveform and can thus be used to provide synchronisation signals to an oscilloscope timebase during sine wave testing, etc. The unit is battery powered, for maximum user convenience.

A fine unusual feature is that the frequency ranges are alternately contra-connected, so that to increase frequency you turn the 'fine' control clockwise on one range, anticlockwise on the next range and clockwise on the next range, etc. This facility enables the frequency to be swept through several decades very rapidly when testing the frequency response of amplifiers and filters, etc. As we said in the introduction, this is a really nice piece of test gear.

Construction

Most of the circuit is built up on a single large PCB. At this stage access to a distortion meter is desirable, so that RV3 and RV4 can be trimmed for minimum distortion. With care, a THD figure of 0.5% can be obtained.

In the absence of a distortion meter, the simple twin-T 1 kHz filter of Fig. 2 can be used in conjunction with the oscilloscope or with a millivoltmeter to set the generator for minimum distortion at 1 kHz. The procedure is to apply the sine wave output of

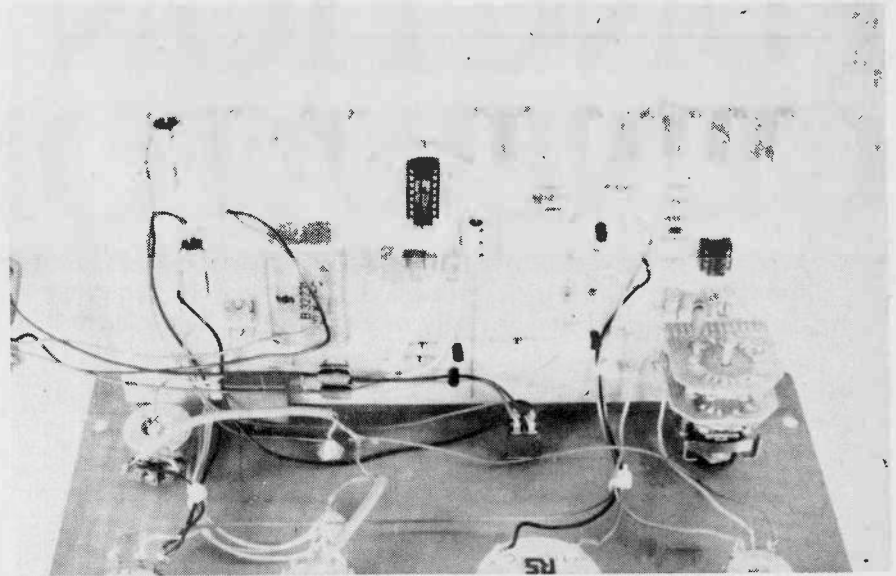

The printed circuit boards is mounted at right-angles to the front panel.

SPECIFICATIONS

Frequency range	1 Hz to 100 kHz in 5 decade ranges.
Output waveforms:	
Sine: distortion (typical)	0.5% at 1 kHz.
Triangle: linearity (typical)	1% at 1 kHz.
Square: rise/fall times (typical)	less than 200 nS.
Waveform stability (typical)	.002% per °C.
	.01%/V supply sensitivity.
Maximum output levels (with 9-0-9 V supply).	Sine = 2 V rms.
	Triangle = 5V6 pk-pk.
	Square = 8 V peak.
Supply	Two 9 V batteries.
Total current consumption	30 mA typical.

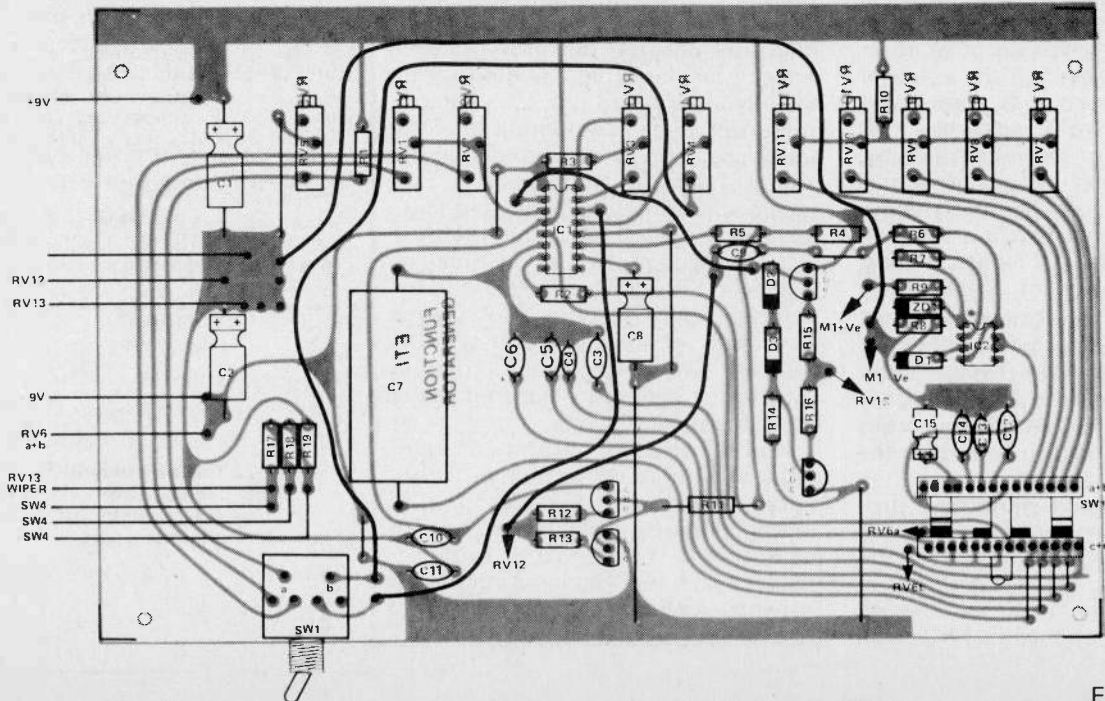

The component sitting on the PCB

the generator to the input of the filter, at about 1 volt rms at approximately 1 kHz and take the output of the filter to the input of the 'scope or millivoltmeter. Next, adjust the generator frequency and R4 of the filter to give minimum output indication and, finally, adjust RV3 and RV4 of the generator to reduce the output indication of the filter to the minimum possible value. At final balance, the output of the filter corresponds to approximately 0.1% thd per mV rms of indicated reading, ie if the indicator shows a reading of 5 mV rms, the thd of the generator approximates 0.5%. Now retrim OFFSET control RV5. The sine wave calibration procedure is then complete.

- (3). Set the unit to TRIANGLE mode. Monitor the waveform on the 'scope and adjust RV2 for a pk-pk amplitude of 5V6.
- (4). Check that the unit is functional on all ranges, in all waveform modes.
- (5). Switch the unit to its top frequency range, set the output frequency to 100 kHz and adjust RV7 for full scale deflection. If necessary, slightly reduce the value of C3 so that 100 kHz can be obtained.
- (6). Repeat the frequency calibration procedure on all ranges, using the appropriate pre-set (RV8 to RV11), noting that a very 'Jerky' reading will be obtained on the lowest (1 Hz to 10 Hz) range. The calibration procedure is then complete, and the unit is ready for use.

A final point to note is that we used 10-turn cermet for all pre-sets on our prototype unit. A slight touch of luxury, this. You can get away with ordinary presets, if you prefer, but in this case you'll have to make slight modifications to the PCB.

Actual construction on the PCB is fairly straightforward, but take extra care to observe the polarities of all electrolytics and all semiconductor devices. When construction is complete, fit the board into a suitable case and complete the interwiring to the remaining switches, pots and to the moving coil meter. The unit is then ready for testing and calibration.

Calibration

Calibration of the unit is fairly tricky

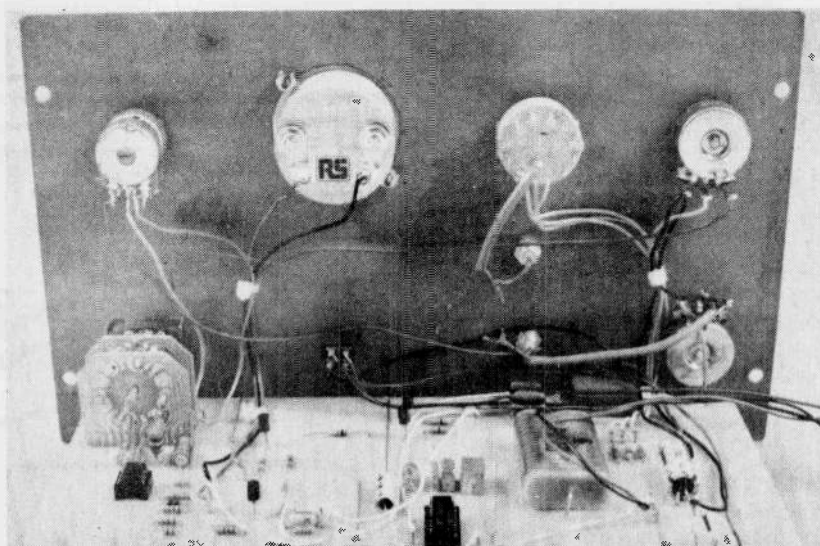

Rear view of the front panel controls.

and requires access to an oscilloscope and some kind of frequency reference (you can use the 'scope timebase as a reference if it is known to be reasonably accurate). The calibration procedure is as follows:

- (1). Set the unit to the SINE mode. Set the attenuator controls for maximum output. Set the frequency controls for approximately 1 kHz on the 1-10 kHz range. Set all pre-set pots at mid value. Switch the unit on, and use a 'scope to check that some kind of waveform is available (the waveform may be pretty awful at this stage). Check that the frequency is variable via RV6.
- (2). Reset RV6 for a 1 kHz output and adjust RV1 for a pk-pk amplitude of about 5V6. Adjust RV4 for a 'passable' sine wave, and then readjust RV1 for 5V6. Now alternately adjust RV4 for MINIMUM DISTORTION and RV3 for best SYMMETRY, occasionally readjusting RV1 for 5V6 pk-pk until a good sine wave is produced. Adjust RV5 for zero offset (so that the output waveform swings symmetrically about the zero volts level) and retrim RV3 and RV4 for a good sine wave. ●

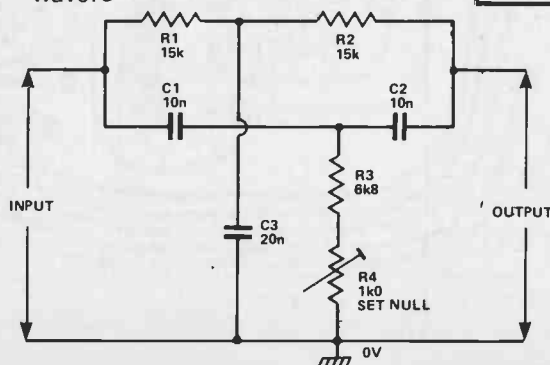

Fig. 2 This simple twin-T filter can be used to set the generator for minimum distortion.

HOW IT WORKS

There is not an enormous amount we can say here, since most of the work of the circuit is carried out inside IC1, which is a special function generator chip that produces a square wave output from pin 11 and a sine or triangle wave from pin 2. The purity of the sine wave can be trimmed via RV3 and RV4 and the maximum amplitude can be pre-set via RV1. The maximum triangle amplitude can be pre-set via RV2 and both waveforms can be offset via RV5. The sine/triangle waveforms are made available to the outside world via buffer amplifier Q3-Q4 and the associated attenuator network. The square wave is made available, in positive-going form only, via the Q1-Q2 buffer and RV12.

The operating frequency of the generator is variable via timing capacitors C3 to C7 and via resistor network R2-RV6. The frequency is monitored on a simple analogue frequency meter that is designed around 555 timer IC2, which is triggered via the square wave output of the Q1-Q2 buffer amplifier.

The entire circuit is powered from two 9 volt batteries, and the circuit consumes a typical total current of about 30 mA.

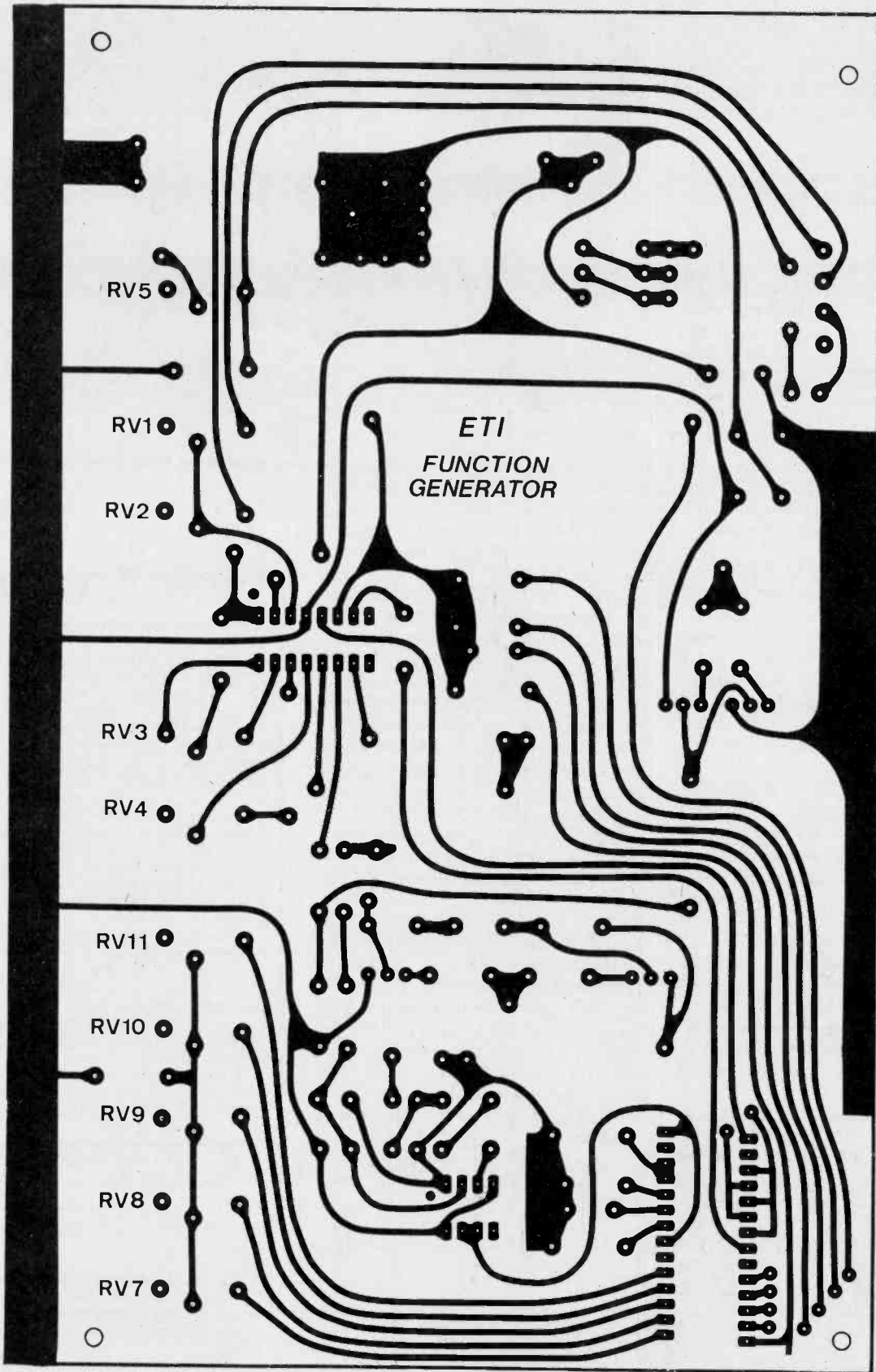

Elements of Electronics

\$8.95 each

1

The Simple Electronic Circuit and Components

Elements of Electronics

2

Alternating Current Theory

Elements of Electronics

3

Semiconductor Technology

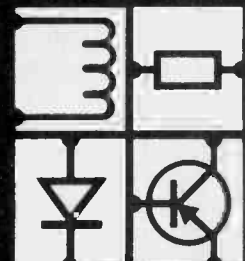

Book 1 (BP 62) introduces the reader to the nature of electricity, it's sources and simple electronic circuitry. Additionally there are chapters on components, electrical safety and electronic math.

Book 2 (BP63) delves into the secrets of AC current theory. Attention is paid to resonance and Q-factors, impedance, phasor diagrams and transformers. Includes ample mathematical appendices.

Book 3 (BP64) centres on semiconductor theory. Chapter 1 starts at the physics and applications theory of semiconductors. Other subjects include diodes, transistors and FETs. Applications studied include rectifiers, amplifiers, oscillators, switching and IC techniques.

To order please use the card facing page 44 or send to:

ETI Magazine,
Unit 6, 25 Overlea Boulevard,
Toronto, Ontario, M4H1B1

Oxfam

Working with people who are helping themselves

Send Your Tax-Deductible Contribution To:

OXFAM-CANADA

BOX 18,000
TORONTO
OTTAWA
HALIFAX
ST. JOHN'S

BOX 12,000
WINNIPEG
REGINA
CALGARY
VANCOUVER

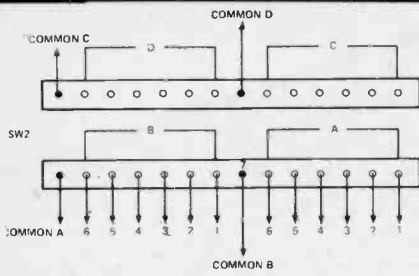
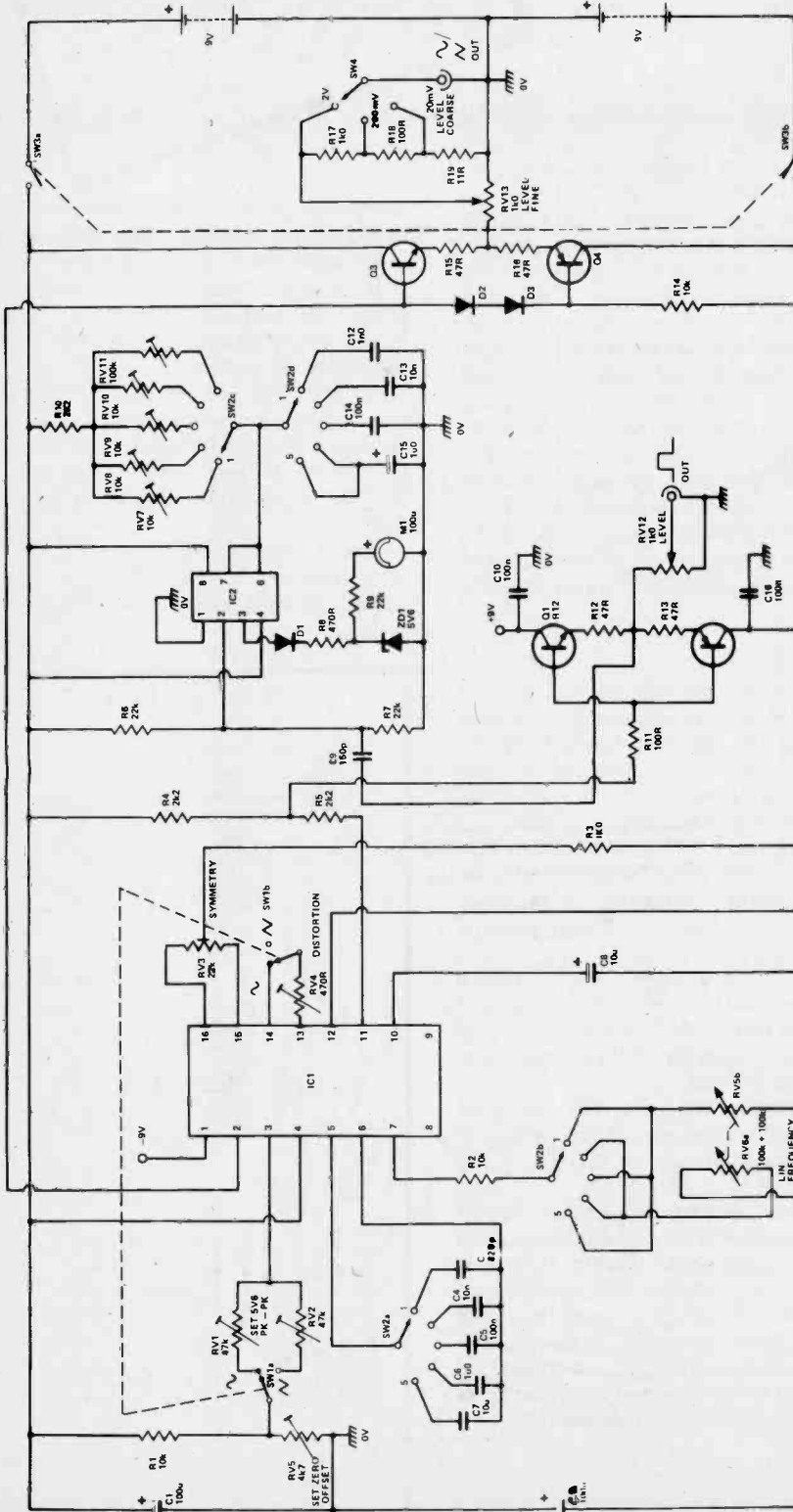

Fig. 4 Circuit diagram.

Fig 3 Range switch wafer pin-out.

NOTES:
IC1 is XR2206CP
IC2 is NE555
D1, D3 are 1N4148
Q1, Q3 are 2N5209
Q2, Q4 are 2N5086
ZD1 5V6 zener
SW2 POSITIONS
1=10kHz-100kHz
2=10Hz-1kHz
3=100Hz-1kHz
4=100Hz-10kHz
5=1Hz-10Hz



Service News

By their very nature, associations have to communicate with the consumer. David Van Ihinger presents his story.

The Association Telephone

WHEN THE NICE lady, who has always done so before, announced her desire to retire from answering the telephone for our provincial television-electronics association, yours truly got the job. Thanks all the same, but everyone knew that since it only took a few minutes a month to write this column, there was plenty of time left over to answer a telephone.

There it is, sitting at the end of my desk, on top of the mobile radio transmitter, a brand new shiny black phone decorated with red Dymo labels, which caution one on how to answer it. It isn't the only phone on the desk. There are two more, which are normally answered with the company name. It was only a matter of time before someone would accidentally answer the association phone the wrong way, and inevitably the outcry reached the board of directors of the association and you can guess the rest.

The phone is needed firstly, because there is a yellow page listing of those association members wishing to identify themselves as such, and this requires a basic phone number.

Secondly, the Better Business Bureau, the province's Consumer Protection Bureau and other interested parties need to get through to the Judicial Chariman, who handles the complaints about which we will talk later.

Thirdly, it serves as an information centre, where people expect to get impartial help with their TV and electronic problems.

Most of the calls come from people who need general information.

"How much is a service call?"

"What tube do I need for my TV? It is two years old and the sound is good but there is no picture."

"But madam, two-year-old sets don't have tubes."

"Where can I call for service?"

"Where do you live? Look on page . . . in the yellow pages under the association listing for someone in your area."

"Is so and so a member of your association?"

"What are the advantages of calling one of your members?"

"Do you all charge the same?"

"No. That would be illegal under the Combines Act."

"If I am not happy with one of your members, whom do I call?"

"Phone this number . . . and ask for . . . , who is our Judicial Chairman."

One of the Dymo labels on the phone reads: "Judicial Chairman, showing his name and phone number, and anyone with a complaint meriting his attention is given this information. They have been referred here by the BBB, Consumer's Bureau, Police Dept., etc. Altogether, there are less than one per week. This seems uncanny when we consider that the population covered exceed 2 million people, and that, so far as we are aware, all complaints from all sources are channelled through this telephone.

Talk To Us

The most common problems seem to stem from poor communication. Either the customer did not understand the technician, or the technician did not take enough time to find out what the customer really expected from him.

Many cases involved subsequent failure of the set after repair, usually revealing a dirty intermittent with which the technician had unwittingly become entrapped.

The Judicial Chairman spends quite a lot of time explaining the actual costs of supplying service and labour. Many customers have no idea of those costs, and need to be advised.

We have learned, also, that people do not like telephone answering devices, or even personal answering services. They want to talk to the MAN.

Not all complaints can be fielded simply. According to our J.C. some come down to poor workmanship, incompetence, or even possible dishonesty, but, fortunately, these do not total a dozen a year, lately anyways. Hearteningly, none have been association members, in my time. A file of complaints has been set up for analysis by the Judicial Committee.

There is a lighter side to this job, though, which by the way, is voluntary

MANUFACTURERS . . . DISTRIBUTORS . . . SERVICE . . . REPRESENTATIVES . . . ORGANISATIONS Send us your news releases on upcoming seminars, new products, ideas for the successful shop. Address them to Service News, Electronics Today Magazine, Unit 6, 25 Overlea Blvd, Toronto, Ontario, M4H 1B1. Please note that your information must be received at least six weeks before the first of the month of the issue in which it is to appear. Any material published at our discretion.

and non-paid. The other day someone called to say that he had a message for me. I asked who he was, and he replied that he was a "messenger fo peace". He started to read, so I placed the phone in our amplifier cradle to let the whole shop hear his sermon.

It was also on that phone that the lady called a few months ago to ask about her Quasar TV which had failed.

"Works In The Drawer?" I asked.

"No, it sits on my dresser in the bedroom."

There goes the phone now. There goes another. And the other. Now lets get this straight. Hello! Hello! Hello!●

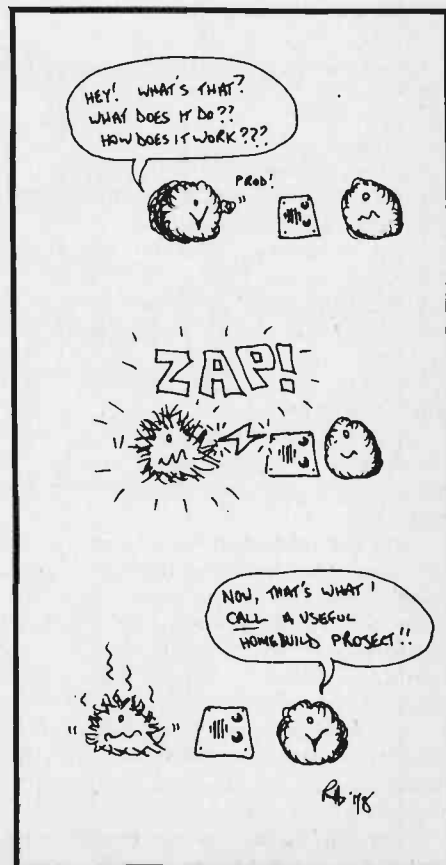

CA3130 PROJECTS

These ten circuits using this popular integrated circuits are taken from the Babani Book '50 Projects Using IC CA3130.' This book is available from the ETI Book Service; see page 32 for more details.

OPERATIONAL AMPLIFIER integrated circuits have become increasingly popular in circuits for the amateur electronics enthusiast. The reason for this is not hard to discover, and is simply that these are probably the most versatile type of semiconductor device currently available. They are also among the least expensive of integrated circuits, and often have an economic advantage over alternative circuit elements.

The CA3130 is manufactured by RCA and is a relatively new device. It is not as inexpensive as certain other popular operational amplifiers, such as the 741C and 748C types, but it is a more advanced in design than its less expensive rivals. This means that it is often capable of a higher level of performance than other devices, and that fewer discrete components are needed. This tends to offset its cost disadvantage.

Operational Amplifiers

A theoretically perfect op amp has an infinite voltage gain, infinite input impedance, zero output impedance, infinite bandwidth, and is capable of giving a peak to peak output voltage swing which is equal to the supply rail potential. The circuit has two inputs, and these are termed the inverting input, and the non-inverting.

If the non-inverting input is made positive of the inverting one, the output of the amplifier will swing positive. If the non-inverting input is negative with respect to the inverting one, the output swings negative. In a theoretically idealised op amp any difference in potentials between the two inputs will be enough to send the output fully positive or fully negative, but of course, no practical amplifier can achieve theoretical perfection for this parameter. Neither can it achieve theoretical perfection in any of the other parameters listed earlier, but most modern devices come close enough to be regarded as perfect in most respects. For instance, most op amps have a voltage gain of something like 100 000 times, and the typical figure for the CA3130 is some 900 000 times.

In a few switching applications this full gain is required, but in all circuits needing linear amplification, this gain is greatly reduced by the application of negative feedback.

One parameter in which many well-known devices fall short of theoretical perfection is that of input impedance. Bipolar transistors have relatively low input impedances, and since these form the basis of the input circuitry of most op amps, this shortcoming exists. An example is the 741C IC which has a typical input impedance of 2M with a minimum figure of 300k. This is not high enough for many applications, and even though the input impedance is increased to quite a large extent by the utilisation of negative feedback, the input impedance may still be too low.

Two chip op amps have been available for some time and these use a FET input stage on one chip, and the

remaining circuitry is contained on a second chip, FETs have extremely high input impedances, and these two chip devices achieve input impedances of thousands of Megohms. However, this is achieved at a price which puts them beyond the use of most amateurs, the actual cost being something like ten times that of a 741C.

The CA3130 is manufactured using techniques which enable the FET input stage and the main bipolar circuitry to be contained on a single chip. It is far less expensive than the two chip ICs and is a very practical proposition. It uses a CMOS (complementary metal oxide semiconductor) input stage which has a voltage gain of only about five times. This is followed by two bipolar amplifying stages, the first having a voltage gain of 6 000 and providing most of the unit's gain. The second is a Class A output stage which has a voltage gain of about 30 times.

Some operational amplifier ICs have internal compensation components, but the CA3130 does not. The purpose of the compensation circuitry is to reduce the upper frequency response of the device and so prevent it from becoming unstable. When used at low gains quite a high degree of high frequency roll-off must be used, but when used at high gains little or no roll-off is needed. Thus, if internal compensation is used, this must provide enough high frequency attenuation to prevent instability at low gains. This limits the bandwidth of the device unnecessarily when it is used at comparatively high gains.

Therefore using external compensation is not really a disadvantage even if it does slightly increase the number of discrete components required. It enables the bandwidth of the device to be optimised for any level of voltage gain. In the case of the CA3130 only a single low value capacitor is used to provide the necessary frequency compensation.

Performance Figures

As will be seen from the main performance figures of the CA3130, which are given below, this device has a high level of performance:

Input Impedance	1.5 million Meg ohms
Open Loop Voltage Gain (the gain without negative feedback)	900,000 times
Input Bias Current	5pA (1pA = 1 millionth of a micro amp).
Gain-Bandwidth Product	15 MHz
Slew Rate	30 V/micro sec.
Operating Temperature Range	-55 to +125 degrees C
Supply Voltage Range	5 V to 16 V of a balanced positive and negative supply of ± 2.7 V, to ± 8 V.

Current consumption from 9V supply with output at half supply voltage

2.5 mA

The above are all typical ratings.

The CA3130 is contained in a TO-5 8 lead metal encapsulation, and its leadout diagram is shown. There are several versions of the IC and the CA3130T and CA3130S versions are the ones that are required for the circuits described. The CA3130T has a standard TO-5 and leadouts whereas the CA3130S has its leadouts formed into an 8 pin dual in line configuration. These two devices are electrically identical.

Other versions of the CA3130 have a more rigid specification in some respect or other, and these will work in these circuits. They are however, more highly priced than the two basic versions.

One advantage over this device when compared to most other op amps is that when lightly loaded, the output can swing to within a matter of a few millivolts of either supply line. Most other devices can only manage an output swing (peak to peak) of about 4 volts less than the supply voltage. This enables the CA3130 to be used in simple circuit configurations which would not be possible using most other op amps.

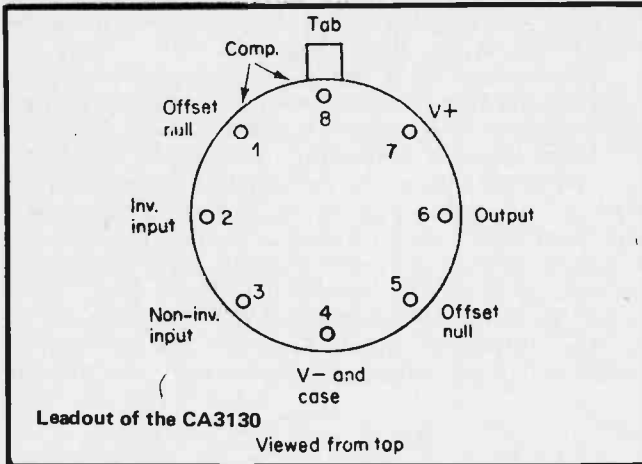

Offset Null

Most op amps have an offset null facility and the CA3130 is one of these devices. The purpose of the two offset null leadouts is to enable the output to be adjusted to zero (in the case of a dual supply), or to half the supply voltage (in the case of a single supply) even though the input terminals are not at quite the same voltage. This is a useful feature, but it is not required in any of the circuits described here.

Metronome

A conventional metronome uses a purely mechanical mechanism to produce a series of clicks at regular intervals. It is quite easy to simulate this electronically, and the simple circuit shown in Fig. 1. performs this task.

This circuit is basically an oscillator but the circuit values have been adjusted to provide a slow rate of oscillation and by enabling the time constant of the feedback circuitry to be varied, the oscillation frequency is made variable. VR1 can be adjusted to produce any beat rate from about 50 beats per minute to over 200 beats per minute.

In this application the output drive of the CA3130 is not sufficient to produce an adequate volume from the speaker without some additional amplification at the output. An emitter follower buffer stage has, therefore,

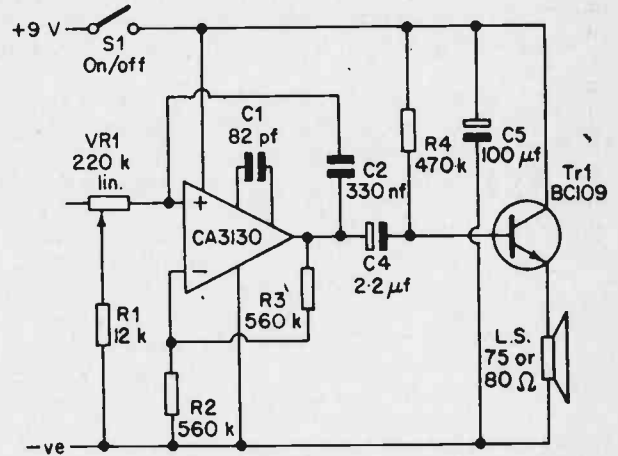

Fig 1. Here the IC is converted as a frequency oscillator operating over the range of 50-200 pulses per minute, this is determined by C2 and VR1. The transistor acts as a simple amplifier to drive the loudspeaker.

been included at the output, and this uses only two components (Tr1 and R4).

It is necessary to mark a dial around the control knob of VR1 so that the unit can be quickly set to any desired beat rate. This is quite easily done as the relatively low frequency range of the unit means that it is quite possible to count the number of pulses produced per minute. It will be quicker if one counts the number of pulses emitted during a fifteen second period, and then multiplies this by four to find the number produced per minute.

Rain Alarm

It is quite a well known fact that pure water is a very poor conductor, and it would probably be more accurate to call it an insulator. Fortunately, raindrops do not consist of pure water and contain relatively high levels of impurities which are picked up from the atmosphere. These dissolve in the rain drops to produce very weak solutions which have fairly low resistances.

The circuit of a simple rain alarm using a CA3130 is shown in Fig.2. This consists of three basic parts, the sensor, an electronic switch, and an audio alarm circuit.

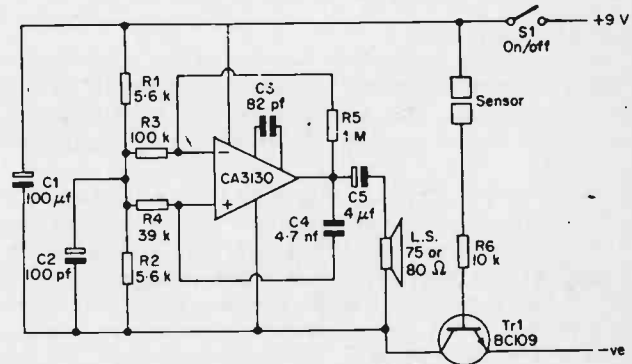

Fig 2. Rain alarm circuit. Basically an audio oscillator with the negative supply controlled by Tr1. When a drop of rain bridges the sensor, Tr1 acts as a low value resistor allowing current to reach the rest of the circuit.

There is more than one way of arranging a suitable sensor, but probably the most simple method is to use a piece of veroboard; 0.1 in. matrix is best for this purpose as it has the most strips for any given area. A piece having 24 strips by 50 holes should be adequate. If the strips are numbered 1 to 24, all the even numbered strips are connected together by link wires on the non-coppered side of the board. All the odd numbered strips are then similarly connected together. One set of strips then connects to the positive supply line of the rain alarm circuit, and the other connects to R6.

The sensor is positioned at any convenient spot outside the house where it is not shielded from rainfall. It is connected to the rest of the circuit via twin insulated cable, and this cable can be several yards long if necessary. The sensor is positioned copper side up so that any raindrops that fall on it form an electrical bridge between two adjacent strips.

With no raindrops on the sensor, Tr1 is cut off and only minute leakage currents will flow in the circuit. This is very important as it ensures that the battery has a very long life and is not run down even when the alarm is not sounding.

When water is present on the sensor, a base current is supplied to the unit through R6 and the sensor. R6 is a current limiting resistor, and is needed to ensure that Tr1 does not pass an excessive base current. Tr1 is used as the electronic switch and when it is biased into conduction it supplies power to a simple audio oscillator utilising a CA3130 IC. This causes an audio tone to be emitted from the unit which is, of course, situated inside the house where it will alert the user.

Light Switches

Switches that are operated automatically by changes in light intensity are among the most useful and popular of electronic projects. They can be used as the basis of many gadgets, such as porch lights that automatically turn on at night, and off at daybreak. Burglar alarm systems can also incorporate this type of switch. They can also be used in applications outside the home, such as in automatic park lighting on cars.

When used as a comparator, an operational amplifier makes an ideal basis for a photo sensitive switch. The circuit diagram of a simple photo switch incorporating a CA3130 IC is shown in Fig. 3. This is designed to close

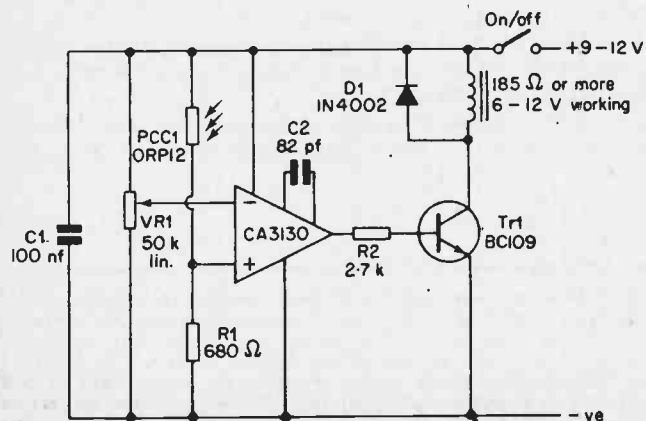

Fig3. If the light on PCC1 falls below a certain level, the output of the IC1 goes high, turning on Tr1 which operates the relay.

the relay contacts when the light falling on the photocell drops below a certain preset level.

VR1 is adjusted so that under normal conditions there is a higher voltage at the inverting input than there is at the non-inverting input. This causes the output of the IC to be normally low, with Tr1 cut off and no significant current flowing through the relay coil.

If the level of light falling upon PCC1 should now drop for some reason, the resistance of PCC1 will increase the voltage at the inverting input will fall. If it falls below the voltage at the non-inverting input, the output of the IC will swing high and will turn Tr1 hard on. This will cause the relay to be activated.

When the light level on PCC1 returns to normal, the relay will turn off once again. By adjusting VR1, this circuit can be adjusted to switch over at virtually any light intensity one desires.

If the relay has changeover contacts, it can be connected so that it either switches the ancillary equipment on when the light level falls below the threshold level, or so that it switches it on when the light level rises above the threshold level. If the relay only has make contacts, it can only be used to perform the former.

The circuit can be modified very easily to enable a relay having only make contacts to turn the ancillary equipment on when the light intensity rises above the threshold level. The modified circuit is shown in Fig 4.

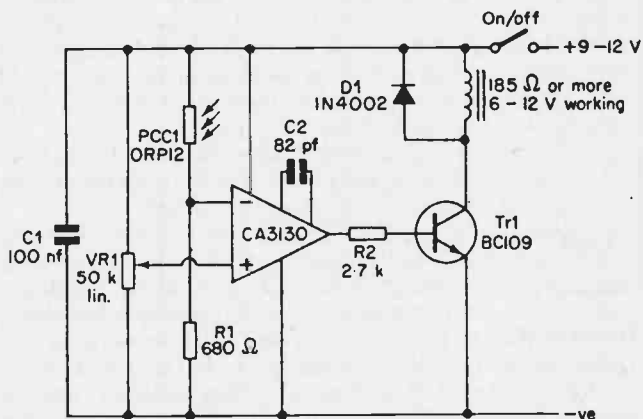

Fig4. Connecting the Fig 3 differently, the same components can be used to switch when the light level increases.

All that has been done here is that the inputs of the IC have been swapped over. Now, under normal conditions VR1 is adjusted so that the voltage at the inverting input is more than that at the non-inverting input, just as before. However, when the light intensity on the photo conductive cell increases, the voltage at the non-inverting input increases, and the output of the IC goes high. This operates the relay, and also the ancillary equipment. This circuit thus operates in the reverse manner to that of the previous design.

Latching Circuits

For certain applications a photo switch that latches is required. This type of switch differs from those just covered in that once the relay comes on, it remains on, regardless of any further changes in the light intensity falling on the photocell.

Circuits such as this can be used in burglar alarms, for example. A photo cell can be positioned so that when light from an intruder's torch falls upon it, the circuit operates an alarm circuit. Obviously this arrangement is

One might think that the relay would be short lived in this circuit anyway, as with such rapid switching it would soon wear out. This is not the case though, as any modern relay of reasonably good quality is guaranteed to last for several hundred thousand operations. The unit can be battery operated, but since it is controlling a mains load, it would be more logical to construct a mains power supply for it.

Simple Organ

The field of electronic musical instrument and effects is one which has increased greatly in popularity over the past few years, and it must now rate as one of the most popular branches of electronics. Electronic musical instruments need not be complicated, and a simple electronic organ can be built using very few components indeed. A simple circuit of this type using a CA3130 IC as a tone generator is shown in Fig. 10.

Here the CA3130 is used once again as a squarewave generator, with the output of the IC being used to drive a common emitter transistor amplifier. R4 is a current limiting resistor and VR1 is the volume control. This is a very economical arrangement as DC coupling is used, and a DC blocking capacitor and bias resistor for Tr1 are therefore unnecessary.

A high impedance loudspeaker is used as the collector load for Tr1, and quite a high volume level (for such a simple instrument) is available. The circuit is most efficient if a high impedance speaker is used, but it will work using speakers with impedances as low as 15 ohms. When using a low impedance speaker R4 should be increased in value to 39k.

A different timing resistor is used for each note, and the preset resistors are used here as it is necessary to be able to adjust each tone for tuning purposes.

There are many ways of arranging a simple keyboard for the instrument, but almost certainly the easiest and most practical method is to etch one along the lines shown in the circuit diagram. The enclosed shaded areas represent the coppered areas of the PCB. A test prod, or anything similar to this (wander plug, banana plug, etc.) can be used as the stylus, and the desired note is obtained by placing this on the appropriate part of the keyboard, so that the necessary circuit is completed and the circuit oscillates.

R6 ensures that when the stylus is not placed on the keyboard, and the circuit is not oscillating, the output of the IC goes low and Tr1 is cut off. This gives a very low quiescent current consumption of only about 1 mA. If R6 were to be omitted, the output of the IC would go high under quiescent conditions, and a current of up to about 50 mA, would flow through Tr1 and the speaker. Apart from giving poor battery economy, a large standing current would not be very good for the speaker.

The current consumption of the unit when the tone generator is oscillating varies from about 1 mA to 30 mA, depending upon how well advanced the volume control is. The output stage is a sort of Class B amplifier, and so the higher the volume level is adjusted, the greater the current consumption. The circuit thus provides the longest possible battery life.

The unit can be tuned over a range extending from well below middle A to the A several octaves above this. By adjusting a preset for a very low value the unit will in fact oscillate at frequencies of the upper limit of human hearing. By increasing the value of C3 the unit can be

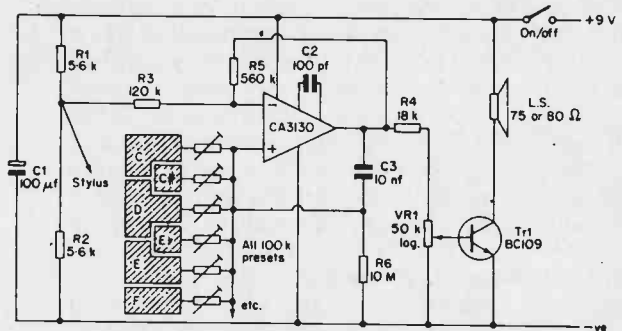

Fig. 10. You can make an electronic organ using the circuit shown here. The stylus is touched onto the sections of the PCB to vary the frequency at which the CA3130 oscillates. By turning the presets you can make almost all musical notes.

made to oscillate at frequencies as low as one wishes.

It is therefore possible to obtain a range of several octaves if required, by using the appropriate number of presets and keyboard positions. For most purposes a single or two octave version will be sufficient. This would have a compass from middle C to the C either one or two octaves above this. Thirteen 100k presets are needed for a single octave unit, and twenty five are required for a two octave version. This gives a chromatic scale.

The unit can be tuned against a piano, organ, pitch pipes, or virtually any properly tuned musical instrument. A reasonably musical ear is required for this, as not everyone will find it possible to tune the notes on the organ to those produced by the instrument it is being tuned against. However, most people will find that this is not too difficult after a little practise.

It should perhaps be pointed out that this instrument is not polyphonic, and cannot be used to play chords. It can only produce one note at a time. The tone is quite pleasant though, particularly at the low frequency end of the compass, and if a reasonably large speaker is used. The absence of chords also makes the unit very easy for a beginner to play.

Component Selection

Readers will notice that some parts listed are of European designation.

The BC 109 is a low noise, high gain npn silicon transistor. Inasmuch as all transistors operate in the switching mode, any small signal npn transistor should work. 2N 2222 or 2N3904 units are recommended.

The OA91 diode is a small signal germanium diode similar to the 1N34. In the applications shown silicon substitutes such as 1N914 or 1N4002.

Any light dependent resistor should serve as a substitute for the ORP12. Try for a dark resistance of less than 1k.

This article is reproduced by kind permission of Bernards (publishers) Ltd, The Grampians, Shepherds Bush Road, London W6 7NF, and taken from '50 Projects Using IC CA3130' by R.A. Penfold. The book contains other sections covering audio, RF, test equipment as well as several miscellaneous circuits. The book (No. 223) is available for \$4.50 plus .30¢ postage and handling through the ETI Book Service.

CANADA'S SOUND ARCHIVES

Historical textbooks abound in our nation's libraries, but what about historical recordings? Jim Essex reports.

"THE QUEEN is dressed in powdered blue", went the radio announcer's voice, overwhelmed with excitement, "and as her bow comes up against the jetty, etc." . . .

He, of course, meant the ship "Empress of Britain" and the occasion he was describing was the visit of the King and Queen to Canada in 1939, the first such visit of a crowned Head. His lack of punctuation makes his commentary ridiculous, but that's the sort of "gem" to be found in our Public Archives in Ottawa. Even the most trivial and (often) innocuous sounds are found in this unique government office located in our National Capitol.

Nowadays, the spoken word has proliferated, thanks to the wide acceptance of the cassette recorder, but it was not always so. That's why, since 1967, Canada's Centennial Year, the Sound Archives Section of the Public Archives of Canada has been collecting recordings of historical significance before they're gone — perhaps forever! Consider just a few, which, in their listings, reads like a "Who's Who" of History:

- July 1967, De Gaulle, President of France, made his famous (or infamous?) speech in Montreal during a state visit to Quebec. The simultaneous translation in English as recorded and broadcast by radio CFMB Montreal is now preserved for posterity;
- Winnipeg General Strike of 1919, interviews of labor leaders and members of the special Police Force;
- William Aberhart, Premier of Alberta who introduced "Funny Money" when the Prairies were struck by a drought during the Depression.
- King George VI — speeches and colourful commentary during the Royal Visit in 1939;
- Albert Lebrun, President of France, who speaks about Canada's Vimy Ridge Memorial. At the unveiling

(in July 1936) also, was King Edward VIII, who tells of Canada's role in wresting the so-called impregnable ridge from the Germans, after Britain and France failed in 1917;

- Speeches, talks and comments by Canadian Army officers about the War in 1939-45, and the German surrender in Holland;
- Nathan Cohen's pithy comments are related in excerpts from the "Fighting Words" program in the late '50s;
- Eugene Forsey talks about the "Character of Canadian Politics" and the life of "Mackenzie King", Canada's longest Prime Minister in office;

There is available a list as long as your arm on talks by world personalities like Lester B. Pearson, Louis St. Laurent, Pierre Trudeau, and John Diefenbaker, and overseas leaders like Lord Louis Mountbatten. Unusual personal-

ities also have a place, like Grey Owl, (really Archie Belaney from England) who, although an amateur set standards for conservation in Canada's Wilds still followed today.

There's the sound and fury of battle, witness the attack on Dieppe by Canadians in 1942. Also, the clarion call to "freedom-loving men" everywhere with the speeches of Sir Winston Churchill and Franklin Delano Roosevelt.

Sports events in Canada's life aren't forgotten either, as we can re-live the excitement of Marilyn Bell swimming Lake Ontario and the famous Grey Cup Games of the '50s.

For the sentimental of heart, you can listen again to all the pathos that recordings can capture as King Edward VIII, in his abdication speech, cites his reasons for giving up the Throne "for the woman I love" in December of 1936, now long ago!

A view of the Canadian Sound Archives in Ottawa.



How can you contribute to the collection? Ernest Dick, Head of the Sound Archives Section of the Public Archives, encourages people to send in recordings they deem of national historical significance. To this end, they are prepared to listen and evaluate your material on this basis. For example, my contributions, listed under my name in their recent publication, Inventory of Main Holdings include, interviews of businessmen, actors, pilots, scientists, and craftsmen about their life and their pastimes. 1969-1974. This is listed under item number 102 and time is given as 5 h 42 min.

All listings are in alphabetical order, according to the name of the depositor. The inventory has been prepared in order to familiarize the public with the wide range of sound recordings to be found there.

This is important for people doing research involving an event in History. All the writer need do is contact the Section, who will then inform him or her of the procedures to follow. The question of accessibility is then dealt with. Some collections, understandably, have been transferred to the Sound Archives with certain restrictions. These include confidentiality, copyright and so on, which, in these cases, Dick says the Archives must respect. He points out, however, these are only in special cases, where a researcher must obtain permission from the depositor or copyright holder (authors, actors, producers, sponsoring companies and so on). However, Dick points out that researchers who do not have a commercial motive are usually granted full access to a recording. After all, it is a public archive, supported by your money and mine.

The equipment is tops, and every effort is made to handle contributions, carefully. It is here that dedicated people maintain tapes and discs of sufficient importance to warrant them being kept in the public domain for our use. ●

Thanks to you
it works...
FOR ALL OF US.



United Way

Special Publications from ETI

CANADIAN PROJECTS BOOK NO. 1



25 of the most popular projects from our earlier issues including: Audio Limiter, 5W Stereo, Bass Enhancer, Modular Disco, 50W/100W Amp modules, IB Metal locator, Heart Rate Monitor, Phaser, Touch Organ, Electronic Mastermind, Double Dice, Reaction Tester, Sound Operated Flash, Burglar Alarm, Injector-Tracer, Digital Voltmeter. 100 pages.

\$3.45 (inc postage)

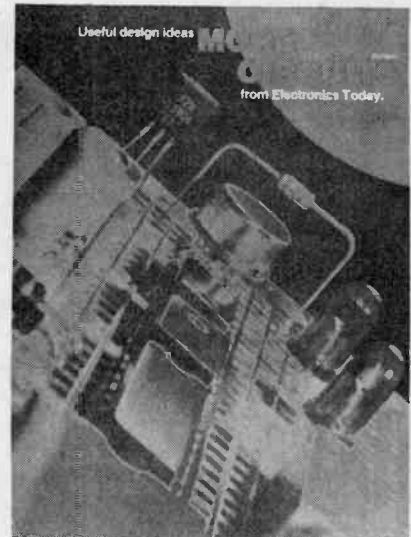

Over 150 circuits plus articles on Circuit Construction, Test Gear, a project on a Digital Panel Meter, Design notes on Speaker Crossovers, TTL pin-outs, Design notes on Crystal Oscillators. 108 Pages.

\$4.95 (inc postage)

To order, use the card facing page 44 or send money to: ETI Magazine, 25 Overlea Blvd., Unit 6, Toronto, Ontario M4H 1B1

ETI Book Service

Single IC Projects

R. A. Penfold

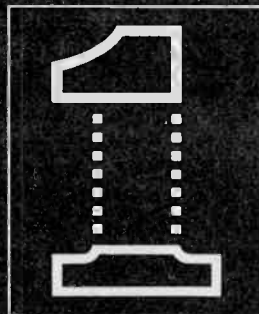

There are now a vast range of IC's available on the amateur market, the majority of which are not necessarily designed for use in a single application and can offer unlimited possibilities.

All the projects contained in this book are simple to construct and are based on a single IC. A few projects employ one or two transistors in addition to an IC but in most cases the IC is the only active device used.

BP65 \$6.25

Electronic Circuits for Model Railways

M. H. BABANI, B.Sc. (Eng.)

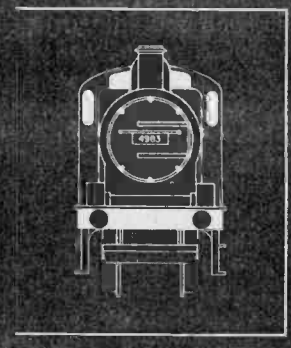

In this book a number of constructional projects and ideas are discussed. Details are given on how to build three types of model train controller and ideas on signalling are considered in detail.

BP213 \$4.50

Use the card facing page 44 or send to: ETI Magazine, Unit 6, 25 Overlea Blvd., Toronto, Ontario. M4H 1B1

Babani Books From ETI

Please order by number using the handy order card in this issue.

These books are specially imported from England by us. If someone has already used the card, write to ETI Magazine, Unit 6, 25 Overlea Blvd. Toronto, Ontario M4H 1B1.

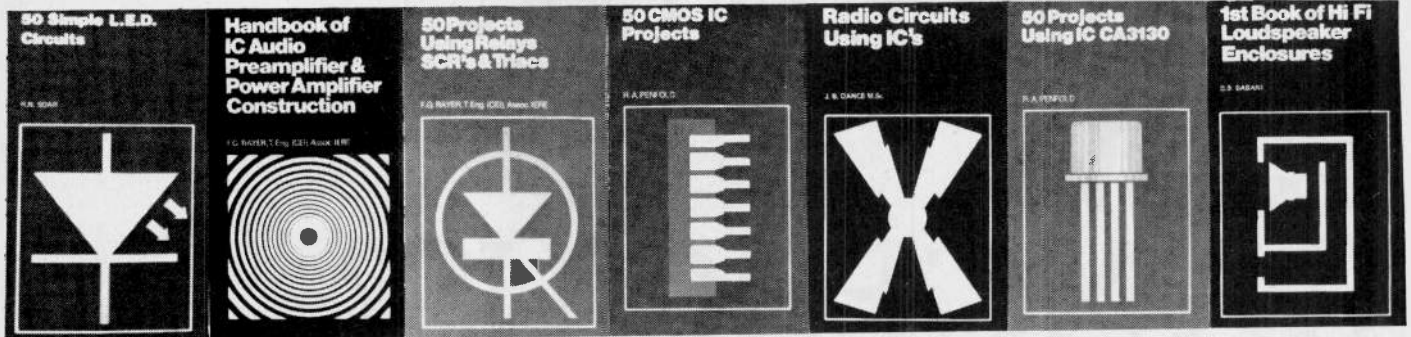

IC 555 Projects

BP44

- Every so often a device appears that is so useful that one wonders how it was done before without it. The 555 timer is such a device.
- It was first manufactured by Signetics, but is now manufactured by almost every semiconductor manufacturer and is inexpensive and very easily obtainable.
- Included in this book are Basic and General Circuits, Motor Car and Model Railway Circuits, Alarms and Noise Makers as well as a section on the 556, 558 and 559 timers.
- An invaluable addition to the library of all those interested in Electronics.

\$7.25 plus 30c postage and handling.

52 Projects Using IC741

BP24

- IC741 is one of the most popular, inexpensive and easily obtainable devices available to the home constructor. It is also extremely versatile and can be used in a great number of different applications.
- This unique book, originally published in Germany, shows fifty-two different projects that can be simply constructed using only the IC741 and a few discrete components.
- An invaluable addition to the library of all those interested in electronics.

\$3.95 plus 30c postage and handling.

Mobile Discotheque Handbook

BP47

- The vast majority of people who start up "Mobile Discos" know very little about their equipment or even what to buy. Many people have wasted a "small fortune" on poor, unnecessary or badly matched apparatus.
- The aim of this book is to give you enough information to enable you to have a better understanding of many aspects of "disco" gear.
- The approach adopted is to assume the reader has no knowledge and starts with the fundamentals, hopefully the explanations given are simplified enough for almost anyone to understand but please note that this is by no means the full story.
- The book is divided into six parts: — Basic Electricity, Audio, Ancillary Equipment, Cables and Plugs, Loudspeakers, Lighting Equipment and the information has been considerably sub-divided for quick and easy reference.

\$5.60 plus 30c postage and handling.

28 Tested Transistor Projects

No.221

- Mr. Richard Torrins is a well experienced electronics development engineer and has designed, developed, built and tested the many useful and interesting circuits included in this book.
- Some of the circuits are completely new and, to the best knowledge of the author, unlike anything previously published while others may bear similarity to more familiar designs.
- The projects themselves can be split down into simpler building blocks, which are shown separated by boxes in the circuits for ease of description, and also to enable any reader who wishes to combine boxes from different projects to realise his own.
- Most of the circuits are very economical on the use of components and in many cases the semiconductor employed are non-critical, commonly available and inexpensive types.

\$5.20 plus 30c postage and handling.

First Book of Transistor Equivalents and Substitutes

BP1

- Shows alternatives and equivalents to many popular transistors made in Great Britain, U.S.A., Europe, Japan and Hong Kong etc.
- Companion Volume to BP14 — SECOND BOOK OF TRANSISTOR EQUIVALENTS AND SUBSTITUTES
- An invaluable addition to the library of all those interested in Electronics by their amateur or professional.

\$2.50 plus 30c postage and handling.

Second Book of Transistor Equivalents and Substitutes

BP14

- Shows alternatives and equivalents to many popular transistors made in Gt. Britain, U.S.A., Europe, Japan and Hong Kong etc.
- Companion Volume to BP1 — FIRST BOOK OF TRANSISTOR EQUIVALENTS AND SUBSTITUTES
- All invaluable addition to the library of all those interested in Electronics by their amateur or professional.

\$4.50 plus 30c postage and handling.

Radio Circuits Using IC's

BP46

- This book describes integrated circuits and how they can be employed in receivers for the reception of either amplitude or frequency modulated signals. The chapter on amplitude modulated (A.M.) receivers will be of most interest to those who wish to receive distant stations at only moderate audio quality, whilst the chapter on frequency modulation (F.M.) receivers will appeal to those who desire high fidelity reception of local v.h.f. stations possibly with stereo (and even quadrophony at some future date). Stereo decoder circuits and the devices available at present for quadrophonic circuits are discussed. Voltage regulator devices are also covered because they are so convenient in all varicap tuned receivers and because they have so many applications in all types of circuit.
- Brian Dance is a highly experienced author who regularly contributes to many of the popular electronic magazines that are available both in the U.K. and overseas.
- An extremely valuable addition to the library of all Electronics enthusiasts.

\$5.60 plus 30c postage and handling.

50 (FET) Field Effect Transistor Projects

BP39

- Field effect transistors (F.E.T.'s) find application in a wide variety of circuits. The projects described here include radio frequency amplifiers and converters, test equipment and receiver aids, tuners, receivers, mixers and tone controls, as well as various miscellaneous devices which are useful in the home.
- It will be found that in general the actual F.E.T. used is not critical and many suitable types will perform satisfactorily. The F.E.T. is a low-noise, high gain device with many uses, and the dual gate F.E.T. is of particular use for mixer and other applications.
- This book contains something of particular interest for every class of enthusiast — showwave listener, radio amateur, experimenter or audio devotee.
- A valuable addition to the library of all electronic enthusiasts.

\$5.20 plus 30c postage and handling.

Popular Electronic Projects

BP49

- Included in this book are a collection of the most popular types of projects which, we feel sure, will provide many designs to interest all electronics enthusiasts.
- All the circuits utilise modern, inexpensive and freely available components.
- The 27 projects selected cover a very wide range and are divided into four basic areas: Radio Projects, Audio Projects, Household Projects and Test Instruments.
- An interesting addition to the library of both the beginner and more advanced constructor.

\$5.95 plus 30c postage and handling.

Electronic Music and Creative Tape Recording

- Electronic Music is the new music of the 20th Century. It plays a large part in "Pop" and "Rock" music and, in fact, there is scarcely a group without some sort of electronic synthesiser or other effects generator.
- It is possible with relatively simple apparatus to create complete compositions using electronic and sometimes non-electronic musical sources.
- This book sets out to show how Electronic Music can be made at home with the simplest and most inexpensive equipment. It describes how the sounds are generated and how these may be recorded to build up the final composition.
- With the constructor in mind, several ideas are given to enable a small studio to be built including a mixer and various sound effect units. Circuits are included for VCOs, VCA's, Envelope Shapers, VCF's, Active and Passive Mixers, Fuzz, Noise Generators, Metronomes and a 10-Note Programmable Sequencer etc.
- All the units shown have been successfully built and used by the author and most of the projects can be built by the beginner.
- An unusual, fascinating and highly rewarding application of electronics.

\$5.20 plus 30c postage and handling. BP51

IC LM3900 Projects

BP50

- The purpose of this book is to introduce the LM3900 to the Technician, Experimenter and Hobbyist. It provides the groundwork for both simple and more advanced uses and is considerable more than just a collection of simple circuits or projects.
- The LM3900 is different from conventional 'Op-Amps'; it can be used for many of the usual applications as well as many new ones. Its one of the most versatile, inexpensive and freely available devices on the market today.
- The book is divided into six basic sections: —
Introduction
Audio Applications —
Simple Linear Applications
Simple Digital Applications
Signal Generator Circuits
Special Applications
- The LM3900 can do much more than is shown here — this is just an introduction. Imagination is the only limitation with this useful device, but first the reader must know the basics and that is what this book is all about.

\$5.60 plus 30c postage and handling.

1st Book of Hi-Fi Loudspeaker Enclosures

- Contains 26 practical designs and over 40 drawings to enable the enthusiast to construct his own Hi-Fi Loudspeaker enclosures.
- Includes the following types of enclosures: —
Corner Reflex, Bass Reflex, Exponential Horn, Folded Horn, Tuned Port, Klipschorn Labyrinth, Tuned Column, Loaded Port, Multispeaker Panoramic etc.
- Also covers general construction hints and embellishing of cabinets as well as a considerable amount of other useful information.
- A must for the library of all audio enthusiasts.

\$3.25 plus 30c postage and handling. No.205

50 Simple L.E.D. Circuits

BP42

- The author of this book, Mr. R.N. Soar, has compiled 50 interesting and useful circuits and applications, covering many different branches of electronics, using one of the most inexpensive and freely available components — the Light Emitting Diode (L.E.D.)
- Also includes circuits for the 707 Common Anode Display.
- A useful book for the library of both beginner and more advanced enthusiast alike.
- Companion volume to book No. BP36 — 50 CIRCUITS USING GERMANIUM, SILICON & ZENER DIODES by the same author.

\$3.25 plus 30c postage and handling.

Handbook of IC Audio Preamplifier & Power Amplifier Construction

BP35

- Shows what audio IC's are, as well as how to use them.
- Includes practical constructional details of various IC and Hybrid IC/Transistor designs of about 250mW to 100W output.
- This book is written by the very experienced and popular author Mr. F. G. Rayer who deals with the subject in four parts:
Part I Understanding Audio IC's
Part II Preamplifiers, Mixers and Tone Controls
Part III Power Amplifiers and Supplies
Part IV Hybrid Circuits
- An ideal book for both beginner and advanced enthusiast alike.

\$5.20 plus 30c postage and handling.

50 Projects Using Relays SCR's & Triacs

BP37

- Relays, silicon controlled rectifiers (SCR's) and bi-directional triodes (TRIACs) have a wide range of applications in electronics today. These may extend over the whole field of motor control, dimming and heat control; delayed timing and light sensitive circuits and include warning devices, various novelties, light modulators, priority indicators, excess voltage breakers etc.
- In this book, the very experienced and popular author — Mr. F. G. Rayer — has given tried and practical working circuits which should present the minimum of difficulty for the enthusiast to construct.
- In most circuits there is a wide latitude in component values and types, allowing easy modification of circuits or ready adaptation of them to individual needs.
- An ideal book for both beginner and advanced enthusiast alike.

\$5.20 plus 30c postage and handling.

50 Projects Using IC CA3130

No.223

- The CA 3130 is currently one of the more advanced operational amplifiers that is available to the home constructor. This means that it is often capable of a higher level of performance than many other devices and that it often needs fewer ancillary components.
- In this book Mr. R.A. Penfold has designed and developed a number of interesting and useful projects which are divided into five general categories:
I Audio Projects
II Test Equipment
III Household Projects
IV Miscellaneous Devices
- An ideal book for both the beginner and more advanced enthusiast alike.

\$5.20 plus 30c postage and handling.

Electronic Projects for Beginners

BP48

- In this book the newcomer to electronics will find a wide range of easily made projects, many complete with actual component and wiring layouts. Furthermore, a number of projects have been arranged so that they can be constructed without any need for soldering and, thus, avoid the need for a soldering iron.
- This book which is written by the very experienced author Mr. F. G. Rayer is divided into four sections —
1. "No Soldering" Projects
2. Miscellaneous Devices
3. Radio and Audio Frequency
4. Power Supplies
- An absolute "must" for all beginners in electronics.

\$5.60 plus 30c postage and handling.

50 CMOS IC Projects

No.224

- CMOS IC's are probably the most versatile range of digital devices for use by the amateur enthusiast. They are suitable for an extraordinarily wide range of applications and are now also some of the most inexpensive and easily available types of IC.
- In this book Mr. R.A. Penfold has designed and developed a number of interesting and useful projects which are divided into four general categories:
I Multivibrators
II Amplifiers and Oscillators
III Trigger Devices
IV Special Devices
- An ideal book for both the beginner and more advanced enthusiasts alike.

\$3.95 plus 30c postage and handling.

Electronic Calculator Users Handbook

BP33

- An invaluable book for all calculator users whatever their age or occupation, or whether they have the simplest or most sophisticated of calculators.
- Presents formulae, data, methods of calculation, conversion factors etc. with the calculator user especially in mind, often illustrated with simple examples.
- Includes:
■ The way to calculate, using only a simple four function calculator.
■ Trigonometric functions (sin, cos, tan)
■ Hyperbolic functions (sinh, cosh, tanh)
■ Logarithms, square roots and powers.
- A comprehensive section of conversion factors covering such common conversions as length, area, volume and weight etc. through to more specialised conversions such as viscosity, illumination, and cargo shipping measures etc.
- Formulae and data for VAT, discounts and mark up, currency conversion, interest, statistics of equations, binary and octal numbers, areas and volumes, statistics and mathematics etc.

\$3.95 plus 30c postage and handling.

BERYLLIUM- HOW DANGEROUS?

Beryllium Compounds are quite safe — Providing they're left well alone. Do not: grind, saw, put with acid, crush, chip, file, brush or vacuum the material!

THERE IS a lot of controversy these days about the toxic effects of everyday substances — saturated hydrocarbons in food, cancer-producing hair dyes, lead in gasoline and so on.

It may surprise you to know that you are in contact with one very toxic substance which has cost the lives of many people over the years and which may have no warning notices or labels attached to it — it's harmless in its present form, but is only waiting for the unwary to tamper with it to turn it into a deadly cancer-forming agent.

The substance is beryllia, long used for its low thermal conductivity and high electrical insulation resistance in applications such as RF power transistors and some 'heat sink compounds'.

In its solid state, beryllia (or beryllium oxide, to give it its proper name) is fairly innocuous. It won't explode, give off noxious fumes or even catch fire. But grind or cut it in any way, and the dust formed may produce insidious lung disease. Cases have been reported in which workers who came into contact with the substance did not exhibit symptoms until five years later, and some in which the damage appeared within one or two months.

It doesn't take much dust to produce toxic effects, either. Some forty years ago, beryllia was used widely in fluorescent lighting tubes, and the number of cases of poisoning were much greater. Because of the incredible virulence of the poison, toxic effects have been reported in people who visited the homes of beryllium workers. Tests have been carried out with soiled clothing that showed the shaking even a lightly-soiled lab apron can give rise to dust concentration five times the recommended maximum.

Imagine, then, the effect of sawing a piece of beryllia in your workshop

(or, worse still, in your kitchen). The worst of it is, you may not realize the effects until five years from now.

Having said all that, solid beryllia is safe enough if treated with respect.

- If there is an alternative, don't use beryllium compounds.
- Don't ever mutilate, grind, cut or even scratch beryllia.
- Always make sure that any beryllia you have is adequately labelled in such a way that there is no way that you, or anyone else, can mistake it for something harmless.
- When you want to throw out a device containing beryllia (which you probably feel like doing round about now), send it back to the manufac-

turer — it's pretty certain that they know how to dispose of it properly.

There is another route through which beryllia can be harmful — through the skin. Experiments with animals have shown that introducing beryllium compounds into open wounds may form tumours. If you're using a heatsink compound that you think contains beryllia, try not to touch it — use plastic gloves and other safety devices.

If you think that beryllia has come into contact with you in any way which could prove harmful — see your doctor.

Bibliography

QST magazine (ARRL journal), issue July 1978, page 37, "How Safe is Your Ham Shack?" (part II). ●

BERYLLIUM OXIDE, BeO (*Beryl, Beryllia, Bromellite*) PHYSICAL, CHEMICAL AND MEDICAL CHARACTERISTICS

VOLUME RESISTIVITY: 6×10^{11} ohm.m at 300°C (98% BeO)

THERMAL CONDUCTIVITY: 210 W/m. °C (98% BeO at 25°C)

SOFTENING TEMPERATURE: 1600°C (98% BeO)

THERMAL EXPANSION: 6.1 ppm/°C (98% BeO)

TOXIC HAZARD RATING: High (acute local irritation, inhalation: may cause death or permanent injury after very short exposure to small quantities)

LOWEST TOXIC AIR CONCENTRATION: 49 mg/m³ (rat, inhalation, four weeks continuous. Cancer)

LOWEST TOXIC UNDER-SKIN DOSAGE: 7 mg/kg (pig, benign tumour)

OSHA STANDARD AIR CONCENTRATION: 2 µg/m³ (time-weighted average)

OSHA STANDARD PEAK AIR CONCENTRATION: 25 µg/m³ (30 min per 8 hours)



TELEVISION, COMMUNICATIONS,
COMPUTER, C.B., ELECTRONICS
TECHNOLOGY

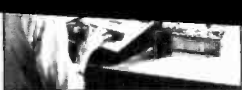

MICROCOMPUTERS
AND
MICROPROCESSORS



APPLIANCE SERVICING

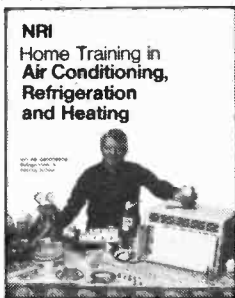

AIR CONDITIONING,
REFRIGERATION & HEATING

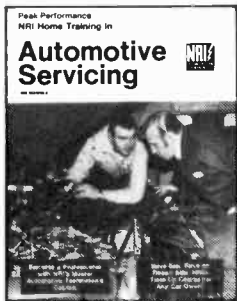

AUTOMOTIVE

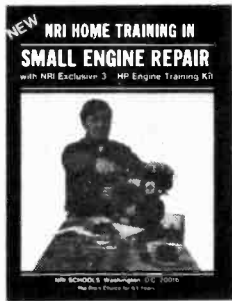

SMALL ENGINE REPAIR

Name _____ Age _____

Address _____ Phone _____

City _____ Prov. _____ Code _____

Employed by _____

Type of Present Work _____

ETI 11-060

**Business
Reply Mail**

No Postage Stamp
Necessary if mailed
in Canada



Postage will be paid by

McGraw-Hill Continuing Education Center

330 Progress Avenue,
Scarborough, Ontario
M1P 9Z9

New from NRI! **25"** color TV that DIAGONAL tunes by computer, programs an entire evening's entertainment.

Just part of NRI's training in servicing TV, stereo systems, video tape and disc players, car and portable radios.

Only NRI home training prepares you so thoroughly for the next great leap forward in TV and audio... digital systems. Already, top-of-the-line TV's feature digital tuning, computer programming is appearing, and new digital audio recording equipment is about to go on the market.

NRI is the only home study school to give you the actual "hands-on" training you need to handle servicing problems on tomorrow's electronic equipment. Because only NRI includes this designed-for-learning, 25" diagonal color TV with electronic tuning, built-in digital clock, and computer programmer as part of your training. With this advanced feature, you can pre-program an entire evening's entertainment... even key lock it in to control children's viewing.

Exclusive Designed-for-learning Concept

The color TV you build as part of NRI's Master Course looks, operates, and performs like the very finest commercial sets. But behind that pretty picture is a unique designed-for-learning chassis. As you assemble it, you perform meaningful experiments. You even introduce defects, troubleshoot and correct them as you would in actual practice. And you end up with a magnificent, big-picture TV with advanced features.

Also Build Stereo, Test Instruments

That's just a start. You demonstrate basic principles on the unique NRI Discovery Lab,[®] then apply them as you assemble a fine AM/FM stereo, complete with speakers. You also learn as you build your own test instruments, including a 5" triggered sweep oscilloscope, CMOS digital frequency counter, color bar generator, and transistorized volt-ohm meter. Use them for learning, use them for earning as a full- or part-time TV, audio, and video systems technician.

Complete, Effective Training Includes Video Systems

You need no previous experience of any kind. Starting with the basics, exclusive "bite-size" lessons cover subjects thoroughly, clearly, and concisely. "Hands-on" experiments reinforce theory for better comprehension and retention. And your personal NRI instructor is always available for advice and help. You'll be prepared to work with stereo systems, car radios, record and tape players, transistor



radios, short-wave receivers, PA systems, musical instrument amplifiers, electronic TV games, even video tape recorders and tape or disc video playback.

Send for Free Detailed Catalog

Mail the postage-paid card today for our free 100-page catalog with color photos of all kits and equipment, complete lesson plans, convenient time payment plans, and information on other electronics courses. You'll also find out about NRI's new Computer Technology Course that includes your personal microcomputer. Or Complete Communications with 2-meter transceiver. If card has been removed, write to:



NRI Schools

McGraw-Hill Continuing
Education Center
330 Progress Avenue
Scarborough, Ontario M1P 2Z5
or telephone 416-293-1911

DYNAMIC NOISE FILTER

Not content with eliminating record clicks as if by magic—the project boys have now found a neat way of reducing tape-hiss.



THE HUMAN BRAIN IS a funny thing really! Its connections to the outside world are via the five senses and it relies on these senses to transmit reliable and accurate information about the outside world. However, as you are probably aware, this information can quite often be distorted (think of the countless optical illusions).

Missing Links.

It is not so often that audio illusions are in the news, probably because they are harder to detect, but that doesn't mean they don't exist, eg. The fact that the ear cannot detect small gaps, say 5 mS, in a passage of music allowed us to build the click eliminator. Every time a click (which always have a duration of less than 5 mS) is detected, the sound is automatically cut out for about 5 mS. The final effect being one of apparent continuity of music without the gaps or clicks.

Hissed Up

Our tape hiss reduction system functions on the principle that on a continuous passage of music the difference between the music and the hiss (signal/noise ratio) is so great that we cannot hear the hiss for the music. All well and good. On a more spasmodic piece of music, where there are gaps of more than say 50 mS between signals, then these gaps have (apparently) a much lower signal/noise ratio, not because the noise level has gone up, but because the signal level has gone down. This means that the hiss is more pronounced.

During these time intervals our device filters out the high frequency

tape noise using a current controlled filter (CCF) — immediately allowing high frequency sound through again when a signal comes along. (The illusion of one type of sound covering up another of about the same frequency is called masking.)

Construction

Printed circuit board construction should be relatively straightforward. We suggest a step by step approach be adopted and testing of each stage be undertaken before construction of the following stage. The main reason for this is that the circuit, although having few components, is quite tricky in operation and this makes fault-finding difficult in cases of malfunction.

First, build up the on-board power supply section (D3, D4, C17, C18, IC3, R28 and LED 1). Check with a voltmeter for 12 V DC at its output ie, between the output of IC3 and ground. If the LED lights up it is a good indication that the supply is working correctly.

Next the buffer amplifiers and associated components (C1, C2, R1, R2, R3, R4, R20, R21, C11, Q1 and Q2) should be inserted. If a signal source and scope are available put signals at the inputs to the circuit and observe the signals at the emitters of Q1 and Q2. They should be the same as the transistors are operating as non-inverting buffers.

Following this, the control circuitry (consisting of R5, R6 through to Q3, R17 and C10 on the circuit diagram) should be soldered in place and this stage now tested. With RV1 at mid-position and a high impedance voltmeter or a scope in

DC mode connected across C10, it should be seen that the voltage across the capacitor varies with varying signal input. If an audio waveform from, say, a cassette deck is used as a signal, then the voltage should be seen to increase with the higher frequencies (above about 7 kHz) but stay quite low for frequencies below this. Adjusting RV1 should adjust the overall voltage range across the capacitor.

Finally, IC3 and the rest of the components can be inserted and the complete board tested and set up. The signal at the output should be of the same amplitude as that at the input.

Setting Up

Once you are sure that everything is working correctly, then setting up is a very simple job. Erase a section of tape and play it back through the unit. Take the output from the unit and amplify it.

Turn RV1 completely anti-clockwise and listen. Slowly turn the preset clockwise until there is a barely perceptible increase in hiss noise. Then, step it back just a fraction, so that the hiss just goes. The device is now set for the tape unit and use with any other tape will require resetting.

A final setup test can be carried out, if necessary, with a signal generator plus an oscilloscope. With an input of about 500 mV, the bandwidth of the device should be up to about 25 or 30 kHz. However, an input of 50 mV should give an output bandwidth of only 6 kHz.

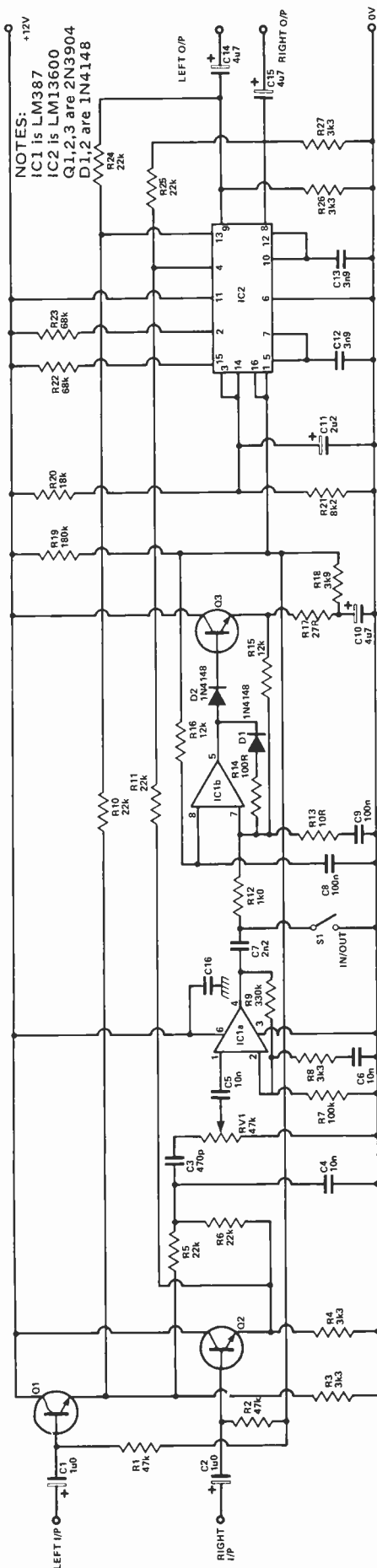

HOW IT WORKS

The device consists of two buffer amplifiers, two current controlled low-pass filters and control circuitry to detect the presence of a signal. The current produced by the control circuit is used to vary the bandwidth of the CCF to allow the signal through i.e. when sufficient signal is present to be able to mask the noise, when there is little or no signal and the noise appears louder then the filter's lowpass range is lowered to a minimum of approximately 1 kHz. The noise is effectively filtered out.

As soon as a signal in the same frequency range as the noise comes along (ie above 7 kHz) the control circuit detects it and applies current to the CCFs thereby increasing the frequency range, allowing the signal through.

The buffer amps are built around the two emitter follower transistors (high I/P impedance — low O/P impedance) and the CCFs around IC2, the LM 13600 which is a new National chip, a dual operational transconductance amplifier. Resistor R19

applies a fixed current to control pins 3 and 14 of the chip, fixing the minimum bandwidth at 1 kHz. The greater the current into these pins the greater the frequency bandwidth.

The control current itself is obtained from the voltage across C10 by connection via R18. As V_{C10} increases then by Ohm's law the current I_{R19} must also increase. The energy stored on C10 is provided from IC1b and Q3, etc. connected as a peak detector. AC into this part of the circuit gives DC out to C10. The values of R17 and C10 are chosen to allow a fast attack time (something under 1 mS) and a comparatively slow decay time (about 40 mS).

IC1a is a mixer, bandpass filter, amplifier. It mixes a sample of signal from both channels via R5 and R6, filtering out frequencies below about 7 kHz, so that only signals with the same general frequencies as that of tape noise will affect the CCFs, and amplifies the signal with a gain of 100.

RV1 adjusts for different noise levels, dependent on a particular tape unit.

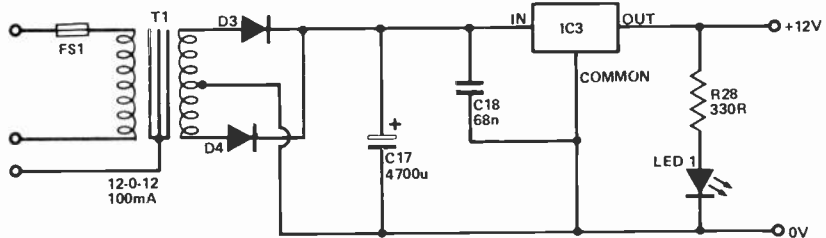

Fig. 2. The power supply.

Fig. 1. Circuit diagram of the dynamic tape noise reduction system.

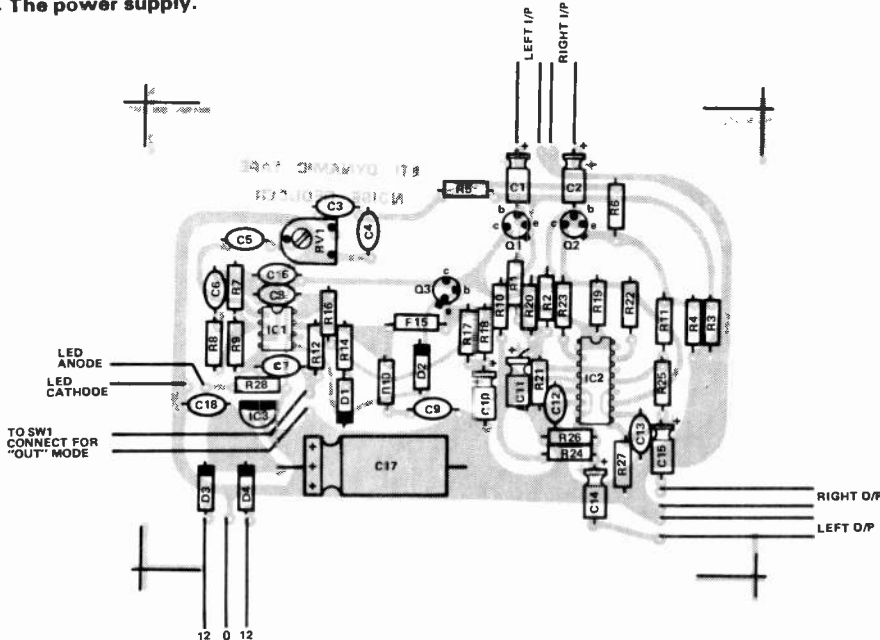

Fig. 3 (above): The component overlay for the Dynamic Noise Filter system. Note that the power supply circuit as shown in Fig. 2 is included on this board, and the input 12-0-12 comes straight from the transformer. As the system is mainly based on just two IC's sockets are heavily recommended!

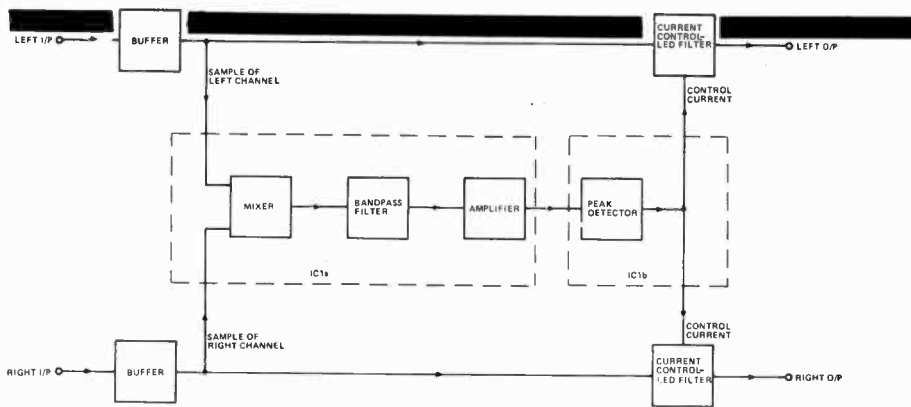
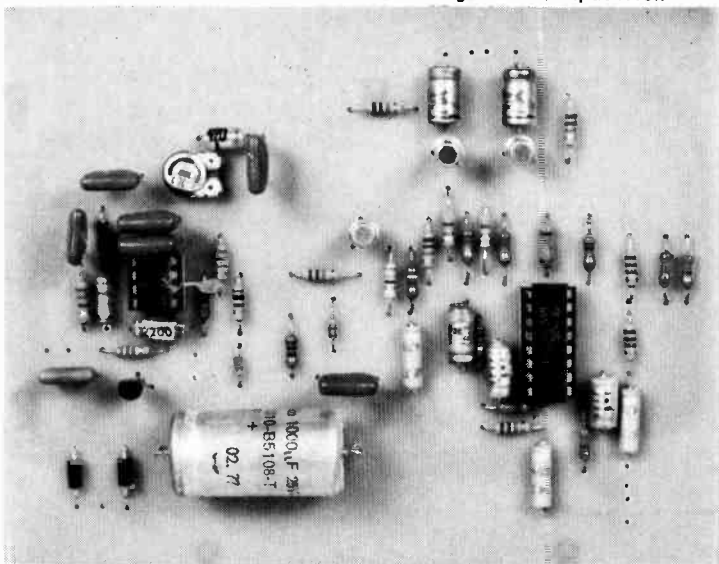

Fig. 4 Above): Block Diagram to the Dynamic Noise Filter project.

Not shown on this simplified diagram is the in/out (bypass) switching. This operates by grounding the output from the first stage.

Such operation will thus prevent the peak detector from operating the filter stage and thus leave a full bandwidth at the output regardless of input level.



Left: Close-up on the board—the only board—for the Filter project.

Using this in conjunction with the component overlay shown overleaf should identify all the component positions, and make sure you don't get any polarised components in the wrong way round.

The holes are leadout positions, and if you're with any over don't call us

PARTS LIST

RESISTORS 'all 1/4W 5%'

R1, 2	47k
R3, 4, 8	3k3
R5, 6, 10,	
11, 24, 25	22k
R7	100k
R9	330k
R12	1k
R13	10R
R14	100R
R15, 16	12k
R17	27R
R18	3k9
R19	180k
R20	18k
R21	8k2
R22, 23	68k
R26, 27	3k3
R28	330R

POTENTIOMETERS

RV1	47k
-----	-----

CAPACITORS

C1, 2	1u0 electrolytic
C3	470p ceramic
C4, 5, 6	10n polyester
C7	2n2 polyester
C8, 9, 16	100n polyester
C10, 14, 15	4u7 electrolytic
C11	2u2 electrolytic
C12, 13	3n9 polyester
C17	4700u electrolytic
C18	68n polyester

SEMICONDUCTORS

IC1	LM387
IC2	LM13600
IC3	78L12
Q1, 2, 3	2N3904
D1, 2	1N4148
D3, 4	1N4001
LED	TIL220

MISCELLANEOUS

T1	12-0-12 c.t. secondary
FS1 + holder,	spot toggle switch, case to suit.

ETI DYNAMIC TAPE NOISE REDUCER

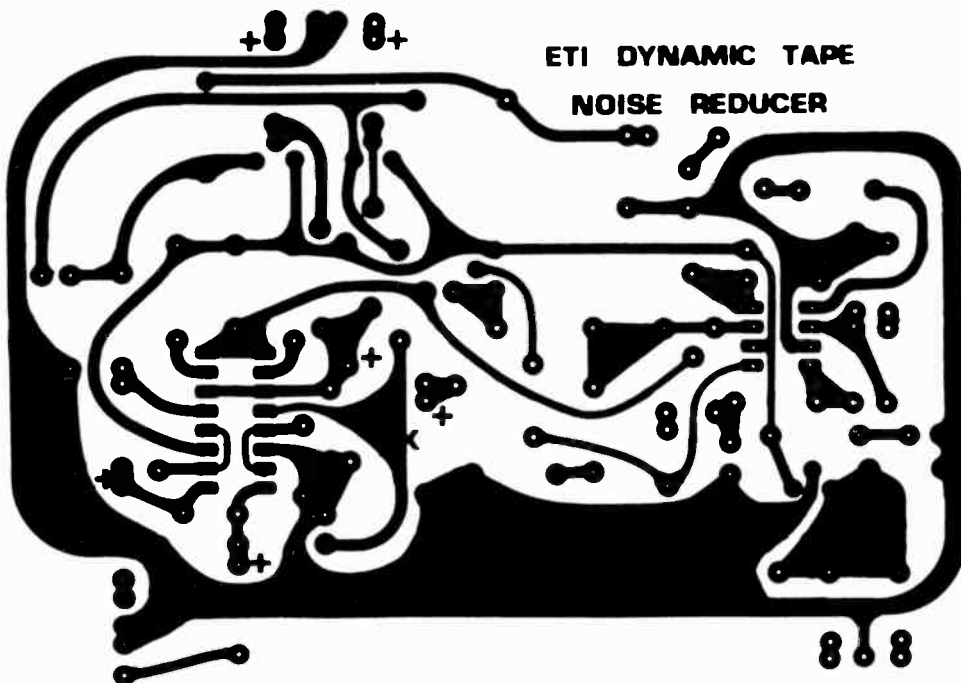

MAGNETIC POWER CONTROL

K.T.Wilson explores the all to frequently ignored and misunderstood field of Magnetic Amplifiers.

THINK OF AMPLIFICATION, and you automatically think of transistors. Perhaps if you're a bit longer in the tooth you remember tubes. Have you ever thought of large amounts of power gain being obtained without using either transistors or tubes? It's power gain we're talking about, too, not just voltage gain. A transformer will give voltage gain, up to 100 times, but at the expense of current, so that the power out is never quite as much as the power in. There's no *power* gain there, but a device called the magnetic amplifier, which looks very like a transformer, can give very large values of power gain, can control AC power into a load very smoothly, and is used in the sort of applications where thyristors would be a natural choice for many.

The magnetic amplifier has been used in industrial control for decades, yet has never really caused any stir of interest anywhere else. Perhaps it's because it's always a ready-made item, but then so is an IC amplifier, and everyone seems to make use of those. Perhaps it's just because so very few people outside the ranks of professional engineers know just what a magnetic amplifier is. Let's remedy that!

Induced Knowledge

To start with, we need a pretty clear idea of what happens inside an inductor. A simple inductor has a winding which consists of insulated wire wound round a core of a soft magnetic material. Soft doesn't mean that you can spread it on your bread, but that the material magnetises easily, and demagnetises just as easily. Take a piece of this material, hold a magnet near it, and it's magnetised. Take a magnet away and it's demagnetised. This material we use for the cores of inductors, transformers, electric motors, relays etc.

An inductor makes use of this 'soft' magnetism. The winding has an alternating current flowing in it. This alternating current (changing smoothly from a peak in one direction to a peak in the opposite direction and back) causes the core of the inductor to magnetise. The magnetism isn't steady like a bar magnet, but alternating, which is the point of using soft magnetic material. a graph of the magnetism (called flux density) of the core plotted against time would, ideally, have exactly the same shape as that of the waveform of the AC applied.

So far so good — it's an alternating magnet. But we've known for about 150 years (or someone has) that

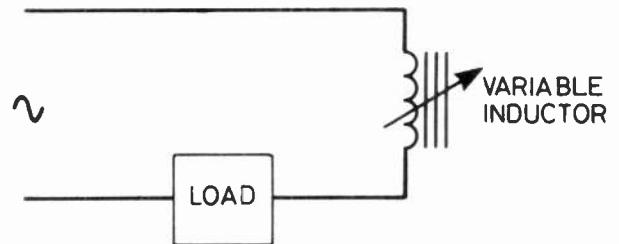

Fig. 1. Control of a load using a variable inductor, this configuration has very little power lost as heat, unlike a resistive controller.

wherever there's an alternating magnetic field, any piece of wire or other metal will have an alternating voltage induced.

Stick a piece of wire near your alternating magnet and you'll find an alternating voltage across the ends of the wire. The voltage is small if you use just a few centimetres of straight wire, but if you wrap several metres or wire round the core, so that all the magnetism of the core is at the centre of the coil of wire, then you find quite a respectable amount of AC. Recognise it? A transformer.

Laying Down The Laws

The laws of Electricity are very consistent, though, *Any* coil of wire around a core that has an alternating magnetic field will have an AC voltage induced. That means that if we have only one coil, and we send AC through to generate the magnetism, it will *also* have an AC voltage induced in it. This voltage which the text books call a 'back EMF', opposes the current which causes the magnetism which causes the voltage.

Result?

It's a darn sight more difficult to pass AC through an inductor than it is to pass DC!

When we use an inductor in a DC circuit, then apart from some effects at the moments of switch-on and switch-off the thing behaves like a resistance, good old Ohm's Law and all the rest, and a fairly low value of resistance at that.

Now you might think that it should pass the same amount of current for AC as for DC, but it doesn't.

Imagine that the resistance is 2R, so that 10 V DC passes 5 A. Apply 10 V AC and the current's nothing like 5 A. It's not because Ohm's law stops working, it's because of the induced voltage. We're trying to push AC

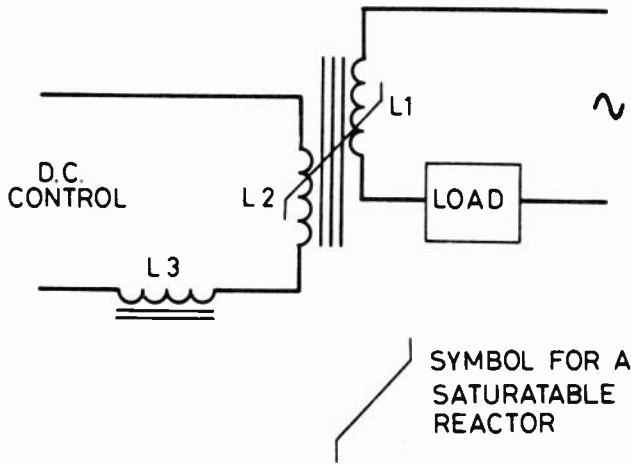

Fig. 2. Simple magnetic amplifier circuit, showing DC control winding.

through with one voltage, and the induced voltage is opposing our efforts. It's only the difference between the two voltages that has any effect at all.

Impedance Impediment

Suppose for example, that with 10 V AC applied, the induced voltage is 9V9. This makes the difference equal to 0V1, and the current is

$$\frac{0.1}{2} = 0.05 \text{ A, (by Ohm's Law)}$$

Now these are calculations we seldom bother to make. Instead we measure a quantity called the self-inductance, L, of the coil and use this quantity and the resistance value to calculate impedance, which is the ratio

$$\frac{\text{AC voltage}}{\text{AC current}}$$

for the coil. In our example, 10 V causes 0.05 A to flow, making the impedance $10 / .05 = 200 \text{ R}$, not a particularly large impedance, but much greater than the resistance of 2 R.

The useful thing about an impedance is that there's practically no loss of power in it. Pass a current through a 200 R resistor, and you lose energy in the form of heat the amount of heat lost per second is $200 \times (\text{current})^2$ joules for a 200 R resistor. The same current through the inductor in our example doesn't look anything like this — only its resistance loses heat, and that's only $2 \times (\text{current})^2$ joules, because the resistance is only 2 R.

We can therefore use an inductor to control the flow of AC in a circuit (see Fig. 1) with none of the power loss that a resistor would cause. Now if we could just have a variable inductor, we could be very neatly control the flow of current in that circuit. Of course, we could use an inductor with tapped turns and slide contacts, built like a potentiometer, and we make use of just such a device, the familiar Variac. It's possible though, to control the inductance of a winding with no mechanical movement at all, and what makes it possible is the effect called saturation.

Control-A-Coil

When we send a current, AC or DC, through a coil of wire which is wound round a magnetic core, we can't pass as much current as we like and expect the magnetism to keep pace. At some stage in the game the core saturates, which means that it's as magnetised as it's ever going to be, no matter how much current is used. Now when a core is saturated like this, a change of current doesn't cause a change in the magnetism, so there's no more induced voltage. In other words, the inductance is no more and the impedance is practically zero.

Let the AC flow to it's load through an inductor whose core we can cause to saturate. How? By passing DC through another winding, by making the core of material which saturates easily, and the making the core continuous with no air gap.

That's our recipe for a magnetic amplifier.

Amps For Amps

Figure 2 shows a simple magnetic amplifier circuit. The inductor L1 has a large inductance when the core is not saturated, because of that, its impedance is very large, enough to make the current in the circuit very small. Now let DC flow through the second winding L2, and the core saturates.

If we can keep the core saturated for the whole of the AC cycle, then the inductance of L1 is almost zero, and the full amount of AC current flows through the load.

We don't of course, have to switch between saturation and no-saturation. We can adjust the control current so that the core saturates only on half of the AC cycle, or in peaks so that the average current through the lead is controlled.

Self Satisfied!

Even such a simple magnetic amplifier has a lot of advantages, such as low power dissipation and high power gain, but better results are possible by using what is called a self-saturating design. Self-saturation is a form of positive feedback, using some of the signal current to assist the DC control current. Fig 3 shows a half-wave self-saturating circuit. The rectifier D1 ensures that only one direction of current flows through the coil L1 and the rated load current will cause the core to be close to saturation. The DC control current in winding L2 need only be quite small to cause the core to saturate on peaks, so that less power is needed to control the load current, and power gain is much higher.

Only half cycles are passing into the load, however, so that a full wave version is more desirable.

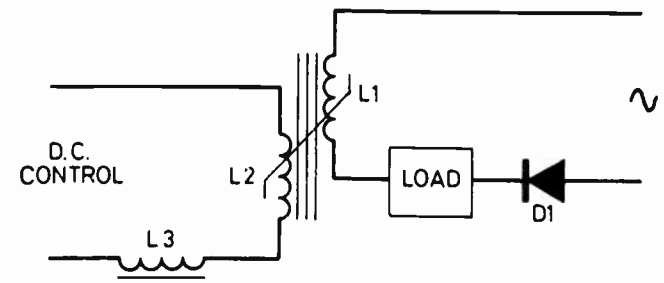

Fig. 3. Half-wave control using self-saturation.

Continued on Page 44

3

Motorola Fiber Optics Kits must be won!

Get into state-of-the-art high speed communications with Motorola and ETI.

It's called **The Link** and it contains the basic components for fiber optics communication. Fiber optics offer such advantages as wide bandwidth, high reliability, high noise immunity and immunity to crosstalk.

Applications include medical electronics, industrial electronics, microprocessor systems, security systems, computer and peripheral devices. . . anywhere reliable, high speed communications are required.

This isn't your basic LED and phototransistor kit either, **The Link** retails for around \$150 each!

Don't get left in the dark, **ENTER NOW!**

THE PROBLEM

An infinite number of 1 ohm resistors are wired so as to form an infinite mesh—as shown. What is the resistance between points A and B?

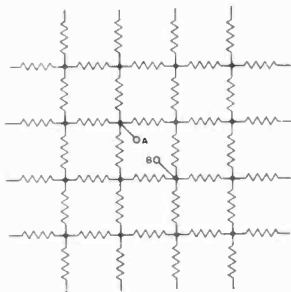

You can win all this!

- 1m Fiber Optic Cable with connectors.
- 2 MFOA02 Fiber Optic Connectors.
- 1 Integrated Detector/Preamplifier, MFOD402FB.
- 1 Emitter, MFOE103FB.
- Application Notes.
- Data Sheets.
- Binder.



HOW TO ENTER

When you have determined your answer to the problem above, enter it, along with your name and address, in the appropriate spaces below. Mail the entry form to:

THE LINK CONTEST
c/o Electronics Today
25 Overlea Blvd.
Unit 6

Toronto, Ontario M4H 1B1

The first three correct (or closest) answers drawn, win. Readers not wishing to cut up their magazines may submit their entry on a photostat or hand drawn copy of this form, but only one entry per person. Multiple entries will be disqualified.

Only one prize per winner.

This contest is open to residents of North America with the exception of the staff members and families of ETI, their printers and distributors and employees of Motorola.

Contest closes July 18, 1980.
Editor's decision is final.

MY ANSWER IS OHMS
(PLEASE PRINT)

NAME
ADDRESS

Should you want more information on **The Link**, tick the box below **OR** if you want it faster, circle No. 27 on the Reader Service Card.



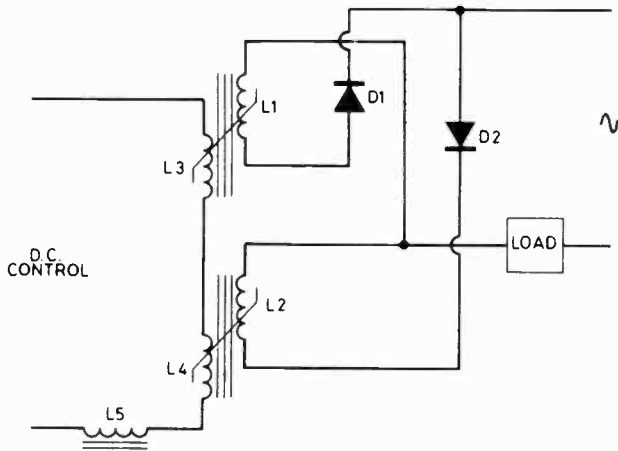

Fig. 4. Full-wave amplification with self saturation, by positive feedback.

A full-wave self-saturating magnetic amplifier is shown in Fig 4. Two sets of windings are used, each handling half of the wave, with rectifiers ensuring that the AC wave is split into its two halves.

In all these circuits, an additional inductor is used in the DC control line to prevent AC appearing in the control circuit because of transformer action.

Going Straight

DC amplification? Simple enough, just rectify the output of the magnetic amplifier — the self-saturating full wave type already has two rectifiers included in the circuit and only two more are needed. More sensitivity? Add another winding to pass DC bias current, and the sensitivity increases because the bias can be set so that the core is very close to saturation.

Nothing could be *that* perfect, there has to be a snag somewhere, and response time is it for magnetic amplifiers. Being slow beasts a sudden change of control signal may not cause much change in the output current until several cycles of AC have passed through. Nevertheless for stabilising AC supplies, for control of large AC loads and for high power gains magnetic amplifiers are not so easily displaced by electronics. There's not much to go wrong, they can be built to order, and they can be repaired.

Ever tried to put a new junction into a thyristor? ●



Cisco.

Reader Service Information

If you would like more information on the products or services mentioned in the advertisements:

- 1 Fill in the attached card with your name, address, etc.
- 2 Circle the appropriate Reader Service number for further information about advertised products.
- 3 Mail the card and the advertiser will send you literature free of charge. If the card has been removed, or if you want the information in a hurry, phone or write direct to the advertiser and refer to the ETI issue and page number.

YOUR COMPANY CLASSIFICATION (IF APPLICABLE):

- A. Manufacturer
- B. Retailer
- C. Government
- D. R&D
- E. Servicer/Installer
- F. Distributor/Representative
- G. Educational Institution

IN THE FIELD OF:

- 1. Computer and Related Equipment
- 2. Communications Equipment and Systems
- 3. Navigation, Guidance or Control Systems
- 4. Test & Measurement Equipment
- 5. Consumer Products
- 6. Industrial Controls & Equipment
- 7. Components and Subassemblies
- 8. Other (Please specify on the card)

YOUR MAJOR JOB FUNCTION (IF APPLICABLE):

- A. Buying
- B. Technologist
- C. Educator
- D. Not employed in an electronics-related field
- E. Engineering
- F. Technician
- G. Management
- H. Sales
- I. Other (Please specify on the card)

WHAT INTERESTS YOU MOST ABOUT ETI? (YOUR FAVOURITE FIVE OR LESS):

- A. Audio
- B. Video
- C. Ham Radio
- D. Shortwave World
- E. Service News
- F. Components and Technology
- G. Reports on the Electronics Industry
- H. Microcomputers
- J. Projects
- K. News Digest
- L. Other (Please specify on the card)
- M. Tech Tips

READER SERVICE CARD

ISSUE: MAY, 1980
(VOID AFTER SEPTEMBER 15, 1980)

PLEASE
PRINT

NAME: _____

TITLE (IF APPLICABLE): _____

COMPANY (IF APPLICABLE): _____

PHONE: AREA() _____

STREET: _____

CITY/TOWN: _____

PROVINCE: _____ POSTAL
CODE: _____

PLEASE ANSWER THE
QUESTIONS BELOW.

FOR ETI USE

80060

DO YOU SUBSCRIBE TO ETI?

YES NO

YOUR COMPANY
CLASSIFICATION?

IN THE
FIELD OF

OTHER

YOUR MAJOR JOB
FUNCTION?

OTHER

WHAT INTERESTS YOU MOST
ABOUT ETI?

OTHER

CIRCLE THE READER SERVICE NUMBERS FOR
THE ITEMS IN WHICH YOU ARE INTERESTED:

1	2	3	4	5	6	7	8	9	10
11	12	13	14	15	16	17	18	19	20
21	22	23	24	25	26	27	28	29	30
31	32	33	34	35	36	37	38	39	40
41	42	43	44	45	46	47	48	49	50
51	52	53	54	55	56	57	58	59	60

SUBSCRIBE NOW! BOOKS, BACK ISSUES BINDERS - SEE OVER



Code

Electronics Today Magazine, Unit 6, 25 Overlea Blvd., Toronto, Ontario M4H 1B1.

SUBSCRIPTIONS: NEW SUBSCRIPTION? OR... RENEWAL? Please check one.
 One year subscription (12 issues) \$14 Two year subscription (24 issues) \$26
 Postage and handling to Canada is included, for U.S. please add \$3, other countries add \$5/yr.

NAME _____
 ADDRESS _____
 TOWN/CITY _____ PROVINCE/STATE _____
 CODE _____ DATE _____

**PLEASE
PRINT
CLEARLY**

0680

Cheque enclosed DO NOT send cash

Bill Mastercharge A/C No. _____

Bill Chargex A/C No. _____

Signature _____

Expiry Date _____

PLEASE ALLOW 6-8 WEEKS FOR YOUR FIRST MAGAZINE TO ARRIVE

ETI ORDER FORM

BACK ISSUES: Please circle issues desired.

1977	February	May	July	November			
1978	March	May	July	August	September		
	October	November	December				
1979	January	February	March	April	May	June	July
	August	September	October	November	December		
1980	January	February	March	April	May	June	

AFFIX
FIRST
CLASS
POSTAGE

QTY.	ITEM	AMOUNT
. .	Back Issues @ \$3 (mark choice above)	\$.
. .	Canadian Projects Book No. 1 @ \$3.45	\$.
. .	ETI Circuits Book @ \$5.45	\$.
. .	'More Circuits' Book @ \$4.95	\$.
. .	Set(s) of Panel Transfers @ \$5.00	\$.
. .	ETI T-Shirts @ \$5.50 (mark size below)	\$.
. .	ETI Binders @ \$6.75	\$.
	Ontario Residents add 7% PST on last three only.	\$.
. .	Subscriptions @ \$14/\$17/\$19/\$26/\$32/\$36	\$.

BOOKS

QTY.	AMOUNT	QTY.	AMOUNT
	BABANI		
. . .BP1	\$2.80 \$BP68	\$7.25 \$.
. . .BP14	\$4.80 \$BP69	\$7.55 \$.
. . .BP24	\$4.25 \$BP70	\$2.40 \$.
. . .BP33	\$4.25 \$No.205	\$3.55 \$.
. . .BP35	\$5.50 \$No.213	\$4.50 \$.
. . .BP37	\$5.50 \$No.215	\$3.70 \$.
. . .BP39	\$5.50 \$No.221	\$5.50 \$.
. . .BP42	\$3.55 \$No.223	\$5.50 \$.
. . .BP44	\$7.55 \$No.224	\$4.25 \$.
. . .BP46	\$5.90 \$.		
. . .BP47	\$5.90 \$.		TAB
. . .BP48	\$5.90 \$800	\$18.30 \$.
. . .BP49	\$6.25 \$804	\$18.35 \$.
. . .BP50	\$5.90 \$841	\$8.55 \$.
. . .BP51	\$5.50 \$1000	\$11.55 \$.
. . .BP62	\$8.95 \$1010	\$9.85 \$.
. . .BP63	\$8.95 \$1015	\$9.70 \$.
. . .BP64	\$8.95 \$1064	\$11.85 \$.
. . .BP65	\$6.55 \$1070	\$12.35 \$.
. . .BP66	\$7.55 \$1071	\$10.90 \$.
. . .BP67	\$7.55 \$1076	\$11.55 \$.
		. . .1088	\$11.85 \$.

SUBTOTAL ➔ \$

* Prices shown include postage and handling.

T-Shirt Sizes

No. of: Small Medium Large

Price is \$5.50 each

**TOTAL
Enclosed**

**Electronics
Today**
INTERNATIONAL

FREE PRODUCT INFORMATION,
UNIT 6,
25 OVERLEA BOULEVARD,
TORONTO, ONTARIO
M4H 1B1



Audio Today

This month Wally Parsons takes a look at frequency range and corrects some widely held misconceptions.

"PAVAROTTI, KING of the High C's," is the title of a recently released album of arias sung by the incomparable Luciano Pavarotti. The title refers to one of the major preoccupations of tenor nuts, the extent to which a singer can soar into the vocal stratosphere. It should be understood that a tenor nut has a great deal in common with an audio nut: just as an audio nut may spend a great deal of time listening to sounds, a tenor nut will devote energy and time to listening to the execution of vocal gymnastics. Along the way both types of nut may also listen to music, but this is not essential. What is essential is an awareness of what constitutes a ringing top C, or a transparent top end. Both types of nut are undoubtedly just a little shy of being certifiable, as are their variants, who also abound in only slightly lesser number. For example, some audiophiles are woofer nuts and will go to any lengths to excavate the subterranean caverns of low, low bass, while a singer I once knew would spend hours listening to Chaliapin records. The CBC's Clyde Gilmour is never more eloquent than when waxing appreciatively over Bjoerling, or Galli-Curci, one of the darlings of the Soprano nuts, of which my mother was one, as was I suspect, the late Louis B. Mayer, judging by his fascination with the Jane Powells and Kathryn Graysons he cast in all those MGM musicals. Of course it could have been a preoccupation with *bosomy* sopranos; after all, there must be *some* explanation for the success of many of them. Surely it wasn't the sound of Jane Powell's top A's getting mangled in the ship's propeller in "Royal Wedding", or Kathryn Grayson trying to pass off a serious problem of wobbly pitch as vibrato. Talk about flutter!

Wait a minute. Back up a little. Did I say something about Chaliapin? Bjoerling? Galli-Curci? Something must be wrong here; after all, most of these

people did all or most of their work back in the acoustical days. Certainly the latest Chaliapin I have was recorded as recently as June 1931. Everybody knows that the old acoustical systems, and even the earlier electrical equipment on which much of Bjoerling's work was recorded was woefully lacking in really low bass and high treble. Maybe a bottom end of 100 Hz and a top of 3500 Hz or even 5000 Hz., but that was it. So why are we talking about basso voices and high tenors and sopranos!

Range Nomenclature

Generally speaking, we think of the range above 1000 Hz as the treble range, while below 1000 Hz lies the bass. If we divide the spectrum into three regions we shift the bass to that region below about 500 Hz and the treble to those frequencies above about 5000 Hz. Everything occupying the decade between is regarded as the midrange. Most three way loudspeakers place their crossover points at these frequencies, the RIAA equalization system uses a turnover of 500 Hz. All things considered this arrangement seems to work pretty well. Or does it?

Scientific Basis

Many people like to do things scientifically. This has the advantage of allowing them to appear competent and knowledgeable, without actually knowing what they are doing. My wife, who works in the provincial ministry of Social Services, informs me that the Social "Scientists" with whom she works devote a great deal of attention to the manner in which various programmes "impact" the people they concern. They also spend a great deal of time "interfacing" with their "clients" and the government. This is all very "Scientific" of course, and sounds very impressive in speeches by the minister and his various "experts" on the CBC.

Similarly, dividing the audio spectrum between treble and bass at 1000 Hz *sounds* very scientific; after all, 1000 Hz is a very nice round figure, has a sort of metric sound to it, which is certainly scientific, and is kind of central to the range of human hearing. And it subdivides nicely to be sort of centralized in the midrange. Mind you, these same scientific minds actually believe that middle C has a frequency of 256 Hz, although for some perverse reason musicians insist on playing a little sharp so that a musician playing middle C produces a tone whose frequency is 261.63 Hz. Come to think of it, why should this be called middle C? Somebody's out of whack here. Being sensible types, musicians who invented the musical scale, after all, thought that middle C should be C in the middle of the musical scale. Why C anyway? Because it's the only key signature with no sharps or flats, except for A minor, which is built on the C major structure. And an octave above this we find tuning A, all of which strikes me as more logical than the rather arbitrary conventions generally encountered in audio. In other words, perhaps old Bach knew what he was doing when he established the modern musical scale.

Back To Music

Returning to the King of the High C's, just where is this stratospheric note placed, as regards pitch? How about 523.25 Hz. That's right, five hundred and twenty three point two five Hertz, just about on one of the most popular bass/midrange crossover points. With some speakers it's comfortably within the *woofer's* range. How about the other end. Well, looking at an extremely popular work with bassos, because it shows off the lower registers, consider Moussogsky's "The Song of the Flea". I happen to have an original English language edition of the score, in the original key. Well, the lowest note I can

Audio Today Letters

In the Nov '79 issue you published an amplifier schematic of a kit available from Audiovision. Would it be possible to obtain a complete schematic for the whole unit including preamp and tone controls?

Since I probably have or can get all the parts, there's no point sending the kit. If I write to Audiovision, they'll probably just want to sell the kit. When you stated in the article that you are rewriting their instruction manual, you were the logical person to write to.

From what little you did publish and a Motorola data book, I have determined that the output transistors are MJ15004, and MJ15003. The 4739 can be replaced by a 4558 or 4136 (good improved 741). However, you left out the following: 1) What are the diodes? 2) Does one of the diodes (or both) go on the heatsink? 3) What is the value of the trimpot across the diodes? 4) The resistors going from the driver transistor emitters to ground, are they 39 Ohms? 5) The 500 Ohms resistors: they must be 510 or 470 if they are standard values? 6) What are the wattage and tolerance values required for all the resistors? 7) In what direction should the 100 uF capacitor go — or is it non-polarized?

If you want me to do something unethical, at least you could offer a bribe. Sorry. The background info on the 4739 is interesting, but not sufficient.

Speaking of which, you imply that the 4739 is some kind of super 741, and that it replaces the ua793/MC1303. I don't have a data sheet on hand for the ua793, but the MC1303 vaguely resembles the ua739, neither of which could be confused with a 741, improved or otherwise. But then, why would you want to replace anything with a 741? If it's speed you want shell out a fin for an LM318, if you want low noise, try the LM381, or the ua739. If you want both, along with high output, build a JE-990 discrete Op Amp (see AES Journal, Jan/Feb, 1980).

Returning to the amplifier, Audiovision is in the business of selling kits, not schematics. But did you ever consider writing to ask if they would sell you one, or even a complete manual. I should think enclosing a stamped, self-addressed envelope would bring you a reply. They can only say "no", at worst.

People pay me money as a private consultant to do things like design speakers, amplifiers, write construction

manuals. Therefore any information I get is privileged and I don't feel I have the right to disclose it. The small section described in October was done in my capacity as a reviewer and audio editor and was intended to indicate something of the design level.

I have no doubt that you can obtain the required components (for free?), but what do you intend to do about the circuit board. Laying that out is a design problem in itself, and it's one of the biggest attractions of kits. If you knew how much time went into laying out the board of the phono preamp referred to earlier you'd see what I mean. It's not just transferring point-to-point wiring to copper.

I'm sure you would have no trouble building this amplifier from the kit, but, from the questions you ask, I question your prospects of successfully completing the project from only a schematic. In a way, it's like buying a Rolls Royce: it's one thing to ask the price in order to make out the cheque, but if you mention a down-payment, you can't afford it.

If it's any consolation, you were right about the output transistors. Excellent devices.●

TABS AT ETI!!

Prices shown include postage and packing. Order using the card facing page 44 or send to Book Service, ETI Magazine, Unit 6, 25 Overlea Blvd, Toronto, Ontario. M4H 1B1

<p>1076 \$11.55</p> <p>Artificial Intelligence Making machines "think"</p>	<p>1071 \$10.90</p> <p>The Complete Handbook of Robotics</p>	<p>1010 \$9.85</p> <p>INTERNATIONAL TRANSISTOR SELECTOR 2ND EDITION</p>	<p>1064 \$11.85</p> <p>HOW TO DESIGN, BUILD, & TEST COMPLETE SPEAKER SYSTEMS A complete 64-0-year-old guide for audio buffs who want the ultimate in sound quality</p>	<p>1088 \$11.85</p> <p>ILLUSTRATED DICTIONARY OF MICROCOMPUTER TERMINOLOGY Clear, concise, encyclopedic definitions of nearly 4,000 computer terms, "buzz" words, and jargon.</p>	
<p>841 \$8.55</p> <p>BUILD YOUR OWN WORKING BY DAVID L. HERSHMAN</p>	<p>800 \$18.30</p> <p>Handbook of 1001 Practical Electronic Circuits Edited by Kendall Webster Sessions</p>	<p>804 \$18.35</p> <p>Master Handbook of 1001 MORE Practical Electronic Circuits Edited by Michael L. Fair</p>	<p>1015 \$9.70</p> <p>A BEGINNER'S GUIDE TO COMPUTERS & MICROPROCESSORS with prof...</p>	<p>1000 \$11.55</p> <p>57 PRACTICAL PROGRAMS & GAMES IN BASIC Programs for everything from space war games to blackjack. From craps to I Ching!</p>	<p>1070 \$12.35</p> <p>Digital Interfacing With An Analog World</p>

GETTING 'ROUND HEX

Offset problems with a circular solution by P.Minch.

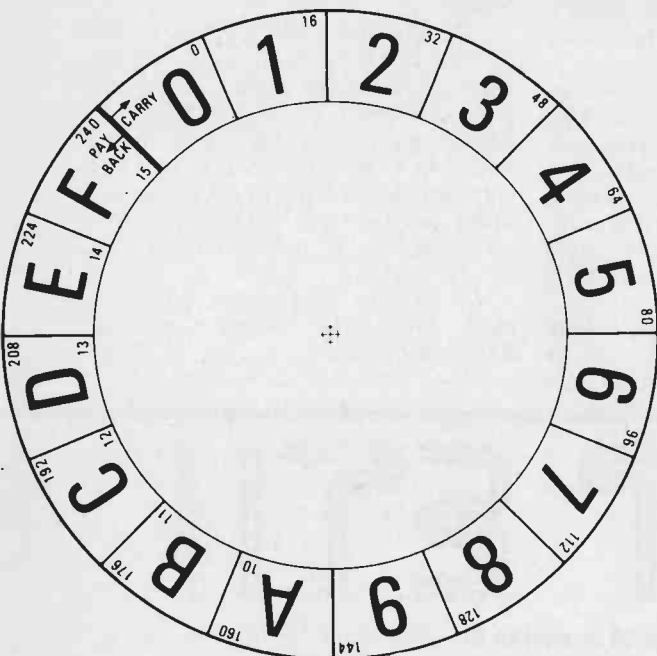
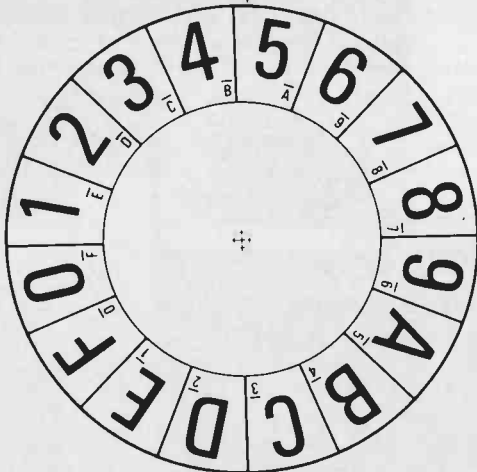

Fig. 1. The two scales must be fastened together with a small nut and bolt through the centre.



If you own a micro that is programmed in hexadecimal but do not have access to an assembler then you have to calculate offsets by hand. Not many people know their hex addition tables by heart (for example $A+B=5$ carry 1) so they use look up tables. The circular slide rule described in this article is much quicker to use.

Making the Rule

Cut out two circular discs of stiff card 10 cms. and 14 cms. in diameter. Divide each scale into 16 equal segments and mark the divisions as shown in Fig. 1, writing the appropriate numbers into each segment. Both scales have the hex digits 0 to F on them as their main inscription. They both also have the decimal equivalent of A to F where the scales meet as a reminder of the hex times 1 table. The outer edge of the outer scale has the 16 times table on it. The inner edge of the inner scale has the 15's complement on it marked as 0, 1, etc.

How to Use a Slide Rule

Now that the only useful scale on a normal slide rule is the one on the edge for drawing straight lines it might be worth reminding the very young or forgetful of us what a slide rule did. As the scales are rotated and the inscribed numbers counted off the distances, or angles in our case, are added or subtracted depending on the direction. Originally the scales were marked logarithmically so the effect was to multiply or divide the numbers, but our scales are linear to give addition and subtraction.

Now For How To Do It

TO ADD e.g. $X + Y = \text{ANSWER}$

Rotate the inner scale until its zero is under X on the outer scale. Clamp the scales together with your fingers and trace round **clockwise** until you find Y on the inner scale. The **ANSWER** is above it on the outer scale. If you pass the outer heavy black line carry 1 to the next column.

TO SUBTRACT e.g. $X - Y = \text{ANSWER}$

Find X on the outer scale. Rotate the inner scale until Y on it is under X. Clamp and trace round **anticlockwise** to zero on the inner scale. The **ANSWER** appears above it on the outer scale. If you pass the outer heavy black line pay back one to the next column.

Practice adding and subtracting with low decimal numbers so that you can easily check the result. Now check through the following examples with your slide rule. They are based on 8 bit bytes and assume 2's complement arithmetic, that is, if the most significant bit is a 1 the number is negative.

Addition

2 D
3 E+
6 B

$D+E=B$ carry 1. The slide rule in Fig. 2 is shown set

for this addition. Remember to add clockwise or you will lose the carry. $2 + 3 + 1 = 6$ you can do in your head of course.

Subtraction

$$\begin{array}{r} 73 \\ 56- \\ \hline 1D \end{array}$$

$3 - 6 = D$ pay back 1. Fig. 2. shows the slide rule set for this calculation also. The pay back 1 makes the 5 into 6 giving $7 - 6 = 1$.

Decimal to Hex Conversion

This is achieved by successive division by 16, the hexadecimal remainders forming the result. It is here that

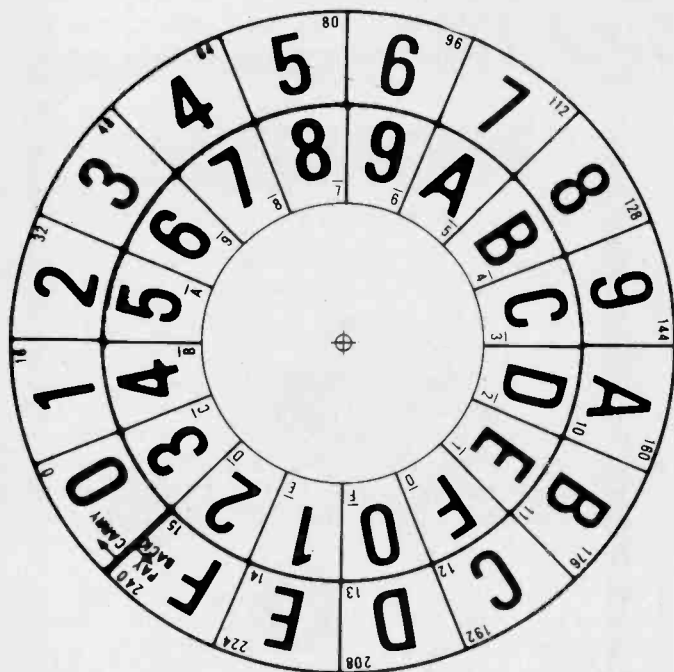

Fig 2. The rule is shown set to add D + E as in the addition example.

you need the 16 times table on the outer ring of the rule. The following example shows the conversion of a double byte (double precision) number, $10,815_{10}$ to $2A3F_{16}$.

$$\begin{array}{r} 16) 10815 \\ 16) \quad 675 \text{ r } F \\ 16) \quad \quad 42 \text{ r } 3 \\ 16) \quad \quad \quad 2 \text{ r } A \\ \quad \quad \quad \quad 0 \text{ r } 2 \end{array} \qquad 2A3F_{16}$$

A common mistake is to forget the last line, that is, 16 into 2 goes zero remainder two.

Hex to Decimal Conversion

For single byte numbers use the 16 times and 1 times tables on the rule to look up the value of each nibble and add them together. For example,

$$\begin{aligned} 3B_{16} &= (3 \times 16) + (B \times 1) \\ &= 48 + 11 \\ &= 59_{10} \end{aligned}$$

For multiple byte numbers you really need a calculator to handle the decimal arithmetic. If your calculator is the sort where the next operator (+ X) completes the previous operation the result is most easily obtained by "expanding the polynomial" without using brackets, for example,

$$\begin{aligned} 6BE4_{16} &= 6 \times 16 + 11 \times 16 + 14 \times 16 + 4 \\ &= 27620_{10} \end{aligned}$$

Negative Thinking

If a single byte number is used as a counter the largest number it can hold is 255_{10} that is FF_{16} . However when the same single byte is used in a two's complement arithmetic calculation the number will be considered as negative if the leading bit is a 1. That is, all single byte Hex codes "higher" than $7F$ are negative numbers. To find what such a number represents in decimal it must first be negated, thus forming its positive hex version, and then converted to decimal in the normal way.

Negative Hex Numbers

To negate a number write down its 15's complement and add 1. The complements of the hex numbers are given as 0 etc. on the inner scale of the rule. Here the example in hex and binary for comparison.

$$\begin{aligned} \text{negative number} &= C5 = 11000101 \\ \text{complement} &= 3A = 00111010 \\ \text{add 1} &= 3B = 00111011 \\ \text{decimal value} &= 59 = 59 \end{aligned}$$

So $C5_{16}$ represents -59_{10} in 2's complement form.

Similarly to load an address with a negative number simply repeat the above procedure, for example.

$$\begin{aligned} \text{negative decimal number} &= -12 \\ \text{positive hex version} &= 0C \\ \text{complement} &= F3 \\ \text{add 1} &= F4 \end{aligned}$$

So $F4_{16}$ represents -12_{10} .

OSCILLOSCOPE HM 312

HAMEG



X-POS. **INTENS.**

X-MAGN. x5: pull

FOCUS

POWER Off/On

~ **TR**

5 Vpp **0.2 Vpp**

Made in Western Germany

Y-POS. I **Mono/Dual** **Alt/Chop** **Trig. I/II** **Y-POS. II**

AMPL. I ● Bal. **AMPL. II** ● Bal.

cm V 1 0.5 0.2 0.1

mV cm 50 20 10

DC **AC** **GD**

VERT. INPUT **1MΩ** **25pF** **Hor. Inp.**

Trig. ext. **TV** **+/-** **Hor. ext.**

TIMEBASE

1 0.5 0.2 0.1 50

2 5 10 20

5 10 20 50

100 200

LEVEL

VARIABLE

Ca

TRIG. EXT.

BCS ELECTRONICS LTD.

980 ALNESS ST. UNIT 35 DOWNSVIEW, ONTARIO

TEL: (416) 661-5585

C.L.I.P.

At University College London, there is a research group working on a method of image processing which could prove to be the link between the human eye and the TV camera. Phil Cohen has been talking to Dr. Michael Duff about Cellular Logic Image Processing:CLIP.

CELLULAR LOGIC IMAGE PROCESSING was first proposed in 1958 by S. Ungar in the States. It was suggested that the cells of the human eye do a lot of the processing *before* what we see is fed up the optic nerve to the brain.

What exactly do we mean by image processing?

Generally, it means processes like perimeter-finding — producing the outline of an object, or skeletonising — finding a set of lines which are unbroken and follow the object's shape.

This sort of process can be used in such diverse applications as fingerprinting, character recognition (OCR) or even intruder detection (spotting movement on a TV picture) but perhaps the two most useful areas will be biomedical scanning — chromosome counting or looking for abnormalities on X-ray plates — and production line quality control.

Parallel Processing

The model of the human eye previous to 1958 was of a simple camera — the point-by-point information was fed to the brain, which did all the clever processing.

However, it was pointed out that for processes such as edge-finding it was much more efficient to use a

parallel processing system.

The essential difference between serial and parallel processing schemes is that in a serial scheme the data is processed bit by bit in a central unit (CPU) and the intermediate results are stored in memory. In parallel processing the data is fed in as an array and the processing takes place all at the same time — *there is one processor for each data element*. The intermediate results are passed from processor to processor as the calculations continue.

In the human eye, then, the question is: could a number of cells just behind the light-detecting ones be the parallel processors, responding to commands from the brain to find the edges of objects, or detect movement? Certainly it is known that the edges of the field of vision are extraordinarily good at spotting movement — could this be because the structure of the eye is different there?

The Processors

Going back to the CLIP machine, in this sort of application the type of processor we are talking about is in no way as complex as a modern MPU. The sort of data it receives are single-bit inputs from the image sensor

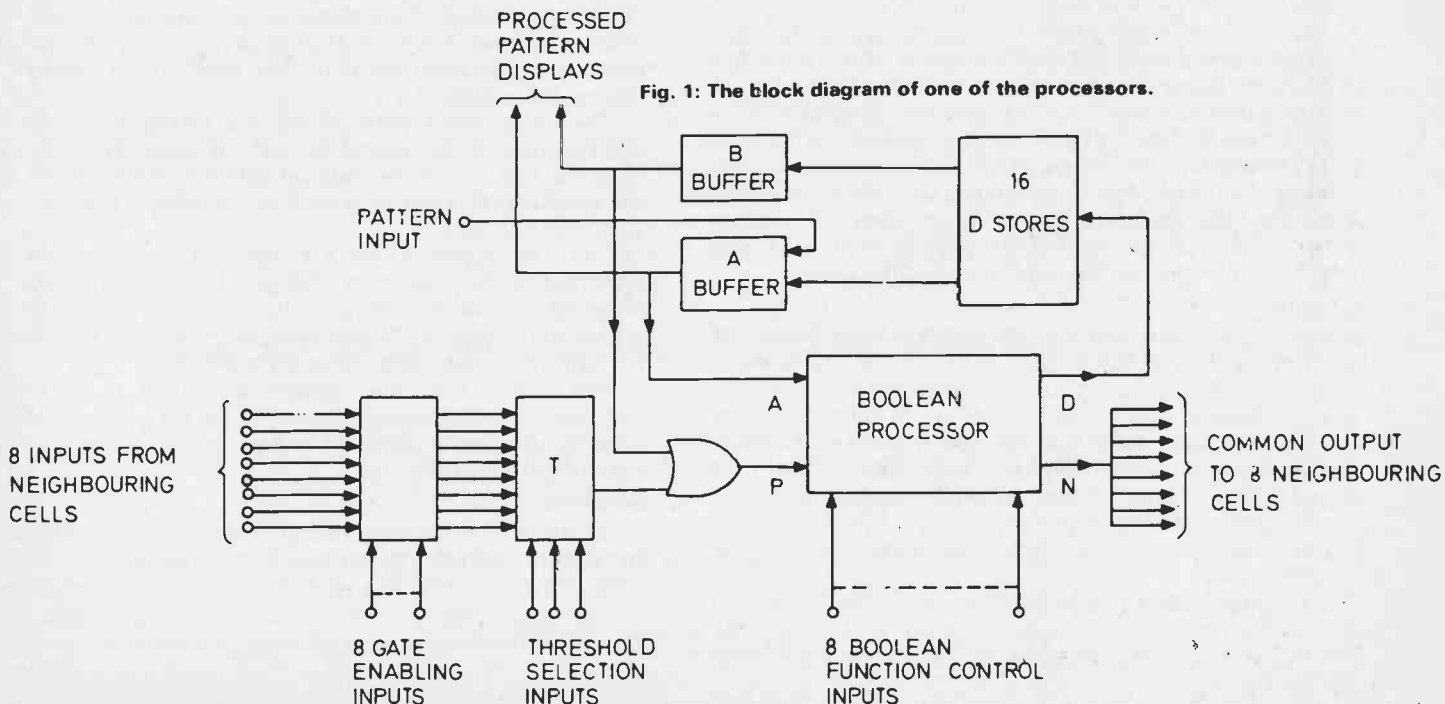

Fig. 1: The block diagram of one of the processors.

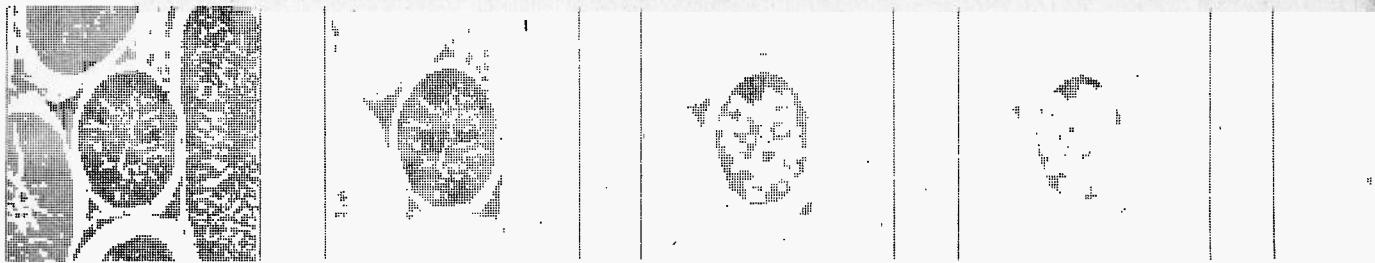

Fig. 2: Stages in the processing of a microscope picture of part of a rat's anatomy.

associated with it and one bit each from the eight nearest processors' outputs.

Why eight? Well, this provides an optimum "connectivity" — too few and the processing becomes slow, too many and the cost of connecting the processors together becomes enormous.

The sort of operation the processor would have to perform would be to give an output if any of its neighbours gave an output *and* the image bit fed to it was a "0"

The program example (in PET BASIC) given shows the usefulness of this sort of process. Of course, we cannot perform parallel processing directly in BASIC — the program has to scan the image bit by bit, simulating the action of each processor in turn.

The important thing about using this sort of scheme for image processing is that the outputs of the units will change in "waves", travelling at speeds dependent on the propagation delay of the devices involved. This means that, by having four "edge registers" which are not connected to the image input, we can do things like finding the outer edge of an object by starting a signal from the edge registers and programming the processors to stop propagating it at the edge of the object. The program example carries out this sort of process.

Structure

In the CLIP machine, the processors each have the structure shown in Fig 1. Each is connected to its eight neighbours and its output fans out to the same neighbours. There is also a "pattern input" for connection to the picture signal (which is derived from a TV camera and multiplexed to provide each processor with a 1-bit signal from one point of the camera's image).

The gate enabling threshold selection and function control inputs are from a programming bus common to all processors.

The gate enabling inputs allow instructions like "If the output from the processor to the left is '1' . . ." The threshold selection inputs allow "If more than three inputs are '1' . . ."

Combining the two allows very comprehensive processing of the inputs — "If any two of the processors to the left give and output . . ." for example.

There are also various buffers for more complex instruction types.

The boolean processor itself can be programmed via the function controls to "look" like any combination of memory-less logic gates.

Implementation

The processors come in custom-built ICs, each chip containing eight units. The CLIP 4 machine contains an array of 96 x 96 processors.

CLIP 4 is the product of ten years of research at University College. It's a commercially viable product — it fits into one 7-foot instrumentation rack, including power supplies and controller. The cost? In the region of \$81 to 108 thousand.

The processors themselves are based on NMOS technology and the control circuitry (the part that acts as a "conductor" — in the musical sense — directing all of the processors) is implemented in hardware — an MPU would be too slow!

The input signal is from a TV camera (only part of the picture is used — 96 lines x 96 points). This is encoded either as a black and white picture with no grey or as a grey-scale image. CLIP can handle grey-scale pictures, performing processes such as smoothing.

The output from the system would be to a video monitor or, in some applications, just a few bits of data to another peripheral, such as a warning indicator in the case of intruder detection.

Software

The software for the system consists of a series of inputs for the function-definition bus of the processors and a loop structure which is linked to the processor outputs.

Looking at Fig. 2, the machine is trying to find the outline of the largest isolated mass of black in the input pattern.

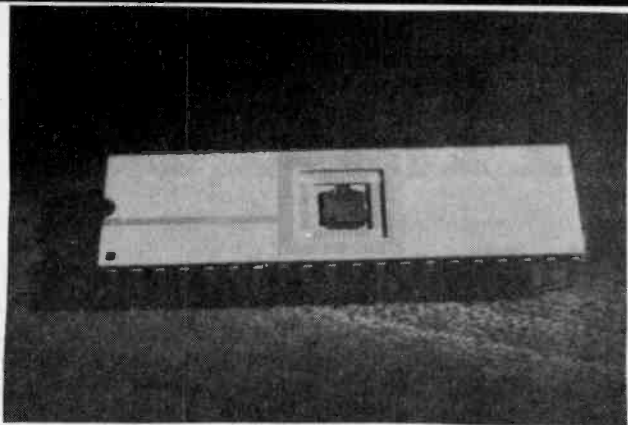

One of the chips in the CLIP — each contains eight processors.

The original input is shown in the top left. The first instruction propagates white from the edge registers through all connected black. This leaves the pattern second from the left on the top line. The program then "erodes" the image by removing all black dots not surrounded by black and then removing their neighbour black dots as well.

It repeats this erosion until one more step would cause all black to vanish completely. This leaves the image as it is at the end of the top line.

The program then surrounds each black by eight blacks. It does this twice. It then recalls from the original input pattern the part which is "connected" to the current pattern. The last step finds its outline.

Naturally, this sort of software cannot be written in a conventional language — the group have developed what is effectively an assembler for the system and all the groups working on image processing worldwide, can considering a suitable high level language

Applications

One very interesting application mentioned earlier is production line control. CLIP can tell the difference between an object which has been correctly punched out of metal and one with the wrong surface area or the wrong number of holes, etc.

The amazing thing is that it can do this fifty times a second! In fact, the machine can perform 1500 parallel processes per TV frame period.

The machine could be fitted to the "reject" solenoid on a production line so that badly produced pieces could be pushed off the line.

Another area in which the machine could be useful is in microscopic counting. There are systems available already which will count the number of items in a picture, or even the number between certain size limits, but the inherent flexibility of CLIP make it invaluable for complex tasks such as red blood cell deformity checking and other applications where previously a human operator was the only alternative.

One slightly more frightening possibility is the use of such a system in facial recognition — enabling authorities to keep track of every individual automatically.

When the system was first proposed about ten years ago, the device which was envisaged was a pair of super-binoculars, with photo-diodes at one end and LEDs at the other, modifying images so that only moving objects, or even more selectively, only enemy tanks would be seen! This is some way from the present state of the art but in a few years . . . who knows?●

We would like to thank Dr Michael Duff and University College in general for their help.

CLIP SIMULATION PROGRAM

The following program simulates the action of the CLIP machine by pretending to be each processor in turn in a 10 x 10 array. It's very slow to run (several minutes) and this shows the advantage which a parallel processing system has over a serial one.

10 S = 10

S is the dimension of the 2-dimensional square processor array.

20 DIM A(S, S), B(S, S)

A is the image input to the system. B represents the processor outputs. Load the image into the system:

```
30 FOR I = 2 TO S - 1
40 FOR J = 2 TO S - 1
50 READ A(S, S)
60 NEXT J
70 NEXT I
```

The outer layer of processors represent the edge register, in which we can initialise processing 'ripples' (see text).

```
80 DATA 0,0,0,0,0,0,0
90 DATA 0,1,1,1,1,1,1,0
100 DATA 0,1,0,0,1,0,0,0
110 DATA 0,1,1,0,1,1,0,0
120 DATA 0,1,1,0,1,1,1,0
130 DATA 0,1,1,1,1,1,0,0
140 DATA 0,0,0,0,0,0,0,0
150 DATA 0,0,0,0,0,0,0,0
```

Now for the 'seed' which will propagate during processing. Note that it's in the edge register:

1010 B(S, S) = 1

Now print the results so far:

```
1014 GOSUB 2000
1015 F = 0
```

F is set to 1 if any changes are made.

```
1020 FOR I = 2 TO S - 1
1030 FOR J = 2 TO S - 1
```

```
... For each processor
1040 FOR K = -1 TO 1
1050 FOR L = -1 TO 1
... For each of the eight 'connected' processors
1055 IF L = 0 AND K = 0 THEN 1090
... Except the one we're simulating
1060 IF B(I+K, J+L) <> 1 OR A(I, J) <> 0 THEN 1090
skips the next bit unless the image is zero at this point and one of
the neighbours outputs is one.
1070 IF B(I, J) = 0 THEN F = 1
B(I, J) is going to be set to 1. F is set to 1 if this represents a change.
1080 B(I, J) = 1
1090 NEXT L: NEXT K: NEXT J: NEXT I
1130 IF F = 1 THEN 1014
1140 STOP
```

repeats the process until the output is stable (ie there were no changes during this pass).

The following subroutine prints the results:

```
2000 REM PRINT
2010 PRINT " " : REM CLEAR SCREEN CHARACTER
2020 FOR I = 1 TO S
2030 FOR J = 1 TO S
2040 IF A(I, J) = 1 THEN PRINT "A": GOTO 2060
2050 PRINT " " :
2060 NEXT J
2070 PRINT " " :
2080 FOR J = 1 TO S
2090 IF B(I, J) = 1 THEN PRINT "B": GOTO 2110
2100 PRINT " " :
2110 NEXT J
2120 PRINT
2120 NEXT I
2140 RETURN
```

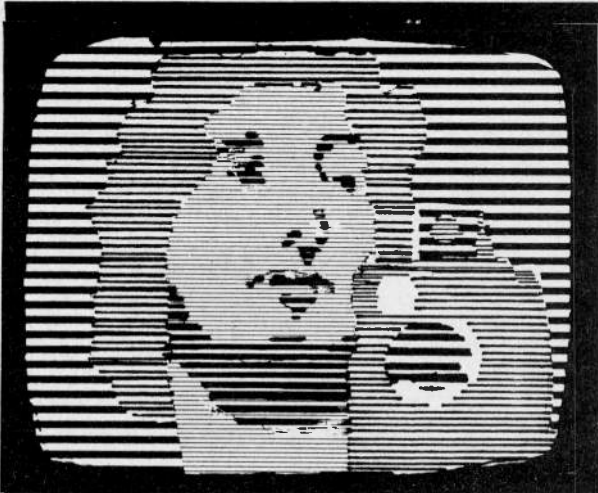

WHAT'S ON

Making your own TV programmes has never been easier. Steve Rimmer examines portable video recorders.

Rover In The Clover

OKAY, GATHER 'ROUND, chill'un. Today, we're gonna talk about folk video. Now, you might be gettin' into thirty-five channel, ultra wide band satellite television downlinks, microprocessor controlled multi edit studio video tape recorders, electronically generated imaging . . . well, I'm here to tell you that all that chrome plated bourgeois flotsam is merely an illusion. It's time to lay those fetid toys by the wayside, friends; abandon your one point three million dollar production studios, your parabolic dish antenna farms, your colour synthesizers and time base correctors, for I hold the true light in my hand.

I've had this revelation, see, a vision of the universe as it really exists, and I can now comprehend the true order of being. It's on five inch reels of black and white video tape. We have to get back to that kind o' simplicity, man . . . like, natural food, organic mood modifiers, Joni Mitchell with the treble turned down, and real shakey camera work with lotsa bad edits. I mean, that's just the eternal truth, friends, that's . . . art.

Now friends, you might be sittin' there in your lotus positions thinkin' that television is for television stations, because, after all, who's got the bread for a van full of recorders and monitors and cameras and all the millions of other technological head trips required. I mean, like, for that matter, who's got enough bread to buy the van to put 'em in? I can dig that. What I'm here today t' tell ya is that all that stuff is just the trappings of professionalism, and professionalism is just a fad. It will pass. Professionalism is something that the man has been tryin' to push on everything from little high school theatres to, praise the Lord, the CBC National News. Hope springs eternal. But, friends, professionalism is not artistic or technical proficiency, no . . . it's merely

a sort of ritualistic uniformity. It's mind games, for those who have not experienced the unfolding of being, the true art of existence. Friends, today, I have come to bring you the word, the complete word, the word that will deliver unto y'all total comprehension and mastery over the medium of video communication and that word is (are you listenin') that word is . . . ROVER!

Yes, Rover

Yes, Rover, The box in figure one is Rover. Unimposing, isn't it? Rover is also known as Sony Videocorder AV-3400, which, in turn, is also known as a Porta-Pak. It might look remarkably like a packing crate for a leprichoun dining room suite, but, if one has sufficient imagination, it can be a complete video studio. Yes, I know, if one has sufficient imagination anything can be a complete video studio . . . we won't get into any more of that Guru head-space stuff for the time being.

The Rover consists, in essence, of two sections. The first is the recorder, which is shown in the picture. It weighs a bit over eighteen pounds, and lives in a fake leather case that lets one carry it over the shoulder . . . for short periods of time. It runs on five inch reels of black and white tape, each of which is good for a half hour of recording. While it can, of course, derive its juice from the wonders of hydro, it is quite comfortable running from an internal ni-cad pack, making it quite independent of external power. This is handy if one is into shooting in the woods, or from a plane . . . five thousand foot extension cords do get in the way. Given sufficient tape and enough charged ni-cads, Rover can rove for indefinite periods of time.

So, with a Rover recorder, one can go out into the middle of nowhere and just rewind tape until the cows come home. This is very symbolic, of course,

but, should it happen that one is desirous of putting images on the tape, the other half of the system should also be checked out, this being the Rover camera. Figure two . . . well, figure two is actually another shot of the recorder, for, as I shall explain shortly, I don't presently have a Rover camera with which to occupy figure two. However, if I did, it would look remarkably like a regular, hand held camera, which is what it is. The standard camera comes with a 16-70mm Canon zoom lens, which is rather nice, and an electronic viewfinder, that is, a little cathode ray tube in the eyepiece that permits one to actually see what is going on the tape. This dwarf TV also serves as a playback monitor, which permits one to review what has already been shot without the use of an external monitor screen.

Now, this particular Rover is quite old, having been born initially, in the mid sixties. There are, at present, considerably better ones available. The latest crop runs three quarter inch cassettes, in full colour, and does on line assembly editing. This is opposed to our little friend here, which is monochrome, does ghastly edits and will spill its tape all over its box given half a chance. However, what keeps the 3400's going is that they are considerably smaller and lighter than their newer cousins, easier on batteries, simpler to use, more rugged, and most important, far more accessible. Even in their day, the Rovers did not cost as much as Porta Paks do today, and, at present, they represent about the most rock bottom approach to doing outside video production imaginable.

Figure one cost twenty bucks, but this was something of a fluke. In more rational terms, quasi functional Rovers can often be found for a couple of hundred dollars, and really well cared for ones, replete with all accessories and tapes, are frequently available for four

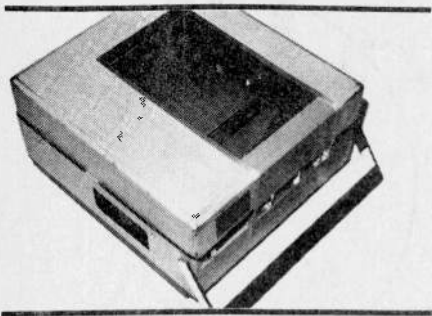

Fig.1. Yegods!! Vintage video, the Sony AV-3400 is a possible cheap way into video.

or five grand. Rather than get into all the acrobatics involved in buying one of these things here, I'll refer any interested parties to the series on this topic which graced these hallowed pages last year. (Getting Into Video, Part II, ETI, January 1979.)

Using a Rover is not at all difficult, especially if you intend to employ it as a portable TV system. (I'll state here that it is more difficult to use as an orange juicer.) It does seem to have been well engineered for operation by even a computer scientist, so, presumably, anyone can figure it out. To get things going, remove the recorder from its case, and place a charged battery pack in the trap door compartment so designed. The battery comes with a cord that plugs into a jack inside the compartment.

Next, with the recorder right side up again, put a spool of tape on the upper spindle, and thread it through the snapping, writhing jungle of wheels, rollers, heads and drums onto the lower spindle, which should be occupied by a take up reel. This is very easy to say, but quite difficult to do correctly, so follow the diagram exactly. The system is most intolerant of threading errors.

Having come thus far, you now have a choice of four possible functions. You can (a) view the material already on the tape (b) record something new on the tape, (c) fast forward to a point somewhere farther along the tape (d) accidentally rewind the tape, at which point it will go best for you if you await the stopping of the video head drum, and there upon rethread the thing. All of these functions are pretty well self-explanatory. The only possibly tricky bit might be in recording; it is necessary to pull the record lever over first, before engaging the forward lever.

See Rover See

Now, about the camera. The camera plugs into a jack on the side of the recorder. Via its cable, it receives sync pulses from the machine, and in return, supplies it with video. It also derives power for its circuits, and provides a control signal to stop and start the recorder. To use the camera, plug it into the appropriate jack, switch the recorder into the camera mode, and set it up to make a recording. As soon as the machine is turned on, the camera will be powered, and, shortly thereafter, the viewfinder screen should come on. With the lens aperture ring on "C" (Closed), point the camera at any normally lit scene, and begin opening the iris until the scene appears on the viewfinder screen. Focussing may prove necessary at this point. The proper setting of the iris is one stop beyond the point where further opening produces no change in the contrast of the image on the screen. At this point, the camera's automatic exposure control has taken over.

In peering myoptically into the finder, you may or may not have noticed the presence of a small red light. If you did, all your focusing and adjustments will have been recorded for the edification of future generations. This bulb comes on whenever the tape is rolling, and the machine is in the record mode. It is possible to put the recorder in a "pause" mode from the camera, using either the button on the camera's hand grip, should you have it, or the small (unmarked) silver button on the front of the camera. The red light indicates the current status of the recorder, i.e., in or out of pause. All the usual cautions regarding the duration of pauses are applicable.

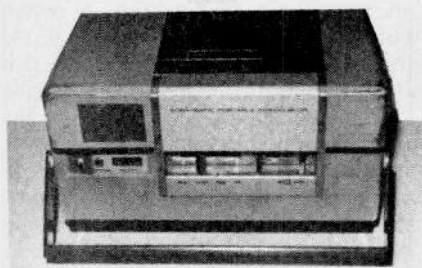

Fig. 2. The cam-er-another view of the Port-a-Pak.

The camera also contains a microphone (of dubious quality), which sticks out above the lens, and, presumably, picks up whatever the lens does. Plugging a hand held mike into the recorder's mike jack disables it, and usually does wonders for the sound.

Walking Rover

The Porta Pak can porta and shoot, but not at the same time with any degree of safety; at least, not with one body serving as camera person and beast of burden. The first rule of Rover is that he does not like to have his tapes rolling when he be in a vertical position. Sometimes he will be tractable at this, but periodically he will unwind a reel all over the inside of the case . . . what a mess. Scolding will avail you not. It is most advisable to lay the thing flat when shooting.

Another thing that bears mentioning is the use of tripods with the camera. If used with its standard zoom lens, the camera makes a pretty hot telescope at full zoom. This, in turn, means that vibrations of a few millimeters or so at the lens end will send the thing sweeping over great, blurred panoramic vistas, making very arty images, but also risking seasickness in one's audience . . . or vidience, as the case may be. Thus, it may be that one might from time to time, wish to use a tripod with the camera. There are, it seems, two ways to catch one. You can wind it on to the nut on the bottom of the handgrip, or remove the handgrip and put the tripod in its place. If you are undecided about which to use, keep one fact in mind. The handgrips break, usually when you are filming over edge of an abyss of some sort or another, and the camera tends to resent being dropped.

One of the accessories that Sony includes with the Rover is an earphone to let you monitor your sound, and this comes in most handy for tying up patch cords, or hanging the lens cap from the camera, should the little string break. It doesn't have much future as an earphone, though, because, in fact, its really quite awful. For some time I looked for a replacement for this device in vain, trying things like headphones and communications headsets, all for not. The amp inside Rover is a bit on the feeble side, and any ambient noise at all is enough to completely overpower it and force it into submission.

A while ago I discovered a practical alternative. Plug a microphone into

the earphone jack. While most any mike will do, the medium grade cassette mikes are a good tradeoff between price and quality. If you hold the mike up to one ear you will really look quite foolish, but you will be able to monitor you audio, and at a reasonable volume. If you wish to avoid being taken for a drunk, consider removing the mike button from its case and mounting it in an old earphone or a pill bottle.

While there isn't nearly enough room to deal with the nuts and bolts maintenance of the Rover's innards, there are a few things one can do to keep his tail wagging from without. Primarily, this involves, (a) keeping his batteries charged, as they quite smartly croak if left too long without feeding, and (b), keeping everything clean. All metal and rubber parts in the tape path must be de-filthed at regular intervals, using pure alcohol (not that guzzle you drink) and Q-tips. The heads can be done this way as well, but I've found the freon spray works as well, and there's less chance of snapping the little monsters off with a stick. Keep in mind that half inch recorders have two video heads, 180° apart.

Rovers can stand a surprising amount of heat, cold and damp, especially for short periods of time. Thus, if one is shooting amongst the elements, a plastic tarp draped over the recorder, and another to protect the camera, is usually usually sufficient. For more arctic situations, insulation may be required, and prolonged exposure might call for auxiliary electric heat. Somewhere around here I have a huge, two piece quilted Rover cover, which is just a pair of fitted canvas mittens and a small mountain of padding. This sort of thing will keep the machinery useable for about half an hour.

As far as feeding goes, Rovers can be powered or charged from an eleven to fourteen volt supply, such as a car battery, bench supply, generator, hand crank, solar cell bank, windmill, or, God willing, even a proper Porta Pak power supply.

Breeding a better Rover

Despite their resplendent wonderfulness, Rovers do have a few drawbacks. First of all, you can't get video in and out of them without buying a very expensive adapter or two from Sony. Although it has taken considerable design ingenuity and effort, not to mention vast expense, I have recently come up with the universal Porta-Pak interface method, as shown in figure three. This permits one to access one or more of the lines on the main camera connector jack. The accompanying diagram lists

the pinout for the thing. This really shouldn't work at all well, but it actually gives no trouble, except that the wires all fall out if you move the recorder. It's a bit klugy, but it's considerably easier than getting the proper hardware.

Now for the big one. One of the real stumbling blocks of the system is the Rover camera, while it is rather a nice arrangement, in terms of size, controls and so forth, it leaves a bit to be desired in terms of image quality. Thus, there is some merit in considering replacing it with a better one. This will, in most cases, require several tradeoffs, as follows.

To have a better camera, one needs a larger vidicon, (a generalization, but somewhat true), and to get this into the appropriate sized package, something has to go. That something is the viewfinder tube. This is a drag, as the viewfinder tube, aside from finding views, is also the playback monitor. Such is life.

Few cameras not intended for portable operation will run off the twelve volt supply provided by the rover recorder. Rather than try to do a lot of regulating and re-converting inside the camera, it is best to provide the camera's existing AC supply with synthesized power from an inverter. As cameras don't usually draw much, this can be quite tiny if designed well. A great deal of care must be taken to be sure that the frequency of the inverter will not upset or wither the camera or the recorder's circuitry, that there are no spikes to pop transistors, and that the resulting voltages are in line with what the camera is expecting. The power for the inverter can be supplied by either an external battery pack or, possibly, derived from the Rover supply via the camera connector jack.

A few other problems crop up with this modification. In order to be able to use the pause feature in the recorder, the camera will have to be outfitted with a stop and start switch. A switch should also be provided to turn the camera's vidicon beam on and off if it will be running from a separate supply. If the new camera is fitted with the Rover's zoom, it would be advisable to mark a series of concentric rectangles on the camera's viewfinder, to have some idea of the field of view at various settings of the lens. It will also be necessary to do some on monitor tests with the camera to determine the effective "speed" of the vidicon tube at the ALC threshold, so that a light meter can be used to set the exposure.

Lastly, it should not cannibalize the existing Rover camera. The improved system will prove, in some cases, to be

Fig. 3. Should you wish to feed your own camera or accessories to Rover, here are some useful pinouts.

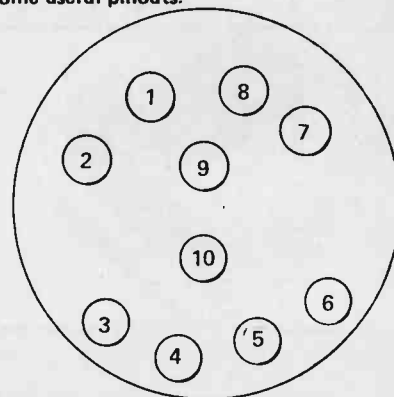

1. Video IN OUT for camera, Video IN from TV set.
2. GND.
3. VERT Drive OUT to camera, composite Video OUT to TV set.
4. GND.
5. HORIZ. Drive OUT to camera, Audio OUT to TV, -2dB, 1k.
6. GND.
7. AUDIO IN from camera or TV, -65dB, Hi-Z
8. GND.

a royal pain, and the increase in image quality will not make up for the relative inconvenience in use. After all, no hassle video is really what Rover is about. A great increase in versatility can be had in having a choice between these two options.

Play dead, Rover

When time permits, we'll look at a software side of Porta Pak video. The system lends itself, and to some degree, requires, a style quite unlike that of familiar studio television. The results of a day's shooting can look marvelously fresh and off the wall, especially if you have been doing the usual canned tube for the past few years. If you have access to a Rover of one sort or another, go out and waste some tape. It's amazing what these things can shoot if you just follow the lens around.

Next month, we'll be seeing about thirty days, interspersed with thirty nights. On the whole, the nights can be expected to be darker than the days. What's On will no doubt be back, unless it should happen not to be, and, as you may have gathered, I have no idea what it's going to be about right at the moment. Keep in mind that reality is simply a crutch for people who cannot face drugs, and by all means . . .

Stay tuned. ●

THE FUN OF ELECTRONICS

By Geiger.

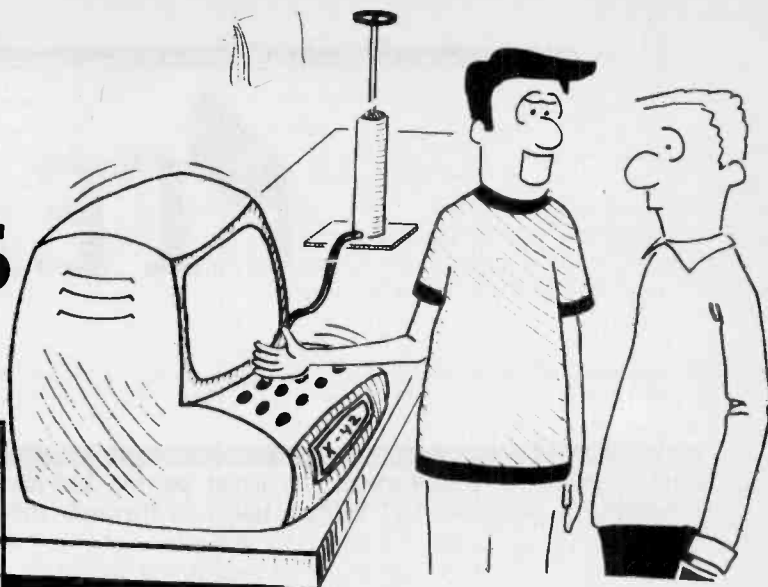

Now that I've become more experienced at programming, I've decided to expand my computer system.

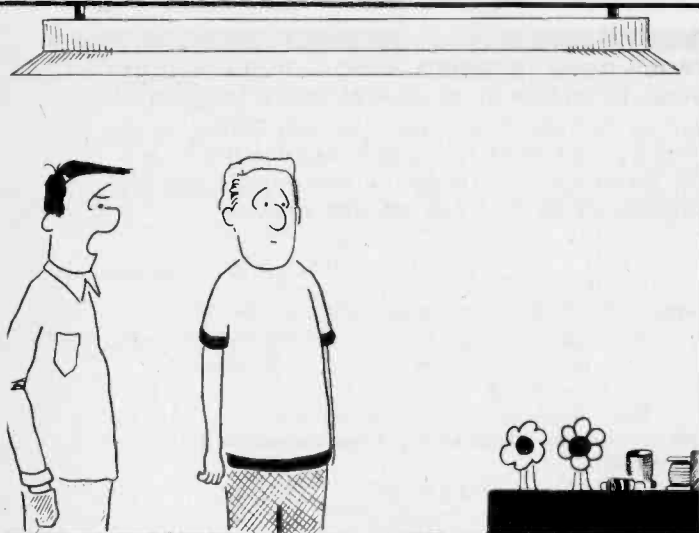

GEIGER

I thought it was strange, too. But the parts list explicitly specified germanium transistors.

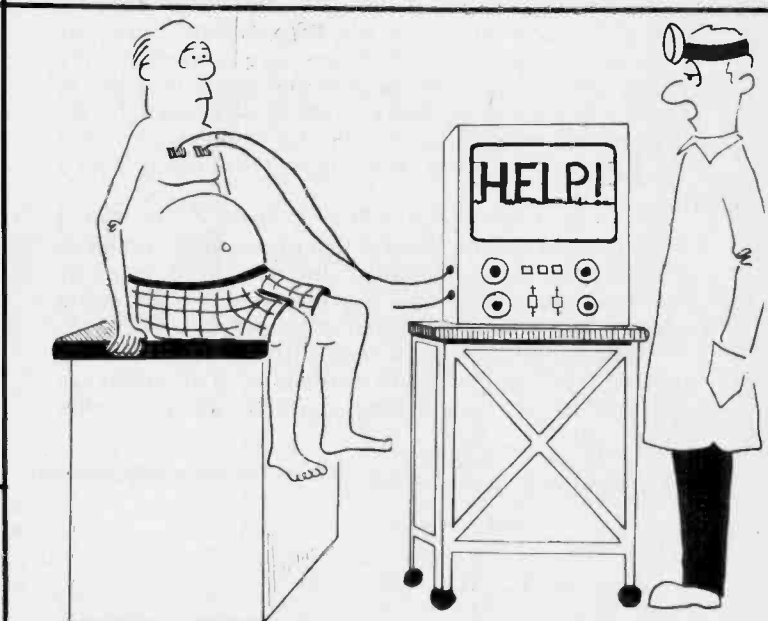

Just offhand, Mr. Swartz, I'd say your heart is trying to tell us something.



GEIGER

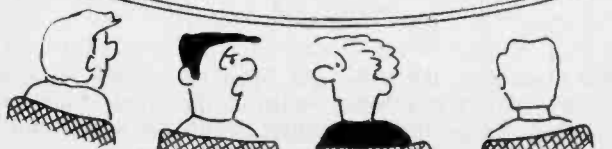

I see he's using a lapel microphone.

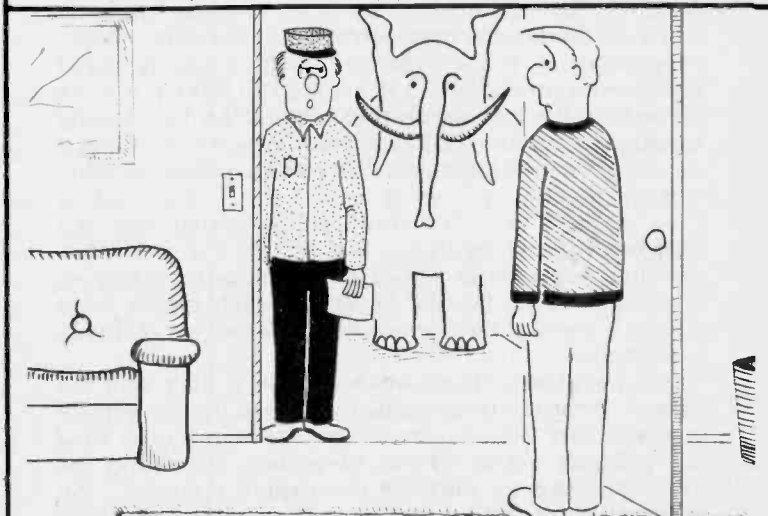

Are you the fella that ordered the "innovative 32 kilobyte memory"?

TEACHER'S TOPICS

Ohm's Law is straightforward to most people but there are many occasions when it won't help us much in solving a problem. K.T.Wilson takes us through the steps to enable us to answer really tough problems.

MOST OF US know Ohm's law in its three forms $V = R \cdot I$, $R = V/I$, $I = V/R$, and in the course of any sort of electronics work we use Ohm's law frequently, it becomes second nature, particularly in faultfinding. Is the current flowing through a particular transistor what we expect it to be? We don't usually measure the current as it means breaking the circuit, we simply measure the voltage across the emitter resistor and use Ohm's law to calculate how much current is flowing. Alternatively, we measure the voltage across the collector resistor and once again calculate the amount of current using Ohm's law.

We're so accustomed to using Ohm's law that it brings us up with a bit of a start when we find a problem which seems to be difficult or impossible to solve by Ohm's law alone. One type of problem of this sort is the two-supply problem, like the simple example in Fig. 1. In this type of circuit, a current through a resistor is supplied from two different sources — a situation we often find, for example, in the circuits of stabilised power

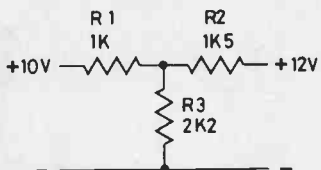

Fig. 1. The two-supply problem.

supplies. The problem here is to find out how much current is flowing through the resistor. We can't assume that each supply will pass current as if the other supply were not there. In our example, the 10 V supply would pass a current of $10/3.3 \text{ mA}$ which is 3.03 mA if we didn't have the 12V supply present, and the 12 V supply would pass a current of $12/3.7 \text{ mA}$, which is 3.24 mA if the 10 V supply didn't exist. We can't use these results, though. If the total current were $3.03 + 3.24 \text{ mA}$, a total of 6.27 mA, then the voltage across the 2k2 resistor would be, by Ohm's law, $6.27 \times 2.2 = 13.8 \text{ V}$, which is more than either of the supply voltages, obviously wrong. Equally obviously, each supply must chip in a share of the current, but how can we calculate how much?

It's not at all difficult when you know how, and the 'how' is provided by a simple rule called the Superposition theorem. The Superposition theorem shows how the voltages across R3 can be added, separating the effects caused by each of the supply voltages. The solution takes as many steps as we have supplies — here goes!

1. Imagine the 12 V terminals shorted. The circuit now looks like Fig. 2, with R2 and R3 parallel. Com-

binning 2k2 and 1k5 in parallel gives 892R, so that the circuit consists of a 10 V supply feeding 892R through a 1k series resistor. Using the potential-divider law, the voltage across the 892R resistor is now

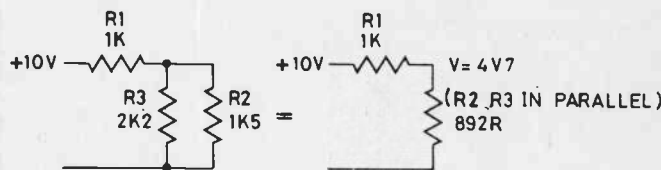

Fig. 2. How the circuit of Fig. 1 looks when the 12V terminals are shorted.

$$\frac{1.0 \times 0.892}{1 + 0.892} = 4.7 \text{ V}$$

(using units of kilohms for resistance). Note this value down.

2. Now imagine the 10 V terminals shorted, and the 12 V supply restored. The circuit now looks as in Fig. 3, with R1 and R3 in parallel. Combining 2k2 and 1k in

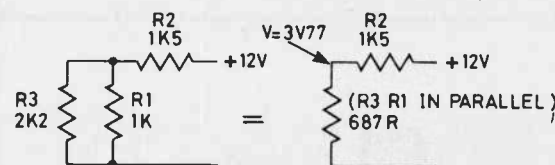

Fig. 3. How the circuit of Fig. 1 looks when the 10V terminals are shorted.

parallel gives 687R, so that the circuit consists of a 12 V feeding a 687R resistor through 1k5 series resistance. The voltage across the 687R resistor is now

$$\frac{10 \times 0.687}{2.187} = 3.77 \text{ V.}$$

Note this value too.

3. By the Superposition theorem, the total voltage across R3 when both supplies are present is simply the sum of the two voltages we have calculated: $4.7 + 3.77 = 8.47 \text{ V}$. By Ohm's law, the current flowing through the 2K2 resistor is

$$\frac{8.47}{2.2} = 3.85 \text{ mA.}$$

This, of course, isn't the only way of solving such problems — there's another method using Kirchoff's Laws — but it's by far the easiest of all the methods, since all you need to know is how to find the sum of resistors in parallel, and how to use Ohm's law.

The Superposition theorem seldom appears in text books — perhaps the authors are told that it's cheating to show an easy method when there are complicated methods around — but it's a real life-saver for these kinds of problems. Just to recap on the method, what you do is to imagine every supply voltage bar one shorted, then work out the resistances in parallel, and then the voltage across the resistors. Do this for each supply, and then add all the voltages. The total voltage is then the voltage which will be caused by all the supplies when the circuit is operating normally. That, incidentally, is where the name Superposition comes from — it means adding each voltage to the rest.

The idea behind the Superposition theorem is a very simple one — that a circuit consists of resistors and power supplies, and each power supply acts like a short circuit for another power supply. This simple idea can be extended to give one of the most useful rules in electronics — Thevenin's theorem. Never heard of it? You haven't lived — read on.

Thevenin's theorem states that any linear network can be represented by a voltage generator in series with a resistance. That's the way it's written in most textbooks, and you can be forgiven if you don't realise at once how useful this is. What it means is that any circuit containing resistances, no matter how complicated, behaves just like a power supply (with zero resistance) and a series resistor (Fig. 4), nothing more. This, of course, wouldn't be of much use unless we could easily

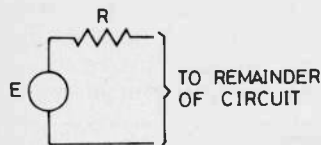

Fig. 4. By Thevenin's theorem, a linear circuit will behave like this — a voltage supply with a resistance in series.

calculate the voltage of the imaginary power supply and the value of the imaginary series resistance. Thevenin's theorem gives quite clear instructions.

(a) The supply voltage of the equivalent circuit is just the open-circuit voltage at the terminals of the circuit we are interested in,

(b) the resistance in the equivalent circuit is the total resistance between the terminals of the real circuit when the supply voltages are imagined short-circuited.

Let's look at an example — the potential divider in Fig. 5. Now when we use a potential divider circuit like this, we often assume that there is no current taken from the circuit. In such a case, the voltage at these terminals is given by the familiar potential divider equation

$$E \frac{R_2}{R_1 + R_2}$$

In our example, this voltage is

$$6 \times \frac{6.8}{10.1} = 4.04 \text{ V.}$$

What you're never told in textbooks, though, is how to calculate the voltage at these terminals of a potential divider when you are drawing a current from it. Odd, when you think of it, because a potential divider circuit is the one we use almost universally for biasing the base of transistor circuits, and we can't always assume that the base current of the transistor is negligibly small.

Now, of course we can make use of Ohm's law, and after a long struggle find the voltage at the terminals when some value of current flows. Thevenin's theorem provides a much easier method, though. Let's take the

values in the circuit of Fig. 5a. The supply voltage for the equivalent circuit is, by Thevenin's theorem, the open-circuit voltage at the terminals, which is just the 4.04 V we have calculated. The resistance between the terminals, assuming the supply to be short-circuited, is a 3k3 in parallel with 6k8, a value of 2k22. The circuit should therefore behave like a 4.04 V supply with a 2k22 resistor in series (Fig. 5c). We can use Ohm's law to find out just what the effect of drawing current will be.

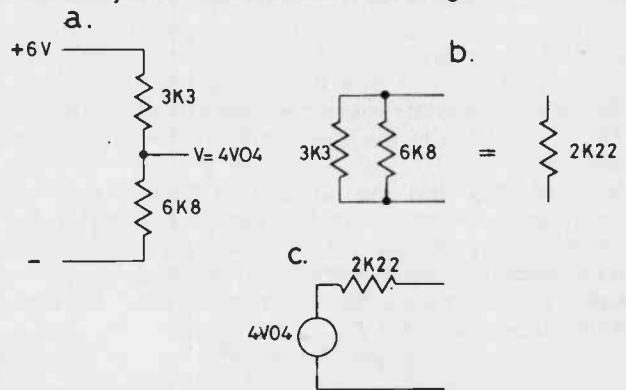

Fig. 5. A potential divider circuit (a) is equivalent to a voltage (the open circuit voltage) in series with resistance, found by combining the resistors in parallel (b). The result is shown (c).

For example, if we draw 1 mA from the circuit, there will be a drop in voltage of $1 \times 2.22 \text{ V}$ across the 2k22 resistor, so that the voltage at the output will be 2.22 V down on the open-circuit voltage of 4.04 V, making the output voltage $4.04 - 2.22 = 1.82 \text{ V}$. If we use this potential divider to feed a transistor whose base takes 80 μA , then the 80 μA will cause a drop of $0.08 \times 2.22 = 0.177 \text{ V}$ across the 2k22, and the voltage at the base will be $4.04 - 0.177 = 3.86 \text{ V}$. Even this small amount of current has caused a noticeable drop of voltage, and a voltmeter connected to the output of the potentiometer would cause an additional voltage drop, since most voltmeters take an appreciable amount of current from the circuit in which they are used.

Thevenin's theorem, however, really comes into its own when we have the sort of nightmare circuit which seems impossible to solve by Ohm's law. One which often crops up is the unbalanced bridge. Now the Wheatstone bridge network is a nice simple one when the bridge is balanced. If $R_1/R_2 = R_3/R_4$ (Fig 6a) then the current through R_5 is zero, no problem. For some types of measurement though, we need to know how much current flows through R_5 when the bridge is *not* balanced — one example is the use of thermistor bridge circuits for measuring temperature. This is a most frustrating problem to attempt to solve by any other method — let's look at the Thevenin method.

We start by removing R_5 , leaving the terminals X and Y (Fig 6b). If we can now reduce the rest of the circuit to one voltage and a resistance in series, as Thevenin's theorem promises, we can easily calculate the current which will flow when R_5 is put into its place again. With the circuit now consisting of two potential dividers, the open-circuit voltage across XY is comparatively easy to calculate. The voltage at X is

$$9 \times \frac{6.8}{10.1} = 6.06 \text{ V}$$

and the voltage at Y is

$$9 \times \frac{5.6}{10.3} = 4.89 \text{ V,}$$

using the potential divider formula each time. The voltage between X and Y is the difference between these two, which is $6.06 - 4.89 = 1.17$ V. It's this value of voltage which goes in as the supply voltage in the equivalent circuit.

Finding the resistance takes a little more agility in re-drawing the circuit. Fig. 6c shows the 9 V supply terminals short-circuited, and the circuit re-arranged so that we can see that it consists of R1 in parallel with R2, and R3 in parallel with R4, the two sets of parallel resistors being in series. Solving for 3k3 in parallel with 6k8 gives 2k22, and 5k6 in parallel with 4k7 gives 2k55, so that the total resistance is the sum of these two, 4k77. This, then, is the resistance in the equivalent circuit.

We can now find the amount of current flowing through any resistor connected between X and Y by using this equivalent circuit. For example, if we have 1k0 connected between X and Y, the total resistance in the (equivalent) circuit is 5k77, the voltage is 1.17 V, so that the current is

$$\frac{1.17}{5.77} = 0.203 \text{ mA}$$

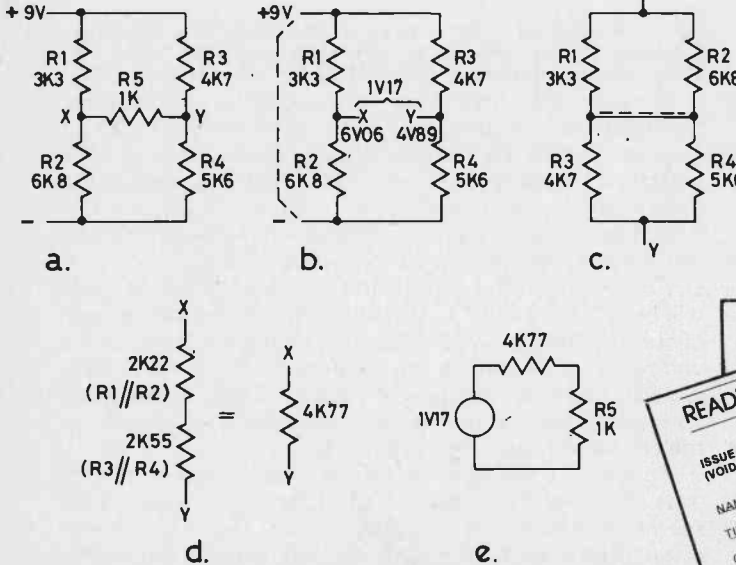

Fig. 6. The bridge circuit (a) is unbalanced. The open circuit voltage across R5 is easily found (b); finding the resistance (c) needs a little bit of re-drawing (d). The final equivalent is shown in (e).

or 203 μ A. The bridge isn't far from balance in this example.

Just for a tail-piece, how about calculating the total current flowing from the 10 V supply through the circuit of Fig. 7. Very nasty by any method other than Thevenin, because you don't know how much current flows through the 4R resistor. The Thevenin method uses two steps —

(1) Remove the 4R, and find the equivalent circuit, which is a 0.67 V supply and a 1R86 resistor as in Fig. 7b.

(2) Replace the 4R, and find the current through it, which is 0.113 A. The rest of the problem is now good old Ohm sweet Ohm. We redraw the circuit, showing the current through the 4R resistor, and the other current I_1 and I_2 as in Fig. 7c. The voltage across the 1R and the 2R in series must be 10 V, since that's the supply voltage, and the voltage across the 2R and the 3R in series must also be 10 V. Because of the current through the 4R

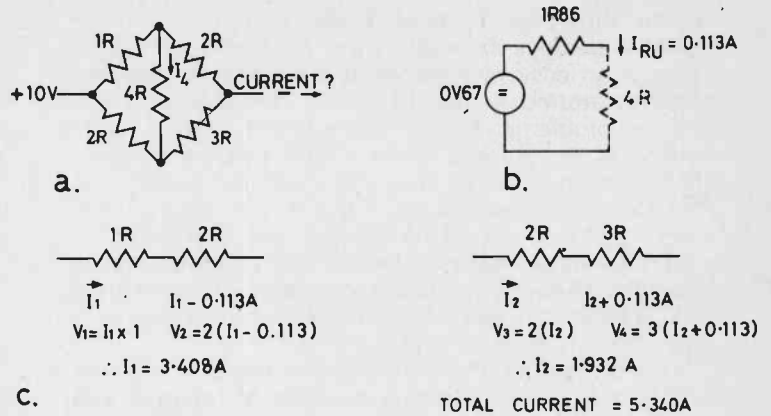

Fig. 7. Another awkward circuit, almost impossible to solve by other methods.

'bridge' resistor, current I_1 flows only through the 1R, and $I_1 - 0.113$ A flows through the 2R. Similarly in the other branch, I_2 flows in the 2R and $I_2 + 0.113$ A in the 3R. Solving gives $I_1 = 3.408$ A and $I_2 = 1.932$ A, a total of 5.34 A drawn from the 10 V supply. Comparatively easy by this method — but just try it any other way!

The rules? Ohm, Superposition, Thevenin, of course. We wouldn't get very far in design work without them, and yet so many texts deal only with Ohm's law. If you want a good demonstration of how easy other rules make the solution of problems, just ask anyone who doesn't know them to solve one of the problems shown here — but first be sure that you can do it yourself ●

Beat Rising Postage Costs!

READER SERVICE CARD

ISSUE: JANUARY 1980
VOID AFTER APRIL 15, 1980

NAME: _____

TITLE (IF APPLICABLE): _____

COMPANY (IF APPLICABLE): _____

PHONE: AREAL _____

STREET: _____

CITY/TOWN: _____

PROVINCE: _____

POSTAL CODE: _____

FOR ETI USE
80015 YES NO

PLEASE ANSWER THE QUESTIONS BELOW

DO YOU SUBSCRIBE TO ETI? _____

YOUR COMPANY CLASSIFICATION: _____

YOUR MAJOR BUSINESS: _____

WHAT INTERESTS YOU MOST ABOUT ETI? _____

CIRCLE THE READER SERVICE NUMBERS FOR THE ITEMS IN WHICH YOU ARE INTERESTED:

1	2	3	4	5	6	7	8	9	10
11	12	13	14	15	16	17	18	19	20
21	22	23	24	25	26	27	28	29	30
31	32	33	34	35	36	37	38	39	40
41	42	43	44	45	46	47	48	49	50
51	52	53	54	55	56	57	58	59	60

PLEASE PRINT

Reader Service Cards are a convenient way to get information about products and services advertised in ETI. With just one stamp and a Reader Service Card you can save yourself time, tongue, and postage. Available to both subscribers and non-subscribers. Read all about it on page 44 of this issue.



QRM QRM QRM

This month our columnist Bill Johnson discusses the use of a microcomputer for decoding teletype.

I'VE BEEN CALLED many things in my life, but if there is one thing that I am not, it's a turnabout! I have received many letters in the short period of time that I have been ETI's amateur radio editor, but ninety percent of them were on the RSO repeater issue. Recently, I published a glowing tribute to Lloyd Ferns, VE3BZF, the man whose thousands of hours of dedication to amateur radio in sending morse practice transmissions sparked the RSO's interest in a repeater. Since then, I have been accused by some readers of doing a flip-flop on the RSO repeater issue - my position, for the record, is still the same: Southern Ontario does not need another two-metre repeater, we shouldn't spend such a huge sum of money on it, and linking on VHF is backward and decadent, and wasteful of valuable spectrum space. There, I've said it. Now on to this month's column.

Now that you have that shiny new TRS80, PET, or whatever sitting next to your rig, and you are tired of playing blackjack, chess, and three-dimensional tic-tac-toe on it, what are you going to do with it? How about combining amateur radio with a little intrigue and romance - the kind you would find in "A Man Called Intrepid", for instance? Yes? Then read on . . .

How To Convert Your Micro Into A UART

I'm serious! Many of you know the UART (Universal Asynchronous Receiver/Transmitter) as being a cheap, single-chip part that replaces boards, nay, racks of communications equipment on earlier computers. It completely handles all timing, sequencing, and logic necessary for the serial-to-parallel and parallel-to-serial conversions required to communicate between the parallel-operation computer and the normally serial communications devices, such as terminals, printers, etc. Early microcomputer evaluation kits such as the Motorola D1 did all the timing by software routines, and the later change to UARTS was seen by most as an advance in technology which left the micro free from such tedious chores. Why, oh why, would a supposedly sane-minded person like me suggest turning back the clock and reverting to the

archaic method of letting the micro do the timing? The answer is quite simple. You have all heard, at one time or another, the high-speed teletype signals that exist inside and outside our bands. If you've ever seriously tried to demodulate them, you will have noticed that it is impossible to do, given the amount of equipment readily available in the average amateur teletype station.

Just to keep our intentions honourable (or legal, depending on your viewpoint), let's assume you are concerned with intercepting this highspeed teletype traffic to make sure that it is legitimate amateur use of the band. You will usually find that, while you can get a good tone demodulation pattern on the scope (they all use relatively similar deviation), the printer will just print garbage. There are three reasons for this: a) The sending machine may be using a different code to your machine; b) It may be sending at a different speed to that which you are capable of receiving. In mechanical teletype machines, such as the ones in common everyday use, the speed, and consequently the baud rate and character timing, are set by a set of enmeshing gears which connect the synchronous motor to the distributor. (The distributor sends the parallel switch settings determined by the keyboard as pulses, one after the other. For more detailed information on this subject, see the series 'Bits, Bytes, and Bauds' in previous issues of ETI).

Just to see how many different types of code and speeds, look at Table 1, which doesn't include many obsolete machines that could be used by amateurs or third-world country spy networks.

As you can see, one cannot keep a complete set of gears for every speed and change them as appropriate, unless one a) knows the speed of transmission in advance, or b) is prepared to miss the first fifteen hours of each ten-minute transmission.

The answer to this dilemma is much easier to explain than the above description of the problem itself. Maybe, one day, I will do an article on a program to accomplish this, but in the meantime, the thinkers amongst us may wish to get

your own head start with a little theory.

The most important thing that must be determined when analysing a strange teletype signal is the baud rate. That is, the inverse of the time between the start and end of each bit. Next is the number of stop bits. Before one can do any analysis, however, one must store the incoming bit stream in memory. This is simply done by connecting the mark and space outputs of the demodulator unit to bits 0 and 1 of a PIA set up for the input. If bit 0 is set, this means that a mark is being received, which is stored as a 1 in memory. Bit 1 being set indicates a space, which will be stored as a zero in memory, and no bits being set will indicate loss of signal, or possibly a bit transition. Either will result in no action being taken at this point except making special note of the time that this happened. At the start of the analysis, a counter is set to zero. The computer has a cycle time of approx. 4 us or so, which is hundreds of times faster than the highest bit rate. Therefore, allowing many computer operations between incoming bits. If a real-time clock is available, then the total sum of all the instructions in the loop should be adjusted with no-ops to be approx 1 mS, at which time the incoming bit stream should be sampled, stored in memory, and the counter incremented. The counter is used to point to successive bits in memory, starting at bit zero of byte one and so on. After a few characters have been received, the incoming bit stream will be faithfully reproduced in memory, and an analysis can be made of bit length, knowing the time represented by each cell in memory. After this is done, patterns can be sought out under program control. Start bits, stop bits, and character frames can be determined which will allow the program to go back through memory and recover all incoming characters and store them as complete characters per memory location, just like any other buffer. Then only problem that remains is that of determining just what code is being used. The obvious guesses are ASCII if it is seven or eight-level, and baudot if five. This can be determined by looking up the codes in a table and seeing if almost

all incoming characters can be found. After the obvious have been checked and found not to match, then the real fun of determining the code begins. To store all data communications codes and variations will require most of the memory of a 64 kB computer (together with the program). Once you have found a code that matches, you can send the translated characters to a crt or printer of your choice by re-translating to the code required by the printer if necessary.

One last word. What you now see on your screen may still not make any sense to you. It could be weather information, which will require a special set of graphic symbols on the CRT, or it could be a message which has been encrypted by some spy agency for its own nefarious reasons. If you end up with the decoded output of an enigma machine, look out, there is a place in Whitby, Ontario, for you!

73 'till next month

Bill Johnson, VE3APZ

P.S. Keep those letters coming to: QRM Letters, ETI Magazine, 25 Overlea Blvd., Unit 6, Toronto, Ontario. M4H 1B1. ●

Use	Baud rate	No. of stop units	wpm
CCITT, 60 wpm			
US Gov't and Bell 60 wpm	45.45	1.5	60.6
Obsolete Western Union	45.45	1.42	61.3
CCITT No. 2, WU Telex	45.45	1.0	64.8
Standard Amateur Radio	50.0	1.5	66.67
US standard 75 wpm			
US standard 100 wpm	56.86	1.42	76.6
US Military	74.2	1.42	100
CCITT standard 100 wpm	74.2	1.0	107
	75.0	1.5	101
Teletype model 35 (optional)			
Teletype model 35 (optional)	55.21	2.0	61.35
W. Union No. 5A stock ticker	69.25	2.0	76.6
NYSE stock ticker (Obsolete)	66.67	1.0	83.3
NYSE 900 stock ticker	80.0	1.5	100
	135.0	2.0	150
Teletype model 35 (optional)			
IBM 1050 (optional)	61.35	2.0	61.35
IBM &TTY 35 (optional)	75.0	1.0	83.3
IBM 2740, 2741, 1050	100	2.0	100
IBM System 1030	134.5	1.0	148
	600	1.0	666.67
Teletype model 35 (optional)			
Teletype model 35 (optional)	67.58	2.0	61.35
Teletype model 35 (optional)	73.33	2.0	66.7
Teletype model 35 (optional)	74.07	2.0	67.3
Teletype model 37	100	1.0	100
Teletype model 35 standard	110	2.0	100

Latest Babani Books from ETI



BP66 Beginners Guide to Microprocessors and Computing. \$7.25 plus 30c post.

Aimed as an introduction to the basic theory and concepts of binary arithmetic, microprocessor operation and machine language programming.

BP67 Counter Driver and Numeral Display Projects. \$7.25 plus 30c postage.

Numeral indicating devices have come very much to the forefront and find increasing applications in all sorts of equipment. The book features many applications and projects using various types of numeral displays, popular counter and driver IC's etc.

BP68 Choosing and Using your Hi-Fi. \$7.25 plus 30c post.

Gives an understanding of the technical specifications of equipment and the author's opinion of the minimum standards to look for. Also describes how to use your equipment properly.

BP69 Electronic Games. \$7.25 plus 30c post.

Contains a number of projects using modern IC's. Contains two sections, the first with basic and simple circuits, the second with projects for the more advanced reader.

BP70 Transistor Radio Fault-Finding Chart. \$2.10 plus 30c post.

Drawn up by the author from several years of experience, it will enable the most common faults to be quickly identified.

To order use the card facing page 44 or send to:

ETI Magazine,
Unit 6, 25 Overlea Blvd.,
Toronto, Ont., M4H 1B1

OVERSPEED ALARM

This unit activates when your vehicle's engine or road speed exceeds pre-set limits. It can be used as a stand-alone project, or can be used in conjunction with the fault monitor described in April 1980 ETI.

THE ETI OVER-SPEED ALARM is designed for use in gas-engined vehicles fitted with 12 volt negative-ground electrical systems only. It is driven from the engine's contact-breaker points, and can be used to activate when the engine RPM exceeds a pre-set limit, or when the vehicle's top-gear road speed exceeds one of four pre-set values.

The unit switches on a LED and energises an optional load, such as a relay or an audible warning device, when it is activated. If the unit is used in conjunction with the 'Fault-Light and Turn-Indicator Audible Repeater' project described elsewhere in this issue, the optional load of the Over-Speed Alarm can be omitted and the unit's auxiliary output can be used to activate the audible warning device that is built into the 'Repeater' unit.

The over-speed alarm is inexpensive, is easy to build and is quite easy to install in the vehicle.

Construction, Installation And Use
Before starting construction, note the following points and add or delete components to or from the design as appropriate.

(1). If you intend to use the unit purely as a single-range excess-RPM alarm, delete SW1 and RV2 to RV4 from the circuit, and connect pin 3 of the IC to ground via RV1 and R6. In this case the circuit's positive supply rail can be taken to the vehicle's battery via the ignition switch, so that the system is permanently enabled when the vehicle is in use.

(2). If you are going to use the unit as a 4-range excess road-speed alarm, note that the system works on the assumption that you will always be in top gear when you exceed a speed limit and is thus designed to be effective only when the vehicle is in top gear. In this case, therefore, the unit's positive supply rail

should be taken to the vehicle's battery via the ignition switch and an on/off switch. The on/off switch can either be a manually-operated type, or can be a microswitch that is activated by the vehicle's gear lever.

(3). If you decide to fit the unit with an optional load, such as a relay or an audible warning device, the load must have an impedance greater than 100R.

(4). If you decide to use the unit in conjunction with the 'Audible Repeater' unit described elsewhere in this issue, you can eliminate R7 and Q1 from the design and connect the auxiliary output terminal of the over-speed alarm to the auxiliary input terminal of the 'Repeater' unit.

(5). The C2 value of the circuit must be chosen to suit the required RPM trigger range of your vehicle. A value of 100n enables an RPM span of 1500 to 6000 to be covered on a 4-cylindered 4-stroke engine. If your vehicle is an 8-cylinder 4-stroke, or a 4-cylinder 2-stroke, halve the value of C2 to get the same RPM span.

Once you've sorted out these five points, you can go ahead with the construction and installation of the unit. Construction is simplicity itself, and should present no problems.

Installation is simply a matter of connecting the unit's 0-volt line to chassis, the positive rail to the vehicle's battery via the ignition switch (and possibly an on/off switch), the input to the vehicle's contact-breaker points and the output to a suitable audible warning unit as already described.

Calibration of the unit is a two-man operation, with one driving the vehicle to the required trip speeds and the other adjusting the unit's pre-set pots to give the required trigger action! ●

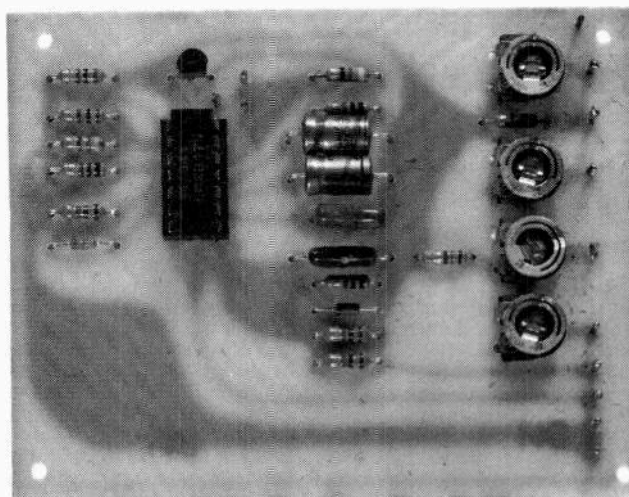

Note:
 IC1 is LM2917N
 Q1 is 2N3417
 D1 is 1N4148
 ZD1 is BZY88 12V

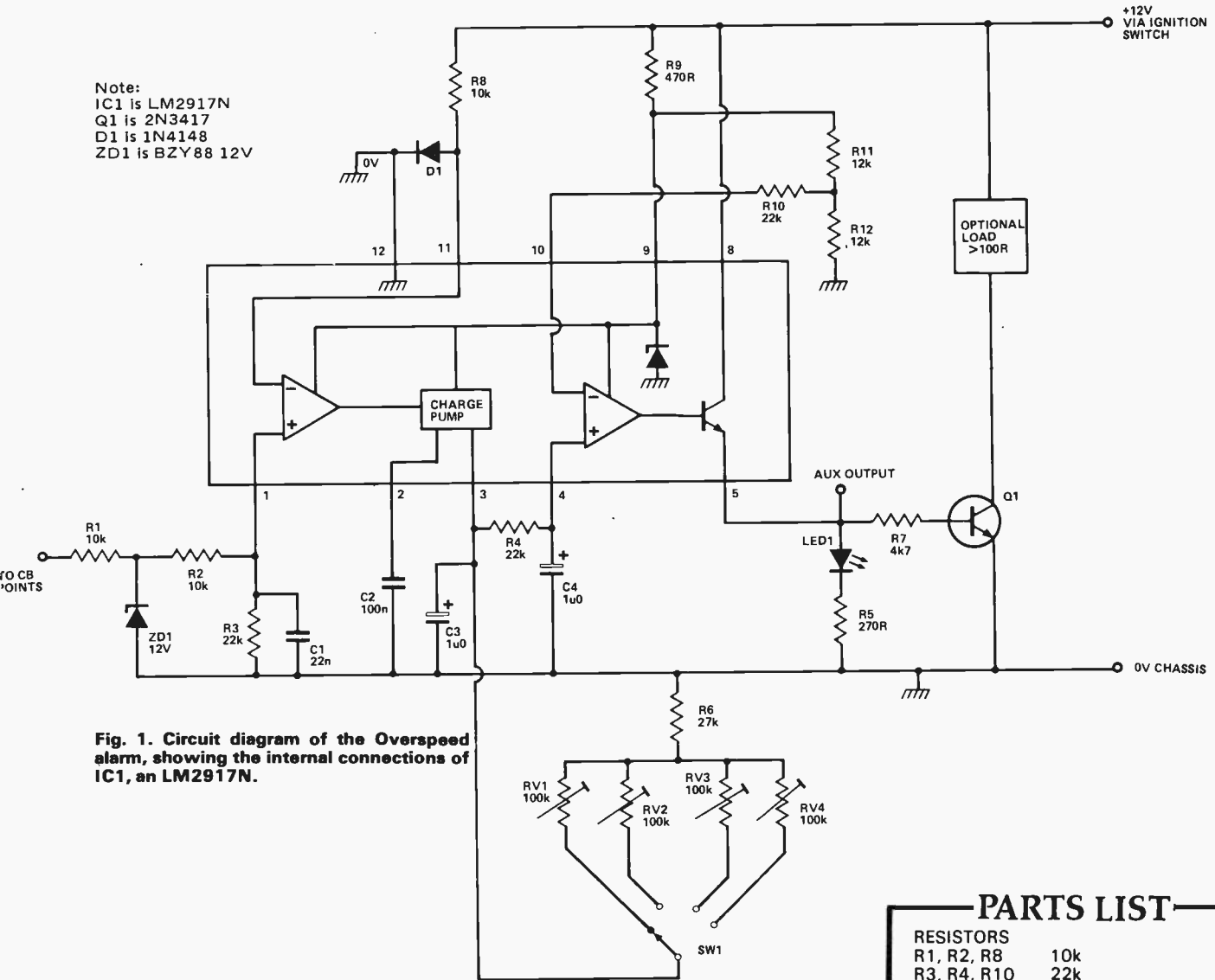

Fig. 1. Circuit diagram of the Overspeed alarm, showing the internal connections of IC1, an LM2917N.

PARTS LIST

RESISTORS	
R1, R2, R8	10k
R3, R4, R10	22k
R5	270R
R6	27k
R7	4k7
R9	470R
R11, R12	12k
POTENTIOMETERS	
RV1-4	100k sub min presets
CAPACITORS	
C1	22n polyester
C2	100n polyester (see text)
C3, C4	1u0 63V electrolytic
SEMICONDUCTORS	
IC1	LM2917N
Q1	2N3417
ZD1	zener diode
D1	1N4148
LED1	0.2" standard red LED
MISCELLANEOUS	
SW1	single pole 4-way rotary switch.

HOW IT WORKS

The over-speed alarm works by detecting the engine RPM rate via the vehicle's contact breaker points, converting the resulting C-B frequency into a linearly proportional voltage and feeding this voltage to a comparator that trips and activates a LED and an audible warning device when the voltage (and thus the RPM) exceeds a pre-set value.

The assumption is made that the unit will only be used as an excess road-speed alarm when the vehicle is being driven in top gear (the engine RPM is directly proportional to road speed). In this case the unit's positive supply rail connection

should be broken when the vehicle is not in top gear.

Most of the work of the unit is done by IC1, a frequency-to-voltage converter chip. Components R1-ZD1-R2-R3 and C1 'condition' the contact-breaker signal and make it suitable for driving the chip. C2 and RV1-RV4 and R6 determine the frequency-to-voltage conversion rate of the IC and C3-R4-C4 remove ripple from the resulting DC signal that is fed to one side of the IC's voltage comparator stage. The output of the IC is used to drive LED 1 and to switch on Q1, which is capable of providing a 120 mA load current.

ETI OVERSPEED

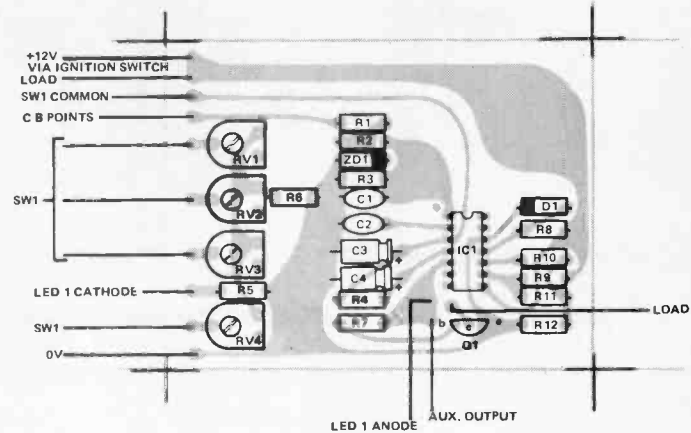
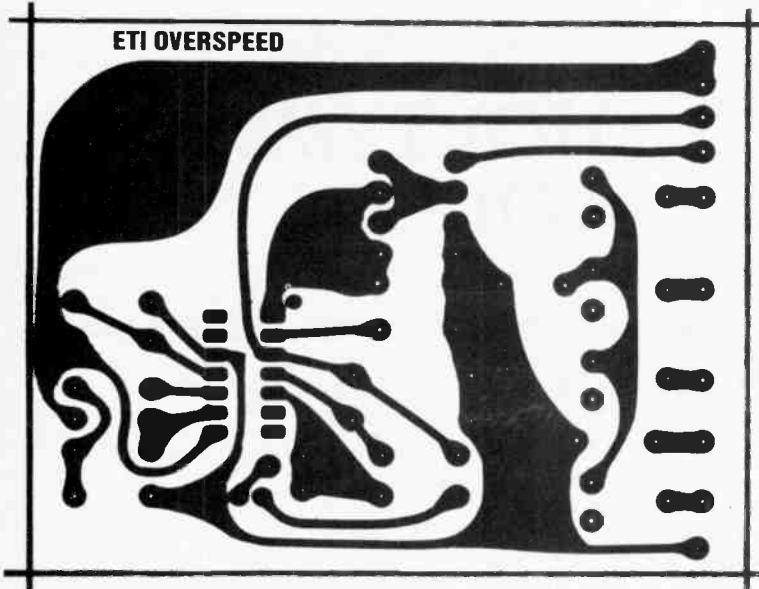

Fig. 2. Component overlay.

Left: full size foil side pattern for the overspeed alarm project.

Now Available!

OUR ALL NEW
LENLINE
ELECTRONIC
COMPONENTS
CATALOGUE.

60 pages contain
ing more than
400 items, all
fully illustrated
and described.

SEND FOR
YOUR FREE
COPY TODAY!



Please send me your LENLINE Electronic Components Catalogue and the name of my nearest LENLINE Dealer.

NAME _____

ADDRESS _____

CITY _____

PROV. _____ CODE _____

len finkler ltd

25 Toro Road, Downsview, Ontario M3J 2A6 • 630-9103



**The cost effective way to
MEASURE CAPACITANCE**

**B&K-PRECISION 820
ONLY \$165**

- Measures capacitance to 1 Farad
- Resolves to 0.1 pF
- 10 ranges
- 0.5% accuracy
- Four digit LED display
- Lead insertion jacks or banana jacks
- Fuse protected
- Battery powered
- Overrange indication

Available for immediate delivery at your local electronic distributor

BK PRECISION DYNASCAN CORPORATION

ATLAS ELECTRONICS LIMITED 50 Wingold Avenue
Toronto, Ontario M6B 1P7 Tel: 416-789-7761 Telex 065-24140

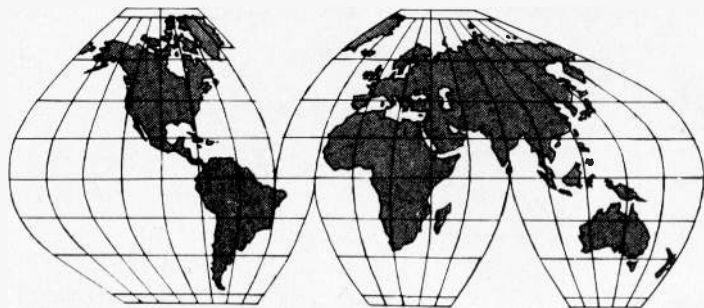

SHORTWAVE WORLD

Due to high static levels and scattered populations, domestic broadcasting in many tropical countries is principally on the lower frequency shortwave bands. John Garner takes a look at these stations.

Listen To The Tropicals

MANY COUNTRIES in the tropical regions of the world use shortwave radio to reach regions of their countries which otherwise would be out of radio reach. Unlike the major international broadcasters, these stations are usually of low power and they broadcast in the language of the land.

The range of frequencies used are usually referred to as the "Tropical Bands" and most of the international broadcasters stay clear of these frequencies as much as possible.

The bands used are:

- 120 metre band (2300 to 2495 kHz)
- 90 metre band (2400 to 3200 kHz)
- 75 metre band (3900 to 4000 kHz)
- 60 metre band (4750 to 6050 kHz)

The tropical band stations do not change frequencies for each season since reception conditions do not vary too much in these areas and their intended target range is usually rather small. However many of these stations are well heard here in Canada despite their lower powers. Of course, at these low frequencies, a darkness path is required between transmitter and receiver.

Don't let the fact that most of these stations are broadcasting in an unfamiliar language scare you away from them. Many of them play native music of their countries for a good portion of the broadcast period and music has an international flavour. The type of music is sometimes a hint as to the identity of a station. ID's are given quite frequently on many tropical band stations and many of these are easy to recognize after you hear them a few times. If you know which stations are transmitting on certain frequencies then you can carefully listen for the station identification (ID) and usually confirm the identity.

A good source of information about Tropical Band stations is the "DSWCI

Tropical Bands Survey" published by The Danish Shortwave Clubs International, Greve Strandvej 144, DK-2670 Greve Strand, Denmark. This 28 page book is completely revised every year and is usually on sale in July. The 8th edition should be available soon. The cost for airmail delivery is 10 International Reply Coupons (IRCs), available from the Post Office or US \$3.10. Canadian Money Orders cannot be cashed in Denmark so payment should be made by Bank International Money Order.

Information about these stations is also contained in the World Radio and TV Handbook. Most club bulletins also contain a number of loggings of tropical band stations each month.

Following is a list of a few Tropical Band stations. Most of these are reported quite frequently as being heard here in North America. Of course there are thousands of others in these bands that you will be able to hear from time to time. I often just tune up and down these bands and usually find a few new stations that I hadn't heard before. Give it a try.

Central America (including the Caribbean and Mexico)

Naturally most of these stations will be broadcasting in Spanish. Many Spanish IDs start with "Esta es.." followed by the station name. They are best heard here after sunset. They will begin to fade out before our sunrise. Fade out for West Coast listeners will probably be several hours before your sunrise.

Belize — Radio Belize - 3300 kHz - 1kilowatt - 1100-0510 GMT - English and Spanish.

Costa Rica — Radio Reloj - 4832 kHz - 1 kilowatt - 24 hours.

— Faro del Caribe - 5055 kHz - 5 kilowatts - some English.

Guatemala — Radio Cultural - 3300 & 5955 kHz - 10 kilowatts - 1100-1530, 2300-0430 GMT

Haiti — 4VEH - 3345 - 250 watts - this station is presently inactive but may return.

Honduras — La Voz Evangelica - 4820 kHz - 5 kilowatts - 1030-0600 GMT

Mexico — Radio Mexico - 5985 kHz - 10 kilowatts - 1100-1530, 2200-0330 GMT

Nicaragua — La Voz de Nicaragua - 5950 kHz - 50 kilowatts - There have been several changes in broadcasting in this country since the revolution so this station may not be heard or it may have a new name. *(Continued on Page 68)*

TRANSMITIENDO GRATAS NUEVAS ALEGRES
Telling the Good News Abroad

From
GUATEMALA
"Beautiful land
of the Quetzal"

Frecuencias.
730 khz
3,300 khz
5,955 khz
9,505 khz
100.8 mhz



Facts:
The Quetzal is the national emblem of Guatemala. This bird seldom survives in captivity, hence, symbol of liberty.

"If the Son (Christ) therefore shall make you free, ye shall be free indeed".
John 8:36.

BUILD YOUR OWN AND SAVE!

140W DC Class AB Stereo Amp	\$129.00
30W + 30W Stereo Amp	\$69.00
100W Class A Power Amp	\$89.00
DC Stereo Pre-Amp	\$79.00
60W DC Class A Power Amp	\$58.00
70W Class AB Power Amp	\$41.00
60W Low T.I.D. Power Amp	\$32.00
I.C. Stereo Pre-Amp	\$43.00
10 Band Graphic Equalizer	\$42.00
15 Steps Power Level Indicator	\$56.00
12 Steps Power Level Indicator	\$34.00
S.E.A. Level Display	\$69.00
Stereo Speaker Protector	\$19.00
Rack Mount Cabinets:	
16"(W)x4"(H)x8"(D)	\$39.00
19"(W)x4"(H)x12"(D)	\$54.00
19"(W)x7"(H)x12"(D)	\$74.00

Add 10% for postage and handling.
Ontario Residents add 7% sales tax.
Send cheque or money order with order.
Master Charge or Visa accepted.

Free Catalogue:

AUDIOVISION SERVICE
P.O. Box 955, Station B,
Willowdale, Ont.
M2K 2T6

Circle No. 2 on Reader Service Card.

Retailers: Write for wholesale price list.

NEW ISO-TIP®

cordless
soldering iron
completely recharges
in 60 minutes.

**MAKES CORDLESS SOLDERING
PRACTICAL FOR
HEAVY-USE APPLICATIONS.**

The Iso-Tip 60 can make up to 125 electronic joints or more per charge. When completely discharged, the iron can be recharged and used in a few minutes or fully recharged in an hour. Low voltage, battery powered, ground free isolated tip design.

WAHL CLIPPER CORPORATION
ORIGINATORS OF PRACTICAL CORDLESS SOLDERING



16 snap-in
tips to fit
any job

plus a
PC Drill.

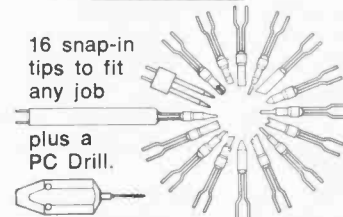

See your Electronics Distributor, or write for Free Lenline Catalogue.

len finkler limited

25 Toro Road, Downsview, Ontario M3J 2A6
Telephone (416) 630-9103 Telex 065-24010



Circle No. 19 on Reader Service Card.

ORION Electronic Supplies Inc.

ELECTRONIC DISTRIBUTOR
INDUSTRIAL — EDUCATIONAL — COMMERCIAL — HOBBYIST

RCA

COSMAC

VIP

Authorized distributor for RCA, COSMAC VIP

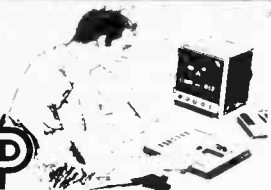

**START WITH ORION FOR A NEW ERA
IN THE WORLD OF ELECTRONICS**

We have the most complete selection
of electronic components.

Full line of TTL, CMOS, Linear, ICs, Computer
Interface, Support Chips and CPUs

SPECIALS THIS MONTH

Experimental 300	\$15.95
AP Super Strip	\$19.75
280 — CPU	\$19.75
6800 — CPU	\$14.50
2102 1K RAM	\$1.35
LM3914 — 3915	\$4.98
3 Channel colour organ	\$15.95
Xenon Strobe Kit	\$13.95
Digital car clock 12V.	\$22.50

Please write for our free catalogue
of electronic bargains.

YES! RUSH ME
YOUR FREE CATALOGUE

**ORION ELECTRONIC
SUPPLIES INC.**
40 Lancaster St. W.
Kitchener, Ont.
N2H 4S9
(519) 576-9902

NAME
ADDRESS
CITY
PROV. POST CODE
Master Charge & Visa, COD, Cheque,
Money orders accepted.
C.O.D.s, shipping and insurance are
extra!

Circle No. 17 on Reader Service Card.

B&K-PRECISION's new digital probe offers more than logic

Model
DP-50
only \$76.80

- Reveals pulse presence to 50MHz
- Multi-family, compatible with TTL, DTL, RTL, CMOS, MOS, and HiNIL
- Clearly displays in-circuit logic activity
- Memory mode to "freeze" pulse display
- Pulse mode to "stretch" short pulses
- 2 megohm input impedance
- Typically detects pulses to 10 nanoseconds
- Overload and reverse polarity protected

Available for immediate delivery at your local distributor.

B&K PRECISION DYNASCAN CORPORATION

ATLAS ELECTRONICS LIMITED 50 Wingold Ave. Toronto,
Ontario M6B 1P7 Tel: 416-789-7761 Telex 065-24140



Circle No. 7 on Reader Service Card.

South America

Again most stations are in Spanish. Brazilian stations broadcast in Portuguese. Times to listen are similar to Central America but the more easterly stations such as those in Brazil will be fading out earlier in the morning.

Bolivia

— Radio Los Andes - 4775 kHz - 1 kilowatt - 1100-0400 GMT

— Radio Nacional de Bolivia - 4817 kHz - 500 watts.

— La Cruz del Sur - 4875 kHz - 10 kilowatts - 0930-1800, 2200-0300 GMT

— Radio Libertad - 5030 kHz - 1 kilowatt.

— Radio Progreso - 6005 kHz - 10 kilowatts - 1100-0400 GMT

— Radio Panamericana - 6034 kHz - 10 kilowatts - 1030-0130 GMT

Brazil

— Radio Diffusion do Amazonas - 4805 kHz - 5 kilowatts - 2230-0130 GMT

— Radio Mundial - 4825 kHz - 10 kilowatts - 0800-2400 GMT

— Radio Nacional de Boa Vista - 4835 kHz - 10 kilowatts - 0900-0300 GMT

— Radio Clube do Para - 4855 kHz - 10 kilowatts - 0800-0330 GMT

Chile — Radio Nuevo Mundo - 5955 kHz - 1 kilowatt - 1100-0500 GMT

Colombia

— Emissora Nuevo Mundo - 4755 kHz - 5 kilowatts - 24 hours.

— Radio Buenaventura - 4835 kHz - 1 kilowatt - 24 hours

— Radio Colosal - 4945 kHz - 20 kilowatts - 24 hours

— Radio Diffusion Nacional - 4955 kHz - 50 kilowatts - 0930-0500 GMT

— Radio Santa Fe - 4965 kHz - 5 kilowatts - 24 hours.

— Radio Surcolombiana - 5010 kHz - 2.5 kilowatts - 24 hours.

— Radio Sutatenza - 5075 kHz - 25 kilowatts and - 5095 - 50 kilowatts - 0900-0400 GMT

Ecuador

— La Voz de los Andes - 3220 kHz - 10 kilowatts - 0900-1300, 2130-0200 GMT

— Radio Zaracuy - 3990 kHz - 12.5 kilowatts - 1000-1400, 1900-0500 GMT

— Radio Nacional Espejo - 4680 kHz - 5 kilowatts - 24 hours

— La Voz de Galapagos - 4810 kHz - 5 kilowatts - 1215 - 0400 GMT

— Radio Paz y Bien - 4820 kHz - 1 kilowatt - 0930-0430 GMT

— Radio Quito - 4920 kHz - 5 kilowatts - 1000-0515 GMT

— Radio Nacional del Ecuador - 4940 kHz - 10 kilowatts - 1000-0430 GMT

Falkland Islands — Falkland Island Broadcasting Service - 2370 kHz - 500 watts - 1400-1600, 2230-0200 GMT in English - This is a tough one. The Falkland Islands are not really in the Tropics but operate this low power station in the 120 metre Tropical Band and is occasionally heard in North America.

French Guyana

— 3385 kHz - 4 kilowatts - 0900-1100, 2000-0100 GMT

— 4972 kHz - 1 kilowatt - 0900-0100 GMT

Guyana

— Action Radio - 5950 kHz - 10 kilowatts - 1100-0250 GMT

— Radio Demarara - 3265 kHz - 5980 kHz - 2 kilowatts - 0817-0200 GMT

Paraguay

— Emisora Paraguay - 6015 kHz - 3 kilowatts - 0930-1700, 2000-0400 GMT

— Radio Nacional - 6025 kHz - 5 kilowatts - 1000-1800, 2100-0300 GMT

Peru

— Radio Independencia - 3350 kHz - 1 kilowatt -

— Radio Inca del Peru - 4762 kHz - 1 kilowatt -

— Radio Pampas - 4854 kHz - 1 kilowatt - 1100-0300 GMT

— Radio Libertad - 4910 kHz - 1 kilowatt - 1100-1900 GMT

— Radio Panamericana - 5980 kHz - 5 kilowatts - 0900-0600 GMT

— Radio Nacional - 5990 kHz - 1 kilowatt

Surinam — Stichting Radio in Paramaribo - 4850 kHz - 10 kilowatts - some Dutch and native languages - 0825-0330 GMT — Indoneaian, Hindustani Languages are also used.

Uruguay — Radiomundo - 600 kHz - 1.2 kilowatts - 1500-2400 GMT

Venezuela

— Radio Occidente - 3225 kHz - 1 kilowatt

— Radio Mara - 3275 kHz - 1 kilowatt

— Radio Lara - 4800 kHz - 10 kilowatts - 0958-0400 GMT

— Radio Maracaibo - 4860 kHz - 10 kilowatts - 0900-0400 GMT

— Radio Juventud - 4900 kHz - 10 kilowatts

— Radio Yaracuy - 4940 kHz - 10 kilowatts

— Radio Rumbos - 4970 kHz - 10 kilowatts - 24 hours

— Ecos del Torbes - 4980 kHz - 10 kilowatts - this is a very popular station and very easily heard here.

— Radio Continente - 5030 kHz - 10 kilowatts - 0930-0500 GMT

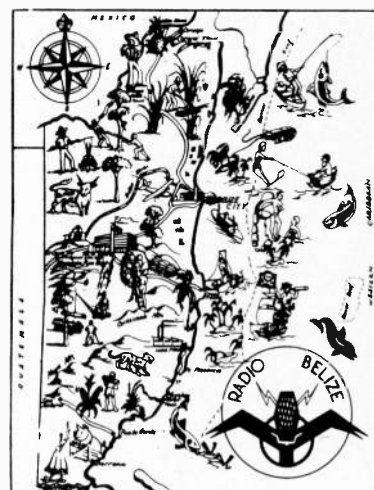

Africa

Many languages are used here — vernaculars, French, English, etc. The best time here would be just after our sunset.

Benin People's Republic — 4870 kHz - 30 kilowatts - 0415-0800, 1300-2300 GMT

Botswana

— 3356 kHz - 0400-0630, 1500-2100 GMT

— 4845 kHz - 0400-0630, 1500-2100 GMT

— 5956 kHz - 0900-1415 GMT

These Radio Botswana frequencies are all operating with 10 kilowatts - in vernacular languages and English. Burundi — La Voix de la Revolution - 3300 kHz - 25 kilowatts - 0300-0600, 1500-2100 GMT

Cameroon — Radiodiffusion Nationale du Cameroun - 4850 kHz - 100 kilowatts - 0400-0700, 1700-2300 GMT

— 4972.5 - 30 kilowatts - 0430-0700, 1700-2210 GMT

The above two frequencies are referred to as Radio Yaounde.

— Radio Garoua - 5010 kHz - 100 kilowatts - 0430-0700, 1900-2200 GMT

Central African Republic — La Voix de Republique Centrafricaine - 5038 kHz - 100 kilowatts - 0430-0700, 1630-2300 GMT

Comoro State — Radio-Comores - 3331 kHz - 4 kilowatts - 0300-0400, 1600-2000 GMT

People's Republic of the Congo — Radiodiffusion Television Congolaise - 3232 kHz - 4 kilowatts - 3265 kHz - 50 kilowatts

4843 kHz - 4 kilowatts - French, English, Portuguese and Venacular languages are used on these frequencies.

Djibouti — Radiodiffusion-Television de Djibouti - 4780 kHz - in French and Arabic

Equatorial Guinea — Radio Ecuatorial - (continued on Page 70)

UHF-VHF-FM ANTENNAS

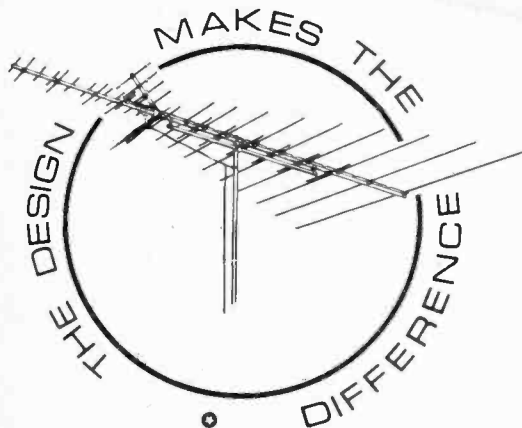

BUILT TO LAST

The antennas sold by GTE Sylvania Canada Limited are backed by 20 years expertise in the engineering, design, development and production of quality home television receiving antennas, from single channel yagis to all channel UHF-VHF-FM models. Over the years more than 1600 engineering drawings of standard and 'area specials' have been accumulated.

Remember, GTE Sylvania antennas are built with 'quality' in mind.

Your requests are invited for any of your antenna needs.



SYLVANIA

**Electronic Components
and Systems**

GTE

GTE Sylvania Canada Limited

8750 COTE DE LIESSE ROAD
MONTREAL, QUEBEC H4T 1H3.
(514) 735-4201

Circle No. 28 on Reader Service Card.

**For the man who has
everything else...**

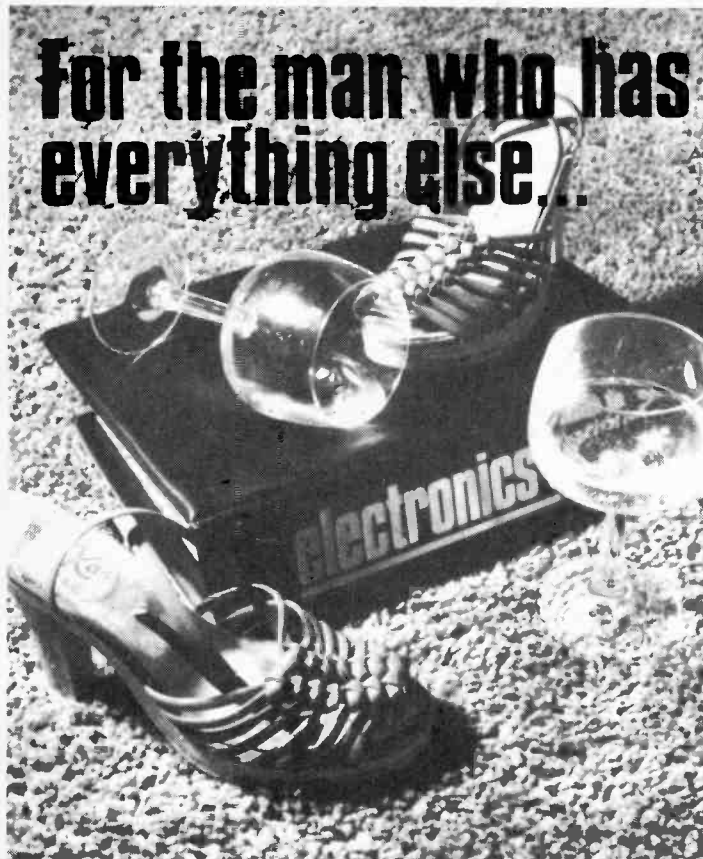

ETI Binders keep your issues in perfect shape. \$6.75 inc postage (Ontario residents add 7% PST. Send to: ETI Binders, Unit 6, 25 Overlea Blvd, Toronto, Ont. M4H 1B1



**Measure
resistance
to .01Ω...**

at a price that has no resistance at all.

- 3½ digit bright LED display • 100μV, .01Ω resolution
- 0.5% accuracy typical • Autozeroing • Completely overload protected on all 29 ranges • RFI shielded for use in RF fields
- 100% over-range reading • Selectable high-/low-power ohms
- Full range of optional accessories available

At \$204.95, the 2810 is a "best buy" among DMM's currently available. Its 10 ohms range allows you to check the low contact resistance of switches, relays, breaker points or connectors. Poor solder connections can also be spotted. Place your order now...contact your local distributor for immediate delivery.

B&K PRECISION DYNASCAN CORPORATION

ATLAS ELECTRONICS LIMITED 50 Wingold Avenue
Toronto, Ontario M6B 1P7 Tel: 416-789-7761 Telex 065-24140

Circle No. 8 on Reader Service Card.

4926, 5003 kHz - 5 kilowatts - 0430-0630, 1000-1600, 1700-2130 GMT - in Spanish and vernaculars
 Ethiopia — Voice of Revolutionary Ethiopia - 5990 kHz - 100 kilowatts - in Amharic, English and regional languages.
 Gabon — La Voix de la Renovation - 3300 kHz - 20 kilowatts
 3350 kHz - 4 kilowatts
 4777 kHz - 100 kilowatts
 4830 kHz - 20 kilowatts
 6030 kHz - 20 kilowatts - they are on in French at various times.
 Ghana — Ghana Broadcasting Corporation - 3350 kHz - 20 kilowatts - 0530-0805, 1200-2305. Also on 3366 kHz - 10 kilowatts - same times.
 - 4915 - 10 kilowatts - 0530-0805, 1200-2305 GMT
 - 4980 kHz - 20 kilowatts - 0530-0805, 1600-2305 GMT
 - 5990 kHz - 10 kilowatts - 1200-1600 GMT - some English may be heard on these frequencies along with vernaculars.
 Guinea-Bissau — Radiodifusao Nacional - 5041 kHz - 10 kilowatts - 0600-2400 GMT - in Portuguese.
 Republic of Guinea — Radiodiffusion Nationale - 4910 kHz - 18 kilowatts - 1230-0730 GMT - French and vernacular languages.
 Ivory Coast — Radiodiffusion Ivoirienne - 4940 kHz - 25 kilowatts - French and vernaculars at various times.
 Kenya — The Voice of Kenya - 4804 kHz - 5 kilowatts
 4915 kHz - 100 kilowatts
 4934 kHz - 20 kilowatts
 4950 kHz - 10 kilowatts - they broadcast in Swahili with some English.
 Lesotho — Radio Lesotho - 4800 kHz - 10 kilowatts - in Se Sotho and English.
 Liberia — Radio ELWA - 3227 kHz - 10 kilowatts
 4770 kHz - 10 kilowatts - both in English and in vernacular languages.
 Madagascar — Radio Madagasikara - 3285 kHz - 100 kilowatts
 5010 kHz - 4 kilowatts - in Malagasy and French languages. They broadcast from 0300-0600 and 1300-2100 GMT
 Malawa — Malawi Broadcasting Corporation - 3380 kHz - 100 kilowatts
 - 5995 kHz - 100 kilowatts - They transmit in English and Chichewa.
 Mali — Radiodiffusion Nationale du Mali - 4825 - kHz - 18 kilowatts
 - 5995 kHz 50 kilowatts - French and local languages with some news in English and Arabic.
 Mauritania — Radiodiffusion Nationale de la République Islamique de Mauritanie - 4845 kHz - 100 kilowatts - 0600-0900, 1800-2310 GMT - in French,

Arabic, Spanish, English and vernaculars
 Mauritius — Mauritius Broadcasting Corporation - 4850 kHz - 1300-1830, 0200-1300 - in English, French and vernaculars.
 Mozambique — Radio Mocambique - 3210 kHz - 100 kilowatts
 3265 kHz - 25 kilowatts
 3338 kHz - 10 kilowatts
 4865 kHz - 7.5 kilowatts
 4925 kHz - 20 kilowatts
 6050 kHz - 10 kilowatts - These are in Portuguese and vernacular languages.
 Niger — Niamey - 3260 kHz - 4 kilowatts
 5020 kHa - 20 kilowatts - in French and vernaculars.
 Nigeria — 4755 kHz - 100 kilowatts; 4932 kHz - 10 kilowatts; 4990 kHz - 50 kilowatts; 5965 kHz - 10 kilowatts; 6025 - 10 kilowatts - English and vernaculars.
 Rwanda — Radiodiffusion de la Republique Rwandaise - 3330 kHz - 5 kilowatts - in French and vernaculars - 0300-0600, 0900-1200, 1330-2100 GMT
 Sao Tome E Principe — 4807.5 kHz - 10 kilowatts is listed in Portuguese from 0530-2300. I've yet to hear this one.
 Senegal — Radiodiffusion du Senegal - 4890 kHz - 25 kilowatts - 0600-0800, 1800-0100 GMT - 6045 kHz - 4 kilowatts - 0600-0800, 1200-1400, 1800-2230 GMT
 Sierra Leone — Sierra Leone Broadcasting Service - 3316 kHz - 50 kilowatts - 0600-0745, 1800-2335 GMT; 5980 kHz - 10 kilowatts - 0800-1030, 1200-2335 GMT - in English and vernaculars.
 South Africa — South African Broadcasting Corporation - 3250, 3955, 3980, 4835, 4880 kHz - these broadcast in Afrikaans with some English.
 Sudan — Home service on 5039 - 20 kilowatts - in Arabic - 0400-1200 GMT
 Swaziland — Swaziland Commercial Radio - 3223 kHz - 0200-0400, 2100-2200 GMT
 - 4980 kHz - 0300-0400, 2000-2200 GMT - broadcasts are in vernaculars with some English.
 Trans World Radio also operate from Swaziland on the following frequencies: 3200, 3240, 3275, 4790, 5055, 5950 - they broadcast in many languages.
 Tanzania — Radio Tanzania - 4785 kHz - 50 kilowatts
 5050 kHz - 10 kilowatts - they are mostly in Swahili with some English as well.
 Radio Tanzania - Zanzibar - 3339 kHz - 10 kilowatts - 0300-0500, 1430-2000 GMT

6005 kHz - 10 kilowatts - 0900-1100 GMT— they transmit Swahili.
 Togo — Radiodiffusion-Television Togolaise - 3222 kHz - 10 kilowatts - 0525-0830, 1630-2230 GMT
 - 5047 kHz - 100 kilowatts - 0530-0800, 1700-2400 GMT - in French and vernaculars.
 Tristan da Cunha — Tristan Radio - 3290 kHz - 40 watts - this is a real tough one but has been heard by a few listeners in North America. They broadcast in English on Sunday, Wednesday and Friday from 1900-2205 GMT
 Uganda — Radio Uganda - 4976 kHz - 7.5 kilowatts
 - 5026 kHz - 7.5 kilowatts - they broadcast in English and vernaculars at various times throughout the day.
 Upper Volta — Radiodiffusion-Television Voltaïque - 4815 kHz - 20 kilowatts - 0530-0900, 1700-2400 GMT - in French and vernaculars.
 Zaire — La Voix du Zaire - 4750 kHz - 10 kilowatts
 5995 kHz - 10 kilowatts - both are in French and vernaculars.
 Zambia — Zambia Broadcasting Services - 3346 kHz - 120 kilowatts - in English and vernaculars - 0355-0530, 1600-2105 GMT
 Zimbabwe Rhodesia — Zimbabwe Rhodesia Broadcasting Corporation - 2425 and 3396 kHz - in English - 0355-0545, 1515-2200, 0545-0615 GMT

Finally
 Next month I will have some more Tropical Bands stations from the East. Listed above are a number of Tropical Band stations that I'm sure will give you a great deal of enjoyment. Listen to some of these. The Tropical Bands present quite a challenge to your listening skills and the results are quite rewarding.
 Until next month, 73 and good listening. ●

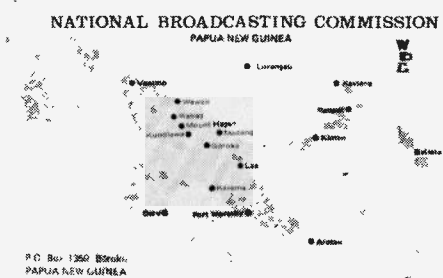

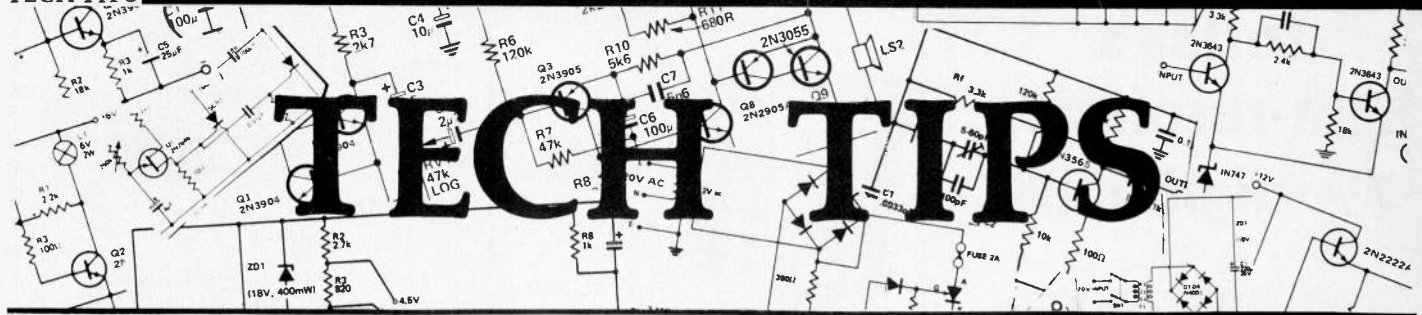

Electronic Capacitor J.P. Macaulay

The circuit shown is essentially a gyrator which amplifies the effect of C1 to produce an equivalent capacitance at the output, many times the value of C1.

PR1 is used to set the output voltage to the required level whilst C1 charges through D1. Once the voltage across the diode drops to less than 0.6V C1 will continue to charge through R1 until the voltage across C1 is equal to that on the slider of PR1.

The equivalent capacitance at the output is equal to the product of the current gain of the circuit and the value in Farads of C1. If we assume that the input impedance at the non-inverting input of the 741 is 1M Ω and the output impedance is 1R Ω then this capacitance will be equal to 10⁻⁴ FX10⁶=100F!

In practice the input impedance at

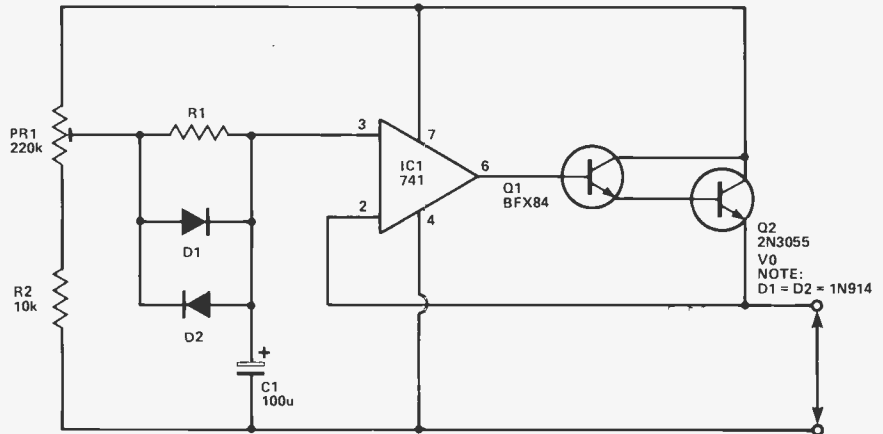

low frequencies is many tens of megohms whilst the output impedance is a small fraction of an ohm, so the above figure is very conservative.

D2 is included to allow the output varying the speed of the clock depending on the setting of the pot on the output selected. The clock is also used to trigger a monostable formed

around a NE555. This circuit provides the gate pulse for the synthesiser. The gate length can be varied by adjusting the 100 k pot.

around a NE555. This circuit provides the gate pulse for the synthesiser. The gate length can be varied by adjusting the 100 k pot.

Rhythm Synthesis J.J.Trinder

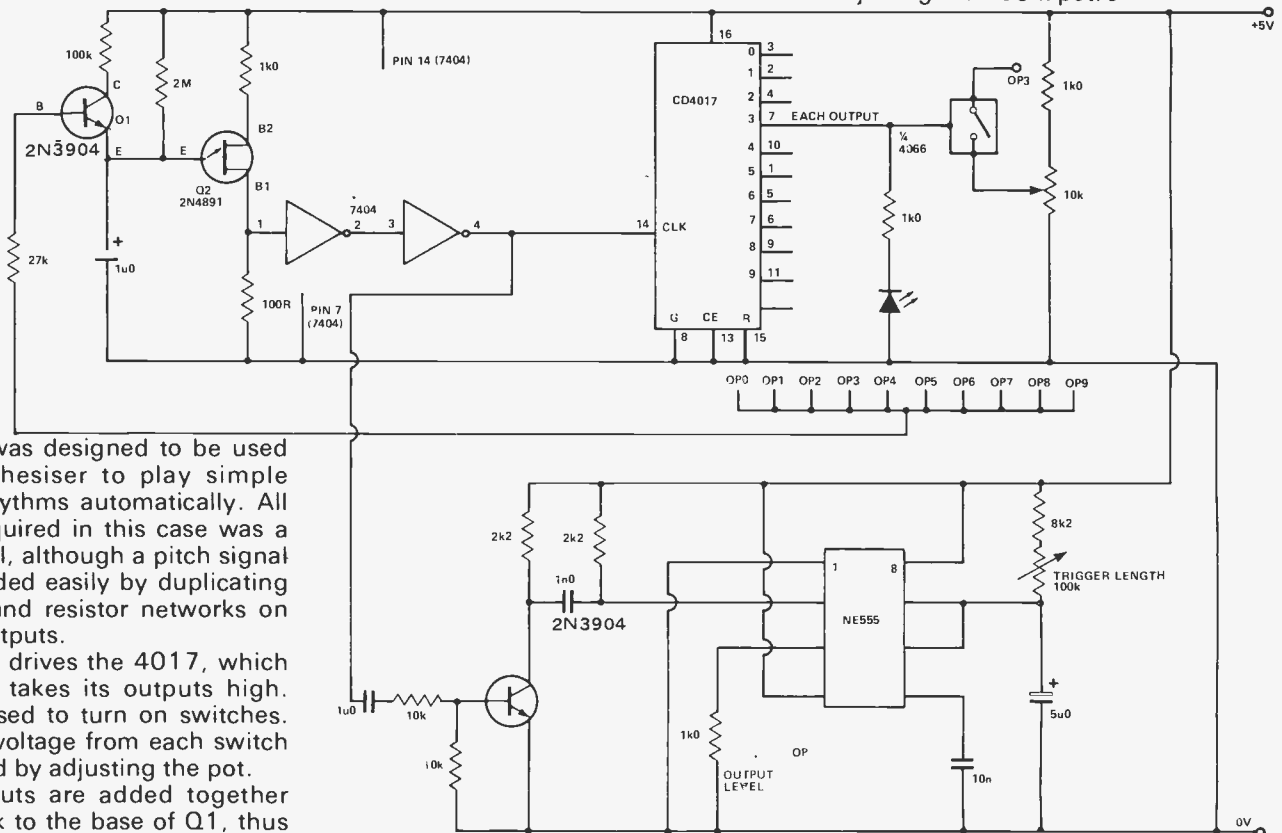

The circuit was designed to be used with a synthesiser to play simple repeating rhythms automatically. All that was required in this case was a trigger signal, although a pitch signal could be added easily by duplicating the switch and resistor networks on the 4017 outputs.

The clock drives the 4017, which sequentially takes its outputs high. These are used to turn on switches. The output voltage from each switch can be varied by adjusting the pot.

The outputs are added together and fed back to the base of Q1, thus

A Simple Sequencer
P.Hill

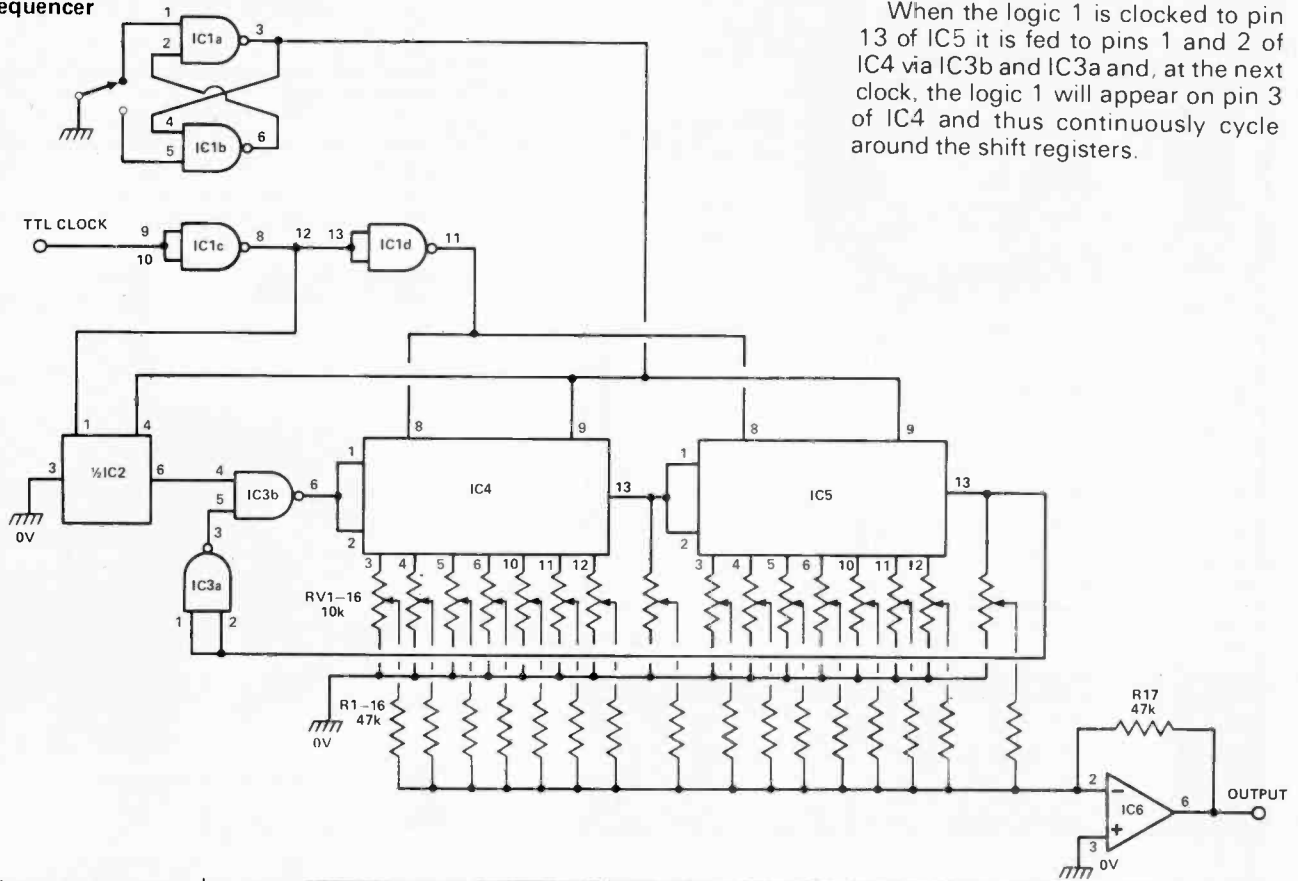

When the logic 1 is clocked to pin 13 of IC5 it is fed to pins 1 and 2 of IC4 via IC3b and IC3a and, at the next clock, the logic 1 will appear on pin 3 of IC4 and thus continuously cycle around the shift registers.

A simple sequencer can be constructed using shift registers.

A logic 1 is shifted down the shift registers (IC4, 5) outputs, otherwise at logic 0, at each clock pulse. This places a voltage across the variable resistors RV1 — 16 in turn. A preset DC voltage is thus available at the output, after being buffered by R1 - 16 and IC6 for each clock pulse. A sequence of control voltages can be set up and used to drive a voltage controlled oscillator

The sequencer is reset by S1. The switch is debounced by IC1a and IC1b. Resetting zeros all shift register outputs and results in a logic 1 appears at the input of IC4.

When a clock is applied a positive going edge at pin 8 of IC4 and 5 corresponds to a negative-going edge at pin 1 of IC2, due to inverters IC1c and IC1d. The first positive going edge at pin 8 of IC4 and 5 causes the logic 1 at pin 1 and 2 of IC4 to be transferred to pin 3. Since IC2 is positive edge triggered it's output remains at logic 0, allowing the logic 1 to be transferred to pin 3. On the following negative edge the logic 0 appears at pin 1 and 2 of IC4. For subsequent positive edges the logic 1 is shifted down the shift register outputs and is replaced by the logic 0 at the input.

Revolutionary!

Sinclair SC110 low power portable Oscilloscope



thandar
BY
sinclair

*Revolutionary 2" diagonal CRT in a case only 1½" thick and weighing less than 2 pounds!
*Full-sized performance with 10MHz bandwidth, 10mV per division sensitivity, and triggered sweep. *Runs on "C" cells or AC adapter, making the SC110 ideal for field or bench use. Probes and carrying case available. Suggested net \$499.00

Call or write for nearest distributor. **audiex ELECTRONICS** 1736 Avenue Rd., Suite B, Toronto Ont. M5M 3Y7 (416) 787-7367.

Anadex AN Printer Model DP-8000



\$1395

LISTS
AT
\$1450

FEATURES

- o 80 Columns, 112 cps
- o 84 Lines Per Minute, Bi-Directional, Nominal Thruput
- o High Reliability — Heavy Duty Cycle, 100M Characters Print Head Life
- o Sprocket Feed
- o Paper Entry Through Bottom or Rear
- o 9x7 Character Font
- o Variable Form Width
- o Selectable baud rate from 110 to 9600 baud.
- o 3 Interfaces:
 - Serial ASCII, RS232C;
 - Serial ASCII Current Input;
 - Parallel Bit, Serial Character Synchronous

2114 1k x 4 static RAM (200ns) \$7.50

Send certified cheque/money order, (NO CASH). Minimum \$5.00 + \$1.00 Handling. Ontario Residents add 7% PST. Master Charge/Chargex accepted. Send A/C No., Signature, Expiry Date & Bank Name.

Write or circle No. 4 on the Reader Service Card for full details on this printer. Circle No. 35 on Reader Service Card for our complete catalogue.

Exceltronix

Components & Computing Inc.

319 College Street, Toronto, Ontario M5T 1S2 Tel. (416) 921-5295

Not just another one.

With all the hand-held DMMs around, it can be tough to pick the one that's best for you. Our Model 130 makes that choice a lot easier.

The 130's 0.5% DCV accuracy is as much as you'll probably need, and we built it to be tough. Yet the unit weighs a mere 283g (10 oz.) and features full overload protection, 10A current range, auto zero and auto polarity. And we give you all this performance at a sensible price.

KEITHLEY

Keithley Instruments, Inc.
28775 Aurora Road
Cleveland, Ohio 44139
(216) 248-0400



REPRESENTED BY:



radionics limited

195 Graveline St. Montreal H4T 1R6, Quebec.
Phone (514) 735-4565 Telex 05-827558

TORONTO (416) 292-1575 VANCOUVER (604) 732-7661
OTTAWA (613) 521-8251

Circle No.25 on Reader Service Card.

ACTIVE SURPLUS ANNEX

345 Queen Street West
Toronto, Ontario

(416) 368-7936

WE ALSO SELL ELECTRONIC COMPONENTS

SORRY, NO MAIL ORDER

GRAPHIC EQUALIZER KIT (See ETI Oct 1977)

GYRATOR BASED DESIGN. COMPLETE KIT (including case but not including front panel or knobs for slider pots).

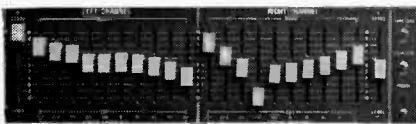

\$75⁰⁰

AM/FM FREQUENCY DISPLAY & CLOCK

Up-date your HI-FI set up with this frequency and time display that can be an add-on accessory or built into a modified AM/FM set.

Receiver or tuner requirements.
All Solid State
All 7 MHz FM IF
455 KHz AM IF

Assembled

\$75⁰⁰

Plus Tax

Limited
Quantities

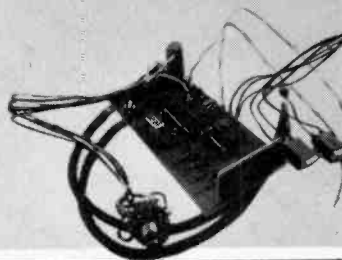

We Buy & Sell Anything

PRINTED CIRCUIT BOARDS FOR ETI PROJECTS

1 Drill Control Jan 77	1.50	48 Audio Oscillator Sept 78	7.00
2 Reaction Tester Feb 77	3.00	49 Roulette Wheel Sept 78	3.00
3 Heads or Tails Feb 77	1.50	50 CCD Phaser Unit Oct 78	5.00
4 5W Stereo Amp Feb 77	5.00	51 Simple Strobe Oct 78	2.00
5 Patch Detector Feb 77	1.00	52 Capacitance Meter Nov 78	2.50
6 General Preamp Mar 77	1.00	53 Eprom Programmer Dec 78	8.00
7 2 Tone Doorbell Mar 77	2.00	54 Tape Noise Eliminator Dec 78	1.50
8 Induction Balance Metal Detector Mar 77	3.00	55 FM Wireless Transmitter Jan 79	3.00
9 Disco Mixer Mar 77	4.00	56 Light Chaser Feb 79	3.00
10 VU Meter Mar 77	2.00	57 Phasemeter Feb 79	4.00
11 50/100W Amp. April 77 3 Boards	10.00	58 Shortwave Receiver Feb 79	3.00
12 Logic Tester April 77	4.00	59 Synthesizer Sequencer Mar 79	5.00
13 Stereo Rumble Filter May 77	1.50	60 Electronic Dual Dice Mar 79	3.50
14 Burglar Alarm May 77	2.00	61 Audio Compressor April 79	4.00
15 Fuzz Box May 77	1.00	62 AM Tuner May 79	2.00
16 Metronome June 77	1.00	63 Light Activated Tachometer Jul 79	5.00
17 The Overlaid July 77	1.50	64 Two Octave Organ Jul 79	2.50
18 Bass Enhancer Aug 77	4.50	65 Road Runner Sound Effect Unit Sept 79	1.50
19 Alarm Sept 77	1.00	66 Solar Controller April 79	4.00
20 Audio Sweep Oscillator Sept 77	4.50	67 Wheel of Fortune April 79	4.00
21 Graphic Equaliser Oct 77	4.00	68 Light Show Controller April 79	7.00
22 Continuity Tester Oct 77	2.50	69 Easy Colour Organ June 79	3.00
23 Loudhailer Oct 77	2.00	70 Light Show Colour Sequencer June 79	4.50
24 Digital Thermometer Nov 77	4.00	71 Stac Timer July 79	5.00
25 3 Channel Tone Control Nov 77	1.75	72 Audio Power Meter Aug 79	6.00
26 Power Amplifier Dec 77	3.50	73 Plant Waterer Aug 79	2.50
27 Egg Timer Dec 77	1.75	74 Wind Meter Sept 79	5.00
28 Expander Compressor Jan 78	4.50	75 Up/Down Presettable Counter Sept 79	4.00
29 Digital Panel Meter Feb 78	3.50	76 Variwiper Wound Field Coil Oct 79	3.00
30 CB Power Supply Feb 78	2.00	77 Variwiper Permanent Magnet Oct 79	3.00
31 True RMS Voltmeter Mar 78	2.50	78 Cable Tester Oct 79	2.00
32 House Alarm Mar 78	5.00	79 Simple Graphic Equalizer Oct 79	4.00
33 Microcomputer Power Supply April 78	3.00	80 Model Train Controller Nov 79	3.00
34 Bucket Brigade Audio Delay Line April 78	5.00	81 Audio Phaser Project Book I	1.00
35 Gas Alarm April 78	2.50	82 Development Timer Dec 79	2.50
36 Audio Feedback Eliminator May 78	5.00	83 High Performance Stereo Preamplifier Dec 79	9.00
37 White Line Follower May 78	2.00	84 Versatile Logic Probe Jan 80	3.00
38 Add Dn FM Tuner May 78	5.00	85 Headphone Amplifier Project Book 1	2.50
39 Ultrasonic Switch June 78	3.00	86 Double Dice Project Book 1	4.00
40 Real Time Analyser MKII July 78	22.00	87 Sound Light Flash Trigger CPB 1	2.50
41 Accentuated Beat Metronome July 78	3.00	88 Audio Limiter CPB 1	4.00
42 Proximity Switch July 78	4.00	89 Curve Tracer Nov 79	3.00
43 Porch Light Aug 78	3.00	90 60W Low Distortion Amplifier Nov 79	4.00
44 Sound Level Meter Aug 78	4.00	91 Moving Coil Preamp Feb 80	6.00
45 Two Chip Siren Aug 78	2.00	92 Egg Timer Feb 80	2.50
46 IB Metal Locator MKII Aug 78	3.00	93 General Purpose Power Supply Feb 80	3.00
47 Shutter Speed Timer Sept 78	4.00		

LED Audio Power Indicators

M.P. Downes

The circuit diagram shows the input circuitry from the loudspeaker terminals. For simplicity only two of the monostable and LED driver circuits are shown. Six of these circuits can be constructed using three 4001s and one 4049 CMOS ICs. The circuit is based on the fact that CMOS has an input threshold of approximately half the supply voltage (actually 0.45 — 0.55 supply volts). IC1a and IC1b are dual input NOR gates connected in a monostable configuration with timing components R1 and C1. When the input to IC1a exceeds the threshold voltage, the monostable's output goes high for a period determined by R1 and C1 (with values shown approximately 200 mS). This output is inverted and buffered to drive a LED for this period. The input to trigger the monostable comes from the speaker terminals where it is full wave rectified and appears across RV1. R3 is a safety resistor in case of bridge failure. IN4005 diodes have the desired voltage and frequency characteristics for the bridge. R2 is to limit the current flowing into IC1a's internal protection diodes under large signal conditions and the value of RV1 depends on the desired input triggering voltage.

The lowest input voltage that can trigger the monostable is limited by the voltage drop across the bridge (OV8) and the threshold voltage of IC1a (approximately 2V5). The threshold limit is largely overcome by using RV2 to bias point A to just below the threshold voltage. In practice, the circuit operates on an input frequency of from less than 5 Hz to more than 50 kHz sinewave and at an input voltage of from approximately 1V4 RMS (0.25 W into 8R) to more than 90 V RMS (1 kW into 8R). A single positive or negative 4 uS wide pulse will also operate the circuit.

The +5 V supply must be stabilised to ensure stable threshold levels and the usual decoupling of ICs and supply is advisable. If two units are required for stereo use, two completely separate +5 V power supplies are essential to prevent partial shorting out of the input bridge, due to a possible common loudspeaker terminal in the amplifier. Greater input sensitivity can be achieved by using OA91 diodes in the input bridge, but with slight loss in high frequency

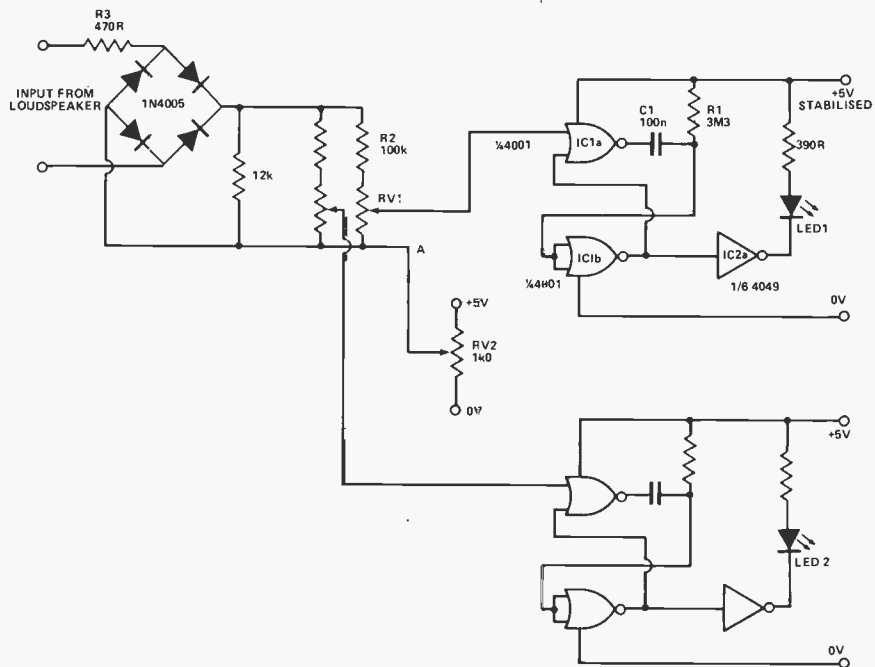

response and a lower maximum input voltage. If there is a variation in the threshold voltage of individual ICs

then the lower threshold ICs should be used in the most sensitive positions of the circuit, i.e. 0.25W.

GLADSTONE ELECTRONICS



sinclair

PDM35 3 1/2 digit multimeter

\$99.50

- * 6 functions, 26 ranges
- * operates from 9V battery
- * 10 day money-back trial offer

SINCLAIR TEST EQUIPMENT IN STOCK:

- DM235. 3 1/2 digit multimeter . . \$179.95
- DM350. 3 1/2 digit multimeter, accuracy 0.1%, 34 ranges. 279.95
- DM450. 4 1/2 digit multimeter, accuracy 0.05%, 34 ranges. 379.95
- PFM200 digital frequency meter 179.95
- NEW SC110 low power portable oscilloscope. 2" CRT, 10 MHz bandwidth. Only 499.00



ILP

Audio Amplifiers *5-year warranty.

- HY50 30 watts RMS \$31.95
- HY120 60 watts RMS \$62.95
- HY200 120 watts RMS. \$87.50
- HY400 240 watts RMS (4ohms) \$110.00
- HY5 mono preamplifier \$24.95

NEW GLADSTONE STORE, now open at 2936 EGLINTON AVE. E., Scarborough, Ont. Telephone 438-3999



PHILIPS DeFOREST

GLADSTONE'S SPEAKERKITS
Quality Loudspeakers

- AD15240/W8 15" Woofer (150W) \$74.95
 - AD12240/W8 12" Woofer (120W) \$74.95
 - AD10240/W8 10" Woofer (120W) \$69.95
 - AD0211/SQ8 (or 4) 5" dome mid \$32.95
 - AD5060/SQ8 (or 8) 5" cone mid \$21.95
 - AD0162/63/T4,8, or 15. dome tweeter \$14.95
 - AD3WXSP. 200 watt 3 way xover \$42.50
 - AD3WXA 60 watt 3-way crossover \$17.95
 - AD2WXA 60 watt 2-way crossover \$10.25
- FREE CABINET PLANS

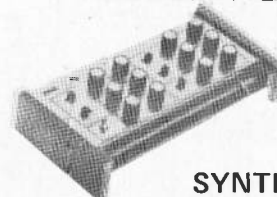

PAIA
\$129.00

GNOME MICRO-SYNTHESIZER

Electronic music mini-synthesizer. Gladstone's carry the complete PAIA line of synthesizers and computer products.

MAIL ORDER ADDRESS and MAIN STORE:

1736 Avenue Rd., Toronto, Ont., M5M 3Y7
Phone order line: (416)787 1448.

Use your Chargex Visa or Mastercharge. Ont. residents add 7% P.S.T. Both locations open Tues-Sat 9:30-6, till 9 Thurs and Fri.

Solder Sucking

A. D. Hextall

Here is a tip for those wealthy enough to possess a solder sucker. Those so fortunate will appreciate the cost of buying replacement nozzles. Great financial saving can be achieved by sliding a piece of rubber sleeving over the nozzle, extending it by about 4 mm. Not only is the sleeving heat-resistant, but when worn can be replaced at a miserly cost.

Tech-Tips is an ideas forum and is not aimed at the beginner; we regret that we cannot answer queries on these items. We do not build up these circuits prior to publication.

ETI is happy to consider circuits or ideas submitted by readers; all items used will be paid for. Drawings should be as clear as possible and the text should be preferably typed. Anything submitted should not be subject to copyright. Items for consideration should be sent to the Editor.

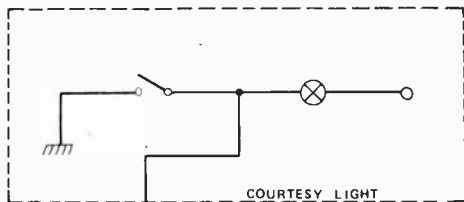

Car Alarm

W. D. Solomon

This circuit offers a greater degree of security than many of the designs previously published, in that there is absolutely no way of controlling, or resetting the alarm from inside the car. When triggered, a relay flips over, to be used for immobilising the car by, say, shorting out the points or disconnecting the solenoid. A siren is also turned on, winding up for a few seconds before an astable turns it on and off, thus producing an effective alarm sound. After a pre-selected time the system resets itself, to avoid draining the battery, or annoying the neighbours.

IC3 provides the trigger logic, the gates being arranged so that if the wire to SW1 (the enable/disable switch) is cut or damaged, the system will still be enabled. IC1 is a 555

being used as a basic timer; the time period (before the system resets itself) is controlled by RV1. The output of IC1 turns on Q1 and thus the relay, while triggering the monostable (IC4a & b) and buffer (IC4c & d), which turns on the siren, via the Darlington pair (Q2 & 3). After a few seconds the astable 555 (IC2) takes over, bleeping the siren on and off. RV2, 3 are adjusted when the alarm is installed to vary the on and off times and produce the desired alarm sound. D2, 3 isolate the outputs of IC2, 4.

ZD1, C1 and R11 provide a stabilized 12V supply; C2, 3, 5, 6 and their associated resistors are a desperate attempt to protect the circuit from a noisy ignition! On the prototype, PB1 and RV1 were mounted on the alarm box, which was bolted inside the engine compartment; SW1 was hidden in the trunk, although a key-switch could be used in a more prominent position.

One final note; if you're in the habit of leaving your alarm-protected car unattended for three months at a time, I would suggest using the new CMOS 555 to save the battery; as it is the current consumption is 12-15 mA.

NOTES

- IC1,2 are 555
- IC3,4 are 4001
- Q1 is 2N3904
- Q2,3 are to suit siren eg. 2N3904 and 2N3055
- D1 is 1N4001
- D2,3 are 1N4148
- ZD1 is 12V 400mW
- RLA is to suit (120R)
- Supply decoupling capacitors should be connected across chip supplies

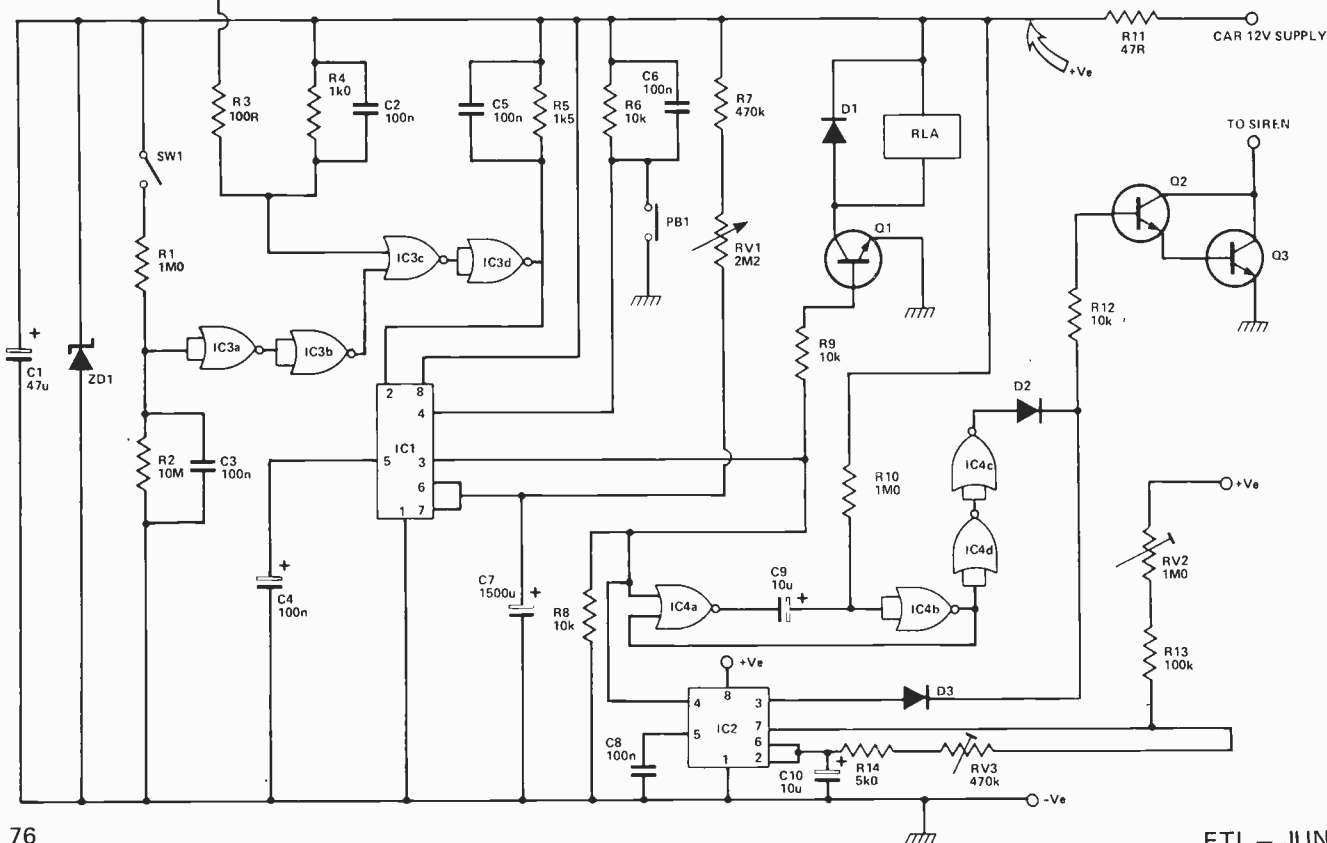

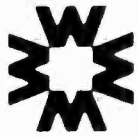

**WEBER
ELECTRONICS
INC.**

invites
YOU
to become a
Distributor/Dealer
for A.P. Products.



**Dealer Support
Dealer Sales
Dealer Profits**

**Breadboards
Jumper Cables
Testing Devices**

For further information:

call: **(416)663-5670**

write: 105 Brisbane Rd.
Downsview, Ont. M3J 2K6
twx: 610/492-1337

Weber is the factory sales
representative for A P Products

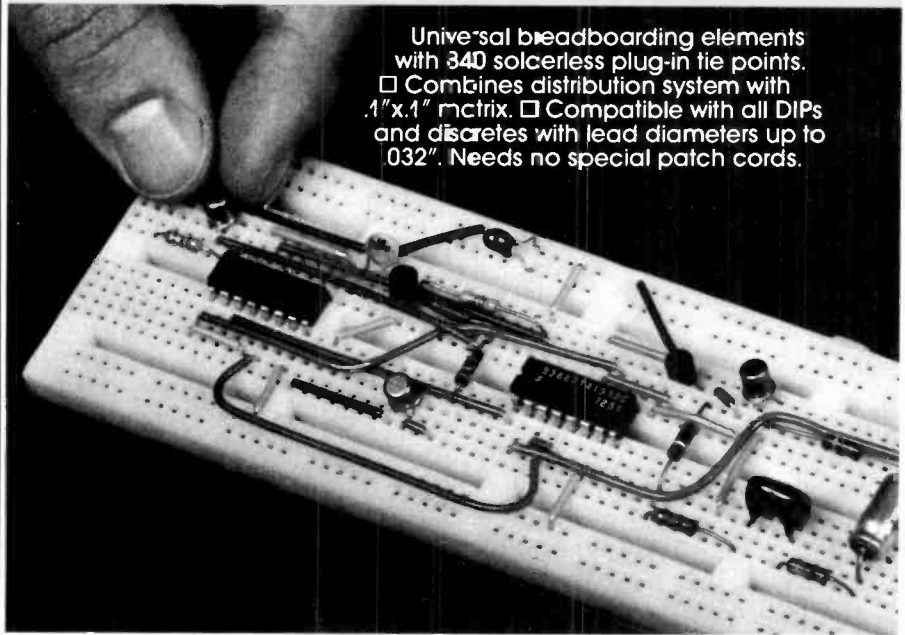

Universal breadboarding elements
with 340 solderless plug-in tie points.
□ Combines distribution system with
.1" x .1" matrix. □ Compatible with all DIPs
and discretes with lead diameters up to
.032". Needs no special patch cords.

Your breadboarding is a super-snap with a solderless A P Super-Strip.

Build a circuit almost as fast
as you dream it up. Pull it
apart and do another —
everything's as good as new.

Our versatile Super-Strip
mini-breadboards give you
the same top-quality con-
tacts you get in our full-scale
ACE All-Circuit Evaluators.
Not so "mini," either. You can

build circuits with as many
as nine 14-pin DIPs.

Instant-mount backing
and quick-removal screws
make stacking and racking
a snap, too.

Call your local A P distributor
listed below. And ask for our
complete A P catalog. The
Faster and Easier Book.

DISTRIBUTORS

Calgary, Alberta	(403) 287-0520	Downsview, Ontario	(416) 663-5650
Edmonton, Alberta	(403) 453-6691	Kitchener, Ontario	(519) 576-9902
Red Deer, Alberta	(403) 346-2088	Ottawa, Ontario	(613) 820-9471
Kamloops, B.C.	(604) 372-3338	Ottawa, Ontario	(613) 746-4413
Vancouver, B.C.	(604) 324-0505	Toronto, Ontario	(416) 868-1315
Vancouver, B.C.	(604) 291-1441	Montreal, P.Q.	(514) 731-7441
Vancouver, B.C.	(604) 324-6831	Montreal, P.Q.	(514) 769-8861
Vancouver, B.C.	(800) 663-9408	Quebec, P.Q.	(418) 647-4422
Victoria, B.C.	(604) 385-2411	Rimouski, P.Q.	(418) 724-6800
Winnipeg, Manitoba	(204) 786-8481	St. Jean, P.Q.	(514) 348-4961
Winnipeg, Manitoba	(204) 786-1471	Trois-Rivieres, P.Q.	(819) 378-5457
Winnipeg, Manitoba	(204) 683-1260	Regina, Saskatchewan	(306) 525-1317
Armdale, Nova Scotia	(902) 876-2920	Saskatoon, Saskatchewan	(306) 652-6424
Downsview, Ontario	(416) 663-5563		

Mail Order (519) 432-8625

Mail Order (514) 731-7441



**AP PRODUCTS
INCORPORATED**

1359 W. Jackson St.,
Painesville, Ohio 44077
Tel. 216/354-2101 TWX: 810-425-2250





CLASSIFIED

**You
can write
for ETI**

**75¢
per
word**

ETI's not-so-new classified advertising section allows you to reach 30,000 readers nationwide. For as little as \$15 (there's a 20 word min.) you can promote your business from coast to coast.

WHAT DO YOU DO?
Send us your typewritten or clearly printed words your permanent address and telephone number, and your money (no cash please). Make your cheque or money order payable to 'ETI Magazine'. We're at Unit 6, 25 Overlea Blvd., Toronto, Ontario. M4H 1B1

WHAT DO WE DO?
We typeset your words (and put the first word and your company name in BOLD capital letters). If we get your message by the 14th of the month, it will appear in ETI 1½ months later. For example if we receive it by October 14th you (and thousands more) will see it in the December issue.



What are we doing about it?

Contact your local Multiple Sclerosis Society
of Canada Chapter.

SOFTWARE for OSI's Superboard II and C1P. Send 50¢ for complete list to **HOBBY SOFTWARE**, Box 1145, Mississauga, Ontario L4Y 2A0.

SPECIAL No. 1: Approximately 1000 new, first quality, electronics parts: capacitor-resistor - relay - switch - etc, etc, for \$10
Special No. 2: Assortment of tantalum capacitors, 2.2 to 100 uf (6 to 35 VDC) for \$10. Unconditional money-back guarantee. Free flyer & sample on request.
SURPLUS ELECTRO-QUEBEC, 2264 Montee Gagnon, Blainville, Quebec J7E 4H5

WSI RADIO - SWL Radios - Ham radios 18 Sheldon Avenue North, Kitchener, Ontario N2H 3M2. Tel. (519) 579-0536. Write for giant catalogue, free of course!! (VF3EHC).

**GIVE... so more
will live
HEART FUND**



NEW STORE! Hobbyist. Parts. Speakers. Kits. Equipment. **GENERAL ELECTRONICS**, 5511 Yonge St., Willowdale, Ont. M2N 5S3, 221-6174. Please write for free catalogue. Monday, Friday, Saturday: 10:00 AM - 6:00 PM. Tuesday, Wednesday, Thursday: 10:00 AM - 8:00 PM

PRINTED CIRCUIT boards from your sketch or artwork. Affordable prices. Also fun kit projects. Free details. **DANOCINTHS INC.** Dept. ETI, Box 261, Westland MI. 48185. U.S.A.

CLASS A 100W power amp \$74.50 PPD., Matching stereo Pre-amp \$69.50 PPD. For free information, please write **AUDIO CONCEPT**, P.O. Box 2653, Thunder Bay, P. Ontario.

PRINTED circuit boards from stock. No. 470-\$5.45; 471-\$17.95; 472-\$5.35; 473-\$8.40; 148-\$1.75; 254-\$2.10; 577-\$3.35; 730-\$5.50; Electromyogram-\$11.35; 731-\$4.75; 730-\$5.50; systems Warning Monitor-\$5.00; Complex Sound Generator-\$13.40. Send Cheque, Money Order, or C.O.D. Post and Pack 50¢. Full list free. **B.&R. ELECTRONICS**, Box 6326F, Hamilton, Ontario. L9C 6L9.

J&J ELECTRONICS LTD., P.O. Box 1437E, Winnipeg, Manitoba R3C 2Z4. Surplus Semiconductor Specialists. Do you get our bargain flyer? Send \$1.00 to receive the current literature and specials and to be placed on the mailing list for future publications.

COMPLETE Electronic Hobby Services. Custom Kits, circuits, technical writing, special parts, original designs. Free information. **TEKNIKIT ASSOCIATES**, 301 Flora St., Carleton Place, Ontario, K7C 3M8.

WE SELL SERVICE! Professional repairs to all types of equipment: amateur, commercial, avionics, marine, CB, broadcasting. We stock Japanese transistors! Service Division, **HAMTRADERS INC.**, 18-45 Brisbane Road, Downsview, Ontario. M3J 2K1. 416-661-8800. Telex 065-22234.

QUALITY printed circuit boards for all ETI projects. Overspeed Alarm \$4.19, Tape Noise Reducer \$7.99, Function Generator \$17.99, Ontario residents please add 7% sales tax. Large selection of parts too. Transistors, resistors, TTL, CMOS, Linear IC's capacitors and more. Write for complete information to **WENTWORTH ELECTRONICS**, R.R. 1, Waterdown, Ontario L0R 2H0.

NO SURPRISES! Prime Components, Low prices, Fast service, Student discounts. Stamp brings latest flyer. **ELECTRONICS** Box 68, Whitecourt, AB. T0E 2L0.

ELECTRONIC ORGAN KITS Obtain one of the most advanced music instruments at significant savings by putting it together yourself. No experience required. Free details. **WW ELECTRONICS**, 52 Plumbrook Dr., Leamington, Ontario. N8H 4K8, Tel. 519-326-1806.

SUPREME ELECTRONICS' newest catalogue will be ready June 1/80. Reserve your copy now by sending \$1.00 (refundable) to our new address: P.O. Box 6370, Stn. C, Victoria, B.C. V8P 5M3.

WHAT?

YOUR PRESENT TESTING CAPABILITY...

CAN'T

TEST DIGITAL AND ANALOG CIRCUITRY WITH EQUAL EASE?

CAN'T

TEST DELICATE IC'S LIKE MOS, CMOS, PROMS, RAMS, EROMS...IN CIRCUIT?

CAN'T

TEST ELECTROLYTICS... ISOLATE PROBLEMS TO A GATE OR JUNCTION?

...IN CIRCUIT.... WITH NO CIRCUIT POWER REQUIRED!

HUNTRON TRACKER **CAN!!**

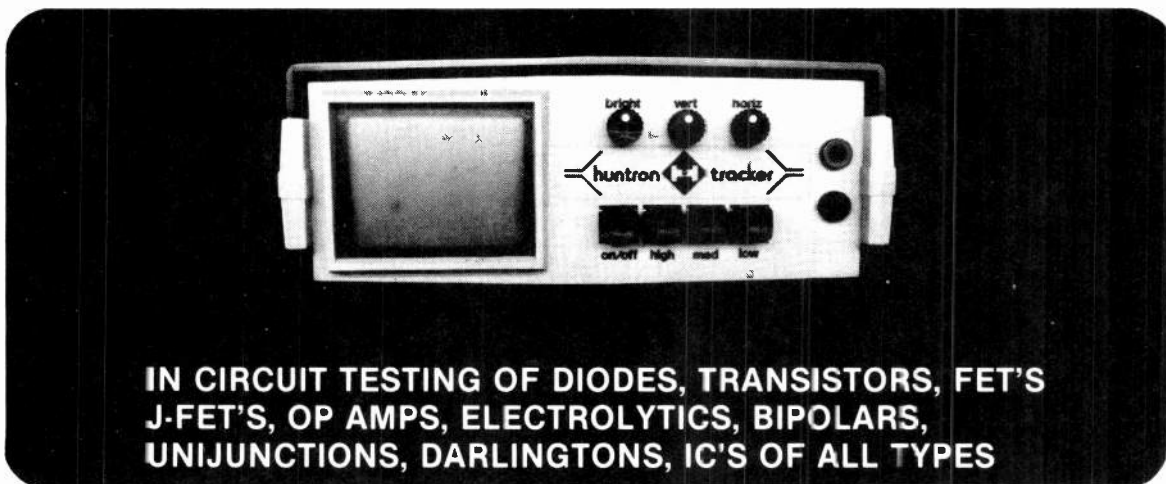

IN CIRCUIT TESTING OF DIODES, TRANSISTORS, FET'S
J-FET'S, OP AMPS, ELECTROLYTICS, BIPOLARS,
UNIUNCTIONS, DARLINGTONS, IC'S OF ALL TYPES

EXCLUSIVE CANADIAN DISTRIBUTOR
CYPRUS PRODUCTS INC.

7117 Tisdall St., Vancouver, B.C. V6P 3N2 • Tel.: (604) 327-3814

Circle No. 11 on Reader Service Card.

Active Component Sales Corp.

Zilog

Z8001 \$195.00 16 Bit CPU with segmented address space to 8 Megabytes.

Z8002 \$150.00 16 Bit CPU with non segmented address space to 64K bytes.

**All Products Stocked in Depth
Largest Zilog Inventory**

Z80-CPU	2.5 MHz	\$10.40	Z80-SIO/0	2.5 MHz	30.50
Z80A-CPU	4.0 MHz	12.05	Z80A-SIO/0	4.0 MHz	36.70
Z80-PIO	2.5 MHz	6.65	Z80-SIO/1	2.5 MHz	36.00
Z80A-PIO	4.0 MHz	8.00	Z80A-SIO/1	4.0 MHz	44.10
Z80-CTC	2.5 MHz	6.65	Z80-SIO/2	2.5 MHz	36.00
Z80A-CTC	4.0 MHz	8.00	Z80A-SIO/2	4.0 MHz	44.10
Z80-DMA	2.5 MHz	\$22.35			
Z80A-DMA	4.0 MHz	28.00			

MICROPROCESSOR CHIP SETS

Part No.	Price	Part No.	Price	Part No.	Price
8080A	\$5.95	6800	\$6.50	6502	\$9.95
8085	11.95	6802	11.95	6504	9.95
				6505	9.95
8212	2.75	6810	3.75		
8214	3.95	6820	4.95	6520	6.95
8216	2.95	6821	3.75	6522	9.95
8224	3.45	6850	3.95	6532	13.95
8226	2.95	6852	3.75	6551	13.95
8228	4.98				
8238	4.98				
8251	6.95				
8253	10.95				
8255	6.95				
8257	10.95				
8259	12.95				

SCR's and TRIAC's

C106D	.34	SCR	5 amp 400V TO-220
TIC116B	.97	SCR	8 amp 200V TO-220
TIC126B	1.09	SCR	12 amp 200V TO-220
TIC216B	.99	Triac	6 amp 200V TO-220
TIC226D	.95	Triac	8 amp 400V TO-220
TIC236D	1.45	Triac	12 amp 400V TO-220
TIC246D	1.45	Triac	16 amp 400V TO-220

Bi-Fet OP AMPS

TL064CN	2.00	Quad low power
TL071CP	.59	Low noise
TL072CP	1.19	Dual low noise
TL081CP	.49	J-FET input
TL082CP	.99	Dual J-FET input
TL084CN	1.95	Quad J-FET input

EPROM'S

C2708	\$ 6.95
1K x 8 450 ns	
TMS2532	\$119.95
32K (4096 x 8) 450 ns	
TMS2716	\$24.95
16K (2K x 8) 450 ns	
(3 power supplies) T.L. Version	
C2716 / TMS2516	\$23.95
16K (2K x 8) 450 ns	
(Single 5V supply—Intel version)	Special \$19.95

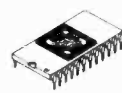

1980 IC MASTER

over 2700 PAGES

Complete integrated circuit data selector. Master guide to the latest I.C.'s including microprocessors and consumer circuits. 45,000 device types listed. 5,000 new device types added. Complete new section on MPU boards & Systems.

Free Quarterly Updates ~~\$78.00~~ **Special \$49.95**



MOS MEMORIES

MOS Static RAM's

Part No.	Price
2102LFPC	1.19
1K (1K x 1) Low Power 350ns 16 PIN	
2102LHPC	1.29
1K (1K x 1) Low Power High Performance 250ns 16 PIN	
2102-1PC	0.99
1K (1K x 1) 450ns 16 PIN	
P2111-45	3.50
1K (256 x 4) 450ns 18 PIN	
P2112-35	3.25
1K (256 x 4) 350ns 18 PIN	
2114L	5.95
Low Power 4K (1024 x 4) 300ns	

MOS Dynamic RAM's

TMS4060-30	3.25
4K (4K x 1) 300ns 22 PIN	
TMS4060-20	3.95
4K (4K x 1) 200ns 22 PIN	

UART's

AY5-1013A	3.95
0 to 40K BAUD 40 PIN	
AY3-1015	4.95
0 to 30K BAUD 40 PIN Single 5V supply	

1K CMOS RAM

5101	5.95
1K (256 x 4) 450ns 22 PIN Low Power	

4K CMOS RAM

P4315-45L	14.95
4K (4K x 1) 450ns 18 PIN	
P6504	13.95
4K (4K x 1) 550ns 18 PIN 110MW	
P6514	16.95
4K (1K x 4) 450ns 18 PIN 110MW	

SHIFT REGISTERS

3341APC FIFO 1 MHz	5.50
3342PC 64 Bit Shift Register	4.45
3347PC 80 Bit Shift Register	3.95

ECL RAM

10410ADC/HM2106 **Special 1.95**

256 x 1 Bit Fully Decoded 15ns 16 PIN

Special of the month

16K MOS DYNAMIC RAM's (16 PIN)

416-5 (300ns) CERAMIC	\$5.95
416-3 (200ns) CERAMIC	\$8.95

1K BiPolar RAM (25ns)

93425APC/2511-1 \$8.95

LINEAR I.C.'s

LM301AN-8	.34	LM723CH	.69
LM304CH	.89	LM723CN-14	.49
LM307N-8	.29	LM725CN-8	1.25
LM308N-8	.89	LM733CN-14	1.59
LM308CH	.95	LM739CN-14	1.29
LM309K	1.29	LM741CH	.65
LM310HC	1.49	LM741CN-8	.44
LM311N-8	.59	LM747CN-14	.59
LM317T (TO-220)	1.49	LM748CN-8	.39
		TBA810DAS	1.29
LM318N-8	1.45	LM1458N-8	.49
LM318CH	1.75	LM1489N-14	.69
LM324N	.59	LM1489N-14	.69
LM339N	.59	LM3046N-14	.99
LM348N-14	.99	LM3302N-14	.55
LM358N-8	.79	LM3403N-14	.89
LM380N-14	1.19	LM3909N	.49
LM555N-8	.49	LM4138N-14	.99
LM556N-14	.49	ULN2003AN	.99

SUMMER SPECIAL

10% qty discount on 100 pieces per device type (offer valid until August 31, 1980)

"ACTIVE IS AGGRESSIVE"

DUAL-IN-LINE — LOW PROFILE — I.C. SOCKETS

CONTACTS	PRICE	CONTACTS	PRICE
8 PIN	.084	22 PIN	.252
14 PIN	.132	24 PIN	.276
16 PIN	.156	28 PIN	.324
18 PIN	.204	40 PIN	.468
20 PIN	.228		

• LOWEST PRICES ANYWHERE FOR THE HIGHEST QUALITY. AN UNBEATABLE COMBINATION.

SOCKET SALE



OPTO SALE

L.E.D. LAMPS

LED209	T-1 3 mm Red	.09
LED211	T-1 3 mm Green	.19
LED212	T-1 3 mm Yellow	.14

DISPLAYS

FND357	.375" Common Cathode	1.99
FND367	.360" Common Cathode (high brightness)	1.24
FND500	.500" Common Cathode (high brightness)	.99
FND507	.500" Common Anode	1.24
FND560	.500" Common Cathode (high brightness)	.99
FND567	.500" Common Anode (high brightness)	1.24
DL704	.300" Common Cathode	1.29
DL707	.300" Common Anode	1.29
DL747	.630" Common Anode	2.29

ISOLATORS

ILD74	Dual Opto Isolator	1500V	1.29
ILQ74	Quad Opto Isolator	1500V	3.95
MCT6	Dual Opto Isolator	1500V	1.29
TIL111	Opto Coupler	1500V	.54
4N26	Opto Isolator	2500V	.54
4N32	Opto Isolator	2500V	.69
4N33	Opto Isolator	1500V	.65
4N36	Opto Isolator	2500V	.79
4N37	Opto Isolator	1500V	.85

74LS447N .59
BCD to 7 segment decoder/driver o/c

CMOS

CD4000BE	.19	CD4021BE	.99	CD4046BE	1.25	CD4081BE	.29	CD4522BE	1.75
CD4001BE	.39	CD4022BE	1.29	CD4047BE	1.25	CD4082BE	.29	CD4526BE	.99
CD4002BE	.34	CD4023BE	.39	CD4049BE	.69	CD4085BE	.79	CD4527BE	1.45
CD4006BE	1.29	CD4024BE	.79	CD4050BE	.69	CD4086BE	.95	CD4552BE	.99
CD4007BE	.29	CD4025BE	.39	CD4051BE	.99	CD4093BE	.79	CD4531BE	.99
CD4008BE	.84	CD4026BE	1.79	CD4052BE	1.25	CD4099BE	1.75	CD4532BE	1.50
CD4009BE	.69	CD4027BE	.49	CD4053BE	1.25	CD4104BE	2.95	CD4539BE	1.15
CD4010BE	.69	CD4028BE	.89	CD4060BE	1.99	CD4502BE	1.45	CD4543BE	1.65
CD4011BE	.49	CD4029BE	1.29	CD4066BE	.89	CD4508BE	1.99	CD4553BE	3.95
CD4012BE	.39	CD4030BE	.79	CD4068BE	.34	CD4510BE	1.25	CD4555BE	.89
CD4013BE	.59	CD4033BE	1.79	CD4069BE	.34	CD4511BE	.99	CD4556BE	.89
CD4014BE	.89	CD4034BE	2.99	CD4070BE	.49	CD4512BE	.99	CD4581BE	2.25
CD4015BE	.89	CD4035BE	1.39	CD4071BE	.39	CD4514BE	2.45	CD4582BE	.99
CD4016BE	.59	CD4040BE	1.89	CD4072BE	.29	CD4515BE	2.45	CD4584BE	.89
CD4017BE	.89	CD4041BE	1.75	CD4073BE	.54	CD4516BE	1.75	CD4585BE	1.50
CD4018BE	.89	CD4042BE	.89	CD4075BE	.59	CD4518BE	1.25	CD4702BE	9.95
CD4019BE	.89	CD4043BE	.99	CD4076BE	1.29	CD4519BE	.89	CD4724BE	1.95
CD4020BE	1.39	CD4044BE	.99	CD4078BE	.45	CD4520BE	1.25		

PLASTIC POWER TRANSISTORS

TIP30	.39	PNP	1 AMP 100V
TIP31	.42	NPN	3 AMP 100V
TIP32	.43	PNP	3 AMP 100V
TIP41	.59	NPN	6 AMP 100V
TIP42	.64	PNP	6 AMP 100V
TIP115	.59	PNP	2 AMP 60V
TIP120	.64	PNP	5 AMP 60V
TIP122	.74	NPN	5 AMP 100V
TIP125	.74	PNP	5 AMP 60V
TIP127	.85	PNP	5 AMP 100V
TIP2955	.83	PNP	15 AMP 60V
TIP3055	.70	NPN	5 AMP 60V
FT3055	.59	NPN	0 AMP 60V

Active Component Sales Corp.

MINIMUM MAIL ORDER \$10.00
Add \$2.00 to cover postage and handling

PRICES ARE IN U.S. FUNDS F.O.B. CANADA
Federal Sales Tax (9%) and Applicable Provincial Sales Tax Extra

If payment to be made in Canadian Funds, an approximate 20% conversion rate will be added at time of purchase

5651 FERRIER ST. MONTREAL, QUEBEC H4P 2K5 Tel. (514) 731-7441

4800 DUFFERIN ST. DOWNSVIEW, ONTARIO M3H 5S9 Tel. (416) 661-1115

BAXTER CENTRE 1050 BAXTER ROAD OTTAWA, ONTARIO K2C 3P2 Tel. (613) 820-9471

3070 KINGSWAY VANCOUVER, B.C. V5R 5J7 Tel. (604) 438-3321

LARGE INVENTORY AT ALL LOCATIONS

STORE HOURS:
Monday to Wednesday 8:30 am - 6:00 pm
Thursday and Friday 8:30 am - 9:00 pm
Saturday 9:00 am - 5:00 pm