

Projects, Audio, Video, Computers, Radio, Servicing, Education \$1.50

# electronics today

NOVEMBER 1979

MM70924

Build These Projects:  
Model Train Controller  
Curve Tracer

Special Offer!  
Power Amp Modules  
High Power —  
Low Price!  
See page 7

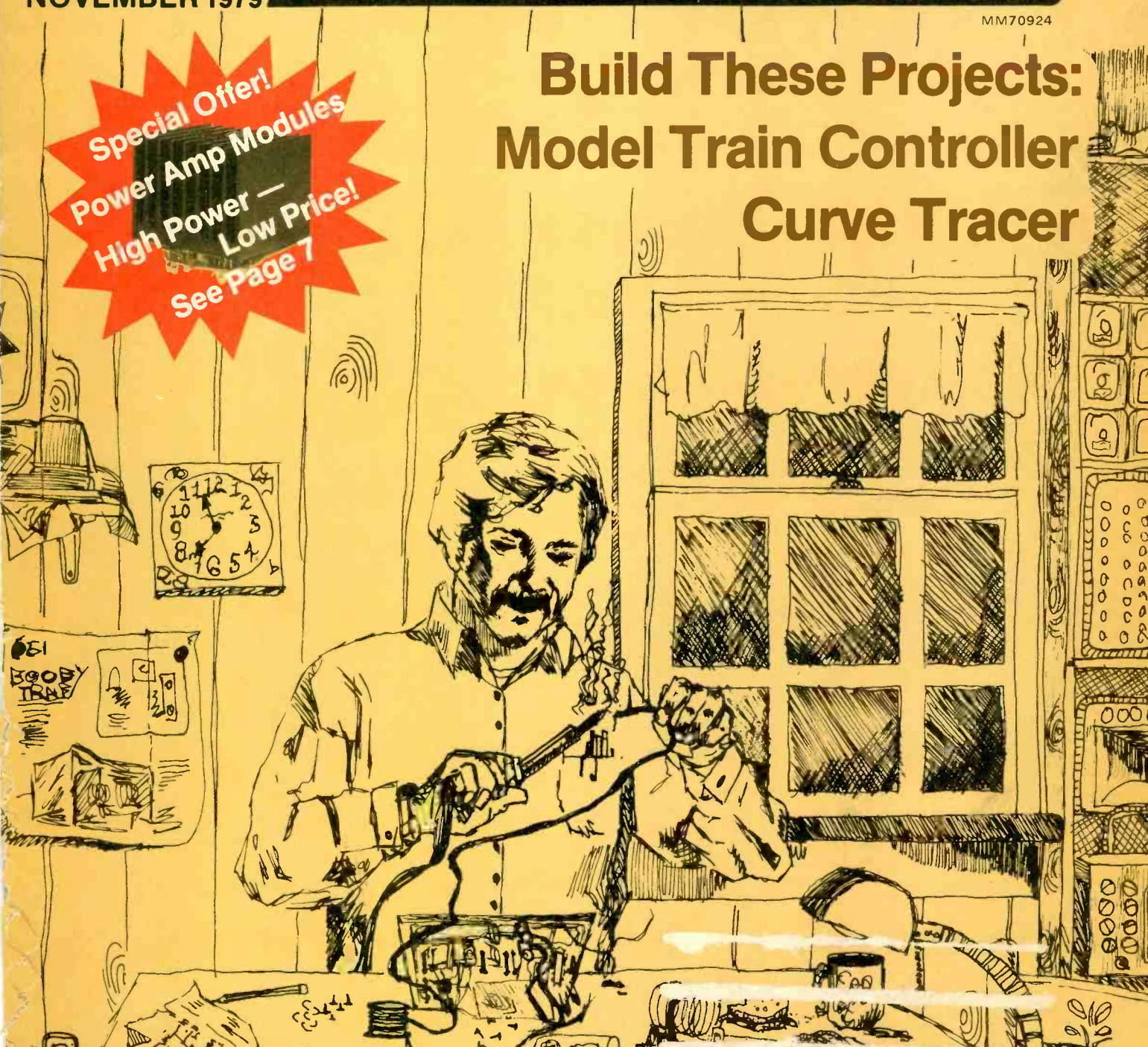

## KIT SURVEY

# Versatility: Here's why B&K-PRECISION's new DMMs offer more



Model 2810  
\$192.95

Model 2830  
\$312.95

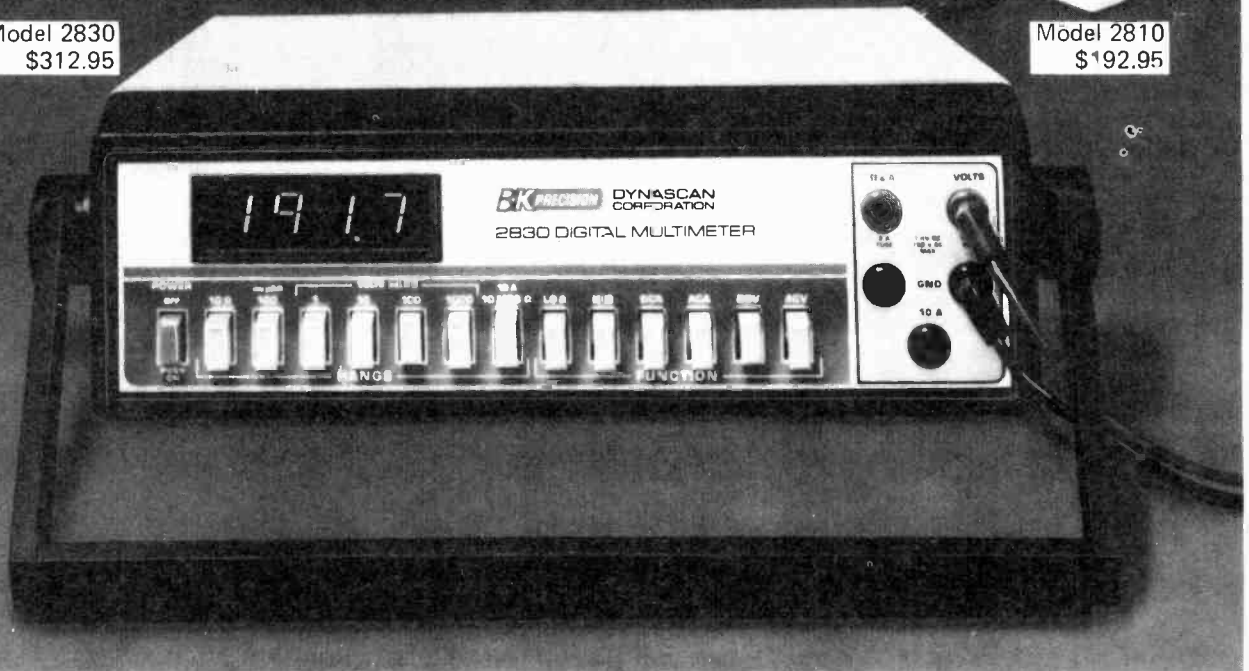

Selecting a DMM isn't simply a matter of looking for the highest accuracy. It's a more complex process of deciding what features and performance characteristics you need, to do as many different jobs as you're likely to encounter. In short, versatility is just as important as accuracy!

The new 2830 digital multimeter from B&K-PRECISION has all the popular features you'd expect to find on a 3½ digit lab DMM, but it also offers some very uncommon features. Because a DMM may be used under poor lighting conditions or in a very bright environment, the 2830 uses bright, high-efficiency 0.43" high LED digits. The readability of this premium display is unmatched by other readout devices.

The 2830 is also one of the very few DMM's available with a 10 ohms range, capable of .01 ohm resolution. This range offers the user accurate resistance measurement of switch and point contacts, or motor or coil condition. AC and DC current measurement capability extends from 100 nA to 20 amps without the need for external plug-in shunts. For voltage measurement, the 2830 can resolve as little as 100  $\mu$ V. For maximum versatility in resistance measurement, selectable high-/low-power ohms permits resistance measurement with or without forward biasing semiconductor junctions.

The unit is housed in an attractive rugged cabinet which features a combination tilt stand/handle. Options include a battery

pack for field use and a carrying case.

B&K-PRECISION's 2810 DMM offers many of the features of the 2830 but in a more compact package and at a substantially lower price. Features include 100  $\mu$ V, .01 ohm resolution; high-/low-power ohms; autozeroing; high immunity to RF interference and complete portability.

## Free DMM Selection Guide

A new B&K-PRECISION DMM selection guide is now available. This full-color brochure details features, applications and specifications. It also includes details of a new probe that turns any DMM into a digital thermometer. Send for your free copy today!

**BK PRECISION** DYNASCAN CORPORATION

Represented in Canada by Atlas Electronics Limited,  
50 Wingold Avenue, Toronto, Ontario M6B 1P7. 416/789-7761

Circle No. 11 on  
Reader Service Card.

Editor  
GRAHAM WIDEMAN BAsc  
Assistant Editor  
JOHN VAN LIERDE

ADVERTISING  
Advertising Manager  
MARK CZERWINSKI BAsc  
Advertising Services  
CHERYL MAY  
Advertising Representatives  
JIM O'BRIEN

Eastern Canada JEAN SEGUIN &  
ASSOCIATES INC. 601 Cote Vertu,  
St. Laurent, Quebec H4L 1X8.  
Telephone (514) 748-6561.

Subscription Department  
BEBE LALL

Accounts Department  
SENGA HARRISON  
Layout and Assembly  
SARAH-JANE NEWMAN

Contributing Editors  
WALLACE PARSONS (Audio)  
BILL JOHNSON (Amateur Radio)  
JOHN GARNER (ShortWave Listening)  
DICK CARTWRIGHT (Servicing)  
STEVE RIMMER (Video)

EDITORIAL AND ADVERTISING  
OFFICES

Unit 6, 25 Overlea Boulevard,  
Toronto, Ontario, M4H 1B1  
Telephone (416) 423-3262

Published by Electronics Today  
International (Canada) Ltd.

Printed by Livingstone Printing Ltd  
Delta Web Graphics

News Stand Distribution  
Master Media, Oakville.

#### COPYRIGHT

All material is subject to worldwide  
copyright protection. All reasonable  
care is taken to ensure the accuracy  
of the information.

All ETI PCB Patterns are copyright .  
No company may sell boards to our  
designs without our permission.

#### INTERNATIONAL EDITIONS

Electronics Today International,  
145 Charing Cross Road,  
London WC2H 8DEE, UK.

Electronics Today International  
Ryrie House, 15 Boundary St.,  
Rushcutters Bay, Sydney, Australia.  
Managing Editor Collyn Rivers.  
Acting Editor Roger Harrison

#### Elrad

Kommanditgesellschaft, Bissendorfer  
Strasse 8, 3000 Hannover 61 Germany  
Editor Udo Wittig

#### Postal Information

Second Class Mail registration number  
3955. Return postage guaranteed. Post  
office returns to Unit 6, 25 Overlea  
Blvd., Toronto, Ontario. M4H 1B1

# electronics today

international

INCORPORATING ELECTRONIC WORKSHOP

## PROJECTS

- 60 WATT AMPLIFIER .....18  
*Simple phase compensated, low TID circuit.*  
MODEL TRAIN CONTROLLER .....26  
*Superior performance for model railroads.*  
CURVE TRACER.....14  
*Simple unit checks transistors quickly.*

## FEATURES

- KIT SURVEY .....34  
*Kits for Christmas shopping.*  
ULTRA FIDELITY PART II .....44  
*The principles behind the super sets.*  
USING UARTS.....50  
*Our Father UART in heaven.....*

## NEWS & COLUMNS

- NEWS DIGEST .....4  
AUDIO TODAY .....9  
*Wally Parsons ponders the rationale of buying a kit.*  
WHAT'S ON .....70  
*Steve Rimmer tells you how to fiddle a VTR successfully.*  
QRM .....32  
*A parable for hams.*  
SERVICE NEWS.....66  
*Frank Drea and the CEASA.*  
SHORTWAVE WORLD .....58  
*Joining a club will increase your fun.*  
TEACHERS' TOPICS .....64  
*Students enthusiastic about electric vehicle program.*  
FUN OF ELECTRONICS .....81  
TECH TIPS.....78

## INFO & MISCELLANEOUS

- ETI Special Offer .....7  
Electronics Books ..... 13,63,69,75  
Next Month in ETI ..... 57  
Towers Trans. Guide ..... 61  
Subscriptions ..... 62  
Reader Service Card.....62  
Classified Ads.....79  
ETI Project File ..... 80  
General Reader Info.....82  
Advertisers' Index .....82

# NEWS DIGEST

## RCA Fall Preview

Recently we were invited to view RCA's Fall line colour televisions and VCRs. To us, one TV set looks much the same as the other.

Of great interest however, was a new portable VCR.

RCA's portable VCR system consists of three elements - a portable deck, tuner/timer module and auxiliary power supply. The VDP150 portable deck measures 11¼" deep by 10-1/16" wide and weighs 14.3 pounds, including the battery. Low power consumption of 8 watts in the unit helps extend the VDP150's camera — recording capabilities up to 1½ hours. All functions are controlled by solenoid switches and a micro-processor.

The tuner/timer module, TDP1000, features electronic tuning and 4-hour off-air recording capability when connected to a matching VDP150 portable. Battery-charging circuitry, which keeps the portable ready for action at all times, is also housed in the TDP1000. A timer that can be pre-set up to 24 hours in advance allows unattended recording.

The third element in the SelectaVision portable system is the PDP500, an accessory containing AC power supply and battery — charger combination.

Featured with VDP150 was RCA's top of the line colour video camera.

The CC004 colour camera from RCA has a F1.8, 6:1 motorized lens and electronic viewfinder. The latter's 1.5 inch monochrome screen also serves as a monitor to permit a review of tapes immediately after shooting. Weight? About 6 pounds, approximately 50 per cent lighter than last year's comparable RCA model.

Prices should be available in early December.

## Memory Mapped ADC

An 8-bit A/D converter which is claimed to perform a full-accuracy conversion in 15 us and can be connected directly to a microprocessor bus and addressed as random-access memory is available from Analog Devices. The AD7574 CMOS is priced from \$5.00 in quantities of 1,000.

The AD7574 acts as a memory mapped peripheral and at the user's option may be interfaced like static RAM, ROM, or slow-memory. For example, in the static RAM mode, a conversion is started by executing a memory WRITE to the AD7574. A data



TDP1000 Tuner/Timer, VDP150 VCR and CC004 video camera in action.

read is performed by executing a memory READ to the AD7574. The AD7574 uses control input signals CS, RD and BUSY which are readily available in all microcomputer memory systems.

Applications include avionics, instrumentation and automated process control.

For Sales Engineering Information, please contact Don Travers, Analog Devices Semiconductor, 829 Woburn Street, Wilmington, Massachusetts 01887. Telephone: 617/935-5565.

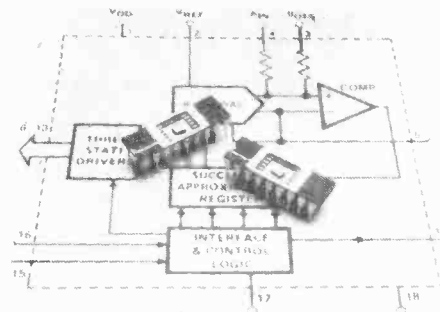

The AD7574 ADC can be addressed as slow memory, RAM, or ROM.

## Electronic Thermostat

A fully automatic electronic thermostat, Autopace 7, manufactured by Autotronics, Inc., reportedly cuts home heating and air conditioning bills by up to 30%. It could pay for itself in as little as six months, depending on locality and climate. The micro-processor "brain" allows programming of 28 temperature changes per week, or four changes per day, fully controlling central heating and air conditioning systems.

The Autopace 7 replaces most existing four-wire thermostat systems. For remodeling it can be adapted to older two-wire systems by simply replacing the two-wire cable with a four-wire cable. The thermostat operates on 24VAC, 60 Hz as supplied in most heating and air conditioning systems.

The system features a 100% solid-state design with no moving parts and is housed in a molded case. The unit has a three inch LED display for easy readability on time and temperature.

For more information contact: A.C. Simmonds & Sons Limited, 975 Dillingham Road, Pickering, Ontario, L1W 3B2.

## Tenna Car Stereo

From their Pro series, Tenna offers an IN-DASH Auto Reverse Cassette AM/FM Stereo: Model C-3039AR that supposedly offers the quality of home stereo.

Installation is simplified with fully adjustable shafts and a universal nose size, short (4½") chassis that makes it easy to fit in most cars including foreign models. It features adjustable FM muting, separate front to rear fader and balance controls, dial-in-the-door and selectable end-of-the-program eject or continuous play. It also has tape direction, mono/stereo, local/distance and AM/FM switches plus locking fast-forward and rewind controls.

Reported specifications are Amplifier: 3 Watts per channel minimum RMS at 4 ohms from 40-20,000 Hz @ 1% THD both channels driven. Output Z; 4 ohms. Pre-Amp Output: 100 MV @ 10 K ohms.

Price, \$199.95 US. Available from most Tenna Dealers or Tenna Corporation, 19201 Cranwood Pkwy., Cleve, OH 44129.



## Video Terminal

The Cybernex APL-100 terminal features true overstrikes using a highly legible 9x13 dot character cell and a 1920 character 80 by 24 display with selectable 48 line, 32 character split screen mode which scrolls all 48 lines from bottom right to top left.

Standard features of the APL-100 in both ASCII and APL modes include read and write cursor address, four direction cursor control, page print and printer port on/off control.

The list price of the APL-100 is \$1795.00 Canadian, FOB Ottawa, Ontario, Canada, (no taxes included), with delivery beginning in September, 1979.

For full information on the APL-100 terminal or the 6 standard models of video terminals, contact Bruce Douglas, V.P. Marketing, 2183 Dunwin Drive, Mississauga, Ontario, Canada, phone (416) 828-2810 or Wayne Reid in Ottawa, at (613) 741-1540.

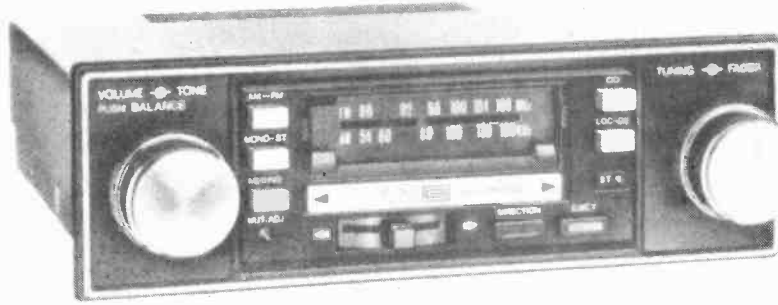

*Tenna Corporation's new auto reverse tape deck has shorter chassis for small dashes.*

## Oaktron 'Mini Hi Fi Systems'

Enclosed speaker systems for vans, boats and R/V's have been introduced by Oaktron Industries, Inc. The speaker enclosure is strongly built, with a black leather-look vinyl finish. You get high-style and high-fidelity in a small package. It is supposed to be specially designed to deliver full, rich sound in confined spaces, even the home bookshelf. The enclosure's acoustic grill has a protective inner mesh, and see-through grill screen. With a dual purpose terminal strip for screw or jack connection, the speaker enclosure has dimensions of 10¾" long, by 77/8" wide, and 57/8" deep. The enclosure is available with three different pre-mounted speakers; the model ENST3 three-way system with woofer, midrange, and tweeter, boasts a frequency response

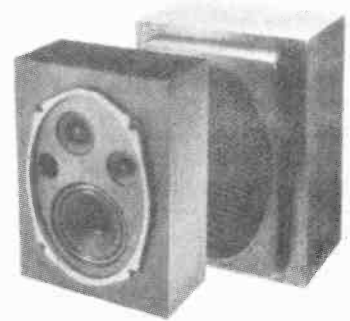

of 50 to 19,000 Hz and 25 watts RMS power, with 50 watts peak; the EN69T "Super Power," with up to 90 watts peak power; and the model EN69H "High Compliance" speaker, up to 40 watts peak power.

For further information write to Omn itronics Limited, 2056 Trans Canada, Dorval Quebec, H9P 2M4

## Function Generator

The Continental Specialties model 2001 is a complete signal-generating capability at a very affordable price. IC circuitry produces stable low-distortion sine waves (less than 2% THD), fast-rise-and-fall-time square waves (less than 100 nsec), high-linearity triangle waves (better than 1%) and TTL square waves with rise and fall times 25 nsec. Frequency is accurate-sweepable and repeatable-to 5% of dial setting, in 5 ranges from 1Hz to 100kHz. Two shortproof 600 ohm outputs are adjustable from 1mV-100mV and 100mV-10VP-P. Variable DC offset control (pushbutton selectable) — provides controlled, variable shifting of the output waveform's center line above or below zero.

For further information contact Len Finkler Ltd., 25 Toro Road, Downsview, Ontario M3J 2A6. Telephone (416) 630-9103 Telex 065-24010

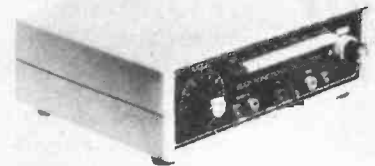

## Expose Yourself

News digest is a regular feature of ETI Magazine. Manufacturers, dealers, clubs and government agencies are invited to submit news releases for possible inclusion. Submissions, or questions about material, should be sent to: News Digest, c/o ETI Magazine Unit 6, 25 Overlea Blvd., Toronto, Ontario, M4H 1B1.

Audio products news will be directed to Audio Today's product department, and similarly Shortwave news will appear in Shortwave World. Sorry, submissions cannot be returned.

## Fiber Optic Kit

Motorola now has a fiber optic evaluation kit, developed to give designers hands-on experience with the latest state of the art fiber optic components. It will acquaint engineers with the new Motorola ferrule semiconductors and the compatible AMP fiber optic connectors. The kit is called "The Link", and refers to the optical link between the transmitter and receiver of any system — with all of the optical portions needed. The kit includes; a fiber optic infrared source(LED), an integrated detector/preamplifier, a one meter length of fiber optic glass cable, terminated with appropriate matching AMP connectors.

In addition, The Link kit contains detailed data sheets for the Motorola fiber optic ferrule semiconductors and the AMP connectors, design consider-



ations, applications and circuit ideas, and a fiber optic cable selector guide.

Price for the "The Link" kit, in unit quantities, is \$99.00 U.S.

Write to Motorola Semiconductor Products, P.O. Box 20912, Phoenix, Arizona 85036

## Catalogues

A new B&K-Precision industrial test instrument catalogue, BK-180, featuring more than forty instruments, is now available from Dynascan Corporation. The 44-page catalogue features a broad range of high-quality test instruments for engineering, production line, MRO and other industrial applications. Each catalogue product description includes a detailed specification section and helpful applications information.

B&K-Precision, Dynascan is represented in Canada by Atlas Electronics Limited, 50 Wingold Avenue, Toronto, M6B 1P7.

## Keithley

Keithley Instruments has a new 87 page catalogue and buyers guide. This catalogue provides complete introduction and selector guides on all their products; digital multimeters, electrometer, picoammeter, nanovoltmeters, etc. There is also a listing of miscellaneous accessories such as rack mount kits, ph adaptors, etc.

For a copy of this catalogue please contact Radionics Limited, 195 Graveline Street, Montreal, Quebec.

## Attention, Ceres Users

We've heard from Ceres that their Ceresist patterns #18, 40, 52/1, 52/2 and 75/1 will not be available until mid-January, 1980. In addition, #20 will not be available at all.

To avoid inconvenience, readers are advised not to order these patterns at this time.

## Hobby World

The new Hobby World Computer Accessory Catalog #112 contains 16 pages of software, computer boards, systems, printers, semi-conductors, and PC aids designed to meet the needs of the computer enthusiast, novice, and business-person. The catalog discusses each product in great detail. Quantity and club discounts are available. Contact, Ms. Goist, Hobby World Electronics, 19511 Business Center Drive, Northridge, Ca. 91324. (213)886-9200, (800) 423-5387.

## R-ohm

R-Ohm recently announced the availability of a short form catalog for its line of resistors and semiconductors.

This four-page catalog covers R-Ohm's small signal transistors, switching diodes, carbon film resistors, metal film resistors and resistor arrays. Specifications and performance graphs are included, as well as a list of R-Ohm's distributors and representatives. R-Ohm Corporation, 16931 Milliken Avenue, P.O. Box 19515, Irvine, CA 92713, (714) 546-7750. Eastern Offices: (312) 843-0404. TWX: 910-595-1701.

## New Stock

Longman Sales Inc. (LSI) is now a stocking representative for FMC Semiconductor and offers a complete inventory of power diodes and SCR's for same day shipment.

Technical assistance is available by contacting Bill McNanny of LSI. Longman Sales Inc., 1715 Meyerside Drive, Unit #1, Mississauga, Ontario, L5T 1C5

## Dip Sockets

O.K. Machine and Tool Corporation offers a wide range of wire-wrapping DIP Sockets for plug-in packaging of Integrated Circuits. Dual-in-line configurations accommodate virtually all SSI, MSI and LSI devices. Sockets feature gold plated 3-level wire-wrapping pins .025 inches (0.63mm) square on .100 inch (2.54mm) centers. Other features include phosphor bronze leaf spring contacts and black bodies of U.L. recognized glass filled thermoplastic. Available in 14, 16, 24, 36 and 40 pin configurations.

For further information please contact Len Finkler Ltd., 25 Toro Road, Downsview, Ontario M3J 2A6 Telephone (416) 630-9103 Telex 065-24010



## Test Noise

American Tracer Corp. introduces a new multi-tester by sound. The operator quickly learns the change in tone patterns with the measured parameter. The Traser is in a compact impact resistant lexan case.

The "five-in-one" tester with automatic range switching and protective mechanism allows freedom to concentrate on the tested circuit with indicates resistance from 0-1 megohm, tone variation AC voltage 300 Mv to 250 Vrms, Tone variation DC voltage 300 Mv to 40 V, detects mixed AC/DC voltage (complex DC) (for telecommunication systems), tests polarity.

Traser can also be used as a continuity tester with low probe current (500 micro-amps), permitting its use with sensitive components. Retail for \$39.95

For further information contact, H. W. Cowan, P.O. Box 268, Richmond Hill, Ontario L4C 4Y2

# What's Under This Heatsink Will Amaze Your Ears!

ETI Special Offer!

**100W**  
**\$44.95**

**55W**  
**\$29.95**

**Order Now!**

PLEASE USE ORDER FORM ON NEXT PAGE  
(Offer closes when stocks run out, or December 5th 1979.)

**Stereo?**  
Buy two.

**Guitar Amp?**  
Buy one.

**BI-Amping?**

Get a 100W for lows.  
And a 55W for highs.

**PA?**

You figure it out!

**Disco?**  
Buy lots.

A WELL KNOWN Canadian manufacturer has decided to discontinue production of their audio power modules, and there are parts for hundreds of these modules left over. ETI has arranged to make kits of these parts available to readers at incredibly low prices. Construction details and schematics come with these kits — all you do is add a power supply, as suggested below. The tools required are just those needed for electronics assembly, and a regular multi-meter.

Please order quickly as we can only be sure that we can fill the orders for the first 500 of each module size.

**SHIPPING DETAILS:** We will ship these units by Canpar where possible, otherwise Certified Mail will be used (we are charging \$2 per amp for packing and shipping). Please allow a total of three to four weeks for delivery, after mailing us your order.

SPECIFICATIONS	MODEL E55	MODEL E100
Power out (Into 8 ohms)	55WRMS	100WRMS
Freq. Response	20 Hz to 20 kHz +/- 1dB	
THD at rated output	0.8%	0.1%
IM Distortion	0.1%	0.1%
Hum and Noise	80dB below full output	
Input Impedance	100 k ohms	
Load Impedance	4 ohms minimum	
Sensitivity	1 V for full output	
Size (inches. . .sorry!)	4x4x2	4x4x4
Weight (Pounds . . .ditto)	1.3	2.5
Power supply required: VDC	+/-38	+/-45
Amps	2	5

**PLEASE NOTE:** To keep costs down, we are offering these kits **ONLY** via mail order. The flood of people who came to our office during our last offer was just too much for us!!

All parts guaranteed to be prime parts. Selected low noise transistors. Fused, current limited.

## Easy Hook-up!

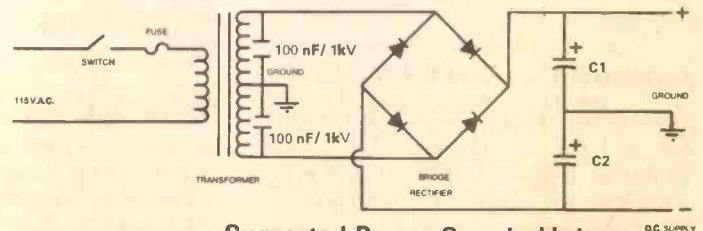
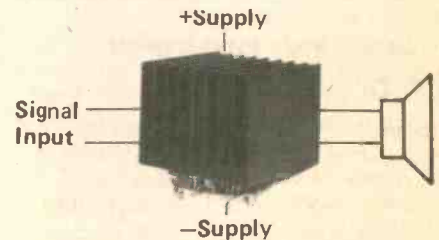

## Suggested Power Supply Unit

POWER SUPPLY SPECIFICATIONS FOR STEREO		E 55	E 100
TRANSFORMER SECONDARY	NO LOAD FULL LOAD	54 Vac 46 Vac at 5A	64 Vac 56 Vac at 10A
CAPACITORS	C1 and C2	10000 to 15000 uF 40 V	10000 to 15000 uF 50 V
BRIDGE RECTIFIER		100 PIV 5A	100 PIV 10A

# ETI Special Offer: Amp Modules

Please use this coupon, or a photocopy thereof.

Please send me:

Quantity	Amount
55W Amps at \$29.95	\$.....
100W Amps at \$44.95	.....
Sub Total	.....
Ont Res Add 7% PST	.....
(That's \$2.10/55W or \$3.15/100W)	.....
Shipping \$2 PER AMP	.....
TOTAL REMITTANCE \$	.....

**PAYMENT:**

Certified Cheque  (No uncert cheques pls!)

Money Order

Charge: Visa  Mastercharge

Credit Card No.: .....

Expiry Date: .....

Signature: .....

SHIP TO:

Name .....

Address: .....

Postal Code .....

Mail this coupon to: Amp Offer, Electronics Today, Unit 6, 25 Overlea Blvd., Toronto ONT., M4H 1B1.

# NEWS DIGEST

## Calendar Dates

The 10th annual Canadian Computer Show and Conference will be held on November 13, 14, & 15 at Toronto's International Centre. This years show will feature over 150 exhibitors. In addition, Hewlett Packard is offering an HP-41C personal calculating system as a door prize.

For a conference brochure or more information, write Canadian Computer Show and Conference, 36 Butterick Rd, Toronto, Ont. M8W 3Z8.

February 12, 13 & 14, 1980 — Toronto, Ontario. The Data 80 Data Communications Conference and Show, Harbour Castle Hilton Hotel and Convention Centre.

The three-day conference program will feature panel sessions, audio-visual presentations, workshops and technical sessions related to the field of data communications.

For more information, write or call Jill Carrothers, Conference Coordinator or Laurie Whitsed, Show Coordinator, 2 Bloor Street West, Suite 2504, Toronto, Ontario M4W 3E2

## Looking Back ...

### Lampert Spelled With a "P"

Sorry Murray! Our credit for Hamtraders' contribution to last month's cover should have Murray's name spelled correctly ... it's Lampert.

### Mystery Power Amp Power

Gladstone's catalogue in Oct 79 issue ETI has an unspecified power amp module on page G11. Please get out your pens and write in "30 Watts".

### New Omega Phone + Address

Omega Computing, reps for Ohio Scientific have moved. Their new address is 200 Steelcase Rd. E., Unit 5, Markham Ontario L3R 1G2. Phone 495 1382.

## 3M PC Breadboard

3M now offers a new way to prototype circuits, the Scotchflex Breadboard System. The system combines the insulation-displacing capabilities of "Scotchflex" 'U'-contacts with a connecting system that permits solderless connection to boards with plated-through holes. Connectors include 8-contact solder strips, plug strips and 16-position dual sockets.

3M says the new system offers several advantages over systems using wrap posts. Cited are labour and time savings, greater accuracy and direct conversion from prototype to production boards.

Connections are made with continuous, 30 AWG solid insulated wire

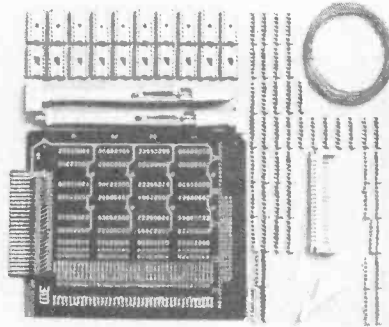

which can be easily inserted in the 'U'-contact with an inexpensive hand tool supplied by 3M.

For more information contact, Mr. A. D. Machuk, 3M Canada Inc., Electronic Products, Box 5757, London, Ontario, N6A 4T1.

## A Canadian Business Micro

Megatel Computer Corporation Inc. of Toronto has just announced the next generation of small business computers — The MEGATEL 2000. Designed, developed and manufactured in Canada, the M2000 uses only one printed circuit board, resulting in substantial savings.

To be marketed by distributors throughout the world the MEGATEL 2000 is available in two models — 48K Central Processing Unit with one million characters of disc storage and a printer at under \$11,000, plus a 64K central processing version with two million characters of disc storage and a faster printer for under \$16,000.

For further information please call Dick Pepperdene at 416-745-7214, or write to Megatel Computer Corporation Inc. 150 Turbine Drive, Toronto,

Ontario, Canada M9L 2S9.



## Memory Interface IC

Motorola now has a memory address multiplexer and refresh counter circuit — the MC3232A — designed specifically for use with most popular 16-pin, 4K dynamic RAMs (such as the MCM4-027).

The address multiplexer splits the 12-bit Address Input signal into two sequential 6-bit outputs representing

the Row Address and Column Address segments, respectively. This satisfies the 16-pin memory requirement which calls for the use of the same six input pins for all address bits in order to reduce the size and complexity of the memory package.

Price is \$4.70 US for plastic package. Availability is from Motorola OEM sales offices and authorized distributor warehouse stock.

Write to Motorola Semiconductor Products Inc., P.O. Box 20912, Phoenix, Arizona 85036, Phone (602) 244-6900.





# Audio Today

Developments in audio reviewed by Wally Parsons

"DOING IT YOURSELF" generally sums up the entire history of the human race; at least for most of its members.

After all, the first cave man to use a tree limb as a club didn't exactly get it from the local sporting goods store, cave wall drawings were not made by a paint by numbers set, and the first wheel did not come in knocked-down form in a box from Canadian Tire.

An odd characteristic of most societies is that intellectuals, persons of wealth, and those in the "elite" professions, have always felt a certain disdain towards those who know how to make things, or make things work. Similarly, the occupations and lifestyles considered high in status have been those which do not involve working with "things", and the mark of status is the servant, who performs even routine menial tasks which most of us do for ourselves.

Even in the business world, one mark of position and importance is the secretary, and God forbid that an executive should know how to operate a typewriter.

Even many writers consider it uncool to do their own typing, and spend piles of money on stenographers to transcribe their illegible scribbles into readable form. The *results* may be unintelligible, but that's not the fault of the typist.

But despite the fact that so many people seem to regard it as a badge of honour that they are technically and/or manually illiterate, enough others remain to keep the world's machines working and allow the former to sleep safely in their beds.

But high technology often demands a high level of knowledge, and aptitude to use, and few of us are able to master these demands in more than one or two fields, yet would like to dabble in others, either for the sheer pleasure of so doing, or to save money, or just to be different. For many such persons, kits are the answer.

## AUDIO KITS

A kit is any packaged assembly containing all parts needed to accomplish a certain result. Thus, a record cleaning kit may contain fluids, pads, brushes etc., to be used for that purpose, and a pickup mounting kit may contain either a specific pickup or a variety of pickups to a specific or variety of arms. On the other hand, a preamp kit may contain all parts necessary to build an preamp, either in complete form, or just a module or circuit board assembly. In addition, it may come with some parts already assembled as sub-assemblies, and with adjustable parts pre-adjusted.

Most kits also include instructions on how to assemble or use the kit, as well as trouble-shooting guides, and application notes. Some may be so complete that the user need know nothing more than how to hold a soldering iron without getting a third degree burn (although one kit-maker even covers that), while others may include only parts and a schematic. Of one thing you can be certain; the more you get, the more it will cost. And you can be reasonably certain of one other thing; most kits will perform as the manufacturer claims, and usually work properly as soon as construction is completed. Provided, that is, that you follow the instructions and don't try to be a Know-it-all.

## A BIT OF HISTORY

Kits of one sort or another in electronics have a history which extends all the way back to the days of the crystal radio. An examination of suppliers' catalogues and electronics magazines show a wealth of devices available in kit form, mostly in the form of simple receivers, but for the budding amateur various pieces of transmitting equipment were also available. Generally, their attraction was based on one simple premise: it was the most

effective way to get a piece of equipment.

But it was not until the advent of the Long Playing record and the concomitant general interest in the high fidelity reproduction that audio equipment kits as such began to appear on the scene.

Many of the first kits were rather simple affairs, perhaps a two-tube amplifier, with volume control and "tone" control, suitable for use with a record player with a crystal pickup, and occasionally a really super job with a push-pull pentode output for all of ten watts and separate bass and treble controls. Later, a few enterprising types added a magnetic phone preamp, using the circuit in the back of the RCA receiving tube manual, for use with the newly developed GE and Pickering pickups, and even some making provision for the variety of equalization curves in existence at the time. And in England, several enterprising manufacturers, many of them primarily transformer manufacturers, were promoting kits of the fabled Williamson amplifier.

## EDUCATION

The primary purpose in offering these kits was simply to make money; but one of the happy end results was the spurring of interest in audio not only among laymen, but students as well, with the result that they performed an educational function.

I vividly recall the second kit I built: it was a ten watt amplifier using 6V6-GT pentode output tubes, and bass and treble controls and no preamp. The preamp I built later using my own design and mounted under the turntable (a practice which, as regular readers know, I still advocate). It was called a Knightkit, and put out by Allied Radio of Chicago who later founded the original chain of Radio Shack stores. It was a pretty good amplifier, too. At least, I thought so at the time, and it

# Audio Today

would certainly wipe out the majority of console sets available then.

I say that was the second kit: the first was built in the Air Force, where our project in the Communications course was a six tube superhet receiver. In fact, with typical Air Force efficiency (and I mean that sincerely) DND purchased a quantity of kits marketed by Meissner, perhaps better well known today for their line of coils. It boasted a Hartley oscillator, an RF stage, aligned like a charm and brought in local stations with no antenna, even within the shop surrounded by steel structures and fluorescent lighting.

This is, perhaps the area in which kits have their greatest value. It's one thing to read theory in a book, and even see it demonstrated in the lab, but it's quite another thing to apply that theory in a practical manner. The bridge between the two is the construction of a useful device designed by an expert, and to ensure proper operation, essential if the student is not to be discouraged, what could be better than to get everything needed as a complete kit of parts with direction for assembly.

In a very real sense, ETI projects can be regarded as partial kits, in that the builder can collect all parts by reading the parts list, then assemble it according to the instructions published in the project. Regular readers will have observed that the better correspondence schools lay emphasis on the kits which are supplied for use in their courses. Indeed, NRI schools has offered this feature at least since the forties when their advertisements appeared on the back pages of comic books and pulp magazines. In those days it was a superhet receiver (the Meissner, perhaps?), while today their courses may include a 25" colour TV set, stereo amplifiers, test equipment, computers, etc., depending on the course.

## TODAY

Most of the old kit makers have left the scene, or greatly restricted their product range. Of them all, only Heathkit can be said to have prospered and expanded their lines, specializing in kits. In the audio line, they can supply everything the audiophile may desire, from muscle amps to turntables, pickups and speakers. These are the guys that do everything but hold the soldering iron for you, but they even teach you to do that. Prices are significantly lower than similar ready-made equipment, although you still pay a premium for the painstaking attention to detail, the careful step-by-step instructions, and the theoretical information which in itself constitutes a section of the course in audio. This is the line also for the guy who wants something that *looks* factory made, *performs* factory made, yet saves money while affording the fun of building your own equipment.

But for those who are somewhat knowledgeable, or want to build their own housing and cabinetry, or otherwise customize the end result, more kit makers are springing up annually in Canada than appeared in the past twenty years. Many of these products are kits for ETI projects, while others have either been developed by the supplier or imported from overseas. On the whole, quality seems to range from very good to excellent, and with any encouragement, the variety of equipment offered promises to

increase over the next few years, as can be seen by examining the list of ETI advertisers.

## MAKING A CHOICE

If you are contemplating going the kit route, your choice will be determined primarily by your purpose. If you primarily wish to save money you'll select a bare bones type kit, such as the one reviewed in this month's products section. If it's a matter of learning by doing, the same applies, but you might consider one of the more elaborate kits such as the Heath. Likewise if you mainly want to save money and have the fun of putting something together. If you're interested in building an ETI project but live in an area where parts availability is a problem, consider some of the ETI project kits offered in these pages.

One particular advantage of the ETI project kits lies in the fact that the supplier is usually able to buy parts in quantities, and so effect price benefits which the single unit buyer cannot, and yet can still make a profit. As a result, unless you have a good, well-stocked parts bin filled at bargain prices, the kits will be a lot cheaper than it would be if you assembled it yourself. And of course you don't have to build and, in some cases, drill holes in the cabinets.

Did you know that in the 1960's a German manufacturer produced an *automobile* in kit form, for about \$900.00? Wonder what ever happened to it.

# Audio Today Products

Audio developments reviewed by ETI's Contributing Audio Editor Wally Parsons.

## AUDIOVISION MODEL 7070 140 W INTEGRATED AMPLIFIER

A two channel amplifier with phono preamp, bass, mid-range, and treble

controls, balance, volume and loudness switch. All signal stages are built-around integrated circuits, and the voltage section of the power amplifier is an integrated circuit. All sections are mounted on one board, with the exception of the power transformer which is mounted separately, and the output transistors and one bias diode per channel, which are mounted on external heat sinks. The amplifier features electronic filtering and constant voltage supply to the IC's regardless of fluctuation in supply. Preamp, tone controls, and power amplifier have their inputs and outputs brought out to terminals on the board and may be internally interconnected or brought out to switches or jacks externally to allow independent operation or the installation of signal processors or tape equipment. Load

## Jensen Triaxial® 3-Way Speakers

Quite simply, the most advanced car stereo speaker ever.

For the best sound ever in your car. The first car stereo speaker with a woofer, a tweeter and a midrange.

Identical in principle to the best home stereo speakers. Jensen's midrange picks up a whole range of tones lost to any other car speaker.

**Write today for Free catalogues and the name of your nearest Jensen Dealer —**



Jensen Finkler Limited

25 Toro Road, Downsview, Ontario M3J 2A6  
Telephone (416) 630-9103 Telex 065-24010

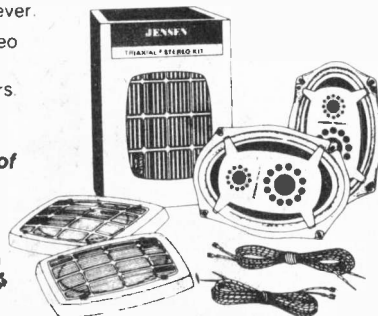

Circle No. 13 on Reader Service Card.

**Building Jana Kits is only half the fun.  
Your friends will go bananas with the results!**

Gorgeous! Romantic!  
**Jana 3-channel  
color organ**



Sends a real radio signal!

**Jana FM mini  
broadcaster**

**Exciting Games!**



Disco dramatic!

**Jana Xenon strobe  
light**

**Amazing Lights!**



Round & round she goes!

**Jana super roulette**

**Strange Noises!**

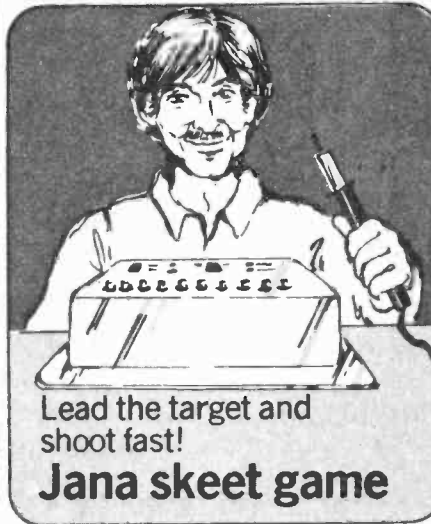

Lead the target and  
shoot fast!

**Jana skeet game**



Just like Las Vegas!

**Jana dice game**

The fun you have afterwards with your friends may be the best of all! Even better than being a proud Jana kit builder.

The true Jana kit builder doesn't mind that his friends sometimes win. Maybe one friend will 'shoot' more ducks on your unpredictably challenging Jana skeet game. Or another may 'roll' natural after natural in the intricately perfect Jana dice game you built.

So you have a friend who is hair-trigger fast. Or lucky.

Everybody can see you are the clever person who can control LED displays so the lights whirl round faster than an intoxicated mind. You can create the disco carnival of light and fun! Even a tiny radio station...

They can also see you are noble. You didn't cheat

so you would always win!\*

Only you will know that Jana miracles are sensible, logical, possible. Jana provides all the parts (even a case). And Jana plans are complete, illustrated, simple to follow.

The fun begins when you open a new Jana kit. (There are 27 besides those shown above.) The fun continues when you share what you have built with your friends!

\*It is firmly believed at Jana headquarters that no Jana Kit builder has ever cheated. Please don't tell us different!

Jana kits are available from dealers and distributors across Canada, including

**Atwater Electronics Limited**

886 Dundas Highway East  
Mississauga, Ontario  
L4Y 2B8  
(416) 276-4550

**Exceltronix Inc.**

319 College Street  
Toronto, Ontario  
M5T 1S2  
(416) 921-5295

Circle No. 10 on Reader Service Card.

**Jana**  
Industrial®

1777 Ellice Ave., Winnipeg, Man. R3H 0W5  
Phone: (204) 786-3133

# Audio Today

fault and speaker protection are provided by a relay.

Power response is specified as from 20 Hz to 20 kHz, and frequency response from DC to 100 kHz, input impedance of 50 Ohm, Damping factor of 100 at 8 Ohms. Power output depends on the transformer used (transformer is not included, but the supplier can provide one at extra cost.)

## HOW IT WENT TOGETHER

This is a bare bones type kit described in AUDIO TODAY, and does not include any type of housing. Although parts are separated in packaging, this is essentially a matter of one poly bag containing resistors, one containing capacitors, one containing semi-conductors, and one with hardware. Therefore, the builder must know how to read a colour code.

Parts layout is identified on the component side of the epoxy glass board, and values labelled. The only criticism in this regard applies to clarity of printing, which appears to have been silk-screened but line delineation is not what it might be. Thus, a resistor location might be labeled "4.7K" and the decimal not clear. It could, therefore, be confused with "47K". The ink used can also rub off fairly easily, so if the board is handled a great deal some of the labelling might be obscured. This could be a problem to someone whose close vision is, shall we say, less than perfect (like mine), but current samples will solve this by providing a layout drawing using standard nomenclature as part of the construction manual.

The board uses what appears to be

silver plating, but there are soldering difficulties unless it is thoroughly cleaned before use to remove oxides. Layout is good, although pad-hole registration is a little less than perfect, and some pads are open as a result. It appears to have been prepared using one to one artwork, rather than reduction, and requires some care in soldering.

## CIRCUIT

The phone preamp and the active tone controls are conventional and straightforward, built around the 739 type IC. Although no data on the specific device are available, it appears to be an internally compensated version, judging by the fact that the pin-out is the same and performance identical, but unlike the 739, it is not possible to access the compensation circuitry, yet the circuitry could not possibly be stable without compensation.

Of special interest is the power amplifier circuit, shown in figure 1. The output stage is a complementary super-beta pair, biased by two diodes, driven by a 739 type IC, with feedback taken from the output to the IC input. Readers familiar with *quasi*-complementary circuits will recognize this as the circuit used in the lower half of such circuits. Although the output stage is operated in the common emitter mode, combination has the characteristics of an emitter-follower with gain.

## PERFORMANCE

As expected, the most outstanding aspect of performance was in the output circuit itself. Since local loop

feedback is used between output stages and drivers, this section is virtually distortionless, with most of the actual gain provided by the power devices themselves. These are new Motorola devices rated at 20 A, 140V, and 250 W. Triangular waves passed without any observable deviation from a straight line, and square waves output looked like the input, right up to clipping level. No trace of cross-over distortion or switching glitches were apparent, thanks to the super-beta circuit, and bias could be accurately set using a scope without need for settling for a compromise setting.

RMS output is limited to 18W with 36V supply, with clipping occurring in the driver stage. The onset of clipping is sudden, but recovery is quick and symmetrical, and use of this limitation eliminates the need for more elaborate load-fault protection. Unusual, but it seems to work, and I can find no reason to fault it.

In the event of output device or power supply failure producing an offset voltage, a relay cuts out the speakers. It also functions during turn-on to prevent clicks and pops.

The manufacturer originally described this kit as only suitable for construction by someone with experience. I don't agree. It's a good performer (good enough for me to use it for speaker measurements) easily constructed. The only justification for the caution is the absence of a comprehensive manual. This has now been corrected as your professor here has agreed to prepare such a manual specifically for ETI readers, and this will be supplied with all future kits. Price: \$129.00 less transformer. Available from: Audiovision, box 955, Stn. B, Willowdale, Ont., M2K 2T6

## STOP THE PRESSES!

Just before deadline Technics demonstrated a new turntable to the press. The term "breakthrough", and "innovative" are greatly overworked adjectives in this business, but the new SL-10 can be rightly described in these terms. Very small, ultra stable, single play automatic operation, with a straight-line tracking system that really works.

It's so foolproof it can literally be handled easily by a blind person. I know — I operated it with my eyes closed with no goofs, and without knowing where the controls were.

Next month I'll describe it in more detail with a picture. It won't be available until next spring. Just thought you'd like to know.

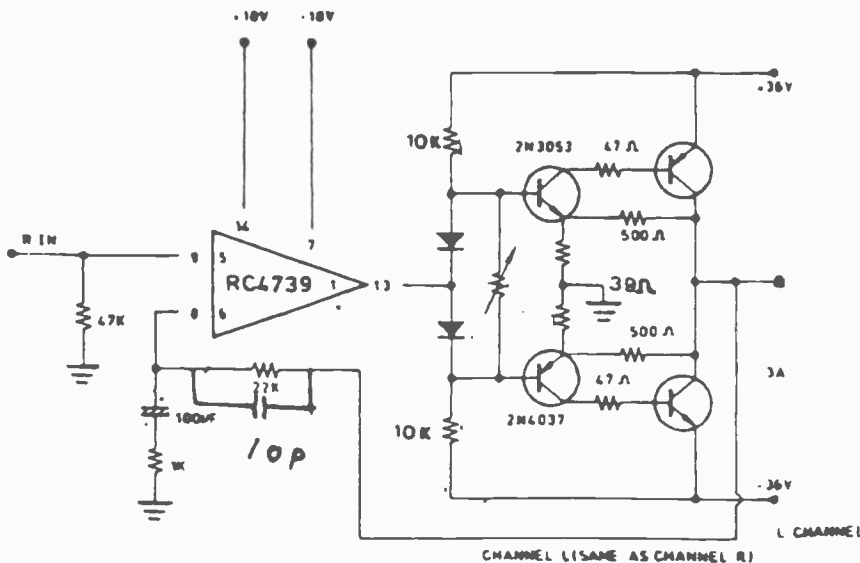

Fig 1 output stage of the Model 7070 power amplifier.

**COLOR LED POWER LEVEL INDICATOR**

The latest advanced way of measuring audio power output

- Works as a pair of VU meters, and adds exciting sights to your sound system.
- 3 color LED display, each channel.
- Enjoy the "dancing color light" show while you enjoy your music. • Responds to musical signals at much faster speed than conventional mechanical VU meters. • Applicable to most power amplifiers. • Very easy to build, and just hook up with the speaker output without affecting the sound. • Operates on battery or AC adaptor. • Display panel, plated fiberglass p.c. board and all electronic parts included.

**SAD-02**

**18 step display**

Front Panel

size 8-1/4"x2-1/2"

- 36 LED (4 colors) with peak, floating and gradual display.
- Suitable for 30W-200W/Ch max. power output amplifiers.
- Operates on DC 6-9V.

**KIT: \$56.00 . . . . Assembled: \$66.00**

10 step display also available. Write for details.

Send cheque or money order. Add 10% for shipping and handling. Ont. residents please add 7% sales tax.

**MONEY BACK GUARANTEE. FREE REPAIR SERVICE.**

For free audio kits catalogue, write to:

**AUDIOVISION SERVICE**  
P.O. Box 955, Stn. B,  
Willowdale, Ont.  
M2K 2T6

**You've heard **

**...more than you've heard of **

If you've heard a lead guitar lately, ringing out a string of clear, crisp notes—or a concert organ thundering a thousand voices, you may have been hearing Oaktron loudspeakers.

Oaktron has made speakers for some of the leading names in the musical instrument field—and the Hi-Fi field. And any field where clear sound is important.

Over the past 25 years, you may have heard more Oaktron speakers than any other brand. You've heard Oaktron in studios, theaters, discos, and homes of the Hi-Fi pros. From steel mill to ballet stage, you've heard Oaktron. And you've liked what you've heard.

Oaktron's M15Y2 Musical speaker. 300 Watts of peak power.

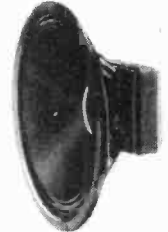

Ask for Oaktron's speaker catalogue by circling the Reader Service Card number or by writing to:

**omnitronix ltd.**  
2056 Trans Canada Highway  
Dorval, Quebec H9P 2N4  
Tel: (514) 683-6993

Circle No. 2 on Reader Service Card.

Specially imported from England for our readers!

**Mobile Discotheque Handbook**

by Colin Carson

\$4.80 including 30 cents postage and handling.

CONTENTS		Page
<b>SECTION ONE: BASIC ELECTRICITY</b>		
1.1 Introduction	1	1
1.2 Safety	1	1
1.3 Current	1	1
1.4 Voltage	1	1
1.5 Resistance	1	1
1.6 Power	1	1
1.7 Ohm's Law	1	1
1.8 Kirchhoff's Laws	1	1
1.9 Capacitors	1	1
1.10 Inductors	1	1
1.11 Transformers	1	1
1.12 Semiconductors	1	1
1.13 Diodes	1	1
1.14 Transistors	1	1
1.15 Tubes	1	1
1.16 Motors	1	1
1.17 Relays	1	1
1.18 Switches	1	1
1.19 Connectors	1	1
1.20 Grounding	1	1
1.21 Shielding	1	1
1.22 EMI/RFI Protection	1	1
1.23 Safety	1	1
1.24 Troubleshooting	1	1
1.25 Appendix	1	1
1.26 Glossary	1	1
1.27 Index	1	1
<b>SECTION TWO: AUDIO</b>		
2.1 Introduction	2	2
2.2 Sound	2	2
2.3 Frequency	2	2
2.4 Amplitude	2	2
2.5 Loudness	2	2
2.6 Pitch	2	2
2.7 Timbre	2	2
2.8 Harmonics	2	2
2.9 Resonance	2	2
2.10 Reflection	2	2
2.11 Refraction	2	2
2.12 Diffraction	2	2
2.13 Interference	2	2
2.14 Standing Waves	2	2
2.15 Acoustic Impedance	2	2
2.16 Sound Power	2	2
2.17 Sound Intensity	2	2
2.18 Sound Pressure	2	2
2.19 Sound Velocity	2	2
2.20 Sound Absorption	2	2
2.21 Sound Reflection	2	2
2.22 Sound Diffraction	2	2
2.23 Sound Interference	2	2
2.24 Sound Standing Waves	2	2
2.25 Sound Resonance	2	2
2.26 Sound Impedance	2	2
2.27 Sound Power	2	2
2.28 Sound Intensity	2	2
2.29 Sound Pressure	2	2
2.30 Sound Velocity	2	2
2.31 Sound Absorption	2	2
2.32 Sound Reflection	2	2
2.33 Sound Diffraction	2	2
2.34 Sound Interference	2	2
2.35 Sound Standing Waves	2	2
2.36 Sound Resonance	2	2
2.37 Sound Impedance	2	2
2.38 Sound Power	2	2
2.39 Sound Intensity	2	2
2.40 Sound Pressure	2	2
2.41 Sound Velocity	2	2
2.42 Sound Absorption	2	2
2.43 Sound Reflection	2	2
2.44 Sound Diffraction	2	2
2.45 Sound Interference	2	2
2.46 Sound Standing Waves	2	2
2.47 Sound Resonance	2	2
2.48 Sound Impedance	2	2
2.49 Sound Power	2	2
2.50 Sound Intensity	2	2
2.51 Sound Pressure	2	2
2.52 Sound Velocity	2	2
2.53 Sound Absorption	2	2
2.54 Sound Reflection	2	2
2.55 Sound Diffraction	2	2
2.56 Sound Interference	2	2
2.57 Sound Standing Waves	2	2
2.58 Sound Resonance	2	2
2.59 Sound Impedance	2	2
2.60 Sound Power	2	2
2.61 Sound Intensity	2	2
2.62 Sound Pressure	2	2
2.63 Sound Velocity	2	2
2.64 Sound Absorption	2	2
2.65 Sound Reflection	2	2
2.66 Sound Diffraction	2	2
2.67 Sound Interference	2	2
2.68 Sound Standing Waves	2	2
2.69 Sound Resonance	2	2
2.70 Sound Impedance	2	2
2.71 Sound Power	2	2
2.72 Sound Intensity	2	2
2.73 Sound Pressure	2	2
2.74 Sound Velocity	2	2
2.75 Sound Absorption	2	2
2.76 Sound Reflection	2	2
2.77 Sound Diffraction	2	2
2.78 Sound Interference	2	2
2.79 Sound Standing Waves	2	2
2.80 Sound Resonance	2	2
2.81 Sound Impedance	2	2
2.82 Sound Power	2	2
2.83 Sound Intensity	2	2
2.84 Sound Pressure	2	2
2.85 Sound Velocity	2	2
2.86 Sound Absorption	2	2
2.87 Sound Reflection	2	2
2.88 Sound Diffraction	2	2
2.89 Sound Interference	2	2
2.90 Sound Standing Waves	2	2
2.91 Sound Resonance	2	2
2.92 Sound Impedance	2	2
2.93 Sound Power	2	2
2.94 Sound Intensity	2	2
2.95 Sound Pressure	2	2
2.96 Sound Velocity	2	2
2.97 Sound Absorption	2	2
2.98 Sound Reflection	2	2
2.99 Sound Diffraction	2	2
2.100 Sound Interference	2	2
2.101 Sound Standing Waves	2	2
2.102 Sound Resonance	2	2
2.103 Sound Impedance	2	2
2.104 Sound Power	2	2
2.105 Sound Intensity	2	2
2.106 Sound Pressure	2	2
2.107 Sound Velocity	2	2
2.108 Sound Absorption	2	2
2.109 Sound Reflection	2	2
2.110 Sound Diffraction	2	2
2.111 Sound Interference	2	2
2.112 Sound Standing Waves	2	2
2.113 Sound Resonance	2	2
2.114 Sound Impedance	2	2
2.115 Sound Power	2	2
2.116 Sound Intensity	2	2
2.117 Sound Pressure	2	2
2.118 Sound Velocity	2	2
2.119 Sound Absorption	2	2
2.120 Sound Reflection	2	2
2.121 Sound Diffraction	2	2
2.122 Sound Interference	2	2
2.123 Sound Standing Waves	2	2
2.124 Sound Resonance	2	2
2.125 Sound Impedance	2	2
2.126 Sound Power	2	2
2.127 Sound Intensity	2	2
2.128 Sound Pressure	2	2
2.129 Sound Velocity	2	2
2.130 Sound Absorption	2	2
2.131 Sound Reflection	2	2
2.132 Sound Diffraction	2	2
2.133 Sound Interference	2	2
2.134 Sound Standing Waves	2	2
2.135 Sound Resonance	2	2
2.136 Sound Impedance	2	2
2.137 Sound Power	2	2
2.138 Sound Intensity	2	2
2.139 Sound Pressure	2	2
2.140 Sound Velocity	2	2
2.141 Sound Absorption	2	2
2.142 Sound Reflection	2	2
2.143 Sound Diffraction	2	2
2.144 Sound Interference	2	2
2.145 Sound Standing Waves	2	2
2.146 Sound Resonance	2	2
2.147 Sound Impedance	2	2
2.148 Sound Power	2	2
2.149 Sound Intensity	2	2
2.150 Sound Pressure	2	2
2.151 Sound Velocity	2	2
2.152 Sound Absorption	2	2
2.153 Sound Reflection	2	2
2.154 Sound Diffraction	2	2
2.155 Sound Interference	2	2
2.156 Sound Standing Waves	2	2
2.157 Sound Resonance	2	2
2.158 Sound Impedance	2	2
2.159 Sound Power	2	2
2.160 Sound Intensity	2	2
2.161 Sound Pressure	2	2
2.162 Sound Velocity	2	2
2.163 Sound Absorption	2	2
2.164 Sound Reflection	2	2
2.165 Sound Diffraction	2	2
2.166 Sound Interference	2	2
2.167 Sound Standing Waves	2	2
2.168 Sound Resonance	2	2
2.169 Sound Impedance	2	2
2.170 Sound Power	2	2
2.171 Sound Intensity	2	2
2.172 Sound Pressure	2	2
2.173 Sound Velocity	2	2
2.174 Sound Absorption	2	2
2.175 Sound Reflection	2	2
2.176 Sound Diffraction	2	2
2.177 Sound Interference	2	2
2.178 Sound Standing Waves	2	2
2.179 Sound Resonance	2	2
2.180 Sound Impedance	2	2
2.181 Sound Power	2	2
2.182 Sound Intensity	2	2
2.183 Sound Pressure	2	2
2.184 Sound Velocity	2	2
2.185 Sound Absorption	2	2
2.186 Sound Reflection	2	2
2.187 Sound Diffraction	2	2
2.188 Sound Interference	2	2
2.189 Sound Standing Waves	2	2
2.190 Sound Resonance	2	2
2.191 Sound Impedance	2	2
2.192 Sound Power	2	2
2.193 Sound Intensity	2	2
2.194 Sound Pressure	2	2
2.195 Sound Velocity	2	2
2.196 Sound Absorption	2	2
2.197 Sound Reflection	2	2
2.198 Sound Diffraction	2	2
2.199 Sound Interference	2	2
2.200 Sound Standing Waves	2	2
2.201 Sound Resonance	2	2
2.202 Sound Impedance	2	2
2.203 Sound Power	2	2
2.204 Sound Intensity	2	2
2.205 Sound Pressure	2	2
2.206 Sound Velocity	2	2
2.207 Sound Absorption	2	2
2.208 Sound Reflection	2	2
2.209 Sound Diffraction	2	2
2.210 Sound Interference	2	2
2.211 Sound Standing Waves	2	2
2.212 Sound Resonance	2	2
2.213 Sound Impedance	2	2
2.214 Sound Power	2	2
2.215 Sound Intensity	2	2
2.216 Sound Pressure	2	2
2.217 Sound Velocity	2	2
2.218 Sound Absorption	2	2
2.219 Sound Reflection	2	2
2.220 Sound Diffraction	2	2
2.221 Sound Interference	2	2
2.222 Sound Standing Waves	2	2
2.223 Sound Resonance	2	2
2.224 Sound Impedance	2	2
2.225 Sound Power	2	2
2.226 Sound Intensity	2	2
2.227 Sound Pressure	2	2
2.228 Sound Velocity	2	2
2.229 Sound Absorption	2	2
2.230 Sound Reflection	2	2
2.231 Sound Diffraction	2	2
2.232 Sound Interference	2	2
2.233 Sound Standing Waves	2	2
2.234 Sound Resonance	2	2
2.235 Sound Impedance	2	2
2.236 Sound Power	2	2
2.237 Sound Intensity	2	2
2.238 Sound Pressure	2	2
2.239 Sound Velocity	2	2
2.240 Sound Absorption	2	2
2.241 Sound Reflection	2	2
2.242 Sound Diffraction	2	2
2.243 Sound Interference	2	2
2.244 Sound Standing Waves	2	2
2.245 Sound Resonance	2	2
2.246 Sound Impedance	2	2
2.247 Sound Power	2	2
2.248 Sound Intensity	2	2
2.249 Sound Pressure	2	2
2.250 Sound Velocity	2	2
2.251 Sound Absorption	2	2
2.252 Sound Reflection	2	2
2.253 Sound Diffraction	2	2
2.254 Sound Interference	2	2
2.255 Sound Standing Waves	2	2
2.256 Sound Resonance	2	2
2.257 Sound Impedance	2	2
2.258 Sound Power	2	2
2.259 Sound Intensity	2	2
2.260 Sound Pressure	2	2
2.261 Sound Velocity	2	2
2.262 Sound Absorption	2	2
2.263 Sound Reflection	2	2
2.264 Sound Diffraction	2	2
2.265 Sound Interference	2	2
2.266 Sound Standing Waves	2	2
2.267 Sound Resonance	2	2
2.268 Sound Impedance	2	2
2.269 Sound Power	2	2
2.270 Sound Intensity	2	2
2.271 Sound Pressure	2	2
2.272 Sound Velocity	2	2
2.273 Sound Absorption	2	2
2.274 Sound Reflection	2	2
2.275 Sound Diffraction	2	2
2.276 Sound Interference	2	2
2.277 Sound Standing Waves	2	2
2.278 Sound Resonance	2	2
2.279 Sound Impedance	2	2
2.280 Sound Power	2	2
2.281 Sound Intensity		

# Curve Tracer

Get the straight dope on your transistors with this useful scope accessory.

**THIS DESIGN WILL** allow the dynamic voltage current characteristics of diodes and transistors to be displayed on the screen of a DC 'scope capable of taking an external X input.

The performance of the unit will not be up to that of a commercial machine. However the unit will give a good indication of the dynamic performance of a wide range of semiconductor devices (as the photograph shows) at a price that is a fraction of commercial equipment.

Construction of the curve tracer is straightforward. Mount all the components on the PCB according to the overlay. The internal layout of our prototype is shown in the photographs. The unit is line powered

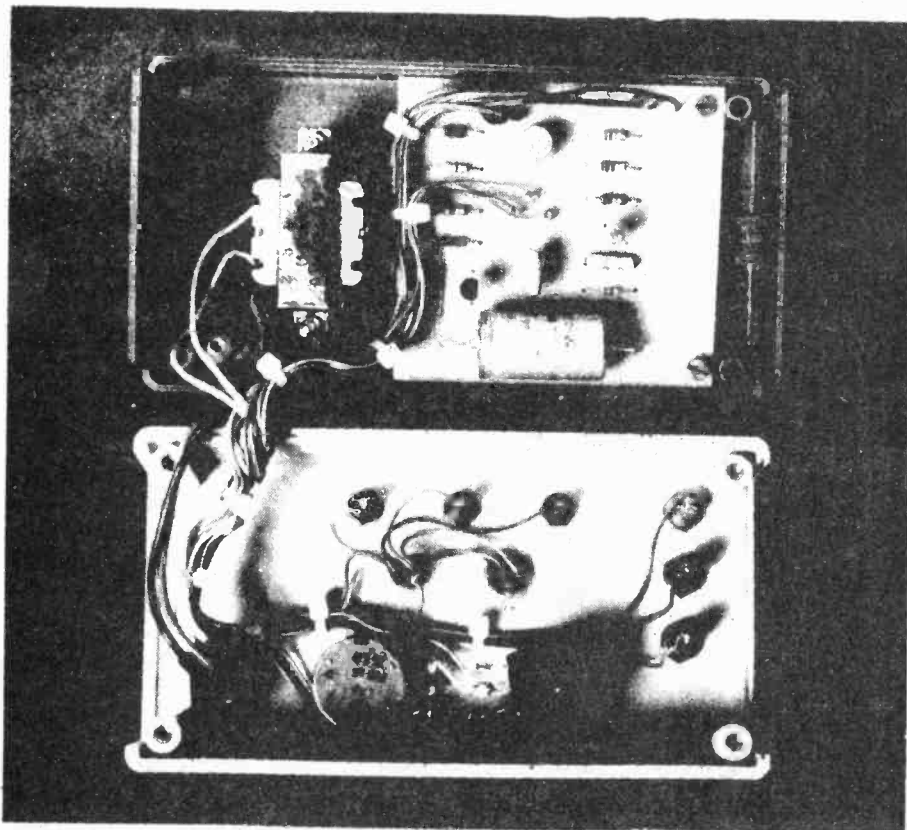
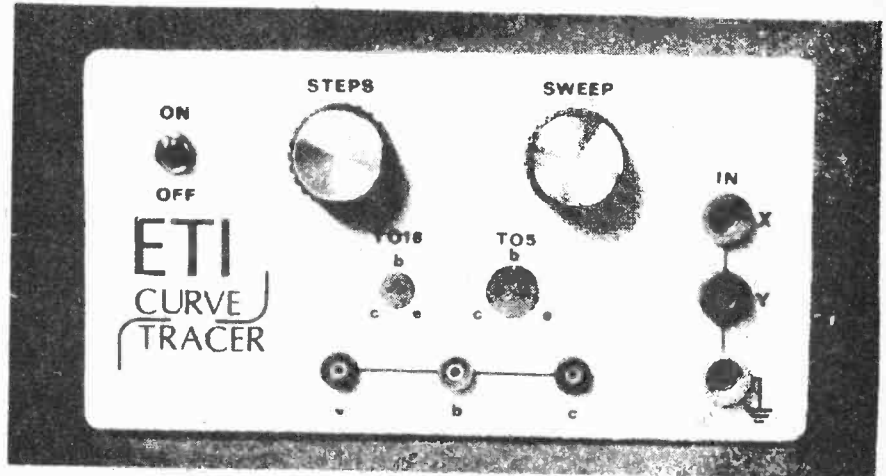

and a battery supply is not suitable for this circuit.

Initially try the curve tracer with a high gain npn transistor, a 2N3904 will be ideal. Connect it to one of the tracer's sockets and connect the unit to the 'scope. Set the Y gain on the 'scope at maximum and set up the maximum required level of collector voltage by adjusting RV1. RV2 will control the number of steps displayed on the screen. The X sensitivity of the 'scope should be 1 V per division.

The performance of the unit is degraded by the slight drop in the DC potential on C1 during the 10 ms sweep and the slight effect of the 100 R sampling resistor, in that its volt drop is included in the observed collector potential.

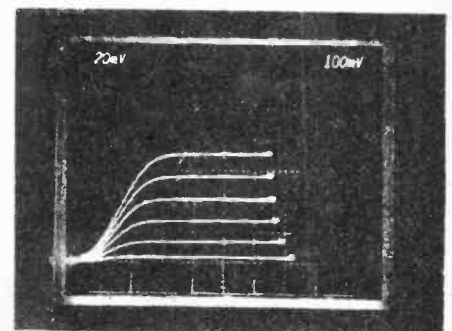

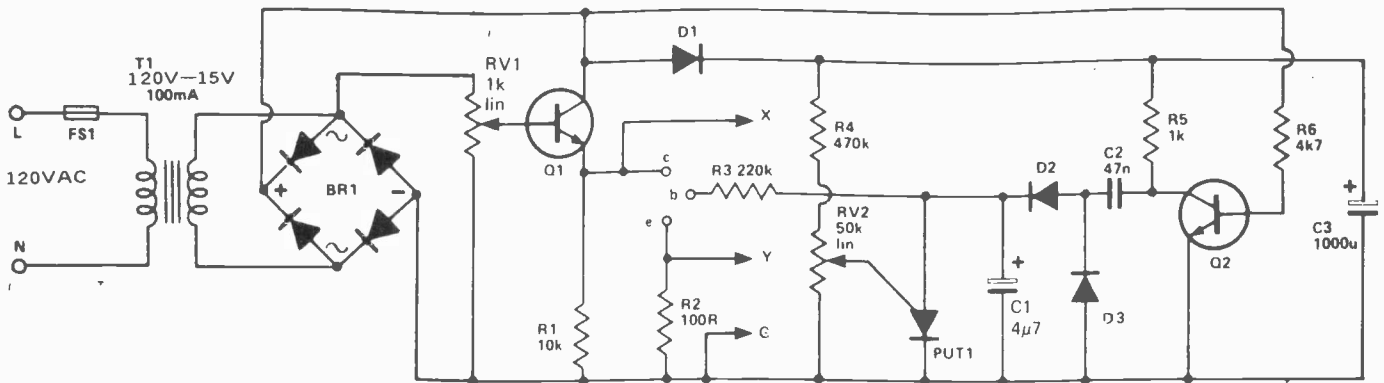

Fig. 1. Full circuit diagram of the curve tracer.

## HOW IT WORKS

The principles of the full circuit can perhaps be best explained by consideration of a simpler form of the circuit. Figs. 2 and 3 show circuits for investigating the dynamic characteristics of a diode and transistor (at fixed base current) respectively.

The 'diode circuit' will, unless an inverter is available, produce a trace that will appear upside down.

Operation of this circuit is quite straight forward. RV1 allows the peak value of the AC supply to be adjusted. This is then applied to the device under test via a current limiting resistor as well as to the X input of the 'scope'. The current flow in the device at any time is proportional to the voltage developed across a low value sampling resistor in the current path. This voltage is fed to the Y input of scope.

The simple transistor tester functions in much the same way. RV1 allows the base current to be adjusted within the range 10µA to 100 mA.

The characteristics of an N-Channel FET (2N3819) may also be examined with this basic building block. The output characteristics are displayed for a gate voltage selected by RV1. Transfer characteristics (gate voltage vs. Drain Current) may be shown by transferring lead X to the gate terminal and joining the 1000µF capacitor to the 15V supply (observing the change in polarity).

Moving now to the full circuit of Fig. 1 that allows a far more informative display providing, as it does, simultaneous displays of the characteristic curves for several equally spaced values of base current.

The circuit operates as follows: Every 10 ms the collector supply swings up and back, over a half cycle of the full-wave rectified supply. At the end of each half cycle, there is a short period during which

the supply potential is below about 0.6 V, and during this time, Q3 turns off, sending a pulse from its collector into the charge store C1 C2 D3 D2. Each pulse increases the potential in C1 by approximately 0.2 V. This would go on until the potential on C1 and 20 V were if not for Q2, the little known and much misdescribed programmable unijunction transistor, PUT. This device is the semiconductor version of a neon lamp, insulating up to a certain p.d. and conducting heavily at potentials above this breakdown value, but with the added advantage that, through a third terminal, this breakdown potential is programmable over quite a wide range. Varying this control potential through the setting of VR2 sets the number of steps that will occur before the potential on C1 is great enough to make Q2 fire, reducing the capacitor's potential to approximately 0.6 V and so re-starting the sweep sequence.

The tracer can hardly be expected to match all the performance of a commercial curve tracer, the prices of which range into thousands of dollars. There are errors, due to the slight droop in d.c. potential on C1, and hence in base current, during the 10ms sweep, and due to the slight effect of the 100R sampling resistor, in that its volt drop is included in the observed collector potential, but as can be seen, these are quite insignificant as regards the final display.

A suitable transistor for the device under test is any reasonably high gain npn transistors, e.g. 2N3904, VR1 controls the maximum collector voltage, whilst VR2 sets the number of sweeps displayed. With the values given, the difference in base current between one step and the next is approximately given by:

$$\frac{1}{SR} \mu\text{A}, \text{ where } R \text{ is in megohms.}$$

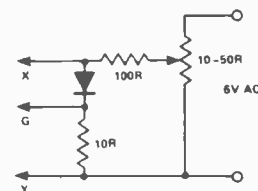

Fig. 2. Simple diode tester.

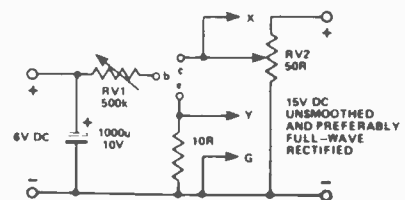

Fig. 3. Fixed current transistor tester.

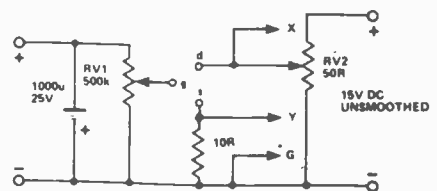
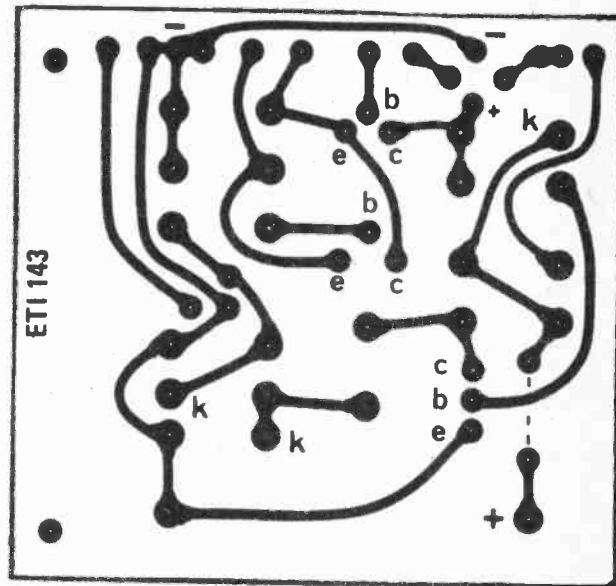

Fig. 4. Circuit for investigating FET transfer characteristics.

**PARTS LIST**

- RESISTORS all 1/4W, 5%
- R1 ..... 10k
  - R2 ..... 100R
  - R3 ..... 220k
  - R4 ..... 470k
  - R5 ..... 1k0
  - R6 ..... 4k7
- POTENTIOMETERS
- RV1 ..... 1k lin
  - RV2 ..... 50k lin
- CAPACITORS
- C1 ..... 4μ7 25V electrolytic
  - C2 ..... 47n polyester
  - C3 ..... 1000 25V electrolytic
- SEMICONDUCTORS
- Q1 ..... 2N2222
  - Q2 ..... 2N3904
  - PUT1 ..... 2N6027
  - D1 ..... 1N4001
  - D2, 3 ..... 1N914
  - BR1 ..... 1 Amp Bridge

MISCELLANEOUS  
 ETI 143 PCB, case to suit, sockets, knobs, cable, etc.



For pcbs for this project, contact Spectrum Electronics, or B&R Electronics, see Classified Advertising Section for addresses.

**FINGERS TO DONUTS**



**KIT 551** **NEW**  
 Photo Reversing Kit  
 for Lifting Off Circuits



This kit may be used to lift off any circuit diagram in a magazine and gives sharp resolution and professional quality negatives. Drafting aids are mounted on a clear layout film over the circuit. This becomes the positive used by the kit to produce a real sharp negative which is then used on boards previously coated with a negative acting resist. This method produces a sharper image than positive resists. The PHOTO REVERSING KIT has 3 sheets of contact film 5 x 8 in., developer, fixer and toner.

**omnitronix Ltd.**

2056 Trans Canada Highway  
 Dorval, Quebec H9P 2N4  
 Telephone: (514) 683-6993

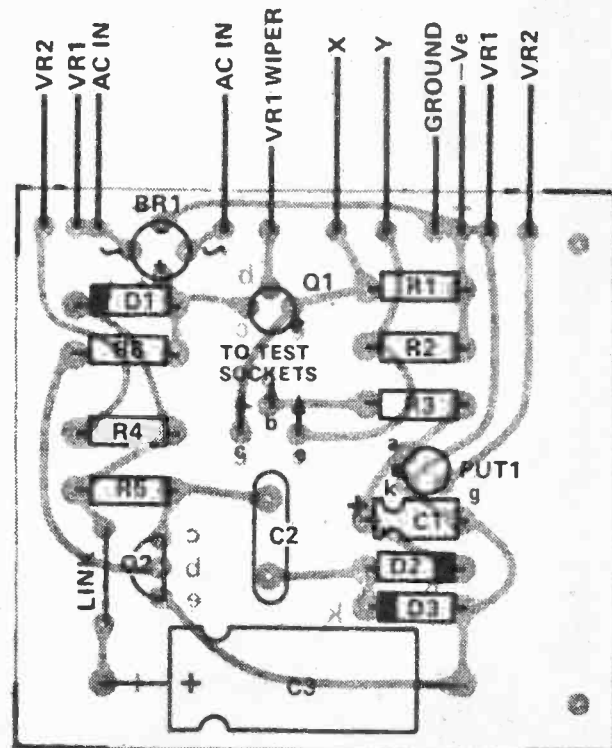



# Active Component Sales Corp.

## MICROPROCESSOR CHIP SETS

Part No.	Price	Part No.	Price
8080A	<del>8.95</del> \$5.95	6800	6.95
8085	12.95	6802	11.95
8212	3.45	6810	3.95
8214	3.95	6820	3.95
8216	3.25	6821	3.95
8224	2.95	6850	4.25
8226	2.25	6852	3.95
8228	3.98		
8238	4.75	SCP1802LE	9.95
8251	5.75	SCP1824LE	3.50
8253	14.95	SCP1852LE	1.50
8255	5.75	SCP1853LE	1.45
8257	10.95	SCP1854LE	6.95
8259	14.95	SCP1856LE	1.95
		SCP1858LE	1.95
		SCP1859LE	1.50

### "TTL"

We are overstocked - SPECIAL OFFER - Major Manufacturer-TTL

7401N	09	Quad 2 Input Nand gate o/c
7430N	16	8 Input nand gate
7437N	19	Quad 2 input nand buffer
7440N	12	Dual 4 input nand buffer
7443N	35	Excess 3 to decimal decoder
7450N	12	Exp. Dual 2 x 2 input and or invert gate
7453N	12	Exp. 4 x 2 input and or invert gate
7460N	12	Dual 4 input expander
7464N	09	4-2-3-2 Input and or invert gate
7465N	09	4-2-3-2 Input and or invert gate o/c
7482N	29	2 Bit binary full adder
74156N	24	Dual 2 to 4 line decoder/demultiplexer o/c
74176N	29	Presetable decade counter
74182N	29	Look ahead carry generator
74195N	29	4 Bit Parallell in. parallell out s/r
74H02N	09	Quad 2 input nor gate
74H03N	09	Quad 2 input nand gate o/c
74H05N	09	Hex/inverter o/c
74H12N	09	Triple 3 input nand gate o/c
74H15N	09	Triple 3 input and gate o/c
74H73N	09	Dual J-K Master slave flip flop
74H65N	09	4-2-3-2 Input and or invert
74H113N	15	Dual J-K neg. edge trig. flip flop
74H114N	15	Dual J-K neg. edge trig. flip flop
74H181N	15	4 Bit arithmetic logic unit

## Texas Instruments Low Profile Sockets

Lowest prices anywhere for the highest quality, an unbeatable combination.

Over one million pieces in stock

Contacts	Price	Contacts	Price
8 PIN	.10	22 PIN	.26
14 PIN	.14	24 PIN	.29
16 PIN	.17	28 PIN	.34
18 PIN	.22	40 PIN	.48
20 PIN	.24		

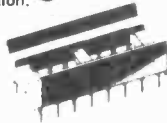

## Metal Power Transistors

Homotaxial - Best Quality

2N3054	.65	60V NPN	TO-66
2N3055	.69	70V NPN	TO-3
2N3442	1.50	160V NPN	TO-3
2N3771	1.95	50V NPN	TO-3
2N3772	1.95	100V NPN	TO-3
2N3773	2.50	160V NPN	TO-3

### Universal SCR

C106D .34 5.0 AMP 400V TO-220

## EPROM'S Special of the Month

C1702A-6 256 x 8 1.5 us \$4.95

C2708 1K x 8 450 ns \$9.95

TMS2716 16K (2K x 8) 450 ns \$34.95 \$29.95  
(3 power supplies) T.I. Version

C2716/TMS2516 16K (2K x 8) 450 ns \$49.95 \$47.95  
(Single 5V supply - Intel version)

1979 IC MASTER 2500 pages "New Special Offer" \$34.95 \$29.95



## VOLTAGE REGULATORS

7800UC Series Positive 1 AMP (TO-220 Plastic) 5.6. 8. 12. 15. 18. 24. Volts \$0.99  
Data Available on Request

### High Current (TO-3)

78H05SC	\$4.92	5 volts/5 amps
78H12SC	\$5.07	12 volts/5 amps
78H15SC	\$5.07	15 volts/5 amps
78P05SC	\$7.56	5 volts/10 amps
78HGKC	\$5.75	5V-24V/5A Positive Adjustable
79HGKC	\$8.32	- 24V to 2 11V/5A Negative Adjustable
SH1605	\$12.22	3V-30V/5A Adj. Step Down Switching
SH1705	\$7.56	5V/5A Fixed Positive

## Zilog

Z8000/1	\$195.00	16 BIT CPU with segmented address space to 8 Megabytes.	
Z8000/2	\$150.00	16 BIT CPU with non segmented address space to 64K bytes.	
Z80-CPU	2.5 Mhz \$9.95	Z80-DMA	2.5 Mhz \$26.85
Z80A-CPU	4.0 Mhz \$11.95	Z80A-DMA	4.0 Mhz \$33.80
Z80-PIO	2.5 Mhz \$7.20	Z80-PIO/O	2.5 Mhz \$36.00
Z80A-PIO	4.0 Mhz \$8.40	Z80A-PIO/O	4.0 Mhz \$39.80
Z80-CTC	2.5 Mhz \$7.20	Z80-810/1	2.5 Mhz \$36.00
Z80A-CTC	4.0 Mhz \$8.40	Z80A-810/1	4.0 Mhz \$39.50
		Z80-810/2	2.5 Mhz \$36.00
		Z80A-810/2	4.0 Mhz \$39.50

## MOS MEMORIES

### MOS Static RAM's

Part No.	Price
2101	<del>\$1.95</del>
1K 22 PIN	
2102LFFC	\$1.19
1K 350NS (Low Power)	
2102-1PC	<del>\$0.94</del>
1K 450NS	
P2111-25	\$2.50
250ns (256 x 4)	
P2112-35	\$2.50
350ns (256 x 4)	
2114	<del>\$5.75</del>
4K (1K x 4) 300NS	

### MOS Dynamic RAM's

Part No.	Price
4K 4027	\$3.50
4K(4K x 1) 300NS 16 PIN	
16K 416-5	\$10.95
16K(16K x 1) 300NS 16 PIN	
TMS4060-30	\$3.95
4K (300NS) 22 PIN	
TMS4060-20	\$4.95
4K (200NS) 22 PIN	

### UART's

Part No.	Price
AY5-1013A	\$4.50
AY3-1015	\$5.50

### 1K CMOS RAM

Part No.	Price
5101	<del>\$3.95</del> \$3.95
450NS (Low Power)	

### 4K CMOS RAM

Part No.	Price
P4315-45L	\$14.95
(4K x 1) 450 NS	

### SHIFT REGISTERS

3341PC	\$4.95	3342PC	\$4.95
3341APC	\$5.95	3347PC	\$4.95

## L.E.D. LAMPS

LED209	T-1 3mm Red	.09
LED211	T-1 3mm Green	.14
LED212	T-1 3mm Yellow	.13
LED220	T-1-3/4 5mm Red	.11
LED222	T-1-3/4 5mm Green	.19
LED224	T-1-3/4 5mm Yellow	.14

### DISPLAYS

MAN74A	300'	Common Cathode	\$0.99
FND357	375	Common Cathode	\$1.45
FND500	500'	Common Cathode	\$1.90
FND507	500'	Common Anode	\$1.90
FND560	500'	Common Anode	\$1.90
FND567	500'	Common Anode (high brightness)	\$1.29
FND567	500'	Common Cathode (high brightness)	\$1.29
DL747	630'	Common Anode	\$2.35
DL704	300'	Common Cathode	\$1.29
DL707	300'	Common Anode	\$1.29

### ISOLATORS

ILQ74	Quad Opto Isolator	1500V	\$3.95
IL1	Opto Coupler	1500V	.49
4N26	Opto Isolator	2500V	.59
MCT6	Dual Opto Isolator	1500V	\$1.29

Prices in this ad are valid only until Nov. 30, 1979

MINIMUM MAIL ORDER \$10.00  
Add \$2.00 to cover postage and handling.

PRICES ARE IN U.S. FUNDS, F.O.B. CANADA.  
Federal and Provincial Sales Taxes Extra.

If payment to be made in Canadian Funds  
an approximate 20% conversion rate will be  
added at time of purchase.

5651 FERRIER ST.  
MONTREAL, QUEBEC  
H4P 2K5  
Tel: (514) 735-6425

4800 OUFFERIN ST.  
OWNSVIEW, ONTARIO  
M3H 5S9  
Tel: (416) 661-1115

BAXTER CENTER  
1050 BAXTER ROAD  
OTTAWA, ONTARIO  
K2C 3P2  
Tel: (613) 820-9471

3070 KINGSWAY  
VANCOUVER, B.C.  
V5R 5J7  
Tel: (604) 438-3321

LARGE INVENTORY AT ALL LOCATIONS.

STORE HOURS:  
Monday to Wednesday 8:30 am - 6:00 pm  
Thursday and Friday 8:30 am - 9:00 pm  
Saturday 9:00 am - 5:00 pm



Active Component Sales Corp.

Circle No. 17 on Reader Service Card.

# Simple 60W Low

The popularity of our first 50 W 'universal' amplifier modules has been very high since they were published two and a half years ago. Since that time the state of the art has moved on. This project, designed by Phil Wait from an original circuit by Trevor Marshall, is intended to replace the ETI 480 and features simpler mechanical construction, low distortion (particularly TID) and generally better performance.

## Distortion Amplifier

MANY DIFFERENT amplifier circuits have appeared in popular electronics magazines over the years.

While these seemed to have satisfied a large demand, our attention has been drawn to the need for something a 'step up' from there — something that approaches the current 'state of the art' for hi-fi equipment. Lower distortion than previously obtained, better bass performance and flexibility was the message we received from reader's letters and kit and component suppliers ("Why don't you . . .", "What I'd like to see . . .", "I need a . . .", etc.).

Late last year we set in motion the 'wheels' necessary to bring this project into fruition.

A great many factors place sometimes quite severe constraints on project design — particularly component availability and ease of construction; not forgetting that this design had to perform significantly better than those that came before it.

There is clearly little point in describing a project that includes components that are impossible to get or one that is difficult to construct.

A strong point that came across to us from reader feedback and from the popularity of our 480 series of amplifiers was that constructors favoured a modular concept. It seems that the days of the single-board stereo amplifier project have come and gone.

This power amplifier offers a significant improvement in specifications

and ease of construction over most kit amplifiers offered to date. It has been designed particularly with low transient intermodulation distortion in mind.

Although a difficult parameter to measure, transient intermodulation distortion is an inherent characteristic of many amplifier designs — especially those which incorporate large amounts

of feedback to even out frequency response and reduce harmonic distortion. The heavy feedback 'school' of design produces an impressive list of specifications — but the difference *to the ear* between such an amplifier and one designed for low TID has to be heard to be believed.

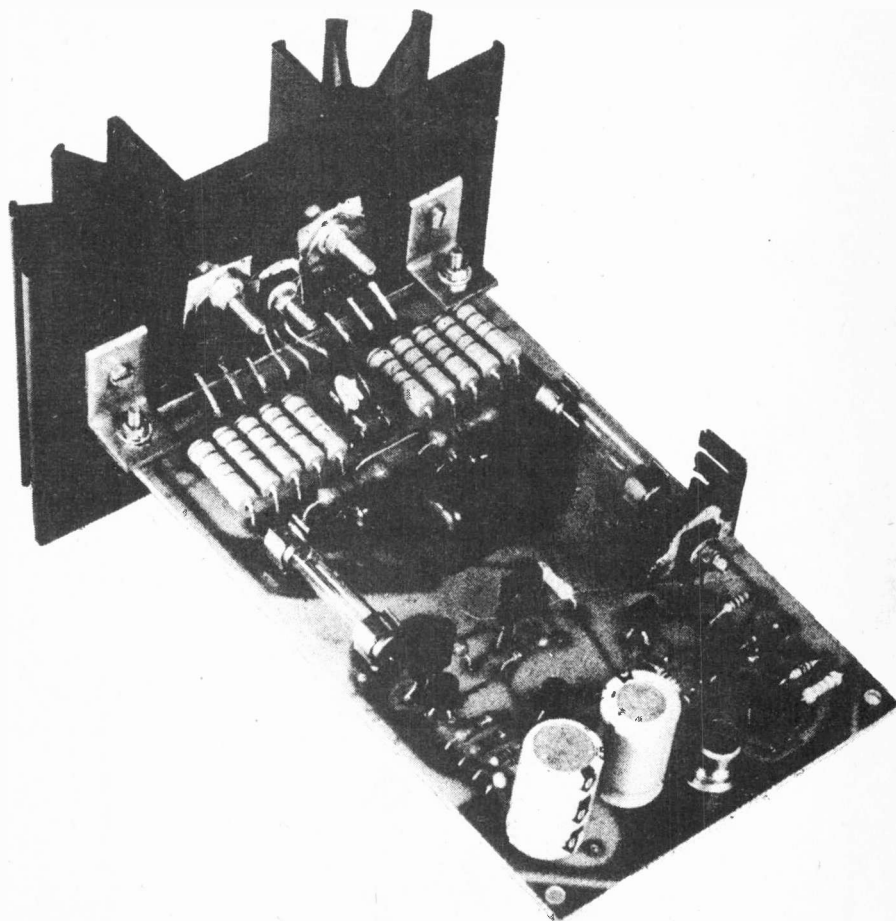

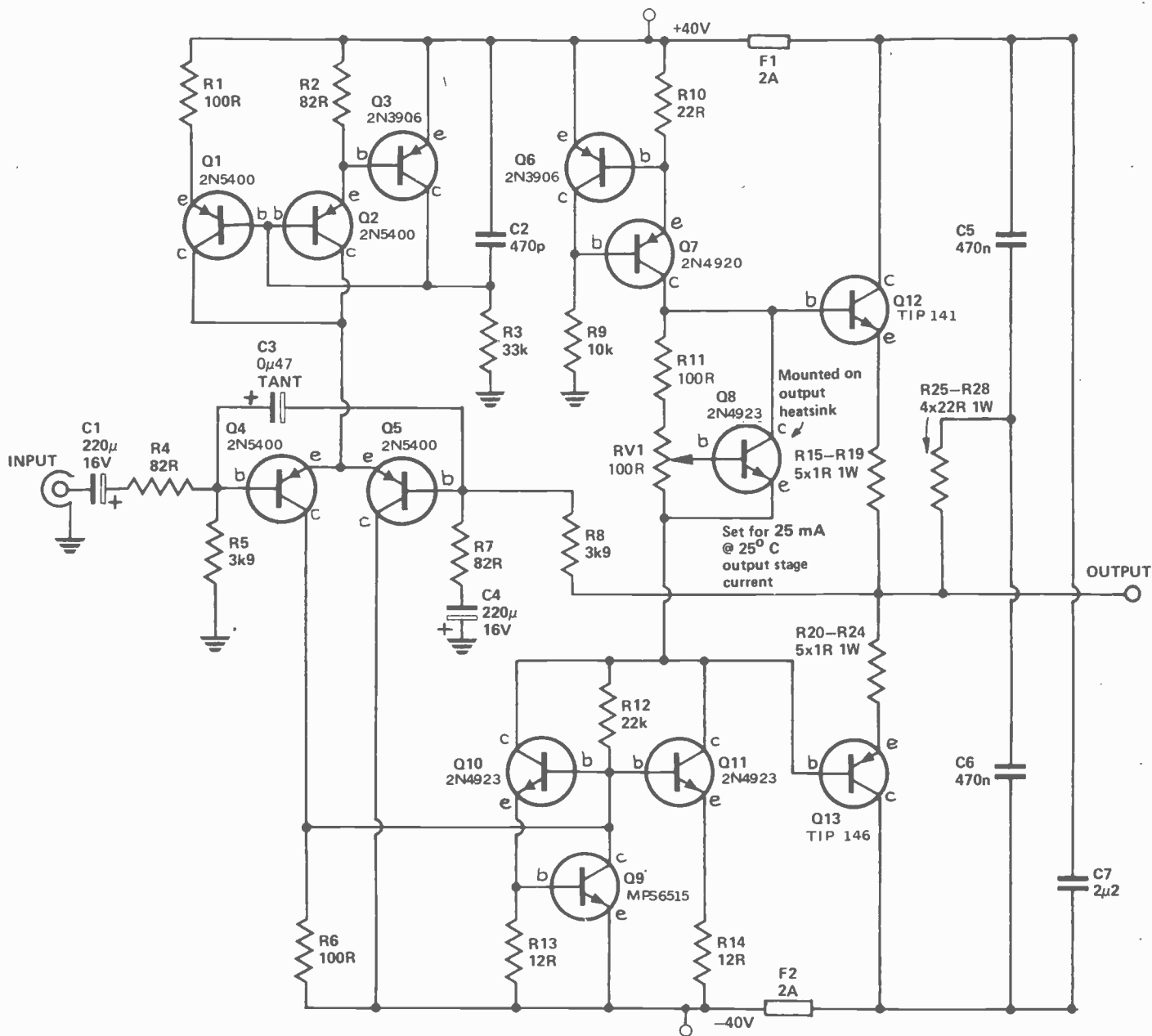

## HOW IT WORKS

The input stage of the amplifier consists of an emitter coupled differential pair (Q4, Q5) with a constant current source (Q1, Q2 and Q3). The use of a constant current source reduces distortion, as well as the possibility of high frequency oscillation and prevents any ripple on the positive supply from unduly affecting the input stage. Unequal emitter resistors (R1, R2) allow the currents in Q4 and Q5 to be optimised. Input lag compensation is provided by C3, limiting the slew rate of the amplifier to reduce high frequency intermodulation. The gain of the differential pair, driving Q10 and Q11, is very low.

Almost all the gain of the amplifier

is obtained from the parallel pair Q10 and Q11. They are operated with series (R13, R14) and shunt (R12) feedback, and a constant current source (Q6, Q7). This results in a highly linear stage.

Q9 protects Q10 and Q11 from high peak currents or damage should a fault occur. When the current through R13 exceeds the safe limit, Q9 conducts and shorts out the drive to Q10 and Q11.

Bias from the output stage is set by RV1 and a shunt regulator (Q8). Q8 is mounted on the same heatsink as the output stages and stabilises the output bias current against heatsink temperature rise. Resistors R15-R24 in the emitters of the output Darlington, Q12 and Q13,

maintain operation in their safe region as well as reducing the chance of thermal run away.

Protection against ultrasonic oscillation is provided by C7 and the network consisting of R25-R28 and C5, C6.

Both DC and AC feedback is taken from the output, via R8, to the negative input of the differential pair, the amount of feedback being set by the ratio of R8 to R7. C4 increases the feedback, and therefore decreases the overall gain, at very low frequencies. The feedback also automatically holds the DC output voltage at close to zero volts.

## Choice of Power Supply

The design of the power supply can mean the success or failure of an otherwise well-designed amplifier. The supply voltage should be well-regulated, varying less than 10% from no load to full load, and be able to supply high peak currents.

However, if a voltage regulator is employed it too must be capable of delivering the very high peak currents occasionally demanded. This necessitates an expensive regulator device and large, expensive filter capacitors.

The alternative is to use a fairly large transformer and large value filter capacitors on a capacitor-input bridge rectifier. This is what we chose.

The circuit given here shows a power supply suitable for supplying a stereo amplifier using two of these modules. The filter capacitors C8 and C9 consist of two 2500  $\mu$ F, 50 volt electrolytic capacitors connected in parallel. This is the minimum we would recommend.

In general, the largest value filter capacitor one can afford is a good rule of thumb! *It has been suggested to us that values as high as 20 000 to 50 000  $\mu$ F makes an audible difference in performance.* (Watch the rectifier specifications though!).

Improved performance can be obtained for a modest increase in cost by having a separate supply for each channel module. This improves the regulation, reduces crosstalk and increases the amount of power available before output clipping commences.

The choice of transformer will determine power output. A 28-0-28 volt, 2A transformer will power a module to 60 watts (RMS) power output, while a 26-0-26 volt, 2 A type will permit 40 watts.

The power supply output should be limited to a peak DC voltage of about 40 volts (for 60 W output). A C-core transformer will generally improve the hum and noise output figures apart from having a reduced field, thereby reducing possible hum pickup problems.

If the amplifier module is to be used with a 4-ohm speaker system the supply voltage must be limited to about 30 volts maximum, otherwise the output devices will attempt to deliver over 100 watts followed by rapid self destruction!

Adventurous constructors may wish to try adding a second set of Darlington output devices, with their own emitter resistors as per the circuit, connected in parallel with the original pair. This combination may supply 100 watts or more into a four ohm speaker load. This technique is also recommended if you are contemplating driving highly

## SPECIFICATIONS

Power Output	60 watts into 8 ohms ( $\mp$ 40V supply)
Frequency Response	10 Hz to 100 kHz $\mp$ 0.5 dB
Input Sensitivity	500 mV rms for 60 W output
Hum and Noise	better than -110 dB on full output (dependent on power supply)
Feedback Ratio	35 dB
Distortion	at 1 kHz, 30 V p-p output into 8 ohms, Closed Loop 0.04 % (open loop 1 %)
Stability:	The amplifier was found to be completely stable when operated into reactive loads consisting of R + C, L + C and pure L
Intermodulation (calculated values)	at 1kHz, 30 V p-p output into 8 ohms, 3rd order less than 0.015 % 5th order less than 0.0023 % (Intermodulation reduces with reduced power)

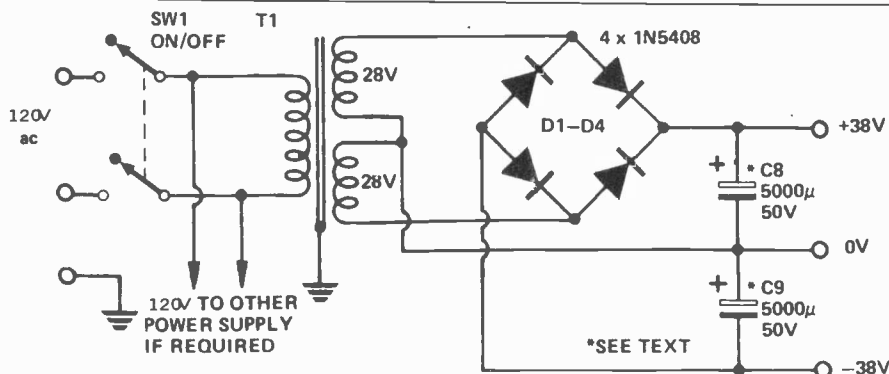

## WHY LOW TID?

Looking at the circuit and a quick glance at the specifications, there's little in the circuit that looks outstandingly different from others. So what makes this amplifier special?

The difference in concept that makes this amplifier unique is the use of a very linear, high gain driver stage (Q10, Q11), with a constant current source (Q6, Q7), so that the gain of *this* stage is dependent upon the input impedance of the output transistors. However, *their* input impedance is dependent upon their gain, and therefore *the gain of the amplifier stage is dependent solely upon the characteristics of the output devices.*

Series and shunt feedback is used with Q10 and Q11 which results in a highly linear stage with a very low input impedance (about 28 ohms). The gain of the differential pair when

fed into this low impedance is close to unity, so almost all the gain of the amplifier is concentrated in Q10 and Q11.

Provided the phase shifts in the differential pair and the gain stage are negligible the feedback loop is unconditionally stable.

There are two other design features which result in low TID.

The total open loop (feedback disconnected) distortion is only 1% at 30 V p-p output. So, very little feedback is necessary to reduce this to an acceptable level.

Protection of the output transistors is done by fuses, rather than electronically, and very high transient currents can be fed to the speaker without being affected by the (inevitably) non-linear impedance of an electronic protection circuit.

# SEMICONDUCTOR PROCUREMENT PROBLEMS?

## LOOKING FOR SPECIAL SOLID STATE DEVICES?

Hard to find Replacements for Unknown Custom Parts Number

Standard Electronics has the answer.

World's largest Supplier of Original Japanese Semiconductors Outside of Japan.

One source for more than 50 semiconductor brands.

### YES! STANDARD IS THE NEW SEMICONDUCTOR SUPERMARKET BUT ONLY TOP QUALITY PARTS IN STOCK

For complete Catalogue and Price List send a Money Order of \$ 2.25 (includes postage). You can obtain a free catalogue with your own letter head. Prices in our catalogue are for your information only; exact prices are available on request.

#### SPECIAL NOVEMBER

##### MOTOROLA SPECIAL

2N 3055 NPN SI EPI-BASE 80V/15A/115W	only 0.99 ea
MJ 2955 PNP SI Complement to 2N 3055	
MOTOROLA	only 1.99 ea
MJ 802 NPN SI 100V/30A/200W	only 4.99 ea
MJ 4502 PNP SI Complement to MJ 802	
MOTOROLA	only 5.99 ea
MJ 2501 PNP Darlington Complement to MJ 3001	only 4.49 ea
MJ 3001 NPN SI Darlington 10A/80V/150W/HFE	
1K min	only 3.99 ea
MJE 6041 PNP Darlington 8A/80V/75W/HFE	
10K max	only 3.99 ea
MJE 6044 NPN Darlington Complement to	
MJE 6041	only 3.69 ea
MJE 1093 PNP Darlington 5A/80V/75W/HFE	
3K min	only 3.89 ea
MJE 1103 NPN Darlington Complement MJE 1093	only 3.59 ea
MJ 1001 NPN Darlington 8A/80V/90W/HFE	
2K TYP	only 3.49 ea
2N 6284 NPN Darlington 20A/60V/160W/HFE	
2400 TYP	only 3.99 ea
2N 6284 NPN Darlington 20A/100V/160W/HFE	
2400 TYP	only 4.49 ea

##### SGS ATE/MOTOROLA SPECIAL

2N 6039 NPN Darlington 4A/80V/40W/HFE 1K min	only 1.09 ea
2N 6036 PNP Darlington Complement 2N 6039	only 1.09 ea

##### GENERAL ELECTRIC SPECIAL

D 40K2 NPN Darlington 50V/2A/10W/HFE 10,000	only 0.89 ea
D 41K2 PNP Darlington Complement to D 40K2	only 0.99 ea

##### MATSUSHITA/PANASONIC SPECIAL

2SA 699 PNP 50V/3A/20W	only 0.49 ea
2SC 1226 NPN Complement to 2SA 699	only 0.45 ea
2SA 564 PNP RF/AF 45V/100mA/250mW/100Mhz	only 0.39 ea
2SC 828A NPN RF/AF Complement to 2SA 564	only 0.30 ea
2SB 512 PNP 60V/4A/40W	only 0.99 ea
2SC 1317 NPN 30V/500mA/500mW/200Mhz	only 0.34 ea
2SC 1567 NPN 100V/500mA/5W	only 0.69 ea
2SC 1853 NPN SI RF/Mix/Osc 30V/50mA/250mW	only 0.29 ea

##### N.E.C. SPECIAL

2SA 643 PNP 60V/1A/1W	only 0.65 ea
2SD 261 NPN 60V/1A/1W	only 0.60 ea
2SC 839 NPN RF/Mix/Osc	
50V/50mA/250mW/300Mhz	only 0.29 ea
2SC 1330 NPN 40V/800mA/500mW	only 0.45 ea

##### SANYO SPECIAL

2SC 693 NPN RF/LN 40V/50mA/100mW NF 8dB/FT	
100Mhz	only 0.29 ea
2SD 325 NPN 40V/2A/25W	only 0.49 ea

##### TOSHIBA SPECIAL

2SC 784 NPN 40V/20mA/100mW/FT 500Mhz	only 0.35 ea
2SC 1569 NPN 300V/200mA/10W TV	
VERTICAL DEFLECTION	only 0.99 ea

##### MES line SPECIAL

MES 12-3AM equivalent to ECG 123A Metal	only 0.49 ea
MES 12-3AP equivalent to ECG 123A Plastic	only 0.45 ea
MES 15-8 equivalent to ECG 158	only 1.39 ea
MES 15-9M equivalent to ECG 159 Metal	only 0.49 ea
MES 17-1 equivalent to ECG 171	only 1.99 ea
MES 18-4 equivalent to ECG 184	only 1.29 ea
MES 18-5 equivalent to ECG 185	only 1.39 ea
MES 18-8 equivalent to ECG 188	only 1.59 ea
MES 19-1 equivalent to ECG 191	only 1.99 ea
MES 19-6 equivalent to ECG 196	only 1.89 ea
MES 19-7 equivalent to ECG 197	only 1.99 ea
MES 19-8 equivalent to ECG 198	only 1.99 ea
MES 29-1 equivalent to ECG 291	only 1.99 ea

##### TTL SPECIAL

7440 Dual 4 input Nand buffer	only 0.39 ea
7450 Exp. Dual 2 x 2 Input or invert gate	only 0.45 ea
7453 Exp 4 x 2 input or invert gate	only 0.39 ea
7460 Dual 4 input expander	only 0.45 ea
7491 8 Bit shift register	only 0.85 ea
7496 5 Bit Universal shift register	only 0.90 ea

##### TTL LOW POWER SCHOTTKY SPECIAL

74LS05 Hex Inverter (Open Collector)	only 1.55 ea
74LS08 Quad 2 input And	only 1.45 ea
74LS30 8input Nand	only 1.25 ea
74LS37 Quad 2 input NAND Buffer	only 1.45 ea
74LS76 Dual J-K Master/Slave Flip Flop	only 2.45 ea
74LS253 Tristate Dual 4 line to 1 line DATA	only 2.55 ea
74LS367 Hex Bus Drivers, True DATA, Tristate,	
4 Bit & 2 Bit	only 1.95 ea
74LS107 Dual J-K Master/Slave Flip Flop	only 1.99 ea
74LS38 Quad 2 input Nand Buffer (open Collector)	only 1.49 ea
Other TTL Low Power Schottky are available in stock.	

##### LINEARS SPECIAL TEXAS INSTRUMENTS

UA 741 CN-8 mini dip OP AMP	only 0.40 ea
LM 324 N Quad OP Amplifier	only 0.79 ea
LM 339N Quad Comporator	only 0.79 ea

##### NATIONAL SEMICONDUCTOR

LM 3065N equivalent to ECG 712	only 2.95 ea
--------------------------------	--------------

##### RCA

CA 3066 equivalent to ECG 728, TV Chroma System	only 5.55 ea
CA 3125E equivalent to ECG 798, TV Chroma	
Demodulator	only 4.95 ea

##### JAPANESE INTEGRATED CIRCUITS SPECIAL TOSHIBA

TA 7205P 5.8W AUDIO Power Amplifier/ CAR RADIO/CB	only 2.99 ea
--	--------------

##### MATSUSHITA/PANASONIC SPECIAL

AN 214Q 4.4W AUDIO Power Amplifier/CAR RADIO	only 2.99 ea
--	--------------

##### N.E.C. SPECIAL

UPC 30C AM Radio Tuner RF Amplifier	only 2.49 ea
UPC 575C2 1.5W AUDIO Power Amplifier	only 2.29 ea
UPC 576H 3.5W AUDIO Power Amplifier Stereo/ CAR RADIO	only 2.49 ea
UPC 1025 4.8W AUDIO Power Amplifier/CAR RADIO	only 2.99 ea

##### R. OHM Corp. SPECIAL

BA 521 Modulator/Audio output/Stereo/CB 5.8W	only 2.99 ea
--	--------------

##### TERMS:

All Parts are subject to prior sale.  
Minimum order \$25.00; postage free  
Quebec residents add 8% Sales Tax.  
All other taxes are included

##### Payment:

Money order or certified check only.  
C.O.D. order are welcome: add \$1.95 postage.  
U.S.A. orders less 15% discount.

**DON'T FORGET OUR SPECIAL  
IN JANUARY'S ETI**

DIVISION OF/DE  
MERIDIAN ELECTRONICS SALES INC.



DIVISION OF/DE  
MERIDIAN ELECTRONICS SALES INC.



QUEBEC CITY DISTRIBUTOR:  
B.G. COMPOSANTES ELECTRONIQUES  
161 QUÉST ST. VALLIER  
QUEBEC CITY, QUEBEC G1K 1J9  
(418) 522-6625



DIVISION OF/DE  
MERIDIAN ELECTRONICS SALES INC.  
8927 boul. Pie IX, Montreal, Que. H1Z 3V3  
tel.: (514) 327-3578  
(514) 327-5958 Telex: 05-828838

TORONTO DISTRIBUTOR:  
JAY SEMICONDUCTORS  
960 ALBANY ST., UNIT 22  
DOWNSVIEW, ONTARIO M3J 2S1  
(416) 661-5237  
Telex: 06-986766

reactive loads such as electrostatic loudspeakers.

### CONSTRUCTION

All components are mounted on a pc board — including the output devices. This method of construction is recommended. The module has been designed so that it is mechanically simple to assemble, much simpler than our ETI 480 module. Wiring errors are also avoided when a pc board is used.

Firstly, assemble and solder all the components on to the printed circuit board with the exception of Q12, Q13 (the output Darlington) and Q8. Carefully observe the polarity of all the electrolytic capacitors and orientation of the transistors.

The board is then mounted hard against the heatsink using small right-angle brackets. Be careful to avoid shorting the ends of the one ohm emitter resistors, R15-19 and R20-24, to the brackets.

Once the board is attached to the heatsink the output Darlington, Q12 and 13, and Q8 may be mounted. Insert them in the pc board and then press them back against the heatsink to form their leads to the right shape. Do not solder their leads yet.

Smear heat conducting compound on either side of the mica insulators (don't use too much though) and insert these between the devices and the heatsink.

Assemble the washers and mounting bolts for these, finally checking with an ohm meter that there is not a short circuit between the metal tags (collectors) of the devices and the heatsink.

The input connection to the module is via a single-hole mounting RCA socket. This is mounted directly on the pc board. The centre pin connects to C1 via a short length of tinned copper wire.

If this facility is not required the RCA socket may be omitted and a length of shielded cable soldered directly between C1 and the pc board common.

The power supply and speaker connections are soldered directly to the appropriate copper lands on the underside of the pc board.

The ground side of the speaker must be returned directly to the zero volt connection of the power supply, as close to the filter capacitors as possible (preferably direct to the negative terminal). Do not connect this side of the speaker to the amplifier board.

### PARTS LIST

**Resistors** all ¼W, 5%, except R15-R28

R1	100R
R2	82R
R3	33k
R4	82R
R5	3k9
R6	100R
R7	82R
R8	3k9
R9	10k
R10	22R
R11	100R
R12	22k
R13, 14	12R
R15-R24	1R 1 watt
R25-R28	22R 1 watt

#### Potentiometer

RV1	100R mini trimpot (vertical)
-----	------------------------------

#### Capacitors

C1	220µ 16V electrolytic
C2	470p ceramic
C3	0µ47 35V tant
C4	220µ 16V electrolytic
C5, 6	470n mylar
C7	2µ2 mylar

#### Semiconductors

Q1, 2	2N5400
Q3	2N3906
Q4, 5	2N5400
Q6	2N3906
Q7	2N4920
Q8	2N4923
Q9	MPS6515
Q10, 11	2N4923
Q12	TIP141
Q13	TIP146

#### Miscellaneous

SK1	single hole, panel mounting RCA socket.
F1, F2	2 Amp 3AG Fuses.
Fuse holders, heatsink for Q7, mica insulating kits (for Q8, Q12 and Q13), flat sided heatsink (75mm x 110mm), angle brackets, ETI 470 pcb.	

#### Parts List for Power Supply

D1-D4	IN5404 or sim
C8, 9	5000µ 50V electro (see text)
SW1	120V Dpdt switch
T1	28V-0V-28V, 2 amp transformer

For pcbs for this project, contact Spectrum Electronics, or B&R Electronics, see Classified Advertising Section for addresses.

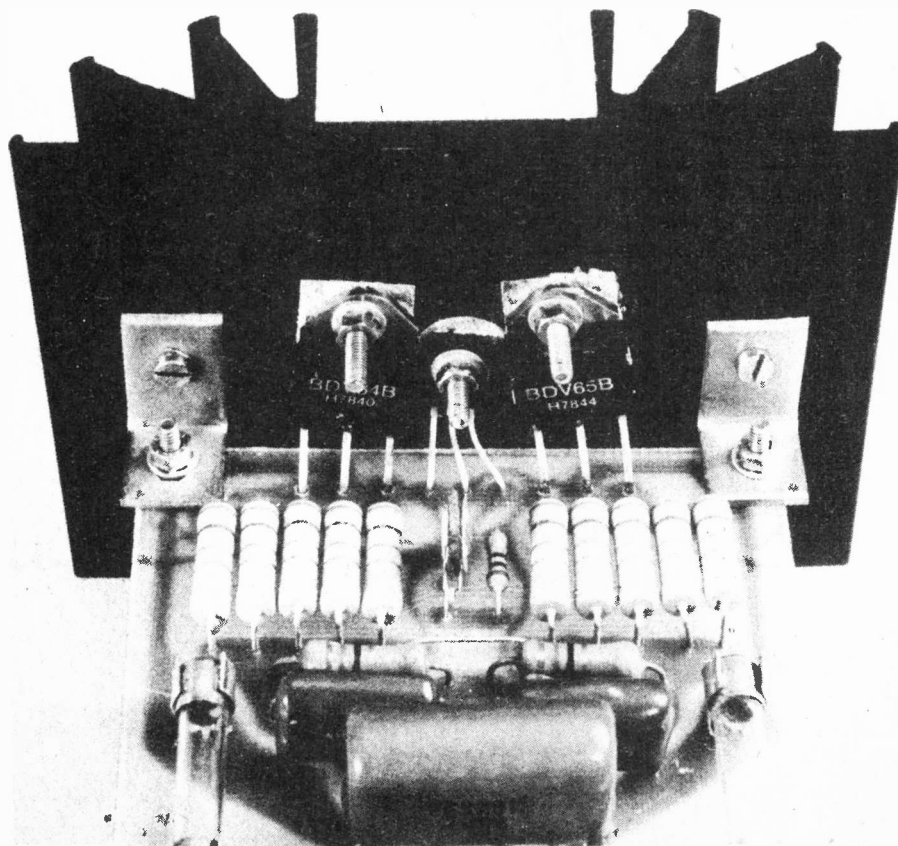

Left: closeup view of the output stage showing how the Darlington transistors are mounted and how the pc board attaches to the heatsink

# Everybody's making money selling microcomputers. Somebody's going to make money servicing them.

**New NRI Home Study Course Shows You How to Make Money Servicing, Repairing,  
and Programming Personal and Small Business Computers**

Seems like every time you turn around, somebody comes along with a new computer for home or business use. And they're being gobbled up to handle things like payrolls, billing, inventory, and other jobs for businesses of every size... to perform household functions like budgeting, environmental systems control, indexing recipes, even playing games.

## **Growing Demand for Computer Technicians... Learn in Your Spare Time**

Even before the microprocessor burst upon the scene, the computer industry forecast over a 100% increase in job openings for the decade through 1985. Most of them *new* jobs created by the expanding world of the computer. NRI can train you at home to service both microcomputers and their big brothers. Train you at your convenience, with clearly written "bite-size" lessons that you do evenings or weekends without quitting your present job.

## **No Experience Needed**

You don't need prior training in electronics or computers to take this exciting new course. NRI starts you with the basics, gives you a firm foundation to build on. And your personal counselor is always available, ready to help whenever you have questions.

## **Assemble Your Own Microcomputer**

NRI training also includes plenty of practical experience. You perform



meaningful experiments building and studying circuits on the NRI Discovery Lab.<sup>®</sup> Then you build your own test instruments like a transistorized volt-ohm meter, CMOS digital frequency counter... equipment you learn on, use later in your work.

And you build your own microcomputer, the only one designed for learning. It looks and operates like the finest of its kind, actually does more than many commercial units. But NRI engineers have designed components and planned assembly so it demonstrates important principles, gives you working experience in detecting and correcting problems. It's the kind of "hands-on" training you need to repair and service units now on the market.

## **Rush Card for Free Catalog**

Send the postage-paid card today for our 100-page, full-color catalog. It describes NRI's new Microcomputer Technology Course in detail, shows all equipment, kits, and lesson plans. And it also tells about other NRI courses... Complete Communications with 2-meter transceiver... TV/Audio/Video Systems Servicing with training on the only designed-for-learning 25" diagonal color TV with state-of-the-art computer programming. With more than a million students since 1914, NRI knows how to give you the most in home training for new opportunity. If card has been removed, write to:

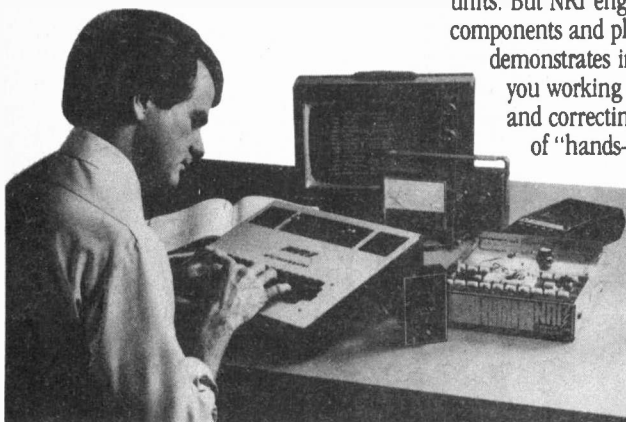

**NRI Schools**  
McGraw-Hill Continuing  
Education Center  
330 Progress Avenue  
Scarborough, Ontario M1P 2Z5  
or telephone 416-293-1911

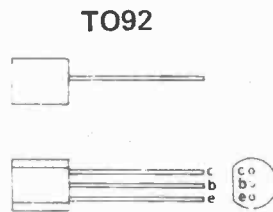
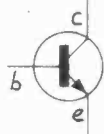
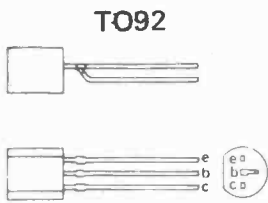
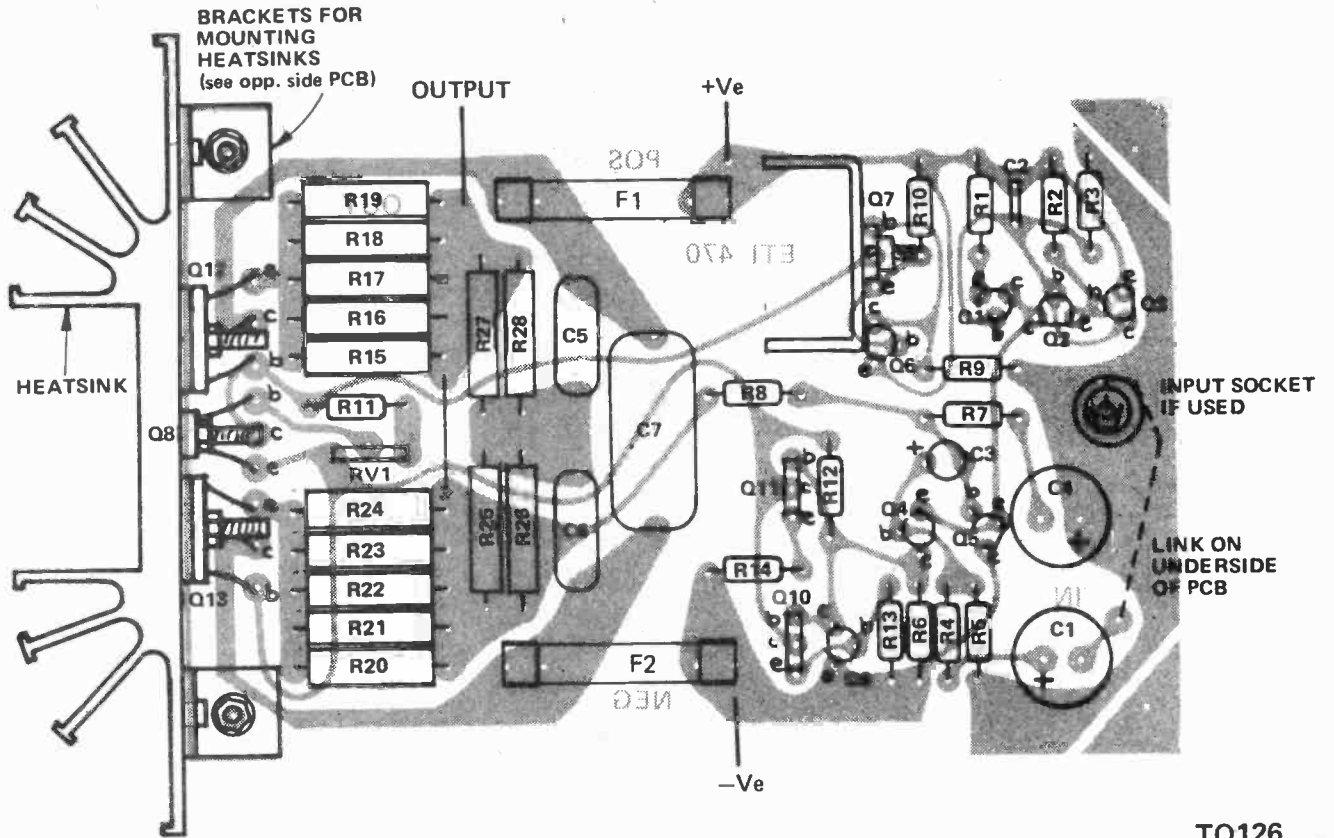

TO126  
2N4923  
2N4920

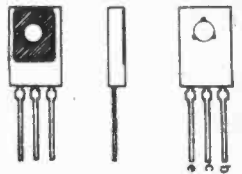

Check pinouts of your TO-92 transistors before using.  
Follow e-b-c lettering on positioning diagram.

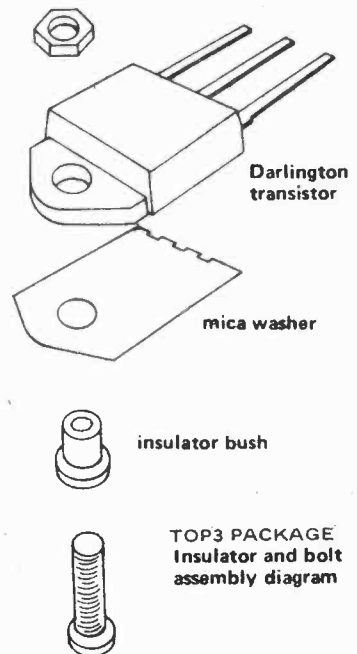
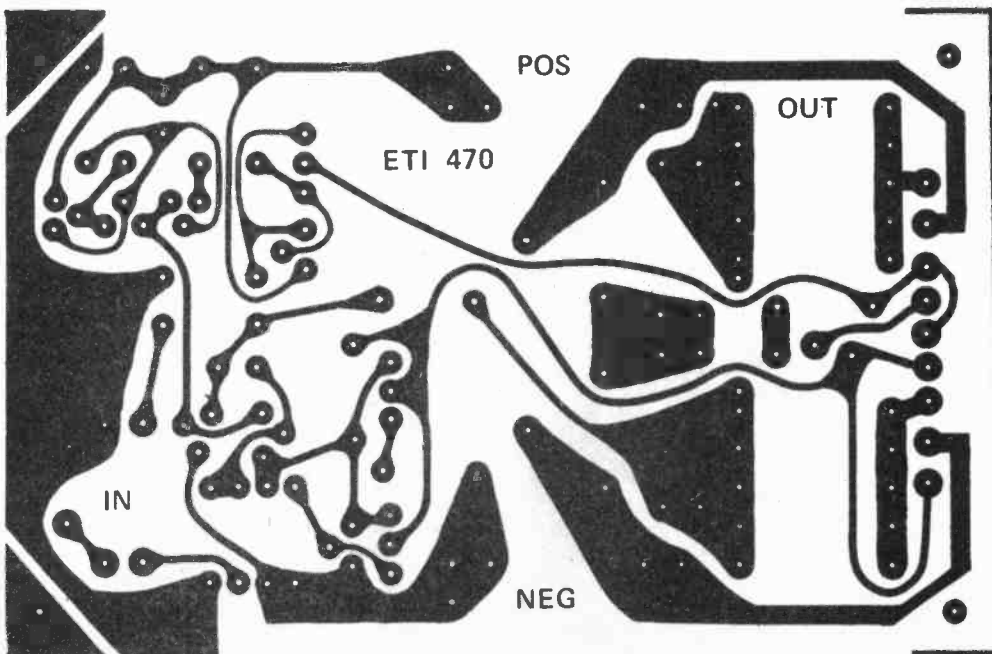



# Simple 60W Low Distortion Amplifier Module

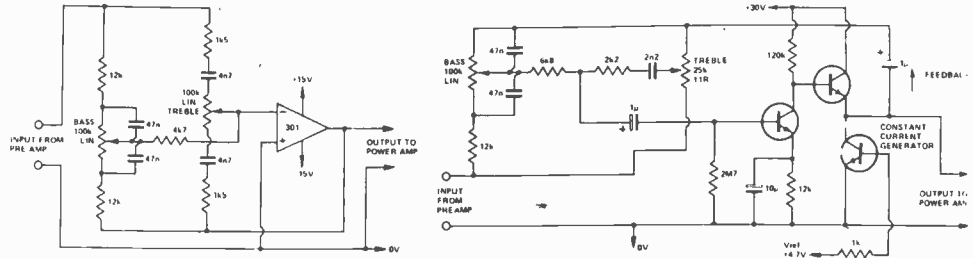

Two suggested tone control circuits for a preamp to suit this module. Low output impedance is an important consideration. Choice of discrete or IC circuitry is given, all transistors, 2N3904

## COMPONENTS

Most semi-conductors are available from Future Electronics and similar suppliers.

The only difficulty might arise finding the 2N4920 & 2N4923 transistors. These are available from Electrosonic. The TIP 29 & TIP 30 will work but the leads are backwards. Remember, it is imperative that Q8 is mounted on the heatsink. In this respect the lead geometry is critical.

There are two varieties of TO 92 small signal transistors available. We have given drawings for both. Verify the leads before soldering them in.

## HEATSINKS

Heatsinks on any amplifier are a compromise between cost and temperature rise.

Unless you are going to play long passages of organ music, or run a disco, you will probably find that relatively small heatsinks run quite cool.

However, Darlington transistors are hard to temperature stabilise and should be run as cool as possible. This is why we have opted for a fairly large heatsink compared to other designs. The transistors should be bolted directly to the heatsink, not through a steel chassis. A slit could be cut in a chassis large enough to slide the assembled amplifier through the rear. Heatsink fins should always be vertical to provide the most efficient convection cooling.

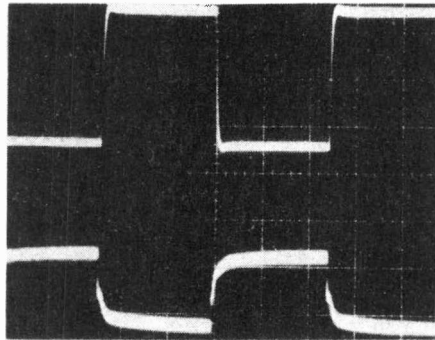
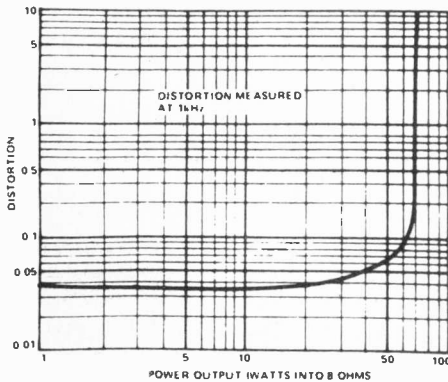

Operation into severely reactive loads was examined by looking at the ac component of the Vbe of Q10 as a measure of the 'overshoot' of the loop and to see if transient overload occurred.

f = 1 kHz. CRO is 0.2 mS/div. Output is 30 V into 8 ohms.

Upper trace 10 V/div. Output into 8 ohms.

Lower trace 10 mV/div. Vbe of Q10, Q11 gain stage. No evidence of transient overload was visible.

The heatsink recommended for the output devices in this project is a flat-sided type with radial fins, 75 mm in length. Other flat-sided types are available with straight fins, and these too would be suitable. A similar length should be used. In general the heatsink should have a thermal resistance, mounting surface to ambient, of around 1°C per watt.

A small 'flag' heatsink is attached to Q7, a 2N4920 flappack transistor. A commercial heatsink may be employed (they're only about 60 cents) or a small strip of aluminium may be bent up, drilled, and bolted to the transistor. See that the metal area of the 2N4920 and a face of this heatsink are in contact. Heatsink compound should be used.

## SETTING UP

Once the amplifier has been assembled and carefully checked, the bias current for the output devices must be set. Remove the fuses, F1 and F2 and connect a 100 ohm resistor across each fuse holder. Remove any input signal. Connect the power supplies and measure the voltage drop across each of these resistors. Adjust the trim pot RV1 for a reading of 2.5 volts across each resis-

## PULSE TESTING

tor. This corresponds to a bias current of 25 mA. The reading should be nearly the same across each resistor. Next check that there is no DC voltage across the output terminals.

If the reading across each of the resistors cannot be adjusted, or if there is a DC voltage across the output greater than one volt then there is a fault and the fuses should not be inserted.

If all is well, remove the two resistors and insert the fuses. Connect the speaker and away you go.

## Preamp Considerations

The input impedance of this amplifier is relatively low, falling at very high frequencies. Consequently, it must be fed from a low impedance source.

When driving the amplifier with a preamp-tone control unit, the output is best taken from an emitter follower circuit (to provide the required low source impedance) or directly from the output of an operational amplifier. In either case, it *must* be taken from the point where the output is fed back to the tone control circuitry.

Two suggested tone control circuits suitable for the application are illustrated in Figure 5. Both use a 'Baxandall' type tone control network with feedback derived from the output point.

The circuit at right uses discrete components which may suit some constructors better. The left circuit, using a commonly available op-amp, has higher distortion than the discrete circuit.

A preamp-control unit project to suit the amplifier module will be described in a forthcoming issue along with details of how to construct a complete stereo amplifier system of high quality.

# Model Train Controller

A simple project offering auto-reverse, inertia, emergency brake and loop track facilities.

MODEL TRAINS HAVE ALWAYS BEEN popular with both lads and dads — with dads perhaps coming first. Many a boy has complained "Daddy won't give me a turn". It seems there is some inexplicable attraction in playing trains which never dims with the passing years. A couple of our friends have recently decided to buy train sets — for the kids (they say). Our model train controller project was designed to give them many features that are not found in commercially available controllers (for roughly the same cost). Most commercial devices cost around \$30 and consist of a transformer followed by a selenium rectifier, a high power rheostat and an carlight bulb. Such controllers have numerous operating disadvantages mainly due to their very poor voltage regulation.

**Our controller** It may look a little complex but in fact it is very simple to build and quite inexpensive. If the full capability is used the features of the controller are:

- Forward or reverse control by a single slide potentiometer (centre for stop)
- Separate reversing switch for the main track
- Short-circuit proof
- Regulator-type control circuitry
- Emergency brake (which stops the train instantly regardless of the position of other controls)
- Simulated inertia (gives more realistic starts and stops)
- The facility to operate with track loops

**Loop operation** Although not possible with simple controllers, loop operation adds much operating fun and realism to any model railroad and the feature is well worth including. A typical loop is shown in Fig. 1, and the operational problems of such a loop are as follows:

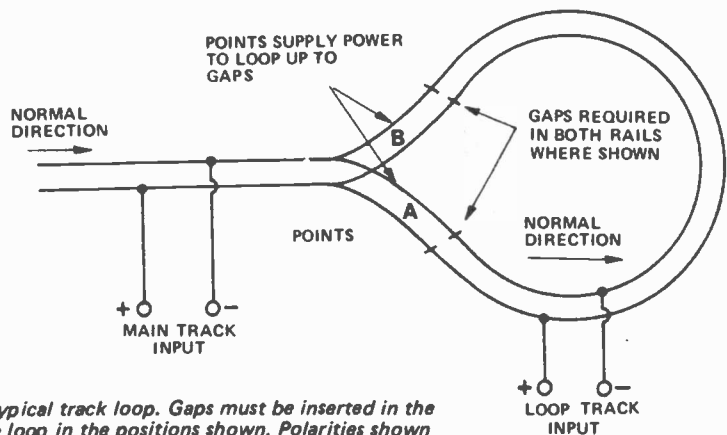

Fig. 1. A typical track loop. Gaps must be inserted in the rails of the loop in the positions shown. Polarities shown are with MAIN and LOOP track switches in the normal position.

If a train is approaching the loop and the 'main' and 'loop' switches are both set at normal, the polarity of the voltages to the track will be as shown. If the

points are set so that the train enters the loop towards 'A' it will continue normally around the loop. If the points are now set to 'B' so that the train may



# MOTOROLA

The MEK6802D3 Microcomputer Module is the heart of the new educational/evaluation product series, the MOKEP Family.

The MEK6802D3 is a self-contained system, utilizing an on-board hexadecimal keypad and an 8-digit LED display, and based on the MC6802 micro-processor and MC6846 ROM/IO/Timer combination. On-board RAM includes 128 bytes in the MC6802, 128 bytes of Stack in one MCM6810 and 128 bytes in a second MCM6810 which may be configured as Stack or User space. A full 2K firmware package is also included. The module has provision for expansion – a ROM socket is available for firmware supplied with some of the optional modules.

The module operates from a single 5-volt power supply. Maximum current required is 1 ampere.

Unit price is \$231.00

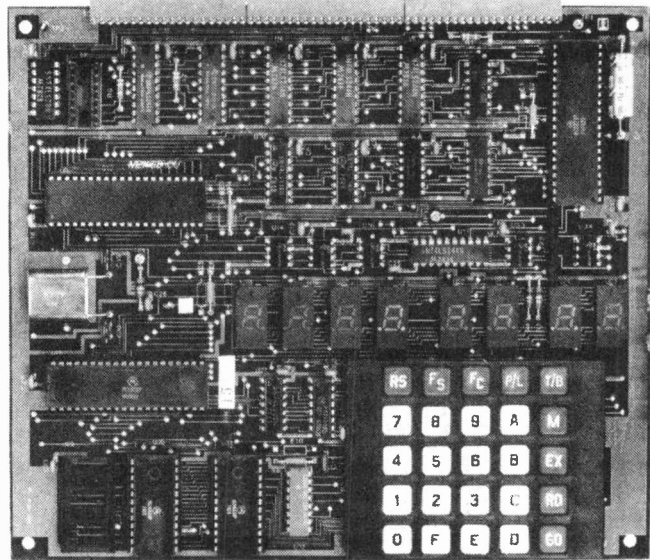

MEK6802D3

The MEK6802D3C Module is the same product without the keypad, display, and associated drivers. Unit price is \$165.00  
EDITOR AND ASSEMBLER AVAILABLE. BASIC COMING.

ACCESSORY MODULES		
Part Number	Description	Unit Price
MEK68MM32	32K-byte, hidden-refresh, dynamic RAM module*	\$495.00
MEK68MM16	16K-byte, hidden-refresh, dynamic RAM module*	\$363.00
MEK68RR	ROM/RAM module, up to 8K static RAM plus eight ROM/EPROM sockets. (1K static RAM provided with module.)*	\$211.20
MEK68R2M	Programmable CRT interface module*	\$264.00
HARDWARE OPTIONS		
MEK6800AB	Adapter/Motherboard for use with MEK6800D2	\$116.16
MEK68MB5	Motherboard with 5 populated slots and 5 sets of stand-alone card guides.	\$118.80
MEK68CC	Card cage for use with MEK68MB5	\$ 99.00
MEK68CMB	Card cage and 10-slot motherboard	\$198.00
MEK68WW	Wirewrap module for use with MEK6800AB*	\$ 66.00
MEK68WW1	Wirewrap module for MEK68MB series*	\$ 66.00

\*indicates assembled module

MOKEP is a trademark of Motorola Inc.

AVAILABLE THROUGH LOCAL MOTOROLA DISTRIBUTORS IN VANCOUVER, EDMONTON, CALGARY, WINNIPEG, TORONTO, LONDON, HAMILTON, OTTAWA, MONTREAL, QUEBEC CITY.



## MOTOROLA

Semiconductor Products Canada  
A Division of Motorola Elect. Sales Ltd.

490 Norfinch Drive  
Downsview, Ontario  
M3N 1Y4  
(416) 661-6400

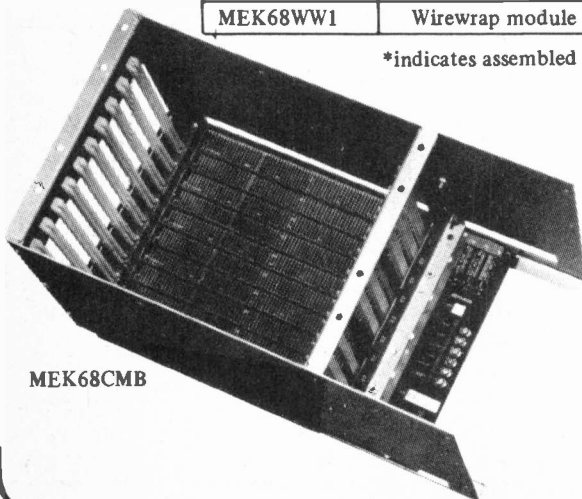

MEK68CMB

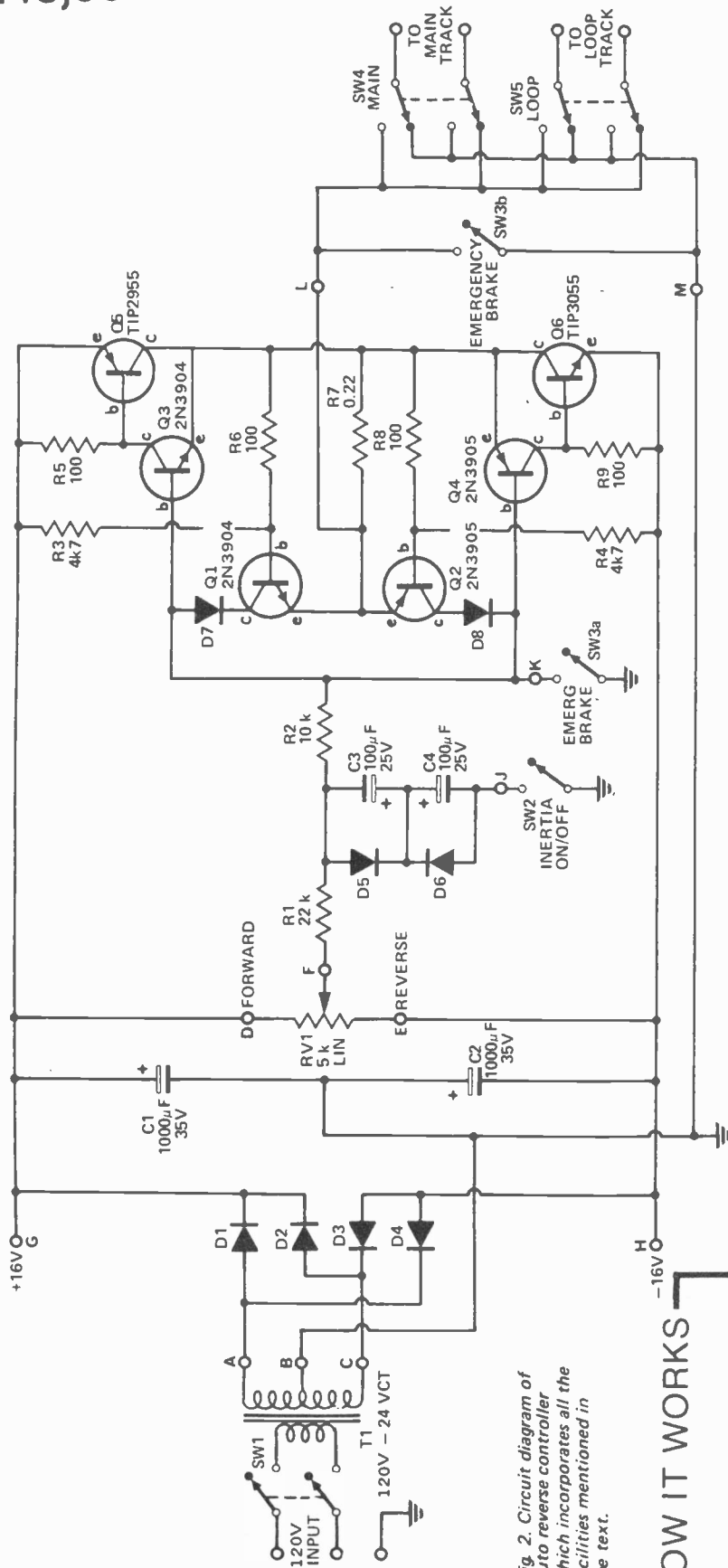

Fig. 2. Circuit diagram of auto reverse controller which incorporates all the facilities mentioned in the text.

### HOW IT WORKS

Transformer T1 reduces the 120V line voltage to a supply of 24 volts (centre tapped) which is then rectified by D1 to D4 to provide supplies of +16 and -16 volts d.c. The speed control potentiometer is connected between these supplies so that its wiper may select any potential between plus and minus 16 volts, depending on setting.

The output of the potentiometer must be well buffered before it can supply enough power to run a train. This is achieved by transistors Q3 and Q5, for the forward direction (that is for output voltages between zero and +15 volts), and by Q4 and Q6, for the reverse direction (that is for output voltages between zero and -15 volts). The output voltage at the collectors of Q5 and Q6 will be about 0.6 volts closer to zero than the voltage at point 'K' (providing the voltage at point 'K' is more than 0.6 volts away from zero). This means that the control

### PARTS LIST

Resistors			
R1	22 k	½ W	5%
R2	10 k	"	"
R3,4	4 k7	"	"
R5,6	100 ohm	"	"
R7	0.22 ohm	5 W	"
R8,9	100 ohm	½ W	"
RV1	5 k lin 45 mm slide potentiometer		

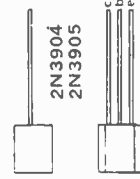
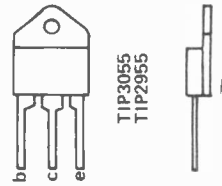

potentiometer will have a small dead band in the centre of its travel where the output voltage remains at zero. This is an advantage because it is frequently necessary to set the controller for exact zero output.

To protect the transistors from damage in the event of an overload or a short circuit, transistors Q1 and Q2 are used to monitor the output current (by measuring the voltage across R7) and the voltage across the output transistors. By this method the power dissipation in the output transistors is controlled such that when driving into a short circuit only about one ampere is available. Yet when set to about 12 volts, about two amps is available to drive normal loads. The diodes D7 and D8 are included to protect the transistors Q1 and Q2 against reverse bias which can occur under certain conditions.

To add the 'inertia' facility or 'momentum', as it is sometimes called, the control voltage from RV1 is filtered by C3 and C4. This means that if the potentiometer is suddenly moved from stop to full forward (for example) the voltage applied to the transistor buffer rises only slowly. The train accelerates at a realistic rate without wheel spin. A similar action takes place when the train is stopped. If the controller is moved from full forward to full reverse the train will slow down and stop for a short time and then start off and increase speed in the reverse direction. The diodes D5 and D6 allow normal electrolytics to be used in this position.

If inertia is being used and an emergency situation occurs, eg train moving into a siding that it should not be entering, the brake facility may be used to short the track (SW3b) and also the input to the buffer stage (SW3a). The brake over-rides the speed control and by its use the train will be stopped in a much shorter distance than it would if the power were simply switched off.

When loops in the track system are used, as described in the introduction, a separate reversing switch is used to control the polarity in the loop with respect to the main line so that the train may go into and come out of the loop without any change in speed. The two controller outputs required for this mode of operation must each be reversible and this is performed by SW4 and SW5.

If a second controller is required for another train in the system then it may be built without the power supply. The second controller may be powered by linking the +16, 0 and -16 volt lines between the two controllers.

### Capacitors

- C1,2 1000  $\mu$ F 35 V pc mounting electro
- C3,4 100  $\mu$ F 25 V pc mounting electro

### Transistors

- Q1, 3 2N3904
- Q2, 4 2N3905
- O5 TIP 2955 \*
- O6 TIP 3055 \*
- \* with insulation kit

### Diodes

- D1-D4 100PIV, 3A power diodes
- D5-D8 1N34

### Miscellaneous

- PC board ETI 541
- Transformer 120v to 24VCT@1A
- SW1 toggle switch DPDT 240 V rated
- SW2 toggle switch SPDT
- SW3-SW5 toggle switch DPDT
- Plastic box 196x113x60 mm
- 12 Pc board pins
- line cord
- Heatsink/support to Fig. 8.
- 8-way connector strip
- 2-way connector strip
- 2 6BA c/s screws & nuts 10 mm long
- Front panel (Scotchcal)

### FOR MANUAL REVERSE CONTROLLER

- Delete R4, R8 and R9
- C2 and C3
- Diodes D3-D8
- Transistors Q2, 4 and 6

If no loops are involved in the track layout SW4 and SW5 can be deleted on automatic reverse controller and SW5 on manual reverse controller.

For a second controller delete T1, SW1, D1-D4 and the power cord in the second controller.

For pcs for this project, contact Spectrum Electronics, or B&R Electronics, see Classified Advertising Section for addresses.

## ETI 541

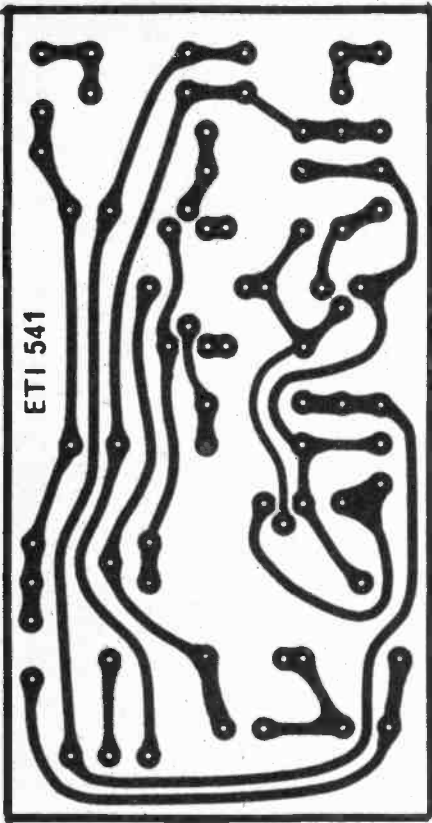

Printed-circuit board layout ETI 541 train controller. Full size 65 x 105 mm.

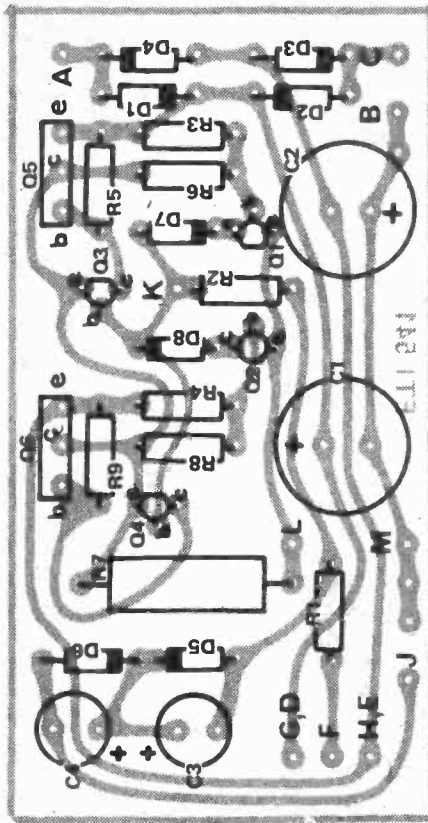

Fig. 3. Component overlay - auto reverse controller.

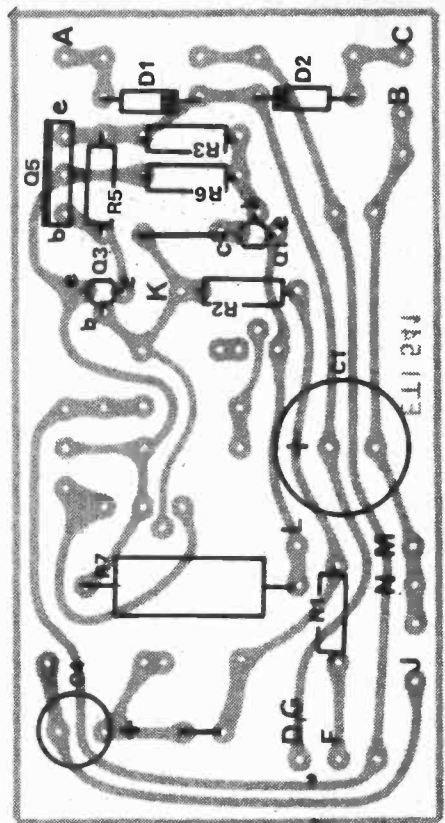

Fig. 4. Component overlay - simple controller.

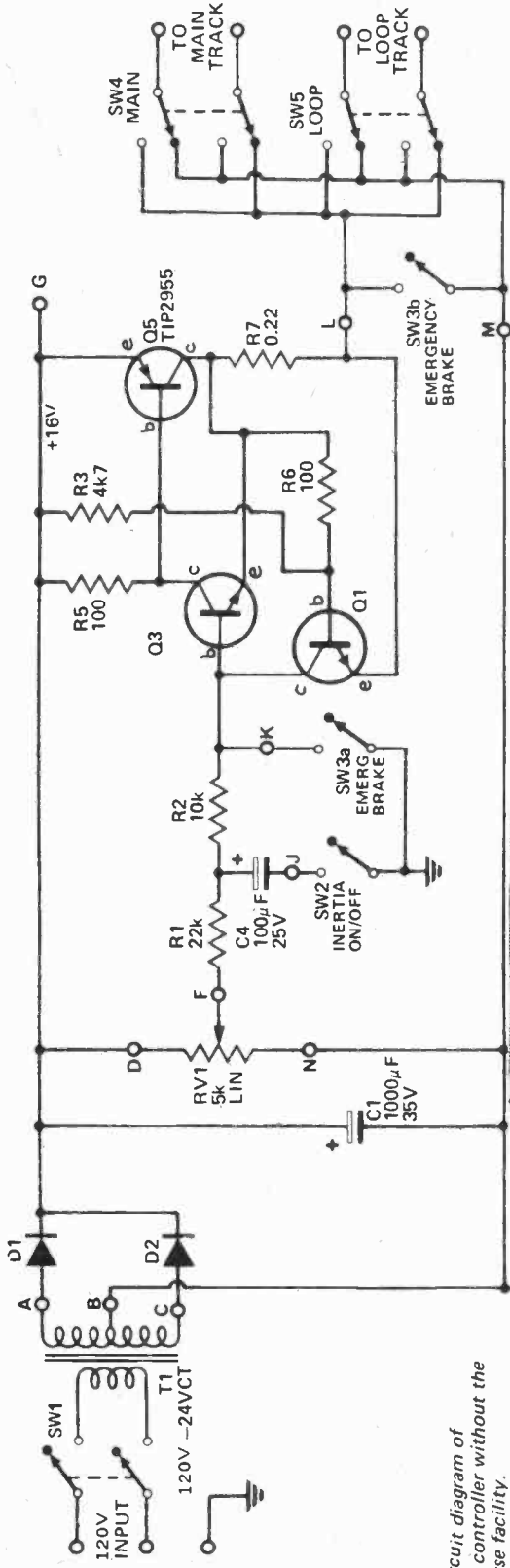
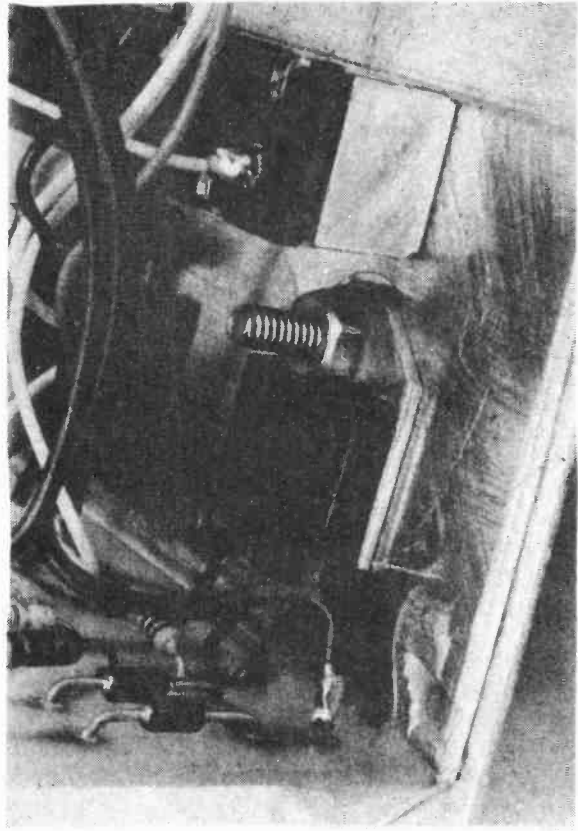
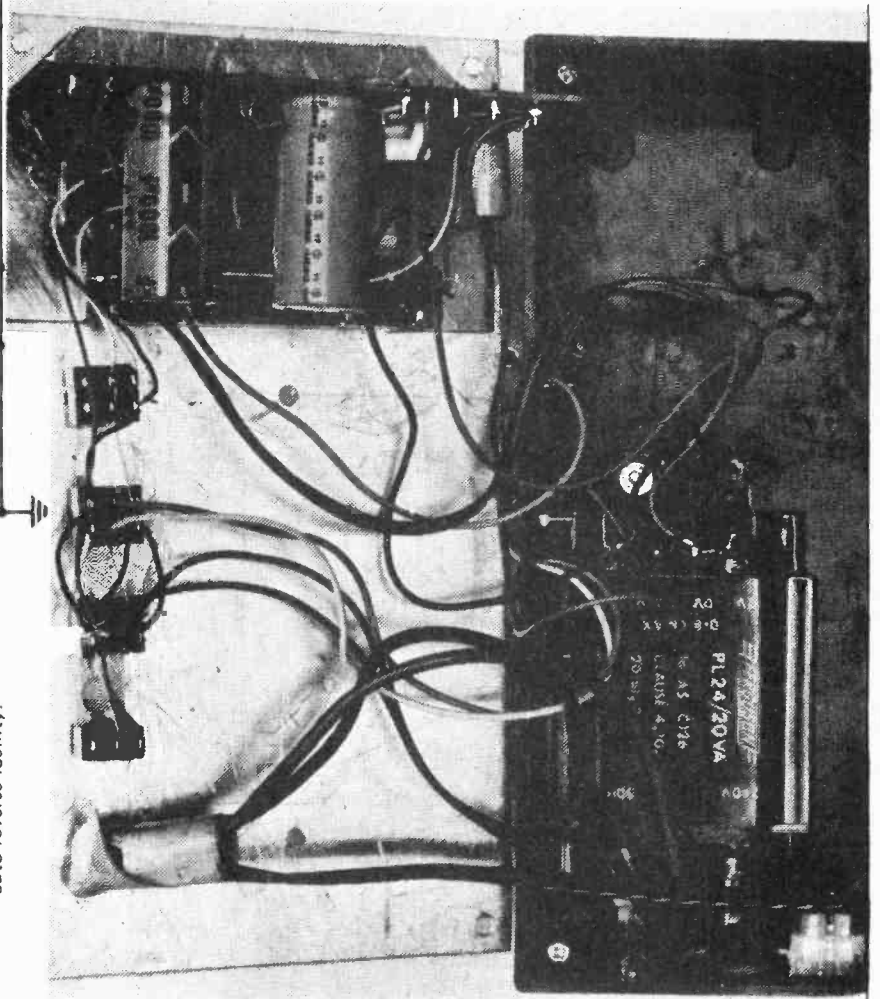

Fig. 5. Circuit diagram of simplified controller without the auto-reverse facility.



The power transistors are mounted to a bracket with countersink bolts. They can, if desired, be mounted directly on the front panel. Note how the pcb is mounted — by epoxying to the bracket.

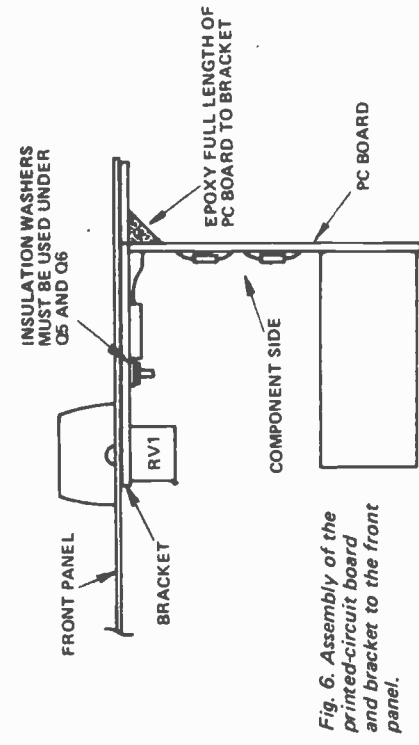

Fig. 6. Assembly of the printed-circuit board and bracket to the front panel.

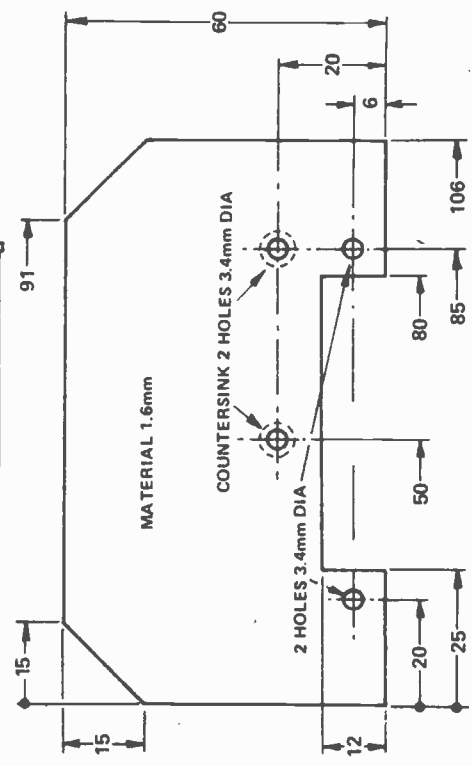

Fig. 8. Mounting bracket for transistors Q5 and Q6.

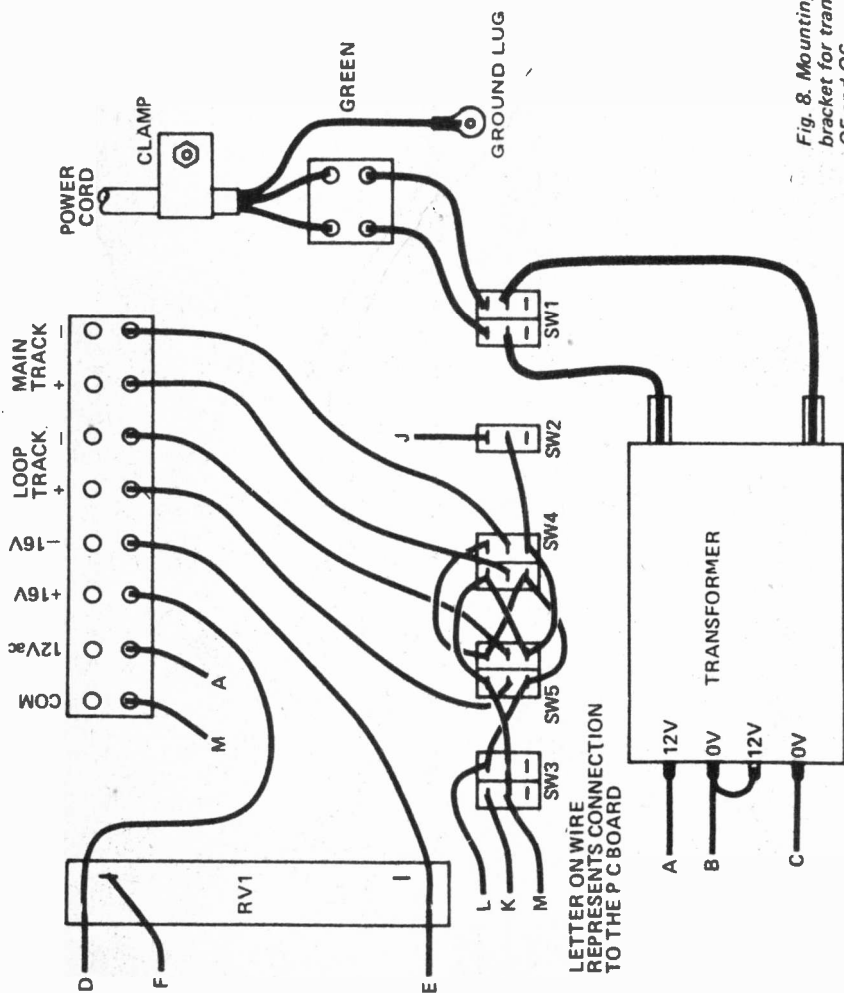
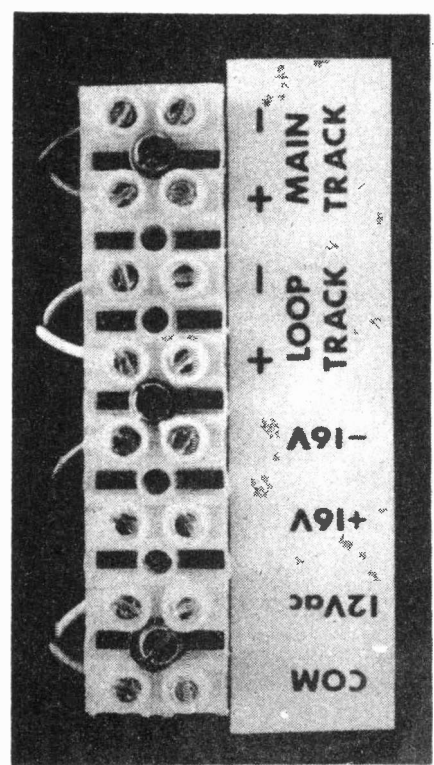

Fig. 7. Interconnection diagram for the auto-reverse controller given in the circuit of Fig. 2.



the controller are not required then it may quite easily be simplified. If only a single direction is required from the throttle control then the same printed-circuit board and the circuit in Fig. 5 may be used. If loop operation is not required then the controller may be further simplified by deleting SW5 and the associated wiring.

### CONSTRUCTION

We built our controller into a plastic box with an aluminium lid. Some people may wish to build the controller into a complete control panel or some other box. This is quite acceptable as the method of construction is not criti-

leave the loop then the train, once it passes the breaks in the track, will find the wrong polarity on the main track. It will be unable to continue in the same direction. To overcome this problem the main-track switch must be changed to 'reverse' whilst the train is within the loop. If the train enters the loop towards 'B' then the loop switch must be reversed before the train enters the loop. Once again the mainline polarity is reversed whilst the train is within the loop. Providing the section of the loop between 'A' and 'B' is longer than the train, loop operation will be simple and trouble free.

**Simpler versions** If all the facilities of

cal. We suggest however that the printed circuit board specified be used as this greatly simplifies construction and minimizes the possibility of wiring errors.

Assemble the components to the printed-circuit board in accordance to the relevant component overlay. Watch that the polarities of components such as diodes, capacitors, and especially transistors, are correct. Note that two different pin connections are available in the BC548 and BC558 transistors, depending on the manufacturer. The Philips type is the one shown on the overlays.

A small bracket was used to hold the printed-circuit board in such a way as to hide the two screws which hold the power transistor. If two extra screw-heads on the front panel do not worry you, then this bracket need not be used. Bolt the power transistor onto the bracket using the insulation kit provided. The Scotchcal panel (if used) should now be fitted to the front panel and all holes drilled and the slot for the slide potentiometer cut. Mount the bracket to the rear of the front panel by means of the slide potentiometer and its mounting screws and then mount the rest of the switches. Drill a hole through the side of the plastic box for the power cord and then fit the cord, the cable clamp and the transformer into the box. Then mount the terminal block to the box and drill small holes for the wires from inside the box to be terminated to it. Finally wire the complete unit and test it.

Once sure that the controller works as it should the board edge should be glued to the front panel (or bracket) with a little epoxy glue. Once this has dried, and you are sure that there is a seal all along the edge of the board, pour epoxy glue along the join so as to form a fillet of glue about 5 to 10 mm wide. (A piece of sticky tape at either end will prevent the glue from running out at the ends). Once the glue has dried the completed front panel assembly may be screwed into the box. Add the rear panel label and the unit is ready for use.



# QRM QRM

A long time ago, in a far-off land, there lived a town full of musicians. The musicians would get up early in the morning and start to practice their craft, and they would practice all day until they were perfect. In the evenings, they would all gather in the public square and have a grand concert. People from all around would come to hear them play. Word of their skill soon reached the king's ears, and he sent his music inspector to listen and make a report. The music inspector told the King what a wonderful group of citizens these musicians were, and before very long, they were playing at the Royal Court. They enjoyed all sorts of special privileges, such as being able to play their instruments all night long, being able to play anywhere they pleased, and being able to play as loud as they pleased, even if people complained. It wasn't often that people complained, but when they did, the King's Department of Music would send along an inspector, and usually discovered that the complainant had far too sensitive ears and told the musician he could go on playing.

Many, many years went by, and music became an important part of life in the kingdom. Very soon after the King recognized music, many people discovered ways to make money at it, but the King was very shrewd and made regulations covering how they could play for profit and how much they could charge. He even made regulations covering how loud all these people could play as years went by, so they would not interfere with each other's playing. Despite the large revenues the King got from the music tax charged on all playing for profit, he had a very soft spot for the amateur musicians. He made special concessions for them and reserved special places for them all to play together. Since they were not all competing for profit, they did not need to be regulated like the commercial musicians, and he more or less let them get on with it unhindered.

Very soon, however, there were far too many amateur musicians for the King to have personal audiences with them, and even too many for his music inspectors to visit. Things were becoming far too busy on the commercial front, where there were many times more musical instruments, including cheap little toy instruments that any

member of the public could play softly without much musical skill. So the amateur musicians formed little clubs at first, which all then banded together to form one club for the whole kingdom. Now the king was happy again because he could quietly whisper into the ear of one of the club leaders about anything that he didn't like about the way the amateur musicians were doing their thing, and words would be said to the offenders and the problem solved, without the king having to make bothersome regulations.

In time, musical instruments became louder and louder, and the King's musicians were heard in other countries. So it became necessary to sign treaties with the other countries promising to keep his musicians in line. More regulations, more bureaucracy. The king hated bureaucracy, but it all seemed necessary. Despite all this, the amateur musicians were still very well-behaved and escaped much of the attention of the King's music inspectors.

Times change, however. Soon, musicians from the big industrialised country next door imported bigger and louder instruments, and started a whole new trend in playing music. It didn't sound half as nice as the music the king was used to, and so he sent out his inspectors to find out what it was all about. They reported back and the King wept. He was so fond of the concerts he had started, how the amateur musicians played so well together. They were now all playing out of tune. It sounded horrible. It seemed that they couldn't decide amongst themselves which way up to put their sheet music while they were playing. Some put it up the normal way, others put it upside down. The result was that they could never keep in time, or play the correct notes. When the King asked for a report on why things had changed this way, he was told that this was the way they had always done it in other countries, and it was better that way.

For a while, the King went along with this way, but he still missed the nice concerts that he had attended in his younger days. But the time came when he could not stand it anymore. He sent his music inspectors out to seize all the instruments from the amateur musicians. They would be much better used by the commercial musicians, since



# QRM

otherwise the king will get angry with us. There are a lot of commercial users out there who would just love to get their hands on some of our frequencies.

Be sure to tune into QRM next month, when, Deo volens, we will have a report on what happened at the Ottawa RSO convention, a VERY SPECIAL interview with an important person, and a report on a recent court case in Toronto that could have a staggering effect on amateur radio's future in the automobile.

If you have anything to say, please write to me at: QRM LETTERS, ETI CANADA, Unit 6, 25 Overlea Blvd, Toronto, Ontario, M4H 1B1.

they created revenue and paid a lot more taxes.

Soon afterwards, the old King died, heartbroken at thinking he had let a good thing be spoiled because he hadn't made enough regulations to keep the amateur musicians in line.

A very short QRM this month, but a very important message. We must stick together and play the same music.

DEAR BILL,

PARDON THE Mousy FORM OF THIS LETTER, BUT I AM TYPING IT ON MY HOME COMPUTER (AIM 65 AND TTY 35) WHICH IS NOT EXACTLY A COMMERCIAL TEXT EDITOR, ANYWAY, IT DOES WHAT I WANT, AND I AM HAVING A LOT OF FUN WITH IT... SETTING IT UP FOR MORSE TRANSCIVE, RTTY AND SOON, PACKET RADIO - HOPE TO JOIN THE LOCAL CROWD WHEN WE GET THE 'DIGIPEATER' GOING THIS FALL ON 222.34.

SO, I JUST FINISHED READING THE SEPTEMBER ISSUE OF 'QRM'.. HAVE BEEN A CHARTER SUBSCRIBER OF ETI, AND HAVE BEEN READING YOUR COLUMN SINCE IT STARTED.. HAVE ENJOYED EVERY COLUMN, AND FIND YOUR VIEWS QUITE AGREEABLE.. ESPECIALLY ON THE RSO REPEATER.. I AGREE WITH THE LOCAL AMATEUR WHO SAID THAT YOU WERE TOO KIND TO THE RSO, AFTER YOUR ORIGINAL CRITICISM.

ENUF SAID ABOUT THAT. I AGREE WITH THIS MONTH'S COLUMN- WHO WILL DO THE EXPERIMENTING IF WE KEEP CRANKING OUT NEW AMATEURS THE WAY WE ARE NOW ??.. IT SURE SOUND LIKE A LOT OF THEM ARE FRESH OFF OF ANOTHER BAND.. NOT THAT I HAVE ANYTHING AGAINST GRS OPS IN GENERAL.. A NUMBER OF THEM OPERATE BETTER THAN THE NEW AMATEURS SHOWING UP ON 2 METRES THESE DAYS WITH THEIR BRAND NEW APPLIANCES.

NOW THE THING THAT BOTHERS ME IS.. CAN WE KEEP 220 AND PACKET EXPERIMENTATION FREE OF THESE TYPES WITH THEIR 'X' RADIOS, MODEL 'B' PLUG-IN PACKET RADIO INTERFACES AND 'Z' COMPUTERS ? THE SAME WITH HF RTTY.. I THINK THAT IT IS GREAT FOR THE DOC TO OPEN UP HF RTTY TO AMATEURS.. POSSIBLY MANY OF THEM ARE MORE TECHNICALLY ORIENTED, BUT HAVE PASSED THE CODE ANYWAY (OUR CLUB RECOMMENDS THIS ROUTE TO NEWCOMERS INTERESTED IN PACKET RADIO, BECAUSE OF THE EXPANDED POSSIBILITIES IT GIVES THEM. WE SUGGEST THAT THEY GET THEIR DIGITAL TICKET AFTERWARD, IF THEY ARE STILL INTERESTED IN HAVING IT)

AND COULD BRING HF RTTY UP TO MORE MODERN STANDARDS - WE SHOULD, AS CANADIANS, WE USING ASCII FAR MORE THAN WE DO ON THE HF BANDS ; I DO KNOW A LOT OF AMATEURS - NOT ADVANCED WOULD BE INTERESTED IN PUTTING THEIR MICROS ETC. ON HF AND HAVING A LOT OF FUN.. BUT WHO ARE PREVENTED BY THE PRESENT SILLY REGS. FORBIDDING FI TO AMATEURS ON HF. (ANY AMATEUR COULD SET UP 2 TRANSMITTERS 170 HZ. APART AND KEY THEM ALTERNATELY, AND BE QUITE LEGAL !) SO I THINK THAT IT WILL GOOD TO GET THE AMATEURS WITH THEIR MICROCOMPUTERS ON HF RTTY, BUT I HOPE THAT WE DON'T SHORTLY SEE A GLUT OF APPLIANCE OPS ON THE BANDS DOING THE SAME THING WITH THEIR PETS, AND PLUG-IN 'AMATEUR TELETYPE INTERFACES'..

SO BACK TO THE MAIN POINT (WHAT WAS THAT..?) ITS ABOUT TIME THAT THE DOC UPGRADED THEIR STANDARDS.. AND ITS OUR FAULT THAT THE NEW APPLICANTS ARE NOT PASSING - EXCEPT FOR THE CODE, POSSIBLY.. LAST FALL AND WINTER I ATTENDED 2 EXAM SESSIONS TO UPGRADE TO ADVANCED, THE THEORY WAS A JOKE, I FELT NOT UP TO ADVANCED LEVEL (BUT BEING AS I AM STUDYING ELECTRICAL ENG. I MIGHT BE BIASED, EVEN THOUGH I TRY NOT TO BE, IN MY EVALUATIONS) BUT I DID NOT COPY THE CODE AT BOTH SESSIONS. MY CODE WAS DARN WELL UP TO PAR.. BUT THE SFNDING WAS NOT A CHEAP (20 DOLLAR, I PRESUME) CASSETTE RECORDER SQUAWKED OUT CHIRPY, THUMPY AUDIO AT A VERY LOW LEVEL. I DON'T THINK THAT AN EXAM IS THE PLACE TO GIVE NEW AMATEURS TO BE PRACTICE AT COPYING CUBAN STATIONS THROUGH QRM. THE CODE TEST WAS NOT UNDER THEIR CONTROL - I AM SURE THAT THE RECEIVER WOULD BE THE FIRST TIME THAT THEY GOT ON. DO YOU REMEMBER THE FIRST TIME THAT YOU GOT ON THE AIR ? DID YOU SEARCH FOR SIG OF THE PREVIOUS QUALITY FOR YOUR FIRST QSO ? NEWCOMERS NEED SOME GOOD EXPERIENCES TO BUILD UP THEIR CONFIDENCE, BEFORE THEY MOVE QW..

ANYWAY, I SEE THAT I ALREADY FILLED UP MY MEASLY 4K - USUALLY ENOUGH FOR MY PURPOSES, AS I ONLY PROGRAM IN ASSEMBLER (I DO MY 'BIG LANGUAGE' PROGRAMMING ON THE MACHINE AT THE UNIVERSITY).. I GUESS THAT MEANS I HAVE BEEN WRITING TOO LONG..

SO, I DON'T KNOW WETHER YOU WILL BE IN TOWN FOR THE RSO CONVENTION, BUT IF YOU ARE, OR ARE EVER UP HERE, GIVE ME A CALL ON THE REPEATER, AND/OR VISIT US AT THE CLUB SHACK.

73,

*Bob Delmaga*  
 BRFTI DPLMAGE VE3JLG  
 PRESIDENT, CARLETON UNIVERSITY A.R.C.  
 VE3OCU-VE3TCA  
 LICENSEE, VE3OCR  
 53.150, 146.25/85, 223.34/4.94 MHz.

**NORTH AMERICAN ELECTRONICS**  
 1949-1979

<b>AMIDON</b>	Toroidal cores, Ferrite beads, Pot cores, etc.....
<b>BARKER &amp; WILLIAMSON</b>	Coils and R.F. switches, etc.....
<b>MAGNET WIRE J.MILLEN</b>	Sizes 10 to 40..... Inductances, Ceramic coil forms, etc.....
<b>J.W.MILLER</b>	Inductances, all types, R.F. Coils, etc.....

**AND MANY MORE .....**  
 Our 40 page No. 17 catalog, marking our 30th anniversary as an electronics distributor is now being sent free of charge. **WRITE** for it or **CALL** us....

**NORAMEL**  
 2407 STE-CATHERINE ST. E.,  
 MONTREAL, QUE., H2K 2J7  
 (514) 522-8422

**HIGH-TECH jewelry**

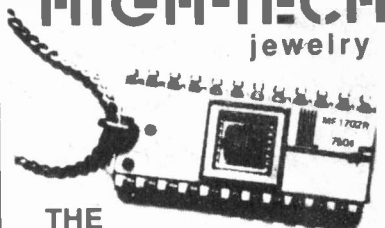

**THE COMPUTER MEMORY PENDANT**

A unique conversation piece and great way of letting your interests be known Ten years ago such a jewel was unimaginable Today this technology is transforming our lives and the society we live in

The white ceramic and quartz package attracts attention, while a closer look reveals the intricacy and precision of the silicon circuit This high-tech symbol of the seventies is a genuine product of the micro-electronic revolution

Pendant available on  
 gold plated chain \$18.95, gold filled chain \$21.95,  
 10 k gold chain \$32.00 or as a stick pin \$16.95

Send check or money order plus \$1.00 postage and handling to:

**HIGH-TECH Jewelry**  
 3 Canterbury Road  
 Islington, Ontario, M9A-5B2

Please find enclosed cheque or money order for pendant on GP  GF  10KG  or SP

Name \_\_\_\_\_  
 Address \_\_\_\_\_  
 City \_\_\_\_\_ Prov. \_\_\_\_\_ Post Code \_\_\_\_\_

# Kit Survey

In this month's Audio Today, Wally Parsons tells you why you should buy a kit, John Van Lierde reviews kits available in Canada.

THE PROBLEM FACING MOST friends and lovers of electronic 'Do-it-Yourselfers', is what to get them for Christmas. Chances are most parents could not walk into a major industrial outlet and select a suitable array of transistors and ICs as stocking stuffers. On the other hand, the true hearted home constructor might be offended on opening his presents and discovering a commercial piece of equipment. After all, HE could have built it HIMSELF if only HE had time. Homehandymen can be a difficult lot.

It is with this dilemma in mind that we proudly present our survey of kits available in Canada (and some from the US).

The virtues and benefits of buying a kit are manyfold. Indeed I had about five pages of them in my original manuscript. But, unfortunately Wally Parsons got the jump on me (he won't get off!) and so I gracefully deleted my material.

Unlike our receiver survey, this month's effort is not intended to list every kit we could possibly find. Rather, we are merely trying to make you aware of what's available from whom.

The material requested from manufacturers consisted of a catalogue, price list and sample instructions. In this way we tried to get a 'feel' for the products and to what level of proficiency they're suited for. Some kits (like Heathkit) are documented to the point of redundancy. Others just give you a schematic and parts and leave you to your own devices. This is not a reflection on the quality of any kit, but it will affect the success of the prospective kit builder.

When you write for catalogues be sure to say you saw it in ETI. It makes our surveys go better.

Like all our surveys, we couldn't reach everyone, and not everyone wanted to participate. It is beyond the ken of mere mortals and assistant editors why manufacturers will turn down free publicity. Maybe we took them by surprise.

## WHERE TO GET IT

### Vansco

●Vansco, 102 Vanscoy Rd., Winnipeg, Manitoba.

### ATV Research

●ATV Research, 13th & Broadway, Dakota City, Nebr. 68731.

### EICO Electronic Instrument Co.

●H.W. Cowan Canada Ltd., P.O. Box 268, Richmond Hill, Ont. L4C 4Y2.

### RAEKIT

●RAE Industrial Electronics Ltd., 3455 Gardner Court, Burnaby, B.C. V5G 4J7.

### Compukit

●Compukit, 1857 Wavell Cres., Mississauga, Ontario L4X 1X2.

●r.n. Longman Sales Inc., 1715 Meyerside Drive, Unit 1, Mississauga, Ontario L5T 1C5.

### PAIA

●Gladstone Electronics Supply Co. Ltd., 1736 Avenue Rd., Toronto, Ontario M5M 3Y7.

### SDS Technical Devices Ltd.

●SDS Technical Devices Ltd., P.O. Box 1998, Winnipeg, Manitoba R3C 3R3.

### Jana Kits

●Jana Industrial Electronics, 1777 Ellice Ave., Winnipeg, Manitoba R3H 0W5.  
or check ads in previous issues of ETI.

### Speakerkits (KEF, Philips, etc.)

●Gladstone Electronics, see PAIA.

### Audiovision

●Audiovision Service, P.O. Box 955, Stn B, Willowdale, Ontario M2K 2T6.

### Paccom

●Paccom, 14905 N.E. 40th Street, Redmond, WA98052.

### Moonlighter Electronics

●Moonlighter Electronics, 117 Inverness, San Francisco, CA94132.

### Heath Company

●1478 Dundas St. E, Mississauga, Ontario L4X 2R7

●1400 Sauve Ouest, Montreal, Quebec H4N 1C5.

●12863-97th Street, Edmonton, Alberta T5E 4C2.

●1315 Portage Ave., Winnipeg, Manitoba R3G 0V3.

●866 Merivale Rd, Ottawa Ontario K1Z 5Z6.

●3058 Kingsway, Vancouver, B.C. V5R 5J7

### Science Of Cambridge

●Gladstone Electronics, see PAIA.

## Audiovision

Audiovision markets a line of basic audio kits intended for the more experienced constructor.

Available are 5 different power amplifiers ranging from 20W (#20A at \$39.00) to 140W (#7070 at \$129.00). A review of the 7070 can be found in this month's Audio Today.

Audiovision sent us two preassembled kits, the SAD-01 Audio Level Display (\$26.00) and the SAD-02 LED Power Indicator (\$56.00).

Both kits appear to use fairly good quality components, and the pc board layout has a clean symmetrical appearance. The SAD-01 has its LEDs arranged in a 'V' type pattern and the outward flashing lights produce an eye catching effect. Both indicators come with pre-cut, silk-screened bezels.

Assembly instructions are by and large sketchy but the boards have component locations silk-screened and a schematic is provided. A little common sense will ensure proper operation.

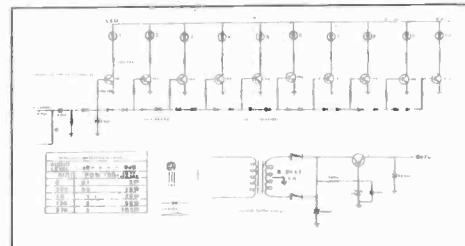
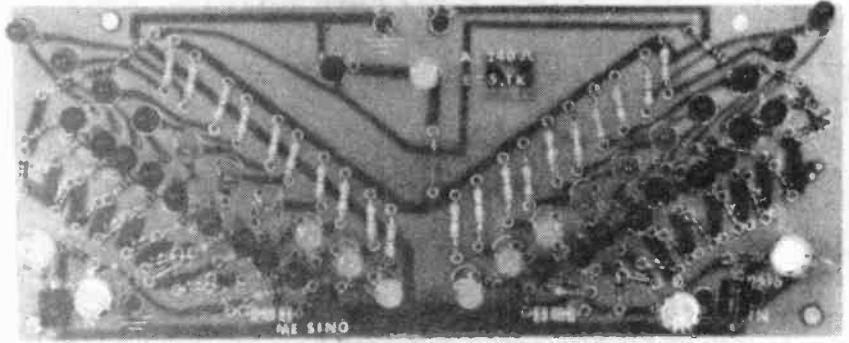

Above and right, the SAD 01 from Audiovision.

## Jana

While not dressed up in flashy cases, the Jana line of educational kits do offer surprising value for the money you spend.

These are one or two evening kits that go together with no bizarre tricks or annoying surprises. With a little care they will invariably work the first time.

Jana offers over 25 kits. There are noise makers such as the Curiosity Box (#7), The Road Runner (#32) or the Loudmouth (#24). Games offered include shootout (#31), Dice (#27), and Roulette Wheel (#25).

In addition, Jana offers kits of a more practical nature.

Kit \$34 starts you off in electronics by having you build your own soldering iron. Price is \$7.95 including tweezers and two screwdrivers.

The Bug Shoo (#3, \$5.25) repels mosquitoes by means of ultrasonic sound.

Other kits include an FM Mini Broadcaster, Code Oscillator, Strobe Light and more.

Most Jana kits come in a plastic box that also serves as a case for the finished product. The box looks rather like a square margarine tub, but is actually considerably more durable. It is easily worked with drill, saw or soldering iron. The printed circuit board is not silk screened, but the instructions include a good parts

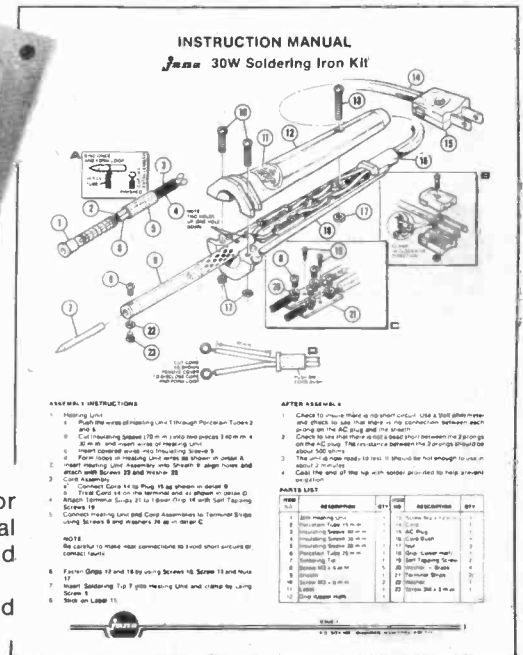
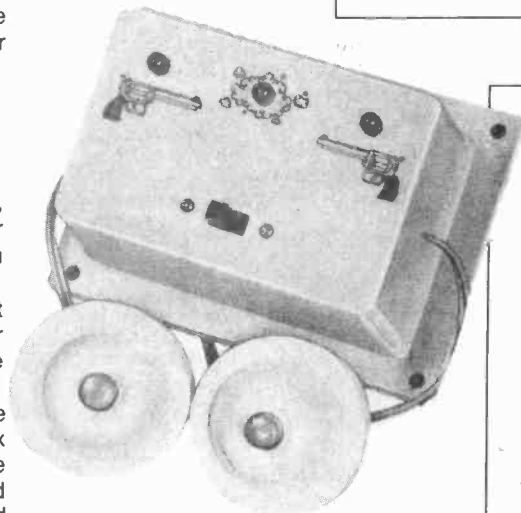

positioning diagram.

Jana kits were originally intended for educational use, but they are also ideal as first kits. They also make good modules for other projects.

Jana kits are widely distributed throughout Canada.

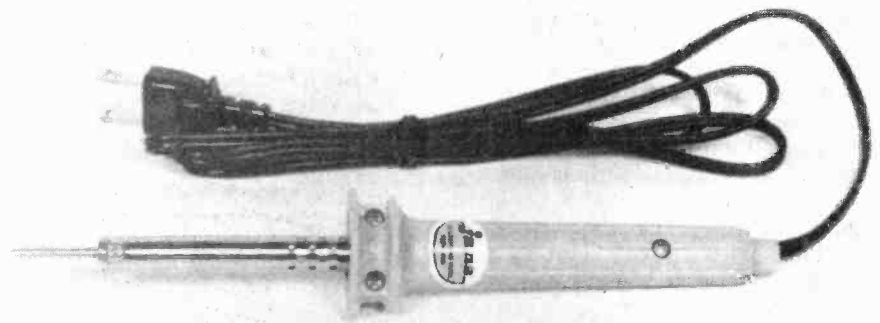

## ATV Research

ATV has been in the closed circuit TV business since the mid-sixties and offer a number of attractive kits to the prospective video buff (buffette?).

Of particular interest is a solid state B&W camera for \$185 US.

The XT1A features video or RF output and automatic light compensation. The catalogue also boasts an illustrated step by step manual. (We didn't get one and therefore can't comment.)

ATV also supplies hard to get CCTV parts such as peaking coils or focus deflection kits for 1" vidicon tubes. The latter come with all necessary hardware to mount the vidicon as well as plans for a complete camera. Price is in the \$20 — 30 US range. ATV will even sell you the vidicon.

Other kits; Pixe-verter, an RF modulator for CCTV cameras at \$8.50 US, the ASC71 Audio Subcarrier Unit (\$28.95 US) to add capability to existing cameras, and the TCS-6, a series of six television test patterns (\$3.50 US).

All orders shipped prepaid and insured from ATV Research.



Above and left, ATV Research has a large line of CCTV equipment.

Above, the TDS-M68 computer trainer.

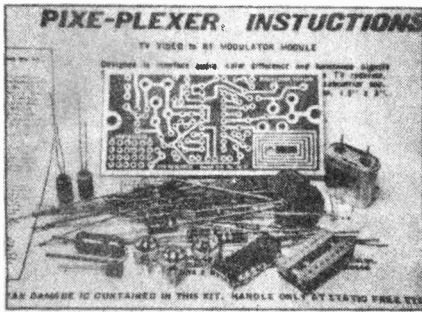

Right, the 5280 line of test instruments offer good value.

Far right, the H89 uses two Z80 micro-processors for faster operation.

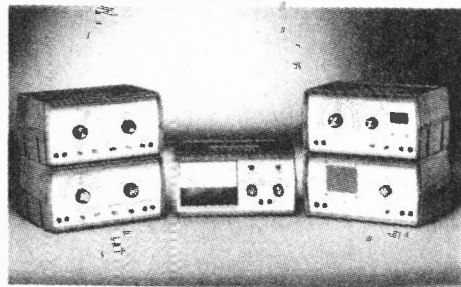

## Heathkit

Over the years Heathkit has grown to be a name synonymous with kit building. Heath supplies kits in every type of electronic hardware imaginable; audio, test and service, amateur radio and more. Flipping through their catalogue, it becomes apparent that their design philosophy encompasses functional ability with aesthetically pleasing styling. Each kit is thoroughly tested and reviewed before it is released for market. In addition, documentation for Heathkits is very complete. The instructions are designed for people with previous experience in electronics or in handling tools.

All this, of course costs you bucks, but then you're paying for all the research and service behind your kit.

Heath's 5280 line of instruments are ideally suited for experimenters on a budget. The series consists of the IG5282 Audio Oscillator, IG5280 RF Generator, IM5284 Multimeter, IB5281 RCL Bridge and IT5283 Signal Tracer. All instruments are \$69.95 each. In addition, there is a power supply (IP5280-1) for all five at \$39.95.

Heathkit also has a wide range of amateur equipment such as 2m transceivers, keyers, 1KW linears and so on. One example is the SB104A transceiver, which will deliver 100W CW or SSB on the 80m to 10m ham bands. Broadband design eliminates the need for pretuning. Tuning is accomplished by means of a 6 digit LED readout. Price, \$1400.

For the audiophile, Heath offers their top of the line Rack Mount system, \$2420 just about covers the cost of the entire system which includes the AJ1600 AM/FM Digital Tuner (with Dolby FM), AP1800 Stereo Preamplifier AD1701 Graphic Output Indicator, AA1600 Stereo Power Amplifier and the AE1705 stereo component rack to house it all. The net result is a professional looking 125W/channel system with terrific sound.

There are six Heathkit Electronic Centres in Canada.

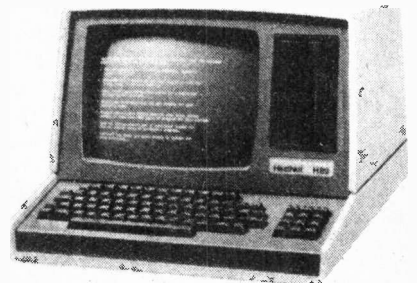
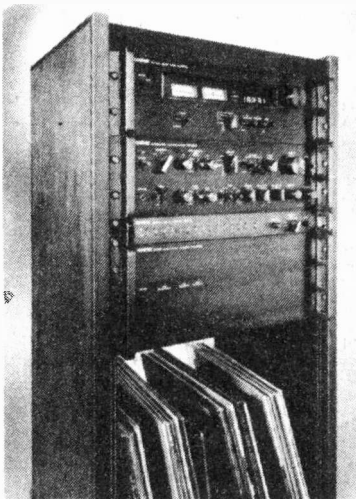

# ARKON HAS MOVED

TO A NEW LARGER STORE LOCATED AT 409 QUEEN STREET WEST (NEXT TO STEVE'S MUSIC STORE) NEAR SPADINA. THE NEW STORE IS TWICE AS BIG AS THE OLD ONE WITH GREAT LAYOUT AND A BRAND NEW COMPUTER STORE RIGHT NEXT DOOR. COME ON OVER.

## ULTRALINEAR POWER AMPLIFIER MODULE KIT

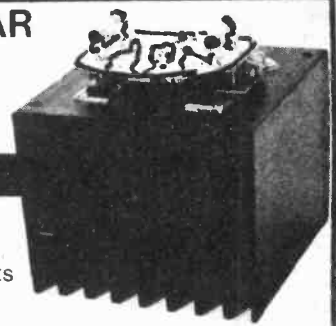

POWER OUTPUT — 100 watts RMS into 8 or 4 ohms  
 FREQUENCY RESPONSE — 20 Hz - 20 KHz ± 1db  
 HARMONIC DISTORTION — 0.15% at 1 KHz at 100 watts  
 IM DISTORTION — 0.1%

INPUT IMPEDANCE — 100K ohms  
 LOAD IMPEDANCE — 4 ohms Min  
 SENSITIVITY — 1.0 V for 100 watts

**\$44.95**

### ARKON KITS

01 5 Transistor 1 W. amp	\$ 8.95	14 3 Self Blinking LED's	\$ 2.95
02 0-24V 1 Amp Power Supply	\$18.95	15 Video Modulator	\$ 8.95
03 Strobelight	\$15.95	16 RS232—TTL Converter	\$ 9.95
04 Light Chaser	\$19.95	17 IC Amp (LM380)	\$ 5.95
05 Light Organ 500w/ch	\$18.95	18 Crystal Radio	\$ 4.95
06 Light Organ 1500w/ch	\$39.95	19 Photo Electric Nightlight	\$ 5.95
07 FM Mike	\$ 3.95	20 1 Channel Light Organ	\$ 5.95
08 FM Mike, with preamp	\$ 4.95	21 Shimmer Strobe	\$ 7.95
09 Tone Decoder 567	6.95	22 Whisper Light	\$ 8.95
10 Timer board 555	\$ 3.95	23 MA1003 Car Clock	\$24.95
11 Code Oscillator 555	\$ 3.95	24 Decision Maker	\$ 3.95
12 Code Key, brass WWII	\$ 3.95	25 Hi-Power 12V Flasher	\$ 5.95
13 LED Blinky	\$ 2.95	26 AM-FM Freq. Readout	\$49.95

**16K UP GRADE**  
**TRS-80**  
**APPLE 129.00**

### HOT PLATE

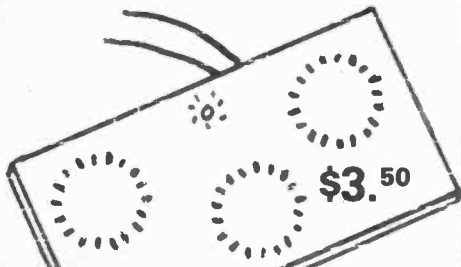

Large Manufacturers Surplus. 5 1/4 x 10 1/2 In. Made of 3/8 in. tempered glass with heating element laminated on back. Works off 120 VAC. Protected by thermostat and two thermal fuses. Rated 120 Watts. Use for any heating applications. Perfect for heating ferric chloride to increase PC board etching efficiency. Units are brand new, non-submersible.

### ARKON CP-10-1

The ARKON CP-10-1 is an S-100 card that has all the CPU, Disc control and IO capability needed to construct a disc based microprocessor system for business, hobby or scientific system. Features are:

- 2 Mhz 8080-A, fully buffered S-100.
- EIA-RS232 port, 110 to 76,000 baud.
- Fully vectored interrupt (TMS-5501).
- 5 Interrupt controlled timers.
- EIA port for printer up to 9600 baud.
- Disc controller on board (1771).
- Shugart 400, 800, Memorex 550, plus.
- On board digital data separator.
- 2K bytes EPROM.
- 24 fully handshaked IO lines.
- Dual mapped IO.
- MWRITE generation on board.
- Software driven-cassette interface.

ARKON CPIO . . . . . \$650.00

**MAGNECRAFT 12V DC**  
 \$3.95

3PDT Relay, \$6.95  
 SPDT Co-Axial RF Relay for antenna use, 1-450 MHz

### OHIO SCIENTIFIC SUPERBOARD \$417.00

You've seen all the ads, at last this great item is in stock. What more can we say.

### FORT//80

FORT//80 is here at an affordable price. A fast, resident Fortran compiler. Produces directly executable, highly condensed machine code for the 8080, (will run on Z80 and 8085). Runs on any CPM system.

- Direct IO to 8080 ports
- Fortran Interrupt control
- Single, double precision
- Memory mapped IO
- Accepts embedded in-line code
- ANSI FORTRAN IV subset
- Custom IO drivers
- Made In Canada

Send now for a full data sheet and sample program.

Copyright Arkon Electronics, Digital Research of Cal.

FORT//80 . . . . .	\$90.00
MANUAL ONLY [APPLIES TO BUY] . . . . .	\$20.00
DATA SHEET AND SAMPLE PGM . . . . .	NC

### PARTS

7805 +5V	\$01.40
7812 +12V	\$01.40
7905 -5V	\$ 1.95
7912 -12V	\$01.90
100V-25A bridge	\$03.50
Red LED S,M,L	5/1.00
Green LED S,M,L	4/1.00
Yellow LED S,M,L	4/1.00
Bi-polar LED	\$0.75
2114 4Kx1	\$11.95
4116 16Kx1	\$13.95
741	3/1.00

**ARKON ELECTRONICS**  
 409 QUEEN ST W  
 TORONTO ONT.  
 (416) 868-1315

## SD SYSTEMS EXPANDORAM

Z-80 STARTER KIT . . . . .	\$325.00	16K . . . . .
SBC 100 KIT . . . . .	\$399.00	32K . . . . .
VERSAFLOPPY KIT . . . . .	\$199.00	48K . . . . .
		64K . . . . .

### VIDEO TERMINAL KIT

DISPLAY: 64 char per line x 16 line per frame of 5x7 dot matrix, 64 ASCII char

VERT SYNC: 60 Hz XTAL controlled

HDR SYNC: 15.840 KHz XTAL controlled

VIDEO O/P: IV P-P composite video

I/O: Parallel port to ASCII keyboard +20ma current loop + RS232 IO

BAUD RATE: 110 to 9600 Baud remote sel

POWER: 5v 1A DC + +12VDC for RS232

RE6416 . . . . . \$169.95

LOWER CASE . . . . . POWER SUPPLY

OPTION . . . \$16.95 OPTION . . . \$16.95

WIRED and TESTED . . . . . \$239.00

### MEMOREX 550

Now you can buy a full sized 8" disc drive fully IBM compatible at a reasonable price in Canada. Ask for a data sheet as there is not enough space here to do justice to this high quality unit.

MEMOREX 550 DRIVE . . . . . \$650.00

### LED BAR GRAPH AND ANALOG METER DRIVER

New from National Semi. #LM3914. Drives 10 LED directly for making bar graphs, audio power meters, analog meters, LED oscilloscopes, etc. Units can be stacked for more LED's. A super versatile and truly remarkable IC. Just out!

SPECIAL PRICE: \$4.95 INCLUDES 12 Page Spec. Sheet

10 Mini bar LED's . . . . . \$2.00

All orders processed promptly, add 5% for shipping. Make sure you include complete Master Charge or ChargeX numbers and expiry date, minimum order \$5.00 Ont. Res. add 7%.



## Eico

Eico Electronic instrument company is a major kit name in North America. They should be, they've been at it since 1945.

Eico instruments feature rugged construction and good solid design. A large number of their kits have been around for over 10 years and while admittedly they use vacuum tubes, you know they are of proven design. In fact, I noticed that one scope, the 460, has a graticule graduated in inches. That's one up on a metric Canada.

By far the largest segment of the Eico line is devoted to test equipment. They offer a wide selection of test meters, oscilloscopes, generators, transistor testers, substitution boxes (pause, deep breath), frequency counters, power supplies, battery eliminators, bridges and more. You can easily stock a lab from the catalogue.

One notable kit is the 270 DMM. This is a 3½ digit, 10 megohm multimeter for \$179.95. Other kits include the DLP6 Logic Probe which can detect pulses as short as 20 ns for \$39.40. The PST-2 Signal Tracer Probe (\$38.30) can demodulate signals all the way up to 200 MHz.

Eicocraft kits are for those people who are after more functional design at lower cost. Prices range from \$15.00 to \$60.00 for a variety of products such as preamplifiers, power supplies, an ESP tester and colour organs.

We were supplied with a 31 page assembly manual for the model 465 DC to 10MHz oscilloscope. Instructions are detailed and straightforward and the average constructor should have no trouble, even if the doctors botched his lobotomy. Also included was a sheaf of 5 large assembly pictorials. Documentation is quite adequate.

Eico kits are distributed in Canada by H.W. Cowan Canada Ltd.



## SDS Technical Devices

With the mushrooming growth of microcomputer applications comes an attendant need to educate users in using such devices.

The TDS-M68 is a wholly self contained 6800 based teaching and development system, aimed at introducing the beginner to the programming, interfacing and applications of a 6800 microprocessor. Features include keyboard, seven segment display, 16K of RAM and 8K of EPROM.

Peripherals include CRT display, floppy disk drive, cassette interface and so on. Also a book, 'Understanding and Applying the 6800' by Allan Robbins and a lab manual are available.

The TDS-M68 is available from SDS for \$750.

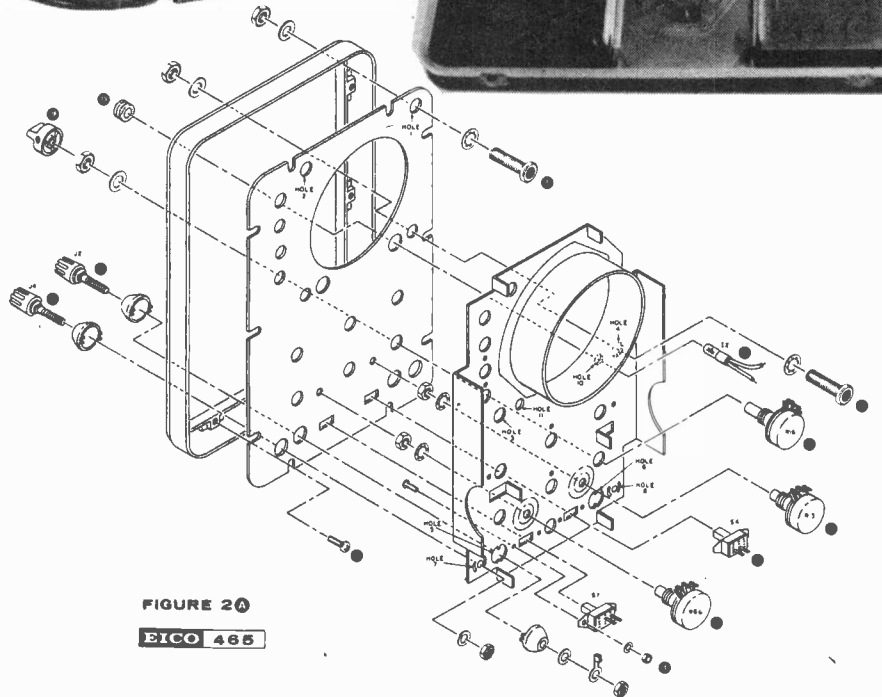
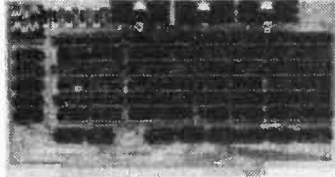

FIGURE 20  
EICO 465

# GODBOUT



## Quality Computer Products

Available in Canada from

# COMPUMART

## The Personal Computer Store

Check these sensational new products (and the oldies) at these sensational new prices!!

Econoram\* boards are generally available in 3 forms: unkit (sockets and bypass caps are pre-soldered in place for simple, one-evening assembly), assembled and tested, or qualified under our high-reliability Certified System Component (CSC) program (200 hour burn-in, immediate replacement in event of failure within 1 year of invoice date). 1 year limited warranty on all products. Refer to chart below for pricing.

NEW	Name	Storage	Bus	Configurations	Notes	Unit	Asm.	CSC
	Econoram IIA	8K X 8	S-100	2-4K blocks	1	\$219	\$259	\$339
	Econoram IV	16K X 8	S-100	1-16K	1	\$379	\$439	\$599
	Econoram VIIA-16	16K X 8	S-100	2-4K, 1-8K	1	\$399	\$459	\$615
	Econoram VIIA-24	24K X 8	S-100	2-4K, 2-8K	1	\$569	\$659	\$849
	Econoram IX-16	16K X 8	Dig Grp	2-4K, 1-8K	1	\$449	\$519	n/a
	Econoram IX-32	32K X 8	Dig Grp	2-4K, 1-8K, 1-16K	1	\$789	\$885	n/a
	Econoram X	32K X 8	S-100	2-8K, 1-16K	1	\$745	\$895	\$1095
	Econoram XI	32K X 8	SBC/BLC	2-8K, 1-16K	1	n/a	n/a	\$1425
NEW	Econoram XII-16	16K X 8	S-100	see notes	1, 2	\$469	\$579	\$739
	Econoram XII-24	24K X 8	S-100	see notes	1, 2	\$595	\$749	\$895
	Econoram XIII	32K X 8	S-100	see notes	1, 3	\$789	\$959	\$1175
	Econoram XIV	16K X 8	S-100	see notes	1, 4, 5	\$409	\$479	\$635
	Econoram XV-16	16K X 8	H8	1-16K	1, 6	\$459	\$559	n/a
	Econoram XV-32	32K X 8	H8	2-16K	1, 6	\$849	\$995	n/a

**Notes:**

1. Works at 5 MHz with 8085 or at 4 MHz with Z80.
2. Bank select board — 2 independent banks addressable on 8K boundaries.
3. Bank select board — 2 independent banks addressable on 16K boundaries.
4. Bank select board — 1 bank addressable on 4K boundaries.
5. 24 address lines for extended addressing.
6. Bank select option for implementing memory systems greater than 64K.

\*Econoram is a trademark of Bill Godbout Electronics.

### "INTERFACER" S-100 I/OBd Unkit \$269.00, assm \$339.00

Dual serial port with 2 full duplex parallel ports for RS-232 handshake; EIA232C line drivers and receivers (1488, 1489) along with current loop (20 mA) and TTL signals on both ports. Onboard crystal-controlled timebase with independently selectable Baud rate generators for each port (up to 19.2 Kbaud). This board has hardware LSI UARTs that don't tie up the computer's CPU, operates with 2 to 5 MHz systems, includes software programmable UART parameters/interrupt enables/handshaking lines, offers provision for custom frequency compensation on both receive and transmit sides to accommodate varying speed/noise situations or unusual cable lengths... and even all this isn't the full story on what this no-excuses board can do for you.

TERMS: Visa/Master Charge (Please include expiry date) cheque or Money Order. Add 2% for shipping and handling. Ontario residents add 7% Provincial Tax.  
COMPUMART, P.O. Box 6132, Station J, Ottawa, Ontario, K2A 1T2. Showroom: 411 Roosevelt Ave.; or phone (613) 725-3192

Circle No. 20 on Reader Service Card.

### LED VU/Peak Meter

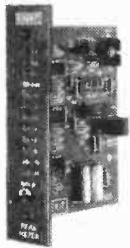

- 12 LED's
  - Red, green, yellow
  - Horiz. or vert. mount
  - Fast "attack" time
- #2100 METER \$22.95  
#2101 DUAL SUPPLY \$19.95

### Light Organ

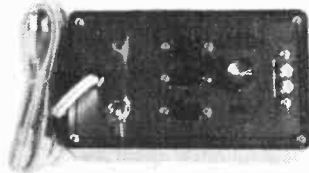

- 3 channels
  - 250W/channel
  - Level control
- #1501-1 PARTS ONLY \$ 9.95  
#1505-2 PARTS & PCB \$14.95  
#1505-3 WITH CASE \$21.95

# RAEKIT

Quality Electronic Kits For Over A Decade

R-A-E Industrial Electronics Ltd.  
3455 Gardner Court, Burnaby, B.C.  
V5G 4J7 Phone: (604) 291-8866

MAIL ORDERS  
WELCOME!

TERMS: Visa/Master Charge (Include signature, number and expiry date), cheque or money order. Add \$2.00 for shipping, B.C. residents add 4% Sales Tax.

CIRCLE #5 ON YOUR READER SERVICE CARD  
FOR YOUR COMPLETE RAEKIT CATALOGUE.

### CMOS Electronic Dice

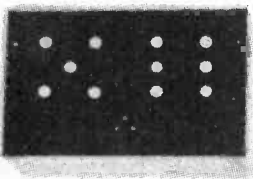

- Touch-actuated
  - Random odds
  - Automatic turnover
  - Last # recall
- #3010 DICE \$24.95

### UNIVERSAL DESIGNER

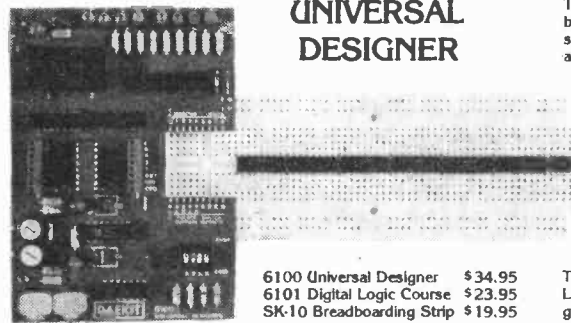

- 6100 Universal Designer \$34.95  
6101 Digital Logic Course \$23.95  
SK-10 Breadboarding Strip \$19.95

The 6100 Universal Designer is an indispensable aid to breadboarding digital IC's. It plugs directly into breadboarding strips such as the Elite SK-10, and provides the most often used inputs and outputs for circuit design.

- 2 Bounceless Pushbuttons
- 8 LED Monitors
- 4 Switch Outputs
- 2 Variable Clock Generators
- Readouts with BCD Inputs
- 2 Decade Counters
- Operates on a 6 Volt Battery
- 5 Volt Supply Pins

The ideal companion to the Universal Designer is the 6101 Digital Logic Course. This kit includes a Laboratory Manual and 21 integrated circuits for an introductory course in digital logic.

Circle No. 5 on Reader Service Card.

## Raekit

RAE Industrial Electronics started in the kit business over ten years ago (see News Digest, Aug. '79 ETI) and now offer some thirteen kits.

For experimenters, RAE offers their Universal Designers Board (#6100, \$39.95) which plugs directly into any breadboarding strip. The 6100 can then supply 5 VDC and two sets of variable clock pulses directly to the circuit. In addition it has 8 LED monitors, 2 decade counters and two BCD inputs.

Another interesting kit is the 2100 LED VU Meter (\$29.95). It features fast attack time and slow decay to indicate otherwise unreadable peaks. The 2100 can be mounted in either vertical or horizontal fashion with the same bezel.

RAE also sent us an 8204-2 Tone Ringer for inspection. The unit can be plugged directly into telephone lines and generates a two toned beep when someone calls. The kit comes with a modular jack that is compatible with Bell's current jacking program. Instructions are clear and detailed. Documentation is quite good and includes an easy to understand technical description.

RAE kits are available from RAE Industrial Electronics Ltd.

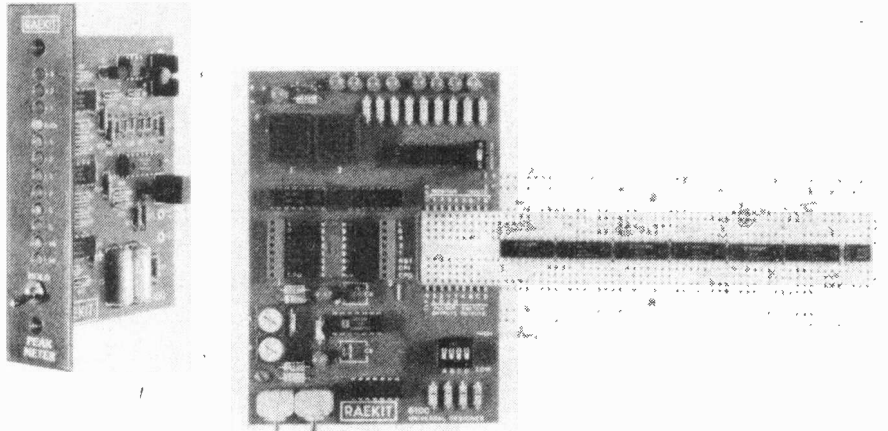

Above, 6100 Universal Designer Board and 2100 LED VU meter.

## RAEKIT 1979 CATALOGUE

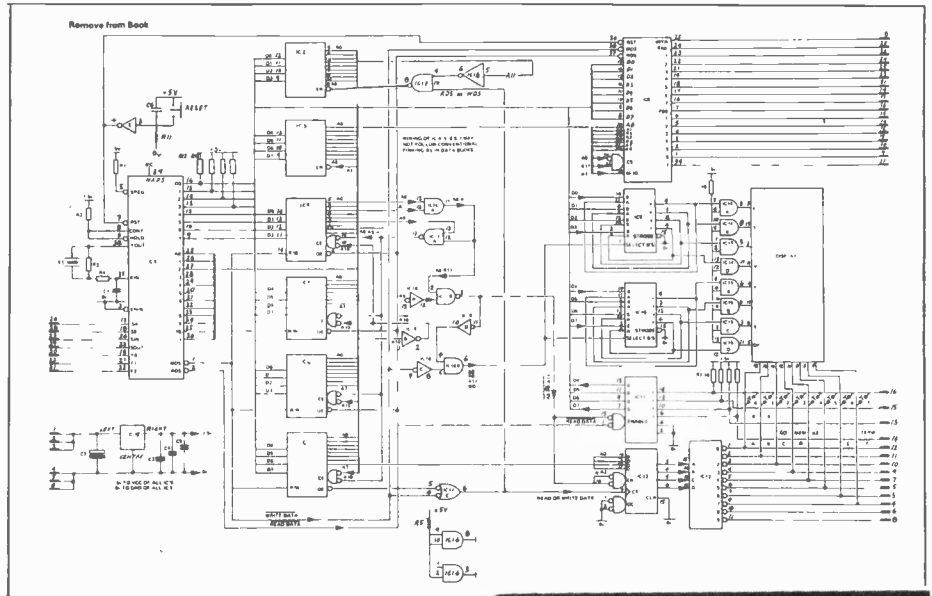

Below, a simple computer from Science Of Cambridge.

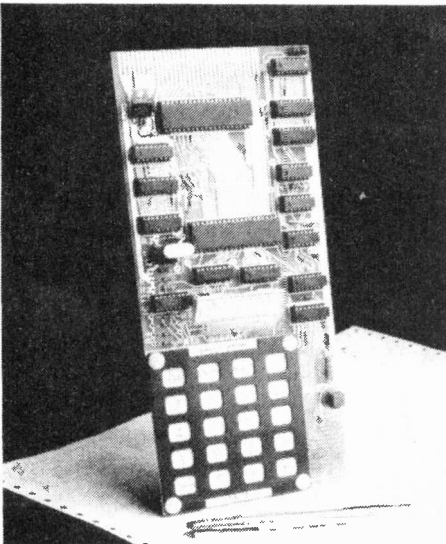

## SCIENCE OF CAMBRIDGE

For a cheap and easy way in to micro computers Science of Cambridge offers a bare bones micro kit.

The MK14 is available for \$139.95. The kit features 256 byte RAM, 512 byte PROMED monitor and the whole thing runs on a 4 MHz clock. In addition you can add another 256 bytes of RAM on Board.

Accessories include a RAM I/O and cassette interface.

The 88 page manual that came with the kit had a very slick appearance and included quite a wide diversification of programs to try. The actual constructional part was 5 pages long. But then the parts count of the kit is low. Documentation is good. The MK 14 is available from Gladstone Electronics.





**ON THE FRONT OF THE BOARD:**

- 21.  14 Pin IC Socket
- 22.  14 Pin IC Socket
- 23.  16 Pin IC Socket
- 24.  6740 Display — Identification numbers on display should face IC sockets.
- 25.  D1,2 Miniature Red LED — painted lead into dotted hole. They should be raised off the board to the height of the display, about 6mm.
- 26.  6740 Display — Identification numbers on display should face IC sockets.

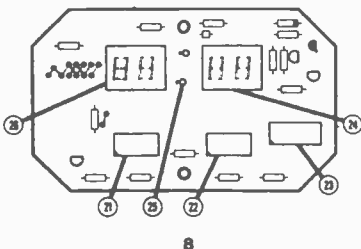

**ON THE REAR OF THE BOARD:**

- 27.  C2 1000 mf Capacitor — **OBSERVE POLARITY**
- 28.  68 ohm Resistor (marked 68R0) This resistor should be spaced about 3 cm. off the board, and bent **SLIGHTLY DOWN** toward the bottom of the board.
- 30.  Strip two 5 cm. lengths of stranded wire on both ends and connect them to the indicated pads.
- 31.  Install the grommet in the hole in the rear of the plastic case. Bring the leads from the plug-in transformer through the grommet and solder them to the indicated pads on the board.  
If you are using a relay, it must be installed now. Solder it in place, **STICKING OUT THE BACK OF THE BOARD**. Then connect an appropriate length of two wires to the Switch Output pads above the relay, and run them through the grommet in the case.
- 32.  K1  
**NOTE**  
Use double-sided tape to fasten the back of the speaker to the back of the Clock Chip. Then solder the two wires (step 30) to the speaker.
- 33.  U1 FCM7030 Clock Chip — Install in socket — **NOTE NOTCH**
- 34.  Use double-sided tape to fasten the back of the speaker to the back of the Clock Chip. Then solder the two wires (step 30) to the speaker.

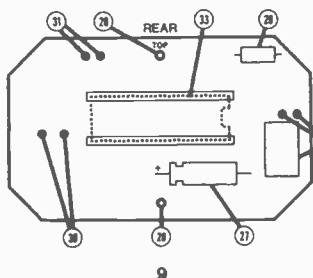

**COMPUKITS**

As a rule, most students go through school on a limited budget. Cost is therefore a primary consideration in selection of kit.

The uSO kit 68 is designed with the student in mind.

It consists of a 6800 microprocessor with 256 bytes of memory and peripheral interface adaptor. The unit is fully expandable to 65 K of RAM and UK of PROM through two 15 pin edge connectors.

All documentation is in one 1/2" thick duotang bound manual. It seems like the sort of book it would take several sleepless nights to complete.

Cost is \$175.00 less power supply. You will require a 5V 2A power supply.

The uSO68 is available from Compu-kits or Longman Sales Inc.

**PACCOM**

Paccomm is another manufacturer of the unboxed type of kit. All their kits feature 'State of the art' design and are complete in that they have on board power supplies.

Paccomm offers a number different clock kits. These range from the FTK0106 Auto Clock with calendar to a full size wall clock (FTK0101) which features 2.5" display (using 28 LEDs per digit).

Other kits include an appliance timer with key board entry (FTK0107) and several power supplies. Unfortunately prices were not available at the time of writing.

Instruction manuals are quite good with an abundance of overlays. The step-by-step instructions are quite explicit and there's no way even a catatonic three year old could screw up these kits.

Write to Paccomm, 14825 NE 40th Street Suite 340, Redmond, Washington 98052.

Above and below, what you can expect from most instructions. Above, RAEKIT. Below, Paccomm. Right, the uSO kit 68 from CompuKIT.

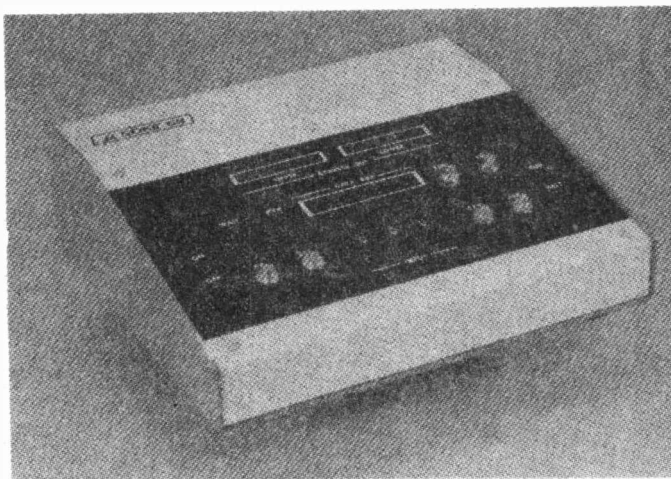

**FTK0110 VARIABLE POWER SUPPLY ASSEMBLY INSTRUCTIONS FAIRCHILD**

The Solid State Technology FTK0110 is an adjustable 0-20 mA power supply. The voltage range is from 0.25V to 20V DC and 0.1V DC to 20V AC. The output range is controlled by an on-board OPDT switch. The power supply operates from 120 V AC 60 Hz. The following cover some one of the components and with all printed circuit board items mounted. The typical specifications are:

Output voltage range	0-20 V DC (2 range)
Output current	200 mA
Line regulation	1%
Load regulation	1%
Quiescent current	20 mA
Output noise voltage	50 mV
Output impedance	50 ohm
Output current peak	500 mA

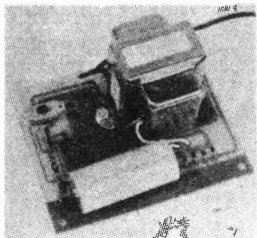

Install the following switches in the location shown, seating the body of the switch firmly to the printed circuit board. Solder the pins to the foil side of the board.

- ( ) S1 OPDT slide switch
- ( ) Solder to the foil side
- ( ) Check the solder connections

Install the transformer, making sure the bleed leads are in the locations shown. Follow the procedure outlined below:

- ( ) Cut the two black transformer leads so that approximately 2.5" remain.
- ( ) Insert the black (primary) leads into the locations shown
- ( ) Solder to the foil side. Make sure that these two points do not short to each other or to any surrounding foil.
- ( ) Insert the white (secondary) leads into the locations shown.
- ( ) Solder to the foil side.
- ( ) Insert the remaining secondary leads (Green) in the location shown.
- ( ) Solder to the foil side.
- ( ) Trim the leads.
- ( ) Check the solder connections.

Install the 120 Vac line cord in the location shown.

- ( ) Insert line cord.
- ( ) Solder to the foil side. Make sure that these two points do not short to each other or to any surrounding foil.
- ( ) Trim the leads.
- ( ) Check the solder connections.

Connect a length of wire to each of the output pads on the printed circuit board. The output pads are labeled "OUTPUT +" and "OUTPUT -" on the diagram.

- ( ) Connect a length of wire to OUTPUT +
- ( ) Solder to the foil side
- ( ) Connect a length of wire to OUTPUT -
- ( ) Solder to the foil side
- ( ) Trim the leads.
- ( ) Check the solder connections

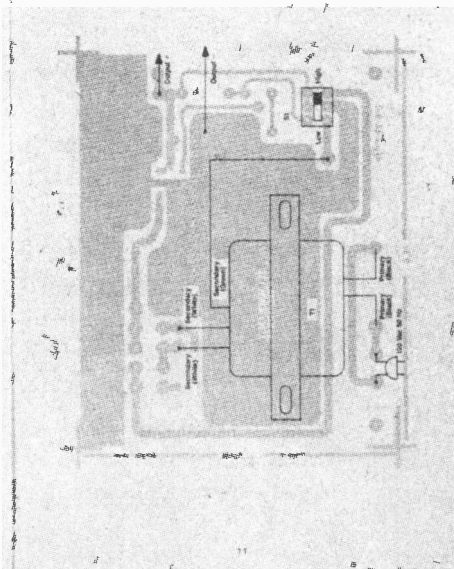

## PAIA

PAIA offers a strong line of music synthesizers and related equipment.

At the top of the line we have the 4700/S. For \$1100.00 you get 2 VCAs Stereo Mixer, three power supplies, control oscillator and noise source, reverberator, 3VCOs, 1 VCF, two envelope generators and 12 event sequencer. To hold it together the system is enclosed in two road cases with keyboard.

There are actually several permutations of the 4700 ranging from \$700 to \$1130. You can also get the 4700 series of modules separately.

If you're into building your own synthesizer there's the 8782 encoded keyboard kit at \$249.

Other kits include the Gnome micro synthesizer, Organtua, Surf Synthesizer, Wind Chimes Kit and more.

We were provided with assembly instructions for the 4750 Programmable Drum Set and a users manual for the 3740 Gnome Synthesizer. Assembly instructions appear to be clear and unambiguous along with a wad of pictorials and schematics. The design analysis is also fairly comprehensive.

The users manual for the Gnome starts out with a quick course on synthesizers before going into actual operation. Once again there are plenty of pictorials and a design analysis at the end. We also noticed that manuals and pictorials were punched for three ring binder use. Nice touch. PAIA Synthesizers are distributed by Gladstone Electronics who kindly provided us with manuals and information.

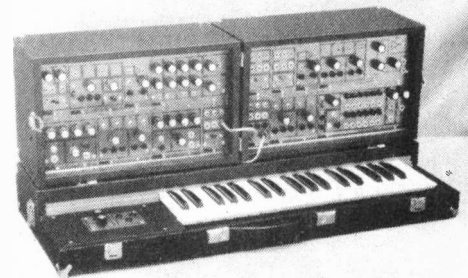
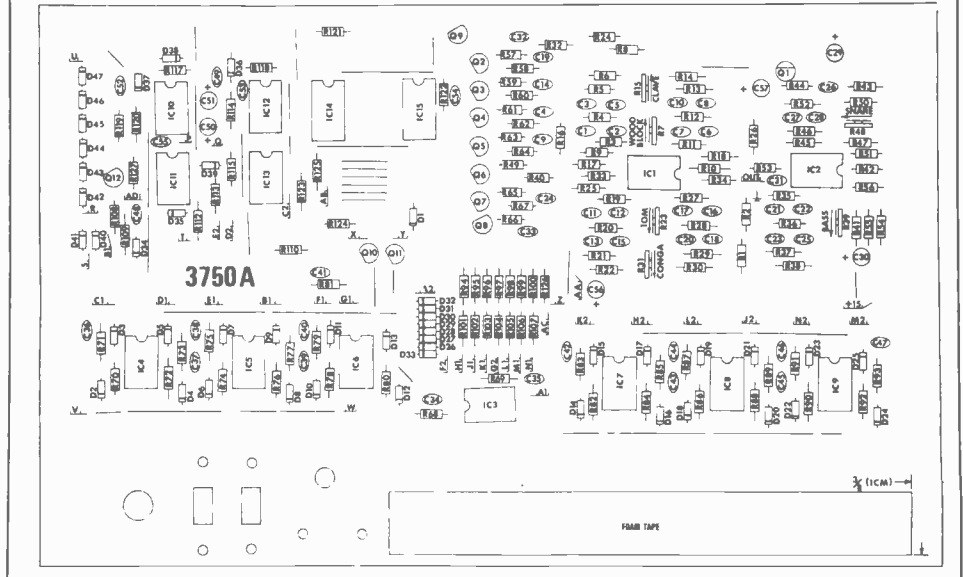

## SPEAKER KITS

Speaker kits is a general name Gladstone applies to all speaker combinations they carry. These include such name brands as KEF, Philips and Decca.

### KEF CANTATA KIT

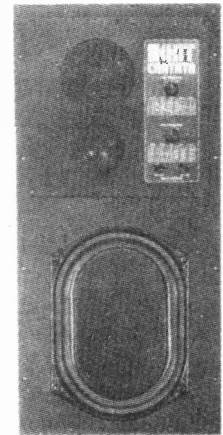

### System 1-15/78

Small Bass Reflex System for Home or Mobile

This kit will give you a small bass reflex system for home or mobile use. It uses the new 88 series 15 inch woofer and a 15 inch tweeter. The tweeter is a 15 inch dome tweeter with a 15 inch horn. The tweeter is a 15 inch dome tweeter with a 15 inch horn. The tweeter is a 15 inch dome tweeter with a 15 inch horn.

Figure 1 indicates the general layout of the enclosure. Except for the tweeter port which must have a 15 inch diameter, all other dimensions are given in inches. The tweeter port must have a 15 inch diameter. The tweeter port must have a 15 inch diameter.

### System 2-60/60

Three Way 60 Watt Floor Standing System 12 inch Woofer

This kit will give you a three way floor standing system. It uses the new 88 series 12 inch woofer, a 6 inch midrange driver, and a 6 inch tweeter. The tweeter is a 6 inch dome tweeter with a 6 inch horn. The tweeter is a 6 inch dome tweeter with a 6 inch horn.

### System 2 - 60/60

Three Way 60 Watt Floor Standing System 12 inch Woofer

Figure 2 shows the general layout of the enclosure. Except for the tweeter port which must have a 6 inch diameter, all other dimensions are given in inches. The tweeter port must have a 6 inch diameter.

The same design can be supplied as described by using the 88 series 12 inch woofer and a 6 inch midrange driver. The tweeter is a 6 inch dome tweeter with a 6 inch horn.

**GLADSTONE ELECTRONICS**  
A LEADING MAIL ORDER SOURCE FOR THE  
OF DO-IT-YOURSELF ELECTRONICS  
DIY

**SPKAKERS**

**sinclair**

**PDM35**  
digital  
multimeter  
meter  
\$89.95

**ORGANTUA**  
ELECTRONIC  
MUSIC  
KITS  
\$619.00

**AMPLIFIER MODULES**

**BUSINESS HOURS**  
Tues. Wed. Sat. 9:30-5  
Thurs. Fri. 9:30-5  
(Closed Mon.)

**2 STORES TO SERVE YOU!!!**

1728 Avenue Rd. Vn  
Toronto, Ont.

1938 Eglinton Ave. East  
Scarborough, Ontario  
M1S 2B9

Telephone Orders  
1-(416)  
787-1448

SCARBOROUGH  
499-8888

Aside from a very popular line of HiFi speakers and crossovers, Philips has also designed a number of very effective enclosure/speaker combinations. You can obtain a flyer detailing eight such systems for \$1.00. Gladstone Electronics will also sell you the proper speaker combinations.

Of course some ability in carpentry is required but diagrams and graphs are clear and should be adequate.

Gladstone is also the exclusive distributor for two new KEF speaker kits.

One of these is the Cantata kit. \$499.00 gets you a T52 tweeter, B110 midrange, B139 9x13" woofer and crossover mounted on, baffle board. The system is capable of handling 150W with a response of 35 to 20000 KHz.

You can get a good idea of Gladstone Electronics selection of speakers from the 16 page insert to October, 79 ETI.

**VANSCO**

Vansco is entering the kit market with two kits, Electronic Dice and Electronic Roulette.

Both utilize CMOS technology and feature automatic shut off after 10 seconds. Price is \$33.98 each. Apparently a burglar alarm kit is in the works for some time in the future.

Instructions are clear and include fairly good technical descriptions. They're also the only instructions we've seen in both French and English.

Vansco kis are available direct from Vansco Electronics .

**MOONLIGHTER**

If your looking for audio kits with a finished appearance at comparatively low cost then a quick look at Moonlighter Electronics is in order.

The most interesting one Moonlighter offers would be the Playmaster Stereo Amplifier. Features include 34W per channel output, bass & Treble controls, RIAA equalization, BI-FET phone amplifier and an overall THD of 0.2%. Price \$169.95 Canadian prepaid.

Another kit to note a 120W per channel power amplifier featuring low TID. A feature of this amplifier is complementary circuitry throughout with feedback to each individual stage. Price \$160.00 US ppd.

Moonlighter also markets a number of clock kits.

Instructions appear adequate though somewhat variable in nature from kit to kit.

All kits shipped post paid from Moonlighter Electronics San Francisco, Ca.

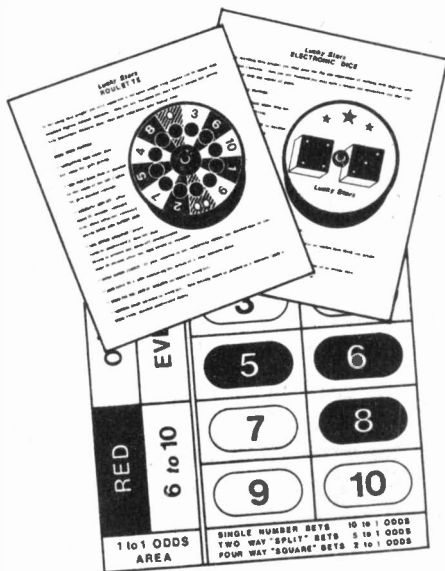
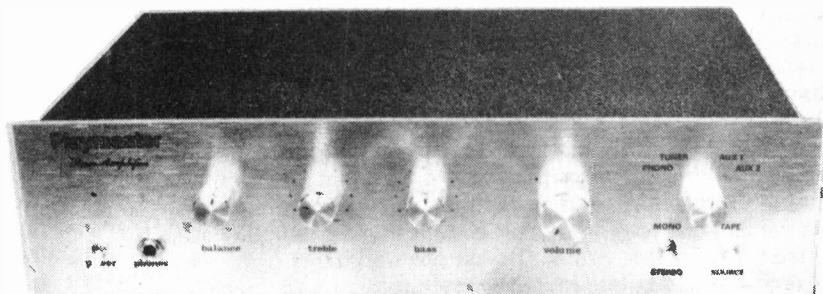
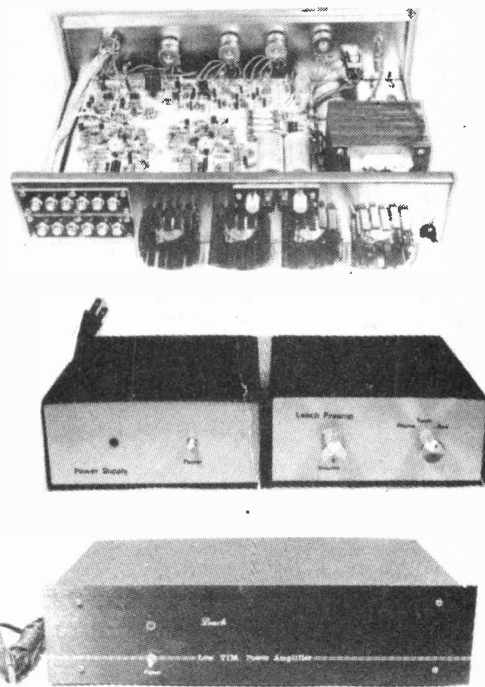

**LAST MENTIONS**

There are several companies who we know are supplying kits, but who we have not included. This was mainly due to lack of material, so it's worthwhile checking the offerings of the following: A1 Electronics: see ads in previous issues of ETI.

Arkon: see ads in this and previous issues.

Dominion Radio: see catalogue in September issue.

(All the above are in the Toronto area.)

Teknikit Associates: see classified ads, this issue.

Northern Bear Electronics: suppliers of some ETI projects as kits: see the classified ads in this issue.

# Ultra Fidelity, Part II

## Design Principles

Last month Stan Curtis looked at the theory behind ultra fidelity, this month he discusses some basic design principles.

### OUT OF THE RUT

A few years ago power-amplifier design had settled into a satisfying rut. In the UK the Quad 303 and the Cambridge P-Series had achieved very satisfactory performance figures and they were generally considered to be good amplifiers. In the USA the Crown DC300 has achieved an almost theoretically perfect specification and was hailed as "State of the Art".

However, the first crack to appear was caused by new loudspeaker designs. Some had very demanding impedance curves which in some cases presented a two ohm load to the amplifier. Such a low value of load (almost a short circuit to some minds!) operated protection circuits in many amplifiers, limiting the current to protect the output transistors.

The operation of these caused a very unpleasant "clipping" sound in some cases and even stranger "clicks" and "bangs" in others. Thus alerted it became apparent to some designers that conventional protection circuits were turning partly-on quite frequently in the course of a piece of music and so giving a sort of premature clipping action.

Without any doubt the best results are achieved when the output stage is devoid of any protection at all. The output stage should be designed to deliver all the current a load demands without limiting. Consider the reproduction of a bass drum. If the amplifier starts to limit the start of the "thump" the sound pressure will collapse and the bass-drum will appear to have no body and thus sound unrealistic.

The output-stage should ideally be able to sink the full energy of the power-supply until its regulation causes the current to limit progressively. So in a good amplifier design the output-stage and the power-supply must be designed as a single item and not as separate circuits. Several amplifiers are designed like this. The Lecson AP3 Mk II, the BGW models 500 and 750, and the Mission Power Amplifier. The Lecson AP3/11 can, for instance, deliver nearly 20 amps to the load before the mains fuse blows and the BGW model 750 even more.

However, with such high current capability it is essential that the amplifiers have speaker muting to prevent switch-on "thumps" (or more accurately, earthquakes) and dc offset protection to protect the loudspeakers from the effects of 20 amps of pure dc!

If the amplifier now has to drive a capacitive load eg.

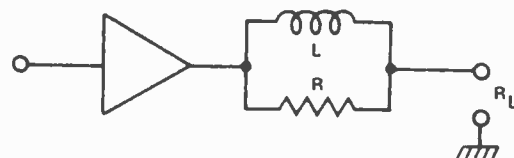

*Ever wondered what this circuit in the output of an amplifier is for? Wonder no more – it's to aid the output stage in handling a capacitive loading by partially cancelling the effect.*

electrostatic speakers, or complex crossover networks; another pole is added at the output.

In the case of the unconditionally stable amplifier the only ill-effect will be some "ringing" in the closed loop step response – but in the case of the marginally stable amplifier it may go completely unstable. The most popular "belt and braces" solution to this problem is to fit a resistor-inductor network at the output to "cancel-out" the effect of the capacitive loading.

It is interesting to note that some marginally stable amplifiers omit those components as most speaker cables have sufficient resistance and inductance. However, some of the new "Super-Cables" (Litz and Lucas, etc) have a very low resistance and almost no inductance but some capacitance – and their use with certain amplifiers has caused instability, with the amplifier (or speakers) eventually blowing-up!

### WHICH PARAMETERS MATTER

For many years it has been usual to specify and compare amplifiers through their ability to handle a continuous (steady state) sine-wave signal. Thus such a signal is used to measure power-output, frequency response, harmonic distortion, crosstalk, input overload capability, intermodulation distortion, damping factor, and gain! Unfortunately many engineers and Hi Fi pundits still believe that such information is ALL that is necessary to quantify an amplifier's performance and to compare it with others. Not so!

Steady-state sine-wave testing can tell only part of the story and can often be misleading. Music contains complex wave forms with a spectral content of greater than eight octaves and dynamic ranges of up to 100 dB. Yet such complexity is readily understood by the human brain which, in mastering the subtleties of spoken language, has evolved the ability of extraordinary auditory sensory perception. The music signal, as with all audio signals, can be considered in terms of two variable qualities – the frequency domain, and the time domain.

The frequency domain has monopolised engineers' thought

for so long — even the most complex music signal can be represented by a Fourier analysis.

This mathematical equation lists separately each frequency making up the signal, (together with its phase and amplitude). However, a Fourier analysis is only complete in the case of simple waveforms, with more complex waveforms it becomes only a convenient approximation.

To make a Fourier analysis of a signal the components of that signal have to be analysed over a period of time such that complete cycles of the lowest frequency can occur. Thus we take consideration of the time domain.

Where steady-state signals are concerned the time domain is not normally considered, as the signal is of a continuous unchanging nature between any two periods. If the "time window", during which the signal is Fourier analysed, is reduced progressively it becomes apparent that an accurate spectral analysis becomes less possible. It can then be seen that the important characteristics of the signal are amplitude and rate of change. In other words its envelope.

## WHAT DO WE WANT

What is required is the amplification of an audio waveform in such a way that the ear can detect no degradation.

Let us consider ways in which such degradation can occur. The waveform envelope can be distorted by amplitude changes of any component or by changes in the phase relationship of the component harmonics.

Experimental work has established that changes in the relative amplitudes of the harmonic structure of the waveform are readily detectable.

Other work has shown that the qualitative characteristics of a complex sound depend upon the phase relationships of the component harmonics. It would seem that as a phase difference must be interpreted as a time delay between the component parts of the signal, then a sufficient phase shift in a system must eventually become audible as these component parts are moved in respect to each other in time. In practice large phase shifts are very audible and indeed telephone lines are often phase and delay corrected to render speech intelligible. However, establishing an acceptable degree of phase shift is extremely difficult.

Following the arrival of "linear phase" loudspeakers great controversy has raged over whether phase shifts affect sound quality. A study of the experimental work performed to date shows that

1. It seems to be very difficult to replicate someone else's experiment.
2. It seems, on balance, that where recurrent waveforms (steady state) such as sine-waves (and instruments producing a "continuous" although decaying tone) are concerned; then quite large phase shifts, between the extremes of the frequency band, have no identifiable effect on sound quality. However, a phase non-linearity on the leading edge of a true transient appears to be audibly more perceptible, particularly on speech and percussive sounds.

## BANDWIDTH AND TID

Transient signals cause many problems of which phase linearity is but one. Other problems include; instability and ringing, clipping, slew-rate limiting, and transient intermodulation distortion.

Transient intermodulation distortion (TID or TIM) is much in vogue but is often misunderstood. TID most

commonly occurs when an amplifier, with overall negative feedback over several stages, is driven by a large enough signal whose frequency (or equivalent rise time) is above the open loop bandwidth of that amplifier.

Because the feedback loop is fed from the output of the amplifier, there is no effective feedback until signal current flows at the output, i.e. during the open-loop rise time of the amplifier.

Very large signals occurring in the intermediate stages of the amplifier cause those stages to distort or even to clip. With some amplifiers this clipping can cause the stage to latch-up for a time until the operating conditions restabilise. Thus not only is the leading edge of the signal severely distorted — in some cases it is removed completely.

TID is therefore a form of overloading that is dependent upon both amplitude and time. It is audibly (but at a higher signal level) similar to cross-over distortion, as both effects cause phase and amplitude modulation of the signal due to momentary change in gain. (Remember that at the cross-over point zero, there is no current flow in the output stage and hence no feedback current and so the amplifier is momentarily open-loop.)

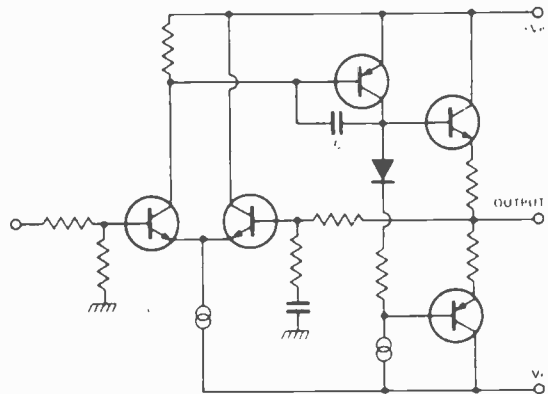

Circuit diagram of a typical amplifier circuit which employs lag compensation techniques — provided by C.

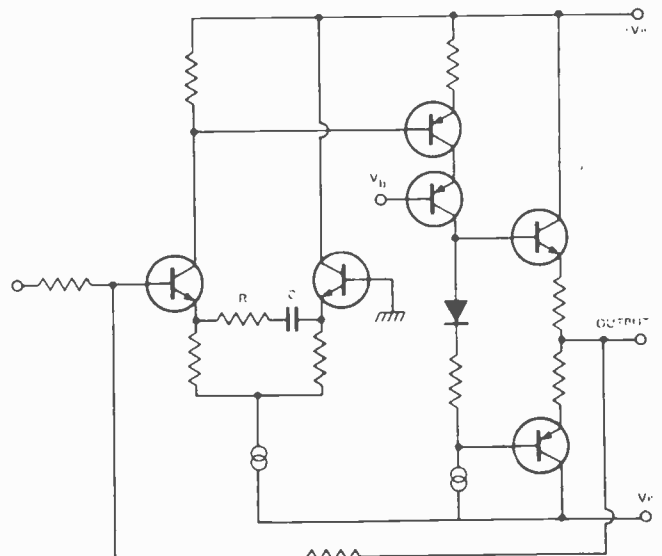

Lead compensation: components R and C provide the time constant.

## MAKING BIG BANDS

TID can be avoided by designing an amplifier whose open-loop bandwidth is greater than the highest frequency of the input signal. The maximum bandwidth can then be defined at the input by a passive RC filter. Thus if we decide upon a maximum signal bandwidth of 20 kHz then our filter will limit the signal waveform rise-time to  $T = 0.35$ .

$$T = \frac{0.35}{20 \text{ kHz}}$$

i.e. 17.5  $\mu\text{s}$ .

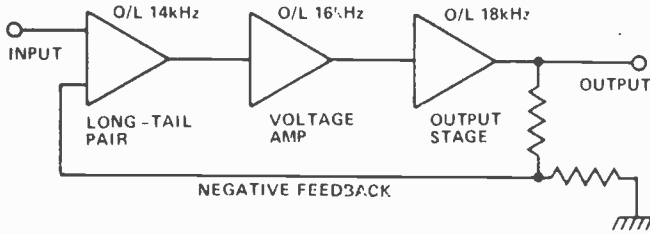

Third method of avoiding TID. Each stage in the design has a wider bandwidth than the preceding one.

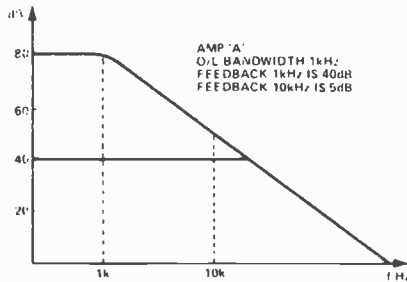

This amplifier design has a limited open loop bandwidth and the THD will rise with frequency.

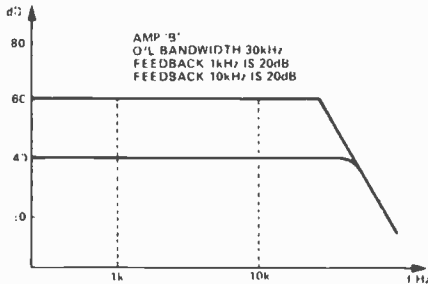

Contrast this with the graph above. The bandwidth here is much wider, resulting in a more linear THD response.

Our amplifier's open-loop bandwidth should be designed to be, say, 23 kHz, giving it an open-loop rise-time of 15  $\mu\text{s}$  and freedom from TID. If however, in the interests of a good specification, and possibly better reproduction, we decide upon a close-loop bandwidth of 100 kHz (i.e. a rise time of 3.5  $\mu\text{s}$ ) then our amplifier will need an open-loop bandwidth of greater than 100 kHz to maintain freedom from TID. In a power amplifier such performance is not easy to obtain. Fast power transistors are notoriously easy to blow-up and are expensive. The common form of lag compensation (used where the open-loop bandwidth is restricted) has to be replaced by lead compensation:—

Another technique is an extension of the first in that the

preceding stage of the power-amplifier is designed to have a lower open-loop band width than the next.

## IMPORTANT OR NOT

Many people now consider that TID is unimportant or even that it doesn't exist. This is partly because it is very difficult to measure and only readily visible (in the laboratory) in the "clipping" state. To reach this stage with most amplifiers (but not TID-free designs) there is a requirement for either fast rise-time or higher signal levels or both, — conditions that are unlikely to occur in practice. However, a large degree of non-linearity and hence bad intermodulation will still occur with more realisable input signals. Although this cannot be measured yet (how do you measure say, 5% IM over a period of 5 milliseconds?) it can be predicted mathematically and, just as important, heard. Amplifiers free of TID have a very "open" quality with accuracy of depth.

An amplifier designed with a wide open-loop bandwidth, for low TID, often has other more tangible benefits. The high frequency THD is usually no higher than at the mid-point; in stark contrast to more traditional designs. This is because gain is still available at high frequencies for negative feedback. Such amplifiers also usually have much higher slew-rate.

## SLEW

Slew-rate defines the speed with which the amplifier can deliver output voltage to the load. For example, if an amplifier has a maximum output of 100 volts p/p and a rise-time of 100  $\mu\text{s}$ , then the amplifier, if it were perfect, should have an output of about 80 volts after 10  $\mu\text{s}$  in response to a suitable square wave input. In other words the output voltage would have risen at the rate of 8 V/ $\mu\text{s}$ . However, amplifiers do not generally respond to large changes as fast as their small signal characteristics predict, for circuit and transistor capacitances can be charged only as fast as their driving circuits allow.

In its simplest form the slew-rate of an amplifier defines how fast the output voltage can change for large signal conditions, and it is normally quoted in volts per micro second. The maximum slew-rate of an amplifier is usually limited by the slowest stage in its circuit.

That stage will have an operating current  $T$  (as set in the design) and a capacitance  $C$  (usually a frequency compensation capacitor)

$$\text{Slew-Rate} = \frac{T}{C}$$

Thus if a transistor stage has a standing current of 100  $\mu\text{A}$  and is compensated by a 43 pF capacitor then its slew-rate will be

$$\frac{100}{33}$$

$$\text{i.e. } 3 \text{ V}/\mu\text{s}$$

Depending upon the design some circuits have a different slew-rate depending upon whether their output is negative-going or positive-going. Slew limiting also defines the full-power bandwidth; a figure more commonly quoted by manufacturers.

$$f_p = \frac{\text{SR}}{2\pi E_{op}} \quad E_{op} = \text{peak output swing in volts}$$

$f_p$  = Full power bandwidth in hertz.

Thus in a 100 watt (into 8 ohms) amplifier having full-power bandwidth of 20 kHz the required minimum slew-

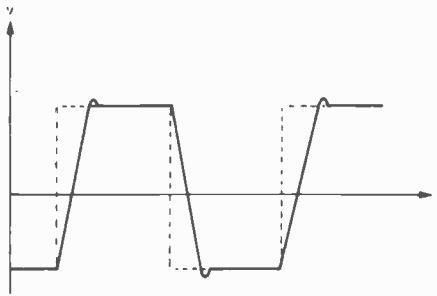

The effects of slew-rate on a signal passing through an amplifier prone to this fault. Top: a square wave, note the slight overshoot. Below that, a sine wave. In both cases the dotted line represents the input.

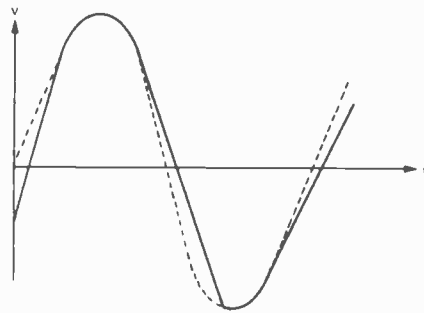

rate would be about  $5 \text{ V}/\mu\text{s}$ . This is, however, the absolute minimum figure and experience suggests that such an amplifier would have a hard, gritty high-frequency sound. Such an amplifier should have a slew-rate greater than  $20 \text{ V}/\mu\text{s}$  to be certain of avoiding the increase in distortion caused by the gradual onset of slew-limiting.

Unfortunately the higher the power output of the amplifier the greater the required slew-rate as more volts swing at the output in the same period of time and so as our 100 W amp needs  $20 \text{ V}/\mu\text{s}$  an otherwise identical 50 W amp needs  $14 \text{ V}/\mu\text{s}$  and a 20 W amp needs only  $9 \text{ V}/\mu\text{s}$ . But these forms of distortion tend to give subtle audible effects compared to the most common amplifier problem — that of clipping.

## CLIPPING

Clipping occurs when an amplifier is overloaded by high level signal peaks. Such peaks occur frequently in much music material and so the manner in which the amplifier clips determines its audibility. A soft, clipping effect where the distortion rises gradually (typical of valve amplifier circuits) is audibly preferable to the hard clipping typical of transistor circuits.

Worse still, some amplifiers tend to suffer saturation effects on clipping and take a time to recover; thus artificially extending the length of time the signal is clipped. The use of overall negative feedback to reduce distortion unfortunately makes things worse. Overall feedback effectively linearises the clipping — the distortion changes from 0.01% (say) to 10%, and quite suddenly too.

## DESIGN PROCEDURE

We have covered just a few of the requirements a designer must consider when working upon the design of power-amplifiers. There are many more to be considered to even

rough out a design specification before the circuit hardware is considered. The following sequence is mandatory:

1. What parameters are important to prevent audible degradation of the signal?
2. Detail a performance specification that meets the requirements of (1).
3. Decide upon the circuit technology necessary; Bipolar; MOSFET; Tube; Class A; Class B; Switching; etc; etc.
4. Undertake a development programme to produce a prototype.

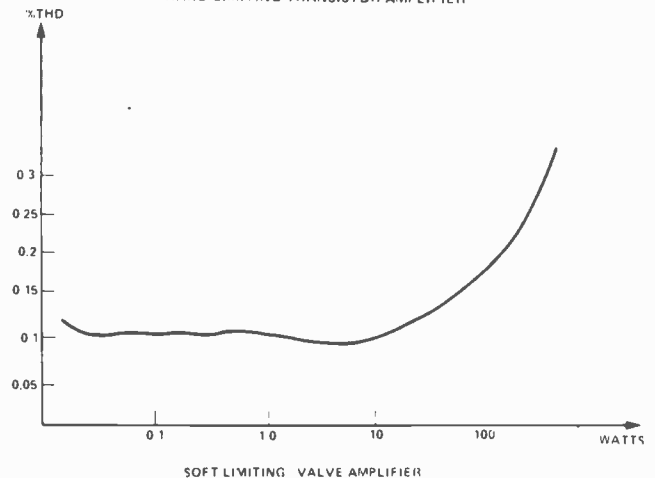
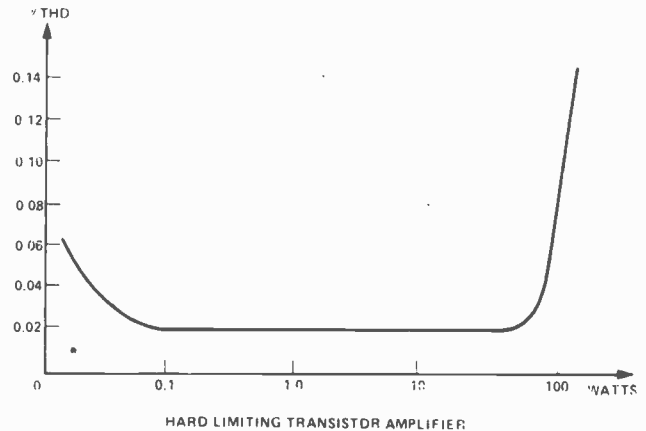

A comparison of the limiting characteristics — in general — of both transistor and valve amplifier types. There is a body of opinion which holds these curves to be the whole truth as to why valve amplifiers are preferred by many musicians.

At this point the designer has to accept that it's a real world and that his performance specification cannot be achieved in a way that is acceptable to accountants, salesmen, customers, customer's wives or whoever else is around. Trade-offs are necessary and much of the "art" is in deciding which defects and degradations are more acceptable than others.

As an illustration of the changes in design approach over the years we will briefly illustrate three designs for which the author has been responsible:

1. Cambridge Audio P60 (P80)
2. Lecson AP3 Mk II
3. Mission Electronics Voltage Amplifier

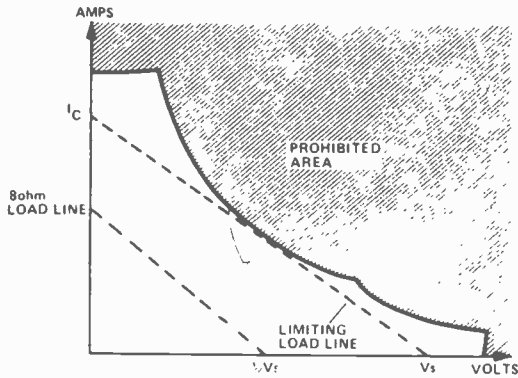

Illustrating the load line conditions for output stages.

The P60 is capable of good mid-band performance (THD 0.01% at 1 kHz is 30 W) but its high frequency distortion is poor because of the limited open-loop bandwidth. Generally this amplifier performs well at low and moderate levels but at high levels its sound quality becomes hard and aggressive. Some improvements to this circuit can be quite simply made as follows:

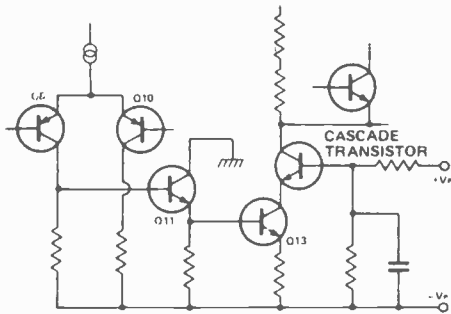

Showing how some of the improvements mentioned can be added to the P60 basic design.

Full circuit diagram of the Cambridge P60 power amplifier design.

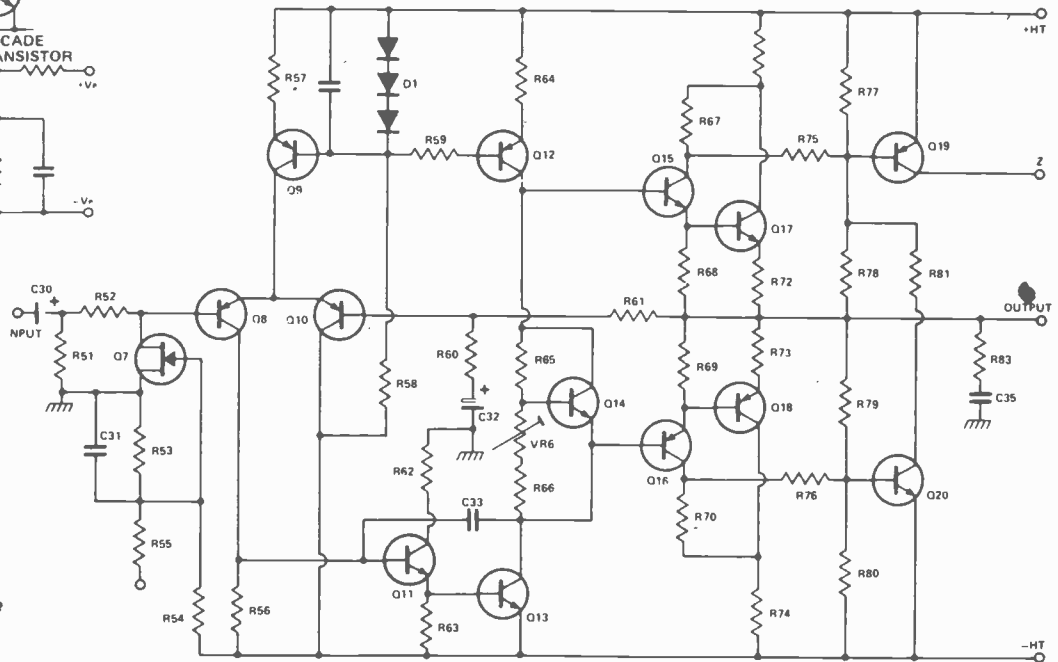

1. A resistor is inserted between Q10 collector and the negative rail to give better balance between Q8 and Q10.
2. A cascade transistor is fitted to Q13 collector to reduce "early effect" distortion due to the collector-base capacitance of Q13.
3. An emitter resistor is fitted to Q13 to provide local negative feedback.

The Lecson AP3 Mk II incorporates much of the thinking in this article and is representative of the latest types of high performance amplifiers. It is a directly-coupled Class B design using a fully complementary output stage of series connected transistors and gives a power output of around 150 watts per channel.

The New Mission Voltage Amplifier represents an attempt to produce an amplifier that performs well irrespective of load. The circuits cannot be described at this stage as they are the subject of patent applications. However, a brief description will illustrate the philosophy behind the design.

The casing contains two completely separate mono amplifiers, each with its own power supply. A separate module carries the dc-voltage offset protection circuits; the delay switched-on circuits; and the thermal protection

## HOW IT WORKS—Cambridge P60

The P60 power amplifier is of a conventional design but with care being taken to optimise each stage. Q8 and Q10 form a long-tailed pair with Q9 as their emitter current source. Q8 and Q10 must be very closely matched for minimum DC offset and for maximum common-mode rejection to avoid H. T. ripple appearing at the output. The next stage is the Q13 voltage amplifier which is loaded by a current source (Q12) instead of the more common "bootstrapped" resistors. Note that Q13 is buffered

from the long-tail pair by an emitter follower (Q11) to prevent any loading of that stage worsening the distortion characteristics.

Capacitor C33 gives lag compensation which defines the dominant pole of the amplifiers. The open-loop bandwidth is quite high (for this type of circuit) at 12 kHz but none the less this amplifier is prone to TID effects. The protection circuit is very unusual in that the output is limited by an FET (Q7), Q19 and Q20 each form conven-

tional V-I summing circuits which monitor the loading on the output stage.

If either Q19 or Q20 turns-on, the gate of the FET Q7 (normally biased-off by R54 to the negative HT) is biased positive and it starts to turn-on. It then acts as a potential divider with R52 and thus attenuates the audio signal. This protection only turns on at the equivalent of 50 W into 2 Ohms load and when it turns on it only adds moderate distortion (0.2% typically) as distinct from clipping.



circuits. Particular attention has been paid in the design to achieving:

1. Low distortion with a very low order of overall feedback
2. Wide open-loop bandwidth with an excellent slewing rate
3. Minimum time and phase distortion
4. A high transient power capability with virtual freedom from clipping effects.

The output stages have a very high current capability but have no protection circuits, the output transistors being designed to sink the full energy of the power-supply into the load. A patented form of voltage feed to this stage gives the amplifier a short term power delivery capability of about 600 watts (compared to the rated 150 watts 8 ohms). This represents a 6 dB increase in power availability over the rated figure. The voltage amplifying stages are designed to clip softly and this combined with the low-overall feedback gives overload characteristics similar to those of an equivalent tube amplifier.

## CONCLUSION

This feature has discussed just some aspects of modern audio amplifier design. At present much attention is still given to whether an amplifier is designed around bipolar transistors, FETs, valves, or switching transistors. However designers are beginning to appreciate that the major stumbling block is not designing a circuit using any of these technologies but in deciding upon what is the performance specification required that will give faithful reproduction of the sound source. Until this problem is solved there will continue to be an element of uncertainty in amplifier design.

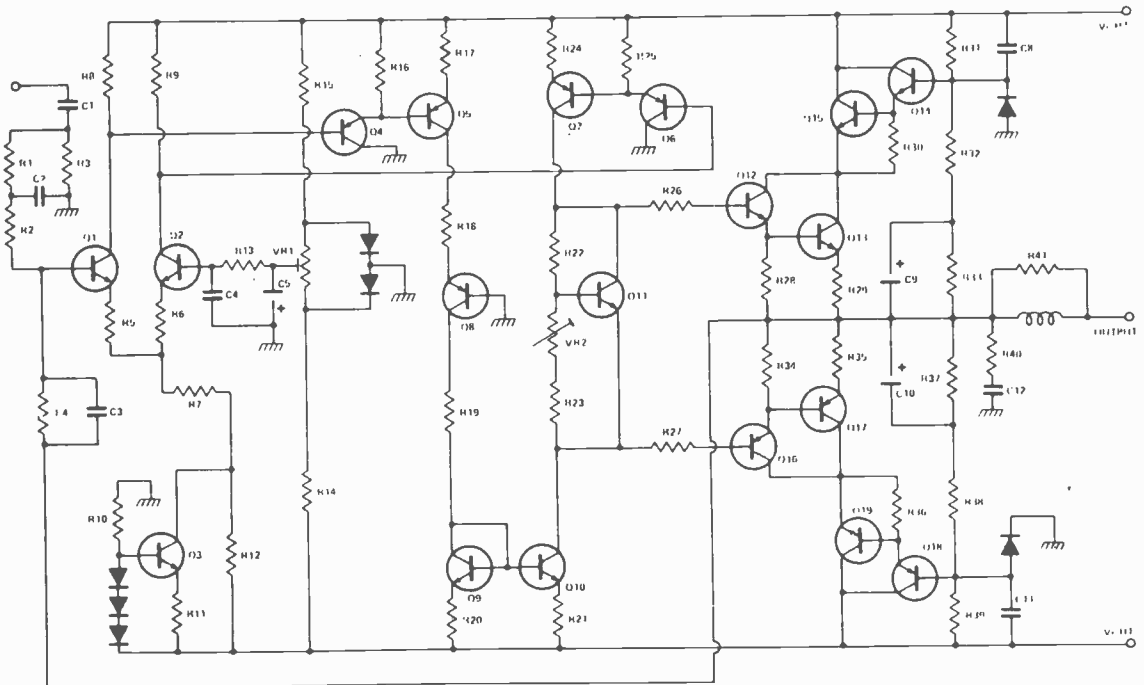

Full circuit diagram for the Lecson AP3 power amplifier design, producing around 150W.

## HOW IT WORKS—Lecson AP3

Transistors Q1 and Q2 form a long-tailed pair differential amplifier with Q3 as the emitter current source. Local feedback is applied in the form of emitter resistors R5 and R6. The base of Q2, instead of being grounded, is connected to a potential divider RV1 which permits the DC offset at the output to be set to zero. The input signal to Q1 is passed through a low-pass filter (R1, C2) which sets the bandwidth to 22 kHz (i.e. below the open loop bandwidth for no TID effects). The bi-phase outputs of the long-tail pair feed a second differential amplifier Q5 and Q7. Transistor Q5 has a constant current load (Q8) whilst is terminated by a current mirror (Q9 and Q10). Transistor Q10 will always deliver the same current as transistor Q9 hence the term "Current Mirror" and the excellent symmetry and balance this stage achieves. Functionally, however, Q10 can be considered as an active load whilst Q7 is a voltage amplifier from whose collector the drive to the output stage is taken. Note that Q5 and Q7 both have local emitter feedback (R17, R24) and that both are buffered from the long-tail pair (Q4 and Q6 emitter followers).

Transistors Q12, Q13, Q16 and Q17 each form conventional Darlington emitter follower stages. Each stage is series connected to a further power transistor (Q14, Q15 and Q18, Q19 respectively) which is permanently biased ON. Their emitter potentials are determined by the ratio of the base potential dividers. This ratio was chosen such that Q13 and Q15 each has half the supply rail across them.

The whole amplifier is in the inverting mode with overall shunt feedback through R4 and C3.

This amplifier is quite fast having an open-loop bandwidth of about 27 kHz. The circuit is stable without the usual compensation capacitors within the loop. THD is low being typically (at 100 W into 8 Ohms) 0.004% at 1 kHz and 0.02% at 10 kHz. The HF distortion can be further improved by selection of transistor Q7 for a device with a low collector-base capacitance.

No conventional protection circuits are used as extremely high power transistors are fitted and these can survive a short-circuit condition in the time taken for the power supply to shut down.

# Using UARTs

Don Rost discusses UARTs, how they work, and when they can be used, with particular attention given to the 5303, and PROM programming.

THE UART, ALIAS the Universal Asynchronous Receiver Transmitter, is a parallel to serial, serial to parallel converter that saves the designer a board full of shift registers and numerous control and error detecting gates, and does it fairly economically too. Applications for this, typical, 40 pin LSI chip include converting the parallel output data bits of a computer into serial form to be used in routing the data to another terminal; conversely, it is often necessary to take the serial data say from a TV Typewriter and translate this back into parallel form for the computer to act upon. Perhaps less obvious applications include centrally monitored alarms, traffic control and meteorological data gathering to name a few (Fig. 1).

## WHAT'S INSIDE?

Looking (Fig. 2) inside the UART we find two sets of shift registers and a considerable assortment of control logic. The two sets of registers are used for the outgoing (transmitting, pins 21-40) and incoming (receiving, pins 1-20) data. Separate clock input pins are assigned to the receiver and transmitter portions to allow different baud rates to each section (in other words the receiver and transmitter of one UART can be used independently of each other). Figure 3 shows how this independent clocking can be used between two terminals and between a faster terminal to computer line.

To function properly the receiver and transmitter at respective ends must be referenced to the same clock rate which is 16 times the line transmission rate; this allows the UART to recheck for valid start signals and to sample data at the center of each interval. Communicating with Teletype the

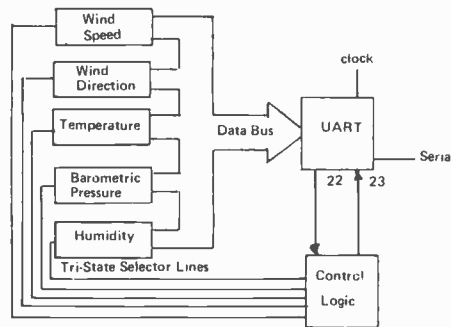

Fig. 1. Meteorological Data Gathering.

transmission rate is often 110 baud (bits/second) and therefore the clock rate equals 1760 Hz, usually clock accuracy of 1% or better is desirable. There are some exceptions to the common clock frequency, such as when a UART is used in a cassette interface circuit (discussed later).

At the start of the transmitting or receiving the internal circuitry must be

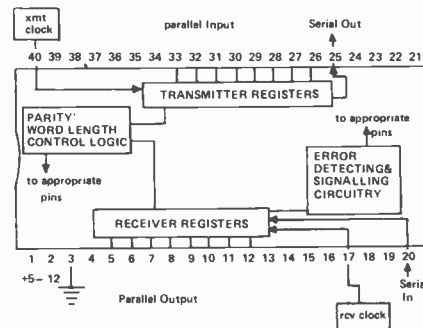

Fig. 2. Basic pin-out and internal structure of the UART.

cleared of any leftover logic states. Reset pin 21 accomplishes this with a logic 1 pulse applied — this might be an automatic circuit that provides this when power is applied as in Figure 4 or it could just be a manual pushbutton switch tied to the +5 volt line. Various control pins allow variations in the way character format is sent or received. These include transmitter stop bit control, no-parity control, parity select, character length and mode control strobe, pins 36, 35, 39, 37 & 38, and 34 respectively. Parity refers to an error testing technique whereby an extra parity bit is added to the data. Even parity means the sum of all 1's in the number and its corresponding parity bit will be even, odd parity indicates the sum of all 1's and parity bit will be odd. Hence, if even parity is being used and data received indicates the 1's are odd, an error has occurred somewhere and the data is unreliable.

Therefore, we have three options concerning parity with the UART, 1) we can select no-parity via a logic 1 on pin

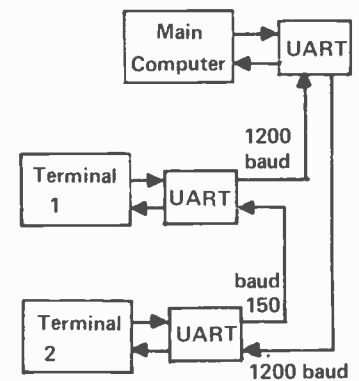

Fig. 3. Independent clocking allows different receive and transmit baud rates.

35 which eliminates the parity bit from transmitted data, removes receiver parity check and causes pin 13 to go to logic 0, 2) we can select even parity by applying logic 1 to pin 39, or 3) odd parity with a logic 0 at pin 39. It might be emphasized that the parity selected controls both halves of the UART being used.

A logic 0 or 1 applied to pin 36 causes, respectively, one or two stop bits to be transmitted — mention of the stop bits will again be made in the discussion on data transmission.

Character length is determined by the logic applied to pins 37 & 38, see Table 1 — 5,6,7, or 8 bits per character are possible.

Logic 1 to pin 34, mode control strobe, enables the previous control bits — often this pin is hard-wired to +5 v.

**TABLE 1**

Pin 37	Pin 38	Character Length
0	0	5
0	1	6
1	0	7
1	1	8

Pin 35	Pin 39	Parity
1	X	None
0	0	Odd
0	1	Even

Pin 36	Stop Bits
0	1
1	2

## TRANSMITTING DATA

Once all control pins have been selected transmission Fig. 5 of parallel data to serial form begins with pins 26 through 33, assuming all 8 bits are used. If less than 8 bits are used the data is right justified, that is, starting with the least significant bit at pin 26. Data is entered into the holding register after a short settling delay by a negative going pulse (logic 0) on pin 23, the input data strobe. When this pulse returns to its logic 1 state, data is transferred to the

transmitter output register, unless the transmitter section is presently transmitting data in which case the new data entry is delayed until the transmission has been performed. As the data is loaded into the output register a start bit appears at output pin 25 after the next negative going clock cycle. This is followed by the data bits (at a rate of one bit for every 16 clock pulses) with the LSB sent first and the MSB last, followed by the parity bit and 1 or 2 stop bits (whichever has been selected). Therefore, the maximum number of bits transmitted would be 12 (1 start, 8 data, 1 parity and 2 stop) and the minimum 7 (1 start, 5 data, 1 stop).

The UART is double buffered which allows the loading of a new character as soon as the one in the output register begins transmitting. Trouble could arise if the input holding register was full (waiting for the output register to clear) and new data was coming in, a kind of traffic jam. To prevent this the input empty flag, pin 22, provides a

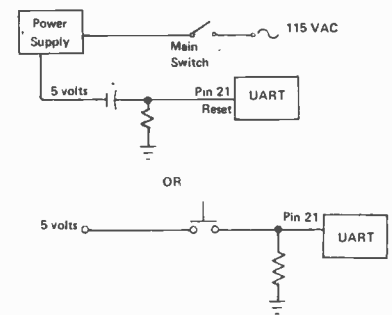

*Fig. 4. Resetting pin 21 can be accomplished automatically or manually.*

signal for indicating the state of the input register. If it is full a 0 appears at pin 22, 1 indicates the UART is ready to accept the data. Pin 24 goes high when the complete character including stop bits has been transmitted from the output register. Thus, via pin 22, we can put a stop on the incoming data from the keyboard, computer, etc. by holding data until the input registers are clear.

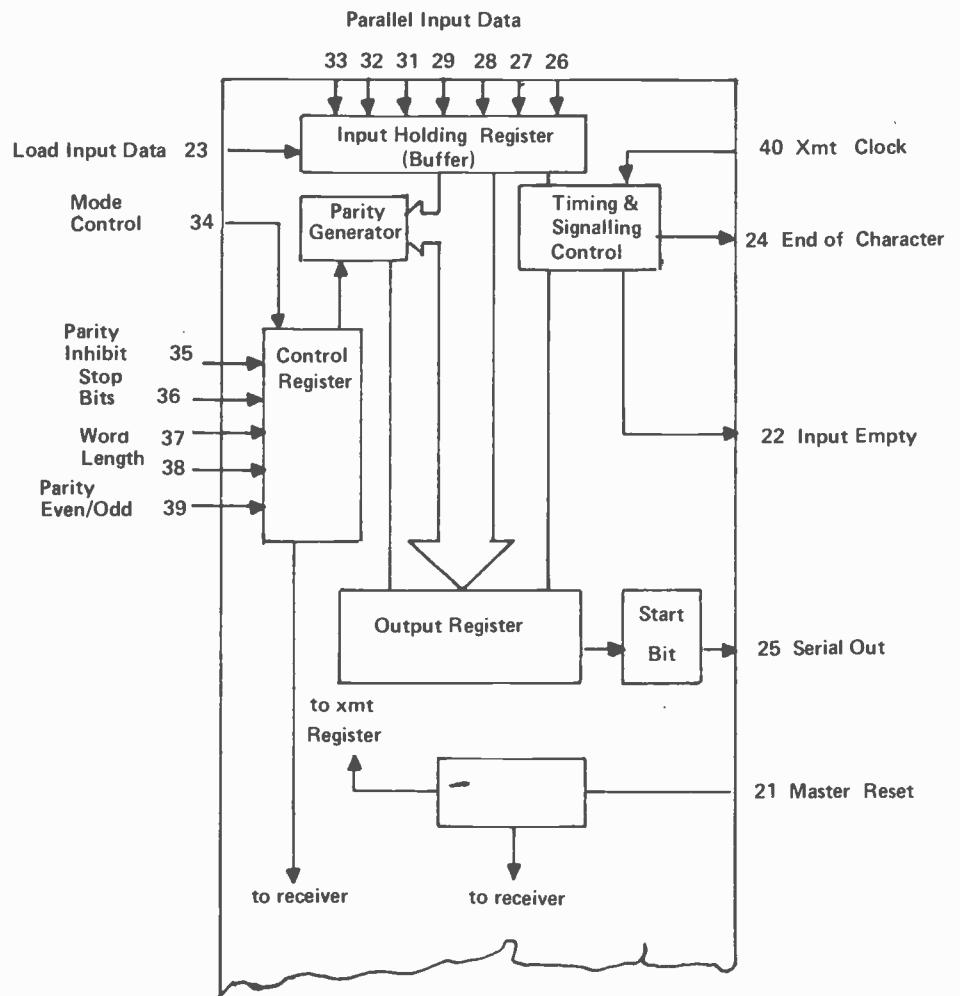

*Fig. 5. Transmitter section of the UART.*

The transmitter can be used in either of 2 modes, unconditional or handshaking. The basic method of sending data is simply to send it as it arrives, thus no conditions are required before the UART accepts the data. Problems arise when the characters are not spaced far enough apart from each other, a log jamming effect resulting in erroneous data transmission. Where this is a problem or might be suspected as a problem the handshaking mode is preferred. In this mode the UART chooses to receive a new character at its parallel input via the outputs of pins 22 &/or 24, the "handshaking" being done between the UART and the device sending the data to the UART. With this set-up, characters are only sent to the UART when the UART agrees that all is well.

When no data is being transmitted the output sits at logic 1. Start of transmission is defined as the transition from a high to low at pin 25.

#### RECEIVING DATA

To agree with the transmitting end the input of the receiver (Fig. 6) must be high with no data present. Internal circuitry monitors the input for a change from high to low which signifies

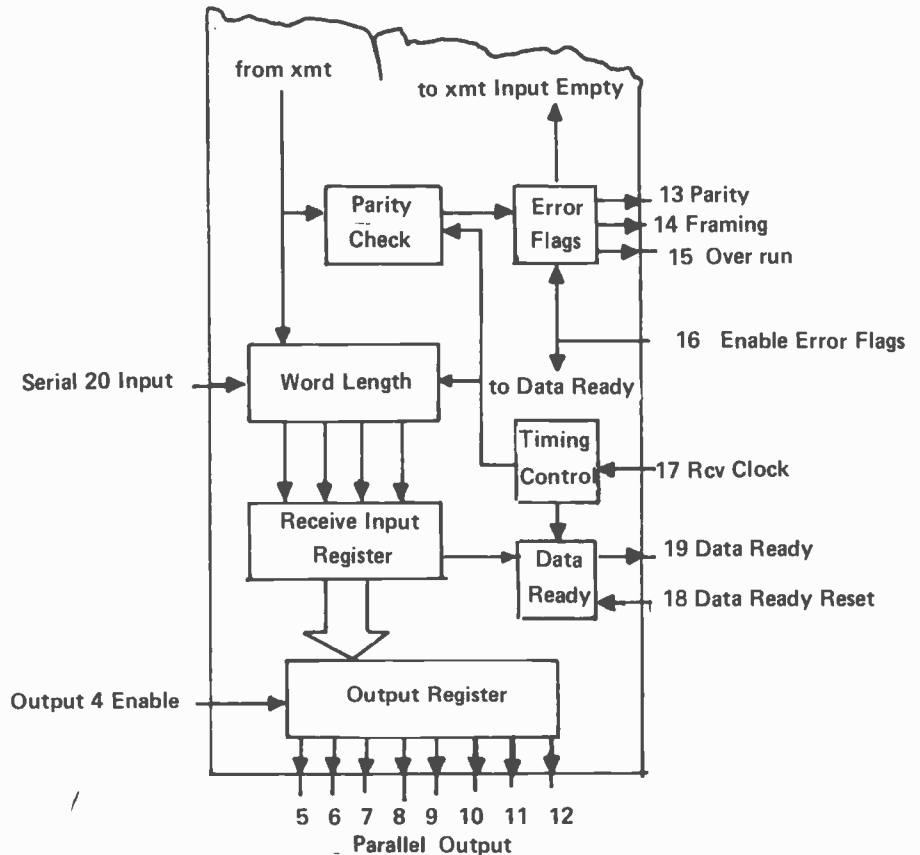

Fig. 6. Receiver section of the UART.

## ILP Amplifier Modules —

### so reliable they carry 5 Year warranty\*

Built-in heatsink for cool reliable operation

**MODEL HY200**  
120 watts into 8 ohms  
**\$79.<sup>50</sup>**

**TRUE HIGH FIDELITY SPECIFICATIONS:**  
Typical distortion - 0.05% at 1kHz  
Frequency response - 10-45 kHz  
Signal/noise ratio - up to 96 db

Amplifier circuitry encapsulated in epoxy for excellent thermal stability

Only 5 simple connections

ILP is the original line of audio amplifier modules, and the only ones with a five-year warranty. Choose from 4 models, conservatively rated 30 - 60 - 120 and 200 watts. Matching preamp module also available. Fully short/open circuit protected. ILP alone offers performance, value, reliability backed up by a five year warranty. In short, ILP is the only choice for the discerning audiophile

\*to original owner when used with recommended power supply.

ILP MODULES ARE AVAILABLE IN: MONTREAL- Addison TV Parts. TORONTO: Dominion Radio, General Electronics, Gladstone Electronics. MISSISSAUGA: Atwater Electronics. OTTAWA: Kris Electronics. KITCHENER: Orion Electronics. LONDON: Provincial Electronics. NOVA SCOTIA: F. Rhodenizer (Bridgeport)

Dealer/distributor enquiries welcome.

**audiex ELECTRONICS**

1736 Avenue Rd., Suite B., Toronto, Ont. (416)787-7367

data being received. When this happens a counter is initiated clocked at 16 times the baud rate. To verify that this is a valid start bit the UART looks for logic 0 at pin 20 again when the counter reaches 8 (the middle of the start bit) (Note: This is not universal with all UARTs, for instance the RCA 1854 uses 6½ clock periods for verification.). Once it is established that a valid start bit has been received, the UART counts in steps of 16 clock pulses identifying each data bit in the center of its pulse or no pulse.

Data is loaded into the serial to parallel input register via shift pulses every 16 clock pulses. Since the LSB was the first bit to be transmitted it is the first data bit to be received. Following the data bits are parity and stop bits that are loaded into the input register to be used by the control circuits to detect errors in transmission and the end of transmission, respectively. If an error in parity is detected pin 13 goes high. To verify the end of transmission the bit following the parity is tested for logic 1 and if the stop bit is not present the framing error flag, pin 14, goes high. The output of the two flags (parity and framing error) are updated each time a character is transferred to the input register. Character length has already

been programmed by the user — corresponding with its respective transmitting character length.

Once the serial data has been fully loaded into the input register it is parallel loaded into the output holding register. Pin 19 then goes high indicating an entire character has been transferred to the holding register and the data is now available to output. Once this go ahead signal is given the processor can read the data from the tri-state outputs by applying logic 0 to pin 4; a logic 1 inhibits the data from being read.

Pin 16 is a status flag disconnect at logic 1 and will disconnect the three state output drivers for pins 13, 14, 15, 19 & 22 allowing these outputs to be bus connected. Normally, pin 16 is held low usually wired directly to ground. Typically, you would use the floating alternative where several UARTs are connected by a common bus. Each

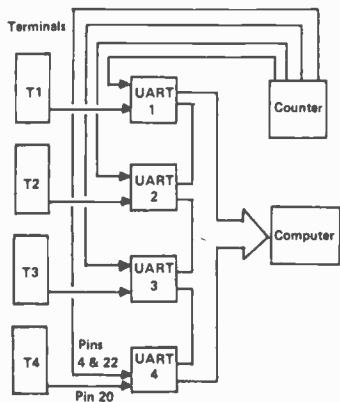

Fig. 7. Multiplexing UARTs.

UART would then be operated by pulsing logic 0 successively to pin 16 (and pin 4) of each UART (Fig. 7).

In order for the new data to output a couple of things must happen. The available data must be removed before the next character is shifted into the first register. Failure to change the data available reset, pin 18, by a logic 0 pulse will result in the overrun flag, pin 15, going high. The output strobe, pin 19, must be reset (via pin 18) before a new output can occur, otherwise new data will be read over the old; in the handshaking mode the circuitry accepting the character sends back a signal driving pin 18 low. In the unconditional mode we can delay the output of pin 19, invert it and reapply it to pin 18 to reset (Fig. 8).

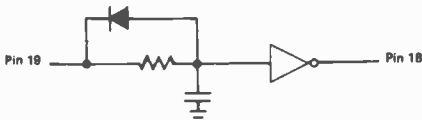

Fig. 8. Unconditional Mode reset.

## VARIATIONS

There are many pin compatible UARTs. It should be noted, however, that most UARTs are very similar to each other and often can be interchanged with little difficulty on the part of the user. Some of the new versions use only a 5 volt supply rather than 5v & -12v, for instance the General Instruments 1013 uses the dual voltage while the 1014 works off a single 5 volt line. A few devices have internal baud rate generators requiring only an external crystal to be connected to two pins of the UART.

Some UARTs are dedicated versions designed to work with certain microprocessors and so are generally only used in such systems. The Intel 8251 and the Motorola 6850 working with the 8080 and 6800, respectively, are examples of this. The RCA 1854 UART is designed to work in either of two ways (user selected), that is 1) as a standard type UART and 2) as a dedicated version interfacing directly with the 1802 uP without additional components.

Another variation really deserves a special title: Some Like it Soft. With software problems being the biggest headache in any computer system one might question the sanity of replacing a readily available IC like the UART with a software program. The reasoning behind this goes something like this: a UART can be looked at as a very dedicated, almost retarded, microprocessor so why not use a program to replace it? Indeed, if our uP is fast enough (not always true) we can replace practically every piece of digital hardware with a program. Also, greater flexibility can be arranged by the use of programming rather than modifying existing hardware designs. This reasoning furnished part of the impetus to design a uP in the first place. Originally, the uP wasn't designed for all you computer hobbyists out there nor was it designed for number crunching companies like IBM, in fact the current trend toward making uP's

into miniature data processing computers does some injustice to the original concept which was to provide the designer (not the programmer) with a programmable digital device that could replace many IC's in dedicated hard-wired complex logic systems. At any rate the UART is one IC and while there are certain times to take advantage of this technique the software addict should remember that he is substituting some form of memory as well as CPU time in place of it.

## DESIGNING WITH UARTS

Now that we have a fair understanding of how the UART works we can look at a few designs using them. Three examples are given which should provide enough variation in design to make you feel comfortable using them.

### EPROM PROGRAMMER

This project (Fig. 9) appeared in the December '78 issue of ETI and compared to most commercial units it represents a real bargain for the computer hobbyist. As well, it could pay for itself if you wanted to start a programming service for 2708's.

The UART used here is a National Semiconductor MM5303 and is typical of most general purpose UARTs. Only the receiver half of the UART is used since the only thing we are concerned with is receiving the transmitted program from the computer, although conceivably with a little redesigning you could, once the EPROM is programmed, verify the EPROM's programming by sending it back to the computer via the transmitter portion of the UART and print the results.

The clock frequency of 16 times the baud rate is applied to pin 17 — in this case the baud rate is 300 so the clock runs at 4800 Hz. Initially, the registers and associated circuitry must be cleared by a logic 1 pulse — this is accomplished in the ETI EPROM Programmer by pressing the RESET button which momentarily sets pin 21 at +5 v. Stop bit control, parity and character length are user defined by tying each of pins 35-39 to either +5 or ground (0 v). For instance, if a full 8 bit character is used (the 2708 is 1K x 8 so this would probably be the case) pins 36 & 37 would both be wired to 5v. Since the controls remain the same throughout the programming, the mode control pin 34 is hard-wired to logic 1. Pin 16 is connected to ground enabling the status bits — in this case only the data available, pin 19, is used. Likewise, pin 4 is grounded allowing the

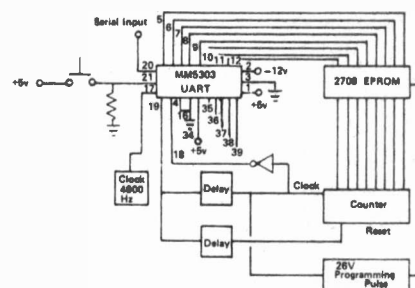
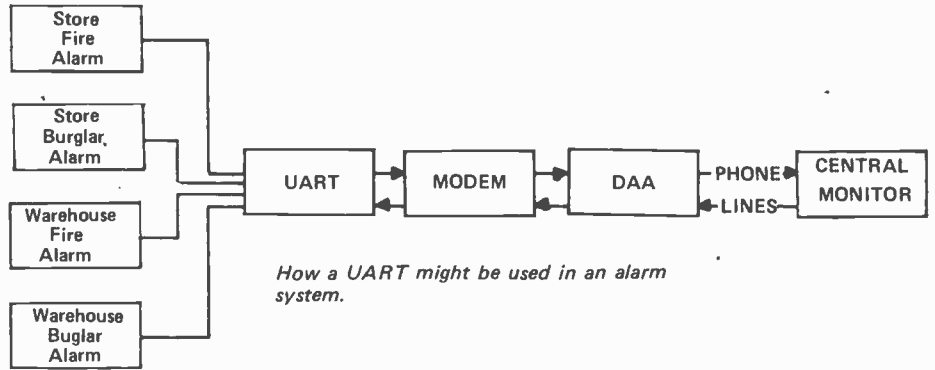

Fig. 9. Basic diagram of the ETI EPROM Programmer.

# Using UARTs

data output lines 5-12 to be read by the EPROM. Pin 19, the data available, provides a signaling pulse that is used to control four important sections of the timing sequence. These are 1) reset, 2) the 26 volt programming pulse required by the 2708, 3) clock pulse for the address counter, and 4) the data available reset pulse going to pin 18 of the UART. Further circuit description of the EPROM Programmer is found in the Dec. '78 issue.



How a UART might be used in an alarm system.

## CASSETTE INTERFACE SYSTEM

This would be a computer hobbyist type arrangement usually run at 300 baud. Since digital signals don't record well (or to be exact not at all) on home audio cassette recorders and since variations in tape speed can cause numerous transcription errors, a method of representing a logic 1 as 8 cycles of 2400 Hz and a logic 0 as 4 cycles of 1200 Hz was devised. By utilizing the services of a UART (Fig. 10) can overcome much of the problems associated with speed variations, thus making the usage of programmed cassette tapes more reliable, both for the hobbyist's own use and for duplicating or sharing other hobbyists'

taped programs via ordinary cassette tape.

The steps involved in recording a program onto tape are 1) serial data from the computer is fed to the serial input of the receiver half of the UART, 2) the data is transformed into parallel data and then back to serial assuring an accurate 300 baud rate, 3) the serial data is fed to a gate that is synchronized with the clock to produce 2400 tones for a 1 and 1200 Hz for a 0, 4) the output filter allows the signals to be recorded on an audio tape recorder.

Notice that the receiver and transmitter portions of the UART are

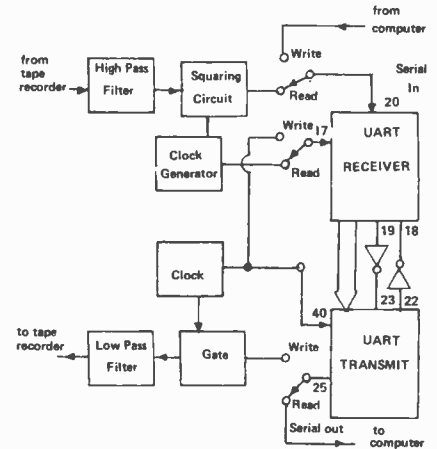

Fig. 10. Cassette Interface System.

wired in the handshaking mode, i.e., pin 22 signals the receiver when the buffer register is empty, then when data is available pin 19 goes high signaling the transmitter load command pin 23.

To read a taped program the interface circuitry works by 1) removing low frequency noise from the tape and squaring the signals, 2) transforming the waveforms into digital 1's and 0's, 3) using the data to clock the UART, 4) feeding the serial data into the receiver portion of the UART, 5) making parallel to serial conversion through the transmitter and 6) sending the serial output to the terminal or computer.

In the case of reading a program the clock for the receiver section of the UART is derived from the tape itself. Tape speed can vary from different and aging cassette recorders but the parallel data will output only after a complete character word is ready. This tends to stabilize the data rate since the only variation will then be between complete characters. Then the transmitter is clocked at a clean and reliable 300 baud from the main clock and will thus transmit the original tape program at a uniform 300 baud to the terminal. This system, therefore,

NEW!

## The Sinclair PFM200 digital frequency meter.

The new SINCLAIR PFM200 brings digital frequency measurements within the range of affordability, for the first time! It is ideal for use with audio, video and radio systems, and all electronic and digital circuitry. It is directly comparable in performance with the very best bench-top instruments, but it's packaged in a compact case which is rugged, lightweight and ready for use anywhere.

- Features:
- 20 Hz - 200 MHz guaranteed range (typically better)
- Frequency resolution down to 0.1Hz
- High sensitivity (10mV typical)
- High-accuracy crystal timebase
- Built-in attenuator
- Variable sampling rate
- Battery or plug-in operation
- Truly portable- weighs 6oz.
- One year warranty.

ONLY  
\$149.95

BUILT, TESTED,  
READY TO GO!

Write or call for your nearest distributor! **audiex ELECTRONICS** 1736 Avenue Rd., Suite B, Toronto, Ont. (416) 787-7367

Circle No. 4 on Reader Service Card.

# SPECIAL \$795

HICKOK MODEL 517  
15 MHz Dual Trace Oscilloscope.

Duty & FST included. Chargex (Visa) accepted.  
Ont. residents add 7% Sales Tax. Shipping extra.

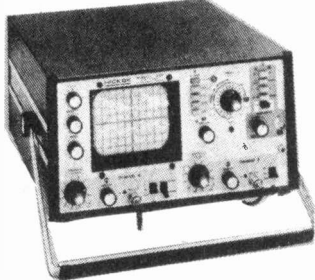

## A value loaded medium bandwidth scope useable to 27 MHz

- 15 MHz response flat within 3dB for all signal levels. Excellent pulse response minimizes overshoot and ringing.
- 5mV/cm sensitivity, useful for solid-state work.
- Foolproof triggering to 27 MHz (30 MHz typical).
- X-Y operation for vectorscope measurements.
- Bright 8 cm x 10 cm display.
- Auto mode triggering provides baseline for recurrent sweep operation.
- CHOP or ALTERNATE mode automatically selected as sweep time is changed for speedy setup.
- Algebraic sum and difference capability.
- Differential input capability.
- Digital logic circuit capability, including CMOS.
- Analyze CB AM and SSB waveforms.
- TV sync separators built in.
- Regulated power supply maintains amplifier gain and sweep rate within 0.1% with changes in line voltage from 105 to 125 volts.

The Hickok Model 517 Dual Trace Oscilloscope is the perfect signal tracing instrument for all servicing jobs. The Model 517 has all the necessary features for professional analysis and results.

With dual trace capability you can display either Signal A or Signal B alone, or both signals simultaneously in these dual trace combinations: Alternate A and B, Chopped (100 kHz) A and B (Chopped and Alternate modes are automatically selected as sweep time is selected), A plus B, and A minus B using the trace invert feature provided for channel A.

Dual trace lets you simultaneously view two waveforms that are frequency or phase related or that have a common sync voltage. For example, you can compare the input and output waveforms of amplifiers and multiple stages triggered by the same pulse; check frequency dividers; check differential amplifiers for balance; and measure amplifier phase shift and nonlinearity. For the critical applications, for fast reliable information when time is money — use the Hickok Model 517 Dual Trace Scope to make the difference.

### SPECIFICATIONS

**Vertical**  
Range: 10mV/cm to 50V/cm in 12 calibrated steps. Uncalibrated continuously variable control operates over span from 5mV/cm to 50V/cm.  
Accuracy:  $\pm 3\%$   
Frequency Response: DC-15MHz (3dB) DC coupled, 2Hz-15MHz (-3dB) AC coupled  
Risetime: 24ns  
Overshoot: 3% or less  
Positioning: 3 screens  
Input impedance: 1 megohm shunted by approximately 30pF  
Maximum Input Voltage: 600V DC plus peak AC  
Vertical Modes: Channel A only, Channel B only, Dual Trace (A and B) automatically selected for chopped mode at all sweep times  
1 SEC/cm and slower, alternate mode for faster sweep times. A + B (single-trace algebraic sum), B-A (single-trace algebraic difference).

**Time Base**  
Sweep Rates: 0.2 SEC/cm to 0.5  $\mu$ SEC/cm (0.1  $\mu$ SEC/cm with X5 expander) in 18 calibrated steps. Uncalibrated continuously variable control operates over span from 0.1  $\mu$ SEC/cm to 1 SEC/cm.  
Accuracy:  $\pm 5\%$  Linearity better than 1% through full horizontal sweep.

**Triggering**  
Auto: Provides continuous sweep without input signal  
Slope: Positive and negative, continuously variable level control.

Sensitivity: Internal 1 division (on CRT) to 27 MHz guaranteed 30 MHz typical, external 200 mV to 5V peak-to-peak  
TV Sync: Vertical and horizontal sync separator circuitry permits locking to TV video waveform. TV-H (lines) and TV-V (frames) sync automatically selected by TIME/CM switch. TV-V: 0.55 SEC/cm to 0.1mSEC/cm. TV-H: 50.5 SEC/cm to 0.5  $\mu$ SEC/cm.

**External Horizontal**  
Range: Continuously variable from 0.5V/cm to 50V/cm with X5 expander  
Frequency Response: DC to 1MHz, DC coupled  
Input Impedance: 1 megohm

**General**  
Probe Calibrator: Approximately 7.5 V peak-to-peak at 1kHz  
CRT: 5-inch flat faced round with viewing area of 8 cm x 10 cm P 31 phosphor  
Z AXIS: Intensity Modulation  
Rear panel connector for display blanking by 5V signal (TTL compatible)  
Power Requirements: 105-125V 50-400Hz, 35 watts (210-250V version Model 517E also available)

**Dimensions & Weight**  
(Not including handle or feet) 14-5/8" w x 7" h x 17-1/2" d (37.1 cm x 17.8 cm x 44.4 cm), 13.5 lb (6.14 kg)

**Accessories included**  
Model 517 includes one SP-6 combination 10:1 direct probe, and 1 SP-7 10:1 probe (see page 23 for details) Vectorscope overlay and instruction manual included. Rack mounting kit RM-3 (PIN 100 205) also available.

Also available: complete line of Hickok Test Equipment including 15 MHz single & dual trace oscilloscopes, 30 MHz Dual Trace oscilloscope, Digital Multimeters, Function Generator, Transistor Testers, CB Service Test Equipment etc. Please write for detailed information.

**HAROGERS electronic instruments Ltd.**  
P.O. Box 310, 595 Mackenzie Avenue Units 1 & 2.  
Ajax, Ontario L1S 3C5. Tel. (416) 683-4211

Circle No. 19 on Reader Service Card.

## COMPUMART The Personal Computer Store

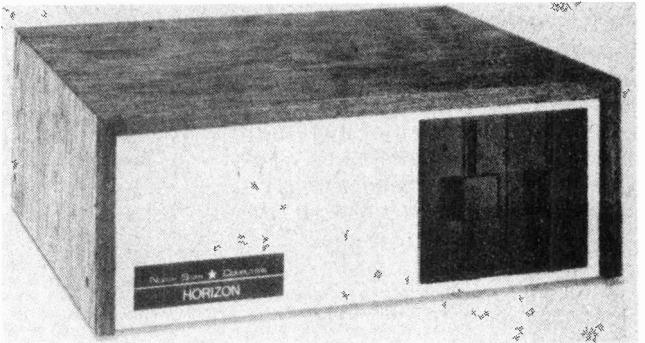

**NorthStar**  KITS from \$2925.  
Assembled from \$3295.

The North Star Computers HORIZON is a high-performance, Z80A based microcomputer system which is especially suited for business, educational, and software development applications. It features fast-access DISK storage as an integral part of the package, 4 MHz microprocessor operation and built-in I/O capability. The HORIZON uses the S-100 bus structure and each disk now stores 180K bytes. Quad density (360K bytes per drive) is also available.

## Thinker Toys™

**DISCUS 2D:** Double-density 8" floppy disk system for the S-100 bus. 600K bytes per drive . . . . . only \$1795.  
Extra drives . . . . . ea. \$1275.

**DISCUS 2+2:** Quad-density!! (double-sided, double density) 1.2 million bytes per drive. . . . . \$2475.  
Extra drives . . . . . \$1895.

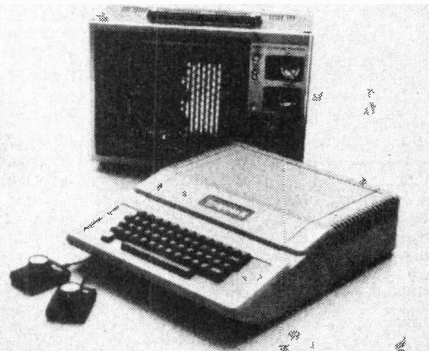

Thousands of people have already discovered the Apple computer — businessmen, students, hobbyists. They are using their Apples for financial management, complex problem solving — and just plain fun. Apples begin at \$1695.00 for the 16K model. Write or call for more information.

**TERMS:** Visa/Master Charge (Please include expiry date), check or money order. Add 2% for shipping and handling. Ontario residents add 7% Provincial Sales Tax.

**COMPUMART, P.O. Box 6132, Station J, Ottawa, Ontario, K2A 1T2; Showroom: 411 Roosevelt Ave.; or phone (613) 725-3192.**

Circle No. 18 on Reader Service Card.

# Using UARTs

corrects for speed errors that may occur from taped programs.

## METEOROLOGICAL DATA GATHERING

Let's suppose you are doing a research project that involves among other things knowing weather conditions on a continuous basis. Your research building is on the other side of the city from the main computer which you need access to for processing your data. You will want to measure wind speed and direction, temperature, barometric pressure and relative humidity all at the same time or at least reasonably close to the same time. What's to be done?

First, you will want to use the phone lines (Fig. 11) to communicate with the computer and you will want all of this to be done automatically — you have better things to do than sit at a terminal all day punching in numbers. So you require digital outputs for all of the instruments, if they are not digital devices then an A/D conversion will be necessary — *ETI* has already saved you some work by providing circuits for a Digital Anemometer (Dec. '78) and a Digital Thermometer (Nov. '77).

Next we will tie all of these instruments to a common bus using tri-state outputs and direct them to a UART

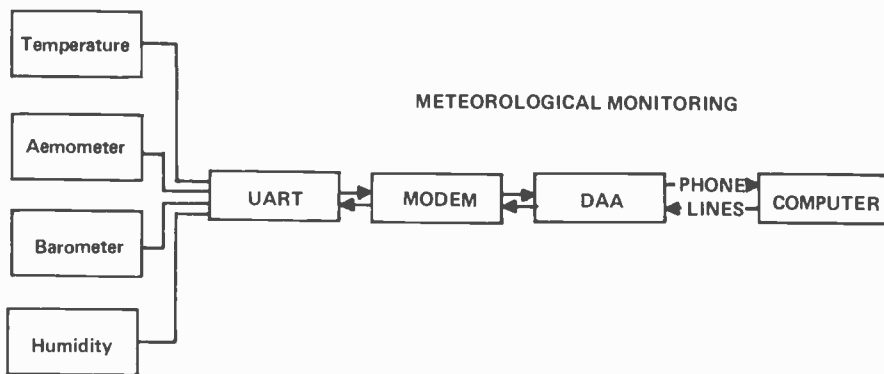

Fig. 11. Some UART applications.

REMOTE TERMINAL



which will transmit the data serially. The UART will then be connected to a modem (modulator-demodulator) which in turn will be connected to an acoustic coupler, Data Access Arrangement (DAA), to the phone lines.

The control logic is shown in a handshaking mode with the UART but the unconditional mode could be implemented, say, using the UART's clock as a reference. The instruments

will be read sequentially via the selector lines and although this is not an exact instantaneous reading of all five it is very close to be considered such.

## READ ON

Hopefully, some of the mystery has vanished by now and the reader feels at home when he sees a UART used in a design. For more information on a particular device consult the manufacturers' specifications sheets, usually obtainable for the asking.

## SOME REFERENCES:

1. "EPROM Programmer," *ETI*, December '78, pp. 29-34.
2. "Generating a UART Function Using Software," *Radio-Electronics*, January '77, pp. 22, 24-25.
3. Lancaster, Don, *CMOS Cookbook*, Howard W. Sams & Co., Indianapolis, 1977, pp. 318, 319.
4. Lancaster, Don, *TV Typewriter Cookbook*, Howard W. Sams & Co., 1976, pp. 51-52, 153-173.
5. Marsh, Robert M., "Computer Users Tape System," *Popular Electronics*, March '76, pp. 88-90.
6. Norris, Bryan (Editor), *MOS and Special Purpose Bipolar Integrated Circuits and RF Power Transistor Circuit Design* (Texas Instruments), McGraw Hill & Co., New York, 1976, pp. 9-12.
7. RCA, CDP 1854 Data Sheet.
8. Ward, Brice, *Microprocessor/Microprogramming Handbook*, TAB Books, Blue Ridge Summit, PA., 1975.
9. Williams, Gerald E., *Digital Technology*, Science Research Associates, Inc., Chicago, 1977.

# GLADSTONE ELECTRONICS



**sinclair**  
PDM35 3 1/2 digit multimeter  
**\$89.50**

\* 6 functions, 26 ranges \* operates from 9V battery \* 10 day money-back trial offer

### SINCLAIR TEST EQUIPMENT IN STOCK:

DM235. 3 1/2 digit multimeter . \$149.95  
DM350. 3 1/2 digit multimeter, accuracy 0.1%, 34 ranges. . . . . 239.95  
DM450. 4 1/2 digit multimeter, accuracy 0.05%, 34 ranges. . . . . 339.95  
PFM200 digital frequency meter. 149.95



**ILP**  
Audio Amplifiers  
\*5-year warranty.

HY50 30 watts RMS . . . . . \$28.95  
HY120 60 watts RMS . . . . . \$57.50  
HY200 120 watts RMS. . . . . \$79.50  
HY400 240 watts RMS (4ohms) \$99.50  
HY5 mono preamplifier . . . . . \$21.95

Just arrived! ACE AUDIO SUBWOOFER CROSSOVER KIT. 100 Hz. 18 db/octave. Model 5000K. Only \$141.00  
NEW GLADSTONE STORE now open at 2936 EGLINTON AVE. E., Scarborough, Ont. Telephone 438-3999.



**PHILIPS DeFOREST**  
Quality Loudspeakers

AD15240/W8 15" Woofer (150W) \$74.95  
AD12240/W8 12" Woofer (120W) \$74.95  
AD10240/W8 10" Woofer (120W) \$69.95  
AD0211/SQ8 (or 4) 5" dome mid \$32.95  
AD5060/SQ8 (or 8) 5" cone mid \$21.95  
AD0162/63/T4,8, or 15. dome tweeter \$14.95

AD3WXSP. 200 watt 3 way xover \$42.50  
AD3WXA 60 watt 3-way crossover \$17.95  
AD2WXA 60 watt 2-way crossover \$10.25  
FREE CABINET PLANS

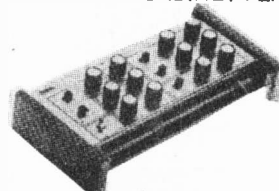

**PAIA**  
\$117.00  
GNOME

Electronic music mini-synthesizer. Gladstone's carry the complete PAIA line of synthesizers and computer products.

### MAIL ORDER ADDRESS and MAIN STORE:

1736 Avenue Rd., Toronto, Ont., M5M 3Y7  
Phone order line: (416) 787 1448.

Use your ChargeX Visa or Mastercharge. Ont. residents add 7% P.S.T.  
Both locations open Tues-Sat 9:30-6, till 9 Thurs and Fri.



# There's never been a better time to buy an Apple<sup>®</sup> II plus

\* THIS ADVERTISEMENT WORTH \$150 ON ANY APPLE II SYSTEM (ONE AD ONLY PER SYSTEM) WHEN PRESENTED TO:

## COMPUSHOP

COMPUTERS FOR HOME & BUSINESS  
CERTIFIED CHEQUE OR MONEY  
ORDER VISA & MASTERCARD  
ACCEPTED

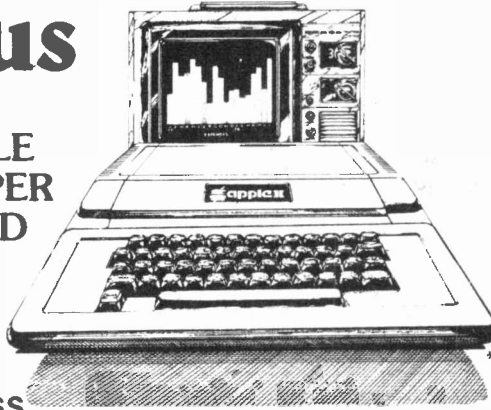

16K ... \$1750.00  
DISK .. \$850.00  
\* MUSIC SYNTHESIZER, LIGHT PEN, SPEECH LAB, AC CONTROLLER, PASCAL, 10 MBYTE HARD DISK, ETC. ALL AVAILABLE FOR APPLE II AND APPLE II PLUS SYSTEMS.  
\* AUTHORIZED SERVICE CENTRE.

CALGARY  
#103 723 - 14 Street N W  
Calgary Alberta T2N 2A4  
(403) 283-0751

CALGARY  
#107 4014 Macleod Trail South  
Calgary Alberta T2G 3R7  
(403) 243-3846

VANCOUVER  
#100 1500 West Georgia Street  
Vancouver B.C. V6G 2Z6  
(604) 687-5545

Circle No. 8 on Reader Service Card.

## Subscriptions      Big News!      Special Offer!

### See Page 62

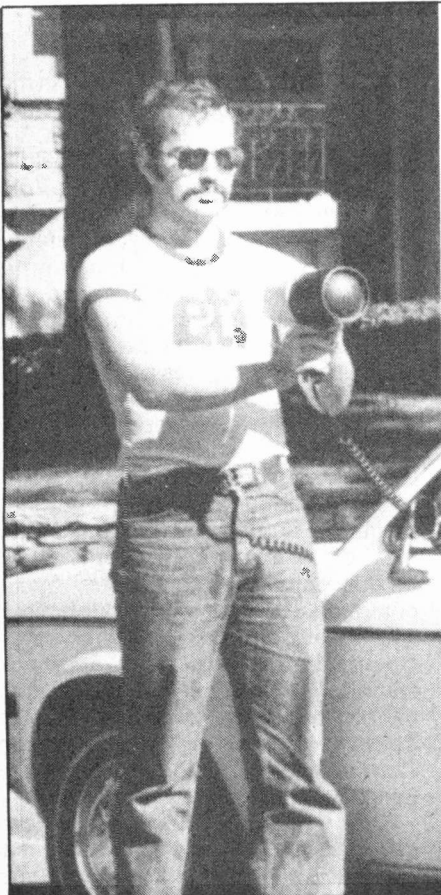

## DECEMBER

WHAT'S ETI'S handsome attractive, young, unattached (phone 416-423-3262) Assistant Editor doing with a Radar Gun? Stopping fast women perhaps? Not likely, he's doing some dead serious research for ETI's Special Report on Speed Measuring Radar. If you've ever driven in a car, you'll want to know how these fascinating devices work, how they're used, and about the Canadian company which is a world leader in these instruments. Did you know you can even rent a speed meter for your own purposes?

See next month's issue of ETI for full details on this subject, and of course exciting projects and other features.

## NOW AVAILABLE \$419\*

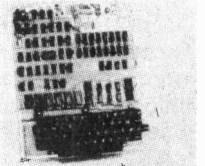

### OSI SUPERBOARD II

- . 8K Microsoft BASIC - in - ROM
  - . 4K RAM on board expandable to 8K
  - . Full 53 - Key keyboard with upper/lower case and user programmability
  - . Audio cassette interface
  - . Graphics and gaming characters
- Fully assembled and tested. Requires +5V at 3 amps and a video monitor or modified TV set.

STEEL CASE (Keyboard hole pre-cut) . . . . . \$45.00  
Power supply KIT . . . . . \$35.00  
RF Modulator KIT . . . . . \$9.50

\* These prices include import duties, federal sales tax & 90 day full warranty service by D.C.B. ELECTRONICS. Ontario residents add 7% Sales Tax. Prices subject to change without notice. Mastercard or Visa accepted. 4% handling charge (does not apply to cash or certified cheque orders). Shipped collect by any method you specify.

**D.C.B. ELECTRONICS**  
333 Denison St. Unit 3, Markham,  
Ontario L3R 2Z4 (416) 495-1599



**SPEED DX**  
*the dx radio magazine  
for active shortwave listeners*

**FRIENDX**

**DX ONTARIO**

THE SOUTH AFRICAN  
SHORTWAVE LISTENER

**CANDX**

Official monthly bulletin of  
Canadian S-W-L International



**AUSTRALIAN DX NEWS**

OFFICIAL MONTHLY PUBLICATION of the  
AUSTRALIAN RADIO DX CLUB  
SERIALS PREMIER ORGANIZATION **DX**<sup>1972</sup> 101 NHD - 1965

EDITORIAL ADDRESS: PO BOX 227, BOX HILL, VICTORIA, 3128  
Administrative Address: PO BOX 67, HIGHETT, VICTORIA, 3190



**SHORT-WAVE NEWS**

monthly bulletin of the DANISH SHORTWAVE CLUBS INTERNATIONAL for shortwave listeners and DXers

**L'ONDE**

PUBLICATION OFFICIELLE DU CLUB ONDES COURTES DU QUÉBEC  
• Subventionné par le Haut-Commissariat à la Jeunesse, aux Loisirs et aux Sports •

**ANARC NEWSLETTER**

Official Publication Of:  
Association of North American Radio Clubs  
557 North Madison Avenue  
Pasadena, California 91101 USA  
(213) 793-0769  
"The All Wave Radio Federation"



JOIN A SHORTWAVE CLUB

IN ORDER TO ENJOY the hobby of shortwave listening to the fullest, I would strongly recommend that you join one of the many DX or SWL clubs. Generally these clubs provide their members with a monthly news bulletin with many pages of valuable information to help the listener find those shortwave stations that are broadcasting to the world. In this month's column I will give you some of the details of a number of clubs around the world. The membership fee is usually just enough to cover the cost of postage and printing costs for the bulletins. The officers and editors of these clubs contribute their time and effort on a voluntary basis and do not get paid thus keeping membership fees as low as possible.

The Association of North American Radio Clubs; (ANARC)

The Association of North American Radio Clubs was founded in February of 1974 as a uniting organization for DX clubs in North America. ANARC's objectives are the following: a) to promote closer ties between radio clubs; b) to promote interchange of ideas and information between radio clubs; c) to work for the common good

of the hobby; d) to provide a forum to work out differences and problems involving radio in North America.

Membership in ANARC is open to any radio club with at least 50 members and which has been in existence for at least 12 months. Associate membership is available to those radio clubs with less than 50 members and which have been in existence for more than six months. At present there are 15 member clubs and five associate member clubs in ANARC, located throughout the United States and Canada. In addition the European DX Council (a federation of European DX clubs), the Southern Cross DX Club in Australia, the Indian DX Club International, and the Japan Broadcasting Listeners' Federation, have affiliate status with ANARC.

ANARC holds an annual summer-time convention at a different site in North America each year. DXers and SWLs from all over North America and other parts of the world attend the annual ANARC convention, which is usually three days long and filled with talks, films quizzes, discussions, demonstrations, exhibits and presentations of various types related to the DX hobby. The 1979 convention was held in Minneapolis, Minnesota

and featured representatives from nine international broadcasters — Radio Israel, Swiss Radio International, The Voice of Turkey, The Voice of Belgian Radio and Television Service, the Voice of America, and Radio Canada International. Approximately 200 listeners attended and during the annual Auction for the Handicapped Aid Program (a program to help the handicapped enjoy the radio listening hobby) over \$2000 was raised.

There are several ANARC committees which serve the radio hobbyists. The Public Relations Committee works to promote ANARC and its member clubs to potential members and to the general public. Most of the information about ANARC in this column was prepared by the chairman of this committee, Jeff White. The Frequency Recommendation Committee helps overseas shortwave stations pick the best frequencies for their broadcasts to North America. There is also a DX Equipment Committee, a QSL committee and a Broadcasters Liaison Committee.

Although only clubs may become members of ANARC, individuals may subscribe to the monthly newsletter called "ANARC Newsletter. This is a six

page paper covering news of ANARC Clubs, DX meetings, committee news, ANARC business and general DX news. The subscription rate in North America is \$4.00 (\$8.00 overseas). Sample copies of the newsletter are available for 30¢. ANARC, 557 North Madison Avenue, Pasadena, CA, 91101, USA.

The following are full member ANARC Clubs:

#### Canadian S-W-L International (C-SWL-I)

C-SWL-I was founded in May, 1977 and now has members in all twelve Canadian provinces and territories as well as in seventeen other countries around the world. The total membership is close to 200. The monthly bulletin, CANDX, contains 40 or more pages of information useful to the shortwave listener such as loggings by members; QSL cards received; Utility report; Broadcast schedules; technical articles; and a members mailbag. Annual dues are \$12.00 worldwide. Sample copies of CANDX are available for \$1.00. Canadian S-W-L International, P.O. Box 142, Thunder Bay, Ontario, P7C 4V5, Canada.

#### Canadian International DX Club (CIDX)

CIDX was founded in 1962. Their monthly bulletin "CIDX Messenger" covers all radio waves, including SW, from CIDX headquarters. Annual dues are \$11.00 in North America or \$13.00 for overseas members. Canadian International DX Club, 169 Grandview Avenue, Winnipeg, Manitoba R2G 0L4, Canada.

#### Club Ondes Courtes Du Quebec (COCQ)

This is a French speaking club, founded in 1974. Their offset monthly bulleting "L'Onde" covers SW, MW, Hams and Utilities. The bulletin is printed in French. Annual dues are \$13.50 in North America and \$17.00 for overseas members. Club Ondes Courtes Du Quebec, 3420 Chemin Ste-Foy, App. 5, Sainte-Foy, Quebec, G1X 1S6, Canada.

#### Ontario DX Association (ODXA)

ODXA was founded in 1974 for DXers in the province of Ontario. While membership is limited to Ontarians others may subscribe to their monthly news bulletin "DX Ontario" which contains 40 or more pages covering short wave and medium wave. Columns are devoted to member's loggings, QSLs received, articles by members

and much more. The annual membership fee or subscription for non-Ontario Residents is \$12.00. Ontario DX Association, 3 Camrose Crescent, Scarborough, Ontario, M1L 2B5, Canada.

#### North American Shortwave Association (NASWA)

The largest club in North America with about 1700 members, NASWA was founded in 1961. The monthly bulletin "Frendx" covers news of shortwave broadcasters only. Station schedules, loggings and QSLs as well as many other items are covered. Annual dues are \$13.00 in North America, \$20.00 (airmail) to Latin America and Europe, \$22.00 to Africa, Asia and the Pacific, or \$14.00 overseas by surface mail. Sample copies of Frendx are available for \$1.00. A mid-month "Update" flashsheet is also available for \$3.00 a year (\$5.00 overseas). North American Shortwave Association, P.O. Box 13, Liberty, IN, 47353, USA.

#### SPEEDX (Society to Preserve the Engrossing Enjoyment of DXing)

Another large club with over a thousand members, SPEEDX was founded in 1971. The monthly bulletin contains 64 pages and is called "SPEEDX". SW and Utility bands are covered. Columns include loggings by countries, QSLs, schedules, technical and others. Annual dues are \$12.00 in North America, \$18.00 in the Caribbean & Central America, \$20.50 in Europe and South America, \$23.50 in Asia, Africa and the Pacific. Sample copies are available for \$1.00. A mid-monthly publication is available for \$3.00 annually (\$5.00 overseas). This flashsheet is called the "SPEEDX-Gram". SPEEDX, P.O. Box E, Elsinore, CA 92330, USA.

#### Newark News Radio Club (NNRC)

The Newark News Radio Club is the oldest club in North America having been founded in 1927. The newspaper by that name started the club but it is no longer connected with the club. The "NNRC Bulletin", published monthly, covers all waves—SW, MW, Longwave, Utility, FM, TV, Ham, and CB. Annual dues are \$15.00 in North America. For Overseas rates write to NNRC Headquarters. Sample copies of the bulletin are \$1.00. Newark News Radio Club, P.O. Box 539, Newark, NJ 07101, USA.

#### American Shortwave Listeners Club (ASWLC)

ASWLC was founded in 1959. Their bulletin "SWL" is published monthly and covers Shortwave, Utilities, QSL news and Time Index. Annual dues are \$13.00. Overseas rates are \$13.00 by surface mail or \$15.00 airmail to Central America and the Caribbean, \$18.00 airmail to Europe and South America and \$20.00 for the rest of the world. Sample copies are \$1.00. American Shortwave Listeners Club, 16182 Ballad Lane, Huntington Beach, CA, 92649, USA.

#### Brooklyn DX Club (BDXC)

The BDXC was founded in 1975. "ALB", their monthly bulletin covers SW, QSLs, Utilities. Propagation, technical and non-technical articles, transmissions in English and other topics. Sample copies are available for 50¢ or 3 IRCs (International Reply Coupons). Annual membership fee is \$6.00 in North America, Overseas rate is \$6.00 for surface mail or \$8.00 for airmail. Other non-periodical publications are also available. Write BDXC for details. Brooklyn DX Club, 1137 E. 12th Street, Brooklyn, NY 11230, USA.

#### International Radio Club of America (IRCA)

IRCA is a medium wave only club, founded in 1964. "DX Monitor" is published by the club 34 times per year. Sample copies are 50¢. Annual dues are \$16.50 in North America. Write the club for overseas rates. A trial membership is also available for \$6.00. This includes 10 issues of "DX Monitor" and a copy of "Principles of Broadcast Band DXing". IRCA also publishes the "Foreign Log Of Medium Wave Stations" on a yearly basis. International Radio Club of America, P.O. Box 26254, San Francisco, CA 94126 USA.

#### Longwave Club of America

Another specialised club, the Longwave Club of America was founded in 1974. "The Lowdown" is published monthly and covers frequencies below 550 kilohertz and the 1750 meter band. A sample copy is available for a self addressed stamped envelope or 2 IRCs. Annual membership dues are \$6.00 in North America or \$12.00 for airmail overseas. Back issues of "The Lowdown" are also available in yearly volumes. Longwave Club of America, Box 33188, Granada Hills, CA 91344, USA.

## National Radio Club (NRC)

Another club that has been around for a long time, the National Radio Club was founded in 1933. This is also a medium wave only club. Their bulletin "DX News" is issued 30 times each year. Sample copies of "DX News" are 50¢ or 3 IRCs overseas. The yearly membership fee is \$15.00 in North America, \$18.00 for Mexico and the Caribbean, \$22.00 overseas (airmail) or \$18.00 for surface mail. National Radio Club, P.O. Box 118, Poquonock, CT 06064, USA.

## Miami Valley DX Club (MVDXC)

Founded in 1973, the Miami Valley DX Club covers all bands with an emphasis on shortwave. Their monthly publication, "DX World" is sent to the members. Annual dues are \$4.00 in North America. Write the club for overseas rates. Sample copies of "DX World" are available for 50¢ (6 IRCs overseas). Miami Valley DX Club, 4666 Larkhall Lane, Columbus, OH 43229, USA.

## Worldwide TV-FM DX Association (WTFDA)

WTFDA was founded in 1967 and, as the name implies, they specialize in TV, FM and VHF/UHF radio. Their "VHF/UHF Digest" is published monthly. Annual dues are \$11.00 in North America, \$18.00 overseas. Samples of the Digest are available for \$1.00 (6 IRCs overseas). WTFDA also have several publications available including "Beyond Shortwave" and "FM Atlas and Station Directory". Worldwide TV-FM DX Association, P.O. Box 202, Whiting, IN 46394, USA.

## Radio Communications Monitoring Association (RCMA)

RCMA was founded in 1975 and covers the VHF/UHF public service bands (police, fire, marine, weather). The "RCMA Newsletter" is published monthly. Sample copies are 30¢ (3 IRCs overseas). Membership dues are \$8.00. Radio Communications Monitoring Association, P.O. Box 4563, Anaheim, CA 92803, USA.

The following five clubs are associate members of ANARC:

## Club DX Quebecois (CDXQ)

This is another French language club, founded in 1977. "L'Echo des Ondes" is their monthly bulletin and it covers shortwave, medium wave and utility bands. Sample copies are 50¢. Membership dues are \$8.50 in North

America and \$10.00 overseas. Club DX Quebecois, 1445 Rue Racine, Ancienne-Lorette, Quebec, G2E 5P4, Canada.

## University of Manitoba DX Club (UMDXC)

UMDXC have no regular bulletins but meetings are held on a regular basis in the Winnipeg area. Write them for details if you live in or around Winnipeg or if you plan on visiting there. They have been in existence since 1972. Membership is limited to residents of the province of Manitoba. University of Manitoba DX Club, Room 517, Box 131, University Centre, Winnipeg, Manitoba, R3T 2N2, Canada.

## Minnesota DX Club (MDXC)

Founded in 1973 this club is basically for residents of Minneapolis, St. Paul. They were the sponsors of this year's ANARC Convention. No regular bulletins are issued but meetings are held in the Minneapolis area. Minnesota DX Club, 5212 Drew Avenue, Minneapolis, MN 55410 USA.

## Association of Illinois DXers (AIDX)

AIDX was founded in 1976 as a regional club but now have members from other parts of North America. The monthly "AIDX Journal" covers shortwave and medium wave. Sample copies may be obtained for a self addressed stamped envelope or 2 IRCs. Annual dues are \$5.00 in North America or \$9.00 overseas. Association of Illinois DXers, P.O. Box 94672, Schaumburg, IL 60194, USA.

## Washington Area DX Association (WADXC)

Founded in 1978 this club is open to anyone in North America. Their quarterly publication, "WADXC Newsletter" covers shortwave, medium wave and utility bands. Meetings are held several times a year in the Washington, DC area. Annual dues are \$2.00. Washington Area DX Association, 606 Forest Glen Road, Silver Spring, MD 20901, USA.

## OVERSEAS CLUBS

Many listeners like to belong to an overseas club to obtain first hand information on stations in their favourite countries. Of course some of the stations heard on the other side of the world quite easily might be more difficult here.

## European DX Council (EDXC)

This is a confederation of European

clubs similar to ANARC. For information about EDXC member clubs and EDXC publications write to them. They were established in 1965. European DX Council, P.O. Box 4, St. Ives, Huntingdon, Cambs. PE17 4FE, England.

## Indian DX Club International (IDXCI)

This club was organized in 1975. Their monthly "DX Digest" covers shortwave and medium wave. For dues and a sample copy of DX Digest write to: Indian DX Club, 26/1B Northern Avenue, Calcutta 700 030, India.

## Southern Cross DX Club (SDC)

This club was founded in 1973 and covers shortwave and medium wave bands. "DX Post" is published monthly except December. Dues are \$5.00 a year in Australia. Write for overseas rates. Southern Cross DX Club, GPO Box 336, Adelaide, South Australia 5001, Australia.

## Japan Broadcasting Listeners' Federation

Shortwave, medium wave, FM/TV (UHF-VHF) bands are covered in their publications — HZ (monthly) and BCL (annually). Both are in Japanese. The organization was founded in 1975. For a sample copy and membership rates write to: Japan Broadcasting Listeners' Federation, 5F UNI Roppongi Bldg, 7-chome 15-17; Roppongi, Minato-ku, Tokyo 106, Japan.

## Danish Shortwave Clubs International (DSWCI)

DSWCI publish a very attractive monthly bulletin in English called "Short Wave News". They cover SW, MW, Utility and clandestine stations. They also publish a very comprehensive Tropical Bands Survey each year. Membership rate is \$14.00 US for surface mail. For airmail to North America the cost is \$19.75. Danish Shortwave Clubs International, Greve Strandvej 144, DX-2670 Greve Strand, Denmark.

For information about the following clubs write to the addresses given:

**Australian Radio DX Club**, P.O. Box 67, Highett, Victoria, 3190, Australia.

**TELEX**, B.P. 68, B-1170, Brussels, Belgium.

**Benelux DX Club**, P.O. Box 1306, Nijmegen 6800, The Netherlands.

**La Salle DX Club**, Apartado Aereo 8528, Bodota, Colombia. (Spanish)

## Shortwave World

**Finnish DX Association**, P.O.B. 454, SF-00101, Helsinki 10, Finland.

**Worldwide DX Club**, P.O.B. 1263, D-6380 Bad Homburg, Fed. Rep. of Germany. Their bulletin "DX Magazine" is in English.

**New Zealand Radio DX League**, P.O. Box 1313, Invercargill, New Zealand.

**South African DX Club**, P.O. Box 145, Milverton, 7405, Cape Province, South Africa.

**Union of Asian DXers**, 32/4a Malwatte Rd., Dehiwala, Sri Lanka.

**Swedish DX Federation**, P.O. Box 3108, S-103 62 Stockholm, Sweden.

**Swiss SW Club**, P.O. Box 309, CH-8051 Zurich, Switzerland.

**World DX Club**, Flat 2, 71 King Charles Road, Surbiton, Surrey, England, KT5 8PG.

I belong to several of these clubs and have seen many of the others' bulletins. They all have much valuable information for the shortwave (or other bands) listener. So join one or more of these clubs and enjoy the great hobby of shortwave listening even more.

Until next month, 73 and good listening.

# THE KING OF TRANSISTOR GUIDES

OK ET1 — I don't want to be in the dark about transistor specs any longer — send me THE KING. Here's my \$8.95 plus .45 for postage and handling. (That's \$9.40 if your calculator battery is flat, or 2 for \$18.80)

NAME \_\_\_\_\_

ADDRESS \_\_\_\_\_

\_\_\_\_\_

\_\_\_\_\_

Cheque enclosed. DO NOT send cash.

Bill Mastercharge. A/C No. \_\_\_\_\_

Bill Charge. Expiry Date \_\_\_\_\_

Signature \_\_\_\_\_

## THE NEW KENWOOD R-1000 SWL RECEIVER



### FEATURES:

- DIGITAL AND ANALOG DISPLAY
- 200 KHz - 30 MHz COVERAGE
- BUILT-IN QUARTZ DIGITAL CLOCK
- NOISE BLANKER
- AM, CW, USB, LSB
- COMPACT 12¼"W x 4½"H x 8½"D

### INTRODUCTORY PRICE

# \$629<sup>00</sup>

ADD 4% SALES TAX FOR B.C. RESIDENTS

**WE ALSO STOCK THE Bearcat® 210, 220 AND 250 SCANNING RECEIVERS WHICH COVER THE 32-50 MHz, 146-174 MHz, and 420-512 MHz BANDS.**

**DETAILED BROCHURES AND OUR MAIL-ORDER CATALOGUE SENT FREE ON REQUEST.**

Canada's largest selection of Ham Radio Equipment

## GLENWOOD TRADING COMPANY LTD.

278 East 1st St., North Vancouver, B.C. V7L 1B3

THE PROS WHO SERVE THE HAMS

Circle No. 14 on Reader Service Card.



# Enjoy reading about electronics? Choose from the informative Babani Series and order using card!

Is electronics your interest? Then get into it more deeply in the special areas of your choice. Electronics Today carries a range of electronics books published by Babani Press and Bernards, amongst which are those described below. (If someone has already used the card, write to Electronics Today Magazine, Unit 6, 25 Overlea Blvd, Toronto, Ontario M4H 1B1)

For Sam's books, and French language technical publications, please see ETI Special Book Service.

## IC 555 Projects

- Every so often a device appears that is so useful that one wonders how life went on before without it. The 555 timer is such a device.
  - It was first manufactured by Signetics, but is now manufactured by almost every semiconductor manufacturer and is inexpensive and very easily obtainable.
  - Included in this book are Basic and General Circuits, Motor Car and Model Railway Circuits, Alarms and Noise Makers as well as a section on the 555, 558 and 559 timer.
  - An invaluable addition to the library of all those interested in Electronics.
- Price \$4.30 including 30¢ postage and handling

## 52 Projects Using IC741

- IC741 is one of the most popular, inexpensive and easily obtainable devices available to the home constructor. It is also extremely versatile and can be used in a great number of various applications.
  - This unique book, originally published in Germany, shows fifty-two different projects that can be simply constructed using only the IC741 and a few discrete components.
  - An invaluable addition to the library of all those interested in electronics.
- Price \$2.70 including 30¢ postage and handling

## Mobile Discotheque Handbook

- The vast majority of people who start up "Mobile Discos" know very little about their equipment or even what to buy. Many people have wasted a "small fortune" on poor, unnecessary or badly matched apparatus.
  - The aim of this book is to give you enough information to enable you to have a better understanding of many aspects of "disco" gear.
  - The approach adopted is to assume the reader has no knowledge and starts with the fundamentals, hopefully the explanations given are simplified enough for almost anyone to understand but please note that this is by no means the full story.
  - The book is divided into six parts — Basic Electricity, Audio, Ancillary Equipment, Cables and Plugs, Loudspeakers, Lighting Equipment and the information has been considerably sub-divided for quick and easy reference.
- Price \$4.80 including 30¢ postage and handling

## 28 Tested Transistor Projects

- Mr Richard Torrins is a well experienced electronics development engineer and has designed, developed, built and tested the many useful and interesting circuits included in this book.
  - Some of the circuits are completely new and, to the best knowledge of the author, unlike anything previously published while others may bear similarity to more familiar designs.
  - The projects themselves can be split down into simpler building blocks which are shown separated by boxes in the circuits for ease of description, and also to enable any reader who wishes to combine boxes from different projects to realise ideas of his own.
  - Most of the circuits are very economical on the use of components and in many cases the semiconductors employed are non-critical commonly available and inexpensive types.
- Price \$3.15 including 30¢ postage and handling

## First Book of Transistor Equivalents and Substitutes

- Shows alternatives and equivalents to many popular transistors made in Great Britain, U.S.A., Europe, Japan and Hong Kong etc.
  - Companion Volume to BP14 — SECOND BOOK OF TRANSISTOR EQUIVALENTS AND SUBSTITUTES
  - An invaluable addition to the library of all those interested in Electronics be they amateur or professional.
- Price \$2.30 including 30¢ postage and handling

## Second Book of Transistor Equivalents and Substitutes

- Shows alternatives and equivalents to many popular transistors made in Gt. Britain, U.S.A., Europe Japan and Hong Kong etc.
  - Companion Volume to BP1 — FIRST BOOK OF TRANSISTOR EQUIVALENTS AND SUBSTITUTES
  - An invaluable addition to the library of all those interested in Electronics be they amateur or professional.
- Price \$3.55 including 30¢ postage and handling

## Radio Circuits Using IC's

- This book describes integrated circuits and how they can be employed in receivers for the reception of either amplitude or frequency modulated signals. The chapter on amplitude modulated (a.m.) receivers will be of most interest to those who wish to receive distant stations at only moderate audio quality, while the chapter on frequency modulation (f.m.) receivers will appeal to those who desire high fidelity reception of local h.f. stations possibly with stereo (and even quadrophony at some future date). Stereo decoder circuits and the devices available at present for quadrophonic circuits are discussed. Voltage regulator devices are also covered because they are so convenient in all varicap tuned receivers and because they have so many applications in all types of circuit.
  - Brian Dance is a highly experienced author who regularly contributes to many of the popular electronic magazines that are available both in the U.K. and overseas.
  - An extremely valuable addition to the library of all Electronics enthusiasts.
- Price \$4.80 including 30¢ postage and handling

## 50 (FET) Field Effect Transistor Projects

- Field effect transistors (F.E.T.'s) find application in a wide variety of circuits. The projects described here include radio frequency amplifiers and converters, test equipment and receiver aids, tuners, receivers, mixers and tone controls, as well as various miscellaneous devices which are useful in the home.
  - It will be found that in general the actual F.E.T. used is not critical and many suitable types will perform satisfactorily. The F.E.T. is a low-noise, high gain device with many uses, and the dual gate F.E.T. is of particular use for mixer and other applications.
  - This book contains something of particular interest for every class of enthusiast — shortwave listener, radio amateur, experimenter or audio devotee.
  - A valuable addition to the library of all electronic enthusiasts.
- Price \$3.85 including 30¢ postage and handling

## Popular Electronic Projects

- Included in this book are a collection of the most popular types of projects which, we feel sure, will provide many designs to interest all electronics enthusiasts.
  - All the circuits utilise modern, inexpensive and freely available components.
  - The 27 projects selected cover a very wide range and are divided into four basic areas: Radio Projects, Audio Projects, Household Projects and Test Instruments.
  - An interesting addition to the library of both the beginner and more advanced constructor.
- Price \$5.10 including 30¢ postage and handling

## Electronic Music and Creative Tape Recording

- Electronic Music is the new music of the 20th Century. It plays a large part in "Pop" and "Rock" music and, in fact, there is scarcely a group without some sort of electronic synthesiser or other effects generator.
  - It is possible with relatively simple apparatus to create complete compositions using electronic and sometimes non-electronic musical sources.
  - This book sets out to show how Electronic Music can be made at home with the simplest and most inexpensive equipment. It describes how the sounds are generated and how these may be recorded to build up the final composition.
  - With the constructor in mind, several ideas are given to enable a small studio to be built including a mixer and various sound effect units.
  - Circuits are included for VCOs, VCA's, Envelope Shapers, VCFs, Active and Passive Mixers, Fuzz, Noise Generators, Metronomes and a 10-Note Programmable Sequencer etc.
  - All the units shown have been successfully built and used by the author and most of the projects can be built by the beginner.
  - An unusual, fascinating and highly rewarding application of electronics.
- Price \$4.50 including 30¢ postage and handling

## IC LM3900 Projects

- The purpose of this book is to introduce the LM3900 to the Technician, Experimenter and Hobbyist. It provides the groundwork for both simple and more advanced uses and is considerably more than just a collection of simple circuits or projects.
  - The LM3900 is different from conventional 'Op-Amps', it can be used for many of the usual applications as well as many new ones. It is one of the most versatile, inexpensive and freely available devices on the market today.
  - The book is divided into six basic sections —
    - Introduction
    - Audio Applications
    - Simple Linear Applications
    - Simple Digital Applications
    - Signal Generator Circuits
    - Special Applications
  - The LM3900 can do much more than is shown here — this is just an introduction. Imagination is the only limitation with this useful device, but first the reader must know the basics and that is what this book is all about.
- Price \$4.80 including 30¢ postage and handling

## 1st Book of Hi-Fi Loudspeaker Enclosures

- Contains 26 practical designs and over 40 drawings to enable the enthusiast to construct his own Hi-Fi Loudspeaker enclosures.
  - Includes the following types of enclosures — Corner Reflex, Bass Reflex, Exponential Horn, Folded Horn, Tuned Port, Klipschorn Labyrinth, Tuned Column, Loaded Port, Multispeaker Panoramic etc.
  - Also covers general construction hints and embellishing of cabinets as well as a considerable amount of other useful information.
  - A must for the library of all audio enthusiasts.
- Price \$3.05 including 30¢ postage and handling

## 50 Simple L.E.D. Circuits

- The author of this book, Mr R.N. Soar, has compiled 50 interesting and useful circuits and applications, covering many different branches of electronics, using one of the most inexpensive and freely available components — the Light Emitting Diode (L.E.D.).
  - Also includes circuits for the 707 Common Anode Display.
  - A useful book for the library of both beginner and more advanced enthusiasts alike.
  - Companion volume to book No. BP36 — 50 CIRCUITS USING GERMANIUM, SILICON & ZENER DIODES by the same author.
- Price \$3.05 including 30¢ postage and handling

## Handbook of IC Audio Preamplifier & Power Amplifier Construction

- Shows what audio IC's are, as well as how to use them.
  - Includes practical constructional details of various IC and Hybrid IC/Transistor designs of about 250mW to 100W output.
  - This book is written by the very experienced and popular author Mr. F.G. Rayer who deals with the subject in four parts:
    - Part I Understanding Audio IC's
    - Part II Preamplifiers, Mixers and Tone Controls
    - Part III Power Amplifiers and Supplies
    - Part IV Hybrid Circuits
  - An ideal book for both beginner and advanced enthusiast alike.
- Price \$3.15 including 30¢ postage and handling

## 50 Projects Using Relays SCR's & Triacs

- Relays, silicon controlled rectifiers (SCR's) and bi-directional triodes (TRIAC's) have a wide range of applications in electronics today. These may extend over the whole field of motor control, dimming and heat control, delayed, timing and light sensitive circuits and include warning devices, various novelties, light modulators, priority indicators, excess voltage breakers etc.
  - In this book, the very experienced and popular author — Mr F.G. Rayer — has given tried and practical working circuits which should present the minimum of difficulty for the enthusiast to construct.
  - In most circuits there is a wide latitude in component values and types, allowing easy modification of circuits or ready adaptation to individual needs.
  - An ideal book for both beginner and advanced enthusiast alike.
- Price \$4.05 including 30¢ postage and handling

## 50 Projects Using IC CA3130

- The CA 3130 is currently one of the more advanced operational amplifiers that is available to the home constructor. This means that it is often capable of a higher level of performance than many other devices and that it often needs fewer ancillary components.
  - In this book Mr R.A. Penfold has designed and developed a number of interesting and useful projects which are divided into five general categories:
    - I Audio Projects
    - II R.F. Projects
    - III Test Equipment
    - IV Household Projects
    - V Miscellaneous Projects
  - An ideal book for both the beginner and more advanced enthusiast alike.
- Price \$3.15 including 30¢ postage and handling

## Electronic Projects for Beginners

- In this book the newcomer to electronics will find a wide range of easily made projects, many complete with actual component and wiring layouts. Furthermore, a number of projects have been arranged so that they can be constructed without any need for soldering and, thus, avoid the need for a soldering iron.
  - This book which is written by the very experienced author Mr F.G. Rayer is divided into four sections —
    1. "No Soldering" Projects
    2. Miscellaneous Devices
    3. Radio and Audio Frequency
    4. Power Supplies
  - An absolute "must" for all beginners in electronics.
- Price \$4.80 including 30¢ postage and handling

## 50 CMOS IC Projects

- CMOS IC's are probably the most versatile range of digital devices for use by the amateur enthusiast. They are suitable for an extraordinarily wide range of applications and are now also some of the most inexpensive and easily available types of IC.
  - In this book Mr R.A. Penfold has designed and developed a number of interesting and useful projects which are divided into four general categories:
    - I Multivibrators
    - II Amplifiers and Oscillators
    - III Trigger Devices
    - IV Special Devices
  - An ideal book for both the beginner and more advanced enthusiasts alike.
- Price \$3.10 including 30¢ postage and handling

## Electronic Calculator Users Handbook

- An invaluable book for all calculator users whatever their age or occupation, or whether they have the simplest or most sophisticated of calculators.
  - Presents formulae, data, methods of calculation, conversion factors etc. with the calculator user especially in mind, often illustrated with simple examples.
  - Includes:
    - The way to calculate, using only a simple four function calculator: Trigonometric functions (sin, cos, tan)
    - Hyperbolic functions (sinh, cosh, tanh)
    - Logarithms, square roots and powers.
    - A comprehensive section of conversion factors covering such common conversions as length, area, volume and weight etc. through to more specialised conversions such as viscosity, illumination, and cargo shipping measures etc.
    - Formulae and data for VAT, discounts and mark up, currency conversion, interest, solutions of equations, binary and octal numbers, areas and volumes, statistics and mathematics etc.
- Price \$3.20 including 30¢ postage and handling

# Teachers' Topics

On students, teachers and electric vehicles.

THIS MONTH, *Teacher's Topics* is looking at the rather unusual program conducted in the *Electrical Technology* course at *Fellowes High School*, in *Pembroke Ontario*. The program is largely the work of instructor *Renton Patterson*, who has long had an interest in electric vehicles as well as teaching. The third electric vehicle to be produced by the student of this course, "ThunderVolt 3" has received wide publicity, and has been shown in the last two *Energy Lifestyle Shows*. It is a very professional looking piece of work, and represents Mr. Patterson's dedication both to giving his students something real to work on, and to alternate-energy transportation. Mr. Patterson told us that it was a case of putting his money where his mouth was. And this he did, to the tune of \$12,000 of his own money.

The story below then comes from *Fellowes High School*, it's both about building cars and boats as school projects, and about the vehicles themselves.

Teachers and students are encouraged to send material for this column on any area involved with the teaching or learning about electronics. We welcome news about what your school, board, or association is doing. (If you wish to contribute news of upcoming events, please note that we need to receive notice, at least 45 days before the first of the issue month.) Send your letters to:

TEACHERS'S TOPICS, *Electronics Today Magazine*, Unit 6, 25 Overlea Blvd., Toronto Ont., M4H 1B1.

If we publish your letter or ideas we will award your department or school library a free subscription to *ETI*.

## WHY AN ELECTRIC CAR?

There are many reasons:

Most high school electrical courses concentrate on a theoretical and experimental approach to the study of electrical principles and devices. When an experiment or exercise has been completed, equipment is disassembled and put back in cabinets. A more motivating and meaningful approach to the study of electrical principles is to have the students work on something



Electric vehicle "ThunderVolt 3" now provides family transportation for teacher *Renton Patterson* (foreground). From left to right are students who designed and modified the car: *Tim McNamara, Carey Bucholtz, Daryle Budarick, Mike Irwin, Al Moreau, Brian Boudens, and Lorne Macdonald*. Photos by *Montaignes*.

which stays together and is used after it is completed. This is the same approach that is used so successfully in the *Architectural Drafting and Carpentry* shops where furniture, toolhouses, cottages, etc. are designed and built; or in the *Mechanical Drafting and Machine* shops where wood lathes, model engines, or other tools and machinery are designed and constructed as student projects. Therefore, an electric vehicle design and construction project for the *Electrical shop* fulfills this same project approach very well.

The success of *ThunderVolt #1* and *ThunderVolt #2* confirmed to the instructor that the learning experience provided by the design and construction of these projects was far superior to any other approach previously used. The students mature so much in their understanding of the real technological world that they are "light years" ahead of their peers who graduate from high school having spent all of their time at a classroom desk. *ThunderVolt* students, along with all other *Technical Course* students, have actually done some-

thing and have experienced a very real contact with the world of work before they graduate.

The concept of the electric vehicle has been described recently as "an idea whose time has come". In view of our dwindling oil supplies there are many experimental electric vehicles traveling the roads of various countries. *ThunderVolt* students are therefore working on the fringes of a new and increasingly important technology. The motto for our *Technical Department* "Educating To-day's Students For Tomorrow's Jobs" is well exemplified in the *ThunderVolt* program.

## THUNDERVOLT 1

In September of 1973, the combination of a world concern for oil supplies and an idea suggested by a superior group of students, finally got an electric car project into action. The aim of this project was to design and construct a small practical electric car suitable for providing transportation to and from work, or for shopping, or other short hops around town.

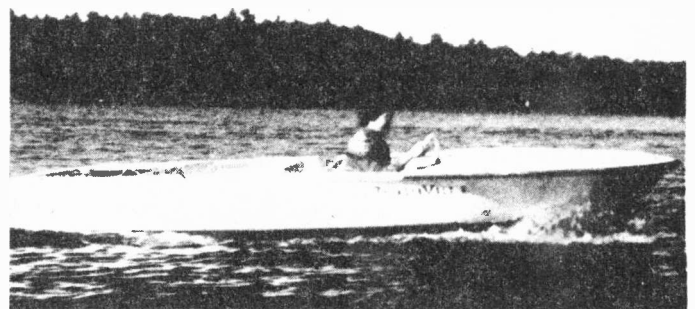
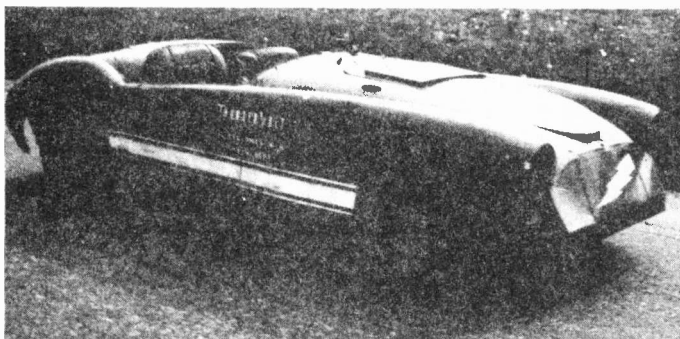



The students first investigated the overall problems: a suitable weight for such a vehicle, the availability of parts at a reasonable cost, the probable maximum range and performance characteristics, etc., and then got busy studying many of the normal things covered in an Electrical Technology course, but which, in the end, would have a definite application. The main areas of investigation were: direct-current motors, motor control, and battery characteristics; then there were the many other related topics such as generators, relays, instruments, wire sizes, etc. This theoretical study took the first of the two years required. The second year concentrated on construction. As well as this design and construction, the students experienced operating as part of a team, scheduling work, and solving problems. The students were motivated to such an extent that during the final stages of assembly they were in working before nine, during their lunch hour, and after school.

The car is an MG of the 1950's purchased from a student for \$15. Two was \$115. surplus in California for about \$30 each. The batteries were borrowed from the Auto Mechanics shop and are standard, but good quality, automotive-type batteries. Not including the batteries, the car's total cost to the school budget was \$115.

The motors develop a total of 7½ hp and are connected by a chain directly to the transmission (no clutch). The car has two electrical speeds: 12 volts obtained from four power batteries in the front, and 24 volts when combined with four more batteries in the rear. Two other batteries in the front operate the controls. As well as the electrical speeds, there are four more available through the transmission.

ThunderVolt 1 had its first trials in June 1975 and performed well right from the start. No major difficulties were encountered. The car is not safety-checked and therefore not operable on the highway. For this reason its range and top speed have not been tested, but calculations show that with two passengers the car should be able to travel 15 miles at a speed of about 25 mph. This range or speed could be improved by adding more batteries for which there is room for another eight. With four passengers and in second gear, a speed of 30 mph can easily be reached in the school parking lot. With driver only, and given the space to try fourth gear, its top speed would be quite respectable.

An unexpected benefit of the project was some good publicity for Fellowes High School and for Pembroke. Renton Patterson, the instructor, was interviewed about the car on the CBC

National Radio Network, national TV (Canada AM on CTV), and the car, instructor and students were featured on three regional TV shows: CHOV News, CBC's "This Day", and CTV's "Regional Contact". There have also been either articles or mention of the car in the Pembroke Observer, "Canadian Automotive Trade", and the international magazine "Electric Vehicle News". The television shows in particular gave the students an extra dimension of experience as well as wide recognition for their work.

## THUNDERVOLT 2

ThunderVolt 2 is an electric boat and was the project chosen by two students, Lorne MacDonald and Bruce Boshart, in the senior Electrical Technical course. It was designed and built during the 1975-76 school year and launched and tested in June.

Unlike ThunderVolt 1, which was financed and is owned by the school, the boat and all its parts were purchased by the teacher, Renton Patterson, to provide transportation for the half mile between the end of the road and his family's cottage. As such, its speed and range requirements are minimal. However, tests indicate that it can attain a top speed of about 10 mph which it can hold for about 40 minutes on one battery charge. It can cruise at 5 mph for 2¾ hours, or 3½ mph for about 12 hours. This performance is when using standard 12-volt automobile batteries. The range, and battery life, will be extended considerably when proper electric-vehicle batteries replace the present ones.

ThunderVolt 2 uses a reconditioned 14-foot molded-plywood hull powered by a 5-hp, 48-volt used electric lift-truck motor. Current is supplied by four 12-volt batteries placed in the stern. The motor is mounted in the bow and drives, via V-belts, two shafts through the boat bottom connected to two 8-inch propellers. Twin props were chosen for two reasons; so that the main central structural member of the boat would not have to be disturbed, and to facilitate a belt drive which allows for different speed reductions by interchanging pulleys.

ThunderVolt 2 cost about \$500 and in 1979 had its fourth summer of operation. It is a very stable boat, starts instantly, is extremely quiet - the only noise is from the bow waves and wake - costs only pennies to run, and is one hundred percent pollution free. It won't pull any water skiers, but for transportation, fishing, or just cruising, electric power makes just as much sense on water as it does on land.

## THUNDERVOLT 3

Renton Patterson has been in the habit of buying a new car every ten

years. In the spring of 1976, the ten-year period for his 1966 Rambler was up, - he needed a new car! Vowing years ago that his next car would be an electric, he investigated the purchase of one, and found at that time no Canadian supplier of personal electric passenger cars. The US was found to have two such manufacturers. The Canadian government, however, while allowing duty-free import of gas-hogging Cadillacs and Lincolns, penalized very severely, the purchase of foreign alternate-energy vehicles. This fact, coupled with three others, led to the initiation of the Thundervolt 3 projects.

The other factors were — 1) The unqualified success of ThunderVolts 1 and 2. 2) The fact that during the research for ThunderVolt 2, it was found from the available literature, that the components necessary for building a modern, practical, high performance electric vehicle are available today. 3) The students moving up to the Senior Electrical Technology course were an unusually capable group. This group also had the advantage of retaining Lorne MacDonald, who led the ThunderVolt 2 team, as the foreman. Lorne was then in Grade 13.

The intricate metal work required was done by some Machine-Shop students under instruction Hank McCann. His boys machined an aluminum adapter plate to go between the electric motor and the transmission bell housing, made a motor coupling, and modified the flywheel.

Since the requirement of ThunderVolt 3 was to fulfill the normal around-town driving needs of the Patterson family of five, as well as a highway range of 40 miles so that the car could get past Renfrew to Hurds Lake where ThunderVolt 2 sits docked, the car to be converted had to be one with the appropriate passenger and battery room. The station-wagon model of the new Aspen-Volare series of Chrysler products fit these requirements best. As soon as final information on the electric motor was received, the required gear ratios were determined and the car was ordered accordingly. As well as allowing us to get exactly what we wanted, a new, rather than a used car was chosen so that the body could be properly treated for rust and hopefully approach the expected life of the electrical drive train; 400,000 miles. Also, the work and expense involved in the conversion did not warrant using a vehicle with its best years behind it. Although an automatic transmission was considered ideal for driving ease, this type was found to consume an

*continued on page 74.*

# Service News

MANUFACTURERS... REPRESENTATIVES... ORGANISATIONS... DISTRIBUTORS... SERVICE... Send us your news ideas for the upcoming seminars, new products, releases on upcoming shop. Address them to Service News, Electronics, Today Magazine, Unit 6, 25 Overlea Blvd, Toronto, Ontario, M4H 1B1. Please note that your information must be received at least six weeks before the first of the month of the issue in which it is to appear. Any material published at our discretion.

Dick Cartwright, ETI's service editor, reports from a CEASA meeting where Frank Drea talks about deregulation.

ON SEPTEMBER 6, 1979 the Canadian Electronic & Appliance Service Association held their Second Annual General Meeting and Luncheon at the Constellation Hotel, Toronto, Ontario. The Honourable Frank Drea, Minister of Consumer & Commercial Relations, Government of Ontario, graciously accepted their invitation to be the guest speaker. Mr. Drea was most warmly received, and in his usual pleasant conversational style he delivered a very fine address, which I quote verbatim: "I appreciate the opportunity to address your association on this your second anniversary. I have followed the development of your association and commend you on the programmes and policies you have set in place so far. "As for my Ministry, I can best describe it by saying 'we are in the honesty business'. Our wish is for business to regulate itself. Self-regulation makes a lot more sense than legislation and so my Ministry encourages self-regulation. The quality of service must keep improving without putting the little guy out of business. De-regulation isn't intended to save tax money. The real thrust is to return to business the very things that business does best. But business must meet the challenge! Government cannot do it alone! In many areas the pattern is for government to regulate for a time, then turn the regulatory functions back to industry. When the government deregulates an industry, it has to dismantle its regulatory forces which is a costly affair involving people and systems. It isn't always easy for an industry to regulate itself but we find that business today is responding very effectively to self-regulation. This I am pleased to see happen for there is always a cost of doing business with the government. "I appreciate the work

being done by your association. At times you may think the going is slow but rather slow than *no action*. There is no model for you to follow and there must be acceptance of your plans and programmes *out there* if your efforts are to be successful. My Ministry has been following the work you are doing unselfishly for persons who cannot afford to do it for themselves.

"In today's society, everything is going from electric to electronic. Many home appliances think for themselves and, although they provide more leisure for the consumer, the function of the appliance is a mystery to many people. The consumer becomes a pawn in the game of chance — left to the mercy of the dealer.

What about Product Warranty Legislation? Quite frankly we have no plans to pursue any regulatory action on warranties. This is no time for the government to get into the warranty field. There is a limit to human resources and I'm not sure we need new warranty regulations. There is a myth that we live in a 'throw-away society', that things can't be fixed any more. Sure, there are cost considerations to be recognized in today's consumer products but isn't always a case of replacing the car because a spark plug is fouled up.

"The government did step into the automobile insurance field recently because we felt an injustice existed and the insurance industry hadn't taken the necessary steps to regulate the business but we didn't want to take the step until it appeared there was no other solution.

"My advice to you is *don't* let government do your thinking for you! A government regulatory body is expensive and hard to get rid of. Why should government issue licences for

employees when they are employed by a licenced dealer? Surely that is enough control since a dealer's license can be reviewed at the time of renewal.

"Yes — self-regulation is the way government wishes to go. The Canadian Electronic & Appliances Service Association is doing it for itself without government assistance.

"May I commend you for the work you are doing. My Ministry appreciates your efforts.

"Thank you."

I was unfortunately ineligible to attend the meeting, but thanks to Mr. Bill White, the General Manager of the Association, a few high-lights from the agenda were passed on to me.

There was some considerable discussion re Provincial service associations. A member opened the discussion by pointing out that there are hundreds of independent technicians across Canada who would like to be members of the CEASA but do not qualify because they cannot belong to a Provincial service association that does not exist. There are even technicians in Provinces where associations do exist who would rather belong to the CEASA than take out membership in their existing Provincial association.

Another member felt that many interested technicians have not formed an association due to lack of knowledge on how to go about it. The secretary reports that the CEASA office is intending to issue a booklet on how to form an association. A member then volunteered to assist in this project based upon the B.C. experience. It is obvious that CEASA is on the move.

Here is an extract from Service Contacts which I feel says it all:



Your Zenith Distributor has the parts and accessories you need in one convenient place — your Zenith One-Stop Shopping Center.

#### REPLACEMENT PICTURE TUBES



Famous Super Chromacolor® picture tubes in a range of sizes to replace a total of 80 industry types. Plus Sunshine® and Cinebeam picture tubes to fit almost any brand of color TV. And Zenith black & white picture tubes to replace 401 other types of B & W tubes.

#### REPLACEMENT RECEIVING TUBES



A complete line of more than 1,000 Zenith quality tubes . . . the same tubes as used in Zenith original equipment. Built to operate with great reliability — to cut your callbacks. And they have the long life needed to increase the satisfaction of your customers.

#### ZENITH QUALITY PARTS



All the parts you need, from bel fuses to TV knobs. The star is the Zenith Instant Parts Program (ZIP). It puts the 100 most used replacement parts at your fingertips, in a specially designed, compact rack. ZIP makes inventory and re-ordering fast and easy for you. Also, Zenith now offers a line of capacitors, resistors, integrated circuits and universal semi-conductors and a full line of universal needles and cartridges.

#### ZENITH QUALITY ACCESSORIES



Here are just a few! Quad, stereo and monaural headphones. Broadened line of outdoor antennas featuring 13 all-new Super Chromatenna models. Complete new Chromatenna indoor antenna line. Antenna rotors. Three grades of batteries in a wide range of sizes. Electronic chemicals, including tuner degreaser, tuner cleaner, circuit cooler and tape head cleaner. Cassette and 8-track recording tape cartridges and record care products. A full line of test equipment & service aids.

Beside parts and accessories, your Zenith Distributor has the specialized "know how" to help solve tough service problems. Come in or phone today.



#### YOUR LOCAL ZENITH DISTRIBUTOR:

Major Appliances Div.,  
Acklands Ltd.,  
1725 Quebec Street,  
Vancouver, B.C.  
Phone-1-604-879-4631

B.R.E. Electric Ltd.,  
5544-5th Street S.E.,  
Calgary, Alta. T2H 1L3  
Phone-1-403-253-7171

B.R.E. Electric Ltd.,  
14840-115th Ave.,  
Edmonton, Alta. T5M 3C1  
Phone-1-403-455-7171

Major Appliances Div.,  
Acklands Ltd.,  
1155 Sherwin Rd.,  
Winnipeg, Man. R2H 0V1  
Phone-1-204-633-6679

Zenith Radio Corporation  
of Canada Ltd.,  
1020 Islington Ave.,  
Toronto, Ont. M8Z 5X5  
Phone-1-416-231-4171

Zenith Radio Corporation  
of Canada Ltd.,  
900 Boul. St. Martin O.,  
Chomedey, Lav. PQ  
H7S 2B6  
Phone-1-514-663-0430

Waldale Limited,  
Station Street, Box 339,  
Amherst, N.S.  
Phone-1-902-667-3308

# LEADER'S FRONT LINE

## Scopes to choose from!



LBO 520

LEADER has a family of 'scopes for your measurement requirements. Engineered for fast and easy portable operation with front panel controls, logically located and grouped. Highly reliable P.C. boards are employed for long term maintenance-free dependability. LEADER Test Instruments have become synonymous with excellence of performance, dependability and value.

- \* Bandwidths . . . . . 10 MHz – 30 MHz
- \* Sensitivities . . . . 1mV/div – 10mV/div
- \* Z modulation
- \* Delayed time base
- \* X-Y operation
- \* TTL compatible
- \* Delay line on input

**2 YEAR WARRANTY**  
Put a LEADER scope to the test

Available in Canada at authorized LEADER distributors.

Represented  
in Canada  
by:

**omnitronix ltd.**

2056 South Service Rd., Trans Canada Hwy,  
Dorval, Québec. H9P 2N4  
Tél. 683-6993 - Téléc. 05-822692



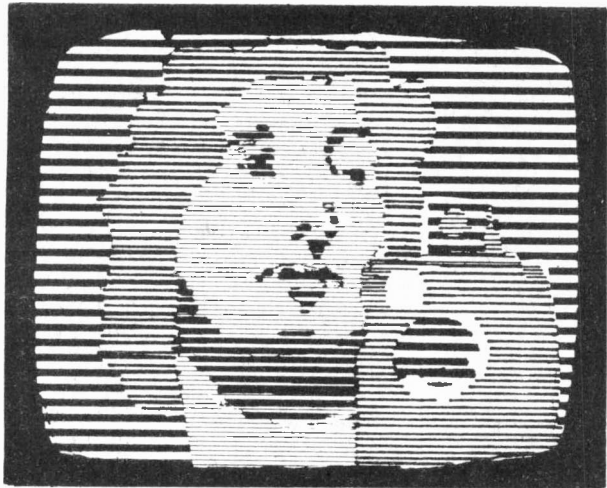

# WHAT'S ON

Steve Rimmer again avoids the topic of video discs.

## THE CONTINUING SAGA OF AMPEX

THIS COLUMN WAS originally going to be concerning TV games. There have been quite a few popping up in the last year. We began with the basic "PONG", and then, "SQUASH", which were both fairly cool and safe. Then we got "TANK", "SPACE WAR", and the like, and things began to heat up a bit. It was the latest round of video armaments, however, that really turned me off the whole scene. "PILLAGE AND RAPE" is a full colour, one chip game for two or four players that gives you the thrill of being a ruthless barbarian. For devotees, there is a second, expander chip that converts the game into "MASS MURDER AND ORGY AFTERWARDS". We also have the ever popular companion to the "TANK" game, "FLAME THROWER". General Incineration, the manufacturers of the IC, are presently working on a full arsenal of video arms. Chips will be combinable for various combat strategies. Lastly, for the real fan of video Armageddon, we have "ICEM". Each player has a button. The rules are probably familiar. Twenty minutes after pushing either button, the chip self-destructs and the set explodes.

So, like I said, I was going to do TV games, but I think I'll hold off for a bit; at least until after SALT II gets ratified and we can see where the industry stands.

Turning toward more peaceful matters, this month we're going to look at the AMPEX one inch video tape recorders. Descendants from the first commercial VTR, the VR-1000, the ones which usually crop up range from the VP-4900 to the VR-7500. Feature-wise, they begin with the basic monochrome players and move on to include everything from full colour to assembly

editing and stereo, sel-sync-able sound. While models made after the VR-7500 are still fairly widely in use, most of those prior to and including this machine have been undergoing retirement for a few years now. No doubt among the most popular machines in the industry in their day, it might be useful to have a more detailed look at the workings of them than was possible in the ETI "old VTR survey" that ran last December to March.

The VR-6000 shown in figure 1 is representative of the machines of this system. They all take much the same configuration. The tape resides on the left hand spool, gets wrapped around the centre head drum assembly and eventually finds its way to the take-up reel on the right. The head drum uses a single head, as opposed to the Japanese recorders, which, for the most part, employ two. This, in itself, is a rather positive feature for those of us who are lazy and/or poor, as there is simply one head less to clean and, eventually, replace. The tape rests over about 180° of the drum when first threaded and gets dragged in to cover a total of a bit more than 355° when things get rolling. Because most of complex tape moving is done by the mechanics of the machine itself, the Ampexes are among the easiest VTRs to thread, short of a cassette deck. There are no little openings through which to jam the ragged and tooth marked ends of your tapes when setting up.

As well, there is really only one point where it is possible to mis-thread one of these things, so the chances of a recording turning out scarfed due to "operator error", or the more common "operator doing a 'j'," are considerably reduced.

Especially considering the age of the system, there are surprisingly few panel

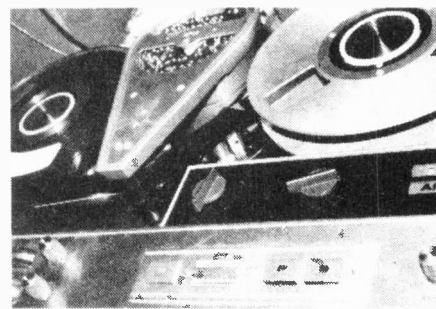

Fig. 1 Ampex VR6000

mounted controls for the user to meddle with on a regular basis. On the basic black and white recorder, these are limited to the audio and video record level pots, and, on playback, the audio volume and video tracking. A seldom-used tension adjustment control is also provided. (We'll ignore any hecklers who query regarding the power switch or the stop, start and record buttons here.)

## PLAYING WITH IT

Turning to the innards, we find . . . well, for a start, there's a bunch of transistors in here. All the circuitry of the machines is built on pc boards, which can be removed for servicing by sliding them out of their respective edge connectors. No desoldering is necessary. Depending upon the specific model in question, there are between ten and twenty internal, trimmer type adjustments on these cards. While the Ampex service manuals give really exact directions concerning how these are to be set up, which includes the test equipment to be used to do the deed (much of which costs more than the recorders themselves), the basement engineer faced with these waving fields of thumbwheel pots can usually get acceptable results simply by turning

them 'til the picture looks right. The whole system, in fact, is quite tolerant of rather wild internal misadjustments, due to the existence of a number of loop type circuits which are intended to keep everything oscillating, turning, tracking and switching more or less in time.

The only really heavy hex that the eternal swamp gnomes of destiny can possibly lay upon one of these things is to have something go wrong inside one of these loops. There is so much data in service manual, dealing with voltage measurements, three waveforms for every single transistor, in some cases, that most common difficulties can be troubleshooted and cleared up without too much difficulty. However, the loop circuits, when they go buns up, start trying to compensate for their own internal malfunctions, thinking that some external factor has shifted. Thus, it is not uncommon to come upon one having a seizure, and find that every voltage in it is trying to be at sixteen levels at once.

The most often encountered difficulty in Ampex VTRs is the ubiquitous Ampex rubber rot, a phenomenon they may be trying to get copyrighted as a trade mark. The sort of belts used in these machines tend to decompose after a time, at which point they begin to slip, slacken off, or even remove themselves from their drive pulleys in extreme circumstances. In itself, this is a very minimal concern, as Ampex stocks lots of spares, and none of the things are terrifically hard to change. However, strange as it may seem, one of these belts is involved in the loop circuitry that drives the head drum, and its eventual demise can lead to the most complex and hardest to find fault that can plague the system. We'll have a look at it here, so that, when you encounter it, you won't feel that the swamp gnomes are laughing at you behind your back.

The circuitry which controls the speed and phase of the video head drum motor is rather complicated. It is, as mentioned before, a loop. When the head drum spins, it induces pulses in a tach pickup, which eventually wind up in a comparator circuit. This compares these pulses with the control track pulses during playback or the stripped vertical sync while recording. Any difference between them produces a proportional error voltage which eventually winds up being applied to the voltage controlled oscillator that drives the head drum motor. A change in the head drum motor speed causes a change in the head drum speed which changes the tach pulse rate. When

these new tach pulses get back to the comparator circuit they, in turn, change, hopefully reduce, the error voltage, which, in turn, goes back into the VCO to further change the tach pulse rate, and around and around we go. However, part of this loop is, in fact, not electronic circuitry at all, but, rather, a mechanical linkage. Coupling the head drum motor to the head drum, itself, is one of those nasty rubber belts we were speaking of earlier.

## SPINNING RUBBER

When the belt gets old, a lot of funny things start happening. Because it is now physically larger, as well as being less firm, there comes a time when there is actually some slack between the motor and the drum. Thus, if the speed of the motor begins to increase in response to the error voltage applied to the VCO, this increase in speed will not be immediately felt by the drum, and, in turn, by the tach pulse generator. However, the control circuit wants more speed, and, seeing that nothing has happened, will say "well, it still isn't going fast enough; let's crank it up some more". Somewhere along the line, the slack runs out. At this point, the frequency of the VCO is artificially high anyway, and, secondly, the belt acts something like a rotary slingshot, so that the drum vastly overshoots the mark. The circuitry then has another fit, and frantically tries to slow the head down, but, again, it overshoots because of the slack in the belt. The result is that the head perpetually hunts, and the picture looks like the set's been dropped.

It isn't hard to spot this particular syndrome, should you suspect that you have it. For one thing, the belt will feel very slack and, in fact, it might actually have become sticky feeling; a sure sign that the artificial rubber blues have taken hold. Secondly, a 'scope on the output of the VCO will show that the pulses, far from being stable, are swaying back and forth like a partygoer who's too stoned to find the family auto. There is no way to repair an aging belt, but for the five bucks or so these things cost, there is also little reason to try.

The belt problem just outlined, when cured, will probably leave you with the aftermath of a still more common complaint; the magic thumbwheel game. Usually, as the belt begins to go, the servo loop circuitry can be adjusted to compensate for it, to a degree. These adjustments can, in fact, pull the loop pretty far off spec, and, of course, when the new belt is installed, they all have to be set right again. Otherwise, you will probably find that you have a picture

that has snow pulsing in and out, which is of some annoyance while viewing video tapes of the Toronto Symphony, Gimme Shelter, or other artsy stuff.

If you peruse the manual . . . probably that paper thing you've been storing under the cat . . . you will be able to find places on the circuit cards that will let you have a look at the ramp waveform, which is controlled by the tach on the head drum, and the vertical sync, which emerges from the video sync stripper. Naturally, you can't adjust the vertical sync rate while recording, but, by meddling about with the ramp trimmers, you will be able to get these two pulses to lock in so that they are both running at the same rate; i.e., they'll be in sync. Now, upon playing back a properly synced recording, you will now want to get the ramp and the control track pulses in gear. This is accomplished via the VCO frequency and stability trimmers. After a bit of fiddling, you should be able to get a stable, no-revulso picture.

## VIDEO SNOW

While we're here, we might as well deal with the actual cause of the snow that was involved in all that pulsing. You may still see some of it around, even with a stable picture, and, while there are numerous causes, the most usual is that the video head driver that puts the video on the tape is not functioning at maximum efficiency, causing a weak signal going on, which, in turn, produces a weak signal coming off that will, now and then, dip down into never-never land. To get the drivers balanced; connect a scope probe alternately to the bases of the two driver transistors whilst adjusting the "RF BAL" trimmer. Stop when you get the signal levels equal for both points. If you haven't been graced with a high frequency 'scope, you can make this adjustment another way. Plug a mike into the mike jack, and slowly adjust the trimmer full range while reading off the positions of the thumbwheel. Since these things aren't calibrated, clock face positions are useful in describing where the adjustment is set at any given moment. Make a recording covering the complete range of the trimmer, and, upon playback, note the setting that provides the best picture. Set the thumbwheel to this position.

Since, in making this adjustment, the overall recording current at the head may have been changed, as the two driver transistors cannot be expected to be closely matched, and because this is another adjustment technicians tend to fool around with, it isn't a bad idea to optimize the record current setting at

this point. This is done, naturally, using the "RECORD CURRENT" trimmer provided for the purpose. Adjust this control in the same manner as the balance pot above, by making a recording, noting the thumbwheel position on the radio track, and then set it for the best picture, as seen on playback.

A troubleshooting guide for something as complex as a VTR, would, of course, run to volumes. However, there are only a few really heavy problems you're likely to encounter in these particular machines, and, of them, this one is about the most likely to drive one wholly, totally mad trying to find the cause. There are a few others that may make you feel that your brain is unwinding at first, but, all in all, the circuitry is fairly intelligently designed, and things can eventually be untangled if you hammer at them long enough.

And, of course, if that doesn't work, try a bigger hammer.

## SURPLUS 2001

It intrigues me to think, upon reading the reams of literature I seem to wind up with every month, that no matter how brilliantly designed a piece of equipment is, no matter how expensive it should happen to be at the moment, in ten or fifteen years it's going to be getting dusty under a plastic dry cleaning bag at the back of someone's studio, and anyone who should inquire about it will be informed that the possessor of a large enough truck will be able to cart it away for fifty cents a pound. And this applies to everything, not just video equipment. For instance, if you can come up with a use for a second hand Conservative Government, just keep your eyes open. There'll be one up for grabs any day now.

The nicest bit of pre-scrap I've run across in many a day arrived at my desk about a week ago, in four colour, glossy paper, and four pages of general specifications. It is the latest grandchild of the Ampex VTRs we've just been dissecting, the VPR-2. Just so you'll have an idea of what to look out for in the years to come, here's a brief look at the beast.

The current crop of video recorders are, curiously enough, reel to reel machines again, just like their predecessors of a decade ago. However, as you are probably aware, the return to the reel format is quite recent, for, over the last five or six years, most of the industry has been having a merry time with the ever decreasing size of the video cassette.

In a practical sense, the cassette boom began with the 3/4" U Matics,



One of the studio machines, the Ampex VPR-2.

which appeared for use in "non-broadcast" situations; school audio-visual departments, industrial training tapes, and cable TV community programming. However, the picture produced by the U-Matics weren't all that bad . . . certainly no worse than could be resolved by the average home TV set, and, thus, a lot of them found their ways into some of the smaller TV stations. The ENG (Electronic News Gathering) folks loved them, because they were small, and you could walk around with them without having the tape spew all over the place. And, by and by, the convenience of not having to thread big, huge spools of tape all the time gained favour, and soon, quite a bit of material was coming off cassettes and winding up out over the waves.

This, of course, is a touchy problem, for, while most people never get to see what TV really should look like, i.e., what a high resolution, low noise picture really looks like, there are some who do have the equipment to actually display what is going out . . . only it isn't really going out anymore.

You can't exactly blame the broadcasters, though. Well, you can, but it won't do any good. The only alternative to the small formats was the massive, two inch Quadruplex system, which was big, complicated and very, very expensive. Thus came the new one inch reels.

The one inch broadcast VTRs offer another advantage over the U-Matic cassettes. You can edit with them. Now, editing video tape is not done in the same manner as one might with audio. You don't use a blade. Instead, material is dubbed from one tape machine to

another, with special synchronization circuitry in there, somewhere, to make sure that the sync pulses of the new material are in phase with the old.

Editing is available for cassette systems, of course, but the narrow track width involved in these slow tape speed formats makes it rather imprecise.

The Ampex VPR-2 is a rather complicated little beastie, but its dozens of lights, knobs, readouts, buttons, switches, furls, zorts, whatzits, widgets and three speed synchronous bandersnatches do make it exceptionally versatile . . . if a bit imposing at first. It has stereo sound for people who are partially schitzo . . . three channels. It uses separate video record and playback heads, which avails one of a wonderful 4.2 MHz bandwidth at -46 db S/N . . . better than the home VCRs even when the manufacturers lie quite a lot. This also permits monitoring of what one has recorded after it has gone on the tape . . . to be sure it has, in fact, actually gone on the tape. It can play back at any speed from the usual blur of normality right on down to still frame without breaking up. And, to make a good thing even better, the system is designed to be expandable. In other words, when you get it, there are pc card slots without any pc cards, so that, if someone comes up with a better on/off switch in a few years, you can just plug it right in. Your family will love it; you'll never be a problem when it comes to finding Christmas gifts.

It is the editing system of the VPR-2 that really deserves some mention, though. A couple of these recorders will essentially provide one with a complete



post-production facility. The editing panel holds a tape jogging system, to permit shuttling the tape around, backwards and forwards, at any speed desired, until the precise location of a perspective edit is found. A digital clock/counter will actually count the frames as they go by, and the insertion circuitry is so precise that a different image could be edited onto every frame. Disney-type animation is well within the scope of the system. Add-ons and accessories for the editing functions include a digital editor console option, complete with a joystick controller.

The price? If you have to ask, you can't afford it.

While machines of this calibre are still denizens of the studio, and probably likely to remain so for the foreseeable future, there is no reason why many of these features could not be incorporated into future home VCRs... in modified forms, of course. For one thing, they'd have to be made out of plastic. Things like editing capabilities would give the advanced TV nut the opportunity to really get into small scale video production. As the manufacturers continue to try to find

ways to sell you this years deck before you've figured out how to load last year's, we may see some of this stuff turn up.

### MORE ABOUT VIDEO DISCS

You may have noticed that this column, like the last, doesn't have much to do with video discs. The data is just not coming in, and the possibility of the things being wholly obsolete before we ever get a chance to look at them is becoming quite real. Next month, for sure, I'll have something to say about them... very likely another little note at the end, like this one.

As always, anyone having any questions concerning video or the placating of eternal swamp gnomes should feel free to write in.

Until next month, stay tuned.

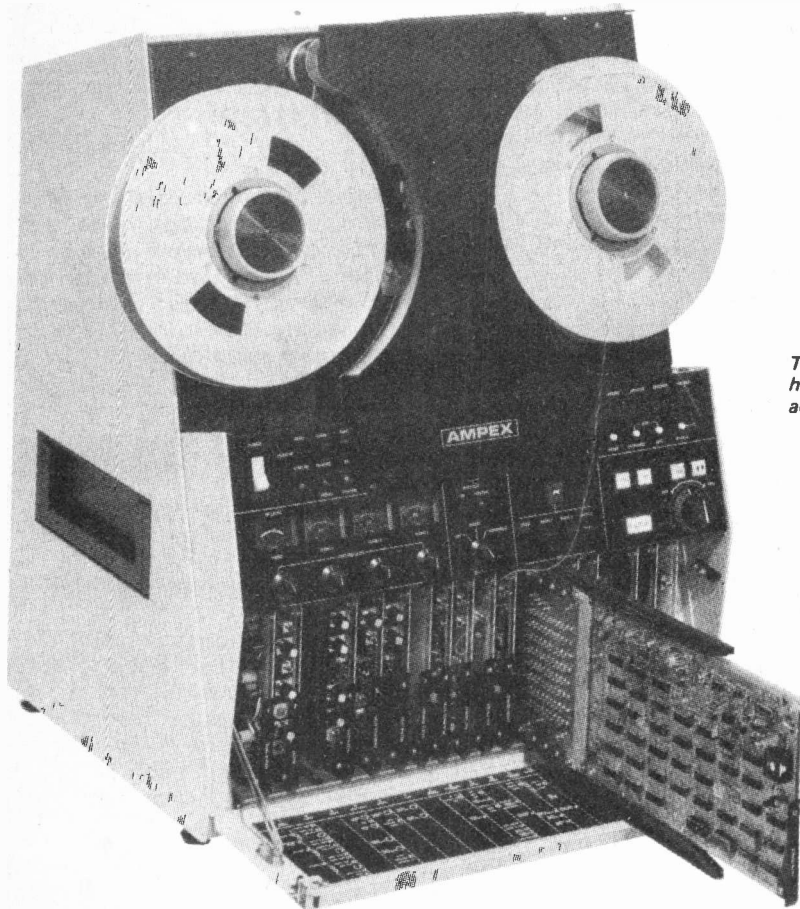

*The VPR-2 comes with extra pc card holders so you can add additional accessories.*

---

**For a Limited Time Only ...  
FREE "More Circuits" With Your  
Electronics Today** — See Page 62  
**Subscription (New OR Renewal)**

# Teachers' Topics

continued from page 65.

exorbitant amount of energy (up to 5hp just to run the oil pump) so a manual 3-speed transmission was chosen. However, as it turns out, no shifting is necessary for normal around-town driving; starting and driving is all done in "second" gear.

The car was delivered in March. It was driven for two days and then moved to the Auto Shop during the winter break. With the help of Keith Curry, the Auto Mechanics instructor, it was stripped of all unnecessary components (engine, exhaust system, gas tank, etc) and moved to an old portable classroom for its transformation.

As spring approached, we were notified of serious delays in component deliveries. This meant that the end of the school year would come with the assembly a little more than half completed. It was keen disappointment for all. Consequently, as items arrived during the summer, Renton Patterson ended up doing a good portion of the assembly and wiring, but with help from the odd team member who dropped in.

The motor was the last item to arrive, promised in four months by an English

firm, it was delivered in eleven, - a full seven months late. Again with the help of Keith Curry and Hank McCann, the Auto Shop was used to bolt the motor to its adapter plate and coupling (both made in the Machine Shop) and secure it firmly in place ahead of the transmission. The other front compartment components were then reinstalled above the motor.

Happily, the last item was put in place over the Christmas holidays when Al and Lorne were back from college and university. On Monday, Dec 26, 1977, ThunderVolt 3 pulled away from the school under its own power. Like its predecessors, the car performed exceedingly well right from the start. There was only one small wiring change and one minor mechanical adjustment necessary to get everything functioning. Performance-wise, only the custom-designed charger is not up to par, the charging rate being lower than specified.

A tremendous achievement for a group of young high school students.

## FROM HERE?

Mr. Patterson tells us that more such EV projects are in the offing, in fact he has a waiting list of local people who now want similar cars built to their specifications, and who are of course willing to pay the price. He has also been involved in the newly formed Canadian Electric Vehicle Association. For more information on the ThunderVolt programs, for more moral support, or conversation on Electric Vehicles, Mr. Patterson may be contacted at Fallowes High School, 420 Bell St. Pembroke, Ontario K8A 2K5. Phone (613) 735-6858.

For information and membership application form for the CEVA, contact Mr. F.T. Green, Membership Chairman, Canadian Electric Vehicle Association, P.O. Box 4044, Station "E", Ottawa, Ontario K1S 5B1.

## LAST MONTH

Looks like those ink electrons were flowing the wrong way in one critical sentence, which should have read: "So the term 'current', when properly used, has come to mean a flow in the opposite direction to ELECTRON flow, but equal in magnitude.

## PERFORMANCE SPECIFICATIONS: (from actual tests)

**Range:** - at 48 km/h: 104 km; at 72 km/h: 68 km

**Acceleration:** — 0 — 32 km/h in 6.6 seconds, 0-48 km/h in 11.8 secs, 0-72 km/h in 23.4 secs.

**Top Speed:** — 100 km/h (62 mph)

**Recharge Time:** — after one or two short city trips (about 4 or 5 km) a few hours in the evening will suffice, more or longer trips require an overnight charge, and a drive to maximum range may require 36 hours or more depending on the equalization charge considered necessary. (A properly-working charger on 220 volts — a stove outlet — would reduce this time considerably.)

**Energy Consumption and Running Costs** (at Pembroke's rate of 2.4¢ per kwh)

At a 48 km/h steady running speed, energy consumption from a-c lines is about 0.25 kwh/km for a cost of about 0.6¢ per km;

At a steady running speed of 72 km/h (45 mph), it is 0.31 kwh/km for a cost of about 0.75¢ per km;

For a stop-and-go driving cycle in the city, with constant acceleration and braking, energy consumption is more like 0.39 kwh/km for a cost of 0.94¢ per km; or 0.62 kwh/mile for a cost of 1.5¢ per mile.

**Maintenance:** — electrolyte level in batteries checked every month and distilled water added as necessary. All components checked for cleanliness yearly. Contactor tips and motor brushes checked for wear every 6000 miles or so.

**Winter Operations:** — same as for summer except that the fuel for the passenger compartment heater should be checked and the battery heaters should be kept plugged in. Energy consumption increases with snow on the road, but driving traction is excellent.

Inside the front and back of ThunderVolt 3.

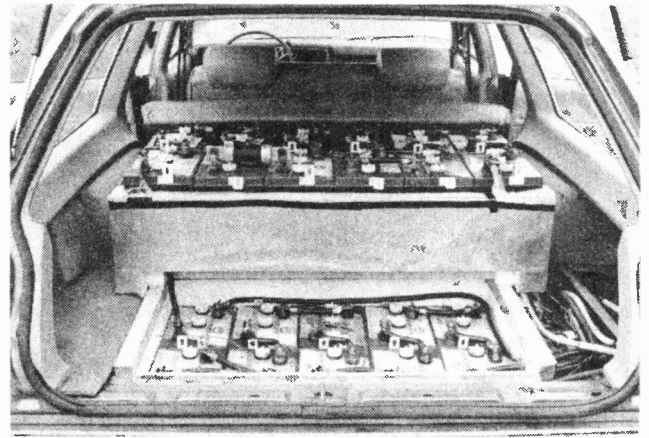
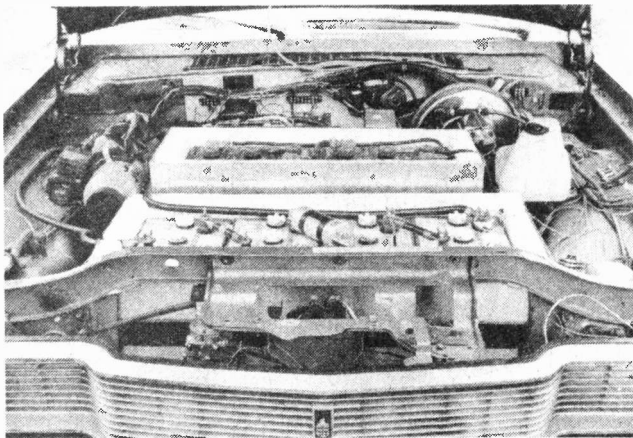

# ETI Special Book Service

Now you can order these Sam's books from ETI. See page 76 for details.

## SECURITY ELECTRONICS (2nd Edition)

by John E. Cunningham. Reflects the recent advances in fighting burglary with electronics security systems. Covers intrusion detection and alarms, object detectors, bugging and debugging devices, computer protection, and personnel identifiers. Planning of complete systems for home, auto, plant, or office are all included. 192 pages; 5½ x 8½; softbound (ISBN: 0-672-21419-9) © 1977  
No. 21419

## REGULATED POWER SUPPLIES (2nd Edition)

by Irving M. Gottlieb. Examines the regulated power supply and provides information that the technician, radio amateur, experimenter, and service personnel can readily use. Updates the progress made in semiconductor devices since 1971. 272 pages, 5½ x 8½, softbound (ISBN: 0-672-21482-2) © 1978  
No. 21482

## TUBE SUBSTITUTION HANDBOOK (20th Edition)

by the Howard W. Sams Engineering Staff. The latest edition of the book which has for years been recognized as the most complete and accurate direct tube substitution guide available. Now contains over 6000 receiving tube substitutes, nearly 4000 monochrome and color picture tube substitutes, over 300 industrial substitutes for receiving tubes, over 600 communications and special purpose substitutes, 1400 American substitutes for foreign receiving tubes, and 1100 foreign substitutes for American receiving tubes. Now made even more useful by the addition of tube basing diagrams. Thus, in addition to being a comprehensive guide to substitutions, the book also serves as a handy reference to tube pin numbers for quick operation checks. 112 pages, 5½ x 8½, softbound (ISBN: 0-672-21405-9) © 1977  
No. 21405

## UNDERSTANDING TUBE & TRANSISTOR CIRCUITS

Detailed information on the operation of tube and transistor circuits. Covers vacuum tubes, semiconductor devices, power supplies, amplifiers, oscillators, transistor circuits, and pulse circuits. 224 pages. (ISBN: 0-672-20169-0) © 1968  
No. 20169

## IC OP-AMP COOKBOOK

by Walter G. Jung. The first book of its kind to be published. Covers not only the basic theory of the IC op amp in great detail, but also includes over 250 practical circuit applications, liberally illustrated. Organized into three basic parts: introduction to the IC op amp and general considerations, practical circuit applications, and appendices of manufacturers' reference material. 592 pages, 5½ x 8½; softbound. (ISBN: 0-672-20969-1) © 1974  
No. 20969

## TTL COOKBOOK

by Donald Lancaster. A complete and detailed guide to transistor-transistor logic. Explains what TTL is, how it works, and how to use it. Discusses practical applications, such as a digital counter and display system, events counter, electronic stopwatch, digital voltmeter, and a digital tachometer. 336 pages; 5½ x 8½; softbound. (ISBN: 0-672-21035-5) © 1974  
No. 21035

## IC TIMER COOKBOOK

by Walter Jung. Provides an excellent introduction to the field of IC timers by presenting a collection of various circuit "recipes" useful in applying the devices. Arranged in three parts, the first part gives basic and generalized information. Part II, the applications section, is the "meat" of the book and includes over 100 different circuits for a wide range of uses. Part III contains reproductions of manufacturers data sheets, second-source manufacturers, and more. This book is a valuable reference for the hobbyist, the technical or engineering student, or professional. 288 pages; 5½ x 8½; softbound. (ISBN: 0-672-21416-4) © 1977  
No. 21416

## CMOS COOKBOOK

by Don Lancaster. Tells all you need to know to understand and profitably use this inexpensive and genuinely fun to work with digital logic family. First an explanation of what CMOS is, how it works, and how to power it, plus usage rules, state testing, breadboarding, interface, and other basics is given. Then a minicatalog of over 100 devices, including pinouts and use descriptions is given. Subjects covered include gate fundamentals, tri-state logic, redundant logic design techniques, multivibrators, nonvolatile memory techniques, clocked JK and D flip-flop, counter and register techniques, op amps, analog switches, phase-locked loops and much more. A must for the student, hobbyist, teacher, technician, or engineer who wants to learn about CMOS. Filled with practical applications. 416 pages; 5½ x 8½; softbound. (ISBN: 0-672-21398-2) © 1977  
No. 21398

## 555 TIMER APPLICATIONS SOURCEBOOK, WITH EXPERIMENTS

by Howard M. Berlin. Deals with the many applications of the popular 555 timer "chip." Uses for voltage regulation, control, sequencing are covered as well as the more usual timing and signal generating functions. With many useful circuits and 15 detailed experiments. 160 pages; 5½ x 8½; softbound. (ISBN: 0-672-21538-1) © 1976  
No. 21538

## TRANSISTOR SUBSTITUTION HANDBOOK (17th Edition)

by The Howard W. Sams Engineering Staff. Allows anyone to obtain accurate transistor substitution information in a matter of seconds. Lists replacements for over 19,000 American and foreign bipolar transistors. The replacements listed include those selected by a computer as having matching electrical and physical parameters plus those recommended by manufacturers of general-purpose replacement transistors. 544 pages; 5½ x 8½, softbound. (ISBN: 0-672-21515-2) © 1978  
No. 21515

## AUDIO IC OP-AMP APPLICATIONS (2nd Edition)

by Walter G. Jung. This second edition describes the methods for realizing the full potential of IC operational amplifiers for audio use. By mastering the facts presented here, the reader will find that IC op amps can be effectively applied to audio use in a wide variety of circuit applications. Features an entirely new section on audio characterization of device distortion and noise performance. 208 pages; 5½ x 8½; softbound. (ISBN: 0-672-21558-6) © 1978  
No. 21558

## LINEAR IC PRINCIPLES, EXPERIMENTS, AND PROJECTS (2nd Edition)

by Edward M. Noll. An introduction to one of electronics most exciting devices—the integrated circuit. Discusses semiconductor theory, internal and external circuitry, differential and operational amplifiers, multipurpose ICs, digital ICs, and applications of linear ICs in commercial, industrial, and test equipment and in home-entertainment audio, a-m, fm, and television. Includes an intriguing collection of school, laboratory, and home construction projects for experimenters. 5½ x 8½; softbound. (ISBN: 0-672-21568-3) © 1978  
No. 21568

## HOW TO BUILD SPEAKER ENCLOSURES

by Alexis Badmaieff and Don Davis. A "do-it-yourself" book providing a wealth of information on the construction of high-quality, top-performance speaker enclosures. Contains detailed drawings and instructions for building the various basic enclosures. Includes infinite-baffle, bass-reflex and horn-projector types as well as combinations of these. 144 pages; 5½ x 8½; softbound (ISBN: 0-672-20520-3) © 1966  
No. 20520

## 99 ELECTRONIC PROJECTS

by Herbert Friedman. Offers a wide variety of electronic projects using solid-state components. Choose from auto, automotive, ham, swl, motor control, musical, photography, test equipment, and remote-control types of projects. 128 pages; 5½ x 8½; softbound (ISBN: 0-672-20818-0) © 1971  
No. 20818

## SEMICONDUCTOR REPLACEMENT GUIDE

by the Howard W. Sams Engineering Staff. Gives general-purpose replacements for over 15,000 semiconductors used in entertainment-type electronic equipment. These general-purpose replacements are produced by the following 7 semiconductor manufacturers: General Electric, International Rectifier, Mallory, Motorola, RCA, Sprague, and Sylvania. 256 pages; 8½ x 11, softbound (ISBN: 0-672-21092-4) © 1972  
No. 21092

## IC CONVERTER COOKBOOK

by Walter G. Jung. Written for the practicing engineer, technician, hobbyist, or student, this book will be an invaluable working guide to the understanding and use of IC a/d and d/a converters. The three parts of the book are concentrated on the basic principles and theories of data conversion; converter application including circuits that are complete working entities with specified part numbers and component values; and an appendix of manufacturers' catalog sheets, part number cross references, and list of manufacturers. 576 pages; 5½ x 8½; softbound. (ISBN: 0-672-21527-6) © 1978  
No. 21527

## BUILD-IT BOOK OF FUN AND GAMES

by Rudolf Graf and George Whalen. All the projects in this book are designed for fun and game applications. The projects include a sight 'n' sound metronome, an electronic football game, a stereo balance meter, a sound-activated switch, and a metal detector. All have a parts list, construction information, diagram, and suggested applications. 96 pages; 5½ x 8½; softbound. (ISBN: 0-672-21219-6) © 1975  
No. 21219

## COMPUTERS

### THE CHEAP VIDEO COOKBOOK

by Don Lancaster. A complete guide to super low cost alphanumeric and graphic microprocessor-based video displays. Contains complete construction details on a seven IC circuit that dramatically slashes the cost of getting words, op-code, and graphics out of a microcomputer and into a television set. Includes thoroughly documented and debugged software. Enables you to produce virtually any alphanumeric format, including scrolling 24 lines by 80 characters, and virtually any graphics format, including high resolution 256 x 256 mode and four-color graphics. Also contains complete details on transparency techniques that let you compute and display at the same time with high throughput. 288 pages; 5½ x 8½; softbound. (ISBN: 0-672-21524-1) © 1978  
No. 21524

### TV TYPEWRITER COOKBOOK

by Don Lancaster. An in-depth coverage of tv typewriters (tv'ts)—the only truly low-cost microcomputer and small-systems display interface. Covers tv terminology, principles of operation, tv configurations, memories, system design, cursor and update circuitry and techniques, hard copy, color graphics, and keyboards and encoders. 256 pages; 5½ x 8½; softbound (ISBN: 0-672-21313) © 1976  
No. 21313

### Z-80 MICROCOMPUTER HANDBOOK

by William Barden, Jr. The Zilog Model Z-80 represents a microprocessor that is extremely sophisticated and attractive to many computer users. This handbook will provide the current user and the prospective user with essential information on the technology of the Z-80. Organized into three sections, the first section concentrates on hardware, the second on software; and the third on microcomputers built around the Z-80. 304 pages, 5½ x 8½, softbound (ISBN: 0-672-21500-4) © 1978  
No. 21500

### THE 8080A BUGBOOK®: MICROCOMPUTER INTERFACING AND PROGRAMMING

by Peter H. Rony, David G. Larsen, and Jonathan A. Titus. The principles, concepts, and applications of an 8-bit microcomputer based on the 8080 microprocessor IC chip. The emphasis is on the computer as a controller. Covers the four fundamental tasks of computer interfacing: (1) generation of device select pulses; (2) latching of output data; (3) acquisition of input data; (4) servicing of interrupt signals. Intended to help develop the skills needed to use an 8080-based breadboard microcomputer system. BUGBOOK® is a registered trademark of E & L Instruments, Inc. Derby, Connecticut 06418. 416 pages; 5½ x 8½; softbound. (ISBN: 0-672-21447-4) © 1977  
No. 21447

### 8080/8085 SOFTWARE DESIGN

by David G. Larsen, Peter R. Rony, Jonathan A. Titus, and Christopher A. Titus. A detailed approach to assembly language programming for 8080 or 8085-based computers. Covers basic and advanced instructions, mathematical manipulations, number-base conversions, command decoders, arrays and tables, interrupt programming, and more. With complete, tested programs in standard mnemonics. 336 pages; 5½ x 8½; softbound. (ISBN: 0-672-21541-1) © 1978  
No. 21541

Continued on page 61

Please see page 76 for price and ordering information.

# Order Form Formule d'inscription

## ETI Special Book Service

### ORDERING INFORMATION

BY SPECIAL ARRANGEMENT, Electronics Today Magazine is able to supply Sam's Technical Books, and certain French language technical publications. These are available through the ETI Special Book Service, from Montreal. Use the coupon on this page to order these books.

In order to bring you these books in the most economical way, we are only able to accept payment by cheque or money order. Please make it payable to: ETI Special Book Service.

PLEASE SEE SEPARATE ORDERING INSTRUCTIONS FOR SUBSCRIPTIONS, BABANI BOOKS, AND OTHER ITEMS ON THE CARD IN THIS ISSUE, PAGE 62.

## Service spécial des livres ETI

### INFORMATION POUR FAIRE VOTRE COMMANDE.

PAR ARRANGEMENT spécial, le magazine ETI peut vous fournir "Sam's Technical Books" et certain d'autres publications techniques dans la langue française. On peut obtenir ces publications par l'intermédiaire du Service spécial des livres ETI à Montréal. Prière de remplir ce coupon pour commander vos livres. Pour expédier vos livres dans une façon la plus économique, nous pouvons accepter paiement par chèque ou par mandat. Faites vos chèques payable à: "ETI Special Book Service".

POUR LES SUBSCRIPTIONS, LES LIVRES BABANI ET AUTRE ITEMS, VOIR, SIL-VOUS-PLAIT, LES INSTRUCTIONS RELATIVES A CES COMMANDES DESCRIRES SUR LA CARTE D'INSCRIPTION DANS CE NUMERO, A LA PAGE 62.

Destination	Postal Rate Chart Carte des tarifs postales				
	0-5	6-10	11-20	21-30	31+
QUE.	.40	.30	.15	.12	.09
ONT.	.45	.35	.20	.14	.12
N.S.					
N.B.					
P.E.I.	.50	.40	.20	.15	.12
NFLD.					
MAN.	.55	.45	.25	.18	.15
SASK.					
ALB.	.60	.50	.25	.20	.17
B.C.	.65	.55	.30	.22	.19
YUKON	.80	.60	.35	.25	.21
NWT	.60	.55	.55	.60	.55

Cents/Pound      Cents/Livre      (Incl. Ins.)

Example: Destination Yukon, weight/poids 261 ounces/onces:  
261 oz = (approx) 17 lb. . . . .  
5 x 80c + 5 x 60c + 7 x 35c = \$9.45

ETI Special Book Service, 4050 Jean Talon W., Montreal PQ H4P 1W1.

NAME/NOM: \_\_\_\_\_

A(D)DRESS(E): \_\_\_\_\_

TOWN/CITY/VILLE: \_\_\_\_\_

PROVINCE: \_\_\_\_\_ POSTAL CODE  
CODE POSTAL: \_\_\_\_\_

DATE: \_\_\_\_\_

QUANTITY QUANTITE	NO.	TITLE TITRE		TOTAL	WEIGHT POIDS
.....	21419	Security...	8.5oz \$7.95	\$ .....	.....oz.
.....	21482	Regulated...	11oz \$13.25	\$ .....	.....oz.
.....	21405	Tube Subst...	6oz \$3.95	\$ .....	.....oz.
.....	20169	Understanding...	13oz \$7.25	\$ .....	.....oz.
.....	20969	IC OP AMP...	24oz \$17.25	\$ .....	.....oz.
.....	21035	TTL Cookbook...	13oz \$12.75	\$ .....	.....oz.
.....	21416	IC Timer...	12oz \$13.25	\$ .....	.....oz.
.....	21398	CMOS Cookbook...	16oz \$13.95	\$ .....	.....oz.
.....	21538	The 555 Timer...	7.5oz \$7.95	\$ .....	.....oz.
.....	21515	Transistor sub...	22oz \$7.95	\$ .....	.....oz.
.....	21558	Audio IC OP...	9oz \$10.50	\$ .....	.....oz.
.....	21568	Linear IC princ...	14oz \$12.75	\$ .....	.....oz.
.....	20520	How to build spkr...	6.5oz \$6.75	\$ .....	.....oz.
.....	20818	99 electronic...	12oz \$5.75	\$ .....	.....oz.
.....	21092	Semicond. Repl. ...	10oz \$5.50	\$ .....	.....oz.
.....	21527	IC converter...	22oz \$18.75	\$ .....	.....oz.
.....	21219	Build-it ... fun ...	5oz \$5.50	\$ .....	.....oz.
.....				\$ .....	.....oz.
.....	21524	Cheap Video...	11oz \$7.95	\$ .....	.....oz.
.....	21313	TV Typewriter...	11oz \$13.25	\$ .....	.....oz.
.....	21500	The Z80...	12.5oz \$11.95	\$ .....	.....oz.
.....	21447	8080A Bugbook...	16oz \$13.95	\$ .....	.....oz.
.....	21541	8080/8085...	14oz \$12.75	\$ .....	.....oz.
.....	21483	Your own comp. ...	4.5oz \$2.75	\$ .....	.....oz.
.....	21486	Getting acq. ...	12oz \$11.95	\$ .....	.....oz.
.....	21459	How to pgm. ...	16oz \$11.95	\$ .....	.....oz.
.....	21512	Using the 6800...	8oz \$9.25	\$ .....	.....oz.
.....	21404	Microcomp. primer...	9oz \$10.50	\$ .....	.....oz.
.....	21351	How to buy...	20oz \$13.25	\$ .....	.....oz.
.....				\$ .....	.....oz.
.....	F3	Comment cons. ...	10oz \$11.40	\$ .....	.....oz.
.....	F168	Calcul et real. ...	13oz \$13.70	\$ .....	.....oz.
.....	F48	50 Jeux calc. ...	6oz \$10.05	\$ .....	.....oz.
.....	F187	Technologie des circ. ...	13oz \$17.15	\$ .....	.....oz.
.....	F125	Initiation micro. ...	16oz \$12.30	\$ .....	.....oz.
.....	F37	50 Montages thyr. ...	11oz \$17.75	\$ .....	.....oz.
.....	F30	Tables de Mixage ...	5oz \$12.30	\$ .....	.....oz.
.....	F124	30 Montages d'alarme ...	5oz \$8.65	\$ .....	.....oz.
.....	F27	Bases d'elect. ...	7oz \$10.50	\$ .....	.....oz.
.....	F14	Les jeux ...	7oz \$14.15	\$ .....	.....oz.
.....				\$ .....	.....oz.

Total Number of Books      SUBTOTAL  
Total des livres      SOUSTOTAL      \$      oz.

POST\*      \$

TOTAL      \$

Please refer to postal rate chart.  
Consultez s. v. p. la carte des tarifs postales.

Please note: we are only able to accept orders by mail!

Cheques over \$25 must be certified.  
Chèques qui dépassent \$25 doivent être certifiés.

Please make cheque or money order payable to:  
Faites le payable, s. v. p. vos chèque ou mandat à:  
"ETI Special Book Service".

Send to:  
Envoyez à:  
ETI Special Book Service, 4050 Jean Talon St., W., Montreal PQ H4P 1W1.

PLEASE PRINT

ETI CANADA - NOVEMBER 1979

# ETI Special Book Service (CONTINUED)

## YOUR OWN COMPUTER

by *Mitchell Waite and Michael Pardee*. This book can be your key to the fascinating world of home computers. Now that computers are available for about the price of a good stereo system, personal computers will soon be used to regulate energy in the home, to regulate spending habits, and even to provide entertainment for the family. The authors have written this book to introduce the novice to home computers and to reveal the potential of these technical marvels. 80 pages; 5 1/2 x 8 1/2; softbound. (ISBN: 0-672-21483-0) © 1977  
No. 21483

## GETTING ACQUAINTED WITH MICROCOMPUTERS

by *Louis E. Frenzel*. Learn about microcomputers in an effective, lowcost manner! The essential information contained in this book has been compiled especially for engineers, technicians, scientists, and others who need to know about microcomputers. It will also prove invaluable to those who want to learn more about hobby and personal computing. This self-instructional book will aid you to obtain an in-depth knowledge of microcomputers, using the Microcomputer Learning Laboratory described in the book. 288 pages; 5 1/2 x 8 1/2; softbound. (ISBN: 0-672-21486-5) © 1978  
No. 21486

## HOW TO PROGRAM MICROCOMPUTERS

by *William Barden, Jr.* This book explains assembly-language programming of microcomputers based on the Intel 8080, Motorola MC6800, and MOS Technology MCS6502 microprocessors. Basic concepts, including number systems and operations, basic computer operation, and computer codes are examined in the first chapters. Microcomputer architecture and operation are discussed. Assembly language programming is noted. The author concludes with a number of useful precanned operations. 256 pages; 5 1/2 x 8 1/2; softbound. (ISBN: 0-672-21459-8) © 1977  
No. 21459

## USING THE 6800 MICROPROCESSOR

by *Elmer Pog*. No special background in digital electronics is necessary to enjoy the 6800 microprocessor. This book will acquaint the reader with the hardware and software of the 6800 "fun" machine. It will guide the reader through the conception, configuration, writing, and running of a variety of programs that demonstrate the practical use of a 6800 system. Features fifteen information-packed chapters with an appendix which includes a detachable programmer's card. 176 pages; 5 1/2 x 8 1/2; softbound. (ISBN: 0-672-21512-8) © 1978  
No. 21512

## MICROCOMPUTER PRIMER

by *Mitchell Waite and Michael Pardee*. Introduces the beginner to the basic principles of the microcomputers. Discusses the five main parts of a Computer—Central processing unit, memory, input/output interfaces, and programs. The important characteristics of several well-known microprocessors are given and a chapter is included on programming your own microcomputer. 224 pages; 5 1/2 x 8 1/2; softbound. (ISBN: 0-672-21404-0) © 1978  
No. 21404

## HOW TO BUY & USE MINICOMPUTERS & MICROCOMPUTERS

by *William Barden, Jr.* Discusses these smaller computers and shows how they can be used in a variety of practical and recreational tasks in the home or business. Explains the basics of minicomputers and microcomputers, their hardware and software, peripheral devices available, and the various programming languages and techniques. Includes selection, buying, and programming your own system and gives detailed descriptions of currently available systems. 240 pages; 8 1/2 x 11; softbound. (ISBN: 0-672-21351-8) © 1978  
No. 21351

Please see page 76 for price and ordering information.

# Service spécial des livres ETI

Livres techniques en Français.

R. BRAULT

F3

## COMMENT CONSTRUIRE BAFFLES ET ENCEINTES ACOUSTIQUES

(8<sup>e</sup> édition)

Les amateurs de reproduction sonore à haute fidélité devenant de plus en plus nombreux, l'auteur a réalisé cet ouvrage dans un but essentiellement pratique. Il a décrit les types les plus courants d'enceintes expérimentés par des firmes spécialisées en se bornant principalement aux modèles facilement réalisables par un amateur. SOMMAIRE: Le Haut-Parleur électrodynamique. Fonctionnement électrique du Haut-Parleur. Fonctionnement acoustique du Haut-Parleur. Baffles ou écrans plans. Coffrets clos. Enceintes acoustiques à ouvertures. Enceintes diverses. Enceintes « Bass-reflex ». Enceintes à papillon. Comment choisir un Haut-Parleur. Réalisations pratiques d'enceintes et baffles. Réglage d'une enceinte. Filtrés pour Haut-Parleur. Caractéristiques des Haut-Parleurs actuellement disponibles.

Un vol broché 112 p. 85 schémas format 15 x 21 couv. couleur

## CALCUL ET RÉALISATION DES TRANSFORMATEURS

4<sup>e</sup> édition, 176 pages, format 16 x 24, 34 figures.

par Ch. Guilbert

F168

Il est bon de savoir comment calculer un transformateur, mais il est profitable de gagner du temps, tout en évitant divers risques d'erreurs, et c'est pourquoi cet ouvrage groupe un certain nombre d'abaques, grâce auxquels l'élaboration des transformateurs est largement facilitée.

Extrait de la table des matières

Le transformateur électrique - Le redressement des courants alternatifs - Le filtrage - Les redresseurs à semi-conducteurs - Les inductances de filtrage - Le calcul des transformateurs - Les autotransformateurs - L'élaboration des amplificateurs B.F. - Le calcul des transformateurs B.F. - La réalisation des transformateurs et des inductances - Transformateurs spéciaux - Conseils pour la réalisation - Les relais et leur calcul.

## 50 JEUX avec votre calculatrice électronique

par E. Schlossberg et J. Brockman

F48

D'une très belle présentation, ce livre propose pour la première fois en France 50 jeux inédits, tous différents, basés sur l'emploi d'une calculatrice de poche. Leur variété est telle qu'il est possible de jouer seul ou à plusieurs, avec une ou plusieurs calculatrices de tous modèles. Certains jeux s'apparentent au « solitaire », à la réussite ou patience, au poker, au bridge, au monopoly, d'autres font appel aux calculs et à la manipulation des nombres. Les auteurs ont aussi voulu susciter la créativité de chacun pour diversifier, perfectionner, et ainsi mieux personnaliser les jeux.

Format poche 13,8 x 20, 128 pages

3<sup>e</sup> édition 240 pages, format 18 x 24, 98 figures, très nombreuses photographies

## TECHNOLOGIE DES CIRCUITS IMPRIMÉS

par J.-P. Chamichon

F187

L'auteur commence par examiner les matériaux de base : isolants cuivrés, résistances, condensateurs, supports et connecteurs divers, après quoi il traite de l'établissement d'un projet sur papier. Il est ensuite question des méthodes de report direct sur cuivre sans opération de photogravure, puis de la réalisation du négatif, puis de la photogravure, c'est-à-dire du report sur le cuivre, à partir du négatif, d'un enduit protecteur.

Extrait de la table des matières

Les matériaux (isolant cuivré, supports; résistances et condensateurs, connecteurs) - Etablissement du projet - Le passage direct sur cuivre - Réalisation du négatif pour photogravure - Le report sur cuivre par photogravure - L'attaque du cuivre - Le montage du circuit - Modification d'un circuit terminé - Evolution et perspectives d'avenir

P. MELUSSON

2<sup>e</sup> édition

## INITIATION A LA MICROINFORMATIQUE LE MICROPROCESSEUR

F125

Grâce au développement des technologies LSI - des circuits intégrés, il apparaît maintenant possible de bénéficier dans le domaine - Grand Public - de réalisations jusque-là réservées aux ordinateurs coûteux et volumineux. - Le microprocesseur a pu ainsi faire son apparition. Il devient la pièce maîtresse d'un microordinateur de conception économique. Son système comportant des circuits intégrés de fonctions complexes sous un faible volume. - Ce principe même de réalisation conduit à des possibilités d'applications dans: - Les domaines - Les télécommunications - le radar - les transmissions HF - les automatismes industriels - l'optoélectronique et la signalisation électrique - l'électro-ménager - l'automobile - la télévision - la radio-médicale - la radiophonie etc. - Le microprocesseur sera bientôt l'instrument de - la qualité de la vie -

Un volume broché de 136 pages, 80 figures format 12 x 16,5 sous couverture pelliculée

176 pages, format 16 x 24, 141 figures

## 50 MONTAGES ELECTRONIQUES A THYRISTORS

par W. Sorokine

F37

W. Sorokine vous invite à faire la connaissance des thyristors au travers de leurs applications. Le meilleur moyen d'y parvenir est de réaliser soi-même, parmi les quelques cinquante montages proposés, ceux qui sont utiles, ou qui simplement excitent la curiosité: gadgets auto, allumage électronique, orgues lumineuses, relais divers, chargeurs automatiques, alimentations stabilisées. Chaque montage est accompagné d'un schéma de principe, d'un plan de câblage, et de tous les détails propres à en faciliter le choix et la réalisation. Ainsi même un débutant n'éprouvera aucune difficulté à faire du bon travail.

Extrait de la table des matières

3 appareils pour l'essai des thyristors, diodes et triacs - 9 gadgets pour automobiles - 5 allumages électroniques - 6 orgues ou jeux lumineux - 14 circuits de temporisation - 8 relais et régulateurs de température - 4 chargeurs de batterie - 4 alimentations stabilisées

SIEGFRIED WIRSUM

F30

## TABLES DE MIXAGE ET MODULES DE MIXAGE

OUVRAGE TRADUIT DE L'ALLEMAND PAR A. CORDRAY

Ce petit livre contient l'essentiel de tous les problèmes concernant les appareils de mixage. EXTRAIT DU SOMMAIRE: Sources de signaux. Connexions. Fonctionnement des tables de mixage. Petites tables. Modules. Eléments spéciaux. Des tables de mixage. Alimentations. Batteries et secteur. Stéréophonie.

Un volume broché 144 pages, format 12 x 16,5. Couverture couleur

F. JUSTER

## 30 MONTAGES ELECTRONIQUES D'ALARME

F124

Un ouvrage qui intéressera tous ceux qui veulent se protéger contre les vols, les incendies, les gaz et les eaux. C'est-à-dire - tout le monde. EXTRAIT DU SOMMAIRE: Alarmes pour divers usages. Alarmes optoélectroniques. Alarmes de température. Sirenes électroniques. Alarmes à circuits logiques. Alarmes à circuits intégrés. Détecteur de fumée et de gaz.

Un volume broché 120 pages, format 12 x 16,5. Couverture couleur

L. SIGRAND - F2X5

F27

## BASES D'ÉLECTRICITÉ ET DE RADIO-ÉLECTRICITÉ pour le radio-amateur et l'exploitant

Ce livre est écrit pour les candidats radio-amateurs pour leur permettre d'apprendre les principes essentiels d'électricité et de radio qui doivent connaître pour passer leur examen et, s'ils le veulent par la suite, aborder des ouvrages d'un niveau plus élevé. Cet ouvrage n'est pas un recueil de notions compliquées ou hors programme qui tout en étant intéressantes par elles-mêmes, pourraient décourager le débutant par une abondance de matière qui il pourrait étudier plus tard. C'est un « instrument » de travail simple qui comprend quatre parties: 1<sup>o</sup> Electricité 2<sup>o</sup> Radio-électricité 3<sup>o</sup> Passage des tubes aux transistors 4<sup>o</sup> Compléments.

Un volume broché 112 pages format 15 x 21, couverture couleur

B. FIGHERA

(3<sup>e</sup> édition)

F14

## LES JEUX DE LUMIERE

et effets sonores pour guitares électrique

Au cours de cette troisième édition, totalement refondue et augmentée, l'auteur a réservé une large place à la description pratique des principaux jeux de lumière. Les effets sonores n'ont pas pour autant été rejetés, puisque la deuxième partie est réservée aux montages vibrato, tremolo, boîtes de distorsion, etc. Les descriptions sont traitées dans un esprit pratique, des plans de câblages, des photographies, des listes de composants guideront les amateurs même débutants.

un ouvrage de 128 pages format 15 x 21, 122 schémas et illustrations, sous couverture quadrichrome pelliculée

Voir la page 76 pour formule d'inscription et autre information propre à votre commande.

# Tech Tips

Tech Tips is an Ideas forum and is not aimed at the beginner. ETI is prepared to consider circuits or ideas submitted by readers for this page. All items used will be paid for. Drawings should be as clear as possible, and the text should preferably be typed. Circuits must not be subject to copyright. Items for consideration should be sent to ETI Tech Tips, Unit 6, 25 Overlea Blvd., Toronto, Ontario, M4H 1B1

## 20 AMPERE LIGHT DIMMER

HUGH GORDON

This circuit was designed primarily as a dimmer for a large 2000 W, 120 V, follow-spotlight used in an auditorium, but can be used for almost any light dimming application. It will handle 20 Amperes with ease, providing the triac has an adequately sized heat sink. L1 and C1 are optional and are used only as an interference filter. L1 must be capable of passing at least 20 Amperes. R2 controls the intensity of the lamp by adjusting the triggering point of the diac.

The prototype used a Radio Shack Universal Heat Sink, No. 276-1361, with an added 1/8-inch aluminum plate. Heat sink compound was applied between the plate and the sink, and also between the triac body and the



FIG. 1  
1. GATE (G)  
2. MAIN TERMINAL (MT1)  
3. MAIN TERMINAL (MT2)

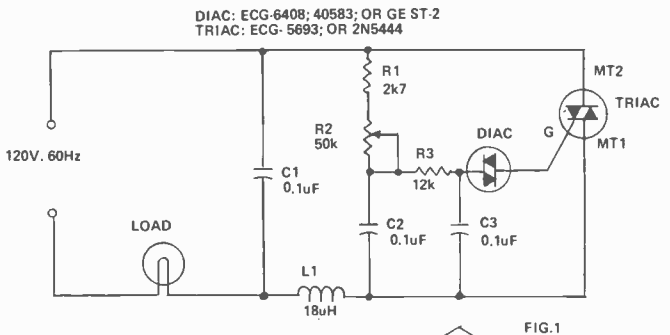

FIG. 1

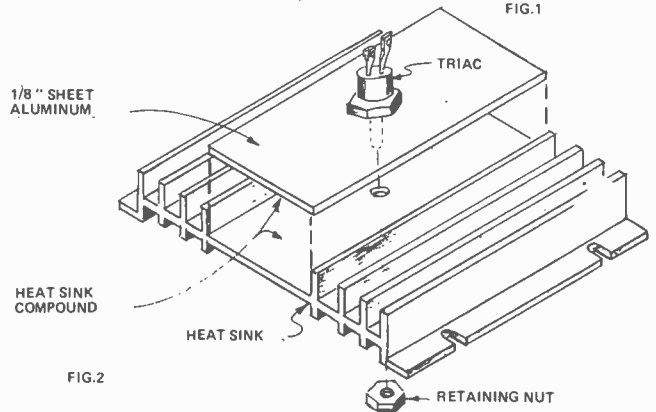

FIG. 2

plate. The triac has a maximum current rating of 40 Amperes. With 20 Amperes of current, the triac was just barely warm.

Care must be taken when mounting as the circuit is connected directly to the AC Power line. Use wire of sufficient size to pass the desired current.

*This circuit should be able to handle up to 40 A with suitable heatsink. For lower power, constructors can substitute a smaller triac to cut cost. ED.*

## Triangle Generator

R.I. Harrison

The circuit consists of a comparator IC2 driving an integrator constructed from IC1, C1 and R1. The output of the two circuits is controlled by the JFET switches Q1 and 2. The peak and trough of the generator is controlled by RV1 and RV2 respectively. The frequency is set by C1 and R1.

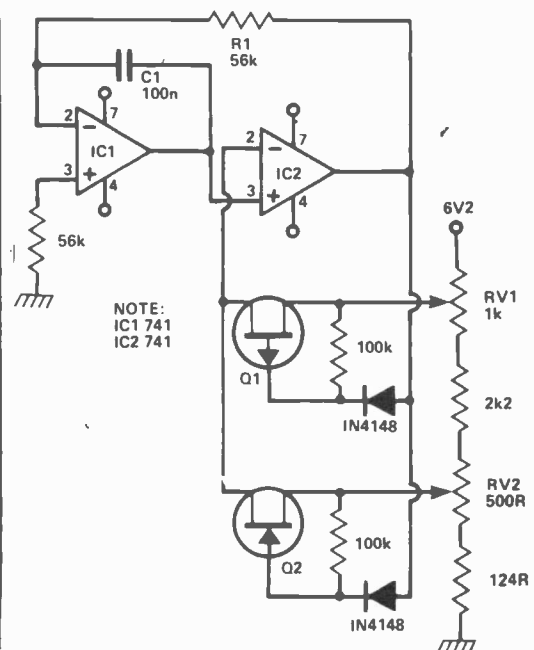

NOTE:  
IC1 741  
IC2 741

## More Info For Readers:

### ETI Introduces Reader Service Cards

The advertisers in this magazine are interested in talking to you about their products or services. That is, of course, why they are advertising. But they can't necessarily say all they would like, and besides, they can't anticipate all your questions. So you may be left wanting more information.

Now ETI Magazine has a convenient way for you to get that information, and from more than one advertiser at a time. For those advertisers who requested it, a Reader Service Number appears below their ad. Circle this number on the card, mail it to us, and

more information will be on its way to you.

The Reader Service Card will also provide advertisers with useful information about what products interest readers, and how best to present their advertisements. The end result is a better response to customer desires, and better business.

Finally, the card will help keep us in touch with our readers, and thus help us to serve and interest you best.

More details on page 62!

# You can write for Etl



## 75 cents per word

ETI's new classified advertising section allows you to reach 30,000 readers nation-wide. For as little as \$15 (there's a 20 word minimum) you can promote your business from coast to coast.

### WHAT DO YOU DO?

Send us your typewritten or clearly printed words, your permanent address and telephone number, and your money (no cash please). Make your cheque or money order payable to 'ETI Magazine'. We're at Unit 6, 25 Overlea Blvd., Toronto, Ontario M4H 1B1.

### WHAT DO WE DO?

We typeset your words (and put the first word and your company name in bold capital letters).

If we get your message by the 14th of the month, it will appear in ETI 1½ months later. For example, if we receive it by November 14th, you (and thousands more) will see it in the January issue

**NEW STORE!** for the Hobbyist, Ham Audio, CB'r. Special: Video Camera and Monitor \$349.95. Ont. res. add 7% sales tax. **GENERAL ELECTRONICS**, 5511 Yonge St., Willowdale, Ont. 221-6174.

**J&J ELECTRONICS LTD.**, P.O. Box 1437 E, Winnipeg, Manitoba R3C 2Z4. Surplus Semiconductor Specialists. Do you get our bargain flyer? Send \$1.00 to receive the current literature and specials and to be placed on the mailing list for future publications.

**50 PRIME I.C.'s**, standard and house numbers, \$4.95 PPD. **ELECTRONICS**, Box 68, Whitecourt, AB. TOE 2L0

**\$1.00 Unusual Canadian and American parts and surplus catalogs.** Hundreds of bargains. **ETCO**, Dept 087, 183G Hymus, Pointe Claire, Que.

**WSI RADIO** - SWL Radios - Ham radios - 18 Sheldon Avenue North, Kitchener, Ontario N2H 3M2. Telephone (519) 579-0536. Write for giant catalog, free of course!! (VE3EHC)

## CLASSIFIED

**COMPONENTS;** Digital and Analog IC's, Transistors, Diodes, Zeners, Resistors, LED's, Displays. Send for Free Price List. **ELECTRONICS LONDON**, Dept ETI, Box 7096, London, Ontario. N5Y 4J9.

**PRINTED CIRCUIT BOARDS** from stock, drilled and plated. No. 551-5.55 o No. 541-2.95 o No. 470-5.45 o No. 135-4.00 o No. 138-9.25 o No. 591A-3.10 o No. 591B-1.65 o No. 550-3.20. Boards available from February 1977, full list free. Post and Pack 50c, send Money Order or Cheque, no C.O.D. **B&R ELECTRONICS**, Box 6326F, Hamilton, Ontario. L9C 6L9.

**DISCO** sound and lighting systems service, design, installation. Custom built equipment our specialty. Send your requirements to: **FRANK HUTCHINGS ELECTRONICS**, Box 575, Stn. K., Toronto, Ont. M4P 2H1.

**FUNCTION** modules are now available. These include: block/ sine/ tri generators, VCO's, timers, amps, filters, you name it. For free literature send to: **BETA INDUSTRIES** c.o. J. Bies, 195 Rexleigh Dr - 401, Toronto, Ont. M4B 2N8.

**HOBBY** Services. Novel construction plans, P.C. boards, complete kits and all associated services. Write for free information. **TEKNIKIT Associates**, 301 Flora St., Carleton Place, Ontario. K7C 3M8.

**CRYSTALS** - All types monitor, marine, CB, amateur, professional, wholesale & retail. Write for information. **K&K ELECTRONICS** P.O. Box 3243, Hamilton L8H 7K6

**NORTHERN BEAR ELECTRONICS**, Box 7260, Saskatoon, SK. S7K 4J2. ETI Kits & Parts. MM57160 STAC TIMER. \$17.95. UP/DOWN COUNTER (parts only). \$39.95. DIGITAL TACH (parts) \$55.00. TWO OCTAVE ORGAN (parts & pcb) \$24.95. COLOUR SEQUENCER (parts & pcb) \$45.00. All orders add \$1.00. Sask. add tax.

**YOU** need it? Chances are we sell it! Send us your parts list for free price quotations. Don't forget our lists and flyers come out regularly. Don't miss out! **BRYAN ELECTRONICS**, P.O. 2068, Bramalea, Ontario. L6T 3S3

**PRINTED CIRCUIT** boards from your sketch or artwork. Affordable prices. Also fun kit projects. Free details. **DANOCINTHS INC.** Dept. ETI, Box 261, Westland MI. 48185. U.S.A.

**SPECTRUM ELECTRONICS;** Quality pcbs Ont. Res. add 7% PST; PO Box 4166D Hamilton, Ontario, Canada, L8V 4L5 ETI 491: \$9.45; 319 A&B: \$3.25; 550 \$1.65; 591: \$1.65; 541: \$3.20; 470: \$5.90; Write for free price list.

**BARGAINS GALORE!** Surplus Electronics, hardware and handyman items for the hobbyist. **K-W SURPLUS** 327 Breithaupt St., Kitchener N2H 5H6 (519) 745 2661.

**SPECIAL!** 1000 pieces for \$10.00. Choke - capacitor - diode - hardware insulator - rectifier - relay - resistor - transistor - speaker - switch - transformer - zener - etc. Money back guarantee. Free flyer & sample on request. **SURPLUS ELECTRO-QUEBEC**, 2264 Montee Gagnon, Blainville, P.Q., J7E 4H5.

# ETI Project File

PLEASE NOTE: WE CANNOT ANSWER PROJECT QUERIES BY TELEPHONE.

Updates, news, information, ETI gives you project support

PROJECT FILE is our department dealing with information regarding ETI Projects. Each month we will publish the Project Chart, any Project Notes which arise, general Project Constructor's Information, and some Reader's Letters and Questions relating to projects

## PROJECT NOTES

Since this magazine is largely put together by humans, the occasional error manages to slip by us into print. In addition variations in component characteristics and availability occur, and many readers write to us about their experiences in building our projects. This gives us information which could be helpful to other readers. Such information will be published in Project File under Project Notes. (Prior to May 78 it was to be found at the end of News Digest.)

Should you find that there are notes you wish to read for which you do not have the issue, you may obtain them in one of two ways. You can buy the back issue from us (refer to Project Chart for date of issue and see also Reader Service Information on ordering). Alternatively you may obtain a photocopy of the note free of charge, so long as

your request includes a self addressed stamped envelope for us to mail it back to you. Requests without SASE will not be answered.

Write to: Project File  
Electronics Today International  
Unit 6, 25 Overlea Blvd.,  
TORONTO, Ontario  
M4H 1B1

## PROJECT CHART

This chart is an index to all information available relating to each project we have published in the preceding year. It guides you to where you will find the article itself, and keeps you informed on any notes that come up on a particular project you are interested in. It also gives you an idea of the importance of the notes, in case you do not have the issue referred to on hand.

## Component Notations and Units

We normally specify components using an international standard. Many readers will be unfamiliar with this but it's simple, less likely to lead to error and will be widely used sooner or later. ETI has opted for sooner!

Firstly decimal points are dropped and substituted with the multiplier, thus 4.7uF is written 4u7. Capacitors also use the multiplier nano (one nanofarad is 1000pF). Thus 0.1uF is 100n, 5600pF is 5n6. Other examples are 5.6pF = 5p6, 0.5pF = 0p5.

Resistors are treated similarly: 1.8M ohms is 1M8, 56k ohms is 56k, 4.7k ohms is 4k7, 100 ohms is 100R, 5.6 ohms is 5R6.

## Kits, PCBs, and Parts

We do not supply parts for our projects, these must be obtained from component suppliers. However, in order to make things easier we cooperate with various companies to enable them to promptly supply kits, printed circuit boards and unusual or hard-to-find parts. Prospective builders should consult the advertisements in ETI for suppliers for current and past projects.

Any company interested in participating in the supply of kits, pcbs or parts should write to us on their letterhead for complete information.

## READER'S LETTERS AND QUESTIONS

We obviously cannot troubleshoot the individual reader's projects, by letter or in person, so if you have a query we can only answer it to the extent of clearing up ambiguities, and providing Project Notes where appropriate. If you desire a reply to your letter it must be accompanied by a self addressed stamped envelope.

ISSUE DATE	ARTICLE
June 78	Audio Analyser
June 78	Ultrasonic Switch & Neg.
June 78	Phone Bell Extender & Neg.
July 78	Proximity Switch
Aug 78	Neg.
July 78	Real Time Analyser MK II (LED)
Aug 78	Neg.
July 78	Acc. Beat Metronome
Aug 78	Neg.
July 78	Race Track
Aug 78	Neg.
Aug 78	Sound Meter & Neg.
Dec 78	Note: N
Aug 78	Porch Light & Neg.
Aug 78	IB Metal Locator & Neg.
Aug 78	Two Chip Siren & Neg.
Sept 78	Audio Oscillator
Nov 78	Neg.
Sept 78	Shutter Timer
Nov 78	Neg.
Sept 78	Rain Alarm
Oct 78	CCD Phaser
Nov 78	Neg.
Oct 78	UFO Detector
Nov 78	Neg.
Sept 79	C,D
Oct 78	Strobe Idea
Apr 79	Note:N
Nov 78	Cap Meter & Neg.
Nov 78	Stars & Dots
Nov 78	CMOS Preamp & Neg.
Dec 78	Digital Anemometer
Feb 79	Neg
Mar 79	Note:C, D
Dec 78	Tape Noise Elim
Feb 79	Neg
Dec 78	EPROM Programmer
Feb 79	Neg

ISSUE DATE	ARTICLE
Jan 79	Log Exp Convert.
Feb 79	Neg
Jan 79	Digital Tach.
Feb 79	Neg
Jan 79	FM Transmitter
Feb 79	Neg
Feb 79	Phasemeter & Neg
Feb 79	SW Radio
Feb 79	Light Chaser & Neg
Mar 79	Tape-Slide Synch
Mar 79	Synth. Sequ.
Mar 79	Dual Dice
Apr 79	Solar Control
Apr 79	Audio Compressor
Apr 79	Wheel of Fortune
May 79	Light Controller
May 79	AM Tuner
May 79	VHF Ant.
June 79	Easy Colour Organ
June 79	LCD Thermometer
July 79	Light Show Seq.
July 79	Note C
June 79	VHF Ant. 2
June 79	Bip Beacon
July 79	STAC Timer
July 79	Two Octave Organ
July 79	Light Activ. Tacho
Aug 79	Audio Power Meter
Aug 79	Two Octave Organ
Aug 79	Light Act Tacho.
Sept 79	Field Strength Meter
Sept 79	Sound Effects Unit
Sept 79	Digital Wind Meter
Sept 79	Up/Down Counter
Oct 79	Simple Graphic Eq
Oct 79	Digital Dial
Oct 79	Variwiper
Oct 79	Cable Tester

# ETI Project Chart

## PROJECT CHART

This chart is an index to all information available relating to each project we have published in the preceding year. It guides you to where you will find the article itself, and keeps you informed on any notes that come up on a particular project you are interested in. It also gives you an idea of the importance of the notes, in case you do not have the issue referred to on hand.

## Canadian Projects Book

Audio Limiter	Metal Locator
5W Stereo	Heart-Rate Monitor
Notes N, D May 79	GSR Monitor
Overled	Phaser
Bass Enhancer	Fuzz Box
Modular Disco	Touch Organ
G P Preamp	Mastermind
Bal. Mic. Preamp	Double Dice
Ceramic Cartridge Preamp	Reaction Tester
Mixer & PSU	Sound-Light Flash
VU Meter Circuit	Burglar Alarm
Headphone Amp	Injector-Tracer
50W-100W Amp	Digital Voltmeter
Note N May 79	

## Key to Project Notes

C:- PCB or component layout  
D:- Circuit diagram  
N:- Parts Numbers, Specs  
Neg:- Negative of PCB pattern printed  
O:- Other  
S:- Parts Supply  
T:- Text  
U:- Update, Improvement, Mods



# The Fun of Electronics

I TELL YA, FRED, IT'S AMAZING HOW INSECTS CAN ADAPT LAST WEEK I BOUGHT AN ELECTRONIC BUG KILLER, AND WITHIN 2 DAYS, ALL THE INSECTS IN MY NEIGHBOURHOOD WERE WEARING TINY LITTLE RUBBER GLOVES.

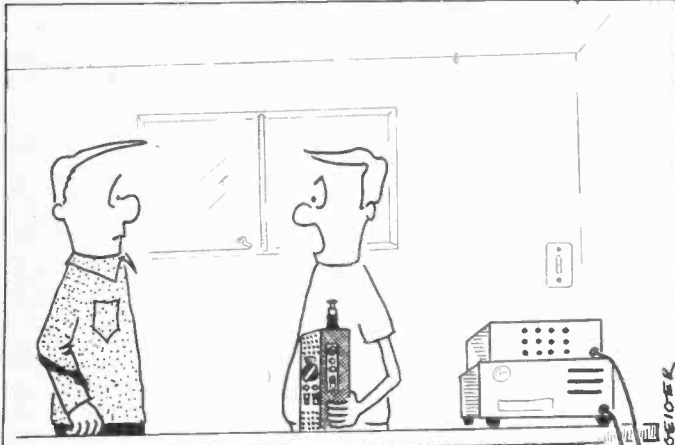

NOW GET THIS STRAIGHT, JIM; THIS IS A 300 DOLLAR HANDHELD RADIO AND DON'T EVER LET ME HEAR YOU CALL IT A WALKIE TALKIE AGAIN!

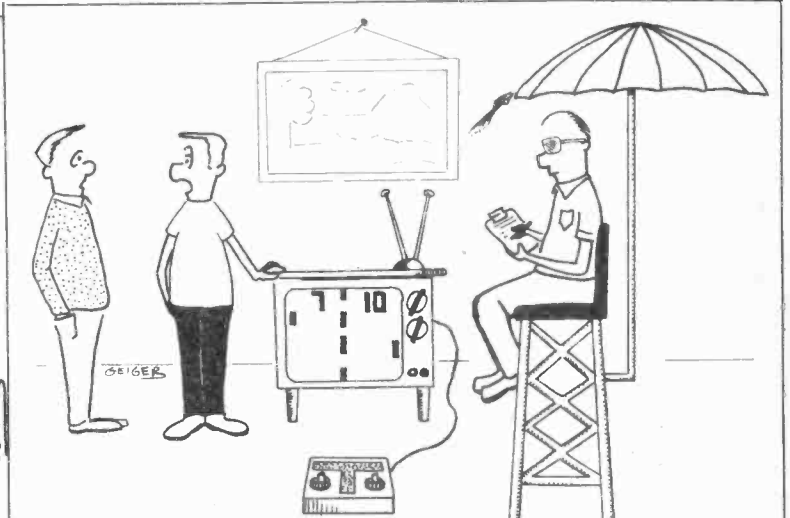

SURE HE'S EXPENSIVE TO HAVE AROUND BUT SINCE I BOUGHT THAT VIDEO TENNIS GAME, IT'S THE ONLY WAY I CAN KEEP PEACE IN THE FAMILY.



TO BE HONEST, MR CAMPBELL, OUR FIRST REACTION WAS ONE OF ANGER BUT THAT GRADUALLY TURNED TO CURIOSITY, AND NOW WE AT THE POWER COMPANY ARE JUST DYING TO KNOW HOW THAT LITTLE MICRO-POWER CIRCUIT OF YOURS MANAGED TO DESTROY ONE OF OUR 900 MEGAWATT GENERATORS.

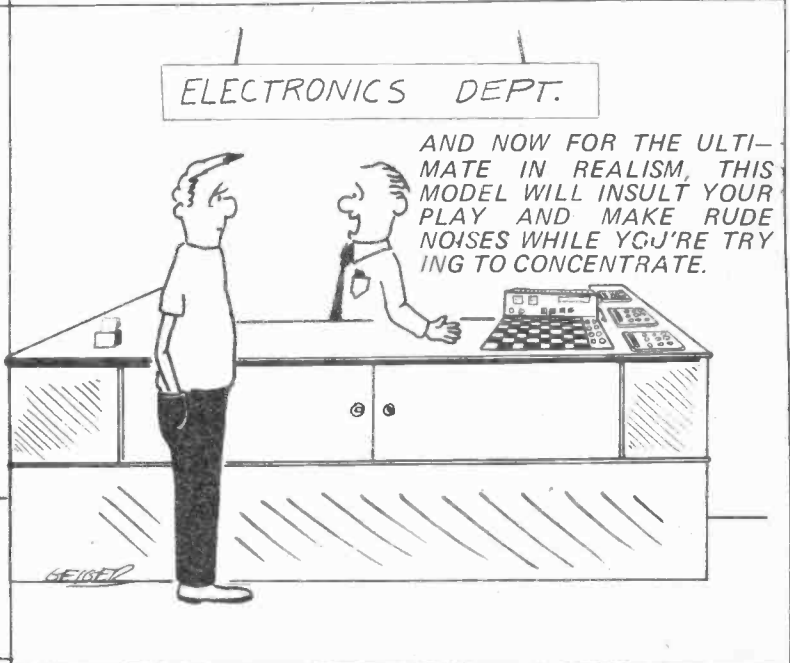

AND NOW FOR THE ULTIMATE IN REALISM, THIS MODEL WILL INSULT YOUR PLAY AND MAKE RUDE NOISES WHILE YOU'RE TRYING TO CONCENTRATE.

## General Information For Readers

### Editorial Queries

Written queries can only be answered when accompanied by a self-addressed, stamped envelope, and the reply can take up to three weeks. These must relate to recent articles and not involve ETI staff in any research. Mark your letter ETI Query.

### Projects, Components, Notation

For information on these subjects please see our Project File section.

### Sell ETI

ETI is available for resale by component stores. We can offer a good discount and quite a big bonus, the chances are customers buying the magazine will come back to you to buy their components. Readers having trouble getting their copy of ETI could suggest to their component store manager that he should stock the magazine.

### Back Issues and Photocopies

Previous issues of ETI-Canada are available direct from our office for \$2.00 each. Please specify issue by the month, not by the features you require. The following back issues are still available for sale.

1977	1978	1979
February	<del>January</del>	January
May	February	February
June	March	March
July	<del>April</del>	April
September	May	May
November	June	June
	July	July
	August	August
	September	September
	October	October
	November	
	December	

We can supply photocopies of any article published in ETI-Canada, for which the charge is \$1.00 per article, regardless of length. Please specify issue and article. (A special consideration applies to errata for projects, see Project File.)

**LIABILITY:** Whilst every effort has been made to ensure that all constructional projects referred to in this edition will operate as indicated efficiently and properly and that all necessary components to manufacture the same will be available, no responsibility whatsoever is accepted in respect of the failure for any reason at all of the project to operate effectively or at all whether due to any fault in design or otherwise and no responsibility is accepted for the failure to obtain any component parts in respect of any such project. Further no responsibility is accepted in respect of any injury or damage caused by any fault in the design of any such project as aforesaid.

## Advertisers' Index

READER SERVICE NUMBER			READER SERVICE NUMBER		
17	Active Components	Page 17		High-Tech	Page 33
	Arkon Electronics	Page 37	10	Jana Industrial Electronics	Page 11
11	Atlas Electronics	Page 2	12	Len Finkler	Outside Cover
3	Audiex Electronics	Page 52	13	Len Finkler	Page 10
4	Audiex Electronics	Page 54	15	McGraw-Hill	Page 23
	Audiovision	Page 13		Motorola	Page 27
6	BCS Electronics	Page 13		Noramel	Page 33
18	Compumart	Page 55	9	Omnitronix	Page 68
20	Compumart	Page 39	2	Omnitronix	Page 13
8	CompuShop	Page 57	1	Omnitronix	Page 16
	D.C.B. Electronics	Page 57	5	RAE Industrial Electronics	Page 39
7	Gladstone Electronics	Page 56	16	Standard Electronics	Page 21
14	Glenwood Trading	Page 61		Zenith Radio Corp.	Page 67
19	H. Rogers Electronic Instruments	Page 55			



# NIBBLER

**03 HEAVY DUTY HAND NIBBLER**  
Cuts sheet metal up to 18 gauge, or plastic material up to 14 gauge quickly and cleanly without bending or distortion. Nickel plated, PVC coated handles and self or spring opening.

# CIRCUIT BOARD HOLDERS AND VISES

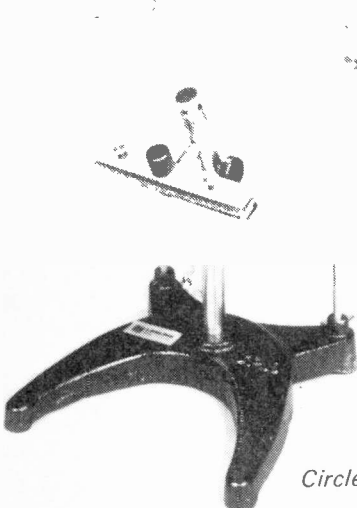

**ST-10 CIRCUIT BOARD HOLDER**  
Freely rotatable with printed circuits clamped on it. Heavy base, clamp tilts for preferred working position. Useable as a soldering iron holder and solder reel keeper.

Circle no. 12 on Reader Service Card.

# SOLDERING IRONS

**7700 WAHL QUICK CHARGE "ISO-TIP" CORDLESS SOLDERING IRON**

Solder anywhere, anytime, indoors or outdoors. Kit consists of cordless soldering iron, recharging stand, one fine tip and one heavy duty tip. Premium long-life nickel cadmium batteries.



**6500 "ISO-TIP" PC DRILL ATTACHMENT**

This high speed drill attachment fits over the "ISO-TIP" Iron after tip has been removed. Ideal for drilling PC boards and removing components.



**180K BURNISHING TOOL**

A pocket size burnishing tool fitted in a handsome pen type case. It is of great value in keeping contacts on relays, solenoids, brushes, thermostats, protectorelays and other electrical devices smooth and free from carbon-like deposits which would otherwise leave them inoperative.

# DESOLDERING TOOLS

from EDSYN

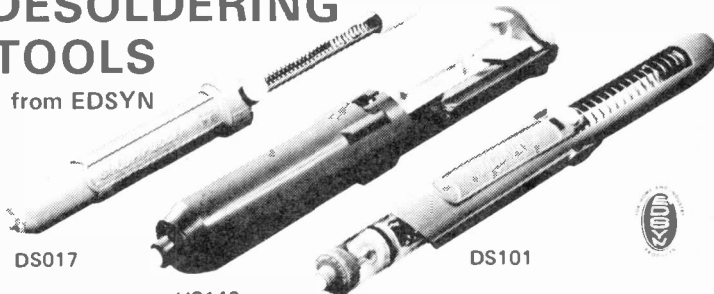

DS017

US140

DS101

**DS017 DELUXE "SOLDAPULLT" DESOLDERING TOOL.** Extremely rugged for volume desoldering.

**US140 UNIVERSAL "SOLDAPULLT" DESOLDERING TOOL.** Compact tool for convenient tool box storage.

**DS101 DELUXE "SOLDAVAC" DESOLDERING TOOL.** Features an enclosed loading shaft with storage locks and clear barrel for easy cleaning.

## PANAVISE® CIRCUIT BOARD HOLDER

Holds boards of any shape, up to 8" wide, in any position . . . flat, vertically, at any angle. It is easily rotated, tipped, tilted, elevated, lowered, moved left or right, or turned over.

## PCSS-1 PRINTED CIRCUIT BOARD HOLDER

The practical and elegant design is particularly suited to shorten the time in mounting components, parts, etc. in printed circuit boards. They are 3 piece units; a frame base, printed circuit holder, and foam rubber component pressing or holding lid. Larger models are available.

**MAIL TO: len finkler Ltd.**  
25 Toro Rd., Downsview, Ont. M3J 2A6

Please send catalogues and brochures describing your complete line of products (mail this coupon or circle no. 12 on the Reader Service Card).

Company Name: \_\_\_\_\_

Address: \_\_\_\_\_

Name: \_\_\_\_\_

# LEAD CUTTING & BENDING TOOLS

## PR/1 COMPONENTS LEAD BENDING TOOL

For bending the legs or leads of resistors, capacitors, transistors, etc. Made of pressed iron with baked enamel finish. The bending clamps are of tempered steel. Bend distance adjustable from 12mm to 50mm. Guides on tool can be set to precise spacing required.

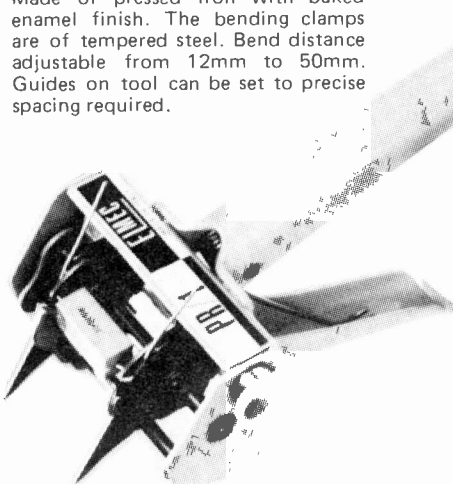

## TP/2A CUTTING & BENDING TOOL

Rugged but light tool evenly cuts and bends, at the same time, the leads on various components to be inserted into the P.C.B. Does leads from .3 to 1.5mm with no adjustment. Made of blue poliamide and glass fibre.

## PD801 SPEEDY BEND

This affordable tool bends 1 component or 100 in less time than it takes to set up and run any automatic bender. 1 tool forms jumper, 1/4 and 1/2 watt resistor, and diode leads. Made of high impact cyclac plastic.

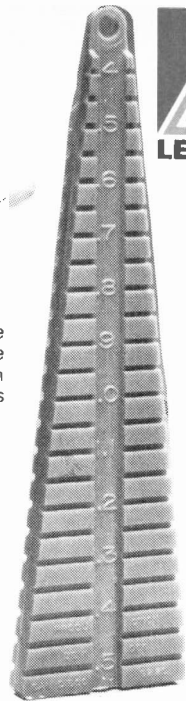

# ok WIRE WRAPPING TOOLS

## 'IC' INSERTERS & EXTRACTORS

### 4990 SERIES DIP INSERTER

Fastest manual inserter available. Compensating screw allows you to adjust for package tolerances and make corrections for lead spacing. Inserts with no stress on package body and is safe for M.O.S. and CMOS devices. Anodized aluminum and stainless steel construction.

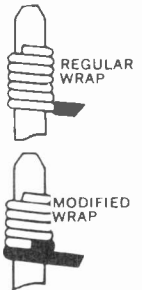
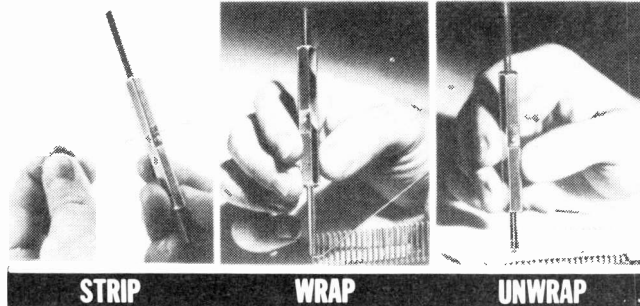
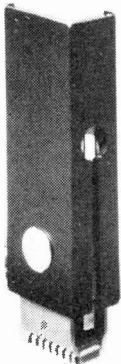

### HOBBY WRAP TOOL

Wire-wrapping, stripping, unwrapping tool for AWG 30 on .025 (0,63mm) Square Post.

## 565 IC EXTRACTOR

For use on up to 16 way D.I.L. integrated circuits. Made of plastic, small clip type opens over IC. Jaws grip IC under leads.

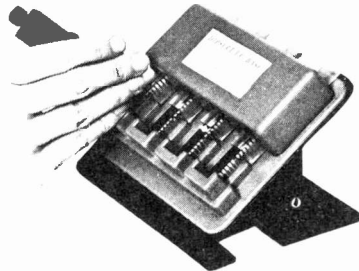

## 800 I.C./DISPENSING BASE

Provides a quick and efficient fixture for I.C. pickup. Eliminate I.C. handling damage, use with plastic or ceramic I.C.'s. Dispenses 4 I.C. varieties simultaneously. Mates with any single-tube I.C. Carrier.

## 4916 IC EXTRACTOR

Unique plier type construction. Withdraws IC straight up out of the board without bending leads of the IC. Removes all 14-16-24 lead dual inline packages. Insulated, made of A.B.S. plastic.

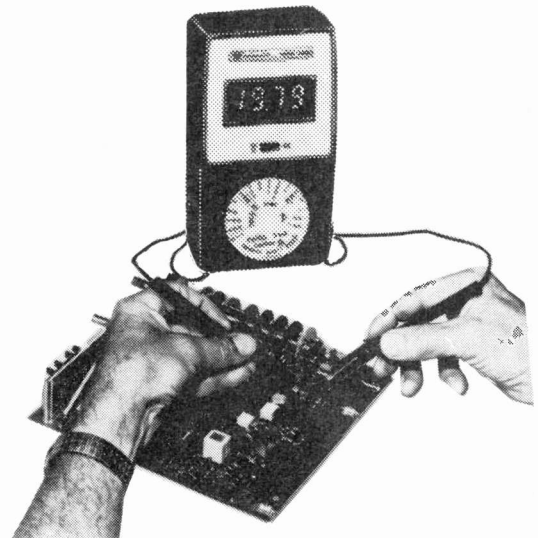
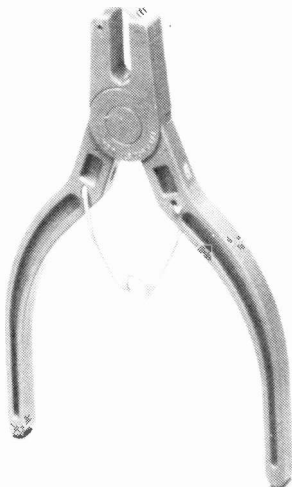

## TRIPLETT DVOMs METER

Built to fit your hand and budget, the new Model 3400 is loaded with features. High and Low Power Ohms for sensitive IC testing, makes the Model 3400 ideal for design, production and maintenance testing, vocational testing, schools, commercial electronic equipment test and measurement use.

Circle no. 12 on Reader Service Card.

FILL IN COUPON FOR CATALOGUES AND BROCHURES DESCRIBING OUR COMPLETE LINE OF PRODUCTS.



# SCREWDRIVERS

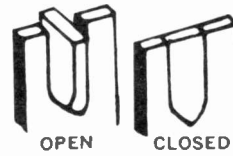

## HUNTER "MAGIC TIP" SCREW HOLDING SCREWDRIVER

Drives and removes steel, nonferrous or nylon screws in areas where other screwdrivers will not work. No rings to push, no bulky clips. Blades are alloy steel, heat treated and hardened. Handles are job matched with Hunter's comfort grip. A genuine precision tool.

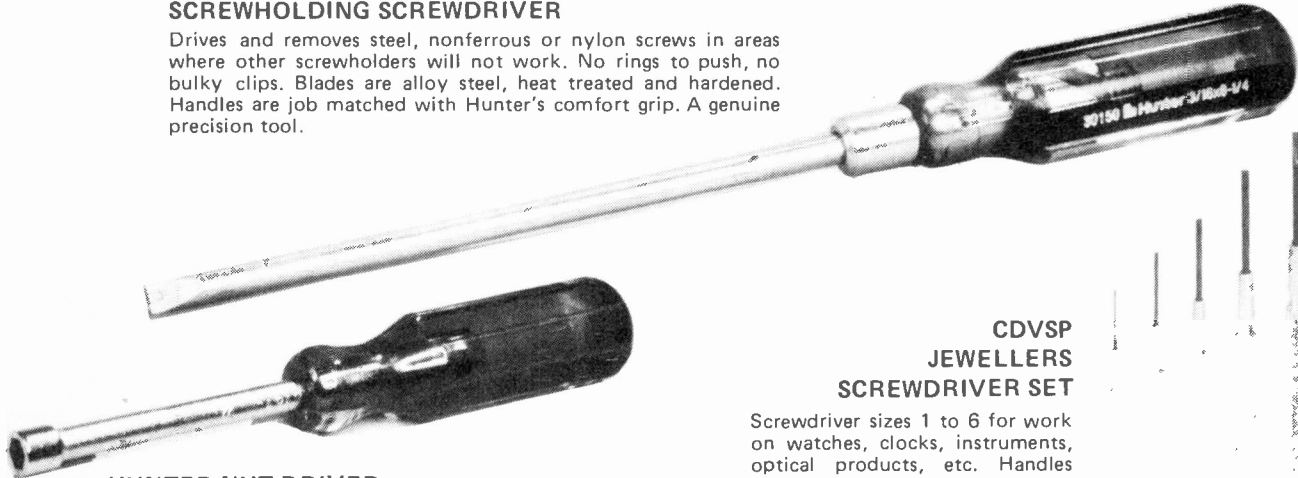

## HUNTER NUT DRIVER

The most popular series of nut drivers. Precision sized socket with solid shaft for strength and durability with colour coded job matched comfort grip handles to take the fatigue out of the job.

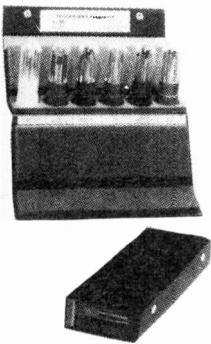

## MMK-4 MASTER TOOL KIT

The ultimate in miniature precision tool kits. The MMK-4 contains 4 individual Moody kits: a screwdriver and an awl kit, a Phillips and Allen wrench kit, and an offset openend wrench kit. These tools are ideal for a variety of applications such as repairing photographic equipment hi-fi, ham radio, CB's and electronic instruments.

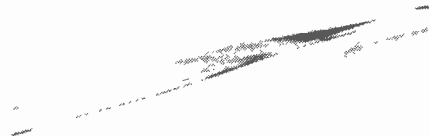

## 1512 TWEEZERS

These are extra long 8" tweezers, bright nickel plated. The tips are serrated. Available with straight or curved tips. For electronic assembly or repair.

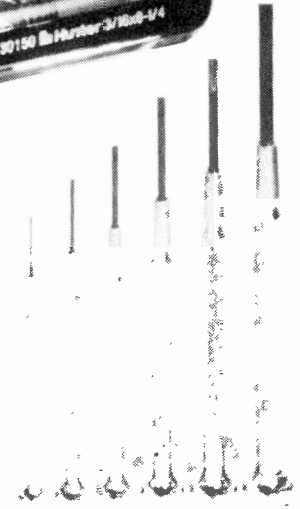

## CDVSP JEWELLERS SCREWDRIVER SET

Screwdriver sizes 1 to 6 for work on watches, clocks, instruments, optical products, etc. Handles and swivel heads solid, non-rusting brass, nickel plated. Tempered tool steel blades. Straight or nurl for good grip. Packed in attractive plastic box.



## 5410 EYE MAGNIFIERS

Jewellers and tool makers series of magnifiers. Loupes for close up examination of all sorts of P.C.B. assemblies, components, machine work, etc.

# PLIERS & WRENCHES

## "SMITTY" HEX WRENCHES

The original and most popular folding Hex Key set from Hunter. Blades of cold alloy steel heat treated and hardened with special attention to the tips. Cases are deburred and heavily nickel plated for comfort and durability.

## 70 SERIES ERASING AND BURNISHING BRUSHES

Designed for a variety of industrial applications. Adjustable for reaching corners, crevices and other hard places. Stiff cleaning action or soft brushing action depending on extension. Removes foreign matter from various surfaces. Cleans contacts, PCB's, removes oxidation and restores contact making surfaces to new condition.

## STR 23 AUTOMATIC WIRE STRIPPER

An automatic wire stripper for stranded or solid wire that strips 6 of the most popular sizes of stranded or solid type hook-up wire from No. 8 thru to No. 24. Rugged die cast frame, vinyl covered handles, spring opening. Stop attachment included for continuous stripping. Individually boxed.

STR-23B Replacement Blades

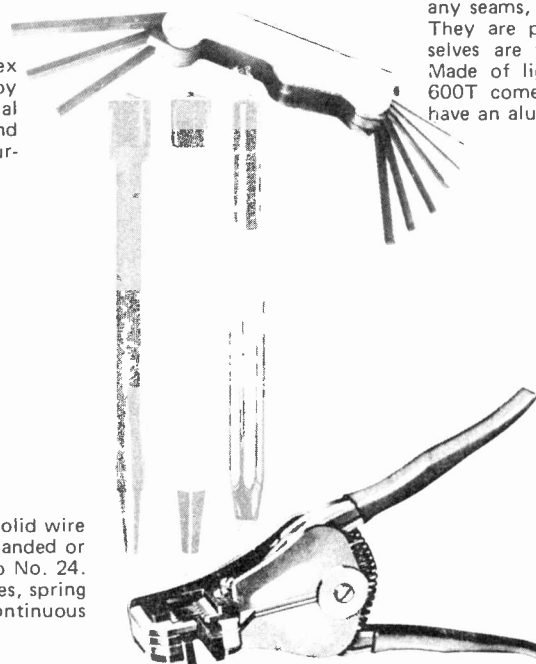

## 605T PLATT TOOL CASE

AT LAST A CASE DESIGNED FOR TOOLS, NOT A CONVERTED ATTACHE CASE.

The pockets of a Platt Pallet are molded without any seams, stitches or rivets to form a one-piece unit. They are practically indestructible. The cases themselves are that same rugged one-piece construction. Made of lightweight ABS thermoplastic. The Model 600T comes with two pallets. All Platt Tool Cases have an aluminum rim for extra strength.



THESE PRODUCTS ARE AVAILABLE FROM YOUR FAVOURITE ELECTRONIC PARTS DISTRIBUTOR. IF YOU CANNOT LOCATE A LOCAL OUTLET PLEASE WRITE US FOR THE NEAREST DISTRIBUTOR IN YOUR AREA.

# LENLINE



## TOOLS FOR ELECTRONICS STRIPPERS & CUTTERS

1979



SD-18



SD-12



SD-13

### SOLVENT DISPENSERS

Precision instruments in every respect. Pump units are constructed of the finest stainless steel obtainable to give a lifetime of satisfactory service. Airtight check valve eliminates evaporation over long periods. Yet the light pressure of an applicator or sponge on dispenser dish pumps solvent to surface the instant you need it. Bottles are molded linear polyethylene. Ideal for dispensing: Methyl Ethyl Ketone, Alcohol, Carbon Tetrachloride, Acetone, Ether, Perchloroethylene, Trichloroethylene and any other solvents.

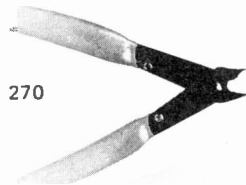

270

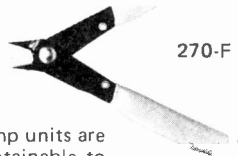

270-F

### 270 THIN PROFILE WIRE CUTTERS

5" angled flushcutters with patented shearing action for soft wire to 20 gauge. This is a U.S. made, quality tool of high carbon steel fabrication with significantly longer life. Its double-coil spring return and thin profile tips give you a smooth effortless flush cut with lower stress and operator fatigue. Unique vinyl foam non-slip handles allow you a comfortable cushion grip. Distinctive green colour.

### 270F THIN PROFILE SAFETY WIRE CUTTER

Same as above cutter but with a built-in lead catcher that retains cutoff wire, eliminating flying ends.



### MILLER STRIPPERS 101-S

An excellent stripper and cutter for all commonly used stranded and solid wire. Features adjustable stop on handles for various wire sizes, and self opening spring.

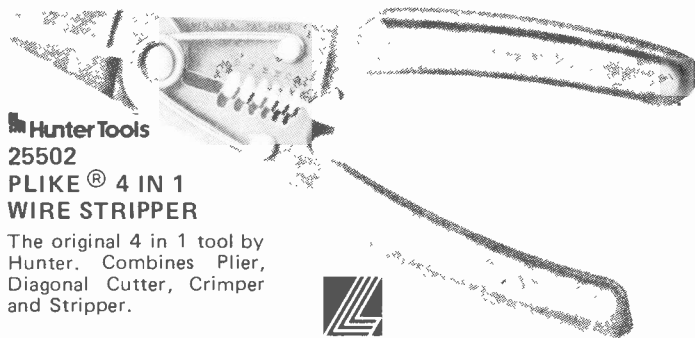
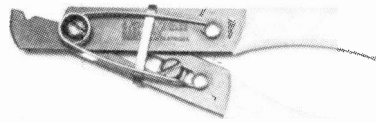

### HunterTools 25502 PLIKE® 4 IN 1 WIRE STRIPPER

The original 4 in 1 tool by Hunter. Combines Plier, Diagonal Cutter, Crimper and Stripper.



### PRECISION PLIERS & CUTTERS Box Joint Type



BOX JOINT

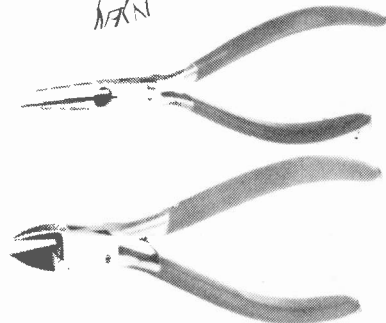

Made from German Tool Steel, wobble free box joints for positive jaw alignment with leaf springs for self opening operation.

**27B-5-1/2**  
5-1/2" long-nose plier with side cutter. Box joint, no spring. Blue cushion handles.

**48C-5**  
5" flush cutter for soft wire. Box joint, leaf spring. General purpose. Blue cushion handles.

### OK JUST WRAP WIRE WRAPPING TOOL

AWG 30 Wire  
.025" Square Posts  
Daisy Chain or Point To Point  
No Stripping or Slitting Required  
..... JUST WRAP .....  
Built in Cut Off  
Easy Loading of Wire  
Available Wire Colours:  
Blue, White, Red & Yellow

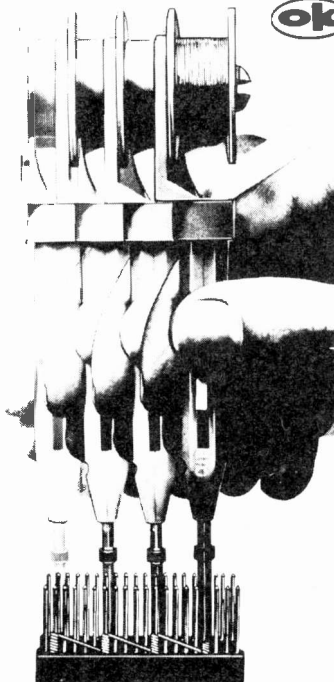

### OK JUST WRAP UNWRAPPING TOOL



OK JUST WRAP  
REPLACEMENT ROLLS (50ft.)  
Blue Wire  
White Wire  
Yellow Wire  
Red Wire

### CSC LOGIC PROBES

Simpler breadboard testing. That's why CSC Logic Probes were created. These hand-held design/test tools give instant overview of circuit conditions. There are three models to choose from, depending on your budget, your project, and the speed of your logic circuits.

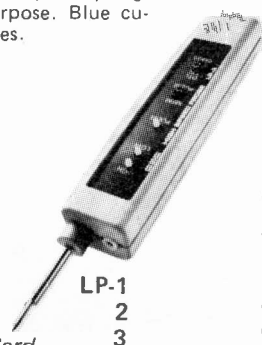

LP-1  
2  
3



### WIRE-WRAPPING TOOL

Battery operated wire-wrapping tool. For .025" (0.63mm) square post "MODIFIED" wrap, positive indexing, anti-overwrapping device.

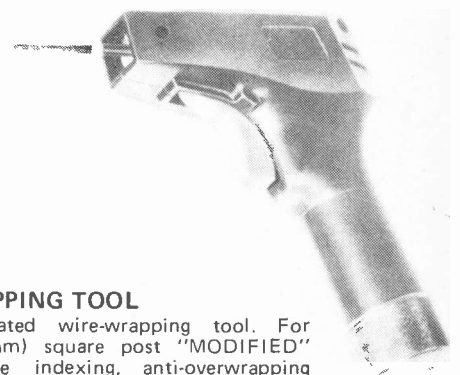

Circle no. 12 on Reader Service Card.