

electronics today

NOVEMBER 1978

GG70409

Bally Arcade: Game or Computer?



Shop Canadian
Magasinons à la canadienne

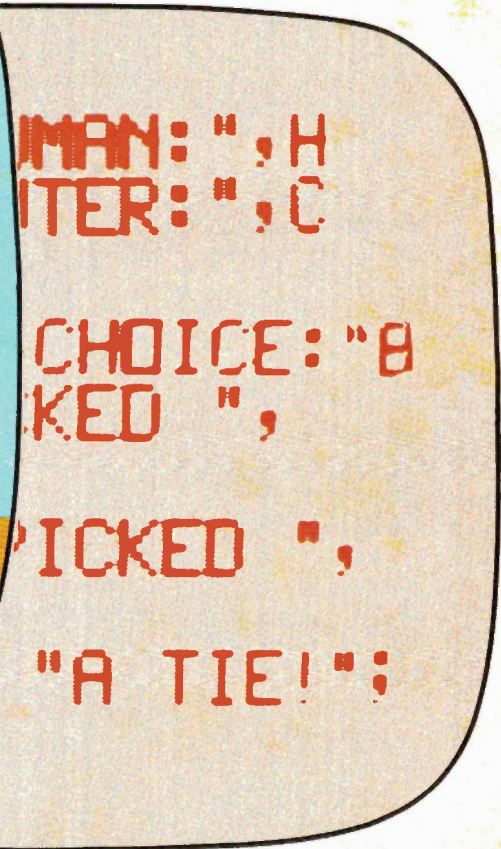

Ham News

**Christmas
Calculator Guide**

Custom PCB Method

PCM Explained

A Look at Lightning

**CMOS Switched
Preamp**

Stars and Dots Game

Easy-to-read

Capacitance Meter

Best way to replace a dipped solid-tantalum capacitor

Use a Sprague Type SD Tantalex® Replacement Capacitor. You can count on its matching or exceeding the original quality of the capacitor it replaces. Quality features include:

- ① High stability with very little capacitance change even at outer limits of operating temperature range of -55°C to $+85^{\circ}\text{C}$ (-67°F to $+185^{\circ}\text{F}$).
- ② Low dissipation factor permits higher ripple currents.
- ③ Capacitance tolerances of $\pm 10\%$.
- ④ Hard epoxy coating that's highly resistant to moisture and mechanical damage.

Sprague makes it easy

Cabinet assortment KT-10 contains 70 Type SD Dipped Tantalex Solid-Tantalum Capacitors in 16 most-frequently-used ratings. They're prefiled for easy finding in six compartmentalized and labeled drawers. You pay for the capacitors only . . . the cabinet is yours at no extra cost!

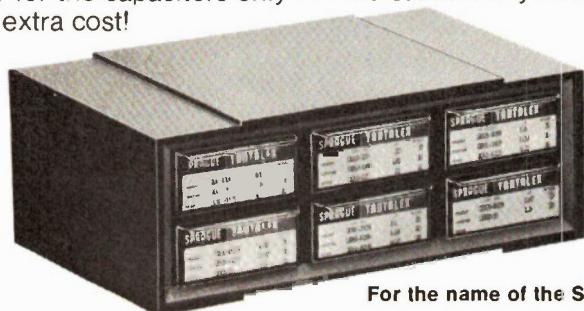

For the name of the Sprague distributor nearest you, write or call:

TRANS CANADA ELECTRONICS LTD.

1900A Eglinton Ave. East
Scarborough, Ont. M1L 2M1
Tel. (416) 757-4171

P.O. Box 117, Dollard Des
Ormeaux, Que. H9G 2H5
Tel. (514) 747-4266

SMITH-PATTERSON & ASSOCIATES

1120 Hamilton St.
Vancouver, B.C. R3E 2T1
Tel. (604) 681-0743

30 Midland St.
Winnipeg, Manitoba R3E 2Y6
Tel. (204) 774-1855

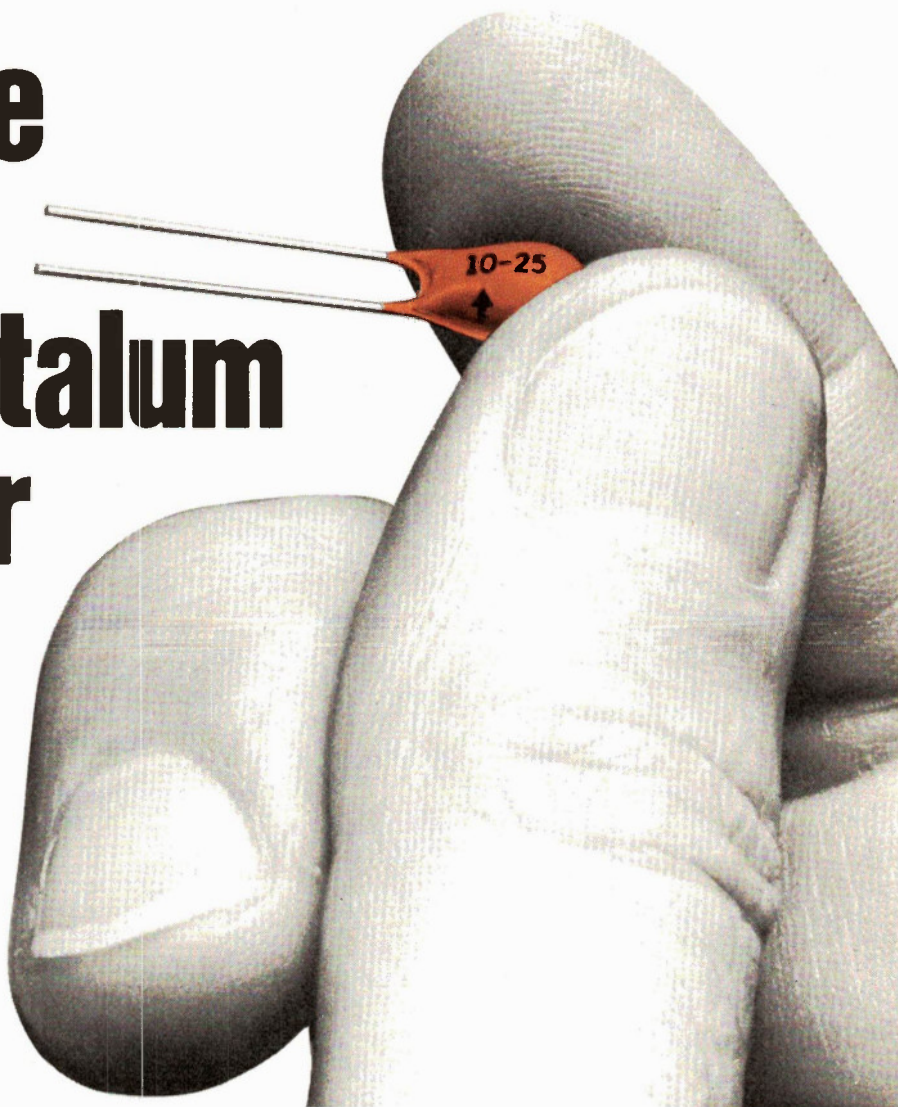

KT-10 ASSORTMENT

(All units 35 WVDC)

Quan	Cat. No.	μF	Quan.	Cat. No.	μF
4	SD35-R109	.1	4	SD35-2R29	2.2
2	SD35-R159	.15	1	SD35-3R39	3.3
2	SD35-R229	.22	8	SD35-4R79	4.7
2	SD35-R339	.33	8	SD35-6R89	6.8
5	SD35-R479	.47	10	SD35-109	10
2	SD35-R689	.68	2	SD35-159	15
8	SD35-19	1.0	8	SD35-229	22
2	SD35-1R59	1.5	2	SD35-339	33

YOUR NUMBER 1 SOURCE FOR ELECTRONIC COMPONENTS

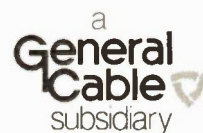

NOVEMBER 1978

Vol. 2. No.11.

Editor

STEVE BRAIDWOOD BSc

Assistant Editor

GRAHAM WIDEMAN BAsC

Advertising

Advertising Manager

MARK CZERWINSKI BAsC

Advertising Services

SHARON WILSON

Advertising Representatives

JIM O'BRIEN

Eastern Canada JEAN SEGUIN &

ASSOCIATES INC., 601 Cote Vertu,

St. Laurent, Quebec H4L 1X8.

Telephone (514) 748-6561.

Subscriptions Department

BEBE LALL

Accounts Department

SENGA HARRISON

Layout and Assembly

GAIL ARMBRUST

Contributing Audio Editor

WALLACE J. PARSONS

EDITORIAL AND ADVERTISING

OFFICES

Unit 6, 25 Overlea Boulevard,

Toronto, Ontario, M4H 1B1

Telephone (416) 423-3262

Second Class Mail registration number 3955.

Return postage guaranteed. Post Office returns

to Unit 6, 25 Overlea Boulevard, Toronto,

Ontario, M4H 1B1.

Published by Electronics Today

International (Canada) Ltd.

Printed by Livingstone Printing Ltd.

News Stand Distribution Gordon &

Gotch, Toronto.

Copyright: All material is subject to world-wide

Copyright protection. All reasonable care is

taken to ensure the accuracy of the information.

ALL ETI PCB PATTERNS ARE COPYRIGHT.

NO COMPANY MAY SELL BOARDS TO OUR

DESIGNS WITHOUT OUR PERMISSION.

INTERNATIONAL EDITIONS

Electronics Today International

25-27 Oxford St., London W1R 1RF, UK.

Editor Halvor Moorshead.

Electronics Today International,

Ryrie House, 15 Boundary St.,

Rushcutters Bay, Sydney, Australia.

Editor Collyn Rivers.

Electronica Top Internationaal,

Postbus 260, Emmen, Holland.

Editor Anton Kriegsman

Elrad,

Kommanditgesellschaft, Bissendorfer

Strasse 8, 3000 Hannover 61, Germany.

Editor Udo Wittig.

electronics today

international

INCORPORATING ELECTRONIC WORKSHOP

PROJECTS

HI-FI AMP WITH CMOS SWITCHING32

A preamp design for use with ETI power amp modules

CAPACITANCE METER41

Uses a linearly-scaled analogue meter

STARS-N-DOTS45

A version of the 'Mastermind' game

FEATURES

THE BALLY ARCADE — GAME OR COMPUTER?15

We review this exciting product

PCM EXPLAINED23

Don Rost looks into Pulse Code Modulation techniques

THE DANGERS OF LIGHTNING27

A technical explanation of what happens when you get zapped

CALCULATOR BUYING GUIDE.....38

Available functions on scientific and specialist models

EASY PCB MAKING48

A new product is a great help

ETI DATA SHEET50

Intersil 8063, Power Amp Driver

ETI SOFTSPOT62

A simple program illustrates calculator programming techniques

TECH-TIPS64

Ideas for experimenters

NEWS & COLUMNS

NEWS DIGEST4

MICROFILE7

AUDIO TODAY10

SERVICE NEWS.....57

SHORT WAVE WORLD59

NEW HAM COLUMN:'QRM'61

THE FUN OF ELECTRONICS72

INFO & MISCELLANEOUS

ETI T-Shirts8

ETI Binders.....44

Audio Today Letters.....12

ETI Back Issues.....49

Next Month's ETI.....13

ETI Subscriptions.....58, 63

Classified Ads Info.....14

Electronics Paperbacks...67, 68

ETI Canadian Projects Book..22

ETI Project File.....72

ETI Panel Transfers.....30

ETI Publications.....73

ETI Marketplace.....31

Reader Service Information...74

ETI Club Call40

Advertisers' Index.....74

NEWS DIGEST

Superboard II: Computer for Hobbyists

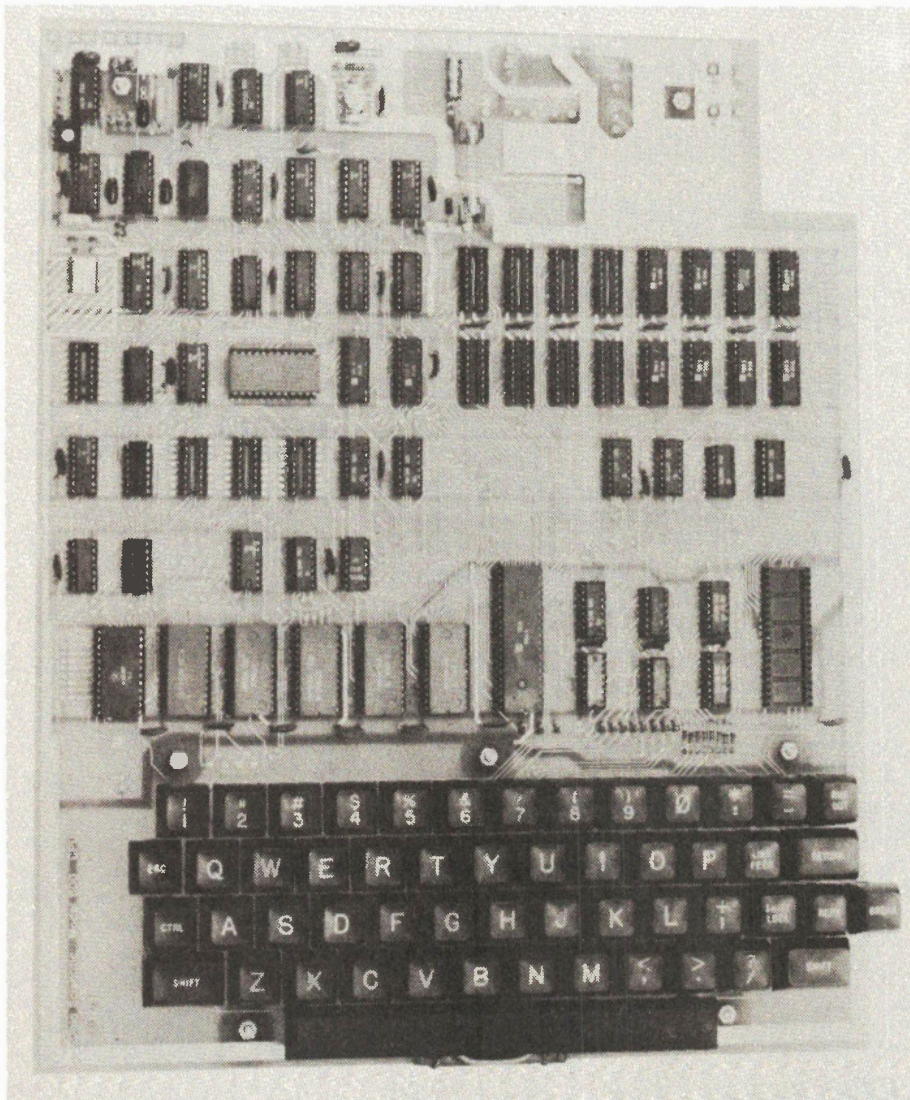

Ohio Scientific has just introduced Superboard II, a complete personal computer system on one board. Superboard II's features include 8K of BASIC in ROM, up to 8K of static RAM, 6502 microprocessor, a 53-key computer keyboard with upper/lower case and user programmability, a video display interface with graphics, and a Kansas City standard audio cassette interface, plus full machine code monitor and I/O utilities in ROM. The BASIC-in-ROM is full-feature BASIC that is claimed to enable the Superboard II to run faster than currently-available personal computers and all 8080-based business computers. The video display is directly accessed with 1K of dedicated memory

in addition to user memory. This display has upper case, lower case, graphics, and gaming characters for an effective screen resolution of up to 256 x 256 points. Normal TVs with overscan display about 24 rows of 24 characters; without overscan up to 30 x 30 characters are visible.

Available options include an expander board that features 24K of additional static RAM, a dual min-floppy interface port adapter for printer and modem, and an Ohio Scientific 48-line expansion interface. Also available is an assembler/editor and extended machine code monitor, as well as a complete software library.

Ohio Scientific's Superboard II comes without a power supply or case.

Windshield-Mount CB Antenna

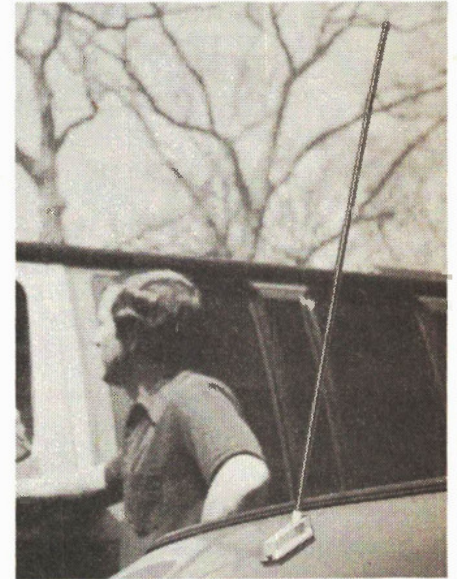

From the Avanti Laboratories in Addison, Illinois, comes a new mobile CB antenna. Called the Astro-Fantom, this 22" fiberglass antenna transmits through and receives through glass! It requires no grounding to metal as do conventional 1/4 wave antennas. There are no holes to drill and no clamps or magnets. No pinched cables run in through doors, windows or trunk, thus avoiding water leaks.

The antenna is coupled inductively to the feeder on the other side of the glass.

For further information, contact Lenbrook Industries Limited, 1145 Bellamy Road N., Unit #2, Scarborough, Ontario. M1H 1H5. Telephone (416) 438-4610.

Any + 5 volt DC 3 amp supply powers it up. The Superboard II packs in a lot of personal computing for low suggested US retail price of \$279.

The Superboard II personal computer has twice the memory of many competitive (and more expensive) systems.

Superboard II is also available as Challenger 1P complete with power supply (on the same board) and case for only US \$349.

For details on where to buy Superboard II or Challenger 1P, or for complete information on other Ohio Scientific microcomputer systems write: Ohio Scientific, Inc, 1333 S Chillicothe Road, Aurora, Ohio, 44202, USA or call (216) 562-3101.

Calculating DMM

A hand-held combined DMM and calculator has been announced by Electro Scientific Industries of Portland, OR 97229, USA. The model 4100 Calcumeter can be programmed to average DMM readings, or it can scale data with the Mx+b key. Comparisons between a measured and a stored value can be expressed in decibels or percentages.

The Calcumeter can show where the measured value falls with respect to two predetermined limits. The interval between the two stored values is divided into eight equal segments and the display has a clever way of showing the location of the reading. The seven

LCD decimal points light up and a minus sign is displayed in one of the eight spaces thus formed. Plus or minus errors indicate the measurement is out of range, and an internal audible warning can be programmed to sound.

The 3 1/2-digit DMM measures up to 1000 V DC (750 V AC) in six automatically selected ranges. Six resistance ranges measure up to 20 megohms, and two current ranges measure to 200 mA. The display modes are scientific, engineering, or fixed decimal point. The product is available from Micrometrics Inc, Portland, OR 97229, USA (Phone 800-547-5637). The cost is US \$389.

Semiconductor Guide Update

Bill Johnson has found another company for his Canadian Semiconductor Guide. Westburne-Haldene handle Precision Monolithics, EDI, Exar Integrated Systems, and Standard Micro Systems. They have five numbers in the Toronto phone book.

We have also heard from companies who sell semiconductors who were not mentioned in the guide. Here there seems to have been a misunderstanding about the purpose of the guide. We did not intend to mention **replacement** lines from any manufacturer. Replacement semiconductors are available from hundreds of outlets and present no problem to our readers.

Superior Electronics in Montreal represent RCA's SK line of general replacement semiconductors and they have many distributors throughout Canada. If you want more information write to Superior Electronics Inc, 1330 Trans Canada Highway S, Montreal, Quebec, H9P 1H8.

Cambion from Zentronics

Cambion products are now available from Zentronics locations in Toronto, Montreal, Ottawa, Waterloo, and Vancouver. The Cambion IC Packaging Hardware catalogue is now available. Zentronics also informs us that they have high-efficiency HP seven-segment LEDs for use under high ambient lighting.

Credit Card Calculator

Sharp Electronics of Canada Ltd. has introduced a 3.8mm (9/64") thin calculator about the size of a credit card. Priced from \$49.95, the EL8140 is a full-fledged 8-digit calculator which includes a storage computer that's ideal for money or metric conversion, etc.

Other features include: no protruding keys, independently accessible 3-key memory, optional audible input check mode, auto power-off function turns calculator off after several minutes non-use, and liquid crystal display. The calculator operates approx 600 hours in silent mode and 400 hours in audible input check mode on two silver oxide batteries.

Scope Inverter

Portable power for all Hewlett-Packard 1700 Series oscilloscopes is now available using the 1112A Inverter Power Supply. This new source provides approximately two hours of oscilloscope operation from its internal battery pack. Power can be derived from the inverter's internal 140 watt-hour nickel-cadmium battery pack or from an external 11.5 to 50 volt dc source.

The Canadian price of the HP 1112A with 400 Hz operation is \$1,109 complete with battery pack, mounting bracket kit, and grounding cable. A 60 Hz is available for another \$31.

Duty and Taxes are extra where applicable. For more information contact the Inquiries Manager, Hewlett-Packard (Canada) Limited, 6877 Goreway Drive, Mississauga, Ontario. L4V 1M8.

Standard Catalogue

Another mail-order catalogue, this one from a specialist semiconductor company in Montreal. It costs \$1.95 from Standard Electronics of 8927 boulevard Pie IX, Montreal, PQ H1Z 3V3. The first 27 pages cover transistors in the "MES" line — the company's own numbers — with brief specs and pin diagrams. Another 7 1/2 pages list Japanese transistors, then there's 2 pages of Japanese ICs, 11 1/2 pages of North American transistors and SCRs, a page of diodes, two of TTL, 11/2 linears ICs and 1/2 on memories (all these pages are ETI-size with approx 450 listings on each). The final 52 pages revert to the MES line linear ICs. The catalogue is nicely produced — heavy paper in a plastic binding.

Digital Thermometer Probe

Any digital multimeter can now be used as a digital thermometer with the addition of an accessory probe introduced by Data Precision and available in Canada from Webster Instruments Ltd..

The TP150/151 accurately registers temperature from -65° C to +150° C (-85° F to +302° F). Operating with any digital voltmeter where input impedance is greater than or equal to 1 megohm, accuracy of +1° C is assured between -10° C and +110° C.

For more information contact Webster Instruments Ltd, PO Box 427 Port Credit PS, Mississauga, Ontario, L5G 4M1. Phone (416) 275-2270.

Lead Rack

This test lead rack sorts test leads, cables, power cords, etc, according to their size. It can accommodate up to 150 test leads and holds up to three lead sizes, 0.125", 0.250", and 0.500". Fobel Enterprises, Dept. C-100, 552 E. El Morado, Ontario, California, 91764, USA.

HP Fiber Optic Link

A complete fiber optic link for data communications applications that requires no expertise in optical design, calibration or adjustment has been introduced by Hewlett-Packard.

The complete HFBR-0010 system is priced at \$739 (plus tax & duty), and delivery is stock from any HP franchised distributor.

The last time you saw a really new bench/portable DMM was 1972.

In 1972, the Fluke 8000A set new standards in the DMM market with reliable LSI design and innovative benefits.

Now look at the Fluke 8010A and 8012A bench/portables destined to be problem-solvers for the eighties!

- Large, razor-sharp LCD readout.
- Touch and hold probe option.
- Fluke hybrid true rms converter with flat response to 50 kHz (within 3dB at 200 kHz).

- Real measurement power with six functions and 31 ranges.
- Conductance ranges for measuring leakage to 10,000 M Ω , also convenient for transistor beta and light intensity.
- Overload protection like no other DMM.
- Simple, extremely reliable single-chip CMOS design.

Choose the 8010A (10A high current) for \$299 or the 8012A (0.001 Ω resolution) for \$389. Canadian prices including duty and federal sales tax.

Contact the ACA office nearest you:



Allan Crawford Associates Ltd.

TORONTO 416/678-1500 MONTREAL 514/670-1212 VANCOUVER 604/294-1326 OTTAWA 613/829-9651 CALGARY 403/276-9658 HALIFAX 902/469-7865

ACA Electronic Centres, Stocking Showrooms

Toronto: 6503 Northam Drive, Mississauga 416/678-1500

Montreal: 1330 Marie Victorin Blvd., Longueuil 514/670-1212

Calgary: 2280-39th Ave., N.E. Calgary 403/276-3658

Vancouver: 3795 William St., Burnaby 604/294-1326

Authorized distributors: Edmonton, Vernon, Winnipeg.

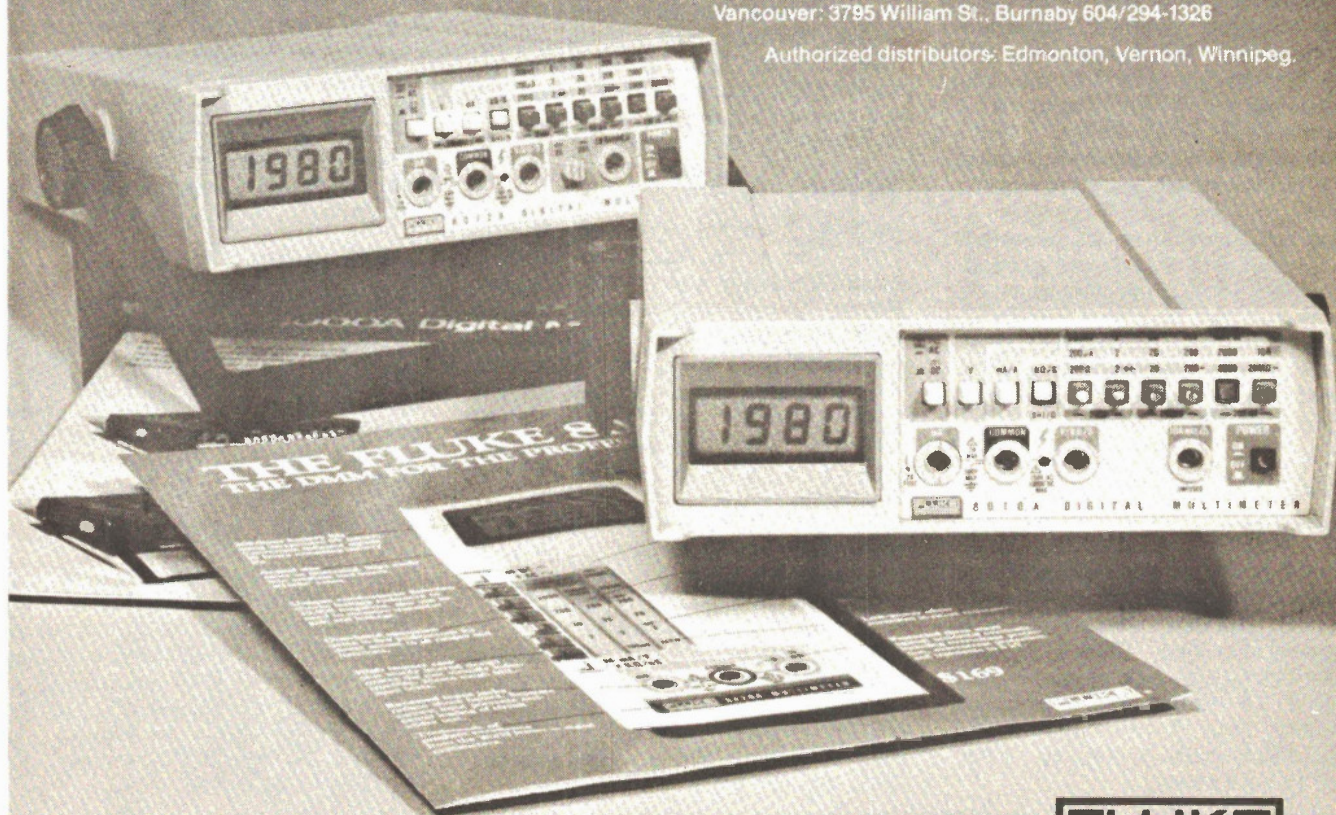

FLUKE

NEWS DIGEST

Charlie The Show-Robot

Sweep Generator

A new broadband sweep generator, the Wavetek model 1061, is available in Canada from Allan Crawford Associates Ltd. It has a frequency range of 1 to 400 MHz and features PIN diode levelling to provide an output flatness of +0.25 dB. Both harmonic and non-harmonic spurious signals are 30 dB below the output.

The model 1061 has provision for up to six crystal controlled, birdy by-pass markers with amplitude adjustment of 2 mV to 2 V peak-to-peak and width adjustment of approximately 100 to 400 KHz. The markers are accurate to 0.005%.

Remotely programmable centre frequency, sweep width and amplitude over the 20 dB vernier range is a standard feature of the model 1061, which is available in either 50 or 75 ohms.

520 MHz, 8-Digit Counter

The Data Precision model 5800 is available in Canada from Webster Instruments Ltd. This frequency counter has a basic sensitivity of 10mV. Two input channels are available: a 1 megohm input impedance channel from 10 Hz to 250 MHz, and a 50 ohm input channel from 5MHz to 520 MHz.

Three front panel selectable gate times provide a maximum resolution of 0.1Hz. Fastest gate time is 0.1 s (10 Hz resolution) on the low frequency channel and 0.2 s (10 Hz resolution) on the prescaled high frequency channel.

A three-position attenuator is provided — allowing inputs as high as 250 V to be applied to the 1 megohm input. The low impedance input will take signals as high as 5 V.

For more information contact: Webster Instruments Ltd., PO Box 427, Port Credit PS, Mississauga, Ontario L5G 4M1. Phone (416) 275-2270.

8085 Troubleshooting

Corporation has announced a new probe subsystem that broadens the applications range of the UScope 820 Microprocessor System Console. With the new Probe 8085 the popular diagnostic instrument can be used to troubleshoot systems based on 8085 and 8085A as well as 8080A microprocessors.

The UScope 820 Console and Probe 8085 may be purchased as a kit (USC 11 Kit) for US \$2,795.

He's not an actor in the latest space fantasy, nor a very scientific experiment, but he sure looks like a lot of fun. Five foot two and screen of blue (sometimes), this 475 pound robot spends much of it's time at various promotions and trade shows entertaining the "kids" (the ones with the three piece suits etc.)

Constructor George Clarke sort of finished Charlie in February, but he's still been growing since then. By radio control, and under his own battery power he is able to cruise about, flash lights and "look" around, wave his arm and grab things (the 3 finger prosthesis was obtained from Variety Village in Toronto).

With limited mobility, ie plugged into the wall, Charlie has enough power to run a built-in TV and Bally Videocade, visible through the front panel. George is also planning the installation of a TV camera in the "head" sometime in the future.

Fairly widely known construction

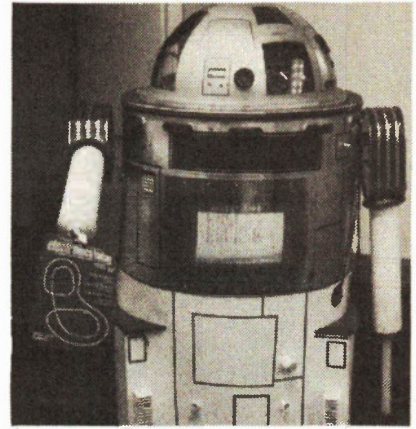

methods are used through out, and a few items like the calculator keyboard on Charlie's chest don't presently do anything, but a lot of fun is packed into this robot. Charlie also talks (via a built in CB rig) and we hear that some of the things he says to the trade show girls (after a few drinks of course) is getting him quite a reputation as a bit of a hustler. However, the digital clock in his head tells them when to send him home.

Radio Act Notice

Below we reproduce a notice from Dr. deMercado of the DOC:

Notice No. DGTR-002-78

Notice is hereby given that the Department of Communications is considering the possibility of introducing a 25 kHz channelling environment into the Aeronautical Mobile (R) Service sub-band 121.9625-123.5875 MHz.

To permit this, appropriate dates need to be established beyond which 100 and 50 kHz assignments would no longer be protected from interference. For discussion purposes we have tentatively selected termination dates of March 31, 1982 for 100 kHz assignments and March 31, 1985 for 50 kHz assignments.

Should a 25 kHz plan evolve, the Department would, of course, continue to renew licences for broadband equipment subsequent to the termination dates with the proviso that their continued use does not cause interference to properly operating narrowband equipment. However, in the event of conflicts between

narrowband and broadband channels, licensees of broadband equipment would be required to modify or replace their equipment.

Comments are solicited on the need for or the desirability of the abovementioned changes and any manufacturer, distributor or importer through an association or otherwise, and any consumer or user organization or group, or any interested person, may make representations. All communications should be addressed to the Director, Operations Branch, Department of Communications, 300 Slater Street, Ottawa, K1A 0C8, and should be postmarked no later than 60 days from the date of this notice.

Comments received in response to this Notice will be made available for public inspection, unless confidentiality is specifically requested, at the Department of Communications library, 300 Slater Street, Ottawa, and at Regional Offices of the Department in Vancouver, Winnipeg, Toronto, Montreal and Moncton. Those wishing to respond to such comments may do so in writing within a further 30-day period.

Dated at Ottawa this 25 day of August 1978.
Dr. John deMercado, Director General,
Telecommunication Regulatory Service.

microfile

Dynamic Memory Controller

Motorola has introduced a two-chip Dynamic Memory Control system that offers a significant reduction in component count for controlling RAM in MPU/MCU systems.

The two components include a Dynamic Memory Controller (MC3480) and an Address Multiplexer and Refresh Counter (MC3242A). Together, the two components provide complete control — row address, column address, read/write selection, refresh, etc. — for up to 64K of memory, the maximum usable memory capability for the most popular MPU systems in use today.

For more information contact Motorola Semiconductors, PO Box 20912, Phoenix, AZ 85036, USA.

Supply Problems: Our efforts to provide you with top-quality shirts have lead to some problems with our suppliers. Until these are resolved there may be delays in getting the shirts you want. By mid-November things should be sorted out, hut in the meantime we will have no large sizes and only a few small shirts. We may even run into problems with our medium stocks.

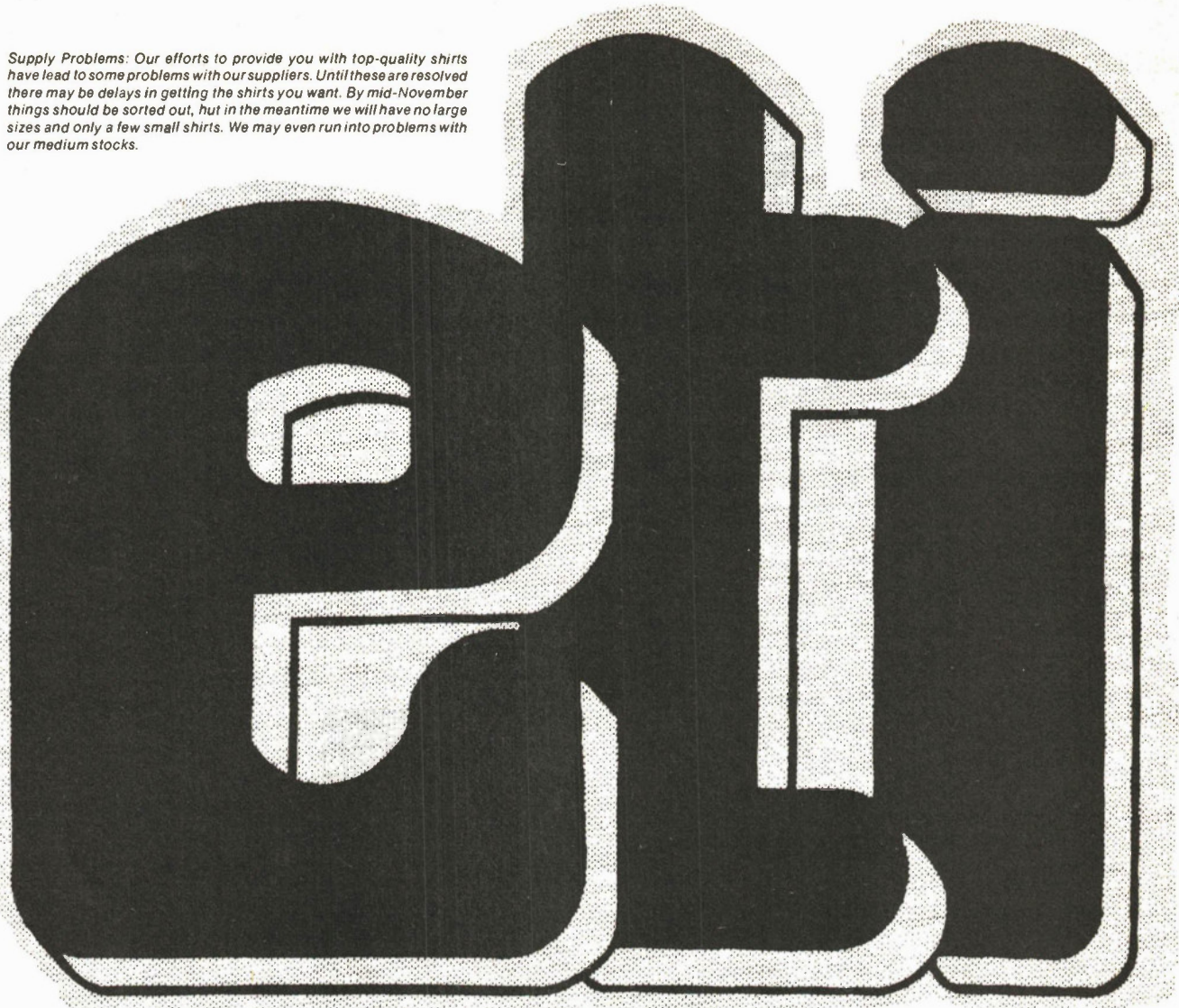

Instructions

- 1) Cut out "eti" graphic
- 2) Hold it up against your/someone's chest.
- 3) Look at yourself him/her in mirror (Mirror not needed for other person) (Imagine background in light blue, lettering dark blue)
- 4) Don't you/him/her look handsome/beautiful?
- 5) Measure hand against scale.
- 6) Use hand to measure chest size. (This may require use of 'add' or 'multiply' functions on calculator)
- 7) Select appropriate shirt size from chart and order ^{of more} one of ETI's quality Canadian-made polyester-cotton T-shirts which are now in our office awaiting your order. These are really sharp merchandise — not cheap foreign shirts that fade and shrink when you wash them. They're nice and long to stop draughts around your midriff and they're trimmed on the collar and sleeves. Colour scheme is light blue with dark blue trim and design.

Fill out this coupon and send to ETIT-Shirts, Unit Six, 25 Overlea Blvd., Toronto, Ontario, M4H 1B1.

Please send me _____ ETI T-Shirts, sizes as indicated. I enclose \$_____.

Number of Shirts	1	2	3	4	5	Ontario Residents add
Price	\$5.50	\$10.00	\$15.00	\$20.00	\$25.00	Provincial Sales Tax



LARGE (40")
 Number required



MEDIUM (37")
 Number required



SMALL (34")
 Number required

Name _____

Address _____

Town _____ Prov. _____ Postal Code _____

DO NOT SEND CASH

Cheque enclosed. A/C No. _____

Bill Mastercharge. Signature _____

Bill Chargex. Expiry Date _____



Thumb

NEWS DIGEST

MPU Interface

Two new series of digital input systems have been introduced by Burr-Brown and are available in Canada from Allan Crawford Associates Ltd.

These new series MP-710 and MP-810 digital inputs are of interest to users of microcomputers where an isolated interface with digital inputs is required. Advantages of the new units include reduced system development time, plug-in compatibility with the microcomputer, ease of programming, and operation directly from the computer power supply.

Each unit provides 24 channels of isolated digital input and protects the microcomputer from voltage transients

and other malfunctions. Because each of the 24 digital inputs is isolated, the voltage to each line is not critical and ground loops are eliminated.

Burr-Brown's MP710 series is electrically and mechanically compatible with Motorola Micro-module and EXORciser microcomputers, while the MP810 series is compatible with Intel SBC, National BLC80 and Intellec MDS microcomputers.

For more information contact Allan Crawford Associates Ltd., 6503 Northam Drive, Mississauga, Ontario L4V 1J2. Phone (416) 678-1500.

Memory and I/O for 8085A-2

Intel Corporation has announced three high performance memory and I/O peripherals for the MCS-85 microcomputer system. The new devices and the recently announced 8085A-2 central processor unit allow the performance of 8085A systems to be upgraded from 3 MHz to 5MHz.

They are: ●8155-2/8156-2. Each contains a 2-kilobit static RAM with 3 programmable I/O ports and a 14-bit programmable counter/timer. ●8355-2. A 16-kilobit ROM with 2 programmable I/O ports.

The 8085A-2, 8155-2/8156-2 and

8355-2 provide a 3-chip microcomputer system that operates 2 1/2 times faster than traditional 8080 based systems. The 3-chip system can replace 10 or more 8080 system components. It operates in a single +5V supply and contains a CPU, 256 bytes of read/write memory, 2 kilobytes of program storage, 38 programmable parallel I/O lines, serial I/O ports, system clock, system controller, multi-level maskable vectored interrupt control and a programmable interval time and event counter.

RCA VIP Color

RCA has announced a new expansion board which will allow its VIP personal computer to provide video displays in eight colors. The VP-590 Color Board, which will retail in the States for \$69 allows the user to select one of three background colors for his display; he then specifies one of eight foreground colors for each sixty-four screen areas. Any bit which is turned on in an area will be displayed in the foreground color, while 'off' bits in the area will display the background color. Both foreground and background colors can be changed at any time.

Software support for the VP-590 will be provided through CHIP-8C, a color graphics language which is upward compatible with the CHIP-8 language used on the present VIP.

For further information, call Rick Simpson at (717) 291-5848, or write RCA Cosmac VIP Marketing, New Holland Avenue, Lancaster PA 17604, USA.

RCA VIP Music

RCA have a new expansion board which will allow the VIP personal computer to generate music. In the US the VP-550 Super Sound Board will retail for \$49. The board is completely assembled and will be sold through RCA industrial distributors and many computer stores.

RCA will also provide a program called PIN (Play It Now) which will allow VIP users to easily transcribe sheet music to play on the VIP, or compose their own music.

The new board allows the user to generate a wide variety of sounds over a four-octave range. Because the user has control over the tone envelope, he can simulate the sound of various conventional musical instruments, such as a clarinet, or create 'new instruments' with unusual sounds.

For further information, call Rick Simpson at (717) 291-5848, or write RCA Cosmac VIP Marketing, New Holland Avenue, Lancaster, PA 17604, USA.

Disk Operating System

Electronic Product Associates, Inc., 1157 Vega Street, San Diego, CA 92110, (714-276-8911) has announced the SDOS as a disk operating system for 6800 microprocessors with at least 24K of RAM and floppy (or other) disk drive. SDOS can support 64K bytes of RAM and any number of compatible disk drives on-line. SDOS can support files on any storage device capable of up to 2.15 billion bytes.

SDOS provides a friendly environment for applications software or development tasks. It supports both random (accessible to the byte) and sequential disk files, device independent I/O, a user customizable command interpreter, and easy tailoring of the disk drivers so that SDOS can be adapted to virtually any disk hardware (so EPA claim). New device drivers can be added, operating with or without interrupts.

New disk files are created automatically as needed. Furthermore SDOS does all space management on a dynamic basis, so files can grow or shrink as desired.

The assembly language interface to SDOS is precisely that of the Software Dynamic I/O package interface, so that all available SD software can be run under SDOS with change.

The command interpreter supports the following commands: LIST, COPY, DELETE, DIR (list names on files), RENAME, and INITILIZE.

The command interpreter allows the user to invoke any program by simply typing its name, including BASIC programs compiled by SD BASIC. Turn-key systems and enhancements to the command interpreter can be built by simply replacing the command interpreter (itself a BASIC program) with the desired application program.

For further information contact: Electronic Product Associates, Inc., 1157 Vega Street, San Diego, CA 92110 Phone 714-276-8911.

Home Computer Courses

Home Computer of Toronto are organising courses for users of the TRS80 microcomputer. The 12 sessions teach BASIC, file handling, and structured programming and design. The class is limited to 20 students and the course fee is \$60. The classes are believed to start this month (November).



Audio Today

Developments in audio reviewed by Wally Parsons

LAST MONTH in these pages we examined multi-amped speaker systems, with particular attention to relative power levels, power distribution versus frequency, and comparisons with single-amped systems. Private conversations on this subject have since revealed not only that much confusion reigns with regard to such matters, but that the subject of power is, in itself, a greatly misunderstood one by many audiophiles, and even some engineers, so this month we'll deal with it by itself.

Simply stated, power is the amount of energy per unit time used in doing work. Think about that for a moment. Usually one thinks of a 50 Watt amplifier as "having" 50 Watts, but what it really has is the capability of delivering 50 Watts of power to a load when conditions demand this power. The load may be a pure capacitance, inductance, a reflected impedance through a transformer, or even the reflected impedance of the acoustical load on a loudspeaker, but whatever it is, it is only delivered as *true* power into a resistance (including a reflected resistance as through a transformer).

CONSERVATION

To understand why this is so, we must realize that energy cannot be created or destroyed, at least in our real world (that proviso is to head off any reader who is into nuclear physics), it can only be changed in form. Thus, a light bulb converts electrical energy into light and heat, an electric motor converts electrical energy into kinetic energy (motion) and heat, an automotive engine converts chemical energy (in gasoline) into kinetic energy and heat, a battery converts chemical energy into electrical energy, and vice versa in the case of a rechargeable type. A

phonograph pickup converts kinetic energy (stylus vibration) into electrical energy (output signal). A microphone converts acoustic energy, which is really a form of kinetic energy, into electrical energy, and a loudspeaker converts electrical energy into acoustic energy, with a kinetic energy stage (diaphragm movement) in between. In every one of these transformations there is some heat, or thermal energy produced, unless the device is 100% efficient, which is never. Some of these energy exchange chains can get very complex: for example, playing an audio cassette in the car involves chemical to kinetic (alternator) to electrical to kinetic (tape transport) joining magnetic (tape) to kinetic (speaker cone) to acoustic, not to mention the transformations which take place in ones hearing system. Even the chemical energy of the gasoline is part of a chain stretching back to a conversion of photonic energy to chemical energy as part of the life process of the plants which form petroleum.

All of this gets summed up in a simple specification such as "Power output: 50 Watts R.M.S."

WHAT IT MEANS

First off, we must understand that amplifiers don't "have" power output, at least in the sense usually meant. Power comes from one of those energy chains described earlier right up to the power supply of the amplifier. And, for all practical purposes, this is where the power comes from, to end up in the speaker. Now this might seem rather obvious after a moment's reflection, but a great many amplifiers are designed and built with close attention paid to output circuitry, while the real power

source is all too frequently ignored. And it's not unheard of for an amplifier constructor to make disastrous compromises in a power supply and wonder why his project doesn't perform to expectations.

So let's take a look at some of the power demands made by signal conditions.

WAVE-FORM AND POWER RELATIONSHIPS

When dealing with DC the power dissipated in a circuit is the product of current and voltage, and follow Ohm's law. If the load is pure inductance there can be no power dissipated in the load because there is no voltage drop; conversely, with pure capacitance there can be no power dissipated because there is no current flow. Only with a resistive load can there be power dissipated. This is also true for AC but for somewhat different reasons.

In Fig. 1 we have a sine wave. When voltage and/or current are rising, power is delivered to the load; for a capacitance, energy is put into the capacitance during the first quarter cycle, and represents an effective current flow, but during the second quarter cycle while input current is falling, energy is returned to the source; for an inductance, energy is put into the load during the first quarter cycle and develops an effective voltage, but that energy is also returned to the source during the second quarter cycle. Hence, no power is dissipated in such loads, and no work is done. Only with a resistive load is energy delivered without being returned, and therefore, work is done. If the *source* (i.e. the amplifier) has any internal resistance, which it usually does, this is the only part of the total circuit in which power is

dissipated, and with a non-resistive load the efficiency, that is the ratio of power input to power output, is zero. Note that this internal resistance is a real characteristic of the amplifier, not the apparent source resistance sometimes specified for an amplifier, and which is usually the result of feedback. Since feedback does not affect power, but only stabilize gain (See "Feedback Explained", ETI Canada July 78). Thus internal dissipation remains the same with or without feedback. And this is one reason why one cannot ignore impedance matching with a low source impedance amplifier, but that's another story.

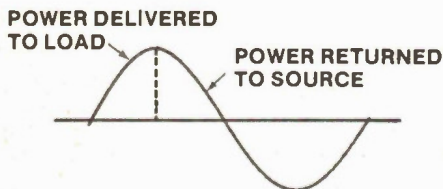

Fig. 1. Sine wave in amplifier.

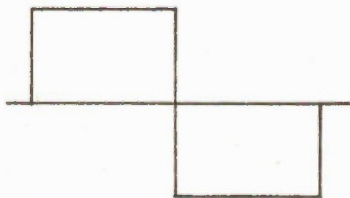

Fig. 2. Square wave signal.

MEASUREMENTS AND RATINGS

DC power is easy to calculate and completely non-ambiguous to specify: $W=EI$ where W = Power in Watts, E = Voltage in Volts, and I = Current in Amperes. Since current and voltage are related to resistance by Ohm's law, power can also be expressed as $W=I^2R$, or $W=E^2/R$. E , I , and R remain constant unless deliberately changed. Not so with AC, including audio signals. As Fig. 1 shows, E and I are constantly changing in instantaneous magnitude, therefore, Ohm's law for power only applies for an instant in time. Therefore, AC power, like voltage and current, is expressed in several ways, primarily "peak", "average" and "RMS" or "effective". Peak power, as its name implies, is the product of current and voltage at its peak; average power is the average of all instantaneous levels through a complete half-cycle. As a power rating, the most useful and meaningful is "RMS" or "effective" power. Remember that power has the

ability to do work, and ordinarily we are concerned with the total work done, not just every milli-second or whatever. Since DC is continuous it is used as a reference. RMS power is the equivalent DC power which would do the same amount of work, which is also why it is called "effective". It is really a statement of equivalency. Mathematicians can prove that there is no such thing as RMS power, only RMS voltage or RMS current, but the system works, which ultimately justifies its use.

What happens if, instead of a sinusoidal wave form we use a square-wave? In terms of work done, it doesn't matter what the polarity is; polarity affects such things as the direction in which a loudspeaker cone moves. Therefore, a perfect square wave represents a source of continuous power, rather than alternating. Therefore, "RMS Power" for a square wave is equal to peak power, and average power. Since a square wave is a lot more like music wave forms than a sine wave an RMS specification also describes more accurately how an amplifier will behave with real programme.

Except when called upon to handle transients. Since a transient may last for a very brief instant it may achieve very high levels without exceeding the power capabilities of the amplifiers --- provided that the voltage level involved is not too high to be handled.

NUMBERS

Earlier it was mentioned that power really came from the power supply, not the amplifier output stages, which simply operate as "current valves". This means that our power supply, to provide 50 Watts amplifier output, must supply 50 Watts to be dissipated in the load, plus what is used up in the output stages, which if efficiency is as high as 50% is also 50 Watts, plus power for other stages. This means a total of perhaps 120 Watts. A 500 Watt per channel amplifier could quite easily cause house lights dimming when driven to full output, and even blow fuses if continuously so driven.

Now, before we examine our hypothetical 50 Watt amplifier, let's look at some relationships.

Peak voltage and peak current in a circuit are equal to 1.414 (square root of 2) times RMS voltage or current. Thus RMS voltage and RMS current in a circuit are equal to 0.707 times peak voltage or current.

Since current is directly proportional to applied voltage (with a resistor-like

load) the above relationships must be squared when dealing with voltage times current, that is, power.

If our amplifier is specified as 50 W RMS output will be 20 V RMS at 2.5 A RMS into an 8 Ohm load. Peak Voltage and current will be, respectively, 1.414×20 V, or 28.28 V and 1.414×2.5 A or 3.535 A. Peak power, therefore, will be 28.28×3.535 , approximately 100 Peak Watts, which equals $1.414^2 \times 50$.

For some reason the notion seems to have gotten around that the magic number 1.414 and its reciprocal, 0.707 are applicable equally to power and voltage. This clearly is not the case. An amplifier with a peak power output of 70.7 Watts is not equivalent to 50 Watts, RMS (70.7×0.707 — figures are rounded out) but to 35.3 Watts, RMS ($70.7 \times 0.707^2 = 70.7 \times .4998$ — also rounded).

The ability of unscrupulous advertisers to use this and other mathematical manipulations is what led to the standardization of RMS ratings in the High Fidelity industry.

What kind of power supply is required to enable our amplifier to flex its muscles as rated without getting a charley horse? Back to the numbers again.

Peak output voltage will be 28.28 V. Assuming a minimum 2 V drop across the output transistors brings this up to 30.28 V. Since this has to be available every half-cycle, for a twin supply this becomes ± 30.38 V and for a single supply it will be 60.56V. Peak output current is 3.535A and since this is delivered in alternate half-cycles it is sufficient. An additional 0.33A is needed to supply the early stages (this is an estimate) for a total of 3.865A. Since this has to come from the power transformer, which may show a 20% power loss, the transformer must have at least a 292VA rating. If one transformer is to be used for both channels we must double this. Since none of these numbers represent standard values, we choose the next higher ratings. Note that if we go to a slightly higher voltage, we cannot accept a lower current rating, because the supply must be capable of delivering the required current.

These figures represent minimum values. There are many possible reasons for using higher supply voltages, for example, which may not increase output capability but optimize for other parameters.

But, in the meantime, isn't it marvellous what can be done with Ohm's Law?

Audio Today Products

Audio developments reviewed by ETI's Contributing Audio Editor Wally Parsons

Lectrotech

From LECTROTECH Inc., 5810 N. Western Ave., Chicago, Ill., 60659, comes news of the model PPI-400, Peak Power Indicator, which monitors peak power output of amplifiers. It can custom program 0 dB to any power-impedance combination between 3.13 Watts to 1250 Watts. A front panel switch provides for 18 other power level-impedance combinations.

It uses coloured LED's as power level indicators, and claims a response which is instantaneous.

Price unknown.

Accu Update

In the September issue I mentioned the ACCU models 10 and 12 loudspeakers made in Canada. I am informed that since publication of data the manufacturers have seen the futility of using electrolytic capacitors in the cross-over network, and have abandoned the practice. I had a chance to hear them, although not for an extended period of time and was quite pleased. It's really nice to see someone take a basically simple design and get the most out of it. Also on hand was a design of cast ceramic. Very non-resonant. And heavy.

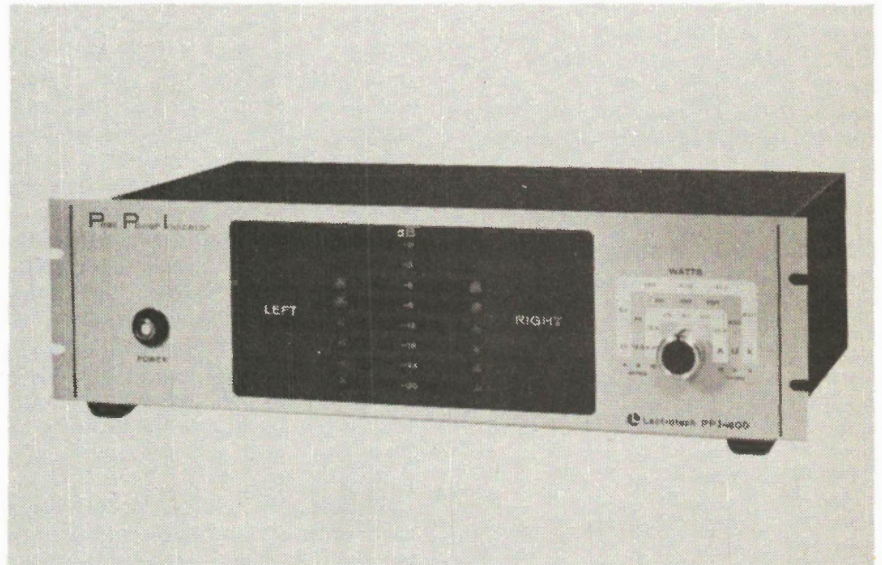

Audio Today Letters

If you want to express your views or report on news write to Audio Today, ETI Magazine, Unit Six, 25 Overlea Blvd, Toronto, Ont. M4H 1B1.

Jensen Triaxial[®] 3-way Speakers

Quite simply, the most advanced car stereo speaker ever.

For the best sound ever in your car. The first car stereo speaker with a woofer, a tweeter and a midrange.

Identical in principle to the best home stereo speakers. Jensen's midrange picks up a whole range of tones lost to any other car speaker.

Write today for Free catalogues and the name of your nearest Jensen Dealer —

len finkler ltd

25 Toro Road, Downsview, Ontario M3J 2A6
Telephone (416) 630-9103 Telex 065-24010

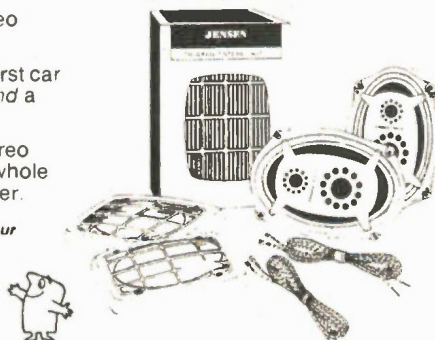

AES

Can you please convey to me information regarding the "Audio Engineering Society" of Toronto.

I have been involved with audio for about 10 years now, and would appreciate any information regarding membership that you pass on to me.

J. D. J., Belleville, Ont.

The Audio Engineering Society is an international organization headquartered in New York city and organized along continental lines, and in Canada and the U.S.A. divided into regions, each with city based chapters. At present the only chapter in Canada is the Toronto chapter, part of the Eastern Region. At one time there was a Montreal chapter but it, alas, has not survived. Meetings are held monthly in

Toronto, except during the summer months and an annual dinner usually in February. During the past year several meetings were held jointly with the Toronto chapter of the Society of Motion Picture and Television Engineers (SMPTE) which proved to be mutually beneficial.

I've passed your name and address on to the Toronto secretary, and you should receive a brochure and application form in the mail.

Other interested readers should write to: Doug Loney, P.O. Box 423, Station "J", Toronto, Ont. M4J 4Y8, or, if you wish, write to me at ETI and I'll pass your name along.

If we get enough new members outside of Toronto, maybe we can start up some new chapters. I know you're out there. How about it, you people in Kitchener-Waterloo, Vancouver, St. Johns, etc.

You don't have to be a certified engineer to be eligible for membership, although we won't hold it against you if you are. Main requirements are either a degree, or an equivalent knowledge gained through experience in the audio field. Essential is an active interest in audio.

There are three basic grades. The above requirements are for full membership. Associate membership is open to anyone with an active interest in audio, but does not require technical expertise. This would include many audiophiles, hobbyists, and I should think any regular reader of this column would be eligible for one or the other grade.

There is also a Student grade open to anyone interested in audio engineering and enrolled in a recognized school, college, or university.

All grades are entitled to all rights and privileges except the right to vote, hold office, or serve as chairman of a standing committee, which are reserved for full members.

Incidentally, the monthly Journal to which all grades of membership are entitled is one of the best technical publications available.

And then there are the Conventions.

Junkie

You have a devoted ETI junkie in your truly. You can fix me up for a while by publishing a project on how to interface the FM Tuner of May '78 with a Digital Frequency readout. Anyhow, someone sooner or later will write to ask you to print the real specs on the tuner so they can be compared with showroom models. I'm not asking, but I am curious. Best of Luck and thanks.

D. McB., New Hamburg, Ont.

I presume you have built the tuner yourself. So why not run specs on your own version and let us know the results. It would be worthwhile comparing your results with those of other readers. This applies to all projects. This is also true of any improvements which any reader feels he or she has made on the original. Unlike some of the American magazines which give projects wrapped up and tied with a ribbon, the whole

point to ETI projects is **not** to compete with commercial manufacturers but to provide a forum for the dissemination of knowledge and to encourage experimentation and construction, the basis of experimentation. Projects are often chosen for the specific reason that they illustrate a novel way of accomplishing a particular end, or an application of a new device. Experimentation, that's the name of this game.

Music Synthesizers

In your June 1977 issue you had an interesting article entitled "Digital Sound Synthesizers". At the end of this article the author hints at a possible follow-up, perhaps from a more practical point of view. I would be in favour of this and in fact would enjoy reading any article on the subject of sound synthesizers in your magazine.

In closing, I would like to say I enjoy reading and re-reading all of your issues.

S. de M., Montreal

Hope you will come up with a good music synthesizer circuit in the near future. It

appears that the introduction of your magazine in Canada has started a few fires to smoke.

Keep up the good work on Canada's number one magazine.

D. M., City Unknown

Just call us "Firebug, Canada". Alas for good intentions, individual projects sometimes take longer getting off the ground. For example, I've been working on an amplifier project for several months. No technical hitches, just things getting in the way. But there does seem to some interest in Music Synthesizers, so possibly in the future. How's that for a definite answer?

Incidentally, response has been especially good to some of my loudspeaker items, showing especially an interest in transmission lines. Possibly I might do a feature on loudspeaker design, construction, and related matters if there is enough reader demand. So, gentle readers, how about it? What, if anything, would you like to see on this subject?

N E X T M O N T H ' S E T I

V I D E O

We have two articles about video — one about getting into video as a hobby, using 'surplus' equipment, etc, and the other about the circuits used in video recorders and how they affect servicing techniques. We plan to start both these articles in December ETI, and it is likely there'll be more to follow in subsequent issues.

D E S I G N I N G O S C I L L A T O R S

That's it. An article about designing oscillators.

P R O J E C T S

Something for everyone. The audiophile will build our TAPE NOISE LIMITER (it works like an automatic tone control, turning down the treble on quiet passages). The digital man will like our EPROM PROGRAMMER, and outdoor types will find a use for our DIGITAL ANEMOMETER.

P L U S

Lots more. The usual columns for the serviceman, the SWL, the audiophile, the ham, ... Humour from Geiger. News. Comment. Advertisements

SAVE!

Repairs to Calculators
All Makes and Models

*HANDHELDS

Non Rechargeable

Flat Rate @ 10.00

*HANDHELDS

Non Scientific Rechargeable

Flat Rate @ 15.00

*HANDHELDS

Scientific Flat Rate @ 25.00

Complete Overhaul
on all Handhelds

*DESKTOPS/PRINTERS

Labour @ 25.00 Flat Rate

Parts Extra

- Free Estimates Available
- Maximum 1 week Service
- Add 2.50 to Above Prices For Handling & Mailing.

* Dealer Inquiries Invited

Ocean Electronics Ltd.

3992 Chesswood Drive
Downsview, Ontario M3J 2W6
Phone: (416) 630-0873

SEMICONDUCTORS

PROCUREMENT PROBLEMS?

LOOKING FOR SPECIAL
SOLID STATE DEVICES?

**Hard to Find Replacements
for Unknown Custom Parts Number**

Standard Electronics has the answer

World's Largest Supplier of
Original Japanese Semiconductors
Outside of Japan.

One source for more than 50 semi-conductors brands including; Motorola, National, ITT, Sprague, G.E., Litronix, Siemens, AGS/ATES, Mfg. of the new "MES" line of semi-conductors replacements, (exact equivalent to Sylvania's ECG) but at lower prices.

For complete Catalogue and Price List send a Money Order of **\$2.25** (includes postage).

C.O.D. Orders are Welcomed
(Minimum \$25.00)

You can obtain a free catalogue with your name & address printed on your own letter head.



STANDARD ELECTRONICS
2 WILSON SQ. 2E
MONTREAL, QUEBEC H3T 1K6
8927 boul. Pie IX, Montreal, Que.
tel.: 327-3578
327-5958 Télec: 05-828838

You can write for ETI



75 cents per word

ETI's new classified advertising section allows you to reach 30,000 readers nation-wide. For as little as \$15 (there's a 20 word minimum) you can promote your business from coast to coast.

WHAT DO YOU DO?

Send us your typewritten or clearly printed words, your permanent address and telephone number, and your money (no cash please). Make your cheque or money order payable to 'ETI Magazine'. We're at Unit 6, 25 Overlea Blvd, Toronto, Ontario, M4H1B1.

There's no charge for including your postal (or zip) code. If you want to test reader reaction you can include 'Dept. ETI' as part of your address (free of charge).

WHAT DO WE DO?

We typeset your words (and put the first word and your company name in bold capital letters).

If we get your message by the 14th of the month, it will appear in ETI 1½ months later. For example, if we receive it by November 14th, you (and thousands more) will see it in the January issue.

Bally Arcade: More Than Fun

The Arcade is part of a new wave of machines. But who's it for? Graham M. Wideman and Mark J. Czerwinski report.

IT HAS BEEN several months since we have looked at the "popular" computer scene, and as expected the aim of some of the new products has moved still further toward the "consumer". In other words, companies are looking for bigger and bigger markets, to people who have (initially) less and less knowledge or experience of computers.

It was a couple of months after our February review that the Commodore PET was finally approved and offered for sale in Canada. Already there are a number of active and enthusiastic PET user clubs. The accessories and adjuncts also are now coming available.

Meanwhile, at the Radio Shack camp, the TRS-80 (basic model reviewed in April) has also been available for some time, and is on display at numerous Radio Shack outlets. This machine can be had with or without the much improved BASIC language version known as "Level II". An extensive collection of accessories present and

future strengthen Radio Shack's computer line.

Upon reviewing these two machines, we were aware that they were a new step in microprocessor based computers, in that they required no hardware knowledge and allowed the owner to start with nothing more than the willingness to learn about BASIC. A big part of this was the fact that these machines have BASIC language built in (in ROM) so there's no time consuming loading of the BASIC interpreter off cassette, nor the agony and heartbreak of BASIC bomb-out due to a bug in your program. For anyone familiar with the earlier hobbyist (fanatic!) computers, this is real luxury!

The general public is at least becoming aware of these small computers, as the PET may be seen at several department stores, and the TRS-80 receives national TV advertising publicity.

But will this attract the big market? How far can you go towards the

consumer to get him to buy a computer? With these questions in mind we were very interested to see the Bally Arcade.

THE ARCADE ITSELF

The least you can buy is the Bally Arcade "box", which on the outside has a calculator style (and labelled) keyboard (Fig. 1), a slot for a Bally cassette (Fig. 3, more on this below), and on top a rack for storing such cassettes. On the back are a number of sockets for plug in accessories. Included with the unit are two hand controls. From the back of the unit also extend the cables for power cord and output to your colour TV's antenna input.

So what can you do with this unit. It may sound initially like a disappointment at \$599, but this unit as is enables you to play 3 video games and to use the machine as a four function calculator with TV display. We have to say however that they are pretty



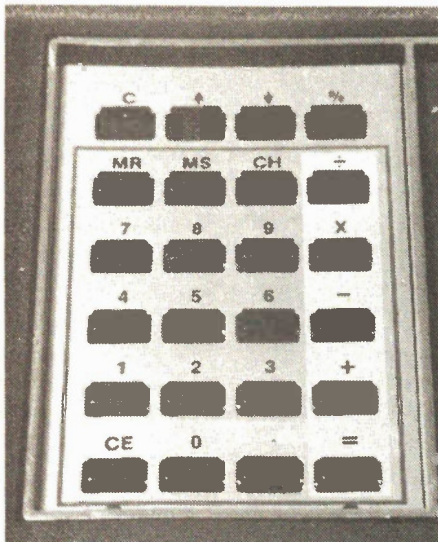
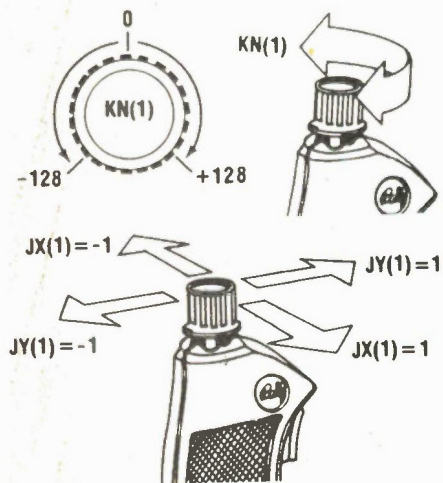

Fig. 1. Calculator style keyboard is labeled with calculator functions. Arrows scroll display.



Fig. 2. One of two hand controls supplied with Arcade. Sockets on machine accommodate two more.



amusing, interesting and skill testing games.

We spent hours with our favourite, "Gunfight", where two six-shooter equipped cowboys march onto the screen to the tune of "Home on the Range", and then each player with hand control walks his man around the screen shooting at each other. (Realistic gun sounds). Various obstacles appear in subsequent shoot-outs, cacti, trees and a wagon. The graphics and action are quite good, with varying gun angle, and bits of cactus and tree which can be shot off. More tunes are played if one cowboy hits the other, (who falls dead on the ground).

This and the other games, apart from being entertaining, demonstrate the machine's ability to produce four colour graphics, and play tunes, both of a nature very sophisticated in comparison to simple video games. One of the games in fact allows you to change (using the keyboard) each of the four colours to others.

The calculator feature was not very impressive, being a simple four function model (10 memories, floating point). It does allow you to see the preceding steps (about 100) of your calculation like a printing calculator, which is good if you don't need the actual paper. One distressing point was that there is no minus sign to indicate a negative number, it simply turns from black to red, which is not so useful if you have a black and white TV. However, it does firmly tell the user that this is not just a video game.

THE "CASSETTE"

So far we haven't stretched the capability of the micro-processor yet, so let's look at an as yet unused feature, the "cassette". It is not an audio tape cassette, but a similar looking package, which contains up to 8K of ROM (permanent memory), and has a row of contacts along the edge which connect to those in the cassette slot. (Fig. 3) This is quite a clever concept, in that the public is already familiar with audio cassettes of similar shape, and does not have to be introduced to a new plugging idea.

A wide range of games cassettes are or will be available at \$34.95, with such appetite whetting names as "Desert Fox", "Space Race", and "Red Baron" (represented on our cover), "Backgammon" and some "educational" games like "Spell'n'Score" and "Crosswords".

However, the most interesting cassette is the one that allows you to

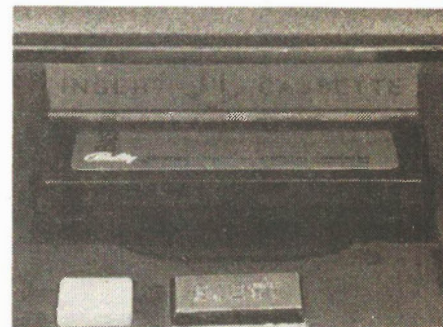
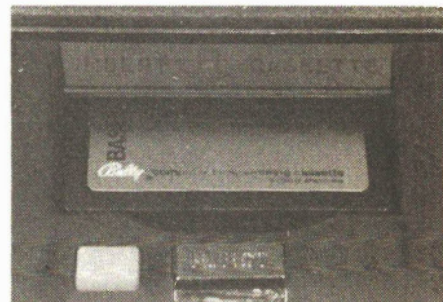

Fig. 3. Just stick it in and pop it down.



program the machine in BASIC language, price \$99.95.

BALLY BASIC

This is not a language for the serious programmer, since in the way of numbers it will handle integers only, up to about 33,000. However, it does include the familiar set of BASIC functions which enable the user to become acquainted with programming. The most important aspect here is motivation, and the user will find this, as Bally has made manipulation of the inputs, sound and graphics quite easy.

Hence the new programmer can quickly be designing his own games, "video art", accompanying tunes, and some graphing etc. The BASIC instruction book is quite comprehensive and gentle in its explanations, and has numerous examples and entertaining programs.

The programmer has available 1800 "memory locations", 26 integer variables (A-Z) and one array called @. While there is no real character or string variable one can fudge it. An attempt to store a character (enclosed in quotes) in the @ array results in its ASCII code value being stored. Hence @(1) = "1" results in @(1) equaling 49. To recover the letter however you would have to write a program with lots of IF statements to decipher the section of the @ array which you know is supposed to be characters.

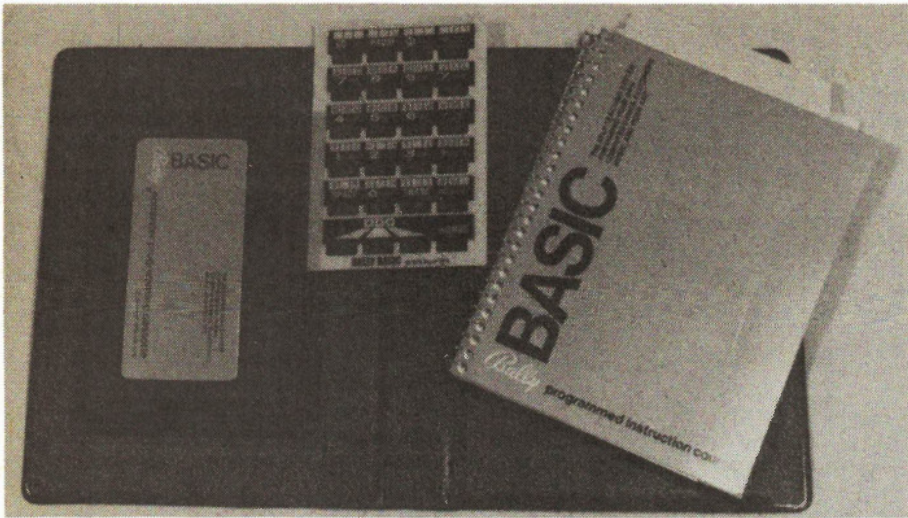

Fig. 4. BASIC pack includes "cassette", overlay, and booklet plus genuine vinyl case.

explaining some of the "machine variables". To input from a hand control, simply look at the values of JX, JY, TR or KN, which correspond to the joystick, trigger, knob positions. To pick the colours for the screen you set BC and FC from 1 to 256 to select the "background" and "foreground" colours. (Only two colours available when using BASIC) To draw on the screen you can write a dot, line or box using only one statement to specify its position, size, and colour. (Fig. 6)

While this is quite a respectable capability, it won't allow you to program games as complex graphically as the Bally has built in, due to speed and memory constraints.

Fig. 5. BASIC overlay on keyboard shows functions and instructions available.

BASIC IN USE

The BASIC kit includes an "overlay" which fits over the keyboard to tell you its new functions. Just as a typewriter has two "cases", the keyboard now has five cases, with the bottom row used when selecting one of four "upper" cases. Referring to Fig. 5, the numbers (and similarly positioned functions) may be obtained by simply pressing that key. The functions such as FOR, TO, NEXT, GO TO etc are obtained by first pressing "WORDS" then the appropriate key. The letters and characters in the white boxes above each key are actually coloured, and are obtained by first pressing the same coloured button at the bottom next to the "WORDS" key.

Needless to say, this keyboard is cheaper than a full keyboard, and can be faster, in that only 2 keystrokes are required to enter something like "LINE" or "STEP" and so on, but it can get confusing. You can of course always see what you've entered since it's on the screen, (and when you push one of those other four buttons the screen changes to that colour!) If you make a mistake you can "backspace" over characters in the same line, but to go back and change a line already entered you'll have to retype the line.

There are two other buttons on the Bally, RESET and EJECT (cassette). You don't want to hit either of these after you've entered a program, otherwise agony! We found the EJECT button much too easy to accidentally brush, perhaps Bally could supply a piece of cardboard to stick over it.!

GRAPHICS

The very best part of this BASIC is the easy interfacing, best described by



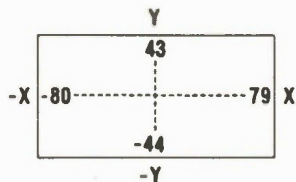

Fig. 6 For graphics purposes the screen is divided into 88 x 160 squares.

SOUND

As each character is printed on the screen a note plays from the TV's speaker. The note varies with each character, may be raised or lowered by an octave using the multiply and divide signs, and made sharp or flat with the plus and minus signs. (Fig. 7) A simple PRINT statement with a series of numbers and signs plays an interesting tune. "Rests" are available, and the note speed can be varied using the machine variable NT. NT however also varies the print-out speed, so don't set it too slow while you're programming or you may never finish. It's initial value is quite satisfactory.

Now, to a musician this doesn't sound like a lot of capability (it's more than enough for punk rock). It's surprising how good it does sound, though, and the simplicity contributes to learning about sound and music. But please Bally, give us some nice satisfying gun and explosion sounds!

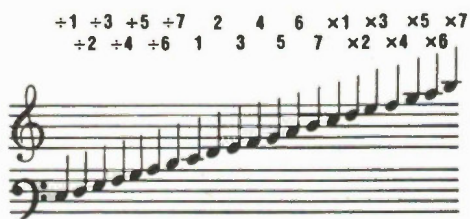

Fig. 7. The numbers corresponding to the musical scale.

AUDIO CASSETTE

In order to store programs for long periods of time the user can purchase the BASIC audio interface to allow recording and retrieving with an ordinary cassette recorder.

HARDWARE

We took our review unit apart (carefully!) and here's what we found inside. Heart of the Arcade is the powerful Zilog Z80 microprocessor (actually Mostek's version: 3880). This is accompanied by 8K of ROM which stores the games, and 4K of RAM which mostly acts as the screen memory. Although the cassette pack is reportedly capable of containing 8K of

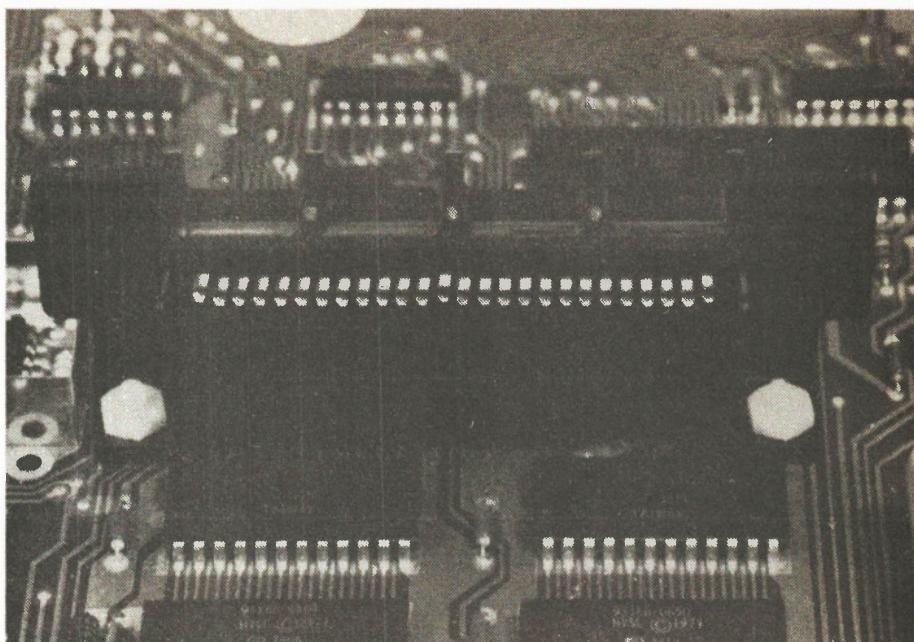

Fig. 9 Cassette socket attached directly to the board.

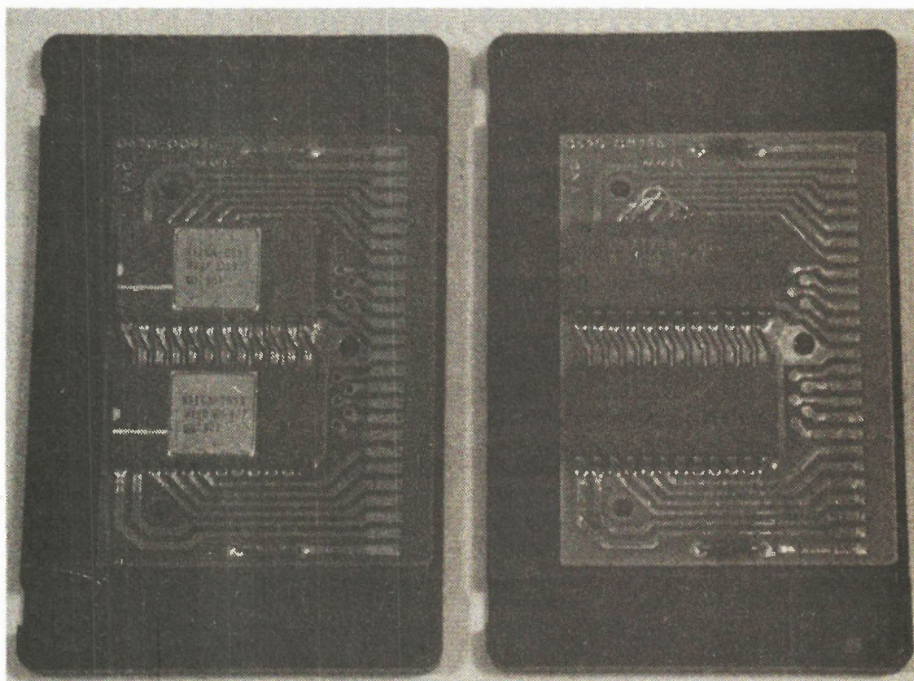

Fig. 10. BASIC cassette exposed.

additional ROM, ours appeared to have only 4K (Fig.10). When the BASIC cassette is in use, half of the 4K RAM is used for program storage, which means that only half as much screen memory is available explaining why only two colours are available to the programmer.

The various support chips are described in Fig. 8. Of special note is the "music processor" chip, which generates the musical tones of the chromatic scale from a single master oscillator.

As shown in Fig. 2 the hand controller gives 3 types of control: trigger, rotary, and "joystick". The trigger is simply a switch; the rotary control is a potentiometer; and the joystick uses four switch contacts, one each for 0, 90, 180, and 270 degrees, and pairs of those contacts used for the intermediate angles 45, 135, 225 and 315 degrees. We found that a little surgery with pliers was required to get all the intermediate angles to work properly, but this was probably due to the hard use that the demo unit had

If it feels like somebody else is making all the money, maybe it's time you looked at NRI home training for TV and audio technicians.

No matter how hard you try, there are some jobs that just seem to go nowhere. And others so monotonous, they drive you up the wall. While all around, you see people enjoying what they do and making a good living at it.

NRI Can Set You Free

There's a way out of the rut. NRI home-training in TV and audio servicing. At home, in your spare time, you can learn to become a TV electronics technician. Qualified to hold down a good paying job as a serviceman or troubleshooter. Even start your own full- or part-time business. And you learn at your own pace without quitting your present job.

Learn by Doing, Actual Bench Experience

NRI is more than book learning. Sure, we give you all the fundamentals and theory. But it's reinforced with practical experience every step of the way. In our Master Course, you build actual electronic circuits and test them. You construct a 4-channel audio center, a 25" diagonal solid state

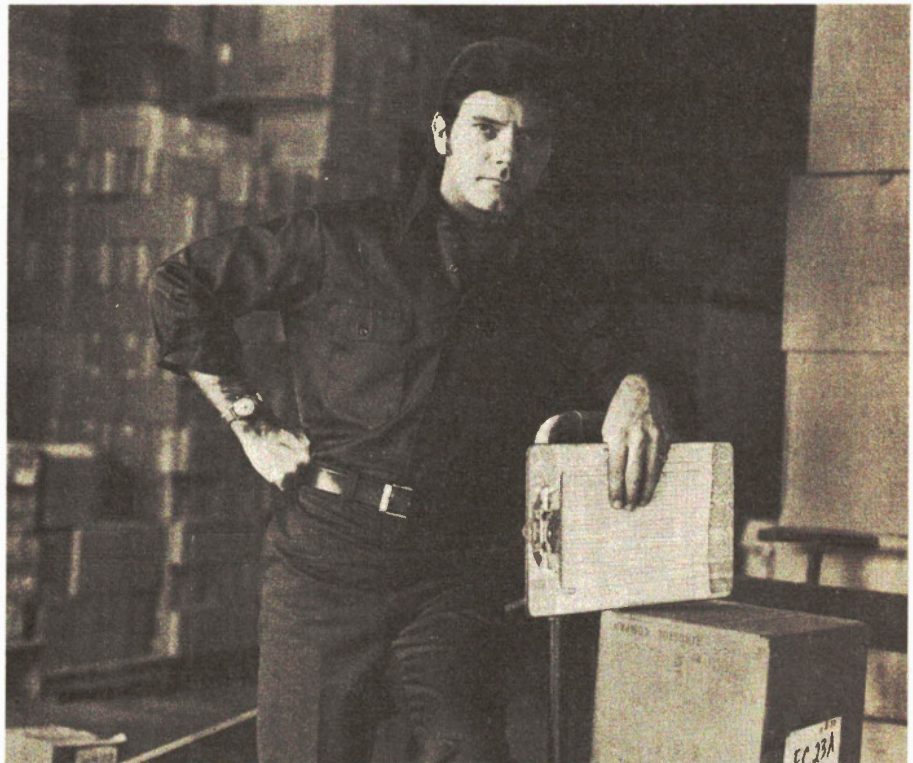

color TV, introduce and correct typical service problems. You even assemble test instruments that you use for learning and earning.

Your equipment includes a transistorized Volt-Ohm Meter, TV color pattern generator, advanced design 5" triggered sweep oscilloscope and CMOS digital frequency counter... the basic tools of the pro. In addition, you build the 4-channel audio center and 25" color TV while performing more than 120 in-set, power-on experiments that give you real bench experience while you learn.

Ask the Professionals

A documented national survey confirms for the second time that almost half the professional TV servicemen have had home-training. And among them, they recommend NRI as first or only choice by more than 3 to 1! That's because NRI training works, as

it has for 63 years and more than a million students.

Send for Free Catalog... No Salesman Will Call

Get all the facts on how NRI career training can mean new opportunities for you. Send for our free catalog describing lessons and equipment, other courses in digital computer electronics, CB radio servicing, communications, and more. No salesman will call. Mail the postage-paid card today and see if you can't make more of yourself in this wide-open field. If card has been removed, write to:



NRI Schools
McGraw Hill Center for
Continuing Education
330 Progress Avenue
Scarborough, Ontario M1P 2Z5

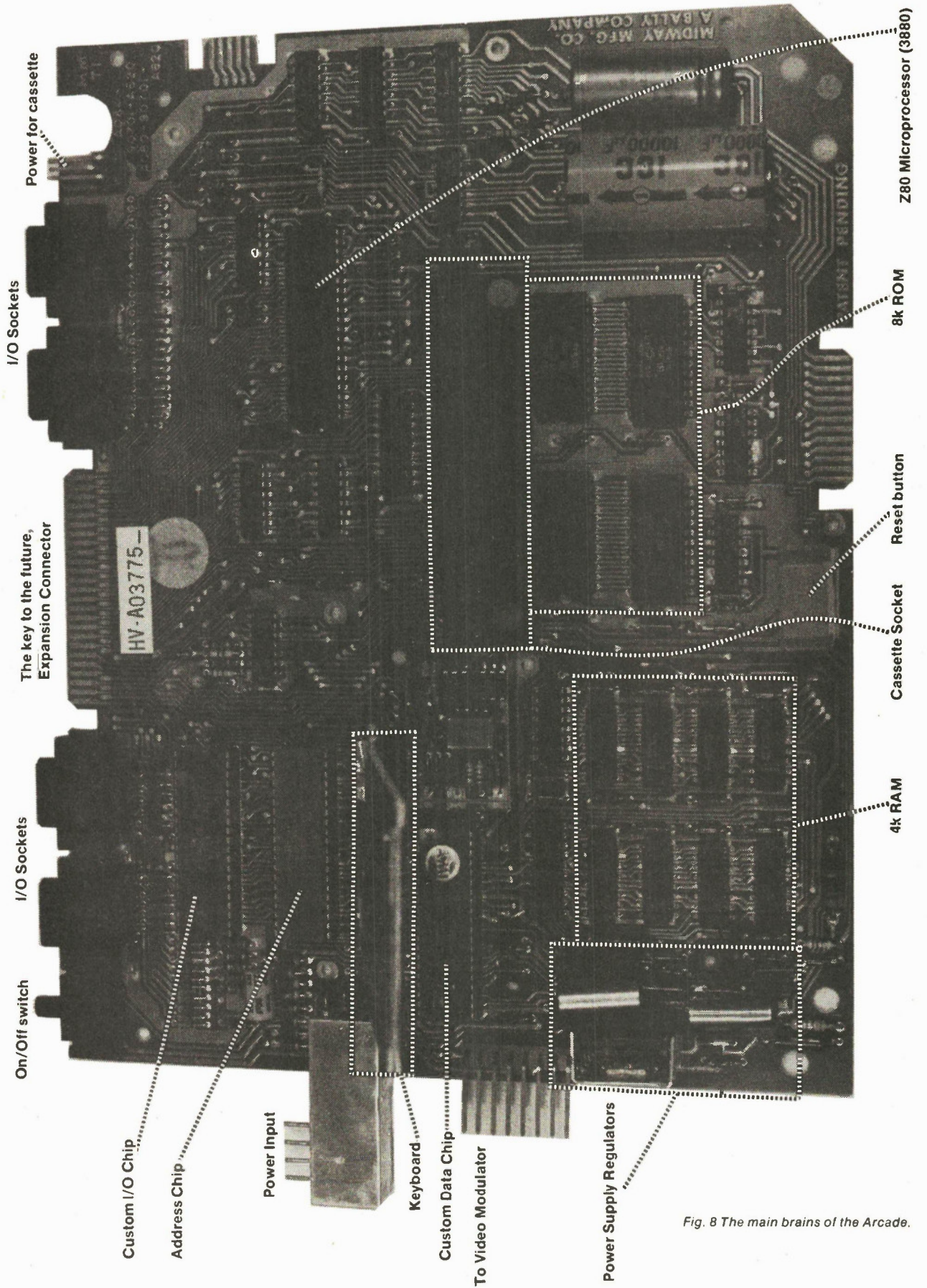

Fig. 8 The main brains of the Arcade.

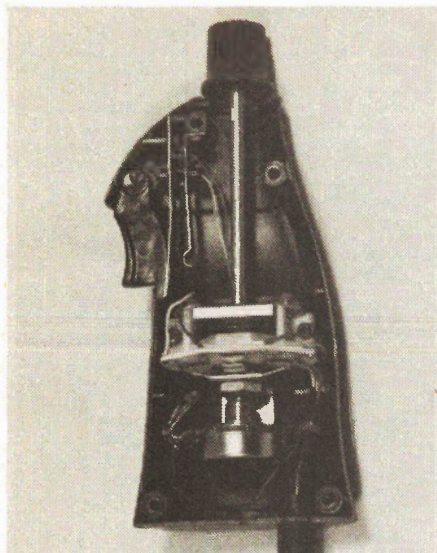

Fig. 11. Open hand control shows trigger switch, pot and four way joystick switch module.

received. This is not a high quality precision control by any means, but it certainly works, and hardware enthusiasts will easily be able to use their own switches and pots for other input applications. (Fig. 11)

WHAT'S COMING

What's available so far appears to be only the iceberg tip. The first upgrade

will be a proper keyboard box, which will reportedly include an additional Z80, more RAM, and ROM containing a "serious" BASIC version. Interface for 2 independent screens and IEEE 488 bus is also being talked about. This is apparently to be introduced in January 79. Also coming are a printer, telephone interface, light pen and floppy disk. Do these sound like add-ons for a video game?

It's pretty obvious that the Bally Arcade is in a new class of product, and will be the most "vertically" extensive product line we have seen so far. The machine has the capability to endear itself to all ages and familiarity-with-computer levels. Once the person is interested they will feel the desire to expand the system and not be afraid to dabble in programming, with the basic BASIC. After some confidence has been obtained with the concept of programming, the user might be encouraged to move up again to the keyboard expander box and advanced BASIC. This is a much more "expand-as-you-learn" approach than the kind of expandability of early home computers, where you had to be pretty knowledgeable to start, and expand as boards became available.

In fact, a learning experience is what the Arcade is all about, not just in

programming, but it is an intriguing exercise in music composition (albeit quite simple), and in colour graphics it provides a no mess, no manual skill artistic tool.

WHERE

The Bally Arcade should start to appear in October 78. It is distributed by Paragon Enterprises, through Zenith Radio's dealer network and also through large department stores. Calculator shops may also be interested, Marketron is already planning to handle the product.

COMPETITION

If this market is going to be big, you can be sure that Bally aren't the only people who thought of getting into it. We have sketchy details of two other possibly similar products being announced in the US (where the Bally Arcade sells for \$300). Magnavox has its "Odyssey 2", which has a full touch keyboard and two joysticks, and a plug in cartridge system. It does not appear to have programming capabilities however. Meanwhile there's a home computer from Interact, again with full keyboard, colour display output, but this time with an audio cassette unit built in; US \$499. Finally, Atari is rumoured to have something in the works. Even if it wasn't rumoured you can bet they have.

NEW FROM

**Bally's
 Professional
 Arcade™**

*with a built-in
 sophisticated 5-function,
 10-memory capability*

For more information about the Bally Home Computer fill in the coupon for the location of your nearest ZENITH dealer.

Dealer inquiries invited.

This Bally Brain microprocessor "memory bank" holds over 12,000 instructions, even before a cassette is inserted. It already "plays" such popular games as CHECKMATE, GUNFIGHT and SCRIBBLING. In addition, the CALCULATOR with scroll button and entry correction can help the user reconcile bank balances, compute taxes and do other home bookkeeping jobs.



Name _____
 Street _____
 City _____ Prov. _____ Code _____

Mail to: Home Computer Zenith Radio Corporation of Canada Ltd.
 1020 Islington Avenue, Toronto, Ontario, M8Z 5X5

CANADIAN PROJECTS BOOK NO. 1

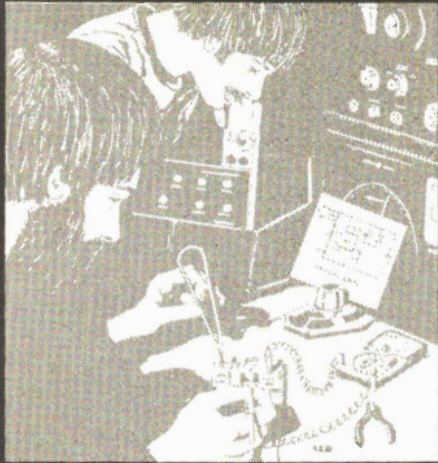

- | | |
|-------------------|-------------------|
| 5W Stereo Overled | Fuzz Box |
| Bass Enhancer | Mastermind |
| Disco Modules | Reaction Tester |
| Metal Locator | Burglar Alarm |
| GSR Monitor | Injector-Tracer |
| | Digital Voltmeter |

HEART-RATE MONITOR

By clipping an illuminated bulb to one side of your ear-lobe and clipping an LDR to the other side, you can monitor the changing translucency of the tissue as blood spurts through the blood vessels. The signal from the ear-lobe detector is cleaned up and squared off and then fed to a frequency-to-voltage converter which, after buffering, drives an analogue meter. This project is not meant for use as a serious diagnostic instrument. It can be used by those experimenting in biofeedback or by sportsmen in training.

DOUBLE DICE

A project to get you started in CMOS digital electronics. A decade counter is made to divide the output from an oscillator by six. The dice rolls while a button is pressed and continues to roll (now slowly) for a short while after release. Consumption from the battery is so low that we use no on-off switch. The results are truly random.

TOUCH ORGAN

What's so neat about this project is that it is all on one PCB. Twenty-seven touch-switches are laid out on the copper side of the board to give a full two-octave keyboard and tremolo switch. There are two voices available, and a volume control. The project is easy to build, uses 12 ICs and runs from a 9V battery.

PHASER

The effect of the phaser or phlanger will be well-known to readers who are interested in popular music. The ETI phaser achieves the desired effect by splitting an audio signal into two paths and re-mixing the components after one has undergone a phase change. This change takes place in six RC networks, each capable of 180° shift at high frequencies. This gives a comb-shaped response (3 minima) for the unit as a whole. The characteristic whooshing sound occurs when we change the resistive elements of each RC section (using a 4049 as six sets of complementary FETs) under voltage control from a triangle-wave oscillator.

AUDIO LIMITER

This stereo device uses a 4049 CMOS hex-inverter IC to provide enhancement-mode FETs for use in a voltage-controlled attenuator circuit. The project can be used to limit audio peaks to prevent amplifier clipping, to reduce the dynamic range of a signal for recording, or as a voltage-controlled volume control for remote or automatic operation.

SOUND-LIGHT FLASH

This project senses a change in light or sound and, after a predetermined delay, operates a photographic flash unit. You can photograph glass shattering, any violent impact, splash, clap, explosion, etc.

Please fill out the card and send to: **ETI Magazine**
Unit 6, 25 Overlea Blvd., Toronto, Ontario, M4H 1B1



THE PET \$1190.00

EXTENDED WARRANTY 1 YEAR \$50.00
(PARTS AND LABOUR)

CENTRONICS 779-1
MICROPRINTER
\$1537.00

WHAT YOU GET WHEN YOU ORDER A PET FROM HOME COMPUTER CENTRE

- PET comes complete with two programs and easy to follow instructions.
- Three business programs on cassette.
- 5% discount on most of the PET peripherals.
- Before Christmas only: 20C-10 blank cassettes. Special program for Christmas.
- Instruction books, Commodore bulletin, and our PET product catalogue.

CHARGE X, MASTER CHARGE VISA ACCEPTED

COME AND SEE US AT THE CANADIAN COMPUTER SHOW!
NOVEMBER 28, 29, 30 INTERNATIONAL CENTRE



HOME COMPUTER CENTRE

(416) 222-1165

Computers for Home & Small Business

222-1166

6101 YONGE STREET, WILLOWDALE, ONTARIO M2M 3W2, CANADA

PET PERIPHERALS

All items listed below are available from our stock now unless otherwise indicated.

CENTRONICS PRINTERS

Interface	100.00
Cable to Printer	35.00
Selectric Interface	315.00
Centronics 779-1	1,537.00
Centronics 779-2-with tractor feed (60 Days ARD)	1,650.00

COMMODORE PRINTER

Pet Printer (available soon) 995.00

PET TO OTHER PRINTER INTERFACE

PET RS-232 Adapter	
ADA 1200 B (BASIC)	142.85
ADA 1200 A (COMPLETE)	245.05

STANDARD ASCII KEYBOARD TO PET INTERFACE

Excel Keyboard Adapter	103.95
GRI Keyboard and enclosure	131.88

EXTERNAL

PET MEMORY EXPANSION	
8K Memory (S100 bus)	315.00
16K Memory (S100 bus)	250.00
16K Memory (S100 bus)	600.00
PET SECOND CASSETTE FROM COMMODORE	120.00

PET S100 BUS EXPANSION

BETSI (KIT)	152.25
BETSI (ASSEMBLED)	234.79
HUH MPA (KIT)	279.95
HUH MPA (ASSEMBLED)	363.95
PET SECOND CASSETTE CONNECTOR	2.75
PET USER PORT CONNECTOR	4.50

OTHER PET PERIPHERALS

PET to T.V. (Video Buffer)	41.95
PET to T.V. (Complete)	83.85
Beeper	34.95
PET Audio (PETUNIA for Music)	41.95
Combo 1 (Video Buffer and Petunia)	79.95
Combo 2 (Plus RF Modulator)	103.95

PCM Explained

Don Rost discusses how pulse modulation gives you the long distance feeling.

IN THE 19TH CENTURY certain transmission experiments were performed that involved the coding of speech and music into digital electrical signals using telegraphic techniques. The experiments weren't too successful but these were actually early attempts at *pulse code modulation*, a technique that is much used by the telecommunications industry and recently by recording and audio firms. The basic principles outlined here particularly concern the telephone industry but they are basically the same for most PCM systems.

One of the real problems in telecommunications has been noise and crosstalk (a type of noise induced from adjacent channels), problems that are costly, difficult and often impossible to eliminate using analog transmission methods. Because PCM uses digital signals not dependent on signal amplitude, these problems are eliminated to a high degree.

TIME DIVISION MULTIPLEXING

Suppose as in Fig. 1 there are three separate phone signals, on three separate "channels," and they are transmitted to their respective destination each down a pair of wires. Further, suppose that these three calls are being made from two cities located 40 km away from each other.

It would be nice if just one cable pair could carry all three calls instead of three separate pairs. There have been different analog techniques for doing this, the one we will concern ourselves with, because it leads us to PCM, is called *time division multiplexing*. We are still talking analog, the speech signals vary in amplitude as the persons are talking. By sampling portions of these signals at regular intervals all three signals can be broken up and sent along the same transmission line. This is illustrated in Fig. 2.

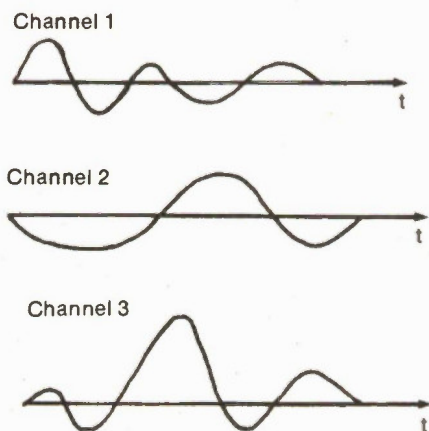

Fig. 1. a. Examples of three signals on separate channels.

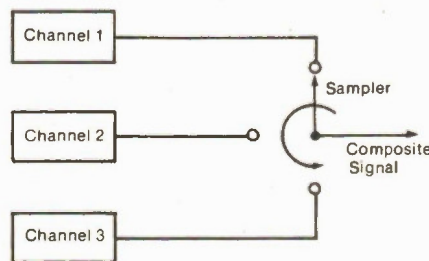

Fig. 1. b. Three channels multiplexed onto a single line by a sampler, here represented as a continuously rotating switch.

This type of composite signal is known as *pulse amplitude modulation* (PAM) because it uses the amplitude samples of the signals multiplexed. The problem with PAM is that it is subject to the same noise and distortion problems as any analog signal. Fig. 10 illustrates this. After a signal has travelled a fair distance the signal will have become attenuated to a great degree and will require amplification along the line. Unfortunately, not only will the signal be amplified but also any distortion and noise now associated with the signal.

To get around this problem a method of digitally encoding the signal was developed. Although Alec H. Reeves patented PCM in 1938, it was not until the development of high-speed solid state switching devices and in particular integrated circuits that the system became practical. PCM changes analog signals into digitally coded pulses and then reverses this process at the receiver to recover the original analog signals. This is accomplished in 3 basic operations: sampling, quantizing and encoding. The basic operation is shown in Fig. 3.

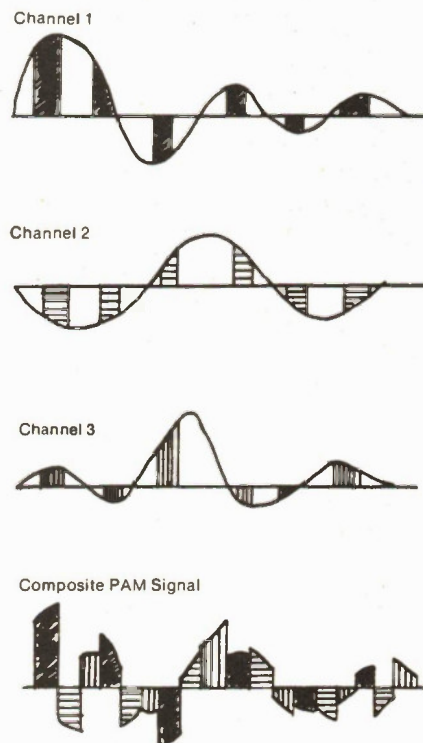

Fig. 2. An example of time division multiplexing using pulse amplitude modulation.

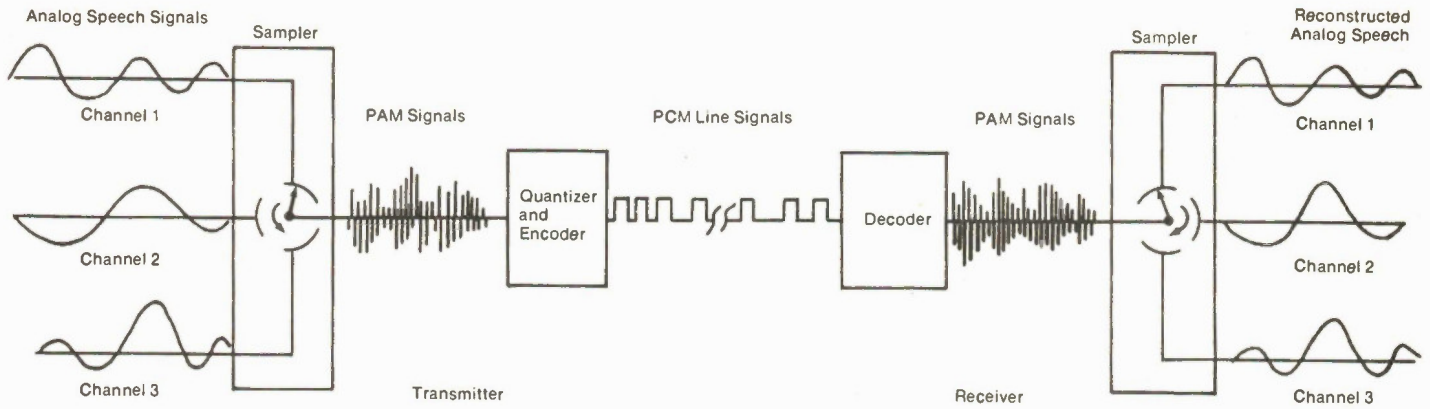

Fig. 3. Basic operation of a time division multiplexed PCM System.

SAMPLING

For accurate reproduction of the signal a sampling rate of twice the highest frequency is required (this according to a theorem from Nyquist) and in telephone channels this works out to an 8kHz sampling rate. This means that once every 125 microseconds (1/8000s) a channel is sampled. Since telephone lines typically multiplex 24 channels on one line 24 channels are sampled successively in that 125 us time slot, called a *frame*. (Fig. 4)

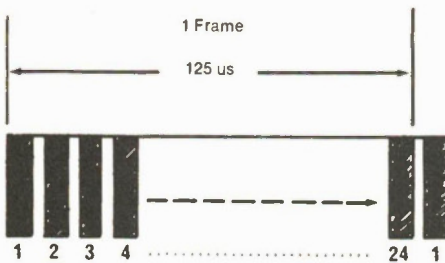

Fig. 4. Twenty four channels multiplexed into 125us "frame".

QUANTIZING

The sampling produces a PAM signal; to prepare these analog samples for digital processing it is necessary to assign values to each of the samples. This assigning of a value is accomplished by establishing a limited number of levels called *quantum steps* and rounding the amplitudes off to the nearest quantum level. This will be more clearly explained by Fig. 5a.

Channel 3 has samples taken of the following quantum values: 3, 5, 3, 3, 2. A reconstructed wave using just these samples would look like Fig. 5b.

The major source of noise in a PCM system is the *quantizing error* which randomly occurs because the quantum

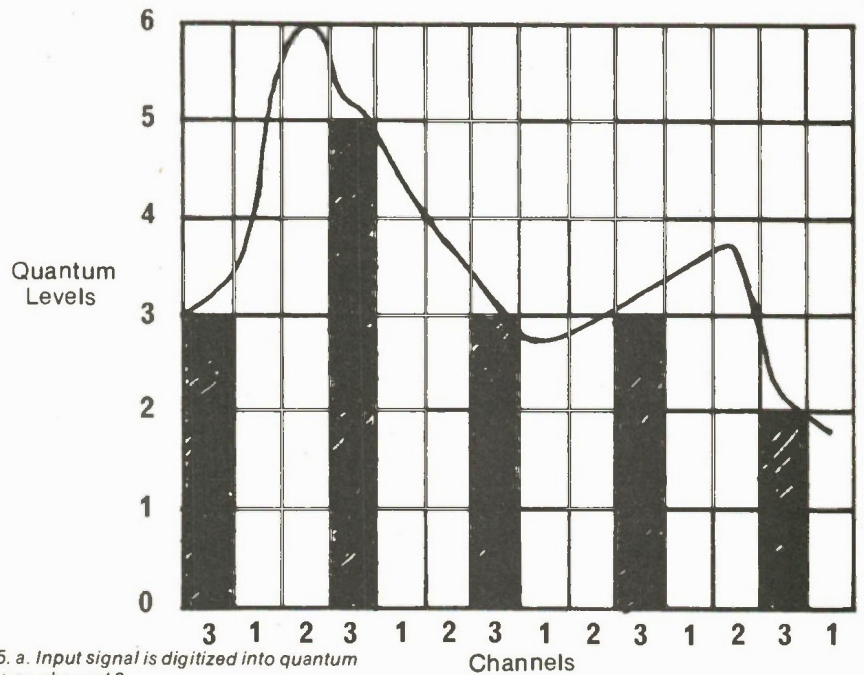

Fig. 5. a. Input signal is digitized into quantum levels on channel 3.

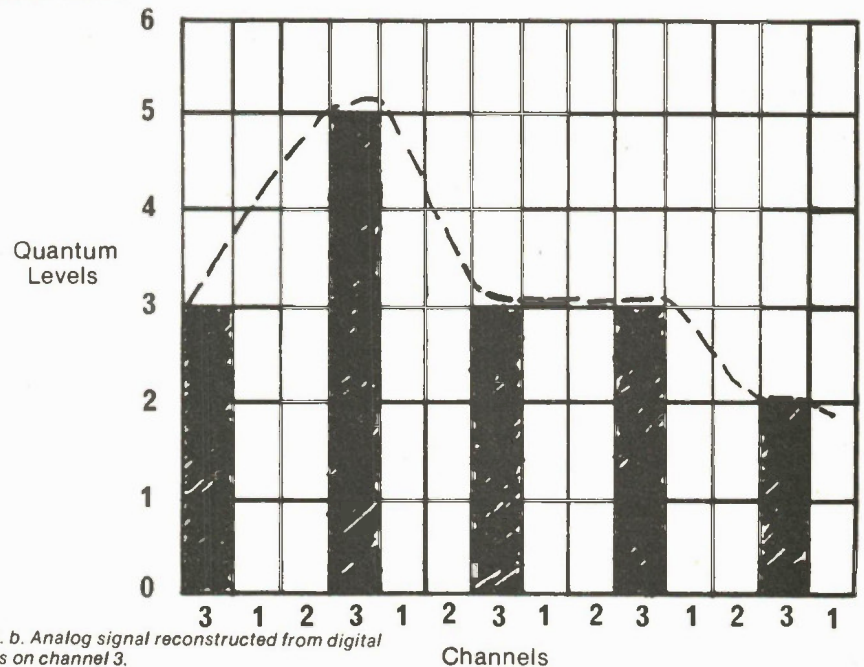

Fig. 5. b. Analog signal reconstructed from digital values on channel 3.

steps are only approximations. By increasing the number of quantum steps the quantizing noise decreases but at the cost of increased bandwidth required in transmitting the data. If quantum steps are assigned in a straight linear fashion (uniform size) approximately 2048 (11 binary bits) are required to provide sufficient signal fidelity. Such a system, however, is impractical in telecommunications due to the large bandwidth involved. To get around this we can do one of two things. Assign small quantum steps at the low amplitudes where it's needed the most and larger steps to the remainder, or what is usually done, *compress* the amplitude *range* before uniform quantization and then *expand* the signal at the receiving end (*companding*). More gain is applied to weak signals than to stronger ones and typically this reduces the amplitude ratio from 1000 to 1 to 63 to 1 or in terms of dB, from 60dB to about 36dB. By using this technique, the number of quantum steps can be reduced from 2048 to 128 (only 7 bits) with the same noise performance. (Fig. 6)

CODING

Once a numerical value is assigned to the samples we can convert this to a binary form. Since $2^7 = 128$ we need a 7 bit code to represent the 128 different levels. As an example of how this works suppose we wish to represent the quantum level 101 in binary form. In binary, $101 = (1 \times 2^6) + (1 \times 2^5) + (0 \times 2^4) + (0 \times 2^3) + (1 \times 2^2) + (0 \times 2^1) + (1 \times 2^0)$. (Fig. 7).

So instead of sending an analog pulse amplitude signal on the transmission line we send its equivalent in binary pulses or if you like, 1's and 0's. Another bit, used for signaling and supervision of the previous channel, is added to make a total of 8 bits per sample; this is actually an older system called the "D1." More commonly used today is the D2 system where all 8 bits are used 5 out of every 6 frames to give a larger quantum range (and therefore less quantum noise in the system). This gives the system 256 quantum levels 5/6 of the time and the one bit in every 6 frames is then used as the signaling bit.

Before sending these pulses one further step is encountered and that is to change the pulses to *bipolar* format. This just means that every other 1 is inverted as in Fig. 8. Now the positive and negative pulses are the 1's and the spaces 0's.

There are several advantages to converting to bipolar format. Most of the energy in the bipolar system is concentrated at $\frac{1}{2}$ the pulse repetition frequency, which results in less energy

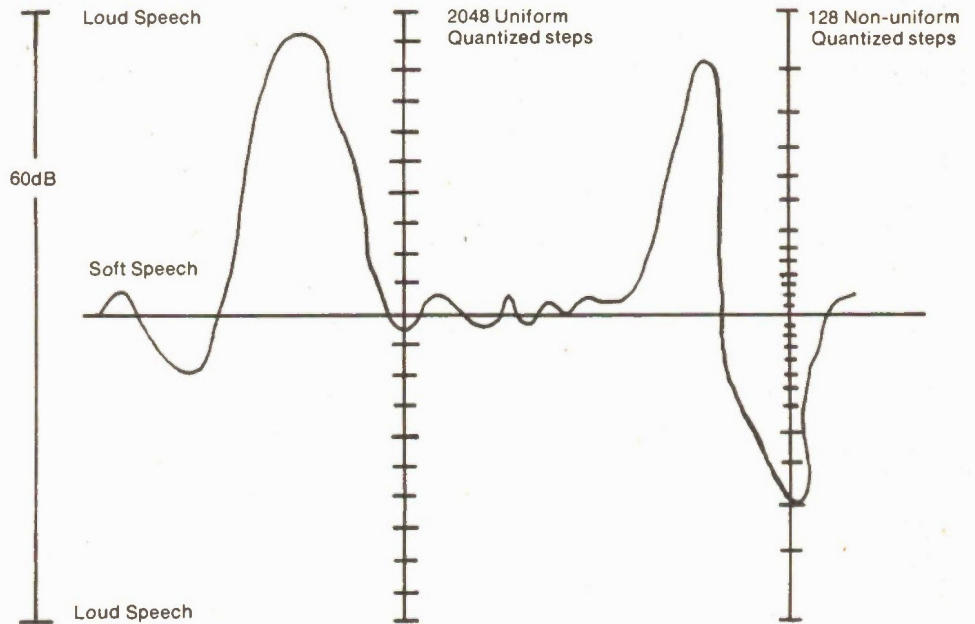

Fig. 6. a. Use of uniform and logarithmic or non linear quantization steps.

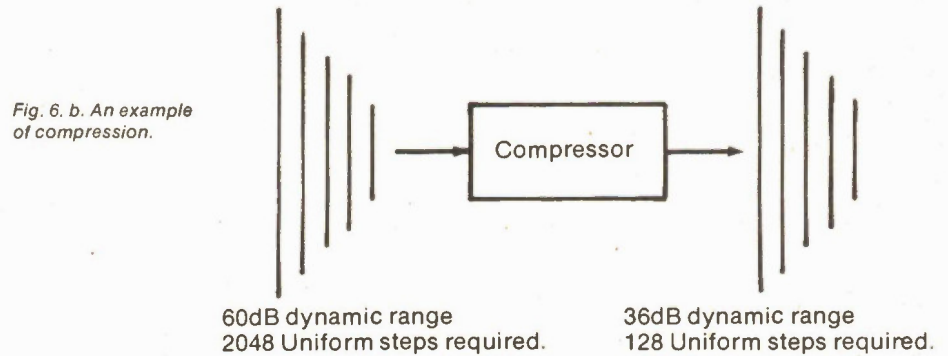

Fig. 6. b. An example of compression.

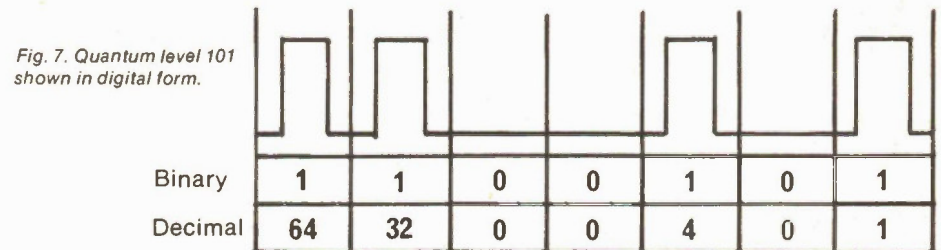
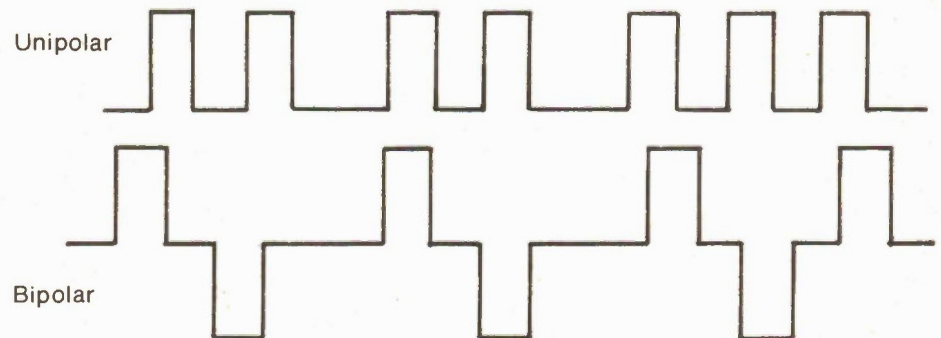

Fig. 7. Quantum level 101 shown in digital form.

Fig. 8. In bipolar format every other binary one pulse is reversed in polarity.



PCM Explained

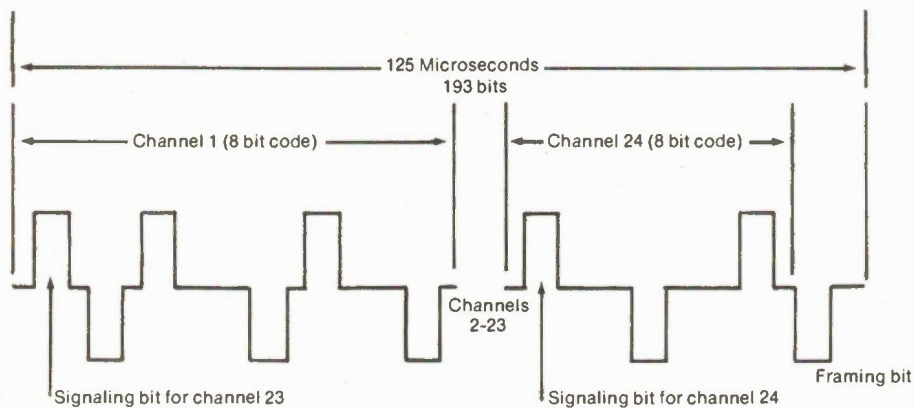

Fig. 9. Typical PCM line signal for a D1 system.

Analog (PAM signal)

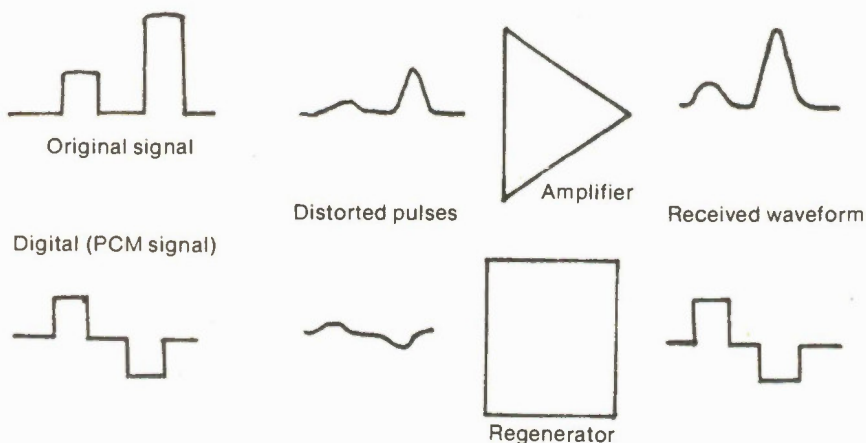

Fig. 10. In a PCM system repeaters regenerate the attenuated signals to look like the original transmitted data.

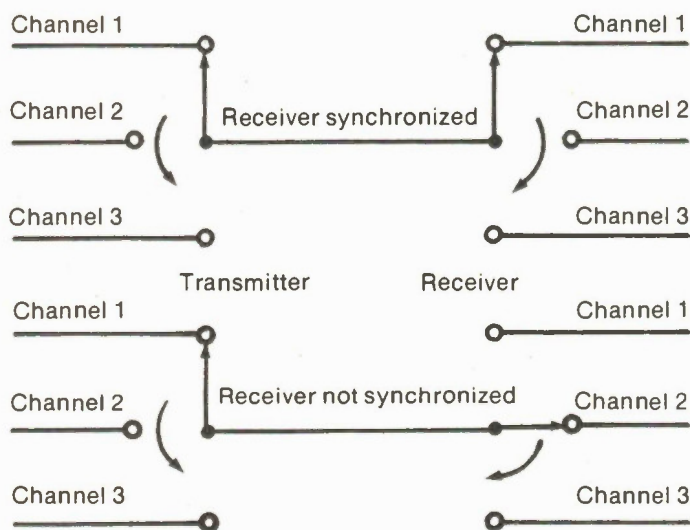

Fig. 11. Improper synchronization with the transmitter will result in random channel selection.

being coupled into adjacent pairs of wire in the cable as crosstalk. There is no DC component so transformer coupling is possible. And error detection is easy since every other 1 bit will be reversed in polarity.

In every frame one additional bit is added as a *framing pulse* to synchronize the receive system with the transmit. Such a 24 channel system then uses 24×8 bits + 1 sync bit for a total of 193 bits. Since the sampling rate equals 8KHz, the transmission rate equals $193 \times 8,000 = 1,544,000$ bits per second. A typical D1 system line signal would look something like Fig. 9. A D2 system would be similar, except every 6th frame would have the signaling bits instead of every frame as in the D1.

REPEATERS

Unlike analog signals that would have to be amplified along with their accompanying distortion, PCM signals are regenerated at repeater stations enroute to their destination. Regeneration involves reshaping the pulses to look like the original signal, so even if the pulses accumulate noise before reaching the repeater the regeneration process cleans them up at each repeater. Remember, in a digital system all that counts is either a pulse or no pulse hence the problem of accumulative distortion and noise are greatly reduced in a PCM system. These repeaters are positioned about every 1.8 km. (Fig. 10)

RECEIVER

The receive side of a PCM system merely operates in the reverse of the transmit section. The PCM line signal is decoded into PAM and then sampled to each respective channel. The key to PCM operation is synchronization so this is where that extra framing bit is important, without it your call would be randomly selected to any one of the 24 channels. (Fig. 11)

This description of PCM has been basic — the complexity of the logic, the analog-digital and digital-analog conversions, and other intricacies of a PCM system make it impossible to go into any great detail here. It should give you some idea, though, of how this technique has benefited the telecommunications industry and promises the audio one with new avenues to reducing noise. Above all, it should be mentioned that because it is a digital method, PCM or something similar can be used extensively in connection with computer based systems. In addition, with fiber optic systems now being field tested PCM lends itself readily to communication via the light spectrum.

The Dangers of Lightning

Because lightning is so spectacularly powerful, it has excited the curiosity and fear of man since the earliest times. Prof. W. R. Lee of the Department of Occupational Health, University of Manchester, explains just how dangerous lightning is.

A FLASH of lightning comprises one or more strokes and rarely lasts more than a second. The lightning stroke generally starts in a negatively charged region of a cloud from which a 'leader-stroke' seems to proceed towards the ground in discrete steps. The electrostatic field which develops below the leader rapidly increases in strength so that, when the tip of the leader has reached a height of some tens of metres above ground level, a short upward streamer can be initiated from a vertical conductor. This might be an isolated tree, a church steeple, a tall building, the mast of a boat, or perhaps a person standing in the open with an umbrella or a golf club above his head.

When the leader makes contact with the ground, or with the short upward streamer, a 'return stroke' develops which may be imagined as a positive current flowing upwards. This may reach tens of thousands, or even one or two hundred thousand amperes.

The electrical potential involved in a lightning strike cannot at present be accurately measured, but it is believed to be about 10^6 to 10^8 volts. Whatever the actual voltage, a lightning stroke can immediately puncture the skin of a victim.

More is known about the characteristics of the lightning current, at least at the point of strike. This is fortunate for physiological responses depend on the current rather than the applied voltage. Characteristic waveshapes of lightning current are unidirectional with a fast rising front and a slower tail usually lasting several tens of microseconds.

In mountainous regions conditions may be different. The bottom of a thundercloud may lie only a short distance above conducting objects, such as human beings from whom arise, as point or brush discharge, currents of several microamperes. These may be felt as a slight tingling, perhaps raising the hair on a bared head. At night they may appear as a luminous glow. In the past this glow, appearing at the tops of ships' masts during stormy conditions, was called St. Elmo's fire — after the patron saint of Mediterranean sailors. Such point discharges can develop into an upward-directed leader stroke which may last several tenths of a second and involve a current of some hundreds of amperes.

FOUR TYPES

When accidents are considered, lightning strokes may be grouped in four types. A direct stroke occurs when the person or something he is holding is struck. The lightning current enters the head or upper part of the trunk, passing through the body and into the ground through the feet. If several persons are standing close together more than one may be struck.

It has been calculated that the current rises rapidly to a peak of 1000 A, immediately falling so that about 10 microseconds from the start it reaches 4 A and remains at that value for the duration of the strike. The occurrence of an external flashover is confirmed by ample evidence from accident reports. If it occurs outside the body and through or outside the clothing, the hair and beard may be singed, there may be burn marks on the soles of the feet and burn marks are found on the soles of the feet and burn marks are found on the clothes, which may catch fire. Metals carried on the body may melt, causing burns. If the flashover is between the body and the clothing, current flowing over the body surface may convert the sweat and skin moisture into steam so that the resulting pressure causes clothes or boots to be torn off.

The second type of lightning stroke is the side flash. This is most clearly understood by considering what happens when someone is sheltering under a tree that is struck. Standing on the ground he is initially at earth potential. However, as the lightning current discharged down the tree trunk increases, the voltage drop down the lower part of the trunk, which might have a resistance of a few kilohms, may become greater than the electrical breakdown strength of the air gap between the trunk and the person. A side flash then occurs through the victim.

There is more than one report of persons struck while cycling past a tree. One victim who was unconscious for 15 minutes, and did not need resuscitation, subsequently recalled a 'blow' and that he saw 'fire' coming to him from the tree and that the handlebars of his bicycle 'became electric'. He sustained no burn marks. Quite a number of accidents are on record of death or injury

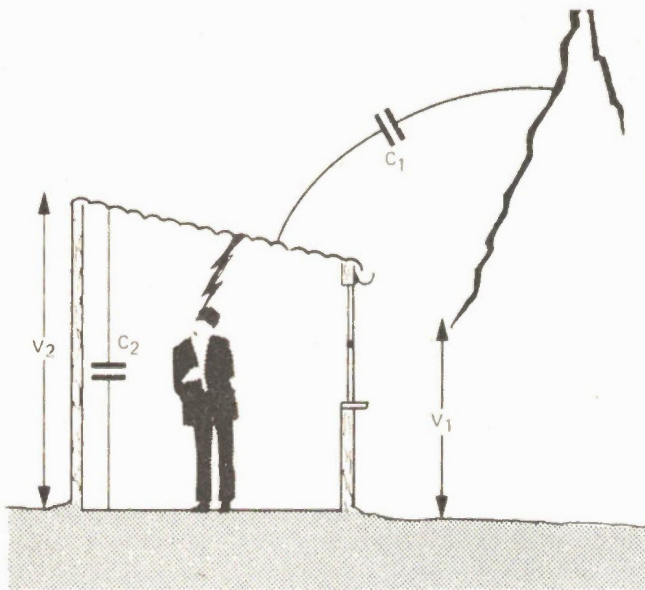

Side flash from a corrugated iron roof insulated from earth by a dry wooden structure. When a lightning stroke develops nearby, the effect of the electrical capacitances represented by C_1 and C_2 is to raise the roof to a potential V_2 with respect to earth, equal to $V_1 C_1 / (C_1 - C_2)$. The potential difference between the roof and the head of the occupant of the shed can become high enough to cause a flashover without the shed being struck.

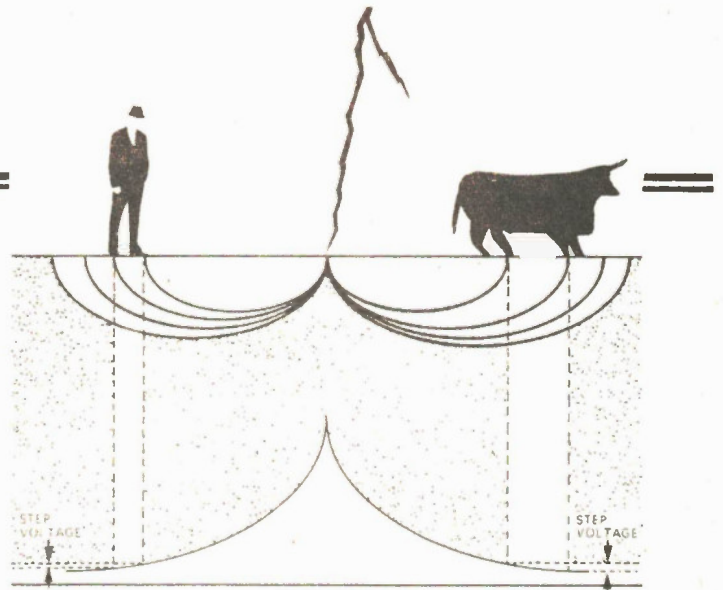

Regular pattern (a) of current in uniformly constituted soil, set up by a direct lightning strike to open ground. The potential distribution curve (b) shows how a 'step' voltage develops between the legs of humans or animals standing nearby.

occurring in persons sheltering in a tent, and the descriptions of the circumstances and of the injuries strongly suggest side flashes from the tent pole or perhaps from the wet fabric.

One of the most dramatic and serious accidents involving side flashes in recent times occurred in the Japanese Alps in 1967. A party of forty-one schoolchildren with five teachers was overtaken by a sudden thunderstorm when they were strung out along a steep ridge immediately below a mountain peak 1 660 metres above sea level. Lightning killed eleven of the boys instantly and most of the remainder were temporarily paralysed, burned or blinded.

The third type of lightning stroke is the step voltage. If lightning strikes open ground, either directly or through a tall object such as a tree or post, the current is discharged into the mass of the earth. On non-uniform ground the current distribution produces differing voltages according to the distance from the site of the strike. A person, or animal, walking along a radius from the site of the strike will be subject to a potential difference between the legs. It will be seen later that quadrupeds are more likely than humans to die from this because the current, flowing between the forelegs and hindlegs, traverses the heart, whereas in the human the pathway is from leg to leg and the heart escapes. When a church in France was struck during a service all the persons standing on the damp flagstones in the nave fell and could not get up for several minutes, as though their lower limbs were paralysed. But people standing in the oak choir stalls at the sides were spared, clearly because they were insulated from the ground.

The fourth type of stroke is the contact voltage, sometimes called a touch potential. It may be regarded as a particular instance of the side flash, in which the victim is actually making contact at the time of the lightning stroke. A case history from Russia about ten years ago gives a clear account of such an accident.

Two women were sheltering under a tall spruce tree which was struck during a thunderstorm. One of them, who was killed, stood with her back against the tree. Her cloth-

ing was not damaged but at the back of her head, on the right hand side, the hair was singed and ash grey in colour over an area 40 mm by 40 mm. In the centre of this the skin damage was like a small abrasion. On the tree trunk there was a longitudinal strip of damage to the bark about 40 to 60 mm wide starting near the top of the tree and stopping about 1.58 m from the ground, that is, on a level with the height of the victim. The other woman was holding on to the tree with her right hand. She lost consciousness for about 10 to 15 minutes and was unable to move or to feel her lower limbs for about two to three hours. She sustained some burning of the body down to the foot, but was discharged from hospital after two days and resumed work after ten days.

An intriguing theoretical study has concluded that anyone touching a lightning conductor when it is struck would not risk death because the current discharged through the body would be too weak. This is not an invitation to test the hypothesis by personal experiment!

HOW LIGHTNING KILLS

How does lightning current produce death? Our knowledge comes from three main sources. Firstly, since the end of the last century, there has been a steady increase in our knowledge of how direct and alternating currents at line frequency cause death. This is based, in a large part, on animal experiments. Secondly, there have been a few studies of the effects of impulse currents on animals. Thirdly, we have accounts of accidents ranging in quality from the anecdotal to the investigation which is fully and carefully documented from both the electrical and medical viewpoints. However, the accounts suffer from two main drawbacks. The obvious one is the absence of any quantitative electrical data and the other is that it is often difficult after an electrical accident to determine exactly why someone died.

Lightning may be considered to produce direct effects in one of three ways: its action on the heart and respiration,

and by heat. There are other indirect effects such as injuries from falls but they are not peculiar to lightning. For currents greater than a few milliamperes, the body behaves as a structureless gel or, for the electrical engineer, as a volume conductor. There is no 'preferred' pathway along which the current flows. It is believed that the body resistance along the path taken by the current in most direct lightning strokes, many side flashes and many contact voltage accidents, is about 500 to 1 000 ohms, possibly falling to the first value after the skin has been punctured. Generally, the effects are produced by direct action on the organs concerned, so it is important to trace the current's pathway through the body.

Careful examination of burn marks usually provides information on the points of entry and exit. Sometimes these may be surprisingly small. The lightning return stroke has a central core with a diameter of a centimetre or so, which may reach a temperature of about $30\,000^{\circ}\text{K}$, but only for the first tens of microseconds. This may save a person from extensive burning, although small metal objects on the clothing may melt. Because the skin has the highest resistance to the current, heat tends to be developed there, often causing relatively small skin burns. But if the lightning current has a long 'tail' it may have a value of several hundred amperes during that period. This so-called 'hot' lightning can cause more severe burning of the body and clothing. Examination of victims frequently reveals 'tree-like' or aborescent markings that are not true burns. They disappear after a few hours.

Lightning current causes death by affecting either the heart or the nervous mechanism controlling respiration. The heart has two main pumping chambers — one to pump blood around the body and the other to pump it through



Side flash from a tree struck by lightning. At first the current flows through the trunk. The electrical resistance of the trunk, between ground and a point level with the head of anyone standing nearby, may be a few kilohms. Build-up of current through it may cause the potential drop across the lower part of the trunk to exceed the electrical break-down strength of the air between the trunk and the victim. At that stage a side flash occurs.

the lungs. The thick walls of these ventricles consist almost entirely of muscle, and the simultaneous contraction of all the individual muscle fibres provides the necessary pumping pressure. An electrical current passing through the heart may disturb the concerted action of the fibres so that they contract individually and fail to establish enough pressure. When seen in this state the ventricles, instead of showing forceful regular contractions, are flaccid, with irregular twitchings (fibrillation) of the individual fibres.

Nearly all the investigations to establish the relationships between some electrical factor and time have been carried out using alternating current at line frequency. The shortest duration studied in such investigations is about eight milliseconds, corresponding to a half wave at 60 Hz. This approaches that of a lightning current with a long tail.

A number of relationships have been suggested. They all accept that current, or a derivative, is important. One of the most widely published relationships suggests that within certain time limits the ventricular fibrillation threshold depends on energy. Another suggestion is that it depends on charge. One theory is that the threshold is a function simply of current but that there are in fact two thresholds, one when the current lasts for less than a heart cycle and another, much lower, if it is more (about 400 to 1 000 milliseconds).

Lightning currents do not last longer than a heart cycle. However, an electrical current will cause fibrillation only if it falls at a certain time in the cycle, the 'T' wave, which occupies about 20 to 25 per cent of the full cycle. Once fibrillation has become established, blood circulation ceases and death follows. Finally, it has recently been stated that in many victims of lightning stroke the heart simply stops altogether — ventricular asystole. First-aid treatment for both is the same.

The centre for the control of respiration by the nervous system is in the lower part of the brain. There is strong evidence that the current has to go through it to stop respiration. Indeed, in so-called electric shock treatment for certain mental disorders it is extremely uncommon for respiration to remain stopped once the current has ceased to flow. There are a number of carefully reported cases in which high voltage or lightning currents passing through the respiratory centre have caused breathing to stop. Some victims have responded to prompt artificial respiration. A current pathway through the head and trunk seems to be more common in lightning than in electric shock accidents.

FIRSTAID

Using our knowledge of how death is caused by lightning, we can attempt to establish a rational basis for first aid. Simply stated, the victim's breathing or circulation — or both — might have stopped. No first-aid manoeuvre is likely to start either again, though fortunately respiration often starts spontaneously after an interval of anything from a few seconds to several hours. Obviously, except in cases of very short arrest, it is necessary to provide artificial respiration, by first-aid and later perhaps in hospital, until breathing starts again. First-aid treatment for arrested circulation is, according to many authorities, not without serious dangers and should not be lightly undertaken. It would be prudent to learn from national first-aid organizations how these conditions may be diagnosed and treated.

Several simple precautions would reduce lightning accidents. An upright person acts like a lightning conductor

Accuracy made easy . . .
Push Button Triggered Scopes
from

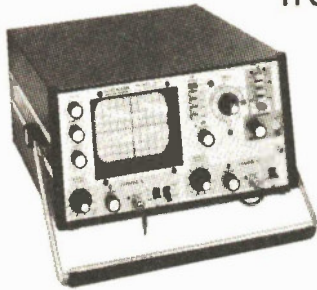

HICKOK
the value innovator

Model 517
Dual-Trace
15 MHz
Triggered
Oscilloscope

A value loaded medium bandwidth scope useable to 27 MHz

The Hickok Model 517 Dual Trace Oscilloscope is the perfect signal tracing instrument for all servicing jobs. The Model 517 has all the necessary features for professional analysis and results.

Dual trace lets you simultaneously view two waveforms that are frequency or phase related or that have a common sync voltage.

This unit is also available in single trace Model 515 and Model 532 30 MHz Dual trace.

ROGERS electronic instruments/ ltd.

P.O. Box 310, 595 Mackenzie Avenue Units 1 & 2.
Ajax, Ontario L1S 3C5. Tel. (416) 683-4211

and thus attracts a lightning strike over a distance which, as a first approximation, is proportional to the square of his height above the ground. It is, therefore, much safer to squat down than to stand up or, worse still, to stand on the top of a vehicle or structure. To increase one's effective height by carrying an umbrella or golf clubs, held upright, is foolish: better to get wet than killed. The risk of side flashes can be minimized by keeping at a distance of a few metres from other people when in a group, by *not* standing near the trunk of an isolated tree and by keeping away from large metallic objects both indoors and outdoors. Tents can be readily protected but it is a wise precaution to keep the greatest possible distance away from the tent pole or the wet fabric.



Original Japanese Transistors & Integrated Circuits

Partial list only write for complete FREE catalogue.

2SA202 .50	2SB473 1.30	2SC1307 3.99	LA4030p 2.40	CB CRYSTALS \$2.50 each*
2SA223 .63	2SB474 1.10	2SC1308k 4.95	LA4032p 2.60	
2SA495 .55	2SB492 .99	2SC1383 .63	LA4100 2.85	10.140 MHz
2SA496 1.10	2SB507 1.95	2SC1507 1.20	LM377N 3.95	10.160 MHz
2SA509 .80	2SB511 1.25	2SC1567 .95	LM1307N 3.90	10.170 MHz
2SA564 .50	2SB514 1.65	2SC2028 1.27	MA6301 3.50	10.180 MHz
2SA634 .85	2SB544 .75	2SC2029 2.65	MM5316 7.95	10.595 MHz
2SA643 .65	2SC372 .45	2SD72 .69	MM5387 7.95	10.615 MHz
2SA666 .65	2SC460 .65	2SD141 1.40	PLL-02A 8.99	10.625 MHz
2SA683 .65	2SC496 1.10	2SD234 1.40	STK-015 5.20	10.635 MHz
2SA699A .95	2SC509 .75	2SD235 1.30	STK-020 5.30	11.730 MHz
2SA715 1.25	2SC515A 1.50	2SD261 .55	STK-433 8.95	11.275 MHz
2SA719 .55	2SC536 .45	2SD313 1.21	TA7120p 1.50	14.950 MHz
2SA733 .50	2SC710 .45	2SK19 .75	TA7203p 3.95	14.960 MHz
2SA794 .99	2SC711 .45	2SK30 .75	TA7204p 2.95	14.970 MHz
2SB33 .55	2SC756 2.50	2SK41 .59	TA7205p 2.95	14.990 MHz
2SB54 .55	2SC789 1.20	2SK44 .59	TBA810 3.95	23.290 MHz
2SB56 .55	2SC799 3.99	AN214Q 2.75	TBA820 2.95	23.340 MHz
2SB173 .45	2SC828 .45	AN274 2.36	UPC16c 2.65	23.390 MHz
2SB175 .55	2SC839 .45	BA511A 2.85	UPC30c 2.75	23.440 MHz
2SB187 .49	2SC1014 1.25	BA521 2.95	UPC1001H 2.95	23.490 MHz
2SB303 .50	2SC1018 1.90	HA1306 3.10	UPC1020H 2.95	23.540 MHz
2SB337 1.95	2SC1030 2.95	HA1339 3.25	UPC1025H 2.95	37.600 MHz
2SB405 .55	2SC1096 .80	LA1201 1.95	UPC1154H 3.95	37.650 MHz
2SB407 1.80	2SC1173 .95	LA3350 2.99	UPC1156H 3.25	37.700 MHz
2SB411 2.99	2SC1226A .89		UPC575C2 2.25	37.750 MHz
2SB434 1.08	2SC1306 2.25		UPC592 1.95	37.800 MHz
			UPC555c 2.25	37.850 MHz

*Note: The CB CRYSTALS are solder in leads

MINIMUM ORDER \$5.00
DEALERS: Volume dis-
counts quoted on request

CANVOX LTD

8235 Mountain Sights, Rm 105
Montreal, Quebec. H4P 2B4
(514) 735-5931

eti PANEL TRANSFERS

A really high quality system for finishing off your projects. The sheets include a mass of lettering and control scales for both rotary and linear pots.

The lettering is transferred simply by laying on to the panel and rubbing down — it's strong and permanent.

The markings are on two sheets (a full-sized one cut in half for easy postage) and contain sufficient lettering for dozens of projects.

Send \$3.50 (including postage) to ETI PANEL TRANSFERS, Unit Six, 25 Overlea Blvd., Toronto, Ontario, M4H 1B1. Ontario Residents add PST.

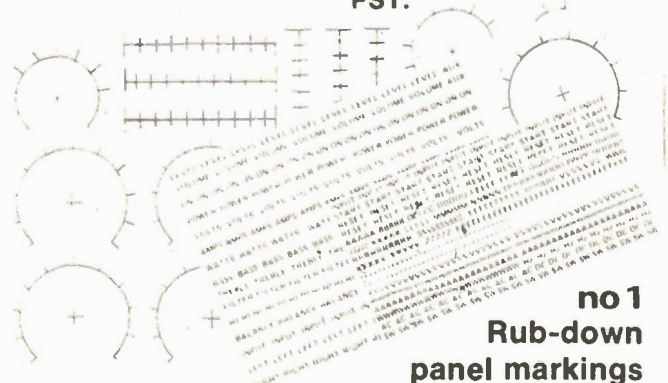

no 1
Rub-down
panel markings



**We
Won't
Set
the
World
on
Fire...**

... Just Your Sales!

The people who brought you ECG® Semiconductors have a new addition to their rapidly expanding ECG family — a complete line of ECG Flameproof Resistors.

And they really can take the heat!

They provide stable resistance to normal operating current.

They open the circuit like a good fuse, taking overloads up to 100 times rate power without shorting or displaying a trace of flame.

Since millions of flameproof resistors operate today in home entertainment products, industrial (MRO) equipment, communications gear and instrumentation, there is an enormous replacement market available to Service Technicians.

The new Sylvania program will help you meet that

demand by providing ECG Flameproof Resistors in packages from individual blister packs to attractive, colorful cabinets perfect for your shop. Either way, Sylvania offers you the most popular flameproof resistor types in 1/4, 1/2, 1 and 2-watt ratings. Values under 10 ohms are 5% tolerance, all other values are 2% tolerance.

Minimize Your Inventory!

Stocking Sylvania ECG Flameproof Resistors will help reduce Dealer inventory, not only by providing the proper quantity balance, but also because Sylvania ECG Flameproof Resistors can replace carbon composition, carbon films, metal film and wirewound resistors with tolerance of 2%, 5%, 10% and 20%. It's such a fantastic package, we can't resist saying, "Come in and let us set fire to your sales."

SYLVANIA Electronic Components and Systems

8750 COTE DE LIESSE ROAD, MONTREAL, QUEBEC H4T 1H3 (514) 735-4201 TELEX: 05-825884

ETI MARKET PLACE

We will allow you up to twenty-five words to advertise items you want to buy or sell, or to publicise meetings of clubs, etc. Advertising will be accepted at our discretion — we will not accept commercial or any form of company advertising. For more Insertions mail in again.

FREE ADVERTISING

PLEASE SEND IN YOUR ADVERTISEMENT IN THIS FORM. USE AN EMPTY SEALED ENVELOPE WITH YOUR MESSAGE ON THE BACK.

ETI MARKETPLACE
UNIT 6, 25 ONARCA BLVD,
TORONTO, ONTARIO,
M4H 1B1

WRITE YOUR MESSAGE HERE.
DON'T FORGET YOUR NAME, ADDRESS & PHONE NUMBER

FOR SALE: DUAL FET LEACH LOW TIM PREAMP KIT 200W POWER AND DRIVER TRANSISTORS, 0-50V 5A REGULATORS, 120W DC CLASS A POWER AMP & KIT. S. H. FONG, P.O. BOX 6211, STATION "A", TORONTO, ONTARIO (416) 483-3088

WANTED - SCHEMATIC OR ASSEMBLY MANUAL FOR DEVRY TECH. INSTITUTE COMBINATION OSCILLOSCOPE - VTVM FROM 1959 HOME STUDY COURSES - D. MOORE, BOX 83, AYLESFORD, N.S. B0P 1C0 902-427-9224.

MUST SELL: ATARI VIDEO COMPUTER SYSTEM, 1 MONTH OLD, MINT CONDITION. INCLUDES ADAPTER, CONTROLLERS, 2 CARTRIDGES. NEW \$330, ASKING \$225. 435-2136, WILLIE, 4706-105 STREET, EDMONTON, ALBERTA.

VIDEO GROUP WANTS OLD MONOSCOPE INDIAN HEAD TEST PATTERN GENERATOR VERY CHEAP (WE'RE VERY POOR), THE UNDERGROUND TUBE, 9 SIR KAY DRIVE, MARKHAM, ONTARIO L3P 2Y9.

WANTED TO BUY: SHORTWAVE SIGNAL BOOSTER, STEVE BYRNS, 92 PENHALE ST., THETFORD MINES, QUEBEC. G6G 3J8.

WANTED: COLLINS 30S-1 AT A REALISTIC PRICE. C. GUTMAN, 7526 MOUNTBATTEN RD., MONTREAL, QUEBEC H4W 1J9.

MUNTZ 4000 TUNER - NEED MANUAL OR SCHEMATIC. L. COLIN CURTIS, 580 MUNRO ST., KAMLOOPS, B.C. V2C 3E4.

CMOS Switched Preamp

A versatile unit designed with our 480 power amplifier modules in mind.

THIS PREAMPLIFIER incorporates rumble and scratch filters, and something new in audio amplifiers, at least in magazine projects in solid-state switching of the audio inputs and filters. This simplifies wiring, as the only wires connected to the selector switches are control wires — not shielded cables as before.

In this design we have used a bank of push-buttons, but there is no reason why touch sensitive circuitry cannot be used. Indeed it is a simple matter to use a remote switch bank with multi-core cable, for armchair selection of input or filter.

CONSTRUCTION.

The ETI 480 power amplifiers are described in detail in the April 1977 issue of ETI Canada. If you are missing this issue do not despair! The modules are also described in our Canadian Projects Book No. 1. Of course other commercially available modules can also be used.

The preamplifier is built on two boards, one being the 'mag' preamp and selector board; the other being the tone control and filter board. These can be assembled with the aid of the appropriate overlay drawing. Note that the mag preamp board has tracks on both sides and must be soldered on both sides where applicable. If you use a small soldering iron and fine solder, this should not prove any problem. Use pc board pins for all external wires as this makes wiring much easier later.

Commence assembly of the chassis with the 12mm spacers for the selector switches and the power switch.

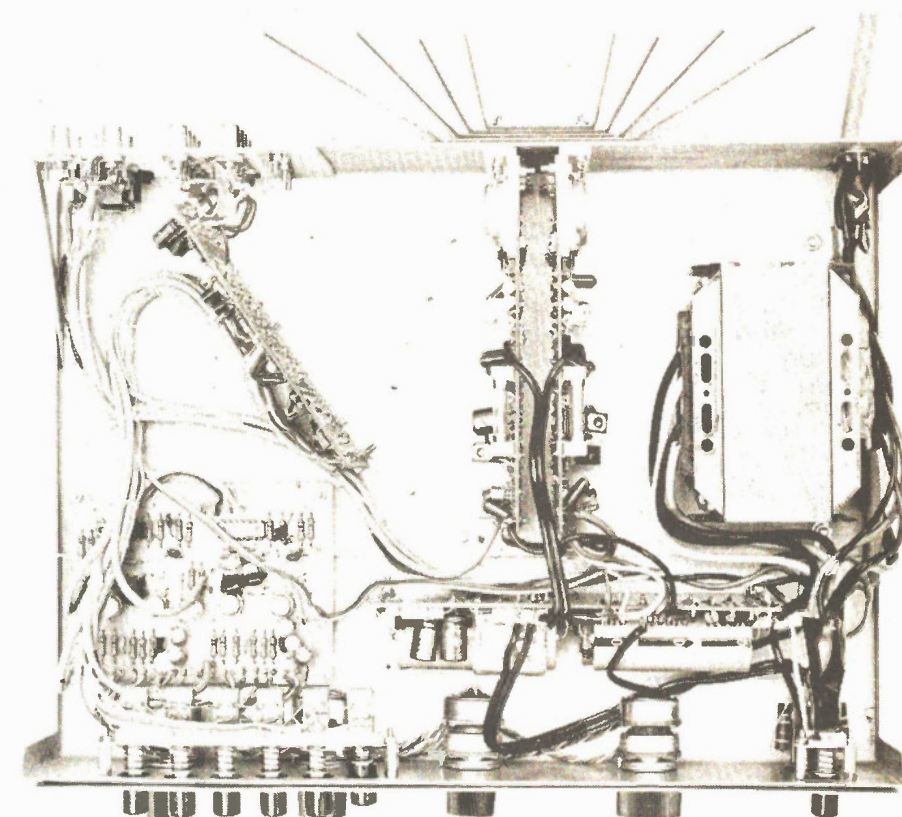

Internal view showing preamp board pivoted forward to allow access to the rear

Although the switches should not be fitted yet, the countersunk screws used to mount them are covered by the front panel and these will not be accessible later. The potentiometer and tone control board can now be installed and interconnected. The small rear panel can be assembled and fixed to the chassis.

Add wires about 40 mm long to each of the 10 inputs to the mag preamp board (it is neater if these are soldered to the rear of the board) and connect

them to the appropriate phono sockets. Also add an earth link from this board to a lug under one of the phono input sockets. Connection of all the commons of the phono input sockets is via the chassis itself. The preamplifier board can now be installed.

Before fitting the amplifier modules they should have the bias current adjusted. While this can be set later, if anything is wrong it is easier to fix before installation. Provided no load is

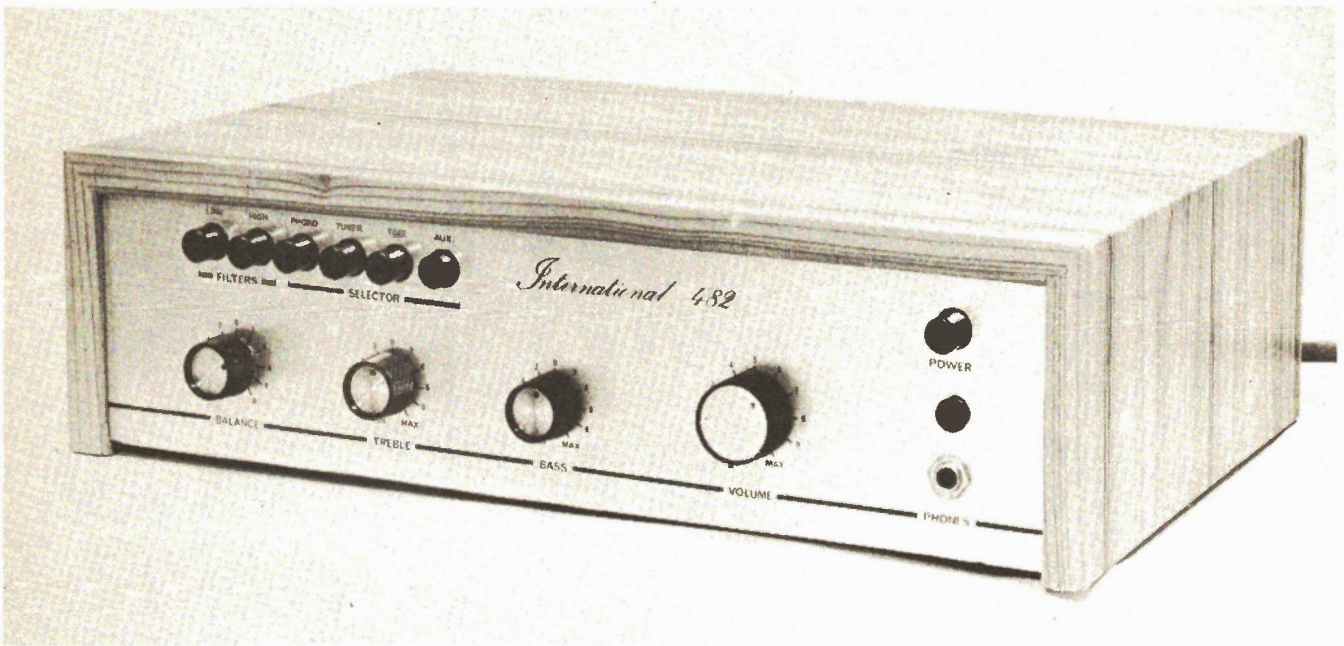

SPECIFICATIONS

Output power	50 watts into 8 ohms	Total harmonic distortion at 1 kHz.	
Frequency response 20Hz–20kHz	± 0.5 dB	50 watts out	0.3%
Signal to noise ratio with 50 W output		10 watts out	0.08%
Tape, tuner and aux inputs	-79 dB	1 watt out	0.08%
Disc input (re 10mV)	-63 dB	Tone controls	see graph
Input sensitivity		Filters	see graph
Tuner and aux inputs	180 mV into 100k	Damping factor	25
Tape input	180 mV into 47k	Channel separation	45 dB
Disc input	2.5 mV into 47k		
Main amp input	500 mV into 10k		

connected, no heatsink is required at this stage. The module can now be fitted, along with the heatsink on the rear of the chassis. The chassis goes between the modules and the heatsink, but the heat loss is not great. While the heatsink used in the 480 modules is not the only one which can be used, it must be about this size — and be capable of being clamped against the rear panel, to ensure adequate cooling.

The power supply board and the selector switches can now be added and the complete amplifier wired with the aid of the diagram in Figure 4. We left the transformer out until this stage to keep the weight down. It can now be added and the wiring completed.

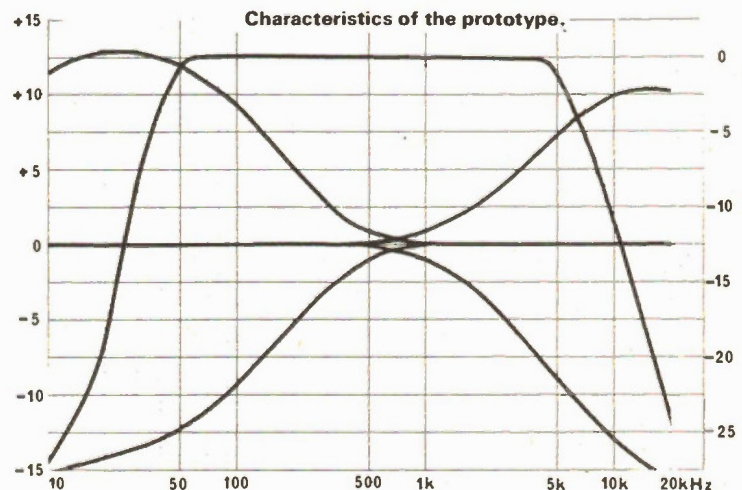

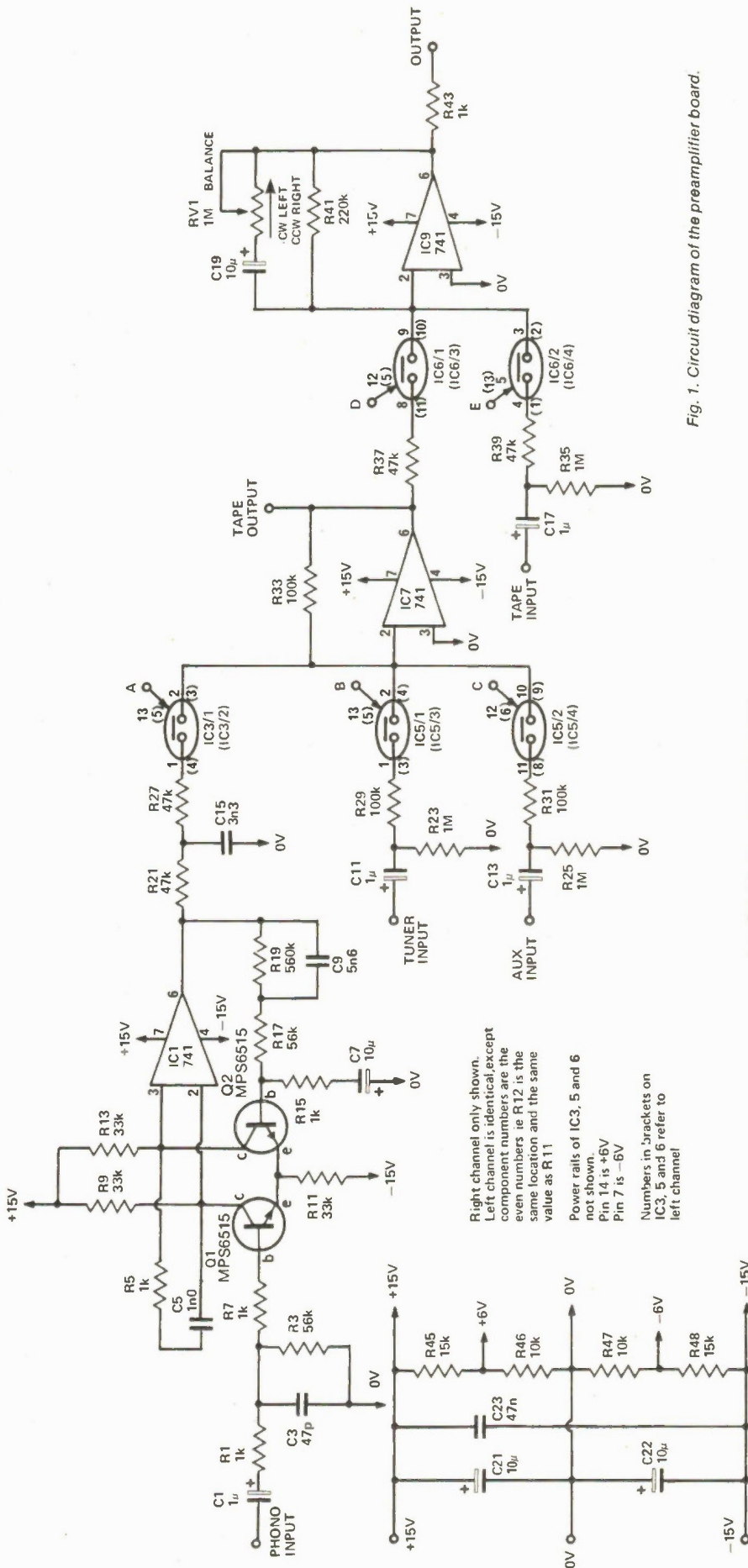

Right channel only shown. Left channel is identical, except component numbers are the even numbers ie R12 is the same location and the same value as R11

Power rails of IC3, 5 and 6 not shown. Pin 14 is +6V Pin 7 is -6V

Numbers in brackets on IC3, 5 and 6 refer to left channel

Fig. 1. Circuit diagram of the preamplifier board.

HOW IT WORKS

switch appears as a 300 ohm resistor and if it is low (-6V), it appears as an open circuit. Therefore, IC3/1, IC5/1 and IC5/2 can select phono, tuner or aux inputs and IC7 buffers the one selected.

The output of IC7 is used as tape output for recording purposes. The tape input is fed with a second buffer, IC9, and IC6/1 disconnects IC7 when this is to allow monitoring (when recording) and this is selected by depressing both the tape button and the input required. The gain of the second buffer, IC9, is variable by means of RV1, which is the balance

control. The two channels are wired to the opposite way around on IC1, so that increasing gain on one channel decreases the gain on the other.

The filters used are two-pole active type and CMOS switches are used to enable or inhibit the circuits. C27 and C29 determining the low filter cutoff frequency and the value can be varied to suit your requirements. The values given give a cutoff at about 50 Hz and increasing the capacitance decreases the cutoff frequency, and vice versa. The high cut filter C31 and C33 determining the frequency and these

ET1 482

The output from a magnetic pickup has to be amplified and equalised before it can be used. This is achieved using Q1, 3 and IC1 to provide a gain of about 40 dB at 1 kHz and using C9 and C15 to provide the equalisation required to meet the RIAA curve. The transistors are used to reduce the noise of the 741 amplifier to acceptable levels.

Selection of the inputs is done by IC3, 5 and 6, which are CMOS analogue switches. If the control input to these devices is high (+6V) the

values can also be varied if required. The approximate ratio between these capacitors should be maintained.

The tone controls are conventional. To reduce the effective noise level, the volume control is wired between the filter section and the tone control stage. This does mean, however, that the input levels are more critical than they would be if the control was further back in the circuit. Input levels should be kept below about 2 volts.

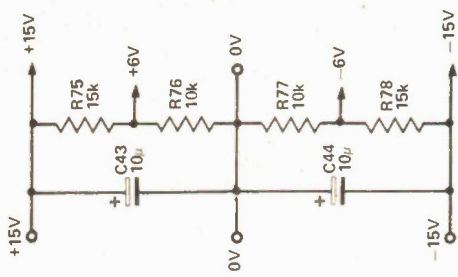

Right channel only shown. Left channel is identical except even numbers ie R62 is the same location and the same value as R61

Power rails of IC11
Pin 14 is +6V
Pin 7 is -6V

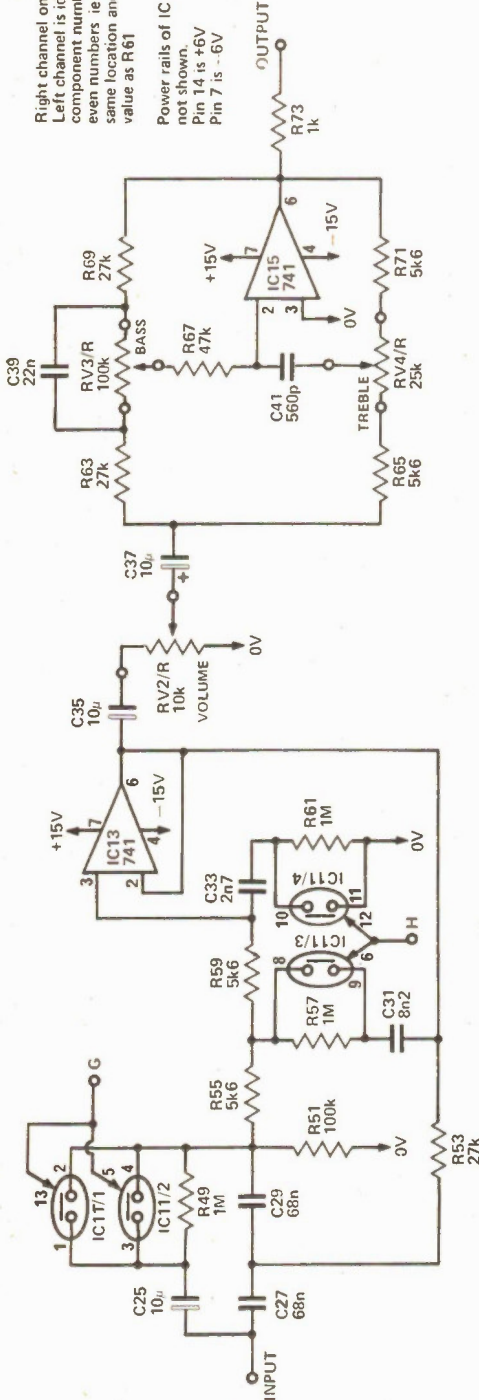

Fig. 2. Circuit diagram of the filter and tone control board.

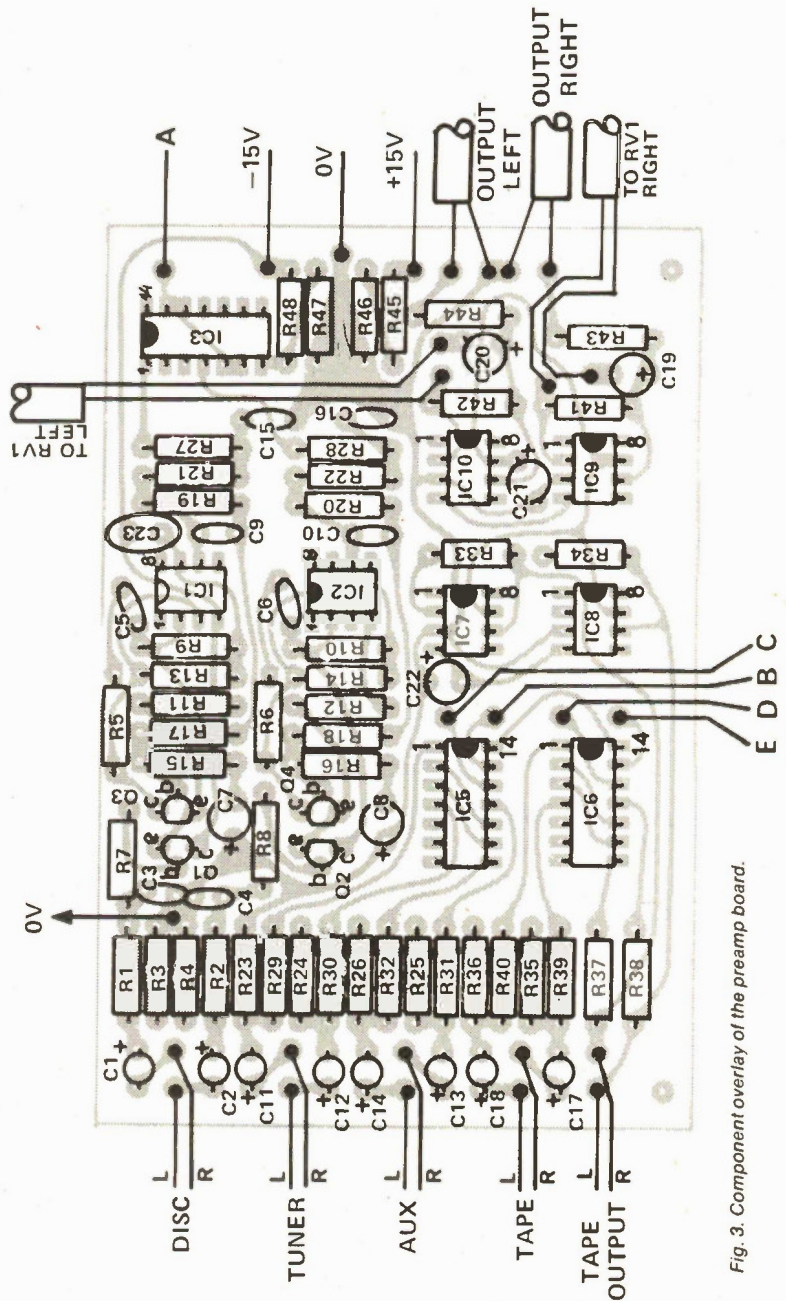

Fig. 3. Component overlay of the preamp board.

PARTS LIST

ETI 482A

RESISTORS all 1/4W 5%

- R1, 2, 5, 8, 15, 16, 43, 44 1 k
- R3, 4, 17, 18 56 k
- R9-14 33 k
- R19-20 560 k
- R21, 22 47 k
- R23-26, 35, 36 1M
- R29-34, 37-40 100 k
- R41, 42 220 k
- R45, 48 15 k
- R46-47 10 k

CAPACITORS

- C1, 2, 1 µ 35 V Tantalum
- C3, 4 47p ceramic
- C5, 6 1n polyester
- C7, 8, 19-22 10 µ 16 V electrolytic
- C9, 10 5n6 polyester
- C11-14, 17, 18 1 µ 35 V electrolytic
- C15, 16 3n3 polyester
- C23 47n polyester

SEMICONDUCTORS

- O1, O2 MPS6515
- IC1, 2 741
- *IC3, 5, 6 4016
- IC7-IC10 741
- *The number IC4 is not used
- PC Board ETI 482A

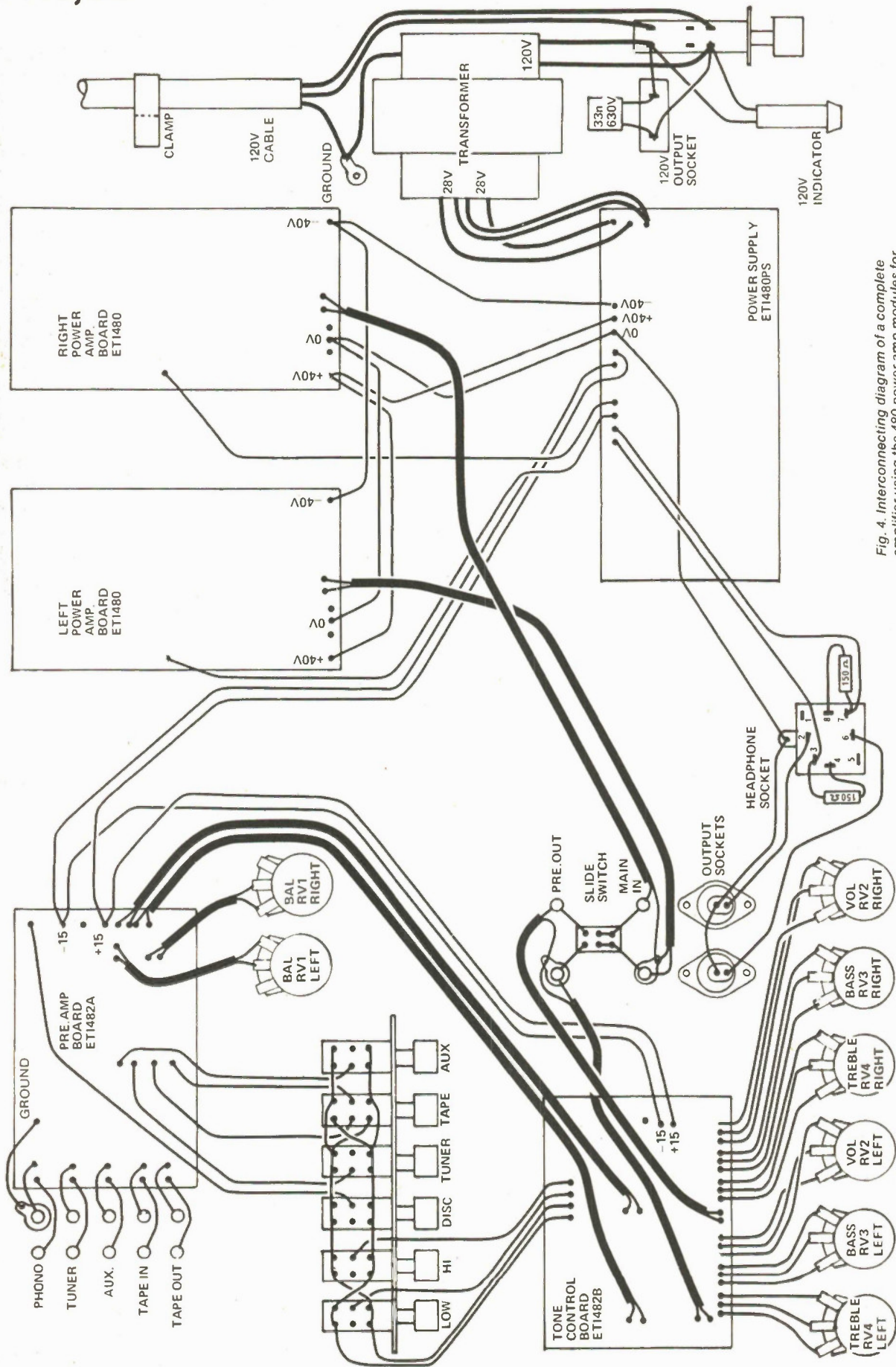
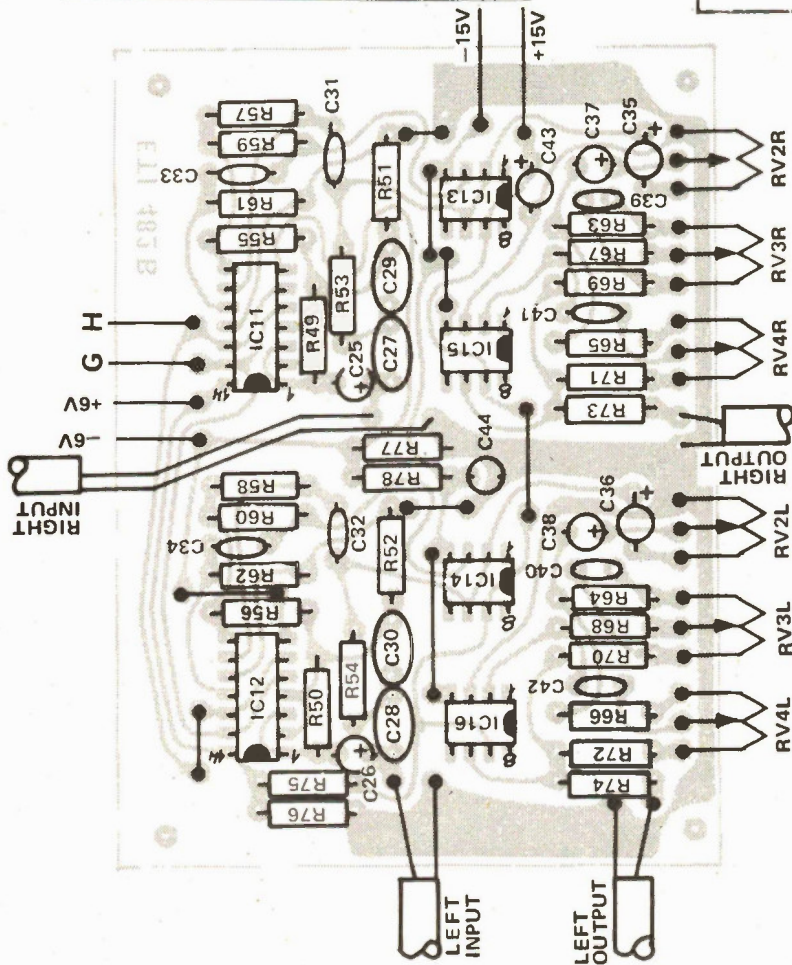

Fig. 4. Interconnecting diagram of a complete amplifier using the 480 power amp modules for output.

PARTS LIST

ETI 482B

RESISTORS all 1/4W 5%	1M	CAPACITORS	10 μ 16 V electro
R49,50,57,58,61,62	100 k	C25,26,35-38,	68 n polyester
R51,52	27 k	43,44	8n2 polyester
R53,54,63,64,69,70	5 k 6	C27-C30	2n7 polyester
R55,56,59,60,65,66,71,72	47 k	C31,32	22 n polyester
R67,68	1 k	C33,34	560 p ceramic
R73,74	15 k	C39,40	
R75,78	10 k	C41,42	
R76,77			
POTENTIOMETERS		INTEGRATED CIRCUITS	
RV2	10 k log dual rotary	IC11,12	4016 or 4066
RV3	100 k lin dual rotary	IC13-IC16	741
RV4	25 k lin dual rotary	PC board	ETI 482 B



Foil pattern for 482B pcb.

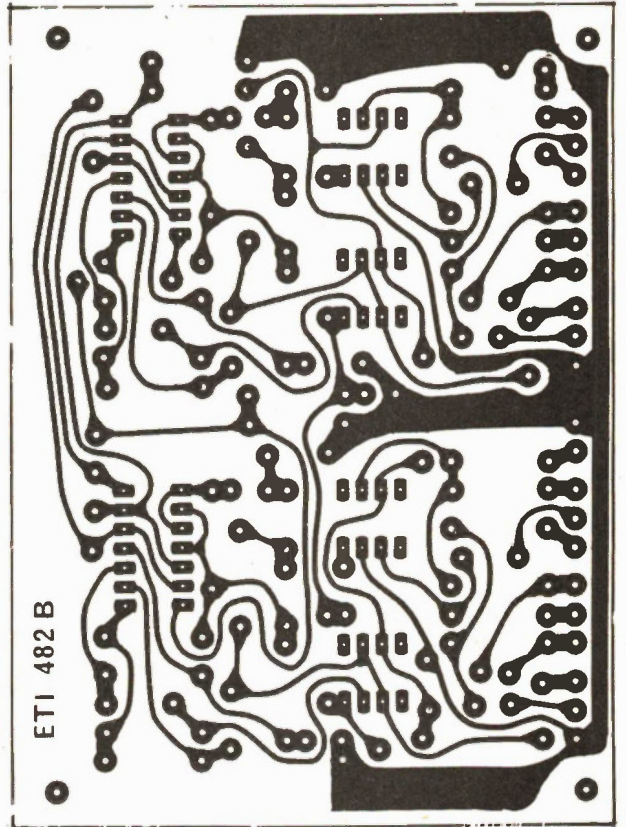

PARTS LIST

ETI 482 GENERAL

- 2 50 W ETI 480 Amplifier modules
- 1 ETI 480 P Power supply module
- chassis
- cover
- Front panel
- Heatsink
- Rear panel
- 5 brackets
- 4 knobs
- 1 Selector switch bank
- 1 Power switch
- 2 pin power socket
- 1 33 n 630 V capacitor
- 1 120V power indicator
- 1 Power cord, grommet and clamp
- 1 Stereo headphone socket
- 14 Single phono sockets
- 1 Small double pole slide switch
- 2 2 pin DIN socket
- 8 12mm spacers
- nuts, bolts, washers etc.

Calculator Buying Guide

SCIENTIFIC AND SPECIAL FUNCTION CALCULATORS

GENERAL FEATURES

Display: R=Red Led; G = Green; L = liquid crystal
 Battery: D = Disposable; R = Rechargeable; L = Long Life
 Number of Digits (Incl. special signs)
 Scientific Notation = S
 Type of Logic: A = Algebraic; R = RPN
 Level of Brackets; 4 Level RPN = R
 Number of Memories
 Keyboard touch: S = Soft; F = Firm; C = Click
 Size: A = Average; C = Compact; S = Slim
 Programmable = P; Number of Keys

SCIENTIFIC FUNCTIONS

Trigonometric & Inv. Trig. Functions = T
 Common & Natural Logs = L; Antilogs = A
 Hyperbolic Function Key = H; Pi = P
 Exponentials = E; Reciprocal Key = R
 Square Root Key = S; Nth Root Key = N
 Exchange Key = E; Square = X
 Deg/Rad Selection = S; Deg/Rad conversion = C
 Polar/Rect Conversion = P; Deg/DMS Conv. = D
 Metric Conversion = M; Decimal Selection = D

STATISTICAL FUNCTIONS

Mean, Std. Deviation, Variance = S
 Linear Regression = L; Correlation Coeff. = C
 Permutation/Combination = P; Factorial = F
 Sum of Products = S; Integer Trunc. = I

FINANCIAL FUNCTIONS

Present & Future Compounded Values = P
 Cost/Sell and Profit Margins = C
 Discount Cash Flow = D; Compound Interest = C
 Bond Yields = B; Depreciation Sched. = D
 Percent Key = P; Delta Percent Key = D
 Amortization = A; Rate of Return = R

PROGRAMMABLE CALC. FUNCTIONS

Programming steps (Merged Steps = M)
 Type of Memory: V = Volatile; P = Permanent
 Magnetic Cards = C; Progr. Module = M
 Conditional Tests
 Subroutine Levels; Printing = P

SPECIAL FUNCTIONS

Refer to "Code Definition" of the Numbers

	COMMODORE										TEXAS INSTRUMENTS										HEWLETT-													
	LC-925	SR-7949	SR-4912	P-50	SR 9190R	PR-100	SR-1540	F-4902	LC-43SR	TI-1750	TI-30	TI-25	TI-50	SR-40	TI-55	TI-57	TI-58	TI-59	BUS. ANAL.	MBA	DATA-CHRON	PROGRAMMER	HP-80	HP-31E	HP-32E	HP-33E	HP-29C	HP-19C	HP-67	HP-91				
L	R	R	R	R	R	R	R	R	L	L	L	L	L	R	R	R	R	R	R	R	R	L	R	R	R	R	R	R	R	R	R			
D	D	D	D	R	R	1	D	L	L	L	L	L	L	R	R	R	R	R	R	R	R	L	R	R	R	R	R	R	R	R	R			
9	9	12	12	12	12	12	12	12	9	9	9	9	9	12	12	12	12	12	9	12	9	8	14	11	11	11	12	12	14	14	14			
S	S	S	S	S	S	S	S	S	S	S	S	S	S	S	S	S	S	S	S	S	S	S	S	S	S	S	S	S	S	S	S			
A	A	A	A	A	A	A	A	A	A	A	A	A	A	A	A	A	A	A	A	A	A	A	R	R	R	R	R	R	R	R	R			
1	2			4	4	2	1	2			15	3	15	15	9	9	9	9	15	15		15	R	R	R	R	R	R	R	R	R			
1	2	3	1	10	10	2	1	1	1	1	1	1	2	1	10	8	60	100	1	12	1	1	1	4	15	8	30	30	26	16	16			
S	S	F	F	F	F	F	F	F	F	S	C	C	C	C	C	C	C	C	C	C	C	F	C	C	C	C	C	C	C	C	C			
A	C	A	A	A	A	S	A	S	S	A	S	S	A	A	A	A	A	A	A	A	A	S	A	A	C	C	C	C	6	A	6			
24	19	49	P/49	40	P/4x	40	49	40	25	40	40	40	40	40	P/40	P/30	P/45	P/45	40	P/40	25	40	35	28	28	P/40	P/30	P/31	P/35	42	42			
T	T	T	T	T	T	T	T	T		T	T	T	T	T	T	T	T	T																
L/A	L/A	L/A	L/A	L/A	L/A	L/A	L/A	L/A		L/A	L/A	L/A	L/A	L/A	L/A	L/A	L/A	L/A	L	L					L/A	L/A	L/A	L/A	L/A	L/A	L/A	L/A		
P	P	P	P	H/P	H/P	P	H/P			P	P	P	P	P	P	P	P	P						P	H/P	P	P	P	P	P	P	P		
E/R	E/R	E/R	E/R	E/R	E/R	E/R	E/R	E/R		E/R	E/R	E/R	E/R	E/R	E/R	E/R	E/R	E/R	E/R	E/R	E/R			E	E/R	E/R	E/R	E/R	E/R	E/R	E/R	E/R		
S	S/N	S/N	S	S/N	S/N	S/N	S/N	S		S	S	S	S	S/N	S	S	S	S	S	S	S		S	S	S	S	S	S	S	S	S	S		
E/X	E/X	E/X	E/X	E	E/X	E/X	E/X	E/X		E/X	E/X	E/X	E/X	E/X	E/X	E/X	E/X	E/X	E/X	E/X					X	X	E/X	E/X	E/X	E/X	E/X	E/X		
S/C	S/C	S	S/C	S/C	S/C	S/C	S/C	S/C		S	S	S	S	S	S	S	S	S						S/C	S/C	S/C	S	S	S/C	S/C	S/C	S/C		
P	P	P/D	P/D	P	P/D		P/D							P/D	P/D	P/D	P/D	P/D						P	P/D	P/D	P/D	P/D	P/D	P/D	P/D	P/D		
				M	M/D		M/D							M/D	M/D	D	D	D	D	D	D	D	D	D	M/D	M/D	D	D	D	D	D	D		
S	S			S	S	S	S	S		S	S			S	S				S					S	S	S	S	S	S	S	S	S		
				L	L		L						L/C				L/C	L/C	L	L/C				L	L/C	L/C					L			
				F	P/F	P/F		F					F	F											F	F				F	F			
				I		I	S	S					S	S/1	S/1									S	S	S	S/1	S/1	S/1	S/1	S	S		
P/D		P		P/D	P/D		P/D		P	P	P	P	P	P/D				P/D	P/D	P			P/D				P	P	P/D	P/D	P/D	P/D	P/D	
								R											A/R				A/R											
				24/M		7.2								32	30/M	48	C	960			32						48/M	96/M	96/M	224/M				
				V		V								V				V			V						V	P	P	V	V	V		
																		M	C/M													C		
				3		1										6	4	4									8	8	8	8	8			
																2	6/P	6/P									3	3	3/P	3	3			
																			2	2														

PACKARD	NATIONAL SEMICONDUCTOR					SHARP					CANON					LLOYD'S			SINCLAIR		CASIO									
HP-92	NS-4510	NS-108	NS-6010	NS-4650	NS-104	EL-8145	EL-5804	EL-5806	EL-5808	PC-1201	EL-8138	CT-550	F 52	F 62	LC-MEM'D	LC-QUARTZ	650	619	617	CAMBRIDGE COLLEGE ENTERPRISE PROGRAMMABLE	FX-31	FX-39	FX-120	FX-2500	FX-3100	FX-8000	FX-48	AL-8		
R	R	L	L	R	L	L	L	L	L	D	L	L	L	L	L	L	D	L	L	D	D	D	L	L	L	L	L	D		
14	11	9	12	12	9	9	12	12	14	9	9	9	11	9	9	12	12	9	9	9	9	11	9	11	9	9	9	9		
S	S	S	S	S	S	S	S	S	S	S	S	S	S	S	S	S	S	S	S	S	S	S	S	S	S	S	S	S		
R	R	R	R	R	R	A	A	A	A	A	A	A	A	A	A	A	A	A	A	A	A	A	A	A	A	A	A	A		
30	20	1	1	1	1	2	1	1	12	1	1	1	1	1	21	1	1	1	1	1	1	1	1	1	1	1	1	1		
C	C	C	C	C	C	F	S	S	F	S	S	S	F	F	F	F	S	S	F	C	C	S	S	S	S	S	S	S		
6	8	C	C	A	A	S	S	S	A	S	S	S	S	S	S	S	A	S	S	C	C	A	C	S	S	S	S	A		
42	P/56	28	P/28	32	32	26	30	37	46	P/40	28	28	35	37	30	38	43	40	28	P/19	P/24	35	38	38	37	39	39	22	24	
L/A	L/A	L/A	L/A	L/A	L/A	L/A	L/A	L/A	L/A	L/A	L/A	L/A	L/A	L/A	L/A	L/A	L/A	L/A	L/A	L/A	L/A	L/A	L/A	L/A	L/A	L/A	L/A	L/A	L/A	
P	P	H/P	H/P	P	P	P	H/P	H/P	P	P	P	P	H/P	H/P	P	P	H/P	H/P	P	P	P	H/P	H/P	H/P	H/P	H/P	H/P	H/P	H/P	
E/R	E/R	E/R	E/R	E/R	E/R	E/R	E/R	E/R	E/R	E/R	E/R	E/R	E/R	E/R	E/R	E/R	E/R	E/R	E/R	E/R	E/R	E/R	E/R	E/R	E/R	E/R	E/R	E/R	E/R	
S	S	S/N	S	S	S	S	S/N	S/N	S/N	S	S	S/N	S/N	S/N	S	S	S	S	S	S	S	S	S	S	S	S	S	S	S	
E/X	E/X	E/X	E/X	E/X	E/X	E/X	E/X	E/X	E/X	E/X	E/X	E/X	E/X	E/X	E/X	E/X	E/X	E/X	E/X	E/X	E/X	E/X	E/X	E/X	E/X	E/X	E/X	E/X	E/X	
S/C	S/C	S/C	S/C	S/C	S/C	S	S/C	S/C	S	S	S	S	S	S	S	S	S/C	S/C	S/C	S/C	S/C	S/C	S/C	S/C	S/C	S/C	S/C	S/C	S/C	
P/D	P/D	P/D	P/D	P/D	P/D	P/D	P/D	P/D	P/D	P/D	P/D	P/D	P/D	P/D	P/D	P/D	P/D	P/D	P/D	P/D	P/D	P/D	P/D	P/D	P/D	P/D	P/D	P/D	P/D	
D	D	M/D	D	D	D	D	D	D	D	D	D	D	D	D	D	D	D	D	D	D	D	D	D	D	D	D	D	D	D	
S	S	S	S	S	S	S	S	S	S	S	S	S	S	S	S	S	S	S	S	S	S	S	S	S	S	S	S	S	S	
L	L	L/C	L	L	L	L	L	L	L	L	L	L	L	L	L	L	L	L	L	L	L	L	L	L	L	L	L	L	L	
F	F	P/F	F	F	F	F	F	F	F	F	F	F	F	F	F	F	F	F	F	F	F	F	F	F	F	F	F	F	F	
S	S	S	S	S	S	S	S	S	S	S	S	S	S	S	S	S	S	S	S	S	S	S	S	S	S	S	S	S	S	
P	P	P	P	P	P	P	P	P	P	P	P	P	P	P	P	P	P	P	P	P	P	P	P	P	P	P	P	P	P	
C	C	C	C	C	C	C	C	C	C	C	C	C	C	C	C	C	C	C	C	C	C	C	C	C	C	C	C	C	C	
D/C	D/C	D/C	D/C	D/C	D/C	D/C	D/C	D/C	D/C	D/C	D/C	D/C	D/C	D/C	D/C	D/C	D/C	D/C	D/C	D/C	D/C	D/C	D/C	D/C	D/C	D/C	D/C	D/C	D/C	D/C
B/D	B/D	B/D	B/D	B/D	B/D	B/D	B/D	B/D	B/D	B/D	B/D	B/D	B/D	B/D	B/D	B/D	B/D	B/D	B/D	B/D	B/D	B/D	B/D	B/D	B/D	B/D	B/D	B/D	B/D	B/D
P/D	P/D	P/D	P/D	P/D	P/D	P/D	P/D	P/D	P/D	P/D	P/D	P/D	P/D	P/D	P/D	P/D	P/D	P/D	P/D	P/D	P/D	P/D	P/D	P/D	P/D	P/D	P/D	P/D	P/D	P/D
A/R	A/R	A/R	A/R	A/R	A/R	A/R	A/R	A/R	A/R	A/R	A/R	A/R	A/R	A/R	A/R	A/R	A/R	A/R	A/R	A/R	A/R	A/R	A/R	A/R	A/R	A/R	A/R	A/R	A/R	A/R
224/M	99/M																													
V	V																													
C	C																													
8	2																													
3/P																														
1	1																													

CODE DEFINITION: 1. Desk Model with A/C Line Cord 2. Optional Printer PC-100A with A/C Cord 3. Displays Time, Date, plus Alarm and Stopwatch 4. Hex/Oct/Dec Conversions and Calculations 5. Built-in Calendar Easy Bond & Compound Calculation 6. Compact-Printing Capability 7. Optional Recharging Kit 8. 23 World Times, Alarm, Stop Watch 9. Calculates in Fractions 10. Scientific with Stop Watch and up-down Timers 11. Price includes 316 Programs in 3 Volume Books and A/C Adapter 12. has 21 Permanent Alphanumeric Memories plus 1 Data Memory.

REMARKS: Manufacturers Warranty on all Models is one Year from Date of Purchase and Service is performed in Canada. While most functions have been listed and defined in detail, some functions on certain Models may not have been covered adequately due to space limitations. For more detail and price/delivery information contact Customer Service at Marketron Corp. Ltd. at 416/923-1917. This information is provided without guarantees for accuracy.

PREPARED BY: MARKETRON CORP. LTD.
1240 Bay Street Mall
TORONTO, Ont. M5R 2A7
Phone: (416) 923-1917

Additional copies of this guide available upon request.

Foil patterns for the printed circuit boards. Note that 482A is double sided — all artwork is correct size.

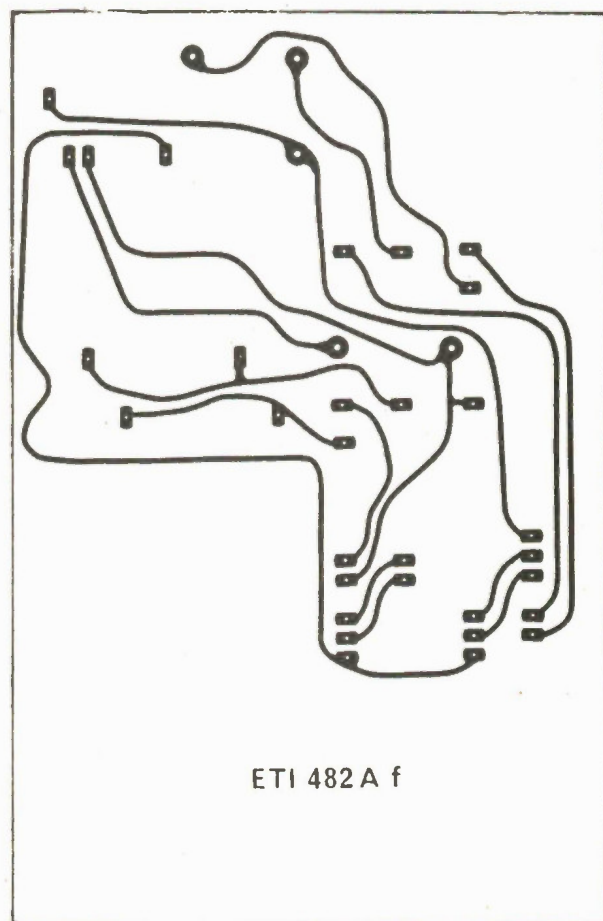
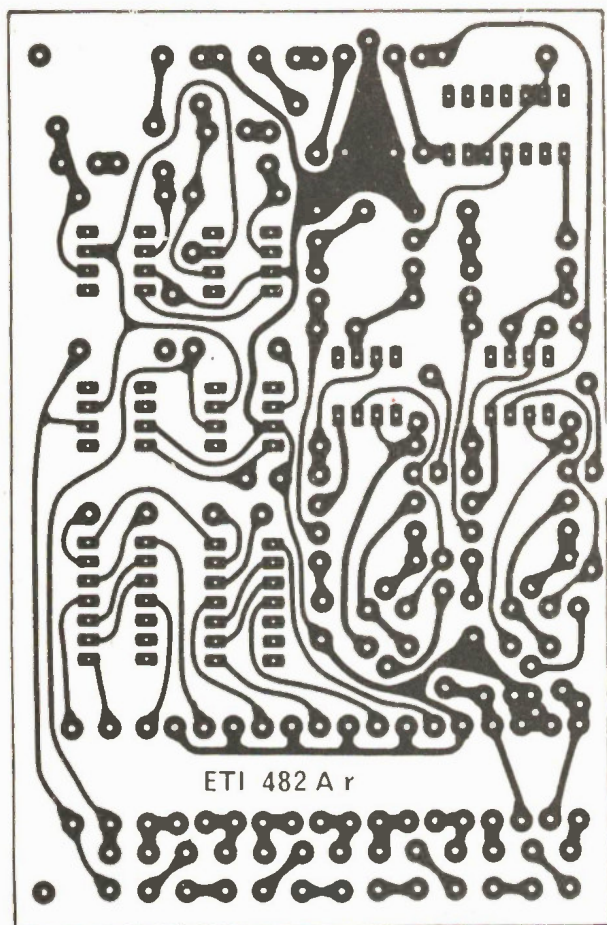

Club Call

GBARC

The Georgian Bay Amateur Radio Club is comprised of about 65 members, mostly in Grey and Bruce Counties. The club is quite active; some of the activities include supplying communications for snowmobile and car rallies, walkathons and bike-athons, as well as sponsoring Amateur

Radio courses and promoting Amateur Radio at fall fairs, etc.

Anyone interested in obtaining more information on the club, or Amateur Radio in general, should contact GBARC president Ian Sutherland at Box 592, Owen Sound, Ontario, N4K 5R1.

Thanks and "73".

Bill Taves, VE3IHV

Previously Listed Clubs

TRACE: Computer Club, Toronto. See p7 Jan 78 ETI.

CSWLI: SWL Club, Thunder Bay. See p7 Mar 78 ETI.

TRAC: Amateur Radio Club, Thornhill. See p7 Mar 78 ETI.

ODXA: SWL Club, Don Mills. See p61 Apr 78 ETI.

CCCC: Computer Club, Montreal. See p61 Apr 78 ETI.

ECEC: Electronics Club, Elphinstone. See p61 Apr 78 ETI.

CHSSCC: (Computer Club, Houston. See p37 May 78 ETI.

WIARC: Amateur Radio Club, Dorval. See p37 May 78 ETI.

OSWCC: SWL Club, Prescott. See p37 May 78 ETI.

LARC: Amateur Radio Club, London. See p. 61 June 78 ETI.

FGARC: Amateur Radio Club, Prince George, See p. 61 June 78 ETI

BARC: Amateur Radio Club, Burlington. See p71 July 78 ETI.

MARC: Amateur Radio Club, Montreal. See p71 July 78 ETI.

ROMS: Computer Club, Regina. See p66 Aug 78 ETI.

VPUG: PET Club, Vancouver. See p 65 Oct 78 ETI.

ACE: Computer Club, Hamilton. See p 65 Oct 78 ETI

Capacitance Meter

If you want to find out what values those odd capacitors are, then here's the instrument for you.

ONE OF THE HANDIEST instruments for an electronics hobbyist, or to have around an electronics workshop, is a capacitance meter. Every multimeter has a resistance scale — and it gets used quite often. But there is often a requirement for measuring capacitance, and few multimeters have a capacitance range.

For example, measuring the value of a variable capacitor used to temporarily 'trim' a filter or oscillator that is to be replaced by a set of fixed capacitors. Or a bagful of 'bargain' unmarked capacitors may have been obtained or the color code or numeral code has disappeared and the value of a component needs to be determined.

Once you have a capacitance meter, you suddenly find uses for it!

This capacitance meter provides a linear scale readout of the value of unknown capacitors generally to within 5% or as good as 2% depending on the accuracy of the meter used.

RANGE

The meter will measure capacitance values down to 5 pF and up to 1 μ F. Scale divisions on the model shown were at 2.5% intervals.

Five ranges are provided: 100 pF, 1 nF, 10 nF, 100 nF and 1 μ F.

Different ranges can be provided by selecting different values for the range resistors R7 to R11. For example, five ranges from 47 pF to 0.47 μ F could be included by changing R7 to 470 ohms, R8 to 4.7k etc. The meter scale would have to be hand-calibrated in this case.

CONSTRUCTION

The construction is quite straightforward. The majority of the small components are mounted on the printed circuit board. The range resistors are mounted on the switch lugs as illustrated in the photographs.



All the range resistors, R7 to R11, and R12 are high tolerance 1% or 2% resistors accurately measured to be within the tolerance required. If only 5% or 10% accuracy of capacitance

value is required then standard 5% or 10% tolerance resistors may be used, obviating the need for selecting them, or buying the expensive high tolerance types.

SPECIFICATIONS

Capacitance ranges	100 pF, 1 nF, 10 nF, 100 nF, 1 μ F.
Accuracy	5% or better (2% possible with component selection)
Calibration	by internal calibration capacitor
Power requirements	240 V AC or 2 x 9V No. 916 batteries

The printed circuit board, meter, range switch, potentiometers, pilot light measurement terminals and on/off switch are all mounted on the front panel as illustrated.

The power supply is mounted on the back panel, as is the mains/battery switch. The batteries (if used) may be mounted inside the case. Overall case size is 180 mm wide by 95 mm deep by 128 mm high.

A small tagstrip is used to terminate the mains input and transformer leads and the rectifier components. Both the back panel and the front panel should be connected to the mains earth which is terminated on the tagstrip, the strip's earth tag being secured under one of the transformer mounting bolts.

The calibration capacitor is a high tolerance (2% or better) polystyrene or, better still a silver mica type. This component is mounted from the appropriate switch lug to a suitable ground lug mounted on the front panel.

The printed circuit board has PC stakes (or pins) soldered in all the positions marked on the component overlay.

Two of these (marked E and Cx on the PCB artwork) are used to mount the PCB directly on the back of the "Cx" terminals, as illustrated in the photographs. This avoids increasing the circuit stray capacitance.

Little difficulty should be experienced if the component overlay is followed and the photographs are referred to during construction.

Note that alternative panel layout is possible if a standard type of panel

meter is used rather than the edgewise meter shown in the photographs.

The front panel was hand-lettered with Letraset on the prototype. A Scotchcal type front panel could also be prepared if desired.

The CAL. potentiometer is a screw-driver-adjust type and was mounted with a fixing collet. Knob-twiddlers can cause havoc.

USING THE METER

Once the instrument has been tested and confirmed to be in working order, switch the range switch to the 100 pF position and turn the SET ZERO control so that the meter reads zero with no capacitor connected to the Cx terminals. Then switch to the CAL. position and adjust the CAL. potentiometer so that the meter reads full scale.

Now you are set to measure all those 'unknown' capacitors.

Any devices used to grip capacitors being measured, and plugged into the Cx terminals, will add stray capacitance and this will need to be compensated for by readjusting the zero set control. However, this will only have to be done on the 100 pF and 1000 pF ranges as the added capacitance will be negligible on the higher ranges.

METERS

An edgewise-mounted panel meter was used in the prototype for several reasons. Firstly, we had one! Secondly, a scale nearly 50 cm long allowed us to calibrate the meter at very close intervals — 2.5% here, and still give accurate readout. Thirdly, the edge meter used little panel space, giving it a clean, uncluttered appearance.

A 0–1 mA meter was used as it has a convenient scale. If you use a range with

full-scale values of 47 pF to 0.47 μ F a 500 μ A FSD meter will have to be used.

The zero-set potentiometer, VR2, provides a small voltage offset as the output, pin 3, or IC1 does not go to zero volts and it also compensates for the effect of the small stray capacitance in the construction.

A calibration position is provided on the range switch for the sake of convenience. The original model did not have this refinement but we soon added it when we found out how useful it was! it also helps to maintain accuracy as a 'standard' capacitor does not have to be kept external to the instrument for this purpose — we kept losing ours until we put it in the circuit!

PARTS LIST

RESISTORS

R1	560k, ¼W
R2	470 ohm. ¼W
R3, 6, 13	1k5. ¼W
R4	120R
R5	10k, ¼W
R7	1k, ¼W. 2%
R8	10k, " " either use 2% tol.
R9	100k " " resistors or selected 5% or 10% tol. see text.
R10, 12	1M " "
R11	10M " "
RV1	10k Audio, screwdriver adjusted
RV2	500R Audio pot.

CAPACITORS

C1	3n3, Philips polystyrene or silver mica
C2	10nF greencap or ceramic
C3	1nF Philips polystyrene (selected, 2%) or silver mica, 2%
C4	100nF greencap
C5	100nF greencap
C6	640 μ F, 25V electrolytic

SEMICONDUCTORS

D1	1N4001
S1	DPST or DPDT, 250 V AC rated min. toggle switch
S2	SPDT or ½-DPDT min. toggle switch
S3	single pole, six-position OAK switch
Q1	2N2646
Q2	2N3904
IC1	LM555 or NE555 timer IC.
IC2	78L12 (preferred) or 7812 or LM340-T12

MISCELLANEOUS

T1	12.6 V C.T. @ 150 mA
Pilot	12 V, 20 mA bayonet lamp and holder.
Case	Instrument case,
M1	0-1 mA meter, see text
Sundries	pk screws, wire, batteries, nuts, bolts, tagstrip, etc.

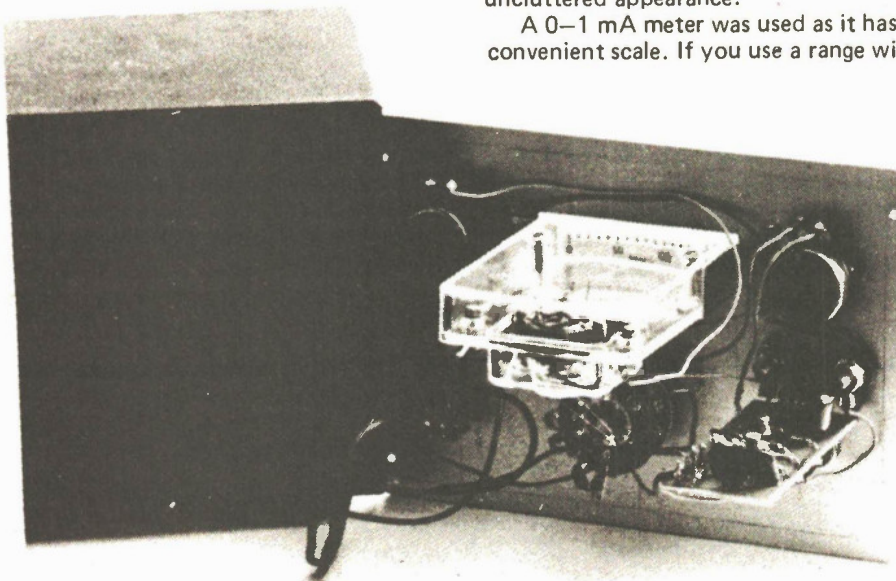

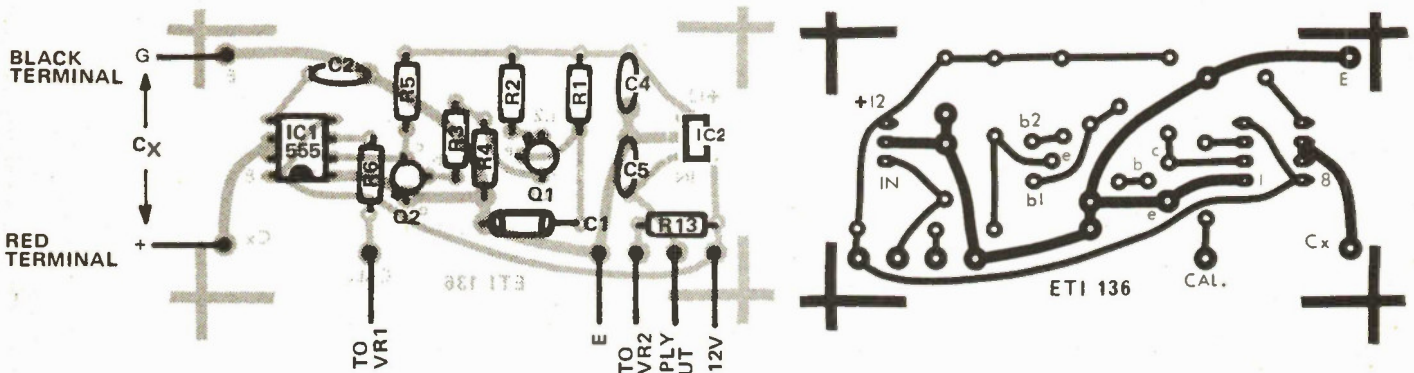
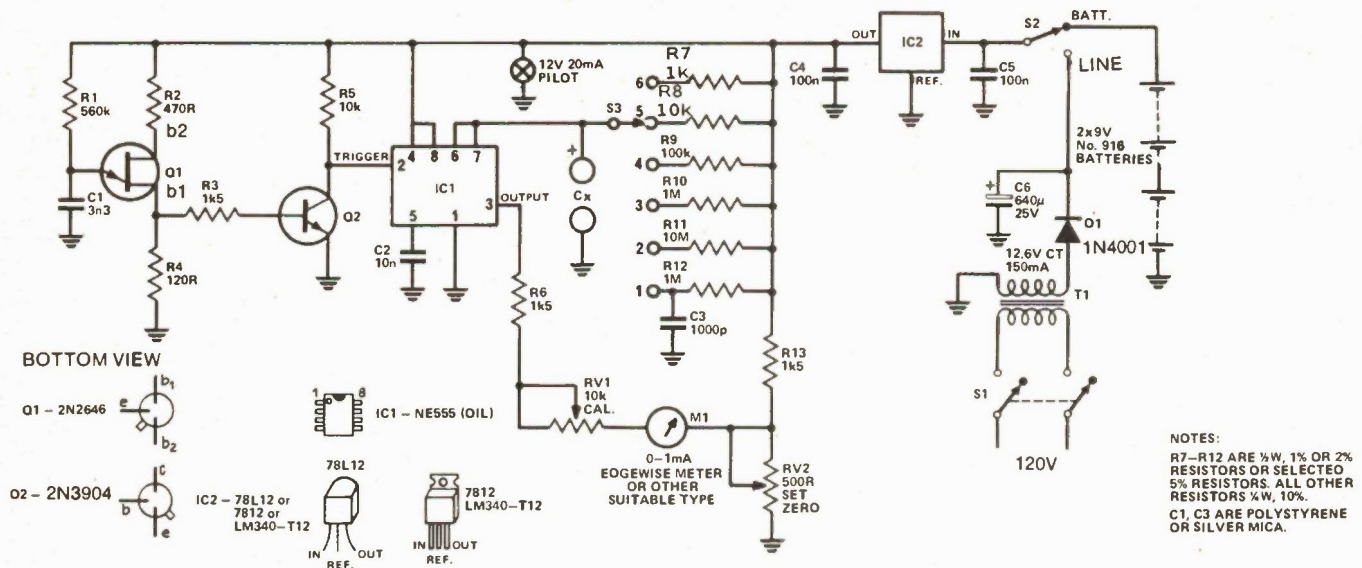

- INSERT P.C. STAKE IN HOLES MARKED **THUS**. Watch the orientation of IC2 carefully. For a 78L12 the flat face should be to the right, while for a 7812 the metal back should be to the left.

R7-R12 and C3 are mounted on the rear of the range switch

HOW IT WORKS

A unijunction transistor, Q1, is connected as a relaxation oscillator with a frequency determined by R1-C1. The frequency of oscillation in this instance is about 1 kHz.

Pulses of about 1 µs duration are produced across R4 each time the UJT "fires". The resistance between b2 and b1 of the UJT reduces to a low value each time the emitter conducts. Much of the charge stored in C1 is "dumped" across R4 for the short duration that the c-b1 junction of Q1 conducts.

The narrow pulses across R4 drive the base of Q2 via R3, which serves as a base-current limiting resistor. The pulses cause Q2 to conduct for the same duration, that is, about 1 µs, and negative-going pulses from the collector of Q2 drive the "TRIGGER" input of the 555 timer, IC1. This is connected to operate as a monostable in this circuit.

When IC1 receives a trigger pulse at pin 2, the flip-flop is set, releasing the short circuit across Cx and driving the output, pin 3, high. The voltage across the capacitor then increases exponentially for a period that depends on the value of the unknown capacitance Cx. The period is determined according to the formula:

$$t = 1.1 R_r C_x$$

At the end of the period, the comparator resets the flip-flop which in turn discharges the unknown capacitor, Cx, and drives the output to its low state.

This cycle is repeated each time a negative-going trigger pulse appears at pin 2 of IC1.

Thus as the range resistor value (Rr) is fixed, the ON/OFF ratio of the output voltage will be determined by the value of Cx. The ON/OFF ratio is independent of

the relaxation oscillator frequency and trigger pulse duration.

The current measured through the 'load' resistor on the output (R6) of IC1 will thus be directly proportional to the value of the unknown capacitance Cx.

The meter, M1, measures the current through R6, the meter inertia 'averaging' the current.

As the voltage at the output pin swings between about 2/3 Vcc and less than 1/3 Vcc in its 'high' and 'low' states respectively the DC offset is compensated for by returning the 'load' current through an offset voltage developed across VR2 via R13 from the supply rail.

Zero-setting is accomplished by making VR2 variable. A calibration control is provided by making a portion of the 'load' resistance variable - VR1 here.

ALPHA.TUNER.SERVICE

Tuners are our only business

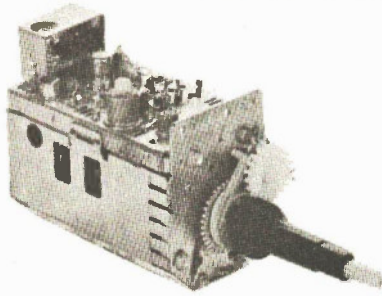

- VHF or UHF \$13.95
- Varactors \$13.95
- FM Tuners \$15.95
- UV Combo \$21.95
- Parts and workmanship carry full 12 months warranty.

Fast Coast-to-Coast Service

Fast 24 hour turn around service is our aim, to help you, keep your fast service promise.

All tuners and modules shipped in protective packaging to eliminate shipping damage. Only top quality components are used for replacement parts. Repairs to all makes and models at competitive prices.

All major parts and shipping charges at cost, (dealer net). Mail or bring your tuner repairs to our premises.

ats electronics

Suite 201, 8400 St. Lawrence Blvd.,
MONTREAL, Quebec, Tel (514) 381-5838



Oscilloscope Probe

This passive probe incorporates a three-position slide switch in the head, and has a cable length of 1.5 metres.

Position x1
Bandwidth: D.C. to 10MHz

Position Ref.
Probe tip grounded via 9MΩ resistor, oscilloscope input grounded.

Position x10
Bandwidth: D.C. to 100MHz
Input Resistance: 10MΩ ± 2% when used with oscilloscopes with a 1MΩ input.
Compensation Range: 15 - 50 pF
Working Voltage: 500 Volts (inc. Peak AC)

Other probes available are:-

- x1 20MHz
- x10 100MHz
- x1 and x10 150MHz
- x10 250MHz

Detector Probes
x100 Probes
H.V. Probes

Model No. P522
Dual switchable
X 1 and X 10 100 MHz

\$41.95

BCS

**ELECTRONICS
LIMITED**

UNIT 35, 980 ALNESS ST.
DOWNSVIEW, ONTARIO M3J 2S2

(416) 661-5585

BINDERS



In response to many requests from our readers we have arranged for binders to be made so that you can keep ETI's first Canadian volume together and protected from damage. The binders are covered in attractive leather-look black plastic and are designed to hold twelve issues. The ETI design is printed in gold letters on the spine.

The binders cost \$6.00 each, which includes postage and packaging. Do not send cash — you can pay by cheque, Mastercharge, or Chargex. Credit card orders must include your account number, the expiry date, and your signature. In all cases allow six weeks for delivery. Send your order to ETI Binders, Unit 6, 25 Overlea Blvd., Toronto, Ontario M4H 1B1. Don't forget to include your name and address. Ontario residents add PST.

Stars and Dots

Easy-to-build version of a popular brain tester.

THIS CODEBREAKER game is based on the traditional pencil-and-paper game known variously as 'Stars and Dots', 'Bulls and Cows', or 'Moo', and which has recently become popularised as 'Mastermind', and is usually played as follows. The first player sets down a four-digit code which his opponent must try to duplicate by a series of guesses for which he is awarded points. In one version of the game a star is given for each correct digit in the right position, and a dot for each correct digit in the wrong position.

ANALOGUE STARS

In the following illustrative game the hidden code is 1633:

	STARS	DOTS
1234	★★	
5634	★★	
3434	★	●
5233	★★	
5244		
1633	★★★	

The object of the game is to crack the code in the least number of guesses, and in order to achieve this it is necessary to analyse carefully the results of previous tries.

This electronic version of the game sets a random code and awards the appropriate score for each attempt, thus allowing the game to be played solo fashion. A pen and paper record is kept as before, or, if a 'Mastermind' board is used, the switches may be marked with colours rather than numbers. Each attempt is duplicated on the switches and the score is shown on the two meter movements. There is no indication in the score as to which of the digits is correct.

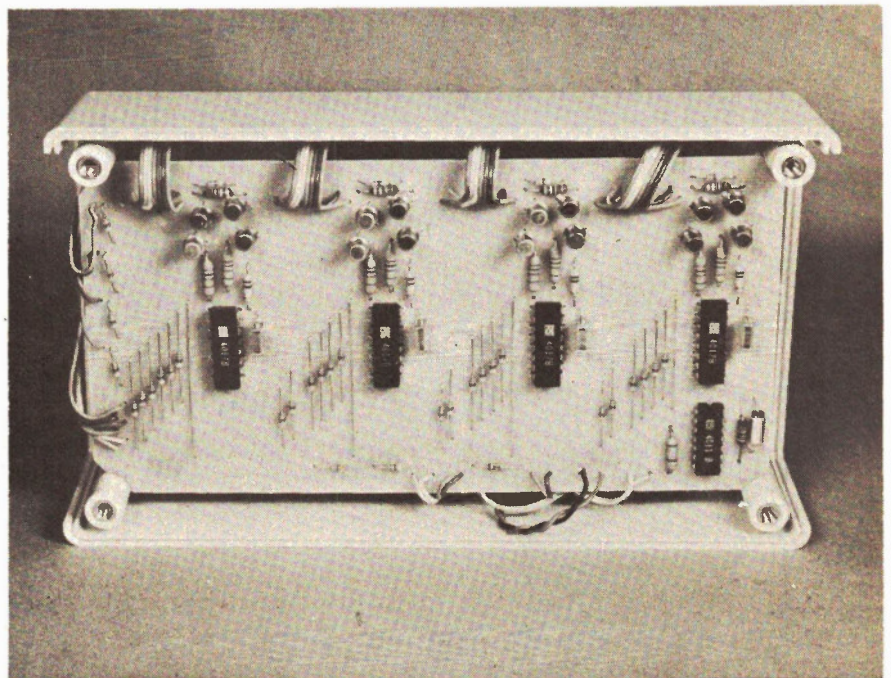
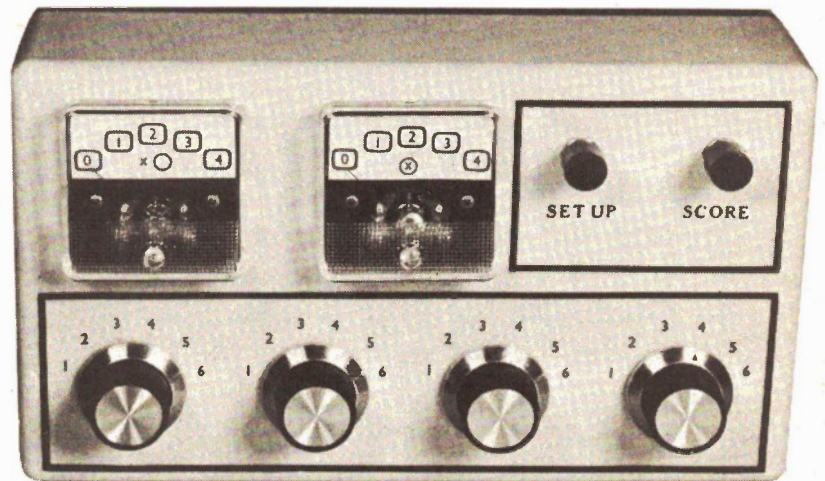

A look at the inside of our stars and dots game.

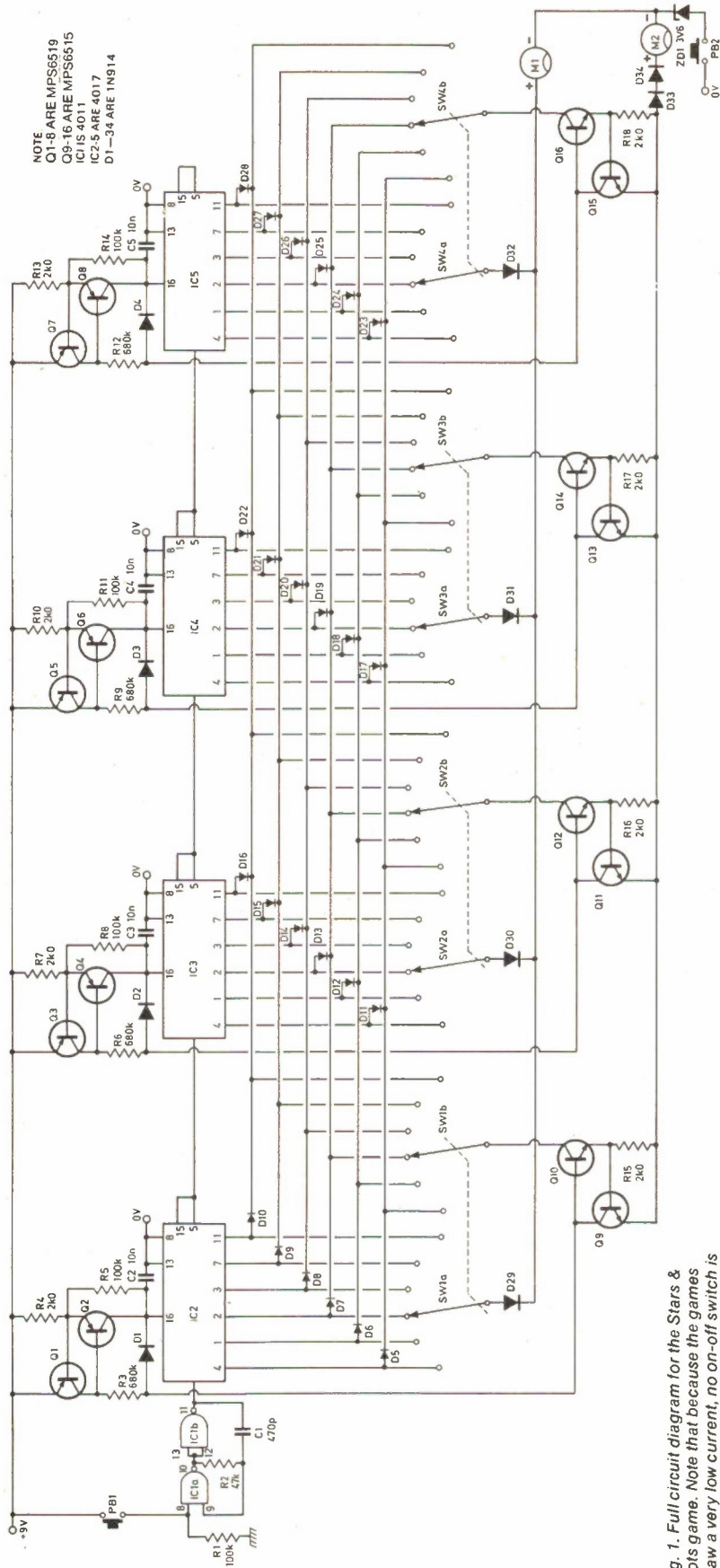

Fig. 1. Full circuit diagram for the Stars & Dots game. Note that because the games draw a very low current, no on-off switch is required or provided.

HOW IT WORKS

The random number generator consists of a four stage counter using 4017 decade counter ICs, locked by IC1 whenever the set-up switch (PB1) is depressed. The state of Q6=1, is unstable, resetting the IC to Q0=1, and also 'carrying' to the next stage. (Q# here refers to IC2-5 outputs). Supply current to each stage when the score button is depressed is limited to 0.25mA by constant current circuits, which means that this 'unit' of current is all that is available at whichever Q output is enabled. Continuity to the ICs at other times to enable the code to be stored is provided by the 100k resistors R5, 8, 11 and 14. The current drawn in this situation is so small as to make an on/off switch unnecessary, and the number remains stored until the set-up switch is again operated. If any of the switches is in the correct number/correct position situation a unit of current will be available at

each relevant switch's 'a' section to be 'added' by M1. This use of analog circuitry avoids the need to randomize the score—there is no indication of which of the stages is correct. Note also that when a switch is in this correct number/correct position situation none of this current is available to pass on to the common lines connected to the 'b' sections, because the diode becomes reverse biased. This is so because the voltage at this output is taken down to a little over ZD1 voltage, incidentally lowering Vdd also, to which it is tied internally. Turning now to the 'b' section of the switches, these deal with the situations where the correct number/incorrect position has been selected. Observe that Q0-Q5 is connected in each case by diodes to common lines, making its particular unit of current available to the other stages. And so if a switch selects the

correct number of another stage, current will flow through its 'b' section, this time to M2 via another constant current stage. These extra constant current stages are necessary for if, say, a switch selects a number which corresponds to the code in two other stages (e.g. code 1233; switches 3456) then two units of current would otherwise flow through M2 instead of the one unit due. If on the other hand two or more switches select a number which only appears once in the code, only one unit will flow because this is all that is available from the IC. The use of analog circuits in this way, by allowing the IC outputs to be commoned, results in a very simple circuit. When a switch has selected a correct number of its 'a' section, its 'b' section must be inhibited, otherwise it will also score on M2 if the same number exists in another stage. The voltage drop on VDD mentioned earlier is utilised to achieve this by removing, via a diode, the bias to the lower constant current stage concerned. The base voltages of the lower constant current stages are raised by the presence of the two diodes in series with M2 to facilitate this. The 3V6 Zener diode maintains a reasonable working voltage for each IC under all conditions, and without this the VDD connection would not follow closely any fall in a Q output level as described earlier. Total consumption is so low that the power requirement is met by an ordinary 9V battery, and if this doesn't last at least a year there's something wrong. Note that if both buttons are depressed together the input level rating of the 4017 IC5 is exceeded due to the changing level of VDD so although perhaps this is to be avoided no damage has resulted in practice when this has been done.

CONSTRUCTION

The version of stars and dots that appears here uses analog circuit techniques rather than the digital methods often used to implement the game. This has resulted in a number of improvements over other electronic versions of the game — namely simple circuitry and low power consumption, so low in the idle state that there is no need to fit an on/off switch to the project. The overlay shows the arrangement of

the onboard components but it can be seen there is a lot of interwiring to-from and between switches. Study the circuit diagram to familiarise yourself with what is going on and take care with this stage of construction as this is where mistakes are likely to occur.

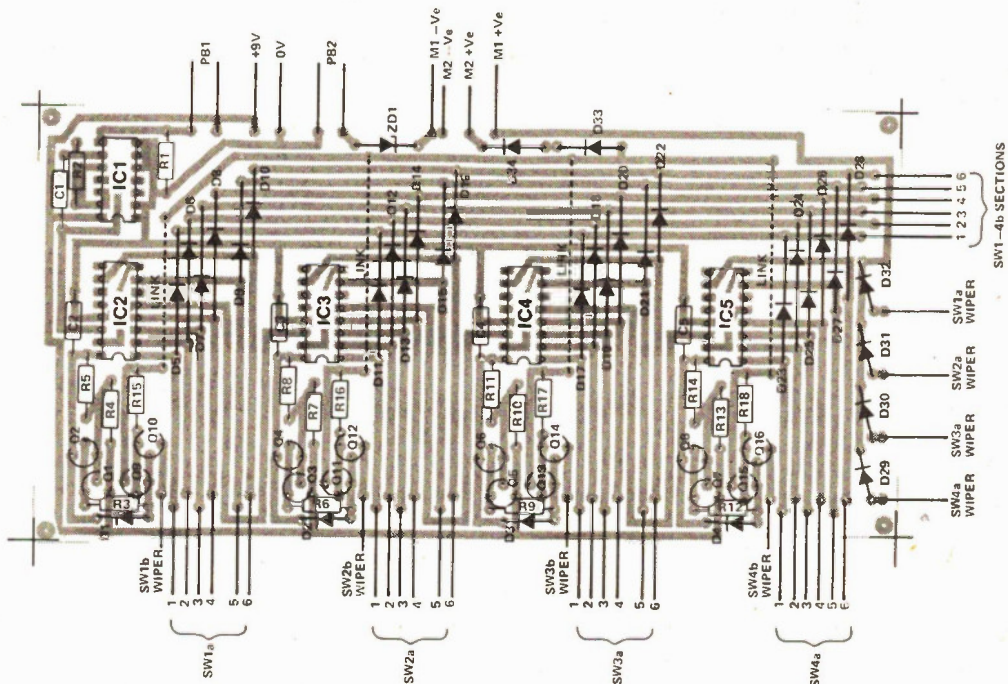

Above: Component overlay for the non-logic stars and dots game. Check IC orientation very carefully.
Right: Foil pattern for the game, shown full size at 175mm x 90mm.

PARTS LIST

RESISTORS (all 1/4w 5%)

R1, 5, 8, 11, 14 100k
R2 47k
R3, 6, 9, 12 680k
R4, 7, 10, 13, 2k0
R15, 16, 17, 18

CAPACITORS

C1 470p Polystyrene
C2, 3, 4, 5 10n Polyester

SEMICONDUCTORS

Q1-8 MPS6519
Q9-16 MPS6515
D1-34 IN914
ZDI 3V6 400mW

SWITCHES

PB1, 2 Single Pole Push-to-make
SW1-4 2p-6w Rotary

METERS

M1, 2 1 mA panel meter

MISCELLANEOUS

PCB as pattern, box to suit, battery

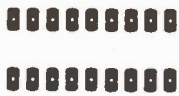

Ceresist

Industrial prototypes or one-off projects, Ceresist does enable quick printed circuit board construction.

We think we have finally found a good solution to the age old problem of producing **one** printed circuit board. As most readers are aware, using a pcb contributes a great deal to project or prototype in the way of neatness, consistent operation, reliability and *confidence* in the reliability. But who's going to go to the trouble of making a proper pcb for a single project or prototype? All that time consuming work with tapes, knife and stick on pads, and **then** you've still only got a master. From there you make a negative and then you're ready for the photo-pcb process.

If you are planning to make several pcs the same, the positive-negative photo pcb route is the way to go, but only perfectionists have ventured to use it for just *one* pcb. Results if you don't use the photo method? You either hand wire the circuit, or perhaps use a pcb pen or other mechanical method such as cutting the foil by knife. In the end however, you don't get a pcb which you can proudly show off to the neighbours.

There is help available! We've tried Ceresist, and it's like a breath of fresh air blowing away the photo resist developer fumes.

The product is simply a collection of "dry transfer" artwork, like Letraset and other lettering products, but shapes suitable for making circuit boards. It is applied directly to the copper clad blank board and forms the resist when you put the board in the etch bath.

STEP BY STEP

Let's go through how you would use it, step by step.

- 1) Finalize your circuit diagram.
- 2) Decide on the mechanical aspects of the circuit, such as size of case, and so on, so that you know the shape of board you need.

- 3) Find out the size of each component, and plan the rough layout of the printed circuit board; using 1/10 inch graph paper makes this step easy.

Note that steps 1 to 3 pretty well have to be done whatever method of construction you use.

- 4) Using carbon paper, roughly trace the design down onto the copper face of the blank board. (Note that your rough layout will either have to be drawn as a bottom view, or be on fairly transparent paper so that it can be traced from the back side.)
- 5) With the rough layout on the pcb, rub down with a pencil Ceresist artwork to make the actual resist pattern. Ceresist is available as IC pads, transistor pads, edge connectors, lines of various thicknesses and so on.
- 6) With the resist pattern complete it's tempting to go straight ahead and etch the board. However, it's a good idea to make a few photo copies of the board for future reference, noting component positioning, or even in case you do end up making a "master" for photo pcb method. (Naturally, Ceresist can be used for making pcb artwork, and in fact we have found the IC pads easier to position than the stick-on variety).
- 7) Now you can etch the board in ferric chloride or perchloride etching solutions.
- 8) After etching, the resist can be easily removed with a solvent such as benzine or gasoline, or by lightly scouring.

IT'S DONE

That's it. Well, you'll have to drill the holes etc, but getting to the stage of having an etched board has been the

most difficult part, and is now much easier.

Some other notes which are useful: The most important thing is to keep the board clean. This allows the transfers to stick, and also the etchant to get at the copper desired dissolved.

Large areas of masking need not be done with Ceresist, Scotch Magic Tape, and other adhesive films will work and are more efficient.

Letraset can be used for applying numbers and letters to be etched for board identification.

USEFUL

There is no doubt that this product fills a major need for single board production. It's also useful for repairing printed circuit boards prepared with photo resist before they are etched, as it frequently happens that the photo resist comes unstuck.

Finally, Ceresist is as good as any other method we know of making artwork masters, though at present it is only available in 1 to 1 scale (any other scale is obviously less useful for applying directly to the copper!)

So, no more giving up on that project or prototype you wanted to build, let's get etching!

Ceresist is available from many dealers in Ontario and British Columbia, including Dominion and Intek, with other outlets being arranged. Price is \$1.99 per sheet 10cm x 10 cm, a variety of different models are available including the popular DIP pattern (correctly spaced pads to accomodate up to 420 legs), transistors, lines, holes etc. Ceresist may also be ordered by mail from: Ceres, 53 Burnett Ave., Willowdale, Ontario M2N 1V2. Also see Ceres' ad in this issue.

LOOK WHAT YOU'VE BEEN MISSING

Since we started publishing ETI in Canada the circulation growth has been dramatic. That means that there's thousands of our readers who have missed some terrific issues.

The chart shows just the main features and projects in the various issues we have available, but for some months we are selling out fast so you'd better hurry and get your copies now. Just send us \$2 (not cash) for each issue you require, to ETI BACK-NUMBERS, Unit 6, 25 Overlea Blvd., Toronto, Ontario M4H 1B1.

Features

THE CN TOWER: MORE THAN JUST A LANDMARK. 22	The technical features in the world's tallest building
BIORYTHM CALCULATOR 24	Find out your condition from a machine!
VCT 31	Can these new devices kill off the off-amp?
555 TIMER APPLICATIONS 35	38 circuits using this popular IC.
YAMAHA B1 REVIEWED 49	Powerful amplifier uses power FETs.
SCOPE TEST YOUR CAR 60	Tune your automobile with just a scope
MICROFILE 65	Microprocessors and microcomputers for the hobbyist
Projects	
FIVE WATT STEREO AMPLIFIER 16	Use just two ICs to make this project.
PHILIPS LOUDSPEAKER SYSTEM 27	An off the shelf speaker!
REACTION TESTER 52	Measure your reaction time against your friends!
SHORT CIRCUITS: PATCH DETECTOR HEADS OR TAILS SCR TESTER 55	

FEB 77

Features

PROJECTION TV 20	The big silver screen in your home
741 COOKBOOK 28	A thorough look at the Op Amp
CATALOGUE SURVEY 51	A look at what's available from whom. By mail
EASIER WAY TO MAKE PCB's 57	How to copy out E.T.I.'s patterns
CHOOSING A MICROCOMPUTER 60	The choice now in Canada is pretty wide
Projects	
BURGLAR ALARM 13	Follow on progress right last month's feature
CERAMIC CARTRIDGE PREAMP 17	Circuits for superior performance
NI-CAD BATTERY CHARGER 43	Tap into your stash with this project
SHORT CIRCUITS: BENCH POWER SUPPLY FUZZ BOX 47	
STEREO RUMBLE FILTER 54	Eliminate rumble noise

MAY 77

Features

DIGITAL SOUND SYNTHESIS 16	From monophonic to polyphonic
A GENERATION AWAY 25	Evolution or revolution
MULTIMETER GUIDE 30	Makes sure you get what you want
LIQUID CRYSTAL DISPLAYS 40	What goes on behind the screen
INTRODUCTION TO COMPUTERS 44	What's involved and how it's evolved

Projects

G.S.R. MONITOR 12	Learn to relax with this unit
TAPE/SLIDE SYNC 36	Update your slide shows
SHORT CIRCUITS	
INJECTOR TRACER 54	
METRONOME 56	
DRILL CONTROLLER 57	

JUNE 77

Features

A GENERATION AWAY 2 10	Evolution or revolution
P.L. EXPLAINED 17	The low technology
C.B. SUPPLEMENT 27	Techniques and technology
INTRODUCTION TO COMPUTERS 2 40	What's involved and how it's evolved

Projects

MASTERMIND 21	Codebreakers electronic game
DIGITAL VOLTMETER 45	High quality test gear!
SHORT CIRCUITS: THE OVERLED TURN INDICATOR CANCELLER 53	

JULY 77

Features

PICKUP PRINCIPLES 20	
SCIENTIFIC CALCULATOR REVIEW 26	
BITS BYTES AND BAUDS 34	
INTRODUCTION TO THE OSCILLOSCOPE 2 37	
ACTIVE FILTERS 2 56	

Projects

AUDIO SWEEP OSCILLATOR 10	High quality test gear!
SHORT CIRCUITS: SOIL MOISTURE INDICATOR 46	
MICROAMP 49	
ELECTRONIC BONGOS 51	
ALARM ALARM 53	

SEPT 77

Features

BASIC CONSTRUCTION METHODS 8	
MICROBIOGRAPHY 17	
LASERS AT PLAY 24	
VFETS FOR EVERYONE Part 2 33	
CHARGE COUPLED DEVICES 41	
BITS BYTES AND BAUDS 50	
THE FIRST CENTURY 52	

Projects

DIGITAL THERMOMETER 12	
SHORT CIRCUITS: THREE-CHANNEL TONE CONTROL 22	
WATCHDOOG 28	

NOV 77

PROJECTS

FIFTY WATT PER CHANNEL AMPLIFIER 28	An easy way to achieve 50W
SPIRIT LEVEL INTOXICATION INDICATOR 37	For those who drink the higher you rise
EGG TIMER 41	We don't have our readers using grainy, overcast photos

FEATURES

AM STEREO 6	How it operates, how to use
BATTERIES 12	How to choose, how to use
THE TUBES THAT WON THE WAR 23	Are they still doing their duty?
DATASHEET 43	How to use an IC datasheet
THE ONE-ARMED MPU 46	How to use an MPU to regulate furnace load
MICROBIOGRAPHY 51	How to use an MPU to regulate furnace load
BITS, BYTES, AND BAUDS 57	Microprocessors and the data stream
TECH TIPS 61	Tips for experimenters
FEEDBACK 64	Letters from our readers

DEC 77

PROJECTS

ETI CLOCK 21	A versatile IC allows you several options
LED PENDANT 25	Excitingly easy to build there's a gift
COMPANION 31	Our simple television remote device for the fish constructor

FEATURES

NOISE REDUCTION TECHNIQUES 8	A look at the different systems available
NOISE REDUCTION BY AUTO-CORRELATION 12	A look at one phase of the noise
MAKE PCB'S FOR ETI PROJECTS 16	You can make your own boards at home
TRANSMISSION LINES 37	How to get signals from A to B, with minimum loss
DATA SHEET 42	The CMOS: How AMS to IC datasheet
CONVERT YOUR TV FOR VIDEO INPUT 45	So you can plug in your video game or computer, without a modulator
BITS, BYTES AND BAUDS 57	Bit patterns introduced more basic computer concepts
MICROBIOGRAPHY 56	The most the RCA CMOS microprocessor COSMAC
TECH TIPS 61	Tips for experimenters
FEEDBACK 64	Letters from our readers

JAN 78

PROJECTS

TACHOMETER 25	A simple guide to effective gear-changing
DIGITAL PANEL METER 32	An accurate digital voltmeter with liquid crystal display
CB POWER SUPPLY 44	A heavy-duty design for using your mobile rig at home
FREEZER ALARM 46	A simple way to safeguard against accidental defrosting

FEATURES

THE COMMODORE PET 10	Answer to the question everyone is asking
ELECTRETS EXPLAINED 20	The most important of many microphones, cartridges and headphones
CLASS C AUDIO AMPLIFIER 22	A new technique used in the recent Dynaflex 'rungs'
DATA SHEET 32	The Intel 1617 1607 digital panel meter IC
TRANSFORMERS 52	How to choose them, how to use them
BITS, BYTES & BAUDS 57	Bit patterns introduced more basic computer concepts
SINCLAIR CAMBRIDGE PROGRAMMABLE CALCULATOR 60	A cheap programmable with astonishing branching
TECH TIPS 64	Tips for experimenters

FEB 78

PROJECTS

HAMMER THROW GAME 18	An 8080 based version of the bumper ball!
TRUE RMS VOLTMETER 22	Using an 8080 microprocessor
HOME BURGLAR ALARM 28	A distributed CMOS design

FEATURES

EQUALISATION 8	Water Retains explains one of the techniques available on audio
DATA SHEET 37	How to use an IC datasheet
THE C20H JUNGLE TELEGRAPH 40	The most important of many microphones, cartridges and headphones
BITS, BYTES AND BAUDS 43	Bit patterns introduced more basic computer concepts
MICROBIOGRAPHY 47	The most the Intel 1617 1607 digital panel meter IC
ETI SOFTSPOT 51	Software for your programmable calculator
TECH TIPS 58	Tips for experimenters
FEEDBACK 63	Letters from our readers
THE FUN OF ELECTRONICS 65	Just for a laugh

MARCH 78

PROJECTS

COMPUTER POWER SUPPLY 28	For those who don't want to pay for it
BUCKET-BRIGADE AUDIO DELAY LINE 32	The best of both worlds
GAS ALARM 42	Protect your home your dog your car etc.

FEATURES

AUDIO TODAY 9	How to choose, how to use
AUDIO TODAY, LETTERS 12	After the first week, how to use
WE REVIEW THE TRS-80 COMPUTER 15	How to use an IC datasheet
P.F.T.S. EXPLAINED 22	How to use an IC datasheet
ETI DATASHEET 36	How to use an IC datasheet
BITS, BYTES & BAUDS 47	Bit patterns introduced more basic computer concepts
ETI SOFTSPOT 49	Software for your programmable calculator
TECH TIPS 57	Tips for experimenters
CLUB CALL 61	How to use an IC datasheet
FEEDBACK 63	Letters from our readers
THE FUN OF ELECTRONICS 65	Just for a laugh

APRIL 78

8063 Power Amp Driver

THE ICL8063 from Intersil drastically reduces the number of components needed for construction of a power amplifier.

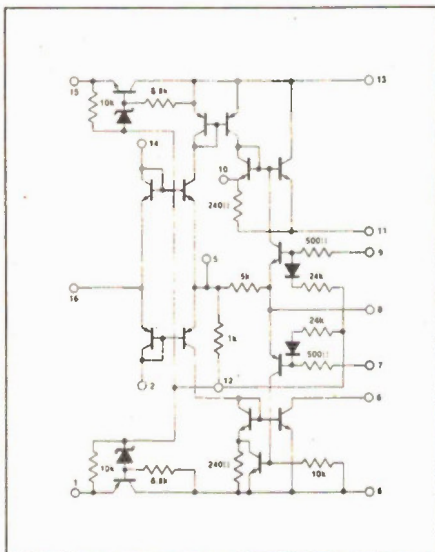

Fig. 1. Schematic diagram.

The ICL8063 is a unique monolithic power transistor driver and amplifier that allows construction of minimum chip power amplifier systems complete with safe operating area circuitry, short circuit protection and built-in voltage regulators, without adding extra power supplies. It is primarily intended for complementary symmetrical outputs.

Designed to operate with all varieties of operational amplifiers, two external power transistors of any construction technique and 8 to 10 passive components, the ICL8063 is ideal for use in such applications as linear and rotary actuator drivers, stepper motor drivers, servo motor drivers, power supplies and power DACs.

The ICL8063 takes the output levels (typically $\pm 11V$) from an op amp and boosts the levels up to $\pm 30V$ to drive any power transistors, (e.g. 2N3055 (NPN) and 2N3789 (PNP)). The outputs from the ICL8063 drive the external power transistors' base leads with up to 100 mA of current.

This amplifier-driver contains internal positive and negative regulators to drive an op amp, or other circuits; thus, only $\pm 30V$ supplies are needed for a complete power amp.

Fig. 2. Connection diagram.

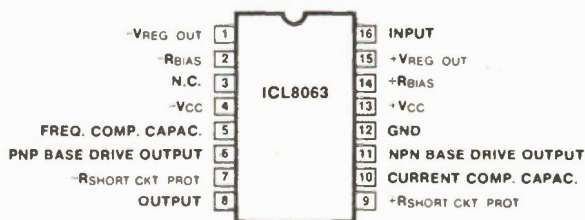

The ICL8063 provides built-in power supplies and will operate from inputs generated by most of the op amps in use today - regardless of technology - as well as many other linear functions, such as timers, comparators and waveform generators. And it will drive almost all power transistors with breakdown voltages up to 70 volts.

ICL 8063 POWER AMPLIFIER

As Figure 3 shows, using the ICL8063 allows the circuit designer to build a power amplifier block capable of delivering ± 2 amperes at ± 25 volts (50 watts) to any load, with only three additional discrete devices and 8 passive components. Moreover, the circuit draws only about ± 30 milliamperes of quiescent current from either of the $\pm 30V$ power supplies. A similar design using discrete components would require anywhere from 50 to 100 components.

Slew rate is about the same as that of a 741 op amp by itself, except that the output current can slew up to 2 amps at roughly $1V/\mu s$ (that's a 10 ohm load to ground and $\pm 20V$ output across this resistance). Input current, voltage offset, CMRR and PSRR are also the same. Use of 1,000 picofarad compensation capacitors (three in this configuration) allows good stability down to unity gain non-inverting (the worst case). This circuit will drive a $1000pF C_L$ to Gnd, with no significant problems. In other words the circuit can drive 30 feet of RG-58 coaxial cable for line driver applications with no problems.

As figure 4 indicates, setting up a current limiting (safe area) protection circuit is straightforward. The 0.4 ohm, 5 watt resistors set the maximum current one can get out of the output. The equation this SOA circuit follows is:

$V_{OUT} + I_L \times 0.4\Omega = 0.7V + I(24.5k)$.
 When $I_L R_3 - I R_2 = 0.7V$ safe area protection is achieved.

As these equations indicate, maximum power delivered to a load is obtained when $V_{OUT} > 24V$, the optimum voltage one needs when driving any DC motor, actuator, etc.

When buying external power transistors, careful attention should be paid to beta values. For 2N3055 and 2N3789 transistors used in this circuit, beta should be no more than 150 max at $I_C = 20\text{ mA}$ and $V_{CE} = 30V$. This beta value sets the quiescent current at less than 30mA when not delivering power to a load.

The design in Figure 3 will tolerate a short to ground indefinitely, provided adequate heat sinking is used. However if V_{OUT} is shunted to +/-30V the output transistors (2N3055 and 2N3789) will be destroyed. But since the safe operating area for both devices is 4 amps at 30 volts, the problem does not occur for $V_{CC} = +/-15V$.

ELECTRICAL CHARACTERISTICS (@ 25°C; $V_{CC} = \pm 30V$)

SYMBOL	CHARACTERISTIC	TEST CONDITIONS	MIN/MAX LIMITS			UNITS
			ICL8063C			
			0°C	+25°C	+70°C	
V_{OS}	Max. Offset Voltage	See Figure 1	150	75	75	mV
I_{OUT}^+	Min. Positive Drive Current	See Figure 2	40	40	40	mA
I_Q^+	Max. Positive Output Quiescent Current	See Figure 3	600	300	300	μA
I_{OUT}^-	Min. Negative Drive Current	See Figure 2	20	20	20	mA
I_Q^-	Max. Negative Output Quiescent Current	See Figure 4	600	300	300	μA
V_{REG}^\pm	Regulator Output Voltages Range	See Figure 5	± 13.7 $\pm 1.0V$	± 13.7 $\pm 1.0V$	± 13.7 $\pm 1.0V$	V
Z_{IN}	A.C. Input Impedance	See Figure 6	400	400	400	k Ω
V_{CC}	Power Supply Range		$\pm 5 - \pm 35V$			V
I_{CC}	Power Supply Quiescent Currents		12	7	7	mA
A_v	Range of Voltage Gain	See Figure 7 $V_{IN} = 8V_{p-p}$	6 ± 2	6 ± 2	6 ± 2	V/V
$V_{OUT(MIN)}$	Minimum Output Swing	See Figure 7; Increase V_{IN} until V_{OUT} flattens	± 27	± 27	± 27	V
I_{IN}	Input Bias Current	See Figure 8	100	100	100	μA

SIMPLE FUNCTION GENERATOR

Using a variation of the fundamental power amplifier building block described in the previous section, the ICL8063 can be utilised in the design of a simple, low cost function generator (Figure 6). It will allow generation of sine waves, triangular waves and square waves at the output from 2 hertz to 20 kilohertz. V_{OUT} will be up to +/-25V (50V p-p) across loads as small as 10 ohms (that's about 2.5 amps maximum output current).

All capacitor working voltages should be greater than 50V DC. All resistors should be 500 mW, unless otherwise indicated. Keep the interconnecting leads from pin 2 of the 741 to the 10k-ohm feedback resistor and 10k-ohm amplitude adjust potentiometer as short as possible. Less than 2 inches long is best, since this point is the summing junction of an operational amplifier. Failure to do so results in oscillation problems. Because of the slewing of the 741, the generator will not produce a 56V p-p amplitude all the way up to 20 kHz. Full output swing is possible up to about 5 kHz. Beyond this point slewing begins and undistorted p-p output will diminish. Due to this effect, amplitude at 20 kHz is about 20V p-p (+/-10V). This could be remedied by using a higher slew rate op amp such as the LF156.

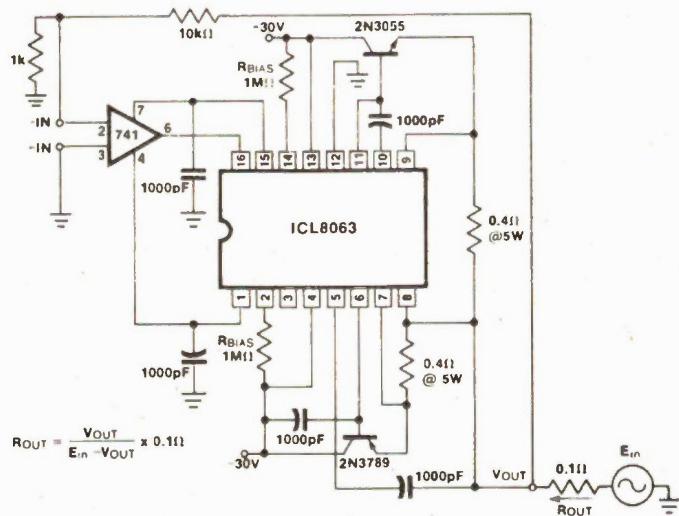

Fig.3. Power Amplifier System.

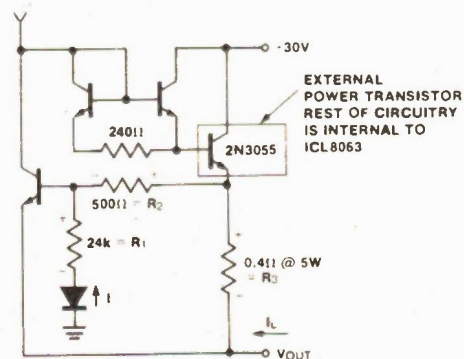

Fig.4. Overload protection circuitry.

LOW COST HI-FI AMPLIFIER

For about \$20 per channel, it's possible to build a high fidelity amplifier using the ICL8063 capable of driving 8 ohm speakers. A channel is defined here as all amplification between turntable or tape output and power stage to drive 8 ohm speakers (Figure 7).

The input 741 stage is a preamplifier with RIAA equalisation for records (disc). Following the first 741 stage is a 10k-ohm control pot, whose wiper arm feeds into the power amplifier stage consisting of a second 741, the ICL8063 and the power transistors. To achieve good listening results, selection of proper resistance values in the power amplifier stage is important. Best listening is at a gain value of $6[(5k\Omega + 1k\Omega)/1k\Omega = 6]$. Don't go below 3, since the first stage 741 preamp puts out only +/-10 volt maximum signals. So, if maximum power is necessary this value must be multiplied by 3 to get +/-30 volt levels at the output of the power amp stage.

Each channel delivers about 56 volts p-p across an 8 ohm speaker and this converts to 50 watts RMS power. This is derived as follows:

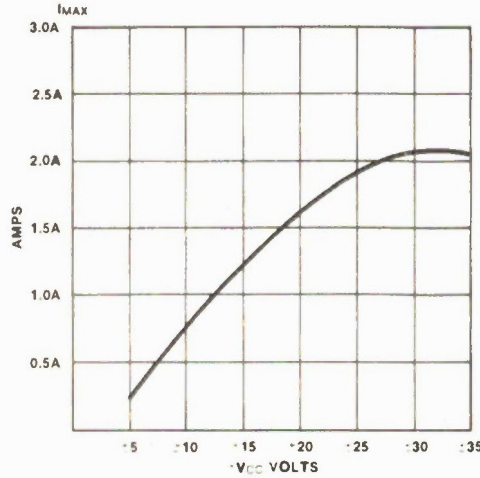

Fig.5. Output current capability for varying supply voltages.

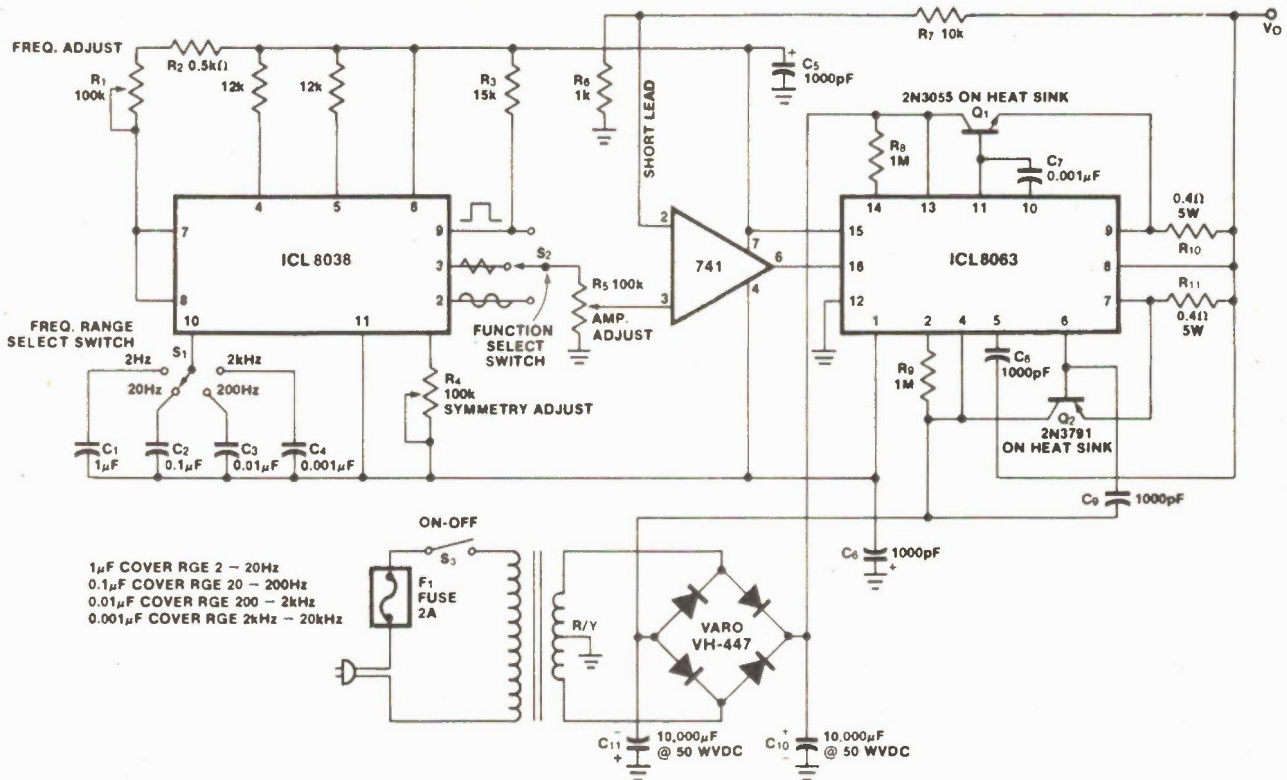

Fig.6. Power function generator.

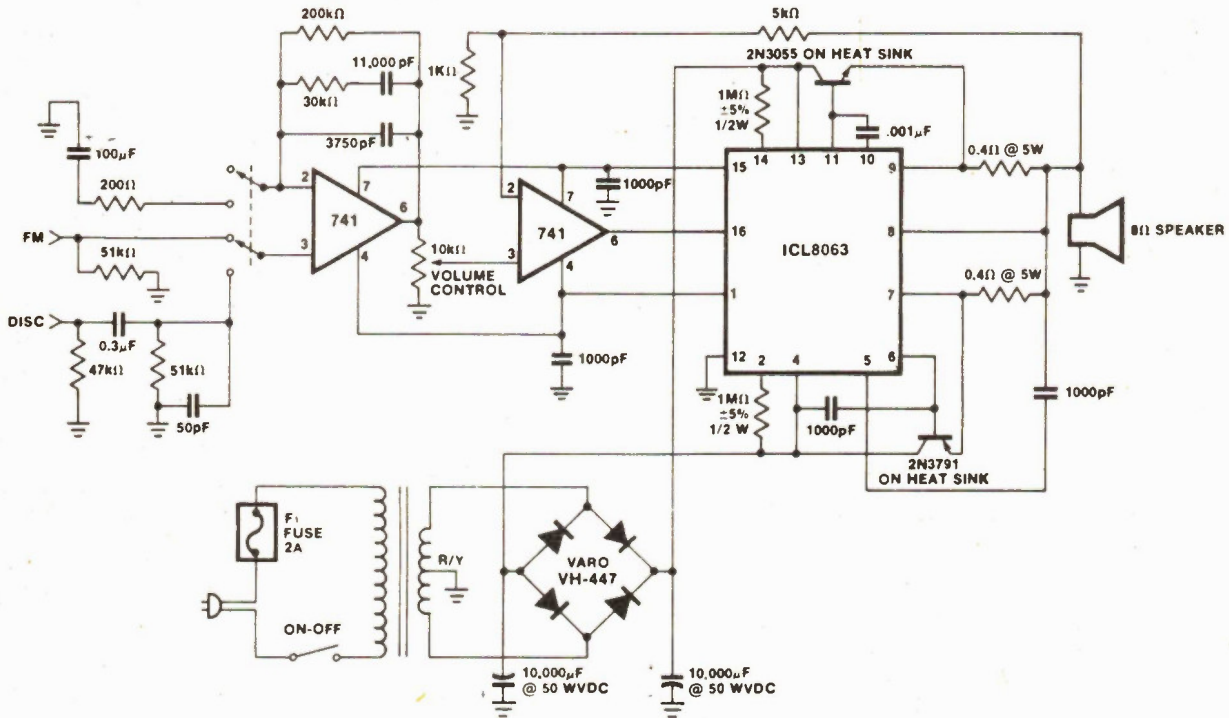

Fig.7. One channel of a hi-fi amplifier.

$$\text{Power} = \frac{V_{\text{rms}}^2}{8 \text{ ohms}}$$

$$V_{\text{rms}} = \frac{56V_{\text{p-p}}}{2.82} = 20V,$$

$$\therefore \text{Power} = \frac{400^2}{8 \text{ ohms}} = 50 \text{ watts RMS Power}$$

Distortion will be < 0.1% up to about 100 Hz, and then it increases as the frequency increases, reaching about 1% at 20 kHz.

The ganged switch at the input is for either disc playing or FM, either from an FM tuner or a tape amplifier. Assuming DC coupling (not capacitive coupling) on the outputs, there is no need for a DC reference to ground (resistor) for FM position. To clear the signal in the FM position, place a 51k-ohm resistor to ground as shown in Figure 7 (from FM input position to ground).

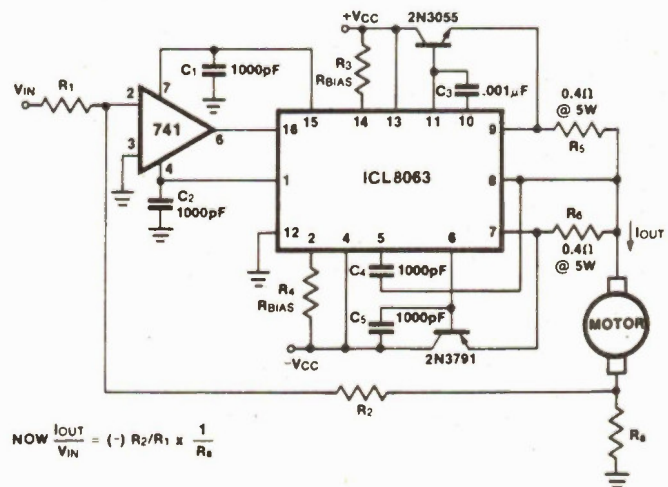

$$\text{NOW } \frac{I_{\text{OUT}}}{V_{\text{IN}}} = (-) R_2/R_1 \times \frac{1}{R_6}$$

Fig.8. Constant current motor drive.



PERSONAL COMPUTER PRODUCTS

Top Quality
Factory Tested
Products
Money Back
Guarantee

The first to offer Prime Products to the Hobbyist
at fair prices now lowers prices even further!

S 100 Products

8080 CPU Board
S 100 Compatible with Vector
Interrupt Fully Socketed
Assembled & Tested \$209.95

8K Static Ram Board
Assembled & Tested
(450 NS) \$243.95

16K Static Ram Board (450 NS)
*Memory Mapping
*Phantom
*Address 1K Boundaries
*Power 1.8 Amps Typ.
*Uses 2114 \$743.95
*S 100 PCP Cabinet

*19 Inch Retma Mounting
*16 Slot Terminated Motherboard
*25 Amp Power Supply
Assembled & Tested \$945.95

Microprocessors

8080 A \$28.95
8008-1 \$18.50

Static Rams

21 LO2 (250 NS) \$ 2.25
and/or Equivalents
2114 (450 NS) \$12.50

Connectors

50/100 (S-100) \$ 7.50
22/44 Dual \$ 5.95

Proms

2708 \$23.95
1702A \$14.95

Orders with cashiers cheque,
money order/charge card
shipped day of receipt.

All shipments under \$100.00 add 5% handling & postage. Orders over \$100.00 add
2 1/2% handling & postage. Ontario residents add 7%.
Mastercharge/ChargeX/COD accepted with 25% cash deposit.

**68 Shorting Road, Agincourt
Ontario, M1S 3S3. Tel. (416) 291-6860**

All in ETI's 741 Cookbook:

Differential voltage comparator	boosted output
Open-loop inverting DC amplifier	Unity-gain inverting DC adder (audio mixer)
Closed-loop inverting DC amplifier	Unity-gain balanced DC phase splitter
Non-inverting DC amplifier	Unity-gain differential DC amplifier (subtractor)
Unity-gain DC voltage follower	Semi-log AC voltage amplifier
X100 inverting DC amplifier	Constant-volume amplifier
Variable gain inverting DC amplifier	1kHz tuned amplifier (twin-T, acceptor)
High impedance x100 inverting DC amplifier	1kHz notch filter
X100 inverting AC amplifier	Variable low-pass filter
Non-inverting x100 DC amplifier	Variable high-pass filter
Non-inverting variable-gain DC amplifier	Variable-voltage supply
High input impedance, non-inv, x100 AC amplifier	Stabilised power supply
Non-inverting x100 AC amplifier	Stabilised power supply with overload protection
DC voltage follower	Precision half-wave rectifier
AC voltage follower	Precision half-wave AC/DC convertor
Very high input impedance voltage follower	DC voltmeter converter
Unidirectional DC v-follower, boosted output	DC voltage or current meter
Bidirectional DC v-follower,	Precision DC millivoltmeter
	Precision AC millivoltmeter
	Linear-scale ohmmeter
	Audio Wien-bridge oscillator
	Square-wave generator
	Precision temperature switch

Available from ETI for \$2 (includes postage). Just order our May 1977 issue from ETI Back Issues Dept, Unit Six, 25 Overlea Blvd, Toronto, M4H 1B1.

CLASSIFIED

HAMTRADERS INC.
45 BRISBANE ROAD, UNIT 18
DOWNSVIEW, ONTARIO M3J 2K1
"CANADA'S FRIENDLIEST
AMATEUR RADIO STORE"

Write for FREE literature
Tel (416) 661-8800

NORTHERN BEAR ELECTRONICS

Box 7260, Saskatoon, Sk S7K 4J2

CA3130 2.99, LM301 .65, LM555 .75,
TIP3055 1.95, 24VCT, 300 mA XFMR 4.50
8080A 17.95, 6800 29.95, SC/MPII 29.50
Nov. only-25K vert. Trim Pots 4/2.00

All orders add \$1.00. Sask. add tax.
Request FREE flyer, TODAY!

J & J ELECTRONICS LTD.,
P.O. Box 1437 E,
Winnipeg, Manitoba R3C 2Z4

Semiconductor Specialists
Do you get our bargain flyers? Send
\$1.00 to receive the current literature
and specials and to be placed on the
mailing list for the future publications.

Are you interested in Studio
Recording Equipment 8 Tr variety,
and know your db, if so, I have some
set-up work for you.
Call 839-5018
Evenings after 6 pm.

NEW STORE!
for the
HOBBYIST • HAM • AUDIO • CB'R
General Electronics
5511 YONGE ST., WILLOWDALE, ONT.
221-6174

MORE P.C. BOARDS FOR ETI PROJECTS

137A Audio Oscillator	6.77	486 Feedback Elim.	7.50
137B Audio Oscillator	5.45	635 Comp Pwr. Supp.	6.20
— Roulette		10-4 C.B.	
Wheel	5.25	Supply	3.25
586 Shutter Timer	5.08	— Clock "a"	5.40
— Rain Alarm	5.17	604 Metronome	2.50

Boards in stock from Feb. 1977.
Send for full list of P.C. boards for past
ETI projects.
**B&R Electronics, Box 6326F, Hamilton,
Ont. L9C-6L9**

AUDIO KITS AND MODULES

60W x 2 Stereo amp with mag. phono amp.,
tone control unit, speaker protector and
power supply \$78.00
30W x 2 Stereo power amp. with pre-amp and
tone control unit \$49.00
15W x 2 I.C. Stereo amp with pre-amp, tone,
and power supply \$39.00
60W Low T.I.D. power amp \$31.00
15W I.C. power amp with tone control unit,
power supply and transformer \$32.00
FREE CATALOGUE: AUDIOVISION
SERVICE, P.O. Box 955, Stn B,
WILLOWDALE, Ontario M2K 2T6

W S I SALES COMPANY

SWL RADIOS - HAM RADIOS -
18 SHELDON AVENUE NORTH
KITCHENER, ONTARIO N2H 3M2
Telephone (519) 579-0536
WRITE FOR GIANT CATALOG
FREE OF COURSE!! (VE3EHC)

ATWATER ELECTRONICS

We carry: Eico Kits • Sylvania Products
Semi-Conductors • TV Towers • Mars-
land Speakers • And Hundreds More
Electronic Components To Choose From.
886 Dundas Hwy. E., Mississauga
Tel. 277-3361
Store hrs: Mon-Thu 9-6 Fri 9-9 Sat 9-5

Canada's Electronics Companies...

Don't Miss This Opportunity!

WE ARE PLANNING for our February 79 issue to publish a survey of electronics companies, or in fact any companies in related engineering, manufacturing or sales areas, who could use students during the summer. Should your company get in on this summertime bonanza? Read on.....

There are a lot of good reasons why your company benefits from hiring students. They are enthusiastic, versatile, and enjoy the challenge and experience of doing whatever you need. They can help make up for vacationing permanent employees. They can help your company explore new opportunities, execute short term projects with none of the 'what do we do with the staff afterwards' problems. Students also have an economical expectation of remuneration in recognition of their state of education or experience.

Finally, and many companies depend on this, what better way is there to select, evaluate and cultivate possible future full time employees.

Amongst our readers you will find large numbers of eager and knowledgeable potential summer employees, all over the country. They can be builders, sellers, or researchers for you. Here's how to tap this valuable resource:

Simply fill in the form below (or photocopy) and mail it to ETI Student Summer Employment, Unit 6, 25 Overlea Blvd, Toronto Ontario, M4H 1B1.

In case it's not apparent, or perhaps unbelievable, this service is entirely free; this is our bit towards helping students, and giving Canadian Electronics a bit of a boost.

Please observe the following date. In order to make the February issue deadline, we must receive your contribution by December 12th. (In the event of a mail strike ONLY, we will accept listings by telephone. Please use the form as a guide to summarizing the information, especially if calling long distance.)

ETI Student Summer Employment Information Form

(Please print neatly)

Company Name and Division:

Address:

Who to contact

How to contact (Write, phone, send resume etc)

Brief description of company or division:

Student Employment Requirements:

Number	Description of Position, Knowledge/Experience Desired
.....
.....
.....
.....
.....
.....
.....
.....
.....
.....

CHROMATENNA II T.M.

with 18 ways you can count on for optimum picture quality!



Transmission Line Termination bleeds off static charges thru antenna system ground. Terminal stub improves front to back ratio on lower channels.



Aluminum Construction of all key metal parts works to eliminate rusting—provides long life. **Golden-Color Alodine Finish** is conductive—helps improve electrical performance!



High-Impact Plastic Insulators double-lock each element to the boom for extra bracing and durability.

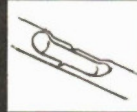

FM Block reduces FM gain up to 12dB. Remove to receive full FM gain.

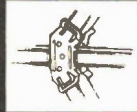

Corner Reflector Bracket improved with larger tabs. (Combination models only.)

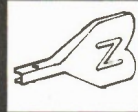

Zenith Dipole on UHF. (Combination models only.)



VHF Colinear Directors provide extra signal boost on both low and high band VHF.



Loading Straps—metal plates close to first VHF element insulators provide compensation for Lo and High band by tuning the first driven element with extra capacity.



Rugged 1" Square Boom provides extra strength compared to many round-type booms.

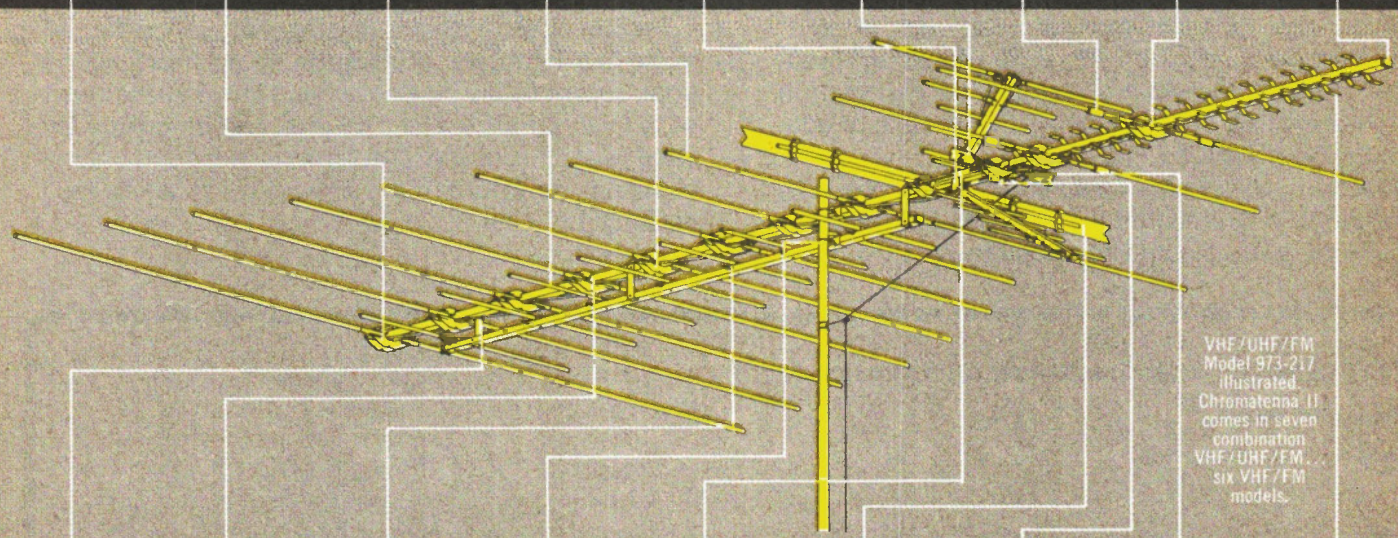

VHF/UHF/FM Model 973-217 illustrated. Chromatenna II comes in seven combination VHF/UHF/FM... six VHF/FM models.

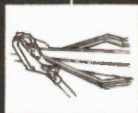

Wide-Spaced, Heavy-Duty Feed Lines help prevent shorting from heavy build-ups of snow or ice.



Sleeved Elements of heavy-duty construction afford extra bracing and protection.



Hi-Bracket with angled ends for added strength.



U-Bolt Mounting provides a larger clamping area; larger locking nut with teeth an integral part assures a more rugged U-BOLT arrangement.



Dual Isolator Bars insure no loss of UHF to VHF signal transfer. (Combination models only.)



Proximity Spaced Signal Balancer (Z elements) provides automatic taper control of periodic driver, improves impedance matching and signal leveling on both Lo and High band channels. Improves Channel 7 pattern.



Electrically Matched Terminals With Stainless Steel Screws eliminate mismatch... protect against rusting, and provide positive electrical contact with improved no strip stainless steel serrated washers for the take off terminals.



Strain Relief Insulator accommodates either 300-OHM twin-lead, Foam lead or Coax downlead.



Optional Break-away UHF Wing Directors provide maximum gain of standard UHF channels with optional coverage of Hi UHF channels and translator frequencies when broken off. (Combination models only.)

Zenith has quality do-it-yourself antenna kits—UHF only, VHF YAGI and Stereo FM antennas as well as a complete line of reception aid equipment.



The quality goes in before the name goes on®

Major Appliances Div.,
Acklands Ltd.,
1725 Quebec Street,
Vancouver, B.C.
Phone-1-604-879-4631

B.R.E. Electric Ltd.,
5544-5th Street S.E.,
Calgary, Alta. T2H 1L3
Phone-1-403-253-7171

B.R.E. Electric Ltd.,
14840-115th Ave.,
Edmonton, Alta. T5M 3C1
Phone-1-403-455-7171

Major Appliances Div.,
Acklands Ltd.,
1155 Sherwin Rd.,
Winnipeg, Man. R3H 0V1
Phone-1-204-633-6679

Zenith Radio Corporation
of Canada Ltd.,
1020 Islington Ave.,
Toronto, Ont. M8Z 5X5
Phone-1-416-231-4171

Zenith Radio Corporation
of Canada Ltd.,
900 Boul St. Martin O.,
Chomedey, Lav. PQ
H7S 2B6
Phone-1-514-663-0430

Waldale Limited,
Station Street, Box 339,
Amherst, N.S.
Phone-1-902-667-3308

Service News

Electrohome to Service Other Brands as R.C. Beats Zenith's Chess Challenger!

NOT RUMOURS ANY MORE! Fact! Service Electrohome are expanding their service facilities to cover not just their own products but those of most major manufacturers. I first heard rumours to that effect some 6 months ago, but a prompt inquiry of my Electrohome representative at that time was shrugged off as someone's speculation, with no foundation whatsoever. At that time I was in no position to pursue the matter further, and other than briefly considering how this could affect my own service operation if there were indeed any truth in the story, I put it completely out of my mind. Until a week ago A serviceman of my acquaintance phoned to ask what if anything could be done. The manufacturers were trying to put him out of business, etc. The story had resurfaced, and I promised him I would contact Electrohome and obtain the truth of the matter.

I phoned Electrohome, and after some initial prevarication on the part of an employee I was finally switched to Mr. Bertin, Branch Supervisor, and was invited to come down to the local centre. I was introduced to Mr. Hoffer, a most knowledgeable ex-service type, now Manager, Eastern Ontario Region. Mr. Bertin had arranged the interview and had admitted to me on the telephone that indeed the company was embarking on this new programme. Mr. Hoffer went to some pains to explain that C.O.D. business (that is, non-service contract) represented only 10% of their total work load, and they did not anticipate an increase in this type of service by more than a further 20%. He further stated that with the tremendously increased reliability of the new products, even with the diversification into computers undertaken by the company, if they did

not expand their service operation they would be unable to protect their not inconsiderable technical staff. Further work sources had to be investigated, and this programme was the end result.

A radio advertising campaign had been planned to commence in Oct/78 but has now been re-scheduled for Jan/79. A new service branch is planned to open in Oshawa, also in Jan/79. Staff should not be a problem; Service Electrohome have already managed to obtain personnel experienced in other major brands and training has been going apace for the last 3-4 months. Space, equipment, etc. of course will not be a problem. This expansion has already been inaugurated as the road service personnel have been handing their customers a flyer which states briefly "We service *most* major brands of colour TV, B & W TV, stereo, air conditioners, fans, etc." The company has already made a start and is extremely optimistic about the way their very considerable research and planning should pay off in the future.

COMMENTS:

It is not so very many years ago that the R.C.A. Victor Company decided to service all major brands of TV, and a number of outlets were opened. They did not last 6 months, if my recollection serves me, and the operation was closed down. I contacted R.C.A. the other day and endeavoured to find somebody who could remember the problems that arose with this type of operation, and was told by one representative that one of the major problems was parts supply. While at Service Electrohome I raised this point with them and was told they could see no real problem, but they admitted that they would be cherry-picking to a certain extent. meaning of course that

they would be extremely selective in the type of work they were prepared to undertake.

REACTION

I decided to check around with some of my ex-competitors in the domestic service field, and I obtained an extremely mixed reaction. A few of the companies expressed no opinion at all. Some were mildly concerned as to how it would affect their business. A small percentage was extremely antagonistic to the idea of a large corporation moving into their particular field, namely out-of-warranty TV service.

My own feelings are mixed. I can understand Electrohome's desire to increase their share of the multi-million dollar service parts industry, but I can't help wondering whether the 20% increase in service envisaged by their researchers will be offset by the possible loss of confidence by the small service-oriented Electrohome dealers.

SOCIALIZING

I took my wife down to the Zenith Show, Tuesday, Sept. 19th. The show was beautifully staged, with a fine dinner. We were well received by Mr. Hall, the President, and Mr. Glenn Andrews, and then as promised in the September issue I played against their electronic chess genius. As also promised, I beat the beast, albeit I played it at its simplest level. Shouts of "Foul" arose from the Paragon representative, but as he was operating the machine I fail to see how he could complain. On the contrary, the complaint should have come from me, as Zenith with their marvellous hospitality had handicapped me by placing a bottle of Scotch within easy reach

Best of luck. R.C.

CDE

THE PROFESSIONALS

In Capacitor Replacement



THE PROFESSIONALS

In Antenna Rotors With The Broadest Line Up In The Industry

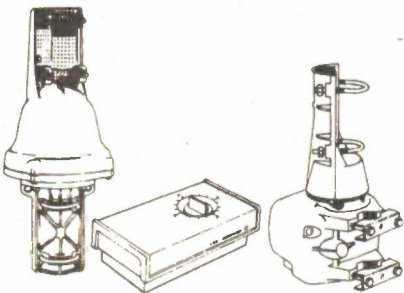

THE PROFESSIONALS

In CB Radios & CB Accessories

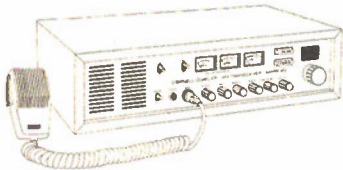

CORNELL-DUBILIER (CANADA) LTD.

35 MOBILE DRIVE
TORONTO, ONTARIO M4A 2P6
PHONE 416/757-5919

With Christmas fast approaching, ETI asks.....

HOW MANY TIMES can you read a tie? Will socks fit in an ETI Binder? Do handkerchiefs come filled with exciting projects? Can you store ETIs in a bottle of aftershave lotion? Will ETI employ new staff to write ad copy?

Well, how **are** you going to solve that annual problem; fulfilling your social obligations to others, ie: buying presents? A subscription to ETI could be the answer, or for the person who has almost everything (like a subscription already) something to put it in.

By special arrangement we are able to send subscriptions and binders to whomever you designate. Binders will be accompanied by a note of greetings saying who's sending the gift, and a note will also be sent to subscription recipients informing them of their good fortune and whom to thank.

If we receive your order before November 30, the gift subscription will start with the January 79 issue, if before December 20 then the February issue (No.1 of Vol 3) will be the first to be sent.

Please use the coupon below (or copy) for your gift order. If more space is needed then attach also a separate sheet.

It's the thought that counts, right? Start thinking... 1..2..3..4....

Please mail to: ETI Gifts, Unit 6, 25 Overlea Blvd, Toronto, Ontario M4H 1B1.

ORDER FOR GIFT SUBSCRIPTIONS AND BINDERS

Donor's Name: _____

Donor's Address: _____

Recipients Name: _____

Address: _____

I am ordering a total of:

_____ Gift subscriptions @\$14 (one year)* \$ _____

_____ Gift Binders @\$6 ea (Ont. res add PST)* \$ _____

Total \$ _____

Cheque enclosed. Do not send cash.

Bill Mastercharge. A/C No. _____ Signature: _____

Bill Chargex. A/C No. _____ Expiry Date: _____

(If more than one recipient, please attach names and addresses, and specify clearly who gets what) *Please note: Prices apply to Canadian addresses only. For foreign orders please refer to subscription card.



John Garner checks into the ham bands.

UTILITY STATIONS are those which are not generally directed towards the general public. These stations may be found throughout the short wave spectrum as well as on long wave and in the very high and ultra high frequencies. Since this column is devoted to shortwave listening we will stick to those Utilities in the 1600 to 30,000 kHz range.

Since Utilities are not intended for the public at large, there is a feeling of excitement in listening in. On the Utility bands you may be able to pick up stations from small or far away countries which you cannot hear on the SW broadcast bands. Since most "Utes" do not operate on regular schedules you need extra patience in scanning the bands looking for something of interest — but there is always something there for you — it may be a Coast Guard rescue operation, ship-to-shore communications, aviation weather forecasts, or almost anything else. You never know what may turn up.

WARNING: In Canada and the USA and most other countries, it is quite all right to listen to Utility stations *but* it is against the law to divulge information obtained from such transmissions or making use of these transmissions for personal gain. (Reporting IDs such as voice mirrors and ID markers etc. is acceptable, but do not report details of traffic heard.)

Most Utility stations now use SSB (Single Side Band) or CW (Morse Code) transmissions. When not transmitting actual messages many stations use a voice mirror (vm) on SSB which is a continuous tape which announces their station. This vm keeps the frequency open and allows the receiving station an opportunity to adjust their receivers. An example of a

voice mirror would go something like this: "This is a station of the American Telephone and Telegraph Co. transmitting for circuit adjustment purposes. This station is located near New York City". CW stations generally use either a V marker or CQ marker for the same purpose. A typical example in Morse Code would be "CQ CQ CQ DE WNU WNU WNU". The DE means "this is". These markers are usually sent in rather slow speed code and are repeated over and over making it quite easy, even for the beginner to identify the Morse Code letters.

There are many types of Utility stations, but we are mainly interested in four types — (a) Coastal Stations, (b) Fixed Point-to-Point Stations, (c) Aeronautical Stations, (d) Time and Frequency Standards Stations.

COASTAL STATIONS

A Coastal Station is a land based station operating in the maritime service. These stations pass on messages to ships at sea and other coastal stations. Broadcasts by these stations include weather reports and forecasts, storm warnings, distress information, and relay telephone and telegraph messages to crew members and passengers on board ships on the high seas. Very much interesting reception may be heard from these stations. But remember when listening to these private stations, not to break the Secrecy of Communications law.

Many of these coastal stations are commercially owned and operated, changing ships for each call. Other coastal stations are operated by the military. The United States Coast Guard operate a large number of stations in this category. Many Navy stations may also be found.

A good place to start looking for Coastal Stations is in the 8 MHz band — there is usually a fair amount of activity there.

FIXED POINT-TO-POINT STATIONS

This category covers many Utility stations. In this group are commercial, military, and aeronautical point-to-point stations, usually abbreviated PTP. This means that these stations direct their transmissions to one specific receiving station. Here again the test transmission is widely heard in order to keep the frequency open for receiver adjustment.

One exception to the use of the test transmission would be the commercial

aeronautical fixed stations. Here, links exist between major air-traffic control centers of the world. These stations exchange data to aid in navigation of all major airlines.

SSB is the usual mode of operation, although some AM stations may be found. Military stations often use scrambled transmissions in order to ensure privacy.

Major international broadcasters also use PTP stations to relay programs to their relay stations around the world. These transmissions are usually carried on in SSB and sometimes a station will even use the uppersideband to relay one program and the lower sideband for another program, perhaps even in a different language. This enables the station to relay the latest news, etc. to their stations for rebroadcast.

TIME AND STANDARD FREQUENCY STATIONS

Time stations are operated in many countries around the world to give extremely accurate time of day information for any number of uses in today's modern technology era. Many of these Time stations also operate on standard frequency carriers which are controlled very accurately. This enables users to set electronic equipment using these standard frequencies as reference points. Also many of them provide other services such as propagation conditions and forecasts, geophysical alerts, weather information. WWV and WWVH are two typical examples, operated by the National Bureau of Standards in the United States. You can find them on 2500, 5000, 10000 and 15000 kHz.

Canada has its own time station — CHU in Ottawa which announces the time every minute in English and French. The frequencies used by CHU are 3330, 7335 and 14670 kHz.

It is a good idea to check your receiver's accuracy once in a while by comparing the dial reading with one of the standard frequency stations. If you can adjust your dial, you will have several checkpoints of high accuracy.

If the power has been off or if you forget to wind up the alarm clock, tune into one of the time stations, such as CHU or WWV for the most accurate time available at any time during the day or night.

Tune into the Utilities. I'm sure you will find much enjoyment. Try any of the frequency ranges that are not used by broadcasters or hams.

Continued overleaf ...

SHORTWAVE MAILBAG

I am using a 26 foot long wire indoors as an antenna — do you have any suggestion for a better interbal antenna? What are the best earphones for shortwave listening? How do you get Radio Tahiti?

Oscar Perlo, Toronto

I am also using an indoor wire about 20 feet long. I had 100 feet of wire outdoors but it blew down a couple of years ago in an ice storm. There seemed to be little difference in reception without the 100 feet of wire, so I have been using the short wire ever since. I hope to do some more experimenting with antennas in the future. Coiled antennas may be useful for apartment dwellers. Earphones — for short wave listening mono headphones are recommended. If you use stereo headphones an adapter should be used so that both ears can hear the signal. Generally speaking, cheaper headphones work better for Short wave listening than more expensive sets. This is due to the fact that SW has a rather narrow range of frequencies and the better sets with their wider range seem to emphasize all the noise on the bands. Radio Tahiti is heard here in Thunder Bay on 15170 kHz at about 0300 GMT (11 PM EDT).

Until next month 73 and good listening.



I will try to answer questions of a general nature pertaining to shortwave, in this column. Send your queries to Shortwave World, P.O. Box 142, Thunder Bay, Ontario, P7C 4V5.

HOLD IT! Anywhere you want it.

PanaVise tilts, turns, rotates. One quick turn of the control knob and you securely position your work exactly where you want it. Holds firmly but gently the most delicate electronic parts and P. C. boards.

Whether you're into building home electronics, trouble shooting, or professional servicing . . . you'll wonder how you got along without this modestly priced 'extra hand.'

Model 396 Wide Opening PanaVise shown. An ingenious variety of other interchangeable bases, holders and accessories also available.

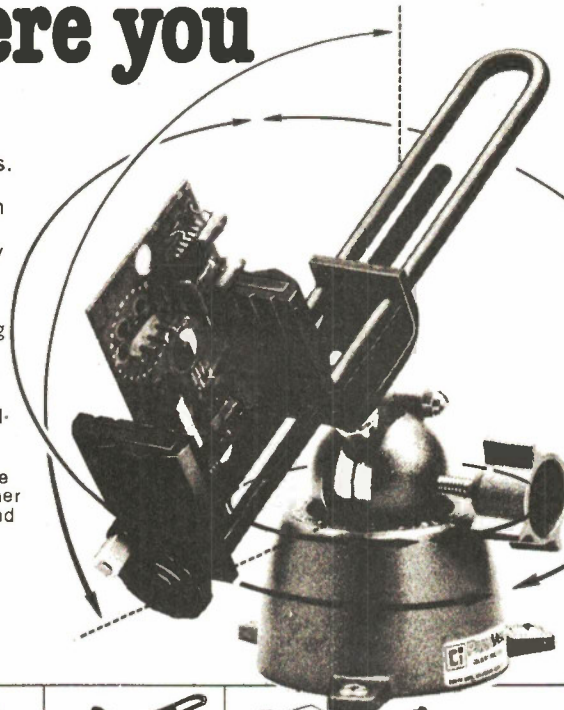

PANAVISE®



See your electronics distributor, or write for FREE brochure.



len finkler ltd

25 Toro Road, Downsview, Ontario M3J 2A6
Telephone (416) 630-9103 Telex 065-24010



DIGITAL CLOCKS

BASIC KIT (MA1010) \$24.95 + TAX (Ont.) Includes clock module, transformer, and cord. 4 digit .84" LEDs display hours and minutes. Push buttons for: seconds, fast set, and slow set. 24 hour module also available.

ASSEMBLED CLOCK \$35.00 + TAX (Ont.) Assembled from basic kit. Enclosed in a custom wooden case (approx 5" wide x 4" x 4") or a clear plexiglass case (choose one).

12V MA1003 car/van/truck module also available. Satisfaction guaranteed.



ENTERPRISE ELECTRONICS
P.O. Box 334, Station "A",
WINDSOR, ONTARIO,
CANADA N9A 6K7

This is A *Mini-Ad!*
You Can Write, Draw or Advertise
Anything You Like in This
Space, for Only

\$100

FOR MORE DETAILS CALL
Sharon
on
416 423 3262

c e r e s i s t^c BUY IT FROM



• A-1 Electronics
5062 Dundas St. W.
Toronto, Ontario



• Dominion Radio & Electronics
535 Yonge Street
Toronto, Ontario



• Carsall Electronics Supply
36 Queen St.
Sault Ste. Marie, Ontario



• Supreme Electronics
P.O. Box 58276
Station "L"
Vancouver, B.C.
V6P 6E3



• Ceres
53 Burnett Ave.
Willowdale, Ontario
M2N 1V2
(Mail orders only)



Nationally advertised.
Unconditionally guaranteed.





QRM QRM QRM

Introducing a column for Radio Amateurs, and interested tinkerers.
Readers letters are welcome and invited. By Bill Johnson VE3APZ

In the first episode of this new column, Bill looks at the commotion surrounding the Department of Communications proposed regulations introducing the "Amateur Experimenter Licence". The regulations, which we printed in our May '78 issue, require a high level of technical knowledge, but drop the Morse Code test for this class of licence.

Shortly before we went to press the new regulations came into effect introducing the new licence class to be known as the "Digital Amateur Radio Operators Certificate".

AS YOU READ this first edition of ETI's new amateur radio column, you will most likely be hearing a lot about Packet radio and Pulse Code Modulation. These are the two main parts of the Department of Communication's new plan for the expansion of amateur radio to explore new worlds and boldly go where no man has gone before. The Trekkian verbology is deliberate. We are dealing with something which is going to be of great use to the many thousands of followers of Spock (i.e. computer nuts) that already practise their dark art in Canada in the secrecy of their own homes, allowing them to further the growth of knowledge by developing universally-interchangeable code that can be sent between systems. For the existing radio amateurs of Canada, it will definitely be a case of boldly going where no man has gone before, because nowhere in the entire world can one find any radio amateur experimenting with packet transmissions at the data rates envisaged by

the Department of Communications. (Our neighbours to the South aren't even allowed to use ASCII.)

To say that these new facets of amateur radio have caused a stir amongst Canada's 15,000 radio amateurs would certainly be an understatement. Dr. John DeMercado, head of the D.O.C.'s Telecommunications Regulatory Service, and the man responsible for the new certificate, has been called many names by amateurs with different viewpoints, everything from stupid to visionary with many colourful variations in between.

Sadly, I must admit that in the early days of the discussions on the experimenter certificate, my own opinion was influenced by the emotional reaction of the masses that this man was merely trying to water down the substance of amateur radio by injecting it with people from the GRS band who could not qualify under the present certificate standards. As facts emerged, however, so did a picture of a man who is trying to put Canada on the map of world radio history — despite the hesitancy of the amateurs themselves to be leaders in the field.

What many amateurs are forgetting is that Dr. DeMercado does not have to consult with us at all — if he really wanted to solve the D.O.C.'s GRS overcrowding problems by moving the better qualified GRSers over to amateur radio, he could do it with two strokes of his pen and a little bit of fine print in the Canada Gazette just for the record, and we would wake up the next day to find all amateur channels clogged with meaningless chatter in a language that we couldn't understand. Don't ever believe that the D.O.C. is scared of the

political implications of such a move, because the number of voters that would be pleased with their new frequencies would far outnumber the amateurs, and people would wonder why we were ever given a monopoly in the first place.

No, the answer lies in the fact that authorities around the world realise that there is tremendous technological value in amateur radio as an experimental hobby. Most of today's modern technology has come, if not from direct experimentation by amateurs, at least from amateurs in industry who have applied the skills learned at the operating bench at home. Amateur radio is a "service of self-training, intercommunications and technical investigations carried on by amateurs, that is by duly authorised persons interested in radio technique solely with a personal aim and without pecuniary interests." (Radio Regulations, Geneva 1959).

If such abundant lethargy had not been exhibited by the amateur body at large, we could have been away to the races months ago. The only reason Dr. DeMercado is viewed by many as a 'bad guy' is because he has a lousy public relations man. You don't boo an actor because the footlights don't work — let's take him for what he is: an unusually hardworking civil servant who is trying to do something innovative for his country's amateurs in the constant fight for recognition, and with it, existence. Let's forget our impulsive objections to somebody changing our secure little world. Let's get out there and put the experimental back in the amateur radio service.

Boxing Figures

How to fit the most into the least, from L. D. Crawford of London, Ontario

THE FOLLOWING PROGRAM provides an example of how a programmable calculator really can be useful. (ie: here we sidestep the issue of whether entertainment is useful). Although fairly simple, it employs iteration to quickly find an accurate solution to a problem which would be otherwise tedious, or require a complex formula.

Indeed, iteration is not needed, the problem can be solved directly, so the author has traded in mathematical sophistication, and algebraic effort, instead letting the calculator do the work.

OPTIMUM DIMENSIONS OF RECTANGULAR BOX

Object: Given the dimensions of a rectangular plate to determine the size of the squares to be cut from each corner to yield the maximum volume of a box formed from the plate.

Operation: The length and width of the plate are stored in separate memories. The width is divided by 9 to yield the initial value of x. This is divided by 11 to yield the increment of x to be used in the iterative calculations.

The volume is calculated (V2) and compared with the previous volume (V1) (initially zero). If $V2 > V1$, the increment is added to x and V2 is stored as V1. The process is repeated until $V2 < V1$.

At this point the increment is subtracted from x and the result displayed as the optimum size of the corner cutouts. The maximum volume is stored and can be recalled.

PROGRAM

Program for Commodore PR 100

STEP	KEY	STEP	KEY
00	MR	36	=
01	0	37	M
02	÷	38	5
03	9	39	-
04	=	40	MR
05	M	41	6
06	2	42	=
07	÷	43	SKIP
08	1	44	GOTO
09	1	45	5
10	=	46	0
11	M	47	GOTO
12	3	48	6
13	MR	49	5
14	1	50	MR
15	-	51	2
16	(52	+
17	2	53	MR
18	x	54	3
19	MR	55	=
20	2	56	M
21	=	57	2
22	x	58	MR
23	(59	5
24	MR	60	M
25	0	61	6
26	-	62	GOTO
27	(63	1
28	2	64	3
29	x	65	MR
30	MR	66	2
31	2	67	-
32	=	68	MR
33	x	69	3
34	MR	70	=
35	2	71	R/S

EXECUTION

Clear all memories
Enter length of plate in memory 1
Enter width of plate in memory 0
GOTO 00

LETTERS

I found the article on "Easy Mortgage Math", (Sept. 78) both interesting and useful, but there were a few slips in the typesetting which should be rectified.

In the middle of page 64 the equation for the monthly payment appears in the form:
 $PMT = P \cdot i / (1 - (1+i)^{-12t})$

This suggests that the quantity $12t$ should be subtracted from the terms which precede it. Actually, we are dealing with an exponential, and the quantity $(1+i)^{-12t}$ is to be raised to the $-12t$ power. To convey this meaning, $-12t$ should be placed on the shoulder of the appropriate bracket.

On page 65, Table 1 is satisfactory but Table 2 has errors in the OP (n-1) and OP (n) columns. These were apparently caused by the omission of the quantity 22407.78, representing the outstanding principal after two payments. Inspection of the two OP columns shows that each payment should decrease the OP by about \$300, but the decrement jumps to about \$600 at the point where the omission occurred.

I cannot comment on the 209-keystroke SR-52 program, because my own calculator is a Commodore P-50 (ETI — June, pages 5, 61).

It has only one memory and a program limit of 24 keystrokes, but with these modest weapons it can handle mortgage calculations with precision and speed by using a few short programs instead of one long one.

Also, if any of your readers would report on their experiences with the Commodore P-50, we might be able to arrange a useful exchange of programs.

Arthur T. Williamson Box 407 PINAWA, Man.
R0E 1L0

FLOW CHART

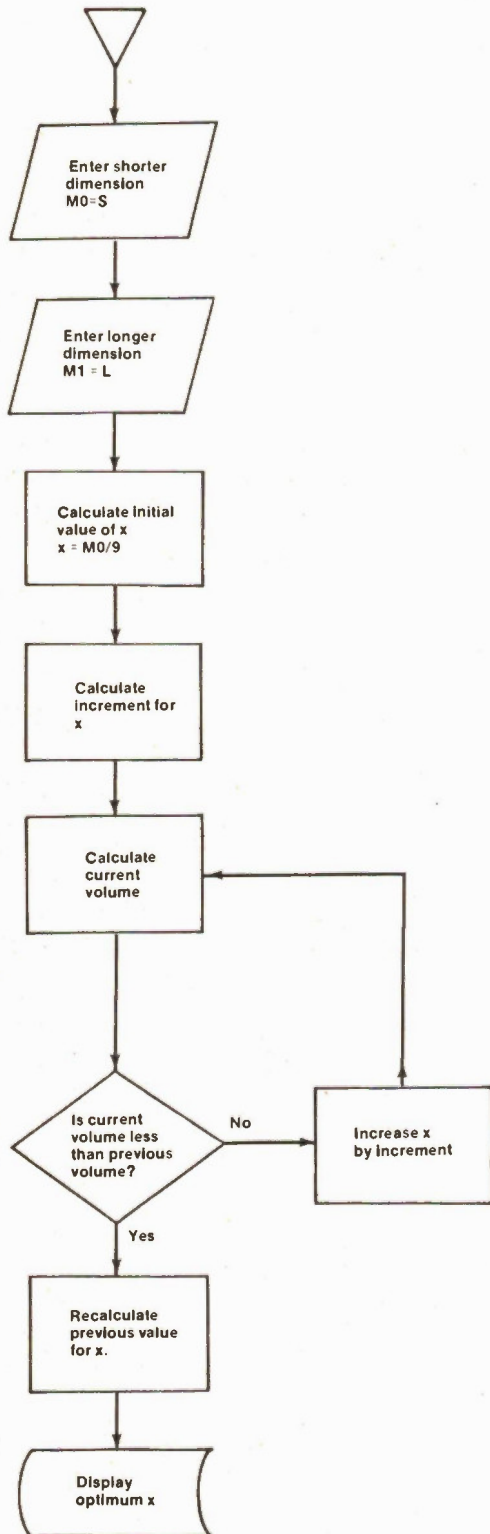

NON-SUBSCRIBERS START HERE

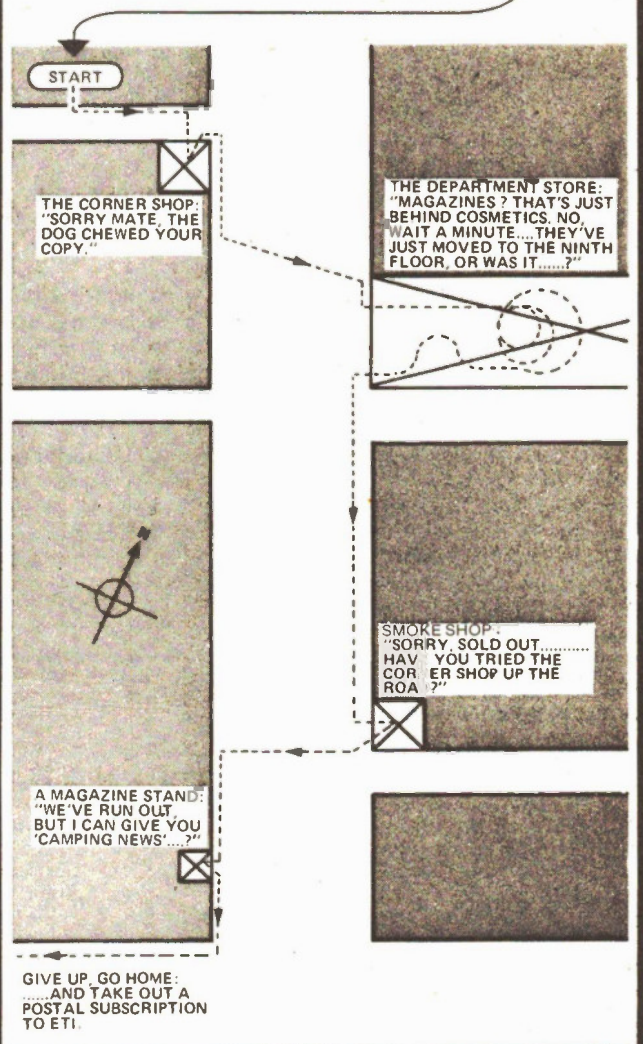

It can be a nuisance can't it, going from newsstand to newsstand? "Sorry buddy don't have it — next one should be out soon."

Although ETI is monthly, it's very rare to find it available after the first week.

Do yourself a favour. Place a regular order for ETI with a postal subscription, so there's nothing for you to remember — we'll do it for you.

For a subscription, send us \$12.00 (12 issues) or \$20.00 (24 issues). Order received after November 1st will have to pay \$14.00 or \$26.00. For US addresses the current rates are \$15.00 and \$26.00; these are going up to \$17.00 and \$32.00. Do not send cash. Credit card orders give card name and number, expiry date and signature. Allow six to eight weeks for first issue.

Send to ETI Subs Dept, Unit 6, 25 Overlea Blvd., TORONTO, Ontario M4H 1B1.

For overseas add \$5.00 per year to Canadian rates.

Tech Tips

Tech-Tips is an ideas forum and is not aimed at the beginner. ETI is prepared to consider circuits or ideas submitted by readers for this page. All items used will be paid for. Drawings should be as clear as possible and the text should preferably be typed. Circuits must not be subject to copyright. Items for consideration should be sent to ETI TECH-TIPS, Electronics Today International, Unit 6, 25 Overlea Blvd., Toronto, Ontario, M4H 1B1.

Distributors stocking
Jana Projects:

A-1 Electronics
ISLINGTON, ONTARIO

Arkon Electronics
TORONTO, ONTARIO

Atwater Electronics
MISSISSAUGA, ONTARIO

Brant Electronic Supply
BRANTFORD, ONTARIO

Carsall Industries
SAULT STE. MARIE, ONTARIO

Robert J. Buckland Co.
LONDON, ONTARIO

Dominion Radio Ltd.
TORONTO, ONTARIO

General Electronics Co.
WILLOWDALE, ONTARIO

Gladstone Electronics
TORONTO, ONTARIO

Heath Company
MISSISSAUGA, ONTARIO

Jerry's T.V.
SARNIA, ONTARIO

Kesco Electric Supply Ltd.
PETERBOROUGH, ONTARIO

Kingston Electronic Supply Ltd.
KINGSTON, ONTARIO

Lighthouse Electronics
WINDSOR, ONTARIO

Lamp Land Ltd.
PETERBOROUGH, ONTARIO

M.I. Supply Co. Ltd.
BELLEVILLE, ONTARIO

Neutron Electronics Ltd.
GUELPH, ONTARIO

Niagara T.V.
NIAGARA FALLS, ONTARIO

Northwestern Electronics Supply
OWEN SOUND, ONTARIO

Provincial Electronics Distributors
LONDON, ONTARIO

Radio Trades Supply Ltd.
TORONTO, ONTARIO

Sonic Northern
SUDBURY, ONTARIO

Teltronics Ltd.
SCARBOROUGH, ONTARIO

D. R. Walling Co. Ltd.
LINDSAY, ONTARIO

Waterloo Electronic Supply
WATERLOO, ONTARIO

Western Radio Supply Co.
HAMILTON, ONTARIO

Westown Electronics
TORONTO, ONTARIO

If you cannot find Jana
Projects in your area,
contact Doug Mann,
Jana Electronics Limited,
P.O. Box 489, Winnipeg,
Manitoba R3C 2B3.

Transistor Tester

G. Smith

This transistor tester works by injecting a known current into the base of the transistor under test, and measuring the collector current. The values of R1, R2 and R3 give a base current of 10, 4 and 1 μ A which gives a FSD on the meter for transistors with a gain of 100, 250, and 1000 respectively. Since the gain of the transistor is proportional to its gain, the gain can be easily deduced from the reading on the meter. Leakage current is measured by leaving the base open circuit.

SW2 reverses the polarity of the battery and the meter to allow the testing of both NPN and PNP transis-

tors. R4 and RV1 protect the meter from excessive currents, and do not affect the reading on the meter. RV1 should be adjusted so that the meter needle just touches the end stop when the collector and emitter terminals are connected together.

A simple transistor socket can be made by mounting three crocodile clips as shown in the diagram.

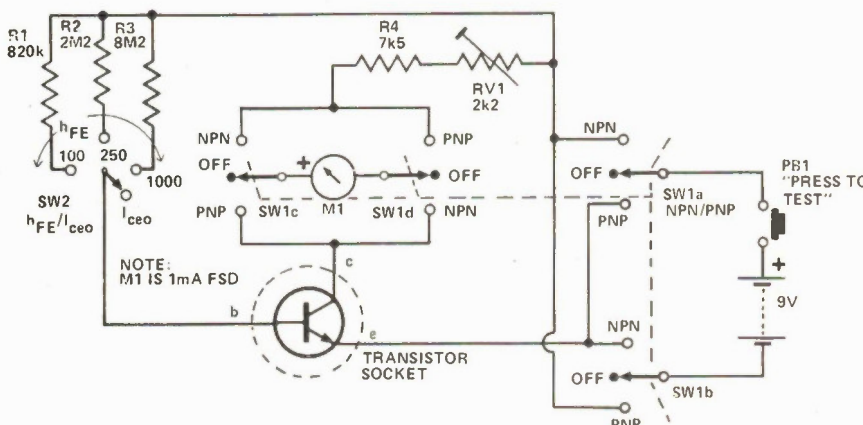
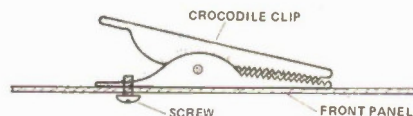

Peak Level Indicator

T. Norris

The diagram shows a simple monostable multivibrator with a LED which is normally lit, but will be briefly extinguished if the input exceeds a preset (by RV1) level. A possible application is to monitor the output voltage across a loudspeaker, when the LED will flicker with large signals.

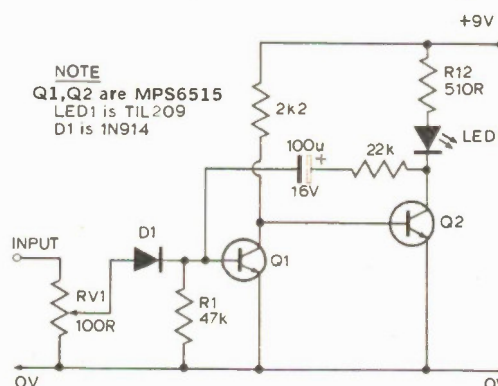

jana Quality Kits



LJ 12016A
Project # 23

Color Organ

The Jana Color Organ is an ideal project for the experimenter who is a musician or a serious audiophile. This project is a three channel color organ with a capacity of 200 watts per channel.* It comes complete with the PC board and instructions and its high power capability makes it ideal for all kinds of lighting effects, either with spotlights or back-lit lucite panels.

Remember, Jana projects come complete with electronic components of the exact value, so there's no need to substitute or hunt for specific capacitors, transistors or IC's.

Pick up a Jana Color Organ kit at your nearest Jana dealer today and while you're there, check out the other Jana Quality Kits.

- | | | |
|---|--------------------------------|-----------------------------------|
| 1. Automatic Headlight Reminder | 10. Fish Caller | 19. Tone Generator |
| 2. Battery Operated Fluorescent Light Kit | 11. Hi Power 12 V DC Flasher | 20. 5 Transistor 1 Watt Amplifier |
| 3. Bug Shoo | 12. Photo Electric Night Light | 21. Tube Continuity Checker |
| 4. Code Oscillator | 13. 6V Power Supply | 22. Xenon Strobe |
| 5. Crystal Radio | 14. 9V Power Supply | 23. LJ 12016A Color Organ |
| 7. Curiosity Box II | 15. 0-24 V Power Supply | 24. Loudmouth Siren |
| 8. Dally Lighter | 16. Single Channel Color Organ | 25. Roulette Wheel |
| 9. Decision Maker | 17. Electronic Siren | 26. Electronic Skeet Game |
| | 18. Shimmer Strobe Light | 27. Electronic Dice |
| | | 28. Super Roulette |
| | | 29. FM Mini Broadcaster |

*Optional circuit to increase wattage capability to 1,000 watts per channel is shown in the instructions.

Available from



Vancouver • Kamloops • Calgary • Edmonton • Red Deer • Regina
Saskatoon • Winnipeg • Halifax • Fredericton • Moncton

Also available from many dealers across Canada.
See partial list on facing page.

jana
ELECTRONICS LTD.
P.O. BOX 489, WINNIPEG, MANITOBA R3C 2J3

Colour Organ Special

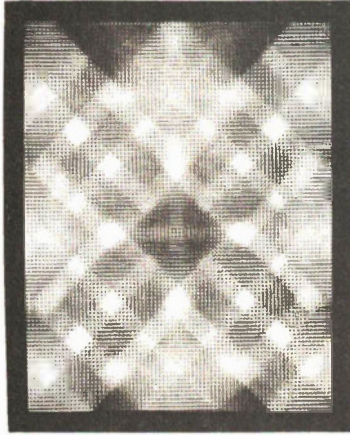

Assembled or kit this colour organ comes with display lights, beautiful walnut display box and electronic parts, nothing else to buy.

Assembled — \$39.00
Kit — \$29.00

- 12V transformer 1 amp with 3 amp cord attached **New \$3.00**
- Computer ribbon wire
 - 40 conductor - .60¢ ft
 - 60 conductor - .90¢ ft

MORE KITS

- Roulette wheel kit **\$8.85**
- Loudmouth siren **\$10.50**
- Xenon strobe **\$9.75**

All prices include shipping etc.

A-1 ELECTRONICS

231-4331

5062 Dundas St. W., Islington M9A 1B9
(2 blocks east of Kipling Ave.)

Hours: Mon. to Wed.: 9:30 to 6:00
Thur. to Fri.: 9:30 to 9:00
Sat.: 9:30 to 6:00

Tech Tips

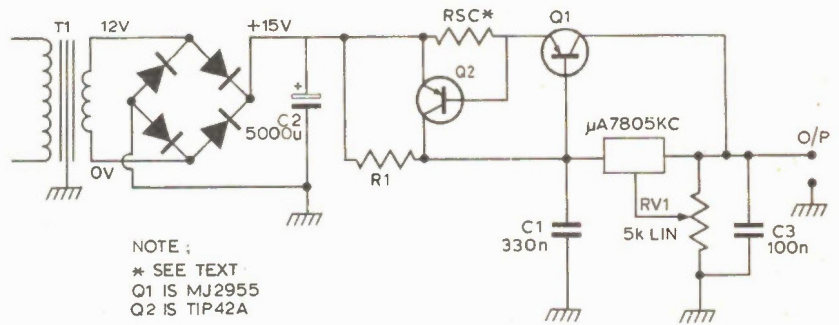

NOTE:
* SEE TEXT
Q1 IS MJ2955
Q2 IS TIP42A

High Current Regulator

N. Gray

This circuit can supply 10A at 5V which falls to about 8A at 15V, — (make sure your transformer can take it!). The circuit is fairly straightforward. Most of the output current flows through Rsc and Q1 (less than 1A flows through the regulator), the current being regulated by the current flowing through the e-b junction of Q1. Voltage is regulated by the

μ A7805 and controlled by RV1, giving a variation from 5V to 15V. Output current is limited by Rsc and can be calculated from.

$$R_{sc} = \frac{0.9}{I_{max}}$$

For currents greater than 5A, Q1 should be mounted on a heatsink. Q2 and the regulator should run cold (if not there's something wrong!).

Morse Code On The Oscilloscope

S. J. Stamps

This circuit enables morse code to be displayed as dots and dashes on an oscilloscope screen. By speaking into a microphone, saying 'dit' and 'dah' as appropriate, short and long pulses appear on the screen in a format similar to that of written morse.

One half of an LM381 and a Q1 are used to amplify the signal from the microphone, which is then

clipped into digital form by the AND gate. The output from the circuitry is fed to an oscilloscope set to 2V/cm and 5ms/cm, set to trigger on the start of a 'dit'.

Input to the circuit can be from a microphone, or tape recorder. If words are recorded onto the tape with the microphone and then played back via the circuit, practice at reading morse is possible.

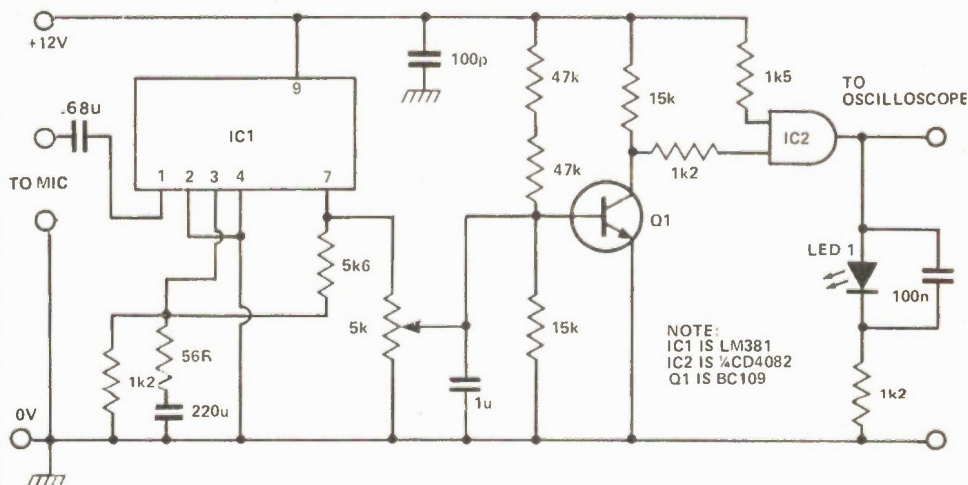

NOTE:
IC1 IS LM381
IC2 IS 1/4 CD4082
Q1 IS BC109

CONTENTS

AN ADD IN CRYSTAL FILTER	5
ADDING AN "S" METER IN YOUR RECEIVER	6
CRYSTAL LOCKED HF RECEIVER	11
EXPERIMENTAL AM TUNER USING A PHASE LOCKED LOOP	20
SHORTWAVE CONVERTER FOR 2 MHz to 6 MHz	27
THE HOMODYNE TUNER - ANOTHER APPROACH	33
TWO SOLID STATE RF PREAMPLIFIERS	36
40 to 800 MEGAHERTZ RF AMPLIFIER	48
BASIC RECEIVER FOR SLOW SCAN TV FOR AMATEUR TRANSMISSIONS	49
14 Mc HAM BEAM USES TV AERIAL PARTS	63
AERIALS FOR THE 52, 144 Mc BANDS	71
AN FM DETECTOR FOR AMATEURS	86
A SOLID STATE CRYSTAL FREQUENCY CALIBRATOR	88

CONTENTS

PROJECT No.	PROJECT	CIRCUIT BOX No.	PAGE
1	Siren	1,2,3	9
2	A.C. Relay	4,5	12
3	Mains A.C. Relay	6,7,8	15
4	Leakage Detector	9,10	18
5	Audio Amplifier	11	21
6	Power Supply	12,13A,13	24
7	Ultrasonic Transmitter	3,14	27
8	Modulator for Project 7	14,15	29
9	Ultrasonic Receiver	16,17,18,19,20	31
10	Tuned Variable Q Preamp	21,22	35
11	Domestic Thermostat	10,23	37
12	Static Electricity Detector	9	40
13	Touch Operated Switch	10,23,34,25	42
14	Person Detector	3,9,26	45
15	Voltage Level Detector & Switch	27,28,29,30,31	48
16	Programmable Thermostat	10,23A	51
17	Using a Calculator as a Timer	12,25A,32,33	53
18	Diode Tester	34	56
19	Diode & Transistor Voltage Tester	35	59
20	Light Controlled Switch	36,37,38,39,40	61
21	Voltage Controlled Light Dimmer	41	64
22	Touch Controlled Voltage Source	42,43A,43B	67
23	Bi-Directional Switch for Triacs	44	70
24	Touch Operated Gain Control	16,42,43A,43B	72
25	Light Flasher	45,38	74
26	Ultrasonic Intruder Alarm	14,22,46,47,48	77
27	Car Windscreen Wiper Control	49	80
28	Lamp for Snap & Musical Chairs	50,51	83

CONTENTS

PART I UNDERSTANDING AUDIO ICs	
What an IC is	7
Simple 3-Stage IC	8
Push-Pull IC	12
Non-IC	13
IC Features	17
Preamp/2nd Main Amp Input	17
DC Stabilisation	20
Complementary and Quasi-Complementary IC and External Circuit	24
Internal Protection	24
F-external Circuits	26
Zobel Network	26
HF Instability	28
Gain	28
Input/Output	29
Bus Termination	30
Hi-Pass	31
Inverting Input	31
IC Disruption	33
Working Conditions	35
Soldering ICs	35
Component Values	37
PART II PREAMPLIFIERS, MIXERS AND TONE CONTROL	
Printed Circuit Boards	ME139P
Lay-out	Passive Tone Control
Earth Return	Tap Cir.
Filtering	Tribe-Bass Control
Drilling	Active Comprehensive Control
Component Assembly	Input Tone Control
Audio Leads	
4:1 Preamplifiers	
Automatic Input Preamp	
Mixer Pre-amplifier	
Mixer Mixer	
3-Channel Mixer	
Push-Up Types	
Lead-in Gear	
Play-Through	
PART III POWER AMPLIFIERS AND SUPPLIES	
TIAB001	43
1 M80 Amplifier	65
SL402/3, SL404/415A	70
SL405	71
TC1A01, TC1A02, TC1A05D	75
SN7002B	76
Steno	78
Push-Pull LM388	80
TL020	81
Basic Circuits	84
MC431	84
MC4010	85
TL0610	85
LM317N	86
Power Supplies	86
Full-Wave Rectification	89
Inductive	90
Transformer Rating	91
Rectifier Rating	92
Smoothing	92
Output Power	94
Capacitor Voltage	94
Power Supply Current	95
Split Power Supply	96
Waveshape	96
PART IV HYBRID CIRCUITS	
Current Fall	101
Limiting Values	102
Relative Power	102
Inductor and Parallel	103
Output Effect	103
Power Distort	104
Testing	106

Shortwave/

Transistor/

Audio IC

Above are the contents pages for these three pocket-sized books. The books were published in England by Babani Press & Bernards (Publishers) Ltd., and we now have stocks in Toronto for ETI's readers. Titles, authors and Canadian prices (including postage) are as follows:

- 'Shortwave Circuits & Gear For Experimenters & Radio Hams' by B.B. Babani, \$2.60.
- '28 Tested Transistor Projects' by R. Torrens, \$2.85.
- 'Handbook of IC Audio Pre-amplifier & Power Amplifier Construction' by F. G. Rayer, \$2.85.

Send order with cheque or Mastercharge/Chargex number to (with expiry date and signature) to ETI Books, Unit 6, 25 Overlea Blvd., Toronto, M4H 1B1.

IT'S YOU AGAINST THE COMPUTER

WE NOW STOCK COMPUTERIZED CHESS, CHECKERS, AND BACKGAMMON



THIS POPULAR CHESS COMPUTER NOW IN THREE VERSIONS

One Level Great for beginners Special \$199.95	Three Levels For more advanced players Only \$399.95	Ten Levels The ultimate Chess Challenger \$499.95
---	---	--

NOTE: Each level can be upgraded to the next level for \$100.00

JUST INTRODUCED TWO MODELS IN CHECKERS AND BACKGAMMON

Level 2 Checkers For beginners and intermediate players Only \$149.95	Level 4 Checkers Two levels for the advanced player Only \$299.95	Gammon Master I Backgammon for the average player \$299.95	Gammon Master II With doubler for greater challenge \$399.95
--	--	---	---

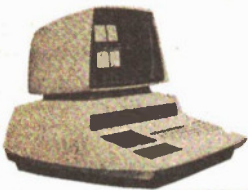

CSA APPROVED COMMODORE PETS NOW IN STOCK
We finally received these improved PETs with better cassette drive and thoroughly tested. Plus new programs from Commodore including the long awaited course on BASIC which will greatly help those new to programming.

PURCHASE THIS NEW PET AT \$1195

And receive a dozen programs, on cassette, plus Commodore Cassette-course on BASIC free.

COMMODORE KIM-1 MICROCOMPUTER SPECIAL AT \$275.

All products (except KIM-1) can be plugged into outlet for immediate operation. Full Mfrs. Warranty.

You may purchase at our store or by mail order.
Please send: Check Money Order Chargex Master Charge American Express

Expires _____

Card # _____
Signature _____

Send To
Marketron Corp Ltd
1240 Bay St. Mall
Toronto, Ont.
M5R 2A7
Phone: 416/923-1917
Store Hrs. 10-6
Thurs. & Fri. 10-7

Product Description	Price
Chess Challenger "1"	199.95
Chess Challenger "3"	399.95
Chess Challenger "10"	499.95
Checker Challenger "2"	149.95
Checker Challenger "4"	299.95
Gammon Master I	299.95
Gammon Master II	399.95
Commodore PET 2001	1195.00
Commodore KIM-1	275.00

Ontario residents add 7% sales tax.
Add shipping charge \$5.00; for PET is \$25.00
Indicate full name and shipping address.

**SERVING CANADIANS
FOR OVER 25 YEARS**

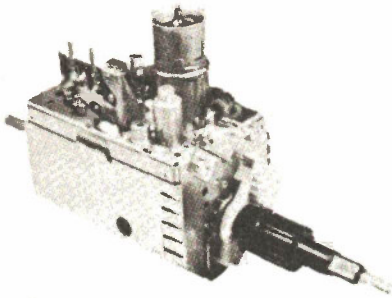

**UHF • VHF • FM
VARACTOR TUNERS**
Solid State our Speciality

We service more TV Tuners than all other tuner companies combined. We also service all makes of TV cable converters.

**CASTLE
TUNER SERVICE**

24 Cranfield Road,
East York, Toronto M4B 3H1
Tel. 752-7330 1

Tech Tips

Linear Scale Ohmmeter

M. Roberts

This circuit has several advantages over other linear scale ohmmeters.

Only one preset resistor is used for all the ranges, simplifying the setting up and reducing the cost. Diode clamping is included to prevent damage to the meter if the unknown resistor is higher than the range

selected. The use of a FET input Op-Amp would reduce any zero error and make offsetting adjustment unnecessary.

When the meter has been assembled, a 10k precision resistor is placed in the test position, R_x , the meter is set to the 10k range and RV1 adjusted for full scale deflection.

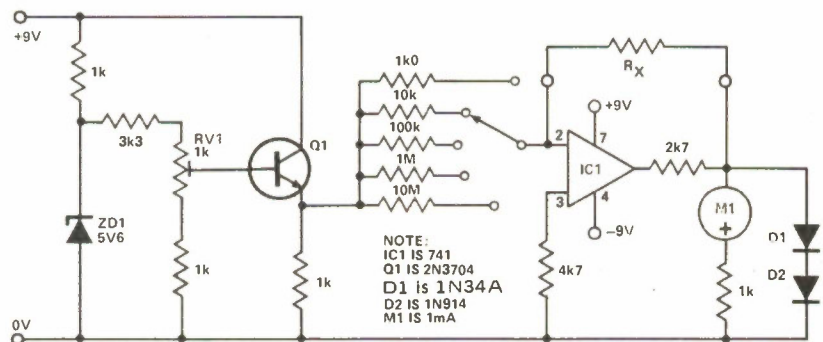

Kits for ETI Projects

Now Available

ETI Project No. 134
True RMS Voltmeter
\$89.95

ETI Project No. 450
Bucket Brigade
Audio Delay Line
\$48.50

ETI Project No. 486
Frequency Shifter
\$69.95

ETI Project No. 585
Ultrasonic Switch
\$29.95

ETI CCD Phaser
\$79.95

Cheque, Money Order
or Master Charge
include card expiry date
and number

DO NOT SEND CASH
Allow 3 weeks for delivery



**DOMINION RADIO &
ELECTRONICS**
535 Yonge St. Toronto
Ontario M4Y 1Y5

*Specially Imported for Canadian
Hobbyists:*

Another Circuits Book:

'CA3130'

50 Projects Using IC CA3140

By R. A. Penfold
96 pages

Published in the UK
in February 1977

- About the IC
- Audio Projects
- RF Projects
- Test Equipment
- Household Projects
- Miscellaneous Projects

\$2.85 (Size 7 1/8" x 4 1/4")

Price includes postage
and packing.

Send order with cheque or
Chargex/Mastercharge number
(with expiry date and signature)
to:

ETI Books, Unit Six, 25 Overlea
Bld., Toronto, M4H 1B1.

MORE ELECTRONICS IN MODEL RAILWAYS

Follow up the article in last month's ETI with more circuits for use in model railroad systems. "Electronic Circuits for Model Railways" was compiled in 1976 by Michael Babani and was published in the UK as a pocket-size 90-page book. Now we have the book in stock for our Canadian readers. Local equivalents are given for transistors used. Canadian price \$2.60 (inc p&p).

Send order with cheque or Mastercharge/Chargex number (with expiry date and signature) to ETI Books, Unit Six, 25 Overlea Blvd., Toronto, M4H 1B1.

DIODES/ZENERS				SOCKETS/BRIDGES				TRANSISTORS, LEDS, etc.					
1N914	100v	10mA	.05	8-pin	pcb	.20	ww	.35	2N2222	NPN (2N2222 Plastic .10)	.15		
1N4005	600v	1A	.08	14-pin	pcb	.20	ww	.40	2N2907	PNP	.15		
1N4007	1000v	1A	.15	16-pin	pcb	.20	ww	.40	2N3906	PNP (Plastic - Unmarked)	.10		
1N4148	75v	10mA	.05	18-pin	pcb	.25	ww	.75	2N3904	NPN (Plastic - Unmarked)	.10		
1N4733	5.1v	1 W Zener	.25	22-pin	pcb	.35	ww	.95	2N3054	NPN	.35		
1N753A	6.2v	500 mW Zener	.25	24-pin	pcb	.35	ww	.95	2N3055	NPN 15A 60v	.50		
1N758A	10v	"	.25	28-pin	pcb	.45	ww	1.25	T1P125	PNP Darlington	.35		
1N759A	12v	"	.25	40-pin	pcb	.50	ww	1.25	LED Green, Red, Clear, Yellow		.15		
1N5243	13v	"	.25	Molex pins	.01	To-3 Sockets	.25		D.L.747	7 seg 5/8" High com-anode	1.95		
1N5244B	14v	"	.25	2 Amp Bridge		100-prv	.95		MAN72	7 seg com-anode (Red)	1.25		
1N5245B	15v	"	.25	25 Amp Bridge		200-prv	1.95		MAN3610	7 seg com-anode (Orange)	1.25		
									MAN82A	7 seg com-anode (Yellow)	1.25		
									MAN74A	7 seg com-cathode (Red)	1.50		
									FND359	7 seg com-cathode (Red)	1.25		

C MOS		- T T L -									
4000	.15	7400	.10	7473	.25	74176	.85	74H72	.35	74S133	.40
4001	.15	7401	.15	7474	.30	74180	.55	74H101	.75	74S140	.55
4002	.20	7402	.15	7475	.35	74181	2.25	74H103	.55	74S151	.30
4004	3.95	7403	.15	7476	.40	74182	.75	74H106	.95	74S153	.35
4006	.95	7404	.10	7480	.55	74190	1.25			74S157	.75
4007	.20	7405	.25	7481	.75	74191	.95	74L00	.25	74S158	.30
4008	.75	7406	.25	7483	.75	74192	.75	74L02	.20	74S194	1.05
4009	.35	7407	.55	7485	.55	74193	.85	74L03	.25	74S257 (8123)	1.05
4010	.35	7408	.15	7486	.25	74194	.95	74L04	.30		
4011	.20	7409	.15	7489	1.05	74195	.95	74L10	.20	74LS00	.20
4012	.20	7410	.15	7490	.45	74196	.95	74L20	.35	74LS01	.20
4013	.40	7411	.25	7491	.70	74197	.95	74L30	.45	74LS02	.20
4014	.75	7412	.25	7492	.45	74198	1.45	74L47	1.95	74LS04	.20
4015	.75	7413	.25	7493	.35	74221	1.00	74L51	.45	74LS05	.25
4016	.35	7414	.75	7494	.75	74367	.75	74L55	.65	74LS08	.25
4017	.75	7416	.25	7495	.60			74L72	.45	74LS09	.25
4018	.75	7417	.40	7496	.80	75108A	.35	74L73	.40	74LS10	.25
4019	.35	7420	.15	74100	1.15	75491	.50	74L74	.45	74LS11	.25
4020	.85	7426	.25	74107	.25	75492	.50	74L75	.55	74LS20	.20
4021	.75	7427	.25	74121	.35			74L93	.55	74LS21	.25
4022	.75	7430	.15	74122	.55			74L123	.85	74LS22	.25
4023	.20	7432	.20	74123	.35	74H00	.15			74LS32	.25
4024	.75	7437	.20	74125	.45	74H01	.20	74S00	.35	74LS37	.25
4025	.20	7438	.20	74126	.35	74H04	.20	74S02	.35	74LS38	.35
4026	1.95	7440	.20	74132	.75	74H05	.20	74S03	.25	74LS40	.30
4027	.35	7441	1.15	74141	.90	74H08	.35	74S04	.25	74LS42	.65
4028	.75	7442	.45	74150	.85	74H10	.35	74S05	.35	74LS51	.35
4030	.35	7443	.45	74151	.65	74H11	.25	74S08	.35	74LS74	.35
4033	1.50	7444	.45	74153	.75	74H15	.45	74S10	.35	74LS86	.35
4034	2.45	7445	.65	74154	.95	74H20	.25	74S11	.35	74LS90	.55
4035	.75	7446	.70	74156	.70	74H21	.25	74S20	.25	74LS93	.55
4040	.75	7447	.70	74157	.65	74H22	.40	74S40	.20	74LS107	.40
4041	.69	7448	.50	74161	.55	74H30	.20	74S50	.20	74LS123	1.00
4042	.65	7450	.25	74163	.85	74H40	.25	74S51	.25	74LS151	.75
4043	.50	7451	.25	74164	.60	74H50	.25	74S64	.15	74LS153	.75
4044	.65	7453	.20	74165	1.10	74H51	.25	74S74	.35	74LS157	.75
4046	1.25	7454	.25	74166	1.25	74H52	.15	74S112	.60	74LS164	1.00
4049	.45	7460	.40	74175	.80	74H53J	.25	74S114	.65	74LS193	.95
4050	.45	7470	.45			74H55	.20			74LS367	.75
4066	.55	7472	.40							74LS368	.65

9000 SERIES		LINEARS, REGULATORS, etc.									
9301	.85	95H03	1.10	MCT2	.95	LM320T5	1.65	LM340K15	1.25	LM723	.40
9309	.35	9601	.20	8038	3.95	LM320T12	1.65	LM340K18	1.25	LM725N	2.50
9322	.65	9602	.45	LM201	.75	LM320T15	1.65	LM340K24	1.25	LM739	1.50
				LM301	.45	LM324N	1.25	78L05	.75	LM741 (8-14)	.25
				LM308 (Mini)	.95	LM339	.75	78L12	.75	LM747	1.10
				LM309H	.65	7805 (340T5)	.95	78L15	.75	LM1307	1.25
				LM309K (340K-5)	.85	LM340T12	.95	78M05	.75	LM1458	.65
				LM310	.85	LM340T15	.95	LM373	2.95	LM3900	.50
				LM311D (Mini)	.75	LM340T18	.95	LM380 (8-14 PIN)	.95	LM75451	.65
				LM318 (Mini)	1.75	LM340T24	.95	LM709 (8, 14 PIN)	.25	NE555	.35
				LM320K5 (7905)	1.65	LM340K12	1.25	LM711	.45	NE556	.85
				LM320K12	1.65					NE565	.95
										NE566	1.25
										NE567	.95

MICRO'S, RAMS, CPU'S, E-PROMS			
74S188	3.00	8214	8.95
1702A	4.50	8224	3.25
MM5314	3.00	8228	6.00
MM5316	3.50	8251	8.50
2102-1	1.45	8255	10.50
2102L-1	1.75	8T13	1.50
2114	9.50	8T23	1.50
TR1602B	3.95	8T24	2.00
TMS 4044-	9.95	8T97	1.00
		2107B-4	4.95
		2708	9.50
8080	8.95	Z80 PIO	8.50
8212	2.95		

INTEGRATED CIRCUITS UNLIMITED

7889 Clairemont Mesa Blvd., San Diego, CA 92111 U.S.A.
No Minimum

All prices in U.S. dollars. Please add postage to cover method of shipping. Orders over \$100 (U.S.) will be shipped air no charge.
Payment should be submitted with order in U.S. dollars.
All IC's Prime/Guaranteed. All orders shipped same day received.

SPECIAL DISCOUNTS

Total Order	Deduct
\$35 - \$99	10%
\$100 - \$300	15%
\$301 - \$1000	20%

Phone (714) 278-4394 BarclayCard / Access / American Express / BankAmericard / Visa / MasterCard

The Fun of Electronics



C'MON JIM, LET'S CALL IT QUITS FOR TODAY. WE'RE NOT GOING TO FIND ANYTHING VALUABLE AROUND HERE.

THE FIRST THING YOU'D BETTER DO WITH THAT COMPUTER YOU TALKED ME INTO LETTING YOU BUY, IS PROGRAM IT TO FIGURE OUT HOW WE'RE GOING TO PAY FOR IT.

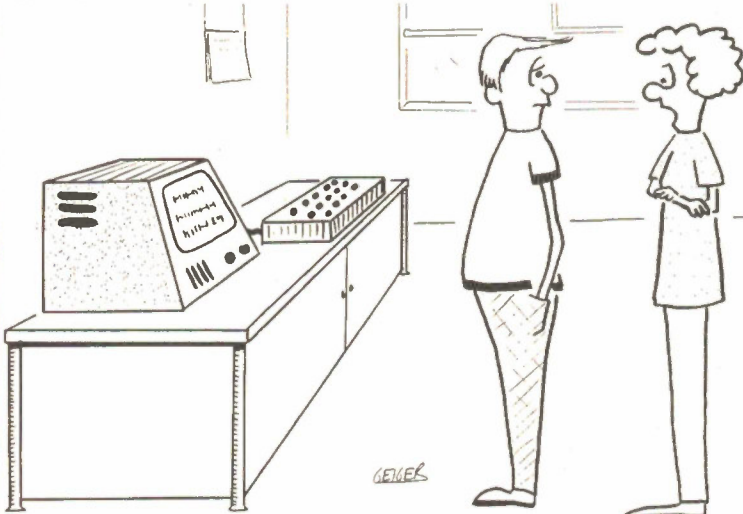

AND OF COURSE, AN IMPORTANT FEATURE IN ANY PROGRAMMABLE CALCULATOR IS BRANCHING...

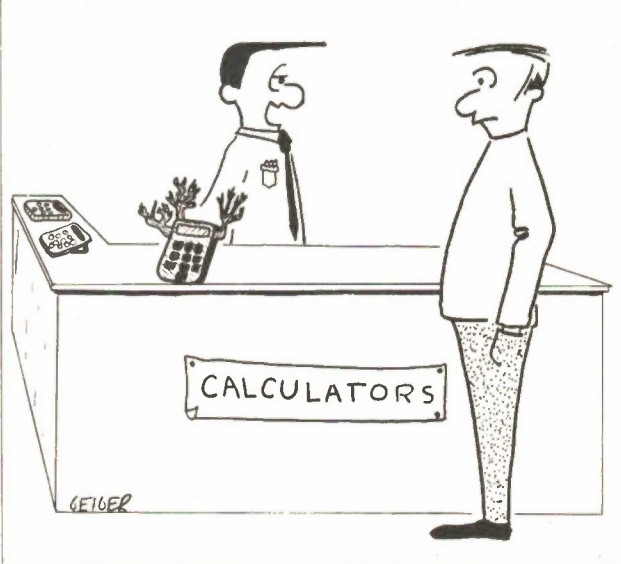

IT ADDS A WHOLE NEW DIMENSION TO VIDEO GAMES... A TARGET PRACTICE GAME THAT SHOOTS BACK!



SEEMS IT ALWAYS HAPPENS THAT WAY - A LITTLE CURRENT SURGE TURNS MY SOLID STATE PROJECTS INTO LIQUID STATE PROJECTS.

MA1002 CLOCK MODULE

MA1002A: 12 Hour Display assembled and tested module only \$14.95
 MA1002A SET: MA1002A Module + 102P3 transformer & switches \$19.95

Actual Size: 1.375" x 3.05" LED display digital electronic clock module 0.50" High Digits

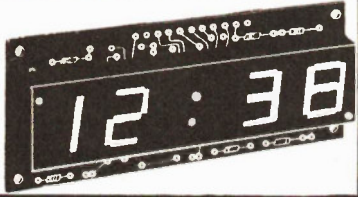

CT-50 FREQUENCY COUNTER

Outstanding Performance at an Incredible Price

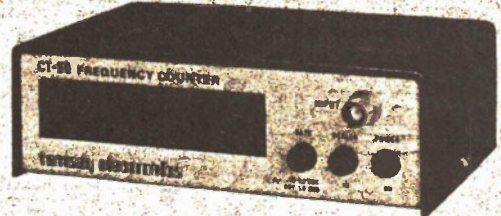

DESCRIPTION: The CT-50 is a versatile and precision frequency counter which will measure frequencies to 60 MHz and up to 600 mhz with the CT-600 option. Large Scale Integration, CMOS circuitry and solid state display technology have enabled this counter to match performance found in units selling for over three times as much. Low power consumption (typically 300-400 ma) makes the CT-50 ideal for portable battery operation. Features of the CT-50 include: large 8 digit LED display, RF shielded all metal case, easy pushbutton operation, automatic decimal point, fully socketed IC chips and input protection to 50 volts to insure against accidental burnout or overload. And, the best feature of all is the easy assembly. Clear, step by step instructions guide you to a finished unit you can rely on. Use the order blank below or call us direct and order yours today!

MA1003 12V CAR CLOCK



Here is an assembled and tested clock ready to run on 12 volts DC. Designed for the new car manufacturers to replace those troublesome mechanical clocks, this module will be useful wherever a crystal controlled clock is desired. Its own crystal time base assures accuracy of 2 seconds per day at 25 degrees C., and 5 seconds per day over the range of minus 25 degrees to plus 65 degrees C. Draws less than 5 MA. with display off yet maintains accurate time.

\$24.95 WITH 3 PB SWITCHES Case available

DEALS

ARKON STEREO CONTROL AMPLIFIER

A stereo control amplifier with bass, treble, balance and volume controls on board. Features low noise operation, detent controls, additional switch for switching front-rear speakers. This is a surplus bargain from a famous Canadian manufacturer and could not be offered for twice the price if it had to be made from scratch.

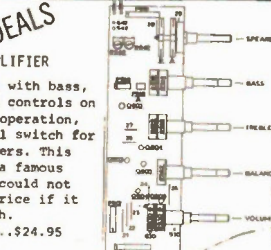

\$24.95

FREQUENCY COUNTER BOARD ONLY

THIS COUNTER HAS BEEN DESIGNED WITH THE HOME BUILDER IN MIND. ALL PARTS ARE AVAILABLE IN MANY PLACES. THE CIRCUIT IS TRIED AND TRUE, THE SINGLE SIDED BOARD IS EASY TO WORK ON AND ANY MISTAKES ARE EASY TO CORRECT THE COUNTER IS USEABLE TO 500 MHZ. SENSITIVITY AT THAT FREQUENCY IS TYPICALLY 100 MV. WE ESTIMATE THAT IF CARE IS TAKEN THE COUNTER CAN BE BUILT FOR ABOUT \$75.00. LESS IF NO CASE IS USED AND A LARGE JUNKBOX IS AVAILABLE.

BOARD ONLY.....\$14.95

LOGIC PROBE KIT

THIS LOGIC PROBE FEATURES A 7 SEGMENT READOUT THAT SHOWS 4 LOGIC LEVELS AS FOLLOWS. An 'H' FOR HIGH IS SHOWN FOR VOLTAGES ABOVE 2.5VDC. An 'L' FOR LOW IS SHOWN FOR VOLTAGES BELOW 0.6VDC. An '0' FOR OPEN IS SHOWN FOR VOLTAGES BETWEEN 0.6 AND 2.6 AND A 'P' SHOWN FOR A PULSE FOLLOWING THE FALLING EDGE OF A PULSE OR WAVEFORM. THE PROBE IS QUITE COMPACT AND SHOULD BE VERY USEFUL AS A TROUBLESHOOTING TOOL.

COMPLETE KIT.....\$14.95

ARKON AM-FM STEREO TUNER KIT

A stereo AM/FM tuner kit featuring a prebuilt chassis with IC stereo decoder, muting, FET front end, de-emphasis, stereo beacon, tuning meter, and 4 stages of tuning selectivity for the best rejection of strong adjacent stations as well as excellent fring area reception. This receiver will easily outperform units costing hundreds of dollars more. A surplus bargain from a famous Canadian builder.

.....\$39.95

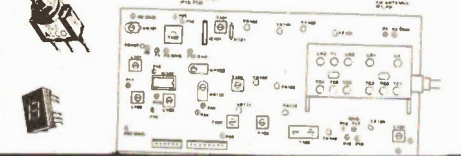

- CT-50, 60 MHZ COUNTER KIT.....\$119.95
- CT-50, WIRED AND TESTED.....\$149.95

- ACCESSORIES
- CT-600, 600 MHZ PRESCALER OPTION.....\$33.95
 - DC PROBE, DIRECT INPUT, GENERAL PURPOSE.....\$16.99
 - HIGH Z PROBE, DOES NOT LOAD CIRCUIT.....\$10.95
 - LOW PASS PROBE, FOR AUDIO USE.....\$19.95
 - VHF RUBBER DUCK ANTENNA WITH BNC CONNECTOR.....\$14.95
 - COLOUR BURST ADAPTOR, USES NETWORK RUBIDIUM STANDARD FOR UP TO .001 PPM ACCURACY.....\$18.95

MINI-KITS

- VIDEO MODULATOR KIT: The most economical video modulator kit around, yet is one of the best at any price.....\$9.95
- ARKON MAG PREAMP KIT: A great kit, stereo mag preamp, puts out 1 volt from 50 mv, low noise, 12 volt.....\$6.95 Built.....\$8.95
- DECISION MAKER KIT: A novel kit much used in Ottawa. 2 cmos ic's flash 2 leds, stops at random. Great fun for all.....\$6.95
- ATARI VIDEO MODULATOR: The famous ATARI tv game video modulator. Not a kit, all set to go, runs on 5vdc.....\$12.95
- TOPE DECODER KIT: A complete line decoder on a single IC Board.....\$5.95
- SUPER-SNOOP AMPLIFIER: A super-sensitive amplifier which will pick up a pin drop at 15 feet! Great for monitoring baby's room or as a general purpose test amplifier. Full 2 watts of output, runs on 8 to 12 volts, uses any type of mike. Requires 8-25 ohm speaker. Complete Kit, BN-9.....\$5.95
- FM WIRELESS MIKE KIT: Transmits up to 300' to any FM broadcast radio, uses any type of mike. Runs on 3 to 9 V. Type FM-1 has added super sensitive mike preamp. FM-1.....\$2.95 FM-2.....\$4.95
- COLOR ORGAN/MUSIC LIGHTS: See music come alive! 3 different lights flicker with music or voice. One light for lows, one for the midrange and one for the highs. Each channel individually adjustable, and drives up to 300 watts. Great for parties, band music, rite clubs and more. Complete Kit, ML-1.....\$9.95
- LED BLINKY KIT: A great attention getter which alternately flashes 2 Jumbo LEDs. Use for name badges, buttons, or warning type panel lights. Runs on 3 to 9 volts. Complete Kit.....\$2.95
- POWER SUPPLY KIT: 5 VDC at 600 MA+ 0-20 VDC at 200 MA ALL PARTS.....\$7.95
- SIREN KIT: Produces upward and downward wail characteristic of police sirens. 5 watts audio output, runs on 3-9 volts, uses 8-45 ohm speaker. Complete Kit, SM-3.....\$2.95
- DECADE COUNTER PARTS: Includes 7490A, 7475, 7447, LED readout, current limit resistors, and instructions on an easy to build low cost frequency counter. Kit of parts, DC-1.....\$3.95

8K STATIC RAM BOARD FULLY BUFFERED, S100 BUS, SOCKETS, 4 5v REGS ON BOARD, USES 21102 RAM'S 450 ns, \$149.50 KIT. ADD \$30.00 FOR 250 ns. DATA ON REQUEST.

RE 6416 TERMINAL A 64x16 VIDEO TERMINAL KIT, RS232, 20 MA CURRENT LOOP ON BOARD, +- STROBE SELECT, 5VDC 700 MA, \$150.05 KIT

8080 BASED S100/BUS CPU BOARD SOON TO BE AVAILABLE THIS UNIT WILL HAVE AN ONBOARD FLOPPY DISC CONTROLLER AS WELL AS 48 K OF RAM POTENTIAL. IT WILL SELL IN THE \$300.00 AREA WRITE IF INTERESTED.

ARKON POLICY ON ORDERS IF THE PART YOU ORDER IS OUT OF STOCK WE WILL PROMPTLY REFUND YOU THAT PART OF YOUR MONEY SO THAT YOU MAY SECURE THE PARTS ELSEWHERE. WE WILL ALSO TELL YOU WHEN WE EXPECT STOCK TO ARRIVE THANK YOU ARKON

250 YARDS FROM SUBWAY ARKON

COME, SEE FOR YOURSELF.

91

CHIPS

74101P.....	4/\$1.00
FET741.....	3/\$1.00
555.....	2/\$1.00
556.....	\$1.50
7447.....	\$.90
7490.....	\$.60
21L02(#50)	\$1.60
7400.....	\$.20
7404.....	\$.20
7805.....	\$1.00
7905.....	\$1.50

+++MOTHERS ASK

Economy plus

ARKON GIFT CERTIFICATES Don't know what to get someone for a gift????? Try an ARKON gift certificate. They are available in any denomination, include all provincial sales taxes (where applicable), they have no expiry date, and the lucky holder can pick and choose from the largest store of new and surplus electronic merchandise in Ontario. Just send a cheque for the amount you wish on the certificate and we will send your gift to you or to the recipient (as you choose) immediately.

GIFT CERTIFICATES

ARKON ELECTRONICS LTD. 91 Queen Street E. Toronto, Ontario M5C 1S1 Phone (416) 868-1315

ORDERING INFORMATION ADDRESS YOUR FULL NAME AND STREET ADDRESS + POSTAL CODE PAYMENT WE ACCEPT CHARGE, PMO, MASTER CHARGE, CHEQUES. DO NOT SEND CASH BY MAIL POSTAGE SEND ENOUGH FOR A 1 LB PARCEL. EXCESS RET'ND Ask for our New Catalogue



ETI Project File

Updates, news, information, ETI gives you project support

PARTS PARTS PARTS

We are continually besieged with letters from readers asking where they can get parts in their area. Since we can't take a country-wide tour to check where all the electronics parts-places are, how about sending us a note on any stores you have found useful, what they are good for (if you own the place you can contribute too!) and so on. At some time in the future we would like to help out the "lost" readers by publishing a rundown of where to get what.

PROJECT FILE is our department dealing with information regarding ETI Projects. Each month we will publish the Project Chart, any Project Notes which arise, general Project Constructor's Information, and some Reader's Letters and Questions relating to projects.

PROJECT NOTES

Since this magazine is largely put together by humans, the occasional error manages to slip by us into print. In addition variations in component characteristics and availability occur, and many readers write to us about their experiences in building our projects. This gives us information which could be helpful to other readers. Such information will be published in Project File under Project Notes. (Prior to May 78 it was to be found at the end of News Digest.)

Should you find that there are notes you wish to read for which you do not have the issue, you may obtain them in one of two ways. You can buy the back issue from us (refer to Project Chart for date of issue and see also Reader Service Information on ordering). Alternatively you may obtain a photocopy of the note free of charge, so long as your request includes a self addressed stamped envelope for us to mail it back to you. Requests without SASE will not be answered.

PROJECT CONSTRUCTOR'S INFORMATION

Useful information on the terminology and notation will be published each month in Project File.

ISSUE DATE	ARTICLE	ISSUE DATE	ARTICLE
Nov 77	Digital Thermometer	Apr 78	Neg.
Jan 78	Note: C, T, S,	Mar 78	Home Burglar Alarm
Jan 78	Neg.	Apr 78	Gas Alarm & Neg.
Feb 78	Note: S	May 78	White Line Follower
Nov 77	3-Channel Tone Control	June 78	Neg.
Jan 78	Neg.	May 78	Acoustic Feedback Eliminator
Nov 77	Watchdog	June 78	Neg.
Jan 78	Neg.	May 78	Add-on FM Tuner
Aug 78	Note: D	June 78	Neg.
Dec 77	50D50 Amplifier	June 78	Audio Analyser
Jan 78	Neg.	June 78	Ultrasonic Switch & Neg.
Feb 78	Note: T	June 78	Phone Bell Extender & Neg.
Dec 77	Spirit Level	July 78	Proximity Switch
Jan 78	Neg.	Aug 78	Neg.
Dec 77	Egg Timer	July 78	Real Time Analyser MK II (LED)
Jan 78	Neg.	Aug 78	Neg.
Jan 78	Option Clock & Neg.	July 78	Acc. Beat Metronome.
July 78	Note: S	Aug 78	Neg.
Jan 78	LED Pendant	July 78	Race Track
May 78	Note: C	Aug 78	Neg.
Jan 78	Compander & Neg.	Aug 78	Sound Meter & Neg.
Feb 78	Tachometer	Aug 78	Porch Light & Neg.
Apr 78	Neg.	Aug 78	IB Metal Locator & Neg.
Feb 78	LCD Panel Meter	Aug 78	Two Chip Siren & Neg.
Apr 78	Note: C	Sept 78	Audio Oscillator
Apr 78	Neg.	Nov 78	Neg.
Feb 78	CB Power Supply	Sept 78	Shutter Timer
Mar 78	Hammer Throw	Nov 78	Neg.
June 78	Neg.	Sept 78	Rain Alarm
Apr 78	Computer PSU & Neg.	Oct 78	CCD Phaser
Apr 78	Audio Delay Line & Neg.	Nov 78	Neg.
Mar 78	True RMS Meter	Oct 78	UFO Detector
Apr 78	Neg.	Nov 78	Neg.
May 78	Note: N	Oct 78	Strobe Idea
Feb 78	Freezer Alarm	Nov 78	Cap Meter & Neg.
Apr 78	Neg.	Nov 78	Stars & Dots
		Nov 78	CMOS Preamp & Neg.

ETI Project Chart

Canadian Projects Book

Audio Limiter	Metal Locator
5W Stereo	Heart-Rate Monitor
Overled	GSR Monitor
Bass Enhancer	Phaser
Modular Disco	Fuzz Box
G P Preamp	Touch Organ
Bal. Mic. Preamp	Mastermind
Ceramic Cartridge Preamp	Double Dice
Mixer & PSU	Reaction Tester
VU Meter Circuit	Sound-Light Flash
Headphone Amp	Burglar Alarm
50W-100W Amp	Injector-Tracer
Note: N Apr. 78	Digital Voltmeter

Key to Project Notes

C:- PCB or component layout
 D:- Circuit diagram
 N:- Parts Numbers, Specs
 Neg:- Negative of PCB pattern printed
 O:- Other
 S:- Parts Supply
 T:- Text
 U:- Update, Improvement, Mods
 ***:- Notes for this project of complicated nature, write for details (enclose S.A.S.E., see text)

PROJECT CHART

This chart is an index to all information available relating to each project we have published in the preceding year. It guides you to where you will find the article itself, and keeps you informed on any notes that come up on a particular project you are interested in. It also gives you an idea of the importance of the notes, in case you do not have the issue referred to on hand.

Every few months we print a pull out section in the magazine which may be used as a photographic negative for making printed circuit boards (as described in our January 78 issue). Each edition of this sheet contains projects from the preceding few issues. Information on where to find which negative is included in the chart.

Write to: Project File
Electronics Today International
Unit 6, 25 Overlea Blvd.,
TORONTO, Ontario
M4H 1B1

Component Notations and Units

We normally specify components using an international standard. Many readers will be unfamiliar with this but it's simple, less likely to lead to error and will be widely used sooner or later. ETI has opted for sooner!

Firstly decimal points are dropped and substituted with the multiplier, thus 4.7 μ F is written 4u7. Capacitors also use the multiplier nano (one nanofarad is 1000pF). Thus 0.1 μ F is 100n, 5600pF is 5n6. Other examples are 5.6pF = 5p6, 0.5pF = 0p5.

Resistors are treated similarly: 1.8M ohms is 1M8, 56k ohms is 56k, 4.7k ohms is 4k7, 100 ohms is 100R, 5.6 ohms is 5R6.

Kits, PCBs, and Parts

We do not supply parts for our projects, these must be obtained from component suppliers. However, in order to make things easier we cooperate with various companies to enable them to promptly supply kits, printed circuit boards and unusual or hard-to-find parts. Prospective builders should consult the advertisements in ETI for suppliers for current and past projects.

Any company interested in participating in the supply of kits, pcbs or parts should write to us on their letterhead for complete information.

READER'S LETTERS AND QUESTIONS

We obviously cannot troubleshoot the individual reader's projects, by letter or in person, so if you have a query we can only answer it to the extent of clearing up ambiguities, and providing Project Notes where appropriate. If you desire a reply to your letter it must be accompanied by a self addressed stamped envelope.

CCD Phaser

Dominion Radio reports that they will be supplying kits of the CCD Phaser very shortly. Check their ads for announcements, or contact them direct.

Spectrum PCBs

Ed Vander Ryd has written to us to say that his company is prepared to supply any single sided pcboard which ETI has published in Canada. Address: Spectrum Electronics, 38 Audubon St. S., Hamilton, Ontario L8J 1J7

General Parts

Jerry Sky wishes to alert ETI readers to the presence of his Toronto parts store. Located at 5511 Yonge St., General Electronics is between highway 401 and Finch Ave., well placed to serve the north of the city. Drop in and see them! Also see their ad in this issue.

4 ETI Publications

Projects Books 3 & 4
now sold out.

Send your order, with payment
(not cash), to

ETI PUBLICATIONS,
Electronics Today International
Unit Six
25 Overlea Boulevard
Toronto, Ontario
M4H 1B1

Please specify which publications
you require, and print your name
and address clearly.

Canadian Projects Book No. 1

\$3.00

Top projects from the early issues of ETI's Canadian edition, plus some of the projects from the UK edition's issues which were distributed in Canada in 1976. All projects use parts available in Canada. Those projects from UK edition have been completely re-worked in Canada for Canadian constructors. Includes a series of modular disco projects, plus games, biofeedback, metal locator, etc.

Circuits No. 1

\$5.00

A brand new concept from the house of ETI. More than 100 pages packed with a wide range of experimenters circuits. Based on the 'Tech Tips' section carried in the overseas editions of ETI, Circuits 1 is the first of a series of specials — produced for the enthusiasts who know what they want, but not where to get it! Circuits 1 will also act as a catalyst for further development of ideas, ideal for the experimenter. The collection of more than 200 circuits is complemented by a comprehensive index, making searches for a particular circuit quick and simple. Also, similar circuits can be compared easily, due to the logical layout and grouping used throughout. Last and by no means least, Circuits 1 has no distracting advertisements in the main section!

Electronics — it's easy Volume 1

\$3.50*

The best introductory series to electronics ever published in a magazine. Volume three completing the series, will be available in a few months. Volume One introduces electronics to the beginner by going through the systems approach, basic concepts, meters and measurements, frequency and wavelengths, electronics and communication, capacitance and inductance, capacitive and inductive reactance, resistance, capacitance and inductance in combination, detection and amplification, elements of transistor amplifiers, emitter followers and DC amplifiers, and basic operational amplifiers.

Electronics — it's easy Volume 2

\$3.50*

Volume Two introduces the sources of power, simple power supplies, how regulated power supplies work, general purpose supplies, generating signal waveforms, generating non-sinusoidal waveforms, all about electronic filters, more about filters, introducing digital systems, the algebra of logic, integrated circuit forms of logic functions, digital sub-systems, counters and shift registers.

\$6.00 For Both*

Reader Service Information

Editorial Queries

Written queries can only be answered when accompanied by a self-addressed, stamped envelope, and the reply can take up to three weeks. These must relate to recent articles and not involve ETI staff in any research. Mark your letter ETI Query.

Projects, Components, Notation

For information on these subjects please see our Project File section.

LIABILITY: Whilst every effort has been made to ensure that all constructional projects referred to in this edition will operate as indicated efficiently and properly and that all necessary components to manufacture the same will be available, no responsibility whatsoever is accepted in respect of the failure for any reason at all of the project to operate effectively or at all whether due to any fault in design or otherwise and no responsibility is accepted for the failure to obtain any component parts in respect of any such project. Further no responsibility is accepted in respect of any injury or damage caused by any fault in the design of any such project as aforesaid.

Sell ETI

ETI is available for resale by component stores. We can offer a good discount and quite a big bonus, the chances are customers buying the magazine will come back to you to buy their components. Readers having trouble getting their copy of ETI could suggest to their component store manager that he should stock the magazine.

1977
February
~~March~~
~~April~~
May
June
July
~~August~~
September
~~October~~
November
December

1978
January
February
March
April
May
June
July
August
September
October

Back Issues and Photocopies

Previous issues of ETI-Canada are available direct from our office for \$2.00 each. Please specify issue by the month, not by the features you require. The following back issues are still available for sale.

We can supply photocopies of any article published in ETI-Canada, for which the charge is \$1.00 per article, regardless of length. Please specify issue and article. (A special consideration applies to errata for projects, see Project File.)

LENLINE AND Tom* present

THE STRIPEX SELF-ADJUSTING Wire Stripper

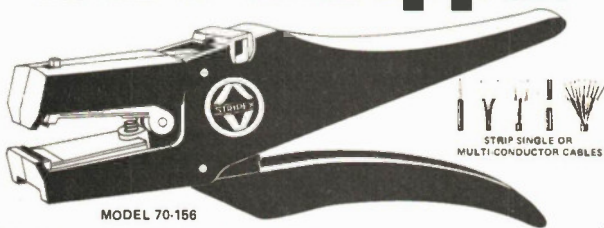

The model 70-156 Stripex is a Swedish made precision wire stripper and cutter with self-adjusting stripping jaws. Will strip most types of PVC wire and cable from 10 to 38 AWG solid or stranded. Strips insulation in one operation. Excellent for multi-conductor cables as well. Outer jacket is taken off in first squeeze and then up to six conductors can be stripped as one, with another squeeze. Does not nick the wire. Adjustable stop controls length of insulation stripped. Has three position cutting depth adjustment and cutting blade cover. Durable and lightweight, made of nylon reinforced with fiberglass. 7-3/8" in length.

*Tom — OUR TOOL OF THE MONTH CAT!

Write for Free Lenline Electronic Catalogue

len finkler limited

25 Toro Road, Downsview, Ontario M3J 2A6
Telephone (416) 630-9103 Telex 065-24010



Advertisers' Index

A-1 Electronics	66
Active Components	75
Allan Crawford Associates	6
Alpha Tuner Service	44
Arkon Electronics	71
BCS Electronics	44
Canvox	30
Castle Tuner Service	68
Classified	54
Cornell-Dubilier	58
Dominion Radio & Electronics	68
Enterprise Electronics	60
GTE Sylvania	31
Home Computer Centre	22
Integrated Circuits Unlimited	69
Jana Electronics	65
Len Finkler Ltd.,	12,60,74
Marketron	67
McGraw-Hill	19
Ocean Electronics	14
Omnitronix	76,PCB sheet
Personal Computer Products	54
Rogers, H.	30
Sprague International	2
Standard Electronics	14
Zenith Radio Corp.,	57,21

A COMPLETE QUALITY LINE FOR INDUSTRY, EDUCATION & SERVICE.

- Oscilloscopes/Vectorscopes
- Color Bar & Pattern Generators
- DVM's
- Multimeters
- Millivolt Meters
- Signal Generators
- Sweep/Marker Generators
- Accessories

L
B
O
5
2
0

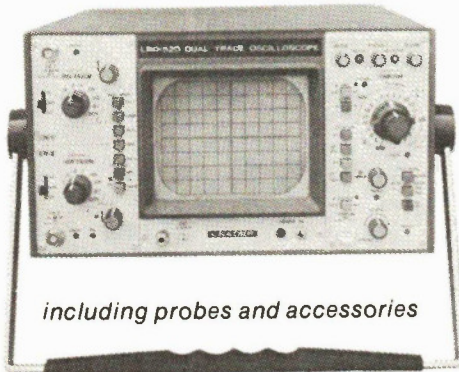

including probes and accessories

LBO 520 30MHz DUAL TRACE OSCILLOSCOPE with signal delay line and post deflection acceleration C.R.T.

The newest addition to a growing family of Leader Oscilloscopes. This 30MHz dual trace oscilloscope has good bandwidth without sacrificing the high sensitivity — 5mV/cm. It is specially suited for display of wave forms generated in "high speed" digital circuits such as those used in computer equipment. The cathode ray tube is the high brilliancy type using the post deflection acceleration voltage. The vertical amplifier includes a delay line — a convenience in observation of the pulse leading edge. Other features are provided for a wide range of applications.

- Wide band—High Sensitivity
- Possible to observe the high speed pulse
- Large clear display with high brightness
- Equipped with various functions
- Portable compact type and improved facility

LBO 508 20MHz DUAL TRACE OSCILLOSCOPE

A brand new addition to a growing family of Leader oscilloscopes. This 20 MHz dual trace oscilloscope is small in size and light in weight. Front panel controls are logically grouped and located for fast and easy operation. The LBO 508 is a 20 MHz oscilloscope with a 10 mV/cm — 20 V/cm sensitivity in 11 calibrated steps. The high intensity CRT delivers excellent contrast while the regulated high voltage supply provides stable brightness.

The applications for this new outstanding oscilloscope are limitless. The LBO 508 is ideally suited for research and development, production, quality control, education and servicing.

- Compact, lightweight, horizontal package
- Add and subtract mode
- Front panel x-y one touch operation
- Automatic and T.V. sync. triggering

L
B
O
5
0
7



including probes and accessories

LBO 507 20MHz SINGLE CHANNEL OSCILLOSCOPE

Yet another brand new addition to the growing family of Leader oscilloscopes. This single channel 20MHz is small in size and light in weight. Front panel controls are logically grouped and located for fast and easy operation. The LBO 507 is a 20MHz oscilloscope with a 10 mV/cm — 20V/cm sensitivity in 11 calibrated steps. A 200mV/cm horizontal amplifier is incorporated to permit front panel x-y operation. The high intensity CRT delivers excellent contrast while the regulated high voltage supply provides stable brightness.

This general purpose oscilloscope is ideally suited for research and development, production, quality control, education and general service applications.

- Compact, lightweight, horizontal package
- DC to 20 MHz bandwidth
- Front panel x-y operation
- Automatic and T.V. sync. triggering
- Unique trigger circuit for maximum display stability

L
B
O
5
0
8



including probes and accessories

Sold and Serviced throughout Canada by

LEADER TEST INSTRUMENTS
"PUT US TO THE TEST."

omnitronix Ltd.

WRITE FOR OUR DETAILED CATALOG.

2056 SOUTH SERVICE RD.
TRANS CANADA HWY
DORVAL, QUE. H9P 2N4
PHONE: (514) 683-6993