

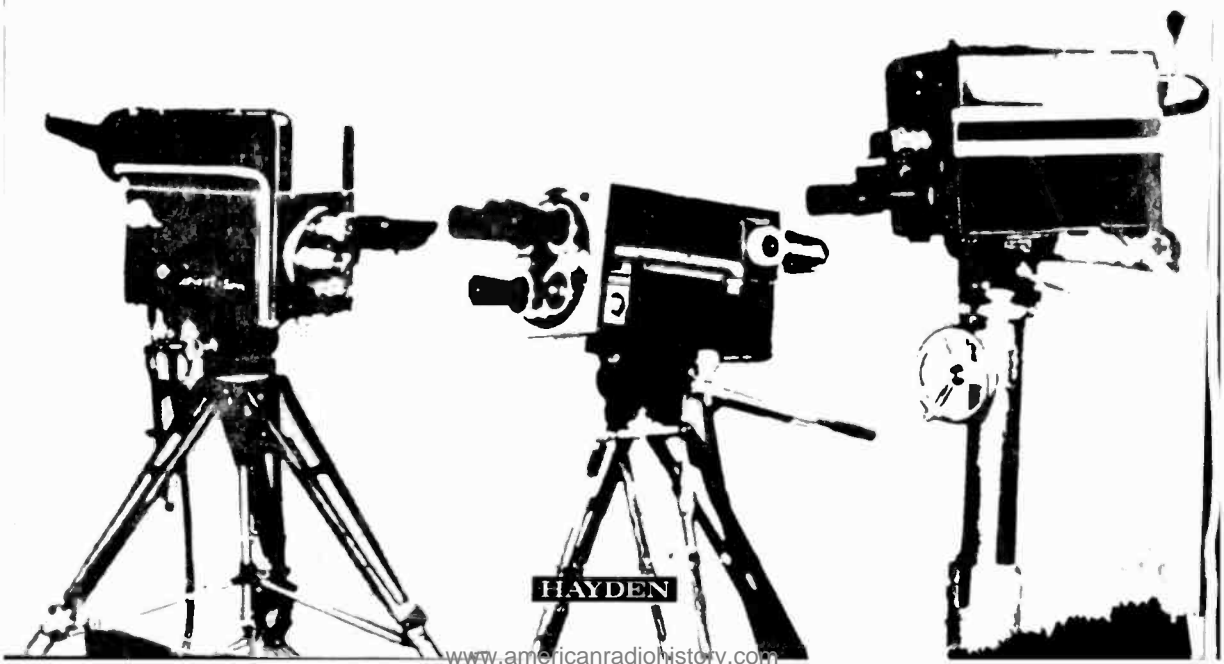

planning the local uhf-tv station

Patrick S. Finnegan



HAYDEN

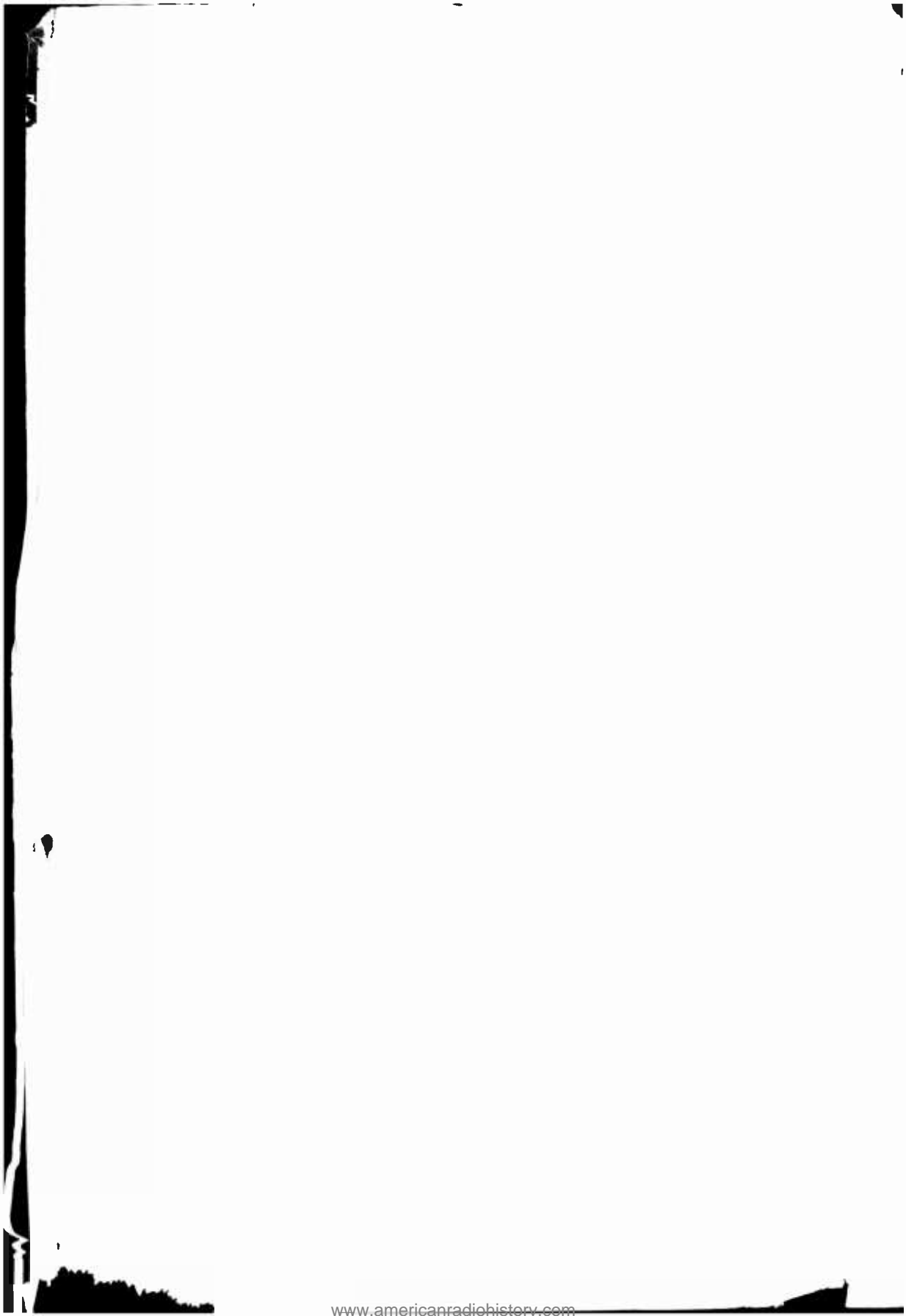

***PLANNING
THE
LOCAL
UHF-TV
STATION***

Patrick S. Finnegan

*Vice President — Chief Engineer
WLBC AM/TV WMUN (FM)
Muncie, Indiana*

HAYDEN BOOK COMPANY, INC., NEW YORK
a division of HAYDEN PUBLISHING COMPANY, INC.

Copyright © 1965

HAYDEN BOOK COMPANY, INC.

All rights reserved. This book or any parts thereof may not be reproduced in any form or in any language without permission of the publisher.

Library of Congress Catalog Card Number 65-12643

Printed in the United States of America

Preface

The day of the small-market, uhf television broadcast station—the television counterpart of the local radio station—is here. An awakening interest on the part of the television audience and industry in this area of broadcasting is slowly but surely gaining momentum. The number of construction permits issued by the Federal Communications Commission to build uhf stations is steadily increasing. The all-channel TV receiver, whose construction is required by law, will permit the public to view both uhf and vhf channels without additional modifications to their sets. Many of the stations now going on the air will have no network affiliation, but will program according to the needs of their communities. As more and more outlets take the air, it is entirely possible that another network will be formed.

This book is an effort to make available to you the author's experience of a number of years in the technical operation of a small-market, uhf TV station. The information contained here, gained from working experience, will guide the reader through the intricacies involved in the planning and building of such a station. The technical side of this operation is exposed to help the owner, manager, and engineer, or anyone else who is interested in this medium, recognize some of its limitations as well as its potential.

Television broadcasting equipment is a highly technical complex. More time, effort, people, and money are required to deliver a message or program to the public than in radio, but the impact is greater. This complexity and cost is one of television's greatest limitations. You will find here a general coverage of the many factors and considerations involved in the planning, building, and operation of a completely new station. Equipment, layout, and building costs are detailed for the minimal working budget. The information contained here will certainly save you money and time and will increase your competence and confidence.

Theory and technical explanations have been avoided deliberately. All of the information is practical and workable. Approximate costs are given where possible even though they may soon be out of date. (This should be taken into account when you work out your own cost estimates.) Technical charts and tables are included so that you may have some idea of their function and use. The actual work of determining coverage, figuring antenna height, etc., will be done by your consulting engineers.

A partial listing of equipment manufacturers, tower companies, and trade magazines is included in the appendix. Any of these organizations will be happy to give you whatever information you may need in the course of your planning and building.

The author would like to express his thanks and appreciation to those manufacturers who have so generously supplied photographs and specifications of their equipment, the uhf stations who have supplied information on their operations, and the many individuals who have offered him so much encouragement as he worked on this book.

Muncie, Indiana

PATRICK S. FINNEGAN

CONTENTS

Chapter 1	SELECTING A SITE	1
	Basic factors in site selection, 3 Location setups, 5 Studio transmitter links—a cost comparison, 9 Site selection and cost (three representative examples), 11	
Chapter 2	ESTIMATING COVERAGE	15
	Antenna location and required field strength, 15 Grade A and Grade B contours, 16 Making a profile, 17 Using the FCC F (50,50) chart, 23	
Chapter 3	THE STUDIO	27
	The basic studio, 27 Lighting, 30 The camera, 37 Microphones, 43 Camera accessories, 47 Backdrops and props, 47 Costs of basic studio equipment, 49	
Chapter 4	THE CONTROL ROOM	53
	Minimum video requirements, 54 Minimum audio requirements, 66 Off/air pickup, 72 Film and slide equipment, 74 Engineering the control room, 79 Television remotes—some examples, 83 Costs of basic control room equipment, 86	
Chapter 5	THE UHF TRANSMITTER	88
	The uhf band, 88 Power and separation, 89 Modulation, 90 Special uhf transmitter features, 91 Monitoring, 99 The visual transmitter, 102 The aural transmitter, 108 Video requirements, 111 Vestigial sideband filter-duplexer, 112 Maintenance techniques, 114 Transmitter modifications, 123 Transmitter costs, 125	

Chapter 6	TRANSMISSION LINES	127
	Basic problems, 127 Teflon line, 128 Flexible line, 128 Line selection, 131 Line ratings, 133 Line handling, 135 Cutting line, 136 Planning the installation, 138 Wave- guide, 145 Cost estimates and examples, 146	
Chapter 7	THE UHF ANTENNA	149
	General characteristics, 149 Antenna types, 150. Antenna terminology, 150 Using the charts, 157 Commercial antennas, 164 Towers, 174 Antenna and tower care, 178 Cost estimate—a representative installation, 182	
Chapter 8	FILM	184
	Film damage, 184 Film previewing and inspection, 185 Preventing film damage, 187 Film cleaners and hard- eners, 190 Reels, 192 Projector maintenance, 193 Film room equipment, 194 Shoot your own, 198 Film equip- ment costs, 204	
Chapter 9	PLANNING THE BUILDING	206
	Types of structure, 208 Traffic problems, 209 Other considerations, 210 A sample floor plan, 211	
Chapter 10	PLANNING THE LAYOUT	219
	General layout, 219 Transmitter, 222 Control room, 224 Studio, 230 Shop area, 234	
Chapter 11	TEST EQUIPMENT	236
	Basic considerations, 236 General station requirements, 238 Basic instruments, 240 Special instruments for special applications, 246 Some testing techniques, 250 Test equipment costs, 255	
Chapter 12	FCC CONSIDERATIONS	257
	On your mark, 257 Get ready, 259 Get set, 261 Go, 262	

CONTENTS

vii

APPENDICES

269

A. Things you can build for the studio, 269 B. Modifying the TC-4A switcher, 274 C. The TV band, 282 D. Equipment suppliers and manufacturers, 283; tower erectors and service companies, 286; trade magazines, 286 E. Bibliography, 287

INDEX

288

Chapter 1

Selecting a Site

The first important consideration for site selection is the geographical location of the station. One cannot just decide to operate in some particular city because he likes the market and then proceed to build a station. If such were the normal procedure, there would be so much interference among stations that few, if any, could provide a suitable signal over any given market. Recognizing this problem in the very early days of radio broadcasting, the United States Congress passed radio laws, now known as the Communications Act, to regulate the use of the airways. The Federal agency set up to administer and enforce these laws is the Federal Communications Commission (FCC). All radio and television stations live and operate under what are known as *The Rules and Regulations of the FCC* and *The Standards of Good Engineering Practice*. In the *Rules* is a Table of Assignments that assigns specific channels for the major communities in this country. You must apply to the FCC for use of an unoccupied channel in a community listed in this table (or within a 15-mile radius of any such community).

You should also be reasonably sure of what your organization proposes to do in television, both for the present and on a long-range basis. Most of the smaller-market uhf TV stations should begin on a small scale, performing an adequate service for their immediate market area, just as small radio stations have achieved their own level of performance according to their own market area.¹ Trying to imitate the

¹ *Market area* and *population center*, as used in this text, are not synonymous terms. Population center indicates villages and communities with a legal and political status and, in many cases, the suburbs that have developed around these communities. Market area refers to any geographical area in which the residents look upon a larger nearby town or city as the center for their buying and business activities.



Fig. 1-1. A 500-foot, self-supporting tower. (WLBC-TV, Muncie, Indiana)

large metropolitan station with its greater reserves of cash, talent, and equipment will most likely produce very unsatisfactory results and often may result in failure of the business.

Basic Factors in Site Selection

Terrain and Population Centers

There will be readily-apparent factors influencing site selection. There are also factors that are not so evident. If your company is an operating AM or FM station, you may already have buildings, towers, and some equipment that can also be used for television. A well-planned use or expansion of these facilities to incorporate television, if feasible, may help reduce initial investment costs considerably.

Terrain and population centers will have a great bearing upon just what can be done when selecting a site for the maximum or most beneficial coverage. Chapter 2 indicates how these factors are to be taken into consideration. The terrain of the immediate and outlying areas must be considered because hilly or mountainous terrain presents different transmission problems than those encountered in an area with flat terrain. Population centers should be considered because the FCC *Rules* specify that a definite amount of signal must be delivered over the entire principal community. (The FCC also specifies signal amounts for the primary and secondary coverage areas.) The signal specified for the principal community must be supplied, unless you can convince the FCC that your situation is different and requires special consideration. Chapter 2 indicates what coverage is necessary and how it is estimated.

Airports, Airlines, and the FAA

The Federal Aviation Authority (FAA) must receive and OK an application for your proposed tower site. If an airport or airline is close to where you want to locate the tower, the FAA may oppose your decision. Usually, however, there is no objection from this agency unless you wish to erect a tall tower or one that will adversely affect air travel. It is possible, though, that you will be required to use special lighting on the tower because of site location; this special lighting will probably increase costs for the station because of the additional equipment required. In one case, a station was required to use three flashing 1000-watt beacons, instead of one flashing beacon at the top and smaller marker lights at lower levels.

Building Codes and Ordinances

Building codes in your community may bar the erection of a tower within the city limits or in certain areas, or the tower may have to meet

certain specifications. Compliance with the building codes or ordinances is not difficult, unless there are some very special restrictions. When there are restrictions, your costs may be increased in meeting them. Early consultation with the proper authorities will certainly help you avoid hidden building costs.

Tower Location and Maintenance

Erecting and maintaining a tower in densely-populated areas can sometimes present a real problem, especially in downtown areas. There will be hazards in erecting, painting, and servicing the tower. There may also be a falling ice hazard in the winter. Such conditions will be reflected in higher costs to the station. In heavily-populated areas the roof of a building may have to be reinforced to support a tower, or building codes may require special structural strength in the tower. Insurance on the tower will probably be higher and on a continuing basis. Tower-servicing companies will be required to pay higher insurance premiums, which will probably be passed on to you as higher costs.

Expansion Plans

Future plans should always be considered, especially potential expansion. Although one piece of real estate may appear to be ideal for present needs, it may not be large enough in the future. For example, a future increase in tower height may require that the guy wires and guy anchors be located well off the present or considered property. If the property appears adequate for the present, it would be wise to investigate adjacent properties and make arrangements with the owners to secure a lease, easement, or some other legal instrument that would permit use of these properties when you need them. In this regard, also, the drainage of the selected property, as well as adjacent properties, should be thoroughly investigated and corrective measures taken before any building is started. One could awake some morning after a night of hard rain to discover that his station is located in the center of a junior-sized lake.

UHF Propagation Problems

Propagation problems also have a definite bearing upon the final site selection. The uhf channels are affected more by hills and buildings than are the lower vhf channels. Such barriers can cause serious shadow areas (Fig. 1-2) in the coverage, especially if there are population centers in such shadows. UHF deteriorates more rapidly after it gets to the horizon and beyond it. If you are to serve several small communities that are some distance apart, you may want to locate in the center between the communities, so that each can be served equally.

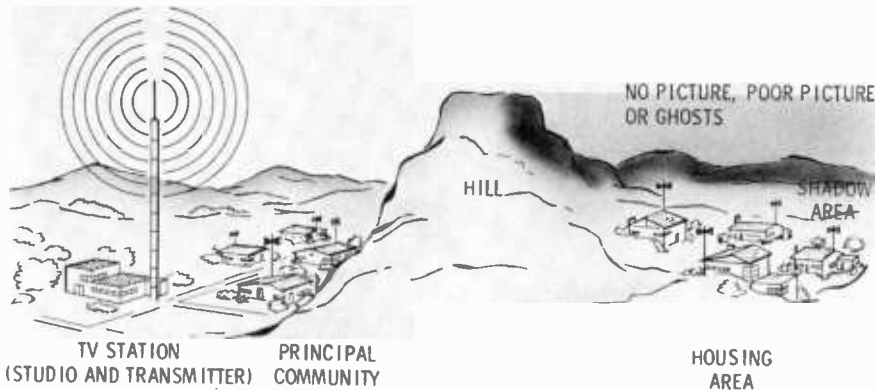

Fig. 1-2. Signal barriers cause shadows in the coverage area.

UHF and VHF Reception. There have been several studies made comparing uhf with vhf signals. The most recent test was conducted in New York City by the FCC and several interested groups. The basic purpose of this test was to determine if uhf would work in a city of canyons formed by tall buildings. Although there is some disagreement over the methods used and the findings of this test, the conclusions are as anticipated: uhf will work satisfactorily in such an area, although it was found to be more susceptible to multi-path (ghosting). However, all signals, vhf and uhf, have ghosting problems at these locations because so many surfaces are reflecting signals.

Measurements made in residential areas, where one- and two-story homes predominate, revealed no difference between pictures obtained from the uhf or vhf signals. As also was expected, the vhf signals were usable at greater distances from the transmitting antenna than were the uhf signals.

Location Setups

There are several basic alternatives that may be considered when selecting sites for a uhf studio and transmitter. Although their applicability is determined primarily by terrain and population density, equipment and construction cost differences should be taken into account.

Separate Studio and Transmitter

It may be desirable to locate the studio in the city and place the transmitter on a high hill or mountain, linking the two with telephone company cable or microwave or your own microwave link.

Advantages. This method has many advantages and may be the only solution in some areas. On a high hill or mountain, important antenna height can be obtained with a relatively small tower, and shadow area problems will be eliminated (Fig. 1-3). Property outside of a built-up area may be less costly to buy or lease, the insurance premiums on the tower will be lower, and there will be fewer building codes and ordinances to contend with. The transmitter building can be a simple, purely functional affair, since there will be few people to see it and no prestige to maintain. Falling ice won't be too much of a problem and there need be no concern with flying paint when the tower is being painted, thereby lowering painting costs.

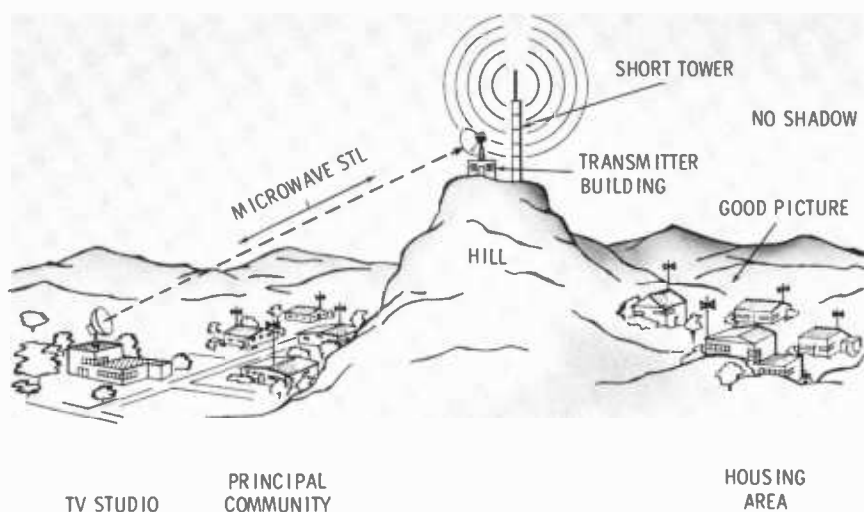

Fig. 1-3. Shadow areas can be eliminated by placing the transmitter on the highest location possible and using microwave between the studio and the transmitter.

Disadvantages. Offsetting these cost-saving features will be the cost of the studio-transmitter link (STL). This may be telephone company cable or microwave, or company-owned microwave. The telephone company will install and service its own equipment and charge you a monthly rate. Your own microwave, if this method is chosen, will be bought, installed, and serviced by your company. You will need a transmitter and microwave antenna at the studio and a microwave antenna and receiver at the transmitter. A line-of-sight path is required and the beam should clear hills and buildings by at least 100 feet to avoid reflections and other problems that would reduce its reliability. Microwave installa-

tion and upkeep are expensive. (Cost figures on telephone company and company-owned microwave systems are given at the end of the chapter.)

UHF television transmitters are usually manned by licensed engineers when in operation. Recent FCC rule changes permit remote control of uhf transmitters, provided that the stability and reliability of the transmitter are demonstrated and that appropriate remote control equipment will be installed.

If the planned TV tower is on the same site as a broadcast radio directional antenna system, there will be other difficulties. The new tower will affect the radio antenna directional pattern, which will have to be retuned to its original pattern. In some cases the directional pattern will be so offset that it can't be retuned to its normal pattern. If so, another site will have to be found for the TV tower. One station, for example, found that the TV tower, which had been erected 500 feet from the radio antenna, changed the antenna's base impedance from 800 ohms to 1000 ohms and put a slight dent in its coverage area in the direction of the TV tower, but it was nothing serious. Another radio station, which had a two-tower directional system, solved its interference problem by cutting the top off one radio tower and mounting the TV antenna on it, which brought the tower height back to normal. By doing this they eliminated interference and saved the cost of a new tower—an acceptable method if the radio tower is high enough to suit television transmission requirements.

Access roads and utilities may prove to be yet another problem. Electric power lines, telephone company circuits, and poles may have to be constructed a long way to get to a separate transmitter building. Local utility companies should be consulted about construction costs. (In some areas, these companies may absorb such costs in anticipation of long-time service.) Also, it may not be possible to get city water extended to the proposed location. A well will have to be drilled, which, on a hill, may be quite deep and unreliable. The higher power transmitters use water cooling for the power tubes and require a reliable supply of water. Well water may have to be filtered to keep mineral deposits from causing high voltage leakage and from clogging or corroding small ports in the tubes and connections. (Klystron tubes do not use small ports within the tubes themselves, but the connections and piping can become corroded.)

Access roads will have to be passable in all seasons, unless the transmitter personnel live at the site. FCC rules require necessary facilities for operating personnel if the transmitter is not remote-controlled. When operators live at the site, greater facilities must be supplied for sleeping, cooking, sanitation, and relaxation.

The separate studio-transmitter arrangement is usually the most expensive to install and maintain. More manpower is required, because crews will be needed at both sites, unless remote control is employed. More equipment is needed; tools and test equipment will be needed in duplicate. (You can well imagine how much air time could be lost because tools or test equipment are at the wrong site when needed.) Additional expensive equipment, such as microwave STL, will be needed.

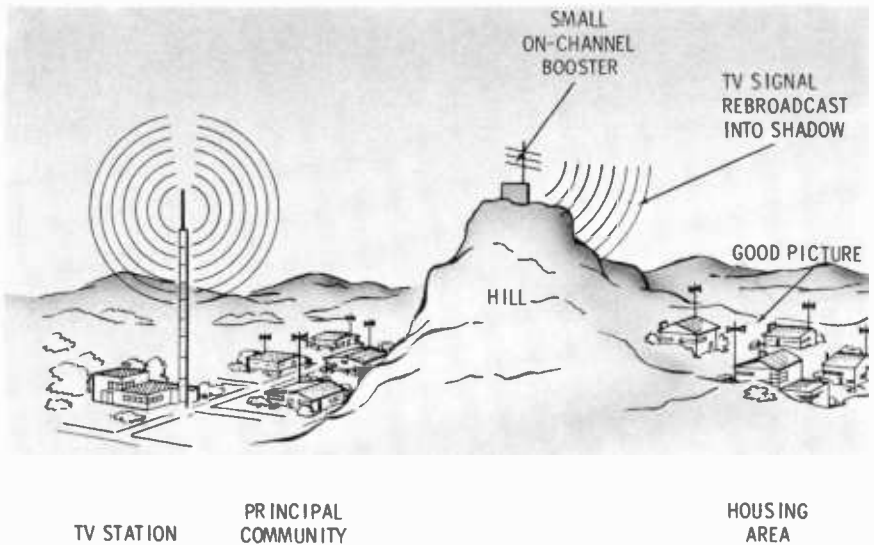

Fig. 1-4. Shadow areas can also be eliminated by using a small, on-channel booster.

Combined Studio-Transmitter

Combining the studio and transmitter location will greatly reduce operational costs and manpower. If you decide to use this method in a highly congested area, such as a downtown site, some of the advantages may be offset if there are higher costs resulting from compliance with building codes or ordinances, costs of erecting and maintaining the tower, and higher insurance premiums on the tower. These additional costs should not be great enough to rule out use of a good downtown site. If you can construct a combined studio and transmitter located at the edge of town, away from densely populated areas, you will achieve the optimum in low costs for the small uhf television station. (However, locating the studio outside the principal community will require a waiver of the FCC rules. This can be obtained with a proper application showing that such a location will best serve the public interest and service for your area.)

Properly planned, this method will reduce manpower requirements, since your transmitter engineers will also be your studio engineers. There will be no cost for remote control equipment and circuits. Expensive microwave or telephone company microwave will not be needed. There will be no duplication of tools and test equipment. Only one section of property and one building will be required, which means lower property taxes, lower insurance rates, and less heating equipment and building facilities. Access roads will be public streets, kept clear and in good condition by street or highway departments. All utilities will be available, including water. Such factors minimize construction and upkeep expenses.

Studio Transmitter Links — A Cost Comparison

Company-Owned Microwave System

Obtaining a permanent microwave studio-transmitter link (STL) requires careful planning to ensure the installation of reliable, high-quality circuits. Manufacturers of microwave equipment will give the station every assistance in selecting the correct equipment, planning the installation, and checking out the system after its completion.

Seldom are two microwave installations identical, because each one is designed to meet specific requirements. The equipment used is standard, but its arrangement and accessories will be dictated by the circumstances. Consequently, the equipment used in the following cost basis has limitations which the reader should keep in mind. This system is used in a minimum installation where the antennas will be mounted directly on the roof of each building without additional towers, and the transmitter and receiver will be mounted directly on their respective parabolas in waterproof cases, using control cables back to the control units inside the buildings. The equipment and figures are based on a portable RCA microwave (MW) system, adapted to this use. Prices are always subject to change and will vary with manufacturer.

Within these limitations, a simple STL microwave system that includes both a video and a sound channel will cost approximately \$14,275, computed as follows:²

 Sending equipment needed at studios (includes portable MW transmitter, antenna parabola, roof mounts, interconnecting cables): \$6,515

 Receiving equipment needed at transmitter (includes portable MW receiver, antenna parabola, roof mounts, interconnecting cables): \$7,760

²No installation costs are included. It is expected that station personnel will install and maintain this system and the station will supply replacement parts and tubes. If special installation procedures are required and outside help is needed, the additional costs could be considerable.

Remember, also, that station engineers must maintain the system and spare parts and tubes will be supplied by the station.

Telephone Company Microwave Service

Telephone company rates for STL service are based on tariffs cleared by the FCC. The rates in the following example are based on the Indiana Bell System tariff. If you are located in or transmit through an area serviced by an independent telephone company, the rates may vary somewhat from this figure.

Two separate structures are involved, one for the video circuit and one for the sound circuit. The telephone company also has certain prerogatives when providing service. They have the right to use any method necessary to obtain the service (e.g., microwave, coaxial cable, multiplexed audio, or wire circuits). Whatever method is used, the results and rates will remain the same.

A *local channel* is a link between any two points within an airline distance of 25 miles. The rates used and discussed here are based on the local channel rates and have nothing to do with network interconnection.

Video Rates. Based on the Indiana Bell System tariff, the monthly video channel rates for a STL system are comprised of a base fee of \$175, a charge of \$20 for each quarter mile up to 8 miles, and a charge of \$35 for each mile or fraction of a mile beyond 8 miles. To illustrate how this tariff is applied, assume the following hypothetical case, where the distance between the studio and transmitter is 6 airline miles. The monthly charge for the video will be \$655, computed as follows:

Base fee	\$175
Quarter-mile units ($\$20 \times 24$)	<u>480</u>
Total	\$655

If the local channel distance in this example were 10 miles, the video circuit monthly charge would have been \$885, computed as follows:

Base fee	\$175
Quarter-mile units ($\$20 \times 32$)	640
Additional miles ($\$35 \times 2$)	<u>70</u>
Total	\$885

Audio Rates. The sound channel rates are lower and are determined in a different fashion. The highest quality audio service, equalized 50 cps to 15,000 cps, is necessary so that the station overall system will meet FCC specifications. There is no base rate. The distance charges are \$4.10 for the first quarter mile plus \$1.85 for each additional quarter-mile

unit. Using our first example of a 6-mile airline distance, the monthly audio circuit charge will be \$46.65, computed as follows:

First quarter-mile unit	\$ 4.10
Additional units ($\$1.85 \times 23$)	<u>42.55</u>
Total	\$46.65

Video Installation and Construction Charges. In the normal STL, there will be no installation or construction charges for the video circuit. Should your system have some special requirements, such as an unusual site problem requiring a multiple hop, there may be some installation charge. Your local telephone company will let you know what your requirements are.

Audio Circuit Installation Charges. There is an installation charge on the audio circuit that is paid at the beginning of service. On a high-quality circuit, such as you will need, this charge will be \$25, paid only once.

All rates considered, the 6-airline mile unit would entail a total monthly charge for audio and video circuits of \$701.65, which would amount to a total yearly charge of \$8,419.80.

Site Selection and Cost (Three Representative Examples)

Building costs will depend upon many factors, as indicated earlier in the chapter. The following examples of what has actually been accomplished will help illustrate what can be done, given a set of conditions and requirements. The reader should keep in mind that these cost figures will not necessarily match his own. The figures given do not include television technical equipment, which, of necessity, will vary with each station. In each example, the station used the combined studio-transmitter operation. (The population figures given in each case are not the true market population. The figures shown are for the principal communities only, as simple reference points. The cost figures should not be considered typical or even average. Any average that could be drawn from them would be meaningless. The figures are given only to show what has been done in particular cases.)

WBJA-TV, Binghamton, N. Y. — Channel 31³

The Binghamton market area is made up of Binghamton and four smaller cities close together. The area population is about 125,000, a medium market.

³On the air November 3, 1962.

The terrain is very rough and mountainous in this area, with the cities concentrated along river valleys. Two rivers join at this point and the mountain ranges form an irregular horseshoe. The necessity of proper coverage of the entire market area from one location narrowed site location to only a few places. The site selected was on a hill overlooking the valley, on the curve of the horseshoe. Since the studio was to be located outside the city limits, a waiver of the FCC rules was required. The lease negotiated for the land costs WBJA-TV \$135 per month.

A completely new building was erected and is owned by the station. Built on one floor, it includes offices, studios, and transmitter in a floor space of 3600 square feet. The total cost of this building was \$37,500, which does not include technical equipment. Most contractors use a "rule-of-thumb" figure to estimate cost of a commercial building of \$20 to \$25 per square foot. This station did much better than that with a cost a little over \$10 per square foot.

Fire insurance premiums were somewhat higher because of the location outside the city limits. No liability figures were supplied for the tower. Insurance premiums were not a large factor when determining the site for this station.

To provide the necessary coverage of the market in this rough terrain, a 545-foot tower and a 12.5-kw transmitter were required. The rough terrain also presented some severe tower-guying problems. Special guying and special anchor sites were required. (This special guying increased the cost of the tower by \$4000.) The total tower cost was \$31,500, which covers tower and guys only, and does not include erection, guy anchors, or antenna. As this was a peculiar situation, it is not an average tower figure.⁴

WTAF-TV, Marion, Indiana — Channel 31⁵

Marion is a small market with an area population of about 76,000 and a city population of about 38,000. The terrain is flat to rolling with some isolated rough spots, but nothing that will interfere with transmission. Coverage of such an area does not require a high tower or high-power transmitter.

One of the largest single factors contributing to site selection was the availability of a building only one block from the city square that was so ideal it appeared to have been designed for television use. It was a regularly-used club building, two stories high, with a basement that included a cafeteria and lounge. The main room on the second floor was

⁴ Information and cost data supplied by Mr. Harold Bennett, National Program Director, Alfred Anscombe Stations.

⁵ On the air October 1, 1962.

quite large (40 × 50 feet) with a high 18-foot ceiling and no posts or similar obstructions. The first floor also contained a large room and smaller rooms. The building was relatively new, modern in every way, with an excellent front entrance to the street.

A five-year lease was obtained for the building (the club retained the basement, with its cafeteria and lounge), which costs the station \$350 a month. The lease is renewable at the end of the five-year period, and the station has first option to buy either at the 5- or 10-year period.

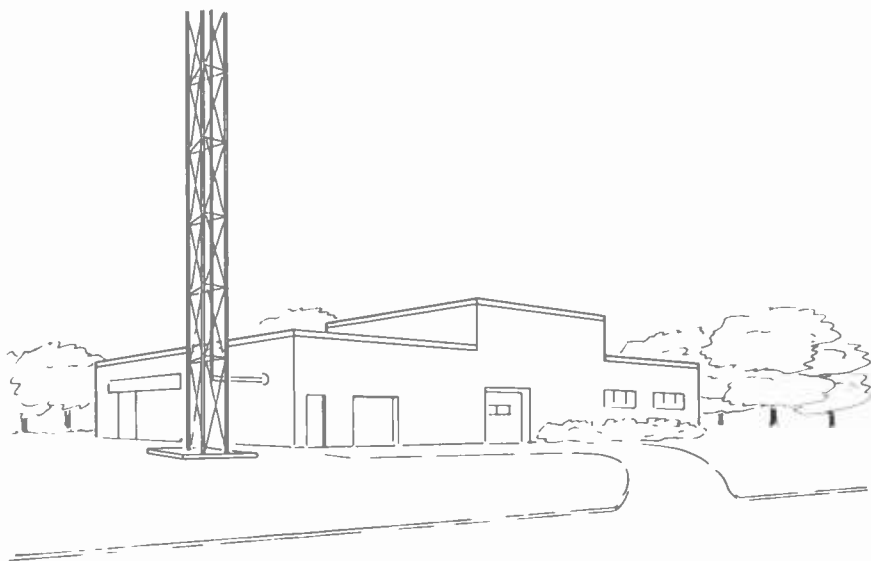

Fig. 1-5. *A typical modern uhf television station using a combined studio-transmitter location.*

The only remodeling necessary consisted almost entirely of installation of necessary electrical components and hardware, such as breaker boxes, conduits, etc., to handle the power requirements of television. This work was done by an electrical contractor for a total approximate cost of \$4000. The remaining remodeling consisted of building a control room at one end of the large room (now the studio) and partitioning off the large room downstairs into offices and work rooms. The actual cost of this work was for the lumber, about \$1000. The carpentry work was done by the owner, who is a confirmed "do-it-yourselfer."

Since a high tower was not required, a 180-foot tower was erected on the ground immediately behind the building. The complete cost for the tower, plus its erection, was about \$9000. This figure does not include

the antenna. Insurance premiums for the tower run higher in this location, but this factor is minor compared to the positive features of this set-up. Figures were not supplied for liability insurance, but premiums for insurance to replace the tower and antenna, should it fall, run about \$150 per month.⁶

WLBC-TV, Muncie, Indiana — Channel 49⁷

The Muncie market is made up of Muncie with a population of approximately 70,000 and several smaller cities within a short distance. This would be classed as a small market.

Terrain is generally very flat, with some rolling ground to the south. Coverage of such a market from a central location with a low-power transmitter is not difficult.

The primary consideration which carried the greatest weight in the site selection was the fact that the TV station was being organized by an established radio operation with property and buildings. The original building was extended to accommodate the television facilities. The new extension added approximately 1700 square feet to the original building. The total cost of this extension was \$30,000, which includes all the necessary electrical work, heating, and other building facilities (but not television technical equipment).

The radio tower was too low in height (a nondirectional system) for television purposes. Since the building was located adjacent to a main highway, there was no room to place guy wires and anchors. Consequently, it was necessary to erect a self-supporting tower. As the tower was located at the edge of the city, many neighborhood children were available to try their daring at tower climbing. This made construction of a strong fence around the base of the tower a necessity. The total cost for this 500-foot tower (heavy-duty, self-supporting), concrete bases, erection, etc., and the fence around the tower base, but not including the antenna and transmission line, was approximately \$80,000.

No problems were encountered with building codes or ordinances. A new insurance policy was taken out to cover the new tower, which, of course, meant an additional insurance premium.⁸

⁶ Cost figures and other data were supplied by Mr. Gene Thompson, president and owner of WLAF-TV.

⁷ On the air May 8, 1953.

⁸ Information and cost data for WLBC-TV were given by Mr. Don Buton, president of Tri-City Radio Corp.

Chapter 2

Estimating Coverage

Antenna Location and Required Field Strength

The FCC *Rules*, paragraphs 73.685 (a) and (b) state:

"The transmitter location shall be chosen so that, on the basis of the effective radiated power and antenna height above average terrain employed, the following minimum field intensity in decibels above one microvolt per meter (dbu) will be provided over the entire principal community to be served: Channels 14–83, 80 dbu."¹

"Location of the antenna at a point of high elevation is necessary to reduce to a minimum the shadow effect on propagation due to hills and buildings which may reduce materially the intensity of the station's signals. In general, the transmitting antenna for the station should be located at the most central point at the highest elevation available. To provide the best degree of service to an area, it is usually preferable to use a high antenna rather than a low antenna with increased transmitter power. The location should be so chosen that line-of-sight can be obtained from the antenna over the principal community to be served; in no event should there be a major obstruction in this path. The antenna must be constructed so that it is as clear as possible of surrounding buildings or objects that would cause shadow problems. It is recognized that topography, shape of the desired service area, and population distribution may make the choice of a transmitter location difficult. In such cases, consideration may be given to the use of a directional antenna system, although it is generally preferable to choose a site where a nondirectional antenna may be employed."

¹ If you do not have a copy of the *FCC Rules and Regulations*, you should obtain one. In particular, order Volume III, Parts 73 and 74 (*Radio Broadcast Services and Experimental, Auxiliary, and Special Broadcast Services*) from the U. S. Government Printing Office, Washington 25, D. C. There are other parts of the *FCC Rules* that affect broadcasting which you will want to have (see Chapter 12); parts 73 and 74 cover the material discussed here.

According to the FCC *Rules*, then, you must provide a minimum of 80 dbu signal strength over the entire principal community you are to serve. The farther away from the community that the transmitter is located, the more difficult it is to meet this minimum. Increasing coverage to meet this minimum will generally mean more power and/or a higher tower, both of which will increase costs. This requirement is not hard to meet as smaller cities and their population centers are not spread out as far as large metropolitan areas; 80 dbu signal strength may be obtained with lower power and antenna height and the transmitter may be located closer to town.

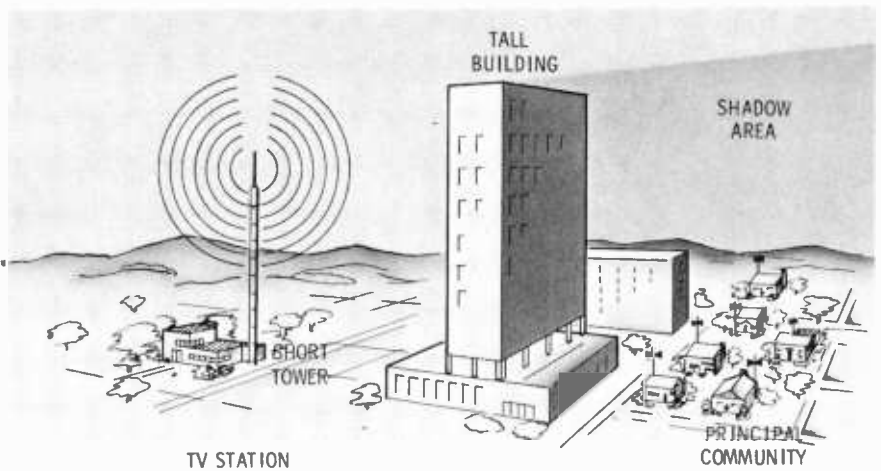

Fig. 2-1. In a situation such as this, use of a short tower seriously impairs service over the principal community.

Grade A and Grade B Contours

The FCC *Rules*, paragraph 73.683, *Field intensity contours*, state:

"In the authorization of television broadcast stations, two field intensity contours are considered. These are specified as Grade A and Grade B and indicate the approximate extent of coverage over average terrain in the absence of interference from other television stations. Under actual conditions, the true coverage may vary greatly from these estimates because the terrain over any specific path is expected to be different from the average terrain on which the field strength charts were based. The required field intensities, $F(50, 50)$,² in decibels above one microvolt per meter (dbu) for the Grade A and Grade B contours are as follows: Channels 14-83, Grade A, 74 dbu; Grade B, 64 dbu."

²The term $F(50, 50)$ means that the estimated field strength of the signal is exceeded 50 percent of the time at 50 percent of the receiving locations.

As stated, the Grade A and B contours are used only to estimate coverage. There are many things which can affect your signal level in any particular area (e.g., a mountain ridge). In licensing procedures, these variations are not considered by the FCC, unless you can demonstrate you have a peculiar problem. The contours are submitted to the FCC for the following purposes: (1) to estimate coverage from a given antenna site; (2) in connection with coverage problems arising from compliance with section 73.636 of the FCC *Rules* (overlap of coverage by multiple station owner); (3) to determine if the required signal strength over the principal community is being supplied.

There should be no difficulty in providing the required signal strength over the principal community in smaller markets, because they are not usually spread out very far. However, when two or more smaller communities that are located close together form the same market area, it may be difficult to find a suitable site. The FCC usually designates these compound markets by joining them with hyphens, such as South Bend-Elkhart, Indiana or Norfolk-Portsmouth-Newport News, Virginia. Such areas represent the principal community and you must provide a signal strength of 80 dbu over each one. Additional difficulties can arise in such cases if the terrain is rough. They can be serviced, but more power and antenna height will be required.

Making a Profile

The easiest way to determine the antenna height above average terrain is to make a profile of the area you wish to cover. Making a profile will require data on the topography of the area. This information can be obtained from topographical maps that indicate elevation contours above sea level.³ Unfortunately, all areas of the country have not been mapped in this way, so you may have to estimate elevations. For your own purposes, you can use fairly rough estimates, although your consulting engineer will have to supply accurate data when making application to the FCC. If you can obtain an altimeter that can be used in an automobile, it should not be difficult to determine variations in elevation in your area (provided that you can find roads going in the directions you wish to cover). If the area is very flat, you can get the estimated coverage merely by using the chart figures and the height of the radiation center of the antenna above ground.

³U. S. Geological Survey Topographical Quadrangle Maps may be obtained from the Department of the Interior, Geological Survey, Washington, D. C.

Topographical Maps

For the benefit of those readers who are not familiar with topographical maps, a brief discussion of some of the terms used may help them understand how average terrain figures are developed.

Topographical maps are similar to road maps, but include much more information in regard to the shape of land formations. These maps indicate topographical features by the use of *contour lines* (Fig. 2-2).

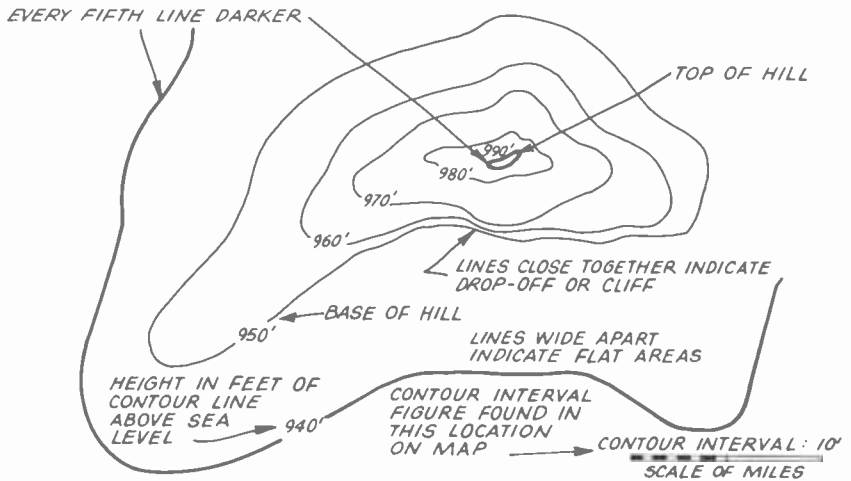

Fig. 2-2. An explanatory representation of contour lines on a typical topographical map.

Contour lines show the shape as well as the height of the land they describe. Ordinarily these lines terminate upon themselves in complete loops, although in very rough ground or deep ravines with a river at the bottom, they may terminate abruptly. Every fifth line is usually emphasized with a heavier color or thicker line. Each line is marked with a number that indicates height, in feet, above sea level. Everywhere that a particular line runs, the ground at that point will be that height above sea level. (Average sea level throughout the world is used as a basis for all land height measurements, with sea level given the value of zero.) For example, a contour line with 980 written on it is 980 feet above sea level.

These heights of land are also called *elevations*. The contour line mentioned above has an elevation of 980 feet above sea level.

Contour lines are labeled according to the *contour interval*. The interval value, given in feet, will be indicated at the bottom of the map near the mileage scale. It represents the interval between adjacent con-

tour lines. This is not the horizontal distance between lines, but the difference in height above sea level. The horizontal distance between adjacent lines will vary, depending upon the land contours. If, for example, the contour interval is 10 feet, a perfectly flat field, several hundred feet long, would cause the contour lines on the map to sweep far apart to describe this flat area, but the next contour line will still be only 10 feet higher in elevation than its neighbor.

As contour lines describe a hill, they will be long and irregular closed loops with each loop being shorter than the preceding one as the height approaches the top of the hill. The top will usually be shown by a small closed loop.

Drawing the Profile

A profile of the land is similar to a profile photograph of a person; it is taken directly from the side. Since it is not possible to view the land this way, land profiles actually are a description of a cut-away or cross-sectional slice of the land.

Drawing a land profile is a simple matter when one has a topographical map. Take a pencil and straight edge and draw a straight line

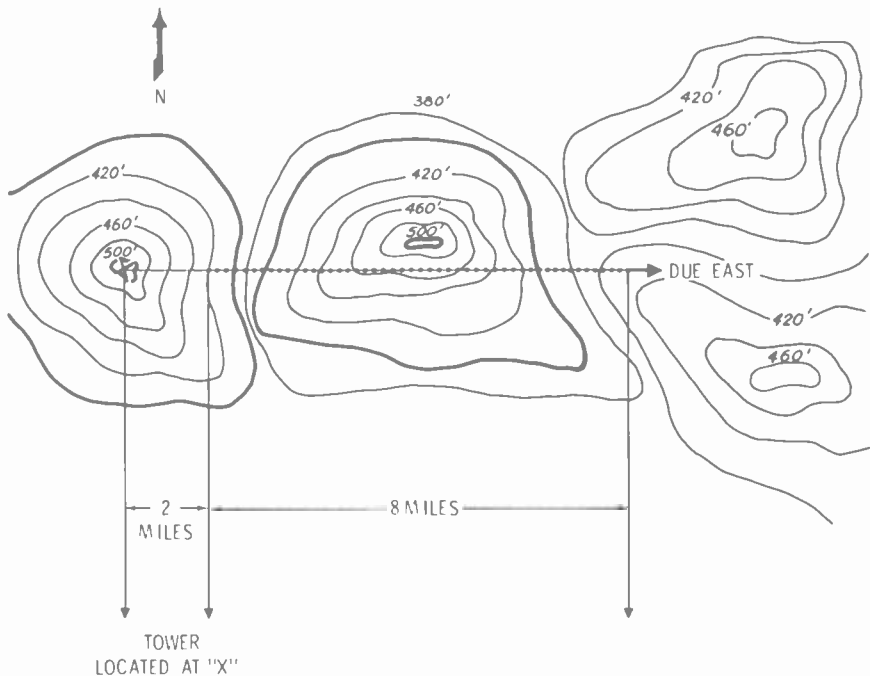

Fig. 2-3. Plotting the east radial for a proposed antenna location. Use 50' elevation points to determine average terrain on this radial.

across the section of the map you wish to profile (Fig. 2-3). Then mark off the divisions on a piece of graph paper to conform with the map scales (Fig. 2-4). On the left side of the graph paper, label the horizontal lines according to the contour intervals of the map. This will be the elevations and the ordinate of the graph. Thus, if the contour interval is 10 feet, each horizontal line or major division will indicate a 10-foot elevation interval. It isn't necessary to carry these lines all the way down to sea level, unless the sea will be part of the map section viewed. Only go as far as, or a little beyond, the lowest point that will be anticipated. The lowest elevation will be at the bottom of the ordinate.

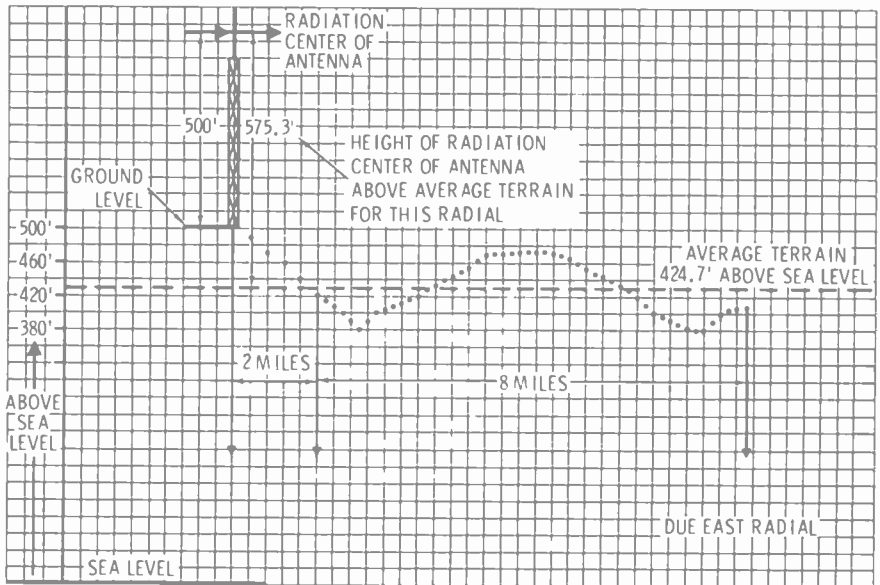

Fig. 2-4. By plotting the elevation points obtained, you will produce an accurate profile for each radial.

Next, divide the line drawn on the map into equally-spaced points, making as many as desired. Starting at the left on the graph paper, mark the points on the vertical lines of the graph paper that correspond with the points marked off on the line drawn on the map. The vertical graph lines will correspond to the distance covered by the straight line drawn on the map and will be the abscissa of the graph.

To plot the profile accurately on the graph, read each point of elevation on the straight line on the map at each of the line divisions. These divisions will not all fall on a contour line and many will be in between. When they are, interpolate the distance between the two adjacent contour lines to determine the elevation at that point. For example, if your

point is halfway between the 970 and 980 contour lines, the elevation at that point is 975 feet above sea level. When all the points are plotted, draw a smooth line connecting all the point of the graph together, and you have completed the profile.

The FCC requirements for profiles that determine the average height above sea level for the antenna site are spelled out in the *FCC Rules*. In them, the term *radial* is used. The line drawn on the map in Fig. 2-3 could be called a radial. However, as used by the FCC, radials are lines drawn outward from the antenna for a specific distance, and a specific number of them are required. When drawn on the map, they look very much like the spokes of a wheel.

Although not directly related to profiles, Grade A and Grade B contours, which are used in discussing signal coverage, can be graphically represented with radials. By using the radials as the spokes of a wheel, with their direction indicating the signal moving away from the antenna, at the points where the signal intensity diminishes to the prescribed minimum values for Grade A and Grade B service, we can draw a rim for the wheel that is a circumference with the radials as radii. The two circles drawn in this fashion would describe the estimated coverage pattern.

For the profile required by the FCC for determining antenna height above average terrain, only the elevations along each radial between 2 and 10 miles from the antenna site are used. The distance from the antenna out to the 2-mile point is not figured into the computations. Eight radials are required, spaced 45 degrees apart, starting at True North (i.e., the number one radial from the antenna must point to True North). One of the eight radials should run through the principal community to be served, even if it is more than 10 miles from the antenna. If one of the eight radials does not run through the principal community, an additional radial should be added that does. It is important to know the signal path and the topography directly between the antenna and the principal community. However, when determining average elevation for the antenna site, only the original 8 radials are used.

The profile along each radial should be plotted on graph paper. The contour intervals on the left side of the graph should be between 40 and 100 feet. The section of the radial between 2 and 10 miles from the antenna should be divided into 50 evenly-spaced points that are plotted on the vertical lines on the graph. In very rugged or mountainous terrain, where 100-foot intervals may result in too many closely spaced points in a short distance, you may use 200- to 400-foot intervals. The profile should indicate the topography accurately along each radial. The graph should also show the radiation center of the antenna. At the bottom or corner of the profile, indicate the radial number or its degree

designation, the name of the map, and the source of topographic information. If these profiles are to be submitted to the FCC this information is required; for your own purposes, it need not all be included.

The radiation center of the antenna is the center of the antenna, not the top of the antenna or the top of the tower. In all discussions of propagation, when the term *antenna height* is used, it most generally means the height of the radiation center of the antenna above average terrain. There can sometimes be a great difference between antenna height above ground and antenna height above average terrain. In some mountain locations, it is possible that the antenna height above average terrain may be a negative value, such as so many feet below average terrain. This could happen where an inaccessible mountain ridge is higher than the antenna.



Fig. 2-5. This antenna location is 3697 feet above average terrain at an altitude of 7622 feet above sea level. Used by KERO-TV, Bakersfield, California, the antenna is enclosed in a radome for protection from severe weather. (GE)

In Fig. 2-4 the height above sea level for the 50 individual points marked off on the sector of the radial from 2 to 10 miles from the antenna were added together, giving a total of 21,235 feet. This figure was divided by 50 (the number of points figured) to get an average height above sea level of 424.7 feet for the terrain along this radial. A dashed line was drawn across the graph to show how much higher the radiation center of the antenna is above average terrain for this radial.

To obtain the final average elevation for the antenna site, the average height above sea level for each of the 8 required radials must be determined. These values are then added together and divided by 8. Naturally, the tower and antenna height is added to this figure to find what the radiation center of the antenna is above average terrain.

Using the FCC F(50, 50) Chart

The FCC F(50, 50) chart for channels 14–83 (Fig. 2-6) is used for predicting coverage. This chart is based on 1 kilowatt of radiated power from a dipole antenna that provides 103 dbu unattenuated field strength at one mile. (Trim the scales provided with the chart or use dividers when the chart is to be used for powers other than 1 kilowatt.) Most small uhf stations will use more than 1 kilowatt radiated power. With present high gain antennas, a 1 kilowatt transmitter will produce an effective radiated power of several thousand watts, depending upon channel and line losses. Use this figure when deciding what tower height and power combination you wish to use to get the desired coverage, but remember that the line loss will increase with higher towers because of longer transmission lines.

For radiated powers other than 1 kilowatt, align the sliding scale in a vertical position, so that the desired power figure on the scale is on the 40 dbu line, which runs horizontally across the chart. The field strength figures in dbu for that power can then be read on the right-hand side of the sliding scale. Basically, there are four bits of information you will wish to learn from this chart: (1) how far, in miles, the required principal city signal strength of 80 dbu will reach; (2) how far, in miles, the Grade A signal strength of 74 dbu will reach; (3) how far, in miles, the Grade B signal strength of 64 dbu will reach; and (4) what antenna height-radiated power combination is required to accomplish these ends. Remember that the antenna height used here is not the tower height, but the height of the radiation center of the antenna above average terrain.

Perfect accuracy of results should not be expected by the use of charts alone. Charts are only guides for your use. Many factors of terrain will affect the final coverage obtained in your area with conditions peculiar only to your location. Results will prove reasonably accurate in most cases for rough estimates. If you want a more accurate estimate of what to expect, a test site can be set up with FCC approval and actual measurements of field strength made. This is not generally done, except in extremely difficult cases.

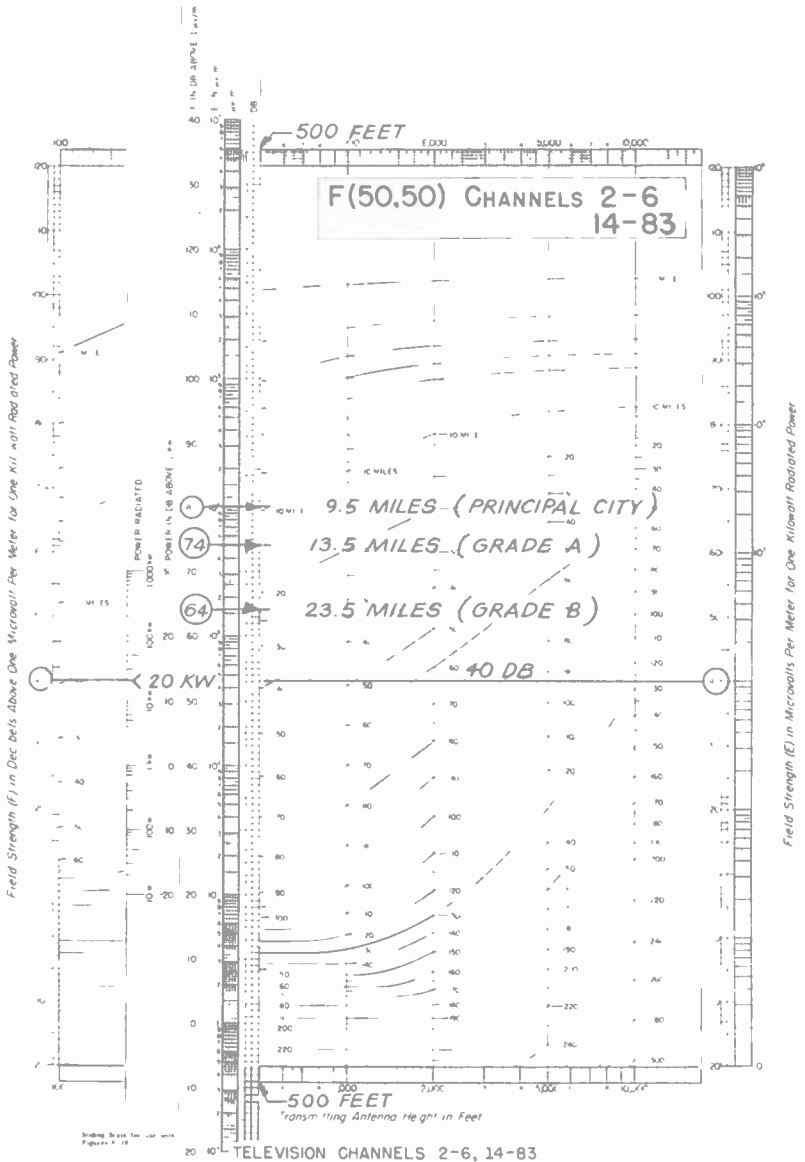

ESTIMATED FIELD STRENGTH EXCEEDED AT 50 PERCENT OF THE POTENTIAL RECEIVER LOCATIONS FOR AT LEAST 50 PERCENT OF THE TIME AT A RECEIVING ANTENNA HEIGHT OF 30 FEET

Fig. 2-6. Use the scale supplied with the FCC's F(50,50) chart to determine coverage. 50, 50 indicates that the estimated field strength is exceeded at 50 per cent of the potential receiver locations for at least 50 per cent of the time.

To illustrate how the chart works, let us assume a case where a station wants to use a 1 kilowatt transmitter. The data for the antenna on the channel desired indicates that this antenna will give a power gain of 20. If we do not consider line losses, the effective radiated power will be 20 kilowatts.⁴ For our example, we desire to use a tower height that places the radiation center of the antenna 500 feet above average terrain. On the chart, set the scale so that the 20 kilowatt marking of the scale is on the horizontal 40 dbu line of the chart and the right-hand edge of the scale is aligned with the 500-foot markings for antenna height at the top and bottom of the chart. This will make the scale perfectly vertical. Now, from the chart and scale, we find (as in Fig. 2-6) that the principal city signal of 80 dbu will reach 9.5 miles; the Grade A signal of 74 dbu will reach 13.5 miles; and the Grade B signal of 64 dbu will reach 23.5 miles. To put it another way, this combination of power and antenna height should provide principal city coverage out to 9.5 miles, Grade A coverage out to 13.5 miles, and Grade B coverage out to 23.5 miles. This combination may be either too much or not enough for your needs. In which case, the required results may be found

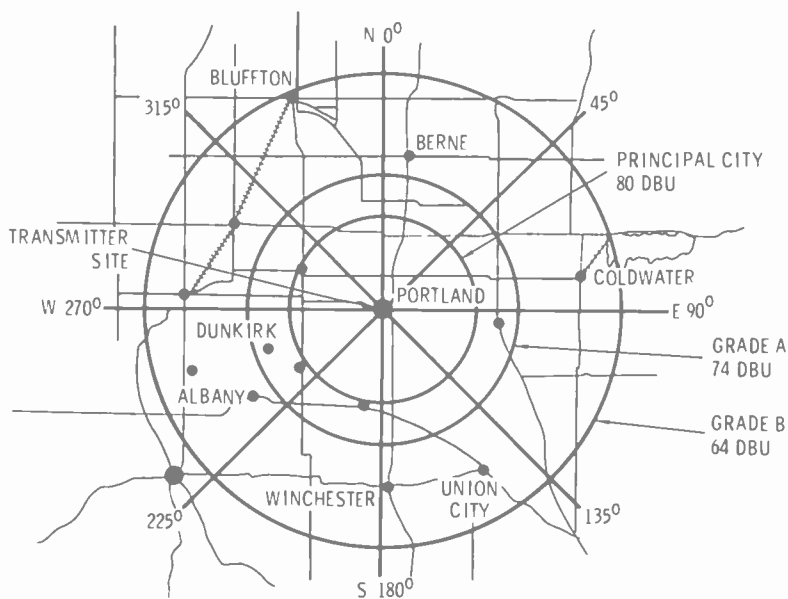

Fig. 2-7. Market and coverage area.

⁴The power gain for an antenna is used to determine effective radiated power (ERP); ERP equals transmitter power, minus transmission line loss, times the antenna power gain figure.

by moving the scale around and noting the indicated combination. Remember to deduct the transmission line losses before a final determination is made, otherwise, the figures may be far from accurate, especially with the higher channels where the loss in transmission lines is greater.

From a cost point of view, many small stations will try to use the minimum power and tower height. While the initial cost of the equipment and tower will be higher for higher powers and towers, the upkeep of higher-powered transmitters will be more than the upkeep of a higher tower. Towers require periodic inspection, repainting, and relamping. Transmitters constantly consume power, require replacement of tubes and components, and constant care.

In our previous example, should the station desire to use a 12.5 kilowatt transmitter and all other conditions remained the same, we would get the following coverage results (radiated power will now be 250 kilowatts): principal city 80 dbu signal, 17.5 miles; Grade A 74 dbu signal, 24 miles; and Grade B 64 dbu signal, 38 miles.

If we were to keep the effective radiated power at 20 kilowatts, but locate the antenna on a high hill so that the height of the radiation center of the antenna is 1000 feet above average terrain, we would get the following coverage results: principal city 80 dbu signal, 13.5 miles; Grade A 74 dbu signal, 19 miles; Grade B 64 dbu signal, 32 miles.

The relationships determined in these three examples are given in Table 2-1 to show a comparison of coverage variation obtained with different combinations of antenna height above average terrain (A.A.T.) and effective radiated power (ERP).

Table 2-1

<i>A.A.T.</i>	<i>ERP</i>	<i>Principal City</i> <i>80 dbu</i>	<i>Grade A</i> <i>74 dbu</i>	<i>Grade B</i> <i>64 dbu</i>
500 feet	20 kw	9.5 miles	13.5 miles	23.5 miles
500 feet	250 kw	17.5 miles	24 miles	38 miles
1,000 feet	20 kw	13.5 miles	19 miles	32 miles

The present-day trend, especially in larger markets and where the population is spread out over a larger area, is toward super powers; i.e., ERP's in the megawatt region. (A megawatt is 1,000,000 watts.) One example of a recent high power installation is KERO-TV in Bakersfield, California. The station changed from vhf channel 10 to uhf channel 23, radiating 1.76 megawatts on the uhf channel. Coverage results show that the new Grade A coverage is actually 5 miles greater than that obtained on the vhf channel and the Grade B coverage seems to be limited only by the horizon.⁵

⁵ These figures are from *The KERO-TV UHF Story* issued by General Electric Company.

Chapter 3

The Studio

The Basic Studio

A discussion of studio size is appropriate at this time because equipment used will depend to a large extent upon whether you have a large or small studio. Most small-market uhf stations will tend to do simple shows, rather than large, complicated productions. There will be occasions when a show has a large number of people involved, although they will not all necessarily be on camera at the same time. (Shows of this nature might include auction sales for some charity, a Rock and Roll dance, a square dance, or a 4-H group display of 4-H projects. All of these program types lend themselves well to local, live programming.)

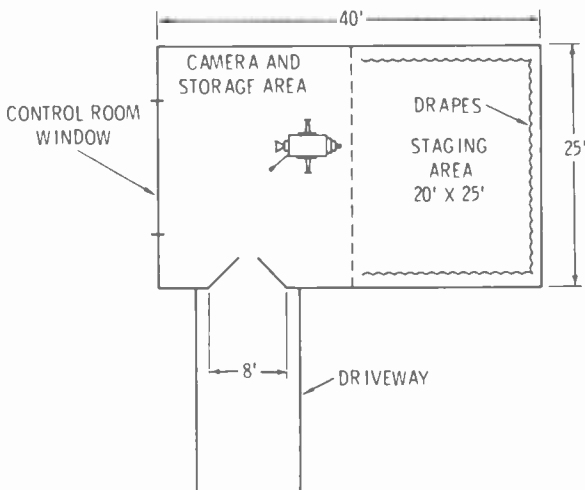

Fig. 3-1. The plan for a small studio, showing staging and camera areas.

A small studio stage of 20' × 25' will handle a surprising variety of live programs, depending upon how well the space is used (Fig. 3-1). Full use of the 20' × 25' staging area can be achieved by adding a 20' × 25' area for the camera to maneuver in. This would be necessary when a large number of people are on the floor, such as dancers, or a large sponsor product is being shown, such as a full bedroom outfit. Without the additional camera space, the camera would be unable to get far enough away to cover very much of the action. For the normal daily shows, News, Weather, Sports, Farm programs, etc., the camera would operate within the staging area.

The additional space also will find considerable use for storing props and advertisers' products, which accumulate at an astonishing rate. One advertiser may be featuring a full bedroom outfit, while another may have major appliances, such as kitchen ranges or refrigerators. These and similar items take up a lot of space. The 40' × 25' studio should handle most of this traffic, at least in the beginning. Should you later discover this amount of floor space is inadequate, you can add more space—providing that the building was planned properly in the beginning.

Don't make the same mistake one station made. It built a beautiful new building, planned for efficiency and free flow of traffic. The studio



Fig. 3-2. *A small station studio staging area. (WLBC-TV, Muncie, Indiana)*

was built in the center, with all other areas leading to it. This was an excellent idea and everything functioned as planned, with the exception of the studio—it was small and inadequate. Because it was located in the center of the building, expansion was out of the question, at least economically. New studio space was later added at a different location in the building, but a subcontrol room was required and much of the original planned efficiency was lost.

When you build your studio, avoid such a trap and place it at the end of the building. Should additional space be required, wings may be added to either side, as shown in Fig. 3-3. These wings may be for prop storage or, if you decide to use all the original space for staging, for a camera maneuvering area. A small wing may be added to handle a rear screen projector.

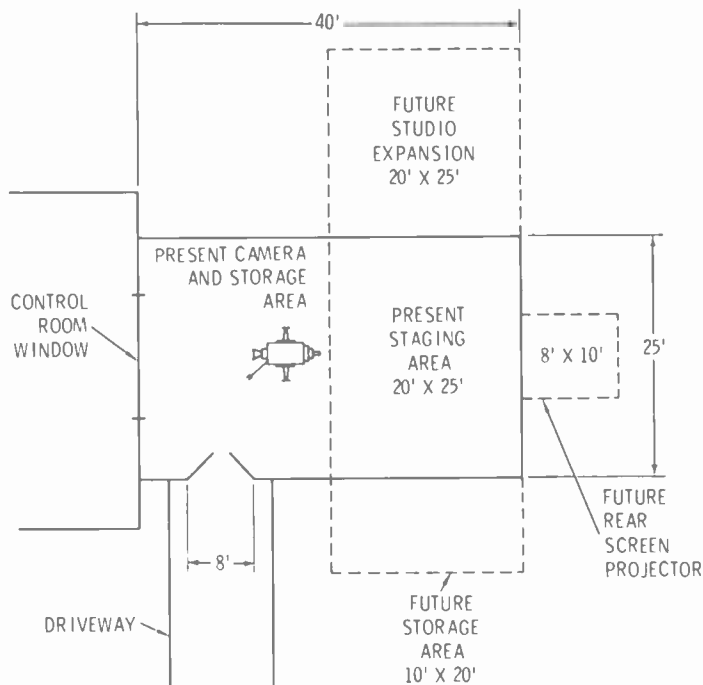

Fig. 3-3. The dotted lines indicate how a properly-planned studio can be conveniently expanded.

Ceiling height is as important a factor in studios as is floor space. Lighting is a most vital element for television broadcasting and space is needed overhead for lighting fixtures. Should the ceilings be too high, lights will be far away and hard to maneuver without the aid of pantographs, hooks, and tall ladders. If the ceiling is too low, it will be difficult

to keep lighting fixtures out of camera range and the lights will be hot and blinding to those in front of the camera.

A small studio with a 20' X 25' staging area can use a ceiling height of 12 feet (Fig. 3-4). The lighting fixtures should not be lower than 10 feet from the floor. These heights are for fixed lighting. Should a more flexible system be desired, a ceiling height of 18 feet is typical; it gives plenty of room for pantographs and other floating equipment.

Another consideration in studio efficiency is an outside door. This door should be large enough to drive an automobile into the studio, which happens quite often, especially with auto dealer advertisers. The door should open onto a driveway so that trucks may deliver advertising products right to the studio. There are several large doors on the market which will serve this purpose well.

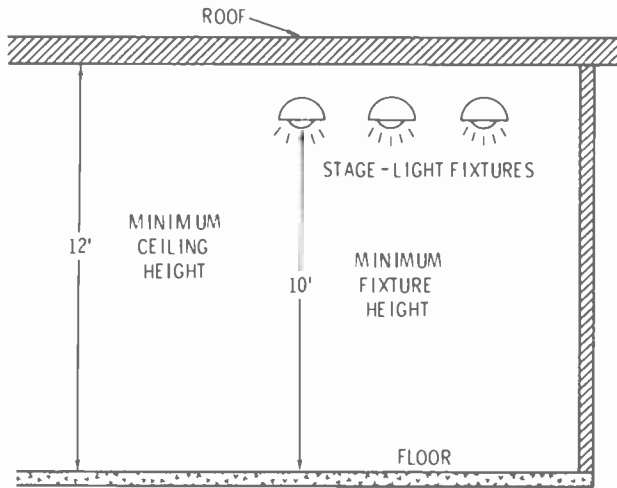

Fig. 3-4. Showing the minimum ceiling and light fixture heights.

Lighting

Many good books have been written on studio lighting techniques. These cover all aspects of stage lighting, including the theory of light. A small station will not likely be doing any great amount of production that would require all these techniques and need only concentrate on basic lighting principles. For our purposes, the following five lighting elements are the most important. The usual positions for these elements are shown in Fig. 3-5.

House lights. The room fixtures used to illuminate the studio for ordinary work, not camera work.

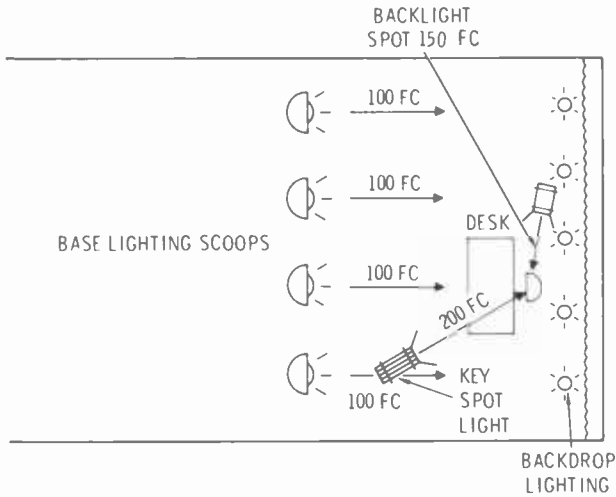

Fig. 3-5. The basic lighting elements with light intensities indicated: key, back, base, and backdrop.

Base light. Flat, diffused illumination that gives general light on the set, raising the basic light level to a predetermined value. Base light should have an intensity of at least 100 foot-candles and will usually be provided by scoops. This light level is suitable for cameras using 5820A image-orthicon tubes. Vidicon tubes require a much higher intensity than this.

Key light. The bright illumination directed on the subject or performer, from the side or front, to produce eye sparkle and make the subject stand out. Key light intensity should be 2 or $2\frac{1}{2}$ times the base light and is provided by spotlights.

Back light. The illumination directed from the back of and above the subject (but not directly overhead), onto the head and shoulders. Its purpose is to separate the subject from the background. Without back lighting, the performer tends to blend into the background. Its intensity should be $1\frac{1}{2}$ times the base light and is provided by spotlights.

Backdrop lighting. The illumination directed from above onto the backdrops. Backdrop lighting erases shadows that will occur from the key lighting. Small floods or spots are used here and the intensity required is only that which will erase shadows and brighten the backdrops.

The Light Meter

A light meter is a necessity and can be obtained easily, since there are many on the market that will give excellent results. The best type for TV studio use is one that will give direct foot-candle meter readings

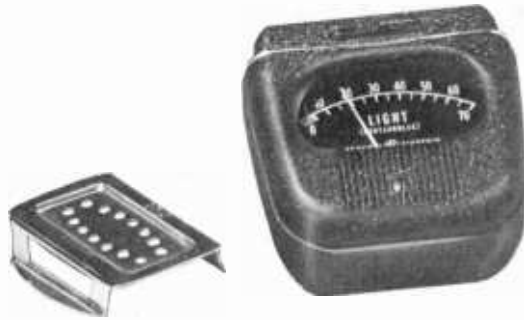

Fig. 3-6. *A simple light meter and shield-type multiplier. (WLBC-TV, Muncie, Indiana)*

and uses a shield for multipliers (Fig. 3-6). Disregard all the other dials and figures, which are designed for photographic work (the electronic camera behaves quite differently from a photographic camera in many respects). Fixed lighting will generally be used, so you will be interested in getting the correct ratios on the many different sets. Different materials reflect light differently, so you will be interested in how lighting from one set will affect the ratios you have set up for another set next to it.

It is good television practice to have the house lights on at all times, otherwise someone will have to remember to shut them off during a show. When measuring the light intensities, shut off all lights except the house lights and those that you intend to measure. Stand or sit where the performer or display will be located and hold the light meter at face or display level, pointing it directly at the light source (Fig. 3-7). Your measurement will indicate the incident light from that source.

To measure the base lighting, hold the meter as previously stated, but move around the set for some distance from the display or performer position. Base lighting intensity should be fairly even throughout the set.

To measure key lighting, hold the meter in the same way, pointed at the proper spotlight. This need only be measured at the face or display point. Most spotlights are adjustable for spot size, so you can usually spot only the area desired.

To measure back lighting, stand or sit at the display area, hold the meter at face or shoulder level, then turn around and point the meter at the light source. Try to place the meter where the head and shoulders will be.

Backdrop lighting is measured in the same manner as back lighting, but the measurement is mostly for reference purposes, since the level required will be that which erases shadows and brightens the backdrops.

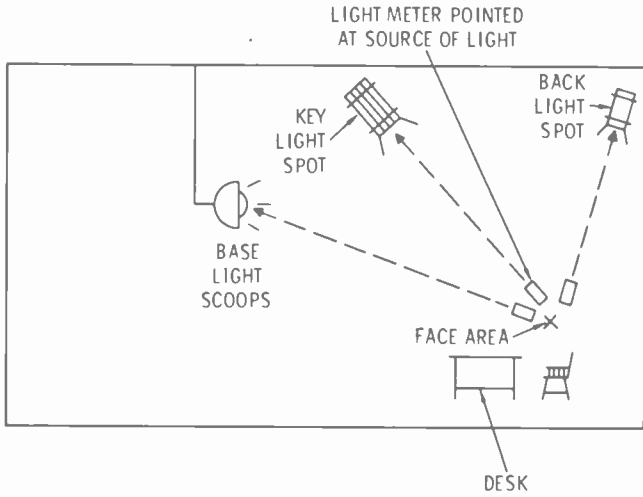

Fig. 3-7. *Light meter positioning for measurement of different light sources.*

A set should not be considered properly lighted until after it is observed through the camera and final adjustments are made.

Dimmers and Pantographs

Large dramatic productions require many special types of lighting. The larger stations who do much of this type work have very elaborate lighting systems with complicated patch and dimmer panels. A small

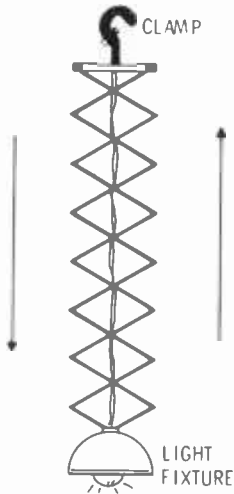

Fig. 3-8. *A pantograph.*

station will rarely, if ever, do this type of programming, so fixed lighting will be used, if not all the time, at least in the majority of cases.

A *pantograph*, shown in Fig. 3-8, is a device used to suspend lighting fixtures from a ceiling grid. It can be raised or lowered to suit the occasion and will stay in the position where you last placed it. A high ceiling is required to use these devices.

A dimmer and patch panel can be quite an elaborate affair; some even incorporate solid-state circuitry. Such instruments will handle almost any lighting requirement, changing light levels to any desired intensity. Some can be preset so that pushing one button in the control room will automatically change the lighting conditions. Needless to say, these units are quite expensive. A small station will find very little justification in their use for the expense involved.

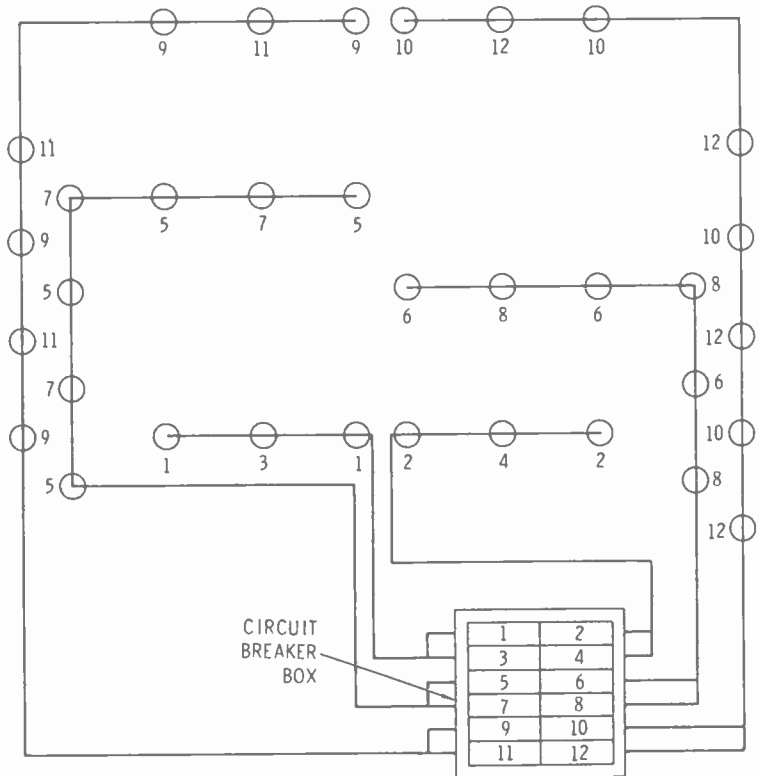

Fig. 3-9. A typical conduit and outlet runs from a breaker box. The outlets are numbered according to circuit breaker numbers.

Fixed Lighting

Fixed lighting does not mean rigid lighting. The scoops, spotlights, and backlights can be rotated and tilted up or down, spot sizes can be changed from flood to spot, and fixtures can be moved from one position to another. However, all the lighting is suspended from the ceiling, clamped to pipes. Instead of using a patch and dimmer panel, conduits with various outlets are run on the ceiling or side walls (Fig. 3-9) and each fixture is plugged into these with twistlock plugs. When it is desired to move a fixture from place to place, simply unplug and unclamp it. Light level is adjusted by using different wattage light bulbs.

Each conduit run should return to a circuit breaker box, so that one breaker controls each run. By plugging fixtures into different outlets, one breaker can turn on all fixtures plugged into that run. In this way, you can easily control whatever fixtures you wish to have on and those you wish to have off at any one time. Make up a chart of the floor plan and light positions, as in Fig. 3-10. Mount this alongside the breaker

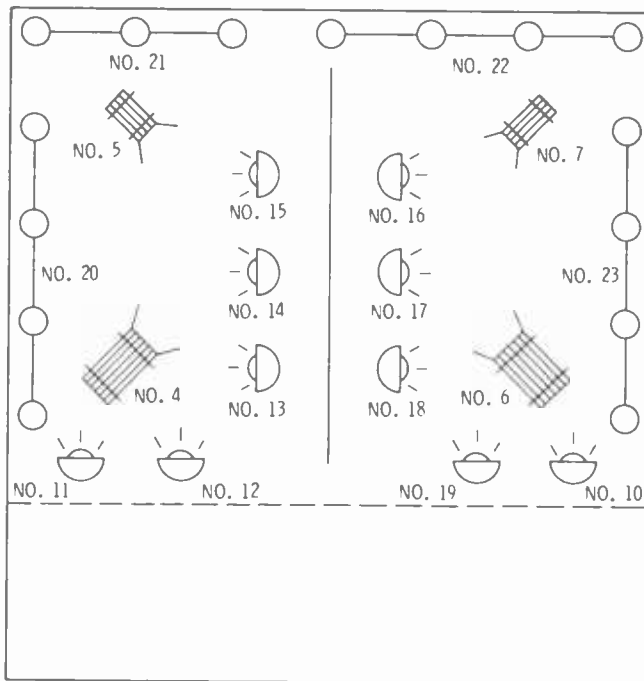

Fig. 3-10. A typical chart indicating light positions and the numbers of the breakers for all light locations in the studio.

box. Number the outlets and fixtures plugged into them with the corresponding breaker number. It is then a simple matter to look at the chart and turn on the correct lights for the set in question.

Some sets will be fixed, for they will occur from the same place in the studio, with the same essential props, every day. (These will be sets for such shows as News, Weather, Sports, Farm, and Kitchen.) For each set, with the desk or other furniture items in their proper place and lighting adjusted the way you want it, mark the floor with a felt pen or other good marking device. These marks will have to be renewed as they begin to fade, because you will probably find the janitor scrubbing extra hard to remove them, believing someone must have dropped a pen and made the floors look bad. If you have an understanding and cooperative janitor, you may even be able to get him to keep the marks renewed. Make a chart of each set, as shown in Fig. 3-11, showing positions of the people and objects, plus the lights used. By keeping these charts handy to the breaker box, it will be quite easy for one person to set up each area with its correct lighting.

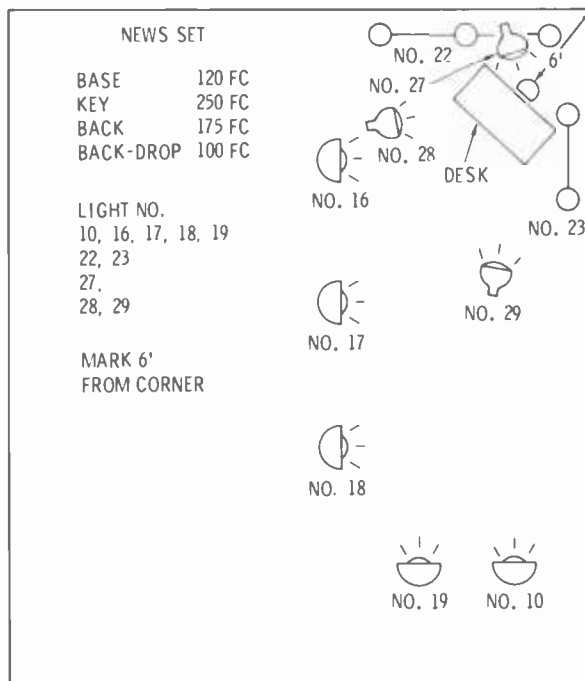

Fig. 3-11. A typical chart for a fixed set, indicating light level, number, and location, and mark on the floor for desk position.

The philosophy behind fixed lighting is that lighting is initially adjusted throughout the staging area, using enough fixtures to cover many individual sets, and then is left alone. Thereafter, the displays are adjusted to the lighting in fixed areas by adjusting the display rather than the lighting. If good lighting is not obtainable in one area for a particular display, the display is simply moved to a more suitable area along with additional lighting fixtures to suit particular needs.

It is not necessary to have special lighting personnel with fixed lighting, which is a saving in manpower; most production people can make a good set. The real success or failure of this method depends upon those who set up displays from day to day. Quite often, these people may get careless and set up a display in the most convenient manner, even without the stage lighting turned on. In such a case, the display may have dull objects in the poorest light and chrome appliances in the hottest light. Since these may be set up long before air use, and their shortcomings discovered at the last minute, even hasty changes may not be possible.

Although you will have to buy most of your lighting fixtures, there are some you can build yourself at a great savings in cost (see Appendix A). Stay away from fluorescent fixtures, as they are usually too large and unwieldy for the amount of light you get from them, particularly for small spaces.

The Camera

An electronic camera behaves quite differently from a photographic camera. That you can see your results immediately is one of its best features and permits immediate adjustments to correct anything that may deteriorate the picture. Some representative cameras are shown in Figs. 3-12, 3-13, and 3-14.

Generally, the camera lenses will be focused on infinity, although in some cases you may wish to set the lens focus in feet, especially when trying for a very tight shot on a display. The television camera focuses by moving the camera tube towards or away from the scene. With respect to depth of field, this camera reacts to light in the same fashion as a photographic camera. The less on the scene, the more open the iris on the lens will have to be to get a good picture. Opening the lens will decrease the depth of field. If you are not familiar with cameras, an example will help demonstrate this point. Let's say that a display product is placed on a desk about 4 feet from the backdrop, which carries the advertiser's sign (Fig. 3-15). If the depth of field is very poor, the product will be in focus but the sign will be out of focus. The reverse of this is also true; if the sign is in focus, the product will be out



Fig. 3-12. (left) General Electric's model PE-20 image orthicon camera. (right) General Electric's model PE-23 studio vidicon camera. (GE)



Fig. 3-13. The Sarkes-Tarzian transistorized studio vidicon camera uses a 1.5-inch vidicon tube. (Model 1500L, Sarkes-Tarzian, Inc.)



Fig. 3-14. This Sarkes-Tarzian studio vidicon camera uses a 1-inch vidicon tube. (Sarkes-Tarzian, Inc.)

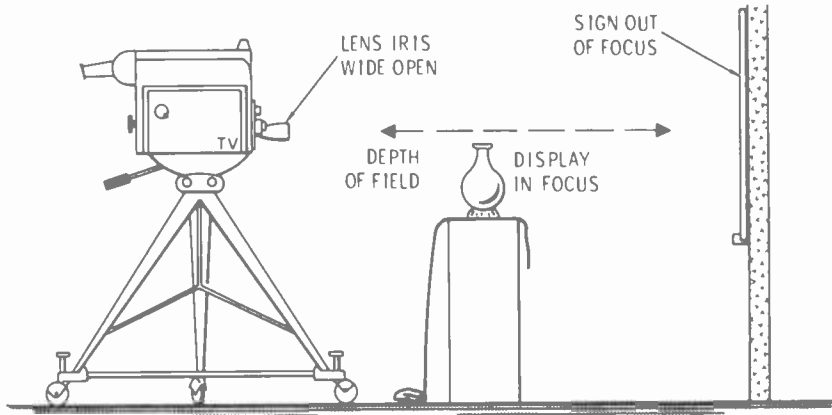

Fig. 3-15. *The camera's depth of field must be adequate enough to hold the display and sign in focus at the same time.*

of focus. To remedy this situation, increase the light on the set. With more light, the lens will require a smaller opening, and the depth of field will improve.

As the sensitivity of the camera tube falls off, the gray scale will gradually move towards black (the average tone of the picture will be darker). You can adjust light, lens opening, beam and target voltage to compensate for this, but only up to a point. After that, the tube will have to be discarded.

If a set does not have enough light on it or if the camera lens is set at too high an f stop, the camera will have a poor gray scale, the scene will not focus very well overall, and the picture will be noisy. When using a vidicon under these conditions, there will also be an increase in the lag factor, a phenomenon found only in the vidicon. Lag appears when the camera is moved while focused on a scene and is more pronounced when the movement is rapid. For example, a person is sitting at a desk and wishes to demonstrate an object on the desk. As the camera quickly pans from his face to the object, a blurred retained image of his face will follow the movement. This image will last only for an instant and will disappear as soon as the camera movement stops, but it can be annoying. You may not be able to eliminate this problem entirely, but you can minimize it by using higher set lighting and beam current, and planning the action so that rapid pans are not required.

Burn Out and Orbitors

After a few hundred hours of operation, the image orthicon camera begins to have sticking pictures. These appear as a negative image of the scene that was last focused upon that remains for some time after

the camera has been moved to another scene. As the tube gets older, it will stick quicker and it will take longer for the negative images to fade out. This fading out of the negative images is called *burn out*. When the tube is quite bad in this respect, you can hasten the burn out process by pointing the camera at one of the lights. Do not focus on the light or you will only make a bad situation worse. While pointed at the light, keep the camera moving in a rapid circular motion. This will help for a while, but the situation will soon become so bad that the tube will have to be discarded.

The greatest moneysaver in this area for image orthicon tubes is an orbitor. An orbitor, shown in Fig. 3-16, is either a mechanical or electro-mechanical device that keeps the image constantly moving on the face-plate of the tube by mechanical movement of the lens or changes the position of the electronic image on the tube's target by continually varying the magnetic field around the image section of the tube. To prevent this movement of the picture from being seen in the final picture, a correction circuit that is synchronized to the orbitor changes the camera centering voltages. This effectively cancels out any movement in the final picture.

There have been a number of other image orthicon tube types developed besides the standard 5820A. These other tubes have been primarily for the color cameras, which require more strict tolerances than does a monochrome camera. New target materials have been developed and are now in use in these tubes, and for some of the types sticking pictures is not a problem. (A sticking tube in a color camera could prove disastrous to the reproduced color picture.) These tubes cost more than 5820A tubes, in the price range of \$1,500 to \$2,000 each.

Lenses

The lenses you use will depend upon the type of camera and the work to be done. A lens is classified by its focal length and by the size of target upon which it focuses the image. The target area of the 5820A image orthicon tube is approximately the size of 35 mm film; the target area of a vidicon tube such as the 7735A is approximately the size of 16 mm film. Therefore, these lenses are designated as 35 mm or 16 mm types.¹

A small station will ordinarily employ a monochrome camera, which uses the 5820A image orthicon tube. Adequate lenses for the camera in a small studio with a staging area of 20' × 25' will be the 50 mm, 90 mm, and 135 mm sizes. When you want to create the impression of a much larger studio, the 35 mm lens will do this nicely. On the other

¹Lenses are sometimes given in inches or in millimeters. There are approximately 25 mm to the inch. Thus a 25 mm lens is a 1 inch lens. The smaller lenses are usually designated in millimeters, while the larger lenses are designated in inches.

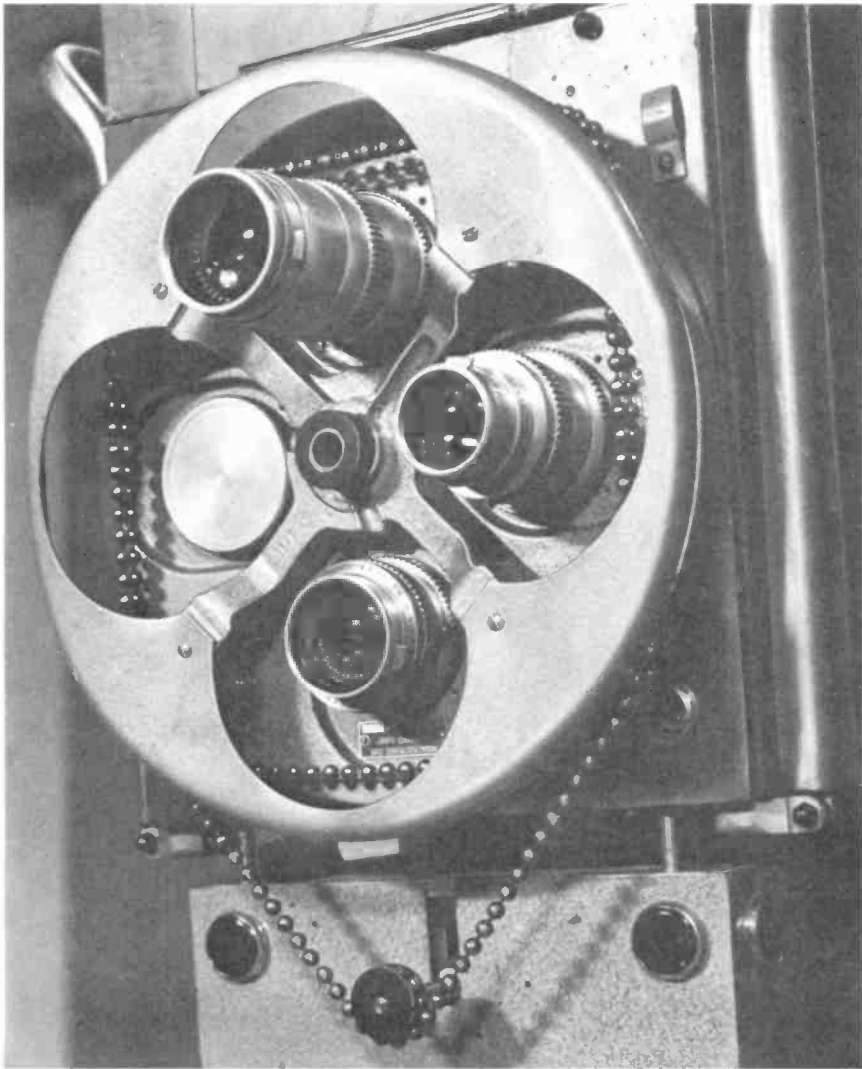

Fig. 3-16. A close-up view of a mechanical orbitor mounted on an image orthicon camera. The case below the camera contains the correction circuit. (WLBC-TV, Muncie, Indiana)

hand, should occasions arise when an overcrowded studio prohibits camera maneuvering, the 8½-inch lens will allow close-up shots from the opposite end of the studio.

A better way to satisfy all lens requirements with only one lens is the use of a zoom lens, but this is expensive. A zoom lens will permit a range of shots from wide-angle long to extreme close-ups at any speed desired

and will keep the scene constantly in focus. Some mechanical orbitors may not permit the use of a zoom lens, but the electronic orbitors will cause no trouble.

Lenses for a vidicon camera, which uses a tube of the 16 mm size, would be the 16 mm, 25 mm, 50 mm, and 75 mm sizes. Note that these lenses are approximately half the focal length of the lenses for the image orthicon camera, but they provide approximately the same coverage as the larger lenses.

Many new camera tubes are being developed and put into use. Extensive use is now made of the 4½-inch diameter image-orthicon tube and RCA is using a 1½-inch diameter vidicon in their transistorized film camera. Lenses will vary according to the size of tube used, and, of course, the prices will vary also. (Two of RCA's vidicon and image-orthicon tubes are shown in Fig. 3-17.)

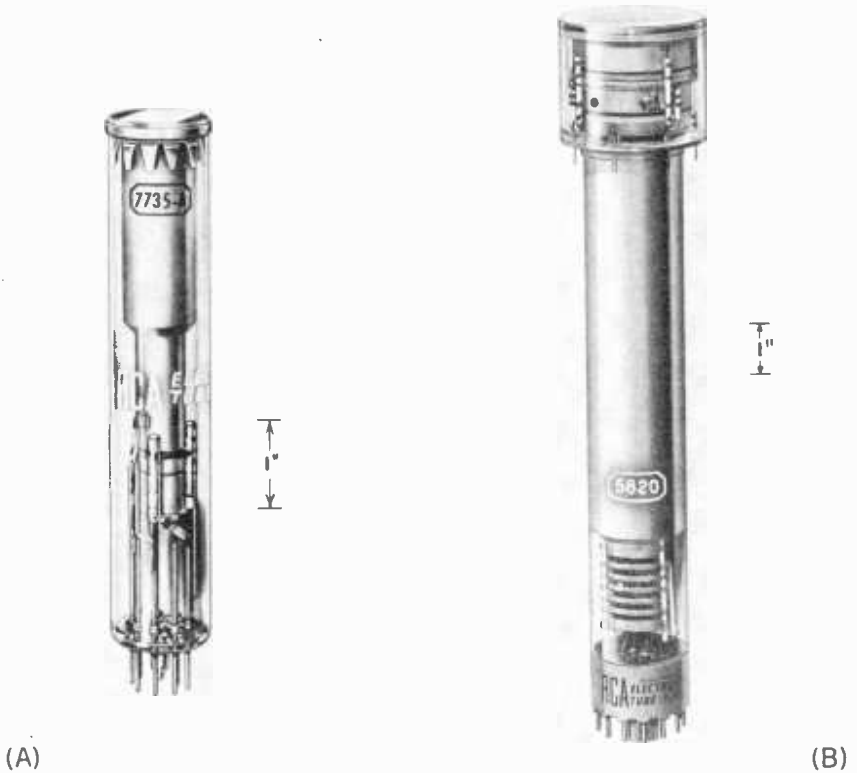

Fig. 3-17. (A) A 1-inch diameter vidicon tube. (B) A 3-inch diameter image orthicon tube. (RCA, Tube Division)

Camera Selection

Your choice of camera will depend upon several factors, the first of which is cost. The vidicon camera for studio use will cost just about half the price of an image-orthicon camera (this cost is based on a complete camera chain).² The second factor to consider will be the type of production you expect to do. The third factor will be lighting and the resulting heat. A vidicon requires a lot more lighting on the set. However, the newer tube types show a marked improvement in this respect, so that the vidicon now requires only about two to three times the light required by the image-orthicon. A vidicon camera, with favorable lighting conditions, will give good pictures, but there is still the lag factor to consider.

It is difficult to balance a vidicon and an image-orthicon camera, so that they should not be used together on the same scene. The usual News, Weather, Farm, Sports, and panel shows can be handled quite well with the vidicon camera. The pedestal may be lighter in weight than the one used for the image-orthicon camera, especially if the vidicon is a transistorized model. The price of the vidicon tube is much lower than a 5820A image-orthicon tube.

Microphones

The microphones you use will depend upon the program. With a mike boom, the mike movements are kept out of camera range and a large group of people can be handled with one mike. However, there are many programs when it is acceptable to show the mike in the picture, and this is becoming a standard practice. Such scenes as a man at a desk, a group of people around a table, or an interview may all use desk stands or lavalier mikes, which are worn around the neck. The mike boom must be constantly tended to keep it in position as the audio source when cameras move, otherwise, it keeps getting in camera range or mike placement will be incorrect, with resulting poor audio. A small studio will soon discover that it can get along quite well without a mike boom and its storage problem.

There are a number of good mikes that serve well in television. You may have your own preference here. Two workhorse mikes have been the RCA BK-1A and RCA BK-6B lavalier mikes (Figs. 3-18 and 3-19). These are both dynamic types and give good pickup. For music or singing groups, the RCA BK-5B (Fig. 3-20) is most suitable.

²The term *camera chain* denotes the complete line of equipment necessary to make the camera operate: the lens, camera, camera cable, control unit, deflection chassis, power supplies, master monitor, and remote control panel.



Fig. 3-18. *The RCA BK-1A pressure microphone on a desk stand. (RCA)*

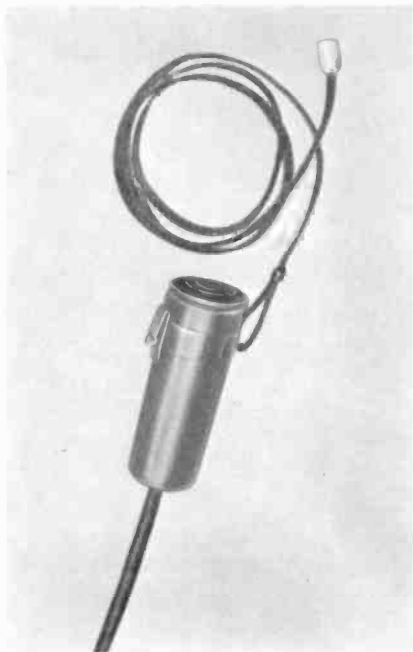

Fig. 3-19. *A lavalier microphone, the RCA BK-6B. (RCA)*



Fig. 3-20. *A uniaxial microphone, the RCA BK-5B. (RCA)*

Acoustics

Television studio acoustics are not as strictly controlled as they are for a radio studio. The soundproofing should be enough to eliminate outside noises, such as street noises. There should be some sound-deadening materials on the ceiling and walls. The ceiling may be padded with blanket insulation, or, if a more finished appearance is desired, there are several good acoustic panels that may be used. The side walls will have drapes or other materials in the staging area, and the rest of the walls and ceiling in the camera maneuvering area should also be covered. Bare concrete may be used for the floors, but this will dust and get into the equipment and all over the props. There are special paints and hardeners to keep concrete from dusting. Asphalt tile or a similar material is the best covering for the studio floor, both for cleanliness and to soften foot noises. Carpeting should never be used as it will be a nuisance and will interfere with camera dollying.

Studio Outlets

Microphone outlets should be placed on at least three walls of the staging area and wired in parallel (three outlets on one circuit). Care must be taken so that only one mike is plugged into any one circuit at a time, otherwise, the sound level will be cut in half or more. If a more



Fig. 3-21. This small 8-inch monitor, mounted in a cabinet, is suitable for use anywhere in the station. (Miratel Electronics, Inc.)

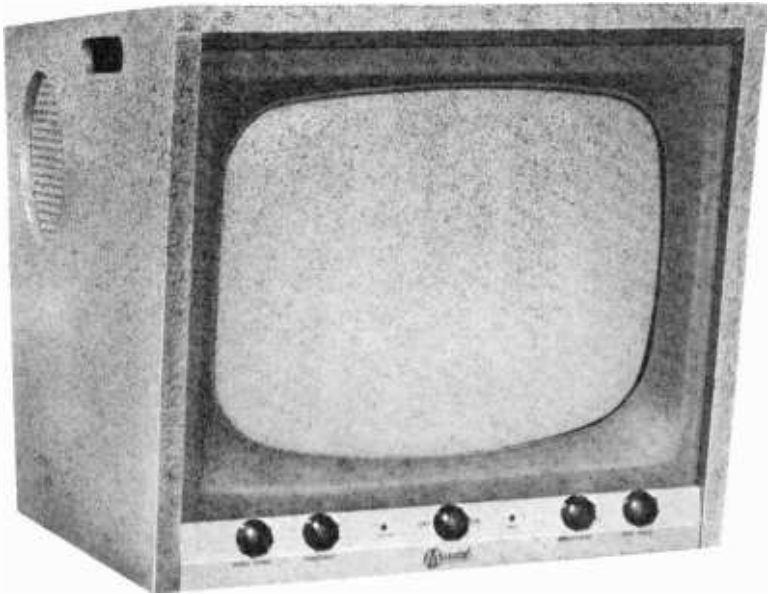

Fig. 3-22. This 17-inch video monitor, in a veneered cabinet, is suitable for studio or lobby use. (Miratel Electronics, Inc.)

flexible arrangement is desired, each outlet can be a separate circuit terminating in jacks in the audio patchboard in the control room. This would prevent the possibility of getting more than one mike on a circuit at a time and would provide alternate circuits if any one should fail. This arrangement is more costly because it requires separate cables to all the outlets and a separate jack on the patchboard.

It is good practice to have at least two spare shielded pairs appear around the studio on earphone or similar jacks. These pairs should appear on the audio patchboard in the control room. These pairs will often be used for such things as feeding audio for cueing purposes when the speaker is muted, or as additional intercom lines, or as a high level audio line from the studio to control room. Here, *shielded pairs* indicates ordinary, 2-wire shielded audio cable.

Video for the studio monitor (Figs. 3-21 and 3-22) should run on coaxial cable and should also appear at different locations around the studio. It is well to have one or two spare coaxial cables along with the first one. They should all appear on video jacks in the control room and coaxial outlets in the studio and should loop through each outlet. Additional lines will find use for preview and any special uses that may occur. These assorted outlets can be combined on outlet plates, as in Fig. 3-23 and wired as shown in Fig. 3-24.

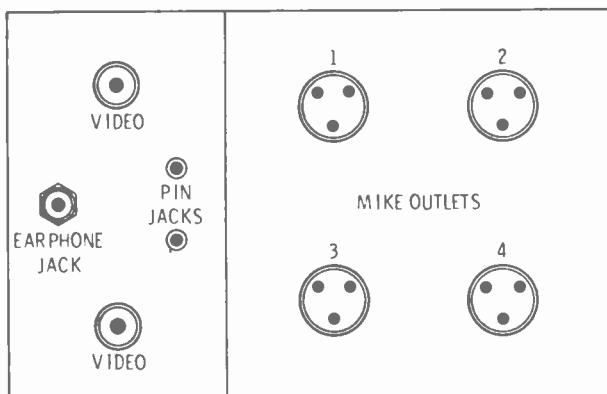

Fig. 3-23. A typical studio wall outlet plate with various receptacles.

With outlets on different sides of the studio, microphones, earphones, or other items can be plugged into the circuit without stretching long cables across the studio floor. The fewer things that are on the floor, the better. A small studio needs to conserve space. Cables on the floor can interfere with camera movement. A microphone cable can stop a dolly dead, with sad on-the-air results. Even a cigarette butt on the floor will jar the camera badly, especially if a fast movement is being made.

Camera Accessories

A cue card holder may be built (see Appendix A) and attached to the front of the camera. These are popularly known as "idiot cards." A regular prompter unit is expensive. A cue card holder needs no one to attend it. The announcer writes the commercial copy on the card and hangs it on the camera just prior to the spot or other demonstration.

A good position for a clock is right on the front of the camera dolly. You can easily rig something to tie it on. In this position, those in front of the camera can keep an eye on the time very easily without looking too far off camera. Most cameras have an auxiliary a-c outlet which you can operate the clock from. A line switch is helpful for setting the clock, because the power will be shut off when the camera is turned off. (Unless the camera is being used throughout the day, the chain is normally shut down.)

Backdrops and Props

Backdrops and props are not difficult to build. All it takes is a little imagination, a few simple materials, paint, and a few tools. Drapes are adequate as general backdrops for many occasions. Colors are important

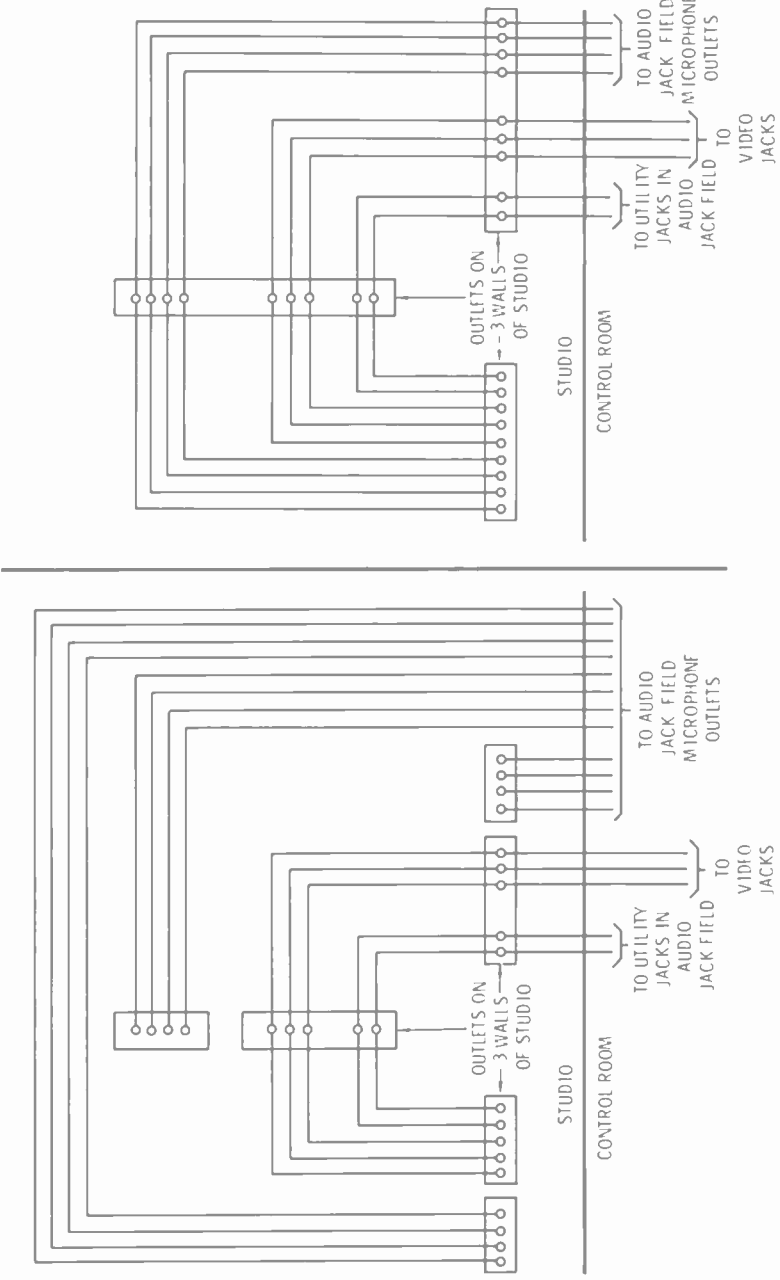

Fig. 3-24. Alternate methods of wiring the studio microphone, video, and utility outlets.

only to the eye, not to the camera, unless they are very dark or very light. The author has viewed a red and a green drape side by side through a camera and it was impossible to tell where one left off and the other began, because the camera is color-blind. Use some blacks, and medium- and light-colored drapes. Drapes that have a metallic thread woven through them provide an interesting and sparkling backdrop. Sets can look very monotonous and drab with the same color drapes as backdrops all the time. Drapes may be hung permanently on the side walls or on pipe hangers.

Backdrops (or flats) may be made from light framing lumber covered with a heavy paper or canvas and then painted. Try to avoid very light colors on flats, because these reflect more light than do drapes. Avoid whites and glossy paint at all costs; a person standing in front of a white background will appear very dark, and, in some cases, it may be impossible to distinguish his features. The backdrops will set the tone of the camera picture. Colors are good for eye appeal but not much help to the camera. If you want both eye appeal and good camera production, paint several large patches of color on a board, side by side. Observe these through the camera and select those which give the best results for both purposes.

Some backdrops may also be made using peg-board. Decorations can be attached to these boards to set a motif for different shows. This may be done by attaching cut-outs or objects to peg-board hangers, and hanging them from the board. For a Sports show, for example, you can use objects representing different sporting events and cut-out figures of players; for a Record Hop, you can hang up records. The peg-board backdrop has many interesting possibilities.

Most sets and props need not be expensive. You can build many varieties of interesting studio furniture, such as simple stands for displays that need only a cloth draped over them, or turntables that rotate to show off jewelry. You can always get samples of different materials and cloths to experiment with, and if any one is not suitable, you will be out very little in money. Browse around lumber companies. There are many new building materials that can be of use for studio props, especially wood paneling and Fiberglas panels.

Costs of Basic Studio Equipment

Studio cost estimating in a general way can only be done by the least common denominator method; there are some basic items that must be purchased but they will not necessarily do all that you want to have done. For particular requirements, you will have to decide what equipment is needed and consult with manufacturers for their current prices.

Costs are also given here for other equipment that will help you expand on the basic items. Figures are approximate and have been rounded off to even dollars.³

Video Equipment

1. RCA TK-14, monochrome image orthicon camera chain . . . (Fig. 3-25) (Camera, viewfinder, electronic orbitor, 3 lenses, 5820A tube, control unit, console housing, TM-6 master monitor, power supplies, interconnecting cables, 50 feet of camera cable)	\$17,900
2. RCA TK-15A studio vidicon camera chain (Fig. 3-26) . . . (Camera, viewfinder, 3 lenses, 7735A tube, control unit, console housing, TM-6 master monitor, power supplies, interconnecting cables, 50 feet of camera cable)	\$10,385
3. RCA TD-10 hydraulic camera pedestal-dolly and cradle head (Fig. 3-27)	\$ 1,100
4. Varotal II, indoor zoom lens ⁴ (for RCA TK-14 image orthicon camera)	\$ 4,975
5. Berthiot Pan-Cinor, L-20 zoom lens (for RCA TK-15A vidicon camera)	\$ 1,550
6. Portable 21-inch video monitor	\$ 325
7. 5820A image orthicon tube ⁵	\$ 1,200
8. 7735A vidicon tube	\$ 200

Audio Equipment

RCA BK-1A microphone	\$ 73
RCA BK-5B microphone	\$146
RCA BK-6B microphone (lavalier)	\$ 86
RCA mike boom (small)	\$450

Lighting Equipment

18-inch scoop	\$45
6-inch fresnel spotlight	\$40
Do-it-yourself spotlights (Appendix A)	\$ 5
Do-it-yourself striplights (10 feet, 10 lights—Appendix A)	\$34

Suggested Basic Items

VIDEO A	Item 1 (image orthicon camera)	\$17,900
	Item 3	\$ 1,100
	Item 6	\$ 325
	Total	\$19,325

³ Most of the figures given are from RCA price lists. Prices will vary from one manufacturer to another. There will be such miscellaneous items as mike plugs, wall outlets, etc., which are not shown. Only the main items have been considered.

⁴ The cost of some extras is given so that you can dress up the basic package.

⁵ Camera tubes come with the camera chains. Figures are shown for comparison purposes.

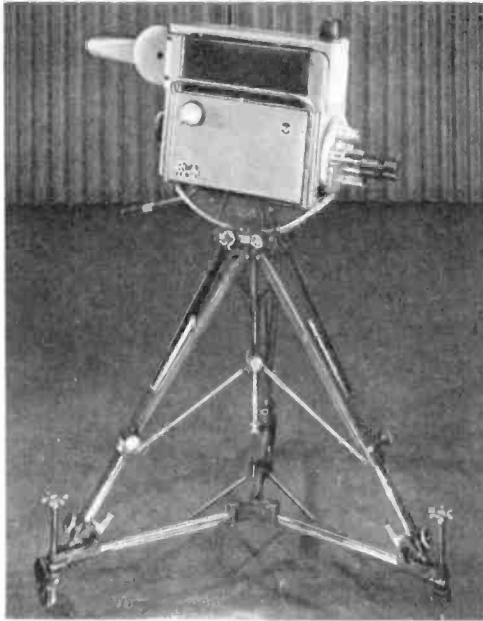

Fig. 3-25. The RCA TK-14, a studio image orthicon camera for monochrome use. This camera, mounted on a portable tripod, uses a 3-inch tube. (RCA)



Fig. 3-26. The RCA TK-15A, a studio vidicon camera, uses a 1-inch vidicon tube. (RCA)

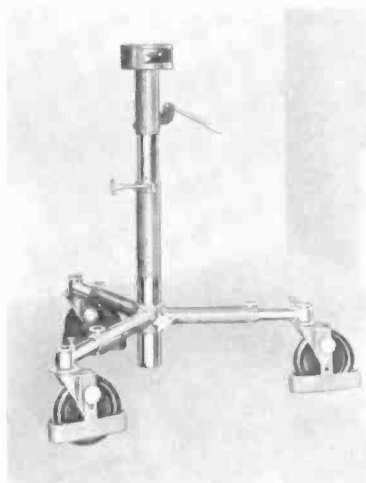

Fig. 3-27. This camera pedestal, the RCA TD-10, is suitable for either a vidicon or monochrome studio camera. (RCA)

VIDEO B	Item 2 (vidicon camera)	\$10,385
	Item 3	\$ 1,100
	Item 6	\$ 325
	Total	\$11,810
AUDIO	2 BK-1A microphones	\$ 146
	3 BK-6B lavalier microphones	\$ 258
	Speaker (inexpensive)	\$ 10
	Total	\$ 414
LIGHTING	10 18-inch scoops	\$ 450
	4 6-inch fresnel spotlights	\$ 160
	6 do-it-yourself spotlights	\$ 30
	6 do-it-yourself striplights	\$ 204
	Lighting installation	\$ 400
	(Approximate cost for wiring with conduits and outlets for 32 fixtures, two circuit breaker panels, etc., not including labor)	
	Total	\$ 1,244

The total cost for these suggested basic items, including video, audio, and lighting amounts to:

VIDEO A	Image orthicon camera	\$20,983
VIDEO B	Vidicon camera	\$13,468

Chapter 4

The Control Room

As the control room design is based on the range of programming a station plans to handle, it is necessary to consider programming first. Large, complicated dramatic productions will require several cameras, many microphones, switchers, audio consoles, and associated equipment, plus all the manpower that is required to run them. The small television station, however, should not anticipate this type of show; its usual live programming will consist of news, sports, weather, farm, kitchen, panel, and discussion shows, which are not complicated, take little equipment, and need only a few people to run them. There may occasionally be more elaborate and complicated production ventures, depending upon the amount of talent available locally. (College and country music groups, Police and Sheriff Departments, and others may wish to present more complicated productions, many of which can be developed into more than the usual panel show.)

Our considerations here are directed to the small station working with basic equipment and personnel at minimal cost. The equipment described is designed to handle local panel shows, some fairly elaborate productions, film shows, and off-air pickup for rebroadcast of network shows or another station's productions. (The studio described in Chapter 3 will accommodate all these various shows.) There is considered to be only one studio camera and one engineer in the control room who will handle all the audio-video switching, make all adjustments, keep the transmitter under control, and handle the film projection work.

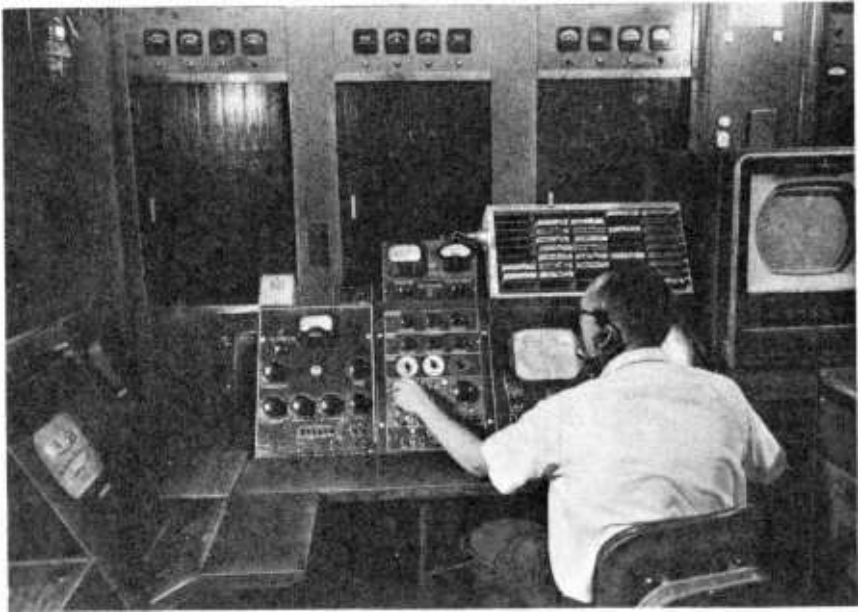

Fig. 4-1. *A control room operating position designed for a one-man control operation. (WLBC-TV, Muncie, Indiana)*

Minimum Video Requirements

Camera Systems

A block diagram for the control room video is shown in Fig. 4-2. The control room setup is not the same for an image-orthicon camera (studio or remote) or vidicon camera. A vidicon camera system will consist of a vidicon camera head, a control-deflection chassis, a control panel, a monitor with a cathode-ray oscilloscope (CRO), and power supplies for the camera and monitor. The control-deflection chassis is usually mounted in a rack, as are the power supplies. The monitor can be either of two types. When the picture monitor and CRO are in one unit it is called a Master Monitor. The second type uses a video monitor in conjunction with a separate oscilloscope called a waveform monitor (WFM). Transistorized camera chains have the control and deflection chassis mounted in a rack or in the console with integral power supplies.

The image orthicon camera system comes in two styles, studio and field, whose major differences are in the control-monitor and power supply. The studio style is housed in the regular console, which contains a master monitor control chassis and panel, and a rack-mounted power

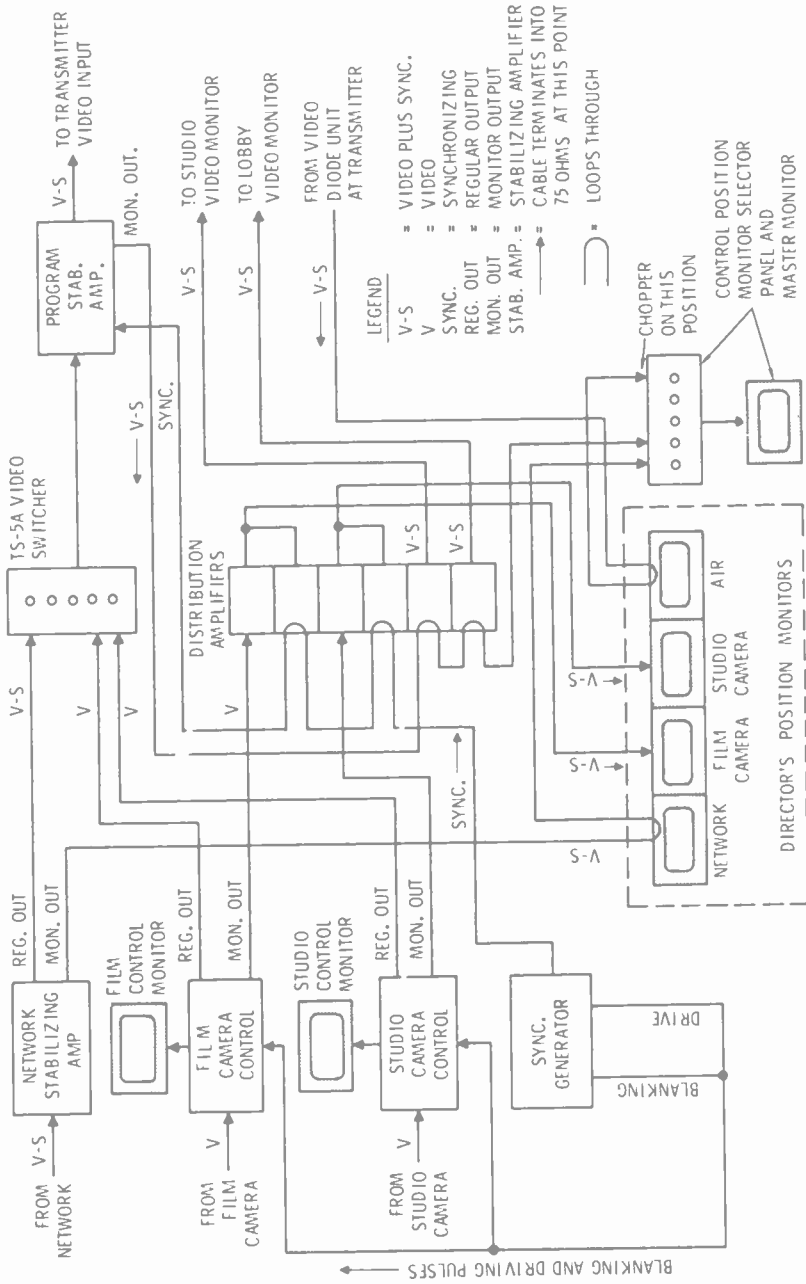

Fig. 4-2. A block diagram of the control room video.

supply. The studio style costs less than a field style. The field style monitor, CRO, and control chassis and panel are housed in one portable case and the power supply for the complete chain is in another. The field style will handle programs just as well as the studio style, but a special stand must be built to hold the power supply and control unit at the console position.

Unless a station anticipates doing remote television pickups, it is just as well not to use the field camera chain. Live remotes are complicated and can be costly. There is very little comparison between a television remote and a radio remote. The radio remote can be accomplished by one man with an amplifier or tape recorder and audio line, and can cover many interesting local events live at very little cost. A television remote will require at least one field camera chain, monitors, and other items, such as a sync generator, plus microwave. In addition, audio facilities are required. If you are considering video tape instead of microwave for live coverage in the field, you will find that a video tape recorder is an expensive item that may cost more than all the technical equipment used in a radio station.

Unless there are enough interesting events to attract enough sponsorship to pay the costs, it is highly unnecessary for a small ulf station to invest in remote equipment. When needed, field coverage can be adequately handled in a much less expensive fashion with good, 16 mm sound film equipment. Naturally, events can't be done live, but they can be done well, even though delayed.

Remote-Controlled Cameras

Chapter 3 did not discuss remote-controlled studio cameras because most of their operation is done from the control room. A remote-controlled camera is mounted on a special motor-driven pan and tilt device so that camera panning and tilting may be handled in the control room. Some cameras, such as the General Electric, model PE-22A, are designed especially for this purpose. This unit, shown in Fig. 4-3, is a transistorized camera with a remote-controlled zoom lens; pan, tilt, and zoom action are controlled from a panel in the control room. It doesn't even have a viewfinder on it. Standard cameras can be operated in this way, but a special pan and tilt assembly must be installed.

Use of a remote-controlled camera cuts some cost by eliminating the need for a camera operator. Such a camera is very effective if the object to be televised is stationary, such as a fixed display or a sponsor's sign or product. With a regular studio camera, for such a production, the cameraman is necessary only to position the camera, focus the lens, and cap the lens when the spot is over. Such a spot may last less than a



Fig. 4-3. A transistORIZED studio vidicon camera designed for remote control use, the GE PE-22A. Note that there is no viewfinder. (GE)

minute. A remote-controlled camera will do the job without a cameraman, but, of course, the display must be set up in the correct position.

Remote-controlled cameras, however, are not suitable for exclusive use, even in a small station. For any type of production work, the camera is stationary, even though it pans, tilts, and zooms, and the scene is shot continually from the same viewpoint. Even a news or panel show will become very boring to a viewer watching it from the same viewpoint all the time. Shifts of viewing angles would require more cameras if only remote-controlled units were used.

As an additional camera facility for commercials, displays, cards, and the like, where there is limited action, the remote-controlled camera has its place. For production work, it is best to be able to move the camera into many positions during a show, especially when there is only one studio camera.

There is another point that should be considered. A cameraman does not have to be a highly-skilled person. Announcers, production people, or anyone with any degree of dexterity and sense of proportion can soon be taught to do a reasonably good job of camera operation. Consequently, no special personnel need be hired just for this purpose. If there is to

be some limited action display, product, or sign, the regular camera can be positioned, focused, and electronically capped in the control room; then, with the flip of a switch, the spot is ready for airing.

Film Cameras

The beginning station has the alternative of using one or two film camera chains. (Figure 4-4 shows two standard film cameras.) A single-camera system (Fig. 4-5) will use some type of multiplexer so that two film and two slide projectors may operate into one camera. With this method, slides or film will often have to be "taken" on the air blind, because one or the other projectors will be showing. This is not an insurmountable problem, but careful stacking of slides and other program

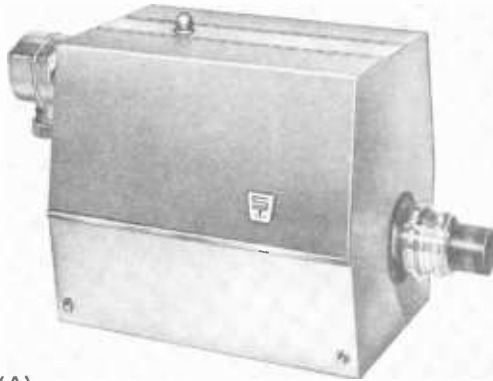

(A)

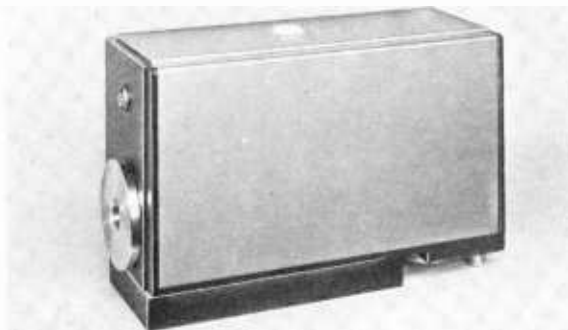

(B)

Fig. 4-4. (A) This transistorized vidicon film camera uses the 1-inch vidicon tube. (Sarkes-Tarzian) (B) This vidicon film camera, the RCA TK-22, uses the 1.5-inch vidicon tube. (RCA)

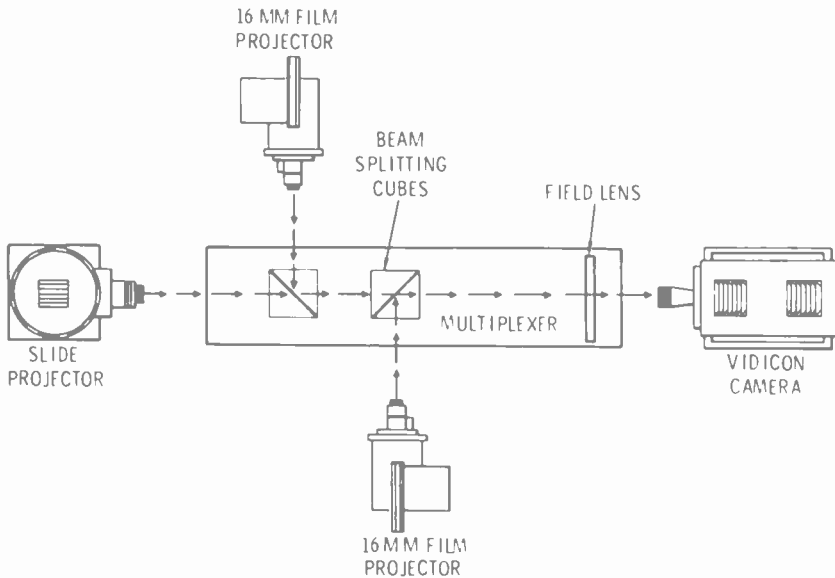

Fig. 4-5. A film camera chain with a single camera, projection equipment, and multiplexer.

material is necessary. It is possible, however, that slides will be stacked upside down or backwards, film leader will get on the air, or the wrong slide may be shown on a commercial.

If the program schedule is a heavy film schedule, much air time can be lost if the single film camera fails and has to be repaired. (A station that gets network programming directly, not on film, will have programming available until the film camera is repaired.)

A two-camera system (Fig. 4-6) requires two complete film camera chains and two multiplexers. There will be one film projector and one slide projector with each camera. Such a system, although more expensive than a single-camera system, provides many advantages and is more flexible. Previewing of material before airing is a simple matter. For example, while one slide is on the air, the next slide is up on the second camera monitor. Thus the operator can be certain that he has the correct slide and any necessary adjustments for setting levels or any other corrections can be made immediately before the slide gets on the air. The two-camera system is also a safeguard against lost air time due to camera failure. Should one of the cameras fail, programming can continue with the other camera.

Equipment breakdown with a single camera chain is not as great a problem with live programming as it is with film. The number of live

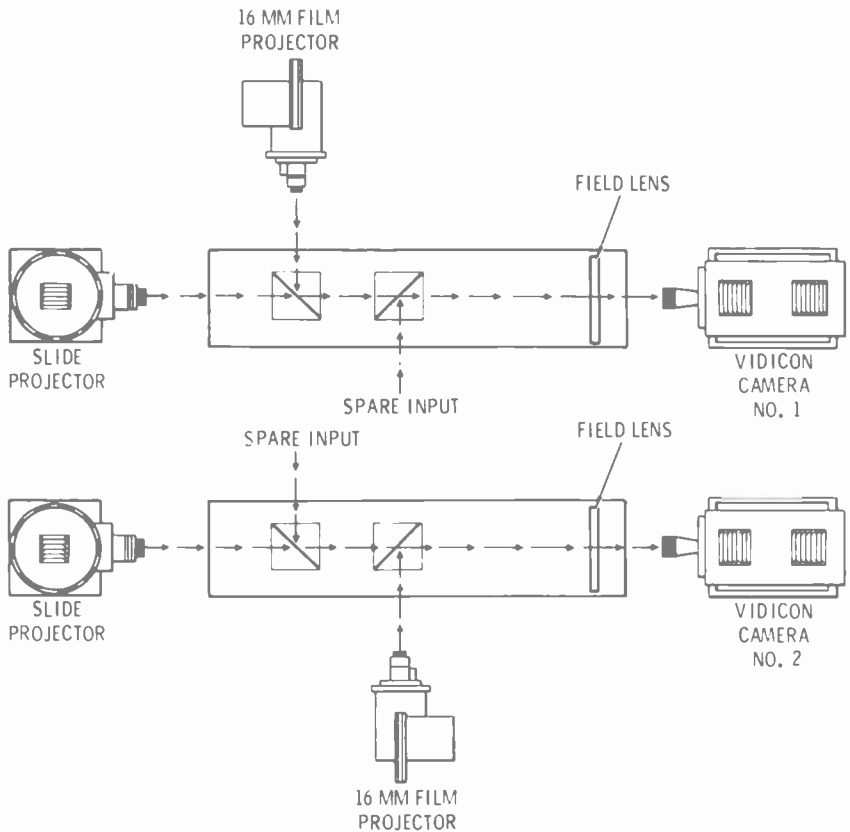

Fig. 4-6. A dual film camera system with two cameras, projection equipment, multiplexer, and spare inputs.

shows will be quite small compared to film shows and commercials. If a news show, for example, is on the air and the studio camera fails, the newsmen can still continue to give the news stories over news pictures and slides. When the script calls for a return to the studio, a slide may be shown instead, while the newsmen continue to give the audio material. However, if a full-length movie is being shown on a single film chain and it goes dead, there is nothing to put on the air until it is repaired. Whether or not to have two film camera chains is a decision your company will have to make.

Multiplexers

Whenever more than one source of program material is to be fed to a camera chain, some type of multiplexer is required. With the vidicon tube, because of its very small target, the direction of light and how it lands on the faceplate are critical. When a vidicon camera is mounted

directly on a film projector, there is no problem. However, when the camera is used with a multiplexer where as many as four picture sources are directed to the one camera, a field lens must be used. This lens is placed between the camera and the light sources, so that the camera focuses on the field lens, as do the light sources. Each light source must take the same path so that they are all on the same axis when they reach the field lens. This is usually accomplished with special prisms in the multiplexer.

In the RCA TP 11-C multiplexer, the camera is mounted on one end of the top table. Immediately out in front of the camera lens is the field lens. At the far end of the table, a slide projector is mounted. The prisms are mounted between these two. The slide projector shoots its picture through the prisms to the field lens. There are three more openings on the sides of the table top so that two projectors may shoot into the multiplexer through different prisms. The fourth input can be used by adding what is called a fourth input kit. This kit includes another field lens and a solenoid operated mirror. In all cases, the light from each source comes along one light path to the vidicon tube. There is a steel cover that encloses the entire top of the multiplexer so that it is free from any extraneous room light that may get into the optical system and is dust tight to keep the lenses and prisms clean. In this fashion, the multiplexer not only provides for the proper direction of light, but also provides the mounting for both the camera and the slide projector. Other models accept different combinations and numbers of light sources and also have provisions for more than one camera.

One accessory for use with the RCA multiplexer is an opaque projector assembly. Actually, this is not a projector, but merely an extension of the lens system of the multiplexer's fourth input. This device will permit the projection of a limited amount of action originating in an area of $4\frac{1}{2} \times 6$ inches to 9×12 inches. Even though the area is small, it will permit such actions as pouring a liquid into a glass (live), showing off a ring on someone's hand or jewelry on a turntable, displaying roll charts, flip charts, or special pictures, etc. These may all be done live in the small area indicated above. When you begin with a multiplexer and one camera you may then eventually add another camera and multiplexer. This will increase the picture sources tremendously and provide a greater flexibility in programming.

The Synchronizing Generator

The heart of the whole system is a synchronizing generator. This unit forms, shapes, and sends all the necessary pulses to all the video equipment, so that it may work properly and in proper synchronization. So much depends upon the sync generator that you should consider having one for standby that may be put in service immediately if the

first one should fail. A station can start with only one generator, but it should obtain a second one just as soon as finances will permit. In conjunction with the sync generators, some switching panel should be bought or built so that one generator can be switched out of service and the other one in without hesitation. Although the cameras have an electronic protection circuit to protect them should the generator fail, if the circuit is not working properly, failure of the sync generator can ruin an expensive camera tube.

The Video Switcher

A video switcher will be required, since more than one source of video information will be used. How complex this unit should be depends upon the number of video sources and what you wish to do.

For a number of years, RCA built a small audio-video switcher, the TC-4A. Its main purpose was to supply the minimal audio and video switching facilities that a station could use, in what RCA termed its "basic buy" package. This switcher had many limitations in both the audio and video functions. Most stations expanded it with a lap-dissolve video unit and audio consoles. The TC-4A is no longer available, but you should be on the lookout for one on the used-equipment market, for it has many possibilities that can expand its usefulness tremendously. Some of the many modifications that can be made on this unit are detailed in Appendix B.

The TS-5A video switcher is a small lap-dissolve unit that permits a total of five video circuits to be switched, dissolved, faded, or superimposed, as the situation requires. Unlike larger switchers, it has no "off" button; if this feature is desired, one of the video inputs should be left unused. Doing so will reduce the input capability to four video sources, but this amount will handle most of the sources a small station will usually have (i.e., one studio camera, one or two film chains, one network or off/air receiver).

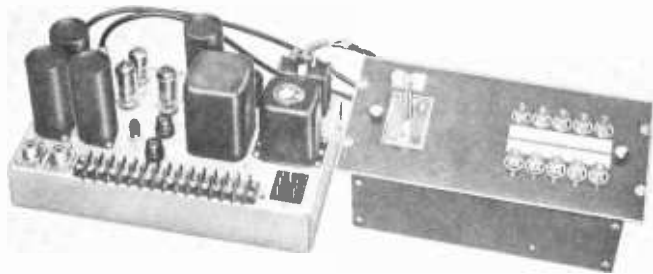

Fig. 4-7. *The RCA TS-5A video switcher, lap-dissolve unit. (RCA)*

The TS-5A is made up of two sections: the push-button/fader panel and the amplifier section, connected by short cables (Fig. 4-7). The fader panel may be mounted either on the well of the table section (Fig. 4-8) or upright in the cabinet section of the console housing, with the amplifier located underneath in both cases.

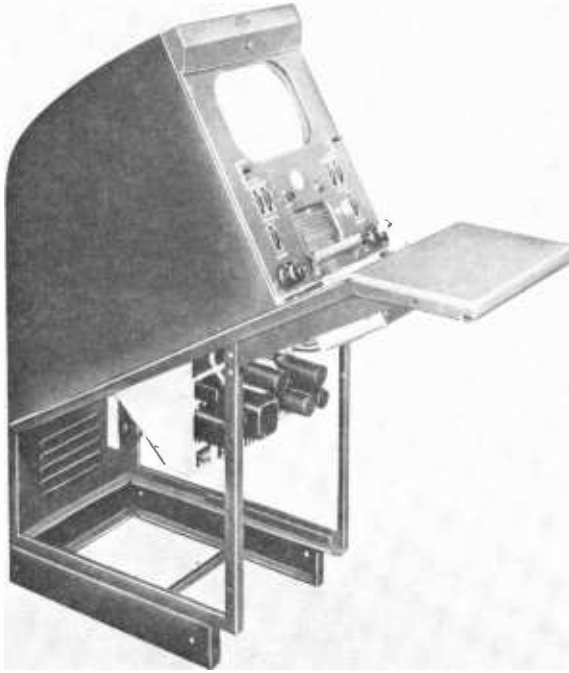

Fig. 4-8. The RCA TS-5A video switcher mounted in a standard console housing with a master monitor. In this arrangement, the fader pushbutton assembly is mounted in the well of the console. (RCA)

Video lines will terminate internally in the switcher, into 75-ohm impedances. Should it be desired to monitor the lines ahead of the switcher, the coax cable should loop through the front end of a high impedance device, such as a distribution amplifier, so that the end of the cable run is at the switcher, as in Fig. 4-9.

Monitoring

Monitoring of the video is important in many areas. At the console, the control engineer should have a monitor with CRO on the film chain, the studio camera chain, one on a monitoring panel with selector buttons. The CRO in these cases will permit checking of video levels and

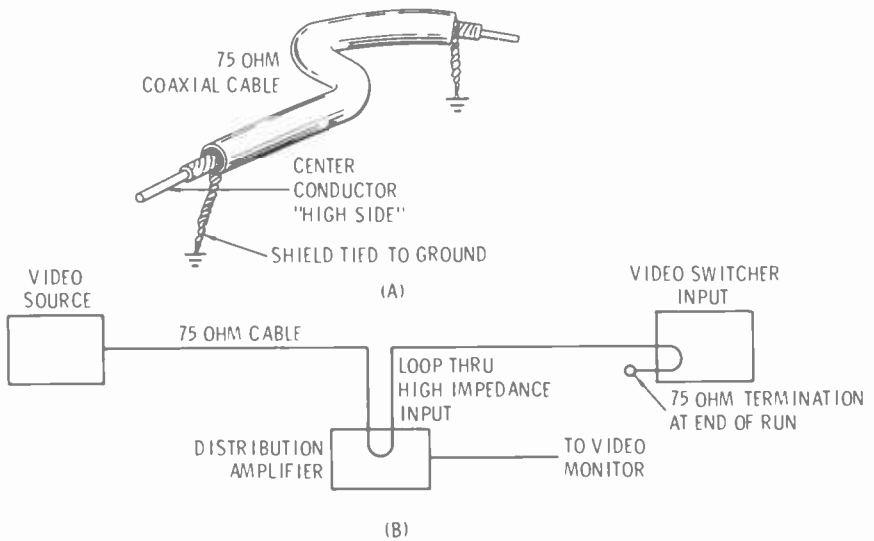

Fig. 4-9. (A) The video cable is an unbalanced system with the shield as its low side. (B) The video cable should loop through a high impedance device and terminate in 75 ohms at the end of the run only.

waveforms. Two of these monitors will come with the film and studio chains. If an outside program source, such as a network or off/air receiver is used, it is helpful to have a monitor on this position all the time. A typical monitor is shown in Fig. 4-10. In some cases, the monitor may be a straight video monitor and the waveform monitor may be separate, which permits one waveform monitor to serve more than one video monitor. There should be monitors at the Director's position for network, studio, film, and air. These need only be video monitors without the CRO, because the Director is interested only in the picture itself, not the waveforms. Additional monitors will be desired in other parts of the station, such as the salesroom or in the lobby. The lobby monitor should always show what is on the air.

Amplifiers

Stabilizing amplifiers are used to help clean up video and sync problems. Some also include high peakers to improve frequency response and sync mixing, white clipping to prevent over-modulation, and white stretching to overcome poor linearity in the transmitter power tubes. At least one of these amplifiers will be needed to add sync to local video programs and feed the transmitter where the video and sync level must be controlled. If an off/air pickup is used for programming, a stabilizing amplifier should follow this receiver to clean up any sync or video deterioration that may have occurred.



(A)

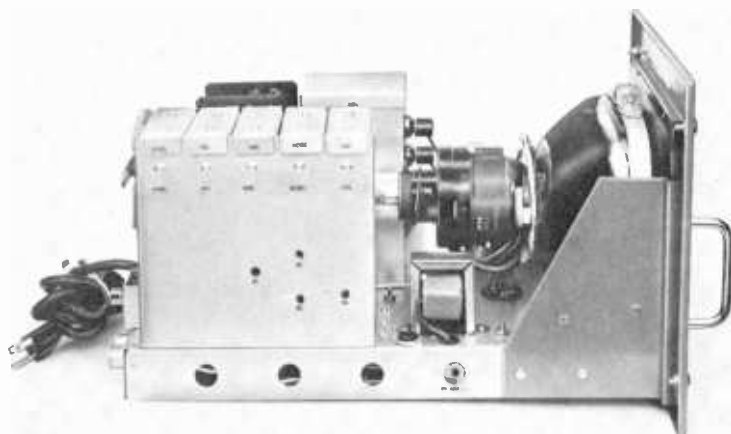

(B)

Fig. 4-10. (A) The 8-inch video monitor may be mounted in dual units in a 19-inch console or rack. It can be either transistorized or tube-type, with internal power supplies. (B) The internal construction of the 8-inch video monitor. (Miratel Electronics, Inc.)

Distribution amplifiers are of at least two types: those that have one input and one output with unity gain and those that have one input and three outputs with gain. These amplifiers have bridging inputs so they will not load the 75-ohm circuits and are used for isolation or to feed monitors or other such runs. Many of these distribution amplifiers are now made as transistorized units, so that a number of them take up only a small space.

Power Supplies

Most video equipment does not have internal power supplies. The power supplies are usually rack-mounted because of their bulk and the heat from the tubes. Cables are run from the power supplies to the individual units. Many items of equipment are becoming transistorized and often have their own power supplies internally in the cabinet. There are also solid-state power supplies that have a high current capacity. These take up much less rack space than a tube supply of comparable capacity.

Minimum Audio Requirements

The studio complement to the video equipment will also be rather simplified, as indicated in the block diagram of Fig. 4-11.

Audio Console

The RCA BC-5B is a small audio console that will provide sufficient facilities to handle the needs of a small studio. It is shown in Fig. 4-12 and its block diagram is given in Fig. 4-13. This unit, 11 inches high, is designed with a sloping front panel to match the video cabinets and is only the width of a 19-inch rack. Completely self-contained, the preamplifiers, line and monitor amplifiers, and power supplies are all within its cabinet. Although tubes are used throughout, it does incorporate special printed wiring boards.

Nothing special is required in the way of a table or counter to mount the console, but it will require mounting, since it does not have its own table or legs. A simple table arrangement may be built right into the control position; its essential features are a flat top and provisions for bringing the external wiring either to the rear or bottom of the console.

Six low-level inputs, such as microphones or turntables, may be switched into three preamplifiers. Only three of these six sources may be in use at one time. These circuits are normally supplied at 150-ohm balanced inputs. They are transformer inputs, so straps may be changed if other impedances are desired. There is an additional preamplifier input that

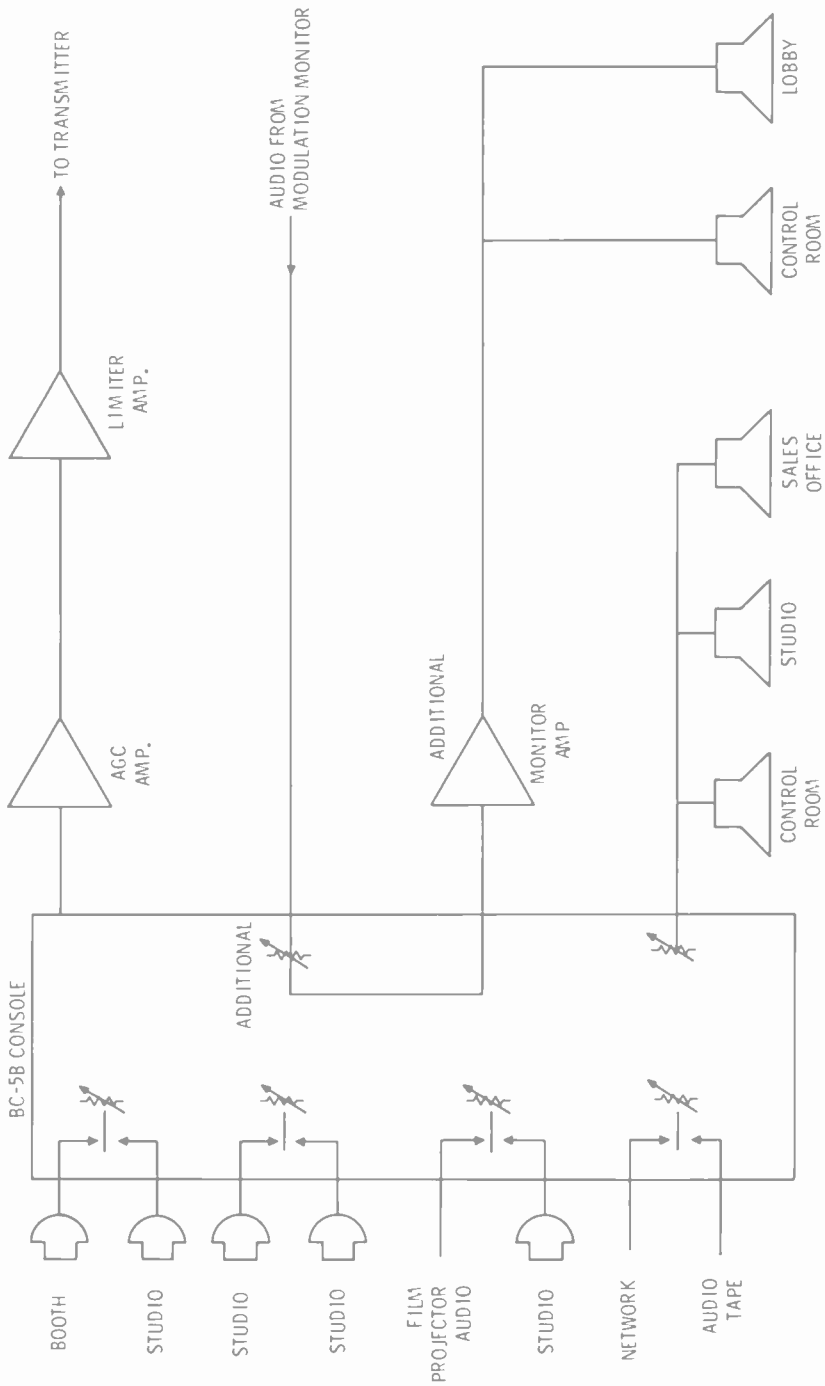

Fig. 4-11. A block diagram of the control room audio system.



Fig. 4-12. *The RCA BC-5B audio console. (RCA)*

is balanced 600-ohm and padded down for a high level input, such as a network line. This input may be switched between either a network line or two preselected remote lines, only one of which may be used at one time. Each of the four mixer inputs may be switched to either program circuit or to the audition circuit.

The monitoring circuit of this console should be expanded so that different areas in the station can monitor for different purposes. For example, auditioning may be desired only in a sales room or other office, the lobby should hear only what is on the air, the control room should always hear what is on the air, even though listening to an audition at the same time. Additional external monitoring amplifiers would be required for these purposes. It is possible that the control engineer may accidentally put the auditioning material on the air; without a separate air monitor this could go on unnoticed for some time. The viewer would not let it go unnoticed, however.

A console with internal amplifiers does have some disadvantages over a console that uses rack-mounted amplifiers. If trouble develops during a program with internal amplifiers, it is difficult to correct it. When separate amplifiers are used, one may easily use patch cords to get around

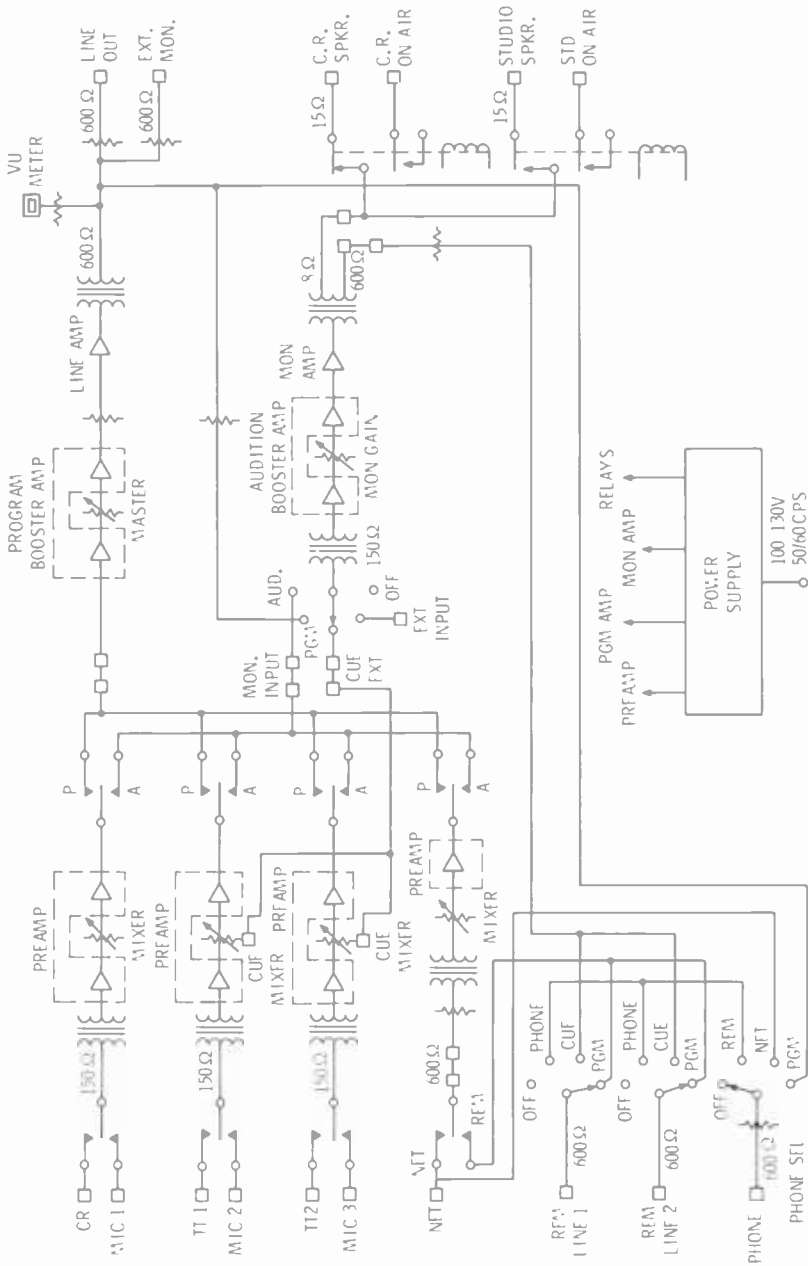

Fig. 4-13. The block diagram of the RCA BC-5B audio console. (RCA)

the defective unit, which can then be pulled out, repaired in the shop, and put back into service without too much interference to the program in progress.

(Since this consolette is operated with lever switches rather than relay switching, there aren't too many modifications that can be made to adapt it to semiautomatic operation, as can be done with the TC-4A switcher.)

The BC-5B is capable of delivering plus 18 dbm program level, which is more than adequate to modulate a transmitter. It is not good practice to drive the transmitter directly from the console. In order that the audio portion of a program may have more consistent levels, both an age amplifier and a peak limiter should be used between the console and the transmitter. The age amplifier will assist the operator in maintaining a consistent program level and the peak limiter will prevent overmodulation of the transmitter, thereby fulfilling FCC regulations and, at the same time, preventing any distortion that may occur in home receivers.

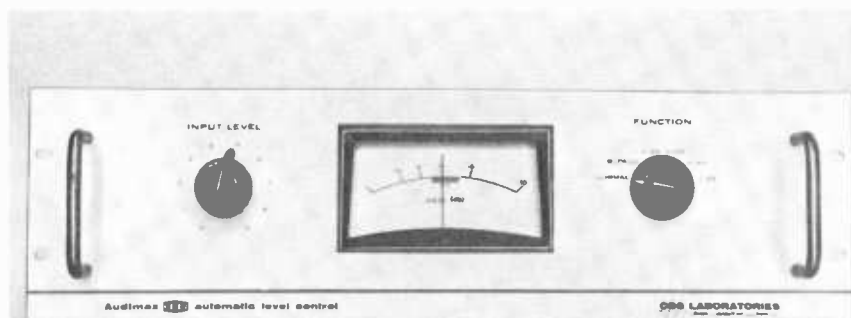

Fig. 4-14. *The Audimax RZ II, an age audio amplifier. (CBS Laboratories, Inc.)*

Audio Amplifiers

In television, straight age amplifiers are useless. Television programs are of a dramatic, demonstration, or discussion nature. There will be many pauses, during which a straight age amplifier will pull up the noise to a very undesirable level. AGC amplifiers that are designed especially for television (such as CBS Laboratories', model RZ II shown in Fig. 4-14, a specially gated type) will prove very helpful for the one man on the control board. This age amplifier uses the previous 10 seconds of program material as its basis for changing the average level. This will allow long pauses between words without the amplifier changing its gain. With no input signal over a period of 45 seconds (e.g., at the end of

a network program), the amplifier will gradually return the gain setting to approximately mid-gain, much as an operator would with his fader control, not knowing what the new program level will be.

Noise level in a television system is generally higher than a comparable radio system. The noise level of film is higher, especially optical sound, and noise levels in the studio are higher due to prop movements, groups of people whispering, and instructions passing over the interphone system. A straight age amplifier, during a pause, will pull this background noise up to program level, which is very objectionable, and will cause quite a "breathing" effect.

Tape Machines

There will be additional audio program sources, such as tape and turntables. Cartridge tape or conventional tape will satisfy all requirements, although conventional tape will not be as efficient or effective as cartridge tape. All commercial announcements that do not require sound on film or an announcer on camera can utilize tape for the audio. Tape machines have a high level, 600-ohm output, so they can be operated directly into either the Net or Remote positions of the consolette. (The reference here is to audio tape machines, not the audio channels on video tape machines.)

A place will be needed to record tapes in, since the control room will have too much noise. Either a recording booth or the studio may be used. A recording booth or position can be set up so that the announcer

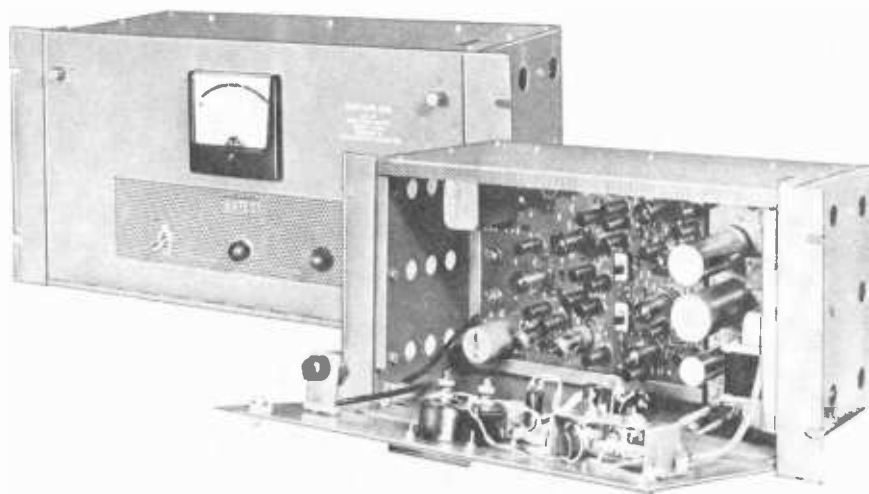

Fig. 4-15. The "Level Devil," an audio age amplifier: (rear) with its panel closed; (front) with its panel opened. (Gates Radio Company)

can record the tapes himself. This will require additional equipment: at least a tape recorder, either conventional or cartridge, and an amplifier. Such an amplifier as the Gates Radio Company, "Level Devil" (Fig. 4-15) a gated type, would be very satisfactory here. The advantage of a separate recording operation is that it allows the announcer and control engineer to work independently, suiting their own particular times and schedules. Sometimes, without a separate recording booth, scheduling can become a problem. This may run into overtime, which, over a year's time, could well pay for the necessary equipment needed.

Off/Air Pickup

If you are going to get a network feed or other program source, you may sometimes use an off/air pickup technique to advantage and at a great savings in money. If the primary station puts a poor signal into your area use the height of your tower to pick up a better signal. You can pick it up, amplify, reshape, and rebroadcast it. However, this cannot be done indiscriminately. You must have a network contract and approval, permission from the originating station, and the FCC must be notified.

For off/air pickup you will need a good rugged antenna, preferably a double-stacked Yagi of the community antenna system type, which will give long trouble-free service. It should be mounted as high as possible on the TV tower (400 feet up is not unreasonable). The down lead should be one of the low-loss, foam-filled, coaxial cables, with aluminum sheath, 75 ohms. The receiver should be one especially built for this purpose, such as the Conrac AV-12E (Fig. 4-16), which will be located in the control room. These receivers may be purchased with either a turret tuner for all vhf stations, or individual plug-in, crystal-controlled tuners for individual channels. Tuner strips are available to insert in the turret tuner to pick up individual uhf channels. Follow the receiver with a stabilizing amplifier so that any deterioration of the signal that may have occurred can be cleaned up. This system is shown in block diagram form in Fig. 4-17.

Some problems may be encountered when attempting to set up an off/air system. If a main street or highway is nearby there will be a high ignition noise level. A very high antenna and good signal strength are required to overcome this problem. Interference may come from a multiplier stage in the TV transmitter, or from an AM or FM transmitter, if they are located nearby. There may also occur, from time to time, co-channel interference. Most of these problems can be solved, but expect many frustrations before finding the final solutions. A second



Fig. 4-16. The Conrac AV-12E is a special receiver for off-the-air pickup. It may be used with a plug-in turret tuner for the 12 vhf channels or individual plug-in crystal controlled channels. It uses strips in the turret tuner for uhf channels. (Conrac Division, Giannini Controls Corp.)

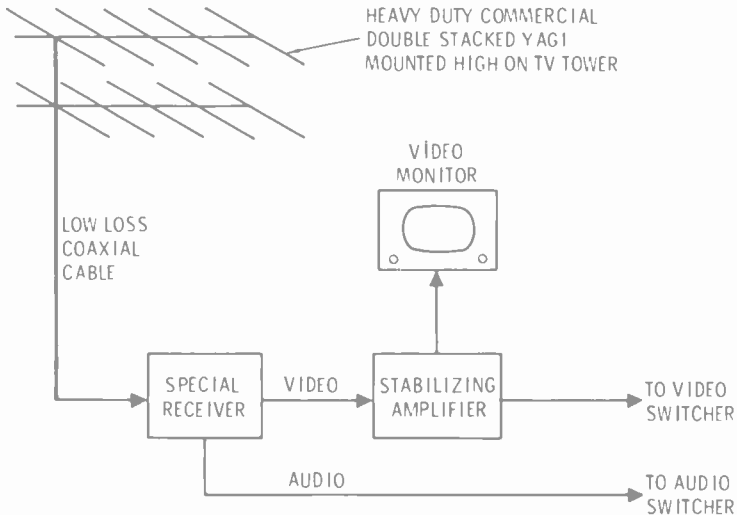

Fig. 4-17. A block diagram illustrating off-the-air pickup.

antenna at a lower level will often prove helpful in combatting co-channel interference. Usually, co-channel interference will be lower or nonexistent at the lower level, but you may have to compromise by accepting some ignition noise in its place.

Film and Slide Equipment

Film Projectors

Several good 16 mm film projectors are available in several price brackets. Most television work is done on 16 mm film, although a few large stations and networks use some 35 mm film equipment. Most projectors are very quiet in operation, while others have been dubbed "coffee grinders" by some operators.

Should a station want the very best in projection equipment and can afford it, the Eastman model 350 (Fig. 4-18), a continuous projector, can do many things impossible with other type projectors. Most projectors are of the intermittent type; they have some type of claw arrangement

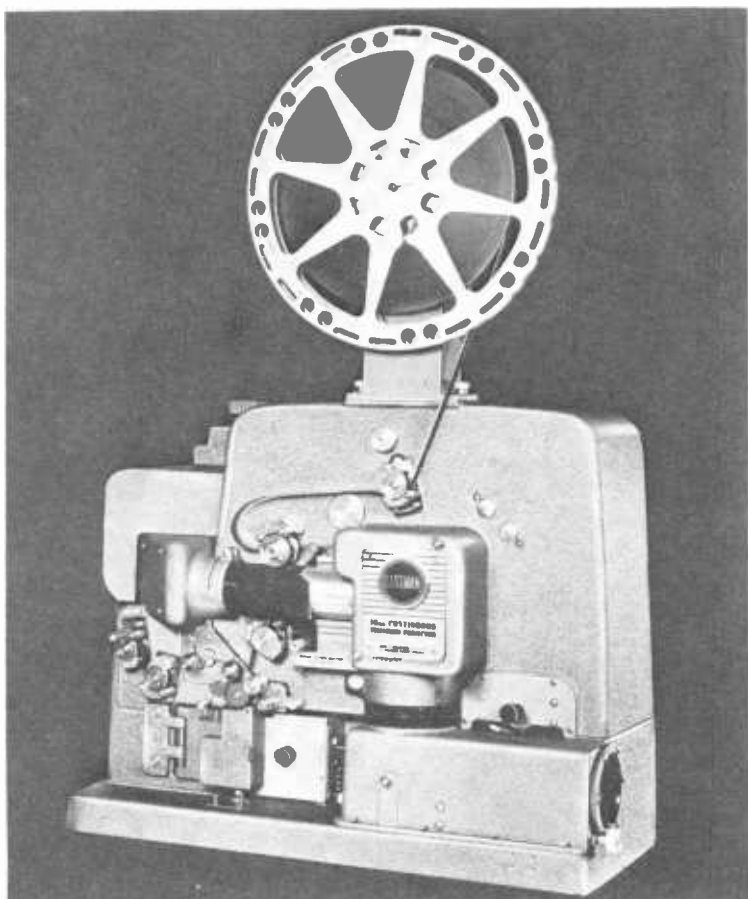

Fig. 4-18. *The Eastman 350, a 16 mm continuous film projector. (Eastman Kodak Co.)*

that reaches out and pulls the film past the gate during blanking time. The shutter or light is synchronized with vertical blanking, so that a burst of light is sent through the film only during the blanking interval. The continuous projector uses a continuous, 100 percent light application. Instead of an intermittent mechanism, a pair of rotating mirrors are used so that there is no appearance of film travel in the projected picture. There is no claw at all. Consequently, the film may be run in reverse for cueing purposes or in the case of an overshoot by the operator. Should this occur with an intermittent type projector, the film would have to be taken out of its path, backed up, and rethreaded.

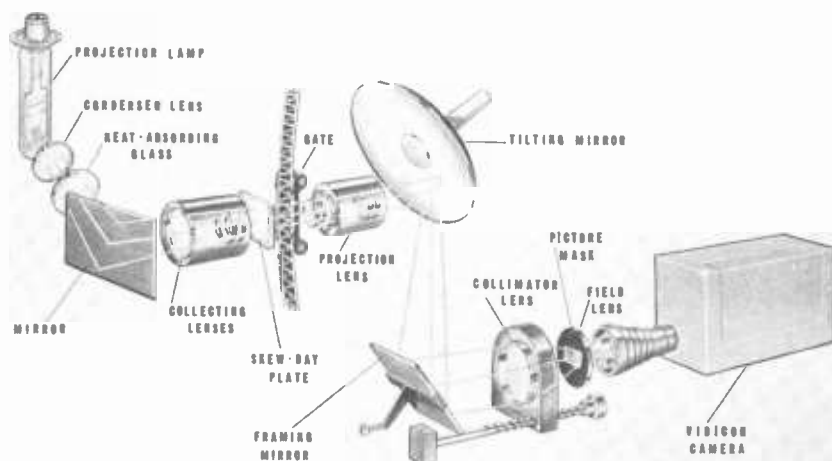

Fig. 4-19. *The optical system, with film defect suppression, of the Eastman 350 projector. (Eastman Kodak Co.)*

The 100 percent light application of the continuous projector permits the use of a device known as a *skew-ray plate*. This plate breaks the light beam up into many random light rays as it passes through the film, thus illuminating it from many different angles, as shown in Fig. 4-19. This effectively erases any scratches that may be on the film; the projected picture does not show them at all (see Fig. 4-20A and B). The Eastman 350 has many, many deluxe features. It will give superior results and many operating conveniences, but it will also cost about three times as much as the RCA TP-16 projector. Eastman builds the model 350 exclusively for General Electric, as part of the GE model PF-10C continuous-motion projector. The model PF-10C is made up of the 350 projector and a pedestal, which contains the operating controls and a blower. This unit costs about \$15,000.



Fig. 4-20. (A) This photo, taken from a monitor, shows that the film is badly scratched. (B) The same film, run on the Eastman 350, demonstrates how the defect suppression system completely eliminates the scratches from the on-the-air picture. (Eastman Kodak Co.)

Between the top and bottom models, there are three other models with various features and price tags. The first in line is the Eastman model 275 (Fig. 4-21). This projector uses the "Geneva Star" movement in its intermittent film-drive system. Isolation between the transport mechanism and the intermittent system makes a quiet, smooth-running projector. Next in price line is the RCA TP-6 which has many nice features to recommend it. The most recent entry is the RCA TP-66 (Fig. 4-22), which uses solid-state amplifiers and power supplies. While it is an intermittent type, it can also be run backwards, will project a single frame, and includes many deluxe features. Pricing on the TP-66 and TP-6 are essentially the same.

Many operators have their own feelings about projectors and manufacturers. There are at least five models in four price ranges to choose from and each one has many additional features that may be added at additional cost to provide greater ease in operation. All but the RCA TP-16 can be adapted for magnetic sound pickup from film. In choosing



Fig. 4-21. *The Eastman 275, a 16 mm film projector. (Eastman Kodak Company)*



Fig. 4-22. *The RCA TP-66, a 16 mm film projector that uses solid-state amplifiers and power supplies. (RCA)*

a model, one major factor should be considered. A small station, unless it can get a network affiliation, will program the bulk of its operating day on film. This may be film features, series, news, commercials, or film made by the station itself. Therefore, film will be the bread and butter operation center of the station and good dependable equipment should be selected.

Stay away from very cheap projectors or home types. Money spent for these will be spent foolishly, as the cheap ones will soon fall apart and not be dependable at all, while the home types will not work in a television system.

A division of RCA Service Company will sell maintenance contracts to television stations. Although intended primarily as a service feature for purchasers of RCA projection equipment, they will accept contracts covering other makes and models of projectors. Included in the contract price will be monthly service calls, emergency calls, and replacement parts.

Two film projectors will handle the bulk of film work for a small station in the control room. A small portable projector can be used to advantage in the film room for previewing film. This will speed up work and will not tie up the regular program projectors.

All television projectors are equipped to run by remote control, so they can be started, shown, switched on audio, dowsed, or stopped from the control console. The projectors should be located in the control room somewhere near the control engineer position, so that he can handle film loading and slide stacking. It is better for him to become accustomed to the noise than to locate the projectors so far away that it requires a second man to do the projection work.

Enough space should be provided around the projectors so that they may be serviced easily, rewinding operations are uncomplicated, and the films to be shown may be kept at hand.

Television projectors are normally equipped for optical sound reproduction. Magnetic sound tracks are gaining in popularity and acceptance. A magnetic sound track on the film will give a sound far superior to an optical track and will possess a considerably better noise figure. You can expect quality from a magnetic track as good as you would get with a quality audio tape recorder. It normally only requires a flip of a switch at the control position to change from optical to magnetic sound on a projector so equipped. Magnetic sound reproducers are listed as accessory items on projectors, so if this feature is desired, it will cost more.

Slide Projectors

Slides make up another important aspect of projection work. There are a variety of slide projectors available. Some are single units (Fig. 4-23A),

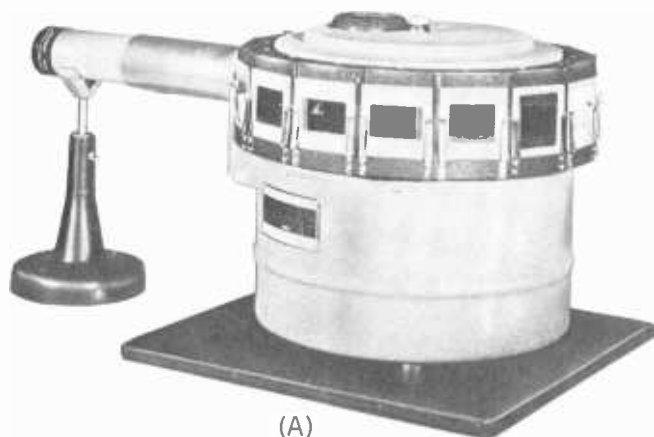

(A)

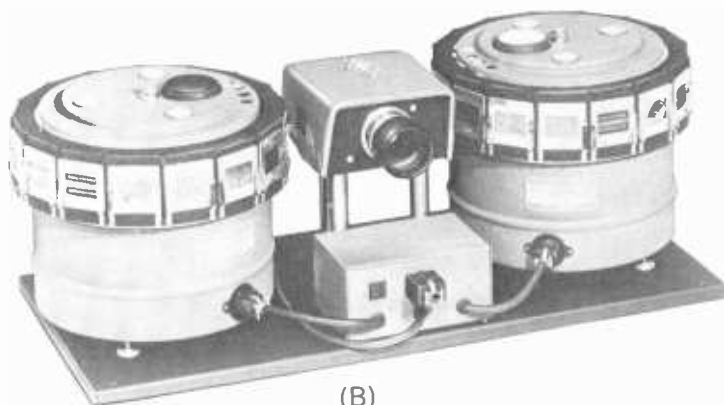

(B)

Fig. 4-23. (A) A single slide projector with 7-inch lens, (B) A dual slide projector with 7-1/2-inch lens. (Spindler & Sauppe, Inc.)

only holding a few slides, while others are dual units (Fig. 4-23B), holding many slides, and some have random selection available at the control position. All slide projectors can be operated by remote control. Slides used are standard 35 mm film positives, set in a slide holder. Many, many things will be made up on slides, from commercials to news.

Engineering the Control Room

First, you should make a plan of the proposed operation, equipment layout, ducts, conduit runs, etc. (See Chapters 9 and 10.) It is also a good idea to have a wiring diagram of what is planned. As wiring proceeds, any changes that are made should be written or drawn into the

diagram. Audio block terminal numbers and jack numbers should be drawn in and recorded on an audio terminal block sheet such as that shown with a wiring diagram in Fig. 4-24. Draw all changes as if they were to be drawn for a stranger who will get no explanations. In a couple of years, you will be this stranger and will appreciate the thoroughness.

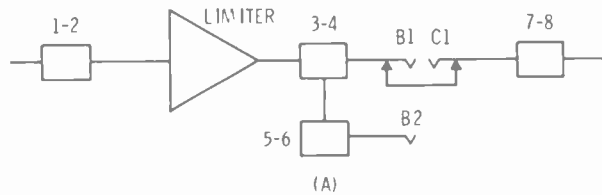

RACK #3 AUDIO BLOCK #2

<u>EXTERNAL</u>	<u>INTERNAL</u>
JACK A1	1 LIMITER
TIPS	2 INPUT
LIMITER	3 JACK B 1 TIPS
OUTPUT	4 (NORMALED TO C1)
STRAPPED TO	5 JACK B 2 TIPS
TERMS 3 & 4	6 (LIMITER OUT MULTIPLE)
TO TRANSMITTER	7 JACK C 1 TIPS
AUDIO INPUT	8 (NORMALED TO B1)
	9
	10

(B)

Fig. 4-24. (A) A typical audio wiring diagram. (B) The terminal block sheet showing recorded wiring data.

Video

Video systems are made up on a 75-ohm, unbalanced system, one side grounded. Consider all video circuits as high-level circuits and keep away from low-level microphone circuits. All video runs should be on flexible coaxial cable. The most common cables have been the RG/11U and RG/59BU, 75-ohm. With the advent of color, which has put more stringent demands on video systems, new coaxial cables have been developed especially for video. One such cable has a double shield and physically is about midway between the RG/11 and RG/59B. In size, the RG/11 is the largest, the video cable next, and the RG/59B is the smallest. Loss figures vary; that of the RG/59B is about twice that of the RG/11 and the special video cable losses are midway between these two. In price, the RG/11 will cost about 10¢ a foot, the special video about 16¢ a foot, and the RG/59B about 4.6¢ a foot, in 1000-foot lots. One should

consider the loss on the cable when very long runs are to be made. This will depend upon how much loss the system can stand at that point. Standard video levels are 1 volt peak-to-peak (composite) when using a color system, and 1.4 volts peak-to-peak when using a monochrome system. The lower levels for the color system are designed to prevent overloading, nonlinearity, and phase shift problems that affect color more than monochrome. With color growing in popularity, it is well to design the system in anticipation of future color operations, even though your initial operations may be only in monochrome. Even though the better cables for color cost more than standard cables, the future cost of replacing them will be avoided if the operation shifts over to color programming. The better cables will also improve the present monochrome system.

Audio

Audio cables should be of the two-wire shielded type, as in good radio practice. If you acquire a TC-4A switcher, which uses 150-ohm unbalanced circuits, use unbalanced for circuits which go directly to the TC-4A, but after getting away from the switcher, as in the limiter and transmitter, go back to the 600-ohm balanced system. The BC-5B console uses standard 600-ohm balanced circuits, so there will be no problems. A good, single audio cable to use will be one that has tinned, solid #22 wires, wraparound shield with separate ground wire, and a plastic outer covering. By using a shielded cable that is insulated, fewer ground problems will arise and there will be less opportunity for bare shields to short out terminals. The inner conductors should not have a plastic insulation because heat often breaks this down, which gives rise to other problems.

Multiple wire cables are also available. These will save much time, be more efficient, and make a neater installation wherever they may be used. Basically, they have a number of individually shielded pairs in one cable, each with their own ground wire. This is the same as making a number of single cable runs and then lacing them all together into a single large cable. You can use multiple cables in runs between the main audio rack and the console or for the microphone runs into the studio, where you may have from four to twelve outlets. Naturally, running a speaker line from the control room to the other end of the building with a 10-pair cable would be a waste of money. When making a cable run, whether audio or video, always pull in some spare circuits when the initial circuits are pulled in or placed in the ducts. All future needs cannot be anticipated and it doesn't take very long before new installations start to modify the original installation. This is the time when the spare circuits come in handy and save a lot of time.

Racks

Each rack should be equipped with a-c power on a plug-in strip, which provides outlets every six inches, as shown in Fig. 4-25. By this method, each individual unit in the rack may be plugged into the power strip. Since each unit will have its own disconnect, it will be a simple matter to remove a defective unit from the rack without shutting down the whole rack, which in many cases may not be possible due to the on the air program material going through the equipment in the rack. It is desirable that all a-c plugs be twistlock, which gives a more positive connection and secures the plug against accidental unplugging.

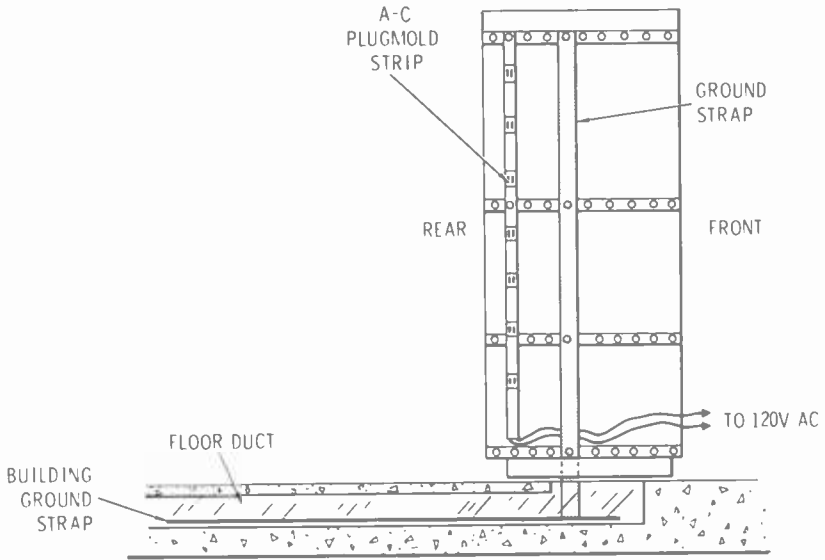

Fig. 4-25. Power is supplied in a rack by tying a plugmold strip into the a-c power. Equipment may then be plugged into a-c outlets on the strip for a quick disconnect. Note also how the copper ground strap is mounted inside the rack and soldered to the building ground bus.

A copper strap for grounding is another good feature to add to the rack (Fig. 4-25). This strap should run down one side of the rack, from top to bottom, and be soldered to the building ground strap in the trench (the wiring duct built into the floor). If you are using overhead wiring raceways or enclosed ducts, take this ground strap out of the top of the rack. The top and bottom of the strap are bolted to the rack. Clean off paint so that it makes good contact. Each unit in the rack is directly grounded to this strap, making it unnecessary to depend upon the panel bolts cutting through paint to make a solid ground. If you are

using open frame racks, there is less shielding available and there may be r-f pickup from a nearby radio station. To overcome this, it is advisable to bond each unit in the rack with a very heavy ground of up to 10-inch wide copper flashing material.

Jacks

Jack fields, both audio and video, should be planned in advance, to make the best cable placement, patch cords, and plugs. Video jacks can become a nightmare when using RG/11 cable. Good audio wiring practice dictates adequate separation between high and low level audio circuits and jacks to prevent cross-talk. Run the audio up the right side of the rack (as viewed from the rear), and the power, control, and d-cables on the left side. Audio wiring should be grouped into cables according to the signal levels they carry (e.g., all low-level circuits below -20 db in one group, -20 db to +8 db in another group, etc.).

Television Remotes—Some Examples

As was pointed out earlier in the chapter, it is very unlikely that a small station will do live remote work. However, there are circumstances when live remotes are entirely feasible and not too expensive. Depending upon the location and available space, here are some types of remote programs that small stations have done.

A station with a downtown studio was only one building away from an important hotel. The ballroom of this hotel catered to conventions and had many important speakers, political gatherings, and the like. The station made arrangements with the hotel and the building in between and ran a coaxial video cable and audio cables from the control room to the hotel ballroom. While the station did have remote equipment, except for microwave, it did many important remotes from this location without the cost of microwave rental.

Another station was located in the downtown section on an important street. Station personnel ran a long camera cable from the third floor control down the stairway to the street. Many man-on-the-street interviews and similar programs were done from this location.

WLBC-TV, Muncie, Indiana, which is located on its own spacious property at the edge of the city, scheduled many events on the lot outside the studio, especially when groups were too large or particular subjects could not be comfortably accommodated in the studio (e.g., a prize-winning bull). Weather is an important factor in "remotes" of this type, but a high degree of success can be achieved. Some such events included college and high-school marching bands, college gymnastic groups, prize-winning show animals that were brought to the station and

"interviewed," plus many local interest features. The camera was simply operated from the studio through the open outside door, using an appropriate lens.

Little League baseball is very popular in Muncie, as in many areas. WLBC-TV was one of the first TV stations to televise these games on a regular 5-day-a-week basis during the season and has been doing so each year since 1957.

Cost was at a minimum, for the ball field was set up on the station's property. The city park department agreed to set up the field and maintain it, while the station built the backstop and a camera platform (Fig. 4-26). The city also donated some portable bleachers. Approximately



Fig. 4-26. *The camera platform used by WLBC-TV to cover Little League baseball games. (WLBC-TV, Muncie, Indiana)*

500 feet of camera cable was purchased and attached to the AM transmission line supports. A telephone pole was set in the ground so that it protruded about three feet above the camera platform and a "top hat" was mounted on this pole for the camera stand, as shown in Fig. 4-27. The only equipment required to do a "remote" from this location was the camera, a viewfinder, a friction head, and a microphone for the play-by-play announcer. For audio, a single, long mike cable was run along with the camera cable. At first, the camera was transported in a car trunk, but later, a specially built cart was made to carry the camera safely to the ball field without damage. A scoreboard was donated, along with metal numbers, by a soft drink company. Many commercials are done live, both from the platform and on the ground.

Other events have been televised from this field, such as an annual field day event of the local Boys' Club.



Fig. 4-27. The camera mount on WLBC-TV's camera platform. Note the rubber shockmounting where the pole comes through the platform floor. (WLBC-TV, Muncie, Indiana)

There will be some special events that will command enough sponsorship for a station to do a live television remote. For these occasions it is sometimes possible to rent remote equipment, even a complete remote truck. Such rentals are usually worked out between the parties for each such occasion. Hence, it is often a good practice to become acquainted with other TV stations around the state, especially the larger ones. Sometimes, during a slack period, a large station may have idle remote equipment. In many cases, they would prefer to receive some income on their investment from rental. One word of caution: try to make arrange-

ments a long time before you would like to rent the equipment. Don't expect to have too much luck with a last-minute request.

These few examples point up what important contributions a small station may make in supplying interesting programs in their daily format, without too much program expense, simply by using some ingenuity.

Costs of Basic Control Room Equipment

There are many deluxe features you can incorporate into the control room to increase its ability to handle a greater production load. The following list, however, is designed around the basic minimum in equipment and cost. Pricing, in most cases, is from RCA's latest lists; it will vary somewhat from that of other manufacturer's equipment.

Video Equipment

TS-5A video switcher, console, and adapter	\$ 1,770
TA-9 stabilizing amplifier (with remote control)	\$ 1,630
TK-21B complete with vidicon film chain	\$ 9,015
(includes camera, vidicon tube, lens, control and deflection chassis, remote panel, console housing, master monitor, power supplies, and cable)	
Console housing, TS-2B switcher, TM-C master monitor	\$ 2,320
5 distribution amplifiers, 3 sync adders, bias supply, mounting frame	\$ 610
TG-2A sync generator	\$ 4,150
6 17-inch video monitors (Miratel Electronics)	\$ 1,494
2 WP-16B solid-state power supplies, 1 centering voltage plug-in unit, 1 24-volt power supply, 1 plate current meter	\$ 1,993
Intercom equipment (4 units)	\$ 425
Video patch board and plugs	\$ 400
Total	\$23,807

Audio Equipment

BC-5B audio consolette	\$ 1,332
BA-6A limiting amplifier	\$ 647
BA-24A additional monitoring amplifier and shelf	\$ 248
2 SL-12A speakers with cabinets	\$ 121
patch panel, mat, and patch cords	\$ 100
Total	\$ 2,448

Film and Slide Equipment

2 RCA TP-16 film projectors with lens, optical sound, and remote changeover panel	\$10,310
RCA TP-11C monochrome multiplexer	\$ 1,770
Spindler & Sauppe model 322A slide projector with lens	\$ 346
Slide cabinet, hand rewinds, film splicer (Neumade Corp)	\$ 139
Total	\$12,565

Equipment Racks

3 equipment racks	\$ 789
-------------------------	--------

Total

Video equipment	\$23,807
Audio equipment	\$ 2,448
Film and slide equipment	\$12,565
Equipment racks	\$ 789
Total	\$39,609

The basic minimum equipment represented in this total figure will permit the following functions: (1) Live studio, audio and video; (2) Film from two projectors with optical sound; (3) Slides from one slide projector; (4) Direct network audio-video feed; (5) Video monitoring at the control position, director's position, a monitor in the studio and one in the lobby; (6) Audio monitoring in the control room, studio, and lobby.

The following items may be added to increase basic flexibility and, of course, increase expenses.

If *cartridge tape* is used, at least two playback machines should be employed in the control room with a recording amplifier and playback machine in the recording booth. If a *conventional tape machine* is used, try to get one with relay starting. This will enable use of a pre-set position on the video console.

A *turntable* may be desired for background and fill music and special effects. Most of the program material can be put on cartridge or conventional tape; if so, the turntable would be in the recording booth.

Magnetic sound may be added to film projectors either at the factory or in the field. If you anticipate using magnetic sound, either immediately or in the future, the projectors noted below (item 3) should be purchased instead of the RCA TP-16.

Cost of additional features:

- | | |
|--|----------|
| 1. 3 cartridge tape machines, RCA RT-7B, plus amplifier | \$ 2,101 |
| 2. RCA BQ-51A turntable, complete with tone arm, cabinet, and stylus | \$ 174 |
| 3. 2 Eastman 275 film projectors, equipped for both optical and magnetic sound | \$15,390 |
| 4. CBS Laboratories' Audimax RZ II (age amplifier) | \$ 600 |
| 5. Gates Radio Co.'s Level Devil (age amplifier) | \$ 375 |

Chapter 5

The UHF Transmitter

The UHF Band

By the late 1940's, the 12 original vhf channels, assigned in 1945, were not sufficient to provide a nationwide service. In 1952, the FCC increased the number of channels by designating 70 uhf channels in the 470-890 megacycle range. The new range of 82 channels (2-83) permitted the FCC to allocate channels so that every community in the country could be served with a local outlet. The location, range, and frequency of each outlet was fixed to prevent the kind of haphazard development that has plagued the AM band. Each community, with the channel or channels assigned to it, is listed in the FCC Table of Assignments. This careful planning has eliminated the need for directional antennas and daytime stations: each uhf station can have full maximum coverage. When a directional antenna is used in this service, it has been designed to overcome coverage problems, rather than to avoid interference to other stations.

The channel designation for a community is governed by rules of mileage separation, which specify required distances between co-channel and adjacent-channel stations. Stations on the same channel (co-channel) can not be closer together than 155 miles in Zone I, 175 miles in Zone II, or 205 miles in Zone III. (Zones are designated in paragraph 73.609 of the FCC *Rules*.) Stations on channels on either side of a channel (adjacent channel) may not be closer together than 55 miles in all zones.

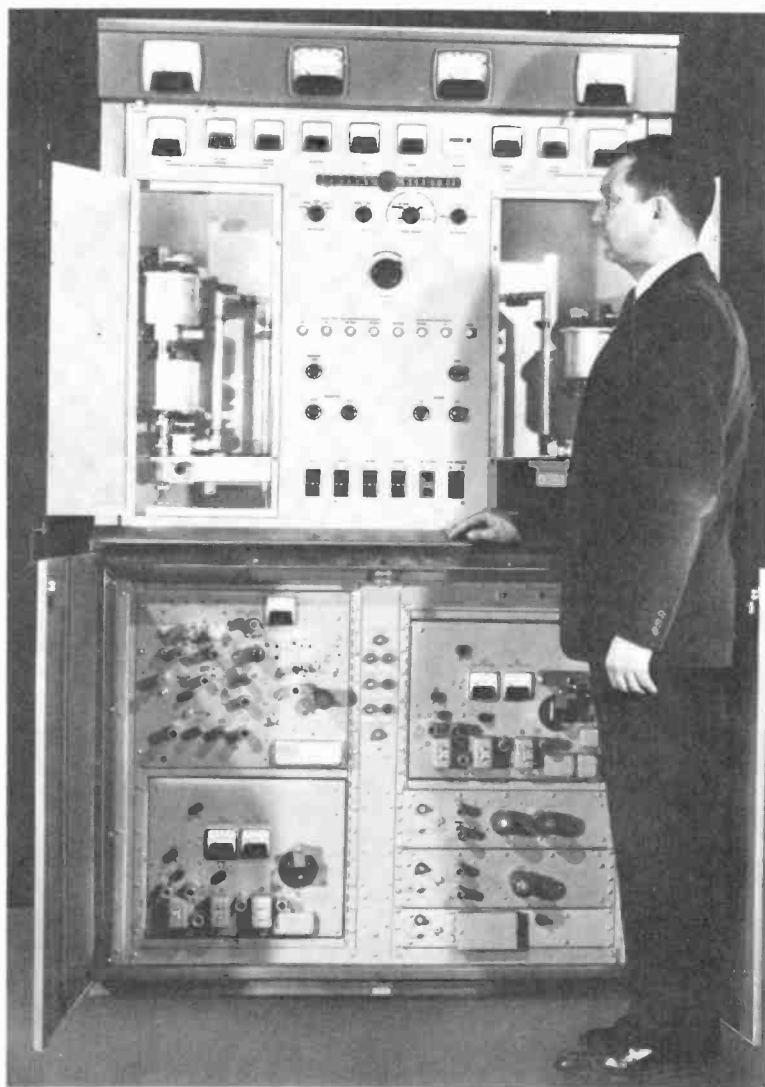

Fig. 5-1. The GE TT-55A, a 100-watt uhf-TV transmitter, may be used as a full transmitter or as a driver for high-power transmitters. The man in the photo is Ralph Thompson, GE project engineer. (GE)

Power and Separation

To overcome some of the propagation factors at uhf, the maximum radiated peak visual power may be 5000 kw with a tower height above average terrain of 2000 feet. The visual carrier frequency must be maintained within ± 1000 cps of the assigned frequency. The aural center

frequency must be maintained at $4.5 \text{ mc} \pm 1000 \text{ cps}$ above the visual carrier. The tolerance for the aural carrier is tighter than for FM radio, which may vary by $\pm 2000 \text{ cps}$ from the assigned frequency.

The separation between carriers is important and must be maintained. If not, the transmitters may go out of tolerance. When both carriers are drifting in the same direction, there will be no problem, unless they go past tolerance. When each carrier drifts away from the other or towards the other, the separation may become too little or too much. If separation is too narrow, it may be difficult to keep the sound out of the picture; if it is too wide, trouble may be experienced on some sets trying to tune both the sound and picture properly.

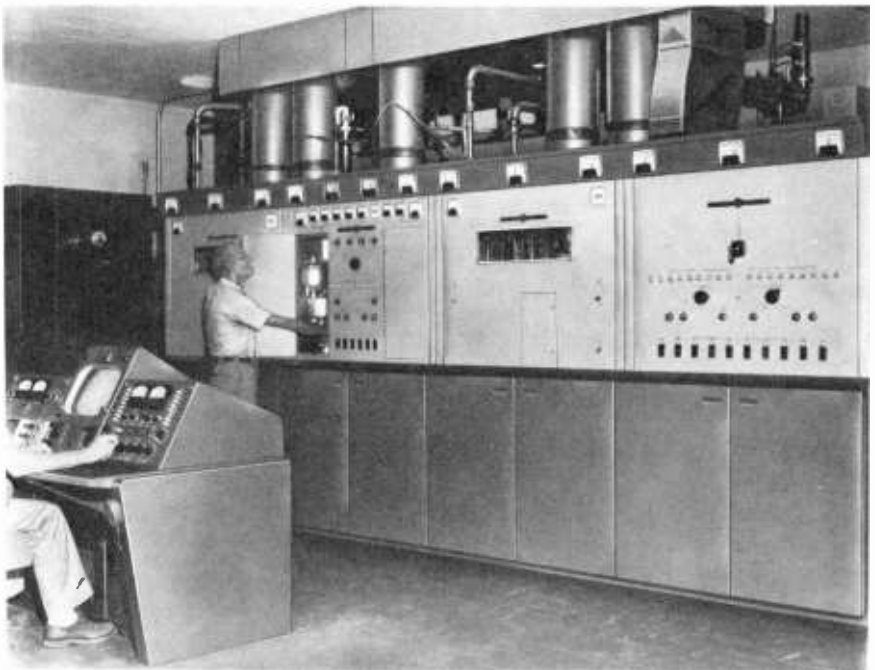

Fig. 5-2. Vern Shatto of KERO-TV is shown inspecting their GE TT-57A uhf transmitter, a 25 kilowatt model. This unit is driven by the TT-55A. (GE)

Modulation

Amplitude modulation of the visual carrier is used. Negative transmission is specified, which means that black and shades of grey near black in the picture information will cause the transmitted power output to increase, and sync, which is in the blacker than black range, will represent the maximum peak power. In AM radio, the audio is normally composed of equal positive and negative peaks, so that modulation is

a matter of preventing the negative peak from cutting the carrier. However, a television modulating signal is not made up of equal positive and negative peaks; it is a varying level of d-c voltages, with some components remaining constant. The audio modulating signal may be reversed in polarity on an AM transmitter without any consequences, but such is not the case with a television signal. Since black or blanking is the only constant value of the television signal, and sync, the second most constant value, sets on this (the least stable component is the video information), blanking was chosen to represent a definite amount of modulation with sync representing the peak of transmitted power. Therefore, the transmitter is constantly being modulated by the sync pulses to 100 percent, allowing the video information to fall where it will inside this figure, but not enough to cut the carrier. Actually, the FCC *Rules* specify definite tolerances around these figures.

Specifications for the aural transmitter are essentially the same as for FM radio, with some exceptions. In TV, 100 percent modulation corresponds to a carrier swing of ± 25 kc. The FM noise requirement is less (minus 55 db is permitted).

Special UHF Transmitter Features

Generating uhf carriers requires several new techniques, circuits, and tubes. Crystals are still the most stable circuits for oscillators, but their size limits the upper range of frequencies at which they will continue to oscillate. Today, you will find third overtone crystals in the uhf exciter operating in the neighborhood of 36 mc. A few years ago, such crystal operation was considered to be improbable, yet these crystals have proven themselves to be both reliable and stable in this service.

Multipliers

Even 36 mc, however, is far below the uhf carrier frequencies. Consequently, a number of multiplier stages are required. For example, the video carrier frequency for channel 83 is 885.25 mc; a crystal operating at 36.885417 mc will require a multiplication factor of 24 to raise it to this frequency. The number of multiplier stages required will depend upon the output that can be obtained when a harmonic is selected for amplification. Output usually diminishes for the higher order harmonics. Therefore, the second and third harmonics are selected because of the higher output obtained.

Spurious Emissions

When a multiplier is also developing power, all of the additional harmonics are quite strong. Good bypassing, trapping, and shielding are

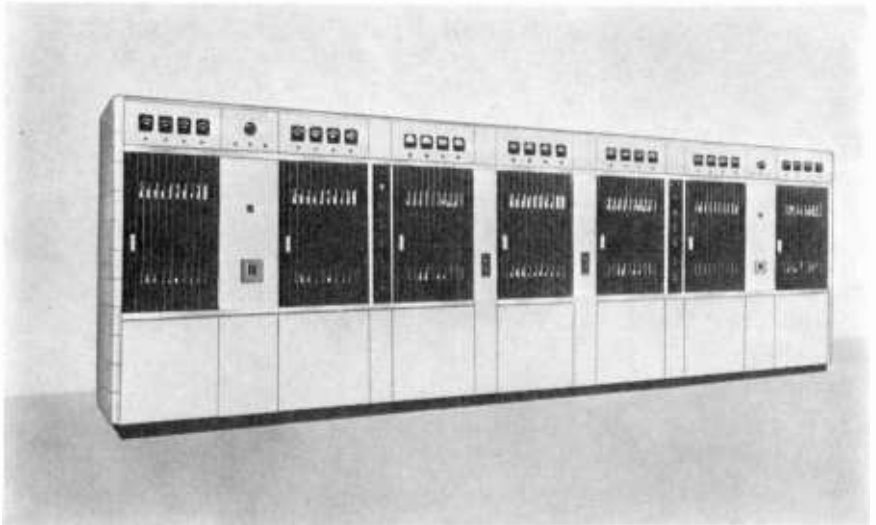

Fig. 5-3. The front view of the RCA TTU-25B, 25 kilowatt uhf transmitter. (RCA)

required to keep these harmonics from radiating as spurious signals. Even the selected harmonic can cause trouble in this regard. Let us assume, for example, that you are operating on channel 33 and that your visual crystal is approximately 32.5 mc. When this is doubled, it is 65 mc (near the audio portion of channel 3), and if it is tripled, it is 97.5 mc (right in the FM band).

Tubes

New power tubes had to be developed for uhf operation. Some tubes operated in this region, but nothing would perform well in TV service except the klystron tube. A predominant tube problem at high frequencies is the *transit time effect*. As higher frequencies are passed through the tube, a point is reached where the element leads and the space between the elements become a critical part or more of the wavelength of the input signal. From an operating standpoint, the transit time effect will cause input circuit losses and backheating of the cathode. The input losses require greater driving power and the backheating will raise the cathode temperature well above the normal design temperature. Unless appropriate measures are taken, the life of the tube will be appreciably shortened. Changing effects on the input will cause unstable operation and the output power will drift up and down because of stage detuning. Parasitics can develop if lead lengths become more resonant at some frequency that can be shocked into oscillation or is some multiple of the operating frequency.

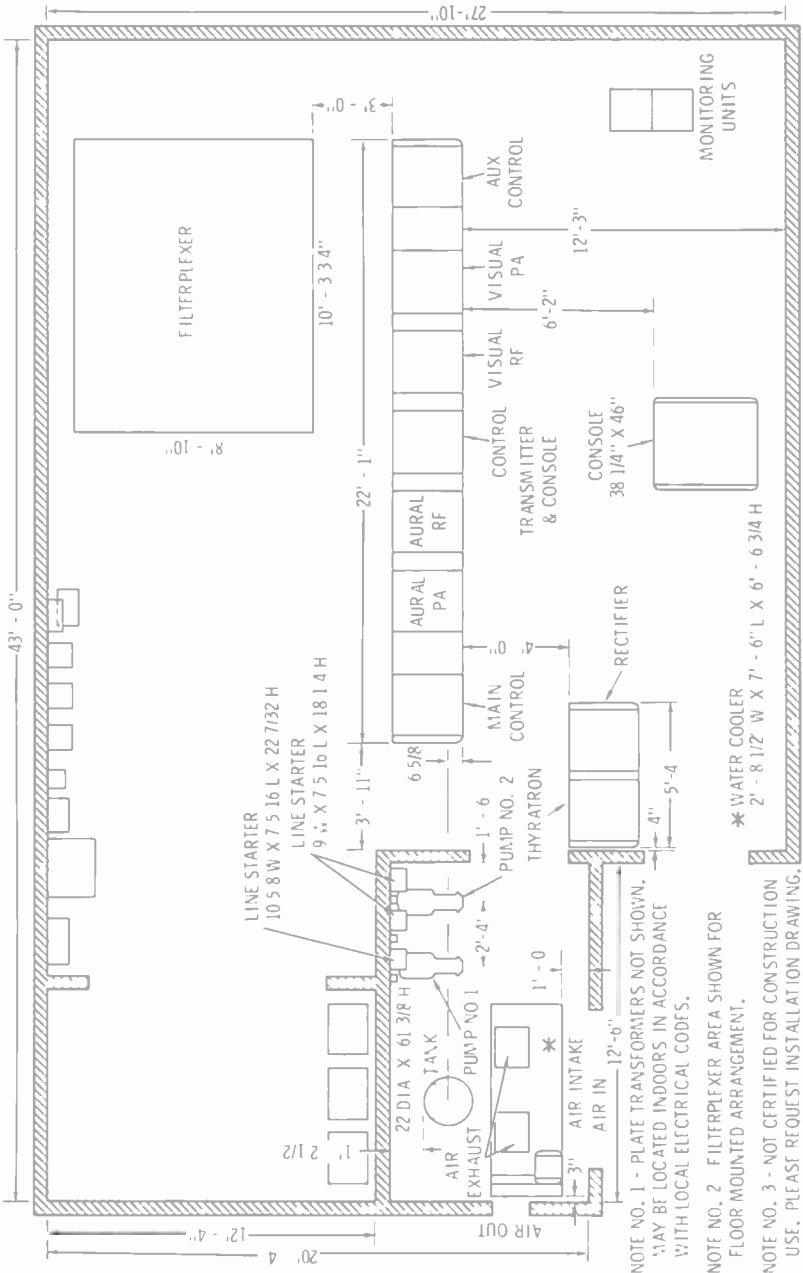

Fig. 5-4. The suggested floor plan for the RCA TTU-25B transmitter. (RC:4)

UHF tubes have either been designed to use the transit time effect, as is done in the klystron, or minimize it, as is done in the uhf tetrode (Fig. 5-5). General Electric now uses a 4-cavity klystron tube (Fig. 5-6) developed by Eimac (Eitel-McCullough, Inc.), as the power amplifier in high power transmitters. RCA had developed air-cooled tetrodes that operate at 1 kw, 2 kw, and 10 kw, and a water-cooled tetrode that operates at higher powers. RCA high-power transmitters of 30 kw and above are now using klystron tubes made by Varian Corp. This tube is vapor-cooled: the Eimac tube is either water-cooled or vapor phase cooled, depending upon type.

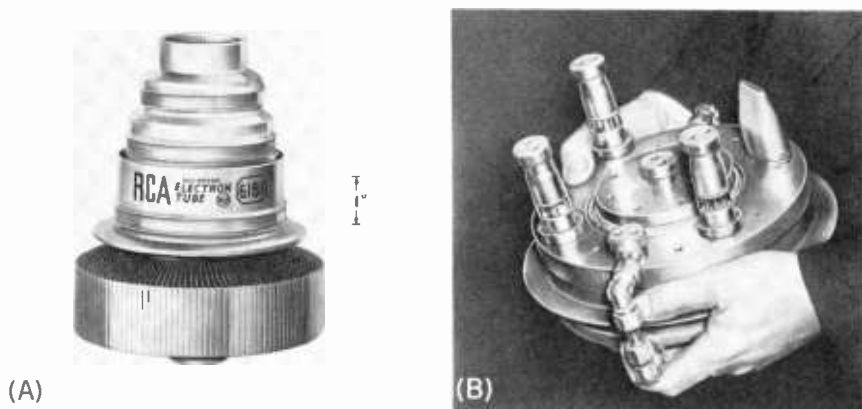

Fig. 5-5. (A) A ceramic, air-cooled, 1 kw uhf tetrode tube. (B) The RCA 6448 water-cooled tetrode tube for use at 12.5 kw. (RCA)

The Klystron Tube

Klystron tubes have been in use for a long time in such high frequency applications as radar and microwave. They were first used for uhf TV broadcasting in General Electric transmitters as power output tubes for high powers.

The klystron is not a tube in the ordinary sense, utilizing control grids and other such internal elements to control the electron stream from the cathode to the plate. Basically, it is a device with an electron gun or cathode at one end of a long cylinder that fires an electron beam at a target or anode on the opposite end (Figs. 5-7 and 5-8). The electrons are collected into a beam at the cathode by focusing plates and are then directed into the cylinder, where the beam is narrowed by an external magnetic field. Along the cylinder are ceramic "windows" that completely encircle the tube. External resonant cavities are mounted around these windows.



Fig. 5-6. The Eimac 4KM1001A klystron tube uses external cavities. (Eitel-McCullough, Inc.)



Fig. 5-7. The Varian klystron tube, used in high power RCA uhf transmitters, has four internal cavities. (RCA)

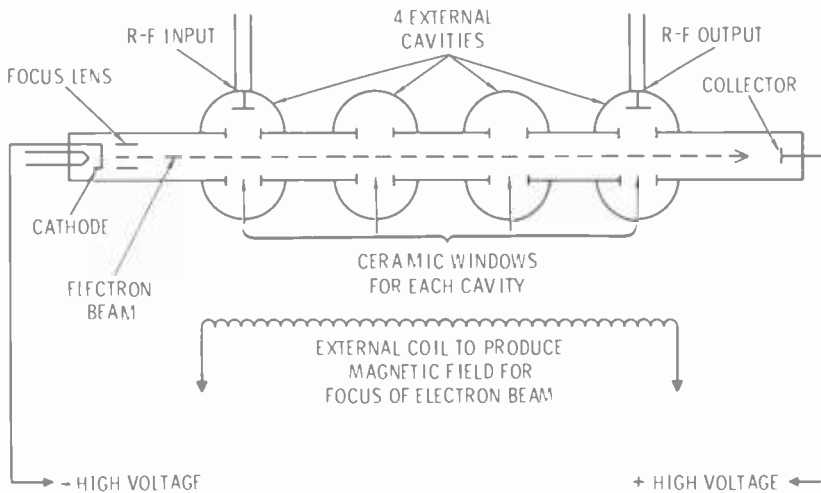

Fig. 5-8. A simplified drawing of the klystron power tube used in uhf-TV transmitters.

The Eimac tubes used in the GE transmitters employ four cavities in sequence along the tube. The Varian klystron tube uses four internal cavities for the 50-kw model and stagger-tuned (4) cavities for the 30-kw model. As the electron beam passes through the first cavity, it is

modulated by the input r-f signal, which enters at this cavity. The positive value of this r-f signal speeds the electrons up and the negative half cycle slows down the next part of the electron stream. This speedup and slowdown of different groups of electrons in accordance with the r-f input voltage increases and is intensified as they pass each of the cavities along the cylinder, so that the electrons are bunched into very dense sections when they pass the last cavity. Hence, the beam is called a *velocity modulated beam*. R-F energy is coupled to the output circuit from the last cavity and the beam terminates on the target, which is called the *collector*.

The klystron tube is ideal for high power applications because it is simple. Since there is nothing in the center of the cylinder, with only the cathode at one end and the collector at the other end, high voltage spacing is not a problem. Water cooling is also a simple process, as the tube has large openings and areas that do not require special filtering of the water or coolant.

This tube's efficiency is spectacular. For example, the GE transmitter only uses a little over 5 to 10 watts rf to drive the klystron to 12.5 kw output power from one klystron tube. Broadbanding is no problem and an 8-mc bandpass is easy to obtain.

These tubes, however, are large and quite heavy. The tubes used in the GE transmitters are approximately 5 feet long, depending upon the channel, and weigh around 100 pounds. The amplifier assemblies are also large and heavy, weighing about 1800 pounds. The assemblies have wheels that permit rolling the unit in and out of the transmitter cabinet. Tubes of such weight and size are not "changed," they are "assembled" into the stage. The klystron tube in the RCA transmitter weighs 250 pounds, and the complete amplifier assembly weighs 250 pounds. This tube is 53 inches long. Even though it weighs less than the Eimac tube, it is still a handful.

Tube Replacement

None of these handling problems are any real concern when it comes to replacing a tube that goes bad in service. A spare amplifier assembly, with the tube installed and pretuned, is kept nearby, and trained people can change the whole assembly in a little more than five minutes. This changing process involves the output line, input line, power connections, and water connections. This same procedure is used with the high-power terrode tubes used in RCA transmitters, where a complete pretuned cavity and tube are mounted on a carriage ready to roll into position in the transmitter should the one in service fail, as shown in Fig. 5-10.

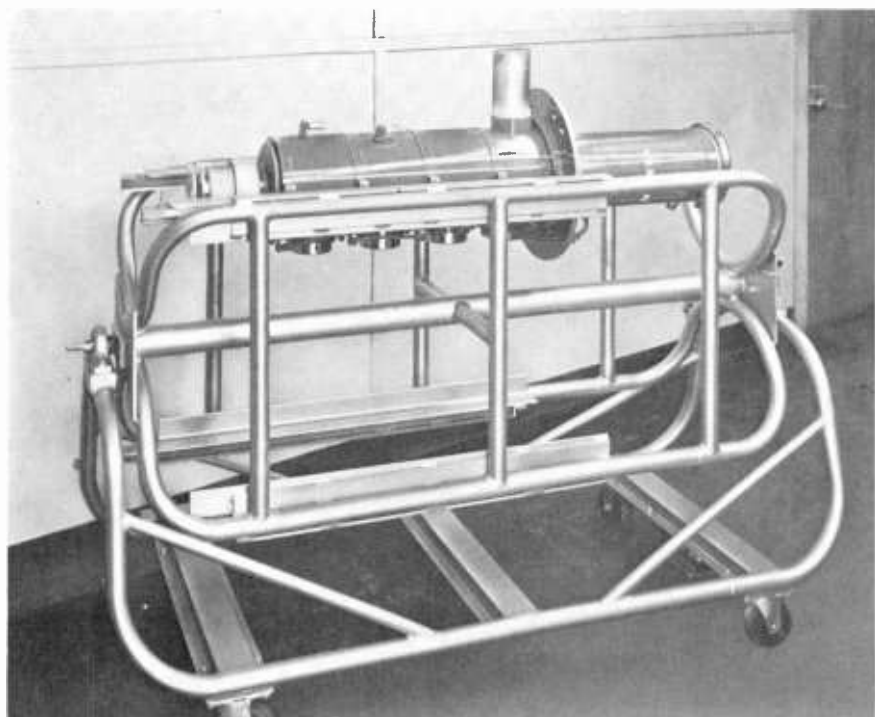

Fig. 5-9. This carriage holds a spare, pretuned klystron tube. (RCA)

Cavity Circuits

R-F stages at low frequencies require large lumped inductances and capacities for resonance. At uhf these values are quite small, so that the lead, tube, and stray capacities of a normal circuit are too much; different circuits are needed. Cavity circuits have been in use for years in microwave and radar, but uhf is a low frequency by their standards, so some adaptation was necessary.

A cavity is nothing more than a specially designed box, whose inside dimensions will resonate at uhf frequencies when coupled with the internal inductance and capacity of the tube. The cavity is tuned by altering its inside dimensions with sliding bars with spring contacts, which are adjusted by a control knob from the outside. This method permits use of the same cavity over the entire uhf band, with only slight modifications at either end of the band. The r-f energy, because of skin effect, is only on the inner surface; the outside of the cavity is at ground potential and is safe for the operator.

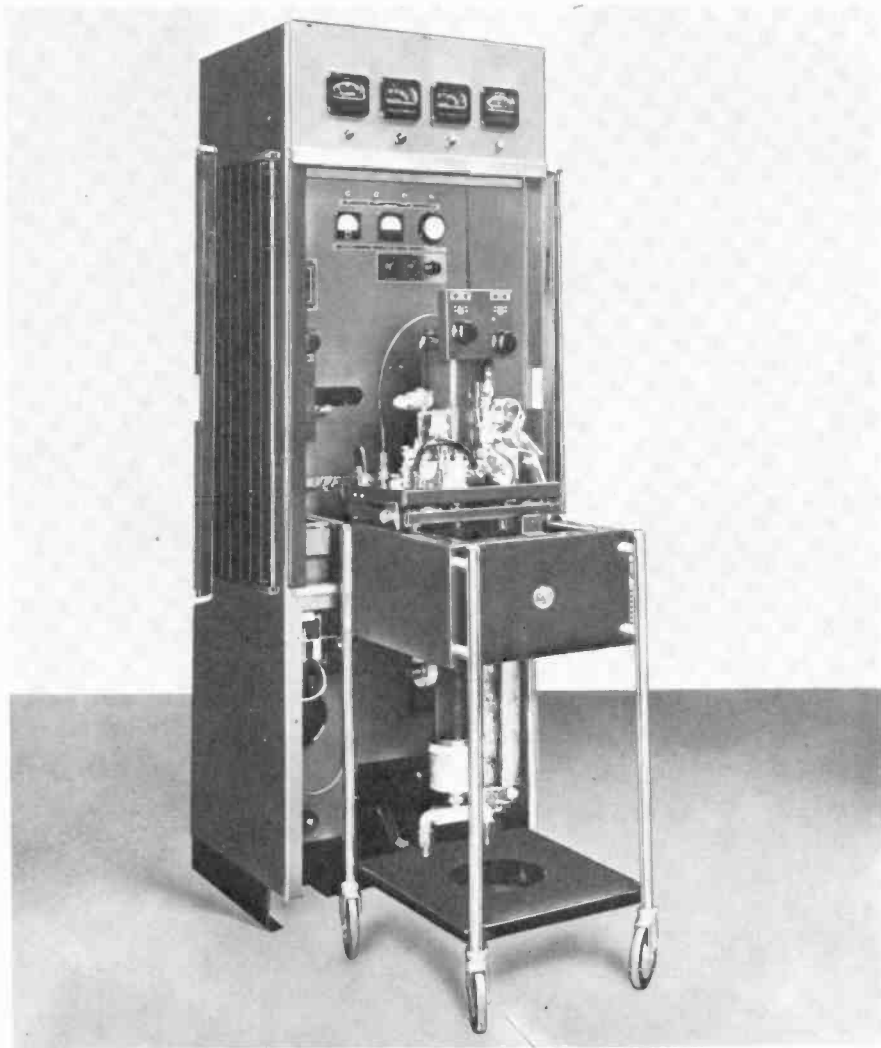

Fig. 5-10. The PA amplifier cabinet of the RCA TTU-25B transmitter, assembled and ready to be rolled into place. (RCA)

Coupling

Since cavities are complete in themselves and rather large, each stage must be coupled to another stage by coaxial cable. The coupling is clamped onto a small loop or disc that is inserted into the cavity (Fig. 5-11). The coupling is adjusted by changing the insertion depth of this coupler. Of course, cables introduce their own problems of losses, voltage standing wave ratio (VSWR), and heating. The coupling between stages should be adjusted for minimum VSWR, so that the best

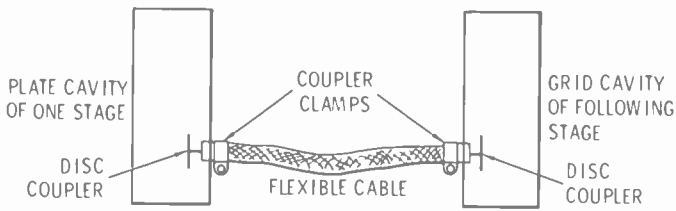

Fig. 5-11. Cavities are connected with disc couplers and flexible cable.

transfer of power will occur and cable heating problems are reduced. High VSWR at these frequencies can melt regular polyethylene cables like tally. Teflon cable should be used where frequencies are multiplied to uhf and power is present. This cable can withstand much higher VSWR than can regular RG 8 cable. A poor connection within the cable plug will burn rapidly at uhf levels.

Unwanted Coupling

Because of the many frequencies (both the desired and unwanted harmonics in the multiplier stages, plus both carriers at 4.5 mc apart), there are many opportunities for unwanted signals to get into places where they don't belong. Extensive interference may result because of poor bypassing and shielding or defective chokes. This interference will show up as beats in the picture signal and can become very troublesome, with a source that is hard to locate. The output stages can also couple back into the lower stages with regeneration problems.

Monitoring

Transmitter monitoring falls into four categories: visual modulation, visual frequency, aural modulation, and aural frequency. Monitoring the aural modulation and aural frequency is accomplished in the normal FM manner. In television, both the visual and aural are contained in a single monitor with one master oscillator serving both. The master oscillator output is fed through multiplier stages up to the two carriers through separate channels. Beyond this point, the aural channel is handled as in the regular FM monitors, while the visual channel has an additional crystal oscillator to provide a beat note that may be read on a meter as a frequency deviation.

The Hewlett-Packard model 335E station monitor (Figs. 5-12 and 5-13) is an ideal instrument designed for this purpose. Separate meters continuously indicate the visual frequency deviation, the aural center frequency deviation, and the aural percent of modulation. Separation between the carriers is simple and direct, without any calculations. All



Fig. 5-12. *The Hewlett-Packard 335E TV station monitor. (Hewlett-Packard)*

adjustments and controls are under a hinged panel that drops down from the front. This is a compact unit that takes up only $12\frac{1}{4}$ inches of rack space.

The visual modulation may be monitored with a diode detector mounted on the transmission line before the sideband suppressor (Fig. 5-14). A receiver is not very good at the transmitter site and cannot give reliable information, anyway. The line should be tapped with a directional coupler (Fig. 5-15), picking up only the incident or transmitted wave, not reflections. By coupling before sideband suppression you will see both sidebands; a diode will display a very distorted picture if it is coupled after the lower sideband suppression. This video information should be sent back on a video cable to the control position. There, it will be monitored with a suitable monitor that also incorporates a CRO display tube, with a graticule etched with percentage of modulation markings to set and read modulation levels.

A chopper is required at the monitor position, also, so that the video may be intermittently reduced to zero (equivalent to no carrier). This chopper is usually a pushbutton-operated relay. When the CRO is set to observe a horizontal sync display, a straight line will appear across the top of its face; this is the reference point. (The industry has accepted as a standard a CRO display on which sync is negative, so that sync is at the bottom of the display. This differs from the display shown in the *FCC Rules* where the sync pulses point upwards. There is really no con-

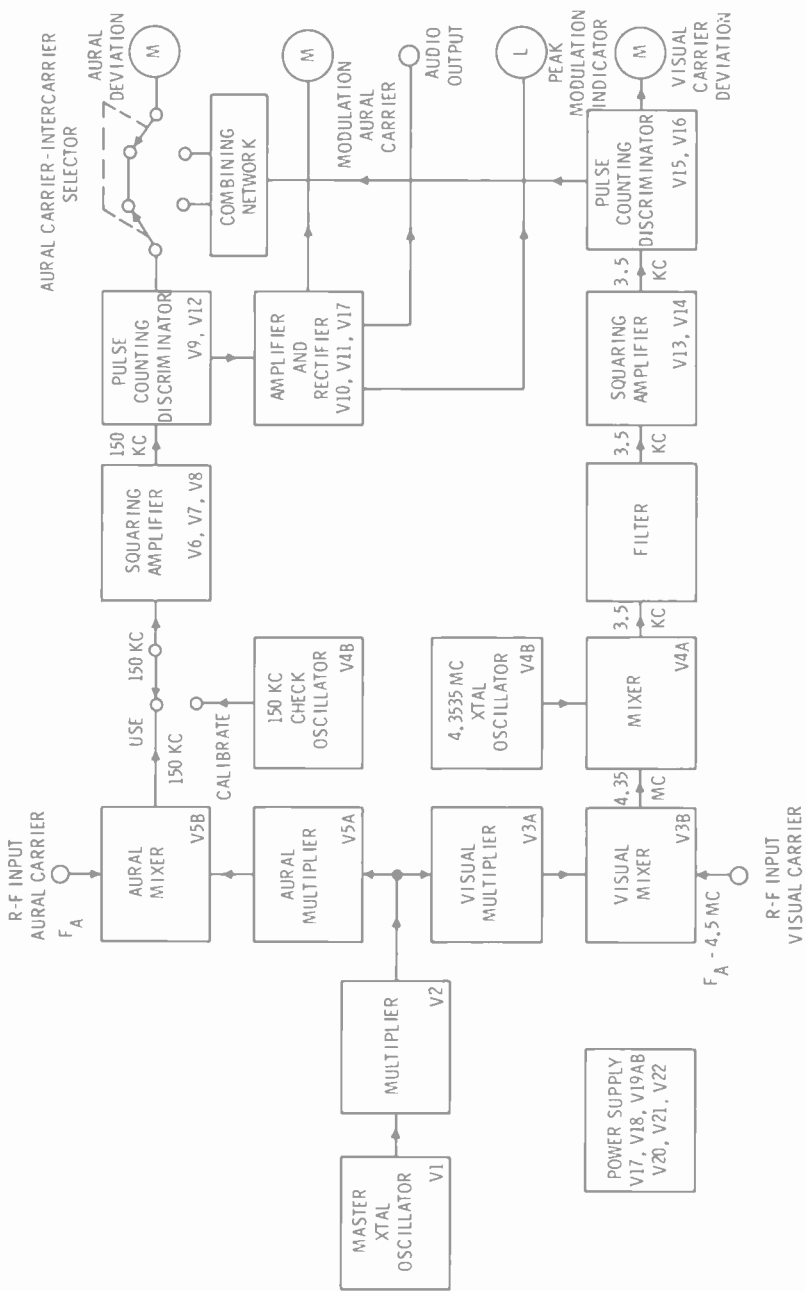

Fig. 5-13. The block diagram of the Heathkit-Packard 535F 'TV' station monitor. (Heathkit-Packard)

flict here, as polarity reversal will take place throughout the system as it progresses stage by stage. The FCC display is intended to show the modulation effect of a composite wave on the transmitter output.)

The Visual Transmitter

Oscillators

The oscillator in the RCA TTU-1B transmitter is a conventional crystal-controlled stage, with a high frequency crystal. This crystal is a third overtone type, operating at approximately 26.18 mc to 36.88 mc, depending upon the channel. For the sake of stability, no multiplication is done. Instead, the stage is followed by a buffer amplifier on a single frequency.

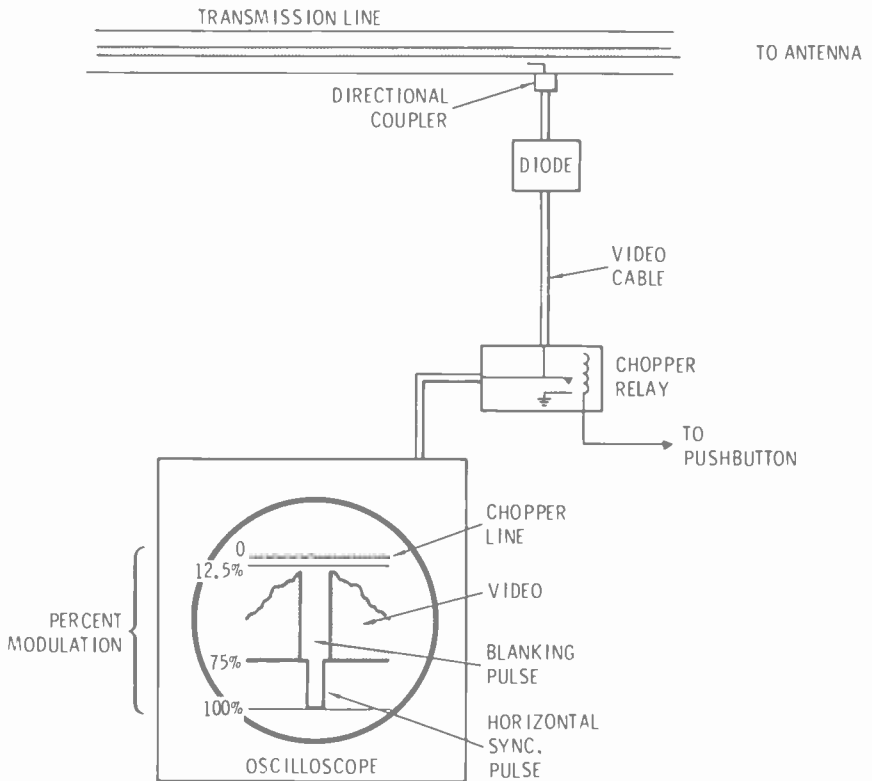

Fig. 5-14. Video monitoring the visual transmitter.

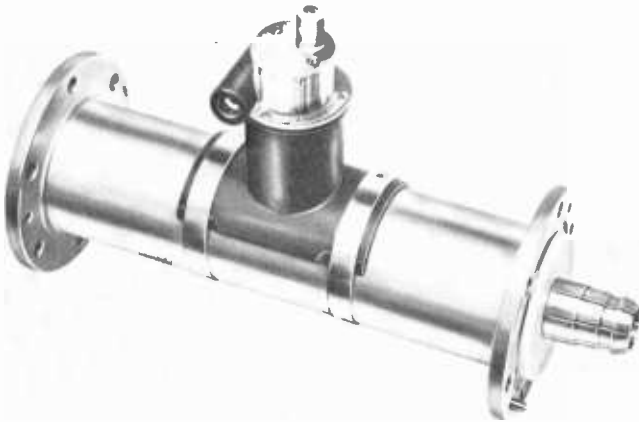

Fig. 5-15. A directional coupler mounted in a short section of 3-1/8-inch transmission line. (RCA)

Multipliers are less efficient as the higher order harmonics are selected for amplification. Generally, second or third order harmonics are strong, so the stages are operated as doublers or triplers. The third overtone type crystal takes a multiplication of 24 times to raise it to carrier level. By using triplers and doublers, only four stages of multiplication are required to accomplish this. As frequency increases with multiplication, these stages are conventional in design and arrangement until the last two are reached; the next to the last multiplier stage uses parallel lines and shorting bars and the final doubler is a cavity.

Tubes and Cavities

The RCA TTU-1B transmitter (Figs. 5-16, 5-17, and 5-18), rated at 1 kw, uses three cavities each on the visual and aural sides. All the stages prior to these three cavities are considered to be the visual exciter, whose power output at this point is about 50 watts. All the prior stages are of conventional design with conventional coupling, except for the differences noted previously. Beyond the cavities, coupling is through coaxial cable.

Cavities use special triodes and a ceramic tetrode (6181) as the power amplifier (PA) output tube. All these tubes are forced air cooled, each having finned radiators on the plate. The cavities have been so designed that the tubes are inserted easily and only the finned plate protrudes. A hinged, clear plastic cover, interlocked to the high voltage, with holes to allow the air to escape, covers the plate of the tube. This

prevents the operator from touching high voltage and allows air to escape into the cabinet. Contact to the tube elements is made by circular spring contacts, so that no guide pins are necessary to insert a tube correctly. The tube cannot be put in incorrectly, because you need only lift the cover and push the tube into the cavity, making certain it is seated properly.

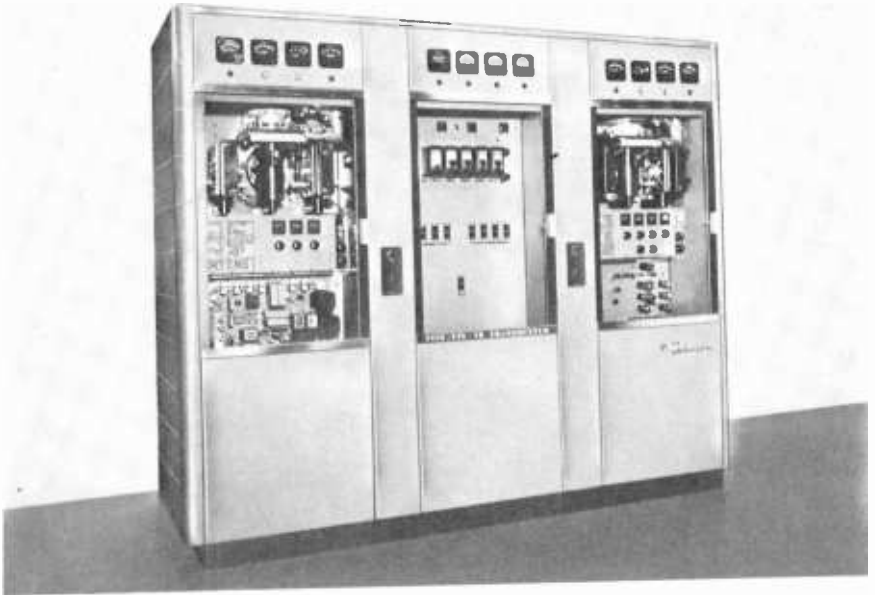

Fig. 5-16. A view of the RCA TTU-1B uhf transmitter with its front doors open. The aural section is on the left; the visual section on the right. (RCA)

Grid and plate circuit cavities are incorporated in one box, with the center divider being common to both. Since the r-f is only on the inside edge of the box, the box is grounded, which provides excellent isolation between input and output. Bypass capacitors are of the circular mica disc type, coated on both sides with a silver material. They are inserted in place, sandwich fashion, so that no connecting leads are used.

High voltage isolation is accomplished by the use of mica insulators, which are plain mica discs without the silver coating.

One cavity is used as a doubler, the second as an intermediate power amplifier (IPA) stage, and the third as the output stage. As the 6161 tube is a triode, neutralization is necessary in the IPA stage. A small

disc protrudes from the plate cavity into the grid cavity. The end of it appears outside the cavity for adjustment purposes and locking in place. Adjustment is simple. The operator merely adjusts the depth the disc is inserted into the opposite side of the cavity until neutralization is accomplished. Power output from the doubler will be approximately 80 to 120 watts; out of the 1PA it will be about 140 to 200 watts, depending upon channel and plate voltage.

The Output Stage

The output cavity of the final stage is somewhat different in design, having a rectangular cavity for the plate circuit and a cylindrical cavity for the cathode circuit. This stage is operated as a grounded grid stage. The plate cavity is adjustable from the front with a single tuning knob and the cathode has a capacitor plate adjustment on the front knob. Internally, four ganged shorting bars are moved by the one tuning knob to change the inside dimensions of the plate circuit. The tube makes contact by springs, as is done with the other cavities, and is simple to insert by lifting the hinged, clear plastic, interlocked top cover. There is one difference, however; four hold-down clamps are provided to ensure proper seating of the tube. Forced air enters the cavity from two points, cooling both the tube seals and the cavity.

The output from the final cavity is directly coupled to a 3 1/8-inch line. Output coupling is adjusted by rotating a small loop that protrudes inside the plate cavity.

This transmitter is used as a driver for all of RCA's older model higher power transmitters. When going to higher powers, PA amplifiers and cavities, with their associated power supplies and control circuits, are added to this transmitter. Only one tube is used for the 12.5-kw output and a different tube type is used for the 25-kw output. These high power amplifiers have cavities designed to accommodate both the tube with its higher voltages and the tube water cooling system. Power is coupled from the driver to the PA amplifier through a larger diameter Teflon cable. The PA is operated as a linear amplifier.

The Modulator

The TTU-1B uses a special modulator of the 6181 PA cathode circuit. As there are no linear stages in this transmitter, tuning of all the lower stages is a simple matter of peaking each stage, using its individual metering as indicators with no worry about sideband clipping. Only the plate circuit tuning of the PA will have any effect on the sidebands, but this is not critical, because the bandpass is set with the output coupling at the point where the stage is peaked.

The 6181 tube draws about 1 amp average plate current and 1.7 amps peak. For those not familiar with high frequency tubes, this plate current value may seem to be especially high, since even medium power AM transmitters use plate currents in terms of milliamperes. There has been a trend, even in FM radio, in the direction of higher plate currents and lower plate voltages. Needless to say, these higher currents demand a huskier power supply and transformer. The transformers for the 12.5-kw and the 25-kw transmitters are very large, necessitating a separate transformer room or vault.

Eight 6146 tubes are used in parallel as a modulator in series with the cathode of the 6181 PA output tube. This large number of modulator tubes is needed to pass the heavy plate current of the 6181. Screen voltage is highly regulated on both the screen grids of the modulator tubes and the screen grid of the PA tube from different power supplies for stability. The modulators get their plate voltage from the PA cathode voltage developed across this cathode load. Metering of each modulator tube is provided, so that it is easier to spot a weak tube and change it before it can upset the modulator characteristics.

Across the modulator is a dynamic negative capacitor. This is a circuit made up of five 6146 tubes. The circuit is designed to cancel out the effect of shunt capacity across the modulator load that is caused by varying plate currents of the output stage. With this circuit, phase changes caused by black to white excursions of the video information are prevented. Color transmission requires a constant phase throughout the system.

Clamping is done on the back porch of horizontal blanking at the modulator grids. Since the modulators are direct coupled to the PA stage, this effectively clamps the output stage. The clamp circuits are conventional except for the pulses, which must be in the region of 75 volts for both positive and negative pulses. For maintenance purposes, the clamp may be switched out of the circuit and d-c bias supplied to the modulator tubes.

Blanking or black level is the only component of the signal that is not adjustable, except at the transmitter. Both video and sync can be changed at will by the operator at the control console. There can be compression of both video and sync, depending upon the linearity of the tube. Hence, clamping on blanking assures a constant reference for power output.

RCA's new 2-kw and 10-kw models are completely new designs, as are the higher power units. Besides the air-cooled tetrode output tubes, other new features include low level modulation, silicon rectifiers throughout, the first traveling-wave tube used in a broadcast transmitter, and new cabinets that are smaller in size and designed for re-

mote control. One unique feature of the traveling-wave tube is a 26 db gain without tuning controls. The TTU-30A and TTU-50B, using klystron tubes, are a complete break from RCA's traditional use of tetrodes in uhf transmitters.

General Electric has taken some new and interesting approaches in their newest models. The visual oscillator circuit in the model TT-55A, their 100-watt transmitter, is a transistorized, crystal-controlled stage. The whole circuit, including crystal, oven, and buffer, is a sealed, plug-in package for high stability. The buffer stage is a tube circuit, as are all of the following stages. A multiplication factor of 96 is used to bring the crystal frequency up to carrier frequency. All multipliers are doublers, with the exception of one tripler stage. As the frequency gets into the higher ranges, cavity circuits are used. The output stage is a 8226 tube, cathode-modulated. The modulator is a 7094 tube. Clamping is done on the back porch of horizontal blanking and circuitry is provided in the modulator to overcome any nonlinearity that may be caused by the output tube.

Mounted in a single cabinet, the TT-55A is a complete 100-watt transmitter, containing both visual and aural transmitters and the necessary power supplies. This unit may be used as a low power transmitter if it will satisfy the needs of the station. Otherwise, it is used as the driver for the higher power 12.5-kw and 25-kw amplifiers. The high power amplifiers use the Eimac 4KM70LA and 4KM100LA klystron tubes, one in the visual and one in the aural. A single, high voltage solid-state power supply is used for both aural and visual amplifiers.

The Aural Transmitter

The Modulator-Exciter

The aural exciter may use any method of modulation, as long as the output is FM. The serrasoid modulator is used in some transmitters. It is a good modulator, that offers the advantage of direct crystal control of the center frequency. However, it does utilize a large number of multiplier stages to bring the crystal level up to carrier level. Since the swing of the carrier is also multiplied as it passes through a multiplier, the initial modulation is very small. Consequently, this modulator is more susceptible to noise problems. Some FM radio transmitters are now using this type of modulator-exciter. A greater carrier swing is required in FM service and fewer multipliers are necessary because the carrier frequency is lower.

The RCA TTU-1B uses a modified version of the straight serrasoid modulator-exciter. Besides the normal low frequency crystal oscillator,

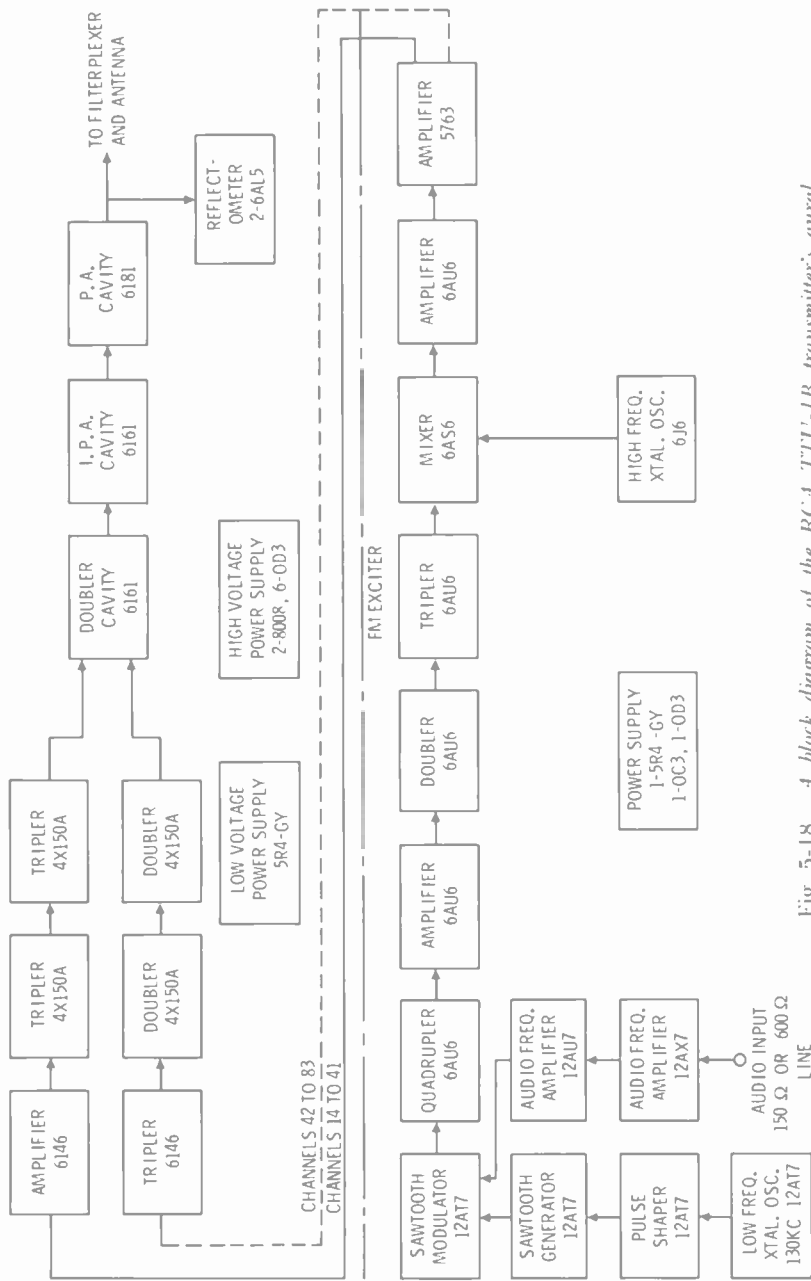

Fig. 5-18. A block diagram of the RCA TTU-1B transmitter's audio section. (RCA)

which operates at 130 kc, a high frequency crystal oscillator is used later to mix with the multiplied low frequency output, which is modulated. The resulting beat provides the output frequency of the exciter, which is approximately 28 mc or similar to the visual exciter output with a 4.5-mc difference. This high frequency translation helps keep the noise figure low without additional multiplication of the modulation swing. Having the output frequency the same for both visual and aural exciters permits the upper stages to be identical on both sides. The upper cavities are interchangeable between visual and aural transmitters.

The first time someone has to troubleshoot in the serrasoid modulator-exciter with an oscilloscope, he may be quite surprised at the waveforms that are discovered. He will find that a sine wave out of the crystal oscillator is converted to pulses that trigger a clipped sawtooth from a sawtooth generator. He may wonder how this thing could possibly produce good audio. It does, if the sawtooth is kept linear and the modulation audio does not drive it out of range.

Broadbanding the Exciter

Broadbanding each stage is important in the aural exciter, since, at these low frequencies, efficient transformers are used which can easily be tuned so that sideband clipping occurs, just as can be done in i-f stages of a receiver. Once the frequency gets to the upper stages, broadbanding is no problem. The Q of these circuits is low enough so that it is necessary only to peak each stage by its meter indication. It should be pointed out that only rarely are adjustments necessary in these stages in the exciter. Such an occasion might be the changing of channels for the transmitter, when a new tuneup would be required.

The Output Stage

The 6181 PA stage operates as a grounded grid stage, cathode-driven. It differs from the visual, for it operates with an FM modulated carrier, just as any conventional FM radio transmitter. The power output is rated at 600 watts. Actually, the visual is putting out this amount of power as an average power and the 1 kw power figure is peak power.

Broadbanding is again no problem, since these cavities are designed broadband. This same cavity in visual service normally passes an 8-mc bandwidth, so it is doubtful that anything can be done to hurt the audio bandpass of 50 kc.

The modulator-oscillator in the GE TT-55A is an interesting, new approach. The crystal oscillator is working at the same frequency as the visual oscillator, except for the separation needed for the final 4.5-mc difference between carriers. This oscillator is also a transistorized unit, with crystal, circuit, buffer, and oven in a sealed plug-in unit. Audio

modulation is accomplished with direct frequency modulation of the crystal oscillator by electrical variation of the capacitance across the crystal. This capacitance is a semiconductor, variable voltage capacitor. The aural and visual exciters are identical, with the exception of the provision for aural modulation. The multiplication rate is the same. The only other difference occurs at the 8226 output stage, which is not modulated as is the visual output stage. Since the power output requirement is not as great on the aural side, it works with one less stage; the final 8226 acts also as the final doubler. Reflectometers are used to monitor power output on both the visual and aural sides for all powers.



Fig. 5-19. The 6161 air-cooled tetrode is used in the lower stages of the RCA TTU-1B transmitter. (RCA, Tube Division)

Video Requirements

White Stretching

Most power tubes have some degree of nonlinearity that will affect the grey scale of a monochrome picture or degrade color. When color is transmitted, this nonlinearity must be compensated for. To do this, the video is pre-emphasized so that white portions are stretched; i.e., amplified more than the dark or black portions. When this passes through the output tube, the video will return to its proper proportions.

This white stretching is usually done in a stabilizing amplifier immediately before the video is fed to the transmitter. Typical circuits use biased diodes across a video stage, usually with adjustable bias on each diode. This permits different levels of video from black to white

to be amplified nonlinearly, according to the way the biasing is adjusted. A trimmer capacitor is mounted across each diode so that any phase displacement caused by these diodes can be corrected.

The Low Pass Filter

Most of the studio equipment is capable of a video bandpass of 8 mc. If the transmitter were permitted to transmit all this information, the sidebands would interfere with adjacent channel stations. (This is the same as modulation of an AM transmitter with 10-kc information—the channel width would be doubled.) The FCC requires, therefore, that a low pass filter be installed before the video gets to the transmitter that will limit the video bandpass to 4.5 mc. Only passive elements of coils, capacitors, and resistors are used in this filter.

The Notch Filter

If your transmitter is capable of monochrome video only and you receive color programs from some source, you will be required to install a 3.58-mc notch filter in the video line to kill the color. This prevents transmission of degraded color. If no color programs are received, this filter is not necessary.

Phase Equalization

Color demands closer tolerances in the transmitter. All electronic color has a phase relationship with the burst and the other color components transmitted. Therefore, it should be passed along with as little phase shift as possible. Suppressing part of the lower sideband, tuned circuits in the diplexer, tuned circuits in the low pass filter, or tuned circuits in home receivers may cause some phase shift. Phase equalizers must be installed in the video line before the transmitter to compensate for all these various phase shift possibilities.

Vestigial Sideband Filter–Diplexer

The lower sideband of the visual signal is partially suppressed. This method is a compromise to enable the transmission of more video information in a given channel width. With no lower sideband suppression, full, double sidebands will be present, as in any AM system, and only 3-mc sidebands on either side of carrier would fit into the channel. Even this would have to be reduced further so that the aural carrier could be accommodated. By suppressing all but 1.25 mc of the lower sideband, the carrier can be moved 1.25 mc above the lower edge of the channel. Some of the lower sideband is retained so that receivers may be adjusted without any complications. By moving the visual

carrier in this fashion, 4.5 mc of video information may be transmitted with room for the aural carrier and its sidebands at the upper edge of the channel.

A diplexer is a device that permits two transmitters to be fed into one transmission line without interference. Recent relaxation of the FCC rules permits low power uhf transmitters of 1 kw or less to transmit double sidebands. If color is transmitted, however, suppression of the 3.58-mc region below carrier is required. RCA uses a single unit, called a filterplexer (Fig. 5-20), to accomplish both purposes.

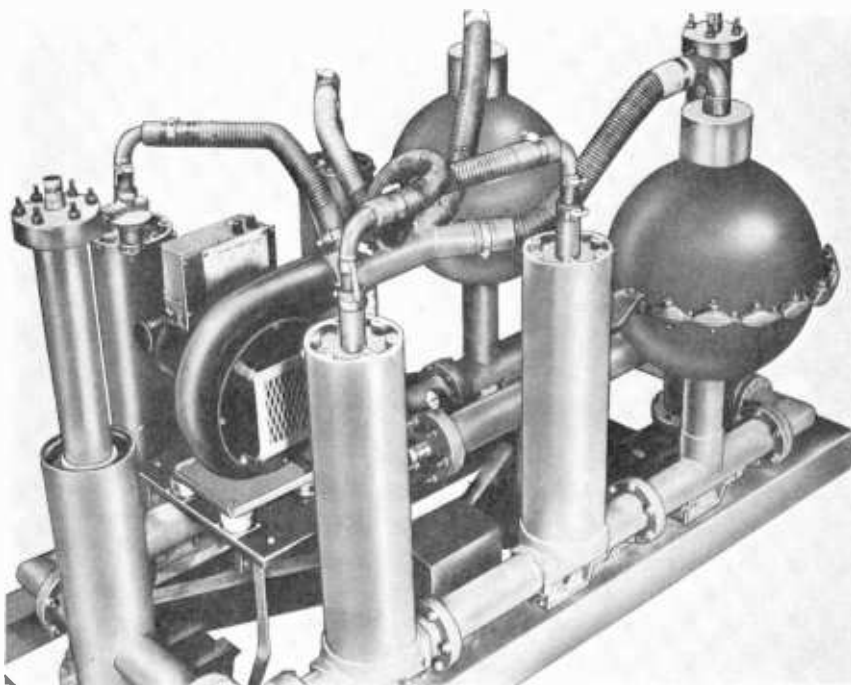

Fig. 5-20. *The complete filterplexer. (RCA)*

The filterplexer is a positive suppression unit that permits the transmitter to be less complicated; tuning can be done without concern for the sidebands. Some transmitters have transmitter circuit tuning to suppress the lower sideband. The problem with this method is that the operator must be careful when operating the transmitter to ensure the lower sideband does not reappear. Filterplexers are built for each channel and the line sections are designed for the correct frequencies. Therefore, you will not be able to purchase a used one unless you can find one used on your channel.

The filterplexer is made up of a number of tuned-line sections, some of which are used to suppress the lower sideband, and two spheres that keep the aural power out of the video transmitter. The spheres and the lower sideband units are tunable, while the diplexer makes use of fixed line sections. Coaxial line sections make a very high Q circuit and do an excellent job. The lower sideband that is suppressed is dissipated in a load resistor. The resonant line sections allow either transmitter to see only the 50-ohm transmission line, while the other transmitter looks like infinity.

Since the line sections are very critical, the whole unit is pressurized internally, with a pressure regulator holding it to 12 pounds per square inch. Normally, nitrogen is used as a gas on lower powers and sulphur-hexafluoride, which has higher insulating properties, is used for higher powers at a pressure of 24 pounds per square inch. As air temperature changes also affect the tuning, it is important that the temperature be relatively constant around the unit; it should not be mounted in a position where it is subject to drafts or continual temperature changes.

Blowers are added when high powers are used. Hoses feed air down inside the tuning cores on the tuned sections to reduce heating at these points. As with any high Q circuits, voltages that are all out of proportion to the applied voltage may appear. R-F arcing within one of the line sections or tuned sections can be a very serious problem.

A passive element, bandpass harmonic filter is installed in the transmission line to the antenna. This suppresses any harmonics that may be radiated and will suppress the harmonic components to within FCC specifications.

Maintenance Techniques

All of the information in this section relates to the RCA TTU-1B 1 kw transmitter. Higher power transmitters will require certain techniques peculiar to their power and associated power supply and control circuits. Since all previous models of RCA's higher power transmitters use the TTU-1B as a driver, the techniques described will still be pertinent as far as the driver is concerned. It is hardly likely that a small market station will be using high power transmitters, unless coverage is a problem.

Calibrating Reflectometers

A reflectometer is a peak-reading diode detector connected into the transmission line with a directional coupler that is oriented so that the incident transmitted wave is intercepted. Another identical diode and

coupler are oriented to intercept the reflected wave. By the use of a switch and calibrating potentiometers, voltage standing-wave ratios may also be read with the reflectometer. Since the reflectometer is simply a diode detector, it must be calibrated if it is to have any meaning.

The Visual Reflectometer. The transmitter must be terminated in a load and wattmeter after the filterplexer and harmonic filter (Fig. 5-21). The video detector and chopper are also necessary. Leave the aural transmitter turned off.

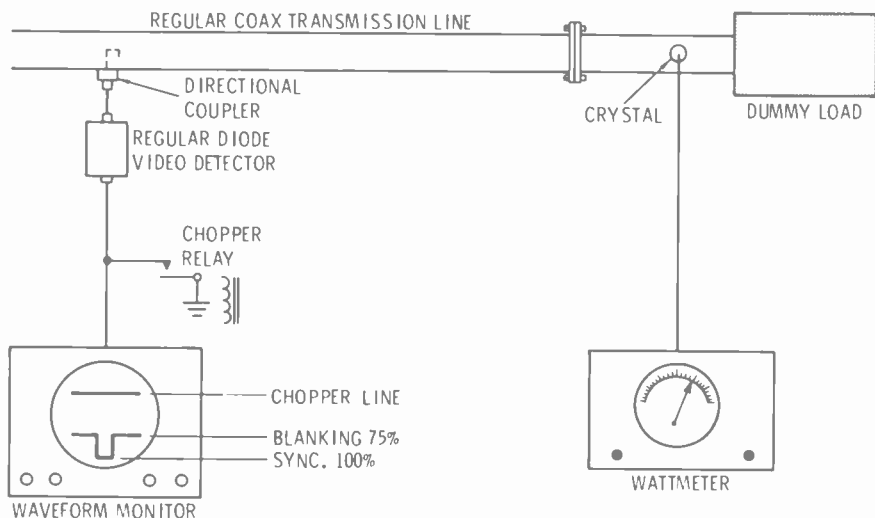

Fig. 5-21. Calibrating the visual reflectometer.

Modulate the transmitter with blanking and sync only. Observe the demodulated blanking and sync on the CRO tube with the chopper in operation. Increase r-f drive and sync and adjust the black level control on the transmitter (which adjusts PA stage bias) until the correct ratio of sync and blanking (75% and 100% modulation) occur at the same time as the wattmeter reads 595 watts. The clamp circuit should be in operation during this measurement. Obtaining all these factors at the same time may be a little tricky at first, but a little practice will soon indicate the direction each must go to bring them all together.

When you have all these factors reading correctly at the same time, adjust the reflectometer meter to read 100% power. A word of caution here: make certain that the filament voltage is adjusted to the normal operating voltage; otherwise, the diode detector tube will not give accurate readings. After all these adjustments have been made correctly, the 6181 plate current will read about 4 ampere.

The 595 watts read on the wattmeter is the average power of the visual. This power, when multiplied by 1.68 will give the peak power. This factor (1.68) is derived from a formula relating to average to peak power ratio and sync width. The use of this factor to determine peak power is specified by the FCC.

When making these adjustments, you will note the great effect that changing the sync and black level has on the average power and peak power. Therefore, while sync will be corrected throughout the day as the need arises, black level should not be adjusted in normal operation.

The Aural Reflectometer. With load and wattmeter connected as for the visual measurement and the visual transmitter turned off, you are ready to check the aural reflectometer. Do not use any modulation, only the carrier.

The wattmeter will be reading the power directly without any multiplying factors. Some confusion may occur because the transmitter is delivering more power than is shown on the wattmeter. The filterplexer is designed for zero loss at the visual carrier, so some loss will obtain at the aural carrier; since the wattmeter is connected behind the filterplexer, this loss will be indicated. Each filterplexer has a checkout sheet supplied with it which shows the losses on that unit on that channel. Deduct this filterplexer loss from the transmitter power output indicated on the station license to find what final figure should appear on the wattmeter. Adjust the reflectometer calibration control so that the meter reads 100%.

Since there has been a relaxation of the rules, which permits the aural power to be from 10% to 70% of the visual peak ERP, a little confusion may occur that can be easily cleared up. Whatever percentage is used, the license will specify the power in watts required of the transmitter.

Installing Tubes in Cavities

6161 Tube in IPA and Doubler. Insert the tube with a slight clockwise motion until it is seated firmly in the cavity (Fig. 5-22). Continue the clockwise motion and back the tube out of the seat by a fraction of an inch. The contact springs in these cavities are spiral-shaped and tend to compress to the side, all in one direction. The tube fits tight. If it is forced straight in or in any other manner, the springs may jam up in the grooves and it will be impossible to get the tube into the cavity.

Small blocks covered with a thin sheet of Teflon are positioned on the bottom of the IPA and doubler cavities. These blocks are placed according to channel. If they are directly below the tube on your channel, the lip of the tube may cut through the Teflon. If this happens, a short circuit will occur, tripping the circuit breakers. Backing the tube

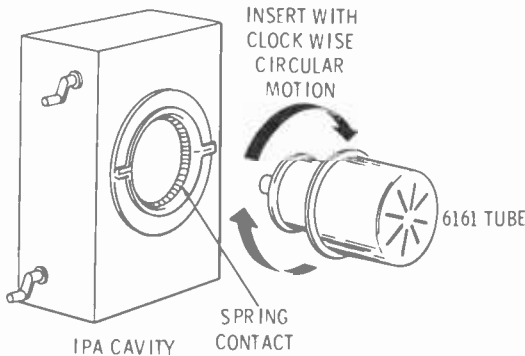

Fig. 5-22. Inserting the 6161 tetrode.

out a fraction of an inch will not affect its operation in any way and it will be held firmly in place.

6181 PA Tube. This tube should also be inserted into the cavity with a clockwise circular motion. Be sure that the fingered plate contact spring has the fingers pointing toward the plate. If not, you may have difficulty making power.

Be certain the tube is all the way in the cavity. When locking it down with the four clamps, do not tighten them so much that the stud breaks off, or the cavity will have to be disassembled. Do not leave any of these clamps loose or r-f will cause burning and arcing.

General. The spring contacts in these cavities are not a complete loop when you get them, but must be attached. Lightly solder the end spiral of each together. Do not get solder on too many spirals or they will be inflexible in the cavity and hamper tube insertion. Another satisfactory joining method is to overlap the two ends of a few spirals and twist them together. This will bind them so that they will stay together in the cavity.

When you change a tube in a cavity, inspect the cavity's insides with a small mirror and a flashlight. Check for bad spring contacts or any burning that may have taken place.

When taking a tube out of a cavity, use the same clockwise rotation method. This will keep the springs tilted in the same direction.

4X150 Stages. The 4X150 stages are not cavities. However, because of their frequencies, they have unusual sockets that require special tube handling. *When inserting or taking one of these tubes out of its socket, never turn it in any direction.* These tubes have an octal base arrangement with base pins. Twisting the tube will damage the socket. It is particularly difficult to insert a tube in the second stage. A small mirror and flashlight will be of assistance here to align the tube properly (Fig. 5-23).

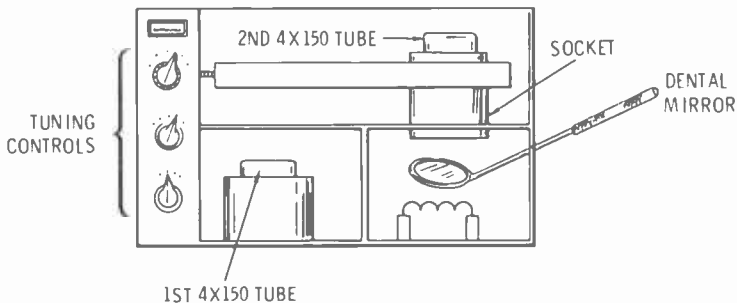

Fig. 5-23. A dental mirror simplifies socket inspection.

The plate contact spring does not allow the tube to drop all the way into the socket by itself, so the mirror should be used to see that the guide pin and base pins are directly over the socket connections before they are pressed into place.

After the tube is inserted, turn on the filament voltage and check with the mirror from underneath to be certain the filaments have lighted up. Most socket damage seems to occur at the filament contacts. Intermittent contact will cause the output power to vary or drop off to nothing if the tube goes out. If a socket has been damaged and you can't take the time to correct it immediately, insert the tube and twist it slightly so that a better contact is made. The plate contact spring will usually hold the tube in the twisted position.

Matching Interstage Cables

Any coaxial cable should be terminated in its characteristic impedance so that the best transfer of power may be obtained with minimum VSWR and less chance of damage to the cable.

When a mismatch is present between two of the cavities the driving stage will be working into a reactive load, so any slight change in this load will cause detuning. Once the driver starts to detune, heating and cooling will cause it to detune further. Output power will drop off, driver grid current may go off scale negative, plate current will rise, and a hole may possibly be blown in the glass of the tube. Unstable operation will be the order of the day.

IPA to PA. Use the micromatch instrument supplied with the transmitter. The PA tube should be operated as a CW signal without clamp, with black level control in a-c position, and no modulation. Under these conditions, the 6181 plate current will be about 1 ampere and the reflectometer will read 60% (600 watts). Set the micromatch to read back power.

Keep the IPA drive low at the beginning, especially if the back power is high because of a serious mismatch. Keep a sharp eye on this IPA plate current and grid current. When the IPA is driving hard under this condition, you can blow a hole in the glass with a few seconds of overload.

The first step is adjustment of the PA cathode input coupling. Loosen the cable clamp and adjust this by inserting or retracting the amount necessary to show a definite minimum in back power reading. This must be a dip, not just a reduction, because the drive will be changing also, due to the changing load when you are moving the coupling. Lock the coupling in place, then adjust both the PA cathode tuning knob and the sliding capacitor at the bottom of the cathode cavity until the back power is zero. Maintain the IPA plate current in resonance at all times and the PA plate in resonance. Manipulate these adjustments until the back power reads zero and the reflectometer reads 60%. After a little practice, you will soon learn where these controls will normally operate on your channel.

While the micromatch is still inserted, adjust the r-f choke on the filament circuit for minimum radiation, which can be indicated by a neon bulb held against the choke. This r-f choke should never be adjusted very much unless the micromatch is in the circuit, because this adjustment can upset the match, which has been set up previously. Output coupling adjustments of the IPA will not affect the match in any way, so it may be adjusted at any time.

Make certain that all connections are clamped tight, then take masking tape and tape the cathode tuning knob in place. This will prevent someone from accidentally tuning this knob. The cathode tuning should not be a daily operational tuning. It is quite difficult to get this tuned correctly without using the micromatch.

After the micromatch is taken out and the cables are restored to normal, adjust the IPA output coupling for zero grid current and lowest plate current on the IPA stage, consistent with power output.

A word of caution about loose clamps. Since these adjustments are made with power on, never loosen the clamp on any coupler so much that a firm metallic contact is broken. If this happens, you can get a bad burn from the r-f energy that is present. Just loosen the clamp enough to turn the coupler with a firm grip.

Other Stages. Matching cables between the other stages can use the same techniques, except there are not as many adjustments to make. Remember to read the back power and reduce this to zero. Actual VSWR ratios are not so important that one needs to know the values. To read the actual VSWR takes too much time and more operations to calibrate and switch movements constantly on the micromatch. Work

only with the back power; when this is zero, the VSWR will also be very low. Check the forward power and record the reading for future reference. The power reading on this micromatch unit will usually be very close in accuracy, and, if in doubt, the reading may be checked with a load and wattmeter.

Getting Multipliers on Correct Harmonic

The first three multipliers in both transmitters (excluding those in the aural exciter) can operate on two different harmonics, depending upon channel. A grid-dip meter is a valuable instrument when working these stages.

If drive is lost for some reason, these stages can sometimes be tuned to a point where they will oscillate and the upper stages can tune this oscillation up to 100% power reading. However, this will work only until a tube blows (usually one of the 4X150 stages).

With the plate voltage off, check each stage so that it is approximately on frequency. Most grid-dip meters are not too accurate on dial readings, because they may not have enough scale divisions, but they will indicate when you are close enough. After plate voltage is applied, tune each stage carefully, using the grid current reading of the next stage each time for the maximum reading. If you must tune too far to get a reading, you had better go back and recheck with the meter. The grid current readings on these 4X150 stages hardly lift the needle off its resting place, so you must watch it closely.

It is customary to read the second 4X150 stage cathode current as a normal daily tuning procedure for the earlier stages. However, when you are having trouble in these stages, this procedure can get you into trouble and may blow a tube.

Some checks can be made as soon as power output from the transmitter starts to read enough to work the monitors. On the aural side, listen to the sound from the monitor speaker. If the transmitter is oscillating, there will be raspy noises and the meter may be kicking up to 100% modulation. The frequency meter may be off-scale or erratic. On the visual side, the frequency may be off-scale or erratic. In either case, as a final check, cut out the crystal. The power should drop to zero. If it does not, the transmitter is oscillating. Leave the crystal off only long enough to see if the power drops to zero. This should be instantaneous.

Another suggestion to assist in multiplier stage troubleshooting is this: stick some strips of masking tape to the cabinet, directly to the side of the grid and plate circuits of the multipliers. Write the frequencies that are supposed to be read there on these tapes and, if the grid-dip calibration is not accurate, include the indicated readings of the

meter. This will save the time it takes to go back through the instruction book tables and look up the information for your channel when it is necessary to use the grid-clip meter to see if the stages are tuned correctly.

Changing Filament Taps

As the 6161 tubes age, they require more filament voltage to get the required output. A filament rheostat is provided and a meter is placed across the 1PA filament. Both tubes have individual transformers, but a single rheostat adjusts both at the same time.

It sometimes happens that a new tube is placed in the 1PA when the doubler has an old tube still working. The new tube should have the filament voltage at minimum, but the older tube will need a higher voltage. Raising the voltage to accommodate the old tube will also increase it on the new tube. The consequent backheating of the cathode due to r-f will shorten its life. Lowering the voltage to accommodate the new tube may cut out the old tube, or all the other stages may have to increase their drive. Such a dilemma can be solved without throwing out the old tube.

Change the primary taps on each of the 1PA and doubler filament transformers (Fig. 5-24). For the new 1PA tube, set the tap on the highest terminal available (this will lower the secondary voltage). For the old tube in the doubler, set the tap for the lowest terminal available (this will raise the secondary voltage). Now the filament rheostat can be adjusted for correct voltage on the 1PA filament meter and, at the same time, the doubler voltage will be increased.

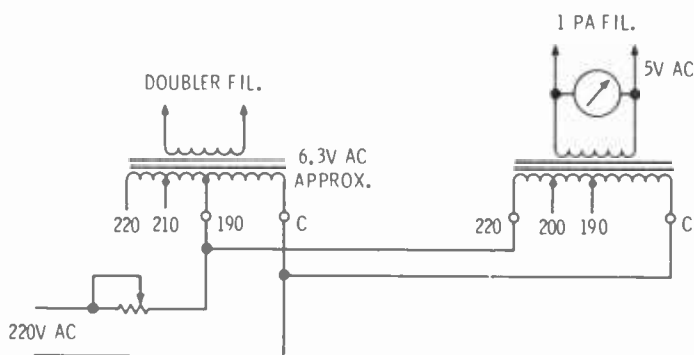

Fig. 5-24. Change the filament transformer primary taps to get correct voltage on your old doubler tube and new 1PA tube.

If the tubes were reversed, reverse the procedure, and if both tubes are old, set the taps so both get higher voltage. Many more hours of service can be obtained from these 6161 tubes when operated this way, but you will have to learn to accommodate them, for the heating and cooling effects of r-f drive will cause the stage to be unstable until the right combination is reached.

Tube Heating and Cooling

Any large transmitting tube should be started up gradually and shut down gradually. The larger the tube, the more expensive it is, and the greater the care that should be given it. All tube manufacturers recommend a slow start and slow shutdown.

A suggested rule to follow is this. At sign on adjust the master filament control for half the normal voltage and operate for five minutes, then adjust to normal voltage and operate for another five minutes before applying plate voltage. At sign off operate the tube with full normal filament voltage, but without plate voltage for five minutes, then at half normal voltage for another five minutes, and finally for five minutes with filament voltage off but blowers still running. When it is necessary to change a tube during the day, try to follow this procedure when practical. There will be pressure to get back on the air, but ruining a \$1000 tube will not make a profit for any show.

Checking New Tubes

When you buy new tubes, check them out at the first opportunity and be sure to keep records.

New 6181 tubes should be checked out in the visual PA amplifier. The tube should not only make power easily, but it should have good bandpass and good sync. You will have to go through the matching process, run video sweep through it, and check linearity and phase if you have equipment to do this. When the tube checks out to your satisfaction, use it in the transmitter for several days or a week. If the tube is not satisfactory for any reason, return it to the distributor and get a new one.

Tube manufacturers do their best to see that only good tubes are shipped out, but many things can happen before you receive it. It may become gassy from sitting too long in a warehouse or it may have rough handling in shipment. One such case should help demonstrate some of the things that can happen. The author received a brand new 6181 tube. When the shipping carton was opened and the tube taken out, the plate fins were all flattened on one side, just as though it had been dropped on the floor. The shipping carton did not have a scratch on it and the tube was packaged perfectly inside the carton. One can only

come to the conclusion that a packer at the plant had dropped the tube and, rather than sending it back to the reject pile, he must have packaged it up and shipped it out. Needless to say, the tube was placed right back in the carton and returned to the distributor.

6161 tubes should be checked in the doublers. This avoids the necessity of reneutralizing the 1PA. Ordinarily, if the tube will work in the doubler, it will work as an 1PA.

4X150 tubes should be tested in the first stage. Because of the difficulty of inserting a tube in the second stage, socket damage occurs more often there. If the tube works in the first stage, it will usually work in the second stage.

All of the preceding techniques are but a few of the many that will be developed by the station engineer as he becomes accustomed to working with a particular make and model of uhf transmitter and can only be learned by working with one.

*Transmitter Modifications*¹

Changing Multipliers

There may be an occasion when a harmonic from one of the multipliers is radiating and giving trouble. These radiations may not be severe enough to give any problems in the neighborhood, but they may interfere with a vhf station that you want to use as an off-air pickup rebroadcast source.

Trapping at the receiver may remedy this, but a more positive approach will be to change the mode of the multipliers so that a different combination will occur. For example, if the first stage is a tripler followed by a doubler, you can reverse this process so that the first stage is a doubler followed by a tripler. If the exciter output frequency in the first arrangement is 28 mc, the output of the tripler will be 84 mc, which is right in the middle of channel 6 video, and the output of the doubler will be 168 mc. If you wish to use a channel 6 as an off-air pickup, this harmonic will cause all sorts of beat patterns that will make it impossible to use a suitable on-the-air picture. By changing the mode of the multipliers, the output of the first stage, which is doubling, will be 56 mc, and the output of the following stage, which is tripling, will be 168 mc. The output frequency of the multiplier chain is the same as before, so the upper stages will work properly, but the beat pattern from channel 6 video will be eliminated.

¹These modifications apply to the RCA TTU-1B transmitter.

Doubling the Micas

Mica capacitors are expensive; continual puncturing with high voltage can be a costly affair. If you are having trouble with blowing mica capacitors because of high line voltage fluctuations, try doubling those areas that seem to be the sore spots. This will not work on all channels because the capacity will be too much, but try it first. The same is true of the mica insulators.

Moving the 4X150 Screen Control

The screen grid voltage of the first 4X150 stage is adjustable by a rheostat mounted on the shelf inside the transmitter. This control is ordinarily a set-up control, rather than an operational control. To adjust it, the rear doors must be opened, which shuts off the high voltage because of the interlocks.

Move this control so that it is mounted on the back panel between the IPA or doubler and the PA cavity, with the shaft and knob protruding out the front. If any undesirable coupling occurs, use shielded wire to the control. The instruction book recommends that the screen voltage on this stage should not be allowed to go over 240 volts. Adjust the voltage until it is 240 volts and mark the front of the cabinet. Now you have an operational control which is more effective than the cathode control of the IPA stage for output power adjustment. The mark on the panel will show the operator how far he can go. He should stay within this range to prevent tube damage. A little experimentation will show that there is more power output per milliamperere plate current of the IPA than there is when using the "excitation" control normally provided.

Moving the Rectifiers

The serrasoid modulator-exciter in the aural is susceptible to noise pickup. The high voltage rectifiers are mounted on the shelf directly behind the modulator. Should they be giving you noise problems, the rectifiers may be moved to the transformer compartment directly below. This will also make it more convenient to work on the exciter. Add a small shelf off the right-hand wall, directly below the tube positions, and remount the tube sockets there. Make sure that all wiring is clear and that exposed high voltage points on the upper shelf are insulated.

Changing Filament Taps

Because of backheating of cathodes from r-f, the filament voltages must be run lower. The voltage can be increased as the tube ages; most of the upper stages are equipped with controls to do this. Sometimes the line voltage may be such that the voltage can't be reduced as low as you would wish. The PA, especially, should be run low.

If all the primary taps are set for 190 volts, then the master filament control will have more room for adjustment.

Operating tubes at the lowest filament voltage that will still give satisfactory output will lengthen their life considerably.

Holes in the R-F Box

The first time you have to disassemble the second 4X150 socket drill four holes, one above each of the assembly mounting screws, so that a screw-holding screwdriver may be inserted directly to the screws (Fig. 5-25). This will speed up the assembly and disassembly considerably and improve your disposition.

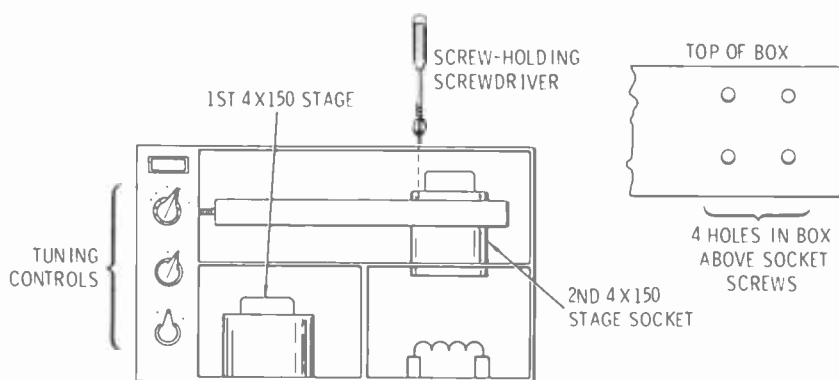

Fig. 5-25. Cut holes in the top of the r-f box to ease socket disassembly and assembly.

Transmitter Costs

For a 2-kw Transmitter Installation

1 RCA TTU-2A, 2-kw uhf transmitter, complete	\$59,500
(includes tubes, crystals, video low-pass filter, filterplexer, harmonic filter, monitoring diode, etc.)	
1 Hewlett-Packard model 335E, TV monitor	\$ 2,700
1 1200 watt load and wattmeter	\$ 1,210
Total	\$63,410

For a 10-kw Transmitter Installation

1 RCA TTU-10A, 10-kw uhf transmitter	\$149,500
(includes all cavities, tubes, crystals, filterplexer, harmonic filter, video low-pass filter, etc.)	
1 Hewlett-Packard model 335E, TV monitor	\$ 2,700
1 15-kw load and wattmeter	\$ 1,890
Total	\$154,090

For a 30-kw Transmitter Installation

1	RCA TTU-30A, 30-kw uhf transmitter, complete	\$199,000
	(includes tubes, filterplexer, harmonic filter, spare kly-	
	stron tube, etc.)	
1	Hewlett-Packard model 335E, TV monitor	\$ 2,700
1	30-kw load and wattmeter	\$ 2,000
	Total	\$203,700

Chapter 6

Transmission Lines

Basic Problems

Losses and Heating Effect

Losses and heating effects at uhf require that a better transmission line be used than that in use for vhf. Most of the uhf losses are caused by leakage at the steatite insulators, by voltage standing wave ratios set up between insulators, and by impedance discontinuity at elbows and joints. (High VSWR, with its high voltage points, has been known to burn steatite insulators to a charred cinder and melt ceramic insulators as though they were wax candles.)

Teflon. Line referred to as teflon line in this chapter indicates that the insulators between the inner and outer conductors are made of teflon, as shown in Fig. 6-1. The rest of the line, although slightly different in construction from standard vhf line, is still copper pipe. Teflon is basically an inert gas in solid form. It has a very low loss factor at uhf frequencies, as it is almost electrically "transparent" to the r-f energy.

The Mitered Elbow. New elbows have been developed for uhf: the 90-degree and 45-degree mitered elbows, which are not at all like the standard, curved vhf elbows. The differences between vhf and uhf elbows are illustrated in Fig. 6-2. These units ensure very good impedance continuity and may be joined in different combinations, some of which are shown in Fig. 6-3.

The Bullet. The need for improved impedance continuity at the flanges and joints of the center conductors has resulted in a teflon-insulated center connector, usually referred to as a *bullet* (Fig. 6-4). The

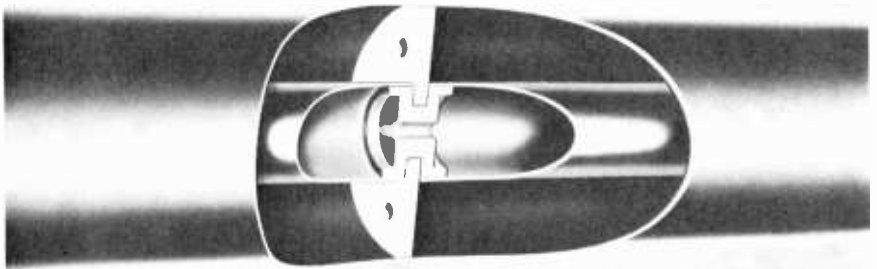

Fig. 6-1. *The cut-away view of a teflon insulator in a coaxial transmission line. (RCA)*

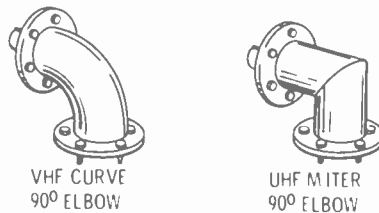

Fig. 6-2. *Comparing the uhf mitered elbow and the vhf curved elbow.*

insulator maintains the correct distance between inner and outer conductors where they cross the flanges. Any sagging that might occur, especially when a section of line is shortened, is prevented.

Teflon Line

The teflon line is a very good uhf coaxial transmission line. Although it can be used for vhf, it was designed primarily to meet the more stringent demands of uhf. RCA manufactures an additional type of line, Universal teflon line, which is designed for use on both vhf and uhf. Its cost is about \$42 more than standard vhf line for each twenty-foot section. Connections between sections of this line are secured with clamps rather than bolts, as shown in Fig. 6-5. The teflon line is a stable, low loss, highly efficient line that will give many years of reliable service. While the cost is more than vhf regular line, it is less than waveguide.

Flexible Line

Heliax, a product of Andrew Corporation, is another reliable low-loss uhf coaxial line. It is a flexible line of one continuous length that is

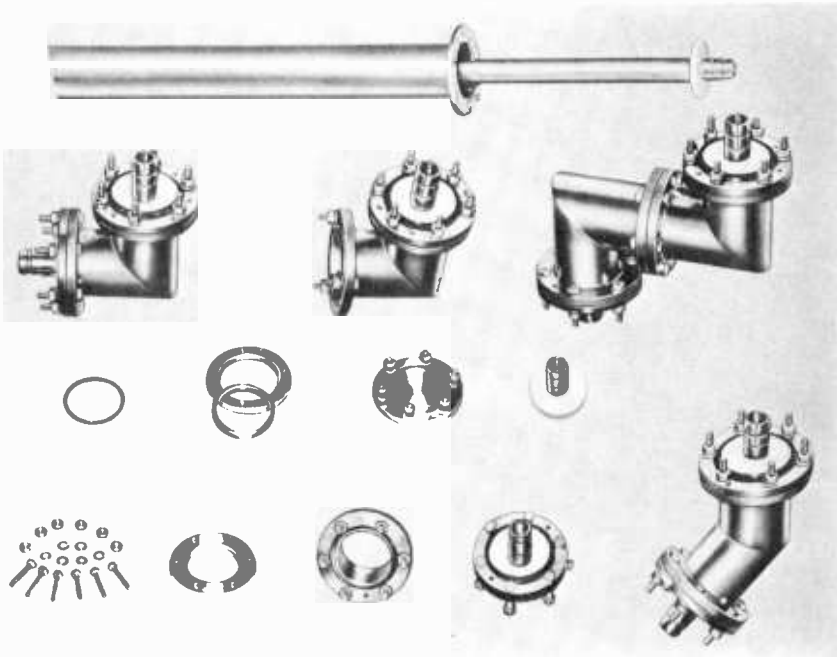

Fig. 6-3. The various mitered elbows and other fittings of standard 3-1/8-inch teflon line. (RCA)

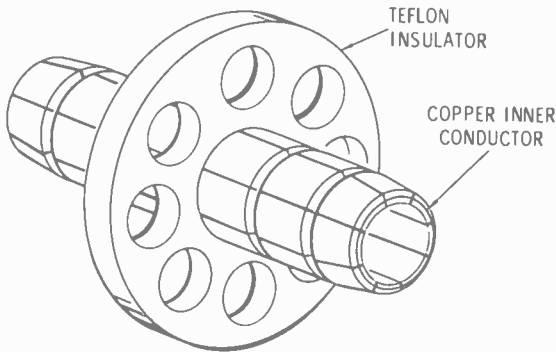

Fig. 6-4. The center conductor anchor insulator for coaxial transmission lines. This "bullet" interconnects two sections of rigid teflon line. The holes in the insulator permit the circulation of gas.

made to each customer's requirements. Several outstanding features make this line worth serious consideration if it will meet your requirements. Sizes are available up to 5 inches in diameter.

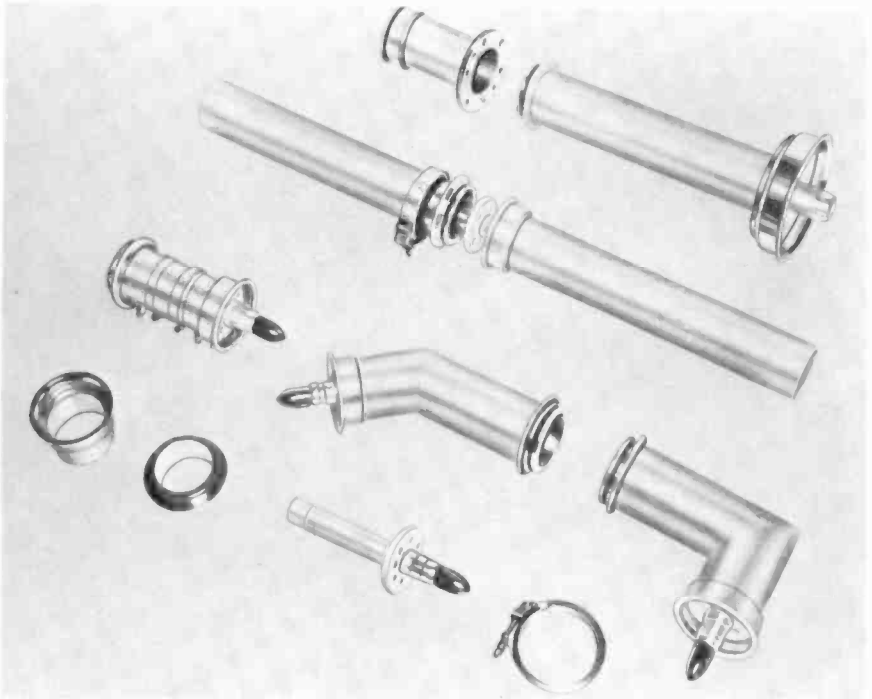

Fig. 6-5. Fittings and elbows of the Universal teflon transmission line. The flanges do not bolt together, but use a clamp arrangement. (RCA)

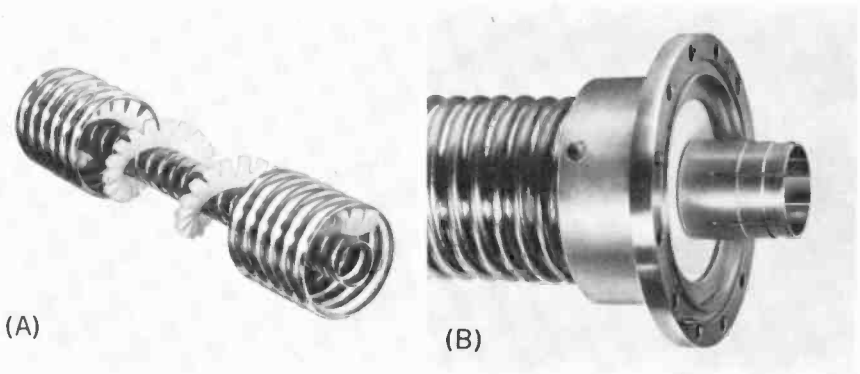

Fig. 6-6. Heliax cable: (A) 3-inch—notice the continuous insulator; (B) 5-inch, fitted with a standard 6-1/8-inch diameter EIA flange. (Andrew Corp.)

Although each size line is made somewhat differently, the $3\frac{1}{8}$ -inch diameter heliax is representative of how this line is manufactured. It has an outer conductor made of copper-clad steel and an inner conductor made of high conductivity copper (Fig. 6-6). The insulating material between the inner and outer conductors is a continuous heliax made from low-loss polyethylene. A jacket of black polyethylene is used on the outside of the cable to prevent corrosion and add abrasion resistance.

When the customer orders the length of line required, the factory makes up the complete line to suit his order. He will be sent a line of one continuous length, without splices, that has an EIA flange on both ends and is gassed before shipment. Ordinarily the gas used is dry air. Should the customer desire other gassing, such as nitrogen, this may be changed after installation.

The main advantages of a continuous length of line are that there are no flanges that can loosen and lose gas or develop impedance discontinuity and there are no inner connectors that will burn or corrode and cause high VSWR. Since the line does not have to be assembled section by section at the tower site, as is standard rigid line, greater control of impedance can be obtained resulting in very low VSWR.

The flexibility of heliax permits making any bends desired without elbows. For the $3\frac{1}{8}$ -inch diameter line, the minimum bend should not be more than 36 inches. Such flexibility will also make it easier to meet the antenna feedpoint on any style tower. Expansion and contraction are distributed along the whole line without any effect on VSWR. No special hangers are required to mount the line, but special techniques are used to install it.

Shipping continuous lengths of heliax, up to 500 feet, is standard. For lengths over 500 feet, special arrangements are made between the factory and customer. A 500-foot length of $3\frac{1}{8}$ -inch line will come on a reel 96 in. \times 42 in. and will weigh 800 pounds. It makes quite a package.

Line Selection

The type and size of line used will depend upon a number of factors peculiar to your planned installation. Each installation must be planned individually.¹

Losses

Figures for losses are usually given in db, although some manufacturers also supply charts in their catalogs that give total loss figures in

¹ The Electronics Industries Association (EIA) has set up standard specifications so that transmission lines and components of one manufacturer will fit together with the line or components of another manufacturer, both electrically and physically.

percent of power transmitted through the line for the total length of line on your channel. Losses will increase as the channel numbers are increased. A line with a certain loss on channel 18 will have a higher loss when used on channel 69. This loss will change the effective radiated power, because less power will be available at the antenna input terminals.

For example, assume that a $3\frac{1}{8}$ -inch, rigid teflon line is to be used. For each 100 feet of line, the loss at channel 18 will be 0.24 db, or an efficiency of 94.5%. The loss for this same line on channel 69 will be 0.31 db, or an efficiency of 93%.

The diameter of the line will have a direct bearing on the loss factor. A line with a larger diameter will have lower losses for a given channel than will a smaller diameter line on the same channel. The cost of the larger line will also be higher.

For example, using $1\frac{1}{8}$ -inch, rigid teflon line on channel 35, the loss will be 0.51 db per 100 feet, or an efficiency of 89%. On the same channel, but using the next larger line, $3\frac{1}{8}$ -inch, the loss will be 0.27 db per 100 feet, or an efficiency of 93.9%.

The length of the line in feet will also affect the losses. The longer lines lose more power. The line length should be considered in relation to the tower and the tower height when locating the transmitter.

The loss and efficiency figures given earlier are for 100-foot sections of line. In most cases, a station will need more than 100 feet of line, so the db losses must be added. The more the overall loss, the poorer the overall efficiency. The term *efficiency*, when used with a transmission line, has the same meaning as when used with other devices: the ratio of power output to power input given in percent. If you feed a given power into a line that has no loss, you will obtain the same amount of power at the output end of the line. Such lines don't exist, because there is always some loss.

As previously indicated, a $3\frac{1}{8}$ -inch line has a loss figure of 0.27 db per 100 feet on channel 35. If a particular installation requires 600 feet of this line, the total loss will be 6×0.27 db, or 1.62 db. This will give a line efficiency of 70%; i.e., you will lose 30% of your power in the line. If the transmitter power output is 1000 watts, only 700 watts would be available at the end of the line that feeds the antenna. For an antenna with a power gain of 25, the ERP, with a 1000 watt signal, will not be 25,000 watts because the line in this case is only 70% efficient, permitting only 700 watts to reach the antenna. The ERP, power input \times antenna gain, will be only 17,500 watts.

Size

The transmitter power will determine to a large degree what diameter size to use. Should a line of too small diameter be installed, say

because of cost factors, in all probability trouble will develop or the line will be damaged if too much power is fed into it. Such circumstances can happen, especially if you start out with a low power transmitter but later decide to operate on higher power. It is best to try and estimate future needs and prepare for them when selecting transmission line, so that the increase in transmitter power at a future date will not require transmission line replacement.

The Andrew Corporation's 1½-inch, rigid teflon line can safely carry transmitter powers of 1 kw or less. However, the next step for power increase in transmitters is to 10 kw, which would seriously overload the smaller line. At least a 3½-inch line would be required. Common practice is to use a much higher rated line than the bare minimum. A larger line will offer less transmission loss. Also, line repairs on the tower can be costly, both in men and materials, plus off-the-air time. Most stations prefer to invest in a more reliable line so that essentially they can install it and forget it, or at least not constantly worry about burning it up.

VSWR

Another factor to consider is VSWR. When an impedance mismatch has occurred for any reason, VSWR will appear on the line and high voltage points will develop. This voltage will be greater with higher VSWR and transmitter powers. A high VSWR will also cause "ghosts" to be transmitted in the picture or may affect color subcarriers.

Although most antennas and transmission lines can be intalled with a very low VSWR, many factors may later increase VSWR. Ice forming on the antenna will cause detuning and, consequently, a mismatch and improperly terminated line. This can happen if the de-icers have failed to operate. Line pressure may fall off, permitting moisture and water to enter the line. Ice falling off the tower may cause large dents in the line, especially on the horizontal run. Flange bolts may loosen or solder joints may break at the flanges because of expansion and contraction. These are just a few examples of ways in which VSWR is increased on transmission lines.

Line Ratings

All transmission-line manufacturers' catalogs give complete data on their lines, including the loss factors and other data for all channels. A few examples here will help illustrate the differences between lines. The average power rating charts, as given in the manufacturer's catalog, are shown in Figs. 6-7 and 6-8.

Rigid, Teflon Line — Channel 35

- 1 $\frac{5}{8}$ inch, 50 ohms impedance, 0.51 db/100 feet, average power — 5.8 kw
- 3 $\frac{1}{8}$ inch, 50 ohms impedance, 0.27 db/100 feet, average power — 19 kw
- 6 $\frac{1}{8}$ inch, 50 ohms impedance, 0.14 db/100 feet, average power — 66 kw

Flexible, Heliax — Channel 35

- 1 $\frac{5}{8}$ inch, 50 ohms impedance, 0.58 db/100 feet, average power — 4.2 kw
- 3 $\frac{1}{8}$ inch, 50 ohms impedance, 0.42 db/100 feet, average power — 11 kw

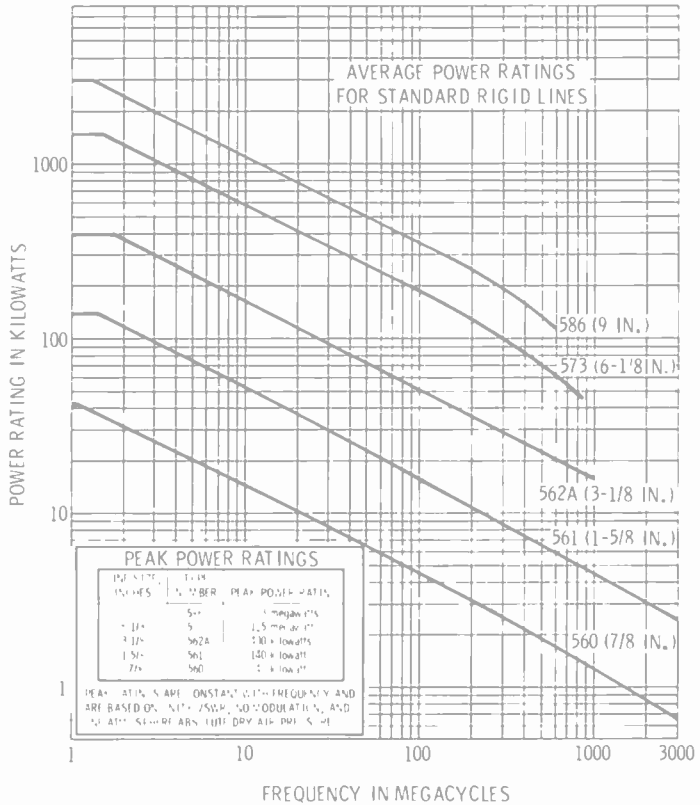

Fig. 6-7. Average power ratings for standard rigid lines. (Andrew Corp.)

Power ratings are based on *unity* voltage standing wave ratios; i.e., a perfect termination on the end of the line. Any VSWR will lower this figure somewhat. Loss figures are for each 100 feet of line. For each 100 feet and fractions, add the db loss figures to get the total loss for the length of line used.

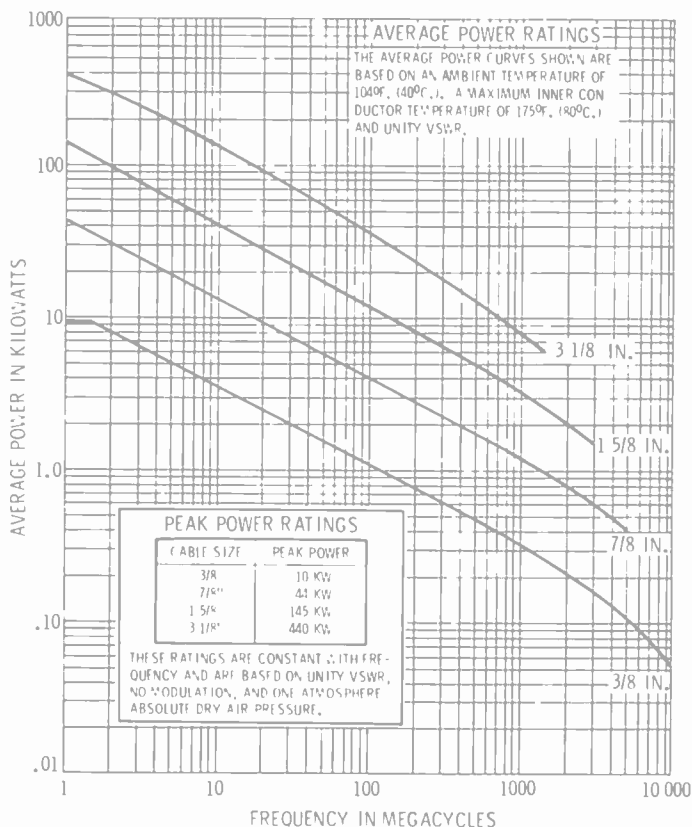

Fig. 6-8. Average power ratings for 50 ohm heliax. (Andrew Corp.)

Line Handling

Coaxial line used on uhf requires special handling so that the finished installation will have a very low VSWR. Here are some things to consider.

Carefully supervise the installation of the line on the tower. Unfortunately, many average steeplejacks cannot understand that coaxial transmission line must be handled with utmost care. To some of them, it is merely copper pipe. Often, when individual sections are being hauled up the tower, they will begin to swing, due to wind or improper handling of the "donkey engine," and the line section may swing into the tower. If this happens, that section of line should be lowered to the ground and carefully inspected for dents and damage at the flanges. Small dents will increase the VSWR, and large dents will not only change the characteristic impedance, but will decrease the distance between inner and outer conductors with possible voltage flashovers resulting.

The steplejack should also be impressed with the importance of careful handling of the inner connector, or bullet, the "O" rings, and the bolts at the flanges. A split bullet (Fig. 6-9) will cause serious impedance discontinuity, resulting in high VSWR. Some types of line have a small fiber piece in the end of the bullet. Its purpose is to prevent the inner conductor from splitting the bullet. Don't take this fiber piece out; install it with the bullet.

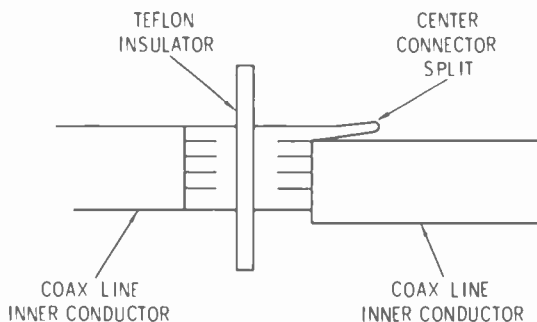

Fig. 6-9. If the inner conductor splits the center connector, a serious impedance discontinuity will develop.

The "O" ring is a gasket and must be seated properly to give a good, airtight seal. A pinched "O" ring will not seat properly and will cause a leak that will incur loss of pressure in the lines. With such a leak, if a dry air pump is used, the pump will run continuously trying to maintain pressure and will burn itself out. A good way to insure proper seating of the gasket is to dab some silicone grease on the gasket. This will make it adhere to the flange until both flanges are pressed together. The silicone grease will not affect the rubber "O" ring.

Loose bolts will cause a pressure leak and poor electrical contact between flanges. Should nitrogen be used to gas the lines, a leak can be expensive because of the amount of gas that is wasted.

Cutting Line

It is often necessary to cut a section of line to make it fit some special application. This should be done carefully. Mark off the line where the cut is to be made, taking into consideration the space taken up by the flange. Whenever possible, try to arrange the run so that the cut will fall between insulators. A little careful planning will often make this possible. To make a perfect circular cut, take a small piece of heavy paper with a straight edge and wrap it around the outer conductor, as in Fig. 6-10.

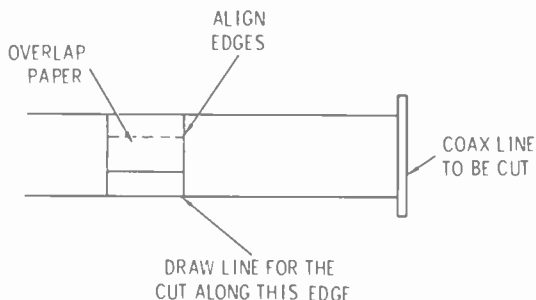

Fig. 6-10. Mark coax line with a piece of paper as your guide in order to ensure a perfect circular cut.

Wrap it far enough so that the edges overlap. Line these overlapped edges with themselves, then draw a pencil line all the way around the outer conductor. When cutting, follow the pencil line as a guide and cut only one side of the pipe at a time. Do not try to cut straight across and all the way through. Keep the end to be cut slanted at an angle, so that filings will not fall inside the line.

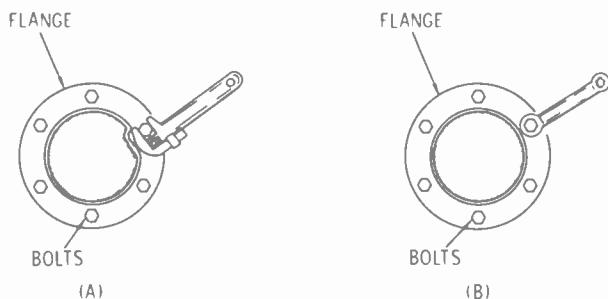

Fig. 6-11. A crescent wrench will dent the line (A); a box wrench will not (B).

When using a wrench on the bolts at the flanges, use a thin box wrench. Crescent and similar type wrenches are too large and will put dents in the line (Fig. 6-11). Be careful not to move the wrench too far so the handle dents the line. Remember that dents mean increased VSWR.

There will be times when sections of line will have to lie exposed on the floor or on the ground, especially when they are to be cut or hauled up the tower. Take extra precautions at these times so that no damage occurs to the line from something falling on it or someone walking on it.

Planning the Installation

Careful planning of the line installation can save money, make repairs easier, and ensure low VSWR.

Antenna Connection

Depending upon the diameter of line you have selected, it may be necessary to use a reducer or increaser to fit the line to feed line inside the antenna. The antenna manufacturer supplies these connections but you must specify what size you need.

Tower Design

The feed line drops straight down from the bottom of the antenna. Much will depend upon the style of tower at this point. If the tower is short and narrow, it will be necessary to bring the transmission line outside and then down the tower. Self-supporting and tall towers are usually wider at this point, so the line will run down the inside of the tower. In both cases, you can't drop straight down from the antenna, because mounting would be too much of a problem. Therefore, two 90-degree elbows will be necessary to direct the line to the side of the tower as in Fig. 6-12A. If the tower has a wide taper coming down, as

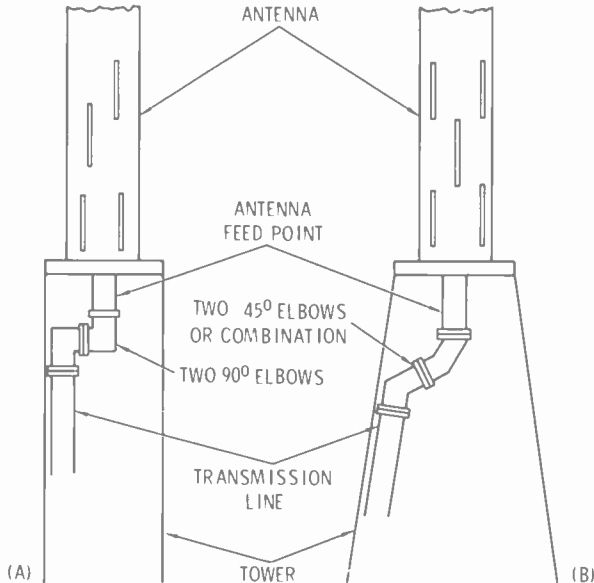

Fig. 6-12. (A) On a linear tower connect the transmission line to the antenna with two 90-degree elbows. (B) On a tapered tower connect the transmission line to the antenna with a combination of 45-degree or 90- and 45-degree elbows.

in Fig. 6-12B, an angle other than 90 degrees will probably be necessary to direct the line to the correct taper. This will usually necessitate a combination of 90- and 45-degree elbows.

Contraction and Expansion

Here is something you just cannot prevent, unless you can control the weather. This is a property of copper affected by temperature change. A long run of line will move a considerable distance with extreme temperature changes and can develop tremendous pressures. Allowances must be made for this movement or trouble will develop.

Hangers and Clamps

Spring hangers have been designed that support the line and allow longitudinal movement. They will restrain the line to hold it in place after a definite amount of displacement has occurred. The hangers are

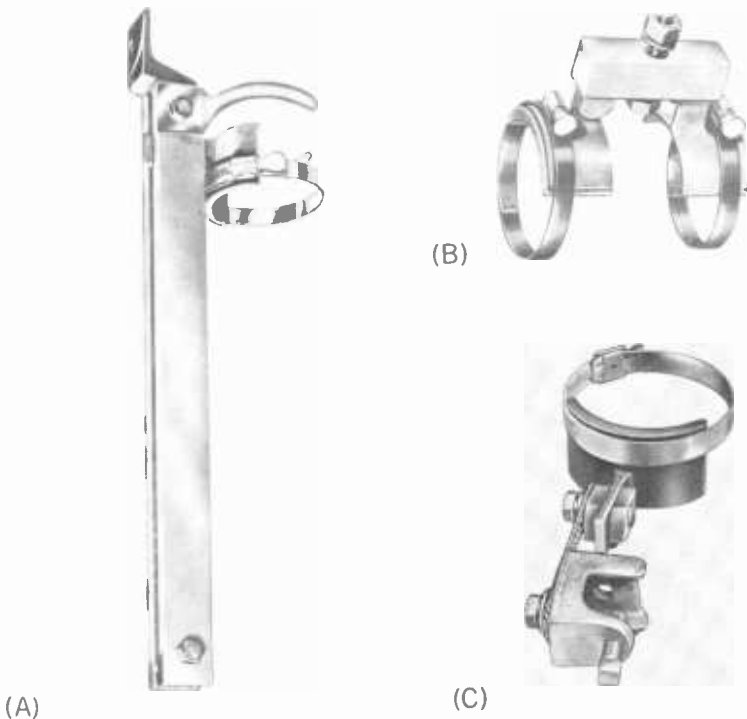

Fig. 6-13. (A) A spring hanger; (B) A rigid clamp to anchor the line at the top of the tower; (C) A grounding clamp, used when the line is insulated and some sections are to be grounded. (Andrew Corp.)

circular clamps that attach to the line and are connected with springs to a clamp on the tower. These spring hangers are used for the vertical run of line on the tower. One type is shown in Fig. 6-13A.

A rigid clamp is also available (Fig. 6-13B). One or two of these are installed at the top of the line next to the antenna connection. The antenna makes its own provision for contraction and expansion, so the transmission line is anchored at the antenna feed point.

Use spring hangers every 10 feet down the length of the tower, at least on the 3 $\frac{1}{8}$ -inch line. The springs are designed to carry 10 feet of line. If the tower is also a broadcast antenna, insulated hangers may be obtained so that the line can be isolated from the radio antenna. One such hanger is shown in Fig. 6-13C.

At the bottom of the tower use a 90-degree elbow, or another angle if the tower slopes, so the vertical run will match up with the horizontal run. Do not rigidly mount the line at the bottom of the tower. Different types of braces are used there and on the horizontal run (Fig. 6-14). The horizontal run must be permitted to expand and contract. For this purpose, use either a roller or slide-through type supporter. The movement of the line can damage equipment inside the building unless it is securely anchored at the building entrance. Use a special, rigid building clamp and entrance at this point, as shown in Fig. 6-15.

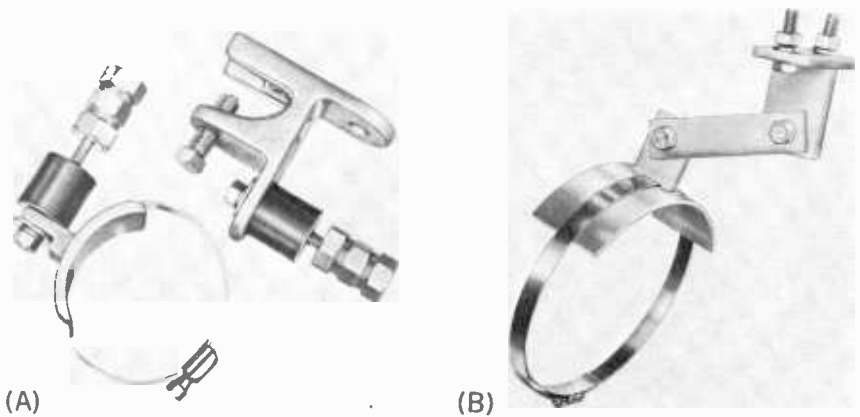

Fig. 6-14. (A) A lateral brace, used at the bottom of the tower to allow movement of the line with temperature changes; (B) A horizontal brace, used to suspend the horizontal run. (Andrew Corp.)

The line is anchored at both ends of the run. Movement of the horizontal run will cause the vertical run to give and movement of the

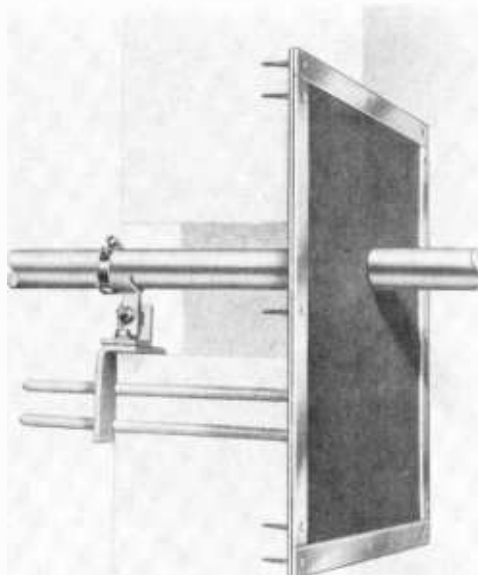

Fig. 6-15. *The horizontal anchor and building entrance. This rigidly anchors the horizontal run at the building. (Andrew Corp.)*

vertical run will cause the horizontal run to give. Thus, most of the movement ends up at the tower base, which is why the line should not be anchored rigidly there.

Gassing

Either dry air or nitrogen should be used to gas the line. High pressure is not needed, unless the transmitter power is working close to the maximum line power rating. Higher gas pressures and/or the use of different gases (such as sulfurhexafluoride, which has a high dielectric strength) will increase the peak power rating of the line. Voltage flashovers are caused by poor insulation between the two conductors. Thus, moisture will reduce the resistance of the gas or air. The average power rating of the line is dependent upon the teflon or other type insulators and how much heating they can stand from the r-f energy before breaking down. As long as there is higher pressure inside the line, any leak that develops will cause the inside air to flow outwards. When the line is un-gassed or all the pressure is gone because of a leak, changes of outside temperature and heating of the copper by the sun will cause the line to "breathe." This happens when the inside pressure becomes lower than the outside pressures and outside air flows into the line, bringing moisture, water, and dirt (and trouble) with it.

Gas Blocks

Gas blocks are devices placed in the line that will permit line continuity but will not allow the gas to pass within the line (Fig. 6-16). Each block has provisions for attaching a copper input air line, exhaust plugs, or pressure gauges. Gas blocks should be used at different locations in the line so that it will not be necessary to empty the entire line if a section of it has to be opened.

Use a gas block at the beginning of the horizontal run, at both ends at the tower base, and at the top of the vertical run, at least. At the bottom of the tower, use a small copper tube to bypass the gas block so that the dry air pump or nitrogen tank may gas the entire line from inside the building and thus keep the whole line pressurized. Insert a small shut-off valve in this copper bypass tube, so that either section of the line may be shut-off. It is easier to detect which line section is leaking if sections can be shut off.

The Dry Air Pump

Dry air pumps are available that use a small compressor to pump the line up to desired pressure and have an automatic pressure switch that will maintain the pressure selected. When line pressure drops for any

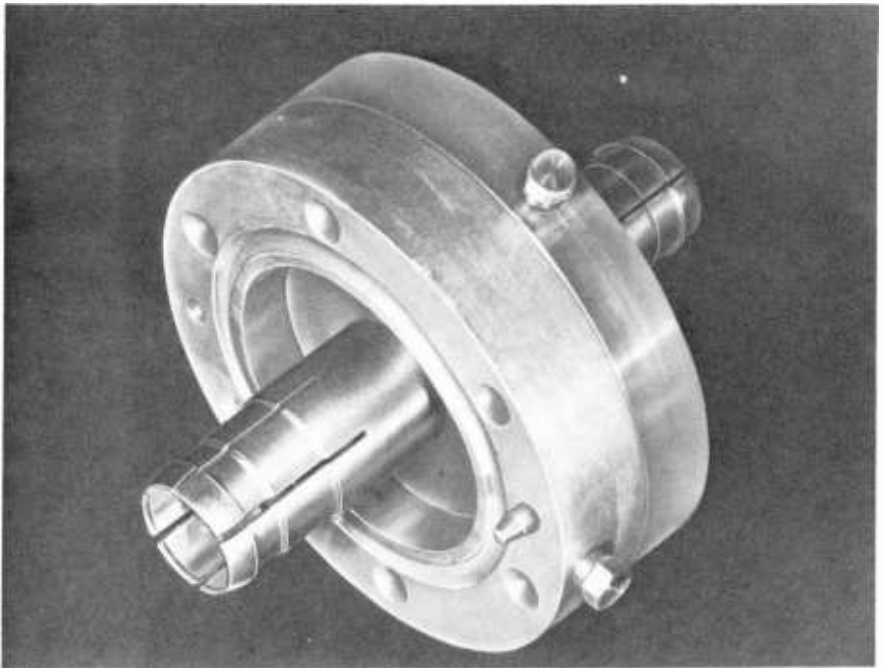

Fig. 6-16. A gas block or barrier for 3/16-inch coaxial line.

reason, the pump will start up and run until pressure is back to normal and then will shut off. The air is filtered through a silica-gel material that absorbs the moisture in the air. When this material reaches a saturation point, the pump will automatically switch into a drying mode and will heat and dry the moisture from the silica-gel. It will not pump into the line during this operation. A drain pipe must be provided to remove the water that is taken out of the silica-gel, or it will be discharged onto the floor.

Gas Supply

Tanks of nitrogen are commonly used as a gas supply. Cylinders of nitrogen are compressed at very high pressures and cannot be fed directly into the transmission line. A regulator is needed to control the flow into the line. Once the regulator is set to desired line pressure, it will shut off the flow of gas when this pressure is reached. The tank need not be shut off, since the regulator will keep it shut off unless pressure drops in the line. In which case, the regulator will allow enough gas to flow until the pressure is back to the preset level.

When ordering nitrogen, be sure to specify oil-pumped dry nitrogen. There is also available a water-pumped nitrogen, but the moisture content is too high for this application.

There have been a few cases, either because of faulty valves or someone tampering with the valves, where a new tank of nitrogen has been delivered that is only partially full. You can easily check on this by mounting the regulators, which also show how much pressure is in the tank.

Each gas tank has a color-coded cap and a stripe of the same color around the top of the tank. The name of the gas should also be printed on the side of the tank. One unfortunate station operator did not observe that the wrong gas had been delivered to him, and pumped neon gas into the transmission line. You can imagine the mess this made and how the transmitter behaved.

After the installation is completed, pressurize it and then bleed it from the top at the antenna point. This will exhaust all the old moist air. Refill it with dry air or gas.

Protecting the Line

In sections of the country where icing is experienced, damage to the horizontal run from falling ice is an ever-present hazard. When ice starts to melt off the antenna and tower, it will come off in sheets, sometimes in heavy pieces that are two or three feet long. Pieces of this size can do a lot of damage, especially because of the heights from which they fall. In such circumstances, it is important that the line be adequately protected.

The best protection is a wooden roof, reinforced with steel, built over the horizontal run (Fig. 6-17). It will shelter the line from falling ice as well as from tools or objects dropped by workmen on the tower.

Other damage can also happen to the horizontal run, especially if it is near the ground. Sources of damage from this quarter would be tractors, mowers, or just plain vandalism. Fencing to keep unwanted personnel away from the line and tower, plus crushed rock to keep down grass and weeds, will be well worth the additional expense.



Fig. 6-17. A protection shelter for a horizontal run of transmission line. (WLBC-TV, Muncie, Indiana)

The polyethylene coated heliax line may be buried in the ground safely. This will eliminate most of the line hazards. However, care must be taken that no one digs into the cable or runs a plow through it. The author has always preferred to have the line out of the ground, where it is accessible when work is needed or testing is required.

The considerations above pertain to a rigid line system. When using heliax, most of these precautions are not necessary, because many of the problems don't exist for heliax. Although the flexible line requires a somewhat different installation technique and different hanging, it is not a very difficult procedure.

Waveguide

Many stations use waveguide (Figs. 6-18 and 6-19) instead of coaxial line. The power ratings are considerably higher and the losses are considerably less than coax. For example, Andrew #1500 waveguide, designed for 470–750 mc, has an average power rating of 425 kilowatts and the loss figure is 0.055 db/100 foot line section. The cost is much higher than coaxial line.

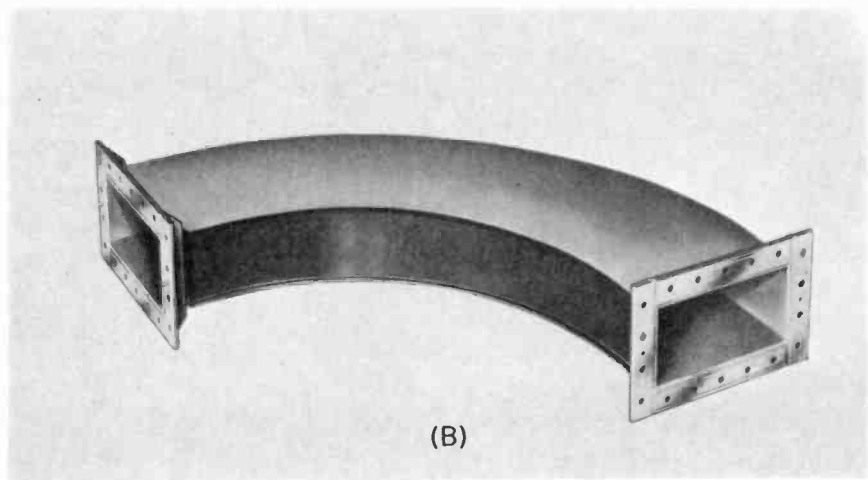
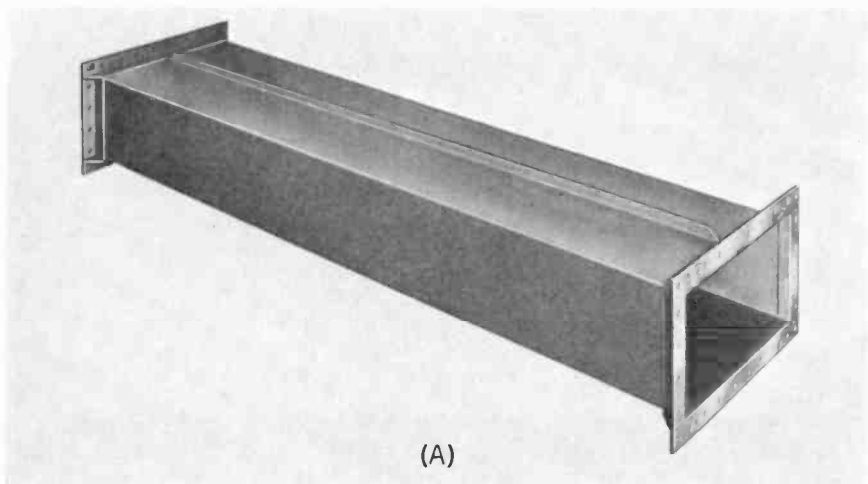

Fig. 6-18. (A) WR-1500 waveguide section. (B) 90-degree bend of waveguide. (Andrew Corp.)

Most waveguide systems must be tailor made for each installation. The manufacturer will assist in designing the system and working up a cost figure for the package. Small uhf stations will seldom use a waveguide system. Coaxial lines will be completely satisfactory in these installations.

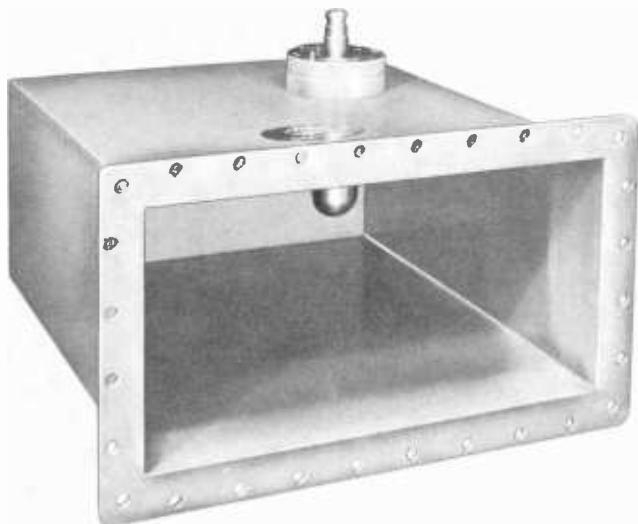

Fig. 6-19. A transition from waveguide to rigid transmission line. (Andrew Corp.)

Cost Estimates and Examples

Individual station requirements will vary. However, an example of a hypothetical installation will illustrate several points discussed in this chapter and help you arrive at a cost estimate for your own system.

In this example, the tower is linear, guyed, and 400 feet tall. The transmitter is located 40 feet from the tower base. The transmitter has a peak visual power output of 1 kw. The line figures have not been derated for VSWR. (A high VSWR will reduce these figures.) The transmitter is on channel 35.

1. Using Andrew 1 $\frac{5}{8}$ -inch Heliax

Loss on 440 feet of line will be $0.58 \text{ db} \times 4.4$, or 2.55 db, for a line efficiency of 57%. Only 570 watts will be available to the antenna; almost half of the transmitter power is lost. Average power rating for this line is 4.2 kw.

Materials needed:

440 feet, 1 $\frac{5}{8}$ -inch heliax, 117-50 (a \$3.00 ft. plus \$16.00 for flange mounting	\$1,336
1 #24312 hoisting kit and top hanger	\$ 12
8 #24811 ground clamp (a \$3.00	\$ 24
4 #12395-1 stainless steel Wrap-Lock (a \$12.50	\$ 50
1 #3901 horizontal anchor, building entrance	\$ 25
2 #77R EIA flanges	\$ 80
Total	\$1,527

2. Using Andrew ± 561 , 1 $\frac{5}{8}$ -inch Rigid, Teflon Line

Loss on 440 feet of line on channel 35 will be $0.51 \text{ db} \times 4.4$, or 2.24 db, for a line efficiency of 60%. This would permit 600 watts to reach the antenna. Average power rating is 5.8 kw.

Material needed:

440 feet, (22 sections, each 20' long, with flanges and inner connectors) (a \$80.00 section	\$1,760
3 #1061 90-degree elbows (a \$36.00	\$ 108
8 #14379 spring hangers (a \$12.00	\$ 96
55 #13550 clamps (a \$4.00	\$ 220
2 #13924 rigid hangers (a \$8.00	\$ 16
40 #14378 sliding hangers (a \$6.00	\$ 240
1 #3921 lateral brace	\$ 18
4 #3911 horizontal hangers (a \$12.00	\$ 48
1 #3901 horizontal brace, building entrance	\$ 25
4 #1261b gas barriers (a \$40.00	\$ 160
Total	\$2,691

3. Using Andrew H2-50, 3 $\frac{1}{8}$ -inch Heliax

Loss on 440 feet of line on channel 35 will be 0.45×4.4 , or 1.8 db, for a line efficiency of 63%. This will permit 630 watts to reach the antenna. Average power rating is 11 kw.

Material needed:

440 feet, 112-50, 3 $\frac{1}{8}$ -inch heliax (a \$9.00 foot, plus \$20.00 for flange mounting	\$3,980
1 #23146 hoisting kit and top hanger	\$ 25
1 #3902 horizontal hanger and building entrance	\$ 30
88 #22417 hangers (a \$16.00	\$1,408
3 #23145 grounding kits (a \$25.00	\$ 75
2 #22R EIA flanges	\$ 200
Total	\$5,718

4. Using Andrew $\pm 562A$, 3 $\frac{1}{8}$ -inch Rigid, Teflon Line

Loss of 440 feet of line on channel 35 will be $0.42 \text{ db} \times 4.4$, or 1.8 db, db, for a line efficiency of 76%. This will permit 760 watts to reach the antenna. Average power rating is 19 kw.

Material needed:

440 feet, Andrew #562A (22 sections, each 20 feet long, with flange connector)	(@) \$130/section	\$2,860
3 #1602 90-degree elbows	(@) \$60.00	\$ 180
4 #1262A gas barriers	(@) \$70.00	\$ 280
2 #13927 rigid hangers	(@) \$12.50	\$ 25
40 #13925 spring hangers	(@) \$15.00	\$ 600
1 #3922 lateral brace		\$ 12
4 #3912 horizontal hanger	(@) \$12.00	\$ 48
47 #13550 clamps	(@) \$ 4.00	\$ 188
1 #3902 horizontal anchor and building entrance		\$ 30
	Total	\$4,223

In any of the line installations, you will need some method of gassing the line and maintaining pressure. Either of two methods may be used.

Andrew #1910A automatic dehydrator	\$ 450
Andrew #858 nitrogen tank fittings and gauges	\$ 48

If you wish to use nitrogen, this gas is purchased locally through a welding supply or bottled-gas supply house. The Andrew automatic dehydrator supplies dry air under pressure to the line.

Chapter 7

The UHF Antenna

General Characteristics

The length of a dipole antenna at uhf frequencies will be quite small in comparison to lower frequency antennas, such as those used in AM radio, FM radio, and high-band vhf television. For example, a half wave dipole in each of the following bands will have the approximate dimensions shown, which in each case were chosen for a mid-band channel. (The general formula used is length in feet equals 468 divided by frequency in megacycles.)

AM, 1000 kc	— 468 feet long
FM, 100 mc	— 4.68 feet long
vhf channel 10, 192 mc	— 2.43 feet long
uhf channel 35, 600 mc	— 9.3 inches long

This small physical size of uhf antennas presents some disadvantages in power handling capability. In a receiving antenna, the small size does not provide an area large enough to intercept or collect much of the signal. There are, however, advantages which lend themselves well to techniques and methods that are not possible on lower frequency antennas.

The first advantages are weight and compactness. The large reduction in weight puts less demand on the tower. The small size permits many dipoles to be stacked in a smaller space with a considerable increase in power gain. Directionalizing and pattern shaping is much simpler, because many different arrangements are possible.

Even though the amount of power that can be fed to single dipoles is limited, high power can be distributed to many dipoles in the array.

With the increased gain available from stacking, more power is radiated from the array than from a single dipole on a lower channel with the same power input.

Antenna Types

There are at least five different types of uhf transmitting antennas on the market: slotted, helical, zig-zag, and two imported models, one a variation of the slotted and the other a stacked, physical dipole.

The Slotted Antenna

The slotted antenna (Fig. 7-1) is a large diameter cylinder with a single feedline running up the inside center, so that the assembly is a very large coaxial transmission line. Slots of the correct dimension are cut in the outside cylinder, much as a window is cut in the side of a building. Proper dimensioning permits these slots to radiate as an antenna. Coupling r-f energy from the center feedline to the antenna slot is accomplished by either a loop or a bar.

The Helical Antenna

The helical antenna (Fig. 7-2) is a wire spiraled about a mounting pole, from which it is insulated. The wire is the radiating element, and, since any supporting structure will affect the pattern, the mounting pole is considered in the antenna design.

The Zig-Zag Antenna

The zig-zag antenna (Fig. 7-3) is a wire formed in a zig-zag shape, mounted on a panel and insulated from it. Again, the wire is the radiating element and the panel is for support and is considered in the design. The antenna works on the traveling-wave principle.

All of these different models are good antennas. Some will prove more advantageous or meet a station's requirements better than others. For example, because of coverage requirements and an already owned radio tower, you may desire to sidemount a zig-zag. The pylon may be too heavy for the tower to support. Thus, selection of an antenna will usually be based on cost, what is on hand, and what is needed. Each choice will be a custom installation.

Antenna Terminology

When reading articles in magazines or specification sheets in catalogs, you will encounter many terms which need some explanation. A few of the more common terms are explained here.

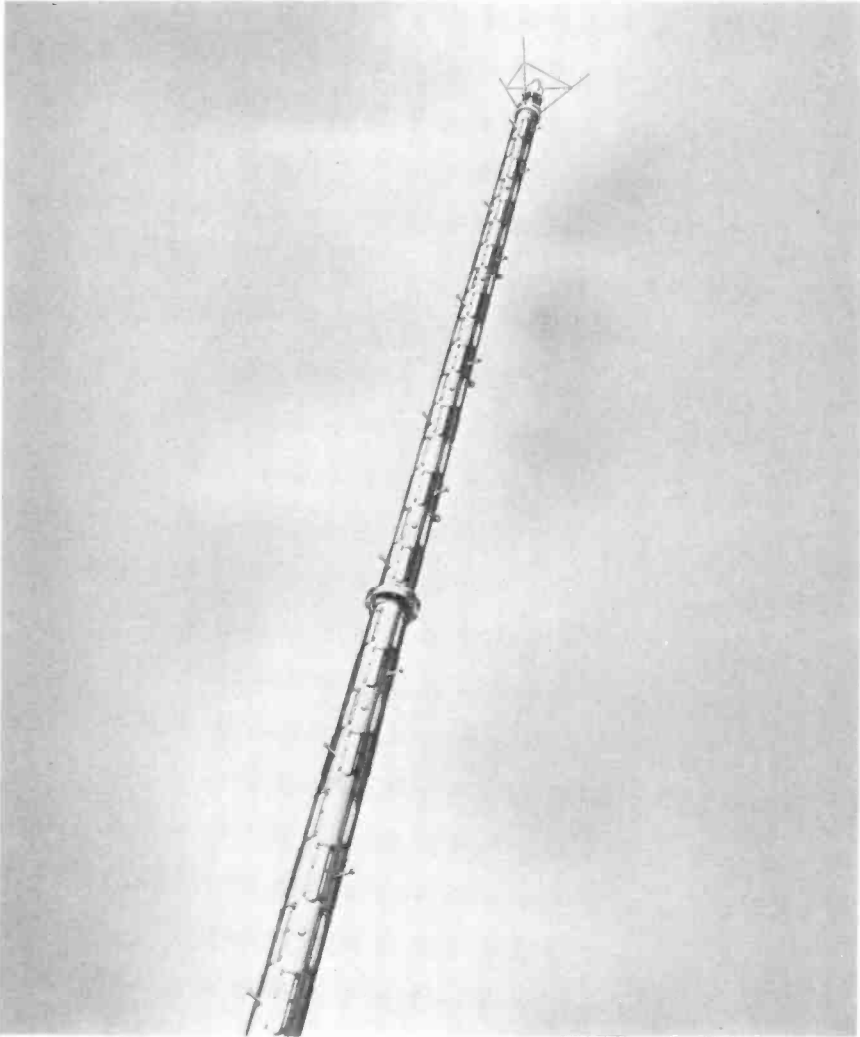

Fig. 7-1. *The RCA slotted antenna. (RCA)*

Aperture. This refers to the overall length of the radiating surface of the dipole or the entire length of a stacked array, which is the more usual case. This does not include the part of the antenna array that is used for mounting beacons or bottom mounting plates. If you picture the antenna as a window in a building and the r-f energy as sunlight, you can see that a short window (antenna) will have a smaller aperture and will let in less light or energy, while a longer window will permit the entrance of more light or energy.

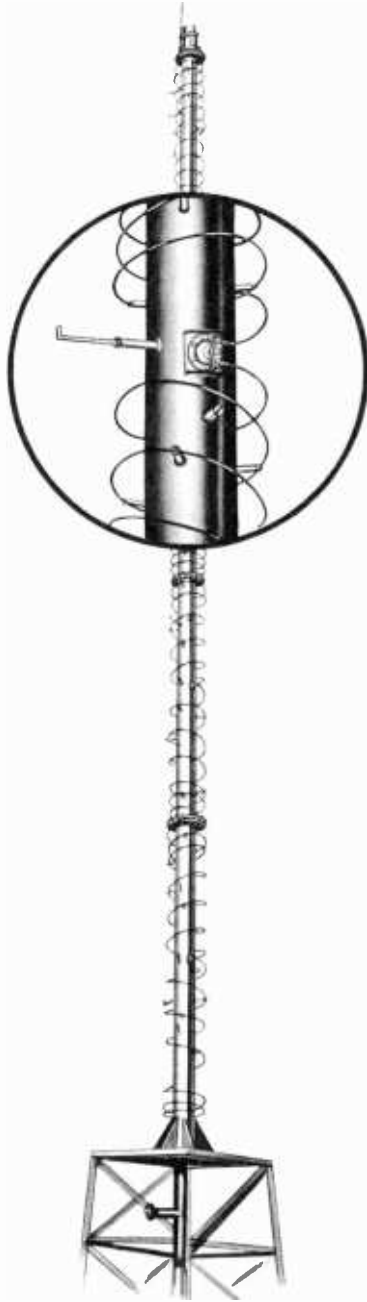

Fig. 7-2. *The General Electric uhf helical antenna. (GE)*

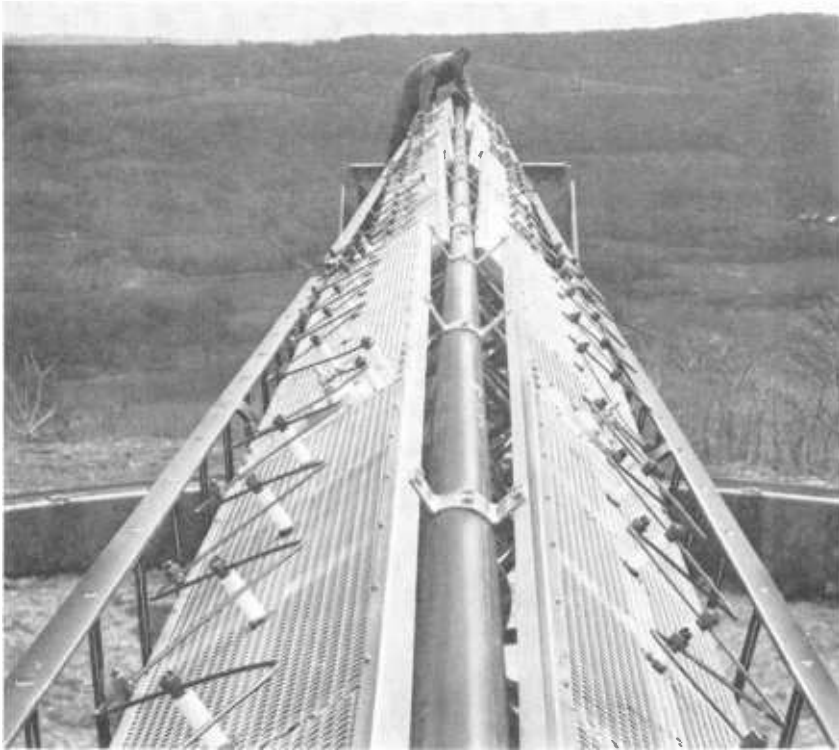

Fig. 7-3. A close-up view of the zig-zag antenna. (GE)

Power Gain. Earlier in this chapter it was indicated that stacking dipoles permits each to contribute to the radiated energy. In such an array, each radiating element, while contributing to the overall energy, will add or subtract from its neighbors, depending upon phasing. Also, the energy normally radiated towards the ends of a single dipole is now compressed more and more into a narrow lobe radiating off the side of the array. However, energy radiated from the dipole ends is of little use in uhf transmission because these waves hit the ionosphere and are lost. They are not bent back or reflected, as are lower frequency waves. Those waves that would shoot off the antenna towards the ground are not too useful either, because no receiving set needs such high power directed at it from a nearby antenna. Therefore, the compression of these ordinarily wasted energies into the main lobe adds to the radiation strength of the stack. This increase in strength is power gain. The power gain figure is used as a multiplying factor. Specification sheets will show the nominal power gain figure for an antenna which represents

power gain before the beam is altered (i.e., by directionalizing or beam tilt).

Bay. A bay is a single radiating element or layer of a stacked antenna array. A single dipole is a single bay, since it can be operated by itself as a complete antenna when used separately. If more than one dipole is around a pole on the same level as this dipole and properly phased to it, all the elements would be a layer and would function as a single bay.

Side-fire. Side-fire radiation indicates that the radiated energy leaves an antenna array at right angles to the physical placement of the antenna. Because TV antennas are mounted vertically on a tower, the r-f energy radiates in the maximum direction toward the horizon, rather than to the sky. The helical and the zig-zag antennas make use of the long wire principle in their individual elements of the antenna: normal radiation from a wire that is several wavelengths longer than the r-f energy it is to radiate will radiate maximum energy off the ends of the wire in the direction the wire is pointing. Through proper phasing and design, the energy radiated from the zig-zag and helix antennas does exactly the opposite; it shoots off the side of the array, which is what is desired for television use.

Effective Radiated Power. The product of the antenna power gain figure times the power input to the antenna gives the effective radiated power (ERP). A single dipole will have a gain of one—power fed to it will also be the effective radiated power; e.g., a single dipole fed with 1 kw of r-f power will have an ERP of 1 kw. If several dipoles are stacked so that the array has a power gain of 25 and 1 kw r-f power is fed to it, the ERP will be 25 kw. Power gain is also given in decibels and may be determined by the use of decibels rather than by straight multiplication. You will also find field strength measurements given in both microvolts and dbu.

Electrical Beam Tilt. The major lobe of radiated energy from a non-directional antenna will be distributed equally around the antenna, much like a flattened doughnut or tire on a wheel. By proper phasing of the energy to individual radiators, the energy can be raised or lowered a few degrees from its normal path, much as an umbrella is raised or lowered. This will tilt the lobe equally on all sides of the antenna (Fig. 7-4).

Mechanical Beam Tilt. The beam is altered by tilting the antenna. This type of beam tilting will lower the major lobe on one side and raise it an equal amount on the opposite side (Fig. 7-5). (Both types of beam tilting, mechanical and electrical, are used for null fill-in, pattern shaping, and directionalizing.)

Directionalizing. The radiating elements of an array are so stacked,

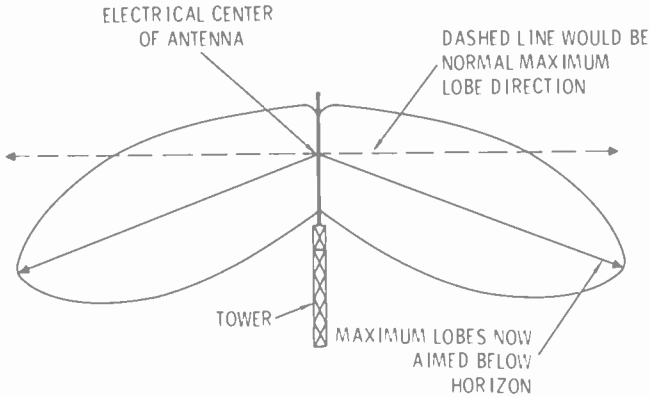

Fig. 7-4. The vertical pattern can be altered by use of electrical beam tilt. The pattern is raised or lowered like an umbrella.

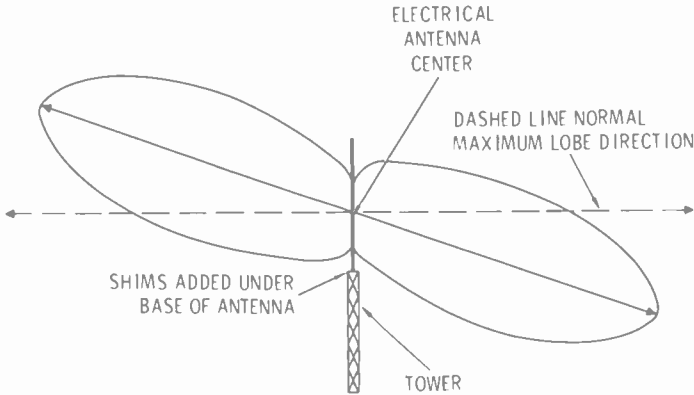

Fig. 7-5. Using mechanical beam tilt, the pattern is raised on one side and lowered on the other.

adjusted, and phased that power is increased or decreased in various directions to suit the station requirements. The same function in radio is supplied by directional antenna systems, where other stations on the same channel must be protected from interference. However, directional antennas used in TV work have other purposes. Because of site locations, a station will try to get the best possible use of its signal by directing it where it will do the most good. For example, if the antenna is located on the seacoast or at the edge of the Great Lakes, half of the signal would be wasted over these bodies of water. By redirecting this energy, more power will be available to provide a more solid coverage in the desired area. The nominal gain figure becomes revised upward when directionalizing is used, at least in the direction of the major lobe. Directionalizing is a simple matter with uhf antennas.

Horizontal Pattern. This is a term for the radiated energy coming off the antenna. A simplified example may help to clarify the difference between this and vertical pattern.

First, assume you can see the r-f energy radiated from the antenna. Then, if you take a ride in a helicopter and hover directly above the antenna, looking down and off to the horizon on all sides, you will see the radiated energy in a circular pattern (if it is a nondirectional antenna). This is the horizontal pattern (Fig. 7-6). It will look much like a large flattened doughnut; when you look down directly at the top of the antenna, you will be looking at the hole in the doughnut.

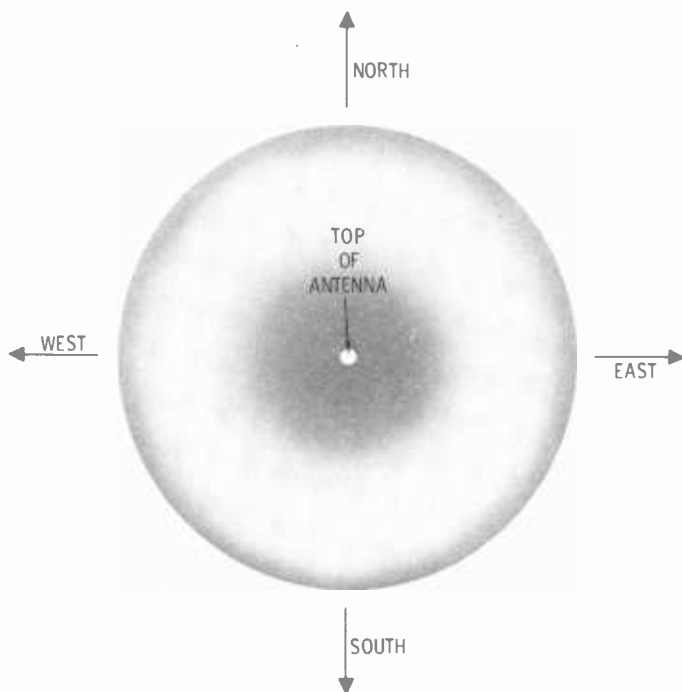

Fig. 7-6. A pictorial representation of the horizontal pattern.

Vertical Pattern. Continuing the simplified analogy used for the horizontal pattern, assume that the helicopter now flies some distance from the antenna and lands on a small hill so that you are on a level with the electrical center of the antenna. If the doughnut were now sliced in two, you could see a silhouette of the energy from the ground to the sky, which is the vertical pattern (Fig. 7-7).

Azimuth and Elevation. Some discussions on antenna theory, especially in regard to directional antennas and contoured patterns, will use these two terms instead of horizontal and vertical patterns. *Azimuth* is the

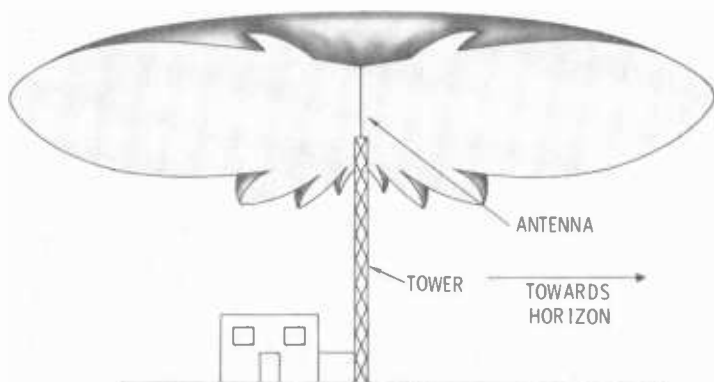

Fig. 7-7. A pictorial representation of the vertical pattern.

horizontal pattern in a particular direction, such as azimuth readings on a compass would indicate. *Elevation* is the vertical pattern in a particular direction. These terms are more specific than horizontal and vertical pattern.

Feedpoint. This term may mean the point where the transmission line feeds energy to the antenna array or where the individual dipoles obtain their energy from the main feeder. All uhf antenna arrays have only one feedpoint from the station transmission line. Both aural and visual outputs are combined with a special device at the transmitter and both are fed on the same transmission line to the antenna. Thus, only one line is required up the tower. There are no separate radiators for the aural and the visual.

De-Icing. It is necessary to keep ice from forming on the antenna or to melt it off after it has formed. While different models of antennas use different methods, the basic means is a 60-cycle current and some heating device to melt the ice.

Most antennas are not affected by a small amount of ice, but heavy icing will detune the antenna, which causes a mismatch to the line. Such a mismatch will cause high standing waves to appear on the transmission line. A high power transmitter can damage tubes, the line, or the antenna, itself, when high standing waves are present. Also, ghosts or multiple images will be transmitted in the picture.

Using the Charts

Antenna specification sheets or discussions of uhf antennas often use special charts and formulas to help describe the performance expected of a particular antenna, especially in regard to radiated patterns.

Generally, the correct antenna and the patterns necessary to provide the best coverage for the station will be determined by the factory engineers and the station consulting engineers. However, after the antenna is installed and in operation, the station engineer may receive complaints of poor signal from some viewers who are close enough to the antenna to see it. Of course, there may be several reasons for this, such as a set working poorly or an improperly installed receiving antenna, but it could also be that there are holes in the coverage area.

Some understanding of the charts and other specification information will prove helpful to the station engineer when he finds himself in such a position. It may be difficult to explain why the set owner can't get a good signal when he only lives a short distance from the antenna and is located in a null or weak signal spot.

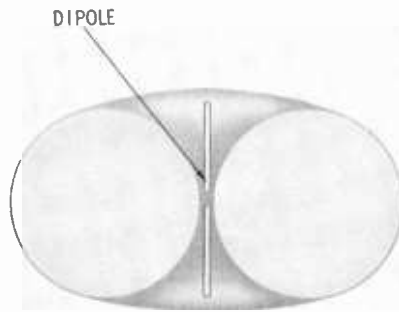

Fig. 7-8. *The field pattern around a single dipole antenna is round and symmetrical.*

First, consider the vertical pattern radiated from a dipole antenna. From the side, it looks like the cross-sectional view of a doughnut: nice full circles of radiated energy (Fig. 7-8). Of course, at uhf much of this signal will be wasted because it radiates where it will serve no useful purpose. As several dipoles are stacked, this wasted energy is directed into the main useful directions and added energy increases signal strength. But this flattens out the doughnut so that the pattern shows elongated lobes instead of circles with smaller lobes clustering around the center (Fig. 7-9). As the stacking continues, this process continues so that the main lobes become very narrow. (You will find these described as lobes, beams, or rays; for practical purposes, these terms are synonymous.)

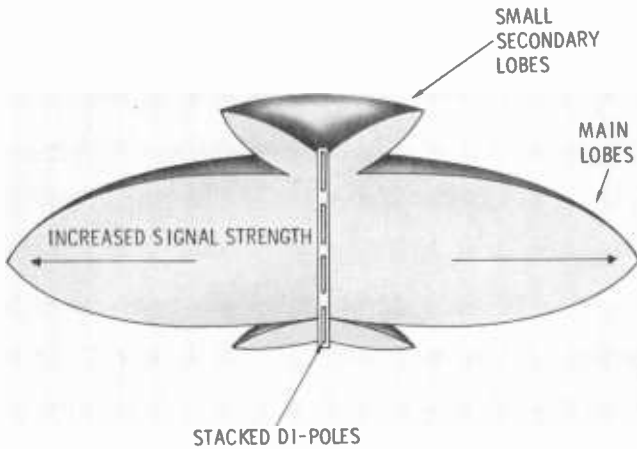

Fig. 7-9. Stacking dipoles alters the vertical pattern. It is flattened into a disc with small lobes appearing near the antenna, increasing signal strength in the main lobes.

Charts of vertical patterns show the lobes in only one direction for clarity. For a nondirectional antenna, they are equal and in a circle around the antenna. Directional antennas will have various shaped patterns in different directions.

Generally, the chart of the vertical pattern has degree markings at the bottom and relative field strength notations on the left-hand side. The curve shows the maximum signal pointing towards the top of the page. You can get an approximate idea of what this pattern looks like by turning the page so that the degree markings appear on the left side and relative field strength readings are at the top of the chart. The curve will then go across the page from the left, which would be antenna location, to the right, which would be the horizon. Remember that this is only an approximate visualization, because the earth is not straight, as are the lines of a chart.

The pointed nose of the curve is the maximum signal lobe from the antenna to the horizon on a direct line. This would shoot right over the horizon and be lost. This lobe narrows as the stacking is increased. The lobe or beam width is measured in degrees at the points where the relative field strength drops 3 db down from maximum (at approximately 70% of maximum). Very high gain antennas have very narrow lobes. For example, the RCA TFU-52H, with a power gain of 52, has a lobe only 1.25 degrees wide. On the other hand, the RCA TFU-6B, with a power gain of 6, has a very broad lobe that is about 7 degrees wide.

Very narrow, unadjusted beams waste much of the signal by shooting it over the horizon, and close-in coverage may suffer with poor or no

signal. Beam tilting, as shown in Fig. 7-10, is used to point the nose of the lobe so that it hits ground before it goes past the horizon. This provides good coverage out to the horizon without losing too much signal.

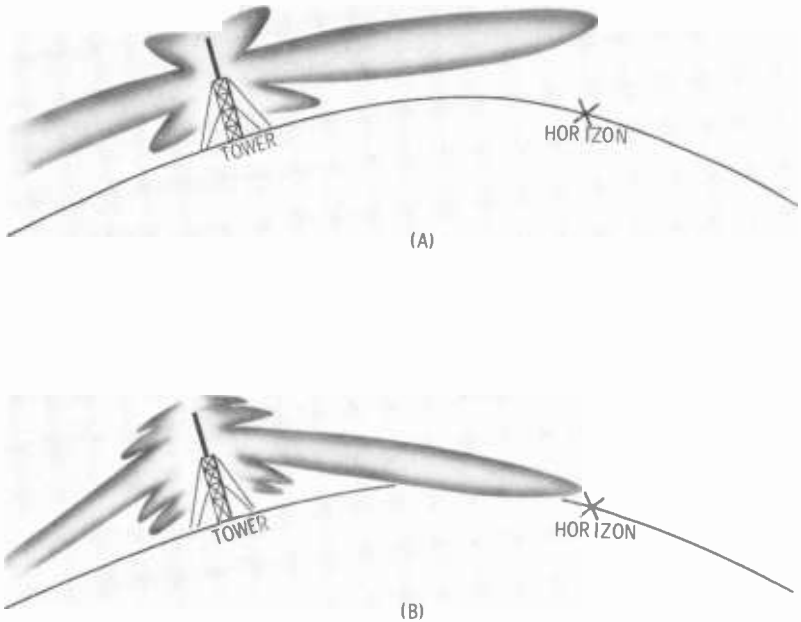

Fig. 7-10. (A) Without beam tilt the main lobe of the signal would pass over the horizon. (B) Beam tilting points the nose of the main lobe at or slightly below the horizon for better coverage out to the horizon.

The uht signals travel in a straight line from the antenna and will not return to earth past the horizon. When the lobe shoots past the horizon, very little of it is useful on the other side unless someone has an antenna that is high enough to intercept some of the signal (which is now heading for the ionosphere and oblivion).

A chart such as that shown in Fig. 7-11 is used, with appropriate formulas, to determine the distance to the horizon and various depression angles from the antenna to receiving antenna locations. Knowing the distance to the horizon and to various receiving locations will help make the vertical pattern more useful. These chart figures are fairly reliable for flat terrain, but having a mountain ridge nearby that is higher than the antenna will change these figures markedly in that direction.

The column under D_h gives the distance to the horizon from the electrical center of the antenna. (The height of the electrical center of

DISTANCES AND DEPRESSION ANGLES FOR VARIOUS ANTENNA HEIGHTS

H Height in feet to Electrical center of antenna
 D₁ Distance to horizon (4/3 earth radius)
 A₁—Depression angle to horizon

The relationship $D = 0.109 H / A$
 holds to right of line within 4°



DISTANCE IN MILES TO RECEIVING LOCATION

HEIGHT IN FEET	DEPRESSION ANGLE																					
	0.5	1	1.5	2	2.5	3	3.5	4	4.5	5	6	7	8	9	10	11	12	13	14	15	D ₁	A ₁
200	4.6	2.21	1.45	1.07	0.86	0.71	0.61	0.54	0.48	0.43	0.36	0.31	0.27	0.24	0.22	0.20	0.18	0.17	0.15	0.14	200	216
300	7.2	3.35	2.18	1.64	1.30	1.07	0.92	0.80	0.71	0.64	0.55	0.46	0.41	0.37	0.33	0.30	0.27	0.25	0.23	0.21	24.5	268
400	9.9	4.49	2.90	2.18	1.75	1.42	1.24	1.06	0.94	0.86	0.73	0.62	0.54	0.49	0.46	0.43	0.36	0.33	0.31	0.29	28.3	304
500	12.6	5.60	3.65	2.72	2.16	1.82	1.55	1.36	1.21	1.09	0.92	0.78	0.68	0.61	0.55	0.50	0.45	0.42	0.39	0.36	31.6	343
600	16.0	6.81	4.8	3.61	2.64	2.15	1.86	1.63	1.42	1.31	1.09	0.92	0.81	0.73	0.65	0.59	0.54	0.50	0.46	0.43	34.6	375
700	19.9	7.98	5.2	3.87	3.08	2.54	2.16	1.90	1.68	1.50	1.25	1.06	0.94	0.87	0.74	0.68	0.62	0.57	0.53	0.50	37.4	405
800	24.2	9.2	5.9	4.49	3.52	2.89	2.50	2.17	1.90	1.75	1.45	1.22	1.05	0.97	0.86	0.78	0.72	0.67	0.61	0.58	40.0	435
900	29.5	10.5	6.7	5.05	3.98	3.28	2.80	2.45	2.13	1.96	1.62	1.36	1.19	1.09	0.97	0.88	0.81	0.75	0.69	0.65	42.4	452
1000	36.2	11.6	7.4	5.51	4.39	3.65	3.10	2.70	2.39	2.15	1.79	1.52	1.32	1.18	1.08	0.98	0.90	0.83	0.77	0.72	45.0	487
200	14.1	9.0	6.75	5.32	4.39	3.77	3.19	2.85	2.61	2.15	1.81	1.59	1.44	1.29	1.18	1.08	1.00	0.92	0.87	49.0	530	
1400	16.7	10.4	7.66	6.12	5.13	4.33	3.77	3.35	3.00	2.48	2.11	1.85	1.63	1.45	1.36	1.24	1.15	1.06	1.00	53.0	577	
1600	19.4	12.0	9.10	7.10	5.85	5.02	4.35	3.80	3.40	2.84	2.40	2.13	1.91	1.72	1.55	1.44	1.32	1.23	1.16	56.6	620	
1800	22.3	13.6	10.25	8.00	6.60	5.65	4.90	4.33	3.90	3.19	2.69	2.33	2.15	1.94	1.75	1.62	1.48	1.38	1.30	60.0	659	
2000	25.4	15.4	11.25	8.89	7.30	6.25	5.45	4.80	4.33	3.60	3.04	2.68	2.38	2.13	2.00	1.83	1.70	1.56	1.46	63.2	683	
9000	—	42.9	29.5	22.80	18.75	15.85	13.75	12.10	10.90	9.01	7.75	6.73	6.00	5.40	4.90	4.50	4.15	3.84	3.60	100.0	1080	

Fig. 7-11. Charts such as this one are used to determine the relationship between the antenna's height, depression angle, and the distance to the horizon. (RCA)

the antenna above average terrain is shown under H.) The column under A_h gives the depression angle from the same point of the antenna to the horizon.

The figures under the given depression angles represent the distances, in miles, to various receiving antennas for that angle and antenna height. The figures, obtained from the formula shown ($D = .0109 H/A$), have been rounded off.

Each manufacturer will compute patterns for the station to meet its individual needs. After the antenna has been assembled, it is tested on a large turntable by making actual measurements to see how it conforms to the computed pattern. In most cases, the measured values will be almost identical to the computed values. The charts and measurements are supplied to the station along with the antenna.

By using the charts and values supplied with the antenna and the charts under discussion here, the station engineer may make his own measurements to determine if the antenna is operating properly.

We can use the charts to obtain much useful information. For example, four calculated vertical pattern charts are shown for the RCA TFU-24DM, a medium-gain antenna. Each chart represents a different value of electrical beam tilt.

In Fig. 7-12A, the antenna has a 0.25° beam tilt, which drops the power gain figure from 24 to 23.2. Follow the zero degree line from the bottom of the chart to the top. The zero degree line is a straight horizontal line out from the antenna. The point of the lobe is not on this line; it is on the 0.25 degree line. Note the nulls in the curve at 2.7 degrees, 5.1 degrees, and 7.2 degrees. The signal strength at each of these points is 11.5% , 1% , and 2% , respectively, of the maximum lobe signal strength. Also, note that the beam width is only 2.1 degrees at the 70% points.

Assume, for this example, that the height of the electrical center of the antenna is 500 feet above average terrain. In Fig. 7-11, locate the 500 foot line under the height column. At this height, the distance to the horizon (under D_h) will be 31.6 miles and the depression angle at the horizon (under A_h) will be 0.343 degrees. Read across this line to the 2.5 , 5 , and 7 degree depression angles. Under 2.5 degrees, read 2.16 miles; under 5 degrees, read 1.09 miles; and under 7 degrees, read 0.78 miles. These are not exactly the points we require, but the exact ones may be figured if desired. For example, the distance to a receiving antenna at the 5.1 degree point will be:

$$D = \frac{0.0109 \times H}{A} = \frac{0.0109 \times 500}{5.1} = \frac{5.45}{5.1} = 1.07 \text{ miles}$$

Thus, a point 1.07 miles from the antenna will have only 1% of the maximum lobe signal.

CALCULATED VERTICAL PATTERNS FOR TFU-24DL AND TFU-24DM ANTENNAS

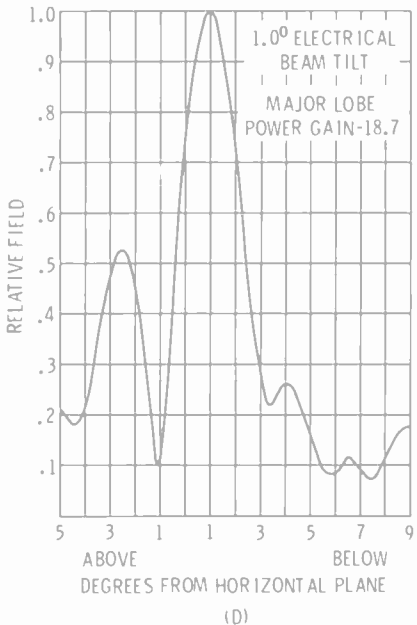
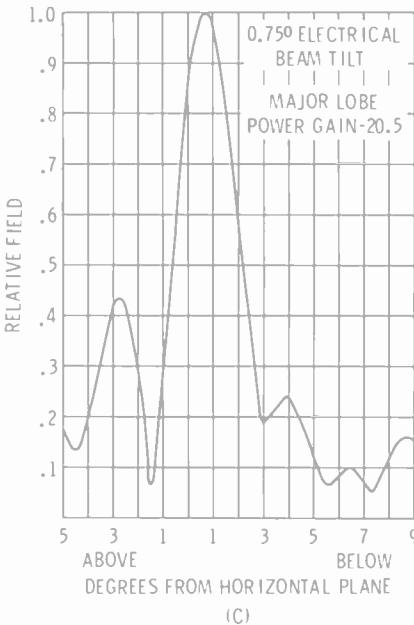
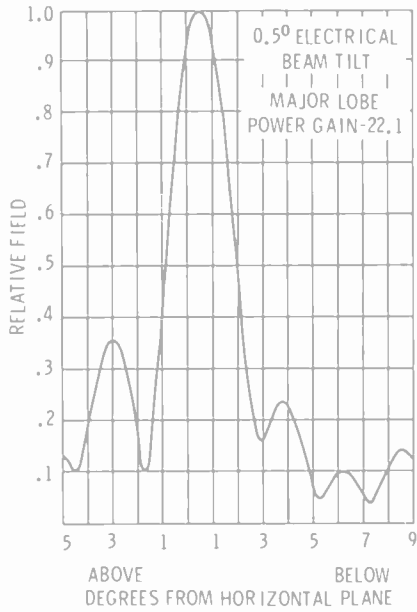
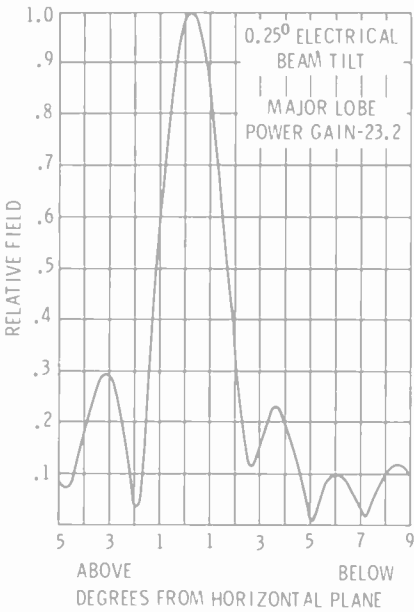

Fig. 7-12. Calculated vertical patterns for the TFU-24DL and TFU-24DM antennas. (RCA)

From Fig. 7-11, we know that the depression angle at the horizon for this antenna height is 0.343 degrees and that the point of the lobe is approximately at and slightly above the horizon and is receiving the maximum lobe signal strength. Each of the four charts in Fig. 7-12 may now be checked for these points to see how electrical beam tilting may help fill the nulls without reducing the signal at the horizon too much.

In Fig. 7-12D, for example, the beam tilt is 1 degree, which reduces the lobe power gain to 18.7. At the horizon, the 0.343 degree point, the signal is down approximately 11% and the 2.7 degree null point is up to 35.5%, the 5.1 degree null point is up to about 15%, and the 7.2 degree null point is up to 7% of maximum lobe signal strength.

The smaller degrees of beam tilt are generally used, except in special cases and contouring. These nulls will not be too serious unless the power radiated is very low. If a station is transmitting an ERP of 200 kilowatts, a receiver located only three-quarters of a mile away can do very well without all this power beamed at it. On the other hand, if only 600 watts are transmitted, the null at this point could be a serious problem.



Fig. 7-13. *This high-gain uhf pylon antenna is being readied for check-out on the turntable at the factory. The window covers are not yet in place. (RCA)*

Commercial Antennas

The RCA Pylon Antenna

The RCA high-gain uhf pylon antenna shown in Fig. 7-13 is more popularly known as the slotted antenna. Its construction is both simple

and rugged. Essentially, it is a large coaxial transmission line with appropriately shaped slots cut in the outside wall so that energy may be radiated.

R-F energy is fed from the station transmission line to the antenna base as shown in Fig. 7-14. The outer conductor of the transmission line is grounded at this point and the inner conductor connects to the inner conductor of the antenna, which is a copper pipe. This center conductor is grounded at the top of the antenna. The length must be correct to do this, but it is part of the antenna design.

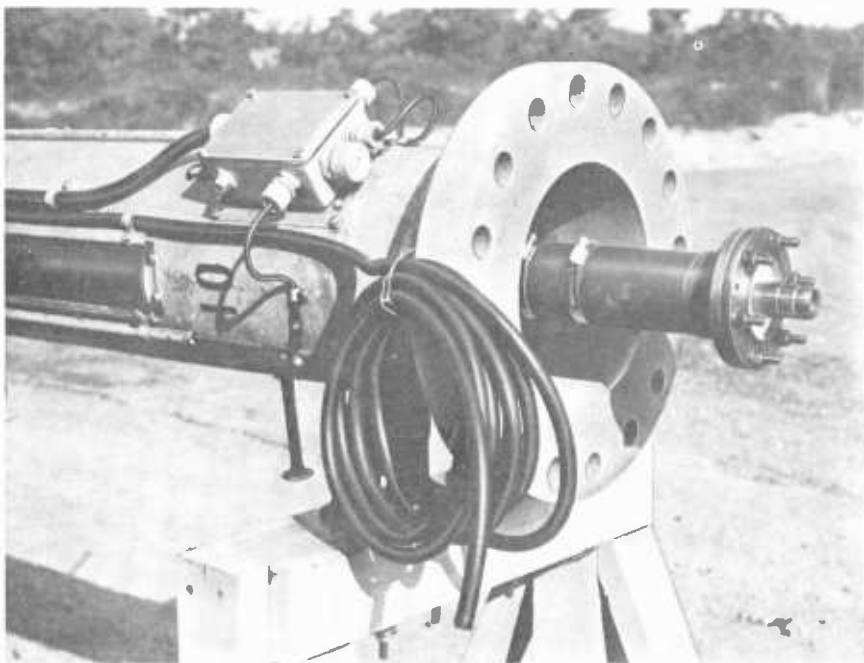

Fig. 7-14. The coaxial feedpoint is prominent at the base of the uhf pylon antenna. Also shown are the cable to the beacon light and the junction box for the heaters. (RCA)

Some styles of pylon use a feedpoint that is half-way up the antenna. As far as the station is concerned, the feedpoint is still at the base of the antenna as in the other style. In this case, the station transmission line ends at the same place, but the line inner conductor, instead of connecting to the antenna center conductor, joins with another pipe that makes a coaxial line with the center conductor. At the midway point, the energy is fed to the inner conductor of the antenna. As before, this inner conductor is grounded at the top of the antenna.

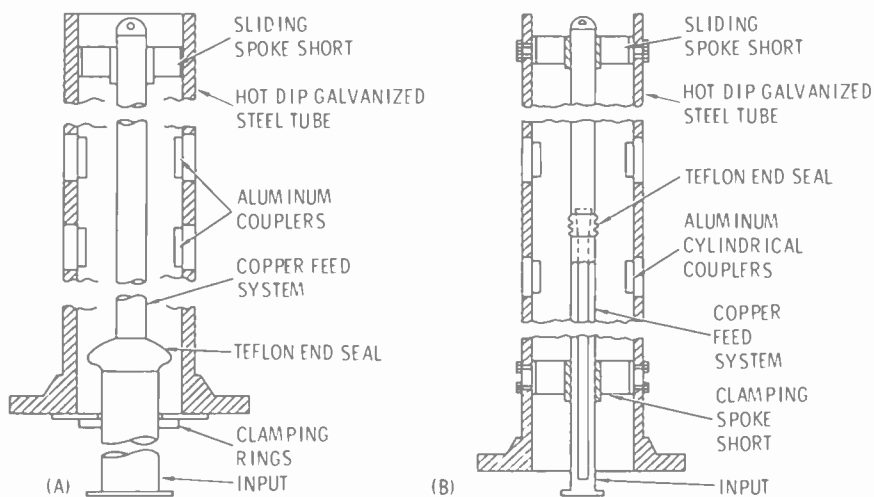

Fig. 7-15. Two methods of feeding r-f energy to different RCA antenna models: (A) the end-fed antenna; (B) the center-fed antenna. (RCA)

As r-f energy travels along the inner conductor of the antenna, some of it is coupled to the individual slots as it passes (Fig. 7-16). This coupling is made with a small loop or a small bar that is connected to the edge of the slot.

The center conductor is a copper pipe and the outer conductor is made of a special steel. The supporters and spacers between the two are made of teflon. At the top, a plate is provided for mounting a standard beacon light, with the power cable running down the outside of the pylon. Also, a branching-type lightning rod system is firmly bolted to the plate. Since both the inner and outer conductors of the antenna are grounded to the tower, a high degree of lightning protection is afforded.

Climbing spikes are provided so that the beacon or antenna may be serviced. At the bottom of the antenna, a flange of special steel is provided for mounting the antenna to the top plate of the tower. The antenna feedline protrudes into the tower a short way for connection to the station transmission line.

Each individual slot is covered with a polyethylene cover or *window*. This cover also contains an anti-oxidant and an ultraviolet inhibiting dye. The main purpose of the covers is to act as a small radome over each slot and keep rain, ice, dirt, birds, etc., from the inside of the antenna.

The entire antenna is designed to mount by itself on the top of the tower. It is designed to EIA windloading specifications of 50 pounds per square foot on flat surfaces and 33 pounds per square foot on

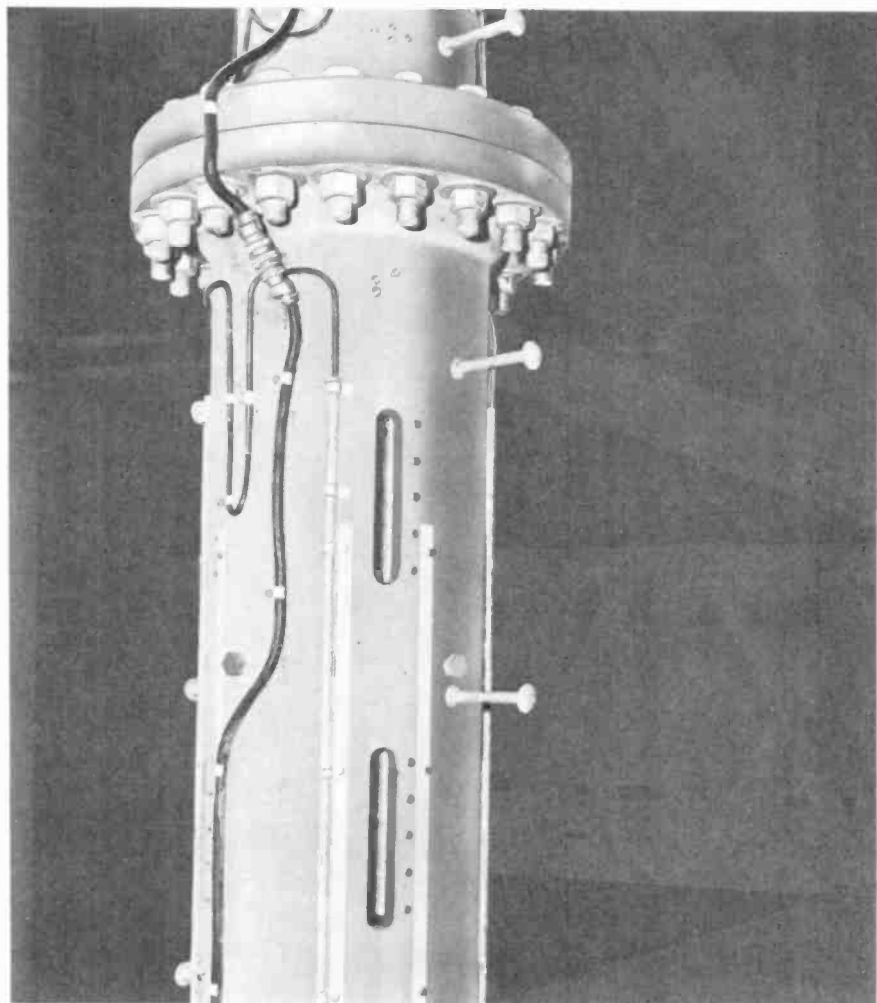
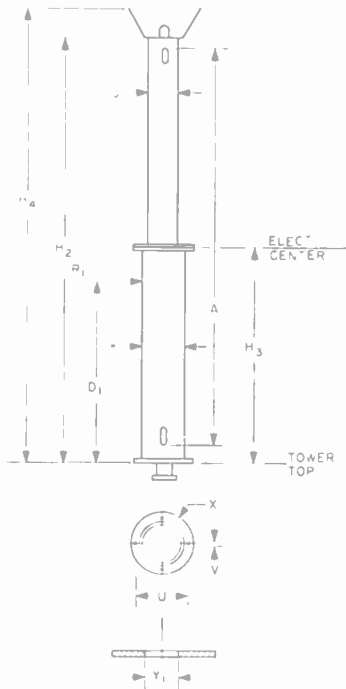

Fig. 7-16. The slot covers have been removed from this pylon antenna. The aluminum bar couplers can be seen inside the slots. (RCA)

round surfaces, which is equivalent to a true wind speed of 110 miles per hour with no ice. The mechanical specifications for such an antenna are given in Fig. 7-17.

De-icing is accomplished generally by the use of calrod heaters that are bolted to the outside of the outer wall. These heaters are covered with asbestos to prevent heat loss to the air and direct contact provides the best transfer of heat to the metal. As an accessory item, RCA will supply an automatic switch that will turn the heaters on when conditions call for it and off when they are not needed.



Definition of Mechanical Symbols

Symbol	Units	Definition
A	feet	Antenna aperture length
D ₁	feet	Distance from tower top to center of wind loaded area of antenna
H	feet	Height of pole (only) above tower top
H	feet	Height of Electrical Center above tower top
H ₁	feet	Height of antenna above tower top including lightning protector
I	psf	Wind pressure for which the antenna is designed
J	inches	Pole diameter top section or entire antenna excluding slot covers
K	inches	Pole diameter bottom section
L	feet	Shipping length of longest pole section
M	Kip/feet	Overturn moment R ₁ D ₁ (thousands of foot pounds)
N		Number of sections in which pole is shipped
P	pounds	Weight of heaviest pole section
R ₁	pounds	Wind reaction at center of wind loaded area
U	inches	Diameter of bolt circle of base flange
V	inches	Bolt diameter used in base flange
W	tans	Weight of complete antenna including inner conductor
X		Number of equally spaced bolts used in base flange
Y ₁	inches	Clearance hole diameter required in tower top for antenna or feed system

TYPE TFU-24DM UHF TELEVISION ANTENNA, MI-19304-B/A

Channel	H	H	I	M	R	W	
31	43.33	22.250	35	30.8	1275	1.2	
32	43.00	22.000	35	30.3	1265	1.2	
33	42.75	21.834	35	29.8	1255	1.2	
34	42.08	21.584	35	29.3	1245	1.2	
35	41.83	21.417	35	28.8	1235	1.2	
36	41.58	21.167	40	28.3	1225	1.1	
37	40.92	20.917	40	27.8	1215	1.1	
38	40.58	20.750	40	27.3	1205	1.1	
39	40.33	20.584	40	26.8	1195	1.1	
40	39.92	20.334	40	26.4	1185	1.1	
41	39.58	20.167	40	26.0	1175	1.1	
42	39.25	20.000	40	25.5	1165	1.1	
43	38.83	19.834	45	25.0	1155	1.1	
44	38.67	19.584	45	24.7	1145	1.1	
45	38.25	19.417	45	24.3	1135	1.1	
46	38.00	19.250	45	23.9	1125	1.1	
47	37.67	19.000	45	23.4	1110	1.1	
48	37.25	18.751	45	23.0	1095	1.0	
49	37.08	18.584	45	22.6	1085	1.0	
50	36.75	18.414	50	22.3	1075	1.0	

							Constants
							H = .5 · H ₁
							H ₁ = H · .52
							I = 50/30
							K = 8 ⁵ⁿ
							L = L ₁
							N = 1
							P = W
							U = 13
							V = 1
							X = 12
							Y ₁ = 8

Fig. 7-17. Mechanical specifications of the RCA uhf pylon antenna, type TFU-24DM. (RCA)

A high-gain antenna, such as the pylon, will have null points in its coverage, some of these as close as a mile from the antenna. By the use of a small amount of electrical beam tilt and adjustment of phase and amplitude to the different slots, these weak signal areas can be filled in so that coverage is solid in the primary service area.

The horizontal and vertical patterns can be shaped and contoured. Your requirements for your area should be worked out with RCA antenna engineers.

Besides the medium and high gain pylons, RCA has a small low gain antenna, the TFU-6B, which is also a slotted pylon antenna. It is lightweight, only 49 to 68 pounds (depending upon channel). It is approximately the same size in diameter as the 3 $\frac{1}{8}$ -inch transmission line and is essentially an extension of the transmission line. However, it is made from heavy aluminum tubing. This antenna has a bottom mounting plate that permits its mounting directly on the top of the tower, on an outrigger, or even inside the tower. Naturally, the side or inside mounting will affect the normal pattern of the antenna, which is calculated for a top mounting position. Since it is possible for this antenna to be mounted in several places, there is no provision for mounting a beacon on the top of it.

The General Electric Helical Antenna

The helical antenna is a simple, rugged antenna that will withstand moderate icing and high winds and is not affected very much by climatic changes. The electrical and mechanical specifications of such an antenna are shown in Fig. 7-18.

Working on the traveling-wave principle, a single feed point delivers r-f energy to each bay, which is wound with two helix wires, each slanting the opposite way. (Working two helixes this way cancels any vertical polarized components that may be radiated, due to the pitch of the helix.)

As with a traveling wave in a long wire, radiation from each spiral of the helix is progressive, so that the signal at the end is low or non-existent. The ends may be grounded or left open without any reflection effects. Generally, about 2 wavelengths per turn are used, which produces a side-fire radiation.

Each bay is made up of a right-hand and left-hand helix, fed from the center point. Since two helixes are placed end to end and fed at the common point, the impedance at this point is low, approximately 100 ohms. There are no high voltage points and the antenna is basically a nonresonant device.

The helix wire is the actual radiating element, supported about the mast with insulators. At the end of each bay are flanges that permit the

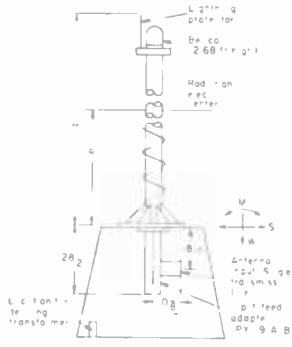

LEGEND

- H₁ Height of antenna above tower top—over-all
(Note Subtract 3.75 feet from H₁ to obtain antenna height),
- R Height of radiation (electrical) center above tower top
- M— Moment measure in foot pounds
- S Shear measure in pounds
- W Weight in pounds

FCC FILING INFORMATION FOR UHF CHANNELS 14-83

Antenna Type for UHF	Booms	Main Diameter (in.)	Height* (ft)				Moment 50 lb W ind (ft-lb)	Shear 50 lb W ind (lb)	Weight (lb)	System Top (ft)	Average Height (ft)	P-Net Gain	Power Gain db	Free Space F-nd (m)	Free Space F-nd (db)
			Ch 14	Ch 16	Ch 18	Ch 20									
Channels 14-16															
TV 21 A	1	10 1/4	16 17	15 80	6 43	6 25	3450	450	1400	30	25 0	5	6 99	3 77	109 8
TV 22 A	2	10 1/4	16 60	25 90	11 65	11 30	10300	810	2200	60	66 0	10	10 00	435 1	112 8
TV 23 A	3	10 1/4	37 05	36 00	16 88	16 35	21000	1170	3000	60	66 0	15	11 76	532 9	114 5
TV 24 A	4	10 1/4	47 30	46 10	22 10	21 40	35500	1520	3800	60	66 0	20	13 01	615 3	115 8
TV 25 A	5	10 1/4	57 95	56 70	27 33	26 45	53000	1870	4305	60	66 0	25	13 98	688 0	116 8
Channels 17-24															
TV 21 B	1	10	15 67	14 88	6 8	5 70	3080	4 5	1220	33	25 0	5	6 99	3 77	109 8
TV 22 B	2	10	25 67	24 06	11 16	10 38	9170	750	1950	60	66 0	10	10 00	435 1	112 8
TV 23 B	3	10	35 59	33 25	16 14	14 97	18670	1080	2900	60	66 0	15	11 76	532 9	114 5
TV 24 B	4	10	45 54	42 47	21 12	20 56	31750	1410	3350	60	66 0	20	13 01	615 3	115 8
TV 25 B	5	10	55 50	51 60	26 10	24 55	45330	1670	4125	60	66 0	25	13 98	688 0	116 8
Channels 25-32															
TV 21 C	1	8 3/8	14 78	14 14	5 74	5 42	2730	350	1090	20	22 0	5	6 99	307 7	109 8
TV 22 C	2	8 3/8	23 86	21 58	10 28	9 64	6920	610	1770	40	44 0	10	10 00	435 1	112 8
TV 23 C	3	8 3/8	32 94	31 42	14 82	14 36	13670	860	2300	60	66 0	15	11 76	532 9	114 5
TV 24 C	4	8 3/8	42 02	39 46	19 36	18 08	22830	1120	2890	60	66 0	20	13 01	615 3	115 8
TV 25 C	5	8 3/8	51 09	47 90	23 90	22 30	34170	1370	3305	60	66 0	25	13 98	688 0	116 8
Channels 33-43															
TV 21 D	1	7 1/4	13 77	12 97	5 17	4 78	2100	330	955	20	22 0	5	6 99	307 7	109 8
TV 22 D	2	7 1/4	21 12	20 52	9 35	8 55	5870	560	1500	40	44 0	10	10 00	435 1	112 8
TV 23 D	3	7 1/4	30 47	28 07	13 52	12 33	11330	785	2010	60	66 0	15	11 76	532 9	114 5
TV 24 D	4	7 1/4	38 8	35 80	17 70	16 10	19170	1020	2500	60	66 0	20	13 01	615 3	115 8
TV 25 D	5	7 1/4	47 17	43 17	21 87	19 88	26830	1170	3060	60	66 0	25	13 98	688 0	116 8
Channels 44-58															
TV 21 E	1	6 3/8	12 07	12 17	4 25	4 38	1570	270	770	15	16 5	5	6 99	307 7	109 8
TV 22 E	2	6 3/8	20 44	18 92	8 50	7 75	4170	430	1180	30	33 0	10	10 00	435 1	112 8
TV 23 E	3	6 3/8	27 92	25 67	12 25	11 13	8033	600	1543	45	49 5	15	11 76	532 9	114 5
TV 24 E	4	6 3/8	35 47	32 42	16 20	14 50	13175	770	1950	60	66 0	20	13 01	615 3	115 8
TV 25 E	5	6 3/8	42 97	39 17	19 75	17 88	19580	930	2515	60	66 0	25	13 98	688 0	116 8
Channels 59-68															
TV 21 F	1	5 1/4	11 95	11 40	4 10	3 82	1170	220	635	5	16 5	5	6 99	307 7	109 8
TV 22 F	2	5 1/4	18 65	17 55	4 45	4 00	3200	370	915	30	33 0	10	10 00	435 1	112 8
TV 23 F	3	5 1/4	25 35	23 70	10 80	9 07	6000	500	1210	45	49 5	15	11 76	532 9	114 5
TV 24 F	4	5 1/4	32 05	28 85	14 15	13 05	9780	630	1460	45	49 5	20	13 01	615 3	115 8
TV 25 F	5	5 1/4	38 75	36 00	17 50	16 12	14420	770	900	45	49 5	25	13 98	688 0	116 8
Channels 69-83															
TV 21 H	1	5	11 27	10 70	3 81	3 52	1000	200	585	15	16 5	5	6 99	307 7	109 8
TV 22 H	2	5	17 49	16 33	6 87	6 29	2580	320	855	30	33 0	10	10 00	435 1	112 8
TV 23 H	3	5	23 61	21 87	9 93	9 16	4900	430	1110	30	33 0	15	11 76	532 9	114 5
TV 24 H	4	5	29 73	26 41	12 99	11 83	7830	550	1350	30	33 0	20	13 01	615 3	115 8
TV 25 H	5	5	35 85	31 95	16 01	14 60	11570	670	1330	30	33 0	25	13 98	688 0	116 8

* Antenna Height and Height of Radiation Center may be linearly interpolated from the values shown for all channels between limits

Fig. 7-18. Electrical and mechanical specifications of the GE helical uhf antenna. (GE)

bay to be rotated. Small stubs can be mounted on the helix at critical points. These stubs, in conjunction with the rotation possible at the flanges, permit electrical beam tilting and pattern contouring.

The power gain for each bay is five. Normally, the bays are stacked, five to an array, for a power gain of 25. Two antennas of five bays each may be stacked one above the other for a power gain of 50.

Distribution of power to the individual bays is from the inside of the mast mounting pole, which is an integral part of the antenna. (As far as the station is concerned, the only feed point to the antenna is at the bottom of the antenna.) The feed point projects down inside the tower for a short length. There are no feedlines or cables outside the mast.

The mounting pole, top plate, flanges, and base plate are made of a special steel. The antenna is designed to withstand a wind pressure on flat surfaces of 50 pounds per square foot, without ice, which corresponds to an actual true wind speed of 112 miles per hour.

Climbing spikes are provided up the side of the mast for service to the beacon lamp or antenna. The top plate will take a standard 300 mm beacon and is provided with a lightning rod that is bolted to the plate. The cable for the light runs down inside the mounting pole. The mast and helix are both grounded to the tower for lightning protection.

De-icing is accomplished by feeding 60 cycle current through the copper helix wire. The antenna is unaffected by small amounts of ice but heavy radial ice will detune and change the windloading figures.

Ordinarily, this antenna is used when a nondirectional, circular pattern is desired. Shaping of the patterns for null fill-in and contouring to meet local coverage problems are usually employed, although some directionalizing may be accomplished.

The General Electric Zig-Zag Antenna

The newest entry into the uhf antenna field is the zig-zag antenna (Fig. 7-19A). UHF stations are now permitted to use any directional pattern desired to meet coverage problems and this antenna is made just for these purposes. Not only can you obtain a normal, circular, non-directional pattern with this antenna, but GE antenna engineers have already computed over 150 different horizontal patterns that may be realized with it by proper arrangement of the panels. Some of them are shown in Fig. 7-20.

Operation is based on the traveling-wave principle in a long wire. The radiation is similar to a broadside array of dipoles over a reflector panel. Of course, wire length and the space between the wire and panels must be correct to accomplish this and are part of the antenna design. The long wire is bent at half-wave intervals to create in-phase conditions and cancel out any vertical polarized components that may be radiated.

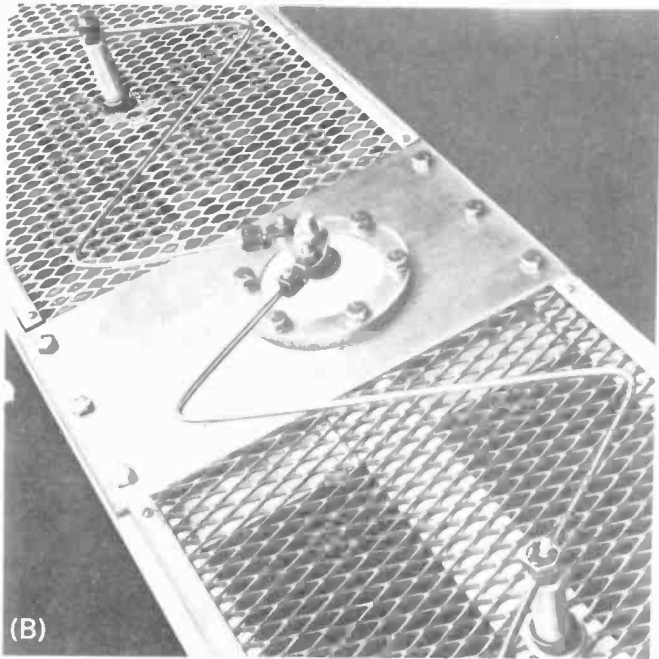
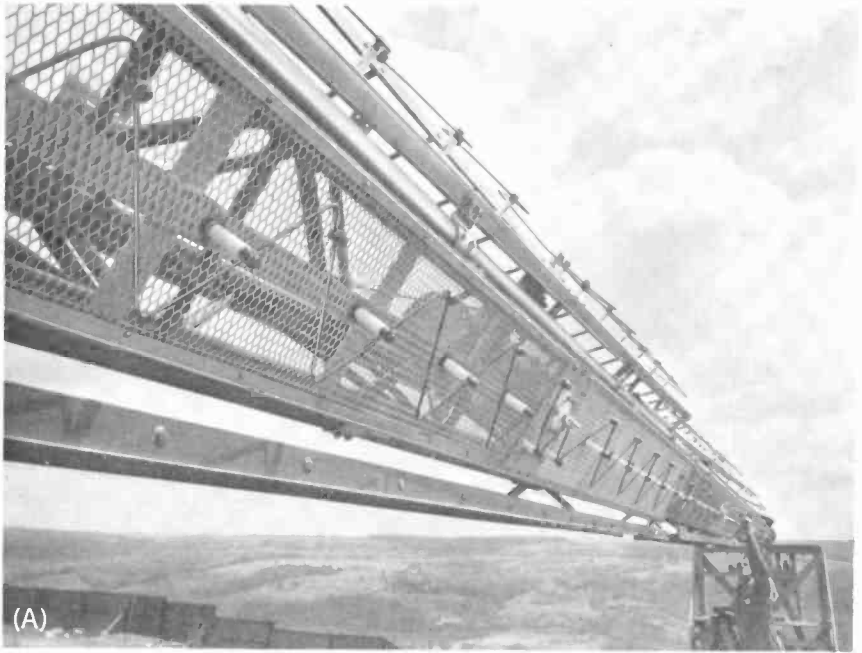
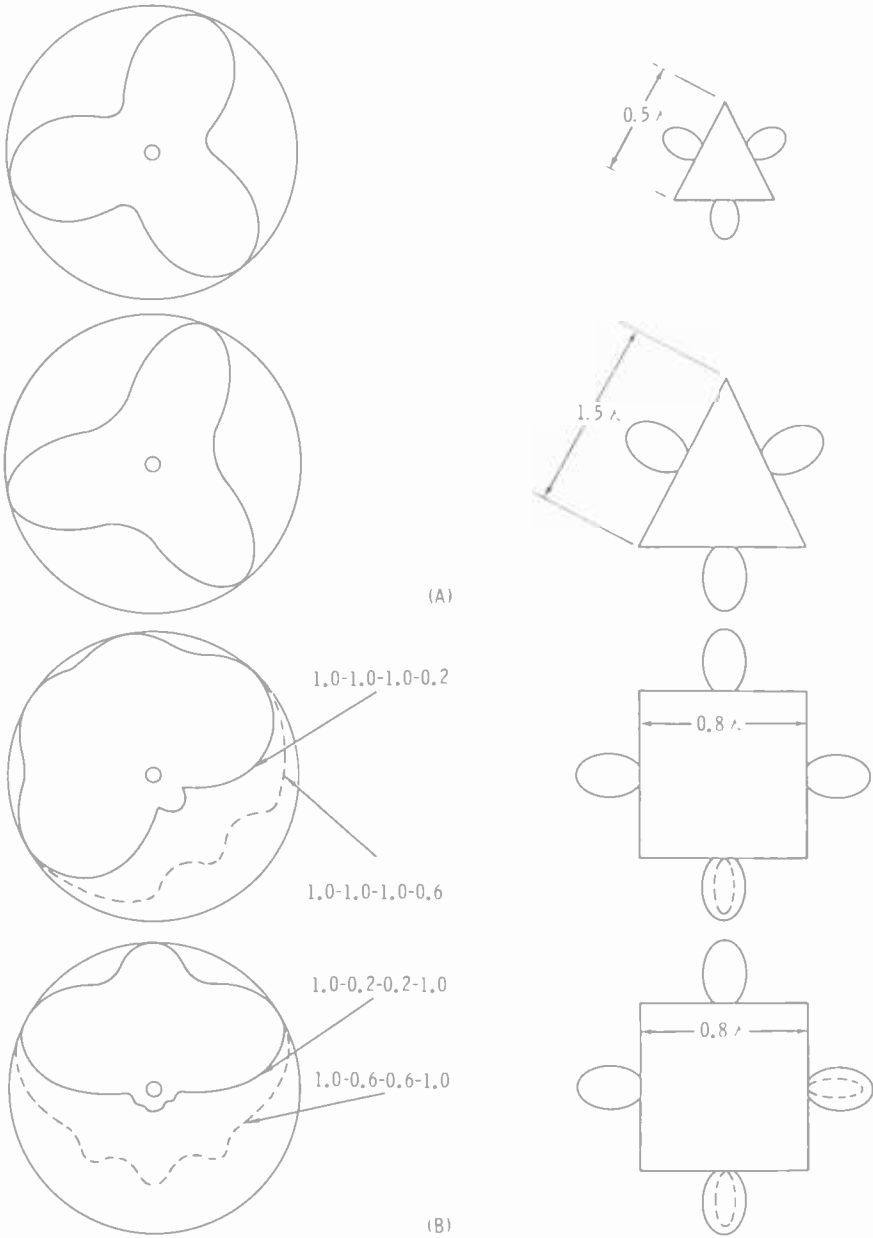

Fig. 7-19. (A) This GE zig-zag antenna has several panels mounted that are being adjusted to the specified pattern. (B) A close-up view of zig-zag panels showing the bent-wire radiating element and the feed point. (GE)

TYPICAL FIELD PATTERN

MECHANICAL ARRANGEMENT



(A)

(B)

Fig. 7-20. Some of the more than 150 calculated patterns available with the GE zig-zag uhf antenna: (A) Three panels forming an equilateral triangle whose side d varies from 0.5λ to 1.5λ in 0.1λ steps ($d = 2.0 \lambda, 2.5 \lambda, 3.0 \lambda$); (B) Four panels forming a square of 0.8λ side. (GE)

Each panel is made up of two bent, half-wave conductors, fed at the center point (Fig. 7-19B). The conductors are made of heavy copper wire mounted on stand-off insulators. The panel is a steel screen, which acts both as a reflector and a mounting device. The reflector is grounded to the tower. The ends of the bent radiator may be left open or grounded without affecting the radiated pattern, because the r-f energy is very low or nonexistent at this point, as in the helix. The feedpoint of the panel is at low impedance, hence, there are no high voltage points.

Panels are basically a nonresonant device, so moderate icing or rain will not have much effect on them. When heavy icing is experienced, de-icers are available. For this purpose, 60-cycle current is fed through the bent wire to melt off any ice that may form.

Gain figures are not given for this antenna because the overall gain will depend upon the final antenna array. Vertical or horizontal patterns of almost any shape may be obtained. With practical directional antennas, a gain of 75 or more may be easily realized.

Antenna arrays may be made up in several ways. General Electric will supply a complete array, with its own mast, beacon top plate, and inside transmission line, that has been completely assembled, adjusted, and tested at the factory to meet customer requirements. In other words, a complete antenna, just as the helical antenna is complete, designed to be top-mounted on a tower with only one feed point at the bottom for the station's transmission line.

The panels may also be mounted on the sides of an existing tower and erected in the field. In this case, GE antenna engineers will compute the desired pattern and arrangement to suit the particular tower and installation.

Towers

Towers come in all shapes, sizes, and styles. There are probably no two identical towers, although some may be very similar. Each one is custom-built to meet station requirements. In regard to tower specifications, many factors must be considered: the needed height, soil conditions for the base, wind and weather expected in that location, available space, weight and type of antenna to be supported, platforms needed for beacon lights, members to support line hangers, elevators, etc. It is not possible merely to order a certain model and size from a catalog. Ordinarily, the tower design engineers will work with the antenna engineers and station consulting engineer to determine what specification the tower must fulfill to meet the requirements of the station.

Cost of tower, base, and erection will vary considerably, because each installation is customized. This was shown in Chapter 1, where three

stations with different requirements had to pay as each requirement demanded. In the case of WBJA-TV, it cost \$4,000 more than would have been usual because they had some very special guying problems.

Guyed Towers

Space to place a tower is of prime importance and may be a deciding factor. Guyed towers require more space for the guys and anchors than

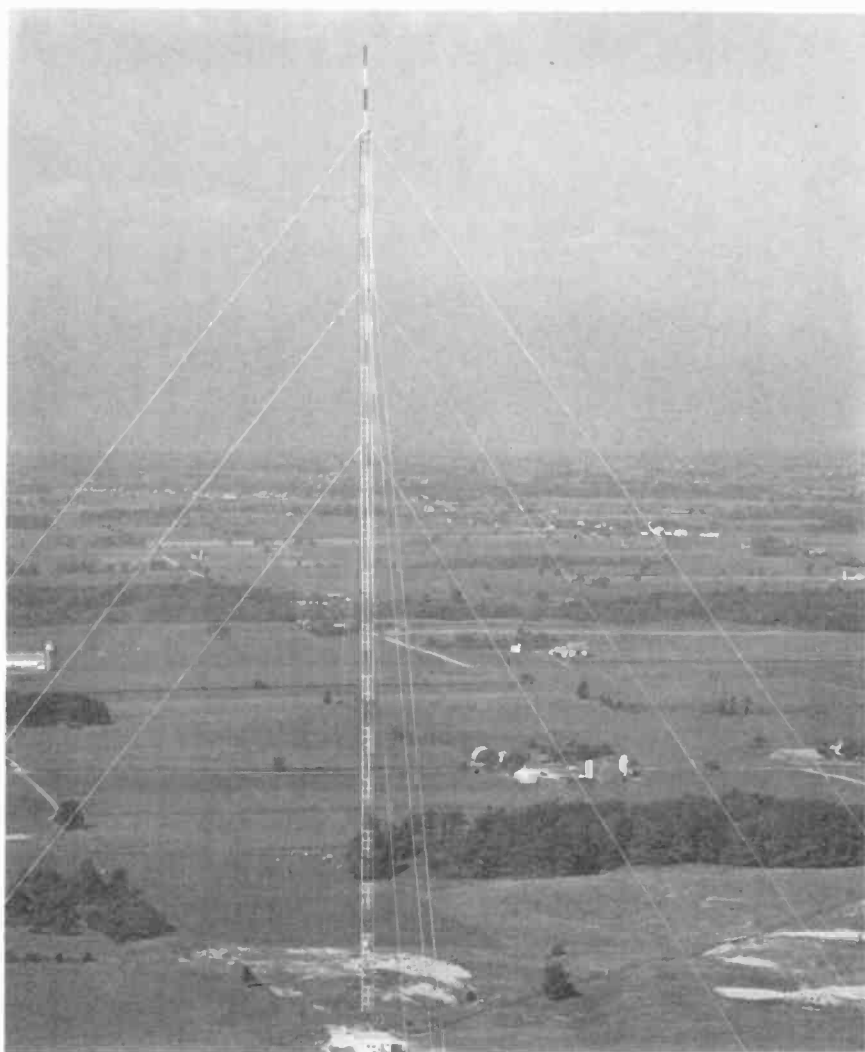

Fig. 7-21. A guyed TV tower. (Stainless, Inc.)

a self-supporting tower. Towers over 500 feet high are usually guyed, although there have been some higher than this that were self-supporting.

Guyed towers are usually triangular (three-sided), and linear without taper from top to bottom (Fig. 7-21). You may estimate the distance from the tower of the guy anchor that will be farthest from the base as 70% of the tower height. For a 500-foot tower, this anchor will be about 350 feet from the base. Remember that guys come off the tower in three directions and take up a lot of room.

Self-Supporting Towers

Self-supporting towers are usually made of heavier members, may be either three or four sided, and taper from a large bottom to a small top. These have no guy wires and depend upon the tower to hold itself up. Such towers are usually more costly than a guyed tower of the same height. Estimate the space required for the base as about 10% of the tower height. For example, a 500-foot self-supporting tower will have a base width of about 50 feet on each side.

Tower Bases

Guyed towers have two types of bases: the fixed base and the pivoted base. On a fixed-base tower, each leg bolts directly to the mounting bolts embedded in the concrete pier. On a pivoted-base tower, the three legs of the base converge to a single mounting point with the concrete pier. This type is generally used when there is a possibility that the foundation may settle because of poor load-bearing qualities of the soil. Should the foundation settle, the tower can still stand straight and plumb, for the base will pivot. The fixed-base tower is used when the foundation is not expected to settle. Before any tower is designed, whether guyed or self-supporting, drillings should be made at several places in the soil and subsoil for soil samples. These samples should be laboratory-tested for load-bearing qualities.

Radio Towers

Many present-day radio antennas are lightweight guyed towers. Although most towers were self-supporting in the earlier days of radio, the number of radio stations today necessitates the use of directional antennas more often than not. In order to keep down the cost of several towers, lighter, less expensive towers are used. These are designed to support only themselves. Many of them cannot carry the added weight of one of the larger uhf antennas, although some towers may be reinforced and reduced in height. Lightweight antennas may be side-mounted on some of these towers. In all cases where you consider using

existing towers, the tower manufacturer's engineers should be consulted about what the station proposes to do. They will soon tell you whether it can be done or not.

The heavier antennas, such as the pylon and the helix, or any antenna designed to be top-mounted, will bolt directly to the top plate of the tower. Guys extend only from the tower as no provision is made for guy points on the antenna.

Lightning Protection

All towers should be grounded for lightning protection, as the concrete pier is not a good ground. A wide copper strap should be brazed or bolted to the tower and run to a copper rod driven several feet into the ground. No tower can be made lightning proof, but lightning rods and a good ground will keep charges drained off before they can build up enough potential to strike. Even with the best protection, a beacon lamp will be knocked out occasionally by lightning.

Painting

Painting galvanized towers takes special preparations so that paint will adhere properly to the metal. Galvanizing makes the best weather protection, especially over the years, and the painting is required by the FAA so that the tower will stand out. Paint, of course, also contributes to preservation of the tower. If surfaces are not properly treated before paint is applied, in a short while large strips of paint will peel off and fall from the tower and a new paint job may be necessary within a year. This is one reason why a station should contract the painting only to a reputable tower-painting company. Many painters can get the paint on the tower, but making it stick for a long time requires experience and know how.

Windloading

Most TV towers are designed for $50/33$ pound windloading. This means they can withstand a steady wind pressure of 50 pounds per square foot on projected flat surfaces and 33 pounds per square foot on round surfaces. For particular areas that have normally higher winds, such as hurricane areas, or where heavy icing can be expected (Fig. 7-22), the tower should be designed for a higher windloading. Some other factors should be considered in the windloading, such as microwave reflectors, which may be added at a later date.

Tower manufacturers are justly proud of the fact that very, very few towers have ever come down and many have been standing for 20 or 30 years. If a tower should fall because of weaknesses or poor design, the tower manufacturer's reputation would be dealt a very serious blow.

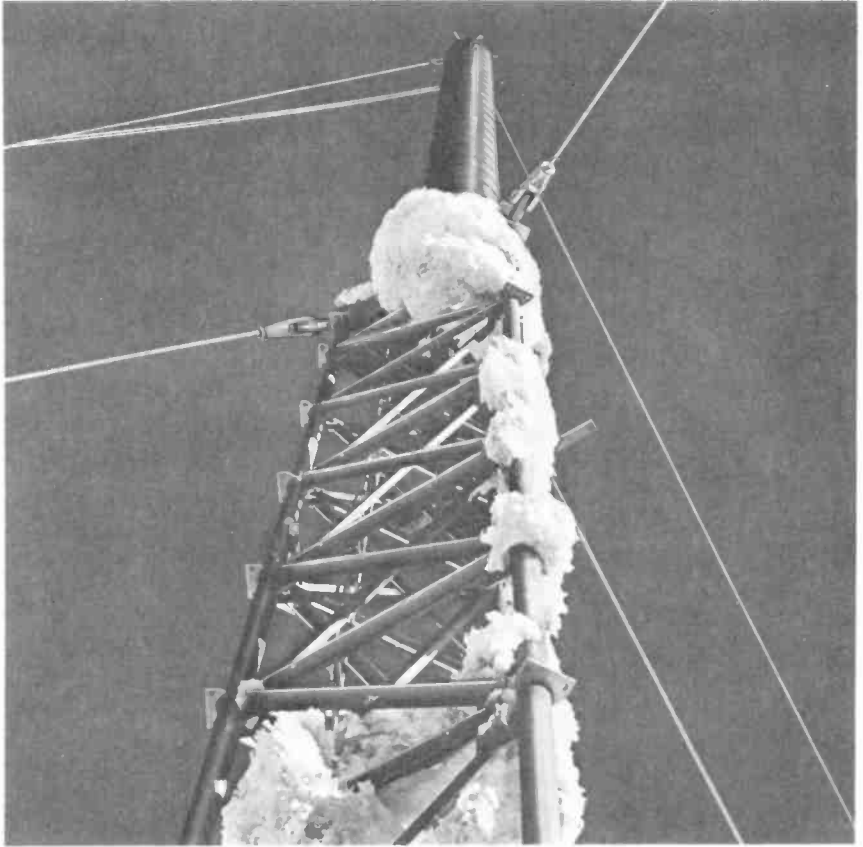

Fig. 7-22. *An ice-encrusted tower. The antenna is enclosed in a radome for this severe weather location. (RCA)*

Few customers will buy from a company that has had one of its towers fall. This is another reason why every tower installation is custom-built. If you already have a tower erected for a radio or an FM side-mounted antenna, you may find the tower manufacturer very reluctant to have you place a one- to three-ton antenna on the top of it.

Antenna and Tower Care

Because the antenna is somewhat out of reach and out of sight for all practical purposes, there is a tendency to forget about it until trouble develops with high standing waves or ghosts. However, there should be regular inspections of the antenna, just as there is with other equipment. Of course, it is more difficult to keep as close a check on the antenna as with other equipment, because few station engineers are also climbers.

Finding someone to climb the tower is generally not difficult. The real problem is finding someone who will also be able to do some good while he is up there. Most climbers can tell you if bolts are missing, members are loose, or paint is peeling off, but they may not recognize small cracks in insulators, lightly-burnt joints, or other sources of pending trouble. There will be times when you are fortunate enough to discover a climber who, even though he may not understand electrical problems, will be alert to almost anything on the tower or antenna. Such a person can be taught to look for and recognize potential troubles and will bring back correct information.

Reporting of information may take several forms. One of the best methods by far is pictures. If a climber can operate a Polaroid camera, much useful information concerning the condition of insulators, connections, windows, and potential trouble sources can be delivered to the ground. Further implementation of this information with sketches and exact measurements will make it easier for both him and you to discuss possible remedies for whatever situation may be present on the tower. The climber should be instructed to look for anything that is obviously wrong, of course, and many of the following conditions, which can eventually develop into real difficulties.

Paint in the wrong places is a real headache that will worsen as it ages and oxidizes. Some painters get very sloppy while working high on the tower, because they believe you cannot inspect the work. Sometimes they will paint over the slot covers on the pylon antenna and the insulators on the helix and zig-zag or the feed points on these latter antennas. On the pylon, painted windows will detune the individual slot, which may cause burning at its feedpoint. The whole pattern will be affected when several slots are not radiating properly. Similar effects will occur on other antennas when insulators or feedpoints are painted.

When the antenna and tower are being painted, if the antenna isn't too high, a good pair of binoculars will be of great assistance in keeping a check on the painters from the ground. Even if you can't see such fine detail as paint spots on the insulators or windows, the painters may think you can and will be more careful.

Cracked or missing windows on the pylon antenna can cause trouble, because rain, snow, ice, dirt, and birds can get inside. Loose or warped edges will allow the weather elements inside and a window in this condition may blow away in a high wind. Damaged or missing windows should be replaced immediately. Don't give the weather a chance at the inside of the antenna. A few spare windows should be kept on hand at all times, so that replacement may be made immediately without waiting for parts to be shipped from the factory. These polyethylene windows come in one standard size only, so each one must be cut for the slot size

on your channel. The plastic is a very tough material and is quite difficult to cut while up on the antenna. It is best to measure one of the original windows while the antenna is still on the ground and to cut the spare windows to that size. This will save time and trips up the tower when a replacement is needed.

Sometimes individual heater elements will burn out, leaving sections of the antenna unprotected from the ice. Turn heaters on and allow them to warm up. The climber can check on them while he is on the antenna.

Two-way conversation between the man on the tower and the ground can be accomplished in different ways. Small, transistorized walkie-talkies will be very helpful from all locations on the tower. Telephones may also be used by running telephone cables up the tower and providing outlets at a number of elevations.

Ice and Its Effects

Many areas of the country experience heavy icing in the winter months. Antennas are designed to handle small amounts of ice, which will not affect antenna performance too much. A heavy icing, however, is a severe problem. The weight of heavy glazing will move the antenna's structural design parameters closer to the limits of safety, even though the antenna design includes an ice factor in its application. Electrically, heavy ice will detune the antenna, causing a mismatch with the transmission line and, consequently, high standing waves and ghosts.

Heaters will take care of the ice problem, if they are turned on and working properly. In a severe ice storm, even the heaters may have trouble keeping ahead of ice formation, but they will prevent enough ice from forming to give any trouble, although you may have to tolerate some increased VSWR and ghosting in the transmitted picture.

Temperatures at the antenna level are usually colder than at ground level. The steel in the tower is colder than surrounding air because the mass of the steel takes longer to change temperature. Any moisture or condensation will freeze on the antenna if the temperature of the steel is below freezing. With this in mind, don't wait until the VSWR starts to increase before turning on the heaters. Try to anticipate ice conditions, especially severe icing, so that the ice will not have a chance to get ahead of the heaters.

Some manufacturers will supply automatic equipment that turns on the heaters when icing conditions are present or equipment can be installed that will turn on with the tower lights (at night there is usually some frosting on high antennas). With the latter method, a switch should be provided so that the heaters may be turned off during the warm months. Some type of indicator at the base of the tower or in the build-

ing should function as a reminder that the heaters are turned on or off. Without it, you may think that the heaters are on when they are not and the ice will get ahead of you. Such an indicator will also prevent the possibility of the heaters operating all summer long (which has happened).

Remember, also, that ice on the antenna will not start to melt until a day or so after melting has occurred on the ground. You may be searching for other troubles after the ground is thawed when the ice is still affecting the antenna's performance.

Checking VSWR

The quickest indication of trouble at the antenna will be a high VSWR. Most operators check the VSWR at the beginning and the end of each day. A low reading in the morning and a higher reading at the end of the day are indications of pending trouble, because something is probably heating with r-f energy in the line. Of course, high VSWR can be in the transmission line itself. A split bullet, poor connection heating, or new dent will change the characteristic impedance of the line and mismatch the antenna and transmission line. In such a case, the new VSWR will probably remain constant.

Regular checks on the line and antenna VSWR with a slotted line are recommended. Such checks should be made throughout your channel width at every quarter megacycle; the reflectometers on the transmitter indicate VSWR at the carriers only. The antenna and line should have a very low VSWR across the whole channel width. Otherwise, degradation of the picture will occur in the form of ringing and ghosts. This is especially true if you transmit color. High standing waves in the area of 3.58 mc above visual carrier will cause phase shifts of the subcarrier. Even color cancellation may take place due to phase changes.

The best method of making VSWR checks is opening the transmission line at the antenna and terminating it with a resistive load of proper impedance. Follow this with a check of both the line and antenna together. This will help indicate where the source of trouble may be developing. A d-c resistance measurement of the whole system will also indicate changes in the joints.

The RCA Service Company will make these measurements on a contractual basis, either as a part of a proof-of-performance of the whole system, which must be done every year, or only a yearly check of the antenna system. They have climbing engineers who do this work. You can purchase the necessary equipment to do the job yourself, but it is quite expensive and will seldom be used, especially since there will be no other use for it except on the antenna. Most consulting engineers have the equipment to do this work, as do the field engineers of different manufacturers.

Cost Estimate — A Representative Installation

It has been pointed out several times that the tower, transmission line, and antenna installations are generally customized to suit each station's requirements. However, the reader may get some idea of costs in this area from the following representative installation. (The estimate for this example has been very generously given by RCA's Tower Merchandising and Antenna Division.)

Example station:

- Channel: 35.
- Antenna: RCA TFU-24DM.
- Tower height: 400 feet.
- Tower type: Guyed (with no special guying problems).
- Transmission line size: 3 $\frac{1}{8}$ -inch, rigid.
- General equipment: Lighting.

Here is RCA's price quotation, given verbatim:

1. One 400-foot guyed, partially galvanized, noninsulated tower.
Tower to be designed to resist a uniform windload of 40 pounds per square foot on flat surfaces and corrected for rounds as outlined in EIA Standards RS-222 while supporting the following equipment:
 - (a) RCA TFU-24DM UHF antenna, channel 35.
 - (b) One 3 $\frac{1}{8}$ -inch transmission line.
 - (c) Lighting in conduit.
 - (d) De-icer conduit and wiring for sleetmelters on antenna and automatic control unit.
 Tower to be uniform, triangular cross-section, 5 feet on a side, with a pivoted or fixed base. Leg members to be of high-strength tubular steel or solid rounds.
Platforms at all light levels.
Provide for an inside ladder.
Leg assemblies will be given one shop coat of paint after fabrication; the balance of material to be hot-dip galvanized after fabrication.
 2. Lighting equipment in accordance with FCC and FAA specifications governing structures of this height, Type A-3 kit. Necessary conduit, wiring, junction boxes, photo-electric control, and flasher included.
 3. De-icer conduit and wiring for operation of sleetmelters on antenna and automatic sleetmelter control unit.
- Price of tower, lights, de-icer material (FOB factory) \$17,000
4. Necessary labor and equipment to erect the tower described above on foundations installed by others according to specifications and drawings. The following work to be performed:
 - (a) Unload tower material at railroad siding and haul to construction site (distance considered, 10 miles).
 - (b) Erect 400-foot tower complete.
 - (c) Install one RCA TFU-24DM UHF antenna, channel 35.
 - (d) Install one run of 3 $\frac{1}{8}$ -inch transmission line and associated support hangers from base of antenna to base of tower.

- (e) Install lighting equipment to base of tower.
- (f) Install de-icing equipment to base of tower.
- (g) Paint tower and antenna—one field-applied coat.

Price for all erection services itemized above \$12,000

This estimate does not include figures for the concrete foundation or guy anchors. These will depend almost entirely upon soil conditions at the tower site, which can be determined after test drillings have been made and the soil analyzed. As a guess, these anchors and base will run somewhere between \$5,000 to \$10,000. This work is usually done by a local contractor according to specifications drawn up by the tower manufacturer.

The price of the antenna is not included in the quotation, although the installation is figured. This RCA TFU-24DM, uhf antenna will cost \$17,500.

The total cost of this installation is as follows:

Cost of tower	\$17,000
Cost of antenna	17,500
Cost of transmission line (from Chapter 6)	4,223
Cost of concrete base and anchors (approximate)	8,000
Cost of erection	<u>12,000</u>
Total	\$58,723

Chapter 8

Film

The single largest item of program material for a non-network affiliated station will be film. This will include features, half-hour shows, fill films, public service and commercial announcements, and locally made film of sporting events, news, and special events.

Film Damage

Good reproduction of film not only requires that projection equipment be kept in good repair, but also that the handling and preparation be done with care, both for a smooth presentation and to avoid damage. Many film distributors, especially of feature films, will require payment for the film if it is damaged. This continued damage payment can become very expensive, especially if one of the projectors is at fault and many films are damaged.

Features or series are usually sent out on a "bicycle": i.e., from one station to another around a definite circuit until they return to the distributor. If your projectors damage the film, the next station on the circuit may not be able to use it and, therefore, may lose revenue for that period. This same thing can happen to you if your predecessor damages the film, especially if the damage is not discovered until immediately before show time, when it is too late to get another print.

The only way to prevent loss of a show due to damaged film received is through inspection of all film received or, at least, inspection of the features and similar revenue-producing shows. Free films and fillers need not be checked, but the short commercial spots should be. Only in this way can you be reasonably sure that film will be in good condition

for showing and that your own equipment is not causing any damage. It could happen that you may find yourself paying for damage caused by others.

Film damage is not the only thing that can be wrong with incoming film. The author has received film features that had not been rewound, so that the end was in the ready-to-show position. On one occasion, an hour show that was on two reels had the second half labeled #1 with the academy leader and title attached to the front of it. The plot line of that particular showing did not make much sense. There have been films that were rewound incorrectly so that the sprocket holes were on the wrong side, with a keyed reel that would go on the projector only one way. Such films have to be wound properly before they may be used. In other cases, broken film had not been respliced but merely wound up, or the break had merely been taped with masking tape. Many odd things can happen to film as it goes around the circuit.

Film Previewing and Inspection

There is a difference between inspection and previewing, as indicated in Fig. 8-1. When a film is previewed, it is run on a small portable projector. The whole show is reviewed on a screen and the sound is heard on a speaker system. There are many occasions when previewing should be done. You will often only preview sections of the show to determine the best place for a commercial. For this purpose, the sound must also be heard so that the correct mood point may be chosen. There are many shows that already have a place for a commercial announcement, some even with white leader in this area, especially those shows that have been television shows and are now coming around the circuit on a re-run basis. Previewing takes up a lot of time; as long, at least, as the film is to run on the air, because most projectors do not have a fast forward arrangement on them.

Inspection, although not as thorough as previewing, at least is faster. This method involves a small viewer mounted on a rewind table. While the film is being run through the timer, it is also run through the viewer. Scratches or bad processing will show up in the viewer. Sprocket hole inspection is done by holding the film lightly between the thumb and forefinger over the sprocket holes as they move swiftly by (Fig. 8-2). Pressure should be light; only enough to feel the holes. With a little practice an operator will be able to determine what condition the holes are in. (If the film is held too tightly, torn film can cut the fingers.) There is no sound check with this method, but if there are no scratches or other damage, you can be reasonably sure the sound will be alright. If the emulsion is scratched badly, the film can be put in a projector and a

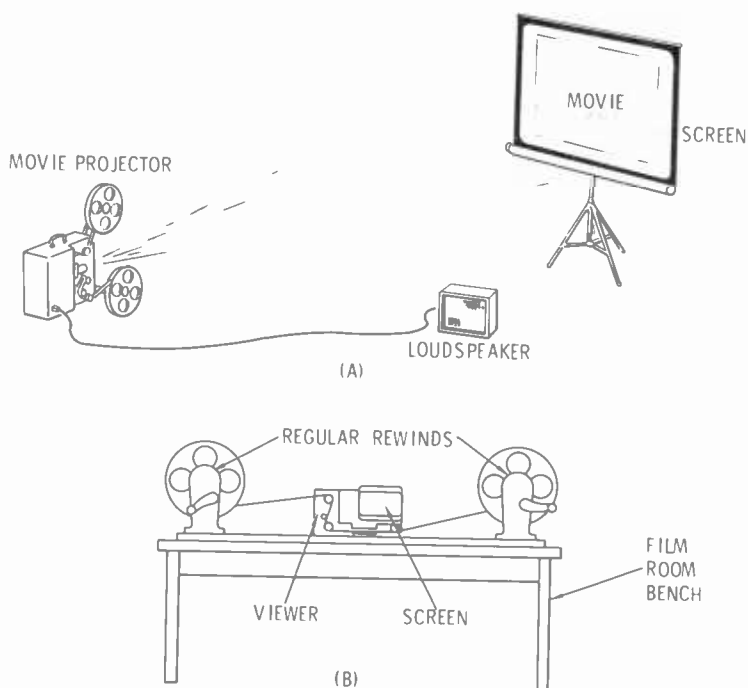

Fig. 8-1. (A) *Previewing film.* (B) *Inspecting film.*

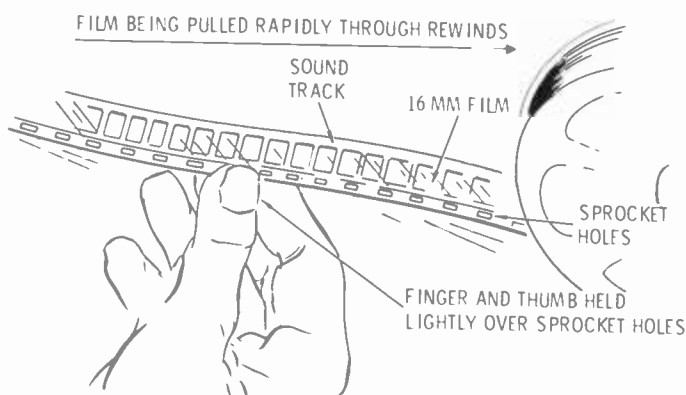

Fig. 8-2. *Manual inspection of sprocket holes on film.*

listening test will determine whether the sound is poor or not. A visual inspection of the emulsion side with the naked eye will often show up scratches. If film with a magnetic stripe is being inspected, you may listen to the sound on the film bench with a small transistorized playback unit, while the picture is being viewed in the viewer.

Preventing Film Damage

Film damage can occur in many places and many ways. Most frequently, the film is broken, the sprocket holes are chipped or torn, the emulsion is scratched, or the outer edges are damaged or torn. (There can be other unusual damages, such as film that has been stepped on or shipping cartons that have been crushed, but these are not usual day-to-day types of damage.)

Scratched Film

Scratches are caused when the emulsion rubs against some rough surface. Generally, all the timer, viewer, and projector sprockets have small ridges or rails that hold the film emulsion away from contact with any surface. When any of these rails are worn down, the emulsion will rub. The greatest offender in this area will be the skids at the top and bottom of the film gate in the projector. At this point, the pressure shoes are holding the film tightly against the runners and the motion of the film is also tending to throw it against the skids. If scratching is occurring, check these skids for wear. The surest sign that scratching is happening will be when "birds' nests" (Fig. 8-3) appear on the aired picture. Most television viewers have seen a "bird's nest" on the screen at one time or another. It will start out as a hair or string flickering near the top of the picture and continue to build up until there is quite a tangled

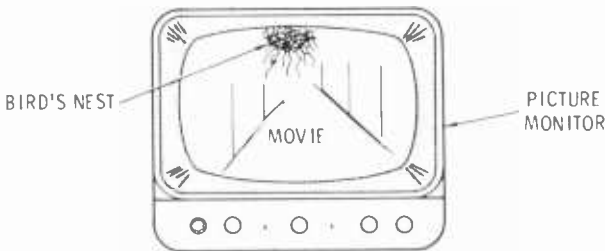

Fig. 8-3. *Birds' nests are created when emulsion is scraped off the film by the projector or dirt accumulates in the projector gate.*

mess of black material, either standing still or wavering around. While this may be dirt or lint that has been picked up, in most cases it will be emulsion that is being scraped off the film. Whichever it is, it should be cleaned out immediately, because this accumulation will contribute to further scratching, as well as look bad on the air. A squirt of film cleaner or even a dab of saliva will clean the gate out quickly when the film is running. Never use oil on a film, as this will cling and cause dirt and dust to cling to the film, and in both cases will show on the aired picture.

When dirt or other foreign material is allowed to build up on a roller where a film must pass, whether it be in the projectors or in viewers or timers, it can cause scratching. All such surfaces should be kept clean at all times. Film scratches will show on the air as uneven or random vertical lines in the picture. Badly scratched film can be very annoying to watch.

Damaged Sprocket Holes

Chipped or worn sprocket holes are caused when the film is pulled over the teeth on a sprocket instead of the teeth seating in the holes as they should. If an intermittent type projector loses loop and the film is pulled either ahead of or behind its correct timing position, the claw will not fall into the holes correctly. If it hits between holes, it will probably tear the film or the hole. If it is mistimed just a small amount, the claw teeth may cut the edge of the sprocket holes and enlarge them (Fig. 8-4). Enlarged holes allow the film to wobble as it goes through and is pulled down, causing the projected picture to jitter.

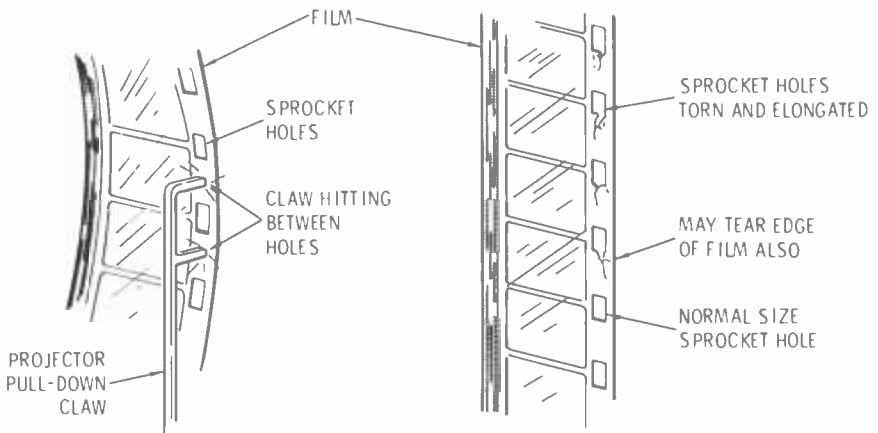

Fig. 8-4. *Film is invariably damaged when the film loop is lost.*

Detecting jitter and wobble can be done readily if you have test film on hand. One such film is a white ball on a black background. A loop of this test film is made up and run in the projector and the picture is viewed on a monitor. Any jitter or wobble will be quite evident. In case there is no test film handy or you can't stop and check out the projector, observe the regular projected program material on the air. This will take longer, of course, and will not be as conclusive as a test film, but these observations should be made all the time that regular programming is being conducted.

Jitter and Wobble

Jitter is a fast vertical movement of the projected image that occurs when succeeding frames of film are not in the same place when the light is projected through them. To check for jitter in a program film, watch the lettering of the titles at the beginning, a building which has a roof line across the top edge of the picture, or a steady background object that has a horizontal edge near the top of the picture. It is best if the line is very near the top, so that the edge of picture blanking can be used as a steady reference. (Persons or other objects in the picture are usually moving around and are not too useful for jitter checking.) You must be certain the sync generator is not causing the electronic picture to jitter. Also, you should observe several films, even if the jitter in one of them is very bad. Film making equipment today is held to close tolerances, but some individual films may come out poorly because the film was stretched.

Wobble is a horizontal weaving of images, usually caused by worn guides in the projector gate. This allows the film to move from side to side as it passes through the gate.

Generally speaking, most movies or feature films will be quite steady in themselves. If jitter or wobble is present, it is probably due to faults in the projectors. Another test to use when a specific film is questionable is to run the film or a section of it on another projector. Compare the same section of film on both projectors. It is highly unlikely that two projectors will be out of adjustment or worn in exactly the same way, so if jitter or wobble is present on both projectors, the fault is most likely to be in the film.

In day-to-day operations, the control operator should be alert to these things as film is being programmed. If such an operating procedure is followed, projectors that are wearing or going out of adjustment can be detected long before the problem becomes serious. However, don't expect film to be as steady as the pictures you get from a live, studio-camera picture. There will always be some slight movements of film. You should not be too concerned with these, but should be able to detect when movements are getting worse.

Green Film

Losing loop on the projector can be due to improper threading of the film onto the projector, sprocket shoes that are not adjusted properly, or "green" film, which is tacky. Green film will usually stick in the gate because of the heat at this point. When the film hesitates, even for an instant, TV projectors will tear it up. If the playout reel has too much tension the film loops may pull out, because the film isn't feeding properly.

Generally, sprocket shoes should be tight enough so that two layers of film will just pass easily and one layer cannot be pulled past the teeth by hand. Clearance for two layers is necessary so that a splice may pass; otherwise, it will be pulled apart or jam (Fig. 8-5).

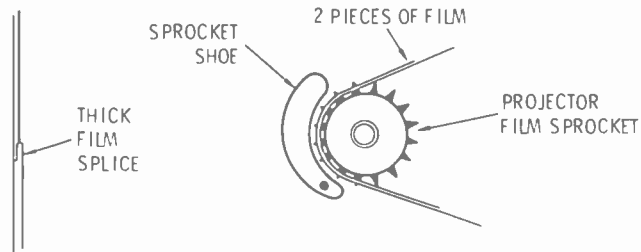

Fig. 8-5. *The sprocket shoe should be adjusted so that it will pass a splice in the film.*

When film does lose loop or is incorrectly threaded, lip sync will be off. The lips of the person talking in the picture will not be synchronized with the words that are heard. Lip sync can be off so far that the person's lips have stopped moving when their speech is still being heard. Many operators have the bad habit of reaching into the machine with a pencil or finger and pulling the film loop down while it is running to correct lip sync. Ordinarily, such a procedure will cure the lip sync problem, but it can also cause film damage. The best procedure is to stop the projector and correct the loop. This can be done in a few seconds and there will be no chance for film damage.

The only way to run green film is to cure it first. This can be done by running the film through a special chemical bath which will cure and harden it. There are machines on the market available for this purpose. There is still a better and less expensive way—the use of small units and some home-made adapters.

Film Cleaners and Hardeners

You can buy a small cleaner unit that is designed to be used on the film bench in the film room. A small container of cleaning fluid is fed to a felt pad, which in turn wets a double layer of flannel. The film is drawn between the flannel layers, which are very soft and lintless. You should have two such units, one for each projector in the control room. You will need to build your own mounting brackets so that the unit will fit on the model projector you have. This cleaner should be mounted so that the film comes directly from the play-out reel through the cleaner.

This can be developed into an automatic system by securing two electrically operated valves that will open up when the projectors run (Fig. 8-6). These valves may be purchased on the surplus market. A single tank may feed both cleaners through hoses if the projectors are close together. Before the fluid gets to the valve, install a small hand-

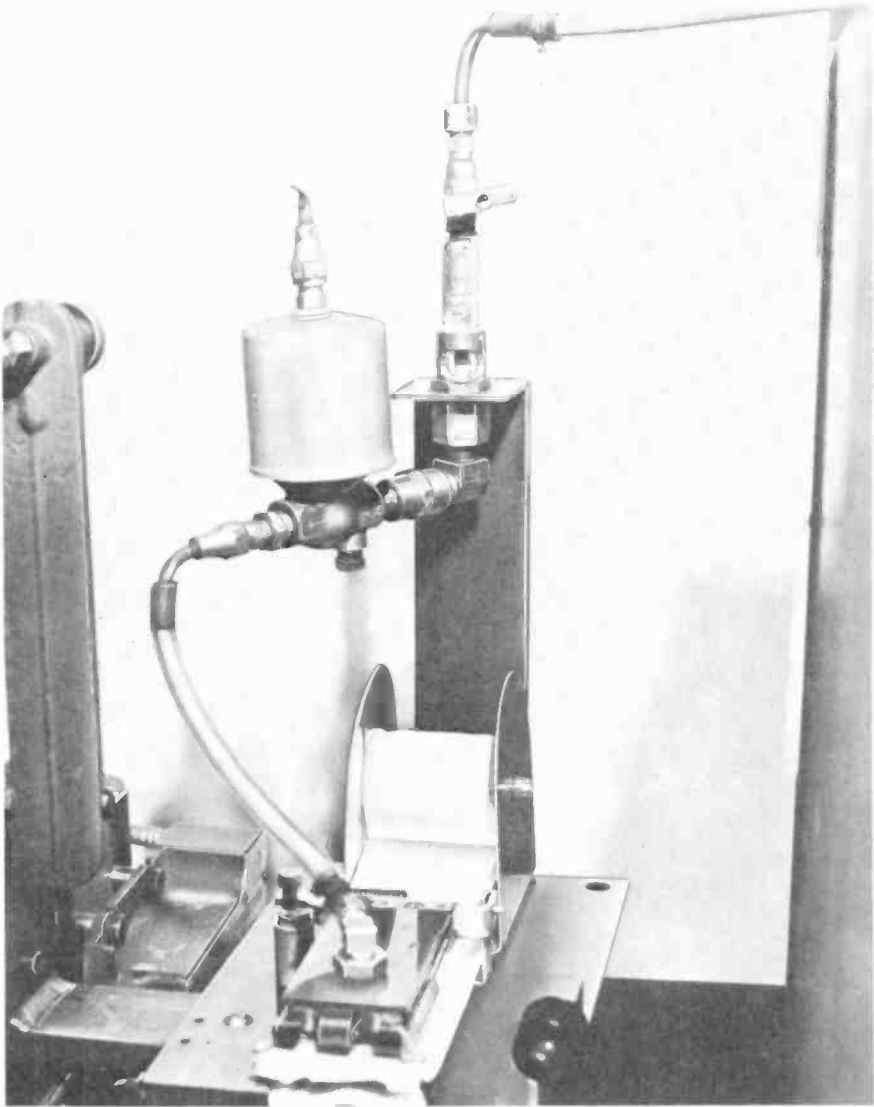

Fig. 8-6. This small, bench-type film cleaner is mounted on the front of an RCA TP-16 projector. It automatically cleans, hardens, and lubricates the film before it goes into the projector. (WLBC-TV, Muncie, Indiana)

operated shutoff valve and a glass tube. This tube is the type that is used as boiler pressure tubes. The small valve will permit adjustment of the flow so that the fluid only drips. Too much fluid will appear on the projected picture as "golf balls," which are really bubbles. The common tank should have a lid on it and should have a capacity of about one gallon. Another feed system may be used for these cleaners. Some old-type oil stoves use a small tank and drip adjustment to feed the burners. Obtain one of these for each cleaner and mount it on the projector in a suitable place.

Running film through rewinds puts a small electrostatic charge on the film which attracts dust. These little cleaners, installed in this fashion, will clean, harden, and lubricate each film just before it goes into the projector and before it has had time to pick up dust or foreign material. The projected picture will always be a clean one.

An inexpensive cleaning and hardening fluid to use in these units is called Chlorothene. For each gallon of cleaning fluid, add one teaspoon of Dow-Corning silicone fluid #200, 350 cs. Both of these may be obtained through chemical supply houses or direct from the manufacturer.

Reels

Bent steel reels will cut the outside edge of the film. The most inexpensive and best way to avoid this damage is to use a plastic reel (Fig. 8-7). A very good, tough plastic reel is available that is pliable and almost indestructible. It holds the film well and will not cause damage in any way. Also, these reels cost less than steel reels. Made from a special plastic, the reel will spring back into shape and will withstand higher temperatures than the film. A steel insert is molded into the plastic reel at the point of greatest stress, the axle point.

The author can attest to the serviceability of these reels. We received a sample reel when they were first released for sale. Being skeptical of plastic reels from past experience, we considered this reel as just another low-quality, plastic reel. The letter that came with the reel suggested we test it any way we desired; we did so. The author put it on the floor and stood on it. Such treatment would normally damage a steel reel beyond repair. Upon inspection, the plastic reel showed no signs of damage. We then tested it rigorously—throwing it on the floor, twisting it out of shape by hand, winding film very tight on it. After trying everything we could think to try and damage the reel, we gave up. That reel looked just like it did when we took it out of the box, in perfect shape with not a mark on it. After two years of daily use as the main takeup reel on our control room projectors, it is still just as good as the day we received it (with the exception of some signs of discoloration due



Fig. 8-7. Several sizes of plastic reel. (Plastic Reel Corp. of America)

to handling). Not only is the reel superior to a steel reel, but it costs less. 1600-foot steel reels will cost about \$1.75 each in quantity pricing, while the same size plastic reel will price out at \$1.30 each in quantities. (The reel is made by Plastic Reel Corp. of America.)

Projector Maintenance

TV projectors are held to tighter tolerances than are home style projectors. Consequently, these machines are often fussy about the condition of the film they will pass. When something goes wrong, more often than not damage will occur to the film. Splices must be good or they will pull apart. If a splice is too thick or if its edges project, the film will likely be torn.

Daily cleaning and oiling of the projectors is a must. If the film schedule is very heavy, the gates and rollers should be cleaned more often than once a day. The projectors should be torn down and gone over thoroughly each month. RCA Service Company, with trained personnel, will service your projectors once a month under contract. Replacement parts are also supplied under these contracts and you will receive as many additional emergency calls as are necessary. Often, the cost of the replacement parts used in a month will more than pay for the contract. Unless your personnel are capable of doing this work, it

is well to investigate a service contract. For a small station, the service contract arrangement will prove to be the best and most economical arrangement.

Film Room Equipment

A heavy film schedule calls for adequate handling equipment in the film room. A few basic items are mentioned here; each station will add other equipment to meet its specific needs. The best equipment available should be purchased to handle film; it will pay for itself in many ways.

Bench

A suitable bench should be constructed that is covered with a counter top of some easy-to-clean material. Cleanliness is a must around film.

Power Rewind

A heavy duty, power rewind (Fig. 8-8) is a worthwhile investment. The smaller rewinds will wear out in a short time and will need to be replaced. A hand-operated rewind will prove to be very inefficient.

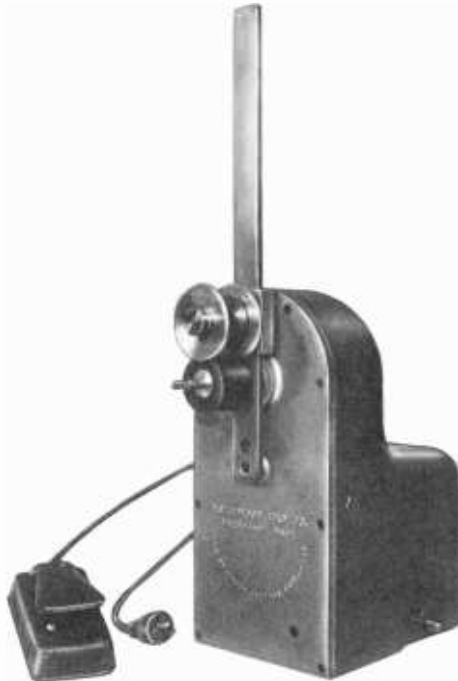

Fig. 8-8. A heavy-duty power rewind. (Hollywood Film Co.)

especially with a heavy film schedule. The power rewind should have a foot-operated control.

Playout Rewind

The playout rewind should be one that has a hand brake. A hand brake will assist in making a tight even wind. Without the brake, damage can occur more often, as well as injury to the operator. If, when film is being rewound rapidly, it begins to spill for some reason, an operator may grab the play-off reel with his bare hand. If this reel is a steel one, he can be cut badly.

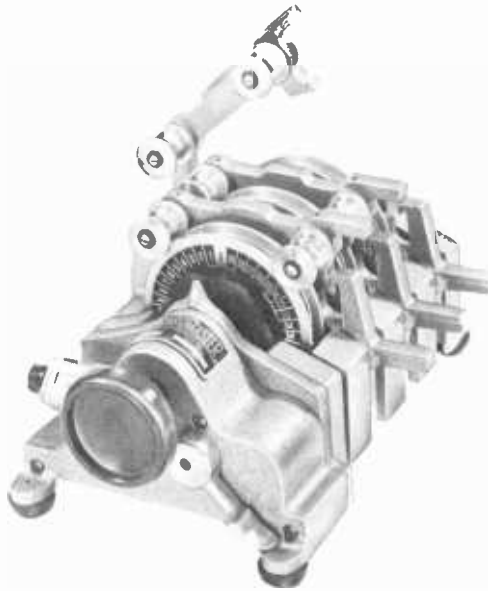

Fig. 8-9. *The Synchronmaster, film timer. This model will time two films simultaneously. (Neumade Products Corp.)*

Film Timer

A film timer is quite useful on the film bench, but it should be constructed so that it will not damage the film. You cannot depend upon the timings shown on the feature films, because they may have been damaged and part of the film removed. Without a timer, programming can become very uncertain and a poor on-the-air product results. Several types of timers are shown in Figs. 8-9 and 8-10.

Viewers

Some viewers are quite dim and must be operated with the room lights turned down or off. Select a viewer that is bright enough to leave the

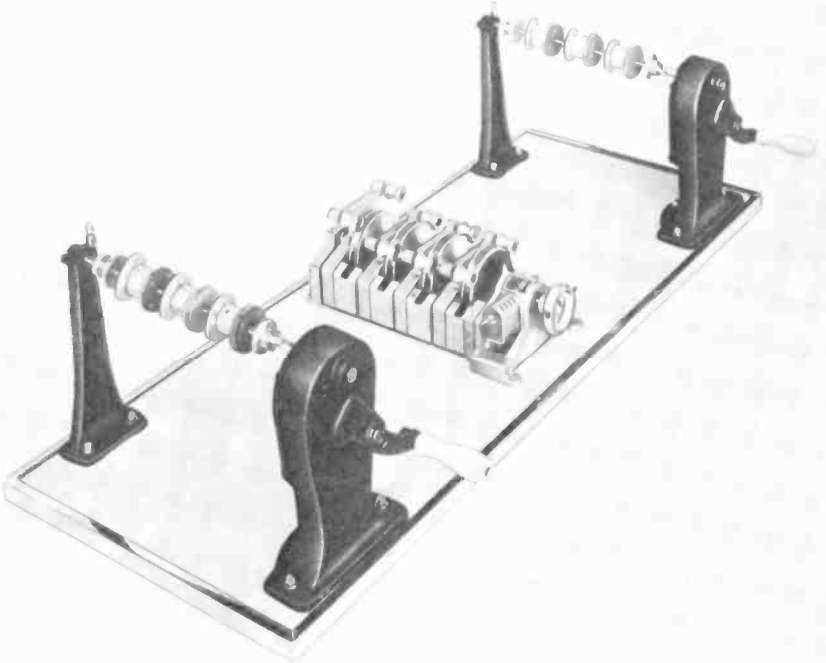

Fig. 8-10. This film timer will time four films simultaneously. (Neumade Products Corp.)

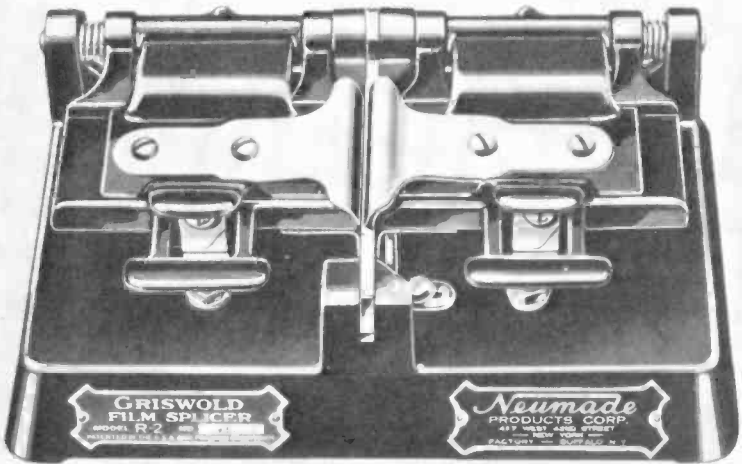

Fig. 8-11. A manual, 16 mm film splicer. (Neumade Products Corp.)

lights on when it is used. It is better when the operator can operate in the light. A viewer is indispensable for film inspection.

Splicers

A splicer (Fig. 8-11) is a must and should be of very good quality. TV projectors are critical of splices and will either pull apart poor splices or the film will be torn. The cement used should be fresh and of good grade. The splicer should be kept clean or splices can't be made properly. There is an automatic splicer available that does a very good job. It is more expensive, but may be well worth the additional cost. As is the case with most automatic equipment, it is more fussy about the handling it receives. Unless it is constantly kept cleaned and properly adjusted, it won't do a very good job. (It also happens that many people who do film work have trouble with any complicated piece of equipment. For such people, a manual splicer will be better.)

Hand Tools

Two small hand tools will be of great assistance in preparing film. One is for punching cue marks on the film. These small holes are usually placed near the end of the film so the operator in the control room knows just how many seconds are left before he has to make a projector switch. This will present such a smooth program flow that viewers may not even know there was a change made from one projector to another. There is only one difficulty with cue marks at the end of a reel of film. After it has been around the circuit, it may have a number of such marks, all different. As these flash onto the corner of the screen, the operator may become very confused.

The second hand tool is intended to clean up sprocket holes that may be torn. This punch will notch out a torn hole so that there are no rough edges to catch. It can't help if more than one hole is damaged in sequence, because the claw needs at least one hole to pull the film down and past the gate in the projector. If several holes are torn out in sequence, it is better to splice the film to correct it.

Film Storage

Storage of film should be given careful consideration. Not only will space be required for day to day film handling (film being prepared for the day's showing, film that is received and that which is being shipped out), but space will also be required for less-frequently used film such as commercials, features, news, documentaries, and other such films that belong to the station. Over a period of time, film in these categories will gradually increase in bulk. They should be stored so that they are kept free from dust and damage. Film may be stored in



Fig. 8-12. *A typical film storage cabinet. (Neumade Products Corp.)*

plastic or steel cans, shipping boxes, or cartons, and should be properly labeled for easy identification when it is needed. Steel cabinets (Fig. 8-12) are also available that have doors on them so that the cabinet may be closed. Such film need not be stored in the film room, although it is the most logical place to keep it.

Preview Projector

A preview projector is a must. This should be one of the better-quality, home-type projectors with good quality sound reproduction (Figs. 8-13 and 8-14). Cleaning and maintenance of this projector is often neglected, with the result that film damage is often caused before it gets shown on the air.

Shoot Your Own

The local market station will do much in the way of local interest material for programming. This may be news, special events, or sport-

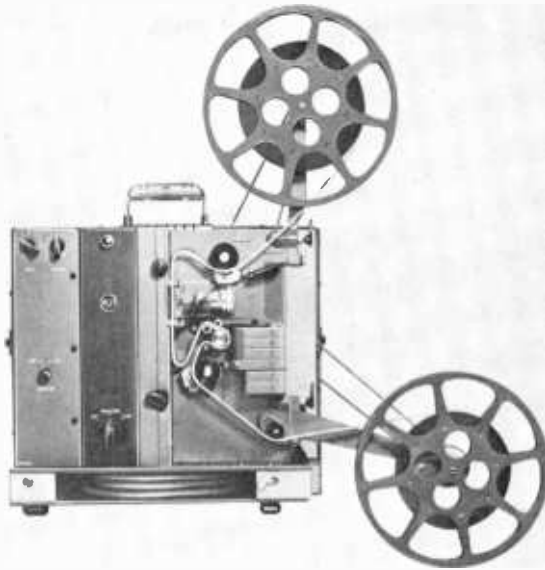

Fig. 8-13. A small 16 mm projector, the RCA 400 Jr., suitable for film previewing. (RCA)

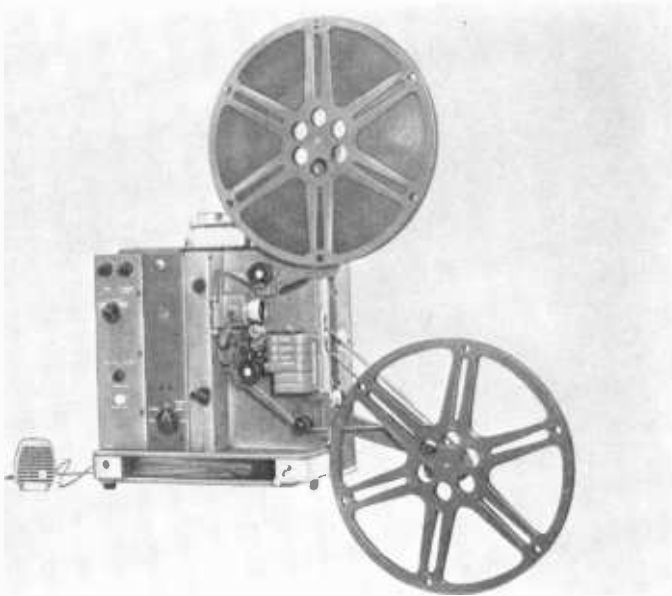

Fig. 8-14. A small 16 mm projector, the RCA 400 Magnetic, suitable for previewing film with optical or magnetic sound tracks. This projector is also a magnetic recorder. (RCA)

ing events. Here again, the extra money spent in buying good filming equipment will pay for itself in a very good quality product for air presentation and there will be fewer maintenance problems.

Many 16-mm movie cameras are available for TV use, such as that shown in Fig. 8-15. Make sure they will operate at 24 frames per second. The older types operated at 16 frames, which is why the movements in old movies shown on TV are very jerky.

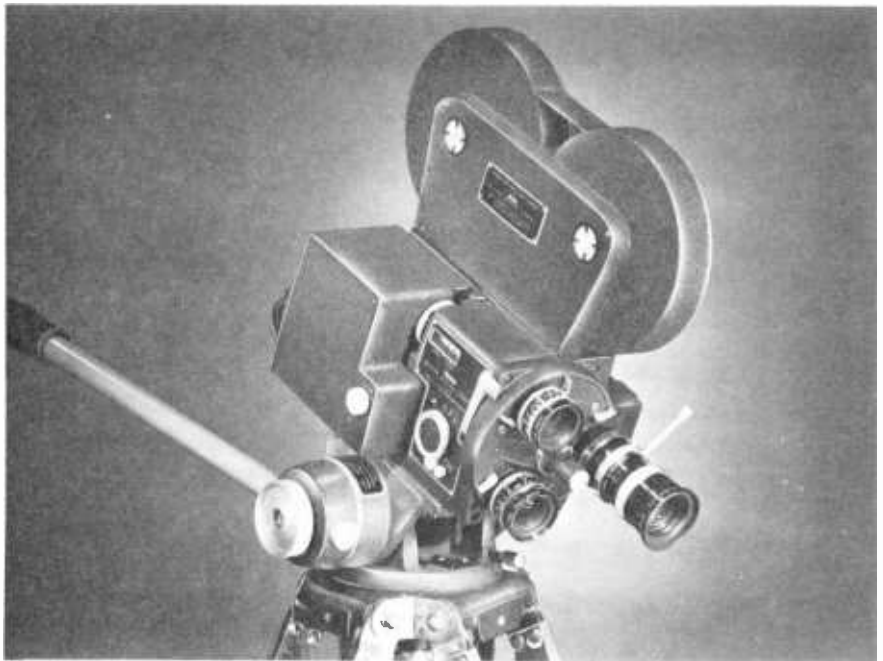

Fig. 8-15. *The Kodak Reflex Special, a 16 mm camera. (Eastman Kodak Company)*

A movie camera can be either a silent model or one that will record sound on film optically or magnetically. Cameras are available in 100, 400, 600, and 1200 foot magazine sizes. Each camera can hold film only up to its maximum magazine capacity. Some adapters to hold larger magazines are supplied for smaller cameras, but they may not work as well, since the mechanism may not be able to pull the extra weight of the film. Consequently, there may be speed variations in these cases. However, a camera designed for larger magazines will handle smaller amounts of film with ease.

While magnetic sound tracks allow a smaller amplifier and give better quality sound reproduction, it should be pointed out that there are some supply problems. As of yet, you cannot buy film with the pre-stripped

magnetic sound tracks. Ordinarily, processing centers and other film centers will do this striping for you at a cost of about 3½ to 4¢ per foot. This is in addition to the cost of raw film. As the demand for pre-stripped film becomes greater, it undoubtedly will be available as a shelf item.

Cameras come in different styles, sizes, and prices. Many of the standard cameras have been modified by other companies, who sell these modified cameras. Most of the modifications are usually in the sound system. Because of their light weight, compactness, and low voltage requirements, transistors are making quite an inroad into camera amplifiers. In most cases, the objective has been to reduce the size and amount of equipment necessary to shoot sound on film. One such modified camera even includes an age amplifier built into it; the whole amplifier is mounted directly on the base plate of the camera.

Magnetic and Optical Sound

Magnetic sound tracks give the best quality sound, but they also have their drawbacks. Because the method is relatively new, many places do not have equipment to play back the sound because the projectors must have magnetic playback heads on the sound system. For your own purposes, both TV projectors and the preview projector must have provisions for magnetic sound if this is to be used. Most TV projectors are often equipped to handle both optical and magnetic sound at the same time.

RCA supplies three, reasonably-priced models of small projectors for film previewing. One model is especially useful if the station is doing any filming with magnetic sound tracks. This unit, the "400 Magnetic," will reproduce both magnetic and optical sound tracks and it also incorporates a magnetic recorder so that sound may be recorded or edited on the magnetic track. For example, during an interview, someone may use language that is not acceptable on the air. If the track is magnetic, it can simply be erased. If the track is optical, the film will have to be cut, the objectionable part removed, and the film respliced. Filming of news events, travelogs, and such, can be done silent. In the studio, the announcer can add the commentary as he previews the film. None of this can be done with the ordinary optical sound tracks.

Many institutions or organizations do not have equipment to play back magnetic sound tracks. In many instances, should a station get permission to film a local sporting event, such as a high school or college football or basketball game, the schools will usually want the film after the station shows it on the air. The coaches and teams use these films to review and discuss their techniques. Giving the film to the school after the station is done with it is a good inducement to get the permission to film in the first place.

The safest procedure in purchasing a camera will be to get one that can record the sound either optically or magnetically. Then, if high-quality sound is desired when making a commercial or other such film, it can be done with the magnetic sound tracks. If a school or other organization will be using the film and they cannot use magnetic sound, the optical track can be used.

Sporting Events

Many sporting events will make good program material for the local station. You will need the cooperation of the schools or organizations concerned. A camera with a 400-foot or 600-foot magazine can do the job. It will take some careful on-the-site editing and footage minding, so that film does not run out in the middle of an exciting play. However, if changes are gauged to be made during time outs or other periods of little inactivity, very little of the action will be lost. Film shot in this manner will also require much editing back in the film room. Since the camera will be started and stopped quite often during the game, there will be many places where the film was exposed with the camera stopped, and, also, the sound may have been open while the camera was getting up to speed. On the air, the exposed film will produce white blips and the sound will wow. These faults can be taken out on the editing bench so that the on-air product will appear to be a smooth-flowing, action film of the game.

Film Processors

Unless there is some nearby concern that will process 16 mm reversal film, you will probably need a processor. Sending the film away to be developed may take so long that the value of the film is lost (especially news items). There are small processors available that will provide reversal processing. Reversal means that the film will come out of the processor as a positive print; i.e., everything looks just the way it is normally. Film cameras in the control room can handle negative film. However, when it is intermixed with positive film and slides (which are positives), complications can develop at the operating position, because the operator must throw a switch to pick up the opposite polarity video. There will also be trouble when it is desired to super a slide over the film picture on the air. In this case, it just won't work.

Small processors are not very speedy, so it will take some time to get the film processed, depending upon the length of film to be handled. They are fast enough to handle news film so that it is available in a relatively short time. A full ball game will take much longer.

In a twenty-four frame system, as is used for television, film runs at 36 feet per minute. Therefore, a 400-foot reel will contain 11 minutes

of program material and a 600-foot reel will hold about 16½ minutes. A full ball game may have about 1600 feet or more of film to be processed.

The Cramer model 60-1 is a processor that is ideally suited for a small station (Fig. 8-16). Although it is not a very speedy machine, it will



Fig. 8-16. *The Cramer 60-1, a 16 mm film processor for both negative and reversal film. (Milco Manufacturing Co.)*

handle the small station film load. It is normally run at 4 feet per minute, but with an auxiliary drier unit, it can run at 6 feet per minute. At the lower speed, a ball game on 1600 feet of film will be processed in about 6½ hours.

The processor makes a full reversal print, but can also make a negative print. Several accessories are available; e.g., a warning buzzer to

warn the operator that processing is done, a temperature control, water-mixing valve that will automatically mix the correct temperature water, or a dolly with casters, etc.

One filling of solution will process 400 feet of reversal film. The company sells the processing chemicals already packaged in kit form, so that no measuring or mixing is required. Each kit will process 400 feet of film. The processing does not have to be done in a dark room, as daylight spools are used for the unprocessed film and full processing action can be carried on in broad daylight. No rewinding is required either, as the film comes off the processor ready to put on a projector, with the front end and sprocket holes in the correct position. The processed film winds onto a regular reel at the end of the processor.

Another feature that makes this processor ideal for the small station is its physical size. It is only 40 inches in overall length, 12 inches wide (16½ inches with legs), and 40 inches high with legs (30 inches high without legs). Thus, it is a small, compact unit that can fit into a small space. No special plumbing is required either, as it can be attached to running water through hoses.

Film Equipment Costs

Basic equipment is specified here as a starting point. The individual station will probably expand to meet its own requirements. Benches or tables are not included, as these may be either home-made or purchased ready-made.

Film Room

Dynamic rewind with handbrake (Neumade)	\$ 27.00
Power rewind (Hollywood Film Co.)	\$124.50
Griswold splicer, model R-3 (Neumade)	\$ 36.00
Synchromaster model 161, film timer (Neumade)	\$135.00
Film viewer (RCA)	\$ 38.50
Spot film cabinet, MM-180-16 (Neumade)	\$415.00
Feature film cabinet, RK-150 (Neumade)	\$165.00
Total	\$941.00

Film Preview Projector

RCA has available three models. Prices given are for the bottom and top models.

RCA model 400 jr., portable projector, less speaker	\$385.00
RCA model 400 magnetic, less speaker	\$754.00

The first model will reproduce optical sound only. The last model will reproduce both magnetic and optical sound, and will also record magnetic sound.

Film Camera

Prices of 16-mm film cameras vary considerably, depending on whether it is silent or sound, optical or magnetic, or both and what you desire in accessories. Magazine size also affects the price. Many modified cameras are available, so only a range estimate of costs will be given.

Sound cameras will run from about \$1500 for a 100-foot magazine to about \$4500 for a 1200-foot magazine. Modified cameras with transistorized amplifiers and 400-foot magazines will average about \$3000 after a suitable selection of lenses, tripod, and so forth, are added.

Film Processor

Cramer Model 60-I (Milsco Mfg. Co.)	\$895.00
Chemical kit for 400 feet of processing	\$ 4.75

Totals

Film Room	\$ 941.00
Preview projector (optical)	\$ 385.00
16 mm camera (average)	\$3,000.00
Processor and kit	<u>\$ 899.75</u>
	\$5,225.75

Chapter 9

Planning the Building

The basic building plan should take the future into consideration. Even when future expansion seems to be a far-fetched fancy, you should provide for it in your building plans so that expansion may take place when the needs are pressing and funds available. Each room or section, although specifically designed to fit and meet a present need, should not be so constructed that it can never be expanded without too great an expense. However, there is a fundamental mistake that is often made in this area. Because some future type of operation is planned and desired, temporary, flimsy buildings and facilities are installed in the beginning, with the thought that they will be replaced later. If the expected revenues do not materialize as rapidly as expected or never reach the desired level, these inefficient, poorly constructed facilities become permanent. Revenues may not reach the expected level for a number of reasons, such as economic or market conditions, but one such reason could be the inefficient facilities that have been initially installed.

Plan your facilities so that future operations will be direct expansions of the present facilities. This doesn't mean a haphazard growth pattern, where additions are fit in anywhere as the need for them becomes pressing. Future additions should be planned for and space should be allotted for them from the start. When this type of planning and construction of facilities is done, if expected revenues do not develop, an efficient facility will be working for you and not against you, so that you can be proud of it even as a terminal facility. Should future additions be made as planned, there will be no lost air time and no duplication of equipment.

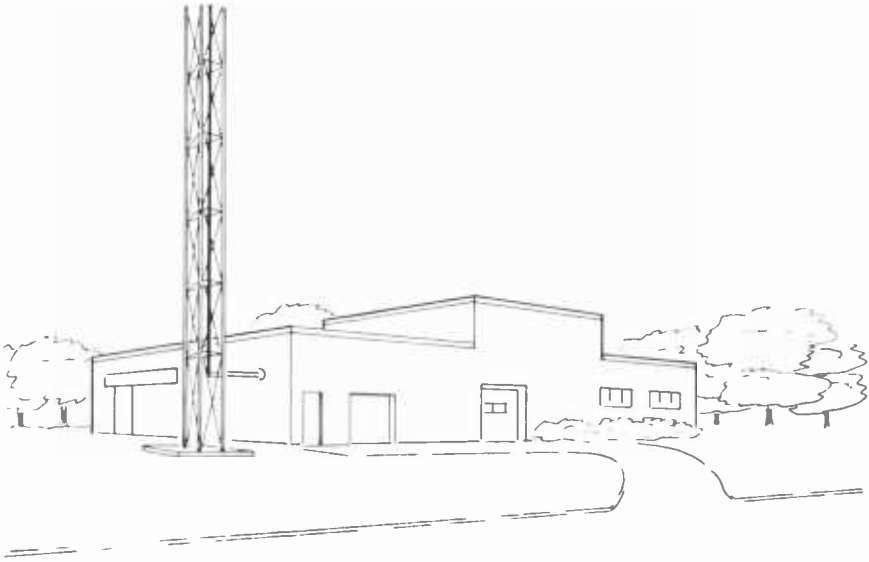

Fig. 9-1. *A modern studio-transmitter building. Notice that the roof line of the studio is higher than the rest of the building.*

The plans and equipment in this book have been geared to a minimum operation, small studio originations, one-man control room operations, and a heavy film schedule. The basic idea has been to demonstrate what can be done and done well by changing some basic concepts in station operation.

The technical operations and plant facilities are the core of the station operation. There must be adequate space in which to keep the technical equipment going, plan for its upkeep, and store spare parts.

The basic staple for a non-network affiliated station will be film. Without a network, the film center takes on great importance. Therefore, space should be provided for film editing, storing, and projection. There will be much live filming, especially of news and other events, which will necessitate a processing center.

A news center will be of the utmost importance in local programming. Since small stations cannot expect to compete directly with the larger market station, viewers must be given something they can get only on

your station, and this product is news of local events and local items worthy of airspace. It is important to provide adequate space for a live wire news operation, not just some cubbyhole with a teletype news-printer and desk.

Programming needs adequate space for traffic and a quiet area for copywriters. Copywriters and those who must do creative work should not be subject to constant interruptions.

Other areas also need adequate space and some need privacy, so there should be some private offices. A place for clients to discuss business, review their prospective spots, view an air presentation, or observe a film is quite helpful in sales work.

While most of these are basic requirements for a television station, just how elaborate the beginning design will be will depend upon what is needed and can be afforded at the beginning.

Types of Structure

Your area and climate will have a great effect on the final design of the building. Hot, dusty areas will call for a different style than that used in cold climates. Masonry is a suitable material in most areas, although other materials will serve just as well.

The section of the city in which you are located will dictate structural design and materials. A transmitter building located on an isolated hill can be purely functional in design without looking nice. However, in the city, there is a certain amount of prestige that must be maintained.

Some consideration should be given to a two-story plan. A one-story plan can become so spread out with future additions that efficiency dwindles and bottlenecks appear. Your original building can be so constructed that the footings, sidewalls, and partitions are of sufficient strength to carry a second floor when later expansion is carried out.

The number of windows and openings will affect insurance premiums and the appearance of the building. Fewer windows and doors provide greater safety against theft and break-ins, but will also cut down light and air. Windows of glass blocks and such materials can be used to provide light. Outside doors should be provided only where necessary to maintain the planned efficiency of operation. For instance, props and products should be delivered directly to the studio from an outside door.

Heating and Air Conditioning

Proper planning of heating and air conditioning both for the beginning and future expansions will pay off in efficiencies in cost and comfort (with a consequent better product).

The transmitter and other technical equipment give off considerable heat. Unless this heat can be diverted to the outside in hot summer months, the control room can become a "boiler room," with consequent poor efficiency from personnel and equipment breakdowns. Air conditioning will be of little help and would probably break down.

Provisions should be made to use this waste heat. In the summer months, it should be exhausted to the outside with outside air piped in for equipment cooling. In the winter months, this waste heat should be exhausted into the building heating ducts and will contribute greatly in reducing the heating costs. Also, there will be less strain on the heating plant. One station using this system was only getting token gas bills each month. The gas company sent an inspector out to check the meter because they suspected it had become faulty, since it should be impossible to heat a building of that size with that small amount of gas. The inspector discovered this small amount of gas was only used to heat a four-car garage with space heaters. Even in the coldest months, the only time the furnace came on was during the period at night after the equipment had been shut down.

WBJA-TV in Binghamton, N.Y., also uses this system of heating. The station reports that they are located on top of Ingraham Hill, known locally as "Windy Hill," and in a completely exposed position. Even though this section of New York state has rather severe winters, the station reports their heating costs are extremely low.

Dusty areas require some type of air filtering to avert equipment troubles because of dust accumulation, especially on high voltage points. One station located in a steel manufacturing center, where the air is quite dirty, even added a device that electrostatically cleans the air with high voltage.

Traffic Problems

For our purpose, the station's traffic means the usual travel of people and/or equipment from place to place. Thought should be given to the flow of the product, from the reception by Sales through the Traffic Department to Program/Production and, finally, to Engineering. Each of these areas should be located so that much of the time will be spent in useful work, not just in walking from place to place delivering materials. A considerable amount of this travel can be eliminated by installing an intercom system of some type, preferably of the telephone style.

Visitors should be able to locate the front entrance with ease. The author has often had the experience of going to a strange station where it was quite difficult to find out which was the main entrance. The entrance should be clearly marked and visible as soon as someone comes

up the drive. Otherwise, visitors may come walking into the studio during a live show or use other entrances into areas where they do not belong.

Products should be delivered directly to the studio door. For this purpose, a large door or doors should be provided directly off the driveway. Otherwise, all materials may have to be carried all the way through the building. These service doors to the studio should be large enough to drive an automobile into the studio. There will be occasions when you will want to do this for commercials or program purposes.

Other Considerations

The placing of the building on the lot can mean cost and future expansion problems.

The tower will usually be located in the center of the lot; this is accepted practice. This permits the guy wires, if used, to be on your own property, and if the tower should fall it will land on your property. There will also be less chance of paint getting on surrounding buildings and ice falling on neighborhood houses, which will lower the insurance premiums. Wherever the building is located, it must connect to the tower by expensive coaxial transmission line. Longer lines have greater r-f losses.

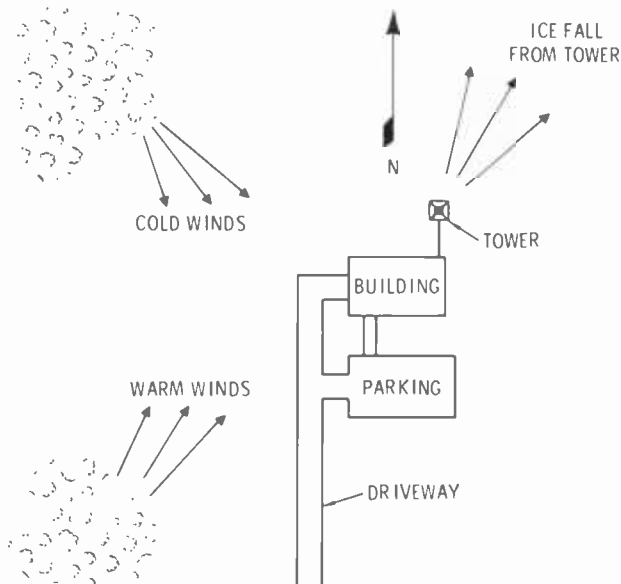

Fig. 9-2. *Proper tower location in relation to building, parking lot, and driveway. (This location is in the midwest.)*

City water and gas lines must be extended to reach the building. The longer these must run, the higher will be the installation cost.

The longer a driveway must be, the higher will be its cost. A long drive will present high snow and ice removal costs in the winter if you are located in an area where snow and ice are a problem. The city and highway crews will keep the main streets cleared, but you will have to pay to clear your own. Sometimes it is difficult to get someone to clear the drive right away, a time lag that may result in stuck cars and traffic jams on the station property.

Another important point to consider is location of the driveway, parking lot, and building with respect to the tower and falling ice. Falling ice is usually dependent upon prevailing winds in your area. In the midwest, the bad, ice-forming weather usually comes from the northwest. Warming winds from the south or southwest melt the ice and blow it off the tower. Therefore, in this area, the tower should be located on the north or northeast side of the building, drive, and parking lot (Fig. 9-2). This will permit the ice to fall harmlessly onto an open field. Falling ice can put dents in cars, break windows and windshields, injure people, damage the building and roof, and damage the transmission line. Proper tower location can eliminate most of these hazards.

Inside the building, some suitable place should be allocated as a lobby, even if it is part of the general office. Outsiders should not be permitted to wander about the station unescorted, both for their own protection against injuries and to prevent interruptions to on-the-air programming. In one radio station, a visitor thought the rear door to the transmitter was a clothes closet and opened it to hang up his coat. Naturally, this put the station off the air.

The operating area should have closed doors. Visitors will not open doors, but if it is just a hallway, they may be inclined to wander around. Large, felt ropes or even a planter will serve to mark off the lobby from the general office. A TV monitor and seats should also be provided.

A Sample Floor Plan

The floor plan presented in Fig. 9-3 will be suitable either as a starting point or as a terminal operation if no future expansion is contemplated. With some modifications, it has been used by an existing uhf television station in a medium market for the past six years.

The floor plan may be reversed in different ways, depending upon how you wish to locate the building with respect to tower and driveway. Reversal may be from left to right, so that the tower is on the left and the driveway is on the right, or reversal may be from the top to the bottom,

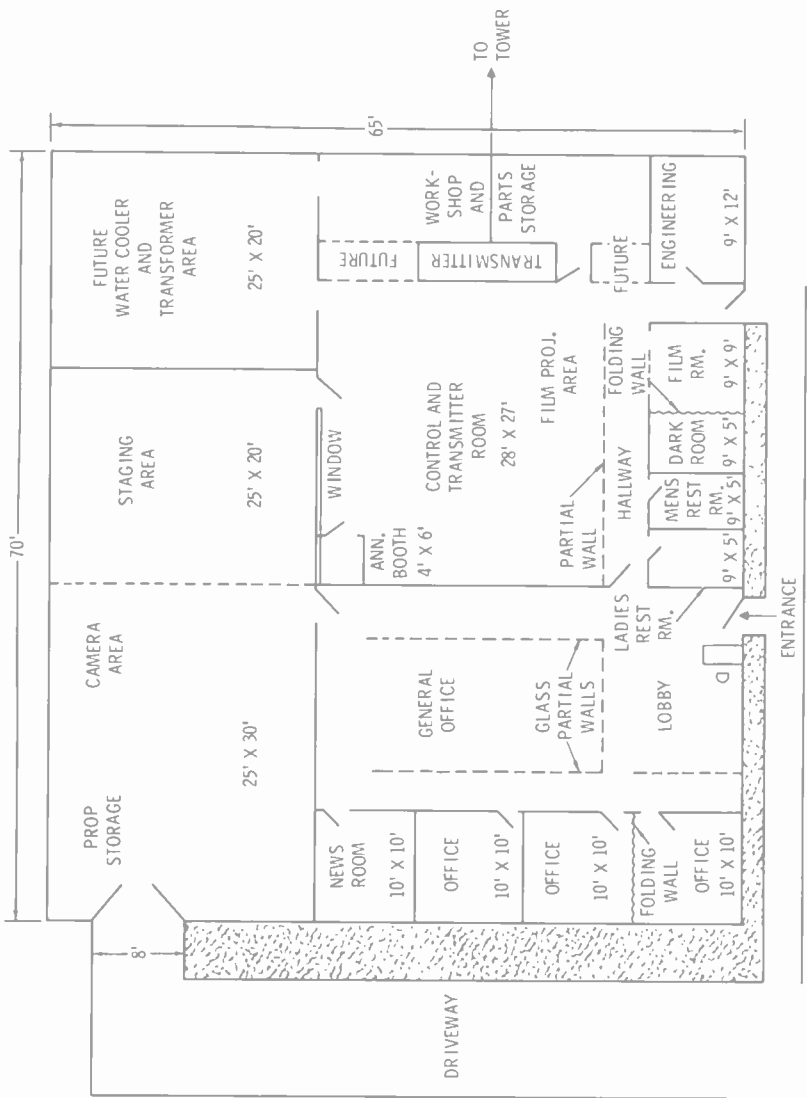

Fig. 9-3. A sample floor plan.

so that the entrance is at the top and the studio is on the bottom. Expansion of the building is possible on three sides. The side toward the tower may be expanded somewhat, depending upon the distance of the tower from the building. It is expected the tower will be close to the building, however.

Foundations, sidewalls, and inner supporting walls should be strong enough to support a second floor if expansion is desired in this way. Although the building has been designed with minimum concepts in mind, all dimensions may be expanded equally by several feet if more "elbow room" is desired.

Transmitter

The basic design started with the transmitter. These units will vary in size, depending upon the manufacturer and power. Enough room is prepared, so that you may start with a lower power unit and later add the higher power units with their water cooling devices and transformers. This method will not disrupt service very much nor require additional equipment during the transitional period. Also, the building will need no additions. The spare areas provided may either be shut off and unused or temporarily used for storage or other purposes.

Ceiling height near the transmitter will be important, especially if your transmitter uses klystron tubes. These tubes are several feet long, depending upon channel. A block and tackle arrangement is the best

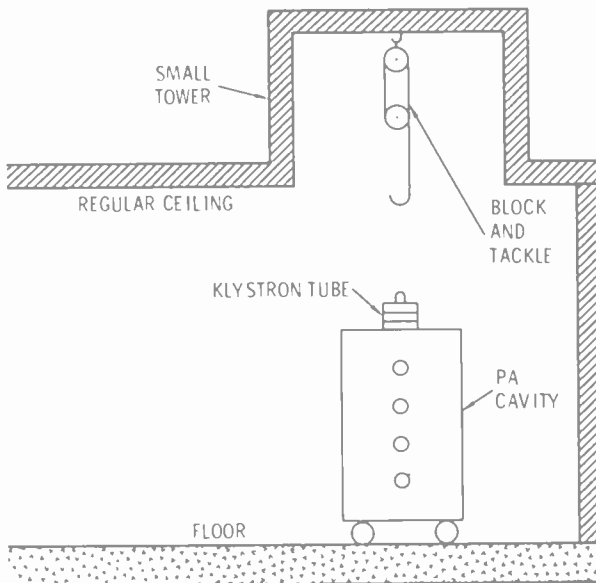

Fig. 9-4. If the transmitter room ceiling is too low, a small tower should be built to facilitate replacement of klystron tubes.

method of changing the tube from the cavity. These tubes are not changed while in the transmitter itself. A small area can be set aside for this changing process, with a small tower built into the ceiling if the height is not enough (Fig. 9-4). This would be similar to the hose-drying towers of fire stations.

Control Room

The control room has been designed for one-man operation of control position, transmitter, and projectors.

The wall off the hallway is simply a partial wall, only a few feet high, intended primarily to define a hallway and at the same time to keep people from wandering into the control room equipment. The part directly across from the film room is also a film storage area, so that film to be used can come directly from the film room to this storage area next to the projection equipment.

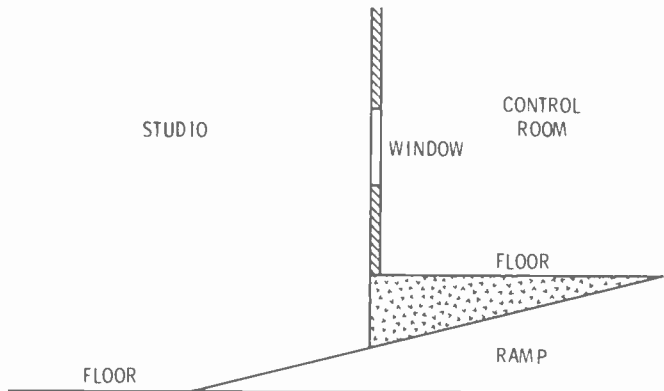

Fig. 9-5. *The floor of the control room should be higher than that of the studio. Use a ramp instead of steps to connect the two rooms.*

The floor of the control room may be raised about two feet higher than the studio floor, if desired (Fig. 9-5). This will permit the director and control operator to see into the studio, even though there may be several people in the way. Another method for clear viewing would be to raise the director's position only. The control room may be on the same level as the studio floor, but people should be instructed to keep the view clear. If the two floors are level, construction problems are eliminated and there will be no need for ramps, steps, and the like.

Engineering Office

Space is provided for engineering work, a drafting board, instruction manual filing, engineering material filing, and the like, directly off the

engineering section. The walls should reach the ceiling (at least the one towards the workshop area) because the other side of this wall should be used for parts storage in bins and shelves that go clear to the ceiling. The wall towards the hallway may be a partial wall, although there are times when quiet and privacy are needed, especially when such work as drafting and planning is being done.

Workshop and Parts Storage

Space is provided behind the transmitter so that work may be done, when necessary, on the transmitter. Because of the transmitter's odd shape, much of this space would ordinarily be waste space, so it can be put to other uses. Much of the wallspace is shelved or made into bins for parts and tube storage and enough room is available for a workbench.

Film Room

The film room is not a large room, but it should provide adequate space for film editing, rewinding, timing, and storage. Film shipping and receiving will also be done from here and deliveries can be made near the rear entrance. Engineering deliveries and shipping are also handled from this entrance.

The wall of the film room that faces the hallway is really no wall at all. It is made up of film storage cabinets that have a solid back.

Dark Room

Although the dark room area is small, it should provide room for a film processor and developing tanks. It is located next to the film room so that processed film may go directly to the film room for editing. This room is located between the film room and the rest rooms. This location provides closer outlets to the running water and drains that are available in the rest rooms.

Studio

As described in Chapter 3, a 20- × 25-foot staging area, with a 20- × 25-foot camera maneuvering area is provided. The additional 10 feet of space may be used for prop storage. This amount of storage and studio space will provide the small station with enough area for some time to come. Should expansion be required, more of the camera maneuvering area can be used for staging.

A large outside doorway, directly onto the driveway, permits direct deliveries of props and advertisers' products to the studio. Eight feet should be the minimum width of this door, so that an automobile may be driven directly into the studio. Several doors of this size are available and will do a suitable job. Whatever door is used, a good weather-tight



Fig. 9-6. The staging area for a small station's studio. (WIBC-TV, Muncie, Indiana)

seal should be provided, so that snow or rain will not run onto the studio floor. A wet floor will make it difficult for the cameraman to maneuver the camera properly. The studio should be above outside grade level and a ramp provided so that an automobile may be safely driven inside. This arrangement does not anticipate that deliveries will be made to the studio during a live show.

There is one other consideration to be made for the studio. Do not have any roof supporting poles or posts in the area. These will be a hindrance to show production and maneuvering the camera. Some city building codes may give you trouble here, but proper supports will permit a ceiling of this width without supporting posts.

The minimum ceiling height should be 12 feet; maximum will be 18 feet. The roof line of the studio may be higher than the rest of the building, which is often normal practice.

General Office

The office should use glass or plastic partial partitions, so the staff, especially the copywriters, may work with a greater degree of privacy and fewer interruptions. Arrangements can be made to suit individual situations. There should be one partition all the way along one side to form a hallway from the lobby to the studio. This will allow visitors to go to the studio without interrupting those working in the office.

Lobby

Glass or plastic partitions are also used to define a lobby. A few chairs and a video monitor will keep those who are waiting occupied and detain them from wandering. The hallway into the operations center is also closed with a door for the same purposes.

A desk should be provided at the door, so a girl may act as a receptionist, even though she may also be doing other work.

Offices

Space is provided for three private offices, with walls that go clear to the ceiling. This space may be adjusted to desired needs. Two of the offices are shown with an adjustable folding wall so they may be converted into a large, single room for conference purposes when a larger group of people are to meet and desire privacy.

Expansion of the office space may take place by adding length to the building or by adding a second floor.

News Room

The news room is located right off the studio. Depending upon the type of operation, more efficiency can sometimes be obtained by placing

this room where the engineering office is. In such an arrangement, the news room would be right next to the film processing room, where news film could be processed and then taken directly to the control room. In such a case, however, some change would be required in the engineering filing system, because such things as equipment manuals should be handy to the control room.

Chapter 10

Planning the Layout

General Layout

Power Entrance

Power should enter the building behind the transmitter room. All power distribution within the building should be made from this point. The direction of the high-lines and pole transformer should be such that they are as far from the guy wires and tower as possible.

When making the preliminary estimates of a-c power requirements, both for the whole building and for various areas within the building, allow at least 30% more capacity than is originally estimated. This will permit later additions to be made without any difficulty.

Circuit breaker panels can be located in different sections of the building if desired. For example, the office area may have all its lighting and outlets controlled from a circuit breaker panel in the hallway, right off the office area. This would permit shutoff of any of the office circuits without going all the way behind the transmitter.

Power may be run in conduit, armored cable, or nonarmored cable, whatever is permitted by electrical codes in your area. These will generally give no problem to the technical operation. However, power that must run within ducts where audio or other low-level circuits are located should run in conduit. It would be even better if these did not run the duct at all, as the conduit can be laid right in the cement floor.

Telephone Entrance

Telephone circuits should also terminate in the area behind the transmitter. Cables may be run from there to outlets at each point in the building where a phone may be anticipated. Make this conduit of large enough diameter so that any future expansion of the system will

permit a larger telephone cable to be pulled through it. Some telephone systems also incorporate an intercom system, which uses large cables. It would be well to consult the local telephone company for size. A less expensive method would be to provide the intercom circuits yourself and use telephone company circuits only for outside lines. Sometimes the station can provide all the inside equipment, but, generally, telephone companies will not permit their circuits to be tied to private circuits. (The intercom circuits referred to here are separate from those associated with the camera, floor men, and directors, which are used for communications during a live studio show.)

When the circuit breaker panels are being mounted on the wall in the power entrance area, insist that the electricians make efficient use of wall space. Some electricians are inclined to be very generous with space when placing boxes on a wall. When future expansion does take place, you will need this additional space.

Insist on a wiring diagram of the completed electrical wiring. Any good electrical contractor will provide this, with all the circuit breakers and outlets identified.

If possible, try to balance the power load on each of the legs of the power input circuit, so that one leg is not carrying more than its share of the load. This will prevent overheated cables, terminals, and breakers and will avoid any hum problems that may develop from this source.

Building Ground

A solid copper strap, four to six inches wide, should be laid throughout the station as a building ground. Everything should be bonded to this, including the transmission line and tower. This strap should connect to a long copper rod that is driven several feet into the ground. A good, solid building ground will do much to prevent ground loops, FM and AM pickup, and other interference problems due to a poor ground system. A heavy ground should be made from the separate units to the strap in the racks. If r-f problems are expected to be severe because a high-power AM transmitter is located nearby, the grounds should be increased in size (possibly to a 10-inch wide strap for the whole ground system). A small wire that is used for a ground will sometimes act as an antenna instead of a ground. The tower should also be grounded by a copper strap across the concrete piers, which is especially important for lightning protection. Lightning rods on the top of the tower will protect the beacon.

Exterior Outlets

Power outlets should be provided at different points outside the building, using weatherproof outlets. There will be many occasions when power tools or similar power equipment will be used outside, so

power should be available. These should be three-wire outlets, so that power tool and equipment frames will be grounded, protecting the operator if a short occurs.

Outside lights should be placed in the parking area and main entrance and around the base of the tower and transmission line. These may be tied into the tower light photocell relay, so that they come on with the tower lights. Outside lighting reduces the chance of break-ins and vandalism around the tower and transmission line.

Heating and Cooling

Heating may be from a central source, using gas, oil, or electricity. No particular type is superior. Overhead space heaters may also be used. In the studio, blowers make too much noise to have them running while a live show is on the air. Since studio lighting gives off a lot of heat, arrange these heaters so that they switch off when the microphone comes on. This can be done automatically by connecting the furnace to the "on-air" light relay.

Heating can be simpler and more effective by using partial walls in many areas of the building. Different types of heaters may be used in different sections. For example, the office may use electric baseboard heaters, while the studio uses an overhead heater and the control room uses exhaust heat from the equipment. Another heating method utilizes a furnace in a small partial basement, with ducts to various sections of the building. The ducts can be laid in the concrete floor while it is being poured. The same arrangement can be used with a hot water system, with copper pipes laid in the concrete floor.

The heat from the transmitter and other equipment should be exhausted into the building in wintertime so that this waste heat may be put to use. For warm weather, this heat is exhausted to the outside. Heating for the building described in Chapter 9 can best be obtained at the least cost by using small auxiliary heaters in different areas, plus waste heat from the equipment.

Cooling the building in the summer months may include the use of air-conditioning equipment. The best method in a new building is a combination heating and cooling system. This will allow a single, large heating and cooling unit to take care of the entire building, using the same air ducts for both functions. A less efficient method would be the use of small units for different areas of the building. Whatever the method selected, the heat from the transmitting and control room equipment should be exhausted to the outside in warm weather, and fresh outside air should be used to cool this equipment. These units generate a large amount of heat; to try to cool the air with this waste heat present will severely tax any air-conditioning system.

Transmitter

Each transmitter has different dimensions, which depend upon the manufacturer and the power output rating. Each manufacturer supplies all the dimensions for his units, along with suggested layouts and ducts. You are not required to use these suggested plans, but you should ask the sales engineer if there are any special reasons for their particular layout.

Once the transmitter and its accessories are selected and your future power increase is determined, you can plan ducts, transmission line run, and sideband/diplexer unit installation. From these dimensions, plan the transmitter and ducts so they will remain permanently in place. Then later additions will only be required to be installed alongside the lower powered units. There may appear to be a lot of waste space when this is done, but it will pay great dividends when future power is added. This space may be put to other uses temporarily. When this is done, however, care should be used not to mount permanent fixtures that may have to be removed later. Such an example would be the filterplexer. If it is installed in the space for future equipment, the station may have to lose air time relocating it.

Air Intake and Exhaust

Air intake on some transmitters is from the rear through an air filter. In hot weather, outside air can be brought in for cooling. Otherwise, air-conditioned air in the building, will be exhausted outside through the transmitter. The transmitter will work cooler, to be sure, but it will severely overtax the air-conditioning unit.

An air duct from the outside should run in the floor so that it appears directly in front of the transmitter air intake, as in Fig. 10-1. This method will prevent an overheated workshop, since the area behind the transmitter is being used for a shop, and the rest of the area will be free from the clutter of an air duct.

Box the top of the transmitter into an exhaust duct to control the waste heat (Fig. 10-1). Movable vents or a duct to the central heating duct should be constructed so that waste heat may be pumped into the regular building heating system. Shutoff dampers will divert this waste heat to the outside in hot weather. This outside exhaust will need a blower at the end of the run or too much pressure will build up, which will prevent most of the air from going outside. The blower at the end of the run will keep pressure down and allow the air to move out freely. Dampers should also be installed in this exhaust line so that the outside outlet can be closed to prevent cold air coming in when the heat is intended to go into the building. Blowers and dampers of this type can

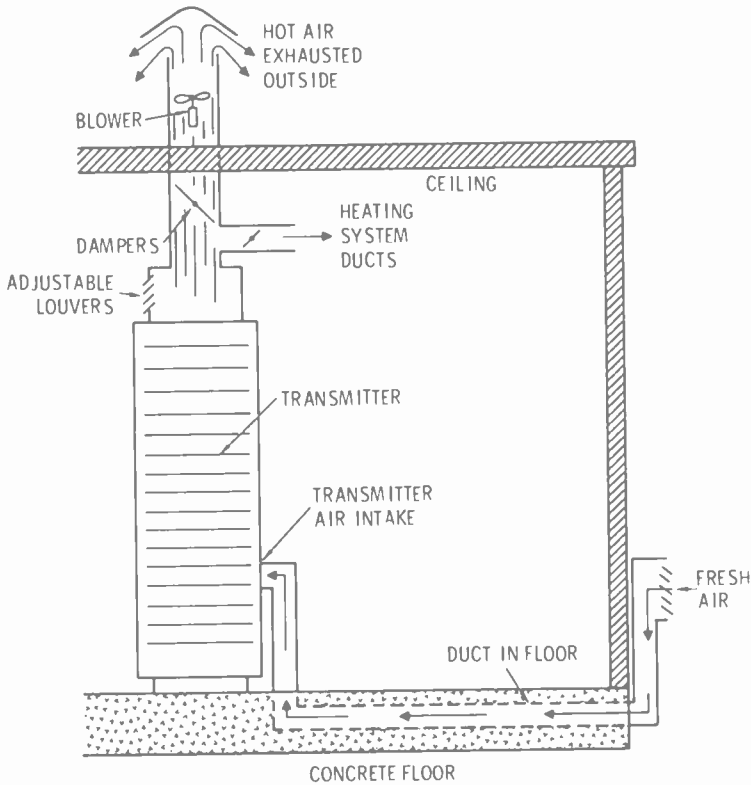

Fig. 10-1. With a setup such as this, fresh air is fed into the transmitter through a floor duct. Hot air is exhausted outside in warm weather and fed into the building's heating system during cold weather.

be wired so that they operate only when the equipment is turned on and are controlled by thermostats. For manual operation, someone will be sure to forget to have them in the correct mode.

When waste heat is being exhausted into the building, remove the outside air intake to the transmitter. This will permit the inside building air to circulate, rather than warming cold outside air and the transmitter will work better, especially in very cold weather. A vent and damper system can be arranged with the air intake system to work automatically and in conjunction with it; when the transmitter is exhausting hot air to the outside, the air intake is getting its air from the outside and when the exhaust is feeding hot air to the inside of the building, the air intake is getting its air from inside the building.

A word of warning might be added here about exhaust blowers. Too many fans pumping air out of the building will develop lower pressures

within the building. Consequently, the outside air pressure will force air inside the building at any point available to it to equalize the inside and outside pressures. This can cause trouble with the exhaust fumes from the furnace, and ammonia fumes from duplicating equipment and the pilot lights in the furnace may blow out. The best procedure is to allow the outside air to enter the building and equalize the pressure, but in a controlled manner. Using outside air ducts to equipment racks, transmitter intake, and the furnace will permit air pressure to equalize.

Heat transmission is also involved with higher power equipment that employs watercooling for the power tubes. The water cooling system uses a heat exchanger, similar to an air-conditioning system; a blower forces air across cooling fins to cool the water inside. The heat produced is blown through an outside vent. During cold weather this vent must be closed when the equipment is shut down. If it is not closed, the water will freeze in the exchanger. If it freezes, you won't be able to get the transmitter on, because it will not work unless there is water circulating.

Frequency and Modulation Monitors

Frequency and modulation monitors should be located somewhere near the transmitter. The input signals to these units are uhf carrier frequencies fed on coaxial, flexible cable. Very long runs of this cable may lose so much signal that there is not enough left to operate the monitors. The video modulation, diode monitor is directly mounted on the transmission line and the demodulated video output can be run a long way on video cable.

Control Room

Ducts should be built into the concrete floor for all the audio, video, and control circuit runs, as shown in Figs. 10-2 and 10-3. When designing these ducts, make sure to connect all present equipment and carry the duct system to other locations where future expansion is planned. A steel cover or some other sturdy lid should be made for these ducts, one that fits flush with the floor level and is tight enough to keep out dirt. If there are ridges or humps on the floor from these ducts, there will be trouble rolling equipment, such as a scope, into place.

Wiring and cables may also be run on overhead ladders. These provide less installation problems and permit the wiring and cables to be readily accessible without tearing up the flooring. They also simplify construction by eliminating many floor ducts.

When it is necessary for some special runs, such as microphone outlets from the studio or power to the racks, conduits can terminate right in the duct at the point of entry to the individual rack.

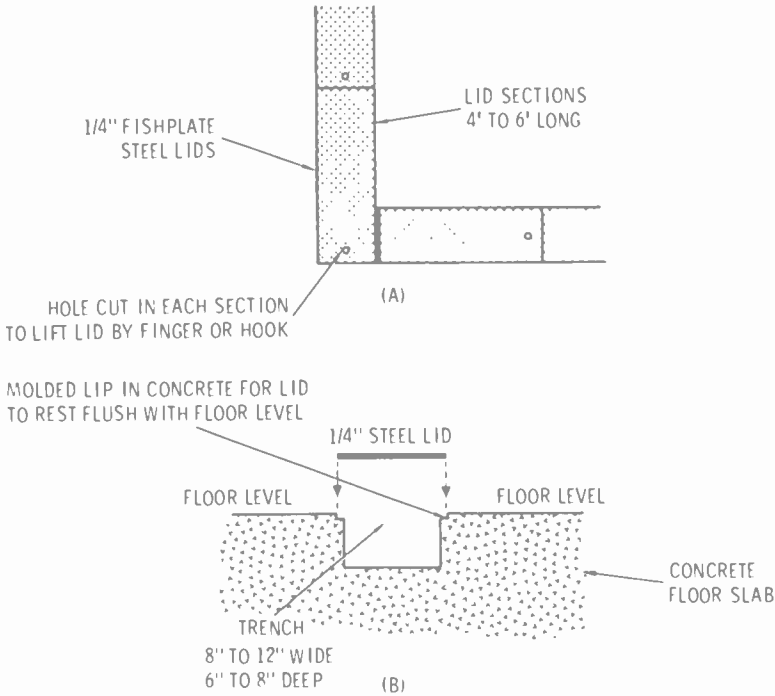

Fig. 10-2. A typical floor trench (or duct): (A) Top view. (B) Cross-section.

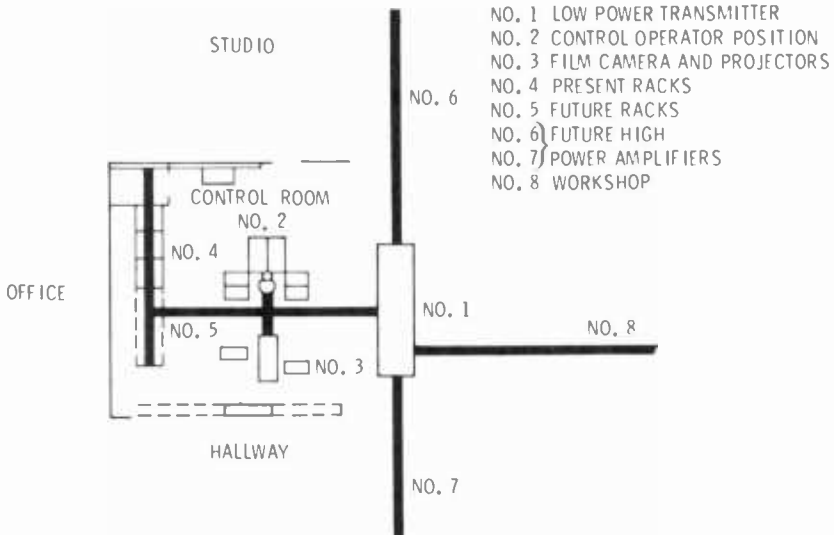

Fig. 10-3. The layout of control room equipment. The broad, heavy lines show the location of wiring ducts in the floor.

One-Man Control Problems

A one man operated control room requires some deviation from accepted practices. Therefore, some discussion of the basic requirements will make some of the equipment placement problems more understandable.

The operator must be able to reach all controls from one sitting position (audio and video switching, remote control of projectors, stabilizing amplifiers, audio and video level setting and shading, audio and video monitoring, audio tape, etc.). He can't do a satisfactory job if he must be constantly sliding up and down the control position from audio to video when the equipment is in the standard in-line arrangement. With a U-shaped arrangement all these functions will be within reach (however, there will be no room for a second operator). The control operator is also stacking slides and loading projectors, so this equipment cannot be placed in another room. If a film should break or a slide jam, he must be able to clear it with as little lost time as possible. Therefore, the projection area is directly behind the operator.

This man is also in charge of the transmitter and the FCC requires that he be able to see the indicating instruments from the operating position. Therefore, an unobstructed view of the transmitter must be

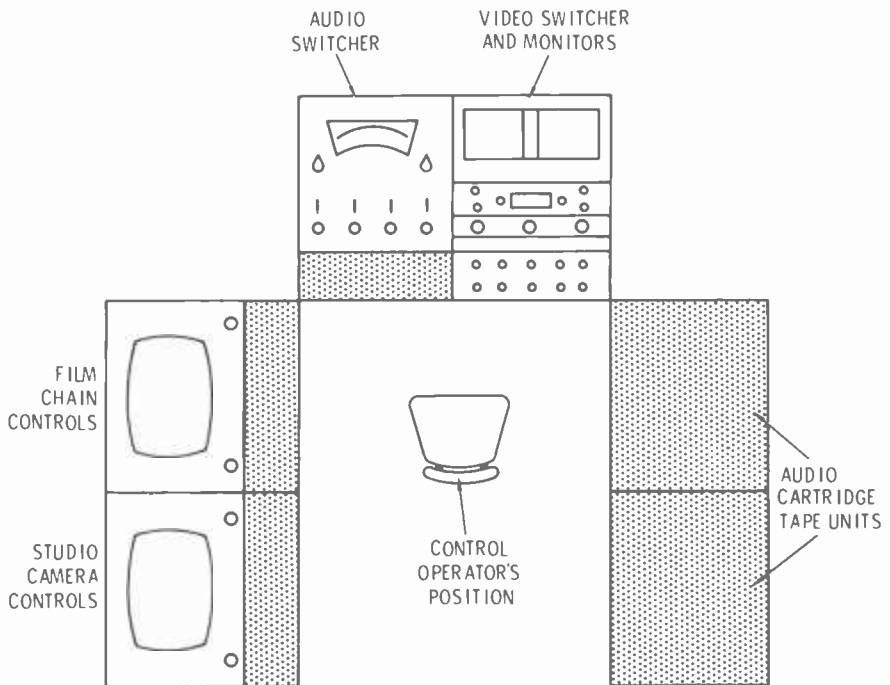

Fig. 10-4. The U-shaped control position.

provided. Frequency and modulation monitors are equipped to use remote meters connected to them, so that the indications may be read at some distance from the unit. The transmitter power output reflectometers also have provision for remote meters. Depending upon the distance of the operator from the transmitter and his position in relation to it, it is sometimes better to make up a remote metering panel, which is mounted at the operating position. On this panel will be meters for the audio and visual transmitter carrier-frequency deviation and audio modulation, overmodulation lamp, and reflectometers for the aural and visual transmitter output.

A U-shaped control position is easy to design (Fig. 10-4). Place the studio and film camera control/monitors on the left side of the U. Place the audio console, video switcher, remote controls, and monitor with pushbutton selectors in front. On the right leg, place the audio tape equipment.

Projection Center

The projection center should be located only a few feet behind the operator. Quiet running projectors are a big advantage in this arrangement. Plan for film and slide storage of the material which is to be used currently in the projection center. A small counter top, equipped with film rewinds and a splicer will also be a big advantage when a film breaks and needs speedy repair.

Equipment Racks

Equipment racks should allow enough space behind them so that maintenance can be carried out without too much difficulty. (Two or three feet will be sufficient, but if more is available, use it.) The top of the racks should be boxed into a duct and handled in the same way as the transmitter to exhaust hot air. The ends of the racks should be closed off with a door to form a plenum chamber. A fresh air inlet to this plenum chamber will provide proper ventilation for the racks.

A plenum chamber is simply an enclosed space where air may be collected and controlled, so that it may be directed from the source of supply to the equipment. As used with the transmitters and equipment racks, it is a room built behind the equipment that is used in the place of air ducts. Actually, this space is walled in from ceiling to floor, with a door at either one or both ends for easy access to the equipment and working space. On the outside wall is a ventilator so that fresh outside air may enter the chamber and at the opposite side are the air intakes of the equipment. The room must be reasonably tight so that the blowers within the equipment will pull fresh air in from the outside, across the room, and into the equipment. If the doors are left open, the trans-



Fig. 10-5. A control room operating position designed for one-man control operation. (WLBC-TV, Muncie, Indiana)

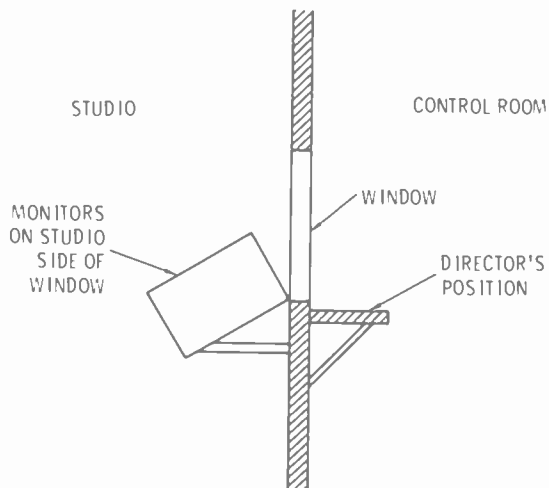

Fig. 10-6. For the director's position, video monitors may be mounted in this fashion on the studio side of the control room.

mitter room air will be pulled into the equipment also. If air conditioning is being used in the transmitter room, the air conditioning unit will be overworked. No harm will come to the equipment and it may even function a little better, but the air conditioner would not. To maintain proper pressures for proper circulation of air, the outside air opening should be at least the same size as that in the transmitter itself and preferably somewhat larger. This will provide an adequate supply of air. The outside opening should have air filters installed to keep out dust, dirt, and bugs.

Director's Position

The director's position at the window will permit him to keep an eye on what is happening in the studio. The monitors for this position may be located on the studio side of the window, either below the eye at an angle or suspended from the studio ceiling (Fig. 10-6). Overhead monitors are not as easy to view, especially when one has to follow copy also, and they are difficult to work on. These monitors may be mounted in the control room if space permits. Normally, these are 17-inch monitors, but smaller 14- or 8-inch monitors may be used if they are closer and space is at a premium.

Announce Booth

The announce booth is an optional feature. Most of the station audio, such as station breaks and the audio portions of slide commercials, will be taped. The booth would then be used only during live shows. However, this announce position can be directly in the studio without sound-proofing. Under these conditions, people on the show must become accustomed to having the announcer's microphone live when they are off camera.

Even though much of the audio would be on tape, the announce booth could be used for making up tapes. This would provide a sound-proofed area so that tapes could be made up almost any time, regardless of what is going on in the studio. This would help scheduling tremendously. For example, the same announcer could also be acting as director during a live show. It would simplify the operation considerably if he taped his commercials or other announcements prior to show time. With the announce booth and its own taping equipment, he could even tape these announcements while props were being hauled in and set up in the studio.

If the control room floor is higher than the studio floor, use ramps to change the level instead of steps. Steps are a nuisance, especially when it is necessary to roll some piece of equipment from one place to another.

Allow enough room around all equipment positions so that test equipment may be brought in for servicing. When equipment fails during programming, haste must be made to restore the program. Difficult or impossible working space at these times can be very frustrating and delay your return to the air.

A sound lock should be constructed if there will be traffic between the control room and studio during a live show, otherwise noise and monitoring will cause feedback on the air. The noise level of the control room will be rather high, especially from the transmitter blowers, monitor speakers, and film projection equipment. Since the control room is not separated from the film room by a wall, the film room will introduce additional noise in to the control room.

Studio

House lighting should be separate from the stage lighting with its own switches and separate breaker boxes. While fluorescent fixtures may be used for the house lighting, faulty ballasts may generate noise to the camera preamplifiers. Fluorescent lighting should not be used anywhere in the studio.

Stage lighting should enter the studio at one location through circuit breaker panels connected directly to the power main circuit breaker. There should not be any other switches along the way. This will permit control of the studio stage lighting in only these boxes. It is optional whether these studio lighting boxes are mounted in the studio or in the control room alongside the director's position. There are many advantages to mounting them alongside the director, as he can turn on and off any lighting during a live show for special effects. A small station will not usually have someone special to do the lighting during a show.

When making stage lighting outlet runs, as recommended in Chapter 3, remember to use wire large enough to carry the light loads that will be placed on each circuit. This is also true of the breakers for each run. Since each run has the possibility of several lamps being plugged into it at one time, it can be easily overlooked. A single 500-watt lamp draws 4 amperes and it wouldn't take too many of them to overload a circuit. Use large enough wire to carry several lamps and then use the correct circuit breakers for that size wire. Should you get too many lamps on the circuit, the breaker will open before the wire can be damaged and you can redistribute the load (Fig. 10-7). This can be a problem, especially since various wattage lamps will be used in the system and lamps will be changed from one circuit to another quite often as new sets are arranged.

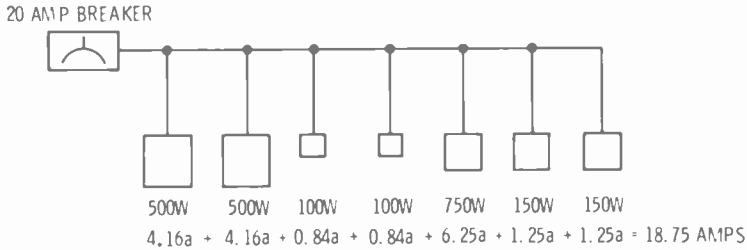

Fig. 10-7. The current developed across each lamp adds and may soon overload the circuit breaker.

To simplify the figuring of light load on each circuit, have a chart at the breaker box position that shows each lamp size by both wattage and amperage. When someone makes up a set, it is then an easy matter to add up the amperage for the run on each individual circuit breaker. Such a method would make it simple for nontechnical people to make up a set, instead of trying to teach them to use power formulas.

Stage lighting outlets should also be provided in the camera maneuver area, even though you will not be using this area for staging at the beginning. Having the outlets here will allow an occasional use of this area for staging. If later expansion calls for continuous use of this area, no new wiring will be necessary.

The microphone outlets should run in conduit and all conduits should be bonded to the building ground system ground bus.

Heat Exhaust

Much heat is given off when the stage lighting is turned on. This heat is no problem in the wintertime, but in the hot summer months it can be very uncomfortable. Air conditioning will greatly alleviate this problem, but if air conditioning is not used some type of exhaust fan should be installed to pump this hot air outside. This exhaust fan should be quiet in operation. Directing a fan onto the set is not satisfactory, because papers will blow away, exhibits may tumble over, and other similar problems will occur. Don't leave the outside doors open for cooling unless they are well screened. Otherwise, the studio will fill up with flies, moths, and wasps. These insects must have a little ham in them, because they are not usually seen until the show gets going. Then, they are right on set, usually in the performer's face.

Camera Cable

The camera cable can be handled in different ways, as indicated in Fig. 10-8. A cable receptacle may be purchased and mounted on the wall, much like a microphone outlet. This outlet uses camera cable back

into the control room where it has a plug on the end of it to connect to the camera control unit. Several of these outlets may be provided around the studio and wired in parallel, although only one camera can be used at any one time on the control unit. These cables should not be disconnected while the camera is turned on, since all the power and control voltages go through it. Camera cables may be bought in bulk and you can put the plugs on yourself. The outlets and plugs have metal screw caps to protect the plug when it is not in use.

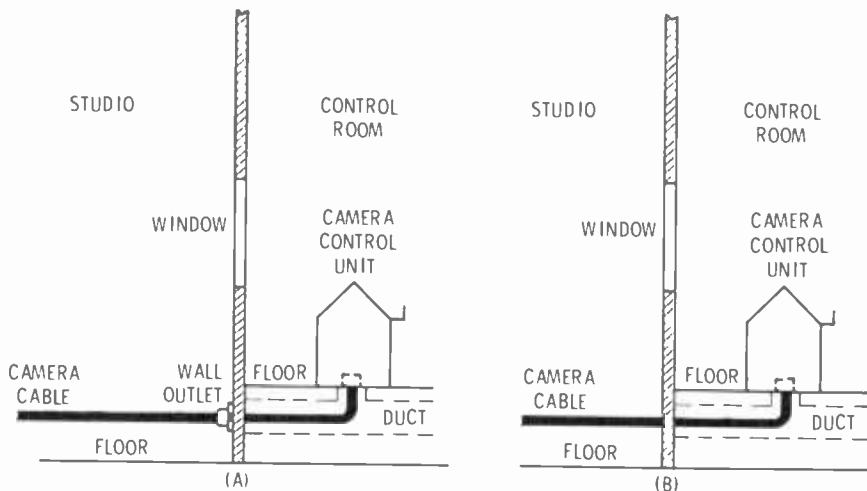

Fig. 10-8. Camera cable connections: (A) Connected to wall outlet; (B) Run through the wall directly to the control unit.

Camera cable can also be connected by running it through a hole in the wall between the studio and the control room with no special attachments. In this fashion, the regular camera cable can enter the control room and plug directly into the control unit. This is an acceptable practice, but caution must be made to cover the hole so that audio feedback and noise does not enter the studio from the control room. The hole should be large enough for the plug to go through it. An easily-made, detachable cover will soundproof this hole (Fig. 10-9). It is best to have this hole open directly into a duct within the control room.

Should the small studio, as described here, be used as a starting facility for a station in a larger market, where future expansion envisions more studios and more cameras, it would be both practical and economical to plan for a camera cable patch panel near the video location in the control room. This would permit cameras and control units to be easily substituted for others in different studios or if one should fail during a live show.

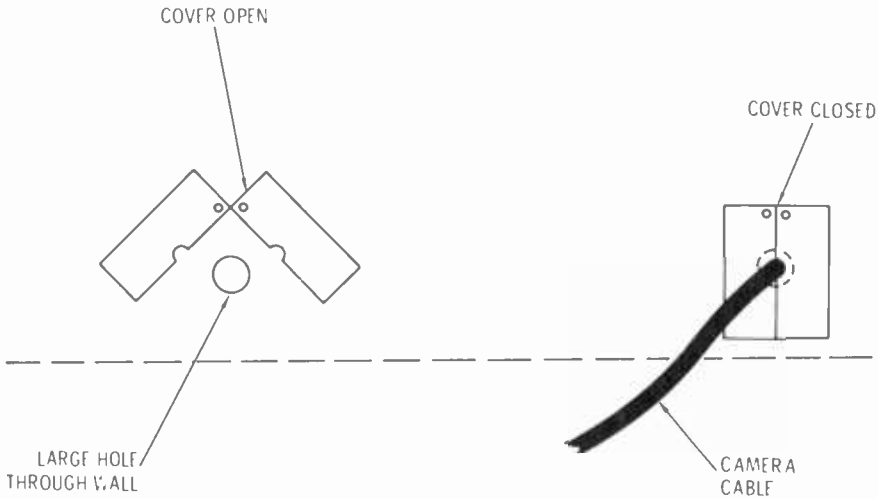

Fig. 10-9. A cover should close off the hole when the cable runs into the control room.

Video Monitors

A video monitor can be mounted on a dolly so that it may be viewed from any position of the staging area. This is especially helpful when sets are located against different walls. When the monitor is rolled in front of the set, the performer on set can glance at the monitor directly, without the viewer being aware of it. Another monitor may be placed on a high stand or suspended from the ceiling, so that visitors or spectators may view the show on a monitor also. The video monitor mounted on a dolly is also called a "roll around." This unit can contain a clock and a speaker and thereby provide completely portable facilities that are always in view on the set, regardless of which wall the set is placed against.

For news, sports, and similar panel shows, where only one person or a few persons sit at a desk or a table, a small 8-inch monitor may be mounted at an angle within the desk, so that only the monitor face is visible above the table top. A small sign in front will conceal it from camera view and those at the desk will be able to see it. A small clock may also be mounted in this position.

A tool caddy should be provided for the studio and left in it. It should contain a few of the most often-used tools. To prevent these tools from becoming "lost" with the other station tools, paint them for quick identification.

Shop Area

Provide several a-c power outlets at the workbench by using plug-mold strips. This will prove quite convenient, especially when many items on the bench need power at the same time.

One or more video cables from the patch panel to the shop will prove very helpful when it is desired to check out a piece of equipment with picture and sync. A jones plug to fit a monitor and a cable running to the power supply racks will also be another big help. Most master monitors and similar equipment do not have internal power supplies, so, to work on the bench with one, the cable can be plugged into either a spare power supply in the rack or the normal power supply for the unit.

All small test equipment may be mounted on a shelf above the bench, plugged into a-c power (if they require it). They will then be ready to use on the bench at any time by merely turning on the power on the instrument.

It is best to mount the tools on a tool board. You can waste a lot of time rummaging in a tool box to find the tool you need. Keeping the tools in the shop area will also discourage others from borrowing them. Announcers, production people, and janitors have occasion to use a few tools, but there are very few of these people who ever bring them back. When their work is done, they just leave the tools right where they were working. The few tools these people use on occasion may be purchased and left in their departments. (A few different screwdrivers, a hammer, a saw, and cutters should be sufficient.)

The diplexer/sideband unit will be mounted in this room also. This may be suspended from the ceiling or positioned on a wooden platform on the floor. It should never be mounted directly on the floor, because drafts and temperature changes will cause detuning of the line sections. Dents in any of the tuned sections can be a serious problem, so it is best to keep this unit out of the way and protected from accidental damage.

The most preferable placement for the filterplexer is to suspend it from the ceiling, high enough so that one may walk under it. Should trouble develop with the unit and it must be taken apart, the ceiling mount makes it a more difficult task. However, there are rarely any problems with this unit. If it is mounted overhead and out of the way, it will not only have more constant temperatures around it, but it will be less susceptible to accidental damage from nonelectronic forces. This position will also conserve valuable floor space.

The shop area is also a good place to make provisions for changing klystron tubes, if you use them. As these tubes are several feet long, a block and tackle suspended from the ceiling is a good method of pull-

ing these tubes out of the cavity. If the ceiling is high, say 12 feet, there may be enough room. If the ceiling is low, a simple raised ceiling may be built to accommodate this operation. If your transmitter uses klystrons, either in the present unit or in planned future power increase amplifiers, consult with the manufacturer to determine just what size the tube will be on your channel. Then you may plan accordingly.

Chapter 11

Test Equipment

Basic Considerations

You will find different test instruments on the market, some of which are multiple purpose, while others will serve only specific functions. It is often tempting to purchase a test set because the sales literature gives such glowing examples of what it will do. However, many instruments will serve in only one capacity for the station and the opportunity to use them may arise only occasionally. If the same tests can be done with another instrument which is already on hand, even though not as quickly or easily, serious consideration must be given to the justification for purchasing a new instrument. Before purchasing any instrument you should determine if using it is the only way to solve the problem and how often the problem can be expected to arise.

There will be applications when only a special instrument will do the work. Even though this work will be infrequent and on a must basis, the special instruments will have to be purchased unless you can borrow or rent them for the special occasions. The station's yearly proof-of-performance measurements are a case in point. A number of special test instruments are required to make some of the needed measurements. However, in this area, there is an alternative: the station consulting engineer can make these measurements, as will the service companies of some manufacturers. These people have all the necessary equipment to make a proof. Of course, these services are not free, but the fees required are much less than the cost of all the necessary equipment involved.

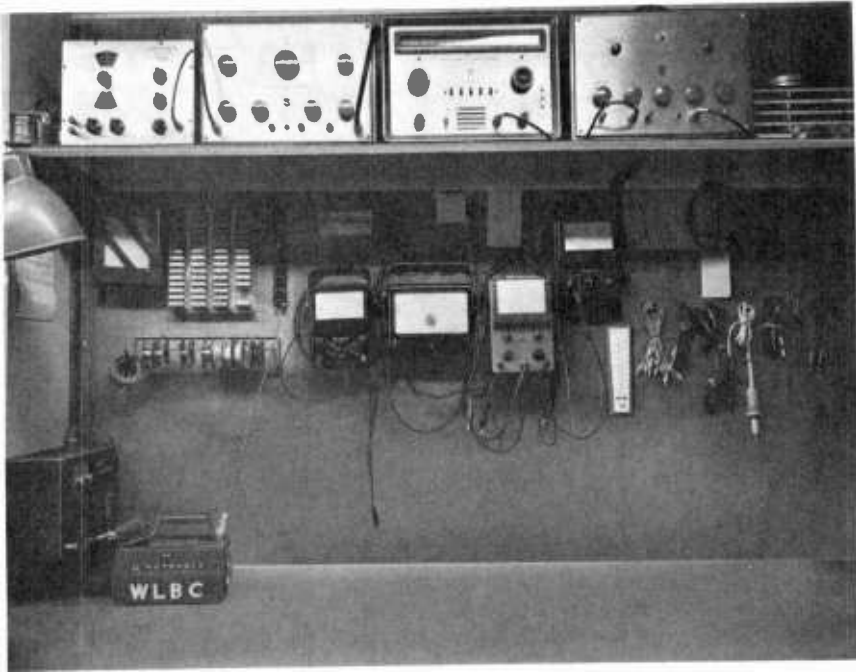

Fig. 11-1. Test equipment is arranged for immediate use on this typical workbench. The instruments at the top are used for aligning off-air receivers and for color. (WLBC-TV, Muncie, Indiana)

Even though a complete proof-of-performance should be done once a year, many tests should be done on a weekly and monthly basis, just to keep the station at peak performance.

When selecting test instruments, buy a very good quality product. It doesn't cost a manufacturer much to enclose an inferior instrument in a fancy cabinet with a low price tag. Buy the best quality available. Many good test instruments have a number of additional uses designed into the basic instrument and you pay for these additional features. In most cases, all the auxiliary uses will never see action and are a waste of money as far as you are concerned. Such features are usually superfluous or duplicate other instruments already on hand. However, when you are selecting equipment with none on hand, it is well to investigate some of the multiple-purpose instruments. Quite often, the cost of the single, multi-purpose instrument will be less than all the individual instruments purchased separately. For example, there are some all-transistorized instruments that provide multiburst frequency tones, sine-squared and window pulses, and stair-step signals, all in one unit. Such instruments sell for \$3000 to \$5000, which is less than the total combined cost of the individual instruments that perform these features.

Do not sacrifice accuracy for cost. An inaccurate or poor-quality instrument is worse than none at all. You will need instruments of dependable accuracy. However, laboratory standards are not needed either. Such instruments are very expensive and have more accuracy than will be needed in a station. On the other hand, many of the instruments used by service shops will not be suitable because a broadcasting station's requirements are more stringent. For example, all studio video equipment has a bandpass of at least 8 megacycles, while one would be lucky to find more than a 3 megacycle bandpass in a home receiver (except a color receiver, which must have at least 4 megacycles).

Test equipment should be treated with special care. Many instruments will be used in all sorts of places about a station while running down trouble. They are more vulnerable to damage in these instances than on the bench. Danger of overloads will be more prevalent, especially when working inside the transmitter with its high voltages.

Test leads and accessories should also be kept in good repair. There is nothing more frustrating than to be required to fix test equipment before work can begin. Broken shields, test clips, and ground clips, and loose knobs all happen with regularity. As each of these conditions occurs, repair it immediately. The usual intention is to repair these as soon as possible after the station is back on the air. Somehow, it always seems difficult to get these small chores done—until the next time the instrument is needed.

General Station Requirements

Most television stations pursue a vigorous maintenance policy, because defects in equipment performance are more quickly discernible to the eye than they are to the ear. Hum is one good example. On a musical or similar radio program, a hum level of 35 to 40 db down may be masked out by the program content and not be detected by the listener. But a small amount of hum in a television picture can be detected almost immediately by even the most inexperienced viewer. This will be worse if the hum is nonsynchronous, such as with a network program when it will roll through the picture vertically.

Frequency response is another good example. The audio system may be off several db at the high end and the only result may be that the audio sounds a bit bassy. But if the high frequency response is off in video, the picture will have soft edges or appear to be out of focus. On the low frequency end, an audio program may sound tinny with poor low frequency response, while poor lows in video will give rise to black or white streaking problems, which can be very objectionable.

Because the maze of technical equipment required to create and transmit video pictures is so complicated, it requires constant attention and many specialized test instruments to keep it at peak performance. As is the case with most good, accurate test equipment, video test instruments are expensive and may quickly be made obsolete by newer instruments.

When a test instrument has been made obsolete by a later model that probably also makes other measurements, it is not useless. It will serve the same purpose as it did before the newer instrument became available. This happens often because of the rapid progress made in technological refinements.

The instruments described in this chapter may soon become obsolete, just as these may have made others obsolete. In many cases, you can find a good used instrument on the market which is an older model. With careful buying, you can build up an impressive array of good used test equipment at a reasonable price, equipment that you may not be able to afford otherwise, and thus keep your station at a top level of performance. Many of the larger stations periodically update their equipment by purchasing the latest models on the market. Their older model instruments are then usually available at a reasonable price.

In the area of overall station technical performance for the smaller station, the author would recommend an agreement or contract with the station consulting engineer, the RCA Service Company, or the field engineering division of your equipment manufacturer, to make the yearly proof-of-performance measurements. These people are equipped with the experience, knowledge, and test equipment to do a complete proof-of-performance. As you acquire the necessary equipment, and if your technical personnel are qualified, then your station may start making the proofs on its own. This method will save considerable expense, at least in the beginning.

Some very basic equipment should be owned by the station, so that day-to-day maintenance can be done. This will be with everyday test instruments such as the multimeter, the tube checker, and the oscilloscope. Some system measuring equipment should also be available for checking the overall audio and video system. The audio system should be checked for noise, distortion, and frequency response at least once a month, while the overall video system should be checked at least once a week for frequency response and the transmitter bandpass. The author has as yet to see a system that will stay within FCC regulations for an entire year without some constant checking of the system during the year.

Basic Instruments

Oscilloscope

The oscilloscope is the most indispensable instrument in a television station. A good scope will help solve half the problems of maintenance. It will be in use constantly, more than any other instrument, except, perhaps, the tube checker. The best scope available should be purchased. It should be one designed for television station use. None of the service-type scopes will be of any real value here, because of their limitations. A good scope should meet these minimum specifications: flat vertical response out to 10 megacycles; preamplifiers which will read very low voltage levels; display of the same polarity voltage on the CRT as is being measured; stable 60-cycle locking; a delay circuit so the entire vertical interval may be viewed; a good stable horizontal oscillator that will retain a stationary display of one equalizing pulse;

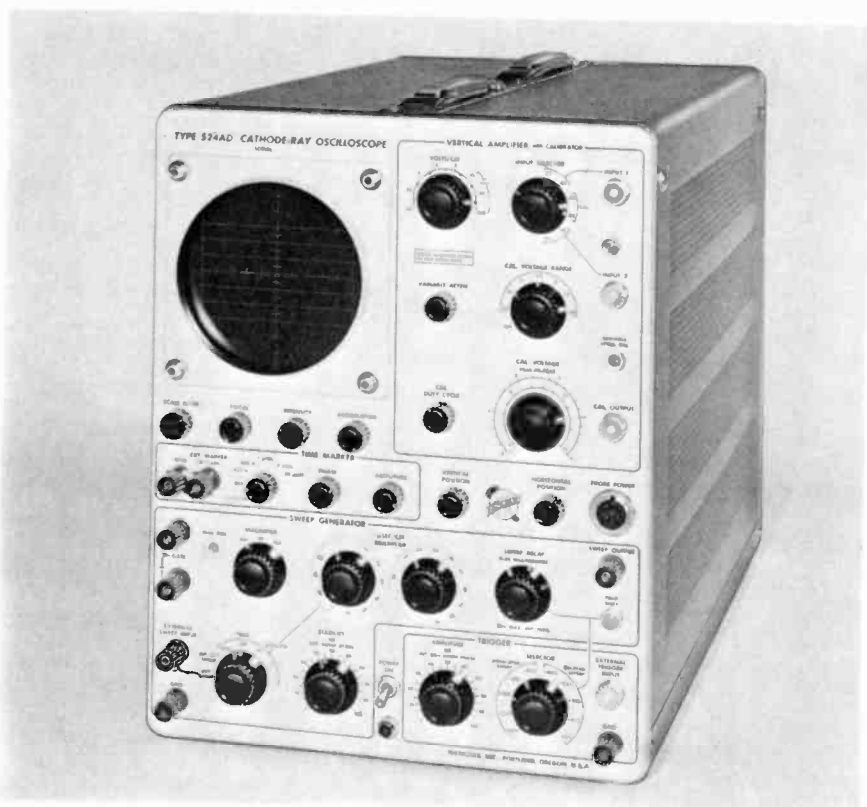

Fig. 11-2. The Tektronix Type 524AD oscilloscope. (Tektronix, Inc.)

a field shift switch so the other field may be viewed; a one microsecond internal marker; an accurate internal voltage calibrator so peak-to-peak waveforms may be measured; and coaxial input connectors.

One such instrument that meets all these specifications is the Tektronix 524AD television oscilloscope shown in Fig. 11-2. This instrument was designed especially for television use to overcome some of the limitations of the other scopes. Since it is a large and bulky instrument, a cart, the Scope-Mobile, is available for moving it from place to place (Fig. 11-3). The scope remains on the Scope-Mobile all the time



Fig. 11-3. The type 500/53A Scope-Mobile dolly for the 524AD oscilloscope. (Tektronix, Inc.)

and is wheeled to where it is needed. A small drawer is available in the cart so that test leads, clips, and other accessories may be kept handy.

Learning to use a scope will take some time, but it will pay off richly in shortened troubleshooting time. Most of your difficulty will be in learning how to interpret the waveforms that are obtained.

Multimeter

You should have a multimeter with at least 20,000 ohms-per-volt d-c scales (Fig. 11-4). Accuracy, again, is a must. This instrument will find use all over the station. It doesn't take power and is much simpler to use for wiring continuity and checking resistance and cables or in the racks, transmitter, and many other places. The case should be Bakelite or some other plastic material so that it is insulated.



Fig. 11-4. *The Simpson 260, a 20K ohms-per-volt multimeter. (Simpson Electric Company)*

VTVM

The vacuum-tube voltmeter (vtvm) does have many uses, especially on the bench, but it is less convenient to use than a regular multimeter. Because of its very high input impedance, it will find its greatest use in checking r-f voltages in the transmitter and aligning off-air receivers. Most vtvm's have high voltage probes available for measuring power supplies for monitors. If you have to make a choice between either a good multimeter or a vtvm, the author would recommend the multimeter. Most vtvm's use an unbalanced input, with the case tied to one



Fig. 11-5. *The Simpson Model 303 vtvm with insulated case. (Simpson Electric Company)*

of the test leads. If you can obtain an instrument that has a Bakelite or other insulated case, this would be preferable (Fig. 11-5).

Video Sweep Generator

A video sweep generator is a necessity. It should be one of the larger TV station models, rather than a service-type instrument. It should be able to sweep below zero frequency as well as above frequency to at least 10 megacycles. This instrument will find many uses in alignment of the camera preamplifiers, video monitors, cables, etc.

RCA has available a combination instrument which will serve as a video sweep generator and check the sidebands of the transmitter under power. This is the RCA Sideband Response Analyzer, model BWU-5B. It is a rack-mounted unit, but may be carried from place to place when needed.

Tube Checker

A tube checker is also a must, because you cannot use the tube substitution method in a system that may have thousands of active tubes.

A dynamic mutual conductance tube tester (Fig. 11-6) is the only kind recommended, the straight emission-type testers are too limited in use. The dynamic type will test tubes under simulated operating conditions. This method will give a truer indication of tube performance, but it still has its limitations, because tubes often behave differently when they are amplifying pulses.



Fig. 11-6. *The Hickok Model 800A dynamic mutual conductance tube-transistor checker. (Hickok Electrical Instrument Co.)*

Grid Dip Meter

A grid dip meter (Fig. 11-7), although limited in use, will sometimes be worth its weight in gold, especially when you have trouble in the multiplier stages of the transmitter or frequency monitors. It should be an instrument that will work either on a hot or cold circuit. The scales should be reasonably accurate, and, if you can get it calibrated, so much the better.

Watt Load and Wattmeter

A small 80- or 150-watt load and wattmeter (Fig. 11-8) will find itself in use quite often when work is being done on the transmitter. With such an instrument, you can often determine quickly if a particular stage is operating properly. This unit should have connectors which mate with flexible cable.



Fig. 11-7. A megacycle (grid-dip) meter. Note the head that is separate from the meter case. (Measurements Corp., a division of McGraw Edison)

Grating and Cross-Hatch Generators

A grating generator or cross-hatch generator is quite a useful device. Without it, it is almost impossible to get the cameras and monitors in correct linearity. Many sync generators have a grating generator incorporated within them. These are also available as separate test instruments. The RCA TG-2A sync generator contains a grating generator and supplies two differently sized dots for making convergence adjustments in color monitors.

Test Film

Test film is available for checking out the optical system as well as the mechanical system of 16-mm film projectors. One such film has a two-tone sound track, known as a buzz track. This permits adjustment of the position of the sound system for correct alignment. Another tone test film permits adjustment for best high frequency response. There are other films available that help check for jitter, wobble, travel ghosts, and system audio response. Some films contain many such tests on one film.



Fig. 11-8. *The Termaline R-F Load and Wattmeter, Model 6150 (150 watt model). (Bird Electronic Corp.)*

Special Instruments for Special Applications

Receiver Sweep Generator

A TV receiver sweep generator will help keep off-air receivers in good alignment if you use an off-air pickup system. These receivers are manufactured with much tighter tolerances than home receivers. When buying a generator for this purpose, get the best available. Accuracy is very important here.

Marker Generator

Marker generators, which are very stable, accurate, and crystal controlled, should be used in conjunction with the receiver sweep generator. Don't skimp on either of these instruments. An inaccurate instrument will only get you into trouble that you may not be able to cure.

Actually, off-air receivers are rugged and seldom need alignment, unless there have been some major repairs, such as replacing the tuner or i-f transformers. In these rare instances, it will probably be less expensive to send the receiver back to the factory for the needed repairs

than to invest in the necessary test equipment. Even sending the receivers back occasionally for a checkout at the factory will prove less expensive than the necessary equipment. However, if one has several receivers in constant use, purchasing the equipment will prove to be the less costly method.

Linearity, Stair-Step Generator

A linearity, stair-step generator is an instrument for checking system linearity, especially in the video transmitter power stages. Poor linearity in a monochrome picture will not be too noticeable, but its effect will be worse on a color picture. If you transmit color, the linearity must be maintained within FCC specifications.

A linearity generator may be modified so that a video sweep signal can be fed into it. This is an excellent method for checking out video equipment without disabling the clamp circuits.

Phase Analyzer

A phase analyzer is important for checking video system phase tolerances. Color is especially susceptible to phase changes and the system phase must be kept within tolerances. A monochrome system can stand larger phase disturbances and still be useable. The FCC requires phase measurements for color stations.

Square Wave Generator

The square wave generator (Fig. 11-9) is an excellent means for checking low frequency response in the video system. Sweep generators are not accurate below 100 kc, so the square wave generator fills this gap. The square wave is also an excellent signal for adjusting phase equalizers, which are required in a color converted station.

Audio Signal Generator

The audio signal generator is the same instrument found in any radio station for making proof-of-performance measurements and troubleshooting and serves in the same category in the aural part of a television station. The Hewlett-Packard signal generator (Fig. 11-10) also incorporates calibrated pads within the instrument so that an external attenuator panel is unnecessary.

Distortion Analyzer

A distortion analyzer is the companion instrument to the signal generator. It measures the noise, distortion, and frequency response of the audio system. The Hewlett-Packard model 330D, shown in Fig. 11-11, also has a calibrated, audio vtm associated with it and calibrated in-



Fig. 11-9. *The Tektronix Square-Wave Generator, Type 105. (Tektronix, Inc.)*



Fig. 11-10. *Hewlett-Packard's Audio Signal Generator, Model 206A. (Hewlett-Packard)*



Fig. 11-11. *Hewlett-Packard's Distortion Analyzer, Model 330D.*
(Hewlett-Packard)

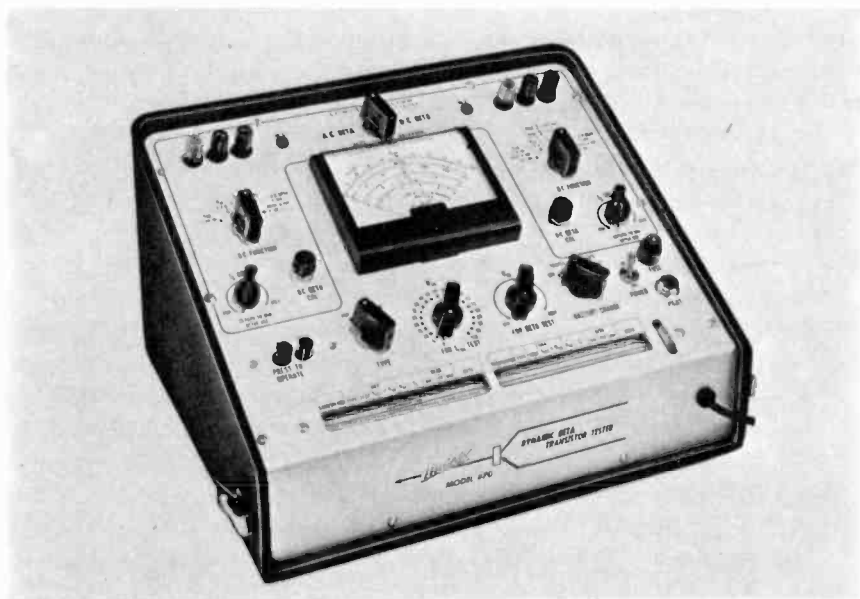

Fig. 11-12. *The Hickok Model 870 Dynamic Beta Transistor Checker.*
(Hickok Electrical Instrument Co.)

ternal attenuators. This is an excellent instrument for accurate audio level checks.

Transistor Checker

Many new models of video and audio equipment and test instruments are now being partly or completely transistorized. Depending upon how many of these you will have in your station, a good transistor checker (Fig. 11-12) should be obtained. Several sophisticated models are on the market; many will test the transistor right in the equipment.

Some Testing Techniques

1. Video amplifiers usually have clamp circuits somewhere along the line. These must be disabled and circuit continuity restored before measurements can be made. If a modified stair-step generator is available, sweep with sync can be fed directly into the amplifier without any modifications of the clamps and the circuits will operate normally. (Since most instruction manuals describe how to sweep by disabling the clamp circuits, it would be unnecessary repetition to add it here.) Most cases of video alignment will not require stage-by-stage checking as in a receiver. Simply feed the correct level of sweep and sync to the input and read the output on a scope with the amplifier properly terminated. The stages are then touched up to make the overall alignment correct. This is for simple problems. You may also check through the system with a scope to make sure that no one stage is overpeaked to compensate for a poor alignment of another stage. Such a case can cause clipping.

A very flat pattern on the scope with an abrupt fall-off in a response curve may look nice on the CRT, but unless there is a gradual roll-off on the high end, the picture will have ringing, or outlining, or both.

Many recommendations have been made to use a detector for detecting the sweep envelope on the scope. A good scope will not need a detector because the response of the scope will also faithfully display the r-f carrier of the sweep voltages. The pattern must be interpreted, though, because both sides of the envelope will be displayed with the insides filled with r-f. A detector only lets you see one side of the envelope, even though both are present in the system (Fig. 11-13). Depending upon polarity anywhere in the system, one side may be overloading. If this is the side observed on a detected envelope, it may indicate a perfectly flat response, which just isn't correct. When both sides are present on the display, it is very easy to see if clipping is taking place. The only real reason for a detector is to overcome the poor vertical response of service-type scopes, since the detected envelope is only a 60-cycle waveform.

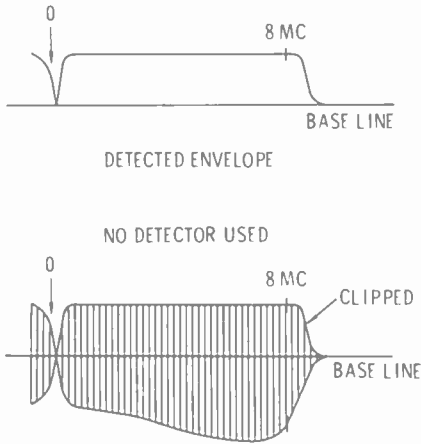

Fig. 11-13. A detector may not reveal that the waveform is being clipped somewhere in the circuit.

2. All video equipment has a coaxial input and output connector, unbalanced 75 ohms. When checking an individual unit, such as a stabilizing amplifier, the unit should be properly terminated so that levels and adjustments will be correct. But when you open the circuit and only have a scope across it, the unit is unloaded and the readings will be incorrect. This situation may be remedied with a "T" coaxial connector at the scope and a screw-type termination (Fig. 11-14). This will not only terminate the amplifier, but will also provide shielding all the way along the circuit.

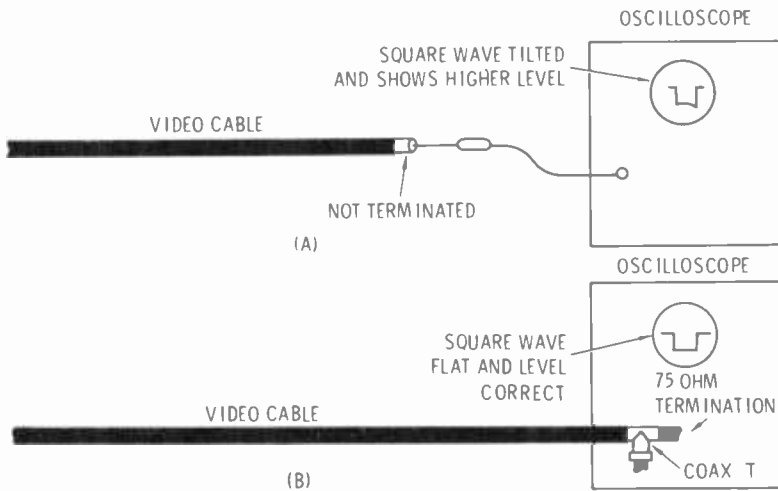

Fig. 11-14. (A) A square wave will be tilted and will read at a high level when the cable is not terminated. (B) With a screw-type termination and T coax connector used as shown the wave will appear and read as it should.

3. An excellent scope cable for test purposes, especially for measuring right in the jack field, can be made from RG-59 coaxial cable. On one end of this cable, mount a regular male coaxial cable connector. On the other end, use the plug from a regular video patch cord (Fig. 11-15). Now you can plug directly into the jack field and will have a termination available at the scope, if needed. Since you tore up a video patch cord, you still have one plug left over. Make up another one of the cables described above. This can be used to feed such things as a sweep generator directly into the jack field.

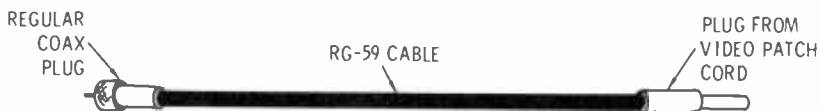

Fig. 11-15. A scope cable made with RG/59 coax cable and the plug from a regular video patch cord.

4. Setting up levels in the audio system or when troubleshooting usually requires correct measurements of levels. The audio signal generator is designed to operate into a definite impedance. Wrong impedances can show up as poor frequency response, especially on the high end, and incorrect levels. All audio amplifiers should be terminated correctly for accurate level measurements. Here again, a couple of simple home-made terminations will prove quite helpful.

Take the plug off a regular audio patch cord. Across the end, mount a 1-watt, 600-ohm resistor inside the plug. This plug (Fig. 11-16) may then be readily used in the audio jack field when a termination is required for test purposes.

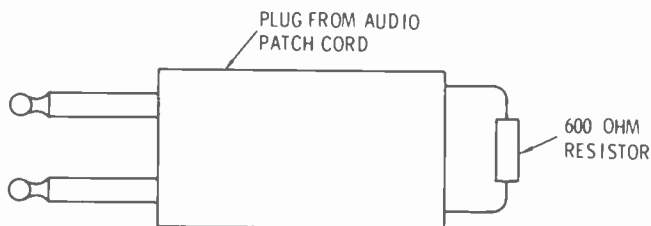

Fig. 11-16. An audio termination suitable for use in the jack field made with a resistor and the plug from a regular audio patch cord.

If there are some spare jacks available in the jack field, another simple termination may be used. Across the tips of a pair of jacks, mount a 600-ohm resistor. When a test termination is required, simply use a patch cord from this set of jacks to the one you want terminated. In

both above instances, different values of resistors may be used if other values of terminations are desired. A short may be used across the terminals, should a short test be desired.

If you have a Hewlett-Packard or similar noise-distortion analyzer that uses banana plugs for the input circuits, another simple terminating device may be made (Fig. 11-17). One can find a double banana plug in any parts store. This plug is designed for making up test leads that can be stacked one on the other. There are solder connections on the outside for connecting test leads. Simply solder a 600-ohm resistor across these terminals. You may use any value desired and make up as many terminations as you wish, since they are very inexpensive. The plug terminations are very handy because they may be plugged right into the banana plug receptacles of the distortion analyzer without moving the test leads. Thus, you may change terminations at will. Storage is simple also. Simply plug all the terminations into each other to keep them from being scattered.

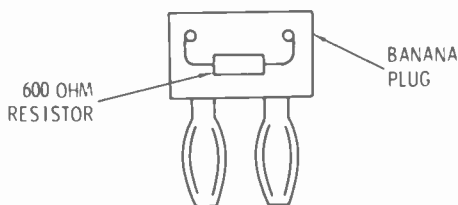

Fig. 11-17. An audio termination suitable for use on an instrument made from a banana plug and a resistor.

5. The scope can be a very useful instrument when making audio measurements, once you have become efficient in its use. When making noise and distortion measurements, plug the scope into the scope terminals of the distortion analyzer (Fig. 11-18). Most modern analyzers use the null method when checking distortion: the fundamental is nulled out and everything left over is read as distortion. This reading may include harmonic distortion, 60- and 120-cycle hum, tube noise, extraneous noise, etc., but there is no way of determining which.

The scope will show what is present immediately. A high hum level will read as a high distortion on the analyzer, which it really isn't. Another advantage of using the scope under these conditions is when you are making adjustments to hum balancing controls. You can watch the hum being balanced out the best way. If the hum is 120 cps from a power supply, this can easily be checked unit by unit, with a shorting plug on the input of each unit in turn. The hum will disappear as soon as the defective unit is passed. This method is also of great assistance

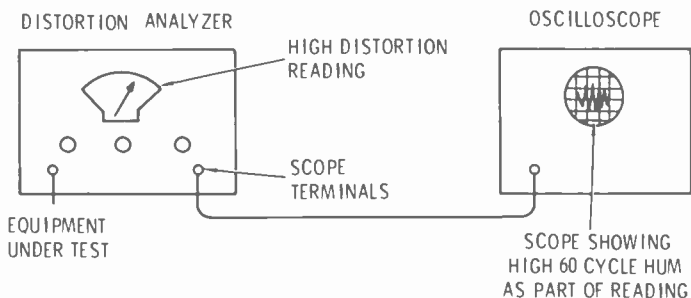

Fig. 11-18. The proper setup of the oscilloscope to the "scope" terminals of the audio distortion analyzer. The scope will show what is present in the reading.

when making overall noise measurements through the transmitter. A high ripple from the three-phase power supply will be quite evident and will indicate where to start looking for the trouble.

6. When making voltage measurements of waveforms, you must remember that a scope reads peak-to-peak voltages. Peak-to-peak means just that, from the highest positive peak to the lowest negative peak. With sine waves this measurement will be about 2.82 times higher than that read on a regular RMS reading meter.

7. The scope is a voltage-reading device; a factor which must be considered when estimating decibels from the CRT. This is especially the case when making video response measurements. (You can do it, but remember to use the voltage formula for decibels: multiply the logarithm of the voltage ratios by 20.)

8. The scope is also an unbalanced input instrument, which must be considered when placing it across a balanced circuit. It may upset the circuit or short out one-half of a transformer winding. When measuring in the transmitter, another hazard can be present due to high voltages. This would most certainly be the case if the ground clip of the scope input were placed across a high voltage point. This would place the cabinet of the scope at the same voltage level as the test clip (Fig. 11-19). When measuring in the transmitter with the scope, always measure from high side to ground, through a capacitor, if possible. Make it a rule. If it is necessary to place the ground clip on a high voltage point to get a waveform, do not do so; try some other safer method. The voltages involved could injure you fatally.

The vtvm can get you into trouble in the transmitter in the same way. It is also an unbalanced input with the ground clip connected to the instrument cabinet and most vtvm's have an uninsulated metal cabinet.

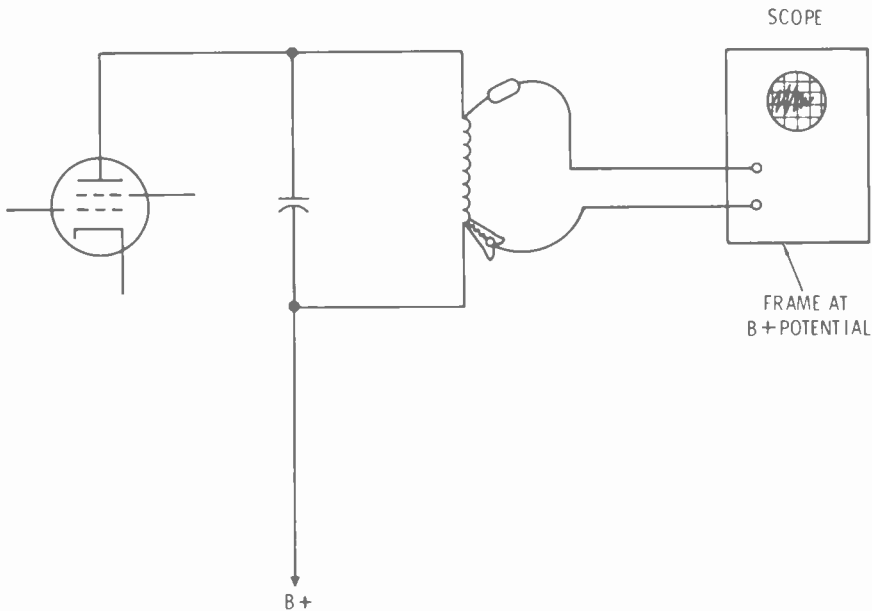

Fig. 11-19. This is a dangerous measurement setup. The ground clip of the scope is connected to the B+ in the equipment, which places the cabinet of the oscilloscope at this potential.

Test Equipment Costs

Two groups of equipment are listed below. The basic group should be in every station and will assist in troubleshooting the day-to-day technical problems that arise. The second group should be added as soon as finances will permit, especially the audio generator and distortion analyzer. The second group will help in keeping a check on the audio system on a regular basis, as well as troubleshooting audio problems. Depending upon how much of the equipment in the station is transistorized, a transistor checker is highly recommended.

If the station will be transmitting color programs, there are several other test instruments that are necessary to maintain the video system within color specifications. In all cases, individual stations will undoubtedly add different test instruments whether they are color or monochrome only, as it suits their own particular requirements. For example, a good field strength meter may be a desirable item if there are a number of complaints from viewers of poor signal strength in their areas, especially when there should be a good signal at that point.

While certain makes and models of equipment are shown here, others of comparable quality may, of course, be used. Specific models are listed to show the particular class of instrument that should be obtained.

Basic Group

Model 524AD, Tektronix oscilloscope with Scope-Mobile	\$1,400.00
Model 1105, Tel-Instruments sweep generator	\$ 770.00
Hickok model 800A, tube checker	\$ 180.00
Simpson model 260, multimeter	\$ 49.00
Measurements Corp., model 59, megacycle meter (grid dip meter)	\$ 168.00
Bird, model 612, 0-20, 0-80 watt load and wattmeter	\$ 175.00
	Total <u>\$2,742.00</u>

Group Two

Hewlett-Packard, model 206A (w/cabinet) audio signal generator	\$ 900.00
Hewlett-Packard, model 330D (w/cabinet) noise and distortion analyzer	\$ 575.00
Simpson, model 303, vtvm (insulated case)	\$ 74.00
Hickok, model 870, transistor checker	\$ 138.00
Tektronix, model 105, square wave generator	\$ 435.00
	Group Two Total <u>\$2,122.00</u>

Chapter 12

FCC Considerations

On Your Mark

As a broadcaster you will soon be familiar with the role of the Federal Communications Commission in the affairs of broadcast stations. Anyone working in broadcasting who is responsible for the affairs or the technical operation of a station should be familiar with the *FCC Rules and Regulations*. This includes such people as station owners, managers, program directors, chief engineers, and others who could make the station directly responsible for violations of the FCC standards.

Since there are so many aspects of station life covered by the *Rules*, it is a good policy to have more than one person keep up to date on them. For example, the station manager or owner can keep close watch on areas with which they are immediately concerned, such as ownership reports, financial statements, commercial time limits, promise vs. performance, political broadcasts, and the like. The program director could be concerned with such things as correct and legal station identifications and be on the lookout for teaser commercials, payola and plugola, guarantees, and so forth. The chief engineer would be concerned with the technical aspects of the *Rules*, such as correct technical operation and proof-of-performance measurements and watch for changes in engineering standards and such things.

When different staff members "specialize" in the areas that correspond to their particular activity, there will be fewer chances of operating outside the *Rules* and getting a notice of violation and, perhaps, a fine. The author does not wish to imply that you should disregard all areas but your own. On the contrary, you should be familiar with the general contents of the *Rules* and watch your own area very closely.

At least one complete set of the *FCC Rules and Regulations* should be available at the station, where all personnel can have access to it. Quite often, individuals will obtain an incomplete set for their own use and keep these at home. A copy of the *FCC Rules and Regulations* may be obtained from the U. S. Government Printing Office, Washington 25, D. C. at a nominal fee. These are printed in a volume series, on a subscription basis. They will send you all the rule changes that occur, so that your set may be kept up-to-date. The volumes of most interest to broadcasters will be Volumes I, II, and III, covering parts 0, 1, 2, 5, 13, 15, 17, 18, 73, and 74 of the rules governing the broadcast services.

All of the station's operating equipment may be purchased in anticipation of receiving a Construction Permit (CP). But it may be advisable to place tentative orders with the equipment manufacturers, rather than buy equipment outright. In some cases, this will hold the price line in the event a price rise is imminent on equipment. This may be advantageous, especially if the application must go into a long hearing. Should the application be denied for some reason, you may lose the retainer deposited on the tentative equipment order, especially if a price rise had taken place, or the length of time it was held was abnormal. When arranging these tentative orders with the manufacturer, be sure to find out exactly what the terms of the arrangement mean and what happens if you fail to get the CP granted. Complete understanding in the beginning can prevent misunderstanding later and hard feelings.

Many FCC rules are clear and implicit, but there are others that are not very clear at all. You will find some that are only implied and others that have been rulings in the past. The latter are the ones that give the station operators the most trouble and warrant the most citations. In all cases of ambiguity or questionable procedure, get your Washington attorney's or consulting engineer's advice before proceeding. These people have a more ready knowledge of these former rulings and can quite often get an unofficial opinion easily from someone at the Commission when they are in doubt.

One such ruling says that construction may not begin before a CP has been granted. Interpretations of this rule have gone so far as to mean you can't turn the first shovel of dirt to build the building, the equipment may not be moved into its operating position, nor may any wiring be run to it. There have been cases where construction had begun prior to granting of the CP and the FCC would not allow the use of anything that had been constructed.

Congress has given the FCC authority to impose fines to augment its authority to revoke licenses or not grant a CP. A station can be penalized \$1000 a day for each day an offense occurs with a limit of \$10,000. Should construction have been carried on before the CP has been grant-

ed and the FCC discovers this, you may not get the CP at all or you may be fined up to \$10,000, or the station license may be revoked if it has already been issued. It is best to play it safe and proceed according to the rules.

Should the decision be made to purchase and accept delivery of equipment before the CP has been granted, let it sit where it is. The crates may be opened and a check made for damage, but don't move the equipment into its normal operating position and especially don't bolt it down or begin wiring. Actually, this is a good period to look over the instruction books and installation diagrams. Measurements may be made to see if they coincide with published specifications. Often, you may have overlooked a small protrusion or opening that was not considered when the original plans and drawings were made. These errors can be corrected on the prints now, before everything gets built up to the error. One 5-kw radio station built a new transmitter into a wall, boxed it in, and dressed it up. As wiring proceeded, the Chief Engineer spent many hours trying to find a main terminal board where all the external control circuits entered the transmitter. He finally discovered that it was on the other side of a panel, which was loaded with the large plate contactors, relays, and various control devices. To get to the panel, he was supposed to take off the cabinet "skin" from the other side. Much to his dismay, he had built the transmitter tight against an outside masonry wall.

Owners will sometimes start putting pressure on the chief engineer to get started on construction. In most cases, these people are just not familiar with the FCC rules in this regard.

A time limit is specified with each CP, so it is well to try and finish within this period. Circumstances beyond the control of the station will sometimes prevent this. In these cases, the FCC will extend the time limit, providing you apply for an extension. The basic purpose of the time limit is to prevent an applicant from holding a CP without the intention of building, so that a competitor may not have it.

Get Ready

Once the CP has been granted, construction may commence. You do not have to wait for the actual instrument of authorization, for the FCC will usually notify the station by telegram that the CP has been granted. The authorization will come along later in the mail.

A CP looks like a license in many regards but it will say Construction Permit on the top of it. This instrument will define all the requirements of site location, studio location, frequency and channel, power, antenna

height, and height above average terrain. The station must be built as it is specified on the CP. You cannot alter any of these specifications without the FCC's approval. For example, your CP specifies a certain make and model of transmitter with a power rating of 12.5 kw. You discover that you can purchase a used transmitter in good condition that is a different make and model and will deliver 25 kw, but can be run at 12.5 kw. Unless you apply for a modification of the CP to the FCC and get their approval, you cannot substitute the other transmitter.

While the tower is being erected, the permanent lighting will not be installed. After construction has reached a height of 150 to 170 feet, depending upon your location, you must mount a temporary red light on the highest point and it must be kept lighted after sunset until sunrise. Make sure to notify the Federal Aviation Authority (FAA) as soon as the erectors begin placing steel on the piers and the tower is starting to be built. This will put them on notice that a new structure will be appearing in the air and that air traffic must now avoid it. Keep them posted of your progress, including the heights attained each day and what type of temporary lighting is being employed. Let them know when the tower has reached its permanent height and the normal lighting has been installed and is in operation.

The FAA control center in your area will be located at the nearest large airport that is used by commercial airliners. Some smaller cities, although served by a few airline flights, will probably not have an FAA center. In this case, the local airport can tell you where it is located. The reports on tower light outages must be made directly to the FAA center, wherever it happens to be. These reports should be made by telephone, not in a letter.

Construction may commence and proceed at whatever pace the circumstances will permit. When you are ready to fire up the transmitter, however, there are certain precautions that should be observed. Most of the transmitter checkout should be done into a dummy load and not into the antenna. Even here, however, trouble may develop.

Spurious emissions may occur from stages that may not be tuned correctly or because of oscillations, parasitics, or defective shielding. Should any of these radiations be taking place during normal program periods of other stations, there may be interference around your area, depending upon the strength of the radiations. These emissions may be interfering with FM sets, TV receivers on both uhf and vhf, and industrial two-way radio services. Defective shielding or traps may allow radiation that is harmful to these services. After the transmitter has been fired up for the first time, check throughout nearby areas to determine whether any interference is showing up.

The experimental period for AM radio is specified in the rules as 12 midnight to local sunrise; for FM the period is 1 AM until 6 AM; nothing is specified for television. The safest method, from an interference standpoint, will be to use the 1 AM to 6 AM period for the first application of power to the antenna. This is especially true if there is another TV station in your city that is programming in the evening hours. Should your transmitter be way off frequency or radiating spurious emissions, the other station's signal may be seriously interfered with. This is no way to endear your station to their viewers, especially since you hope they will change to viewing your signals after programming is started.

Before signal is applied to the antenna, you must notify both the FCC in Washington, D.C., and the Radio Inspector in charge of your district. Simply send a telegram to each of them, stating the date you expect to begin equipment tests. Do this well in advance of the date you expect to start tests. If the FCC doesn't want you to put a signal on the air for some reason, they will notify you by telegram. Equipment test authority is automatically granted when the CP is granted, so no new request is necessary.

There is another rule which is not clearly defined, but upon which most inspectors agree: the operator must be able to observe the transmitter meters. It is questioned whether this means that he must also be able to read them. It is safest to assume he should. Arrange the console and transmitter so that the operator can observe the meters from his operating position at the console and is close enough to observe if the readings are deviating too far out of tolerance. He does not necessarily have to be able, from this position, to determine just exactly how much they are deviating. The power reflectometers, frequency deviation meters, and modulation meters can be remotod to the console position if necessary for good installation circumstances. By doing this, you will remove any question the inspector may have and avoid later citations.

Once the transmitter room is in reasonable condition, the construction permit and other FCC telegrams should be hung on the wall. Once testing begins and power is being applied to the antenna, the operator's license should also be posted with the CP.

Get Set

A proof-of-performance is required to show that the new station is performing according to the specifications of the CP and that it will operate according to the FCC's *Rules of Good Engineering Practice*.

Few small stations will have all the necessary test equipment to make all the required measurements for a complete proof-of-performance.

The station's consulting engineer, the RCA Service Company, or the equipment manufacturer's field engineering department will make all the necessary measurements for you. Of course, there is a fee for this service.

The proof must be completed and its date specified in the application for station license. Most of the questions in the application form are self-explanatory, but your Washington attorney and consulting engineer should review the final form before application is made to the FCC. Improperly filled-out forms or missing information will usually cause the application to be returned without action. This will cause unnecessary delays before programming is begun.

Once the application for license has been filed with the FCC, you may apply for program test authority. This authority is not automatically included in the CP as is the equipment test authority. The request must be made to the FCC at least 10 days before you plan to start programming and you must wait until this authority has been granted before you may start. Even though a big gala opening is planned, with the Mayor cutting a ribbon and all the trimmings, unless the telegram is received which says you can go ahead, you just can't go on.

At the same time the request is made to Washington for program test authority, you must also notify the inspector in charge of your district that you have done so and that the station stands ready for his inspection. The inspector may decide to inspect the station immediately or may wait until a later date. In either case, this will not interfere with the programming going ahead as planned, unless his inspection tells him the station is not ready to go on.

Program test authority is just that. It is not a license, although you can program after it is granted and sell commercial time. The FCC reserves the right to withdraw the test authority if they have good reason, although this hasn't been done very often. The time of the test period, unless revoked, will run until the license is granted and no new request for extensions are necessary. This is also true for the CP; it does not have to be extended during this time.

Go

Now you are in the category of an operating television station and many day-to-day actions must be made to conform to the *Rules* and good engineering practices.

Logs

Daily logs of the station's operations must be kept by persons competent to do so. There will be three logs: the program log, the operating or transmitter log, and the maintenance log.

No special form is required as long as the necessary information, in legible, permanent form, is given. Logs may be typed, hand-written in ink, preprinted, or on special automatic logging devices. Signatures must always be in ink; never use pencil or something that can be easily erased. If abbreviations or key letters are used, they must be explained elsewhere in the log.

Signatures are required in many places, such as in the case of the operator who keeps the log during his watch. These must be full legal signatures, not just nicknames or initials. For example, a full signature would be James A. Doe, or J. A. Doe, not J. A. D. or Jim Doe.

Any corrections to the log must be initialed and dated, again in ink, by the person making the corrections. Also, don't blot out the information that has been corrected, just run a single line through it so that it can still be read. When preprinted logs are in use, trouble often develops. Before it is used, it is a run sheet, but as the times and program changes are made to conform with what actually went on the air, this becomes the program log. Many times, traffic people will not be familiar with the FCC rules concerning corrections and, consequently, will make changes during the day as changes are sometimes required. These people may blot out the old data, make changes with a pencil, or not initial the entry. The operator on duty must be careful to see that these changes are made and logged correctly.

The transmitter log should have all the required readings of both visual and aural transmitters on a single sheet. If they are kept on separate sheets, it might be confusing.

All readings of both transmitters, plus frequency monitors, must be logged as they are. They should not be logged after corrections for loss of power, line voltage changes, or other reasons which have caused the transmitter to be acting abnormally. Commission spokesmen have been quite firm about this. If one makes the necessary corrections and then logs everything as being 100% normal, the log is really meaningless, since it doesn't indicate the true behavior of the transmitter, which is the purpose of the log.

The maintenance log is a new feature, recently required by the FCC. It had its origin in the granting of permission to use automatic logging devices. Automatic logging takes many forms, such as roll charts which are marked by an electronically driven marker, or printing devices. With such logs there is no place to add all the additional information that is normally required, other than meter readings. Such things as tower light inspections, transmitter outages and their reason, and many more are therefore recorded in a separate log—the maintenance log.

One of the requirements of the maintenance log is that the person making the entry or the person who performed the action the entry describes should sign the entry. For example, if the Chief Engineer

happens to walk by the transmitter just as the overload relays kick it off the air, he obviously will reset and return the transmitter to the air immediately. Even though another licensed operator is on duty, the Chief would make the entry in the maintenance log in this instance.

All three logs should be kept for a period of three years. The *Rules* specify only two years, but the license renewal application will require information that will go back through the full three-year license period.

Station Identification

While there are many points spelled out in the *Rules* concerning log keeping, there are too many to try and cover in this chapter. The author would like to point out one area—station identification. The television rules are somewhat different from radio in this regard.

Station identification means full call letters and location. For example, “channel 49, Muncie,” would not be an adequate identification, although it is suitable for other occasions. A full station identification would be “WLBC-TV, Muncie, Indiana.”

A full station identification must be made on both the sound and picture transmitters, at the same time, when the station signs on in the morning or its regular time and at sign off at the end of the broadcast day. There should be a slide that gives the full information, plus an announcement on the sound channel that gives the full information. These are the only two times in the day when full announcements are required on both picture and sound transmitters. During the day, the announcement may be made on the hour on either the picture or the sound transmitter. (There are exceptions to the hour rule, such as long speeches, long plays, etc., which are spelled out in the *Rules*.)

The transmitter must be operated by a licensed first-class radiotelephone operator. Anyone may operate the other equipment, but the licensed man must be in charge of the transmitter and the transmitter and maintenance logs. He must be working in the transmitter room all the time, not somewhere else, such as the studio on camera during a live program. The operator in a one-man control room should have a first-class license and work the control room all the time. The operator's original license, as well as the station's original license, must be posted in the transmitter room. If you are also operating a radio station and the licensed men work at both places, a photostatic copy of the operator's license may be posted in the radio transmitter room. Any telegrams which have to do with permissions or other authorizations, while they are in effect, should be posted in the transmitter room, not kept in a file.

Tower Lighting

At sunset each day, a visual inspection must be made of the tower lights after they come on. You should not wait too long after this time to

make an inspection because it may be forgotten and the lights may be out. Some type of indicator should be mounted in the control room so that either a visual or aural signal will indicate that the photocell has operated the lights. This indicator cannot be used for inspection because it may show that the lights are on when a bulb may be burned out. It is for your own benefit as well as public safety to have the tower lighted properly. A tall tower is especially dangerous to aircraft. Should a plane hit the tower, lives will be lost, much damage will occur, and you will probably be off the air for a long time while repairs are being made. Such damage could entail the purchase of a new tower, antenna, and transmission line.

When the lights are inspected and a beacon or marker light is out, the FAA must be notified within one half hour. The lights must be restored to normal within 48 hours, unless there are circumstances that prevent this. The FAA should be notified of such difficulty. Remember to report to the FAA when the lights are back in normal operation, also. All this information should be noted on the maintenance log by the person making the report and signed by him.

Every three months it is required that you make an inspection of all the tower lighting equipment. This inspection will include a check of the photocell, relays and their contacts, plus anything else that may be associated with the tower lighting equipment. This inspection is a preventative maintenance measure to ensure that the tower lighting will continue to operate with few outages. This inspection should be noted on the maintenance log. Remembering to do this every three months can become something of a problem. Setting up a schedule to do this once a month will be more helpful in that you will be less apt to forget it. If you fail to make these inspections, you will receive a citation from the FCC the next time the inspector is around.

Frequency Checking

Getting the transmitter frequency checked once a month by an outside source can sometimes be a problem, especially if there is no commercial frequency measuring company within range of your signals. In some cases, these people will send someone with portable equipment to the station to make the frequency measurements. If you can't find someone who will do this in your area, then you will need some method of making the measurements yourself. Secure a frequency meter of good accuracy that can be calibrated against WWV, the Bureau of Standard's station in Washington, D.C. You may not be able to find a meter that will go as high as your carrier frequencies and, therefore, will have to measure one of the lower frequencies from one of the multiplier stages. You will find these stages very rich in all sorts of harmonics once you tap into them. Make certain that you pick out the correct one and also

remember that the multiplication factor of the multiplier stage must be taken into consideration when you compute the final measurement.

Every six months the reflectometers must be calibrated against a dummy load. This is the maximum interval allowed by the *Rules*. The author would recommend shorter gaps of time, such as three-month intervals. It is to the station's advantage that it is radiating the correct amount of power that is authorized.

Each year a full proof-of-performance should be made. These measurements are filed at the station and are available for the inspector when he makes an inspection of the station. One set of measurements must be made in the four-month period preceding the application for license renewal. Remember that the date for filing the application is 90 days before the license expires, so the four-month period should precede this 90 day period.

Tower Inspection

An inspection of the tower is required once a year. There are many tower service companies who do this type of work. A climber will go up the tower and inspect it for defects, weaknesses, and paint chipping. He will change light bulbs, and, if you request it, check the plumb of the tower with a transit, tighten the guys, and straighten the tower if it is necessary. A written report will be given to the station at the end of this inspection. File this report and note the inspection on the maintenance log.

License Renewal

A license is not permanent, but is issued on a three-year basis and must be renewed at the end of this period. It is not an automatic renewal; a renewal application must be filed. These renewal periods are staggered so that all stations in the country do not require renewal at the same time. Sections of the country are divided into groups, which are listed in the *Rules*. The renewal date will be shown on the station license.

The application for renewal must be filed with the FCC in Washington 90 days before the license expires.

Preparing the license renewal application can be a lot of work, especially if you wait until the last minute to begin its preparation. There will be all types of questions asked whose answers should give the FCC enough information to render a judgment on how well the station is operating, technically and legally, and whether or not it is providing the service to its community that was promised in the original application for a license.

At any time during the license period, if the FCC receives complaints, or the Field Monitoring division inspectors find the station to be operating out of technical tolerance, or transmitting illegal programs and the like, the license can be put in jeopardy. If the station is found guilty of such actions, depending upon how serious the offense is, the station may be fined or its license may be revoked. When a station loses its license, it cannot sell out to another party, because there is nothing to sell, only such physical assets as equipment and buildings. Another operator cannot buy this equipment and put the station back on the air. He would have to present a formal application to the FCC, as would anyone else who wishes to put a new station on the air.

In all such cases of infractions of the *Rules* during the license period, the FCC must prove that the station is operating in such a manner as to justify taking such harsh measures. On the other hand, at license renewal time, it is the station that must prove that it has operated in the manner it had promised. Therefore, renewal applications should be prepared in advance, slowly and carefully. It is well to keep up to date records on a running basis for such things as the program log analysis, political files, and other such areas which would require considerable file-searching and research when the renewal application is made out.

APPENDIX A

Things You Can Build for the Studio

You do not need expensive tools, equipment, or materials to build many usable items for the studio at a great savings in cost. The primary requisite is the mental attitude of doing things your own way. Just because many things in the industry have become accepted practices, it doesn't mean they are suited for the occasion you have in mind. Do your own experimenting and use the industry practices only when they suit you; otherwise, discard them.

The examples given here are just that—examples. Consider them an indication of the sort of money-saving materials you can produce yourself.

Strip Lights (Fig. A-1)

Wiremold raceway comes in 10' and 20' strips, with cover. The sockets are separate items you can buy; they snap right into the base of the wiremold. The cover strip can be cut to fill in the gaps between the lights.

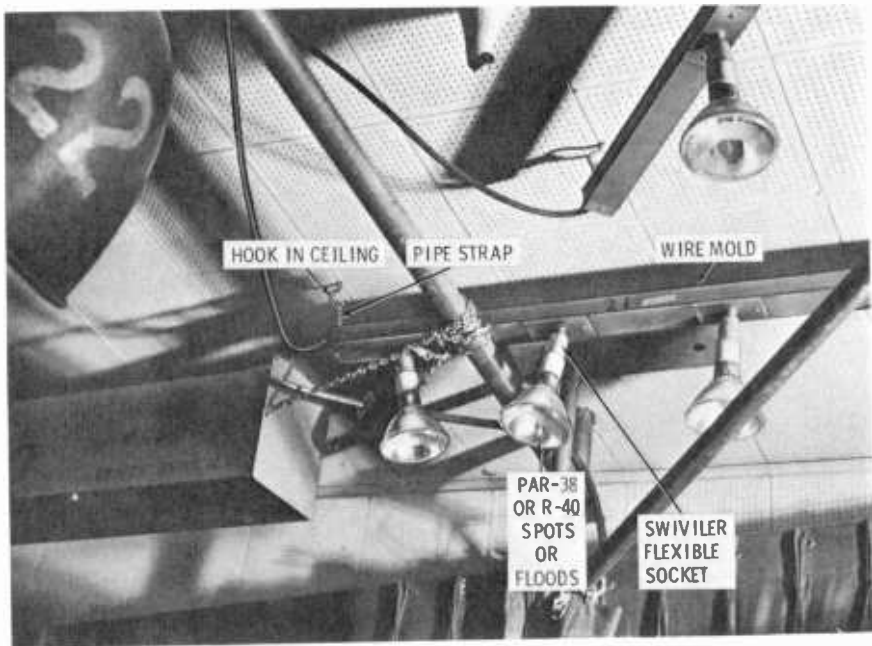

Fig. A-1. *Homemade wire-mold strip lights. (WLBC-TV, Muncie, Indiana)*

The sockets swivel and can be turned in any direction; they take a Par-38 or R-40 lamp.

Use regular pipe strap, bolted to the base of the wiremold at each end. Place large hooks in the studio ceiling or hook the strip light onto pipes to hang it in place.

Par-38 or R-40 lamps come in both spot or flood styles. The wattage ratings obtainable are 100 w, 150 w, and 300 w. Use any combination you wish for the desired results.

Parts required:

#3000B wiremold raceway (with cover), 10-foot length	\$ 4.42
10 #730 sockets (Swivlier Corp.) (@\$2.75)	\$27.50
	<hr/>
	\$31.92

Parts can be bought at any local electrical supply house.

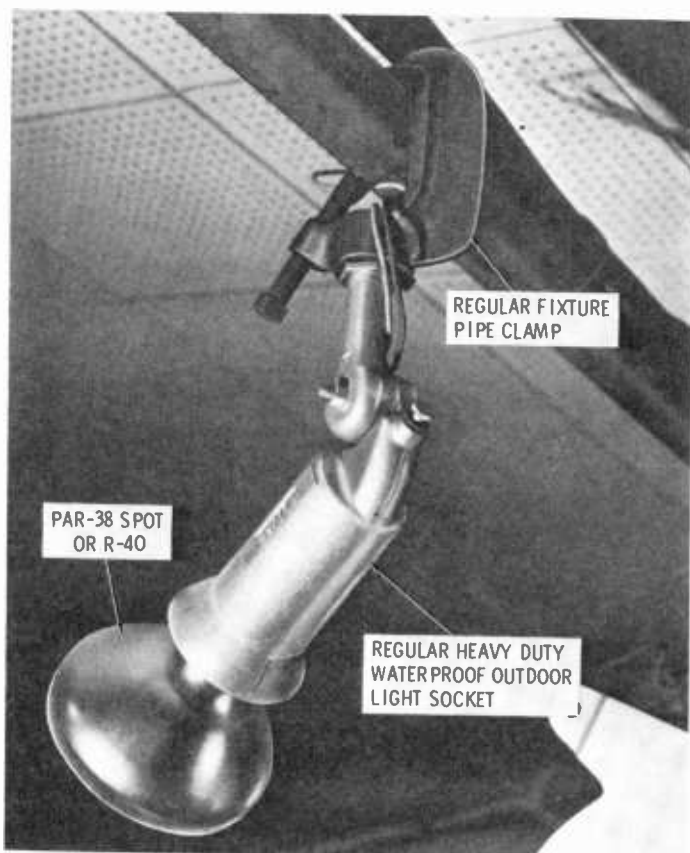

Fig. A-2. *A small, homemade spotlight. (WLBC-TV, Muncie, Indiana)*

Small Spotlight (Fig. A-2)

This is an inexpensive, small spotlight. The fixture is the regular outdoor type, which is more rugged than the indoor type. It can be tilted up or down and will take a Par-38 or R-40 lamp. Attach this fixture to a regular lighting fixture, pipe clamp, which is obtainable at a stage-lighting company supply house. The fixture itself can be obtained locally at an electrical supply house.

These make excellent small spotlights for key and back lighting in close places.

Parts needed:

Cat. #SL11, Killark Co., outdoor spotlight	\$ 2.00
"C" clamp for 2-inch pipe	\$ 2.75
	<hr/>
	\$ 4.75

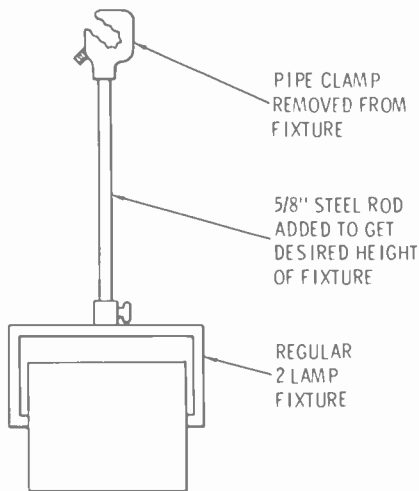

Fig. A-3. A light hanger.

Light Hanger (Fig. A-3)

This is simply a device for hanging one of the regular studio fixtures, either a spot or scoop, without additional expensive hangers, such as a pantograph. The small stub that holds the pipe clamp to the fixture is replaced by a length of pipe long enough to place the light where you want it and still have it clamped to the overhead pipes. The longer pipe is simply a $\frac{5}{8}$ -inch steel rod, which may be purchased at a local machine shop.

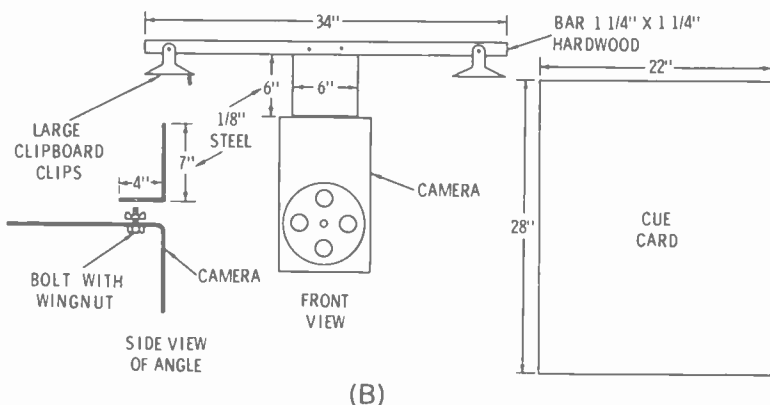
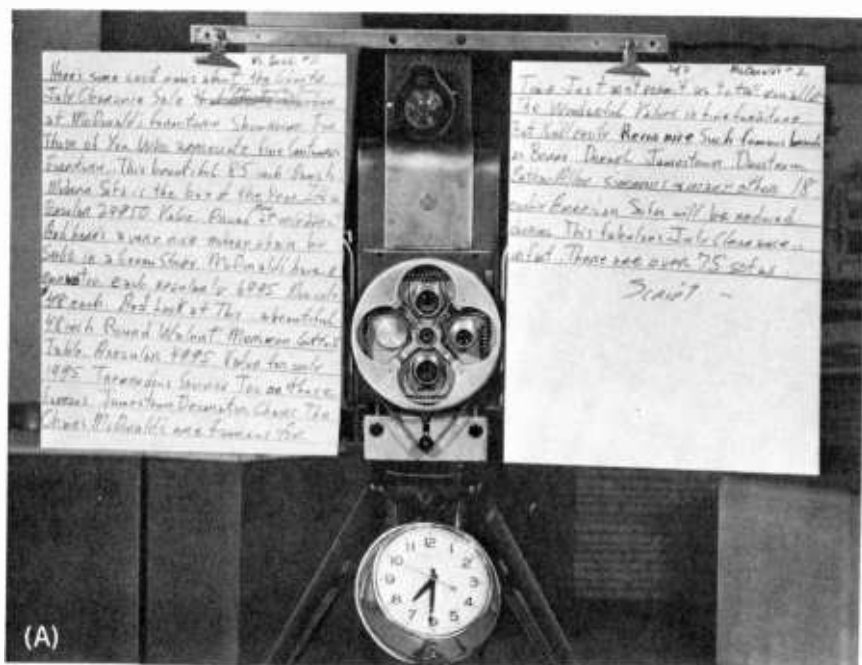

Fig. A-4. (A) A cue card holder. (B) Mounted on the camera.

Cue Card Holder (Fig. A-4)

This is an inexpensive prompter unit. The dimensions shown are for the image orthicon camera. For use on a vidicon camera, some adjustments would be required.

Make the crossarm out of $1\frac{1}{4} \times 1\frac{1}{4}$ -inch hardwood. The angle bracket is made of $\frac{1}{8}$ -inch steel, bent at a 90-degree angle. Two bolts are all that are required to mount it to the camera. Mount the bolts so they project above the camera case and are rigid (attached to the camera).

All you need are two wingnuts to hold the cue card holder to the camera. Two bolts will hold the crossarm. If you have no machine to bend the steel, have a machine shop bend it for you.

Bolt large clipboard clips on each side of the crossarm. This will then hold a card on both sides of the camera. The cards are 22" × 28" "railroad cards," a heavy signboard material. These cards are obtainable at a local paper-supply house. Make sure there is no spotlight behind the camera when the cue card is being used, as it will cast a shadow on the scene.

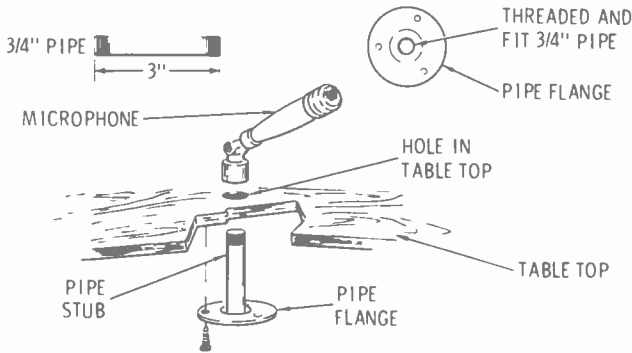

Fig. A-5. A desk holder for a stationary microphone.

Microphone Desk Holder (Fig. A-5)

Here is a very simple item that will cost practically nothing. Use a $\frac{3}{4}$ -inch pipe nipple and a threaded pipe flange. Cut a hole in the top of the desk, big enough for the pipe nipple to go through easily. Underneath the desk top, mount the pipe holder with wood screws. To use the device, simply screw the pipe nipple into the pipe flange and mount the microphone on the other end of the nipple. There should be about three of these on a large desk.

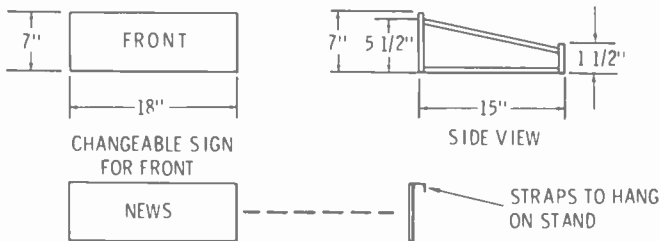

Fig. A-6. A copy holder and sign.

Copy and Sign Holder (Fig. A-6)

This copy holder is quite helpful both to the announcer behind the desk and to overall scene appearance. It will hold the copy at an angle for easier reading and also keep it out of view. The stand may be made from plywood or masonite, or both.

The sign is rigid cardboard, with clips on top so it will snap onto the copy holder. An alternative fastening method is the use of a magnetic latch, embedded in the front of the holder that will fasten to a metal strip glued to the back of the sign. Several signs may be made up for different occasions, all using the one copy holder.

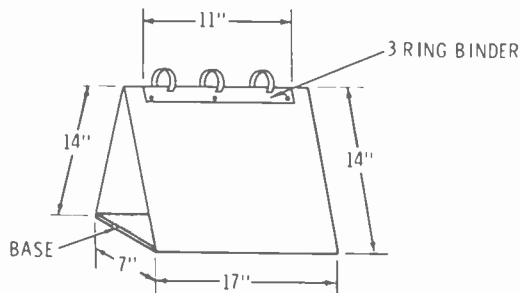

Fig. A-7. A flipboard.

Flipboard (Fig. A-7)

Another example of an inexpensive, simple device made from scraps. The board may be made from either masonite or plywood. The snap rings are from an old, large ring binder.

The whole thing is small enough to set on a desk alongside the announcer. When he wishes to go to flip charts, the camera can pan to the flip chart, with the announcer reading the copy and flipping cards as needed, out of camera range.

APPENDIX B

Modifying the TC-4A Switcher

Even though the TC-4A switcher is no longer available, it is possible that your installation is already equipped with one or you may buy one on the used equipment market. If so, there are many modifications that can be made that will increase its usefulness many times over, converting it to a semi-automatic operation.

Many of these modifications are applicable to other switchers. The basic ingredient is a relay system. Audio consoles that use manual switching, such as the BC-5B, do not allow too much modification, unless you want to change all the manual switches to relays.

The following points should be considered when modifying switchers:

1. Tally light voltages are available on all video switchers. These may be 6.3 volts a-c, +280 volts d-c, or both.
2. Many lap-dissolve faders have limit switches attached to them. These often have spare contacts available.
3. Be careful not to mix voltages (e.g., a 6.3 volt a-c tally light voltage with +24 volt d-c relay voltages). When such a condition exists, it will be necessary to add additional relays for "voltage conversion."
4. Be careful not to overload the power supplies with too many additional relays.

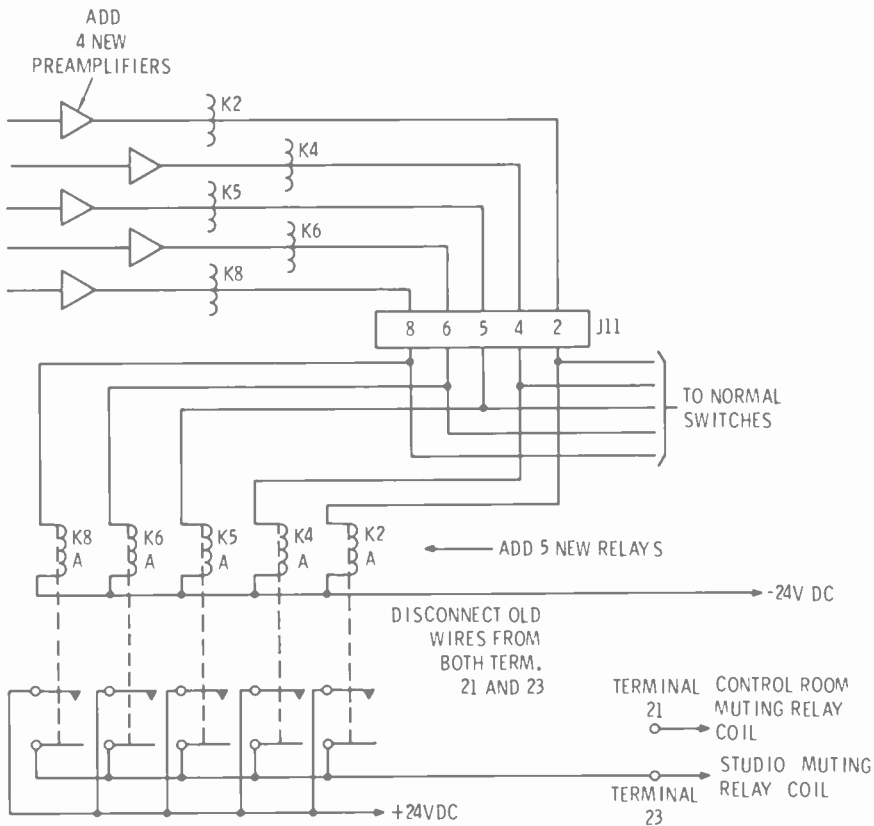

Fig. B-1. TC-A-A modifications to add new microphone channels and to add new relays so that the new microphone positions will mute the studio relay.

1. Providing More Microphone Circuits (Fig. B-1)

Ordinarily, the TC-4A will handle two microphones at a time, because they appear on opposite sides of the same key (#3). Four microphones may be used at one time by using TT1, TT2, C Rm, Spare positions. All four microphones will appear on their own key, which will be the right-hand position of the switch. A preamplifier will be required for each microphone. The preamplifier outputs should be strapped for 150 ohms, unbalanced, to match the switcher. None of these relays will operate the studio muting relay or air light. To remedy this, the following changes will have to be made.

Add a wire from each of the following pins of J11 (pins 2, 4, 5, 6, and 8). Run the wire from each pin number to a new relay for each circuit. The common side of the new relay coil will go to -24 volts d-c. Disconnect the wire that normally goes to terminal 21 on the audio block, which normally connects to relay K6. Also, disconnect the wire that goes to terminal 23 on the audio block, which normally goes to relay K5.

Wire contacts of the new relays in parallel. One side of this wiring will run to terminal 23 on the audio block, which is the studio muting relay; the other side of the wiring will to to +24 volts d-c.

The new relays may be mounted in a box or on a strip alongside the regular relay box within the TC-4A cabinet. Use 24-volt d-c relays.

Throwing any of the microphone keys will now mute the speaker in the studio and turn on the "on Air" light. As the control room with its transmitter and projectors will be too noisy to use a microphone, the control room speaker muting is not used.

2. Adding Microphone Presets (Fig. B-2)

Any microphone (or all of them), tape machine, turntable, or off-air receiver audio may be preset, so that the audio circuit will be energized when the video fader on the lap-dissolve unit is operated in a position that permits the video fader to be faded up. When using this method, the regular console switch will not have to be operated each time you wish to turn on a microphone. This modification is an extension of the previous one.

For each microphone that is to be preset, simply extend the control circuit for the relay coil (which was added in the previous modification) through a toggle switch. Tie one side of each of the toggle switches together to make a common side. The other side of each switch will go to the particular control circuit that was extended. The common side of the switches will wire to the switch located on the video fader of the lap-dissolve unit. If the lap-dissolve unit does not have plain switch circuits, but carries tally light voltage, you will need to substitute additional relays at this point, having coils of the tally light voltage rating;

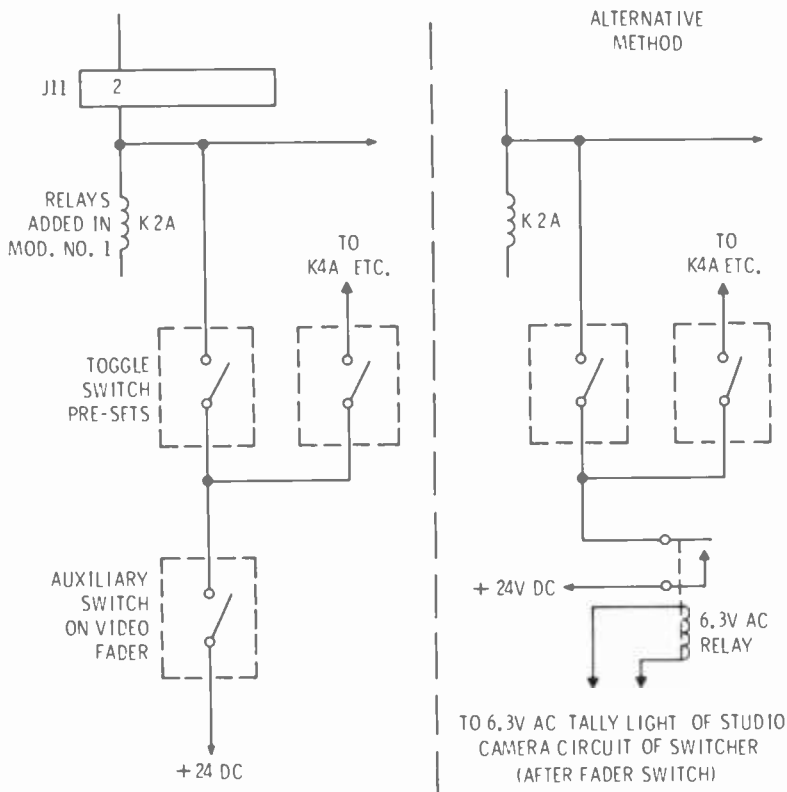

Fig. B-2. TC-4A modifications to add presets. The alternate method indicates changes possible when tally light voltage is present on the video fader contacts.

otherwise, the two different voltages will mix and blow fuses. If you cannot pick up tally light voltage at the faders, it can be picked up on the tally lights themselves.

3. Presetting Tape

This modification is the same as 2, except the control circuit is tied into the film chain video circuit. Normally, audio tape will be used with slides, so the film chain is the logical place to tie in. Tie the control lead to K3, which is the audio relay for remote position, if this is the position you will use. The connecting point is pin 3 of J11.

4. Tape Cue-Up and Remote Start (Fig. B-3)

A conventional tape machine may be automatically started from the console. Extend the lead of modification 3 to a relay mounted in the tape machine, across its start circuit. When the audio circuit is activated

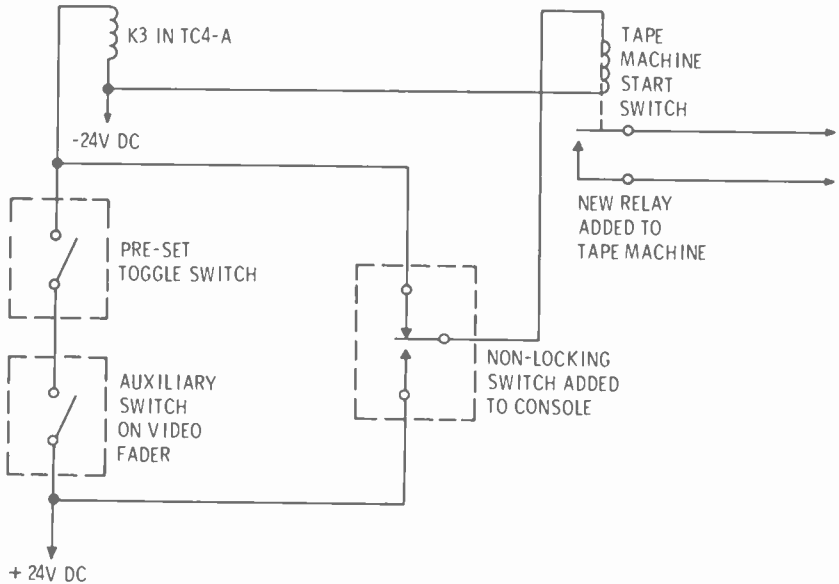

Fig. B-3. *TC-4A modifications to add remote start to a conventional audio tape machine.*

in the console, the tape machine will also run. (Cartridge tape machines use a momentary contact switching action for starting. The control circuits in the TC-4A are on all the time the circuit is activated, which would prevent stopping of the cartridge machine.) Add a spdt, non-locking switch, wired as shown in Fig. B-3. This arrangement will permit the operator to run up the tape machine until it is properly cued up without activating the audio circuits in the TC-4A.

5. Turntable Remote Start

A turntable can be started in the same way as a tape machine. Extend the TC-4A relay control circuit for the position desired to operate a relay mounted across the start circuit of the turntable. When the audio circuit is activated in the TC-4A, the turntable will run.

6. Off-Air Audio Circuits (Fig. B-4)

If you have two off-air pickups, the network may be brought into the network and remote video buttons of the switcher. If it is desired to use only one fader for the audio, a relay can be used to do this. Use a dpdt relay with a 6.3 volt a-c coil. Connect this coil to the tally light circuit of the remote position, which is terminal 11 of terminal board P-10B. Connect the other side of the coil to terminal 24 or to ground. Wire the contacts so that the number 1 receiver audio feeds straight through to

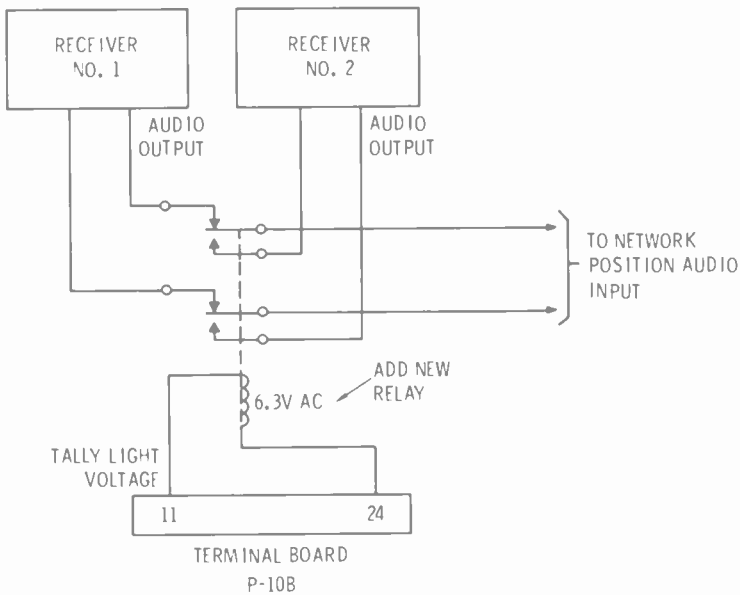

Fig. B-4. TC-4A modifications to operate two off-air receivers' audio into one switch position of the console.

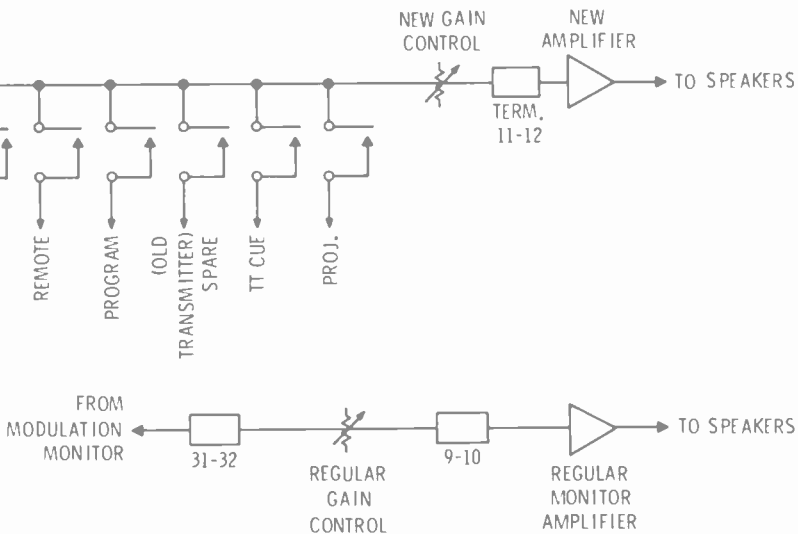

Fig. B-5. TC-4A modifications to separate regular air monitoring so that it is in operation at all times. Addition of fader and amplifier so that all cue positions may be monitored without bothering the regular speaker system.

the network audio circuit in its relaxed position. When the number 2 receiver is to be used, the remote video button tally light voltage will operate this new relay, feeding the audio from this source into the same place as the first receiver.

7. Monitoring (Fig. B-5)

It may be desirable to separate cueing circuits from the regular transmitter audio monitoring. This would be helpful when it is necessary to preview something which may take some time when it is not desirable to have the transmitter monitor off for a long period. Also, you may not wish this cueing to be fed on the line to the lobby.

Disconnect wires from terminals 31-32 which connect to the "transmitter" pushbutton. Disconnect wires from terminals 11-12, which go to the turntable pushbutton. Disconnect regular monitor gain control from monitor bus.

Connect regular monitor gain control directly to terminals 31-32 on audio block, which will be the air monitor, now nonswitchable. This will provide the studio, lobby, and control room with on-air material and allow cueing on another monitoring system.

Add a new gain control and connect it to the monitor bus. This gain control should be bridging. Add a 4700-ohm resistor to each side if it is

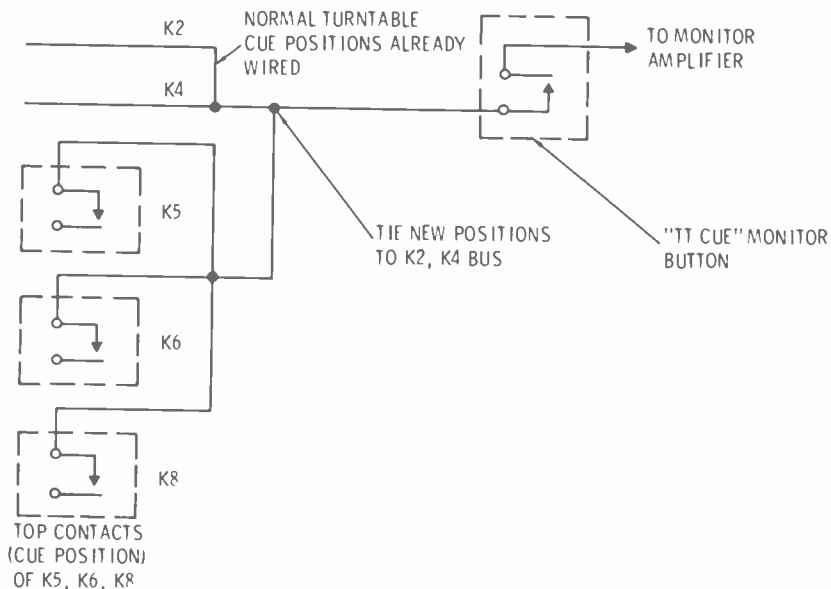

Fig. B-6. TC-4A modifications to pick up cue terminals of relays so that added microphones may be checked out on the cue system without getting them on the air.

not bridging. Connect output of the new gain control to terminals 11-12, which will now feed the new amplifier and speaker.

8. Microphone Checkout (Fig. B-6)

The additional microphone channels provide no method of checking out the mikes before use without trying them on the air, which is poor practice. Two of these circuits will already be wired in to Cue, since they were originally turntable positions.

On relays K5, K6, K8, in the TC-4A, pick up the unused cue contact on the relay itself and to the turntable cue button. Now all microphones with the preamplifiers, including the studio announce position, may be checked out without getting them on the air.

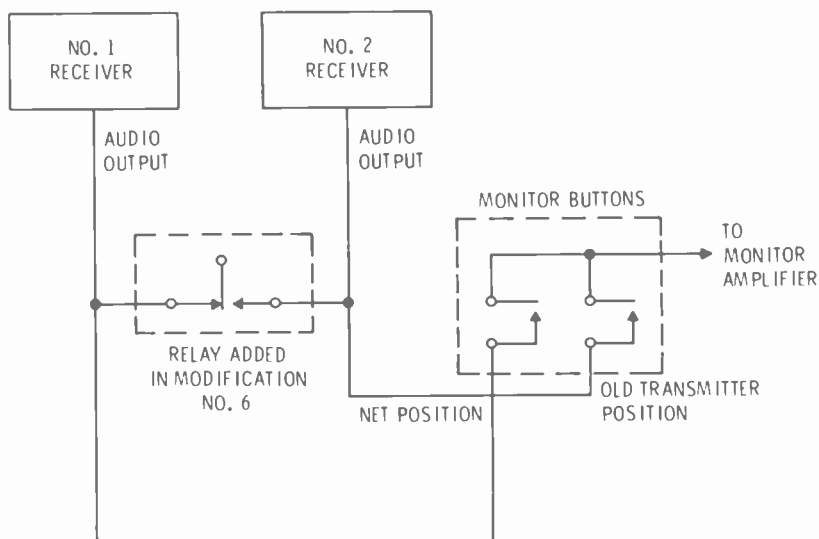

Fig. B-7. TC-4A modifications to wire monitor buttons and both receivers so that they may both be checked out if one is on the air.

9. Off-Air Receiver Audio Monitoring (Fig. B-7)

If modification 6 has been installed, there will be no way of checking the audio of the receiver that is not being broadcast. This situation may be remedied.

Disconnect the cue line from network monitoring position on K1, which goes to Cue button. Wire the network cue button to first receiver audio before receiver switching relay that has been added. Wire the second receiver audio, before this relay, to the former transmitter cue button, which is now spare. This arrangement will allow both receivers to be monitored separately, using only one audio circuit in the switcher.

APPENDIX C

The TV Band

Chan. No.	Frequency Band (MC)	Video Carrier	Audio Carrier	Chan. No.	Frequency Band (MC)	Video Carrier	Audio Carrier
2	54-60	55.25	59.75	43	644-650	645.25	649.75
3	60-66	61.25	65.75	44	650-656	651.25	655.75
4	66-72	67.25	71.75	45	656-662	657.25	661.75
5	76-82	77.25	81.75	46	662-668	663.25	667.75
6	82-88	83.25	87.75	47	668-674	669.25	673.75
7	174-180	175.25	179.75	48	674-680	675.25	679.75
8	180-186	181.25	185.75	49	680-686	681.25	685.75
9	186-192	187.25	191.75	50	686-692	687.25	691.75
10	192-198	193.25	197.75	51	692-698	693.25	697.75
11	198-204	199.25	203.75	52	698-704	699.25	703.75
12	204-210	205.25	209.75	53	704-710	705.25	709.75
13	210-216	211.25	215.75	54	710-716	711.25	715.75
14	470-476	471.25	475.75	55	716-722	717.25	721.75
15	476-482	477.25	481.75	56	722-728	723.25	727.75
16	482-488	483.25	487.75	57	728-734	729.25	733.75
17	488-494	489.25	493.75	58	734-740	735.25	739.75
18	494-500	495.25	499.75	59	740-746	741.25	745.75
19	500-506	501.25	505.75	60	746-752	747.25	751.75
20	506-512	507.25	511.75	61	752-758	753.25	757.75
21	512-518	513.25	517.75	62	758-764	759.25	763.75
22	518-524	519.25	523.75	63	764-770	765.25	769.75
23	524-530	525.25	529.75	64	770-776	771.25	775.75
24	530-536	531.25	535.75	65	776-782	777.25	781.75
25	536-542	537.25	541.75	66	782-788	783.25	787.75
26	542-548	543.25	547.75	67	788-794	789.25	793.75
27	548-554	549.25	553.75	68	794-800	795.25	799.75
28	554-560	555.25	559.75	69	800-806	801.25	805.75
29	560-566	561.25	565.75	70	806-812	807.25	811.75
30	566-572	567.25	571.75	71	812-818	813.25	817.75
31	572-578	573.25	577.75	72	818-824	819.25	823.75
32	578-584	579.25	583.75	73	824-830	825.25	829.75
33	584-590	585.25	589.75	74	830-836	831.25	835.75
34	590-596	591.25	595.75	75	836-842	837.25	841.75
35	596-602	597.25	601.75	76	842-848	843.25	847.75
36	602-608	603.25	607.75	77	848-854	849.25	853.75
37	608-614	609.25	613.75	78	854-860	855.25	859.75
38	614-620	615.25	619.75	79	860-866	861.25	865.75
39	620-626	621.25	625.75	80	866-872	867.25	871.75
40	626-632	627.25	631.75	81	872-878	873.25	877.75
41	632-638	633.25	637.75	82	878-884	879.25	883.75
42	638-644	639.25	643.75	83	884-890	885.25	889.75

APPENDIX D

Equipment Suppliers and Manufacturers

(A more complete listing of suppliers and manufacturers can be found in the proper section of *Broadcasting Yearbook*.)

Alford Manufacturing Co. 299 Atlantic Ave. Boston 10, Mass.	(Antennas)
Andrew Corp. P. O. Box 807 Chicago 42, Ill.	(Complete line of transmission lines, waveguide, microwave antennas)
Automatic Tape Control, Inc. 1107 East Croxton Bloomington, Ill.	(Audio cartridge tape equipment)
Behrend Cine Corp. 161 E. Grand Ave. Chicago 11, Ill.	(Film handling equipment)
Berndt-Bach, Inc. 6900 Romaine St. Hollywood 38, Calif.	(Sound on film cameras)
Bird Electronic Corp. 30303 Aurora Rd. Cleveland 39, Ohio	(Load and wattmeters)
CBS Laboratories 227 High Ridge Rd. Stamford, Connecticut	(AGC amplifiers and specialized audio)
Century Lighting, Inc. 521 W. 43rd St. New York 36, N. Y.	(Studio lighting equipment)
Conrac Division Giannini Controls Corp. 19217 E. Foothill Blvd. Glendora, Calif.	(Off-air receivers, video monitors)

- Dresser-Ideco Co. (Towers)
887 Michigan Ave.
Columbus 15, Ohio
- Eastman Kodak Co. (Film projectors, processors, cameras, etc.)
343 State St.
Rochester 4, N. Y.
- Federal Mfg. & Engineering Corp. (Modified sound on film cameras)
1055 Stewart Ave.
Garden City, N. Y.
- Gates Radio Co. (Complete line of studio and transmitting equipment for radio stations)
123 Hampshire St.
Quincy, Ill.
- General Electric Co. (Complete line of audio, video, transmitting, microwave, etc.)
Technical Products Dept.
212 W. Division St.
Syracuse 3, N. Y.
- Hewlett-Packard Co. (Station monitor, noise-distortion measurements, audio generator)
1501 Page Mill Rd.
Palo Alto, Calif.
- Hollywood Film Co. (Film handling equipment)
956 N. Seward St.
Hollywood 38, Calif.
- Houston Fearless Corp. (Camera pedestals, cradles)
Westwood Div.
11801 W. Olympic Blvd.
Los Angeles 64, Calif.
- Kliegl Bros. Lighting (Studio lighting equipment)
32-32 48th Ave.
Long Island City, N. Y.
- Milsco Manufacturing Co. (Film processors)
2758 N. 33rd St.
Milwaukee 45, Wisc.
- Miratel Electronics Inc. (Video monitors)
3600 Richardson St.
New Brighton 12, Minn.

Measurements Corp. P. O. Box 180 Boonton, N. J.	(Precision instruments, grid dip meters)
Neumade Products Corp. 250 W. 57th St. New York 19, N. Y.	(Film handling equip- ment)
Plastic Reel Corp. Box 750 Union City, N. J.	(Plastic film reels and reel paks)
Radio Corp. of America Broadcast & Communications Prod. Div. Front & Cooper Sts. Camden 2, N. J.	(Complete line of audio, video, transmitting, mi- crowave, film, etc.)
Raytheon Co. 1415 Providence Turnpike Norwood, Mass.	(Microwave equipment)
Rohn Manufacturing Co. P. O. Box 2000 Peoria, Ill.	(Microwave towers)
Sarkes Tarzian, Inc. Broadcast Equipment Div. E. Hillside Drive Bloomington, Indiana	(Complete line of studio equipment, microwave equipment)
Spindler & Sauppe 2201 Beverly Blvd. Los Angeles 37, Calif.	(Slide projection equip- ment)
Stainless, Inc. Third St. at Montgomery Ave. North Wales, Pa.	(Television towers)
Tektronix, Inc. P. O. Box 500 Beaverton, Oregon	(High quality oscillo- scopes, test equipment)
Visual Electronics, Inc. 356 West 40th St. New York 18, N. Y.	(Complete line of tele- vision station equip- ment)

Tower Erectors and Service Companies

Airway Steel Erectors, Inc.
735 N. Oakland Ave.
Griffith, Indiana

John F. Beasley Construction Co.
P. O. Box 1624
Muskogee, Okla.

Dresser-Ideco Co.
875 Michigan Ave.
Columbus, Ohio

Kentuckiana Tower Service, Inc.
P. O. Box 96
English, Indiana

Mid-South
General Contractors, Inc.
P. O. Box 2503
West Jackson Station
Jackson, Miss.

RCA Service Co.
Cherry Hill, Delaware Township
Camden 8, N. J.

Tower Builders Co. Inc.
P. O. Box 356
Angola, Indiana

Tower Specialties Co.
600 S. Summit Ave.
Villa Park, Ill.

Tower Maintenance of Illinois, Inc.
2248 E. Broadway
Alton, Ill.

Tower Maintenance Co., Inc.
P. O. Box 246
Glen Burne, Maryland

Most tower manufacturers usually erect their own towers or have a subcontractor who will do the work. Tower service companies are located throughout the country. Your broadcast equipment salesman can usually recommend a company in your area.

*Trade Magazines**Broadcasting*

Broadcasting Publications, Inc.
1735 DeSales St., N.W.
Washington, D. C.

(Weekly: a general news coverage with other items of interest to broadcasters)

Television Age

Television Editorial Corp.
Publication Office
Garden City, N. Y.

(Weekly: special coverage of programming, trends, and business aspects of television broadcasting)

Broadcast Engineering

Technical Publications, Inc.
4300 W. 62nd St.
Indianapolis 6, Indiana

(Monthly: devoted to the technical aspects of broadcasting)

*Broadcasting Yearbook*Published by *Broadcasting Magazine*

(Yearly: complete fact and data book on markets, stations, and personnel, equipment manufacturers, etc.)

APPENDIX E***Bibliography***

These texts and articles will supplement the information presented in this book and serve as engineering reference texts and guides to equipment use.

Auditore, C. J. "Television Broadcast Translators," *Broadcast Engineering*, July 1959.

Bernstein, Julian. *Video Tape Recording*. New York: John F. Rider Publisher, Inc., 1960.

Broadcast News, RCA, Color TV Issue, Vol. 77.

Broadcast News, RCA, Special UHF Issue, Vol. 116.

Eitel-McCullough. "Care and Feeding of Eimac UHF Television Power Klystrons."

Ficchi, Rocco. *Electrical Interference*. New York: Hayden Book Company, Inc., 1963.

General Electric. "Lighting Exposure and Life of the Image Orthicon."

General Electric. "Field Mesh Image Orthicon—Setup and Alignment."

Helt, Scott. *Practical Television Engineering*. New York: Holt, Rinehart & Winston, 1953.

National Association of Broadcasters, Inc. *NAB Engineering Handbook*, 5th Ed. New York: McGraw-Hill Book Company, Inc., 1960.

O'Brien, Richard S. "CBS Television Staging and Lighting Practices," *Journal of the SMPTE*, Vol. 55, September 1950.

Turner, Rufus P. *Oscilloscope Handbook*. New York: John F. Rider Publisher, Inc., 1964.

Young, Victor. *Understanding Microwaves*. New York: John F. Rider Publisher, Inc., 1960.

INDEX

A

A.A.T. (antenna height above average terrain), 21, 26
Access roads, 7
Acoustics, studio, 45
Adjacent channel stations, 88
Adjacent properties, 4
AGC amplifier, 70
Air conditioning, 209, 221
Air duct, 222
Airport, proximity, 3
Alignment, video, 250
Amplifiers
 agc, 70
 audio, 70
 distribution, 66
 Level Devil, 72
 monitoring, 68
 stabilizing, 64
Amplitude modulation, 90
Announce booth, 229
Antenna charts, use of, 157
Antennas
 field intensity contours, 16
 GE helical, 169
 GE zig-zag, 171
 height above average terrain, estimating, 17, 21, 26
 helical, 150, 169
 location, 15
 maintenance, 178
 pylon, 164
 radiation center, 22
 RCA pylon, 164
 required field strength, 16
 slotted, 150
 suppliers and manufacturers, 283
 terminology, 150
 transmission line connection, 138
 use of charts for, 157
 zig-zag, 150, 171
Aperture, antenna, 151
Array, stacked, 151, 158
Audio
 amplifiers, 70
 aural transmitter, 108
 basic control room equipment costs, 86
 basic studio equipment costs, 50
 cables, 81
 control room requirements, 66
 in film, 201
 microphones, 43

 monitoring, 68
 rates for STL service, 10
 studio acoustics, 45
 studio outlets, 46
 terminations, 252
Audio jackfields, 83
Audio modulating signal, 91
Audio signal generator, 247
Audio tape, 229
 cartridge tape, 278
Audio terminal block sheet, 80
Aural center frequency, tolerance, 90
Aural modulation, 99
Aural reflectometer, 116
 calibration, 116
Aural transmitter, 108
 broadbanding, 110
 maintenance techniques, 114
 modulator-exciter, 108
 output, 110
Azimuth, antenna, 156

B

Backdrop lighting, 31
Backdrops, 47
 colors of, 47
Backheating, cathode (UHF tubes), 92, 121
Back light, 31
Banana plugs, 253
Base light, 31
Bay, antenna, 154
Beam, antenna, 158
Beam tilt, antenna, 160
Beam width, antenna, 159
Birds' nests, film, 187
Black level, 107, 116
Bleeding lines, 143
Bonding, 83
Box wrench, 137
Breathing effect (AGC amplifiers), 71
Broadbanding
 aural exciter, 110
 klystrons, 96
Broadcast antenna towers, 176
Building
 airconditioning, 209, 221
 basic floor plan, 211
 cost examples, 11, 12, 13
 expansion, 206
 front entrance, 209
 heating, 208, 221

- Building (cont.)
 location, 5, 6
 planning, 206
 structure types, 208
 studio, 27, 28
 tower location, 210
 traffic problems, 210
 Building codes, 3, 8
 Building ground, 220
 Bullet, 127, 136
 Burn out (image orthicon), 39
 Buzz track, test film, 245
- C**
- Cable
 audio, 46, 81
 camera, 231
 for cavity coupling, 97
 conduits for, 219
 ducts for, 224
 grouping of audio, 83
 matching interstage, 118
 multiple wire, 81
 for remote pickup, 84
 scope, 251
 telephone, 219
 video, 46, 80
 video switcher, 63
 Camera accessories, 47
 Camera chain, defined, 43
 Cameras (*see also* Film camera, Image orthicon camera, Vidicon camera)
 accessories, 47
 basic costs, 49
 cable, 231
 control room requirements, 54
 depth of field, 37
f stop, 39
 gray scale, 39
 lenses, 40
 lighting for, 31
 operator qualifications, 57
 patch panel, 232
 remote-controlled, 56
 selection of, 43
 zoom lens, 41
 Cathode ray oscilloscope, 54
 Cavity circuits, 97, 103, 104
 Ceiling height
 studio, 29
 transmitter, 213
 Center frequency of aural, tolerance, 90
 Channel assignment, 1
 Chloroethene, 192
 Chopper, 100
 Circuit breaker boxes (studio), 230
 Circuit breaker panels (building), 219
 Citations, FCC, 258
 Clamping (ITTU-1B), 107
 Claw, projector, 75
 Clock, studio, 47, 233
 Coaxial cable, rf, 103
 matching, 118
 video, 81
 Co-channel stations, 88
 Collector, 96
 Color coding tools, 233
 Color programming, future plans, 81
 Combined studio-transmitter, 8
 Communications Act, 1
 Complaints, 267
 Compound markets, 17
 Construction permit (CP), 258
 display, 261
 time limit, 259
 Contour intervals, 18, 20
 Contour lines, 18
 Contours
 field intensity, 16
 map lines, 18
 Control room
 audio consolette, 66
 audio requirements, 66
 camera systems, 54
 control position, 226
 engineering, 79
 film and slide equipment, 74
 instrument monitoring, 227
 layout, 214
 projection center, 227
 tape machines, 71
 video requirements, 54
 Costs
 antenna, 182
 building (examples), 11
 camera tubes, 40, 43
 color camera tubes, 40
 control room equipment, 86
 do-it-yourself spotlight, 271
 do-it-yourself striplight, 270
 film equipment, 204
 film processing, 201
 film projectors, 75
 film reels, 193
 microwave, 9, 10, 11
 studio equipment, 49, 50
 studio transmitter links, 9
 telephone company microwave, 10
 test equipment, 255
 tower, 174, 182
 transmission line, 146
 transmitter, 125
 Coupling, cavity, 98

Coverage areas, 3
 estimated coverage, 17
 true coverage, 16
 Coverage estimation, 15
 Cross-hatch (grating) generator, 245
 Crystals, transmitter, 91
 Cue card holder, 47, 272
 Cue marks, film, 197

D

Damage, film, 184
 scratches, 187
 Damper system, 223
 Dark room, 215
 Dbu, 15
 Defect suppression, film, 75
 De-icing (*see also*, Antennas, VSWR),
 133, 157, 167, 171
 Depression angle, 162
 Depth of field, 37
 Detector, diode (transmitter monitoring), 100
 Diplexer, 113
 Dipole antenna, 158
 Directional coupler, 100
 Directionalizing, antennas, 154, 171
 Director's position, 229
 Distortion analyzer, 247
 Distribution amplifier, video, 66
 Dolly, 233
 Drainage, land, 4
 Drapes, 49
 Dry air pump, 142, 143
 Ducts, wiring, 79, 224

E

Effective radiated power (ERP), 132,
 154
 EIA flange, 131
 Elbows, mitered, 127
 Electrical beam tilt, 154
 Electronics Industries Association
 (EIA) standards, 131
 Elevations, topographical, 18
 Envelope, sweep, 250
 Equipment test authority, 261
 Equipment tests, 261
 Estimated coverage pattern, 21
 Exhaust fumes, 224
 Expansion plans, 4
 studio, 28

F

F(50,50) chart, 16, 23
 use of, 23
 FAA Control Center, 260, 265
 Falling ice, 211
 Federal Aviation Authority (FAA), 3
 Federal Communications Commission
 (FCC), 1, 257
 FCC field monitoring division, 267
 FCC Rules and Regulations, 1, 257,
 258
 meanings, 258
 Feedpoint, antenna, 157, 165, 171
 Field lens, multiplexers, 61
 Field strength, required, 15
 F(50,50) chart, 24
 Filament taps, changing, 121
 Film
 birds' nests on, 187
 cameras, 58, 200, 205
 circulation, 184
 cleaners, 190
 cleaning, 191, 192
 damage, 184
 dark room, 215
 equipment, 194
 green, 189
 hardeners, 190
 inspection, 185
 jitter, 189
 making, 198
 monitoring, 64
 previewing, 59, 185
 processors, 202
 projection center, 227
 projector location, 226
 projectors, 74
 reels, 192
 room, 215
 scratched, 187
 scratch elimination, 75
 splicers, 197
 storage, 197
 timer, 195
 viewers, 195
 wobble, 189
 Film cameras, 58
 chains, 58
 field lens, 61
 multiplexers, 60
 opaque projector, 61
 synchronizing generator, 61
 video switcher, 62
 Film projectors, 74
 Film room, 215
 Filterplexer, 113, 116
 temperature changes, 114

- Fines, FCC, 258
 Fixed base tower, 176
 Fixed lighting, studio, 32, 34
 definition, 35, 37
 Flats, 49
 Flexible line (helix), 125
 Flipboard, 274
 Floor plan, basic, 211
 Fluorescent lighting, 230
 Focusing plates, 94
 Footage minding, 202
 Foot-candle readings, 31
 Frame, film, 202
 Frequency check, 265
 Frequency meter, 120
 Frequency monitor, 224, 226
F stop, lens, 39
- G**
- Gas blocks, 142
 Gas supply, 143
 Ghosting, 5, 157
 Ghosts, 133
 Grade A and B signals, 23
 Graticule, 100
 Grating (cross-hatch) generator, 245
 Gray scale, 39
 Grid dip meter, 243
 Ground, building, 83
 Ground rod, 220
- H**
- Hand tools, film, 197
 Harmonic filter, 114
 Heater elements, 180
 Helix transmission line, 128
 Helical antenna, 150, 169
 Horizontal pattern, antenna, 156
 Horizontal run, line, 144
 House lights, 30, 230
- I**
- Ice effects, 180
 Ice fall, 113
 Idiot cards, 47
 Illegal programs, 267
 Illumination (incident light), 30, 31
 Image orthicon camera
 basic costs, 50
 burn out, 39
 in camera chain, 60
 control room requirements for, 54
 lenses, 40
 orbitor, 40
 Image orthicon tube, 37, 39, 40
 burn out, 39
 Instruments, basic
 generator, grating and cross-hatch,
 245
 grid dip meter, 244
 multimeter, 242
 oscilloscope, 240
 tube checker, 243
 video sweep generator, 243
 vtvm, 242
 wattmeter, 244
 Instruments, special
 audio signal generator, 247
 distortion analyzer, 247
 linearity, stair-step generator, 247
 marker generator, 246
 phase analyzer, 247
 receiver sweep generator, 246
 square wave generator, 247
 transistor checker, 250
 Insulation, plastic, 81
 Intercom system, 220
 Interference, 260
 directional antennas, 155
 off/air pickups, 72, 123
 spurious emissions, 91, 99
 Intermittent mechanism, projector, 75
- J**
- Jack fields, 152
 Jacks, video, 46
 Jitter, film, 188, 189
- K**
- Klystron tubes, 92, 94, 95
 ceiling height required, 213, 235
 changing, 96, 234
 description, 94
 efficiency, 96
 water cooling, 96
- L**
- Lag, vidicon tube, 39, 43
 Lap-dissolve, 62
 Lavalier microphone, 43
 Lease, property, 4
 Lens cap, electronic, 57
 Lenses, 37, 40, 41, 42

- License, 266
 - application filing time, 266
 - display, 261
 - renewal, 266
 - Licensed operators, 264
 - Light
 - back, 31
 - backdrop, 31
 - base, 31
 - fixed, 35
 - incident, 32
 - key, 31
 - Lighting
 - back, 31
 - backdrop, 31
 - base, 31
 - effects on camera selection, 43
 - fixed, 35
 - floor plan chart, 35
 - house, 30, 230
 - intensities, 31
 - key, 31
 - load distribution, 231
 - measuring techniques, 32
 - personnel, 37
 - set chart, 36
 - Lighting controls, pre-set, 34
 - Lighting equipment inspection, tower, 265
 - Lighting fixtures, 30
 - dimmer, 34
 - do-it-yourself spotlight, 270
 - do-it-yourself striplight, 269
 - grid, 34
 - hanger, 271
 - pantograph, 34
 - Light meter, 31
 - Lightning protection, 177
 - Line, transmission (*see* Transmission lines)
 - Linear amplifier, transmitter, 105
 - Linearity (stair-step) generator, 247
 - Line gas pressure, 141
 - Line installation, planning, 138
 - Line shelter, 143, 144
 - Live programs, 27
 - Load and wattmeter, 244
 - Lobby, building, 211, 217
 - Lobe, 153
 - Local channel, 10
 - Logs
 - maintenance, 263
 - making corrections, 263
 - program, 263
 - retaining, 264
 - signatures, 263
 - transmitter, 263
 - Low pass filter, 112
- M**
- Magnetic sound, projector, 77, 78
 - Magnetic sound tracks, 201
 - Magnetic stripe, film, 186
 - Maintenance, 238
 - antenna, 178
 - film, 190
 - overall, 239
 - projectors, 193
 - proof-of-performance, 181, 236, 239
 - RCA Service Co., 78, 181, 193, 239, 262
 - test instruments, 240, 246
 - tower, 178
 - tower painting, 177
 - transmitter, 28
 - Maintenance contracts
 - antenna and line, 181
 - film equipment, 78
 - overall, 239
 - projectors, 193
 - Marker generator, 246
 - Market area, 1
 - Mechanical beam tilt, antenna, 154
 - Metropolitan areas, coverage, 16
 - Mica insulators, 104
 - Micro-match, 118, 119
 - Microphones, 43
 - lavalier, 43
 - outlets, 45, 81
 - pre-sets, 276
 - Microwave links, 5, 9
 - Microwave reflectors, 177
 - Mike boom, 43
 - Modulation, visual, 90
 - Modulation monitor, 224, 226
 - Modulator (TTU-1B), 105
 - aural, 108
 - Monitoring
 - audio, 68
 - film, 64
 - placement of monitors, 227, 229, 233
 - transmitter, 99
 - video, 63
 - vswr, 181
 - Multimeter, 242
 - Multi-path (ghosting), 5
 - Multiplexer, 58, 60
 - accessories, 61
 - field lens, 61
 - Multipliers, transmitter, 91, 103, 108, 120
 - changing, 123

N

Negative capacitor, 107
 Negative film, 202
 News center, 207
 News rooms, 217, 218
 Nitrogen gas, 114
 Noise, film sound tracks, 78
 Noise-distortion analyzer, 253
 Noise level, 71
 Notch filter, 112
 Null, 158

O

Off/air pickups, 72
 alignment instrument, 246
 antenna used, 72
 audio circuits (TC-4A switcher), 278
 permission required, 72
 Offices, 217
 Oiling film, 187
 Operator license display, 261
 Optical sound, projector, 71, 78
 Optical sound tracks, 201
 Orbiters, camera, 40
 "O" rings, 136
 Oscillators, transmitter, 102
 Oscilloscope, 240
 testing, 253, 254
 Outlets
 audio, 46
 studio, 45
 video, 46
 Outside lights, building, 221

P

Pan and tilt assembly, 56
 Pantograph, 34
 Parallel lines, 103
 Parasitics, 92
 Patchboard, audio, 46
 Patch panel, lighting, 35
 Peak-to-peak measurements, 254
 Pedestal, camera, 43
 Personnel
 announcer, 229
 cameraman, 57
 for combined studio-transmitter, 9
 control room engineer, 53
 director, 229
 facilities for, 7, 206
 lighting, 37
 one-man control, 226
 tower climber, 179

 transmitter operator, 7, 264
 at transmitter site, 7
 Phase analyzer, 247
 Phase equalization, 112
 Pipe hangers, backdrop, 49
 Pivot base tower, 176
 Plenum chamber, 227
 Political files, 267
 Polyethylene, 131
 Population centers, 3, 4
 Positive film, 202
 Power, maximum radiated, 89
 Power gain, antenna, 153
 Power rating charts (line), 134, 135
 Power rewind, 194
 Power supplies, 66
 Power transformers, building, 219
 entrance, 219
 load balance, 220
 Power tube testing, 122
 Pre-printed logs, 263
 Pre-tuned cavity, 96
 Previewing, 59
 film, 185
 Principal community, 3, 17
 required signal, 16, 21
 Prisms, multiplexer, 61
 Processing film, speed, 203
 Profile construction, 17, 19
 Program log analysis, 267
 Programming
 remotes, 83
 sets, 35
 types, 27, 53
 typical small-market, 53
 Program sources
 film, 58, 74, 184, 198
 live, 27, 53
 off/air, 72
 remotes, 83
 slides, 78
 Program test authority, 262
 Projection area, 226
 center, 227
 Projector, film, 58, 74
 continuous, 74
 intermittent, 74
 magnetic sound, 77, 78
 maintenance, 193
 optical sound, 78
 preview, 198
 Projector, opaque, 61
 Projector, slide, 58, 78
 Proof-of-performance, 257, 261, 266
 measurements, 236
 Props, 28, 47
 colors, 47
 Pylon antenna, 174

Q

- Q, exciter circuits, 110
- Q, filterplexer sections, 114

R

- Racks, equipment, 82, 227
 - a-c outlets, 82
- Radial, 21
- Radiation center of antenna, 22
- Radio inspector, 262
- Radome, 166
- Ramps, 214, 229
- RCA Service Co., 78, 181, 193, 239, 262
- Recording booth, 71
- Reels, plastic film, 192
- Reflected wave, 100
- Reflectometers, 111, 227
 - calibration technique, 114
 - FCC required calibration, 266
- Remote control, projectors, 78
- Remote meters, 227
- Remote pickups, 56
 - examples, 83
- Reversal film, 202
- Roads, access, 7, 9
- Rules and Regulations of the FCC, 1, 15
 - waivers, 8

S

- Screen control, 4X150 stage, 124
- Separation, between carriers, 90
- Serrasoid modulator, 110
 - noise pickup, 124
- Set building, 49
- Shadow areas, 4, 6
- Shielded pairs, audio, 46, 81
- Shutoff dampers, 222
- Shutter, projector, 75
- Sidebands, 112
- Side-fire radiation, antenna, 154
- Side mounting, antenna, 176, 177
- Silicone grease, 136
- Site selection, 1
 - alternatives, 5
 - basic factors in, 3
 - examples, 11
 - location setups, 5
- Skew-ray plate, projector, 75
- Skids, projector, 187
- Skin effect, 97

- Slot covers, 179
- Slotted antenna, 150
- Soil samples, tower base, 176
- Sound
 - magnetic, 77, 78, 201
 - optical, 201
- Sound lock, 230
- Sound tracks, 201
- Splicers, film, 197
- Split bullet, 181
- Spotlight, 271
- Spring contacts, 104, 117
- Sprocket holes, damaged, 188
- Sprocket shoes, 190
- Spurious emissions, 91, 99, 260
- Square wave generator, 247
- Stabilizing amplifier, 64
- Stage lighting, 230
 - heat, 231
- Stage oscillations, 120
- Staging area, studio, 27, 45
- Stair-step (linearity) generator, 247
- Standards of Good Engineering Practice, 1
- Station identification, 264
- Station inspection (FCC), 262
- Steeplejacks, 135
- Striplights, 269
- Studio
 - basic, 27, 215
 - cooling, 231
 - expansion, 232
 - floor covering, 45
 - outside door, 30, 210
 - wet floor, 217
- Studio transmitter link (STL), 6
 - rates for service, 10
- Sulfur-hexafluoride gas, 114
- Sweep generator, video, 243
 - receiver, 246
- Switcher, video, 62
- Switcher (TC-4A), 62, 274
- Sync generator, 56, 61

T

- Table of Assignments, 1, 88
- Tape machines, audio, 71
- "T" connector, coaxial, 251
- Teflon line, 127
- Telephone circuits, 219
- Telephone company microwave, 10
- Terminated cables, 251
- Termination, screw type, 251
- Test equipment (*see also* Instruments, basic, Instruments, special), 236
 - accuracy, 238
 - film, 245

- Testing techniques, 250
 - Test lead repair, 238
 - Tool board, 234
 - Tool caddy, studio, 233
 - Topographical maps, 18
 - Towers
 - bases, 176
 - cost example, 182
 - design, 138
 - determining height, 23
 - erection, 260
 - erection hazards, 4
 - FAA considerations, 3, 260
 - galvanizing, 177
 - guyed, 175
 - inspection, 266
 - insurance, 4
 - lighting, 3, 260, 264
 - lightning protection, 177
 - location, 4, 5, 210
 - maintenance, 26, 178
 - maximum height, 89
 - painting, 177
 - radio, 176
 - self-supporting, 176
 - soil testing, 176
 - special lighting, 3
 - windloading, 177
 - Transformer vault, 107
 - Transistor checker, 250
 - Transit time effect, 92
 - Transmission lines
 - air pumps, 142
 - antenna connection, 138
 - bleeding, 143
 - bullet, 127, 136
 - clamps, 139
 - contraction and expansion, 139
 - cost estimates, 146
 - cutting, 136
 - diameter, 132
 - efficiency, 132
 - elbow, 127
 - flexible, 128
 - gas block, 142
 - gassing, 141
 - gas supply, 143
 - handling, 135
 - hangers, 139
 - heliac, 128
 - icing, 143
 - length, 132
 - line shelter, 144
 - losses, 25, 127, 132
 - planning installation, 138
 - protection, 137, 143
 - ratings, 133
 - selection, 131
 - size, 132
 - teflon, 127
 - vswr, 133
 - waveguide, 145
 - Transmitters
 - air intake and exhaust, 222
 - aural, 108
 - ceiling height, 214
 - combined with studio, 8
 - cooling, 209, 213
 - layout, 213, 222
 - and line size, 132
 - links with studio, 9
 - maintenance, 28
 - modifications, 123
 - monitoring, 99
 - remote control, 7
 - separate from studio, 5
 - tubes, 92
 - uhf features, 91
 - vestigial sideband filter-diplexer, 112
 - video requirements, 111
 - visual, 102
 - Traveling wave principle, 171
 - Traveling wave tube, 108
 - Trench, 82
 - Tube checker, 243
 - Twistlock plugs, 35, 82
- U**
- UHF
 - antennas, 149
 - audio requirements, 66
 - channels, 88
 - compared with vhf, 5
 - control room engineering, 79
 - equipment suppliers and manufacturers, 283
 - power, 89
 - propagation problems, 3
 - separation, 89
 - special transmitter features, 91
 - transmission lines, 127
 - transmitters, 88
 - tubes, 92
 - video requirements, 54, 111
 - Unity vswr, 134
 - Universal line, 125
 - Unwanted coupling, 99
 - U-shaped console, 226
 - Utilities, 7, 9

V

Vacuum tube voltmeter, 242
Variable voltage capacitor, 111
Velocity modulated beam, 96
Vertical pattern, antenna, 156
 charts, 159, 163
VHF reception, 5
Video jackfields, 83
Video levels, standard, 81
Video response pattern, 250
Vidicon camera
 basic costs, 50
 in camera chain, 60
 control room requirements for, 54
 lag, 39
 lenses, 42
Vidicon tube, 39, 61
 lag factors, 39
 sensitivity, 43
Viewers, film, 195
Violation, notice of, 257
Visual reflectometer, 115
Voltage conversion, 275
VSWR, 98, 119, 131

W

Water cooling
 power tubes, 224
 transmitters, 213

Wattmeter, 244
Waveform monitor, 54
Waveguide, 145
WBJA-TV, 11
Well water, filtering, 7
White stretching, 111
Windloading, antenna and tower, 166,
 177
Windows
 klystron tubes, 94
 slotted antenna, 166
WLBC-TV, 14
Wobble, film, 188, 189
Workshop, 215
 area, 234
WTAF-TV, 12

Y

Yagi antenna, 72

Z

Zig-zag antenna, 150, 171
Zones, 88
Zoom lens, 41



planning the local uhf-tv station

Patrick S. Finnegan

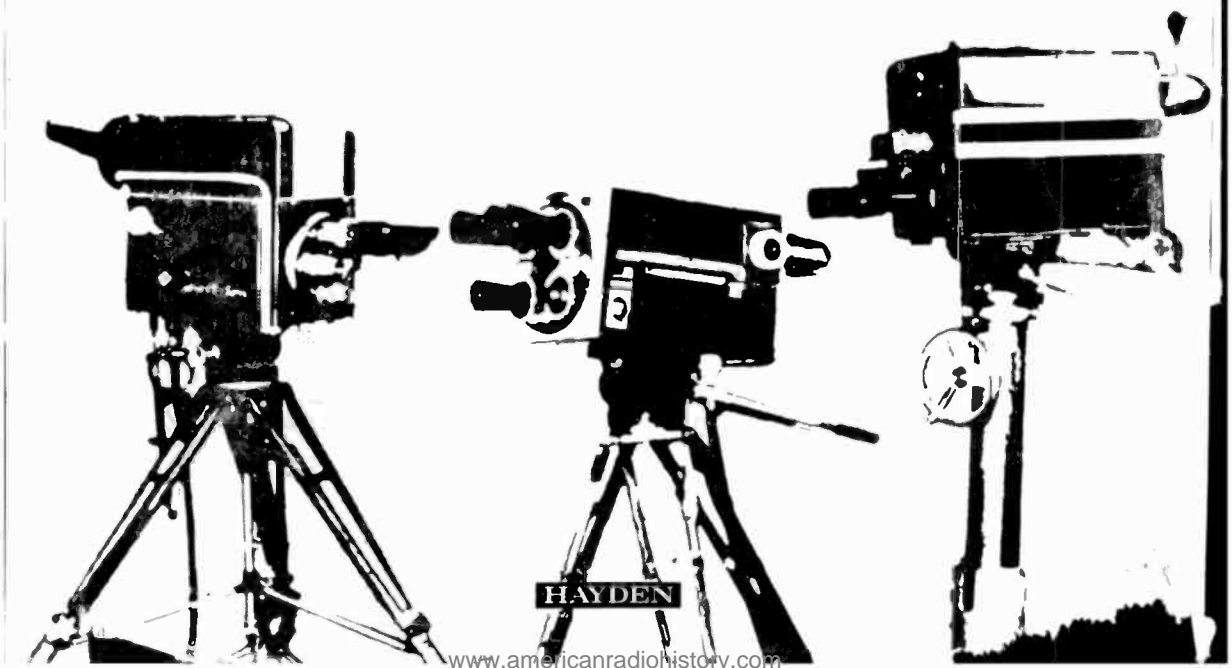

HAYDEN

